

KENWOOD

Document Copyrights

Copyright 2006 by Kenwood Corporation. All rights reserved.

No part of this manual may be reproduced, translated, distributed, or transmitted in any form or by any means, electronic, mechanical, photocopying, recording, or otherwise, for any purpose without the prior written permission of Kenwood.

Disclaimer

While every precaution has been taken in the preparation of this manual, Kenwood assumes no responsibility for errors or omissions. Neither is any liability assumed for damages resulting from the use of the information contained herein. Kenwood reserves the right to make changes to any products herein at any time for improvement purposes.

KGP-2A/2B

SERVICE MANUAL

KGP-2A

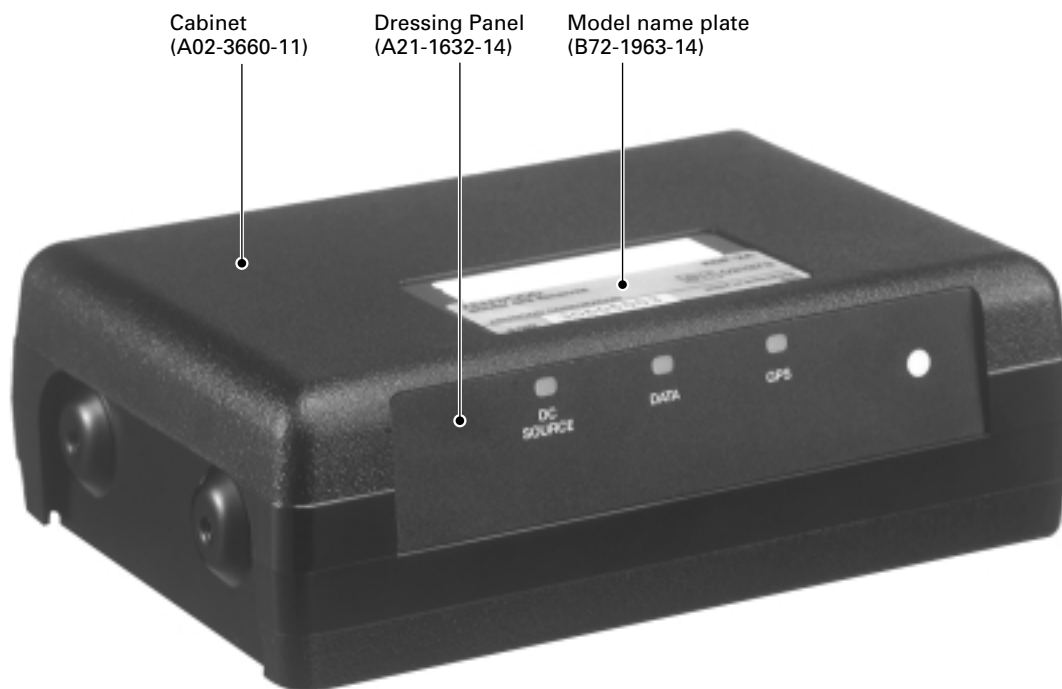

KGP-2B

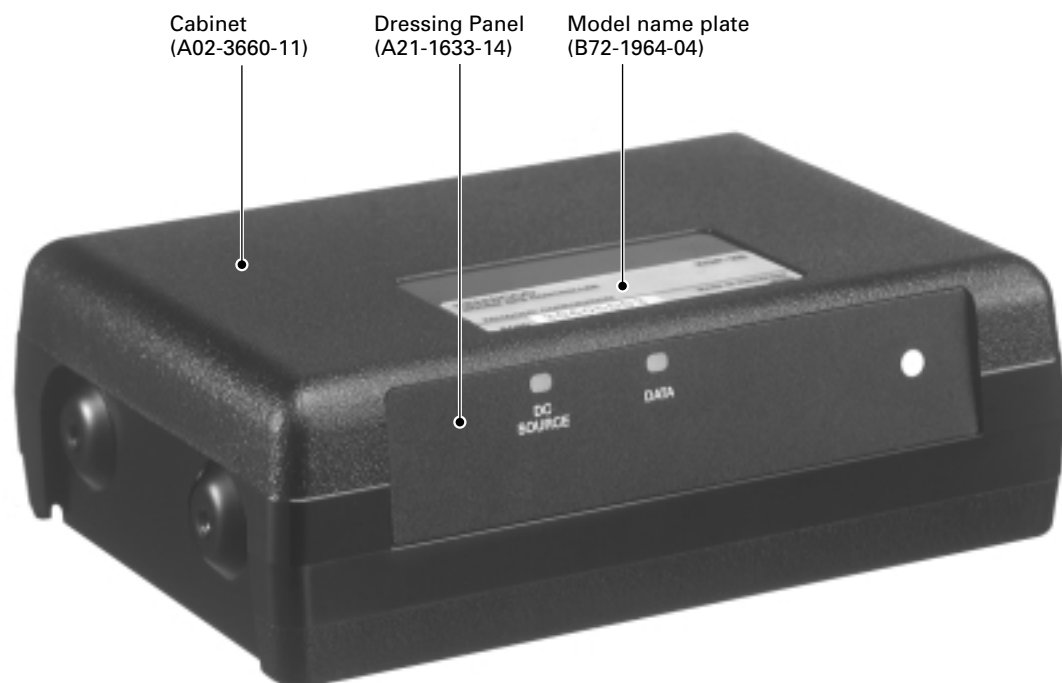

CONTENTS / INSTALLATION

CONTENTS

INSTALLATION	2
REALIGNMENT	3
MODIFICATION	5
DISASSEMBLY FOR REPAIR	6
ADJUSTMENT	6
CIRCUIT DESCRIPTION	8
DESCRIPTION OF COMPONENTS	10
SEMICONDUCTOR DATA	11
PARTS LIST	12
EXPLODED VIEW	19
PACKING	20
PC BOARD VIEWS	
CONTROL UNIT (X53-3980-20)	21
CONTROL UNIT (X53-3980-21)	25
SCHEMATIC DIAGRAM	29
BLOCK DIAGRAM	33
LEVEL DIAGRAM	37
TERMINAL FUNCTION	38
SPECIFICATIONS	39

INSTALLATION

TK-780/880/980/981 Series (TK-*80 Series)

■ Installing the KCT-34 in the Transceiver

1. Remove the upper cover from the transceiver.
2. Lift the DC cord bushing (❶) from the chassis.
3. Remove the pad as shown in the Figure 1 (❷).
4. Insert the KCT-34 cable (❸) into the chassis (❹). The wire harness band (❺) must be inside the chassis.
5. Replace the DC cord bushing (❻).
6. Connect the KCT-34 to the TX-RX unit (A/2) as shown in Figure 2 (❼).

Connector	Wire Color	Pin No.	Connector	Wire Color	Pin No.
A-1	Brown	4	B-1	NC	–
A-2	NC	–	B-2	White	11
A-3	NC	–	B-3	Green	7
A-4	Orange	5	C-1	Purple	9
A-5	Gray	10	C-2	Light blue	14
A-6	NC	–	C-3	Light green	15
A-7	Yellow	6	D-1	NC	–
A-8	Blue	8	D-2	Black	3
			D-3	Red	1

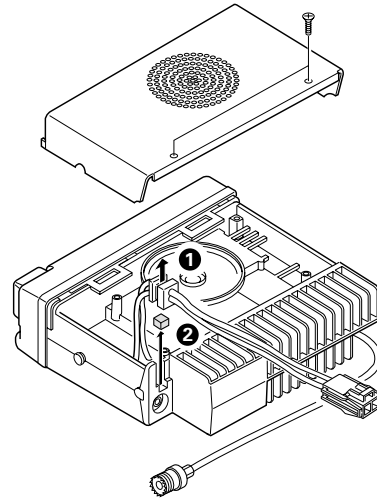

Fig. 1

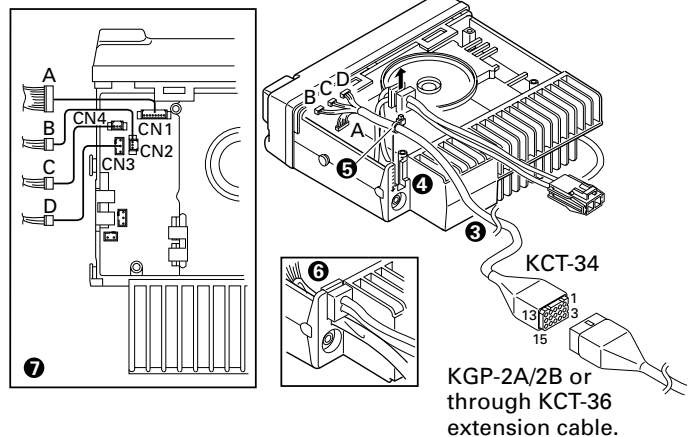

Fig. 2

INSTALLATION / REALIGNMENT

TK-760G/762G/860G/862G/768G/868G Series (TK-*60G Series)

■ Installing the KCT-35 in the Transceiver

1. Remove the upper cover from the transceiver.
2. Lift the DC cord bushing (❶) from the chassis.
3. Remove the pad as shown in the Figure 3 (❷).
4. Insert the KCT-35 cable (❸) into the chassis (❹). The wire harness band (❺) must be inside the chassis.
5. Replace the DC cord bushing (❻).
6. Connect the KCT-35 to the TX-RX unit (A/2) as shown in Figure 4 (❼).

Connector	Wire Color	Pin No.	Connector	Wire Color	Pin No.
A-1	Brown	4	B-1	Gray	10
A-2	Green	7	B-2	White	11
A-3	NC	-	B-3	Purple	9
A-4	Orange	5	C-1	NC	-
A-5	NC	-	C-2	Black	3
A-6	NC	-	C-3	Red	1
A-7	Yellow	6			
A-8	Blue	8			

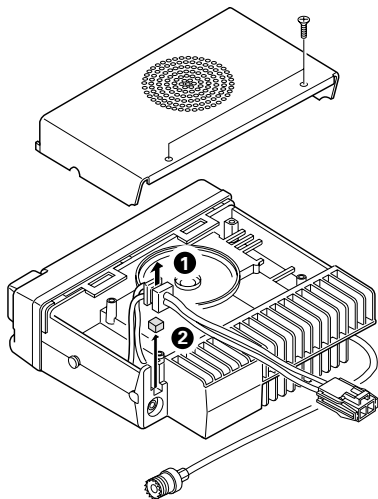

Fig. 3

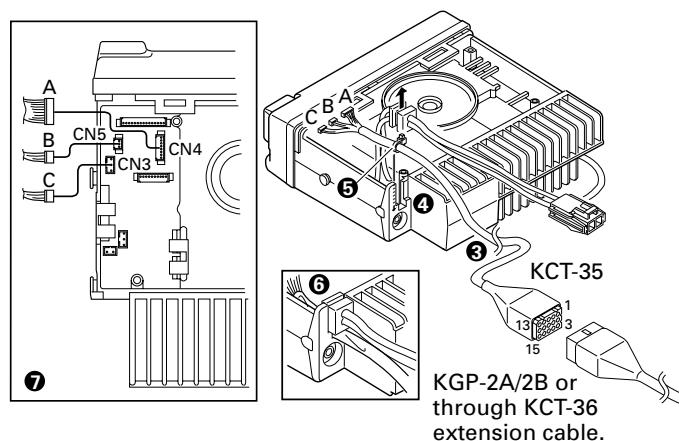

Fig. 4

REALIGNMENT

Transceiver Setting

When the KGP-2A/2B is connected to a transceiver, the transceiver functions must be set. The transceiver FPU is used to make this setting.

For a connection method, see Figure 1.

■ TK-*80 Series Setting Method

1. Setting with KPG-49D (K and M markets FPU)

- 1) Select "Optional Features" from "Edit" on the menu bar and change Com2 (Internal Port) from "[None]" to "[AUX Hook/PTT]".

2. Setting with KPG-60D (E markets FPU)

- 1) Select "Extended Function" from "Edit" on the menu bar and change Com2 from "[None]" to "[AUX Hook/PTT]".

■ TK-*60G Series Setting Method

Use the KPG-56D as the FPU.

- 1) Select "Key assignment" from "Edit" on the menu bar, and set "Foot Switch" to "[None]".
- 2) Select "Optional Features" from "Edit" on the menu bar and change "ACC Hook/DTC" from "[ACC Hook]" to "[DTC]".

Note :

Applicable only for S/No. 302XXXXX or later.

KGP-2A/2B Setting

After programming the transceiver, you need to configure the KGP-2A/2B. Using the FPU (KPG-73D), you can configure the KGP-2A/2B.

Using a cross-wired serial cable (KGP-2A/2B side : D-sub 9-pin female) as shown in Figure 2, plug one connector into the RS-232C (COM) port of your PC and the other end to the ACC1 connector on the rear panel of the KGP-2A/2B.

■ KGP-2A/2B Setting Method

- 1) Create a data file using the FPU (KPG-73D).
- 2) After configuring the KGP-2A/2B to the Programming Menu mode, upload the data file to the KGP-2A/2B.

* For detailed instructions, refer to the Help file included in the FPU.

* To set the KGP-2A/2B in the Programming Menu mode, refer to "Start the Programming Menu mode" on page 6.

KGP-2A/2B

REALIGNMENT

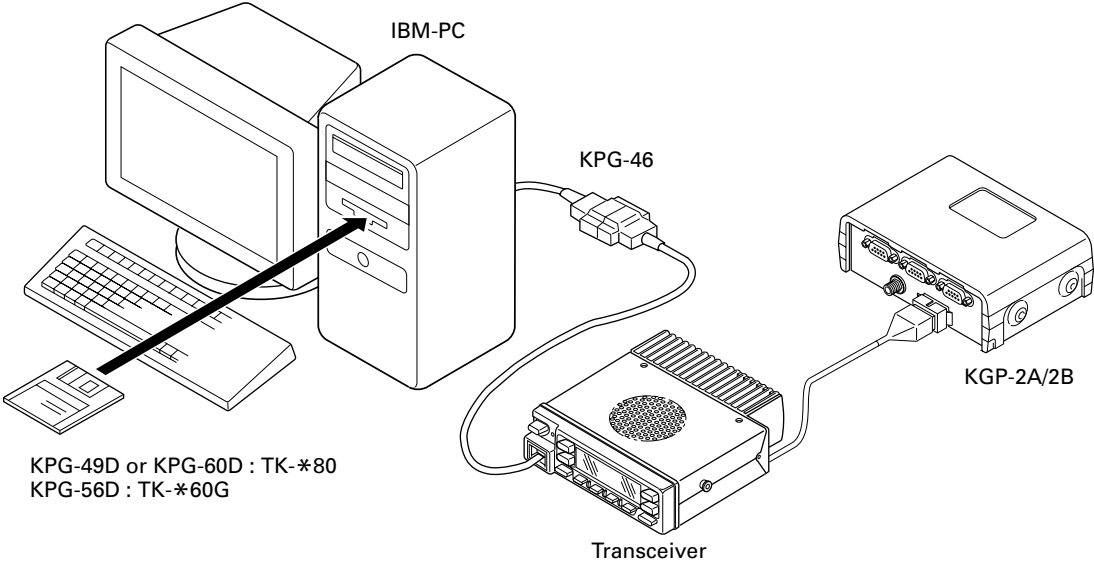

Fig. 1

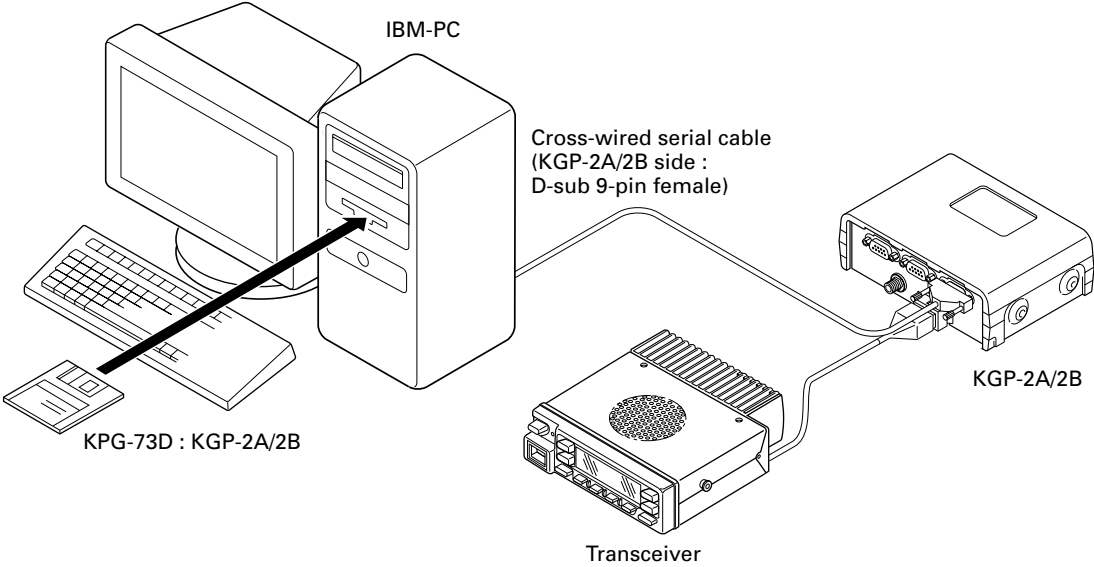

Fig. 2

MODIFICATION

Connecting a Separate Microphone for Emergency Mode (KGP-2A only)

If you apply the modification as described below, you can connect a separate microphone to the KGP-2A in place of the transceiver's microphone for Emergency mode. The base station application software which can send out a corresponding command is required for the change of a microphone which operates in the time of emergency transmission.

■ Modification

1. Remove R171 (0Ω).
2. Remove R172 (0Ω).
3. Add 0Ω (R92-0670-05) to the \$R17 location.
4. Add 0Ω (R92-0670-05) to the \$R18 location.

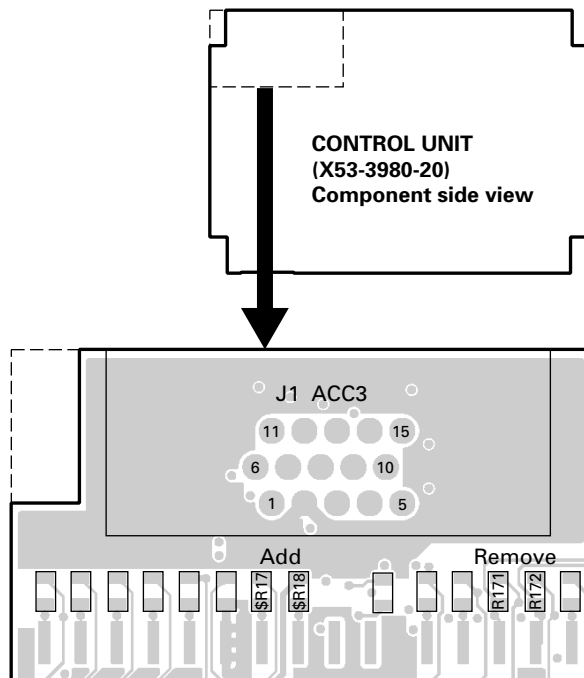

J1 (ACC3) Pin 5 : Microphone input
 J1 (ACC3) Pin 6 : Microphone ground (GND)

Since 5V DC goes through R55 (56kΩ) and then it is supplied to the microphone input, an electric condenser-type microphone can be connected to this terminal.

You can also adjust the microphone sensitivity by changing the R206 (560Ω) constant between 330Ω and approximately 1kΩ. The microphone pre-emphasis and IDC are carried out by the DSP IC (IC29).

Modification Setting for DGPS (KGP-2A only)

Input method of DGPS signal	\$R192 (0Ω)	R186 (0Ω)	\$R184 (0Ω)	\$R185 (0Ω)	R191 (0Ω)
5V input from ACC2	Yes	No	Yes	No	No
RS-232C level input from ACC2	Yes	No	Yes	No	Yes
5V input from ACC3	Yes	No	No	Yes	No
RS-232C level input from ACC3	Yes	No	No	Yes	Yes
Input method of DGPS signal	\$R190 (0Ω)	\$R221 (0Ω)	R162 (0Ω)	R169 (0Ω)	
5V input from ACC2	No	No	No	N/A	
RS-232C level input from ACC2	Yes	Yes	No	N/A	
5V input from ACC3	No	No	N/A	No	
RS-232C level input from ACC3	Yes	Yes	N/A	No	

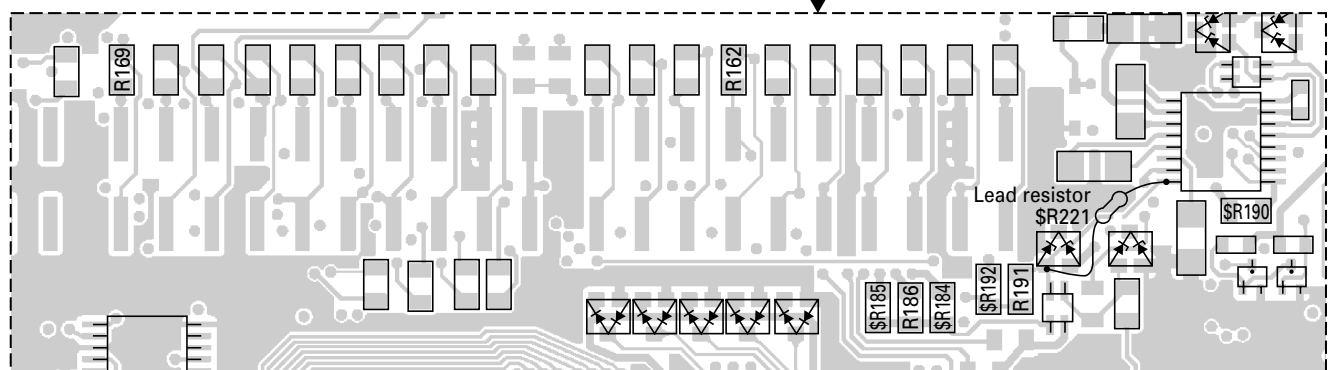
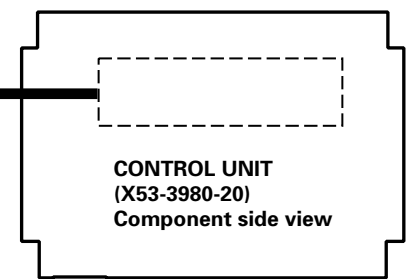

KGP-2A/2B

DISASSEMBLY FOR REPAIR / ADJUSTMENT

Remove the Case from the Chassis

1. Remove 4 screws (❶).
2. Hold the KGP-2A/2B upside down as shown in Figure 2, then lift the chassis upward by pulling the tabs on its side (❷). Also, lift the chassis on the other side in same manner.
3. Grab the chassis from the top and lift it upward (❸), then slide and pull the chassis slightly (❹). Lift the chassis upward (❺) to remove it from the case.

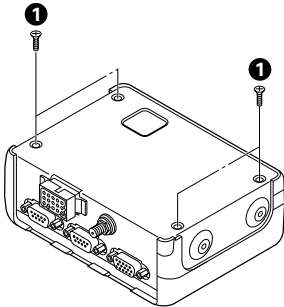

Fig. 1

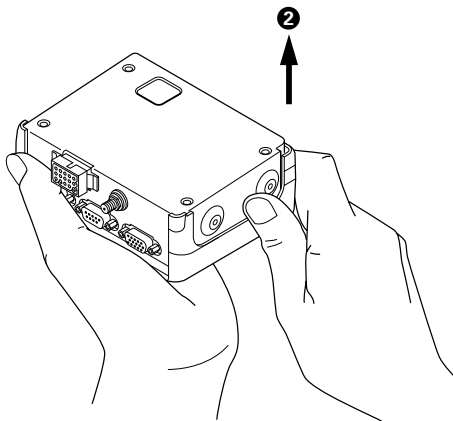

Fig. 2

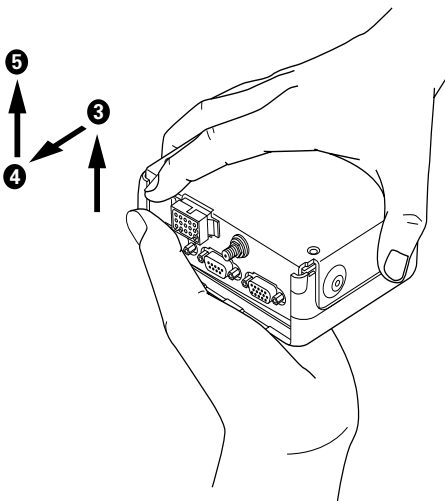
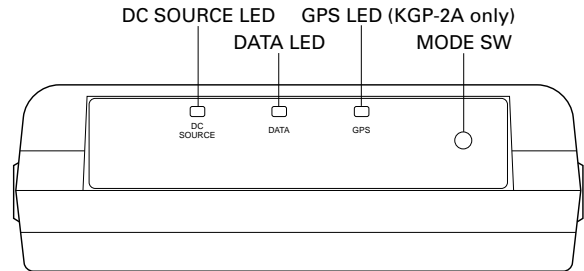

Fig. 3

ADJUSTMENT

Front Panel



Start the Programming Menu Mode

Press and hold the MODE SW key for more than 2 seconds. "DC SOURCE" LED blinks and then the KGP-2A/2B enters the programming menu mode.

Note : If the KGP-2A/2B does not receive any programming commands from a PC within 30 seconds after the "DC SOURCE" LED starts blinking. It returns normal operation (User mode). If you press MODE SW key while the "DC SOURCE" LED is blinking, the KGP-2A/2B returns to User mode.

Updating the Firmware

- 1) Connect the transceiver and KGP-2A/2B as shown in Figure 2 on page 4.
- 2) Double-click the "Fpro.exe" file (Ver. 3.01 or later) in the folder where the KPG-73D is installed.
- 3) After the program starts, click the "Open a file" icon [], then select the new firmware data file.
- 4) Configure the KGP-2A/2B to enter the Programming menu mode, then, click [Write] on the Fpro screen to start revising the firmware. (The Fpro program first erases the firmware file on the KGP-2A/2B, then writes the new firmware file.)
 - While erasing the firmware, the "DC SOURCE" LED blinks green and the "DATA" LED lights orange.
 - While writing the firmware, the "DC SOURCE" and "DATA" LEDs blink green.
 - When the firmware is successfully revised, only the "DC SOURCE" LED blinks green.
 - When an error occurs, the "DC SOURCE" LED blinks green and the "DATA" LED blinks red. In this case, switch the KGP-2A/2B OFF, then turn it ON again. The "DC SOURCE" LED blinks green and the "DATA" LED lights orange. Click [Write] on the Fpro screen to restart revising the firmware.
- 5) Click "OK" when the confirmation dialog box appears. Select [Exit] to exit the program.
- 6) Turn the KGP-2A/2B OFF and then back ON to return to User mode.

ADJUSTMENT

MSK Modulation Adjustment

Adjust deviation as follows: Wide: 3kHz and Narrow: 1.5kHz.

- 1) Connect a transceiver and a PC to the KGP-2A/2B (Figure 2 on page 4). After configuring the KGP-2A/2B to enter the Programming menu mode, select "Test Mode" from "Program" on the FPU (KPG-73D) menu.
- 2) Adjust the "Output Level" DIGIT value on the "MSK" screen.
- 3) When you click on "OK" on the PC screen, the adjustment value is written into the KGP-2A/2B memories.

MSK Detection Input Level Adjustment

Set the input voltage at pin 2 of the CODEC IC (IC22) of the KGP-2A/2B to 1000mVp-p.

- 1) Adjust the SSG level as shown below. Then connect the output to the transceiver.
 Frequency : Same frequency that the transceiver is receiving.
 Modulation Frequency : 1200Hz (or 1000Hz)
 Frequency Deviation : 3kHz (Wide), 1.5kHz (Narrow)
 Output Level : -53dBm (60dBμ)
- 2) Measure the KGP-2A/2B DI voltage (DI: CN1 pin 3, transceiver detection output voltage) with a AF-VTVM.
- 3) Set the "Input Level" DIGIT value according to the following conversion table on the "MSK" screen in "Test Mode" so that the measured voltage (mVrms) is the CODEC IC input voltage (1000mVp-p).
- 4) When you click on "OK" on the PC screen, the adjustment value is written into the KGP-2A/2B memories.

DI input level (mVrms)	DIGIT value	CODEC IC (IC22) pin 2 input level (mVp-p)
50	145	1000
100	59	
200	29	
300	20	
400	15	
500	12	
600	10	
700	9	
800	8	
900	7	
1000	7	
1100	6	
1200	6	

Conversion table

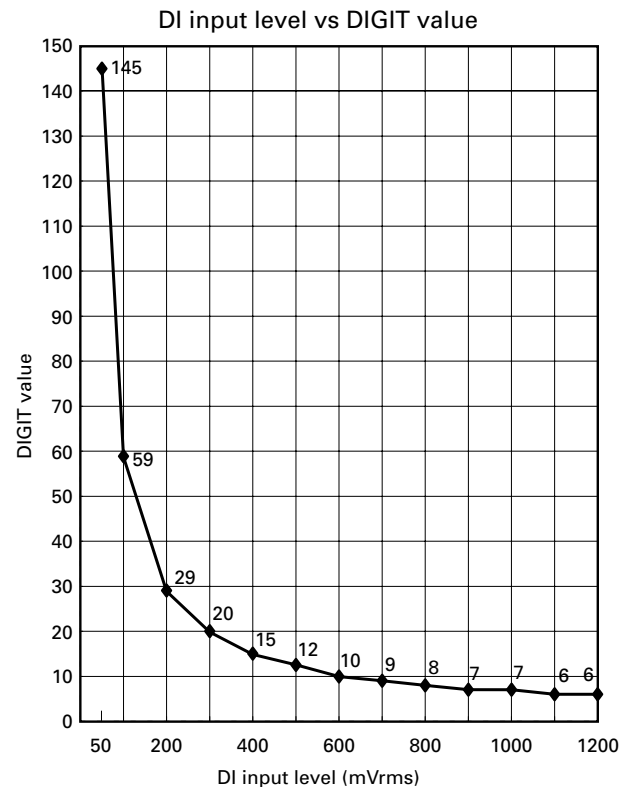

CIRCUIT DESCRIPTION

1. Power Supply Circuit

The KGP-2A/2B power supply circuit uses a dedicated regulator IC for each circuit application so that the circuits do not interfere with each other. (Figure 1)

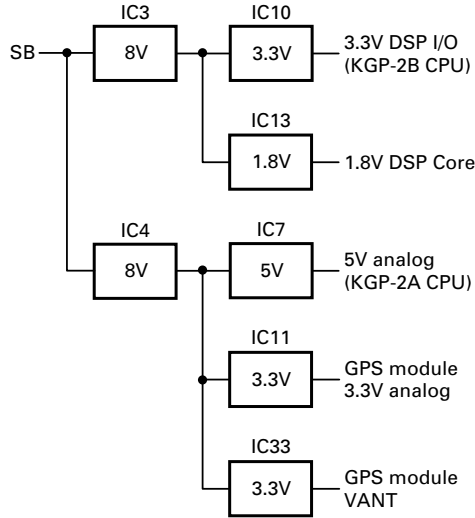

Fig. 1

2. LED Control Circuit

The LEDs of "DC SOURCE", "DATA" (TX/RX status), and "GPS" (KGP-2A only) are controlled by the CPU (IC17), using the shift register (IC12). (Figure 2)

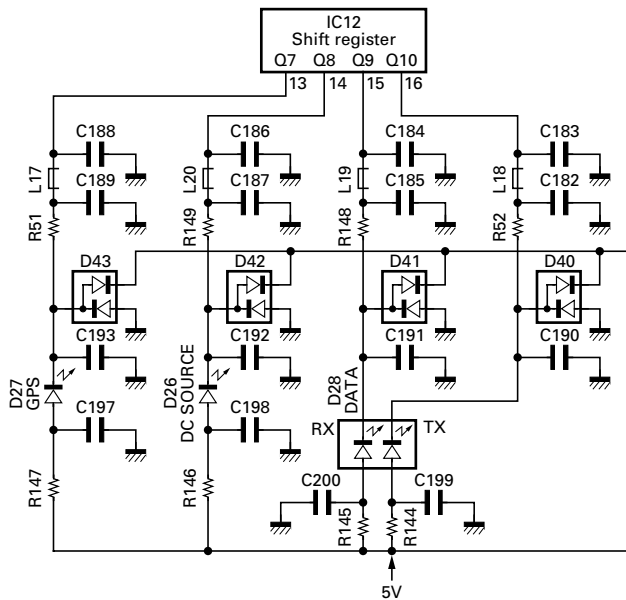

Fig. 2

3. Digital Control Circuit

■ Overview

The KGP-2A/2B control circuit consists of the CPU (IC17) and DSP IC (IC29).

The DSP functions as a MSK modem.

Figure 3 is a block diagram of a digital control circuit.

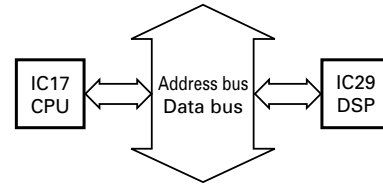

Fig. 3

■ Address control circuit

The CPU is running at "Single chip mode" that utilize the internal RAM and ROM. It exchanges data by using the external data bus to communicate with an external DSP IC. Although the CPU in the KGP-2A is running at 5V DC, the FLASH ROM (IC25) and DSP IC uses 3V DC. So, there are the 5V-3V level converter IC (IC19, IC20, IC21 and IC31) in the address bus and data bus to interface among these ICs. (Figure 4A)

Since the CPU in the KGP-2B is running at 3V DC, it does not require the voltage level conversion. So, the address bus and data bus of the CPU is connected to the FLASH ROM and DSP IC without using the 5V-3V level converter IC. (Figure 4B)

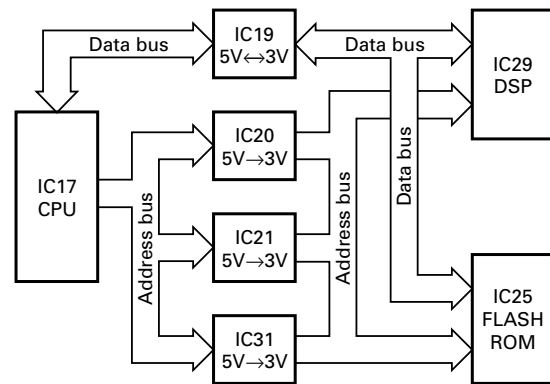

Fig. 4A

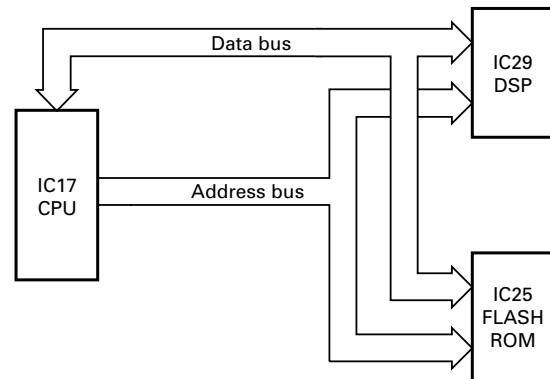

Fig. 4B

CIRCUIT DESCRIPTION

■ GPS module (KGP-2A only)

The location data is measured by the internal GPS module. When the KGP-2A is turned OFF, it enters the backup mode and the power is supplied by the internal rechargeable lithium battery. It takes approximately 45 seconds to calculate the location data when the KGP-2A is "cold" started (full initializing).

■ System reset

The reset IC (IC1) monitors the power supply voltage (SB : 13.6V). If the voltage drops, the IC outputs LOW-level on the OUT port. At the same time, PFINT port (CPU : IC17) becomes LOW-level and the program executes the backup routine. If the power supply voltage of the CPU (5V for the KGP-2A or 3 V for the KGP-2B) becomes lower than the specified value, the CPU stops working. When the power supply voltage of the CPU becomes normal (the above voltage), the reset IC (IC14) outputs the reset signal to the CPU RESET port. Then the CPU initializes the settings and starts working again.

■ Serial (COM) port

The KGP-2A/2B communicates to an external PC through the ACC1 connector on the rear panel. The KGP-2A/2B has an internal, bi-directional RS-232C/TTL voltage level converter (IC6) that converts the signal levels between the CPU and the ACC1 connector. (Figure 5)

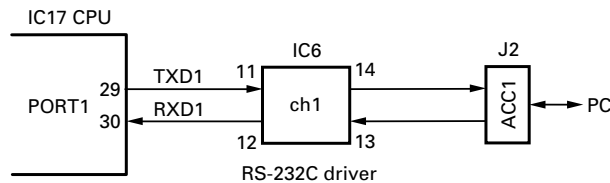

Fig. 5

4. Transmit/Receive Signal Flow

■ Receive Data Signal

The transceiver's detector output passes through CN1 pin 3 (DI) and amplifier (IC16), and the output level is adjusted by the D/A converter (IC18). The signal is amplified by the same amplifier (IC16) again, passes through the CODEC IC (IC22), and then it is converted to digital data.

The data is serially transferred from the CODEC IC to the DSP IC (IC29) and then further processed by the DSP IC. (Figure 6)

■ Transmit data signal

The digital data processed by the DSP IC, is serially transferred from the DSP IC to the CODEC IC. Then the signal is converted to analog signal. The signal is amplified by the amplifier (IC26) and then passes through the D/A converter (IC18) to adjust the voltage level. The signal is used as the transmitting data for the transceiver after passing through CN1 pin 5 (DO). (Figure 6)

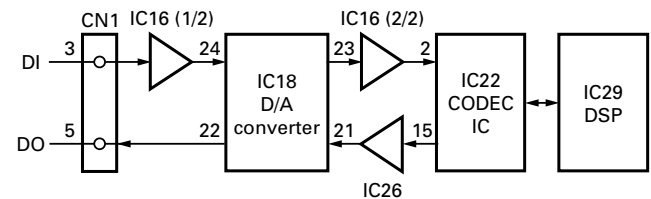

Fig. 6

KGP-2A/2B

DESCRIPTION OF COMPONENTS

Control Unit (X53-3980-XX)

Ref. No.	Use / Function	Operation / Condition
Q1,2	Switching	Level converter 3V→5V
Q4	Switching	Power switch of GPS module
Q5,6	Switching	Output terminal open-collector
Q10~14	Switching	Level converter 3V→5V
Q15	Switching	Logic inverter
Q16~26	Switching	Level converter 3V→5V
IC1	Reset IC	Monitor of SB power supply voltage
IC3,4	Regulator	8V (1A)
IC6	RS-232C driver	Level converter 5V↔RS-232C
IC7	Regulator	5V (500mA)
IC9	Extended I/O	Radio control, Serial/parallel conversion
IC10,11	Regulator	3.3V
IC12	Shift register	LED (D26~28) control, Power switch of GPS module
IC13	Regulator	1.8V
IC14	Reset IC	Monitor of CPU power supply voltage
IC15	EEPROM	Memory backup
IC16	Amplifier	Input data
IC17	CPU	16 Bit
IC18	D/A converter	
IC19	Level converter	5V↔3V
IC20,21	Level converter	5V→3V
IC22	CODEC IC	A/D,D/A conversion
IC23	Gate IC	IC19 direction control
IC24	Gate IC	A19 (IC17) Logic inverter
IC25	Memory IC	3.3V FLASH ROM

Ref. No.	Use / Function	Operation / Condition
IC26	Amplifier	Output data
IC28	Clock demultiplier	for DSP
IC29	DSP IC	
IC31	Level converter	5V→3V
IC32	Amplifier	Microphone input signal
IC33	Regulator	3.3V
D1	Over current protection	0.75A
D2	Backward voltage protection	
D5	Reverse current protection	
D7~9	Surge absorption	
D12	Surge absorption	
D18	Reverse current protection	
D24	Surge absorption	
D26	LED	DC SOURCE (Power)
D27	LED	GPS
D28	LED	DATA (TX/RX)
D30	Reverse current protection	
D31~48	Surge absorption	
D50~62	Surge absorption	

Additional PCB

Ref. No.	Use / Function	Operation / Condition
Q7,8	Switching	Output terminal open-collector

SEMICONDUCTOR DATA

CPU : 30620M8A-2M6GP (Control unit IC17)

Pin No.	Pin Name	I/O	Function
1~5	SEN12~	I/O	KGP-2A Sensor 12~8
	SEN8	I	KGP-2B Not used
6	BYTE	I	Data bus width 8 bit
7	CNVSS	I	Memory extended mode select (GND)
8	MES	I	Microprocessor operation mode
9	FRBSY	I	FLASH ROM busy detect
10	RESET	I	Reset input
11	XOUT	O	Clock output
12	VSS	-	GND
13	XIN	I	Clock input
14	VCC	-	Power supply
15	NMI	I	Not used
16	SRCLK1	I	KGP-2A SWIPE READER CLOCK1 input
			KGP-2B Not used
17	SRCLK2	I	KGP-2A SWIPE READER CLOCK2 input
			KGP-2B Not used
18	PFINT	I	Power supply voltage monitor input
19	E2PSCL	O	E2PROM SK
20	VRLD	O	Electronic VR LD
21	-	I	Not used
22	SEN_ACC2/1	I	Not used
23	SEN_ACC2/2	I	Not used
24	SEN_ACC3	I	Not used
25	RADOE	O	IC9 OE (for RADIO)
26	RADST	O	IC9 ST (for RADIO)
27	RXD2	I	KGP-2A Radio data input
			KGP-2B Not used
28	TXD2	O	KGP-2A Radio data output
			KGP-2B Not used
29	TXD1	O	PC data output
30	RXD1	I	PC data input
31	CLK	O	Common CLOCK
32	DATA	O	Common DATA
33	TXD0	O	KGP-2A GPS receiver output (GPSTXD)
			KGP-2B Not used
34	RXD0	I	KGP-2A GPS receiver input (GPSRXD)
			KGP-2B Not used

Pin No.	Pin Name	I/O	Function
35	RADSQ	I	Radio SQ input
36	RADTXS	I	Radio TXS input
37	RDY	I	Not used
38	ALE	O	Not used
39	HOLD	I	Not used
40	HLDA	O	Not used
41	BCLK	O	Not used
42	RD	O	Read signal
43	BHE	O	Not used
44	WR	O	Write signal
45	DSPCS	O	DSP chip select
46	E2PSDA	I	E2PROM DI
47	E2PWP	O	E2PROM DO
48	FROMCE	O	FLASH ROM CE
49~59	A19~A9	-	Address bus 19~9
60	VCC	-	Power supply
61	A8	-	Address bus 8
62	VSS	-	GND
63~70	A7~A0	-	Address bus 7~0
71	MODESW	O	Mode SW
72	DSPRINT	I	DSP RX interrupt
73	DSPTINT	I	DSP TX interrupt
74	DPSCCLR	O	DSP reset output
75	SRSEL	I	KGP-2A SWIPE READER SELECT
			KGP-2B Not used
76	SRDAT1	I	KGP-2A SWIPE READER DATA1
			KGP-2B Not used
77	SRDAT2	I	KGP-2A SWIPE READER DATA2
			KGP-2B Not used
78	LEDLCK	O	IC12 LCK (for LED)
79~86	D7~D0	-	Data bus 7~0
87~93	SEN7~SEN1	I/O	KGP-2A Sensor 7~1
			KGP-2B Not used
94	AVSS	-	Analog power supply (GND)
95	SEN0	I/O	KGP-2A Sensor0
			KGP-2B Not used
96	VREF	-	Reference voltage
97	AVCC	-	Analog power supply
98~100	SEN13~ SEN15	I/O	KGP-2A Sensor 13~15
			KGP-2B Not used

PARTS LIST

CAPACITORS

CC 45 TH 1H 220 J
 1 2 3 4 5 6

- 1 = Type ... ceramic, electrolytic, etc.
- 2 = Shape ... round, square, ect.
- 3 = Temp. coefficient
- 4 = Voltage rating
- 5 = Value
- 6 = Tolerance

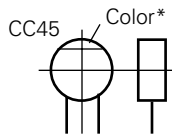

• Capacitor value

- 010 = 1pF
- 100 = 10pF
- 101 = 100pF
- 102 = 1000pF = 0.001μF
- 103 = 0.01μF

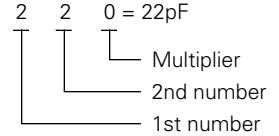

• Temperature coefficient

1st Word	C	L	P	R	S	T	U
Color*	Black	Red	Orange	Yellow	Green	Blue	Violet
ppm/°C	0	-80	-150	-220	-330	-470	-750

2nd Word	G	H	J	K	L
ppm/°C	±30	±60	±120	±250	±500

Example : CC45TH = -470 ± 60ppm/°C

• Tolerance (More than 10pF)

Code	C	D	G	J	K	M	X	Z	P	No code
(%)	±0.25	±0.5	±2	±5	±10	±20	+40 -20	+80 -20	+100 -0	More than 10μF -10 ~ +50 Less than 4.7μF -10 ~ +75

(Less than 10pF)

Code	B	C	D	F	G
(pF)	±0.1	±0.25	±0.5	±1	±2

• Voltage rating

2nd word \ 1st word	A	B	C	D	E	F	G	H	J	K	V
0	1.0	1.25	1.6	2.0	2.5	3.15	4.0	5.0	6.3	8.0	-
1	10	12.5	16	20	25	31.5	40	50	63	80	35
2	100	125	160	200	250	315	400	500	630	800	-
3	1000	1250	1600	2000	2500	3150	4000	5000	6300	8000	-

• Chip capacitors

(EX) C C 7 3 F S L 1 H 0 0 0 J
 1 2 3 4 5 6 7

(Chip) (CH, RH, UJ, SL)

(EX) C K 7 3 F F 1 H 0 0 0 Z
 1 2 3 4 5 6 7

(Chip) (B, F)

Refer to the table above.

- 1 = Type
- 2 = Shape
- 3 = Dimension
- 4 = Temp. coefficient
- 5 = Voltage rating
- 6 = Value
- 7 = Tolerance

Dimension (Chip capacitors)

Dimension code	L	W	T
Empty	5.6 ± 0.5	5.0 ± 0.5	Less than 2.0
A	4.5 ± 0.5	3.2 ± 0.4	Less than 2.0
B	4.5 ± 0.5	2.0 ± 0.3	Less than 2.0
C	4.5 ± 0.5	1.25 ± 0.2	Less than 1.25
D	3.2 ± 0.4	2.5 ± 0.3	Less than 1.5
E	3.2 ± 0.2	1.6 ± 0.2	Less than 1.25
F	2.0 ± 0.3	1.25 ± 0.2	Less than 1.25
G	1.6 ± 0.2	0.8 ± 0.2	Less than 1.0
H	1.0 ± 0.05	0.5 ± 0.05	0.5 ± 0.05

RESISTORS

• Chip resistor (Carbon)

(EX) R D 7 3 E B 2 B 0 0 0 J
 1 2 3 4 5 6 7

(Chip) (B,F)

• Carbon resistor (Normal type)

(EX) R D 1 4 B B 2 C 0 0 0 J
 1 2 3 4 5 6 7

- 1 = Type ... ceramic, electrolytic, etc.
- 2 = Shape ... round, square, ect.
- 3 = Dimension
- 4 = Temp. coefficient
- 5 = Voltage rating
- 6 = Value
- 7 = Tolerance

Dimension

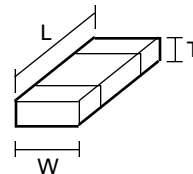

Dimension (Chip resistor)

Dimension code	L	W	T
E	3.2 ± 0.2	1.6 ± 0.2	1.0
F	2.0 ± 0.3	1.25 ± 0.2	1.0
G	1.6 ± 0.2	0.8 ± 0.2	0.5 ± 0.1
H	1.0 ± 0.05	0.5 ± 0.05	0.35 ± 0.05

Rating wattage

Code	Wattage	Code	Wattage	Code	Wattage
1J	1/16W	2C	1/6W	3A	1W
2A	1/10W	2E	1/4W	3D	2W
2B	1/8W	2H	1/2W		

PARTS LIST

* New Parts. Δ indicates safety critical components.
 Parts without **Parts No.** are not supplied.
 Les articles non mentionnés dans le **Parts No.** ne sont pas fournis.
 Teile ohne **Parts No.** werden nicht geliefert.

L : Scandinavia **K** : USA **P** : Canada
Y : PX (Far East, Hawaii) **T** : England **E** : Europe
Y : AAFES (Europe) **X** : Australia **M** : Other Areas

KGP-2A CONTROL UNIT (X53-3980-20)

Ref. No.	Address	New parts	Parts No.	Description	Desti-nation	Ref. No.	Address	New parts	Parts No.	Description	Desti-nation
KGP-2A						KGP-2A					
1	2A	*	A02-3660-11	CABINET		C24			C92-0720-05	ELECTRO 100UF 25WV	
2	2B	*	A21-1632-14	DRESSING PANEL		C25			CK73GB1H471K	CHIP C 470PF K	
4	1A		B09-0355-05	CAP (D-SUB 9P)		C26-28			CC73GCH1H101J	CHIP C 100PF J	
5	1A	*	B09-0626-05	CAP (D-SUB 15P)		C30-35			CC73GCH1H101J	CHIP C 100PF J	
6	1A		B42-3395-04	STANDARD LABEL		C37			CC73GCH1H101J	CHIP C 100PF J	
7	2A	*	B42-7033-04	STICKER (ID)		C38			CK73GB1E103K	CHIP C 0.010UF K	
8	1D	*	B62-1481-00	INSTRUCTION MANUAL		C39,40			CC73GCH1H101J	CHIP C 100PF J	
9	2A	*	B72-1963-14	MODEL NAME PLATE		C41-43			CK73GB1C104K	CHIP C 0.10UF K	
11	2B	*	E33-1987-05	PROCESSED WIRE KIT (ADDITIONAL PCB)		C44,45			CC73GCH1H101J	CHIP C 100PF J	
12	1A	*	E37-0982-05	LEAD WIRE WITH CONNECTOR (15P : RADIO)		C47			CK73GB1E103K	CHIP C 0.010UF K	
13	1A	*	E37-0983-05	LEAD WIRE WITH CONNECTOR (ANT)		C48			CK73GB1C104K	CHIP C 0.10UF K	
14	1A	*	E37-1001-05	LEAD WIRE WITH CONNECTOR (4P : CN19)		C49-51			CK73GB1C104K	CHIP C 0.10UF K	
16	1B	*	F20-3339-04	INSULATING SHEET		C54			CK73GB1C104K	CHIP C 0.10UF K	
18	1B	*	G10-1292-04	FIBROUS SHEET (CHASSIS:REAR-TOP)		C55,56			C92-0519-05	CHIP-TAN 1.0UF 25WV	
19	1B	*	G10-1293-04	FIBROUS SHEET (CHASSIS:REAR-R&L)		C57			CK73GB1C104K	CHIP C 0.10UF K	
20	1B	*	G10-1294-04	FIBROUS SHEET (CHASSIS:BOTTOM-R&L)		C58			CK73GB1C104K	CHIP C 0.10UF K	
21	1B	*	G10-1295-04	FIBROUS SHEET (CHASSIS:BOTTOM-FRONT)		C59			C92-0519-05	CHIP-TAN 1.0UF 25WV	
22	2B		G10-0792-14	FIBROUS SHEET (ADDITIONAL PCB)		C61			C92-0519-05	CHIP-TAN 1.0UF 25WV	
23	2A	*	G13-1882-04	CUSHION (15P CONNECTOR)		C62			CK73GB1C104K	CHIP C 0.10UF K	
24	1A	*	G13-1888-04	CUSHION (CHASSIS BOTTOM)		C65			CK73GB1C104K	CHIP C 0.10UF K	
25	2A	*	G13-1889-14	CUSHION (D-SUB)		C66			CK73GB1E103K	CHIP C 0.010UF K	
26	1A	*	G13-1915-04	CUSHION (CHASSIS D-SUB)		C67-69			CK73GB1C104K	CHIP C 0.10UF K	
27	2B	*	G13-1931-04	CUSHION (ADDITIONAL PCB)		C70			CK73GB1E103K	CHIP C 0.010UF K	
29	3E		H25-0796-04	PROTECTION BAG		C72			CK73GB1C104K	CHIP C 0.10UF K	
30	1E	*	H52-1860-02	ITEM CARTON CASE		C74			CK73GB1E103K	CHIP C 0.010UF K	
32	2E		J29-0627-23	BRACKET ACCESSORY		C75			CK73GB1H471K	CHIP C 470PF K	
33	1A		J61-0307-05	BAND		C76,77			C92-0628-05	CHIP-TAN 10UF 10WV	
35	2B	*	K29-9176-04	KEY TOP (MODE SW)		C81			CC73GCH1H101J	CHIP C 100PF J	
A	1A	*	N14-0596-05	HEXAGON NUT (ANT)		C82,83			CK73GB1C104K	CHIP C 0.10UF K	
B	1A		N15-1060-46	FLAT WASHER (ANT)		C87,88			C92-0628-05	CHIP-TAN 10UF 10WV	
C	1A	*	N17-1060-46	TOOTHED LOCK WASHER (ANT)		C89			CK73GB1C104K	CHIP C 0.10UF K	
D	2A		N83-2610-45	PAN HEAD TAPTITE SCREW (D-SUB)		C91			CC73GCH1H101J	CHIP C 100PF J	
E	2A,2B		N87-2605-46	BRAZIER HEAD TAPTITE SCREW (PCB)		C94,95			CK73GB1E103K	CHIP C 0.010UF K	
F	1A,1B		N88-3008-45	FLAT HEAD TAPTITE SCREW (CHASSIS)		C96,97			C92-0628-05	CHIP-TAN 10UF 10WV	
37	2E		N99-0395-05	SCREW SET ACCESSORY		C98			CK73GB1E103K	CHIP C 0.010UF K	
39	2D	*	T90-1002-15	ANTENNA (GPS) ACCESSORY		C99			C92-0628-05	CHIP-TAN 10UF 10WV	
41	2A	*	W02-3628-05	ELECTRIC CIRCUIT MODULE (GPS MODULE)		C101			C92-0628-05	CHIP-TAN 10UF 10WV	
CONTROL UNIT (X53-3980-20) : KGP-2A						CONTROL UNIT (X53-3980-20)					
D26,27			B30-2056-05	LED		C102,103			CK73GB1C104K	CHIP C 0.10UF K	
D28			B30-2019-05	LED (RE/GR)		C104,105			C92-0628-05	CHIP-TAN 10UF 10WV	
C1-11			CC73GCH1H101J	CHIP C 100PF J		C106			CK73GB1E103K	CHIP C 0.010UF K	
C12			CK73GB1E103K	CHIP C 0.010UF K		C107			CK73GB1C104K	CHIP C 0.10UF K	
C13-17			CC73GCH1H101J	CHIP C 100PF J		C108,109			C92-0628-05	CHIP-TAN 10UF 10WV	
C18			CK73GB1E103K	CHIP C 0.010UF K		C110			CK73GB1E103K	CHIP C 0.010UF K	
C19-23			CC73GCH1H101J	CHIP C 100PF J		C114			C92-0628-05	CHIP-TAN 10UF 10WV	
						C115			CK73GB1E103K	CHIP C 0.010UF K	
						C117			CK73GB1C104K	CHIP C 0.10UF K	
						C118			CK73GB1H332K	CHIP C 3300PF K	
						C119			C92-0628-05	CHIP-TAN 10UF 10WV	
						C120			CC73GCH1H271J	CHIP C 270PF J	
						C121			CK73GB1C104K	CHIP C 0.10UF K	
						C122			C92-0628-05	CHIP-TAN 10UF 10WV	
						C123,124			CK73GB1E103K	CHIP C 0.010UF K	
						C125-127			C92-0628-05	CHIP-TAN 10UF 10WV	
						C128,129			CK73GB1H471K	CHIP C 470PF K	
						C130			C92-0628-05	CHIP-TAN 10UF 10WV	

KGP-2A/2B

PARTS LIST

CONTROL UNIT (X53-3980-20)

Ref. No.	Address	New parts	Parts No.	Description	Destination	Ref. No.	Address	New parts	Parts No.	Description	Destination
C131-134			CK73GB1E103K	CHIP C 0.010UF K		CP35			RK75GB1J102J	CHIP-COM 1.0K J 1/16W	
C135,136			CK73GB1H471K	CHIP C 470PF K		CP36		*	RK75GA1J102J	CHIP-COM 1.0K J 1/16W	
C137,138			C92-0628-05	CHIP-TAN 10UF 10WV		CP37			RK75GB1J473J	CHIP-COM 47K J 1/16W	
C139,140			CK73GB1H471K	CHIP C 470PF K		CP38			RK75GB1J102J	CHIP-COM 1.0K J 1/16W	
C141-144			CK73GB1E103K	CHIP C 0.010UF K		CP39-43			RK75GB1J101J	CHIP-COM 100 J 1/16W	
C145			CK73GB1H471K	CHIP C 470PF K		CP46		*	RK75GA1J473J	CHIP-COM 47K J 1/16W	
C146			C92-0628-05	CHIP-TAN 10UF 10WV		CP47,48		*	RK75GA1J101J	CHIP-COM 100 J 1/16W	
C147			CC73GCH1H270J	CHIP C 27PF J		CP51		*	RK75GA1J101J	CHIP-COM 100 J 1/16W	
C148			CK73GB1H102K	CHIP C 1000PF K		CP60		*	RK75GA1J473J	CHIP-COM 47K J 1/16W	
C149			CC73GCH1H270J	CHIP C 27PF J		CP67		*	RK75GA1J101J	CHIP-COM 100 J 1/16W	
C151			CK73GB1E103K	CHIP C 0.010UF K		CP70			RK75GB1J101J	CHIP-COM 100 J 1/16W	
C152			CK73GB1H471K	CHIP C 470PF K		CP71-74			RK75GB1J102J	CHIP-COM 1.0K J 1/16W	
C153			C92-0628-05	CHIP-TAN 10UF 10WV		CP75		*	RK75GA1J473J	CHIP-COM 47K J 1/16W	
C154,155			CK73GB1E103K	CHIP C 0.010UF K		CP76		*	RK75GA1J471J	CHIP-COM 470 J 1/16W	
C156			CK73GB1H471K	CHIP C 470PF K		CP79			RK75GB1J101J	CHIP-COM 100 J 1/16W	
C157,158			CK73GB1E103K	CHIP C 0.010UF K		CP81		*	RK75GA1J101J	CHIP-COM 100 J 1/16W	
C159			CK73GB1H471K	CHIP C 470PF K		CP82			RK75GB1J473J	CHIP-COM 47K J 1/16W	
C160,161			C92-0628-05	CHIP-TAN 10UF 10WV		R2			R92-1252-05	CHIP R 0 OHM J 1/16W	
C162			CK73GB1H471K	CHIP C 470PF K		R4			RK73GB1J273J	CHIP R 27K J 1/16W	
C163			C92-0628-05	CHIP-TAN 10UF 10WV		R5			RK73GB1J123J	CHIP R 12K J 1/16W	
C165			CK73GB1H471K	CHIP C 470PF K		R6			RK73FB2A102J	CHIP R 1.0K J 1/10W	
C166			C92-0628-05	CHIP-TAN 10UF 10WV		R7			RK73GB1J102J	CHIP R 1.0K J 1/16W	
C175,176			CK73GB1E103K	CHIP C 0.010UF K		R8			R92-0670-05	CHIP R 0 OHM	
C177			C92-0720-05	ELECTRO 100UF 25WV		R9			R92-3556-05	CHIP R 0 OHM J 1W	
C178-195			CC73GCH1H101J	CHIP C 100PF J		R10			R92-0685-05	CHIP R 22 J 1/2W	
C196			C92-0628-05	CHIP-TAN 10UF 10WV		R11-16			R92-0670-05	CHIP R 0 OHM	
C197-201			CC73GCH1H101J	CHIP C 100PF J		R33			RK73FB2A221J	CHIP R 220 J 1/10W	
C202			C92-0628-05	CHIP-TAN 10UF 10WV		R37			RK73FB2A221J	CHIP R 220 J 1/10W	
C203			CC73GCH1H101J	CHIP C 100PF J		R51			RK73GB1J820J	CHIP R 82 J 1/16W	
C204,205			CK73GB1E103K	CHIP C 0.010UF K		R52			RK73GB1J681J	CHIP R 680 J 1/16W	
C206			CC73GCH1H101J	CHIP C 100PF J		R55			RK73GB1J563J	CHIP R 56K J 1/16W	
C208			C92-0628-05	CHIP-TAN 10UF 10WV		R56			R92-1252-05	CHIP R 0 OHM J 1/16W	
C209			CC73GCH1H101J	CHIP C 100PF J		R58			RK73GB1J102J	CHIP R 1.0K J 1/16W	
CN1			E40-6047-05	PIN ASSY (15P)		R59			R92-1252-05	CHIP R 0 OHM J 1/16W	
J1		*	E58-0489-05	SUB SOCKET (D) (D-SUB 15P : ACC3)		R62			RK73GB1J122J	CHIP R 1.2K J 1/16W	
J2		*	E59-0413-05	SUB PLUG (D) (D-SUB 9P : ACC1)		R63			R92-1252-05	CHIP R 0 OHM J 1/16W	
J3		*	E59-0413-05	SUB PLUG (D) (D-SUB 9P : ACC2)		R65-67			R92-1252-05	CHIP R 0 OHM J 1/16W	
-		*	F20-3332-04	INSULATING SHEET (LITHIUM CELL)		R71,72			RK73GB1J473J	CHIP R 47K J 1/16W	
L1			L92-0140-05	FERRITE CHIP		R73			R92-1252-05	CHIP R 0 OHM J 1/16W	
L8			L92-0140-05	FERRITE CHIP		R75			R92-1252-05	CHIP R 0 OHM J 1/16W	
L10-13			L92-0140-05	FERRITE CHIP		R77			R92-1252-05	CHIP R 0 OHM J 1/16W	
L15			L92-0140-05	FERRITE CHIP		R80			RK73GB1J223J	CHIP R 22K J 1/16W	
L17-20			L92-0140-05	FERRITE CHIP		R82			RK73GB1J473J	CHIP R 47K J 1/16W	
L23			L92-0140-05	FERRITE CHIP		R84			RK73GB1J393J	CHIP R 39K J 1/16W	
L24			L40-1011-14	SMALL FIXED INDUCTOR 100UH		R86			RK73GB1J473J	CHIP R 47K J 1/16W	
X1		*	L78-1401-05	RESONATOR (7.373MHZ)		R90			RK73GB1J473J	CHIP R 47K J 1/16W	
X2			L77-1679-05	CRYSTAL RESONATOR (12.288MHZ)		R92,93			RK73GB1J473J	CHIP R 47K J 1/16W	
CP3,4			RK75GB1J101J	CHIP-COM 100 J 1/16W		R95			RK73GB1J473J	CHIP R 47K J 1/16W	
CP5		*	RK75GA1J471J	CHIP-COM 470 J 1/16W		R96			R92-1252-05	CHIP R 0 OHM J 1/16W	
CP22			RK75GB1J101J	CHIP-COM 100 J 1/16W		R98			RK73GB1J223J	CHIP R 22K J 1/16W	
CP23		*	RK75GA1J102J	CHIP-COM 1.0K J 1/16W		R99			RK73GB1J393J	CHIP R 39K J 1/16W	
CP25			RK75GB1J101J	CHIP-COM 100 J 1/16W		R100			RK73GB1J102J	CHIP R 1.0K J 1/16W	
CP27			RK75GB1J101J	CHIP-COM 100 J 1/16W		R101			RK73GB1J333J	CHIP R 33K J 1/16W	
CP28		*	RK75GA1J102J	CHIP-COM 1.0K J 1/16W		R102			RK73GB1J563J	CHIP R 56K J 1/16W	
CP29,30			RK75GB1J101J	CHIP-COM 100 J 1/16W		R104			RK73GB1J223J	CHIP R 22K J 1/16W	
CP31			RK75GB1J473J	CHIP-COM 47K J 1/16W		R105,106			RK73GB1J393J	CHIP R 39K J 1/16W	
CP32			RK75GB1J101J	CHIP-COM 100 J 1/16W		R107-109			R92-1252-05	CHIP R 0 OHM J 1/16W	
CP34			RK75GB1J101J	CHIP-COM 100 J 1/16W		R110			RK73GB1J473J	CHIP R 47K J 1/16W	
						R111			R92-1252-05	CHIP R 0 OHM J 1/16W	
						R112			RK73GB1J101J	CHIP R 100 J 1/16W	

PARTS LIST

CONTROL UNIT (X53-3980-20)
KGP-2B

Ref. No.	Address	New parts	Parts No.	Description	Destination	Ref. No.	Address	New parts	Parts No.	Description	Destination
R113			R92-1252-05	CHIP R 0 OHM J 1/16W		D48			DA204U	DIODE	
R114			RK73GB1J470J	CHIP R 47 J 1/16W		D50-58			DA204U	DIODE	
R115			R92-1252-05	CHIP R 0 OHM J 1/16W		D59-61	*		UMZ8.2T	ZENER DIODE	
R116			RK73GB1J473J	CHIP R 47K J 1/16W		D62			MTZJ6.8B	ZENER DIODE	
R117-119			R92-1252-05	CHIP R 0 OHM J 1/16W		IC1			RN5VL30C	IC (RESET IC)	
R120,121			RK73GB1J102J	CHIP R 1.0K J 1/16W		IC3,4			TA7808F	IC (REGULATOR)	
R122			RK73GB1J223J	CHIP R 22K J 1/16W		IC6			ADM202EARU	IC (RS-232C DRIVER)	
R123			R92-1252-05	CHIP R 0 OHM J 1/16W		IC6			ADM3202ARU	IC (RS-232C DRIVER)	
R124			RK73GB1J473J	CHIP R 47K J 1/16W		IC7			TA78L05F	IC (REGULATOR)	
R125			R92-1252-05	CHIP R 0 OHM J 1/16W		IC9			TC74HC4094AF	IC (EXTENDED I/O)	
R129,130			R92-1252-05	CHIP R 0 OHM J 1/16W		IC10,11			XC62FP3302P	IC (REGULATOR)	
R132			RK73GB1J393J	CHIP R 39K J 1/16W		IC12			BU2099FV	IC (SHIFT REGISTER)	
R133			RK73GB1J563J	CHIP R 56K J 1/16W		IC13			XC62FP1802P	IC (REGULATOR)	
R134,135			RK73GB1J102J	CHIP R 1.0K J 1/16W		IC14			RN5VL45C	IC (RESET IC)	
R136			RK73GB1J562J	CHIP R 5.6K J 1/16W		IC15			24LC08BT-ISN	IC (EEPROM)	
R137			RK73GB1J332J	CHIP R 3.3K J 1/16W		IC16			NJM4558M	IC (AMPLIFIER)	
R138			RK73GB1J562J	CHIP R 5.6K J 1/16W		IC17	*		30620M8A-2M6GP	IC (CPU)	
R139			RK73GB1J332J	CHIP R 3.3K J 1/16W		IC18			M62364FP	IC (D/A CONVERTER)	
R140			RK73GB1J473J	CHIP R 47K J 1/16W		IC19			TC74LVX4245FS	IC (LEVEL CONVERTER)	
R144-149			RK73GB1J820J	CHIP R 82 J 1/16W		IC20,21			TC74LVX244FT	IC (LEVEL CONVERTER)	
R152			RK73GB1J102J	CHIP R 1.0K J 1/16W		IC22			AK4550VT	IC (CODEC IC)	
R154,155			R92-1252-05	CHIP R 0 OHM J 1/16W		IC23			TC7S08F	IC (GATE IC)	
R157-177			R92-0670-05	CHIP R 0 OHM		IC24			TC7S04F	IC (GATE IC)	
R179-183			R92-0670-05	CHIP R 0 OHM		IC25	*		MBM29LV800B90	IC (MEMORY IC)	
R186			R92-0670-05	CHIP R 0 OHM		IC26			NJM4558M	IC (AMPLIFIER)	
R189			R92-0670-05	CHIP R 0 OHM		IC28			TC74VHC4040FT	IC (CLOCK DEMULTIPLIER)	
R191			R92-0670-05	CHIP R 0 OHM		IC29			320VC5402PGE	IC (DSP IC)	
R194			R92-0670-05	CHIP R 0 OHM		IC31			TC74LVX244FT	IC (LEVEL CONVERTER)	
R199			RK73GB1J102J	CHIP R 1.0K J 1/16W		IC32			NJM4558M	IC (AMPLIFIER)	
R200,201			RK73GB1J473J	CHIP R 47K J 1/16W		IC33			XC62FP3302P	IC (REGULATOR)	
R205			RK73GB1J184J	CHIP R 180K J 1/16W		Q1,2			DTC114YE	DIGITAL TRANSISTOR	
R206			RK73GB1J561J	CHIP R 560 J 1/16W		Q4			2SB798(DL,DK)	TRANSISTOR	
R208			R92-1252-05	CHIP R 0 OHM J 1/16W		Q5,6			DTC144EE	DIGITAL TRANSISTOR	
R209			RK73GB1J122J	CHIP R 1.2K J 1/16W		Q11			DTC114YE	DIGITAL TRANSISTOR	
R210			RK73GB1J222J	CHIP R 2.2K J 1/16W		Q12-14	*		RN47A4	TRANSISTOR	
R211			RK73GB1J223J	CHIP R 22K J 1/16W		Q15			DTC114EUA	DIGITAL TRANSISTOR	
R212			RK73GB1J222J	CHIP R 2.2K J 1/16W		BA1	*		W09-0985-05	LITHIUM CELL	
R213			RK73GB1J393J	CHIP R 39K J 1/16W							
R214			RK73GB1J122J	CHIP R 1.2K J 1/16W							
R216,217			RK73GB1J122J	CHIP R 1.2K J 1/16W							
R218			RK73GB1J473J	CHIP R 47K J 1/16W							
R219,220			RK73GB1J222J	CHIP R 2.2K J 1/16W							
R222			RK73GB1J393J	CHIP R 39K J 1/16W							
R223			RK73GB1J563J	CHIP R 56K J 1/16W							
R224			RK73GB1J222J	CHIP R 2.2K J 1/16W							
S1			S70-0446-05	TACT SWITCH							
D1			1812L075PR	VARIATOR							
D2			DSM3MA1	DIODE							
D5			MA2S111	DIODE							
D7	*		UMZ8.2T	ZENER DIODE							
D8			NNCD6.8G	ZENER DIODE							
D9	*		UMZ8.2T	ZENER DIODE							
D12			NNCD6.8G	ZENER DIODE							
D18			MA2S111	DIODE							
D24			NNCD6.8G	ZENER DIODE							
D30			MA2S111	DIODE							
D31-35			NNCD6.8G	ZENER DIODE							
D36-45			DA204U	DIODE							
D46,47	*		UMZ8.2T	ZENER DIODE							
KGP-2B											
						1	2C	*	A02-3660-11	CABINET	
						3	2C	*	A21-1633-14	DRESSING PANEL	
						4	1B		B09-0355-05	CAP (D-SUB 9P)	
						6	1C		B42-3395-04	STANDARD LABEL	
						8	1D	*	B62-1481-00	INSTRUCTION MANUAL	
						10	2C	*	B72-1964-04	MODEL NAME PLATE	
						11	2C	*	E33-1987-05	PROCESSED WIRE KIT (ADDITIONAL PCB)	
						12	1B	*	E37-0982-05	LEAD WIRE WITH CONNECTOR (15P : RADIO)	
						15	1B	*	F15-1003-04	SHIELDING PLATE (CHASSIS REAR)	
						18	1C	*	G10-1292-04	FIBROUS SHEET (CHASSIS:REAR-TOP)	
						19	1C	*	G10-1293-04	FIBROUS SHEET (CHASSIS:REAR-R&L)	
						20	1C	*	G10-1294-04	FIBROUS SHEET (CHASSIS:BOTTOM-R&L)	
						21	1C	*	G10-1295-04	FIBROUS SHEET (CHASSIS:BOTTOM-FRONT)	
						22	2C		G10-0792-14	FIBROUS SHEET (ADDITIONAL PCB)	
						23	2B	*	G13-1882-04	CUSHION (15P CONNECTOR)	

KGP-2A/2B

PARTS LIST

KGP-2B CONTROL UNIT (X53-3980-21)

Ref. No.	Address	New parts	Parts No.	Description	Destination
28	2B	*	G13-1883-14	CUSHION (D-SUB)	
27	2C	*	G13-1931-04	CUSHION (ADDITIONAL PCB)	
29	3E		H25-0796-04	PROTECTION BAG	
30	1E	*	H52-1861-02	ITEM CARTON CASE	
35	2C	*	K29-9176-04	KEY TOP (MODE SW)	
D	2C		N83-2610-45	PAN HEAD TAPTITE SCREW (D-SUB)	
E	2C		N87-2605-46	BRAZIER HEAD TAPTITE SCREW (PCB)	
F	1B,1C		N88-3008-45	FLAT HEAD TAPTITE SCREW (CHASSIS)	
CONTROL UNIT (X53-3980-21) : KGP-2B					
D26			B30-2056-05	LED	
D28			B30-2019-05	LED (RE/GR)	
C4,5			CC73GCH1H101J	CHIP C 100PF J	
C7			CC73GCH1H101J	CHIP C 100PF J	
C9			CC73GCH1H101J	CHIP C 100PF J	
C11			CC73GCH1H101J	CHIP C 100PF J	
C14			CC73GCH1H101J	CHIP C 100PF J	
C16,17			CC73GCH1H101J	CHIP C 100PF J	
C20			CC73GCH1H101J	CHIP C 100PF J	
C23			CC73GCH1H101J	CHIP C 100PF J	
C24			C92-0720-05	ELECTRO 100UF 25WV	
C25			CK73GB1H471K	CHIP C 470PF K	
C28			CC73GCH1H101J	CHIP C 100PF J	
C31			CC73GCH1H101J	CHIP C 100PF J	
C33			CC73GCH1H101J	CHIP C 100PF J	
C35			CC73GCH1H101J	CHIP C 100PF J	
C41-43			CK73GB1C104K	CHIP C 0.10UF K	
C47			CK73GB1E103K	CHIP C 0.010UF K	
C50,51			CK73GB1C104K	CHIP C 0.10UF K	
C54			CK73GB1C104K	CHIP C 0.10UF K	
C55,56			C92-0519-05	CHIP-TAN 1.0UF 25WV	
C58			CK73GB1C104K	CHIP C 0.10UF K	
C59			C92-0519-05	CHIP-TAN 1.0UF 25WV	
C61			C92-0519-05	CHIP-TAN 1.0UF 25WV	
C62,63			CK73GB1C104K	CHIP C 0.10UF K	
C66			CK73GB1E103K	CHIP C 0.010UF K	
C67-69			CK73GB1C104K	CHIP C 0.10UF K	
C70			CK73GB1E103K	CHIP C 0.010UF K	
C72			CK73GB1C104K	CHIP C 0.10UF K	
C74			CK73GB1E103K	CHIP C 0.010UF K	
C75			CK73GB1H471K	CHIP C 470PF K	
C76,77			C92-0628-05	CHIP-TAN 10UF 10WV	
C81			CC73GCH1H101J	CHIP C 100PF J	
C82,83			CK73GB1C104K	CHIP C 0.10UF K	
C87,88			C92-0628-05	CHIP-TAN 10UF 10WV	
C89			CK73GB1C104K	CHIP C 0.10UF K	
C91			CC73GCH1H101J	CHIP C 100PF J	
C95			CK73GB1E103K	CHIP C 0.010UF K	
C96			C92-0628-05	CHIP-TAN 10UF 10WV	
C99			C92-0628-05	CHIP-TAN 10UF 10WV	
C101			C92-0628-05	CHIP-TAN 10UF 10WV	
C102,103			CK73GB1C104K	CHIP C 0.10UF K	
C104,105			C92-0628-05	CHIP-TAN 10UF 10WV	
C106			CK73GB1E103K	CHIP C 0.010UF K	
C107			CK73GB1C104K	CHIP C 0.10UF K	
C108,109			C92-0628-05	CHIP-TAN 10UF 10WV	
C110			CK73GB1E103K	CHIP C 0.010UF K	
C114			C92-0628-05	CHIP-TAN 10UF 10WV	
C117			CK73GB1C104K	CHIP C 0.10UF K	
C118			CK73GB1H332K	CHIP C 3300PF K	
C119			C92-0628-05	CHIP-TAN 10UF 10WV	
C120			CC73GCH1H271J	CHIP C 270PF J	
C121			CK73GB1C104K	CHIP C 0.10UF K	
C122			C92-0628-05	CHIP-TAN 10UF 10WV	
C124			CK73GB1E103K	CHIP C 0.010UF K	
C125-127			C92-0628-05	CHIP-TAN 10UF 10WV	
C128,129			CK73GB1H471K	CHIP C 470PF K	
C130			C92-0628-05	CHIP-TAN 10UF 10WV	
C131-134			CK73GB1E103K	CHIP C 0.010UF K	
C135,136			CK73GB1H471K	CHIP C 470PF K	
C137,138			C92-0628-05	CHIP-TAN 10UF 10WV	
C139,140			CK73GB1H471K	CHIP C 470PF K	
C141-144			CK73GB1E103K	CHIP C 0.010UF K	
C145			CK73GB1H471K	CHIP C 470PF K	
C146			C92-0628-05	CHIP-TAN 10UF 10WV	
C147			CC73GCH1H270J	CHIP C 27PF J	
C148			CK73GB1H102K	CHIP C 1000PF K	
C149			CC73GCH1H270J	CHIP C 27PF J	
C151			CK73GB1E103K	CHIP C 0.010UF K	
C152			CK73GB1H471K	CHIP C 470PF K	
C153			C92-0628-05	CHIP-TAN 10UF 10WV	
C154,155			CK73GB1E103K	CHIP C 0.010UF K	
C156			CK73GB1H471K	CHIP C 470PF K	
C157,158			CK73GB1E103K	CHIP C 0.010UF K	
C159			CK73GB1H471K	CHIP C 470PF K	
C160,161			C92-0628-05	CHIP-TAN 10UF 10WV	
C162			CK73GB1H471K	CHIP C 470PF K	
C163			C92-0628-05	CHIP-TAN 10UF 10WV	
C165			CK73GB1H471K	CHIP C 470PF K	
C177			C92-0720-05	ELECTRO 100UF 25WV	
C178-187			CC73GCH1H101J	CHIP C 100PF J	
C190-192			CC73GCH1H101J	CHIP C 100PF J	
C194,195			CC73GCH1H101J	CHIP C 100PF J	
C196			C92-0628-05	CHIP-TAN 10UF 10WV	
C198-200			CC73GCH1H101J	CHIP C 100PF J	
C205			CK73GB1E103K	CHIP C 0.010UF K	
C206			CC73GCH1H101J	CHIP C 100PF J	
C209			CC73GCH1H101J	CHIP C 100PF J	
CN1			E40-6047-05	PIN ASSY (15P)	
J2		*	E59-0413-05	SUB PLUG (D) (D-SUB 9P : ACC1)	
L1			L92-0140-05	FERRITE CHIP	
L8			L92-0140-05	FERRITE CHIP	
L10-13			L92-0140-05	FERRITE CHIP	
L15			L92-0140-05	FERRITE CHIP	
L18-21			L92-0140-05	FERRITE CHIP	
X1		*	L78-1401-05	RESONATOR (7.373MHZ)	
X2			L77-1679-05	CRYSTAL RESONATOR (12.288MHZ)	
CP3,4			RK75GB1J101J	CHIP-COM 100 J 1/16W	
CP5		*	RK73GA1J471J	CHIP-COM 470 J 1/16W	
CP22			RK75GB1J101J	CHIP-COM 100 J 1/16W	
CP23		*	RK75GA1J102J	CHIP-COM 1.0K J 1/16W	
CP25			RK75GB1J101J	CHIP-COM 100 J 1/16W	
CP27			RK75GB1J101J	CHIP-COM 100 J 1/16W	
CP28		*	RK75GA1J102J	CHIP-COM 1.0K J 1/16W	

PARTS LIST

CONTROL UNIT (X53-3980-21)

Ref. No.	Address	New parts	Parts No.	Description	Destination	Ref. No.	Address	New parts	Parts No.	Description	Destination
CP29,30			RK75GB1J101J	CHIP-COM 100 J 1/16W		R122			RK73GB1J223J	CHIP R 22K J 1/16W	
CP31			RK75GB1J473J	CHIP-COM 47K J 1/16W		R123			R92-1252-05	CHIP R 0 OHM J 1/16W	
CP32			RK75GB1J101J	CHIP-COM 100 J 1/16W		R124			RK73GB1J473J	CHIP R 47K J 1/16W	
CP34			RK75GB1J101J	CHIP-COM 100 J 1/16W		R125-131			R92-1252-05	CHIP R 0 OHM J 1/16W	
CP35			RK75GB1J102J	CHIP-COM 1.0K J 1/16W		R132			RK73GB1J393J	CHIP R 39K J 1/16W	
CP36		*	RK75GA1J102J	CHIP-COM 1.0K J 1/16W		R133			RK73GB1J563J	CHIP R 56K J 1/16W	
CP37			RK75GB1J473J	CHIP-COM 47K J 1/16W		R144-146			RK73GB1J820J	CHIP R 82 J 1/16W	
CP38			RK75GB1J102J	CHIP-COM 1.0K J 1/16W		R148,149			RK73GB1J820J	CHIP R 82 J 1/16W	
CP39-43			RK75GB1J101J	CHIP-COM 100 J 1/16W		R150,151			RK73GB1J474J	CHIP R 470K J 1/16W	
CP47,48		*	RK75GA1J101J	CHIP-COM 100 J 1/16W		R152			RK73GB1J102J	CHIP R 1.0K J 1/16W	
CP51		*	RK75GA1J101J	CHIP-COM 100 J 1/16W		R154,155			R92-1252-05	CHIP R 0 OHM J 1/16W	
CP52-59			RK75GB1J101J	CHIP-COM 100 J 1/16W		R157,158			R92-0670-05	CHIP R 0 OHM	
CP67		*	RK75GA1J101J	CHIP-COM 100 J 1/16W		R186			R92-0670-05	CHIP R 0 OHM	
CP75		*	RK75GA1J473J	CHIP-COM 47K J 1/16W		R189			R92-0670-05	CHIP R 0 OHM	
CP76		*	RK75GA1J471J	CHIP-COM 470 J 1/16W		R191			R92-0670-05	CHIP R 0 OHM	
CP77,78			RK75GB1J102J	CHIP-COM 1.0K J 1/16W		R194			R92-0670-05	CHIP R 0 OHM	
CP80			RK75GB1J102J	CHIP-COM 1.0K J 1/16W		R201			RK73GB1J473J	CHIP R 47K J 1/16W	
CP82			RK75GB1J473J	CHIP-COM 47K J 1/16W		R210			RK73GB1J222J	CHIP R 2.2K J 1/16W	
R2			R92-1252-05	CHIP R 0 OHM J 1/16W		R213			RK73GB1J393J	CHIP R 39K J 1/16W	
R4			RK73GB1J273J	CHIP R 27K J 1/16W		R214			RK73GB1J122J	CHIP R 1.2K J 1/16W	
R5			RK73GB1J123J	CHIP R 12K J 1/16W		R216			RK73GB1J122J	CHIP R 1.2K J 1/16W	
R6			RK73FB2A102J	CHIP R 1.0K J 1/10W		R218			RK73GB1J473J	CHIP R 47K J 1/16W	
R7			RK73GB1J102J	CHIP R 1.0K J 1/16W		R219,220			RK73GB1J222J	CHIP R 2.2K J 1/16W	
R8			R92-0670-05	CHIP R 0 OHM		R222			RK73GB1J393J	CHIP R 39K J 1/16W	
R9			R92-3556-05	CHIP R 0 OHM J 1W		R223			RK73GB1J563J	CHIP R 56K J 1/16W	
R10			R92-0685-05	CHIP R 22 J 1/2W		R224			RK73GB1J222J	CHIP R 2.2K J 1/16W	
R52			RK73GB1J681J	CHIP R 680 J 1/16W		S1			S70-0446-05	TACT SWITCH	
R56			R92-1252-05	CHIP R 0 OHM J 1/16W		D1			1812L075PR	VARISTOR	
R58			RK73GB1J102J	CHIP R 1.0K J 1/16W		D2			DSM3MA1	DIODE	
R62			RK73GB1J122J	CHIP R 1.2K J 1/16W		D5			MA2S111	DIODE	
R63			R92-1252-05	CHIP R 0 OHM J 1/16W		D7	*		UMZ8.2T	ZENER DIODE	
R64			RK73GB1J473J	CHIP R 47K J 1/16W		D8			NNCD6.8G	ZENER DIODE	
R65-67			R92-1252-05	CHIP R 0 OHM J 1/16W		D9	*		UMZ8.2T	ZENER DIODE	
R72			RK73GB1J473J	CHIP R 47K J 1/16W		D12			NNCD6.8G	ZENER DIODE	
R73			R92-1252-05	CHIP R 0 OHM J 1/16W		D24			NNCD6.8G	ZENER DIODE	
R75			R92-1252-05	CHIP R 0 OHM J 1/16W		D30			MA2S111	DIODE	
R77			R92-1252-05	CHIP R 0 OHM J 1/16W		D36-42			DA204U	DIODE	
R80			RK73GB1J223J	CHIP R 22K J 1/16W		D44,45			DA204U	DIODE	
R82			RK73GB1J473J	CHIP R 47K J 1/16W		D46,47	*		UMZ8.2T	ZENER DIODE	
R84			RK73GB1J393J	CHIP R 39K J 1/16W		D59	*		UMZ8.2T	ZENER DIODE	
R86			RK73GB1J473J	CHIP R 47K J 1/16W		IC1			RN5VL30C	IC (RESET IC)	
R90			RK73GB1J473J	CHIP R 47K J 1/16W		IC3,4			TA7808F	IC (REGULATOR)	
R92,93			RK73GB1J473J	CHIP R 47K J 1/16W		IC6			ADM202EARU	IC (RS-232C DRIVER)	
R95			RK73GB1J473J	CHIP R 47K J 1/16W		IC6			ADM3202ARU	IC (RS-232C DRIVER)	
R98			RK73GB1J223J	CHIP R 22K J 1/16W		IC7			TA78L05F	IC (REGULATOR)	
R99			RK73GB1J393J	CHIP R 39K J 1/16W		IC9			TC74HC4094AF	IC (EXTENDED I/O)	
R100			RK73GB1J102J	CHIP R 1.0K J 1/16W		IC10,11			XC62FP3302P	IC (REGULATOR)	
R102			R92-1252-05	CHIP R 0 OHM J 1/16W		IC12			BU2099FV	IC (SHIFT REGISTER)	
R104			RK73GB1J223J	CHIP R 22K J 1/16W		IC13			XC62FP1802P	IC (REGULATOR)	
R105,106			RK73GB1J393J	CHIP R 39K J 1/16W		IC14			RN5VL30C	IC (RESET IC)	
R107-109			R92-1252-05	CHIP R 0 OHM J 1/16W		IC15			24LC08BT-1SN	IC (EEPROM)	
R110			RK73GB1J473J	CHIP R 47K J 1/16W		IC16			NJM4558M	IC (AMPLIFIER)	
R111			R92-1252-05	CHIP R 0 OHM J 1/16W		IC17	*		30620M8A-2M6GP	IC (CPU)	
R112			RK73GB1J101J	CHIP R 100 J 1/16W		IC18			M62364FP	IC (D/A CONVERTER)	
R113			R92-1252-05	CHIP R 0 OHM J 1/16W		IC22			AK4550VT	IC (CODEC IC)	
R114			RK73GB1J470J	CHIP R 47 J 1/16W		IC24			TC7S04F	IC (GATE IC)	
R115			R92-1252-05	CHIP R 0 OHM J 1/16W		IC25	*		MBM29LV800B90	IC (MEMORY IC)	
R116			RK73GB1J473J	CHIP R 47K J 1/16W		IC26			NJM4558M	IC (AMPLIFIER)	
R117-119			R92-1252-05	CHIP R 0 OHM J 1/16W							
R120,121			RK73GB1J274J	CHIP R 270K J 1/16W							

KGP-2A/2B

PARTS LIST

CONTROL UNIT (X53-3980-21)

ADDITIONAL PCB

Ref. No.	Address	New parts	Parts No.	Description	Destination
IC28			TC74VHC4040FT	IC (CLOCK DEMULTIPLIER)	
IC29			320VC5402PGE	IC (DSP IC)	
Q5,6			DTC144EE	DIGITAL TRANSISTOR	
Q10,11			DTC114YE	DIGITAL TRANSISTOR	
Q15			DTC114EUA	DIGITAL TRANSISTOR	
Q16-26			DTC114YE	DIGITAL TRANSISTOR	
ADDITIONAL PCB					
R202,203			RK73GB1J222J	CHIP R 2.2K J 1/16W	
Q7,8			DTC144EE	DIGITAL TRANSISTOR	

EXPLODED VIEW

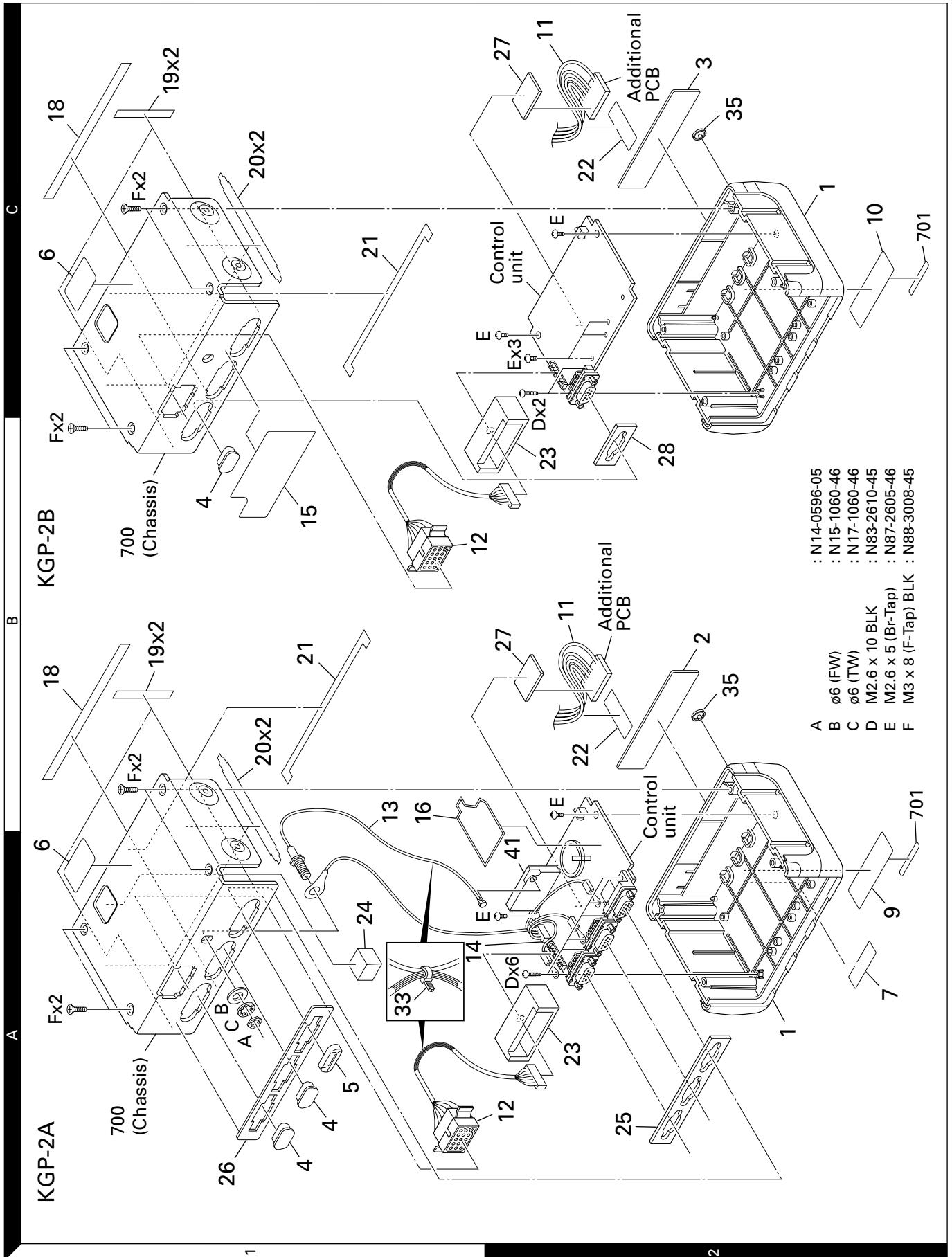

Parts with the exploded numbers larger than 700 are not supplied.

KGP-2A/2B

PACKING

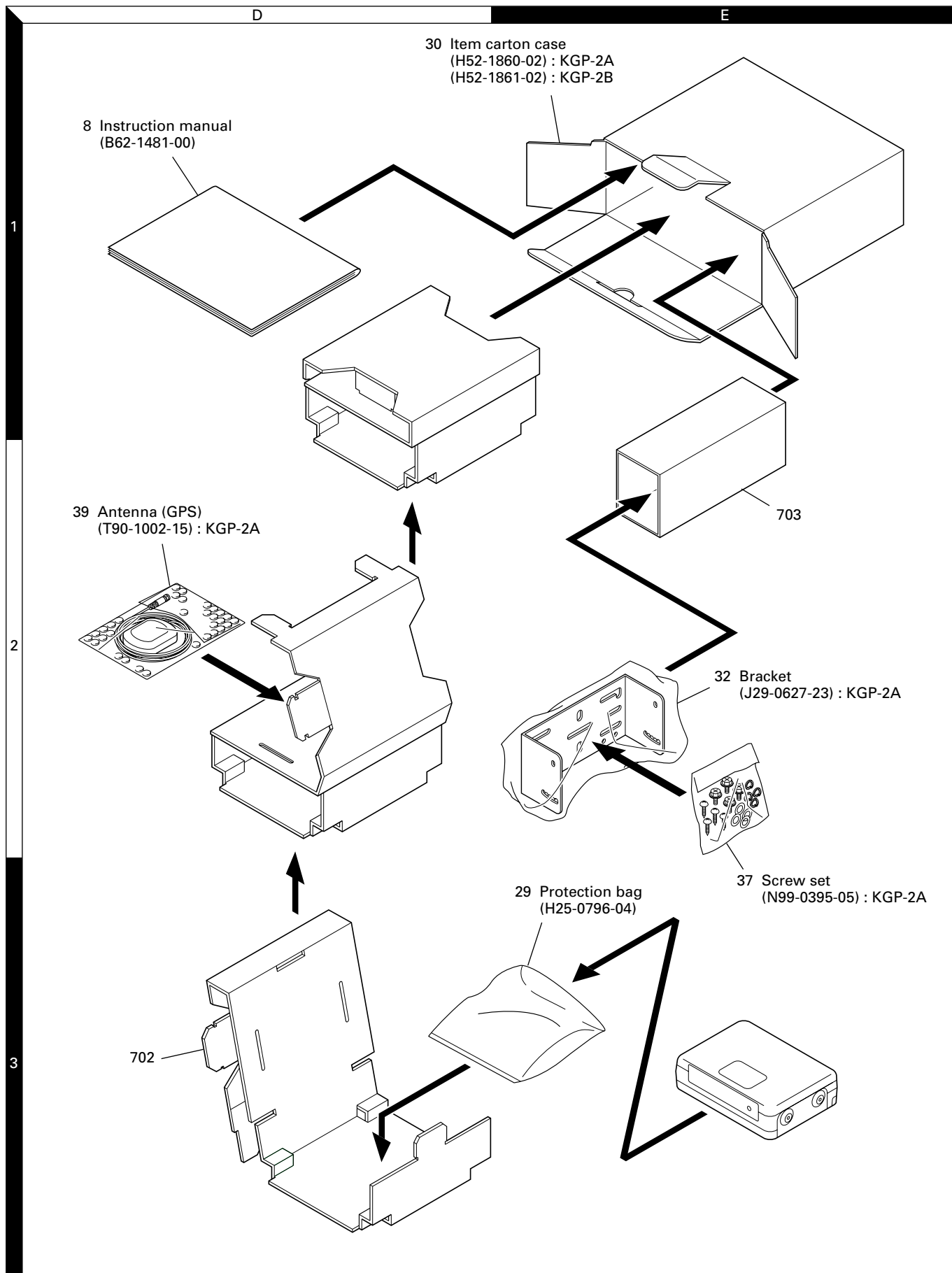

CONTROL UNIT (X53-3980-20) Component side view

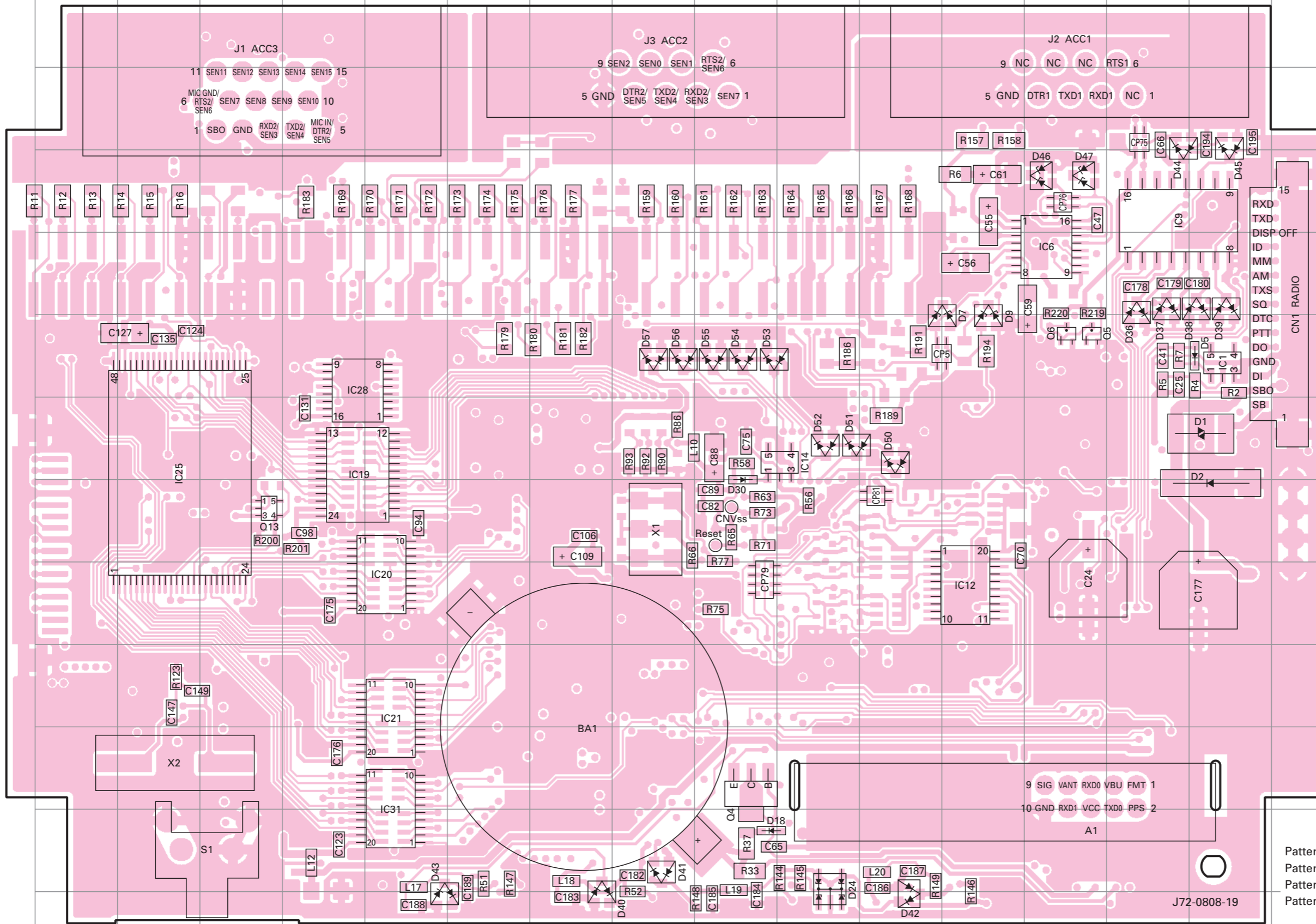

Ref No.	Address	Ref No.	Address	Ref No.	Address
IC1	6O	D1	7O	D43	12F
IC6	5M	D2	8O	D44	4N
IC9	4N	D5	6O	D45	4O
IC12	9L	D7	6L	D46	4M
IC14	7J	D9	6L	D47	4M
IC19	7D	D18	12I	D50	7K
IC20	9E	D24	12J	D51	7J
IC21	10E	D30	8I	D52	7J
IC25	7B	D36	6N	D53	6I
IC28	6D	D37	5N	D54	6I
IC31	12E	D38	5O	D55	6I
Q4	11I	D39	5O	D56	6H
Q5	6M	D40	13G	D57	6H
Q6	6M	D41	12H		
Q13	8C	D42	13K		

- DTC114YE
- DTC144EE
- 2SB798
- DTC114EUA
- RN47A4
- NJM4558M
- TC74HC4094AF
- TA78L05F
- DA204U
- TC7S04F
- TC7S08F
- RN5VL30C
- RN5VL45C
- XC62FP1802P
- XC62FP3302P

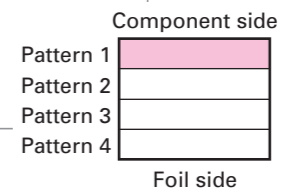

KGP-2A PC BOARD VIEW

Additional PCB

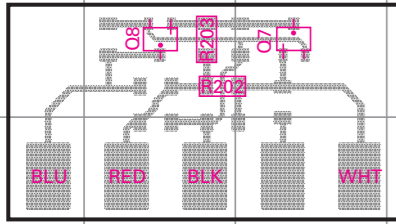

CONTROL UNIT (X53-3980-20) Foil side view

Ref No.	Address	Ref No.	Address	Ref No.	Address
IC3	11I	IC26	5H	D27	13N
IC4	9F	IC29	8Q	D28	13K
IC7	10G	IC32	8H	D31	5P
IC10	11H	IC33	10H	D32	5O
IC11	9H	Q1	12F	D33	5M
IC13	11O	Q2	12F	D34	5N
IC15	11M	Q11	7J	D35	5K
IC16	7E	Q12	7N	D48	5S
IC17	8L	Q14	7N	D58	9H
IC18	8F	Q15	7Q	D59	6H
IC22	6G	D8	5E	D60	4Q
IC23	11M	D12	5E	D61	4R
IC24	11M	D26	13H	D62	11H

ADM202EARU
AK4550VT
TC74VHC4040FT

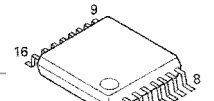

ADM3202ARU

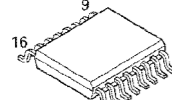

24LC08BT-ISN

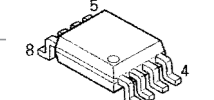

TA7808F

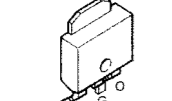

M62364FP
TC74LVX4245FS

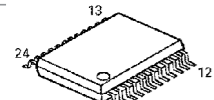

BU2099FV
TC74LVX244FT

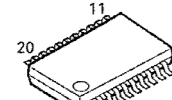

320VC5402PGE

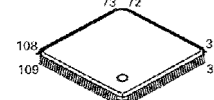

30620M8A-2M6GP

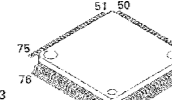

MBM29LV800B90

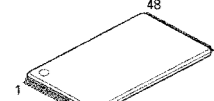

Component side

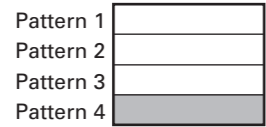

Foil side

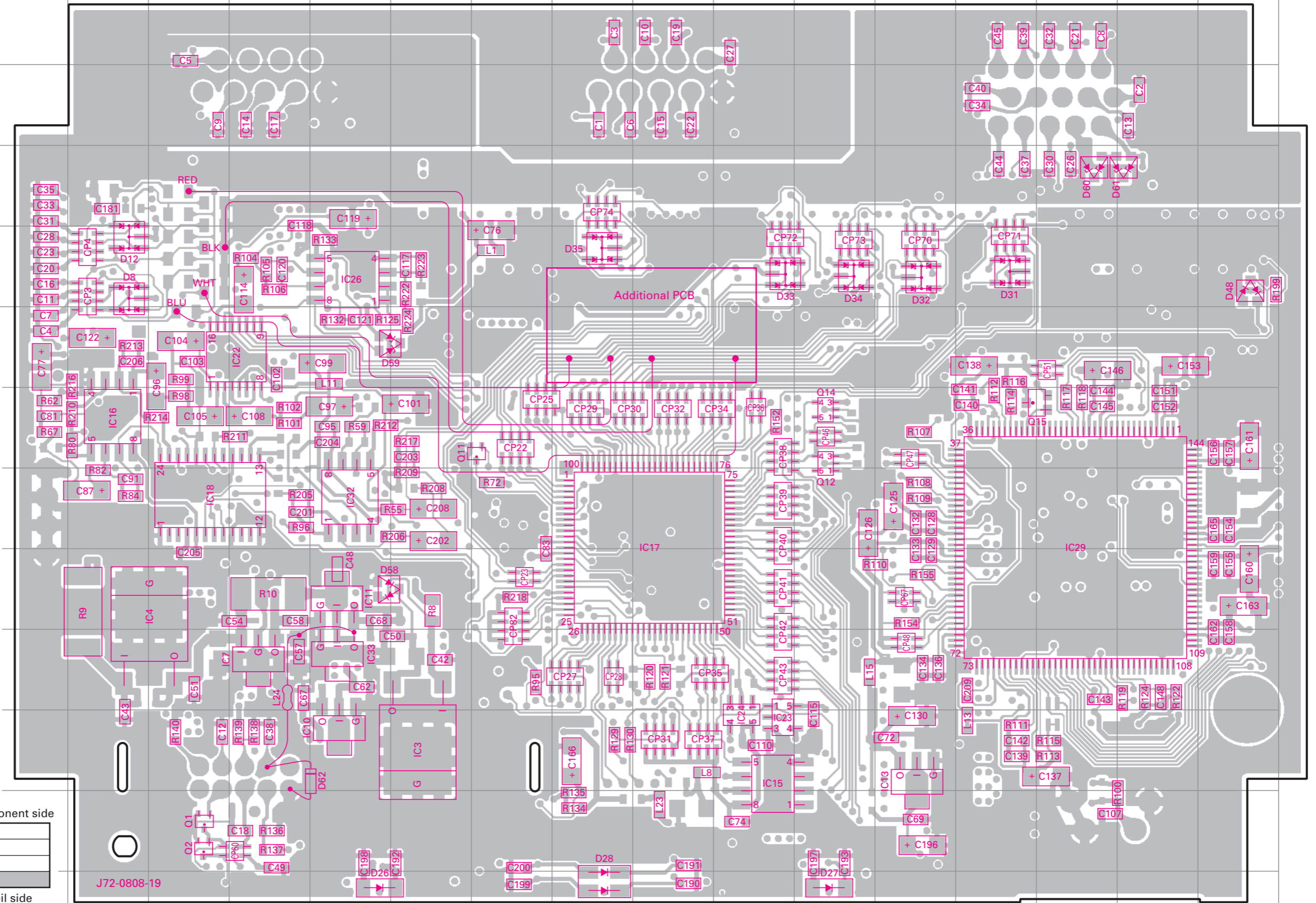

J72-0808-19

PC BOARD VIEW KGP-2B

CONTROL UNIT (X53-3980-21) Component side view

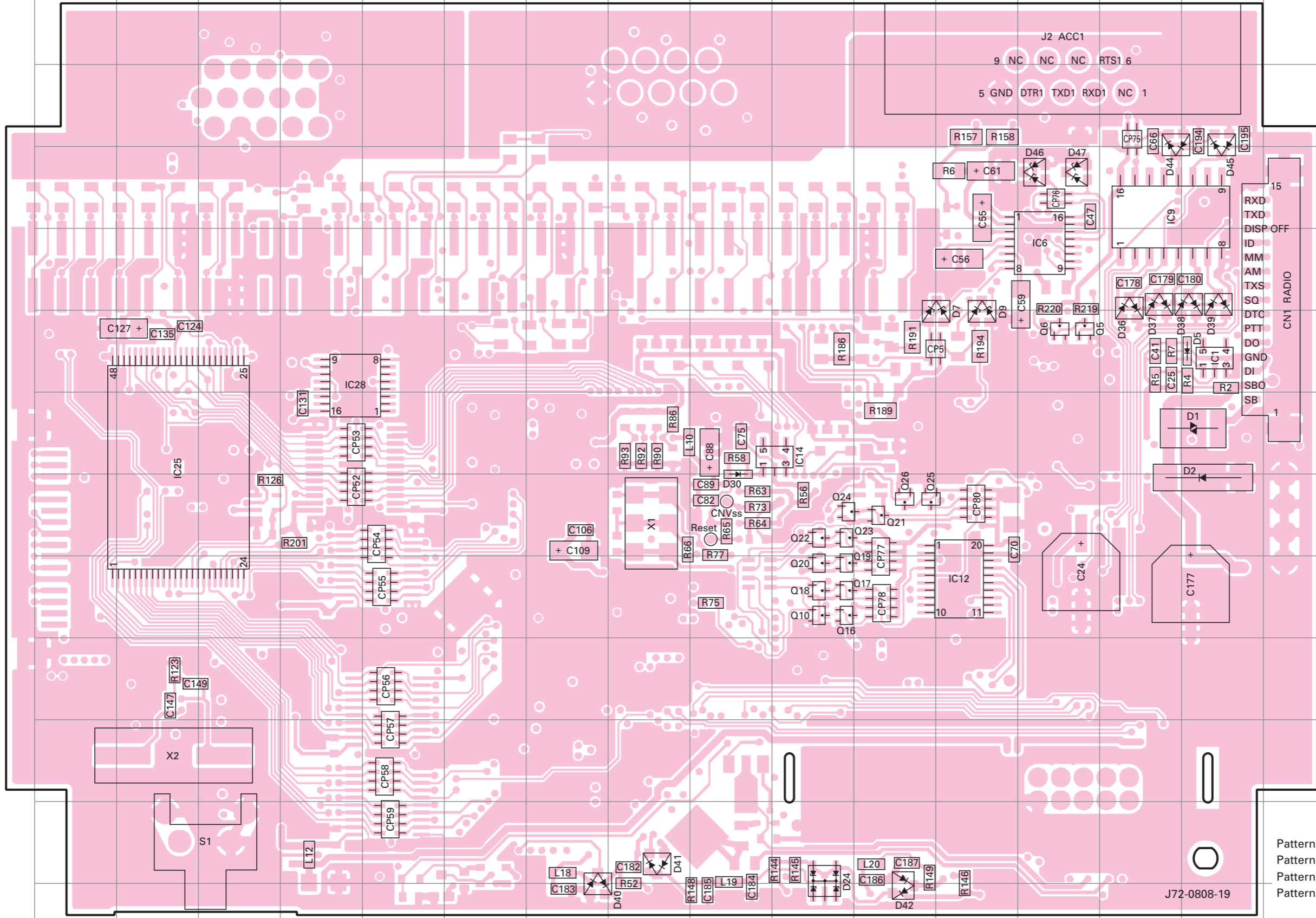

Ref No.	Address	Ref No.	Address	Ref No.	Address
IC1	6O	Q19	9J	D24	12J
IC6	5M	Q20	9J	D30	8I
IC9	4N	Q21	8K	D36	6N
IC12	9L	Q22	8J	D37	5N
IC14	7J	Q23	8J	D38	5O
IC25	7B	Q24	8J	D39	5O
IC28	6D	Q25	8K	D40	13G
Q5	6M	Q26	8K	D41	12H
Q6	6M	D1	7O	D42	13K
Q10	9J	D2	8O	D44	4N
Q16	9J	D5	6O	D45	4O
Q17	9J	D7	6L	D46	4M
Q18	9J	D9	6L	D47	4M

DTC114YE DTC144EE	DA204U
DTC114EUA	TC7S04F
NJM4558M	RN5VL30C
TC74HC4094AF	XC62FP1802P XC62FP3302P
TA78L05F	

Component side

Pattern 1

Pattern 2

Pattern 3

Pattern 4

Foil side

KGP-2B PC BOARD VIEW

Additional PCB

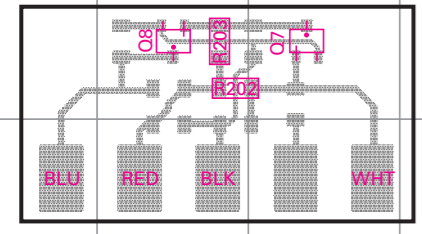

Ref No.	Address	Ref No.	Address	Ref No.	Address
IC3	11I	IC16	7E	Q11	7J
IC4	9F	IC17	8L	Q15	7Q
IC7	10G	IC18	8F	D8	5E
IC10	11H	IC22	6G	D12	5E
IC11	9H	IC24	11M	D26	13H
IC13	11O	IC26	5H	D28	13K
IC15	11M	IC29	8Q	D59	6H

ADM202EARU
AK4550VT
TC74VHC4040FT

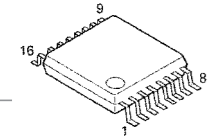

ADM3202ARU

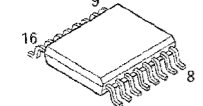

TA7808F

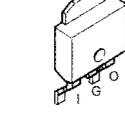

24LC08BT-ISN

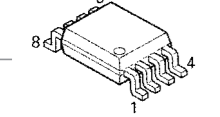

BU2099FV

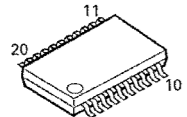

M62364FP

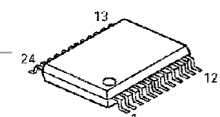

30620M8A-2M6GP

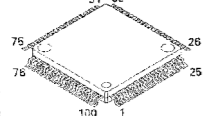

320VC5402PGE

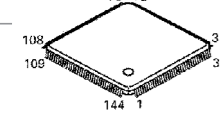

MRM291V800R90

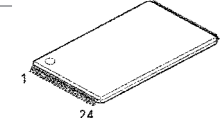

CONTROL UNIT (X53-3980-21) Foil side view

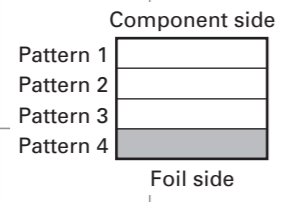
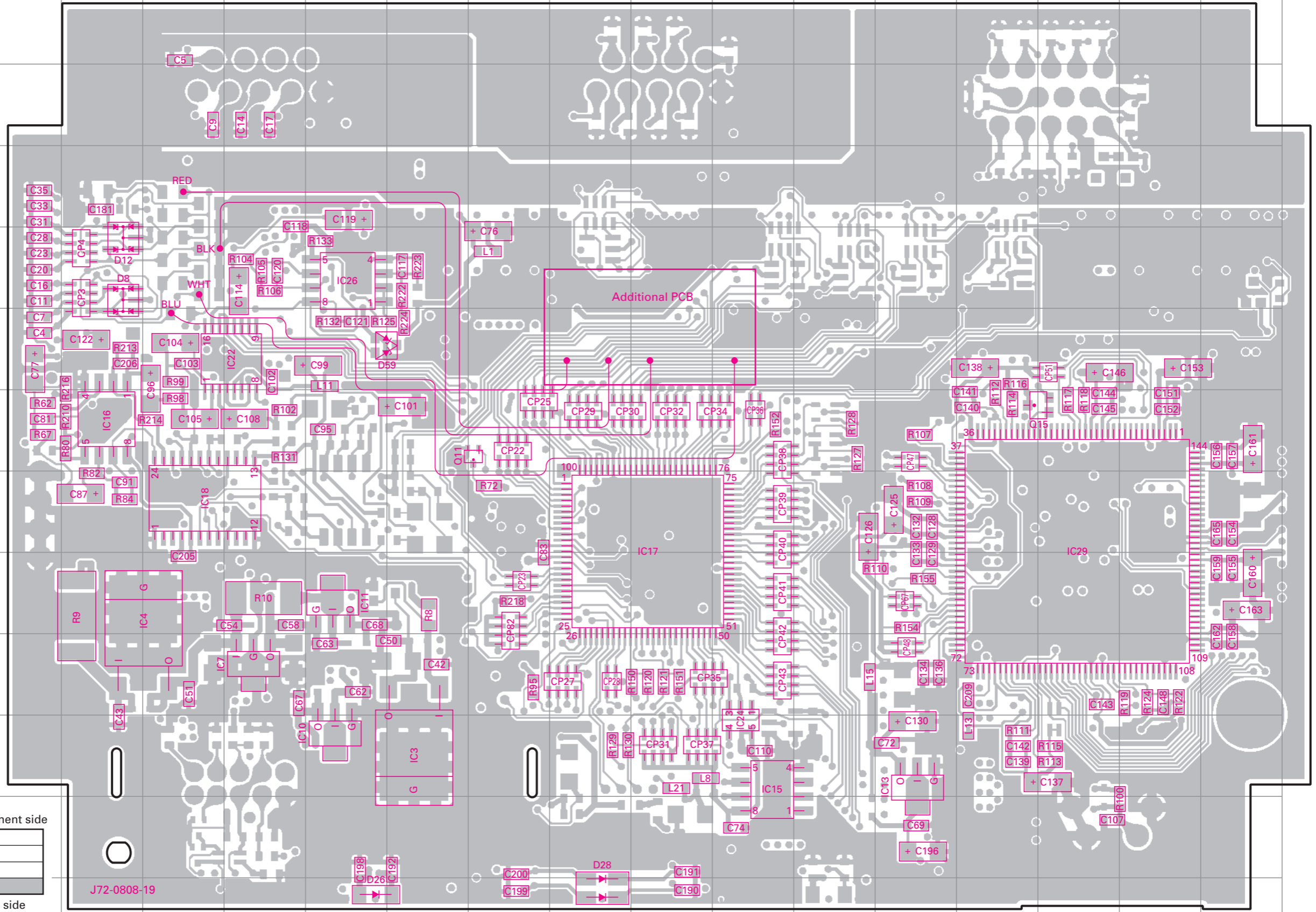

LEVEL DIAGRAM

Receiver Section

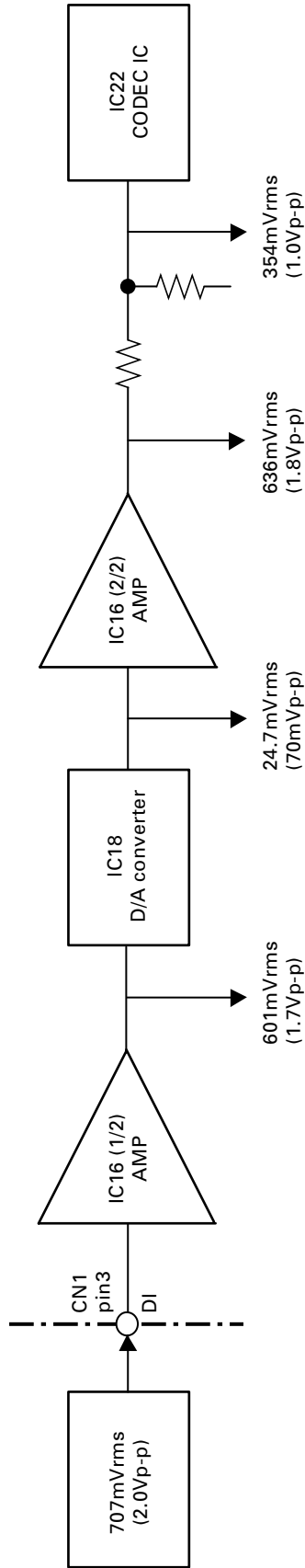

All voltage values are measured by using either an AF-VTVM or oscilloscope when 707mVrms (2.0Vp-p) is applied to the CN1 terminal pin 3 (DI).

Transmitter Section

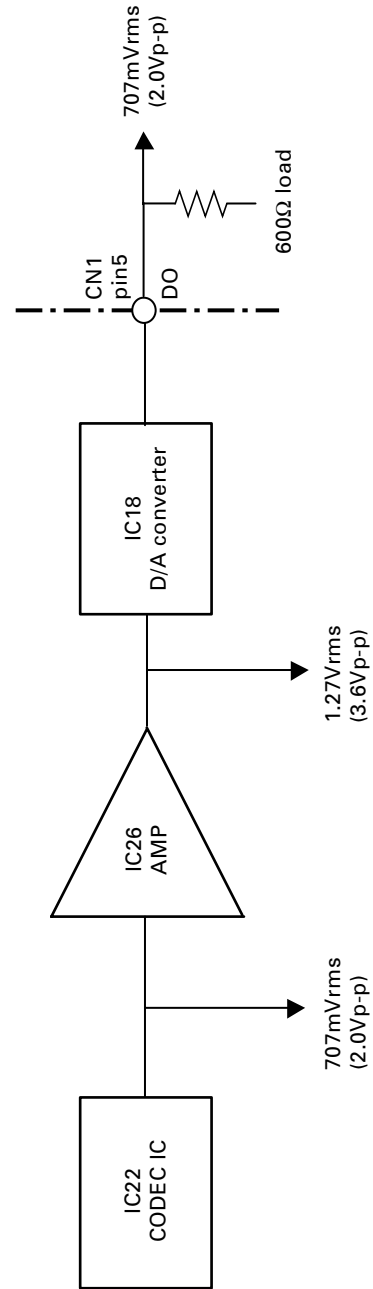

All voltage values are measured by using either an AF-VTVM or oscilloscope when 707mVrms (2.0Vp-p) is applied to the CN1 terminal pin 5 (DO).

TERMINAL FUNCTION

Connector No.	Pin No.	Pin Name	I/O	Function
CN1	1	SB	I	Main power supply input (13.6V)
	2	SBO	O	DC output (13.6V)
	3	DI	I	Modem input from radio DEO (Detector output)
	4	GND	-	Ground
	5	DO	O	Modem output to radio DI (Modulation input)
	6	PTT	O	PTT output
	7	DTC (DATA PTT)	O	Data TX control output (Data transmission output)
	8	SQ	I	Squelch input
	9	TXS	I	Radio TX detect input
	10	AM	O	Audio mute
	11	MM	O	Microphone mute
	12	ID	O	ID detect output (KGP protocol)
	13	DISP OFF	O	Controls radio LCD on/off
	14	TXD	O	Serial output (CMOS level)
	15	RXD	I	Serial input (CMOS level)
CN19 KGP-2A only	1~4	-	-	Ground
J2 (ACC1)	PC serial port (COM1)			
	1	NC	-	No connection
	2	RXD1	I	Serial 1 input (RS-232C level)
	3	TXD1	O	Serial 1 output (RS-232C level)
	4	DTR1	O	DTR1 output (RS-232C level)
	5	GND	-	Ground
	6	RTS1	O	RTS1 output (RS-232C level)
	7	NC	-	No connection
	8	NC	-	No connection
J3 (ACC2) KGP-2A only	Sensor I/O, Multi-purpose serial port (COM2)			
	1	SEN7*	I/O	Sensor 7 input/output
		NC	-	No connection
	2	SEN3*	I/O	Sensor 3 input/output
		RXD2	I	Serial 2 input (RS-232C level)
	3	SEN4*	I/O	Sensor 4 input/output
		TXD2	O	Serial 2 output (RS-232C level)
	4	SEN5*	I/O	Sensor 5 input/output
		DTR2	O	DTR2 output (RS-232C level)
	5	GND	-	Ground
	6	SEN6*	I/O	Sensor 6 input/output
		RTS2	O	RTS2 output (RS-232C level)
	7	SEN1*	I/O	Sensor 1 input/output
		NC	-	No connection
	8	SEN0*	I/O	Sensor 0 input/output
NC		-	No connection	

Connector No.	Pin No.	Pin Name	I/O	Function
	9	SEN2*	I/O	Sensor 2 input/output
		NC	-	No connection
J1 (ACC3) KGP-2A only	Sensor I/O, Multi-purpose serial port (COM2)			
	1	SBO	O	DC output (13.6V)
	2	GND	-	Ground
	3	SEN3*	I/O	Sensor 3 input/output
		RXD2	I	Serial 2 input (RS-232C level)
	4	SEN4*	I/O	Sensor 4 input/output
		TXD2	O	Serial 2 output (RS-232C level)
	5	SEN5*	I/O	Sensor 5 input/output
		DTR2	O	DTR2 output (RS-232C level)
		MI	I	Microphone input
	6	SEN6*	I/O	Sensor 6 input/output
		RTS2	O	RTS2 output (RS-232C level)
		ME	-	Microphone earth
	7	SEN7	I/O	Sensor 7 input/output
	8	SEN8	I/O	Sensor 8 input/output
9	SEN9	I/O	Sensor 9 input/output	
10	SEN10	I/O	Sensor 10 input/output	
11	SEN11	I/O	Sensor 11 input/output	
12	SEN12	I/O	Sensor 12 input/output	
13	SEN13	I/O	Sensor 13 input/output	
14	SEN14	I/O	Sensor 14 input/output	
15	SEN15	I/O	Sensor 15 input/output	
RADIO	1	SB	I	Main power supply input (13.6V)
	2	SBO	O	DC output (13.6V)
	3	GND	-	Ground
	4	DI	I	Modem input from radio DEO (Detector output)
	5	DO	O	Modem output to radio DI (Modulation input)
	6	PTT	O	PTT output
	7	DTC	O	Data TX control output
	8	SQ	I	Squelch input
	9	TXS	I	Radio TX detect input
	10	AM	O	Audio mute
	11	MM	O	Microphone mute
	12	ID	O	ID detect output (KGP protocol)
	13	DISP OFF	O	Controls radio LCD on/off
	14	TXD	O	Serial output (CMOS level)
	15	RXD	I	Serial input (CMOS level)
ANT KGP-2A only	-	-	I	GPS antenna connector

* : Default

SPECIFICATIONS

General

Standard Input Voltage	13.6V DC negative ground (Supplying from connected Radio)
Current Drain	KGP-2A : Less than 300mA KGP-2B : Less than 240mA
Temperature Range	-30°C to +60°C (-22°F to +140°F)
Dimensions (W x H x D, Dimensions not including protrusions)	140 (5.5) x 46 (1.8) x 100 (4.0) mm (inch)
Weight	KGP-2A : 460g (1.01lbs) KGP-2B : 420g (0.93lbs)
Environment Standard	
Dust	MIL810C : 510.1/Procedure 1 MIL810D : 510.2/Procedure 1 MIL810E : 510.3/Procedure 1
Vibration	MIL810C : 514.2/Procedure 8,10 MIL810D : 514.3/Procedure 1 Cat, 8 MIL810E : 514.4/Procedure 1 Cat, 8
Shock	MIL810C : 516.2/Procedure 1,2,5 MIL810D : 516.3/Procedure 1,4 MIL810E : 516.4/Procedure 1,4

GPS Receiver Section (KGP-2A only)

Receiver Type	Parallel 9 channels
Receiver Frequency	1575.42MHz
Receiver Sensitivity (With supplied GPS antenna)	-130dBm or less
Supply Voltage to Antenna	DC 3.3V ± 0.2V

Modem Section

Modem Encode Level Range	100 to 1000mVrms
Modem Decode Level Range	100 to 1000mVrms
Modem Output Impedance	600Ω
Modem Input Impedance	600Ω
Modulation	MSK
Modulation Rate	1200bps or 2400bps

KENWOOD follows a policy of continuous advancement in development.
For this reason specifications may be changed without notice.

KGP-2A/2B

KENWOOD CORPORATION

14-6, Dogenzaka 1-chome, Shibuya-ku, Tokyo 150-8501, Japan

KENWOOD SERVICE CORPORATION

P.O. BOX 22745, 2201 East Dominguez Street, Long Beach, CA 90801-5745, U.S.A.

KENWOOD ELECTRONICS CANADA INC.

6070 Kestrel Road, Mississauga, Ontario, Canada L5T 1S8

KENWOOD ELECTRONICS DEUTSCHLAND GMBH

Rembrücker Str. 15, 63150 Heusenstamm, Germany

KENWOOD ELECTRONICS BELGIUM N.V.

Leuvensesteenweg 248 J, 1800 Vilvoorde, Belgium

KENWOOD ELECTRONICS FRANCE S.A.

13, Boulevard Ney, 75018 Paris, France

KENWOOD ELECTRONICS U.K. LIMITED

KENWOOD House, Dwight Road, Watford, Herts., WD1 8EB United Kingdom

KENWOOD ELECTRONICS EUROPE B.V.

Amsterdamseweg 37, 1422 AC Uithoorn, The Netherlands

KENWOOD ELECTRONICS ITALIA S.p.A.

Via G. Sirtori, 7/9 20129 Milano, Italy

KENWOOD IBERICA S.A.

Bolivia, 239-08020 Barcelona, Spain

KENWOOD ELECTRONICS AUSTRALIA PTY. LTD.

(A.C.N. 001 499 074)

16 Giffnock Avenue, Centrecourt Estate, North Ryde, N.S.W. 2113 Australia

KENWOOD ELECTRONICS (HONG KONG) LTD.

Unit 3712-3724, Level 37, Tower one Metroplaza, 223 Hing Fong Road, Kwai Fong, N.T., Hong Kong

KENWOOD ELECTRONICS TECHNOLOGIES(S) PTE LTD.

Sales Marketing Division

1 Ang Mo Kio Street 63, Singapore 569110

