

SPEAKER MICROPHONE  
**KMC-41D**  
SERVICE MANUAL

**KENWOOD**

JVCKENWOOD Corporation

© 2014-2 PRINTED IN JAPAN  
RQ023 (K) B5B-7119-00

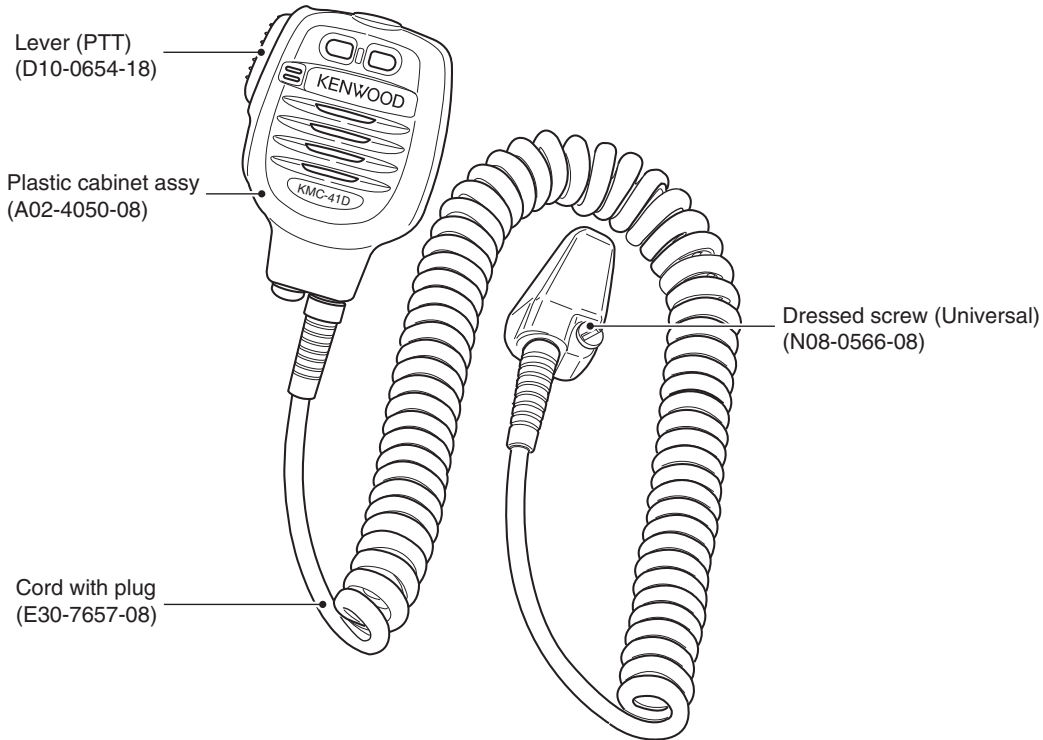

### Document Copyrights

Copyright 2014 by JVC KENWOOD Corporation. All rights reserved.

No part of this manual may be reproduced, translated, distributed, or transmitted in any form or by any means, electronic, mechanical, photocopying, recording, or otherwise, for any purpose without the prior written permission of JVC KENWOOD Corporation.

### Disclaimer

While every precaution has been taken in the preparation of this manual, JVC KENWOOD Corporation assumes no responsibility for errors or omissions. Neither is any liability assumed for damages resulting from the use of the information contained herein. JVC KENWOOD Corporation reserves the right to make changes to any products herein at any time for improvement purposes.

## SPECIFICATIONS

### Microphone

Impedance ..... 2.2k $\Omega$  (MAX)  
Sensitivity ..... -65dB  $\pm$  4dB at 1kHz

### Speaker

Impedance ..... 16 $\Omega$   $\pm$  15% at 1kHz  
Rating input ..... 0.5W  
Maximum input ..... 1.5W  
Dimensions (W x H x D)  
..... 67.8 x 91.5 x 43.3 mm (2.67 x 3.60 x 1.70 in)  
Weight ..... Approx. 260g/9.2oz



## DISASSEMBLY FOR REPAIR

### 1. Removing the cable ASSY

- 1) Pull out the holder that is set into the fixing bracket of the cable ASSY, using a pair of pliers.

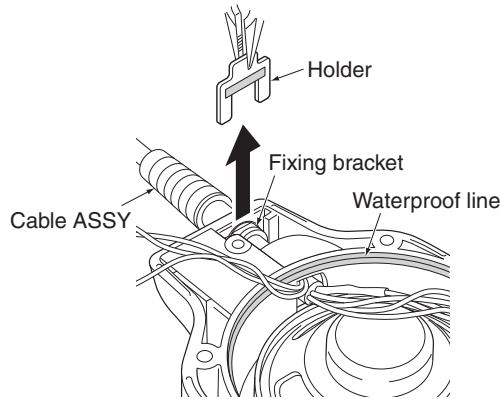

Fig. 1

- 2) Completely peel off the bond (\*1) glued to the cable ASSY, using a set of nippers.

**Note:** Please be careful not to damage the coating of the cable ASSY and the waterproofing line of the front case.

\*1: Use the following bond:

- Manufacture name: Shin-Etsu Chemical Co., Ltd.
- Bond name: Shin-Etsu silicone One-component RTV silicone rubbers Alcohol type KE-4898-T

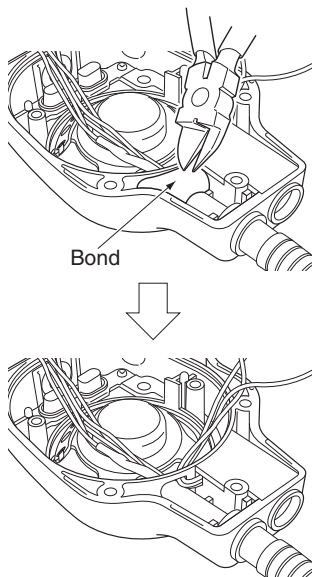

Fig. 2

- 3) Following the procedure below, pass through the connector part of the cable ASSY into the hole of the front case (waterproof line part).

- (1) Move the three lead wires soldered onto the PCB to the upper corner of the hole.
- (2) The yellow lead wire side of the connector comes in the inside of the front case.

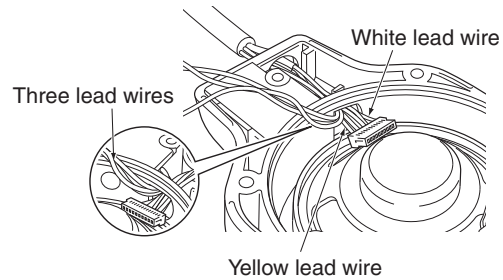

Fig. 3

- (3) Push the cable ASSY to the earphone jack side with the connector part bent as shown in the figure, then hook the end of the connector (white lead wire side) into the outside corner of the hole, using your finger.

- (4) Pass the connector through the hole, pushing the connector (yellow lead wire side) using a pair of tweezers or similar tool.

**Note:** Attach adhesive tape or rubber to the end of the tweezers so as not to damage the connector of the cable ASSY.

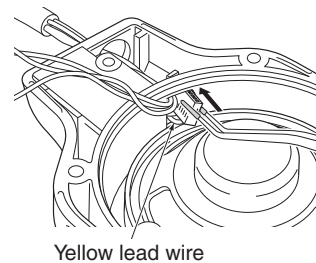

Fig. 4

- 4) Pull the cable ASSY, then remove the cable ASSY from the front case by passing the connector part through the hole of the front case.

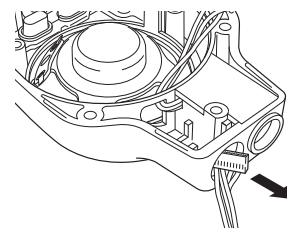

Fig. 5

## DISASSEMBLY FOR REPAIR

### 2. Installing the cable ASSY

- 1) Pass the connector part of cable ASSY through the hole of the front case.
- 2) Move the three lead wires soldered onto the PCB to the upper corner of the hole.

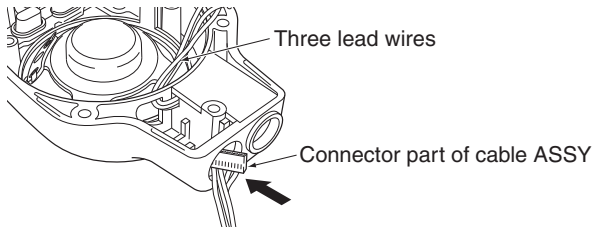

Fig. 6

- 3) Make sure the yellow lead wire side of the connector is in the inside of the front case.

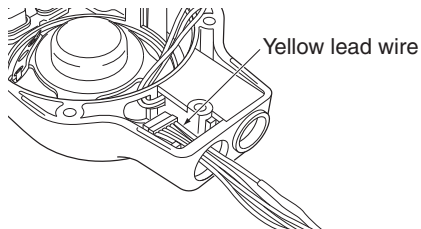

Fig. 7

- 4) Push the connector (yellow lead wire side) to the lower corner of the hole using a pair of tweezers.  
**Note:** Attach adhesive tape or rubber to the end of the tweezers so as not to damage the connector of the cable ASSY.
- 5) Pass the connector through the hole by pushing the connector (white lead wire side) using a pair of tweezers or similar tool.

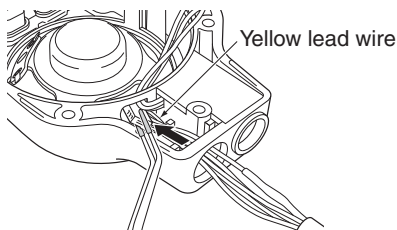

Fig. 8

- 6) Push the cable ASSY to the inside of the case, then insert the fixing bracket of the cable ASSY to the hole of the front case.
- 7) Fit the holder to the fixing bracket of the cable ASSY.

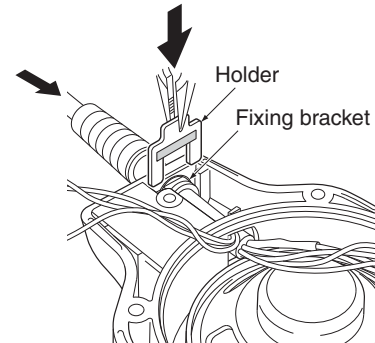

Fig. 9

- 8) Insert the cap in the earphone jack hole of the front case.
- 9) Apply the bond (\*1) at the position shown in the figure, then firmly attach the cable ASSY and case.

**Note:** Take care not to apply the bond to the waterproofing line of the front case.

\*1: Use the following bond :

- Manufacture name: Shin-Etsu Chemical Co., Ltd.
- Bond name: Shin-Etsu silicone One-component RTV silicone rubbers Alcohol type KE-4898-T

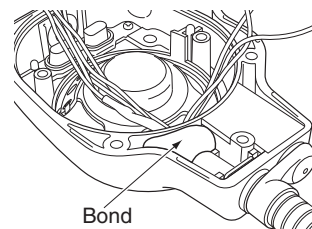
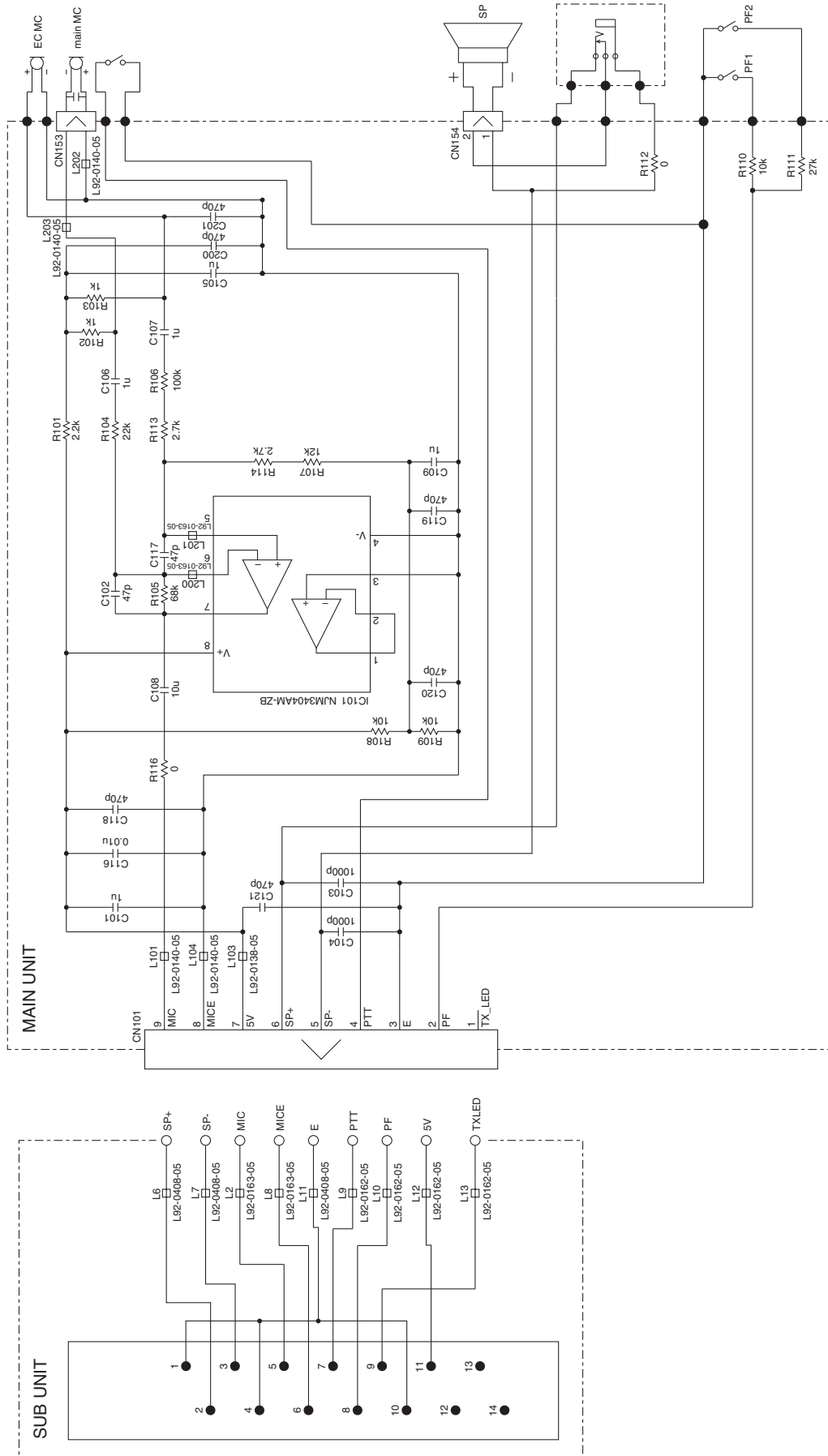

Fig. 10

# KMC-41D

## SCHEMATIC DIAGRAM



## EXPLODED VIEW

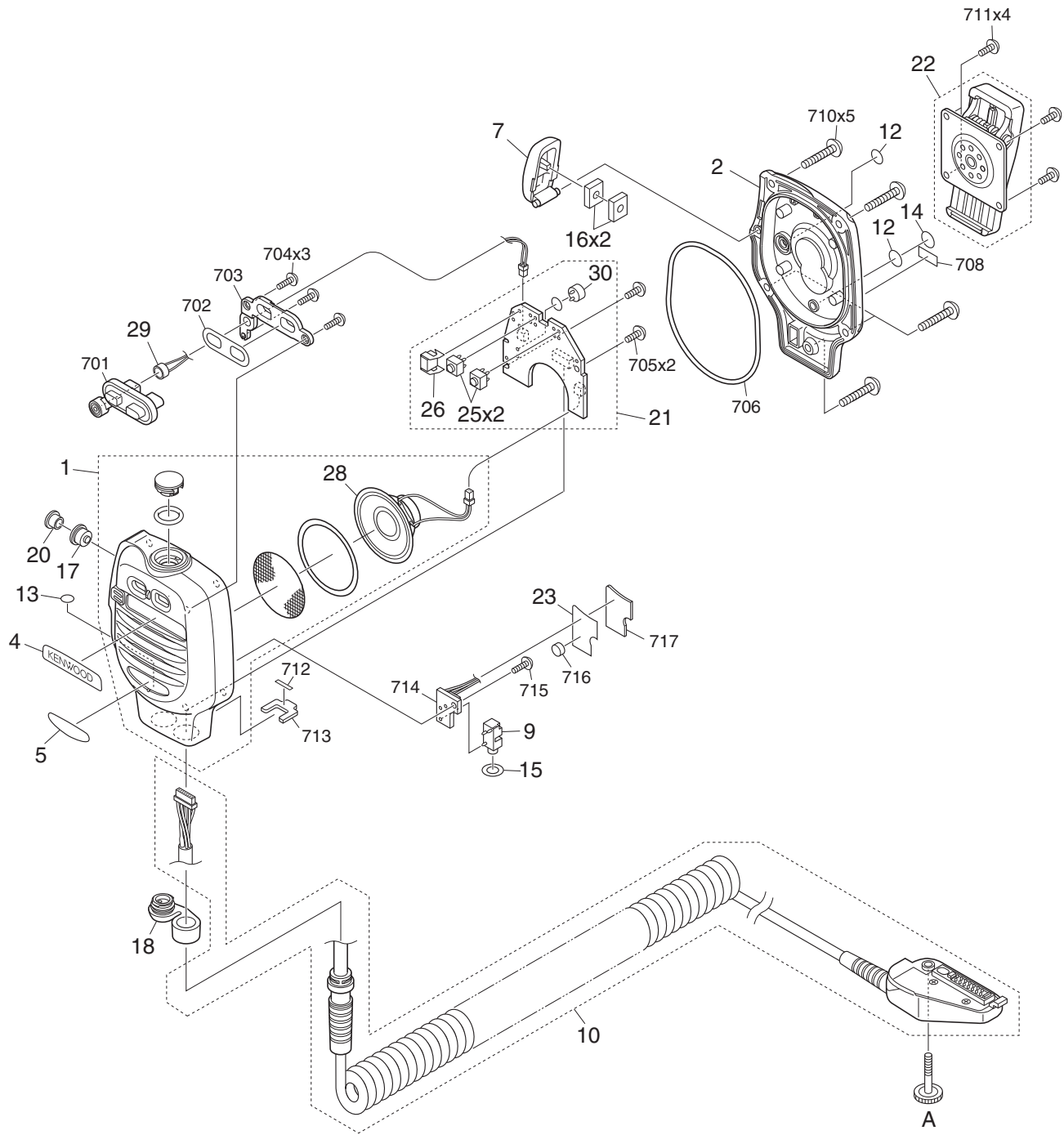

Parts with the exploded numbers larger than 700 are not supplied.

# KMC-41D

## PARTS LIST

### KMC-41D

Ref. No.	Address	Parts No.	Description	Destination
<b>KMC-41D</b>				
1		A02-4050-08	PLASTIC CABINET ASSY	
2		A82-0073-08	REAR PANEL	
4		B43-1616-08	BADGE (KENWOOD)	
5		B4C-0005-00	BADGE (KMC-41D)	
7		D10-0654-18	LEVER (PTT)	
9		E11-0712-08	3.5D PHONE JACK	
10		E30-7657-08	CURL CABLE ASSY	
12		G10-1358-08	FIBROUS SHEET	
13		G10-1386-08	FIBROUS SHEET (PHONE JACK)	
14		G11-4450-08	SHEET (LEAK TEST)	
15		G11-4452-08	SHEET (PHONE JACK)	
16		G13-2241-08	CUSHION (PTT)	
17		G53-1779-08	PACKING (PTT)	
18		G53-1784-08	PACKING (BOTTOM CAP)	
20		J19-5515-08	HOLDER (PTT)	
21		W0C-0024-00	PRINTED WIRING BOARD ASSY	
22		J29-0740-08	BELT HOOK ASSY	
23		J99-0729-08	ADHESIVE SHEET (JACK COVER)	
A		N08-0566-08	DRESSED SCREW (UNIVERSAL)	
25		S70-0471-08	TACT SWITCH (PF)	
26		S70-0511-08	TACT SWITCH (PTT)	
28		T07-0359-18	SPEAKER	
29		T91-0584-08	MIC ELEMENT (MAIN MIC)	
30		T91-0660-08	MIC ELEMENT (SUB MIC)	

# KENWOOD

JVC KENWOOD Corporation  
Communications Equipment Div