

SPEAKER MICROPHONE  
**KMC-52D**  
SERVICE MANUAL

**KENWOOD**

JVCKENWOOD Corporation

© 2014-2 PRINTED IN JAPAN  
RQ026 (K) B5B-7122-00

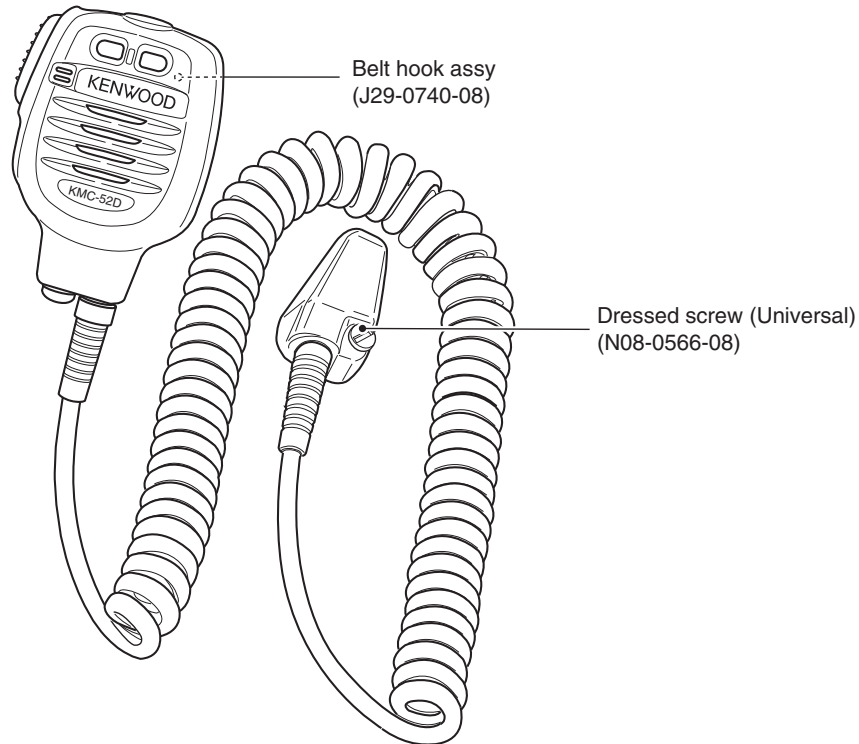

### Document Copyrights

Copyright 2014 by JVC KENWOOD Corporation. All rights reserved.

No part of this manual may be reproduced, translated, distributed, or transmitted in any form or by any means, electronic, mechanical, photocopying, recording, or otherwise, for any purpose without the prior written permission of JVC KENWOOD Corporation.

### Disclaimer

While every precaution has been taken in the preparation of this manual, JVC KENWOOD Corporation assumes no responsibility for errors or omissions. Neither is any liability assumed for damages resulting from the use of the information contained herein. JVC KENWOOD Corporation reserves the right to make changes to any products herein at any time for improvement purposes.

## SPECIFICATIONS

### General

Operating temperature range  
.....-30°C ~ +60°C (-22°F ~ +140°F)

### Microphone

Impedance .....600Ω (MAX)  
Sensitivity .....-39dB ±3.5dB at 1kHz

### Speaker

Impedance .....16Ω ±15% at 1.2kHz  
Rating input ..... 0.8W  
Maximum input ..... 1.6W  
Dimensions (W x H x D)  
..... 67.8 x 91.5 x 43.3 mm (2.67 x 3.60 x 1.70 in)  
Weight ..... Approx. 260g/9.2oz



# KMC-52D

# SCHEMATIC DIAGRAM

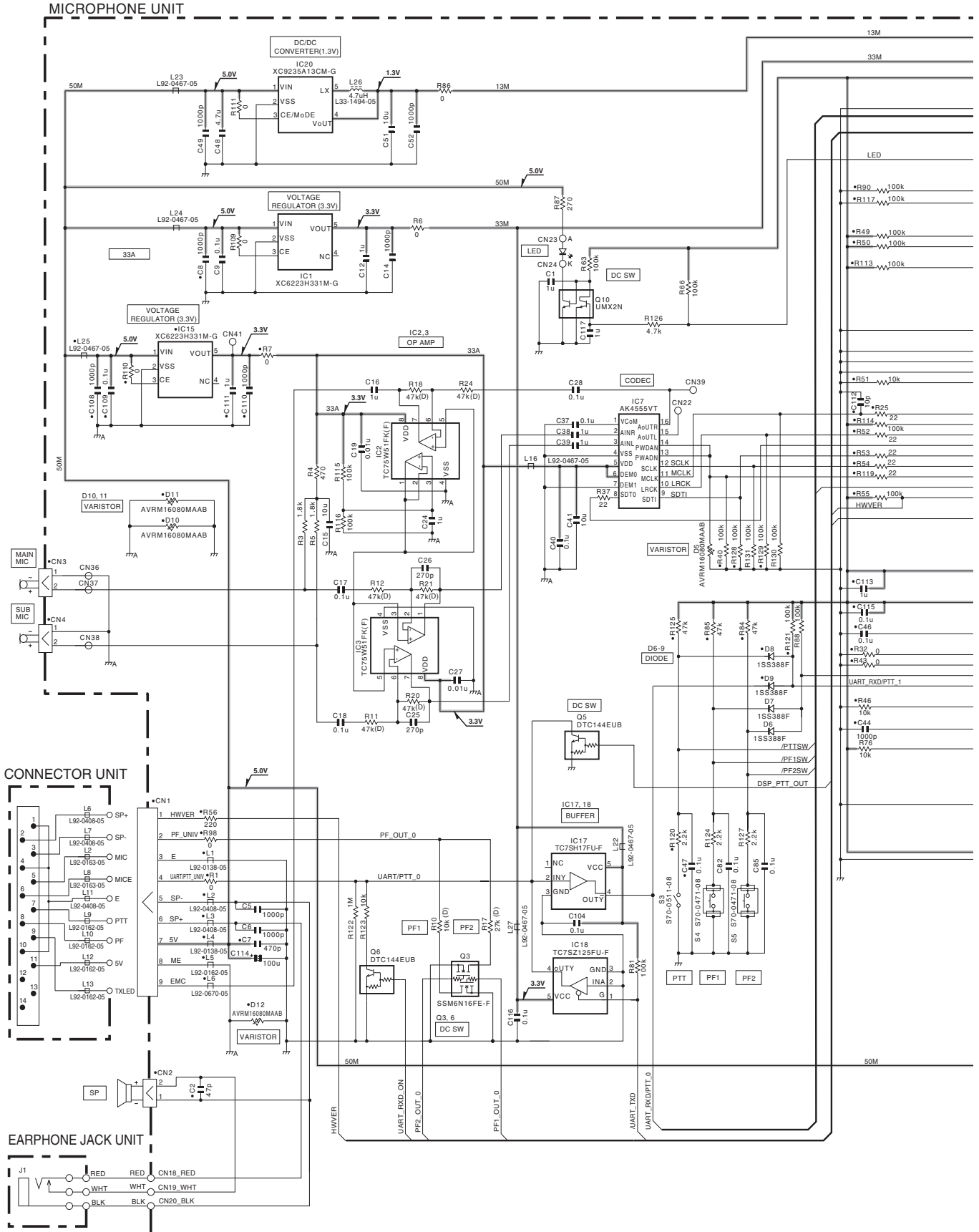



# KMC-52D

## NOISE CANCELLATION OPERATION CHECK METHOD

Check the noise cancellation operation according to the following procedures.

### ■ Preparation

Procedure 1. Prepare the two transceivers (transmitting side and receiving side) and one microphone. (The receiving side can also use the radio communication tester, etc..)

Procedure 2. Set the two transceivers so that they can communicate.

Procedure 3. Connect the microphone to the universal connector on the transmitting transceiver.

Procedure 4. Press the PTT switch of the microphone (the transceiver will transmit if the LED lights up).

### ■ Checking the main microphone

Procedure 5. Blow into the front side microphone hole, from a distance of 3 to 4 cm (1.18 to 1.57 inches).

#### [Expected Result]

It is OK if you can hear a wind noise from the speaker of the receiving transceiver.

### ■ Checking the sub microphone

Procedure 6. Blow into the rear side microphone hole for 5 seconds, from a distance of 3 to 4 cm (1.18 to 1.57 inches).

#### [Expected Result]

You can hear a wind noise from the speaker of the receiving transceiver for about 1 second. Then, it is OK if the wind noise level becomes quieter.

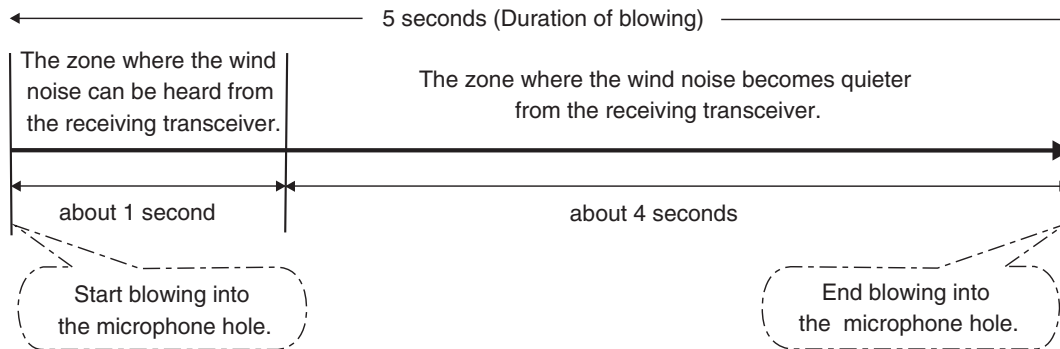
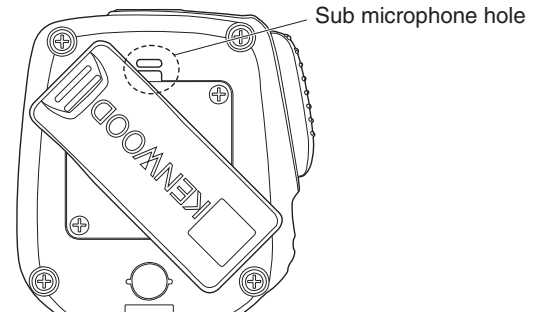

# KENWOOD

JVC KENWOOD Corporation  
Communications Equipment Div

MICROPHONE UNIT

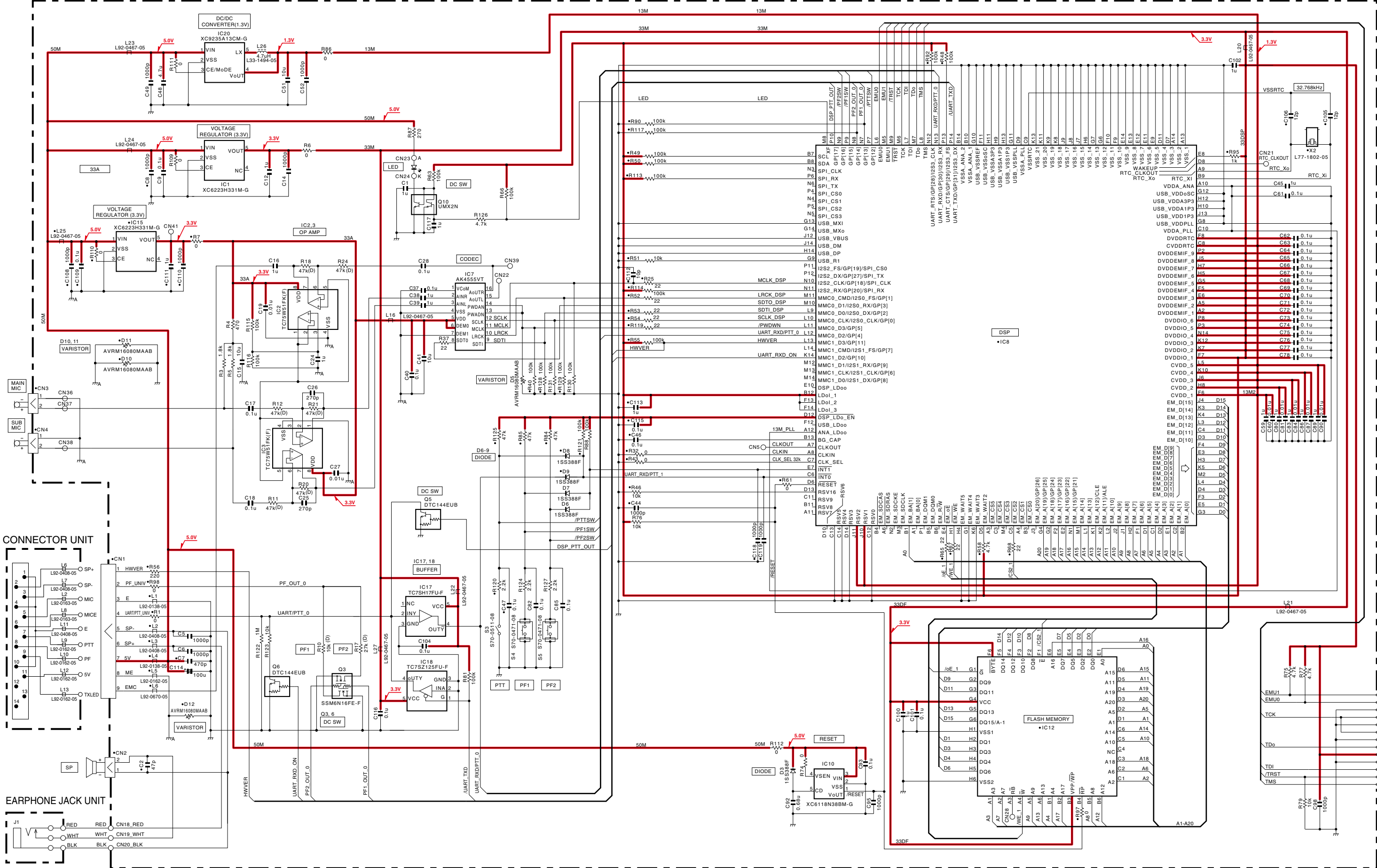

CONNECTOR UNIT

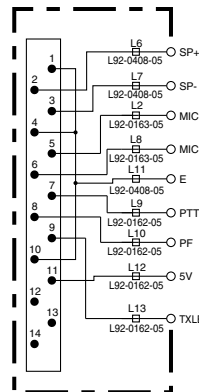

EARPHONE JACK UNIT

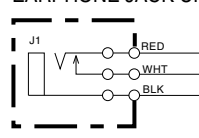

DC/DC CONVERTER(1.3V)

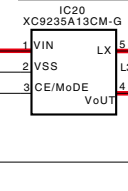

VOLTAGE REGULATOR (3.3V)

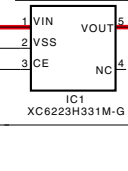

VOLTAGE REGULATOR (3.3V)

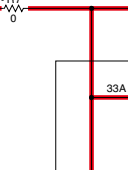

OP AMP

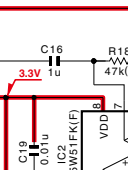

CODEC

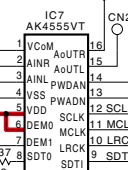

DC SW

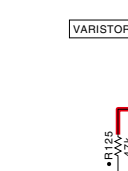

DC SW

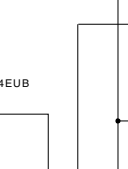

DC SW

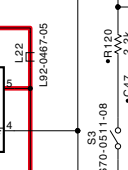

DC SW

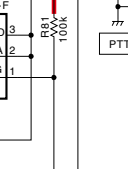

DC SW

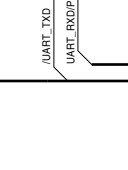

LED



LED

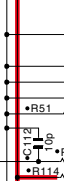

LED

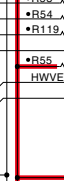

LED

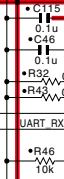

LED



LED



LED



LED

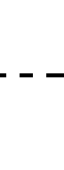

FLASH MEMORY

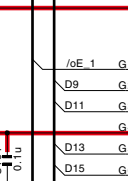

FLASH MEMORY

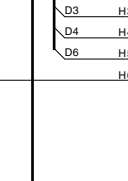

FLASH MEMORY

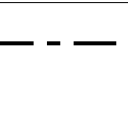

DSP



DSP

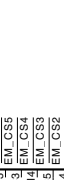

DSP

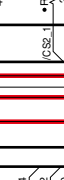

DSP



DSP

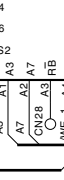

DSP

