

SPEAKER MICROPHONE
KMC-52
SERVICE MANUAL

KENWOOD

JVC KENWOOD Corporation

© 2012-3 PRINTED IN JAPAN
B53-7021-00 (Y) 250

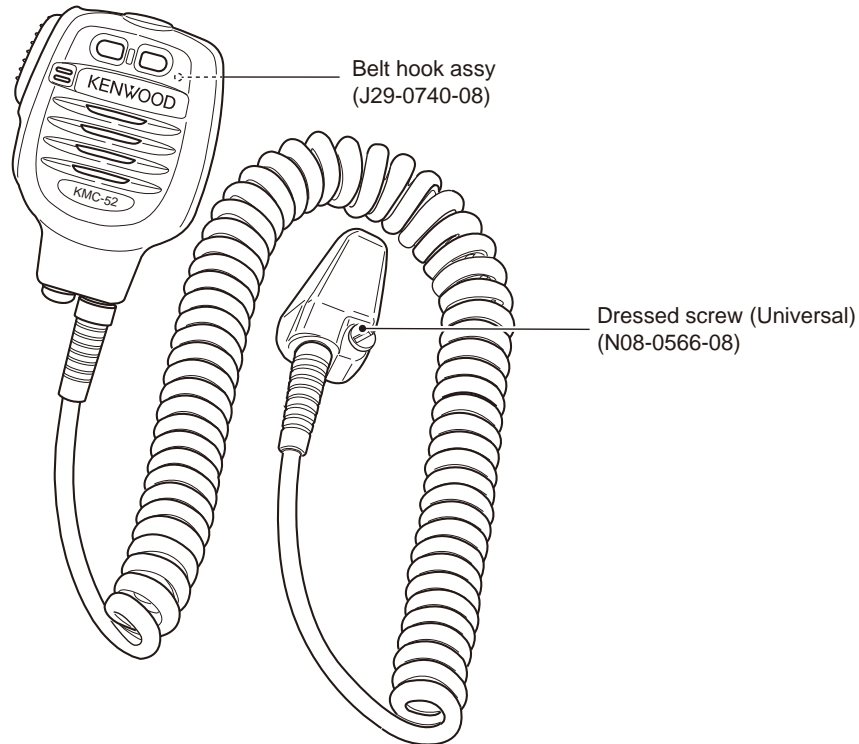

Document Copyrights

Copyright 2012 by JVC KENWOOD Corporation. All rights reserved.

No part of this manual may be reproduced, translated, distributed, or transmitted in any form or by any means, electronic, mechanical, photocopying, recording, or otherwise, for any purpose without the prior written permission of JVC KENWOOD Corporation.

Disclaimer

While every precaution has been taken in the preparation of this manual, JVC KENWOOD Corporation assumes no responsibility for errors or omissions. Neither is any liability assumed for damages resulting from the use of the information contained herein. JVC KENWOOD Corporation reserves the right to make changes to any products herein at any time for improvement purposes.

SPECIFICATIONS

General

Operating temperature range
.....-30°C ~ +60°C (-22°F ~ +140°F)

Microphone

Impedance600Ω (MAX)
Sensitivity-39dB ±3.5dB at 1kHz

Speaker

Impedance16Ω ±15% at 1.2kHz
Rating input 0.8W
Maximum input 1.6W
Dimensions (W x H x D)
..... 67.8 x 91.5 x 43.3 mm (2.67 x 3.60 x 1.70 in)
Weight Approx. 260g/9.2oz



KMC-52

SCHEMATIC DIAGRAM

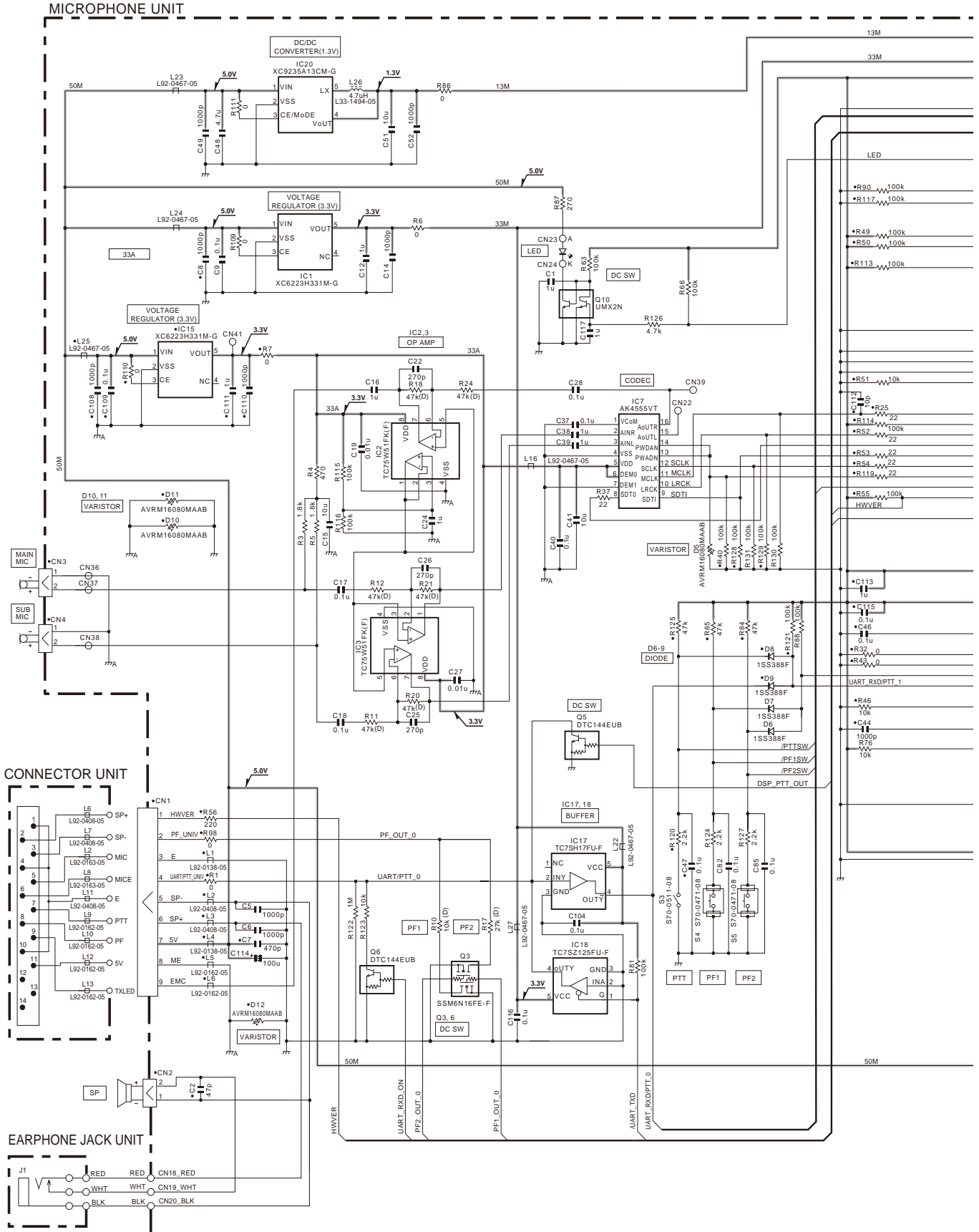

SCHEMATIC DIAGRAM

KMC-52

MICROPHONE UNIT

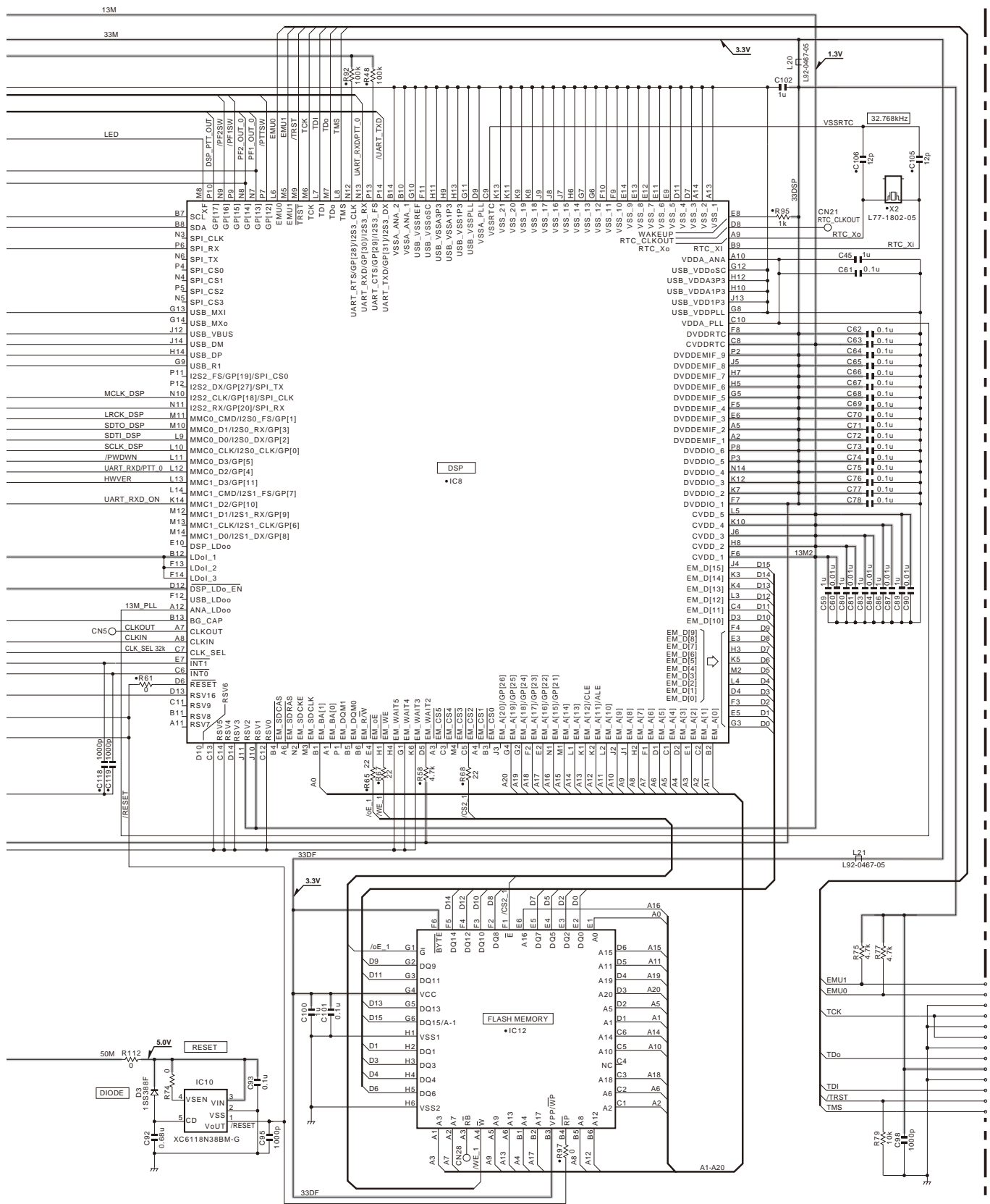

KMC-52

NOISE CANCELLATION OPERATION CHECK METHOD

Check the noise cancellation operation according to the following procedures.

■ Preparation

Procedure 1. Prepare the two transceivers (transmitting side and receiving side) and one microphone. (The receiving side can also use the radio communication tester, etc..)

Procedure 2. Set the two transceivers so that they can communicate.

Procedure 3. Connect the microphone to the universal connector on the transmitting transceiver.

Procedure 4. Press the PTT switch of the microphone (the transceiver will transmit if the LED lights up).

■ Checking the main microphone

Procedure 5. Blow into the front side microphone hole, from a distance of 3 to 4 cm (1.18 to 1.57 inches).

[Expected Result]

It is OK if you can hear a wind noise from the speaker of the receiving transceiver.

■ Checking the sub microphone

Procedure 6. Blow into the rear side microphone hole for 5 seconds, from a distance of 3 to 4 cm (1.18 to 1.57 inches).

[Expected Result]

You can hear a wind noise from the speaker of the receiving transceiver for about 1 second. Then, it is OK if the wind noise level becomes quieter.

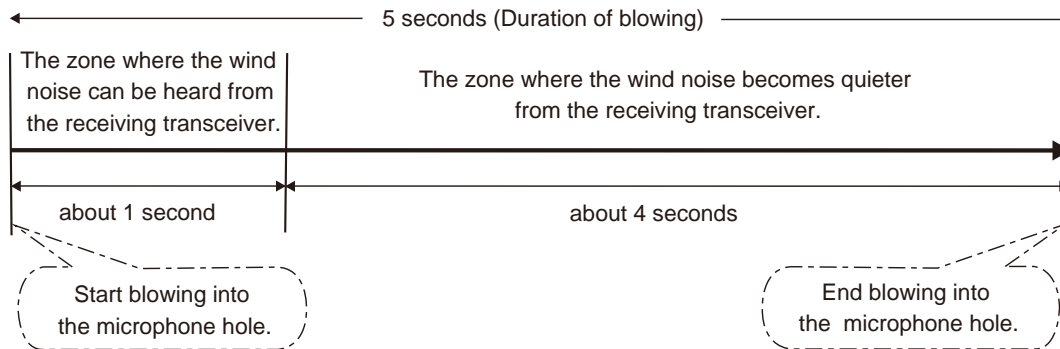
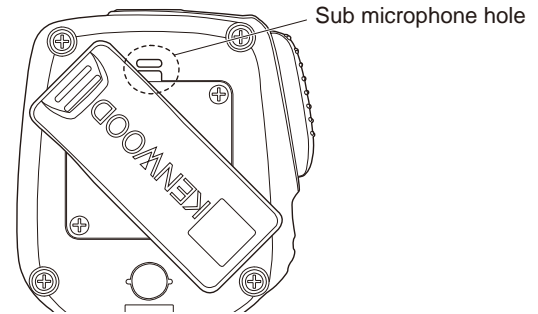

JVC KENWOOD Corporation

3-12, Moriyacho, Kanagawa-ku, Yokohama-shi,
Kanagawa, 221-0022 Japan

Kenwood U.S.A. Corporation

P.O. BOX 22745, 2201 East Dominguez Street, Long Beach,
CA 90801-5745, U.S.A.

Kenwood Electronics Canada Inc.

6070 Kestrel Road, Mississauga, Ontario, Canada L5T 1S8

Kenwood Electronics Deutschland GmbH

Rembrücker Str. 15, 63150 Heusenstamm, Germany

Kenwood Electronics Belgium N.V.

Leuvensesteenweg 248 J, 1800 Vilvoorde, Belgium

Kenwood Electronics France S.A.

L'Etoile Paris Nord 2, 50 Allée des Impressionnistes,
Bp 58416 Villepinte, 95944 Roissy Ch De Gaulle Cedex

Kenwood Electronics UK Limited

Kenwood House, Dwight Road, Watford, Herts.,
WD18 9EB United Kingdom

Kenwood Electronics Europe B.V.

Amsterdamseweg 37, 1422 AC Uithoorn, The Netherlands

Kenwood Electronics Italia S.p.A.

Via G. Sirtori, 7/9 20129 Milano, Italy

Kenwood Ibérica, S.A.

Carretera de Rubi, 88 Planta 1 A 08174 Sant Cugat del Vallès
Barcelona, Spain

Kenwood Electronics Australia Pty. Ltd.

Talavera Business Park Building A, 4 Talavera Road,
North Ryde NSW 2113 Australia

Kenwood Electronics (Hong Kong) Ltd.

Suite 2504, 25/F, Tower 2, Nina Tower, No. 8 Yeung Uk Road,
Tsuen Wan, New Territories, Hong Kong

Kenwood Electronics Singapore Pte Ltd

1 Ang Mo Kio Street 63, Singapore 569110

MICROPHONE UNIT

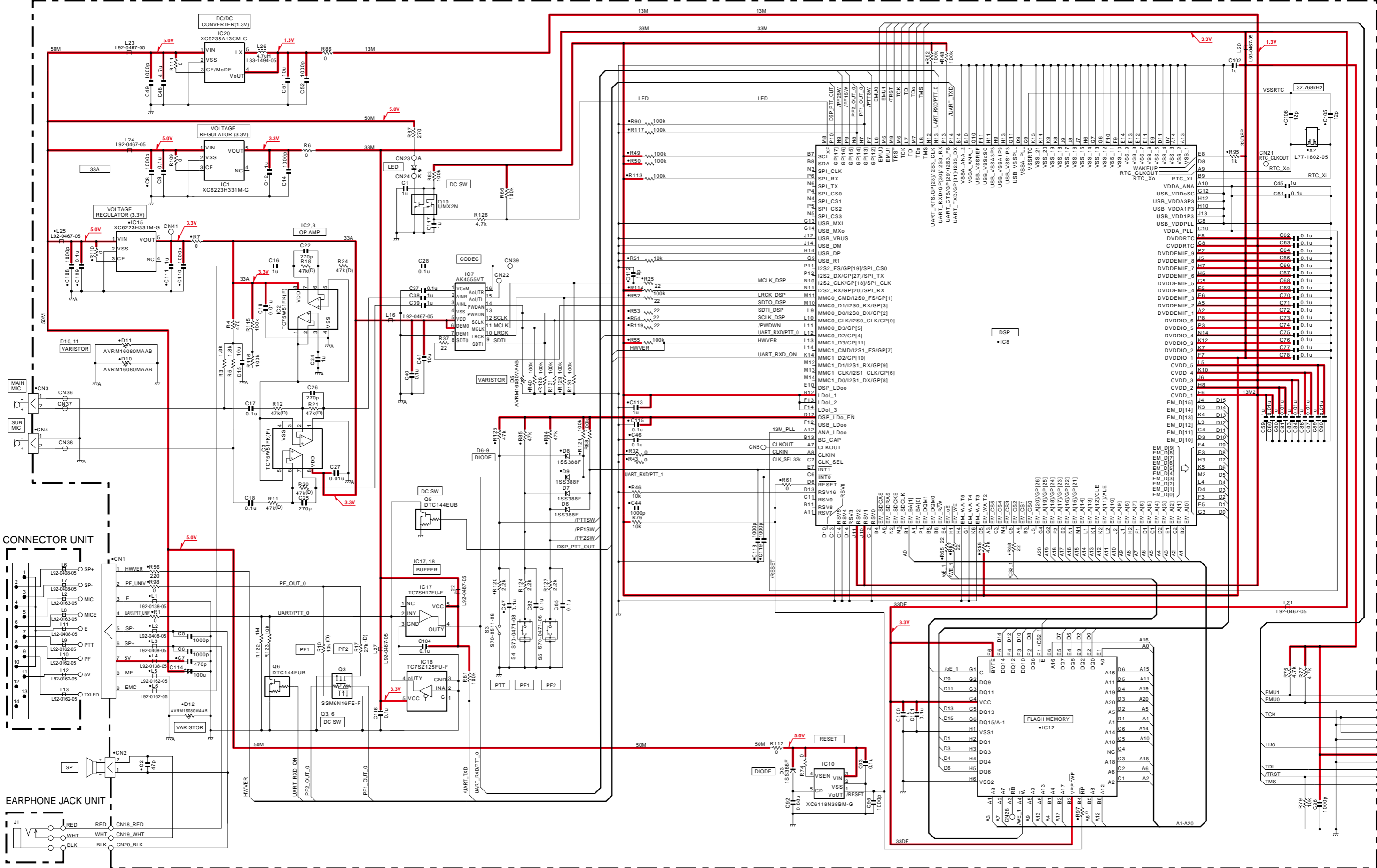

CONNECTOR UNIT

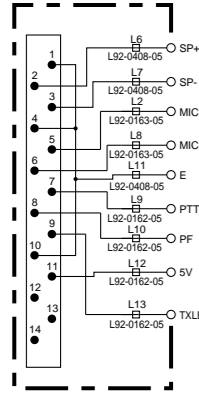

EARPHONE JACK UNIT

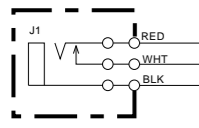

DC/DC CONVERTER(1.3V)

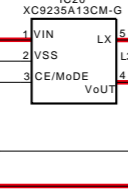

VOLTAGE REGULATOR (3.3V)

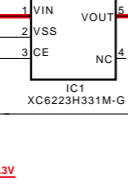

VOLTAGE REGULATOR (3.3V)

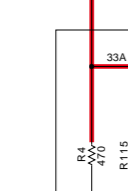

OP AMP

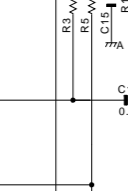

CODEC

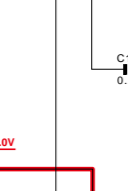

DC SW

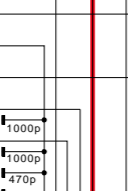

DC SW

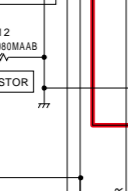

DC SW

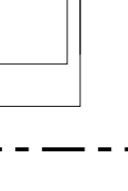

LED

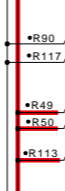

LED



LED



LED

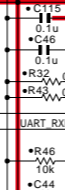

LED



LED



LED



LED

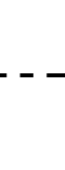

DSP

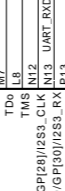

DSP

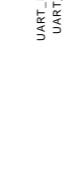

DSP



DSP



DSP

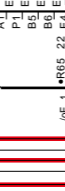

DSP



DSP

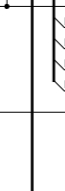

DSP

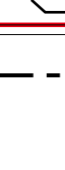

FLASH MEMORY

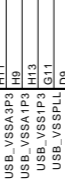

FLASH MEMORY

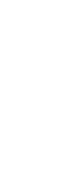

FLASH MEMORY



FLASH MEMORY

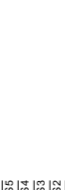

FLASH MEMORY

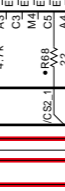

FLASH MEMORY

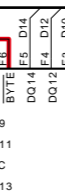

FLASH MEMORY



FLASH MEMORY

