

RAPID CHARGER

KSC-14

SERVICE MANUAL

KENWOOD

© 1993-11 PRINTED IN JAPAN
B51-8260-00(O)1657

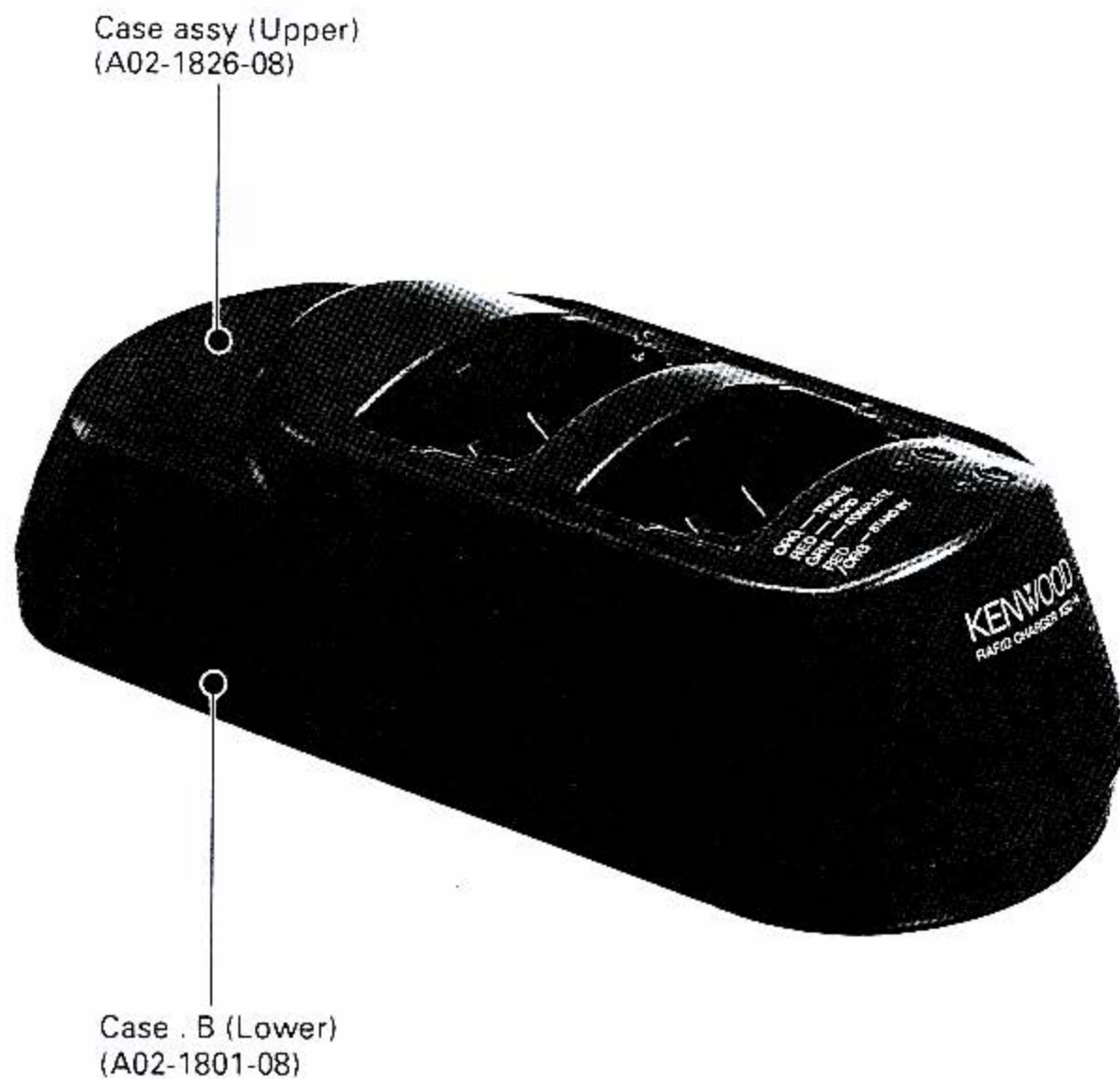

CONTENTS

CIRCUIT DESCRIPTION

Overview

The KSC-14 is a rapid charger for Ni-Cd batteries. PB-11, PB-30, PB-32, PB-33, PB-34, KNB-5/5A, KNB-6/6A, KNB-7/7A, and KNB-9A.

Theory of Operation

The circuit for channel 1 is explained below. (See the general flowchart in Fig. 3.) The descriptions enclosed in brackets [] apply to channel 2.

• Battery pack detection circuit

This circuit detects a battery pack inserted in the recharger.

For the PB-11, PB-34, and KNB-7/7A battery packs, if the voltage at IC1 PA0 [PA2] is lower than the prescribed value, this circuit recognizes that a battery pack is inserted in the recharger. For other battery packs, if the voltage at PA1 [PA3] is lower than the prescribed value, the circuit determines that a battery pack is inserted in the recharger.

Prescribed value: If the voltage at recharging pin 3 is 20V or higher, a battery pack is installed, and if it is lower than 20V, one is not installed. (Fig. 1)

• Battery identification circuit

This circuit identifies the type of battery pack inserted in the recharger.

It determines the type of battery pack according to the voltage at IC1 PA0 and PA1 [PA2 and PA3] and the state of PB0 [PB1]. (See Fig. 1 for details.)

• Trickle recharging

When a battery pack is inserted, trickle current flows to the battery pack through Q1 [Q7].

• Rapid recharging start

When SW1 [SW2] is turned on, IC1 PF2 [PF3] goes high. If a battery pack is inserted in the recharger, it starts rapid recharging or goes into standby.

If the battery pack is a PB-11, PB-34, or KNB-7/7A, IC1 PC0 [PC2] goes high, otherwise PC1 [PC3] goes high, and transistors Q1 and Q2 [Q7 and Q8] turn on.

• Rapid recharging stop

When SW1 [SW2] is pressed again, trickle charging returns.

If the battery pack is a PB-11, PB-34, or KNB-7/7A, IC1 PC0 [PC2] goes low, otherwise PC1 [PC3] goes low, and transistors Q1 and Q2 [Q7 and Q8] turn off.

• Timer circuit

When rapid recharging starts, the count begins, and when about 120 minutes elapse, IC1 PC1 [PC3] goes low and recharging is forced to be terminated.

• Short detection circuit

For the PB-11, PB-34, and KNB-7/7A battery packs, if the voltage at IC1 PA0 [PA2] is lower than the prescribed value, this circuit recognizes that the battery pack is shorted. For other battery packs, if the voltage at PA1 [PA3] is lower than the prescribed value, the circuit determines that the battery pack is shorted. If this condition continues for more than 20 minutes after recharging begins, an error is displayed (the orange LED flashes).

Prescribed value:

PB-30	4.5V
PB-32, PB-33	5.4V
KNB-5/5A, KNB-6/6A, KNB-9A	6.6V
PB-34	8.7V
PB-11, KNB-7/7A	10.8V

• Display circuit

When IC1 PD0 [PD2] goes low, the LED lights in red, and when PD1 [PD3] goes low, it lights in green, according to the display contents.

The LED lights in orange by lighting both the red and green LEDs.

For details of the display contents, see Basic Operation (page 6).

• Reset circuit

If the PB-11, PB-34, or KNB-7/7A battery pack is removed from the recharger and the voltage at IC1 PA0 [PA2] becomes higher than the prescribed value, this circuit determines that no battery pack is inserted and resets the microcomputer. If another type of battery pack is removed from the recharger and the voltage at IC1 PA1 [PA3] becomes higher than the prescribed value, this circuit determines that no battery pack is inserted and resets the microcomputer.

• Recharging detection circuit

This circuit checks the voltage at IC1 PA0 [PA2] for the PB-11, PB-34, and KNB-7/7A battery packs, or PA1 [PA3] for other battery packs, and stops recharging if the battery recharging voltage reaches the peak.

• Recharging current switching

If the recharging current is 800mA, IC1 PED goes high, and if it is 1200mA, PEO goes low according to the battery type to switch the recharging current.

• Recharging channel selection

See the flowchart in Fig. 2.

CIRCUIT DESCRIPTION

Battery Installation and Type Identification (For Each Channel)

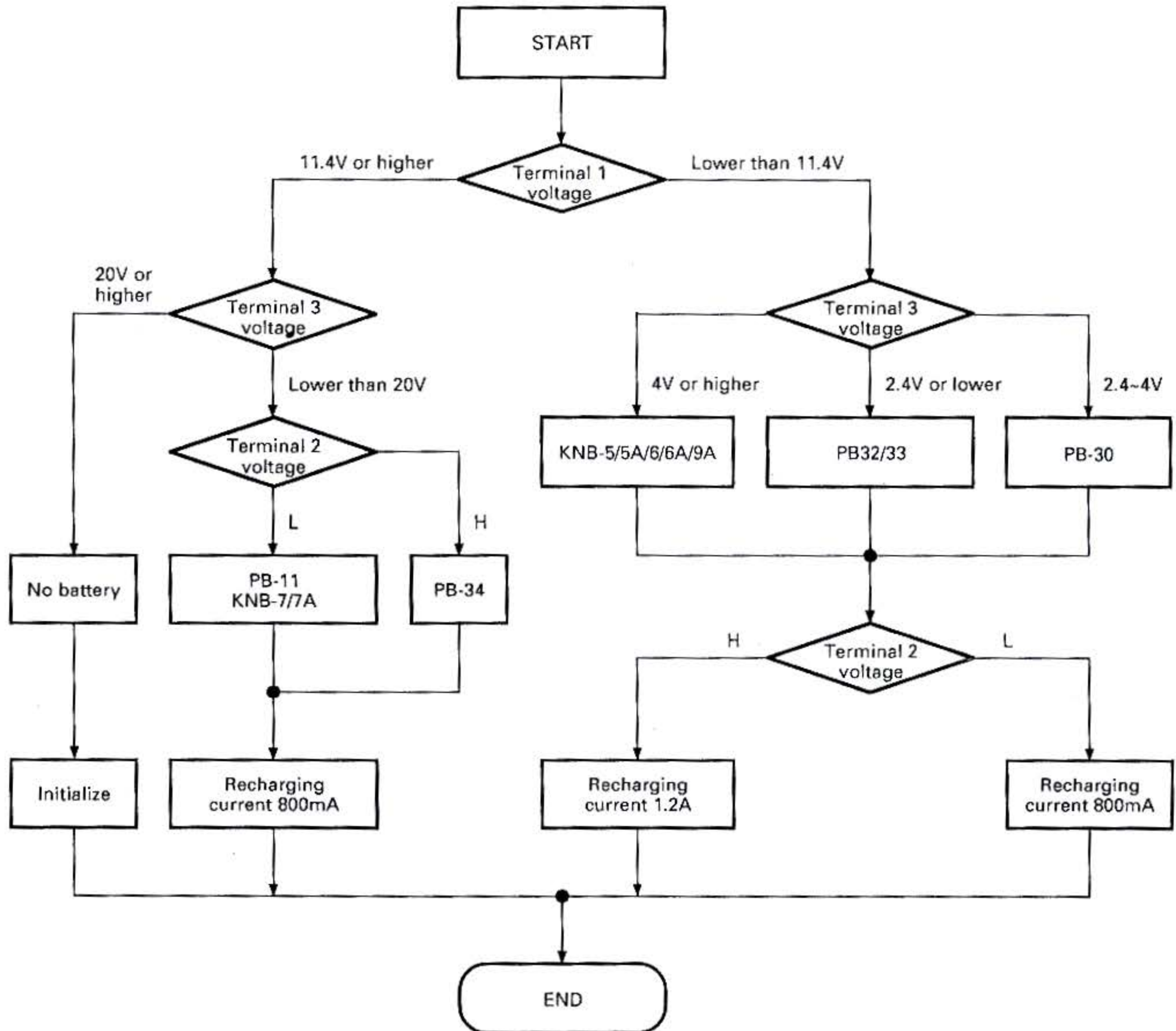

Fig. 1

CIRCUIT DESCRIPTION

Recharging Channel Selection

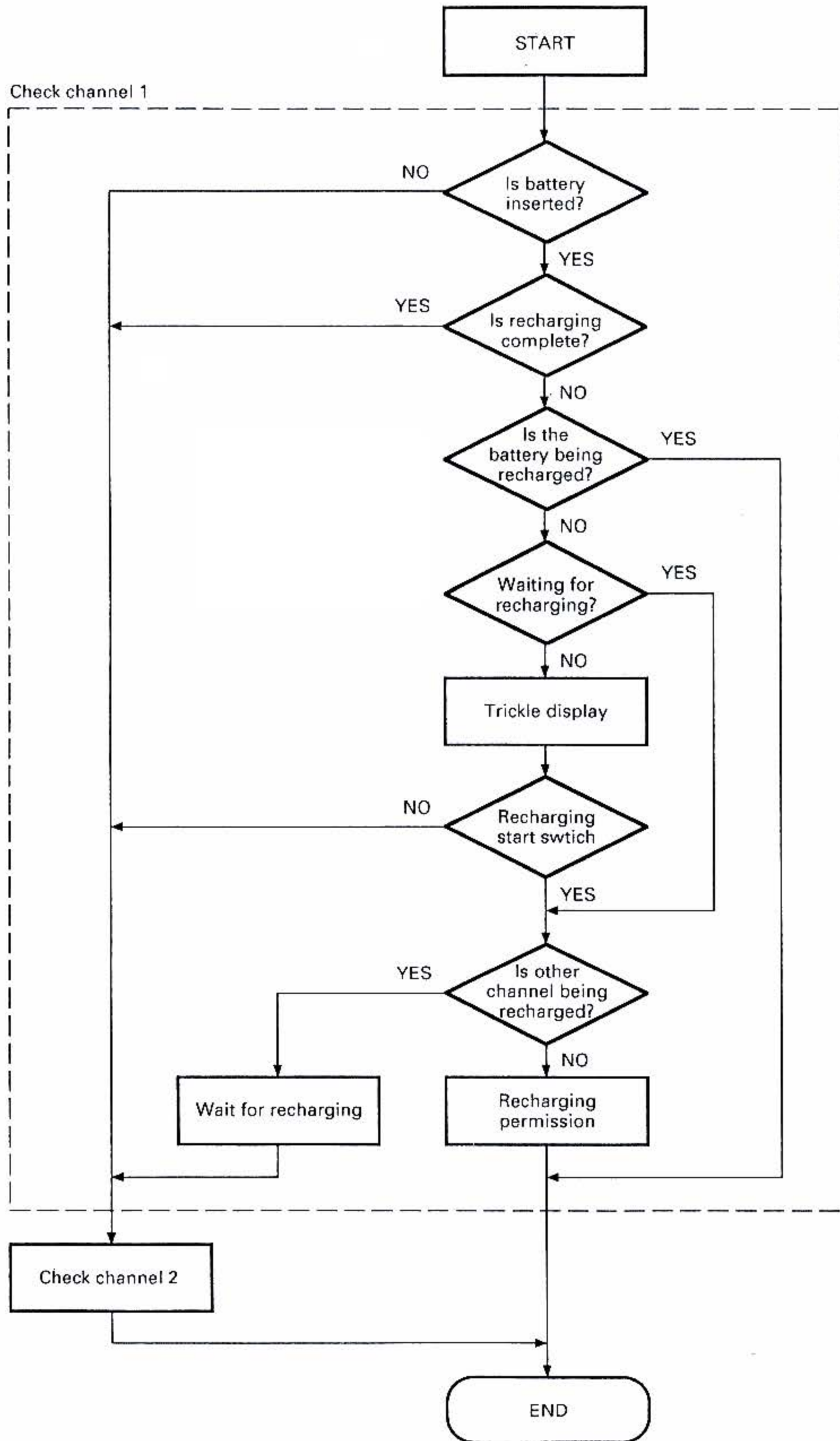

Fig. 2

CIRCUIT DESCRIPTION

General Flowchart

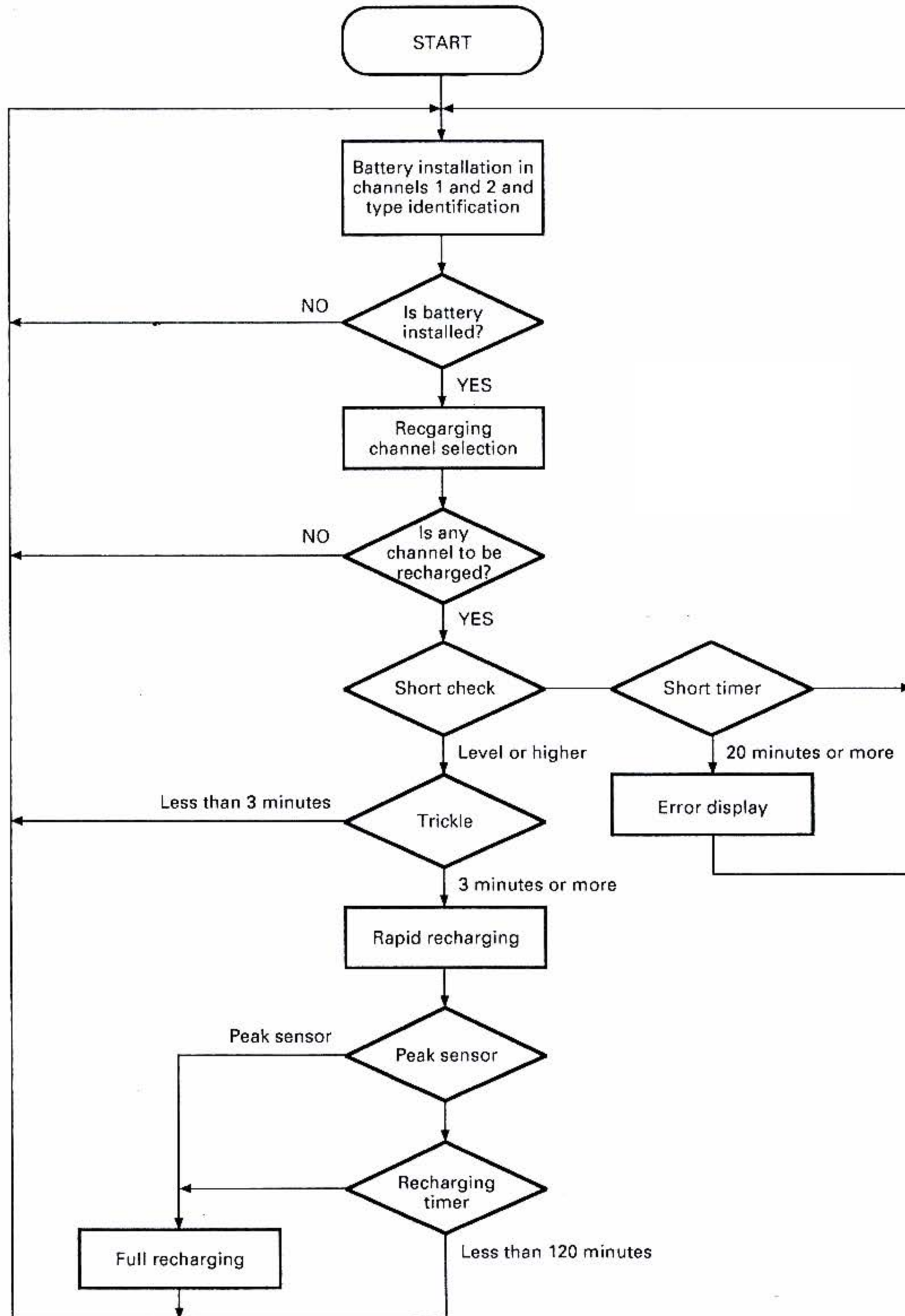

Fig. 3

CIRCUIT DESCRIPTION

Basic Operation

Basic system	<ul style="list-style-type: none"> Trickle recharging is performed when a battery pack is inserted. Rapid recharging starts when the recharging start switch is pressed. Two battery packs can be recharged in sequence. The recharging status for each channel is indicated by the LED. Battery types Two recharging currents are available. The voltage for short judgement can be changed according to the battery type. 		
Recharging sensor system	<ul style="list-style-type: none"> Peak sensor system 		
Recharging operation	<ul style="list-style-type: none"> Battery pack insertion → Trickle charging → Recharging start switch ON → Trickle charging (3 minutes) → Rapid recharging → Full recharging detection → Trickle charging 		
Recharging display	<ul style="list-style-type: none"> Indicated by the LED for each channel. The LED lights in red and green. (It lights in orange by lighting both red and green.) <table border="1" style="width: 100%; border-collapse: collapse;"> <tr> <td style="width: 60%;"> <ul style="list-style-type: none"> Power on Trickle charging Trickle charging (wait for rapid recharging) Rapid recharging (contain 3 to 20 minutes for trickle charging) Recharging complete Error display </td> <td style="width: 40%;"> <ul style="list-style-type: none"> Light in green Light in orange Flash in red and orange alternately. Light in red Light in green Flash in orange </td> </tr> </table>	<ul style="list-style-type: none"> Power on Trickle charging Trickle charging (wait for rapid recharging) Rapid recharging (contain 3 to 20 minutes for trickle charging) Recharging complete Error display 	<ul style="list-style-type: none"> Light in green Light in orange Flash in red and orange alternately. Light in red Light in green Flash in orange
<ul style="list-style-type: none"> Power on Trickle charging Trickle charging (wait for rapid recharging) Rapid recharging (contain 3 to 20 minutes for trickle charging) Recharging complete Error display 	<ul style="list-style-type: none"> Light in green Light in orange Flash in red and orange alternately. Light in red Light in green Flash in orange 		
Recharging start switch	<ul style="list-style-type: none"> The recharging start switch is effective for unrecharged batteries only. (Recharged batteries cannot be recharged unless they are removed and installed again.) If the other channel is being rapidly recharged, this channel performs trickle charging and waits for recharging. If the recharging of the other channel is complete, rapid recharging starts. When the switch is pressed again during recharging or waiting for recharging, trickle charging returns. 		
Sequential recharging	<ul style="list-style-type: none"> Rapid recharging is performed sequentially if the recharging start switch is pressed only when one battery pack is being recharged and the other battery pack is waiting for recharging. The battery pack for which the switch is pressed first is recharged first, unless both switches are pressed at the same time. 		
Battery identification Recharging current switching judgement	<ul style="list-style-type: none"> The battery pack is identified by checking the connection of the battery pack terminals. 		
Short detection	<ul style="list-style-type: none"> The voltage for short judgement is changed according to the battery type. If the short detection time (20 minutes) is exceeded, an error is displayed. 		
Timer cut	<ul style="list-style-type: none"> If the timer is cut, the end of recharging is displayed. The timer time is fixed at 120 minutes. 		

PARTS LIST

× New Parts

Parts without Parts No. are not supplied.

Les articles non mentionnés dans le Parts No. ne sont pas fournis.

Teile ohne Parts No. werden nicht geliefert.

KSC-14

CHARGE CONTROL UNIT (W02-179X-08)

7-08 : K, P, M 8-08 : X, T, E

Ref. No. 参照番号	Address 位置	New Parts 新	Parts No. 部品番号	Description 部品名 / 規格	Desti- nation 仕 向	Re- marks 備考
KSC-14						
1	3A, 3B	*	A02-1801-08	CASE B (LOWER)		
2	1A, 1B	*	A02-1826-08	CASE ASSY(UPPER)		
703	2D		B62-0377-18	INSTRUCTION MANUAL(ENGLISH)	KPMXT	
703	2D		B62-0378-08	INSTRUCTION MANUAL(ENG./ITALY)	E	
704	3B		B72-0613-08	RATING LABEL	KP	
704	3B		B72-0614-08	RATING LABEL	M	
704	3B		B72-0615-08	RATING LABEL	X	
704	3B		B72-0616-08	RATING LABEL	T	
704	3B		B72-0617-08	RATING LABEL	E	
LED1, 2	2A	*	B30-2121-08	LED		
△ 6	2B	*	E30-3180-08	AC CORD	K, P, M	
△ 6	2B	*	E30-3181-08	AC CORD	X	
△ 6	2B	*	E30-3182-08	AC CORD(CONTAINS 3A FUSE)	T	
△ 6	2B	*	E30-3183-08	AC CORD	E	
		*	E69-0403-08	AC PLUG(ADAPTOR)	M	
△ 8	2A	*	E37-0444-08	CONNECTING WIRE		
9	3A, 3B	*	F10-2122-08	SHIELDING PLATE		
710	2C		H12-1457-08	PACKING FIXTURE		
711	3C		H52-0530-08	ITEM CARTON BOX		
12	1B	*	J30-0596-08	SPACER		
13	2A		N83-2606-46	TAPTITE SCREW		
14	3A, 3B	*	N83-2610-45	TAPTITE SCREW		
SW1, 2	2A	*	S70-0429-08	SWITCH		
△ 716	2A, 2B	*	W02-1797-08	CHARGE CONTROL UNIT	K, P, M	
△ 716	2A, 2B	*	W02-1798-08	CHARGE CONTROL UNIT	X, T, E	
CHARGE CONTROL UNIT (W02-179X-08) 7-08 : K, P, M 8-08 : X, T, E						
△ C1		*	C91-1142-08	CAPACITOR 220PF 500WV		
△ C2		*	C91-1143-08	CAPACITOR 560PF 500WV		
△ C3		*	C90-4023-08	ELECTRO 470UF 35WV		
△ C4		*	C90-4024-08	ELECTRO 1200UF 16WV		
△ C5		*	C90-4025-08	ELECTRO 470UF 16WV		
△ C6		*	C90-4026-08	ELECTRO 100UF 35WV		
C7		*	C91-1145-08	CAPACITOR 0.0047UF 16WV		
C8		*	C91-1144-08	CAPACITOR 0.0047UF 25WV		
C9 -14		*	C91-1140-08	CAPACITOR 0.1UF 50WV		
△ C15		*	C90-4027-08	ELECTRO 22UF 25WV		
C16 -18		*	C91-1140-08	CAPACITOR 0.1UF 50WV		
C19		*	C90-4027-08	ELECTRO 22UF 25WV		
C20		*	C91-1140-08	CAPACITOR 0.1UF 50WV		
△ C22		*	C90-4026-08	ELECTRO 100UF 35WV		
△ C101		*	C91-1139-08	CAPACITOR 0.22UF 250WV		
△ C102		*	C91-1146-08	CAPACITOR 2200PF	X, T, E	
△ C102		*	C91-1147-08	CAPACITOR 1000PF	K, P, M	
△ C103		*	C91-1146-08	CAPACITOR 2200PF	X, T, E	
△ C104		*	C91-1146-08	CAPACITOR 2200PF	X, T, E	
△ C104		*	C91-1147-08	CAPACITOR 1000PF	K, P, M	
△ C105		*	C91-1146-08	CAPACITOR 2200PF	X, T, E	
△ C106		*	C91-1146-08	CAPACITOR 2200PF		

L:Scandinavia

K:USA

P:Canada

Y:PX(Far East, Hawaii)

T:England

E:Europe

Y:AAFES(Europe)

X:Australia

M:Other Areas

△ indicates safety critical components.

PARTS LIST

× New Parts

Parts without Parts No. are not supplied.

Les articles non mentionnés dans le Parts No. ne sont pas fournis.

Teile ohne Parts No. werden nicht geliefert.

CHARGE CONTROL UNIT (W02-179X-08)

7-08 : K, P, M 8-08 : X, T, E

Ref. No. 参照番号	Address 位置	New Parts 新	Parts No. 部品番号	Description 部品名 / 規格	Desti- nation 仕向	Re- marks 備考
△ C107		*	C90-4028-08	ELECTRO 33UF 400WV		
△ C108		*	C91-1141-08	CAPACITOR 0.01UF 630WV		
△ C109		*	C90-4021-08	ELECTRO 4.7UF 50WV		
△ C110		*	C90-4022-08	ELECTRO 47UF 25WV		
21	2A, 2B	*	E23-0960-08	TERMINAL		
CN101		*	E40-5685-08	PLUG	X, T, E	
PLG1		*	E40-5687-08	PIN ASSY(8P)		
24	2A, 2B	*	F01-1002-08	RADIATOR		
△ F101		*	F50-0038-08	FUSE(1.25A/250V)	K, P, M	
△ F101		*	F50-0039-08	FUSE(1.25A/250V)	X, T, E	
△ F102		*	F09-0446-08	FUSE	X, T, E	
△ F102		*	F09-0447-08	FUSE	K, P, M	
25	2A, 2B	*	J19-1551-08	TERMINAL HOLDER		
		*	J21-4467-08	MOUNTING HARDWARE		
L1		*	L33-0787-08	CHOKER COIL		
△ L101		*	L33-0785-08	LINE FILTER	X, T, E	
△ L102		*	L33-0786-08	LINE FILTER		
△ T101		*	L19-0372-08	TRANSFORMER(CONVERTER)		
X1		*	L78-0333-08	CRYSTAL RESONATOR		
			N30-3005-46	SCREW(Q101, D1, D2)		
R1			RD14BB2C103J	RD 10K J 1/6W		
R2		*	R92-1361-08	RESISTOR 0.1 J		
R3			RD14BB2C392J	RD 3.9K J 1/6W		
R4			RN14BK2C15R0F	RN 15.0 F 1/6W		
R5		*	RD14DB3D201J	SMALL-RD 200 J 2W		
R6			RD14BB2C302J	RD 3.0K J 1/6W		
R7 , 8			RD14BB2C271J	RD 270 J 1/6W		
R9		*	RD14DB3D221J	SMALL-RD 220 J 2W		
R10			RN14BK2C15R0F	RN 15.0 F 1/6W		
R11		*	RD14DB3D201J	SMALL-RD 200 J 2W		
R12			RD14BB2C302J	RD 3.0K J 1/6W		
R13 , 14			RD14BB2C271J	RD 270 J 1/6W		
R15		*	RD14DB3D221J	SMALL-RD 220 J 2W		
R16			RD14BB2C512J	RD 5.1K J 1/6W		
R17			RD14BB2C183J	RD 18K J 1/6W		
R18			RN14BK2C2002F	RN 20.0K F 1/6W		
R19			RN14BK2C1002F	RN 10.0K F 1/6W		
R20			RN14BK2C1203F	RN 120K F 1/6W		
R21			RN14BK2C3002F	RN 30.0K F 1/6W		
R22			RD14BB2C202J	RD 2.0K J 1/6W		
R23			RD14BB2C303J	RD 30K J 1/6W		
R24			RD14BB2C512J	RD 5.1K J 1/6W		
R25			RD14BB2C183J	RD 18K J 1/6W		
R26			RN14BK2C2002F	RN 20.0K F 1/6W		
R27			RN14BK2C1002F	RN 10.0K F 1/6W		
R28			RN14BK2C1203F	RN 120K F 1/6W		
R29			RN14BK2C3002F	RN 30.0K F 1/6W		
R30			RD14BB2C202J	RD 2.0K J 1/6W		
R31			RD14BB2C303J	RD 30K J 1/6W		
R34			RN14BK2C82R0F	RN 82.0 F 1/6W		
R36			RD14BB2C391J	RD 390 J 1/6W		
R37 -39			RD14BB2C391J	RD 390 J 1/6W		
R40			RD14BB2C103J	RD 10K J 1/6W		

L:Scandinavia

K:USA

P:Canada

Y:PX(Far East, Hawaii)

T:England

E:Europe

Y:AAFES(Europe)

X:Australia

M:Other Areas

△ indicates safety critical components.

PARTS LIST

× New Parts

Parts without Parts No. are not supplied.

Les articles non mentionnés dans le Parts No. ne sont pas fournis.

Teile ohne Parts No. werden nicht geliefert.

CHARGE CONTROL UNIT (W02-179X-08)

7-08 : K, P, M 8-08 : X, T, E

Ref. No. 参照番号	Address 位置	New Parts 新	Parts No. 部品番号	Description 部品名 / 規格	Desti- nation 仕向	Re- marks 備考
R41		*	R92-1363-08	RESISTOR 0.22 J		
R45		*	R92-1364-08	RESISTOR 10 J		
R46 ,47		*	R92-1365-08	RESISTOR 47 J		
△ R101		*	R92-1362-08	RESISTOR 2.7M J		
△ R102		*	RD14DB3D3R3J	SMALL-RD 3.3 J 2W		
△ R103,104			RD14BB2C823J	RD 82K J 1/6W		
△ R105		*	R92-1373-08	RESISTOR 82K J		
△ R106		*	R92-1359-08	RESISTOR 47K J		
△ R107		*	R92-1360-08	RESISTOR 0.22 J		
△ R108			RD14BB2C332J	RD 3.3K J 1/6W		
△ D1		*	F5KF20	DIODE		
△ D2		*	F10KF20	DIODE		
D3 ,4		*	1SS138	DIODE		
D5 ,6		*	DSK-10E	DIODE		
D7		*	ERB83-004U	DIODE		
D8		*	31D004	DIODE		
D9 ,10			GMA01	DIODE		
D11 ,12		*	1SS138	DIODE		
D13 ,14		*	DSK-10E	DIODE		
D15		*	ERB83-004U	DIODE		
D16		*	ERC81-004L	DIODE		
D17 -19			GMA01	DIODE		
△ D101		*	S1WB(A)60	DIODE		
△ D102,103		*	ERA22-08	DIODE		
△ D104			GMA01	DIODE		
DZ1		*	GZS5.1X	DIODE		
DZ2		*	GZS27Y	DIODE		
DZ3			MTZJ9.1A	DIODE		
DZ4		*	GZS27Y	DIODE		
DZ5		*	GZS5.1X	DIODE		
DZ6		*	GZS27Y	DIODE		
DZ7		*	RD18-F-B1	DIODE		
DZ8		*	GZS27Y	DIODE		
DZ9		*	GZS5.1X	DIODE		
DZ10			MTZJ9.1A	DIODE		
△ DZ101		*	GZS18Y	DIODE		
△ DZ102		*	GZS30Y	DIODE		
△ HIC1		*	W02-1806-08	HIC		
HIC2		*	W02-1807-08	HIC		
HIC3		*	W02-1808-08	HIC		
△ IC1		*	LC65104A	IC		
△ IC2		*	M5278L05	IC		
△ IC101		*	PC120FY2	IC		
Q1		*	2SB892	TRANSISTOR		
Q2		*	2SB1142	TRANSISTOR		
Q3			2SC3402	TRANSISTOR		
Q4		*	2SB1140	TRANSISTOR		
Q5			2SC3402	TRANSISTOR		
Q6			2SA1346	TRANSISTOR		
Q7		*	2SB892	TRANSISTOR		
Q8		*	2SB1142	TRANSISTOR		
Q9			2SC3402	TRANSISTOR		
Q10		*	2SB1140	TRANSISTOR		
Q11			2SC3402	TRANSISTOR		
Q12			2SA1346	TRANSISTOR		

L:Scandinavia

K:USA

P:Canada

Y:PX(Far East, Hawaii)

T:England

E:Europe

Y:AAFES(Europe)

X:Australia

M:Other Areas

△ indicates safety critical components.

PARTS LIST

× New Parts

Parts without Parts No. are not supplied.

Les articles non mentionnés dans le Parts No. ne sont pas fournis.

Teile ohne Parts No. werden nicht geliefert.

CHARGE CONTROL UNIT (W02-179X-08)

7-08 : K, P, M 8-08 : X, T, E

Ref. No. 参照番号	Address 位置	New Parts 新	Parts No. 部品番号	Description 部品名 / 規格	Desti- nation 仕向	Re- marks 備考
Q13 Q14 -17 △ Q101 △ Q102			2SC3402 2SA1348 * 2SK951-M * 2SD1835	TRANSISTOR TRANSISTOR FET TRANSISTOR		

L:Scandinavia

K:USA

P:Canada

Y:PX(Far East, Hawaii)

T:England

E:Europe

Y:AAFES(Europe)

X:Australia

M:Other Areas

△ indicates safety critical components

EXPLODED VIEW

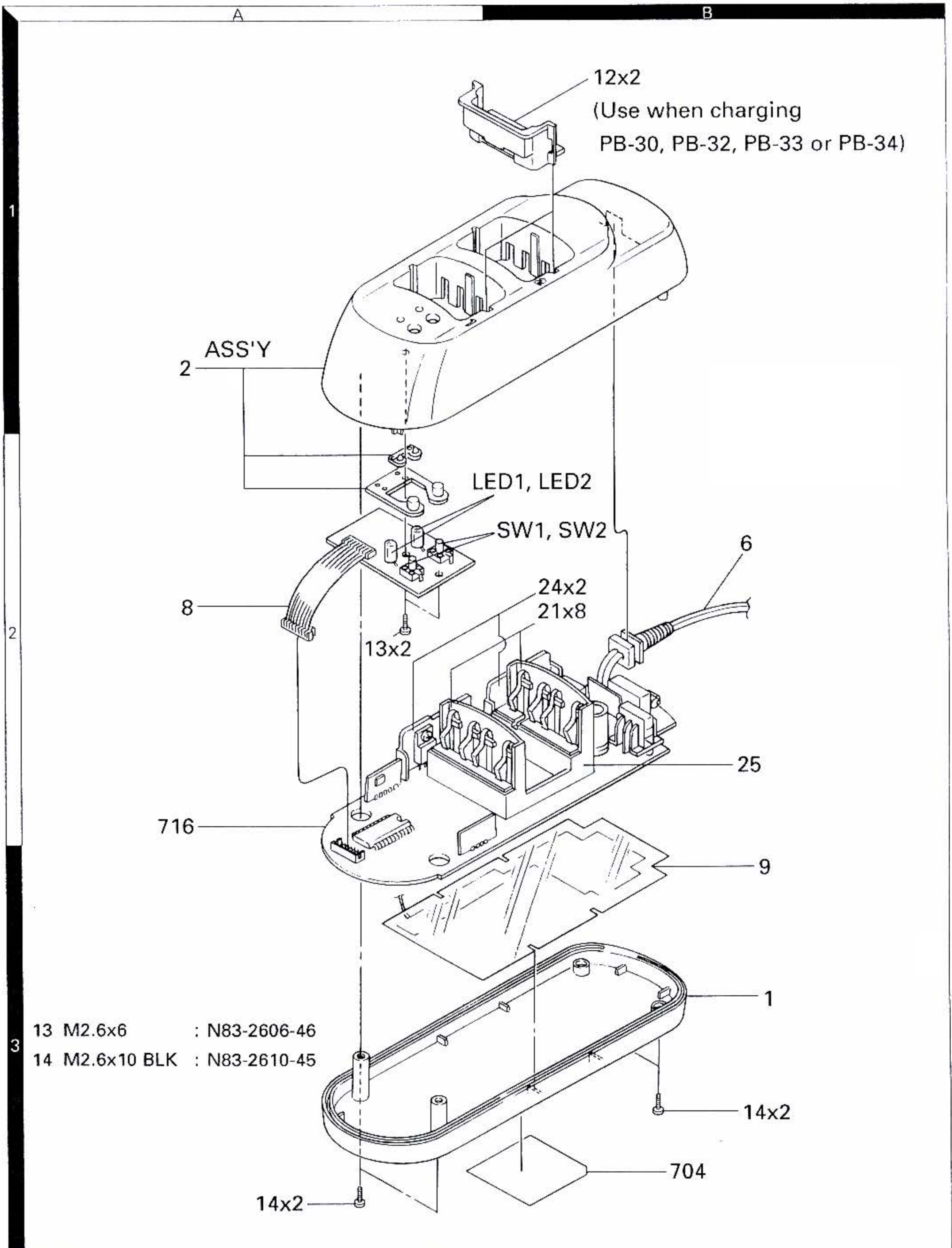

Parts with the exploded numbers larger than 700 are not supplied.

PACKING

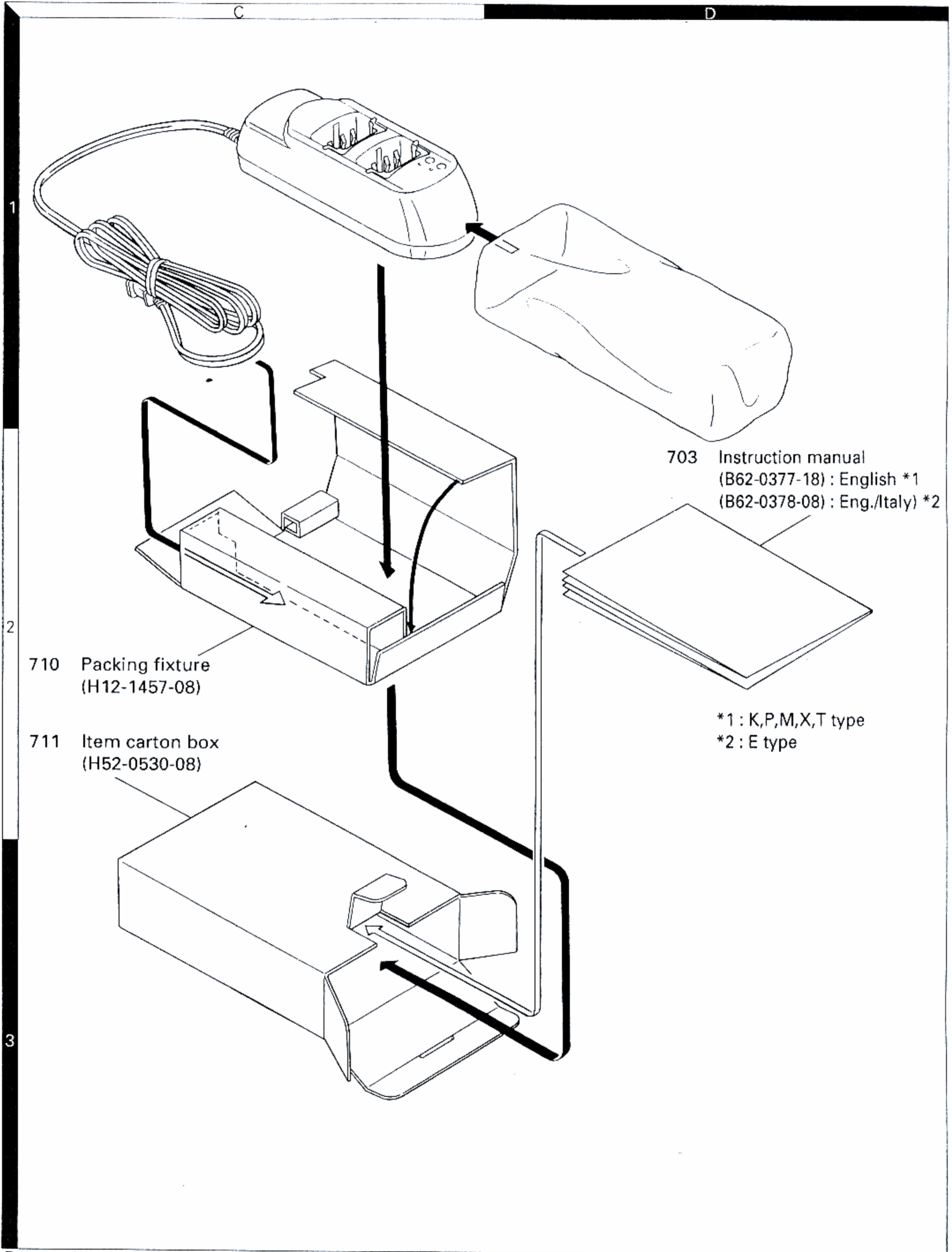

Parts with the exploded numbers larger than 700 are not supplied.

KSC-14 PC BOARD VIEWS

Charge control unit (W02-179X-08)

7-08 : K,P,M 8-08 : X,T,E

Component side view

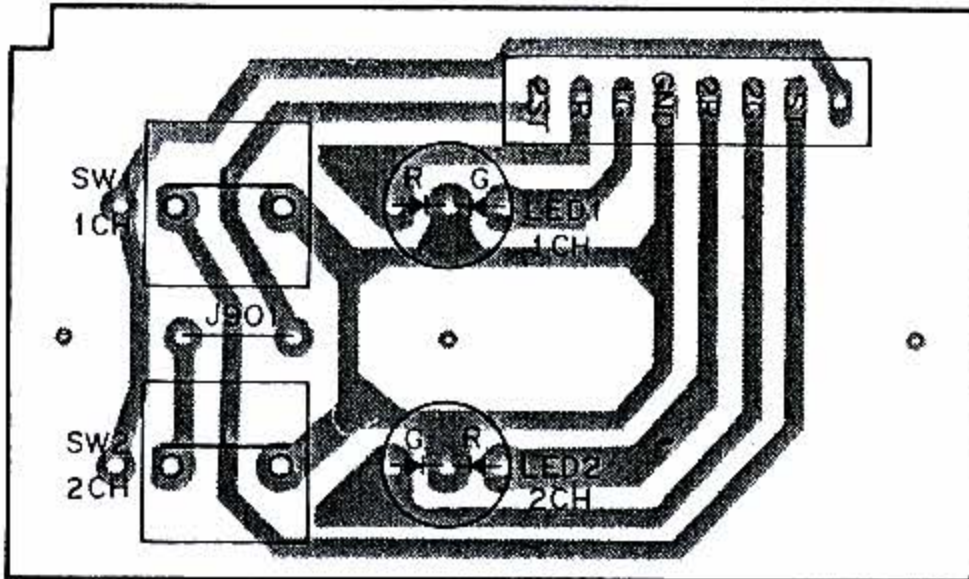

Charge control unit (W02-179X-08)

7-08 : K,P,M 8-08 : X,T,E

Foil side view

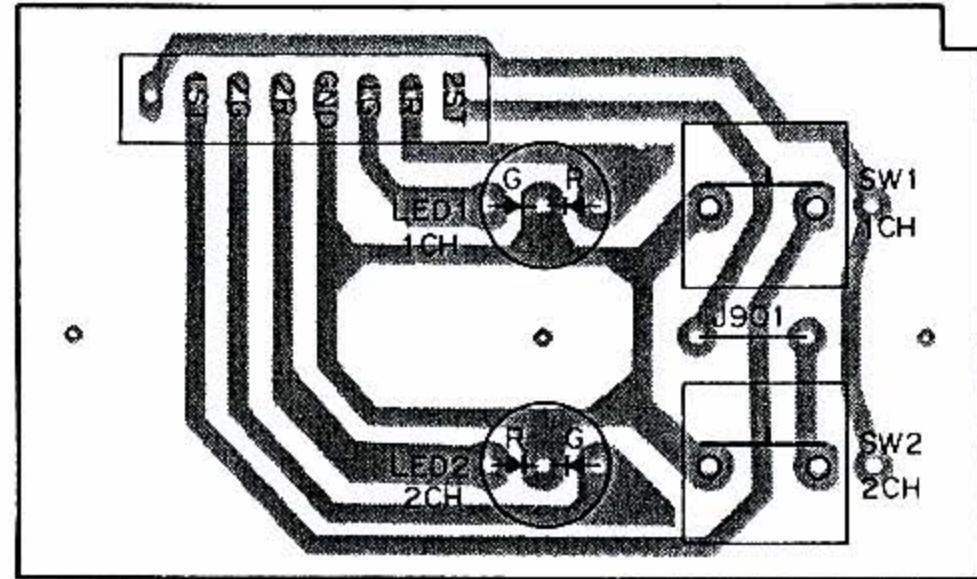

2SA1346
2SA1348
2SC3402

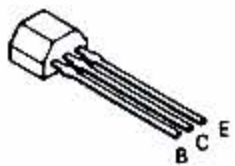

2SB892
2SD1835

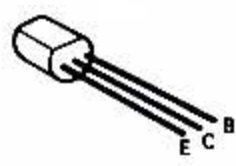

2SB1140
2SB1142

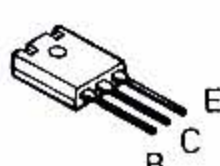

2SK951-M

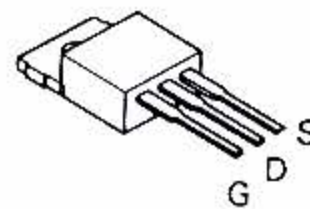

LC65104A

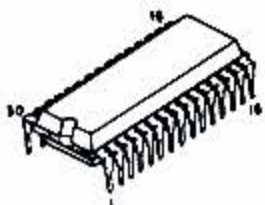

M5278L05

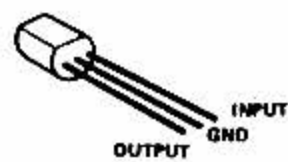

PC120FY2

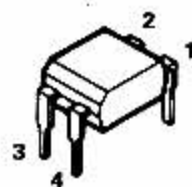

Charge control unit (W02-1797-08) : K,P,M
Component side view

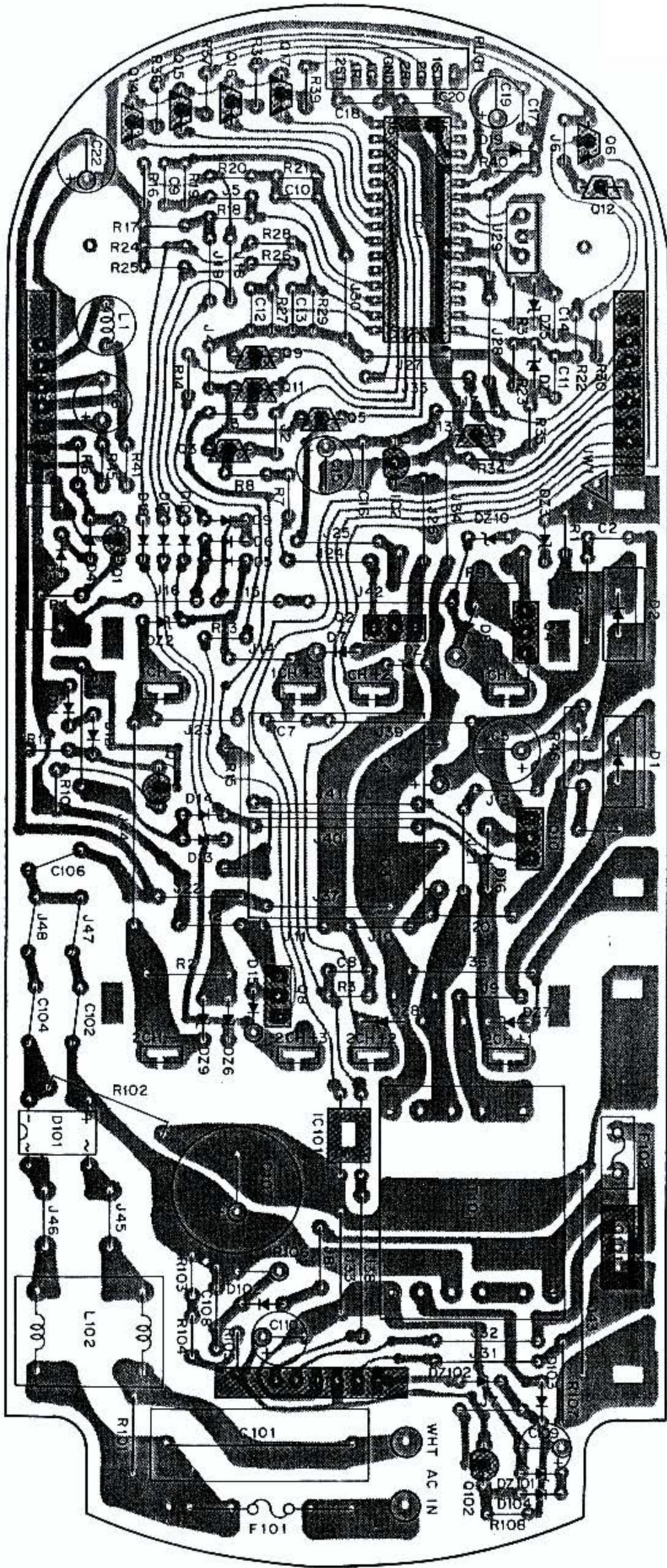

Charge control unit (W02-1797-08) : K,P,M
Foil side view

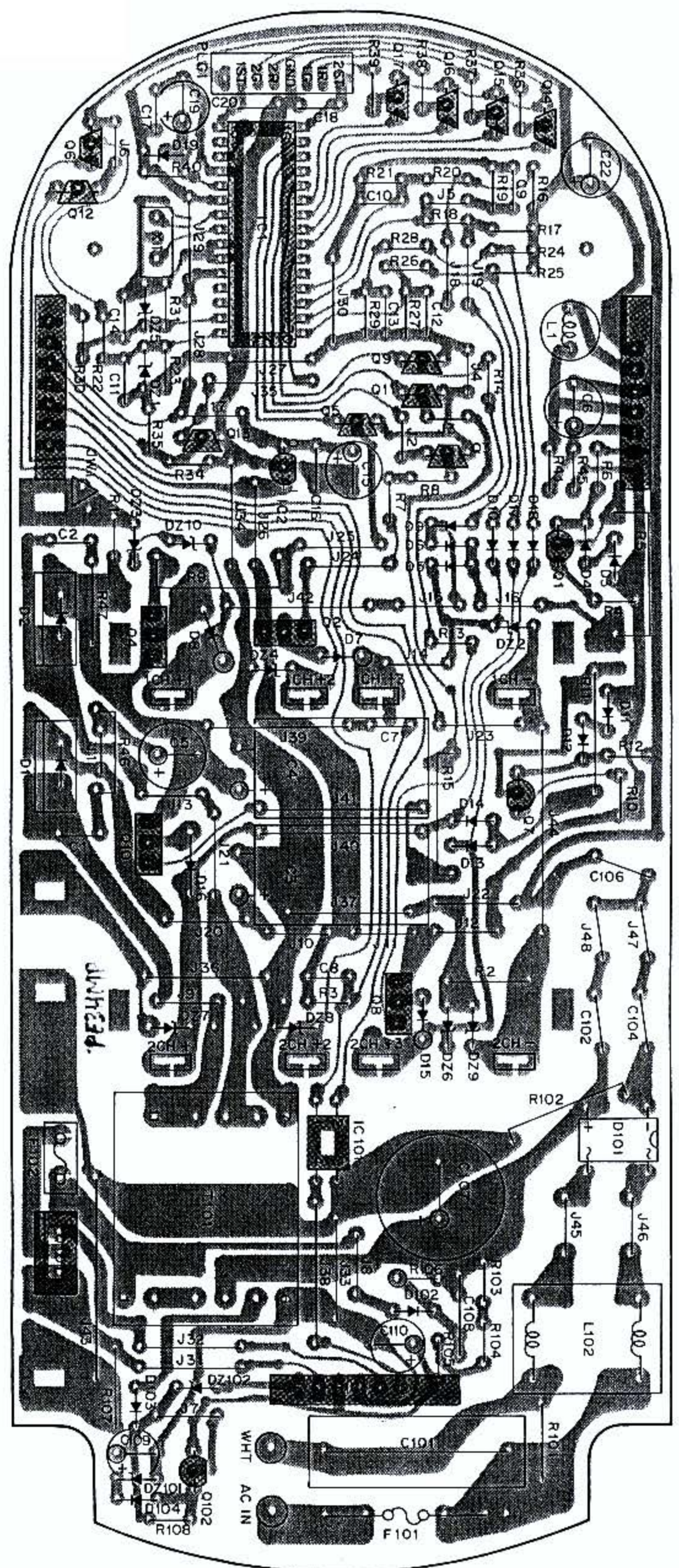

KSC-14 SCHEMATIC DIAGRAM (X,T,E TYPE)

CHARGER CONTROL UNIT (W02-1798-08) : T, X, E TYPE

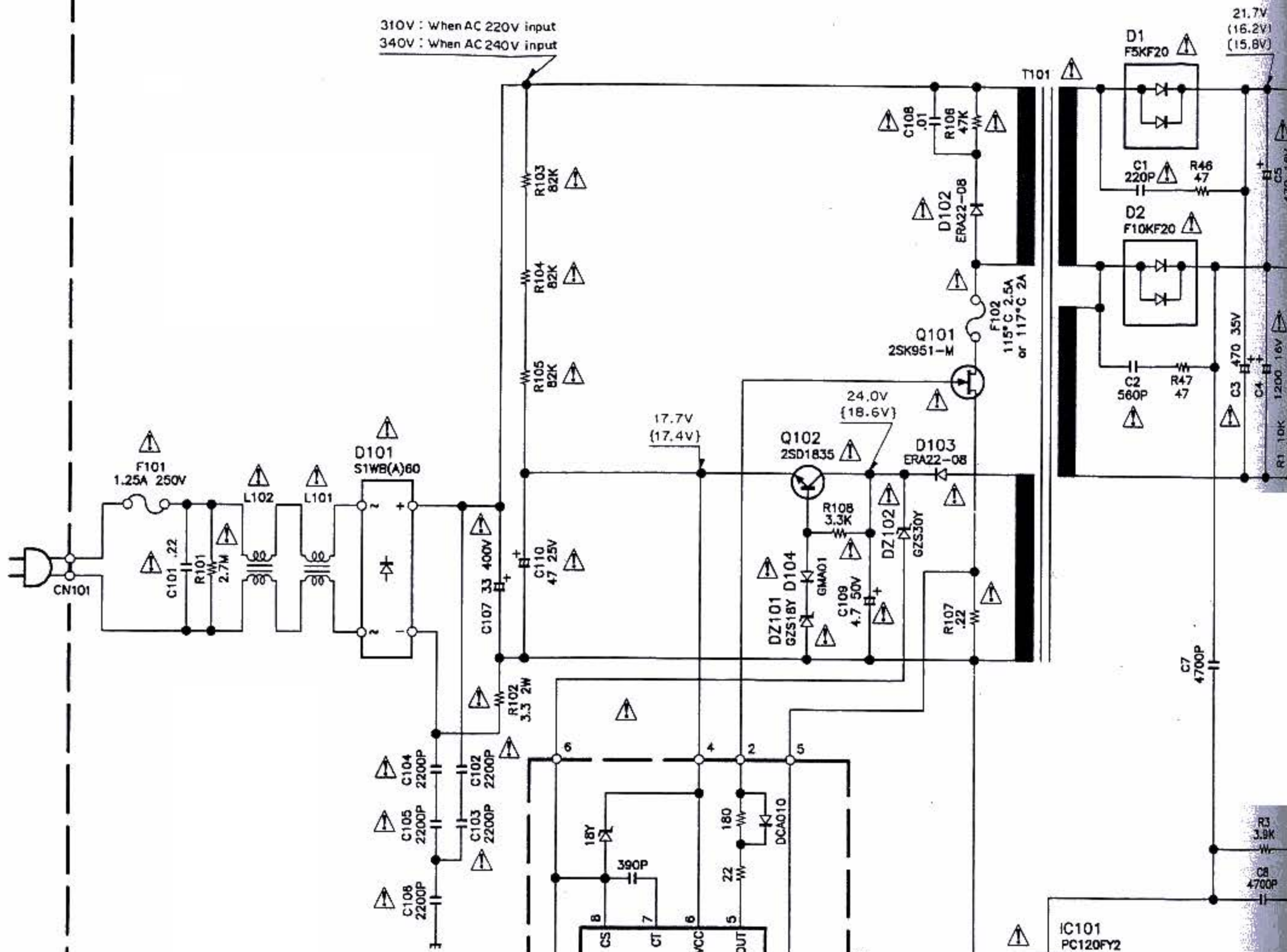

- No mark : No battery
- () : 7.2V/1100mAh quick charging
- [] : 12V/800mAh quick charging
- () : Quick charging

CAUTION : For continued safety, replace safety critical components only with manufacturer's recommended parts (refer to parts list). Δ Indicates safety critical components. To reduce the risk of electric shock, leakage-current or resistance measurements shall be carried out (exposed parts are acceptably insulated from the supply circuit) before the appliance is returned to the customer.

D1	: F5KF20	Q1,7	: 2SB892
D2	: F10KF20	Q2,8	: 2SB1142
D3,4,11,12	: 1SS138	Q3,5,9,11,13	: 2SC3402
D5,6,13,14	: DSK-10E	Q4,10	: 2SB1140
D7,15	: ERB83-004U	Q6,12	: 2SA1346
D8	: 31DQ04	Q14~17	: 2SA1348
D9,10,17~19,104	: GMA01	Q101	: 2SK951-M
D16	: ERC81-004L	Q102	: 2SD1835

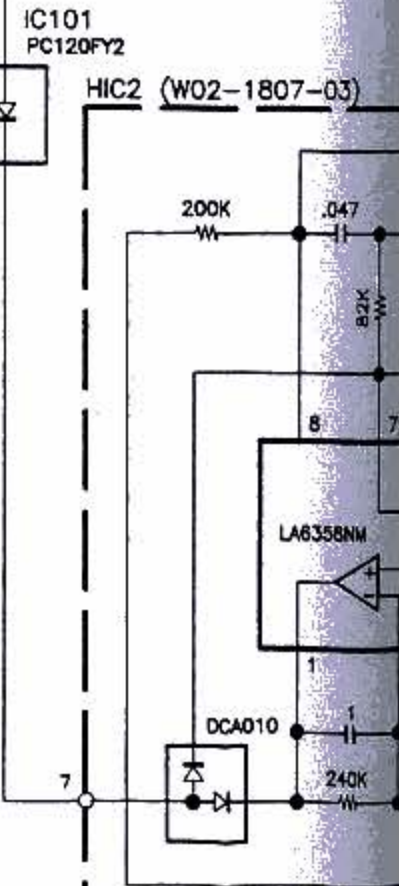

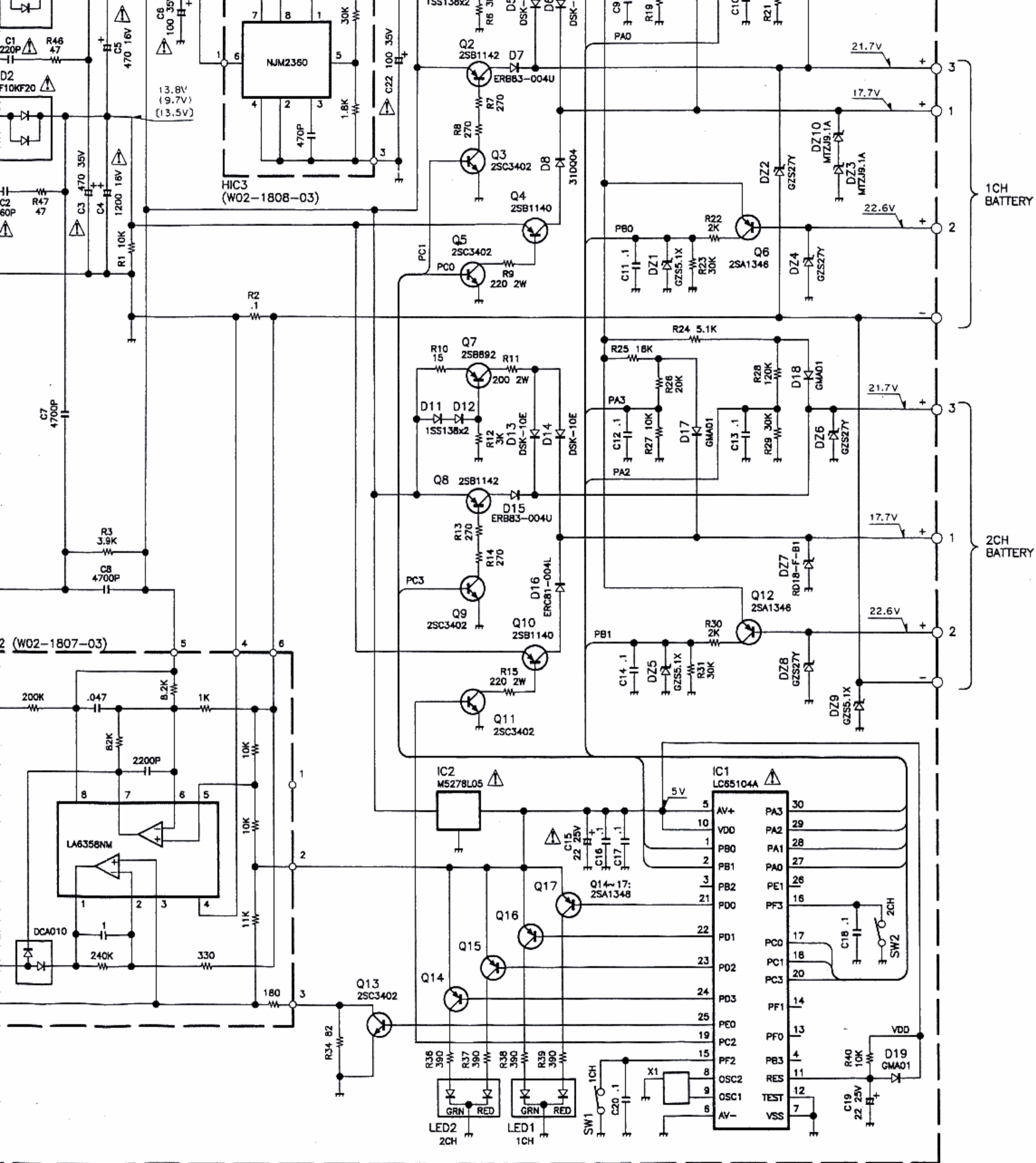

CHARGER CONTROL UNIT (W02-1797-08) : K, P, M TYPE

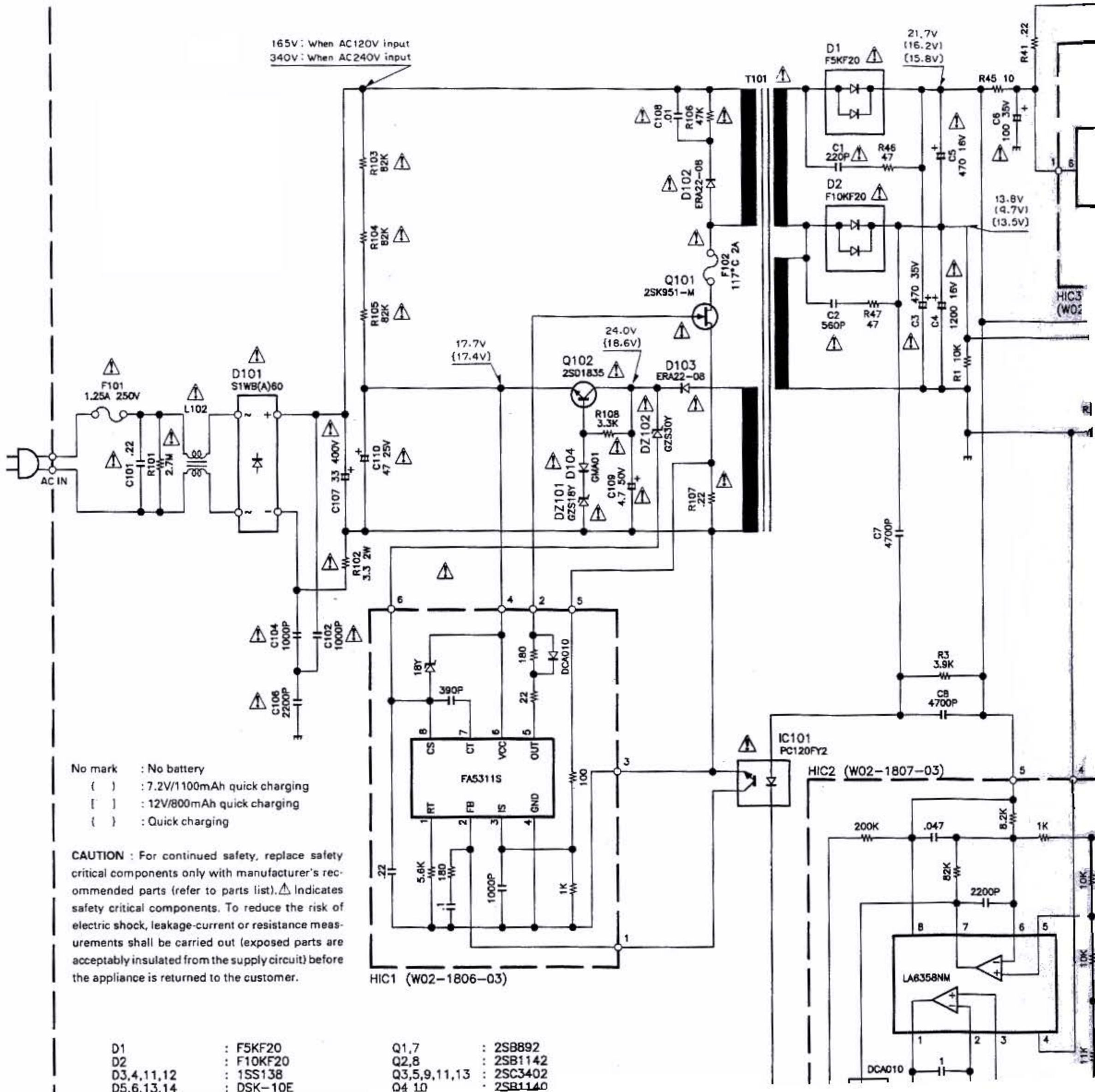

165V : When AC120V input
340V : When AC240V input

- No mark : No battery
- () : 7.2V/1100mAh quick charging
- [] : 12V/800mAh quick charging
- { } : Quick charging

CAUTION : For continued safety, replace safety critical components only with manufacturer's recommended parts (refer to parts list). Δ Indicates safety critical components. To reduce the risk of electric shock, leakage-current or resistance measurements shall be carried out (exposed parts are acceptably insulated from the supply circuit) before the appliance is returned to the customer.

- | | | | |
|------------|-----------|--------------|-----------|
| D1 | : F5KF20 | Q1,7 | : 2SB892 |
| D2 | : F10KF20 | Q2,8 | : 2SB1142 |
| D3,4,11,12 | : 1SS138 | Q3,5,9,11,13 | : 2SC3402 |
| D5,6,13,14 | : DSK-10E | Q4,10 | : 2SB1140 |

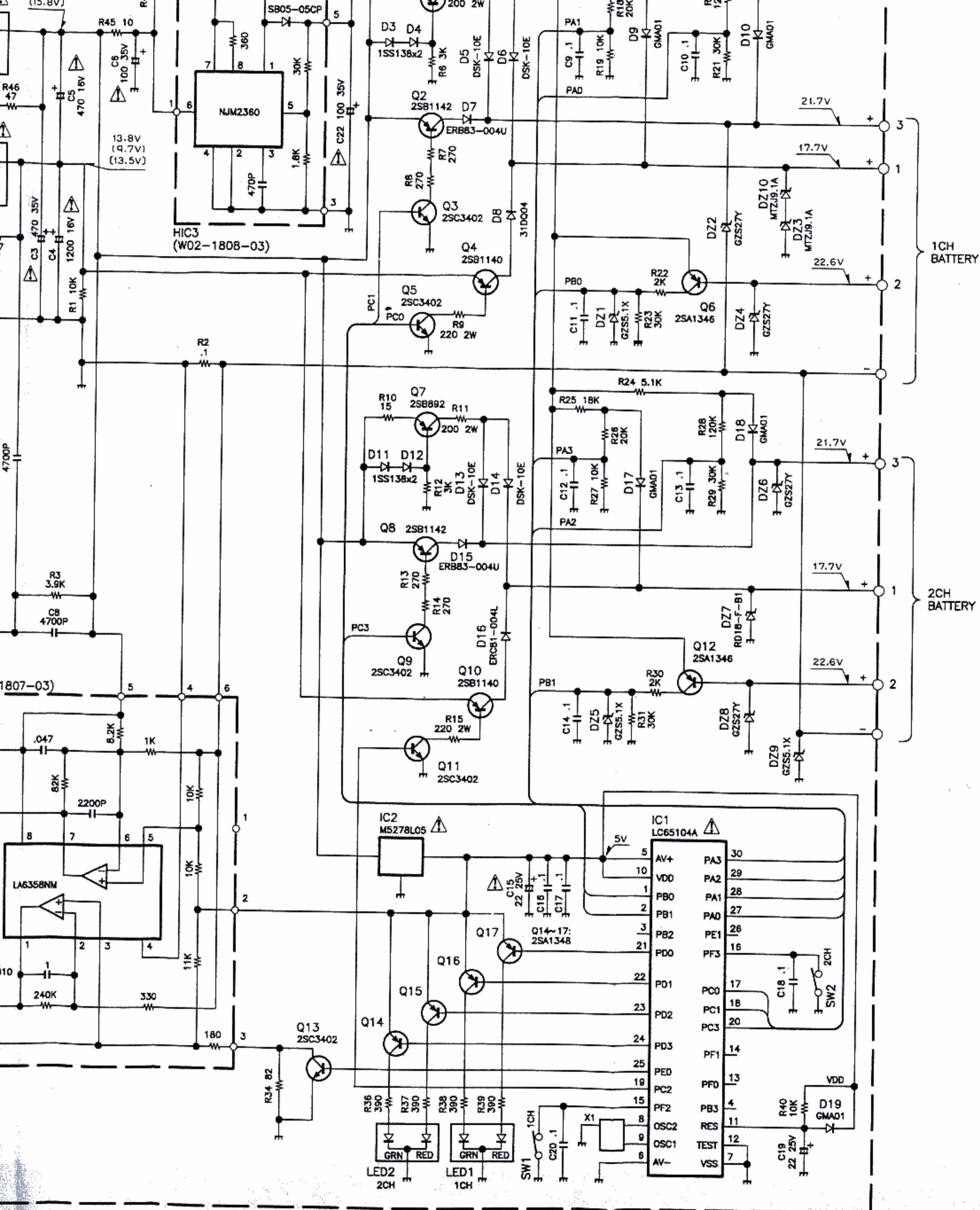

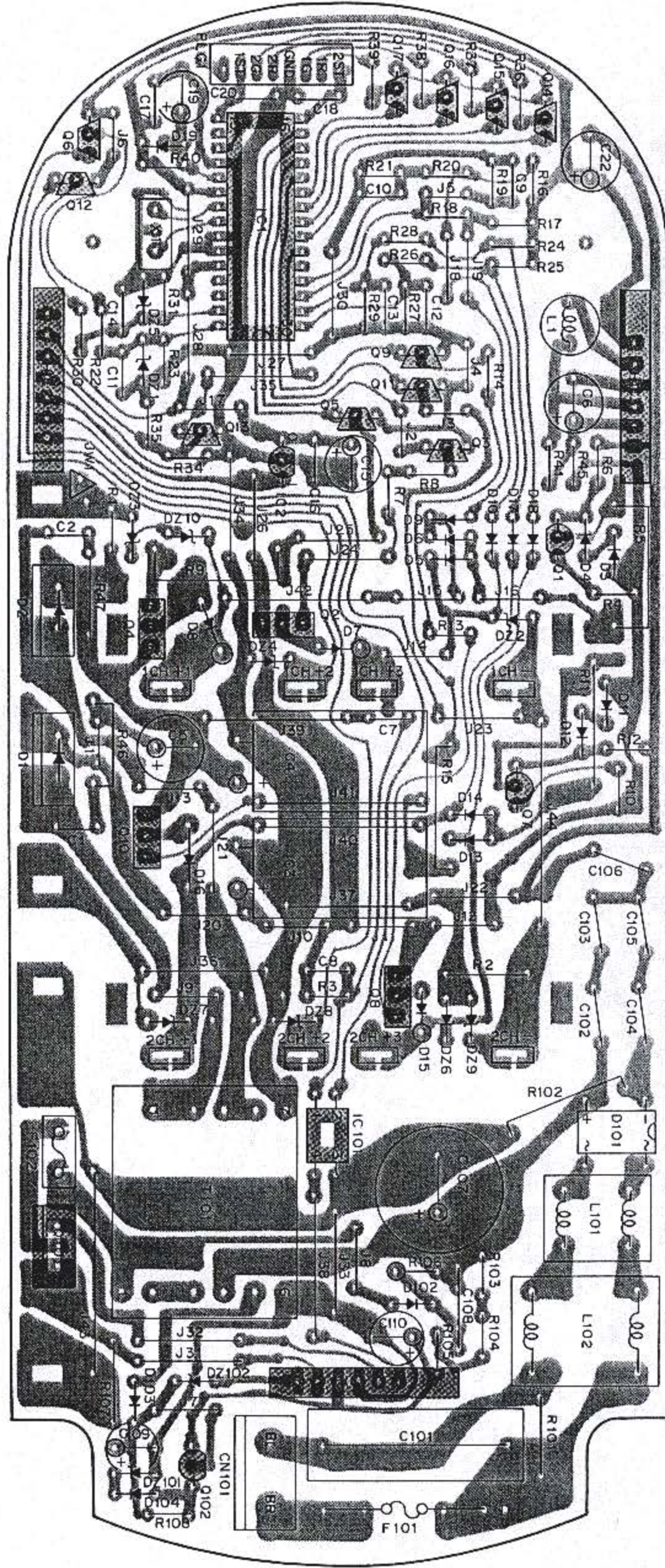
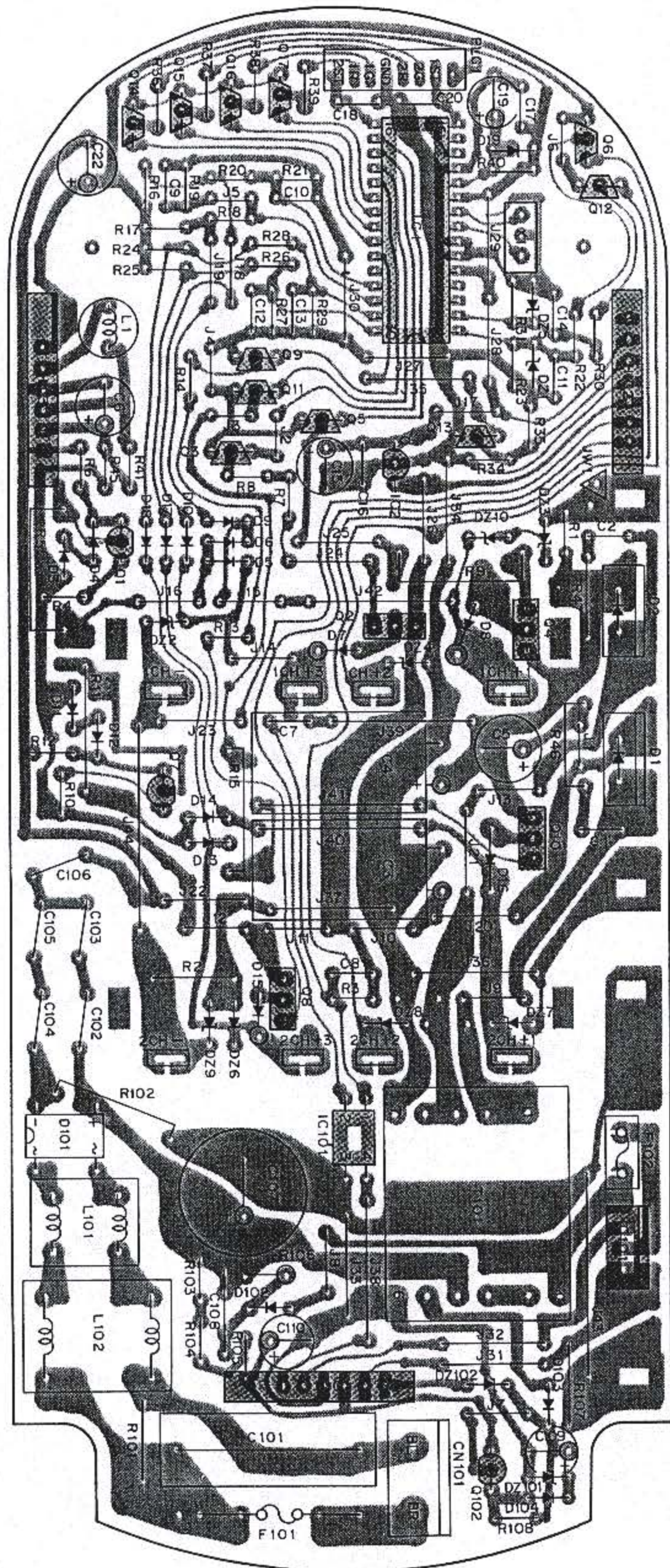

Approx. 70 minutes: PB-33, KNB-5A, KNB-6, KNB-7A, KNB-9A

Aprox. 90 minutes :KNB-6A

Ambient temperature 5°C to 40°C (41°F to 104°F)

Dimensions (Body only) 3.54" (90mm) W x 7.95" (202mm) D x 2.44" (62mm) H

Weight..... Approx. 520g

Note : This recharger is designed for recharging only.

It cannot be used as a DC power supply for the transceiver.

If you use it as a base stand, turn the recharger off. Frequent recharging shortens the life of the battery.

KENWOOD CORPORATION

Alive Mitake, 2-5, Shibuya 1-chome, Shibuya-ku, Tokyo 150, Japan

KENWOOD SERVICE CORPORATION

P.O. BOX 22745, 2201 East Dominguez Street, Long Beach, CA 90801-5745, U.S.A.

KENWOOD ELECTRONICS DEUTSCHLAND GMBH

Rembrücker Str. 15, 6056 Heusenstamm, Germany

KENWOOD ELECTRONICS BENELUX N.V.

Mechelsesteenweg 418 B-1930 Zaventem, Belgium

TRIO-KENWOOD FRANCE S.A.

13, Boulevard Ney, 75018 Paris, France

TRIO-KENWOOD U.K. LIMITED

KENWOOD House, Dwight Road, Watford, Herts., WD1 8EB United Kingdom

KENWOOD ELECTRONICS NEDERLAND B.V.

Amsterdamseweg 35, 1422 AC Uithoorn, The Netherlands

KENWOOD ELECTRONICS ITALIA S.p.A.

Via G. Sirtori, 7/9 20129 Milano, Italy

KENWOOD ESPAÑA S.A.

Bolivia, 239-08020 Barcelona, Spain

KENWOOD ELECTRONICS AUSTRALIA PTY. LTD.

(A.C.N. 001 499 074)

P.O. Box 504, 8 Figtree Drive, Australia Centre, Homebush, N.S.W. 2140, Australia

KENWOOD & LEE ELECTRONICS, LTD.

Unit 3712-3724, Level 37, Tower one Metroplaza, 223 Hing Fong Road, Kwai Fong, N.T., Hong Kong

KENWOOD ELECTRONICS CANADA INC.

6070 Kestrel Road, Mississauga, Ontario, Canada L5T 1S8