

KENWOOD

Document Copyrights

Copyright 2006 by Kenwood Corporation. All rights reserved.

No part of this manual may be reproduced, translated, distributed, or transmitted in any form or by any means, electronic, mechanical, photocopying, recording, or otherwise, for any purpose without the prior written permission of Kenwood.

Disclaimer

While every precaution has been taken in the preparation of this manual, Kenwood assumes no responsibility for errors or omissions. Neither is any liability assumed for damages resulting from the use of the information contained herein. Kenwood reserves the right to make changes to any products herein at any time for improvement purposes.



Photo is K type.

Circuit Description

■ Power Supply Section

1. The power supply generates constant current (1.1A) from the input voltage (rated 15V DC) from the adapter.
2. IC101 is a DC/DC converter.
3. R117 is a resistor for current detection.
4. R110 and R111 are resistors for no-load voltage detection (non-load voltage : 14V).
5. IC201 is a power supply/reset IC for the microcomputer (IC202).
 - Power output : 5V
 - Reset output : "H" (Normal)
 - After reset : "L"

■ Charging Control Section

1. The microcomputer (IC202) controls the following;
 - Peak detection (Detected when fully charged, pin 27 of IC202)
 - Temperature control (Pin 2)
 - Detection of abnormality, such as a short terminal (Pin 27)
 - LED control (Red : Pin 21, Green : Pin 22)
 - Trickle charging (Pin 18)
 - Quick charging (Pin 17)
2. X201 is an oscillator that generates clocks for the microcomputer (4MHz).

■ Charging Switch Section

1. Q201 is a transistor that turns quick charging on and off.
2. Q202 is a transistor that turns trickle charging on and off.
3. The resistor (R204) determines the leakage current.

■ Display Section

1. LED201 is a two-color LED that indicates the charging state.
2. Red on Quick charging or warming up
Green on Charging is complete
Red blinking Abnormal (short terminal, short battery, or open terminal)

Charging

The charging time for each pack is shown in the table.

Battery Pack	Battery Type	Voltage (Volts)	Battery Capacity (mAh)	Approximate Charging Time (Minutes)
KNB-14	Ni-Cd	7.2	600	40
KNB-15A	Ni-Cd	7.2	1100	60
KNB-16A	Ni-Cd	7.2	1100	60
KNB-17A	Ni-Cd	7.2	1500	80
KNB-20N	Ni-MH	7.2	1600	80
KNB-21N	Ni-MH	7.2	1600	80
KNB-22N	Ni-MH	7.2	2100	110

KSC-24

PARTS LIST / EXPLODED VIEW / PC BOARD VIEW

Parts List

* : New parts

Ref. No.	New parts	Parts No.	Description	Destination
1	*	A02-3626-08	Cabinet (Upper)	
2	*	A02-3652-08	Cabinet (Lower)	
3		E03-0187-08	DC jack	
4		E23-1058-08	Relay terminal	
5		F09-0455-08	Thermal fuse	
6		F53-0149-08	Fuse (2A)	
7		G13-1546-08	Cushion	
A		N80-2610-45	Pan head taptite screw	
8		W02-1932-08	Electric circuit module	
-		W08-0523-15	AC adapter (120V/60Hz)	K
-		W08-0524-15	AC adapter (230V/50Hz)	E
-	*	W08-0939-05	AC adapter (230V/50Hz)	T

Exploded View

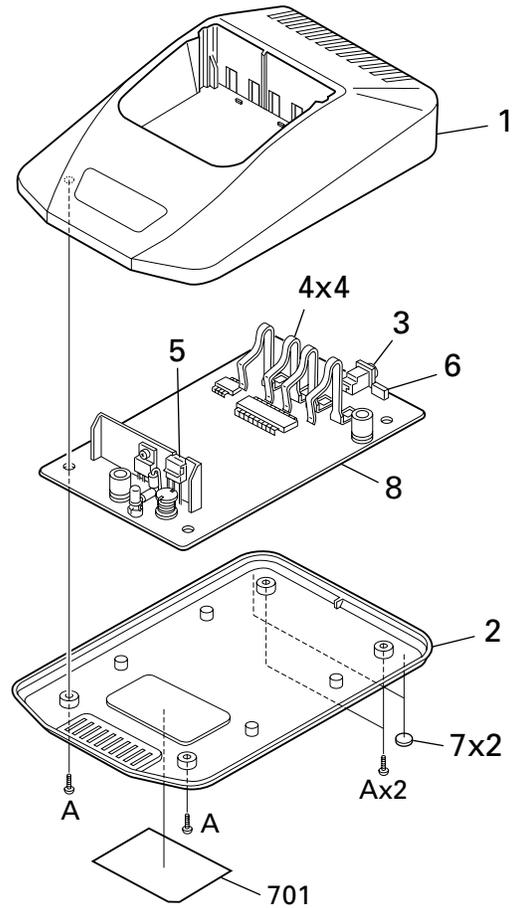

PC Board View

Electric circuit module (W02-1932-08) Component side view

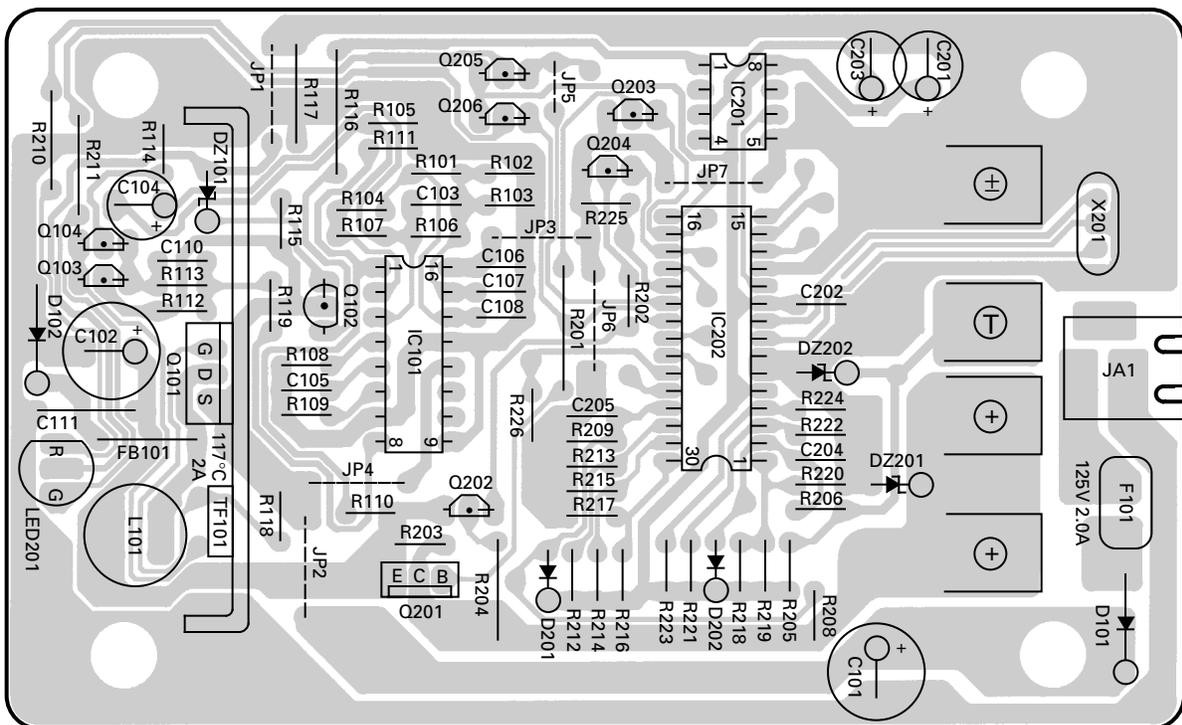

CIRCUIT DIAGRAM

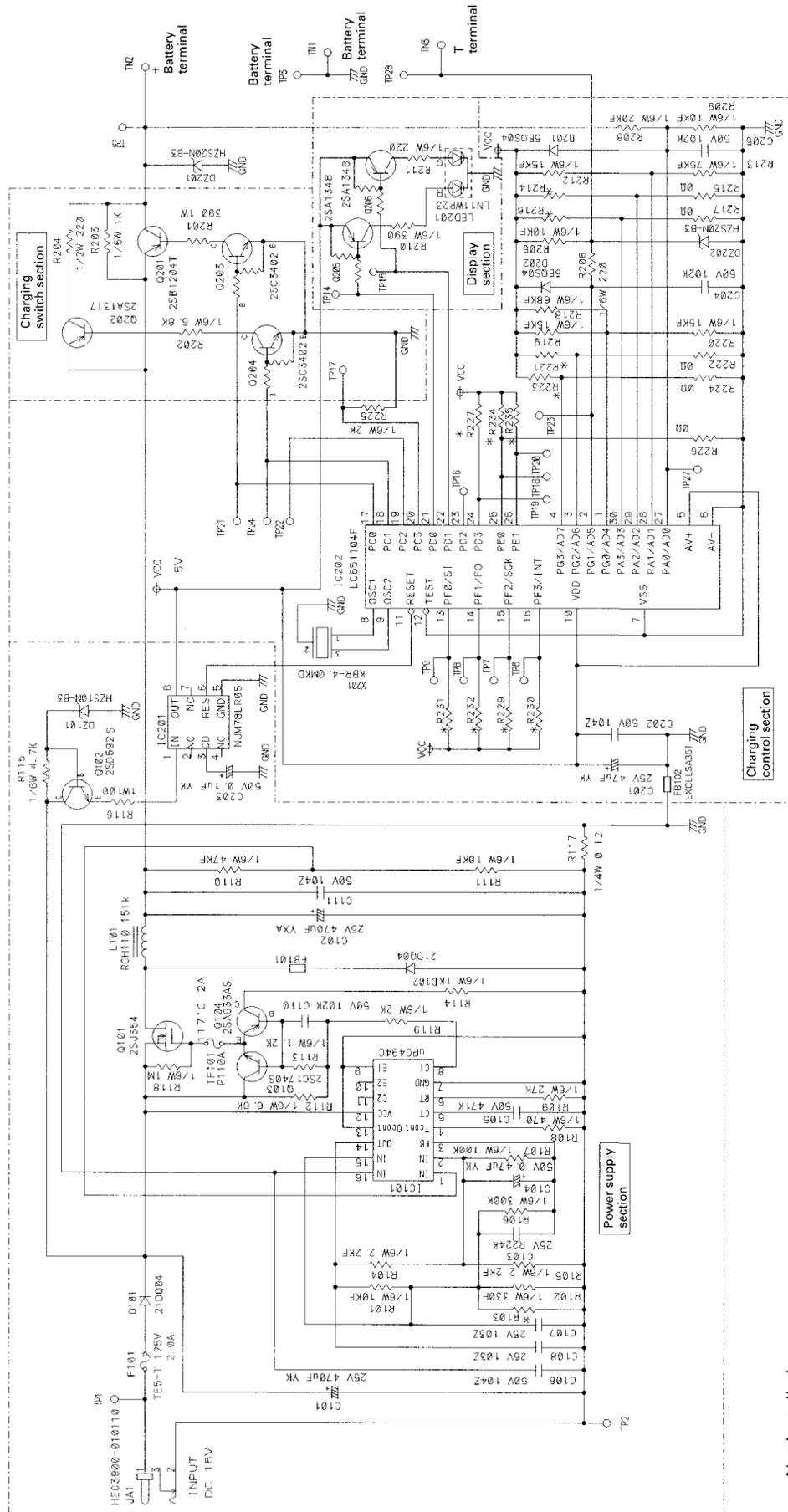

* : Not installed
Vcc : +5V

KSC-24

SPECIFICATIONS

Charging current	1100 ± 150mA
Source voltage	Approx. 15V
Usable temperature range	0°C to 40°C (32°F to 104°F)
Line voltage (AC adapter)	120V AC (K) 230V AC (E) 230V AC (T)
Dimensions (Body only)	2-11/64 in (55mm) H x 4-1/8 in (105mm) W x 5-5/16 in (135mm) D
Weight (Body only)	Approx. 180g / 6.3oz

KENWOOD CORPORATION

14-6, Dogenzaka 1-chome, Shibuya-ku, Tokyo 150-8501, Japan

KENWOOD SERVICE CORPORATION

P.O. BOX 22745, 2201 East Dominguez Street, Long Beach, CA 90801-5745, U.S.A.

KENWOOD ELECTRONICS CANADA INC.

6070 Kestrel Road, Mississauga, Ontario, Canada L5T 1S8

KENWOOD ELECTRONICS DEUTSCHLAND GMBH

Rembrücker Str. 15, 63150 Heusenstamm, Germany

KENWOOD ELECTRONICS BELGIUM N.V.

Mechelsesteenweg 418 B-1930 Zaventem, Belgium

KENWOOD ELECTRONICS FRANCE S.A.

13, Boulevard Ney, 75018 Paris, France

KENWOOD ELECTRONICS U.K. LIMITED

KENWOOD House, Dwight Road, Watford, Herts., WD1 8EB United Kingdom

KENWOOD ELECTRONICS EUROPE B.V.

Amsterdamseweg 37, 1422 AC Uithoorn, The Netherlands

KENWOOD ELECTRONICS ITALIA S.p.A.

Via G. Sirtori, 7/9 20129 Milano, Italy

KENWOOD IBERICA S.A.

Bolivia, 239-08020 Barcelona, Spain

KENWOOD ELECTRONICS AUSTRALIA PTY. LTD.

(A.C.N. 001 499 074)

16 Giffnock Avenue, Centrecourt Estate, North Ryde, N.S.W. 2113 Australia

KENWOOD ELECTRONICS (HONG KONG) LTD.

Unit 3712-3724, Level 37, Tower one Metroplaza, 223 Hing Fong Road, Kwai Fong, N.T., Hong Kong

KENWOOD ELECTRONICS TECHNOLOGIES(S) PTE LTD.

Sales Marketing Division

1 Ang Mo Kio Street 63, Singapore 569110

