

# KENWOOD

## **Document Copyrights**

Copyright 2006 by Kenwood Corporation. All rights reserved.

No part of this manual may be reproduced, translated, distributed, or transmitted in any form or by any means, electronic, mechanical, photocopying, recording, or otherwise, for any purpose without the prior written permission of Kenwood.

## **Disclaimer**

While every precaution has been taken in the preparation of this manual, Kenwood assumes no responsibility for errors or omissions. Neither is any liability assumed for damages resulting from the use of the information contained herein. Kenwood reserves the right to make changes to any products herein at any time for improvement purposes.

CHARGER

# KSC-34

## SERVICE MANUAL

# KENWOOD

Kenwood Corporation

© 2005-2 PRINTED IN JAPAN  
B51-8724-00 (S) 365

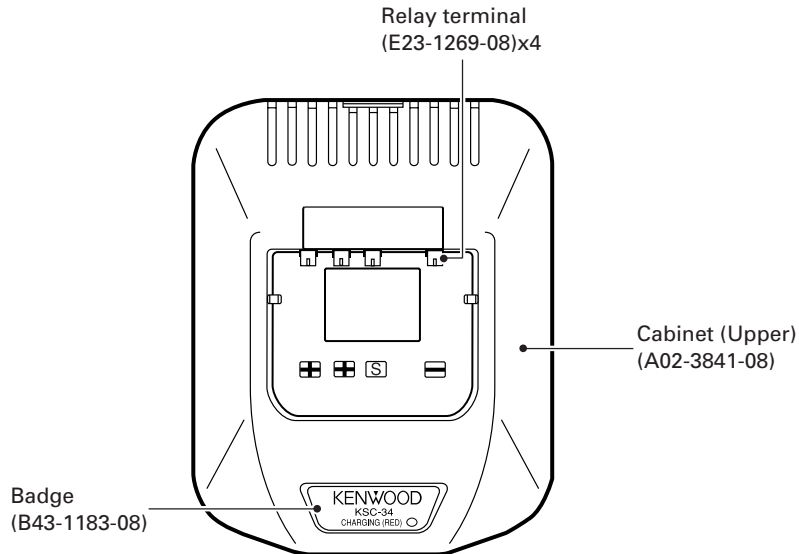

### SPECIFICATIONS

Input voltage ..... AC 230V (Use the supplied AC adapter)  
 Charging current..... Approx. 200mA  
 Approximately charging time  
     KNB-25A (Ni-Cd: 7.2V 1200mAh) ..... 8 hours  
     KNB-26N (Ni-MH:7.2V 2000mAh) ..... 11 hours  
     KNB-38A (Ni-Cd: 7.2V 1200mAh) ..... 8 hours  
     KNB-39N (Ni-MH:7.2V 2000mAh) ..... 11 hours  
 Usable temperature range ..... 5°C to 40°C  
 Dimensions (W x H x D, charger only) ..... 105 x 55 x 135 mm  
 Weight (Charger only) ..... Approx. 155g

### PARTS LIST

\* : New Parts  
 △ : Safety critical components

#### KSC-34 (Y56-5630-30)

Ref. No.	New parts	Parts No.	Description	Destination
<b>KSC-34</b>				
		A02-3656-08	CABINET	BOTTOM
		A02-3841-08	CABINET	UPPER
	*	B43-1183-08	BADGE	
	*	B62-1826-00	INSTRUCTION MANUAL	
		E03-0453-08	DC JACK	
	*	E23-1269-08	RELAY TERMINAL	
	*	G13-2099-08	CUSHION	
		N83-2610-45	PAN HEAD TAPTITE SCREW	
	*	W02-3691-08	ELECTRIC CIRCUIT MODULE	
	*	W08-0985-08	AC ADAPTER	230V AC 50HZ



# KSC-34

## OPERATING FLOW CHART

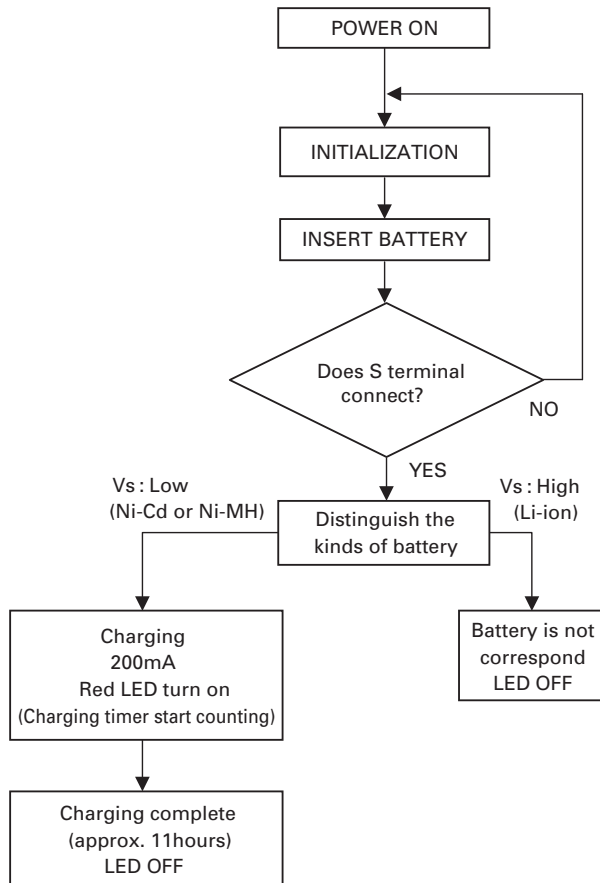

## SCHEMATIC DIAGRAM

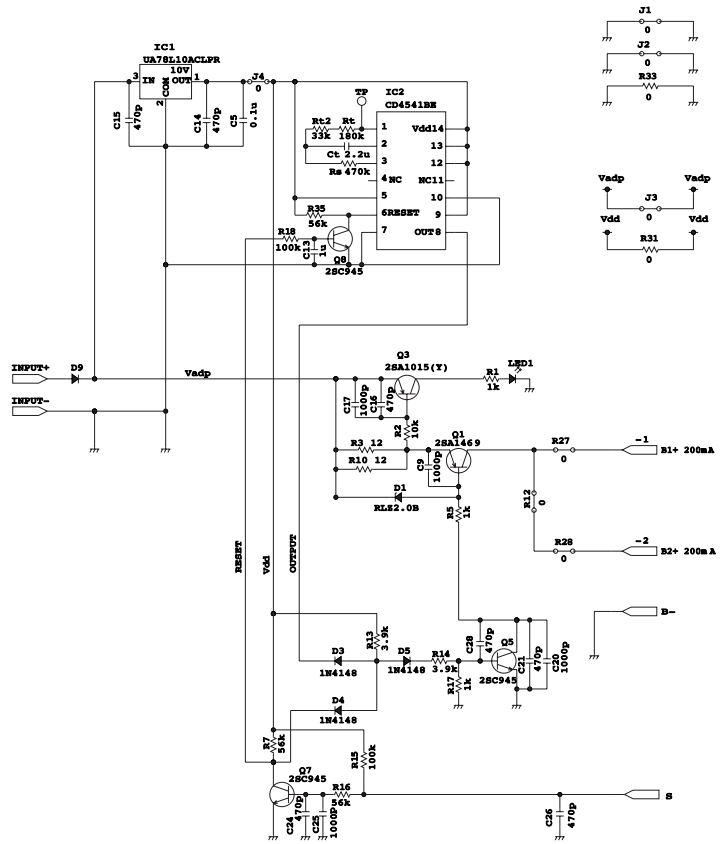

## Kenwood Corporation

2967-3, Ishikawa-machi, Hachioji-shi, Tokyo, 192-8525 Japan

### Kenwood U.S.A. Corporation

P.O. BOX 22745, 2201 East Dominguez Street, Long Beach, CA 90801-5745, U.S.A.

### Kenwood Electronics Canada Inc.

6070 Kestrel Road, Mississauga, Ontario, Canada L5T 1S8

### Kenwood Electronics Deutschland GmbH.

Rembrücker Str. 15, 63150 Heusenstamm, Germany

### Kenwood Electronics Belgium N.V.

Leuvensesteenweg 248 J, 1800 Vilvoorde, Belgium

### Kenwood Electronics France S.A.

13, Boulevard Ney, 75018 Paris, France

### Kenwood Electronics U.K. Ltd.

KENWOOD House, Dwight Road, Watford, Herts., WD18 9EB United Kingdom

### Kenwood Electronics Europe B.V.

Amsterdamseweg 37, 1422 AC Uithoorn, The Netherlands

### Kenwood Electronics Italia S.p.A.

Via G. Sirtori, 7/9 20129 Milano, Italy

### Kenwood Electronics Iberica S.A.

Bolivia, 239-08020 Barcelona, Spain

### Kenwood Electronics Australia Pty. Ltd.

(A.C.N. 001 499 074)

16 Giffnock Avenue, Centrecourt Estate, North Ryde, N.S.W. 2113 Australia

### Kenwood Electronics (Hong Kong) Ltd.

Unit 3712-3724, Level 37, Tower one Metroplaza, 223 Hing Fong Road, Kwai Fong, N.T., Hong Kong

### Kenwood Electronics Singapore Pte. Ltd.

1 Ang Mo Kio Street 63, Singapore 569110

