

NX-220

SERVICE MANUAL / 维修手册

C,C2 versions / C,C2 版本

KENWOOD

Kenwood Corporation

© 2011-4 PRINTED IN CHINA
B51-8966-00 (N)

NX-220 C

NX-220 C2

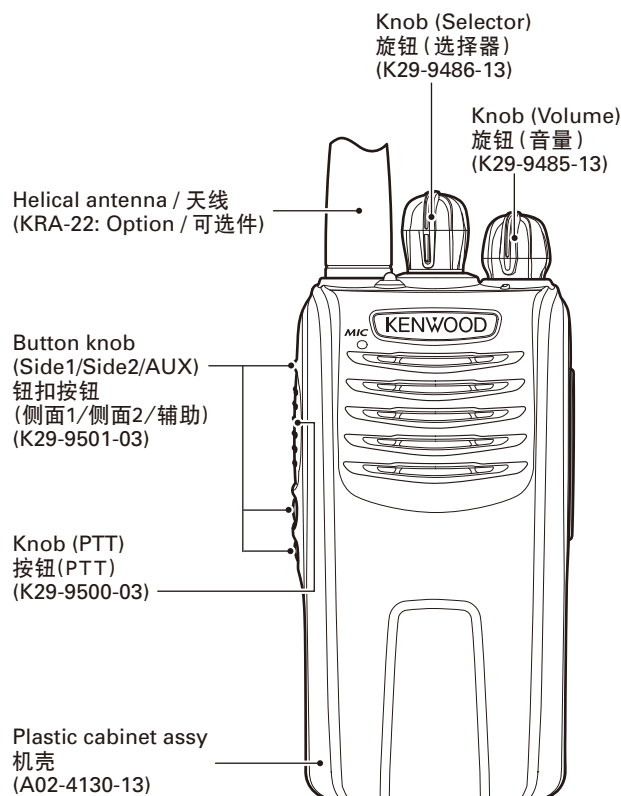
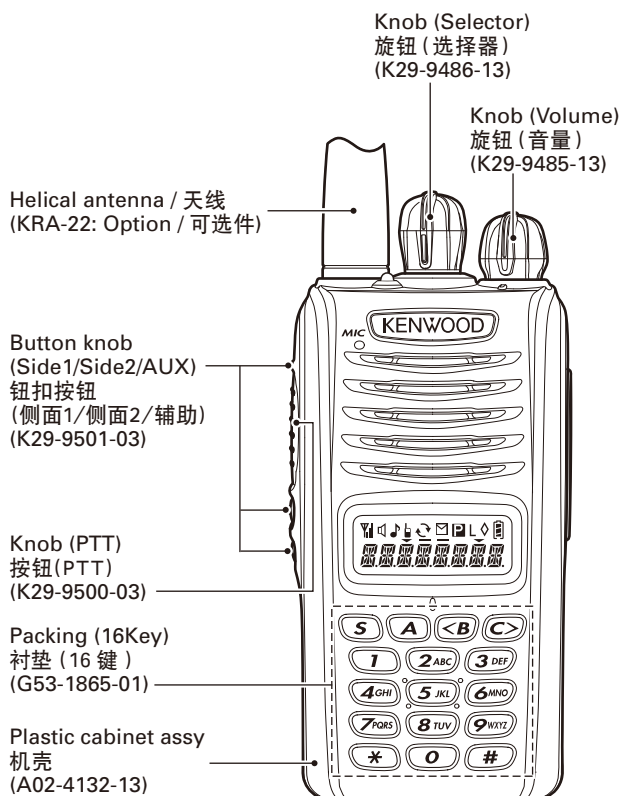

Does not come with antenna. Antenna is available as an option.

不附带天线。天线是选购件。

无铅焊接通信产品  
保护环境建伍领先

⚠ 注意：本产品是无铅化焊接产品
在维修时请使用无铅焊锡
和相应的焊接工具
详细事项请访问如下网址了解：
<http://www.kenwoodhk.com.hk/>



CONTENTS / 目录

GENERAL	3	概 述.....	3
SYSTEM SET-UP	4	系统体系.....	4
REALIGNMENT	5	模式组合.....	5
DISASSEMBLY FOR REPAIR	10	维修拆卸.....	10
CIRCUIT DESCRIPTION	17	电路说明.....	17
COMPONENTS DESCRIPTION	25	元件说明.....	25
TERMINAL FUNCTION	28	端子功能.....	28
PARTS LIST	31	零 件 表.....	31
EXPLODED VIEW	40	部件分解图.....	40
PACKING	41	包 装.....	41
TROUBLE SHOOTING	42	故障排除.....	43
ADJUSTMENT	48	调 整.....	49
PC BOARD		印刷电路板	
DISPLAY UNIT (X54-3760-XX)	86	显示单元 (X54-3760-XX).....	86
TX-RX UNIT (X57-8040-10)	90	收发单元 (X57-8040-10).....	90
LEVEL DIAGRAM	94	电 平 图.....	94
INTERCONNECTION DIAGRAM	95	互 连 图.....	95
SCHEMATIC DIAGRAM	96	原 理 图.....	96
BLOCK DIAGRAM	106	方 块 图.....	106
OPTIONAL ACCESSORIES		可选附件	
KNB-55L (Li-ion Battery Pack)	109	KNB-55L(锂离子电池).....	109
KNB-57L (Li-ion Battery Pack)	109	KNB-57L(锂离子电池).....	109
SPECIFICATIONS	110	规 格.....	111

Document Copyrights

Copyright 2011 by Kenwood Corporation. All rights reserved.

No part of this manual may be reproduced, translated, distributed, or transmitted in any form or by any means, electronic, mechanical, photocopying, recording, or otherwise, for any purpose without the prior written permission of Kenwood.

Disclaimer

While every precaution has been taken in the preparation of this manual, Kenwood assumes no responsibility for errors or omissions. Neither is any liability assumed for damages resulting from the use of the information contained herein. Kenwood reserves the right to make changes to any products herein at any time for improvement purposes.

文档版权信息

Kenwood Corporation 拥有版权 2011。保留所有权利。

未经 Kenwood 公司预先书面同意，无论出于何种目的，均不得以任何形式或任何方式包括电子、机械、影印、录音或其他方式复制、翻译、分发或传播本手册的任何部分。

免责声明

Kenwood 公司在准备本文档时已采取所有必要的预防措施，恕不对错误或疏漏承担任何责任，也不对因使用本文中所含的信息而导致的损害负责。Kenwood 公司保留出于改进的需要而随时对文中的产品信息做出更改的权利。

GENERAL / 概述

INTRODUCTION

SCOPE OF THIS MANUAL

This manual is intended for use by experienced technicians familiar with similar types of commercial grade communications equipment. It contains all required service information for the equipment and is current as of the publication date. Changes which may occur after publication are covered by either Service Bulletins or Manual Revisions. These are issued as required.

ORDERING REPLACEMENT PARTS

When ordering replacement parts or equipment information, the full part identification number should be included. This applies to all parts: components, kits, or chassis. If the part number is not known, include the chassis or kit number of which it is a part, and a sufficient description of the required component for proper identification.

PERSONAL SAFETY

The following precautions are recommended for personal safety:

- DO NOT transmit until all RF connectors are verified secure and any open connectors are properly terminated.
- SHUT OFF and DO NOT operate this equipment near electrical blasting caps or in an explosive atmosphere.
- This equipment should be serviced by a qualified technician only.

SERVICE

This transceiver is designed for easy servicing. Refer to the schematic diagrams, printed circuit board views, and alignment procedures contained within.

引言

本手册的范围

本手册是提供给熟悉通信专业并且具有维修经验的技术人员使用的。它包括了维修该设备所需要的全部资料和现行出版日期。在出版后可能发生变动，如果需要，可以参照《维修通报》或《手册修订本》进行补充。

替换零件的订购

当订购替换零件或设备资料时，应注意完整的零件识别号码。所有的零件均有识别号码：元件，组件或机壳。如果不知道零件的号码，为了正确地识别，必须注明此元件所属的机壳或组件的号码，并对元件进行充分的说明。

个人安全

为了个人的安全，请注意下列事项：

- 在没有认真核实所有射频插头之前或有任何一个脱开的插头没有连接到相应端口上的情况下均不要发射。
- 在电爆管附近或在易燃性气体环境中，必须关闭电源，不要操作本设备。
- 本设备只应该由有资格的技术人员进行维修。

维修服务

为了便于维修本设备，建立了完整的维修服务体系，提供了包括原理图，印刷电路板图和调整步骤在内的资料供参考。

Model & Destination (Market code) 型号和类型 (市场代码)		Display unit / 显示单元 X54-376X-XX		TX-RX unit 收发单元 X57-8040-10	Frequency range 频率范围	Remarks 备注	LCD	DTMF keypad DTMF 键盘
		0-10	0-12					
NX-220	C	✓		✓	136~174MHz	1st IF: 49.95MHz LOC: 50.4MHz	✓	✓
	C2		✓	✓			-	-

SYSTEM SET-UP / 系统体系

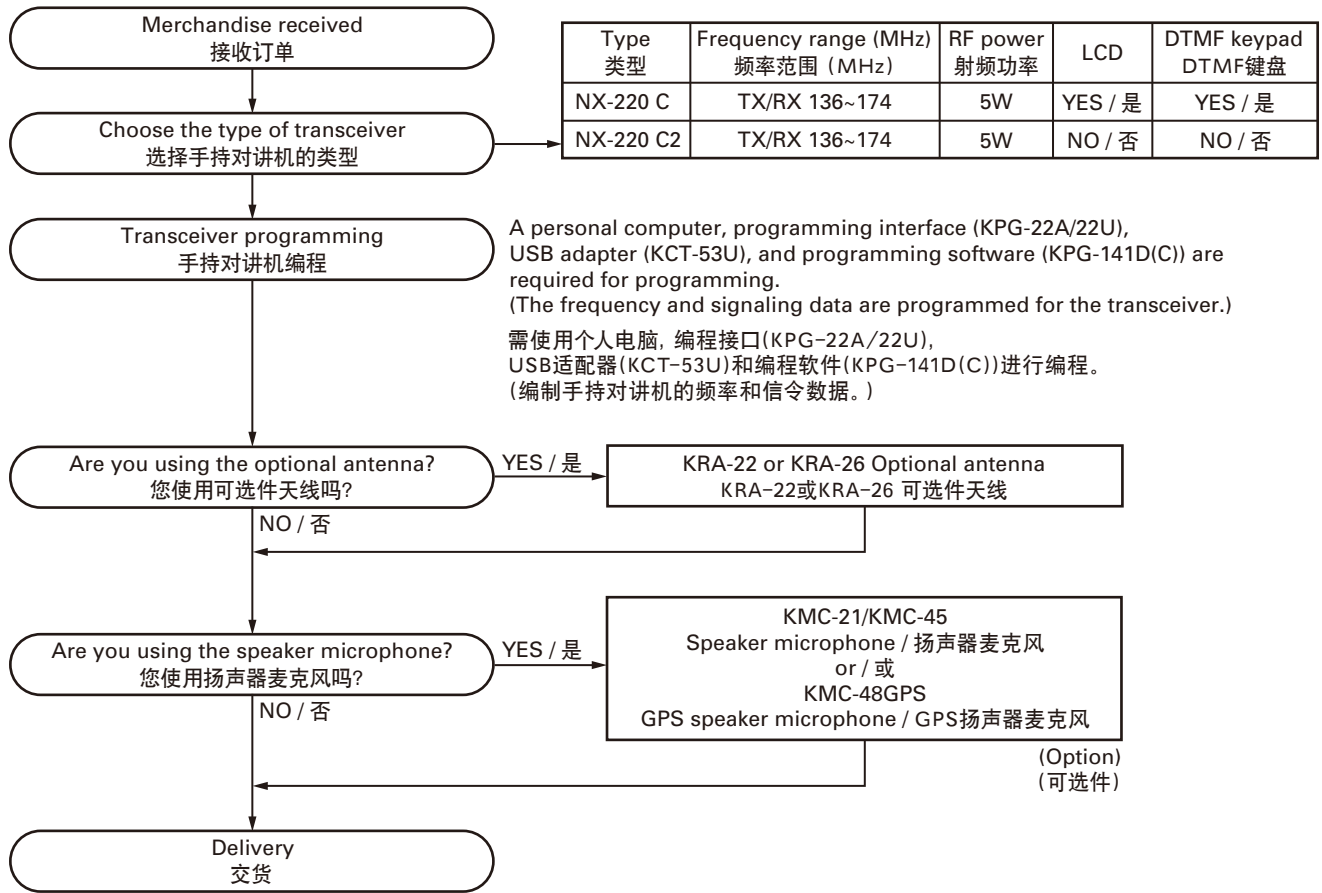

REALIGNMENT / 模式组合

1. Modes

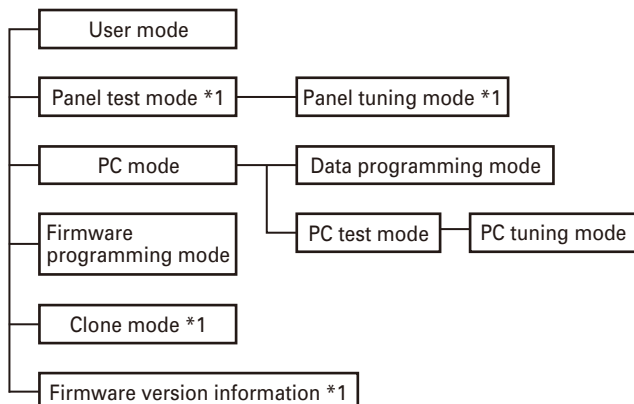

Mode	Function
User mode	For normal use.
Panel test mode *1	Used by the dealer to check the fundamental characteristics.
Panel tuning mode *1	Used by the dealer to tune the transceiver.
PC mode	Used for communication between the transceiver and PC.
Data programming mode	Used to read and write frequency data and other features to and from the transceiver.
PC test mode	Used to check the transceiver using the PC. This feature is included in the FPU.
Firmware programming mode	Used when changing the main program of the flash memory.
Clone mode *1	Used to transfer programming data from one transceiver to another.
Firmware version information *1	Used to confirm the internal firmware version.

*1: C model only

2. How to Enter Each Mode

Mode	Operation
User mode	Power ON
Panel test mode *2	[A] + Power ON
PC mode	Received commands from PC
Panel tuning mode *2	[Panel test mode] + [S]
Firmware programming mode	[Side1] + Power ON
Clone mode *2	[< B] + Power ON
Firmware version information *2	[S] + Power ON

*2: C model only

3. Panel Test Mode (C model only)

Setting method refer to ADJUSTMENT.

4. Panel Tuning Mode (C model only)

Setting method refer to ADJUSTMENT.

1. 模式

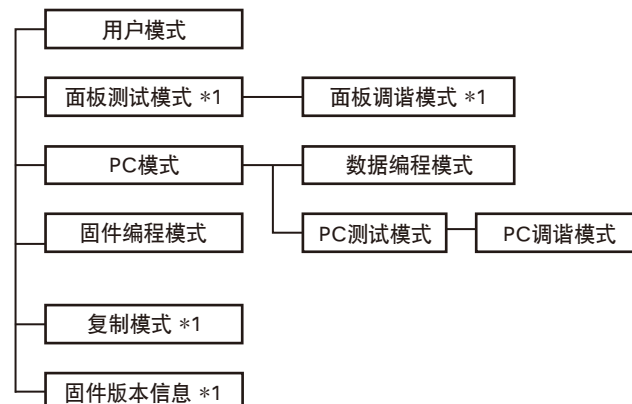

模式	功能
用户模式	一般使用。
面板测试模式 *1	用于经销商检查基本功能。
面板调谐模式 *1	用于经销商调整手持对讲机指标。
PC 模式	用于手持对讲机与 PC 之间的通信。
数据编程模式	用于阅读和写入频率数据以及其他功能。
PC 测试模式	用于通过 PC 检查手持对讲机。该功能内置于 FPU 中。
固件编程模式	当改变闪存中操作主程序时使用。
复制模式 *1	用于将一台手持对讲机的编程数据传送到另一台。
固件版本信息 *1	用于确认内部固件版本。

*1: 仅限 C 型号

2. 如何进入每一种模式

模式	操作
用户模式	接通电源
面板测试模式 *2	[A]+ 接通电源
PC 模式	从 PC 接收指令
面板调谐模式 *2	[面板测试模式]+[S]
固件编程模式	[侧面 1]+ 接通电源
复制模式 *2	[< B]+ 接通电源
固件版本信息 *2	[S]+ 接通电源

*2: 仅限 C 型号

3. 关于面板测试模式 (仅限 C 型号)

关于设定方式, 参见调整。

4. 关于面板调谐模式 (仅限 C 型号)

关于设定方式, 参见调整。

REALIGNMENT / 模式组合

5. PC Mode

5-1. Preface

The transceiver is programmed by using a personal computer, programming interface (KPG-22A/22U), USB adapter (KCT-53U) and programming software (KPG-141D(C)).

The programming software can be used with a PC. Figure 1 shows the setup of a PC for programming.

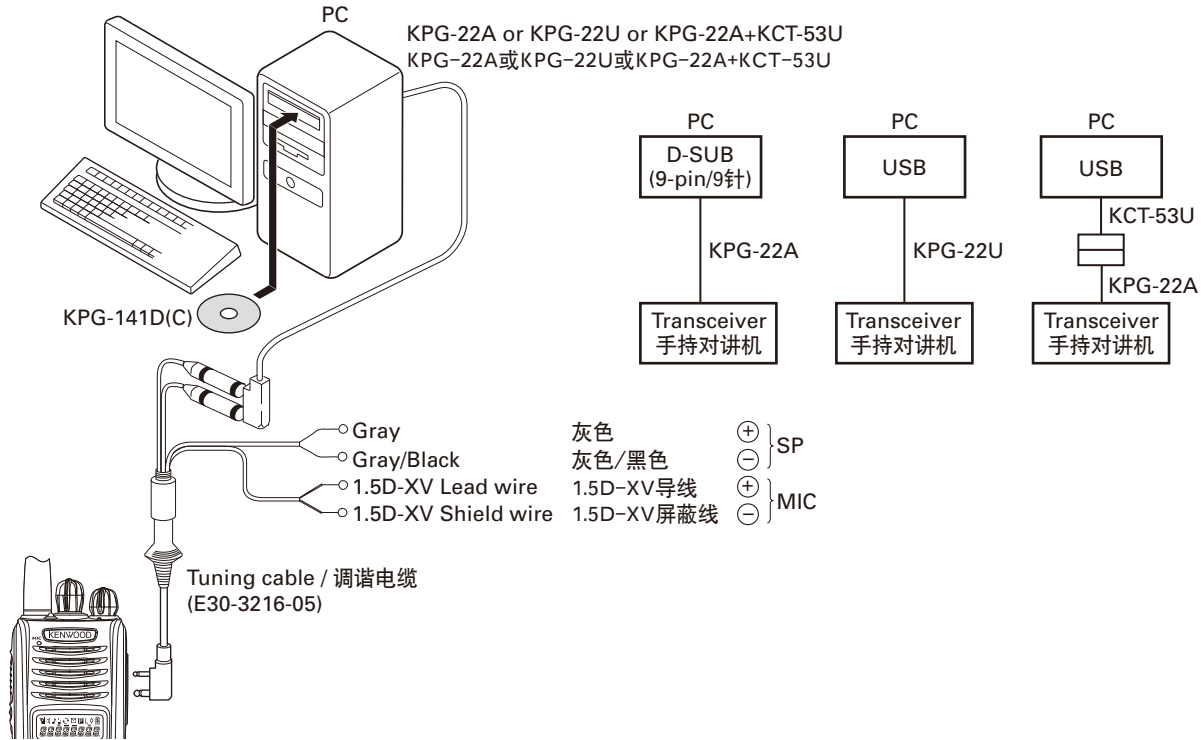

Fig. 1 / 图 1

5-2. Connection procedure

1. Connect the transceiver to the computer using the interface cable and USB adapter (When the interface cable is KPG-22A, the KCT-53U can be used.).

Note:

- You must install the KPG-22U driver in the computer to use the USB programming interface cable (KPG-22U).
- You must install the KCT-53U driver in the computer to use the USB adapter (KCT-53U).
- When using the USB adapter (KCT-53U) for the first time, plug the KCT-53U into a USB port on the computer with the computer power ON.

2. When the POWER is switched on, you can immediately enter user mode. When the PC sends a command, the transceiver enters PC mode, and "PROGRAM" is displayed on the LCD.

When data is transmitting from the transceiver, the red LED lights.

When data is receiving by the transceiver, the green LED lights.

5. PC 模式

5-1. 前言

手持对讲机采用个人电脑、编程接口 (KPG-22A/22U), USB 适配器 (KCT-53U) 和编程软件 (KPG-141D(C)) 进行编程。

编程软件可在 PC 上使用。图 1 说明了 PC 进行编程的设置。

5-2. 连接操作

1. 用接口电缆和 USB 适配器将手持对讲机连接到电脑 (接口电缆为 KPG-22A 时, 可以使用 KCT-53U)。

注意:

- 必须在电脑上安装 KPG-22U 驱动程序才能使用 USB 编程接口电缆 (KPG-22U)。
- 必须在电脑上安装 KCT-53U 驱动程序才能使用 USB 适配器 (KCT-53U)。
- 首次使用 USB 适配器 (KCT-53U) 时, 请在电脑电源打开的情况下将 KCT-53U 插入电脑的 USB 端口。

2. 手持对讲机电源开关打开时, 可以立即进入用户模式。PC 发出手持对讲机进入 PC 模式的指令时, LCD 上显示 "PROGRAM"。

手持对讲机正在发送数据时, 红色的 LED 点亮。

手持对讲机正在接收数据时, 绿色的 LED 点亮。

REALIGNMENT / 模式组合

Note:

The data stored in the computer must match the "Model Name" when it is written into the flash memory.

5-3. KPG-22A description

(PC programming interface cable: Option)

The KPG-22A is required to interface the transceiver to the computer. It has a circuit in its D-sub connector case that converts the RS-232C logic level to the TTL level.

The KPG-22A connects the SP/MIC connector of the transceiver to the RS-232C serial port of the computer.

5-4. KPG-22U description

(USB programming interface cable: Option)

The KPG-22U is a cable which connects to a USB port on a computer.

When using the KPG-22U, install the supplied CD-ROM (with driver software) in the computer. The KPG-22U driver runs under Windows XP, Vista or 7.

5-5. KCT-53U description (USB adapter: Option)

The KCT-53U is a cable which connects the KPG-22A to a USB port on a computer.

When using the KCT-53U, install the supplied CD-ROM (with driver software) in the computer. The KCT-53U driver runs under Windows 2000, XP or Vista (32-bit).

5-6. Programming software KPG-141D(C) description

The KPG-141D(C) is the programming software for the transceiver supplied on a CD-ROM. This software runs under Windows XP, Vista or 7 on a PC.

The data can be input to or read from the transceiver and edited on the screen. The programmed or edited data can be printed out. It is also possible to tune the transceiver.

6. Firmware Programming Mode

6-1. Preface

Flash memory is mounted on the transceiver. This allows the transceiver to be upgraded when new features are released in the future. (For details on how to obtain the firmware, contact Customer Service.)

6-2. Connection procedure

Connect the transceiver to the personal computer using the interface cable (KPG-22A/22U) and USB adapter (KCT-53U: when the interface cable is KPG-22A, the KCT-53U can be used.). (Connection is the same as in the PC Mode.)

6-3. Programming

1. Start up the firmware programming software (Fpro.exe (ver. 6.0 or later)). The Fpro.exe exists in the KPG-141D(C) installed folder.
2. Set the communications speed (normally, 115200 bps) and communications port in the configuration item.
3. Set the firmware to be updated by File name item.
4. Press and hold the [Side1] key while turning the transceiver power ON. Then, the orange LED on the transceiver lights and "FIRM PRG" is displayed.

注意:

电脑保存的数据写入闪存时, 必须与“型号名称”相符。

5-3. KPG-22A 说明

(PC 编程接口电缆: 选购件)

将手持对讲机连接到电脑需要 KPG-22A。该电缆的 D-sub 连接器 盒具有将 RS-232C 逻辑电平转换为 TTL 电平的电路。

KPG-22A 将手持对讲机的 SP/MIC 连接器连接到电脑的 RS-232C 串行端口。

5-4. KPG-22U 说明

(USB 编程接口电缆: 选购件)

KPG-22U 是连接到电脑 USB 端口的电缆。

使用 KPG-22U 时, 请在电脑上安装附带的 CD-ROM (带有驱动程序)。KPG-22U 驱动程序可以在 Windows XP、Vista 或 7 下运行。

5-5. KCT-53U 说明 (USB 适配器: 选购件)

KCT-53U 是将 KPG-22A 连接到电脑 USB 端口的电缆。

使用 KCT-53U 时, 请在电脑上安装附带的 CD-ROM (带有驱动程序)。KCT-53U 驱动程序在 Windows 2000, XP 或 Vista (32 位) 下运行。

5-6. 编程软件 KPG-141D(C) 说明

KPG-141D(C) 是 CD-ROM 附带的用于手持对讲机的编程软件。该软件在 PC 的 Windows XP, Vista 或 7 下运行。

可在手持对讲机上写入或读取数据, 并可在电脑屏幕上进行编辑。可以打印编程或编辑的数据。此外, 还可调谐手持对讲机。

6. 固件编程模式

6-1. 前言

闪存安装在手持对讲机上。将来发布新功能时, 可以使手持对讲机进行升级。(有关如何获得固件的详情, 请咨询客户服务机构。)

6-2. 连接操作

用接口电缆 (KPG-22A/22U) 和 USB 适配器 (KCT-53U: 接口电缆为 KPG-22A 时, 可以使用 KCT-53U) 将手持对讲机连接到个人电脑。(连接方式与 PC 模式下相同。)

6-3. 编程

1. 启动固件编程软件 (Fpro.exe (ver. 6.0 或更高版本))。Fpro.exe 存在于 KPG-141D(C) 安装文件夹内。
2. 在配置项中设置通信速度 (通常为 115200 bps) 和通信端口。
3. 通过文件名项目设置要更新的固件。
4. 打开手持对讲机电源时, 按住 [侧面 1] 键。然后, 手持对讲机上的橙色 LED 点亮, 并显示 "FIRM PRG"。

REALIGNMENT / 模式组合

5. Check the connection between the transceiver and the personal computer, and make sure that the transceiver is in the Program mode.
6. Press "write" button in the window. When the transceiver starts to receive data, the [LOADING] display lights.
7. If writing ends successfully, the checksum is calculated and a result is displayed.
8. If you want to continue programming other transceivers, repeat steps 4 to 7.

6-4. Function

If you press the [Side1] key while "FIRM PRG" is displayed, the checksum is calculated, and a result is displayed. If you press the [Side1] key again while the checksum is displayed, "FIRM PRG" is redisplayed.

Note:

- This mode cannot be entered if the Firmware Programming mode is set to Disable in the Programming software.
- Normally, write in the high-speed mode.
- The text message are displayed for C model only.

7. Clone Mode (C model only)

Programming data can be transferred from one transceiver to another by connecting them via their external SP/MIC connectors. The operation is as follows (the transmit transceiver is the source and the receive transceiver is a target).

The following data cannot be cloned.

- Tuning data
- Embedded message with password
- Model name data
- ESN (Electronic Serial Number) data

Note:

The following data can be cloned.

- Fleet (own)/ID (own) for FleetSync
- Unit ID (own) for NXDN
- ID (own) for MDC-1200

1. Press and hold the [**B**] key while turning the transceiver power ON. If the Read authorization password is set to the transceiver, the transceiver displays "CLN LOCK". If the password is not set, the transceiver displays "CLONE".
2. When you enter the correct password, and "CLONE" is displayed, the transceiver can be used as the cloning source. The following describes how to enter the password.
3.
 - **How to enter the password using the keypad;**
If one of keys 0 to 9 is pressed while the "CLN LOCK" is displayed, the pressed number is displayed on the LCD. Each press of the key shifts the display in order to the left.

5. 检查手持对讲机与个人电脑之间的连接，确认手持对讲机处于编程模式。
6. 按窗口中的“write”按钮。手持对讲机开始接收数据时，显示 [LOADING]。
7. 如果写入操作成功完成，则计算校验和并显示结果。
8. 若要继续为其他手持对讲机编程，请重复步骤 4 至 7。

6-4. 功能

如果在显示“FIRM PRG”时按 [侧面 1] 键，则计算校验和并显示结果。如果在显示校验和时再次按 [侧面 1] 键，则重新显示“FIRM PRG”。

注意：

- 如果手持对讲机的固件编程模式设为禁用，则无法进入此模式。
- 通常以高速模式写入。
- 文本信息显示仅限 C 型号。

7. 复制模式 (仅限 C 型号)

用外部 SP/MIC 连接器连接手持对讲机，可以将编程数据从一台手持对讲机传输到另一台手持对讲机。具体操作如下（发射机是主对讲机，接收机是子对讲机）。

不能复制以下数据。

- 调谐数据
- 带密码的嵌入信息
- 机型数据
- ESN (电子序列号) 数据

注意：

可以复制以下数据。

- FleetSync 的 Fleet (自身)/ID (自身)
- NXDN 的 Unit ID (自身)
- MDC-1200 的 ID (自身)

1. 打开手持对讲机电源时，按住 [**B**] 键。如果手持对讲机设置了读取授权密码，则手持对讲机显示“CLN LOCK”。如果没有设置密码，则手持对讲机显示“CLONE”。
2. 输入正确的密码后，显示“CLONE”，手持对讲机可以用作复制源。以下介绍如何输入密码。
3.
 - **如何使用键盘输入密码；**
如果在显示“CLN LOCK”时按 0 至 9 当中的某个键，LCD 上将显示按下的数字。
每次按键依次向左移动显示。

REALIGNMENT / 模式组合

When you enter the password and press the [S] or [*] key, "CLONE" is displayed if the entered password is correct. If the password is incorrect, "CLN LOCK" is re-displayed.

- **How to enter the password using the Selector;**

If the Selector is rotated while "CLN LOCK" is displayed, the Read authorization password input screen is displayed.

If the Selector is rotated while the Read authorization password input screen is displayed, the number (0 to 9) blinks on the LCD. When you press the [S] key, the currently selected number is determined. If you press the [S] key after entering the password in this procedure, "CLONE" is displayed if the entered password is correct. If the password is incorrect, "CLN LOCK" is re-displayed.

4. Power ON the target transceiver.
5. Connect the cloning cable (part No. E30-3410-05) to the SP/MIC connectors on the source and target.
6. Press the [S] key on the source while the source displays "CLONE". The data of the source is sent to the target. While the target is receiving the data, "PROGRAM" is displayed. When cloning of data is completed, the source displays "END", and the target automatically operates in the User mode. The target can then be operated by the same program as the source.
7. The other target can be continuously cloned. When the [S] key on the source is pressed while the source displays "END", the source displays "CLONE". Carry out the operation in step 4 to 6.

Note:

- Cannot be cloned if the password (overwrite password) is programmed to the target.
- "Model Name" must be same to clone the transceiver.

输入密码并按 [S] 或 [*] 键时，如果输入的密码正确，则显示 "CLONE"。如果密码错误，则再次显示 "CLN LOCK"。

- **如何使用选择器输入密码；**

如果在显示 "CLN LOCK" 时转动选择器，将显示读取授权密码输入画面。

如果在显示读取授权密码输入画面时转动选择器，数字 (0 至 9) 将在 LCD 上闪烁。按 [S] 键时，确定当前选择的数字。在此步骤输入密码后按 [S] 键时，如果输入的密码正确，则显示 "CLONE"。

如果密码错误，则再次显示 "CLN LOCK"。

4. 打开子手持对讲机的电源。
5. 将复制电缆 (零件号 E30-3410-05) 连接到主对讲机和子对讲机的 SP/MIC 连接器上。
6. 主对讲机上显示 "CLONE" 时，按主对讲机上的 [S] 键。主对讲机的数据被发送到子对讲机上。子对讲机接收数据时，显示 "PROGRAM"。数据复制完成后，主对讲机显示 "END"，子对讲机自动按用户模式操作。然后子对讲机便可按与主对讲机相同的程序操作。
7. 可以继续对另一子对讲机进行复制。如果在主对讲机显示 "END" 时按主对讲机的 [S] 键，主对讲机将显示 "CLONE"。执行步骤 4 至 6 的操作。

注意：

- 如果子对讲机设有密码 (改写密码)，则无法复制。
- "型号名称" 必须相同，才能复制手持对讲机。

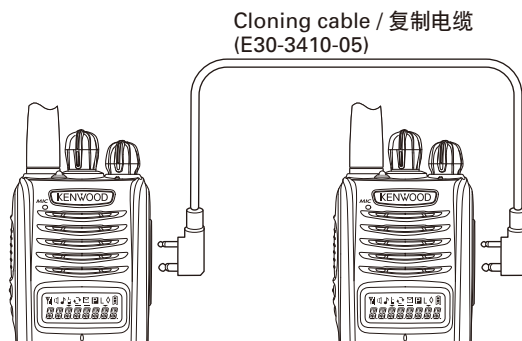

Fig. 2 / 图 2

8. Firmware Version Information (C model only)

Press and hold the [S] key while turning the transceiver power ON and then keep pressing and holding the [S] key, the firmware version information appears on the LCD.

8. 固件版本信息 (仅限 C 型号)

打开手持对讲机电源时按住 [S] 键，然后一直按住 [S] 键，LCD 上便出现固件版本信息。

DISASSEMBLY FOR REPAIR / 维修拆卸

1. Precautions for Disassembly

■ Removing the selector knob and volume knob

1. Using a thin tool, insert it in the hole on the selector knob side and push the knob spring. ①

Note: When you push the knob spring, take care not to damage the resin of the knob.

2. Lift and remove the selector knob ② while pushing the knob spring.

3. Repeat steps 1 and 2 for the volume knob, to remove the volume knob ③.

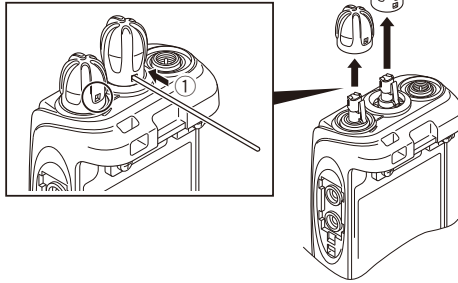

Note:

Perform the following procedures when installing the selector knob and volume knob.

1) Match the direction for the hole of the knob and the knob spring.

2) Push the knob onto the knob spring until a click sounds.

■ Removing the selector knob spring and volume knob spring

1. Lightly grasp the left and right sides of the selector knob spring, then shift the knob spring to the left and right, little by little, as shown in the figure. ①

Note: Do not grasp the knob spring tightly.

2. Remove the selector knob spring ②.

Note: Do not bring your fingers into contact with the flat spring of the knob spring as much as possible.

3. Repeat steps 1 and 2 for the volume knob spring, to remove the volume knob spring ③.

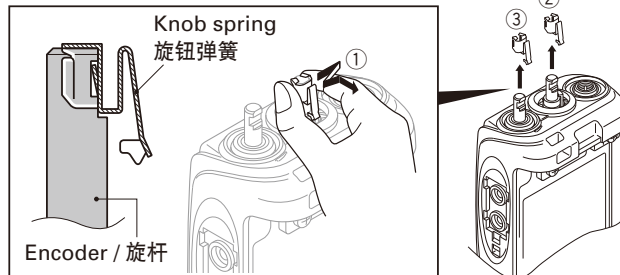

Note:

Perform the following procedures when installing the selector knob spring and volume knob spring.

1) Match the direction for the knob spring and the encoder.

2) Insert the encoder onto the knob spring until a click sounds.

1. 拆卸注意事项

■ 拆下选择器旋钮和音量旋钮

1. 使用薄型工具，将其插入选择器旋钮一侧的开孔，然后推动旋钮弹簧。①

注意：推动旋钮弹簧时，小心不要损坏旋钮的树脂。

2. 在推动旋钮弹簧的同时，将选择器旋钮②提起并拆下。

3. 对于音量旋钮，重复步骤1和2，将音量旋钮③拆下。

注意：

安装选择器旋钮和音量旋钮时，执行以下步骤。

1) 将旋钮开孔和旋钮弹簧的方向保持一致。

2) 将旋钮推压在旋钮弹簧上，直到听到“咔嗒”的到位声。

■ 拆下选择器旋钮弹簧和音量旋钮弹簧

1. 轻轻抓住选择器旋钮弹簧的左右两侧，然后一点点地左右移动旋钮弹簧，如图所示。①

注意：不要紧握旋钮弹簧。

2. 拆下选择器旋钮弹簧②。

注意：尽量不要让手指接触到旋钮弹簧的板簧。

3. 对于音量旋钮弹簧，重复步骤1和2，将音量旋钮弹簧③拆下。

注意：

安装选择器旋钮弹簧和音量旋钮弹簧时，执行以下步骤。

1) 将旋钮弹簧和旋杆的方向保持一致。

2) 将旋钮弹簧插在旋杆上，直到听到“咔嗒”的到位声。

DISASSEMBLY FOR REPAIR / 维修拆卸

■ Removing the mechanical stopper (C2 model only)

1. Pick up and lift the tab of a mechanical stopper using a pair of tweezers. ①

Note: Take care not to damage the packing.

2. Remove the mechanical stopper ②.

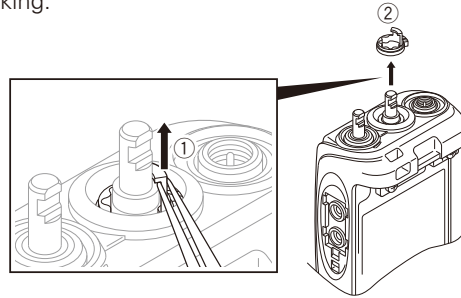

■ 拆下机械挡块（仅限 C2 型号）

1. 用镊子夹住机械挡块的扣环并将其提起。①

注意：小心不要损坏密封件。

2. 拆下机械挡块②。

■ Removing the TX-RX unit from the chassis

1. Remove the flat cable from the connector (CN2). ①
2. Remove the Speaker lead wire from the connector (CN4). ②
3. Remove the PTT FPC from the connector (CN3). ③
4. Remove the VOL/SEL FPC from the connector (CN1). ④

■ 从底座拆下收发单元

1. 从连接器 (CN2) 上取下扁平电缆。①
2. 从连接器 (CN4) 上取下扬声器导线。②
3. 从连接器 (CN3) 上取下 PTT FPC 扁平电缆。③
4. 从连接器 (CN1) 上取下 VOL/SEL FPC 扁平电缆。④

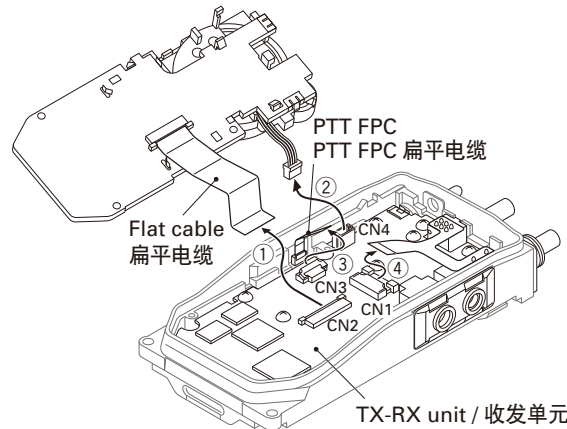

5. Remove the packing ⑤ from the SP/MIC jack.
6. Remove the 14 screws ⑥.
7. Anchor the screw hole of the TX-RX unit using the tip of a pair of tweezers as shown in the figure. Then lift the TX-RX unit to remove it from the chassis. ⑦

5. 从 SP/MIC 插孔上取下密封件⑤。
6. 拆下 14 颗螺钉⑥。
7. 用镊子的末端夹住收发单元的螺孔，如图所示。然后，提起收发单元，将其从底座上取下。⑦

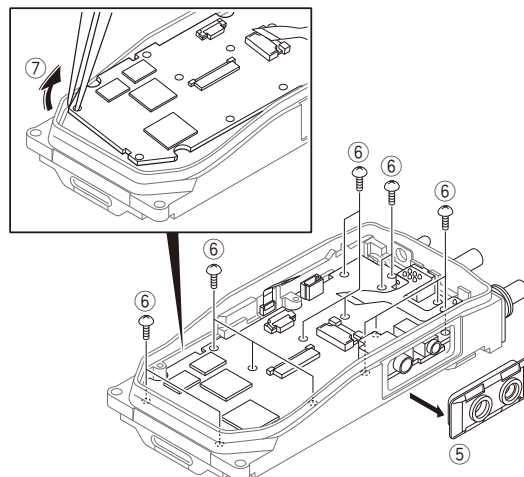

DISASSEMBLY FOR REPAIR / 维修拆卸

■ Removing the speaker holder

There is a space of approximately 1mm (0.04 inch) between the center part of the front glass of the speaker holder and the surface of the Display unit. Set your finger on the space in the center part of the front glass, then lift and remove it.

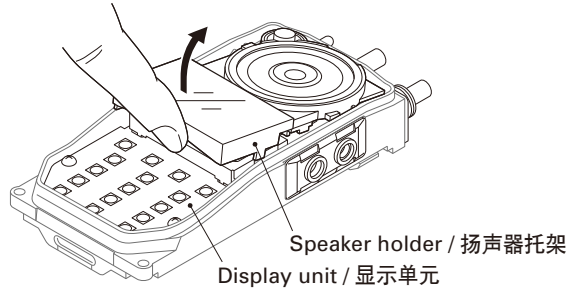

■ 拆下扬声器托架

在扬声器托架前玻璃的中间部分和显示单元表面之间存在约 1mm 的空隙。将手指置于前玻璃中间部分的空隙处，然后将其提起并拆下。

■ Removing the TOP packing

1. Pull the TOP packing to the left to remove the packing that is fit into the left groove of the chassis. ①
2. Pull the TOP packing to the right to remove the packing that is fit into the right groove of the chassis. ②
3. Pull the TOP packing to the center to remove the packing that is fit into the center groove of the chassis. ③
4. Remove the TOP packing. ④

Note:

Remove the packing slowly, as the packing of the selector part might overset when the TOP packing is removed. If the packing is turned over, return it to the normal position using a soft tipped item (e.g., your finger).

■ 拆下顶盖

1. 将顶盖拉至左侧，拆下装在底座左侧凹槽内的盖。①
2. 将顶盖拉至右侧，拆下装在底座右侧凹槽内的盖。②
3. 将顶盖拉至中央，拆下装在底座中央凹槽内的盖。③
4. 拆下顶盖。④

注意：

慢慢拆下密封件，因为在拆下顶盖时，选择器部分的密封件可能会翻转。如果密封件翻转，可用尖形的软物（如手指）将其恢复到正常的位置。

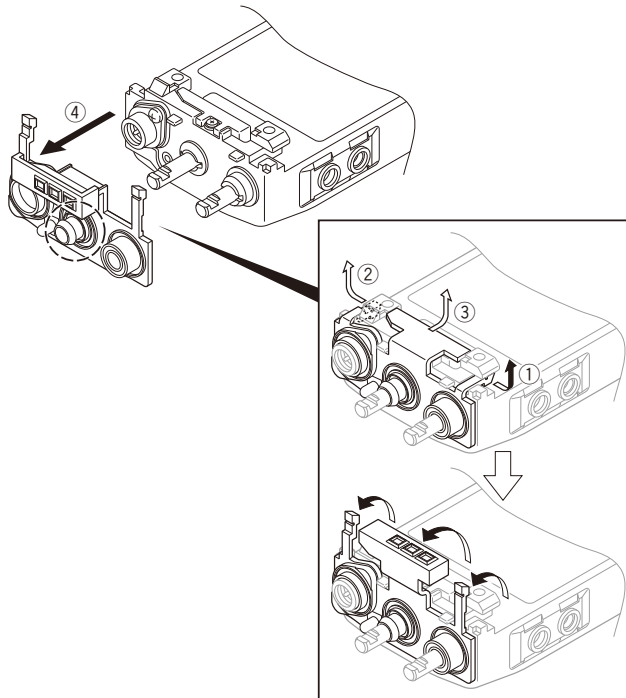

DISASSEMBLY FOR REPAIR / 维修拆卸

2. Precautions for Reassembly

■ Apply the bond to the inside of the selector circle nut and volume circle nut

Apply the bond (W05-0019-00) or "THREE BOND 1401B" at two points inside of the circle nut before tightening the circle nut.

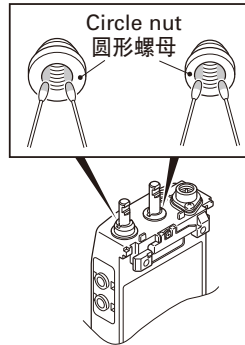

2. 重新组装注意事项

■ 将粘合剂涂在选择器圆形螺母和音量圆形螺母上

拧紧圆形螺母前，将粘合剂 (W05-0019-00) 或 "THREE BOND 1401B" 涂在圆形螺母内的两端。

■ Mounting the chassis onto the case

1. Place the key top on the chassis. Then, fit the chassis tightly into the groove of the key top. ①

Note:

Confirm that the entire groove of the key top fits to the chassis tightly.

2. Mount the chassis onto the case. ②

Note:

- After mounting the chassis onto the case, if the 16-key part on the key top gets stuck inside the case as shown in the figure, return it to the normal position using a soft tipped item (e.g., your finger). ③

Prying it with a pointed metal tool such as forceps, may damage the key top or packing.

- Confirm that the TOP packing is not caught in the Antenna or Volume holes of the case.

■ 将底座安装到机壳上

1. 将按键放置到底座上。然后，将底座紧紧嵌入键帽的凹槽内。

①

注意：

确认键帽的整个凹槽与底座紧密吻合。

2. 将底座安装到机壳上。②

注意：

- 将底座安装到机壳上之后，如果键帽上的 16 键部分卡在机壳内，如图所示，可使用尖形软物（如手指）将其恢复到正常位置。③

用镊子等尖头金属工具撬动可能会损坏键帽或衬垫。

- 确认顶盖未卡在机壳的天线孔或音量孔中。

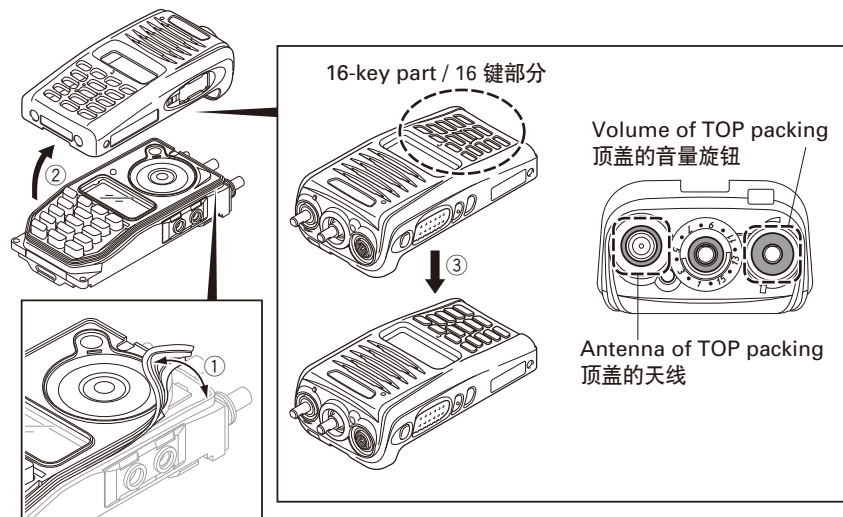

DISASSEMBLY FOR REPAIR / 维修拆卸

■ Forming the flat cable

Form the right and left end of the flat cable as shown in the figure. (Bend the terminal surface of the flat cable on the inside.)

Note: When bending the flat cable, bend it squarely. There is a possibility of disconnecting when the flat cable is bent too much.

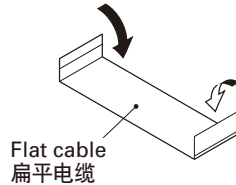

■ 弯折扁平电缆

弯折扁平电缆的左右两端，如图所示。（向内弯折扁平电缆的终端表面。）

注意：弯折扁平电缆时，应以直角进行弯折。如果扁平电缆弯折过大，则可能无法连接。

■ Changing the channel selector from 16-channel operation to free (C2 model only)

1. Remove the channel selector knob ①. (Refer to page 10 for how to remove the channel selector knob.)
2. Remove the knob spring ②. (Refer to page 10 for how to remove the knob spring.)
3. Remove the mechanical stopper ③. (Refer to page 10 for how to remove the mechanical stopper.)
4. Reassemble the channel selector knob and knob spring that were removed in steps 1 and 2, in their original positions.

Note: Refer to page 10 for how to install the channel selector knob and knob spring.

■ 将信道选择器由 16 信道操作改为自由操作 (仅限 C2 型号)

1. 拆下信道选择器旋钮①。（有关信道选择器旋钮的拆卸方法，请参阅第 10 页。）
2. 取下旋钮弹簧②。（有关旋钮弹簧的拆卸方法，请参阅第 10 页。）
3. 拆下机械挡块③。（有关机械挡块的拆卸方法，请参阅第 10 页。）
4. 将步骤 1 和 2 中拆下的信道选择器旋钮和旋钮弹簧重新装回原位。

注意：有关信道选择器旋钮和旋钮弹簧的安装方法，请参阅第 10 页。

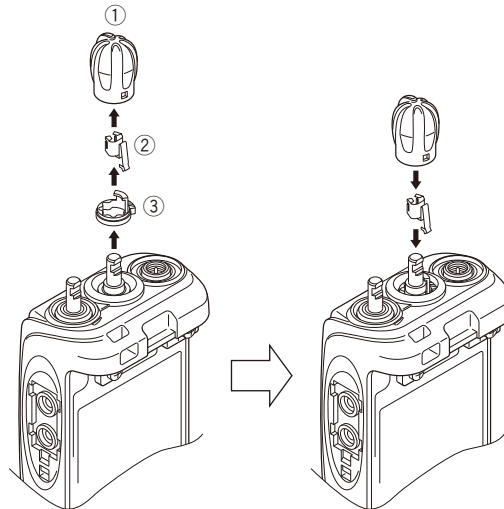

■ Changing the channel selector from free operation to 16-channel (C model only)

1. Remove the channel selector knob ①. (Refer to page 10 for how to remove the channel selector knob.)
2. Remove the knob spring ②. (Refer to page 10 for how to remove the knob spring.)
3. Pinch the supplied mechanical stopper ③ using your fingers, then install it into the groove of the selector part on the case.
4. Reassemble the channel selector knob and knob spring that were removed in steps 1 and 2, in their original positions.

■ 将信道选择器由自由操作改为 16 信道操作 (仅限 C 型号)

1. 拆下信道选择器旋钮①。（有关信道选择器旋钮的拆卸方法，请参阅第 10 页。）
2. 拆下旋钮弹簧②。（有关旋钮弹簧的拆卸方法，请参阅第 10 页。）
3. 用手指捏住随机提供的机械挡块③，然后将其装于机壳选择器部分的凹槽内。
4. 将步骤 1 和 2 中拆下的信道选择器旋钮和旋钮弹簧重新装回原位。

DISASSEMBLY FOR REPAIR / 维修拆卸

Note: Refer to page 10 for how to install the channel selector knob and knob spring.

注意: 有关信道选择旋钮和旋钮弹簧的安装方法, 请参阅第 10 页。

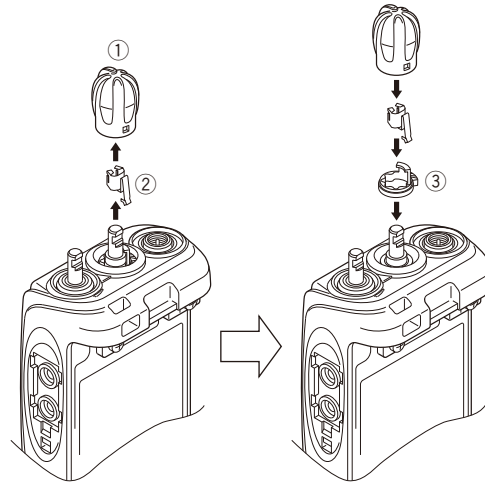

■ Connection place of the antenna hot pin and antenna terminal

An antenna hot pin is connected with the antenna terminal at the position shown in the figure.

Confirm that the antenna hot pin has firmly come in contact with the terminal when the TX-RX unit is tightened with the screw.

Additionally, refer to the following figures for the connection place of the antenna terminal and the TX-RX unit.

■ 天线棒和天线端子的连接位置

在图示的位置连接天线棒和天线端子。

用螺钉拧紧收发单元后, 确认天线棒已与天线端子牢固接触。

此外, 有关天线端子与收发单元的连接位置, 请参阅下图。

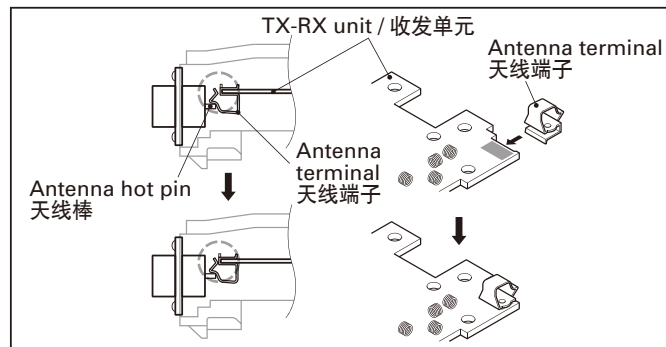

■ Align the SP/MIC lead wire

Align the SP/MIC lead wire as shown in the figure. It is possible to fix temporarily by interweaving the two lead wires between the tabs (tab A and tab B) and boss of the speaker holder.

■ 对准 SP/MIC 导线

对准 SP/MIC 导线, 如图所示。可将扣环 (扣环 A 和扣环 B) 与扬声器托架凸起部之间的导线暂时固定起来。

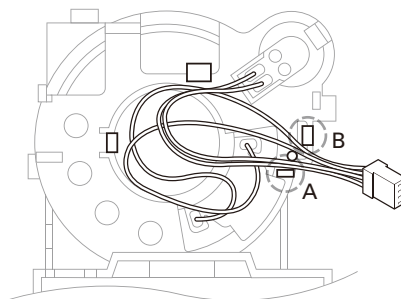

DISASSEMBLY FOR REPAIR / 维修拆卸

■ Assembly information (Sheet/Cushion)

When "Main Parts" is changed (ordered), "Assembled Sheet/Cushion" should also be changed (ordered) together.

The Sticker and Sheet etc are non-reusable parts. It requires the new one to get the radio's performance after repairs.

For example, when "Plastic Cabinet Assy (A02-4130-13 (without key)/A02-4132-13 (16-key))" is changed, "Sticker (B42-7417-04)" and "Fibrous Sheet (G10-1827-04)" should be ordered and changed together because Sticker (B42-7417-04) and Fibrous Sheet (G10-1827-04) are non-reusable.

■ 组装信息 (薄片 / 缓冲垫)

更换 (订购) "主要部件" 时, "组装的薄片 / 缓冲垫" 也应当一同更换 (订购)。

标签和薄片等属于不可重复使用的部件。需使用新部件方可在维修后获得对讲机的性能。

例如, 更换 "塑料机壳组件 (A02-4130-13 (无按键) / A02-4132-13 (16 键))" 时, "标签 (B42-7417-04)" 和 "纤维片 (G10-1827-04)" 也应一并订购和更换, 因为标签 (B42-7417-04) 和纤维片 (G10-1827-04) 不能重复使用。

Main Parts		Assembled Sheet/ Cushion		
Part Name	Part Number	Part Name	Part Number	Remark
Plastic Cabinet Assy (without key)	A02-4130-13	Sticker	B42-7417-04	"NEXEDGE" is printed.
Plastic Cabinet Assy (16-key)	A02-4132-13	Fibrous Sheet (SP)	G10-1827-04	
Speaker	T07-0787-05	Rubber Cushion (SP)	G11-4272-14	
		Sheet (SP)	G11-4527-04	
Chassis	A10-4148-01	Sheet (PTT)	G11-4543-04	
		Rubber Sheet (FET)	G11-4315-14	Used for stabilizing the radiation performance of the FET.
		Sheet (Air)	G11-4500-04	This sheet is put on the air vent hole. This sheet lets air through, but does not let water through.
		Cushion	G13-2249-04	
MIC Element	T91-0673-05	Sheet (ECM)	G11-4558-04	

主要部件		组装的薄片 / 缓冲垫		
零件名称	零件号	零件名称	零件号	备注
塑料机壳组件 (无键)	A02-4130-13	标签	B42-7417-04	印有 "NEXEDGE"。
塑料机壳组件 (16 键)	A02-4132-13	纤维片 (扬声器)	G10-1827-04	
扬声器	T07-0787-05	橡胶垫 (扬声器)	G11-4272-14	
		薄片 (扬声器)	G11-4527-04	
底座	A10-4148-01	薄片 (PTT)	G11-4543-04	
		橡胶片 (场效应管)	G11-4315-14	用于稳定 FET 的辐射性能。
		薄片 (空气)	G11-4500-04	该薄片置于通气孔上。此薄片可透过空气, 但不透水。
		缓冲垫	G13-2249-04	
MIC 元件	T91-0673-05	薄片 (ECM)	G11-4558-04	

CIRCUIT DESCRIPTION / 电路说明

1. Overview

The NX-220 is a VHF portable transceiver designed to operate in the frequency range of 136 to 174MHz. The unit consists of a receiver, transmitter, phase-locked loop (PLL) frequency synthesizer, baseband parts, power supply, and control circuits.

2. Frequency Configuration

The receiver is a double-conversion superheterodyne using the first intermediate frequency (IF) of 49.95MHz and the second IF of 450kHz. Incoming signals from the antenna are mixed with the local signal from the PLL circuit to produce the first IF of 49.95MHz. This is then mixed with the 50.4MHz second local oscillator output to produce the 450kHz second IF. The transmit signal frequency is generated by the PLL VCO, and modulated by the signal from the DSP. It is then amplified and fed to the antenna.

1. 概述

NX-220 为 VHF 便携式手持对讲机，设计用于 136 至 174MHz 的频率范围。该设备由接收机、发射机、锁相环 (PLL) 频率合成器、基带部件、电源和控制电路组成。

2. 频率构成

接收机为二次变频超外差方式，使用的第一中频 (IF) 为 49.95MHz，第二中频为 450kHz。天线接收到的信号与 PLL 电路的本振信号混频，从而产生第一个 49.95MHz 的中频。然后与第二个 50.4MHz 的本地振荡器输出信号混频，进而产生第二个 450kHz 的中频。发射的信号频率由 PLL VCO 生成，并经 DSP 信号调制。最后，该信号频率经过放大并发送到天线。

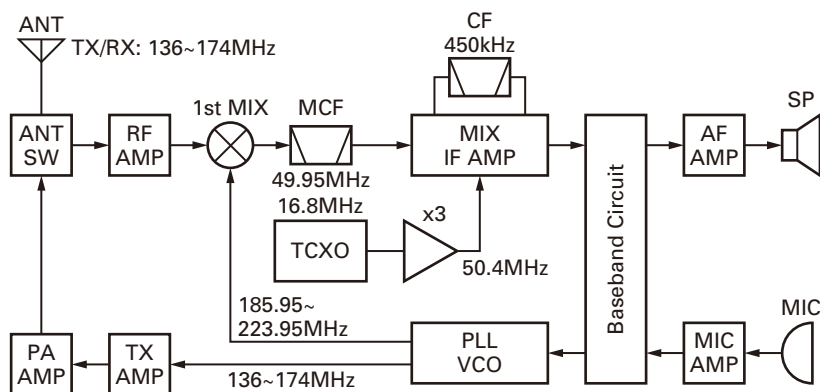

Fig. 1 Frequency configuration / 图 1 频率构成

3. Receiver System

3-1. RF circuit

An incoming RF signal from the antenna terminal is passed through the antenna switch (D102, D103, D105 and D106) and then the band-pass filter (L212, L213). The band-pass filter is adjusted by a variable capacitor. The input voltage to the variable capacitor is regulated by the voltage output from the D/A converter (IC4). The signal is amplified by an RF amplifier (Q202), and passed through the band-pass filter (L207, L208 and L211). The resulting signal is applied to the first mixer (Q201), where it is mixed with the first local oscillator signal output from the frequency synthesizer to produce the first IF (49.95MHz).

3-2. IF circuit

The first IF signal is passed through a four-pole monolithic crystal filter (XF1) to reject adjacent channel signals. The filtered first IF signal is amplified by the first IF amplifier (Q303) and then applied to the IF system IC (IC302). The IF system IC provides a second mixer, AGC amplifier, and RSSI (Received Signal Strength Indicator).

3. 接收部系统

3-1. RF 电路

天线端子接收到的 RF 输入信号依次通过天线开关 (D102、D103、D105 和 D106) 和带通滤波器 (L212、L213)。带通滤波器经由可变电容器调整。可变电容器的输入电压经由数模转换器 (IC4) 的输出电压进行调整。随后，信号被 RF 放大器 (Q202) 放大，然后通过带通滤波器 (L207、L208 和 L211)。最终的信号被运用到第一混频器 (Q201)。在该混频器中，信号与频率合成器输出的第一本地振荡器信号混频，从而产生第一中频 (49.95MHz)。

3-2. 中频电路

第一中频信号经过一个四极单片晶体滤波器 (XF1) 以消除临近信道的信号。滤波后的第一中频信号经过第一中频放大器 (Q303) 的放大后，加载到中频系统 IC (IC302) 上。中频系统 IC 提供一个第二混频器、AGC 放大器和 RSSI (接收信号强度指示器)。

CIRCUIT DESCRIPTION / 电路说明

The second mixer mixes the first IF signal with the 50.4MHz of the second local oscillator output and produces the second IF signal of 450kHz.

The second IF signal is passed through the ceramic filter (CF1) to reject the adjacent channel signal. The filtered second IF signal is amplified by the AGC amplifier.

The signal from the AGC amplifier is input to the ASIC (IC610) through the ceramic filter (CF2).

第二混频器混合第一中频信号及 50.4MHz 的第二本地振荡器输出，生成 450kHz 的第二中频信号。

第二中频信号通过陶瓷滤波器 (CF1) 以消除临近信道的信号。滤波后的信号由 AGC 放大器进行放大。

AGC 放大器的信号通过陶瓷滤波器 (CF2) 被输入 ASIC (IC610)。

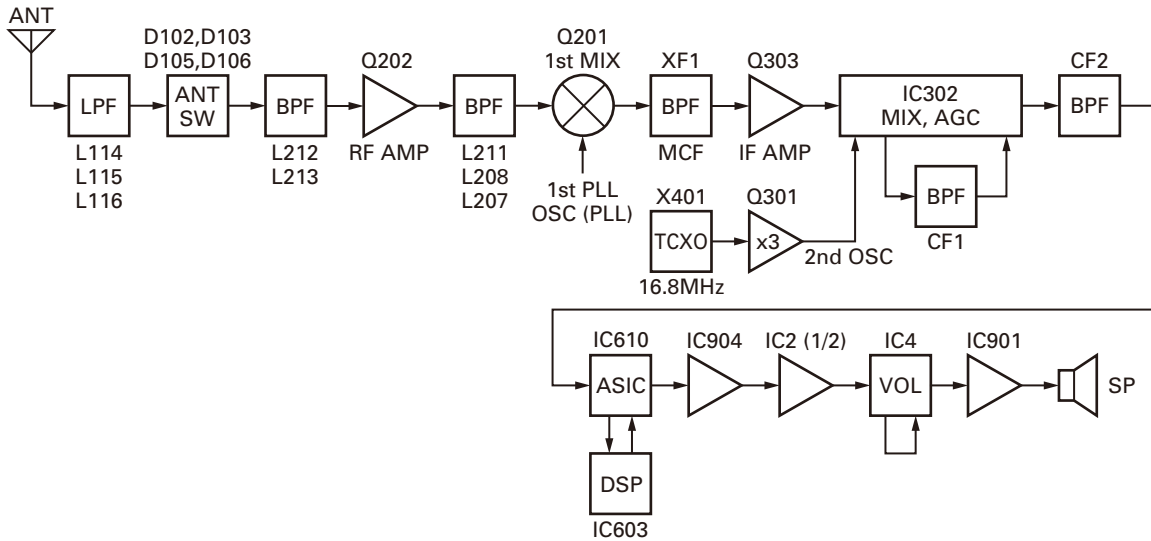

Fig. 2 RF and IF circuit / 图 2 RF 和 IF 电路

3-3. Audio amplifier circuit

Audio processing (high-pass filter, low-pass filter, deemphasized and so on) at FM mode and decoding at NXDN mode are processed by the DSP. The audio signal from IC610 and IC603 goes through the amplifier (IC904). The signal then goes through an electronic volume control (IC4), and AF amplifier (IC901).

While AFSW is High, the power supply of audio power amplifier (IC901) is activated, and the output to the speaker turns ON.

3-3. 音频放大器电路

FM 模式的音频处理 (高通滤波器、低通滤波器、去加重等) 和 NXDN 模式的解码由 DSP 进行处理。IC610 和 IC603 的音频信号通过放大器 (IC904)。然后信号通过电子音量控制器 (IC4) 和 AF 放大器 (IC901)。

当 AFSW 为高电平时，音频功率放大器 (IC901) 的电源被激活，扬声器的输出信号开启。

3-4. Squelch circuit

It amplifies the demodulated noise signal from IC610 after filtering through the LPF and HPF circuit. The amplified signal is then converted to a DC signal by the detection circuit. The converted signal is fed back to IC610.

3-4. 静噪电路

通过 LPF 和 HPF 电路滤波后，该电路放大 IC610 的已解调噪声信号。随后，放大的信号由检测电路转换为 DC 信号。转换的信号被反馈给 IC610。

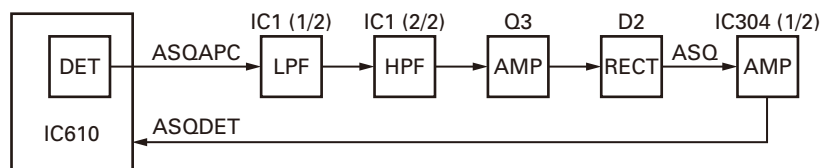

Fig. 3 Squelch circuit / 图 3 静噪电路

CIRCUIT DESCRIPTION / 电路说明

4. Transmitter System

4-1. Audio band circuit

The signal from the microphone is amplified by IC2 (2/2) and limited by the AGC circuit which is composed of D3, D4, Q4 and Q5. IC2 works as an anti-aliasing LPF filter.

4-2. Baseband circuit

The audio signal output from the baseband circuit is converted to digital data with a sampling frequency of 48kHz. This digital data is sent to the DSP (IC603), and voice signals of 300Hz or lower and frequencies of 3kHz or higher are cut off and the audio range of 300Hz to 3kHz is extracted. The audio signal is then pre-emphasized in FM mode and synthesized with the signals, such as QT and DQT, as required, and is then output from IC610. In Digital mode, the audio signal is converted to the 4-Level FSK baseband signal and output from IC610. The DTMF and MSK baseband signals are also generated by the DSP and output by IC610.

The LPF (IC6) works as a smoothing filter. The level output according to the transmit carrier is fine-adjusted according to each modulation method.

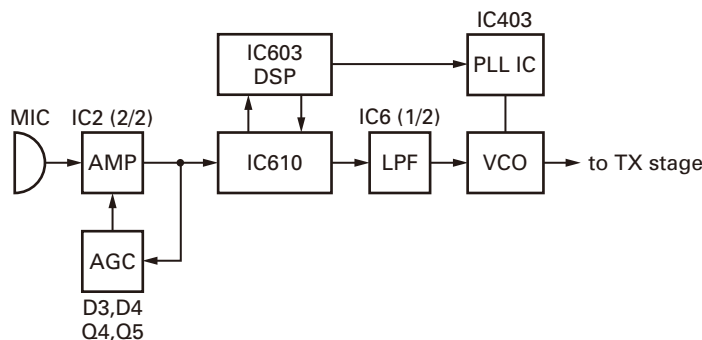

Fig. 4 Audio band and Baseband circuit / 图4 音频频带和基带电路

4-3. VOX

The DSP detects the audio level. If the detected level becomes higher than the threshold level, the VOX starts.

4-4. Drive and Final amplifier

The signal from the T/R switch (D413 is on) is amplified by the pre-drive amplifier (Q102) to 16~17dBm. It makes it possible to spoil input to the drive amplifier by controlling the power supply of the pre-drive amplifier with the PD switch (Q110). The output of the pre-drive amplifier is amplified by the drive and final amplifiers (Q103, Q104) to 5.0W (1.0W when the power is low). Q103 and Q104 are MOS FETs. The output of the final amplifier is then passed through the harmonic filter (LPF) and antenna switch (D102, D103 are on) and applied to the antenna terminal.

4-5. APC circuit

The APC circuit always monitors the current flowing through the RF power amplifier (Q104) and keeps a constant current. The voltage drop at R153, R154 and R155 is caused

4. 发射部系统

4-1. 音频频带电路

麦克风信号被 IC2 (2/2) 放大并被 D3、D4、Q4 和 Q5 组成的 AGC 电路所限制。IC2 用作抗混叠 LPF 滤波器。

4-2. 基带电路

从基带电路输出的音频信号被转换为取样频率为 48kHz 的数字数据。该数字数据被发送给 DSP (IC603)，300Hz 或更低的语音信号以及 3kHz 或更高的频率被截止，并选取 300Hz 至 3kHz 的音频范围。然后，音频信号以 FM 模式预加重，并与所需的 QT 和 DQT 等信号合成，然后从 IC610 输出。在数字模式下，音频信号被转换为 4 级 FSK 基带信号并从 IC610 输出。DTMF 和 MSK 基带信号也由 DSP 生成并由 IC610 输出。

LPF (IC6) 用作平滑滤波器。根据各自的调制方式对按照发射载波输出的电平进行微调。

4-3. VOX (声控发射)

DSP 检测音频电平。如果检测到的电平变得高于阈值电平，VOX 启动。

4-4. 驱动器和末级放大器

T/R 开关 (D413 开启) 的信号由预驱动放大器 (Q102) 放大到 16~17dBm。这有可能通过使用 PD 开关 (Q110) 控制预驱动放大器的电源而损坏输入到驱动放大器的信号。预驱动放大器的输出信号由驱动器和末级放大器 (Q103、Q104) 放大到 5.0W (当功率低为 1.0W 时)。Q103 和 Q104 为 MOS FET。末级放大器的输出信号随即通过谐波滤波器 (LPF) 及天线开关 (D102、D103 开启)，然后加载到天线端子上。

4-5. APC 电路

APC 电路随时监测通过 RF 功率放大器 (Q104) 的电流，并保持恒定电流。R153、R154 及 R155 的压降是由通过 RF 功率放大器的电流所形成的，并将此电压加载到差分放大器 (IC101

CIRCUIT DESCRIPTION / 电路说明

by the current flowing through the RF power amplifier and this voltage is applied to the differential amplifier (IC101 1/2). IC101 (2/2) compares the output voltage of IC101 (1/2) with the reference voltage from IC610, and the output of IC101 (2/2) controls the VGG of Q103 and Q104 to make the both current constant. The change of power high/low is carried out by the change of the reference voltage. Q106, Q107 and Q108 are turned on and Q105 and Q109 are turned off during transmission and the APC circuit is active.

1/2) 上。IC101 (2/2) 将 IC101 (1/2) 的输出电压与 IC610 的基准电压进行比较, 同时 IC101 (2/2) 的输出信号对 Q103 和 Q104 的 VGG 进行控制, 使两者的电流保持恒定。功率高/低的变化通过基准电压的变化来执行。在发射时 Q106、Q107 及 Q108 开启, Q105 和 Q109 关闭, 同时 APC 电路激活。

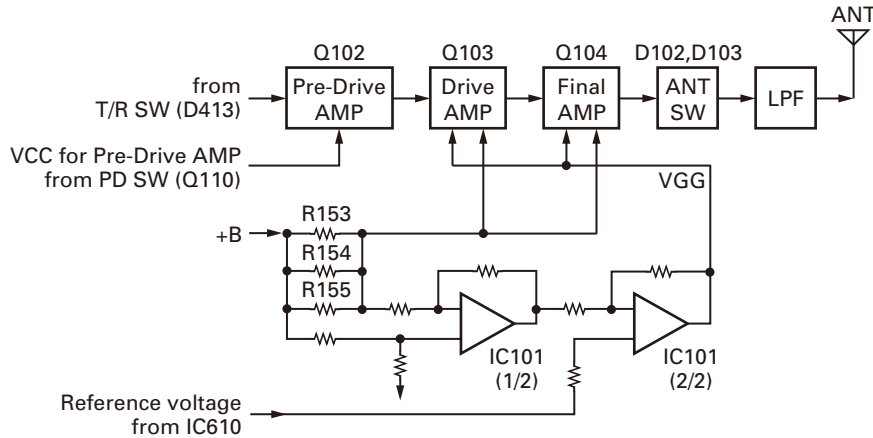

Fig. 5 Drive and final amplifier and APC circuit / 图 5 驱动器和末级放大器 and APC 电路

5. PLL Frequency Synthesizer

5-1. TCXO (X401)

The TCXO (X401) generates a reference frequency of 16.8MHz for the PLL frequency synthesizer. This reference frequency is applied to pin 9 of the PLL IC (IC403) and is connected to the IF circuit as a 2nd local signal through the Tripler (Q301).

The frequency adjustment is achieved by switching the ratio of dividing frequency. The resolution of the adjusting frequency is approximately 4Hz.

5-2. VCO

There is a RX VCO and a TX VCO.

The TX VCO (Q402) generates a transmit carrier and the RX VCO (Q401) generates a 1st local signal. For the VCO oscillation frequency, the transmit carrier is 136 to 174MHz and the 1st local receive signal is 185.95 to 223.95MHz.

The VCO oscillation frequency is determined by one system of operation switching terminal "T/R" and two systems of voltage control terminals "CV" and "ASSIST".

The operation switching terminal, "T/R", is controlled by the control line (/T_R) output from the ASIC (IC610). When the /T_R logic is low, the VCO outputs the transmit carrier and when it is high, it outputs a 1st local receive signal.

The voltage control terminals, "CV" and "ASSIST", are controlled by the PLL IC (IC403) and ASIC (IC610) and the output frequency changes continuously according to the applied voltage. For the modulation input terminal, "VCO_MOD", the output frequency changes according to the applied voltage. This is used to modulate the VCO output. "VCO_MOD" works only when "/T_R" is low.

5. PLL 频率合成器

5-1. TCXO (X401)

TCXO (X401) 生成 16.8MHz PLL 频率合成器的基准频率。该基准频率作为第 2 本振信号通过三倍频器 (Q301), 被加载到 PLL IC (IC403) 的第 9 脚并送至 IF 电路。

通过切换分频比进行频率调整。调整频率的分辨率约为 4Hz。

5-2. VCO

设有一个 RX VCO 和一个 TX VCO。

TX VCO (Q402) 生成发射载波, RX VCO (Q401) 生成第 1 本振信号。对于 VCO 振荡频率, 发射载波为 136 至 174MHz, 第 1 本振接收信号为 185.95 至 223.95MHz。

VCO 振荡频率由一个操作切换端子 "T/R" 系统和两个电压控制端子 "CV" 和 "ASSIST" 系统确定。

操作切换端子 "T/R" 由 ASIC (IC610) 控制线路 (/T_R) 的输出信号进行控制。/T_R 逻辑低时, VCO 输出发射载波; 高时, 输出第 1 本振接收信号。

电压控制端子 "CV" 和 "ASSIST" 由 PLL IC (IC403) 和 ASIC (IC610) 控制, 输出频率根据加载的电压持续改变。对于调制输入端子 "VCO_MOD", 输出频率根据加载的电压改变。籍此调制 VCO 输出。"VCO_MOD" 仅在 "/T_R" 低时工作。

CIRCUIT DESCRIPTION / 电路说明

5-3. PLL IC (IC403)

The PLL IC compares the differences in phases of the VCO oscillation frequency and the TCXO reference frequency, returns the difference to the VCO CV terminal and realizes the “Phase Locked Loop” for the return control. This allows the VCO oscillation frequency to accurately match (lock) the desired frequency.

When the frequency is controlled by the PLL, the frequency convergence time increases as the frequency difference increases when the set frequency is changed. To supplement this, the ASIC is used before control by the PLL IC to bring the VCO oscillation frequency close to the desired frequency. As a result, the VCO CV voltage does not change and is always stable at approximately 2.5V.

The desired frequency is set for the PLL IC by the ASIC (IC610) through the 3-line “SDO1”, “PCK_RF”, “/PCS_RF” serial bus. Whether the PLL IC is locked or not is monitored by the ASIC through the “PLD” signal line. If the VCO is not the desired frequency (unlocked), the “PLD” logic is low.

The modulation signal of the Low-speed data is applied to pin 23 of the PLL IC (IC403).

The modulation signal is digital data of a sampling frequency of 96kHz set for the PLL IC by the DSP (IC603) through the “PLLMOD” line.

5-4. Local switch (D412, D413)

The connection destination of the signal output from the buffer amplifier (Q408) is changed with the diode switch (D413) that is controlled by the transmission power supply, 50T, and the diode switch (D412) that is controlled by the receive power supply, 50R. If the 50T logic is high, it is connected to a send-side pre-drive (Q102). If the 50T logic is low, it is connected to a receive-side mixer (Q201).

5-3. PLL IC (IC403)

PLL IC 对比 VCO 振荡频率和 TCXO 基准频率的相位差，将相位差返回至 VCO CV 端子，从而实现反馈控制的“锁相环路”。这样可以使 VCO 振荡频率与所需的频率精确匹配（锁定）。

频率由 PLL 控制时，频率锁定时间将随着设定频率改变时频率差的增大而增加。为对此进行补充，在由 PLL IC 控制之前使用 ASIC 以使 VCO 振荡频率接近所需的频率。因此，VCO CV 的电压不变，始终稳定在约 2.5V。

PLL IC 的所需频率由 ASIC (IC610) 通过 3 线“SDO1”、“PCK_RF”、“/PCS_RF” 串行总线进行设置。PLL IC 是否锁定由 ASIC 通过“PLD”信号线路进行监测。如果 VCO 不是所需的频率（失锁），则“PLD”逻辑变低。

低速数据调制信号被加载到 PLL IC (IC403) 的第 23 脚。

调制信号是 DSP (IC603) 通过“PLLMOD”线路为 PLL IC 设置的 96kHz 采样频率的数字数据。

5-4. 本振开关 (D412, D413)

缓冲放大器 (Q408) 输出信号的连接目标由发射电源 50T 控制的二极管开关 (D413) 和接收电源 50R 控制的二极管开关 (D412) 进行切换。如果 50T 逻辑为高，则被连接到发送侧预驱动 (Q102)。如果 50T 逻辑为低，则被连接到接收侧混频器 (Q201)。

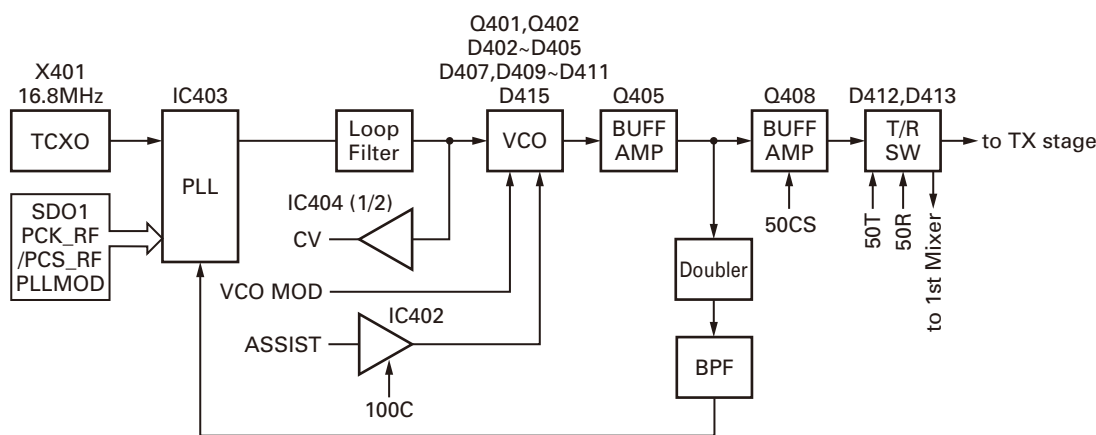

Fig. 6 PLL block diagram / 图 6 PLL 结构图

6. Control Circuit

The control circuit consists of the ASIC (IC610) and its peripheral circuits. IC610 mainly performs the following:

- 1) Switching between transmission and reception by PTT signal input.
- 2) Reading system, zone, frequency, and program data from the memory circuit.

6. 控制电路

控制电路由 ASIC (IC610) 和外围电路组成。IC610 主要执行以下功能：

- 1) 由输入的 PTT 信号切换发射和接收。
- 2) 从存储电路读取系统、区域、频率和编程数据。

CIRCUIT DESCRIPTION / 电路说明

- 3) Sending frequency program data to the PLL.
- 4) Controlling squelch on/off by the DC voltage from the squelch circuit.
- 5) Controlling the audio mute circuit by decode data input.

6-1. ASIC

The ASIC (IC610) is a 32-bit RISC processor, equipped with peripheral function and ADC/DAC.

This ASIC operates at 18.432MHz clock and 3.3V/1.5V DC. It controls the flash memory, SRAM, DSP, the receive circuit, the transmitter circuit, the control circuit, and the display circuit and transfers data to or from an external device.

6-2. Memory circuit

The memory circuit consists of the ASIC (IC610), the SRAM (IC605), and the flash memory (IC601). The flash memory has a capacity of 32M-bit that contains the transceiver control program for the ASIC and stores the data. It also stores the data for transceiver channels and operating parameters that are written by the FPU. This program can be easily written from external devices. The SRAM has a capacity of 1M-bit that contains work area and data area.

■ Flash memory

Note: The flash memory stores the data that is written by the FPU (KPG-141D(C)), tuning data (Deviation, Squelch, etc.), and firmware program (User mode, Test mode, Tuning mode, etc.).

■ SRAM (Static memory)

Note: The SRAM has a temporary data area and work area.

6-3. LCD

The LCD is controlled using the 4 serial lines (SDIO, /LCDCS, SCK0, SDO0) from the ASIC (IC610).

6-4. Key detection circuit

Keys are detected using the LCD controller driver IC (IC8). If a pressed key is detected by IC8, it is informed to IC610 through the serial line.

6-5. Low battery warning

The battery voltage is divided using R514 and R515 and is detected by the ASIC (IC610). When the battery voltage falls below the voltage set by the Low battery warning adjustment, the red LED blinks to notify the operator that it is time to replace the battery. If the battery voltage falls even more (approx. 5.8V), a beep sounds and transmission stops.

Low battery warning	Battery condition
The red LED blinks during transmission.	The battery voltage is low but the transceiver is still usable.
The red LED blinks and the warning tone beeps while the PTT switch is pressed.	The battery voltage is low and the transceiver is not usable to make calls.

6-6. DSP

The DSP circuit consists of a DSP (IC603) and processes the baseband signal. The DSP operates on an external clock

- 3) 将频率数据发送到 PLL。
- 4) 由静噪电路的 DC 电压控制静噪的开 / 关。
- 5) 由输入的解码数据控制音频静音电路。

6-1. ASIC

ASIC (IC610) 是 32 位 RISC 处理器，具备外围功能和 ADC/DAC。

该 ASIC 以 18.432MHz 时钟和 3.3V/1.5V DC 运行。用以控制闪存、SRAM、DSP、接收电路、发射电路、控制电路以及显示电路，并与外部设备双向传输数据。

6-2. 存储电路

存储电路由 ASIC (IC610)、SRAM (IC605) 和闪存 (IC601) 组成。闪存具有 32M 位的容量，包含 ASIC 的手持对讲机控制程序并储存数据。同时还保存手持对讲机信道的数据及 FPU 写入的运行参数。可以轻松通过外部设备写入此程序。SRAM 具有 1M 位的容量，包含工作区和数据区。

■ 闪存

注意：闪存可储存 FPU (KPG-141D(C)) 写入的数据、调谐数据（频偏、静噪等）以及固件程序（用户模式、测试模式、调谐模式等）。

■ SRAM (静态存储器)

注意：SRAM 设有临时数据区和工作区。

6-3. LCD

LCD 通过 ASIC (IC610) 的 4 条串行控制线 (SDIO、/LCDCS、SCK0、SD00) 进行控制。

6-4. 按键检测电路

使用 LCD 控制器驱动 IC (IC8) 检测按键。如果 IC8 检测到已有按键按下，则会通过串行线路通知 IC610。

6-5. 低电池电量警告

电池电压用 R514 和 R515 进行分压，并由 ASIC (IC610) 进行检测。当电池电压下降到低电池电量警告调整设定的电压以下时，红色 LED 闪烁，通知操作者及时更换电池。如果电池电压进一步下降（约 5.8V），则会响起提示音，并将停止发射。

低电池电量警告	电池状态
发射期间红色 LED 闪烁。	电池电压低，但手持对讲机仍可使用。
按下 PTT 开关时，红色 LED 闪烁并响起警告音。	电池电压低，不能使用手持对讲机进行呼叫。

6-6. DSP

DSP 电路由 DSP (IC603) 组成，用以处理基带信号。DSP 在 18.432MHz 的外部时钟上运行（与 IC610 相同），I/O 部分以

CIRCUIT DESCRIPTION / 电路说明

of 18.432MHz (the same as the IC610), the I/O section operates at 3.3V and the core section operates at 1.5V. The DSP carries out the following processes:

- 4 Level FSK processing
- Analog FM pre-emphasis/de-emphasis
- Vocoder processing between audio codec and modulation/demodulation
- CAI processing, such as error correction encoding
- QT/DQT encoding/decoding
- LTR encoding/decoding
- DTMF encoding/decoding
- MSK encoding/decoding
- 2-tone encoding/decoding
- Compressor/expander processing
- Voice scrambler processing
- Transmit/receive audio filtering processing
- Microphone amplifier AGC processing
- Audio mute processing
- Modulation level processing

7. Power Supply Circuit

The battery voltage (+B) is provided from the battery terminal on the TX-RX unit (X57). The battery voltage passes through the 2.5A fuse (F1), and goes to the RF final amplifier, AVR ICs (IC504, IC902), DC/DC converter (IC506), and voltage detector IC (IC507). The voltage detector watches the battery voltage. If the battery voltage is 5.6V or higher, the detector outputs High.

When the VOL SW is turned on, SB1 becomes high (battery voltage). DC/DC (IC506) operates if both SB1 and the output of the detector are high. IC506 outputs 3.8V and activates IC502 (33M), IC503 (15M), IC501 (33A) and IC505 (33C). As a result, the ASIC and DSP operate.

The SBC signal becomes High after the ASIC operates, IC504 (50C), IC902 (50V) and Q501 (SB2) are turned on.

When the /SAVE signal becomes High, Q512 (50C) operates. Switches (Q503, Q505) are controlled by the ASIC. Q505 (50T) is turned on in transmit mode. Q503 (50R) is turned on in receive mode.

When the VOL SW is turned off, the /PSW signal becomes Low. After detecting the /PSW signal, the ASIC changes the SBC signal to Low.

50C is fed to IC509 (100C). IC509, D511 and D512 consist of a voltage doubler. C543 is charged to 5V by 50C and switched to C545 by the "DDCLK" control signal. The 100C circuit then outputs approximately +10VDC.

8. Signaling Circuit

8-1. Encode (QT/DQT/LTR/DTMF/2-tone/MSK)

Each signaling data signal of QT, DQT, LTR, DTMF, 2-tone and MSK is generated by the DSP circuit, superimposed on a modulation signal and output from IC610. Each deviation of the TX QT, DQT, LTR, DTMF, 2-tone and MSK tone is adjusted by changing the output level of IC603 and the resulting signal is routed to the VCO and PLL.

8-2. Decode (QT/DQT/LTR/DTMF/2-tone/MSK)

The audio signal is removed from the FM detection signal sent to the DSP circuit and the resulting signal is decoded.

3. 3V 运行，核心部分以 1.5V 运行。DSP 进行以下处理：

- 4 级 FSK 处理
- 模拟 FM 预加重 / 去加重
- 音频编解码器和调制 / 解调之间的声码器处理
- CAI 处理，例如纠错编码
- QT/DQT 编码 / 解码
- LTR 编码 / 解码
- DTMF 编码 / 解码
- MSK 编码 / 解码
- 2 音编码 / 解码
- 压缩器 / 扩展器处理
- 语音扰频器处理
- 发射 / 接收音频滤波处理
- 麦克风放大器 AGC 处理
- 音频静音处理
- 调制电平处理

7. 电源电路

电池电压 (+B) 从收发单元 (X57) 上的电池端子提供。电池电压通过 2.5A 保险丝 (F1)，进入 RF 末级放大器、AVR IC (IC504、IC902)、DC/DC 转换器 (IC506) 和电压检测 IC (IC507)。电压检测器监测电池电压。如果电池电压为 5.6V 或更高，则检测器输出高。

VOL SW 打开时，SB1 变高 (电池电压)。如果 SB1 和检测器的输出都为高，DC/DC (IC506) 将会运行。IC506 输出 3.8V 电压并激活 IC502 (33M)、IC503 (15M)、IC501 (33A) 和 IC505 (33C)。从而使 ASIC 和 DSP 运行。

在 ASIC 运行，IC504 (50C)、IC902 (50V) 和 Q501 (SB2) 开启后，SBC 信号变高。

当 /SAVE 信号变高时，Q512 (50C) 运行。开关 (Q503、Q505) 由 CPU 控制。在发射模式中开启 Q505 (50T)。在接收模式中开启 Q503 (50R)。

VOL SW 关闭时，/PSW 信号变低。检测 /PSW 信号之后，ASIC 将 SBC 信号改为低。

50C 馈送至 IC509 (100C)。IC509、D511 和 D512 组成电压倍增器。C543 由 50C 充电至 5V，并由 "DDCLK" 控制信号切换为 C545。100C 电路随即输出约 +10VDC。

8. 信令电路

8-1. 编码 (QT/DQT/LTR/DTMF/2 音 /MSK)

DSP 电路生成 QT、DQT、LTR、DTMF、2 音和 MSK 的各信令信号，这些信号被叠加到调制信号上并从 IC610 输出。TX QT、DQT、LTR、DTMF、2 音和 MSK 音各自的频偏通过改变 IC603 的输出电平进行调整，产生的信号被送至 VCO 和 PLL。

8-2. 解码 (QT/DQT/LTR/DTMF/2 音 /MSK)

音频信号从发送到 DSP 电路的 FM 检测信号中提取，产生的信号被解码。

CIRCUIT DESCRIPTION / 电路说明

9. Componder Circuit

The term “componder” means compressor and expander. The compander reduces noise by utilizing a compressor and an expander. The transceiver contains a DSP (IC603) to perform this operation. The transceiver compander can be turned on or off using the FPU.

9. 压扩器电路

“componder”一词表示压缩器和扩展器。压扩器利用压缩器和扩展器减低噪音。手持对讲机包含 DSP (IC603)，用以执行此操作。可用 FPU 开启或关闭手持对讲机的压扩器。

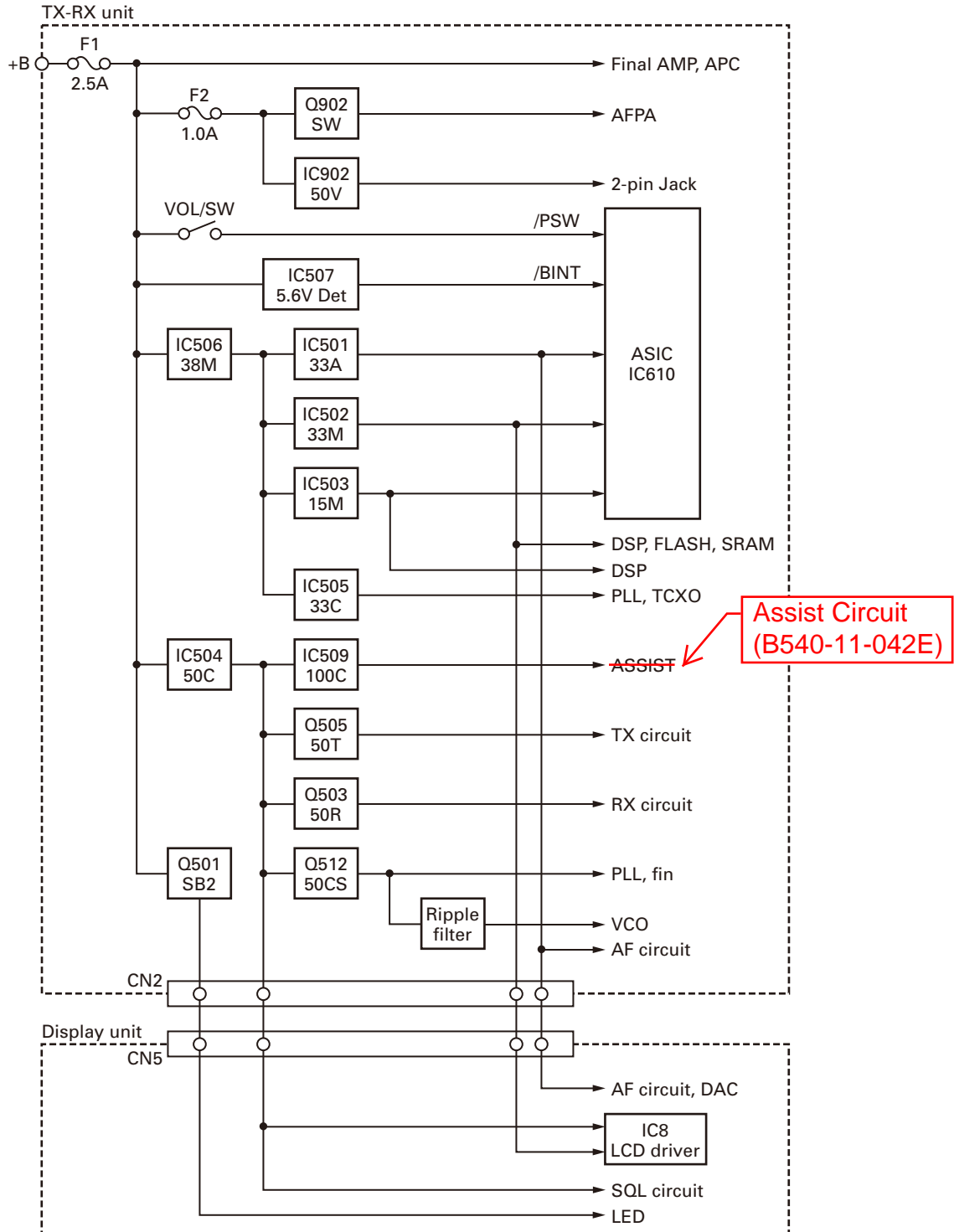

Fig. 7 Power supply circuit / 图 7 电源电路

COMPONENTS DESCRIPTION / 元件说明

Display unit (X54-3760-XX)

Ref. No.	Part Name	Description
IC1	IC	ASQ BPF
IC2	IC	AF LPF/MIC amplifier
IC4	IC	D/A converter
IC6	IC	VCO MOD/VREF
IC8	IC	LCD driver
Q1	Transistor	TX/BUSY LED switch
Q2	FET	SQL noise BW switch
Q3	Transistor	SQL noise amplifier
Q4,5	Transistor	MIC AGC
Q6	Transistor	KEY backlight switch
Q7	Transistor	KEY backlight switch control
Q8	Transistor	LCD backlight switch
D1	LED	TX/BUSY LED
D2	Diode	Noise detector
D3,4	Diode	AGC detector
D7~14	LED	KEY backlight
D15,16	Diode	KEY control
D18,19	LED	LCD backlight

显示单元 (X54-3760-XX)

有关号码	零件名称	说明
IC1	IC	ASQ BPF
IC2	IC	AF LPF/ 麦克风放大器
IC4	IC	D/A 转换器
IC6	IC	VCO 调制 /VREF
IC8	IC	LCD 驱动
Q1	晶体管	LED 开关 (TX/BUSY)
Q2	场效应管	静噪噪声 BW 开关
Q3	晶体管	静噪噪声放大器
Q4, 5	晶体管	麦克风 AGC
Q6	晶体管	键背光开关
Q7	晶体管	键背光开关控制
Q8	晶体管	LCD 背光开关
D1	LED	TX/BUSY LED
D2	二极管	噪声检测
D3, 4	二极管	AGC 检测
D7~14	LED	键背光
D15, 16	二极管	键控制
D18, 19	LED	LCD 背光

TX-RX unit (X57-8040-10)

Ref. No.	Part Name	Description
IC101	IC	OP AMP (APC)
IC201	IC	DC amplifier (BPF)
IC302	IC	FM system
IC304	IC	DC amplifier (RSSI/ASQL)
IC402	IC	DC amplifier (Assist)
IC403	IC	PLL system
IC404	IC	DC amplifier (CV/APC)
IC501	IC	Voltage regulator (33A)
IC502	IC	Voltage regulator (33M)
IC503	IC	DC/DC converter (15M)
IC504	IC	Voltage regulator (50C)
IC505	IC	Voltage regulator (33C)
IC506	IC	DC/DC converter (38M)
IC507	IC	Voltage detector (BATT)
IC509	IC	DC/DC converter (100C)
IC601	IC	Flash memory
IC603	IC	DSP
IC605	IC	SRAM
IC607	IC	Voltage detector (Reset)
IC609	IC	Buffer (Clock)
IC610	IC	ASIC
IC611,612	IC	AND gate (2 input)
IC613	IC	Acceleration sensor

收发单元 (X57-8040-10)

有关号码	零件名称	说明
IC101	IC	OP 放大器 (APC)
IC201	IC	直流放大器 (BPF)
IC302	IC	FM 系统
IC304	IC	直流放大器 (RSSI/ASQL)
IC402	IC	直流放大器 (辅助)
IC403	IC	PLL 系统
IC404	IC	直流放大器 (CV/APC)
IC501	IC	稳压器 (33A)
IC502	IC	稳压器 (33M)
IC503	IC	DC/DC 转换器 (15M)
IC504	IC	稳压器 (50C)
IC505	IC	稳压器 (33C)
IC506	IC	DC/DC 转换器 (38M)
IC507	IC	电压检测器 (BATT)
IC509	IC	DC/DC 转换器 (100C)
IC601	IC	闪存
IC603	IC	DSP
IC605	IC	SRAM
IC607	IC	电压检测器 (复位)
IC609	IC	缓冲器 (时钟)
IC610	IC	ASIC
IC611, 612	IC	AND 栅 (2 输入)
IC613	IC	加速度传感器

COMPONENTS DESCRIPTION / 元件说明

Ref. No.	Part Name	Description
IC901	IC	AF power amplifier
IC902	IC	Voltage regulator (50V)
IC904	IC	OP AMP (BEEP/VOICE/RX AF)
Q102	Transistor	Pre-drive amplifier
Q103	FET	Drive amplifier
Q104	FET	RF final amplifier
Q105~109	Transistor	APC switch
Q110	FET	PD switch
Q201	FET	1st mixer
Q202	FET	RF AMP (RX)
Q301	Transistor	Tripler (2nd local)
Q303	Transistor	IF amplifier
Q401	FET	RX VCO
Q402	FET	TX VCO
Q403	Transistor	Ripple filter
Q404	Transistor	Doubler (PLL in)
Q405	Transistor	Buffer amplifier
Q406,407	FET	T/R VCO switch
Q408	Transistor	Buffer amplifier
Q501	FET	DC switch (SB2)
Q502	FET	DC switch control (SB2)
Q503	Transistor	DC switch (50R)
Q505	Transistor	DC switch (50T)
Q506,507	FET	Level converter
Q509	Transistor	DC/DC control (100C)
Q510	Transistor	DC/DC control (38M)
Q511	Transistor	DC switch control (50T)
Q512	FET	DC switch (50CS)
Q602	FET	DC switch (System)
Q901	Transistor	DC switch (AF mute)
Q902	Transistor	DC switch (AF PA amplifier)
Q903	Transistor	DC switch (AF mute)
Q904,905	FET	AF power mute
Q906	Transistor	EXT/MIC switch
Q907	FET	Level converter
D101	Zener diode	APC protect
D102,103	Diode	Antenna switch
D105,106	Diode	Antenna switch
D202~204	Variable capacitance diode	BPF tune
D206	Variable capacitance diode	BPF tune
D401	Diode	Bypass
D402	Variable capacitance diode	Assist tune
D403	Variable capacitance diode	TX VCO tune

有关号码	零件名称	说明
IC901	IC	AF 功率放大器
IC902	IC	稳压器 (50V)
IC904	IC	OP 放大器 (BEEP/VOICE/RX AF)
Q102	晶体管	预驱动放大器
Q103	场效应管	驱动放大器
Q104	场效应管	末级放大器
Q105~109	晶体管	APC 开关
Q110	场效应管	PD 开关
Q201	场效应管	第一混频器
Q202	场效应管	射频放大器
Q301	晶体管	三倍频器 (第二本振)
Q303	晶体管	IF 放大器
Q401	场效应管	RX VCO 振荡器
Q402	场效应管	TX VCO 振荡器
Q403	晶体管	纹波滤波器
Q404	晶体管	倍频器 (PLL IN)
Q405	晶体管	射频缓冲放大器
Q406, 407	场效应管	收发 VCO 直流开关
Q408	晶体管	射频缓冲放大器
Q501	场效应管	直流开关 (SB2)
Q502	场效应管	直流开关控制 (SB2)
Q503	晶体管	直流开关 (50R)
Q505	晶体管	直流开关 (50T)
Q506, 507	场效应管	电平转换器
Q509	晶体管	DC/DC 转换器控制 (100C)
Q510	晶体管	DC/DC 转换器控制 (38M)
Q511	晶体管	直流开关控制 (50T)
Q512	场效应管	直流开关 (50CS)
Q602	场效应管	直流开关 (系统)
Q901	晶体管	直流开关 (AF 静音)
Q902	晶体管	AF 放大器开关
Q903	晶体管	直流开关 (AF 静音)
Q904, 905	场效应管	AF 放大器静音开关
Q906	晶体管	外部麦克风开关
Q907	场效应管	电平转换器
D101	稳压二极管	过电压保护
D102, 103	二极管	天线开关
D105, 106	二极管	天线开关
D202~204	可变电容二极管	RX BPF 调谐
D206	可变电容二极管	RX BPF 调谐
D401	二极管	侧路
D402	可变电容二极管	VCO 辅助调谐
D403	可变电容二极管	频率调谐 /TX VCO

COMPONENTS DESCRIPTION / 元件说明

Ref. No.	Part Name	Description
D404	Variable capacitance diode	RX VCO tune
D405	Variable capacitance diode	Assist tune
D407	Variable capacitance diode	Assist tune
D409	Variable capacitance diode	Assist tune
D410	Variable capacitance diode	TX modulation
D411	Variable capacitance diode	Assist tune
D412,413	Diode	T/R switch
D414	Diode	Speed up
D415	Variable capacitance diode	Assist tune
D416,417	Variable capacitance diode	Fin filter tune
D501	Diode	Reverse protection
D502	Diode	Speed up
D505,506	Diode	DC/DC converter
D508	Diode	DC/DC converter
D509	Diode	Reverse current protection
D511,512	Diode	DC/DC converter
D901	Diode	Reverse current protection
D902	Diode	50V switch control

有关号码	零件名称	说明
D404	可变电容二极管	频率调谐 /RX VCO
D405	可变电容二极管	VCO 辅助调谐
D407	可变电容二极管	VCO 辅助调谐
D409	可变电容二极管	VCO 辅助调谐
D410	可变电容二极管	调制器
D411	可变电容二极管	VCO 辅助调谐
D412, 413	二极管	收发开关
D414	二极管	加速
D415	可变电容二极管	VCO 辅助调谐
D416, 417	可变电容二极管	FIN 滤波器调谐
D501	二极管	逆向保护
D502	二极管	加速
D505, 506	二极管	DC/DC 转换器
D508	二极管	DC/DC 转换器
D509	二极管	逆向电流保护
D511, 512	二极管	DC/DC 转换器
D901	二极管	逆向电流保护
D902	二极管	50V 开关控制

TERMINAL FUNCTION / 端子功能

Display unit (X54-3760-XX A/3)

Pin No.	Name	I/O	Function
CN5			
1	33M	I	33M input
2	SCK0	I	Clock input
3	SDI0	I	Serial data input
4	SDO0	O	Serial data output
5	DISP_VER	O	Display version detection
6	/EVCS	I	Chip enable
7	/LCDCS	I	LCD IC chip enable
8	GND	-	Ground
9	RXAF_2	I	RX AF input with BEEP and VOICE
10	ASQ	O	Analog squelch voltage output
11	ASQAPC	I	Analog squelch signal input
12	VOX	O	VOX voltage output
13	MIC	O	MIC modulation output
14	50C	I	50C input
15	MOD	I	AF modulation input
16	GND	-	Ground
17	VCO_MOD	O	VCO modulation output
18	33A	I	33A input
19	TV2	O	Tuning control voltage 2 output
20	TV1	O	Tuning control voltage 1 output
21	SPAF	O	AF output for AF amplifier
22	GND	-	Ground
23	MICI	I	MIC modulation input
24	SB2	I	SB2 input

显示单元 (X54-3760-XX A/3)

管脚号码	名称	输入/输出	功能
CN5			
1	33M	输入	33M 输入
2	SCK0	输入	时钟输入
3	SDI0	输入	串行数据输入
4	SDO0	输出	串行数据输出
5	DISP_VER	输出	检测显示器版本
6	/EVCS	输入	芯片启用
7	/LCDCS	输入	LCD IC 芯片启用
8	GND	-	接地
9	RXAF_2	输入	带有 BEEP 和 VOICE 的 RX 音频输入
10	ASQ	输出	模拟静噪电压输出
11	ASQAPC	输入	模拟静噪信号输入
12	VOX	输出	VOX (声控发射) 电压输出
13	MIC	输出	麦克风调制输出
14	50C	输入	50C 输入
15	MOD	输入	音频调制输出
16	GND	-	接地
17	VCO_MOD	输出	VCO 调制输出
18	33A	输入	33A 输入
19	TV2	输出	调谐控制电压 2 输出
20	TV1	输出	调谐控制电压 1 输出
21	SPAF	输出	音频放大器用的音频输出
22	GND	-	接地
23	MICI	输入	麦克风调制输入
24	SB2	输入	SB2 输入

Display unit (X54-3760-XX B/3)

Pin No.	Name	I/O	Function
CN6			
1	GND	-	Ground
2	PTT	O	Internal PTT output
3	/S1	O	Key output (Side1 key)
4	/S2	O	Key output (Side2 key)
5	/EMG	O	Key output (AUX key)
6	GND	-	Ground

显示单元 (X54-3760-XX B/3)

管脚号码	名称	输入/输出	功能
CN6			
1	GND	-	接地
2	PTT	输出	内置 PTT 输出
3	/S1	输出	键输出 (侧面 1 键)
4	/S2	输出	键输出 (侧面 2 键)
5	/EMG	输出	键输出 (辅助键)
6	GND	-	接地

TX-RX unit (X57-8040-10)

Pin No.	Name	I/O	Function
CN1			
1	+B	O	Power output after passing through the fuse
2	SB1	I	Power input after power switch
3	NC	-	No connection
4	33A	O	33A output

收发单元 (X57-8040-10)

管脚号码	名称	输入/输出	功能
CN1			
1	+B	输出	通过保险丝后的电源输出
2	SB1	输入	电源开关后的电源输入
3	NC	-	未连接
4	33A	输出	33A 输出

TERMINAL FUNCTION / 端子功能

Pin No.	Name	I/O	Function
5	VOL	I	Volume level input for audio control
6	VOL_GND	-	Ground for volume level
7	ENC3	I	Rotary switch input
8	GND	-	Ground
9	ENC4	I	Rotary switch input
10	ENC2	I	Rotary switch input
11	ENC1	I	Rotary switch input
CN2			
1	SB2	O	SB2 output
2	MICI	O	MIC modulation output
3	GND	-	Ground
4	SPAF	I	AF input for AF amplifier
5	TV1	I	Tuning control voltage 1 input
6	TV2	I	Tuning control voltage 2 input
7	33A	O	33A output
8	VCO_MOD	I	VCO modulation input
9	GND	-	Ground
10	MOD	O	AF modulation output
11	50C	O	50C output
12	MIC	I	MIC modulation input
13	VOX	I	VOX voltage input
14	ASQAPC	O	Analog squelch signal output
15	ASQ	I	Analog squelch voltage input
16	RXAF_2	O	RX AF output with BEEP and VOICE
17	GND	-	Ground
18	/LCDCS	O	LCD IC chip enable
19	/EVCS	O	Chip enable
20	DISP_VER	I	Display version detection
21	SDO0	O	Serial data output
22	SDI0	I	Serial data input
23	SCK0	O	Clock output
24	33M	O	33M output
CN3			
1	GND	-	Ground
2	PTT	I	Internal PTT input
3	/S1	I	Key input (Side1 key)
4	/S2	I	Key input (Side2 key)
5	/EMG	I	Key input (AUX key)
6	GND	-	Ground
CN4			
1	MIC+	I	Internal MIC input
2	MIC-	-	Internal MIC ground
3	SP+	O	Internal speaker output
4	SP-	-	Internal speaker ground

管脚号码	名称	输入/输出	功能
5	VOL	输入	用于音频控制的音量电平输入
6	VOL_GND	-	用于音量电平的接地
7	ENC3	输入	旋转开关输入
8	GND	-	接地
9	ENC4	输入	旋转开关输入
10	ENC2	输入	旋转开关输入
11	ENC1	输入	旋转开关输入
CN2			
1	SB2	输出	SB2 输出
2	MICI	输出	麦克风调制输出
3	GND	-	接地
4	SPAF	输入	音频放大器用的音频输入
5	TV1	输入	调谐控制电压 1 输入
6	TV2	输入	调谐控制电压 2 输入
7	33A	输出	33A 输出
8	VCO_MOD	输入	VCO 调制输入
9	GND	-	接地
10	MOD	输出	音频调制输出
11	50C	输出	50C 输出
12	MIC	输入	麦克风调制输入
13	VOX	输入	VOX (声控发射) 电压输入
14	ASQAPC	输出	模拟静噪信号输出
15	ASQ	输入	模拟静噪信号输入
16	RXAF_2	输出	带有 BEEP 和 VOICE 的 RX 音频输出
17	GND	-	接地
18	/LCDCS	输出	LCD IC 芯片启用
19	/EVCS	输出	芯片启用
20	DISP_VER	输入	检测显示器版本
21	SDO0	输出	串行数据输出
22	SDI0	输入	串行数据输入
23	SCK0	输出	时钟输出
24	33M	输出	33M 输出
CN3			
1	GND	-	接地
2	PTT	输入	内置 PTT 输入
3	/S1	输入	键输入 (侧面 1 键)
4	/S2	输入	键输入 (侧面 2 键)
5	/EMG	输入	键输入 (辅助键)
6	GND	-	接地
CN4			
1	MIC+	输入	内置麦克风输入
2	MIC -	-	内置麦克风接地
3	SP+	输出	内置扬声器输出
4	SP -	-	内置扬声器接地

TERMINAL FUNCTION / 端子功能

SP/MIC Connector Specification

Pin No.	Pin Name	I/O	Signal Type	Description	Item and Condition	Min	Typ	Max	Unit	Note
1	PTT/RXD	I	Digital	PTT/RXD input Zin=10kΩ	Input Voltage (High)	4	5	6	V	
					Input Voltage (Low)	0		0.5	V	
2	MICI	I	Analog	External MIC input Zin=1.8kΩ@1kHz	Maximum Input Voltage			1100	mVrms	
					Standard Input Voltage	6.7	12.5	18.3	mVrms	AF=1kHz 60% deviation MIC sens=Normal
3	MICO	O	Analog	Internal MIC output						
4	OPTDET	I	Digital	External option detection Zin=74kΩ						
5	50V	O	Power	DC 5V output	Output Voltage	4.9	5.0	5.1	V	Io=30mA
					Maximum Output Current			100	mA	
6	AE	-	GND	Ground	Maximum Input Current			700	mA	
7	TXD	O	Digital	TXD output Zout=6.8kΩ	Output Voltage (High)	4.9	5.0	5.1	V	Load=Open
					Output Voltage (Low)	0		0.1	V	Load=Open
8	SPI	I	Analog	Internal Speaker input						
9	SPO	O	Analog	Internal Audio output	Maximum Output Power			1300	mW	AF=0.3~3kHz FM Dev.=Maximum Load=8Ω P.S.=9.0V
					Standard Output Power		400		mW	AF=1kHz Load=8Ω THD=10% P.S.=7.5V

SP/MIC 连接器规格

管脚号码	名称	输入/输出	信号类型	说明	项目和条件	最小	标准	最大	单位	注意
1	PTT/RXD	输入	数字	PTT/RXD 输入 Zin=10kΩ	输入电压(高)	4	5	6	V	
					输入电压(低)	0		0.5	V	
2	MICI	输入	模拟	外部麦克风输入 Zin=1.8kΩ@1kHz	最大输入电压			1100	mVrms	
					标准输入电压	6.7	12.5	18.3	mVrms	音频=1kHz 60% 频偏 麦克风灵敏度=常规
3	MICO	输出	模拟	内置麦克风输出						
4	OPTDET	输入	数字	外部可选件检测 Zin=74kΩ						
5	50V	输出	电源	DC 5V 输出	输出电压	4.9	5.0	5.1	V	Io=30mA
					最大输出电流			100	mA	
6	AE	-	接地	接地	最大输入电流			700	mA	
7	TXD	输出	数字	TXD 输出 Zout=6.8kΩ	输出电压(高)	4.9	5.0	5.1	V	负载=开放
					输出电压(低)	0		0.1	V	负载=开放
8	SPI	输入	模拟	内置扬声器输入						
9	SPO	输出	模拟	内置音频输出	最大输出功率			1300	mW	音频=0.3~3kHz FM 频偏=最大 负载=8Ω 电源=9.0V
					标准输出功率		400		mW	音频=1kHz 负载=8Ω 综合谐波和失真=10% 电源=7.5V

PARTS LIST / 零件表

CAPACITORS

$\frac{C}{1} \frac{C}{2} \frac{45}{3} \frac{TH}{4} \frac{1H}{5} \frac{220}{6} \frac{J}{6}$

- 1 = Type ... ceramic, electrolytic, etc.
- 2 = Shape ... round, square, etc.
- 3 = Temp. coefficient
- 4 = Voltage rating
- 5 = Value
- 6 = Tolerance

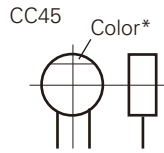

• Capacitor value

- 010 = 1pF
- 100 = 10pF
- 101 = 100pF
- 102 = 1000pF = 0.001μF
- 103 = 0.01μF

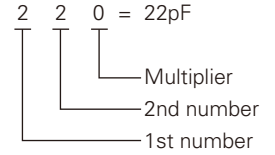

• Temperature coefficient

1st Word	C	L	P	R	S	T	U
Color*	Black	Red	Orange	Yellow	Green	Blue	Violet
ppm/°C	0	-80	-150	-220	-330	-470	-750

2nd Word	G	H	J	K	L
ppm/°C	±30	±60	±120	±250	±500

Example : CC45TH = -470±60ppm/°C

• Tolerance (More than 10pF)

Code	C	D	G	J	K	M	X	Z	P	No code
(%)	±0.25	±0.5	±2	±5	±10	±20	+40 -20	+80 -20	+100 -0	More than 10μF : -10~+50 Less than 4.7μF : -10~+75

(Less than 10pF)

Code	B	C	D	F	G
(pF)	±0.1	±0.25	±0.5	±1	±2

• Voltage rating

1st word \ 2nd word	A	B	C	D	E	F	G	H	J	K	V
0	1.0	1.25	1.6	2.0	2.5	3.15	4.0	5.0	6.3	8.0	-
1	10	12.5	16	20	25	31.5	40	50	63	80	35
2	100	125	160	200	250	315	400	500	630	800	-
3	1000	1250	1600	2000	2500	2150	4000	5000	6300	8000	-

• Chip capacitors

- (EX) $\frac{C}{1} \frac{C}{2} \frac{73}{3} \frac{F}{4} \frac{SL}{5} \frac{1H}{6} \frac{000}{7} \frac{J}{7}$ → Refer to the table above.
- (Chip) (CH, RH, UJ, SL)
- (EX) $\frac{C}{1} \frac{K}{2} \frac{73}{3} \frac{F}{4} \frac{F}{5} \frac{1H}{6} \frac{000}{7} \frac{Z}{7}$ →
- (Chip) (B, F)
- 1 = Type
 - 2 = Shape
 - 3 = Dimension
 - 4 = Temp. coefficient
 - 5 = Voltage rating
 - 6 = Value
 - 7 = Tolerance

• Dimension

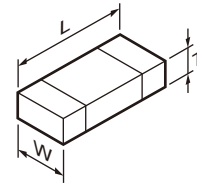

Chip capacitor

Code	L	W	T
Empty	5.6±0.5	5.0±0.5	Less than 2.0
A	4.5±0.5	3.2±0.4	Less than 2.0
B	4.5±0.5	2.0±0.3	Less than 2.0
C	4.5±0.5	1.25±0.2	Less than 1.25
D	3.2±0.4	2.5±0.3	Less than 1.5
E	3.2±0.2	1.6±0.2	Less than 1.25
F	2.0±0.3	1.25±0.2	Less than 1.25
G	1.6±0.2	0.8±0.2	Less than 1.0
H	1.0±0.05	0.5±0.05	0.5±0.05

Chip resistor

Code	L	W	T
E	3.2±0.2	1.6±0.2	1.0
F	2.0±0.3	1.25±0.2	1.0
G	1.6±0.2	0.8±0.2	0.5±0.1
H	1.0±0.05	0.5±0.05	0.35±0.05

RESISTORS

• Chip resistor (Carbon)

- (EX) $\frac{R}{1} \frac{D}{2} \frac{73}{3} \frac{E}{4} \frac{B}{5} \frac{2B}{6} \frac{000}{7} \frac{J}{7}$
- (Chip) (B, F)

• Carbon resistor (Normal type)

- (EX) $\frac{R}{1} \frac{D}{2} \frac{14}{3} \frac{B}{4} \frac{B}{5} \frac{2C}{6} \frac{000}{7} \frac{J}{7}$

- 1 = Type
- 2 = Shape
- 3 = Dimension
- 4 = Temp. coefficient
- 5 = Rating wattage
- 6 = Value
- 7 = Tolerance

• Rating wattage

Code	Wattage	Code	Wattage	Code	Wattage
1J	1/16W	2C	1/6W	3A	1W
2A	1/10W	2E	1/4W	3D	2W
2B	1/8W	2H	1/2W		

NX-220

PARTS LIST / 零件表

* New Parts. Δ indicates safety critical components.

Parts without **Parts No.** are not supplied.

* 新零件。Δ代表对安全至关重要的零件。

我们不会提供没有零件号的零件。

L : Scandinavia

Y : PX (Far East, Hawaii)

C : China

K : USA

T : England

X : Australia

P : Canada

E : Europe

M : Other Areas

NX-220

DISPLAY UNIT (X54-3760-XX)

Ref. No.	Address	New parts	Parts No.	Description	Destination
NX-220					
1	2B	*	A02-4130-13	PLASTIC CABINET ASSY	C2
3	1B	*	A02-4132-13	PLASTIC CABINET ASSY (16KEY)	C
4	3A	*	A10-4148-01	CHASSIS	
6	3A		B01-0694-13	ESCUTCHEON	
7	1C		B09-0686-03	CAP ACCESSORY	
8	3B		B11-1869-04	ILLUMINATION GUIDE (TX/BUSY)	
9	1A	*	B11-1890-04	FILTER (LCD)	C
10	1A	*	B11-1891-02	ILLUMINATION GUIDE (LCD)	C
11	1A		B38-0935-05	LCD	C
12	1A		B42-7417-04	STICKER	
13	2D	*	B62-2320-00	INSTRUCTION MANUAL	
16	1B,1D	*	D32-0454-04	STOPPER (16CH)	
18	3A		E04-0467-15	RF COAXIAL RECEPTACLE (SMA)	
19	2A	*	E23-1363-04	TERMINAL (ANT)	C
20	1A	*	E29-1232-05	INTER CONNECTOR (LCD)	
21	1A	*	E37-1532-15	LEAD WIRE WITH CONNECTOR (SP/ECM)	
22	2A	*	E37-1537-05	FLAT CABLE (TXRX-DISPLAY)	
23	3A	*	E72-0435-03	TERMINAL BLOCK	
25	1A	*	G02-1864-04	EARTH SPRING (DISPLAY PCB)	
26	1B	*	G09-0443-04	KNOB SPRING (VOL/SELECTOR)	
27	1B	*	G10-1827-04	FIBROUS SHEET (SP)	
28	1A		G11-4272-14	RUBBER CUSHION (SP)	
29	3A		G11-4315-14	SHEET (FET)	
30	1A		G11-4335-14	SHEET (LCD)	C
31	3A		G11-4368-04	SHEET (TERMINAL BLOCK)	
32	3A		G11-4500-04	SHEET (AIR)	
33	1A		G11-4527-04	SHEET (SP)	
34	3A	*	G11-4543-04	SHEET (PTT)	
35	1A	*	G11-4558-04	SHEET (ECM)	
36	3A	*	G11-4561-04	SHEET (CHASSIS:TX/BUSY)	
37	1A	*	G11-4562-04	SHEET (SP HOLDER)	
38	3A		G13-2068-04	CUSHION	
39	2A		G13-2220-04	CUSHION (DISPLAY PCB)	
40	3A		G13-2249-04	CUSHION (CHASSIS)	
41	3A		G53-1603-04	PACKING (SMA)	
42	3A		G53-1832-03	PACKING (JACK)	
43	2B	*	G53-1862-02	PACKING (TOP)	
44	2B	*	G53-1863-01	PACKING	C2
45	1B	*	G53-1865-01	PACKING (16KEY)	C
46	1A,3A	*	G53-1866-04	PACKING (TERMINAL)	
49	1D		J19-5483-23	HOLDER ACCESSORY	
50	1A	*	J19-5547-01	HOLDER (FG-SP)	
51	1A	*	J21-8631-03	MOUNTING HARDWARE (LCD)	C
52	1D		J29-0701-15	BELT CLIP ACCESSORY	
53	3A		J87-0027-05	FPC (LEAD FREE) (PTT)	
54	2A	*	J87-0040-05	FPC (LEAD FREE) (VOL/SELECTOR)	
56	1B	*	K29-9485-13	KNOB (VOL)	
57	1B	*	K29-9486-13	KNOB (SELECTOR)	
58	1A	*	K29-9500-03	KNOB (PTT)	
59	1B	*	K29-9501-03	BUTTON KNOB (SIDE1/SIDE2/AUX)	

Ref. No.	Address	New parts	Parts No.	Description	Destination
A	3A		N09-2438-05	BINDING HEAD SCREW (ANT)	
B	3A	*	N09-6608-05	SPECIAL SCREW (CASE)	
C	3A	*	N14-0864-04	CIRCULAR NUT (VOL)	
D	3A	*	N14-0865-04	CIRCULAR NUT (SELECTOR)	
E	3A		N30-3006-43	PAN HEAD MACHINE SCREW (ESCUT)	
F	1A,2A,3A		N83-2005-48	PAN HEAD TAPTITE SCREW (PCB)	
VR1	3A	*	R31-0685-05	VARIABLE RESISTOR (VOL)	
S101	3A	*	S60-0448-05	ROTARY SWITCH (SELECTOR)	
65	1A		T07-0787-05	SPEAKER	
-		*	X57-8040-11	SERVICE TX-RX UNIT	
DISPLAY UNIT (X54-3760-XX) -10: C -12: C2					
D1			B30-2278-05	LED (RED/YELLOW)	
D7-14			B30-2337-05	LED (YELLOW)	C
D18,19			B30-2210-05	LED (TLY)	C
C1			CK73HB1H471K	CHIP C 470PF	K
C2			CK73HB1H681K	CHIP C 680PF	K
C3			CC73HCH1H270J	CHIP C 27PF	J
C4			CK73HB1H471K	CHIP C 470PF	K
C5			CK73HB1A104K	CHIP C 0.10UF	K
C6			CK73HB1H102K	CHIP C 1000PF	K
C7,8			CC73HCH1H470J	CHIP C 47PF	J
C10			CC73HCH1H101J	CHIP C 100PF	J
C11			CK73HB1H681K	CHIP C 680PF	K
C13			CC73HCH1H101J	CHIP C 100PF	J
C15			CK73HB1E103K	CHIP C 0.010UF	K
C16			CK73HB1H102K	CHIP C 1000PF	K
C19			CK73HB1A104K	CHIP C 0.10UF	K
C20			CK73HB1H102K	CHIP C 1000PF	K
C21			CK73HB1E103K	CHIP C 0.010UF	K
C22			CK73HB1A224K	CHIP C 0.22UF	K
C23			CC73HCH1H470J	CHIP C 47PF	J
C25			CK73HB1A224K	CHIP C 0.22UF	K
C26			CC73HCH1H470J	CHIP C 47PF	J
C28,29			CC73HCH1H470J	CHIP C 47PF	J
C30			CK73HB0J105K	CHIP C 1.0UF	K
C31			CC73HCH1H470J	CHIP C 47PF	J
C32			CK73HB1H122K	CHIP C 1200PF	K
C33,34			CC73HCH1H470J	CHIP C 47PF	J
C35			CK73HB1A104K	CHIP C 0.10UF	K
C36			CC73HCH1H470J	CHIP C 47PF	J
C37			CK73HB1H472K	CHIP C 4700PF	K
C38			CC73HCH1H181J	CHIP C 180PF	J
C39			CK73HB1A104K	CHIP C 0.10UF	K
C40			CC73HCH1H470J	CHIP C 47PF	J
C42-44			CC73HCH1H470J	CHIP C 47PF	J
C45			CK73HB1H102K	CHIP C 1000PF	K
C47			CK73HB1A104K	CHIP C 0.10UF	K
C48			CK73HB0J105K	CHIP C 1.0UF	K
C49			CK73HB1H102K	CHIP C 1000PF	K

PARTS LIST / 零件表

DISPLAY UNIT (X54-3760-XX)
TX-RX UNIT (X57-8040-10)

Ref. No.	Address	New parts	Parts No.	Description	Desti-nation	Ref. No.	Address	New parts	Parts No.	Description	Desti-nation
C52,53			CK73HB1A104K	CHIP C 0.10UF K		R41,42			RK73HB1J683J	CHIP R 68K J 1/16W	
C54			CK73HB1H331K	CHIP C 330PF K		R44,45			RK73HB1J104J	CHIP R 100K J 1/16W	
C58			CC73HCH1H680J	CHIP C 68PF J		R47			RK73HB1J223J	CHIP R 22K J 1/16W	
C62			CC73HCH1H101J	CHIP C 100PF J		R50			RK73HB1J223J	CHIP R 22K J 1/16W	
C63,64			CK73HB0J105K	CHIP C 1.0UF K		R52			RK73HB1J471J	CHIP R 470 J 1/16W	
C67			CK73HB1H102K	CHIP C 1000PF K		R53			RK73HB1J182J	CHIP R 1.8K J 1/16W	
C68			CK73HB1E103K	CHIP C 0.010UF K		R61-64			RK73HB1J332J	CHIP R 3.3K J 1/16W	C
C70			CK73HB0J105K	CHIP C 1.0UF K		R65			RK73HB1J682J	CHIP R 6.8K J 1/16W	C
C71			CK73HB1A104K	CHIP C 0.10UF K		R66			RK73HB1J000J	CHIP R 0.0 J 1/16W	C
C73			CK73GB0J106K	CHIP C 10UF K		R67			RK73HB1J471J	CHIP R 470 J 1/16W	C
C74			CK73HB0J105K	CHIP C 1.0UF K		R69			RK73HB1J222J	CHIP R 2.2K J 1/16W	C
C78			CK73HB1E103K	CHIP C 0.010UF K	C	R70-72			RK73HB1J103J	CHIP R 10K J 1/16W	C
C79			CK73HB1A473K	CHIP C 0.047UF K	C	R73			RK73GB2A433J	CHIP R 43K J 1/10W	C
C83			CK73HB1H102K	CHIP C 1000PF K	C	R74			RK73HB1J121J	CHIP R 120 J 1/16W	C
C84			CK73HB1A473K	CHIP C 0.047UF K	C	R75			RK73HB1J222J	CHIP R 2.2K J 1/16W	C
C85			CK73HB1H681K	CHIP C 680PF K	C	R76			RK73HB1J681J	CHIP R 680 J 1/16W	C
C90			CK73HB1E103K	CHIP C 0.010UF K	C	R77			RK73HB1J103J	CHIP R 10K J 1/16W	
C91			CK73HB1H471K	CHIP C 470PF K		R78			RK73HB1J682J	CHIP R 6.8K J 1/16W	
C92			CK73HB1H102K	CHIP C 1000PF K		R79			RK73HB1J563J	CHIP R 56K J 1/16W	
C93,94			CK73HB1E103K	CHIP C 0.010UF K		R81			RK73HB1J000J	CHIP R 0.0 J 1/16W	
CN5		*	E40-6893-05	FLAT CABLE CONNECTOR (24P)		R82			RK73HB1J332J	CHIP R 3.3K J 1/16W	C2
CN6			E40-6883-05	FLAT CABLE CONNECTOR (6P)		R83			RK73HB1J000J	CHIP R 0.0 J 1/16W	C2
L1,2			L92-0408-05	CHIP FERRITE		R83,84			RK73HB1J000J	CHIP R 0.0 J 1/16W	C
L3			L92-0138-05	CHIP FERRITE	C	R86			RK73HB1J000J	CHIP R 0.0 J 1/16W	C2
CP1			RK74HB1J101J	CHIP-COM 100 J 1/16W		R88			RK73HB1J000J	CHIP R 0.0 J 1/16W	
CP2			RK74HB1J102J	CHIP-COM 1.0K J 1/16W	C	S1-4			S70-0516-05	TACT SWITCH	
CP3			RK74HB1J471J	CHIP-COM 470 J 1/16W	C	S5-20		*	S70-0519-05	TACT SWITCH	C
CP4,5			RK74HB1J102J	CHIP-COM 1.0K J 1/16W	C	MIC1	1A		T91-0673-05	MIC ELEMENT	
CP6			RK74HB1J471J	CHIP-COM 470 J 1/16W	C	D2			KDR731	DIODE	
CP7-9			RK74HB1J102J	CHIP-COM 1.0K J 1/16W	C	D3,4			DA221	DIODE	
CP10			RK74HB1J101J	CHIP-COM 100 J 1/16W	C	D15			HN2S03FE	DIODE	C
CP11-13			RK74HB1J102J	CHIP-COM 1.0K J 1/16W	C	D16			1SS388F	DIODE	C
CP14			RK74HA1J102J	CHIP-COM 1.0K J 1/16W	C	IC1,2			TC75W51FK(F)	MOS-IC	
R1			RK73HB1J472J	CHIP R 4.7K J 1/16W		IC4			R2A20178NP	MICROCONTROLLER IC	
R2			RK73HB1J103J	CHIP R 10K J 1/16W		IC6			TC75W51FK(F)	MOS-IC	
R3			RK73HB1J391J	CHIP R 390 J 1/16W		IC8			LC75857W-E	MOS-IC	C
R4			RK73HB1J823J	CHIP R 82K J 1/16W		Q1			UMG9N	TRANSISTOR	
R5			RK73HB1J100J	CHIP R 10 J 1/16W		Q2			SSM3K15TE(F)	FET	
R6			RK73HB1J821J	CHIP R 820 J 1/16W		Q3			KTC4075E(Y,GR)	TRANSISTOR	
R7			RK73HB1J472J	CHIP R 4.7K J 1/16W		Q4			2SC4738(GR)F	TRANSISTOR	
R8			RK73HB1J153J	CHIP R 15K J 1/16W		Q5			2SA1832(GR)F	TRANSISTOR	
R9			RK73HB1J333J	CHIP R 33K J 1/16W		Q6			2SA1362-F(GR)	TRANSISTOR	C
R10			RK73HB1J000J	CHIP R 0.0 J 1/16W		Q7,8			2SC5383-T111	TRANSISTOR	C
R11,12			RK73HB1J334J	CHIP R 330K J 1/16W		TH1			ERTJ0EV104H	THERMISTOR	
R13			RK73HB1J471J	CHIP R 470 J 1/16W		TX-RX UNIT (X57-8040-10)					
R14			RK73HB1J334J	CHIP R 330K J 1/16W		C101			CK73HB1H471K	CHIP C 470PF K	
R15			RK73HB1J332J	CHIP R 3.3K J 1/16W		C102			CK73HB1H102K	CHIP C 1000PF K	
R16			RK73HB1J470J	CHIP R 47 J 1/16W		C104			CK73HB1H102K	CHIP C 1000PF K	
R17			RK73HB1J104J	CHIP R 100K J 1/16W		C106			CK73HB1H102K	CHIP C 1000PF K	
R18			RK73HB1J393J	CHIP R 39K J 1/16W		C107			CC73HCH1H100B	CHIP C 10PF B	
R19,20			RK73HB1J224J	CHIP R 220K J 1/16W		C110			CK73HB1H102K	CHIP C 1000PF K	
R21,22			RK73HB1J563J	CHIP R 56K J 1/16W		C111			CK73HB1H471K	CHIP C 470PF K	
R23			RK73HB1J222J	CHIP R 2.2K J 1/16W		C112			CK73HB1A104K	CHIP C 0.10UF K	
R24			RK73HB1J000J	CHIP R 0.0 J 1/16W		C113			CC73HCH1H330J	CHIP C 33PF J	
R26			RK73HB1J683J	CHIP R 68K J 1/16W		C114			CK73HB1H102K	CHIP C 1000PF K	
R28-30			RK73HB1J000J	CHIP R 0.0 J 1/16W							
R33-35			RK73HB1J104J	CHIP R 100K J 1/16W							
R37			RK73HB1J154J	CHIP R 150K J 1/16W							
R39,40			RK73HB1J103J	CHIP R 10K J 1/16W							

PARTS LIST / 零件表

TX-RX UNIT (X57-8040-10)

Ref. No.	Address	New parts	Parts No.	Description	Destination	Ref. No.	Address	New parts	Parts No.	Description	Destination
C115			CC73HCH1H180J	CHIP C 18PF J		C223			CK73HB1H102K	CHIP C 1000PF K	
C116			CK73HB1H102K	CHIP C 1000PF K		C224			CC73HCH1H040B	CHIP C 4.0PF B	
C118			CC73HCH1H270J	CHIP C 27PF J		C225			CC73HCH1H470J	CHIP C 47PF J	
C119			CK73HB1H102K	CHIP C 1000PF K		C227			CK73HB1H102K	CHIP C 1000PF K	
C120			CC73HCH1H101J	CHIP C 100PF J		C228			CC73HCH1H1R5B	CHIP C 1.5PF B	
C121,122			CK73HB1H102K	CHIP C 1000PF K		C229			CC73HCH1H270J	CHIP C 27PF J	
C125			CC73HCH1H151J	CHIP C 150PF J		C231			CK73HB1H102K	CHIP C 1000PF K	
C126			CK73GB1E105K	CHIP C 1.0UF K		C232			CC73HCH1H020B	CHIP C 2.0PF B	
C127			CC73HCH1H151J	CHIP C 150PF J		C233			CK73HB1E103K	CHIP C 0.010UF K	
C128			CK73GB1C104K	CHIP C 0.10UF K		C235			CK73HB1H102K	CHIP C 1000PF K	
C129			CK73HB1H102K	CHIP C 1000PF K		C236			CK73GB1E105K	CHIP C 1.0UF K	
C130			CK73HB1H471K	CHIP C 470PF K		C237			CK73HB1A104K	CHIP C 0.10UF K	
C139			CC73HCH1H390J	CHIP C 39PF J		C240,241			CK73HB1H102K	CHIP C 1000PF K	
C141			CC73GCH1H300G	CHIP C 30PF G		C242			CK73HB1A104K	CHIP C 0.10UF K	
C142			CC73GCH1H470G	CHIP C 47PF G		C244			CK73HB1H102K	CHIP C 1000PF K	
C143			CC73GCH1H080B	CHIP C 8.0PF B		C246			CC73HCH1H330J	CHIP C 33PF J	
C144			CC73GCH1H180G	CHIP C 18PF G		C247			CC73HCH1H030B	CHIP C 3.0PF B	
C145			CK73GB1H102K	CHIP C 1000PF K		C249			CC73HCH1H180G	CHIP C 18PF G	
C146			CC73GCH1H040B	CHIP C 4.0PF B		C251			CC73HCH1H1R5B	CHIP C 1.5PF B	
C147			CC73FCH1H050B	CHIP C 5.0PF B		C255			CK73HB1H102K	CHIP C 1000PF K	
C148			CC73GCH1H020B	CHIP C 2.0PF B		C258			CC73HCH1H180G	CHIP C 18PF G	
C149			CK73GB1H102K	CHIP C 1000PF K		C260			CC73HCH1H080B	CHIP C 8.0PF B	
C150			CK73HB1H471K	CHIP C 470PF K		C261			CC73HCH1H390J	CHIP C 39PF J	
C151			CK73GB1H102K	CHIP C 1000PF K		C262			CC73HCH1H120G	CHIP C 12PF G	
C152			CC73GCH1H100C	CHIP C 10PF C		C293			CK73HB1H471K	CHIP C 470PF K	
C153			CC73GCH1H150G	CHIP C 15PF G		C301,302			CK73HB1E103K	CHIP C 0.010UF K	
C154			CC73GCH1H220G	CHIP C 22PF G		C303			CK73HB1A104K	CHIP C 0.10UF K	
C155			CC73GCH1H060B	CHIP C 6.0PF B		C307			CC73HCH1H100B	CHIP C 10PF B	
C156			CC73GCH1H240G	CHIP C 24PF G		C308			CC73HCH1H101J	CHIP C 100PF J	
C157			CC73GCH1H080B	CHIP C 8.0PF B		C310			CC73HCH1H101J	CHIP C 100PF J	
C158			CC73GCH1H130G	CHIP C 13PF G		C311			CC73HCH1H151J	CHIP C 150PF J	
C160			CC73GCH1H200G	CHIP C 20PF G		C313			CC73HCH1H330G	CHIP C 33PF G	
C161			CC73HCH1H220G	CHIP C 22PF G		C314-316			CK73HB1A104K	CHIP C 0.10UF K	
C168			CK73HB1H102K	CHIP C 1000PF K		C317			CK73FB1A106K	CHIP C 10UF K	
C169			CK73HB1A104K	CHIP C 0.10UF K		C318			CC73HCH1H680G	CHIP C 68PF G	
C170			CK73HB1H471K	CHIP C 470PF K		C319			CK73HB1E103K	CHIP C 0.010UF K	
C173			CK73HB1H471K	CHIP C 470PF K		C320-323			CK73HB1A104K	CHIP C 0.10UF K	
C174			CK73FB1E225K	CHIP C 2.2UF K		C324			CK73FB1A106K	CHIP C 10UF K	
C175			CK73HB1A333K	CHIP C 0.033UF K		C327			CC73HCH1H100B	CHIP C 10PF B	
C177,178			CK73HB1H471K	CHIP C 470PF K		C330			CK73HB1A104K	CHIP C 0.10UF K	
C179			CC73HCH1H101J	CHIP C 100PF J		C332			CK73HB1E103K	CHIP C 0.010UF K	
C180,181			CK73HB1H471K	CHIP C 470PF K		C335			CK73HB1A104K	CHIP C 0.10UF K	
C182			CK73HB1A104K	CHIP C 0.10UF K		C338			CK73HB1E103K	CHIP C 0.010UF K	
C186			CC73HCH1H010B	CHIP C 1.0PF B		C339-341			CK73HB1A104K	CHIP C 0.10UF K	
C201			CK73HB1H103K	CHIP C 0.010UF K		C343			CK73GB1A474K	CHIP C 0.47UF K	
C202			CK73HB1E103K	CHIP C 0.010UF K		C346			CC73HCH1H470J	CHIP C 47PF J	
C203			CK73HB1H471K	CHIP C 470PF K		C350			CK73HB1H471K	CHIP C 470PF K	
C204			CK73FB1E475K	CHIP C 4.7UF K		C351			CK73HB1E103K	CHIP C 0.010UF K	
C205			CK73HB1H471K	CHIP C 470PF K		C353,354			CK73HB1E103K	CHIP C 0.010UF K	
C207			CK73HB1H102K	CHIP C 1000PF K		C356			CC73HCH1H030B	CHIP C 3.0PF B	
C208			CC73HCH1H100B	CHIP C 10PF B		C357			CC73HCH1H180J	CHIP C 18PF J	
C209			CC73HCH1H120G	CHIP C 12PF G		C358			CC73HCH1H060B	CHIP C 6.0PF B	
C210			CK73HB1H103K	CHIP C 0.010UF K		C359			CC73HCH1H470J	CHIP C 47PF J	
C211			CC73HCH1H040B	CHIP C 4.0PF B		C360			CK73HB1E103K	CHIP C 0.010UF K	
C212			CC73HCH1H220G	CHIP C 22PF G		C398			CC73HCH1H100B	CHIP C 10PF B	
C213			CC73HCH1H050B	CHIP C 5.0PF B		C401			CK73HB1E103K	CHIP C 0.010UF K	
C214			CC73HCH1H150J	CHIP C 15PF J		C402			CK73GB1C225K	CHIP C 2.2UF K	
C215,216			CK73HB1H102K	CHIP C 1000PF K		C405			CC73HCH1H101J	CHIP C 100PF J	
C217			CC73HCH1H3R5B	CHIP C 3.5PF B		C406			CC73HCH1H100B	CHIP C 10PF B	
C218			CC73HCH1H070B	CHIP C 7.0PF B		C408			CK73HB1E103K	CHIP C 0.010UF K	

PARTS LIST / 零件表

TX-RX UNIT (X57-8040-10)

Ref. No.	Address	New parts	Parts No.	Description	Destination	Ref. No.	Address	New parts	Parts No.	Description	Destination
C409			CC73HCH1H100B	CHIP C 10PF B		C501,502			CK73HB1H471K	CHIP C 470PF K	
C410			CC73HCH1H101J	CHIP C 100PF J		C503			CK73HB1H102K	CHIP C 1000PF K	
C411			CK73HB1E103K	CHIP C 0.010UF K		C504			CK73HB1E682K	CHIP C 6800PF K	
C412			CC73HCH1H100B	CHIP C 10PF B		C505			CK73HB1E103K	CHIP C 0.010UF K	
C413,414			CK73HB1E103K	CHIP C 0.010UF K		C506			CC73HCH1H220G	CHIP C 22PF G	
C416-420			CC73HCH1H101J	CHIP C 100PF J		C507			CK73HB1H471K	CHIP C 470PF K	
C421			CK73HB1A104K	CHIP C 0.10UF K		C508,509			CK73HB1A105K	CHIP C 1.0UF K	
C422			CC73HCH1H101J	CHIP C 100PF J		C510			CK73HB1H471K	CHIP C 470PF K	
C423			CK73HB1A104K	CHIP C 0.10UF K		C511			CK73GB1E105K	CHIP C 1.0UF K	
C424,425			CC73HCH1H101J	CHIP C 100PF J		C512			CK73HB1H102K	CHIP C 1000PF K	
C426			CS77CA1VR15M	CHIP TNTL 0.15UF 35WV		C513			CK73HB1E682K	CHIP C 6800PF K	
C427			CS77BA1D100M	CHIP TNTL 10UF 20WV		C514			CK73GB0J475K	CHIP C 4.7UF K	
C428			C92-0863-05	CHIP TNTL 0.047UF 35WV		C515			CK73HB1A105K	CHIP C 1.0UF K	
C429			CK73HB1E103K	CHIP C 0.010UF K		C516			CK73HB1A104K	CHIP C 0.10UF K	
C431			CC73HCH1H101J	CHIP C 100PF J		C517,518			CK73HB1A105K	CHIP C 1.0UF K	
C432			C93-0787-05	CHIP C 0.1UF J		C519			CK73HB1H102K	CHIP C 1000PF K	
C434			CC73HCH1H101J	CHIP C 100PF J		C520			CK73HB1A104K	CHIP C 0.10UF K	
C437,438			CC73HCH1H101J	CHIP C 100PF J		C521			CK73GB0J106K	CHIP C 10UF K	
C439			CK73HB1A104K	CHIP C 0.10UF K		C522			CK73HB1A224K	CHIP C 0.22UF K	
C440-442			CC73HCH1H101J	CHIP C 100PF J		C523			CK73HB1H471K	CHIP C 470PF K	
C443			CK73HB1A105K	CHIP C 1.0UF K		C524			CK73HB1A105K	CHIP C 1.0UF K	
C444			CK73HB1H102K	CHIP C 1000PF K		C525			CK73HB1H102K	CHIP C 1000PF K	
C445			CC73HCH1H180G	CHIP C 18PF G		C526			CS77CP1A100M	CHIP TNTL 10UF 10WV	
C446			CC73HCH1H330G	CHIP C 33PF G		C527			CK73GB0J106K	CHIP C 10UF K	
C447			CC73HCH1H680G	CHIP C 68PF G		C528			CK73HB1A105K	CHIP C 1.0UF K	
C448			CC73HCH1H040B	CHIP C 4.0PF B		C529			CK73GB1E105K	CHIP C 1.0UF K	
C449			CC73HCH1H020B	CHIP C 2.0PF B		C530			CK73HB1A105K	CHIP C 1.0UF K	
C450			CK73FB1A106K	CHIP C 10UF K		C532			CC73HCH1H560J	CHIP C 56PF J	
C451			CC73HCH1H150G	CHIP C 15PF G		C533-535			CK73HB1H102K	CHIP C 1000PF K	
C453			CC73HCH1HR75B	CHIP C 0.75PF B		C536			CK73HB1E682K	CHIP C 6800PF K	
C454			CC73HCH1H181J	CHIP C 180PF J		C537			CK73HB1E103K	CHIP C 0.010UF K	
C455			CC73HCH1H080B	CHIP C 8.0PF B		C538			CK73HB1H471K	CHIP C 470PF K	
C456,457			CC73HCH1H100B	CHIP C 10PF B		C539			CK73HB1H102K	CHIP C 1000PF K	
C458			CC73HCH1H120G	CHIP C 12PF G		C540			CK73FB1E475K	CHIP C 4.7UF K	
C459			CC73HCH1H150G	CHIP C 15PF G		C541			CK73HB1E103K	CHIP C 0.010UF K	
C460			CK73GB0J475K	CHIP C 4.7UF K		C543			CS77BP1C010M	CHIP TNTL 1.0UF 16WV	
C461			CK73HB1H471K	CHIP C 470PF K		C545			CK73GB1E105K	CHIP C 1.0UF K	
C462			CK73HB1H103K	CHIP C 0.010UF K		C548			CK73HB1H471K	CHIP C 470PF K	
C463			CK73HB1H102K	CHIP C 1000PF K		C549			CK73HB1A104K	CHIP C 0.10UF K	
C464			CK73HB1H471K	CHIP C 470PF K		C550-552			CK73HB1H471K	CHIP C 470PF K	
C465			CC73HCH1H181J	CHIP C 180PF J		C553			CK73FB1C106K	CHIP C 10UF K	
C466,467			CC73HCH1H0R5B	CHIP C 0.5PF B		C555			CK73HB1H471K	CHIP C 470PF K	
C468			CC73HCH1H120G	CHIP C 12PF G		C558			CK73GB0J106K	CHIP C 10UF K	
C469			CK73HB1H471K	CHIP C 470PF K		C599			CK73HB1H471K	CHIP C 470PF K	
C470			CK73HB1H102K	CHIP C 1000PF K		C601			CC73HCH1H101J	CHIP C 100PF J	
C471			CC73HCH1H100B	CHIP C 10PF B		C602			CK73HB1A104K	CHIP C 0.10UF K	
C472			CK73HB1H471K	CHIP C 470PF K		C603			CK73HB1E103K	CHIP C 0.010UF K	
C473			CC73HCH1H120G	CHIP C 12PF G		C604			CK73HB1A683K	CHIP C 0.068UF K	
C474			CK73HB1H102K	CHIP C 1000PF K		C605			CK73HB1A104K	CHIP C 0.10UF K	
C475			CC73HCH1H030B	CHIP C 3.0PF B		C606-608			CK73HB1E103K	CHIP C 0.010UF K	
C476,477			CC73HCH1H100B	CHIP C 10PF B		C609,610			CK73GB0J106K	CHIP C 10UF K	
C478			CK73HB1H102K	CHIP C 1000PF K		C616			CC73HCH1H470J	CHIP C 47PF J	
C480			CK73HB1A104K	CHIP C 0.10UF K		C618			CC73HCH1H470J	CHIP C 47PF J	
C481			CK73HB1H102K	CHIP C 1000PF K		C620			CC73HCH1H470J	CHIP C 47PF J	
C482			CC73HCH1H100B	CHIP C 10PF B		C622			CC73HCH1H470J	CHIP C 47PF J	
C483			CK73HB1H102K	CHIP C 1000PF K		C624			CC73HCH1H470J	CHIP C 47PF J	
C484			CK73HB1H471K	CHIP C 470PF K		C626-631			CC73HCH1H470J	CHIP C 47PF J	
C486			CC73HCH1H101J	CHIP C 100PF J		C638-644			CC73HCH1H470J	CHIP C 47PF J	
C491			CC73HCH1H101J	CHIP C 100PF J		C646,647			CK73HB1A104K	CHIP C 0.10UF K	
C492			CC73GCH1H101J	CHIP C 100PF J		C648			CK73HB1E103K	CHIP C 0.010UF K	

PARTS LIST / 零件表

TX-RX UNIT (X57-8040-10)

Ref. No.	Address	New parts	Parts No.	Description	Destination	Ref. No.	Address	New parts	Parts No.	Description	Destination
C649,650			CK73HB1H102K	CHIP C 1000PF K		F1			F53-0324-15	FUSE (2.5A)	
C652			CK73HB1A105K	CHIP C 1.0UF K		F2			F53-0319-15	FUSE (1A)	
C653			CK73HB1E103K	CHIP C 0.010UF K		CF1			L72-1017-05	CERAMIC FILTER	
C655			CK73HB1H102K	CHIP C 1000PF K		CF2			L72-1040-05	CERAMIC FILTER	
C657-660			CK73HB1A104K	CHIP C 0.10UF K		L102			L40-3375-71	SMALL FIXED INDUCTOR (33NH)	
C661			CK73HB1A105K	CHIP C 1.0UF K		L103			L40-1085-92	SMALL FIXED INDUCTOR (100NH)	
C663			CK73HB1A105K	CHIP C 1.0UF K		L104			L40-3975-71	SMALL FIXED INDUCTOR (39NH)	
C664-667			CC73HCH1H470J	CHIP C 47PF J		L105			L41-1085-43	SMALL FIXED INDUCTOR (100NH)	
C668			CK73HB1E103K	CHIP C 0.010UF K		L106			L92-0149-05	CHIP FERRITE	
C669			CK73HB1C473K	CHIP C 0.047UF K		L107	*		L41-4763-53	SMALL FIXED INDUCTOR (4.7NH)	
C670,671			CK73HB1E103K	CHIP C 0.010UF K		L108			L92-0149-05	CHIP FERRITE	
C673			CK73HB1A104K	CHIP C 0.10UF K		L109			L34-4569-05	AIR-CORE COIL	
C674			CK73HB1E103K	CHIP C 0.010UF K		L110			L34-4563-05	AIR-CORE COIL	
C675			CK73HB1A104K	CHIP C 0.10UF K		L111,112			L34-4565-05	AIR-CORE COIL	
C677			CK73GB0J106K	CHIP C 10UF K		L113			L34-4574-05	AIR-CORE COIL	
C678,679			CK73HB1E103K	CHIP C 0.010UF K		L114			L34-4566-05	AIR-CORE COIL	
C680			CK73HB1A105K	CHIP C 1.0UF K		L115			L34-4569-05	AIR-CORE COIL	
C681			CK73HB1A104K	CHIP C 0.10UF K		L116			L34-4568-05	AIR-CORE COIL	
C682			CK73HB1H102K	CHIP C 1000PF K		L117			L41-2295-39	SMALL FIXED INDUCTOR (2.2UH)	
C683			CK73HB1A104K	CHIP C 0.10UF K		L118			L34-4577-05	AIR-CORE COIL	
C684			CK73HB1E682K	CHIP C 6800PF K		L120			L92-0163-05	BEADS CORE	
C685			CK73GB0J106K	CHIP C 10UF K		L121			L40-1085-71	SMALL FIXED INDUCTOR (100NH)	
C686			CC73HCH1H030B	CHIP C 3.0PF B		L201			L92-0138-05	CHIP FERRITE	
C687			CK73HB1E103K	CHIP C 0.010UF K		L202			L41-5685-39	SMALL FIXED INDUCTOR (0.56UH)	
C688			CK73HB1A105K	CHIP C 1.0UF K		L203			L41-2785-39	SMALL FIXED INDUCTOR (0.27UH)	
C689			CK73HB1A104K	CHIP C 0.10UF K		L204,205			L40-3375-71	SMALL FIXED INDUCTOR (33NH)	
C691			CK73HB1E103K	CHIP C 0.010UF K		L206			L41-8275-53	SMALL FIXED INDUCTOR (82NH)	
C692			CK73HB1A105K	CHIP C 1.0UF K		L207			L41-2285-14	SMALL FIXED INDUCTOR (220NH)	
C693			CK73HB1A104K	CHIP C 0.10UF K		L208			L41-6878-14	SMALL FIXED INDUCTOR (68NH)	
C695			CK73HB1E103K	CHIP C 0.010UF K		L210			L92-0138-05	CHIP FERRITE	
C696,697			CK73HB1H102K	CHIP C 1000PF K		L211-213			L41-6878-14	SMALL FIXED INDUCTOR (68NH)	
C698-700			CK73HB1E103K	CHIP C 0.010UF K		L302			L40-5681-86	SMALL FIXED INDUCTOR (0.56UH)	
C701			CK73HB1A104K	CHIP C 0.10UF K		L305			L40-5675-92	SMALL FIXED INDUCTOR (56NH)	
C901,902			CK73HB1H102K	CHIP C 1000PF K		L306			L40-1085-57	SMALL FIXED INDUCTOR (100NH)	
C903			CK73HB1A105K	CHIP C 1.0UF K		L307			L40-1591-86	SMALL FIXED INDUCTOR (1.5UH)	
C904			CC73HCH1H221J	CHIP C 220PF J		L308			L92-0138-05	CHIP FERRITE	
C905			CK73HB1A105K	CHIP C 1.0UF K		L401			L41-4795-39	SMALL FIXED INDUCTOR (4.7UH)	
C906			CK73HB1A104K	CHIP C 0.10UF K		L402,403			L92-0163-05	BEADS CORE	
C907			CK73GB0J106K	CHIP C 10UF K		L404			L40-3391-86	SMALL FIXED INDUCTOR (3.3UH)	
C908			CC73HCH1H101J	CHIP C 100PF J		L405			L40-1891-86	SMALL FIXED INDUCTOR (1.8UH)	
C909			CK73HB1A473K	CHIP C 0.047UF K		L408-410			L40-2285-92	SMALL FIXED INDUCTOR (220NH)	
C910			CK73GB1E105K	CHIP C 1.0UF K		L411			L40-2785-92	SMALL FIXED INDUCTOR (270NH)	
C913			CK73GB1E105K	CHIP C 1.0UF K		L412			L40-2285-92	SMALL FIXED INDUCTOR (220NH)	
C914			CS77BB20J101M	CHIP TNTL 100UF 6.3WV		L413			L40-1085-92	SMALL FIXED INDUCTOR (100NH)	
C915,916			CC73HCH1H101J	CHIP C 100PF J		L414			L40-5663-57	SMALL FIXED INDUCTOR (5.6NH)	
C917			CK73HB1H102K	CHIP C 1000PF K		L415			L40-5678-67	SMALL FIXED INDUCTOR (56NH)	
C918			CC73HCH1H101J	CHIP C 100PF J		L416			L40-2778-67	SMALL FIXED INDUCTOR (27NH)	
C920			CK73HB1H102K	CHIP C 1000PF K		L417			L92-0446-05	BEADS CORE	
C921			CC73HCH1H101J	CHIP C 100PF J		L418,419			L40-3391-86	SMALL FIXED INDUCTOR (3.3UH)	
C922			CK73HB1H102K	CHIP C 1000PF K		L421			L40-5663-57	SMALL FIXED INDUCTOR (5.6NH)	
C923			CC73HCH1H470J	CHIP C 47PF J		L422			L40-1285-71	SMALL FIXED INDUCTOR (120NH)	
C927			CC73HCH1H470J	CHIP C 47PF J		L423			L40-8275-92	SMALL FIXED INDUCTOR (82NH)	
CN1			E40-6573-05	FLAT CABLE CONNECTOR (11P)		L424			L40-1285-92	SMALL FIXED INDUCTOR (120NH)	
CN2	*		E40-6893-05	FLAT CABLE CONNECTOR (24P)		L425			L92-0163-05	BEADS CORE	
CN3			E40-6568-05	FLAT CABLE CONNECTOR (6P)		L502			L92-0163-05	BEADS CORE	
CN4			E41-2359-05	PIN ASSY		L503			L33-1494-05	SMALL FIXED INDUCTOR (4.7UH)	
J1			E11-0484-05	3.5D PHONE JACK (3.5D/3P)		L504			L92-0149-05	CHIP FERRITE	
J2			E11-0715-05	2.5D PHONE JACK		L505			L92-0467-05	CHIP FERRITE	
						L506			L92-0162-05	BEADS CORE	

PARTS LIST / 零件表

TX-RX UNIT (X57-8040-10)

Ref. No.	Address	New parts	Parts No.	Description	Destination	Ref. No.	Address	New parts	Parts No.	Description	Destination
L508			L92-0467-05	CHIP FERRITE		R165			RK73HB1J563J	CHIP R 56K J 1/16W	
L509			L33-1530-05	SMALL FIXED INDUCTOR (15UH)		R166			RK73HB1J000J	CHIP R 0.0 J 1/16W	
L511		*	L41-1092-02	SMALL FIXED INDUCTOR (1.0UH)		R167			RK73HB1J222J	CHIP R 2.2K J 1/16W	
L602-605			L92-0408-05	CHIP FERRITE		R168			RK73HB1J823J	CHIP R 82K J 1/16W	
L607			L92-0444-05	CHIP FERRITE		R169			RK73HB1J104J	CHIP R 100K J 1/16W	
L609			L92-0444-05	CHIP FERRITE		R201			RK73HB1J470J	CHIP R 47 J 1/16W	
L611			L92-0444-05	CHIP FERRITE		R203			RK73HB1J681J	CHIP R 680 J 1/16W	
L613			L92-0163-05	BEADS CORE		R204			RK73HB1J472J	CHIP R 4.7K J 1/16W	
L614-616			L92-0444-05	CHIP FERRITE		R205			RK73HH1J331D	CHIP R 330 D 1/16W	
L617			L92-0162-05	BEADS CORE		R207			RK73HB1J104J	CHIP R 100K J 1/16W	
L901-903			L92-0408-05	CHIP FERRITE		R208			RK73HB1J154J	CHIP R 150K J 1/16W	
X401		*	L77-3073-05	TCXO (16.8MHZ)		R209			RK73HB1J104J	CHIP R 100K J 1/16W	
X601			L77-3015-05	TCXO (18.432MHZ)		R210			RK73HB1J224J	CHIP R 220K J 1/16W	
XF1			L71-0655-05	MCF (49.95MHZ)		R211			RK73HB1J000J	CHIP R 0.0 J 1/16W	
						R212			RK73HB1J105J	CHIP R 1.0M J 1/16W	
CP401			RK74HB1J100J	CHIP-COM 10 J 1/16W		R213			RK73HB1J104J	CHIP R 100K J 1/16W	
CP501			RK74HB1J104J	CHIP-COM 100K J 1/16W		R216			RK73HB1J563J	CHIP R 56K J 1/16W	
CP601			RK74HB1J104J	CHIP-COM 100K J 1/16W		R217			RK73HB1J104J	CHIP R 100K J 1/16W	
CP602			RK74HB1J103J	CHIP-COM 10K J 1/16W		R220			RK73HB1J105J	CHIP R 1.0M J 1/16W	
CP603-605			RK74HB1J104J	CHIP-COM 100K J 1/16W		R221			RK73HB1J103J	CHIP R 10K J 1/16W	
CP607			RK74HB1J101J	CHIP-COM 100 J 1/16W		R223			RK73HB1J102J	CHIP R 1.0K J 1/16W	
CP608			RK74HB1J000J	CHIP-COM 0.0 J 1/16W		R224			RK73HB1J103J	CHIP R 10K J 1/16W	
CP610			RK74HB1J102J	CHIP-COM 1.0K J 1/16W		R225			RK73HB1J680J	CHIP R 68 J 1/16W	
R101			RK73HB1J472J	CHIP R 4.7K J 1/16W		R226			RK73HH1J221D	CHIP R 220 D 1/16W	
R102			RK73HB1J180J	CHIP R 18 J 1/16W		R227			RK73HB1J224J	CHIP R 220K J 1/16W	
R103,104			RK73HB1J271J	CHIP R 270 J 1/16W		R228			RK73HB1J104J	CHIP R 100K J 1/16W	
R109			RK73HB1J220J	CHIP R 22 J 1/16W		R231			RK73HB1J823J	CHIP R 82K J 1/16W	
R110			RK73HB1J222J	CHIP R 2.2K J 1/16W		R232			RK73HB1J154J	CHIP R 150K J 1/16W	
R111			RK73HB1J472J	CHIP R 4.7K J 1/16W		R233,234			RK73HB1J104J	CHIP R 100K J 1/16W	
R112			RK73HB1J561J	CHIP R 560 J 1/16W		R235			RK73HB1J000J	CHIP R 0.0 J 1/16W	
R113			RK73GB2A270J	CHIP R 27 J 1/10W		R236,237			RK73HB1J104J	CHIP R 100K J 1/16W	
R114			RK73GB2A100J	CHIP R 10 J 1/10W		R239			RK73GB2A000J	CHIP R 0.0 J 1/10W	
R115			RK73HB1J120J	CHIP R 12 J 1/16W		R240			RK73HB1J000J	CHIP R 0.0 J 1/16W	
R116,117			RK73HB1J471J	CHIP R 470 J 1/16W		R245			RK73HB1J102J	CHIP R 1.0K J 1/16W	
R118			RK73HB1J180J	CHIP R 18 J 1/16W		R301			RK73HB1J561J	CHIP R 560 J 1/16W	
R119			RK73HB1J823J	CHIP R 82K J 1/16W		R302			RK73HB1J102J	CHIP R 1.0K J 1/16W	
R120			RK73HB1J393J	CHIP R 39K J 1/16W		R304			RK73HB1J000J	CHIP R 0.0 J 1/16W	
R121			RK73HB1J470J	CHIP R 47 J 1/16W		R305			RK73HB1J100J	CHIP R 10 J 1/16W	
R122			RK73HB1J101J	CHIP R 100 J 1/16W		R306			RK73HB1J334J	CHIP R 330K J 1/16W	
R123			RK73HB1J563J	CHIP R 56K J 1/16W		R308			RK73HB1J000J	CHIP R 0.0 J 1/16W	
R124			RK73HB1J683J	CHIP R 68K J 1/16W		R310			RK73HB1J103J	CHIP R 10K J 1/16W	
R129,130			RK73HB1J271J	CHIP R 270 J 1/16W		R317			RK73HB1J102J	CHIP R 1.0K J 1/16W	
R131			RK73GB2A823J	CHIP R 82K J 1/10W		R320			RK73HB1J274J	CHIP R 270K J 1/16W	
R132,133			RK73GB2A000J	CHIP R 0.0 J 1/10W		R321			RK73HB1J102J	CHIP R 1.0K J 1/16W	
R141,142			RK73HB1J474J	CHIP R 470K J 1/16W		R326			RK73HB1J104J	CHIP R 100K J 1/16W	
R143			RK73HB1J102J	CHIP R 1.0K J 1/16W		R327			RK73HB1J103J	CHIP R 10K J 1/16W	
R144			RK73HB1J273J	CHIP R 27K J 1/16W		R328			RK73HB1J472J	CHIP R 4.7K J 1/16W	
R146			RK73HB1J000J	CHIP R 0.0 J 1/16W		R329			RK73HB1J223J	CHIP R 22K J 1/16W	
R147			RK73HB1J561J	CHIP R 560 J 1/16W		R330			RK73HB1J183J	CHIP R 18K J 1/16W	
R148-150			RK73HB1J102J	CHIP R 1.0K J 1/16W		R331			RK73HB1J103J	CHIP R 10K J 1/16W	
R152			RK73HB1J103J	CHIP R 10K J 1/16W		R332			RK73HB1J473J	CHIP R 47K J 1/16W	
R153-155			RK73EB2ER39K	CHIP R 0.39 K 1/4W		R335			RK73HH1J221D	CHIP R 220 D 1/16W	
R156,157			RK73HH1J154D	CHIP R 150K D 1/16W		R338			RK73HB1J101J	CHIP R 100 J 1/16W	
R158			RK73HB1J000J	CHIP R 0.0 J 1/16W		R340			RK73HB1J564J	CHIP R 560K J 1/16W	
R159			RK73HH1J474D	CHIP R 470K D 1/16W		R341			RK73HB1J104J	CHIP R 100K J 1/16W	
R160			RK73HB1J000J	CHIP R 0.0 J 1/16W		R344			RK73HB1J682J	CHIP R 6.8K J 1/16W	
R161			RK73HH1J474D	CHIP R 470K D 1/16W		R345,346			RK73HB1J271J	CHIP R 270 J 1/16W	
R162			RK73HB1J103J	CHIP R 10K J 1/16W		R349			RK73HB1J102J	CHIP R 1.0K J 1/16W	
R163			RK73HB1J224J	CHIP R 220K J 1/16W		R351			RK73HB1J104J	CHIP R 100K J 1/16W	
R164			RK73HB1J104J	CHIP R 100K J 1/16W		R352			RK73HB1J103J	CHIP R 10K J 1/16W	

PARTS LIST / 零件表

TX-RX UNIT (X57-8040-10)

Ref. No.	Address	New parts	Parts No.	Description	Destination	Ref. No.	Address	New parts	Parts No.	Description	Destination
R354			RK73HB1J000J	CHIP R 0.0 J 1/16W		R504			RK73HB1J222J	CHIP R 2.2K J 1/16W	
R355,356			RK73HB1J822J	CHIP R 8.2K J 1/16W		R505			RK73HH1J184D	CHIP R 180K D 1/16W	
R357			RK73GB2A821J	CHIP R 820 J 1/10W		R506			RK73HB1J101J	CHIP R 100 J 1/16W	
R400			RK73HB1J470J	CHIP R 47 J 1/16W		R507			RK73HB1J683J	CHIP R 68K J 1/16W	
R404			RK73HB1J470J	CHIP R 47 J 1/16W		R508			RK73HB1J102J	CHIP R 1.0K J 1/16W	
R407			RK73HB1J100J	CHIP R 10 J 1/16W		R509			RK73HB1J222J	CHIP R 2.2K J 1/16W	
R408,409			RK73HB1J102J	CHIP R 1.0K J 1/16W		R510			RK73HB1J100J	CHIP R 10 J 1/16W	
R410			RK73HH1J124D	CHIP R 120K D 1/16W		R511			RK73HB1J471J	CHIP R 470 J 1/16W	
R411,412			RK73HB1J100J	CHIP R 10 J 1/16W		R512			RK73HH1J683D	CHIP R 68K D 1/16W	
R413			RK73HB1J473J	CHIP R 47K J 1/16W		R513			RK73HH1J333D	CHIP R 33K D 1/16W	
R414			RK73HB1J102J	CHIP R 1.0K J 1/16W		R514			RK73HH1J394D	CHIP R 390K D 1/16W	
R415			RK73HB1J100J	CHIP R 10 J 1/16W		R515			RK73HH1J154D	CHIP R 150K D 1/16W	
R416,417			RK73HB1J000J	CHIP R 0.0 J 1/16W		R516			RK73HB1J103J	CHIP R 10K J 1/16W	
R418			RK73HH1J121D	CHIP R 120 D 1/16W		R517,518			RK73HB1J474J	CHIP R 470K J 1/16W	
R419			RK73HH1J391D	CHIP R 390 D 1/16W		R519			RK73HB1J103J	CHIP R 10K J 1/16W	
R420			RK73HH1J473D	CHIP R 47K D 1/16W		R520			RK73GB2A2R2J	CHIP R 2.2 J 1/10W	
R421			RK73HB1J103J	CHIP R 10K J 1/16W		R524			RK73HB1J474J	CHIP R 470K J 1/16W	
R422			RK73HB1J106J	CHIP R 10M J 1/16W		R529			RK73HB1J000J	CHIP R 0.0 J 1/16W	
R423			RK73HH1J474D	CHIP R 470K D 1/16W		R530-533			RK73HB1J104J	CHIP R 100K J 1/16W	
R424,425			RK73HB1J000J	CHIP R 0.0 J 1/16W		R539,540			RK73HB1J474J	CHIP R 470K J 1/16W	
R426			RK73HB1J473J	CHIP R 47K J 1/16W		R542,543			RK73HB1J474J	CHIP R 470K J 1/16W	
R427			RK73HB1J683J	CHIP R 68K J 1/16W		R544			RK73HB1J103J	CHIP R 10K J 1/16W	
R428-431			RK73HB1J000J	CHIP R 0.0 J 1/16W		R545			RK73HB1J474J	CHIP R 470K J 1/16W	
R432			RK73HH1J124D	CHIP R 120K D 1/16W		R546			RK73HB1J103J	CHIP R 10K J 1/16W	
R433			RK73HB1J000J	CHIP R 0.0 J 1/16W		R547			RK73GB2A000J	CHIP R 0.0 J 1/10W	
R434			RK73HB1J182J	CHIP R 1.8K J 1/16W		R548			RK73GB2A101J	CHIP R 100 J 1/10W	
R435			RK73HB1J103J	CHIP R 10K J 1/16W		R549,550			RK73HB1J474J	CHIP R 470K J 1/16W	
R436			RK73HB1J393J	CHIP R 39K J 1/16W		R551			RK73HB1J102J	CHIP R 1.0K J 1/16W	
R437,438			RK73HB1J473J	CHIP R 47K J 1/16W		R552			RK73HB1J101J	CHIP R 100 J 1/16W	
R439			RK73HB1J472J	CHIP R 4.7K J 1/16W		R553			RK73GB2A000J	CHIP R 0.0 J 1/10W	
R440			RK73HB1J104J	CHIP R 100K J 1/16W		R554			RK73GB2A1R0J	CHIP R 1.0 J 1/10W	
R441			RK73HB1J474J	CHIP R 470K J 1/16W		R604			RK73HB1J102J	CHIP R 1.0K J 1/16W	
R442			RK73HB1J104J	CHIP R 100K J 1/16W		R606			RK73HB1J102J	CHIP R 1.0K J 1/16W	
R443,444			RK73HH1J331D	CHIP R 330 D 1/16W		R609			RK73HB1J101J	CHIP R 100 J 1/16W	
R445			RK73HB1J104J	CHIP R 100K J 1/16W		R610,611			RK73HB1J000J	CHIP R 0.0 J 1/16W	
R446,447			RK73HB1J220J	CHIP R 22 J 1/16W		R612-614			RK73HB1J101J	CHIP R 100 J 1/16W	
R448			RK73HB1J474J	CHIP R 470K J 1/16W		R615,616			RK73HB1J472J	CHIP R 4.7K J 1/16W	
R449			RK73HB1J102J	CHIP R 1.0K J 1/16W		R617			RK73HB1J101J	CHIP R 100 J 1/16W	
R450			RK73HB1J473J	CHIP R 47K J 1/16W		R618			RK73HB1J474J	CHIP R 470K J 1/16W	
R451			RK73HB1J224J	CHIP R 220K J 1/16W		R619,620			RK73HB1J100J	CHIP R 10 J 1/16W	
R452			RK73HB1J101J	CHIP R 100 J 1/16W		R623			RK73HB1J103J	CHIP R 10K J 1/16W	
R453			RK73HB1J560J	CHIP R 56 J 1/16W		R624,625			RK73HB1J472J	CHIP R 4.7K J 1/16W	
R454			RK73HB1J561J	CHIP R 560 J 1/16W		R628,629			RK73HB1J220J	CHIP R 22 J 1/16W	
R455			RK73HB1J563J	CHIP R 56K J 1/16W		R630			RK73HB1J474J	CHIP R 470K J 1/16W	
R456			RK73HB1J103J	CHIP R 10K J 1/16W		R631			RK73HB1J102J	CHIP R 1.0K J 1/16W	
R457			RK73HB1J472J	CHIP R 4.7K J 1/16W		R632			RK73HB1J104J	CHIP R 100K J 1/16W	
R458			RK73HB1J332J	CHIP R 3.3K J 1/16W		R633,634			RK73HB1J102J	CHIP R 1.0K J 1/16W	
R459			RK73HB1J331J	CHIP R 330 J 1/16W		R635			RK73HH1J103D	CHIP R 10K D 1/16W	
R460			RK73HB1J222J	CHIP R 2.2K J 1/16W		R636			RK73HB1J104J	CHIP R 100K J 1/16W	
R461			RK73HB1J470J	CHIP R 47 J 1/16W		R637			RK73HH1J104D	CHIP R 100K D 1/16W	
R462			RK73HB1J102J	CHIP R 1.0K J 1/16W		R638			RK73HB1J183J	CHIP R 18K J 1/16W	
R463			RK73HB1J224J	CHIP R 220K J 1/16W		R639			RK73HB1J000J	CHIP R 0.0 J 1/16W	
R464			RK73HB1J183J	CHIP R 18K J 1/16W		R640-642			RK73HB1J102J	CHIP R 1.0K J 1/16W	
R467			RK73HB1J000J	CHIP R 0.0 J 1/16W		R646,647			RK73HB1J000J	CHIP R 0.0 J 1/16W	
R468			RK73HB1J102J	CHIP R 1.0K J 1/16W		R649			RK73HB1J104J	CHIP R 100K J 1/16W	
R469			RK73HB1J104J	CHIP R 100K J 1/16W		R650			RK73HB1J474J	CHIP R 470K J 1/16W	
R474			RK73HB1J000J	CHIP R 0.0 J 1/16W		R653			RK73HB1J000J	CHIP R 0.0 J 1/16W	
R501			RK73HH1J274D	CHIP R 270K D 1/16W		R655			RK73HB1J000J	CHIP R 0.0 J 1/16W	
R502			RK73HB1J272J	CHIP R 2.7K J 1/16W		R656			RK73HB1J563J	CHIP R 56K J 1/16W	
R503			RK73HB1J000J	CHIP R 0.0 J 1/16W		R657,658			RK73HB1J103J	CHIP R 10K J 1/16W	

PARTS LIST / 零件表

TX-RX UNIT (X57-8040-10)

Ref. No.	Address	New parts	Parts No.	Description	Destination	Ref. No.	Address	New parts	Parts No.	Description	Destination
R659			RK73HB1J563J	CHIP R 56K J 1/16W		IC501,502			NJM2878F4-33	BI-POLAR IC	
R660			RK73HB1J823J	CHIP R 82K J 1/16W		IC503			XC9235A15CM-G	MOS-IC	
R661			RK73HB1J184J	CHIP R 180K J 1/16W		IC504			XC6209B502P-G	MOS-IC	
R662			RK73HB1J103J	CHIP R 10K J 1/16W		IC505			XC6209B332M-G	MOS-IC	
R663			RK73HB1J223J	CHIP R 22K J 1/16W		IC506			LT1616ES6-PBF	ANALOGUE IC	
R664			RK73HB1J153J	CHIP R 15K J 1/16W		IC507			XC61CC5602N-G	MOS-IC	
R665			RK73GB2A000J	CHIP R 0.0 J 1/10W		IC509			TC7W53FK(F)	MOS-IC	
R666,667			RK73HB1J000J	CHIP R 0.0 J 1/16W		IC601			Note 1	ROM IC	
R668			RK73HB1J103J	CHIP R 10K J 1/16W		IC603			Note 1	MICROPROCESSOR IC	
R690			RK73HB1J000J	CHIP R 0.0 J 1/16W		IC605			Note 1	SRAM IC	
R901			RK73HB1J103J	CHIP R 10K J 1/16W		IC607			XC6119C29ANR	MOS-IC	
R902			RK73HB1J563J	CHIP R 56K J 1/16W		IC609			SM5023CNDH-G	MOS-IC	
R903			RK73HB1J473J	CHIP R 47K J 1/16W		IC610			Note 1	MOS-IC	
R904			RK73HB1J222J	CHIP R 2.2K J 1/16W		IC611,612			TC7SH08FU-F	MOS-IC	
R905			RK73HB1J474J	CHIP R 470K J 1/16W		IC613	*		KXSD9-2050	MOS-IC	
R906			RK73HB1J151J	CHIP R 150 J 1/16W		IC901			TA7368FG	MOS-IC	
R907			RK73HB1J103J	CHIP R 10K J 1/16W		IC902			XC6209B502P-G	MOS-IC	
R908			RK73HB1J334J	CHIP R 330K J 1/16W		IC904			TC75S51FE(F)	MOS-IC	
R909			RK73HB1J274J	CHIP R 270K J 1/16W		Q102			2SC4926YD	TRANSISTOR	
R910			RK73HB1J473J	CHIP R 47K J 1/16W		Q103			RD01MUS1-T113	FET	
R911			RK73HB1J273J	CHIP R 27K J 1/16W		Q104			RD07MUS2BT112	FET	
R912			RK73HB1J681J	CHIP R 680 J 1/16W		Q105			2SC5383-T111	TRANSISTOR	
R913			RK73HB1J101J	CHIP R 100 J 1/16W		Q106			RT1N441U-T111	TRANSISTOR	
R914			RK73HB1J562J	CHIP R 5.6K J 1/16W		Q107			SSM3K15TE(F)	FET	
R917,918			RK73HB1J000J	CHIP R 0.0 J 1/16W		Q108			SSM3J05FU-F	FET	
R919			RK73GB2A104J	CHIP R 100K J 1/10W		Q109			SSM3K15TE(F)	FET	
R920			RK73HB1J473J	CHIP R 47K J 1/16W		Q110			SSM6L05FU-F	FET	
R921			RK73HB1J682J	CHIP R 6.8K J 1/16W		Q201			3SK318	FET	
D101			HZU5CLL	ZENER DIODE		Q202			3SK294-FP	FET	
D102,103			HVC131	DIODE		Q301			2SC5108(Y)F	TRANSISTOR	
D105,106			RN142S	DIODE		Q303			2SC4215-F(Y)	TRANSISTOR	
D202-204			1SV305F	VARIABLE CAPACITANCE DIODE		Q401,402			MCH3914(7)-H	FET	
D206			1SV305F	VARIABLE CAPACITANCE DIODE		Q403			2SC5383-T111	TRANSISTOR	
D401			DA221	DIODE		Q404			2SC5636	TRANSISTOR	
D402-405			1SV325F	VARIABLE CAPACITANCE DIODE		Q405			2SC5108(Y)F	TRANSISTOR	
D407			1SV325F	VARIABLE CAPACITANCE DIODE		Q406			SSM6L05FU-F	FET	
D409			1SV325F	VARIABLE CAPACITANCE DIODE		Q407			SSM3J05FU-F	FET	
D410			1SV278F	VARIABLE CAPACITANCE DIODE		Q408			2SC5636	TRANSISTOR	
D411			1SV325F	VARIABLE CAPACITANCE DIODE		Q501			2SJ648-A	FET	
D412,413			HSC277	DIODE		Q502			SSM3K15TE(F)	FET	
D414			HSC119	DIODE		Q503			EMD5	TRANSISTOR	
D415			1SV325F	VARIABLE CAPACITANCE DIODE		Q505			2SA1955A-F	TRANSISTOR	
D416,417			1SV305F	VARIABLE CAPACITANCE DIODE		Q506,507			SSM6N16FE-F	FET	
D501			1SR154-400	DIODE		Q509			EMD12	TRANSISTOR	
D502			1SS388F	DIODE		Q510			RT1N141U-T111	TRANSISTOR	
D505			1SS388F	DIODE		Q511			RT1N441U-T111	TRANSISTOR	
D506			HRB0502A	DIODE		Q512			SSM6L05FU-F	FET	
D508			DAN222	DIODE		Q602			SSM3K15TE(F)	FET	
D509			1SS388F	DIODE		Q901			RT1N141U-T111	TRANSISTOR	
D511,512			1SS416	DIODE		Q902			2SA1362-F(GR)	TRANSISTOR	
D901			1SS416	DIODE		Q903			RT1N441U-T111	TRANSISTOR	
D902			DAN222	DIODE		Q904,905			2SK3577-A	FET	
IC101			TA75W01FUF	MOS-IC		Q906			RT1N141U-T111	TRANSISTOR	
IC201			TC75W51FK(F)	MOS-IC		Q907			UPA672T-A	FET	
IC302			TK10931VTL-G	ANALOGUE IC		TH101			ERTJ0EV104H	THERMISTOR	
IC304			TC75W51FK(F)	MOS-IC		TH402			ERTJ0EV104H	THERMISTOR	
IC402			XC221A1200MRG	MOS-IC							
IC403			SKY72310-362	MOS-IC							
IC404			TC75W51FK(F)	MOS-IC							

Note 1: This part cannot be replaced. Therefore, this part is not supplied as a service part.

注意 1: 该零件不可以替换。所以, 对该零件不能供应它的维修零件。

EXPLODED VIEW / 部件分解图

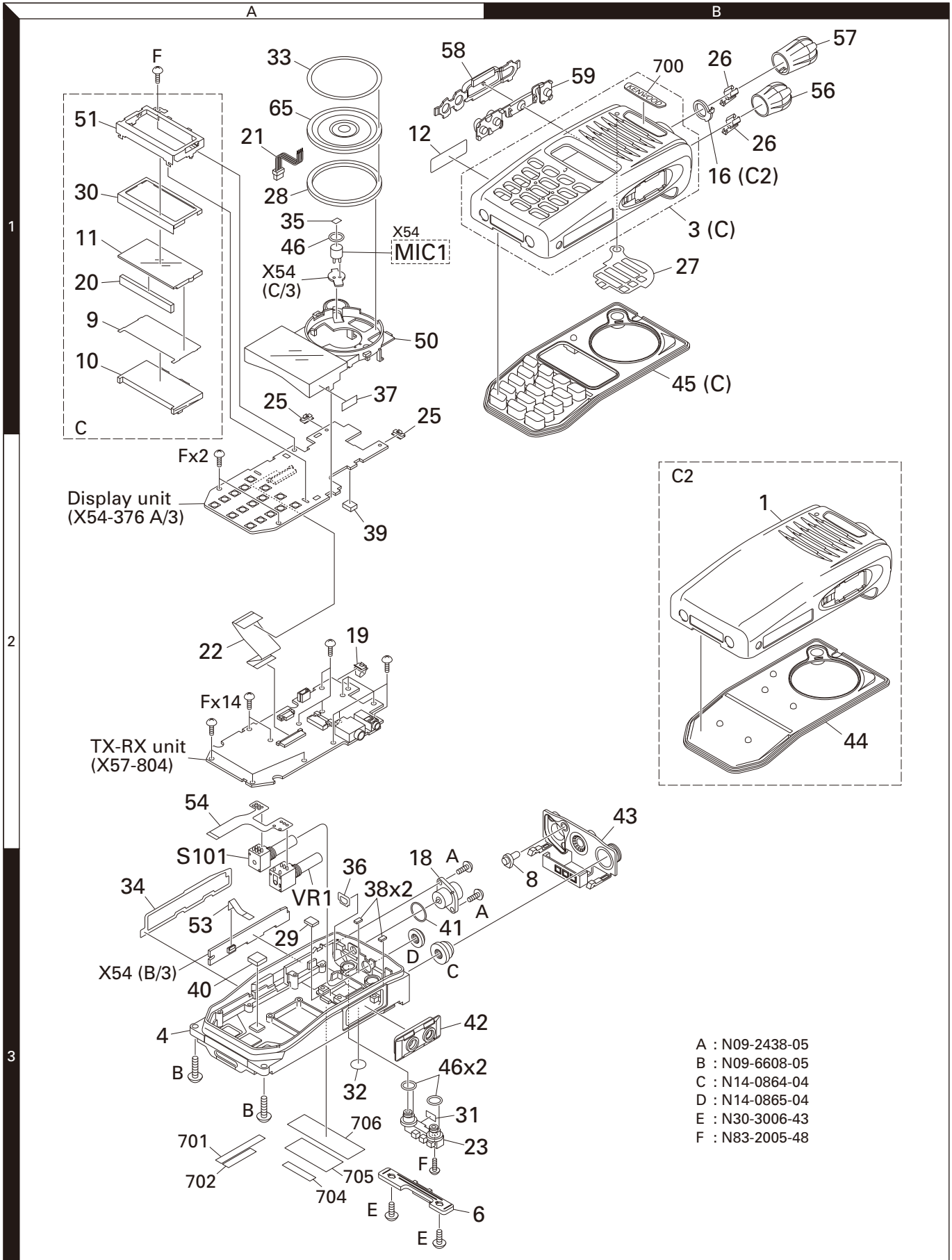

PACKING / 包装

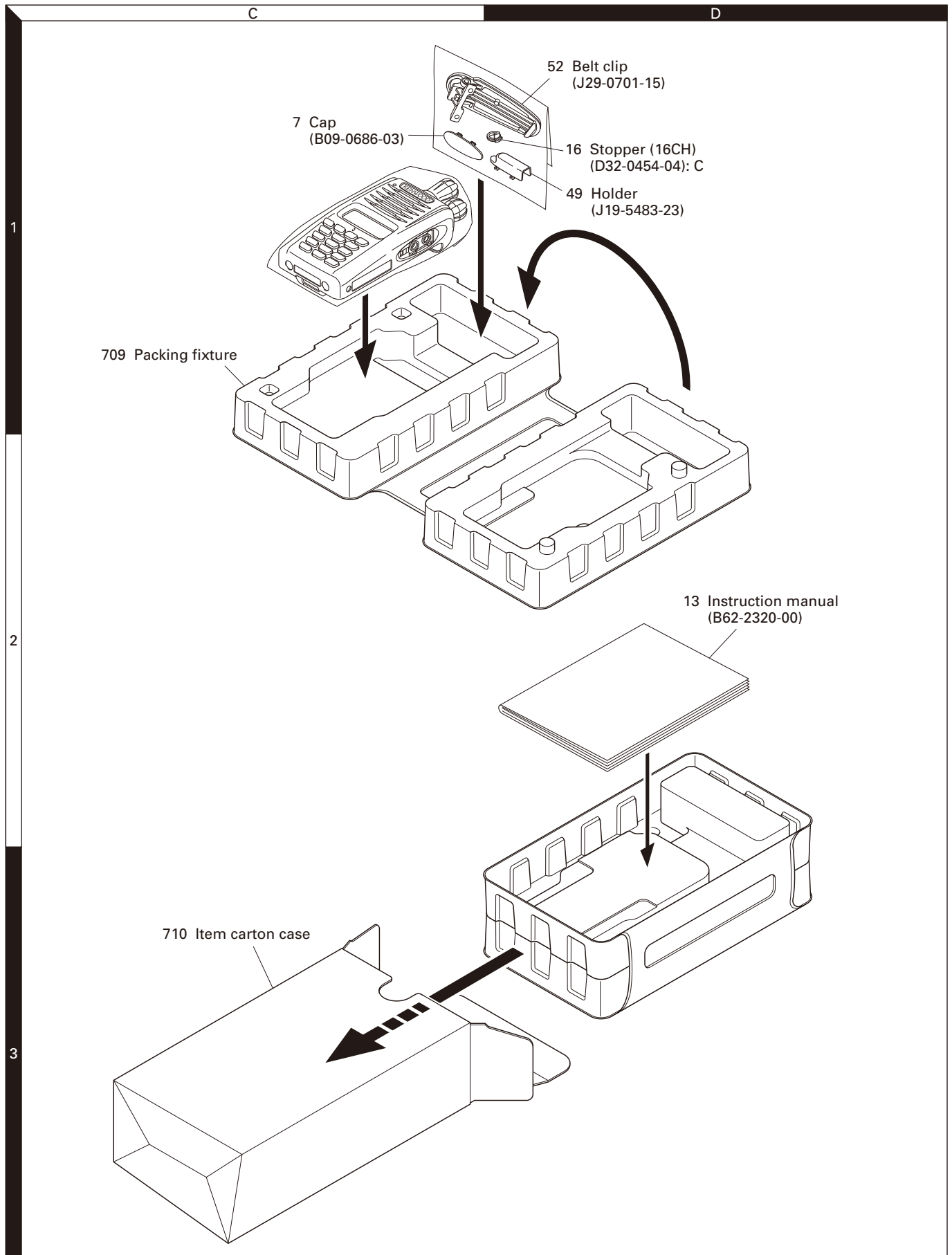

Parts with the exploded numbers larger than 700 are not supplied. / 编号大于 700 的零件未提供分解图。

TROUBLE SHOOTING

Fault Diagnosis of the BGA (Ball Grid Array) IC

■ Overview

A flowchart for determining whether or not the transceiver can be powered on (the LCD does not function even if the power switch is turned on) due to broken BGA parts.

■ BGA parts

ASIC (IC610), DSP (IC603), FLASH (IC601), SRAM (IC605)

When the BGA IC is problematic, please bring the printed circuit board (X57-8040-11) in for service. Various ESN/default adjustment values are written on the printed circuit board for service.

Additionally various ESN stickers are included. (Please refer to pages 44 and 46.)

After the printed circuit board has been readjusted, please attach any ESN stickers to the chassis. When "ESN Validation" is used with Trunking, you must modify the ESN register.

● Checking power supply voltage

Checking voltage	
Points to be checked	Normal voltage
33M IC502 (3 pin)	3.3V
15M IC503 (4 pin)	1.5V
33A IC501 (3 pin)	3.3V

Power supply of each device is connected through the coil.
[ASIC]
33M: L616, 15M: L615, 33A: L614
[DSP]
33M: L611, 15M: R665
[FLASH]
33M: L607
[SRAM]
33M: L609

When an abnormal value is confirmed.

Checking for an abnormal point

33M has an abnormal voltage.
[ASIC]
Remove L616 to check the voltage of the 33M.
If the voltage becomes normal, the ASIC is broken.
[DSP]
Remove L611 to check the voltage of the 33M.
If the voltage becomes normal, the DSP is broken.
[FLASH]
Remove L607 to check the voltage of the 33M.
If the voltage becomes normal, the FLASH is broken.
[SRAM]
Remove L609 to check the voltage of the 33M.
If the voltage becomes normal, the SRAM is broken.

15M has an abnormal voltage.
[ASIC]
Remove L615 to check the voltage of the 15M.
If the voltage becomes normal, the ASIC is broken.
[DSP]
Remove R665 to check the voltage of the 15M.
If the voltage becomes normal, the DSP is broken.

33A has an abnormal voltage.
[ASIC]
Remove L614 to check the voltage of the 33A.
If the voltage becomes normal, the ASIC is broken.

If the voltage is not corrected, there is a problem other than the BGA parts.

● Checking the clock

Checking the clock	
Points to be checked	Normal voltage (3.3V)
18.432MHz ASIC side R628	18.432MHz
DSP side R629	18.432MHz

When a normal value is confirmed.

When an abnormal value is confirmed.

● Checking the Reset/Control signal

Checking the control signal input to the ASIC	
Points to be checked	Normal voltage
RESET IC607 (4 pin)	3.3V
/BINT Q507 (6 pin)	3.3V
/PSW Q506 (3 pin)	3.3V

When a normal value is confirmed.

When an abnormal value is confirmed.

The BGA parts are not broken.

● Checking the control signal output from the ASIC

Checking the control signal output from the ASIC	
Points to be checked	Normal voltage
/FRST C655	3.3V

When a normal value is confirmed.

When an abnormal value is confirmed.

If the /FRST is always 0V, the ASIC is broken.
If the /FRST repeats 3.3V and 0V at intervals, The ASIC, FLASH and SRAM may be broken.

● Checking the output signal from the ASIC

Checking the output signal from the ASIC	
Points to be checked	Normal voltage
SBC R544	3.3V

When a normal value is confirmed.

When an abnormal value is confirmed.

Remove R544, Q502 and R518. If the ASIC side is 0V, the ASIC/FLASH/SRAM may be broken.

● Checking the output signal from the ASIC

Checking the output signal from the ASIC	
Points to be checked	Normal voltage
/DRST R604	3.3V

When a normal value is confirmed.

When an abnormal value is confirmed.

If the /DRST is 0V, the ASIC/FLASH/SRAM are broken.

When a normal value is confirmed.

故障排除

BGA(球状矩阵排列)IC的故障诊断

■ 概述

用于确定手持对讲机因 BGA 部分损坏时是否可以开启电源（即使打开电源开关 LCD 也不工作）的流程。

■ BGA 部分

ASIC(IC610), DSP(IC603), FLASH(IC601), SRAM(IC605)

BGA IC 出现问题时, 请带印刷电路板 (X57-8040-11) 进行维修。各种 ESN/ 默认调整值写在用于维修的印刷电路板上。此外还包括各种 ESN 标签。(请参阅第 45 和 47 页。)

印刷电路板经过重新调整后, 请将 ESN 标签贴到底座上。“ESN 验证”用于集群时, 必须修改 ESN 登记。

● 检查电源电压

检查电压	
检查点	正常电压
33M IC502 (3针)	3.3V
15M IC503 (4针)	1.5V
33A IC501 (3针)	3.3V
各装置的电源连通线圈。	
[ASIC]	
33M: L616, 15M: L615, 33A: L614	
[DSP]	
33M: L611, 15M: R665	
[FLASH]	
33M: L607	
[SRAM]	
33M: L609	

确认数值异常时

检查异常点

检查异常点33M有异常电压。
[ASIC]
取出L616检查33M的电压。
如果电压变正常, 则ASIC已损坏。
[DSP]
取出L611检查33M的电压。
如果电压变正常, 则DSP已损坏。
[FLASH]
取出L607检查33M的电压。
如果电压变正常, 则FLASH已损坏。
[SRAM]
取出L609检查33M的电压。
如果电压变正常, 则SRAM已损坏。

确认数值正常时

● 检查时钟

检查时钟	
检查点	正常电压 (3.3V)
18.432MHz ASIC侧 R628	18.432MHz
DSP侧 R629	18.432MHz

确认数值异常时

检查异常点15M有异常电压。
[ASIC]
取出L615检查15M的电压。
如果电压变正常, 则ASIC已损坏。
[DSP]
取出R665检查15M的电压。
如果电压变正常, 则DSP已损坏。

确认数值正常时

● 检查复位/控制信号

检查输入到ASIC的控制信号	
检查点	正常电压
RESET IC607 (4针)	3.3V
/BINT Q507 (6针)	3.3V
/PSW Q506 (3针)	3.3V

确认数值异常时

检查异常点33A有异常电压。
[ASIC]
取出L614检查33A的电压。
如果电压变正常, 则ASIC已损坏。

如果电压无法纠正,
则是BGA部分之外的其他部分的问题。

确认数值正常时

BGA部分未损坏。

检查从ASIC输出的控制信号	
检查点	正常电压
/FRST C655	3.3V

确认数值异常时

如果 /FRST始终为0V, 则ASIC已损坏。
如果 /FRST交替重复3.3V和0V,
则ASIC、FLASH和SRAM可能已损坏。

确认数值正常时

检查ASIC的输出信号	
检查点	正常电压
SBC R544	3.3V

确认数值异常时

取下R544, Q502和R518。如果ASIC侧为0V,
则ASIC/FLASH/SRAM可能已损坏。

确认数值正常时

检查点	正常电压
/DRST R604	3.3V

确认数值异常时

如果 /DRST侧为0V, 则ASIC/FLASH/SRAM已损坏。

确认数值正常时

TROUBLE SHOOTING

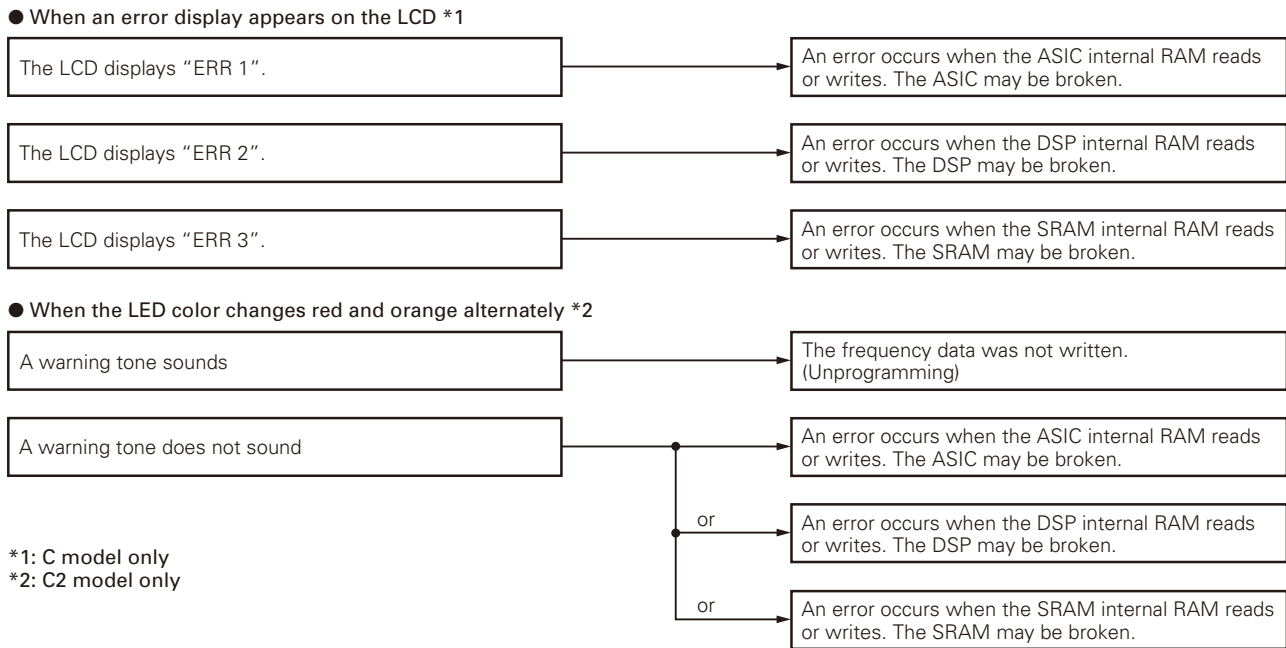
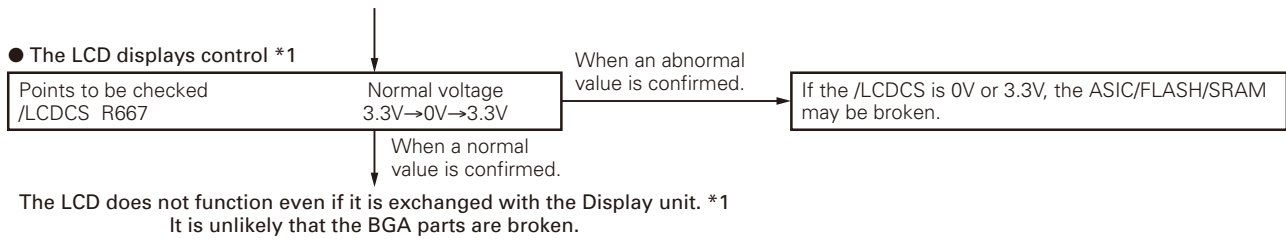

■ Descriptions of signal names

1) RST(RESET)	: ASIC reset signal	LOW → Reset
2) /BINT	: Battery final voltage monitoring	LOW → Final voltage
3) PSW	: Power switch signal	HIGH → ON
4) /FRST	: FLASH reset signal	LOW → Reset
5) SBC	: Switch B control	HIGH → ON
6) /DRST	: DSP reset signal	LOW → Reset

Replacing TX-RX Unit

■ TX-RX unit Information

Model Name	Original TX-RX unit Number	For Service TX-RX unit Number
NX-220	X57-8040-10	X57-8040-11

■ Method of confirming "Original TX-RX unit" and "Service TX-RX unit"

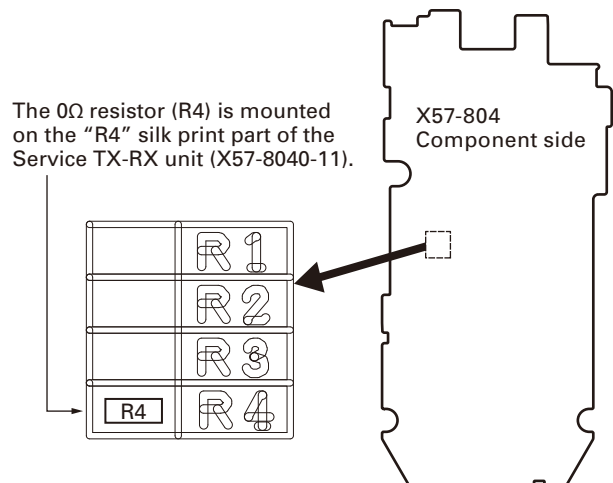

故障排除

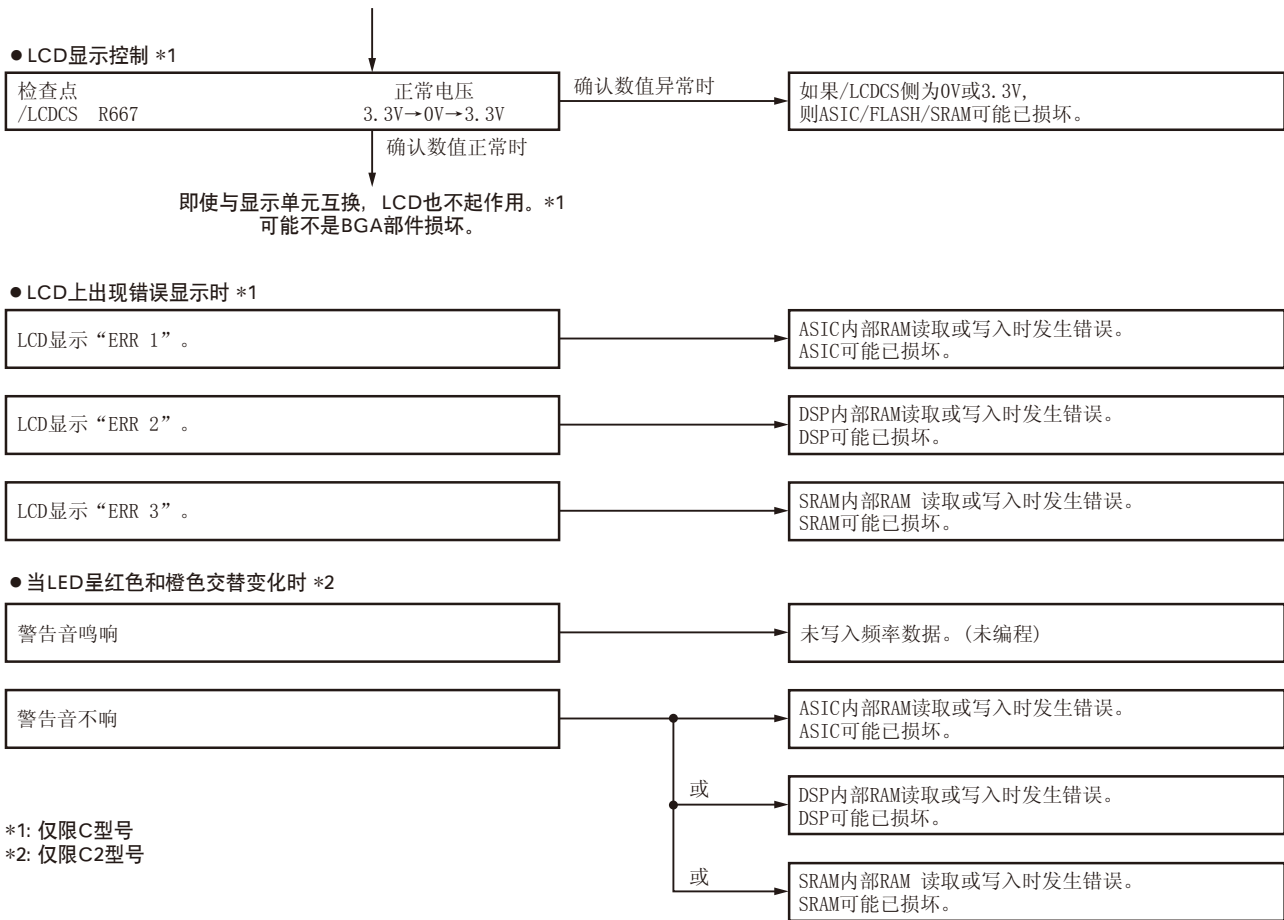

■ 信号名称说明

- | | | |
|----------------|--------------|------------|
| 1) RST (RESET) | : ASIC 复位信号 | LOW → 复位 |
| 2) /BINT | : 电池终止电压监测 | LOW → 终止电压 |
| 3) PSW | : 电源开关信号 | HIGH → ON |
| 4) /FRST | : FLASH 复位信号 | LOW → 复位 |
| 5) SBC | : 开关 B 控制 | HIGH → ON |
| 6) /DRST | : DSP 复位信号 | LOW → 复位 |

更换收发单元

■ 收发单元信息

型号名称	原始收发单元编号	维修收发单元编号
NX-220	X57-8040-10	X57-8040-11

■ “原始收发单元”和“维修收发单元”的确认方法

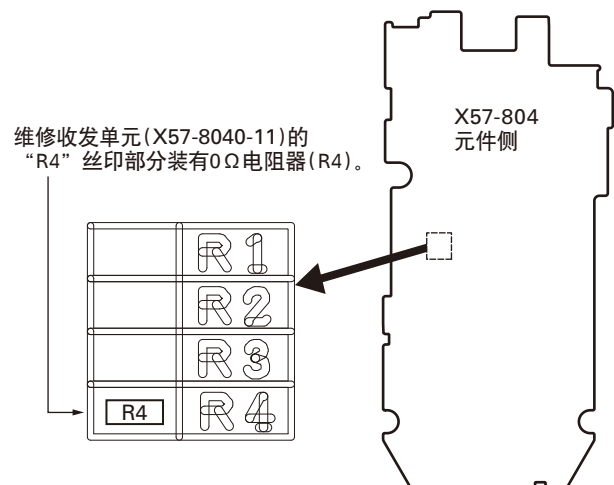

TROUBLE SHOOTING

X57-804	R4
0-10	(None)
0-11	0Ω

Note:

- The 0Ω resistor (R4) is used to differentiate the destination with a visual check. These are not connected with any PCB pattern; they are specifically for production control. There is no need to change the mount of the resistor.
- There is no difference between the schematic diagram of the Service TX-RX unit (X57-8040-11) and the schematic diagram of the original TX-RX unit (X57-8040-10). (R4 is connected with GND (ground) only.)

■ Supplied Accessories of “Service TX-RX unit”

Item (Including Parts Number)	Quantity
TX-RX Unit (X57-804)	1
Kenwood ESN Label	1
NXDN ESN Label	1
MPT ESN Label	1
Addendum (B59-2655-XX)	1

■ “Service TX-RX unit” Data

The following data is written on the service TX-RX unit:

Data Type	Description
Firmware	NX-220 K type Firmware.
FPU Data (PC programming mode)	X57-804 (NX-220) Kx type data.
Various Adjustment Data (PC Test mode)	General adjustment values for the X57-804 (NX-220).
Kenwood ESN	Model name: NX-220S Type: Kx The same number as the Kenwood ESN label is written.
NXDN ESN/MPT ESN	The same number as the NXDN ESN/MPT ESN label is written.

■ After Changing the PCB

1. After changing the printed circuit board, write the up-to-date Firmware following the instructions in the “REALIGNMENT - 6.Firmware Programming Mode”.
 - Write the Firmware in accordance to the Market. If you write different Market Firmware, there are times communication with the FPU is not possible.
2. Using the KPG-141D(C), select your desired item (Model Name and Frequency) from the Model> Product Information menu, then use Program> Write Data to the Transceiver to write the FPU data (PC Programming mode). When writing to the transceiver, a Warning Message, corresponding to the item selected, appears. Click [OK] to continue writing the data.
3. Enter Program> Test Mode, then adjust the various adjustment data (PC Test Mode) as described in the “ADJUSTMENT”.

4. Attach the new labels corresponding to the new printed circuit board. (Refer to the images below for label placement.)
5. If necessary, write the FPU data used by the customer with the KPG-141D(C).

Note:

- When using the ESN Validation function of Trunking, the ESN number changes when the circuit board is changed (the number is written on the circuit board); the Trunking System cannot be accessed. Maintain the ESN data of the Trunking System following the new ESN.
- When a new printed circuit board is used, the Kenwood ESN changes, as does the Transceiver Information display of the KPG-141D(C), but this does not have any effect on the operation of the transceiver.
- If changing to the original ESN, please contact our service center.

■ ESN Label Layout

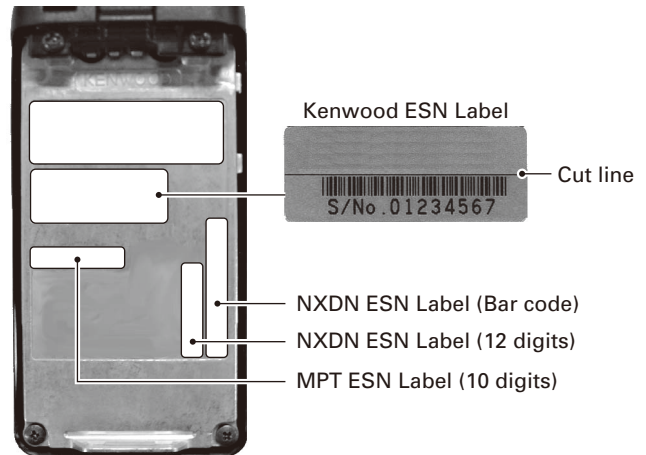
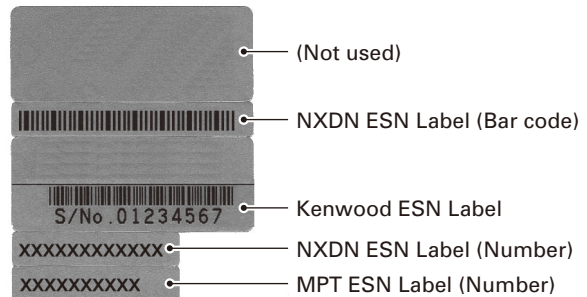

Note:

A UPC code and UPC barcode is not printed on the Kenwood ESN Label. If necessary, cut the label at the cut-off line and attach only the serial number.

故障排除

X57-804	R4
0-10	(无)
0-11	0Ω

注意：

- 0Ω 电阻器 (R4) 用于通过目视检查区分目标。它们不与任何 PCB 图形相连，专门用于生产控制。无须改动安装的这些电阻器。
- 维修收发单元 (X57-804-11) 的原理图和原始收发单元 (X57-804-10) 的原理图并无差别。(R4 仅连接 GND (接地))。

■ “维修收发单元”的附件

项目 (包括零件号)	数量
收发单元 (X57-804)	1
Kenwood ESN 标签	1
NXDN ESN 标签	1
MPT ESN 标签	1
附加物 (B59-2655-XX)	1

■ “维修收发单元”数据

维修收发单元上写有以下数据。

数据类型	说明
固件	NX-220 K 型固件。
FPU 数据 (PC 编程模式)	X57-804 (NX-220) Kx 型数据。
各种调整数据 (PC 测试模式)	X57-804 (NX-220) 的一般调整值。
Kenwood ESN	型号名称 :NX-220S 型式 :Kx 写有与 Kenwood ESN 标签相同的编号。
NXDN ESN/MPT ESN	写有与 NXDN ESN/MPT ESN 标签相同的编号。

■ 更换 PCB 后

1. 更换印刷电路板之后，按照“模式组合 -6. 固件编程模式”的说明写入最新的固件。
 - 根据市场写入固件。如果写入不同的市场固件，则无法与 FPU 进行通信。
2. 使用 KPG-141D (C)，从机型 > 产品信息菜单中选择所需的项目 (型号名称和频率)，然后用编程 > 向通信机写入数据写入 FPU 数据 (PC 编程模式)。写入手持对讲机时，会出现与所选项目对应的警告讯息。单击 [OK] 继续写入数据。
3. 进入编程 > 测试模式，然后按照“调整”中的说明调整各项调整数据 (PC 测试模式)。

4. 贴上新印刷电路板对应的新标签。(关于标签位置，请参见下图。)
5. 如有必要，可使用 KPG-141D (C) 写入用户使用的 FPU 数据。

注意：

- 使用集群通信的 ESN 验证功能时，ESN 编号会在更换电路板时发生改变 (该编号写在电路板上)；无法访问集群通信系统。根据新的 ESN 保持集群通信系统的 ESN 数据。
- 使用新印刷电路板时，Kenwood ESN 会改变，就像 KPG-141D (C) 的手持对讲机信息显示一样，但这并不影响手持对讲机的操作。
- 若要改为原来的 ESN，请与本公司的服务中心联系。

■ ESN 标签布局

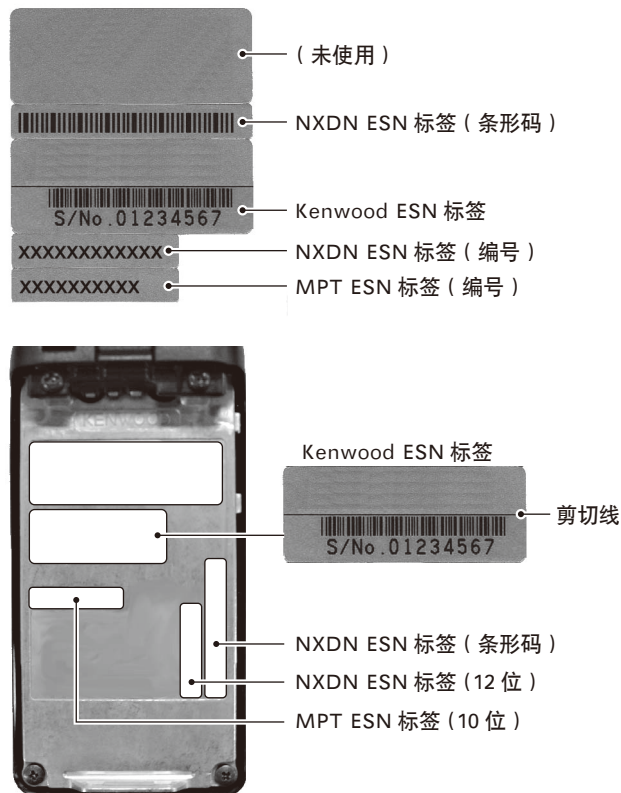

注意：

Kenwood ESN 标签上未印制 UPC 代码和 UPC 条码。如有必要，可在剪切线处切断标签，仅贴上序列号。

ADJUSTMENT

Controls

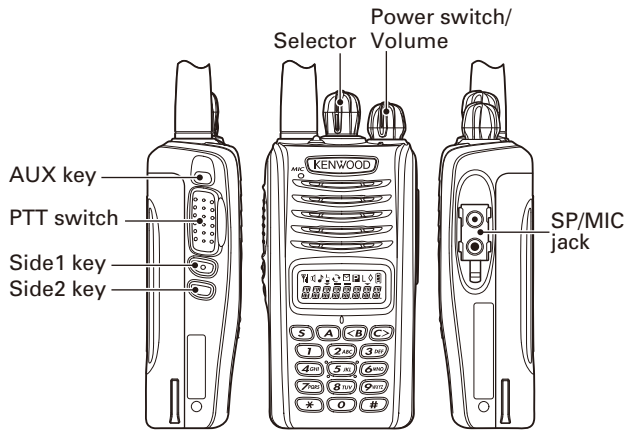

■ Preparations for checking/tuning the transceiver

Before attempting to check/tune the transceiver, connect the unit to a suitable power supply.

Whenever the transmitter is turned on, the unit must be connected to a suitable dummy load (i.e. power meter).

The speaker output connector must be terminated with an 8Ω dummy load and connected to an AC voltmeter and an audio distortion meter or a SINAD measurement meter at all times during checking/tuning.

Panel Test Mode (C model only)

■ Test mode operation features

This transceiver has a test mode. **To enter test mode, press and hold the [A] key while turning the transceiver power ON. Before the transceiver enters test mode, the frequency version information appears on the LCD momentarily.** Test mode can be inhibited by programming. To exit test mode, turn the transceiver power OFF. The following functions are available in test mode.

■ Key operation

Key	"—" not appears on the LCD display	
	Function	Display
[Selector]	Test channel up/down	Channel No.
[Side1]	Push: Squelch level up Hold: Squelch off	Squelch level Squelch off: icon appears
[Side2]	Wide/Narrow/Very narrow	Wide: "W" Narrow: "N" Very narrow: "V"
[S]	Shift to panel tuning mode	-
[A]	Function on	"—" appears on the LCD display
[<B]	MSK 1200bps and 2400bps	2400bps: icon appears
[C>]	Push: Test signaling up Hold: Test signaling up continuously	Signaling No.
[AUX]	Analog/NXDN	Analog: "A", NXDN: "N"
[PTT]	Transmit	-

Key	"—" not appears on the LCD display	
	Function	Display
[0] to [9] and [#], [*]	Use as the DTMF keypad. If a key is pressed during transmission, the DTMF corresponding to the key that was pressed is sent.	-

Key	"—" appears on the LCD display	
	Function	Display
[Selector]	Test channel up/down	Channel No.
[Side1]	Function off	-
[Side2]	LCD all lights	LCD all point appears
[S]	High power/Low power	High: icon not appears Low: icon appears
[A]	Function off	-
[<B]	Compander on/off	On: icon appears
[C>]	Beat shift on/off	On: icon appears
[AUX]	Function off	-
[PTT]	Transmit	-
[0] to [9] and [#], [*]	Function off	-

• LED indicator

Red LED Lights during transmission.
Green LED Lights when there is carrier.

• LCD display in panel test mode

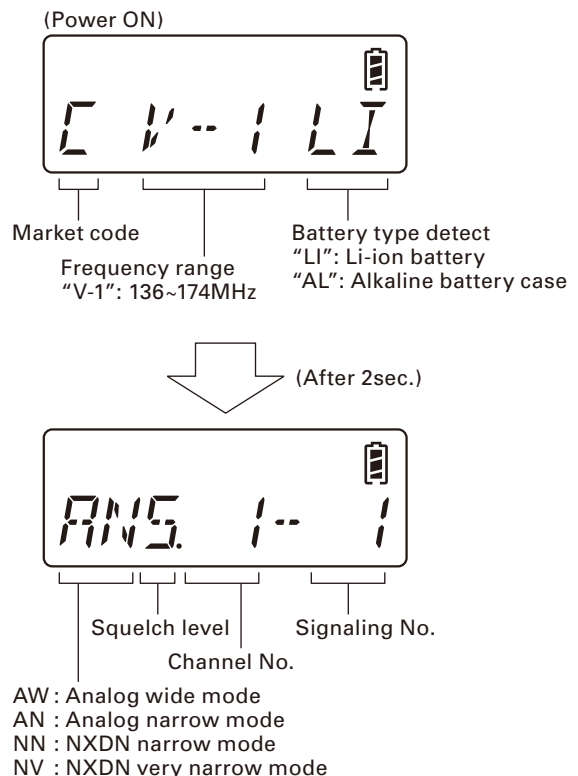

调整

控制



■ 准备检查和调谐手持对讲机的

在尝试调谐手持对讲机前，请将手持对讲机连接到合适的电源上。

发射打开时，手持对讲机必须连接到合适的等效负载上（如功率表）。

扬声器输出连接器必须端接 8Ω 的等效负载，调谐期间，必须始终连接到交流电压表和音频失真仪或 SINAD 测量仪表上。

面板测试模式（仅限 C 型号）

■ 测试模式操作功能

本手持对讲机有测试模式。要进入测试模式，打开手持对讲机电源时，按住 [A] 键。手持对讲机进入测试模式之前，LCD 上短时间出现频率版本信息。可以通过编程禁用测试模式。如需退出测试模式，请关闭手持对讲机电源。在测试模式可以使用下列功能。

■ 键操作

键	LCD 显示上不出现 “—”	
	功能	显示
[选择器]	测试信道递增 / 递减	信道号
[侧面 1]	按下：静噪电平递增 按住：静噪关	静噪电平 静噪关：🔊 图标出现
[侧面 2]	宽带 / 窄带 / 甚窄带	宽带：“W” 窄带：“N” 甚窄带：“V”
[S]	换到面板调谐模式	—
[A]	功能开	LCD 显示上出现 “—”
[<B]	MSK 1200bps 和 2400bps	2400bps: ☑ 图标出现
[>C]	按下：测试信令递增 按住：测试信令持续递增	信令号
[辅助]	模拟 / NXDN	模拟：“A”，NXDN：“N”
[PTT]	发射	—

键	LCD 显示上不出现 “—”	
	功能	显示
[0] 至 [9] 和 [#], [*]	用作 DTMF 键盘。如果在发射时按下某个键，则发送与按下的键对应的 DTMF。	—

键	LCD 显示上出现 “—”	
	功能	显示
[选择器]	测试信道递增 / 递减	信道号
[侧面 1]	功能关	—
[侧面 2]	LCD 全亮	LCD 全点显示
[S]	高功率 / 低功率	高：🔊 图标不出现 低：🔊 图标出现
[A]	功能关	—
[<B]	压扩器打开 / 关闭	开：🔊 图标出现
[>C]	拍频偏移打开 / 关闭	开：🔊 图标出现
[辅助]	功能关	—
[PTT]	发射	—
[0] 至 [9] 和 [#], [*]	功能关	—

• LED 指示灯

红色 LED 发射时点亮。
绿色 LED 有载波时点亮。

• 面板测试模式时的 LCD 显示

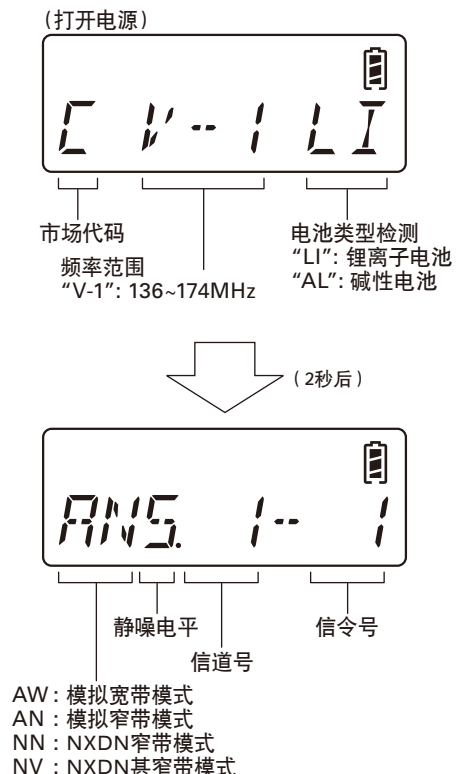

ADJUSTMENT

■ Frequency and Signaling

The transceiver has been adjusted for the frequencies shown in the following table. When required, readjust them following the adjustment procedure to obtain the frequencies you want in actual operation.

• Test frequency

CH	RX (MHz)	TX (MHz)
1	155.05000	155.10000
2	136.05000	136.10000
3	173.95000	173.90000
4	155.00000	155.00000
5	155.20000	155.20000
6	155.40000	155.40000
7~16	-	-

• Analog mode signaling

No.	RX	TX
1	None	None
2	None	100Hz Square Wave
3	LTR Data: AREA=0, GOTO=12 HOME=12 ID=47, FREE=25	LTR Data: AREA=0, GOTO=12 HOME=12 ID=47, FREE=25
4	QT: 67.0Hz	QT: 67.0Hz
5	QT: 151.4Hz	QT: 151.4Hz
6	QT: 210.7Hz	QT: 210.7Hz
7	QT: 254.1Hz	QT: 254.1Hz
8	DQT: D023N	DQT: D023N
9	DQT: D754I	DQT: D754I
10	DTMF: 159D	DTMF: 159D
11	None	DTMF Code 9
12	2-tone: A: 304.7Hz B: 3106.0Hz	2-tone: A: 304.7Hz B: 3106.0Hz
13	Single Tone: 979.9Hz	Single Tone: 979.9Hz
14	None	Single Tone: 1000Hz
15	None	MSK
16	MSK	MSK

• NXDN mode signaling

No.	RX	TX
1	RAN1	RAN1
2	None	PN9
3	RAN1	Maximum deviation pattern
7	None	FSW+PN9 (PC test mode only)

RAN: Radio Access Number

PN9: Pseudo-Random Pattern (for production only)

Panel Tuning Mode (C model only)

■ Transceiver tuning (To enter tuning mode)

To enter tuning mode, press the [**S**] key while the transceiver is in test mode. Use the [**<B**] key to write tuning data through tuning modes, and the [Selector] to adjust tuning requirements (1 to 4096 appears on the LCD).

Use the [**C>**] key to select the adjustment item through tuning modes. Use the [**A**] key to adjust 5 reference level adjustments, and use the [Side2] key to switch between Wide/Narrow/Very narrow.

• LCD display in panel tuning mode

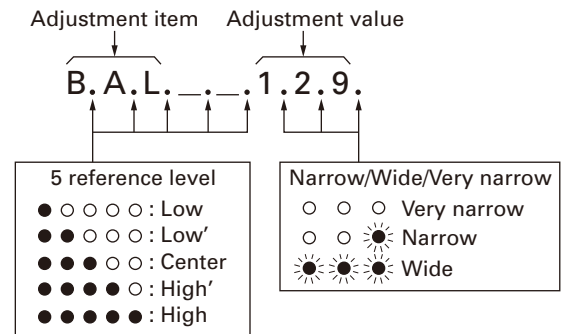

■ Key operation

Key	Function	
	Push	Hold (1 second)
[Selector]	Adjustment value up/down	
[Side1]	20Hz/2kHz (During transmission in balance adjustment)	-
[Side2]	Wide/Narrow/Very narrow	-
[S]	Shift to panel test mode	-
[A]	To enter 5 reference level adjustments	-
[<B]	Writes the adjustment value	-
[C>]	Go to next adjustment item	Back to last adjustment item
[AUX]	-	
[PTT]	Transmit	
[0] to [9] and [#], [✖]	-	

■ 5 reference level adjustments frequency

Tuning point	RX (MHz)	TX (MHz)
Low	136.05000	136.10000
Low'	145.55000	145.60000
Center	155.05000	155.10000
High'	164.55000	164.60000
High	173.95000	173.90000

调 整

■ 频率和信令

已经根据下表所示的频率调整了设置。需要时，按调整步骤重新调整，以获得实际操作时想要的频率。

• 测试频率

信道	接收 (MHz)	发射 (MHz)
1	155.05000	155.10000
2	136.05000	136.10000
3	173.95000	173.90000
4	155.00000	155.00000
5	155.20000	155.20000
6	155.40000	155.40000
7~16	-	-

• 模拟模式信令

编号	接 收	发 射
1	无	无
2	无	100Hz 方波
3	LTR 数据： AREA=0, GOTO=12 HOME=12 ID=47, FREE=25	LTR 数据： AREA=0, GOTO=12 HOME=12 ID=47, FREE=25
4	QT:67.0Hz	QT:67.0Hz
5	QT:151.4Hz	QT:151.4Hz
6	QT:210.7Hz	QT:210.7Hz
7	QT:254.1Hz	QT:254.1Hz
8	DQT:D023N	DQT:D023N
9	DQT:D754I	DQT:D754I
10	DTMF:159D	DTMF:159D
11	无	DTMF 代码 9
12	2-音： A:304.7Hz B:3106.0Hz	2-音： A:304.7Hz B:3106.0Hz
13	单音:979.9Hz	单音:979.9Hz
14	无	单音:1000Hz
15	无	MSK
16	MSK	MSK

• NXDN 模式信令

编号	接 收	发 射
1	RAN1	RAN1
2	无	PN9
3	RAN1	最大频偏模式
7	无	FSW+PN9 (仅限 PC 测试模式)

RAN: 无线接入编号

PN9: 伪随机模式 (仅限用于生产)

面板调谐模式 (仅限 C 型号)

■ 手持对讲机调谐 (进入调谐模式)

要进入调谐模式，请在手持对讲机处于测试模式时按 [S] 键。用 [<B] 键写入调谐模式的调谐数据，用 [选择器] 调整调谐要求 (LCD 上出现 1 到 4096)。

用 [C>] 键选择调谐模式的调整项目。用 [A] 键调整 5 点基准电平调整，然后用 [侧面 2] 键切换宽带 / 窄带 / 甚窄带。

• 面板调谐模式时的 LCD 显示

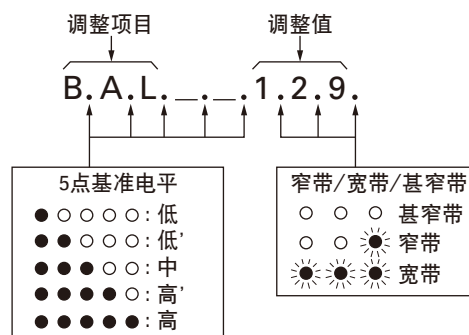

■ 键操作

键	功 能	
	按 下	按住 (1 秒钟)
[选择器]	调整值递增 / 递减	
[侧面 1]	20Hz/2kHz (在平衡调整的发射期间)	-
[侧面 2]	宽带 / 窄带 / 甚窄带	-
[S]	换到面板测试模式	-
[A]	进入 5 点基准电平调整	-
[<B]	写入调整值	-
[C>]	转到下一调整项目	返回到最后调整的项目
[辅助]	-	
[PTT]	发射	
[0] 至 [9] 和 [#], [*]	-	

■ 5 点基准电平调节频率

调谐点	接收 (MHz)	发射 (MHz)
低	136.05000	136.10000
低'	145.55000	145.60000
中	155.05000	155.10000
高'	164.55000	164.60000
高	173.95000	173.90000

ADJUSTMENT

■ Adjustment item supplement

Adjustment Item	Description
Counterclockwise Volume	"Counterclockwise Volume" is adjusted at the minimum volume position. "Clockwise Volume" is adjusted at the maximum volume position. These adjustments can correct the volume variation. Both "Counterclockwise Volume" and "Clockwise Volume" must be adjusted. (The curve data of volume is applied.)
Clockwise Volume	
Receive Assist	The lock voltage of VCO (Receive) is adjusted. This item must be adjusted before all adjustment items for receiver section are adjusted. This item can be adjusted only in PC Test Mode.
Transmit Assist	The lock voltage of VCO (Transmit) is adjusted. This item must be adjusted before all adjustment items for transmitter section are adjusted. This item can be adjusted only in PC Test Mode.
Frequency	Frequency stability is adjusted under receiving condition with SSG. The SSG needs 0.003ppm accuracy so please use a standard oscillator if necessary. This item can be adjusted only in PC Test Mode so that the adjustment value is not changed easily.
High Transmit Power	High Transmit Power is adjusted.
Low Transmit Power	Low Transmit Power is adjusted.
Balance	The transmit audio frequency response is adjusted. This item is adjusted so that the deviation of 2kHz becomes the same deviation of 20Hz. This item must be adjusted before all adjustment items for deviations are adjusted.
Maximum Deviation (NXDN Narrow/Very Narrow)	Maximum Deviation of NXDN (Narrow/Very Narrow) is adjusted.
Maximum Deviation (Analog Wide/Narrow)	Maximum Deviation of Analog (Wide/Narrow) is adjusted. This item must be adjusted before all adjustment items for tone deviations are adjusted. Note: "Maximum Deviation (Analog Narrow)" must be adjusted before "CW ID Deviation (NXDN Very Narrow)" is adjusted.
QT Deviation	QT tone deviation is adjusted.
DQT Deviation	DQT tone deviation is adjusted.
LTR Deviation	LTR tone deviation is adjusted.
DTMF Deviation	DTMF tone deviation is adjusted.
Single Tone Deviation	The deviation of Single Tone used in "2-tone" is adjusted.
MSK Deviation	MSK tone deviation is adjusted.
CW ID Deviation	CW ID tone deviation is adjusted. CW ID is used to inform the others who is transmitting on a 6.25 kHz spacing channel. (In FCC rule, Analog mode or CW ID is required for each channel-spacing.)
Sensitivity 1	Band-Pass Filter is adjusted. The performance of Receive Sensitivity is improved. This item can be adjusted only in PC Test Mode.
Sensitivity 2	The gain of RF amplifier is adjusted. The performance of the interfering wave is improved. This item can be adjusted only in PC Test Mode.
RSSI Reference	The minimum RSSI level for scan stop is adjusted.
Open Squelch	The squelch level at level "5" is adjusted.
Low RSSI	RSSI display level "Y" is adjusted. Both "Low RSSI" and "High RSSI" must be adjusted. (The curve data of RSSI level is applied.)
High RSSI	
Tight Squelch	The squelch level at level "9" is adjusted.
Battery Warning Level	Battery Warning Level (LED blinking level) is adjusted. Battery Warning Level minus 0.4V is the transmission inhibited level.

调 整

■调整项目补充

调整项目	说明
逆时针音量	“逆时针音量”调整在最小音量位置。 “顺时针音量”调整在最大音量位置。 这些调整可纠正音量差异。 “逆时针音量”和“顺时针音量”都必须调整。 (应用音量的曲线数据。)
顺时针音量	
接收辅助	调整 VCO(接收)的锁定电压。 必须在调整接收部分的所有调整项目之前调整此项。 仅可在 PC 测试模式中调整此项。
发射辅助	调整 VCO(发射)的锁定电压。 必须在调整发射部分的所有调整项目之前调整此项。 仅可在 PC 测试模式中调整此项。
频率	调整 SSG 接收条件下的频率稳定性。 SSG 需要 0.003ppm 的精度,因此,必要时请使用标准振荡器。 此项只能在 PC 测试模式下进行调整,以使调整值不易改变。
高发射功率	调整高发射功率。
低发射功率	调整低发射功率。
平衡	调整发射音频频率响应。 通过调整此项,使 2kHz 的频偏变成 20Hz 的相同频偏。 必须在调整频偏的所有调整项目之前调整此项。
最大频偏(NXDN 窄带/甚窄带)	调整 NXDN 最大频偏(窄带/甚窄带)。
最大频偏(模拟宽带/窄带)	调整模拟最大频偏(宽带/窄带)。 必须在调整音调频偏的所有调整项目之前调整此项。 注意: 必须在调整“CW ID 频偏(NXDN 甚窄带)”之前调整“最大频偏(模拟窄带)”。
QT 频偏	调整 QT 音调频偏。
DQT 频偏	调整 DQT 音调频偏。
LTR 频偏	调整 LTR 音调频偏。
DTMF 频偏	调整 DTMF 音调频偏。
单音频偏	调整“2 音”中使用的单音频偏。
MSK 频偏	调整 MSK 音调频偏。
CW ID 频偏	调整 CW ID 音调频偏。 CW ID 用于通知在 6.25 kHz 间隔信道上发射的其他人。 (按照 FCC 规则,各信道间隔须使用模拟模式或 CW ID。)
灵敏度 1	调整带通滤波器。 提高接收灵敏度的性能。 仅可在 PC 测试模式中调整此项。
灵敏度 2	调整 RF 放大器的增益。 提高干涉波的性能。 仅可在 PC 测试模式中调整此项。
RSSI 参考	调整扫描停止的最低 RSSI 电平。
静噪(浅)	调整“5”级的静噪电平。
低 RSSI	调整 RSSI 显示电平“  ”。 “低 RSSI”和“高 RSSI”都必须调整。 (应用 RSSI 电平的曲线数据。)
高 RSSI	
静噪(深)	调整电平“9”的静噪电平。
电池告警电平	调整电池告警电平(LED 闪烁电平)。 电池告警电平减去 0.4V 为发射禁止电平。

ADJUSTMENT

■ Adjustment item and Adjustment range

Order	Adjustment item	Panel tuning	PC test	AW (Analog Wide)	AN (Analog Narrow)	NN (NXDN Narrow)	NV (NXDN Very Narrow)	Adjust item Number
				Adjustment range				
1	Counterclockwise Volume	✓	✓	1 point ADJ				Common Section 2
				1~256				
2	Clockwise Volume	✓	✓	1 point ADJ				Common Section 3
				1~256				
3	Receive Assist		✓	5 point ADJ				Common Section 4
				1~4096				
4	Transmit Assist		✓	5 point ADJ				Common Section 5
				1~4096				
5	Frequency		✓	1 point ADJ				Common Section 6
				1~4096				
6	High Transmit Power	✓	✓	-	5	-	-	Transmitter Section 1
				1~1024				
7	Low Transmit Power	✓	✓	-	5	-	-	Transmitter Section 2
				1~1024				
8	Balance	✓	✓	-	5	-	-	Transmitter Section 3
				1~1024				
9	Maximum Deviation (NXDN)	✓	✓	-	-	5	5	Transmitter Section 4
				1~1024				
10	Maximum Deviation (Analog)	✓	✓	5	5	-	-	Transmitter Section 5
				1~1024				
11	QT Deviation	✓	✓	1	1	-	-	Transmitter Section 6
				1~1024				
12	DQT Deviation	✓	✓	1	1	-	-	Transmitter Section 7
				1~1024				
13	LTR Deviation	✓	✓	1	1	-	-	Transmitter Section 8
				1~1024				
14	DTMF Deviation	✓	✓	1	1	-	-	Transmitter Section 9
				1~1024				
15	Single Tone Deviation	✓	✓	1	1	-	-	Transmitter Section 10
				1~1024				
16	MSK Deviation	✓	✓	1	1	-	-	Transmitter Section 11
				1~1024				
17	CW ID Deviation	✓	✓	-	-	-	1	Transmitter Section 12
				1~1024				
18	Sensitivity 1		✓	-	5	-	-	Receiver Section 2
				1~256				
19	Sensitivity 2		✓	-	5	-	-	Receiver Section 3
				1~256				
20	RSSI Reference	✓	✓	5	5	- *1	5	Receiver Section 4
				1~256				
21	Open Squelch	✓	✓	5	5	- *1	5	Receiver Section 5
				1~256				

调 整

■ 调整项目和调整范围

顺序	调整项目	面板 调谐	PC 测试	AW (模拟宽带)	AN (模拟窄带)	NN (NXDN 窄带)	NV (NXDN 甚窄带)	调整项目 编号
				调整范围				
1	逆时针音量	✓	✓	1点调整				共通部分 2
				1~256				
2	顺时针音量	✓	✓	1点调整				共通部分 3
				1~256				
3	接收辅助		✓	5点调整				共通部分 4
				1~4096				
4	发射辅助		✓	5点调整				共通部分 5
				1~4096				
5	频率		✓	1点调整				共通部分 6
				1~4096				
6	高发射功率	✓	✓	-	5	-	-	发射部分 1
				1~1024				
7	低发射功率	✓	✓	-	5	-	-	发射部分 2
				1~1024				
8	平衡	✓	✓	-	5	-	-	发射部分 3
				1~1024				
9	最大频偏 (NXDN)	✓	✓	-	-	5	5	发射部分 4
				1~1024				
10	最大频偏 (模拟)	✓	✓	5	5	-	-	发射部分 5
				1~1024				
11	QT 频偏	✓	✓	1	1	-	-	发射部分 6
				1~1024				
12	DQT 频偏	✓	✓	1	1	-	-	发射部分 7
				1~1024				
13	LTR 频偏	✓	✓	1	1	-	-	发射部分 8
				1~1024				
14	DTMF 频偏	✓	✓	1	1	-	-	发射部分 9
				1~1024				
15	单音频偏	✓	✓	1	1	-	-	发射部分 10
				1~1024				
16	MSK 频偏	✓	✓	1	1	-	-	发射部分 11
				1~1024				
17	CW ID 频偏	✓	✓	-	-	-	1	发射部分 12
				1~1024				
18	灵敏度 1		✓	-	5	-	-	接收部分 2
				1~256				
19	灵敏度 2		✓	-	5	-	-	接收部分 3
				1~256				
20	RSSI 参考	✓	✓	5	5	- *1	5	接收部分 4
				1~256				
21	静噪 (浅)	✓	✓	5	5	- *1	5	接收部分 5
				1~256				

ADJUSTMENT

Order	Adjustment item	Panel tuning	PC test	AW (Analog Wide)	AN (Analog Narrow)	NN (NXDN Narrow)	NV (NXDN Very Narrow)	Adjust item Number
				Adjustment range				
22	Low RSSI	✓	✓	5	5	- *1	5	Receiver Section 6
				1~256				
23	High RSSI	✓	✓	5	5	- *1	5	Receiver Section 7
				1~256				
24	Tight Squelch	✓	✓	5	5	-	-	Receiver Section 8
				1~256				
25	Battery Warning Level	✓	✓	1 point ADJ				Transmitter Section 13
				1~256				

*1: Because NXDN Narrow is adjusted by adjusting Analog Narrow, it is not necessary to adjust NXDN Narrow.

■ Panel tuning mode flow chart

Note: In this Panel tuning mode flow chart, the Adjustment item name is modified.

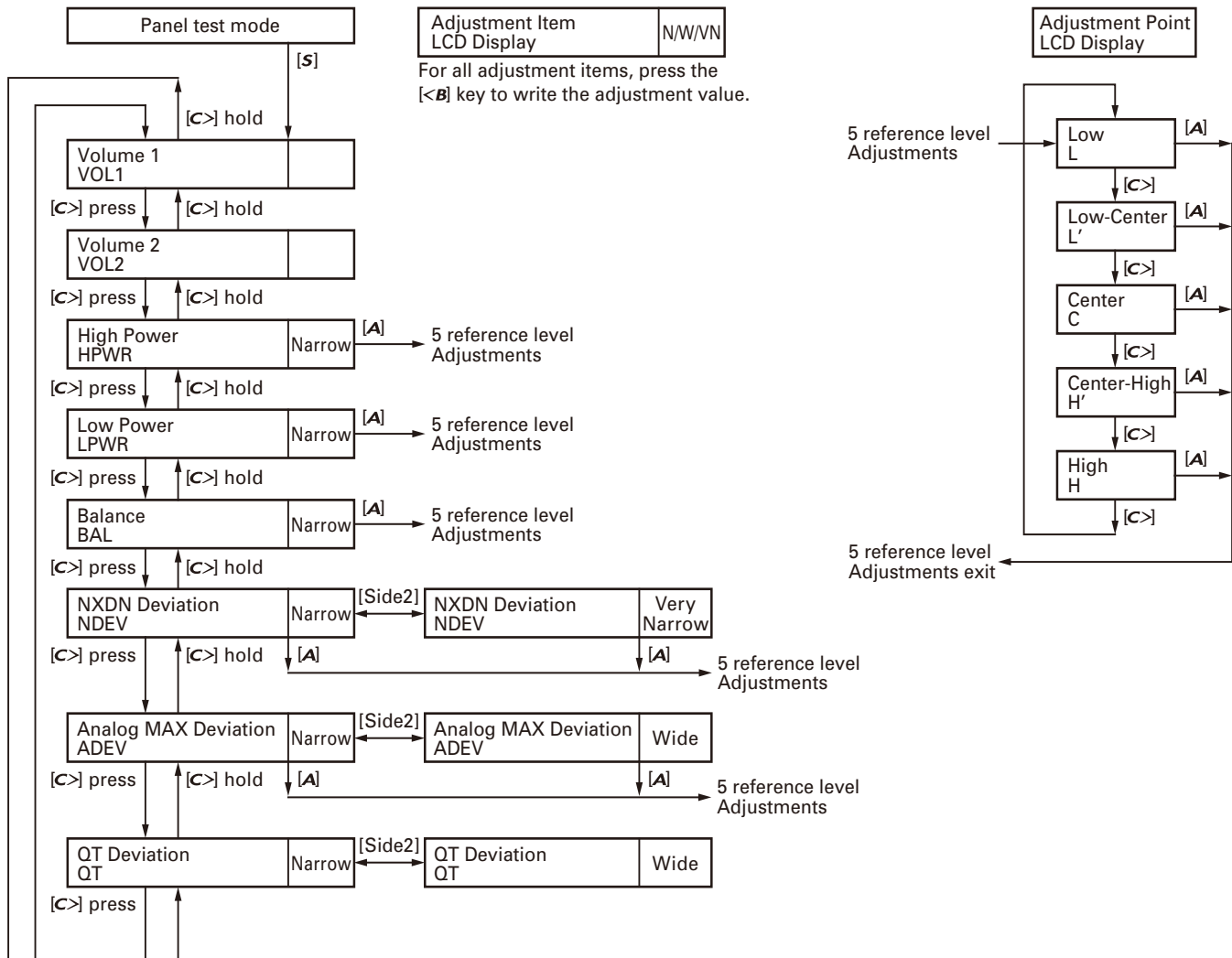

调 整

顺序	调整项目	面板调谐	PC测试	AW (模拟宽带)	AN (模拟窄带)	NN (NXDN窄带)	NV (NXDN甚窄带)	调整项目编号
				调整范围				
22	低RSSI	✓	✓	5	5	- *1	5	接收部分 6
				1~256				
23	高RSSI	✓	✓	5	5	- *1	5	接收部分 7
				1~256				
24	静噪(深)	✓	✓	5	5	-	-	接收部分 8
				1~256				
25	电池告警电平	✓	✓	1点调整				发射部分 13
				1~256				

*1: 由于NXDN窄带通过调整模拟窄带进行调整, 因此不需要调整NXDN窄带。

■ 面板调谐模式流程图

注意: 在此面板调谐模式流程图中, 调整项目的名称作了修改。

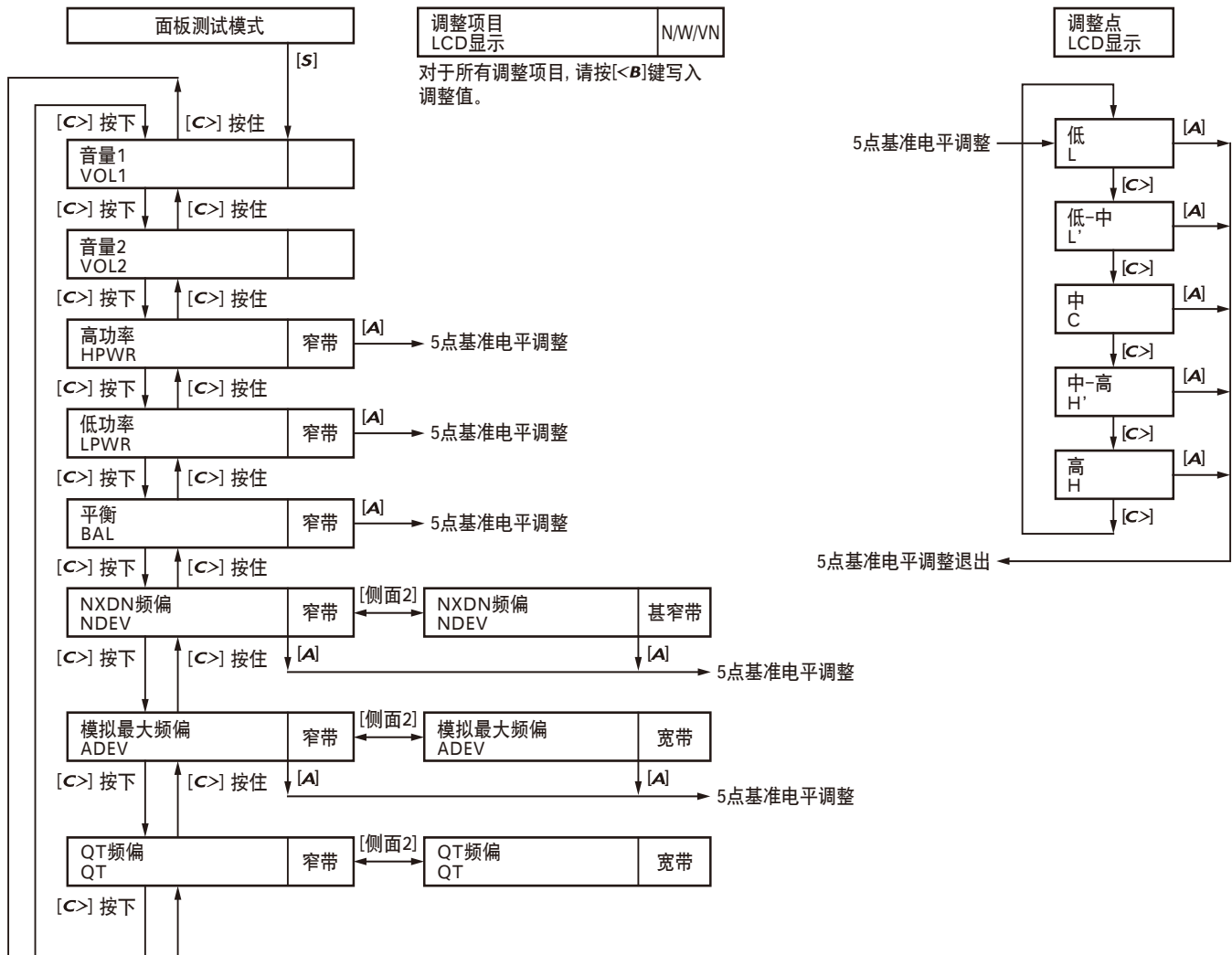

ADJUSTMENT

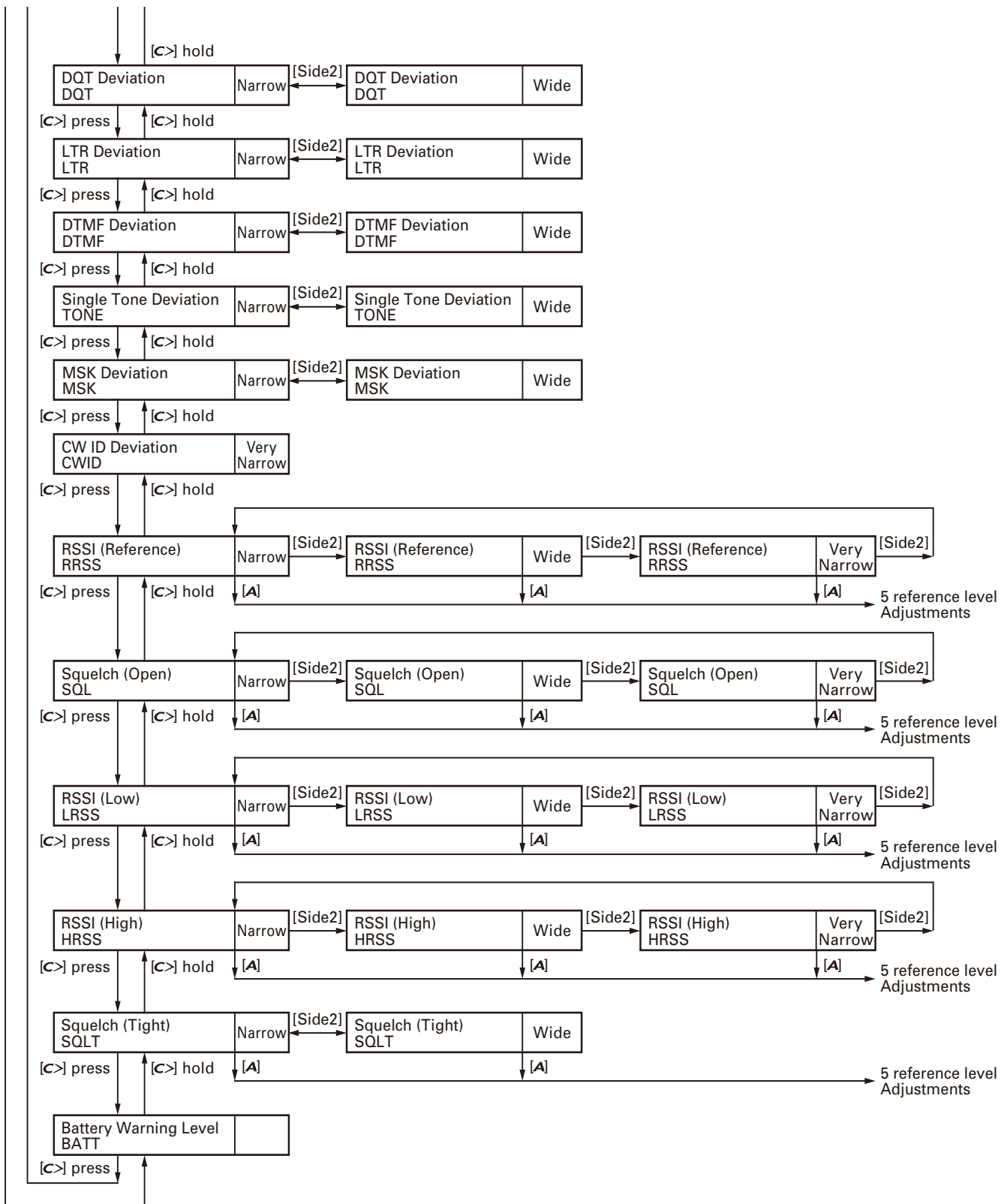

调整

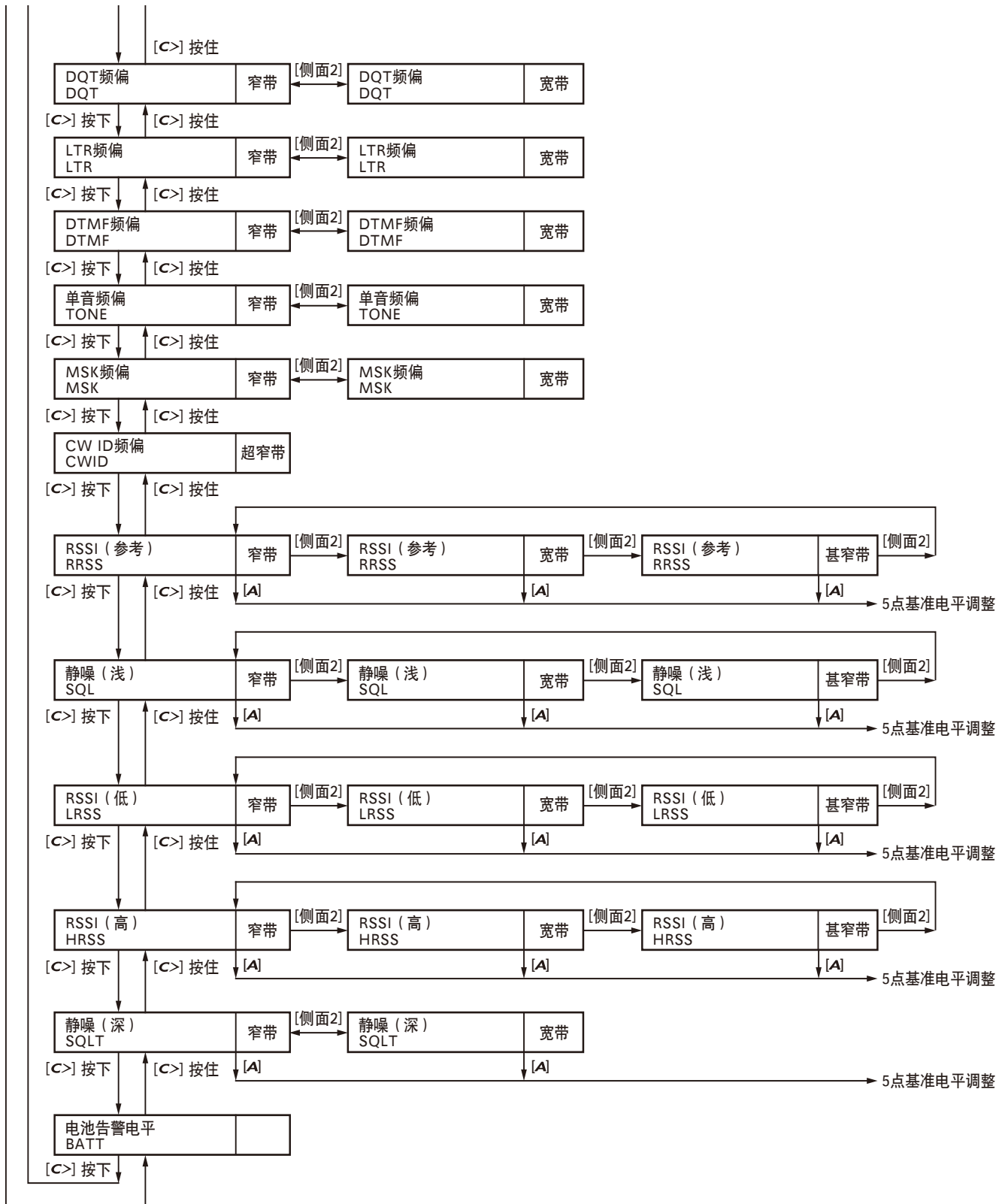

ADJUSTMENT

Test Equipment Required for Alignment

Test Equipment	Major Specifications	
1. Standard Signal Generator (SSG)	Frequency Range Modulation Output When performing the Frequency adjustment, the following accuracy is necessary. • 0.003ppm Use a standard oscillator for adjustments, if necessary.	136 to 174MHz Frequency modulation and external modulation -127dBm/0.1μV to greater than -20dBm/22.4mV
2. Power Meter	Input Impedance Operation Frequency Measurement Capability	50Ω 136 to 174MHz Vicinity of 10W
3. Deviation Meter	Frequency Range	136 to 174MHz
4. Digital Volt Meter (DVM)	Measuring Range Input Impedance	10mV to 10V DC High input impedance for minimum circuit loading
5. Oscilloscope		DC through 30MHz
6. High Sensitivity Frequency Counter	Frequency Range Frequency Stability	10Hz to 1000MHz 0.2ppm or less
7. Ammeter		5A
8. AF Volt Meter (AF VTVM)	Frequency Range Voltage Range	50Hz to 10kHz 1mV to 10V
9. Audio Generator (AG)	Frequency Range Output	50Hz to 5kHz or more 0 to 1V
10. Distortion Meter	Capability Input Level	3% or less at 1kHz 50mV to 10Vrms
11. 8Ω Dummy Load		Approx. 8Ω, 3W
12. Regulated Power Supply		5V to 10V, approx. 3A Useful if ammeter equipped

■ Antenna connector adapter

The antenna connector of this transceiver uses an SMA terminal.

Use an antenna connector adapter [SMA(f) – BNC(f) or SMA(f) – N(f)] for adjustment. (The adapter is not provided as an option, so buy a commercially-available one.)

■ Nut wrench

In order to turn the volume nut and the channel selector nut, use a recommendation tool.

KENWOOD part No.: W05-1123-00

■ Battery Jig (W05-0909-00)

Connect the power cable properly between the battery jig installed in the transceiver and the power supply, and be sure output voltage and the power supply polarity prior to switching the power supply ON, otherwise over voltage and reverse connection may damage the transceiver, or the power supply or both.

When using the battery jig in user mode, the transceiver assumes that a lithium-ion battery pack is attached to the transceiver. In adjustment mode, battery type detection is not performed.

Note: When using the battery jig, you must measure the voltage at the terminals of the battery jig. Otherwise, a slight voltage drop may occur within the power cable, between the power supply and the battery jig, especially while the transceiver transmits.

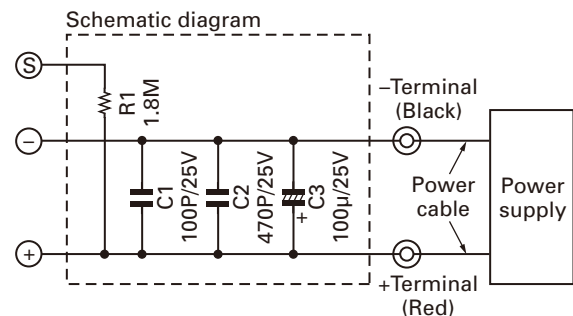
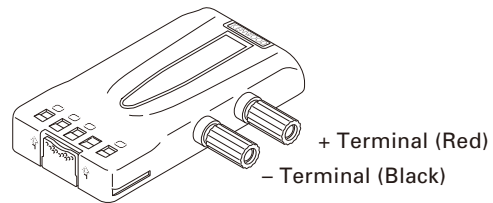

调整

调整所需的测试设备

测试设备	主要规格
1. 标准信号发生器 (SSG)	频率范围 136 到 174MHz 调制 调频和外部调制 输出 -127dBm/0.1μV 到大于 -20dBm/22.4mV 进行频率调整时，需要以下精度。 • 0.003ppm 如有必要，请使用标准振荡器进行调整。
2. 功率计	输入阻抗 50Ω 操作频率 136 到 174MHz 测量范围 10W 左右
3. 频偏仪	频率范围 136 到 174MHz
4. 数字电压表 (DVM)	测量范围 直流 10mV 到 10V 输入阻抗 为最小电路负载高输入阻抗
5. 示波器	直流到 30MHz
6. 高灵敏度频率计数器	频率范围 10Hz 到 1000MHz 频率稳定性 0.2ppm 或更低
7. 电流表	5A
8. 音频电压表 (AF VTVM)	频率范围 50Hz 到 10kHz 电压范围 1mV 到 10V
9. 音频发生器 (AG)	频率范围 50Hz 到 5kHz 或更高 输出 0 到 1V
10. 失真测试仪	能力 在 1kHz 时 3% 或更低 输入电平 50mV 到 10Vrms
11. 8Ω 假负载	大约 8Ω, 3W
12. 可调电源	5V 到 10V, 大约 3A 配备了电流表时更好

■ 天线接口转换头

此手持对讲机的天线接口使用 SMA 终端。

使用天线接口转换头 [SMA (f) -BNC (f) 或 SMA (f) -N (f)] 进行调整。(转换头不作为可选件提供，因此请购买商用转换头。)

■ 螺母扳手

为了转动音量螺母和信道选择螺母，请使用推荐的工具。

KENWOOD 零件号：W05-1123-00

■ 电池夹具 (W05-0909-00)

在通手持对讲机电源夹具和电源之间连接适当的电源电缆，确认了输出电压之后接通电源开关，电压超过或极性颠倒都有可能损坏手持对讲机。

当在用户模式使用电池夹具时，手持对讲机假定安装的是锂离子电池。在调整模式，请确认电池类型。

注：当使用电池夹具时，你必须测定电池夹具的终端电压。因为，电源和电池夹具之间会有一些的电压下降，尤其在手持对讲机发射的时候。

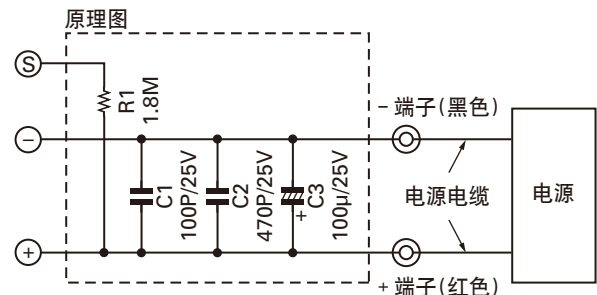
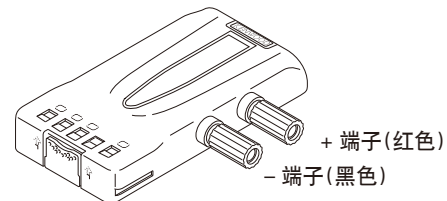

ADJUSTMENT

Radio Check Section

Item	Condition		Measurement			Adjustment			Specifications / Remarks
	Panel test mode	PC test mode	Test-equipment	Unit	Terminal	Unit	Parts	Method	
1. Frequency check	1) CH-Sig: 1-1 PTT: ON	1) Test Channel Channel: 1 Test Signaling Mode: Analog Signaling: 1 PTT: Press [Transmit] button.	f. counter	Panel	ANT			Check an internal temperature of radio from 20°C to 26°C.	155.099962~ 155.100038MHz (±0.25ppm @155.1MHz)
2. High power check (Batt: 7.5V)	1) CH-Sig: 1-1 PTT: ON	1) Test Channel Channel: 1 Test Signaling Mode: Analog Signaling: 1 PTT: Press [Transmit] button.	Power meter Ammeter					Check	4.0W~6.0W 2.0A or less
	2) CH-Sig: 2-1 PTT: ON	2) Test Channel Channel: 2 Test Signaling Mode: Analog Signaling: 1 PTT: Press [Transmit] button.							
	3) CH-Sig: 3-1 PTT: ON	3) Test Channel Channel: 3 Test Signaling Mode: Analog Signaling: 1 PTT: Press [Transmit] button.							
3. Low power check (Batt: 7.5V)	1) CH-Sig: 1-1 PTT: ON	1) Test Channel Channel: 1 Test Signaling Mode: Analog Signaling: 1 PTT: Press [Transmit] button.							0.7W~1.3W 1.0A or less
	2) CH-Sig: 2-1 PTT: ON	2) Test Channel Channel: 2 Test Signaling Mode: Analog Signaling: 1 PTT: Press [Transmit] button.							
	3) CH-Sig: 3-1 PTT: ON	3) Test Channel Channel: 3 Test Signaling Mode: Analog Signaling: 1 PTT: Press [Transmit] button.							
4. MIC sensitivity check	1) CH-Sig: 1-1 AG: 1kHz PTT: ON	1) Test Channel Channel: 1 Test Signaling Mode: Analog Signaling: 1 AG: 1kHz PTT: Press [Transmit] button.	Deviation meter Oscilloscope AG AF VTVM	Panel	ANT SP/MIC connector			Adjust AG input to get a standard MOD.	12.5mV±5.8mV

调 整

通信机检查部分

项 目	条 件		测 量			调 整			规 格 / 备 注
	面板测试模式	PC 测试模式	测量装置	单元	端子	单元	部件	方 法	
1. 频率检查	1)CH-Sig:1-1 PTT: 开启	1)测试信道 信道 :1 测试信令 模式 : 模拟 信令 :1 PTT: 按 [发射] 按钮。	频率计数器	面板	天线			确认手持对讲机的内部温度在 20℃至 26℃范围内。	155.099962~ 155.100038MHz (±0.25ppm @155.1MHz)
2. 高功率 检查 (电池电 压 :7.5V)	1)CH-Sig:1-1 PTT: 开启	1)测试信道 信道 :1 测试信令 模式 : 模拟 信令 :1 PTT: 按 [发射] 按钮。	功率计 电流表					检查	4.0W~6.0W 2.0A 或更低
	2)CH-Sig:2-1 PTT: 开启	2)测试信道 信道 :2 测试信令 模式 : 模拟 信令 :1 PTT: 按 [发射] 按钮。							
	3)CH-Sig:3-1 PTT: 开启	3)测试信道 信道 :3 测试信令 模式 : 模拟 信令 :1 PTT: 按 [发射] 按钮。							
3. 低功率 检查 (电池电 压 :7.5V)	1)CH-Sig:1-1 PTT: 开启	1)测试信道 信道 :1 测试信令 模式 : 模拟 信令 :1 PTT: 按 [发射] 按钮。							0.7W~1.3W 1.0A 或更低
	2)CH-Sig:2-1 PTT: 开启	2)测试信道 信道 :2 测试信令 模式 : 模拟 信令 :1 PTT: 按 [发射] 按钮。							
	3)CH-Sig:3-1 PTT: 开启	3)测试信道 信道 :3 测试信令 模式 : 模拟 信令 :1 PTT: 按 [发射] 按钮。							
4. 麦克风 灵敏度 检查	1)CH-Sig:1-1 AG:1kHz PTT: 开启	1)测试信道 信道 :1 测试信令 模式 : 模拟 信令 :1 AG:1kHz PTT: 按 [发射] 按钮。	频偏仪 示波器 AG AF VTVM	面板	天线 SP/MIC 连接器			调整 AG 输入以获得标准 MOD。	12.5mV ± 5.8mV

ADJUSTMENT

Item	Condition		Measurement			Adjustment			Specifications / Remarks
	Panel test mode	PC test mode	Test-equipment	Unit	Terminal	Unit	Parts	Method	
5. Sensitivity check	1) CH-Sig : 1-1 SSG output Wide: -117dBm (0.32μV) (MOD: 1kHz/±3kHz) Narrow: -117dBm (0.32μV) (MOD: 1kHz/±1.5kHz)	1) Test Channel Channel: 1 Test Signaling Mode: Analog Signaling: 1 SSG output Wide: -117dBm (0.32μV) (MOD: 1kHz/±3kHz) Narrow: -117dBm (0.32μV) (MOD: 1kHz/±1.5kHz)	SSG AF VTVM Oscilloscope Distortion meter 8Ω dummy load	Panel	ANT SP/MIC connector			Check	12dB SINAD or more

Common Section

Item	Condition		Measurement			Adjustment			Specifications / Remarks
	Panel tuning mode	PC test mode	Test-equipment	Unit	Terminal	Unit	Parts	Method	
1. Setting	1) BATT terminal voltage: 7.5V 2) SSG standard modulation [Wide] MOD: 1kHz, DEV: 3kHz [Narrow] MOD: 1kHz, DEV: 1.5kHz								
2. Counterclockwise Volume	1) Adj item: [VOL1] Adjust: [***]	1) Adj item: [Counterclockwise Volume]						<p>[Panel tuning mode] Turn the volume knob counterclockwise fully. Press [<B] key to store the adjustment value.</p> <p>[PC test mode] Turn the volume knob counterclockwise fully. Press [Apply] button to store the adjustment value.</p>	This item is needed when the variable resistor (R31-0685-05) is replaced.
3. Clockwise volume	1) Adj item: [VOL2] Adjust: [***]	1) Adj item: [Clockwise Volume]						<p>[Panel tuning mode] Turn the volume knob clockwise fully. Press [<B] key to store the adjustment value.</p> <p>[PC test mode] Turn the volume knob clockwise fully. Press [Apply] button to store the adjustment value.</p>	This item is needed when the variable resistor (R31-0685-05) is replaced.

调 整

项 目	条 件		测 量			调 整			规 格 / 备 注
	面板测试模式	PC 测试模式	测量装置	单元	端子	单元	部件	方 法	
5. 灵敏度检查	1)CH-Sig:1-1 SSG 输出 宽带： -117dBm(0.32μV) (MOD:1kHz/±3kHz) 窄带： -117dBm(0.32μV) (MOD:1kHz/±1.5kHz)	1)测试信道 信道:1 测试信令 模式:模拟 信令:1 SSG 输出 宽带： -117dBm(0.32μV) (MOD:1kHz/±3kHz) 窄带： -117dBm(0.32μV) (MOD:1kHz/±1.5kHz)	SSG AF VTVM 示波器 失真测试仪 8Ω 假负载	面板	天线 SP/MIC 连接器			检查	12dB SINAD 或更高

共通部分

项 目	条 件		测 量			调 整			规 格 / 备 注
	面板调谐模式	PC 测试模式	测量装置	单元	端子	单元	部件	方 法	
1. 设置	1)BATT 端子电压 :7.5V 2)SSG 标准调制 [宽带] MOD:1kHz, DEV:3kHz [窄带] MOD:1kHz, DEV:1.5kHz								
2. 逆时针音量	1)调整项目:[VOL1] 调整:[***]	1)调整项目:[逆时针音量]						<p>[面板调谐模式] 逆时针完全转动音量旋钮。 按 [<B] 键储存调整值。</p> <p>[PC 测试模式] 逆时针完全转动音量旋钮。 按 [应用] 按钮储存调整值。</p>	更换可变电阻器 (R31-0685-05) 时需调整此项。
3. 顺时针音量	1)调整项目:[VOL2] 调整:[***]	1)调整项目:[顺时针音量]						<p>[面板调谐模式] 顺时针完全转动音量旋钮。 按 [<B] 键储存调整值。</p> <p>[PC 测试模式] 顺时针完全转动音量旋钮。 按 [应用] 按钮储存调整值。</p>	更换可变电阻器 (R31-0685-05) 时需调整此项。

ADJUSTMENT

Item	Condition		Measurement			Adjustment			Specifications / Remarks
	Panel tuning mode	PC test mode	Test-equipment	Unit	Terminal	Unit	Parts	Method	
4. Receive Assist	* This adjustment can be performed only in PC test mode.	1) Adj item: [Receive Assist] 2) Adj item: [Low], [Low'], [Center], [High'], [High] Press [Apply All] button to store the adjustment value.				Panel	[PC test mode] [◀], [▶]	[PC test mode] [Automatic Adjustment] 1) Press [Tune Assist Voltage] button. 2) Press [Apply All] button to store the adjustment value after the automatic adjustment has finished. [Manual Adjustment] [V] indicator on the PC window shows VCO lock voltage. Change the adjustment value to get VCO lock voltage within the limit of the specified voltage. Note: Confirm the VCO lock voltage approximately 3 seconds after the adjustment value is changed.	2.5V±0.1V [Automatic Adjustment] After the automatic adjustment is performed, verify that the VCO lock voltage is within the voltage range which is specified by the manual adjustment. [Manual Adjustment] Press [Apply All] button to store the adjustment value after all adjustment points have been adjusted. Note: The assist adjustment value must be between from 340 to 3550.
5. Transmit Assist	* This adjustment can be performed only in PC test mode.	1) Adj item: [Transmit Assist] 2) Adj item: [Low], [Low'], [Center], [High'], [High] PTT: Press [Transmit] button. Press [Apply All] button to store the adjustment value.							
6. Frequency	* This adjustment can be performed only in PC test mode.	1) Adj item: [Frequency] SSG output: -20dBm (22.4mV) (CW (without modulation)) Caution: Perform the frequency adjustment under the following conditions. • Temperature range of +20°C to +26°C (+68.0°F to +78.8°F). (The temperature is displayed on the Frequency adjustment screen of the KPG-141D(C).) • Use an accuracy of 0.003ppm for the SSG. (Use a standard oscillator if necessary.)	SSG	Panel	ANT			[PC test mode] Press [Start] button of "Auto Tuning". Press [Apply] button to store the adjustment value after the automatic adjustment has finished.	[PC test mode] "IF20" value = Within 0±12 digits. The value of "IF20" will become around "0" after the adjustment has finished. Remark: "Frequency" is adjusted under receiving condition with SSG.

调 整

项 目	条 件		测 量			调 整			规 格 / 备 注
	面板调谐模式	PC 测试模式	测量装置	单元	端子	单元	部件	方 法	
4. 接收辅助	* 仅可在 PC 测试模式中进行调整。	1) 调整项目:[接收辅助] 2) 调整项目:[低],[低'],[中],[高'],[高] 按[全部应用]按钮储存调整值。				面板	[PC 测试模式] [自动调整] 1) 按[调整辅助电压]按钮。 2) 自动调整完成后,按[全部应用]按钮储存调整值。 [手动调整] PC 窗口上的[V]指示显示 VCO 锁定电压。更改调整值,以获得指定电压范围内的 VCO 锁定电压。 注意: 在更改调整值约 3 秒后确认 VCO 锁定电压。	2. 5V±0. 1V [自动调整] 执行自动调整后,验证 VCO 锁定电压是否处于手动调整指定的电压范围内。 [手动调整] 在所有调整点调整之后,按[全部应用]按钮储存调整值。 注意: 辅助调整值必须介于 340 至 3550 之间。	
5. 发射辅助	* 仅可在 PC 测试模式中进行调整。	1) 调整项目:[发射辅助] 2) 调整项目:[低],[低'],[中],[高'],[高] PTT: 按[发射]按钮。 按[全部应用]按钮储存调整值。							
6. 频率	* 仅可在 PC 测试模式中进行调整。	1) 调整项目:[频率] SSG 输出: -20dBm (22. 4mV) (CW (无调制)) 注意: 在下述条件下进行频率调整。 • 温度范围 +20℃至 +26℃。 (KPG-141D(C) 的频率调整画面和手持对讲机的 LCD 上显示频率。) • 使用 0. 003ppm 的 SSG 精度。(如有必要,请使用标准振荡器。)	SSG	面板	天线		[PC 测试模式] 按“自动调整”的[开始]按钮。 自动调整完成之后,按[应用]按钮储存调整值。	[PC 测试模式] “IF20”值=0±12 位以内。 调整结束后,“IF20”的值将变成“0”左右。 备注: 在 SSG 接收条件下调整“频率”。	

ADJUSTMENT

Transmitter Section

Item	Condition		Measurement			Adjustment			Specifications / Remarks
	Panel tuning mode	PC test mode	Test-equipment	Unit	Terminal	Unit	Parts	Method	
1. High power (Batt: 7.5V)	1) Adj item: [HPWR] Adjust: [*****.] 2) Adj item: [H.PWR_]→ [H.P.WR_]→[H.P.W.R_]→ [H.P.W.R_]→[H.P.W.R._] Adjust: [*****.] PTT: ON Press [<B] key to store the adjustment value.	1) Adj item: [High Transmit Power] 2) Adj item: [Low], [Low'], [Center], [High'], [High] PTT: Press [Transmit] button. Press [Apply All] button to store the adjustment value.	Power meter Ammeter	Panel	ANT	Panel	[Panel tuning mode] Selector [PC test mode] [◀,▶]	5.0W	±0.1W 2.0A or less [PC test mode] Press [Apply All] button to store the adjustment value after all adjustment points have been adjusted.
2. Low power (Batt: 7.5V)	1) Adj item: [LPWR] Adjust: [*****.] 2) Adj item: [L.PWR_]→ [L.P.WR_]→[L.P.W.R_]→ [L.P.W.R_]→[L.P.W.R._] Adjust: [*****.] PTT: ON Press [<B] key to store the adjustment value.	1) Adj item: [Low Transmit Power] 2) Adj item: [Low], [Low'], [Center], [High'], [High] PTT: Press [Transmit] button. Press [Apply All] button to store the adjustment value.						1.0W	±0.05W 1.0A or less [PC test mode] Press [Apply All] button to store the adjustment value after all adjustment points have been adjusted.
3. Balance *2	1) Adj item: [BAL] Adjust: [*****.] Deviation meter LPF: 3kHz HPF: OFF 2) Adj item: [B.AL_]→ [B.A.L_]→[B.A.L_]→ [B.A.L_]→[B.A.L._] Adjust: [*****.] PTT: ON Press [<B] key to store the adjustment value. [Side1] key: Press while transmitting to change 20Hz and 2kHz. 20Hz: “-” not appears 2kHz: “-” appears	1) Adj item: [Balance] Deviation meter LPF: 3kHz HPF: OFF 2) Adj item: [Low], [Low'], [Center], [High'], [High] PTT: Press [Transmit] button. Press [Apply All] button to store the adjustment value. [2kHz Sine Wave] Check box: Check while transmitting change to 2kHz.	Deviation meter Oscilloscope	Panel	ANT	Panel	[Panel tuning mode] Selector [PC test mode] [◀,▶]	The Deviation of 20Hz frequency is fixed. Change the 2kHz adjustment value to become the same deviation of 20Hz within the specified range.	2kHz Tone deviation is within ±1.0% of 20Hz tone deviation. [PC test mode] Press [Apply All] button to store the adjustment value after all adjustment points have been adjusted.
*2: Refer to the “Necessary Deviation adjustment item for each signaling and mode” table on pages 76 and 78. Balance adjustment is common with the adjustment of all signaling deviations.									
4. Maximum Deviation (NXDN) *3 [Narrow]	1) Adj item: [NDEV] Adjust: [*****.] Deviation meter LPF: 3kHz HPF: OFF 2) Adj item: [N.DEV_]→ [N.D.E.V_]→[N.D.E.V_]→ [N.D.E.V_]→[N.D.E.V._] Adjust: [*****.] PTT: ON Press [<B] key to store the adjustment value.	1) Adj item: [Maximum Deviation (NXDN Narrow)] Deviation meter LPF: 3kHz HPF: OFF 2) Adj item: [Low], [Low'], [Center], [High'], [High] PTT: Press [Transmit] button. Press [Apply All] button to store the adjustment value.	Deviation meter Oscilloscope	Panel	ANT	Panel	[Panel tuning mode] Selector [PC test mode] [◀,▶]	3056Hz Write the value as followings. 513 (Reference value)	2995~3117Hz [PC test mode] Press [Apply All] button to store the adjustment value after all adjustment points have been adjusted.

调 整

发射部分

项 目	条 件		测 量			调 整			规 格 / 备 注
	面板调谐模式	PC 测试模式	测量装置	单元	端子	单元	部件	方 法	
1. 高发射功率 (电池电压 :7.5V)	1) 调整项目 : [HPWR] 调整 : [*****.] 2) 调整项目 : [H.PWR] → [H.P.WR_] → [H.P.W.R_] → [H.P.W.R._] 调整 : [*****.] PTT: 开启 按 [<B] 键储存调整值。	1) 调整项目 : [高发射功率] 2) 调整项目 : [低], [低'], [中], [高'], [高] PTT: 按 [发射] 按钮。 按 [全部应用] 按钮储存调整值。	功率计 电流表	面板	天线	面板	[面板调谐模式] 选择器 [PC 测试模式] [◀], [▶]	5.0W	±0.1W 2.0A 或更低 [PC 测试模式] 调整所有调整点之后, 按 [全部应用] 按钮储存调整值。
2. 低发射功率 (电池电压 :7.5V)	1) 调整项目 : [LPWR] 调整 : [*****.] 2) 调整项目 : [L.PWR] → [L.P.WR_] → [L.P.W.R_] → [L.P.W.R._] 调整 : [*****.] PTT: 开启 按 [<B] 键储存调整值。	1) 调整项目 : [低发射功率] 2) 调整项目 : [低], [低'], [中], [高'], [高] PTT: 按 [发射] 按钮。 按 [全部应用] 按钮储存调整值。						1.0W	±0.05W 1.0A 或更低 [PC 测试模式] 调整所有调整点之后, 按 [全部应用] 按钮储存调整值。
3. 平衡 *2	1) 调整项目 : [BAL] 调整 : [*****.] 频偏仪 LPF: 3kHz HPF: 关闭 2) 调整项目 : [B.AL_] → [B.A.L_] → [B.A.L._] → [B.A.L._.] 调整 : [*****.] PTT: 开启 按 [<B] 键储存调整值。 [侧面 1] 键 : 发射时按此键更改 20Hz 和 2kHz。 20Hz: “ - ” 不出现 2kHz: “ - ” 出现	1) 调整项目 : [平衡] 频偏仪 LPF: 3kHz HPF: 关闭 2) 调整项目 : [低], [低'], [中], [高'], [高] PTT: 按 [发射] 按钮。 按 [全部应用] 按钮储存调整值。 [2kHz 正弦波] 复选框 : 发射时复选此项改为 2kHz。	频偏仪 示波器	面板	天线	面板	[面板调谐模式] 选择器 [PC 测试模式] [◀], [▶]	20Hz 频率的频偏固定。 更改 2kHz 调整值, 变成指定范围内 20Hz 的相同频偏。	2kHz 音调频偏在 20Hz 音调频偏的 ±1.0% 以内。 [PC 测试模式] 调整所有调整点之后, 按 [全部应用] 按钮储存调整值。
*2: 请参阅第 77 和 79 页的“各信令和模式所需的频偏调整项目”表。 所有信令频偏的平衡调整共用。									
4. 最大频偏 (NXDN) *3 [窄带]	1) 调整项目 : [NDEV] 调整 : [*****.] 频偏仪 LPF: 3kHz HPF: 关闭 2) 调整项目 : [N.DEV_] → [N.D.EV_] → [N.D.E.V_] → [N.D.E.V._] 调整 : [*****.] PTT: 开启 按 [<B] 键储存调整值。	1) 调整项目 : [最大频偏 (NXDN 窄带)] 频偏仪 LPF: 3kHz HPF: 关闭 2) 调整项目 : [低], [低'], [中], [高'], [高] PTT: 按 [发射] 按钮。 按 [全部应用] 按钮储存调整值。	频偏仪 示波器	面板	天线	面板	[面板调谐模式] 选择器 [PC 测试模式] [◀], [▶]	3056Hz 写入以下值。 513 (基准值)	2995~3117Hz [PC 测试模式] 调整所有调整点之后, 按 [全部应用] 按钮储存调整值。

ADJUSTMENT

Item	Condition		Measurement			Adjustment			Specifications / Remarks
	Panel tuning mode	PC test mode	Test-equipment	Unit	Terminal	Unit	Parts	Method	
Maximum Deviation (NXDN) *3 [Very Narrow]	1) Adj item: [NDEV] Adjust: [****] 2) Adj item: [N.DEV_]→ [N.D.EV_]→[N.D.E.V_]→ [N.D.E.V_]→[N.D.E.V_]→ Adjust: [****] PTT: ON Press [<B] key to store the adjustment value.	1) Adj item: [Maximum Deviation (NXDN Very Narrow)] 2) Adj item: [Low], [Low'], [Center], [High'], [High] PTT: Press [Transmit] button. Press [Apply All] button to store the adjustment value.	Deviation meter Oscilloscope	Panel	ANT	Panel	[Panel tuning mode] Selector [PC test mode] [◀,▶]	1337Hz Write the value as followings. 513 (Reference value)	1311~1363Hz [PC test mode] Press [Apply All] button to store the adjustment value after all adjustment points have been adjusted.
5. Maximum Deviation (Analog) *3 [Narrow]	1) Adj item: [ADEV] Adjust: [****.] Deviation meter LPF: 15kHz HPF: OFF 2) Adj item: [A.DEV_]→ [A.D.EV_]→[A.D.E.V_]→ [A.D.E.V_]→[A.D.E.V_]→ Adjust: [****.] PTT: ON Press [<B] key to store the adjustment value.	1) Adj item: [Maximum Deviation (Analog Narrow)] Deviation meter LPF: 15kHz HPF: OFF 2) Adj item: [Low], [Low'], [Center], [High'], [High] PTT: Press [Transmit] button. Press [Apply All] button to store the adjustment value.						2100Hz Write the value as followings. 513 (Reference value)	2050~2150Hz [PC test mode] Press [Apply All] button to store the adjustment value after all adjustment points have been adjusted.
[Wide]	1) Adj item: [ADEV] Adjust: [**.*.]. 2) Adj item: [A.DEV_]→ [A.D.EV_]→[A.D.E.V_]→ [A.D.E.V_]→[A.D.E.V_]→ Adjust: [**.*.]. PTT: ON Press [<B] key to store the adjustment value.	1) Adj item: [Maximum Deviation (Analog Wide)] 2) Adj item: [Low], [Low'], [Center], [High'], [High] PTT: Press [Transmit] button. Press [Apply All] button to store the adjustment value.						4200Hz Write the value as followings. 513 (Reference value)	4150~4250Hz [PC test mode] Press [Apply All] button to store the adjustment value after all adjustment points have been adjusted.
*3: Refer to the "Necessary Deviation adjustment item for each signaling and mode" table on pages 76 and 78. Regarding Maximum Deviation (Analog), it is common with the adjustment of all analog signalings.									
6. QT Deviation *4 [Narrow]	1) Adj item: [QT] Adjust: [****.] Deviation meter LPF: 3kHz HPF: OFF PTT: ON Press [<B] key to store the adjustment value.	1) Adj item: [QT Deviation (Analog Narrow)] Deviation meter LPF: 3kHz HPF: OFF PTT: Press [Transmit] button. Press [Apply] button to store the adjustment value.	Deviation meter Oscilloscope	Panel	ANT	Panel	[Panel tuning mode] Selector [PC test mode] [◀,▶]	Write the value as followings. 513 (Reference value)	0.35kHz±0.05kHz
[Wide]	1) Adj item: [QT] Adjust: [**.*.]. PTT: ON Press [<B] key to store the adjustment value.	1) Adj item: [QT Deviation (Analog Wide)] PTT: Press [Transmit] button. Press [Apply] button to store the adjustment value.							0.75kHz±0.05kHz

调 整

项 目	条 件		测 量			调 整			规 格 / 备 注
	面板调谐模式	PC 测试模式	测量装置	单元	端子	单元	部件	方 法	
最大频偏 (NXDN) *3 [窄带]	1) 调整项目:[NDEV] 调整:[*****] 2) 调整项目: [N.DEV_]→[N.D.EV_]→ [N.D.E.V_]→ [N.D.E.V.] 调整:[*****] PTT: 开启 按 [<B] 键储存调整值。	1) 调整项目:[最大 频偏 (NXDN 甚窄 带)] 2) 调整项目:[低], [低'], [中], [高'], [高] PTT: 按 [发射] 按钮。 按 [全部应用] 按钮储存调整值。	频偏仪 示波器	面板	天线	面板	[面板调 谐模式] 选择器 [PC 测 试模式] [<], [>]	1337Hz 写入以下值。 513 (基准值)	1311~1363Hz [PC 测试模式] 调整所有调整点之 后, 按 [全部应用] 按钮储存调整值。
5. 最大频偏 (模拟) *3 [窄带]	1) 调整项目:[ADEV] 调整:[*****.] 频偏仪 LPF: 15kHz HPF: 关闭 2) 调整项目: [A.DEV_]→[A.D.EV_]→ [A.D.E.V_]→ [A.D.E.V.] 调整:[*****.] PTT: 开启 按 [<B] 键储存调整值。	1) 调整项目:[最大 频偏 (模拟窄带)] 频偏仪 LPF: 15kHz HPF: 关闭 2) 调整项目:[低], [低'], [中], [高'], [高] PTT: 按 [发射] 按钮。 按 [全部应用] 按钮储存调整值。						2100Hz 写入以下值。 513 (基准值)	2050~2150Hz [PC 测试模式] 调整所有调整点之 后, 按 [全部应用] 按钮储存调整值。
[宽带]	1) 调整项目:[ADEV] 调整:[**.*.*.] 2) 调整项目: [A.DEV_]→[A.D.EV_]→ [A.D.E.V_]→ [A.D.E.V.] 调整:[**.*.*.] PTT: 开启 按 [<B] 键储存调整值。	1) 调整项目:[最大 频偏 (模拟宽带)] 2) 调整项目:[低], [低'], [中], [高'], [高] PTT: 按 [发射] 按钮。 按 [全部应用] 按钮储存调整值。						4200Hz 写入以下值。 513 (基准值)	4150~4250Hz [PC 测试模式] 调整所有调整点之 后, 按 [全部应用] 按钮储存调整值。
*3: 请参阅第 77 和 79 页的“各信令和模式所需的频偏调整项目”表。 对于最大频偏 (模拟), 所有模拟信令的调整共用。									
6. QT 频偏 *4 [窄带]	1) 调整项目:[QT] 调整:[*****.] 频偏仪 LPF: 3kHz HPF: 关闭 PTT: 开启 按 [<B] 键储存调整值。	1) 调整项目:[QT 频 偏 (模拟窄带)] 频偏仪 LPF: 3kHz HPF: 关闭 PTT: 按 [发射] 按钮。 按 [应用] 按钮储 存调整值。	频偏仪 示波器	面板	天线	面板	[面板调 谐模式] 选择器 [PC 测 试模式] [<], [>]	写入以下值。 513 (基准值)	0. 35kHz ± 0. 05kHz
[宽带]	1) 调整项目:[QT] 调整:[**.*.*.] PTT: 开启 按 [<B] 键储存调整值。	1) 调整项目:[QT 频 偏 (模拟宽带)] PTT: 按 [发射] 按钮。 按 [应用] 按钮储 存调整值。							0. 75kHz ± 0. 05kHz

ADJUSTMENT

Item	Condition		Measurement			Adjustment			Specifications / Remarks
	Panel tuning mode	PC test mode	Test-equipment	Unit	Terminal	Unit	Parts	Method	
7. DQT Deviation *4 [Narrow]	1) Adj item: [DQT] Adjust: [****.] Deviation meter LPF: 3kHz HPF: OFF PTT: ON Press [<B] key to store the adjustment value.	1) Adj item: [DQT Deviation (Analog Narrow)] Deviation meter LPF: 3kHz HPF: OFF PTT: Press [Transmit] button. Press [Apply] button to store the adjustment value.	Deviation meter Oscilloscope	Panel	ANT	Panel	[Panel tuning mode] Selector [PC test mode] [◀,▶]	Write the value as followings. 430 (Reference value)	0.35kHz±0.05kHz
	[Wide]	1) Adj item: [DQT] Adjust: [***.***.] PTT: ON Press [<B] key to store the adjustment value.							1) Adj item: [DQT Deviation (Analog Wide)] PTT: Press [Transmit] button. Press [Apply] button to store the adjustment value.
8. LTR Deviation *4 [Narrow]	1) Adj item: [LTR] Adjust: [****.] Deviation meter LPF: 3kHz HPF: OFF PTT: ON Press [<B] key to store the adjustment value.	1) Adj item: [LTR Deviation (Analog Narrow)] Deviation meter LPF: 3kHz HPF: OFF PTT: Press [Transmit] button. Press [Apply] button to store the adjustment value.						Write the value as followings. 465 (Reference value)	0.75kHz±0.05kHz
	[Wide]	1) Adj item: [LTR] Adjust: [***.***.] PTT: ON Press [<B] key to store the adjustment value.							1) Adj item: [LTR Deviation (Analog Wide)] PTT: Press [Transmit] button. Press [Apply] button to store the adjustment value.
9. DTMF Deviation *4 [Narrow]	1) Adj item: [DTMF] Adjust: [****.] Deviation meter LPF: 15kHz HPF: OFF PTT: ON Press [<B] key to store the adjustment value.	1) Adj item: [DTMF Deviation (Analog Narrow)] Deviation meter LPF: 15kHz HPF: OFF PTT: Press [Transmit] button. Press [Apply] button to store the adjustment value.						Write the value as followings. 540 (Reference value)	1.25kHz±0.05kHz
	[Wide]	1) Adj item: [DTMF] Adjust: [***.***.] PTT: ON Press [<B] key to store the adjustment value.							1) Adj item: [DTMF Deviation (Analog Wide)] PTT: Press [Transmit] button. Press [Apply] button to store the adjustment value.

调 整

项 目	条 件		测 量			调 整			规 格 / 备 注
	面板调谐模式	PC 测试模式	测量装置	单元	端子	单元	部件	方 法	
7. DQT 频偏 *4 [窄带]	1) 调整项目 : [DQT] 调整 : [****.] 频偏仪 LPF: 3kHz HPF: 关闭 PTT: 开启 按 [<B] 键储存调整值。	1) 调整项目 : [DQT 频偏 (模拟窄带)] 频偏仪 LPF: 3kHz HPF: 关闭 PTT: 按 [发射] 按钮。 按 [应用] 按钮储存调整值。	频偏仪 示波器	面板	天线	面板	[面板调谐模式] 选择器 [PC 测试模式] [<], [>]	写入以下值。 430 (基准值)	0.35kHz ± 0.05kHz
[宽带]	1) 调整项目 : [DQT] 调整 : [**.*.*.] PTT: 开启 按 [<B] 键储存调整值。	1) 调整项目 : [DQT 频偏 (模拟宽带)] PTT: 按 [发射] 按钮。 按 [应用] 按钮储存调整值。							0.75kHz ± 0.05kHz
8. LTR 频偏 *4 [窄带]	1) 调整项目 : [LTR] 调整 : [****.] 频偏仪 LPF: 3kHz HPF: 关闭 PTT: 开启 按 [<B] 键储存调整值。	1) 调整项目 : [LTR 频偏 (模拟窄带)] 频偏仪 LPF: 3kHz HPF: 关闭 PTT: 按 [发射] 按钮。 按 [应用] 按钮储存调整值。						写入以下值。 465 (基准值)	0.75kHz ± 0.05kHz
[宽带]	1) 调整项目 : [LTR] 调整 : [**.*.*.] PTT: 开启 按 [<B] 键储存调整值。	1) 调整项目 : [LTR 频偏 (模拟宽带)] PTT: 按 [发射] 按钮。 按 [应用] 按钮储存调整值。							1.00kHz ± 0.05kHz
9. DTMF 频偏 *4 [窄带]	1) 调整项目 : [DTMF] 调整 : [****.] 频偏仪 LPF: 15kHz HPF: 关闭 PTT: 开启 按 [<B] 键储存调整值。	1) 调整项目 : [DTMF 频偏 (模拟窄带)] 频偏仪 LPF: 15kHz HPF: 关闭 PTT: 按 [发射] 按钮。 按 [应用] 按钮储存调整值。						写入以下值。 540 (基准值)	1.25kHz ± 0.05kHz
[宽带]	1) 调整项目 : [DTMF] 调整 : [**.*.*.] PTT: 开启 按 [<B] 键储存调整值。	1) 调整项目 : [DTMF 频偏 (模拟宽带)] PTT: 按 [发射] 按钮。 按 [应用] 按钮储存调整值。							2.50kHz ± 0.05kHz

ADJUSTMENT

Item	Condition		Measurement			Adjustment			Specifications / Remarks
	Panel tuning mode	PC test mode	Test-equipment	Unit	Terminal	Unit	Parts	Method	
10. Single Tone Deviation *4 [Narrow]	1) Adj item: [TONE] Adjust: [****.] Deviation meter LPF: 15kHz HPF: OFF PTT: ON Press [<B] key to store the adjustment value.	1) Adj item: [Single Tone Deviation (Analog Narrow)] Deviation meter LPF: 15kHz HPF: OFF PTT: Press [Transmit] button. Press [Apply] button to store the adjustment value.	Deviation meter Oscilloscope	Panel	ANT	Panel	[Panel tuning mode] Selector [PC test mode] [◀,▶]	Write the value as followings. 513 (Reference value)	1.50kHz±0.05kHz
	[Wide]	1) Adj item: [TONE] Adjust: [***.***.] PTT: ON Press [<B] key to store the adjustment value.							1) Adj item: [Single Tone Deviation (Analog Wide)] PTT: Press [Transmit] button. Press [Apply] button to store the adjustment value.
11. MSK Deviation *4 [Narrow]	1) Adj item: [MSK] Adjust: [****.] Deviation meter LPF: 15kHz HPF: OFF PTT: ON Press [<B] key to store the adjustment value.	1) Adj item: [MSK Deviation (Analog Narrow)] Deviation meter LPF: 15kHz HPF: OFF PTT: Press [Transmit] button. Press [Apply] button to store the adjustment value.						Write the value as followings. 513 (Reference value)	1.50kHz±0.05kHz
	[Wide]	1) Adj item: [MSK] Adjust: [***.***.] PTT: ON Press [<B] key to store the adjustment value.							1) Adj item: [MSK Deviation (Analog Wide)] PTT: Press [Transmit] button. Press [Apply] button to store the adjustment value.
12. CW ID Deviation *4 [NXDN Very Narrow]	1) Adj item: [CWID] Adjust: [****] Deviation meter LPF: 15kHz HPF: OFF PTT: ON Press [<B] key to store the adjustment value.	1) Adj item: [CW ID Deviation (NXDN Very Narrow)] Deviation meter LPF: 15kHz HPF: OFF PTT: Press [Transmit] button. Press [Apply] button to store the adjustment value.						Write the value as followings. 376 (Reference value)	1.00kHz±0.10kHz

*4: Refer to the "Necessary Deviation adjustment item for each signaling and mode" table on pages 76 and 78.

调 整

项 目	条 件		测 量			调 整			规 格 / 备 注
	面板调谐模式	PC 测试模式	测量装置	单元	端子	单元	部件	方 法	
10. 单音 频偏 *4 [窄带]	1) 调整项目:[TONE] 调整:[****.] 频偏仪 LPF:15kHz HPF: 关闭 PTT: 开启 按 [<B] 键储存调整值。	1) 调整项目:[单音 频偏 (模拟窄带)] 频偏仪 LPF:15kHz HPF: 关闭 PTT: 按 [发射] 按钮。 按 [应用] 按钮储存调整值。	频偏仪 示波器	面板	天线	面板	[面板调 谐模式] 选择器 [PC 测 试模式] [<], [>]	写入以下值。 513 (基准值)	1. 50kHz ± 0. 05kHz
	[宽带]	1) 调整项目:[TONE] 调整:[*. *. *. .] PTT: 开启 按 [<B] 键储存调整值。							1) 调整项目:[单音 频偏 (模拟宽带)] PTT: 按 [发射] 按钮。 按 [应用] 按钮储存调整值。
11. MSK 频偏 *4 [窄带]	1) 调整项目:[MSK] 调整:[****.] 频偏仪 LPF:15kHz HPF: 关闭 PTT: 开启 按 [<B] 键储存调整值。	1) 调整项目:[MSK 频 偏 (模拟窄带)] 频偏仪 LPF:15kHz HPF: 关闭 PTT: 按 [发射] 按钮。 按 [应用] 按钮储存调整值。						写入以下值。 513 (基准值)	1. 50kHz ± 0. 05kHz
	[宽带]	1) 调整项目:[MSK] 调整:[*. *. *. .] PTT: 开启 按 [<B] 键储存调整值。							1) 调整项目:[MSK 频 偏 (模拟宽带)] PTT: 按 [发射] 按钮。 按 [应用] 按钮储存调整值。
12. CW ID 频偏 *4 [甚窄带]	1) 调整项目:[CWID] 调整:[****] 频偏仪 LPF:15kHz HPF: 关闭 PTT: 开启 按 [<B] 键储存调整值。	1) 调整项目:[CW ID 频偏 (NXDN 甚窄 带)] 频偏仪 LPF:15kHz HPF: 关闭 PTT: 按 [发射] 按钮。 按 [应用] 按钮储存调整值。						写入以下值。 376 (基准值)	1. 00kHz ± 0. 10kHz

*4: 请参阅第 77 和 79 页的“各信令和模式所需的频偏调整项目”表。

ADJUSTMENT

Item	Condition		Measurement			Adjustment			Specifications / Remarks
	Panel tuning mode	PC test mode	Test-equipment	Unit	Terminal	Unit	Parts	Method	
13. Battery Warning Level writing	1) Adj item: [BATT] Adjust: [***] PTT: ON	1) Adj item: [Battery Warning Level] PTT: Press [Transmit] button.	Power meter DVM	Panel	ANT BATT terminal			Press the PTT switch or [Transmit] button on the PC window. Apply 6.20V to battery terminal. Confirm that one pre-determined numeric in the range 1 to 256 appears. [Panel tuning mode] Press [<B] key to store the adjustment value. [PC test mode] Press [Apply] button to store the adjustment value.	
14. Battery Warning Level check	[Panel test mode] 1) CH-Sig: 1-1 BATT terminal voltage: 6.0V while transmitting	1) Test Channel Channel: 1 Test Signaling Mode: Analog Signaling: 1 BATT terminal voltage: 6.0V while transmitting						Check	The transceiver can transmit with causing the LED to blink.

■ Necessary Deviation adjustment item for each signaling and mode

The following shows the necessary adjustment items for each signaling deviation. Please read the following table like the following example. In the case of the signaling "QT (Wide)", this signaling is composed of three elements [Balance, Maximum Deviation (Analog Wide) and QT Deviation (Wide)]. Please adjust Balance and Maximum Deviation (Analog Wide) before adjusting QT Deviation (Wide).

Mode	Signaling	Necessary adjustment and order		
		Wide	Narrow	Very Narrow
Analog	Audio	Step 1. Balance adjust Step 2. Maximum Deviation (Analog Wide)	Step 1. Balance adjust Step 2. Maximum Deviation (Analog Narrow)	-
	QT	Step 1. Balance adjust Step 2. Maximum Deviation (Analog Wide) Step 3. QT Deviation (Wide)	Step 1. Balance adjust Step 2. Maximum Deviation (Analog Narrow) Step 3. QT Deviation (Narrow)	-
	DQT	Step 1. Balance adjust Step 2. Maximum Deviation (Analog Wide) Step 3. DQT Deviation (Wide)	Step 1. Balance adjust Step 2. Maximum Deviation (Analog Narrow) Step 3. DQT Deviation (Narrow)	-
	LTR	Step 1. Balance adjust Step 2. Maximum Deviation (Analog Wide) Step 3. LTR Deviation (Wide)	Step 1. Balance adjust Step 2. Maximum Deviation (Analog Narrow) Step 3. LTR Deviation (Narrow)	-
	DTMF	Step 1. Balance adjust Step 2. Maximum Deviation (Analog Wide) Step 3. DTMF Deviation (Wide)	Step 1. Balance adjust Step 2. Maximum Deviation (Analog Narrow) Step 3. DTMF Deviation (Narrow)	-
	MSK (FleetSync)	Step 1. Balance adjust Step 2. Maximum Deviation (Analog Wide) Step 3. MSK Deviation (Analog Wide)	Step 1. Balance adjust Step 2. Maximum Deviation (Analog Narrow) Step 3. MSK Deviation (Analog Narrow)	-

调 整

项 目	条 件		测 量			调 整			规 格 / 备 注
	面板调谐模式	PC 测试模式	测量装置	单元	端子	单元	部件	方 法	
13. 电池告警电平写入	1)调整项目:[BATT] 调整:[***] PTT: 开启	1)调整项目:[电池告警电平] PTT: 按 [发射] 按钮。	功率计 DVM	面板	天线 BATT 终端			按 PTT 开关或 PC 窗口上的 [发射] 按钮。 在电池端子上施加 6.20V。确认范围 1 至 256 中出现预定的数字。 [面板调谐模式] 按 [<B] 键储存调整值。 [PC 测试模式] 按 [应用] 按钮储存调整值。	
14. 电池告警电平检查	[面板测试模式] 1)CH-Sig:1-1 BATT 端子电压 : 发射时 6.0V	1)测试信道 信道:1 测试信令 模式: 模拟 信令:1 BATT 端子电压 : 发射时 6.0V						检查	手持对讲机可以发射, 使 LED 闪烁。

■ 各信令和模式所需的频偏调整项目

下表显示了各信令频偏所需的调整项目。请按照以下示例阅读下表。对于信令“QT (宽带)”, 该信令包含三个组成部分 [平衡, 最大频偏 (模拟宽带) 和 QT 频偏 (宽带)]。请在调整 QT 频偏 (宽带) 之前调整平衡和最大频偏 (模拟宽带)。

模式	信令	所需的调整和顺序		
		宽 带	窄 带	甚 窄 带
模拟	音频	步骤 1. 平衡调整 步骤 2. 最大频偏 (模拟宽带)	步骤 1. 平衡调整 步骤 2. 最大频偏 (模拟窄带)	-
	QT	步骤 1. 平衡调整 步骤 2. 最大频偏 (模拟宽带) 步骤 3. QT 频偏 (宽带)	步骤 1. 平衡调整 步骤 2. 最大频偏 (模拟窄带) 步骤 3. QT 频偏 (窄带)	-
	DQT	步骤 1. 平衡调整 步骤 2. 最大频偏 (模拟宽带) 步骤 3. DQT 频偏 (宽带)	步骤 1. 平衡调整 步骤 2. 最大频偏 (模拟窄带) 步骤 3. DQT 频偏 (窄带)	-
	LTR	步骤 1. 平衡调整 步骤 2. 最大频偏 (模拟宽带) 步骤 3. LTR 频偏 (宽带)	步骤 1. 平衡调整 步骤 2. 最大频偏 (模拟窄带) 步骤 3. LTR 频偏 (窄带)	-
	DTMF	步骤 1. 平衡调整 步骤 2. 最大频偏 (模拟宽带) 步骤 3. DTMF 频偏 (宽带)	步骤 1. 平衡调整 步骤 2. 最大频偏 (模拟窄带) 步骤 3. DTMF 频偏 (窄带)	-
	MSK (FleetSync)	步骤 1. 平衡调整 步骤 2. 最大频偏 (模拟宽带) 步骤 3. MSK 频偏 (模拟宽带)	步骤 1. 平衡调整 步骤 2. 最大频偏 (模拟窄带) 步骤 3. MSK 频偏 (模拟窄带)	-

ADJUSTMENT

Mode	Signaling	Necessary adjustment and order		
		Wide	Narrow	Very Narrow
NXDN	Audio	-	Step 1. Balance adjust Step 2. Maximum Deviation (NXDN Narrow)	Step 1. Balance adjust Step 2. Maximum Deviation (NXDN Very Narrow)
	CW ID	-	-	Step 1. Balance adjust Step 2. Maximum Deviation (Analog Narrow) Step 3. CW ID Deviation (NXDN Very Narrow)

- Balance is common with all the above deviation adjustments. If Balance (Transmitter Section 3) has already adjusted, please skip Step 1 and adjust from Step 2.
- Maximum Deviation (Analog Wide/Narrow) is common with all the analog signaling deviations and CW ID Deviation (NXDN Very Narrow). If Balance and Maximum Deviation (Analog Wide/Narrow) (Transmitter Section 5) have already adjusted, please skip Step 2 and adjust from Step 3.

Receiver Section

Item	Condition		Measurement			Adjustment			Specifications / Remarks
	Panel tuning mode	PC test mode	Test-equipment	Unit	Terminal	Unit	Parts	Method	
1. AF level setting	[Panel test mode] 1) CH-Sig: 1-1 SSG output: -47dBm (1mV) (MOD: 1kHz/±1.5kHz) Wide/Narrow : Narrow Beat Shift: Uncheck Compander: Uncheck	1) Test Channel Channel: 1 Test Signaling Mode: Analog Signaling: 1 Wide/Narrow : Narrow Beat Shift: Uncheck Compander: Uncheck SSG output: -47dBm (1mV) (MOD: 1kHz/±1.5kHz)	SSG DVM AF VTVM Dummy load	Panel	ANT SP/MIC connector	Panel	Volume knob	Turn the Volume Knob to obtain 0.63V AF output.	0.63V±0.1V
2. Sensitivity 1	* This adjustment can be performed only in PC test mode.	1) Adj item: [Sensitivity 1] 2) Adj item: [Low], [Low'], [Center], [High'], [High] Press [Apply All] button to store the adjustment value. 3) Adj item: [Low'], [Center], [High'], [High] Press [Apply All] button to store the adjustment value.	SSG AF VTVM Dummy load Oscilloscope	Panel	ANT SP/MIC connector		[PC test mode] [◀],[▶]	Write the value as followings. [Low]: 15 (Fixed) [Low']: 35 (Preset) [Center]: 80 (Preset) [High']: 135 (Preset) [High]: 180 (Preset) Decrease the adjustment value from the preset value to get 12dB SINAD. SSG output: -119dBm (0.25μV) (MOD: 1kHz/±1.5kHz)	Note: The Preset value of Sensitivity 2 must be written before adjusting Sensitivity 1.
3. Sensitivity 2	* This adjustment can be performed only in PC test mode.	1) Adj item: [Sensitivity 2] 2) Adj item: [Low], [Low'], [Center], [High'], [High] Press [Apply All] button to store the adjustment value. 3) Adj item: [Low] Press [Apply All] button to store the adjustment value.						Write the value as followings. [Low]: 190 (Preset) [Low']: 165 (Fixed) [Center]: 165 (Fixed) [High']: 165 (Fixed) [High]: 165 (Fixed) Decrease the adjustment value from the preset value to get 12dB SINAD. SSG output: -119dBm (0.25μV) (MOD: 1kHz/±1.5kHz)	

调 整

模式	信令	所需的调整和顺序		
		宽 带	窄 带	甚 窄 带
NXDN	音频	-	步骤 1. 平衡调整 步骤 2. 最大频偏 (NXDN 窄带)	步骤 1. 平衡调整 步骤 2. 最大频偏 (NXDN 甚窄带)
	CW ID	-	-	步骤 1. 平衡调整 步骤 2. 最大频偏 (模拟窄带) 步骤 3. CW ID 频偏 (NXDN 甚窄带)

- 上述所有频偏调整的平衡共用。如果已经调整了平衡 (发射部分 3), 请跳过步骤 1, 从步骤 2 开始调整。
- 对于所有的模拟信令频偏和 CW ID 频偏 (NXDN 甚窄带), 最大频偏 (模拟宽带 / 窄带) 共用。
如果已经调整了平衡和最大频偏 (模拟宽带 / 窄带) (发射部分 5), 请跳过步骤 2, 从步骤 3 开始调整。

接收部分

项 目	条 件		测 量			调 整			规 格 / 备 注
	面板调谐模式	PC 测试模式	测量装置	单元	端子	单元	部件	方 法	
1. AF 电平设置	[面板测试模式] 1) CH-Sig: 1-1 SSG 输出: -47dBm (1mV) (MOD: 1kHz/±1.5kHz) 宽带 / 窄带: 窄带 拍频偏移: 不选 压缩扩展器: 不选	1) 测试信道 信道: 1 测试信令 模式: 模拟 信令: 1 宽带 / 窄带: 窄带 拍频偏移: 不选 压缩扩展器: 不选 SSG 输出: -47dBm (1mV) (MOD: 1kHz/±1.5kHz)	SSG DVM AF VTVM 假负载	面板	天线 SP/MIC 连接器	面板	音量 旋钮	转动音量旋钮以获得 0.63V AF 输出。	0.63V ± 0.1V
2. 灵敏度 1	* 仅可在 PC 测试模式中进行调整。	1) 调整项目: [灵敏度 1] 2) 调整项目: [低], [低'], [中], [高'], [高] 按 [全部应用] 按钮 储存调整值。 3) 调整项目: [低'], [中], [高'], [高] 按 [全部应用] 按钮 储存调整值。	SSG AF VTVM 假负载 示波器	面板	天线 SP/MIC 连接器		[PC 测试模式] [◀], [▶]	写入以下值。 [低]: 15 (固定) [低']: 35 (预设) [中]: 80 (预设) [高']: 135 (预设) [高]: 180 (预设)	注意: 在调整灵敏度 1 之前, 必须写入灵敏度 2 的预设值。
3. 灵敏度 2	* 仅可在 PC 测试模式中进行调整。	1) 调整项目: [灵敏度 2] 2) 调整项目: [低], [低'], [中], [高'], [高] 按 [全部应用] 按钮 储存调整值。 3) 调整项目: [低] 按 [全部应用] 按钮 储存调整值。						写入以下值。 [低]: 190 (预设) [低']: 165 (固定) [中]: 165 (固定) [高']: 165 (固定) [高]: 165 (固定)	
								减小预设值的调整值以获得 12dB SINAD。 SSG 输出: -119dBm (0.25μV) (MOD: 1kHz/±1.5kHz)	
								减小预设值的调整值以获得 12dB SINAD。 SSG 输出: -119dBm (0.25μV) (MOD: 1kHz/±1.5kHz)	

ADJUSTMENT

Item	Condition		Measurement			Adjustment			Specifications / Remarks
	Panel tuning mode	PC test mode	Test-equipment	Unit	Terminal	Unit	Parts	Method	
4. RSSI reference *5 [Analog Narrow]	1) Adj item: [RRSS] Adjust: [***.] 2) Adj item: [R.RSS_]→ [R.R.SS_]→[R.R.S.S_]→ [R.R.S.S.S_]→[R.R.S.S.S._] SSG output: 12dB SINAD level -3dB (MOD: 1kHz/±1.5kHz)	1) Adj item: [RSSI Reference (Analog Narrow)] 2) Adj item: [Low], [Low'], [Center], [High'], [High] SSG output: 12dB SINAD level -3dB (MOD: 1kHz/±1.5kHz)	SSG	Panel	ANT SP/MIC connector			[Panel tuning mode] After input signal from SSG, press [<B] key to store the adjustment value. [PC test mode] After input signal from SSG, press [Apply] button to store the adjustment value.	Adjust with the analog signal.
[Analog Wide]	1) Adj item: [RRSS] Adjust: [***.] 2) Adj item: [R.RSS_]→ [R.R.SS_]→[R.R.S.S_]→ [R.R.S.S.S_]→[R.R.S.S.S._] SSG output: 12dB SINAD level -3dB (MOD: 1kHz/±3kHz)	1) Adj item: [RSSI Reference (Analog Wide)] 2) Adj item: [Low], [Low'], [Center], [High'], [High] SSG output: 12dB SINAD level -3dB (MOD: 1kHz/±3kHz)							
[NXDN Very Narrow]	1) Adj item: [RRSS] Adjust: [***] 2) Adj item: [R.RSS_]→ [R.R.SS_]→[R.R.S.S_]→ [R.R.S.S.S_]→[R.R.S.S.S._] SSG output: 12dB SINAD level -3dB (MOD: 1kHz/±1.5kHz)	1) Adj item: [RSSI Reference (NXDN Very Narrow)] 2) Adj item: [Low], [Low'], [Center], [High'], [High] SSG output: 12dB SINAD level -3dB (MOD: 1kHz/±1.5kHz)							
*5: Because RSSI Reference (NXDN Narrow) is adjusted by adjusting RSSI Reference (Analog Narrow), it is not necessary to adjust RSSI Reference (NXDN Narrow).									
5. Open Squelch *6 (Squelch level 5 adjust) [Analog Narrow]	1) Adj item: [SQL] Adjust: [***.] 2) Adj item: [S.QL_]→ [S.Q.L_]→[S.Q.L._]→ [S.Q.L._]→[S.Q.L._] SSG output: 12dB SINAD level +1dB (MOD: 1kHz/±1.5kHz)	1) Adj item: [Open Squelch (Analog Narrow)] 2) Adj item: [Low], [Low'], [Center], [High'], [High] SSG output: 12dB SINAD level +1dB (MOD: 1kHz/±1.5kHz)	SSG	Panel	ANT SP/MIC connector			[Panel tuning mode] After input signal from SSG, press [<B] key to store the adjustment value. [PC test mode] After input signal from SSG, press [Apply] button to store the adjustment value.	"Open Squelch" will not be adjusted correctly if MOD and Deviation are wrong. Remark: During production, a fixed value is written. 110 (Fixed)
[Analog Wide]	1) Adj item: [SQL] Adjust: [***.] 2) Adj item: [S.QL_]→ [S.Q.L_]→[S.Q.L._]→ [S.Q.L._]→[S.Q.L._] SSG output: 12dB SINAD level +1dB (MOD: 1kHz/±3kHz)	1) Adj item: [Open Squelch (Analog Wide)] 2) Adj item: [Low], [Low'], [Center], [High'], [High] SSG output: 12dB SINAD level +1dB (MOD: 1kHz/±3kHz)							

调 整

项 目	条 件		测 量			调 整			规 格 / 备 注
	面板调谐模式	PC 测试模式	测量装置	单元	端子	单元	部件	方 法	
4. RSSI 参考 *5 [模拟 窄带]	1) 调整项目 : [RRSS] 调整 : [***.] 2) 调整项目 : [R. RSS] → [R. R. SS_] → [R. R. S. S_] → [R. R. S. S.] → [R. R. S. S.] SSG 输出 : 12dB SINAD 电平 -3dB (MOD: 1kHz/±1.5kHz)	1) 调整项目 : [RSSI 参考 (模拟窄带)] 2) 调整项目 : [低], [低'], [中], [高'], [高] SSG 输出 : 12dB SINAD 电平 -3dB (MOD: 1kHz/±1.5kHz)	SSG	面板	天线 SP/MIC 连接器			[面板调谐模式] 从 SSG 输入信号之 后, 按 [<B] 键储 存调整值。 [PC 测试模式] 从 SSG 输入信号之 后, 按 [应用] 按 钮储存调整值。	
[模拟 宽带]	1) 调整项目 : [RRSS] 调整 : [*.*.*.] 2) 调整项目 : [R. RSS] → [R. R. SS_] → [R. R. S. S_] → [R. R. S. S.] → [R. R. S. S.] SSG 输出 : 12dB SINAD 电平 -3dB (MOD: 1kHz/±3kHz)	1) 调整项目 : [RSSI 参考 (模拟宽带)] 2) 调整项目 : [低], [低'], [中], [高'], [高] SSG 输出 : 12dB SINAD 电平 -3dB (MOD: 1kHz/±3kHz)							
[NXDN 甚窄带]	1) 调整项目 : [RRSS] 调整 : [***] 2) 调整项目 : [R. RSS] → [R. R. SS_] → [R. R. S. S_] → [R. R. S. S.] → [R. R. S. S.] SSG 输出 : 12dB SINAD 电平 -3dB (MOD: 1kHz/±1.5kHz)	1) 调整项目 : [RSSI 参考 (NXDN 甚窄 带)] 2) 调整项目 : [低], [低'], [中], [高'], [高] SSG 输出 : 12dB SINAD 电平 -3dB (MOD: 1kHz/±1.5kHz)							用模拟信号进行调 整。
*5: 由于 RSSI 参考 (NXDN 窄带) 通过调整 RSSI 参考 (模拟窄带) 进行调整, 因此不需要调整 RSSI 参考 (NXDN 窄带)。									
5. 静噪 (浅) *6 (静噪电 平 5 调整) [模拟 窄带]	1) 调整项目 : [SQL] 调整 : [***.] 2) 调整项目 : [S. QL_] → [S. Q. L_] → [S. Q. L. _] → [S. Q. L. _] → [S. Q. L. _.] SSG 输出 : 12dB SINAD 电平 +1dB (MOD: 1kHz/±1.5kHz)	1) 调整项目 : [静噪 (浅)(模拟窄带)] 2) 调整项目 : [低], [低'], [中], [高'], [高] SSG 输出 : 12dB SINAD 电平 +1dB (MOD: 1kHz/±1.5kHz)	SSG	面板	天线 SP/MIC 连接器			[面板调谐模式] 从 SSG 输入信号之 后, 按 [<B] 键储 存调整值。 [PC 测试模式] 从 SSG 输入信号之 后, 按 [应用] 按 钮储存调整值。	如果 MOD 和频偏错 误, 则不能正确调 整“静噪 (浅)”。 备注: 在生产过程中, 写 入固定值。 110 (固定)
[模拟 宽带]	1) 调整项目 : [SQL] 调整 : [*.*.*.] 2) 调整项目 : [S. QL_] → [S. Q. L_] → [S. Q. L. _] → [S. Q. L. _] → [S. Q. L. _.] SSG 输出 : 12dB SINAD 电平 +1dB (MOD: 1kHz/±3kHz)	1) 调整项目 : 静噪 (浅)(模拟宽带)] 2) 调整项目 : [低], [低'], [中], [高'], [高] SSG 输出 : 12dB SINAD 电平 +1dB (MOD: 1kHz/±3kHz)							

ADJUSTMENT

Item	Condition		Measurement			Adjustment			Specifications / Remarks
	Panel tuning mode	PC test mode	Test-equipment	Unit	Terminal	Unit	Parts	Method	
Open Squelch *6 (Squelch level 5 adjust) [NXDN Very Narrow]	1) Adj item: [SQL] Adjust: [***] 2) Adj item: [S.Q.L_]→ [S.Q.L_]→[S.Q.L_]→ [S.Q.L_]→[S.Q.L_]→ SSG output: 12dB SINAD level for Analog Narrow -4dB (MOD: 400Hz±1.1kHz)	1) Adj item: [Open squelch (NXDN Very Narrow)] 2) Adj item: [Low], [Low'], [Center], [High'], [High] SSG output: 12dB SINAD level for Analog Narrow -4dB (MOD: 400Hz±1.1kHz)	SSG	Panel	ANT SP/MIC connector			[Panel tuning mode] After input signal from SSG, press [<B] key to store the adjustment value. [PC test mode] After input signal from SSG, press [Apply] button to store the adjustment value.	Adjust with the analog signal. This item is adjusted under the condition that MOD is "400Hz" and Deviation is "±1.1kHz" due to the circuit configuration. Remark: During production, a fixed value is written. 200 (Fixed)
*6: Because Open Squelch (NXDN Narrow) is adjusted by adjusting Open Squelch (Analog Narrow), it is not necessary to adjust Open Squelch (NXDN Narrow).									
6. Low RSSI at -118dBm *7 [Analog Narrow]	1) Adj item: [LRSS] Adjust: [***.] 2) Adj item: [L.RSS_]→ [L.R.S.S_]→[L.R.S.S_]→ [L.R.S.S_]→[L.R.S.S_]→ SSG output: -118dBm (0.28µV) (MOD: 1kHz±1.5kHz)	1) Adj item: [Low RSSI (Analog Narrow)] 2) Adj item: [Low], [Low'], [Center], [High'], [High] SSG output: -118dBm (0.28µV) (MOD: 1kHz±1.5kHz)	SSG	Panel	ANT SP/MIC connector			[Panel tuning mode] After input signal from SSG, press [<B] key to store the adjustment value. [PC test mode] After input signal from SSG, press [Apply] button to store the adjustment value.	
[Analog Wide]	1) Adj item: [LRSS] Adjust: [*.*.]. 2) Adj item: [L.RSS_]→ [L.R.S.S_]→[L.R.S.S_]→ [L.R.S.S_]→[L.R.S.S_]→ SSG output: -118dBm (0.28µV) (MOD: 1kHz±3kHz)	1) Adj item: [Low RSSI (Analog Wide)] 2) Adj item: [Low], [Low'], [Center], [High'], [High] SSG output: -118dBm (0.28µV) (MOD: 1kHz±3kHz)							
[NXDN Very Narrow]	1) Adj item: [LRSS] Adjust: [***] 2) Adj item: [L.RSS_]→ [L.R.S.S_]→[L.R.S.S_]→ [L.R.S.S_]→[L.R.S.S_]→ SSG output: -118dBm (0.28µV) (MOD: 1kHz±1.5kHz)	1) Adj item: [Low RSSI (NXDN Very Narrow)] 2) Adj item: [Low], [Low'], [Center], [High'], [High] SSG output: -118dBm (0.28µV) (MOD: 1kHz±1.5kHz)							Adjust with the analog signal.
*7: Because Low RSSI at -118dBm (NXDN Narrow) is adjusted by adjusting Low RSSI at -118dBm (Analog Narrow), it is not necessary to adjust Low RSSI at -118dBm (NXDN Narrow).									

调 整

项 目	条 件		测 量			调 整			规 格 / 备 注
	面板调谐模式	PC 测试模式	测量装置	单元	端子	单元	部件	方 法	
静噪（浅） *6 （静噪电 平 5 调整） [NXDN 甚窄带]	1) 调整项目：[SQL] 调整：[***] 2) 调整项目： [S.Q.L_]→[S.Q.L_]→ [S.Q.L_]→ [S.Q.L_]→ [S.Q.L_]→ [S.Q.L_]→ SSG 输出：12dB SINAD 电平 -4dB (MOD:400Hz/±1.1kHz)	1) 调整项目：[静噪 (浅)(NXDN 甚窄 带)] 2) 调整项目：[低], [低'], [中], [高'], [高] SSG 输出：12dB SINAD 电平 -4dB (MOD:400Hz/±1.1kHz)	SSG	面板	天线 SP/MIC 连接器			[面板调谐模式] 从 SSG 输入信号之 后，按 [<B] 键储 存调整值。 [PC 测试模式] 从 SSG 输入信号之 后，按 [应用] 按 钮储存调整值。	用模拟信号进行调 整。 由于电路结构， 此项在 MOD 为 “400Hz” 和频偏为 “±1.1kHz” 的条 件下进行调整。 备注： 在生产过程中，写 入固定值。 200(固定)
*6: 由于静噪（浅）(NXDN 窄带) 通过调整静噪（浅）(模拟窄带) 进行调整，因此不需要调整静噪（浅）(NXDN 窄带)。									
6. -118dBm 低 RSSI *7 [模拟 窄带]	1) 调整项目：[LRSS] 调整：[***.] 2) 调整项目：[L.RSS]→ [L.R.SS_]→[L.R.S.S_]→ [L.R.S.S.]→[L.R.S.S._] SSG 输出： -118dBm (0.28μV) (MOD:1kHz/±1.5kHz)	1) 调整项目：[低 RSSI(模拟窄带)] 2) 调整项目：[低], [低'], [中], [高'], [高] SSG 输出： -118dBm (0.28μV) (MOD:1kHz/±1.5kHz)	SSG	面板	天线 SP/MIC 连接器			[面板调谐模式] 从 SSG 输入信号之 后，按 [<B] 键储 存调整值。 [PC 测试模式] 从 SSG 输入信号之 后，按 [应用] 按 钮储存调整值。	
[模拟 宽带]	1) 调整项目：[LRSS] 调整：[*.*.*.] 2) 调整项目：[L.RSS]→ [L.R.SS_]→[L.R.S.S_]→ [L.R.S.S.]→[L.R.S.S._] SSG 输出： -118dBm (0.28μV) (MOD:1kHz/±3kHz)	1) 调整项目：低 RSSI(模拟宽带)] 2) 调整项目：[低], [低'], [中], [高'], [高] SSG 输出： -118dBm (0.28μV) (MOD:1kHz/±3kHz)							
[NXDN 甚窄带]	1) 调整项目：[LRSS] 调整：[***] 2) 调整项目：[L.RSS]→ [L.R.SS_]→[L.R.S.S_]→ [L.R.S.S.]→[L.R.S.S._] SSG 输出： -118dBm (0.28μV) (MOD:1kHz/±1.5kHz)	1) 调整项目：[低 RSSI(NXDN 甚窄 带)] 2) 调整项目：[低], [低'], [中], [高'], [高] SSG 输出： -118dBm (0.28μV) (MOD:1kHz/±1.5kHz)							用模拟信号进行调 整。
*7: 由于 -118dBm 低 RSSI (NXDN 窄带) 通过调整 -118dBm 低 RSSI (模拟窄带) 进行调整，因此不需要调整 -118dBm 低 RSSI (NXDN 窄带)。									

ADJUSTMENT

Item	Condition		Measurement			Adjustment			Specifications / Remarks
	Panel tuning mode	PC test mode	Test-equipment	Unit	Terminal	Unit	Parts	Method	
7. High RSSI at -80dBm *8 [Analog Narrow]	1) Adj item: [HRSS] Adjust: [***.] 2) Adj item: [H.RSS_]→ [H.R.SS_]→[H.R.S.S_]→ [H.R.S.S.]→[H.R.S.S._] SSG output: -80dBm (22.4μV) (MOD: 1kHz/±1.5kHz)	1) Adj item: [High RSSI (Analog Narrow)] 2) Adj item: [Low], [Low'], [Center], [High'], [High] SSG output: -80dBm (22.4μV) (MOD: 1kHz/±1.5kHz)	SSG	Panel	ANT SP/MIC connector			[Panel tuning mode] After input signal from SSG, press [<B] key to store the adjustment value. [PC test mode] After input signal from SSG, press [Apply] button to store the adjustment value.	Adjust with the analog signal.
[Analog Wide]	1) Adj item: [HRSS] Adjust: [***.] 2) Adj item: [H.RSS_]→ [H.R.SS_]→[H.R.S.S_]→ [H.R.S.S.]→[H.R.S.S._] SSG output: -80dBm (22.4μV) (MOD: 1kHz/±3kHz)	1) Adj item: [High RSSI (Analog Wide)] 2) Adj item: [Low], [Low'], [Center], [High'], [High] SSG output: -80dBm (22.4μV) (MOD: 1kHz/±3kHz)							
[NXDN Very Narrow]	1) Adj item: [HRSS] Adjust: [***] 2) Adj item: [H.RSS_]→ [H.R.SS_]→[H.R.S.S_]→ [H.R.S.S.]→[H.R.S.S._] SSG output: -80dBm (22.4μV) (MOD: 1kHz/±1.5kHz)	1) Adj item: [High RSSI (NXDN Very Narrow)] 2) Adj item: [Low], [Low'], [Center], [High'], [High] SSG output: -80dBm (22.4μV) (MOD: 1kHz/±1.5kHz)							
*8: Because "RSSI at -80dBm adjust" of NXDN Narrow is adjusted by adjusting "RSSI at -80dBm adjust [Analog Narrow]", it is not necessary to adjust "RSSI at -80dBm adjust" of NXDN Narrow.									
8. Tight Squelch [Analog Narrow]	1) Adj item: [SQLT] Adjust: [***.] 2) Adj item: [S.QLT_]→ [S.Q.LT_]→[S.Q.L.T_]→ [S.Q.L.T.]→[S.Q.L.T._] SSG output: 12dB SINAD level +5dB (MOD: 1kHz/±1.5kHz)	1) Adj item: [Tight Squelch (Analog Narrow)] 2) Adj item: [Low], [Low'], [Center], [High'], [High] SSG output: 12dB SINAD level +5dB (MOD: 1kHz/±1.5kHz)	SSG	Panel	ANT SP/MIC connector			[Panel tuning mode] After input signal from SSG, press [<B] key to store the adjustment value. [PC test mode] After input signal from SSG, press [Apply] button to store the adjustment value.	Remark: During production, a fixed value is written. 225 (Fixed)
[Analog Wide]	1) Adj item: [SQLT] Adjust: [***.] 2) Adj item: [S.QLT_]→ [S.Q.LT_]→[S.Q.L.T_]→ [S.Q.L.T.]→[S.Q.L.T._] SSG output: 12dB SINAD level +5dB (MOD: 1kHz/±3kHz)	1) Adj item: [Tight Squelch (Analog Wide)] 2) Adj item: [Low], [Low'], [Center], [High'], [High] SSG output: 12dB SINAD level +5dB (MOD: 1kHz/±3kHz)							

调 整

项 目	条 件		测 量			调 整			规 格 / 备 注
	面板调谐模式	PC 测试模式	测量装置	单元	端子	单元	部件	方 法	
7. -80dBm 高 RSSI *8 [模拟 窄带]	1) 调整项目 : [HRSS] 调整 : [***.] 2) 调整项 : [H. RSS_] → [H. R. SS_] → [H. R. S. S_] → [H. R. S. S_] → [H. R. S. S. _] SSG 输出 : -80dBm (22. 4μV) (MOD: 1kHz/±1. 5kHz)	1) 调整项目 : [高 RSSI (模拟窄带)] 2) 调整项目 : [低], [低'], [中], [高'], [高] SSG 输出 : -80dBm (22. 4μV) (MOD: 1kHz/±1. 5kHz)	SSG	面板	天线 SP/MIC 连接器			[面板调谐模式] 从 SSG 输入信号之 后, 按 [<B] 键储 存调整值。 [PC 测试模式] 从 SSG 输入信号之 后, 按 [应用] 按 钮储存调整值。	
[模拟 宽带]	1) 调整项目 : [HRSS] 调整 : [*. *. *.] 2) 调整项 : [H. RSS_] → [H. R. SS_] → [H. R. S. S_] → [H. R. S. S. _] SSG 输出 : -80dBm (22. 4μV) (MOD: 1kHz/±3kHz)	1) 调整项目 : [高 RSSI (模拟宽带)] 2) 调整项目 : [低], [低'], [中], [高'], [高] SSG 输出 : -80dBm (22. 4μV) (MOD: 1kHz/±3kHz)							
[NXDN 甚窄带]	1) 调整项目 : [HRSS] 调整 : [***] 2) 调整项 : [H. RSS_] → [H. R. SS_] → [H. R. S. S_] → [H. R. S. S.] → [H. R. S. S. _] SSG 输出 : -80dBm (22. 4μV) (MOD: 1kHz/±1. 5kHz)	1) 调整项目 : [高 RSSI (NXDN 甚窄 带)] 2) 调整项目 : [低], [低'], [中], [高'], [高] SSG 输出 : -80dBm (22. 4μV) (MOD: 1kHz/±1. 5kHz)							用模拟信号进行调 整。
*8: 由于 -80dBm 高 RSSI (NXDN 窄带) 通过调整 -80dBm 高 RSSI (模拟窄带) 进行调整, 因此不需要调整 -80dBm 高 RSSI (NXDN 窄带)。									
8. 静噪 (深) [模拟 窄带]	1) 调整项目 : [SQLT] 调整 : [***.] 2) 调整项目 : [S. QLT_] → [S. Q. LT_] → [S. Q. L. T_] → [S. Q. L. T. _] SSG 输出 : 12dB SINAD 电平 +5dB (MOD: 1kHz/±1. 5kHz)	1) 调整项目 : [静噪 (深) (模拟窄带)] 2) 调整项目 : [低], [低'], [中], [高'], [高] SSG 输出 : 12dB SINAD 电平 +5dB (MOD: 1kHz/±1. 5kHz)	SSG	面板	天线 SP/MIC 连接器			[面板调谐模式] 从 SSG 输入信号之 后, 按 [<B] 键储 存调整值。 [PC 测试模式] 从 SSG 输入信号之 后, 按 [应用] 按 钮储存调整值。	备注: 在生产过程中, 写 入固定值。 225 (固定)
[模拟 宽带]	1) 调整项目 : [SQLT] 调整 : [*. *. *.] 2) 调整项目 : [S. QLT_] → [S. Q. LT_] → [S. Q. L. T_] → [S. Q. L. T. _] SSG 输出 : 12dB SINAD 电平 +5dB (MOD: 1kHz/±3kHz)	1) 调整项目 : [静噪 (深) (模拟宽带)] 2) 调整项目 : [低], [低'], [中], [高'], [高] SSG 输出 : 12dB SINAD 电平 +5dB (MOD: 1kHz/±3kHz)							

NX-220 PC BOARD / 印刷电路板

DISPLAY UNIT (X54-3760-XX) -10: C -12: C2
Component side view (J79-0312-09)

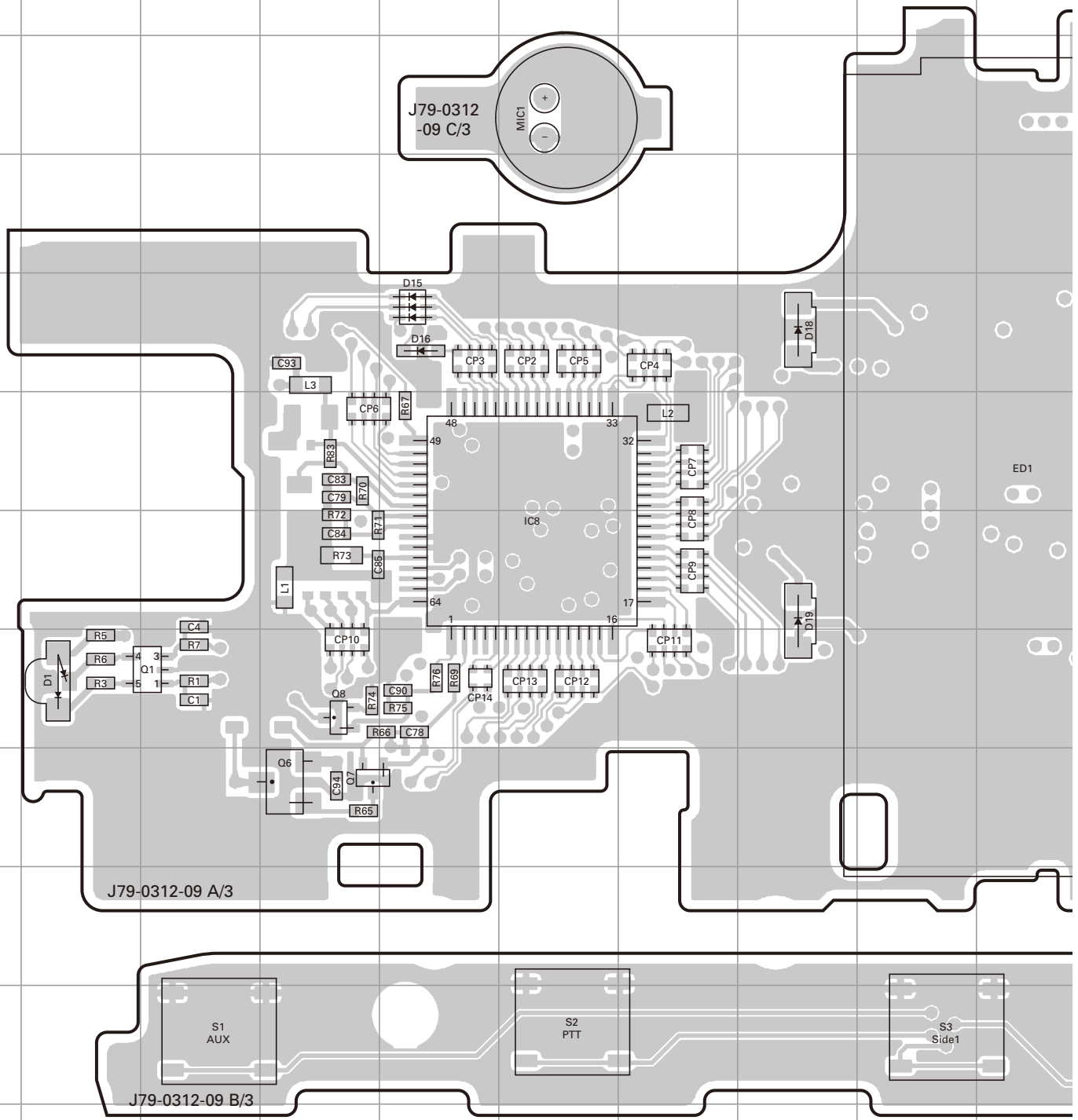

PC BOARD / 印刷电路板 NX-220

DISPLAY UNIT (X54-3760-XX) -10: C -12: C2
Component side view (J79-0312-09)

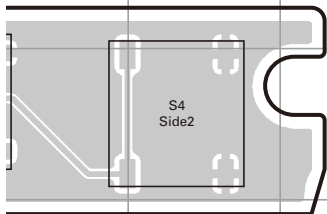
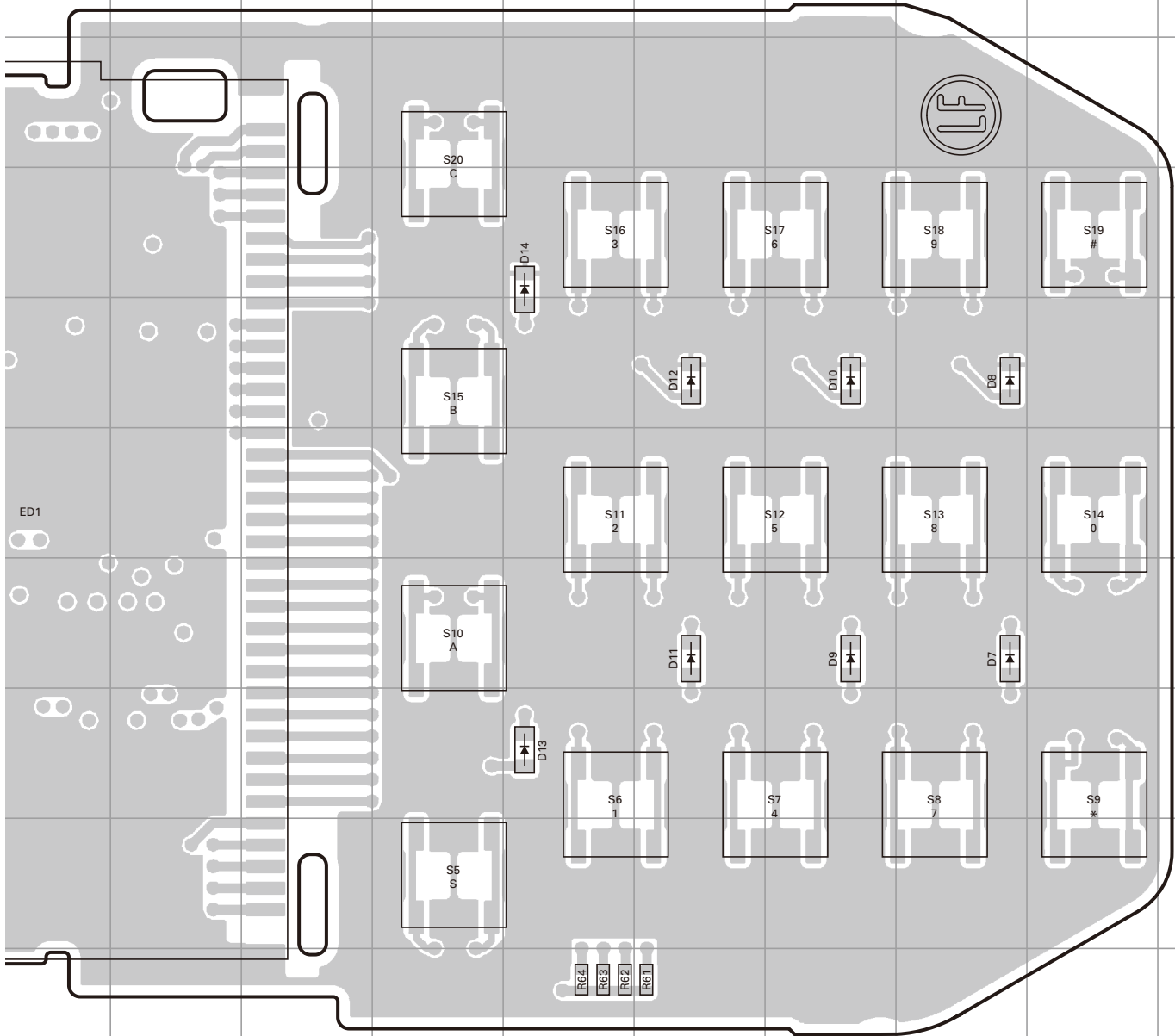

Ref. No.	Address	Ref. No.	Address
IC8	7F	D10	5P
Q1	8C	D11	7O
Q6	9D	D12	5O
Q7	9D	D13	8N
Q8	8D	D14	4N
D1	8B	D15	5E
D7	7Q	D16	5E
D8	5Q	D18	5H
D9	7P	D19	7H

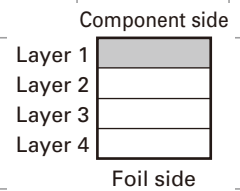

NX-220 PC BOARD / 印刷电路板

DISPLAY UNIT (X54-3760-XX) -10: C -12: C2
Foil side view (J79-0312-09)

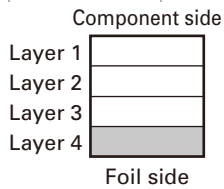
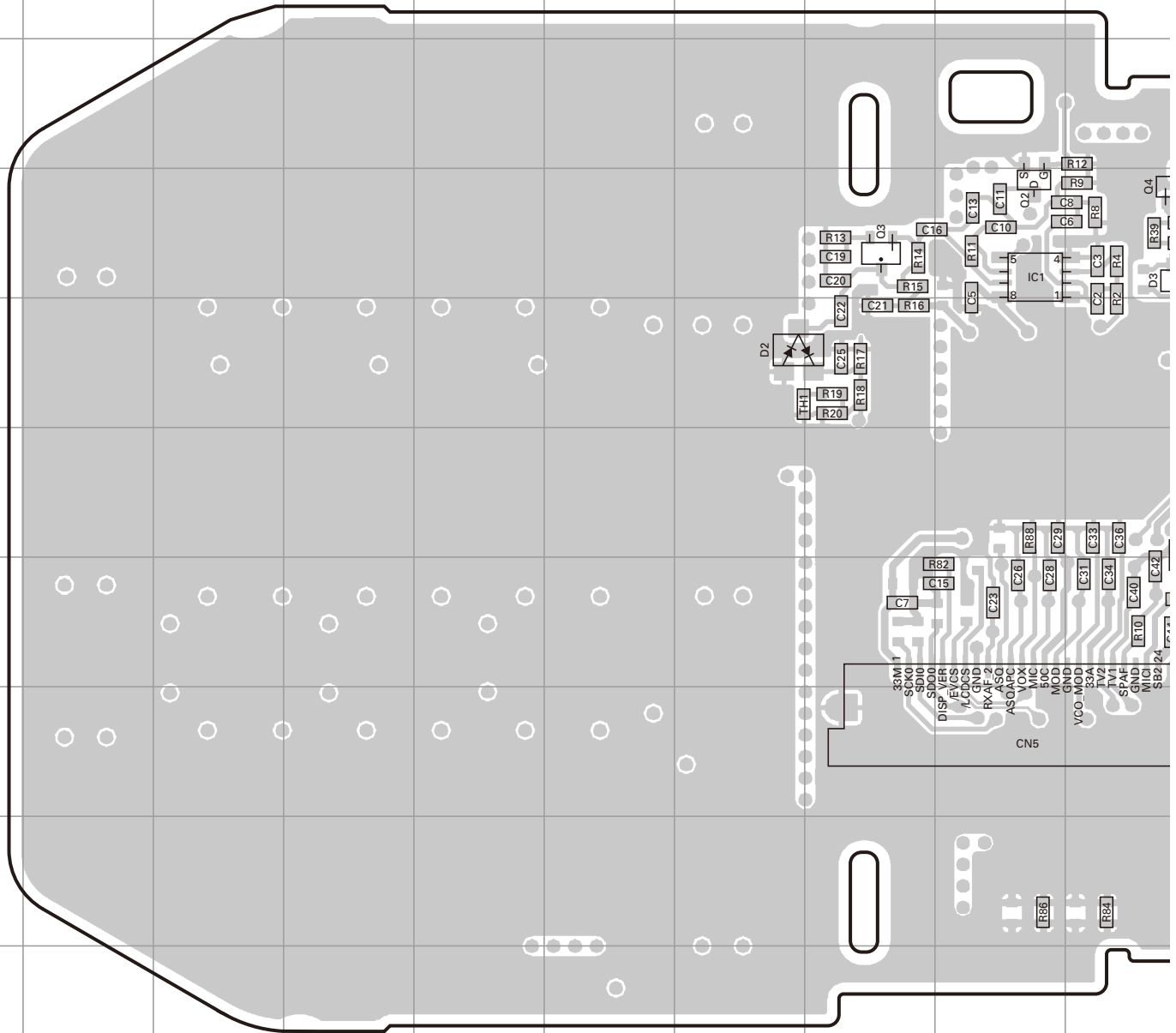

Ref. No.	Address	Ref. No.	Address
IC1	4I	Q4	4J
IC2	6L	Q5	4K
IC4	8N	D2	5G
Q2	4I	D4	4K
Q3	4H		

PC BOARD / 印刷电路板 NX-220

DISPLAY UNIT (X54-3760-XX) -10: C -12: C2
Foil side view (J79-0312-09)

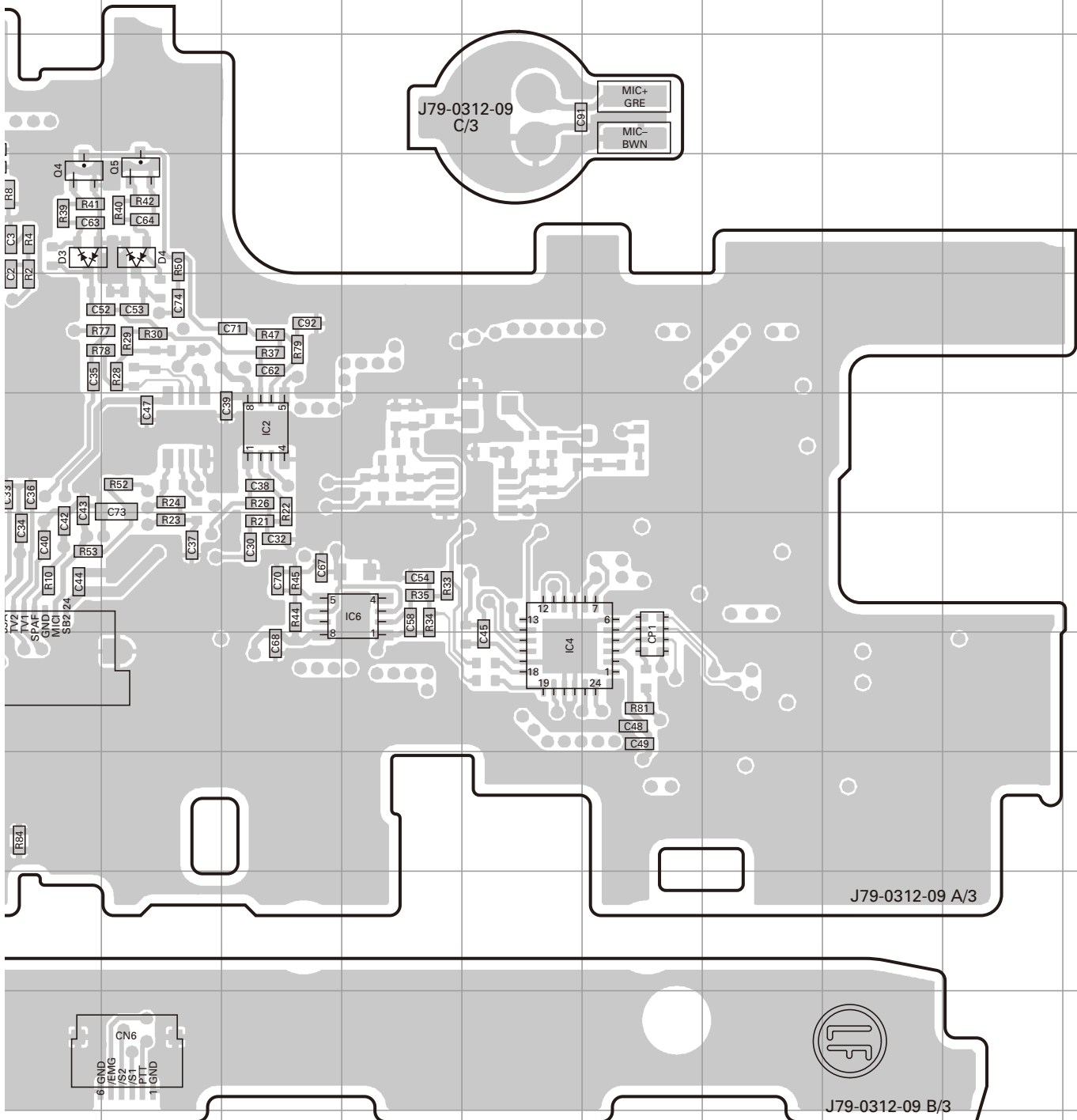

NX-220 PC BOARD / 印刷电路板

TX-RX UNIT (X57-8040-10) Component side view (J79-0313-19)

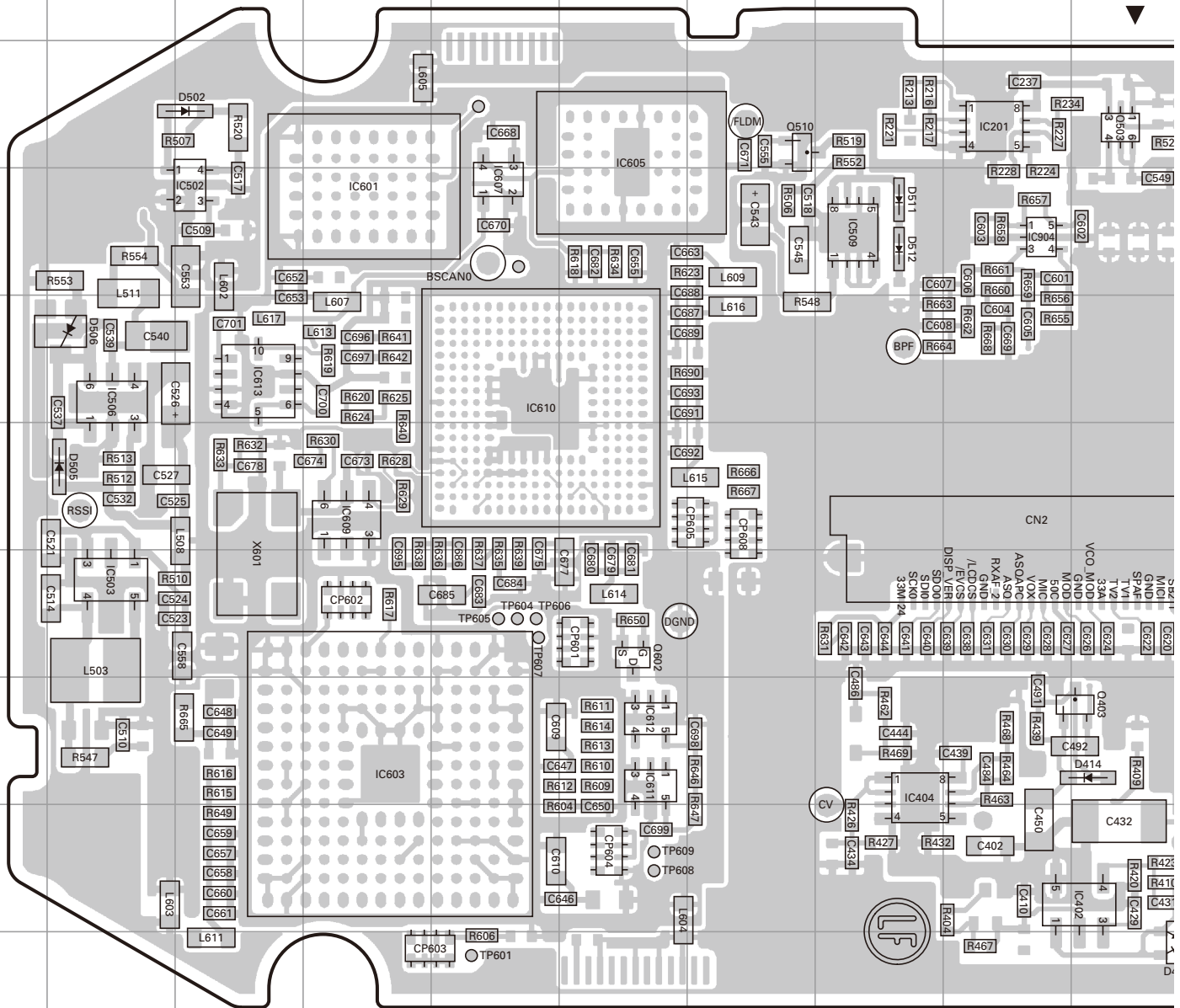

Ref. No.	Address	Ref. No.	Address	Ref. No.	Address	Ref. No.	Address	Ref. No.	Address	Ref. No.	Address
IC101	3O	IC601	4D	IC901	6P	Q501	6K	Q902	5P	D502	3C
IC201	3I	IC603	8D	IC902	6O	Q502	7K	Q903	7Q	D505	6B
IC402	9J	IC605	3F	IC904	4I	Q503	3J	Q904	7P	D506	5B
IC404	8H	IC607	4E	Q105	8K	Q505	4M	Q905	8P	D509	5M
IC502	4C	IC609	6D	Q106	3O	Q510	3G	Q907	9N	D511	4H
IC503	7B	IC610	5E	Q107	4O	Q511	4M	D101	8L	D512	4H
IC504	4M	IC611	8F	Q108	5O	Q512	5L	D401	10J	D902	7O
IC506	5B	IC612	8F	Q109	5N	Q602	7F	D414	8J		
IC509	4H	IC613	5C	Q403	8J	Q901	7Q	D501	4Q		

PC BOARD / 印刷电路板 NX-220

TX-RX UNIT (X57-8040-10) Component side view (J79-0313-19)

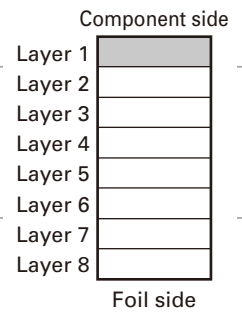
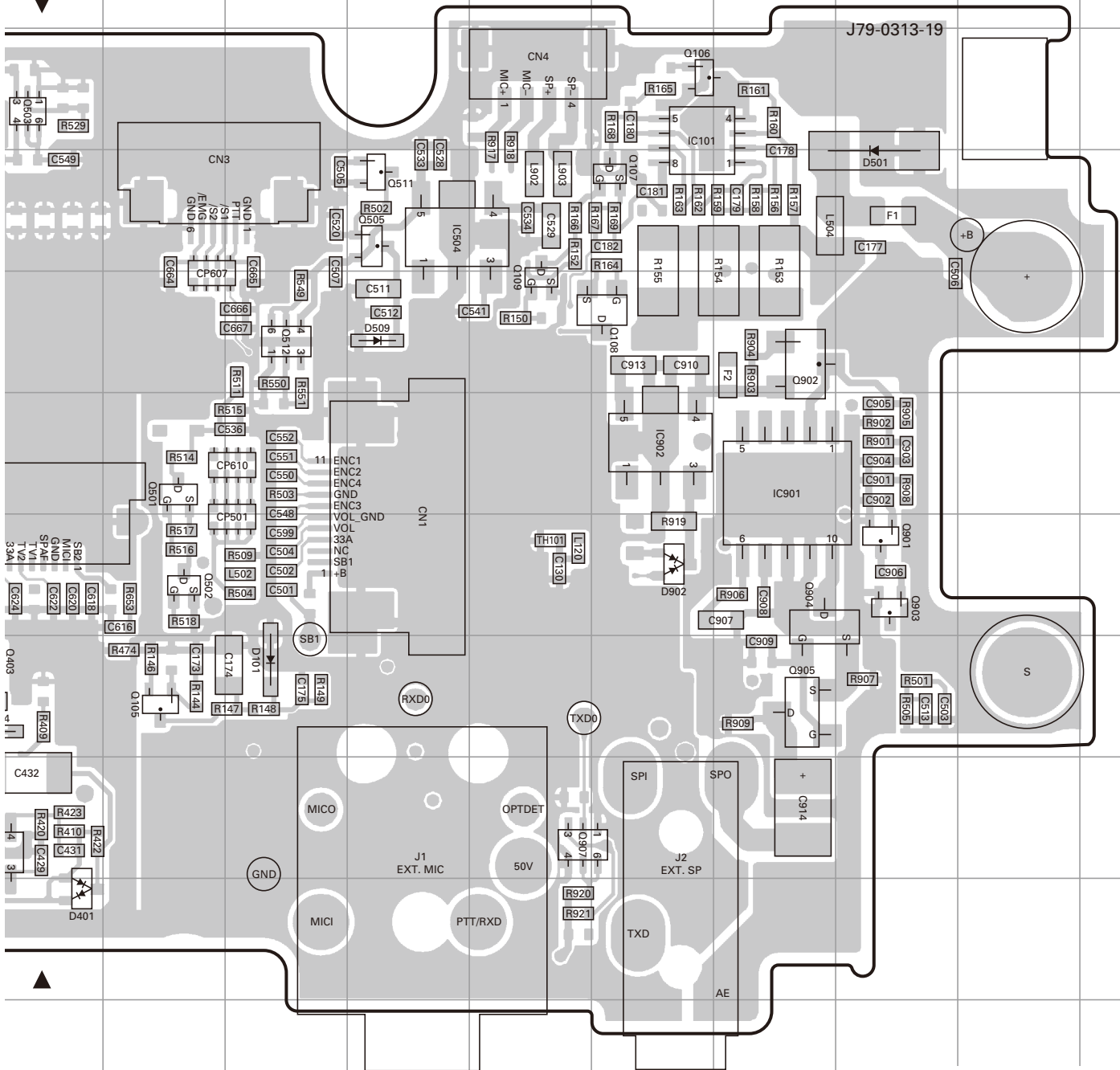

NX-220 PC BOARD / 印刷电路板

TX-RX UNIT (X57-8040-10) Foil side view (J79-0313-19)

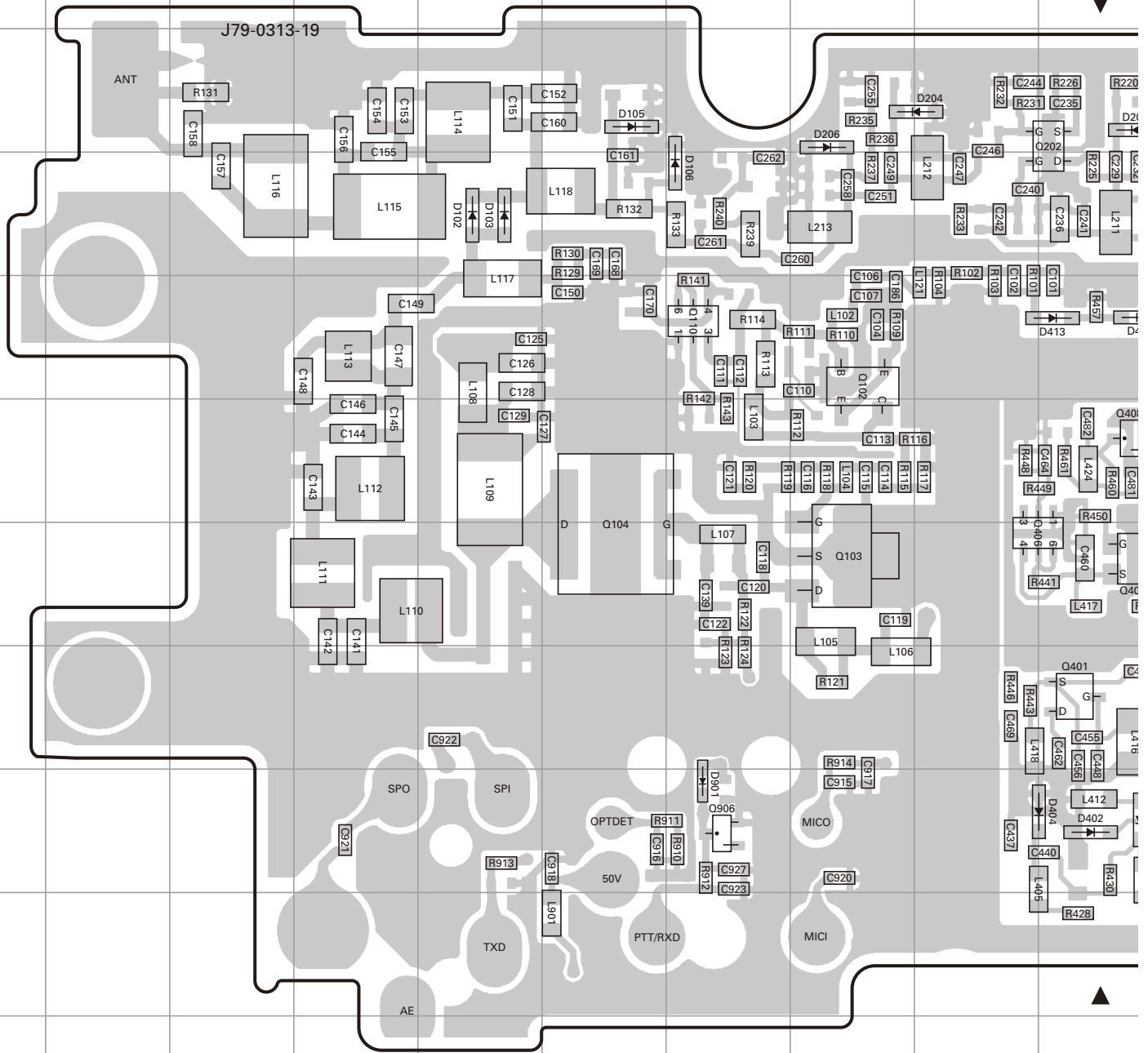

Ref. No.	Address	Ref. No.	Address	Ref. No.	Address	Ref. No.	Address	Ref. No.	Address
IC302	6P	Q201	4M	Q408	6J	D203	3J	D411	9K
IC304	6R	Q202	3J	Q506	8R	D204	3I	D412	5J
IC403	7N	Q301	8O	Q507	8Q	D206	3H	D413	5J
IC501	7R	Q303	5O	Q509	9R	D402	9J	D415	9L
IC505	5M	Q401	8J	Q906	9G	D403	9K	D416	7L
IC507	9Q	Q402	8K	D102	4E	D404	9J	D417	6L
Q102	5H	Q404	7K	D103	4E	D405	9K	D508	9Q
Q103	7H	Q405	7K	D105	3F	D407	9L	D901	9G
Q104	7F	Q406	7I	D106	4G	D409	9J		
Q110	5G	Q407	7J	D202	3K	D410	8L		

PC BOARD / 印刷电路板 NX-220

TX-RX UNIT (X57-8040-10) Foil side view (J79-0313-19)

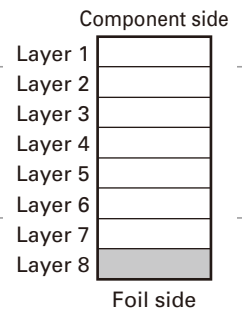
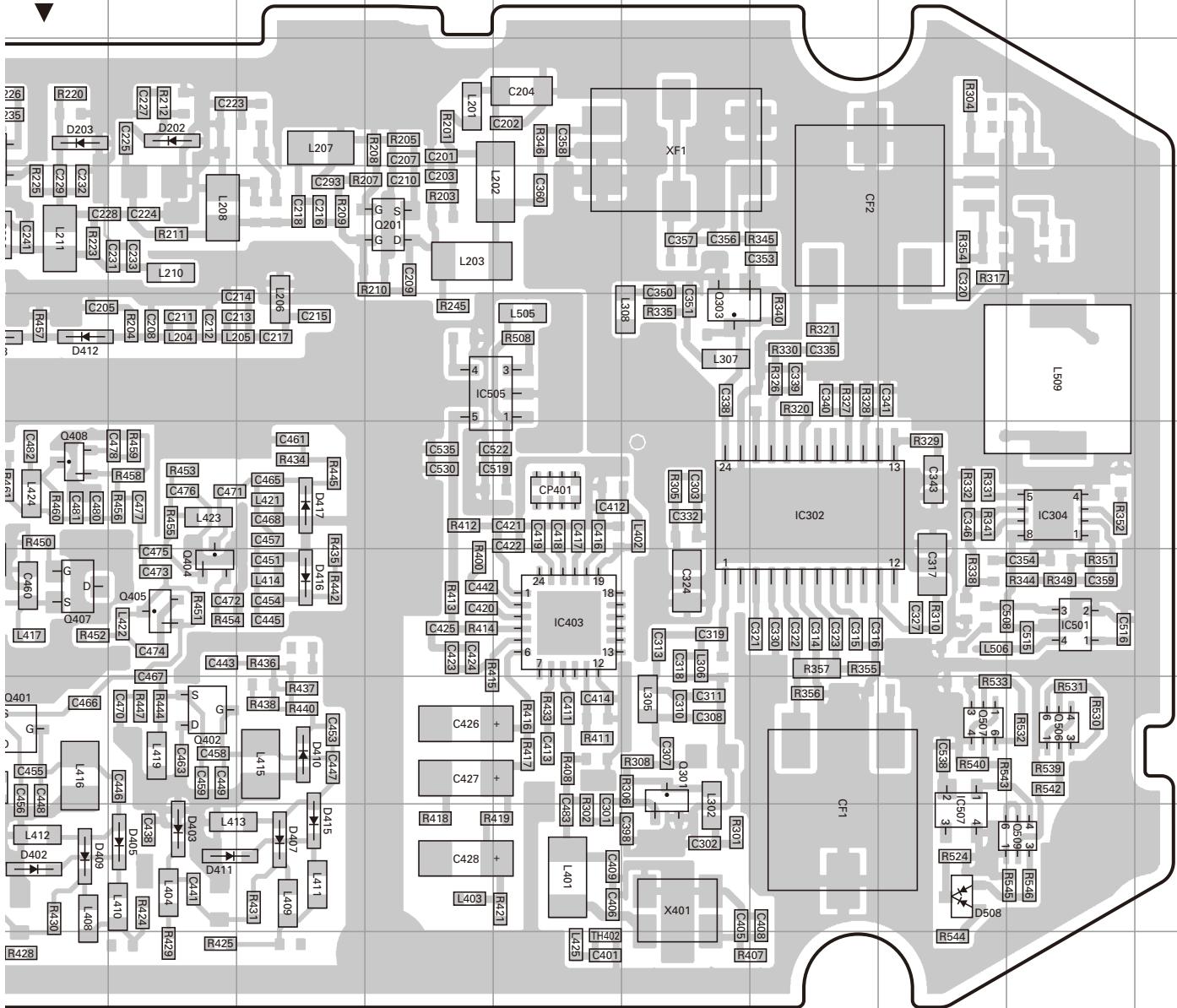

LEVEL DIAGRAM / 电平图

Receiver Section / 接收部分

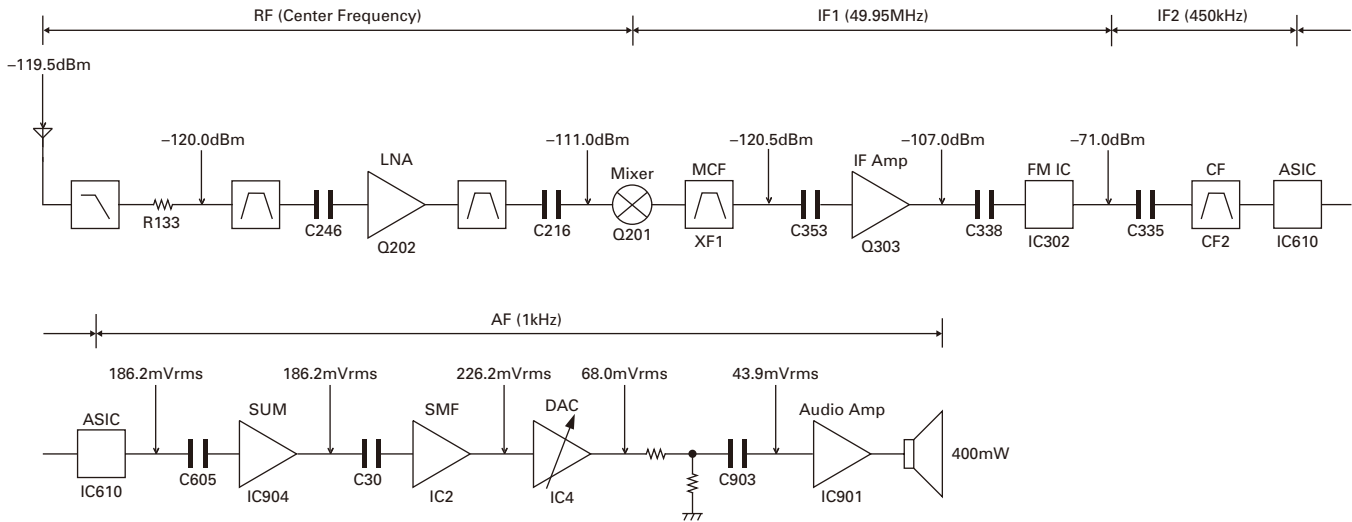

To make measurements in the AF section, connect the AC level meter. (ANT input: -53dB, 1kHz FM, 3kHz DEV (Wide))
 In the RF section, use a 1000pF coupling capacitor.
 (The display shows the SSG input value required to obtain 12dB SINAD without local level.)
 如要在AF部测量, 则连接AC电平表。(天线输入: -53dBm, 1kHz FM, 3kHz DEV(宽带))
 如要在RF部测量, 请使用1000pF耦合电容器。
 (图中显示了获得12dB SINAD所需的SSG输入值, 没有本地电平。)

Transmitter Section / 发射部分

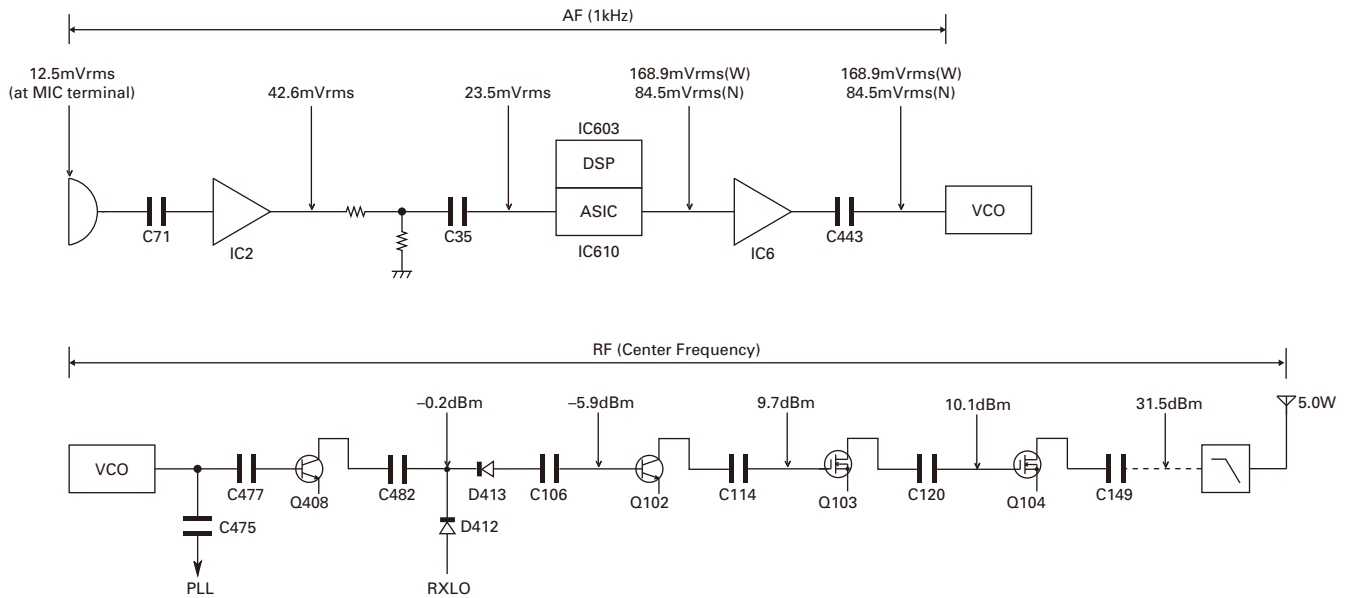

AG is set to the MIC input becomes 3kHz/1.5kHz DEV at 1kHz MOD (Wide/Narrow).
 To make measurements in the AF section, connect the AC level meter.
 In the RF section, use a 1000pF coupling capacitor.
 AG被设为麦克风输入, 在1kHz MOD(宽带/窄带)时为3kHz/1.5kHz DEV。
 如要在AF部测量, 则连接AC电平表。
 如要在RF部测量, 请使用1000pF耦合电容器。

INTERCONNECTION DIAGRAM / 互连图

X54-3760-XX	LCD
-10	C
-12	C2

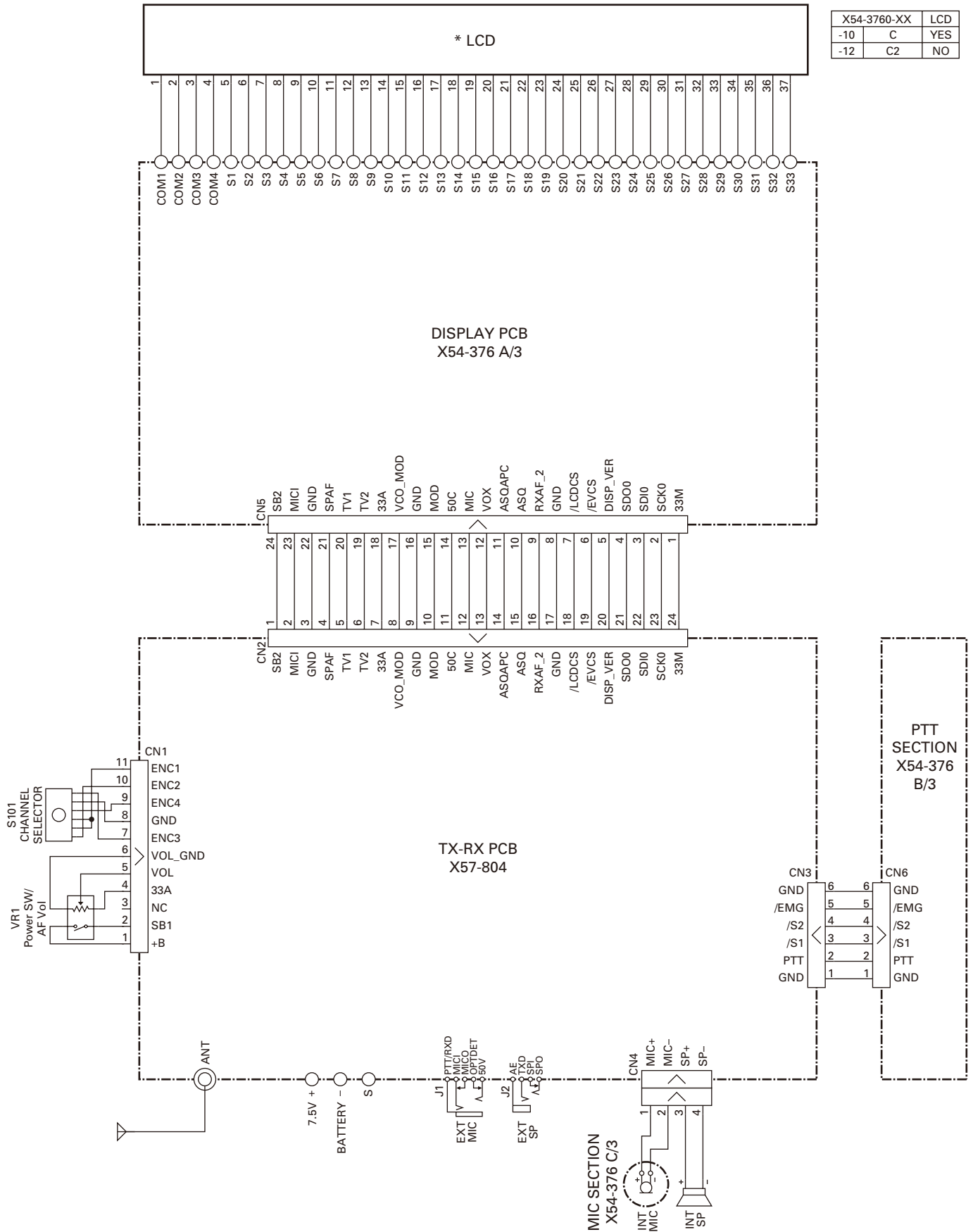

NX-220 SCHEMATIC DIAGRAM / 原理图

*LCD

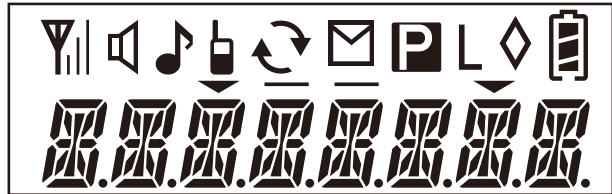

X54-3760-XX	LCD	R61	R62	R63	R64	R65	R66	R67	R69	R70	R71	R72	R73
-10	C	YES	3.3k	3.3k	3.3k	3.3k	6.8k	0	470	2.2k	10k	10k	43k
-12	C2	NO	NO	NO	NO	NO	NO	NO	NO	NO	NO	NO	NO

X54-3760-XX	R74	R75	R76	C78	C79	C83	C84	C85	C90
-10	C	120	2.2k	680	0.01u	0.047u	1000p	0.047u	680p
-12	C2	NO	NO	NO	NO	NO	NO	NO	NO

DISPLAY UNIT (X54-3760-XX) (A/3)

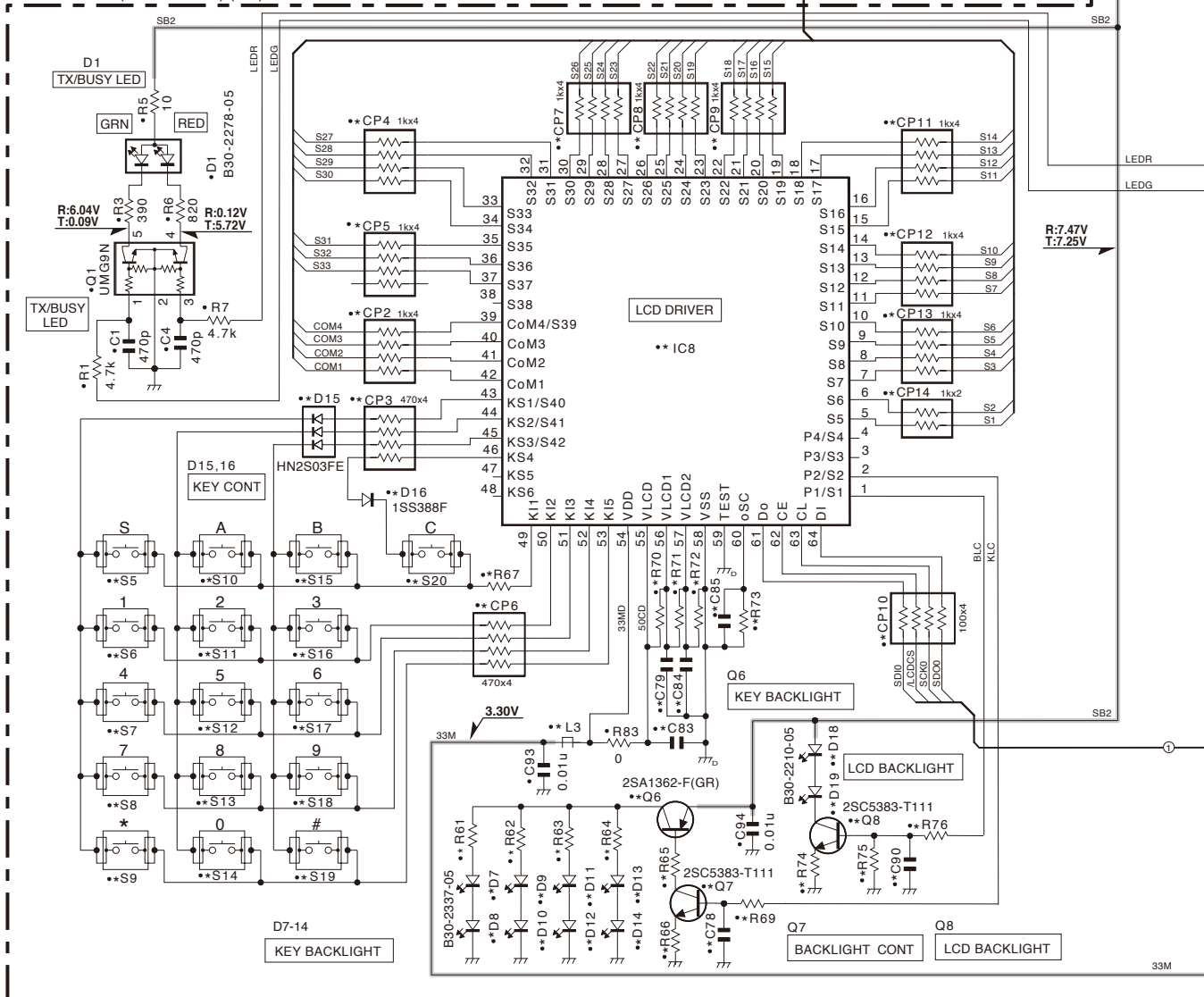

X54-3760-XX	CP2	CP3	CP4	CP5	CP6	CP7	CP8	CP9	CP10	CP11	CP12	CP13	CP14	L3
-10	C	RK74HB1J102J	RK74HB1J471J	RK74HB1J102J	RK74HB1J102J	RK74HB1J471J	RK74HB1J102J	RK74HB1J102J	RK74HB1J101J	RK74HB1J102J	RK74HB1J102J	RK74HB1J102J	RK74HB1J102J	L92-0138-05
-12	C2	NO	NO	NO	NO	NO	NO	NO	NO	NO	NO	NO	NO	NO

X54-3760-XX	D7	D8	D9	D10	D11	D12	D13	D14	D15	D16	D18	D19	IC8	Q6	Q7	Q8
-10	C	B30-2337-05	B30-2337-05	B30-2337-05	B30-2337-05	B30-2337-05	B30-2337-05	B30-2337-05	HN2S03FE	1SS388F	B30-2210-05	B30-2210-05	LC75857W-E	2SA1362-F(GR)	2SC5383-T111	2SC5383-T111
-12	C2	NO	NO	NO	NO	NO	NO	NO	NO	NO	NO	NO	NO	NO	NO	NO

X54-3760-XX	S5	S6	S7	S8	S9	S10	S11	S12	S13	S14	S15	S16	S17	S18	S19	S20
-10	C	S70-0519-05	S70-0519-05	S70-0519-05	S70-0519-05	S70-0519-05	S70-0519-05	S70-0519-05	S70-0519-05	S70-0519-05	S70-0519-05	S70-0519-05	S70-0519-05	S70-0519-05	S70-0519-05	S70-0519-05
-12	C2	NO	NO	NO	NO	NO	NO	NO	NO	NO	NO	NO	NO	NO	NO	NO

SCHEMATIC DIAGRAM / 原理图 NX-220

DISPLAY UNIT (X54-3760-XX) (A/3)



X54-3760-XX	R82	R84	R86
-10	C	NO	0
-12	C2	3.3k	NO

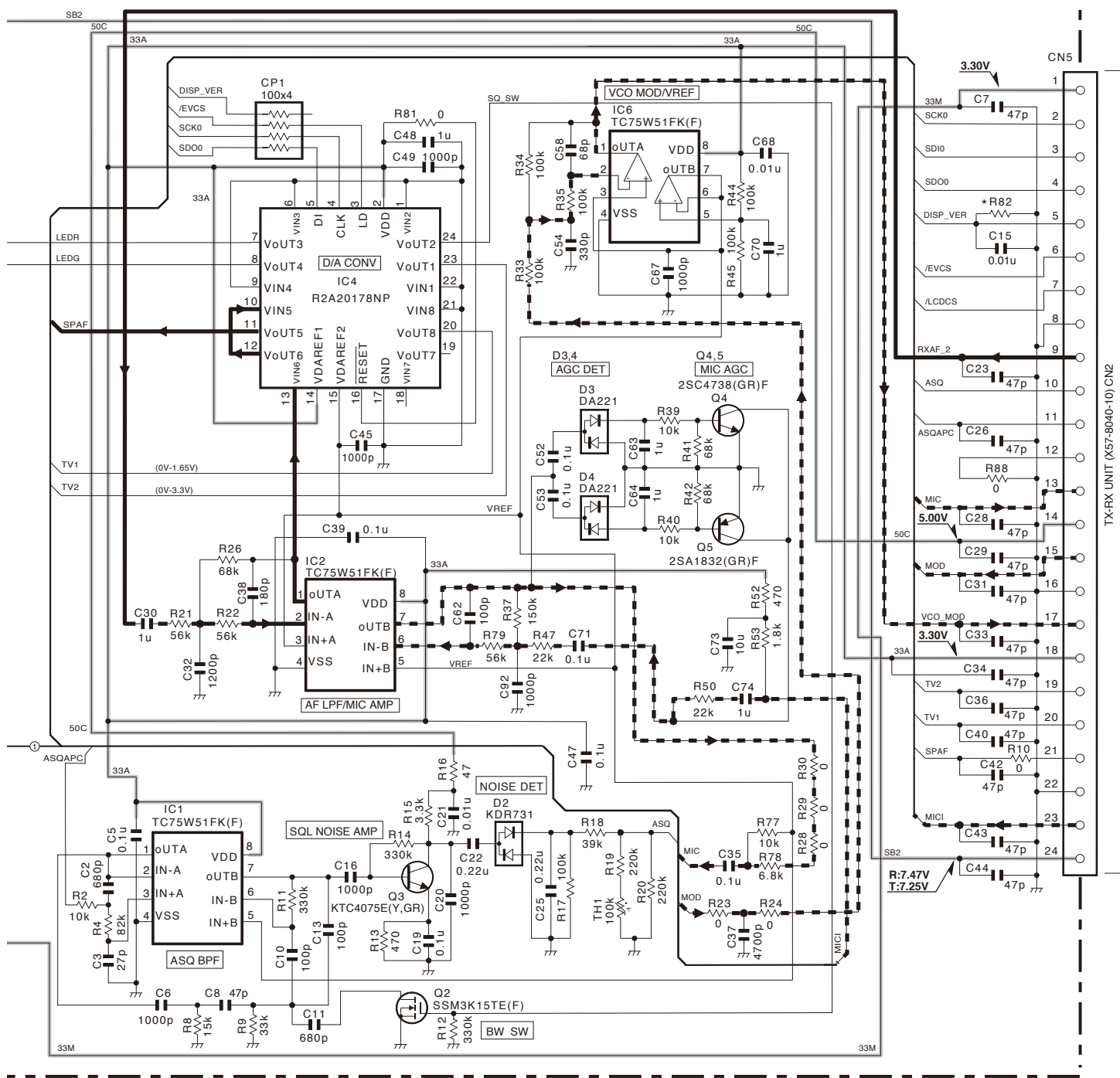

PTT SECTION (X54-3760-XX) (B/3)

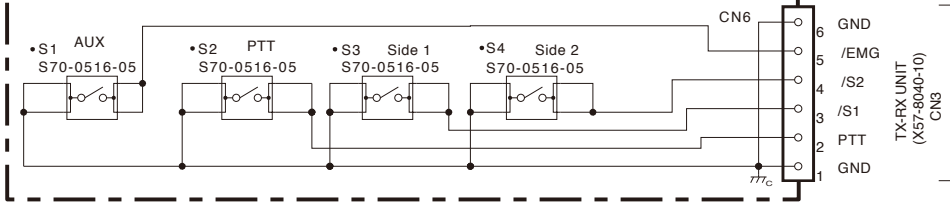

NX-220 SCHEMATIC DIAGRAM / 原理图

TX-RX UNIT (X57-8040-10)

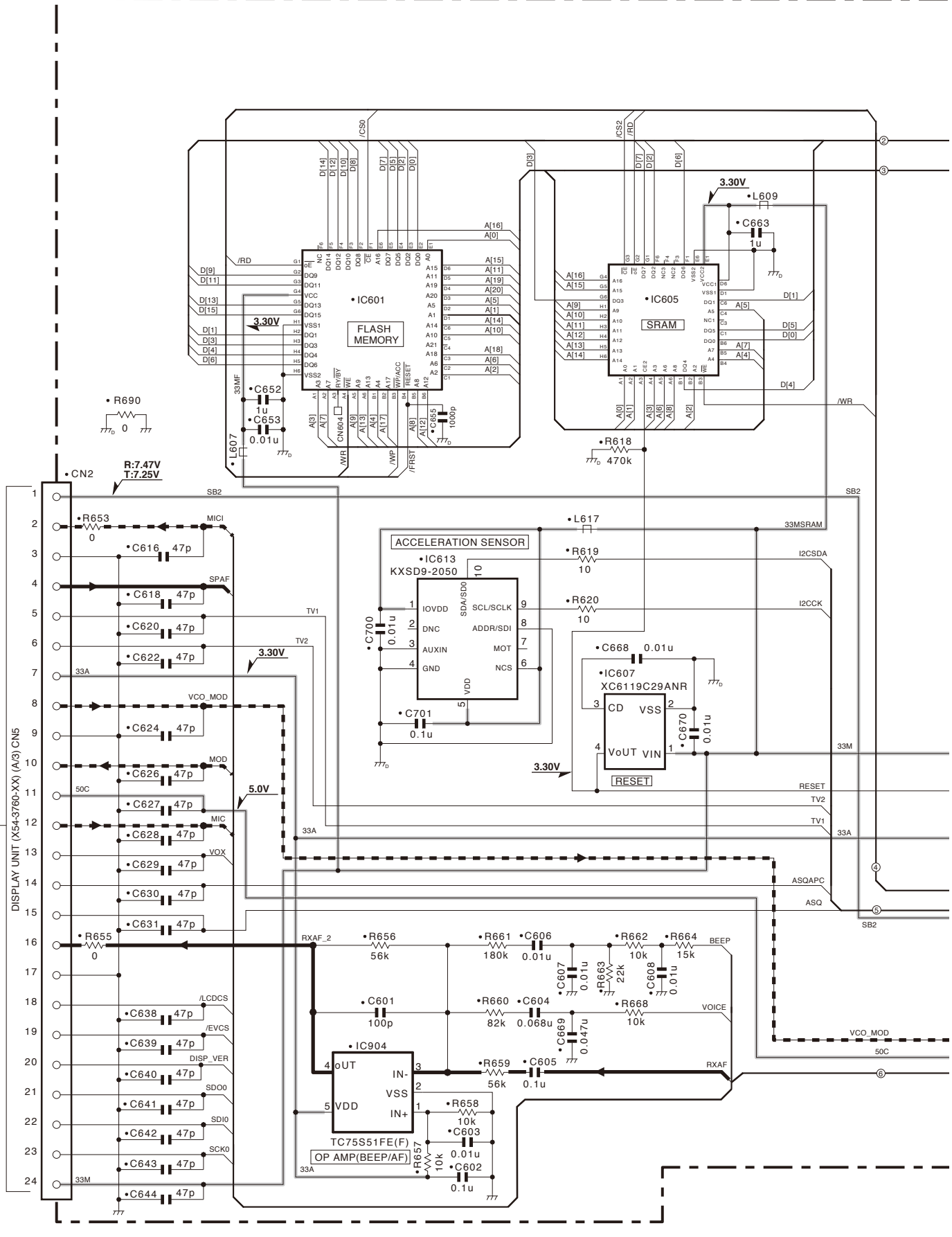

SCHEMATIC DIAGRAM / 原理图 NX-220

TX-RX UNIT (X57-8040-10)

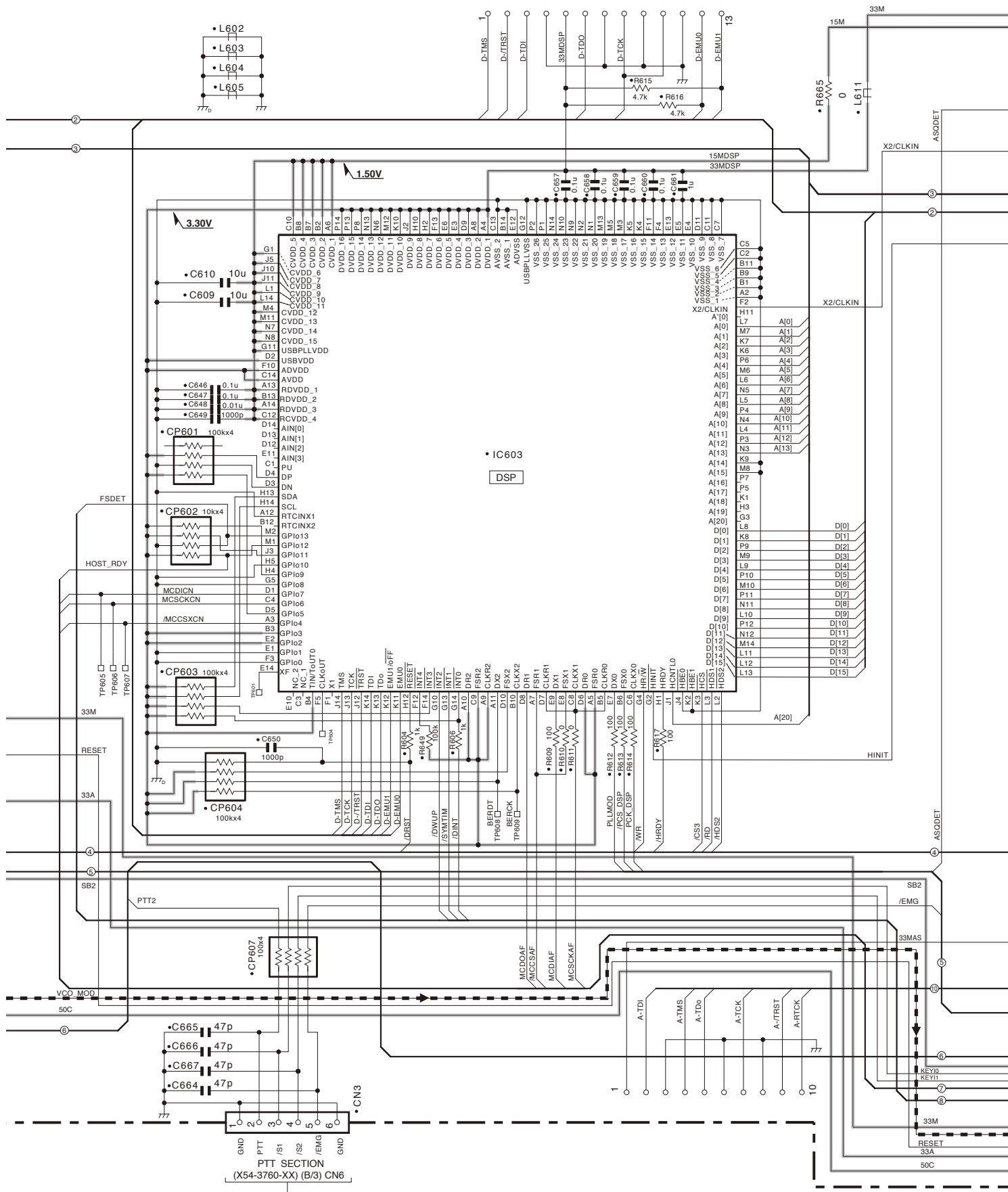

NX-220 SCHEMATIC DIAGRAM / 原理图

TX-RX UNIT (X57-8040-10)

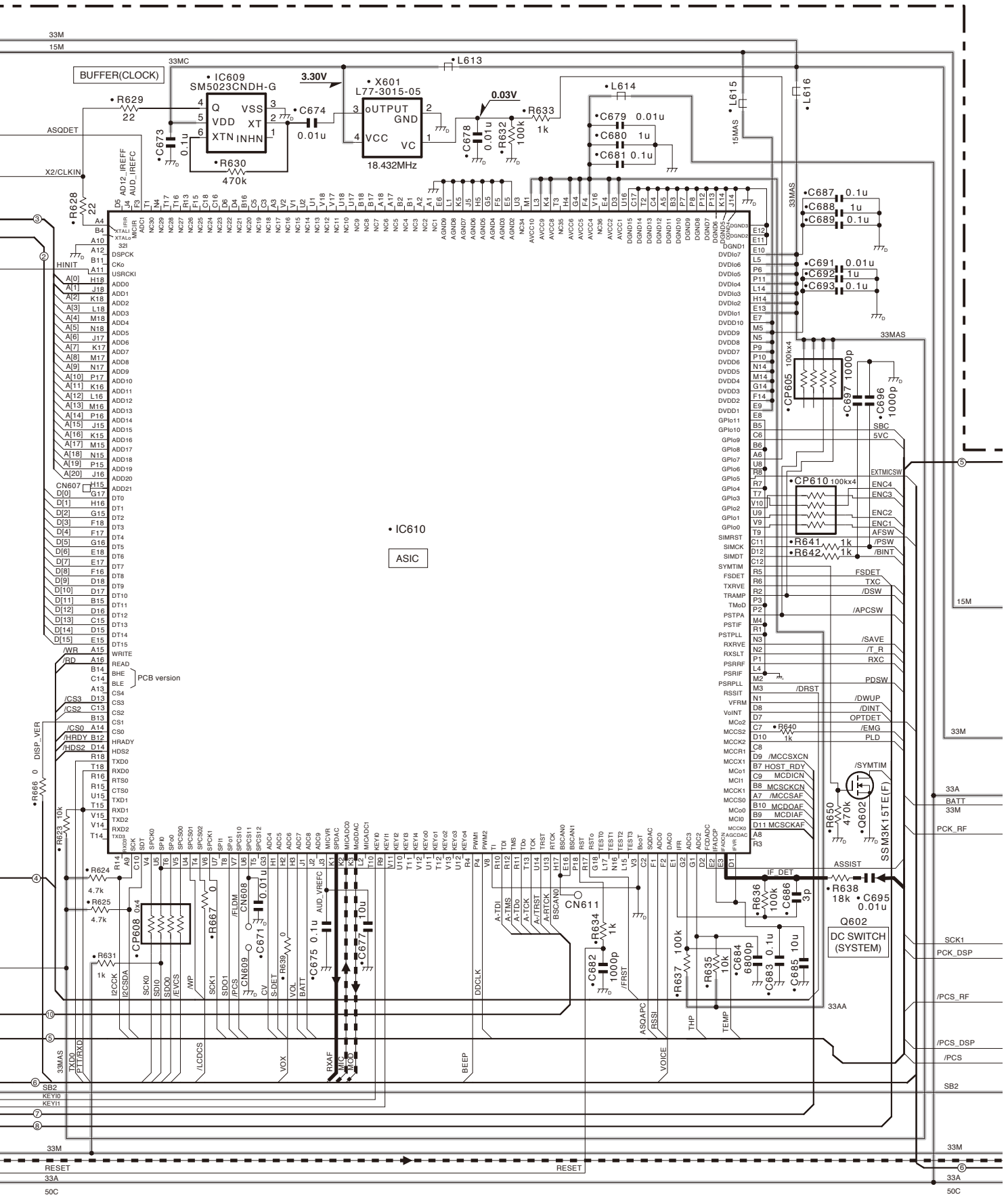

SCHEMATIC DIAGRAM / 原理图 NX-220

TX-RX UNIT (X57-8040-10)

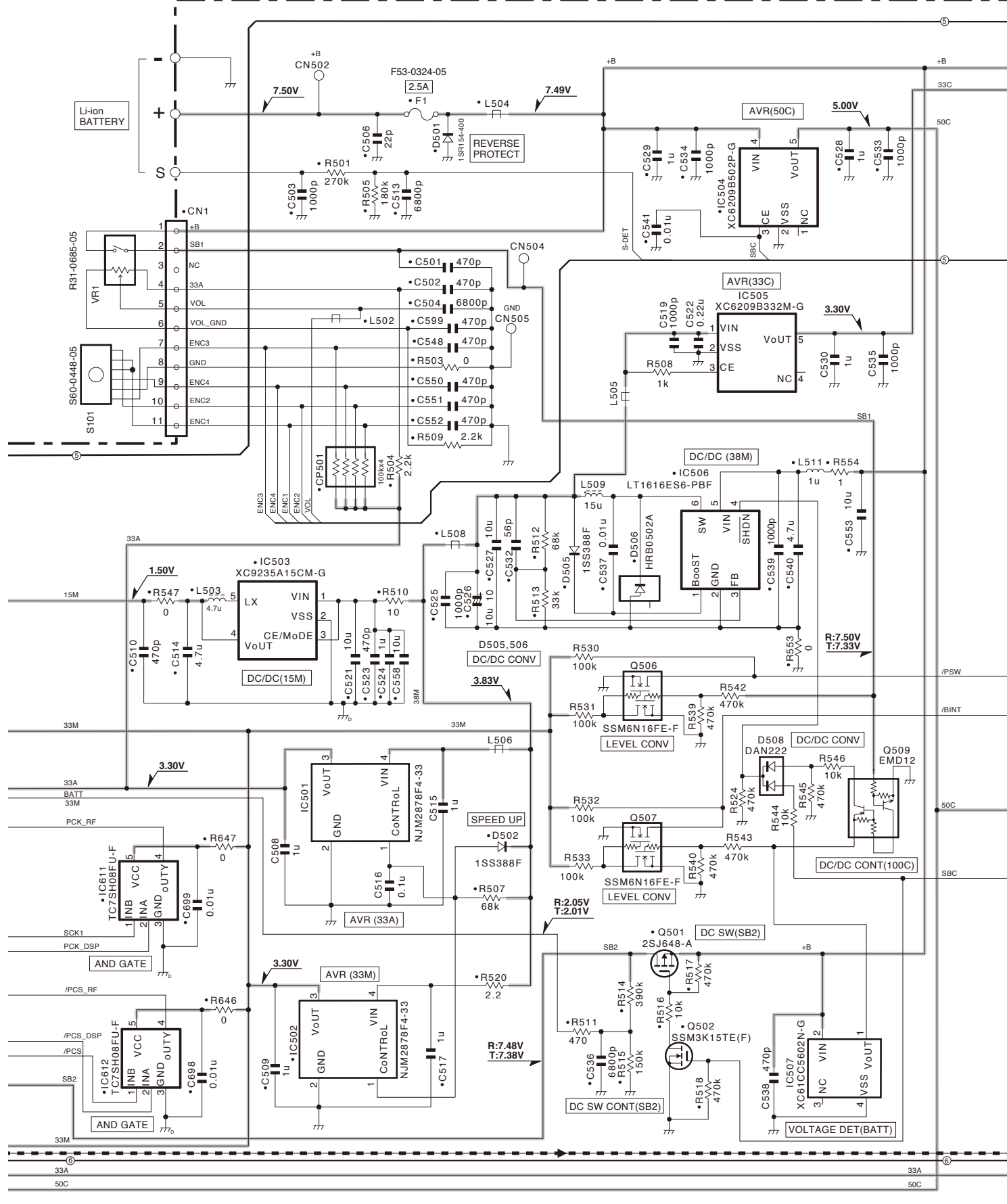

NX-220 SCHEMATIC DIAGRAM / 原理图

TX-RX UNIT (X57-8040-10)

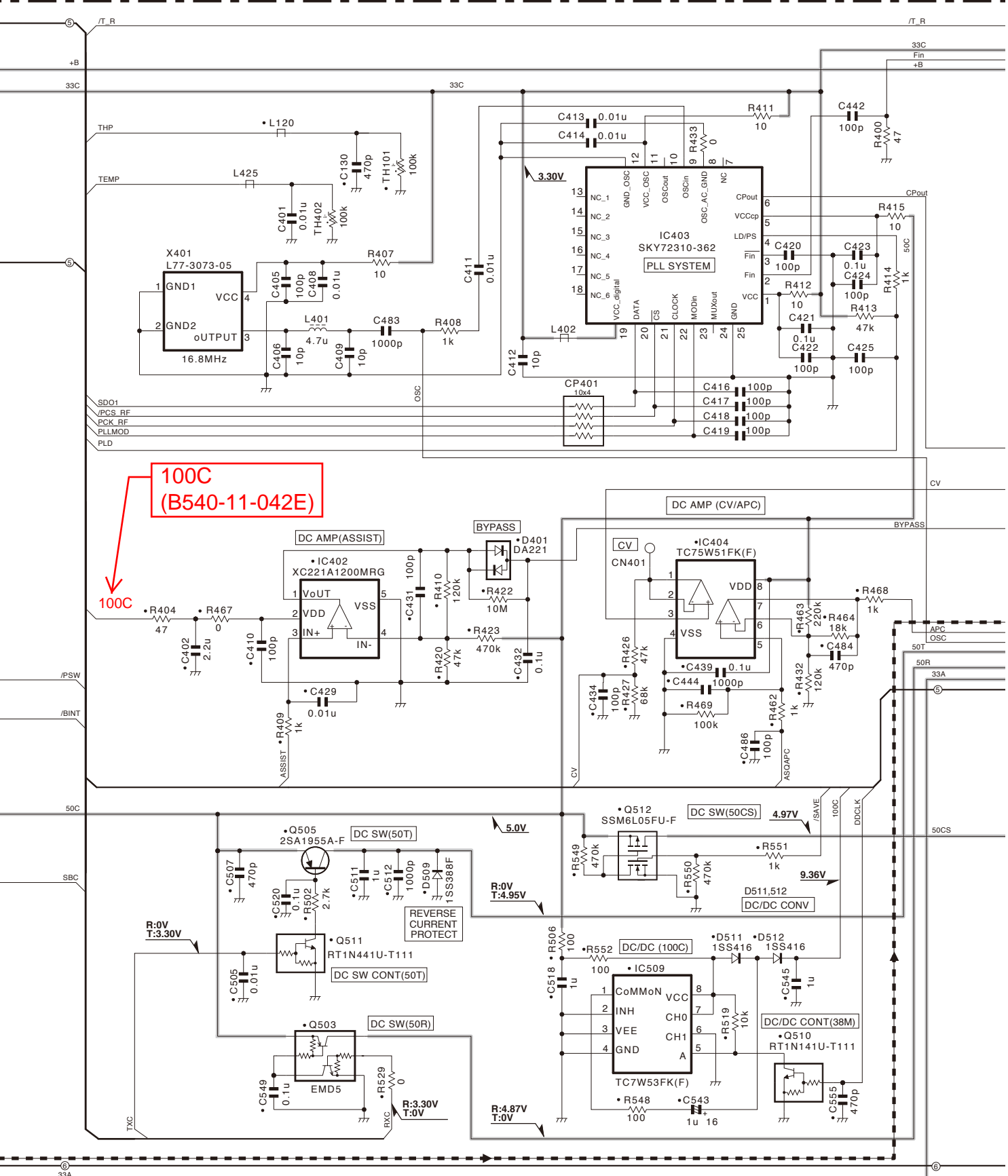

100C
(B540-11-042E)

100C

SCHEMATIC DIAGRAM / 原理图 NX-220

TX-RX UNIT (X57-8040-10)

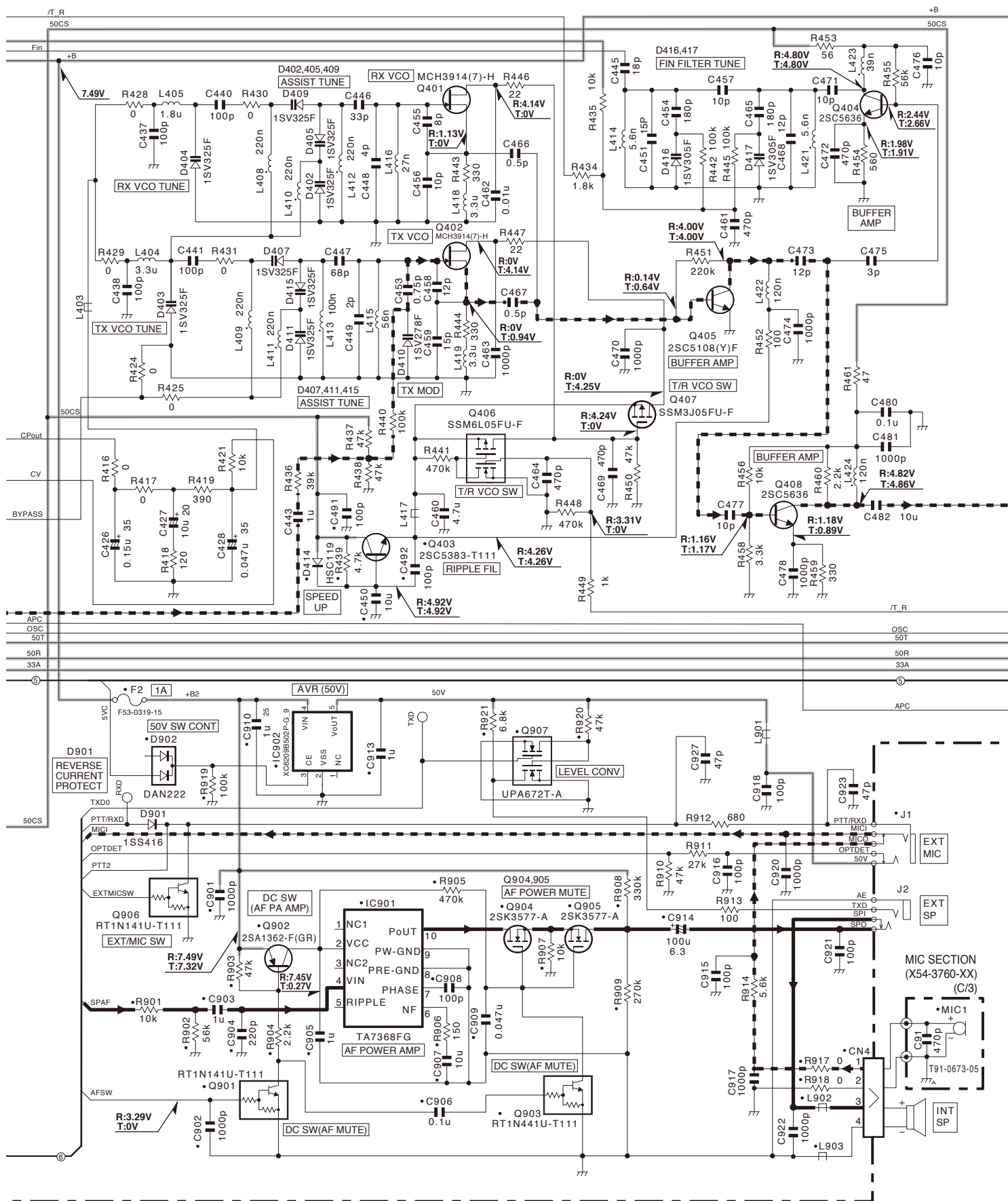

NX-220 SCHEMATIC DIAGRAM / 原理图

TX-RX UNIT (X57-8040-10)

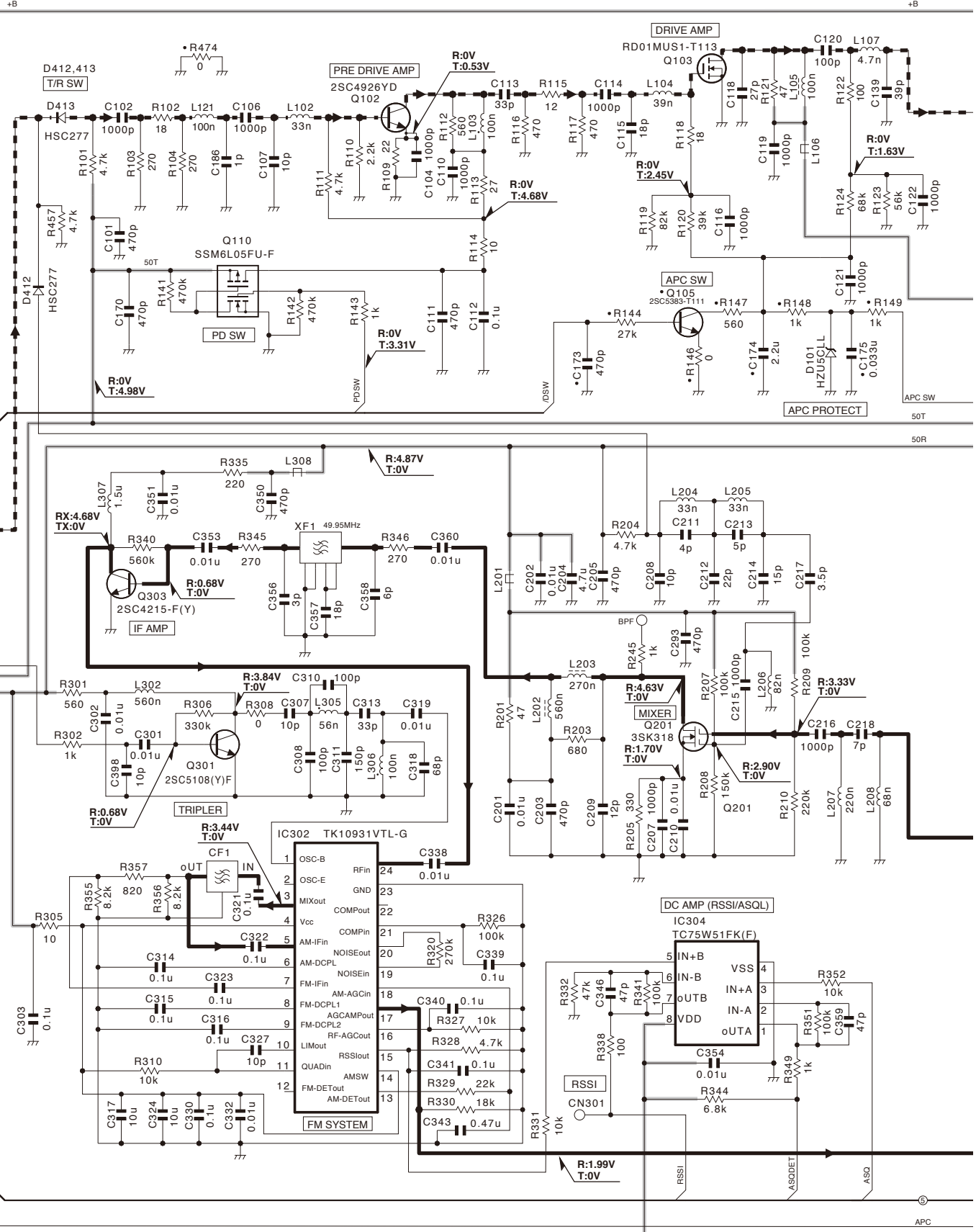

SCHEMATIC DIAGRAM / 原理图 NX-220

TX-RX UNIT (X57-8040-10)

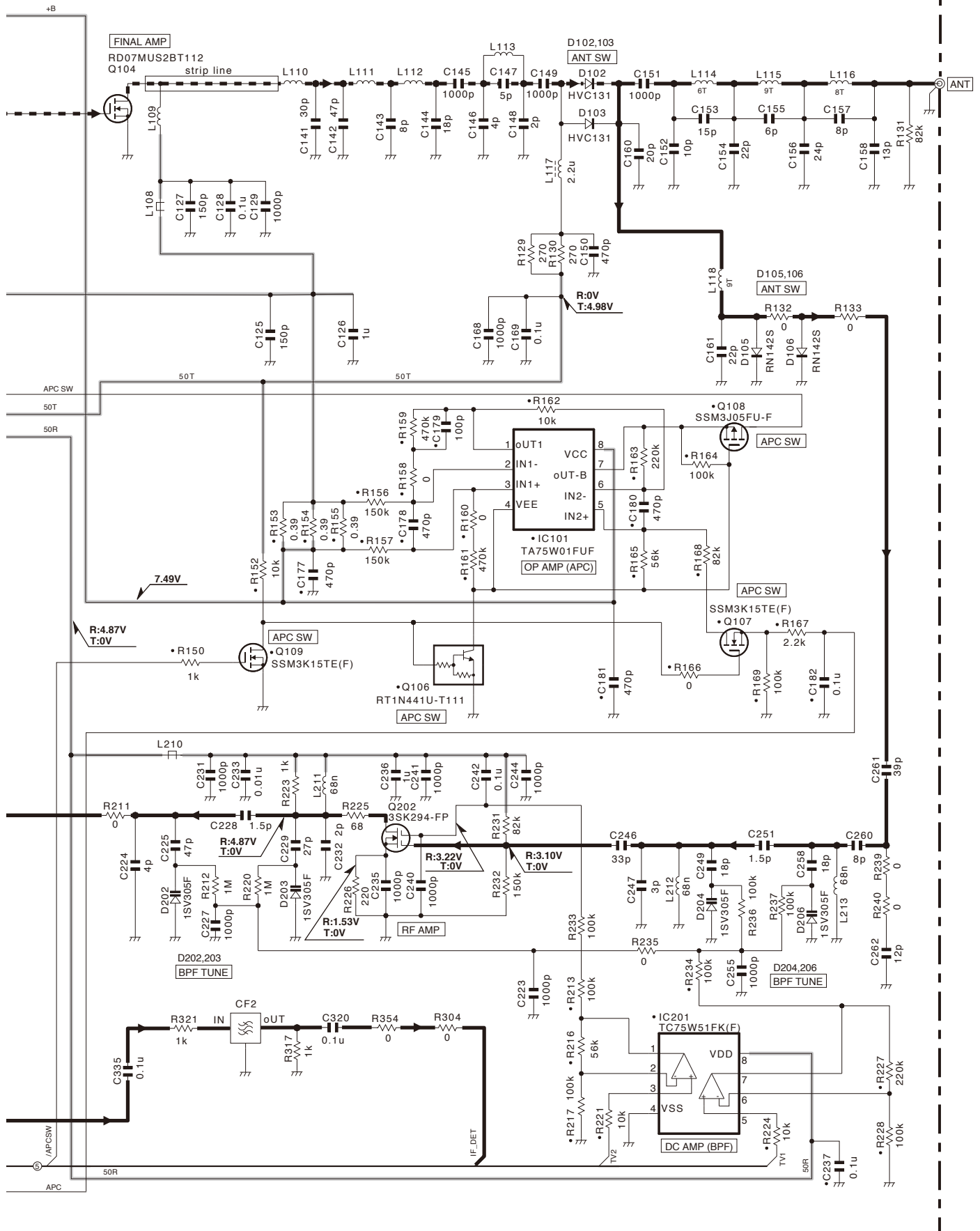

Note : The components marked with a dot (•) are parts of layer 1.

注意：标有点号(•)的零件为第一层的零件。

NX-220 BLOCK DIAGRAM / 方块图

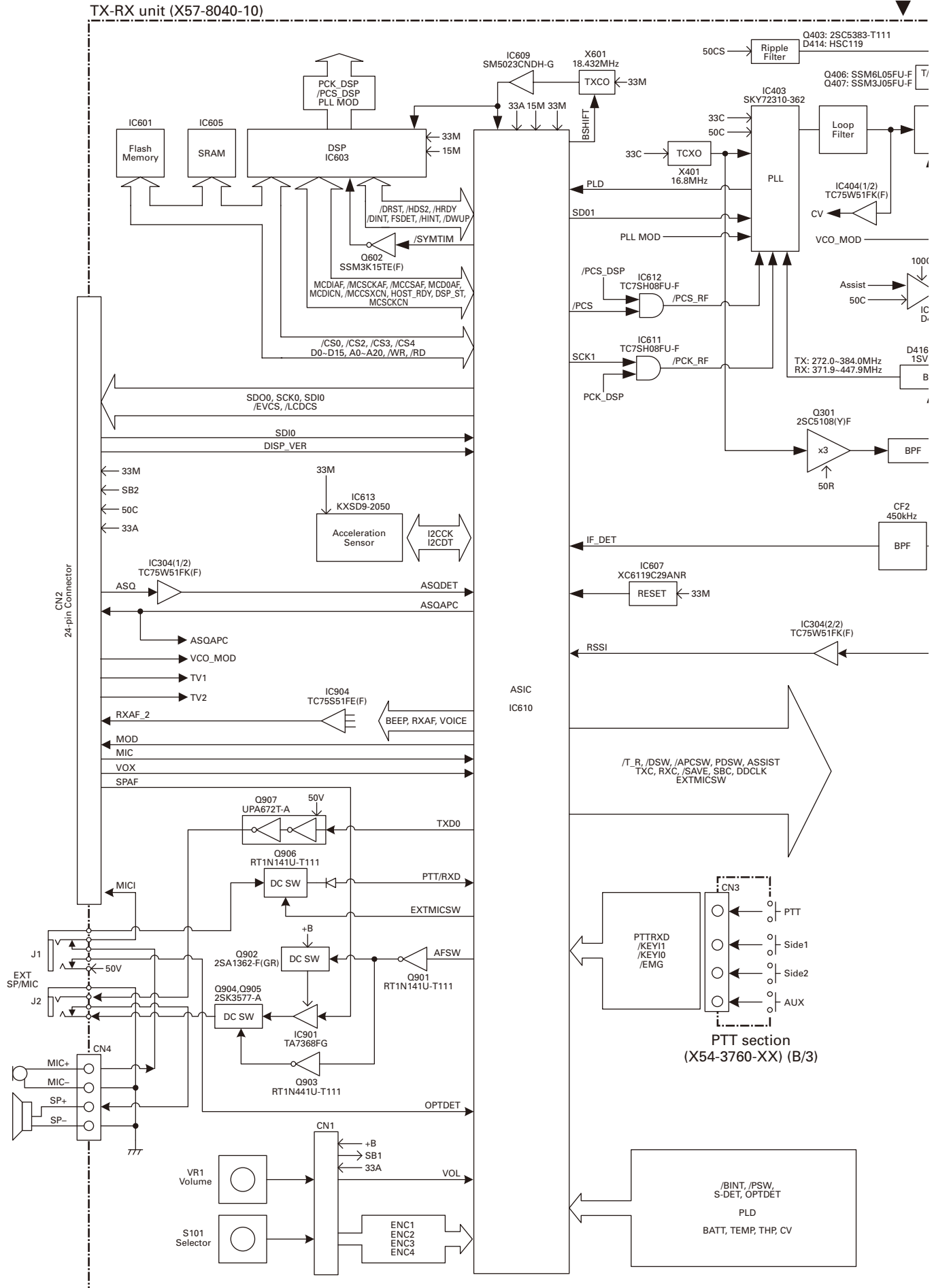

BLOCK DIAGRAM / 方块图 NX-220

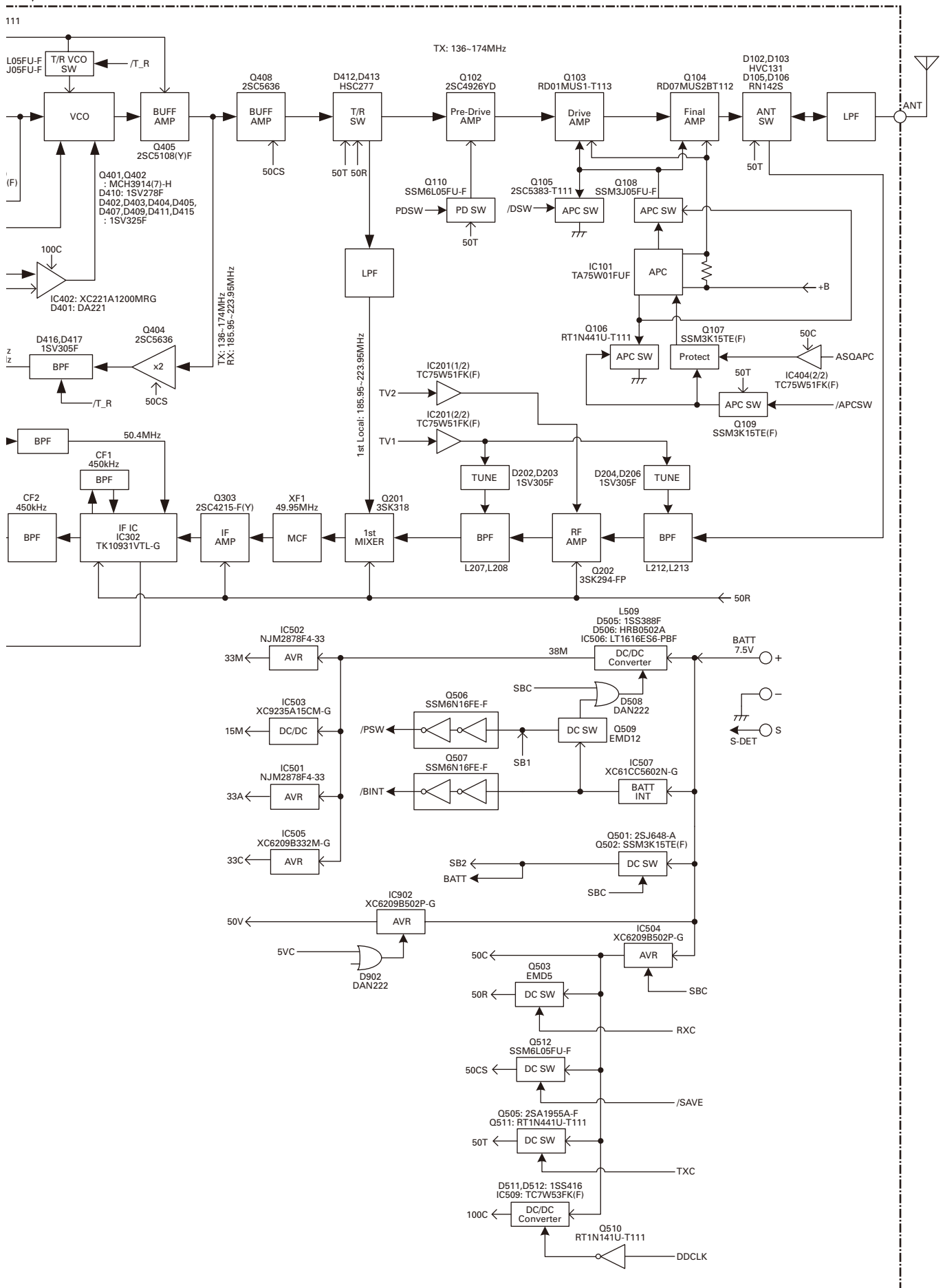

BLOCK DIAGRAM / 方块图

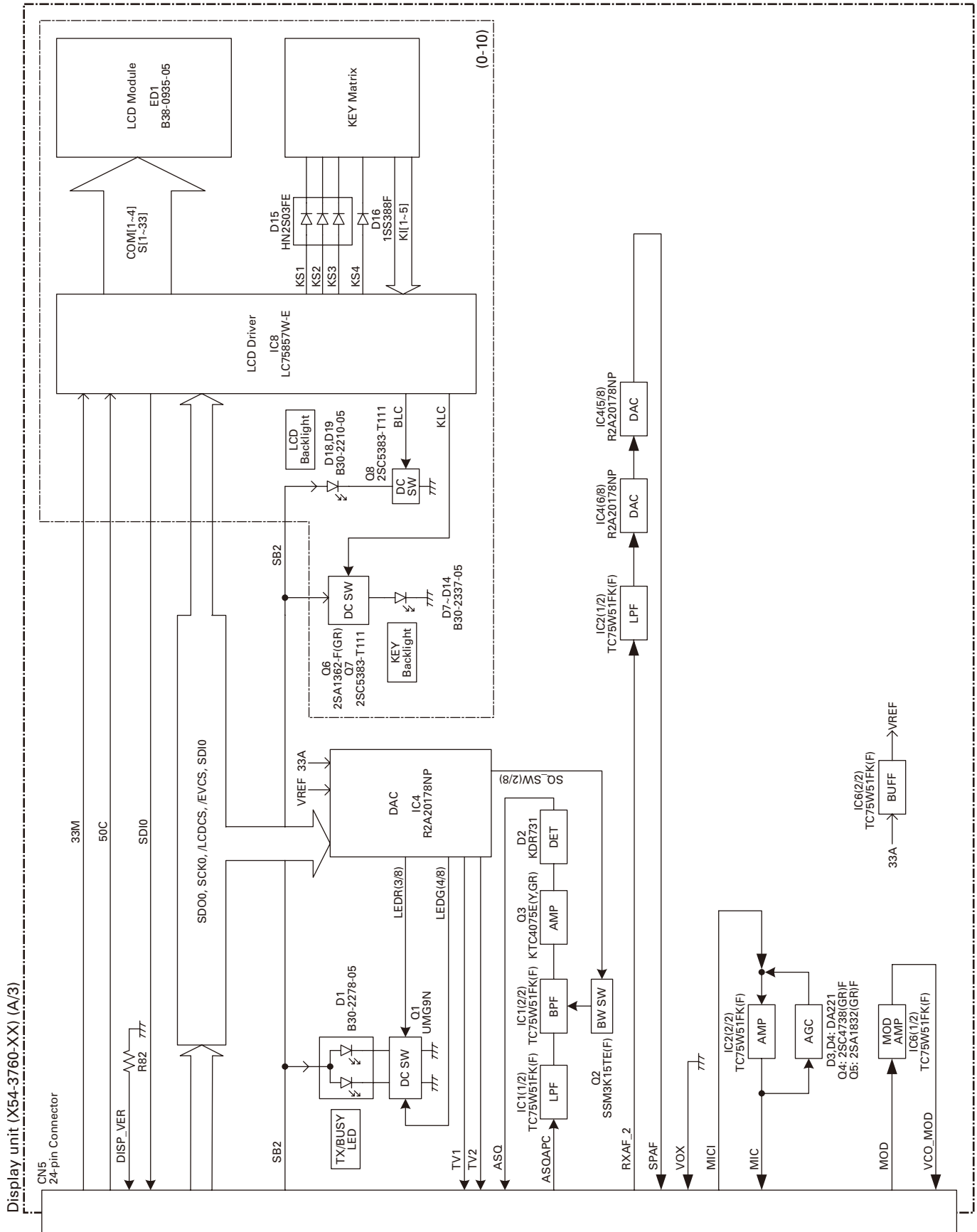

OPTIONAL ACCESSORIES / 可选附件

KNB-55L (Li-ion Battery Pack / 锂离子电池)

■ External View / 外视图



■ Specifications / 规格

Voltage / 电压.....7.4V (3.7V x 2)
Battery capacity / 电池容量..... typ./ 标准 1480mAh

KNB-57L (Li-ion Battery Pack / 锂离子电池)

■ External View / 外视图



■ Specifications / 规格

Voltage / 电压.....7.4V (3.7V x 2)
Battery capacity / 电池容量..... typ./ 标准 2000mAh

SPECIFICATIONS

GENERAL

Frequency Range.....	136~174MHz	
Number of Channels.....	C: 260	C2: 64
Zones.....	C: 128	C2: 4
Max. Channels per Zone.....	C: 250	C2: 16
Channel Spacing.....	Analog: 12.5/25kHz	Digital: 6.25/12.5kHz
Operating Voltage.....	7.5V DC \pm 20%	
Battery Life (5-5-90)		
with KNB-55L.....	Approx. 8.5 hours	
with KNB-57L.....	Approx. 11.5 hours	
Operating Temperature Range.....	-30°C to +60°C	
Frequency Stability.....	\pm 2.0ppm	
Antenna Impedance.....	50 Ω	
Dimensions (W x H x D) (Projections not included)		
C		
Radio only.....	56 x 110.5 x 36.9 mm	
with KNB-55L.....	56 x 110.5 x 37.5 mm	
with KNB-57L.....	56 x 110.5 x 39.5 mm	
C2		
Radio only.....	56 x 110.5 x 37.5 mm	
with KNB-55L.....	56 x 110.5 x 38.1 mm	
with KNB-57L.....	56 x 110.5 x 40.1 mm	
Weight (net)		
Radio only.....	C: 210g	C2: 205g
with KNB-55L.....	C: 305g	C2: 300g
with KNB-57L.....	C: 330g	C2: 325g

RECEIVER

Sensitivity		
Digital @6.25kHz (3% BER).....	0.25 μ V	
Digital @12.5kHz (3% BER).....	0.32 μ V	
Analog @12.5kHz (12dB SINAD).....	0.32 μ V	
Analog @25kHz (12dB SINAD).....	0.28 μ V	
Adjacent Channel Selectivity (Analog).....	25kHz: 76dB	12.5kHz: 68dB
Intermodulation (Analog).....	65dB	
Spurious Response Rejection (Analog).....	75dB	
Audio Distortion.....	Less than 3%	
Audio Output.....	500mW/8 Ω	

TRANSMITTER

RF Power Output (High/Low).....	5W/1W	
Modulation Limiting (Analog).....	\pm 5.0kHz (25kHz)	\pm 2.5kHz (12.5kHz)
Spurious Emission.....	-36dBm \leq 1GHz, -30dBm > 1GHz	
FM Noise (EIA) (Analog).....	25kHz: 45dB	12.5kHz: 40dB
Modulation Distortion.....	Less than 3%	
Microphone Impedance.....	1.8k Ω	
Modulation.....	16K0F3E, 14K0F2D, 8K50F3E, 7K50F2D, 8K30F1E, 8K30F1D, 8K30F7W, 4K00F1E, 4K00F1D, 4K00F7W, 4K00F2D	

Analog measurements made per EN standards or TIA/EIA 603 and specifications shown are typical.
Kenwood reserves the right to change specifications without prior notice or obligation.

规 格

概 述

频率范围.....	136~174MHz	
信道数量.....	C:260	C2:64
区域数量.....	C:128	C2:4
每区域最大信道数量.....	C:250	C2:16
信道间隔.....	模拟 :12.5/25kHz	数字 :6.25/12.5kHz
工作电源电压.....	7.5V DC \pm 20%	
电池使用时间 (5-5-90)		
使用 KNB-55L 电池时	约 8.5 小时	
使用 KNB-57L 电池时	约 11.5 小时	
工作温度范围.....	-30°C ~ +60°C	
频率稳定度.....	\pm 2.0ppm	
天线阻抗.....	50 Ω	
外型尺寸 (宽 \times 高 \times 长) (未包括凸起部分)		
C		
仅主机	56 \times 110.5 \times 36.9 mm	
带 KNB-55L 电池时	56 \times 110.5 \times 37.5 mm	
带 KNB-57L 电池时	56 \times 110.5 \times 39.5 mm	
C2		
仅主机	56 \times 110.5 \times 37.5 mm	
带 KNB-55L 电池时	56 \times 110.5 \times 38.1 mm	
带 KNB-57L 电池时	56 \times 110.5 \times 40.1 mm	
重量 (净重)		
仅主机	C:210g	C2:205g
带 KNB-55L 电池时	C:305g	C2:300g
带 KNB-57L 电池时	C:330g	C2:325g

接 收

接收灵敏度		
数字 @6.25kHz (3% 误码率)	0.25 μ V	
数字 @12.5kHz (3% 误码率)	0.32 μ V	
模拟 @12.5kHz (12dB SINAD)	0.32 μ V	
模拟 @25kHz (12dB SINAD)	0.28 μ V	
邻道选择性 (模拟)	25kHz:76dB	12.5kHz:68dB
互调抑制 (模拟)	65dB	
杂散响应 (模拟)	75dB	
音频失真.....	小于 3%	
音频输出功率.....	500mW (8 Ω 时)	

发 射

发射功率 (高 / 低)	5W/1W	
调制限制 (模拟)	\pm 5.0kHz (25kHz)	\pm 2.5kHz (12.5kHz)
杂散抑制.....	-36dBm \leq 1GHz, -30dBm $>$ 1GHz	
调频噪声 (EIA) (模拟)	25kHz:45dB	12.5kHz:40dB
调制失真.....	小于 3%	
麦克风阻抗.....	1.8k Ω	
电波类型.....	16K0F3E, 14K0F2D, 8K50F3E, 7K50F2D, 8K30F1E, 8K30F1D, 8K30F7W, 4K00F1E, 4K00F1D, 4K00F7W, 4K00F2D	

依据 EN 标准或 TIA/EIA 603 获得的模拟测量值和所示规格均为典型值。
建伍公司有权变更技术规格，恕不预先通知。

NX-220

Kenwood Corporation

2967-3, Ishikawa-machi, Hachioji-shi, Tokyo, 192-8525 Japan

Kenwood U.S.A. Corporation

P.O. BOX 22745, 2201 East Dominguez Street, Long Beach,
CA 90801-5745, U.S.A.

Kenwood Electronics Canada Inc.

6070 Kestrel Road, Mississauga, Ontario, Canada L5T 1S8

Kenwood Electronics Deutschland GmbH

Rembrücker Str. 15, 63150 Heusenstamm, Germany

Kenwood Electronics Belgium N.V.

Leuvensesteenweg 248 J, 1800 Vilvoorde, Belgium

Kenwood Electronics France S.A.

L'Etoile Paris Nord 2, 50 Allée des Impressionnistes,
Bp 58416 Villepinte, 95944 Roissy Ch De Gaulle Cedex

Kenwood Electronics UK Limited

KENWOOD House, Dwight Road, Watford, Herts.,
WD18 9EB United Kingdom

Kenwood Electronics Europe B.V.

Amsterdamseweg 37, 1422 AC Uithoorn, The Netherlands

Kenwood Electronics Italia S.p.A.

Via G. Sirtori, 7/9 20129 Milano, Italy

Kenwood Ibérica, S.A.

Bolivia, 239-08020 Barcelona, Spain

Kenwood Electronics Australia Pty. Ltd.

Talavera Business Park Building A, 4 Talavera Road,
North Ryde NSW 2113 Australia

Kenwood Electronics (Hong Kong) Ltd.

Suite 2504, 25/F, Tower 2, Nina Tower, No. 8 Yeung Uk Road,
Tsuen Wan, New Territories, Hong Kong

Kenwood Electronics Singapore Pte Ltd

1 Ang Mo Kio Street 63, Singapore 569110

NX-220 PC BOARD / 印刷电路板

PC BOARD / 印刷电路板 NX-220

DISPLAY UNIT (X54-3760-XX) -10: C -12: C2
Component side view (J79-0312-09)

DISPLAY UNIT (X54-3760-XX) -10: C -12: C2
Component side view (J79-0312-09)

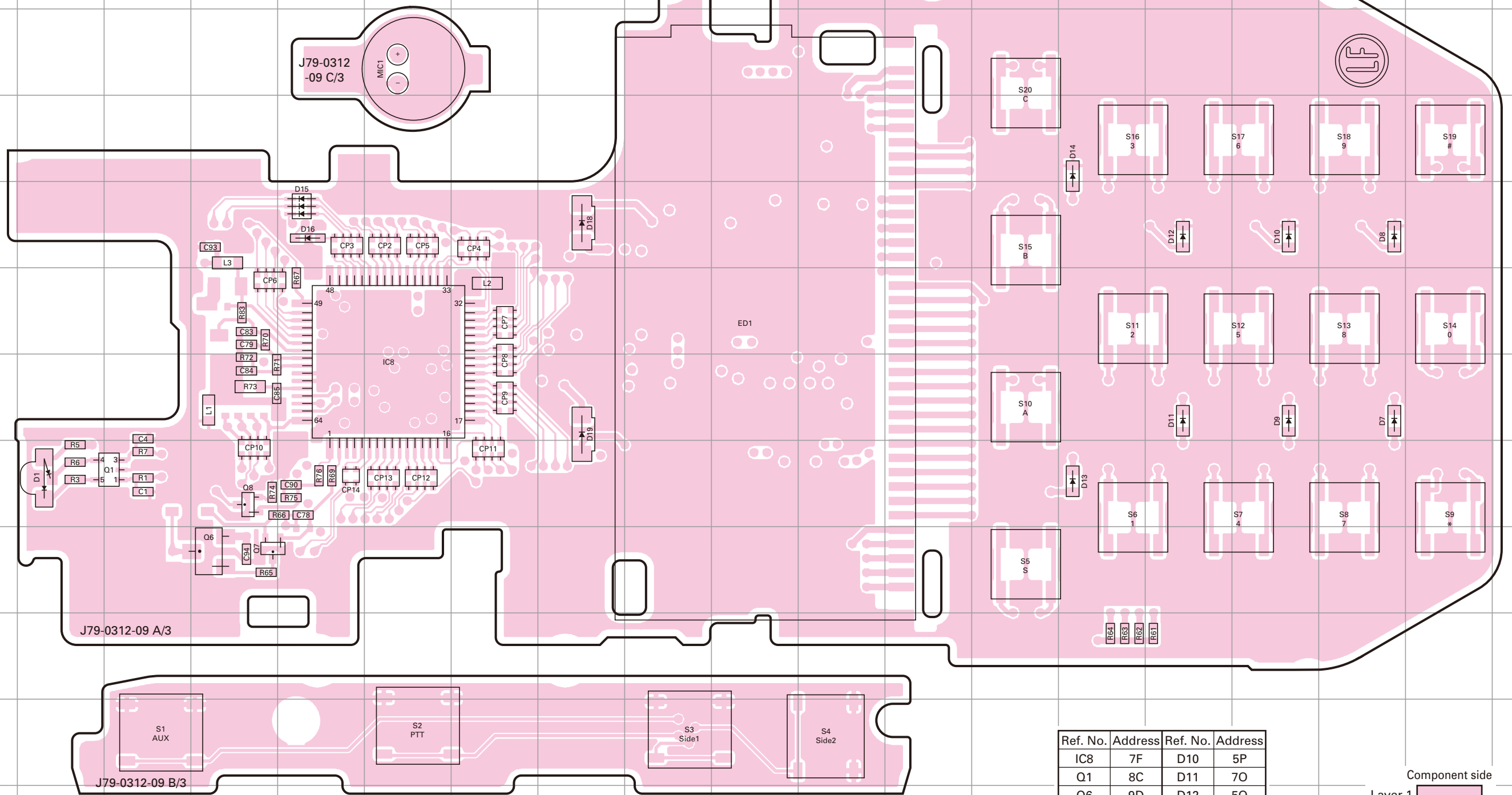

Ref. No.	Address	Ref. No.	Address
IC8	7F	D10	5P
Q1	8C	D11	7O
Q6	9D	D12	5O
Q7	9D	D13	8N
Q8	8D	D14	4N
D1	8B	D15	5E
D7	7Q	D16	5E
D8	5Q	D18	5H
D9	7P	D19	7H

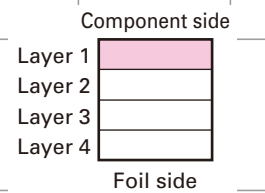

NX-220 PC BOARD / 印刷电路板

PC BOARD / 印刷电路板 NX-220

DISPLAY UNIT (X54-3760-XX) -10: C -12: C2
Foil side view (J79-0312-09)

DISPLAY UNIT (X54-3760-XX) -10: C -12: C2
Foil side view (J79-0312-09)

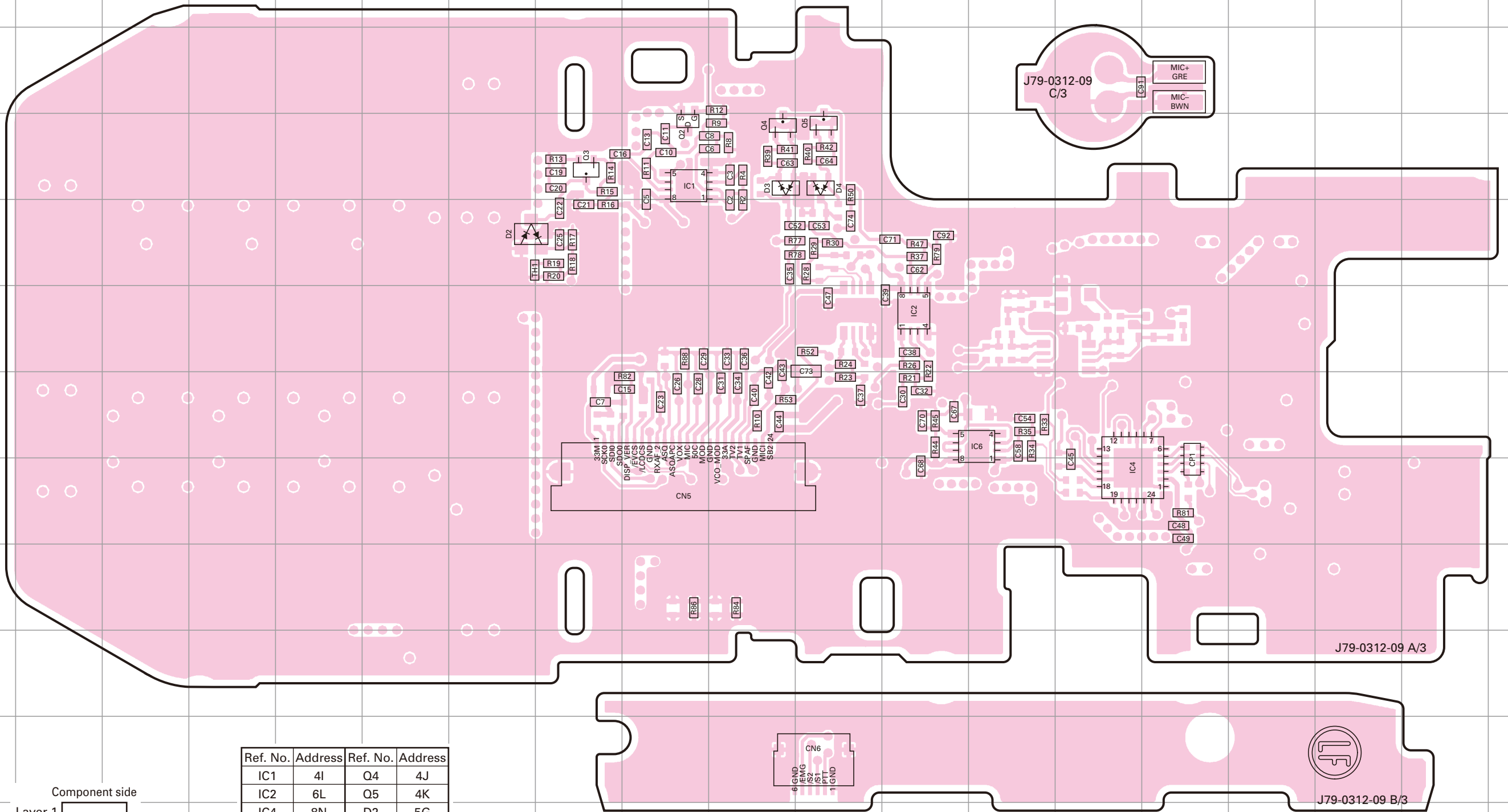

Ref. No.	Address	Ref. No.	Address
IC1	4I	Q4	4J
IC2	6L	Q5	4K
IC4	8N	D2	5G
IC6	7M	D3	4J
Q2	4I	D4	4K
Q3	4H		

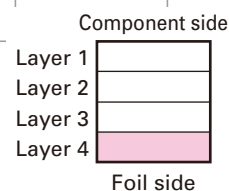

TX-RX UNIT (X57-8040-10) Component side view (J79-0313-19)

TX-RX UNIT (X57-8040-10) Component side view (J79-0313-19)

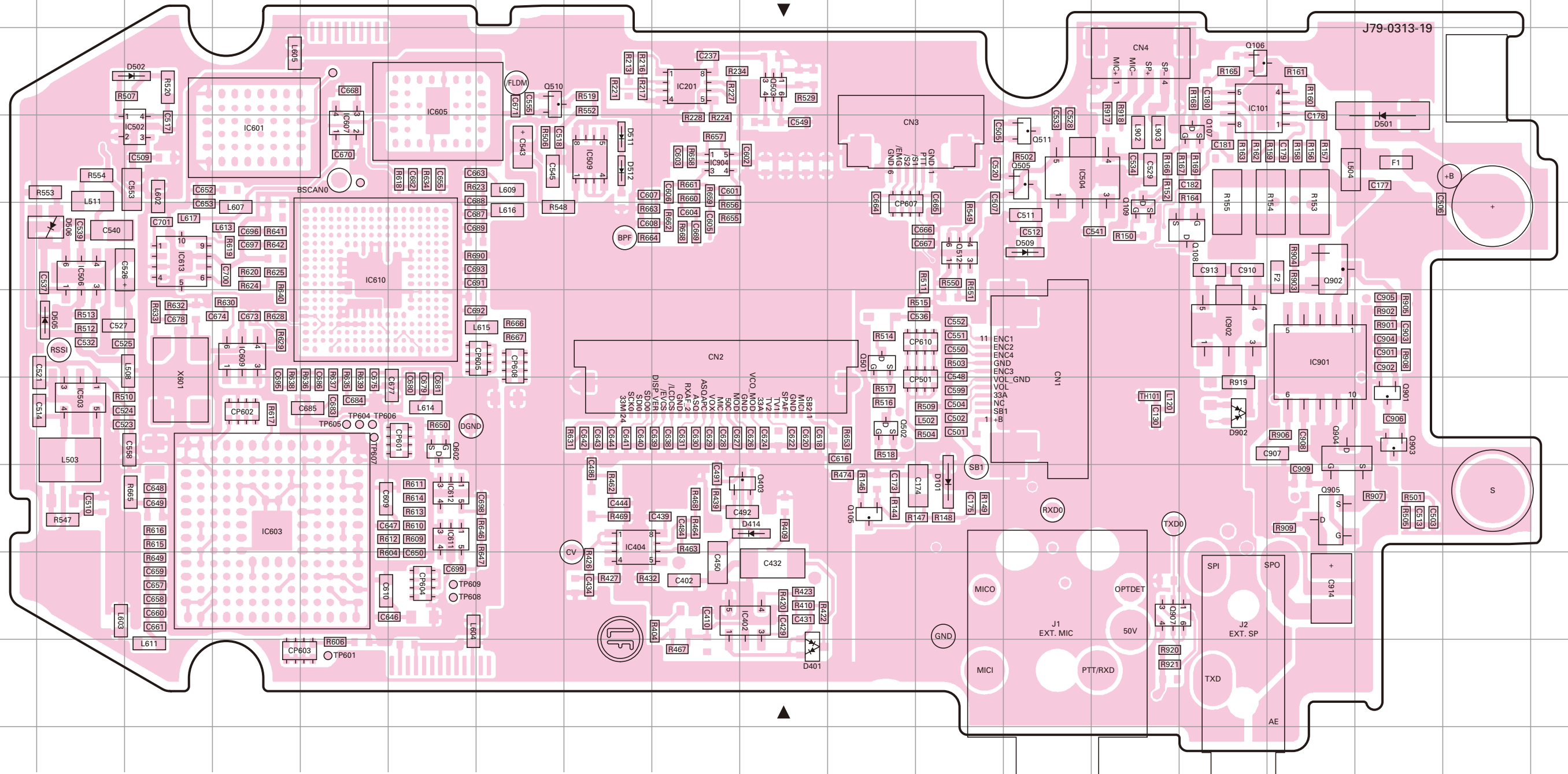

Ref. No.	Address	Ref. No.	Address	Ref. No.	Address	Ref. No.	Address	Ref. No.	Address	Ref. No.	Address
IC101	3O	IC601	4D	IC901	6P	Q501	6K	Q902	5P	D502	3C
IC201	3I	IC603	8D	IC902	6O	Q502	7K	Q903	7Q	D505	6B
IC402	9J	IC605	3F	IC904	4I	Q503	3J	Q904	7P	D506	5B
IC404	8H	IC607	4E	Q105	8K	Q505	4M	Q905	8P	D509	5M
IC502	4C	IC609	6D	Q106	3O	Q510	3G	Q907	9N	D511	4H
IC503	7B	IC610	5E	Q107	4O	Q511	4M	D101	8L	D512	4H
IC504	4M	IC611	8F	Q108	5O	Q512	5L	D401	10J	D902	7O
IC506	5B	IC612	8F	Q109	5N	Q602	7F	D414	8J		
IC509	4H	IC613	5C	Q403	8J	Q901	7Q	D501	4Q		

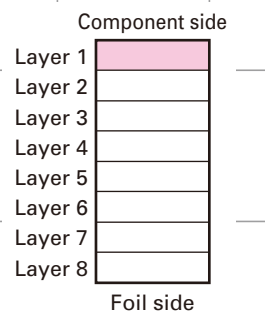

NX-220 PC BOARD / 印刷电路板

PC BOARD / 印刷电路板 NX-220

TX-RX UNIT (X57-8040-10) Foil side view (J79-0313-19)

TX-RX UNIT (X57-8040-10) Foil side view (J79-0313-19)

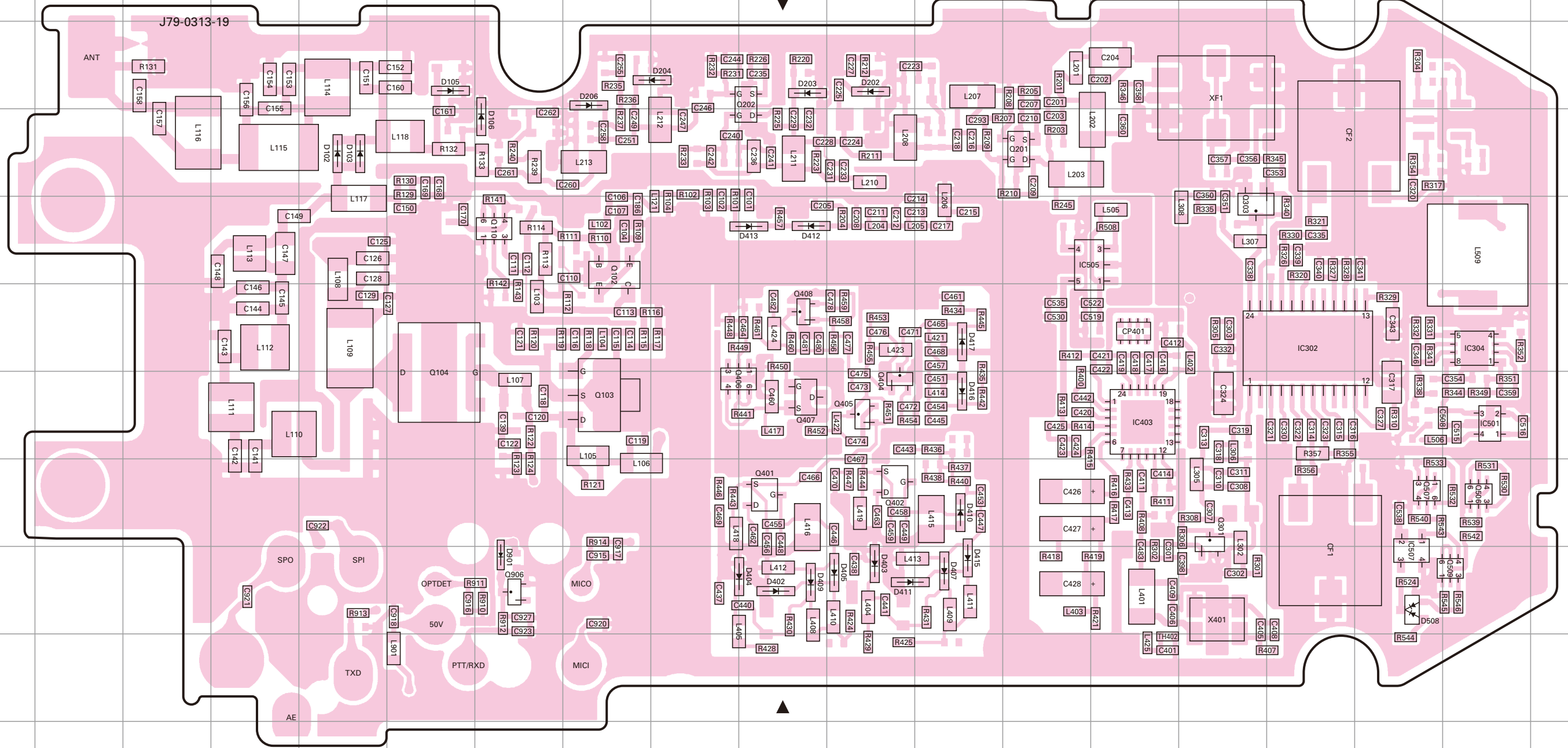

Ref. No.	Address	Ref. No.	Address	Ref. No.	Address	Ref. No.	Address	Ref. No.	Address
IC302	6P	Q201	4M	Q408	6J	D203	3J	D411	9K
IC304	6R	Q202	3J	Q506	8R	D204	3I	D412	5J
IC403	7N	Q301	8O	Q507	8Q	D206	3H	D413	5J
IC501	7R	Q303	5O	Q509	9R	D402	9J	D415	9L
IC505	5M	Q401	8J	Q906	9G	D403	9K	D416	7L
IC507	9Q	Q402	8K	D102	4E	D404	9J	D417	6L
Q102	5H	Q404	7K	D103	4E	D405	9K	D508	9Q
Q103	7H	Q405	7K	D105	3F	D407	9L	D901	9G
Q104	7F	Q406	7I	D106	4G	D409	9J		
Q110	5G	Q407	7J	D202	3K	D410	8L		

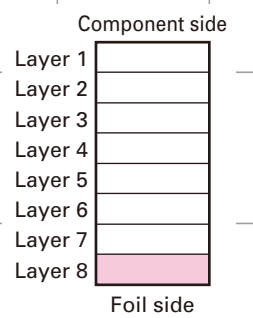



TX-RX unit (X57-8040-10)

