

KENWOOD

SERVICE MANUAL

UHF DIGITAL TRANSCEIVER

NX-340, NX-340(U)

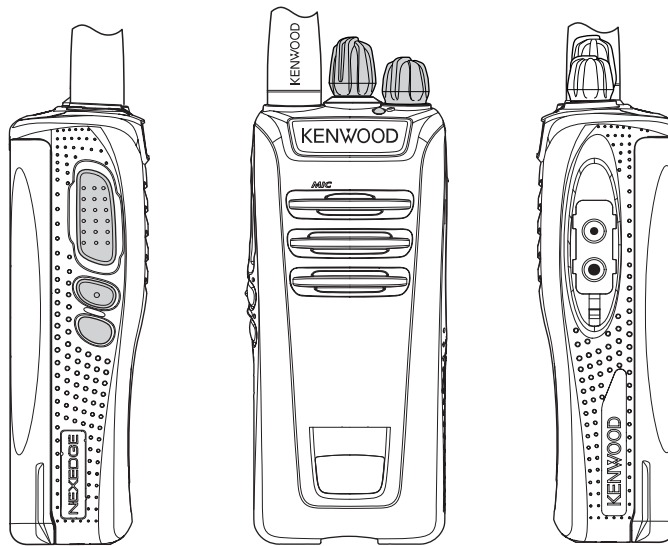

Note :

Lead free solder used in the board (material : Sn, Ag, In, Bi, melting point : 227 Centigrade)

TABLE OF CONTENTS

1	PRECAUTION	1-4
2	SPECIFIC SERVICE INSTRUCTIONS	1-4
3	DISASSEMBLY	1-13
4	ADJUSTMENT	1-16
5	TROUBLESHOOTING	1-22

This service manual is applied for Hardware Ver 2.0 transceivers (K, M types) with B52xxxxx or subsequent serial numbers.

This product complies with the RoHS directive for the European market.



This product uses Lead Free solder.

Document Copyrights

Copyright 2015 by JVC KENWOOD Corporation. All rights reserved.

No part of this manual may be reproduced, translated, distributed, or transmitted in any form or by any means, electronic, mechanical, photocopying, recording, or otherwise, for any purpose without the prior written permission of JVC KENWOOD Corporation.

Disclaimer

While every precaution has been taken in the preparation of this manual, JVC KENWOOD Corporation assumes no responsibility for errors or omissions. Neither is any liability assumed for damages resulting from the use of the information contained herein.

JVC KENWOOD Corporation reserves the right to make changes to any products herein at any time for improvement purposes.

Firmware Copyrights

The title to and ownership of copyrights for firmware embedded in KENWOOD product memories are reserved for JVC KENWOOD Corporation. Any modifying, reverse engineering, copy, reproducing or disclosing on an Internet website of the firmware is strictly prohibited without prior written consent of JVC KENWOOD Corporation. Furthermore, any reselling, assigning or transferring of the firmware is also strictly prohibited without embedding the firmware in KENWOOD product memories.

Transceivers containing AMBE+2™ Vocoder: The AMBE+2™ voice coding technology is embedded in the firmware under the license of Digital Voice Systems, Inc.

SPECIFICATION

GENERAL		
Frequency Range		450~520MHz
Number of Channels		32
Zones		2
Max. Channels per Zone		16
Channel Spacing	Analog	12.5/25kHz
	Digital	6.25/12.5kHz
Operating Voltage		7.5V DC \pm 20%
Battery Life Battery Saver OFF/ON (5-5-90 at high power with KNB-45L (2000mAh))		Approx. 10/12 hours
Operating Temperature Range		-30°C~+60°C (-22°F to +140°F)
Frequency Stability		\pm 1.0ppm
Antenna Impedance		50 Ω
Dimensions (W x H x D) (Projections not included)	with KNB-45L	54 x 122 x 35.3 mm (2.13 x 4.80 x 1.39 in)
Weight (net)	Radio only	165 g (5.8 oz)
	with KNB-45L	281 g (9.9 oz)
RECEIVER		
Sensitivity	Digital@6.25kHz	0.25 μ V (3% BER)
	Digital@12.5kHz	0.25 μ V (3% BER)
	Analog	0.25 μ V (EIA 12dB SINAD)
Selectivity	Analog@25kHz	70dB
	Analog@12.5kHz	60dB
Intermodulation Distortion	Analog	70dB
Spurious Response	Analog	70dB
Audio Distortion		Less than 10%
Audio Output		1W/12 Ω (Internal speaker) 500mW/8 Ω (External output)
TRANSMITTER		
RF Power Output	High/Low	5W/1W
Spurious Response		70dB
FM Hum & Noise	Analog@25kHz	45dB
	Analog@12.5kHz	40dB
Audio Distortion		Less than 10%
Modulation		16K0F3E, 11K0F3E, 4K00F1E, 4K00F1D, 4K00F7W, 4K00F2D, 8K30F1E, 8K30F1D, 8K30F7W

Analog measurements made per TIA/EIA-603 and specifications shown are typical.

Digital measurements made per NXDN CA1 and specifications shown are typical.

JVC KENWOOD Corporation reserves the right to change specifications without prior notice or obligation.

SECTION 1 PRECAUTION

This service manual does not describe PRECAUTION.

SECTION 2 SPECIFIC SERVICE INSTRUCTIONS

2.1 CIRCUIT DESCRIPTION

2.1.1 Frequency Configuration

The receiver utilizes double conversion. The first IF is 49.95MHz and the second IF is 450kHz. The first Local oscillator is supplied from the PLL circuit.

The PLL circuit in the transmitter generates the necessary frequencies. Figure 1 shows the frequencies.

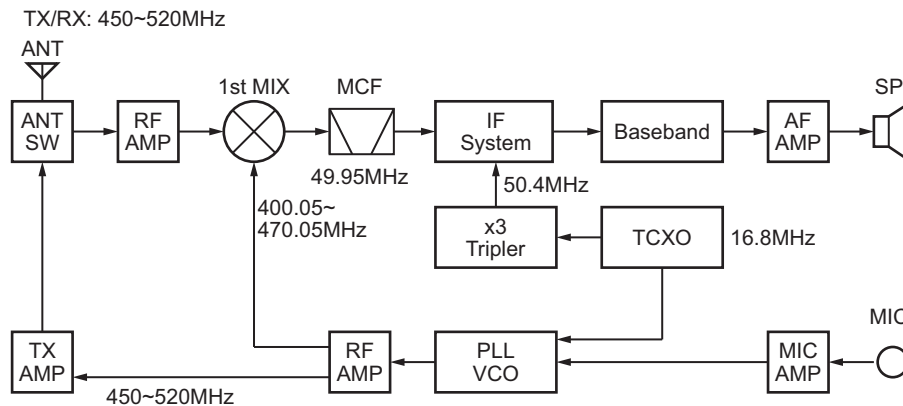

Fig.1 Frequency configuration

2.1.2 Receiver System

The receiver system is shown in Figure 2.

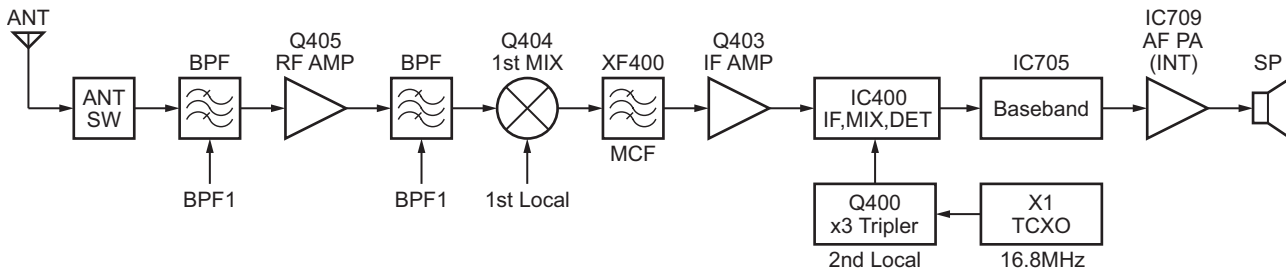

Fig.2 Receiver system

2.1.2.1 Front End (RF Amplifier) Circuit

The signal coming from the antenna passes through the transmit/receive switching diode circuit (D201, D202, D203 and D204) and a BPF (L415 and L416), and is then amplified by the RF amplifier (Q405).

The resulting signal passes through a BPF (L410, L411 and L413) and goes to the mixer. The BPF is adjusted by variable capacitance diodes (D400, D401, D402, D403 and D404). The input voltage to the variable capacitance diodes is the regulated voltage output from the DC amplifier (IC704).

2.1.2.2 First Mixer

The signal from the front end is mixed with the first local oscillator signal generated in the PLL circuit by Q404 to produce the first IF frequency of 49.95MHz.

The resulting signal passes through the XF400 MCF to cut the adjacent spurious and provide optimum characteristics, such as adjacent frequency selectivity.

2.1.2.3 IF Amplifier Circuit

The first IF signal is passed through a four-pole monolithic crystal filter (XF400) to remove the adjacent channel signal. The filtered first IF signal is amplified by the first IF amplifier (Q403) and is then applied to the IF system IC (IC400).

The IF system IC provides a second mixer, AGC+BPF, PLL FM detector, noise squelch and RSSI circuit.

The second mixer mixes the first IF signal (49.95MHz) with the signal of the second local oscillator output (Q400) and produces the second IF signal of 450kHz.

The second IF signal is passed through the internal bandpass filter of the IF system IC to remove the adjacent channel signal. The filtered second IF signal is amplified by the limiting amplifier and demodulated by the internal discriminator of the IF system IC.

The demodulated signal is routed to the audio circuit.

2.1.2.4 Audio Amplifier Circuit

The demodulated signal from IC400 is sent to an AF amplifier through IC705, and is routed to an audio power amplifier (INT:IC709, EXT:IC707) where it is amplified and output to the speaker.

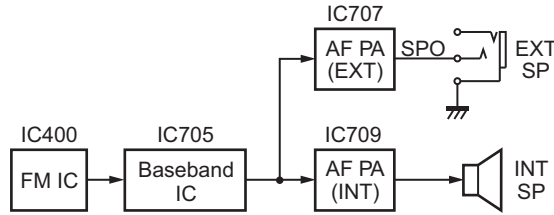

Fig.3 Audio amplifier circuit

2.1.2.5 Squelch Circuit

Part of the AF signal from the IC400 enters the FM IC (IC400) again, and the noise component is amplified and rectified by a filter and an amplifier to produce a DC voltage corresponding to the noise level.

There are 2 noise filters. Analog Narrow band, NXDN Narrow band and NXDN Very Narrow band will share the same noise filter (W_N control is Low) where as analog wide band will use another noise filter (W_N control is HIGH).

The selection of different noise filter is by 2 multiplexer (IC719 and IC720).

The DC signal from the FM IC goes to the analog port of the MCU (IC710). IC710 determines whether or not to output sounds from the speaker by checking if the input voltage is higher or lower than the preset value.

To output sounds from the speaker, IC710 sends a high signal to the EXTSPSW line and turns IC707 on through Q709, Q710, Q713 and Q716. This explanation is for the external speaker amplifier. For the internal loudspeaker amplifier, IC710 sends a high signal to the INTSPSW line and turns IC709 on through Q711 and Q714.

2.1.3 Transmitter System

2.1.3.1 Microphone Amplifier Circuit

The signal from the microphone is limited by the AGC circuit, which is composed of D700, D701, Q705, Q706 and the mute switch (Q704). IC705 is composed of a high-pass filter, low-pass filter and pre-emphasis/IDC circuit.

The signal from the microphone and the low speed data from the MCU (IC710) enter the baseband IC (IC705) and pass through each path and are mixed inside the IC.

The output signal from the audio processor MOD2 goes to the VCO modulation input. The other output signal from MOD1 goes to the TCXO modulation input.

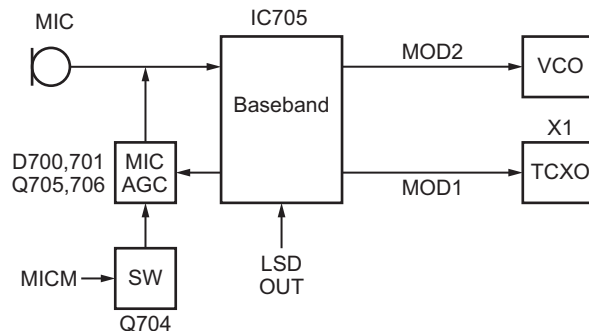

Fig.4 Microphone amplifier circuit

2.1.3.2 Drive and Final Amplifier Circuit

The signal from the T/R switch (D15 is on) is amplified by the pre-drive amplifier (Q201) to 20mW.

The output of the pre-drive amplifier is amplified by the drive amplifier (Q206) and the RF final amplifier (Q208) to 5.0W (1W when the power is low).

The drive amplifier and the RF final amplifier consist of two MOS FET stages.

The output of the RF final amplifier is then passed through the antenna switch (D203 and D204) and harmonic filter (LPF) and is applied to the antenna terminal.

2.1.3.3 APC Circuit

The APC circuit always monitors the current flowing through the drive amplifier (Q206) and RF power amplifier (Q208), and keeps it constant. The voltage drop at R230, R231 and R233 is caused by the current flowing through the RF final amplifier. This voltage is applied to the differential amplifier IC200 (1/2).

IC200 (2/2) compares the output voltage of IC200 (1/2) with the reference voltage from IC705 (32pin:AUXDAC1). The output of IC200 (2/2) controls the gate bias voltage of the RF power amplifier and the drive amplifier to make both voltages the same.

The change of power (high/low) is carried out by the change of the reference voltage.

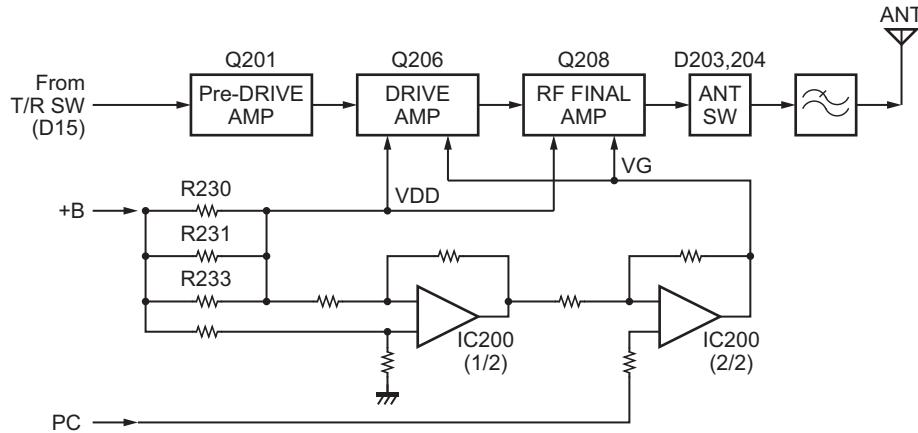

Fig.5 Drive and final amplifier and APC circuit

2.1.4 Frequency Synthesizer Unit

2.1.4.1 Frequency synthesizer

The frequency synthesizer consists of the TCXO (X1), VCO, PLL-IC (IC2), and buffer amplifiers.

The TCXO generates 16.8MHz. The frequency stability of TCXO is 0.5ppm within the temperature range of -30°C to +60°C. The frequency tuning and modulation of the TCXO are done to apply voltage to pin 1 of the TCXO. The TCXO output is applied to pin 10 of the PLL-IC.

The VCO consists of 2 VCOs and covers a dual range of 400.05~470.05MHz and 450~520MHz. The VCO generates 400.05~470.05MHz to provide the first local signal for reception. The operating frequency is generated by Q6 in transmitting mode and Q5 in receiving mode. The oscillation frequency is controlled by applying the VCO control voltage, obtained from the phase comparator (IC2) to the variable capacitance diodes (D5, D9, D11, and D13 while transmitting and D4, D7 and D12 while receiving).

The TX/RX pin of IC710 goes "high" in transmission mode, causing Q8 to turn off, and Q7 turn on. The TX/RX pin goes "low" in reception mode.

The output from Q5 and Q6 are amplified by a buffer amplifier (Q9) and RF amplifier (Q2), and are then sent to the PLL-IC. The PLL-IC consists of a prescaler, reference divider, phase comparator, and charge pump.

The input signal from pin 10 and 17 of the PLL-IC is divided down and compared at the phase comparator. The pulse output signal of the phase comparator is applied to the charge pump and transformed into a DC signal in the loop filter (LPF). The DC signal is applied to the CV of the VCO and is locked to keep the VCO frequency constant.

PLL data is output from PLL_LE (pin 87), PLL_DATA (pin 86) and PLL_CLK (pin 88) of the MCU (IC710). The data is input to the PLL-IC when the channel is changed or when transmission is changed to reception and vice-versa. The PLL lock condition is always monitored by pin 70 (PLL_LD) of the MCU. When the PLL is unlocked, PLL_LD goes low.

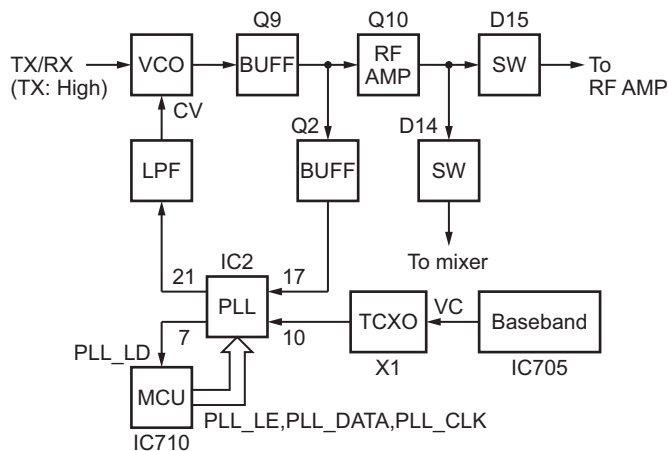

Fig.6 PLL block diagram

2.1.5 Control Circuit

The control consists of the MCU (IC710) and its peripheral circuits. It controls the TX-RX unit. IC710 mainly performs the following;

- (1) Switching between transmission and reception via the PTT signal input.
- (2) Reading channel information, frequency, and program data from the memory circuit.
- (3) Sending frequency program data to the PLL.
- (4) Controlling squelch on/off via the DC voltage from the squelch circuit.
- (5) Controlling the audio mute circuit via the decode data input.
- (6) Transmitting tone and encode data.

2.1.5.1 Frequency Shift Circuit

The MCU (IC710) and baseband IC (IC705) operate at a clock frequency of 19.2MHz.

This oscillator frequency can be shifted by pin 8 of the MCU (IC710). When pin 8 is set to high, the beat shift function is ON.

A beat sound may be able to be evaded from generation if "Beat Shift" is set to ON when it is generated in the internal spurious transmission modulated sound of the transceiver.

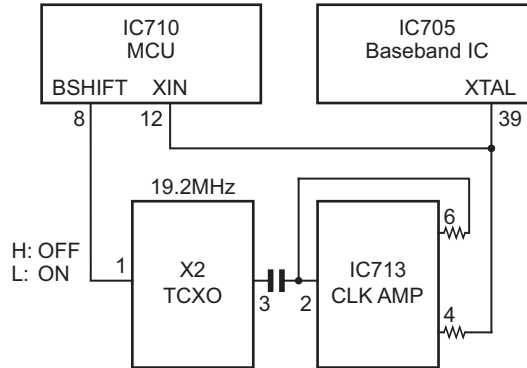

Fig.7 Frequency shift circuit

2.1.5.2 Memory Circuit

The Memory circuit consists of the MCU (IC710) and EEPROM (IC700). The EEPROM has a capacity of 64K-bit and stores the channel information, the last channel data, the scan on status, and other parameters.

■EEPROM

Note:

- The EEPROM stores tuning data (Deviation, Squelch, etc.).
- Realign the transceiver after replacing the EEPROM.

2.1.5.3 Low Battery Warning

The battery voltage is monitored by the MCU (IC710 pin 33: BATT). When the battery voltage falls below 6.4V approximately, the red LED blinks, notifying the operator that it is time to replace the battery (When "Always" option (default setting) under the Battery Warning function in the FPU is selected).

If the battery voltage falls below 5.8V approximately, the transceiver does not transmit and a warning tone beeps when the PTT switch is pressed (When the Battery Warning Tone is selected in the FPU).

2.1.5.4 Key Input

Keys and channel selector circuit.

The signal from the keys and channel selector are directly input to the MCU, as shown in Figure 8.

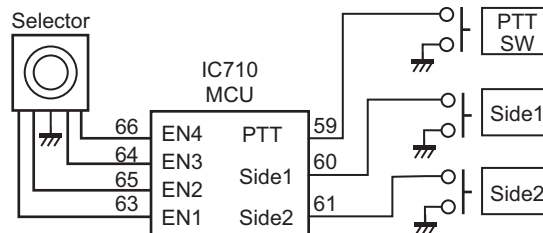

Fig.8 Key input

2.1.6 Signaling Circuit

2.1.6.1 Encode

■ Low-speed data (QT, DQT)

Low-speed data is output from pin 29 of the MCU. The signal passes through the low pass CR filter, and goes to the audio processor (IC705). The signal is mixed with the audio signal and goes to the VCO and TCXO (X1) modulation input after passing through the D/A converter inside the audio processor (IC705) for BAL adjustment.

■ High-speed data (2-tone,DTMF)

High-speed data (HSD) is output from pin 30 of the MCU. HSD deviation made by an adjustment in the MCU is passed through the low pass CR filter and is then applied to the baseband IC (IC705).

The signal is mixed with the audio signal and goes to the VCO and TCXO. The signal passes through low pass CR filter and D/A converter, and goes to the audio power amplifier. The level is controlled by the MCU.

■ MSK (Fleet Sync/MDC-1200)

The MSK signal is generated in the audio processor (IC705). The signal passes through the D/A converter (inside the baseband IC: IC705) and is routed to the VCO. When encoding the MSK, the microphone input signal is muted.

2.1.6.2 Decode

■ QT/DQT

The output signal from the FM IC (IC400) enters the MCU (IC710) through IC705. IC710 determines whether or not the QT or DQT matches the preset value, and controls the AFSW and speaker output sounds according to the squelch results.

■ 2-tone

Part of the received AF signal output from the FM IC (IC400) passes through the baseband IC (IC705), and is compared before going to the MCU (IC710). IC710 checks whether or not the 2-tone data is necessary. If it matches, IC710 carries out a specified operation, such as turning the speaker on.

■ MSK (Fleet Sync)

The MSK input signal from the FM IC (IC400) goes to IC705. The decoded information is then processed by the MCU.

■ DTMF

The DTMF input signal from the FM IC (IC400) goes to IC705. The decoded information is then processed by the MCU.

2.1.7 Power Supply

There are five 5V power supplies and five 3.3V power supplies: 50M, 50V, 50C, 50R, 50T, 33M, 33MS, 33B, 33R and 33MD.

50M and 33M are always output while the power is on.

33MS is always output, but turns off when the power is turned off, to prevent a malfunction of the MCU.

50C is a common 5V and is output when SAVE is not set to ON.

50R is 5V for reception and is output during reception.

50T is 5V for transmission and is output during transmission.

50V is 5V for the SP/MIC connector.

33B is 3.3V for the baseband IC (IC705).

3R is 3.3V for the IF IC (IC400) and is sent when SAVE is not set to ON.

33MD is 3.3V for the MCU digital supply.

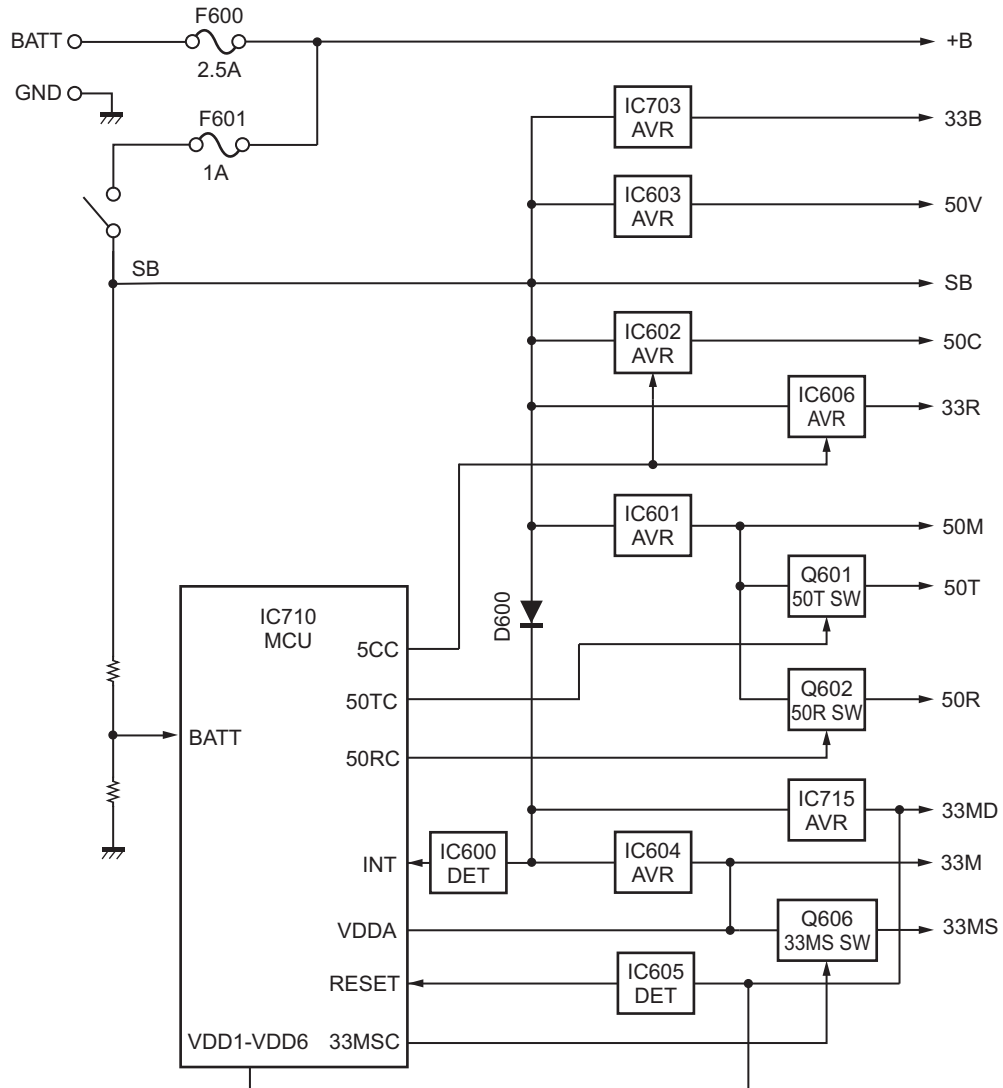

Fig.9 Power supply

2.1.8 NXDN Receiving

2.1.8.1 For Digital Data Mode

The demodulated signal from IC400 (Pin13) is fed into the baseband IC (Pin 16) for NXDN decoding. The decoded digital data will pass to the MCU through the C-BUS. The MCU determines whether or not to output sound from the speaker by checking if the data matches.

2.1.8.2 For Digital Voice Mode

If the digital data matches in the MCU, the digital voice payload data will go into the Vocoder in the MCU for conversion to PCM. The PCM data will go to the baseband IC through the SPI input, where it will be converted to analog by the DAC. Analog voice will be filtered and finally sent to the audio amplifier.

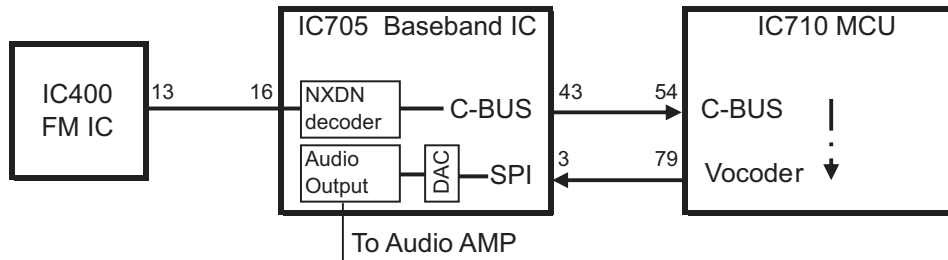

Fig.10 NXDN receiver system

2.1.9 NXDN Transmitting

2.1.9.1 For Digital Data Mode

The digital data will be generated by the MCU, where it will be passed to the baseband IC, through the C-BUS for the encoding process. The encoded data will finally transmit through the TCXO and VCO modulation.

2.1.9.2 For Digital Voice Mode

The analog voice from the microphone will go to the ADC (after the audio filter) to convert to PCM data. The PCM data will be sent to the Vocoder through the SPI output. The Vocoder will convert the PCM to NXDN protocol, where it will be sent to the baseband through the C-BUS. In the baseband IC, the data will be encoded and finally transmitted through the TCXO and VCO modulation.

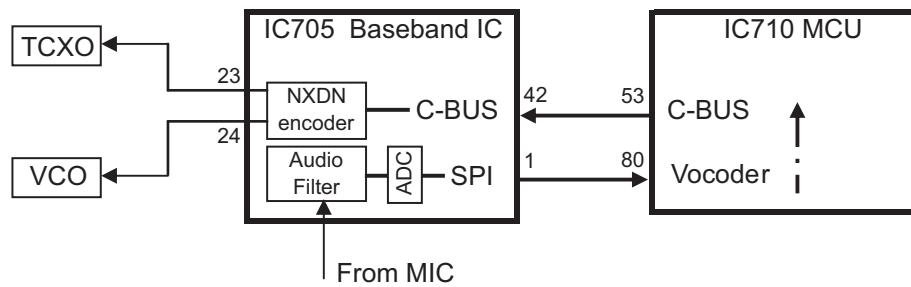

Fig.11 NXDN transmit system

2.2 SEMICONDUCTOR DATA

2.2.1 MCU: 2F405VGT6KFAA (TX-RX unit IC710)

Pin No.	Name	I/O	Function
1	MINVOL	O	Minimum volume control
2	DCSW	O	APC voltage discharge switch
3	APCSW	O	APC switch
4	TEST_1	O	Test land 1
5	TEST_2	O	Test land 2
6	VBAT	-	3.3V
7	BLUED	O	Blue LED light control (Hi: LED ON)
8	BSHIFT	O	MPU clock frequency shift
9	INSPMT	O	Internal speaker mute
10	VSS1	-	GND
11	VDD1	-	3.3V
12	XIN	I	Crystal (19.2MHz)
13	NC	O	No connection
14	NRST	I	MCU reset input
15	LSDI	I	QT/DQT decode
16	HSDDEC	I	2-tone decode

Pin No.	Name	I/O	Function
17	VOX	I	VOX level input
18	OPT4	I/O	Option port 4
19	VDD	-	33MD
20	VSSA	-	GND
21	VREF+	-	33M
22	VDDA	-	33M
23	5CC	O	5C control
24	CVIN	I	VCO lock voltage (for automatic alignment)
25	EMPTT	O	Emergency PTT
26	50VC	O	5V AVR control for GPS MIC option/OPT detection
27	VSS2	-	GND
28	VDD3	-	33MD
29	LSDO	O	QT/DQT output
30	HSDENC	O	BEEP/HSD output
31	5RC	O	5R control
32	1PINDET	I	2.5mm phone jack detection
33	BATT	I	Battery level input

Pin No.	Name	I/O	Function
34	RSSI	I	RSSI input
35	BUSY	I	BUSY input
36	TH_DET	I	Thermistor detection (Temperature detection)
37	33MSC	I/O	33M switch control
38	OPT1	O	Option port 1
39	OPTDET	I	Option detection
40	GRNLED	O	Green LED control (Hi: LED ON)
41	REDLED	O	Red LED control (Hi: LED ON)
42	MIC_MT	O	MIC mute
43	EXTSPMT	O	Speaker mute
44	ASSTSW	O	Assist switch
45	TX/RX	O	TX/RX switch (Hi: TX, Lo: RX)
46	INSPSW	O	Internal speaker switch
47	TEST_TX	O	UART_TX for test
48	TEST_RX	I	UART_RX for test
49	VCAP_1	-	2.2uF
50	VDD4	-	33MD
51	CML_CSN	O	Chip select for baseband IC
52	CML_SCLK	O	SCLK for baseband IC
53	CML_CDATA	O	Command for baseband IC
54	CML_RDATA	I	REPLY for baseband IC
55	FM_RSTN	O	Hardware reset for FM IC
56	FM_CSN	O	Chip select for FM IC
57	FM_SCLK	O	Clock for FM IC
58	FM_SDATA	I/O	Data I/O for FM IC
59	PTT	I	PTT key
60	PF1	I	Programmable function key input 1
61	PF2	I	Programmable function key input 2
62	FM_PDN	O	Power down port for LDO of FM IC
63	EN1	I	Encoder input 1
64	EN3	I	Encoder input 3
65	EN2	I	Encoder input 2
66	EN4	I	Encoder input 4
67	OPT3	I/O	Option port 3
68	TXD	O	Serial data to MIC jack
69	RXD	I	Serial data from MIC jack
70	PLL_UL	I	Unlock voltage for PLL
71	OPT2	I/O	Option port 2
72	SWDIO	I/O	SWDIO for SWD
73	VCAP_2	-	2.2uF
74	VSS3	-	GND
75	VDD5	-	33MD
76	SWCLK	I/O	SWCLK for SWD
77	CML_SSOUT	I	SPI chip select for baseband IC
78	CML_EPSCCLK	I	Clock for SPI

Pin No.	Name	I/O	Function
79	CML_EPSO	O	SPI output
80	CML_EPSI	I	SPI input
81	EEP_DATAI	I	Data input for EEPROM
82	EEP_DATAO	O	Data output to EEPROM
83	EEP_CS	O	Chip select for EEPROM
84	EEP_CLK	O	Clock for EEPROM
85	EEP_WP	O	Write protect for EEPROM
86	PLL_DATA	O	Data output for PLL
87	PLL_LE	O	Chip select for PLL
88	PLL_CLK	O	Clock for PLL
89	SWO	O	SWO for SWD
90	SRST	I	SRST for SWD
91	OPT5	I/O	Option port 5
92	OPT6	I/O	Option port 6
93	OPT7	I/O	Option port 7
94	NC	I	No connection
95	W_N	O	Wide/Narrow Switch (Hi:W, Lo:other)
96	5TC	O	5T control
97	INT	I	Interrupt
98	CML_IRQN	I	IRQ for baseband IC
99	PDR_ON	-	GND
100	VDD6	-	33MD

2.3 COMPONENTS DESCRIPTION

2.3.1 TX-RX unit (X57-8510-XX)

Ref. No.	Part Name	Description
IC2	IC	PLL System
IC3	IC	DC amplifier (CV)
IC200	IC	DC amplifier (APC)
IC400	IC	IF System
IC600	IC	Voltage detector (INT)
IC601	IC	Voltage regulator (50M)
IC602	IC	Voltage regulator (50C)
IC603	IC	Voltage regulator (50V)
IC604	IC	Voltage regulator (33M)
IC605	IC	Voltage detector (Reset)
IC606	IC	Voltage regulator (33R)
IC700	IC	EEPROM
IC703	IC	Voltage regulator (33B)
IC704	IC	DC amplifier (BPF tune)
IC705	IC	Baseband system
IC706	IC	DC amplifier (VOX)
IC707	IC	AF power amplifier (EXT)
IC708	IC	AF amplifier

Ref. No.	Part Name	Description
IC709	IC	AF power amplifier (INT)
IC710	IC	MCU
IC713	IC	Clock buffer amplifier
IC715	IC	Voltage regulator (33MD)
IC717	IC	Audio buffer amplifier
IC719, 720	IC	Wide/Narrow multiplexer
Q1	FET	DC switch (Assist)
Q2	Transistor	PLL Fin amplifier
Q3	FET	Q1 control
Q4	Transistor	Rippler filter
Q5	FET	RX VCO
Q6	FET	TX VCO
Q7	FET	Q8 control
Q8	FET	TX/RX VCO DC switch
Q9	Transistor	Buffer amplifier
Q10	Transistor	RF amplifier
Q201	Transistor	Pre-drive amplifier
Q203	Transistor	Discharge switch
Q205	FET	APC control switch
Q206	FET	Drive amplifier
Q207	Transistor	DC switch (APC)
Q208	FET	Final amplifier
Q209	FET	DC switch (Power control)
Q210	Transistor	DC switch (Power control)
Q400	Transistor	Tripler (2nd local)
Q403	Transistor	1st IF amplifier
Q404	FET	1st mixer
Q405	FET	RX RF amplifier
Q600	Transistor	DC switch (BUSY LED)
Q601	FET	DC switch (50T)
Q602	FET	DC switch (50R)
Q603	FET	DC switch (MIN VOL)
Q604	Transistor	DC switch (RED LED)
Q605	Transistor	DC switch (BLUE LED)
Q606	FET	DC switch (33MS)
Q703	FET	Level shift (TXD)
Q704	Transistor	MIC mute switch
Q705	Transistor	MIC AGC amplifier
Q706	Transistor	MIC AGC amplifier
Q707	FET	Level shift (RXD)
Q708	Transistor	DC switch (EXT PTT)
Q709	Transistor	Q710 control
Q710	Transistor	DC switch (IC707 SB)
Q711	Transistor	Q715 control
Q712	Transistor	Pop noise mute control

Ref. No.	Part Name	Description
Q713	FET	AF switch (EXT SP)
Q714	Transistor	DC switch (IC709 SB)
Q715	Transistor	Q714 control
Q716	FET	AF switch (EXT SP)
D4	Variable capacitance diode	RX VCO tune
D5	Variable capacitance diode	TX VCO tune
D7	Variable capacitance diode	RX VCO tune
D9	Variable capacitance diode	TX VCO tune
D10	Diode	Speed up
D11	Variable capacitance diode	TX assist
D12	Variable capacitance diode	RX assist
D13	Variable capacitance diode	Modulation
D14, 15	Diode	TX/RX switch
D200	Zener diode	Over voltage protection
D201-204	Diode	Antenna switch
D400-404	Variable capacitance diode	RX BPF tuning
D405	Variable capacitance diode	RX notch tune
D600	Diode	Voltage drop
D601	LED	Green (BUSY)
D602	LED	Red (TX)
D603	Diode	Voltage prevention
D604	LED	Blue
D700, 701	Diode	AF detector (MIC)
D702	Diode	AF detector (VOX)
D703	Diode	Limiter
D754	Diode	1 pin detection

SECTION 3 DISASSEMBLY

3.1 Precautions for Disassembly

3.1.1 Removing the Case Assembly from the Chassis

- (1) Remove the selector knob <1> and volume knob <2>.
- (2) Remove the two screws <3>.
- (3) Lift and remove the chassis from the case assembly <4>.
(Use a flat-blade screwdriver to easily lift the chassis.)

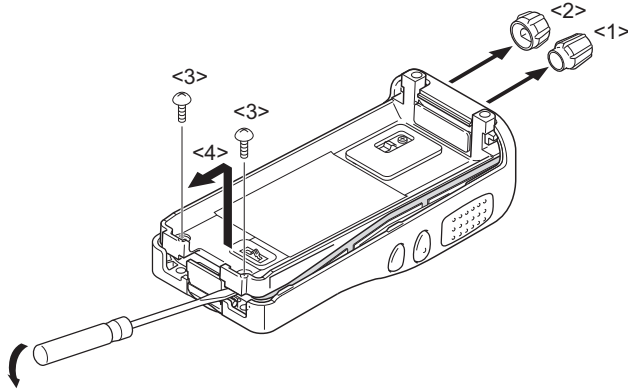

3.1.2 Removing the Holder Assembly from the Chassis

- (1) Remove the packing <5> from the SMA, volume and selector.
- (2) Remove the holder from the chassis.

Note:

- Take care to not cut the speaker and microphone leads.
- (3) Detach the solder of the speaker and microphone leads from the PCB beforehand.
 - (4) Remove the packing <6> from the SP/MIC jack of the TX-RX unit.

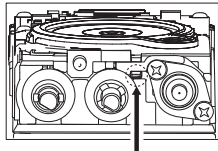

Note: To remove the Holder Assy from the Chassis, use a flat-blade screwdriver and insert to this hole.

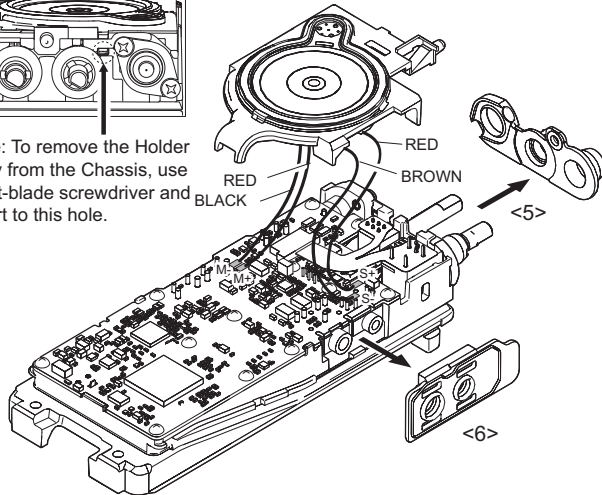

3.1.3 Removing the TX-RX unit from the Chassis

- (1) Remove the thirteen screws <7> fixing the TX-RX unit.
- (2) Remove the solder of the antenna terminal with a soldering iron <8>.
- (3) Remove the solder of the positive terminal with a soldering iron <9>.

Note:

- You can remove the TX-RX unit from the chassis without removing the solder at the positive terminal. However, in this case, you cannot attach the packing (G53-2218-03) that is on the positive terminal to the chassis during assembly. So, we advise you to remove the solder on the positive terminal first.
- (4) Remove the FPC from the flat cable connector <10>.
 - (5) Lift and remove the TX-RX unit from the chassis <11>.

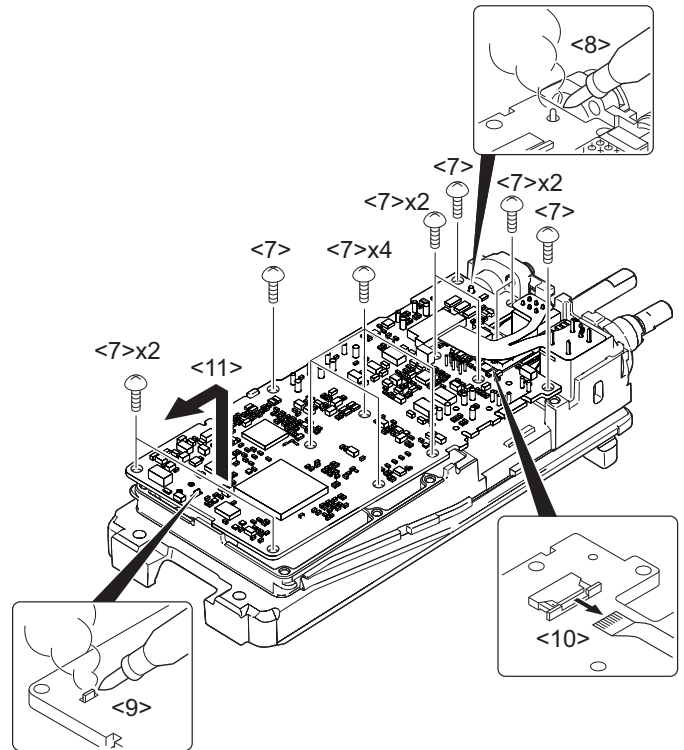

3.1.4 Removing the Battery Release Lever from the Case Assembly

- (1) Press the upper part of the lever toward the inside of the case assembly. One side of the shaft will be removed <1>.
- (2) Lift and remove the battery release lever from the case assembly <2>.

Note:

Scratch and widen the glue hole if you are having difficulty removing the other end of the shaft. No glue is required when you reassemble the battery release lever.

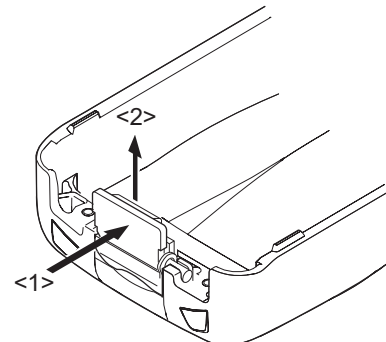

3.2 Precautions for Reassembly

3.2.1 Attaching the Battery Release Lever to the Case Assembly

- (1) Insert one side of the shaft into the hole at the lever fitting section on the case assembly <1>.

Caution:

Position the thin spring (G01-4543-14) above the two tabs of the lever.

- (2) Tilt the battery release lever slightly forward <2>, so that the thick spring (G01-4542-04) is positioned below the case surface.
- (3) With the thick spring positioned below the case surface, attach the other side of the shaft to the case assembly by pressing the battery release lever <3> until it snaps into place <4>.

Caution:

Be careful to not tilt the battery release lever too far forward.

If the battery release lever is pushed in this state where the two tabs come below the case surface, there is a possibility of damaging the two tabs.

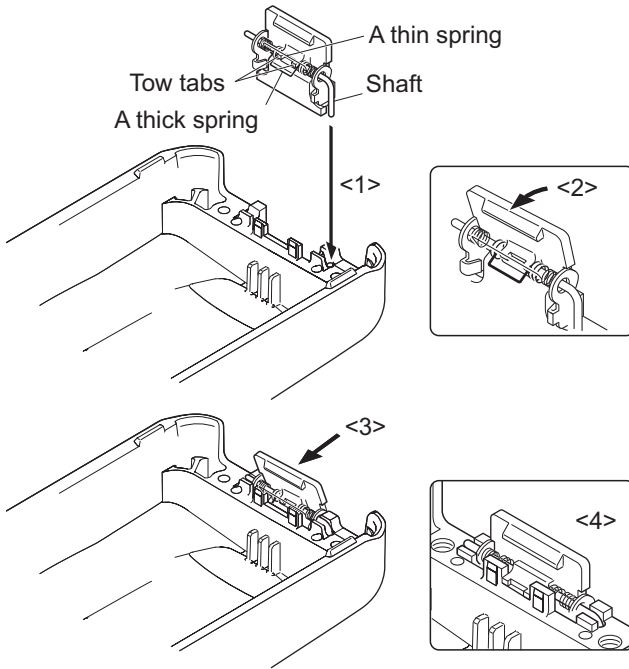

3.2.2 Assembling the Battery Release Lever

- (1) Place the lever <2> onto the stopper <1>.
- (2) Place the thick spring <3> onto the lever.
- (3) Hook the right and left ends of the thin spring <4> onto the tabs of the stopper, then place the thin spring onto the lever <5>.
- (4) Slide the shaft through the hole of the stopper and lever <6>.

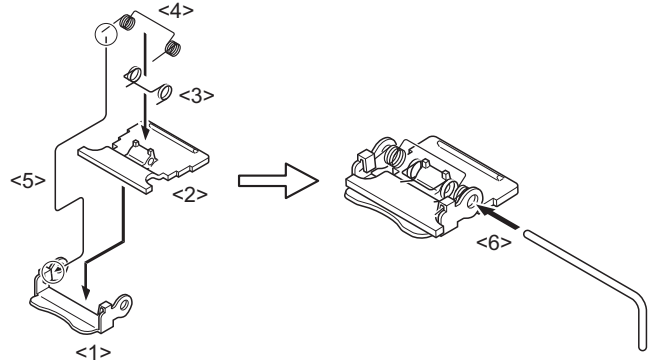

3.2.3 Attaching the Positive Terminal to the Chassis

Always attach the positive terminal to the chassis using the following procedures, before mounting the TX-RX unit onto the chassis.

- (1) Remove the holder assembly <2> from the packing <1> of the positive terminal.
- (2) Mount the packing of the positive terminal into the chassis hole <3>.
- (3) Mount the holder assembly into the packing of the positive terminal <4>.

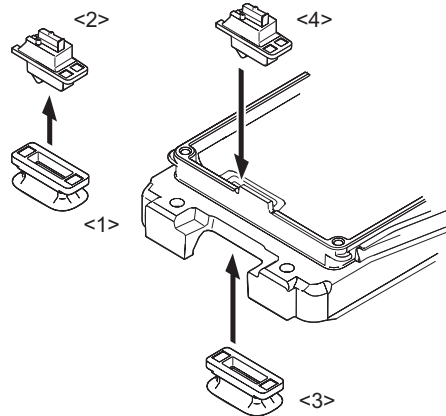

3.2.4 Mounting the Chassis to the Case Assembly

- (1) Confirm that the waterproof packing attached to the circumference of the chassis is securely inserted in the groove of the chassis <1>.
- (2) Insert the upper part of the chassis into the case assembly <2>.
- (3) Press the chassis <3> and the case assembly together to attach them.

Caution:

If the packing of the SP/MIC is not at the correct position after attaching the chassis to the case assembly, reposition the packing with your fingers.

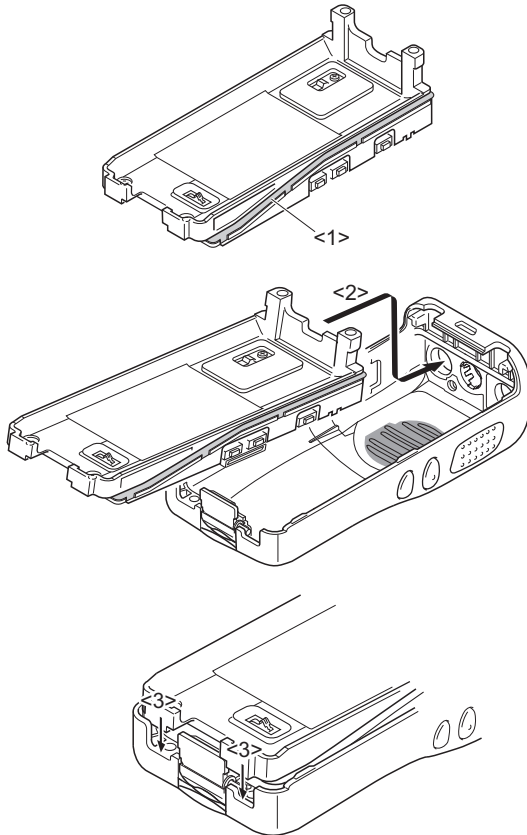

3.2.5 Attaching the Antenna Receptacle to the Chassis

Screw the antenna receptacle to the chassis in the order shown in the drawing so that the antenna receptacle comes to the center of the case hole.

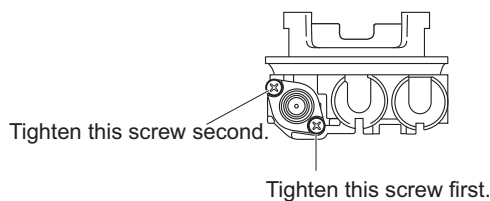

3.2.6 The Nuts of the Volume Knob and Channel Knob

Note that the shape, color and height of the nuts of the volume knob and channel knob are different from one another. (The nut of volume knob is silver, and the nut of channel knob is gold.) Use the following jig when removing the nuts of the volume knob and channel knob:

- Jig (Part No.: W05-1012-00)

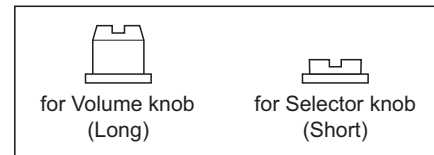

SECTION 4 ADJUSTMENT

4.1 Test Equipment Required for Alignment

Test Equipment	Major Specifications	
1. Standard Signal Generator (SSG)	Frequency Range	100 to 520MHz
	Modulation	Frequency modulation and external modulation
	Output	-127dBm/0.1μV to greater than -47dBm/1mV
2. Power Meter	Input Impedance	50Ω
	Operation Frequency	100 to 520MHz
	Measuring Range	Vicinity of 10W
3. Deviation Meter	Frequency Range	100 to 520MHz
4. Digital Volt Meter (DVM)	Measuring Range	10mV to 10V DC
	Input Impedance	High input impedance for minimum circuit loading
5. Oscilloscope		DC through 30MHz
6. High Sensitivity Frequency Counter	Frequency Range	10Hz to 1000MHz
	Frequency Stability	0.2ppm or less
7. Ammeter		5A
8. AF Volt Meter (AF VM)	Frequency Range	50Hz to 10kHz
	Voltage Range	1mV to 10V
9. Audio Generator (AG)	Frequency Range	50Hz to 5kHz or more
	Output	0 to 1V
10. Distortion Meter	Capability	3% or less at 1kHz
	Input Level	50mV to 10Vrms
11. 8Ω Dummy Load		Approx. 8Ω, 3W
12. Regulated Power Supply		5V to 10V, approx. 3A Useful if ammeter equipped

*The test equipment which is not used for adjustment is contained in this table.

■Antenna connector adapter

The antenna connector of this transceiver uses an SMA terminal.

Use an antenna connector adapter [SMA(f) - BNC(f) or SMA(f) - N(f)] for adjustment. (The adapter is not provided as an option, so buy a commercially-available one.)

■Repair Jig (Chassis)

Use jig (Chassis) for repairing the transceiver. Place the TX-RX unit on the jig and fit it with screws.

The jig facilitates the voltage check and protects the final amplifier FET when the voltage on the flow side of the TX-RX unit is checked during repairs.

■Battery Jig (W05-1011-00)

Connect the power cable properly between the battery jig installed in the transceiver and the power supply, and be sure output voltage and the power supply polarity prior to switching the power supply ON, otherwise over voltage and reverse connection may damage the transceiver, or the power supply or both.

Note:

When using the battery jig, you must measure the voltage at the terminals of the battery jig. Otherwise, a slight voltage drop may occur within the power cable, between the power supply and the battery jig, especially while the transceiver transmits.

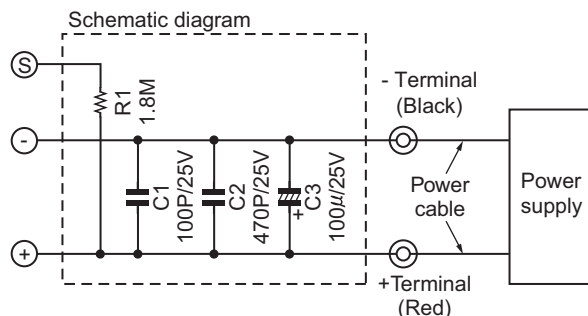
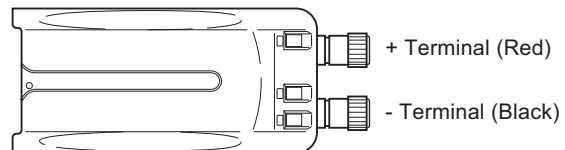

4.2 Frequency and Signaling

The transceiver has been adjusted for the frequencies shown in the following table. When required, readjust them following the adjustment procedure to obtain the frequencies you want in actual operation.

■Test frequency

CH	RX (MHz)	TX (MHz)
1	485.05000	485.10000
2	450.05000	450.10000
3	519.95000	519.90000
4	485.00000	485.00000
5	485.20000	485.20000
6	485.40000	485.40000
7~16	-	-

■Analog mode signaling

No.	RX	TX
1	None	None
2	None	20 Hz Square Wave
3	QT 67.0 Hz	QT 67.0 Hz
4	QT 151.4 Hz	QT 151.4 Hz
5	QT 210.7 Hz	QT 210.7 Hz
6	QT 254.1 Hz	QT 254.1 Hz
7	DQT D023N	DQT D023N
8	DQT D754I	DQT D754I
9	DTMF Decode (Code: 159D)	DTMF Encode (Code: 159D)
10	None	DTMF (Code: 9)
11	None	MSK (1010..)
12	FleetSync: 100-1000	FleetSync: 100-1000
13	None	Single Tone: 1000 Hz
14	2-tone Decode: A: 304.7 Hz B: 3106.0 Hz	2-tone Encode: A: 304.7 Hz B: 3106.0 Hz
15	None	DTMF Tone: 1477 Hz
16	Single Tone: 979.9 Hz	Single Tone: 979.9 Hz
17	None	MSK PN9
18	None	DTMF (Code: 3)

■NXDN mode signaling

No.	RX	TX
1	RAN1	RAN1
2	None	PN9
3	RAN1	Maximum Deviation Pattern
4	FSW+PN9	Mod set-up *1
5	Tone Pattern (1031 Hz)	Tone Pattern (1031 Hz)

RAN: Radio Access Number

PN9: Pseudo-Random Pattern (for production only)

*1: To output 150Hz square wave (for production only)

4.3 Preparations for Tuning the Transceiver

Before attempting to tune the transceiver, connect the unit to a suitable power supply.

Whenever the transmitter is tuned, the unit must be connected to a suitable dummy load (i.e. power meter).

The speaker output connector must be terminated with a 8Ω dummy load and connected to an AC voltmeter and an audio distortion meter or a SINAD measurement meter at all times during tuning.

■5 reference level adjustments frequency

TEST CH	RX (MHz)	TX (MHz)
Low	450.05000	450.10000
Low'	467.55000	467.60000
Center	485.05000	485.10000
High'	502.55000	502.60000
High	519.95000	519.90000

4.4 Adjustment Points

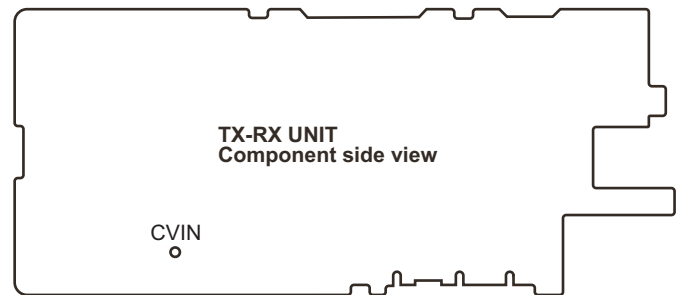

4.5 Common Section

Item	Condition	Measurement			Adjustment			Specifications /Remarks
		Test-equipment	Unit	Terminal	Unit	Parts	Method	
1. Setting	1) Power supply voltage DC power supply terminal : 7.5V							
2. Receive Assist voltage	1) Auto tuning *Note 1					FPU		4.0 ± 0.1V
	2) CH: Low *Note 2	DVM	TX-RX	CVIN			Check	0.6V or more (at CVIN terminal)
3. Transmit Assist voltage	1) Auto tuning *Note 1					FPU		4.0 ± 0.1V
	2) CH: Low *Note 2	DVM	TX-RX	CVIN			Check	0.6V or more (at CVIN terminal)

***Note 1:**

During test mode, click the [Tune Assist Voltage] button in test mode dialog box, then start automatic adjustment of the Receive/ Transmit assist voltage.

***Note 2:**

The CV voltage checking of CH:2 (Default value) test frequency must be performed in test mode.

4.6 Transmitter Section

Item	Condition	Measurement			Adjustment			Specifications /Remarks
		Test-equipment	Unit	Terminal	Unit	Parts	Method	
1. Frequency	(1)TEST CH: Center PTT ON	Frequency counter		ANT		FPU	485.100MHz	±50Hz
2. High Transmit Power	(1)TEST CH: Low, Low', Center, High', High (5 point)	Power meter Ammeter		ANT		FPU	5.0W	±0.1W 2.0A or less
	(2)Battery Terminal voltage:7.5V (3)PTT ON							
3. Low Transmit Power	(1)TEST CH: Low, Center, High (3 point)	Power meter Ammeter		ANT		FPU	1.0W	±0.1W 1.0A or less
	(2)Battery Terminal voltage:7.5V (3)PTT ON							
4. DQT Balance 1 *Note 3	(1)TEST CH: Low, Low', Center, High', High (5 point)	Deviation meter Oscilloscope		ANT		FPU	Make the demodulation wave into square wave.	
	(2)Deviation meter filter LPF: 3kHz HPF: OFF (3)PTT ON							
DQT Balance 2 *Note 3	(1)TEST CH: Low, Low', Center, High', High (5 point)	Deviation meter Oscilloscope		ANT		FPU	The Deviation of 20Hz frequency is fixed. Change the 1kHz adjustment value to become the same deviation of 20Hz within the specified range.	±15Hz
	(2)Deviation meter filter LPF: 3kHz HPF: OFF (3)PTT ON							
5. Maximum Deviation (Analog Narrow)	(1)TEST CH: Low, Low', Center, High', High (5 point) (2)Deviation meter filter LPF: 15kHz HPF: OFF (3)PTT ON	Deviation meter Oscilloscope		ANT		FPU	2.0kHz (According to larger +, -)	±80Hz Note: FPU auto input 1kHz/ 150mV

Item	Condition	Measurement			Adjustment			Specifications /Remarks
		Test-equipment	Unit	Terminal	Unit	Parts	Method	
(Analog Wide)	(1)TEST CH: Low, Low', Center, High', High (5 point) (2)Deviation meter filter LPF: 15kHz HPF: OFF (3)PTT ON	Deviation meter Oscilloscope		ANT		FPU	4.0kHz (According to larger +, -)	±80Hz Note: FPU auto input 1kHz/150mV
6. Maximum Deviation (NXDN Very Narrow) *Note 4	(1)TEST CH: Low, Low', Center, High', High (5 point) (2)Deviation meter filter LPF: 15kHz HPF: OFF (3)PTT ON	Deviation meter Oscilloscope		ANT		FPU	1.337kHz	±26Hz
(NXDN Narrow)	(1)TEST CH: Low, Low', Center, High', High (5 point) (2)Deviation meter filter LPF: 15kHz HPF: OFF (3)PTT ON	Deviation meter Oscilloscope		ANT		FPU	3.056kHz	±59Hz
7. CW ID Deviation (NXDN Very Narrow) *Note 4	(1)TEST CH: Center (2)Deviation meter filter LPF: 15kHz HPF: OFF (3)PTT ON	Deviation meter Oscilloscope		ANT		FPU	1.00kHz	±100Hz
8. DQT Deviation (Analog Narrow)	(1)TEST CH: Center (2)Deviation meter filter LPF: 3kHz HPF: OFF (3)PTT ON	Deviation meter Oscilloscope		ANT		FPU	0.35kHz	±50Hz
(Analog Wide)	(1)TEST CH: Center (2)Deviation meter filter LPF: 3kHz HPF: OFF (3)PTT ON	Deviation meter Oscilloscope		ANT		FPU	0.75kHz	±50Hz
9. QT Deviation (Analog Narrow)	(1)TEST CH: Center (2)Deviation meter filter LPF: 3kHz HPF: OFF (3)PTT ON	Deviation meter Oscilloscope		ANT		FPU	0.35kHz	±50Hz
(Analog Wide)	(1)TEST CH: Center (2)Deviation meter filter LPF: 3kHz HPF: OFF (3)PTT ON	Deviation meter Oscilloscope		ANT		FPU	0.75kHz	±50Hz
10. DTMF Deviation (Analog Narrow)	(1)TEST CH: Center (2)Deviation meter filter LPF: 15kHz HPF: OFF (3)PTT ON	Deviation meter Oscilloscope		ANT		FPU	1.5kHz	±50Hz
(Analog Wide)	(1)TEST CH: Center (2)Deviation meter filter LPF: 15kHz HPF: OFF (3)PTT ON	Deviation meter Oscilloscope		ANT		FPU	3.0kHz	±50Hz

Item	Condition	Measurement			Adjustment			Specifications /Remarks
		Test-equipment	Unit	Terminal	Unit	Parts	Method	
11. MSK Deviation (Analog Narrow)	(1)TEST CH: Center (2)Deviation meter filter LPF: 15kHz HPF: OFF (3)PTT ON	Deviation meter Oscilloscope		ANT		FPU	1.5kHz	±50Hz
(Analog Wide)	(1)TEST CH: Center (2)Deviation meter filter LPF: 15kHz HPF: OFF (3)PTT ON	Deviation meter Oscilloscope		ANT		FPU	3.0kHz	±50Hz

***Note 3:**

Only 1 DQT Balance needs to be adjusted (either DQT Balance 1 or DQT Balance 2).

***Note 4:**

For the adjustment of the Maximum Deviation (NXDN Very Narrow) and CW ID Deviation (NXDN Very Narrow).

After adjusting the DQT Balance and Maximum Deviation (Analog), it is necessary to adjust the Maximum Deviation (NXDN Very Narrow) and CW ID Deviation (NXDN Very Narrow).

4.7 Receiver Section

Item	Condition	Measurement			Adjustment			Specifications /Remarks
		Test-equipment	Unit	Terminal	Unit	Parts	Method	
1. RX Sensitivity (Semiautomatic) *Note 5	(1)TEST CH: Low, Center, High (3 point) (2)SSG output: -90dBm (7.08uV) AF Freq : 1kHz Mod Dev : ±1.5kHz	SSG Oscilloscope Audio Analyzer		ANT		FPU	Press [Start] (Auto tuning)	
2. Open Squelch 5 (Analog Narrow)	(1)TEST CH: Low, Center, High (3 point) (2)SSG output: -120dBm (0.22uV) AF Freq : 1kHz Mod Dev : ±1.5kHz	SSG Oscilloscope Audio Analyzer		ANT		FPU	Press [Start] (Auto tuning)	
(Analog Wide)	(1)TEST CH: Low, Center, High (3 point) (2)SSG output: -120dBm (0.22uV) AF Freq : 1kHz Mod Dev : ±3.0kHz	SSG Oscilloscope Audio Analyzer		ANT		FPU	Press [Start] (Auto tuning)	
(NXDN Very Narrow)	(1)TEST CH: Low, Center, High (3 point) (2)SSG output: -123dBm (0.158uV) AF Freq : 400Hz Mod Dev : ±1.1kHz	SSG Oscilloscope Audio Analyzer		ANT		FPU	Press [Start] (Auto tuning)	
(NXDN Narrow)	(1)TEST CH: Low, Center, High (3 point) (2)SSG output: -122dBm (0.178uV) AF Freq : 400Hz Mod Dev : ±2.2kHz	SSG Oscilloscope Audio Analyzer		ANT		FPU	Press [Start] (Auto tuning)	
3. Tight squelch (Analog Narrow)	(1)TEST CH: Low, Center, High (3 point) (2)SSG output : -116dBm (0.35uV) AF Freq : 1kHz Mod Dev : ±1.5kHz	SSG Oscilloscope Audio Analyzer		ANT		FPU	Press [Start] (Auto tuning)	
(Analog Wide)	(1)TEST CH: Low, Center, High (3 point) (2)SSG output : -116dBm (0.35uV) AF Freq : 1kHz Mod Dev : ±3.0kHz	SSG Oscilloscope Audio Analyzer		ANT		FPU	Press [Start] (Auto tuning)	
4. Low RSSI (Analog Narrow)	(1)TEST CH: Low, Center, High (3 point) (2)SSG output: -120dBm (0.22uV) AF Freq : 1kHz Mod Dev : ±1.5kHz	SSG Oscilloscope Audio Analyzer		ANT		FPU	Press [Start] (Auto tuning)	

Item	Condition	Measurement			Adjustment			Specifications /Remarks
		Test-equipment	Unit	Terminal	Unit	Parts	Method	
(Analog Wide)	(1)TEST CH: Low, Center, High (3 point) (2)SSG output: -120dBm (0.22uV) AF Freq : 1kHz Mod Dev : ±3.0kHz	SSG Oscilloscope Audio Analyzer		ANT		FPU	Press [Start] (Auto tuning)	
(NXDN Very Narrow)	(1)TEST CH: Low, Center, High (3 point) (2)SSG output: -120dBm (0.22uV) AF Freq : 1kHz Mod Dev : ±1.5kHz	SSG Oscilloscope Audio Analyzer		ANT		FPU	Press [Start] (Auto tuning)	
(NXDN Narrow)	(1)TEST CH: Low, Center, High (3 point) (2)SSG output: -120dBm (0.22uV) AF Freq : 1kHz Mod Dev : ±1.5kHz	SSG Oscilloscope Audio Analyzer		ANT		FPU	Press [Start] (Auto tuning)	
5. High RSSI (Analog Narrow)	(1)TEST CH: Low, Center, High (3 point) (2)SSG output: -80dBm (22.4uV) AF Freq : 1kHz Mod Dev : ±1.5kHz	SSG Oscilloscope Audio Analyzer		ANT		FPU	Press [Start] (Auto tuning)	
(Analog Wide)	(1)TEST CH: Low, Center, High (3 point) (2)SSG output: -80dBm (22.4uV) AF Freq : 1kHz Mod Dev : ±3.0kHz	SSG Oscilloscope Audio Analyzer		ANT		FPU	Press [Start] (Auto tuning)	
High RSSI (NXDN Very Narrow)	(1)TEST CH: Low, Center, High (3 point) (2)SSG output: -80dBm (22.4uV) AF Freq : 1kHz Mod Dev : ±1.5kHz	SSG Oscilloscope Audio Analyzer		ANT		FPU	Press [Start] (Auto tuning)	
(NXDN Narrow)	(1)TEST CH: Low, Center, High (3 point) (2)SSG output: -80dBm (22.4uV) AF Freq : 1kHz Mod Dev : ±1.5kHz	SSG Oscilloscope Audio Analyzer		ANT		FPU	Press [Start] (Auto tuning)	

***Note 5:**

(1) Only RX Sensitivity (Semiautomatic) needs to be adjusted (RX Sensitivity does not need to be adjusted again).

SECTION 5 TROUBLESHOOTING

5.1 SYSTEM SET-UP

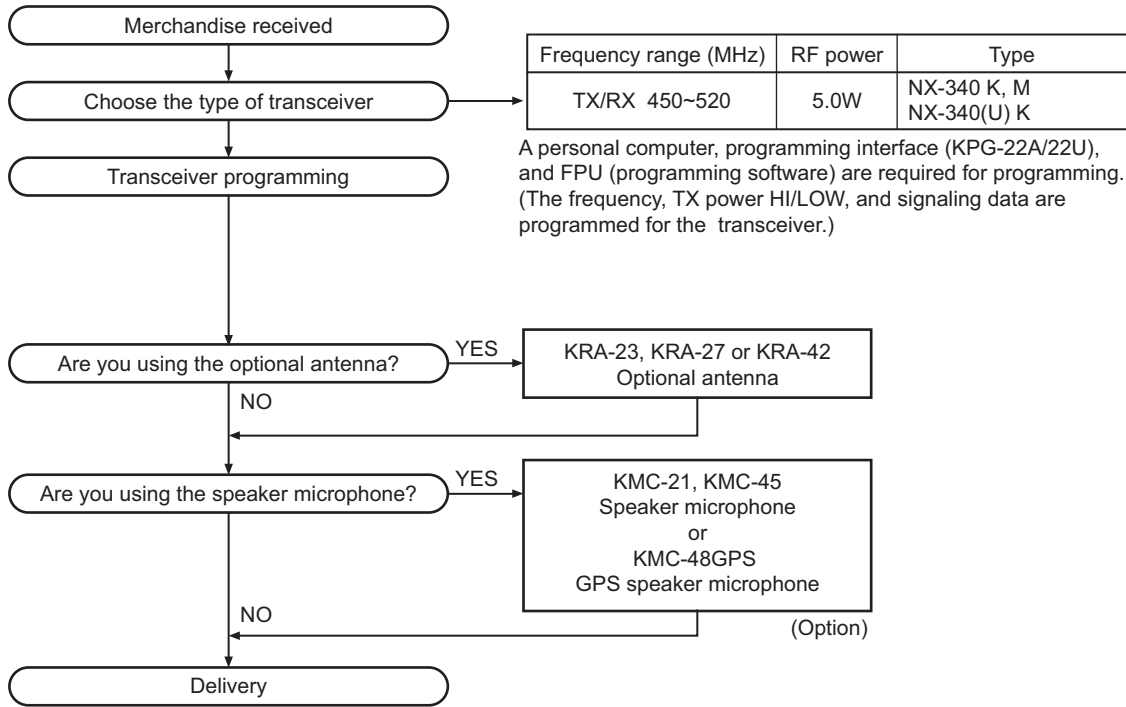

5.2 REALIGNMENT

5.2.1 Modes

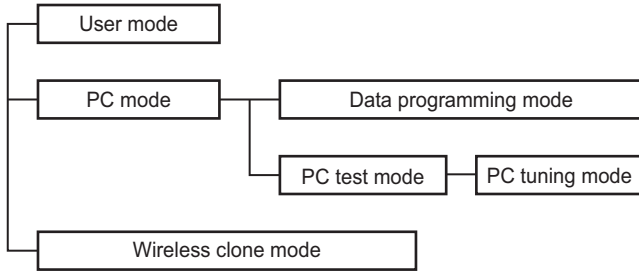

Mode	Function
User mode	For normal use.
PC mode	Used to communication between the transceiver and PC.
Data programming mode	Used to read and write frequency data and other features to and from the transceiver.
PC test mode	Used to check the transceiver using the PC. This feature is included in the FPU.
Wireless clone mode	Used to transfer programming data from one transceiver to another.

5.2.2 How to Enter Each Mode

Mode	Operation
User mode	Power ON
PC mode	Received commands from PC
Wireless clone mode	[PTT] + [Side2] + Power ON (Two seconds)

5.2.3 PC Mode

5.2.3.1 Preface

The transceiver is programmed by using a personal computer, a programming interface (KPG-22A/22U) and the FPU (programming software).

The programming software can be used with a PC. Figure 1 shows the setup of a PC for programming.

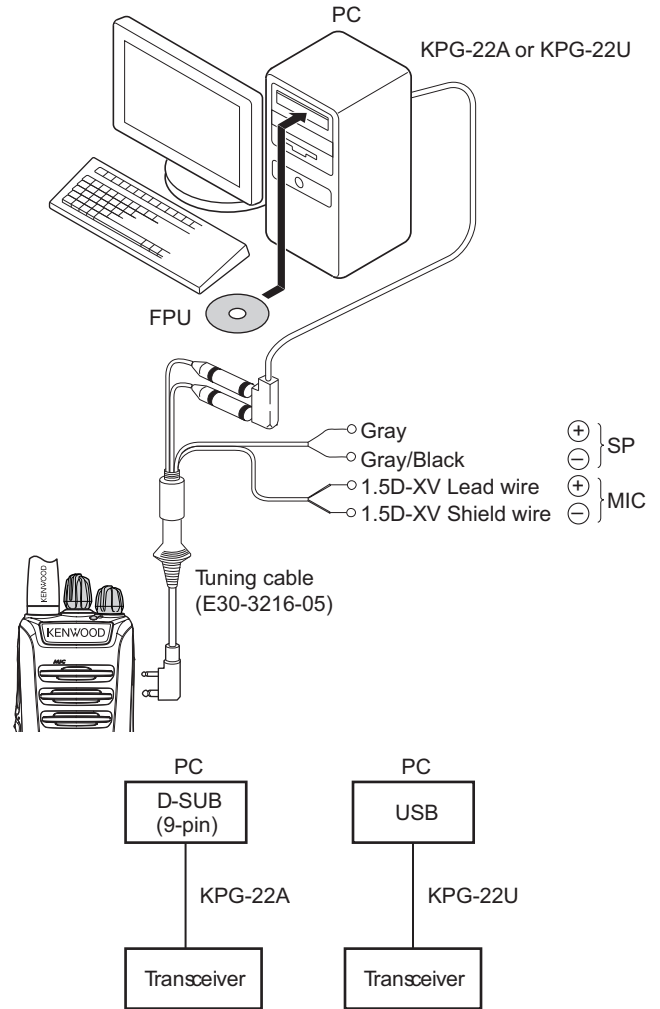

Fig.1

5.2.3.2 Connection procedure

- (1) Connect the transceiver to the computer using the interface cable.

Note:

You must install the KPG-22U driver in the computer to use the USB programming interface cable (KPG-22U).

- (2) When the Power is switched on, you can immediately enter user mode. When the PC sends a command, the transceiver enters PC mode.

When data is transmitting from the transceiver, the red LED lights.

When data is being received by the transceiver, the green LED lights.

Note:

- The data stored in the computer must match the "Model Name and Model Type" when it is written into the EEPROM.
- Do not press the [PTT] key during data transmission or reception.

5.2.3.3 KPG-22A description (PC programming interface cable: Option)

The KPG-22A is required to interface the transceiver with the computer. It has a circuit in its D-sub connector (KPG-22A: 9-pin) case that converts the RS-232C logic level to the TTL level. The KPG-22A connects the SP/MIC connector of the transceiver to the RS-232C serial port of the computer.

5.2.3.4 KPG-22U description (USB programming interface cable: Option)

The KPG-22U is a cable which connects to a USB port on a computer.

When using the KPG-22U, install the supplied CD-ROM (with driver software) in the computer. The KPG-22U driver runs under Windows XP, Vista, 7 or 8.

The latest version of the USB driver is available for download from the following URL:

<http://www.kenwood.com/usb-com/>

(This URL may change without notice.)

5.2.3.5 Programming software description

The FPU is the programming software for the transceiver supplied on a CD-ROM. This software runs under Windows XP, Vista, 7 or 8 on a PC. The software on this disk allows a user to program the transceiver via the Programming interface cable (KPG-22A/22U).

- Use the FPU that matches the market when you first set the market code and model name/frequency data to the service unit. A unit set by mistake cannot be restored.
- List of FPU for transceiver

Model	Type	FPU
NX-340	K, M	KPG-169D
NX-340(U)	K	KPG-170D

5.2.3.6 Programming with a PC

If data is transferred to the transceiver from a PC with the FPU, the data for each set can be modified.

Data can be programmed into the EEPROM in RS-232C format via the SP/MIC jack.

In this mode, the PTT line operate as TXD and RXD data lines, respectively.

5.2.4 Wireless Clone Mode

5.2.4.1 Outline

“Wireless Clone Mode” copies the transceiver data to another transceiver.

The dealer can copy the transceiver data to another transceiver even without the use of a personal computer.

5.2.4.2 Example

The transceiver can copy the programming data to one or more transceivers via RF communication.

The clone source and clone target(s) must be in wireless clone mode.

5.2.4.3 Operation

- (1) To switch the clone target(s) to Wireless Clone mode, press and hold the [PTT] and [Side2] keys while turning the transceiver power ON.
- (2) Wait for 2 seconds. The LED will light orange and the transceiver will announce “Clone”.

- (3) Select a channel table number using the Side1 (increment channel table) and Side2 (decrement channel table) keys.
- (4) To switch the clone source to wireless clone mode, press and hold the [PTT] and [Side2] keys while turning the transceiver power ON.
- (5) Wait for 2 seconds. The LED will light orange and the transceiver will announce “Clone”.
- (6) Select the same channel table number as the clone target(s).
- (7) Press [PTT] on the clone source to begin data transmission.
When the clone target starts to receive data, the LED will light green.
When the clone source finishes sending data, a “confirmation” tone will sound.
If data transmission fails while cloning, an “error” tone will sound from the target unit.
- (8) If the cloning fails, no data will be available in the target unit when it is returned to User mode.
- (9) When the cloning is successful, the target unit’s “Scan” and “Key lock” functions will return to their default values (Scan = OFF, Key lock = OFF).

Note:

- The dealer can clone data to two or more transceivers by repeating the above procedures.
- If the transceiver’s wireless clone Mode is configured as “Disabled”, it cannot enter Clone mode.
- The table shown in the next page covers the frequencies used for wireless cloning.
- Wireless clone mode cannot be entered in battery low state.
- A unit cannot be a “Source Unit” if it is not programmed. If [PTT] is pressed, an “error” tone will sound.
- The language available is only English.
- Once a unit is set to be the source, it cannot be a target after the data has been transmitted. This protects the data in the source unit.
- Electronic interface may cause a failure in data transfer during Wireless Cloning, such as when waveforms or electromagnetic fields are being performed at the workbench.
- **Wireless clone mode can be used ONLY by authorized service personnel.**
- **The wireless clone mode setting must be configured as “Disable” before being delivered to the end-user.**
- **To clone, replace the antenna from both the source transceiver and the target transceiver with a dummy load.**
- **The transmit output power is automatically set to Low in clone mode.**
- **Wireless clone mode does not function if Read Authorization Password or Overwrite Password has been configured in Data Password.**

• Clone frequency table

No.	Operating frequency 450~520 (MHz)
1	450.000
2	452.000
3	454.000
4	456.000
5	458.000
6	460.000
7	462.000
8	464.000
9	466.000
10	469.000
11	470.000
12	472.000
13	474.000
14	476.000
15	478.000
16	480.500
17	482.000
18	484.000
19	486.000
20	488.000

5.3 Replacing TX-RX Unit

■ TX-RX unit Information

Model Name	Original TX-RX unit Number	For Service TX-RX unit Number
NX-340 K	X57-8510-10	XC2-0100-10
NX-340 M	X57-8510-10	XC2-0100-21
NX-340U K	X57-8510-10	XC2-0100-11

■ Supplied Accessories of "Service TX-RX unit"

Item (Including Parts Number)	Quantity
TX-RX Unit (XC2-010)	1
Model Name Plate	1

■ "Service TX-RX unit" Data

The following data is written on the service TX-RX unit:

Data Type	Description
Firmware	NX-240/340 Firmware
FPU Data (PC programming mode)	XC2-010 (NX-340/340U) K type data. XC2-010 (NX-340) M type data.
KENWOOD ESN	Model name: NX-340 or NX-340U Type: K, M The same number as the Model Name Plate label is written.
NXDN ESN	The same number as the Model Name Plate label is written.

■ After Changing the PCB

- (1) Using the KPG-169D (NX-340) / KPG-170D (NX-340U), select your desired item (Model Name and Frequency) from the Model> Product Information menu, then use Program> Write Data to the Transceiver to write the FPU data (PC Programming mode). When writing to the transceiver, a Warning Message, corresponding to the item selected, appears. Click [OK] to continue writing the data.
- (2) Enter Program> Test Mode, then adjust the various adjustment data (PC Test Mode) as described in the "SECTION 4 ADJUSTMENT".
- (3) Attach the new labels corresponding to the new printed circuit board. (Refer to the images below for label placement.)
- (4) If necessary, write the FPU data used by the customer with the KPG-169D (NX-340) / KPG-170D (NX-340U).

Note:

- When a new printed circuit board is used, the KENWOOD ESN changes, as does the Transceiver Information display of the KPG-169D (NX-340) / KPG-170D (NX-340U), but this does not have any effect on the operation of the transceiver.
- If changing to the original ESN, please contact our service center.

■ Model Name Plate Label Layout

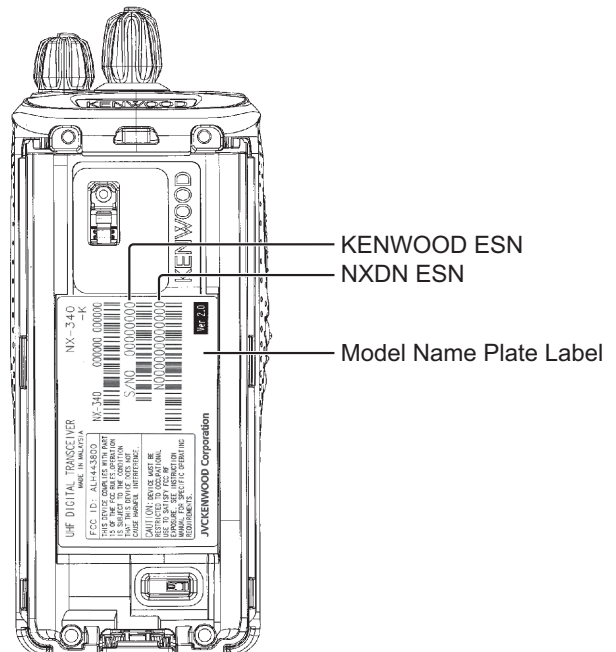

5.4 TERMINAL FUNCTION

5.4.1 TX-RX unit (X57-8510-XX)

Pin No.	Name	I/O	Function
CN600			
1	VOLOUT	O	Volume output to audio amplifier
2	VOLIN	I	Volume level input for audio control
3	SB	I	Power input after power switch
4	SB	I	Connect to pin 3
5	B	O	Power output after passing through the fuse
6	B	O	Connect to pin 5
7	VOLGND	-	GND for volume level
8	EN2	I	Rotary switch input
9	EN4	I	Rotary switch input
10	GND	-	GND
11	EN3	I	Rotary switch input
12	EN1	I	Rotary switch input

5.4.2 SP/MIC Connector Specification

Pin No.	Name	I/O	Signal Type	Function
1	PTT/RXD	I	Digital	PTT/RXD input
2	MICIN	I	Analog	External MIC input
3	MICO	O	Analog	Internal MIC output
4	OPTDET	I	Digital	External option detection
5	50V	O	Power	DC 5V output
6	AE	-	GND	GND
7	TXD	O	Digital	TXD output
8	NC	-	-	No connection
9	NC	-	-	No connection
10	SPO	O	Analog	Internal audio output

SCHEMATIC DIAGRAM

TX-RX UNIT (X57-8510-10)

CP401	CP402	D5	D9	L4	L5	L16	L26	L27	L204	L211	L405	L407	L408	L417	L420	R9	R25	R31	R32	R33	R35	R36	R42	R44	R211	R213	R214	R227	R236	R239	R417	R430	R435	R436	R438	R439	R775	R797	R798	C35	C36	C37	C46	C47	C48	C49	C54	C55	C58	C60	C61	C63	C68	C78	C79	C81	C202	C207	C208	C216	C227	C234	C242	C244	C248		
UHF 450.52MHz	0-10	RK79H147L1	RK79H147L1	1S1925F	1S1925F	6.8k	15k	18k	8.2k	180k	8.2k	1.2k _{min}	15k	15k	15k	56k	15k	100k	1M	18k	4.7k	220k	68	150	6.8k	22	1.5k	22	500	10k	15	18k	600k	47k	180	47k	100k	82k	0	330k	150k	5p	1u	3p	56p	22p	7p	15p	0.75p	0.75p	5p	6p	3p	4p	0.3p	7p	4p	15p	8p	18p	15p	5p	1u	30p	30p	15p	15p

C87	C88	C210	C211	C212	C213	C214	C215	C216	C219	C280	C429	C430	C434	C436	C438	C439	C440	C445	C448	C449	C450	C451	C452	C455	C456	C457	C459	C460	C469	C470	C471	C472	C473	C474	C475	C476	C478	C480	C481	TH400	R413	C415	C416	C462	C493	R458	C461	C457	C504	C501	R459	IC719	IC720	C500	C582	D154	R817	R811	R464	D700	D701	D201	D603	Q707	IC705	IC706	C223	C228	R705	D865		
UHF 450.52MHz	0-10	5p	100p	4p	5p	100p	0.1uF	2p	5p	0.3p	1p	3.3p	10p	2p	1p	2.5p	5p	2p	1.5p	2p	1.5k	15p	2p	270p	0.75p	15p	0.75p	270p	11p	2.5p	100p	0.3p	11p	270p	4p	4p	11p	1.5p	30p	5p	5p	5p	NCP16M22403	180k	10k	10k	100p	100p	82k	180k	0	100p	880p	3.3k	IC705(PKF)	IC705(PKF)	0.5u	1u	R810F-40AC	1k	47k	1k	R810F-40AC	R810F-40AC	GS10L	NTJ04001NG	CMK741	BR50128FV1.5G	50p	150p	27k	UD2W5181

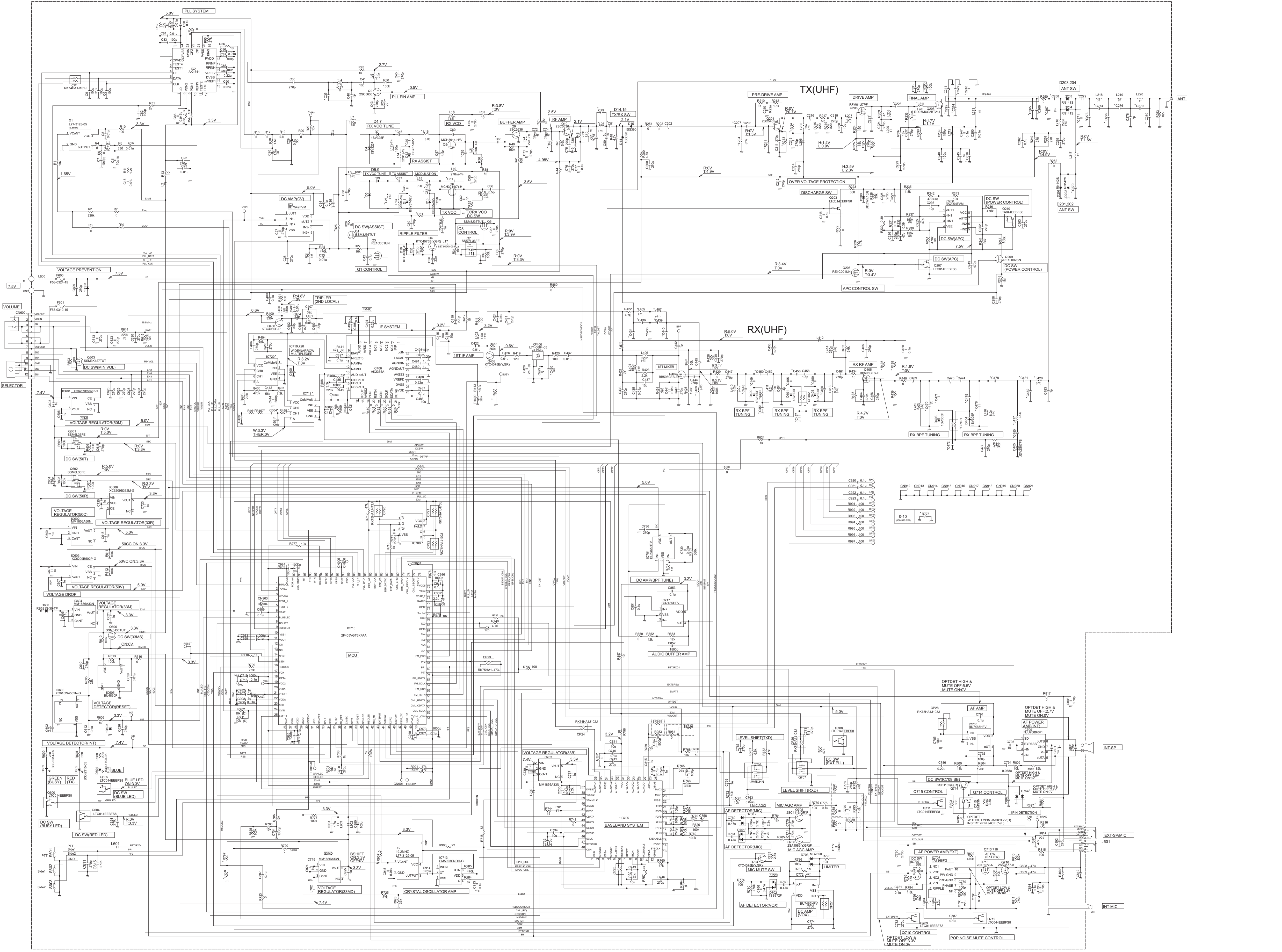

■ TX-RX UNIT (X57-8510-10)

--- Foil side view (J7C-0114-00) ---

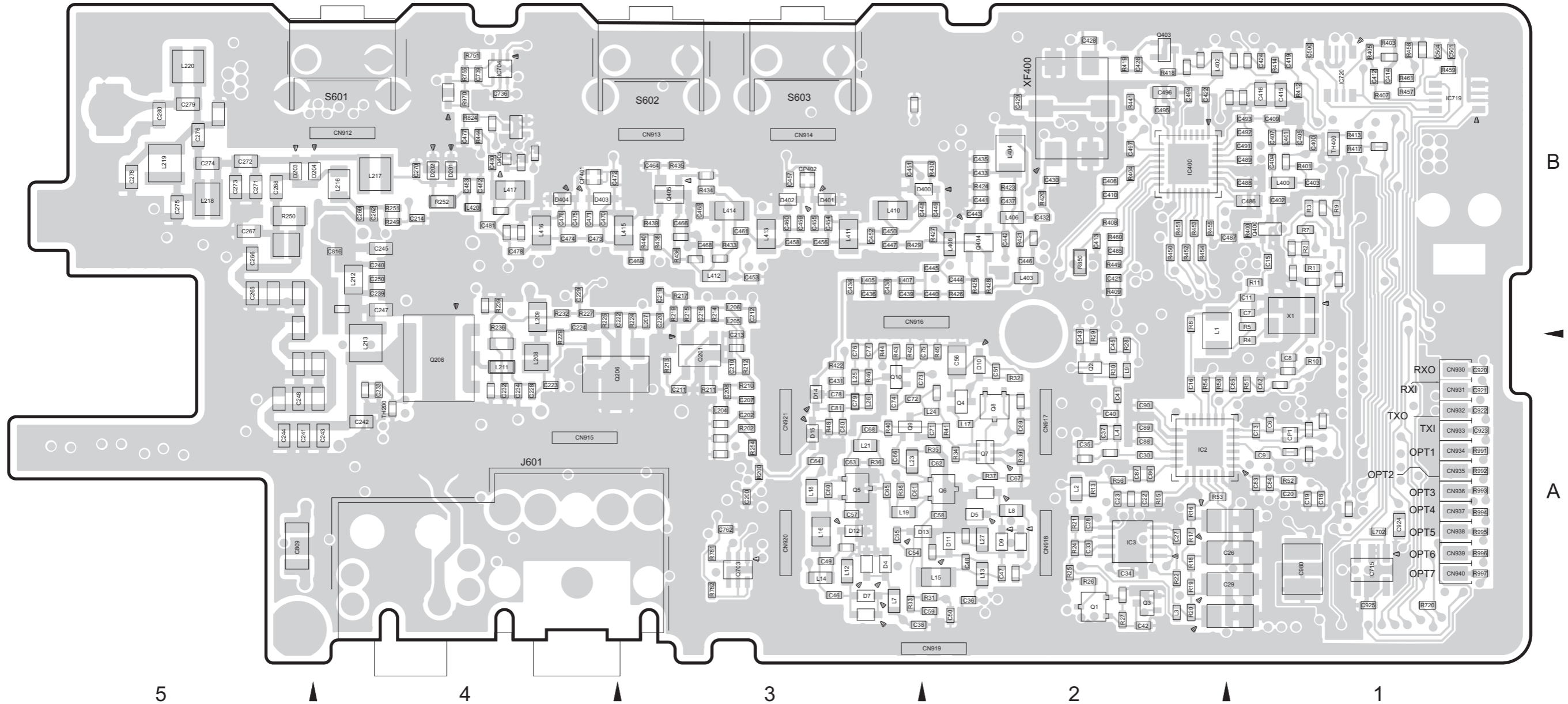

● ADDRESS TABLE OF BOARD PARTS

Each address may have an address error by one interval.



REF.NO. LOCATION	REF.NO. LOCATION	REF.NO. LOCATION	REF.NO. LOCATION	REF.NO. LOCATION	REF.NO. LOCATION	REF.NO. LOCATION	REF.NO. LOCATION	REF.NO. LOCATION	REF.NO. LOCATION	REF.NO. LOCATION	REF.NO. LOCATION	REF.NO. LOCATION	REF.NO. LOCATION	REF.NO. LOCATION	REF.NO. LOCATION	REF.NO. LOCATION	REF.NO. LOCATION																
IC	B-2A	R3	B-1B	R34	B-2A	R213	B-3A	R413	B-1B	R450	B-2B	C40	B-2A	C69	B-2A	C211	B-3A	C265	B-5B	C414	B-1B	C446	B-2B	C475	B-4B	C809	B-5A	S603	B-3B	L204	B-3A	L413	B-3B
IC2	B-2A	D4	B-1A	R35	B-2A	R214	B-3B	R414	B-1B	R451	B-2B	C41	B-2A	C71	B-2A	C212	B-3B	C266	B-5B	C415	B-1B	C447	B-3B	C476	B-4B	C816	B-4B	CP1	B-1A	L205	B-3B	L414	B-3B
IC3	B-2A	D5	B-2A	R36	B-3A	R215	B-3B	R417	B-1B	R452	B-2B	C42	B-2A	C72	B-3A	C213	B-3B	C267	B-5B	C416	B-1B	C448	B-2B	C477	B-4B	C920	B-1A	CP401	B-4B	L206	B-3B	L415	B-3B
IC400	B-2B	D7	B-3A	R37	B-1B	R217	B-3B	R418	B-2B	R453	B-2B	C43	B-2A	C73	B-3A	C214	B-4B	C268	B-5B	C419	B-1B	C449	B-2B	C478	B-4B	C921	B-1A	CP402	B-3B	L207	B-3B	L416	B-4B
IC704	B-4B	D8	B-3A	R38	B-2B	R219	B-3B	R419	B-2B	R454	B-2B	C45	B-2A	C74	B-3A	C216	B-3B	C269	B-4B	C421	B-2B	C450	B-2B	C480	B-4B	C922	B-1A	J601	B-4A	L208	B-4A	L417	B-4B
IC715	B-1A	D9	B-2A	R39	B-1B	R224	B-3B	R420	B-2B	R455	B-2B	C46	B-3A	C75	B-2A	C219	B-3B	C270	B-4B	C422	B-2B	C451	B-3B	C481	B-4B	C923	B-1A	L1	B-2B	L209	B-4B	L420	B-4B
		D10	B-2A	R40	B-1A	R225	B-4B	R421	B-2B	R457	B-1B	C47	B-2A	C76	B-3A	C220	B-3B	C271	B-5B	C424	B-1B	C452	B-3B	C482	B-4B	C924	B-1A	L2	B-2A	L211	B-4A	L421	B-1A
TRANSISTOR		D11	B-2A	R41	B-1B	R227	B-4B	R422	B-3A	R458	B-2B	C13	B-1A	C48	B-2A	C222	B-3B	C272	B-5B	C426	B-2B	C453	B-3B	C483	B-4B	C925	B-1A	L3	B-2A	L212	B-4B	L422	B-4B
Q1	B-2A	D12	B-3A	R42	B-2A	R229	B-4A	R423	B-2B	R459	B-1B	C15	B-1B	C49	B-3A	C223	B-4A	C273	B-5B	C428	B-2B	C454	B-3B	C485	B-2B	C980	B-1A	L4	B-2A	L213	B-4A	L423	B-4B
Q2	B-2A	D13	B-2A	R16	B-2A	R232	B-4B	R424	B-2B	R460	B-2B	C16	B-2A	C50	B-2A	C224	B-4B	C274	B-5B	C429	B-2B	C455	B-3B	C486	B-1B			L7	B-3A	L216	B-4B	L424	B-4B
Q3	B-2A	D14	B-3A	R17	B-2A	R236	B-4B	R425	B-2B	R461	B-1B	C18	B-1A	C51	B-1A	C228	B-4A	C275	B-5B	C430	B-2B	C456	B-3B	C487	B-1B	OTHER		L8	B-2A	L217	B-4B	L425	B-4B
Q4	B-2A	D15	B-3A	R18	B-2A	R239	B-4B	R426	B-2B	R720	B-1A	C19	B-1A	C54	B-3A	C229	B-4B	C276	B-5B	C431	B-3A	C457	B-3B	C488	B-1B	X1	B-1B	L9	B-2A	L218	B-5B	L426	B-5B
Q5	B-3A	D201	B-4B	R19	B-2A	R249	B-4B	R427	B-2B	R751	B-4B	C20	B-1A	C55	B-3A	C232	B-4A	C278	B-5B	C432	B-2B	C458	B-3B	C489	B-1B	TH200	B-4A	L12	B-3A	L219	B-5B	L427	B-5B
Q6	B-2A	D202	B-4B	R20	B-2A	R250	B-5B	R428	B-2B	R755	B-4B	C22	B-2A	C56	B-2A	C233	B-4A	C279	B-5B	C433	B-2B	C459	B-3B	C491	B-1B	TH400	B-1B	L13	B-2A	L220	B-5B	L428	B-5B
Q7	B-2A	D203	B-5B	R21	B-2A	R251	B-4B	R429	B-2B	R781	B-3A	C23	B-2A	C57	B-3A	C234	B-4A	C280	B-5B	C434	B-3B	C460	B-3B	C492	B-1B	CN912	B-4B	L14	B-2A	L400	B-1B	L429	B-1B
Q8	B-2A	D204	B-4B	R22	B-2A	R252	B-4B	R430	B-2B	R782	B-3A	C26	B-1A	C58	B-2A	C239	B-4B	C400	B-1B	C435	B-2B	C461	B-3B	C493	B-1B	CN913	B-3B	L15	B-2A	L401	B-1B	L430	B-1B
Q9	B-3A	D400	B-2B	R24	B-2A	R254	B-3A	R433	B-3B	R824	B-4B	C27	B-2A	C59	B-2A	C240	B-4B	C402	B-1B	C436	B-2B	C464	B-3B	C494	B-2B	CN914	B-3B	L16	B-2A	L402	B-2B	L431	B-2B
Q10	B-3A	D401	B-3B	R25	B-2A	R254	B-3A	R433	B-3B	R850	B-2B	C28	B-2A	C60	B-3A	C241	B-5A	C403	B-1B	C437	B-2B	C465	B-3B	C495	B-2B	CN915	B-4A	L17	B-2A	L403	B-2B	L432	B-2B
Q201	B-3A	D402	B-3B	R26	B-2A	R255	B-2A	R401	B-1B	R970	B-4B	C29	B-1A	C61	B-3A	C242	B-4A	C404	B-1B	C438	B-3B	C466	B-3B	C496	B-2B	CN916	B-3B	L18	B-2A	L404	B-2B	L433	B-2B
Q206	B-4A	D403	B-4B	R27	B-2A	R256	B-2A	R403	B-1B	R991	B-1A	C30	B-2A	C62	B-2A	C243	B-4A	C405	B-1B	C439	B-3B	C468	B-3B	C497	B-2B	CN917	B-2A	L19	B-3A	L405	B-3B	L434	B-3B
Q208	B-4A	D404	B-4B	R28	B-2A	R258	B-2A	R404	B-2B	R992	B-1A	C33	B-2A	C63	B-3A	C244	B-5A	C406	B-2B	C440	B-2B	C469	B-3B	C500	B-1B	CN918	B-2A	L21	B-3A	L406	B-2B	L435	B-2B
Q400	B-1B	D405	B-4B	R29	B-2A	R200	B-3A	R405	B-1B	R993	B-3A	C34	B-2A	C64	B-3A	C245	B-4B	C407	B-1B	C441	B-2B	C470	B-4B	C501	B-1B	CN919	B-2A	L23	B-3A	L407	B-3B	L436	B-3B
Q403	B-2B			R30	B-2A	R202	B-3A	R407	B-1B	R994	B-1A	C35	B-2A	C65	B-3A	C202	B-3A	C409	B-1B	C442	B-2B	C471	B-4B	C504	B-1B	CN920	B-3A	L24	B-2A	L408	B-2B	L437	B-2B
Q404	B-2B	RESISTOR		R31	B-2A	R210	B-3A	R408	B-2B	R995	B-2A	C36	B-2A	C66	B-3A	C207	B-3A	C410	B-2B	C443	B-2B	C472	B-4B	C736	B-4B	CN921	B-3A	L25	B-3A	L410	B-3B	L438	B-3B
Q405	B-3B	R1	B-1B	R32	B-2A	R211	B-3A	R409	B-2B	R996	B-1A	C37	B-2A	C67	B-2A	C208	B-3A	C412	B-1B	C444	B-2B	C473	B-4B	C739	B-4B	S601	B-4B	L26	B-3A	L411	B-3B	L439	B-3B
Q703	B-3A	R2	B-1B	R33	B-3A	R212	B-3A	R412	B-1B	R997	B-1A	C38	B-3A	C68	B-3A	C210	B-3A	C413	B-2B	C445	B-2B	C474	B-4B	C762	B-3A	S602	B-3B	L27	B-2A	L412	B-3B	L440	B-3B

LEVEL DIAGRAM

Receiver Section

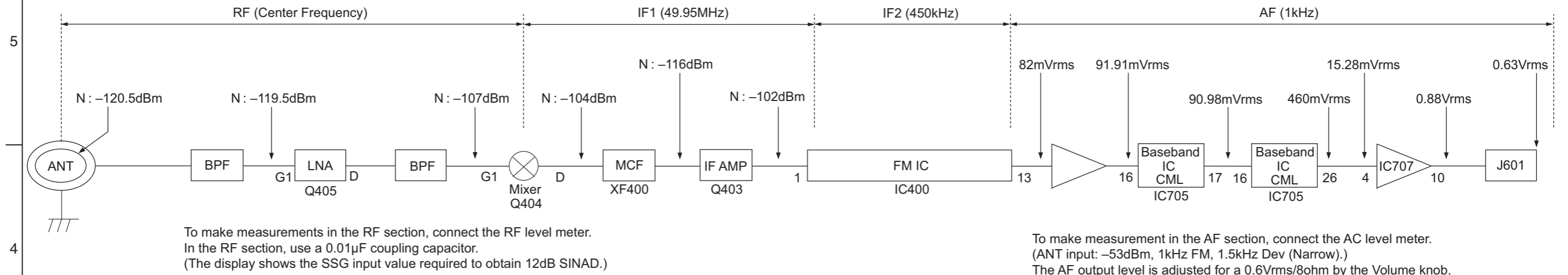

Transmitter Section

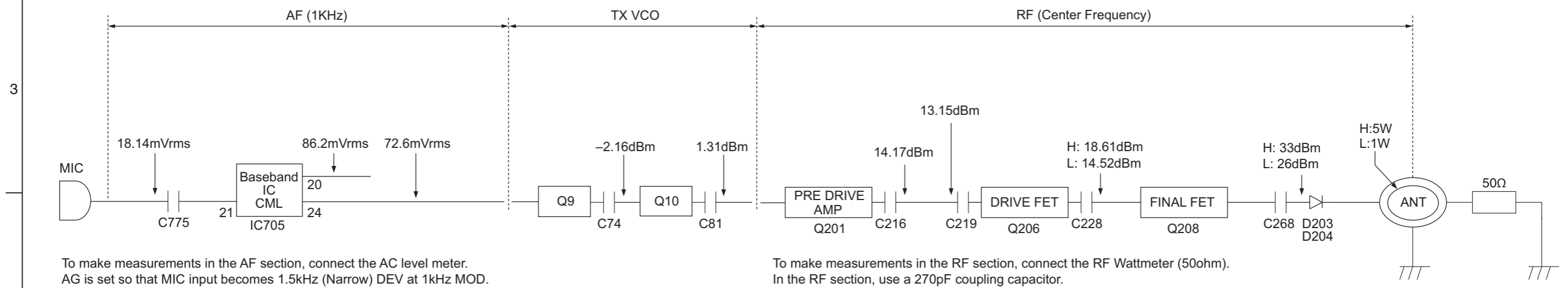

BLOCK DIAGRAM

TX-RX UNIT (X57-8510-10)

5

4

3

2

1

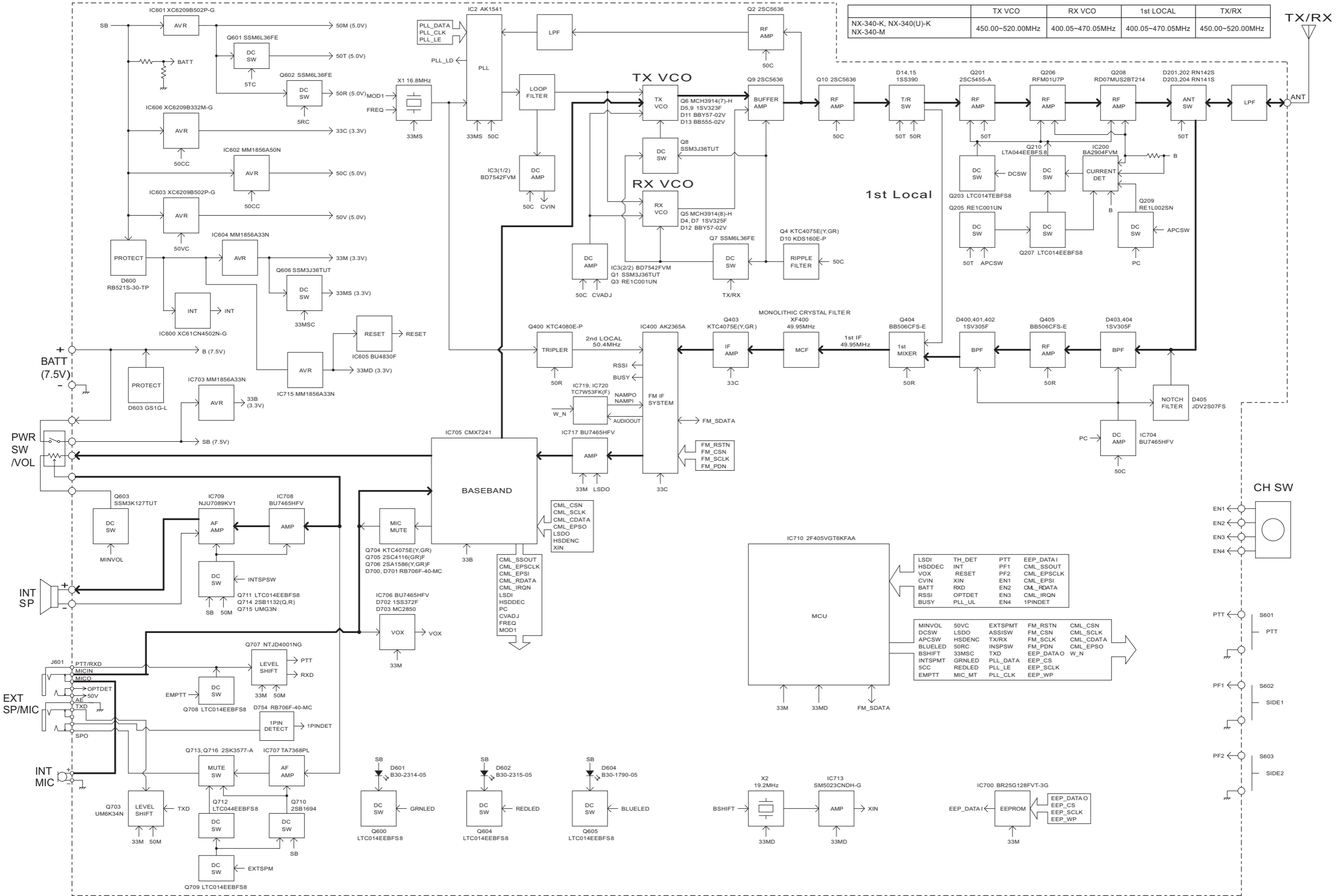

PARTS LIST

[NX-340,NX-340(U)]

* SAFETY PRECAUTION

Parts identified by the ⚠ symbol are critical for safety. Replace only with specified part numbers.

* BEWARE OF BOGUS PARTS

Parts that do not meet specifications may cause trouble in regard to safety and performance. We recommend that genuine parts be used.

* (x_) in a description column shows the number of the used part.

- Contents -

Exploded view of general assembly and parts list	3-2
Electrical parts list	3-4
Packing materials and accessories parts list	3-10

Exploded view of general assembly and parts list

Block No.M1MM

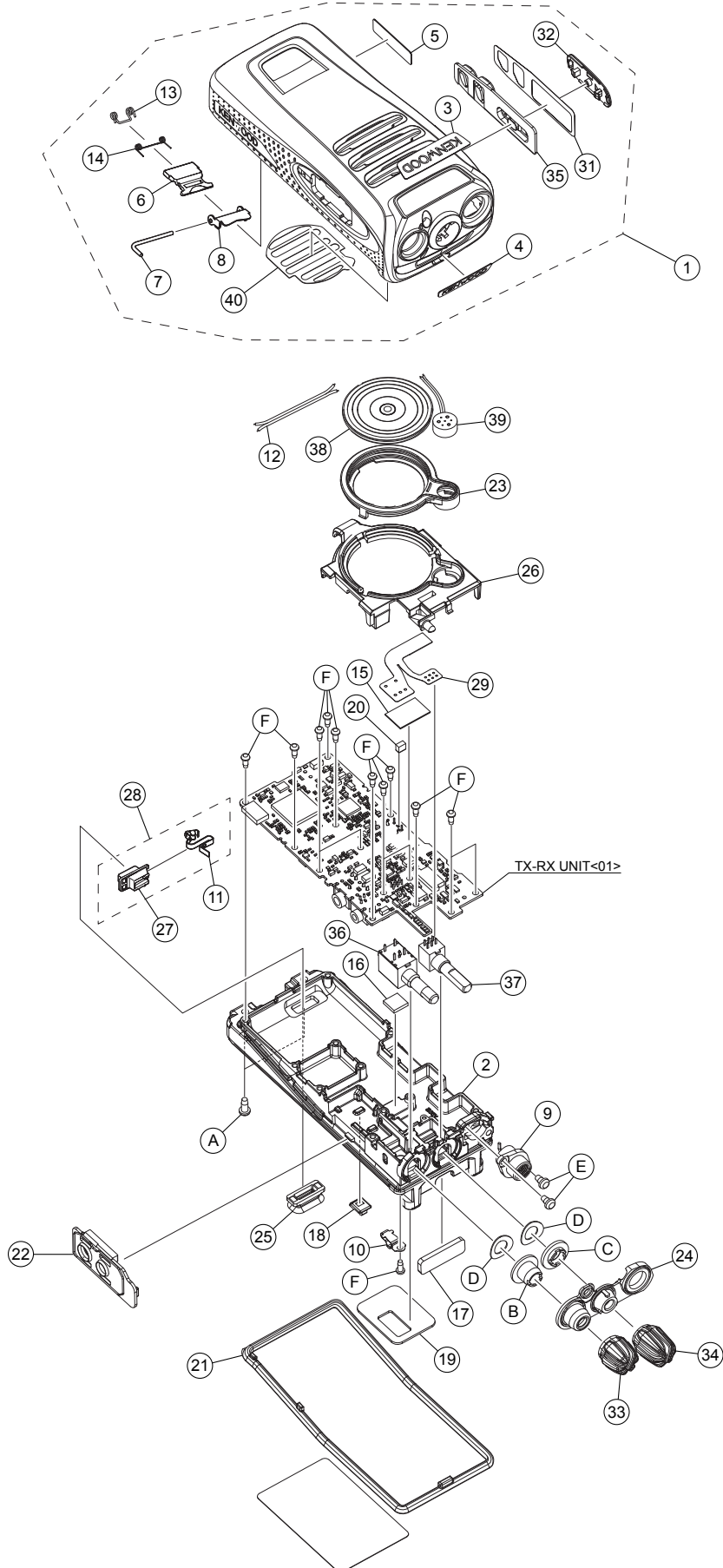

General assembly

Block No. [M][1][M][M]

△ Symbol No.	Part No.	Part Name	Description	Local
1	A02-4228-23	PLASTIC CABINET ASSY		
2	A1A-0029-00	CHASSIS		
3	B43-1693-04	BADGE(KENWOOD-FRONT)		
4	B43-1694-04	BADGE(KENWOOD)		
5	B43-1700-04	BADGE(NEXEDGE)		
6	D10-0649-03	LEVER		
7	D21-0863-04	SHAFT		
8	D32-0441-13	STOPPER		
9	E04-0477-15	RF COAXIAL RECEPTACLE(SMA)		
10	E23-1253-24	TERMINAL(GROUND)		
11	E23-1395-04	TERMINAL(+VE)		
12	E37-1288-05	PARALLEL CORD		
13	G01-4542-04	COIL SPRING(LEVER)		
14	G01-4543-14	COIL SPRING(STOPPER)		
15	G10-1348-04	FIBROUS SHEET(X57-IC)		
16	G11-4465-04	RUBBER SHEET(FET)		
17	G13-2009-04	CUSHION(CHASSIS)		
18	G13-2033-04	CUSHION(GROUND)		
19	G13-2034-24	CUSHION(CHASSIS)		
20	G13-2448-04	CUSHION(X57.SP)		
21	G53-1604-03	PACKING(CHASSIS)		
22	G53-2215-03	PACKING(SP/MIC)		
23	G53-2216-03	PACKING(SP)		
24	G53-2217-02	PACKING(VOLUME/SELECTOR)		
25	G53-2218-03	PACKING(+VE)		
26	J19-5578-22	HOLDER(SP)		
27	J19-5579-03	HOLDER(+VE)		
28	J19-5580-03	HOLDER ASSY		
29	J87-0054-05	FPC(VOLUME/SELECTOR)		
31	J99-0783-04	ADHESIVE SHEET(PTT)		
32	K29-9612-03	BUTTON KNOB(PTT)		
33	K29-9614-03	KNOB(VOLUME)		
34	K29-9615-03	KNOB(SELECTOR)		
35	K29-9625-03	BUTTON KNOB(PF)		
36	R31-0670-35	VARIABLE RESISTOR		
37	S60-0450-05	ROTARY SWITCH		
38	T0H-0011-00	SPEAKER		
39	T91-0659-15	MIC ELEMENT		
40	G10-1854-04	FIBROUS SHEET(SP)		
A	N09-6621-05	PAN HEAD SCREW	(x2)	
B	N14-0849-05	CIRCULAR NUT(VOLUME)		
C	N14-0869-05	CIRCULAR NUT(SELECTOR)		
D	N19-2214-05	SPECIAL WASHER(VOL/SELECTOR)	(x2)	
E	N30-2604-48	PAN HEAD MACHINE SCREW	(x2)	
F	N83-2005-48	PAN HEAD TAPTITE SCREW	(x14)	
-	XC2-0100-10	SERVICE TX-RX UNIT		340_K
-	XC2-0100-11	SERVICE TX-RX UNIT		340U_K
-	XC2-0100-21	SERVICE TX-RX UNIT		340_M

Electrical parts list

TX-RX UNIT

X57-8510-10

Block No. [0][1]

△ Symbol No.	Part No.	Part Name	Description	Local
IC2	AK1541	IC(MOS-IC)		
IC3	BD7542FVM	IC(MOS-IC)		
IC200	BA2904FVM	IC(MOS-IC)		
IC400	AK2365A	IC		
IC600	XC61CN4502N-G	IC(MOS-IC)		
IC601	XC6209B502P-G	IC(MOS-IC)		
IC602	MM1856A50N	BI-POLAR IC		
IC603	XC6209B502P-G	IC(MOS-IC)		
IC604	MM1856A33N	BI-POLAR IC		
IC605	BU4830F	IC(MOS-IC)		
IC606	XC6209B332M-G	IC(MOS-IC)		
IC700	BR25G128FVT-3G	ROM IC		
IC703	MM1856A33N	BI-POLAR IC		
IC704	BU7465HFV	IC(MOS-IC)		
IC705	CMX7241	IC(MOS-IC)		
IC706	BU7465HFV	IC(MOS-IC)		
IC707	TA7368FG	IC(MOS-IC)		
IC708	BU7465HFV	IC(MOS-IC)		
IC709	NJU7089KV1	IC(MOS-IC)		
IC710	2F405VGT6KFAA	MICROPROCESSOR IC		
IC713	SM5023CNDH-G	IC(MOS-IC)		
IC715	MM1856A33N	BI-POLAR IC		
IC717	BU7465HFV	IC(MOS-IC)		
IC719	TC7W53FK(F)	IC(MOS-IC)		
IC720	TC7W53FK(F)	IC(MOS-IC)		
Q1	SSM3J36TUT	FET		
Q2	2SC5636	TRANSISTOR		
Q3	RE1C001UN	FET		
Q4	KTC4075E(Y,GR)	TRANSISTOR		
Q5	MCH3914-H/8/	FET		
Q6	MCH3914(7)-H	FET		
Q7	SSM6L36FE	FET		
Q8	SSM3J36TUT	FET		
Q9	2SC5636	TRANSISTOR		
Q10	2SC5636	TRANSISTOR		
Q201	2SC5455-A	TRANSISTOR		
Q203	LTC014TEBFS8	DIGI TRANSISTOR		
Q205	RE1C001UN	FET		
Q206	RFM01U7PF	FET		
Q207	LTC014EEBFS8	DIGI TRANSISTOR		
Q208	RD07MUS2BT214	FET		
Q209	RE1L002SN	FET		
Q210	LTA044EEBFS8	DIGI TRANSISTOR		
Q400	KTC4080E-P	TRANSISTOR		
Q403	KTC4075E(Y,GR)	TRANSISTOR		
Q404	BB506CFS-E	FET		
Q405	BB506CFS-E	FET		
Q600	LTC014EEBFS8	DIGI TRANSISTOR		
Q601	SSM6L36FE	FET		
Q602	SSM6L36FE	FET		
Q603	SSM3K127TUT	FET		
Q604	LTC014EEBFS8	DIGI TRANSISTOR		
Q605	LTC014EEBFS8	DIGI TRANSISTOR		
Q606	SSM3J36TUT	FET		
Q703	UM6K34N	FET		
Q704	KTC4075E(Y,GR)	TRANSISTOR		
Q705	2SC4116(GR)F	TRANSISTOR		
Q706	2SA1586(Y,GR)F	TRANSISTOR		
Q707	NTJD4001NG	FET		
Q708	LTC014EEBFS8	DIGI TRANSISTOR		
Q709	LTC014EEBFS8	DIGI TRANSISTOR		
Q710	2SB1694	TRANSISTOR		
Q711	LTC014EEBFS8	DIGI TRANSISTOR		
Q712	LTC044EEBFS8	DIGI TRANSISTOR		
Q713	2SK3577-A	FET		
Q714	2SB1132(Q,R)	TRANSISTOR		
Q715	UMG3N	DIGITAL TRANSISTOR ARRAY		
Q716	2SK3577-A	FET		

△ Symbol No.	Part No.	Part Name	Description	Local
D4	1SV325F	VARIABLE CAPACITANCE DIODE		
D5	1SV325F	VARIABLE CAPACITANCE DIODE		
D7	1SV325F	VARIABLE CAPACITANCE DIODE		
D9	1SV325F	VARIABLE CAPACITANCE DIODE		
D10	KDS160E-P	DIODE		
D11	BBY57-02V	VARIABLE CAPACITANCE DIODE		
D12	BBY57-02V	VARIABLE CAPACITANCE DIODE		
D13	BB555-02V	VARIABLE CAPACITANCE DIODE		
D14	1SS390	DIODE		
D15	1SS390	DIODE		
D200	UDZW5.1(B)	ZENER DIODE		
D201	RN142S	DIODE		
D202	RN142S	DIODE		
D203	RN141S	DIODE		
D204	RN141S	DIODE		
D400	1SV305F	VARIABLE CAPACITANCE DIODE		
D401	1SV305F	VARIABLE CAPACITANCE DIODE		
D402	1SV305F	VARIABLE CAPACITANCE DIODE		
D403	1SV305F	VARIABLE CAPACITANCE DIODE		
D404	1SV305F	VARIABLE CAPACITANCE DIODE		
D405	JDV2S07FS	VARIABLE CAPACITANCE DIODE		
D600	RB521S-30-TP	DIODE		
D601	B30-2314-05	LED(GREEN)		
D602	B30-2315-05	LED(RED)		
D603	GS1G-L	DIODE		
D604	B30-1790-05	LED(BLUE)		
D605	UDZW5.1(B)	ZENER DIODE		
D700	RB706F-40-MC	DIODE		
D701	RB706F-40-MC	DIODE		
D702	1SS372F	DIODE		
D703	MC2850	DIODE		
D754	RB706F-40-MC	DIODE		
C6	CC73HCH1H101J	C CAPACITOR	100PF J	
C7	CC73HCH1H100B	C CAPACITOR	10PF B	
C8	CK73HBB1E103K	C CAPACITOR	0.01UF K	
C9	CC73HCH1H101J	C CAPACITOR	100PF J	
C11	CC73HCH1H100B	C CAPACITOR	10PF B	
C13	CC73HCH1H101J	C CAPACITOR	100PF J	
C15	CK73HBB1E103K	C CAPACITOR	0.01UF K	
C16	CK73HBB1E103K	C CAPACITOR	0.01UF K	
C18	CK73HB1H271K	C CAPACITOR	270PF K	
C19	CK73HBB1E103K	C CAPACITOR	0.01UF K	
C20	CK73HBB1A104K	C CAPACITOR	0.1UF K	
C22	CK73HB1H271K	C CAPACITOR	270PF K	
C23	CK73HBB1E103K	C CAPACITOR	0.01UF K	
C26	CS77MA1D1R5M	TA E CAPACITOR	1.5UF 35WV	
C27	CK73HB1H271K	C CAPACITOR	270PF K	
C28	CK73HB1H271K	C CAPACITOR	270PF K	
C29	CS77MA1V0R1M	TA E CAPACITOR	0.1UF 35WV	
C30	CK73HB1H271K	C CAPACITOR	270PF K	
C33	CK73HBB1E103K	C CAPACITOR	0.01UF K	
C34	CK73HBB1A104K	C CAPACITOR	0.1UF K	
C35	CC73HCH1H080B	C CAPACITOR	8.0PF B	
C36	CK73HB1A105K	C CAPACITOR	1.0UF K	
C37	CC73HCH1H030B	C CAPACITOR	3.0PF B	
C38	CK73HB1H271K	C CAPACITOR	270PF K	
C40	CC73HCH1H080B	C CAPACITOR	8.0PF B	
C41	CC73HCH1H100C	C CAPACITOR	10PF C	
C42	CK73HBB1A104K	C CAPACITOR	0.1UF K	
C43	CK73HB1H271K	C CAPACITOR	270PF K	
C45	CK73HB1H271K	C CAPACITOR	270PF K	
C46	CC73HCH1H560J	C CAPACITOR	56PF J	
C47	CC73HCH1H220J	C CAPACITOR	22PF J	
C48	CC73HCH1H070B	C CAPACITOR	7.0PF B	
C49	CC73HCH1H100C	C CAPACITOR	10PF C	
C50	CK73HB1H271K	C CAPACITOR	270PF K	
C51	CK73HB1H271K	C CAPACITOR	270PF K	
C54	CC73HCH1HR75B	C CAPACITOR	0.75PF B	
C55	CC73HCH1HR75B	C CAPACITOR	0.75PF B	
C56	CK73FB0J226M	C CAPACITOR	22UF M	
C57	CC73HCH1H4R5B	C CAPACITOR	4.5PF B	
C58	CC73HCH1H050B	C CAPACITOR	5.0PF B	
C59	CK73HB1A105K	C CAPACITOR	1.0UF K	
C60	CC73HCH1H060B	C CAPACITOR	6.0PF B	
C61	CC73HCH1H030B	C CAPACITOR	3.0PF B	

△ Symbol No.	Part No.	Part Name	Description	Local	△ Symbol No.	Part No.	Part Name	Description	Local
C62	CC73HCH1H050B	C CAPACITOR	5.0PF B		C278	CC73GCH1H070B	C CAPACITOR	7.0PF B	
C63	CC73HCH1H040B	C CAPACITOR	4.0PF B		C279	CC73GCH1H010B	C CAPACITOR	1.0PF B	
C64	CK73HB1H271K	C CAPACITOR	270PF K		C280	CC73GCH1H3R5B	C CAPACITOR	3.5PF B	
C65	CK73HB1H271K	C CAPACITOR	270PF K		C400	CK73HBB1A104K	C CAPACITOR	0.1UF K	
C66	CC73HCH1H0R5B	C CAPACITOR	0.5PF B		C402	CC73HCH1H330J	C CAPACITOR	33PF J	
C67	CK73HB1H271K	C CAPACITOR	270PF K		C403	CK73HBB1E103K	C CAPACITOR	0.01UF K	
C68	CC73HCH1H0R3B	C CAPACITOR	0.3PF B		C404	CC73HCH1H220J	C CAPACITOR	22PF J	
C69	CK73HB1H271K	C CAPACITOR	270PF K		C405	CC73HCH1H820J	C CAPACITOR	82PF J	
C71	CK73HB1H271K	C CAPACITOR	270PF K		C406	CK73HB1H271K	C CAPACITOR	270PF K	
C72	CC73HCH1H330J	C CAPACITOR	33PF J		C407	CC73HCH1H390J	C CAPACITOR	39PF J	
C73	CC73HCH1H100B	C CAPACITOR	10PF B		C409	CC73HCH1H820J	C CAPACITOR	82PF J	
C74	CC73HCH1H150J	C CAPACITOR	15PF J		C410	CK73HB1H271K	C CAPACITOR	270PF K	
C75	CK73HB1H271K	C CAPACITOR	270PF K		C412	CC73HCH1H560J	C CAPACITOR	56PF J	
C76	CK73HB1H271K	C CAPACITOR	270PF K		C413	CK73HB1H182K	C CAPACITOR	1800PF K	
C77	CK73HBB1A104K	C CAPACITOR	0.1UF K		C414	CK73HBB1H681K	C CAPACITOR	680PF K	
C78	CC73HCH1H070B	C CAPACITOR	7.0PF B		C415	CK73GBOJ106K	C CAPACITOR	10UF K	
C79	CC73HCH1H040B	C CAPACITOR	4.0PF B		C416	CK73GBOJ106K	C CAPACITOR	10UF K	
C80	CC73HCH1H050B	C CAPACITOR	5.0PF B		C419	CK73HB1H271K	C CAPACITOR	270PF K	
C81	CC73HCH1H150J	C CAPACITOR	15PF J		C421	CK73HB1A333K	C CAPACITOR	0.033UF K	
C82	CC73HCH1H101J	C CAPACITOR	100PF J		C422	CK73HBB1E103K	C CAPACITOR	0.01UF K	
C83	CC73HCH1H101J	C CAPACITOR	100PF J		C424	CK73HBB1E103K	C CAPACITOR	0.01UF K	
C84	CK73HB1H103K	C CAPACITOR	0.010UF K		C426	CK73HBB1E103K	C CAPACITOR	0.01UF K	
C85	CK73HB1A473K	C CAPACITOR	0.047UF K		C428	CC73HCH1H020B	C CAPACITOR	2.0PF B	
C86	CK73HBB1E103K	C CAPACITOR	0.01UF K		C429	CC73HCH1H100C	C CAPACITOR	10PF C	
C87	CC73HCH1H101J	C CAPACITOR	100PF J		C430	CC73HCH1H020B	C CAPACITOR	2.0PF B	
C88	CC73HCH1H101J	C CAPACITOR	100PF J		C431	CK73HB1H271K	C CAPACITOR	270PF K	
C89	CK73HB1A224K	C CAPACITOR	0.22UF K		C432	CK73HBB1E103K	C CAPACITOR	0.01UF K	
C90	CK73HB1A224K	C CAPACITOR	0.22UF K		C433	CK73HB1H271K	C CAPACITOR	270PF K	
C200	CK73HB1H271K	C CAPACITOR	270PF K		C434	CC73HCH1H010B	C CAPACITOR	1.0PF B	
C202	CC73HCH1H080B	C CAPACITOR	8.0PF B		C435	CK73HBB1E103K	C CAPACITOR	0.01UF K	
C207	CC73HCH1H180J	C CAPACITOR	18PF J		C436	CC73HCH1H2R5B	C CAPACITOR	2.5PF B	
C208	CC73HCH1H150J	C CAPACITOR	15PF J		C437	CC73HCH1H150J	C CAPACITOR	15PF J	
C210	CK73HB1A224K	C CAPACITOR	0.22UF K		C438	CC73HCH1H050B	C CAPACITOR	5.0PF B	
C211	CK73HB1H271K	C CAPACITOR	270PF K		C439	CC73HCH1H020B	C CAPACITOR	2.0PF B	
C212	CK73HB1H271K	C CAPACITOR	270PF K		C440	CC73HCH1H1R5B	C CAPACITOR	1.5PF B	
C213	CK73HB1H271K	C CAPACITOR	270PF K		C441	CK73HBB1E103K	C CAPACITOR	0.01UF K	
C214	CK73HB1H271K	C CAPACITOR	270PF K		C442	CC73HCH1H010B	C CAPACITOR	1.0PF B	
C216	CC73HCH1H050B	C CAPACITOR	5.0PF B		C443	CK73HB1H271K	C CAPACITOR	270PF K	
C218	CK73HBB1A104K	C CAPACITOR	0.1UF K		C444	CK73HB1H271K	C CAPACITOR	270PF K	
C219	CK73HB1H271K	C CAPACITOR	270PF K		C445	CC73HCH1H020B	C CAPACITOR	2.0PF B	
C220	CC73HCH1H100C	C CAPACITOR	10PF C		C446	CK73HB1H271K	C CAPACITOR	270PF K	
C222	CK73HB1H271K	C CAPACITOR	270PF K		C447	CK73HB1H271K	C CAPACITOR	270PF K	
C223	CC73HCH1H160J	C CAPACITOR	16PF J		C448	CC73HCH1H1R5B	C CAPACITOR	1.5PF B	
C224	CK73HB1H271K	C CAPACITOR	270PF K		C449	CC73HCH1H110G	C CAPACITOR	11PF G	
C225	CK73HB1H271K	C CAPACITOR	270PF K		C450	CC73HCH1H020B	C CAPACITOR	2.0PF B	
C226	CK73HB1H271K	C CAPACITOR	270PF K		C451	CK73HB1H271K	C CAPACITOR	270PF K	
C227	CK73FB1A105K	C CAPACITOR	1.0UF K		C452	CC73HCH1HR75B	C CAPACITOR	0.75PF B	
C228	CC73HCH1H151J	C CAPACITOR	150PF J		C453	CK73HB1H271K	C CAPACITOR	270PF K	
C229	CK73HB1H271K	C CAPACITOR	270PF K		C454	CC73HCH1H040B	C CAPACITOR	4.0PF B	
C230	CC73HCH1H470J	C CAPACITOR	47PF J		C455	CC73HCH1H110G	C CAPACITOR	11PF G	
C232	CK73HB1H271K	C CAPACITOR	270PF K		C456	CC73HCH1HR75B	C CAPACITOR	0.75PF B	
C233	CK73HB1H271K	C CAPACITOR	270PF K		C457	CK73HB1H271K	C CAPACITOR	270PF K	
C234	CC73HCH1H330J	C CAPACITOR	33PF J		C458	CC73HCH1H1R5B	C CAPACITOR	1.5PF B	
C235	CC73HCH1H470J	C CAPACITOR	47PF J		C459	CC73HCH1H110G	C CAPACITOR	11PF G	
C236	CC73HCH1H100B	C CAPACITOR	10PF B		C460	CC73HCH1H2R5B	C CAPACITOR	2.5PF B	
C239	CC73HCH1H151J	C CAPACITOR	150PF J		C461	CK73HB1H271K	C CAPACITOR	270PF K	
C240	CC73HCH1H151J	C CAPACITOR	150PF J		C464	CK73HB1H271K	C CAPACITOR	270PF K	
C242	CC73GCH1H330J	C CAPACITOR	33PF J		C465	CK73HB1H271K	C CAPACITOR	270PF K	
C244	CC73GCH1H150G	C CAPACITOR	15PF G		C466	CK73HB1H271K	C CAPACITOR	270PF K	
C245	CK73GBB1A105K	C CAPACITOR	1.0UF K		C468	CK73HBB1A104K	C CAPACITOR	0.1UF K	
C247	CK73GBB1C104K	C CAPACITOR	0.1UF K		C469	CC73HCH1H101J	C CAPACITOR	100PF J	
C248	CC73GCH1H150G	C CAPACITOR	15PF G		C470	CC73HCH1H0R3B	C CAPACITOR	0.3PF B	
C249	CK73HBB1H471K	C CAPACITOR	470PF K		C471	CC73HCH1H110G	C CAPACITOR	11PF G	
C250	CK73HBB1E103K	C CAPACITOR	0.01UF K		C472	CK73HB1H271K	C CAPACITOR	270PF K	
C252	CK73HB1H271K	C CAPACITOR	270PF K		C473	CC73HCH1H040B	C CAPACITOR	4.0PF B	
C258	CK73HB1H271K	C CAPACITOR	270PF K		C474	CC73HCH1H040B	C CAPACITOR	4.0PF B	
C262	CK73HBB1A104K	C CAPACITOR	0.1UF K		C475	CC73HCH1H110G	C CAPACITOR	11PF G	
C263	CK73HB1H271K	C CAPACITOR	270PF K		C476	CC73HCH1H1R5B	C CAPACITOR	1.5PF B	
C267	CC73GCH1H060B	C CAPACITOR	6.0PF B		C477	CK73HB1H271K	C CAPACITOR	270PF K	
C268	CC73GCH1H101J	C CAPACITOR	100PF J		C478	CC73HCH1H300J	C CAPACITOR	30PF J	
C269	CK73HB1H271K	C CAPACITOR	270PF K		C480	CC73HCH1H090B	C CAPACITOR	9.0PF B	
C270	CC73HCH1H040B	C CAPACITOR	4.0PF B		C481	CC73HCH1H050B	C CAPACITOR	5.0PF B	
C271	CC73GCH1H060B	C CAPACITOR	6.0PF B		C483	CC73HCH1H010B	C CAPACITOR	1.0PF B	
C272	CC73GCH1H101J	C CAPACITOR	100PF J		C485	CK73HBB1H102K	C CAPACITOR	1000PF K	
C273	CC73GCH1HR75B	C CAPACITOR	0.75PF B		C486	CK73GBOJ106K	C CAPACITOR	10UF K	
C274	CC73GCH1H020B	C CAPACITOR	2.0PF B		C487	CK73HBB1A104K	C CAPACITOR	0.1UF K	
C275	CC73GCH1H060B	C CAPACITOR	6.0PF B		C488	CK73HB1A224K	C CAPACITOR	0.22UF K	
C276	CC73GCH1H0R3B	C CAPACITOR	0.3PF B		C489	CK73HB1A105K	C CAPACITOR	1.0UF K	

△ Symbol No.	Part No.	Part Name	Description	Local	△ Symbol No.	Part No.	Part Name	Description	Local
C491	CK73HB1A105K	C CAPACITOR	1.0UF K		C771	CK73HB1H271K	C CAPACITOR	270PF K	
C492	CC73HCH1H101J	C CAPACITOR	100PF J		C772	CC73HCH1H470J	C CAPACITOR	47PF J	
C493	CC73HCH1H101J	C CAPACITOR	100PF J		C773	CK73HB1H271K	C CAPACITOR	270PF K	
C494	CK73HB1A224K	C CAPACITOR	0.22UF K		C774	CK73HB1H271K	C CAPACITOR	270PF K	
C495	CK73HBB1A104K	C CAPACITOR	0.1UF K		C775	CK73HBB1A104K	C CAPACITOR	0.1UF K	
C496	CK73GB0J106K	C CAPACITOR	10UF K		C777	CK73HBB1A683K	C CAPACITOR	0.068UF K	
C497	CK73HBB1A104K	C CAPACITOR	0.1UF K		C778	CK73HB1H271K	C CAPACITOR	270PF K	
C500	CK73HBB1A104K	C CAPACITOR	0.1UF K		C779	CK73GB0J106K	C CAPACITOR	10UF K	
C501	CK73HBB1H681K	C CAPACITOR	680PF K		C780	CK73HB1H271K	C CAPACITOR	270PF K	
C504	CC73HCH1H101J	C CAPACITOR	100PF J		C781	CK73HBB1A104K	C CAPACITOR	0.1UF K	
C600	CK73GB1A105K	C CAPACITOR	1.0UF K		C782	CK73HB1H271K	C CAPACITOR	270PF K	
C601	CK73GB1A105K	C CAPACITOR	1.0UF K		C783	CK73GB1A105K	C CAPACITOR	1.0UF K	
C602	CK73GXR1C225K	C CAPACITOR	2.2UF K		C784	CK73GXR1C225K	C CAPACITOR	2.2UF K	
C603	CK73GB1A105K	C CAPACITOR	1.0UF K		C785	CK73GB0J106K	C CAPACITOR	10UF K	
C604	CK73HB1H271K	C CAPACITOR	270PF K		C786	CK73HB1A224K	C CAPACITOR	0.22UF K	
C605	CK73GB1A105K	C CAPACITOR	1.0UF K		C787	CK73HBB1A104K	C CAPACITOR	0.1UF K	
C606	CK73GB1A105K	C CAPACITOR	1.0UF K		C788	CK73FB0J226M	C CAPACITOR	22UF M	
C607	CK73GB1A105K	C CAPACITOR	1.0UF K		C789	CC73HCH1H101J	C CAPACITOR	100PF J	
C609	CK73HB1H271K	C CAPACITOR	270PF K		C790	CK73HB1A473K	C CAPACITOR	0.047UF K	
C610	CK73HB1H271K	C CAPACITOR	270PF K		C791	CK73HBB1A104K	C CAPACITOR	0.1UF K	
C611	CK73HB1H271K	C CAPACITOR	270PF K		C792	CC73HCH1H101J	C CAPACITOR	100PF J	
C612	CK73HBB1A104K	C CAPACITOR	0.1UF K		C794	CK73HBB1A683K	C CAPACITOR	0.068UF K	
C613	CK73HB1H271K	C CAPACITOR	270PF K		C795	CK73GB1A105K	C CAPACITOR	1.0UF K	
C615	CK73HB1H271K	C CAPACITOR	270PF K		C798	CK73HB1H271K	C CAPACITOR	270PF K	
C616	CK73HB1H271K	C CAPACITOR	270PF K		C801	CK73GB1A105K	C CAPACITOR	1.0UF K	
C618	CK73GB1A105K	C CAPACITOR	1.0UF K		C802	CK73HB1H271K	C CAPACITOR	270PF K	
C620	CK73HB1H271K	C CAPACITOR	270PF K		C805	CK73HB1H271K	C CAPACITOR	270PF K	
C621	CK73GB1A105K	C CAPACITOR	1.0UF K		C806	CK73HB1H271K	C CAPACITOR	270PF K	
C623	CK73HB1H271K	C CAPACITOR	270PF K		C807	CK73HBB1A104K	C CAPACITOR	0.1UF K	
C624	CK73HB1H271K	C CAPACITOR	270PF K		C808	CK73EB0J476M	C CAPACITOR	47UF M	
C625	CK73HB1H271K	C CAPACITOR	270PF K		C809	CK73EB0J476M	C CAPACITOR	47UF M	
C626	CK73HB1H271K	C CAPACITOR	270PF K		C814	CK73HBB1A104K	C CAPACITOR	0.1UF K	
C628	CK73HB1H271K	C CAPACITOR	270PF K		C815	CK73HB1A105K	C CAPACITOR	1.0UF K	
C629	CK73HBB1E103K	C CAPACITOR	0.01UF K		C851	CK73HBB1A104K	C CAPACITOR	0.1UF K	
C630	CK73HB1H271K	C CAPACITOR	270PF K		C852	CK73HBB1H152K	C CAPACITOR	1500PU K	
C631	CK73HB1H271K	C CAPACITOR	270PF K		C853	CK73HBB1A104K	C CAPACITOR	0.1UF K	
C700	CK73HB1H271K	C CAPACITOR	270PF K		C882	CK73HB1A105K	C CAPACITOR	1.0UF K	
C704	CK73HBB1H102K	C CAPACITOR	1000PF K		C905	CK73HBB1A104K	C CAPACITOR	0.1UF K	
C706	CK73HBB1A104K	C CAPACITOR	0.1UF K		C906	CK73HB1H103K	C CAPACITOR	10000PF K	
C711	CK73HB1H271K	C CAPACITOR	270PF K		C907	CK73HB1H103K	C CAPACITOR	10000PF K	
C718	CK73HBB1A104K	C CAPACITOR	0.1UF K		C908	CK73HXR0J105K	C CAPACITOR	1.0UF K	
C719	CK73HBB1H102K	C CAPACITOR	1000PF K		C909	CK73HBB1A104K	C CAPACITOR	0.1UF K	
C720	CK73GB1A105K	C CAPACITOR	1.0UF K		C910	CK73HB0J225K	C CAPACITOR	2.2UF K	
C723	CK73GB1A105K	C CAPACITOR	1.0UF K		C911	CK73HBB1A104K	C CAPACITOR	0.1UF K	
C730	CK73GB1A105K	C CAPACITOR	1.0UF K		C912	CK73HB0J225K	C CAPACITOR	2.2UF K	
C732	CK73HB1H271K	C CAPACITOR	270PF K		C913	CK73HBB1A104K	C CAPACITOR	0.1UF K	
C734	CK73GB0J106K	C CAPACITOR	10UF K		C914	CK73HB1H103K	C CAPACITOR	0.010UF K	
C735	CK73GB0J106K	C CAPACITOR	10UF K		C915	CK73HB1H103K	C CAPACITOR	0.010UF K	
C736	CK73HB1H271K	C CAPACITOR	270PF K		C920	CK73HBB1A104K	C CAPACITOR	0.1UF K	
C737	CK73HB1A105K	C CAPACITOR	1.0UF K		C921	CK73HBB1A104K	C CAPACITOR	0.1UF K	
C739	CK73HBB1E103K	C CAPACITOR	0.01UF K		C922	CK73HBB1A104K	C CAPACITOR	0.1UF K	
C740	CK73HBB1A104K	C CAPACITOR	0.1UF K		C923	CK73HBB1A104K	C CAPACITOR	0.1UF K	
C741	CK73GB0J106K	C CAPACITOR	10UF K		C924	CK73GB1A105K	C CAPACITOR	1.0UF K	
C742	CK73HB1H271K	C CAPACITOR	270PF K		C925	CK73HB1A105K	C CAPACITOR	1.0UF K	
C743	CK73HB1H103K	C CAPACITOR	0.010UF K		C970	CK73HBB1H102K	C CAPACITOR	1000PF K	
C744	CK73GB0J106K	C CAPACITOR	10UF K		C971	CK73HBB1A104K	C CAPACITOR	0.1UF K	
C745	CK73HBB1A104K	C CAPACITOR	0.1UF K		C980	CS77MB20J101M	TA E CAPACITOR	100UF 35WV	
C746	CK73HB1H271K	C CAPACITOR	270PF K		C981	CK73HB0J475M	C CAPACITOR	4.7UF M	
C747	CK73HBB1H152K	C CAPACITOR	1500PF K		C982	CK73HXR0J105K	C CAPACITOR	1.0UF K	
C748	CK73HB1A105K	C CAPACITOR	1.0UF K		C983	CK73HBB1H102K	C CAPACITOR	1000PF K	
C749	CC73HCH1H101J	C CAPACITOR	100PF J		C984	CK73HBB1H102K	C CAPACITOR	1000PF K	
C750	CC73HCH1H101J	C CAPACITOR	100PF J		C985	CK73HBB1H102K	C CAPACITOR	1000PF K	
C751	CK73HB1H271K	C CAPACITOR	270PF K		C986	CK73HBB1H102K	C CAPACITOR	1000PF K	
C754	CC73HCH1H101J	C CAPACITOR	100PF J		C989	CK73HBB1A104K	C CAPACITOR	0.1UF K	
C756	CK73HB1A105K	C CAPACITOR	1.0UF K		C999	CK73HBB1A104K	C CAPACITOR	0.1UF K	
C758	CK73HB0J475M	C CAPACITOR	4.7UF M						
C759	CK73HB1A105K	C CAPACITOR	1.0UF K		R1	RK73HB1J103J	MG RESISTOR	10K J 1/16W	
C760	CK73HB1A474K	C CAPACITOR	0.47UF K		R2	RK73HB1J334J	MG RESISTOR	330K J 1/16W	
C761	CK73HB1A474K	C CAPACITOR	0.47UF K		R3	RK73HB1J000J	MG RESISTOR	0.0 J 1/16W	
C762	CK73HB1H271K	C CAPACITOR	270PF K		R4	RK73HB1J000J	MG RESISTOR	0.0 J 1/16W	
C763	CK73HB1A473K	C CAPACITOR	0.047UF K		R5	RK73HB1J000J	MG RESISTOR	0.0 J 1/16W	
C764	CK73HB1H271K	C CAPACITOR	270PF K		R7	RK73HB1J000J	MG RESISTOR	0.0 J 1/16W	
C765	CK73HB1H271K	C CAPACITOR	270PF K		R8	RK73HB1J331J	MG RESISTOR	330 J 1/16W	
C766	CK73HB1A474K	C CAPACITOR	0.47UF K		R9	RK73HB1J104J	MG RESISTOR	100K J 1/16W	
C767	CK73GB0J225K	C CAPACITOR	2.2UF K		R10	RK73HB1J101J	MG RESISTOR	100 J 1/16W	
C768	CK73GB0J225K	C CAPACITOR	2.2UF K		R11	RK73HB1J122J	MG RESISTOR	1.2K J 1/16W	
C769	CK73HB1A474K	C CAPACITOR	0.47UF K		R13	RK73HB1J100J	MG RESISTOR	10 J 1/16W	
C770	CK73HB1H271K	C CAPACITOR	270PF K		R16	RK73HB1J000J	MG RESISTOR	0.0 J 1/16W	

△ Symbol No.	Part No.	Part Name	Description	Local	△ Symbol No.	Part No.	Part Name	Description	Local
R17	RK73HB1J000J	MG RESISTOR	0.0 J 1/16W		R401	RK73HB1J101J	MG RESISTOR	100 J 1/16W	
R18	RK73HB1J152J	MG RESISTOR	1.5K J 1/16W		R403	RK73HB1J222J	MG RESISTOR	2.2K J 1/16W	
R19	RK73HB1J391J	MG RESISTOR	390 J 1/16W		R404	RK73HB1J564J	MG RESISTOR	560K J 1/16W	
R20	RK73HB1J000J	MG RESISTOR	0.0 J 1/16W		R405	RK73HB1J474J	MG RESISTOR	470K J 1/16W	
R21	RK73HB1J105J	MG RESISTOR	1.0M J 1/16W		R407	RK73HB1J332J	MG RESISTOR	3.3K J 1/16W	
R22	RK73HB1J103J	MG RESISTOR	10K J 1/16W		R408	RK73HB1J332J	MG RESISTOR	3.3K J 1/16W	
R24	RK73HB1J474J	MG RESISTOR	470K J 1/16W		R409	RK73HB1J563J	MG RESISTOR	56K J 1/16W	
R25	RK73HB1J105J	MG RESISTOR	1.0M J 1/16W		R412	RK73HB1J100J	MG RESISTOR	10 J 1/16W	
R26	RK73HB1J102J	MG RESISTOR	1.0K J 1/16W		R413	RK73HB1J184J	MG RESISTOR	180K J 1/16W	
R27	RK73HB1J103J	MG RESISTOR	10K J 1/16W		R414	RK73HB1J101J	MG RESISTOR	100 J 1/16W	
R28	RK73HB1J102J	MG RESISTOR	1.0K J 1/16W		R417	RK73HB1J684J	MG RESISTOR	680K J 1/16W	
R29	RK73HB1J220J	MG RESISTOR	22 J 1/16W		R418	RK73HB1J564J	MG RESISTOR	560K J 1/16W	
R30	RK73HB1J154J	MG RESISTOR	150K J 1/16W		R419	RK73HB1J121J	MG RESISTOR	120 J 1/16W	
R31	RK73HB1J183J	MG RESISTOR	18K J 1/16W		R420	RK73HB1J101J	MG RESISTOR	100 J 1/16W	
R32	RK73HB1J472J	MG RESISTOR	4.7K J 1/16W		R421	RK73HB1J470J	MG RESISTOR	47 J 1/16W	
R33	RK73HB1J224J	MG RESISTOR	220K J 1/16W		R422	RK73HB1J472J	MG RESISTOR	4.7K J 1/16W	
R34	RK73HB1J104J	MG RESISTOR	100K J 1/16W		R423	RK73HB1J222J	MG RESISTOR	2.2K J 1/16W	
R35	RK73HB1J680J	MG RESISTOR	68 J 1/16W		R424	RK73HB1J391J	MG RESISTOR	390 J 1/16W	
R36	RK73HB1J151J	MG RESISTOR	150 J 1/16W		R425	RK73HB1J563J	MG RESISTOR	56K J 1/16W	
R37	RK73HB1J100J	MG RESISTOR	10 J 1/16W		R426	RK73HB1J124J	MG RESISTOR	120K J 1/16W	
R38	RK73HB1J100J	MG RESISTOR	10 J 1/16W		R427	RK73HB1J104J	MG RESISTOR	100K J 1/16W	
R39	RK73HB1J104J	MG RESISTOR	100K J 1/16W		R428	RK73HB1J563J	MG RESISTOR	56K J 1/16W	
R40	RK73HB1J154J	MG RESISTOR	150K J 1/16W		R429	RK73HB1J000J	MG RESISTOR	0.0 J 1/16W	
R41	RK73HB1J101J	MG RESISTOR	100 J 1/16W		R430	RK73HB1J474J	MG RESISTOR	470K J 1/16W	
R42	RK73HB1J682J	MG RESISTOR	6.8K J 1/16W		R433	RK73HB1J562J	MG RESISTOR	5.6K J 1/16W	
R43	RK73HB1J562J	MG RESISTOR	5.6K J 1/16W		R434	RK73HB1J100J	MG RESISTOR	10 J 1/16W	
R44	RK73HB1J220J	MG RESISTOR	22 J 1/16W		R435	RK73HB1J181J	MG RESISTOR	180 J 1/16W	
R45	RK73HB1J331J	MG RESISTOR	330 J 1/16W		R436	RK73HB1J474J	MG RESISTOR	470K J 1/16W	
R46	RK73HB1J222J	MG RESISTOR	2.2K J 1/16W		R438	RK73HB1J104J	MG RESISTOR	100K J 1/16W	
R48	RK73HB1J472J	MG RESISTOR	4.7K J 1/16W		R439	RK73HB1J823J	MG RESISTOR	82K J 1/16W	
R51	RK73HB1J102J	MG RESISTOR	1.0K J 1/16W		R440	RK73HB1J000J	MG RESISTOR	0.0 J 1/16W	
R52	RK73HB1J100J	MG RESISTOR	10 J 1/16W		R441	RK73HB1J473D	MG RESISTOR	47K D 1/16W	
R53	RK73HB1J000J	MG RESISTOR	0.0 J 1/16W		R444	RK73HB1J474J	MG RESISTOR	470K J 1/16W	
R54	RK73HB1J103J	MG RESISTOR	10K J 1/16W		R449	RK73HB1J224J	MG RESISTOR	220K J 1/16W	
R55	RK73HB1J273J	MG RESISTOR	27K J 1/16W		R450	RK73HB1J000J	MG RESISTOR	0.0 J 1/16W	
R56	RK73HB1J100J	MG RESISTOR	10 J 1/16W		R451	RK73HB1J000J	MG RESISTOR	0.0 J 1/16W	
R58	RK73HB1J103J	MG RESISTOR	10K J 1/16W		R452	RK73HB1J000J	MG RESISTOR	0.0 J 1/16W	
R200	RK73HB1J472J	MG RESISTOR	4.7K J 1/16W		R453	RK73HB1J000J	MG RESISTOR	0.0 J 1/16W	
R202	RK73HB1J000J	MG RESISTOR	0.0 J 1/16W		R454	RK73HB1J000J	MG RESISTOR	0.0 J 1/16W	
R210	RK73HB1J102J	MG RESISTOR	1.0K J 1/16W		R455	RK73HB1J104J	MG RESISTOR	100K J 1/16W	
R211	RK73HB1J152J	MG RESISTOR	1.5K J 1/16W		R457	RK73HB1J000J	MG RESISTOR	0.0 J 1/16W	
R212	RK73HB1J182J	MG RESISTOR	1.8K J 1/16W		R458	RK73HB1J821J	MG RESISTOR	820 J 1/16W	
R213	RK73HB1J220J	MG RESISTOR	22 J 1/16W		R459	RK73HB1J332J	MG RESISTOR	3.3K J 1/16W	
R214	RK73HB1J561J	MG RESISTOR	560 J 1/16W		R460	RK73HB1J105J	MG RESISTOR	1.0M J 1/16W	
R215	RK73HB1J821J	MG RESISTOR	820 J 1/16W		R461	RK73HB1J184J	MG RESISTOR	180K J 1/16W	
R217	RK73HB1J5R6J	MG RESISTOR	5.6 J 1/16W		R464	RK73HB1J102J	MG RESISTOR	1.0K J 1/16W	
R219	RK73HB1J821J	MG RESISTOR	820 J 1/16W		R600	RK73GB2A221J	MG RESISTOR	220 J 1/10W	
R222	RK73HB1J000J	MG RESISTOR	0.0 J 1/16W		R601	RK73HB1J104J	MG RESISTOR	100K J 1/16W	
R223	RK73HB1J561J	MG RESISTOR	560 J 1/16W		R602	RK73HB1J104J	MG RESISTOR	100K J 1/16W	
R224	RK73HB1J151J	MG RESISTOR	150 J 1/16W		R603	RK73HB1J101J	MG RESISTOR	100 J 1/16W	
R225	RK73HB1J183J	MG RESISTOR	18K J 1/16W		R604	RK73GB2A331J	MG RESISTOR	330 J 1/10W	
R226	RK73HB1J472J	MG RESISTOR	4.7K J 1/16W		R605	RK73HB1J223J	MG RESISTOR	22K J 1/16W	
R227	RK73HB1J103J	MG RESISTOR	10K J 1/16W		R606	RK73HB1J104J	MG RESISTOR	100K J 1/16W	
R228	RK73HB1J333J	MG RESISTOR	33K J 1/16W		R607	RK73HB1J104J	MG RESISTOR	100K J 1/16W	
R229	RK73HB1J470J	MG RESISTOR	47 J 1/16W		R608	RK73GB2A271J	MG RESISTOR	270 J 1/10W	
R230	RK73EB2ER39J	MG RESISTOR	0.39 J 1/4W		R609	RK73HB1J102J	MG RESISTOR	1.0K J 1/16W	
R231	RK73EB2ER39J	MG RESISTOR	0.39 J 1/4W		R610	RK73HB1J104J	MG RESISTOR	100K J 1/16W	
R232	RK73HB1J183J	MG RESISTOR	18K J 1/16W		R611	RK73HB1J104J	MG RESISTOR	100K J 1/16W	
R233	RK73EB2ER39J	MG RESISTOR	0.39 J 1/4W		R612	RK73HB1J104J	MG RESISTOR	100K J 1/16W	
R235	RK73HB1J182J	MG RESISTOR	1.8K J 1/16W		R613	RK73HB1J104J	MG RESISTOR	100K J 1/16W	
R236	RK73HB1J150J	MG RESISTOR	15 J 1/16W		R614	RK73HH1J824D	MG RESISTOR	820K D 1/16W	
R237	RK73HH1J154D	MG RESISTOR	150K D 1/16W		R615	RK73HH1J394D	MG RESISTOR	390K D 1/16W	
R238	RK73HH1J154D	MG RESISTOR	150K D 1/16W		R616	RK73HB1J000J	MG RESISTOR	0.0 J 1/16W	
R239	RK73HB1J183J	MG RESISTOR	18K J 1/16W		R701	RK73HH1J103D	MG RESISTOR	10K D 1/16W	
R241	RK73HH1J474D	MG RESISTOR	470K D 1/16W		R702	RK73HH1J103D	MG RESISTOR	10K D 1/16W	
R242	RK73HH1J474D	MG RESISTOR	470K D 1/16W		R703	RK73HB1J153J	MG RESISTOR	15K J 1/16W	
R243	RK73HB1J103J	MG RESISTOR	10K J 1/16W		R705	RK73HB1J103J	MG RESISTOR	10K J 1/16W	
R244	RK73HB1J563J	MG RESISTOR	56K J 1/16W		R708	RK73HB1J102J	MG RESISTOR	1.0K J 1/16W	
R246	RK73HB1J474J	MG RESISTOR	470K J 1/16W		R709	RK73HB1J222J	MG RESISTOR	2.2K J 1/16W	
R247	RK73HB1J104J	MG RESISTOR	100K J 1/16W		R710	RK73HB1J102J	MG RESISTOR	1.0K J 1/16W	
R248	RK73HB1J105J	MG RESISTOR	1.0M J 1/16W		R711	RK73HH1J103D	MG RESISTOR	10K D 1/16W	
R249	RK73HB1J271J	MG RESISTOR	270 J 1/16W		R712	RK73HB1J473J	MG RESISTOR	47K J 1/16W	
R250	RK73FB2B000J	MG RESISTOR	0.0 J 1/8W		R715	RK73HB1J102J	MG RESISTOR	1.0K J 1/16W	
R251	RK73HB1J271J	MG RESISTOR	270 J 1/16W		R718	RK73HB1J820J	MG RESISTOR	82 J 1/16W	
R252	RK73GB2A000J	MG RESISTOR	0.0 J 1/10W		R720	RK73HB1J000J	MG RESISTOR	0.0 J 1/16W	
R253	RK73GB2A823J	MG RESISTOR	82K J 1/10W		R723	RK73HB1J000J	MG RESISTOR	0.0 J 1/16W	
R254	RK73HB1J000J	MG RESISTOR	0.0 J 1/16W		R725	RK73HB1J473J	MG RESISTOR	47K J 1/16W	
R400	RK73HB1J334J	MG RESISTOR	330K J 1/16W		R726	RK73HB1J102J	MG RESISTOR	1.0K J 1/16W	

△ Symbol No.	Part No.	Part Name	Description	Local	△ Symbol No.	Part No.	Part Name	Description	Local
R736	RK73HB1J101J	MG RESISTOR	100 J 1/16W		R907	RK73HB1J000J	MG RESISTOR	0.0 J 1/16W	
R737	RK73HB1J101J	MG RESISTOR	100 J 1/16W		R960	RK73HB1J000J	MG RESISTOR	0.0 J 1/16W	
R740	RK73HB1J472J	MG RESISTOR	4.7K J 1/16W		R970	RK73HB1J000J	MG RESISTOR	0.0 J 1/16W	
R744	RK73HB1J150J	MG RESISTOR	15 J 1/16W		R977	RK73HB1J103J	MG RESISTOR	10K J 1/16W	
R746	RK73HB1J222J	MG RESISTOR	2.2K J 1/16W		R978	RK73HB1J103J	MG RESISTOR	10K J 1/16W	
R748	RK73HB1J000J	MG RESISTOR	0.0 J 1/16W		R979	RK73HB1J103J	MG RESISTOR	10K J 1/16W	
R751	RK73HB1J105J	MG RESISTOR	1.0M J 1/16W		R983	RK73GB2A000J	MG RESISTOR	0.0 J 1/10W	
R752	RK73HB1J000J	MG RESISTOR	0.0 J 1/16W		R984	RK73GB2A000J	MG RESISTOR	0.0 J 1/10W	
R755	RK73HB1J564J	MG RESISTOR	560K J 1/16W		R987	RK73GB2A000J	MG RESISTOR	0.0 J 1/10W	
R756	RK73HB1J100J	MG RESISTOR	10 J 1/16W		R988	RK73GB2A000J	MG RESISTOR	0.0 J 1/10W	
R757	RK73HB1J473J	MG RESISTOR	47K J 1/16W		R991	RK73HB1J101J	MG RESISTOR	100 J 1/16W	
R759	RK73HB1J153J	MG RESISTOR	15K J 1/16W		R992	RK73HB1J101J	MG RESISTOR	100 J 1/16W	
R760	RK73HB1J473J	MG RESISTOR	47K J 1/16W		R993	RK73HB1J101J	MG RESISTOR	100 J 1/16W	
R762	RK73HB1J104J	MG RESISTOR	100K J 1/16W		R994	RK73HB1J101J	MG RESISTOR	100 J 1/16W	
R763	RK73HB1J104J	MG RESISTOR	100K J 1/16W		R995	RK73HB1J101J	MG RESISTOR	100 J 1/16W	
R764	RK73HB1J000J	MG RESISTOR	0.0 J 1/16W		R996	RK73HB1J101J	MG RESISTOR	100 J 1/16W	
R765	RK73HB1J273J	MG RESISTOR	27K J 1/16W		R997	RK73HB1J101J	MG RESISTOR	100 J 1/16W	
R766	RK73HB1J334J	MG RESISTOR	330K J 1/16W						
R767	RK73HB1J104J	MG RESISTOR	100K J 1/16W		L1	LR77Z0AE4R7J	SMALL FIXED INDUCTOR(4.7UH)		
R768	RK73HB1J103J	MG RESISTOR	10K J 1/16W		L2	L92-0442-05	SMALL FIXED INDUCTOR(21.9NH)		
R769	RK73HB1J104J	MG RESISTOR	100K J 1/16W		L3	LB73H0AV-003	SMALL FIXED INDUCTOR(220NH)		
R770	RK73HB1J124J	MG RESISTOR	120K J 1/16W		L4	LK73H0AM6N8J	SMALL FIXED INDUCTOR(16.9NH)		
R772	RK73HB1J154J	MG RESISTOR	150K J 1/16W		L7	L41-1885-53	SMALL FIXED INDUCTOR(12.2NH)		
R773	RK73HB1J103J	MG RESISTOR	10K J 1/16W		L8	L41-1885-53	SMALL FIXED INDUCTOR(12.9NH)		
R774	RK73HB1J101J	MG RESISTOR	100 J 1/16W		L9	LK73H0AM22NJ	SMALL FIXED INDUCTOR(16.9NH)		
R775	RK73HB1J000J	MG RESISTOR	0.0 J 1/16W		L12	L41-1885-53	SMALL FIXED INDUCTOR(0.18UH)		
R777	RK73HB1J104J	MG RESISTOR	100K J 1/16W		L13	L41-2285-53	SMALL FIXED INDUCTOR(0.22UH)		
R780	RK73HB1J474J	MG RESISTOR	470K J 1/16W		L14	L41-2285-53	SMALL FIXED INDUCTOR(0.22UH)		
R781	RK73HB1J682J	MG RESISTOR	6.8K J 1/16W		L15	L41-1578-14	SMALL FIXED INDUCTOR(15NH)		
R782	RK73HB1J473J	MG RESISTOR	47K J 1/16W		L16	L41-1878-14	SMALL FIXED INDUCTOR(18NH)		
R783	RK73HB1J272J	MG RESISTOR	2.7K J 1/16W		L17	LB73H0AV-003	CHIP FERRITE BEADS		
R784	RK73HB1J123J	MG RESISTOR	12K J 1/16W		L18	L41-2785-53	SMALL FIXED INDUCTOR(0.27UH)		
R785	RK73HB1J273J	MG RESISTOR	27K J 1/16W		L19	L41-2785-53	SMALL FIXED INDUCTOR(0.27UH)		
R786	RK73HB1J104J	MG RESISTOR	100K J 1/16W		L21	L41-2285-53	SMALL FIXED INDUCTOR(0.22UH)		
R787	RK73HB1J105J	MG RESISTOR	1.0M J 1/16W		L23	L41-1885-53	SMALL FIXED INDUCTOR(0.18UH)		
R788	RK73HB1J473J	MG RESISTOR	47K J 1/16W		L24	LK73H0AM27NJ	SMALL FIXED INDUCTOR(27NH)		
R789	RK73HB1J103J	MG RESISTOR	10K J 1/16W		L25	LK73H0AM27NJ	SMALL FIXED INDUCTOR(27NH)		
R790	RK73HB1J103J	MG RESISTOR	10K J 1/16W		L26	LK73H0AM8N2J	SMALL FIXED INDUCTOR(8.2NH)		
R792	RK73HB1J471J	MG RESISTOR	470 J 1/16W		L27	L41-1885-53	SMALL FIXED INDUCTOR(0.18UH)		
R793	RK73HB1J182J	MG RESISTOR	1.8K J 1/16W		L204	LK73H0AM8N2J	SMALL FIXED INDUCTOR(8.2NH)		
R794	RK73HB1J152J	MG RESISTOR	1.5K J 1/16W		L205	LK73H0AM33NJ	SMALL FIXED INDUCTOR(33NH)		
R795	RK73HB1J473J	MG RESISTOR	47K J 1/16W		L206	LB73H0AV-002	CHIP FERRITE BEADS		
R796	RK73HB1J561J	MG RESISTOR	560 J 1/16W		L207	LK73H0AM12NJ	SMALL FIXED INDUCTOR(12NH)		
R797	RK73HH1J334D	MG RESISTOR	330K D 1/16W		L208	L34-4574-05	AIR-CORE COIL		
R798	RK73HH1J154D	MG RESISTOR	150K D 1/16W		L209	LB73F0AV-002	CHIP FERRITE BEADS		
R800	RK73HB1J183J	MG RESISTOR	18K J 1/16W		L211	L40-1263-92	SMALL FIXED INDUCTOR(1.2NH)		
R801	RK73HB1J101J	MG RESISTOR	100 J 1/16W		L212	LB73F0AV-002	CHIP FERRITE BEADS		
R802	RK73HB1J474J	MG RESISTOR	470K J 1/16W		L213	LR79Z0DD21N9J	SMALL FIXED INDUCTOR(21.9NH)		
R803	RK73HB1J331J	MG RESISTOR	330 J 1/16W		L216	LR79Z0CAR22J	SMALL FIXED INDUCTOR(220NH)		
R804	RK73HB1J124J	MG RESISTOR	120K J 1/16W		L217	LR79Z0DD16N9J	SMALL FIXED INDUCTOR(16.9NH)		
R805	RK73HB1J000J	MG RESISTOR	0.0 J 1/16W		L218	LR79Z0DD12N2J	SMALL FIXED INDUCTOR(12.2NH)		
R806	RK73HB1J103J	MG RESISTOR	10K J 1/16W		L219	LR79Z0DD21N9J	SMALL FIXED INDUCTOR(21.9NH)		
R807	RK73HB1J332J	MG RESISTOR	3.3K J 1/16W		L220	LR79Z0DD16N9J	SMALL FIXED INDUCTOR(16.9NH)		
R809	RK73HB1J103J	MG RESISTOR	10K J 1/16W		L400	L41-1885-53	SMALL FIXED INDUCTOR(0.18UH)		
R810	RK73HB1J334J	MG RESISTOR	330K J 1/16W		L401	L40-1085-71	SMALL FIXED INDUCTOR(100NH)		
R811	RK73HB1J274J	MG RESISTOR	270K J 1/16W		L402	L40-1591-86	SMALL FIXED INDUCTOR(1.5UH)		
R812	RK73HB1J473J	MG RESISTOR	47K J 1/16W		L403	LB73G0BD-005	CHIP FERRITE BEADS		
R813	RK73HB1J823J	MG RESISTOR	82K J 1/16W		L404	L41-6885-39	SMALL FIXED INDUCTOR(0.68UH)		
R814	RK73HB1J273J	MG RESISTOR	27K J 1/16W		L405	LK73H0AM15NJ	SMALL FIXED INDUCTOR(15NH)		
R815	RK73HB1J101J	MG RESISTOR	100 J 1/16W		L406	L41-2285-53	SMALL FIXED INDUCTOR(0.22UH)		
R816	RK73HB1J102J	MG RESISTOR	1.0K J 1/16W		L407	LK73H0AM15NJ	SMALL FIXED INDUCTOR(15NH)		
R817	RK73HB1J000J	MG RESISTOR	0.0 J 1/16W		L408	LK73G0AF18NJ	SMALL FIXED INDUCTOR(18NH)		
R824	RK73HB1J102J	MG RESISTOR	1.0K J 1/16W		L410	L41-8268-14	SMALL FIXED INDUCTOR(8.2NH)		
R825	RK73HB1J104J	MG RESISTOR	100K J 1/16W		L411	L41-8268-14	SMALL FIXED INDUCTOR(8.2NH)		
R826	RK73HB1J104J	MG RESISTOR	100K J 1/16W		L412	LB73G0BD-005	CHIP FERRITE BEADS		
R828	RK73HB1J333J	MG RESISTOR	33K J 1/16W		L413	L41-8268-14	SMALL FIXED INDUCTOR(8.2NH)		
R850	RK73GB2A000J	MG RESISTOR	0.0 J 1/10W		L414	L41-2785-14	SMALL FIXED INDUCTOR(270NH)		
R852	RK73HB1J123J	MG RESISTOR	12K J 1/16W		L415	L41-8268-14	SMALL FIXED INDUCTOR(8.2NH)		
R853	RK73HB1J123J	MG RESISTOR	12K J 1/16W		L416	L41-8268-14	SMALL FIXED INDUCTOR(8.2NH)		
R857	RK73HB1J100J	MG RESISTOR	10 J 1/16W		L417	L41-5678-14	SMALL FIXED INDUCTOR(56NH)		
R860	RK73HB1J000J	MG RESISTOR	0.0 J 1/16W		L420	LK73H0AM18NJ	SMALL FIXED INDUCTOR(18NH)		
R877	RK73HB1J102J	MG RESISTOR	1.0K J 1/16W		L600	L92-0472-05	CHIP FERRITE		
R881	RK73HB1J473J	MG RESISTOR	47K J 1/16W		L601	LB73G0BD-005	CHIP FERRITE BEADS		
R901	RK73HB1J473J	MG RESISTOR	47K J 1/16W		L700	L92-0161-05	BEADS CORE		
R902	RK73HB1J473J	MG RESISTOR	47K J 1/16W		L701	L92-0161-05	BEADS CORE		
R903	RK73HB1J220J	MG RESISTOR	22 J 1/16W		L702	L92-0161-05	BEADS CORE		
R904	RK73HB1J820J	MG RESISTOR	82 J 1/16W		L901	LB73H0AV-003	CHIP FERRITE BEADS		
R905	RK73HB1J474J	MG RESISTOR	470K J 1/16W		L902	LB73H0AV-003	CHIP FERRITE BEADS		

△ Symbol No.	Part No.	Part Name	Description	Local
L903	LB73H0AV-003	CHIP FERRITE BEADS		
CN600	E40-6922-05	FLAT CABLE CONNECTOR		
CN912	E23-1167-05	TERMINAL		
CN913	E23-1167-05	TERMINAL		
CN914	E23-1167-05	TERMINAL		
CN915	E23-1167-05	TERMINAL		
CN916	E23-1167-05	TERMINAL		
CN917	E23-1167-05	TERMINAL		
CN918	E23-1167-05	TERMINAL		
CN919	E23-1167-05	TERMINAL		
CN920	E23-1167-05	TERMINAL		
CN921	E23-1167-05	TERMINAL		
CP1	RK74HA1J101J	CHIP-COM	100 J 1/16W	
CP20	RK75HA1J473J	CHIP-COM	47K J 1/16W	
CP21	RK75HA1J473J	CHIP-COM	47K J 1/16W	
CP22	RK74HA1J102J	CHIP-COM	1.0K J 1/16W	
CP23	RK75HA1J473J	CHIP-COM	47K J 1/16W	
CP24	RK74HA1J102J	CHIP-COM	1.0K J 1/16W	
CP25	RK75HA1J473J	CHIP-COM	47K J 1/16W	
CP26	RK75HA1J103J	CHIP-COM	10K J 1/16W	
CP27	RK75HA1J474J	CHIP-COM	470K J 1/16W	
CP28	RK75HA1J103J	CHIP-COM	10K J 1/16W	
CP401	RK75HA1J474J	CHIP-COM	470K J 1/16W	
CP402	RK75HA1J474J	CHIP-COM	470K J 1/16W	
F600	F53-0324-15	FUSE(2.5A)		
F601	F53-0319-15	FUSE(1A)		
J601	E11-0703-05	PHONE JACK (SP/MIC)		
S601	S70-0414-05	TACT SWITCH		
S602	S70-0414-05	TACT SWITCH		
S603	S70-0414-05	TACT SWITCH		
TH200	ERTJ0EV104J	THERMISTOR		
TH400	NCP18WM224J03	THERMISTOR		
X1	L77-3128-05	TCXO(16.8MHZ)		
X2	L77-3129-05	TCXO(19.2MHZ)		
XF400	L71-0684-05	MCF(49.95MHZ)		

Packing materials and accessories parts list

Block No.M2MM

Illustration is
NX-340(K)
and NX-340(U)(K).

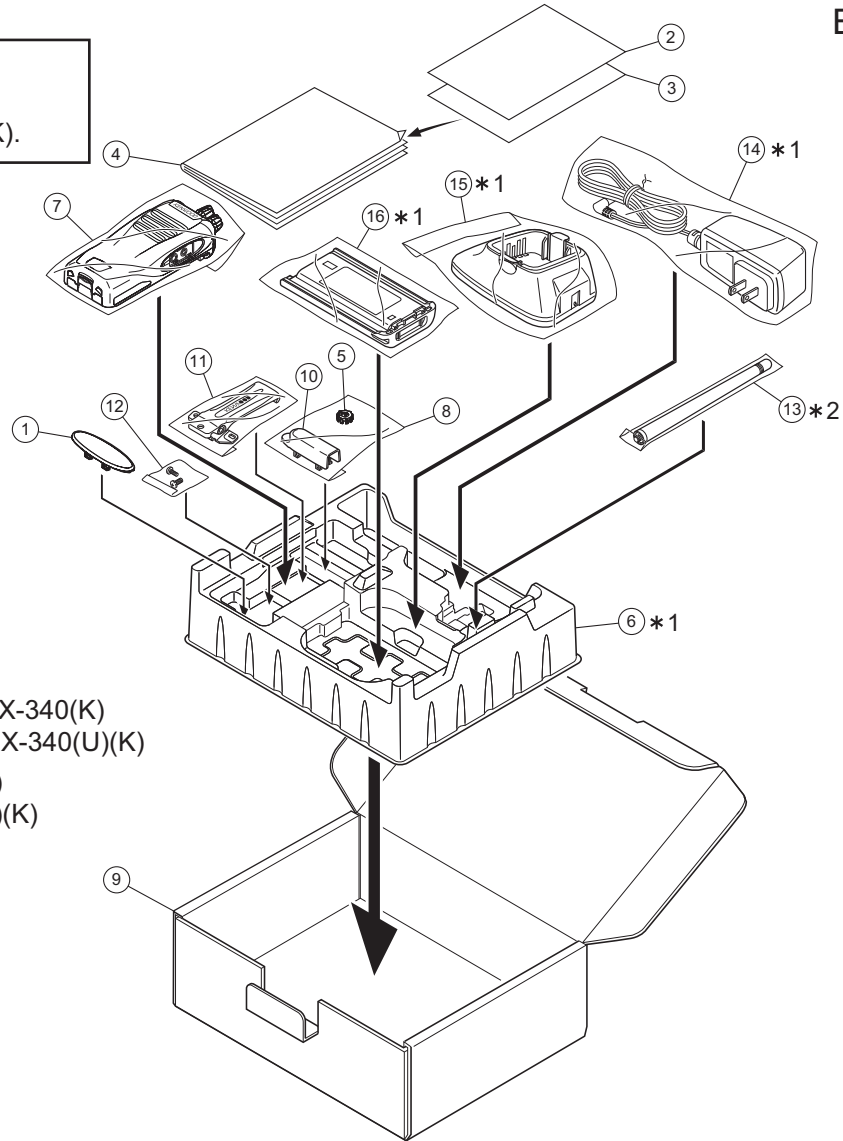

* 1 (6), (14), (15), (16) : NX-340(K)
/NX-340(U)(K)

* 2 (13) : NX-340(K)
/NX-340(U)(K)

Packing and accessories

Block No. [M][2][M][M]

△ Symbol No.	Part No.	Part Name	Description	Local
1	B09-0758-03	CAP(SP/MIC)		
2	-----	PAMPHLET(SAR)		
3	-----	PAMPHLET(VOCODER)		
4	B62-2580-00	INSTRUCTION MANUAL		340_K,340U_K
4	B62-2581-00	INSTRUCTION MANUAL		340_M
5	D32-0456-03	STOPPER(SELECTOR)		
6	H12-4319-05	PACKING FIXTURE		340_K,340U_K
7	-----	PROTECTION BAG (100/200/0.07)		
8	-----	PROTECTION BAG		
9	H52-2589-01	ITEM CARTON CASE		340_K,340U_K
9	H52-2588-01	ITEM CARTON CASE		340_M
10	J19-5577-03	HOLDER(SP/MIC)		
11	J29-0734-15	BELT CLIP		
12	N99-2089-05	SCREW SET		
13	T90-1039-25	WHIP ANTENNA		340_K,340U_K
14	W08-1247-25	AC ADAPTER		340_K,340U_K
15	W08-1249-45	CHARGER		340_K,340U_K
16	-----	BATTERY ASSY(KNB-45L)		340_K,340U_K

MEMO



KENWOOD

JVC KENWOOD Corporation
Communications Systems BU

(No.RA024<Rev.001>)

Printed in Japan
VSE