

KENWOOD

SERVICE MANUAL

VHF DIGITAL TRANSCEIVER

NX-5600HB



TABLE OF CONTENTS

1	PRECAUTION.....	1-4
2	SPECIFIC SERVICE INSTRUCTIONS.....	1-4
3	DISASSEMBLY.....	1-34
4	ADJUSTMENT.....	1-37
5	TROUBLESHOOTING.....	1-57

This product complies with the RoHS directive for the European market.



This product uses Lead Free solder.

Document Copyrights

Copyright 2019 by JVC KENWOOD Corporation. All rights reserved.

No part of this manual may be reproduced, translated, distributed, or transmitted in any form or by any means, electronic, mechanical, photocopying, recording, or otherwise, for any purpose without the prior written permission of JVC KENWOOD Corporation.

Disclaimer

While every precaution has been taken in the preparation of this manual, JVC KENWOOD Corporation assumes no responsibility for errors or omissions. Neither is any liability assumed for damages resulting from the use of the information contained herein. JVC KENWOOD Corporation reserves the right to make changes to any products herein at any time for improvement purposes.

Firmware Copyrights

The title to and ownership of copyrights for firmware embedded in KENWOOD product memories are reserved for JVC KENWOOD Corporation. Any modifying, reverse engineering, copy, reproducing or disclosing on an Internet website of the firmware is strictly prohibited without prior written consent of JVC KENWOOD Corporation. Furthermore, any reselling, assigning or transferring of the firmware is also strictly prohibited without embedding the firmware in KENWOOD product memories.

Transceivers containing AMBE+2™ Vocoder:

The AMBE+2™ voice coding technology is embedded in the firmware under the license of Digital Voice Systems, Inc.

Bluetooth Copyrights

The Bluetooth® word mark and logos are registered trademarks owned by Bluetooth SIG, Inc. and any use of such marks by JVC KENWOOD Corporation is under license. Other trademarks and trade names are those of their respective owners.

SPECIFICATION

GENERAL		
Frequency Range		39~50MHz
Max. Channels per Radio		1024 (Up to 4000 channels with option)
Number of Zones		128
Max. Channels per Zone		512
Channel Spacing	Analog	20kHz
	Digital	12.5kHz
Operating Voltage		13.4V DC \pm 15%
Operating Temperature Range		-22°F to +140°F (-30°C to +60°C)
Frequency Stability (-30°C to + 60°C; +25°C Ref.)		\pm 0.5ppm
Dimensions (W x H x D) (Projections not included)		7.01 x 2.56 x 13.84 in (178 x 65 x 351.5 mm)
Weight		12.1 lbs (5.5 kg)
RECEIVER		
Sensitivity	NXDN 12.5kHz Digital (3% BER)	0.25 μ V
	Analog 20kHz (12dB SINAD)	0.25 μ V
Selectivity	Analog	85dB
	Digital	57dB
Intermodulation		80dB
Spurious Rejection		90dB
Audio Distortion		Less than 3%
Audio Output Power		12W / 4ohm (Remote Control Head: 3W / 4ohm)
TRANSMITTER		
RF Power Output (Preset: High/Mid/Low)		110 to 25 W (110 / 70 / 25 W)
Spurious Emission		-80dB
FM Hum & Noise		55dB
Audio Distortion		Less than 2%
Emission Designator	Analog	16K0F3E
	Digital	8K30F1E, 8K30F1D, 8K30F7W

Analog measurements made per TIA 603, and NXDN digital measurements made per NXDN Conformance Test. Specifications shown are typical.

JVC KENWOOD Corporation reserves the right to change specifications without prior notice or obligation.

SECTION 1 PRECAUTION

This service manual does not describe PRECAUTION.

SECTION 2 SPECIFIC SERVICE INSTRUCTIONS

2.1 SYSTEM SET-UP

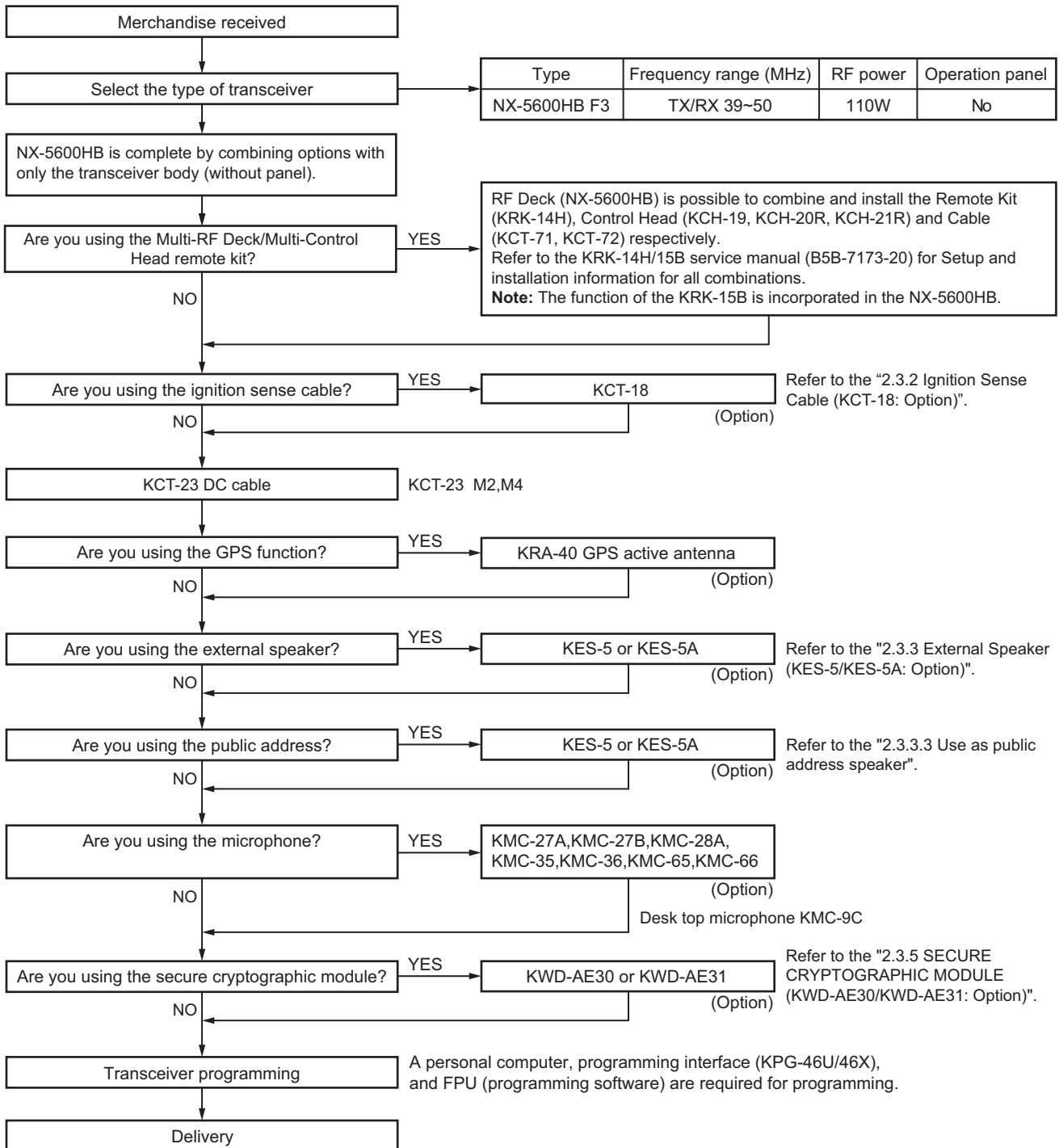

2.2 REALIGNMENT

2.2.1 Modes

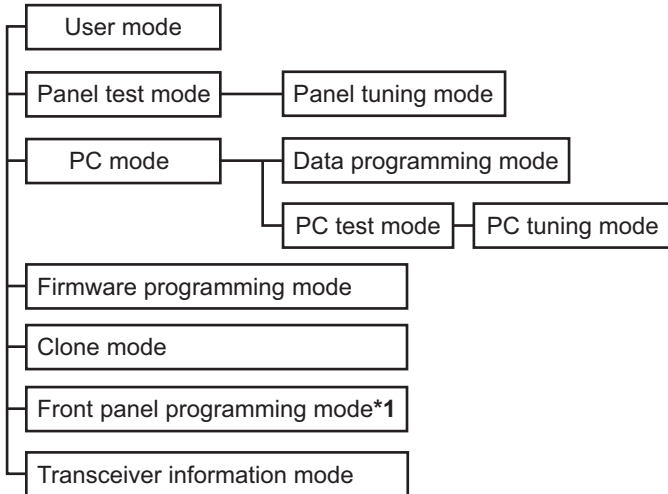

*1: In order to use the Front panel programming mode, it is necessary to purchase the "Front panel program" feature option.

Mode	Function
User mode	For normal use.
Panel test mode	Used by the dealer to check the fundamental characteristics.
Panel tuning mode	Used by the dealer to tune the transceiver.
PC mode	Used for communication between the transceiver and PC.
Data programming mode	Used to read and write frequency data and other features to and from the transceiver.
PC test mode	Used to check the transceiver using the PC. This feature is included in the FPU.
Firmware programming mode	Used when changing the main program of the flash memory.
Clone mode	Used to transfer programming data from one transceiver to another.
Front panel programming mode	Frequency, signaling and features write to the transceiver.
Transceiver information mode	Used to confirm the transceiver firmware version, SCM firmware version and SCM Hardware version.

2.2.2 How to Enter Each Mode

Mode	Operation
User mode	Power ON
Panel test mode*2	<ul style="list-style-type: none"> • [↩] + Power ON • [⏏] + Power ON Select the "Panel Test" using the [▲] / [▼] key. Press the [⏏] key.
PC mode	Received commands from PC
Panel tuning mode	[Panel test mode] + [⏏]

Mode	Operation
Firmware programming mode*2	<ul style="list-style-type: none"> • [AUX (Orange)] + Power ON • [⏏] + Power ON Select the "Firmware Prog" using the [▲] / [▼] key. Press the [⏏] key. <ul style="list-style-type: none"> • If Write is performed by KFL, Firmware programming mode will start automatically.
Clone mode*2	<ul style="list-style-type: none"> • [○] + Power ON • [⏏] + Power ON Select the "Clone" using the [▲] / [▼] key. Press the [⏏] key.
Front panel programming mode*2	<ul style="list-style-type: none"> • Press the PF key to which Front panel programming mode is set during the user mode. • Press the [⏏] key and enter the Menu mode. Select the any icon assigned the Front panel programming mode using the [▲] / [▼] key. Press [⏏] key. Select the "Panel Program" using the [▲] / [▼] key. Press the [⏏] key.
Transceiver information mode*2	<ul style="list-style-type: none"> • [+] + Power ON • [⏏] + Power ON Select the "Transceiver Info" using the [▲] / [▼] key. Press the [⏏] key.

*2 There is the two or three as how to enter.

2.2.3 Panel Test Mode

Setting method refer to ADJUSTMENT.

2.2.4 Panel Tuning Mode

Setting method refer to ADJUSTMENT.

2.2.5 PC Mode

2.2.5.1 Preface

The transceiver is programmed by using a personal computer (PC), a USB programming cable (KPG-46U/46X) and a Programming software (FPU).

The programming software can be used with a PC. Figure 1 shows the setup of a PC for programming.

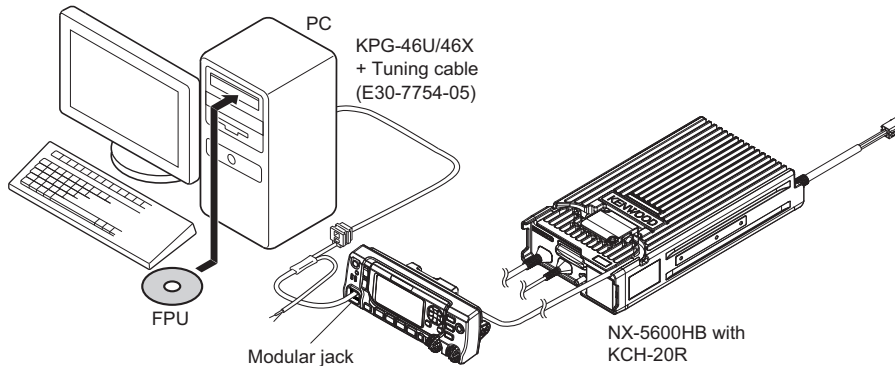

Fig.1

2.2.5.2 Connection procedure

- (1) Connects the transceiver to the PC using the KPG-46U/46X.

Note:

You must install the KPG-46U/46X driver in the PC to use the KPG-46U/46X.

- (2) When the POWER is switched on, you can immediately enter user mode. When PC sends command the transceiver enter PC mode, and "PROGRAM" is displayed on the LCD.
When data transmitting from the transceiver, the red LED lights.
When data receiving to the transceiver, the green LED lights.

Note:

The data stored in the PC must match the "Model Name" when it is written into the flash memory.

2.2.5.3 KPG-46U/46X description (USB programming interface cable: Option)

The KPG-46U/46X is a cable which connects to a USB port on a PC.

When using the KPG-46U/46X, install the supplied CD (with driver software) in the PC. The KPG-46U driver runs under Windows 7, 8.1 or 10.

The KPG-46X driver runs under Windows 7, 8.1 or 10.

The latest version of the USB driver is available for download from the following URL:

<https://www.kenwood.com/usb-com/>

(This URL may change without notice.)

2.2.5.4 Programming software KPG-D1/D1N (Ver. 3.10 or later) description

The FPU is the programming software for the transceiver supplied on a CD. This software runs under Windows 7, 8.1 or 10.

The data can be input to or read from the transceiver and edited on the screen.

2.2.6 Firmware Programming Mode

2.2.6.1 Preface

Flash memory is mounted on the transceiver. This allows the transceiver to be upgrade when new features are released in the future. (For details on how to obtain the firmware, contact Customer Service.)

2.2.6.2 Connection procedure

Connect the transceiver to the PC using the programming interface (KPG-46U/46X). (Connection is same as in the PC mode.)



2.2.6.3 Programming

- (1) Start up the firmware programming software (KENWOOD Firmware Loader). The KFL.exe exists in the KPG-D1/D1N installed folder.
- (2) Set the baud rate to "auto" or 1152000, 576000, 115200, and 57600.
- (3) Set the firmware to be upgrade by file name item.
- (4) Check the connection between the transceiver and the PC.
- (5) Press "Write" key in the window. When the transceiver starts to receive data, the "LOADING" is displayed on LCD, and the green LED lights.
- (6) If writing ends successfully, the checksum is calculated and a result is displayed on the LCD. Also the Red LED lights.
- (7) If you want to continue programming other transceivers, repeat step (5) to (6).

Note:

If write is performed by KFL, Firmware programming mode will start automatically even if Firmware programming is set to disable in the programming software.

2.2.6.4 Function

If you press the [] key while "FIRMWARE PROG" is displayed, the checksum is calculated, and a result is displayed. If you press the [] key again while checksum is displayed, "FIRMWARE PROG" is redisplayed.



2.2.7 Clone Mode

Programming data can be transferred from one transceiver to another by connecting them via their modular microphone jacks. The operation is as follows.

■The following data cannot be cloned.

- Tuning data
- Embedded message with password
- ESN (Electronic Serial Number) data

■Key guide on the Clone/ Front Panel Programming Password input screen.

- Confirm ([] key): The password confirmation
- Delete ([] key): Delete the latest digit from the current password number (Press and hold to delete all password numbers)
- Select ([] key): Determine the latest digit of the password number.

(1) In the source transceiver, enter the clone mode by using section "2.2.2 How to Enter Each Mode". When the Clone/ Front Panel Programming Password is set to the transceiver, "Input Password" is displayed on the LCD. If the password is not set, the transceiver displays "CLONE MODE".

(2) When you enter the correct password, "CLONE MODE" is displayed, the transceiver can be used as the cloning source. The following describes how to enter the password.

(3) There are two methods to enter the password as follows.

- How to enter the password using the MIC keypad;



If one of the keys 0 to 9 is pressed while the "Input Password" is displayed, the password number is displayed on the LCD.



Each press of the key shifts the display in order to the left.

When you enter the password and press [] or [*] key, "CLONE MODE" displayed if the entered password is correct. If password is incorrect, "Input Password" is redisplayed.

- How to enter password using the [▲] and [▼] keys;

If the [▲] / [▼] key is pressed while "Input Password" is displayed, the Clone/ Front Panel Programming Password input screen is displayed.

If the [▲] or [▼] key is pressed while the clone/ Front Panel Programming Password input screen is displayed, the number (0 to 9) blinks on the LCD. When you press the [] key, currently selected number is determined. If you press the [] key after entering password in this procedure, "CLONE MODE" is displayed if entered password is correct. If the password is incorrect, "Input Password" is redisplayed.

- (4) Power ON the target transceiver.
- (5) Connecting the cloning cable (part No.E30-3382-05) to the modular microphone jacks on the source and target.
- (6) Press [] key on the source while the source displays "CLONE MODE". The data of the source is sent to the target. While the target is receiving the data, "PROGRAM" is displayed. When cloning of the data is completed, the source displays "END", and the target automatically operates in the User mode. The target can then be operated by the same program as the source.
- (7) The other target can be continuously cloned. When the [] key on the source is pressed while the source displays "END", the source displays "CLONE MODE". Carry out the operation in step (4) to (6).

Note:

- Cannot be cloned if the password (overwrite password) is programmed to the target.
- "Model name" must be same to clone the transceiver.

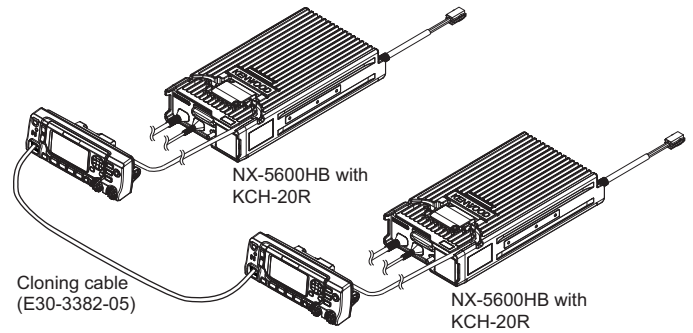

Fig.2

2.2.8 Front Panel Programming Mode



If the Front Panel Programming Mode is used, the frequency or other data of the conventional channel is rewritable only by the transceiver.

Moreover, the conventional channel can be added.

■The following setup items can be changed or added by using the Front panel programming mode.

- RX/TX Frequency
- Channel Type
- Decode QT/DQT/RAN, Encode QT/DQT/RAN
- Transmit Power
- Channel Name

■Key guide on the Clone/ Front Panel Programming Password input screen.

- Confirm ([] key): The password confirmation
- Delete ([] key): Delete the latest digit from the current password number (Press and hold to delete all password numbers)
- Select ([] key): Determine the latest digit of the password number.

2.2.8.1 How to enter the Front panel programming mode

Press the PF key which is assigned as "Panel Program" by the FPU, or select the "Panel Program" which is assigned into the Menu key by the FPU.

If the Clone/Front panel programming Password is not set to the transceiver, "Panel Program" is displayed on the LCD. If the Clone/Front panel programming Password is set to the transceiver, "Panel Program" is displayed on the LCD when you enter the correct password while "Input Password" is displayed.

2.2.8.2 Data Writing

Before moving to next Zone/Channel, "Keep This Change?" appears on the LCD, if you select "OK", the new data is written to memory. If you select "Cancel", the new data not be written; the new data will be erased.

- The setup items for Front panel programming mode are as follows.

■The setup items for Front panel programming mode

No.	Setup item	Display	Remarks
1	RX Frequency	RX Frequency	Receive Frequency
2	TX Frequency	TX Frequency	Transmit Frequency
3	Channel Type	Channel Type	NXDN: Analog/NXDN/Mixed
4	Transmit Mode	Transmit Mode	NXDN: Analog/NXDN
5	RX Signaling	RX QT/DQT	Receive QT/DQT
6	TX Signaling	TX QT/DQT	Transmit QT/DQT
7	RX RAN	RX RAN	None, 1~63
8	TX RAN	TX RAN	None, 1~63
9	Transmit Power	Transmit Power	Low/Medium/High
10	Channel Name	Channel Name	

■ Key operation (1/3)

Key Item	Zone Select	Channel Select	RX Frequency	TX Frequency	Channel Type	Transmit Mode *3	RX Signaling
[F1]	Decision	Decision	Decision	Decision	Decision	Decision	Decision
[←]	Unused	Back to the previous item	Back to the previous item	Back to the previous item	Back to the previous item	Back to the previous item	Back to the previous item
[O]	Unused	Unused	Unused	TX Frequency OFF	Unused	Unused	Unused
[Home]	Exit panel program mode	Exit panel program mode	Exit panel program mode	Exit panel program mode	Exit panel program mode	Exit panel program mode	Exit panel program mode
[▲]	Zone change	Channel change	Frequency up	Frequency up	Channel type change	Transmit Mode change	Signaling number change
[▼]	Zone change	Channel change	Frequency down	Frequency down	Channel type change	Transmit Mode change	Signaling number change
[▶]	Unused	Unused	Frequency step change	Frequency step change	Unused	Unused	Signaling type change
[◀]	Unused	Unused	Frequency step change	Frequency step change	Unused	Unused	Signaling type change
MIC Keypad [0] ~ [9]	Zone number select	Channel number select	Entry a Frequency directly		Channel type select ([1], [2] or [3]) *4	Transmit Mode select ([1] or [2]) *5	Entry a Frequency directly
MIC Keypad [*]	Decision	Decision	Decision	Decision	Decision	Decision	Decision
MIC Keypad [#]	Unused	Back to the previous item	Back to the previous item	Back to the previous item	Back to the previous item	Back to the previous item	Back to the previous item

*3: Mixed Mode only

*4: [1] = "Analog", [2] = "NXDN", [3] = "Mixed"

*5: [1] = "Analog", [2] = "NXDN"

■ Key operation (2/3)

Key Item	TX Signaling	RX RAN	TX RAN	Transmit Power
[]	Decision	Decision	Decision	Decision
[↶]	Back to the previous item	Back to the previous item	Back to the previous item	Back to the previous item
[○]	Unused	Unused	Unused	Unused
[]	Exit panel program mode	Exit panel program mode	Exit panel program mode	Exit panel program mode
[▲]	Signaling number change	RX RAN up	TX RAN up	Transmit power change
[▼]	Signaling number change	RX RAN down	TX RAN down	Transmit power change
[▶]	Signaling type change	RX RAN ON/OFF	TX RAN ON/OFF	Unused
[◀]	Signaling type change	RX RAN ON/OFF	TX RAN ON/OFF	Unused
MIC Keypad [0] ~ [9]	Entry a Frequency directly	Entry a code directly		Transmit power select ([1], [2] or [3]) *6
MIC Keypad [*]	Decision	Decision	Decision	Decision
MIC Keypad [#]	Back to the previous item	Back to the previous item	Back to the previous item	Back to the previous item

*6: [1] = "Low", [2] = "Medium", [3] = "High"

■ Key operation (3/3)

Key/Item	Channel Name
[]	Decision and exit the "Manual Entry mode"
[↶]	Back to the previous item
[○]	Change the character type (Capital font → Small font → Numerical value)
[]	Delete
[▲]	Character selection ("A", "a" or "0" to "Z", "z" or "9")
[▼]	Character selection ("Z", "z" or "9" to "A", "a" or "0")
[▶]	Move a cursor to the right
[◀]	Move a cursor to the left
MIC Keypad [0] ~ [9]	Character selection (Follow to the "Keypad Character Entry" in the FPU setting)
MIC Keypad [*]	Change the character type (Capital font → Small font → Numerical value)
MIC Keypad [#]	Delete

• Front panel programming mode flow chart

Enter the Front panel programming mode by using section "2.2.2 How to Enter Each Mode".

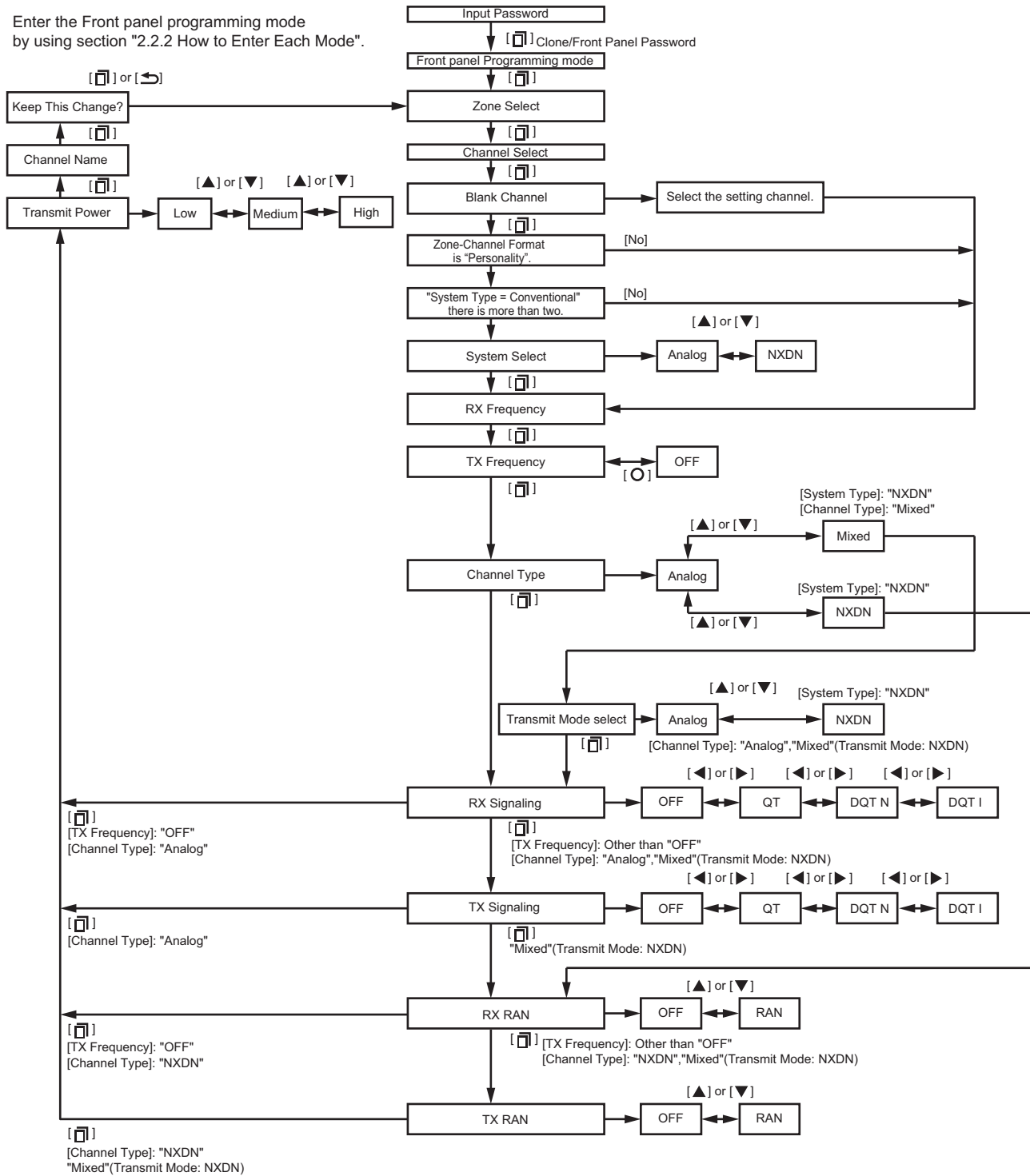

Note: Zone-Channel Format allows you to whether to configure for each zone the channels in the same system, or channels in different system.

2.3 INSTALLATION

External View

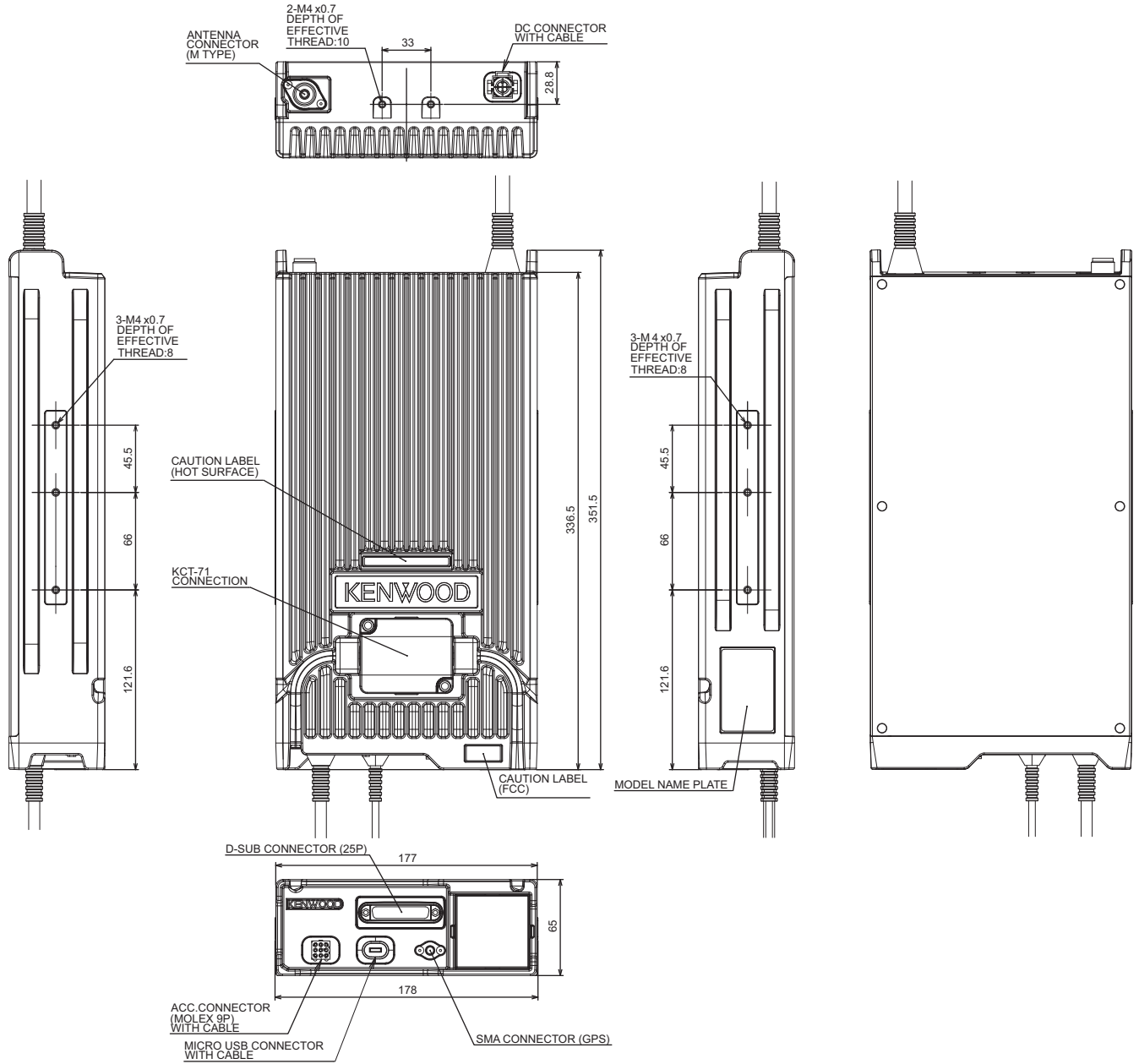

2.3.1 Installation for the remote control system

The KCH-19, KCH-20R REMOTE CONTROL HEAD, and KCH-21R HANDHELD CONTROL HEAD can be connected to the NX-5600HB with the KCT-71 or KCT-77 REMOTE CONTROL CABLE.

The figure below shows the configuration of the control head system and the setting of the DIP switch. The DIP switch settings are very important for the proper operation of a Multi Control Head system. The DIP switches are used for number management of the Control Heads in the system; they also determine termination for CAN (Controller Area Network) communications.

■REMOTE CONTROL HEAD configuration and DIP switch setting

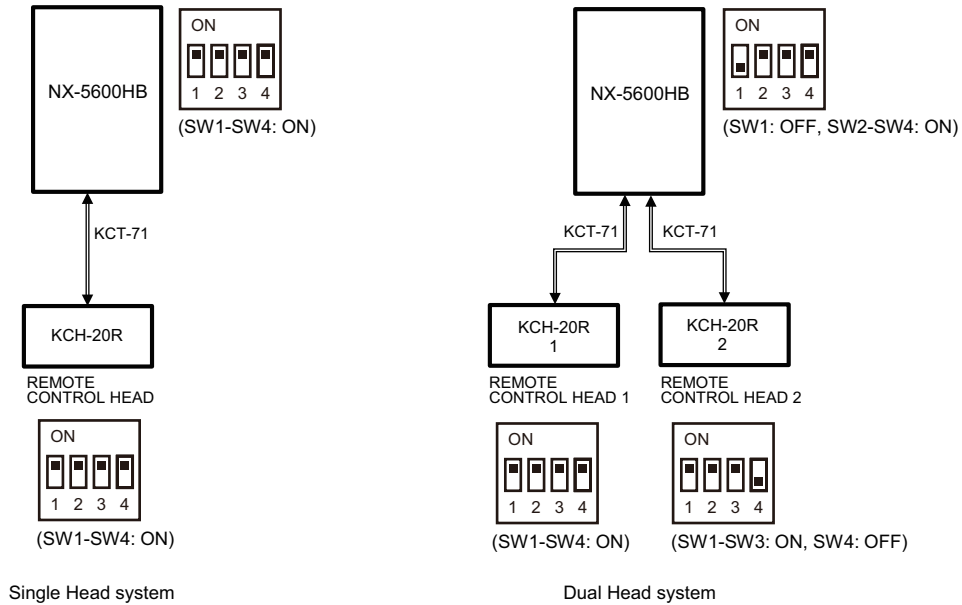

■HANDHELD CONTROL HEAD configuration and DIP switch setting

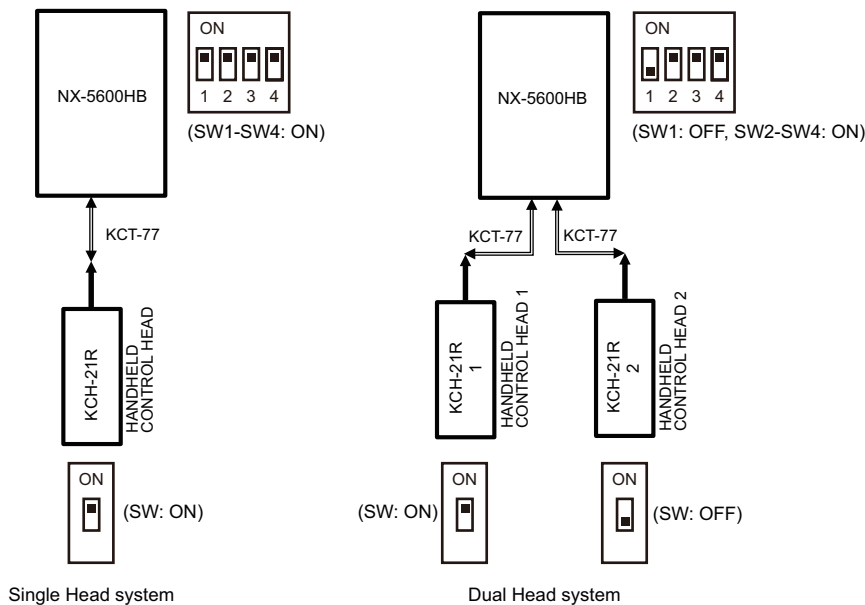

Note:

For the multi RF Deck system, refer to the KRK-14H/KRK-15B service manual (B5B-7173-20). Because the NX-5600HB has the function of the KRK-15B, it can be connected directly to the REMOTE CONTROL HEAD. The KRK-14H interface kit is required to connect the KCH-19 and radio. Refer to the KRK-14H/KRK-15B service manual (B5B-7173-20).

2.3.1.1 Connecting procedure of the REMOTE CONTROL CABLE for Single Head system

(The procedure for connecting the KCT-71 to the radio and the procedure for connecting the KCT-77 to the radio are the same.)

- (1) Insert the connector of the KCT-71 into the connector of the radio.

(Even if the connector of the KCT-71 is inserted into either of the 2 connectors of the radio, the conditions are the same, there is no influence on the operation.)

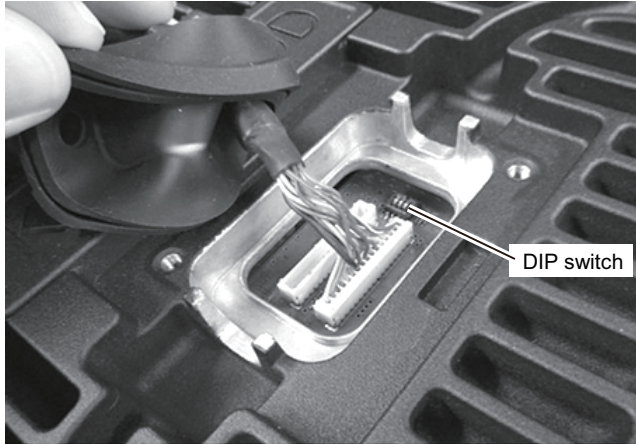

- (2) Fit the waterproof packing to the chassis, then press it in the direction of the arrow and flatten its surface.

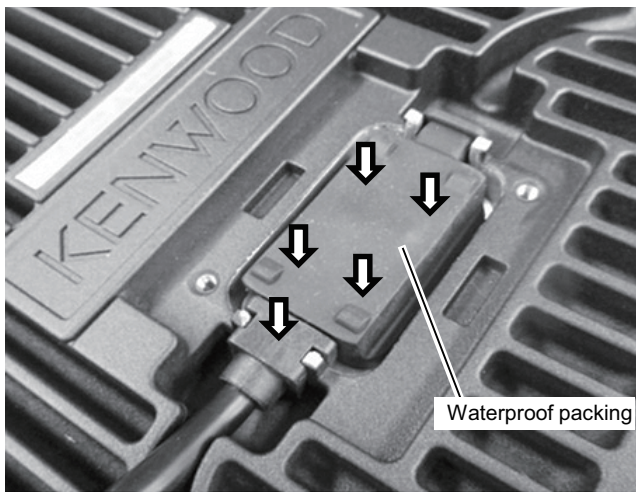

- (3) Form the cable of the KCT-71 so as not to protrude from the groove of the chassis as shown below.

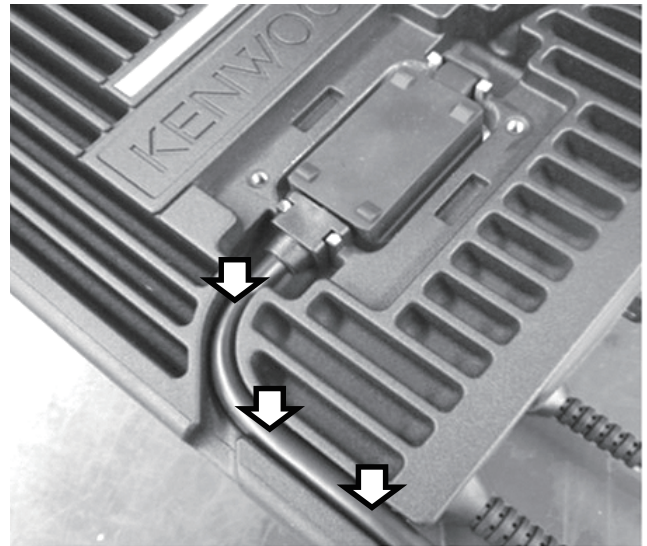

- (4) Attach the MOLDING COVER of the radio accessory to the chassis, and tighten the 2 screws.

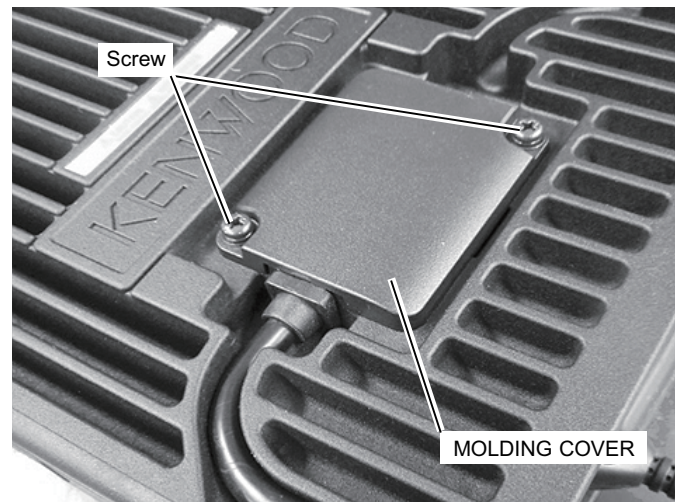

- (5) Attach the other side of the KCT-71 or KCT-77 to the KCH-20R REMOTE CONTROL HEAD, KCH-21R HANDHELD CONTROL HEAD.

For the installation method, refer to the service manuals of the KCH-20R or KCH-21R.

2.3.1.2 Connecting procedure of the REMOTE CONTROL CABLE for Dual Head system

(The procedure for connecting the KCT-71 to the radio and the procedure for connecting the KCT-77 to the radio are the same.)

- (1) Cut the waterproof packing of the KCT-71 along the dotted line with a cutting tool so as to make the hole for the passage of another KCT-71 connector wire.

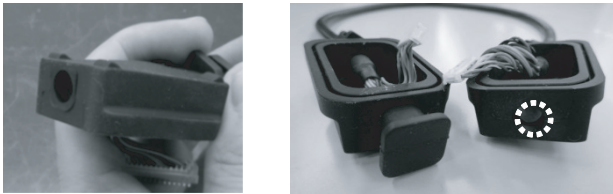
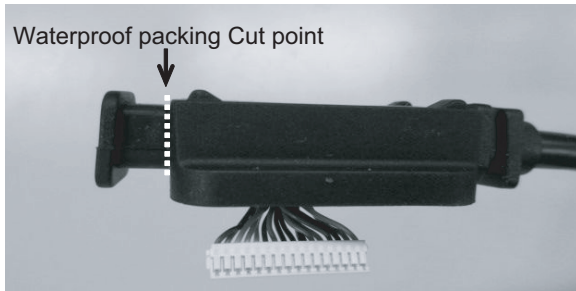

- (2) Push out the connector from the hole of another KCT-71 waterproof packing.

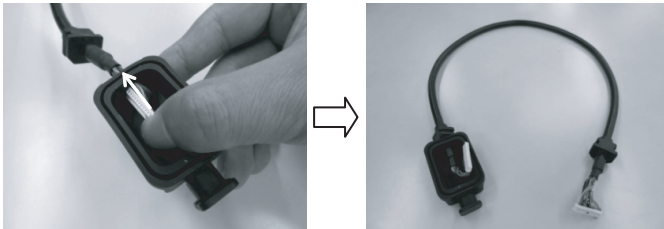

- (3) Combine the modified KCT-71 of step (1) and KCT-71 of step (2). Plug the connector of the KCT-71 of step (2) into the hole of the KCT-71 waterproof packing of step (1).

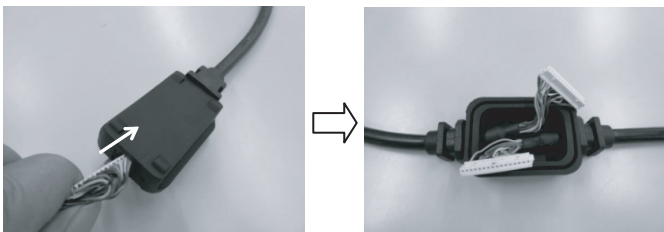

- (4) Insert each of the 2 connectors of the KCT-71 made in step (3) into the connectors of the radio.

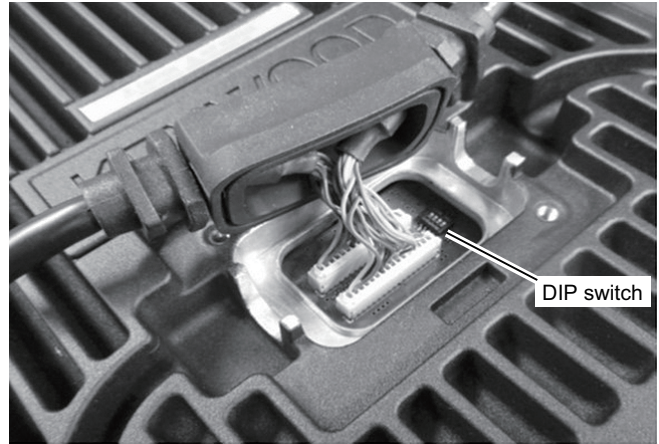

- (5) Fit the waterproof packing to the chassis, then press it in the direction of the arrow and flatten its surface.

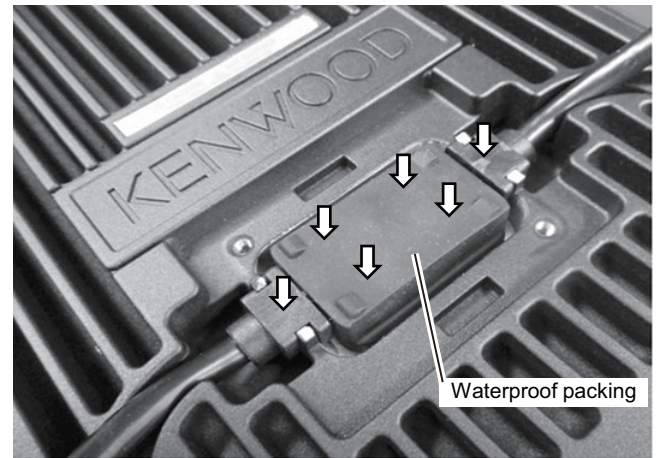

- (6) Form the cable of the modified KCT-71 so as not to protrude from the groove of the chassis as shown below.

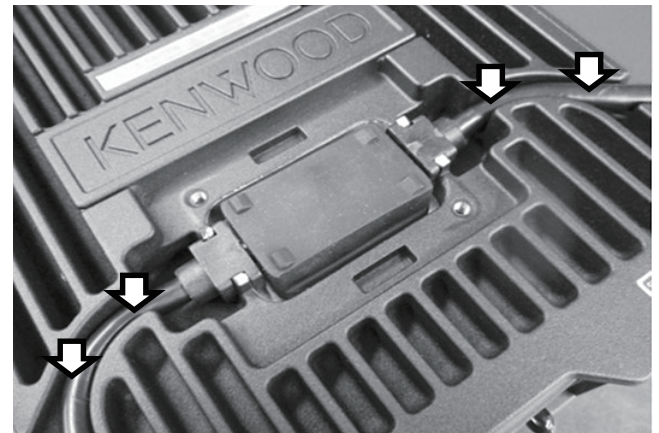

- (7) Attach the MOLDING COVER of the radio accessory to the chassis, and tighten the 2 screws.

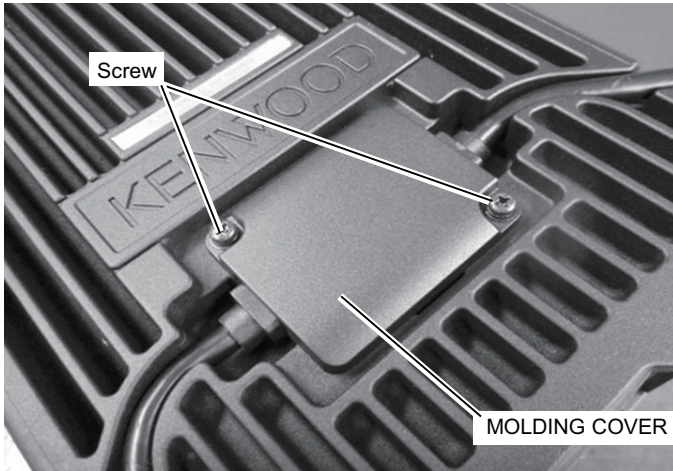

- (8) Attach the other side of the KCT-71 or KCT-77 to the KCH-20R REMOTE CONTROL HEAD, KCH-21R HANDHELD CONTROL HEAD.

For the installation method, refer to the service manuals of the KCH-20R or KCH-21R.

2.3.2 Ignition Sense Cable (KCT-18: Option)

The KCT-18 is an optional cable to use the following functions:

■ Ignition function

The ignition function allows you to turn the radio's power on and off with the ignition key of your car.

2.3.2.1 Connecting the KCT-18 cable to the radio

- (1) Insert the KCT-18 lead terminal into pin 1 (IGN) of the Socket (9-pin) NX-5600HB accessory.
- (2) Connect the socket (9-pin) to the connector (9-pin) for accessory on the front of the radio.

Socket (9-pin) NX-5600HB accessory

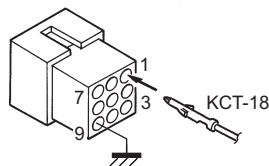

2.3.2.2 Connecting the KCT-18 cable to the KCH-20R Remote Control Head

When connecting the KCT-18 to the KCH-20R, the KCT-72 connection cable is used.

- (1) To connect the KCT-72 to the KCH-20R, modify (cut) the waterproof packing of the KCT-71 (KCH-20R side). The cutting position and procedure of the KCT-71 waterproof packing are the same as "2.3.1.2 Connecting procedure of the REMOTE CONTROL CABLE for Dual Head system". Refer to the "2.3.1.2 Connecting procedure of the REMOTE CONTROL CABLE for Dual Head system".
- (2) Combine the modified KCT-71 and KCT-72. Plug the connector of the KCT-72 into the hole of the modified KCT-71 waterproof packing.

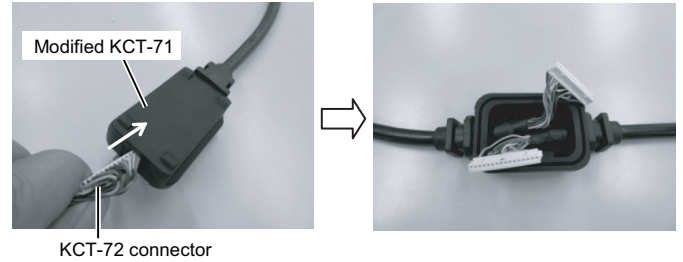

- (3) Insert each of the 2 connectors of the KCT-71 and KCT-72 made in step (2) into the KCH-20R.

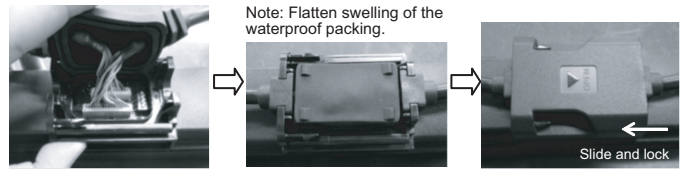

- (4) Insert the KCT-18 lead terminal into pin 1 (IGN) of the socket (12-pin) KCT-72 accessory.

Socket (12-pin) KCT-72 accessory

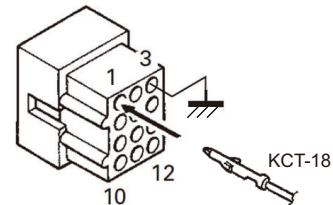

- (5) Connect the socket (12-pin) made in step(4) of the KCT-18 to the KCT-72 of the control head.

2.3.3 External Speaker (KES-5/KES-5A: Option)

The speaker output is as follows:

- (1) The external speaker output from the connector (9-pin) for accessory on the front of the NX-5600HB is 12 W / 4 ohm.
- (2) The KCH-20R Remote Control Head does not have a built-in speaker. By connecting the KCT-72 to KCH-20R, an external speaker can be connected. When using the KCT-72, the speaker output from the KCH-20R is 3 W / 4 ohm.

Note:

Since the radio uses a BTL audio amplifier, do not ground the speaker output pin.

2.3.3.1 Connecting the KES-5/5A to the accessory connector (9-pin) of the NX-5600HB

- (1) Connect the speaker lead of KES-5/5A to the Socket (9-pin) NX-5600HB accessory. Insert the black and white stripe speaker lead into hole pin 2 of the socket (9-pin), and black lead into hole pin 6 of the socket.

Socket (9-pin) NX-5600HB accessory

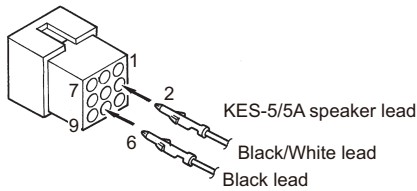

- (2) Connect the socket of KES-5/5A made in step (1) to the connector (9-pin) for accessory on the front of the NX-5600HB.

2.3.3.2 Connecting the KES-5/5A to the KCH-20R

When connecting the KES-5/5A to the KCH-20R, the KCT-72 connection cable is used.

- (1) Connecting the KCT-72 to the KCH-20R is same as "2.3.2.2 Connecting the KCT-18 cable to the KCH-20R Remote Control Head". Refer to the "2.3.2.2 Connecting the KCT-18 cable to the KCH-20R Remote Control Head".
- (2) Connect the speaker lead of KES-5/5A to the socket (12-pin) KCT-72 accessory. Insert the Black/White lead into hole pin 10 of the socket (12-pin), and the Black lead into hole pin 11 of the socket.

Socket (12-pin) KCT-72 accessory

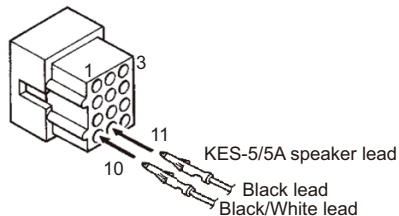

- (3) Connect the socket of KES-5/5A made in step (2) to the accessory connector (12-pin) of the KCT-72.

2.3.3.3 Use as public address speaker

The 20W PA (Public Address) voice signal is output from pins 7 and 8.

- (1) Connect the lead wire of the KES-5/5A to the Socket (9-pin) NX-5600HB accessory. Insert the black and white stripe lead into hole pin 7 of the socket, and the black lead into hole pin 8 of the socket.

Socket (9-pin) NX-5600HB accessory

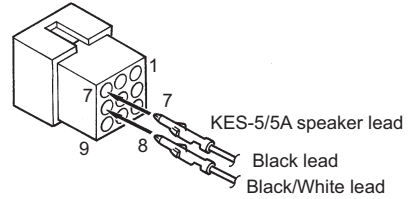

2.3.4 Horn Alert Function

Installation procedure for the Horn alert function (maximum 2A drive).

Connect the car horn warning control signal with the 4 pin and 5 pin of the Socket (9-pin) NX-5600HB accessory.

Socket (9-pin) NX-5600HB accessory

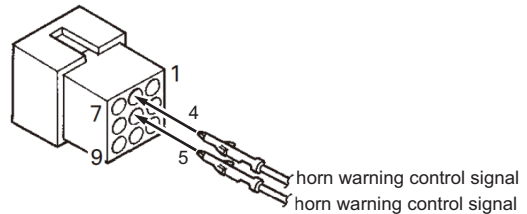

The Horn alert function is turned on / off by the FET switch circuit inside the radio.

Horn alert function can be controlled by signaling decoding.

This switch is the FET switch of P-channel type.

Therefore, a DC power supply is necessary to use the HR1.

The voltage range is from 5V to 16V. The maximum current is 2A.

Pay attention to the input and output of the Socket (9-pin) NX-5600HB accessory.

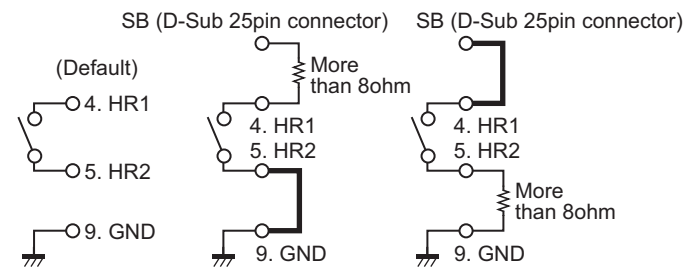

2.3.5 SECURE CRYPTOGRAPHIC MODULE (KWD-AE30/KWD-AE31:Option)

2.3.5.1 SUPPLIED ACCESSORIES

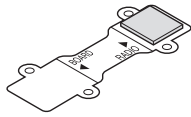

Connecting cable *
(X42-3330-XX)



Cushion A *
(G13-2179-XX)

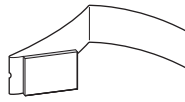

Cushion B
(G13-2178-XX)



Cushion C
(G1D-0006-XX)

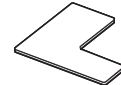

Cushion D *
(G1D-0055-XX)

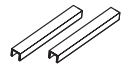

Spacer *
(F3K-0004-XX)

Note:

Supplied accessories with * mark are not used for the NX-5600HB.

2.3.5.2 INSTALLING THE MODULE IN THE TRANSCEIVER

(1) Remove the M.CABINET and RUBBER SEAL of the transceiver.

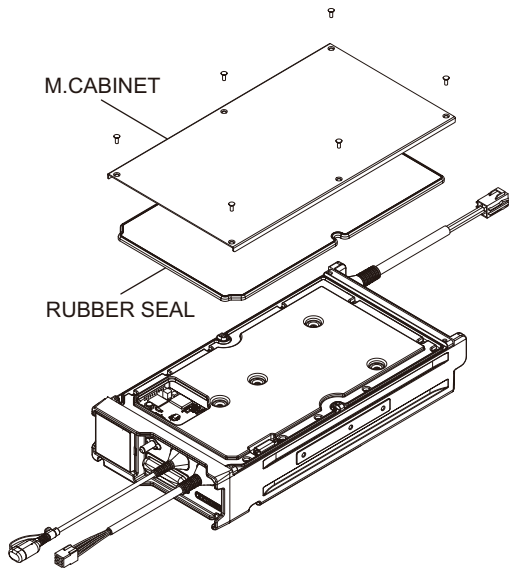

(2) Attach the cushion B and C to the module backside.

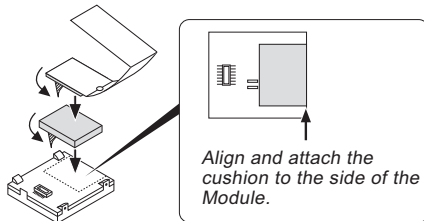

Note:

Refer to the figure for how to attach cushion B. If the release paper is reversed, it cannot be pulled out.

(3) Fold the release paper as indicated in the figure.

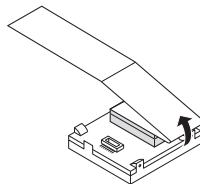

(4) Insert the connector of the module into the CN5 of the Main unit.

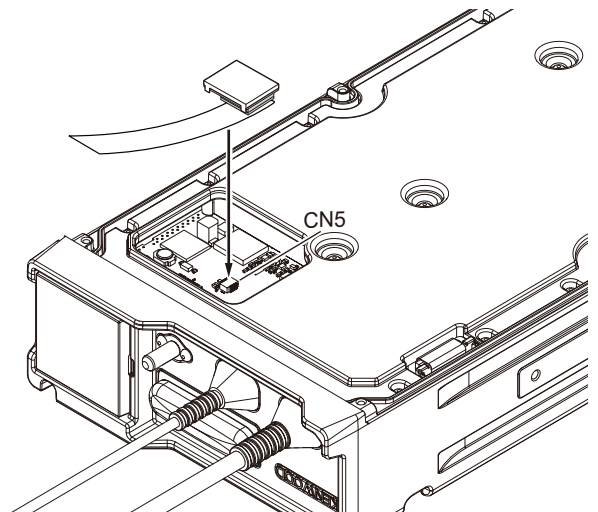

(5) Pull and remove the release paper while pressing down on the module with your finger to hold it in place, to attach the module to the Main unit.

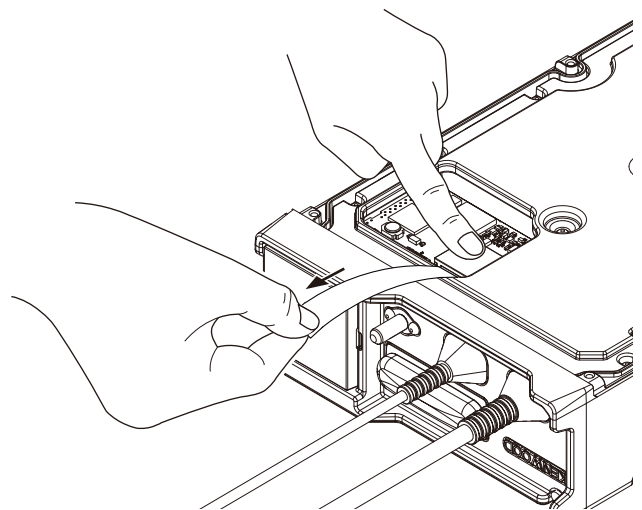

Note:

- When it is necessary to remove the module, do so by peeling the module off using your finger, while pulling it vertically. Do not use a screwdriver or other similar implement to remove the module; you may inadvertently damage the Main unit and the module.
- Cushion B cannot be reused. Attach a new cushion B when you remove the cushion from the module.

(6) Reinstall the M.CABINET and RUBBER SEAL of the transceiver.

Note:

- When the KWD-AE30/ KWD-AE31 is installed, select the "Secure Cryptographic Module" checkbox in the Product Information of the Programming software [FPU (Field Programming Unit)], and then set each parameter.
- If the KWD-AE30/ KWD-AE31 connector is not properly installed, the TX/RX indicator will blink red or "No SCM" will appear on the display when the transceiver power is turned on.
- If the Encryption Key data is not written at the Keyloader, or the Encryption Key data is zeroized, "Key Fail" will appear on the display.
- If the KWD-AE30/ KWD-AE31 is installed in other transceivers, the Encryption Key data will be forced to zeroize.

2.3.6 Changing D-SUB 25-pin connector (4 pin, 5 pin) configuration

2.3.6.1 Change configuration of D-SUB 25-pin connector from AUXIO9 to CTS

■4 pin

The output (4 pin) of D-SUB 25-pin connector is configured at the AUXIO9 as the default value.
Remove the R950 chip jumpers and solder the chip jumpers to \$R953.

Ref. No.			Function
R950	\$R953	Default	AUXIO9
\$R950	R953	-	CTS (RS-232C)

2.3.6.2 Change configuration of D-SUB 25-pin connector from DI to RTS

■5 pin

The input (5 pin) of D-SUB 25-pin connector is configured at the DI as the default value.
Remove the R943 chip jumpers and solder the chip jumpers to \$R946.

Ref. No.			Function
R943	\$R946	Default	DI
\$R943	R946	-	RTS (RS-232C)

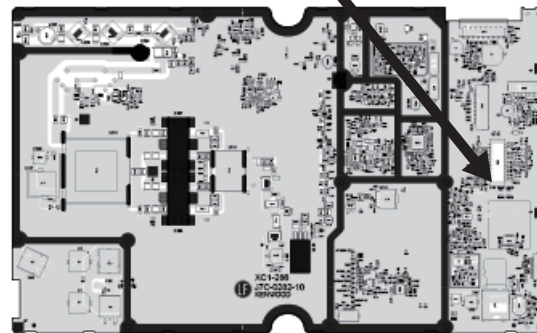
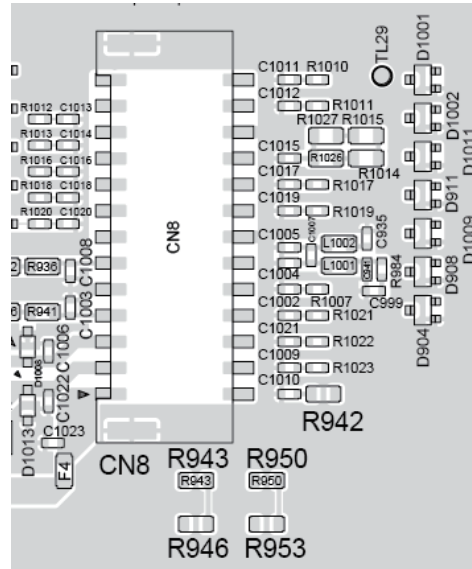

MAIN UNIT Component side

2.4 CIRCUIT DESCRIPTION

2.4.1 Overview

The NX-5600HB is a Low Band Analog FM & Digital Mobile transceiver designed to operate in the frequency range of 39 to 50MHz. The unit consists of a receiver, a transmitter, a phase-locked loop (PLL) frequency synthesizer, a digital control unit, and a power supply circuit.

2.4.2 Frequency Configuration

The receiver is a double-conversion super-heterodyne using first intermediate frequency (IF) of 10.70MHz and second IF of 2.10MHz. Incoming signals from the antenna are mixed with the local signal from the VCO/PLL circuit to produce the first IF of 10.70MHz. This is then mixed with the 12.80MHz second local oscillator output to produce the 2.10MHz second IF. The transmit signal frequency is generated by the PLL and the VCO-B, and modulated by the signal from the Baseband Circuit. It is then amplified and fed to the antenna.

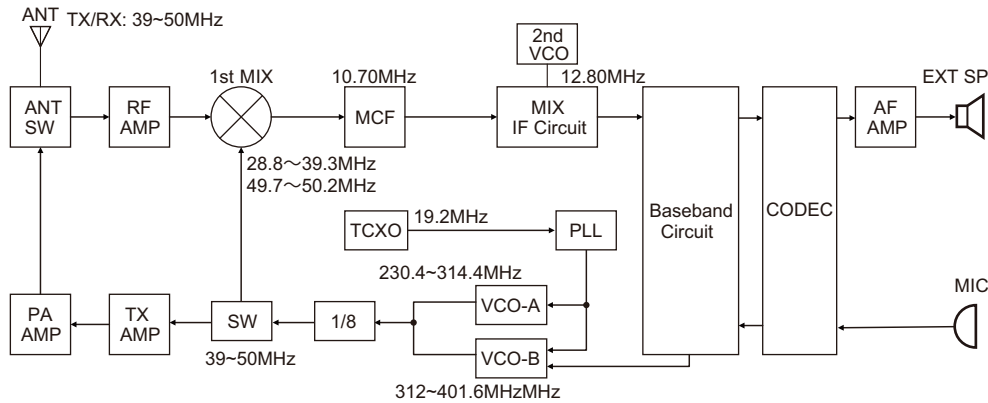

Fig.1 Frequency configuration

2.4.3 Receiver System

2.4.3.1 RF Circuit

The receive signal from antenna switch (D306, D307, D308, D309 and D310) is amplified by a RF amplifier (Q505) and passes through the band-pass filter (L503, L510, L511, L512, L516, L521, L524, L526, L527 and L531) to remove unwanted signals. The signal is then fed to the 1st mixer (Q502, Q503, Q504 and Q514).

2.4.3.2 IF Circuit

Since there is a noise blanker circuit in the IF circuit section, the IF signal first passes through the delay circuit.

When the noise blanker function is effective, noise is suppressed.

The first IF signal then passed through a four-pole monolithic crystal filter (XF601) to reject adjacent channel signal. The filtered first IF signal is amplified by the first IF amplifier (Q604 and Q603) and then applied to the IF system IC (IC600). The IF system IC provides a second mixer, second PLL, AGC and A/D converter.

The second mixer mixes the first IF signal with the 12.80MHz of second local oscillator output and produces the second IF signal of 2.10MHz.

The second IF signal is then be fed into an A/D converter, generates the "I" and "Q" data. This data is in the form of SSI (Serial Synchronous Interface), and sent to the MPU/DSP (IC706).

2.4.3.3 Audio Amplifier Circuit

Audio processing (high-pass filter, low-pass filter, de-emphasized and so on) at Analog FM mode and decoding at Digital mode are processed by DSP. SSI signal from DSP is converted to audio signal at CODEC (IC902). The signal goes to connector for external speaker (CN9) through the amplifier (IC903), electronic volume control (IC719), the amplifier (IC906), Changeover switch (IC912) and audio amplifier (IC911).

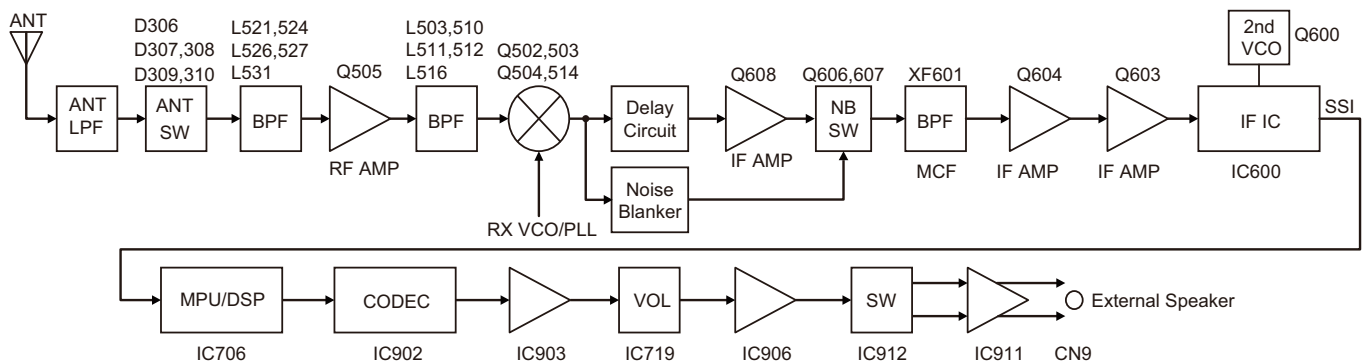

Fig.2 RF and IF circuit

2.4.4 Transmitter System

2.4.4.1 Audio Band Circuit

Refer to the "LEVEL DIAGRAM" in this manual. The signal from microphone is amplified and converted to digital signal by CODEC (IC902). IC902 includes AGC function.

Digital signal is transferred to MPU/DSP (IC706) through SSI.

2.4.4.2 Baseband Circuit

Refer to the "LEVEL DIAGRAM" in this manual. The audio signal transferred from CODEC (IC902) is processed at MPU/DSP (IC706). Voice signals of 300Hz or lower and frequencies of 3kHz or higher are cut off and an audio range 300Hz to 3kHz is extracted. The audio signal is then pre-emphasized in FM mode and synthesized with the signals, such as CTCSS and DCS, as required, and is transferred to PLL Frequency Synthesizer block. The DTMF and MDC baseband signals are also generated by MPU/DSP (IC706). In Digital mode, the audio signal is converted to the 4-Level FSK baseband signal and is transferred to PLL Frequency Synthesizer block.

The output level according to the transmit carrier is fine-adjusted according to each modulation method.

2.4.4.3 Drive and Final Amplifier

The signal from the TX PLL is amplified by pre-drive amplifier 1 (IC301) and pre-drive amplifier 2 (Q301). The output of the pre-drive amplifier is amplified by the drive amplifier (Q308) and RF Power amplifier (Q306 and Q307) to 110W (70W when the power is middle and 25W when the power is low). IC301 is MMIC. Q301, Q306, Q307 and Q308 is MOS FET. The output of the final amplifier is then passed through the coupler, antenna switch (D306, D307, D308, D309 and D310), harmonic filter (LPF) and applied to the antenna terminal.

2.4.4.4 APC Circuit

The Automatic transmission power control circuit (APC) controls the transmitter output in adjusted value by monitoring it with a coupler. RF detection and comparison functions are included in the power-control IC (IC306).

The power control IC output is given as a drive source of the RF power amplifier's gate (Q306 and Q307), and completes APC feedback loop.

When a normal antenna load is connected, the Forward RF Power is referenced by the coupler and sent to power-control IC (IC306). Forward RF Power is converted into DC voltage at IC306 and is compared with the SPC.

The output voltage goes through DC amplifier (IC305 B/2) to pre-drive amplifier 2 (Q301), Drive amplifier (Q308) and RF Power amplifier (Q306 and Q307).

The voltage controls the gate bias voltage of Q301, Q306, Q307 and Q308, and keeps transmission output stable.

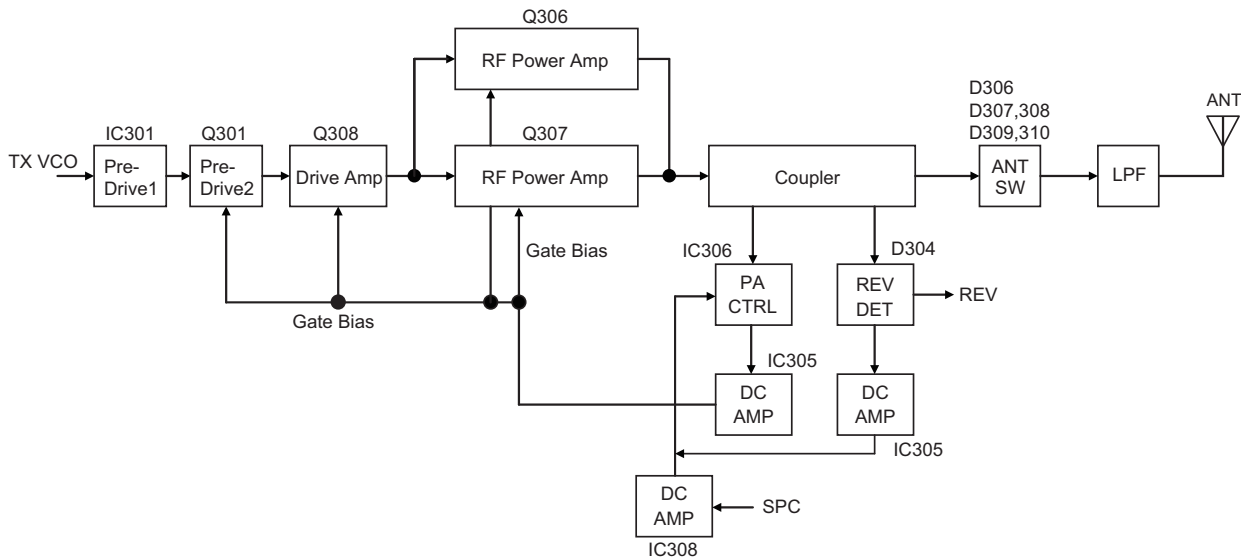

Fig.3 Drive and Final amplifier and APC circuit

2.4.5 PLL Frequency Synthesizer

2.4.5.1 TCXO (X700)

TCXO (X700) generates a reference frequency of 19.2MHz for the PLL frequency synthesizer. This reference signal is buffered by Q700 and IC703. And it is distributed to PLL (IC100), IF IC (IC600), and MPU/DSP (IC706).

The frequency adjustment is achieved by adjusting a D/A converter (IC715) output in the voltage of the control terminal of TCXO. The resolution of adjusting frequency is approximately 8Hz.

2.4.5.2 VCO

There are VCO-A and VCO-B, which generate 8 times the transmit frequency and first local frequency. The VCO output is divided by 8 with a prescaler.

The VCO-B (Q107) generates part of the first local signal for the receiver and the carrier for the transmitter. The VCO oscillation frequency range is 312 to 401.6MHz. The transmit frequency range is 39 to 50MHz. The 1st local signal frequency range is 49.7 to 50.195MHz.

The VCO-A (Q105) generates the 1st local signal for the receiver.

VCO oscillation frequency range is 230.4 to 314.4MHz. The 1st local signal frequency range is 28.8 to 39.3MHz.

The VCO oscillation frequency is determined by voltage control terminals "CV" and "ASSIST".

The voltage control terminal "CV" is controlled by PLL IC (IC100). The voltage control terminal "ASSIST" is controlled by the control voltage from D/A converter (IC715).

For the modulation input terminal, "VCO_MOD" of VCO-B, the output frequency changes according to the applied voltage. This is used to modulate the VCO output.

2.4.5.3 PLL IC

PLL IC (IC100) compares a difference in phases of the VCO oscillation signal and the TCXO reference frequency. And it returns the difference voltage to the VCO CV terminal and realizes the "Phase Locked Loop". This allows the VCO oscillation frequency to accurately match (lock) the desired frequency.

When the frequency is controlled by the PLL IC (IC100), the frequency convergence time increases as the frequency difference increases when the set frequency is changed. To supplement this, the MPU/DSP (IC706) is used before control by the PLL IC to bring the VCO oscillation frequency close to the desired frequency. As a result, the VCO CV voltage does not change and is always stable at approximately 2.5V.

The modulation input terminal, "PLL_MOD" of the PLL IC (IC100), is used to modulate the VCO output. The modulation data is generated by the IC706.

The desired frequency is set for the PLL IC by the MPU/DSP (IC706) through the 3-line "SDO1", "P_SCK1", "/PCS_RF" serial bus for PLL. MPU/DSP (IC706) monitors through the "PLD", whether the PLL IC (IC100) is locked or not. If the VCO does not lock to desired frequency (unlock), the "PLD" logic is low.

2.4.6 Control Circuit

The control circuit consists of MPU/DSP (IC706) and its peripheral circuits. MPU/DSP (IC706) mainly performs the following;

- (1) Switching between transmission and reception by PTT signal input.
- (2) Reading system, zone, frequency, and program data from the memory circuit.
- (3) Sending frequency program data to the PLL.
- (4) Controlling the audio mute circuit by decode data input.

2.4.6.1 MPU/DSP

The MPU/DSP (IC706) is 32bit RISC processor and fixed floating-Point VLIW DSP Fixed/Floating-Point VLIW DSP, equipped with peripheral function.

This MPU/DSP operates at 288MHz (MAX) clock and 3.3V/1.8V/1.2V DC. Controls the flash memory, Mobile DDR, the receive circuit, the transmitter circuit, the control circuit, and the display circuit and transfers data to or from an external device.

2.4.6.2 Memory Circuit

Memory circuit consists of the MPU/DSP, the Mobile DDR (IC702), and the flash memory (IC701). The flash memory has capacity of 512Mbit that contains the transceiver control program for the MPU/DSP (IC706) and stores the data. It also stores the data for transceiver channels and operating parameter that are written by the FPU. This program can be easily written from external devices. The Mobile DDR has capacity of 512Mbit. The MPU/DSP copies the program to the Mobile DDR from Flash memory.

■Flash memory

Note:

The flash memory stores the data that is written by the FPU (KPG-D1/D1N), tuning data (Deviation, Squelch, etc.), and firmware program (User mode, Test mode, Tuning mode, etc.).

■Mobile DDR

Note:

Mobile DDR is used as a work area of the MPU/DSP (IC706).

2.4.6.3 Interface Circuit

The Interface unit is connected by a flexible cable (CN7 of the Main unit, CN1 of the Interface unit).

Up to 2 control heads can be connected to the Interface unit.

The control head is used for control and display of the radio equipment.

2.4.6.4 DSP

The DSP circuit consists of a MPU/DSP (IC706) and processes the base band signal. The DSP operates at 288MHz (MAX) clock, the I/O section operates at 3.3V/1.8V and the core section operates at 1.2V.

The DSP carries out the following processes;

- 4-Level FSK processing
- Analog FM pre-emphasis/de-emphasis
- Vocoder processing between audio codec and modulation/demodulation
- CAI processing, such as error correction encoding
- QT/DQT encoding/decoding
- DTMF encoding/decoding
- MSK encoding/decoding
- 2-tone encoding/decoding
- Compressor/expander processing
- Voice scrambler processing
- Transmit/receive audio filtering processing
- Microphone amplifier AGC processing
- Audio mute processing
- Modulation level processing
- Active Noise Reduction
- Voice recording/playback processing
- Voice announce processing

2.4.7 Power Supply Circuit

+B voltage is connected to RF Power amplifier (Q306, Q307), Drive amplifier (Q308), 50BU regulator (Q8, Q9 and D11) through the fuse (F1), DC/DC converter IC (IC8) via fuse (F1), SB1 switch (Q5 and Q6) through the fuse (F2) and SB2 switch (Q10 and Q11) through the fuse (F3).

Q8, Q9 and D11 regulates +B voltage to 5V (50BU). Then IC1 regulates 50BU to 3.1V (31BU). Then IC3 regulates 31BU to 1.2V (12BU). 50BU, 31BU and 12BU operate whenever +B is supplied.

IC8 regulates +B voltage to 5.4V (54M). 54M is controlled by BAT_CNT signal from Power management IC (IC2). When Power switch is turned on, BAT_CNT signal is controlled by /PSW signal. 54M goes to DC/DC converter (IC24, IC11), AVR ICs (IC5, IC4, IC12, IC14, IC7, IC10, IC17 and IC6).

IC24 (12M) is enabled while the 54M is operating. 12M provides the power to the MPU/DSP (IC706) and turns on IC11 (18M). 18M provides the power to the MPU/DSP and Mobile DDR (IC702) and turns on IC5 (33M), IC14 (33OPT). 33M provides the power to the MPU/DSP, Flash memory (IC701) and many control circuits and turns on IC4 (33A), IC10 (50A). Then 33A turns on IC9 (18M_3).

The Power management IC (IC2) watches +B voltage. If +B voltage is higher than 6.2V, IC2 outputs high voltage to the /BINT terminal. If the /BINT is high, SB1 (Q5 and Q6) and SB2 (Q10 and Q11) are turned on by SBC_2 signal from MPU/DSP. In the same way, IC12 (33C) and IC6 (50C) are turned on by SBC_2. 50C is fed to IC13 (200C). IC13 (200C) is the DC/DC boost converter. The 200C circuit then outputs approximately +20VDC.

SB1 supplies Interface unit, D-sub 25 and IC1013 (50USB) with +B voltage. 50USB are turned on by USB_HOST_EN signal from IC711 (I/O Expander). SB2 supplies Audio power amplifier (IC911) and 9V AVR (IC15) with +B voltage. Then IC15 regulates +B to 9V (90C). Then IC16 regulates 90C to 5V (50CT). If the MPU/DSP controls TXC, ANTSW and ASSW signals to High, Q15, Q16 (90T), Q17, Q18 (90ANT) and Q14 are turned on and transmission circuits are enabled to transmit. If the MPU/DSP controls RXC signal to High, IC17 (50R) and Q13, Q19 (90R) is turned on and reception circuits are enabled to receive.

When the Power management IC and MPU/DSP detect /PSW signal (Power switch), /IGN signal (Ignition sense) and /BINT signal, they set the SBC_2 signal to Low, and turn the transceiver power off.

When D1, Q4 detect over-voltage condition, they turn SB1 and SB2 off, and transfer that the MPU/DSP through IC2.

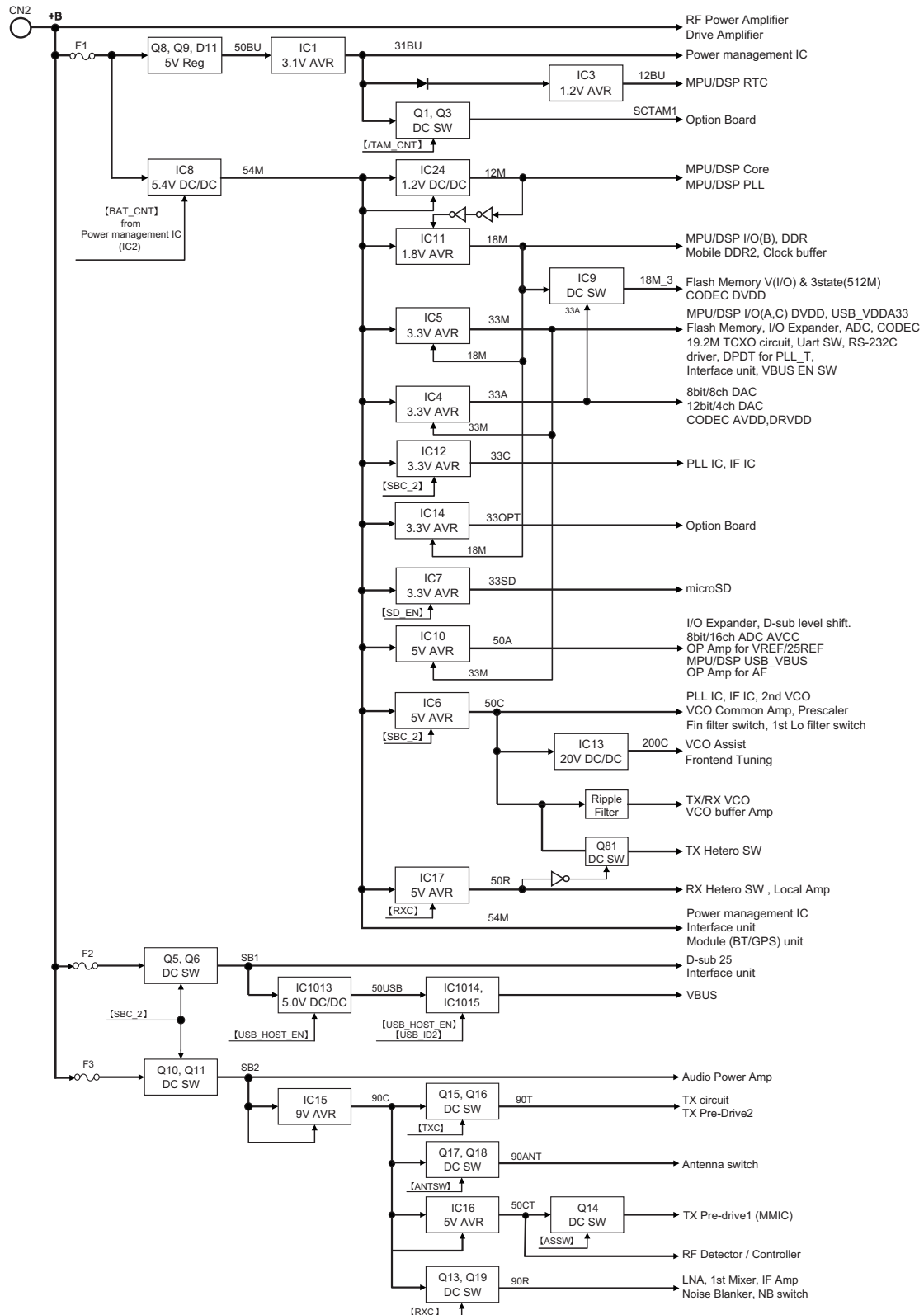

Fig.4 Power supply circuit

2.4.8 Signaling Circuit

2.4.8.1 Encode (QT/DQT/ DTMF/ 2-tone/ MSK)

Each signaling data signal of QT, DQT, DTMF, 2-tone and MSK is generated by MPU/DSP (IC706), superposed on a modulation signal and output to VCO-B and PLL IC.

2.4.8.2 Decode (QT/DQT/ DTMF/ 2-tone/ MSK)

The audio signal is removed from the FM detection signal is sent to the MPU/DSP (IC706) and the resulting signal is decoded by MPU/DSP (IC706).

2.4.9 Bluetooth/GPS Circuit

The main component of the Bluetooth/GPS circuit is Bluetooth / GPS IC (IC5) on Module (BT/GPS) unit.

The clocks of Bluetooth/GPS IC require 19.2MHz for core and 32.768kHz slow clock (X1 and X2) for UART.

Bluetooth/GPS IC communicates to the MPU/DSP (IC706) on the HCI UART. Interface of UART & Digital audio (PCM) between the MPU/DSP (IC706) and the Bluetooth/GPS IC (IC5), have level conversion at the level shift IC (IC6 and IC7) on Module (BT/GPS) unit. The Bluetooth/GPS IC is powered by 1.8V and 3.3V which are supplied from 2 discrete external regulators (IC2 and IC3) on Module (BT/GPS) unit.

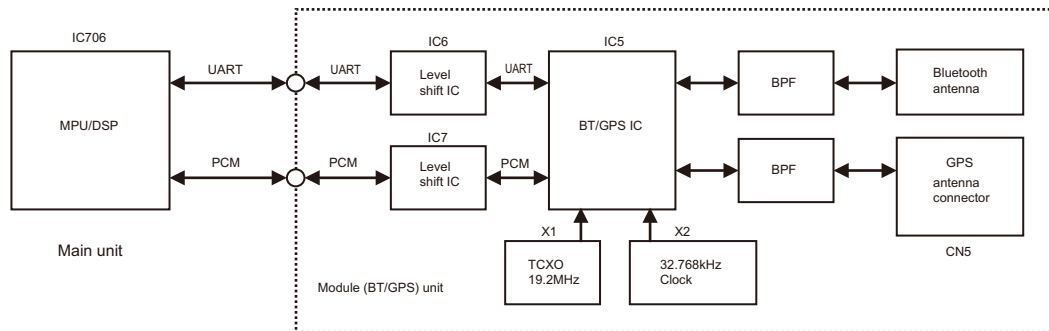

Fig.5 Bluetooth/GPS circuit

2.4.9.1 Bluetooth Circuit

The Bluetooth / GPS IC (IC5) supports the Bluetooth 4.0 up to HCI level.

■Basic Rate

TX/RX frequency is 2400-2483.5MHz (79ch Hopping, 2402-2480MHz, 1MHz step). Transmitting power is +2dBm (Max.: +4dBm) at Bluetooth antenna input.

■Low Energy

TX/RX frequency is 2400-2483.5MHz (40ch (3 advertising channel: Single carrier, 37data channel: Hopping), 2402-2480MHz, 2MHz step). Transmitting power is +2dBm (Max.: +4dBm) at Bluetooth antenna input.

■Common

Using the printed antenna with Bluetooth, and it is connected to the Bluetooth / GPS IC (IC5) through the saw filter (L11).

Frequency configuration for Bluetooth is following:

There are 2 LO modes: 2X and Offset LO (OSLO). 2X where LO is $2 * RF_FREQ$ (e.g. when transmitting at 2441MHz it is at 4882MHz). OSLO where LO is at $(2/3) * RF_FREQ$ (e.g. when transmitting at 2441MHz it is at 1627.333MHz).

In RX the 2X is always used.

In GFSK TX if power is >10dBm then OSLO is used

In EDR2 TX if power is >-12dBm then OSLO is used

In EDR3 TX if power is >-12dBm then OSLO is used

Otherwise 2X is used for TX as well.

2.4.9.2 GPS Circuit

The GPS RF signal is received with the active antenna, and connected to the Bluetooth / GPS IC (IC5) through the terminal (CN5) and saw filter (L9).

The output is passed to pin L2 of the GPS IC. The input match for pin L2 comprises of C38, C36 and L7. The control and data lines for the GPS IC are GPS_PA_EN, BTFM_nSHUTDOWN, GPS_TX and GPS_RX. GPS_TX and GPS_RX are shared with Bluetooth data line.

Frequency configuration for GPS is following:

Lo is GPS: 1571.324MHz

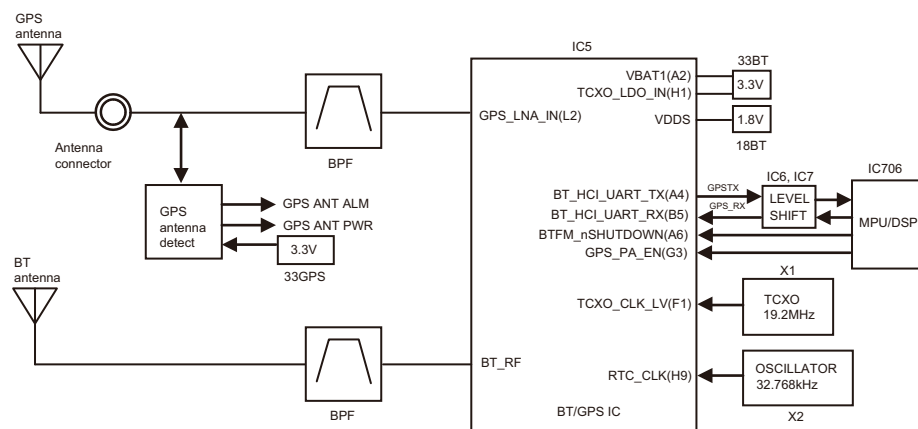

Fig.6 GPS circuit

2.5 COMPONENTS DESCRIPTION

2.5.1 Main Unit (XC1-286F-00)

REF. NO.	PART NAME	USE / FUNCTION
IC1	IC	VOLTAGE REGULATOR (31BU) [3.1V AVR]
IC2	IC	POWER MANAGEMENT
IC3	IC	VOLTAGE REGULATOR (12BU) [1.2V AVR]
IC4	IC	VOLTAGE REGULATOR (33A) [3.3V AVR]
IC5	IC	VOLTAGE REGULATOR (33M) [3.3V AVR]
IC6	IC	VOLTAGE REGULATOR (50C) [5.0V AVR]
IC7	IC	VOLTAGE REGULATOR (33SD) [3.3V AVR]
IC8	IC	DC-DC CONVERTER (54M) [5.4V DC-DC CONV]
IC9	IC	DC SWITCH (18M_3) [DC SW]
IC10	IC	VOLTAGE REGULATOR (50A) [5.0V AVR]
IC11	IC	VOLTAGE REGULATOR (18M) [1.8V AVR]
IC12	IC	VOLTAGE REGULATOR (33C) [3.3V AVR]
IC13	IC	DC-DC CONVERTER (200C) [20V DC-DC CONV]
IC14	IC	VOLTAGE REGULATOR (33OPT) [3.3V AVR]
IC15	IC	VOLTAGE REGULATOR (90C) [9.0V AVR]
IC16	IC	VOLTAGE REGULATOR (50CT) [5.0V AVR]
IC17	IC	VOLTAGE REGULATOR (50R) [5.0V AVR]
IC18	IC	VOLTAGE DETECT [V DET]
IC24	IC	VOLTAGE REGULATOR (12M) [1.2V AVR]
IC100	IC	PLL IC
IC101	IC	SCHMITT TRIGGER
IC102	IC	DC AMPLIFIER (CV/ASSIST) [DC AMP]
IC103	IC	PRESCALER IC
IC301	IC	TX PRE-DRIVE AMPLIFIER [PRE-DRIVE AMP]
IC305	IC	AUTO POWER CONTROL [APC]
IC306	IC	TX POWER CONTROL [TX PWR CTL]
IC308	IC	AUTO POWER CONTROL [APC]
IC500, 501	IC	NOISE BLANKER [NB]
IC502, 503	IC	DC AMPLIFIER (TV1~TV4) [DC AMP]
IC600	IC	IF IC

REF. NO.	PART NAME	USE / FUNCTION
IC701	IC	FLASH MEMORY
IC702	IC	MOBILE DDR
IC703	IC	CLOCK BUFFER [CLK BUFF]
IC704, 705	IC	LOGIC CONTROL [LOGIC CTL]
IC706	IC	MPU / DSP
IC707, 708	IC	ANALOG SWITCH [ANALOG SW]
IC711	IC	I/O EXPANDER [I/O EXP]
IC712	IC	A/D CONVERTER [A/D CONV]
IC714	IC	ANALOG SWITCH [ANALOG SW]
IC715	IC	D/A CONVERTER [DA CONV]
IC719	IC	D/A CONVERTER [DA CONV]
IC720	IC	VOLTAGE DETECT [V DET]
IC901	IC	DC AMPLIFIER (25REF/VREF) [DC AMP]
IC902	IC	CODEC
IC903	IC	AF AMPLIFIER (EXSP/DSUB) [AF AMP]
IC904	IC	LOGIC CONTROL [LOGIC CTL]
IC905	IC	BUFFER AMPLIFIER (BER CK/BER DT) [BUFF AMP]
IC906	IC	BUFFER AMPLIFIER [BUFF AMP]
IC907	IC	ANALOG SWITCH [ANALOG SW]
IC909	IC	RS-232C DRIVER
IC910	IC	I/O EXPANDER [I/O EXP]
IC911	IC	AUDIO AMPLIFIER [AF AMP]
IC912	IC	MULTIPLEXER
IC1013	IC	DC-DC CONVERTER (50USB) [5.0V DC-DC CONV]
IC1014	IC	VBUS SUPPLY
IC1015	IC	LOGIC CONTROL [LOGIC CTL]
Q1	TRANSISTOR	DC SWITCH (SCTAM1) [DC SW]
Q3	FET	DC SWITCH [DC SW]
Q4	TRANSISTOR	DC SWITCH [DC SW]
Q5	FET	DC SWITCH (SB1) [DC SW]
Q6,7	TRANSISTOR	DC SWITCH [DC SW]
Q8,9	TRANSISTOR	VOLTAGE REGULATOR (50BU) [5.0V AVR]
Q10	FET	DC SWITCH (SB2) [DC SW]
Q11	TRANSISTOR	DC SWITCH [DC SW]
Q12	FET	DC SWITCH [DC SW]
Q13	FET	DC SWITCH (90R) [DC SW]
Q14	FET	DC SWITCH [DC SW]
Q15	TRANSISTOR	DC SWITCH [DC SW]
Q16	FET	DC SWITCH (90T) [DC SW]
Q17	TRANSISTOR	DC SWITCH [DC SW]
Q18	FET	DC SWITCH (90ANT) [DC SW]

REF. NO.	PART NAME	USE / FUNCTION
Q19	TRANSISTOR	DC SWITCH [DC SW]
Q20	TRANSISTOR	DC SWITCH [DC SW]
Q81	FET	TX/RX SWITCH [TX-RX SW]
Q100	TRANSISTOR	DC SWITCH (FIN FILTER/LO FILTER) [DC SW]
Q101	FET	DC SWITCH [DC SW]
Q102	TRANSISTOR	DC SWITCH (FIN FILTER/LO FILTER) [DC SW]
Q103	FET	DC SWITCH [DC SW]
Q104	TRANSISTOR	RIPPLE FILTER
Q105	FET	VCO
Q107	FET	VCO
Q108	FET	DC SWITCH [DC SW]
Q109	FET	VCO-A/B SWITCH [VCO-A/B SW]
Q110, 111	TRANSISTOR	BUFFER AMPLIFIER [BUFF AMP]
Q301	FET	TX PRE-DRIVE AMPLIFIER [TX PRE-DRIVE AMP]
Q302	TRANSISTOR	DC SWITCH [DC SW]
Q304	FET	DC SWITCH [DC SW]
Q305	TRANSISTOR	DC SWITCH [DC SW]
Q306, 307	FET	POWER AMPLIFIER [FINAL AMP]
Q308	FET	TX DRIVE AMPLIFIER [DRIVE AMP]
Q501	TRANSISTOR	RX LOCAL AMPLIFIER [LOCAL AMP]
Q502-504	FET	MIXER
Q505	TRANSISTOR	LNA
Q506	TRANSISTOR	DC SWITCH [DC SW]
Q507-512	TRANSISTOR	NOISE BLANKER [NB]
Q513	FET	NOISE BLANKER[NB]
Q514	FET	MIXER
Q600	FET	VCO
Q601	TRANSISTOR	DC SWITCH [DC SW]
Q602	TRANSISTOR	RIPPLE FILTER
Q603	TRANSISTOR	IF AMPLIFIER [IF AMP]
Q604	FET	IF AMPLIFIER [IF AMP]
Q606, 607	FET	NOISE BLANKER SWITCH [NB SW]
Q608	FET	IF AMPLIFIER [IF AMP]
Q700	TRANSISTOR	TCXO BUFFER [TCXO BUFF]
Q701	FET	DC SWITCH [DC SW]
Q703, 704	FET	DC SWITCH [DC SW]
Q705	TRANSISTOR	DC SWITCH [DC SW]
Q903	FET	LOAD SWITCH [LOAD SW]
Q911	TRANSISTOR	AF MUTE SWITCH [AF MUTE SW]

REF. NO.	PART NAME	USE / FUNCTION
Q912	TRANSISTOR	DC SWITCH [DC SW]
Q913	FET	DC SWITCH (HR) [DC SW]
Q914	TRANSISTOR	DC SWITCH [DC SW]
Q915	FET	PA MUTE SWITCH [PA MUTE SW]
Q1001, 1002	FET	DC SWITCH [DC SW]
Q1003	TRANSISTOR	DC SWITCH [DC SW]
D1	ZENER DIODE	OVER VOLTAGE PROTECTION
D2	DIODE	REVERSE CURRENT PREVENTION
D3	ZENER DIODE	OVER VOLTAGE PROTECTION
D5	DIODE	SURGE PROTECTION
D6	DIODE	BACK UP BATTERY CHARGE
D8,9	DIODE	REVERSE CURRENT PREVENTION
D11	ZENER DIODE	OVER VOLTAGE PROTECTION
D12,13	DIODE	REVERSE CURRENT PREVENTION
D14	DIODE	DC-DC CONVERTER (54M) [5.4V DC-DC CONV]
D15	DIODE	DC-DC CONVERTER (200C) [20V DC-DC CONV]
D16,17	DIODE	REVERSE CURRENT PREVENTION
D100	ZENER DIODE	OVER VOLTAGE PROTECTION
D101, 102	DIODE	VCO-A/B SWITCH (FIN FILTER) [VCO-A/B SW]
D103, 104	VARIABLE CAPACITANCE DIODE	VOLTAGE FREQUENCY CONTROL [VCO]
D105-112	VARIABLE CAPACITANCE DIODE	VCO ASSIST TUNE
D113	DIODE	SPEED UP
D114, 115	DIODE	VCO-A/B SWITCH (FIN FILTER) [VCO-A/B SW]
D117	VARIABLE CAPACITANCE DIODE	TX MODULATION [VCO]
D118-121	DIODE	VCO-A/B SWITCH (LO FILTER) [VCO-A/B SW]
D301	DIODE	T/R SWITCH [T/R SW]
D304	DIODE	TX REVERSE POWER DETECTION [REV DET]
D306-310	DIODE	ANTENNA SWITCH [ANT SW]
D311	ZENER DIODE	OVER VOLTAGE PROTECTION
D313	DIODE	SURGE PROTECTION
D315	DIODE	SPEED UP
D500	DIODE	T/R SWITCH [T/R SW]
D501, 502	VARIABLE CAPACITANCE DIODE	RX BAND-PASS FILTER TUNE [RX BPF TUN]

REF. NO.	PART NAME	USE / FUNCTION
D505-507	VARIABLE CAPACITANCE DIODE	RX BAND-PASS FILTER TUNE [RX BPF TUN]
D509-515	VARIABLE CAPACITANCE DIODE	RX BAND-PASS FILTER TUNE [RX BPF TUN]
D517-519	VARIABLE CAPACITANCE DIODE	RX BAND-PASS FILTER TUNE [RX BPF TUN]
D521-525	VARIABLE CAPACITANCE DIODE	RX BAND-PASS FILTER TUNE [RX BPF TUN]
D526	DIODE	NOISE DETECTION STABILIZATION
D528, 529	DIODE	OVER VOLTAGE PROTECTION
D600, 601	VARIABLE CAPACITANCE DIODE	VOLTAGE FREQUENCY CONTROL [VCO]
D602	DIODE	OVER VOLTAGE PROTECTION
D700, 701	DIODE	REVERSE CURRENT PREVENTION
D708	ZENER DIODE	OVER VOLTAGE PROTECTION
D710, 711	DIODE	REVERSE CURRENT PREVENTION
D801	DIODE	REVERSE CURRENT PREVENTION
D903	ZENER DIODE	LINE PROTECTION
D904	DIODE	LINE PROTECTION
D905	VARISTOR	SURGE PROTECTION
D906	ZENER DIODE	LINE PROTECTION
D907	DIODE	REVERSE CURRENT PREVENTION
D908	DIODE	LINE PROTECTION
D910	VARISTOR	SURGE PROTECTION
D911	DIODE	LINE PROTECTION
D1001-1006	DIODE	LINE PROTECTION
D1007	DIODE	REVERSE CURRENT PREVENTION
D1008	ZENER DIODE	OVER VOLTAGE PROTECTION
D1009-1011	DIODE	LINE PROTECTION
D1012	DIODE	REVERSE CURRENT PREVENTION
D1013	ZENER DIODE	OVER VOLTAGE PROTECTION
D1019	ZENER DIODE	OVER VOLTAGE PROTECTION
D1020, 1021	VARISTOR	SURGE PROTECTION
D1024	ZENER DIODE	OVER VOLTAGE PROTECTION
D1025	DIODE	DC-DC CONVERTER (50USB) [5.0V DC-DC CONV]

2.5.2 Module (BT/GPS) Unit (XC2-0031-80)

REF. NO.	PART NAME	USE / FUNCTION
IC1	IC	LEVEL CONVERTER [LEVEL CONV]
IC2	IC	VOLTAGE REGULATOR (18BT) [1.8V AVR]
IC3	IC	VOLTAGE REGULATOR (33BT) [3.3V AVR]
IC4	IC	VOLTAGE REGULATOR (33GPS) [3.3V AVR]
IC5	IC	BLUETOOTH/GPS [BT/GPS]
IC6,7	IC	LEVEL CONVERTER [LEVEL CONV]
Q1	FET	DC SWITCH [DC SW]
D17,18	DIODE	OVER VOLTAGE PROTECTION

2.5.3 Interface Unit (XC3-073F-00)

REF. NO.	PART NAME	USE / FUNCTION
IC1	IC	AF AMPLIFIER [AF AMP]
IC2	IC	CAN TRANSCEIVER IC [CAN]
IC3	IC	VOLTAGE REGULATOR (33A) [3.3V AVR]
IC4,5	IC	ANALOG SWITCH (AF) [ANALOG SW]
IC6	IC	DC AMPLIFIER (VREF) [DC AMP]
IC7	IC	I/O EXPANDER [I/O EXP]
IC8	IC	AF AMPLIFIER [AF AMP]
IC9,10	IC	ANALOG SWITCH (AF) [ANALOG SW]

2.6 TERMINAL FUNCTION

2.6.1 Main unit (XC1-286F-00)

Pin No.	Name	I/O	Function
CN5 (for production)			
1~20	-	-	-
CN6 (to Module (BT/GPS) unit CN1)			
1	GPS_PWR	I	Antenna power supply detection
2	GPS_ALM	I	Antenna open/short detection
3	GND	-	Ground
4	GND	-	Ground
5	GPS_ANT_SW	O	Enable signal for 33GPS
6	GPS_PA_EN	O	GPS receiver part switching signal output
7	BT_SHUTDOWN	O	Shutdown signal output
8	WCLK	O	Audio serial data bus word clock output
9	BCLK	O	Audio serial data bus bit clock output
10	BT_AUD_DI	I	Audio signal input
11	BT_AUD_DO	O	Audio signal output
12	RTS2	O	Serial data output
13	CTS2	I	Serial data input
14	RXD2	I	Serial data input
15	TXD2	O	Serial data output
16	BT_SW	O	Enable signal for 33BT and 18BT
17	GND	-	Ground
18	GND	-	Ground
19	54M	O	5.4V output
20	54M	O	5.4V output
CN7 (to Interface unit CN1)			
1	IGN	I	Ignition input
2	NC	-	No connection
3	GND	-	Ground
4	54M	O	5.4V output
5	GND	-	Ground
6	GND	-	Ground
7	NC	-	No connection
8	SB1	O	Switched B output
9	SB1	O	Switched B output
10	SB1	O	Switched B output
11	SB1	O	Switched B output
12	SB1	O	Switched B output
13	NC	-	No connection
14	GND	-	Ground
15	GND	-	Ground
16	GND	-	Ground
17	GND	-	Ground
18	GND	-	Ground

Pin No.	Name	I/O	Function
19	NC	-	No connection
20	NC	-	No connection
21	NC	-	No connection
22	NC	-	No connection
23	NC	-	No connection
24	NC	-	No connection
25	NC	-	No connection
26	NC	-	No connection
27	NC	-	No connection
28	/PRST	O	Reset
29	/KEYINT	I	Key state change signal
30	I2CCK	O	I2C serial clock
31	I2CDT	I/O	I2C serial data
32	GND	-	Ground
33	NC	-	No connection
34	NC	-	No connection
35	GND	-	Ground
36	33M	O	3.3V output
37	NC	-	No connection
38	GND	-	Ground
39	RXD0	I	Serial data input
40	TXD0	O	Serial data output
41	NC	-	No connection
42	/PSW	I	Detection signal input of power switch
43	AFO+	O	AF signal output plus
44	AFO-	O	AF signal output minus
45	MIC	I	MIC signal input
46	ME	-	MIC ground
47	R_SET2	I	Radio setting signal 2
48	R_SET1	I	Radio setting signal 1
49	R_SET0	I	Radio setting signal 0
50	GND	-	Ground
CN8 (to D-Sub 25pin connector)			
1	SB	O	Switched power supply
2	NC	-	No connection
3	AUXO2	O	AUX input/output 2
4	RXD0	I	Serial data input
5	AUXO1	O	AUX input/output 1
6	TXD0	O	Serial data output
7	AFO	O	RX filtered AF signal output
8	AUXIO9/CTS	I/O	AUX input
9	GND	-	Ground
10	DI/RTS	I	Data signal input
11	DEO	O	RX detected signal output
12	MI2	I	External MIC signal input

Pin No.	Name	I/O	Function
13	AUXIO5	I/O	AUX input/output 5
14	GND	-	Ground
15	AUXIO4	I/O	AUX input/output 4
16	AUXIO8	I/O	AUX input/output 8
17	AUXIO3	I/O	AUX input/output 3
18	TXD2/AUXIO9	O	Serial data output 2
19	AUXIO2	I/O	AUX input/output 2
20	RXD2/DT	I	Serial data input 2
21	AUXIO1	I/O	AUX input/output 1
22	GND	-	Ground
23	ME	-	MIC ground
24	AUXIO7	I/O	AUX input/output 7
25	NC	-	No connection
26	AUXIO6/BERCK	I/O	AUX input/output 6
CN9 (to Molex 9pin connector)			
1	IGN	I	Ignition sense
2	GND	-	Ground
3	HR1	I	Horn alert signal
4	HR2	O	Horn alert signal
5	OS2	O	Audio signal
6	OS1	O	Audio signal
7	ES2	O	Audio signal
8	ES1	O	Audio signal
9	NC	-	No connection
CN10 (Micro USB connector)			
1	VBUS	I/O	USB VBUS (5V) input/output VBUS(5V) power
2	D-	I/O	USB data
3	D+	I/O	USB data
4	USB_GND	-	Ground
5	USB_ID	I	USB identification
6	GND	-	Ground
J700 (microSD)			
1	DAT2	I/O	Data 2
2	CD/DAT3	I/O	Data 3
3	CMD	I/O	Command input/output
4	VDD	O	3.3V output
5	CLK	O	Clock output
6	VSS	-	Ground
7	DAT0	I/O	Data 0
8	DAT1	I/O	Data 1
9	CD	I	Card detect switch
10	COMMON	-	Ground
11	GND1	-	Ground
12	GND2	-	Ground

Pin No.	Name	I/O	Function
25pin ACCESSORY CONNECTOR			
1	NC	-	Refer to "D-sub 25pin connector specification".
2	RXD0	I	
3	TXD0	O	
4	AUXIO9	I/O	
5	DI	I	
6	MI2	I	
7	GND	-	
8	AUXIO8	I/O	
9	TXD2	O	
10	RXD2	I	
11	GND	-	
12	AUXIO7	I/O	
13	AUXIO6	I/O	
14	SB	-	
15	AUXO2	O	
16	AUXO1	O	
17	AFO	O	
18	GND	-	
19	DEO	O	
20	AUXIO5	I/O	
21	AUXIO4	I/O	
22	AUXIO3	I/O	
23	AUXIO2	I/O	
24	AUXIO1	I/O	
25	ME	-	
9pin ACCESSORY CONNECTOR			
1	IGN	I	Refer to "Molex 9pin connector specification".
2	ES2	O	
3	NC	-	
4	HR1	I	
5	HR2	O	
6	ES1	O	
7	OS1	O	
8	OS2	O	
9	GND	-	

2.6.2 Module (BT/GPS) unit (XC2-0031-80)

Pin No.	Name	I/O	Function
CN1 (to Main unit CN6)			
1	54M	I	5.4V input
2	54M	I	5.4V input
3	GND	-	Ground
4	GND	-	Ground
5	BT_SW	I	Enable signal for 33BT and 18BT
6	TXD2	I	Serial data input
7	RXD2	O	Serial data output

Pin No.	Name	I/O	Function
8	CTS2	O	Serial data output
9	RTS2	I	Serial data input
10	BT_AUD_DO	I	Audio signal input
11	BT_AUD_DI	O	Audio signal output
12	BCLK	I	Audio serial data bus bit clock input
13	WCLK	I	Audio serial data bus word clock input
14	BT_SHUTDOWN	I	Shutdown signal input
15	GPS_PA_EN	I	GPS receiver part switching signal input
16	GPS_ANT_SW	I	Enable signal for 33GPS
17	GND	-	Ground
18	GND	-	Ground
19	GPS_ALM	O	Antenna open/short detection
20	GPS_PWR	O	Antenna power supply detection

2.6.3 Interface unit (XC3-073F-00)

Pin No.	Name	I/O	Function
CN1 (to Main unit CN7)			
1	GND	-	Ground
2	R_SET0	O	Radio setting signal 0
3	R_SET1	O	Radio setting signal 1
4	R_SET2	O	Radio setting signal 2
5	ME	-	MIC ground
6	MIC	O	MIC signal output
7	AFi-	I	AF signal input minus
8	AFi+	I	AF signal input plus
9	/PSW	O	Detection signal input of power switch
10	NC	-	No connection
11	TXD2	I	Serial data input
12	RXD2	O	Serial data output
13	GND	-	Ground
14	NC	-	No connection
15	33M	I	3.3V input
16	GND	-	Ground
17	NC	-	No connection
18	NC	-	No connection
19	GND	-	Ground
20	I2CDT	I/O	I2C serial data
21	I2CCK	I	I2C serial clock
22	/KEYINT	O	Key state change signal
23	/PRST	I	Reset
24	NC	-	No connection
25	NC	-	No connection
26	NC	-	No connection
27	NC	-	No connection

Pin No.	Name	I/O	Function
28	NC	-	No connection
29	NC	-	No connection
30	NC	-	No connection
31	NC	-	No connection
32	NC	-	No connection
33	GND	-	Ground
34	GND	-	Ground
35	GND	-	Ground
36	GND	-	Ground
37	GND	-	Ground
38	NC	-	No connection
39	SB	I	Switched B input
40	SB	I	Switched B input
41	SB	I	Switched B input
42	SB	I	Switched B input
43	SB	I	Switched B input
44	NC	-	No connection
45	GND	-	Ground
46	GND	-	Ground
47	54M	I	5.4V input
48	GND	-	Ground
49	NC	-	No connection
50	IGN	O	Ignition output
CN3/CN4 (to Control Head)			
1	/PRST	O	Reset
2	/PSW	I	Pull Up: 3.1V/35k + Diode Level Shifter
3	MIC_A+	I	MIC signal input plus_A
4	MIC_A-	I	MIC signal input minus_A
5	MIC_B+	I	MIC signal input plus_B
6	MIC_B-	I	MIC signal input minus_B
7	GND	-	Ground
8	SB	I	Switched B
9	NC	-	No connection
10	IGN	I	Ignition sense
11	AFo_A+	O	Audio signal output plus_A
12	AFo_A-	O	Audio signal output minus_A
13	AFo_B+	O	Audio signal output plus_B
14	AFo_B-	O	Audio signal output minus_B
15	CAN+	I/O	CAN data plus
16	CAN-	I/O	CAN data minus

2.6.4 D-Sub 25pin connector specification

Pin No.	Pin Name	I/O	Signal Type	Rating and Condition				
				Parameter	Min	Typ	Max	Unit
1	NC	-	-	-				
2	RXD0	I	Digital	Input Voltage Range	-30		30	V
				Threshold Low	0.5	1.3		V
				Threshold High		1.60	2.45	V
				Baud Rate	-		300k	bps
				CL		100		pF
3	TXD0	O	Digital	Voltage Swing (3kohm Load)	±5	±5.2		V
				Baud Rate	-		300k	bps
				CL		100		pF
4	AUXIO9	I/O	Digital	VIH	4	-	5.2	V
				VIL	-0.5	-	1	V
				VOH (Io=-1.5mA)	4	-	5.2	V
				VOL (Io=1.5mA)	-	-	1.1	V
5	DI	I	Analog	Input Voltage range (STD Deviation)	-	0.5	-	Vp-p
				Frequency Response (STD Deviation) 20~9600Hz	-3		3	dB
6	MI2	I	Analog	Audio Level (STD Deviation)	-	5	-	mVrms
				Allowable Frequency	300		3000	Hz
				Input Impedance	-	600	-	ohm
7	GND	-	GND					
8	AUXIO8	I/O	Digital	VIH	4	-	5.2	V
				VIL	-0.5	-	1	V
				VOH (Io=-1.5mA)	4	-	5.2	V
				VOL (Io=1.5mA)	-	-	1.1	V
9	TXD2	O	Digital	VOH (Io=-1.5mA)	3.7	-	5.2	V
				VOL (Io=1.5mA)	-	-	1.1	V
				CL		100		pF
10	RXD2	I	Digital	VIH	2.8	-	5.2	V
				VIL	-	-	0.65	V
				CL		100		pF
11	GND	-	GND					
12	AUXIO7	I/O	Digital	VIH	4	-	5.2	V
				VIL	-0.5	-	1	V
				VOH (Io=-1.5mA)	3.7	-	5.2	V
				VOL (Io=1.5mA)	-	-	1.1	V
13	AUXIO6	I/O	Digital	VIH	4	-	5.2	V
				VIL	-0.5	-	1	V
				VOH (Io=-1.5mA)	3.7	-	5.2	V
				VOL (Io=1.5mA)	-	-	1.1	V
14	SB	-	Power	Voltage	This parameter depends on Battery Voltage.			
				Supply Current	-	-	2	A
15	AUXO2	O	Digital	The type of this port is open collector.				
				VOL			0.4	V
				IOL			-500	mA

Pin No.	Pin Name	I/O	Signal Type	Rating and Condition				
				Parameter	Min	Typ	Max	Unit
16	AUXO1	O	Digital	The type of this port is open collector.				
				VOL			0.4	V
				IOL			-500	mA
17	AFO	O	Analog	Output Level		0.7		Vp-p
				Coupling Capacitor		10		uF
				Allowable Load	100	-	-	kohm
				Allowable Frequency	300		3000	Hz
18	GND	-	GND					
19	DEO	O	Analog	Output Level	-	0.28	-	Vp-p
				Coupling Capacitor	-	10	-	uF
				Allowable Load	47	-	-	kohm
				Frequency Response (STD Deviation)	-6		1	dB
				Wide 20~4800Hz				
				4800~7200Hz	-24		1	dB
20	AUXIO5	I/O	Digital	VIH	4	-	5.2	V
				VIL	-0.5	-	1	V
				VOH (Io=-1.5mA)	4	-	5.2	V
				VOL (Io=1.5mA)	-	-	1.1	V
21	AUXIO4	I/O	Digital	VIH	4	-	5.2	V
				VIL	-0.5	-	1	V
				VOH (Io=-1.5mA)	4	-	5.2	V
				VOL (Io=1.5mA)	-	-	1.1	V
22	AUXIO3	I/O	Digital	VIH	4	-	5.2	V
				VIL	-0.5	-	1	V
				VOH (Io=-1.5mA)	4	-	5.2	V
				VOL (Io=1.5mA)	-	-	1.1	V
23	AUXIO2	I/O	Digital	VIH	4	-	5.2	V
				VIL	-0.5	-	1	V
				VOH (Io=-1.5mA)	4	-	5.2	V
				VOL (Io=1.5mA)	-	-	1.1	V
24	AUXIO1	I/O	Digital	VIH	4	-	5.2	V
				VIL	-0.5	-	1	V
				VOH (Io=-1.5mA)	4	-	5.2	V
				VOL (Io=1.5mA)	-	-	1.1	V
25	ME	-	Analog	This is GND port for Microphone.				

2.6.5 Molex 9pin connector specification

Pin No.	Pin Name	I/O	Signal Type	Rating and Condition				
				Parameter	Min	Typ	Max	Unit
1	IGN	I	Analog	Voltage Range	0	-	30	V
				VIH	6.0	-	-	V
				VIL	-	5.0	-	V
2	ES2	O	Analog	Audio Output (3% Distortion)	-	12	-	W
				RL	4	-	-	ohm
				Allowable Frequency	300	-	3000	Hz
3	NC	-	-	-	-	-	-	-
4	HR1	I	Analog	Input Voltage	5.0	-	16.0	V
				Input Current	-	-	2.0	A
5	HR2	O	Analog	Output Voltage	This parameter depends on HR1 Voltage.			
				Output Voltage Loss	-	-	1.0	V
				Input Current	-	-	2.0	A
6	ES1	O	Analog	Audio Output (3% Distortion)	-	12	-	W
				RL	4	-	-	ohm
				Allowable Frequency	300	-	3000	Hz
7	OS1	O	Analog	Audio Output (3% Distortion)	-	12	-	W
				RL	4	-	-	ohm
				Allowable Frequency	300	-	3000	Hz
8	OS2	O	Analog	Audio Output (3% Distortion)	-	12	-	W
				RL	4	-	-	ohm
				Allowable Frequency	300	-	3000	Hz
9	GND	-	GND	-	-	-	-	-

SECTION 3 DISASSEMBLY

3.1 Precautions for Disassembly

3.1.1 Removing the M.CABINET, RUBBER SEAL and SHIELDING COVER

- (1) Remove 6 screws fixing the M.CABINET(bottom).<1>
- (2) Remove the M.CABINET and RUBBER SEAL.
- (3) Remove 15 screws fixing the SHIELDING COVER.<2>
- (4) Remove the SHIELDING COVER. **Note 1**

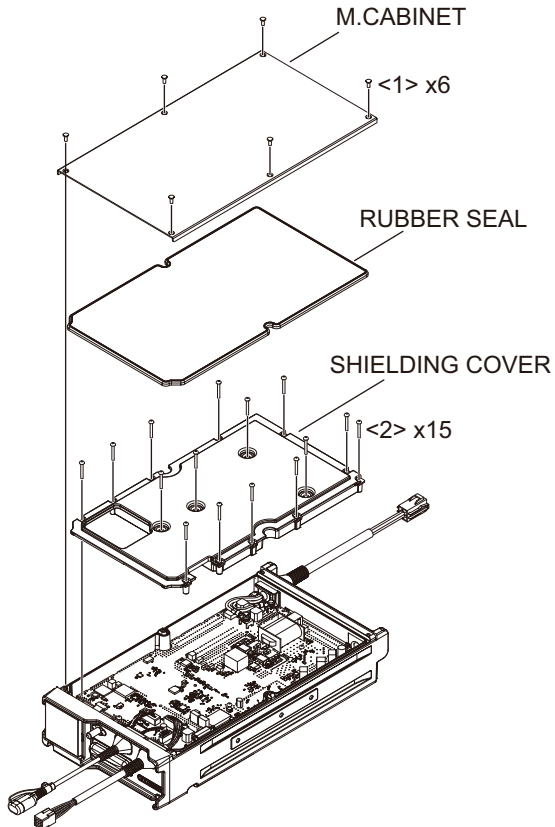

Note 1:

The Conductive Silicone Rubber has been applied to SHIELDING COVER's rib (dark line). Please handle carefully so as not to peel off the Conductive Silicone Rubber.

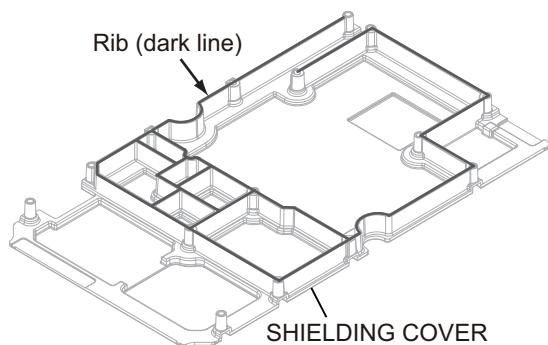

3.1.2 Removing the Main unit

- (1) Disconnect the connectors of the Main unit. **Note 2**
- (2) Remove the solder fixing the antenna.
- (3) Remove the FLAT SPRING.
- (4) Remove the 7 screws of the parts that are fixed on the chassis.<1>-<7>
- (5) Remove the 6 screws fixing the Main unit. x6

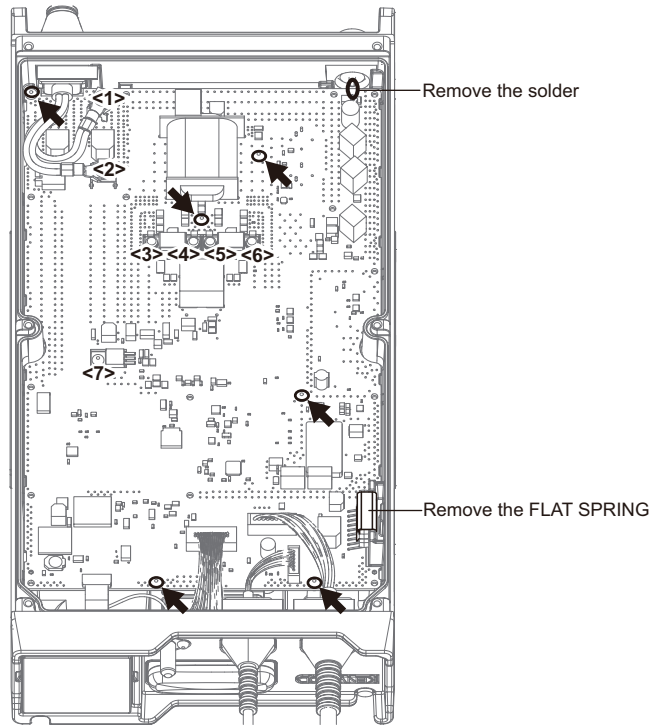

Note 2:

The 2 connectors shown below are lock type. When disconnecting the connector, pinch it in the direction of the arrow and pull it out.

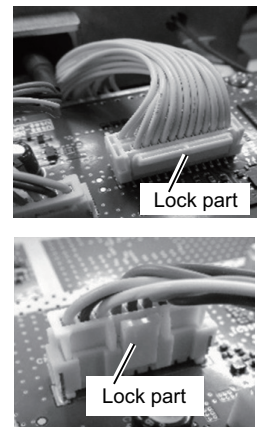
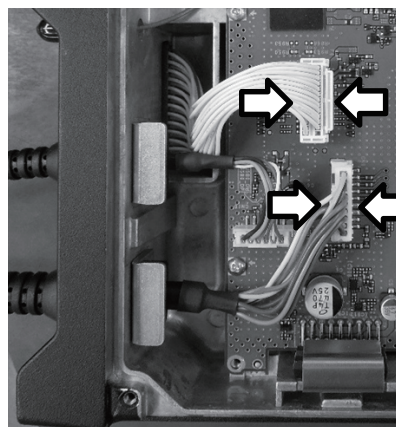

(6) The Main unit and the Interface unit are connected by FFC. When removing the Main unit, be careful not to apply excessive force to the FFC and the connectors.

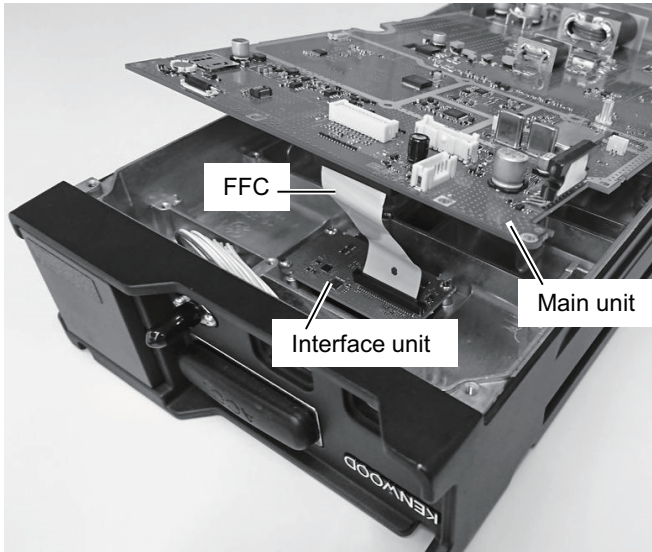

3.1.3 Removing the MOLDING COVER

Because the MOLDING COVER is fixed on the chassis with double-sided tape, remove it by the following procedure. Insert a flat-head screwdriver into the gap of MOLDING COVER <1>, then twist it in the direction of the arrow <2> and remove it.

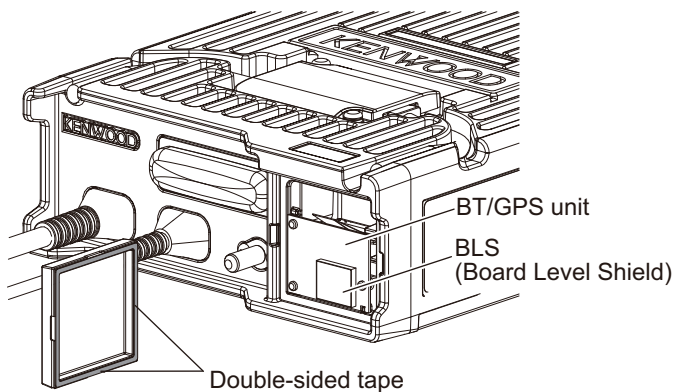
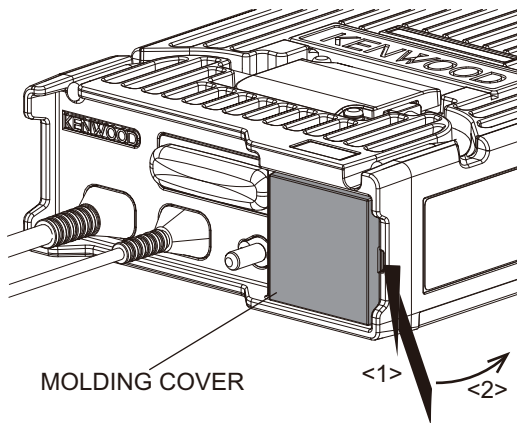

3.2 Precautions for Reassembly

3.2.1 Wire forming

Refer to the following pictures.

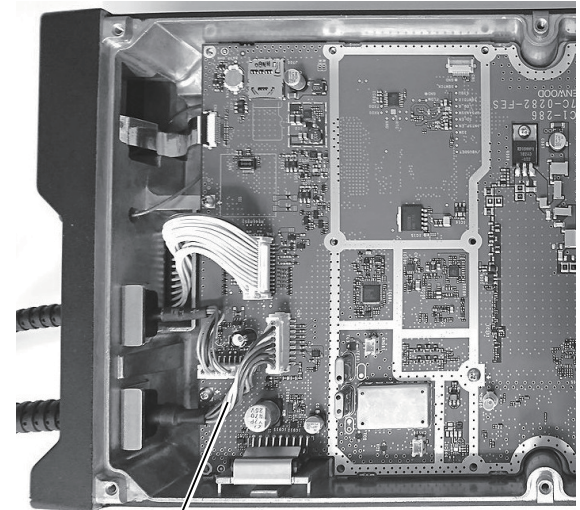

Avoid the capacitor

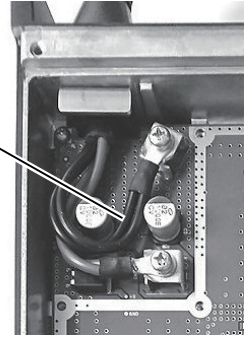

Pass the wire of COAXIAL RECEPTACLE-SMA through the underside of the FFC.

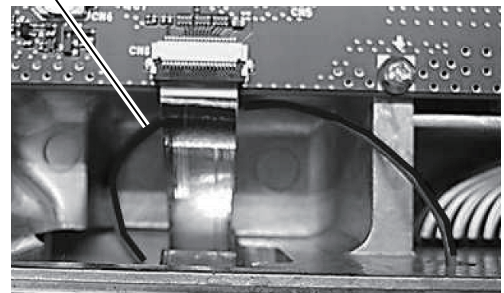

3.2.2 Attaching the RUBBER SEAL on the Chassis

There is a groove on the outer circumference of the RUBBER SEAL.

When attaching the RUBBER SEAL, fit the groove of the RUBBER SEAL to the rib on the chassis.

Note:

Make sure to press the outer circumference along the dotted line of the RUBBER SEAL to confirm that the groove and the rib of the chassis are fitted.

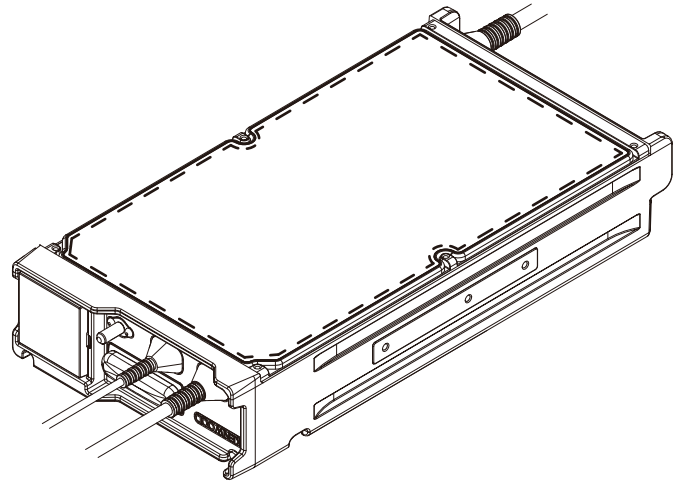
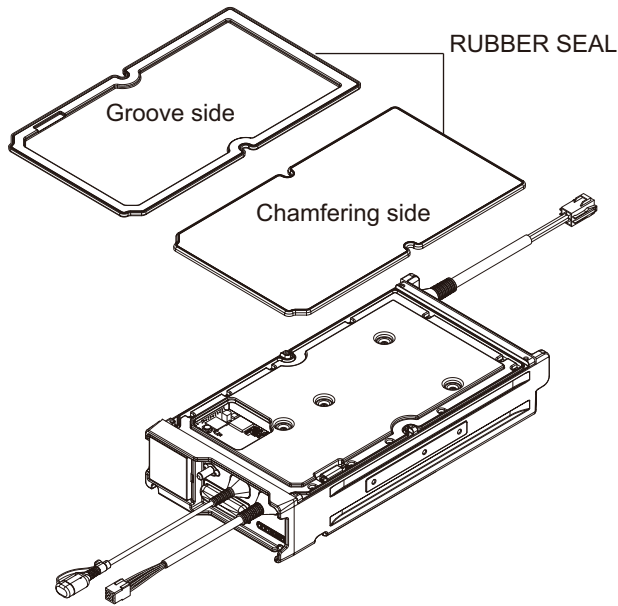

3.2.3 Assembly Information (Sheet/Cushion)

When "Main Parts" is changed (ordered), "Assembled Sheet / Cushion" should also be changed (ordered) together.

The Sticker and Sheet etc are non-reusable parts. It requires the new one to get the radio's performance after repairs.

Main Parts		Assembled Sheet/ Cushion		
Part Name	Part Number	Part Name	Part Number	QTY
SHIELDING COVER	F1B-0115-20	FIBROUS SHEET	G1A-0110-00	3
		CUSHION	G1D-0071-10	1
		INS.SHEET	F2A-0095-00	2
MODULE UNIT (BT/GPS)	XC2-0031-80	SHIELDING COVER (BLS)	F10-3225-05	1

SECTION 4 ADJUSTMENT

4.1 Controls

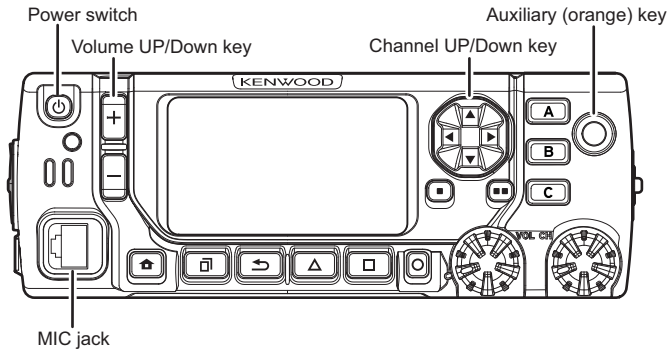

KMC-36 or KMC-66 (OPTION)

The illustration is the KMC-36.

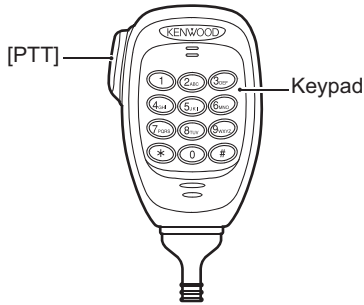

4.1.1 Preparations for checking/tuning the transceiver

Before attempting to check/tune the transceiver, connect the unit to a suitable power supply.

Whenever the transmitter is turned on, the unit must be connected to a suitable dummy load (i.e. power meter).

The speaker output connector must be terminated with a 4ohm dummy load and connected to an AC voltmeter and an audio distortion meter or a SINAD measurement meter at all times during checking/tuning.

4.2 Panel Test Mode

4.2.1 Test mode operation features

This transceiver has a test mode. To enter test mode, press and hold the [↵] key while turning the transceiver power ON. Before the transceiver enters test mode, the frequency version information appears on the LCD momentarily. Test mode can be inhibited by programming. To exit test mode, turn the transceiver power OFF. The following functions are available in test mode.

- When the panel test mode is activated, the last used channel and signaling numbers are displayed. When the panel test mode is activated for the first time, the channel and signaling numbers are 1.
- If test signaling 7 (NXDN Mode) is selected, the result of Bit Error Rate (BER) calculation is displayed on the LCD.

4.2.2 Key operation

■Function OFF: "Func" not appears on the sub LCD display

Key	Function	Display
[+]	Push: Volume up Hold: Volume up continuously	-
[-]	Push: Volume down Hold: Volume down continuously	-
[▲]	Push: Test channel up Hold: Test channel up continuously	Channel No.
[▼]	Push: Test channel down Hold: Test channel down continuously	Channel No.
[◀]	Push: Squelch level up *1 Hold: Squelch off	Squelch level Squelch off: [🔊] icon appears
[▶]	Wide/Narrow *2	Wide : "w" Narrow: "n"
[📺]	Shift to panel tuning mode	-
[↵]	Function on	"Func" appears on the sub LCD display
[○]	MSK 1200bps and 2400bps *1	2400bps: [☑] icon appears
[🏠]	Push: Test signaling up Hold: Test signaling up continuously	Signaling No.
[AUX (Orange)]	-	-
[PTT]	Transmit	-
[0] to [9] and [#], [✖]	-	-

*1: When the mode is selected as Analog, this function is enabled.

*2: When the mode is selected as NXDN, bandwidth is fixed to Narrow. When the mode is selected as Analog, bandwidth is fixed to Wide.

■Function ON: "Func" appears on the sub LCD display

Key	Function	Display
[+]	Function off	-
[-]	Function off	-
[▲]	Function off	-
[▼]	Mode selection Analog/NXDN	Analog: "A" NXDN: "N"
[◀]	Function off	-
[▶]	Key/LCD check	The contents of the pressed key etc., appear.

Key	Function	Display
[]	High power/Medium power/Low power	High: "H" Medium: "M" Low: "L"
[]	Function off	-
[]	Compander on/off	On: icon appears
[]	External Speaker on/off	On: icon appears
[AUX (Orange)]	Function off	-
[PTT]	Transmit	-
[0] to [9] and [#], [*]	Function off	-

■LED indicator

Red LED lights during transmission.
Green LED lights when there is carrier.

■LCD display in panel test mode

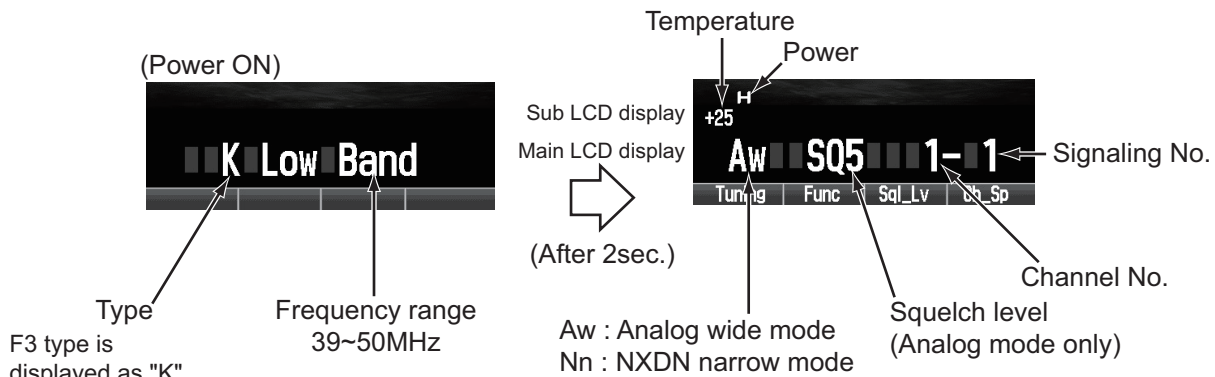

4.2.3 Frequency and Signaling

The transceiver has been adjusted for the frequencies shown in the following table. When required, readjust them following the adjustment procedure to obtain the frequencies you want in actual operation.

(1)Test frequency

Channel	RX (MHz)	TX (MHz)
1	44.600000	44.500000
2	39.100000	39.000000
3	49.900000	50.000000
4	44.500000	44.500000
5	44.700000	44.700000
6	44.900000	44.900000

(2)Test signaling

■Analog mode signaling

No.	RX	TX
1	None	None
2	None	Square Wave
4	QT:67.0Hz	QT:67.0Hz
5	QT:151.4Hz	QT:151.4Hz
6	QT:210.7Hz	QT:210.7Hz
7	QT:254.1Hz	QT:254.1Hz
8	DQT:D023N	DQT:D023N
9	DQT:D754I	DQT:D754I
10	DTMF Decode (CODE: 159D)	DTMF Encode (CODE: 159D)
11	None	DTMF Encode (CODE: 9)
12	2-tone Decode (A: 304.7Hz, B: 3106.0Hz)	2-tone Encode (A: 304.7Hz, B: 3106.0Hz)
13	Single Tone Decode (979.9Hz)	Single Tone Encode (979.9Hz)
14	None	Single Tone Encode (1000Hz)
15	None	MSK PN9
16	MSK Decode	MSK Encode







■NXDN Mode signaling

No.	RX	TX
1	RAN1	RAN1
2	None	PN9
3	RAN1	Maximum Deviation Pattern
7	FSW + PN9	FSW + PN9
9	Tone Pattern (1031Hz)	Tone Pattern (1031Hz)

RAN: Radio Access Number
 PN9: Pseudo-Random Pattern
 No.7, 9 Item: PC test mode only

4.3 Panel Tuning Mode







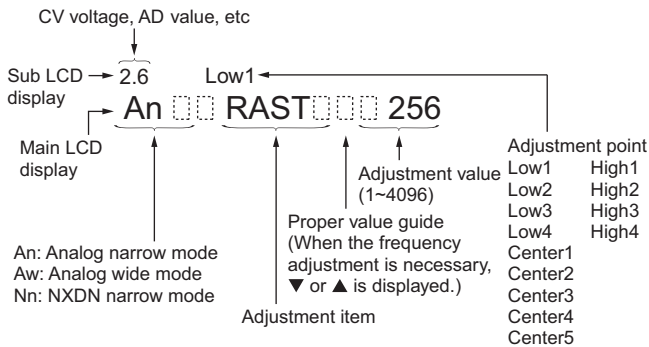

4.3.1 Transceiver tuning (To enter tuning mode)

To enter tuning mode, press the [] key while the transceiver is in test mode. Use the [] key to write tuning data through tuning modes, and the []/[] key to adjust tuning requirements (1 to 4096 appears on the LCD). Use the [] key to select the adjustment item through tuning modes. Use the [] key to adjust 5, 6, 7 or 13 reference level adjustments, and use the [] key to switch between Wide/Narrow/NXDN narrow.

■LCD display in panel tuning mode



4.3.2 Key operation

Key	Function	
	Push	Hold (1 second)
[+]	Volume up	Continuation up
[-]	Volume down	Continuation down
[]	Adjustment value up	Continuation up
[]	Adjustment value down	Continuation down
[]	Auto adjustment start	-
[]	Wide/Narrow/NXDN	Overlap point switching
[]	Shift to panel test mode	-
[]	To enter 5, 6, 7 or 13 reference level adjustments	-
[]	Writes the adjustment value	-
[]	Go to next adjustment item (At the time of 5, 6, 7 or 13 point adjustment: Adjustment point change)	Back to last adjustment item

Key	Function	
	Push	Hold (1 second)
[AUX (Orange)]	Output tone pattern change of balance adjustment (A change is possible only during balance adjustment.)	-
[PTT] (MIC)	Transmit	
[0] to [9] and [#],[*] (MIC)	-	

4.3.3 5, 6, 7 or 13 reference level adjustments frequency

■5 reference level adjustment

Sensitivity 1, Sensitivity 2, Sensitivity 3, Sensitivity 4, RSSI Reference, Open Squelch, Low RSSI, High RSSI, Tight Squelch

Tuning point	Display	RX (MHz)	TX (MHz)
1	Low 1	39.050000	39.100000
2	Low 4	41.050000	41.100000
3	Center 3	44.050000	44.100000
4	High 1	47.050000	47.100000
5	High 4	49.950000	49.900000

■6 reference level adjustment

High Maximum Power, Medium Maximum Power, Low Maximum Power, High Transmit Power, Medium Transmit Power, Low Transmit Power

Tuning point	Display	RX (MHz)	TX (MHz)
1	Low 1	39.050000	39.100000
2	Low 4	41.050000	41.100000
3	Center 2	43.050000	43.100000
4	Center 4	45.050000	45.100000
5	High 1	47.050000	47.100000
6	High 4	49.950000	49.900000

■7 reference level adjustment

Balance, Maximum Deviation, NXDN High Deviation, QT Deviation, DQT Deviation, DTMF Deviation, Single Tone Deviation, MSK Deviation

Tuning point	Display	RX (MHz)	TX (MHz)
1	Low 1	39.050000	39.100000
2	Low 3	40.050000	40.100000
3	Center 1	42.050000	42.100000
4	Center 3	44.050000	44.100000
5	Center 5	46.050000	46.100000
6	High 2	48.050000	48.100000
7	High 4	49.950000	49.900000

■13 reference level adjustment

Receive Assist, Transmit Assist

Tuning point	Display	RX (MHz)	TX (MHz)
1	Low 1	39.050000	39.100000
2	Low 2	39.500000	39.600000
3	Low 3	40.050000	40.100000
4	Low 4	41.050000	41.100000
5	Center 1	42.050000	42.100000
6	Center 2	43.050000	43.100000
7	Center 3	44.050000	44.100000
8	Center 4	45.050000	45.100000
9	Center 5	46.050000	46.100000
10	High 1	47.050000	47.100000
11	High 2	48.050000	48.100000
12	High 3	49.050000	49.100000
13	High 4	49.950000	49.900000

4.3.4 Adjustment item supplement

Adjustment Item	Description
Receive Assist	The lock voltage of VCO (Receive) is adjusted. This item must be adjusted before all adjustment items for receiver section are adjusted.
Transmit Assist	The lock voltage of VCO (Transmit) is adjusted. This item must be adjusted before all adjustment items for transmitter section are adjusted.
Frequency	Frequency is adjusted under receiving condition with SSG. The SSG needs 0.003ppm accuracy so please use a standard oscillator if necessary. This item can be adjusted only in PC Test Mode so that the adjustment value is not changed easily.
Ramp Offset	Adjust this item to the optimal Ramp voltage.
High Maximum Power	High Maximum Power is adjusted.
Medium Maximum Power	Medium Maximum Power is adjusted.
Low Maximum Power	Low Maximum Power is adjusted.
High Transmit Power	High Transmit Power is adjusted.
Medium Transmit Power	Medium Transmit Power is adjusted.
Low Transmit Power	Low Transmit Power is adjusted.

Adjustment Item	Description
Balance	The transmit modulation frequency response is adjusted. This item is adjusted so that the deviation of 2kHz becomes the same deviation of 20Hz. This item must be adjusted before all adjustment items for deviations are adjusted.
High Deviation (NXDN)	High Deviation of NXDN is adjusted.
Maximum Deviation (Analog Wide)	Maximum Deviation of Analog (Wide) is adjusted. This item must be adjusted before all adjustment items for tone deviations are adjusted.
QT Deviation	QT tone deviation is adjusted.
DQT Deviation	DQT tone deviation is adjusted.
DTMF Deviation	DTMF tone deviation is adjusted.
Single Tone Deviation	The deviation of Single Tone used in "2-tone" is adjusted.
MSK Deviation	MSK tone deviation is adjusted.
Sensitivity 1	Band-Pass Filter is adjusted. The performance of Receive Sensitivity is improved.
Sensitivity 2	Band-Pass Filter is adjusted. The performance of Receive Sensitivity is improved.
Sensitivity 3	Band-Pass Filter is adjusted. The performance of Receive Sensitivity is improved.
Sensitivity 4	Band-Pass Filter is adjusted. The performance of Receive Sensitivity is improved.
RSSI Reference	The minimum RSSI level for scan stop is adjusted.
Open Squelch	The squelch level at level "1" is adjusted.
Low RSSI	RSSI display level " ∇ " is adjusted.
High RSSI	Both "Low RSSI" and "High RSSI" must be adjusted. (The curve data of RSSI level is applied.)
Tight Squelch	The squelch level at level "9" is adjusted.

4.3.5 Adjustment item and Display

Order	Adjustment item	Main LCD display	Sub LCD display	Aw (Analog Wide)	An (Analog Narrow)	Nn (NXDN Narrow)	Adjust item Number
				Adjustment range			
1	Receive Assist	RAST	(CV voltage)	13 point ADJ			Common Section 2
				1 ~ 4096			
2	Transmit Assist	TAST	(CV voltage)	13 point ADJ			Common Section 3
				1 ~ 4096			
3	Frequency	-	-	1 point ADJ			Common Section 4
				1~4096			
4	RTC Correction	RTC	-	-			Common Section 5
				-2.00~-0.01 , 0.00 , +0.01~+2.00			
5	High Maximum Power	MAX-H	-	-	6	-	Transmitter Section 1
				1~256			
6	Medium Maximum Power	MAX-M	-	-	6	-	Transmitter Section 2
				1~256			
7	Low Maximum Power	MAX-L	-	-	6	-	Transmitter Section 3
				1~256			
8	High Transmit Power	H_PWR	-	-	6	-	Transmitter Section 4
				1~1024			
9	Medium Transmit Power	M_PWR	-	-	6	-	Transmitter Section 5
				1~1024			
10	Low Transmit Power	L_PWR	-	-	6	-	Transmitter Section 6
				1~1024			
11	Ramp Up Offset	RAMPU	(ADC measurement value)	-			Transmitter Section 7
				1~1024			
12	Ramp Down Offset	RAMPD	(ADC measurement value)	-			Transmitter Section 8
				1~1024			
13	Balance	BAL	(Encode frequency)	-	7	-	Transmitter Section 9
				1~1024			
14	Maximum Deviation	ADEV	-	7	-	-	Transmitter Section 10
				1~1024			
15	NXDN High Deviation	NDEV	-	-	-	7	Transmitter Section 11
				1~1024			
16	QT Deviation	QT	-	7	-	-	Transmitter Section 12
				1~1024			
17	DQT Deviation	DQT	-	7	-	-	Transmitter Section 13
				1~1024			
18	DTMF Deviation	DTMF	-	7	-	-	Transmitter Section 14
				1~1024			
19	Single Tone Deviation	TONE	-	7	-	-	Transmitter Section 15
				1~1024			
20	MSK Deviation	MSK	-	7	-	-	Transmitter Section 16
				1~1024			
21	Sensitivity 1	SENS1	(RSSI measurement value)	-	5	-	Receiver Section 5
				1~256			
22	Sensitivity 2	SENS2	(RSSI measurement value)	-	5	-	Receiver Section 2
				1~256			
23	Sensitivity 3	SENS3	(RSSI measurement value)	-	5	-	Receiver Section 3
				1~256			

Order	Adjustment item	Main LCD display	Sub LCD display	Aw (Analog Wide)	An (Analog Narrow)	Nn (NXDN Narrow)	Adjust item Number
				Adjustment range			
24	Sensitivity 4	SENS4	(RSSI measurement value)	-	5	-	Receiver Section 4
				1~256			
25	RSSI Reference	RRSSI	(RSSI measurement value)	-	5	-	Receiver Section 6
				1~256			
26	Open Squelch	SQL	(ASQDET measurement value)	5	-	5	Receiver Section 7
				1~256			
27	Low RSSI	LRSSI	(RSSI measurement value)	-	5	-	Receiver Section 8
				1~256			
28	High RSSI	HRSSI	(RSSI measurement value)	-	5	-	Receiver Section 9
				1~256			
29	Tight Squelch	SQLT	(ASQDET measurement value)	5	-	-	Receiver Section 10
				1~256			

4.3.6 Panel tuning mode flow chart

Note:

* In this Panel tuning mode flow chart, the Adjustment item name is modified.

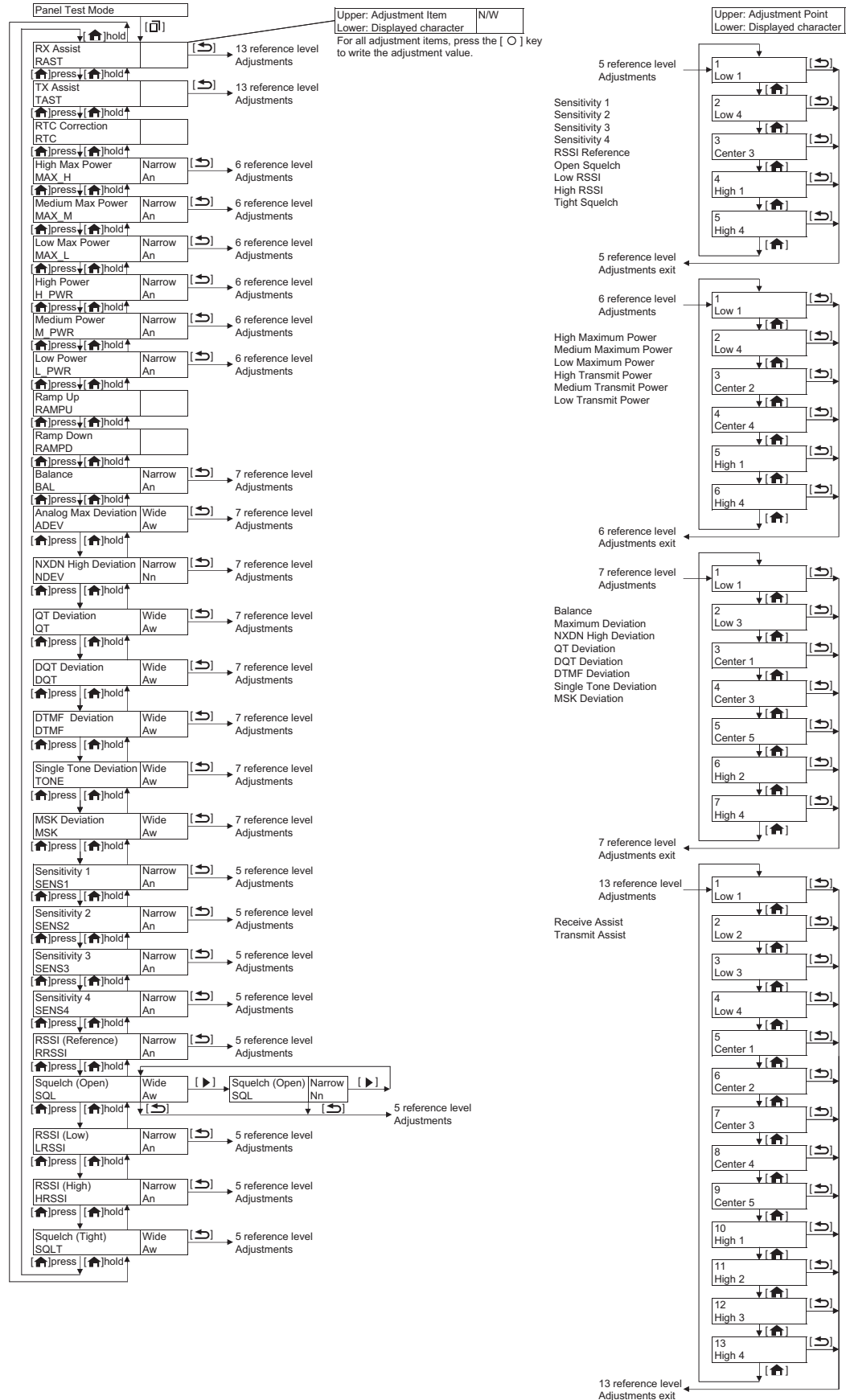

4.4 BER (Bit Error Rate) Measurement

- (1) The Panel Test Mode is used to measure the BER (Refer "4.2.1 Test mode operation features").
- (2) Select "7" (NXDN Mode) for test signaling (Refer to "4.2.3 Frequency and Signaling" (2) Test signaling).

Note:

"7" (NXDN Mode) can be selected only by PC test mode.

- (3) The bandwidth is fixed to Narrow.
- (4) Select a test frequency ("4.2.3 Frequency and Signaling" (1) Test frequency).

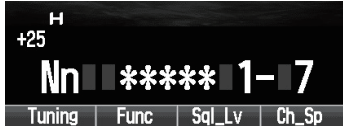

- (5) Measure the BER (Bit Error Rate) using the digital radio tester.
Enter a standard input signal into the transceiver as a FSW+PN9 for NXDN.
- (6) Adjust the input signal level to achieve the standard bit error rate (BER).

(For example, if the BER is 0.86%, the display shows "0.86".)



4.5 Adjustment points

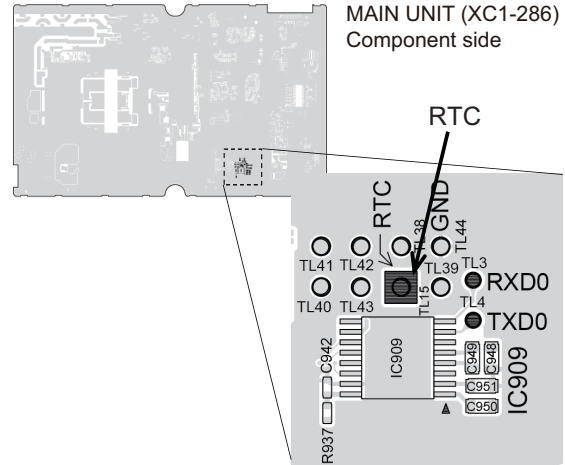

4.6 Test Equipment Required for Alignment

Test Equipment	Major Specifications	
1. Standard Signal Generator (SSG)	Frequency Range	10 to 100MHz
	Modulation	Frequency modulation and external modulation
	Output	-127dBm/0.1uV to greater than -20dBm/22.4mV
	When performing the Frequency adjustment, the following accuracy is necessary.	
	• 0.003ppm	
	Use a standard oscillator for adjustments, if necessary.	
2. Power Meter	Input Impedance	50ohm
	Operation Frequency	10 to 100MHz
	Measurement Capability	Vicinity of 200W
3. Deviation Meter	Frequency Range	10 to 100MHz
4. Digital Volt Meter (DVM)	Measuring Range	10mV to 20V DC
	Input Impedance	High input impedance for minimum circuit loading
5. Oscilloscope		DC through 30MHz
6. Frequency Counter	Frequency Range	10Hz to 1000MHz
	Frequency Stability	0.2ppm or less
	To measure the oscillating frequency of the internal clock 32766.00Hz~32770.00Hz for RTC Correction Resolution 0.01Hz is better for accuracy adjustment.	
7. Ammeter		30A or more
8. AF Volt Meter (AF VM)	Frequency Range	50Hz to 10kHz
	Voltage Range	1mV to 10V
9. Audio Generator (AG)	Frequency Range	50Hz to 5kHz or more
	Output	0 to 1V
10. Distortion Meter	Capability	3% or less at 1kHz
	Input Level	50mV to 10Vrms
11. Spectrum Analyzer	Measuring Range	DC to 1GHz or more
12. 4ohm Dummy Load		Approx. 4ohm, 30W
13. Regulated Power Supply		13.4V, approx. 30A (adjustable from 9V to 17V) Useful if ammeter equipped

*The test equipment which is not used for adjustment is contained in this table.

■ Test cable for microphone input (E30-3360-28)

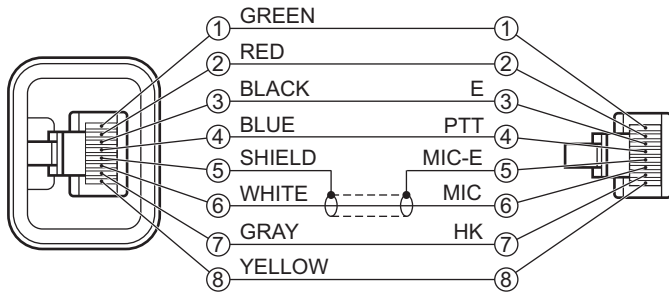

■ MIC connector (Front panel view)

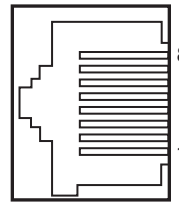

- 1 : BLC
- 2 : +B
- 3 : GND
- 4 : PTT/TXD (PC serial data from radio)
- 5 : MICE
- 6 : MIC
- 7 : HOOK/RXD (PC serial data to radio)
- 8 : DM

■ Tuning cable (E30-7754-05)

Tuning cable (E30-7754-05) is required for injecting an audio if PC tuning is used.
See "PC Mode" section for the connection.

4.7 Radio check Section

Item	Condition <PC>: PC test mode <Panel>: Panel test mode	Measurement	Adjustment		Specifications /Remarks
			Unit Parts	Method	
1. Frequency check	<PC> 1) Test Channel: 1 Test Signaling Mode: Analog Signaling: 1 2) Press [Transmit] key.	f. counter		Check an internal temperature of radio from 20°C to 33°C.	±0.5ppm ±22.2Hz @44.5MHz
	<Panel> 1) CH-Sig: 1-1 2) PTT: ON				
2. High power check	<PC> 1) Test Channel: 1 Test Signaling Mode: Analog Signaling: 1 2) Press [Transmit] key.	Power meter Ammeter		Check	100~120W 20A or less
	1) Test Channel: 2 Test Signaling Mode: Analog Signaling: 1 2) Press [Transmit] key.				
	1) Test Channel: 3 Test Signaling Mode: Analog Signaling: 1 2) Press [Transmit] key.				
	<Panel> 1) CH-Sig: 1-1 2) PTT: ON	Power meter Ammeter			
	1) CH-Sig: 2-1 2) PTT: ON				
	1) CH-Sig: 3-1 2) PTT: ON				

Item	Condition	Measurement	Adjustment		Specifications /Remarks
	<PC>: PC test mode <Panel>: Panel test mode		Unit Parts	Method	
3. Medium power check	<PC> 1) Test Channel: 1 Test Signaling Mode: Analog Signaling: 1 2) Press [Transmit] key.	Power meter Ammeter		Check	65~75W 16A or less
	1) Test Channel: 2 Test Signaling Mode: Analog Signaling: 1 2) Press [Transmit] key.				
	1) Test Channel: 3 Test Signaling Mode: Analog Signaling: 1 2) Press [Transmit] key.				
	<Panel> 1) CH-Sig: 1-1 2) PTT: ON	Power meter Ammeter			
	1) CH-Sig: 2-1 2) PTT: ON				
	1) CH-Sig: 3-1 2) PTT: ON				
3. Low power check	<PC> 1) Test Channel: 1 Test Signaling Mode: Analog Signaling: 1 2) Press [Transmit] key.	Power meter Ammeter		Check	22~28W 11A or less
	1) Test Channel: 2 Test Signaling Mode: Analog Signaling: 1 2) Press [Transmit] key.				
	1) Test Channel: 3 Test Signaling Mode: Analog Signaling: 1 2) Press [Transmit] key.				
	<Panel> 1) CH-Sig: 1-1 2) PTT: ON	Power meter Ammeter			
	1) CH-Sig: 2-1 2) PTT: ON				
	1) CH-Sig: 3-1 2) PTT: ON				
4. MIC sensitivity check	<PC> 1) Test Channel: 1 Test Signaling Mode: Analog Signaling: 1 2) AG: 1kHz 3) Press [Transmit] key.	Deviation meter Oscilloscope AG AF VM		Adjust AG input to get a standard MOD. <Standard MOD> Wide: ±3.0kHz	5mV ±1.5mV
	<Panel> 1) CH-Sig: 1-1 2) AG: *Same as above 3) PTT: ON				

Item	Condition	Measurement	Adjustment		Specifications /Remarks
	<PC>: PC test mode <Panel>: Panel test mode		Unit Parts	Method	
5. Sensitivity check	<p><PC></p> <p>1) Test Channel: 1 Test Signaling Mode: Analog Signaling: 1</p> <p>2) SSG output: -117dBm (0.32μV) Wide: MOD: 1kHz/±3.0kHz</p> <p><Panel></p> <p>1) CH-Sig: 1-1 2) SSG output: *Same as above</p>	SSG AF VM Oscilloscope Distortion meter 4ohm Dummy load		Check	12dB SINAD or more

4.8 Common Section

Item	Condition	Measurement	Adjustment		Specifications /Remarks
	<PC>: PC tuning mode <Panel>: Panel tuning mode		Unit Parts	Method	
1. Setting	1) DC voltage:13.4V 2) SSG standard modulation [Wide] MOD:1kHzDEV:3kHz				
2. Receive Assist	<p><PC></p> <p>1) Adj item: [Receive Assist] 2) Adj points: 13 points [Low1], [Low2], [Low3], [Low4], [Center1], [Center2], [Center3], [Center4], [Center5], [High1], [High2], [High3], [High4]</p> <p><Panel></p> <p>1) Adj item: [RAST] 2) Adj points: 13 points [Low1 RAST], [Low2 RAST], [Low3 RAST], [Low4 RAST], [Center1 RAST], [Center2 RAST], [Center3 RAST], [Center4 RAST], [Center5 RAST], [High1 RAST], [High2 RAST], [High3 RAST], [High4 RAST]</p>		<p>[←], [→]</p> <p>[▲], [▼]</p>	<p><PC></p> <p>[Automatic Adjustment]</p> <p>1) Press [Tune Assist Voltage] key. 2) Press [Apply All] key to store the adjustment value after the automatic adjustment has been finished. 3) Verify that the VCO lock voltage is within the specification.</p> <p><PC> <Panel></p> <p>[Manual Adjustment]</p> <p>1) [V] indicator on the PC window or LCD shows VCO lock voltage. Change the adjustment value to get VCO lock voltage within the specified voltage. 2) Press [Apply All] key for <PC>, or [O] key for <Panel> to store the adjustment value.</p>	2.5V±0.1V
<p>Note 1: Confirm the VCO lock voltage approximately 3 seconds after the adjustment value is changed.</p> <p>Note 2: The assist adjustment value must be between from 340 to 3550.</p> <p>Note 3: [Low2] is an overlap point. It is necessary to adjustment both Low and High.</p>					

Item	Condition	Measurement	Adjustment		Specifications /Remarks
	<PC>: PC tuning mode <Panel>: Panel tuning mode		Unit Parts	Method	
3. Transmit Assist	<p><PC></p> <p>1) Adj item: [Transmit Assist]</p> <p>2) Adj points: 13 points [Low1], [Low2], [Low3], [Low4], [Center1], [Center2], [Center3], [Center4], [Center5], [High1], [High2], [High3], [High4]</p>		[←], [→]	<p><PC></p> <p>[Automatic Adjustment]</p> <p>1) Press [Tune Assist Voltage] key.</p> <p>2) Press [Apply All] key to store the adjustment value after the automatic adjustment has finished.</p> <p>3) Verify that the VCO lock voltage is within the specification.</p>	2.5V±0.1V
	<p><Panel></p> <p>1) Adj item: [TAST]</p> <p>2) Adj points: 13 points [Low1 TAST], [Low2 TAST], [Low3 TAST], [Low4 TAST], [Center1 TAST], [Center2 TAST], [Center3 TAST], [Center4 TAST], [Center5 TAST], [High1 TAST], [High2 TAST], [High3 TAST], [High4 TAST]</p>		[▲], [▼]	<p><PC> <Panel></p> <p>[Manual Adjustment]</p> <p>1) [V] indicator on the PC window or LCD shows VCO lock voltage. Change the adjustment value to get VCO lock voltage within the specified voltage.</p> <p>2) Press [Apply All] key for <PC>, or [○] key for <Panel> to store the adjustment value.</p>	
<p>Note 1: Confirm the VCO lock voltage approximately 3 seconds after the adjustment value is changed.</p> <p>Note 2: The assist adjustment value must be between from 340 to 3550.</p>					
4. Frequency	<p><PC></p> <p>1) Adj item: [Frequency]</p> <p>2) SSG output : -20dBm (22.4mV) (CW (without modulation))</p>	SSG	[←], [→]	<p>Press [Start] key of "Auto Tuning". Press [Apply] key to store the adjustment value after the automatic adjustment has finished.</p>	
	<p><Panel></p> <p>*The Frequency adjustment can be performed only in PC tuning mode.</p>			<p>IF20" value = Within 0±10 digits. The value of "IF20" will become around "0" after the adjustment has finished.</p>	
<p>Caution: Perform the frequency adjustment under the following conditions.</p> <ul style="list-style-type: none"> • Temperature range of +20°C to +33°C (+68.0°F to +91.4°F). (The temperature is displayed on the Frequency adjustment screen of the KPG-D1/D1N and the LCD of the transceiver.) • Use an accuracy of 0.003ppm for the SSG. (Use a standard oscillator if necessary.) <p>Remark: "Frequency" is adjusted under receiving condition with SSG.</p>					
5. RTC Correction	<p><PC></p> <p>1) Adj item: [RTC Correction]</p>	Frequency Counter	[←], [→]	The adjustment value should input the display of the Frequency Counter.	
	<p><Panel></p> <p>1) Adj item: [RTC]</p>	Test Point (TL15)	[▲], [▼]	Press [Apply] key for <PC>, or [○] key for <Panel> to store the adjustment value.	
<p>Remarks:</p> <p>Change the adjustment value so that the frequency currently displayed on Crystal Oscillation Frequency on the PC window and the frequency currently displayed on the frequency counter are in agreement.</p>					

4.9 Transmitter Section

Item	Condition	Measurement	Adjustment		Specifications /Remarks
	<PC>: PC tuning mode <Panel>: Panel tuning mode		Unit Parts	Method	
1. High Maximum Power	<PC> 1) Adj item: [High Maximum Power] 2) Adj points: 6 points [Low1], [Low4], [Center2], [Center4], [High1], [High4] 3) Press [Transmit] key.	Power meter Ammeter	[←], [→]	125W Press [Apply All] key for <PC> after all adjustment points have been adjusted. Or press [O] key for <Panel> to store the adjustment value at each adjustment point.	±10W 25A or less
	<Panel> 1) Adj item: [MAX-H] 2) Adj points: *Same as above 3) PTT : ON		[▲], [▼]		
2. Medium Maximum Power	<PC> 1) Adj item: [Medium Maximum Power] 2) Adj points: 6 points [Low1], [Low4], [Center2], [Center4], [High1], [High4] 3) Press [Transmit] key.	Power meter Ammeter	[←], [→]	125W Press [Apply All] key for <PC> after all adjustment points have been adjusted. Or press [O] key for <Panel> to store the adjustment value at each adjustment point.	±10W 25A or less
	<Panel> 1) Adj item: [MAX-M] 2) Adj points: *Same as above 3) PTT : ON		[▲], [▼]		
3. Low Maximum Power	<PC> 1) Adj item: [Low Maximum Power] 2) Adj points: 6 points [Low1], [Low4], [Center2], [Center4], [High1], [High4] 3) Press [Transmit] key.	Power meter Ammeter	[←], [→]	125W Press [Apply All] key for <PC> after all adjustment points have been adjusted. Or press [O] key for <Panel> to store the adjustment value at each adjustment point.	±10W 25A or less
	<Panel> 1) Adj item: [MAX-L] 2) Adj points: *Same as above 3) PTT : ON		[▲], [▼]		
4. High Transmit Power	<PC> 1) Adj item: [High Transmit Power] 2) Adj points: 6 points [Low1], [Low4], [Center2], [Center4], [High1], [High4] 3) Press [Transmit] key.	Power meter Ammeter	[←], [→]	110W Press [Apply All] key for <PC> after all adjustment points have been adjusted. Or press [O] key for <Panel> to store the adjustment value at each adjustment point.	±2W 20A or less
	<Panel> 1) Adj item: [H_PWR] 2) Adj points: *Same as above 3) PTT : ON		[▲], [▼]		
5. Medium Transmit Power	<PC> 1) Adj item: [Medium Transmit Power] 2) Adj points: 6 points [Low1], [Low4], [Center2], [Center4], [High1], [High4] 3) Press [Transmit] key.	Power meter Ammeter	[←], [→]	70W Press [Apply All] key for <PC> after all adjustment points have been adjusted. Or press [O] key for <Panel> to store the adjustment value at each adjustment point.	±1.5W 16A or less
	<Panel> 1) Adj item: [M_PWR] 2) Adj points: *Same as above 3) PTT : ON		[▲], [▼]		

Item	Condition	Measurement	Adjustment		Specifications /Remarks
	<PC>: PC tuning mode <Panel>: Panel tuning mode		Unit Parts	Method	
6. Low Transmit Power	<PC> 1) Adj item: [Low Transmit Power] 2) Adj points: 6 points [Low1], [Low4], [Center2], [Center4], [High1], [High4] 3) Press [Transmit] key.	Power meter Ammeter	[←], [→]	25W Press [Apply All] key for <PC> after all adjustment points have been adjusted. Or press [O] key for <Panel> to store the adjustment value at each adjustment point.	±1W 11A or less
	<Panel> 1) Adj item: [L_PWR] 2) Adj points: *Same as above 3) PTT : ON		[▲], [▼]		
7. Ramp Up Offset	<PC> 1) Adj item: [Ramp Up Offset] 2) Press [Transmit] key.	Power meter Ammeter	[←], [→]	<PC> [Automatic Adjustment] 1) Press [Tune Ramp Offset] key. 2) Press [Apply All] key to store the adjustment value after the automatic adjustment has finished. <PC> <Panel> [Manual Adjustment] 1) Set the adjustment value to "1". 2) Press [Transmit] key for <PC> or [PTT] key for <Panel> and increase the adjustment value slowly while monitoring the offset monitor value. 3) Set the adjustment value when the offset monitor value exceed "65". 4) Press [Apply] key for <PC>, or [O] key for <Panel> to store the adjustment value.	
	<Panel> 1) Adj item: [RAMPU] 2) PTT: ON		[▲], [▼]		
8. Ramp Down Offset	<PC> 1) Adj item: [Ramp Down Offset] 2) Press [Transmit] key.	Power meter Ammeter	[←], [→]	<PC> [Automatic Adjustment] 1) Press [Tune Ramp Offset] key. 2) Press [Apply All] key to store the adjustment value after the automatic adjustment has finished. <PC> <Panel> [Manual Adjustment] 1) Set the adjustment value to "1". 2) Press [Apply] key for <PC>, or [O] key for <Panel> to store the adjustment value.	
	<Panel> 1) Adj item: [RAMPD] 2) PTT: ON		[▲], [▼]		
9. Balance	<PC> 1) Adj item: [Balance] 2) Deviation meter LPF: 3kHz/ HPF: OFF 3) Adj points: 7 points [Low1], [Low3], [Center1], [Center3], [Center5], [High2], [High4] 4) Press [Transmit] key.	Deviation meter Oscilloscope	[←], [→]	The Deviation of 20Hz frequency is fixed. Change the 2kHz adjustment value to become the same deviation of 20Hz within the specified range. <PC> While pressing [Transmit] key, click the check box "2kHz Sine Wave" to change the 20Hz/2kHz. Press [Apply All] key to store the adjustment value. <Panel> While PTT is ON, press the [▲] key to change the 20Hz/2kHz. Press [O] key to store the adjustment value.	2kHz Tone deviation is within ± 1.0% of 20Hz tone deviation.
	<Panel> 1) Adj item: [BAL] 2) Deviation meter *Same as above 3) Adj points: *Same as above 4) PTT : ON		[▲], [▼]		

Item	Condition	Measurement	Adjustment		Specifications /Remarks
	<PC>: PC tuning mode <Panel>: Panel tuning mode		Unit Parts	Method	
10. Maximum Deviation [Analog Wide]	<PC> 1) Adj item: [Maximum Deviation (Analog Wide)] 2) Deviation meter LPF: 15kHz/ HPF: OFF 3) Adj points: 7 points [Low1], [Low3], [Center1], [Center3], [Center5], [High2], [High4] 4) Press [Transmit] key.	Deviation meter Oscilloscope	[←], [→]	Set a fixed value "500" for each adjustment point. Transmit at each adjustment point and check that the deviation is within the Specifications. Press [Apply All] key for <PC> after all adjustment points have been adjusted. Or press [O] key for <Panel> to store the adjustment value at each adjustment point.	4150~4250Hz
	<Panel> 1) Adj item: [Aw ADEV] 2) Deviation meter *Same as above 3) Adj points: *Same as above 4) PTT : ON		[▲], [▼]		
11. NXDN High Deviation [NXDN Narrow]	<PC> 1) Adj item: [NXDN High Deviation (NXDN Narrow)] 2) Deviation meter LPF: 3kHz/ HPF: OFF 3) Adj points: 7 points [Low1], [Low3], [Center1], [Center3], [Center5], [High2], [High4] 4) Press [Transmit] key.	Deviation meter Oscilloscope	[←], [→]	Set a fixed value "505" for each adjustment point. Transmit at each adjustment point and check that the deviation is within the Specifications. Press [Apply All] key for <PC> after all adjustment points have been adjusted. Or press [O] key for <Panel> to store the adjustment value at each adjustment point.	2995~3117Hz
	<Panel> 1) Adj item: [Nn NDEV] 2) Deviation meter *Same as above 3) Adj points: *Same as above 4) PTT : ON		[▲], [▼]		
12. QT Deviation [Analog Wide]	<PC> 1) Adj item: [QT Deviation (Analog Wide)] 2) Deviation meter LPF: 3kHz/ HPF: OFF 3) Adj points: 7 points [Low1], [Low3], [Center1], [Center3], [Center5], [High2], [High4] 4) Press [Transmit] key.	Deviation meter Oscilloscope	[←], [→]	Set a fixed value "525" for each adjustment point. Press [Apply All] key for <PC> after all adjustment points have been adjusted. Or press [O] key for <Panel> to store the adjustment value at each adjustment point.	0.75kHz ±0.05kHz
	<Panel> 1) Adj item: [Aw QT] 2) Deviation meter *Same as above 3) Adj points: *Same as above 4) PTT : ON		[▲], [▼]		

Item	Condition	Measurement	Adjustment		Specifications /Remarks
	<PC>: PC tuning mode <Panel>: Panel tuning mode		Unit Parts	Method	
13. DQT Deviation [Analog Wide]	<p><PC></p> <p>1) Adj item: [DQT Deviation (Analog Wide)]</p> <p>2) Deviation meter LPF: 3kHz/ HPF: OFF</p> <p>3) Adj points: 7 points [Low1], [Low3], [Center1], [Center3], [Center5], [High2], [High4]</p> <p>4) Press [Transmit] key.</p>	Deviation meter Oscilloscope	[←], [→]	<p>Set a fixed value "425" for each adjustment point.</p> <p>Press [Apply All] key for <PC> after all adjustment points have been adjusted.</p> <p>Or press [O] key for <Panel> to store the adjustment value at each adjustment point.</p>	0.75kHz ±0.05kHz
	<p><Panel></p> <p>1) Adj item: [Aw DQT]</p> <p>2) Deviation meter *Same as above</p> <p>3) Adj points: *Same as above</p> <p>4) PTT : ON</p>		[▲], [▼]		
14. DTMF Deviation [Analog Wide]	<p><PC></p> <p>1) Adj item: [DTMF Deviation (Analog Wide)]</p> <p>2) Deviation meter LPF: 15kHz/ HPF: OFF</p> <p>3) Adj points: 7 points [Low1], [Low3], [Center1], [Center3], [Center5], [High2], [High4]</p> <p>4) Press [Transmit] key.</p>	Deviation meter Oscilloscope	[←], [→]	<p>Set a fixed value "550" for each adjustment point.</p> <p>Press [Apply All] key for <PC> after all adjustment points have been adjusted.</p> <p>Or press [O] key for <Panel> to store the adjustment value at each adjustment point.</p>	2.50kHz ±0.05kHz
	<p><Panel></p> <p>1) Adj item: [Aw DTMF]</p> <p>2) Deviation meter *Same as above</p> <p>3) Adj points: *Same as above</p> <p>4) PTT : ON</p>		[▲], [▼]		
15. Single Tone Deviation [Analog Wide]	<p><PC></p> <p>1) Adj item: [Single Tone Deviation (Analog Wide)]</p> <p>2) Deviation meter LPF: 15kHz/ HPF: OFF</p> <p>3) Adj points: 7 points [Low1], [Low3], [Center1], [Center3], [Center5], [High2], [High4]</p> <p>4) Press [Transmit] key.</p>	Deviation meter Oscilloscope	[←], [→]	<p>Set a fixed value "518" for each adjustment point.</p> <p>Press [Apply All] key for <PC> after all adjustment points have been adjusted.</p> <p>Or press [O] key for <Panel> to store the adjustment value at each adjustment point.</p>	3.00kHz ±0.05kHz
	<p><Panel></p> <p>1) Adj item: [Aw TONE]</p> <p>2) Deviation meter *Same as above</p> <p>3) Adj points: *Same as above</p> <p>4) PTT : ON</p>		[▲], [▼]		

Item	Condition	Measurement	Adjustment		Specifications /Remarks
	<PC>: PC tuning mode <Panel>: Panel tuning mode		Unit Parts	Method	
16. MSK Deviation [Analog Wide]	<PC> 1) Adj item: [MSK Deviation (Analog Wide)] 2) Deviation meter LPF: 15kHz/ HPF: OFF 3) Adj points: 7 points [Low1], [Low3], [Center1], [Center3], [Center5], [High2], [High4] 4) Press [Transmit] key.	Deviation meter Oscilloscope	[←], [→]	Set a fixed value "505" for each adjustment point. Press [Apply All] key for <PC> after all adjustment points have been adjusted. Or press [O] key for <Panel> to store the adjustment value at each adjustment point.	3.00kHz ±0.05kHz
	<Panel> 1) Adj item: [Aw MSK] 2) Deviation meter *Same as above 3) Adj points: *Same as above 4) PTT : ON		[▲], [▼]		

4.9.1 Necessary Deviation adjustment item for each signaling and mode

The following shows the necessary adjustment items for each signaling deviation

For example, in a case of the signaling "QT (Analog Wide)", this signaling deviation is composed of three elements [Balance, Maximum Deviation (Analog Wide) and QT Deviation (Analog Wide)]. Therefore, it is necessary to adjust Balance and Maximum Deviation (Analog Wide) before adjusting QT Deviation (Analog Wide).

Mode	Signaling	Necessary adjustment and order	
		Wide	Narrow
Analog	Audio	1. Balance adjust 2. Maximum Deviation [Analog Wide]	-
	QT	1. Balance adjust 2. Maximum Deviation [Analog Wide] 3. QT Deviation [Analog Wide]	-
	DQT	1. Balance adjust 2. Maximum Deviation [Analog Wide] 3. DQT Deviation [Analog Wide]	-
	DTMF	1. Balance adjust 2. Maximum Deviation [Analog Wide] 3. DTMF Deviation [Analog Wide]	-
	2TONE	1. Balance adjust 2. Maximum Deviation [Analog Wide] 3. Single TONE Deviation [Analog Wide]	-
	MSK	1. Balance adjust 2. Maximum Deviation [Analog Wide] 3. MSK Deviation [Analog Wide]	-
NXDN	Audio	-	1. Balance adjust 2. NXDN High Deviation [NXDN Narrow]

- Balance is common with all deviation adjustments as above. If Balance (Transmitter Section 9) has already adjusted, please skip Step 1 and adjust from Step 2.
- Maximum Deviation (Analog Wide) is common with all the analog signaling deviations. If Balance and Maximum Deviation (Analog Wide) (Transmitter Section 10) have already adjusted, please skip Step 2 and adjust from Step 3.

4.10 Receiver Section

Item	Condition <PC>: PC tuning mode <Panel>: Panel tuning mode	Measurement	Adjustment		Specifications /Remarks
			Unit Parts	Method	
1. AF level setting	<PC test mode> 1) Test Channel: 1 Test Signaling Mode: Analog Signaling 1 2) SSG output: -47dBm (1mV) (MOD: 1kHz/±3.0kHz)	SSG AF VM Dummy load	Volume [←], [→]	Turn the Volume knob to obtain 1.41V AF output. (0.5W @ 4ohm Dummy load)	1.41V±0.1V
	<Panel test mode> 1) CH-Sig: 1-1 2) SSG output: *Same as above		[+], [-]		
2. Sensitivity 2	<PC> 1) Adj item: [Sensitivity 2] 2) Adj points: 5 points [Low1], [Low4], [Center3], [High1], [High4]	SSG AF VM Dummy load	[←], [→]	Set a following fixed values. [Low1]: 20 [Low4]: 47 [Center3]: 81 [High1]: 122 [High4]: 164 Press [Apply All] key for <PC> after all adjustment points have been set. Or press [O] key for <Panel> to store the adjustment value at each adjustment point.	
	<Panel> 1) Adj item: [An SENS2] 2) Adj points: *Same as above		[▲], [▼]		
3. Sensitivity 3	<PC> 1) Adj item: [Sensitivity 3] 2) Adj points: 5 points [Low1], [Low4], [Center3], [High1], [High4]	SSG AF VM Dummy load	[←], [→]	Set a following fixed values. [Low1]: 30 [Low4]: 37 [Center3]: 76 [High1]: 108 [High4]: 106 Press [Apply All] key for <PC> after all adjustment points have been set. Or press [O] key for <Panel> to store the adjustment value at each adjustment point.	
	<Panel> 1) Adj item: [An SENS3] 2) Adj points: *Same as above		[▲], [▼]		
4. Sensitivity 4	<PC> 1) Adj item: [Sensitivity 4] 2) Adj points: 5 points [Low1], [Low4], [Center3], [High1], [High4]	SSG AF VM Dummy load	[←], [→]	Set a following fixed values. [Low1]: 15 [Low4]: 25 [Center3]: 46 [High1]: 72 [High4]: 100 Press [Apply All] key for <PC> after all adjustment points have been set. Or press [O] key for <Panel> to store the adjustment value at each adjustment point.	
	<Panel> 1) Adj item: [An SENS4] 2) Adj points: *Same as above		[▲], [▼]		

Item	Condition	Measurement	Adjustment		Specifications /Remarks
	<PC>: PC tuning mode <Panel>: Panel tuning mode		Unit Parts	Method	
5. Sensitivity 1	<p><PC></p> <p>1) Adj item: [Sensitivity 1] 2) SSG output: -100dBm (2.24µV) (MOD: 1kHz/±1.5kHz) 3) Adj points: 5 points [Low1], [Low4], [Center3], [High1], [High4]</p>	SSG Distortion meter Oscilloscope	[←], [→]	<p><PC> [Automatic Adjustment] 1) Press the "Start" key in the Auto Tuning, and the RSSI value is updated. 2) Continue to above process for each adjustment point. 3) Press [Apply All] key after all adjustments are finished and check the newest RSSI.</p> <p><PC> <Panel> [Manual Adjustment] 1) The PC window or the sub LCD display shows the RSSI level. 2) Change the adjustment value to get maximum RSSI level. 3) Press [Apply All] key for <PC>, or press [O] key for <Panel> to store the adjustment value.</p>	
	<p><Panel></p> <p>1) Adj item: [An SENS1] 2) SSG output: *Same as above 3) Adj points: *Same as above</p>		[▲], [▼]		
6. RSSI Reference	<p><PC></p> <p>1) Adj item: [RSSI Reference (Analog Narrow)] 2) SSG output: 12dB SINAD level -3dB (MOD: 1kHz/±1.5kHz) 3) Adj points: 5 points [Low1], [Low4], [Center3], [High1], [High4]</p>	SSG Distortion meter Oscilloscope		<p>After input signal from SSG;</p> <p>Press [Apply] key for <PC> to store the adjustment value at each adjustment point. Or press [O] key for <Panel> to store the adjustment value at each adjustment point.</p>	
	<p><Panel></p> <p>1) Adj item: [An RRSSI] 2) SSG output: *Same as above 3) Adj points: *Same as above</p>				
7. Open Squelch [Analog Wide]	<p><PC></p> <p>1) Adj item: [Open Squelch (Analog Wide)] 2) SSG output: 12dB SINAD level at Analog Wide -3dB (MOD: 1kHz/±3kHz) 3) Adj points: 5 points [Low1], [Low4], [Center3], [High1], [High4]</p>	SSG Distortion meter Oscilloscope		<p>After input signal from SSG;</p> <p>Press [Apply] key for <PC> to store the adjustment value at each adjustment point. Or press [O] key for <Panel> to store the adjustment value at each adjustment point.</p>	
	<p><Panel></p> <p>1) Adj item: [Aw SQL] 2) SSG output: *Same as above 3) Adj points: *Same as above</p>				
[NXDN Narrow]	<p><PC></p> <p>1) Adj item: [Open Squelch (NXDN Narrow)] 2) SSG output: 12dB SINAD level at Analog Wide -1dB (MOD: 400Hz/±2.5kHz) 3) Adj points: 5 points [Low1], [Low4], [Center3], [High1], [High4]</p>	SSG Distortion meter Oscilloscope		<p>After input signal from SSG;</p> <p>Press [Apply] key for <PC> to store the adjustment value at each adjustment point. Or press [O] key for <Panel> to store the adjustment value at each adjustment point.</p>	
	<p><Panel></p> <p>1) Adj item: [Nn SQL] 2) SSG output: *Same as above 3) Adj points: *Same as above</p>				

Item	Condition	Measurement	Adjustment		Specifications /Remarks
	<PC>: PC tuning mode <Panel>: Panel tuning mode		Unit Parts	Method	
8. Low RSSI	<PC> 1) Adj item: [Low RSSI (Analog Narrow)] 2) SSG output: -118dBm (0.28μV) (MOD: 1kHz/±1.5kHz) 3) Adj points: 5 points [Low1], [Low4], [Center3], [High1], [High4]	SSG Distortion meter Oscilloscope		After input signal from SSG; Press [Apply] key for <PC> to store the adjustment value at each adjustment point. Or press [O] key for <Panel> to store the adjustment value at each adjustment point.	
	<Panel> 1) Adj item: [An LRSSI] 2) SSG output: *Same as above 3) Adj points: *Same as above				
9. High RSSI	<PC> 1) Adj item: [High RSSI (Analog Narrow)] 2) SSG output: -80dBm (22.4μV) (MOD: 1kHz/±1.5kHz) 3) Adj points: 5 points [Low1], [Low4], [Center3], [High1], [High4]	SSG Distortion meter Oscilloscope		After input signal from SSG; Press [Apply] key for <PC> to store the adjustment value at each adjustment point. Or press [O] key for <Panel> to store the adjustment value at each adjustment point.	
	<Panel> 1) Adj item: [An HRSSI] 2) SSG output: *Same as above 3) Adj points: *Same as above				
10. Tight Squelch [Analog Wide]	<PC> 1) Adj item: [Squelch Tight (Analog Wide)] 2) SSG output: 12dB SINAD level +6dB (MOD: 1kHz/±3.0kHz) 3) Adj points: 5 points [Low1], [Low4], [Center3], [High1], [High4]	SSG Distortion meter Oscilloscope		After input signal from SSG; Press [Apply] key for <PC> to store the adjustment value at each adjustment point. Or press [O] key for <Panel> to store the adjustment value at each adjustment point.	
	<Panel> 1) Adj item: [Aw SQLT] 2) SSG output: *Same as above 3) Adj points: *Same as above				

SECTION 5 TROUBLESHOOTING

5.1 Fault Diagnosis of the BGA (Ball Grid Array) IC

■ Overview

A flowchart for determining whether or not the transceiver can be powered on (the LCD does not function even if the power switch is turned on) due to broken BGA parts.

■ BGA parts

MPU/DSP (IC706), mobile DDR (IC702), Flash memory (IC701)

When the BGA IC is problematic, please bring the printed circuit board (XCA-074F-00) in for service. Various ESN/ default adjustment values are written on the printed circuit board for service.

Additionally various ESN stickers are included. (Please refer to "5.4 Replacing Main Unit".)

After the printed circuit board has been readjusted, please attach any ESN stickers to the chassis.

When "ESN Validation" is used, you must modify the ESN register.

● Checking power supply voltage

Checking voltage		
Points to be checked		Normal voltage
12M	C39	1.2V
18M	C64	1.8V
33M	IC5 (5pin)	3.3V
18M_3	IC9 (1pin)	1.8V

Power supply of each device is connected through the coil.
[MPU/DSP]
12M : L714, L715, L717
18M : L720, L721
33M : L722

[mobile DDR]
18M : L702

[Flash Memory]
33M: L700
18M_3: L724

Fail

Checking for an abnormal point	
12M has an abnormal voltage. [MPU/DSP] Remove L714 and L715 and L717 to check the voltage of the 12M. If the voltage becomes normal, the MPU/DSP is broken.	Note: A1(12M DC/DC Converter Device) is fragile in the scratch. Be careful when you touch this parts.
18M has an abnormal voltage. [MPU/DSP] Remove L720 and L721 to check the voltage of the 18M. If the voltage becomes normal, the MPU/DSP is broken.	
[mobile DDR] Remove L702 to check the voltage of the 18M. If the voltage becomes normal, the mobile DDR is broken.	
33M has an abnormal voltage. [MPU/DSP] Remove L722 to check the voltage of the 33M. If the voltage becomes normal, the MPU/DSP is broken.	
[Flash Memory] Remove L700 to check the voltage of the 33M. If the voltage becomes normal, Flash memory is broken.	
18M_3 has an abnormal voltage. [Flash Memory] Remove L724 to check the voltage of the 18M_3. If the voltage becomes normal, Flash memory is broken.	
If the voltage is not corrected, there is a problem other than the BGA parts. *1 (Page 1-59)	
The BGA parts are not broken.	
The BGA parts are not broken. Check the peripheral circuit of IC2. *2 (Page 1-59)	

Pass

● Checking the clock

Checking the clock	
Points to be checked	Normal voltage (1.2V)
19.2MHz	19.2MHz
MPU/DSP side R708	

Fail

Pass

● Checking the Reset/Control signal

Checking the control signal input to the MPU/DSP		
Points to be checked		Normal voltage
/RST	D12 (Anode side)	1.8V
/BINT	IC2 (13pin)	3.1V
/OVRB_OUT	IC2 (12pin)	3.1V

Fail

Pass

Checking the MPU/DSP input switch signal	
The POWER key is pressed and held.	
Points to be checked	Normal voltage
/PSW_OUT IC2 (15pin)	ON : 0V ON : 0V → 3.1V
The ignition key is kept ON.	
Points to be checked	Normal voltage
/IGN_OUT IC2 (9pin)	ON : 0V ON : 0V → 3.1V

Fail

Pass

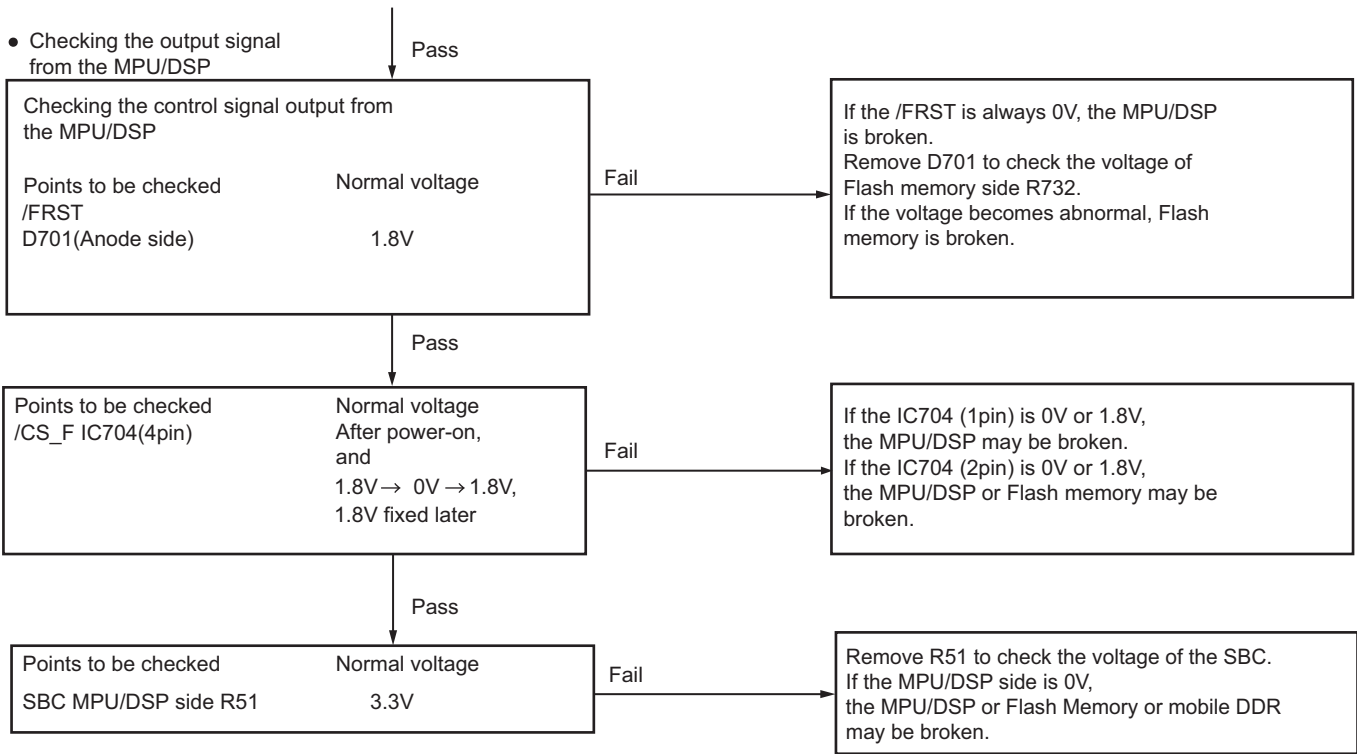

■ Descriptions of signal names

(1) /RST	:MPU/DSP reset signal	LOW → Reset
(2) /BINT	:Battery final voltage monitoring	LOW → Final voltage
(3) /OVRB_OUT	:Battery overvoltage monitoring	LOW → Overvoltage
(4) /PSW_OUT	:Power switch signal	LOW → ON
(5) /IGN_OUT	:Ignition switch signal	LOW → ON
(6) /FRST	:Flash Memory reset signal	LOW → Reset
(7) /CS_F	:Flash Memory chip select signal	LOW → Active
(8) SBC	:Switch +B control	HIGH → ON
(9) PRST	:LCD reset signal	LOW → Reset

*1 If 12M, 18M or 33M has still abnormal voltage after the implementation of each procedure above, 54M (IC8), 12M (IC24), 18M (IC11), 33M (IC5) or one of these peripheral circuit is broken. 54M (normally 5.4V at L12) has an abnormal voltage, check the MSP430G25XXXX (IC2) according to the following procedure.

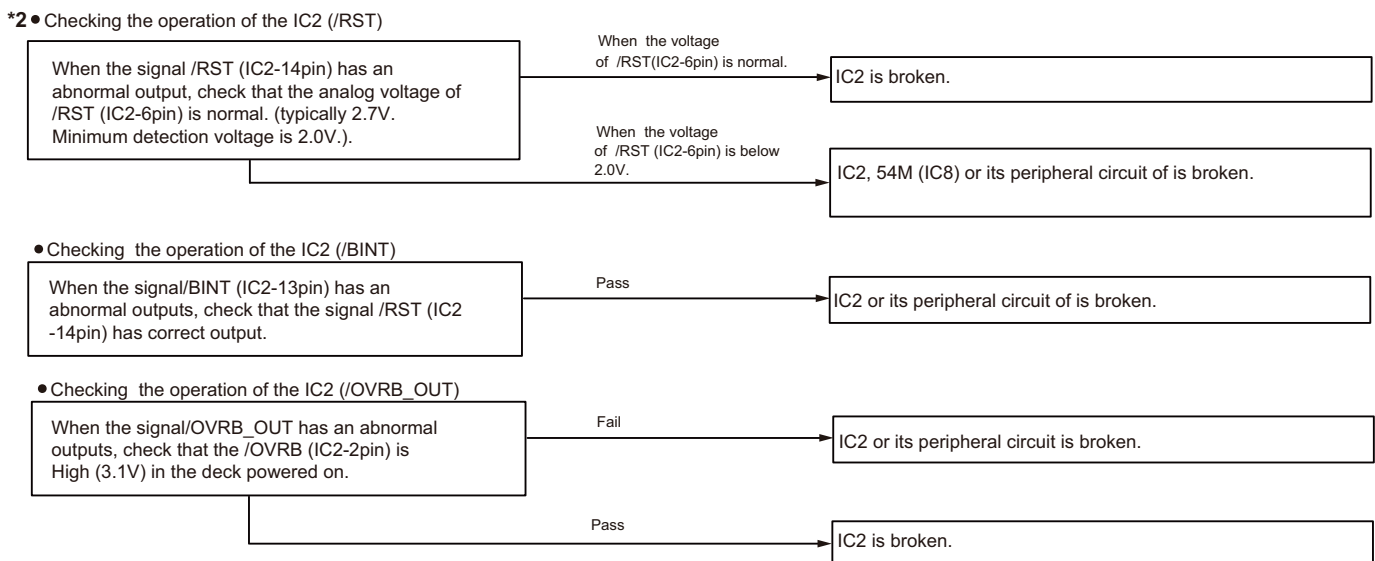
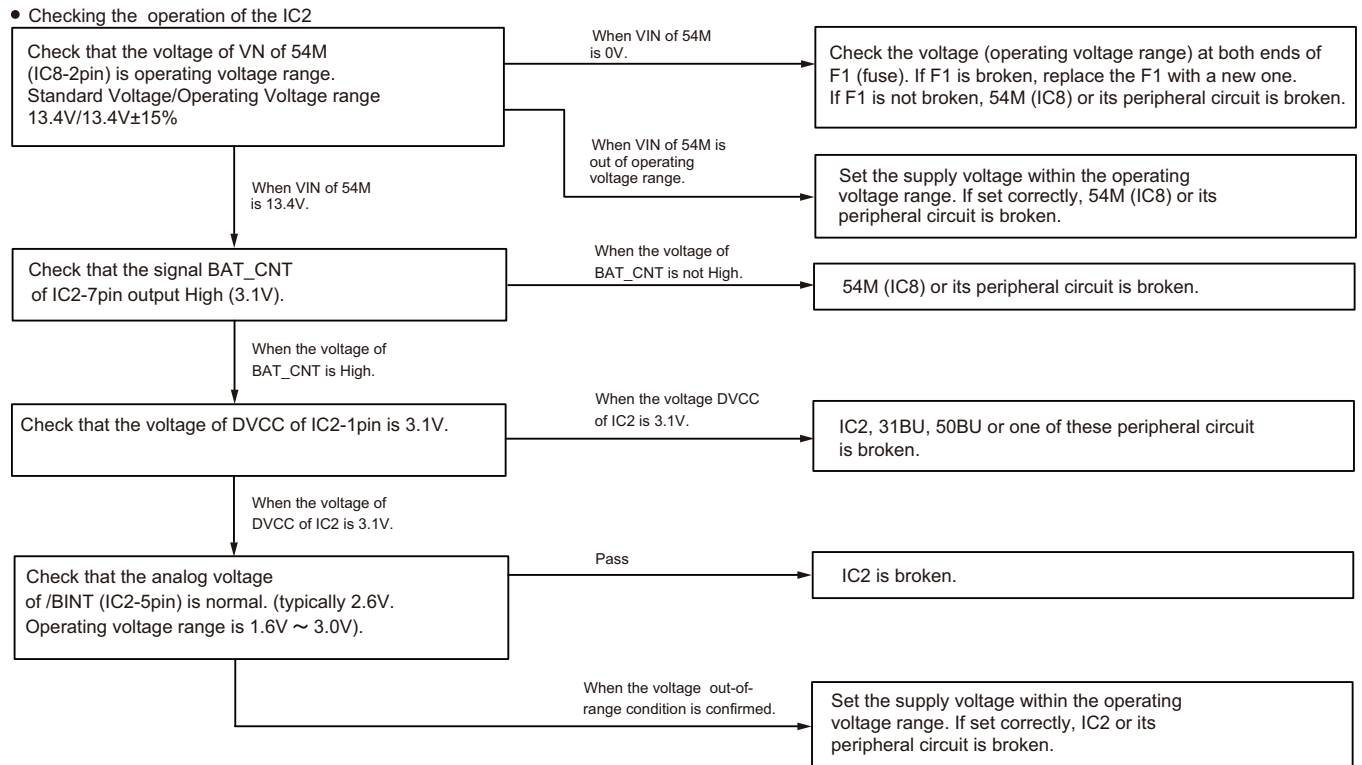

- Checking the operation of IC2 (/PSW and /IGN)
Check that the signal /PSW (IC2-10pin) and /PSW_OUT (IC2-15pin) are linked with the power key on KCH-20R in power on state.

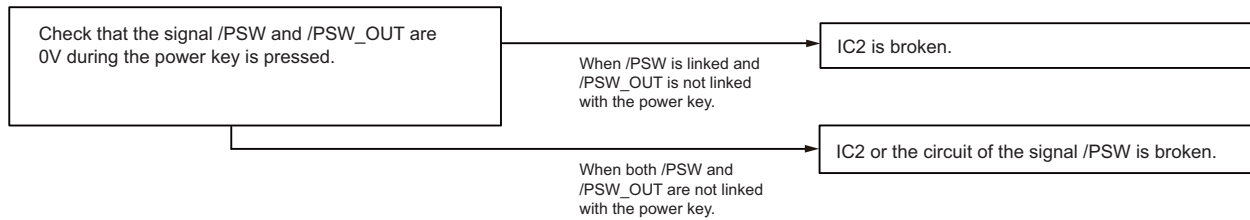

If the ignition function is enabled, check that the signal /IGN (IC2-8pin) and /IGN_OUT (IC2-9pin) are linked with the ignition sense.

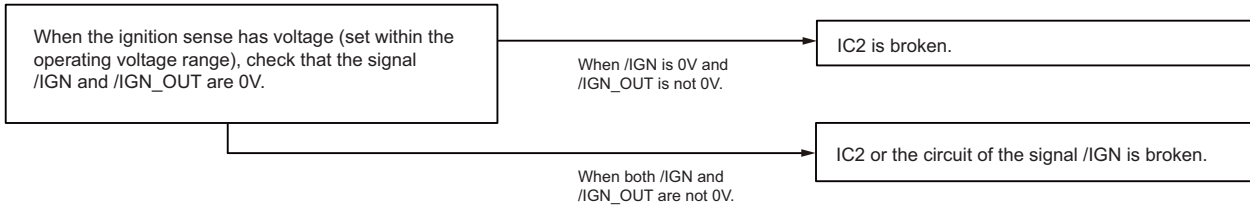

■ Remarks related MSP430G25XXXX (IC2)

- IC2 is written the program.
- MPU/DSP (IC706) communicates with IC2 by serial communication at startup of deck.
Only firmware version of IC2 is confirmed IC706 in serial communication.
Even when firmware version of IC2 cannot be acquired, the system of IC2 is started.
- If there is the difference of firmware version between IC2 and IC706, the firmware version of IC2 is updated with the serial communication by IC706.
“Upgrading MSP...” is displayed on the LCD during the firmware update. When the firmware update fails, the system of IC2 is started and IC706 is trying to update again at next startup.

5.2 Failure diagnosis of the GPS section

Overview:

When the GPS function does not operate, use this flowchart to determine the problem.

Major parts for a GPS circuit

- GPS antenna (KRA-40 (option))
- Coaxial cable (E0E-0034-00)
- SAW Filter (L9)
- BT/GPS IC (IC5)
- Level conversion IC (IC6,IC7)
- TCXO 19.2MHz (X1)
- 32.768kHz clock (X2)
- 33BT Regulator (IC3)
- 18BT Regulator (IC2)
- 33GPS Regulator (IC4)
- MPU/DSP IC (IC706)

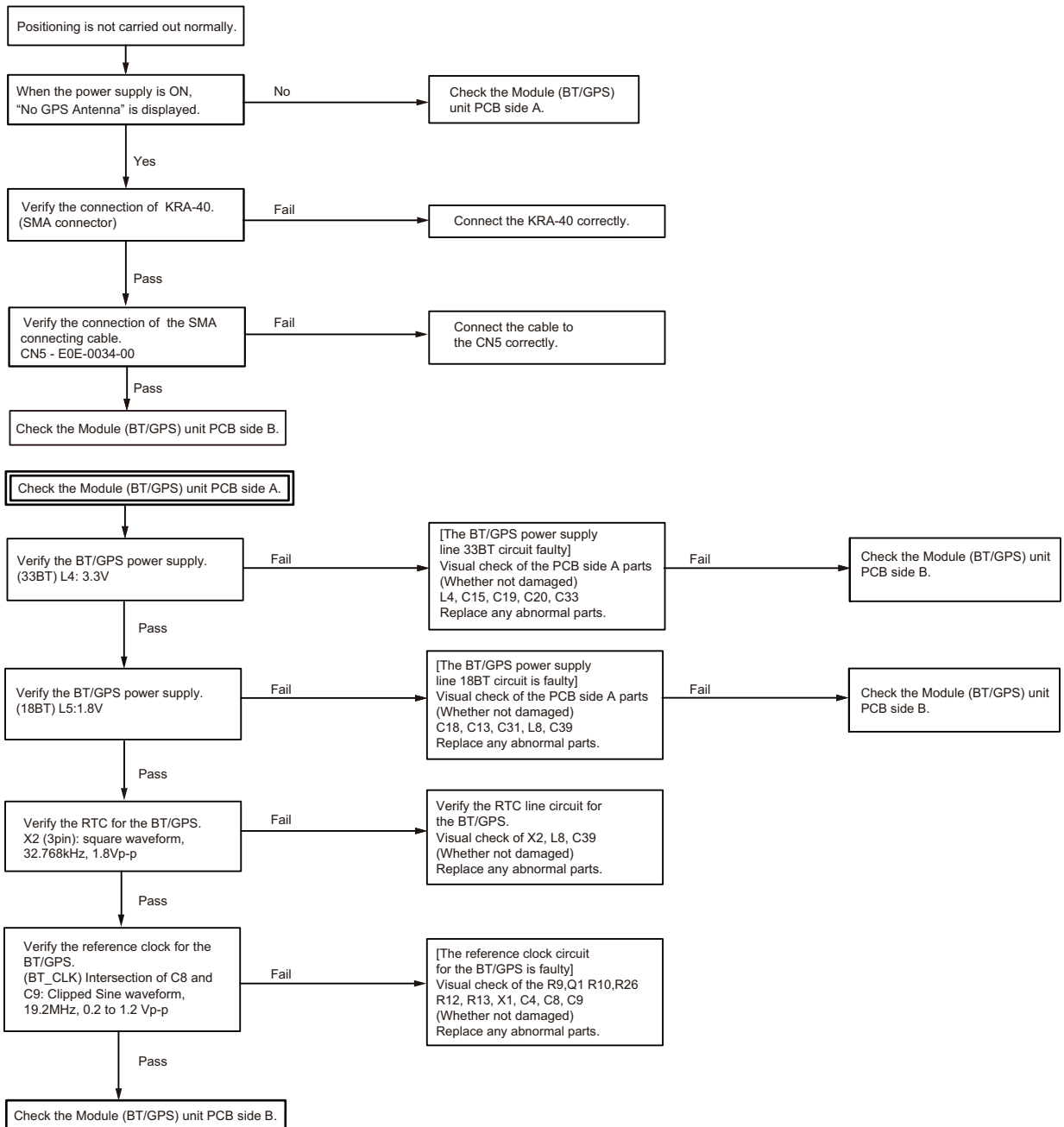
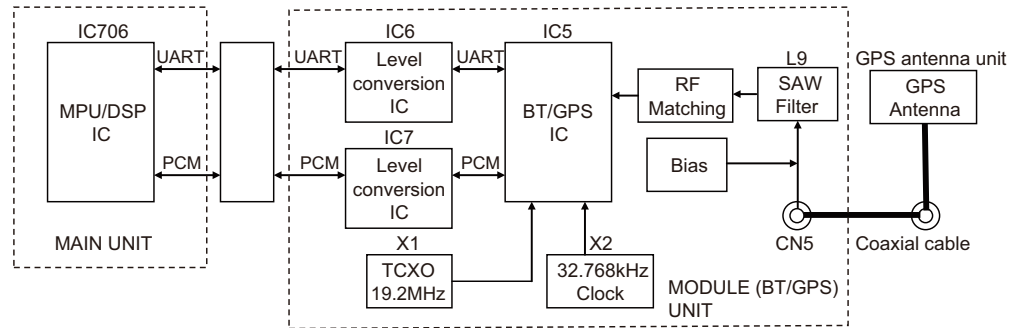

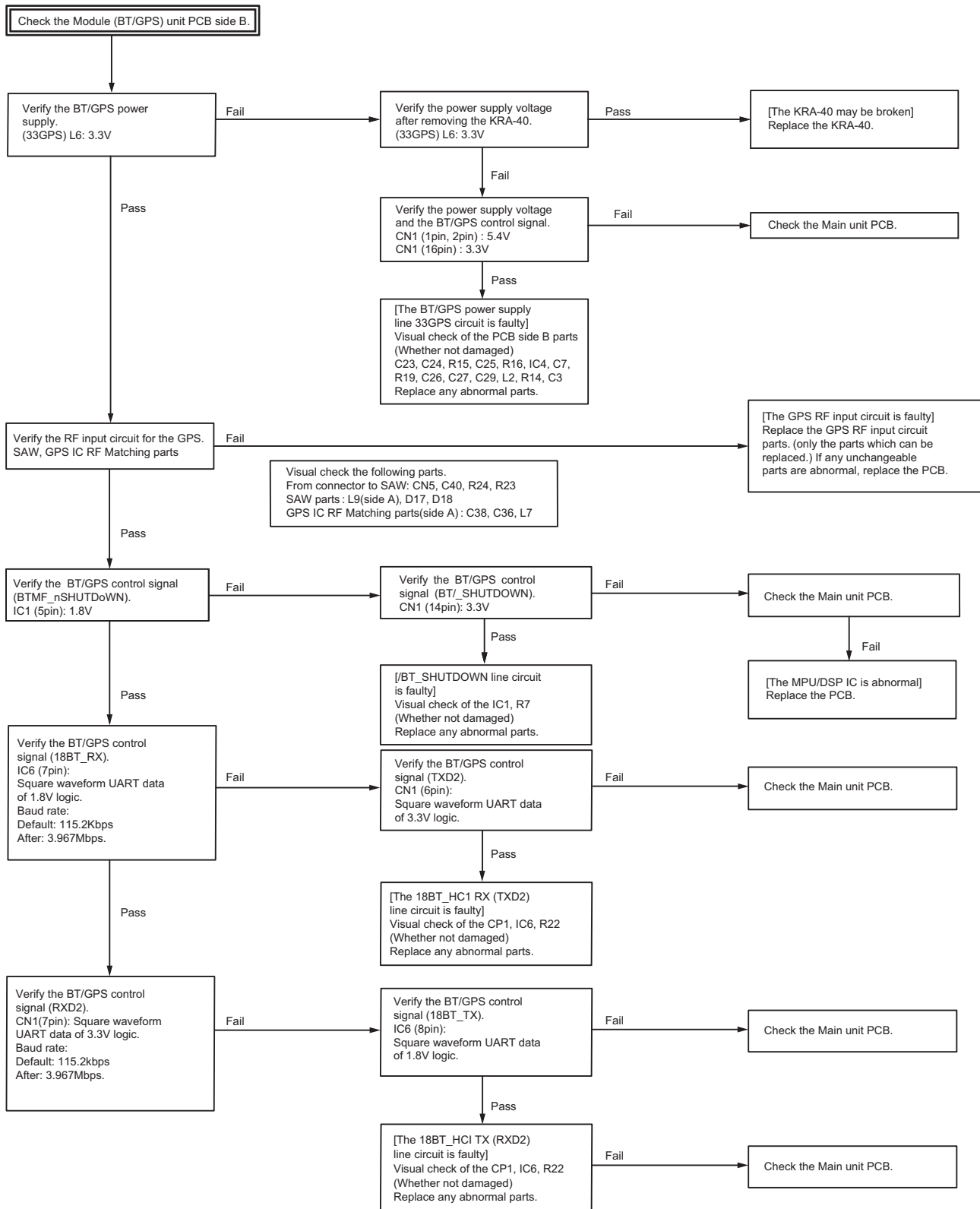

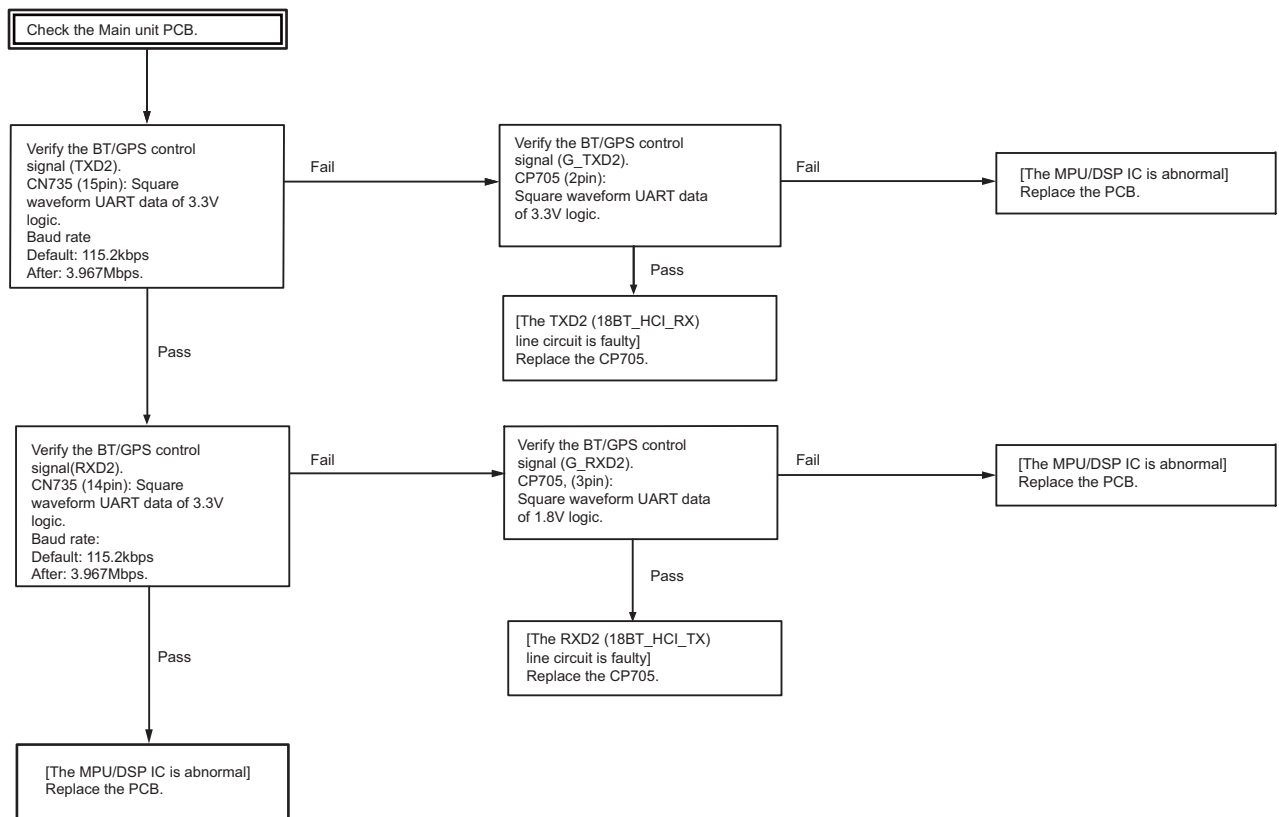

■ Descriptions of signal names

- (1) 33BT: BT/GPS IC 3.3V power supply
- (2) 18BT: BT/GPS IC 1.8V power supply
- (3) 33GPS: BT/GPS IC 3.3V power supply
- (4) TXD2: BT/GPS serial data line connected to UART TX of MPU/DSP IC (MPU/DSP to BT/GPS IC)
- (5) RXD2: BT/GPS serial data line connected to UART RX of MPU/DSP IC (MPU/DSP to BT/GPS IC)
- (6) 18BT_HCI_RX: BT/GPS serial data line connected to UART RX of BT/GPS IC (MPU/DSP to BT/GPS IC)
- (7) 18BT_HCI_TX: BT/GPS serial data line connected to UART TX of GPS IC (BT/GPS IC to MPU/DSP)
- (8) /BT_SHUTDOWN: BT/GPS active control of MPU/DSP IC (MPU/DSP to BT/GPS IC) High → Active, Low → Reset

5.3 Failure diagnosis of the Bluetooth section

Overview:

When the Bluetooth function does not operate, use this flowchart to determine the problem.

Major parts for a Bluetooth circuit

- Bluetooth antenna (Pattern Antenna)
- LC filter (L11)
- BT/GPS IC (IC5)
- Level conversion IC (IC6, IC7)
- TCXO 19.2MHz (X1)
- 32.768kHz clock (X2)
- 33BT Regulator (IC3)
- 18BT Regulator (IC2)
- MPU/DSP IC (IC706)

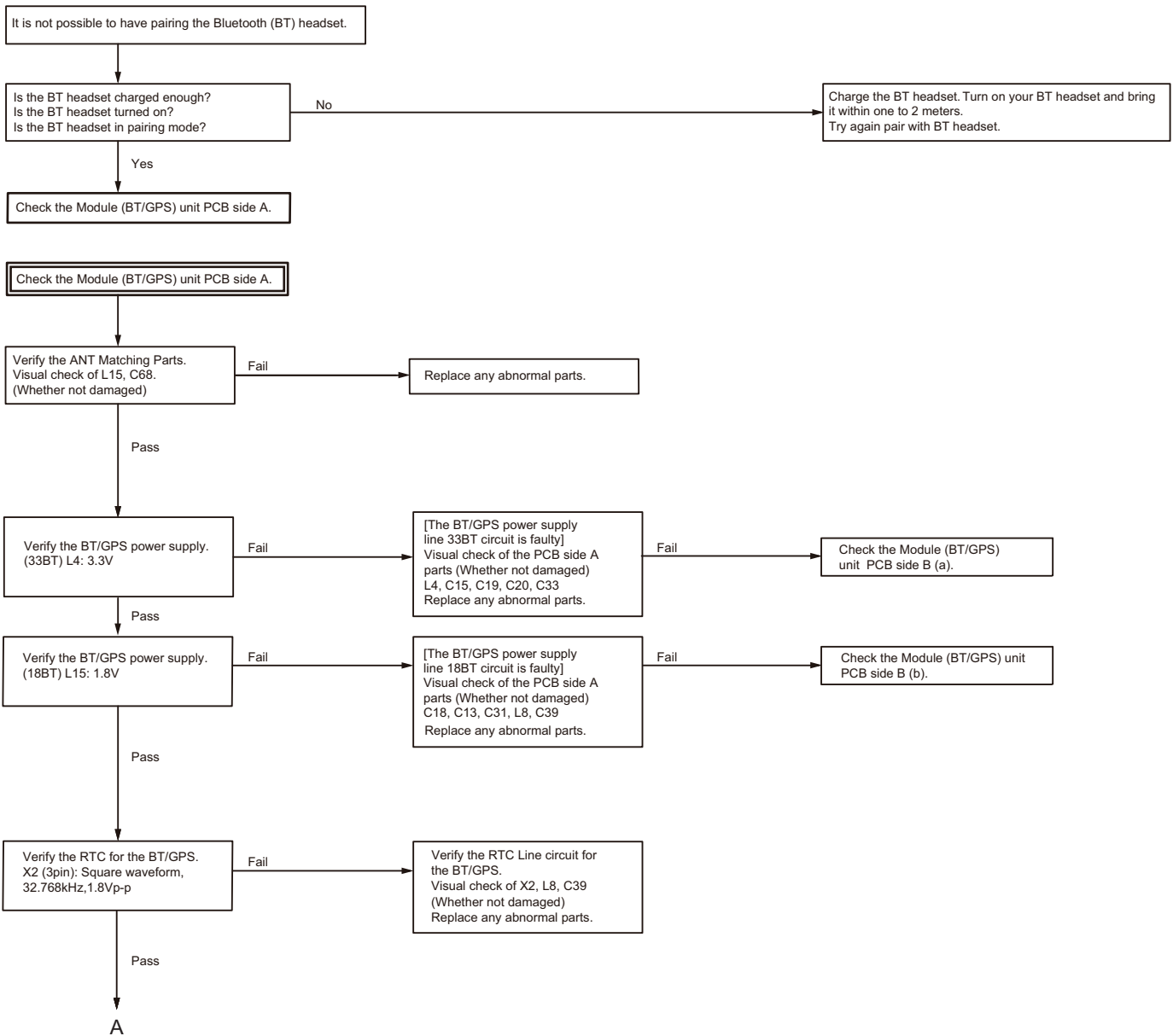
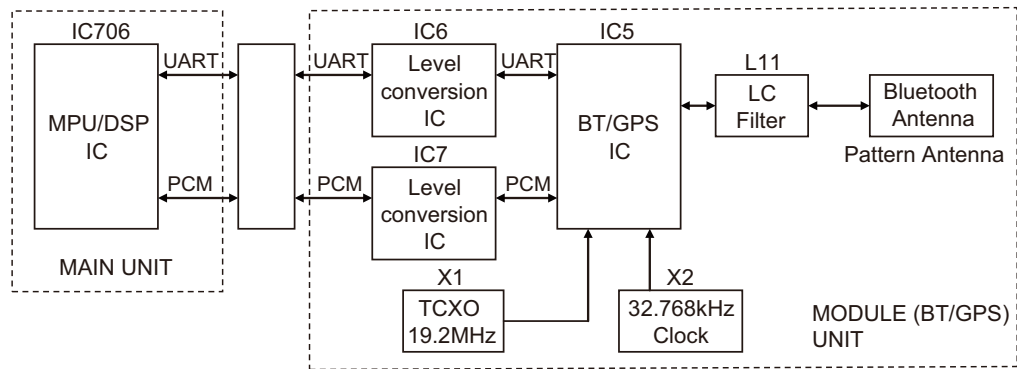

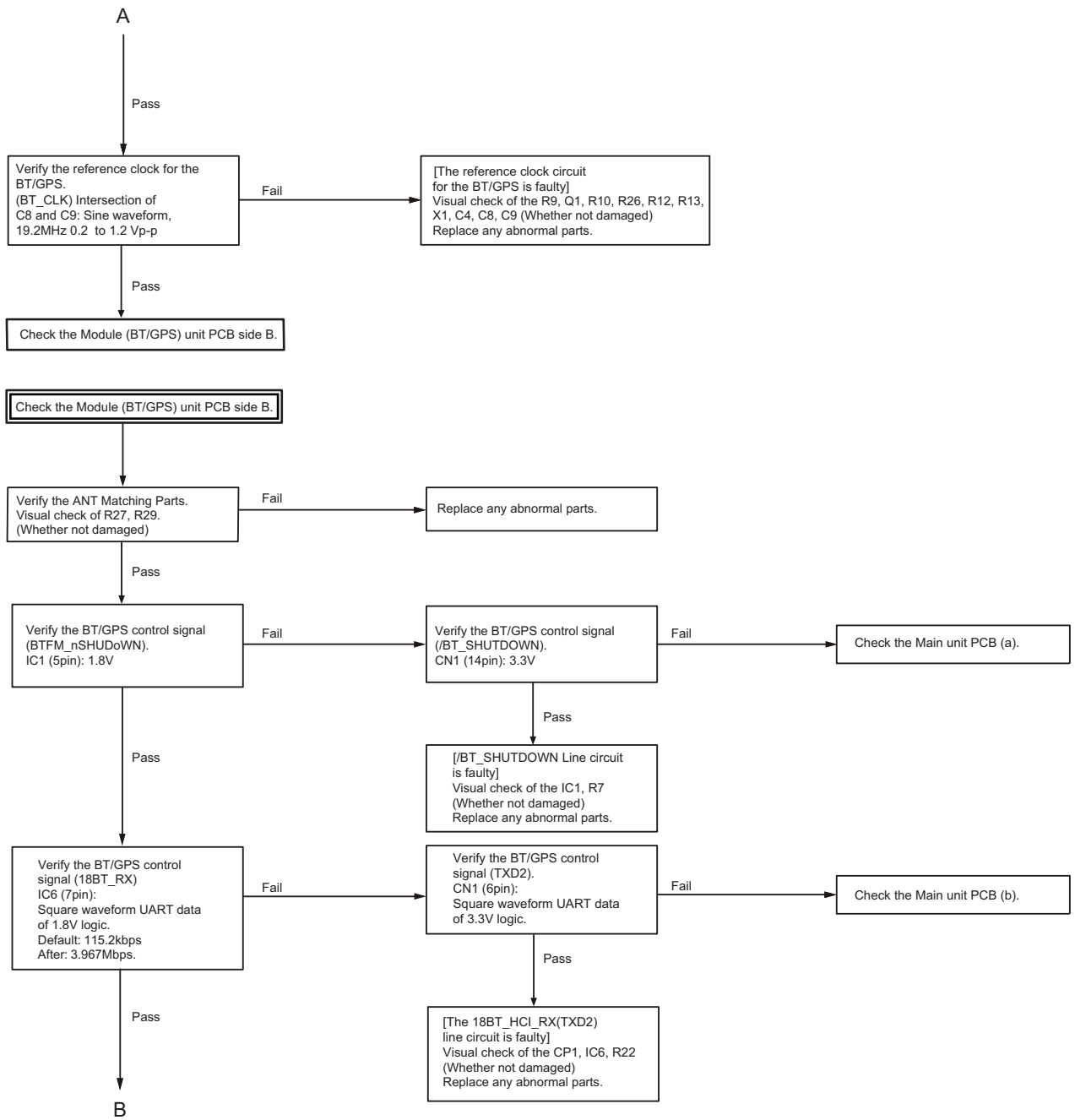

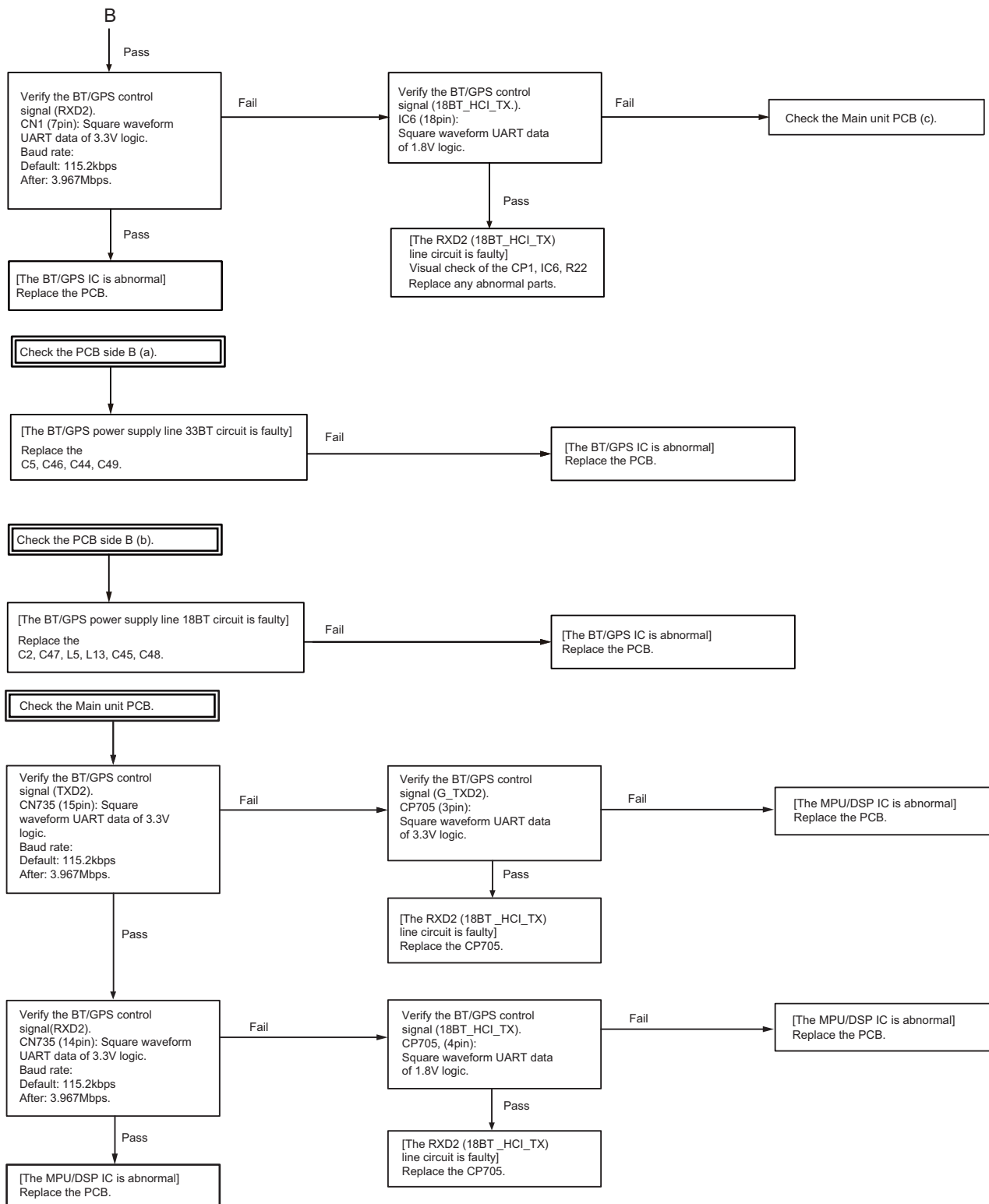

■ Descriptions of signal names

- (1) 33BT: BT/GPS IC 3.3V power supply
- (2) 18BT: BT/GPS IC 1.8V power supply
- (3) TXD2: BT/GPS serial data line connected to UART TX of MPU/DSP IC (MPU/DSP to BT/GPS IC)
- (4) RXD2: BT/GPS serial data line connected to UART RX of MPU/DSP IC (MPU/DSP to BT/GPS IC)
- (5) 18BT_HCI_RX: BT/GPS serial data line connected to UART RX of BT/GPS IC (MPU/DSP to BT/GPS IC)
- (6) 18BT_HCI_TX: BT/GPS serial data line connected to UART TX of GPS IC (BT/GPS IC to MPU/DSP)
- (7) /BT_SHUTDOWN: BT/GPS active control of MPU/DSP IC (MPU/DSP to BT/GPS IC) High → Active, Low → Reset

5.4 Replacing Main Unit

■Main unit Information

Model Name	Original Main unit Number	For Service Main unit Number
NX-5600HB (F3)	XC1-286F-00	XCA-074F-00

■Method of confirming "Original Main unit" and "Service Main unit"

The marking seal (XCA-074F-00) is affixed at the position of the arrow on the service Main unit.



■Supplied Accessories of "Service Main unit"

Item (Including Parts Number)	Quantity
Main Unit (XCA-074)	1
KENWOOD ESN/ NXDN ESN/ MPT ESN/ P25 ESN Label	1

■"Service Main unit" Data

The following data is written on the service unit:

Data Type	Description
Firmware	NX-5600HB Firmware
FPU Data (PC programming mode)	XCA-074 (NX-5600HB) F3 type data
Various Adjustment Data (PC Test mode)	General adjustment values for the XCA-074 (NX-5600HB).
KENWOOD ESN	Model name: [XCA-074] NX-5600HS Type: F3 The same number as the KENWOOD ESN label is written.
NXDN ESN (N)/ MPT ESN (M)/ P25 ESN (P)	The same number as the NXDN ESN/MPT ESN/P25 ESN label is written.

■After Changing the PCB

- After changing the printed circuit board, write the up-to-date Firmware following the instructions in the "2.2 REALIGNMENT - 2.2.6 Firmware Programming Mode".
 - Write the Firmware in accordance to the Market. If you write different Market Firmware, there are times communication with the FPU is not possible.
- Using the KPG-D1/D1N, select your desired item (Model Name and Frequency) from the Model> Product Information menu, then use Program> Write Data to the Transceiver to write the FPU data (PC Programming mode). When writing to the transceiver, a Warning Message, corresponding to the item selected, appears. Click [OK] to continue writing the data.
- Enter Program> Test Mode, then adjust the various adjustment data (PC Test Mode) as described in the "SECTION 4 ADJUSTMENT".
- Attach the new labels corresponding to the new printed circuit board. (Refer to the images below for label placement.)
- If necessary, write the FPU data used by the customer with the KPG-D1/D1N.

Note:

- When using the ESN Validation function of NXDN Trunking, the NXDN ESN number changes when the circuit board is changed (the number is written on the circuit board); the NXDN Trunking System cannot be accessed.
Use the NEXEDGE 1st and NEXEDGE 2nd Generation Trunking System side to reprogram the NXDN ESN number.
- When a new printed circuit board is used, the KENWOOD ESN changes, as does the Transceiver Information display of the KPG-D1/D1N, but this does not have any effect on the operation of the transceiver.
- If changing to the original ESN, please contact our service center.

■ESN Label Layout

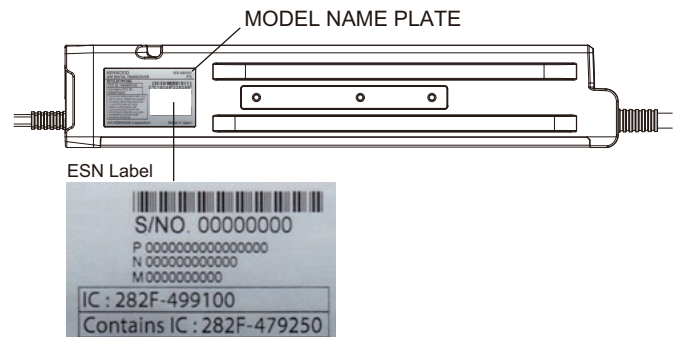

5.5 Operating Method of Enforced Firmware Overwriting Mode

Enforced firmware overwriting mode is a mode to forcibly overwrite the transceiver firmware when the operations as instructed in Section 2.2.2 "How to Enter Each Mode" does not allow the transceiver to enter the firmware programming mode, for instance, when the transceiver fails to start up due to the transceiver failure.

(1) Prepare the followings:

- Transceiver (NX-5600HB)
- Control Head (KCH-19, KCH-20R or KCH-21R)
- Remote control cable (KCT-71 or KCT-77)
- Regulated DC power supply
- Programming interface cable (KPG-46U or KPG-46X)
- Power cable

(2) Remove the M.CABINET, RUBBER SEAL and SHIELDING COVER of the transceiver.

Connect a transceiver, Control Head, Remote control cable, regulated DC power supply, programming interface cable (KPG-46U or KPG-46X) and power cable.

(3) While FLDM terminal has a short-circuit with GND terminal on the PCB, turn the DC Power supply output ON.

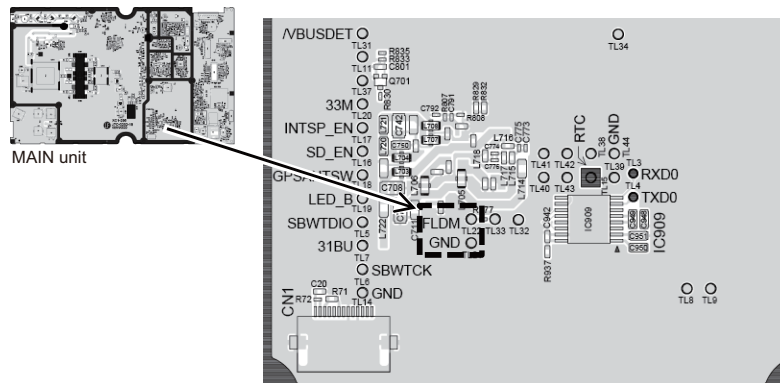

(4) Upon startup of FLDM loader, "FIRMWARE PROG" appears on an LCD screen.

(5) Start KFL up, select the desired firmware you wish to overwrite, select the COM port number and baud rate, and then click the "Write" key.

Note:

Configuring "Auto" for baud rate automatically apply the maximal speed of baud rate allowed for a programming cable connected to the selected COM port number.

Upon start of overwriting on the transceiver, "LOADING" appears on an LCD screen.

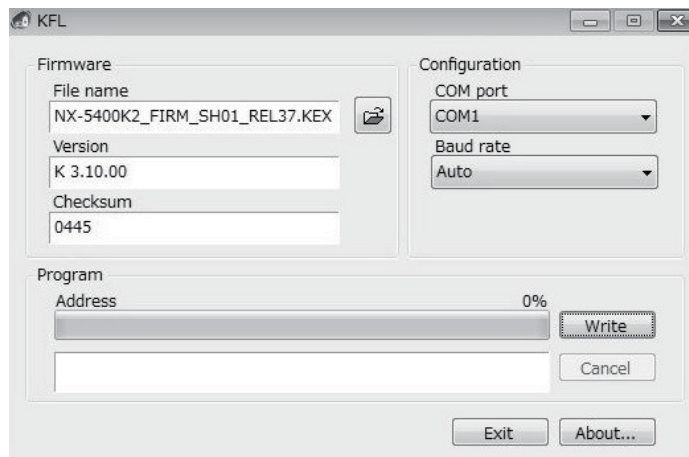

(6) Upon completion of the firmware overwriting, "CHECKSUM xxxx" appears on an LCD screen.

PRECAUTIONS ON SCHEMATIC DIAGRAMS

- * Due to the improvement in performance, some part numbers shown in the circuit diagrams may not agree with those indicated in the Parts List.
- * The parts numbers, values and rated voltage etc. in the Schematic Diagrams are for reference only.
- * Since the circuit diagrams are standard ones, the circuits and circuit constants may be subject to change for improvement without any notice.
- * The parts of the symbol with " * " may vary depending on model. Refer to the parts list for details.
- * The parts of the symbol with " \$ " are unmounted parts.

LEVEL DIAGRAM

Receiver Section

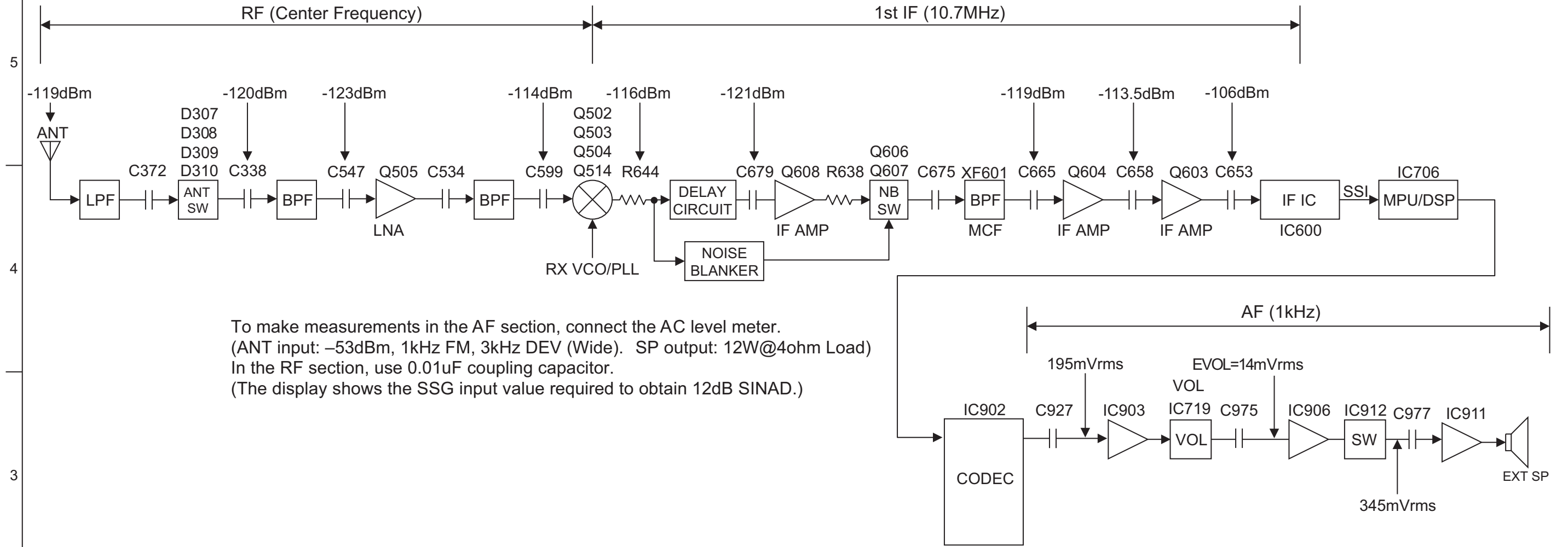

Transmitter Section

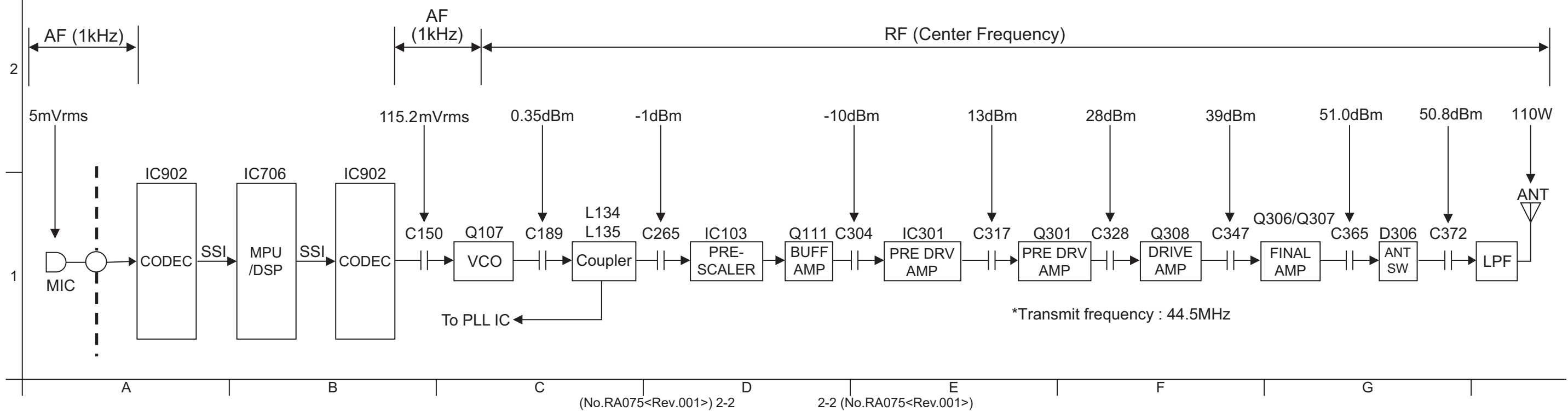

INTERCONNECTION DIAGRAM

5
4
3
2
1

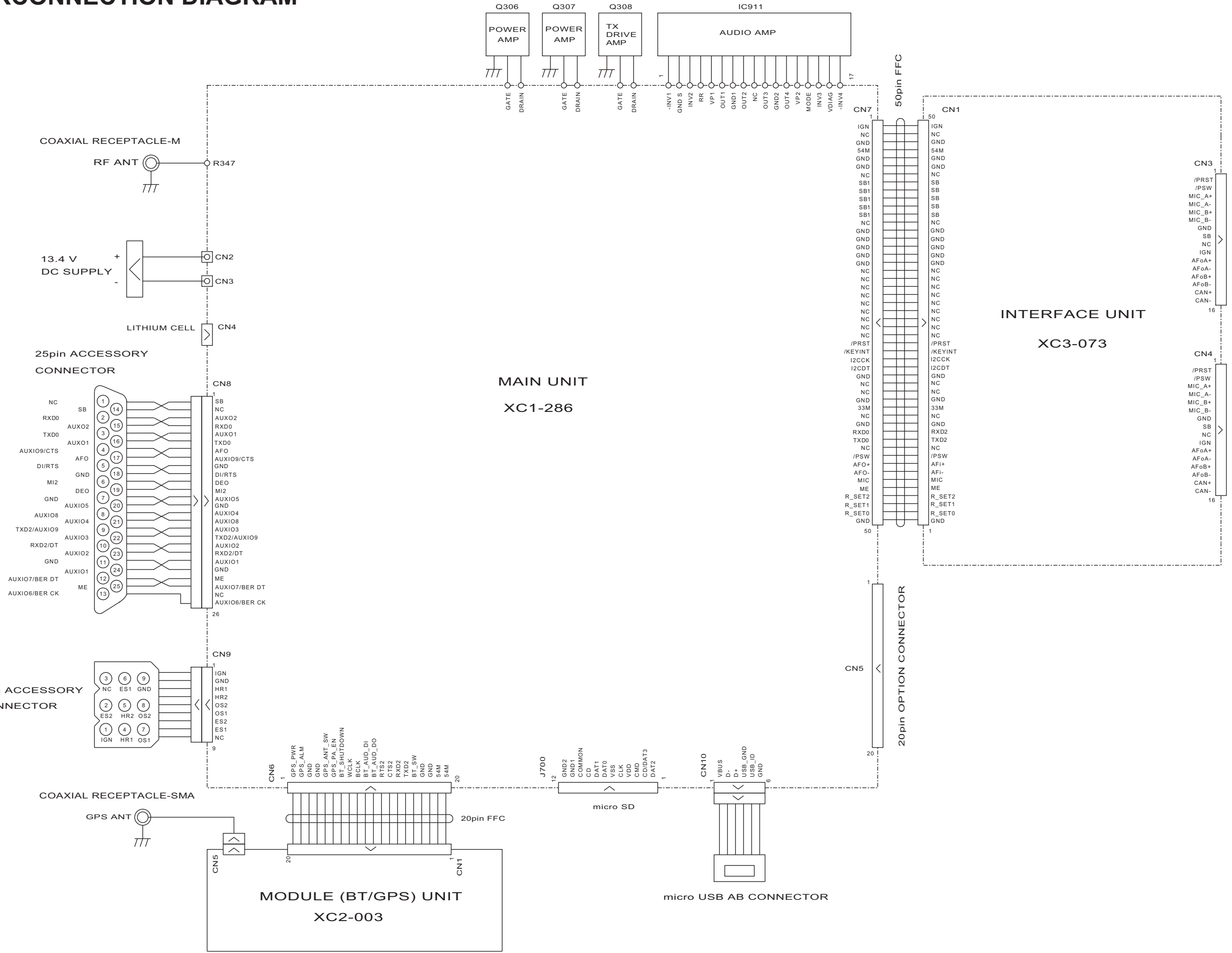

A B C D E F G

PRINTED CIRCUIT BOARD

INTERFACE UNIT (XC3-073F-00)

--- Component side view/Side A (J7C-0301-00) ---

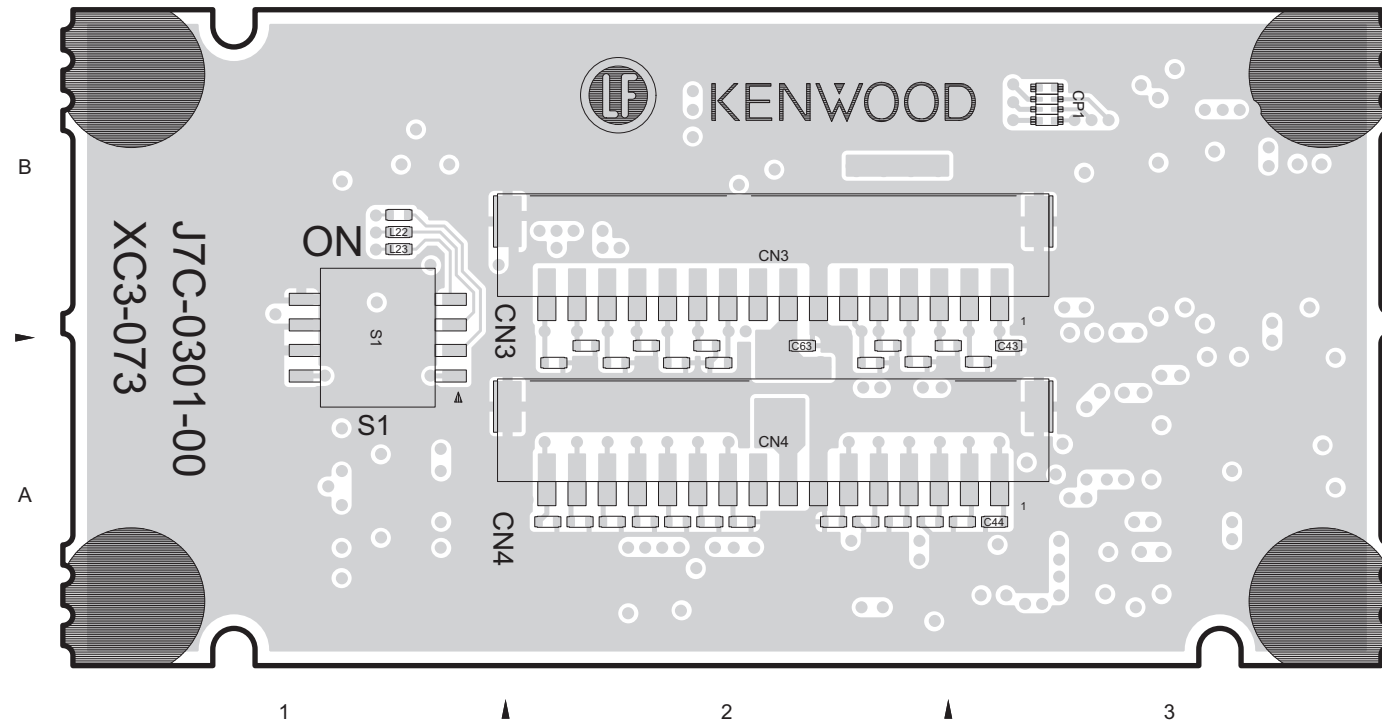

--- Foil side view/Side B (J7C-0301-00) ---

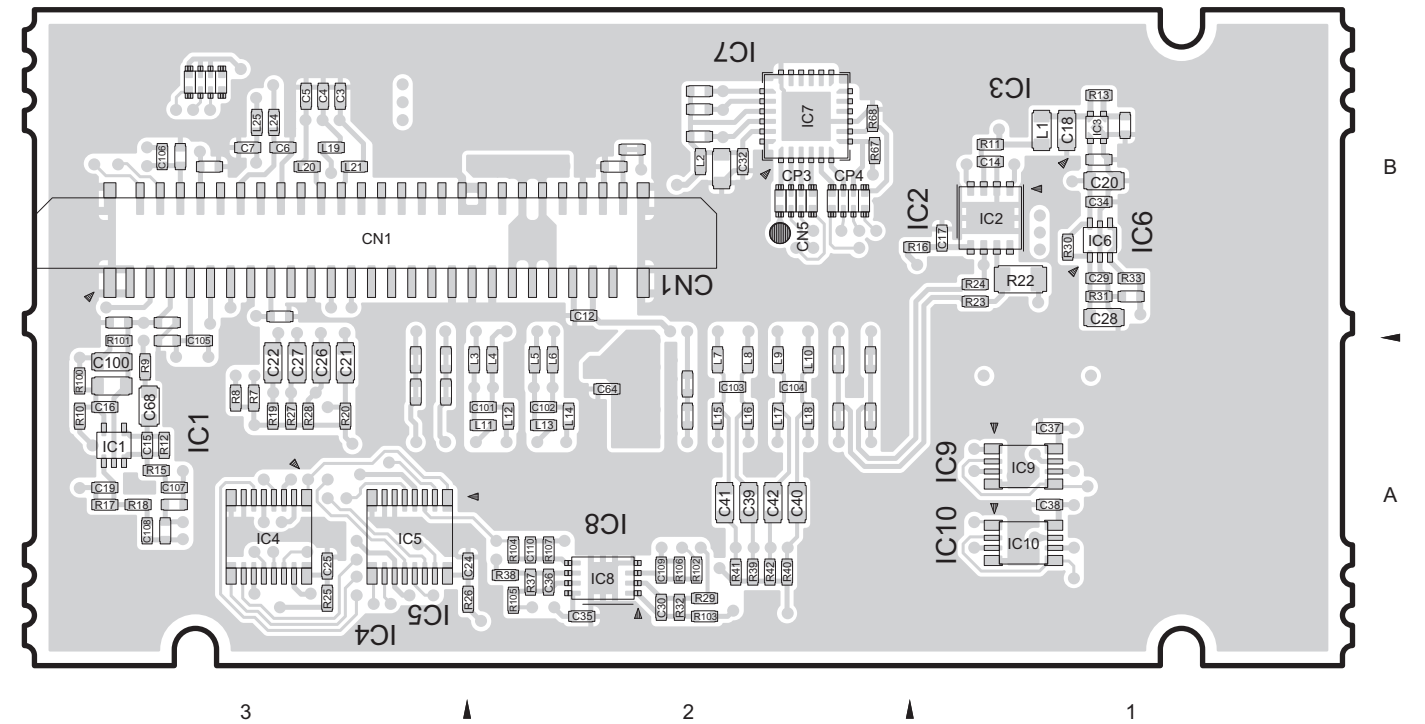

ADDRESS TABLE OF BOARD PARTS

Each address may have an address error by one interval.



REF.NO.	LOCATION	REF.NO.	LOCATION	REF.NO.	LOCATION	REF.NO.	LOCATION	REF.NO.	LOCATION
IC		R27	B-3A	C14	B-1B	C100	B-3A	L8	B-2A
IC1	B-3A	R28	B-3A	C15	B-3A	C101	B-2A	L9	B-2A
IC2	B-1B	R29	B-2A	C16	B-3A	C102	B-2A	L10	B-2A
IC3	B-1B	R30	B-1B	C17	B-1B	C103	B-2A	L11	B-2A
IC4	B-3A	R31	B-1B	C18	B-1B	C104	B-2A	L12	B-2A
IC5	B-3A	R32	B-2A	C19	B-3A	C105	B-3A	L13	B-2A
IC6	B-1B	R33	B-1B	C20	B-1B	C106	B-3B	L14	B-2A
IC7	B-2B	R37	B-2A	C21	B-3A	C107	B-3A	L15	B-2A
IC8	B-2A	R38	B-2A	C22	B-3A	C108	B-3A	L16	B-2A
IC9	B-1A	R39	B-2A	C24	B-2A	C109	B-2A	L17	B-2A
IC10	B-1A	R40	B-2A	C25	B-3A	C110	B-2A	L18	B-2A
		R41	B-2A	C26	B-3A			L19	B-3B
		R42	B-2A	C27	B-3A			L20	B-3B
RESISTOR		R47	B-2B	C28	B-1B	OTHER		L21	B-3B
R7	B-3A	R67	B-2B	C29	B-1B	CN1	B-3B	L22	A-1B
R8	B-3A	R68	B-2B	C30	B-2A	CN3	A-2B	L23	A-1B
R9	B-3A	R100	B-3A	C32	B-2B	CN4	A-2A	L24	B-3B
R10	B-3A	R101	B-3A	C34	B-1B	CN5	B-2B	L25	B-3B
R11	B-1B	R102	B-2A	C35	B-2A	S1	A-1B		
R12	B-3A	R103	B-2A	C36	B-2A				
R13	B-1B	R104	B-2A	C37	B-1A	CP1	A-3B		
R15	B-3A	R105	B-2A	C38	B-1A	CP3	B-2B		
R16	B-1B	R106	B-2A	C39	B-2A	CP4	B-2B		
R17	B-3A	R107	B-2A	C40	B-2A				
R18	B-3A			L1	B-1B				
R19	B-3A	CAPACITOR		L2	B-2B				
R20	B-3A	C3	B-3B	L3	B-2A				
R22	B-1B	C4	B-3B	L4	B-2A				
R23	B-1B	C5	B-3B	L5	B-2A				
R24	B-1B	C6	B-3B	L6	B-2A				
R25	B-3A	C7	B-3B	L7	B-2A				
R26	B-2A	C12	B-2B						

■ MODULE UNIT (XC2-0031-80)

--- Component side view/Side A (J7C-0037-10) ---

--- Foil side view/Side B (J7C-0037-10) ---

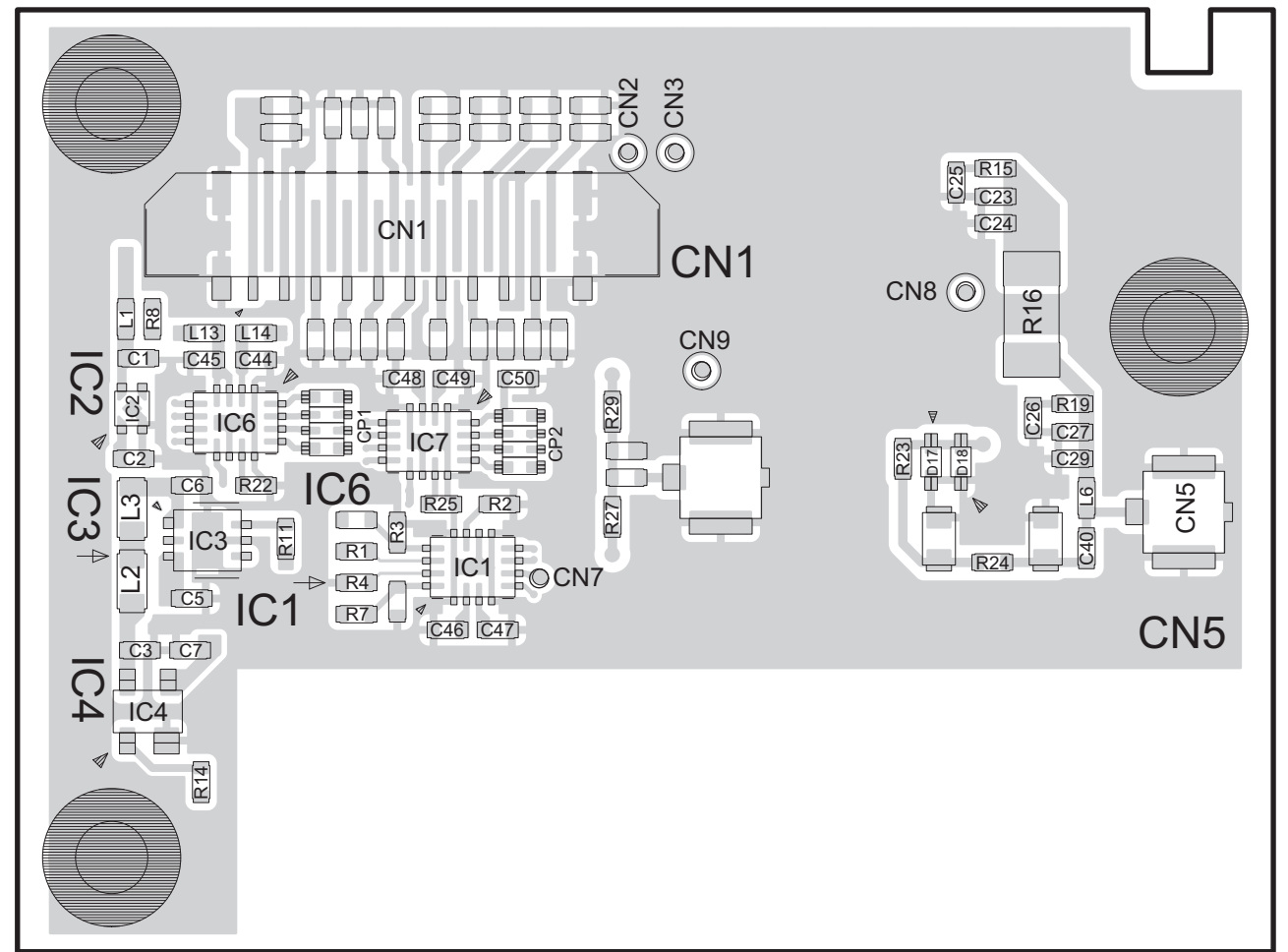
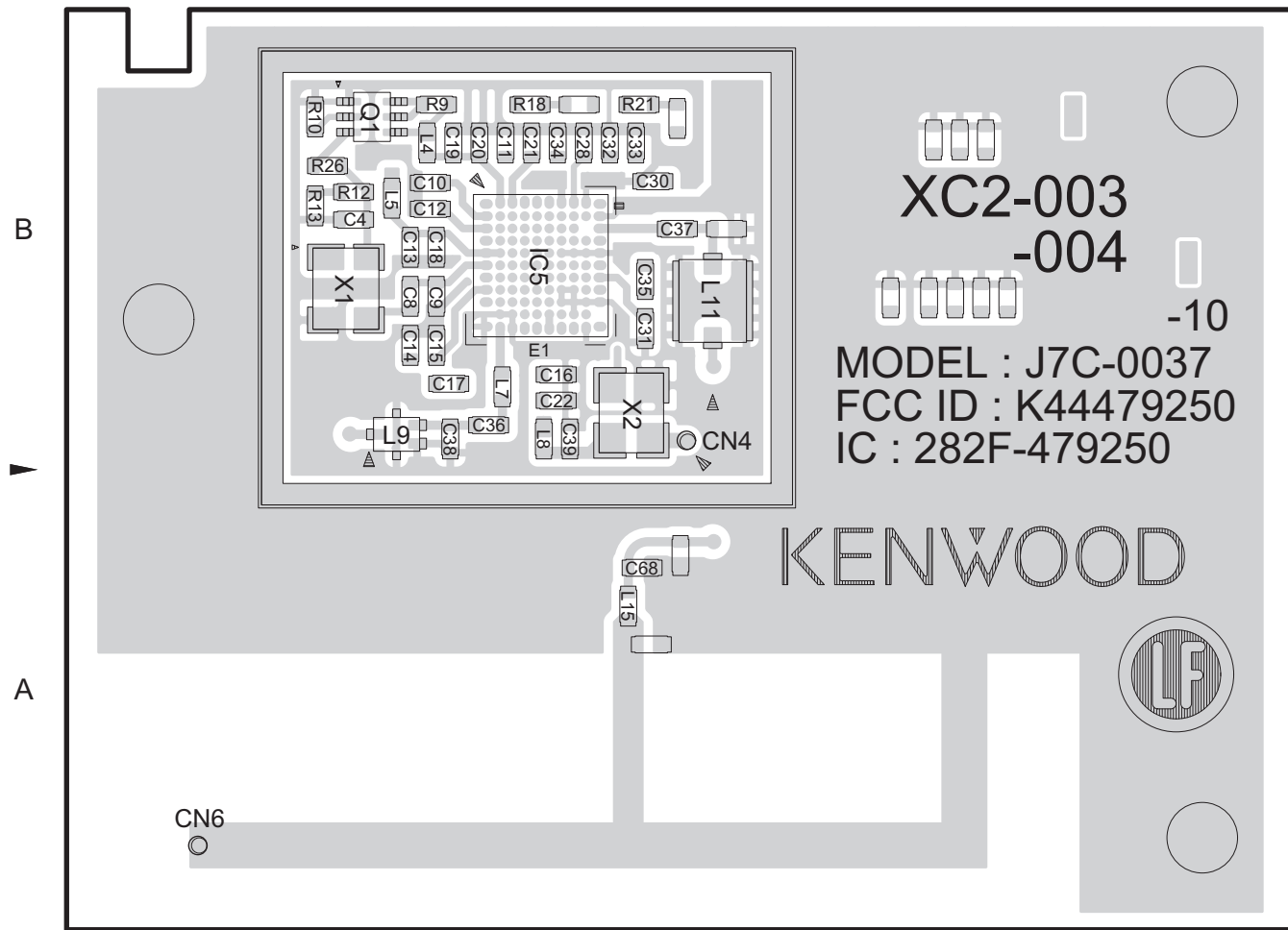

1

2

3

3

2

1

● ADDRESS TABLE OF BOARD PARTS

Each address may have an address error by one interval.



REF.NO.	LOCATION	REF.NO.	LOCATION	REF.NO.	LOCATION	REF.NO.	LOCATION	REF.NO.	LOCATION	REF.NO.	LOCATION
IC		R9	A-1B	C4	A-1B	C27	B-1B	OTHER	L5	A-1B	
IC1	B-2A	R10	A-1B	C5	B-3A	C28	A-2B	X1	A-1B	L6	B-1A
IC2	B-3B	R11	B-3A	C6	B-3A	C29	B-1B	X2	A-2B	L7	A-2B
IC3	B-3A	R12	A-1B	C7	B-3A	C30	A-2B	CN1	B-3B	L8	A-2B
IC4	B-3A	R13	A-1B	C8	A-1B	C31	A-2B	CN2	B-2B	L9	A-1B
IC5	A-2B	R14	B-3A	C9	A-1B	C32	A-2B	CN3	B-2B	L11	A-2B
IC6	B-3B	R15	B-1B	C10	A-1B	C33	A-2B	CN4	A-2B	L13	B-3B
IC7	B-3B	R16	B-1B	C11	A-2B	C34	A-2B	CN5	B-1A	L14	B-3B
		R18	A-2B	C12	A-1B	C35	A-2B	CN6	A-1A	L15	A-2A
TRANSISTOR		R19	B-1B	C13	A-1B	C36	A-2B	CN7	B-2A		
Q1	A-1B	R21	A-2B	C14	A-1B	C37	A-2B	CN8	B-1B		
		R22	B-3A	C15	A-1B	C38	A-1B	CN9	B-2B		
DIODE		R23	B-1B	C16	A-2B	C39	A-2B				
D17	B-1B	R24	B-1A	C17	A-1B	C40	B-1A				
D18	B-1B	R25	B-2A	C18	A-1B	C44	B-3B	CP1	B-3B		
		R26	A-1B	C19	A-1B	C45	B-3B	CP2	B-2B		
RESISTOR		R27	B-2A	C20	A-2B	C46	B-2A				
R1	B-3A	R29	B-2B	C21	A-2B	C47	B-2A	E1	A-2B		
R2	B-2A			C22	A-2B	C48	B-3B				
R3	B-3A	CAPACITOR		C23	B-1B	C49	B-2B	L1	B-3B		
R4	B-3A	C1	B-3B	C24	B-1B	C50	B-2B	L2	B-3A		
R7	B-3A	C2	B-3B	C25	B-1B	C68	A-2A	L3	B-3A		
R8	B-3B	C3	B-3A	C26	B-1B			L4	A-1B		

MAIN UNIT (XC1-286F-00)

ADDRESS TABLE OF BOARD PARTS

Each address may have an address error by one interval.



Table with columns for REF.NO., LOCATION, and component details. It lists various electronic components like ICs, resistors, capacitors, and transistors with their respective reference numbers and board locations.

■ MAIN UNIT (XC1-286F-00)

--- Component side view/Side A (J7C-0282-10) ---

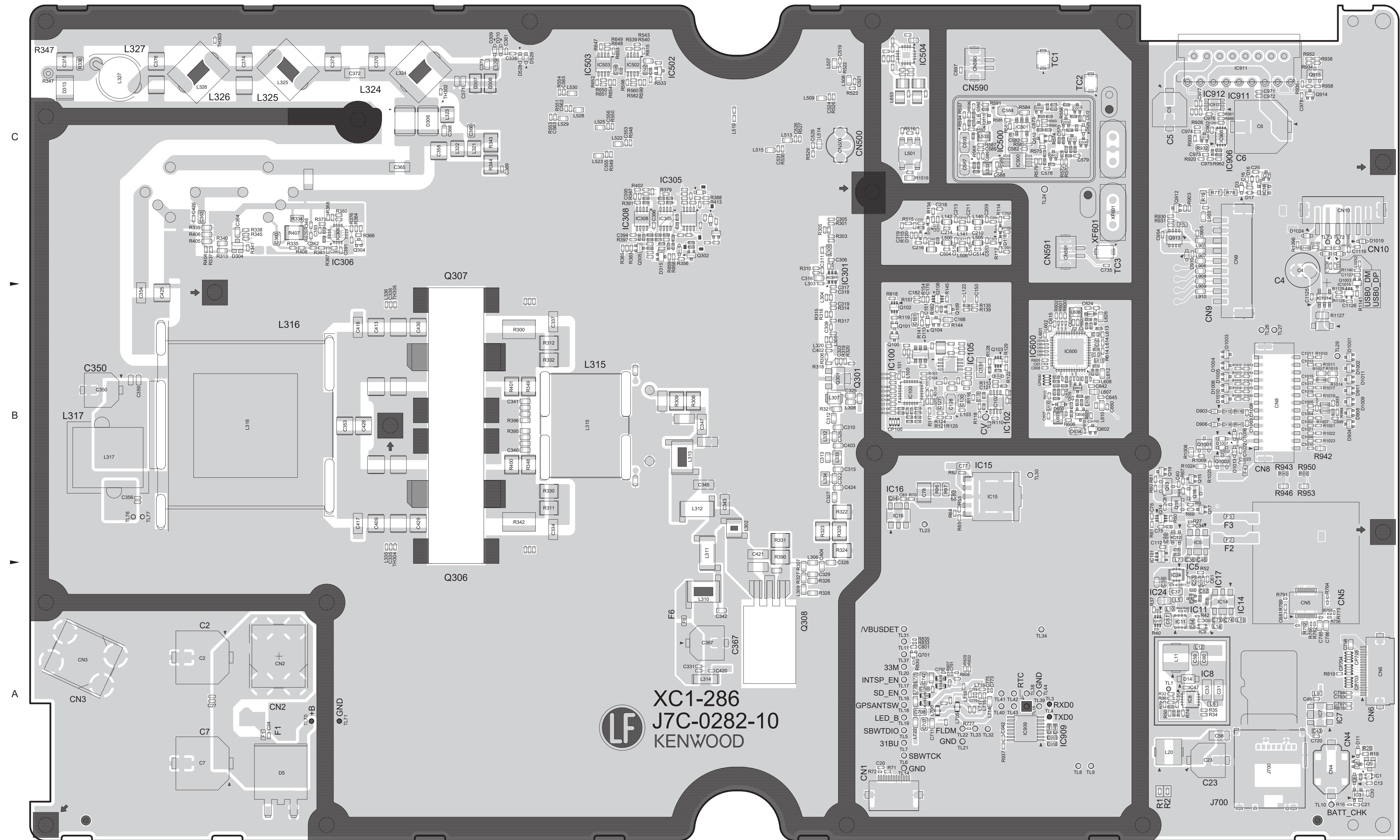

■ MAIN UNIT (XC1-286F-00)

--- Foil side view/Side B (J7C-0282-10) ---

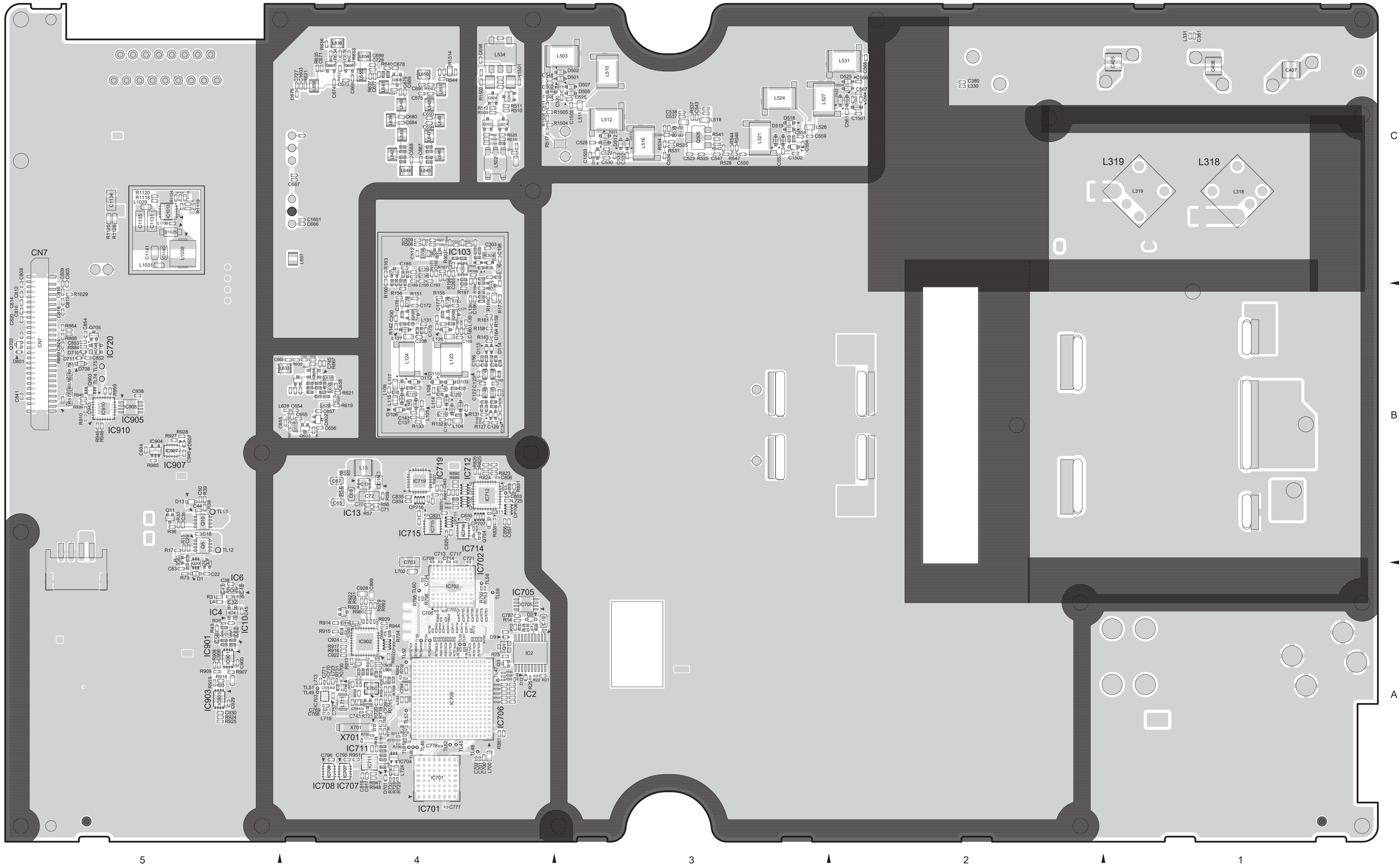

SCHEMATIC DIAGRAM

INTERFACE UNIT (XC3-073F-00)

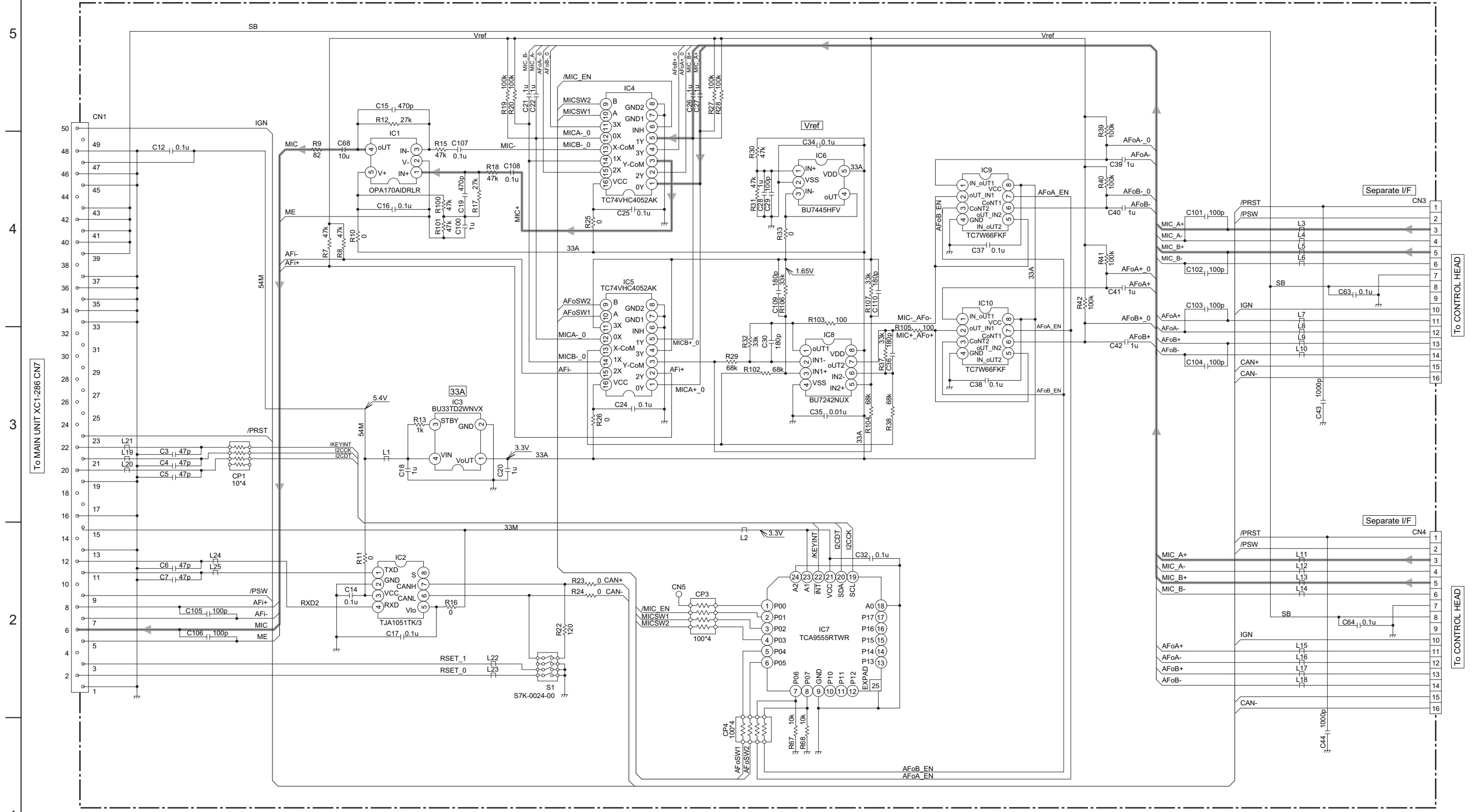

MODULE (BT/GPS) UNIT (XC2-0031-80)

5

4

3

2

1

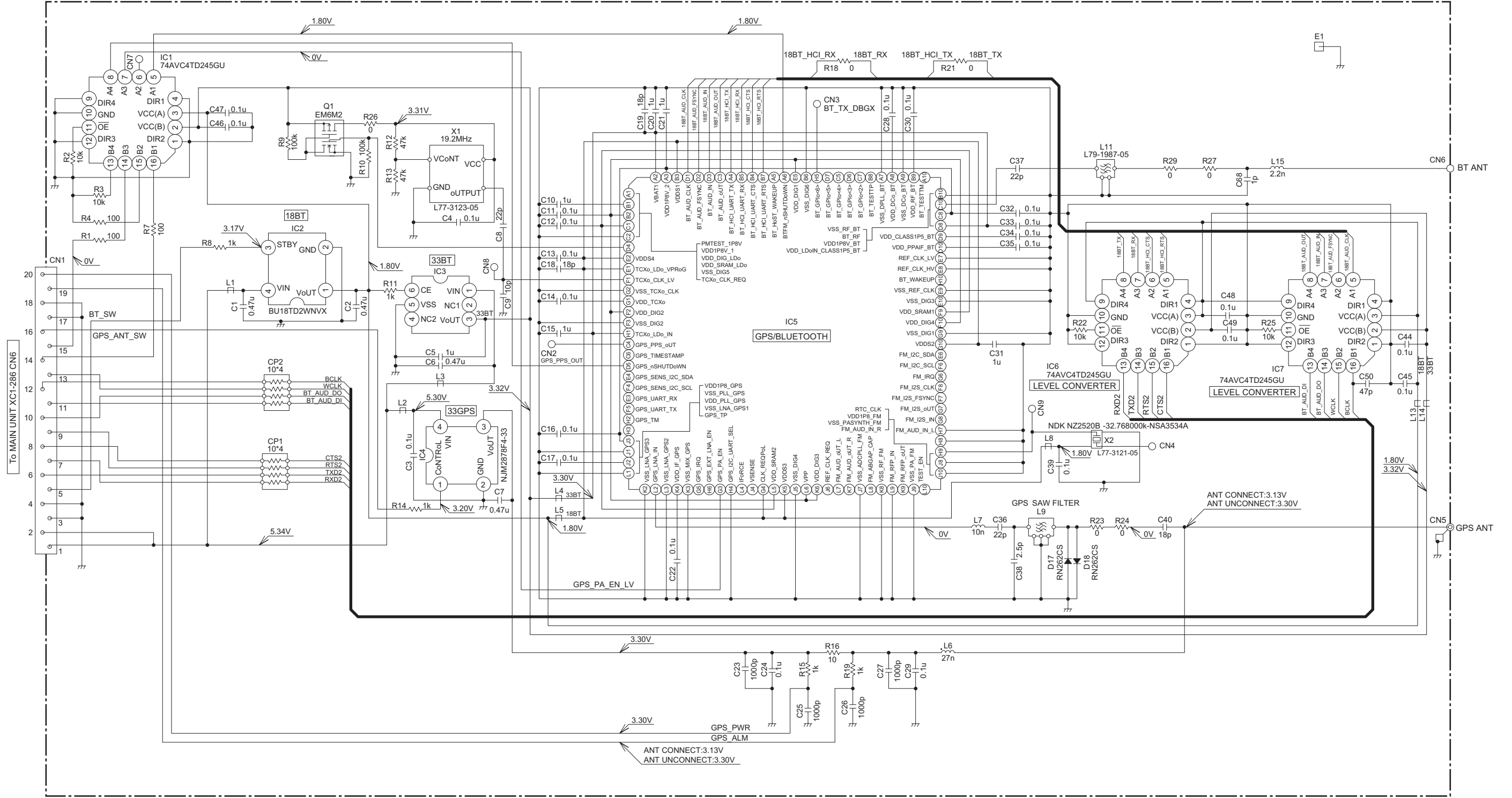

To MAIN UNIT XC1-286 CN6

A

B

C

D

E

F

G

MAIN UNIT (XC1-286F-00)

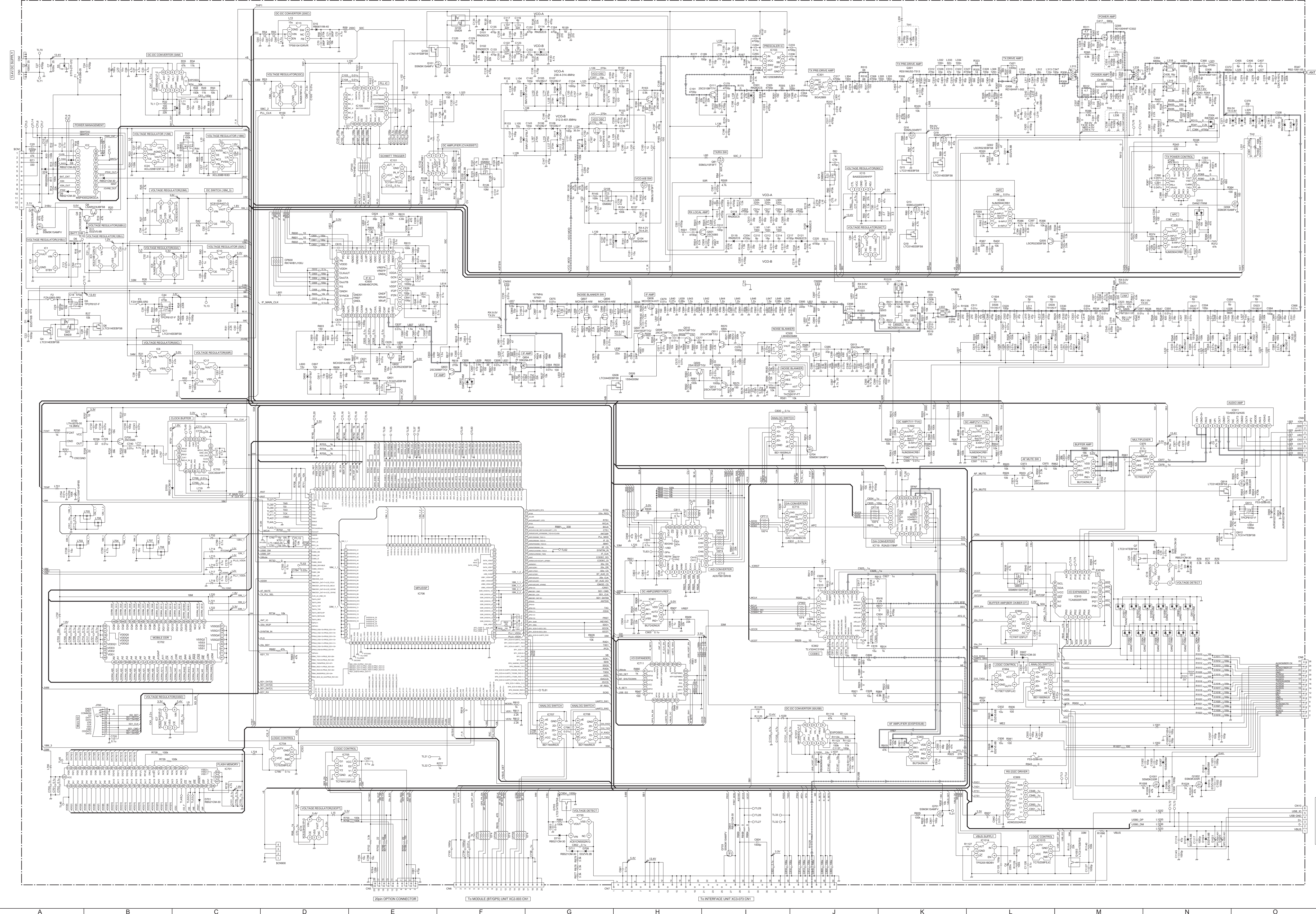

BLOCK DIAGRAM

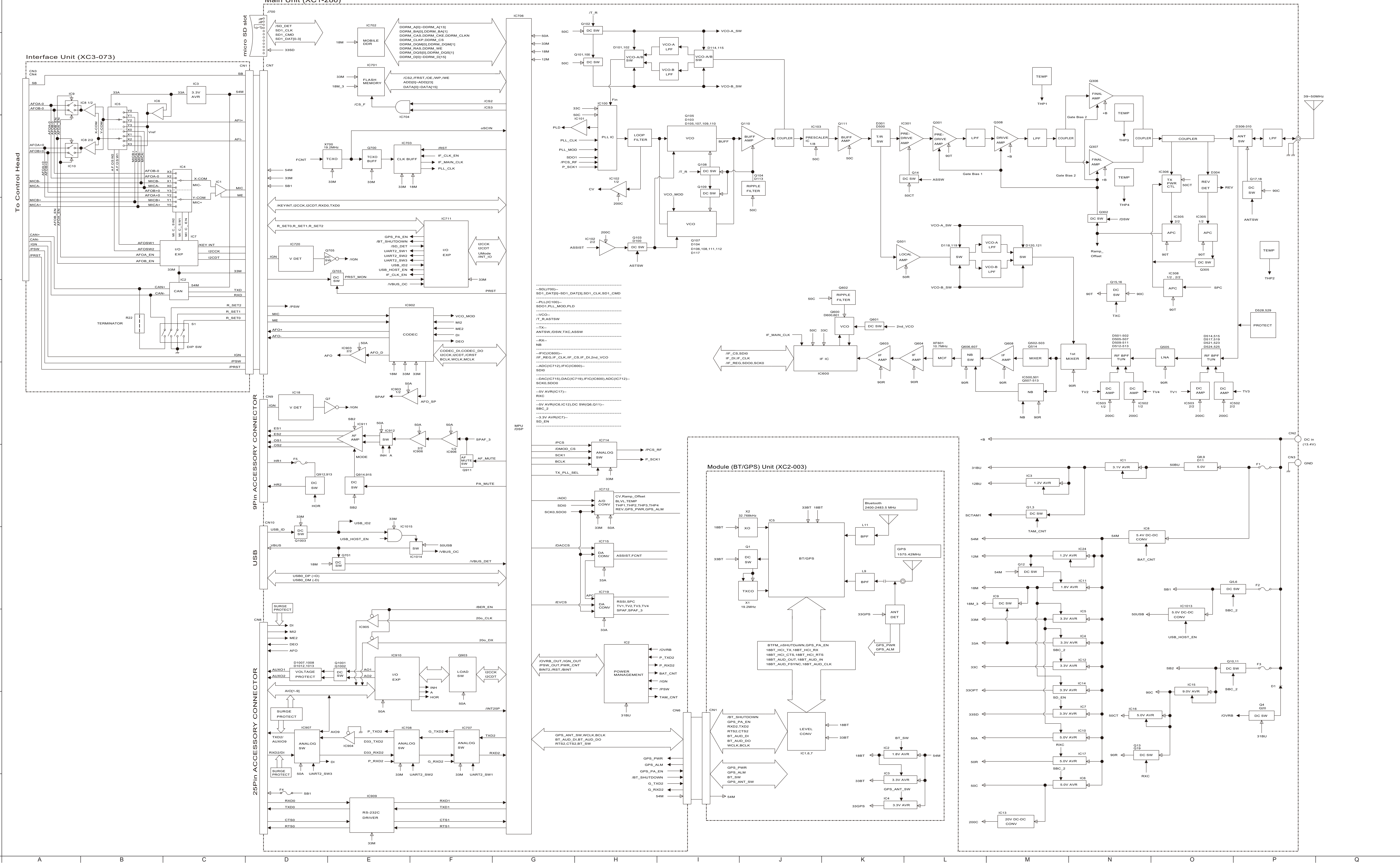

PARTS LIST

[NX-5600HB]

*** SAFETY PRECAUTION**

Parts identified by the \triangle symbol are critical for safety. Replace only with specified part numbers.

*** BEWARE OF BOGUS PARTS**

Parts that do not meet specifications may cause trouble in regard to safety and performance. We recommend that genuine parts be used.

* (x_) in a description column shows the number of the used part.

- Contents -

Exploded view of general assembly and parts list	3-2
Electrical parts list	3-4
Packing materials and accessories parts list	3-20

Exploded view of general assembly and parts list

Block No.M1MM

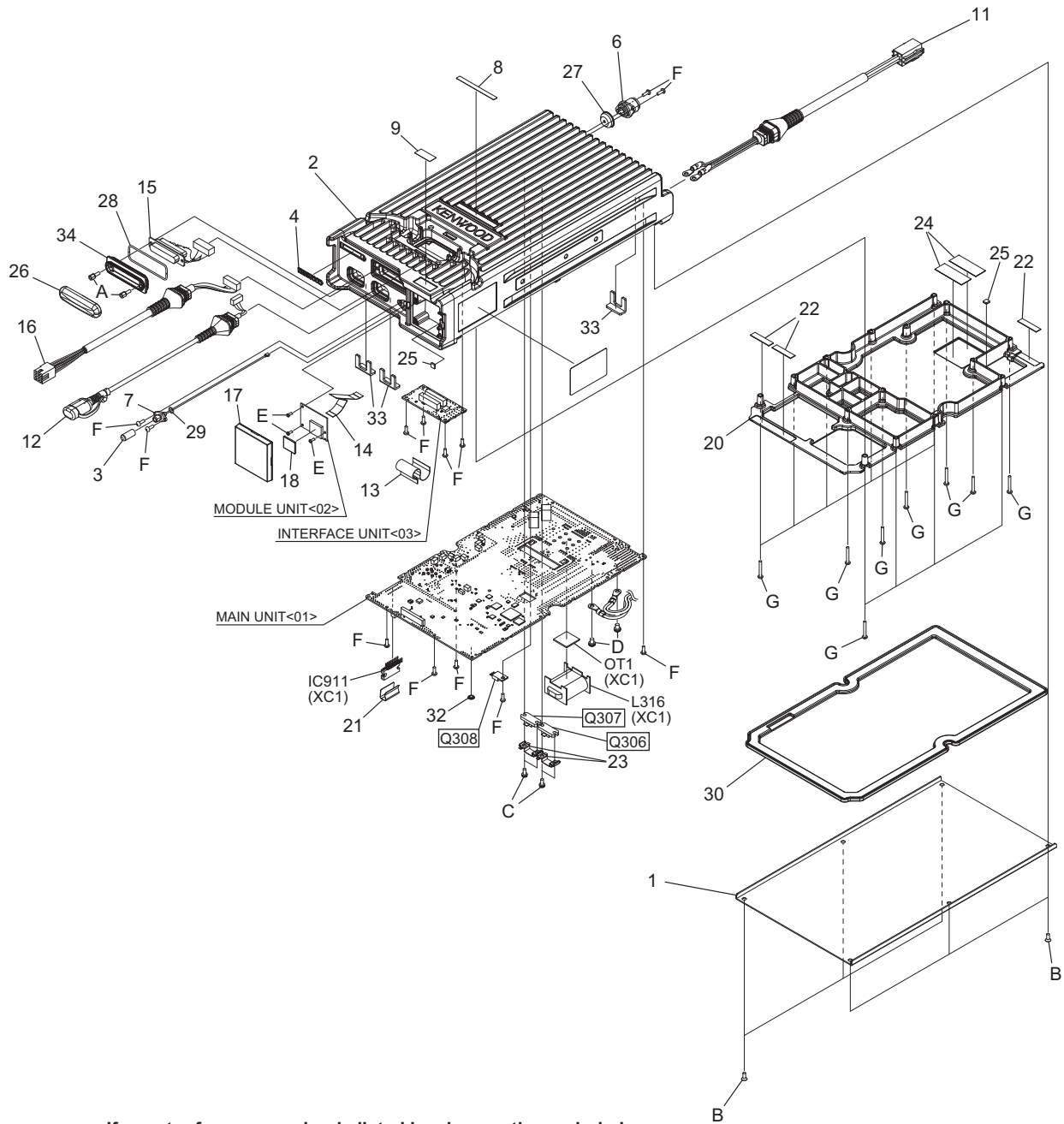

If a part reference number is listed in a box on the exploded view of the PCB, that part does not come with the PCB. These parts must be ordered separately.

General assembly

Block No. [M][1][M][M]

△ Symbol No.	Part No.	Part Name	Description	Local
1	-----	M.CABINET		
2	-----	CHASSIS		
3	B09-0754-05	CAP	SMA	
4	B43-0336-04	BADGE	KENWOOD	
6	E04-0167-15	C.RECEPTACLE-M		
7	E0E-0034-00	C.RECEPTACLE-SM	GPS	
8	B41-1837-04	CAUTION STICKER	HOT SURFACE	
9	B4B-0008-00	CAUTION STICKER	FCC	
11	E3A-0558-00	DC CORD		
12	E3A-0574-00	CORD WITH PLUG	USB	
13	E3G-0119-00	FFC WIRE	50P	
14	E3G-0127-00	FFC WIRE	20P(BT/GPS)	
15	E3K-0435-00	LEAD.WIRE W.C.	DSUB 25P	
16	E3K-0436-00	LEAD.WIRE W.C.	MOLEX 9P	
17	F0G-0318-00	MOLDING COVER	FRONT(BT/GPS)	
18	F10-3225-05	SHIELDING COVER	BLS(BT/GPS)	
20	F1B-0115-20	SHIELDING COVER	ADC12	
21	G02-0861-14	FLAT SPRING	AUDIO AMP	
22	G1A-0110-00	FIBROUS SHEET	SHIELD COVER(x3)	
23	G02-0894-14	EARTH SPRING	FET(x2)	
24	F2A-0095-00	INS.SHEET	SHIELD COVER(x2)	
25	G1D-0071-10	CUSHION	CHASSIS, SHIELD COVER(x2)	
26	G53-1626-03	PACKING	DSUB CAP	
27	G53-1662-04	PACKING	ANT M	
28	G53-1687-04	PACKING	DSUB	
29	G53-1768-04	PACKING	SMA	
30	G5D-0200-00	RUBBER SEAL		
32	W09-0971-05	LITHIUM CELL		
33	-----	HOLDER	DC, USB, MOLEX(x3)	
34	J21-8503-22	MOUNTING	DSUB	
A	N09-2409-05	HEX.HEAD SCREW	DSUB(x2)	
B	N32-3008-43	F.HEAD M.SCREW	M.CABINET(x6)	
C	N67-3008-48	P.H.SEMS SCREW	FET(x4)	
D	N68-4006-48	P.H.SEMS SCREW	DC(+/-)(x2)	
E	N83-2005-48	P.HEAD T.SCREW	BT/GPS UNIT(x3)	
F	N87-2608-48	BR.HEAD T.SCREW	PCB, ANT, SMA(x15)	
G	N87-2620-48	BR.HEAD T.SCREW	SHIELD COVER(x15)	
-	XCA-074F-00	MAIN UNIT	SERVICE UNIT	
-	XC2-0031-80	MODULE UNIT	BT/GPS	
-	XC3-073F-00	INTERFACE UNIT	PANEL SEPARATE	

Electrical parts list

MAIN UNIT

XC1-286F-00

***Note: This part cannot be replaced. Therefore, this part is not supplied as a service part.**

Block No. [0][1]

△ Symbol No.	Part No.	Part Name	Description	Local
IC1	-----	IC	*Note	
IC2	MSP430G25KGCA	IC		
IC3	XC6215B122N-G	IC		
IC4	NJM2878F4-33	IC		
IC5	XC6223D331P-G	IC		
IC6	-----	IC	*Note	
IC7	XC6223H331P-G	IC		
IC8	MP2560DQ-LF-Z	IC		
IC9	XC8102AA07-G	IC		
IC10	-----	IC	*Note	
IC11	XCL208B183D	IC		
IC12	NJM2878F4-33	IC		
IC13	TPS61041DRVR	IC		
IC14	XC6223H331P-G	IC		
IC15	BA00DD0WHFP	IC		
IC16	XC6209B502P-G	IC		
IC17	-----	IC	*Note	
IC18	XC61CN5002N-G	IC		
IC24	XCL220B123F-G	IC		
IC100	SKY72310362LF	IC		
IC101	TC7SH17FUJC	IC		
IC102	NJM2904CRB1	IC		
IC103	MC12093MNR4G	IC		
IC301	BGA2869	IC		
IC305	NJM2904CRB1	IC		
IC306	ADL5513	IC		
IC308	NJM2904CRB1	IC		
IC500	LMH6505MM	IC		
IC501	TA75S01F-FT	IC		
IC502	NJM2904CRB1	IC		
IC503	NJM2904CRB1	IC		
IC600	AD9864BCPZRL	IC		
IC701	-----	IC	*Note	
IC702	-----	IC	*Note	
IC703	CDC3S04YFF	IC		
IC704	TC7SZ08FEJC	IC		
IC705	TC7WH126FUJC	IC		
IC706	-----	IC	*Note	
IC707	BD11600NUX	IC		
IC708	BD11600NUX	IC		
IC711	-----	IC	*Note	
IC712	ADS7961SRHB	IC		
IC714	BD11600NUX	IC		
IC715	DAC124S085CIS	IC		
IC719	R2A20178NP	IC		
IC720	XC61CN5002N-G	IC		
IC901	BU7242NUX	IC		
IC902	TLV32AIC3104I	IC		
IC903	BU7242NUX	IC		
IC904	TC7SET125FUJC	IC		
IC905	TC7WT125FUT	IC		
IC906	BU7242NUX	IC		
IC907	BD11600NUX	IC		
IC909	ADM3202ARUZ	IC		
IC910	TCA9555RTWR	IC		
IC911	TDA8561Q/N3S	IC		

△ Symbol No.	Part No.	Part Name	Description	Local
IC912	TC7W53FKFT	IC		
IC1013	MP2560DQ-LF-Z	IC		
IC1014	TPS2051BDBV	IC		
IC1015	TC7SZ08FEJC	IC		
Q1	LSAR523UBF8	TRANSISTOR		
Q3	SSM3K15AMFV	FET		
Q4	LTC014EEBFS8	DIGI TRANSISTOR		
Q5	TPCP8107-F	FET		
Q6	LTC014EEBFS8	DIGI TRANSISTOR		
Q7	LTC014TEBFS8	DIGI TRANSISTOR		
Q8	LSCR523EBFS8	TRANSISTOR		
Q9	LSAR523UBF8	TRANSISTOR		
Q10	TPCP8107-F	FET		
Q11	LTC014EEBFS8	DIGI TRANSISTOR		
Q12	EM6M2	FET		
Q13	SSM3J334RFT	FET		
Q14	EM6M2	FET		
Q15	LTC014EEBFS8	DIGI TRANSISTOR		
Q16	SSM3J334RFT	FET		
Q17	LTC014EEBFS8	DIGI TRANSISTOR		
Q18	SSM3J334RFT	FET		
Q19	LTC014EEBFS8	DIGI TRANSISTOR		
Q20	EMD9	TRANSISTOR		
Q81	SSM3J15FSFT	FET		
Q100	LTA014YEBFS8	DIGI TRANSISTOR		
Q101	SSM3K15AMFV	FET		
Q102	EMD9	TRANSISTOR		
Q103	EM6M2	FET		
Q104	2SD2654/W/	TRANSISTOR		
Q105	MCH3914-H/8/	FET		
Q107	MCH3914-H/8/	FET		
Q108	EM6M2	FET		
Q109	SSM3J15FSFT	FET		
Q110	2SC5108FT/Y/	TRANSISTOR		
Q111	2SC5108FT/Y/	TRANSISTOR		
Q301	RD01MUS2-T513	FET		
Q302	LSCR523EBFS8	TRANSISTOR		
Q304	SSM3K15AMFV	FET		
Q305	LSCR523EBFS8	TRANSISTOR		
Q306	RD100HHF1C502	FET		
Q307	RD100HHF1C502	FET		
Q308	RD16HHF1-502	FET		
Q501	2SC5585	TRANSISTOR		
Q502	MCH3914-H/8/	FET		
Q503	MCH3914-H/8/	FET		
Q504	MCH3914-H/8/	FET		
Q505	MT3S111P	TRANSISTOR		
Q506	LTC044EEBFS8	DIGI TRANSISTOR		
Q507	2SA1832FT/G/	TRANSISTOR		
Q508	2SC4738FT/G/	TRANSISTOR		
Q509	2SA1832FT/G/	TRANSISTOR		
Q510	2SC4738FT/G/	TRANSISTOR		
Q511	2SC4738FT/G/	TRANSISTOR		
Q512	2SC4738FT/G/	TRANSISTOR		
Q513	3SK294-FP	FET		
Q514	MCH3914-H/8/	FET		
Q600	MCH3914-H/8/	FET		
Q601	LTC023JEBFS8	DIGI TRANSISTOR		
Q602	LSCR523EBFS8	TRANSISTOR		
Q603	2SC5066FT/O/	TRANSISTOR		
Q604	3SK294-FP	FET		
Q606	MCH3914-H/8/	FET		
Q607	MCH3914-H/8/	FET		
Q608	MCH3914-H/7/	FET		

△ Symbol No.	Part No.	Part Name	Description	Local	△ Symbol No.	Part No.	Part Name	Description	Local
Q700	2SC5585	TRANSISTOR			D507	1SV282-F	VARI CAP DIODE		
Q701	SSM3K15AMFV	FET			D509	1SV282-F	VARI CAP DIODE		
Q703	SSM3K15AMFV	FET			D510	1SV282-F	VARI CAP DIODE		
Q704	SSM3K15AMFV	FET			D511	1SV282-F	VARI CAP DIODE		
Q705	LTC014TEBFS8	DIGI TRANSISTOR			D512	1SV282-F	VARI CAP DIODE		
Q903	SSM6N15AFEM	DUAL FET			D513	1SV282-F	VARI CAP DIODE		
Q911	2SD2654/W/	TRANSISTOR			D514	1SV282-F	VARI CAP DIODE		
Q912	LTC014TEBFS8	DIGI TRANSISTOR			D515	1SV282-F	VARI CAP DIODE		
Q913	TPCP8107-F	FET			D517	1SV282-F	VARI CAP DIODE		
Q914	LTC014EEBFS8	DIGI TRANSISTOR			D518	1SV282-F	VARI CAP DIODE		
Q915	SSM3K335R	FET			D519	1SV282-F	VARI CAP DIODE		
Q1001	SSM3K335R	FET			D521	1SV282-F	VARI CAP DIODE		
Q1002	SSM3K335R	FET			D522	1SV282-F	VARI CAP DIODE		
Q1003	LTC014TEBFS8	DIGI TRANSISTOR			D523	1SV282-F	VARI CAP DIODE		
Q1003	LTC014TEBFS8	DIGI TRANSISTOR			D524	1SV282-F	VARI CAP DIODE		
D1	EDZV18B	ZENER DIODE			D525	1SV282-F	VARI CAP DIODE		
D2	RB520SM-30	DIODE			D526	1SS400SM	DIODE		
D3	EDZV8.2B	ZENER DIODE			D528	RN142SM	DIODE		
D5	ST70-27F-572	ZENER DIODE			D529	RN142SM	DIODE		
D6	RB520SM-30	DIODE			D600	SMV1251-079LF	VARI CAP DIODE		
D8	RB521CM-30	DIODE			D601	SMV1705-079LF	VARI CAP DIODE		
D9	RB521CM-30	DIODE			D602	DAN217WM	DIODE		
D11	EDZV5.6B	ZENER DIODE			D700	RB521CM-30	DIODE		
D12	RB521CM-30	DIODE			D701	RB521CM-30	DIODE		
D13	1SS400SM	DIODE			D708	EDZV8.2B	ZENER DIODE		
D14	RB060MM-40	SCHOTTKY DIODE			D710	RB521CM-30	DIODE		
D15	RB561VM-40	SCHOTTKY DIODE			D711	RB521CM-30	DIODE		
D16	RB521CM-30	DIODE			D801	RB521CM-30	DIODE		
D17	RB521CM-30	DIODE			D903	EDZV5.6B	ZENER DIODE		
D100	EDZV8.2B	ZENER DIODE			D904	DAN217WM	DIODE		
D101	RN262CS	DIODE			D905	AVRM10270K10N	VARIATOR		
D102	RN262CS	DIODE			D906	EDZV5.6B	ZENER DIODE		
D103	SMV1251-079LF	VARI CAP DIODE			D907	RB521CM-30	DIODE		
D104	SMV1251-079LF	VARI CAP DIODE			D908	DAN217WM	DIODE		
D105	1SV282-F	VARI CAP DIODE			D910	AVRM10270K10N	VARIATOR		
D106	1SV282-F	VARI CAP DIODE			D911	DAN217WM	DIODE		
D107	1SV282-F	VARI CAP DIODE			D1001	DAN217WM	DIODE		
D108	1SV282-F	VARI CAP DIODE			D1002	DAN217WM	DIODE		
D109	1SV282-F	VARI CAP DIODE			D1003	DAN217WM	DIODE		
D110	1SV282-F	VARI CAP DIODE			D1004	DAN217WM	DIODE		
D111	1SV282-F	VARI CAP DIODE			D1005	DAN217WM	DIODE		
D112	1SV282-F	VARI CAP DIODE			D1006	DAN217WM	DIODE		
D113	1SS400SM	DIODE			D1007	1SS400SM	DIODE		
D114	RN262CS	DIODE			D1008	EDZV18B	ZENER DIODE		
D115	RN262CS	DIODE			D1009	DAN217WM	DIODE		
D117	1SV323FT	VARI CAP DIODE			D1010	DAN217WM	DIODE		
D118	RN262CS	DIODE			D1011	DAN217WM	DIODE		
D119	RN262CS	DIODE			D1012	1SS400SM	DIODE		
D120	RN262CS	DIODE			D1013	EDZV18B	ZENER DIODE		
D121	RN262CS	DIODE			D1019	EDZV6.8B	ZENER DIODE		
D301	RN262CS	DIODE			D1020	SPC10501A01	VARIATOR		
D304	RB706F-40	DIODE			D1021	SPC10501A01	VARIATOR		
D306	MA4P4002F1091	DIODE			D1024	EDZV6.8B	ZENER DIODE		
D307	L8104	DIODE			D1025	RB060MM-40	SCHOTTKY DIODE		
D308	L8104	DIODE			C2	CE32EJ1E102M	E CAPACITOR	1000uF 25V M	
D309	RN142SM	DIODE			C4	C90-6990-05	E CAPACITOR	220uF 10V	
D310	RN142SM	DIODE			C5	CE32BM1V470M	E CAPACITOR	47uF 35V M	
D311	EDZV6.8B	ZENER DIODE			C6	C92-0968-05	E CAPACITOR	470uF 25V	
D313	CSA70-401L	SURGE ABSORBER			C7	CE32EJ1E102M	E CAPACITOR	1000uF 25V M	
D315	DAN217WM	DIODE			C10	CK73FB1C106K	C CAPACITOR	10uF 16V K	
D500	RN262CS	DIODE			C11	CK73HB1E104K	C CAPACITOR	0.1uF 25V K	
D501	1SV282-F	VARI CAP DIODE			C12	C93-1959-05	C CAPACITOR	0.1uF 16V	
D502	1SV282-F	VARI CAP DIODE			C13	CK73HB1A474K	C CAPACITOR	0.47uF 10V K	
D505	1SV282-F	VARI CAP DIODE			C16	CK73HB1H103K	C CAPACITOR	0.01uF 50V K	
D506	1SV282-F	VARI CAP DIODE			C18	CC73HCH1H471J	C CAPACITOR	470pF 50V J	

△ Symbol No.	Part No.	Part Name	Description	Local	△ Symbol No.	Part No.	Part Name	Description	Local
C19	CK73HB1C105K	C CAPACITOR	1uF 16V K		C103	CK73HB1H103K	C CAPACITOR	0.01uF 50V K	
C20	CK73HBB1H222K	C CAPACITOR	2200pF 50V K		C104	CK73HB1H103K	C CAPACITOR	0.01uF 50V K	
C21	CK73HB1C105K	C CAPACITOR	1uF 16V K		C106	CC73HCH1H101J	C CAPACITOR	100pF 50V J	
C22	CK73HBB1H102K	C CAPACITOR	1000pF 50V K		C107	CC73HCH1H101J	C CAPACITOR	100pF 50V J	
C23	CE32BM1E101M	E CAPACITOR	100uF 25V M		C108	CC73HCH1H101J	C CAPACITOR	100pF 50V J	
C24	CK73HBB1H472K	C CAPACITOR	4700pF 50V K		C109	CC73HCH1H101J	C CAPACITOR	100pF 50V J	
C25	CK73HBB1H102K	C CAPACITOR	1000pF 50V K		C110	CC73HCH1H101J	C CAPACITOR	100pF 50V J	
C27	CK73HBB1H472K	C CAPACITOR	4700pF 50V K		C111	CC73HCH1H101J	C CAPACITOR	100pF 50V J	
C28	CK73HBB1H102K	C CAPACITOR	1000pF 50V K		C112	CK73HB1E104K	C CAPACITOR	0.1uF 25V K	
C29	CK73HBB1H102K	C CAPACITOR	1000pF 50V K		C113	CK73HB1E104K	C CAPACITOR	0.1uF 25V K	
C30	CK73HB1C105K	C CAPACITOR	1uF 16V K		C114	CC73HCH1H101J	C CAPACITOR	100pF 50V J	
C31	CK73EB1H475KM	C CAPACITOR	4.7uF 50V M		C115	CK73HB1E104K	C CAPACITOR	0.1uF 25V K	
C32	CK73GXR1H105K	C CAPACITOR	1uF 50V K		C116	CC73HCH1H101J	C CAPACITOR	100pF 50V J	
C33	CK73EB1H475KM	C CAPACITOR	4.7uF 50V M		C117	CC73HCH1H040B	C CAPACITOR	4pF 50V B	
C34	CK73HB1E104K	C CAPACITOR	0.1uF 25V K		C118	CK73HB1H103K	C CAPACITOR	0.01uF 50V K	
C35	CK73HBB1H102K	C CAPACITOR	1000pF 50V K		C119	CC73HCH1H040B	C CAPACITOR	4pF 50V B	
C36	CK73GXR1H105K	C CAPACITOR	1uF 50V K		C120	CC73HCH1H101J	C CAPACITOR	100pF 50V J	
C37	CK73FB1C106K	C CAPACITOR	10uF 16V K		C121	CC73HCH1H330G	C CAPACITOR	33pF 50V G	
C38	CK73HBB1H102K	C CAPACITOR	1000pF 50V K		C122	CC73HCH1H020B	C CAPACITOR	2pF 50V B	
C39	CK73GB0J106K	C CAPACITOR	10uF 6.3V K		C123	CC73HCH1H020B	C CAPACITOR	2pF 50V B	
C40	CC73HCH1H470G	C CAPACITOR	47pF 50V G		C124	CC73HCH1H101J	C CAPACITOR	100pF 50V J	
C41	CK73GXR1H105K	C CAPACITOR	1uF 50V K		C125	CK73GXR1H105K	C CAPACITOR	1uF 50V K	
C43	CK73GXR1C225K	C CAPACITOR	2.2uF 16V K		C126	CC73HCH1H101J	C CAPACITOR	100pF 50V J	
C44	CC73HCH1H471J	C CAPACITOR	470pF 50V J		C127	CK73FB1E104K	C CAPACITOR	0.1uF 25V K	
C45	CK73HB1C105K	C CAPACITOR	1uF 16V K		C128	CS77ABE1D100M	TA E CAPACITOR	10uF 20V M	
C46	CK73GXR1C225K	C CAPACITOR	2.2uF 16V K		C129	CC73HCH1H471J	C CAPACITOR	470pF 50V J	
C47	CK73HB1E104K	C CAPACITOR	0.1uF 25V K		C130	CK73FB1E104K	C CAPACITOR	0.1uF 25V K	
C48	CK73GXR1C225K	C CAPACITOR	2.2uF 16V K		C131	CC730AD1H104J	C CAPACITOR	0.1uF 50V J	
C49	CK73HB1C105K	C CAPACITOR	1uF 16V K		C132	CC73HCH1H471J	C CAPACITOR	470pF 50V J	
C50	CK73HBB1H102K	C CAPACITOR	1000pF 50V K		C133	CC73HCH1H471J	C CAPACITOR	470pF 50V J	
C51	CC73HCH1H101J	C CAPACITOR	100pF 50V J		C134	CC73HCH1H471J	C CAPACITOR	470pF 50V J	
C52	CK73HB1E104K	C CAPACITOR	0.1uF 25V K		C135	CC73HCH1H471J	C CAPACITOR	470pF 50V J	
C53	CK73GXR1H105K	C CAPACITOR	1uF 50V K		C136	CC73HCH1H101J	C CAPACITOR	100pF 50V J	
C54	CK73GXR1H105K	C CAPACITOR	1uF 50V K		C137	CC73HCH1H101J	C CAPACITOR	100pF 50V J	
C55	CK73HBB1H102K	C CAPACITOR	1000pF 50V K		C138	CC73HCH1H050B	C CAPACITOR	5pF 50V B	
C56	CK73EB1H475KM	C CAPACITOR	4.7uF 50V M		C139	CC73HCH1H080B	C CAPACITOR	8pF 50V B	
C57	CK73FXR1E475K	C CAPACITOR	4.7uF 25V K		C142	CC73HCH1H101J	C CAPACITOR	100pF 50V J	
C59	CK73FB1C106K	C CAPACITOR	10uF 16V K		C143	CC73HCH1H101J	C CAPACITOR	100pF 50V J	
C60	CK73FB1C106K	C CAPACITOR	10uF 16V K		C144	CC73HCH1H100B	C CAPACITOR	10pF 50V B	
C61	CK73HBB1H102K	C CAPACITOR	1000pF 50V K		C145	CC73HCH1H150G	C CAPACITOR	15pF 50V G	
C62	CK73GXR1C225K	C CAPACITOR	2.2uF 16V K		C146	CC73HCH1H471J	C CAPACITOR	470pF 50V J	
C63	CK73HBB1H102K	C CAPACITOR	1000pF 50V K		C147	CC73HCH1H471J	C CAPACITOR	470pF 50V J	
C64	CK73GB0J106K	C CAPACITOR	10uF 6.3V K		C148	CC73HCH1H080B	C CAPACITOR	8pF 50V B	
C65	CK73FB1C106K	C CAPACITOR	10uF 16V K		C149	CC73HCH1H050B	C CAPACITOR	5pF 50V B	
C66	CK73HB1C105K	C CAPACITOR	1uF 16V K		C150	CK73HB1C105K	C CAPACITOR	1uF 16V K	
C67	CK73FB1C106K	C CAPACITOR	10uF 16V K		C151	CC73HCH1H471J	C CAPACITOR	470pF 50V J	
C68	CK73FXR1E475K	C CAPACITOR	4.7uF 25V K		C152	CC73HCH1H471J	C CAPACITOR	470pF 50V J	
C69	CK73GXR1C225K	C CAPACITOR	2.2uF 16V K		C153	CC73HCH1H471J	C CAPACITOR	470pF 50V J	
C70	CC73HCH1H391J	C CAPACITOR	390pF 50V J		C154	CK73HBB1H102K	C CAPACITOR	1000pF 50V K	
C71	CC73HCH1H391J	C CAPACITOR	390pF 50V J		C155	CC73HCH1H101J	C CAPACITOR	100pF 50V J	
C72	CK73EB1H475KM	C CAPACITOR	4.7uF 50V M		C156	CC73HCH1H471J	C CAPACITOR	470pF 50V J	
C73	CK73GXR1H105K	C CAPACITOR	1uF 50V K		C157	CC73HCH1H010B	C CAPACITOR	1pF 50V B	
C74	CK73GXR1C225K	C CAPACITOR	2.2uF 16V K		C159	CC73HCH1H471J	C CAPACITOR	470pF 50V J	
C75	CK73HB1C105K	C CAPACITOR	1uF 16V K		C161	CK73FB1C106K	C CAPACITOR	10uF 16V K	
C76	CC73HCH1H471J	C CAPACITOR	470pF 50V J		C162	CC73HCH1H010B	C CAPACITOR	1pF 50V B	
C77	CK73FXR1E475K	C CAPACITOR	4.7uF 25V K		C164	CC73HCH1H471J	C CAPACITOR	470pF 50V J	
C78	CK730DT1C476K	C CAPACITOR	47uF 16V K		C165	CC73HCH1H080B	C CAPACITOR	8pF 50V B	
C80	CK73GXR1H104K	C CAPACITOR	0.1uF 50V K		C167	CC73HCH1H040B	C CAPACITOR	4pF 50V B	
C81	CC73HCH1H470G	C CAPACITOR	47pF 50V G		C168	CK73GXR1H105K	C CAPACITOR	1uF 50V K	
C82	CK73GXR1C225K	C CAPACITOR	2.2uF 16V K		C169	CC73HCH1H471J	C CAPACITOR	470pF 50V J	
C83	CK73HB1C105K	C CAPACITOR	1uF 16V K		C170	CC73HCH1H060B	C CAPACITOR	6pF 50V B	
C84	CK73GXR1C225K	C CAPACITOR	2.2uF 16V K		C171	CC73HCH1H080B	C CAPACITOR	8pF 50V B	
C100	CK73HB1H103K	C CAPACITOR	0.01uF 50V K		C172	CC73HCH1H050B	C CAPACITOR	5pF 50V B	
C101	CC73HCH1H471J	C CAPACITOR	470pF 50V J		C174	CC73HCH1H101J	C CAPACITOR	100pF 50V J	
C102	CC73HCH1H100B	C CAPACITOR	10pF 50V B		C175	CC73HCH1H101J	C CAPACITOR	100pF 50V J	

△ Symbol No.	Part No.	Part Name	Description	Local	△ Symbol No.	Part No.	Part Name	Description	Local
C176	CC73HCH1H471J	C CAPACITOR	470pF 50V J		C334	CC730DZ2J681J	C CAPACITOR	680pF 630V J	
C177	CC73HCH1H0R5B	C CAPACITOR	0.5pF 50V B		C335	CK73HBB1H472K	C CAPACITOR	4700pF 50V K	
C178	CC73HCH1H0R5B	C CAPACITOR	0.5pF 50V B		C336	CK73HBB1H472K	C CAPACITOR	4700pF 50V K	
C179	CK73HBB1H472K	C CAPACITOR	4700pF 50V K		C337	CC730DZ2J681J	C CAPACITOR	680pF 630V J	
C180	CK73HB1C105K	C CAPACITOR	1uF 16V K		C338	CK73HB1H103K	C CAPACITOR	0.01uF 50V K	
C181	CC73HCH1H471J	C CAPACITOR	470pF 50V J		C340	CK73GGB1H472K	C CAPACITOR	4700pF 50V K	
C182	CC73HCH1H471J	C CAPACITOR	470pF 50V J		C341	CK73GGB1H472K	C CAPACITOR	4700pF 50V K	
C183	CK73HB1C105K	C CAPACITOR	1uF 16V K		C342	CK73GGB1H472K	C CAPACITOR	4700pF 50V K	
C184	CC73HCH1H471J	C CAPACITOR	470pF 50V J		C343	CC730DP2J121J	C CAPACITOR	120pF 630V J	
C185	CC73HCH1H090B	C CAPACITOR	9pF 50V B		C345	CC730DP2J121J	C CAPACITOR	120pF 630V J	
C187	CC73HCH1H471J	C CAPACITOR	470pF 50V J		C347	CC730DP2J101J	C CAPACITOR	100pF 630V J	
C189	CC73HCH1H101J	C CAPACITOR	100pF 50V J		C350	CE32BM1V470M	E CAPACITOR	47uF 35V M	
C190	CC73HCH1H100B	C CAPACITOR	10pF 50V B		C353	CC730DF2H101J	C CAPACITOR	100pF 500V J	
C191	CK73HBB1H472K	C CAPACITOR	4700pF 50V K		C354	C93-0717-05	C CAPACITOR	6800pF 630V	
C192	CC73HCH1H050B	C CAPACITOR	5pF 50V B		C356	CK73HBB1H472K	C CAPACITOR	4700pF 50V K	
C193	CC73HCH1H050B	C CAPACITOR	5pF 50V B		C358	CC730DF2H080C	C CAPACITOR	8pF 500V C	
C195	CK73HBB1H472K	C CAPACITOR	4700pF 50V K		C359	CK73GGB1H472K	C CAPACITOR	4700pF 50V K	
C196	CK73HBB1H472K	C CAPACITOR	4700pF 50V K		C360	CK73FB1H472K	C CAPACITOR	4700pF 50V K	
C198	CC73HCH1H120G	C CAPACITOR	12pF 50V G		C361	CC73HCH1H220G	C CAPACITOR	22pF 50V G	
C200	CC73HCH1H471J	C CAPACITOR	470pF 50V J		C362	CK73HBB1H472K	C CAPACITOR	4700pF 50V K	
C201	CK73HBB1H472K	C CAPACITOR	4700pF 50V K		C363	CK73FB1H472K	C CAPACITOR	4700pF 50V K	
C202	CK73HBB1H472K	C CAPACITOR	4700pF 50V K		C364	CK73GGB1H472K	C CAPACITOR	4700pF 50V K	
C203	CK73HBB1H472K	C CAPACITOR	4700pF 50V K		C365	C93-0717-05	C CAPACITOR	6800pF 630V	
C204	CK73HBB1H472K	C CAPACITOR	4700pF 50V K		C366	CK73FB1H472K	C CAPACITOR	4700pF 50V K	
C206	CC73HCH1H471J	C CAPACITOR	470pF 50V J		C367	CE32BM1V470M	E CAPACITOR	47uF 35V M	
C207	CC73HCH1H100B	C CAPACITOR	10pF 50V B		C368	CK73GGB1H472K	C CAPACITOR	4700pF 50V K	
C208	CC73HCH1H471J	C CAPACITOR	470pF 50V J		C369	CK73HBB1H472K	C CAPACITOR	4700pF 50V K	
C209	CC73HCH1H330G	C CAPACITOR	33pF 50V G		C370	CC730DF2H680G	C CAPACITOR	68pF 500V G	
C210	CC73HCH1H080B	C CAPACITOR	8pF 50V B		C371	CC730AY2E820G	C CAPACITOR	82pF 250V G	
C211	CC73HCH1H680G	C CAPACITOR	68pF 50V G		C372	C93-0717-05	C CAPACITOR	6800pF 630V	
C212	CC73HCH1H180G	C CAPACITOR	18pF 50V G		C373	CC730DF2H390G	C CAPACITOR	39pF 500V G	
C213	CC73HCH1H680G	C CAPACITOR	68pF 50V G		C374	CC730DF2H101G	C CAPACITOR	100pF 500V G	
C214	CC73HCH1H080B	C CAPACITOR	8pF 50V B		C376	CC730DF2H820G	C CAPACITOR	82pF 500V G	
C215	CC73HCH1H330G	C CAPACITOR	33pF 50V G		C378	CC730DF2H390G	C CAPACITOR	39pF 500V G	
C216	CK73HBB1H472K	C CAPACITOR	4700pF 50V K		C379	CC730AY2E330G	C CAPACITOR	33pF 250V G	
C217	CK73HBB1H472K	C CAPACITOR	4700pF 50V K		C380	CK73HBB1H472K	C CAPACITOR	4700pF 50V K	
C218	CK73HBB1H472K	C CAPACITOR	4700pF 50V K		C381	CK73HBB1H472K	C CAPACITOR	4700pF 50V K	
C219	CK73HBB1H472K	C CAPACITOR	4700pF 50V K		C382	CK73HB1C105K	C CAPACITOR	1uF 16V K	
C220	CK73HBB1H472K	C CAPACITOR	4700pF 50V K		C386	CK73HB1H103K	C CAPACITOR	0.01uF 50V K	
C233	CK73HBB1H472K	C CAPACITOR	4700pF 50V K		C387	CK73HB1H103K	C CAPACITOR	0.01uF 50V K	
C263	CK73HBB1H472K	C CAPACITOR	4700pF 50V K		C388	CC73HCH1H101J	C CAPACITOR	100pF 50V J	
C264	CK73HB1E104K	C CAPACITOR	0.1uF 25V K		C390	CK73HB1E473K	C CAPACITOR	0.04uF 25V K	
C265	CC73HCH1H471J	C CAPACITOR	470pF 50V J		C391	CK73HB1E473K	C CAPACITOR	0.04uF 25V K	
C303	CK73HBB1H472K	C CAPACITOR	4700pF 50V K		C392	CC73HCH1H150G	C CAPACITOR	15pF 50V G	
C304	CK73HBB1H472K	C CAPACITOR	4700pF 50V K		C393	CK73HBB1H102K	C CAPACITOR	1000pF 50V K	
C305	CK73HBB1H472K	C CAPACITOR	4700pF 50V K		C394	CK73HBB1H682K	C CAPACITOR	6800pF 50V K	
C306	CC73HCH1H270G	C CAPACITOR	27pF 50V G		C395	CK73HBB1H472K	C CAPACITOR	4700pF 50V K	
C308	CK73HBB1H472K	C CAPACITOR	4700pF 50V K		C396	CK73HB1H103K	C CAPACITOR	0.01uF 50V K	
C310	CC73GCH1H470J	C CAPACITOR	47pF 50V J		C397	CK73HB1H103K	C CAPACITOR	0.01uF 50V K	
C311	CK73HBB1H472K	C CAPACITOR	4700pF 50V K		C402	CC73HCH1H070B	C CAPACITOR	7pF 50V B	
C312	CC73GCH1H271J	C CAPACITOR	270pF 50V J		C403	CC73GCH1H151J	C CAPACITOR	150pF 50V J	
C313	CC73GCH1H470J	C CAPACITOR	47pF 50V J		C404	CC73GCH1H560J	C CAPACITOR	56pF 50V J	
C315	CC73GCH1H181J	C CAPACITOR	180pF 50V J		C405	CC730DF2H080C	C CAPACITOR	8pF 500V C	
C316	CC73GCH1H471J	C CAPACITOR	470pF 50V J		C406	CC730DF2H270G	C CAPACITOR	27pF 500V G	
C317	CK73HBB1H472K	C CAPACITOR	4700pF 50V K		C407	CC730DF2H470G	C CAPACITOR	47pF 500V G	
C318	CC73HCH1H680G	C CAPACITOR	68pF 50V G		C409	CC730DF2H101J	C CAPACITOR	100pF 500V J	
C319	CC73HCH1H680G	C CAPACITOR	68pF 50V G		C413	CC730DF2H101J	C CAPACITOR	100pF 500V J	
C322	CC73GCH1H150J	C CAPACITOR	15pF 50V J		C417	CC730DZ2J681J	C CAPACITOR	680pF 630V J	
C323	CC73HCH1H471J	C CAPACITOR	470pF 50V J		C418	CC730DZ2J681J	C CAPACITOR	680pF 630V J	
C325	CK73GGB1H472K	C CAPACITOR	4700pF 50V K		C420	CK73HBB1H472K	C CAPACITOR	4700pF 50V K	
C326	CC73GCH1H330J	C CAPACITOR	33pF 50V J		C421	C93-0716-05	C CAPACITOR	3300pF 630V	
C327	CK73GGB1H472K	C CAPACITOR	4700pF 50V K		C424	CC73GCH1H820J	C CAPACITOR	82pF 50V J	
C328	CC73GCH1H101J	C CAPACITOR	100pF 50V J		C425	CC730DF2H100G	C CAPACITOR	10pF 500V G	
C329	CK73GGB1H472K	C CAPACITOR	4700pF 50V K		C426	CC73HCH1H180G	C CAPACITOR	18pF 50V G	
C331	CK73HBB1H472K	C CAPACITOR	4700pF 50V K		C428	CC730DF2H560G	C CAPACITOR	56pF 500V G	

△ Symbol No.	Part No.	Part Name	Description	Local	△ Symbol No.	Part No.	Part Name	Description	Local
C429	CC730DF2H101J	C CAPACITOR	100pF 500V J		C570	CK73HB1H103K	C CAPACITOR	0.01uF 50V K	
C430	CC730DF2H101J	C CAPACITOR	100pF 500V J		C571	CK73HB1H103K	C CAPACITOR	0.01uF 50V K	
C499	CC730DP2J221J	C CAPACITOR	220pF 630V J		C572	CK73HB1H103K	C CAPACITOR	0.01uF 50V K	
C501	CK73HBB1H472K	C CAPACITOR	4700pF 50V K		C573	CK73HBB1H102K	C CAPACITOR	1000pF 50V K	
C502	CC73HCH1H470G	C CAPACITOR	47pF 50V G		C574	CK73HB1H103K	C CAPACITOR	0.01uF 50V K	
C503	CK73HBB1H472K	C CAPACITOR	4700pF 50V K		C575	CC73HCH1H390G	C CAPACITOR	39pF 50V G	
C504	CC73HCH1H150G	C CAPACITOR	15pF 50V G		C576	CC73HCH1H221J	C CAPACITOR	220pF 50V J	
C505	CC73HCH1H330G	C CAPACITOR	33pF 50V G		C577	CC73HCH1H680G	C CAPACITOR	68pF 50V G	
C506	CK73HBB1H472K	C CAPACITOR	4700pF 50V K		C578	CK73HBB1H102K	C CAPACITOR	1000pF 50V K	
C507	CK73HBB1H472K	C CAPACITOR	4700pF 50V K		C579	CK73HB1C105K	C CAPACITOR	1uF 16V K	
C508	CK73HB1H103K	C CAPACITOR	0.01uF 50V K		C580	CK73HBB1H102K	C CAPACITOR	1000pF 50V K	
C509	CK73HBB1H472K	C CAPACITOR	4700pF 50V K		C581	CK73HB1H103K	C CAPACITOR	0.01uF 50V K	
C510	CK73HBB1H472K	C CAPACITOR	4700pF 50V K		C582	CK73HB1H103K	C CAPACITOR	0.01uF 50V K	
C511	CK73HB1H103K	C CAPACITOR	0.01uF 50V K		C583	CK73HB1H103K	C CAPACITOR	0.01uF 50V K	
C512	CC73HCH1H101J	C CAPACITOR	100pF 50V J		C584	CS77MA1C3R3M	TA E CAPACITOR	3.3uF 16V M	
C513	CC73HCH1H330G	C CAPACITOR	33pF 50V G		C585	CC73HCH1H330G	C CAPACITOR	33pF 50V G	
C514	CC73HCH1H100B	C CAPACITOR	10pF 50V B		C586	CK73HB1H103K	C CAPACITOR	0.01uF 50V K	
C515	CK73HB1H103K	C CAPACITOR	0.01uF 50V K		C587	CS77MA1D4R7M	TA E CAPACITOR	4.7uF 20V M	
C516	CC73HCH1H820J	C CAPACITOR	82pF 50V J		C588	CK73HB1H103K	C CAPACITOR	0.01uF 50V K	
C517	CC73HCH1H330G	C CAPACITOR	33pF 50V G		C589	CC73HCH1H330G	C CAPACITOR	33pF 50V G	
C518	CC73HCH1H820J	C CAPACITOR	82pF 50V J		C590	CK73HB1H103K	C CAPACITOR	0.01uF 50V K	
C519	CK73HB1H103K	C CAPACITOR	0.01uF 50V K		C591	CK73HB1E104K	C CAPACITOR	0.1uF 25V K	
C520	CC73HCH1H101J	C CAPACITOR	100pF 50V J		C592	CC73HCH1H680G	C CAPACITOR	68pF 50V G	
C521	CK73HB1H103K	C CAPACITOR	0.01uF 50V K		C593	CS77MA1D4R7M	TA E CAPACITOR	4.7uF 20V M	
C522	CC73HCH1H471J	C CAPACITOR	470pF 50V J		C594	CK73HB1H103K	C CAPACITOR	0.01uF 50V K	
C523	CK73HBB1H102K	C CAPACITOR	1000pF 50V K		C595	CK73HB1H103K	C CAPACITOR	0.01uF 50V K	
C524	CK73HB1H103K	C CAPACITOR	0.01uF 50V K		C596	CK73GXR1H104K	C CAPACITOR	0.1uF 50V K	
C525	CC73HCH1H470G	C CAPACITOR	47pF 50V G		C597	CK73HB1H103K	C CAPACITOR	0.01uF 50V K	
C526	CK73HB1H103K	C CAPACITOR	0.01uF 50V K		C599	CK73HB1H103K	C CAPACITOR	0.01uF 50V K	
C527	CC73HCH1H470G	C CAPACITOR	47pF 50V G		C600	CC73JCH1H101J	C CAPACITOR	100pF 50V J	
C528	CC73HCH1H471J	C CAPACITOR	470pF 50V J		C601	CC73JCH1H101J	C CAPACITOR	100pF 50V J	
C529	CK73HB1H103K	C CAPACITOR	0.01uF 50V K		C602	CC73JCH1H101J	C CAPACITOR	100pF 50V J	
C530	CC73HCH1H101J	C CAPACITOR	100pF 50V J		C603	CC73JCH1H101J	C CAPACITOR	100pF 50V J	
C531	CK73HB1H103K	C CAPACITOR	0.01uF 50V K		C604	CC73JCH1H101J	C CAPACITOR	100pF 50V J	
C532	CC73HCH1H471J	C CAPACITOR	470pF 50V J		C605	CC73JCH1H101J	C CAPACITOR	100pF 50V J	
C533	CC73HCH1H470G	C CAPACITOR	47pF 50V G		C606	CC73JCH1H101J	C CAPACITOR	100pF 50V J	
C534	CK73HB1H103K	C CAPACITOR	0.01uF 50V K		C607	CC73HCH1H120G	C CAPACITOR	12pF 50V G	
C536	CK73HB1H103K	C CAPACITOR	0.01uF 50V K		C608	CK73HB1E104K	C CAPACITOR	0.1uF 25V K	
C537	CK73HB1H103K	C CAPACITOR	0.01uF 50V K		C609	CK73HBB1H102K	C CAPACITOR	1000pF 50V K	
C538	CK73HB1E104K	C CAPACITOR	0.1uF 25V K		C610	C93-1959-05	C CAPACITOR	0.1uF 16V	
C542	CK73GXR1H104K	C CAPACITOR	0.1uF 50V K		C611	CC730CC1H1R5B	C CAPACITOR	1.5pF 50V B	
C543	CC73HCH1H821J	C CAPACITOR	820pF 50V J		C612	CK73HB1C105K	C CAPACITOR	1uF 16V K	
C546	CK73HBB1H472K	C CAPACITOR	4700pF 50V K		C613	C93-1959-05	C CAPACITOR	0.1uF 16V	
C547	CK73HB1H103K	C CAPACITOR	0.01uF 50V K		C614	CK73HB1H103K	C CAPACITOR	0.01uF 50V K	
C548	CC73HCH1H471J	C CAPACITOR	470pF 50V J		C615	CK73HB1E104K	C CAPACITOR	0.1uF 25V K	
C550	CK73HB1H103K	C CAPACITOR	0.01uF 50V K		C616	CC73HCH1H680G	C CAPACITOR	68pF 50V G	
C551	CC73HCH1H390G	C CAPACITOR	39pF 50V G		C617	CC73HCH1H470G	C CAPACITOR	47pF 50V G	
C552	CK73HB1H103K	C CAPACITOR	0.01uF 50V K		C618	CK73HB1H103K	C CAPACITOR	0.01uF 50V K	
C553	CK73HB1H103K	C CAPACITOR	0.01uF 50V K		C619	C93-1959-05	C CAPACITOR	0.1uF 16V	
C554	CC73HCH1H101J	C CAPACITOR	100pF 50V J		C620	CK73HB1C105K	C CAPACITOR	1uF 16V K	
C555	CK73HB1H103K	C CAPACITOR	0.01uF 50V K		C621	CK73HB1H103K	C CAPACITOR	0.01uF 50V K	
C556	CK73HB1H103K	C CAPACITOR	0.01uF 50V K		C622	CK73HBB1H102K	C CAPACITOR	1000pF 50V K	
C557	CK73HB1H103K	C CAPACITOR	0.01uF 50V K		C623	CC73HCH1H150G	C CAPACITOR	15pF 50V G	
C558	CC73HCH1H390G	C CAPACITOR	39pF 50V G		C624	CC73HCH1H390G	C CAPACITOR	39pF 50V G	
C559	CC73HCH1H080B	C CAPACITOR	8pF 50V B		C625	C93-1959-05	C CAPACITOR	0.1uF 16V	
C560	CC73HCH1H390G	C CAPACITOR	39pF 50V G		C626	CK73HB1E104K	C CAPACITOR	0.1uF 25V K	
C561	CK73HB1H103K	C CAPACITOR	0.01uF 50V K		C627	C93-1953-05	C CAPACITOR	0.01uF 25V	
C562	CK73HB1H103K	C CAPACITOR	0.01uF 50V K		C628	C93-1959-05	C CAPACITOR	0.1uF 16V	
C563	CK73HB1H103K	C CAPACITOR	0.01uF 50V K		C629	C93-1953-05	C CAPACITOR	0.01uF 25V	
C564	CC73HCH1H101J	C CAPACITOR	100pF 50V J		C630	C93-1959-05	C CAPACITOR	0.1uF 16V	
C565	CK73HB1H103K	C CAPACITOR	0.01uF 50V K		C631	C93-1959-05	C CAPACITOR	0.1uF 16V	
C566	CK73HB1H103K	C CAPACITOR	0.01uF 50V K		C632	C93-1953-05	C CAPACITOR	0.01uF 25V	
C567	CC73HCH1H390G	C CAPACITOR	39pF 50V G		C633	C93-1959-05	C CAPACITOR	0.1uF 16V	
C568	CK73HB1H103K	C CAPACITOR	0.01uF 50V K		C634	CK73FB1C106K	C CAPACITOR	10uF 16V K	
C569	CC73HCH1H391J	C CAPACITOR	390pF 50V J		C635	C93-1959-05	C CAPACITOR	0.1uF 16V	

△ Symbol No.	Part No.	Part Name	Description	Local	△ Symbol No.	Part No.	Part Name	Description	Local
C636	CK73HB1C105K	C CAPACITOR	1uF 16V K		C705	C93-1959-05	C CAPACITOR	0.1uF 16V	
C637	CK73HB1H103K	C CAPACITOR	0.01uF 50V K		C706	C93-1959-05	C CAPACITOR	0.1uF 16V	
C638	CK73HBB1H682K	C CAPACITOR	6800pF 50V K		C707	CK73FB1C106K	C CAPACITOR	10uF 16V K	
C639	CC73HCH1H101J	C CAPACITOR	100pF 50V J		C708	CK73FB1C106K	C CAPACITOR	10uF 16V K	
C640	CK73HBB1H102K	C CAPACITOR	1000pF 50V K		C709	C93-1959-05	C CAPACITOR	0.1uF 16V	
C641	CC73HCH1H101J	C CAPACITOR	100pF 50V J		C711	CK73GB1A475K	C CAPACITOR	4.7uF 10V K	
C642	CC73HCH1H221J	C CAPACITOR	220pF 50V J		C713	C93-1959-05	C CAPACITOR	0.1uF 16V	
C643	CC73JCH1H101J	C CAPACITOR	100pF 50V J		C714	C93-1959-05	C CAPACITOR	0.1uF 16V	
C644	C93-1953-05	C CAPACITOR	0.01uF 25V		C717	C93-1959-05	C CAPACITOR	0.1uF 16V	
C645	CC73HCH1H471J	C CAPACITOR	470pF 50V J		C720	CK73HB1E104K	C CAPACITOR	0.1uF 25V K	
C646	CC73HCH1H151J	C CAPACITOR	150pF 50V J		C721	C93-1959-05	C CAPACITOR	0.1uF 16V	
C647	C93-1959-05	C CAPACITOR	0.1uF 16V		C722	CC73JCH1H101J	C CAPACITOR	100pF 50V J	
C648	CC73JCH1H101J	C CAPACITOR	100pF 50V J		C724	C93-1959-05	C CAPACITOR	0.1uF 16V	
C650	CC73HCH1H221J	C CAPACITOR	220pF 50V J		C726	C93-1953-05	C CAPACITOR	0.01uF 25V	
C651	C93-1959-05	C CAPACITOR	0.1uF 16V		C727	CC73HCH1H330G	C CAPACITOR	33pF 50V G	
C652	C93-1959-05	C CAPACITOR	0.1uF 16V		C728	CK73HB1E473K	C CAPACITOR	0.047uF 25V K	
C653	CC73HCH1H331J	C CAPACITOR	330pF 50V J		C729	CK73HB1H103K	C CAPACITOR	0.01uF 50V K	
C654	CK73HB1H103K	C CAPACITOR	0.01uF 50V K		C735	CK73HB1H103K	C CAPACITOR	0.01uF 50V K	
C655	CK73HB1H103K	C CAPACITOR	0.01uF 50V K		C738	CC73JCH1H101J	C CAPACITOR	100pF 50V J	
C656	CC73HCH1H100B	C CAPACITOR	10pF 50V B		C740	CK73HB1H103K	C CAPACITOR	0.01uF 50V K	
C657	CC73HCH1H470G	C CAPACITOR	47pF 50V G		C742	CK73FB1C106K	C CAPACITOR	10uF 16V K	
C658	CK73HB1H103K	C CAPACITOR	0.01uF 50V K		C743	C93-1953-05	C CAPACITOR	0.01uF 25V	
C659	CK73HB1H103K	C CAPACITOR	0.01uF 50V K		C745	CK73HB1H103K	C CAPACITOR	0.01uF 50V K	
C660	CC73HCH1H680G	C CAPACITOR	68pF 50V G		C748	CC73HCH1H100B	C CAPACITOR	10pF 50V B	
C661	CK73HB1H103K	C CAPACITOR	0.01uF 50V K		C750	CK73GB1A475K	C CAPACITOR	4.7uF 10V K	
C662	CK73HB1H103K	C CAPACITOR	0.01uF 50V K		C757	CK73HB1C105K	C CAPACITOR	1uF 16V K	
C664	CK73HB1H103K	C CAPACITOR	0.01uF 50V K		C768	C93-1953-05	C CAPACITOR	0.01uF 25V	
C665	CC73HCH1H330G	C CAPACITOR	33pF 50V G		C769	CK73HB1C105K	C CAPACITOR	1uF 16V K	
C666	CC73HCH1H330G	C CAPACITOR	33pF 50V G		C770	CK73HB1C105K	C CAPACITOR	1uF 16V K	
C667	CC73HCH1H020B	C CAPACITOR	2pF 50V B		C771	C93-1959-05	C CAPACITOR	0.1uF 16V	
C668	CK73HBB1H102K	C CAPACITOR	1000pF 50V K		C772	C93-1959-05	C CAPACITOR	0.1uF 16V	
C669	CC73HCH1H390G	C CAPACITOR	39pF 50V G		C773	C93-1959-05	C CAPACITOR	0.1uF 16V	
C671	CK73HB1H103K	C CAPACITOR	0.01uF 50V K		C774	C93-1959-05	C CAPACITOR	0.1uF 16V	
C673	CC73HCH1H050B	C CAPACITOR	5pF 50V B		C775	C93-1959-05	C CAPACITOR	0.1uF 16V	
C674	CK73HBB1H102K	C CAPACITOR	1000pF 50V K		C776	C93-1959-05	C CAPACITOR	0.1uF 16V	
C675	CK73HB1H103K	C CAPACITOR	0.01uF 50V K		C777	C93-1959-05	C CAPACITOR	0.1uF 16V	
C676	CC73HCH1H681J	C CAPACITOR	680pF 50V J		C778	C93-1959-05	C CAPACITOR	0.1uF 16V	
C677	CC73HCH1H390G	C CAPACITOR	39pF 50V G		C779	CK73HB1C105K	C CAPACITOR	1uF 16V K	
C678	CK73HB1H103K	C CAPACITOR	0.01uF 50V K		C780	C93-1959-05	C CAPACITOR	0.1uF 16V	
C679	CK73HB1H103K	C CAPACITOR	0.01uF 50V K		C781	CC73HCH1H150G	C CAPACITOR	15pF 50V G	
C680	CC73HCH1H101J	C CAPACITOR	100pF 50V J		C782	CC73HCH1H150G	C CAPACITOR	15pF 50V G	
C681	CC73HCH1H471J	C CAPACITOR	470pF 50V J		C783	CK73HB1E104K	C CAPACITOR	0.1uF 25V K	
C682	CC73HCH1H221J	C CAPACITOR	220pF 50V J		C784	CK73HB1A224K	C CAPACITOR	0.22uF 10V K	
C683	CC73HCH1H221J	C CAPACITOR	220pF 50V J		C785	CK73GB0J106K	C CAPACITOR	10uF 6.3V K	
C684	CC73HCH1H331J	C CAPACITOR	330pF 50V J		C786	CK73GB0J106K	C CAPACITOR	10uF 6.3V K	
C685	CC73HCH1H331J	C CAPACITOR	330pF 50V J		C787	CK73HB1E104K	C CAPACITOR	0.1uF 25V K	
C686	CC73HCH1H181J	C CAPACITOR	180pF 50V J		C791	C93-1959-05	C CAPACITOR	0.1uF 16V	
C687	CC73HCH1H271J	C CAPACITOR	270pF 50V J		C792	C93-1959-05	C CAPACITOR	0.1uF 16V	
C688	CC73HCH1H271J	C CAPACITOR	270pF 50V J		C793	CK73HBB1H102K	C CAPACITOR	1000pF 50V K	
C689	CC73HCH1H331J	C CAPACITOR	330pF 50V J		C794	CK73HBB1H102K	C CAPACITOR	1000pF 50V K	
C690	CC73HCH1H181J	C CAPACITOR	180pF 50V J		C795	CK73HB1H103K	C CAPACITOR	0.01uF 50V K	
C691	CC73HCH1H221J	C CAPACITOR	220pF 50V J		C796	CK73HB1H103K	C CAPACITOR	0.01uF 50V K	
C692	CC73HCH1H221J	C CAPACITOR	220pF 50V J		C797	CK73HB1H103K	C CAPACITOR	0.01uF 50V K	
C693	CC73HCH1H101J	C CAPACITOR	100pF 50V J		C798	CK73GXR1H105K	C CAPACITOR	1uF 50V K	
C694	CC73HCH1H331J	C CAPACITOR	330pF 50V J		C799	CK73HB1E104K	C CAPACITOR	0.1uF 25V K	
C695	CC73HCH1H221J	C CAPACITOR	220pF 50V J		C801	CC73HCH1H101J	C CAPACITOR	100pF 50V J	
C696	CK73HBB1H152K	C CAPACITOR	1500pF 50V K		C802	CK73HB1C105K	C CAPACITOR	1uF 16V K	
C697	CK73HB1H103K	C CAPACITOR	0.01uF 50V K		C803	C93-1959-05	C CAPACITOR	0.1uF 16V	
C698	CK73HB1H103K	C CAPACITOR	0.01uF 50V K		C804	C93-1959-05	C CAPACITOR	0.1uF 16V	
C699	CK73HB1H103K	C CAPACITOR	0.01uF 50V K		C805	CC73HCH1H101J	C CAPACITOR	100pF 50V J	
C700	CK73HB1C105K	C CAPACITOR	1uF 16V K		C806	C93-1959-05	C CAPACITOR	0.1uF 16V	
C701	C93-1959-05	C CAPACITOR	0.1uF 16V		C808	CC73HCH1H101J	C CAPACITOR	100pF 50V J	
C702	C93-1959-05	C CAPACITOR	0.1uF 16V		C809	CC73HCH1H101J	C CAPACITOR	100pF 50V J	
C703	CK73EXR1E226K	C CAPACITOR	22uF 25V K		C810	CC73HCH1H101J	C CAPACITOR	100pF 50V J	
C704	CK73HB1H103K	C CAPACITOR	0.01uF 50V K		C811	C93-1959-05	C CAPACITOR	0.1uF 16V	

△ Symbol No.	Part No.	Part Name	Description	Local	△ Symbol No.	Part No.	Part Name	Description	Local
C812	CC73HCH1H101J	C CAPACITOR	100pF 50V J		C955	CC73HCH1H101J	C CAPACITOR	100pF 50V J	
C813	CC73HCH1H101J	C CAPACITOR	100pF 50V J		C971	CC73HCH1H471J	C CAPACITOR	470pF 50V J	
C814	CC73HCH1H101J	C CAPACITOR	100pF 50V J		C972	CC73HCH1H101J	C CAPACITOR	100pF 50V J	
C816	CC73HCH1H101J	C CAPACITOR	100pF 50V J		C973	CK73HB1C105K	C CAPACITOR	1uF 16V K	
C817	CK73HBB1H102K	C CAPACITOR	1000pF 50V K		C974	CK73HB1A474K	C CAPACITOR	0.47uF 10V K	
C818	CC73HCH1H101J	C CAPACITOR	100pF 50V J		C975	CK73HB1C105K	C CAPACITOR	1uF 16V K	
C819	CK73HB1H103K	C CAPACITOR	0.01uF 50V K		C976	CK73HB1E104K	C CAPACITOR	0.1uF 25V K	
C820	CK73HB1E104K	C CAPACITOR	0.1uF 25V K		C977	CK73HB1C105K	C CAPACITOR	1uF 16V K	
C821	CC73HCH1H470G	C CAPACITOR	47pF 50V G		C978	CK73HB1C105K	C CAPACITOR	1uF 16V K	
C822	CC73HCH1H470G	C CAPACITOR	47pF 50V G		C999	CK73HB1C105K	C CAPACITOR	1uF 16V K	
C824	CK73HBB1H102K	C CAPACITOR	1000pF 50V K		C1002	CC73HCH1H101J	C CAPACITOR	100pF 50V J	
C829	CK73HB1C105K	C CAPACITOR	1uF 16V K		C1003	CC73HCH1H101J	C CAPACITOR	100pF 50V J	
C830	C93-1959-05	C CAPACITOR	0.1uF 16V		C1004	CC73HCH1H101J	C CAPACITOR	100pF 50V J	
C831	C93-1959-05	C CAPACITOR	0.1uF 16V		C1005	CC73HCH1H101J	C CAPACITOR	100pF 50V J	
C834	CK73HB1C105K	C CAPACITOR	1uF 16V K		C1006	CK73HBB1H102K	C CAPACITOR	1000pF 50V K	
C835	CC73HCH1H101J	C CAPACITOR	100pF 50V J		C1007	CC73HCH1H101J	C CAPACITOR	100pF 50V J	
C841	CK73HB1E104K	C CAPACITOR	0.1uF 25V K		C1008	CC73HCH1H101J	C CAPACITOR	100pF 50V J	
C843	CK73HBB1H472K	C CAPACITOR	4700pF 50V K		C1009	CC73HCH1H101J	C CAPACITOR	100pF 50V J	
C852	CK73HB1E104K	C CAPACITOR	0.1uF 25V K		C1010	CC73HCH1H101J	C CAPACITOR	100pF 50V J	
C853	CK73HB1H103K	C CAPACITOR	0.01uF 50V K		C1011	CC73HCH1H101J	C CAPACITOR	100pF 50V J	
C854	CK73HBB1H102K	C CAPACITOR	1000pF 50V K		C1012	CC73HCH1H101J	C CAPACITOR	100pF 50V J	
C856	CC73HCH1H470G	C CAPACITOR	47pF 50V G		C1013	CC73HCH1H101J	C CAPACITOR	100pF 50V J	
C857	CC73HCH1H470G	C CAPACITOR	47pF 50V G		C1014	CC73HCH1H101J	C CAPACITOR	100pF 50V J	
C899	CK73GB0J106K	C CAPACITOR	10uF 6.3V K		C1015	CC73HCH1H101J	C CAPACITOR	100pF 50V J	
C902	CK73HB1E104K	C CAPACITOR	0.1uF 25V K		C1016	CC73HCH1H101J	C CAPACITOR	100pF 50V J	
C904	CK73HB1C105K	C CAPACITOR	1uF 16V K		C1017	CC73HCH1H101J	C CAPACITOR	100pF 50V J	
C905	CK73HB1E104K	C CAPACITOR	0.1uF 25V K		C1018	CC73HCH1H101J	C CAPACITOR	100pF 50V J	
C906	CK73HB1C105K	C CAPACITOR	1uF 16V K		C1019	CC73HCH1H101J	C CAPACITOR	100pF 50V J	
C908	C93-1959-05	C CAPACITOR	0.1uF 16V		C1020	CC73HCH1H101J	C CAPACITOR	100pF 50V J	
C909	CK73HB1C105K	C CAPACITOR	1uF 16V K		C1021	CC73HCH1H101J	C CAPACITOR	100pF 50V J	
C910	C93-1959-05	C CAPACITOR	0.1uF 16V		C1022	CK73HBB1H102K	C CAPACITOR	1000pF 50V K	
C911	C93-1959-05	C CAPACITOR	0.1uF 16V		C1023	CK73HBB1H102K	C CAPACITOR	1000pF 50V K	
C912	C93-1959-05	C CAPACITOR	0.1uF 16V		C1116	CC73HCH1H470G	C CAPACITOR	47pF 50V G	
C913	C93-1959-05	C CAPACITOR	0.1uF 16V		C1117	CK73HBB1H102K	C CAPACITOR	1000pF 50V K	
C914	C93-1959-05	C CAPACITOR	0.1uF 16V		C1125	CC73HCH1H101J	C CAPACITOR	100pF 50V J	
C915	CK73HB1E104K	C CAPACITOR	0.1uF 25V K		C1126	CK73HB1E104K	C CAPACITOR	0.1uF 25V K	
C916	CK73GB0J106K	C CAPACITOR	10uF 6.3V K		C1127	CK73HBB1H102K	C CAPACITOR	1000pF 50V K	
C917	CK73HB1C105K	C CAPACITOR	1uF 16V K		C1131	CK73EB1H475KM	C CAPACITOR	4.7uF 50V M	
C918	C93-1959-05	C CAPACITOR	0.1uF 16V		C1134	CK73EB1H475KM	C CAPACITOR	4.7uF 50V M	
C919	CK73HB1C105K	C CAPACITOR	1uF 16V K		C1135	CK73EB1H475KM	C CAPACITOR	4.7uF 50V M	
C920	C93-1959-05	C CAPACITOR	0.1uF 16V		C1136	CK73HB1E104K	C CAPACITOR	0.1uF 25V K	
C921	CC73HCH1H101J	C CAPACITOR	100pF 50V J		C1137	CC73HCH1H101J	C CAPACITOR	100pF 50V J	
C922	CK73HBB1H472K	C CAPACITOR	4700pF 50V K		C1140	CK73FB1C106K	C CAPACITOR	10uF 16V K	
C923	CC73HCH1H101J	C CAPACITOR	100pF 50V J		C1141	CK73FB1C106K	C CAPACITOR	10uF 16V K	
C924	CK73HB1C105K	C CAPACITOR	1uF 16V K		C1145	CK73HBB1H102K	C CAPACITOR	1000pF 50V K	
C925	CK73HB1C105K	C CAPACITOR	1uF 16V K		C1501	CC73HCH1H080B	C CAPACITOR	8pF 50V B	
C926	CK73HB1C105K	C CAPACITOR	1uF 16V K		C1502	CC73HCH1H080B	C CAPACITOR	8pF 50V B	
C927	CK73HB1C105K	C CAPACITOR	1uF 16V K		C1503	CC73HCH1H080B	C CAPACITOR	8pF 50V B	
C928	CK73GB0J106K	C CAPACITOR	10uF 6.3V K		C1504	CC73HCH1H080B	C CAPACITOR	8pF 50V B	
C929	CK73HB1E104K	C CAPACITOR	0.1uF 25V K		C1505	CC73HCH1H030B	C CAPACITOR	3pF 50V B	
C930	CC73HCH1H680G	C CAPACITOR	68pF 50V G		C1601	CC73HCH1H050B	C CAPACITOR	5pF 50V B	
C932	CK73GB0J106K	C CAPACITOR	10uF 6.3V K		C1603	CC73HCH1H050B	C CAPACITOR	5pF 50V B	
C934	CK73HB1H103K	C CAPACITOR	0.01uF 50V K		R8	RK73HH1J104D	MG RESISTOR	100kΩ 1/16W D	
C935	CC73HCH1H101J	C CAPACITOR	100pF 50V J		R10	RK73HH1J104D	MG RESISTOR	100kΩ 1/16W D	
C936	CK73GB0J106K	C CAPACITOR	10uF 6.3V K		R11	RK73HH1J104D	MG RESISTOR	100kΩ 1/16W D	
C938	CK73HB1H103K	C CAPACITOR	0.01uF 50V K		R12	RK73HB1J000J	MG RESISTOR	0Ω 1/16W J	
C941	CC73HCH1H101J	C CAPACITOR	100pF 50V J		R13	RK73HH1J104D	MG RESISTOR	100kΩ 1/16W D	
C942	CK73HB1H103K	C CAPACITOR	0.01uF 50V K		R14	RK73HH1J223D	MG RESISTOR	22kΩ 1/16W D	
C943	CK73HB1E104K	C CAPACITOR	0.1uF 25V K		R15	RK73HH1J103D	MG RESISTOR	10kΩ 1/16W D	
C945	CK73HB1H103K	C CAPACITOR	0.01uF 50V K		R16	RK73JB1H102J	MG RESISTOR	1kΩ 1/20W J	
C948	CK73GXR1H105K	C CAPACITOR	1uF 50V K		R17	RK73HH1J103D	MG RESISTOR	10kΩ 1/16W D	
C949	CK73GXR1H105K	C CAPACITOR	1uF 50V K		R18	RK73JB1H104J	MG RESISTOR	100kΩ 1/20W J	
C950	CK73GXR1H105K	C CAPACITOR	1uF 50V K		R19	RK73HH1J473D	MG RESISTOR	47kΩ 1/16W D	
C951	CK73GXR1H105K	C CAPACITOR	1uF 50V K		R20	RK73GB2A000J	MG RESISTOR	0Ω 1/10W J	
C954	CK73HBB1H102K	C CAPACITOR	1000pF 50V K		R21	RK73HH1J104D	MG RESISTOR	100kΩ 1/16W D	

△ Symbol No.	Part No.	Part Name	Description	Local	△ Symbol No.	Part No.	Part Name	Description	Local
R22	RK73JB1H103J	MG RESISTOR	10kΩ 1/20W J		R104	RN73HH1J100D	MF RESISTOR	10Ω 1/16W D	
R23	RK73JB1H102J	MG RESISTOR	1kΩ 1/20W J		R105	RK73HB1J272J	MG RESISTOR	2.7kΩ 1/16W J	
R24	RK73JB1H104J	MG RESISTOR	100kΩ 1/20W J		R106	RK73HH1J473D	MG RESISTOR	47kΩ 1/16W D	
R25	RK73JB1H472J	MG RESISTOR	4.7kΩ 1/20W J		R107	RK73HB1J102J	MG RESISTOR	1kΩ 1/16W J	
R26	RK73JB1H102J	MG RESISTOR	1kΩ 1/20W J		R108	RK73HB1J102J	MG RESISTOR	1kΩ 1/16W J	
R27	RK73JB1H103J	MG RESISTOR	10kΩ 1/20W J		R109	RK73HB1J470J	MG RESISTOR	47Ω 1/16W J	
R30	RK73HH1J223D	MG RESISTOR	22kΩ 1/16W D		R110	RK73HB1J102J	MG RESISTOR	1kΩ 1/16W J	
R31	RK73HB1J000J	MG RESISTOR	0Ω 1/16W J		R111	RK73HH1J223D	MG RESISTOR	22kΩ 1/16W D	
R32	RK73HB1J101J	MG RESISTOR	100Ω 1/16W J		R112	RK73HB1J152J	MG RESISTOR	1.5kΩ 1/16W J	
R33	RK73HH1J103D	MG RESISTOR	10kΩ 1/16W D		R113	RK73HB1J124J	MG RESISTOR	120kΩ 1/16W J	
R34	RK73HH1J113D	MG RESISTOR	11kΩ 1/16W D		R114	RK73HB1J152J	MG RESISTOR	1.5kΩ 1/16W J	
R35	RK73HH1J473D	MG RESISTOR	47kΩ 1/16W D		R115	RK73HB1J152J	MG RESISTOR	1.5kΩ 1/16W J	
R36	RK73HH1J103D	MG RESISTOR	10kΩ 1/16W D		R116	RK73HB1J000J	MG RESISTOR	0Ω 1/16W J	
R37	RK73HB1J101J	MG RESISTOR	100Ω 1/16W J		R117	RK73HB1J000J	MG RESISTOR	0Ω 1/16W J	
R38	RK73HB1J224J	MG RESISTOR	220kΩ 1/16W J		R118	RK73HB1J222J	MG RESISTOR	2.2kΩ 1/16W J	
R39	RK73HH1J104D	MG RESISTOR	100kΩ 1/16W D		R119	RK73HB1J474J	MG RESISTOR	470kΩ 1/16W J	
R40	RK73JB1H104J	MG RESISTOR	100kΩ 1/20W J		R121	RK73HB1J101J	MG RESISTOR	100Ω 1/16W J	
R41	RK73JB1H104J	MG RESISTOR	100kΩ 1/20W J		R122	RK73HH1J472D	MG RESISTOR	4.7kΩ 1/16W D	
R42	RK73JB1H473J	MG RESISTOR	47kΩ 1/20W J		R123	RK73HH1J104D	MG RESISTOR	100kΩ 1/16W D	
R43	RK73HB1J000J	MG RESISTOR	0Ω 1/16W J		R124	RK73HH1J151D	MG RESISTOR	150Ω 1/16W D	
R44	RK73JB1H102J	MG RESISTOR	1kΩ 1/20W J		R125	RK73HH1J103D	MG RESISTOR	10kΩ 1/16W D	
R45	RK73HB1J124J	MG RESISTOR	120kΩ 1/16W J		R126	RK73HB1J106J	MG RESISTOR	10MΩ 1/16W J	
R46	RK73JB1H104J	MG RESISTOR	100kΩ 1/20W J		R127	RK73HH1J472D	MG RESISTOR	4.7kΩ 1/16W D	
R47	RK73HB1J000J	MG RESISTOR	0Ω 1/16W J		R128	RK73HB1J470J	MG RESISTOR	47Ω 1/16W J	
R48	RK73HH1J154D	MG RESISTOR	150kΩ 1/16W D		R129	RK73HH1J104D	MG RESISTOR	100kΩ 1/16W D	
R49	RK73HH1J113D	MG RESISTOR	11kΩ 1/16W D		R130	RK73HH1J223D	MG RESISTOR	22kΩ 1/16W D	
R50	RK73HH1J103D	MG RESISTOR	10kΩ 1/16W D		R131	RK73HH1J223D	MG RESISTOR	22kΩ 1/16W D	
R51	RK73HB1J222J	MG RESISTOR	2.2kΩ 1/16W J		R132	RK73HB1J000J	MG RESISTOR	0Ω 1/16W J	
R52	RK73HB1J102J	MG RESISTOR	1kΩ 1/16W J		R133	RK73HB1J000J	MG RESISTOR	0Ω 1/16W J	
R53	RK73HB1J000J	MG RESISTOR	0Ω 1/16W J		R134	RK73HB1J152J	MG RESISTOR	1.5kΩ 1/16W J	
R54	R92-3769-05	MG RESISTOR	10Ω 0.25W		R135	RK73HH1J473D	MG RESISTOR	47kΩ 1/16W D	
R55	R92-3769-05	MG RESISTOR	10Ω 0.25W		R136	RK73HH1J223D	MG RESISTOR	22kΩ 1/16W D	
R56	RK73HB1J274J	MG RESISTOR	270kΩ 1/16W J		R137	RK73HH1J223D	MG RESISTOR	22kΩ 1/16W D	
R57	RK73HB1J183J	MG RESISTOR	18kΩ 1/16W J		R138	RK73HH1J473D	MG RESISTOR	47kΩ 1/16W D	
R58	RK73HB1J102J	MG RESISTOR	1kΩ 1/16W J		R139	RK73HH1J473D	MG RESISTOR	47kΩ 1/16W D	
R59	RN73HH1J100D	MF RESISTOR	10Ω 1/16W D		R141	RK73HH1J103D	MG RESISTOR	10kΩ 1/16W D	
R60	RK73HB1J474J	MG RESISTOR	470kΩ 1/16W J		R142	RK73HH1J104D	MG RESISTOR	100kΩ 1/16W D	
R61	RK73HB1J102J	MG RESISTOR	1kΩ 1/16W J		R143	RK73HH1J472D	MG RESISTOR	4.7kΩ 1/16W D	
R62	RK73HB1J102J	MG RESISTOR	1kΩ 1/16W J		R144	RK73HB1J000J	MG RESISTOR	0Ω 1/16W J	
R63	RK73HH1J273D	MG RESISTOR	27kΩ 1/16W D		R145	RK73HH1J104D	MG RESISTOR	100kΩ 1/16W D	
R64	RK73HH1J152D	MG RESISTOR	1.5kΩ 1/16W D		R150	RK73HH1J121D	MG RESISTOR	120Ω 1/16W D	
R65	RK73HH1J472D	MG RESISTOR	4.7kΩ 1/16W D		R151	RK73HH1J181D	MG RESISTOR	180Ω 1/16W D	
R66	RK73HH1J103D	MG RESISTOR	10kΩ 1/16W D		R152	RN73HH1J100D	MF RESISTOR	10Ω 1/16W D	
R67	RK73HH1J472D	MG RESISTOR	4.7kΩ 1/16W D		R153	RN73HH1J100D	MF RESISTOR	10Ω 1/16W D	
R68	RK73HH1J103D	MG RESISTOR	10kΩ 1/16W D		R154	RK73HH1J104D	MG RESISTOR	100kΩ 1/16W D	
R69	RK73HH1J472D	MG RESISTOR	4.7kΩ 1/16W D		R155	RK73HB1J000J	MG RESISTOR	0Ω 1/16W J	
R70	RK73HB1J000J	MG RESISTOR	0Ω 1/16W J		R156	RK73HB1J000J	MG RESISTOR	0Ω 1/16W J	
R71	RK73HB1J331J	MG RESISTOR	330Ω 1/16W J		R157	RK73HB1J102J	MG RESISTOR	1kΩ 1/16W J	
R72	RK73JB1H473J	MG RESISTOR	47kΩ 1/20W J		R158	RK73HB1J271J	MG RESISTOR	270Ω 1/16W J	
R73	RK73HB1J471J	MG RESISTOR	470Ω 1/16W J		R159	RK73HB1J180J	MG RESISTOR	18Ω 1/16W J	
R74	RK73HH1J303D	MG RESISTOR	30kΩ 1/16W D		R160	RK73HB1J392J	MG RESISTOR	3.9kΩ 1/16W J	
R75	RK73HB1J474J	MG RESISTOR	470kΩ 1/16W J		R161	RK73HB1J271J	MG RESISTOR	270Ω 1/16W J	
R76	RK73FB2B332J	MG RESISTOR	3.3kΩ 1/8W J		R162	RK73HH1J473D	MG RESISTOR	47kΩ 1/16W D	
R77	RK73FB2B332J	MG RESISTOR	3.3kΩ 1/8W J		R163	RK73HB1J562J	MG RESISTOR	5.6kΩ 1/16W J	
R78	RK73FB2B332J	MG RESISTOR	3.3kΩ 1/8W J		R164	RK73HB1J820J	MG RESISTOR	82Ω 1/16W J	
R79	RK73HH1J113D	MG RESISTOR	11kΩ 1/16W D		R165	RK73HB1J101J	MG RESISTOR	100Ω 1/16W J	
R80	RK73HH1J103D	MG RESISTOR	10kΩ 1/16W D		R167	RK73HB1J000J	MG RESISTOR	0Ω 1/16W J	
R81	RK73HH1J472D	MG RESISTOR	4.7kΩ 1/16W D		R169	RK73HH1J223D	MG RESISTOR	22kΩ 1/16W D	
R84	RK73HB1J000J	MG RESISTOR	0Ω 1/16W J		R170	RK73HH1J223D	MG RESISTOR	22kΩ 1/16W D	
R96	RK73FB2B2R7J	MG RESISTOR	2.7Ω 1/8W J		R171	RK73HB1J101J	MG RESISTOR	100Ω 1/16W J	
R97	RK73FB2B3R3J	MG RESISTOR	3.3Ω 1/8W J		R172	RK73HB1J221J	MG RESISTOR	220Ω 1/16W J	
R100	RK73HB1J000J	MG RESISTOR	0Ω 1/16W J		R173	RK73HB1J680J	MG RESISTOR	68Ω 1/16W J	
R101	RN73HH1J100D	MF RESISTOR	10Ω 1/16W D		R174	RK73HB1J470J	MG RESISTOR	47Ω 1/16W J	
R102	RK73HB1J000J	MG RESISTOR	0Ω 1/16W J		R175	RK73HB1J000J	MG RESISTOR	0Ω 1/16W J	
R103	RN73HH1J100D	MF RESISTOR	10Ω 1/16W D		R176	RK73HH1J472D	MG RESISTOR	4.7kΩ 1/16W D	

△ Symbol No.	Part No.	Part Name	Description	Local	△ Symbol No.	Part No.	Part Name	Description	Local
R177	RK73HB1J000J	MG RESISTOR	0Ω 1/16W J		R371	RK73HB1J333J	MG RESISTOR	33kΩ 1/16W J	
R178	RK73HB1J272J	MG RESISTOR	2.7kΩ 1/16W J		R372	RK73HH1J473D	MG RESISTOR	47kΩ 1/16W D	
R190	RK73HB1J102J	MG RESISTOR	1kΩ 1/16W J		R373	RK73HB1J333J	MG RESISTOR	33kΩ 1/16W J	
R196	RK73HB1J470J	MG RESISTOR	47Ω 1/16W J		R374	RK73HH1J223D	MG RESISTOR	22kΩ 1/16W D	
R197	RN73HH1J100D	MF RESISTOR	10Ω 1/16W D		R375	RK73HB1J124J	MG RESISTOR	120kΩ 1/16W J	
R198	RK73HH1J152D	MG RESISTOR	1.5kΩ 1/16W D		R376	RK73HH1J681D	MG RESISTOR	680Ω 1/16W D	
R199	RK73HB1J272J	MG RESISTOR	2.7kΩ 1/16W J		R378	RK73HH1J223D	MG RESISTOR	22kΩ 1/16W D	
R300	RZ73Z0CU471J	RESISTOR	470Ω J		R379	RK73HB1J104J	MG RESISTOR	100kΩ 1/16W J	
R301	RK73HH1J151D	MG RESISTOR	150Ω 1/16W D		R380	RK73HB1J222J	MG RESISTOR	2.2kΩ 1/16W J	
R303	RK73HH1J151D	MG RESISTOR	150Ω 1/16W D		R381	RK73HB1J000J	MG RESISTOR	0Ω 1/16W J	
R304	RK73FB2B332J	MG RESISTOR	3.3kΩ 1/8W J		R382	RK73HB1J154J	MG RESISTOR	150kΩ 1/16W J	
R305	RK73HB1J390J	MG RESISTOR	39Ω 1/16W J		R383	RK73HB1J392J	MG RESISTOR	3.9kΩ 1/16W J	
R306	RK73HB1J330J	MG RESISTOR	33Ω 1/16W J		R385	RK73HH1J152D	MG RESISTOR	1.5kΩ 1/16W D	
R307	RK73GB2A220J	MG RESISTOR	22Ω 1/10W J		R386	RK73HH1J472D	MG RESISTOR	4.7kΩ 1/16W D	
R308	RK73PB2H4R7J	MG RESISTOR	4.7Ω 1/2W J		R387	RK73HH1J223D	MG RESISTOR	22kΩ 1/16W D	
R309	RK73PB2H4R7J	MG RESISTOR	4.7Ω 1/2W J		R388	RK73HB1J000J	MG RESISTOR	0Ω 1/16W J	
R310	RK73HB1J000J	MG RESISTOR	0Ω 1/16W J		R390	RK73PB2H561J	MG RESISTOR	560Ω 1/2W J	
R311	RK73PB2H4R7J	MG RESISTOR	4.7Ω 1/2W J		R391	RK73HB1J224J	MG RESISTOR	220kΩ 1/16W J	
R312	RK73PB2H4R7J	MG RESISTOR	4.7Ω 1/2W J		R392	RK73HH1J223D	MG RESISTOR	22kΩ 1/16W D	
R313	RK73GB2A000J	MG RESISTOR	0Ω 1/10W J		R393	RK73HB1J183J	MG RESISTOR	18kΩ 1/16W J	
R314	RK73HB1J151J	MG RESISTOR	150Ω 1/16W J		R394	RK73HB1J682J	MG RESISTOR	6.8kΩ 1/16W J	
R315	RK73HB1J680J	MG RESISTOR	68Ω 1/16W J		R395	RK73GB2A682J	MG RESISTOR	6.8kΩ 1/10W J	
R316	RK73HB1J680J	MG RESISTOR	68Ω 1/16W J		R396	RK73GB2A682J	MG RESISTOR	6.8kΩ 1/10W J	
R317	RK73HH1J151D	MG RESISTOR	150Ω 1/16W D		R397	RK73HB1J822J	MG RESISTOR	8.2kΩ 1/16W J	
R318	RK73HB1J331J	MG RESISTOR	330Ω 1/16W J		R398	RK73HH1J103D	MG RESISTOR	10kΩ 1/16W D	
R319	RK73HB1J103J	MG RESISTOR	10kΩ 1/16W J		R400	RK73PB2H220J	MG RESISTOR	22Ω 1/2W J	
R320	RK73HB1J103J	MG RESISTOR	10kΩ 1/16W J		R401	RK73PB2H220J	MG RESISTOR	22Ω 1/2W J	
R321	RK73GB2A820J	MG RESISTOR	82Ω 1/10W J		R402	RK73HH1J103D	MG RESISTOR	10kΩ 1/16W D	
R322	RK73PB2H561J	MG RESISTOR	560Ω 1/2W J		R404	RK73HB1J101J	MG RESISTOR	100Ω 1/16W J	
R323	RK73PB2H180J	MG RESISTOR	18Ω 1/2W J		R405	RK73GB2A331J	MG RESISTOR	330Ω 1/10W J	
R324	RK73PB2H561J	MG RESISTOR	560Ω 1/2W J		R406	RK73GB2A331J	MG RESISTOR	330Ω 1/10W J	
R325	RK73PB2H180J	MG RESISTOR	18Ω 1/2W J		R407	RK73PB2H470J	MG RESISTOR	47Ω 1/2W J	
R326	RK73GB2A153J	MG RESISTOR	15kΩ 1/10W J		R408	RK73HB1J222J	MG RESISTOR	2.2kΩ 1/16W J	
R327	RK73GB2A562J	MG RESISTOR	5.6kΩ 1/10W J		R409	RK73HB1J470J	MG RESISTOR	47Ω 1/16W J	
R328	RK73GB2A000J	MG RESISTOR	0Ω 1/10W J		R413	RK73HB1J000J	MG RESISTOR	0Ω 1/16W J	
R329	RK73HB1J101J	MG RESISTOR	100Ω 1/16W J		R501	RK73HB1J000J	MG RESISTOR	0Ω 1/16W J	
R330	RK73PB2H4R7J	MG RESISTOR	4.7Ω 1/2W J		R503	RK73HH1J103D	MG RESISTOR	10kΩ 1/16W D	
R331	RK73PB2H561J	MG RESISTOR	560Ω 1/2W J		R504	RK73HB1J822J	MG RESISTOR	8.2kΩ 1/16W J	
R332	RK73PB2H4R7J	MG RESISTOR	4.7Ω 1/2W J		R505	RK73HB1J272J	MG RESISTOR	2.7kΩ 1/16W J	
R334	RK73FB2B3R3J	MG RESISTOR	3.3Ω 1/8W J		R506	RK73HB1J330J	MG RESISTOR	33Ω 1/16W J	
R335	RK73HB1J221J	MG RESISTOR	220Ω 1/16W J		R507	RK73HB1J560J	MG RESISTOR	56Ω 1/16W J	
R336	RK73FB2B224J	MG RESISTOR	220kΩ 1/8W J		R508	RK73HH1J472D	MG RESISTOR	4.7kΩ 1/16W D	
R337	RK73HB1J221J	MG RESISTOR	220Ω 1/16W J		R509	RN73HH1J100D	MF RESISTOR	10Ω 1/16W D	
R338	RK73HB1J102J	MG RESISTOR	1kΩ 1/16W J		R510	RN73HH1J100D	MF RESISTOR	10Ω 1/16W D	
R339	RK73GB2A221J	MG RESISTOR	220Ω 1/10W J		R511	RN73HH1J100D	MF RESISTOR	10Ω 1/16W D	
R340	RK73GB2A101J	MG RESISTOR	100Ω 1/10W J		R512	RN73HH1J100D	MF RESISTOR	10Ω 1/16W D	
R341	RK73HB1J222J	MG RESISTOR	2.2kΩ 1/16W J		R514	RK73HB1J331J	MG RESISTOR	330Ω 1/16W J	
R342	RZ73Z0CU471J	RESISTOR	470Ω J		R515	RK73HB1J000J	MG RESISTOR	0Ω 1/16W J	
R343	RK73PB2H560J	MG RESISTOR	56Ω 1/2W J		R516	RK73HH1J103D	MG RESISTOR	10kΩ 1/16W D	
R344	RK73PB2H560J	MG RESISTOR	56Ω 1/2W J		R517	RK73HB1J000J	MG RESISTOR	0Ω 1/16W J	
R345	RK73HH1J223D	MG RESISTOR	22kΩ 1/16W D		R519	RK73HB1J331J	MG RESISTOR	330Ω 1/16W J	
R346	RN73HH1J100D	MF RESISTOR	10Ω 1/16W D		R520	RK73HH1J103D	MG RESISTOR	10kΩ 1/16W D	
R347	R92-1061-05	C RESISTOR	0.008Ω		R521	RK73HH1J103D	MG RESISTOR	10kΩ 1/16W D	
R348	RK73PB2H220J	MG RESISTOR	22Ω 1/2W J		R522	RK73HH1J104D	MG RESISTOR	100kΩ 1/16W D	
R349	RK73PB2H220J	MG RESISTOR	22Ω 1/2W J		R523	RK73HH1J104D	MG RESISTOR	100kΩ 1/16W D	
R350	RK73HB1J222J	MG RESISTOR	2.2kΩ 1/16W J		R525	RK73HB1J471J	MG RESISTOR	470Ω 1/16W J	
R353	RK73HH1J223D	MG RESISTOR	22kΩ 1/16W D		R526	RK73HH1J104D	MG RESISTOR	100kΩ 1/16W D	
R356	RK73HB1J470J	MG RESISTOR	47Ω 1/16W J		R527	RK73HH1J104D	MG RESISTOR	100kΩ 1/16W D	
R357	RK73HB1J471J	MG RESISTOR	470Ω 1/16W J		R528	RK73HB1J000J	MG RESISTOR	0Ω 1/16W J	
R364	RK73HH1J101D	MG RESISTOR	100Ω 1/16W D		R529	RK73HH1J104D	MG RESISTOR	100kΩ 1/16W D	
R366	RK73HH1J101D	MG RESISTOR	100Ω 1/16W D		R530	RK73HH1J104D	MG RESISTOR	100kΩ 1/16W D	
R367	RK73HB1J470J	MG RESISTOR	47Ω 1/16W J		R531	RK73HB1J221J	MG RESISTOR	220Ω 1/16W J	
R368	RK73HB1J000J	MG RESISTOR	0Ω 1/16W J		R533	RK73HB1J000J	MG RESISTOR	0Ω 1/16W J	
R369	RN73HH1J104D	MF RESISTOR	100kΩ 1/16W D		R534	RK73HB1J220J	MG RESISTOR	22Ω 1/16W J	
R370	RK73HB1J683J	MG RESISTOR	68kΩ 1/16W J		R535	RK73HB1J221J	MG RESISTOR	220Ω 1/16W J	

△ Symbol No.	Part No.	Part Name	Description	Local	△ Symbol No.	Part No.	Part Name	Description	Local
R537	RK73HB1J330J	MG RESISTOR	33Ω 1/16W J		R606	RK73HB1J000J	MG RESISTOR	0Ω 1/16W J	
R538	RK73GB2A221J	MG RESISTOR	220Ω 1/10W J		R607	RK73HB1J220J	MG RESISTOR	22Ω 1/16W J	
R539	RK73HH1J103D	MG RESISTOR	10kΩ 1/16W D		R608	RK73HB1J561J	MG RESISTOR	560Ω 1/16W J	
R540	RK73HB1J224J	MG RESISTOR	220kΩ 1/16W J		R609	RK73HB1J182J	MG RESISTOR	1.8kΩ 1/16W J	
R541	RK73HB1J682J	MG RESISTOR	6.8kΩ 1/16W J		R610	RK73HB1J562J	MG RESISTOR	5.6kΩ 1/16W J	
R542	RK73HB1J182J	MG RESISTOR	1.8kΩ 1/16W J		R611	RK73HB1J471J	MG RESISTOR	470Ω 1/16W J	
R543	RK73HH1J104D	MG RESISTOR	100kΩ 1/16W D		R612	RK73JB1H472J	MG RESISTOR	4.7kΩ 1/20W J	
R544	RK73HB1J821J	MG RESISTOR	820Ω 1/16W J		R613	RK73HH1J104D	MG RESISTOR	100kΩ 1/16W D	
R546	RK73HB1J821J	MG RESISTOR	820Ω 1/16W J		R614	RK73HB1J470J	MG RESISTOR	47Ω 1/16W J	
R547	RK73HB1J5R6J	MG RESISTOR	5.6Ω 1/16W J		R615	RK73HH1J104D	MG RESISTOR	100kΩ 1/16W D	
R548	RK73HH1J104D	MG RESISTOR	100kΩ 1/16W D		R616	RK73HH1J103D	MG RESISTOR	10kΩ 1/16W D	
R549	RK73HH1J104D	MG RESISTOR	100kΩ 1/16W D		R617	RK73HB1J101J	MG RESISTOR	100Ω 1/16W J	
R550	RK73HH1J104D	MG RESISTOR	100kΩ 1/16W D		R618	RK73HB1J274J	MG RESISTOR	270kΩ 1/16W J	
R551	RK73HH1J104D	MG RESISTOR	100kΩ 1/16W D		R619	RK73HB1J151J	MG RESISTOR	150Ω 1/16W J	
R553	RK73HH1J104D	MG RESISTOR	100kΩ 1/16W D		R620	RK73HB1J390J	MG RESISTOR	39Ω 1/16W J	
R554	RK73HH1J104D	MG RESISTOR	100kΩ 1/16W D		R621	RK73HB1J151J	MG RESISTOR	150Ω 1/16W J	
R555	RK73HB1J102J	MG RESISTOR	1kΩ 1/16W J		R622	RK73HB1J470J	MG RESISTOR	47Ω 1/16W J	
R556	RK73HB1J102J	MG RESISTOR	1kΩ 1/16W J		R623	RK73HB1J681J	MG RESISTOR	680Ω 1/16W J	
R557	RK73HB1J101J	MG RESISTOR	100Ω 1/16W J		R624	RK73HB1J683J	MG RESISTOR	68kΩ 1/16W J	
R558	RK73HH1J103D	MG RESISTOR	10kΩ 1/16W D		R625	RK73HB1J223J	MG RESISTOR	22kΩ 1/16W J	
R559	RK73HB1J102J	MG RESISTOR	1kΩ 1/16W J		R626	RK73HB1J683J	MG RESISTOR	68kΩ 1/16W J	
R560	RK73HB1J224J	MG RESISTOR	220kΩ 1/16W J		R627	RK73HB1J153J	MG RESISTOR	15kΩ 1/16W J	
R561	RK73HH1J104D	MG RESISTOR	100kΩ 1/16W D		R630	RK73HB1J101J	MG RESISTOR	100Ω 1/16W J	
R562	RK73HB1J684J	MG RESISTOR	680kΩ 1/16W J		R631	RK73HH1J103D	MG RESISTOR	10kΩ 1/16W D	
R563	RK73HB1J333J	MG RESISTOR	33kΩ 1/16W J		R632	RK73HB1J822J	MG RESISTOR	8.2kΩ 1/16W J	
R564	RK73HB1J330J	MG RESISTOR	33Ω 1/16W J		R633	RK73HB1J222J	MG RESISTOR	2.2kΩ 1/16W J	
R565	RK73HH1J103D	MG RESISTOR	10kΩ 1/16W D		R634	RK73HB1J222J	MG RESISTOR	2.2kΩ 1/16W J	
R566	RK73HH1J223D	MG RESISTOR	22kΩ 1/16W D		R635	RK73HH1J103D	MG RESISTOR	10kΩ 1/16W D	
R567	RK73HB1J102J	MG RESISTOR	1kΩ 1/16W J		R636	RK73HB1J102J	MG RESISTOR	1kΩ 1/16W J	
R568	RK73HB1J101J	MG RESISTOR	100Ω 1/16W J		R637	RK73HH1J103D	MG RESISTOR	10kΩ 1/16W D	
R569	RK73HB1J222J	MG RESISTOR	2.2kΩ 1/16W J		R638	RK73HB1J331J	MG RESISTOR	330Ω 1/16W J	
R570	RK73HB1J684J	MG RESISTOR	680kΩ 1/16W J		R639	RK73HH1J152D	MG RESISTOR	1.5kΩ 1/16W D	
R571	RK73HH1J104D	MG RESISTOR	100kΩ 1/16W D		R640	RK73HH1J152D	MG RESISTOR	1.5kΩ 1/16W D	
R572	RK73HB1J334J	MG RESISTOR	330kΩ 1/16W J		R641	RK73HH1J151D	MG RESISTOR	150Ω 1/16W D	
R573	RK73HH1J151D	MG RESISTOR	150Ω 1/16W D		R642	RK73HB1J470J	MG RESISTOR	47Ω 1/16W J	
R574	RK73HH1J103D	MG RESISTOR	10kΩ 1/16W D		R644	RK73HB1J000J	MG RESISTOR	0Ω 1/16W J	
R575	RK73HH1J223D	MG RESISTOR	22kΩ 1/16W D		R647	RK73HH1J103D	MG RESISTOR	10kΩ 1/16W D	
R576	RK73HB1J562J	MG RESISTOR	5.6kΩ 1/16W J		R648	RK73HB1J474J	MG RESISTOR	470kΩ 1/16W J	
R577	RK73HH1J273D	MG RESISTOR	27kΩ 1/16W D		R649	RK73HH1J104D	MG RESISTOR	100kΩ 1/16W D	
R579	RK73HB1J272J	MG RESISTOR	2.7kΩ 1/16W J		R650	RK73HB1J474J	MG RESISTOR	470kΩ 1/16W J	
R581	RK73HH1J103D	MG RESISTOR	10kΩ 1/16W D		R651	RK73HH1J104D	MG RESISTOR	100kΩ 1/16W D	
R582	RK73HH1J104D	MG RESISTOR	100kΩ 1/16W D		R652	RK73HH1J103D	MG RESISTOR	10kΩ 1/16W D	
R583	RK73HH1J103D	MG RESISTOR	10kΩ 1/16W D		R653	RK73HH1J104D	MG RESISTOR	100kΩ 1/16W D	
R584	RK73GB2A123J	MG RESISTOR	12kΩ 1/10W J		R654	RK73HH1J104D	MG RESISTOR	100kΩ 1/16W D	
R585	RK73HH1J103D	MG RESISTOR	10kΩ 1/16W D		R667	RK73HB1J820J	MG RESISTOR	82Ω 1/16W J	
R586	RK73HB1J101J	MG RESISTOR	100Ω 1/16W J		R700	RK73HB1J102J	MG RESISTOR	1kΩ 1/16W J	
R587	RK73HB1J681J	MG RESISTOR	680Ω 1/16W J		R701	RK73HB1J000J	MG RESISTOR	0Ω 1/16W J	
R588	RK73HB1J101J	MG RESISTOR	100Ω 1/16W J		R702	RN73HH1J100D	MF RESISTOR	10Ω 1/16W D	
R589	RK73HB1J562J	MG RESISTOR	5.6kΩ 1/16W J		R703	RK73JB1H102J	MG RESISTOR	1kΩ 1/20W J	
R590	RK73HH1J103D	MG RESISTOR	10kΩ 1/16W D		R704	RK73JB1H102J	MG RESISTOR	1kΩ 1/20W J	
R591	RK73HH1J151D	MG RESISTOR	150Ω 1/16W D		R705	RK73JB1H102J	MG RESISTOR	1kΩ 1/20W J	
R592	RK73HH1J103D	MG RESISTOR	10kΩ 1/16W D		R706	RK73JB1H103J	MG RESISTOR	10kΩ 1/20W J	
R593	RK73HH1J104D	MG RESISTOR	100kΩ 1/16W D		R707	RN73HH1J100D	MF RESISTOR	10Ω 1/16W D	
R594	RK73HB1J333J	MG RESISTOR	33kΩ 1/16W J		R708	RK73HB1J220J	MG RESISTOR	22Ω 1/16W J	
R595	RK73HB1J333J	MG RESISTOR	33kΩ 1/16W J		R709	RK73HB1J220J	MG RESISTOR	22Ω 1/16W J	
R596	RK73HH1J104D	MG RESISTOR	100kΩ 1/16W D		R710	RK73JB1H103J	MG RESISTOR	10kΩ 1/20W J	
R597	RN73HH1J100D	MF RESISTOR	10Ω 1/16W D		R711	RK73JB1H103J	MG RESISTOR	10kΩ 1/20W J	
R598	RK73HH1J103D	MG RESISTOR	10kΩ 1/16W D		R719	RK73HB1J183J	MG RESISTOR	18kΩ 1/16W J	
R599	RK73HH1J104D	MG RESISTOR	100kΩ 1/16W D		R720	RK73HB1J393J	MG RESISTOR	39kΩ 1/16W J	
R600	RN73HH1J100D	MF RESISTOR	10Ω 1/16W D		R721	RN73HH1J100D	MF RESISTOR	10Ω 1/16W D	
R601	RN73HH1J100D	MF RESISTOR	10Ω 1/16W D		R722	RK73HB1J681J	MG RESISTOR	680Ω 1/16W J	
R602	RN73HH1J100D	MF RESISTOR	10Ω 1/16W D		R727	RK73HB1J821J	MG RESISTOR	820Ω 1/16W J	
R603	RK73HH1J151D	MG RESISTOR	150Ω 1/16W D		R728	RK73JB1H104J	MG RESISTOR	100kΩ 1/20W J	
R604	RK73HB1J561J	MG RESISTOR	560Ω 1/16W J		R729	RK73JB1H104J	MG RESISTOR	100kΩ 1/20W J	
R605	RK73HH1J103D	MG RESISTOR	10kΩ 1/16W D		R731	RK73JB1H473J	MG RESISTOR	47kΩ 1/20W J	

△ Symbol No.	Part No.	Part Name	Description	Local	△ Symbol No.	Part No.	Part Name	Description	Local
R732	RK73JB1H472J	MG RESISTOR	4.7kΩ 1/20W J		R811	RK73JB1H222J	MG RESISTOR	2.2kΩ 1/20W J	
R733	RK73HB1J000J	MG RESISTOR	0Ω 1/16W J		R812	RK73JB1H222J	MG RESISTOR	2.2kΩ 1/20W J	
R734	RK73JB1H103J	MG RESISTOR	10kΩ 1/20W J		R813	RK73JB1H220J	MG RESISTOR	22Ω 1/20W J	
R735	RK73JB1H103J	MG RESISTOR	10kΩ 1/20W J		R814	RK73JB1H220J	MG RESISTOR	22Ω 1/20W J	
R736	RK73HB1J000J	MG RESISTOR	0Ω 1/16W J		R815	RK73JB1H220J	MG RESISTOR	22Ω 1/20W J	
R738	RK73HB1J102J	MG RESISTOR	1kΩ 1/16W J		R816	RK73HB1J102J	MG RESISTOR	1kΩ 1/16W J	
R740	RK73HB1J102J	MG RESISTOR	1kΩ 1/16W J		R817	RK73JB1H220J	MG RESISTOR	22Ω 1/20W J	
R742	RK73HB1J102J	MG RESISTOR	1kΩ 1/16W J		R818	RK73HB1J000J	MG RESISTOR	0Ω 1/16W J	
R744	RK73HB1J102J	MG RESISTOR	1kΩ 1/16W J		R819	RK73HB1J471J	MG RESISTOR	470Ω 1/16W J	
R746	RK73HB1J102J	MG RESISTOR	1kΩ 1/16W J		R823	RK73HB1J101J	MG RESISTOR	100Ω 1/16W J	
R747	RK73JB1H220J	MG RESISTOR	22Ω 1/20W J		R824	RK73HB1J101J	MG RESISTOR	100Ω 1/16W J	
R748	RK73JB1H220J	MG RESISTOR	22Ω 1/20W J		R825	RK73HB1J101J	MG RESISTOR	100Ω 1/16W J	
R749	RK73JB1H220J	MG RESISTOR	22Ω 1/20W J		R826	RK73HB1J101J	MG RESISTOR	100Ω 1/16W J	
R750	RK73JB1H220J	MG RESISTOR	22Ω 1/20W J		R827	RK73HH1J103D	MG RESISTOR	10kΩ 1/16W D	
R751	RK73JB1H220J	MG RESISTOR	22Ω 1/20W J		R828	RK73HH1J103D	MG RESISTOR	10kΩ 1/16W D	
R752	RK73FB2B332J	MG RESISTOR	3.3kΩ 1/8W J		R829	RK73HB1J101J	MG RESISTOR	100Ω 1/16W J	
R753	RK73JB1H220J	MG RESISTOR	22Ω 1/20W J		R830	RK73JB1H103J	MG RESISTOR	10kΩ 1/20W J	
R754	RK73JB1H220J	MG RESISTOR	22Ω 1/20W J		R831	RK73HB1J102J	MG RESISTOR	1kΩ 1/16W J	
R755	RK73JB1H104J	MG RESISTOR	100kΩ 1/20W J		R832	RK73HB1J101J	MG RESISTOR	100Ω 1/16W J	
R756	RK73JB1H104J	MG RESISTOR	100kΩ 1/20W J		R833	RK73JB1H104J	MG RESISTOR	100kΩ 1/20W J	
R757	RK73JB1H220J	MG RESISTOR	22Ω 1/20W J		R835	RK73JB1H104J	MG RESISTOR	100kΩ 1/20W J	
R758	RK73JB1H220J	MG RESISTOR	22Ω 1/20W J		R838	RK73HB1J000J	MG RESISTOR	0Ω 1/16W J	
R759	RK73JB1H220J	MG RESISTOR	22Ω 1/20W J		R843	RK73HH1J104D	MG RESISTOR	100kΩ 1/16W D	
R760	RK73JB1H220J	MG RESISTOR	22Ω 1/20W J		R844	RK73HH1J103D	MG RESISTOR	10kΩ 1/16W D	
R761	RK73JB1H220J	MG RESISTOR	22Ω 1/20W J		R845	RK73HH1J103D	MG RESISTOR	10kΩ 1/16W D	
R762	RK73JB1H220J	MG RESISTOR	22Ω 1/20W J		R858	RK73HH1J223D	MG RESISTOR	22kΩ 1/16W D	
R763	RK73JB1H220J	MG RESISTOR	22Ω 1/20W J		R859	RK73HH1J223D	MG RESISTOR	22kΩ 1/16W D	
R764	RK73JB1H104J	MG RESISTOR	100kΩ 1/20W J		R862	RK73HB1J222J	MG RESISTOR	2.2kΩ 1/16W J	
R765	RK73JB1H220J	MG RESISTOR	22Ω 1/20W J		R864	RK73HB1J000J	MG RESISTOR	0Ω 1/16W J	
R766	RK73JB1H220J	MG RESISTOR	22Ω 1/20W J		R865	RK73HB1J222J	MG RESISTOR	2.2kΩ 1/16W J	
R767	RK73JB1H220J	MG RESISTOR	22Ω 1/20W J		R867	RK73HH1J223D	MG RESISTOR	22kΩ 1/16W D	
R768	RK73JB1H220J	MG RESISTOR	22Ω 1/20W J		R868	RK73HB1J000J	MG RESISTOR	0Ω 1/16W J	
R770	RK73JB1H220J	MG RESISTOR	22Ω 1/20W J		R869	RK73HB1J000J	MG RESISTOR	0Ω 1/16W J	
R772	RK73JB1H220J	MG RESISTOR	22Ω 1/20W J		R874	RK73JB1H104J	MG RESISTOR	100kΩ 1/20W J	
R773	RK73JB1H104J	MG RESISTOR	100kΩ 1/20W J		R875	RK73HB1J000J	MG RESISTOR	0Ω 1/16W J	
R774	RK73JB1H220J	MG RESISTOR	22Ω 1/20W J		R877	RK73FB2B332J	MG RESISTOR	3.3kΩ 1/8W J	
R775	RK73JB1H220J	MG RESISTOR	22Ω 1/20W J		R878	RK73FB2B332J	MG RESISTOR	3.3kΩ 1/8W J	
R777	RK73JB1H102J	MG RESISTOR	1kΩ 1/20W J		R879	RK73FB2B332J	MG RESISTOR	3.3kΩ 1/8W J	
R778	RK73JB1H220J	MG RESISTOR	22Ω 1/20W J		R880	RK73HB1J102J	MG RESISTOR	1kΩ 1/16W J	
R779	RK73JB1H220J	MG RESISTOR	22Ω 1/20W J		R881	RK73HB1J331J	MG RESISTOR	330Ω 1/16W J	
R781	RK73JB1H220J	MG RESISTOR	22Ω 1/20W J		R882	RK73JB1H473J	MG RESISTOR	47kΩ 1/20W J	
R782	RK73JB1H220J	MG RESISTOR	22Ω 1/20W J		R883	RK73JB1H473J	MG RESISTOR	47kΩ 1/20W J	
R783	RK73JB1H220J	MG RESISTOR	22Ω 1/20W J		R884	RK73HH1J104D	MG RESISTOR	100kΩ 1/16W D	
R785	RK73JB1H220J	MG RESISTOR	22Ω 1/20W J		R885	RK73HB1J183J	MG RESISTOR	18kΩ 1/16W J	
R787	RK73JB1H220J	MG RESISTOR	22Ω 1/20W J		R886	RK73HB1J823J	MG RESISTOR	82kΩ 1/16W J	
R788	RK73JB1H220J	MG RESISTOR	22Ω 1/20W J		R889	RK73HH1J103D	MG RESISTOR	10kΩ 1/16W D	
R789	RK73HB1J101J	MG RESISTOR	100Ω 1/16W J		R890	RK73HH1J103D	MG RESISTOR	10kΩ 1/16W D	
R790	RK73JB1H220J	MG RESISTOR	22Ω 1/20W J		R902	RN73HH1J100D	MF RESISTOR	10Ω 1/16W D	
R791	RK73JB1H220J	MG RESISTOR	22Ω 1/20W J		R903	RK73HH1J472D	MG RESISTOR	4.7kΩ 1/16W D	
R792	RK73JB1H220J	MG RESISTOR	22Ω 1/20W J		R904	RK73HH1J223D	MG RESISTOR	22kΩ 1/16W D	
R794	RK73JB1H220J	MG RESISTOR	22Ω 1/20W J		R905	RK73HH1J223D	MG RESISTOR	22kΩ 1/16W D	
R795	RK73JB1H220J	MG RESISTOR	22Ω 1/20W J		R906	RK73HB1J000J	MG RESISTOR	0Ω 1/16W J	
R797	RK73JB1H220J	MG RESISTOR	22Ω 1/20W J		R907	RK73HB1J000J	MG RESISTOR	0Ω 1/16W J	
R798	RK73JB1H220J	MG RESISTOR	22Ω 1/20W J		R908	RK73HH1J223D	MG RESISTOR	22kΩ 1/16W D	
R799	RK73JB1H220J	MG RESISTOR	22Ω 1/20W J		R909	RK73HH1J223D	MG RESISTOR	22kΩ 1/16W D	
R800	RK73JB1H220J	MG RESISTOR	22Ω 1/20W J		R910	RK73HH1J103D	MG RESISTOR	10kΩ 1/16W D	
R801	RK73JB1H220J	MG RESISTOR	22Ω 1/20W J		R911	RK73HH1J104D	MG RESISTOR	100kΩ 1/16W D	
R802	RK73JB1H220J	MG RESISTOR	22Ω 1/20W J		R912	RK73HB1J102J	MG RESISTOR	1kΩ 1/16W J	
R803	RK73JB1H220J	MG RESISTOR	22Ω 1/20W J		R913	RK73HB1J000J	MG RESISTOR	0Ω 1/16W J	
R804	RK73JB1H220J	MG RESISTOR	22Ω 1/20W J		R914	RK73HB1J102J	MG RESISTOR	1kΩ 1/16W J	
R806	RK73JB1H220J	MG RESISTOR	22Ω 1/20W J		R915	RK73HB1J000J	MG RESISTOR	0Ω 1/16W J	
R807	RK73JB1H102J	MG RESISTOR	1kΩ 1/20W J		R916	RK73HB1J222J	MG RESISTOR	2.2kΩ 1/16W J	
R808	RK73JB1H102J	MG RESISTOR	1kΩ 1/20W J		R917	RK73HB1J000J	MG RESISTOR	0Ω 1/16W J	
R809	RK73JB1H220J	MG RESISTOR	22Ω 1/20W J		R918	RK73HB1J683J	MG RESISTOR	68kΩ 1/16W J	
R810	RK73JB1H102J	MG RESISTOR	1kΩ 1/20W J		R919	RK73HH1J473D	MG RESISTOR	47kΩ 1/16W D	

△ Symbol No.	Part No.	Part Name	Description	Local	△ Symbol No.	Part No.	Part Name	Description	Local
R920	RK73HH1J103D	MG RESISTOR	10kΩ 1/16W D		R1119	RK73HH1J113D	MG RESISTOR	11kΩ 1/16W D	
R921	RK73HB1J102J	MG RESISTOR	1kΩ 1/16W J		R1120	RK73HH1J113D	MG RESISTOR	11kΩ 1/16W D	
R922	RK73HB1J681J	MG RESISTOR	680Ω 1/16W J		R1122	RK73HH1J113D	MG RESISTOR	11kΩ 1/16W D	
R923	RK73HB1J000J	MG RESISTOR	0Ω 1/16W J		R1123	RK73HH1J154D	MG RESISTOR	150kΩ 1/16W D	
R924	RK73HH1J473D	MG RESISTOR	47kΩ 1/16W D		R1124	RK73HH1J303D	MG RESISTOR	30kΩ 1/16W D	
R925	RK73HH1J273D	MG RESISTOR	27kΩ 1/16W D		R1125	RK73GB2A000J	MG RESISTOR	0Ω 1/10W J	
R926	RK73HH1J103D	MG RESISTOR	10kΩ 1/16W D		R1126	RK73GB2A000J	MG RESISTOR	0Ω 1/10W J	
R927	RK73HB1J474J	MG RESISTOR	470kΩ 1/16W J		R1127	RK73FB2B000J	MG RESISTOR	0Ω 1/8W J	
R928	RK73HH1J103D	MG RESISTOR	10kΩ 1/16W D		R1128	RK73HB1J102J	MG RESISTOR	1kΩ 1/16W J	
R929	RN73HH1J100D	MF RESISTOR	10Ω 1/16W D		R1129	RK73HH1J104D	MG RESISTOR	100kΩ 1/16W D	
R930	RK73HH1J472D	MG RESISTOR	4.7kΩ 1/16W D		R1130	RK73HB1J124J	MG RESISTOR	120kΩ 1/16W J	
R931	RK73HH1J473D	MG RESISTOR	47kΩ 1/16W D		R1140	RK73HH1J104D	MG RESISTOR	100kΩ 1/16W D	
R932	RK73FB2B332J	MG RESISTOR	3.3kΩ 1/8W J		R1141	RK73HH1J223D	MG RESISTOR	22kΩ 1/16W D	
R933	RK73HB1J000J	MG RESISTOR	0Ω 1/16W J		R1501	RK73HB1J000J	MG RESISTOR	0Ω 1/16W J	
R934	RK73HH1J103D	MG RESISTOR	10kΩ 1/16W D		R1502	RK73HB1J000J	MG RESISTOR	0Ω 1/16W J	
R935	RK73HB1J474J	MG RESISTOR	470kΩ 1/16W J		R1504	RK73HB1J271J	MG RESISTOR	270Ω 1/16W J	
R936	RK73GB2A101J	MG RESISTOR	100Ω 1/10W J		R1505	RK73HB1J271J	MG RESISTOR	270Ω 1/16W J	
R937	RK73HB1J000J	MG RESISTOR	0Ω 1/16W J		R1506	RK73HB1J180J	MG RESISTOR	18Ω 1/16W J	
R938	RK73HB1J474J	MG RESISTOR	470kΩ 1/16W J		R1507	RK73HB1J101J	MG RESISTOR	100Ω 1/16W J	
R939	RK73HH1J472D	MG RESISTOR	4.7kΩ 1/16W D		R1514	RK73GB2A000J	MG RESISTOR	0Ω 1/10W J	
R940	RK73HH1J472D	MG RESISTOR	4.7kΩ 1/16W D		R1515	RK73GB2A221J	MG RESISTOR	220Ω 1/10W J	
R941	RK73GB2A101J	MG RESISTOR	100Ω 1/10W J		R1516	RK73GB2A000J	MG RESISTOR	0Ω 1/10W J	
R943	RK73GB2A000J	MG RESISTOR	0Ω 1/10W J		L4	LB73H0AV-002	CHIP FERRITE		
R944	RN73HH1J100D	MF RESISTOR	10Ω 1/16W D		L5	LB73G0AM-004	CHIP FERRITE		
R945	RK73HH1J472D	MG RESISTOR	4.7kΩ 1/16W D		L6	LB73G0AM-004	CHIP FERRITE		
R947	RK73HB1J101J	MG RESISTOR	100Ω 1/16W J		L7	LB73G0AM-004	CHIP FERRITE		
R948	RK73HB1J101J	MG RESISTOR	100Ω 1/16W J		L9	LB73G0AM-004	CHIP FERRITE		
R949	RK73HH1J472D	MG RESISTOR	4.7kΩ 1/16W D		L10	LB73G0AM-004	CHIP FERRITE		
R950	RK73GB2A000J	MG RESISTOR	0Ω 1/10W J		L11	LR79Z0FQ100M	CHIP INDUCTOR		
R951	RK73HB1J101J	MG RESISTOR	100Ω 1/16W J		L12	LB73G0AM-004	CHIP FERRITE		
R952	RK73HH1J103D	MG RESISTOR	10kΩ 1/16W D		L13	LR79Z0PF150M	CHIP INDUCTOR		
R958	RK73HH1J103D	MG RESISTOR	10kΩ 1/16W D		L14	LB73G0AM-004	CHIP FERRITE		
R959	RK73HH1J472D	MG RESISTOR	4.7kΩ 1/16W D		L15	LB73G0AM-004	CHIP FERRITE		
R961	RK73HB1J000J	MG RESISTOR	0Ω 1/16W J		L16	LB73H0AV-002	CHIP FERRITE		
R962	RK73HH1J103D	MG RESISTOR	10kΩ 1/16W D		L20	LR79Z0FQ100M	CHIP INDUCTOR		
R963	RK73HB1J563J	MG RESISTOR	56kΩ 1/16W J		L80	LB73H0AV-002	CHIP FERRITE		
R979	RK73HB1J681J	MG RESISTOR	680Ω 1/16W J		L100	LB73H0AV-002	CHIP FERRITE		
R980	RK73HB1J000J	MG RESISTOR	0Ω 1/16W J		L101	LB73H0AV-002	CHIP FERRITE		
R984	RK73HB1J682J	MG RESISTOR	6.8kΩ 1/16W J		L102	LB73H0AV-002	CHIP FERRITE		
R985	RK73HH1J104D	MG RESISTOR	100kΩ 1/16W D		L103	LB73H0AV-002	CHIP FERRITE		
R992	RK73HB1J102J	MG RESISTOR	1kΩ 1/16W J		L104	LK73G0AQ100K	M.CHIP INDUCTOR		
R1007	RK73HB1J101J	MG RESISTOR	100Ω 1/16W J		L105	LK73G0AQ100K	M.CHIP INDUCTOR		
R1008	RK73GB2A102J	MG RESISTOR	1kΩ 1/10W J		L106	LR79G0CQ22NG	CHIP INDUCTOR		
R1009	RK73HH1J473D	MG RESISTOR	47kΩ 1/16W D		L107	LR79G0CQ22NG	CHIP INDUCTOR		
R1010	RK73HB1J101J	MG RESISTOR	100Ω 1/16W J		L108	LB73H0AV-003	CHIP FERRITE		
R1011	RK73HB1J101J	MG RESISTOR	100Ω 1/16W J		L109	LB73H0AV-002	CHIP FERRITE		
R1012	RK73HB1J471J	MG RESISTOR	470Ω 1/16W J		L110	L41-2785-53	CHIP INDUCTOR		
R1013	RK73HB1J471J	MG RESISTOR	470Ω 1/16W J		L112	LR79G0CQ22NG	CHIP INDUCTOR		
R1014	RK73GB2A221J	MG RESISTOR	220Ω 1/10W J		L113	LR79G0CQ22NG	CHIP INDUCTOR		
R1015	RK73GB2A221J	MG RESISTOR	220Ω 1/10W J		L114	L41-2785-53	CHIP INDUCTOR		
R1016	RK73HB1J471J	MG RESISTOR	470Ω 1/16W J		L115	L41-2785-53	CHIP INDUCTOR		
R1017	RK73HB1J101J	MG RESISTOR	100Ω 1/16W J		L116	L41-2785-53	CHIP INDUCTOR		
R1018	RK73HB1J471J	MG RESISTOR	470Ω 1/16W J		L117	L41-2785-53	CHIP INDUCTOR		
R1019	RK73HB1J471J	MG RESISTOR	470Ω 1/16W J		L120	L41-2785-53	CHIP INDUCTOR		
R1020	RK73HB1J471J	MG RESISTOR	470Ω 1/16W J		L121	L41-2785-53	CHIP INDUCTOR		
R1021	RK73HB1J101J	MG RESISTOR	100Ω 1/16W J		L122	LB73H0AV-002	CHIP FERRITE		
R1022	RK73HB1J101J	MG RESISTOR	100Ω 1/16W J		L123	L34-4612-05	AIR CORE COIL		
R1023	RK73HB1J101J	MG RESISTOR	100Ω 1/16W J		L124	L34-4610-15	AIR CORE COIL		
R1024	RK73GB2A102J	MG RESISTOR	1kΩ 1/10W J		L126	L41-2785-53	CHIP INDUCTOR		
R1025	RK73HH1J473D	MG RESISTOR	47kΩ 1/16W D		L127	L41-2785-53	CHIP INDUCTOR		
R1026	RK73GB2A221J	MG RESISTOR	220Ω 1/10W J		L128	L41-2785-53	CHIP INDUCTOR		
R1027	RK73GB2A221J	MG RESISTOR	220Ω 1/10W J		L129	L41-2785-53	CHIP INDUCTOR		
R1029	RK73HB1J000J	MG RESISTOR	0Ω 1/16W J		L130	LB73H0AV-002	CHIP FERRITE		
R1096	RK73HB1J000J	MG RESISTOR	0Ω 1/16W J		L131	LB73H0AV-002	CHIP FERRITE		
R1118	RK73HH1J473D	MG RESISTOR	47kΩ 1/16W D		L132	LK73H0AM47NJ	M.CHIP INDUCTOR	47nH	

△ Symbol No.	Part No.	Part Name	Description	Local	△ Symbol No.	Part No.	Part Name	Description	Local
L134	L41-2775-53	CHIP INDUCTOR			L523	LB73G0AM-004	CHIP FERRITE		
L135	L41-2775-53	CHIP INDUCTOR			L524	L34-4615-05	AIR CORE COIL		
L136	LB73H0AV-002	CHIP FERRITE			L525	LB73G0AM-004	CHIP FERRITE		
L138	L41-2785-53	CHIP INDUCTOR			L526	LK73G0BBR56K	M.CHIP INDUCTOR		
L139	LB73H0AV-002	CHIP FERRITE			L527	L34-4615-05	AIR CORE COIL		
L140	LR79G0CQR15G	CHIP INDUCTOR			L528	LB73G0AM-004	CHIP FERRITE		
L141	LR79G0CQR15G	CHIP INDUCTOR			L529	LB73G0AM-004	CHIP FERRITE		
L142	LR79G0CQR15G	CHIP INDUCTOR			L530	LB73G0AM-004	CHIP FERRITE		
L167	L41-2785-53	CHIP INDUCTOR			L531	L34-4615-05	AIR CORE COIL		
L301	LR79G0GKR33G	CHIP INDUCTOR			L532	LR73Z0AE120J	CHIP INDUCTOR		
L302	LR79Z0DA12N5G	CHIP INDUCTOR			L533	LR73Z0AE120J	CHIP INDUCTOR		
L303	LK73H0AM4N7S	M.CHIP INDUCTOR	4.7nH		L534	L3K-0069-00	TOROIDAL COIL		
L304	LK73H0AMR15J	M.CHIP INDUCTOR			L600	LK73G0AQ100K	M.CHIP INDUCTOR		
L305	LK73H0AMR15J	M.CHIP INDUCTOR			L601	LB73H0AV-002	CHIP FERRITE		
L306	L41-1285-53	CHIP INDUCTOR			L602	LB73H0AV-002	CHIP FERRITE		
L307	LR77Z0AER33J	CHIP INDUCTOR			L603	LR73Z0AE4R7J	CHIP INDUCTOR		
L308	LB73G0AM-004	CHIP FERRITE			L604	LB73H0AV-002	CHIP FERRITE		
L309	LB73G0AM-004	CHIP FERRITE			L605	L41-2785-53	CHIP INDUCTOR		
L310	L34-4612-05	AIR CORE COIL			L606	LR73Z0AE4R7J	CHIP INDUCTOR		
L311	L34-4611-15	AIR CORE COIL			L607	LK73G0BB1R5K	M.CHIP INDUCTOR		
L312	LR79Z0CM28NG	CHIP INDUCTOR			L608	LB73H0AV-002	CHIP FERRITE		
L313	L34-4615-05	AIR CORE COIL			L609	LB73H0AV-002	CHIP FERRITE		
L314	LB73Z0AF-001	CHIP FERRITE			L610	LK73G0BB1R5K	M.CHIP INDUCTOR		
L315	L39-1520-05	TOROIDAL COIL			L611	LK73G0AQ100K	M.CHIP INDUCTOR		
L316	L39-1521-15	TOROIDAL COIL			L612	LK73G0AQ100K	M.CHIP INDUCTOR		
L317	L33-0625-15	TOROIDAL COIL			L613	LB73H0AV-002	CHIP FERRITE		
L318	L39-1420-25	TOROIDAL COIL			L614	LB73H0AV-002	CHIP FERRITE		
L319	L39-1420-25	TOROIDAL COIL			L626	LK73G0AQ100K	M.CHIP INDUCTOR		
L320	LK73H0AMR18J	M.CHIP INDUCTOR			L627	LK73G0BB1R5K	M.CHIP INDUCTOR		
L321	LR79Z0MW4R7J	CHIP INDUCTOR			L628	LB73H0AV-002	CHIP FERRITE		
L322	LR79Z0MW4R7J	CHIP INDUCTOR			L629	LK73G0BB3R9K	M.CHIP INDUCTOR		
L323	LR79Z0MW4R7J	CHIP INDUCTOR			L630	LK73G0BB2R7K	M.CHIP INDUCTOR		
L324	L34-4895-05	AIR CORE COIL			L631	LK73G0BB2R7K	M.CHIP INDUCTOR		
L325	L34-4884-05	AIR CORE COIL			L632	LB73H0AV-002	CHIP FERRITE		
L326	L34-4883-05	AIR CORE COIL			L633	LR73Z0AE5R6J	CHIP INDUCTOR		
L327	L34-4885-05	AIR CORE COIL			L636	LR73Z0AE220J	CHIP INDUCTOR		
L329	LR79G0GKR10G	CHIP INDUCTOR			L639	LR73Z0AER68J	CHIP INDUCTOR		
L330	LB73H0AV-002	CHIP FERRITE			L640	LR73Z0AER27J	CHIP INDUCTOR		
L331	LB73H0AV-002	CHIP FERRITE			L641	LR73Z0AE680J	CHIP INDUCTOR		
L332	LR79Z0JGR10J	CHIP INDUCTOR			L642	LR73Z0AE1R2J	CHIP INDUCTOR		
L333	LR79Z0JG82NJ	CHIP INDUCTOR			L643	LR73Z0AE1R0J	CHIP INDUCTOR		
L334	LR79Z0JGR10J	CHIP INDUCTOR			L644	LR73Z0AE1R2J	CHIP INDUCTOR		
L335	LB73H0AV-002	CHIP FERRITE			L645	LR73Z0AE1R2J	CHIP INDUCTOR		
L336	LB73H0AV-002	CHIP FERRITE			L646	LR73Z0AE1R2J	CHIP INDUCTOR		
L500	LR79G0CQR22G	CHIP INDUCTOR			L647	LR73Z0AE1R0J	CHIP INDUCTOR		
L501	L39-1272-15	TOROIDAL COIL			L648	LR73Z0AER27J	CHIP INDUCTOR		
L502	L39-1272-15	TOROIDAL COIL			L649	LR73Z0AER68J	CHIP INDUCTOR		
L503	L34-4615-05	AIR CORE COIL			L650	LR73Z0AER15J	CHIP INDUCTOR		
L504	LK73G0AQR47K	M.CHIP INDUCTOR			L651	LR73Z0AE1R0J	CHIP INDUCTOR		
L505	LR79G0CQR22G	CHIP INDUCTOR			L653	LR73Z0AE6R8J	CHIP INDUCTOR		
L506	LR79G0CQR22G	CHIP INDUCTOR			L654	LR73Z0AE470J	CHIP INDUCTOR		
L507	LB73G0AM-004	CHIP FERRITE			L655	LR73Z0AE4R7J	CHIP INDUCTOR		
L508	LB73G0AM-004	CHIP FERRITE			L656	LR73Z0AE4R7J	CHIP INDUCTOR		
L509	LB73G0AM-004	CHIP FERRITE			L657	LR73Z0AE5R6J	CHIP INDUCTOR		
L510	L34-4615-05	AIR CORE COIL			L700	LB73G0AM-004	CHIP FERRITE		
L511	LK73G0BBR82K	M.CHIP INDUCTOR			L701	LB73H0AV-002	CHIP FERRITE		
L512	L34-4615-05	AIR CORE COIL			L702	LB73G0AM-004	CHIP FERRITE		
L513	LB73G0AM-004	CHIP FERRITE			L703	L79-1946-05	FILTER		
L514	LB73G0AM-004	CHIP FERRITE			L704	L79-1946-05	FILTER		
L515	LB73G0AM-004	CHIP FERRITE			L705	L79-1946-05	FILTER		
L516	L34-4615-05	AIR CORE COIL			L706	L79-1946-05	FILTER		
L518	L41-1575-53	CHIP INDUCTOR			L707	L79-1946-05	FILTER		
L519	LB73H0AV-002	CHIP FERRITE			L708	L79-1946-05	FILTER		
L521	L34-4615-05	AIR CORE COIL			L711	LR77Z0AE4R7J	CHIP INDUCTOR		
L522	LB73G0AM-004	CHIP FERRITE			L713	LB73H0AV-002	CHIP FERRITE		

△ Symbol No.	Part No.	Part Name	Description	Local	△ Symbol No.	Part No.	Part Name	Description	Local
L714	LB73G0AM-004	CHIP FERRITE			TH303	NCU15WF104F6S	N THERMISTOR		
L715	L92-1101-05	CHIP FERRITE			TH304	NCU15WF104F6S	N THERMISTOR		
L716	L92-1101-05	CHIP FERRITE			TH305	NCU15WF104F6S	N THERMISTOR		
L717	L92-1101-05	CHIP FERRITE			TH700	NCU15WF104F6S	N THERMISTOR		
L718	L92-1101-05	CHIP FERRITE			X700	L7H-0076-00	TCXO		
L719	LB73H0AV-002	CHIP FERRITE			X701	L77-1802-05	QUARTZ CRYSTAL		
L720	LB73G0AM-004	CHIP FERRITE			XF601	L7B-0046-00	MCF		
L721	LB73G0AM-004	CHIP FERRITE							
L722	LB73G0AM-004	CHIP FERRITE							
L723	LB73H0AV-002	CHIP FERRITE							
L724	LB73G0AM-004	CHIP FERRITE							
L725	LB73H0AV-002	CHIP FERRITE							
L732	L92-1101-05	CHIP FERRITE							
L901	LB73H0AV-002	CHIP FERRITE							
L902	LB73H0AV-002	CHIP FERRITE							
L903	LB73G0AM-003	CHIP FERRITE							
L905	LB73G0AM-003	CHIP FERRITE							
L906	LB73G0AM-003	CHIP FERRITE							
L907	LB73G0AM-003	CHIP FERRITE							
L908	LB73G0AM-003	CHIP FERRITE							
L909	LB73G0AM-003	CHIP FERRITE							
L910	LB73G0AM-003	CHIP FERRITE							
L1001	LB73G0AM-004	CHIP FERRITE							
L1002	LB73G0AM-004	CHIP FERRITE							
L1029	LB73G0AM-004	CHIP FERRITE							
L1030	LR79Z0FQ100M	CHIP INDUCTOR							
L1031	LB73G0AM-004	CHIP FERRITE							
L1032	LB73H0AV-002	CHIP FERRITE							
L1033	LB73G0AM-004	CHIP FERRITE							
L1035	LB73H0AV-002	CHIP FERRITE							
L1036	LB73H0AV-002	CHIP FERRITE							
CN2	E23-1116-05	RELAY TERMINAL							
CN3	E23-1116-05	RELAY TERMINAL							
CN4	J19-5386-05	HOLDER							
CN5	E40-6720-05	SOCKET FOR PIN							
CN6	EC720AA-0520A	FFC FPC CONNE							
CN7	EC710AM-0550A	FFC FPC CONNE							
CN8	E4A-0039-00	PIN ASSY							
CN9	EA710AE-2009A	W TO B CONNE							
CN10	E41-2685-05	PIN ASSY							
CN500	E04-0491-05	PIN SOCKET							
CN590	E41-2735-05	PIN ASSY							
CN591	E41-2735-05	PIN ASSY							
CP100	RK74HB1J100J	NET RESISTOR	10Ω 1/16W J						
CP600	RK74HB1J100J	NET RESISTOR	10Ω 1/16W J						
CP703	RK74HB1J100J	NET RESISTOR	10Ω 1/16W J						
CP704	RK74HB1J100J	NET RESISTOR	10Ω 1/16W J						
CP705	RK74HB1J100J	NET RESISTOR	10Ω 1/16W J						
CP706	RK74HB1J101J	NET RESISTOR	100Ω 1/16W J						
CP707	RK74HB1J101J	NET RESISTOR	100Ω 1/16W J						
CP709	RK74HB1J101J	NET RESISTOR	100Ω 1/16W J						
CP710	RK74HB1J101J	NET RESISTOR	100Ω 1/16W J						
CP711	RK74HB1J101J	NET RESISTOR	100Ω 1/16W J						
CP716	RK74HB1J101J	NET RESISTOR	100Ω 1/16W J						
CP900	RK74HB1J100J	NET RESISTOR	10Ω 1/16W J						
E1	-----	SHIELDING CASE	*Note						
F1	F53-0286-05	FUSE							
F2	FZA10BS-5R0	FUSE (CC)							
F3	FZA10BS-5R0	FUSE (CC)							
F4	F53-0286-05	FUSE							
F5	F53-0286-05	FUSE							
F6	FZA10BS-5R0	FUSE (CC)							
J700	E68-0426-05	JACK OTHERS							
OT1	G1B-0413-00	RUBBER SHEET							
TH302	NCU15WF104F6S	N THERMISTOR							

MODULE UNIT

XC2-0031-80

***Note: This part cannot be replaced. Therefore, this part is not supplied as a service part.**

Block No. [0][2]

△ Symbol No.	Part No.	Part Name	Description	Local
IC1	74AVC4TD245GU	IC		
IC2	BU18TD2WNVX	IC		
IC3	-----	IC	*Note	
IC4	NJM2878F4-33	IC		
IC5	-----	IC	*Note	
IC6	74AVC4TD245GU	IC		
IC7	74AVC4TD245GU	IC		
Q1	EM6M2	FET		
D17	RN262CS	DIODE		
D18	RN262CS	DIODE		
C1	CK73HB1A474K	C CAPACITOR	0.47uF 10V K	
C2	CK73HB1A474K	C CAPACITOR	0.47uF 10V K	
C3	CK73HB1E104K	C CAPACITOR	0.1uF 25V K	
C4	CK73HB1E104K	C CAPACITOR	0.1uF 25V K	
C5	CK73HB1A105K	C CAPACITOR	1uF 10V K	
C6	CK73HB1A474K	C CAPACITOR	0.47uF 10V K	
C7	CK73HB1A474K	C CAPACITOR	0.47uF 10V K	
C8	CC73HCH1H220J	C CAPACITOR	22pF 50V J	
C9	CC73HCH1H100B	C CAPACITOR	10pF 50V B	
C10	CK73HB1A105K	C CAPACITOR	1uF 10V K	
C11	CK73HB1E104K	C CAPACITOR	0.1uF 25V K	
C12	CK73HB1E104K	C CAPACITOR	0.1uF 25V K	
C13	CK73HB1E104K	C CAPACITOR	0.1uF 25V K	
C14	CK73HB1E104K	C CAPACITOR	0.1uF 25V K	
C15	CK73HB1A105K	C CAPACITOR	1uF 10V K	
C16	CK73HB1E104K	C CAPACITOR	0.1uF 25V K	
C17	CK73HB1E104K	C CAPACITOR	0.1uF 25V K	
C18	CC73HCH1H180J	C CAPACITOR	18pF 50V J	
C19	CC73HCH1H180J	C CAPACITOR	18pF 50V J	
C20	CK73HB1A105K	C CAPACITOR	1uF 10V K	
C21	CK73HB1A105K	C CAPACITOR	1uF 10V K	
C22	CK73HB1E104K	C CAPACITOR	0.1uF 25V K	
C23	CK73HBB1H102K	C CAPACITOR	1000pF 50V K	
C24	CK73HB1E104K	C CAPACITOR	0.1uF 25V K	
C25	CK73HBB1H102K	C CAPACITOR	1000pF 50V K	
C26	CK73HBB1H102K	C CAPACITOR	1000pF 50V K	
C27	CK73HBB1H102K	C CAPACITOR	1000pF 50V K	
C28	CK73HB1E104K	C CAPACITOR	0.1uF 25V K	
C29	CK73HB1E104K	C CAPACITOR	0.1uF 25V K	
C30	CK73HB1E104K	C CAPACITOR	0.1uF 25V K	
C31	CK73HB1A105K	C CAPACITOR	1uF 10V K	
C32	CK73HB1E104K	C CAPACITOR	0.1uF 25V K	

△ Symbol No.	Part No.	Part Name	Description	Local
C33	CK73HB1E104K	C CAPACITOR	0.1uF 25V K	
C34	CK73HB1E104K	C CAPACITOR	0.1uF 25V K	
C35	CK73HB1E104K	C CAPACITOR	0.1uF 25V K	
C36	CC73HCH1H220J	C CAPACITOR	22pF 50V J	
C37	CC73HCH1H220J	C CAPACITOR	22pF 50V J	
C38	CC73HCH1H2R5B	C CAPACITOR	2.5pF 50V B	
C39	CK73HB1E104K	C CAPACITOR	0.1uF 25V K	
C40	CC73HCH1H180J	C CAPACITOR	18pF 50V J	
C44	CK73HB1E104K	C CAPACITOR	0.1uF 25V K	
C45	CK73HB1E104K	C CAPACITOR	0.1uF 25V K	
C46	CK73HB1E104K	C CAPACITOR	0.1uF 25V K	
C47	CK73HB1E104K	C CAPACITOR	0.1uF 25V K	
C48	CK73HB1E104K	C CAPACITOR	0.1uF 25V K	
C49	CK73HB1E104K	C CAPACITOR	0.1uF 25V K	
C50	CC73HCH1H470J	C CAPACITOR	47pF 50V J	
C68	CC73HCH1H010B	C CAPACITOR	1pF 50V B	
R1	RK73HB1J101J	MG RESISTOR	100Ω 1/16W J	
R2	RK73HB1J103J	MG RESISTOR	10kΩ 1/16W J	
R3	RK73HB1J103J	MG RESISTOR	10kΩ 1/16W J	
R4	RK73HB1J101J	MG RESISTOR	100Ω 1/16W J	
R7	RK73HB1J101J	MG RESISTOR	100Ω 1/16W J	
R8	RK73HB1J102J	MG RESISTOR	1kΩ 1/16W J	
R9	RK73HB1J104J	MG RESISTOR	100kΩ 1/16W J	
R10	RK73HB1J104J	MG RESISTOR	100kΩ 1/16W J	
R11	RK73HB1J102J	MG RESISTOR	1kΩ 1/16W J	
R12	RK73HB1J473J	MG RESISTOR	47kΩ 1/16W J	
R13	RK73HB1J473J	MG RESISTOR	47kΩ 1/16W J	
R14	RK73HB1J102J	MG RESISTOR	1kΩ 1/16W J	
R15	RK73HB1J102J	MG RESISTOR	1kΩ 1/16W J	
R16	RK73EB2E100J	MG RESISTOR	10Ω 1/4W J	
R18	RK73HB1J000J	MG RESISTOR	0Ω 1/16W J	
R19	RK73HB1J102J	MG RESISTOR	1kΩ 1/16W J	
R21	RK73HB1J000J	MG RESISTOR	0Ω 1/16W J	
R22	RK73HB1J103J	MG RESISTOR	10kΩ 1/16W J	
R23	RK73HB1J000J	MG RESISTOR	0Ω 1/16W J	
R24	RK73HB1J000J	MG RESISTOR	0Ω 1/16W J	
R25	RK73HB1J103J	MG RESISTOR	10kΩ 1/16W J	
R26	RK73HB1J000J	MG RESISTOR	0Ω 1/16W J	
R27	RK73HB1J000J	MG RESISTOR	0Ω 1/16W J	
R29	RK73HB1J000J	MG RESISTOR	0Ω 1/16W J	
L1	LB73H0AV-002	CHIP FERRITE		
L2	LB73G0AK-001	CHIP FERRITE		
L3	LB73G0BJ-002	CHIP FERRITE		
L4	L92-0487-05	CHIP FERRITE		
L5	L92-0487-05	CHIP FERRITE		
L6	LK73H0AG27NJ	M.CHIP INDUCTOR		
L7	LK73H0AM10NJ	M.CHIP INDUCTOR	10nH	
L8	L92-0487-05	CHIP FERRITE		
L9	L7K-0059-00	FILTER		
L11	L79-1987-05	FILTER		
L13	L92-0487-05	CHIP FERRITE		
L14	L92-0487-05	CHIP FERRITE		
L15	L40-2263-71	CHIP INDUCTOR		
CN1	E40-6879-05	F.C.CONNECTOR		
CN5	E0E-0012-00	RF C.RECEPTACLE		
CP1	RK74HB1J100J	MG RESISTOR	10Ω 1/16W J	
CP2	RK74HB1J100J	MG RESISTOR	10Ω 1/16W J	
E1	F10-3226-05	SHIELDING CASE		
X1	L77-3123-05	TCXO		
X2	L77-3121-05	QUARTZ CRYSTAL		

INTERFACE UNIT

XC3-073F-00

Block No. [0][3]

△ Symbol No.	Part No.	Part Name	Description	Local
IC1	OPA170AIDRLR	IC		
IC2	TJA1051TK/3	IC		
IC3	BU33TD2WNVX	IC		
IC4	TC74VHC4052AK	IC		
IC5	TC74VHC4052AK	IC		
IC6	BU7445HFV	IC		
IC7	TCA9555RTWR	IC		
IC8	BU7242NUX	IC		
IC9	TC7W66FKF	IC		
IC10	TC7W66FKF	IC		
C3	CC73HCH1H470J	C CAPACITOR	47pF 50V J	
C4	CC73HCH1H470J	C CAPACITOR	47pF 50V J	
C5	CC73HCH1H470J	C CAPACITOR	47pF 50V J	
C6	CC73HCH1H470J	C CAPACITOR	47pF 50V J	
C7	CC73HCH1H470J	C CAPACITOR	47pF 50V J	
C12	CK73HB1E104K	C CAPACITOR	0.1uF 25V K	
C14	CK73HB1E104K	C CAPACITOR	0.1uF 25V K	
C15	CK73HBB1H471K	C CAPACITOR	470pF 50V K	
C16	CK73HB1E104K	C CAPACITOR	0.1uF 25V K	
C17	CK73HB1E104K	C CAPACITOR	0.1uF 25V K	
C18	CK73GB1E105K	C CAPACITOR	1uF 25V K	
C19	CK73HBB1H471K	C CAPACITOR	470pF 50V K	
C20	CK73GB1E105K	C CAPACITOR	1uF 25V K	
C21	CK73GB1E105K	C CAPACITOR	1uF 25V K	
C22	CK73GB1E105K	C CAPACITOR	1uF 25V K	
C24	CK73HB1E104K	C CAPACITOR	0.1uF 25V K	
C25	CK73HB1E104K	C CAPACITOR	0.1uF 25V K	
C26	CK73GB1E105K	C CAPACITOR	1uF 25V K	
C27	CK73GB1E105K	C CAPACITOR	1uF 25V K	
C28	CK73GB1E105K	C CAPACITOR	1uF 25V K	
C29	CC73HCH1H101J	C CAPACITOR	100pF 50V J	
C30	CC73HCH1H181J	C CAPACITOR	180pF 50V J	
C32	CK73HB1E104K	C CAPACITOR	0.1uF 25V K	
C34	CK73HB1E104K	C CAPACITOR	0.1uF 25V K	
C35	CK73HB1H103K	C CAPACITOR	0.01uF 50V K	
C36	CC73HCH1H181J	C CAPACITOR	180pF 50V J	
C37	CK73HB1E104K	C CAPACITOR	0.1uF 25V K	
C38	CK73HB1E104K	C CAPACITOR	0.1uF 25V K	
C39	CK73GB1E105K	C CAPACITOR	1uF 25V K	
C40	CK73GB1E105K	C CAPACITOR	1uF 25V K	
C41	CK73GB1E105K	C CAPACITOR	1uF 25V K	
C42	CK73GB1E105K	C CAPACITOR	1uF 25V K	
C43	CK73HBB1H102K	C CAPACITOR	1000pF 50V K	
C44	CK73HBB1H102K	C CAPACITOR	1000pF 50V K	
C63	CK73HB1E104K	C CAPACITOR	0.1uF 25V K	
C64	CK73HB1E104K	C CAPACITOR	0.1uF 25V K	
C68	CK73GB0J106K	C CAPACITOR	10uF 6.3V K	
C100	CK73GB1E105K	C CAPACITOR	1uF 25V K	
C101	CC73HCH1H101J	C CAPACITOR	100pF 50V J	
C102	CC73HCH1H101J	C CAPACITOR	100pF 50V J	
C103	CC73HCH1H101J	C CAPACITOR	100pF 50V J	
C104	CC73HCH1H101J	C CAPACITOR	100pF 50V J	
C105	CC73HCH1H101J	C CAPACITOR	100pF 50V J	
C106	CC73HCH1H101J	C CAPACITOR	100pF 50V J	
C107	CK73HB1E104K	C CAPACITOR	0.1uF 25V K	
C108	CK73HB1E104K	C CAPACITOR	0.1uF 25V K	
C109	CC73HCH1H181J	C CAPACITOR	180pF 50V J	
C110	CC73HCH1H181J	C CAPACITOR	180pF 50V J	
R7	RK73HB1J473J	MG RESISTOR	47kΩ 1/16W J	
R8	RK73HB1J473J	MG RESISTOR	47kΩ 1/16W J	

△ Symbol No.	Part No.	Part Name	Description	Local	△ Symbol No.	Part No.	Part Name	Description	Local
R9	RK73HB1J820J	MG RESISTOR	82Ω 1/16W J		CN1	EC710AM-0550A	FFC FPC CONNE		
R10	RK73HB1J000J	MG RESISTOR	0Ω 1/16W J		CN3	EA710AC-1516B	W TO B CONNE		
R11	RK73HB1J000J	MG RESISTOR	0Ω 1/16W J		CN4	EA710AC-1516B	W TO B CONNE		
R12	RK73HB1J273J	MG RESISTOR	27kΩ 1/16W J		CP1	RK74HB1J100J	MG RESISTOR	10Ω 1/16W J	
R13	RK73HB1J102J	MG RESISTOR	1kΩ 1/16W J		CP3	RK74HB1J101J	NET RESISTOR	100Ω 1/16W J	
R15	RK73HB1J473J	MG RESISTOR	47kΩ 1/16W J		CP4	RK74HB1J101J	NET RESISTOR	100Ω 1/16W J	
R16	RK73HB1J000J	MG RESISTOR	0Ω 1/16W J		S1	S7K-0024-00	DIP SWITCHES		
R17	RK73HB1J273J	MG RESISTOR	27kΩ 1/16W J						
R18	RK73HB1J473J	MG RESISTOR	47kΩ 1/16W J						
R19	RK73HB1J104J	MG RESISTOR	100kΩ 1/16W J						
R20	RK73HB1J104J	MG RESISTOR	100kΩ 1/16W J						
R22	RK73FB2B121J	MG RESISTOR	120Ω 1/8W J						
R23	RK73HB1J000J	MG RESISTOR	0Ω 1/16W J						
R24	RK73HB1J000J	MG RESISTOR	0Ω 1/16W J						
R25	RK73HB1J000J	MG RESISTOR	0Ω 1/16W J						
R26	RK73HB1J000J	MG RESISTOR	0Ω 1/16W J						
R27	RK73HB1J104J	MG RESISTOR	100kΩ 1/16W J						
R28	RK73HB1J104J	MG RESISTOR	100kΩ 1/16W J						
R29	RK73HB1J683J	MG RESISTOR	68kΩ 1/16W J						
R30	RK73HB1J473J	MG RESISTOR	47kΩ 1/16W J						
R31	RK73HB1J473J	MG RESISTOR	47kΩ 1/16W J						
R32	RK73HB1J333J	MG RESISTOR	33kΩ 1/16W J						
R33	RK73HB1J000J	MG RESISTOR	0Ω 1/16W J						
R37	RK73HB1J333J	MG RESISTOR	33kΩ 1/16W J						
R38	RK73HB1J683J	MG RESISTOR	68kΩ 1/16W J						
R39	RK73HB1J104J	MG RESISTOR	100kΩ 1/16W J						
R40	RK73HB1J104J	MG RESISTOR	100kΩ 1/16W J						
R41	RK73HB1J104J	MG RESISTOR	100kΩ 1/16W J						
R42	RK73HB1J104J	MG RESISTOR	100kΩ 1/16W J						
R67	RK73HB1J103J	MG RESISTOR	10kΩ 1/16W J						
R68	RK73HB1J103J	MG RESISTOR	10kΩ 1/16W J						
R100	RK73HB1J473J	MG RESISTOR	47kΩ 1/16W J						
R101	RK73HB1J473J	MG RESISTOR	47kΩ 1/16W J						
R102	RK73HB1J683J	MG RESISTOR	68kΩ 1/16W J						
R103	RK73HB1J101J	MG RESISTOR	100Ω 1/16W J						
R104	RK73HB1J683J	MG RESISTOR	68kΩ 1/16W J						
R105	RK73HB1J101J	MG RESISTOR	100Ω 1/16W J						
R106	RK73HB1J333J	MG RESISTOR	33kΩ 1/16W J						
R107	RK73HB1J333J	MG RESISTOR	33kΩ 1/16W J						
L1	LB73G0AM-004	CHIP FERRITE							
L2	LB73H0AV-003	CHIP FERRITE							
L3	LB73H0AV-003	CHIP FERRITE							
L4	LB73H0AV-003	CHIP FERRITE							
L5	LB73H0AV-003	CHIP FERRITE							
L6	LB73H0AV-003	CHIP FERRITE							
L7	LB73H0AV-003	CHIP FERRITE							
L8	LB73H0AV-003	CHIP FERRITE							
L9	LB73H0AV-003	CHIP FERRITE							
L10	LB73H0AV-003	CHIP FERRITE							
L11	LB73H0AV-003	CHIP FERRITE							
L12	LB73H0AV-003	CHIP FERRITE							
L13	LB73H0AV-003	CHIP FERRITE							
L14	LB73H0AV-003	CHIP FERRITE							
L15	LB73H0AV-003	CHIP FERRITE							
L16	LB73H0AV-003	CHIP FERRITE							
L17	LB73H0AV-003	CHIP FERRITE							
L18	LB73H0AV-003	CHIP FERRITE							
L19	LB73H0AV-003	CHIP FERRITE							
L20	LB73H0AV-003	CHIP FERRITE							
L21	LB73H0AV-003	CHIP FERRITE							
L22	LB73H0AV-003	CHIP FERRITE							
L23	LB73H0AV-003	CHIP FERRITE							
L24	LB73H0AV-003	CHIP FERRITE							
L25	LB73H0AV-003	CHIP FERRITE							

Packing materials and accessories parts list

Block No.M2MM

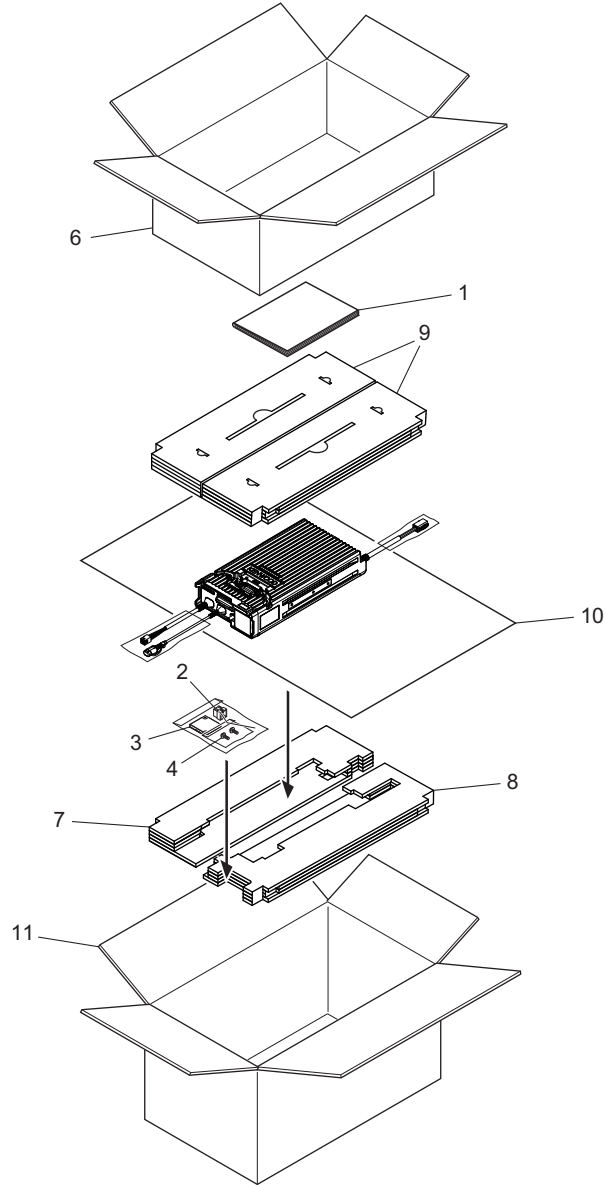

Packing and accessories

Block No. [M][2][M][M]

△ Symbol No.	Part No.	Part Name	Description	Local
1	B5A-2531-20	INST.MANUAL		
2	E6J-0019-00	SOCKET	ACC	
3	F0G-0296-00	MOLDING COVER	ACC(KCT-71)	
4	N67-4010-43	P.H.SEMS SCREW	ACC(KCT-71)(x2)	
6	H02-0626-04	INNER CARTON	OPTION	
7	H1C-0209-00	PACKING FIXTURE	BOTTOM LEFT	
8	H1C-0210-00	PACKING FIXTURE	BOTTOM RIGHT	
9	H1C-0228-00	PACKING FIXTURE	UP(x2)	
10	H2B-0072-10	PROTECT SHEET	MIRAMAT	
11	H52-2129-22	ITEM CARTON		

MEMO



KENWOOD

JVCKENWOOD Corporation
Communications Systems Division

(No.RA075<Rev.001>)

Printed in Japan
JKS