

KENWOOD

SERVICE MANUAL

UHF DIGITAL TRANSCEIVER

NX-5800, NX-5800(B)

NX-5800 is a model that operation panel is attached.
NX-5800(B) is a model that operation panel is not attached.
The illustration is NX-5800.

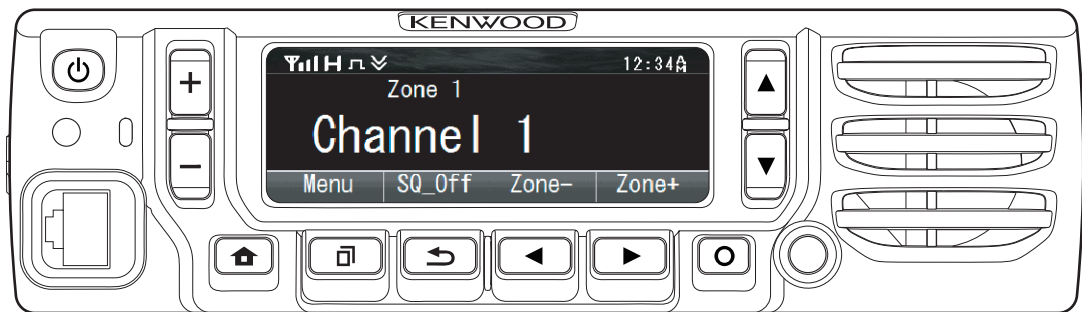

Note :

Lead free solder used in the board (material : Sn, Ag, In, Bi, melting point : 227 Centigrade)

TABLE OF CONTENTS

1	PRECAUTION.....	1-4
2	SPECIFIC SERVICE INSTRUCTIONS.....	1-4
3	DISASSEMBLY	1-29
4	ADJUSTMENT	1-32
5	TROUBLESHOOTING	1-65



Document Copyrights

Copyright 2014 by JVC KENWOOD Corporation. All rights reserved.

No part of this manual may be reproduced, translated, distributed, or transmitted in any form or by any means, electronic, mechanical, photocopying, recording, or otherwise, for any purpose without the prior written permission of JVC KENWOOD Corporation.

Disclaimer

While every precaution has been taken in the preparation of this manual, JVC KENWOOD Corporation assumes no responsibility for errors or omissions. Neither is any liability assumed for damages resulting from the use of the information contained herein.

JVC KENWOOD Corporation reserves the right to make changes to any products herein at any time for improvement purposes.

Firmware Copyrights

The title to and ownership of copyrights for firmware embedded in KENWOOD product memories are reserved for JVC KENWOOD Corporation. Any modifying, reverse engineering, copy, reproducing or disclosing on an Internet website of the firmware is strictly prohibited without prior written consent of JVC KENWOOD Corporation. Furthermore, any reselling, assigning or transferring of the firmware is also strictly prohibited without embedding the firmware in KENWOOD product memories.

Transceivers containing AMBE+2™ Vocoder:

The AMBE+2™ voice coding technology is embedded in the firmware under the license of Digital Voice Systems, Inc.

Bluetooth Copyrights

The Bluetooth® word mark and logos are registered trademarks owned by Bluetooth SIG, Inc. and any use of such marks by JVC KENWOOD Corporation is under licence. Other trademarks and trade names are those of their respective owners.

SPECIFICATION

GENERAL		
Frequency Range		380~470MHz
Max. Channels per Radio		1024 (Up to 4000)
Zones		128
Max. Channels per Zone		512
Channel Spacing	Analog	12.5 / 25 kHz
	Digital	6.25 / 12.5 kHz
Operating Voltage		13.6V DC \pm 15%
Operating Temperature Range		-22°F to +140°F (-30°C to +60°C)
Frequency Stability		\pm 1.0ppm
Dimensions (W x H x D) (Projections not included)	Radio only	6.69 x 1.89 x 6.93 in. (170 x 48 x 176 mm)
Weight (net)	Radio only	3.53 lb (1.6 kg)
RECEIVER		
Sensitivity	NXDN 6.25kHz Digital (3%BER)	0.20 μ V
	NXDN 12.5kHz Digital (3%BER)	0.25 μ V
	P25 Digital (5% BER)	0.25 μ V
	P25 Digital (1% BER)	0.40 μ V
	Analog (12dB SINAD)	0.25 μ V
Selectivity	P25 Digital	63dB
	Analog @ 12.5kHz	70dB
	Analog @ 25kHz	80dB
Intermodulation Distortion		75dB
Spurious Response		85dB
Audio Distortion		Less than 2%
Audio Output		4W / 4 Ω (Remote Control Head: 3W / 4 Ω)
TRANSMITTER		
RF Power Output		45W to 5W
Spurious Response		-75dB
FM Hum & Noise	Analog @ 12.5kHz	40dB
	Analog @ 25kHz	45dB
Audio Distortion		Less than 2%
Modulation		16K0F3E, 11K0F3E, 8K30F1E, 8K30F1D, 8K30F7W, 4K00F1E, 4K00F1D, 4K00F7W, 4K00F2D, 8K10F1W, 8K10F1E, 8K10F1D

Measurements made per TIA/EIA-603 and specifications shown are typical.

JVC KENWOOD Corporation reserves the right to change specifications without prior notice or obligation.

SECTION 1 PRECAUTION

This service manual does not describe PRECAUTION.

SECTION 2 SPECIFIC SERVICE INSTRUCTIONS

2.1 SYSTEM SET-UP

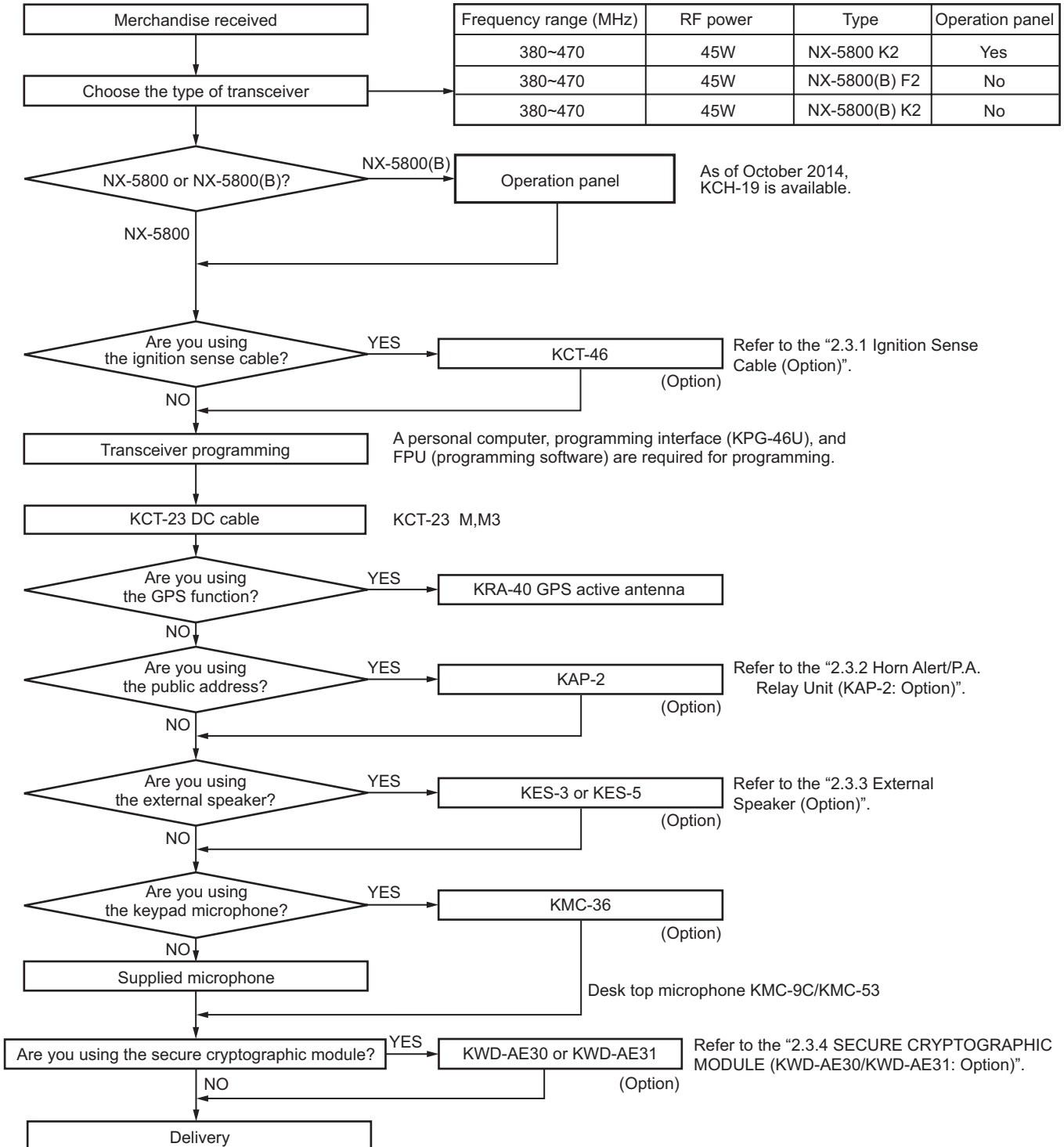

2.2 REALIGNMENT

2.2.1 Modes

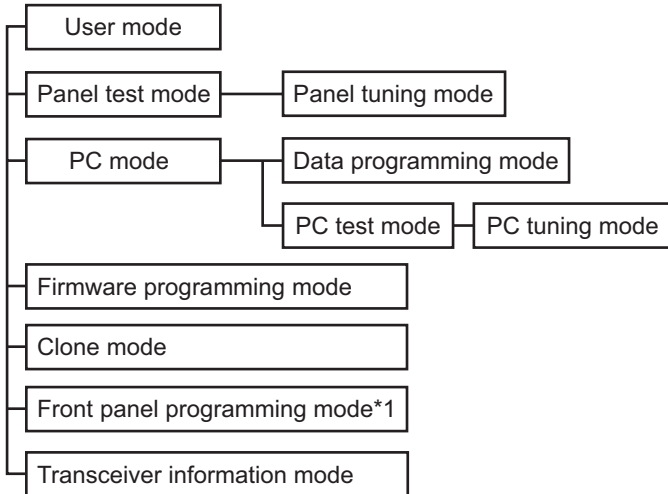

*1: In order to use the Front panel programming mode, it is necessary to purchase the "Front panel program" feature option.

Mode	Function
User mode	For normal use.
Panel test mode	Used by the dealer to check the fundamental characteristics.
Panel tuning mode	Used by the dealer to tune the transceiver.
PC mode	Used for communication between the transceiver and PC.
Data programming mode	Used to read and write frequency data and other features to and from the transceiver.
PC test mode	Used to check the transceiver using the PC. This feature is included in the FPU.
Firmware programming mode	Used when changing the main program of the flash memory.
Clone mode	Used to transfer programming data from one transceiver to another.
Front panel programming mode	Frequency, signaling and features write to the transceiver.
Transceiver information mode	Used to confirm the transceiver firmware version, SCM firmware version and SCM Hardware version.

2.2.2 How to Enter Each Mode

Mode	Operation
User mode	Power ON
Panel test mode*2	<ul style="list-style-type: none"> • [↩] + Power ON • [] + Power ON Select the "Panel Test" using the [▲] / [▼] key. Press the [] key.
PC mode	Received commands from PC
Panel tuning mode	[Panel test mode] + []

Mode	Operation
Firmware programming mode*2	<ul style="list-style-type: none"> • [AUX (Orange)] + Power ON • [] + Power ON Select the "Firmware Prog" using the [▲] / [▼] key. Press the [] key. • If Write is performed by KFL, Firmware programming mode will start automatically.
Clone mode*2	<ul style="list-style-type: none"> • [] + Power ON • [] + Power ON Select the "Clone" using the [▲] / [▼] key. Press the [] key.
Front panel programming mode*2	<ul style="list-style-type: none"> • Press the PF key to which Front panel programming mode is set during the user mode. • Press the [] key and enter the Menu mode. Select the any icon assigned the Front panel programming mode using the [▲] / [▼] key. Press [] key. Select the "Panel Program" using the [▲] / [▼] key. Press the [] key.
Transceiver information mode*2	<ul style="list-style-type: none"> • [+] + Power ON • [] + Power ON Select the "Transceiver Info" using the [▲] / [▼] key. Press the [] key.

*2 There is the two or three as how to enter.

2.2.3 Panel Test Mode

Setting method refer to ADJUSTMENT.

2.2.4 Panel Tuning Mode

Setting method refer to ADJUSTMENT.

2.2.5 PC Mode

2.2.5.1 Preface

The transceiver is programmed by using a personal computer, programming interface (KPG-46U) and FPU (programming software).

The programming software can be used with a PC. Figure 1 shows the setup of a PC for programming.

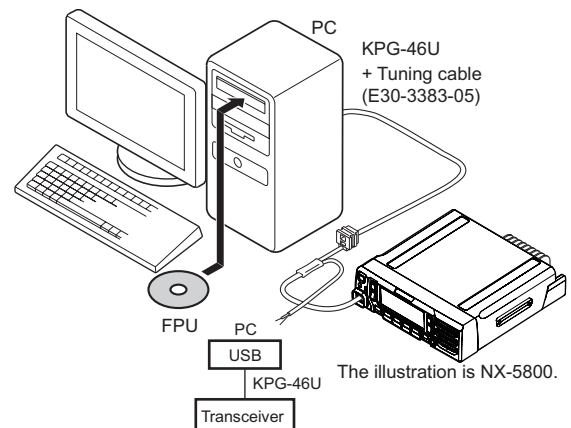

Fig.1

2.2.5.2 Connection procedure

- (1) Connects the transceiver to the computer using the interface cable (KPG-46U).

Note:

You must install the KPG-46U driver in the computer to use the USB programming interface cable (KPG-46U).

- (2) When the POWER switch on, user mode can be entered immediately. When PC sends command the transceiver enter PC mode, and "PROGRAM" is displayed on the LCD. When data transmitting from the transceiver, the red LED lights. When data receiving to the transceiver, the green LED lights.

Note:

The data stored in the computer must match the "Model Name" when it is written into the flash memory.

2.2.5.3 KPG-46U description (USB programming interface cable: Option)

The KPG-46U is a cable which connects to a USB port on a computer.

When using the KPG-46U, install the supplied CD (with driver software) in the computer. The KPG-46U driver runs under Windows XP, Vista, 7, 8 or 8.1.

The latest version of the USB driver is available for download from the following URL:

<http://www.kenwood.com/usb-com/>

(This URL may change without notice.)

2.2.5.4 Programming software KPG-D1/D1N description

The FPU is the programming software for the transceiver supplied on a CD. This software runs under Windows Vista, 7, 8 or 8.1 on a PC.

The data can be input to or read from the transceiver and edited on the screen.

2.2.6 Firmware Programming Mode

2.2.6.1 Preface

Flash memory is mounted on the transceiver. This allows the transceiver to be upgrade when new features are released in the future. (For details on how to obtain the firmware, contact Customer Service.)

2.2.6.2 Connection procedure

Connect the transceiver to the personal computer using the programming interface (KPG-46U). (Connection is same as in the PC mode.)



2.2.6.3 Programming

- (1) Start up the firmware programming software (KENWOOD Firmware Loader). The KFL.exe exists in the KPG-D1/D1N installed folder.
- (2) Set the baud rate to "auto" or 1152000, 576000, 115200, and 57600.
- (3) Set the firmware to be upgrade by file name item.
- (4) Enter the Firmware programming mode by using section "2.2.2 How to Enter Each Mode". Then, the yellow LED on the transceiver light and "FIRMWARE PROG" is displayed.
- (5) Check the connection between the transceiver and the personal computer, and make sure that the transceiver is in the Program mode.
- (6) Press "Write" button in the window. When the transceiver starts to receive data, the "LOADING" display lights.
- (7) If writing ends successfully, the checksum is calculated and a result is displayed.
- (8) If you want to continue programming other transceivers, repeat step (4) to (7).

Note:

If write is performed by KFL, Firmware programming mode will start automatically even if Firmware programming is set to disable in the programming software.

2.2.6.4 Function

If you press the [] key while "FIRMWARE PROG" is displayed, the checksum is calculated, and a result is displayed. If you press the [] key again while checksum is displayed, "FIRMWARE PROG" is redisplayed.



2.2.7 Clone Mode

Programming data can be transferred from one transceiver to another by connecting them via their modular microphone jacks. The operation is as follows.

■The following data cannot be cloned.

- Tuning data
- Embedded message with password
- ESN (Electronic Serial Number) data

■Key guide on the Clone/ Front Panel Programming Password input screen.

- Confirm ([] key): The password confirmation
- Delete ([] key): Delete the latest digit from the current password number (Press and hold to delete all password numbers)
- Select([] key): Determine the latest digit of the password number.

- (1) In the source transceiver, enter the clone mode by using section "2.2.2 How to Enter Each Mode". When the Clone/ Front Panel Programming Password is set to the transceiver, "Input Password" is displayed on the LCD. If the password is not set, the transceiver displays "CLONE MODE".
- (2) When you enter the correct password, "CLONE MODE" is displayed, the transceiver can be used as the cloning source. The following describes how to enter the password.
- (3)

- How to enter the password using the MIC keypad;



If one of the keys 0 to 9 is pressed while the "Input Password" is displayed, the password number is displayed on the LCD.

Each press of the key shifts the display in order to the left.



When you enter the password and press [] or [*] key, "CLONE MODE" displayed if the entered password is correct. If password is incorrect, "Input Password" is redisplayed.

- How to enter password using the [▲] and [▼] keys;

If the [▲] / [▼] key is pressed while "Input Password" is displayed, the Clone/ Front Panel Programming Password input screen is displayed.

If the [▲] or [▼] key is pressed while the clone/ Front Panel Programming Password input screen is displayed, the number (0 to 9) blinks on the LCD. When you press the [] key, currently selected number is determined. If you press the [] key after entering password in this procedure, "CLONE MODE" is displayed if entered password is correct. If the password is incorrect, "Input Password" is redisplayed.

- (4) Power ON the target transceiver.
- (5) Connecting the cloning cable (part No.E30-3382-05) to the modular microphone jacks on the source and target.

- (6) Press [] key on the source while the source displays "CLONE MODE". The data of the source is sent to the target. While the target is receiving the data, "PROGRAM" is displayed. When cloning of the data is completed, the source displays "END", and the target automatically operates in the User mode. The target can then be operated by the same program as the source.
- (7) The other target can be continuously cloned. When the [] key on the source is pressed while the source displays "END", the source displays "CLONE MODE". Carry out the operation in step (4) to (6).

Note:

- Cannot be cloned if the password (overwrite password) is programmed to the target.
- "Model name" must be same to clone the transceiver.

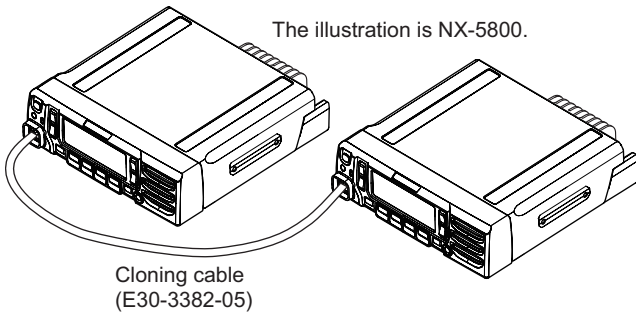

Fig.2

2.2.8 Front Panel Programming Mode



If the Front Panel Programming Mode is used, the frequency or other data of the conventional channel is rewritable only by the transceiver.

Moreover, the conventional channel can be added.

■The following setup items can be changed or added by using the Front panel programming mode.

- RX/TX Frequency
- Channel Type
- Channel Spacing
- Decode QT/DQT/RAN/NAC, Encode QT/DQT/RAN/NAC
- Talkgroup ID List No.
- Transmit Power
- Channel Name

■Key guide on the Clone/ Front Panel Programming Password input screen.

- Confirm ([] key): The password confirmation
- Delete ([] key): Delete the latest digit from the current password number (Press and hold to delete all password numbers)
- Select ([] key): Determine the latest digit of the password number.

2.2.8.1 Enter to the Front panel programming mode.

Enter to the Menu Mode by pressing [Front Panel Mode] PF key or [Menu] key. When the Front Panel Mode is selected, it can enter to the Front panel programming mode.

If the Clone/Front panel programming Password is not set to the transceiver, "Panel Program" is displayed on the LCD.

If the Clone/Front panel programming Password is set to the transceiver, "Panel Program" is displayed on the LCD when you enter the correct password while "Input Password" is displayed.

2.2.8.2 Data Writing

Before moving to next Zone/Channel, "Keep This Change?" appears on the LCD, if you select "OK", the new data is written to memory. If you select "Cancel", the new data not be written; the new data will be erased.

- The setup items for Front panel programming mode are as follows.

No.	Setup item	Display	Remarks
1	RX Frequency	RX Frequency	Receive Frequency
2	TX Frequency	TX Frequency	Transmit Frequency
3	Channel Type	Channel Type	Analog/NXDN/P25
4	Channel Spacing	Channel Space	Analog: 12.5kHz/25kHz
			NXDN: 6.25kHz/12.5kHz
			P25: 12.5kHz
5	RX Signaling	RX QT/DQT	Receive QT/DQT
6	TX Signaling	TX QT/DQT	Transmit QT/DQT
7	RX RAN	RX RAN	None, 1~63
8	TX RAN	TX RAN	None, 1~63
9	RX NAC	RX NAC	000~FFF (Hexadecimal) Note: "F7F" cannot set.
10	TX NAC	TX NAC	000~FFF (Hexadecimal) Note: "F7E" and "F7F" cannot set.
11	Talkgroup ID List Number	Talkgroup	None, 1~1500
12	Transmit Power	Transmit Power	Low/Medium/High
13	Channel Name	Channel Name	

• Key operation

Key/Item	Zone Select	Channel Select	RX Frequency	TX Frequency	Channel Type	Channel Spacing	RX Signaling	TX Signaling
[□]	Decision	Decision	Decision	Decision	Decision	Decision	Decision	Decision
[↶]	Unused	Back to the previous item	Back to the previous item	Back to the previous item	Back to the previous item	Back to the previous item	Back to the previous item	Back to the previous item
[○]	Unused	Unused	Unused	TX Frequency OFF	Unused	Unused	Unused	Unused
[⏏]	Exit panel program mode	Exit panel program mode	Exit panel program mode	Exit panel program mode	Exit panel program mode	Exit panel program mode	Exit panel program mode	Exit panel program mode
[▲]	Zone change	Channel change	Frequency up	Frequency up	Channel type change	Channel Spacing Change	Signaling number change	Signaling number change
[▼]	Zone change	Channel change	Frequency down	Frequency down	Channel type change	Channel Spacing Change	Signaling number change	Signaling number change
[▶]	Unused	Unused	Frequency step change	Frequency step change	Unused	Unused	Signaling type change	Signaling type change
[◀]	Unused	Unused	Frequency step change	Frequency step change	Unused	Unused	Signaling type change	Signaling type change
MIC Keypad [0] ~ [9]	Zone number select	Channel number select	Go to the direct enter mode		Channel number select (1 or 2)	Channel spacing select (1 or 2)	Go to the direct enter mode	
MIC Keypad [*]	Decision	Decision	Decision	Decision	Decision	Decision	Decision	Decision
MIC Keypad [#]	Unused	Back to the previous item	Back to the previous item	Back to the previous item	Back to the previous item	Back to the previous item	Back to the previous item	Back to the previous item

Key/Item	RX RAN	TX RAN	RX NAC	TX NAC	TG ID List No.	Transmit Power	Channel Name
[□]	Decision	Decision	Decision	Decision	Decision	Decision	Decision
[↶]	Back to the previous item	Back to the previous item	Back to the previous item	Back to the previous item	Back to the previous item	Back to the previous item	Back to the previous item/Delete
[○]	Unused	Unused	Unused	Unused	Unused	Unused	Character/Digit switching
[⏏]	Exit panel program mode	Exit panel program mode	Exit panel program mode	Exit panel program mode	Exit panel program mode	Exit panel program mode	Exit panel program mode
[▲]	RX RAN up	TX RAN up	RX NAC up	TX NAC up	TG List number up	Transmit power change	Go to the direct enter mode
[▼]	RX RAN down	TX RAN down	RX NAC down	TX NAC down	TG List number down	Transmit power change	
[▶]	RX RAN ON/OFF	RX RAN ON/OFF	Unused	Unused	Unused	Unused	
[◀]	RX RAN ON/OFF	RX RAN ON/OFF	Unused	Unused	Unused	Unused	
MIC Keypad [0] ~ [9]	Go to the direct enter mode				Talkgroup List number select	Transmit power select (1, 2 or 3)	Decision/ Character/ Digit switching
MIC Keypad [*]	Decision	Decision	Decision	Decision	Decision	Decision	
MIC Keypad [#]	Back to the previous item	Back to the previous item	Back to the previous item	Back to the previous item	Back to the previous item	Back to the previous item	Back to the previous item

• Direct enter mode

Key/Item	RX Frequency	TX Frequency	RX Signaling	TX Signaling	RX RAN	TX RAN	RX NAC	TX NAC	Channel Name
[☒]	Decision								Character/Channel name decision
[↵]	Delete								
[○]	Unused								
[🏠]	Exit panel program mode								
[▲]	Unused								Character selection (upper case character → lower-case character → digit → upper case character...)
[▼]									Character selection (upper case character → lower-case character → digit → upper case character...)
[▶]									Move a cursor to the right
[◀]									Move a cursor to the left
MIC Key-pad [0] ~ [9]	Add a digit to the current number								
MIC Key-pad [*]	Decision								Input character switching
MIC Key-pad [#]	Delete/Back to the previous item								Delete

• Front panel programming mode flow chart

Enter the Front panel programming mode by using section "2.2.2 How to Enter Each Mode".

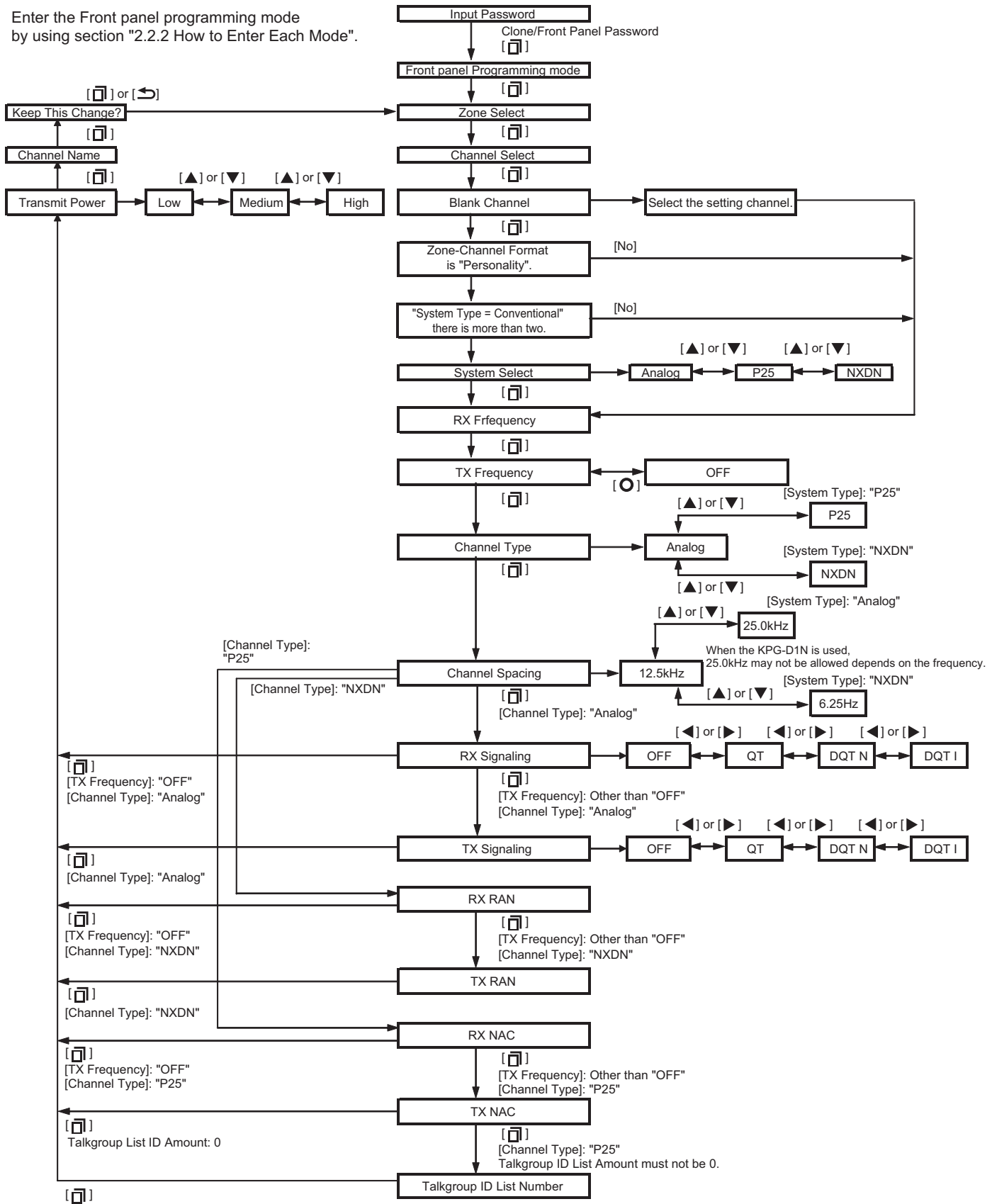

Note: Zone-Channel Format allows you to whether to configure for each zone the channels in the same system, or channels in different system. P25 can be configured for System Select or Channel Type if one or more P25 conventional system is preconfigured by the FPU.

2.2.9 Transceiver Information Mode

Use this function to confirm the transceiver firmware version, SCM Firmware version and SCM Hardware version.

- (1) Enter the Transceiver Information mode by using section "2.2.2 How to Enter Each Mode".
- (2) The transceiver firmware version appears on the LCD.
- (3) Use the [▲] and [▼] keys to select the confirmation items.

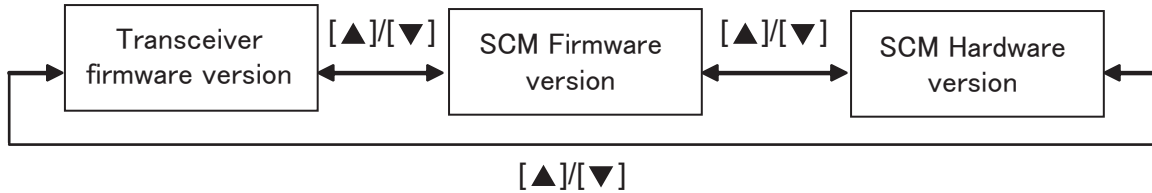

- (4) To exit the transceiver information mode, turn the transceiver power OFF.

Note:

When the SCM board is not equipped to the transceiver, SCM Firmware Version and SCM Hardware Version are displayed as "-.-.-"

2.3 INSTALLATION

ATTENTION:

When installing the option, please take measures to prevent static electricity.

2.3.1 Ignition Sense Cable (KCT-46: Option)

The KCT-46 is an optional cable for enabling the ignition function. The ignition function lets you turn the power to the transceiver on and off with the car ignition key.

2.3.1.1 Connecting the KCT-46 cable to the transceiver

- (1) Open the KCT-46 fuse holder and insert a mini blade fuse (3A). <1>
- (2) While holding a clear protective cover, remove the black cap at the end of the yellow cable (ignition sense cable) of the transceiver. <2>
- (3) Connect the plug of the KCT-46 to the yellow cable terminal of the transceiver. <3>
- (4) Connect the other end of the KCT-46 to the ignition line of the car. <4>

Note:

You must setup using the KPG-D1/D1N.

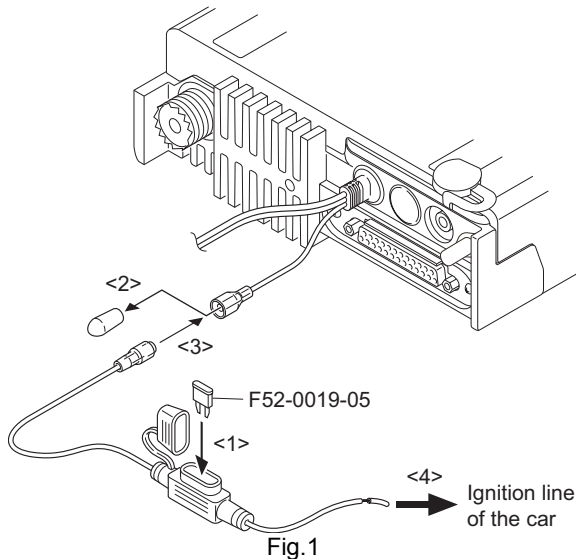

2.3.2 Horn Alert/P.A. Relay Unit (KAP-2: Option)

The Horn alert (max. 2A drive), Public address and External speaker function are enabled by installing the KAP-2 in the transceiver.

2.3.2.1 Installing the KAP-2 unit in the transceiver (The kit A is not used in the KAP-2 accessories)

- (1) Remove the cabinet, top packing and shielding plate of the transceiver.
- (2) Set the KAP-2 relay unit jumper pins according to the purpose of use.
- (3) Remove the 6-pin jumper connector inserted in the TXRX unit (A/2) connector (CN910). <1>

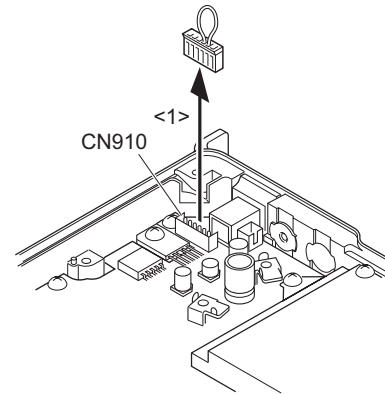

Fig.2-1

- (4) Insert one side of the lead wire with connector (E37-1114-05) into the relay unit connector (CN3) <2> and the other side into the TX-RX unit (A/2) connector (CN910) <3>

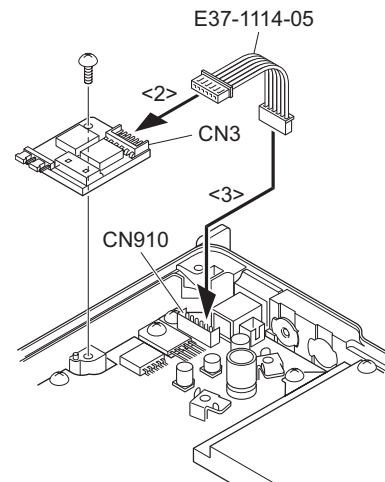

Fig.2-2

- (5) Place the relay unit at the position shown in Figure 2-2 and secure it to the chassis with a screw.

- (6) Remove the cap on the rear of the chassis by pushing it from the inside with your finger. <4>

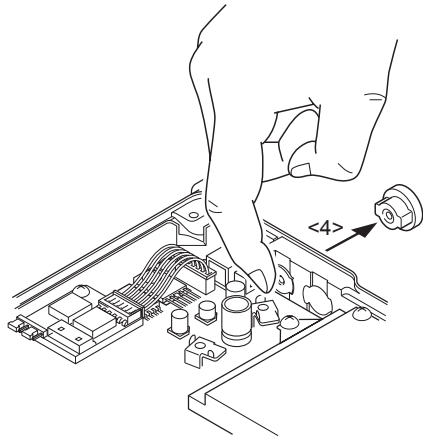

Fig.2-3

- (7) Pass the 6-pin connector of the cable (E37-1113-25) through the chassis hole <5> and insert the bush into the chassis hole.
 (8) Rotate the bush of the cable 90 degrees counterclockwise as viewed from the rear of the chassis. <6>
 (9) Insert the 6-pin connector of the cable into the connector (CN2) of the KAP-2 relay unit. <7>

Note:

You must setup using the KPG-D1/D1N.

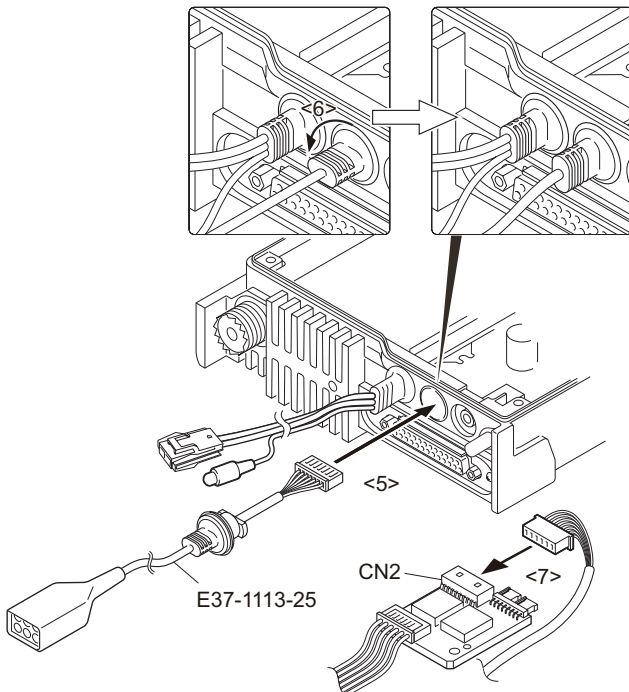
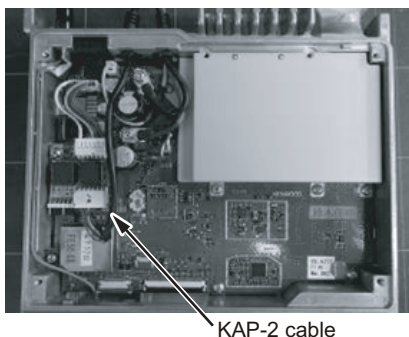

Fig.2-4

- (10) Form the KAP-2 cable as shown in the figure.



2.3.3 External Speaker (Option)

2.3.3.1 KES-3

The KES-3 is an external speaker for the 3.5-mm-diameter speaker jack.

■Connection Procedure

Connect the KES-3 to the 3.5-mm-diameter speaker jack on the rear of the transceiver.

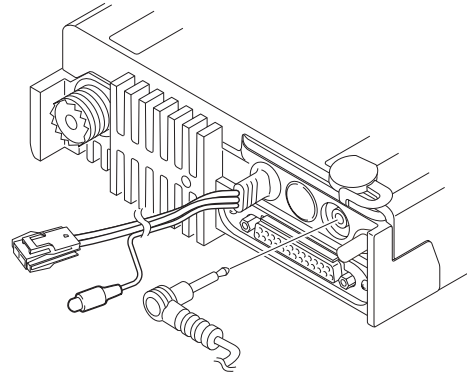

Fig.3-1

2.3.3.2 KES-5

External speaker KES-5 can be installed for KAP-2. If KES-5 is installed, it can be set by changing the CN1 short pin from pins 4 and 5 to pins 5 and 6 on the KAP-2.

KAP-2 CN1 Connect	Set Up
4-5	INT. SP or KES-3
5-6	KES-5

When you use the KES-5, plug the short pin to pins 5 and 6 on the KAP-2.

When you use the INT. SP or KES-3, plug the short pin to pins 4 and 5 on the KAP-2.

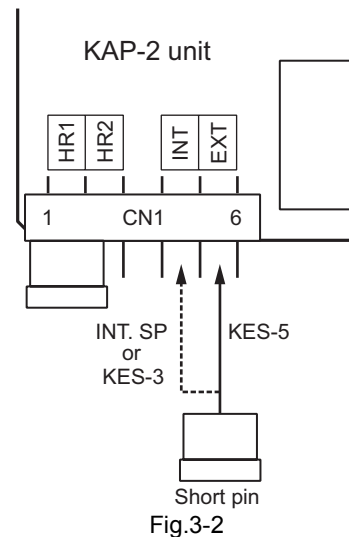

Fig.3-2

■Connection Procedure

Insert the crimp terminal into the Square plug supplied with the KAP-2.

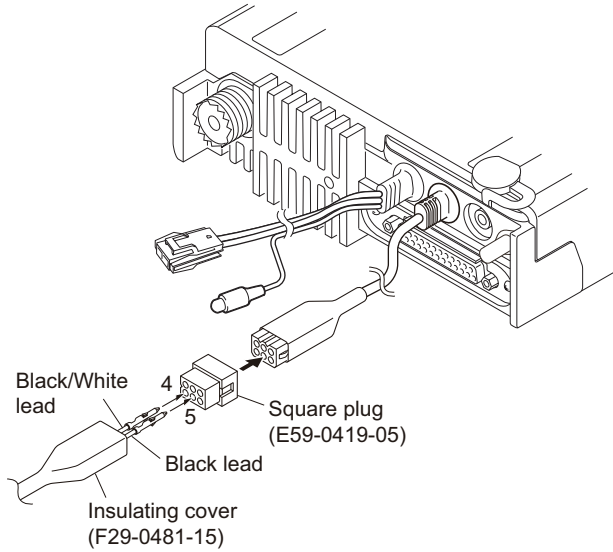
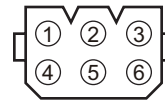

Fig.3-3

■KAP-2 Cable (E37-1113-25) 6-pin Connector



Pin No.	Color	Name
1	Red	HR2
2	Blue	GND
3	Yellow	OSP
4	Green	ESP
5	Brown	GND
6	Black	HR1

2.3.4 SECURE CRYPTOGRAPHIC MODULE (KWD-AE30/KWD-AE31:Option)

2.3.4.1 SUPPLIED ACCESSORIES

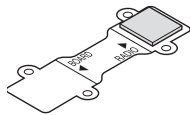

Connecting cable
(X42-3330-XX)



Cushion A*
(G13-2179-XX)

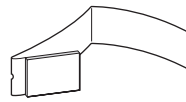

Cushion B
(G13-2178-XX)



Cushion C
(G1D-0006-XX)

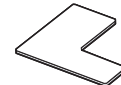

Cushion D*
(G1D-0055-XX)

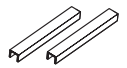

Spacer*
(F3K-0004-XX)

Note:

Supplied accessories with * mark are not used for the NX-5800.

2.3.4.2 INSTALLING THE MODULE IN THE TRANSCIEVER

(1) Remove the cabinet, top packing and shielding plate of the transceiver.

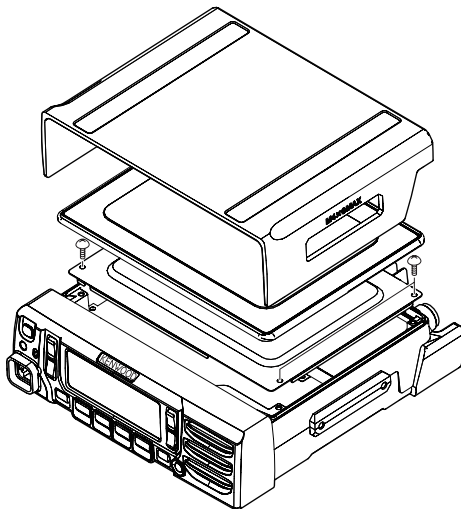

(2) Attach the cushion B and C to the module backside.

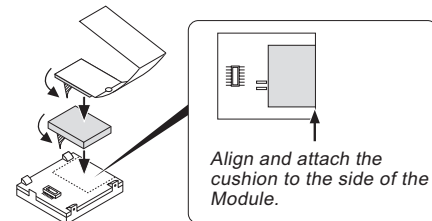

Note:

Refer to the figure for how to attach cushion B. If the release paper is reversed, it cannot be pulled out.

(3) Fold the release paper as indicated in the figure.

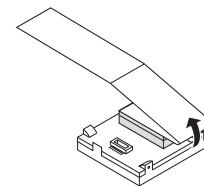

- (4) Insert the connector of the module the connector (CN731) of the TX/RX PCB into.

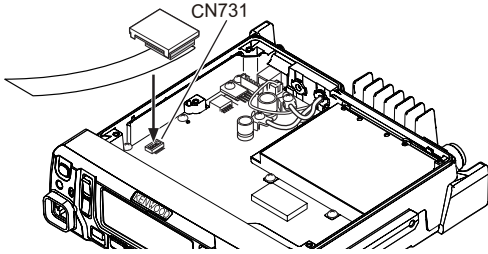

- (5) Pull and remove the release paper while pressing down on the module with your finger to hold it in place, to attach the module to the TX/RX PCB.

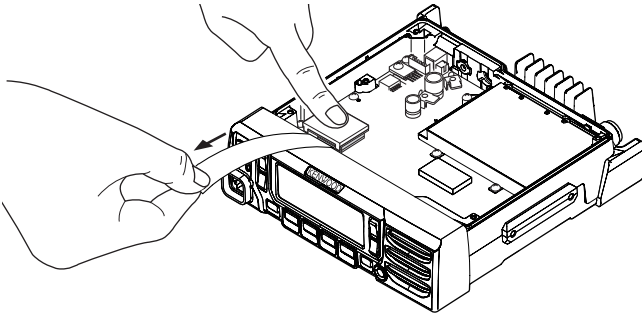

Note:

- When it is necessary to remove the module, do so by peeling the module off using your finger, while pulling it vertically. Do not use a screwdriver or other similar implement to remove the module; you may inadvertently damage the TX/RX PCB and the module.
- Cushion B cannot be reused. Attach a new cushion B when you remove the cushion from the module.

- (6) Reinstall the cabinet, top packing and shielding plate of the transceiver.

Note:

- When the KWD-AE30/ KWD-AE31 is installed, select the "Secure Cryptographic Module" checkbox in the Product Information of the Programming software [FPU (Field Programming Unit)], and then set each parameter.
- If the KWD-AE30/ KWD-AE31 connector is not properly installed, the TX/RX indicator will blink red or "No SCM" will appear on the display when the transceiver power is turned on.
- If the Encryption Key data is not written at the Keyloader, or the Encryption Key data is zeroized, "Key Fail" will appear on the display.
- If the KWD-AE30/ KWD-AE31 is installed in other transceivers, the Encryption Key data will be forced to zeroize.

2.3.5 Changing D-SUB 25-pin connector (4 pin, 5 pin) configuration

2.3.5.1 Change configuration of D-SUB 25-pin connector from AUXIO9 to CTS

■4 pin

The output (4 pin) of D-SUB 25-pin connector is configured at the AUXIO9 as the default value.

Remove the R950 chip jumpers and solder the chip jumpers to \$R952.

Ref. No.			Function
R950	\$R952	Default	AUXIO9
\$R950	R952	-	CTS (RS-232C)

2.3.5.2 Change configuration of D-SUB 25-pin connector from DI to RTS

■5 pin

The input (5 pin) of D-SUB 25-pin connector is configured at the DI as the default value.

Remove the R943 chip jumpers and solder the chip jumpers to \$R946.

Ref. No.			Function
R943	\$R946	Default	DI
\$R943	R946	-	RTS (RS-232C)

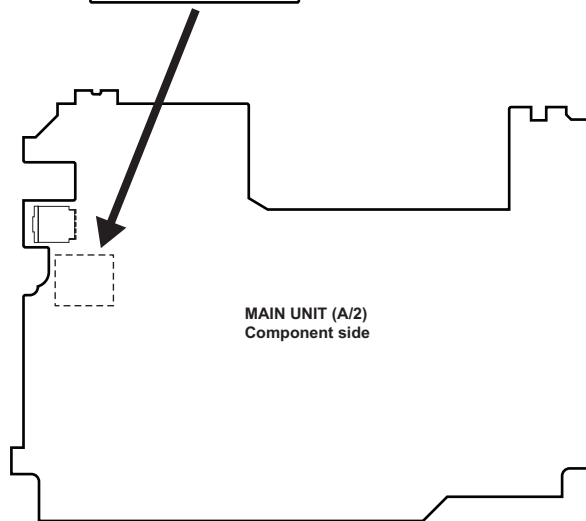
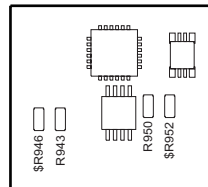

2.4 CIRCUIT DESCRIPTION

2.4.1 Overview

The NX-5800 is a UHF Analog FM & Digital Mobile transceiver designed to operate in the frequency range of 380 to 470MHz. The unit consists of a receiver, a transmitter, a phase-locked loop (PLL) frequency synthesizer, a digital control unit, and a power supply circuit.

2.4.2 Frequency Configuration

The receiver is a double-conversion super-heterodyne using first intermediate frequency (IF) of 49.95MHz and second IF of 2.25MHz. Incoming signals from the antenna are mixed with the local signal from the VCO/PLL circuit to produce the first IF of 49.95MHz. This is then mixed with the 47.7MHz second local oscillator output to produce the 2.25MHz second IF. The transmit signal frequency is generated by the TX VCO, and modulated by the signal from the DSP. It is then amplified and fed to the antenna.

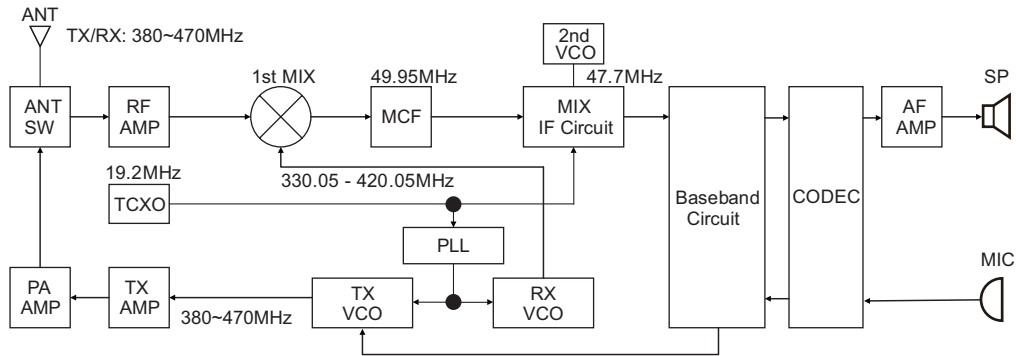

Fig.1 Frequency configuration

2.4.3 Receiver System

2.4.3.1 RF circuit

The receive signal from antenna switch (D310, D311, D312, D313, D314 and D315) is amplified by a RF amplifier (Q502) and passes through the band-pass filter (L511, L510, L509 and L508) to remove unwanted signals. The signal is then fed to the 1st mixer (IC500).

2.4.3.2 IF circuit

The first IF signal is passed through a four-pole monolithic crystal filter (XF600) to reject adjacent channel signal. The filtered first IF signal is amplified by the first IF amplifier (Q604 and Q603) and then applied to the IF system IC (IC600). The IF system IC provides a second mixer, second PLL, AGC and A/D converter.

The second mixer mixes the first IF signal with the 47.7MHz of second local oscillator output and produces the second IF signal of 2.25MHz.

The second IF signal is then fed into an A/D converter, generates the I and Q data. This data is in the form of SSI (Serial Synchronous Interface), and sent to the DSP (IC706).

2.4.3.3 Audio amplifier circuit

Audio processing (high-pass filter, low-pass filter, de-emphasized and so on) at Analog FM mode and decoding at Digital mode are processed by DSP. SSI signal from DSP is converted to audio signal at IC902. The signal goes to internal speaker and connector for external speaker (J900) through the amplifier (IC903), electronic volume control (IC719) and audio amplifier (IC911).

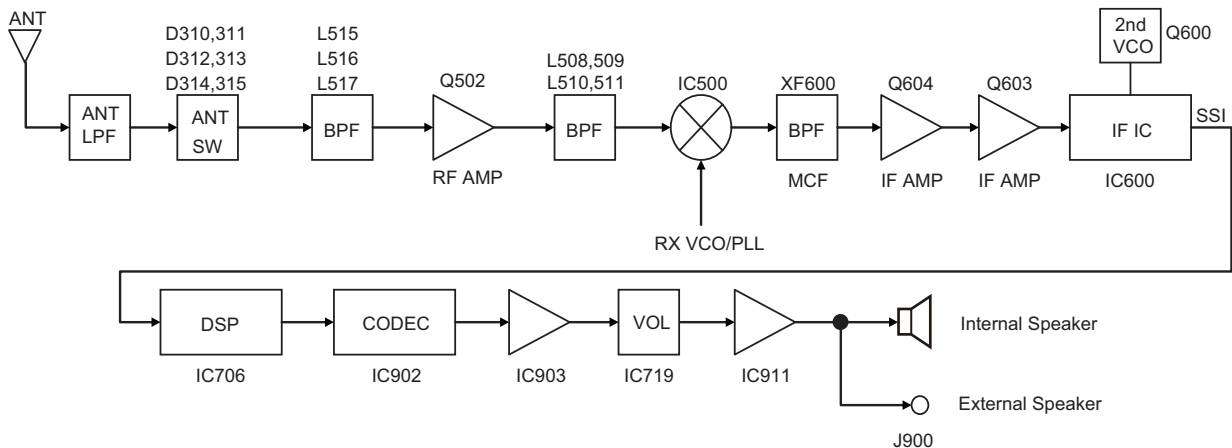

Fig.2 RF and IF circuit

2.4.4 Transmitter System

2.4.4.1 Audio Band Circuit

The signal from microphone is amplified and converted to digital signal by IC902. IC902 includes AGC function. Digital signal is transferred to IC706 thru SSI.

2.4.4.2 Base Band Circuit

The audio signal transferred from IC902 is processed at IC706. Voice signals of 300Hz or lower and frequencies of 3kHz or higher are cut off and an audio range 300Hz to 3kHz is extracted. The audio signal is then pre-emphasized in FM mode and synthesized with the signals, such as QT and DQT, as required, and is transferred to PLL Frequency Synthesizer block. The DTMF and MSK base band signals are also generated by IC706.

In Digital mode, the audio signal is converted to the 4-Level FSK base band signal and is transferred to PLL Frequency Synthesizer block.

The output level according to the transmit carrier is fine-adjusted according to each modulation method.

2.4.4.3 Drive and Final amplifier

The signal from the TX VCO is amplified by pre-drive amplifier (IC300). The output of the pre-drive amplifier is amplified by the drive amplifier (Q300) and RF Power module (IC302) to 45W (5W when the power is low).

IC300 is MMIC. Q300 is MOS FET. The output of the final amplifier is then passed through the coupler, antenna switch (D310, D311, D312, D313, D314 and D315), harmonic filter (LPF) and applied to the antenna terminal.

2.4.4.4 APC circuit

The Automatic transmission power control (APC) circuit controls the transmitter output in adjusted value by monitoring it with a coupler. RF detection and comparison functions are included in the power-control IC (IC304).

The power control IC output is given as a drive source of the RF power module's gate (IC302), and completes APC feedback loop.

When a normal antenna load is connected, reflected Forward RF Power is detected by the coupler and direct in power-control IC (IC304). Forward RF Power is converted into DC voltage in IC304 and is compared with the APC1.

The output voltage goes through DC amp (IC301 2/2) to Drive amp (Q300) and RF Power module (IC302).

The voltage controls the gate bias1 voltage of Q300 and IC302, and keeps transmission output stable. SPC controls the gate bias2 voltage of IC302 too.

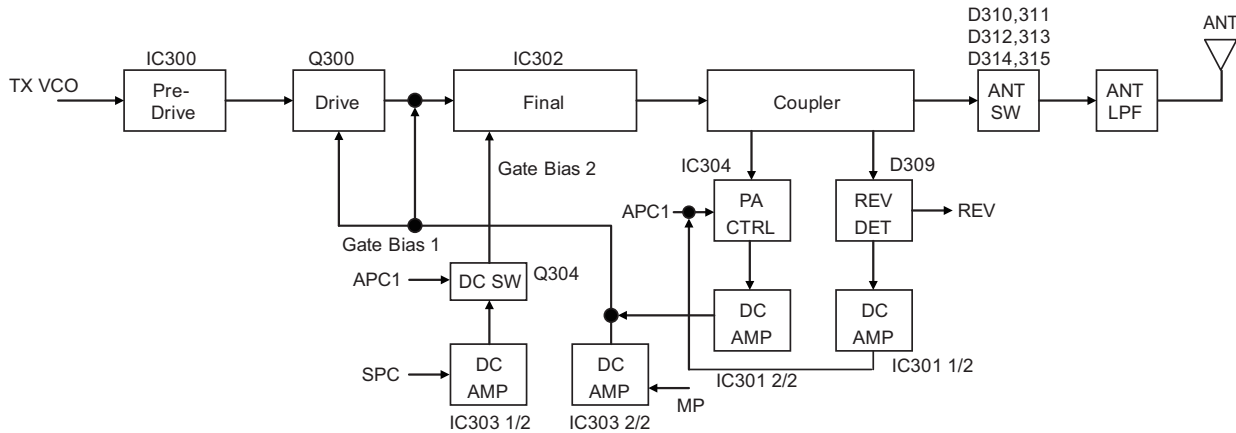

Fig.3 Drive and Final amplifier and APC circuit

2.4.5 PLL Frequency Synthesizer

2.4.5.1 TCXO (X700)

TCXO (X700) generates a reference frequency of 19.2MHz for the PLL frequency synthesizer. This reference signal is buffered by Q700 and IC703. And it is distributed to PLL (IC100), IF IC (IC600), and IC706.

The frequency adjustment is achieved by adjusting a D/A converter (IC715) output in the voltage of the control terminal of TCXO.

2.4.5.2 VCO

There are TX VCO and RX VCO.

The TX VCO (Q107) generates the carrier for the transmitter. The VCO oscillation frequency range is 380 to 470MHz. The transmit frequency range is 380 to 470MHz.

The RX VCO (Q105) generates the 1st local signal for the receiver.

The VCO oscillation frequency range is 330.05 to 420.05MHz. The 1st local signal frequency range is 330.05 to 420.05MHz.

The VCO oscillation frequency is determined by voltage control terminals "CV" and "ASSIST".

The voltage control terminal "CV" is controlled by PLL IC (IC100). The voltage control terminal "ASSIST" is controlled by the control voltage from D/A converter (IC715).

For the modulation input terminal, "VCO_MOD" of TX VCO, the output frequency changes according to the applied voltage. This is used to modulate the VCO output.

2.4.5.3 PLL IC

PLL IC (IC100) compare the difference in phases of the VCO oscillation signal and the TCXO reference frequency. And it returns the difference voltage to the VCO CV terminal and realizes the "Phase Locked Loop".

This allows the VCO oscillation frequency to accurately match (lock) the desired frequency.

When the frequency is controlled by the PLL, the frequency convergence time increases as the frequency difference increases when the set frequency is changed. To supplement this, the MPU is used before control by the PLL IC to bring the VCO oscillation frequency close to the desired frequency. As a result, the VCO CV voltage does not change and is always stable at approx. 2.5V.

The desired frequency is set for the PLL IC by the MPU (IC706) through the 3-line "SDO1", "P_SCK1", "/PCS_RF" serial bus for PLL. MPU monitors through the "PLD", whether the PLL IC is locked or not. If the VCO does not lock to desired frequency (unlock), the "PLD" logic is low.

2.4.6 Control Circuit

The control circuit consists of MPU/DSP (IC706) and its peripheral circuits. IC706 mainly performs the following;

- (1) Switching between transmission and reception by PTT signal input.
- (2) Reading system, zone, frequency, and program data from the memory circuit.
- (3) Sending frequency program data to the PLL.
- (4) Controlling the audio mute circuit by decode data input.

2.4.6.1 MPU

The MPU/DSP (IC706) is 32bit RISC processor and fixed floating-Point VLIW DSP Fixed/Floating-Point VLIW DSP, equipped with peripheral function.

This MPU operates at 288MHz (MAX) clock and 3.3V/1.8V/1.2V DC. Controls the flash memory, Mobile DDR, the receive circuit, the transmitter circuit, the control circuit, and the display circuit and transfers data to or from an external device.

2.4.6.2 Memory Circuit

Memory circuit consists of the MPU and the Mobile DDR (IC702), the flash memory (IC701). The flash memory has capacity of 512Mbit that contains the transceiver control program for the MPU and stores the data.

It also stores the data for transceiver channels and operating parameter that are written by the FPU. This program can be easily written from external devices. The Mobile DDR has capacity of 512Mbit. The MPU copies the program to the Mobile DDR from Flash memory. And MPU is used as a work area Mobile DDR.

■Flash memory

Note:

The flash memory stores the data that is written by the FPU (KPG-D1/D1N), tuning data (Deviation, Squelch, etc.) , and firmware program (User mode, Test mode, Tuning mode, etc.). This data must be rewritten when replacing the flash memory.

■Mobile DDR (static memory)

Note:

Mobile DDR is used as a work area of the MPU.

2.4.6.3 LCD

LCD interface connector (CN4) of the display unit.

The LCD is controlled using parallel interface from MPU (IC706) through the interface connectors (CN749 of the main unit and CN6 of display unit) and flexible cable.

2.4.6.4 Key Detection Circuit

Keys are detected using I/O Expander IC (IC10) of the display unit. If pressed key is detected by IC10, it is informed to MPU (IC706) of the main unit through serial line.

2.4.6.5 DSP

The DSP circuit consists of a MPU/DSP (IC706) and processes the baseband signal. The DSP operates at 288MHz (MAX) clock, the I/O section operates at 3.3V/1.8V and the core section operates at 1.2V.

The DSP carries out the following processes:

- 4Level FSK processing
- Analog FM pre-emphasis/de-emphasis
- Vocoder processing between audio codec and modulation/demodulation
- CAI processing, such as error correction encoding
- QT/DQT encoding/decoding
- DTMF encoding/decoding
- MSK encoding/decoding
- 2-tone encoding/decoding
- Compressor/expander processing
- Voice scrambler processing
- Transmit/receive audio filtering processing
- Microphone amplifier AGC processing
- Audio mute processing
- Modulation level processing
- Active Noise Reduction
- Voice recording/playback processing
- Voice announce processing

2.4.7 Power Supply Circuit

+B voltage is connected to RF Power Module, 50BU regulator (Q8, Q9 and D11) through the fuse (F1), DC/DC converter IC (IC8) via fuse (F1), SB1 switch (Q5 and Q6) through the fuse (F2) and SB2 switch (Q10) through the fuse (F3).

Q8, Q9 and D11 regulates +B voltage to 5V (50BU). Then IC1 regulates 50BU to 3.1V (31BU). Then IC3 regulates 31BU to 1.2V (12BU). 50BU, 31BU and 12BU operate whenever +B is supplied.

IC8 regulates +B voltage to 5.4V (54M). 54M is controlled by BAT_CNT signal from Power management IC (IC2). When Power switch is turned on, BAR_CNT signal is controlled by /PSW signal. 54M goes to DC/DC converter (A1, IC11), AVR ICs (IC5, IC4, IC12, IC14, IC7, IC10, IC6 and IC17).

A1 (12M) is enabled while the 54M is operating. 12M provides the power to the MPU/DSP (IC706) and turns on IC11 (18M). 18M provides the power to the MPU/DSP and Mobile DDR (IC702) and turns on IC5 (33M), IC14 (33OPT). 33M provides the power to the MPU/DSP, Flash memory (IC701) and many control circuits and turns on IC4 (33A), IC10 (50A). Then 33A turns on IC9 (18M_3).

The Power management IC (IC2) watches +B voltage. If +B voltage is higher than 6.2V, IC2 outputs high voltage to the /BINT terminal. If the /BINT is high, SB1 (Q5 and Q6) and SB2 (Q10 and Q11) are turned on by SBC_2 signal from MPU. In the same way, IC12 (33C) and IC6 (50C) are turned on by SBC_2. 50C is fed to IC13 (200C). IC13 (200C) is the DC/DC boost converter. The 200C circuit then outputs approximately +20VDC.

SB1 supplies Sub (Display) unit and D-sub 25 with +B voltage. SB2 supplies Audio power amplifier (IC911) and 9V AVR (IC15) with +B voltage. Then IC15 regulates +B to 9V (90C). Then IC16 regulates 90C to 5V (50CT). If the MPU controls TXC, ANT SW and ASSW signals to High, Q15, Q16 (90T), Q17, Q18 (90ANT) and Q14 are turned on and transmission circuits are enabled to transmit. If the MPU controls RXC signal to High, IC17 (50R) is turned on and reception circuits are enabled to receive.

When the Power management IC and MPU detect /PSW signal (Power switch), /IGN signal (Ignition sense) and /BINT signal, they set the SBC_2 signal to Low, and turn the transceiver power off.

When D1, Q4 detect over-voltage condition, they turn SB1 and SB2 off, and transfer that the MPU through IC2.

2.4.8 Signaling Circuit

2.4.8.1 Encode (QT/DQT/DTMF/2-tone/MSK)

Each signaling data signal of QT, DQT, DTMF, 2-tone and MSK is generated by IC706, superposed on a modulation signal and output to TX VCO and PLL IC.

2.4.8.2 Decode (QT/DQT/DTMF/2-tone/MSK)

The audio signal is removed from the FM detection signal sent to the IC706 and the resulting signal is decoded by IC706.

2.4.9 Bluetooth/GPS Circuit

The main component of the Bluetooth/GPS circuit is Bluetooth / GPS IC (IC5) on BT/GPS unit.

The clocks of Bluetooth/GPS IC require 19.2MHz for core and 32.768kHz slow clock (X1 and X2) for UART.

Bluetooth/GPS IC communicates to the OMAP processor (IC706) on the HCI UART. Interface of UART & Digital audio (PCM) between the OMAP processor (IC706) and the Bluetooth/GPS IC (IC5), have level conversion at the level shift IC (IC6 and IC7) on BT/GPS unit. The Bluetooth/GPS IC is powered by 1.8V and 3.3V which are supplied from 2 discrete external regulators (IC2 and IC3) on BT/GPS unit.

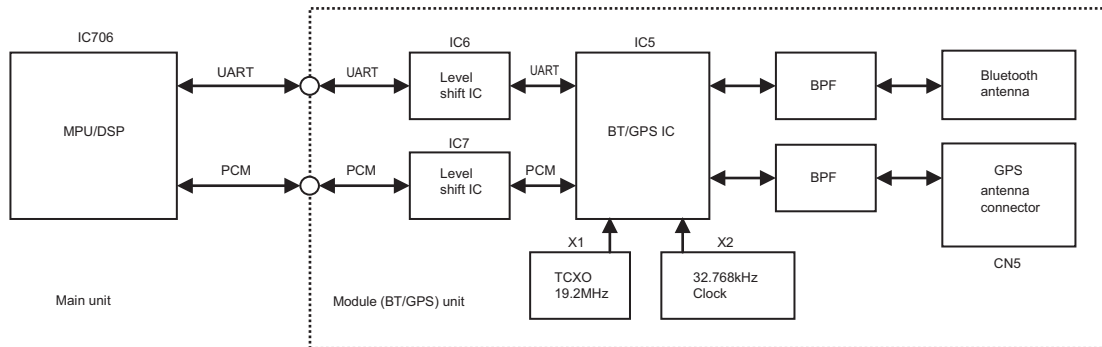

Fig.5 Bluetooth/GPS circuit

2.4.9.1 Bluetooth Circuit

The Bluetooth / GPS IC (IC5) support Bluetooth 3.0 up to HCI level.

TX/RX frequency is 2400-2483.5MHz (79ch Hopping, 2402-2480MHz, 1MHz step). Transmitting power is +2dBm at Bluetooth antenna input.

Using the printed antenna with Bluetooth, and connected to the Bluetooth / GPS IC (IC5) through the saw filter (L11).

Frequency configuration for Bluetooth is following:

There are two LO modes: 2X and Offset LO (OSLO). 2X where LO is $2 * RF_FREQ$ (e.g. when transmitting at 2441MHz it is at 4882MHz). OSLO where LO is at $(2/3) * RF_FREQ$ (e.g. when transmitting at 2441MHz it is at 1627.333MHz).

In RX the 2X is always used.

In GFSK TX if power is $>10\text{dBm}$ then OSLO is used

In EDR2 TX if power is $>-12\text{dBm}$ then OSLO is used

In EDR3 TX if power is $>-12\text{dBm}$ then OSLO is used

Otherwise 2X is used for TX as well.

2.4.9.2 GPS Circuit

The GPS RF signal is received with the active antenna, and connected to the Bluetooth / GPS IC (IC5) through the terminal (CN5) and saw filter (L9).

The output is passed to pin L2 of the GPS IC. The input match for pin L2 comprises of C38, C36 and L7.

The control and data lines for the GPS IC are GPS_PA_EN, BTFM_nSHUTDOWN, GPS_TX and GPS_RX.

GPS_TX and GPS_RX are shared with Bluetooth data line.

Frequency configuration for GPS is following: Lo is GPS: 1571.324MHz

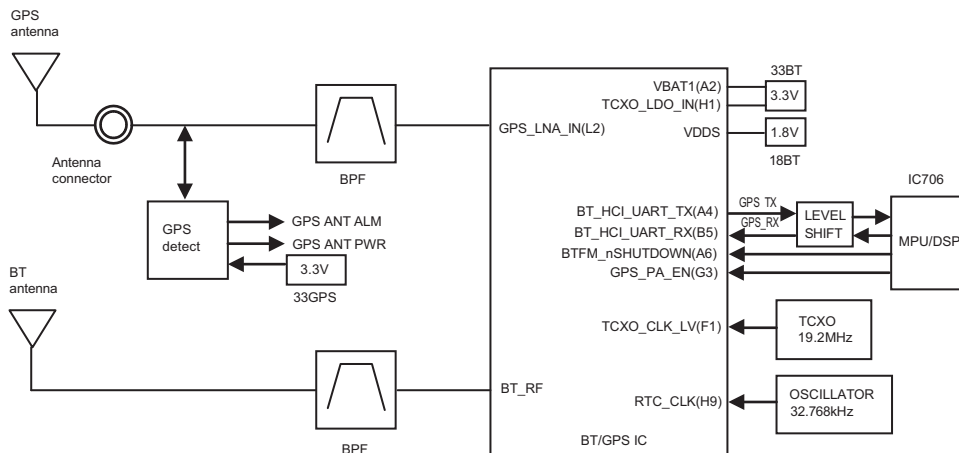

Fig.6 GPS circuit

2.5 COMPONENTS DESCRIPTION

2.5.1 Main unit (XC1-0391-81)

Ref.No	Part Name	Description
IC1	IC	Voltage regulator (31BU)
IC2	IC	Power management
IC3	IC	Voltage regulator (12BU)
IC4	IC	Voltage regulator (33A)
IC5	IC	Voltage regulator (33M)
IC6	IC	Voltage regulator (50C)
IC7	IC	Voltage regulator (33SD)
IC8	IC	DC/DC Converter (54M)
IC9	IC	Load SW (18M 3)
IC10	IC	Voltage regulator (50A)
IC11	IC	DC/DC Converter (18M)
IC12	IC	Voltage regulator (33C)
IC13	IC	DC/DC Converter (200C)
IC14	IC	Voltage regulator (33OPT)
IC15	IC	Voltage regulator (90C)
IC16	IC	Voltage regulator (50CT)
IC17	IC	Voltage regulator (50R)
IC18	IC	Reset
IC100	IC	PLL IC
IC101	IC	Schmitt trigger
IC102	IC	DC AMP (CV/Assist)
IC300	IC	TX pre-drive AMP
IC301, 303	IC	APC
IC304	IC	TX power control
IC500	IC	RX 1st mixer
IC501	IC	DC AMP (CV/Assist)
IC600	IC	IF IC
IC700	IC	Level shift
IC701	IC	Flash memory
IC702	IC	Mobile DDR
IC703	IC	Clock buffer
IC704, 705	IC	Logic control
IC706	IC	MPU/DSP
IC707, 708	IC	Analog SW
IC709, 710	IC	Logic control
IC711	IC	I/O expander
IC712	IC	A/D converter
IC714	IC	Analog SW
IC715	IC	D/A converter
IC719	IC	D/A converter
IC720	IC	Reset
IC900	IC	Logic control
IC901	IC	DC AMP (25REF/VREF)
IC903	IC	AF AMP

Ref.No	Part Name	Description
IC902	IC	Codec
IC904	IC	Logic control
IC905	IC	Buffer AMP (BER CK/BER DT)
IC906	IC	Level shift
IC907	IC	Analog SW
IC908	IC	Schmitt trigger
IC909	IC	RS-232C driver
IC910	IC	I/O expander
IC912	IC	Logic control
Q1	Transistor	DC SW (SCTAM1)
Q3	FET	DC SW
Q4	Transistor	DC SW
Q5	FET	DC SW (SB1)
Q6, 7	Transistor	DC SW
Q8, 9	Transistor	Voltage regulator (50BU)
Q10	FET	DC SW (SB2)
Q11	Transistor	DC SW
Q12	FET	DC SW
Q14	FET	DC SW
Q15	Transistor	DC SW
Q16	FET	DC SW (90T)
Q17	Transistor	DC SW
Q18	FET	DC SW (90ANT)
Q81	FET	T/R SW
Q100	Transistor	DC SW (fin filter)
Q101	FET	DC SW
Q102	Transistor	DC SW (fin filter)
Q103	FET	DC SW
Q104	Transistor	Ripple filter
Q105	FET	VCO oscillation
Q106	Transistor	Fin AMP
Q107	FET	VCO oscillation
Q108	FET	DC SW
Q109	FET	T/R SW (VCO)
Q110, 111	Transistor	Buffer AMP
Q112	FET	DC SW
Q300	FET	TX drive AMP
Q301~303	Transistor	DC SW
Q304, 305	FET	DC SW
Q500	Transistor	RX local AMP
Q502	Transistor	LNA
Q600	FET	VCO oscillation
Q601	Transistor	DC SW
Q602	Transistor	Ripple filter
Q603	Transistor	IF AMP
Q604	FET	IF AMP

Ref.No	Part Name	Description
Q700	Transistor	TCXO buffer
Q701	FET	DC SW
Q703, 704	FET	DC SW
Q705	Transistor	DC SW
Q900, 901	FET	Audio mute
Q902	Transistor	DC SW
Q905, 906	FET	Audio mute
Q907, 908	FET	DC SW
D1	Zener diode	Overvoltage protection
D2	Diode	Reverse current prevention
D3	Zener diode	Overvoltage protection
D4	Diode	Reverse current prevention
D5	Surge absorber	Surge protection
D6	Diode	Backup battery charge
D7~10	Diode	Reverse current prevention
D11	Zener diode	Voltage regulator (50BU)
D12, 13	Diode	Reverse current prevention
D14	Diode	DC/DC converter (54M)
D15	Diode	DC/DC converter (200C)
D100	Zener diode	Overvoltage protection
D101, 102	Diode	T/R SW (fin filter)
D103, 104	Variable capacitance diode	VCO frequency control
D105~112	Variable capacitance diode	VCO assist tune
D113	Diode	Speed up
D114, 115	Diode	T/R SW (fin filter)
D117	Variable capacitance diode	TX modulation
D300	Diode	T/R SW
D301	Diode	Reverse current prevention
D302	Zener diode	Overvoltage protection
D307	Zener diode	Overvoltage protection
D309	Diode	TX Reverse power detection
D310~315	Diode	Antenna SW
D500	Diode	T/R SW
D501~507	Variable capacitance diode	RX band-pass filter tune
D508, 509	Diode	Overvoltage protection
D600, 601	Variable capacitance diode	VCO frequency control
D602	Diode array	Overvoltage protection
D700, 701	Diode	Reverse current prevention
D702~706	Varistor	Line protection
D708	Zener diode	Overvoltage protection
D801	Diode	Reverse current prevention
D900	Diode array	External speaker detection

Ref.No	Part Name	Description
D903	Zener diode	Overvoltage protection
D904	Diode array	Line protection
D905	Diode	Line protection
D906	Zener diode	Overvoltage protection
D907	Diode	Reverse current prevention
D908	Diode array	Line protection
D909	Diode array	External speaker detection
D910~915	Diode array	Line protection
D916	Diode	Reverse current prevention
D917	Zener diode	Overvoltage protection
D918~920	Diode array	Line protection
D921	Diode	Reverse current prevention
D922	Zener diode	Overvoltage protection
D923	Diode array	Line protection
D924	Diode	Reverse current prevention

2.5.2 Module (BT/GPS) unit (XC2-0031-80)

Ref.No	Part Name	Description
IC1	IC	Level converter
IC2	IC	Voltage regulator (18BT)
IC3	IC	Voltage regulator (33BT)
IC4	IC	Voltage regulator (33GPS)
IC5	IC	GPS/Bluetooth
IC6, 7	IC	Level converter
Q1	FET	DC SW

2.5.3 SUB (Display) unit (XC3-0020-20) (Only NX-5800)

Ref.No	Part Name	Description
IC1	IC	Voltage regulator (50M)
IC2	IC	Voltage regulator (30LCD)
IC3	IC	Logic control
IC4	IC	Analog SW
IC6	IC	Illuminance sensor
IC8	IC	LED driver
IC9	IC	Logic control
IC10	IC	I/O expander
IC12	IC	Logic control
Q2	FET	DC SW
Q3, 4	Transistor	DC SW
Q6	Transistor	DC SW
D1, 2	Zener diode	Overvoltage protection
D4~7	LED	LED
D9~12	LED	LED
D14~16	LED	LED
D20	Zener diode	Overvoltage protection
D21	LED	LED
D22	Diode	Overvoltage protection

Ref.No	Part Name	Description
D23, 24	Zener diode	Overvoltage protection
D25	Varistor	Surge protector
D26~32	Zener diode	Overvoltage protection

2.6 TERMINAL FUNCTION

2.6.1 Main unit (XC1-0391-81)

Pin No.	Name	I/O	Function
CN4 (Ignition)			
1	IGN	I	Ignition sense input
2	GND	-	Ground
CN731 (for production)			
1~20	-	-	-
CN735 (to Module (BT/GPS) unit CN1)			
1	GPS_PWR	I	Antenna power supply detection
2	GPS_ALM	I	Antenna open/short detection
3	GND	-	Ground
4	GND	-	Ground
5	GPS_ANT_SW	O	Enable signal for 33GPS
6	GPS_PA_EN	O	GPS receiver part switching signal output
7	BT_SHUTDOWN	O	Shutdown signal output
8	WCLK	O	Audio serial data bus word clock output
9	BCLK	O	Audio serial data bus bit clock output
10	BT_AUD_DI	I	Audio signal input
11	BT_AUD_DO	O	Audio signal output
12	RTS2	O	Serial data output
13	CTS2	I	Serial data input
14	G_RXD2	I	Serial data input
15	G_TXD2	O	Serial data output
16	BT_SW	O	Enable signal for 33BT and 18BT
17	GND	-	Ground
18	GND	-	Ground
19	54M	O	5.4V output
20	54M	O	5.4V output
CN749 (to Sub (Display) unit CN6)			
1	NC (IGN)	-	No connection (Ignition sense input)
2	NC	-	No connection
3	GND	-	Ground
4	54M	O	5.4V output
5	GND	-	Ground
6	GND	-	Ground
7	18M	O	1.8V output
8	D[15]	I/O	LCD driver data output
9	D[14]	I/O	LCD driver data output

Pin No.	Name	I/O	Function
10	D[13]	I/O	LCD driver data output
11	D[12]	I/O	LCD driver data output
12	D[11]	I/O	LCD driver data output
13	D[10]	I/O	LCD driver data output
14	D[9]	I/O	LCD driver data output
15	D[8]	I/O	LCD driver data output
16	D[7]	I/O	LCD driver data output
17	D[6]	I/O	LCD driver data output
18	D[5]	I/O	LCD driver data output
19	D[4]	I/O	LCD driver data output
20	D[3]	I/O	LCD driver data output
21	D[2]	I/O	LCD driver data output
22	D[1]	I/O	LCD driver data output
23	D[0]	I/O	LCD driver data output
24	/CS_LCD	O	LCD driver chip-select signal
25	DC	O	LCD driver data/command switch signal
26	/WR_LCD	O	LCD driver WR signal
27	/RD_LCD	O	LCD driver RD signal
28	PRST	O	LCD driver reset signal
29	/KEYINT	I	Key state change signal
30	I2CCK	O	I2C serial clock
31	I2CDT	I/O	I2C serial data
32	GND	-	Ground
33	USB_D-	I/O	USB0 PHY data minus
34	USB_D+	I/O	USB0 PHY data plus
35	GND	-	Ground
36	33M	O	3.3V output
37	DM/KVL	I/O	MIC data detection
38	GND	-	Ground
39	RXD	I	Serial data input
40	TXD	O	Serial data output
41	/PTT	I	PTT input
42	/PSW	I	Detection signal input of power switch
43	AFO+	O	AF signal output plus
44	AFO-	O	AF signal output minus
45	MIC	I	MIC signal input
46	ME	-	MIC ground
47	R_SET2	I	Radio setting signal 2
48	R_SET1	I	Radio setting signal 1
49	R_SET0	I	Radio setting signal 0
50	GND	-	Ground
CN900 (to Sub (Display) unit CN2)			
1	SPO	O	Speaker output
2	SPG	-	Speaker ground
3	GND	-	Ground

Pin No.	Name	I/O	Function
4	SB1	O	Switched power supply
CN906 (to Main unit B/2 CN907)			
1	NC	-	No connection
2~7	SB1	O	Switched power supply
8	AFO	O	RX filtered AF signal out
9	DI	I	Data signal input
10	50A	O	5V output
11	GND	-	Ground
12	DEO	O	RX detected signal output
13	MI2	I	External MIC signal input
14	ME	-	MIC ground
15	GND	-	Ground
16	RXD0	I	Serial data input 0
17	AUXO2	O	AUX output2
18	TXD0	O	Serial data output 0
19	AUXO1	O	AUX output1
20	AUXIO9	I/O	AUX input/output 9
21	AUXIO5	I/O	AUX input/output 5
22	AUXIO8	I/O	AUX input/output 8
23	AUXIO4	I/O	AUX input/output 4
24	TXD2	O	Serial data output 2
25	AUXIO3	I/O	AUX input/output 3
26	RXD2	I	Serial data input 2
27	AUXIO2	I/O	AUX input/output 2
28	AUXIO1	I/O	AUX input/output 1
29	AUXIO7	I/O	AUX input/output 7
30	AUXIO6	I/O	AUX input/output 6
CN907 (to Main unit A/2 CN906)			
1	AUXIO6	I/O	AUX input/output 6
2	AUXIO7	I/O	AUX input/output 7
3	AUXIO1	I/O	AUX input/output 1
4	AUXIO2	I/O	AUX input/output 2
5	RXD2	O	Serial data output 2
6	AUXIO3	I/O	AUX input/output 3
7	TXD2	I	Serial data input 2
8	AUXIO4	I/O	AUX input/output 4
9	AUXIO8	I/O	AUX input/output 8
10	AUXIO5	I/O	AUX input/output 5
11	AUXIO9	I/O	AUX input/output 9
12	AUXO1	I	AUX input1
13	TXD0	I	Serial data input 0
14	AUXO2	I	AUX input2
15	RXD0	O	Serial data output 0
16	GND	-	Ground
17	ME	-	MIC ground
18	MI2	O	External MIC signal output

Pin No.	Name	I/O	Function
19	DEO	I	RX detected signal input
20	GND	-	Ground
21	50C	I	5V input
22	DI	O	Data signal output
23	AFO	I	RX filtered AF signal in
24~29	SB1	I	Switched power supply
30	NC	-	No connection
CN910			
1	SB2	O	Switched power supply
2	SPI	O	Speaker output
3	SPO	I	Speaker input
4	PA	O	Control signal of Public address function
5	HOR	O	Control signal of Horn alert function
6	GND	-	Ground
J700 (microSD)			
1	DAT2	I/O	Data2
2	CD/DAT3	I/O	Data3
3	CMD	I/O	Command input/output
4	VDD	O	3.3V output
5	CLK	O	Clock output
6	VSS	-	Ground
7	DAT0	I/O	Data0
8	DAT1	I/O	Data1
9	CD	I	Card detect switch
10	COMMON	-	Ground
11	GND1	-	Ground
12	GND2	-	Ground
J901 (ACC. D-Sub 25-pin)			
1	NC	-	Refer to "D-sub 25-pin connector specification".
2	RXD1	I	
3	TXD1	O	
4	AUXIO9	I/O	
5	DI	I	
6	MI2	I	
7	GND	-	
8	AUXIO8	I/O	
9	TXD2	O	
10	RXD2	I	
11	GND	-	
12	AUXIO7	I/O	
13	AUXIO6	I/O	

Pin No.	Name	I/O	Function
14	SB	-	Refer to "D-sub 25-pin connector specification".
15	AUXO2	O	
16	AUXO1	O	
17	AFO	O	
18	GND	-	
19	DEO	O	
20	AUXIO5	I/O	
21	AUXIO4	I/O	
22	AUXIO3	I/O	
23	AUXIO2	I/O	
24	AUXIO1	I/O	
25	ME	-	

2.6.2 Module (BT/GPS) unit (XC2-0031-80)

Pin No.	Name	I/O	Function
CN1(to Main unit A/2 CN735)			
1	54M	I	5.4V input
2	54M	I	5.4V input
3	GND	-	Ground
4	GND	-	Ground
5	BT_SW	I	Enable signal for 33BT and 18BT
6	G_TXD2	I	Serial data input
7	G_RXD2	O	Serial data output
8	CTS2	O	Serial data output
9	RTS2	I	Serial data input
10	BT_AUD_DO	I	Audio signal input
11	BT_AUD_DI	O	Audio signal output
12	BCLK	I	Audio serial data bus bit clock input
13	WCLK	I	Audio serial data bus word clock input
14	BT_SHUTDOWN	I	Shutdown signal input
15	GPS_PA_EN	I	GPS receiver part switching signal input
16	GPS_ANT_SW	I	Enable signal for 33GPS
17	GND	-	Ground
18	GND	-	Ground
19	GPS_ALM	O	Antenna open/short detection
20	GPS_PWR	O	Antenna power supply detection

2.6.3 Sub (Display) unit (XC3-0020-20)

Pin No.	Name	I/O	Function
CN2 (to Main unit A/2 CN900)			
1	SP+	I	Speaker output
2	SPG	-	Speaker ground
3	GND	-	Ground

Pin No.	Name	I/O	Function
4	SB	I	Switched power supply
CN4 (LCD)			
1	VSSA	-	Ground
2	VSSA	-	Ground
3	VSSA	-	Ground
4	VCC	O	3V output
5	VCC	O	3V output
6	VSSD	-	Ground
7	VSSD	-	Ground
8	VSSD	-	Ground
9	IOVCC	O	1.8V output
10	IOVCC	O	1.8V output
11	RDX	O	LCD driver RD signal
12	WRX	O	LCD driver WR signal
13	DCX	O	LCD driver data/command switch signal
14	CSX	O	LCD driver chip-select signal
15	DB1	I/O	LCD driver data output
16	DB2	I/O	LCD driver data output
17	DB3	I/O	LCD driver data output
18	DB4	I/O	LCD driver data output
19	DB5	I/O	LCD driver data output
20	DB6	I/O	LCD driver data output
21	DB7	I/O	LCD driver data output
22	DB8	I/O	LCD driver data output
23	DB10	I/O	LCD driver data output
24	DB11	I/O	LCD driver data output
25	DB12	I/O	LCD driver data output
26	DB13	I/O	LCD driver data output
27	DB14	I/O	LCD driver data output
28	DB15	I/O	LCD driver data output
29	DB16	I/O	LCD driver data output
30	DB17	I/O	LCD driver data output
31	CABC	-	No connection
32	RESX	O	LCD driver reset signal
33	IM0	O	Interface mode select
34	LEDA	O	54M output (LED light anode)
35	LED1	I	LED light cathode 1
36	LED2	I	LED light cathode 2
37	LED3	I	LED light cathode 3
38	LED4	-	No connection
CN5 (Internal speaker)			
1	SPG	-	Speaker ground
2	SP+	O	Speaker output
CN6 (to Main unit A/2 CN749)			
1	GND	-	Ground

Pin No.	Name	I/O	Function
2	R_SET0	O	Radio setting signal 0
3	R_SET1	O	Radio setting signal 1
4	R_SET2	O	Radio setting signal 2
5	ME	-	MIC ground
6	MIC	O	MIC signal output
7	AFO-	I	AF signal input minus
8	AFO+	I	AF signal input plus
9	/PSW	O	Detection signal input of power switch
10	/PTT	O	PTT output
11	TXD	I	Serial data input
12	RXD	O	Serial data output
13	GND	-	Ground
14	DM/KVL	I/O	MIC data detection
15	33M	I	3.3V input
16	GND	-	Ground
17	USB_D+	I/O	USB0 PHY data plus
18	USB_D-	I/O	USB0 PHY data minus
19	GND	-	Ground
20	I2CDT	I/O	I2C serial data
21	I2CCK	I	I2C serial clock
22	/KEYINT	O	Key state change signal
23	PRST	I	LCD driver reset signal
24	/RD_LCD	I	LCD driver Read signal
25	/WR_LCD	I	LCD driver Write signal
26	DC	I	LCD driver data/command switch signal
27	/CS_LCD	I	LCD driver chip-select signal
28	D[0]	I/O	LCD driver data input
29	D[1]	I/O	LCD driver data input
30	D[2]	I/O	LCD driver data input
31	D[3]	I/O	LCD driver data input
32	D[4]	I/O	LCD driver data input
33	D[5]	I/O	LCD driver data input
34	D[6]	I/O	LCD driver data input
35	D[7]	I/O	LCD driver data input
36	D[8]	I/O	LCD driver data input
37	D[9]	I/O	LCD driver data input
38	D[10]	I/O	LCD driver data input
39	D[11]	I/O	LCD driver data input
40	D[12]	I/O	LCD driver data input
41	D[13]	I/O	LCD driver data input
42	D[14]	I/O	LCD driver data input
43	D[15]	I/O	LCD driver data input
44	18M	I	1.8V input
45	GND	-	Ground
46	GND	-	Ground

Pin No.	Name	I/O	Function
47	54M	I	5.4V input
48	GND	-	Ground
49	NC	-	No connection
50	NC (IGN)	-	No connection (Ignition sense input)
J1 (MIC jack)			
1	DM/KVL_3	I/O	MIC data detection
2	HOOK/RXD/D-2	I/O	Hook detection / Serial data input / USB PHY data minus
3	MIC_3	I	MIC signal input
4	ME_3	-	MIC ground
5	PTT/TXD_3	I/O	PTT input / Serial data output
6	GND	-	Ground
7	SB_2	O	Switched power supply
8	BLC_4/D+2	I/O	Back light control signal / USB PHY data plus

2.6.4 D-Sub 25-pin connector specification

Pin No.	Pin Name	I/O	Signal Type	Rating and Condition				
				Parameter	Min	Typ	Max	Unit
1	NC	-	-	-				
2	RXD1	I	Digital	Input Voltage Range	-30		30	V
				Threshold Low	0.5	1.3		V
				Threshold High		1.6	2.45	V
				Baud Rate	-		300k	bps
				CL		100		pF
3	TXD1	O	Digital	Voltage Swing (3kΩ Load)	±5	±5.2		V
				Baud Rate	-		300k	bps
				CL		100		pF
4	AUXIO9	I/O	Digital	VIH	4	-	5.2	V
				VIL	-0.5	-	1	V
				VOH (I _o =-1.5mA)	4	-	5.2	V
				VOL (I _o =1.5mA)	-	-	1.1	V
	CTS (RS-232C)	I	Digital	Input Voltage Range	-30		30	V
				Threshold Low	0.5	1.3		V
				Threshold High		1.75	2.6	V
5	DI	I	Analog	Input Voltage range (STD Deviation)	-	0.5	-	Vp-p
				Freq Response (STD Dev.) 20~9600Hz	-3		3	dB
	RTS (RS-232C)	O	Digital	Voltage Swing (3kΩ Load)	±5	±5.2		V
6	MI2	I	Analog	Audio Level (STD Deviation)	-	5	-	mVrms
				Allowable Freq	300		3000	Hz
				Input Impedance	-	600	-	Ω
7	GND	-	GND					
8	AUXIO8	I/O	Digital	VIH	4	-	5.2	V
				VIL	-0.5	-	1	V
				VOH (I _o =-1.5mA)	4	-	5.2	V
				VOL (I _o =1.5mA)	-	-	1.1	V
9	TXD2	O	Digital	VOH (I _o =-1.5mA)	3.7	-	5.2	V
				VOL (I _o =1.5mA)	-	-	1.1	V
				CL		100		pF
10	RXD2	I	Digital	VIH	2.8	-	5.2	V
				VIL	-	-	0.65	V
				CL		100		pF
11	GND	-	GND					
12	AUXIO7	I/O	Digital	VIH	4	-	5.2	V
				VIL	-0.5	-	1	V
				VOH (I _o =-1.5mA)	3.7	-	5.2	V
				VOL (I _o =1.5mA)	-	-	1.1	V
13	AUXIO6	I/O	Digital	VIH	4	-	5.2	V
				VIL	-0.5	-	1	V
				VOH (I _o =-1.5mA)	3.7	-	5.2	V
				VOL (I _o =1.5mA)	-	-	1.1	V

Pin No.	Pin Name	I/O	Signal Type	Rating and Condition				
				Parameter	Min	Typ	Max	Unit
14	SB	-	Power	Voltage	This parameter depends on Battery Voltage			
				Supply Current	-	-	2	A
15	AUXO2	O	Digital	The type of this port is open collector.				
				VOL			0.4	V
				IOL			-500	mA
16	AUXO1	O	Digital	The type of this port is open collector.				
				VOL			0.4	V
				IOL			-500	mA
17	AFO	O	Analog	Output Level		0.7		Vp-p
				Coupling Capacitor		10		uF
				allowable Load	100	-	-	kΩ
				allowable freq	300		3000	Hz
18	GND	-	GND					
19	DEO	O	Analog	Output Level	-	0.28	-	Vp-p
				Coupling Capacitor	-	10	-	uF
				allowable Load	47	-	-	kΩ
				Frequ. Response (STD Dev) Wide 20~4800Hz	-6		1	dB
				4800~7200Hz	-24		1	dB
				Narrow 20~4800Hz	-15		1	dB
20	AUXIO5	I/O	Digital	VIH	4	-	5.2	V
				VIL	-0.5	-	1	V
				VOH (Io=-1.5mA)	4	-	5.2	V
				VOL (Io=1.5mA)	-	-	1.1	V
21	AUXIO4	I/O	Digital	VIH	4	-	5.2	V
				VIL	-0.5	-	1	V
				VOH (Io=-1.5mA)	4	-	5.2	V
				VOL (Io=1.5mA)	-	-	1.1	V
22	AUXIO3	I/O	Digital	VIH	4	-	5.2	V
				VIL	-0.5	-	1	V
				VOH (Io=-1.5mA)	4	-	5.2	V
				VOL (Io=1.5mA)	-	-	1.1	V
23	AUXIO2	I/O	Digital	VIH	4	-	5.2	V
				VIL	-0.5	-	1	V
				VOH (Io=-1.5mA)	4	-	5.2	V
				VOL (Io=1.5mA)	-	-	1.1	V
24	AUXIO1	I/O	Digital	VIH	4	-	5.2	V
				VIL	-0.5	-	1	V
				VOH (Io=-1.5mA)	4	-	5.2	V
				VOL (Io=1.5mA)	-	-	1.1	V
25	ME	-	Analog	This is GND port for Microphone.				

SECTION 3 DISASSEMBLY

3.1 Precautions for Disassembly

3.1.1 Main PCB (Main unit A/2) disassembly

- (1) Remove all screws and antenna terminals on the Main PCB.
- (2) Rotate the bush of the power supply cable 90 degrees counterclockwise as viewed from the rear of the chassis <1> and remove the power supply cable from the chassis <2>.
- (3) When the speaker phone jack is pushed up, using your finger, from the rear of the chassis <3>, the Main PCB is removed from the chassis.

Note:

The Main PCB and D-sub PCB (Main unit B/2) are connected with a flat cable.

Remove them carefully.

- (4) Turn the Main PCB over and remove the flat cable from the connector (CN906). <4>
- (5) Remove the Main PCB from the chassis.

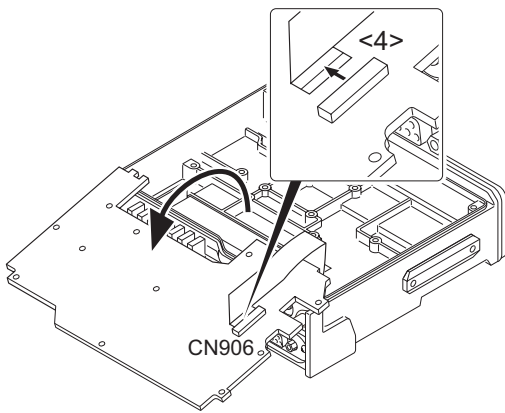
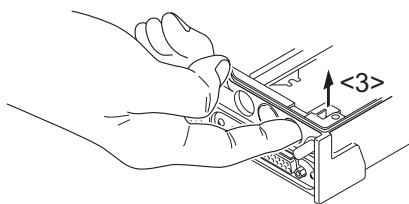
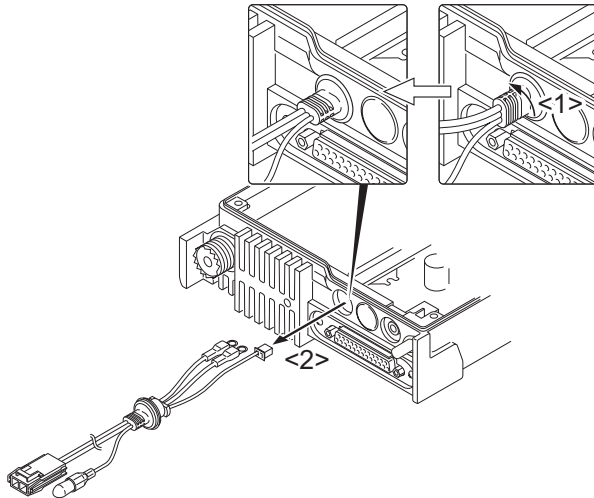

3.1.2 Removing the speaker hardware fixture (J2B-0023-00) and holder (J1K-0019-00)

- (1) Remove the speaker lead from the holder hook. <1>
- (2) Remove the speaker connector from the display unit connector (CN5). <2>
- (3) When removing the speaker hardware fixture, insert a flat-head screwdriver at the position shown in Figure 2-1 and tilt it in the direction shown by the arrow. <3>
- (4) To remove the holder, insert a flat-head screwdriver into tab of the holder and tilt it in the direction shown by the arrow. <4>

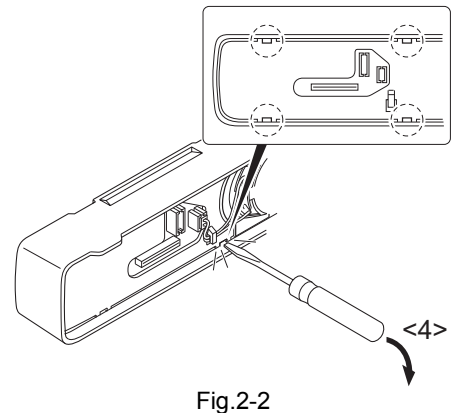
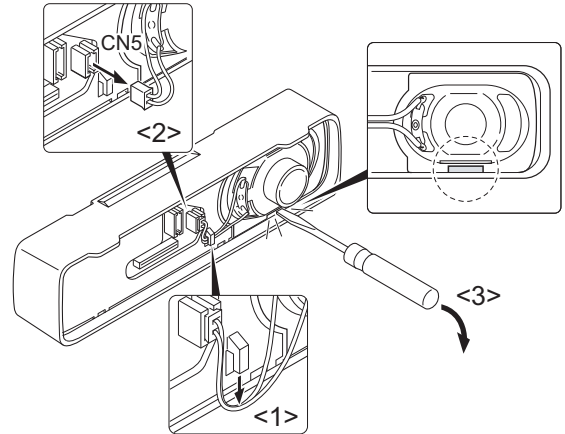

3.2 Precautions for Reassembly

3.2.1 Main PCB (Main unit A/2) reassembly

- (1) With the Main PCB turned over, insert the flat cable from the D-sub PCB (Main unit B/2) into the connector (CN906) on the Main PCB.
- (2) Place the Main PCB at its original position as shown in Figure 3.

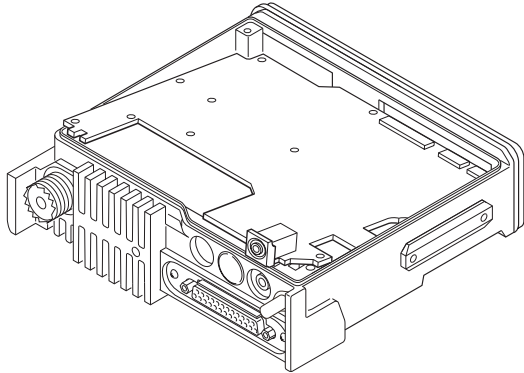

Fig.3

3.2.2 Power supply cable installation procedure

- (1) Pass the power supply cable through the chassis hole <1> as shown in Figure 4-1 and insert the bush into the chassis hole.
- (2) Rotate the bush of the power supply cable 90 degrees clockwise as viewed from the rear of the chassis. <2>
- (3) Align the ignition sense connector (yellow) of the power supply cable around the chemical capacitor (C401) and connect it to the Main unit (A/2) connector (CN4).
- (4) Align the + (positive) terminal of the power supply cable (red) as shown in Figure 4-2 and fix it to the terminal strip with a screw.
- (5) Align the - (negative) terminal of the power supply cable (black) as shown in Figure 4-2 and fix it to the terminal strip with a screw.

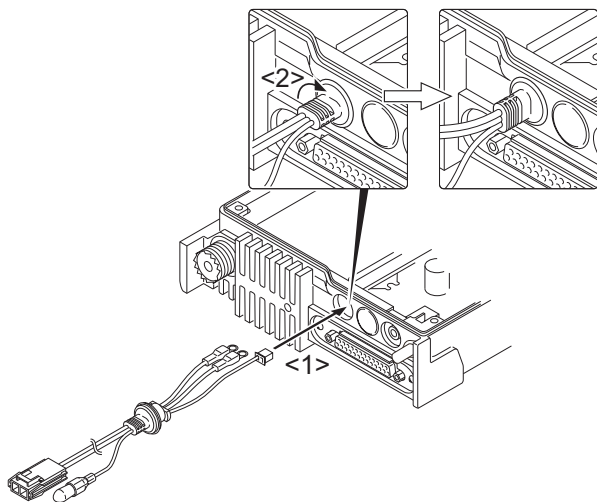

Fig.4-1

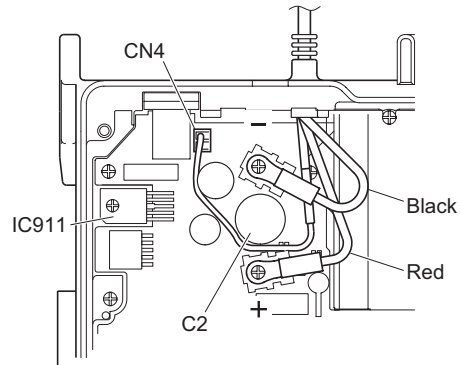
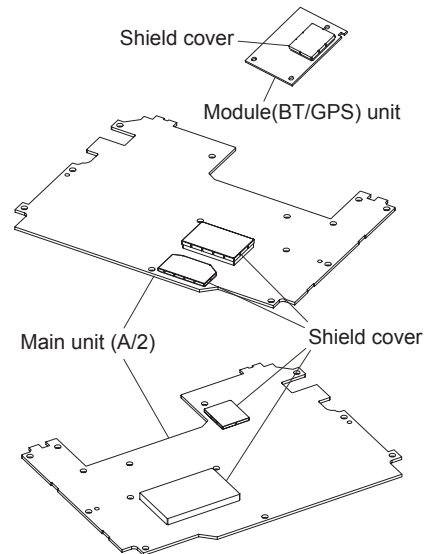

Fig.4-2

3.2.3 Remove the top cover from the shield cover

- (1) There are five shield covers on the Main unit (A/2) and Module (BT/GPS) unit, the top covers can be removed.



- (2) Use tweezers to slightly lift the edge of the top cover. <1>
- (3) As you do step 2 above, vary the position you hold the top cover as you lift it, and remove the top cover <2>.

Note:

Once the top cover is removed, it cannot be used again.

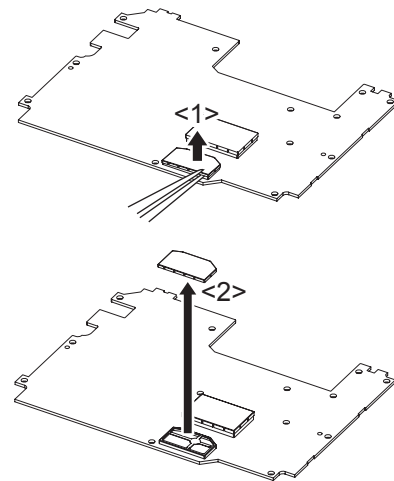

Note:

Push evenly on the top cover and be careful that you do not bend it as you install it on the shield cover.

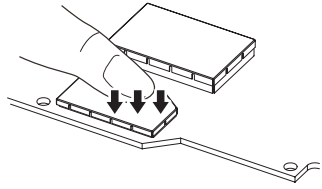

3.2.4 Top packing installation procedure

- (1) Place the top packing over the shielding plate.
- (2) Fit the convex tab of the top packing into the hollow of the chassis. <1>
- (3) Fit the chassis into the groove of the top packing. <2>
Verify that the top packing is in close contact with the chassis.

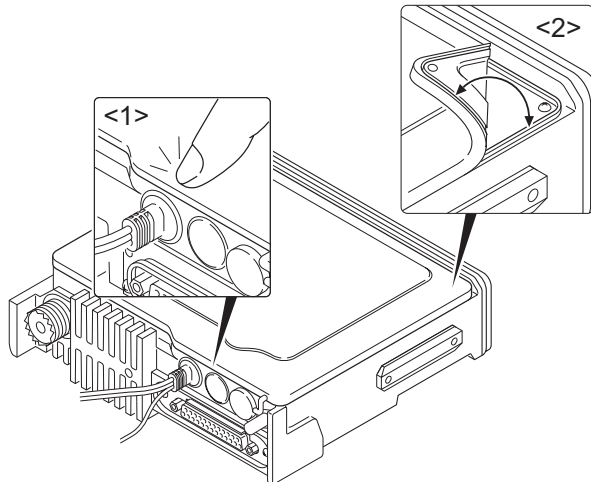

Fig.5

3.2.5 D-sub cap installation procedure

To improve water resistance, fit the D-sub cap into the D-sub terminal hardware fixture of the transceiver in the following order:

- (1) Fit the left side <1> of the D-sub cap into the hardware fixture.
- (2) Fit the right side <2> of the D-sub cap into the hardware fixture.
- (3) Fit the center <3> of the D-sub cap into the hardware fixture.

Verify that the D-sub cap is in close contact with the hardware fixture.

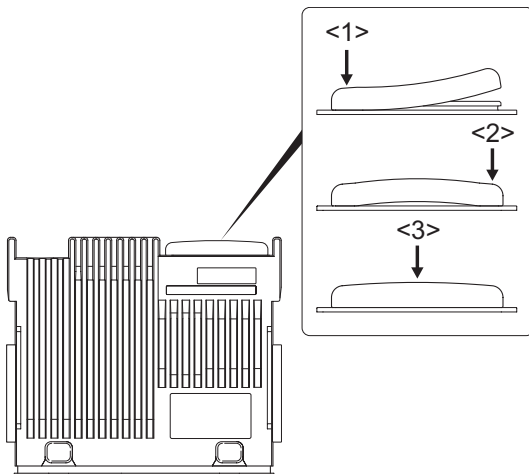

Fig.6

3.2.6 Installing the holder (J1K-0019-00) and speaker hardware fixture (J2B-0023-00)

- (1) Insert two tabs of the holder (J1K-0019-00) into the hollows in the top of the panel. <1>
- (2) Push the two tabs of the holder in on the opposite side of those in step 1 above and fit them into the hollow in the bottom of the panel. <2>

Note:

Push in the holder until it snaps in place.

- (3) Install the speaker holder onto the panel. <3>

Note:

To improve water resistance, fit the panel into the groove of the holder.

- (4) Place the speaker into the speaker holder.

Note:

The speaker must not ride on the holder rib.

- (5) Place the spacer on the speaker.
- (6) Insert the hardware fixture (J2B-0023-00) into the hollow of the panel as shown in Figure 7-3, then push two parts of the hardware fixture and fit it into the hollow of the top of the panel. (Fig. 7-3 <4>)

Note:

Push in the hardware fixture until it snaps in place.

- (7) Insert the speaker connector into the display unit connector (CN5).
- (8) Place the speaker lead on the holder hook.

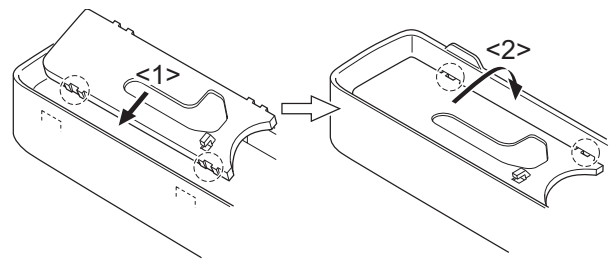

Fig.7-1

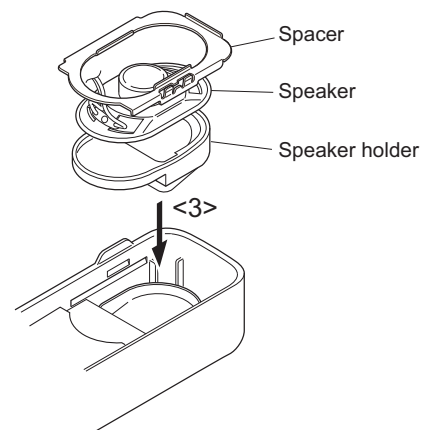

Fig.7-2

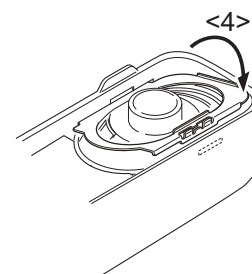
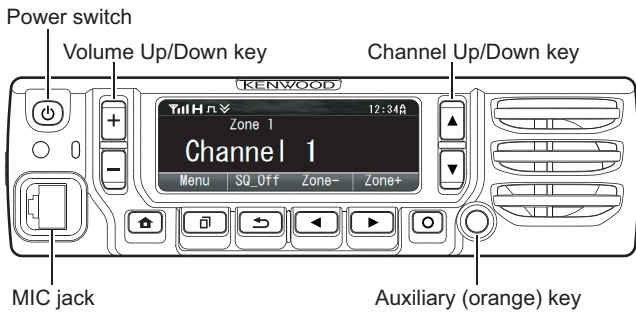

Fig.7-3

SECTION 4 ADJUSTMENT

4.1 Controls



KMC-36 (OPTION)

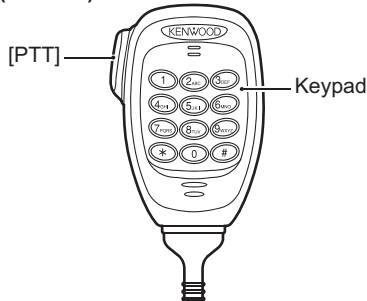

4.1.1 Preparations for checking/tuning the transceiver

Before attempting to check/tune the transceiver, connect the unit to a suitable power supply.

Whenever the transmitter is turned on, the unit must be connected to a suitable dummy load (i.e. power meter).

The speaker output connector must be terminated with an 4Ω dummy load and connected to an AC voltmeter and an audio distortion meter or a SINAD measurement meter at all times during checking/tuning.

4.2 Panel Test Mode

4.2.1 Test mode operation features

This transceiver has a test mode. To enter test mode, press and hold the [↵] key while turning the transceiver power ON. Before the transceiver enters test mode, the frequency version information appears on the LCD momentarily. Test mode can be inhibited by programming. To exit test mode, turn the transceiver power OFF. The following functions are available in test mode.

- When the panel test mode is activated, the last used channel and signaling numbers are displayed. When the panel test mode is activated for the first time, the channel and signaling numbers are 1.
- If test signaling 10 (P25 Phase1), 7 (P25 Phase2) and 7 (NXDN Mode) is selected, the result of Bit Error Rate (BER) calculation is displayed on the LCD.

4.2.2 Key operation

Key	"Func" not appears on the sub LCD display	
	Function	Display
[+]	Push: Volume up Hold: Volume up continuously	-
[-]	Push: Volume down Hold: Volume down continuously	-
[▲]	Push: Test channel up Hold: Test channel up continuously	Channel No.
[▼]	Push: Test channel down Hold: Test channel down continuously	Channel No.
[◀]	Push: Squelch level up *1 Hold: Squelch off	Squelch level Squelch off: [🔊] icon appears
[▶]	Wide/Narrow/ Very Narrow *2	Wide : "w" Narrow: "n" Very Narrow: "v"
[🔊]	Shift to panel tuning mode	-
[↵]	Function on	"Func" appears on the sub LCD display
[○]	MSK 1200bps and 2400bps *1	2400bps: [📧] icon appears
[🏠]	Push: Test signaling up Hold: Test signaling up continuously	Signaling No.
[AUX (Orange)]	-	-
[PTT]	Transmit	-
[0] to [9] and [#], [*]	-	-

*1: When the mode is selected as Analog, this function is enabled.

*2: When the mode is selected as P25, bandwidth is fixed to Narrow.

Key	"Func" appears on the sub LCD display	
	Function	Display
[+]	P25 Modulation Type (C4FM/LSM) *3	LSM : [📡] icon appears
[-]	Function off	-
[▲]	Talk Around on/off	On: [🗣️] icon appears
[▼]	Mode selection Analog/P25 Phase1 /P25 Phase2/NXDN	Analog: "A" P25 Phase1: "P1" P25 Phase2: "P2" NXDN: "N"
[◀]	-	-

Key	"Func" appears on the sub LCD display	
	Function	Display
[▶]	Key/LCD check	The contents of the pressed key etc., appear.
[📶]	High power/Medium power/Low power	High: "H" Medium: "M" Low: "L"
[⏻]	Function off	-
[🔊]	Compander on/off	On: 📶 icon appears
[🔊]	External Speaker on/off	On: 📶 icon appears
[AUX (Orange)]	Function off	-

Key	"Func" appears on the sub LCD display	
	Function	Display
[PTT]	Transmit	-
[0] to [9] and [#], [*]	Function off	-

*3: When the mode is selected as P25, this function is enabled.

- **LED indicator**
Red LED Lights during transmission.
Green LED Lights when there is carrier.
- **Sub LCD indicator**
"Func" Appears at function on.

• LCD display in panel test mode

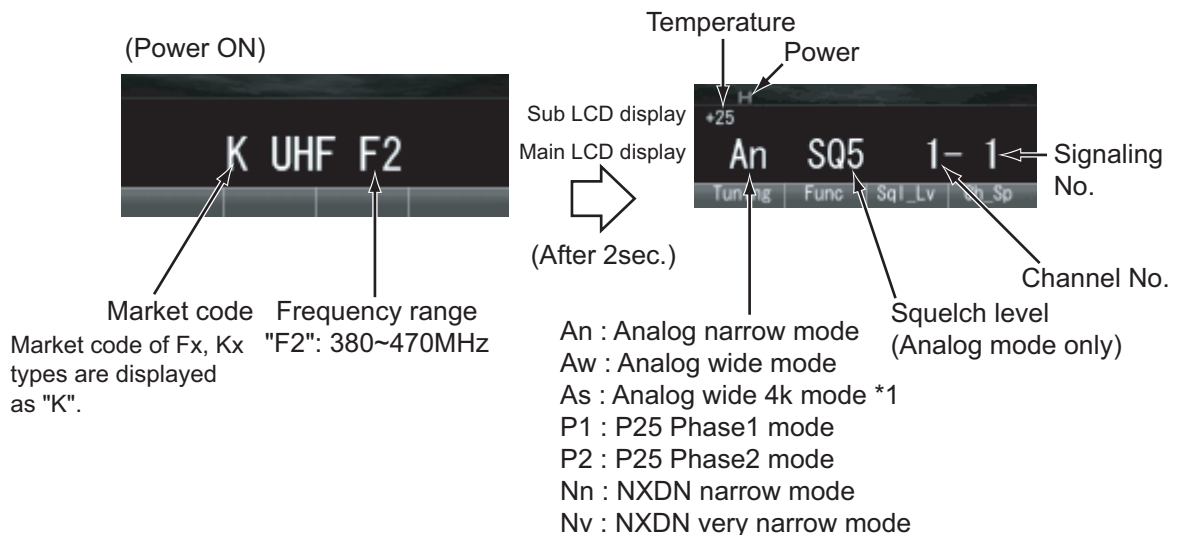

*1: Wide 4k is displayed only when the PC test mode is used. However, it aims at production for factory, or a operation verification of the transceiver. It is not necessary in operation of the transceiver to adjust.

4.2.3 Frequency and Signaling

The transceiver has been adjusted for the frequencies shown in the following table. When required, readjust them following the adjustment procedure to obtain the frequencies you want in actual operation.

(1) Test frequency

CH	RX (MHz)	TX (MHz)
1	425.05000	425.10000
2	380.05000	380.10000
3	469.95000	469.90000
4	425.00000	425.00000
5	425.20000	425.20000
6	425.40000	425.40000
7~16	-	-

(2) Test signaling

■ Analog mode signaling

No.	RX	TX
1	None	None
2	None	Square Wave
3	LTR Data	LTR Data
4	QT:67.0Hz	QT:67.0Hz
5	QT:151.4Hz	QT:151.4Hz
6	QT:210.7Hz	QT:210.7Hz
7	QT:254.1Hz	QT:254.1Hz
8	DQT:D023N	DQT:D023N
9	DQT:D754I	DQT:D754I
10	DTMF Decode (CODE: 159D)	DTMF Encode (CODE: 159D)
11	None	DTMF Encode (CODE: 9)
12	2-tone Decode (A: 304.7Hz, B: 3106.0Hz)	2-tone Encode (A: 304.7Hz, B: 3106.0Hz)

No.	RX	TX
13	Single Tone Decode (979.9Hz)	Single Tone Encode (979.9Hz)
14	None	Single Tone Encode (1000Hz)
15	None	MSK PN9
16	MSK Decode	MSK Encode

■P25 Phase1 signaling

No.	RX	TX
1	NAC 293	NAC 293
2	NAC 023	NAC 023
3	NAC 5EA	NAC 5EA
4	None	PN9
5	NAC 293	Symbol Rate Pattern
6	NAC 293	1/3 Deviation Pattern
7	NAC 293	0 Continuous Pattern
8	NAC 293	Fidelity Pattern
9	None	FSW+PN9
10	None	1011Hz Tone Test Pattern
11	Tone Pattern	1011Hz Tone Test Pattern
12	Silence Pattern	Silence Pattern
13	Audio Test Pattern	NAC293 + Audio Test Pattern
14	Vocoder Loop	None

■P25 Phase2 signaling

No.	RX	TX
1	STTP-OB-1031-0	STTP-IB1031-1+Audio
2	None	PN9 Phase2
3	STTP-OB-1031-1	Symbol Rate Pattern Phase2
4	STTP-OB-1031-1	1/3 Deviation Pattern Phase2
5	STTP-OB-1031-1	0 Continuous Pattern
6	STTP-OB-1031-1	0 Burst Pattern
7	STTP-OB-1031	Symmetrical STTP-IB1031-1
8	Tone Pattern (Half rate)	STTP-IB1031-1
9	Silence Pattern (Half Rate)	STP-IB-1 + Silence Pattern (Half Rate)
10	Audio Test Pattern (Half Rate)	STTP-IB1031-1 + Audio Test Pattern (Half Rate)
11	Codec Loop	STTP-IB1031-1 + Codec Loop
12	Vocoder Loop (Half Rate)	STTP-IB1031-1 + Vocoder Loop (Half Rate)





■NXDN Mode signaling



No.	RX	TX
1	RAN1	RAN1
2	None	PN9
3	RAN1	Maximum Deviation Pattern
7	FSW + PN9	FSW + PN9
9	Tone Pattern (1031Hz)	Tone Pattern (1031Hz)

RAN: Radio Access Number
 PN9: Pseudo-Random Pattern
 No.7, 9 Item: PC test mode only

4.3 Panel Tuning Mode

4.3.1 Transceiver tuning (To enter tuning mode)



To enter tuning mode, press the [] key while the transceiver is in test mode. Use the [] key to write tuning data through tuning modes, and the []/[] key to adjust tuning requirements (1 to 4096 appears on the LCD).

Use the [] key to select the adjustment item through tuning modes. Use the [] key to adjust 4, 6 or 8 reference level adjustments, and use the [] key to switch between Wide5k/Wide4k/Narrow.

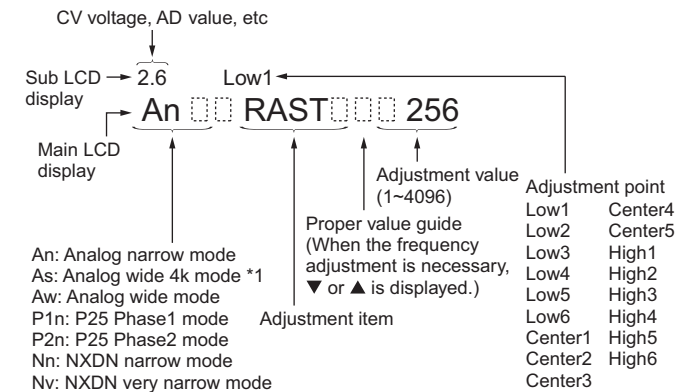
- LCD display in panel tuning mode



4.3.2 Key operation

Key	Function	
	Push	Hold (1 second)
[+]	Volume up	Continuation up
[-]	Volume down	Continuation down
[▲]	Adjustment value up	Continuation up
[▼]	Adjustment value down	Continuation down
[◀]	Auto adjustment start	-
[▶]	Wide/Narrow/P25/NXDN	-
[]	Shift to panel test mode	-
[]	To enter 5,9 or 17 reference level adjustments	-
[○]	Writes the adjustment value	-
[]	Go to next adjustment item	Back to last adjustment item (At the time of 5, 9 or 17 point adjustment: Adjustment point change)
[AUX (Orange)]	Output tone pattern change of balance adjustment (A change is possible only during balance adjustment.)	-
[PTT (MIC)]	Transmit	
[0] to [9] and [#].[*] (MIC)	-	

4.3.3 5, 9 or 17 reference level adjustments frequency

High Maximum Power, Medium Maximum Power, Low Maximum Power, High Transmit Power Limit, Mid Transmit Power Limit, Low Transmit Power Limit, High Transmit Power, Medium Transmit Power, Low Transmit Power, Sensitivity 1, Sensitivity 2, RSSI Reference, Open Squelch, Low RSSI, High RSSI, Tight Squelch

Tuning point	Display	RX (MHz)	TX (MHz)
1	Low 1	380.050000	380.100000
2	Low 5	402.550000	402.600000
3	Center 3	425.050000	425.100000
4	High 2	447.550000	447.600000
5	High 6	469.950000	469.900000

Maximum Deviation, P25 High Deviation, P25 H-CPM Deviation, NXDN High Deviation, QT Deviation, DQT Deviation, LTR Deviation, DTMF Deviation, Single Tone Deviation, MSK Deviation, CW ID Deviation

Tuning point	Display	RX (MHz)	TX (MHz)
1	Low 1	380.050000	380.100000
2	Low 3	391.050000	391.100000
3	Low 5	402.550000	402.600000
4	Center 1	413.550000	413.600000
5	Center 3	425.050000	425.100000
6	Center 5	436.050000	436.100000
7	High 2	447.550000	447.600000
8	High 4	458.550000	458.600000
9	High 6	469.950000	469.900000

Receive Assist, Transmit Assist

Tuning point	Display	RX (MHz)	TX (MHz)
1	Low 1	380.050000	380.100000
2	Low 2	385.550000	385.600000
3	Low 3	391.050000	391.100000
4	Low 4	396.550000	396.600000
5	Low 5	402.550000	402.600000
6	Low 6	408.050000	408.100000
7	Center 1	413.550000	413.600000
8	Center 2	419.050000	419.100000
9	Center 3	425.050000	425.100000
10	Center 4	430.550000	430.600000
11	Center 5	436.050000	436.100000
12	High 1	441.550000	441.600000
13	High 2	447.550000	447.600000
14	High 3	453.050000	453.100000
15	High 4	458.550000	458.600000
16	High 5	464.050000	464.100000
17	High 6	469.950000	469.900000

4.3.4 Adjustment item supplement

Adjustment Item	Description
Receive Assist	The lock voltage of VCO (Receive) is adjusted. This item must be adjusted before all adjustment items for receiver section are adjusted.
Transmit Assist	The lock voltage of VCO (Transmit) is adjusted. This item must be adjusted before all adjustment items for transmitter section are adjusted.
Frequency	Frequency is adjusted under receiving condition with SSG. The SSG needs 0.001ppm accuracy so please use a standard oscillator if necessary. This item can be adjusted only in PC Test Mode so that the adjustment value is not changed easily.
Ramp Offset	Adjust this item to the optimal Ramp voltage.
High Maximum Power	High Maximum Power is adjusted.
Medium Maximum Power	Medium Maximum Power is adjusted.
Low Maximum Power	Low Maximum Power is adjusted.
High Transmit Power Limit	High Transmit Power Limit is adjusted.
Medium Transmit Power Limit	Medium Transmit Power Limit is adjusted.
Low Transmit Power Limit	Low Transmit Power Limit is adjusted.
High Transmit Power	High Transmit Power is adjusted.
Medium Transmit Power	Medium Transmit Power is adjusted.
Low Transmit Power	Low Transmit Power is adjusted.
Balance	The transmit modulation frequency response is adjusted. This item is adjusted so that the deviation of 2kHz becomes the same deviation of 20Hz. This item must be adjusted before all adjustment items for deviations are adjusted.
High Deviation (P25/NXDN)	High Deviation of P25/NXDN is adjusted.
Maximum Deviation (Analog Wide/Narrow)	Maximum Deviation of Analog (Wide/Narrow) is adjusted. This item must be adjusted before all adjustment items for tone deviations are adjusted.
QT Deviation	QT tone deviation is adjusted.
DQT Deviation	DQT tone deviation is adjusted.

Adjustment Item	Description
LTR Deviation	LTR tone deviation is adjusted.
DTMF Deviation	DTMF tone deviation is adjusted.
Single Tone Deviation	The deviation of Single Tone used in "2-tone" is adjusted.
MSK Deviation	MSK tone deviation is adjusted.
CWID Deviation	CWID tone deviation is adjusted. CWID is used to inform the others who is transmitting on a 6.25-kHz spacing channel. (In FCC rule, Analog mode or CWID is required for each channel-spacing.)
Sensitivity 1	Band-Pass Filter is adjusted. The performance of Receive Sensitivity is improved.
Sensitivity 2	The gain of RF amplifier is adjusted. The performance of the interfering wave is improved.
RSSI Reference	The minimum RSSI level for scan stop is adjusted.
Open Squelch	The squelch level at level "5" is adjusted.
Low RSSI	RSSI display level "1" is adjusted.
High RSSI	Both "Low RSSI" and "High RSSI" must be adjusted. (The curve data of RSSI level is applied.)
Tight Squelch	The squelch level at level "9" is adjusted.

4.3.5 Adjustment item and Display

Order	Adjustment item	Main LCD display	Sub LCD display	Aw (Analog Wide)	As *2 (Analog Wide 4k)	An (Analog Narrow)	P1 (P25 Phase1)	P2 (P25 Phase2)	Nn (NXDN Narrow)	Nv (NXDN Very Narrow)	Adjust item Number
				Adjustment range							
1	Receive Assist	RAST	(CV voltage)	17 point ADJ							Common Section 2
				1 ~ 4096							
2	Transmit Assist	TAST	(CV voltage)	17 point ADJ							Common Section 3
				1 ~ 4096							
3	RTC Correction	RTC	-	-							Common Section 5
				-2.00~-0.01 ,0.00 ,+0.01~+2.00							
4	Ramp Up Offset	RAMPU	(ADC measurement value)	-							Transmitter Section 1
				1~1024							
5	Ramp Down Offset	RAMPD	(ADC measurement value)	-							Transmitter Section 2
				1~1024							
6	High Maximum Power	MAX_H	-	-	-	5	-	-	-	-	Transmitter Section 3
				1~256							
7	Medium Maximum Power	MAX_M	-	-	-	5	-	-	-	-	Transmitter Section 4
				1~256							
8	Low Maximum Power	MAX_L	-	-	-	5	-	-	-	-	Transmitter Section 5
				1~256							
9	High Transmit Power Limit	H_LMT	-	-	-	5	-	-	-	-	Transmitter Section 6
				1~256							
10	Medium Transmit Power Limit	M_LMT	-	-	-	5	-	-	-	-	Transmitter Section 7
				1~256							
11	Low Transmit Power Limit	L_LMT	-	-	-	5	-	-	-	-	Transmitter Section 8
				1~256							
12	High Transmit Power	H_PWR	-	-	-	5	-	-	-	-	Transmitter Section 9
				1~1024							
13	Medium Transmit Power	M_PWR	-	-	-	5	-	-	-	-	Transmitter Section 10
				1~1024							
14	Low Transmit Power	L_PWR	-	-	-	5	-	-	-	-	Transmitter Section 11
				1~1024							
15	Balance	BAL	(Encode frequency)	-	-	9	-	-	-	-	Transmitter Section 12
				1~1024							
16	Maximum Deviation	ADEV	-	9	9 *2	9	-	-	-	-	Transmitter Section 13
				1~1024							
17	P25 High Deviation	PDEV	-	-	-	-	9	-	-	-	Transmitter Section 14
				1~1024							
18	P25 H-CPM Deviation	P2DEV	(RSSI measurement value)	-	-	-	-	9	-	-	Transmitter Section 15
				1~1024							
19	NXDN High Deviation	NDEV	-	-	-	-	-	-	9	9	Transmitter Section 16
				1~1024							
20	QT Deviation	QT	-	9	9 *2	9	-	-	-	-	Transmitter Section 17
				1~1024							
21	DQT Deviation	DQT	-	9	9 *2	9	-	-	-	-	Transmitter Section 18
				1~1024							

Order	Adjustment item	Main LCD display	Sub LCD display	Aw	As *2	An	P1	P2	Nn	Nv	Adjust item Number
				(Analog Wide)	(Analog Wide 4k)	(Analog Narrow)	(P25 Phase1)	(P25 Phase2)	(NXDN Narrow)	(NXDN Very Narrow)	
Adjustment range											
22	LTR Deviation	LTR	-	9	9 *2	9	-	-	-	-	Transmitter Section 19
				1~1024							
23	DTMF Deviation	DTMF	-	9	9 *2	9	-	-	-	-	Transmitter Section 20
				1~1024							
24	Single Tone Deviation	TONE	-	9	9 *2	9	-	-	-	-	Transmitter Section 21
				1~1024							
25	MSK Deviation	MSK	-	9	9 *2	9	-	-	-	-	Transmitter Section 22
				1~1024							
26	CW ID Deviation	CWID	-	-	-	-	-	-	-	9	Transmitter Section 23
				1~1024							
27	Sensitivity 1	SENS1	(RSSI measurement value)	-	-	5	-	-	-	-	Receiver Section 3
				1~256							
28	Sensitivity 2	SENS2	(RSSI measurement value)	-	-	5	-	-	-	-	Receiver Section 2
				1~256							
29	RSSI Reference	RRSSI	(RSSI measurement value)	-	-	5	-	-	-	-	Receiver Section 4
				1~256							
30	Open Squelch	SQL	(ASQDET measurement value)	5	5 *2	5	5 *3	-	5	5	Receiver Section 5
				1~256							
31	Low RSSI	LRSSI	(RSSI measurement value)	-	-	5	-	-	-	-	Receiver Section 6
				1~256							
32	High RSSI	HRSSI	(RSSI measurement value)	-	-	5	-	-	-	-	Receiver Section 7
				1~256							
33	Tight Squelch	SQLT	(ASQDET measurement value)	5	5 *2	5	-	-	-	-	Receiver Section 8
				1~256							

*2: Wide 4k can be set up only when the PC test mode is used.

*3: When P25 Phase1 is selected, in C4FM and LSM, there is an adjustment item, respectively.

4.3.6 Panel tuning mode flow chart

Note:

* In this Panel tuning mode flow chart, the Adjustment item name is modified.

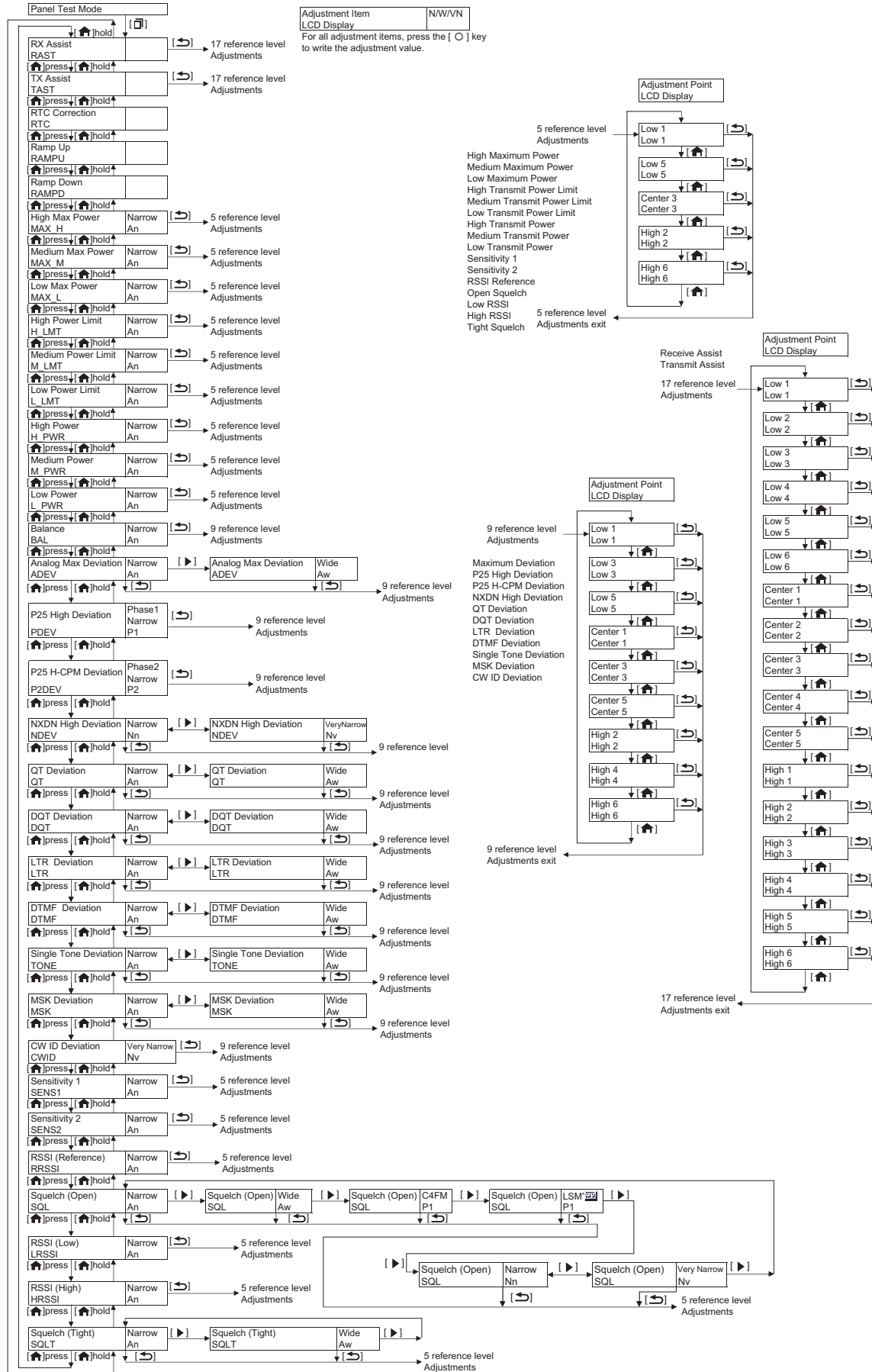

4.4 BER (Bit Error Rate) Measurement

- (1) The Panel Test Mode is used to measure the BER (Refer "4.2.1 Test mode operation features").
- (2) Select "10" (P25 Phase1), "7" (P25 Phase2) and "7" (NXDN Mode) for test signaling (Refer to "4.2.3 Frequency and Signaling" (2) Test signaling).

Note:

"7" (NXDN Mode) can be selected only by PC test mode.

- (3) Select a bandwidth (Narrow/Very Narrow) by pressing the [▶] key. When P25 Phase1 or P25 Phase2 is selected, it is not necessary to select a bandwidth.
- (4) Select a test frequency ("4.2.3 Frequency and Signaling" (2) Test signaling Test frequency).

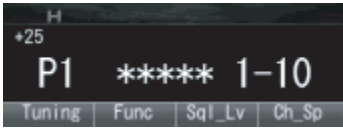

- (5) Measure the BER (Bit Error Rate) using the digital radio tester.
Enter a standard input signal into the transceiver as a standard tone test pattern for P25, FSW+PN9 for NXDN.
- (6) Adjust the input signal level to achieve the standard bit error rate (BER).

(For example, if the BER is 0.86%, the display shows "0.86".)



4.5 Adjustment points

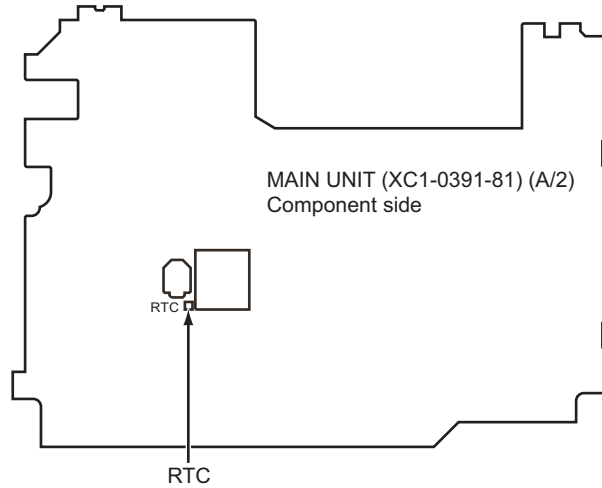

4.6 Test Equipment Required for Alignment

Test Equipment	Major Specifications	
1. Standard Signal Generator (SSG)	Frequency Range	100 to 900MHz
	Modulation	Frequency modulation and external modulation
	Output	-127dBm/0.1uV to greater than -20dBm/22.4mV
	When performing the Frequency adjustment, the following accuracy is necessary.	
	• 0.001ppm	
	Use a standard oscillator for adjustments, if necessary.	
2. Power Meter	Input Impedance	50Ω
	Operation Frequency	100 to 900MHz
	Measurement Capability	Vicinity of 100W
3. Deviation Meter	Frequency Range	100 to 900MHz
4. Digital Volt Meter (DVM)	Measuring Range	10mV to 20V DC
	Input Impedance	High input impedance for minimum circuit loading
5. Oscilloscope		DC through 30MHz
6. Frequency Counter	Frequency Range	10Hz to 1000MHz
	Frequency Stability	0.2ppm or less
	To measure the oscillating frequency of the internal clock 32766.00Hz~32770.00Hz for RTC Correction Resolution 0.01Hz is better for accuracy adjustment.	
7. Ammeter		20A or more
8. AF Volt Meter (AF VM)	Frequency Range	50Hz to 10kHz
	Voltage Range	1mV to 10V
9. Audio Generator (AG)	Frequency Range	50Hz to 5kHz or more
	Output	0 to 1V
10. Distortion Meter	Capability	3% or less at 1kHz
	Input Level	50mV to 10Vrms
11. Spectrum Analyzer	Measuring Range	DC to 1GHz or more
12. 4Ω Dummy Load		Approx. 4Ω, 10W
13. Regulated Power Supply		13.6V, approx. 20A (adjustable from 9V to 17V) Useful if ammeter equipped

*The test equipment which is not used for adjustment is contained in this table.

■ Test cable for microphone input (E30-3360-28)

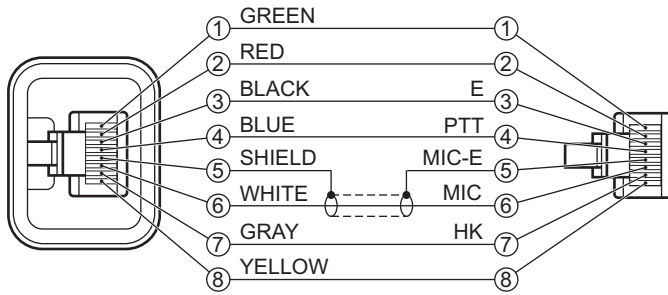

■ Tuning cable (E30-3383-05 or E30-7754-05)

Adapter cable (E30-3383-05) is required for injecting an audio if PC tuning is used.
See "PC Mode" section for the connection.

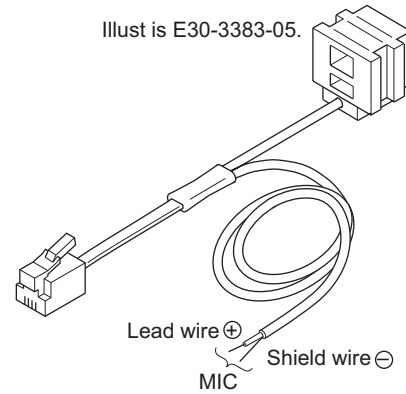

■ MIC connector (Front panel view)

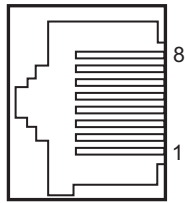

- 1 : MBL
- 2 : +B
- 3 : GND
- 4 : PTT/TXD (PC serial data from radio)
- 5 : MICE
- 6 : MIC
- 7 : HOOK/RXD (PC serial data to radio)
- 8 : DM

4.7 Radio check Section

Item	Condition		Measurement			Adjustment			Specifications /Remarks
	Panel test mode	PC test mode	Test-equipment	Unit	Terminal	Unit	Parts	Method	
1. Frequency check	1)CH-Sig: 1-1 PTT: ON	1)Test Channel Channel: 1 Test Signaling Mode: Analog Signaling: 1 PTT: Press [Transmit] button.	f. counter	Panel	ANT			Check an internal temperature of radio from 20°C to 33°C.	±0.25ppm ±106.2Hz @425.1MHz
2. High power check	1)CH-Sig: 1-1 PTT: ON TA: OFF	1)Test Channel Channel: 1 Test Signaling Mode: Analog Signaling: 1 PTT: Press [Transmit] button.	Power meter Ammeter	Panel	ANT			Check	40W~50W 13A or less
	2)CH-Sig: 2-1 PTT: ON TA: OFF	2)Test Channel Channel: 2 Test Signaling Mode: Analog Signaling: 1 PTT: Press [Transmit] button.	Power meter Ammeter	Panel	ANT			Check	40W~50W 13A or less
	3)CH-Sig: 3-1 PTT: ON TA: OFF	3)Test Channel Channel: 3 Test Signaling Mode: Analog Signaling: 1 PTT: Press [Transmit] button.	Power meter Ammeter	Panel	ANT			Check	40W~50W 13A or less

Item	Condition		Measurement			Adjustment			Specifications /Remarks
	Panel test mode	PC test mode	Test-equipment	Unit	Terminal	Unit	Parts	Method	
3. Low power check	1)CH-Sig: 1-1 PTT: ON TA: OFF	1)Test Channel Channel: 1 Test Signaling Mode: Analog Signaling: 1 PTT: Press [Transmit] button.	Power meter Ammeter	Panel	ANT			Check	3.5W~6.5W 7A or less
	2)CH-Sig: 2-1 PTT: ON TA: OFF	2)Test Channel Channel: 2 Test Signaling Mode: Analog Signaling: 1 PTT: Press [Transmit] button.	Power meter Ammeter	Panel	ANT			Check	3.5W~6.5W 7A or less
	3)CH-Sig: 3-1 PTT: ON TA: OFF	3)Test Channel Channel: 3 Test Signaling Mode: Analog Signaling: 1 PTT: Press [Transmit] button.	Power meter Ammeter	Panel	ANT			Check	3.5W~6.5W 7A or less
4. MIC sensitivity check	1)CH-Sig: 1-1 AG: 1kHz PTT: ON	1)Test Channel Channel: 1 Test Signaling Mode: Analog Signaling: 1 AG: 1kHz PTT: Press [Transmit] button.	Deviation meter Oscilloscope AG AF VM	Panel	ANT Ext. SP connector			Adjust AG input to get a standard MOD.	5mV ±1mV
5. Sensitivity check	1)CH-Sig: 1-1 SSG output Wide: -117dBm (0.32μV) (MOD: 1kHz/±3kHz) Narrow: -117dBm (0.32μV) (MOD: 1kHz/ ±1.5kHz)	1)Test Channel Channel: 1 Test Signaling Mode: Analog Signaling: 1 SSG output Wide: -117dBm (0.32μV) (MOD: 1kHz/±3kHz) Narrow: -117dBm (0.32μV) (MOD: 1kHz/±1.5kHz)	SSG AF VTVM Oscilloscope Distortion meter 4Ω Dummy load	Panel	ANT Ext. SP connector			Check	12dB SINAD or more

4.8 Common Section

Item	Condition		Measurement			Adjustment			Specifications /Remarks
	Panel tuning mode	PC test mode	Test-equip-ment	Unit	Ter-minal	Unit	Parts	Method	
1. Setting	1) DC voltage:13.6V 2) SSG standard modulation [Wide] MOD:1kHz,DEV:3kHz [Narrow] MOD:1kHz,DEV:1.5kHz								
2. Receive Assist	<p>1) Adj item: [RAST] Adjust:[****]</p> <p>2) Adj item: [Low1 RAST]→ [Low2 RAST]→ [Low3 RAST]→ [Low4 RAST]→ [Low5 RAST]→ [Low6 RAST]→ [Center1 RAST]→ [Center2 RAST]→ [Center3 RAST]→ [Center4 RAST]→ [Center5 RAST]→ [High1 RAST]→ [High2 RAST]→ [High3 RAST]→ [High4 RAST]→ [High5 RAST]→ [High6 RAST]→</p> <p>Adjust:[****] Press [O] key to store the adjustment value.</p>	<p>1) Adj item: [Receive Assist]</p> <p>2) Adj item: [Low1],[Low2], [Low3],[Low4], [Low5],[Low6], [Center1], [Center2], [Center3], [Center4], [Center5], [High1],[High2] [High3],[High4] [High5],[High6]</p> <p>Press [Apply All] button to store the adjustment value.</p>				Panel	<p>[Panel tuning mode] [▲], [▼] [PC test mode] [←], [→]</p>	<p>[PC test mode] [Automatic Adjustment] 1) Press [Tune Assist Voltage] button. 2) Press [Apply All] button to store the adjustment value after the automatic adjustment has finished. [Manual Adjustment] [V] indicator on the PC window shows VCO lock voltage. Change the adjustment value to get VCO lock voltage within the limit of the specified voltage. Note: Confirm the VCO lock voltage approximately 3 seconds after the adjustment value is changed.</p>	<p>2.5V±0.1V [Automatic Adjustment] After the automatic adjustment is performed, verify that the VCO lock voltage is within the voltage range which is specified by the manual adjustment. [Manual Adjustment] Press [Apply All] button to store the adjustment value after all adjustment point have been adjusted. Note: The assist adjustment value must be between from 340 to 3550.</p>

Item	Condition		Measurement			Adjustment			Specifications /Remarks
	Panel tuning mode	PC test mode	Test-equip-ment	Unit	Ter-minal	Unit	Parts	Method	
3. Transmit Assist	1) Adj item: [TAST] Adjust:[****] 2) Adj item: [Low1 TAST]→ [Low2 TAST]→ [Low3 TAST]→ [Low4 TAST]→ [Low5 TAST]→ [Low6 TAST]→ [Center1 TAST]→ [Center2 TAST]→ [Center3 TAST]→ [Center4 TAST]→ [Center5 TAST]→ [High1 TAST]→ [High2 TAST]→ [High3 TAST]→ [High4 TAST]→ [High5 TAST]→ [High6 TAST]→ Adjust:[****] PTT: ON Press [O] key to store the adjustment value.	1) Adj item: [Transmit Assist] 2) Adj item: [Low1],[Low2], [Low3],[Low4], [Low5],[Low6], [Center1], [Center2], [Center3], [Center4], [Center5], [High1],[High2] [High3],[High4] [High5],[High6] PTT: Press [Transmit] button. Press [Apply All] button to store the adjustment value.				Panel	[Panel tuning mode] [▲], [▼] [PC test mode] [←], [→]	[PC test mode] [Automatic Adjustment] 1) Press [Tune Assist Voltage] button. 2) Press [Apply All] button to store the adjustment value after the automatic adjustment has finished. [Manual Adjustment] [V] indicator on the PC window shows VCO lock voltage. Change the adjustment value to get VCO lock voltage within the limit of the specified voltage. Note: Confirm the VCO lock voltage approximately 3 seconds after the adjustment value is changed.	2.5V±0.1V [Automatic Adjustment] After the automatic adjustment is performed, verify that the VCO lock voltage is within the voltage range which is specified by the manual adjustment. [Manual Adjustment] Press [Apply All] button to store the adjustment value after all adjustment point have been adjusted. Note: The assist adjustment value must be between from 340 to 3550.
4. Frequency	*The Frequency adjustment can be performed only in PC test mode.	1) Adj item: [Frequency] SSG output: -20dBm (22.4mV) (CW (without modulation)) Caution: Perform the frequency adjustment under the following conditions. <ul style="list-style-type: none"> Temperature range of +20°C to +33°C (+68.0°F to +91.4°F). (The temperature is displayed on the Frequency adjustment screen of the KPG-D1/D1N and the LCD of the transceiver.) Use an accuracy of 0.001ppm for the SSG. (Use a standard oscillator if necessary.) 	SSG	Panel	ANT	Panel	[Panel tuning mode] [▲], [▼] [PC test mode] [←], [→]	[PC test mode] Press [Start] button of "Auto Tuning". Press [Apply] button to store the adjustment value after the automatic adjustment has finished.	[PC test mode] "IF20" value = Within 0±20 digits. The value of "IF20" will become around "0" after the adjustment has finished. Remark: "Frequency" is adjusted under receiving condition with SSG.

Item	Condition		Measurement			Adjustment			Specifications /Remarks
	Panel tuning mode	PC test mode	Test-equip-ment	Unit	Ter-minal	Unit	Parts	Method	
5. RTC Corre- cition	1) Adj item: [RTC] Adjust:[****] Press [O] key to store the ad- justment val- ue.	1) Adj item: [RTC Correction] Data: {****} Press [Apply] button to store the adjust- ment value.	Fre- quency Counter	Panel	TEST POINT (CN715)		[Panel tuning mode] [▲],[▼] [PC test mode] [←],[→]	[Panel tuning mode] Press [O] key to store the adjustment value. [PC test mode] Press [Apply] button to store the adjustment value.	Remaks: Change the adjust- ment value so that the frequency cur- rently displayed on “Crystal Oscillation Frequency” on the PC window and the frequency currently displayed on the frequency counter are in agreement.

4.9 Transmitter Section

Item	Condition		Measurement			Adjustment			Specifications /Remarks
	Panel tuning mode	PC test mode	Test-equipment	Unit	Terminal	Unit	Parts	Method	
1. Ramp up Offset	1) Adj item: [RAMPU] Adjust:[****] PTT : ON Press [O] key to store the adjustment value.	1) Adj item: [Ramp Up Offset] Press [Transmit] button. Press [Apply] button to store the adjustment value.	Power meter Ammeter	Panel	ANT	Panel	[Panel tuning mode] [▲], [▼] [PC test mode] [←], [→]	<p>[PC test mode] [Automatic Adjustment] 1) Press [Tune Rump Offset] button. 2) Press [Apply All] button to store the adjustment value after the automatic adjustment has finished. 3) Check Ramp UP Offset Monitor Value Over 45.</p> <p>[Manual Adjustment] 1) Set the adjustment value to "1". 2) Increase the adjustment value slowly while monitoring the offset monitor value. 3) Set the adjustment value when the offset monitor value exceed "50".</p>	
2. Ramp down Offset	1) Adj item: [RAMPD] Adjust:[****] PTT : ON Press [O] key to store the adjustment value.		Power meter Ammeter	Panel	ANT	Panel	[Panel tuning mode] [▲], [▼] [PC test mode] [←], [→]	<p>[PC test mode] [Automatic Adjustment] 1) If "Automatic Adjustment" is completed in the item of "Ramp up Offset", this item is Completed in addition. Check Ramp down Offset Monitor Value under 50 with PTT ON.</p> <p>[Manual Adjustment] 1) Set the following value with reference to the value that you applied in the item of "Ramp up Offset" 2)Write calculated Value "Ramp up Offset-70". 3)If the subtraction result is less than "1", apply"1".</p>	

Item	Condition		Measurement			Adjustment			Specifications /Remarks
	Panel tuning mode	PC test mode	Test-equipment	Unit	Terminal	Unit	Parts	Method	
3. High Maximum Power	1) Adj item: [MAX_H] Adjust:[****] 2) Adj item: [Low1]→ [Low5]→ [Center3]→ [High2]→ [High6] Adjust:[****] PTT : ON Press [O] key to store the adjustment value.	1) Adj item: [High Maximum Power] 2) Adj item: [Low1]→ [Low5]→ [Center3]→ [High2]→ [High6] Press [Transmit] button. Press [Apply] button to store the adjustment value.	Power meter Ammeter	Panel	ANT	Panel	[Panel tuning mode] [▲], [▼] [PC test mode] [←], [→]	55W	±1W 15A or less [PC test mode] Press [Apply All] button to store the adjustment value after all adjustment points have been adjusted.
4. Medium Maximum power	1) Adj item: [MAX_M] Adjust:[****] 2) Adj item: [Low1]→ [Low5]→ [Center3]→ [High2]→ [High6] Adjust:[****] PTT : ON Press [O] key to store the adjustment value.	1) Adj item: [Medium Maximum Power] 2) Adj item: [Low1]→ [Low5]→ [Center3]→ [High2]→ [High6] Press [Transmit] button. Press [Apply] button to store the adjustment value.	Power meter Ammeter	Panel	ANT	Panel	[Panel tuning mode] [▲], [▼] [PC test mode] [←], [→]	55W	±1W 15A or less [PC test mode] Press [Apply All] button to store the adjustment value after all adjustment points have been adjusted.
5. Low Maximum power	1) Adj item: [MAX_L] Adjust:[****] 2) Adj item: [Low1]→ [Low5]→ [Center3]→ [High2]→ [High6] PTT : ON Press [O] key to store the adjustment value.	1) Adj item: [Low Maximum Power] 2) Adj item: [Low1]→ [Low5]→ [Center3]→ [High2]→ [High6] Press [Transmit] button. Press [Apply] button to store the adjustment value.	Power meter Ammeter	Panel	ANT	Panel	[Panel tuning mode] [▲], [▼] [PC test mode] [←], [→]	55W	±1W 15A or less [PC test mode] Press [Apply All] button to store the adjustment value after all adjustment points have been adjusted.
6. High Transmit Power Limit	1) Adj item: [H_LMT] Adjust:[****] 2) Adj item: [Low1]→ [Low5]→ [Center3]→ [High2]→ [High6] PTT : OFF Press [O] key to store the adjustment value.	1) Adj item: [High Transmit Power Limit] 2) Adj item: [Low1]→ [Low5]→ [Center3]→ [High2]→ [High6] Press [Apply] button to store the adjustment value.	Power meter Ammeter	Panel	ANT	Panel	[Panel tuning mode] [▲], [▼] [PC test mode] [←], [→]	Write the value as followings. 256 (Fixed)	

Item	Condition		Measurement			Adjustment			Specifications /Remarks
	Panel tuning mode	PC test mode	Test-equipment	Unit	Terminal	Unit	Parts	Method	
7. Medium Transmit Power Limit	1) Adj item: [M_LMT] Adjust:[****] 2) Adj item: [Low1]→ [Low5]→ [Center3]→ [High2]→ [High6] PTT : OFF Press [O] key to store the adjustment value.	1) Adj item: [Medium Transmit Power Limit] 2) Adj item: [Low1]→ [Low5]→ [Center3]→ [High2]→ [High6] Press [Apply] button to store the adjustment value.	Power meter Ammeter	Panel	ANT	Panel	[Panel tuning mode] [▲], [▼] [PC test mode] [←], [→]	Write the value as followings. 256 (Fixed)	
8. Low Transmit Power Limit	1) Adj item: [L_LMT] Adjust:[****] 2) Adj item: [Low1]→ [Low5]→ [Center3]→ [High2]→ [High6] PTT : OFF Press [O] key to store the adjustment value.	1) Adj item: [Low Transmit Power Limit] 2) Adj item: [Low1]→ [Low5]→ [Center3]→ [High2]→ [High6] Press [Apply] button to store the adjustment value.	Power meter Ammeter	Panel	ANT	Panel	[Panel tuning mode] [▲], [▼] [PC test mode] [←], [→]	Write the value as followings. 256 (Fixed)	
9. High Transmit Power	1) Adj item: [H_PWR] Adjust:[****] 2) Adj item: [Low1]→ [Low5]→ [Center3]→ [High2]→ [High6] Adjust:[****] PTT : ON Press [O] key to store the adjustment value.	1) Adj item: [High Transmit Power] 2) Adj item: [Low1]→ [Low5]→ [Center3]→ [High2]→ [High6] Press [Transmit] button. Press [Apply All] button to store the adjustment value.	Power meter Ammeter	Panel	ANT	Panel	[Panel tuning mode] [▲], [▼] [PC test mode] [←], [→]	45W	±1W 12A or less [PC test mode] Press [Apply All] button to store the adjustment value after all adjustment points have been adjusted.
10. Medium Transmit Power	1) Adj item: [M_PWR] Adjust:[****] 2) Adj item: [Low1]→ [Low5]→ [Center3]→ [High2]→ [High6] Adjust:[****] PTT : ON Press [O] key to store the adjustment value.	1) Adj item: [Medium Transmit Power] 2) Adj item: [Low1]→ [Low5]→ [Center3]→ [High2]→ [High6] Press [Transmit] button. Press [Apply All] button to store the adjustment value.	Power meter Ammeter	Panel	ANT	Panel	[Panel tuning mode] [▲], [▼] [PC test mode] [←], [→]	Note: Medium transmit power is the purpose of the custom power (adjustment). This power must be lower than High transmit power. In the production, this Medium transmit power is adjusted at same power as Low transmit power.	[PC test mode] Press [Apply All] button to store the adjustment value after all adjustment points have been adjusted.

Item	Condition		Measurement			Adjustment			Specifications /Remarks
	Panel tuning mode	PC test mode	Test-equipment	Unit	Terminal	Unit	Parts	Method	
11. Low Transmit Power	1) Adj item: [L_PWR] Adjust:[****] 2) Adj item: [Low1]→ [Low5]→ [Center3]→ [High2]→ [High6] Adjust:[****] PTT : ON Press [O] key to store the adjustment value.	1) Adj item: [Low Transmit Power] 2) Adj item: [Low1]→ [Low5]→ [Center3]→ [High2]→ [High6] Press [Transmit] button. Press [Apply All] button to store the adjustment value.	Power meter Ammeter	Panel	ANT	Panel	[Panel tuning mode] [▲], [▼] [PC test mode] [←], [→]	5W	±0.5W 10A or less [PC test mode] Press [Apply All] button to store the adjustment value after all adjustment points have been adjusted.
12. Balance *1	1) Adj item: [Balance] Adjust:[****] Deviation meter LPF: 3kHz HPF: OFF 2) Adj item: [Low1]→ [Low3]→ [Low5]→ [Center1]→ [Center3]→ [Center5]→ [High2]→ [High4]→ [High6] Adjust:[****] PTT : ON Press [O] key to store the adjustment value.	1) Adj item: [Balance] Deviation meter LPF: 3kHz HPF: OFF 2) Adj item: [Low1]→ [Low3]→ [Low5]→ [Center1]→ [Center3]→ [Center5]→ [High2]→ [High4]→ [High6] Press [Transmit] button. Press [Apply All] button to store the adjustment value.	Deviation meter Oscilloscope	Panel	ANT	Panel	[Panel tuning mode] [▲], [▼] [PC test mode] [←], [→]	The Deviation of 20Hz frequency is fixed. Change the 2kHz adjustment value to become the same deviation of 20Hz within the specified range. (a supplementary explanation: Another way to adjust is ready. (Same as TK-5810, the old model of NX-5800). Press [AUX(Orange)] key to switch the tone to 100Hz square wave. Then, make the demodulation waveform shown on oscilloscope into square shape.)	2kHz Tone deviation is within ± 1.0% of 20Hz tone deviation. [PC test mode] Press [Apply All] button to store the adjustment value after all adjustment points have been adjusted.
*1 : Refer to the “4.9.1 Necessary Deviation adjustment item for each signaling and mode” table. Balance adjustment is common with the adjustment of all signaling deviations.									

Item	Condition		Measurement			Adjustment			Specifications /Remarks
	Panel tuning mode	PC test mode	Test-equipment	Unit	Terminal	Unit	Parts	Method	
13. Maximum Deviation *2 [Analog Wide]	1) Adj item: [ADEV] Adjust:[****] Deviation meter LPF: 15kHz HPF: OFF 2) Adj item: [Low1]→ [Low3]→ [Low5]→ [Center1]→ [Center3]→ [Center5]→ [High2]→ [High4]→ [High6] Adjust:[****] PTT : ON Press [O] key to store the adjustment value.	1) Adj item: [Maxmum Deviation (Analog Wide)] Deviation meter LPF: 15kHz HPF: OFF 2) Adj item: [Low1]→ [Low3]→ [Low5]→ [Center1]→ [Center3]→ [Center5]→ [High2]→ [High4]→ [High6] Press [Transmit] button. Press [Apply All] button to store the adjustment value.	Deviation meter Oscilloscope	Panel	ANT	Panel	[Panel tuning mode] [▲], [▼] [PC test mode] [←], [→]	Write fixed value for each adjustment point. (The value is written below.) Transmit at each adjustment point and check that the deviation is between 4150Hz and 4250Hz. Deviation meter LPF: 15kHz HPF: OFF 503 (Reference value) [Panel tuning mode] PTT: ON [PC test mode] PTT: Press [Transmit] button	4150~4250Hz [PC test mode] Press [Apply All] button to store the adjustment value after all adjustment points have been adjusted.
[Analog Narrow]	1) Adj item: [An ADEV] Adjust:[****] 2) Adj item: [Low1]→ [Low3]→ [Low5]→ [Center1]→ [Center3]→ [Center5]→ [High2]→ [High4]→ [High6] Adjust:[****] PTT : ON Press [O] key to store the adjustment value.	1) Adj item: [Maxmum Deviation (Analog Narrow)] 2) Adj item: [Low1]→ [Low3]→ [Low5]→ [Center1]→ [Center3]→ [Center5]→ [High2]→ [High4]→ [High6] Press [Transmit] button. Press [Apply All] button to store the adjustment value.	Deviation meter Oscilloscope	Panel	ANT	Panel	[Panel tuning mode] [▲], [▼] [PC test mode] [←], [→]	Write fixed value for each adjustment point. (The value is written below.) Transmit at each adjustment point and check that the deviation is between 2050Hz and 2150Hz. Deviation meter LPF: 15kHz HPF: OFF 499 (Reference value) [Panel tuning mode] PTT: ON [PC test mode] PTT: Press [Transmit] button	2050~2150Hz [PC test mode] Press [Apply All] button to store the adjustment value after all adjustment points have been adjusted.
*2 : Refer to the "4.9.1 Necessary Deviation adjustment item for each signaling and mode" table. Regarding Maximum Deviation (Analog), it is common with the adjustment of all analog signalings.									

Item	Condition		Measurement			Adjustment			Specifications /Remarks
	Panel tuning mode	PC test mode	Test-equipment	Unit	Terminal	Unit	Parts	Method	
14. P25 High Deviation	<p>1) Adj item: [P1 PDEV] Adjust:[****] Deviation meter LPF: 3kHz HPF: OFF</p> <p>2) Adj item: [Low1]→ [Low3]→ [Low5]→ [Center1]→ [Center3]→ [Center5]→ [High2]→ [High4]→ [High6] Adjust:[****] PTT : ON Press [O] key to store the adjustment value.</p>	<p>1) Adj item: [P25 High Deviation] Deviation meter LPF: 3kHz HPF: OFF</p> <p>2) Adj item: [Low1]→ [Low3]→ [Low5]→ [Center1]→ [Center3]→ [Center5]→ [High2]→ [High4]→ [High6] Press [Transmit] button. Press [Apply All] button to store the adjustment value.</p>	Deviation meter Oscilloscope	Panel	ANT	Panel	[Panel tuning mode] [▲], [▼] [PC test mode] [←], [→]	<p>Write fixed value for each adjustment point. (The value is written below.) Transmit at each adjustment point and check that the deviation is between 2771Hz and 2883Hz. Deviation meter LPF: 3kHz HPF: OFF</p> <p>504 (Reference value)</p> <p>[Panel tuning mode] PTT: ON</p> <p>[PC test mode] PTT: Press [Transmit] button</p>	2771~2883Hz [PC test mode] Press [Apply All] button to store the adjustment value after all adjustment points have been adjusted.
15. P25 H-CPM Deviation	<p>1) Adj item: [P2 P2DEV] Adjust:[****] Deviation meter LPF: 3kHz HPF: OFF</p> <p>2) Adj item: [Low1]→ [Low3]→ [Low5]→ [Center1]→ [Center3]→ [Center5]→ [High2]→ [High4]→ [High6] Adjust:[****] PTT : ON Press [O] key to store the adjustment value.</p>	<p>1) Adj item: [P25 H-CPM Deviation] Deviation meter LPF: 3kHz HPF: OFF</p> <p>2) Adj item: [Low1]→ [Low3]→ [Low5]→ [Center1]→ [Center3]→ [Center5]→ [High2]→ [High4]→ [High6] Press [Transmit] button. Press [Apply All] button to store the adjustment value.</p>	Deviation meter Oscilloscope	Panel	ANT	Panel	[Panel tuning mode] [▲], [▼] [PC test mode] [←], [→]	<p>Write fixed value for each adjustment point. (The value is written below.) Transmit at each adjustment point and check that the deviation is between 3090Hz and 3215Hz. Deviation meter LPF: 3kHz HPF: OFF</p> <p>483 (Reference value)</p> <p>[Panel tuning mode] PTT: ON</p> <p>[PC test mode] PTT: Press [Transmit] button</p>	3090~3215Hz [PC test mode] Press [Apply All] button to store the adjustment value after all adjustment points have been adjusted.

Item	Condition		Measurement			Adjustment			Specifications /Remarks
	Panel tuning mode	PC test mode	Test-equipment	Unit	Terminal	Unit	Parts	Method	
16. NXDN High Deviation [NXDN Narrow]	1) Adj item: [Nn NDEV] Adjust:[****] Deviation meter LPF: 3kHz HPF: OFF 2) Adj item: [Low1]→ [Low3]→ [Low5]→ [Center1]→ [Center3]→ [Center5]→ [High2]→ [High4]→ [High6] Adjust:[****] PTT : ON Press [O] key to store the adjustment value.	1) Adj item: [NXDN High Deviation (NXDN Narrow)] Deviation meter LPF: 3kHz HPF: OFF 2) Adj item: [Low1]→ [Low3]→ [Low5]→ [Center1]→ [Center3]→ [Center5]→ [High2]→ [High4]→ [High6] Press [Transmit] button. Press [Apply All] button to store the adjustment value.	Deviation meter Oscilloscope	Panel	ANT	Panel	[Panel tuning mode] [▲], [▼] [PC test mode] [←], [→]	Write fixed value for each adjustment point. (The value is written below.) Transmit at each adjustment point and check that the deviation is between 2995Hz and 3117Hz. Deviation meter LPF: 3kHz HPF: OFF 504 (Reference value) [Panel tuning mode] PTT: ON [PC test mode] PTT: Press [Transmit] button	2995~3117Hz [PC test mode] Press [Apply All] button to store the adjustment value after all adjustment points have been adjusted.
[NXDN Very Narrow]	1) Adj item: [Nv NDEV] Adjust:[****] 2) Adj item: [Low1]→ [Low3]→ [Low5]→ [Center1]→ [Center3]→ [Center5]→ [High2]→ [High4]→ [High6] Adjust:[****] PTT : ON Press [O] key to store the adjustment value.	1) Adj item: [NXDN High Deviation (NXDN Very Narrow)] Deviation meter LPF: 3kHz HPF: OFF 2) Adj item: [Low1]→ [Low3]→ [Low5]→ [Center1]→ [Center3]→ [Center5]→ [High2]→ [High4]→ [High6] Press [Transmit] button. Press [Apply All] button to store the adjustment value.	Deviation meter Oscilloscope	Panel	ANT	Panel	[Panel tuning mode] [▲], [▼] [PC test mode] [←], [→]	Write fixed value for each adjustment point. (The value is written below.) Transmit at each adjustment point and check that the deviation is between 1311Hz and 1363Hz. Deviation meter LPF: 3kHz HPF: OFF 505 (Reference value) [Panel tuning mode] PTT: ON [PC test mode] PTT: Press [Transmit] button	1311~1363Hz [PC test mode] Press [Apply All] button to store the adjustment value after all adjustment points have been adjusted.

Item	Condition		Measurement			Adjustment			Specifications /Remarks
	Panel tuning mode	PC test mode	Test-equipment	Unit	Terminal	Unit	Parts	Method	
17. QT Deviation *3 [Analog Wide]	1) Adj item: [Aw QT] Adjust:[****] Deviation meter LPF: 3kHz HPF: OFF 2) Adj item: [Low1]→ [Low3]→ [Low5]→ [Center1]→ [Center3]→ [Center5]→ [High2]→ [High4]→ [High6] Adjust:[****] PTT : ON Press [O] key to store the adjustment value.	1) Adj item: [QT Deviation (Analog Wide)] Deviation meter LPF: 3kHz HPF: OFF 2) Adj item: [Low1]→ [Low3]→ [Low5]→ [Center1]→ [Center3]→ [Center5]→ [High2]→ [High4]→ [High6] Press [Transmit] button. Press [Apply All] button to store the adjustment value.	Deviation meter Oscilloscope	Panel	ANT	Panel	[Panel tuning mode] [▲], [▼] [PC test mode] [←], [→]	Write the value as followings. 521 (Reference value)	0.75kHz±0.05 kHz
[Analog Narrow]	1) Adj item: [An QT] Adjust:[****] 2) Adj item: [Low1]→ [Low3]→ [Low5]→ [Center1]→ [Center3]→ [Center5]→ [High2]→ [High4]→ [High6] Adjust:[****] PTT : ON Press [O] key to store the adjustment value.	1) Adj item: [QT Deviation (Analog Narrow)] Deviation meter LPF: 3kHz HPF: OFF 2) Adj item: [Low1]→ [Low3]→ [Low5]→ [Center1]→ [Center3]→ [Center5]→ [High2]→ [High4]→ [High6] Press [Transmit] button. Press [Apply All] button to store the adjustment value.	Deviation meter Oscilloscope	Panel	ANT	Panel	[Panel tuning mode] [▲], [▼] [PC test mode] [←], [→]	Write the value as followings. 522 (Reference value)	0.35kHz±0.05 kHz

Item	Condition		Measurement			Adjustment			Specifications /Remarks
	Panel tuning mode	PC test mode	Test-equipment	Unit	Terminal	Unit	Parts	Method	
18. DQT Deviation *3 [Analog Wide]	<p>1) Adj item: [Aw DQT] Adjust:[****] Deviation meter LPF: 3kHz HPF: OFF</p> <p>2) Adj item: [Low1]→ [Low3]→ [Low5]→ [Center1]→ [Center3]→ [Center5]→ [High2]→ [High4]→ [High6] Adjust:[****] PTT : ON Press [O] key to store the adjustment value.</p>	<p>1) Adj item: [DQT Deviation (Analog Wide)] Deviation meter LPF: 3kHz HPF: OFF</p> <p>2) Adj item: [Low1]→ [Low3]→ [Low5]→ [Center1]→ [Center3]→ [Center5]→ [High2]→ [High4]→ [High6] Press [Transmit] button. Press [Apply All] button to store the adjustment value.</p>	Deviation meter Oscilloscope	Panel	ANT	Panel	[Panel tuning mode] [▲], [▼] [PC test mode] [←], [→]	Write the value as followings. 432 (Reference value)	0.75kHz±0.05 kHz
[Analog Narrow]	<p>1) Adj item: [An DQT] Adjust:[****] Deviation meter LPF: 3kHz HPF: OFF</p> <p>2) Adj item: [Low1]→ [Low3]→ [Low5]→ [Center1]→ [Center3]→ [Center5]→ [High2]→ [High4]→ [High6] Adjust:[****] PTT : ON Press [O] key to store the adjustment value.</p>	<p>1) Adj item: [DQT Deviation (Analog Narrow)] Deviation meter LPF: 3kHz HPF: OFF</p> <p>2) Adj item: [Low1]→ [Low3]→ [Low5]→ [Center1]→ [Center3]→ [Center5]→ [High2]→ [High4]→ [High6] Press [Transmit] button. Press [Apply All] button to store the adjustment value.</p>	Deviation meter Oscilloscope	Panel	ANT	Panel	[Panel tuning mode] [▲], [▼] [PC test mode] [←], [→]	Write the value as followings. 436 (Reference value)	0.35kHz±0.05 kHz

Item	Condition		Measurement			Adjustment			Specifications /Remarks
	Panel tuning mode	PC test mode	Test-equipment	Unit	Terminal	Unit	Parts	Method	
19. LTR Deviation *3 [Analog Wide]	1) Adj item: [Aw LTR] Adjust:[****] 2) Adj item: [Low1]→ [Low3]→ [Low5]→ [Center1]→ [Center3]→ [Center5]→ [High2]→ [High4]→ [High6] Adjust:[****] PTT : ON Press [O] key to store the adjustment value.	1) Adj item: [LTR Deviation (Analog Wide)] Deviation meter LPF: 3kHz HPF: OFF 2) Adj item: [Low1]→ [Low3]→ [Low5]→ [Center1]→ [Center3]→ [Center5]→ [High2]→ [High4]→ [High6] Press [Transmit] button. Press [Apply All] button to store the adjustment value.	Deviation meter Oscilloscope	Panel	ANT	Panel	[Panel tuning mode] [▲], [▼] [PC test mode] [←], [→]	Write the value as followings. 477 (Reference value)	1.00kHz±0.05 kHz
[Analog Narrow]	1) Adj item: [An LTR] Adjust:[****] 2) Adj item: [Low1]→ [Low3]→ [Low5]→ [Center1]→ [Center3]→ [Center5]→ [High2]→ [High4]→ [High6] Adjust:[****] PTT : ON Press [O] key to store the adjustment value.	1) Adj item: [LTR Deviation (Analog Narrow)] Deviation meter LPF: 3kHz HPF: OFF 2) Adj item: [Low1]→ [Low3]→ [Low5]→ [Center1]→ [Center3]→ [Center5]→ [High2]→ [High4]→ [High6] Press [Transmit] button. Press [Apply All] button to store the adjustment value.	Deviation meter Oscilloscope	Panel	ANT	Panel	[Panel tuning mode] [▲], [▼] [PC test mode] [←], [→]	Write the value as followings. 477 (Reference value)	0.75kHz±0.05 kHz

Item	Condition		Measurement			Adjustment			Specifications /Remarks
	Panel tuning mode	PC test mode	Test-equipment	Unit	Terminal	Unit	Parts	Method	
20. DTMF Deviation *3 [Analog Wide]	1) Adj item: [Aw DTMF] Adjust:[****] 2) Adj item: [Low1]→ [Low3]→ [Low5]→ [Center1]→ [Center3]→ [Center5]→ [High2]→ [High4]→ [High6] Adjust:[****] PTT : ON Press [O] key to store the adjustment value.	1) Adj item: [DTMF Deviation (Analog Wide)] Deviation meter LPF: 15kHz HPF: OFF 2) Adj item: [Low1]→ [Low3]→ [Low5]→ [Center1]→ [Center3]→ [Center5]→ [High2]→ [High4]→ [High6] Press [Transmit] button. Press [OK] button to store the adjustment value.	Deviation meter Oscilloscope	Panel	ANT	Panel	[Panel tuning mode] [▲], [▼] [PC test mode] [←], [→]	Write the value as followings. 548 (Reference value)	2.50kHz±0.05 kHz
[Analog Narrow]	1) Adj item: [An DTMF] Adjust:[****] 2) Adj item: [Low1]→ [Low3]→ [Low5]→ [Center1]→ [Center3]→ [Center5]→ [High2]→ [High4]→ [High6] Adjust:[****] PTT : ON Press [O] key to store the adjustment value.	1) Adj item: [DTMF Deviation (Analog Narrow)] Deviation meter LPF: 15kHz HPF: OFF 2) Adj item: [Low1]→ [Low3]→ [Low5]→ [Center1]→ [Center3]→ [Center5]→ [High2]→ [High4]→ [High6] Press [Transmit] button. Press [Apply All] button to store the adjustment value.	Deviation meter Oscilloscope	Panel	ANT	Panel	[Panel tuning mode] [▲], [▼] [PC test mode] [←], [→]	Write the value as followings. 547 (Reference value)	1.25kHz±0.05 kHz

Item	Condition		Measurement			Adjustment			Specifications /Remarks
	Panel tuning mode	PC test mode	Test-equipment	Unit	Terminal	Unit	Parts	Method	
21. Single Tone Deviation *3 [Analog Wide]	1) Adj item: [Aw TONE] Adjust:[****] 2) Adj item: [Low1]→ [Low3]→ [Low5]→ [Center1]→ [Center3]→ [Center5]→ [High2]→ [High4]→ [High6] Adjust:[****] PTT : ON Press [O] key to store the adjustment value.	1) Adj item: [Single Tone Deviation (Analog Wide)] Deviation meter LPF: 15kHz HPF: OFF 2) Adj item: [Low1]→ [Low3]→ [Low5]→ [Center1]→ [Center3]→ [Center5]→ [High2]→ [High4]→ [High6] Press [Transmit] button. Press [Apply All] button to store the adjustment value.	Deviation meter Oscilloscope	Panel	ANT	Panel	[Panel tuning mode] [▲], [▼] [PC test mode] [←], [→]	Write the value as followings. 514 (Reference value)	3.00kHz±0.05 kHz
[Analog Narrow]	1) Adj item: [An TONE] Adjust:[****] 2) Adj item: [Low1]→ [Low3]→ [Low5]→ [Center1]→ [Center3]→ [Center5]→ [High2]→ [High4]→ [High6] Adjust:[****] PTT : ON Press [O] key to store the adjustment value.	1) Adj item: [Single Tone Deviation (Analog Narrow)] 2) Adj item: [Low1]→ [Low3]→ [Low5]→ [Center1]→ [Center3]→ [Center5]→ [High2]→ [High4]→ [High6] Press [Transmit] button. Press [Apply All] button to store the adjustment value.	Deviation meter Oscilloscope	Panel	ANT	Panel	[Panel tuning mode] [▲], [▼] [PC test mode] [←], [→]	Write the value as followings. 513 (Reference value)	1.50kHz±0.05 kHz

Item	Condition		Measurement			Adjustment			Specifications /Remarks
	Panel tuning mode	PC test mode	Test-equipment	Unit	Terminal	Unit	Parts	Method	
22. MSK Deviation *3 [Analog Wide]	1) Adj item: [Aw MSK] Adjust:[****] Deviation meter LPF: 15kHz HPF: OFF 2) Adj item: [Low1]→ [Low3]→ [Low5]→ [Center1]→ [Center3]→ [Center5]→ [High2]→ [High4]→ [High6] Adjust:[****] PTT : ON Press [O] key to store the adjustment value.	1) Adj item: [MSK Deviation (Analog Wide)] Deviation meter LPF: 15kHz HPF: OFF 2) Adj item: [Low1]→ [Low3]→ [Low5]→ [Center1]→ [Center3]→ [Center5]→ [High2]→ [High4]→ [High6] Press [Transmit] button. Press [Apply All] button to store the adjustment value.	Deviation meter Oscilloscope	Panel	ANT	Panel	[Panel tuning mode] [▲], [▼] [PC test mode] [←], [→]	Write the value as followings. 504 (Reference value)	3.00kHz±0.05 kHz
[Analog Narrow]	1) Adj item: [An MSK] Adjust:[****] 2) Adj item: [Low1]→ [Low3]→ [Low5]→ [Center1]→ [Center3]→ [Center5]→ [High2]→ [High4]→ [High6] Adjust:[****] PTT : ON Press [O] key to store the adjustment value.	1) Adj item: [MSK Deviation (Analog Narrow)] 2) Adj item: [Low1]→ [Low3]→ [Low5]→ [Center1]→ [Center3]→ [Center5]→ [High2]→ [High4]→ [High6] Press [Transmit] button. Press [Apply All] button to store the adjustment value.	Deviation meter Oscilloscope	Panel	ANT	Panel	[Panel tuning mode] [▲], [▼] [PC test mode] [←], [→]	Write the value as followings. 503 (Reference value)	1.50kHz±0.05 kHz

Item	Condition		Measurement			Adjustment			Specifications /Remarks
	Panel tuning mode	PC test mode	Test-equipment	Unit	Terminal	Unit	Parts	Method	
23. CWID Deviation *3 [Analog Narrow]	1) Adj item: [An CWID] Adjust:[****] Deviation meter LPF: 15kHz HPF: OFF 2) Adj item: [Low1]→ [Low3]→ [Low5]→ [Center1]→ [Center3]→ [Center5]→ [High2]→ [High4]→ [High6] Adjust:[****] PTT : ON Press [O] key to store the adjust- ment value.	1) Adj item: [CWID Deviation (Analog Narrow)] Deviation meter LPF: 15kHz HPF: OFF 2) Adj item: [Low1]→ [Low3]→ [Low5]→ [Center1]→ [Center3]→ [Center5]→ [High2]→ [High4]→ [High6] Press [Transmit] button. Press [Apply All] button to store the adjustment value.	Devia- tion meter Oscil- lo- scope	Panel	ANT	Panel	[Panel tuning mode] [▲], [▼] [PC test mode] [←], [→]	Write the value as fol- lowings. 508 (Reference value)	1.10kHz±0.10 kHz
*3: Refer to the "4.9.1 Necessary Deviation adjustment item for each signaling and mode" table.									

4.9.1 Necessary Deviation adjustment item for each signaling and mode

The following shows the necessary adjustment items for each signaling deviation. Please read the following table like the following example. In the case of the signaling "QT (Analog Wide)", this signaling is composed of three elements [Balance, Maximum Deviation (Analog Wide) and QT Deviation (Analog Wide)]. Please adjust Balance and Maximum Deviation (Analog Wide) before adjusting QT Deviation (Analog Wide).

Mode	Signaling	Necessary adjustment and order		
		Wide	Narrow	Very Narrow
Analog	Audio	1. Balance adjust 2. Maximum Deviation [Analog Wide]	1. Balance adjust 2. Maximum Deviation [Analog Narrow]	-
	QT	1. Balance adjust 2. Maximum Deviation [Analog Wide] 3. QT Deviation [Analog Wide]	1. Balance adjust 2. Maximum Deviation [Analog Narrow] 3. QT Deviation [Analog Narrow]	-
	DQT	1. Balance adjust 2. Maximum Deviation [Analog Wide] 3. DQT Deviation [Analog Wide]	1. Balance adjust 2. Maximum Deviation [Analog Narrow] 3. DQT Deviation [Analog Narrow]	-
	LTR	1. Balance adjust 2. Maximum Deviation [Analog Wide] 3. LTR Deviation [Analog Wide]	1. Balance adjust 2. Maximum Deviation [Analog Narrow] 3. LTR Deviation [Analog Narrow]	-
	DTMF	1. Balance adjust 2. Maximum Deviation [Analog Wide] 3. DTMF Deviation [Analog Wide]	1. Balance adjust 2. Maximum Deviation [Analog Narrow] 3. DTMF Deviation [Analog Narrow]	-
	2TONE	1. Balance adjust 2. Maximum Deviation [Analog Wide] 3. Single TONE Deviation [Analog Wide]	1. Balance adjust 2. Maximum Deviation [Analog Narrow] 3. Single TONE Deviation [Analog Narrow]	-
	MSK (Fleet sync)	1. Balance adjust 2. Maximum Deviation [Analog Wide] 3. MSK Deviation [Analog Wide]	1. Balance adjust 2. Maximum Deviation [Analog Narrow] 3. MSK Deviation [Analog Narrow]	-
P25	-	1. Balance adjust 2. P25 High Deviation 3. P25 High Deviation (H-CPM)	-	
NXDN	Audio	-	1. Balance adjust 2. High Deviation [NXDN Narrow]	1. Balance adjust 2. High Deviation [NXDN Very Narrow]
	CWID	-	-	1. Balance adjust 2. High Deviation [NXDN Very Narrow] 3. CWID Deviation [NXDN Very Narrow]

- Balance is common with all the above deviation adjustments. If Balance (Transmitter Section 12) has already adjusted, please skip Step1 and adjust from Step2.
- Maximum Deviation (Analog Wide/Narrow) is common with all the analog signaling deviations. If Balance and Maximum Deviation (Analog Wide /Narrow) (Transmitter Section 13) have already adjusted, please skip Step2 and adjust from Step3.

4.10 Receiver Section

Item	Condition		Measurement			Adjustment			Specifications /Remarks
	Panel tuning mode	PC test mode	Test-equipment	Unit	Terminal	Unit	Parts	Method	
1. AF level setting	[Panel test mode] 1) CH-Sig: 1-1 SSG output: -47dBm (1mV) (MOD: 1kHz/ ±1.5kHz)	1) Test Channel Channel: 1 Test Signaling Mode: Analog Signaling: 1 SSG output: -47dBm (1mV) (MOD:1kHz/ ±1.5kHz)	SSG DVM AF VM Dummy load	Panel	ANT Ext. SP con- nector	Panel	[Panel tuning mode] [+], [-] [PC test mode] [←], [→]	Volume Up/Down knob to obtain 1.41V AF output. (0.5W @ 4Ω load)	1.41V ±0.1V
2. Sensitivity 2	1) Adj item: [An SENS2] Adjust:[***] 2) Adj item: [Low1]→ [Low5]→ [Center3]→ [High2]→ [High6] Adjust:[***] Press [O] key to store the adjust- ment value.	1) Adj item: [Sensitivity 2] 2) Adj item: [Low1], [Low5], [Center3], [High2], [High6] Press [Apply All] button to store the adjustment value.		Panel	ANT Ext. SP con- nector	Panel	[Panel tuning mode] [▲], [▼] [PC test mode] [←], [→]	Write the value as follow- ings. [Low1]: 61 (Fixed) [Low5]: 72 (Fixed) [Center3]: 83 (Fixed) [High2]: 113 (Fixed) [High6]: 132 (Fixed)	
3. Sensitivity 1	1) Adj item: [An SENS1] Adjust:[***] 2) Adj item: [Low1]→ [Low5]→ [Center3]→ [High2]→ [High6] SSG output: -118.5dBm (0.3μV) (MOD: 1kHz/ ±1.5kHz) Adjust:[***] Press [O] key to store the adjust- ment value.	1) Adj item: [Sensitivity 1] 2) Adj item: [Low1], [Low5], [Center3], [High2], [High6] SSG output: -118.5dBm (0.3μV) (MOD: 1kHz/ ±1.5kHz) Press [Apply All] button to store the adjustment value.	SSG AF VM Dummy load	Panel	ANT Ext. SP con- nector	Panel	[Panel tuning mode] [▲], [▼] [PC test mode] [←], [→]	1) Write the value as fol- lowings. [Low1]: 63 (Fixed) [Low5]: 86 (Fixed) [Center3]: 110 (Fixed) [High2]: 138 (Fixed) [High6]: 168 (Fixed) 2) Increase the adjustment value until the AF VM shows 12dB SINAD. 3) Store the adjustment value.	
4. RSSI reference	1) Adj item: [An RRSSI] Adjust:[***] 2) Adj item: [Low1]→ [Low5]→ [Center3]→ [High2]→ [High6] SSG output: 12dB SINAD level -3dB (MOD: 1kHz/±1.5kHz)	1) Adj item: [RSSI Reference (Analog Narrow)] 2) Adj item: [Low1]→ [Low5]→ [Center3]→ [High2]→ [High6] SSG output: 12dB SINAD level -3dB (MOD: 1kHz/±1.5kHz)	SSG Distor- tion meter Oscillo- scope	Panel	ANT Ext. SP con- nector	Panel	[Panel tuning mode] After input signal from SSG, press [O] key to store the adjustment val- ue. [PC test mode] After input signal from SSG, press [Apply] button to store the adjustment value.		

Item	Condition		Measurement			Adjustment			Specifications /Remarks
	Panel tuning mode	PC test mode	Test-equipment	Unit	Terminal	Unit	Parts	Method	
5. Open Squelch [Analog Wide]	1) Adj item: [Aw SQL] Adjust:[***] 2) Adj item: [Low1]→ [Low5]→ [Center3]→ [High2]→ [High6] SSG output: 12dB SINAD level -3dB (MOD: 1kHz/ ±3kHz)	1) Adj item: [Open Squelch (Analog Wide)] 2) Adj item: [Low1]→ [Low5]→ [Center3]→ [High2]→ [High6] SSG output: 12dB SINAD level -3dB (MOD: 1kHz/±3kHz)	SSG Distortion meter Oscilloscope	Panel	ANT Ext. SP connector	Panel		[Panel tuning mode] After input signal from SSG, press [O] key to store the adjustment value. [PC test mode] After input signal from SSG, press [Apply] button to store the adjustment value.	
[Analog Narrow]	1) Adj item: [An SQL] Adjust:[***] 2) Adj item: [Low1]→ [Low5]→ [Center3]→ [High2]→ [High6] SSG output: 12dB SINAD level -3dB (MOD: 1kHz/ ±1.5kHz)	1) Adj item: [Open Squelch (Analog Narrow)] 2) Adj item: [Low1]→ [Low5]→ [Center3]→ [High2]→ [High6] SSG output: 12dB SINAD level -3dB (MOD: 1kHz/ ±1.5kHz)	SSG Distortion meter Oscilloscope	Panel	ANT Ext. SP connector	Panel		[Panel tuning mode] After input signal from SSG, press [O] key to store the adjustment value. [PC test mode] After input signal from SSG, press [Apply] button to store the adjustment value.	
[P25 (C4FM)]	1) Adj item: [P1 SQL] Adjust:[***] 2) Adj item: [Low1]→ [Low5]→ [Center3]→ [High2]→ [High6] SSG output: 12dB SINAD level at Analog Narrow -1dB (MOD: 1kHz/ ±2.2kHz)	1) Adj item: [Open Squelch (P25 C4FM)] 2) Adj item: [Low1]→ [Low5]→ [Center3]→ [High2]→ [High6] SSG output: 12dB SINAD level at Analog Narrow -1dB (MOD: 1kHz/ ±2.2kHz)	SSG Distortion meter Oscilloscope	Panel	ANT Ext. SP connector	Panel		[Panel tuning mode] After input signal from SSG, press [O] key to store the adjustment value. [PC test mode] After input signal from SSG, press [Apply] button to store the adjustment value.	
[P25 (LSM)]	1) Adj item: [P1 SQL] Adjust:[***] 2) Adj item: [Low1]→ [Low5]→ [Center3]→ [High2]→ [High6] SSG output: 12dB SINAD level at Analog Narrow -3dB (MOD: 1kHz/ ±3.3kHz)	1) Adj item: [Open Squelch (P25 LSM)] 2) Adj item: [Low1]→ [Low5]→ [Center3]→ [High2]→ [High6] SSG output: 12dB SINAD level at Analog Narrow -3dB (MOD: 1kHz/ ±3.3kHz)	SSG Distortion meter Oscilloscope	Panel	ANT Ext. SP connector	Panel		[Panel tuning mode] After input signal from SSG, press [O] key to store the adjustment value. [PC test mode] After input signal from SSG, press [Apply] button to store the adjustment value.	

Item	Condition		Measurement			Adjustment			Specifications /Remarks
	Panel tuning mode	PC test mode	Test-equip-ment	Unit	Ter-minal	Unit	Parts	Method	
[NXDN Narrow]	1) Adj item: [Nn SQL] Adjust:[***] 2) Adj item: [Low1]→ [Low5]→ [Center3]→ [High2]→ [High6] SSG output: 12dB SINAD level at Analog Narrow -1dB (MOD: 400Hz/ ±2.5kHz)	1) Adj item: [Open Squelch (NXDN Narrow)] 2) Adj item: [Low1]→ [Low5]→ [Center3]→ [High2]→ [High6] SSG output: 12dB SINAD level at Analog Narrow -1dB (MOD: 400Hz/ ±2.5kHz)	SSG Distortion meter Oscillo- scope	Panel	ANT Ext. SP con- nector	Panel		[Panel tuning mode] After input signal from SSG, press [O] key to store the adjustment val- ue. [PC test mode] After input signal from SSG, press [Apply] button to store the adjustment value.	
[NXDN Very Narrow]	1) Adj item: [Nv SQL] Adjust:[***] 2) Adj item: [Low1]→ [Low5]→ [Center3]→ [High2]→ [High6] SSG output: 12dB SINAD level at Analog Narrow -3dB (MOD: 400Hz/ ±1.2kHz)	1) Adj item: [Open Squelch (NXDN Very Nar- row)] 2) Adj item: [Low1]→ [Low5]→ [Center3]→ [High2]→ [High6] SSG output: 12dB SINAD level at Analog Narrow -3dB (MOD: 400Hz/ ±1.2kHz)	SSG Distortion meter Oscillo- scope	Panel	ANT Ext. SP con- nector	Panel		[Panel tuning mode] After input signal from SSG, press [O] key to store the adjustment val- ue. [PC test mode] After input signal from SSG, press [Apply] button to store the adjustment value.	
6. Low RSSI	1) Adj item: [An LRSSI] Adjust:[***] 2) Adj item: [Low1]→ [Low5]→ [Center3]→ [High2]→ [High6] SSG output: -118dBm (0.28μV) (MOD: 1kHz/ ±1.5kHz)	1) Adj item: [Low RSSI (Analog Narrow)] 2) Adj item: [Low1]→ [Low5]→ [Center3]→ [High2]→ [High6] SSG output: -118dBm (0.28μV) (MOD: 1kHz/ ±1.5kHz)	SSG	Panel	ANT Ext. SP con- nector	Panel		[Panel tuning mode] After input signal from SSG, press [O] key to store the adjustment val- ue. [PC test mode] After input signal from SSG, press [Apply] button to store the adjustment value.	
7. High RSSI	1) Adj item: [An HRSSI] Adjust:[***] 2) Adj item: [Low1]→ [Low5]→ [Center3]→ [High2]→ [High6] SSG output: -80dBm (22.4μV) (MOD: 1kHz/ ±1.5kHz)	1) Adj item: [High RSSI (Analog Narrow)] 2) Adj item: [Low1]→ [Low5]→ [Center3]→ [High2]→ [High6] SSG output: -80dBm (22.4μV) (MOD: 1kHz/ ±1.5kHz)	SSG	Panel	ANT Ext. SP con- nector	Panel		[Panel tuning mode] After input signal from SSG, press [O] key to store the adjustment val- ue. [PC test mode] After input signal from SSG, press [Apply] button to store the adjustment value.	

Item	Condition		Measurement			Adjustment			Specifications /Remarks
	Panel tuning mode	PC test mode	Test-equipment	Unit	Terminal	Unit	Parts	Method	
8. Tight Squelch [Analog Wide]	1) Adj item: [Aw SFLT] Adjust:[***] 2) Adj item: [Low1]→ [Low5]→ [Center3]→ [High2]→ [High6] SSG output: 12dB SINAD level at Analog Narrow +6dB (MOD: 1kHz/ ±3kHz)	1) Adj item: [Tight Squelch (Analog Wide)] 2) Adj item: [Low1]→ [Low5]→ [Center3]→ [High2]→ [High6] SSG output: 12dB SINAD level at Analog Narrow +6dB (MOD: 1kHz/±3kHz)	SSG Distortion meter Oscilloscope	Panel	ANT Ext. SP connector	Panel		[Panel tuning mode] After input signal from SSG, press [O] key to store the adjustment value. [PC test mode] After input signal from SSG, press [Apply] button to store the adjustment value.	
[Analog Narrow]	1) Adj item: [An SFLT] Adjust:[***] 2) Adj item: [Low1]→ [Low5]→ [Center3]→ [High2]→ [High6] SSG output: 12dB SINAD level at Analog Narrow +6dB (MOD: 1kHz/ ±1.5kHz)	1) Adj item: [Tight Squelch (Analog Narrow)] 2) Adj item: [Low1]→ [Low5]→ [Center3]→ [High2]→ [High6] SSG output: 12dB SINAD level at Analog Narrow +6dB (MOD: 1kHz/ ±1.5kHz)	SSG Distortion meter Oscilloscope	Panel	ANT Ext. SP connector	Panel		[Panel tuning mode] After input signal from SSG, press [O] key to store the adjustment value. [PC test mode] After input signal from SSG, press [Apply] button to store the adjustment value.	

SECTION 5 TROUBLESHOOTING

5.1 Fault Diagnosis of the BGA (Ball Grid Array) IC

■ Overview

A flowchart for determining whether or not the transceiver can be powered on (the LCD does not function even if the power switch is turned on) due to broken BGA parts.

■ BGA parts

MPU/DSP (IC706), mobile DDR (IC702), Flash memory (IC701)

When the BGA IC is problematic, please bring the printed circuit board (XC1-0341-83) in for service. Various ESN/ default adjustment values are written on the printed circuit board for service.

Additionally various ESN stickers are included. (Please refer to "5.4 Replacing Main Unit".)

After the printed circuit board has been readjusted, please attach any ESN stickers to the chassis. When "ESN Validation" is used, you must modify the ESN register.

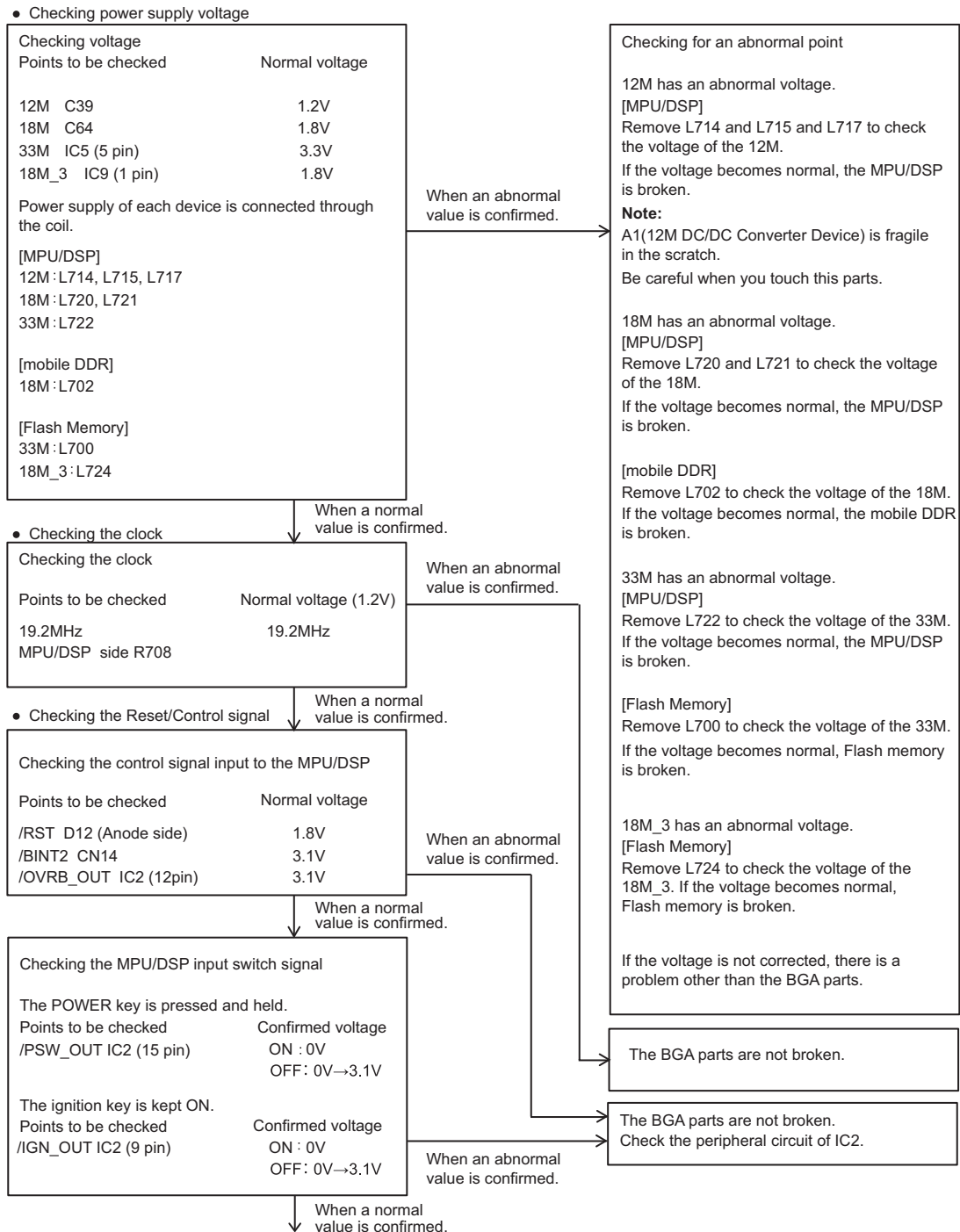

- Checking the output signal from the MPU/DSP.

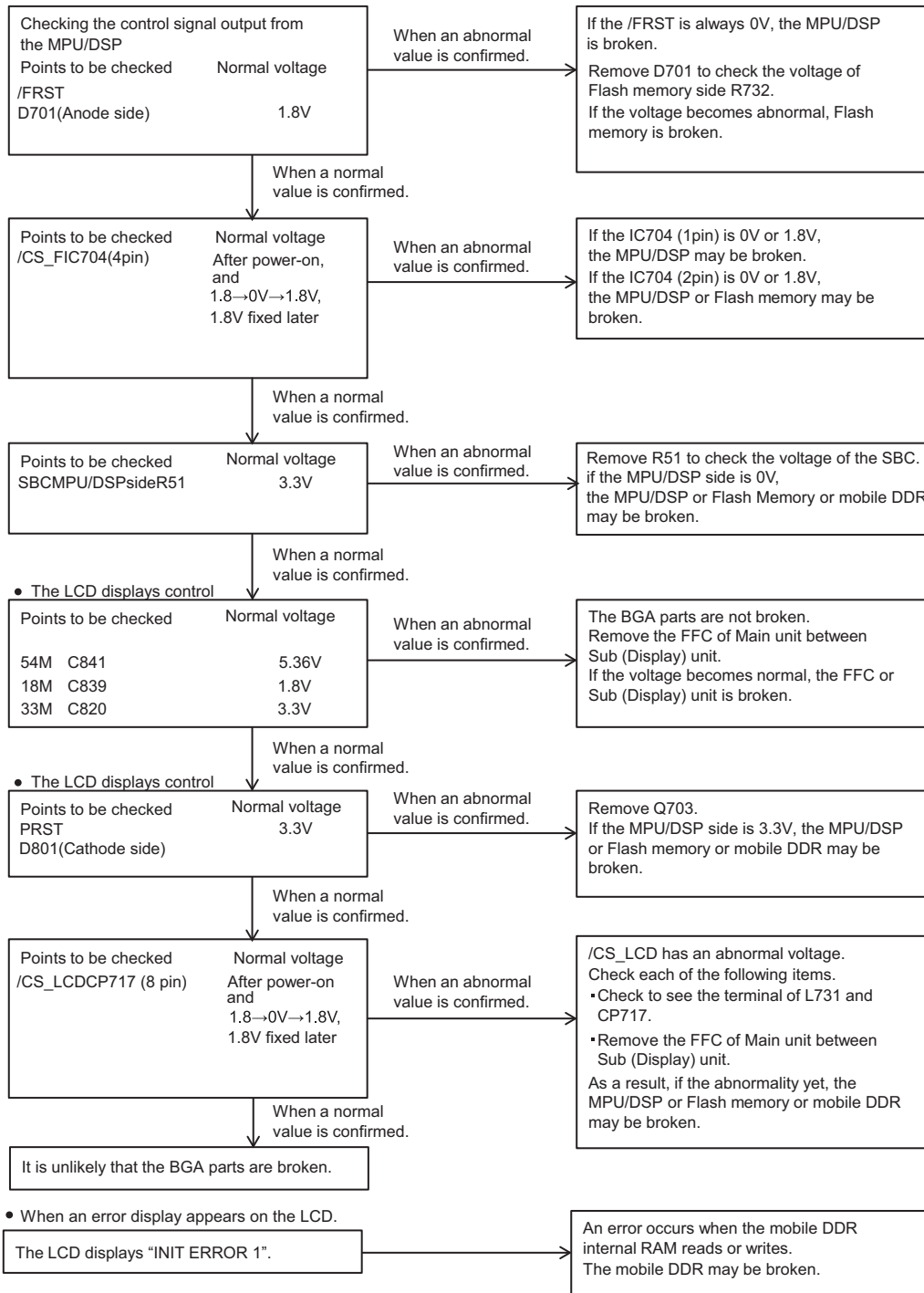

■Descriptions of signal names

(1) /RST	:MPU/DSP reset signal	LOW→Reset
(2) /BINT2	:Battery final voltage monitoring	LOW→Final voltage
(3) /OVRB_OUT	:Battery overvoltage monitoring	LOW→Overvoltage
(4) /PSW_OUT	:Power switch signal	LOW→ON
(5) /IGN_OUT	:Ignition switch signal	LOW→ON
(6) /FRST	:Flash Memory reset signal	LOW→Reset
(7) /CS_F	:Flash Memory chip select signal	LOW→Active
(8) SBC	:Switch +B control	HIGH→ON
(9) 30LCD	:LCD module control 3.0V power supply	
(10) PRST	:LCD reset signal	LOW→Reset
(11) /CS_LCD	:LCD controller chip select signal	LOW→Active

5.2 Failure diagnosis of the GPS section

Over view:

When the GPS function does not operate, use this flowchart to determine the problem.

Major parts for a GPS circuit

- GPS antenna (KRA-40 (option))
- Coaxial cable (E0E-0003-00)
- SAW Filter (L9)
- Bluetooth/GPS IC (IC5)
- Level conversion IC (IC6,IC7)
- TCXO 19.2MHz (X1)
- 32.7698kHz clock (X2)
- 33BT Regulator (IC3)
- 18BT Regulator (IC2)
- 33GPS Regulator (IC4)
- MPU/DSP IC (IC706)

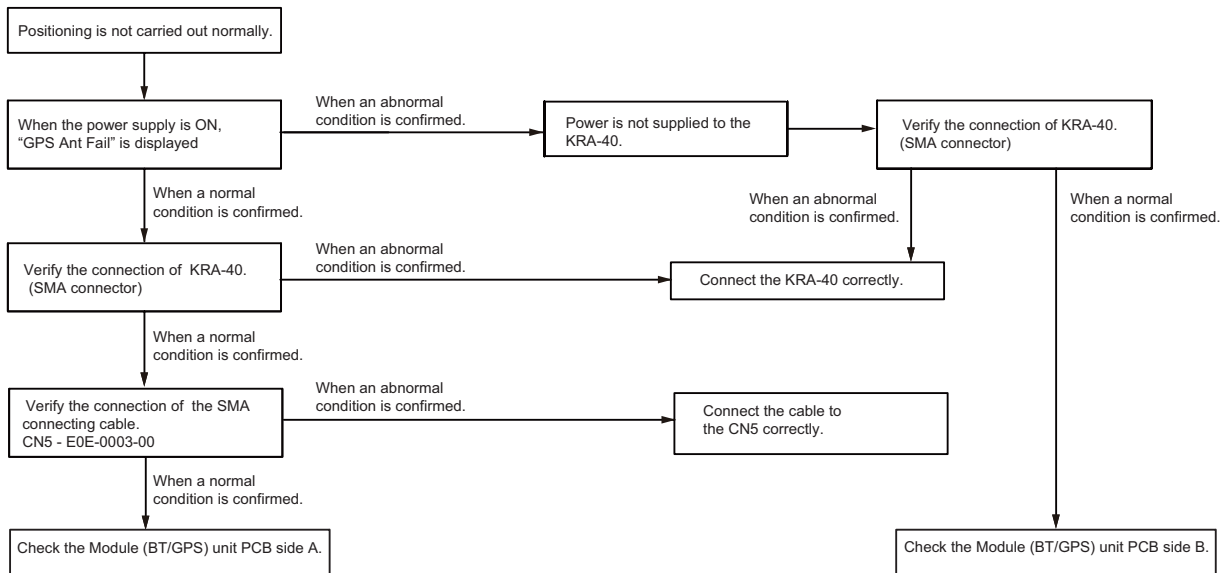
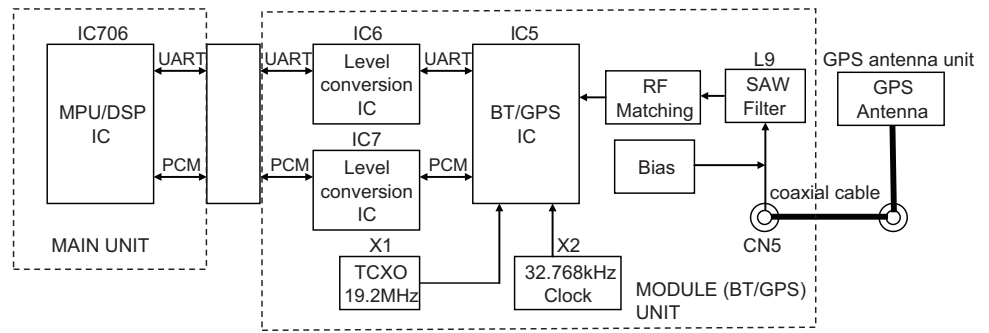

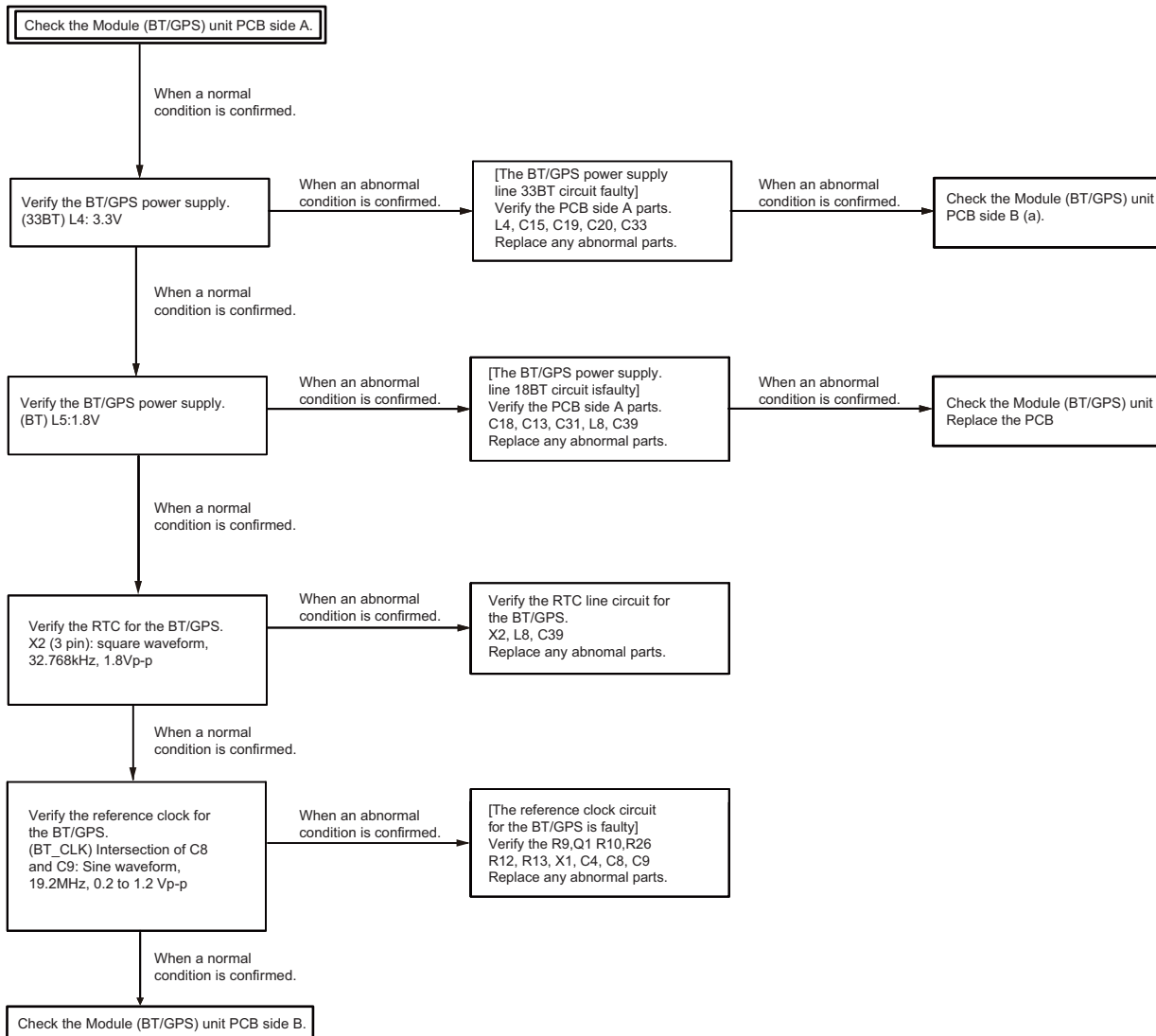

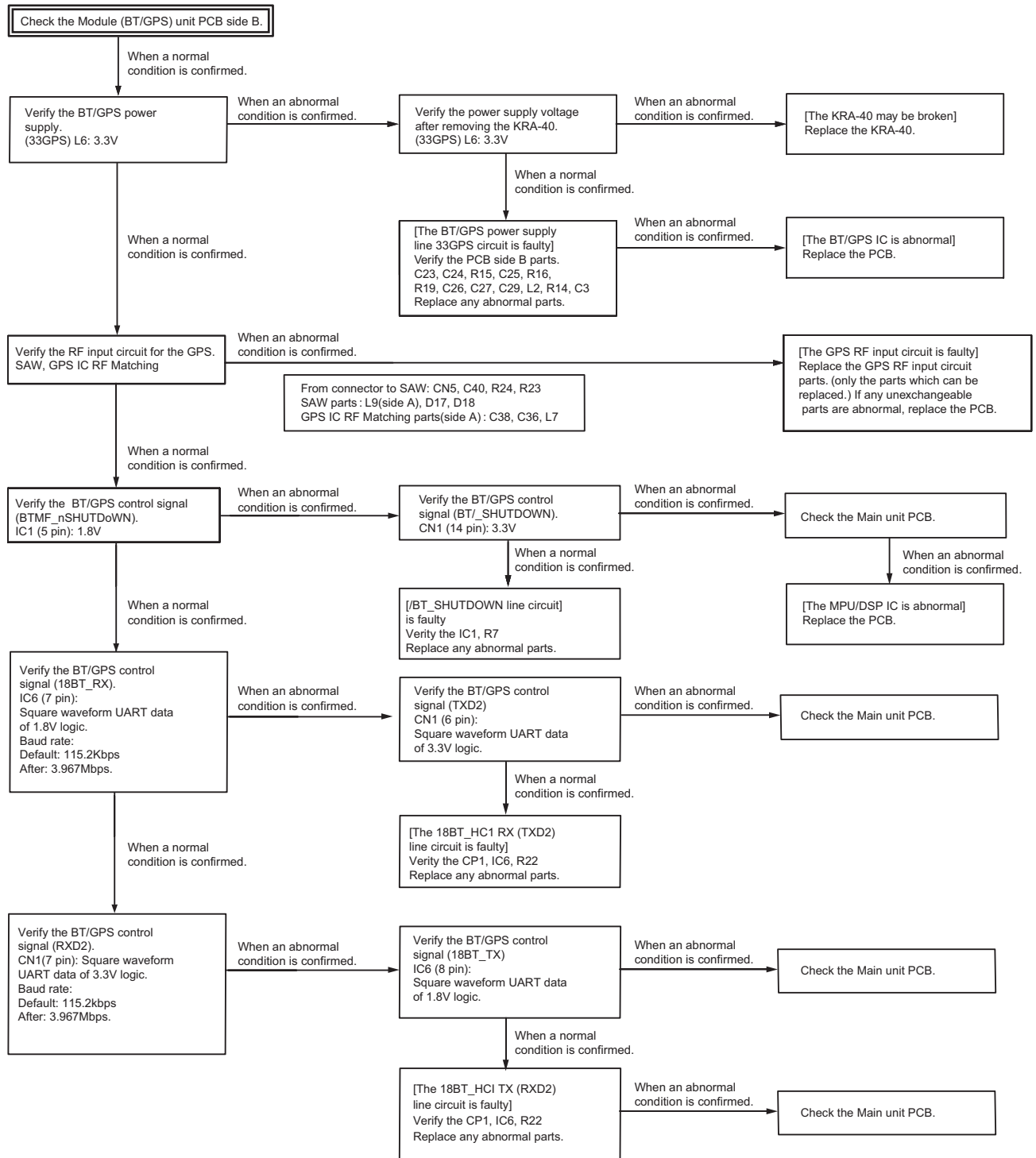

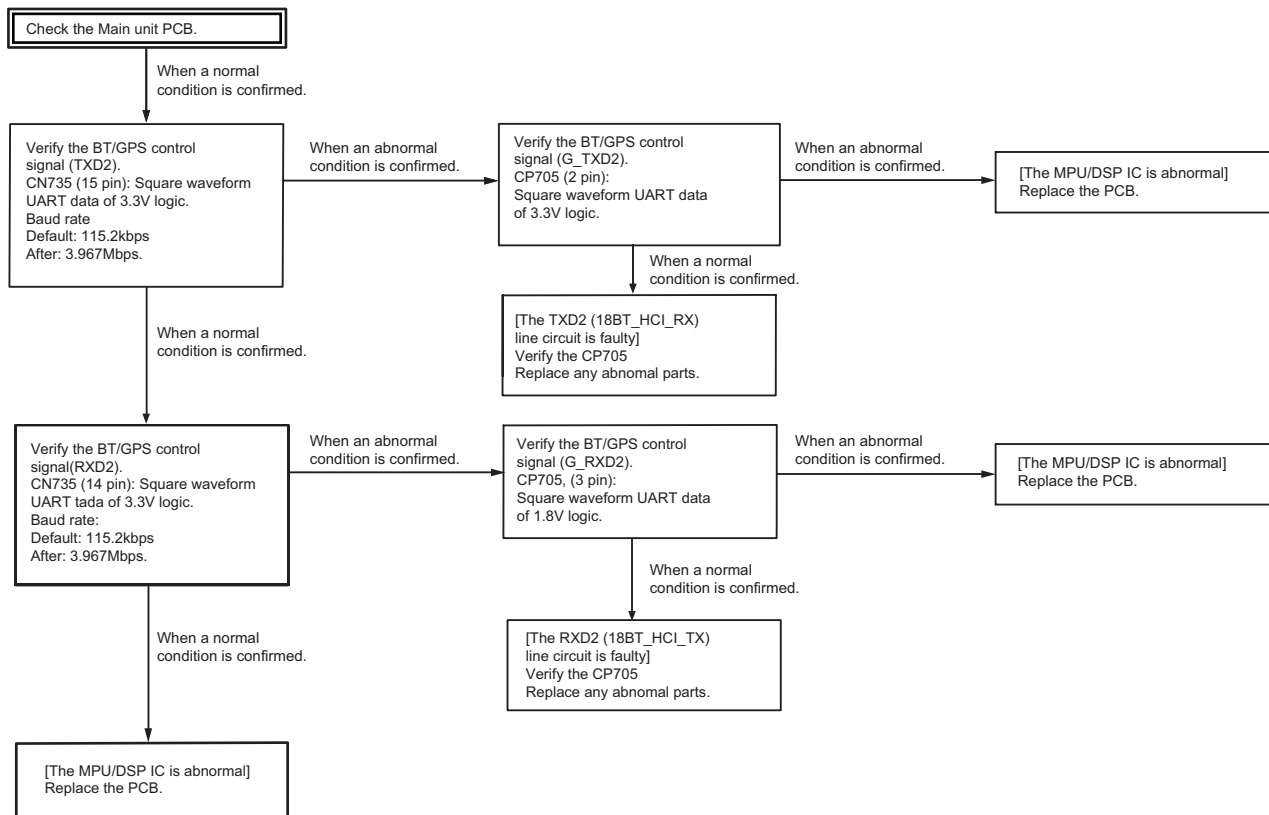

■ Descriptions of signal names

- (1) 33BT: BT/GPS IC 3.3V power supply
- (2) 18BT: BT/GPS IC 1.8V power supply
- (3) 33GPS: BT/GPS IC 3.3V power supply
- (4) TXD2: BT/GPS serial data line connected to UART TX of MPU/DSP IC (MPU/DSP to BT/GPS IC)
- (5) RXD2: BT/GPS serial data line connected to UART RX of MPU/DSP IC (MPU/DSP to BT/GPS IC)
- (6) 18BT_HCI_RX: BT/GPS serial data line connected to UART RX of BT/GPS IC (MPU to BT/GPS IC)
- (7) 18BT_HCI_TX: BT/GPS serial data line connected to UART TX of GPS IC (BT/GPS IC to MPU)
- (8) /BT_SHUTDOWN: BT/GPS active control of MPU/DSP IC (MPU/DSP to BT/GPS IC) High → Active, Low → Reset

5.3 Failure diagnosis of the Bluetooth section

Over view:

When the GPS function does not operate, use this flowchart to determine the problem.

Major parts for a GPS circuit

- Bluetooth antenna (Pattern Antenna)
- LC filter (L11)
- Bluetooth/GPS (IC5)
- Level conversion IC (IC6, IC7)
- TCXO 19.2MHz (X1)
- 32.768kHz clock (X2)
- 33BT Regulator (IC3)
- 18BT Regulator (IC2)
- MPU/DSP IC (IC706)

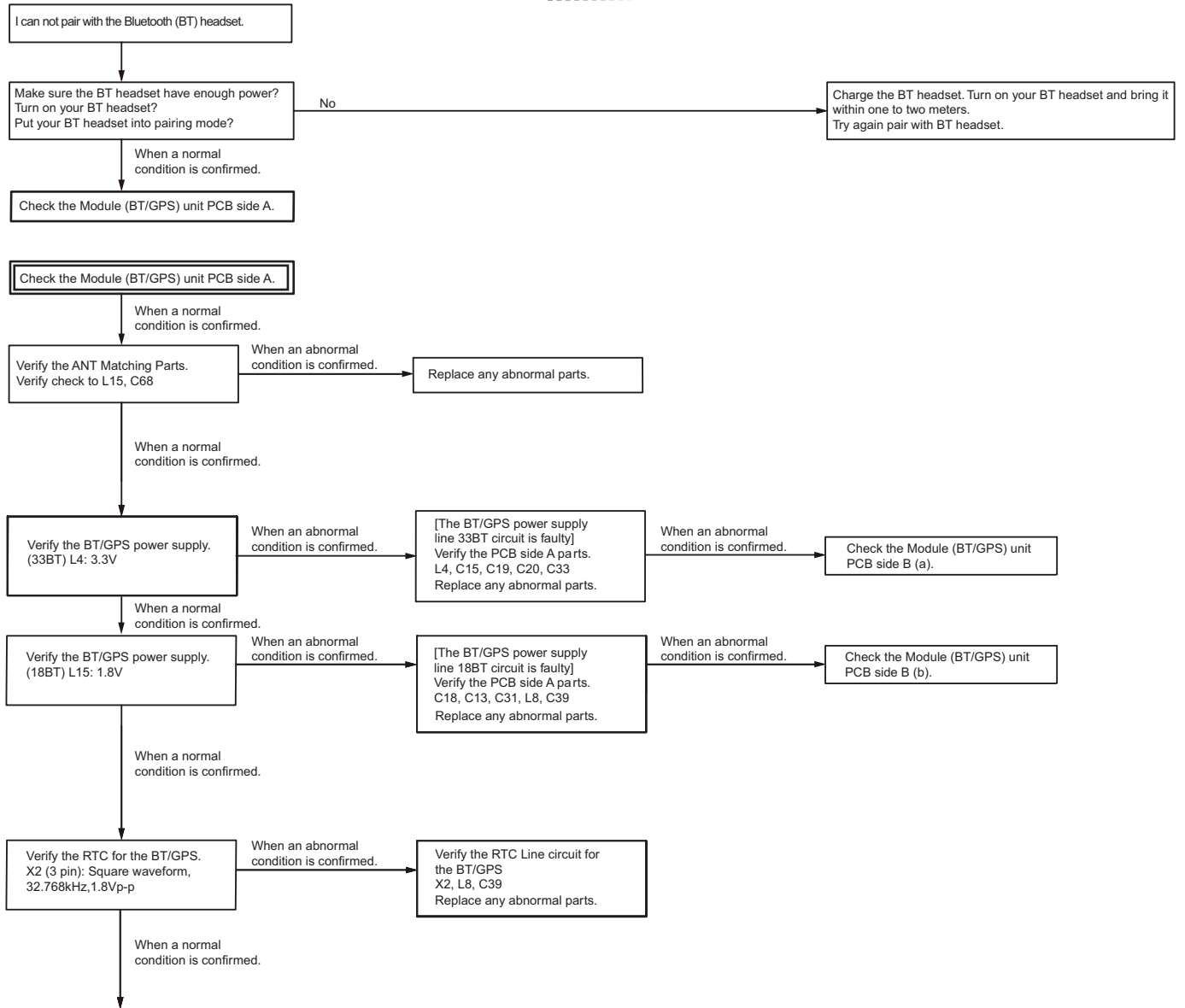
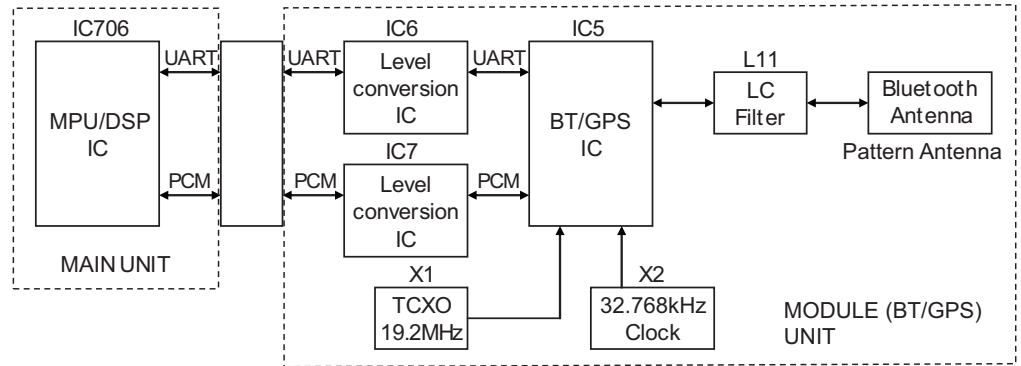

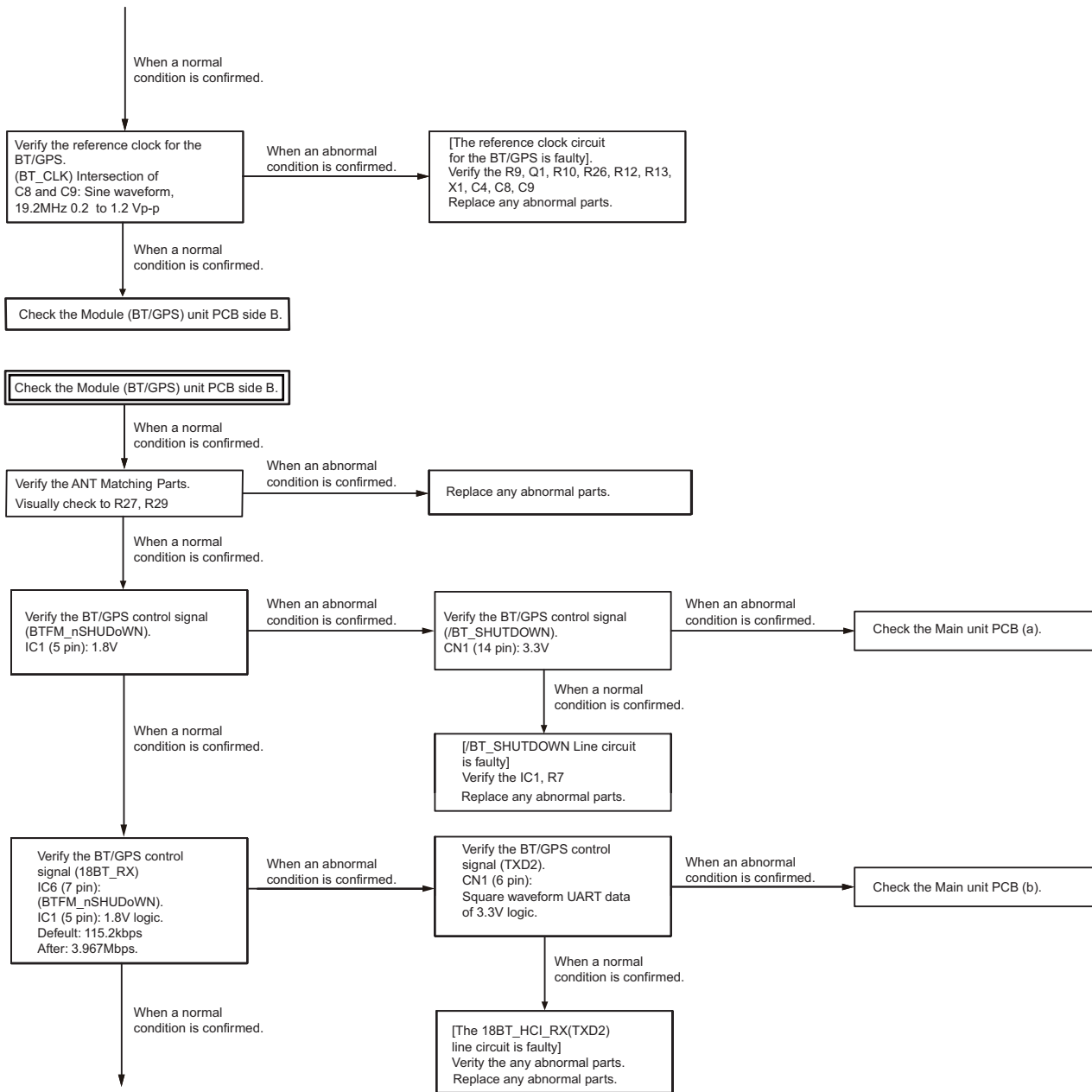

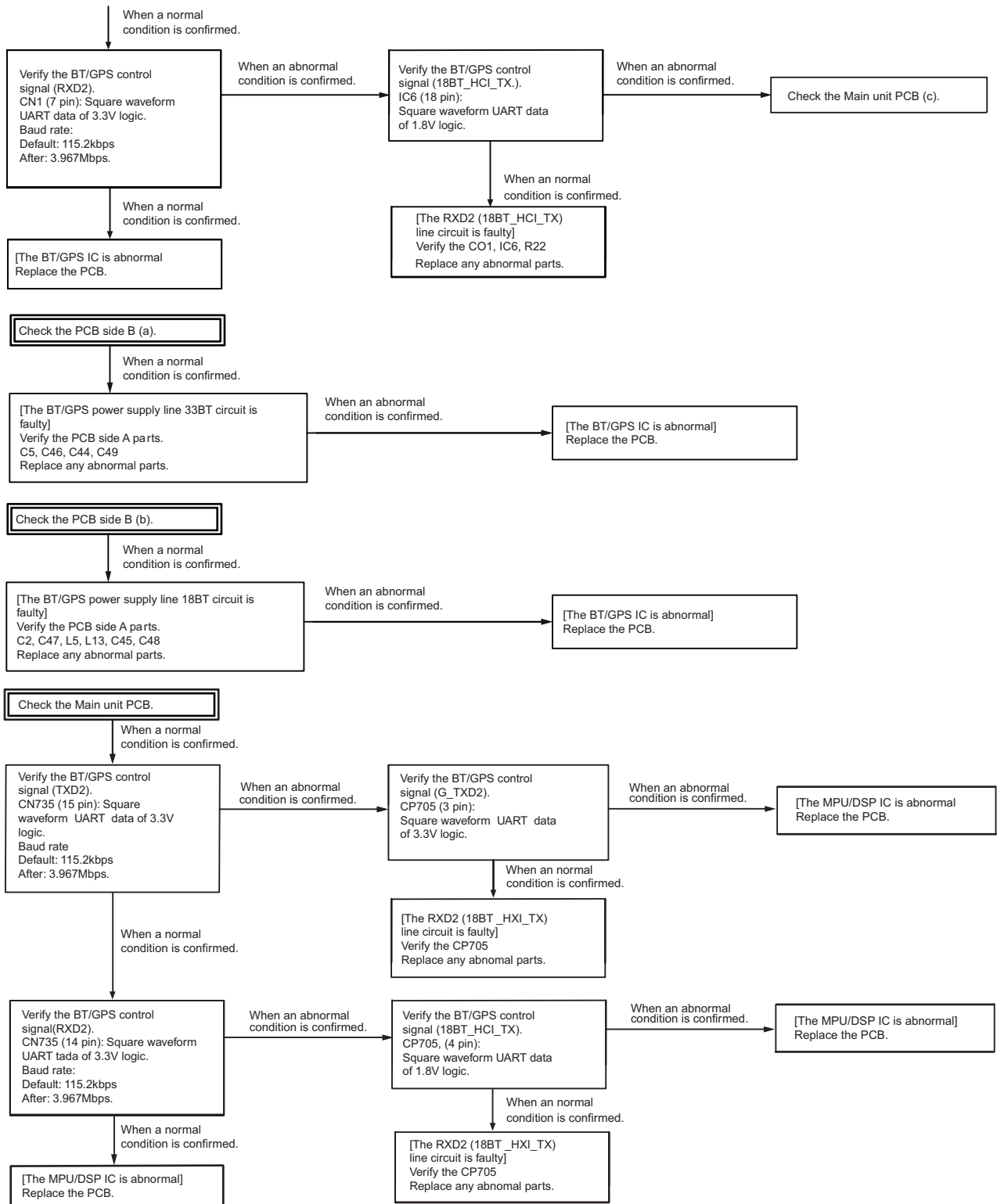

■ Descriptions of signal names

- 1) 33BT: BT/GPS IC 3.3V power supply
- 2) 18BT: BT/GPS IC 1.8V power supply
- 3) TXD2: BT/GPS serial data line connected to UART TX of MPU/DSP IC (MPU/DSP to BT/GPS IC)
- 4) RXD2: BT/GPS serial data line connected to UART RX of MPU/DSP IC (MPU/DSP to BT/GPS IC)
- 5) 18BT_HCI_RX: BT/GPS serial data line connected to UART RX of BT/GPS IC (MPU to BT/GPS IC)
- 6) 18BT_HCI_TX: BT/GPS serial data line connected to UART TX of GPS IC (BT/GPS IC to MPU)
- 7) /BT_SHUTDOWN: BT/GPS active control of MPU/DSP IC (MPU/DSP to BT/GPS IC) High →Active, Low→Reset

5.4 Replacing Main Unit

■Main unit Information

Model Name	Original Main unit Number	For Service Main unit Number
NX-5800 (F2,K2)	XC1-0391-81	XC1-0391-83

■Method of confirming “Original Main unit” and “Service Main unit”

The 0Ω resistor (R1) is mounted on the “R1” silk print part of the Service Main unit (XC1-0391-83).

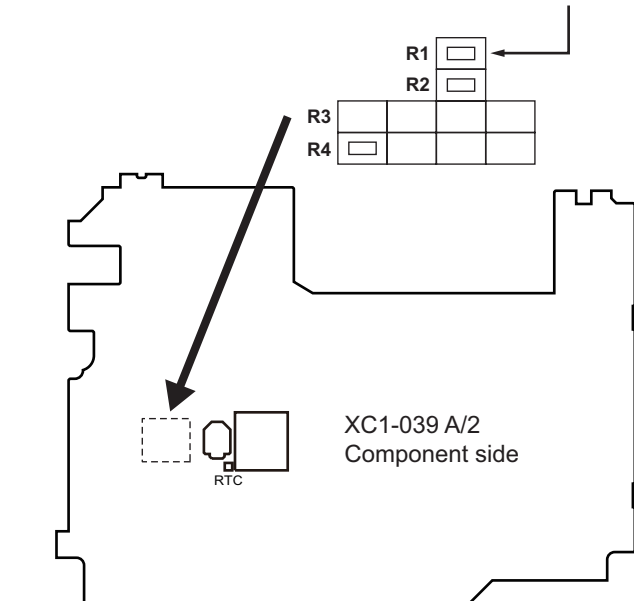

XC1-039	R1	R2	R4
1-81	(None)	0Ω	0Ω
1-83	0Ω	0Ω	0Ω

Note:

- The 0Ω resistor (R1, R2, R4) is used to differentiate the destination with a visual check. These are not connected with any PCB pattern; they are specifically for production control. There is no need to change the mount of these resistors.
- There is no difference between the schematic diagram of the Service Main unit (XC1-0391-83) and the schematic diagram of the original Main unit (XC1-0391-81). (R1, R2 and R4 are connected with GND (ground) only.)

■Supplied Accessories of “Service Main unit”

Item (Including Parts Number)	Quantity
Main Unit (XC1-039)	1
KENWOOD ESN/ NXDN ESN/ Product Number/ MPT ESN/ P25 ESN Label	1

■Service Main unit” Data

The following data is written on the service unit:

Data Type	Description
Firmware	NX-5800 Firmware.
FPU Data (PC programming mode)	XC1-039 (NX-5800) F2, K2 type data.
Various Adjustment Data (PC Test mode)	General adjustment values for the XC1-039 (NX-5800).
KENWOOD ESN	Model name: [XC1-039] NX-5800S2 Type: F2 The same number as the KENWOOD ESN label is written.
NXDN ESN/MPT ESN/ Product number/ P25 ESN	The same number as the NXDN ESN/ MPT ESN/Product Number/P25 ESN label is written.

■After Changing the PCB

- After changing the printed circuit board, write the up-to-date Firmware following the instructions in the “2.2 REALIGNMENT - 2.2.6 Firmware Programming Mode”.
 - Write the Firmware in accordance to the Market. If you write different Market Firmware, there are times communication with the FPU is not possible.
- Using the KPG-D1/D1N, select your desired item (Model Name and Frequency) from the Model> Product Information menu, then use Program> Write Data to the Transceiver to write the FPU data (PC Programming mode). When writing to the transceiver, a Warning Message, corresponding to the item selected, appears. Click [OK] to continue writing the data.
- Enter Program> Test Mode, then adjust the various adjustment data (PC Test Mode) as described in the “SECTION 4 ADJUSTMENT”.
- Attach the new labels corresponding to the new printed circuit board. (Refer to the images below for label placement.)
- If necessary, write the FPU data used by the customer with the KPG-D1/D1N.

Note:

- When using the ESN Validation function of NXDN Trunking, the NXDN ESN number changes when the circuit board is changed (the number is written on the circuit board); the NXDN Trunking System cannot be accessed. Use the KPG-110SM on the NXDN Trunking System side to reprogram the NXDN ESN number.

- When a new printed circuit board is used, the KENWOOD ESN changes, as does the Transceiver Information display of the KPG-D1/D1N, but this does not have any effect on the operation of the transceiver.
- If changing to the original ESN, please contact our service center.

■ESN Label Layout

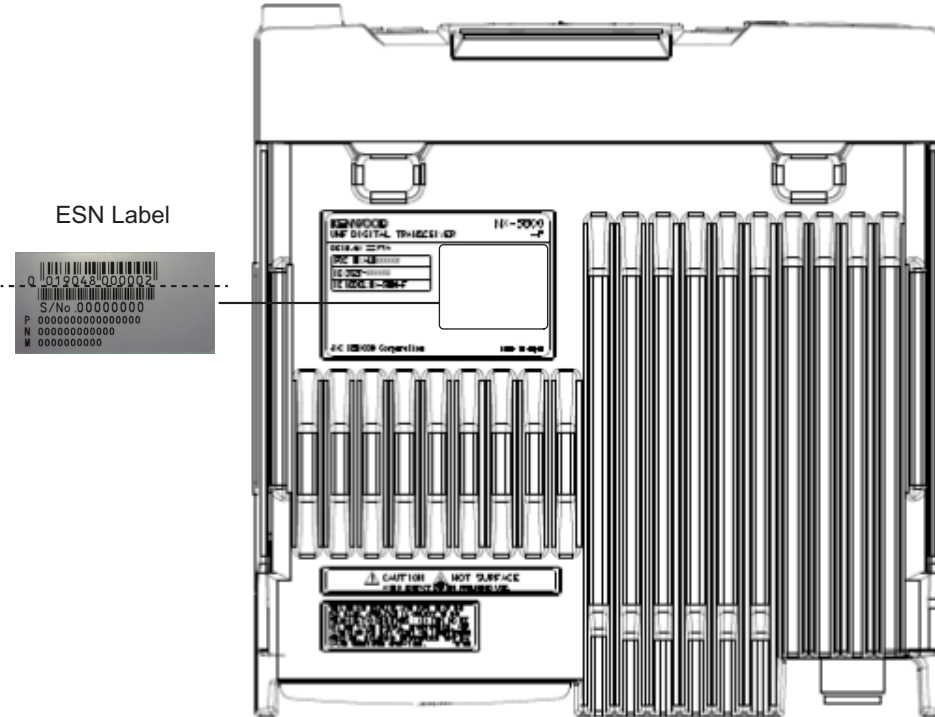

MEMO

SCHEMATIC DIAGRAM

MAIN UNIT (XC1-0391-81)

MAIN UNIT (A2)(XC1-0391)

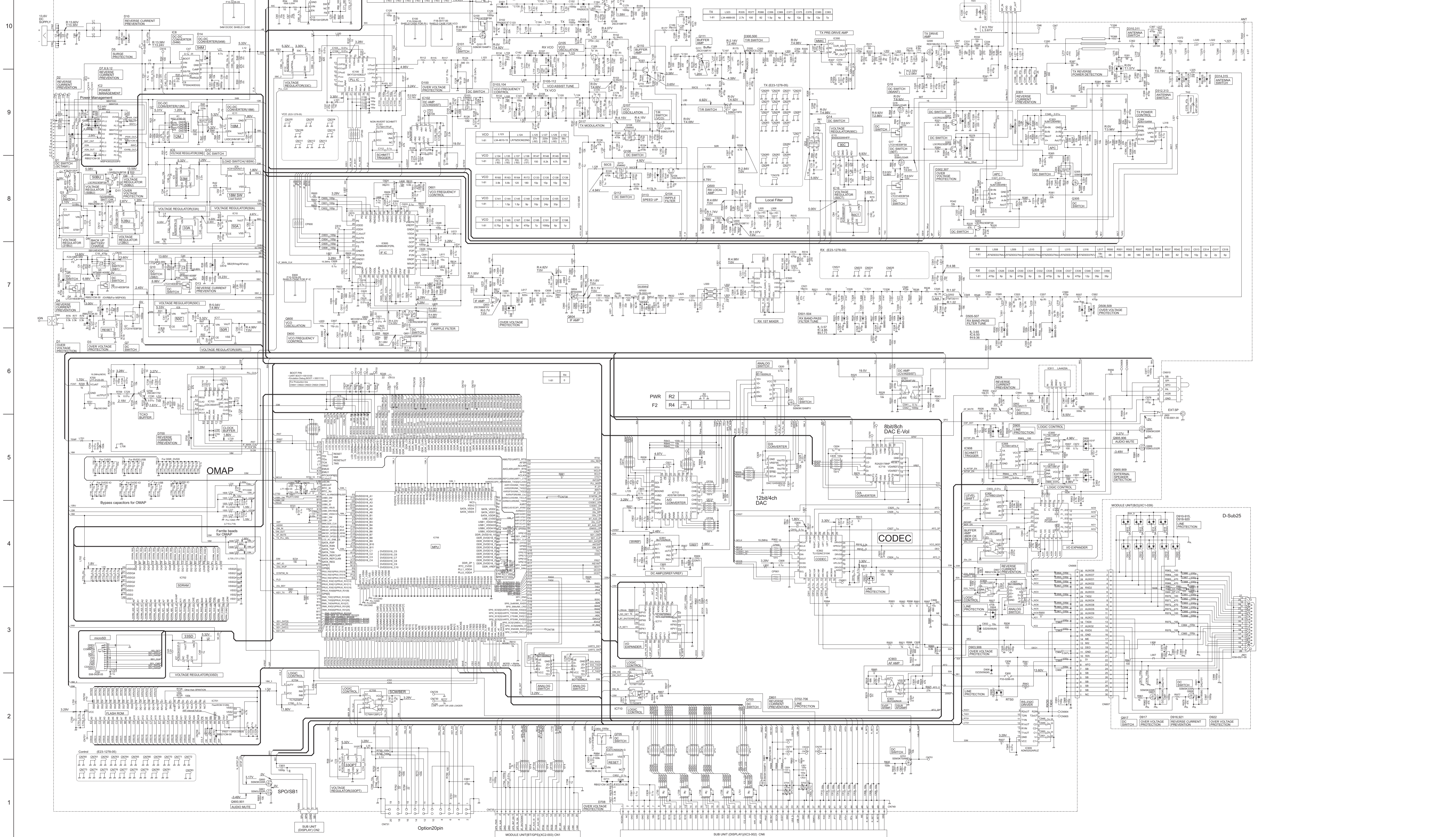

■ SUB (Display) UNIT

Sub (Display) Unit (XC3-002)

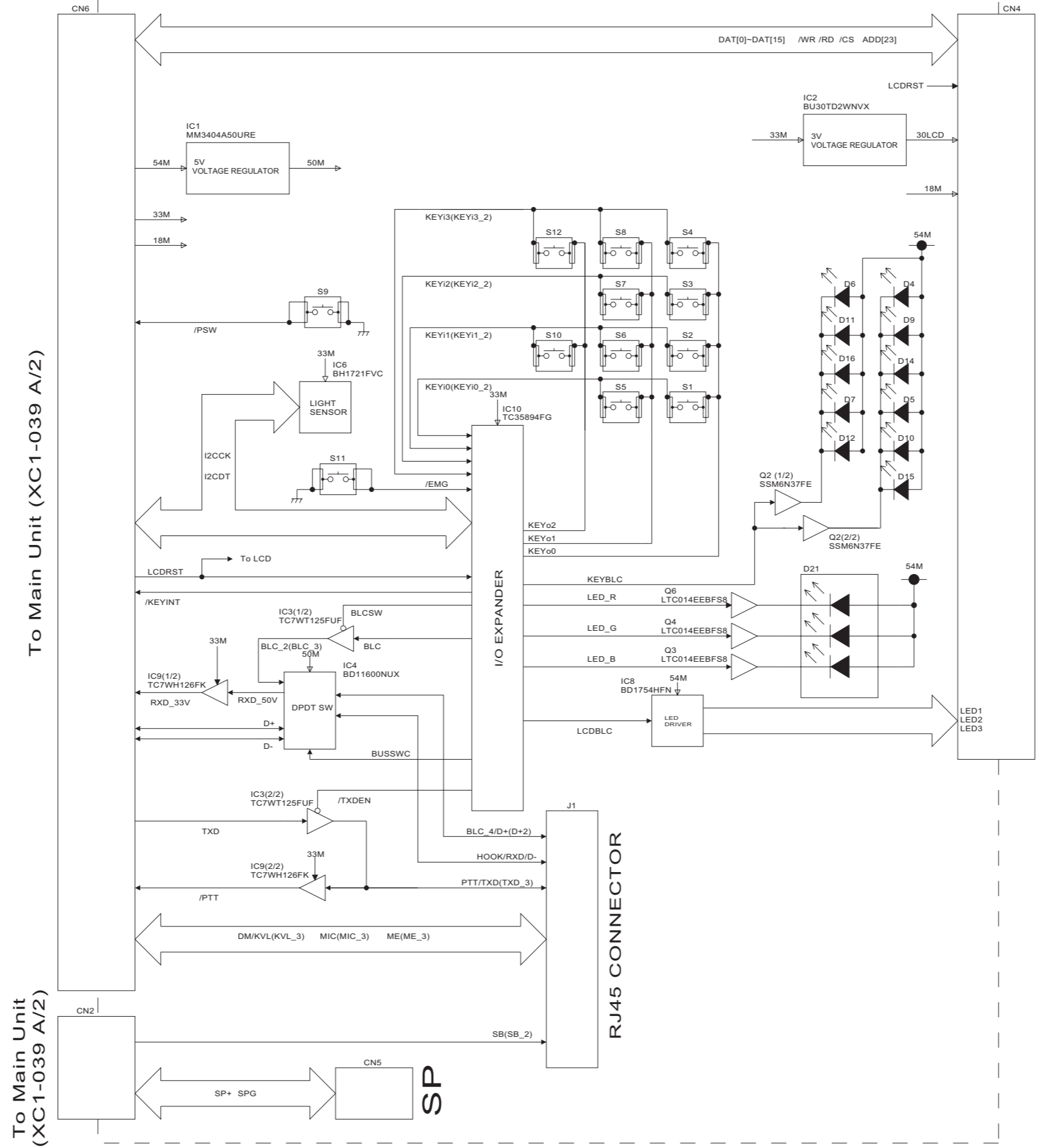

■ MAIN UNIT (XC1-0391-81)

--- Foil side view (J7C-0036-00) ---

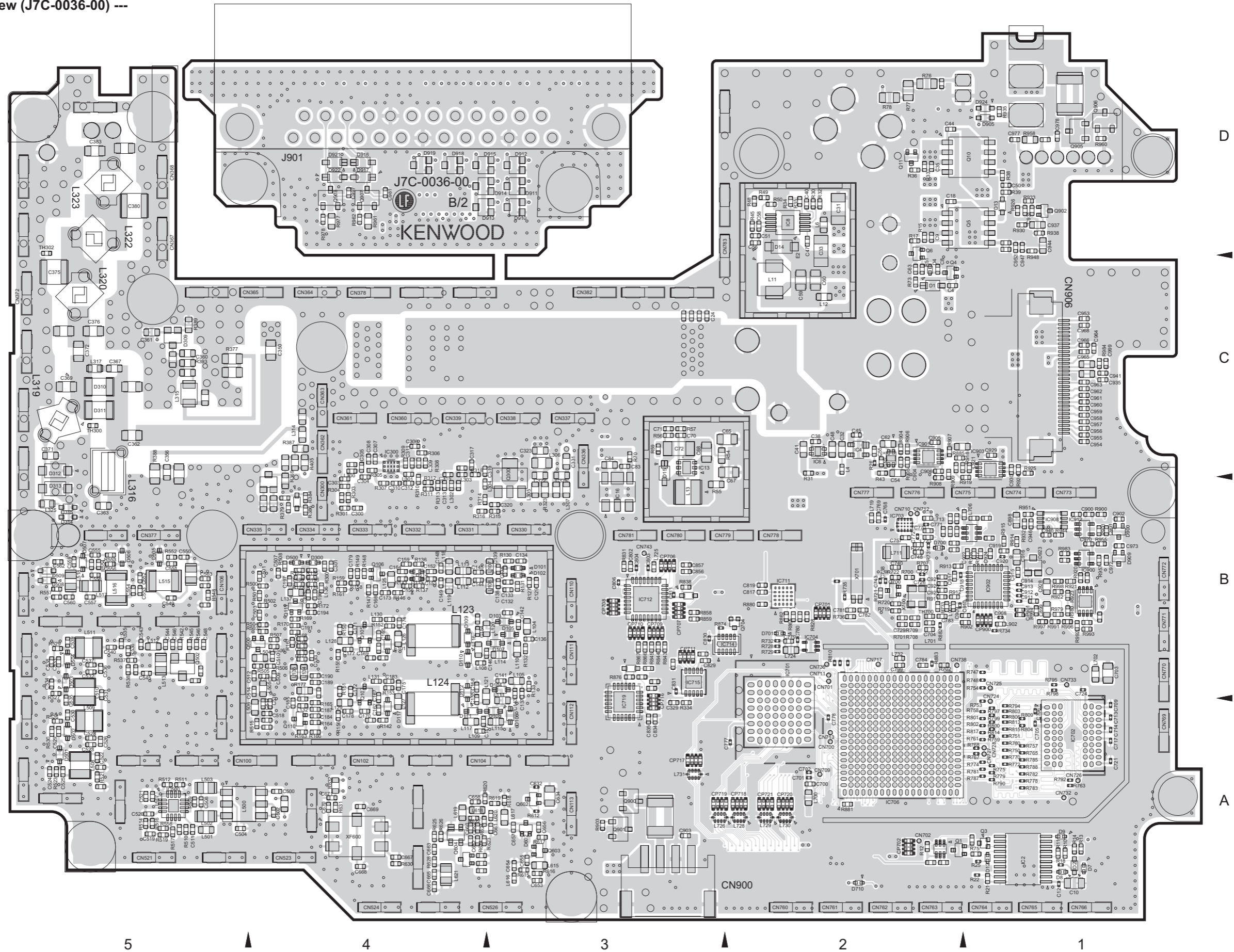

■ MODULE (BT/GPS) UNIT (XC2-0031-80)

--- Component side view (J7C-0037-00) ---

--- Foil side view (J7C-0037-00) ---

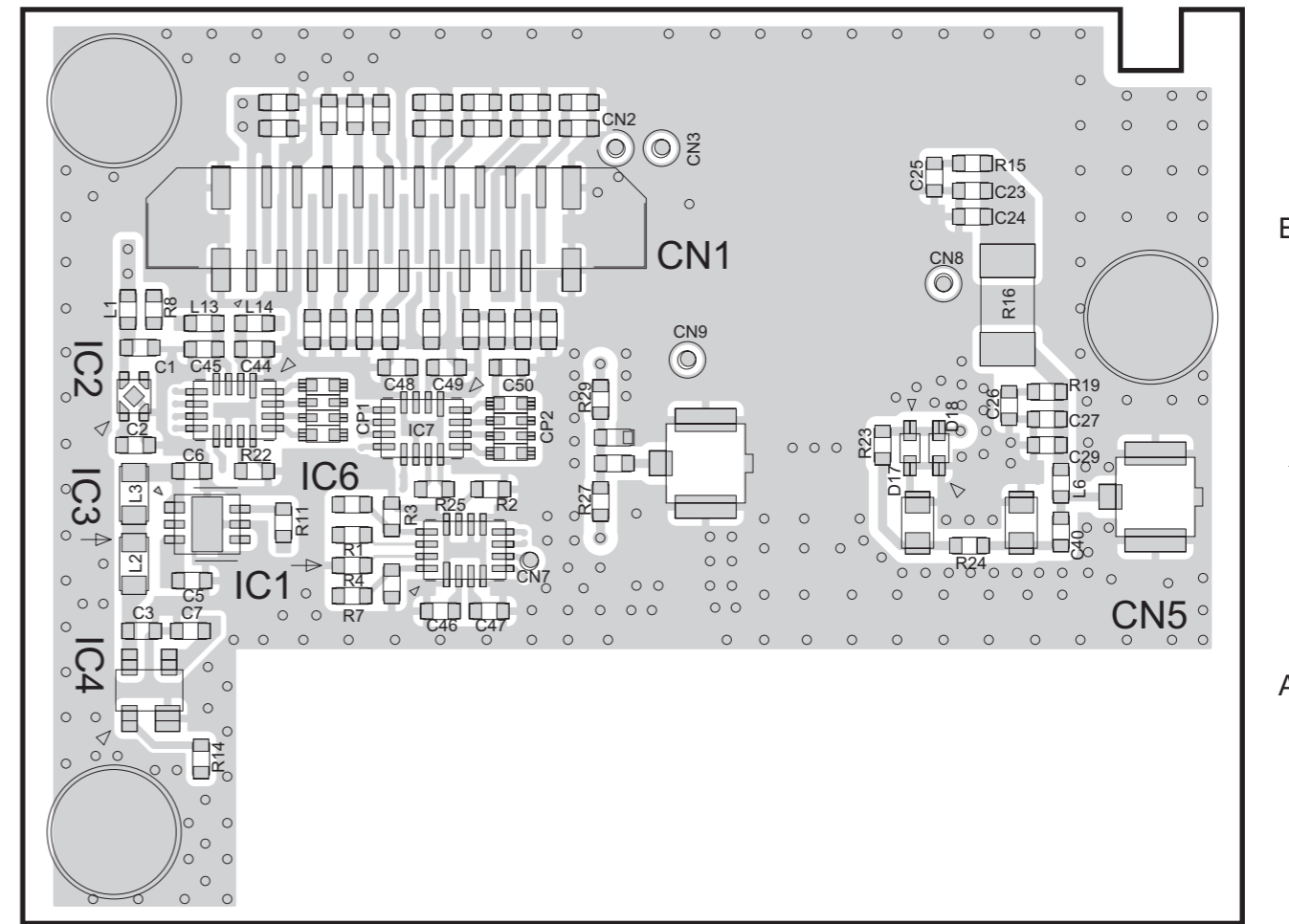
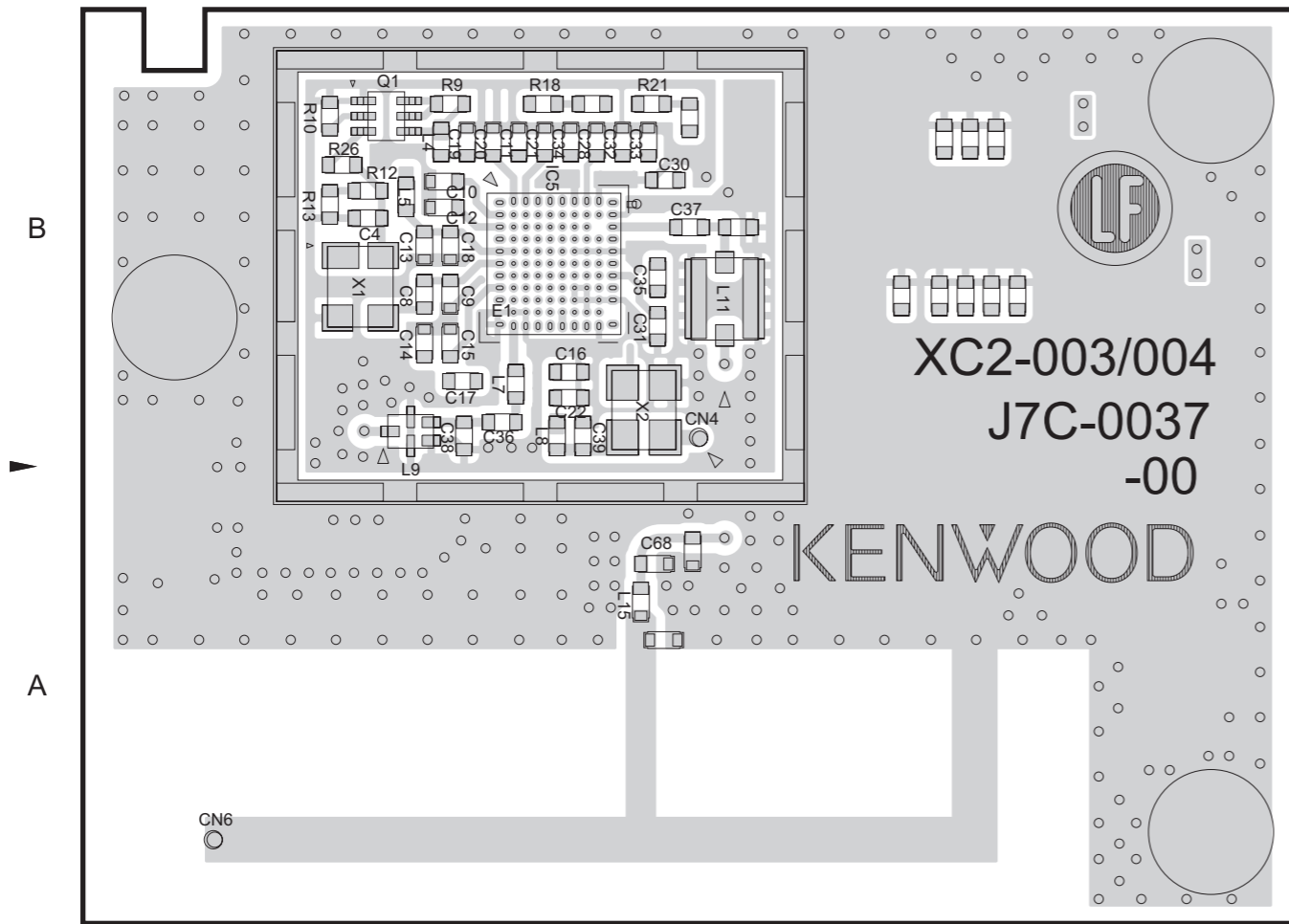

1 2 3 3 2 1

● ADDRESS TABLE OF BOARD PARTS

Each address may have an address error by one interval.



REF.NO.	LOCATION	REF.NO.	LOCATION	REF.NO.	LOCATION	REF.NO.	LOCATION	REF.NO.	LOCATION	REF.NO.	LOCATION
IC		R7	B-3A	CAPACITOR	C21	A-2B	C45	B-3B			
IC1	B-2A	R8	B-3B	C1	B-3B	C22	A-2B	C46	B-2A	CP1	B-3B
IC2	B-3B	R9	A-1B	C2	B-3B	C23	B-1B	C47	B-2A	CP2	B-2B
IC3	B-3A	R10	A-1B	C3	B-3A	C24	B-1B	C48	B-3B		
IC4	B-3A	R11	B-3A	C4	A-1B	C25	B-1B	C49	B-2B	E1	A-2B
IC5	A-2B	R12	A-1B	C5	B-3A	C26	B-1B	C50	B-2B		
IC6	B-3B	R13	A-1B	C6	B-3A	C27	B-1B	C68	A-2A	L1	B-3B
IC7	B-3B	R14	B-3A	C7	B-3A	C28	A-2B			L2	B-3A
		R15	B-1B	C8	A-1B	C29	B-1B	OTHER		L3	B-3A
TRANSISTOR		R16	B-1B	C9	A-1B	C30	A-2B	X1	A-1B	L4	A-1B
Q1	A-1B	R18	A-2B	C10	A-1B	C31	A-2B	X2	A-2B	L5	A-1B
		R19	B-1B	C11	A-2B	C32	A-2B			L6	B-1A
DIODE		R21	A-2B	C12	A-1B	C33	A-2B	CN1	B-3B	L7	A-2B
D17	B-1B	R22	B-3A	C13	A-1B	C34	A-2B	CN2	B-2B	L8	A-2B
D18	B-1B	R23	B-1B	C14	A-1B	C35	A-2B	CN3	B-2B	L9	A-1B
		R24	B-1A	C15	A-1B	C36	A-2B	CN4	A-2B	L11	A-2B
RESISTOR		R25	B-2A	C16	A-2B	C37	A-2B	CN5	B-1A	L13	B-3B
R1	B-3A	R26	A-1B	C17	A-1B	C38	A-1B	CN6	A-1A	L14	B-3B
R2	B-2A	R27	B-2A	C18	A-1B	C39	A-2B	CN7	B-2A	L15	A-2A
R3	B-3A	R29	B-2B	C19	A-1B	C40	B-1A	CN8	B-1B		
R4	B-3A			C20	A-2B	C44	B-3B	CN9	B-2B		

■ SUB (DISPLAY) UNIT (XC3-0020-20) (NX-5800_K2)

--- Component side view (J7C-0038-00) ---

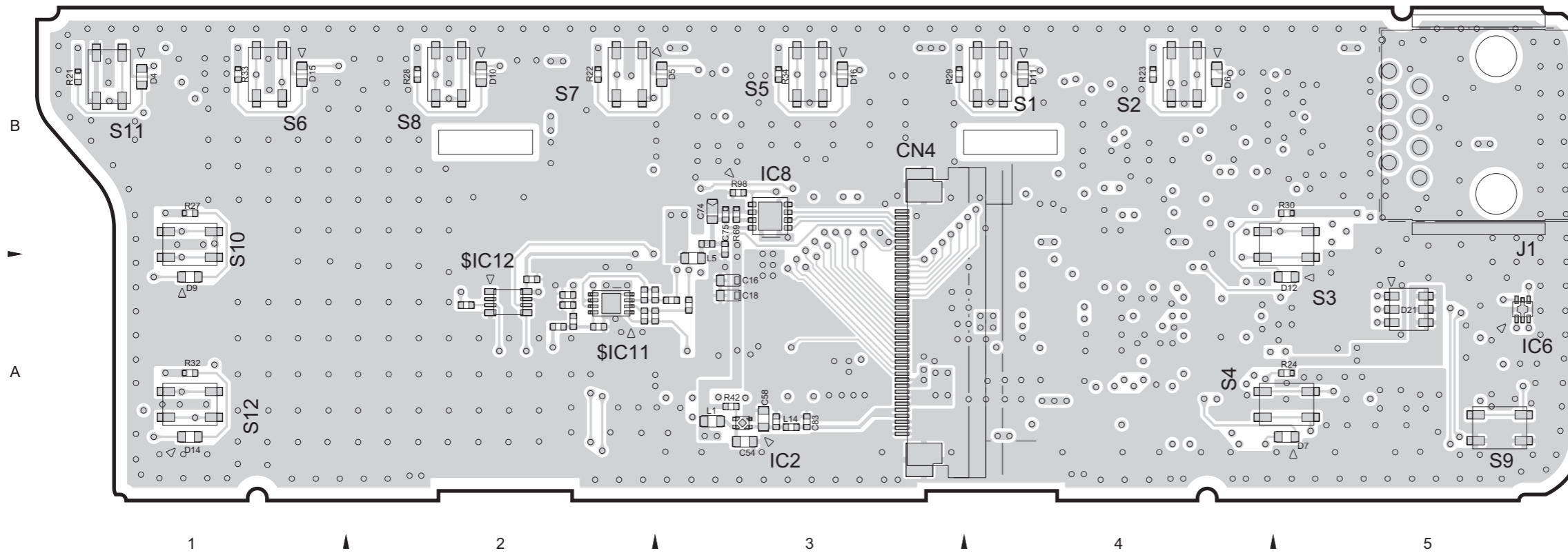

● ADDRESS TABLE OF BOARD PARTS

Each address may have an address error by one interval.



REF.NO.	LOCATION	REF.NO.	LOCATION	REF.NO.	LOCATION
IC		R52	B-5A	S7	A-2B
IC1	B-4B	R53	B-4B	S8	A-2B
IC2	A-3A	R54	B-4A	S9	A-5A
IC3	B-4B	R55	B-4A	S10	A-1B
IC4	B-4B	R60	B-5B	S11	A-1B
IC6	A-5A	R61	B-5B	S12	A-1A
IC8	A-3B	R62	B-5B		
IC9	B-4B	R63	B-5B	J1	A-5B
IC10	B-4A	R64	B-5A		
IC12	B-3B	R65	B-5B	L1	A-3A
		R66	B-5B	L2	B-4B
TRANSISTOR					
		R69	A-3B	L3	B-4A
		R71	B-5B	L4	B-5A
Q2	B-3B	R77	B-5A	L5	A-3A
Q3	B-5A	R78	B-5A	L11	B-3A
Q4	B-5A	R79	B-4B	L14	A-3A
Q6	B-5A	R81	B-4A	L15	B-4A
		R82	B-5A	L16	B-3A
		R83	B-4A	L17	B-3A
		R86	B-2A	L18	B-3A
DIODE					
D1	B-3B	R87	B-4B		
D2	B-3B	R88	B-4B		
D4	A-1B	R98	A-3B		
D5	A-3B	R99	B-4B		
D6	A-4B				
D7	A-5A	CAPACITOR			
D9	A-1A	C2	B-2B		
D10	A-2B	C5	B-2B		
D11	A-4B	C8	B-2B		
D12	A-5A	C9	B-3A		
D14	A-1A	C11	B-3A		
D15	A-1B	C16	A-3A		
D16	A-3B	C18	A-3A		
D20	B-5B	C22	B-4A		
D21	A-5A	C24	B-4A		
D22	B-5B	C29	B-3A		
D23	B-5B	C32	B-3B		
D24	B-5B	C42	B-3A		
D25	B-5B	C43	B-3A		
D26	B-5B	C44	B-3B		
D27	B-5B	C45	B-3A		
D28	B-5B	C46	B-3B		
D29	B-5B	C48	B-3A		
D30	B-5B	C50	B-3A		
D31	B-5B	C52	B-4B		
D32	B-5B	C53	B-4A		
RESISTOR					
R3	B-3A	C54	A-3A		
R4	B-3A	C55	B-4A		
R5	B-3A	C56	B-4A		
R6	B-3A	C57	B-4B		
R7	B-3B	C58	A-3A		
R9	B-3A	C59	B-4B		
R10	B-2A	C62	B-4B		
R11	B-3B	C63	B-4A		
R12	B-3A	C64	B-4A		
R17	B-2A	C65	B-4A		
R18	B-3B	C66	B-4B		
R19	B-3B	C67	B-5A		
R20	B-4A	C68	B-5A		
R21	A-1B	C69	B-4B		
R22	A-2B	C70	B-5B		
R23	A-4B	C71	B-5A		
R24	A-5A	C73	B-3B		
R25	B-4A	C74	A-3B		
R26	B-3B	C75	A-3B		
R27	A-1B	C76	B-5A		
R28	A-2B	C79	B-5B		
R29	A-3B	C83	A-3A		
R30	A-5B	C84	B-3A		
R31	B-4A	C87	B-5A		
R32	A-1A	C90	B-3B		
R33	A-1B	C101	B-4A		
R34	A-3B	OTHER			
R38	B-4A	CN2	B-2B		
R39	B-4A	CN4	A-3A		
R40	B-4A	CN5	B-2B		
R41	B-4A	CN6	B-3A		
R42	A-3A				
R43	B-4B				
R46	B-5A	S1	A-4B		
R47	B-4B	S2	A-4B		
R48	B-4B	S3	A-5B		
R49	B-5A	S4	A-5A		
R50	B-5A	S5	A-3B		
R51	B-5B	S6	A-1B		

--- Foil side view (J7C-0038-00) ---

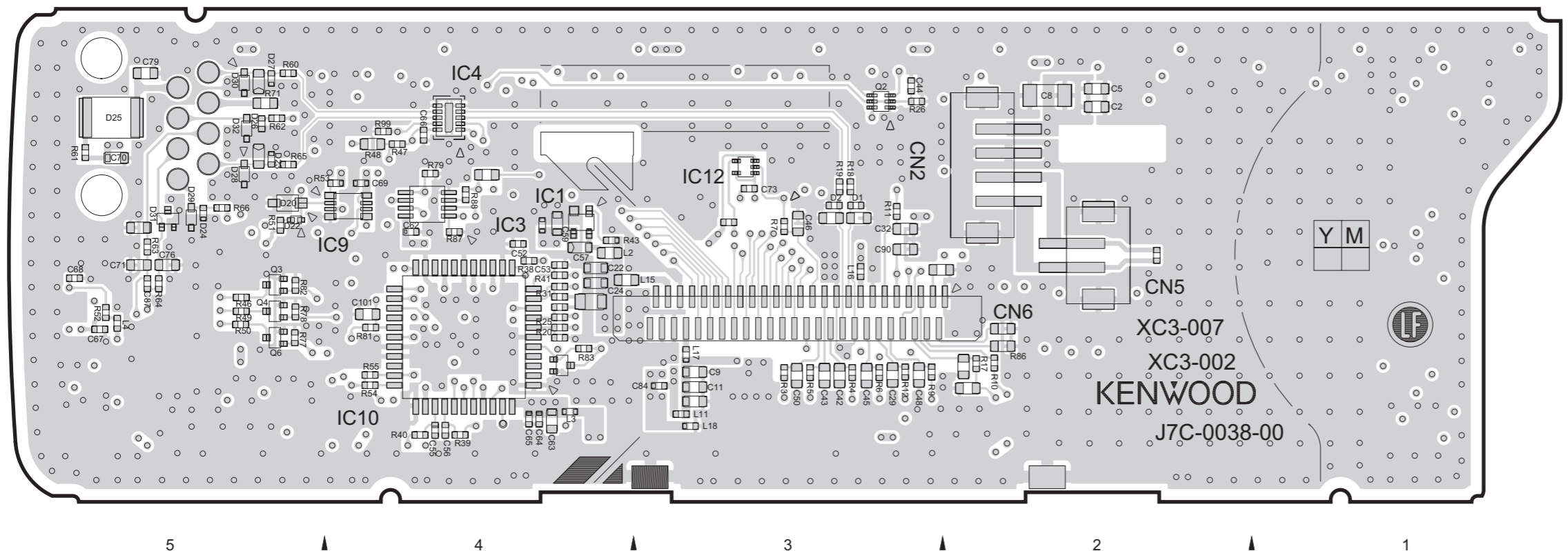

MODULE (BT/GPS) UNIT (XC2-0031-80)

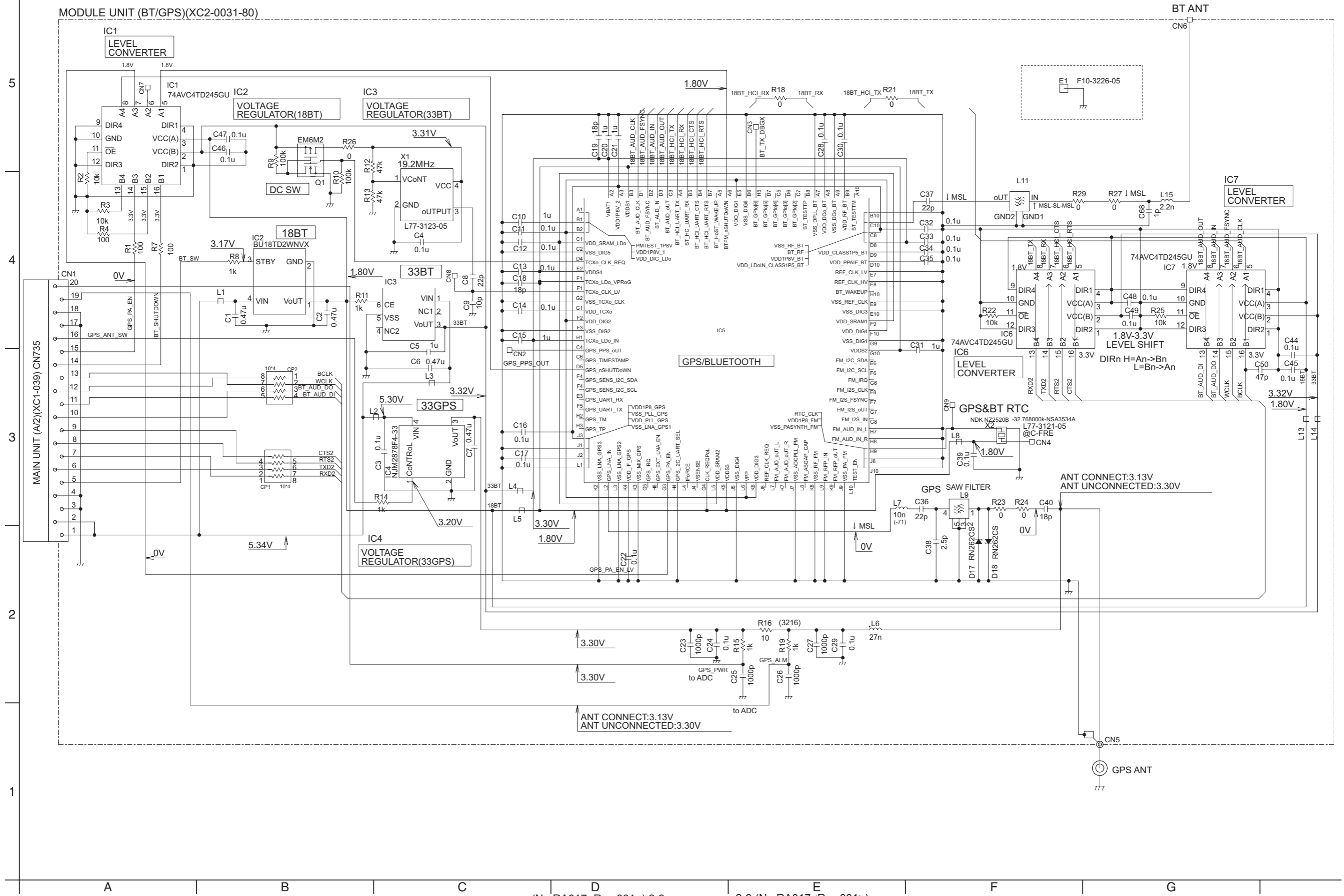

■ SUB (DISPLAY) UNIT (XC3-0020-20) (NX-5800_K2)

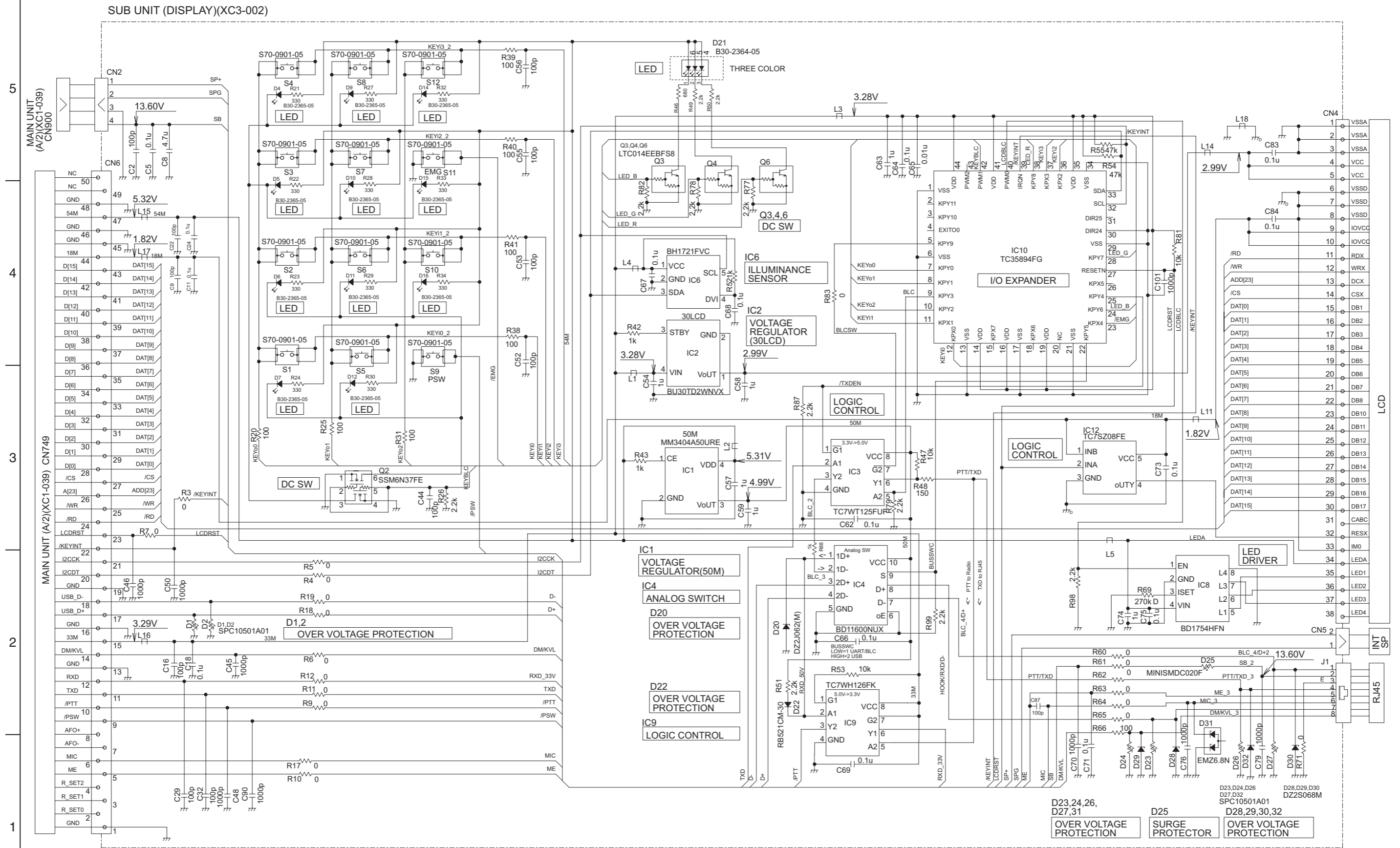

INTERCONNECTION DIAGRAM

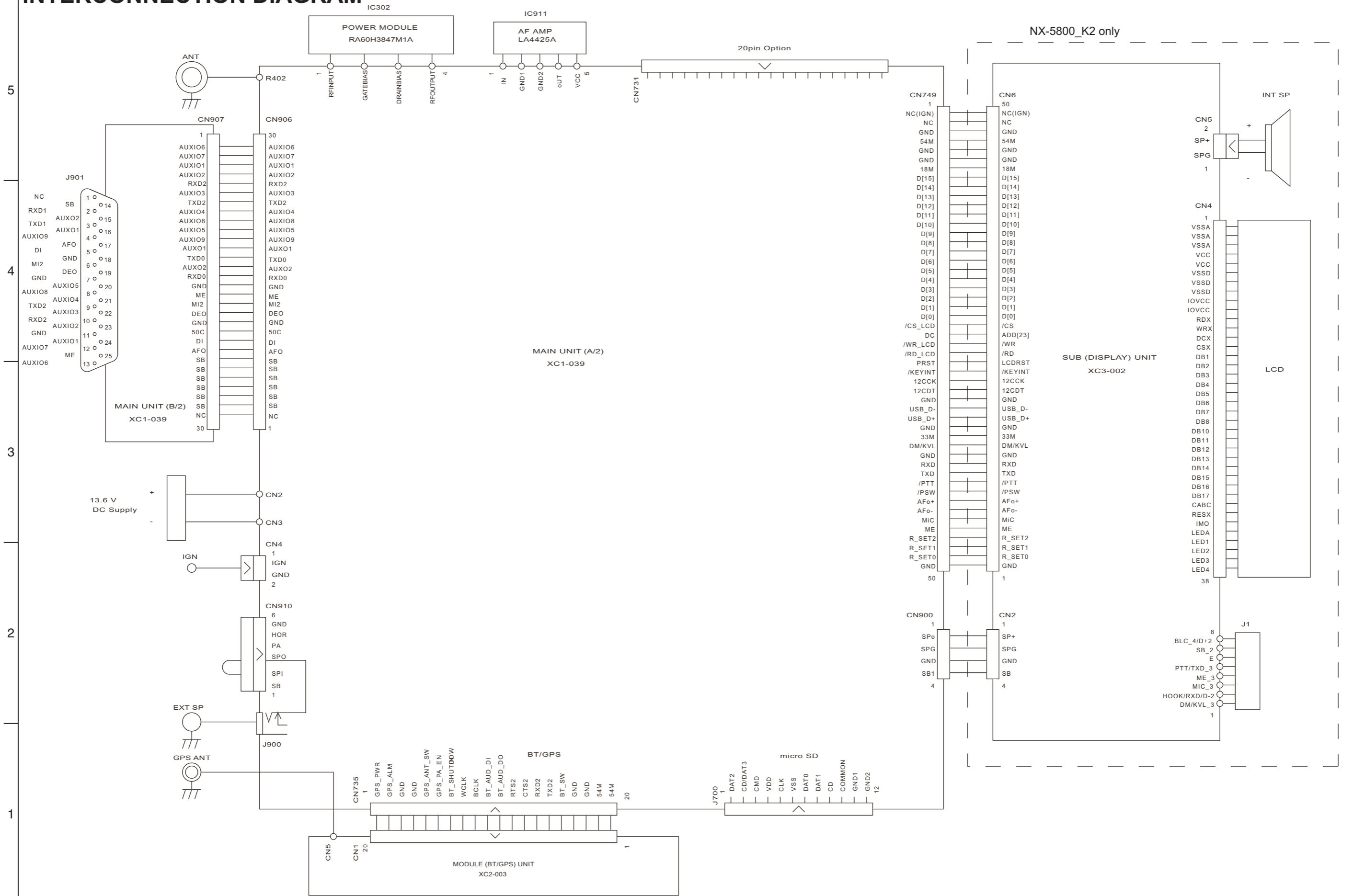

LEVEL DIAGRAM

Receiver section

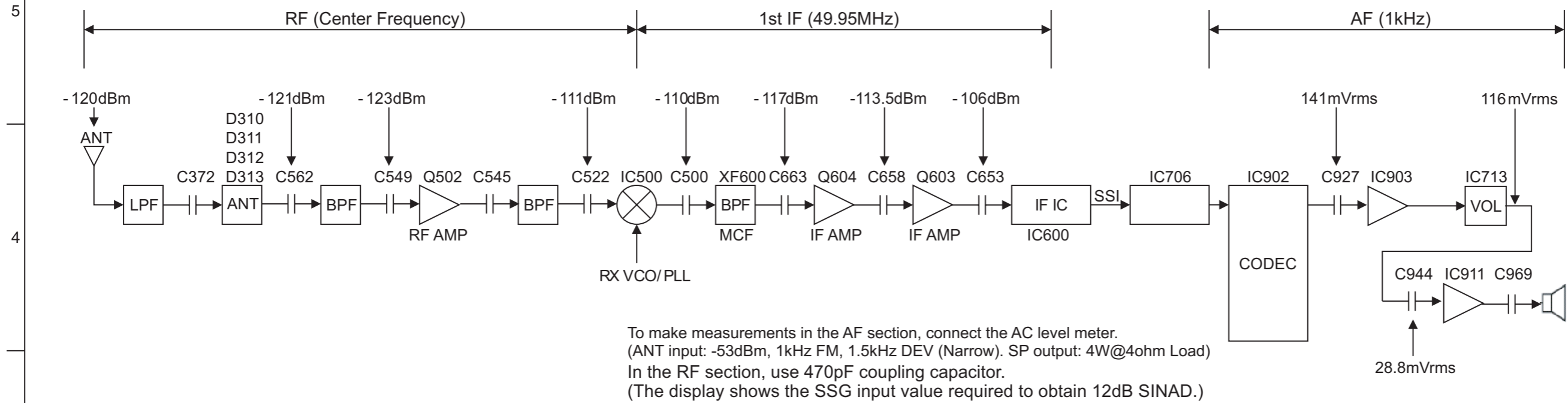

Transmitter section

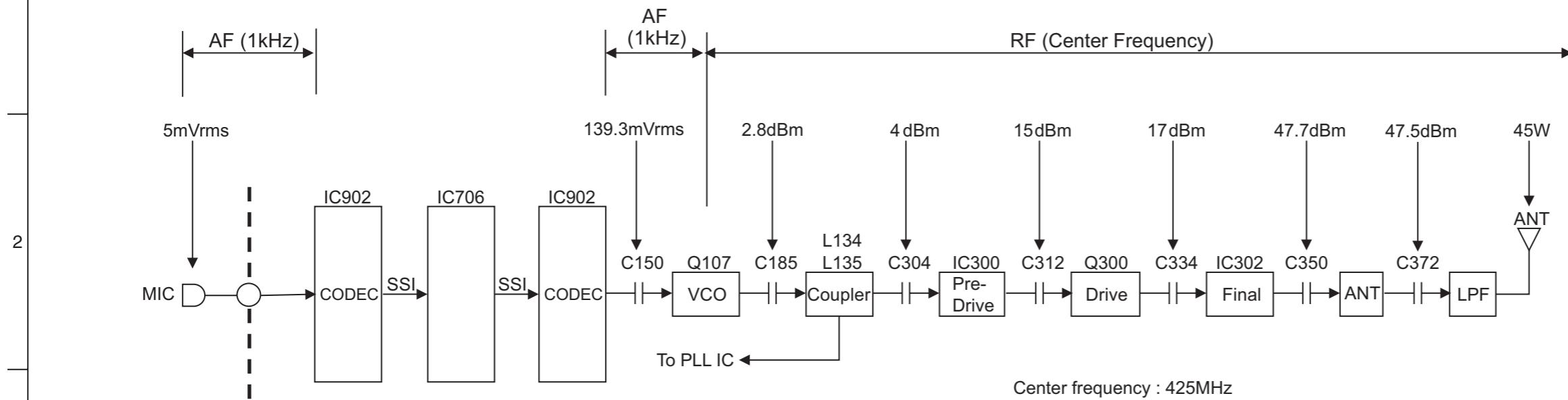

PARTS LIST

[NX-5800,NX-5800(B)]

* SAFETY PRECAUTION

Parts identified by the \triangle symbol are critical for safety. Replace only with specified part numbers.

* BEWARE OF BOGUS PARTS

Parts that do not meet specifications may cause trouble in regard to safety and performance. We recommend that genuine parts be used.

* (x_) in a description column shows the number of the used part.

- Contents -

Exploded view of general assembly and parts list	3-2
Electrical parts list	3-4
Packing materials and accessories parts list	3-17

Exploded view of general assembly and parts list

Block No.M1MM

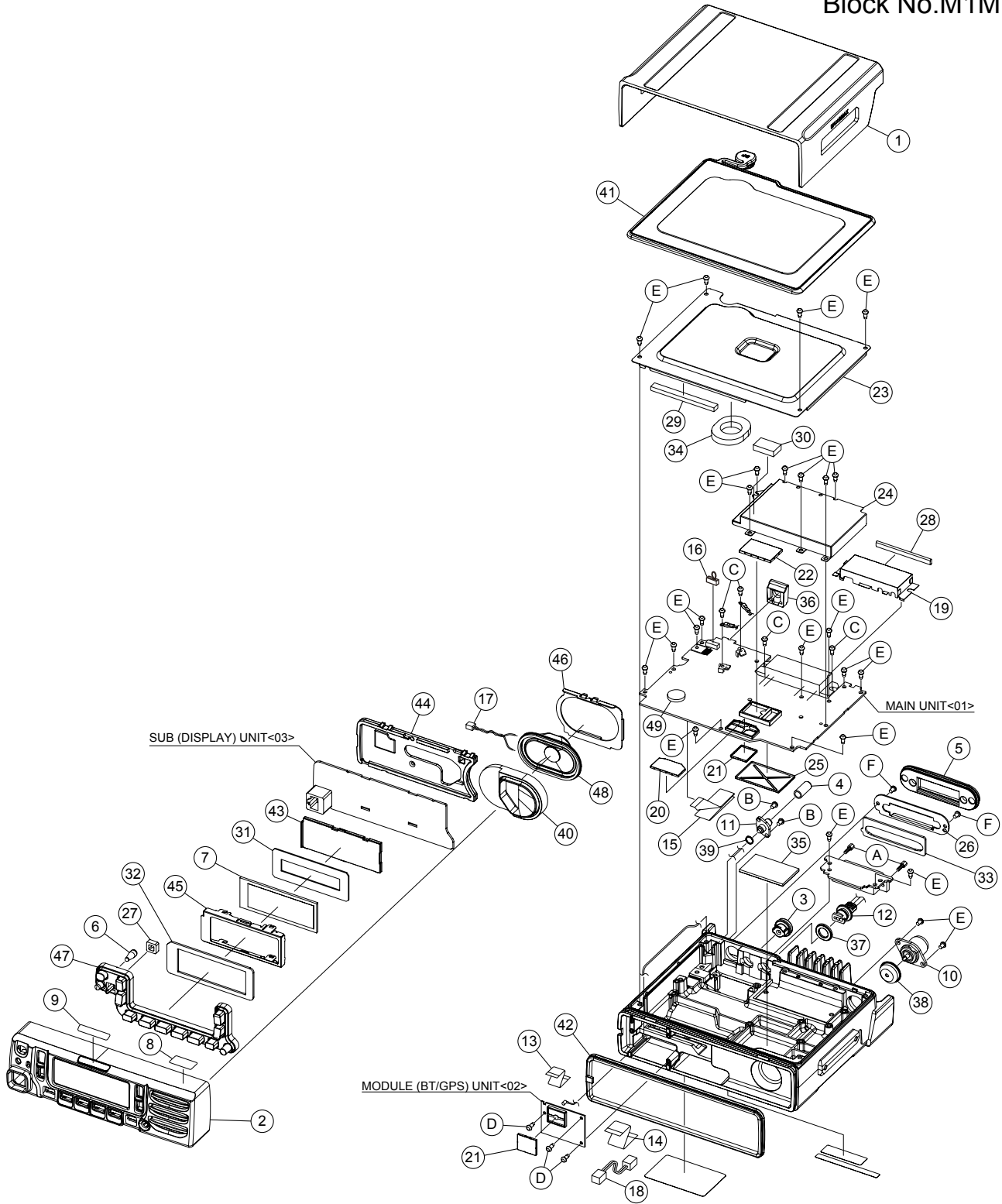

General assembly

Block No. [M][1][M][M]

△ Symbol No.	Part No.	Part Name	Description	Local
1	A0C-0034-00	PLASTIC CABINET		
2	A6C-0003-10	PANEL ASSY		NX-5800_K2
3	B09-0681-03	CAP(KAP-2)		
4	B09-0754-05	CAP(SMA)		
5	B0K-0004-00	CAP(D-SUB)		
6	B1B-0017-00	ILLUMINATION GUIDE		NX-5800_K2
7	B38-0966-05	LCD ASSY		NX-5800_K2
8	B4B-0008-00	CAUTION STICKER		NX-5800_K2
9	B4D-0021-00	BADGE		NX-5800_K2
10	E04-0167-15	RF COAXIAL RECEPTACLE(M)(ANT)		
11	E0E-0003-00	RF COAXIAL RECEPTACLE-SMA(GPS)		
12	E30-7520-35	DC CORD		
13	E3F-0017-00	FLAT CABLE(20P)		
14	E3F-0019-00	FLAT CABLE(50P)		
15	E3F-0021-00	FLAT CABLE(30P)		
16	E37-1118-05	LEAD WIRE WITH CONNECTOR(SHORT CABLE)		
17	E37-1693-05	LEAD WIRE WITH CONNECTOR(SP 2P)		NX-5800_K2
18	E3H-0008-00	LEAD WIRE WITH CONNECTOR(4P)		
19	F10-3112-03	SHIELDING CASE(PM)		
20	F10-3223-05	SHIELDING COVER(BLS(IF IC))		
21	F10-3225-05	SHIELDING COVER(BLS(BT/GPS,DCDC54M)) (x2)		
22	F10-3243-15	SHIELDING COVER(BLS(PLL IC))		
23	F1A-0003-00	SHIELDING PLATE(TOP)		
24	F1B-0013-00	SHIELDING CASE(FINAL)		
25	F1B-0021-00	SHIELDING COVER(BLS(VCO))		
26	F1E-0001-00	SHIELDING PLATE(D-SUB)		
27	F1E-0002-00	SHADE(TX-BUSY)		NX-5800_K2
28	G13-2101-04	CONDUCTIVE CUSHION		
29	G13-1837-04	CUSHION		
30	G13-2153-04	CONDUCTIVE CUSHION		
31	G1D-0011-00	CUSHION(LCD-HOLDER)		NX-5800_K2
32	G1D-0012-00	CUSHION(LCD-F.GLASS)		NX-5800_K2
33	G1D-0018-00	CUSHION(D-SUB)		
34	G1D-0028-00	CUSHION(DC SCREW)		
35	G1D-0049-00	CUSHION(VCO)		
36	G53-1616-03	PACKING(PHONE JACK)		
37	G53-1643-04	PACKING(DC CORD)		
38	G53-1662-04	PACKING(ANT(M))		
39	G53-1768-04	PACKING(SMA)		
40	G5D-0015-00	PACKING(SP)		NX-5800_K2
41	G5D-0016-00	PACKING(TOP)		
42	G5D-0017-00	PACKING(FRONT)		
43	J1K-0018-00	HOLDER(LCD)		NX-5800_K2
44	J1K-0019-00	HOLDER(PCB PANEL)		NX-5800_K2
45	J2B-0021-00	MOUNTING HARDWARE(LCD)		NX-5800_K2
46	J2B-0023-00	MOUNTING HARDWARE(SP)		NX-5800_K2
47	K2K-0100-00	KEY TOP		NX-5800_K2
48	T07-0810-05	SPEAKER		NX-5800_K2
49	W09-0971-05	LITHIUM CELL(MAIN UNIT)		
A	N09-2292-05	HEXAGON HEAD SCREW(D-SUB)	(x2)	
B	N30-2605-48	PAN HEAD MACHINE SCREW(SMA)	(x2)	
C	N67-3008-48	PAN HEAD SEMS SCREW(DC,PM)	(x4)	
D	N83-2005-48	PAN HEAD TAPTITE SCREW(BT/GPS)	(x3)	
E	N87-2608-48	BRAZIER HEAD TAPTITE SCREW	(x24)	
F	N89-2606-43	BINDING HEAD TAPTITE SCREW(D-SUB)	(x2)	

Electrical parts list

MAIN UNIT

XC1-0391-81

***Note : This part cannot be replaced. Therefore, this part is not supplied as a service part.**

Block No. [0][1]

△ Symbol No.	Part No.	Part Name	Description	Local
IC1	-----	*Note		
IC2	MSP430G2533P0	MICROPROCESSOR IC		
IC3	XC6215B122N-G	IC(MOS-IC)		
IC4	NJM2878F4-33	BIPOLAR IC		
IC5	XC6223D331P-G	IC(MOS-IC)		
IC6	-----	*Note		
IC7	XC6223H331P-G	IC(ANALOGUE)		
IC8	TPS54240DGQ	IC(MOS-IC)		
IC9	XC8102AA07-G	IC(MOS-IC)		
IC10	-----	*Note		
IC11	LXDC2HN18F163	IC(MOS-IC)		
IC12	NJM2878F4-33	BIPOLAR IC		
IC13	TPS61041DRVVR	IC(ANALOGUE)		
IC14	XC6223H331P-G	IC(ANALOGUE)		
IC15	BA00DD0WHFP	IC(MOS-IC)		
IC16	XC6209B502P-G	IC(MOS-IC)		
IC17	-----	*Note		
IC18	XC61CN5002N-G	IC(MOS-IC)		
IC100	SKY72310362LF	IC(MOS-IC)		
IC101	TC7SH17FUF	IC(MOS-IC)		
IC102	BA2904FVM	IC(MOS-IC)		
IC300	-----	*Note		
IC301	NJM12904RB1	BIPOLAR IC		
IC302	RA60H3847M1A	MOS-IC(POWER MODULE)		
IC303	NJM12904RB1	BIPOLAR IC		
IC304	AD8315ARM	IC(MOS-IC)		
IC500	AK1224	IC(MOS-IC)		
IC501	BA2904FVM	IC(MOS-IC)		
IC600	AD9864BCPZRL	IC(MOS-IC)		
IC701	-----	*Note		
IC702	-----	*Note		
IC703	CDC3S04YFF	IC(MOS-IC)		
IC704	TC7SZ08FE	IC(MOS-IC)		
IC705	TC7WH126FU-F	IC(MOS-IC)		
IC706	-----	*Note		
IC707	BD11600NUX	IC(MOS-IC)		
IC708	BD11600NUX	IC(MOS-IC)		
IC709	TC7SET125FUF	IC(MOS-IC)		
IC710	TC7SZ08FE	IC(MOS-IC)		
IC711	-----	*Note		
IC712	ADS7961SRHB	IC(MOS-IC)		
IC714	BD11600NUX	IC(MOS-IC)		
IC715	DAC124S085CIS	IC(MOS-IC)		
IC719	R2A20178NP	MICROCONTROLLER IC		
IC720	XC61CN5002N-G	IC(MOS-IC)		
IC900	TC7SET08FUF	IC(MOS-IC)		
IC901	BU7242NUX	IC(MOS-IC)		
IC902	TLV32AIC3104I	IC(MOS-IC)		
IC903	BU7242NUX	IC(MOS-IC)		
IC904	TC7SET125FUF	IC(MOS-IC)		
IC905	TC7WT125FUF	IC(MOS-IC)		
IC906	TC7WBD125AFK	IC(MOS-IC)		
IC907	BD11600NUX	IC(MOS-IC)		
IC908	TC7WH14FK-F	IC(MOS-IC)		
IC909	ADM3202ARUZ	IC(MOS-IC)		
IC910	PCA9555AHF	IC(MOS-IC)		
IC911	LA4425A	IC(MOS-IC)		
IC912	TC7SET08FUF	IC(MOS-IC)		
Q1	KTA2012EP	TRANSISTOR		
Q3	SSM3K15AMFV	FET		
Q4	LTC014EEBFS8	DIGI TRANSISTOR		
Q5	MTM981400BF	FET		
Q6	LTC014EEBFS8	DIGI TRANSISTOR		
Q7	LTC014TEBFS8	DIGI TRANSISTOR		
Q8	LSCR523EBFS8	TRANSISTOR		
Q9	LSAR523UBFS8	TRANSISTOR		

△ Symbol No.	Part No.	Part Name	Description	Local
Q10	MTM981400BF	FET		
Q11	LTC014EEBFS8	DIGI TRANSISTOR		
Q12	EM6M2	FET		
Q14	EM6M2	FET		
Q15	LTC014EEBFS8	DIGI TRANSISTOR		
Q16	SSM3J334R	FET		
Q17	LTC014EEBFS8	DIGI TRANSISTOR		
Q18	SSM3J334R	FET		
Q81	SSM3J15FS	FET		
Q100	LTA014YEBFS8	TRANSISTOR		
Q101	SSM3K15AMFV	FET		
Q102	EMD9	TRANSISTOR		
Q103	EM6M2	FET		
Q104	DSC9A01/T/	TRANSISTOR		
Q105	MCH3914-H/8/	FET		
Q106	2SC5108F/Y/	TRANSISTOR		
Q107	MCH3914-H/8/	FET		
Q108	EM6M2	FET		
Q109	SSM3J15FS	FET		
Q110	2SC5108F/Y/	TRANSISTOR		
Q111	2SC5108F/Y/	TRANSISTOR		
Q112	EM6M2	FET		
Q300	RD01MUS2-T113	FET		
Q301	LSCR523EBFS8	TRANSISTOR		
Q302	LSCR523EBFS8	TRANSISTOR		
Q303	LSCR523EBFS8	TRANSISTOR		
Q304	EM6M2	FET		
Q305	SSM3K15AMFV	FET		
Q500	2SC5108F/Y/	TRANSISTOR		
Q502	MT3S111	TRANSISTOR		
Q600	MCH3914-H/8/	FET		
Q601	LTC023JEBFS8	DIGI TRANSISTOR		
Q602	LSCR523EBFS8	TRANSISTOR		
Q603	2SC5066F/O/	TRANSISTOR		
Q604	BF5020W	FET		
Q700	2SC4617/S/	TRANSISTOR		
Q701	SSM3K15AMFV	FET		
Q703	SSM3K15AMFV	FET		
Q704	SSM3K15AMFV	FET		
Q705	LTC014TEBFS8	DIGI TRANSISTOR		
Q900	SSM3K335R	FET		
Q901	SSM3J332R	FET		
Q902	DSC9A01/T/	DIGI TRANSISTOR		
Q905	SSM3K335R	FET		
Q906	SSM3J332R	FET		
Q907	SSM3K335R	FET		
Q908	SSM3K335R	FET		
D1	DZ2J180(M)	ZENER DIODE		
D2	RB520SM-30	DIODE		
D3	EDZV8.2B	ZENER DIODE		
D4	RB521CM-30	DIODE		
D5	22ZR-10D	SURGE ABSORBER		
D6	RB520SM-30	DIODE		
D7	RB521CM-30	DIODE		
D8	RB521CM-30	DIODE		
D9	RB521CM-30	DIODE		
D10	DSA3A1	DIODE		
D11	DZ2S056(M)	ZENER DIODE		
D12	RB521CM-30	DIODE		
D13	1SS400SM	DIODE		
D14	RB060M-40	DIODE		
D15	DB2J40700	DIODE		
D16	RB521CM-30	DIODE		
D17	RB521CM-30	DIODE		
D100	EDZV8.2B	ZENER DIODE		
D101	RN262CS	DIODE		
D102	RN262CS	DIODE		
D103	BBY58-02V	VARIABLE CAPACITANCE DIODE		
D104	BBY58-02V	VARIABLE CAPACITANCE DIODE		
D105	BB664-02V	VARIABLE CAPACITANCE DIODE		
D106	BB664-02V	VARIABLE CAPACITANCE DIODE		
D107	BB664-02V	VARIABLE CAPACITANCE DIODE		
D108	BB664-02V	VARIABLE CAPACITANCE DIODE		
D109	BB664-02V	VARIABLE CAPACITANCE DIODE		
D110	BB664-02V	VARIABLE CAPACITANCE DIODE		

△ Symbol No.	Part No.	Part Name	Description	Local	△ Symbol No.	Part No.	Part Name	Description	Local
D111	BB664-02V	VARIABLE CAPACITANCE DIODE			C21	CK73HB1C105K	C CAPACITOR	1.0UF K	
D112	BB664-02V	VARIABLE CAPACITANCE DIODE			C24	CK73HBB1H471K	C CAPACITOR	470PF K	
D113	1SS400SM	DIODE			C25	CK73HBB1H102K	C CAPACITOR	0.010UF K	
D114	RN262CS	DIODE			C30	CK73HB1C105K	C CAPACITOR	1.0UF K	
D115	RN262CS	DIODE			C31	CK73EB1H475KM	C CAPACITOR	4.7UF K	
D117	BB555-02V	VARIABLE CAPACITANCE DIODE			C32	CK73GB1E105K	C CAPACITOR	1.0UF K	
D300	RN262CS	DIODE			C33	CK73EB1H475KM	C CAPACITOR	4.7UF K	
D301	RB520SM-30	DIODE			C34	CK73HB1E104K	C CAPACITOR	0.10UF K	
D302	DZ2S056(M)	ZENER DIODE			C35	CK73HBB1H471K	C CAPACITOR	470PF K	
D307	DZ2S056(M)	ZENER DIODE			C36	CK73GB1E105K	C CAPACITOR	1.0UF K	
D309	RB706F-40	DIODE			C37	CK73FB1C106K	C CAPACITOR	10UF K	
D310	L8104	DIODE			C38	CK73HBB1H471K	C CAPACITOR	470PF K	
D311	L8104	DIODE			C39	CK73GB0J106K	C CAPACITOR	10UF K	
D312	JDP2S12CR	DIODE			C40	CK73HB1H103K	C CAPACITOR	0.010UF K	
D313	JDP2S12CR	DIODE			C41	CK73GB1E105K	C CAPACITOR	1.0UF K	
D314	RN142S	DIODE			C43	CK73GXR1C225K	C CAPACITOR	2.2UF K	
D315	RN142S	DIODE			C44	CK73HBB1H471K	C CAPACITOR	470PF K	
D500	RN262CS	DIODE			C45	CK73HB1C105K	C CAPACITOR	1.0UF K	
D501	BB565-02V	VARIABLE CAPACITANCE DIODE			C46	CK73GXR1C225K	C CAPACITOR	2.2UF K	
D502	BB565-02V	VARIABLE CAPACITANCE DIODE			C47	CK73HB1E104K	C CAPACITOR	0.10UF K	
D503	BB565-02V	VARIABLE CAPACITANCE DIODE			C48	CK73GXR1C225K	C CAPACITOR	2.2UF K	
D504	BB565-02V	VARIABLE CAPACITANCE DIODE			C49	CK73HB1C105K	C CAPACITOR	1.0UF K	
D505	BB565-02V	VARIABLE CAPACITANCE DIODE			C50	CK73HBB1H102K	C CAPACITOR	0.010UF K	
D506	BB565-02V	VARIABLE CAPACITANCE DIODE			C51	CK73HBB1H332K	C CAPACITOR	0.033UF K	
D507	BB565-02V	VARIABLE CAPACITANCE DIODE			C52	CK73HB1E104K	C CAPACITOR	0.10UF K	
D508	RN142S	DIODE			C53	CK73GB1E105K	C CAPACITOR	1.0UF K	
D509	RN142S	DIODE			C54	CK73GB1E105K	C CAPACITOR	1.0UF K	
D600	SMV1705-079LF	VARIABLE CAPACITANCE DIODE			C55	CK73HBB1H471K	C CAPACITOR	470PF K	
D601	SMV1705-079LF	VARIABLE CAPACITANCE DIODE			C56	CK73HB1H392K	C CAPACITOR	3900PF K	
D602	DA3S101F	MULTIPLE DIODE			C57	CK73FXR1E475K	C CAPACITOR	4.7UF K	
D700	RB521CM-30	DIODE			C58	CC73HCH1H220G	C CAPACITOR	22PF G	
D701	RB521CM-30	DIODE			C59	CK73FB1C106K	C CAPACITOR	10UF K	
D702	SPC10501A01	VARISTOR			C60	CK73FB1C106K	C CAPACITOR	10UF K	
D703	SPC10501A01	VARISTOR			C61	CK73HBB1H471K	C CAPACITOR	470PF K	
D704	SPC10501A01	VARISTOR			C62	CK73GXR1C225K	C CAPACITOR	2.2UF K	
D705	SPC10501A01	VARISTOR			C63	CK73HBB1H102K	C CAPACITOR	1000PF K	
D706	SPC10501A01	VARISTOR			C64	CK73GB0J106K	C CAPACITOR	10UF K	
D708	EDZV8.2B	ZENER DIODE			C65	CK73FB1C106K	C CAPACITOR	10UF K	
D710	RB521CM-30	DIODE			C66	CK73HB1C105K	C CAPACITOR	1.0UF K	
D711	RB521CM-30	DIODE			C67	CK73FB1C106K	C CAPACITOR	10UF K	
D801	RB521CM-30	DIODE			C68	CK73FXR1E475K	C CAPACITOR	4.7UF K	
D900	DA3S101F	MULTIPLE DIODE			C69	CK73GXR1C225K	C CAPACITOR	2.2UF K	
D903	DZ2S056(M)	ZENER DIODE			C70	CK73HB1H391K	C CAPACITOR	390PF K	
D904	DA204U	MULTIPLE DIODE			C71	CK73HB1H391K	C CAPACITOR	390PF K	
D905	1SS400SM	DIODE			C72	CK730FA1H475K	C CAPACITOR	4.7UF K	
D906	DZ2S056(M)	ZENER DIODE			C73	CK73GB1E105K	C CAPACITOR	1.0UF K	
D907	RB521CM-30	DIODE			C74	CK73GXR1C225K	C CAPACITOR	2.2UF K	
D908	DA204U	MULTIPLE DIODE			C75	CK73HB1C105K	C CAPACITOR	1.0UF K	
D909	DA3S101F	MULTIPLE DIODE			C76	CK73HBB1H471K	C CAPACITOR	470PF K	
D910	DA204U	MULTIPLE DIODE			C77	CK73FXR1E475K	C CAPACITOR	4.7UF K	
D911	DA204U	MULTIPLE DIODE			C78	CK730DT1C476K	C CAPACITOR	4.7UF K	
D912	DA204U	MULTIPLE DIODE			C80	CK73GXR1H104K	C CAPACITOR	0.1UF K	
D913	DA204U	MULTIPLE DIODE			C81	CC73HCH1H470G	C CAPACITOR	47PF G	
D914	DA204U	MULTIPLE DIODE			C82	CK73GXR1C225K	C CAPACITOR	2.2UF K	
D915	DA204U	MULTIPLE DIODE			C83	CK73HB1C105K	C CAPACITOR	1.0UF K	
D916	DA2J101	DIODE			C84	CK73GXR1C225K	C CAPACITOR	10000PF K	
D917	DZ2J180(M)	ZENER DIODE			C85	C92-0968-05	ELECTRO	470UF 25WV	
D918	DA204U	MULTIPLE DIODE			C100	CK73HB1H103K	C CAPACITOR	0.010UF K	
D919	DA204U	MULTIPLE DIODE			C101	CK73HBB1H471K	C CAPACITOR	470PF K	
D920	DA204U	MULTIPLE DIODE			C102	CC73HCH1H100B	C CAPACITOR	10PF B	
D921	DA2J101	DIODE			C103	CK73HB1H103K	C CAPACITOR	0.010UF K	
D922	DZ2J180(M)	ZENER DIODE			C104	CK73HB1H103K	C CAPACITOR	0.010UF K	
D923	DA204U	MULTIPLE DIODE			C106	CC73HCH1H101J	C CAPACITOR	100PF J	
D924	RB520SM-30	DIODE			C107	CC73HCH1H101J	C CAPACITOR	100PF J	
C1	CK73HB1C105K	C CAPACITOR	1.0UF K		C108	CC73HCH1H101J	C CAPACITOR	100PF J	
C2	CD04CK1E102M	E CAPACITOR	1000UF 25WV		C109	CC73HCH1H101J	C CAPACITOR	100PF J	
C3	CK73HBB1H222K	C CAPACITOR	0.022UF K		C110	CC73HCH1H101J	C CAPACITOR	100PF J	
C4	CK73HBB1H471K	C CAPACITOR	470PF K		C111	CC73HCH1H101J	C CAPACITOR	100PF J	
C5	CK73HBB1H471K	C CAPACITOR	470PF K		C112	CK73HB1E104K	C CAPACITOR	0.10UF K	
C8	CK73HBB1H102K	C CAPACITOR	0.010UF K		C113	CK73HB1E104K	C CAPACITOR	0.10UF K	
C9	CK73HBB1H471K	C CAPACITOR	470PF K		C114	CC73HCH1H101J	C CAPACITOR	100PF J	
C10	CK73FB1C106K	C CAPACITOR	10UF K		C115	CK73HB1E104K	C CAPACITOR	0.10UF K	
C11	CK73HB1E104K	C CAPACITOR	0.10UF K		C116	CC73HCH1H101J	C CAPACITOR	100PF J	
C12	C93-1959-05	C CAPACITOR	0.10UF B		C118	CK73HB1H103K	C CAPACITOR	0.010UF K	
C13	CK73HB1A474K	C CAPACITOR	0.47UF K		C120	CC73HCH1H101J	C CAPACITOR	100PF J	
C16	CK73HB1H103K	C CAPACITOR	0.010UF K		C121	CC73HCH1H330G	C CAPACITOR	33PF G	
C18	CK73HBB1H471K	C CAPACITOR	470PF K		C124	CC73HCH1H101J	C CAPACITOR	100PF J	
					C125	CK73GB1H105K	C CAPACITOR	1.0UF K	

△ Symbol No.	Part No.	Part Name	Description	Local	△ Symbol No.	Part No.	Part Name	Description	Local
C126	CC73HCH1H101J	C CAPACITOR	100PF J		C312	CK73HBB1H471K	C CAPACITOR	470PF K	
C127	CK73FBB1H154K	C CAPACITOR	0.15UF K		C313	CC73HCH1H050B	C CAPACITOR	5.0PF B	
C128	CS77ABE1D100M	TA E CAPACITOR	10UF M		C315	CC73HCH1H100B	C CAPACITOR	10PF B	
C129	CK73HBB1H102K	C CAPACITOR	0.010UF K		C317	CC73HCH1H050B	C CAPACITOR	5.0PF B	
C130	CK73FB1H473K	C CAPACITOR	0.047UF K		C318	CC73HCH1H180G	C CAPACITOR	18PF G	
C131	CC730AD1H104J	C CAPACITOR	100PF J		C319	CC73HCH1H120G	C CAPACITOR	12PF G	
C132	CK73HBB1H471K	C CAPACITOR	470PF K		C320	CC73HCH1H101J	C CAPACITOR	100PF J	
C133	CC73HCH1H100B	C CAPACITOR	10PF B		C321	CK73HBB1H471K	C CAPACITOR	470PF K	
C134	CK73HBB1H471K	C CAPACITOR	470PF K		C322	CK73GB1H471K	C CAPACITOR	470PF K	
C135	CC73HCH1H100B	C CAPACITOR	10PF B		C323	CK73GB1H471K	C CAPACITOR	470PF K	
C136	CC73HCH1H101J	C CAPACITOR	100PF J		C325	CC73GCH1H100B	C CAPACITOR	10PF B	
C137	CC73HCH1H101J	C CAPACITOR	100PF J		C326	CK73HBB1H222K	C CAPACITOR	0.022UF K	
C138	CC73HCH1H100B	C CAPACITOR	10PF B		C327	CK73HB1H103K	C CAPACITOR	0.010UF K	
C139	CC73HCH1H100B	C CAPACITOR	10PF B		C328	CK73GB1H183K	C CAPACITOR	0.018UF K	
C142	CC73HCH1H151J	C CAPACITOR	150PF J		C329	CK73HBB1H472K	C CAPACITOR	0.047UF K	
C143	CC73HCH1H151J	C CAPACITOR	150PF J		C330	CC73HCH1H470G	C CAPACITOR	47PF G	
C144	CC73HCH1H1R5B	C CAPACITOR	1.5PF B		C331	CK73GB1H471K	C CAPACITOR	470PF K	
C145	CC73HCH1H1R5B	C CAPACITOR	1.5PF B		C332	CK73HBB1H472K	C CAPACITOR	0.047UF K	
C146	CK73HBB1H471K	C CAPACITOR	470PF K		C333	CK73HBB1H332K	C CAPACITOR	0.033UF K	
C147	CK73HBB1H471K	C CAPACITOR	470PF K		C334	CK73GB1H471K	C CAPACITOR	470PF K	
C148	CC73HCH1H090B	C CAPACITOR	9.0PF B		C335	CK73GB1H471K	C CAPACITOR	470PF K	
C149	CC73HCH1H100B	C CAPACITOR	10PF B		C336	CC73HCH1H220G	C CAPACITOR	22PF G	
C150	CK73HB1C105K	C CAPACITOR	1.0UF K		C338	CC73HCH1H470G	C CAPACITOR	47PF G	
C151	CC73HCH1H101J	C CAPACITOR	100PF J		C341	CC73HCH1H101J	C CAPACITOR	100PF J	
C152	CK73HBB1H102K	C CAPACITOR	0.010UF K		C343	CK73HBB1H332K	C CAPACITOR	0.0H33UF K	
C153	CK73HBB1H102K	C CAPACITOR	0.010UF K		C345	CK73HBB1H471K	C CAPACITOR	470PF K	
C154	CC73HCH1H240G	C CAPACITOR	24PF G		C346	CK73HB1H103K	C CAPACITOR	0.010UF K	
C155	CC73HCH1H330G	C CAPACITOR	33PF G		C348	CK73HB1E473K	C CAPACITOR	0.047UF K	
C156	CK73HBB1H471K	C CAPACITOR	470PF K		C349	CE32BY1E470M	E CAPACITOR	47UF 25WV	
C158	CC73HCH1HR75B	C CAPACITOR	0.75PF B		C350	C93-1866-05	C CAPACITOR	27PF G	
C159	CK73HBB1H471K	C CAPACITOR	470PF K		C351	CK73HB1E333K	C CAPACITOR	0.033UF K	
C161	CK73FB1C106K	C CAPACITOR	10UF K		C356	CC73GCH1H1R5B	C CAPACITOR	1.5PF K	
C162	CC73HCH1H0R5B	C CAPACITOR	0.5PF B		C360	CK73GB1H471K	C CAPACITOR	470PF K	
C164	CK73HBB1H102K	C CAPACITOR	0.0H10UF K		C361	CK73GB1H471K	C CAPACITOR	470PF K	
C165	CC73HCH1H050B	C CAPACITOR	5.0PF B		C362	C93-1866-05	C CAPACITOR	27PF G	
C166	CK73HBB1H471K	C CAPACITOR	470PF K		C363	CK73GB1H471K	C CAPACITOR	470PF K	
C167	CC73HCH1H050B	C CAPACITOR	5.0PF B		C364	CC73HCH1H121J	C CAPACITOR	120PF J	
C168	CK73GB1E105K	C CAPACITOR	1.0UF K		C365	CK73HB1H391K	C CAPACITOR	390PF K	
C169	CC73HCH1H070B	C CAPACITOR	7.0PF B		C367	CK73GB1H471K	C CAPACITOR	470PF K	
C170	CC73HCH1H070B	C CAPACITOR	7.0PF B		C368	CK73HBB1H471K	C CAPACITOR	470PF K	
C171	CC73HCH1H060B	C CAPACITOR	6.0PF B		C369	C93-1846-05	C CAPACITOR	4.0PF B	
C172	CC73HCH1H060B	C CAPACITOR	6.0PF B		C370	CK73HB1E104K	C CAPACITOR	0.10UF K	
C173	CK73HBB1H471K	C CAPACITOR	470PF K		C371	CC73GCH1H040B	C CAPACITOR	4.0PF B	
C174	CK73HBB1H471K	C CAPACITOR	470PF K		C372	C93-1932-05	C CAPACITOR	100PF B	
C175	CK73HBB1H471K	C CAPACITOR	470PF K		C374	CK73HBB1H472K	C CAPACITOR	0.047UF K	
C176	CK73HBB1H471K	C CAPACITOR	470PF K		C375	C93-2043-05	C CAPACITOR	12PF B	
C177	CC73HCH1H0R5B	C CAPACITOR	0.5PF B		C376	C93-1849-05	C CAPACITOR	12PF G	
C178	CC73HCH1H0R5B	C CAPACITOR	0.5PF B		C378	CC73HCH1H470G	C CAPACITOR	47PF G	
C179	CK73HBB1H102K	C CAPACITOR	0.010UF K		C380	C93-2043-05	C CAPACITOR	5.0PF B	
C181	CK73HBB1H471K	C CAPACITOR	470PF K		C383	C93-1855-05	C CAPACITOR	7.0PF B	
C182	CK73HBB1H102K	C CAPACITOR	0.010UF K		C385	CK73HBB1H222K	C CAPACITOR	0.022UF K	
C183	CC73HCH1H101J	C CAPACITOR	100PF J		C386	CK73HBB1H471K	C CAPACITOR	470PF K	
C184	CK73HBB1H471K	C CAPACITOR	470PF K		C500	CK73HB1H103K	C CAPACITOR	0.010UF K	
C185	CC73HCH1H070B	C CAPACITOR	7.0PF B		C501	CK73HBB1H471K	C CAPACITOR	470PF K	
C187	CK73HBB1H471K	C CAPACITOR	470PF K		C502	CK73HB1H103K	C CAPACITOR	0.010UF K	
C189	CC73HCH1H390G	C CAPACITOR	39PF G		C503	CK73HBB1H471K	C CAPACITOR	470PF K	
C190	CC73HCH1H120G	C CAPACITOR	12PF G		C504	CK73HB1H103K	C CAPACITOR	0.010UF K	
C191	CK73HBB1H102K	C CAPACITOR	0.010UF K		C506	CK73HBB1H102K	C CAPACITOR	0.010UF K	
C192	CC73HCH1H060B	C CAPACITOR	6.0PF B		C507	CK73HBB1H471K	C CAPACITOR	470PF K	
C193	CC73HCH1H060B	C CAPACITOR	6.0PF B		C508	CC73HCH1H030B	C CAPACITOR	3.0PF B	
C194	CK73HBB1H471K	C CAPACITOR	470PF K		C509	CK73HBB1H471K	C CAPACITOR	470PF K	
C195	CK73HBB1H102K	C CAPACITOR	0.010UF K		C510	CK73HBB1H102K	C CAPACITOR	0.010UF K	
C196	CK73HBB1H471K	C CAPACITOR	470PF K		C511	CK73HB1H103K	C CAPACITOR	0.010UF K	
C197	CC73HCH1H060B	C CAPACITOR	6.0PF B		C512	CC73HCH1H100B	C CAPACITOR	10PF B	
C198	CC73HCH1H010B	C CAPACITOR	1.0PF B		C513	CC73HCH1H100B	C CAPACITOR	10PF B	
C201	CK73HB1C105K	C CAPACITOR	1.0UF K		C514	CC73HCH1H020B	C CAPACITOR	2.0PF B	
C202	CK73HBB1H471K	C CAPACITOR	470PF K		C516	CC73HCH1H120G	C CAPACITOR	12PF G	
C300	CK73HBB1H471K	C CAPACITOR	470PF K		C517	CC73HCH1H020B	C CAPACITOR	2.0PF B	
C301	CK73HBB1H471K	C CAPACITOR	470PF K		C518	CC73HCH1H060B	C CAPACITOR	6.0PF B	
C303	CC73HCH1H050B	C CAPACITOR	5.0PF B		C519	CK73HBB1H471K	C CAPACITOR	470PF K	
C304	CK73HBB1H471K	C CAPACITOR	470PF K		C520	CK73HB1H103K	C CAPACITOR	0.010UF K	
C305	CC73HCH1H050B	C CAPACITOR	5.0PF B		C521	CC73HCH1H180G	C CAPACITOR	18PF G	
C306	CK73HBB1H471K	C CAPACITOR	470PF K		C522	CK73HBB1H471K	C CAPACITOR	470PF K	
C307	CK73HBB1H471K	C CAPACITOR	470PF K		C523	CC73HCH1H070B	C CAPACITOR	7.0PF B	
C308	CK73HB1E473K	C CAPACITOR	0.047UF K		C524	CK73HBB1H471K	C CAPACITOR	470PF K	
C309	CK73HBB1H472K	C CAPACITOR	0.047UF K		C525	CC73HCH1H471J	C CAPACITOR	470PF J	
C310	CC73HCH1H101J	C CAPACITOR	100PF J		C526	CC73HCH1H080B	C CAPACITOR	8.0PF B	
C311	CK73HBB1H471K	C CAPACITOR	470PF K		C528	CC73HCH1H030B	C CAPACITOR	3.0PF B	

△ Symbol No.	Part No.	Part Name	Description	Local	△ Symbol No.	Part No.	Part Name	Description	Local
C529	CK73HBB1H471K	C CAPACITOR	470PF K		C645	CC73HCH1H330G	C CAPACITOR	33PF G	
C530	CC73HCH1H471J	C CAPACITOR	470PF J		C646	CC73HCH1H151J	C CAPACITOR	150PF J	
C531	CC73HCH1H060B	C CAPACITOR	6.0PF B		C647	C93-1959-05	C CAPACITOR	0.10UF B	
C532	CC73HCH1H020B	C CAPACITOR	2.0PF B		C648	CC73JCH1H101J	C CAPACITOR	100PF J	
C533	CK73HBB1H471K	C CAPACITOR	470PF K		C649	CC73HCH1H100B	C CAPACITOR	10PF B	
C534	CK73HBB1H471K	C CAPACITOR	470PF K		C650	CC73HCH1H101J	C CAPACITOR	100PF J	
C535	CC73HCH1H471J	C CAPACITOR	470PF J		C651	C93-1959-05	C CAPACITOR	0.10UF B	
C536	CC73HCH1H050B	C CAPACITOR	5.0PF B		C652	C93-1959-05	C CAPACITOR	0.10UF B	
C537	CC73HCH1H060B	C CAPACITOR	6.0PF B		C653	CC73HCH1H560J	C CAPACITOR	56PF J	
C538	CK73HBB1H471K	C CAPACITOR	470PF K		C654	CK73HBB1H102K	C CAPACITOR	0.010UF K	
C539	CC73HCH1H471J	C CAPACITOR	470PF J		C655	CK73HB1H103K	C CAPACITOR	0.010UF K	
C540	CK73HBB1H471K	C CAPACITOR	470PF K		C656	CC73HCH1H100B	C CAPACITOR	10PF B	
C541	CK73GXR1H104K	C CAPACITOR	0.1UF K		C657	CC73HCH1H060B	C CAPACITOR	6.0PF B	
C542	CK73HBB1H102K	C CAPACITOR	1000PF K		C658	CK73HB1H103K	C CAPACITOR	0.010UF K	
C543	CK73HBB1H471K	C CAPACITOR	470PF K		C659	CK73HB1H103K	C CAPACITOR	0.010UF K	
C544	CK73HBB1H471K	C CAPACITOR	470PF K		C660	CC73HCH1H120G	C CAPACITOR	12PF G	
C545	CC73HCH1H080B	C CAPACITOR	8.0PF B		C661	CK73HBB1H102K	C CAPACITOR	0.010UF K	
C546	CK73HBB1H471K	C CAPACITOR	470PF K		C662	CK73HBB1H102K	C CAPACITOR	0.010UF K	
C548	CC73HCH1H120G	C CAPACITOR	12PF G		C663	CK73HB1H103K	C CAPACITOR	0.010UF K	
C549	CC73HCH1H040B	C CAPACITOR	4.0PF B		C665	CC73HCH1H080B	C CAPACITOR	8.0PF B	
C550	CK73HBB1H471K	C CAPACITOR	470PF K		C666	CC73HCH1H220G	C CAPACITOR	22PF G	
C551	CC73HCH1H390G	C CAPACITOR	39PF G		C667	CC73HCH1H060B	C CAPACITOR	6.0PF B	
C552	CC73HCH1H030B	C CAPACITOR	3.0PF B		C668	CC73HCH1H180G	C CAPACITOR	18PF G	
C553	CC73HCH1H020B	C CAPACITOR	2.0PF B		C669	CC73HCH1H020B	C CAPACITOR	2.0PF B	
C554	CC73HCH1H030B	C CAPACITOR	3.0PF B		C670	CC73HCH1H020B	C CAPACITOR	2.0PF B	
C555	CK73HBB1H471K	C CAPACITOR	470PF K		C671	CC73HCH1H180G	C CAPACITOR	18PF G	
C556	CC73HCH1H390G	C CAPACITOR	39PF G		C681	CK73HBB1H471K	C CAPACITOR	470PF K	
C557	CC73HCH1H040B	C CAPACITOR	4.0PF B		C700	CK73HB1C105K	C CAPACITOR	1.0UF K	
C558	CC73HCH1H050B	C CAPACITOR	5.0PF B		C701	C93-1959-05	C CAPACITOR	0.10UF B	
C559	CC73HCH1H060B	C CAPACITOR	6.0PF B		C702	C93-1959-05	C CAPACITOR	0.10UF B	
C560	CK73HBB1H471K	C CAPACITOR	470PF K		C703	CK73FXR0J226M	C CAPACITOR	22UF M	
C562	CK73HBB1H471K	C CAPACITOR	470PF K		C704	CK73HB1H103K	C CAPACITOR	0.010UF K	
C563	CK73HBB1H471K	C CAPACITOR	470PF K		C705	C93-1959-05	C CAPACITOR	0.10UF B	
C600	CC73JCH1H101J	C CAPACITOR	100PF J		C706	C93-1959-05	C CAPACITOR	0.10UF B	
C601	CC73JCH1H101J	C CAPACITOR	100PF J		C707	CK73FXR0J226M	C CAPACITOR	22UF M	
C602	CC73JCH1H101J	C CAPACITOR	100PF J		C708	CK73GB0J106K	C CAPACITOR	10UF K	
C603	CC73JCH1H101J	C CAPACITOR	100PF J		C709	C93-1959-05	C CAPACITOR	0.10UF B	
C604	CC73JCH1H101J	C CAPACITOR	100PF J		C711	C93-1959-05	C CAPACITOR	0.10UF B	
C605	CC73JCH1H101J	C CAPACITOR	100PF J		C712	C93-1959-05	C CAPACITOR	0.10UF B	
C606	CC73JCH1H101J	C CAPACITOR	100PF J		C713	C93-1959-05	C CAPACITOR	0.10UF B	
C607	CC73HCH1H120G	C CAPACITOR	12PF G		C714	C93-1959-05	C CAPACITOR	0.10UF B	
C608	CK73HB1E104K	C CAPACITOR	0.10UF K		C715	C93-1959-05	C CAPACITOR	0.10UF B	
C609	CK73HB1E562K	C CAPACITOR	5600PF K		C716	C93-1959-05	C CAPACITOR	0.10UF B	
C610	C93-1959-05	C CAPACITOR	0.10UF B		C717	C93-1959-05	C CAPACITOR	0.10UF B	
C611	CC73HCH1H100B	C CAPACITOR	10PF B		C718	C93-1959-05	C CAPACITOR	0.10UF B	
C612	CK73HB1A224K	C CAPACITOR	0.22UF K		C719	CC73JCH1H101J	C CAPACITOR	100PF J	
C613	C93-1959-05	C CAPACITOR	0.10UF B		C720	CK73HB1E104K	C CAPACITOR	0.10UF K	
C614	CK73HB1H123K	C CAPACITOR	0.012UF K		C721	C93-1959-05	C CAPACITOR	0.10UF B	
C615	CK73HB1E104K	C CAPACITOR	0.10UF K		C722	CC73JCH1H101J	C CAPACITOR	100PF J	
C616	CC73HCH1H390G	C CAPACITOR	39PF G		C723	C93-1959-05	C CAPACITOR	0.10UF B	
C617	CC73HCH1H390G	C CAPACITOR	39PF G		C724	C93-1959-05	C CAPACITOR	0.10UF B	
C618	CK73HB1H103K	C CAPACITOR	0.010UF K		C725	CC73JCH1H101J	C CAPACITOR	100PF J	
C619	C93-1959-05	C CAPACITOR	0.10UF B		C726	C93-1953-05	C CAPACITOR	0.10UF B	
C620	CK73HB1C105K	C CAPACITOR	1.0UF K		C728	CK73GB0J106K	C CAPACITOR	10UF K	
C621	CK73HB1H103K	C CAPACITOR	0.010UF K		C729	CK73HB1H103K	C CAPACITOR	0.010UF K	
C622	CK73HBB1H102K	C CAPACITOR	0.010UF K		C730	CK73GB0J106K	C CAPACITOR	10UF K	
C623	CC73HCH1H390G	C CAPACITOR	39PF G		C731	C93-1959-05	C CAPACITOR	0.10UF B	
C624	CC73HCH1H390G	C CAPACITOR	39PF G		C732	C93-1959-05	C CAPACITOR	0.10UF B	
C625	C93-1959-05	C CAPACITOR	0.10UF B		C733	C93-1959-05	C CAPACITOR	0.10UF B	
C626	CK73HB1E104K	C CAPACITOR	0.10UF K		C734	C93-1959-05	C CAPACITOR	0.10UF B	
C627	C93-1953-05	C CAPACITOR	0.10UF B		C735	CC73JCH1H101J	C CAPACITOR	100PF J	
C628	C93-1959-05	C CAPACITOR	0.10UF B		C736	C93-1959-05	C CAPACITOR	0.10UF B	
C629	C93-1953-05	C CAPACITOR	0.10UF B		C737	CC73JCH1H101J	C CAPACITOR	100PF J	
C630	C93-1959-05	C CAPACITOR	0.10UF B		C738	CC73JCH1H101J	C CAPACITOR	100PF J	
C631	C93-1959-05	C CAPACITOR	0.10UF B		C739	CK73GB0J106K	C CAPACITOR	10UF K	
C632	C93-1953-05	C CAPACITOR	0.10UF B		C740	CK73HB1H103K	C CAPACITOR	0.010UF K	
C633	C93-1959-05	C CAPACITOR	0.10UF B		C741	C93-1959-05	C CAPACITOR	0.10UF B	
C634	CK73FB1C106K	C CAPACITOR	10UF K		C742	CK73GB0J106K	C CAPACITOR	10UF K	
C635	C93-1959-05	C CAPACITOR	0.10UF B		C743	C93-1953-05	C CAPACITOR	0.10UF B	
C636	CK73HB1C105K	C CAPACITOR	1.0UF K		C745	C93-1959-05	C CAPACITOR	0.10UF B	
C637	CK73HB1H103K	C CAPACITOR	0.010UF K		C746	CK73GB0J106K	C CAPACITOR	10UF K	
C638	CK73HBB1H682K	C CAPACITOR	6800PF K		C747	CK73GB0J106K	C CAPACITOR	10UF K	
C639	CC73HCH1H101J	C CAPACITOR	100PF J		C748	CC73HCH1H100B	C CAPACITOR	10PF B	
C640	C93-1969-05	C CAPACITOR	1000PF G		C749	C93-1959-05	C CAPACITOR	0.10UF B	
C641	CC73HCH1H101J	C CAPACITOR	100PF J		C750	CK73GB0J106K	C CAPACITOR	10UF K	
C642	CC73HCH1H100B	C CAPACITOR	10PF B		C751	C93-1959-05	C CAPACITOR	0.10UF B	
C643	CC73JCH1H101J	C CAPACITOR	100PF J		C752	C93-1959-05	C CAPACITOR	0.10UF B	
C644	C93-1953-05	C CAPACITOR	0.10UF B		C754	C93-1959-05	C CAPACITOR	0.10UF B	

△ Symbol No.	Part No.	Part Name	Description	Local	△ Symbol No.	Part No.	Part Name	Description	Local
C755	C93-1959-05	C CAPACITOR	0.10UF B		C902	CK73HB1E104K	C CAPACITOR	0.10UF K	
C756	C93-1959-05	C CAPACITOR	0.10UF B		C903	CK73HBB1H102K	C CAPACITOR	0.010UF K	
C757	CK73HB1H103K	C CAPACITOR	0.010UF K		C904	CK73HB1C105K	C CAPACITOR	1.0UF K	
C758	C93-1959-05	C CAPACITOR	0.10UF B		C905	CK73HB1E104K	C CAPACITOR	0.10UF K	
C759	CC73JCH1H101J	C CAPACITOR	100PF J		C906	CK73HB1C105K	C CAPACITOR	1.0UF K	
C760	C93-1959-05	C CAPACITOR	0.10UF B		C908	C93-1959-05	C CAPACITOR	0.10UF B	
C762	C93-1959-05	C CAPACITOR	0.10UF B		C909	CK73HB1C105K	C CAPACITOR	1.0UF K	
C764	C93-1959-05	C CAPACITOR	0.10UF B		C910	C93-1959-05	C CAPACITOR	0.10UF B	
C766	C93-1959-05	C CAPACITOR	0.10UF B		C911	C93-1959-05	C CAPACITOR	0.10UF B	
C768	C93-1953-05	C CAPACITOR	0.10UF B		C912	C93-1959-05	C CAPACITOR	0.10UF B	
C769	CK73HB1C105K	C CAPACITOR	1.0UF K		C913	C93-1959-05	C CAPACITOR	0.10UF B	
C770	CK73HB1C105K	C CAPACITOR	1.0UF K		C914	C93-1959-05	C CAPACITOR	0.10UF B	
C771	C93-1959-05	C CAPACITOR	0.10UF B		C915	CK73HB1E104K	C CAPACITOR	0.10UF K	
C772	C93-1959-05	C CAPACITOR	0.10UF B		C916	CK73GB0J106K	C CAPACITOR	10UF K	
C773	C93-1959-05	C CAPACITOR	0.10UF B		C917	CK73HB1C105K	C CAPACITOR	1.0UF K	
C774	C93-1959-05	C CAPACITOR	0.10UF B		C918	C93-1959-05	C CAPACITOR	0.10UF B	
C775	C93-1959-05	C CAPACITOR	0.10UF B		C919	CK73HB1C105K	C CAPACITOR	1.0UF K	
C776	C93-1959-05	C CAPACITOR	0.10UF B		C920	C93-1959-05	C CAPACITOR	0.10UF B	
C777	C93-1959-05	C CAPACITOR	0.10UF B		C921	CC73HCH1H101J	C CAPACITOR	100PF J	
C778	C93-1959-05	C CAPACITOR	0.10UF B		C922	CK73HBB1H472K	C CAPACITOR	0.047UF K	
C779	CK73HB1C105K	C CAPACITOR	1.0UF K		C924	CK73HB1C105K	C CAPACITOR	1.0UF K	
C780	C93-1959-05	C CAPACITOR	0.10UF B		C925	CK73HB1C105K	C CAPACITOR	1.0UF K	
C781	CC73HCH1H150G	C CAPACITOR	15PF G		C926	CK73HB1C105K	C CAPACITOR	1.0UF K	
C782	CC73HCH1H150G	C CAPACITOR	15PF G		C927	CK73HB1C105K	C CAPACITOR	1.0UF K	
C783	CK73HB1E104K	C CAPACITOR	0.10UF K		C928	CK73GB0J106K	C CAPACITOR	10UF K	
C784	CK73HB1A224K	C CAPACITOR	0.22UF K		C929	CK73HB1E104K	C CAPACITOR	0.10UF K	
C785	CK73GB0J106K	C CAPACITOR	10UF K		C930	CC73HCH1H680J	C CAPACITOR	68PF J	
C786	CK73GB0J106K	C CAPACITOR	10UF K		C931	CK73HB1A474K	C CAPACITOR	0.47UF K	
C787	CK73HB1E104K	C CAPACITOR	0.10UF K		C932	CK73GB0J106K	C CAPACITOR	10UF K	
C791	C93-1959-05	C CAPACITOR	0.10UF B		C933	CK73HB1H103K	C CAPACITOR	0.010UF K	
C792	C93-1959-05	C CAPACITOR	0.10UF B		C934	CK73HB1H103K	C CAPACITOR	0.010UF K	
C793	CK73HBB1H102K	C CAPACITOR	0.010UF K		C935	CC73HCH1H101J	C CAPACITOR	100PF J	
C794	CK73HBB1H102K	C CAPACITOR	0.010UF K		C936	CK73GB0J106K	C CAPACITOR	10UF K	
C795	CK73HB1H103K	C CAPACITOR	0.010UF K		C937	CK73GB1E105K	C CAPACITOR	1.0UF K	
C796	CK73HB1H103K	C CAPACITOR	0.010UF K		C938	CK73HB1H103K	C CAPACITOR	0.010UF K	
C797	CK73HB1H103K	C CAPACITOR	0.010UF K		C940	CK73HBB1H102K	C CAPACITOR	0.010UF K	
C798	CK73GB1E105K	C CAPACITOR	1.0UF K		C941	CC73HCH1H101J	C CAPACITOR	100PF J	
C799	CK73HB1E104K	C CAPACITOR	0.10UF K		C942	CK73HB1H103K	C CAPACITOR	0.010UF K	
C800	CK73HB1H103K	C CAPACITOR	0.010UF K		C943	CK73HB1E104K	C CAPACITOR	0.10UF K	
C801	CC73HCH1H101J	C CAPACITOR	100PF J		C944	CK73GB1E105K	C CAPACITOR	1.0UF K	
C802	CK73HB1C105K	C CAPACITOR	1.0UF K		C945	CK73HB1H103K	C CAPACITOR	0.010UF K	
C803	C93-1959-05	C CAPACITOR	0.10UF B		C946	CK73HB1H103K	C CAPACITOR	0.010UF K	
C804	C93-1959-05	C CAPACITOR	0.10UF B		C947	CK73HBB1H102K	C CAPACITOR	0.010UF K	
C805	CC73HCH1H101J	C CAPACITOR	100PF J		C948	CK73GB1E105K	C CAPACITOR	1.0UF K	
C806	C93-1959-05	C CAPACITOR	0.10UF B		C949	CK73GB1E105K	C CAPACITOR	1.0UF K	
C807	CK73HB1H103K	C CAPACITOR	0.010UF K		C950	CK73GB1E105K	C CAPACITOR	1.0UF K	
C808	CC73HCH1H101J	C CAPACITOR	100PF J		C951	CK73GB1E105K	C CAPACITOR	1.0UF K	
C809	CC73HCH1H101J	C CAPACITOR	100PF J		C952	CK73HBB1H102K	C CAPACITOR	0.010UF K	
C810	CC73HCH1H101J	C CAPACITOR	100PF J		C953	CC73HCH1H101J	C CAPACITOR	100PF J	
C811	C93-1959-05	C CAPACITOR	0.10UF B		C954	CC73HCH1H101J	C CAPACITOR	100PF J	
C812	CC73HCH1H101J	C CAPACITOR	100PF J		C955	CC73HCH1H101J	C CAPACITOR	100PF J	
C813	CC73HCH1H101J	C CAPACITOR	100PF J		C956	CC73HCH1H101J	C CAPACITOR	100PF J	
C814	CC73HCH1H101J	C CAPACITOR	100PF J		C957	CC73HCH1H101J	C CAPACITOR	100PF J	
C815	CC73HCH1H101J	C CAPACITOR	100PF J		C958	CC73HCH1H101J	C CAPACITOR	100PF J	
C816	CC73HCH1H101J	C CAPACITOR	100PF J		C959	CC73HCH1H101J	C CAPACITOR	100PF J	
C817	CK73HBB1H102K	C CAPACITOR	0.010UF K		C960	CC73HCH1H101J	C CAPACITOR	100PF J	
C818	CC73HCH1H101J	C CAPACITOR	100PF J		C961	CC73HCH1H101J	C CAPACITOR	100PF J	
C819	CK73HB1H103K	C CAPACITOR	0.010UF K		C962	CC73HCH1H101J	C CAPACITOR	100PF J	
C820	CK73HB1E104K	C CAPACITOR	0.10UF K		C963	CC73HCH1H101J	C CAPACITOR	100PF J	
C821	CC73HCH1H101J	C CAPACITOR	100PF J		C964	CK73HB1E473K	C CAPACITOR	0.047UF K	
C822	CC73HCH1H101J	C CAPACITOR	100PF J		C965	CC73HCH1H101J	C CAPACITOR	100PF J	
C824	CK73HBB1H102K	C CAPACITOR	0.010UF K		C966	CC73HCH1H101J	C CAPACITOR	100PF J	
C829	CK73HB1C105K	C CAPACITOR	1.0UF K		C967	CK73HBB1H102K	C CAPACITOR	0.010UF K	
C830	C93-1959-05	C CAPACITOR	0.10UF B		C968	CC73HCH1H101J	C CAPACITOR	100PF J	
C831	C93-1959-05	C CAPACITOR	0.10UF B		C969	C92-0906-05	ELECTRO	330UF 16WV	
C834	CK73HB1C105K	C CAPACITOR	1.0UF K		C970	CK73HB1H103K	C CAPACITOR	0.010UF K	
C835	CC73HCH1H101J	C CAPACITOR	100PF J		C971	CE32BY1E470M	E CAPACITOR	47UF 25WV	
C839	CK73HB1E104K	C CAPACITOR	0.10UF K		C972	CK73HB1E104K	C CAPACITOR	0.10UF K	
C841	CK73HB1E104K	C CAPACITOR	0.10UF K		C973	CK73HB1E104K	C CAPACITOR	0.10UF K	
C852	CK73HB1E104K	C CAPACITOR	0.10UF K		C975	CC73HCH1H101J	C CAPACITOR	100PF J	
C853	CK73HB1H103K	C CAPACITOR	0.010UF K		C976	CC73HCH1H101J	C CAPACITOR	100PF J	
C854	CK73HBB1H102K	C CAPACITOR	0.010UF K		C977	CK73HBB1H102K	C CAPACITOR	0.010UF K	
C856	CC73HCH1H470G	C CAPACITOR	47PF G		C978	CK73HBB1H471K	C CAPACITOR	470PF K	
C857	CC73HCH1H470G	C CAPACITOR	47PF G		C979	CC73HCH1H101J	C CAPACITOR	100PF J	
C898	CK73GB1E105K	C CAPACITOR	1.0UF K		C980	CC73HCH1H101J	C CAPACITOR	100PF J	
C899	CK73GB0J106K	C CAPACITOR	10UF K		C981	CK73HBB1H102K	C CAPACITOR	0.010UF K	
C900	CK73HB1H103K	C CAPACITOR	0.010UF K		C982	CC73HCH1H101J	C CAPACITOR	100PF J	
C901	CK73HB1E104K	C CAPACITOR	0.10UF K		C983	CC73HCH1H101J	C CAPACITOR	100PF J	

△ Symbol No.	Part No.	Part Name	Description	Local	△ Symbol No.	Part No.	Part Name	Description	Local
C984	CC73HCH1H101J	C CAPACITOR	100PF J		R69	RK73HB1J472J	MG RESISTOR	4.7K J 1/16W	
C985	CC73HCH1H101J	C CAPACITOR	100PF J		R70	RK73HB1J000J	MG RESISTOR	0.0 J 1/16W	
C986	CC73HCH1H101J	C CAPACITOR	100PF J		R71	RK73HB1J331J	MG RESISTOR	330 J 1/16W	
C987	CC73HCH1H101J	C CAPACITOR	100PF J		R72	RK73JB1H473J	MG RESISTOR	47K J 1/20W	
C988	CC73HCH1H101J	C CAPACITOR	100PF J		R73	RK73HB1J471J	MG RESISTOR	470 J 1/16W	
C989	CC73HCH1H101J	C CAPACITOR	100PF J		R75	RK73HB1J474J	MG RESISTOR	470K J 1/16W	
C990	CC73HCH1H101J	C CAPACITOR	100PF J		R76	RK73FB2B332J	MG RESISTOR	3.3K J 1/8W	
C991	CC73HCH1H101J	C CAPACITOR	100PF J		R77	RK73FB2B332J	MG RESISTOR	3.3K J 1/8W	
C992	CC73HCH1H101J	C CAPACITOR	100PF J		R78	RK73FB2B332J	MG RESISTOR	3.3K J 1/8W	
C993	CC73HCH1H101J	C CAPACITOR	100PF J		R84	RK73HB1J000J	MG RESISTOR	0.0 J 1/16W	
C994	CC73HCH1H101J	C CAPACITOR	100PF J		R96	RK73FB2B2R7J	MG RESISTOR	2.7 J 1/16W	
C995	CC73HCH1H101J	C CAPACITOR	100PF J		R97	RK73FB2B3R3J	MG RESISTOR	3.3 J 1/16W	
C996	CC73HCH1H101J	C CAPACITOR	100PF J		R100	RK73HB1J821J	MG RESISTOR	820 J 1/16W	
C997	CK73HBB1H102K	C CAPACITOR	0.010UF K		R101	RK73HB1J100J	MG RESISTOR	10 J 1/16W	
C998	CK73HBB1H102K	C CAPACITOR	0.010UF K		R102	RK73HB1J000J	MG RESISTOR	0.0 J 1/16W	
C999	CK73HB1C105K	C CAPACITOR	1.0UF K		R103	RK73HB1J100J	MG RESISTOR	10 J 1/16W	
R2	RK73HB1J000J	MG RESISTOR	0.0 J 1/16W		R104	RK73HB1J100J	MG RESISTOR	10 J 1/16W	
R4	RK73HB1J000J	MG RESISTOR	0.0 J 1/16W		R105	RK73HB1J474J	MG RESISTOR	470K J 1/16W	
R8	RK73HB1J104J	MG RESISTOR	100K J 1/16W		R106	RK73HB1J473J	MG RESISTOR	47K J 1/16W	
R10	RK73HH1J104D	MG RESISTOR	100K D 1/16W		R107	RK73HB1J102J	MG RESISTOR	1.0K J 1/16W	
R11	RK73HH1J104D	MG RESISTOR	100K D 1/16W		R108	RK73HB1J102J	MG RESISTOR	1.0K J 1/16W	
R12	RK73HB1J000J	MG RESISTOR	0.0 J 1/16W		R109	RK73HB1J470J	MG RESISTOR	47 J 1/16W	
R13	RK73HH1J104D	MG RESISTOR	100K D 1/16W		R110	RK73HB1J102J	MG RESISTOR	1.0K J 1/16W	
R14	RK73HH1J223D	MG RESISTOR	22K D 1/16W		R111	RK73HB1J223J	MG RESISTOR	22K J 1/16W	
R15	RK73HB1J103J	MG RESISTOR	10K J 1/16W		R112	RK73HB1J000J	MG RESISTOR	0.0 J 1/16W	
R16	RK73JB1H102J	MG RESISTOR	1.0K J 1/20W		R113	RK73HB1J124J	MG RESISTOR	120K J 1/16W	
R17	RK73HB1J103J	MG RESISTOR	10K J 1/16W		R115	RK73HB1J000J	MG RESISTOR	0.0 J 1/16W	
R18	RK73JB1H104J	MG RESISTOR	100K J 1/20W		R116	RK73HB1J000J	MG RESISTOR	0.0 J 1/16W	
R19	RK73HB1J473J	MG RESISTOR	47K J 1/16W		R117	RK73HB1J000J	MG RESISTOR	0.0 J 1/16W	
R20	RK73GB2A000J	MG RESISTOR	0.0 J 1/10W		R118	RK73HB1J222J	MG RESISTOR	2.2K J 1/16W	
R21	RK73HB1J104J	MG RESISTOR	100K J 1/16W		R119	RK73HB1J474J	MG RESISTOR	470K J 1/16W	
R22	RK73JB1H103J	MG RESISTOR	10K J 1/20W		R121	RK73HB1J151J	MG RESISTOR	150 J 1/16W	
R23	RK73JB1H102J	MG RESISTOR	1.0K J 1/20W		R122	RK73HB1J472J	MG RESISTOR	4.7K J 1/16W	
R24	RK73JB1H104J	MG RESISTOR	100K J 1/20W		R123	RK73HB1J104J	MG RESISTOR	100K J 1/16W	
R25	RK73JB1H472J	MG RESISTOR	4.7K J 1/20W		R124	RK73HH1J391D	MG RESISTOR	390 D 1/16W	
R26	RK73JB1H102J	MG RESISTOR	1.0K J 1/20W		R125	RK73HB1J103J	MG RESISTOR	10K J 1/16W	
R27	RK73JB1H103J	MG RESISTOR	10K J 1/20W		R126	RK73HB1J106J	MG RESISTOR	10M J 1/16W	
R29	RK73JB1H473J	MG RESISTOR	47K J 1/20W		R127	RK73HB1J472J	MG RESISTOR	4.7K J 1/16W	
R30	RK73HB1J223J	MG RESISTOR	22K J 1/16W		R128	RK73HB1J470J	MG RESISTOR	47 J 1/16W	
R31	RK73HB1J000J	MG RESISTOR	0.0 J 1/16W		R129	RK73HB1J104J	MG RESISTOR	100K J 1/16W	
R32	RK73HB1J101J	MG RESISTOR	100 J 1/16W		R130	RK73HB1J223J	MG RESISTOR	22K J 1/16W	
R33	RK73HB1J103J	MG RESISTOR	10K J 1/16W		R131	RK73HB1J223J	MG RESISTOR	22K J 1/16W	
R34	RK73HH1J333D	MG RESISTOR	33K D 1/16W		R132	RK73HB1J000J	MG RESISTOR	0.0 J 1/16W	
R35	RK73HH1J103D	MG RESISTOR	10K D 1/16W		R133	RK73HB1J000J	MG RESISTOR	0.0 J 1/16W	
R36	RK73HB1J103J	MG RESISTOR	10K J 1/16W		R135	RK73HB1J123J	MG RESISTOR	12K J 1/16W	
R37	RK73HB1J101J	MG RESISTOR	100 J 1/16W		R136	RK73HB1J223J	MG RESISTOR	22K J 1/16W	
R38	RK73HB1J224J	MG RESISTOR	220K J 1/16W		R137	RK73HB1J223J	MG RESISTOR	22K J 1/16W	
R39	RK73HB1J104J	MG RESISTOR	100K J 1/16W		R138	RK73HB1J473J	MG RESISTOR	47K J 1/16W	
R40	RK73JB1H104J	MG RESISTOR	100K J 1/20W		R139	RK73HB1J473J	MG RESISTOR	47K J 1/16W	
R41	RK73JB1H104J	MG RESISTOR	100K J 1/20W		R141	RK73HB1J103J	MG RESISTOR	10K J 1/16W	
R42	RK73JB1H473J	MG RESISTOR	47K J 1/20W		R142	RK73HB1J104J	MG RESISTOR	100K J 1/16W	
R43	RK73HB1J000J	MG RESISTOR	0.0 J 1/16W		R143	RK73HB1J472J	MG RESISTOR	4.7K J 1/16W	
R44	RK73JB1H102J	MG RESISTOR	1.0K J 1/20W		R144	RK73HB1J000J	MG RESISTOR	0.0 J 1/16W	
R45	RK73HB1J103J	MG RESISTOR	10K J 1/16W		R145	RK73HB1J474J	MG RESISTOR	470K J 1/16W	
R46	RK73JB1H104J	MG RESISTOR	100K J 1/20W		R146	RK73HB1J330J	MG RESISTOR	33 J 1/16W	
R47	RK73HB1J000J	MG RESISTOR	0.0 J 1/16W		R147	RK73HB1J151J	MG RESISTOR	150 J 1/16W	
R48	RK73HH1J103D	MG RESISTOR	10K D 1/16W		R148	RK73HB1J822J	MG RESISTOR	8.2K J 1/16W	
R49	RK73HH1J473D	MG RESISTOR	47K D 1/16W		R149	RK73HB1J472J	MG RESISTOR	4.7K J 1/16W	
R50	RK73HH1J103D	MG RESISTOR	10K D 1/16W		R150	RN73HOAJ181D	MF RESISTOR	180 J 1/16W	
R51	RK73HB1J222J	MG RESISTOR	2.2K J 1/16W		R151	RN73HH1J151D	MG RESISTOR	150 D 1/16W	
R52	RK73HB1J102J	MG RESISTOR	1.0K J 1/16W		R152	RN73HH1J100D	MG RESISTOR	10 D 1/16W	
R53	RK73HB1J000J	MG RESISTOR	0.0 J 1/16W		R153	RN73HH1J100D	MG RESISTOR	10 D 1/16W	
R54	R92-3769-05	MG RESISTOR	10 J 1/4W 10/0.25W/8		R154	RK73HB1J474J	MG RESISTOR	470K J 1/16W	
R55	R92-3769-05	MG RESISTOR	10 J 1/4W 10/0.25W/8		R155	RK73HB1J000J	MG RESISTOR	0.0 J 1/16W	
R56	RK73HB1J334J	MG RESISTOR	330K J 1/16W		R156	RK73HB1J000J	MG RESISTOR	0.0 J 1/16W	
R57	RK73HB1J223J	MG RESISTOR	22K J 1/16W		R157	RK73HB1J102J	MG RESISTOR	1.0K J 1/16W	
R58	RK73HB1J102J	MG RESISTOR	1.0K J 1/16W		R158	RK73HB1J331J	MG RESISTOR	330 J 1/16W	
R59	RK73HB1J100J	MG RESISTOR	10 J 1/16W		R159	RK73HB1J270J	MG RESISTOR	27 J 1/16W	
R60	RK73HB1J474J	MG RESISTOR	470K J 1/16W		R160	RK73HB1J392J	MG RESISTOR	3.9K J 1/16W	
R61	RK73HB1J102J	MG RESISTOR	1.0K J 1/16W		R161	RK73HB1J331J	MG RESISTOR	330 J 1/16W	
R62	RK73HB1J102J	MG RESISTOR	1.0K J 1/16W		R162	RK73HB1J473J	MG RESISTOR	47K J 1/16W	
R63	RK73HH1J273D	MG RESISTOR	27K D 1/16W		R163	RK73HB1J562J	MG RESISTOR	5.6K J 1/16W	
R64	RK73HH1J152D	MG RESISTOR	1.5K D 1/16W		R164	RK73HB1J121J	MG RESISTOR	120 J 1/16W	
R65	RK73HH1J472D	MG RESISTOR	4.7K D 1/16W		R165	RK73HB1J101J	MG RESISTOR	100 J 1/16W	
R66	RK73HB1J103J	MG RESISTOR	10K J 1/16W		R166	RK73HB1J331J	MG RESISTOR	330 J 1/16W	
R67	RK73HB1J472J	MG RESISTOR	4.7K J 1/16W		R167	RK73HB1J270J	MG RESISTOR	27 J 1/16W	
R68	RK73HB1J103J	MG RESISTOR	10K J 1/16W		R168	RK73HB1J331J	MG RESISTOR	330 J 1/16W	
					R169	RK73HB1J103J	MG RESISTOR	10K J 1/16W	

△ Symbol No.	Part No.	Part Name	Description	Local	△ Symbol No.	Part No.	Part Name	Description	Local
R170	RK73HB1J822J	MG RESISTOR	8.2K J 1/16W		R389	RK73GB2A000J	MG RESISTOR	0.0 J 1/10W	
R171	RK73HB1J101J	MG RESISTOR	100 J 1/16W		R391	RK73HB1J102J	MG RESISTOR	1.0K J 1/16W	
R172	RK73HB1J181J	MG RESISTOR	180 J 1/16W		R393	RK73GB2A560J	MG RESISTOR	56 J 1/10W	
R173	RK73HB1J272J	MG RESISTOR	2.7K J 1/16W		R394	RK73HB1J183J	MG RESISTOR	18K J 1/16W	
R174	RK73HB1J470J	MG RESISTOR	47 J 1/16W		R395	RK73HB1J223J	MG RESISTOR	22K J 1/16W	
R175	RK73HB1J000J	MG RESISTOR	0.0 J 1/16W		R396	RK73HB1J223J	MG RESISTOR	22K J 1/16W	
R176	RK73HB1J472J	MG RESISTOR	4.7K J 1/16W		R397	RK73PB2H470J	MG RESISTOR	47 J 1/2W	
R177	RK73GB2A000J	MG RESISTOR	0.0 J 1/10W		R398	RK73HB1J223J	MG RESISTOR	22K J 1/16W	
R178	RK73HB1J474J	MG RESISTOR	470K J 1/16W		R399	RK73PB2H470J	MG RESISTOR	47 J 1/2W	
R179	RK73HB1J102J	MG RESISTOR	1.0K J 1/16W		R402	R92-1061-05	JUMPER REST	0 OHM	
R300	RK73HB1J332J	MG RESISTOR	3.3K J 1/16W		R403	RK73GB2A000J	MG RESISTOR	0.0 J 1/10W	
R301	RK73HB1J221J	MG RESISTOR	220 J 1/16W		R405	RK73GB2A560J	MG RESISTOR	56 J 1/10W	
R303	RK73HB1J220J	MG RESISTOR	22 J 1/16W		R500	RK73HB1J680J	MG RESISTOR	68 J 1/16W	
R304	RK73HB1J221J	MG RESISTOR	220 J 1/16W		R501	RK73HB1J151J	MG RESISTOR	150 J 1/16W	
R305	RK73HB1J220J	MG RESISTOR	22 J 1/16W		R502	RK73HB1J680J	MG RESISTOR	68 J 1/16W	
R306	RK73HB1J000J	MG RESISTOR	0.0 J 1/16W		R503	RK73HB1J103J	MG RESISTOR	10K J 1/16W	
R307	RK73HB1J102J	MG RESISTOR	1.0K J 1/16W		R504	RK73HB1J682J	MG RESISTOR	6.8K J 1/16W	
R308	RK73HB1J121J	MG RESISTOR	120 J 1/16W		R505	RK73HB1J222J	MG RESISTOR	2.2K J 1/16W	
R309	RK73HB1J822J	MG RESISTOR	8.2K J 1/16W		R506	RK73HB1J470J	MG RESISTOR	47 J 1/16W	
R310	RK73HB1J271J	MG RESISTOR	270 J 1/16W		R507	RK73HB1J181J	MG RESISTOR	180 J 1/16W	
R311	RK73HB1J390J	MG RESISTOR	39 J 1/16W		R508	RK73HB1J472J	MG RESISTOR	4.7K J 1/16W	
R312	RK73HB1J390J	MG RESISTOR	39 J 1/16W		R509	RK73HB1J222J	MG RESISTOR	2.2K J 1/16W	
R313	RK73HB1J271J	MG RESISTOR	270 J 1/16W		R510	RK73HB1J393J	MG RESISTOR	39K J 1/16W	
R314	RK73HB1J470J	MG RESISTOR	47 J 1/16W		R511	RK73HB1J000J	MG RESISTOR	0.0 J 1/16W	
R315	RK73HB1J392J	MG RESISTOR	3.9K J 1/16W		R512	RK73HB1J000J	MG RESISTOR	0.0 J 1/16W	
R316	RK73HB1J472J	MG RESISTOR	4.7K J 1/16W		R514	RK73HB1J101J	MG RESISTOR	100 J 1/16W	
R318	RK73HB1J473J	MG RESISTOR	47K J 1/16W		R515	RK73HB1J000J	MG RESISTOR	0.0 J 1/16W	
R319	RK73HB1J222J	MG RESISTOR	2.2K J 1/16W		R516	RK73HB1J101J	MG RESISTOR	100 J 1/16W	
R321	RK73HB1J222J	MG RESISTOR	2.2K J 1/16W		R517	RK73HB1J271J	MG RESISTOR	270 J 1/16W	
R322	RK73HB1J103J	MG RESISTOR	10K J 1/16W		R519	RK73HB1J180J	MG RESISTOR	18 J 1/16W	
R323	RK73GB2A560J	MG RESISTOR	56 J 1/10W		R521	RK73HB1J000J	MG RESISTOR	0.0 J 1/16W	
R324	RK73HB1J223J	MG RESISTOR	22K J 1/16W		R523	RK73HB1J104J	MG RESISTOR	100K J 1/16W	
R325	RK73HB1J223J	MG RESISTOR	22K J 1/16W		R525	RK73HB1J000J	MG RESISTOR	0.0 J 1/16W	
R327	RK73HB1J223J	MG RESISTOR	22K J 1/16W		R526	RK73HB1J104J	MG RESISTOR	100K J 1/16W	
R328	RK73HB1J104J	MG RESISTOR	100K J 1/16W		R527	RK73HB1J104J	MG RESISTOR	100K J 1/16W	
R329	RK73HB1J470J	MG RESISTOR	47 J 1/16W		R528	RK73HB1J103J	MG RESISTOR	10K J 1/16W	
R330	RK73GB2A271J	MG RESISTOR	270 J 1/10W		R529	RK73HB1J104J	MG RESISTOR	100K J 1/16W	
R332	RK73GB2A390J	MG RESISTOR	39 J 1/10W		R530	RK73HB1J101J	MG RESISTOR	100 J 1/16W	
R333	RK73HB1J103J	MG RESISTOR	10K J 1/16W		R531	RK73HB1J104J	MG RESISTOR	100K J 1/16W	
R334	RK73HB1J103J	MG RESISTOR	10K J 1/16W		R532	RK73HB1J274J	MG RESISTOR	270K J 1/16W	
R335	RK73HB1J272J	MG RESISTOR	2.7K J 1/16W		R533	RK73HB1J333J	MG RESISTOR	33K J 1/16W	
R336	RK73HB1J221J	MG RESISTOR	220 J 1/16W		R535	RK73HB1J821J	MG RESISTOR	820 J 1/16W	
R337	RK73GB2A271J	MG RESISTOR	270 J 1/10W		R536	RK73HB1J5R6J	MG RESISTOR	5.6 J 1/16W	
R338	RK73GB2A390J	MG RESISTOR	39 J 1/10W		R537	RK73HB1J821J	MG RESISTOR	820 J 1/16W	
R339	RK73HB1J223J	MG RESISTOR	22K J 1/16W		R538	RK73HB1J000J	MG RESISTOR	0.0 J 1/16W	
R340	RK73HB1J223J	MG RESISTOR	22K J 1/16W		R539	RK73HB1J274J	MG RESISTOR	270K J 1/16W	
R341	RK73GB2A331J	MG RESISTOR	330 J 1/10W		R540	RK73HB1J333J	MG RESISTOR	33K J 1/16W	
R342	RK73HB1J103J	MG RESISTOR	10K J 1/16W		R542	RK73HB1J820J	MG RESISTOR	82 J 1/16W	
R343	RK73HB1J271J	MG RESISTOR	270 J 1/16W		R543	RK73HB1J103J	MG RESISTOR	10K J 1/16W	
R345	RK73GB2A562J	MG RESISTOR	5.6K J 1/10W		R545	RK73HB1J183J	MG RESISTOR	18K J 1/16W	
R346	RK73HB1J000J	MG RESISTOR	0.0 J 1/16W		R546	RK73HB1J183J	MG RESISTOR	18K J 1/16W	
R347	RK73HB1J223J	MG RESISTOR	22K J 1/16W		R548	RK73HB1J000J	MG RESISTOR	0.0 J 1/16W	
R348	RK73HB1J153J	MG RESISTOR	15K J 1/16W		R551	RK73HB1J104J	MG RESISTOR	100K J 1/16W	
R350	RK73GB2A332J	MG RESISTOR	3.3K J 1/10W		R552	RK73HB1J104J	MG RESISTOR	100K J 1/16W	
R355	RK73HB1J104J	MG RESISTOR	100K J 1/16W		R553	RK73HB1J104J	MG RESISTOR	100K J 1/16W	
R356	RK73HB1J182J	MG RESISTOR	1.8K J 1/16W		R554	RK73HB1J104J	MG RESISTOR	100K J 1/16W	
R357	RK73HB1J223J	MG RESISTOR	22K J 1/16W		R556	RK73HB1J271J	MG RESISTOR	270 J 1/16W	
R358	RK73HB1J223J	MG RESISTOR	22K J 1/16W		R557	RK73HB1J000J	MG RESISTOR	0.0 J 1/16W	
R359	RK73HB1J104J	MG RESISTOR	100K J 1/16W		R600	RK73HB1J100J	MG RESISTOR	10 J 1/16W	
R360	RK73HB1J223J	MG RESISTOR	22K J 1/16W		R601	RK73HB1J100J	MG RESISTOR	10 J 1/16W	
R364	RK73HB1J222J	MG RESISTOR	2.2K J 1/16W		R602	RK73HB1J100J	MG RESISTOR	10 J 1/16W	
R365	RK73HB1J471J	MG RESISTOR	470 J 1/16W		R603	RK73HB1J102J	MG RESISTOR	1.0K J 1/16W	
R366	RK73HB1J104J	MG RESISTOR	100K J 1/16W		R604	RK73HB1J681J	MG RESISTOR	680 J 1/16W	
R368	RK73HB1J223J	MG RESISTOR	22K J 1/16W		R605	RK73JB1H103J	MG RESISTOR	10K J 1/20W	
R369	RK73GB2A391J	MG RESISTOR	390 J 1/16W		R606	RK73HB1J000J	MG RESISTOR	0.0 J 1/16W	
R371	RK73HB1J470J	MG RESISTOR	47 J 1/16W		R607	RK73HB1J220J	MG RESISTOR	22 J 1/16W	
R374	RK73HB1J223J	MG RESISTOR	22K J 1/16W		R608	RK73HB1J391D	MG RESISTOR	390 D 1/16W	
R375	RK73HB1J223J	MG RESISTOR	22K J 1/16W		R609	RK73HB1J182J	MG RESISTOR	1.8K J 1/16W	
R377	RK73FB2B101J	MG RESISTOR	100 J 1/8W		R610	RK73HB1J562J	MG RESISTOR	5.6K J 1/16W	
R378	RK73HB1J101J	MG RESISTOR	100 J 1/16W		R611	RK73HB1J471J	MG RESISTOR	470 J 1/16W	
R379	RK73HB1J333J	MG RESISTOR	33K J 1/16W		R612	RK73JB1H472J	MG RESISTOR	4.7K J 1/20W	
R380	RK73HB1J223J	MG RESISTOR	22K J 1/16W		R613	RK73HB1J104J	MG RESISTOR	100K J 1/16W	
R381	RK73HB1J223J	MG RESISTOR	22K J 1/16W		R614	RK73HB1J470J	MG RESISTOR	47 J 1/16W	
R384	RK73HB1J000J	MG RESISTOR	0.0 J 1/16W		R615	RK73HB1J103J	MG RESISTOR	10K J 1/16W	
R385	RK73HB1J470J	MG RESISTOR	47 J 1/16W		R616	RK73HB1J101J	MG RESISTOR	100 J 1/16W	
R386	RK73HB1J103J	MG RESISTOR	10K J 1/16W		R617	RK73HB1J274J	MG RESISTOR	270K J 1/16W	
R387	RK73GB2A560J	MG RESISTOR	56 J 1/10W		R618	RK73HB1J271J	MG RESISTOR	270 J 1/16W	
R388	RK73FB2B820J	MG RESISTOR	82 J 1/8W		R619	RK73HB1J180J	MG RESISTOR	18 J 1/16W	

△ Symbol No.	Part No.	Part Name	Description	Local	△ Symbol No.	Part No.	Part Name	Description	Local
R620	RK73HB1J271J	MG RESISTOR	270 J 1/16W		R797	RK73JB1H220J	MG RESISTOR	22 J 1/20W	
R621	RK73HB1J470J	MG RESISTOR	47 J 1/16W		R798	RK73JB1H220J	MG RESISTOR	22 J 1/20W	
R622	RK73HB1J681J	MG RESISTOR	680 J 1/16W		R799	RK73JB1H220J	MG RESISTOR	22 J 1/20W	
R623	RK73HB1J104J	MG RESISTOR	100K J 1/16W		R800	RK73JB1H220J	MG RESISTOR	22 J 1/20W	
R624	RK73HB1J473J	MG RESISTOR	47K J 1/16W		R801	RK73JB1H220J	MG RESISTOR	22 J 1/20W	
R625	RK73HB1J104J	MG RESISTOR	100K J 1/16W		R802	RK73JB1H220J	MG RESISTOR	22 J 1/20W	
R626	RK73HB1J333J	MG RESISTOR	33K J 1/16W		R803	RK73JB1H220J	MG RESISTOR	22 J 1/20W	
R628	RK73HB1J101J	MG RESISTOR	100 J 1/16W		R804	RK73JB1H220J	MG RESISTOR	22 J 1/20W	
R630	RK73HB1J101J	MG RESISTOR	100 J 1/16W		R805	RK73GH2A49R9D	MG RESISTOR	49.9 D 1/10W	
R631	RK73HB1J000J	MG RESISTOR	0.0 J 1/16W		R806	RK73JB1H220J	MG RESISTOR	22 J 1/20W	
R632	RK73GB2A220J	MG RESISTOR	22 J 1/10W		R807	RK73JB1H102J	MG RESISTOR	1.0K J 1/20W	
R700	RK73HB1J102J	MG RESISTOR	1.0K J 1/16W		R808	RK73JB1H102J	MG RESISTOR	1.0K J 1/20W	
R701	RK73HB1J000J	MG RESISTOR	0.0 J 1/16W		R809	RK73JB1H220J	MG RESISTOR	22 J 1/20W	
R702	RK73HB1J100J	MG RESISTOR	10 J 1/16W		R810	RK73JB1H102J	MG RESISTOR	1.0K J 1/20W	
R707	RK73HB1J100J	MG RESISTOR	10 J 1/16W		R813	RK73JB1H220J	MG RESISTOR	22 J 1/20W	
R708	RK73HB1J220J	MG RESISTOR	22 J 1/16W		R814	RK73JB1H220J	MG RESISTOR	22 J 1/20W	
R709	RK73HB1J102J	MG RESISTOR	1.0K J 1/16W		R815	RK73JB1H220J	MG RESISTOR	22 J 1/20W	
R719	RK73HB1J153J	MG RESISTOR	15K J 1/16W		R816	RK73HB1J102J	MG RESISTOR	1.0K J 1/16W	
R720	RK73HB1J333J	MG RESISTOR	33K J 1/16W		R817	RK73JB1H220J	MG RESISTOR	22 J 1/20W	
R721	RK73HB1J100J	MG RESISTOR	10 J 1/16W		R828	RK73HB1J103J	MG RESISTOR	10K J 1/16W	
R722	RK73HB1J681J	MG RESISTOR	680 J 1/16W		R830	RK73JB1H103J	MG RESISTOR	10K J 1/20W	
R727	RK73HB1J821J	MG RESISTOR	820 J 1/16W		R831	RK73HB1J102J	MG RESISTOR	1.0K J 1/16W	
R728	RK73JB1H104J	MG RESISTOR	100K J 1/20W		R833	RK73JB1H104J	MG RESISTOR	100K J 1/20W	
R729	RK73JB1H104J	MG RESISTOR	100K J 1/20W		R835	RK73JB1H104J	MG RESISTOR	100K J 1/20W	
R731	RK73JB1H473J	MG RESISTOR	47K J 1/20W		R837	RK73HB1J102J	MG RESISTOR	1.0K J 1/16W	
R732	RK73JB1H472J	MG RESISTOR	4.7K J 1/20W		R838	RK73HB1J000J	MG RESISTOR	0.0 J 1/16W	
R733	RK73HB1J000J	MG RESISTOR	0.0 J 1/16W		R839	RK73HB1J473J	MG RESISTOR	47K J 1/16W	
R734	RK73JB1H103J	MG RESISTOR	10K J 1/20W		R843	RK73HH1J104D	MG RESISTOR	100K D 1/16W	
R735	RK73JB1H103J	MG RESISTOR	10K J 1/20W		R844	RK73HB1J103J	MG RESISTOR	10K J 1/16W	
R736	RK73HB1J000J	MG RESISTOR	0.0 J 1/16W		R845	RK73HB1J103J	MG RESISTOR	10K J 1/16W	
R738	RK73HB1J102J	MG RESISTOR	1.0K J 1/16W		R854	RK73HB1J000J	MG RESISTOR	0.0 J 1/16W	
R740	RK73HB1J102J	MG RESISTOR	1.0K J 1/16W		R857	RK73HB1J333J	MG RESISTOR	33K J 1/16W	
R742	RK73HB1J102J	MG RESISTOR	1.0K J 1/16W		R858	RK73HB1J223J	MG RESISTOR	22K J 1/16W	
R744	RK73HB1J102J	MG RESISTOR	1.0K J 1/16W		R859	RK73HB1J223J	MG RESISTOR	22K J 1/16W	
R746	RK73HB1J102J	MG RESISTOR	1.0K J 1/16W		R862	RK73HB1J222J	MG RESISTOR	2.2K J 1/16W	
R747	RK73JB1H220J	MG RESISTOR	22 J 1/20W		R863	RK73HB1J000J	MG RESISTOR	0.0 J 1/16W	
R748	RK73JB1H220J	MG RESISTOR	22 J 1/20W		R864	RK73HB1J000J	MG RESISTOR	0.0 J 1/16W	
R749	RK73JB1H220J	MG RESISTOR	22 J 1/20W		R865	RK73HB1J222J	MG RESISTOR	2.2K J 1/16W	
R750	RK73JB1H220J	MG RESISTOR	22 J 1/20W		R866	RK73HB1J103J	MG RESISTOR	10K J 1/16W	
R751	RK73JB1H220J	MG RESISTOR	22 J 1/20W		R867	RK73HB1J223J	MG RESISTOR	22K J 1/16W	
R752	RK73HB1J332J	MG RESISTOR	3.3K J 1/16W		R868	RK73HB1J000J	MG RESISTOR	0.0 J 1/16W	
R753	RK73JB1H220J	MG RESISTOR	22 J 1/20W		R869	RK73HB1J000J	MG RESISTOR	0.0 J 1/16W	
R754	RK73JB1H220J	MG RESISTOR	22 J 1/20W		R874	RK73JB1H104J	MG RESISTOR	100K J 1/20W	
R755	RK73JB1H104J	MG RESISTOR	100K J 1/20W		R876	RK73HB1J102J	MG RESISTOR	1.0K J 1/16W	
R756	RK73JB1H104J	MG RESISTOR	100K J 1/20W		R877	RK73FB2B332J	MG RESISTOR	3.3K J 1/8W	
R757	RK73JB1H220J	MG RESISTOR	22 J 1/20W		R878	RK73FB2B332J	MG RESISTOR	3.3K J 1/8W	
R758	RK73JB1H220J	MG RESISTOR	22 J 1/20W		R879	RK73FB2B332J	MG RESISTOR	3.3K J 1/8W	
R759	RK73JB1H220J	MG RESISTOR	22 J 1/20W		R880	RK73HB1J102J	MG RESISTOR	1.0K J 1/16W	
R760	RK73JB1H220J	MG RESISTOR	22 J 1/20W		R881	RK73HB1J000J	MG RESISTOR	0.0 J 1/16W	
R761	RK73JB1H220J	MG RESISTOR	22 J 1/20W		R882	RK73JB1H473J	MG RESISTOR	47K J 1/20W	
R762	RK73JB1H220J	MG RESISTOR	22 J 1/20W		R883	RK73JB1H473J	MG RESISTOR	47K J 1/20W	
R763	RK73JB1H220J	MG RESISTOR	22 J 1/20W		R884	RK73HB1J104J	MG RESISTOR	100K J 1/16W	
R764	RK73JB1H104J	MG RESISTOR	100K J 1/20W		R885	RK73HB1J000J	MG RESISTOR	0.0 J 1/16W	
R765	RK73JB1H220J	MG RESISTOR	22 J 1/20W		R900	RK73HB1J100J	MG RESISTOR	10 J 1/16W	
R766	RK73JB1H220J	MG RESISTOR	22 J 1/20W		R901	RK73HB1J101J	MG RESISTOR	100 J 1/16W	
R767	RK73JB1H220J	MG RESISTOR	22 J 1/20W		R902	RK73HB1J100J	MG RESISTOR	10 J 1/16W	
R768	RK73JB1H220J	MG RESISTOR	22 J 1/20W		R903	RK73HB1J103J	MG RESISTOR	10K J 1/16W	
R770	RK73JB1H220J	MG RESISTOR	22 J 1/20W		R904	RK73HH1J223D	MG RESISTOR	22K D 1/16W	
R772	RK73JB1H220J	MG RESISTOR	22 J 1/20W		R905	RK73HH1J223D	MG RESISTOR	22K D 1/16W	
R773	RK73JB1H104J	MG RESISTOR	100K J 1/20W		R906	RK73HB1J000J	MG RESISTOR	0.0 J 1/16W	
R774	RK73JB1H220J	MG RESISTOR	22 J 1/20W		R907	RK73HB1J000J	MG RESISTOR	0.0 J 1/16W	
R775	RK73JB1H220J	MG RESISTOR	22 J 1/20W		R908	RK73HH1J223D	MG RESISTOR	22K D 1/16W	
R766	RK73JB1H220J	MG RESISTOR	22 J 1/20W		R909	RK73HH1J223D	MG RESISTOR	22K D 1/16W	
R777	RK73JB1H102J	MG RESISTOR	1.0K J 1/20W		R911	RK73HB1J104J	MG RESISTOR	100K J 1/16W	
R778	RK73JB1H220J	MG RESISTOR	22 J 1/20W		R912	RK73HB1J102J	MG RESISTOR	1.0K J 1/16W	
R779	RK73JB1H220J	MG RESISTOR	22 J 1/20W		R913	RK73HB1J000J	MG RESISTOR	0.0 J 1/16W	
R781	RK73JB1H220J	MG RESISTOR	22 J 1/20W		R914	RK73HB1J102J	MG RESISTOR	1.0K J 1/16W	
R782	RK73JB1H220J	MG RESISTOR	22 J 1/20W		R915	RK73HB1J000J	MG RESISTOR	0.0 J 1/16W	
R783	RK73JB1H220J	MG RESISTOR	22 J 1/20W		R916	RK73HB1J222J	MG RESISTOR	2.2K J 1/16W	
R785	RK73JB1H220J	MG RESISTOR	22 J 1/20W		R917	RK73HB1J000J	MG RESISTOR	0.0 J 1/16W	
R787	RK73JB1H220J	MG RESISTOR	22 J 1/20W		R918	RK73HB1J683J	MG RESISTOR	68K J 1/16W	
R788	RK73JB1H220J	MG RESISTOR	22 J 1/20W		R919	RK73HH1J473D	MG RESISTOR	47K D 1/16W	
R789	RK73HB1J101J	MG RESISTOR	100 J 1/16W		R920	RK73HB1J000J	MG RESISTOR	0.0 J 1/16W	
R790	RK73JB1H220J	MG RESISTOR	22 J 1/20W		R921	RK73HB1J102J	MG RESISTOR	1.0K J 1/16W	
R791	RK73JB1H220J	MG RESISTOR	22 J 1/20W		R922	RK73HB1J681J	MG RESISTOR	680 J 1/16W	
R792	RK73JB1H220J	MG RESISTOR	22 J 1/20W		R923	RK73HB1J000J	MG RESISTOR	0.0 J 1/16W	
R794	RK73JB1H220J	MG RESISTOR	22 J 1/20W		R924	RK73HB1J473J	MG RESISTOR	47K J 1/16W	
R795	RK73JB1H220J	MG RESISTOR	22 J 1/20W		R925	RK73HB1J273J	MG RESISTOR	27K J 1/16W	

△ Symbol No.	Part No.	Part Name	Description	Local	△ Symbol No.	Part No.	Part Name	Description	Local
R926	RK73HB1J103J	MG RESISTOR	10K J 1/16W		L101	LB73H0AV-003	CHIP FERRITE BEADS		
R927	RK73HB1J474J	MG RESISTOR	470K J 1/16W		L102	LB73H0AV-003	CHIP FERRITE BEADS		
R928	RK73HB1J103J	MG RESISTOR	10K J 1/16W		L103	LB73H0AV-003	CHIP FERRITE BEADS		
R930	RK73HH1J103D	MG RESISTOR	10K D 1/16W		L104	LK73G0AQ100K	SMALL FIXED INDUCTOR(10UH)		
R932	RK73HB1J473J	MG RESISTOR	47K J 1/16W		L105	LK73G0AQ100K	SMALL FIXED INDUCTOR(10UH)		
R933	RK73HB1J000J	MG RESISTOR	0.0K J 1/16W		L106	L40-2263-92	SMALL FIXED INDUCTOR(2.2NH)		
R935	RK73HB1J102J	MG RESISTOR	1.0K J 1/16W		L107	L40-3363-92	SMALL FIXED INDUCTOR(3.3NH)		
R936	RK73GB2A101J	MG RESISTOR	100 J 1/10W		L108	LB73H0AV-003	CHIP FERRITE BEADS		
R937	RK73HB1J000J	MG RESISTOR	0.0 J 1/16W		L109	LB73H0AV-003	CHIP FERRITE BEADS		
R938	RK73HB1J332J	MG RESISTOR	3.3K J 1/16W		L110	LK73G0AFR27J	SMALL FIXED INDUCTOR(270NH)		
R939	RK73HB1J392J	MG RESISTOR	3.9K J 1/16W		L111	LK73G0AFR22J	SMALL FIXED INDUCTOR(220NH)		
R940	RK73HB1J392J	MG RESISTOR	3.9K J 1/16W		L112	LK73G0AF18NJ	SMALL FIXED INDUCTOR(18NH)		
R941	RK73GB2A101J	MG RESISTOR	100 J 1/10W		L113	LK73G0AF27NJ	SMALL FIXED INDUCTOR(27NH)		
R943	RK73GB2A000J	MG RESISTOR	0.0 J 1/10W		L114	LK73G0AFR27J	SMALL FIXED INDUCTOR(270NH)		
R944	RK73HB1J473J	MG RESISTOR	47K J 1/16W		L115	LK73G0AFR22J	SMALL FIXED INDUCTOR(220NH)		
R945	RK73HB1J472J	MG RESISTOR	4.7K J 1/16W		L116	LK73G0AFR27J	SMALL FIXED INDUCTOR(270NH)		
R947	RK73HB1J101J	MG RESISTOR	100 J 1/16W		L117	LK73G0AFR22J	SMALL FIXED INDUCTOR(220NH)		
R948	RK73HB1J000J	MG RESISTOR	0.0 J 1/16W		L118	L40-3363-92	SMALL FIXED INDUCTOR(3.3NH)		
R949	RK73HB1J472J	MG RESISTOR	4.7K J 1/16W		L119	L40-2263-92	SMALL FIXED INDUCTOR(2.2NH)		
R950	RK73GB2A000J	MG RESISTOR	0.0 J 1/10W		L120	LK73G0AFR27J	SMALL FIXED INDUCTOR(270NH)		
R951	RK73HB1J100J	MG RESISTOR	10 J 1/16W		L121	LK73G0AFR22J	SMALL FIXED INDUCTOR(220NH)		
R953	RK73HB1J472J	MG RESISTOR	4.7K J 1/16W		L122	LB73H0AY-004	CHIP FERRITE BEADS		
R954	RK73HB1J472J	MG RESISTOR	4.7K J 1/16W		L123	L34-4610-15	AIR-CORE COIL		
R955	RK73HB1J100J	MG RESISTOR	10 J 1/16W		L124	LR79Z0CM22NG	SMALL FIXED INDUCTOR(22NH)		
R956	RK73HB1J000J	MG RESISTOR	0.0 J 1/16W		L125	LK73G0AF27NJ	SMALL FIXED INDUCTOR(27NH)		
R957	RK73HB1J101J	MG RESISTOR	100 J 1/16W		L126	LK73G0AFR27J	SMALL FIXED INDUCTOR(270NH)		
R958	RK73GB2A102J	MG RESISTOR	1.0K J 1/10W		L127	LK73G0AFR22J	SMALL FIXED INDUCTOR(220NH)		
R960	RK73HB1J103J	MG RESISTOR	10K J 1/16W		L128	LK73G0AFR27J	SMALL FIXED INDUCTOR(270NH)		
R961	RK73GB2A102J	MG RESISTOR	1.0K J 1/10W		L129	LK73G0AFR22J	SMALL FIXED INDUCTOR(220NH)		
R962	RK73HB1J473J	MG RESISTOR	47K J 1/16W		L130	LB73H0AY-004	CHIP FERRITE BEADS		
R963	RK73HB1J101J	MG RESISTOR	100 J 1/16W		L131	LB73H0AY-004	CHIP FERRITE BEADS		
R964	RK73HB1J101J	MG RESISTOR	100 J 1/16W		L132	LK73H0AM56NJ	SMALL FIXED INDUCTOR(56NH)		
R965	RK73HB1J471J	MG RESISTOR	470 J 1/16W		L134	LK73G0AF27NJ	SMALL FIXED INDUCTOR(27NH)		
R966	RK73HB1J471J	MG RESISTOR	470 J 1/16W		L135	LK73G0AF27NJ	SMALL FIXED INDUCTOR(27NH)		
R967	RK73GB2A221J	MG RESISTOR	220 J 1/10W		L136	LB73H0AV-003	CHIP FERRITE BEADS		
R968	RK73GB2A221J	MG RESISTOR	220 J 1/10W		L137	LK73G0AF33NJ	SMALL FIXED INDUCTOR(33NH)		
R969	RK73HB1J471J	MG RESISTOR	470 J 1/16W		L138	LK73H0AG27NJ	SMALL FIXED INDUCTOR(27NH)		
R970	RK73HB1J101J	MG RESISTOR	100 J 1/16W		L139	LB73H0AY-004	CHIP FERRITE BEADS		
R971	RK73HB1J471J	MG RESISTOR	470 J 1/16W		L300	LK73H0AM15NJ	SMALL FIXED INDUCTOR(15NH)		
R972	RK73HB1J471J	MG RESISTOR	470 J 1/16W		L301	LK73H0AMR12J	SMALL FIXED INDUCTOR(120NH)		
R973	RK73HB1J471J	MG RESISTOR	470 J 1/16W		L302	LK73H0AM15NJ	SMALL FIXED INDUCTOR(15NH)		
R974	RK73HB1J101J	MG RESISTOR	100 J 1/16W		L303	LK73H0AM15NJ	SMALL FIXED INDUCTOR(15NH)		
R975	RK73HB1J101J	MG RESISTOR	100 J 1/16W		L304	LK73H0AM6N8J	SMALL FIXED INDUCTOR(6.8NH)		
R976	RK73HB1J101J	MG RESISTOR	100 J 1/16W		L305	LK73G0AF4N7S	SMALL FIXED INDUCTOR(4.7NH)		
R977	RK73GB2A102J	MG RESISTOR	1.0K J 1/10W		L306	LB73FOAW-002	CHIP FERRITE BEADS		
R978	RK73HB1J473J	MG RESISTOR	47K J 1/16W		L307	LK73G0AF10NJ	SMALL FIXED INDUCTOR(10NH)		
R979	RK73HB1J681J	MG RESISTOR	680 J 1/16W		L308	LB73H0AV-003	CHIP FERRITE BEADS		
R980	RK73HB1J000J	MG RESISTOR	0.0 J 1/16W		L309	LB73G0BA-004	CHIP FERRITE BEADS		
R981	RK73GB2A221J	MG RESISTOR	220 J 1/10W		L310	LB73Z0AF-001	CHIP FERRITE BEADS		
R982	RK73GB2A221J	MG RESISTOR	220 J 1/10W		L311	LB73Z0AF-001	CHIP FERRITE BEADS		
R983	RK73HB1J101J	MG RESISTOR	100 J 1/16W		L312	LB73Z0AF-001	CHIP FERRITE BEADS		
R984	RK73HB1J682J	MG RESISTOR	6.8K J 1/16W		L314	LK73G0AF47NJ	SMALL FIXED INDUCTOR(47NH)		
R985	RK73HB1J104J	MG RESISTOR	100K J 1/16W		L315	LR77Z0AA68NJ	SMALL FIXED INDUCTOR(68NH)		
R991	RK73HB1J000J	MG RESISTOR	0.0 J 1/16W		L316	L34-4896-05	AIR-CORE COIL		
R992	RK73HB1J102J	MG RESISTOR	1.0K J 1/16W		L317	L41-8278-55	SMALL FIXED INDUCTOR(82NH)		
R993	RK73HB1J000J	MG RESISTOR	0.0 J 1/16W		L318	LB73G0BD-005	CHIP FERRITE BEADS		
R994	RK73HB1J000J	MG RESISTOR	0.0 J 1/16W		L319	L34-4694-05	AIR-CORE COIL		
R996	RK73HB1J000J	MG RESISTOR	0.0 J 1/16W		L320	L34-4669-05	AIR-CORE COIL		
R997	RK73HB1J000J	MG RESISTOR	0.0 J 1/16W		L321	LB73H0AV-003	CHIP FERRITE BEADS		
R998	RK73HB1J000J	MG RESISTOR	0.0 J 1/16W		L322	L34-4669-05	AIR-CORE COIL		
					L323	L34-4669-05	AIR-CORE COIL		
					L324	L34-4667-05	AIR-CORE COIL		
L1	LB73Z0AF-001	CHIP FERRITE BEADS			L325	L41-3965-55	SMALL FIXED INDUCTOR(3.9NH)		
L2	LB73Z0AF-001	CHIP FERRITE BEADS			L500	L39-1498-05	TOROIDAL COIL		
L3	LB73Z0AF-001	CHIP FERRITE BEADS			L501	LB73G0BD-005	CHIP FERRITE BEADS		
L4	LB73H0AV-002	CHIP FERRITE BEADS			L502	L41-1095-14	SMALL FIXED INDUCTOR(1.0UH)		
L5	LB73G0AK-001	CHIP FERRITE BEADS			L503	L41-1095-14	SMALL FIXED INDUCTOR(1.0UH)		
L6	LB73G0AM-004	CHIP FERRITE BEADS			L504	LK73G0AF22NJ	SMALL FIXED INDUCTOR(22NH)		
L7	LB73G0AK-001	CHIP FERRITE BEADS			L505	LK73G0AF15NJ	SMALL FIXED INDUCTOR(15NH)		
L9	LB73G0AK-001	CHIP FERRITE BEADS			L506	LK73G0AF18NJ	SMALL FIXED INDUCTOR(18NH)		
L10	LB73G0AK-001	CHIP FERRITE BEADS			L507	LK73H0AM27NJ	SMALL FIXED INDUCTOR(27NH)		
L11	L41-4792-69	SMALL FIXED INDUCTOR(4.7UH)			L508	LR79Z0DD27N4J	CHIP INDUCTOR		
L12	LB73G0AM-004	CHIP FERRITE BEADS			L509	LR79Z0DD27N4J	CHIP INDUCTOR		
L13	LR79Z0AA150M	SMALL FIXED INDUCTOR(15UH)			L510	LR79Z0DD27N4J	CHIP INDUCTOR		
L14	LB73G0AK-001	CHIP FERRITE BEADS			L511	LR79Z0DD27N4J	CHIP INDUCTOR		
L15	LB73G0AK-001	CHIP FERRITE BEADS			L512	LB73G0BD-005	CHIP FERRITE BEADS		
L16	LB73H0AY-004	CHIP FERRITE BEADS			L513	L41-1578-14	SMALL FIXED INDUCTOR(15NH)		
L80	LB73H0AV-003	CHIP FERRITE BEADS			L515	LR79Z0DD37N7J	CHIP INDUCTOR		
L100	LB73H0AV-003	CHIP FERRITE BEADS							

△ Symbol No.	Part No.	Part Name	Description	Local	△ Symbol No.	Part No.	Part Name	Description	Local
L516	LR79Z0DD37N7J	CHIP INDUCTOR			CN339	E23-1278-05	TERMINAL		
L517	L41-1878-14	SMALL FIXED INDUCTOR(18NH)			CN360	E23-1278-05	TERMINAL		
L518	L41-8278-14	SMALL FIXED INDUCTOR(82NH)			CN361	E23-1278-05	TERMINAL		
L600	LK73G0AQ100K	SMALL FIXED INDUCTOR(10UH)			CN362	E23-1278-05	TERMINAL		
L601	LB73H0AV-003	CHIP FERRITE BEADS			CN363	E23-1278-05	TERMINAL		
L602	LB73H0AV-003	CHIP FERRITE BEADS			CN364	E23-1278-05	TERMINAL		
L603	L41-2788-55	SMALL FIXED INDUCTOR(270NH)			CN367	E23-1278-05	TERMINAL		
L604	LB73H0AV-003	CHIP FERRITE BEADS			CN368	E23-1278-05	TERMINAL		
L605	LK73G0AFR27J	M.CHIP INDUCTOR			CN372	E23-1278-05	TERMINAL		
L606	L41-4798-14	SMALL FIXED INDUCTOR(4.7UF)			CN377	E23-1278-05	TERMINAL		
L607	L41-1885-53	SMALL FIXED INDUCTOR(0.18UH)			CN382	E23-1278-05	TERMINAL		
L608	LB73H0AV-003	CHIP FERRITE BEADS			CN521	E23-1278-05	TERMINAL		
L609	LB73H0AV-003	CHIP FERRITE BEADS			CN523	E23-1278-05	TERMINAL		
L610	L41-2285-53	SMALL FIXED INDUCTOR(0.22UH)			CN524	E23-1278-05	TERMINAL		
L611	LK73G0AQ100K	SMALL FIXED INDUCTOR(10UH)			CN526	E23-1278-05	TERMINAL		
L612	LK73G0AQ100K	SMALL FIXED INDUCTOR(10UH)			CN731	E40-6720-05	SOCKET FOR PIN ASSY		
L613	LB73H0AV-003	CHIP FERRITE BEADS			CN735	E40-6862-05	FLAT CABLE CONNECTOR		
L614	LB73H0AV-003	CHIP FERRITE BEADS			CN749	EC720AA-0550A	FLAT CABLE CONNECTOR SMD		
L615	LK73G0AQR33K	SMALL FIXED INDUCTOR(330NH)			CN760	E23-1278-05	TERMINAL		
L616	LB73H0AV-002	CHIP FERRITE BEADS			CN761	E23-1278-05	TERMINAL		
L617	LK73G0AQR82K	SMALL FIXED INDUCTOR(330NH)			CN762	E23-1278-05	TERMINAL		
L618	LK73G0AQ2R2K	SMALL FIXED INDUCTOR(10UH)			CN763	E23-1278-05	TERMINAL		
L619	L40-6881-86	SMALL FIXED INDUCTOR(680NH)			CN764	E23-1278-05	TERMINAL		
L620	LB73H0AV-002	CHIP FERRITE BEADS			CN765	E23-1278-05	TERMINAL		
L621	L41-1098-14	SMALL FIXED INDUCTOR(1UH)			CN766	E23-1278-05	TERMINAL		
L625	LK73G0ASR47J	SMALL FIXED INDUCTOR(470NH)			CN769	E23-1278-05	TERMINAL		
L626	LK73G0AQ100K	SMALL FIXED INDUCTOR(10UH)			CN770	E23-1278-05	TERMINAL		
L700	LB73G0AK-001	CHIP FERRITE BEADS			CN771	E23-1278-05	TERMINAL		
L701	LB73H0AV-003	CHIP FERRITE BEADS			CN772	E23-1278-05	TERMINAL		
L702	LB73G0AK-001	CHIP FERRITE BEADS			CN773	E23-1278-05	TERMINAL		
L706	LB73H0AV-002	CHIP FERRITE BEADS			CN774	E23-1278-05	TERMINAL		
L711	LR77Z0AE4R7J	SMALL FIXED INDUCTOR(4.7UH)			CN775	E23-1278-05	TERMINAL		
L713	LB73H0AV-002	CHIP FERRITE BEADS			CN776	E23-1278-05	TERMINAL		
L714	LB73G0AM-004	CHIP FERRITE BEADS			CN777	E23-1278-05	TERMINAL		
L715	L92-1101-05	CHIP FERRITE			CN778	E23-1278-05	TERMINAL		
L716	L92-1101-05	CHIP FERRITE			CN779	E23-1278-05	TERMINAL		
L717	L92-1101-05	CHIP FERRITE			CN780	E23-1278-05	TERMINAL		
L718	L92-1101-05	CHIP FERRITE			CN781	E23-1278-05	TERMINAL		
L719	LB73H0AV-002	CHIP FERRITE BEADS			CN783	E23-1278-05	TERMINAL		
L720	LB73G0AK-001	CHIP FERRITE BEADS			CN900	E41-2723-05	PIN ASSY		
L721	LB73G0AK-001	CHIP FERRITE BEADS			CN906	E40-6560-05	FLAT CABLE CONNECTOR		
L722	LB73G0AK-001	CHIP FERRITE BEADS			CN907	E40-6560-05	FLAT CABLE CONNECTOR		
L723	LB73H0AV-002	CHIP FERRITE BEADS			CN910	E40-6582-05	PIN ASSY		
L724	LB73G0AK-001	CHIP FERRITE BEADS			CP100	RK74HB1J100J	NET RESISTOR	10 J 1/16W	
L725	LB73H0AV-002	CHIP FERRITE BEADS			CP600	RK74HB1J100J	NET RESISTOR	10 J 1/16W	
L726	L79-1984-05	FILTER			CP701	RK74HB1J103J	NET RESISTOR	10K J 1/16W	
L728	L79-1984-05	FILTER			CP702	RK74HB1J102J	NET RESISTOR	1.0K J 1/16W	
L729	L79-1984-05	FILTER			CP703	RK74HB1J100J	NET RESISTOR	10 J 1/16W	
L730	L79-1984-05	FILTER			CP704	RK74HB1J100J	NET RESISTOR	10 J 1/16W	
L731	L79-1984-05	FILTER			CP705	RK74HB1J100J	NET RESISTOR	10 J 1/16W	
L732	L92-1101-05	CHIP FERRITE			CP706	RK74HB1J101J	NET RESISTOR	100 J 1/16W	
L901	LB73H0AV-003	CHIP FERRITE BEADS			CP707	RK74HB1J101J	NET RESISTOR	100 J 1/16W	
L902	LB73H0AV-003	CHIP FERRITE BEADS			CP708	RK74HB1J101J	NET RESISTOR	100 J 1/16W	
L906	LB73G0BA-004	CHIP FERRITE BEADS			CP709	RK74HB1J101J	NET RESISTOR	100 J 1/16W	
L907	LB73G0BA-004	CHIP FERRITE BEADS			CP710	RK74HB1J101J	NET RESISTOR	100 J 1/16W	
					CP711	RK74HB1J101J	NET RESISTOR	100 J 1/16W	
A1	W02-3785-05	DC-DC CONVERTER			CP716	RK74HB1J101J	NET RESISTOR	100 J 1/16W	
CN2	E23-1260-14	TERMINAL			CP717	RK74HB1J470J	NET RESISTOR	47 J 1/16W	
CN3	E23-1260-14	TERMINAL			CP718	RK74HB1J470J	NET RESISTOR	47 J 1/16W	
CN4	E41-1682-05	PIN ASSY			CP719	RK74HB1J470J	NET RESISTOR	47 J 1/16W	
CN12	J19-5386-05	HOLDER			CP720	RK74HB1J470J	NET RESISTOR	47 J 1/16W	
CN100	E23-1278-05	TERMINAL			CP721	RK74HB1J470J	NET RESISTOR	47 J 1/16W	
CN102	E23-1278-05	TERMINAL			CP900	RK74HB1J100J	NET RESISTOR	10 J 1/16W	
CN104	E23-1278-05	TERMINAL			CP901	RK74HA1J100J	NET RESISTOR	10 J 1/16W	
CN106	E23-1278-05	TERMINAL			E2	F10-3226-05	SHIELDING CASE		
CN110	E23-1278-05	TERMINAL			E100	F10-3244-05	SHIELDING CASE		
CN111	E23-1278-05	TERMINAL			E101	F1B-0017-00	SHIELDING CASE		
CN112	E23-1278-05	TERMINAL			E600	F10-3224-05	SHIELDING CASE		
CN113	E23-1278-05	TERMINAL			F1	F53-0286-05	FUSE(2.5A)		
CN300	E23-1278-05	TERMINAL			F2	FZA10BS-5R0	FUSE(5A)		
CN330	E23-1278-05	TERMINAL			F3	FZA10BS-5R0	FUSE(5A)		
CN331	E23-1278-05	TERMINAL			F900	F53-0286-05	FUSE(2.5A)		
CN332	E23-1278-05	TERMINAL			J700	E68-0426-05	JACK(OTHERS)		
CN333	E23-1278-05	TERMINAL			J900	E1B-0001-00	3.5D PHONE JACK		
CN334	E23-1278-05	TERMINAL			J901	E58-0521-05	SUB SOCKET(D)		
CN335	E23-1278-05	TERMINAL			TH300	ERTJ0V104H	NEGATIVE TEMP THERMISTOR		
CN337	E23-1278-05	TERMINAL			TH301	ERTJ0V104H	NEGATIVE TEMP THERMISTOR		
CN338	E23-1278-05	TERMINAL			TH302	ERTJ0V104H	NEGATIVE TEMP THERMISTOR		

Symbol No.	Part No.	Part Name	Description	Local
TH700	ERTJ0V104H	NEGATIVE TEMP THERMISTOR		
X700	L77-3123-05	TCXO(19.2MHZ)		
X701	L77-1802-05	CRYSTAL RESONATOR(32.768KHZ)		
XF600	L7B-0003-00	MCF		

Symbol No.	Part No.	Part Name	Description	Local
C50	CC73HCH1H470J	C CAPACITOR	47PF J	
C68	CC73HCH1H010B	C CAPACITOR	1.0PF B	
R1	RK73HB1J101J	MG RESISTOR	100 J 1/16W	
R2	RK73HB1J103J	MG RESISTOR	10K J 1/16W	
R3	RK73HB1J103J	MG RESISTOR	10K J 1/16W	
R4	RK73HB1J101J	MG RESISTOR	100 J 1/16W	
R7	RK73HB1J101J	MG RESISTOR	100 J 1/16W	
R8	RK73HB1J102J	MG RESISTOR	1.0K J 1/16W	
R9	RK73HB1J104J	MG RESISTOR	100K J 1/16W	
R10	RK73HB1J104J	MG RESISTOR	100K J 1/16W	
R11	RK73HB1J102J	MG RESISTOR	1.0K J 1/16W	
R12	RK73HB1J473J	MG RESISTOR	47K J 1/16W	
R13	RK73HB1J473J	MG RESISTOR	47K J 1/16W	
R14	RK73HB1J102J	MG RESISTOR	1.0K J 1/16W	
R15	RK73HB1J102J	MG RESISTOR	1.0K J 1/16W	
R16	RK73EB2E100J	MG RESISTOR	10 J 1/4W	
R18	RK73HB1J000J	MG RESISTOR	0.0 J 1/16W	
R19	RK73HB1J102J	MG RESISTOR	1.0K J 1/16W	
R21	RK73HB1J000J	MG RESISTOR	0.0 J 1/16W	
R22	RK73HB1J103J	MG RESISTOR	10K J 1/16W	
R23	RK73HB1J000J	MG RESISTOR	0.0 J 1/16W	
R24	RK73HB1J000J	MG RESISTOR	0.0 J 1/16W	
R25	RK73HB1J103J	MG RESISTOR	10K J 1/16W	
R26	RK73HB1J000J	MG RESISTOR	0.0 J 1/16W	
R27	RK73HB1J000J	MG RESISTOR	0.0 J 1/16W	
R29	RK73HB1J000J	MG RESISTOR	0.0 J 1/16W	

MODULE (BT/GPS) UNIT

XC2-0031-80

***Note : This part cannot be replaced. Therefore, this part is not supplied as a service part.**

Block No. [0][2]

Symbol No.	Part No.	Part Name	Description	Local
IC1	74AVC4TD245GU	IC(MOS-IC)		
IC2	BU18TD2WNVX	IC(MOS-IC)		
IC3	-----	*Note		
IC4	NJM2878F4-33	BIPOLAR IC		
IC5	-----	*Note		
IC6	74AVC4TD245GU	IC(MOS-IC)		
IC7	74AVC4TD245GU	IC(MOS-IC)		
Q1	EM6M2	FET		
D17	RN262CS	DIODE		
D18	RN262CS	DIODE		
C1	CK73HB1A474K	C CAPACITOR	0.47UF K	
C2	CK73HB1A474K	C CAPACITOR	0.47UF K	
C3	CK73HB1E104K	C CAPACITOR	0.10UF K	
C4	CK73HB1E104K	C CAPACITOR	0.10UF K	
C5	CK73HB1A105K	C CAPACITOR	1.0UF K	
C6	CK73HB1A474K	C CAPACITOR	0.47UF K	
C7	CK73HB1A474K	C CAPACITOR	0.47UF K	
C8	CC73HCH1H220J	C CAPACITOR	22PF J	
C9	CC73HCH1H100B	C CAPACITOR	10PF B	
C10	CK73HB1A105K	C CAPACITOR	1.0UF K	
C11	CK73HB1E104K	C CAPACITOR	0.10UF K	
C12	CK73HB1E104K	C CAPACITOR	0.10UF K	
C13	CK73HB1E104K	C CAPACITOR	0.10UF K	
C14	CK73HB1E104K	C CAPACITOR	0.10UF K	
C15	CK73HB1A105K	C CAPACITOR	1.0UF K	
C16	CK73HB1E104K	C CAPACITOR	0.10UF K	
C17	CK73HB1E104K	C CAPACITOR	0.10UF K	
C18	CC73HCH1H180J	C CAPACITOR	18PF J	
C19	CC73HCH1H180J	C CAPACITOR	18PF J	
C20	CK73HB1A105K	C CAPACITOR	1.0UF K	
C21	CK73HB1A105K	C CAPACITOR	1.0UF K	
C22	CK73HB1E104K	C CAPACITOR	0.10UF K	
C23	CK73HBB1H102K	C CAPACITOR	0.010UF K	
C24	CK73HB1E104K	C CAPACITOR	0.10UF K	
C25	CK73HBB1H102K	C CAPACITOR	0.010UF K	
C26	CK73HBB1H102K	C CAPACITOR	0.010UF K	
C27	CK73HBB1H102K	C CAPACITOR	0.010UF K	
C28	CK73HB1E104K	C CAPACITOR	0.10UF K	
C29	CK73HB1E104K	C CAPACITOR	0.10UF K	
C30	CK73HB1E104K	C CAPACITOR	0.10UF K	
C31	CK73HB1A105K	C CAPACITOR	1.0UF K	
C32	CK73HB1E104K	C CAPACITOR	0.10UF K	
C33	CK73HB1E104K	C CAPACITOR	0.10UF K	
C34	CK73HB1E104K	C CAPACITOR	0.10UF K	
C35	CK73HB1E104K	C CAPACITOR	0.10UF K	
C36	CC73HCH1H220J	C CAPACITOR	22PF J	
C37	CC73HCH1H220J	C CAPACITOR	22PF J	
C38	CC73HCH1H2R5B	C CAPACITOR	2.5PF B	
C39	CK73HB1E104K	C CAPACITOR	0.10UF K	
C40	CC73HCH1H180J	C CAPACITOR	18PF J	
C44	CK73HB1E104K	C CAPACITOR	0.10UF K	
C45	CK73HB1E104K	C CAPACITOR	0.10UF K	
C46	CK73HB1E104K	C CAPACITOR	0.10UF K	
C47	CK73HB1E104K	C CAPACITOR	0.10UF K	
C48	CK73HB1E104K	C CAPACITOR	0.10UF K	
C49	CK73HB1E104K	C CAPACITOR	0.10UF K	

Symbol No.	Part No.	Part Name	Description	Local
L1	LB73H0AV-002	CHIP FERRITE BEADS		
L2	LB73G0AK-001	CHIP FERRITE BEADS		
L3	LB73G0BJ-002	CHIP FERRITE BEADS		
L4	L92-0487-05	CHIP FERRITE		
L5	L92-0487-05	CHIP FERRITE		
L6	LK73H0AG27NJ	SMALL FIXED INDUCTOR(27NH) 27n		
L7	LK73H0AM10NJ	SMALL FIXED INDUCTOR(10NH) 10n		
L8	L92-0487-05	CHIP FERRITE		
L9	L79-1985-05	FILTER		
L11	L79-1987-05	FILTER		
L13	L92-0487-05	CHIP FERRITE		
L14	L92-0487-05	CHIP FERRITE		
L15	L40-2263-71	SMALL FIXED INDUCTOR(2.2NH) 2.2n		
CN1	E40-6879-05	FLAT CABLE CONNECTOR		
CN5	E0E-0012-00	RF COAXIAL CABLE RECEPTACLE		
CP1	RK74HB1J100J	NET RESISTOR	10 J 1/16W	
CP2	RK74HB1J100J	NET RESISTOR	10 J 1/16W	
E1	F10-3226-05	SHIELDING CASE		
X1	L77-3123-05	TCXO(19.2MHZ)		
X2	L77-3121-05	CRYSTAL RESONATOR(32.768KHZ)		

SUB (DISPLAY) UNIT

XC3-0020-20(NX-5800_K2)

Block No. [0][3]

Symbol No.	Part No.	Part Name	Description	Local
IC1	MM3404A50URE	IC(MOS-IC)		
IC2	BU30TD2WNVX	IC(MOS-IC)		
IC3	TC7WT125FUF	IC(MOS-IC)		
IC4	BD11600NXX	IC(MOS-IC)		
IC6	BH1721FVC	IC(MOS-IC)		
IC8	BD1754HFN	IC(MOS-IC)		
IC9	TC7WH126FK	IC(MOS-IC)		
IC10	TC35894FG	IC(MOS-IC)		
IC12	TC7SZ08FE	IC(MOS-IC)		
Q2	SSM6N37FE	FET		
Q3	LTC014EEBFS8	DIGI TRANSISTOR		
Q4	LTC014EEBFS8	DIGI TRANSISTOR		
Q6	LTC014EEBFS8	DIGI TRANSISTOR		
D1	SPC10501A01	VARISTOR		
D2	SPC10501A01	VARISTOR		

△ Symbol No.	Part No.	Part Name	Description	Local	△ Symbol No.	Part No.	Part Name	Description	Local
D4	B30-2365-05	LED(WHITE)			R11	RK73HB1J000J	MG RESISTOR	0.0 J 1/16W	
D5	B30-2365-05	LED(WHITE)			R12	RK73HB1J000J	MG RESISTOR	0.0 J 1/16W	
D6	B30-2365-05	LED(WHITE)			R17	RK73HB1J000J	MG RESISTOR	0.0 J 1/16W	
D7	B30-2365-05	LED(WHITE)			R18	RK73HB1J000J	MG RESISTOR	0.0 J 1/16W	
D9	B30-2365-05	LED(WHITE)			R19	RK73HB1J000J	MG RESISTOR	0.0 J 1/16W	
D10	B30-2365-05	LED(WHITE)			R20	RK73HB1J101J	MG RESISTOR	100 J 1/16W	
D11	B30-2365-05	LED(WHITE)			R21	RK73HB1J331J	MG RESISTOR	330 J 1/16W	
D12	B30-2365-05	LED(WHITE)			R22	RK73HB1J331J	MG RESISTOR	330 J 1/16W	
D14	B30-2365-05	LED(WHITE)			R23	RK73HB1J331J	MG RESISTOR	330 J 1/16W	
D15	B30-2365-05	LED(WHITE)			R24	RK73HB1J331J	MG RESISTOR	330 J 1/16W	
D16	B30-2365-05	LED(WHITE)			R25	RK73HB1J101J	MG RESISTOR	100 J 1/16W	
D20	DZ2J062(M)	ZENER DIODE			R26	RK73HB1J222J	MG RESISTOR	2.2K J 1/16W	
D21	B30-2364-05	LED(RGB)			R27	RK73HB1J331J	MG RESISTOR	330 J 1/16W	
D22	RB521CM-30	DIODE			R28	RK73HB1J331J	MG RESISTOR	330 J 1/16W	
D23	SPC10501A01	VARISTOR			R29	RK73HB1J331J	MG RESISTOR	330 J 1/16W	
D24	SPC10501A01	VARISTOR			R30	RK73HB1J331J	MG RESISTOR	330 J 1/16W	
D25	MINISMDC020F	VARISTOR			R31	RK73HB1J101J	MG RESISTOR	100 J 1/16W	
D26	SPC10501A01	VARISTOR			R32	RK73HB1J331J	MG RESISTOR	330 J 1/16W	
D27	SPC10501A01	VARISTOR			R33	RK73HB1J331J	MG RESISTOR	330 J 1/16W	
D28	DZ2S068M	ZENER DIODE			R34	RK73HB1J331J	MG RESISTOR	330 J 1/16W	
D29	DZ2S068M	ZENER DIODE			R38	RK73HB1J101J	MG RESISTOR	100 J 1/16W	
D30	DZ2S068M	ZENER DIODE			R39	RK73HB1J101J	MG RESISTOR	100 J 1/16W	
D31	EMZ6.8N	ZENER DIODE			R40	RK73HB1J101J	MG RESISTOR	100 J 1/16W	
					R41	RK73HB1J101J	MG RESISTOR	100 J 1/16W	
C2	CC73GCH1H101J	C CAPACITOR	100PF J		R42	RK73HB1J102J	MG RESISTOR	1.0K J 1/16W	
C5	CK73GXR1H104K	C CAPACITOR	0.1UF K		R43	RK73HB1J102J	MG RESISTOR	1.0K J 1/16W	
C8	C93-1810-05	C CAPACITOR	4.7UF K		R46	RK73HB1J102J	MG RESISTOR	1.0K J 1/16W	
C9	CC73GCH1H101J	C CAPACITOR	100PF J		R47	RK73HB1J103J	MG RESISTOR	10K J 1/16W	
C11	CK73GXR1H104K	C CAPACITOR	0.1UF K		R48	RK73GB2A151J	MG RESISTOR	150 J 1/10W	
C16	CC73GCH1H101J	C CAPACITOR	100PF J		R49	RK73HB1J562J	MG RESISTOR	5.6K J 1/16W	
C18	CK73GXR1H104K	C CAPACITOR	0.1UF K		R50	RK73HB1J222J	MG RESISTOR	2.2K J 1/16W	
C22	CC73GCH1H101J	C CAPACITOR	100PF J		R51	RK73HB1J102J	MG RESISTOR	1.0K J 1/16W	
C24	CK73GXR1H104K	C CAPACITOR	0.1UF K		R52	RK73HB1J102J	MG RESISTOR	1.0K J 1/16W	
C29	CC73GCH1H101J	C CAPACITOR	100PF J		R53	RK73HB1J103J	MG RESISTOR	10K J 1/16W	
C32	CC73GCH1H101J	C CAPACITOR	100PF J		R54	RK73HB1J473J	MG RESISTOR	47K J 1/16W	
C44	CC73HCH1H101J	C CAPACITOR	100PF J		R55	RK73HB1J473J	MG RESISTOR	47K J 1/16W	
C45	CK73GBB1H102K	C CAPACITOR	0.010UF K		R60	RK73HB1J000J	MG RESISTOR	0.0 J 1/16W	
C46	CK73GBB1H102K	C CAPACITOR	0.010UF K		R61	RK73HB1J000J	MG RESISTOR	0.0 J 1/16W	
C48	CK73GBB1H102K	C CAPACITOR	0.010UF K		R62	RK73HB1J101J	MG RESISTOR	100 J 1/16W	
C50	CK73GBB1H102K	C CAPACITOR	0.010UF K		R63	RK73HB1J000J	MG RESISTOR	0.0 J 1/16W	
C52	CC73HCH1H101J	C CAPACITOR	100PF J		R64	RK73HB1J000J	MG RESISTOR	0.0 J 1/16W	
C53	CC73HCH1H101J	C CAPACITOR	100PF J		R65	RK73HB1J000J	MG RESISTOR	0.0 J 1/16W	
C54	CK73GB1E105K	C CAPACITOR	1.0UF K		R66	RK73HB1J101J	MG RESISTOR	100 J 1/16W	
C55	CC73HCH1H101J	C CAPACITOR	100PF J		R69	RK73HH1J274D	MG RESISTOR	270K D 1/16W	
C56	CC73HCH1H101J	C CAPACITOR	100PF J		R71	RK73GB2A000J	MG RESISTOR	0.0 J 1/10W	
C57	CK73GB1E105K	C CAPACITOR	1.0UF K		R77	RK73HB1J222J	MG RESISTOR	2.2K J 1/16W	
C58	CK73GB1E105K	C CAPACITOR	1.0UF K		R78	RK73HB1J222J	MG RESISTOR	2.2K J 1/16W	
C59	CK73GB1E105K	C CAPACITOR	1.0UF K		R79	RK73HB1J222J	MG RESISTOR	2.2K J 1/16W	
C62	CK73HB1E104K	C CAPACITOR	0.10UF K		R81	RK73HB1J103J	MG RESISTOR	10K J 1/16W	
C63	CK73GB1E105K	C CAPACITOR	1.0UF K		R82	RK73HB1J222J	MG RESISTOR	2.2K J 1/16W	
C64	CK73HB1E104K	C CAPACITOR	0.10UF K		R83	RK73HB1J000J	MG RESISTOR	0.0 J 1/16W	
C65	CK73HBB1E103K	C CAPACITOR	0.10UF K		R87	RK73HB1J222J	MG RESISTOR	2.2K J 1/16W	
C66	CK73HB1E104K	C CAPACITOR	0.10UF K		R88	RK73HB1J102J	MG RESISTOR	1.0K J 1/16W	
C67	CK73HB1E104K	C CAPACITOR	0.10UF K		R98	RK73HB1J222J	MG RESISTOR	2.2K J 1/16W	
C68	CK73HB1E104K	C CAPACITOR	0.10UF K		R99	RK73HB1J222J	MG RESISTOR	2.2K J 1/16W	
C69	CK73HB1E104K	C CAPACITOR	0.10UF K						
C70	CK73GBB1H102K	C CAPACITOR	0.010UF K		L1	LB73G0AM-004	CHIP FERRITE BEADS		
C71	CK73GXR1H104K	C CAPACITOR	0.1UF K		L2	LB73G0AM-004	CHIP FERRITE BEADS		
C73	CK73HB1E104K	C CAPACITOR	0.10UF K		L3	LB73H0AV-003	CHIP FERRITE BEADS		
C74	CK73GB1E105K	C CAPACITOR	1.0UF K		L4	LB73H0AV-003	CHIP FERRITE BEADS		
C75	CK73HB1E104K	C CAPACITOR	0.10UF K		L5	LB73G0AM-004	CHIP FERRITE BEADS		
C76	CK73GBB1H102K	C CAPACITOR	0.010UF K		L11	LB73H0AV-003	CHIP FERRITE BEADS		
C79	CK73GBB1H102K	C CAPACITOR	0.010UF K		L14	LB73H0AV-003	CHIP FERRITE BEADS		
C83	CK73HB1E104K	C CAPACITOR	0.10UF K		L15	LB73G0AM-004	CHIP FERRITE BEADS		
C84	CK73HB1E104K	C CAPACITOR	0.10UF K		L16	LB73H0AV-003	CHIP FERRITE BEADS		
C87	CC73HCH1H101J	C CAPACITOR	100PF J		L17	LB73H0AV-003	CHIP FERRITE BEADS		
C90	CK73GBB1H102K	C CAPACITOR	0.010UF K		L18	LB73H0AV-003	CHIP FERRITE BEADS		
C91	CC73GCH1H470J	C CAPACITOR	47PF J						
C92	CC73GCH1H470J	C CAPACITOR	47PF J		CN2	E41-2673-05	PIN ASSY		
C101	CK73GBB1H102K	C CAPACITOR	0.010UF K		CN4	E40-6965-05	FLAT CABLE CONNECTOR		
					CN5	E41-2671-05	PIN ASSY		
R3	RK73HB1J000J	MG RESISTOR	0.0 J 1/16W		CN6	E40-6913-05	FLAT CABLE CONNECTOR		
R4	RK73HB1J000J	MG RESISTOR	0.0 J 1/16W		J1	E58-0535-05	MODULAR JACK		
R5	RK73HB1J000J	MG RESISTOR	0.0 J 1/16W		S1	S70-0901-05	TACT SWITCH		
R6	RK73HB1J000J	MG RESISTOR	0.0 J 1/16W		S2	S70-0901-05	TACT SWITCH		
R7	RK73HB1J000J	MG RESISTOR	0.0 J 1/16W		S3	S70-0901-05	TACT SWITCH		
R9	RK73HB1J000J	MG RESISTOR	0.0 J 1/16W		S4	S70-0901-05	TACT SWITCH		
R10	RK73HB1J000J	MG RESISTOR	0.0 J 1/16W		S5	S70-0901-05	TACT SWITCH		

△ Symbol No.	Part No.	Part Name	Description	Local
S6	S70-0901-05	TACT SWITCH		
S7	S70-0901-05	TACT SWITCH		
S8	S70-0901-05	TACT SWITCH		
S9	S70-0901-05	TACT SWITCH		
S10	S70-0901-05	TACT SWITCH		
S11	S70-0901-05	TACT SWITCH		
S12	S70-0901-05	TACT SWITCH		

Packing materials and accessories parts list (NX-5800_K2)

Block No.M2MM

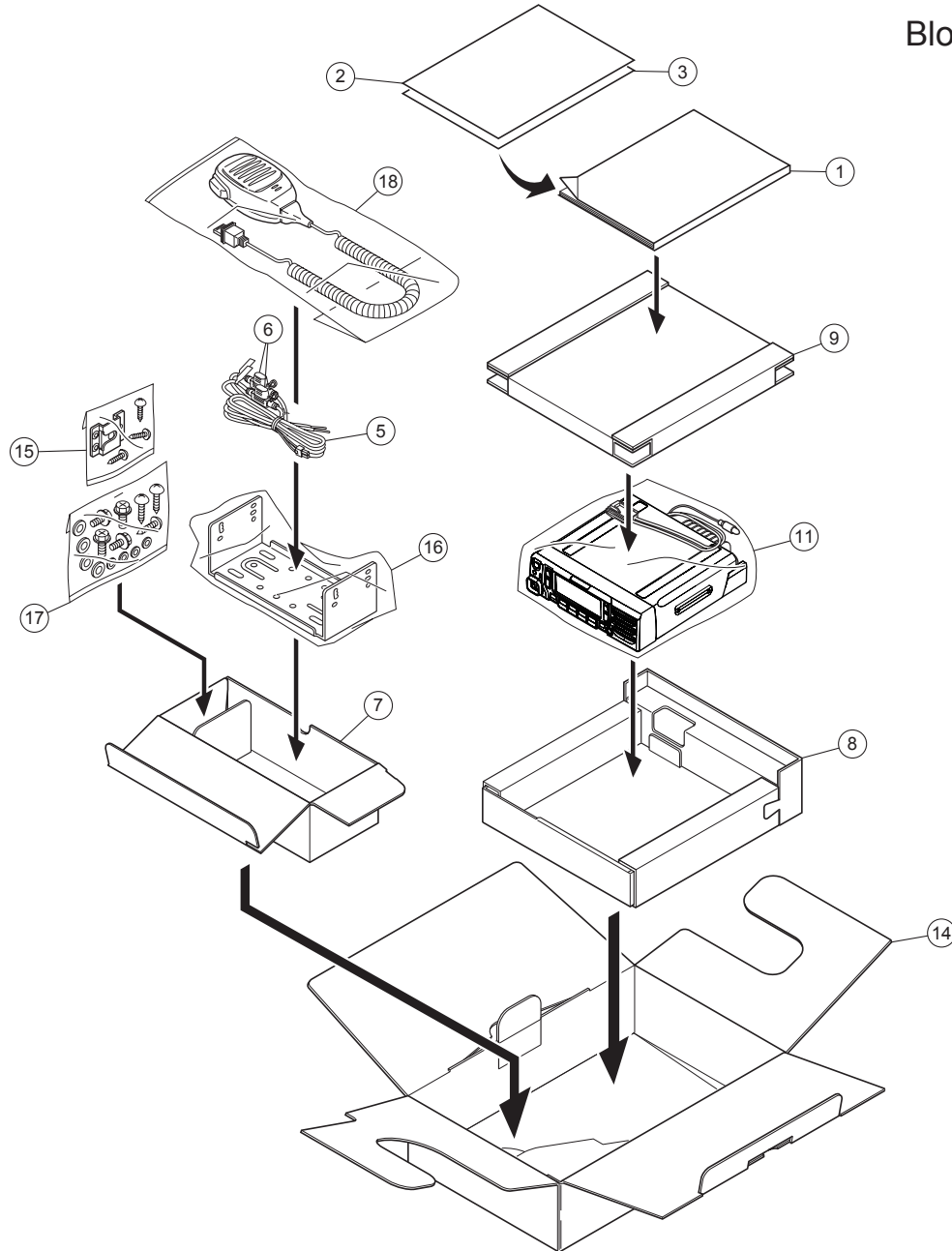

Packing and accessories

Block No. [M][2][M][M]
Local

△ Symbol No.	Part No.	Part Name	Description	Local
1	B5A-0056-00	INSTRUCTION MANUAL		
2	-----	PAMPHLET		
3	-----	PAMPHLET		
4	E30-7523-55	DC CORD ASSY		
5	F52-0024-05	FUSE(BLADE TYPE)(15A)	(x2)	
6	H0C-0007-00	INNER CARTON CASE		
7	H1C-0012-00	PACKING FIXTURE(LOWER)		
8	H1C-0013-00	PACKING FIXTURE(UPPER)		
9	-----	PROTECTION BAG		
10	H5A-0233-00	ITEM CARTON CASE		
11	J19-1584-15	HOLDER(MIC)		
12	-----	BRACKET(KMB-33)		
13	N99-2039-05	SCREW SET		
14	T91-0639-65	MICROPHONE		

Packing materials and accessories parts list (NX-5800B_F2,NX-5800B_K2)

Block No.M3MM

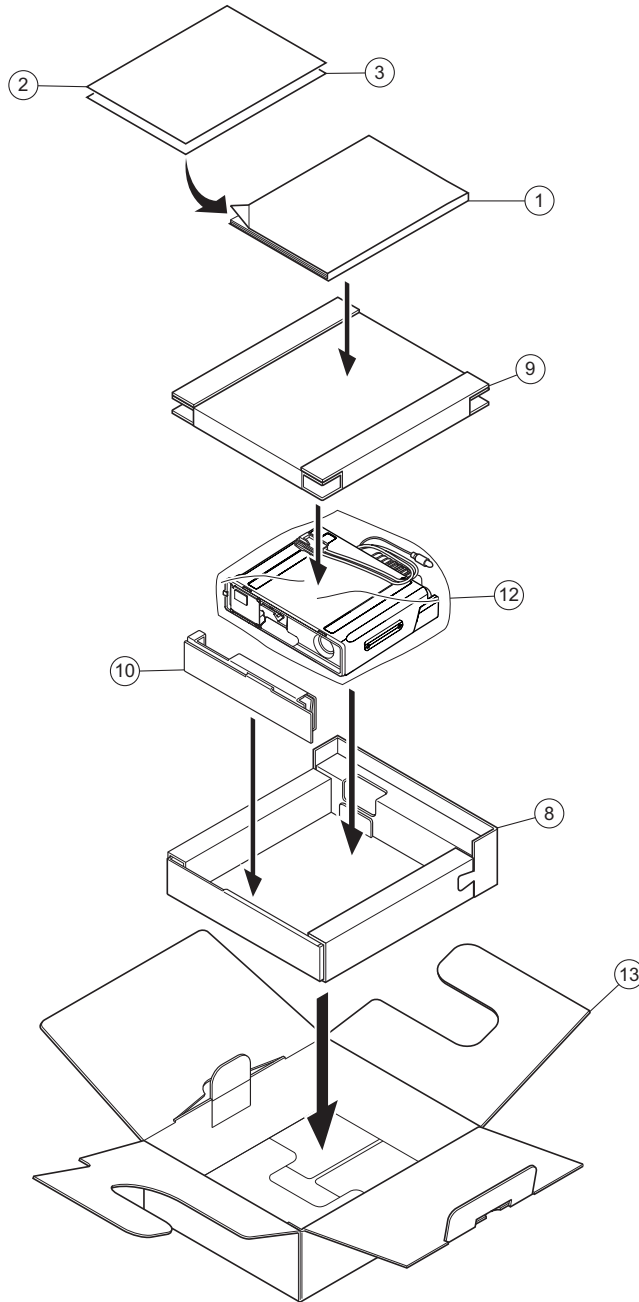

Packing and accessories

Block No. [M][3][M][M]
Local

△ Symbol No.	Part No.	Part Name	Description	Block No. [M][3][M][M] Local
1	B5A-0056-00	INSTRUCTION MANUAL		
2	-----	PAMPHLET		
3	-----	PAMPHLET		
8	H1C-0012-00	PACKING FIXTURE(LOWER)		
9	H1C-0013-00	PACKING FIXTURE(UPPER)		
10	H1C-0027-00	PACKING FIXTURE(SPACER)		
12	-----	ANTI-STATIC BAG		
13	H5A-0014-00	ITEM CARTON CASE		

MEMO



KENWOOD

JVC KENWOOD Corporation
Communications Equipment BU

(No.RA017<Rev.001>)

Printed in Japan
VSE