

NX-700

SERVICE MANUAL / 维修手册

C version / C 版本

KENWOOD

Kenwood Corporation

© 2009-10 PRINTED IN CHINA
B51-8893-00 (N)

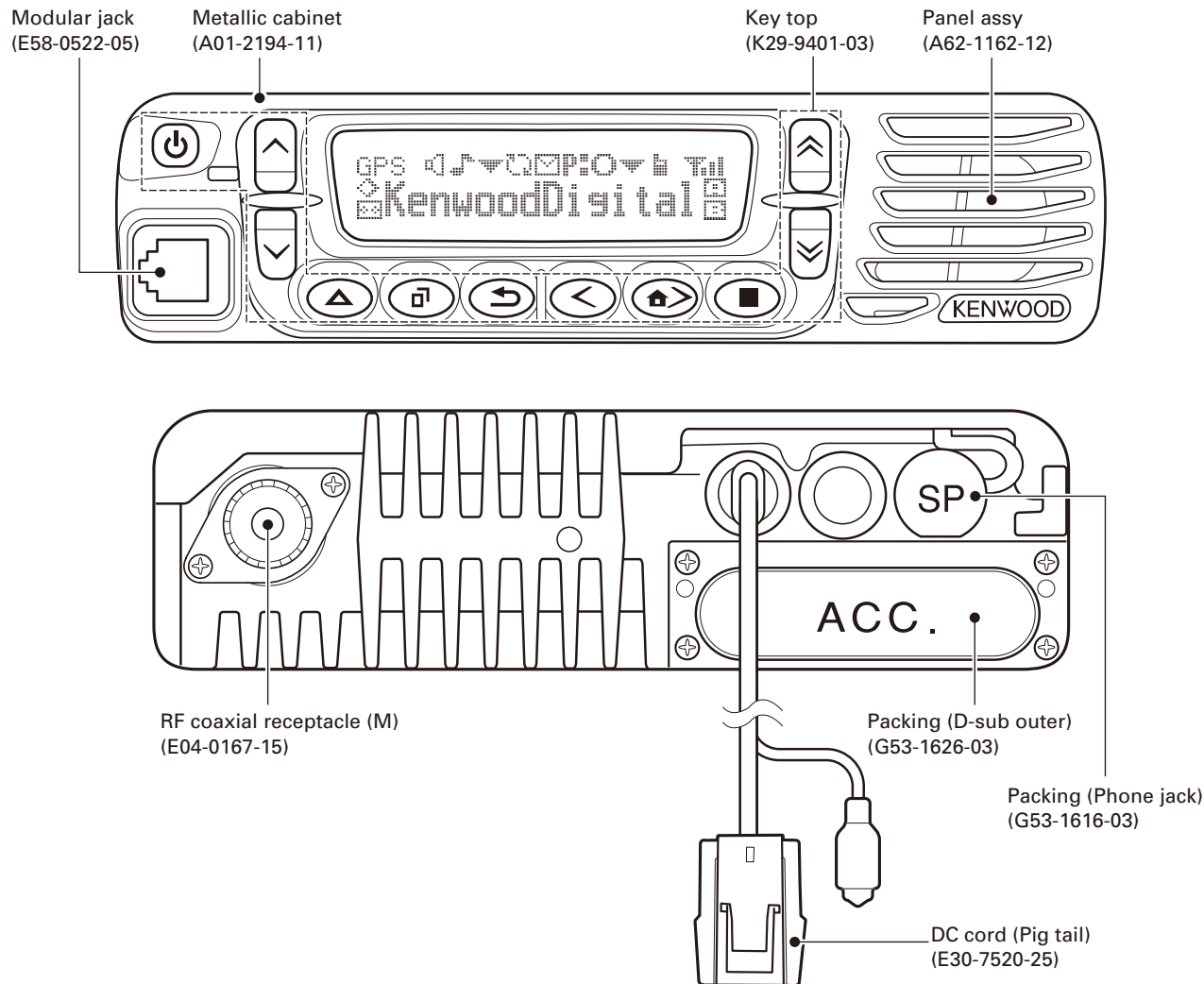

无铅焊接通信产品  

保护环境建伍领先

⚠ 注意：本产品是无铅化焊接产品
在维修时请使用无铅焊锡
和相应的焊接工具
详细事项请访问如下网址了解：
<http://www.kenwoodhk.com.hk/>



CONTENTS / 目录

GENERAL	3	概 述.....	3
SYSTEM SET-UP	6	系统体系.....	7
REALIGNMENT	8	模式组合.....	8
INSTALLATION	13	安 装.....	13
DISASSEMBLY FOR REPAIR	22	维修拆卸.....	22
CIRCUIT DESCRIPTION	27	电路说明.....	27
COMPONENTS DESCRIPTION	36	元件说明.....	36
PARTS LIST	41	零 件 表.....	41
EXPLODED VIEW	54	部件分解图.....	54
PACKING	55	包 装.....	55
TROUBLE SHOOTING	56	故障排除.....	57
ADJUSTMENT	62	调 整.....	62
TERMINAL FUNCTION	102	端子功能.....	103
PC BOARD		PC 板	
DISPLAY UNIT (X54-3680-10)	122	DISPLAY 单元 (X54-3680-10).....	122
TX-RX UNIT (X57-7742-71) (A/2)	124	TX-RX 单元 (X57-7742-71) (A/2).....	124
TX-RX UNIT (X57-7742-71) (B/2)	128	TX-RX 单元 (X57-7742-71) (B/2).....	128
INTERCONNECTION DIAGRAM	129	互 连 图.....	129
SCHEMATIC DIAGRAM	130	原 理 图.....	130
LEVEL DIAGRAM	148	电 平 图.....	148
BLOCK DIAGRAM	150	方 块 图.....	150
SPECIFICATIONS	153	规 格.....	封底

Document Copyrights

Copyright 2009 by Kenwood Corporation. All rights reserved.

No part of this manual may be reproduced, translated, distributed, or transmitted in any form or by any means, electronic, mechanical, photocopying, recording, or otherwise, for any purpose without the prior written permission of Kenwood.

Disclaimer

While every precaution has been taken in the preparation of this manual, Kenwood assumes no responsibility for errors or omissions. Neither is any liability assumed for damages resulting from the use of the information contained herein. Kenwood reserves the right to make changes to any products herein at any time for improvement purposes.

文档版权信息

Kenwood Corporation 拥有版权 2009。保留所有权利。

未经 Kenwood 公司预先书面同意，无论出于何种目的，均不得以任何形式或任何方式包括电子、机械、影印、录音或其他方式复制、翻译、分发或传播本手册的任何部分。

免责声明

Kenwood 公司在准备本文档时已采取所有必要的预防措施，恕不对错误或疏漏承担任何责任，也不对因使用本文中所含的信息而导致的损害负责。Kenwood 公司保留出于改进的需要而随时对文中的产品信息做出更改的权利。

GENERAL / 概述

INTRODUCTION

SCOPE OF THIS MANUAL

This manual is intended for use by experienced technicians familiar with similar types of commercial grade communications equipment. It contains all required service information for the equipment and is current as of this publication date. Changes which may occur after publication are covered by either Service Bulletins or Manual Revisions, which are issued as required.

ORDERING REPLACEMENT PARTS

When ordering replacement parts or equipment information, the full part identification number should be included. This applies to all parts: components, kits, and chassis. If the part number is not known, include the chassis or kit number of which it is a part and a sufficient description of the required component for proper identification.

PERSONAL SAFETY

The following precautions are recommended for personal safety :

- DO NOT transmit if someone is within two feet (0.6 meter) of the antenna.
- DO NOT transmit until all RF connectors are secure and any open connectors are properly terminated.
- SHUT OFF this equipment when near electrical blasting caps or while in an explosive atmosphere.
- All equipment should be properly grounded before power-up for safe operation.
- This equipment should be serviced by only qualified technicians.

PRE-INSTALLATION CONSIDERATIONS

1. UNPACKING

Unpack the radio from its shipping container and check for accessory items. If any item is missing, please contact KENWOOD immediately.

2. PRE-INSTALLATION CHECKOUT

2-1. Introduction

Each radio is adjusted and tested before shipment. However, it is recommended that receiver and transmitter operation be checked for proper operation before installation.

2-2. Testing

The radio should be tested complete with all cabling and accessories as they will be connected in the final installation. Transmitter frequency, deviation, and power output should be checked, as should receiver sensitivity, squelch operation, and audio output. Signaling equipment operation should be verified.

引言

本手册的范围

本手册是提供给熟悉通信专业并且具有维修经验的技术人员使用的。它包括了维修该设备所需要的全部资料和现行出版日期。在出版后可能发生变动，如果需要，可以参照《维修通报》或《手册修订本》进行补充。

替换零件的订购

当订购替换零件或设备资料时，应注意完整的零件识别号。所有的零件均有识别号：元件，组件或机壳。如果不知道零件的号码，为了正确地识别，必须注明此元件所属的机壳或组件的号码，并对元件进行充分的说明。

个人安全

为了个人的安全，请注意下列事项：

- 如果有人在天线两英尺 (0.6 米) 范围之内时，不要进行发射。
- 在没有认真核实所有射频插头之前或有任何一个脱开的插头没有连接到相应端口上的情况下均不要发射。
- 在电爆管附近或在易燃性气体环境中，必须关闭电源，不要操作本设备。
- 为了操作的安全，在接通电源之前所有设备应该连接地线。
- 本设备只应该由有资格的技术人员进行维修。

安装前条件

1. 开箱

从运输包装中取出本无线电设备并检查附件。如果有任何组件遗失，请立即与 KENWOOD 联系。

2. 安装前检查

2-1. 说明

在运输之前每一台无线电设备均已调整和测试过。但是，在安装之前最好检查接收和发射以便操作正确。

2-2. 测试

无线电设备应该按照电缆和附件最终安装时的连接进行完整的测试。应该检查发射频率，频偏和输出功率，同样应该检查接收灵敏度，静噪和音频输出。应该检验信令操作。

GENERAL / 概述

3. PLANNING THE INSTALLATION

3-1. General

Inspect the vehicle and determine how and where the radio antenna and accessories will be mounted.

Plan cable runs for protection against pinching or crushing wiring, and radio installation to prevent overheating.

3-2. Antenna

The favored location for an antenna is in the center of a large, flat conductive area, usually at the roof center. The trunk lid is preferred, bond the trunk lid and vehicle chassis using ground straps to ensure the lid is at chassis ground.

3-3. Radio

The universal mount bracket allows the radio to be mounted in a variety of ways. Be sure the mounting surface is adequate to support the radio's weight. Allow sufficient space around the radio for air cooling. Position the radio close enough to the vehicle operator to permit easy access to the controls when driving.

3-4. DC Power and wiring

1. This radio may be installed in negative ground electrical systems only. Reverse polarity will cause the cable fuse to blow. Check the vehicle ground polarity before installation to prevent wasted time and effort.
2. Connect the positive power lead directly to the vehicle battery positive terminal. Connecting the Positive lead to any other positive voltage source in the vehicle is not recommended.
3. Connect the ground lead directly to the battery negative terminal.
4. The cable provided with the radio is sufficient to handle the maximum radio current demand. If the cable must be extended, be sure the additional wire is sufficient for the current to be carried and length of the added lead.

4. INSTALLATION PLANNING – CONTROL STATIONS

4-1. Antenna system

Control station. The antenna system selection depends on many factors and is beyond the scope of this manual. Your KENWOOD dealer can help you select an antenna system that will best serve your particular needs.

4-2. Radio location

Select a convenient location for your control station radio which is as close as practical to the antenna cable entry point. Secondly, use your system's power supply (which supplies the voltage and current required for your system). Make sure sufficient air can flow around the radio and power supply to allow adequate cooling.

3. 安装步骤

3-1. 概述

检查车辆并确认如何以及在何处安装无线电天线和附件。

安排好电缆的位置，避免挤压或碾碎布线，同时无线电设备避免过热。

3-2. 天线

天线的最佳位置应该在一个宽阔，平整导电区域的中心，通常在车顶的中心。行李箱的盖子更好，将地线黏结在行李箱的盖子和车辆的外壳上确保行李箱盖子接地。

3-3. 无线电设备

通用安装托架允许以多种方法安装无线电设备。确认安装的表面足以支撑无线电设备的重量。无线电设备的周围留出适当的空间进行散热。将无线电设备尽可能的安装在靠近车辆操作者的位置上，以便在驾驶时易于控制。

3-4. 直流电源和布线

1. 本无线电设备只能被安装在负极接地电子系统中。反向极性将导致电缆保险丝熔断。在安装之前检查车辆的接地极性，避免工作效率低以及浪费时间。
2. 将电源的正极引线直接连接到车载电池的正极端点上。不要将正极引线与其他正极电压连接。
3. 将接地引线直接与电池的负极连接。
4. 与无线电设备一起提供的电缆适用于所需的最大无线电流。如果电缆必须加长，要确认附加的电线适用于所载的电流和添加引线的长度。

4. 安装步骤 – 基站

4-1. 天线系统

基站。天线系统的选择取决于许多因素和本手册的范围。用户的 KENWOOD 销售商可以帮助用户选择最能满足用户特殊要求的天线系统。

4-2. 无线电位置

为用户的基站无线电设备选择一个方便的位置，此位置应尽量靠近天线电缆输入点。其次，使用用户系统的电源（为用户的系统提供所需的电压和电流）。确认无线电设备周围的空气流通顺畅并且足以使电源冷却。

GENERAL / 概述

SERVICE

This radio is designed for easy servicing. Refer to the schematic diagrams, printed circuit board views, and alignment procedures contained in this manual.

NOTE

- If you do not intend to use the speaker 3.5-mm jack and the D-sub 25-pin connector, fit the supplied speaker-jack cap and D-sub cap to stop dust and sand from getting in.
- If the transceiver is turned ON or OFF when the power-on/off status message is enabled, the transceiver sends the status.

维修服务

为了便于维修本设备，建立了完整的维修服务体系，提供了包括原理图，印刷电路板图和调整步骤在内的资料供参考。

注意

- 如果不打算使用 3.5mm 扬声器插孔和 25 针 D-sub 连接器，请装上附带的扬声器插孔盖和 D-sub 盖，防止灰尘和沙粒进入。
- 启用开机 / 关机状态信息时，如果打开或关闭车载对讲机，则车载对讲机会发送状态信息。

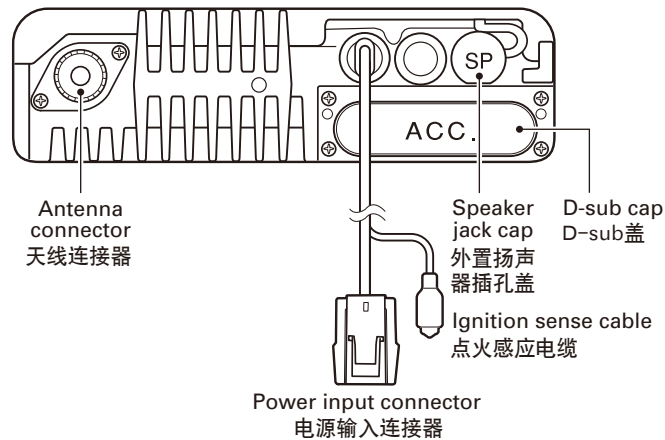

SYSTEM SET-UP

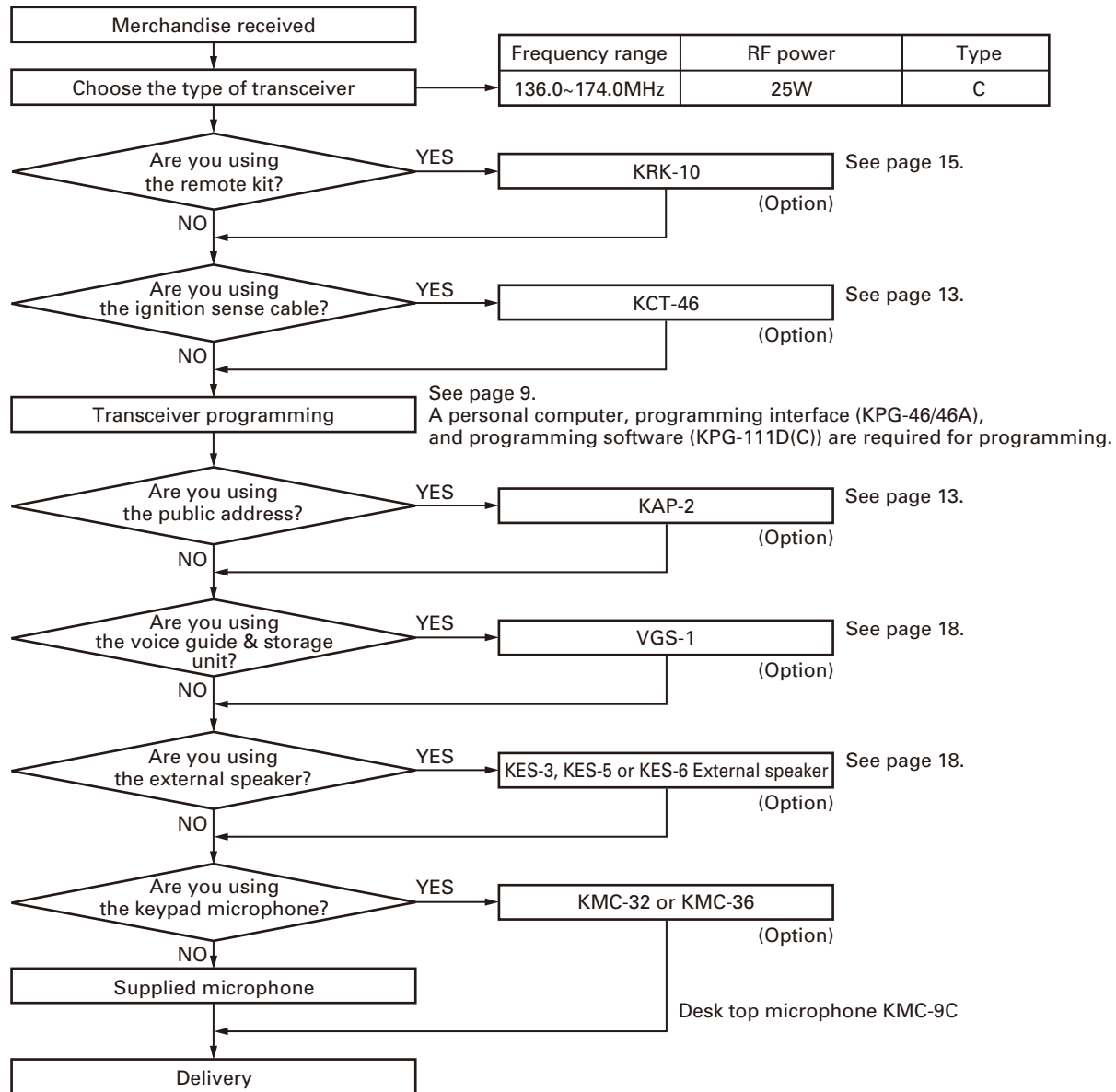

系统体系

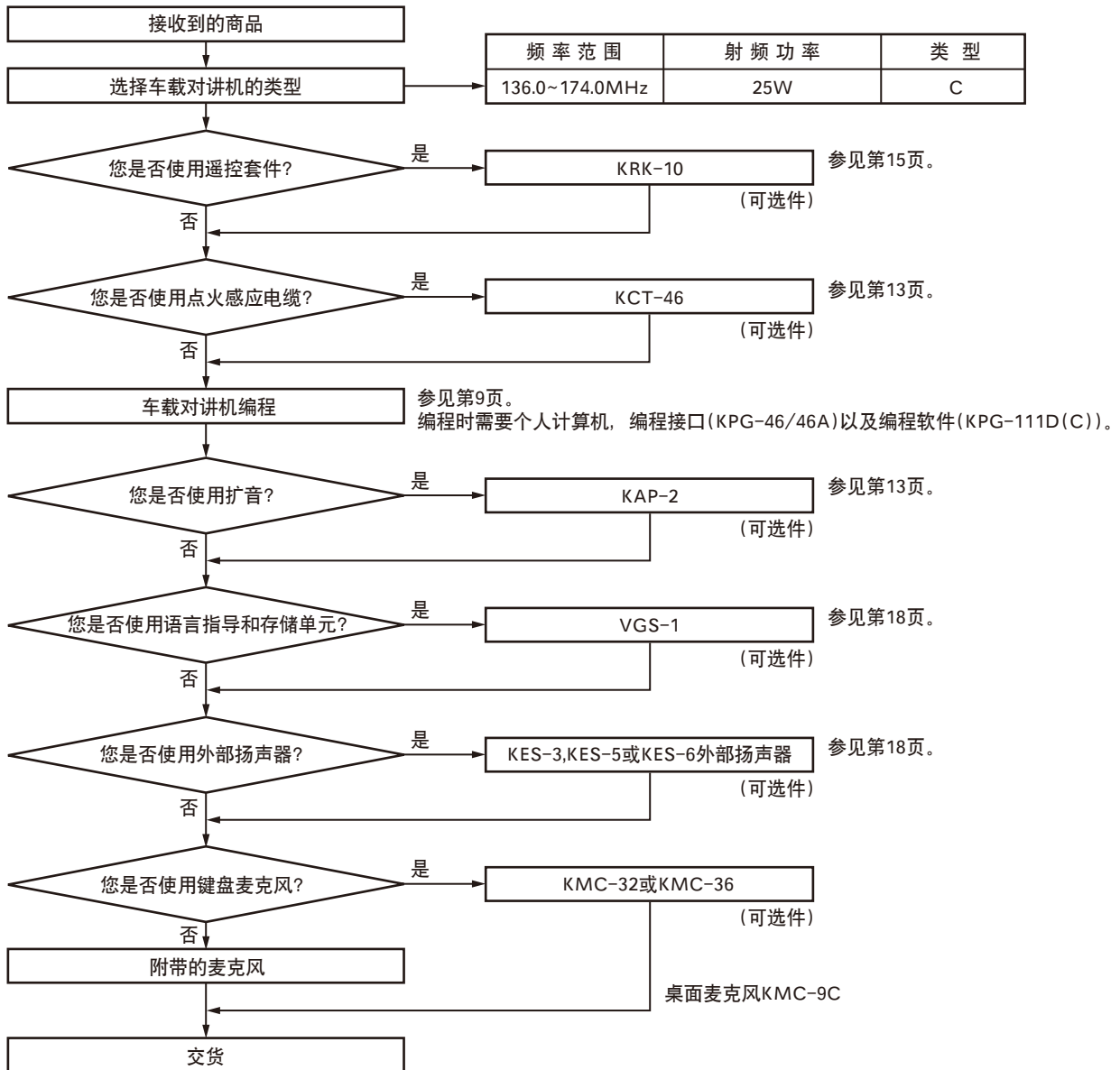

REALIGNMENT / 模式组合

1. Modes

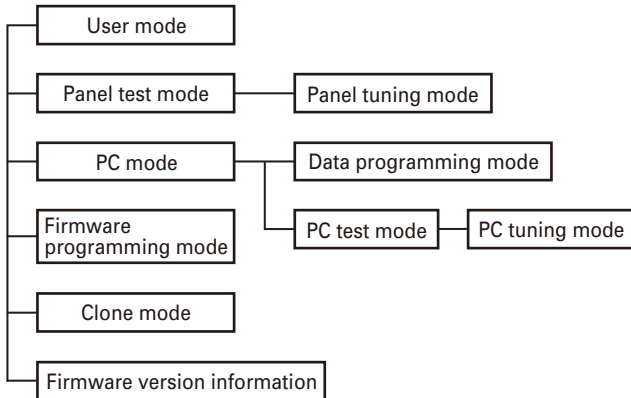

Mode	Function
User mode	For normal use.
Panel test mode	Used by the dealer to check the fundamental characteristics.
Panel tuning mode	Used by the dealer to tune the transceiver.
PC mode	Used for communication between the transceiver and PC.
Data programming mode	Used to read and write frequency data and other features to and from the transceiver.
PC test mode	Used to check the transceiver using the PC. This feature is included in the FPU.
PC tuning mode	Used to tune the transceiver using the PC. This feature is included in the FPU.
Firmware programming mode	Used when changing the main program of the flash memory.
Clone mode	Used to transfer programming data from one transceiver to another.
Firmware version information	Used to confirm the internal firmware version.

2. How to Enter Each Mode

Mode	Operation
User mode	Power ON
Panel test mode	[↵] + Power ON
PC mode	Received commands from PC
Panel tuning mode	[Panel test mode] + [↻]
Firmware programming mode	[↻] + Power ON
Clone mode	[<] + Power ON
Firmware version information	[▲] + Power ON

3. Panel Test Mode

Setting method refer to ADJUSTMENT.

4. Panel Tuning Mode

Setting method refer to ADJUSTMENT.

1. 模式

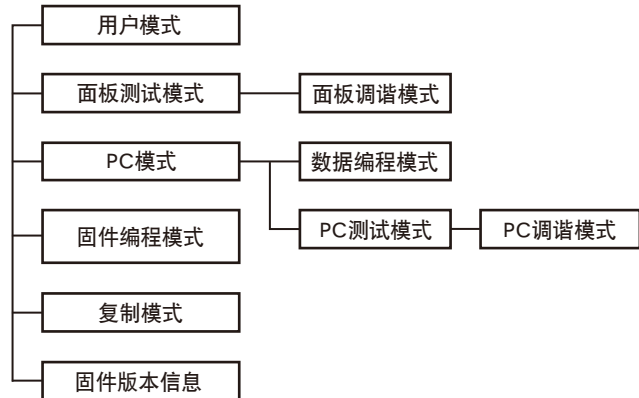

模式	功能
用户模式	一般使用。
面板测试模式	用于经销商检查基本功能。
面板调谐模式	用于经销商调整车载对讲机指标。
PC 模式	用于车载对讲机与 PC 之间的通信。
数据编程模式	用于阅读和写入频率数据以及其他功能。
PC 测试模式	用于通过 PC 检查车载对讲机。该功能内置于 FPU 中。
PC 调谐模式	用于通过 PC 调谐车载对讲机。该功能内置于 FPU 中。
固件编程模式	当改变闪存中操作主程序时使用。
复制模式	用于从一个车载对讲机编程数据复制到另一个车载对讲机。
固件版本信息	用于确认内部固件版本。

2. 如何进入每一种模式

模式	操作
用户模式	接通电源
面板测试模式	[↵] + 接通电源
PC 模式	从 PC 接收指令
面板调谐模式	[面板测试模式] + [↻]
固件编程模式	[↻] + 接通电源
复制模式	[<] + 接通电源
固件版本信息	[▲] + 接通电源

3. 关于面板测试模式

关于设定方式，参见调整。

4. 关于面板调谐模式

关于设定方式，参见调整。

REALIGNMENT / 模式组合

5. PC Mode

5-1. Preface

The transceiver is programmed by using a personal computer, programming interface (KPG-46/46A) and programming software (KPG-111D(C)).

The programming software can be used with a PC. Figure 1 shows the setup of a PC for programming.

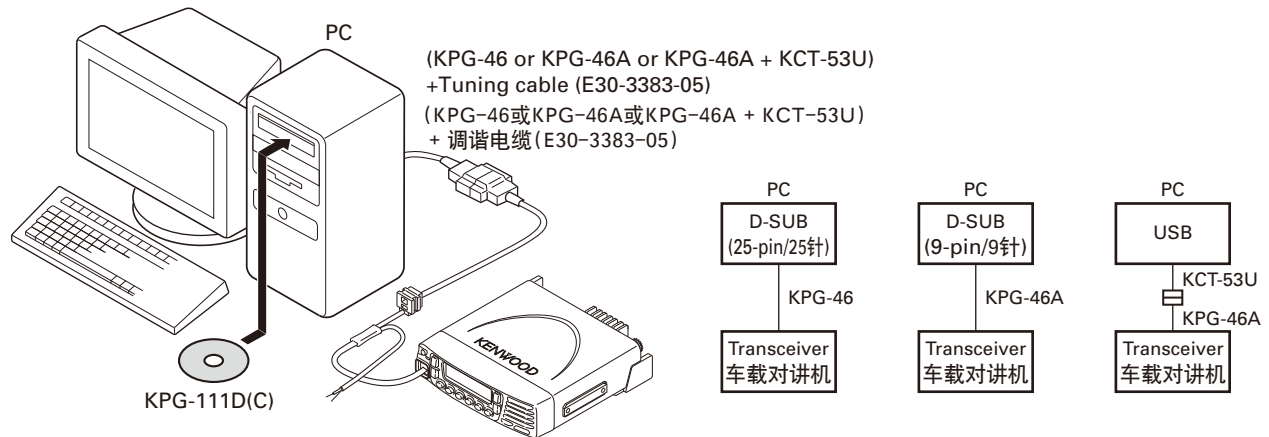

Fig. 1 / 图 1

5-2. Connection procedure

1. Connect the transceiver to the computer using the interface cable and USB adapter (When the interface cable is KPG-46A, the KCT-53U can be used.).

Note:

- You must install the KCT-53U driver in the computer to use the USB adapter (KCT-53U).
 - When using the USB adapter (KCT-53U) for the first time, plug the KCT-53U into a USB port on the computer with the computer power ON.
2. When the POWER switch on, user mode can be entered immediately. When PC sends command the transceiver enter PC mode, and "PROGRAM" is displayed on the LCD.
When data transmitting from transceiver, the red LED is lights.
When data receiving to transceiver, the green LED is lights.

Note:

The data stored in the computer must match the "Model Name" when it is written into the flash memory.

5. PC 模式

5-1. 前言

车载对讲机采用个人电脑、编程接口 (KPG-46/46A) 和编程软件 (KPG-111D(C)) 进行编程。

编程软件可在 PC 上使用。图 1 说明了 PC 进行编程的设置。

5-2. 连接操作

1. 用接口电缆和 USB 适配器将车载对讲机连接到电脑 (接口电缆为 KPG-46A 时, 可以使用 KCT-53U)。

注意:

- 必须在电脑上安装 KCT-53U 驱动程序才能使用 USB 适配器 (KCT-53U)。
 - 首次使用 USB 适配器 (KCT-53U) 时, 请在电脑电源打开的情况下将 KCT-53U 插入电脑的 USB 端口。
2. 车载对讲机电源开关打开时, 可以立即进入用户模式。PC 发出车载对讲机进入 PC 模式的指令时, LCD 上显示 "PROGRAM"。
车载对讲机正在发送数据时, 红色的 LED 点亮。
车载对讲机正在接收数据时, 绿色的 LED 点亮。

注意:

电脑保存的数据写入闪存时, 必须与 "型号名称" 相符。

REALIGNMENT / 模式组合

5-3. KPG-46/KPG-46A description

(PC programming interface cable: Option)

The KPG-46/46A is required to interface the transceiver to the computer. It has a circuit in its D-sub connector (KPG-46: 25-pin, KPG-46A: 9-pin) case that converts the RS-232C logic level to the TTL level.

The KPG-46/46A connects the 8-pin microphone connector of the transceiver to the RS-232C serial port of the computer.

5-4. KCT-53U description (USB adapter: Option)

The KCT-53U is a cable which connects the KPG-46A to a USB port on a computer.

When using the KCT-53U, install the supplied CD-ROM (with driver software) in the computer. The KCT-53U driver runs under Windows 2000, XP or Vista (32-bit).

5-5. Programming software KPG-111D(C) description

The KPG-111D(C) is the programming software for the transceiver supplied on a CD-ROM. This software runs under Windows 2000, XP or Vista (32-bit) on a PC.

The data can be input to or read from the transceiver and edited on the screen. The programmed or edited data can be printed out. It is also possible to tune the transceiver.

6. Firmware Programming Mode

6-1. Preface

Flash memory is mounted on the transceiver. This allows the transceiver to be upgraded when new features are released in the future. (For details on how to obtain the firmware, contact Customer Service.)

6-2. Connection procedure

Connect the transceiver to the personal computer using the interface cable (KPG-46/46A) and USB adapter (KCT-53U: when the interface cable is KPG-46A, the KCT-53U can be used.). (Connection is the same as in the PC Mode.)

Note:

You can only program firmware from the 8-pin microphone connector on the front panel. Using the 25-pin logic interface on the rear panel will not work.

6-3. Programming

1. Start up the firmware programming software (Fpro.exe (ver. 4.0 or later)). The Fpro.exe exists in the KPG-111D(C) installed folder.
2. Set the communications speed (normally, 115200 bps) and communications port in the configuration item.
3. Set the firmware to be updated by File name item.
4. Turn the transceiver power ON with the [P] key held down. Then, the orange LED on the transceiver lights and "PROGRAM 115200" is displayed.
5. Check the connection between the transceiver and the personal computer, and make sure that the transceiver is in the Program mode.
6. Press "write" button in the window. When the transceiver starts to receive data, the [LOADING] display lights.

5-3. KPG-46/KPG-46A 说明

(PC 编程接口电缆: 选购件)

将车载对讲机连接到电脑需要 KPG-46/46A。该电缆的 D-sub 连接器 (KPG-46:25 针, KPG-46A:9 针) 盒具有将 RS-232C 逻辑电平转换为 TTL 电平的电路。

KPG-46/46A 将车载对讲机的 8 针麦克风连接器连接到电脑的 RS-232C 串行端口。

5-4. KCT-53U 说明 (USB 适配器: 选购件)

KCT-53U 是将 KPG-46A 连接到电脑 USB 端口的电缆。

使用 KCT-53U 时, 请在电脑上安装附带的 CD-ROM (带有驱动程序软件)。KCT-53U 驱动程序在 Windows 2000、XP 或 Vista (32 位) 下运行。

5-5. 编程软件 KPG-111D(C) 说明

KPG-111D(C) 是 CD-ROM 附带的用于车载对讲机的编程软件。

该软件在 PC 的 Windows 2000、XP 或 Vista (32 位) 下运行。

可在车载对讲机上写入或读取数据, 并可在电脑屏幕上进行编辑。可以打印编程或编辑的数据。此外, 还可调谐车载对讲机。

6. 固件编程模式

6-1. 前言

闪存安装在车载对讲机上。将来发布新功能时, 可以使车载对讲机进行升级。(有关如何获得固件的详情, 请洽询客户服务机构。)

6-2. 连接操作

用接口电缆 (KPG-46/46A) 和 USB 适配器 (KCT-53U: 接口电缆为 KPG-46A 时, 可以使用 KCT-53U) 将车载对讲机连接到个人电脑。(连接方式与 PC 模式下相同。)

注意:

您只能通过前面板的 8 针麦克风连接器对固件进行编程。使用后面板的 25 针逻辑接口进行编程时不起作用。

6-3. 编程

1. 启动固件编程软件 (Fpro.exe (ver. 4.0 或更高版本))。Fpro.exe 存在于 KPG-111D(C) 安装文件夹内。
2. 在配置项中设置通信速度 (通常为 115200 bps) 和通信端口。
3. 通过文件名项目设置要更新的固件。
4. 打开车载对讲机电源时, 按住 [P] 键。然后, 车载对讲机上的橙色 LED 点亮, 并显示 "PROGRAM 115200"。
5. 检查车载对讲机与个人电脑之间的连接, 确认车载对讲机处于编程模式。
6. 按窗口中的 "write" 按钮。车载对讲机开始接收数据时, 显示 [LOADING]。

REALIGNMENT / 模式组合

- If writing ends successfully, the checksum is calculated and a result is displayed.
- If you want to continue programming other transceivers, repeat steps 4 to 7.

Note:

This mode cannot be entered if the Firmware Programming mode is set to Disable in the Programming software.

6-4. Function

- If you press the [■] key while "PROGRAM 115200" is displayed, the display changes to "PROGRAM 19200" (The LED blinks green) to indicate that the write speed is low speed (19200 bps). If you press the [■] key again while "PROGRAM 19200" is displayed, the display changes to "PROGRAM 38400" (The LED lights red and orange alternatively). If you press the [■] key again while "PROGRAM 38400" is displayed, the display changes to "PROGRAM 57600" (The LED blinks orange). If you press the [■] key again while "PROGRAM 57600" is displayed, the display returns to "PROGRAM 115200" (The LED lights orange).
- If you press the [▲] key while "PROGRAM 115200" is displayed, the checksum is calculated, and a result is displayed. If you press the [▲] key again while the checksum is displayed, "PROGRAM 115200" is redisplayed.

Note:

Normally, write in the high-speed mode.

7. Clone Mode

Programming data can be transferred from one transceiver to another by connecting them via their 8-pin microphone connectors. The operation is as follows (the transmit transceiver is the source and the receive transceiver is a target).

The following data cannot be cloned.

- Tuning data
- Embedded message with password
- ESN (Electronic Serial Number) data

Note:

The following data can be cloned.

- Fleet (own)/ID (own) for FleetSync
- Unit ID (own) for NXDN

- Turn the source transceiver power ON with the [<] key held down. If the read authorization password is set to the transceiver, the transceiver displays "CLONE LOCK". If the password is not set, the transceiver displays "CLONE MODE".
- When you enter the correct password, and "CLONE MODE" is displayed, the transceiver can be used as the cloning source. The following describes how to enter the password.

- If writing operation is completed, calculate the checksum and display the result.
- If you want to continue programming other transceivers, repeat steps 4 to 7.

注意:

如果车载对讲机的固件编程模式设为禁用, 则无法进入此模式。

6-4. 功能

- 如果在显示 "PROGRAM 115200" 时按 [■] 键, 则显示变为 "PROGRAM 19200" (LED 呈绿色闪烁), 表示写入速度为低速 (19200bps)。如果在显示 "PROGRAM 19200" 时再次按 [■] 键, 则显示变为 "PROGRAM 38400" (LED 呈红色和橙色交替点亮)。如果在显示 "PROGRAM 38400" 时再次按 [■] 键, 则显示变为 "PROGRAM 57600" (LED 呈橙色闪烁)。如果在显示 "PROGRAM 57600" 时再次按 [■] 键, 则显示返至 "PROGRAM 115200" (LED 呈橙色点亮)。
- 如果在显示 "PROGRAM 115200" 时按 [▲] 键, 则计算校验和并显示结果。如果在显示校验和时再次按 [▲] 键, 则重新显示 "PROGRAM 115200"。

注意:

通常以高速模式写入。

7. 复制模式

用 8 针麦克风连接器连接车载对讲机, 可以将编程数据从一台车载对讲机传输到另一台车载对讲机。具体操作如下 (发射车载对讲机是主机, 接收车载对讲机是子机)。

不能复制以下数据。

- 调谐数据
- 带密码的嵌入消息
- ESN (电子序列号) 数据

注意:

可以复制以下数据。

- FleetSync 的 Fleet (自身)/ID (自身)
- NXDN 的 Unit ID (自身)

- 按住 [<] 键打开主车载对讲机的电源。如果车载对讲机设置了读取授权密码, 则车载对讲机显示 "CLONE LOCK"。如果未设置密码, 则车载对讲机显示 "CLONE MODE"。
- 输入正确的密码后, 显示 "CLONE MODE", 车载对讲机可以作为复制源使用。下面描述如何输入密码。

REALIGNMENT / 模式组合

3.
 - **How to enter the password with the microphone keypad;**
If you press a key while "CLONE LOCK" is displayed, the number that was pressed is displayed on the transceiver. Each press of the key shifts the display in order to the left. When you enter the password and press the [*] key, "CLONE MODE" is displayed if the entered password is correct. If the password is incorrect, "CLONE LOCK" is redisplayed.
 - **How to enter the password with the [↵] and [↶] keys;**
If the [↵] and [↶] keys is pressed while "CLONE LOCK" is displayed, number (0 to 9) are displayed flashing. When you press the [↵] key, the currently selected number is determined. If you press the [↵] key after entering the password in this procedure, "CLONE MODE" is displayed if the entered password is correct. If the password is incorrect, "CLONE LOCK" is redisplayed.
4. Power on the target transceiver.
5. Connect the cloning cable (Part No. E30-3382-05) to the modular microphone jacks on the source and target.
6. Press the [↵] key on the source while the source displays "CLONE MODE". The data of the source is sent to the target. While the target is receiving the data, "PROGRAM" is displayed. When cloning of data is completed, the source displays "END", and the target automatically operates in the User mode. The target can then be operated by the same program as the source.
7. The other target can be continuously cloned. When the [↵] key on the source is pressed while the source displays "END", the source displays "CLONE MODE". Carry out the operation in step 4 to 6. Can not be cloned if the overwrite password is programmed to the target.

Note:

Only the same models can be cloned together.

3.
 - **如何用麦克风键盘输入密码；**
如果在显示“CLONE LOCK”时按某个键，则会在车载对讲机上显示被按下的数字。每次按键按向左的顺序移动显示。输入密码并按[*]键时，如果输入的密码正确，则显示“CLONE MODE”。如果密码不正确，则重新显示“CLONE LOCK”。
 - **如何使用[↵]和[↶]键输入密码；**
如果在显示“CLONE LOCK”时按[↵]和[↶]键，闪烁显示数字(0至9)。按[↵]键时，确定当前选择的数字。按该步骤输入密码后按[↵]键时，如果输入的密码正确，则显示“CLONE MODE”。如果密码不正确，则重新显示“CLONE LOCK”。
4. 打开子车载对讲机的电源。
5. 将复制电缆(零件号E30-3382-05)连接到主车载对讲机和子车载对讲机上的模块化麦克风插孔。
6. 主车载对讲机显示“CLONE MODE”时，按主车载对讲机上的[↵]键，主车载对讲机的数据便发送到子车载对讲机。子车载对讲机正在接收数据时，显示“PROGRAM”。数据复制完成后，主车载对讲机显示“END”，子车载对讲机自动按用户模式操作。然后子车载对讲机就可以按照与主车载对讲机相同的程序操作。
7. 可以继续对另一台子车载对讲机进行复制。如果在主车载对讲机显示“END”时按主车载对讲机上的[↵]键，则主车载对讲机显示“CLONE MODE”。
执行步骤4至6的操作。如果子车载对讲机编程设有改写密码，则不能复制。

注意：

只有相同型号的车载对讲机才能放在一起复制。

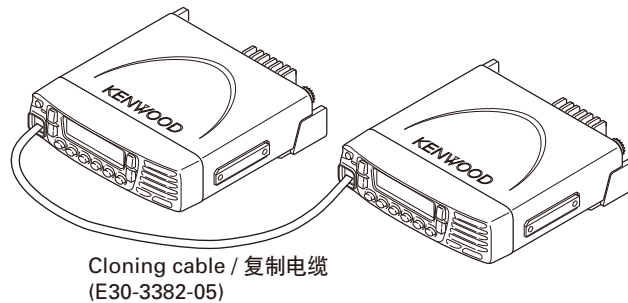

Fig. 2 / 图 2

8. Firmware Version Information

Press and hold the [▲] key while turning the transceiver power ON and then keep pressing and holding the [▲] key, the firmware version information appears on the LCD.

8. 固件版本信息

打开车载对讲机电源时按住[▲]键，然后一直按住[▲]键，LCD上便出现固件版本信息。

INSTALLATION / 安装

1. Ignition Sense Cable (KCT-46: Option)

The KCT-46 is an optional cable for enabling the ignition function. The ignition function lets you turn the power to the transceiver on and off with the car ignition key.

1-1. Connecting the KCT-46 cable to the transceiver

1. Open the KCT-46 fuse holder and insert a mini blade fuse (3A). (①)
2. While holding a clear protective cover, remove the black cap at the end of the yellow cable (ignition sense cable) of the transceiver. (②)
3. Connect the plug of the KCT-46 to the yellow cable terminal of the transceiver. (③)
4. Connect the other end of the KCT-46 to the ignition line of the car. (④)

Note: You must setup using the KPG-111D(C).

1. 点火感应电缆 (KCT-46: 可选件)

KCT-46 为用于启用点火功能的选购电缆。点火功能让您能够通过点火钥匙打开和关闭车载对讲机的电源。

1-1. 将 KCT-46 电缆连接到车载对讲机

1. 打开 KCT-46 保险丝盒并插入微型刀片式保险丝 (3A)。 (①)
2. 握住透明保护盖的同时取下车载对讲机黄色电缆 (点火感应电缆) 末端的黑色保护盖。 (②)
3. 将 KCT-46 的插头连接到车载对讲机的黄色电缆端子。 (③)
4. 将 KCT-46 的另一端连接到汽车点火线。 (④)

注意: 必须使用 KPG-111D(C) 进行设置。

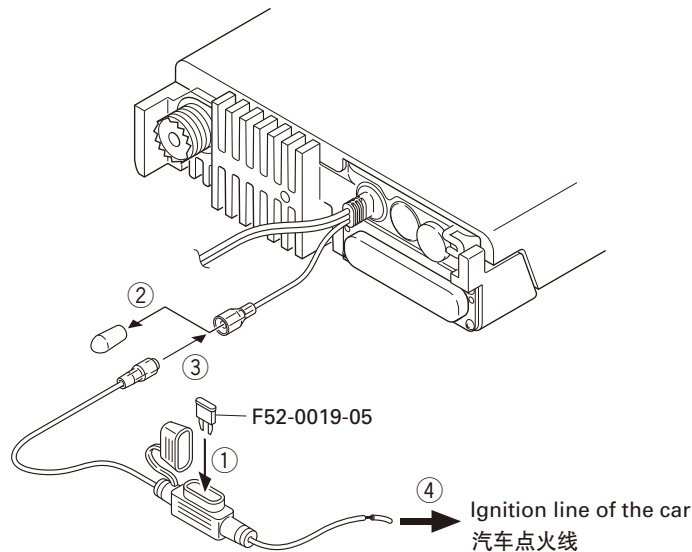

Fig. 1 / 图 1

2. Horn Alert/P.A. Relay Unit (KAP-2: Option)

The Horn alert (max. 2A drive), Public address and External speaker function are enabled by installing the KAP-2 in the transceiver.

2-1. Installing the KAP-2 unit in the transceiver (The kit A is not used in the KAP-2 accessories)

1. Remove the cabinet, top packing and shielding plate of the transceiver.
2. Set the KAP-2 relay unit jumper pins according to the purpose of use.
3. Remove the 6-pin jumper connector inserted in the TX-RX unit (A/2) connector (CN705). (①)
4. Insert one side of the lead wire with connector (E37-1114-05) into the relay unit connector (CN3) (②) and the other side into the TX-RX unit (A/2) connector (CN705) (③).
5. Place the relay unit at the position shown in Figure 2-2 and secure it to the chassis with a screw.

2. 喇叭提示 /P.A. 中继单元 (KAP-2: 可选件)

通过在车载对讲机中安装 KAP-2 即可启用喇叭提示 (最大 2A 驱动)、扩音和外部扬声器功能。

2-1. 在车载对讲机中安装 KAP-2 单元 (KAP-2 附件中没有使用套件 A)

1. 取下车载对讲机的机壳、顶盖和屏蔽板。
2. 根据使用目的的设置 KAP-2 中继单元的跳线引脚。
3. 取出插入 TX-RX 单元 (A/2) 连接器 (CN705) 的 6 针跳线连接器。 (①)
4. 将带有连接器的导线 (E37-1114-05) 一端插入中继单元连接器 (CN3) (②), 另一端插入 TX-RX 单元 (A/2) 连接器 (CN705) (③)。
5. 将中继单元放置在如图 2-2 所示的位置, 然后用螺丝将其固定到底座。

INSTALLATION / 安装

6. Remove the cap on the rear of the chassis by pushing it from the inside with your finger. (④)
7. Pass the 6-pin connector of the cable (E37-1113-25) through the chassis hole (⑤) and insert the bush into the chassis hole.
8. Rotate the bush of the cable 90 degrees counterclockwise as viewed from the rear of the chassis. (⑥)
9. Insert the 6-pin connector of the cable into the connector (CN2) of the KAP-2 relay unit. (⑦)

6. 用手指从内而外推底座后部的保护盖，将其取下。(④)
7. 将电缆 (E37-1113-25) 的 6 针连接器穿过底座孔 (⑤)，然后将套管插入底座孔。
8. 从底座后部方向上看，逆时针 90 度转动电缆的套管。(⑥)
9. 将电缆的 6 针连接器插入 KAP-2 中继单元的连接器的 (CN2)。(⑦)

注意：必须使用 KPG-111D(C) 进行设置。

Note: You must setup using the KPG-111D(C).

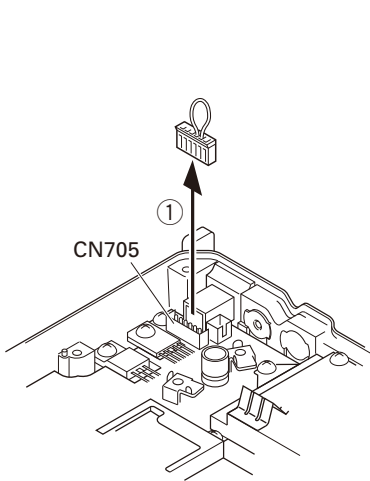

Fig. 2-1 / 图 2-1

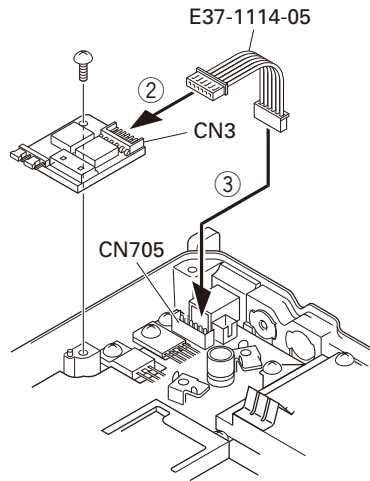

Fig. 2-2 / 图 2-2

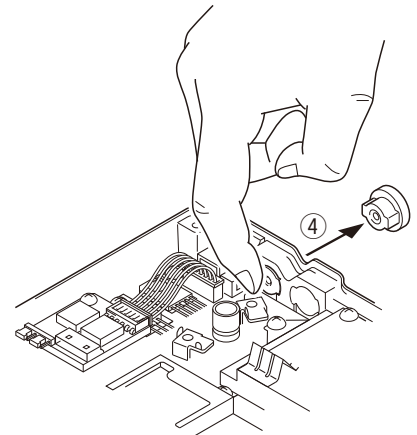

Fig. 2-3 / 图 2-3

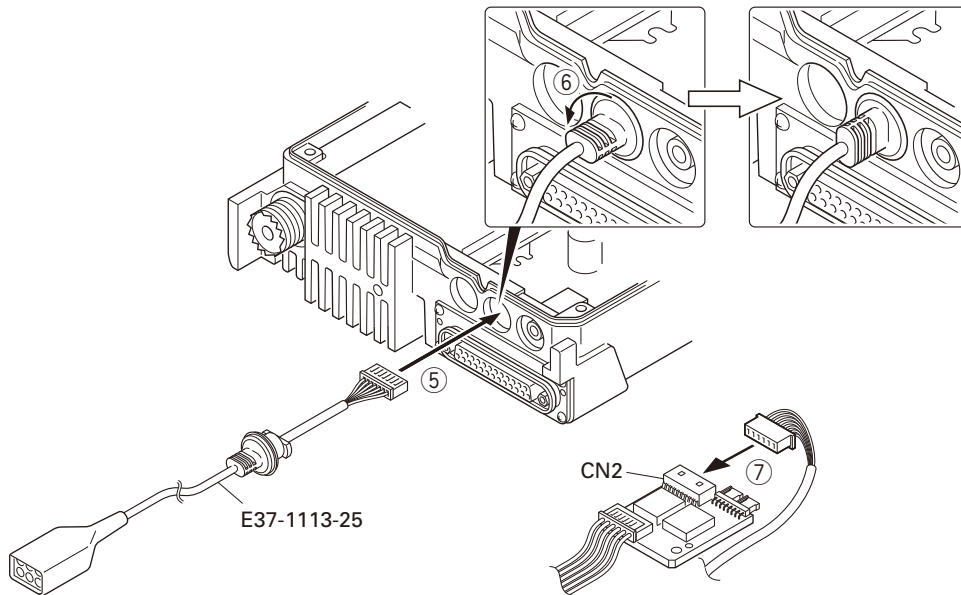

Fig. 2-4 / 图 2-4

INSTALLATION / 安装

3. Control Head Remote Kit (KRK-10: Option)

The KRK-10 remote kit is used to remotely operate the transceiver.

3-1. Installing the KRK-10 kit to the transceiver

1. Remove the front panel from the transceiver.
2. Install the KRK-10 main panel onto the transceiver.
3. Install the KRK-10 rear panel onto the front panel.
4. Connect the KRK-10 main panel to the rear panel with the cable.

■ Remove the front panel from the transceiver

1. Lift the two tabs of the panel on the bottom of the transceiver with a flat-head screwdriver (①) and remove the panel from the chassis (②).

Note: Confirm that the tabs of the speaker hardware fixture and holder is securely fitted in the front panel.

2. Remove the flat cable from the connector (CN901) of the display unit of the panel. (③)
3. Fold the black line of the flat cable (in three parts) as shown in Figure 3-2. (④, ⑤, ⑥)

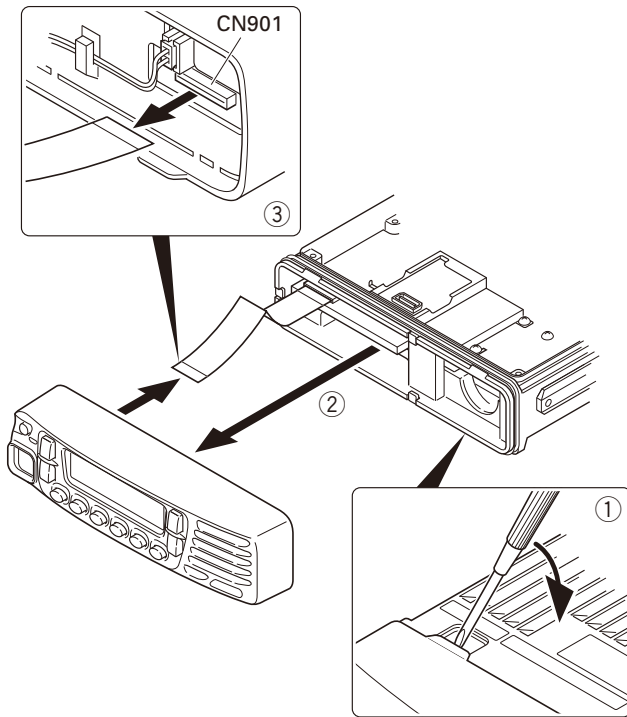

Fig. 3-1 / 图 3-1

3. 控制头遥控套件 (KRK-10: 可选件)

KRK-10 遥控套件用于远程操作车载对讲机。

3-1. 将 KRK-10 套件安装到车载对讲机

1. 从车载对讲机取下前面板。
2. 将 KRK-10 主控制盘安装到车载对讲机上。
3. 将 KRK-10 后面板安装到车载对讲机前面板上。
4. 用电缆将 KRK-10 主控制盘连接到后面板。

■ 从车载对讲机取下前面板

1. 用平头螺丝刀翘起车载对讲机底部的两个面板凸起 (①)，然后从底座取下面板 (②)。

注意: 请确保扬声器硬件夹具和扬声器座牢牢地固定在前面板中。

2. 从面板显示单元的连接器 (CN901) 取下带状电缆。(③)
3. 如图 3-2 所示折叠带状电缆的黑线。(④, ⑤, ⑥)

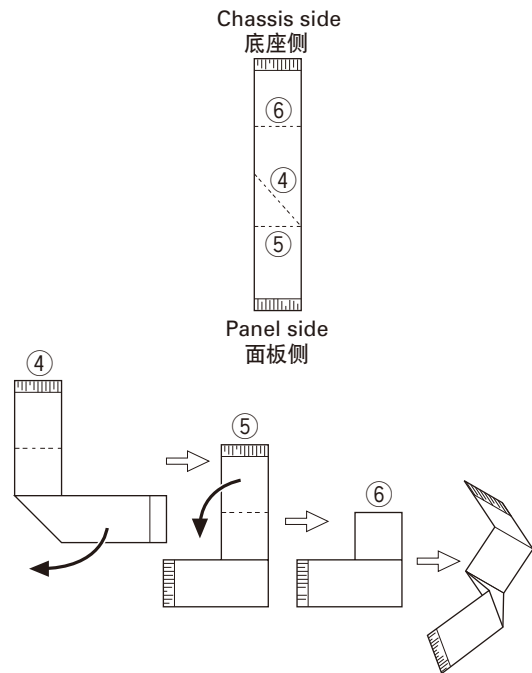

Fig. 3-2 / 图 3-2

INSTALLATION / 安装

■ Install the KRK-10 main panel onto the transceiver

4. Insert the flat cable that was removed in step 2 above into the connector (CN1) of the interface unit (A/2) of the KRK-10 main panel (A62-1101-11). (⑦)

Note: The terminal side of the flat cable must face down when inserting the flat cable into the connector.

5. Fit the main panel with four tabs onto the front of the chassis. (⑧)

Note: When installing the main panel onto the front of the chassis, hold down the flat cable with your fingers to prevent it from being caught.

■ 将 KRK-10 主控制盘安装到车载对讲机上

4. 将上述步骤 2 取下的带状电缆插入 KRK-10 主控制盘 (A62-1101-11) 接口单元 (A/2) 连接器 (CN1)。(⑦)

注意: 将带状电缆插入连接器时, 带状电缆的端子侧必须面朝下。

5. 将带有四个凸起的主控制盘安放在底座的前面。(⑧)

注意: 将主控制盘安装到底座的前面时, 请用手指压住带状电缆, 以防带状电缆卡住。

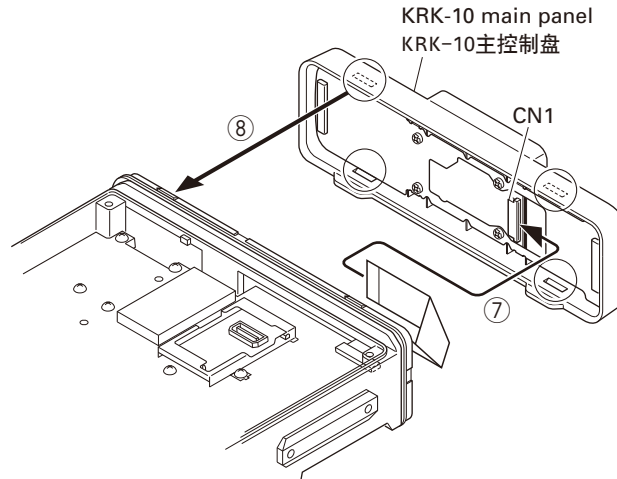

Fig. 3-3 / 图 3-3

■ Install the KRK-10 rear panel onto the front panel

6. Insert the flat cable attached to the interface unit (A/2) of the KRK-10 rear panel (A82-0056-21) into the connector (CN901) of the display unit of the panel (⑨). (The flat cable has been pre-inserted in the connector (CN2) of the rear panel at the time of shipping.)

Note: The terminal side of the flat cable must face down when inserting the flat cable into the connector.

7. Fit the four tabs of the rear panel into the front panel. (⑩)

■ 将 KRK-10 后面板安装到车载对讲机前面板上

6. 将 KRK-10 后面板 (A82-0056-21) 接口单元 (A/2) 安装的带状电缆插入面板显示单元的连接器的 (CN901) (⑨)。(出厂时, 后面板连接器中 (CN2) 已经预先插入带状电缆。)

注意: 将带状电缆插入连接器时, 带状电缆的端子侧必须面朝下。

7. 将后面板的四个凸起安装到前面板上。(⑩)

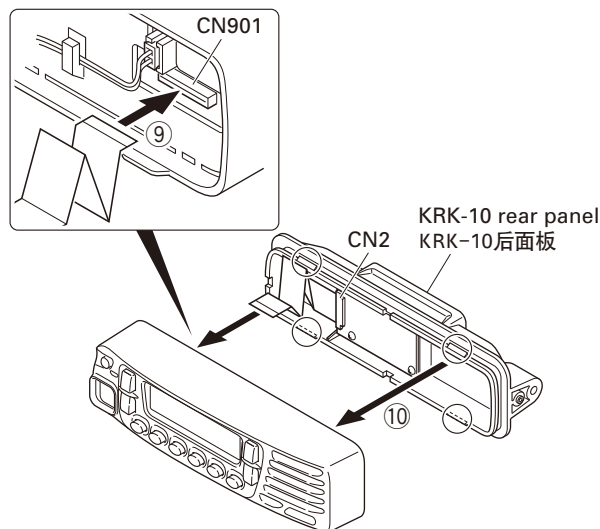

Fig. 3-4 / 图 3-4

INSTALLATION / 安装

■ Connect the KRK-10 main panel to the rear panel with the cable

8. Insert one 14-pin connector of the cable (E30-7514-15) into the connector (CN3) of the interface unit (A/2) of the main panel. (⑪)

Note: Insert the connector that has a sticker onto the cable to the connector of the main panel.

9. Secure the cable bush on the main panel and fit the waterproof packing (orange) (⑫) securely over top.

10. Install the molded cover (⑬) over the connector on the main panel and secure it with two screws (⑭).

11. Insert the other 14-pin connector of the cable into the connector (CN4) of the interface unit (B/2) of the rear panel. (⑮)

12. Secure the cable bush on the rear panel and fit the waterproof packing (orange) (⑯) securely over top.

13. Install the molded cover (⑰) over the connector on the rear panel and secure it with two screws (⑱).

Note: A cable can be connected from the left side as shown in the Figure 3-5 or from right side.

However, the 14-pin connector must be connected to correct direction.

■ 用电线将 KRK-10 主控制盘连接到后面板

8. 将电缆 (E30-7514-15) 的一个 14 针连接器插入主控制盘接口单元 (A/2) 的连接器 (CN3)。(⑪)

注意: 将电缆上带有标签的连接器插入主控制盘的连接器。

9. 将电缆套管固定在主控制盘上并将防水盖 (橙色) (⑫) 牢牢地固定在顶部。

10. 将模制保护盖 (⑬) 安装到主控制盘连接器上并用两颗螺丝 (⑭) 将其固定。

11. 将电缆的另一个 14 针连接器插入后面板接口单元 (B/2) 的连接器 (CN4)。(⑮)

12. 将电缆套管固定在后面板上并将防水盖 (橙色) (⑯) 牢牢地固定在顶部。

13. 将模制保护盖 (⑰) 安装到后面板连接器上并用两颗螺丝 (⑱) 将其固定。

注意: 可以从左侧 (如图 3-5) 或右侧连接电缆。

但是, 14 针连接器必须连接到正确的方向。

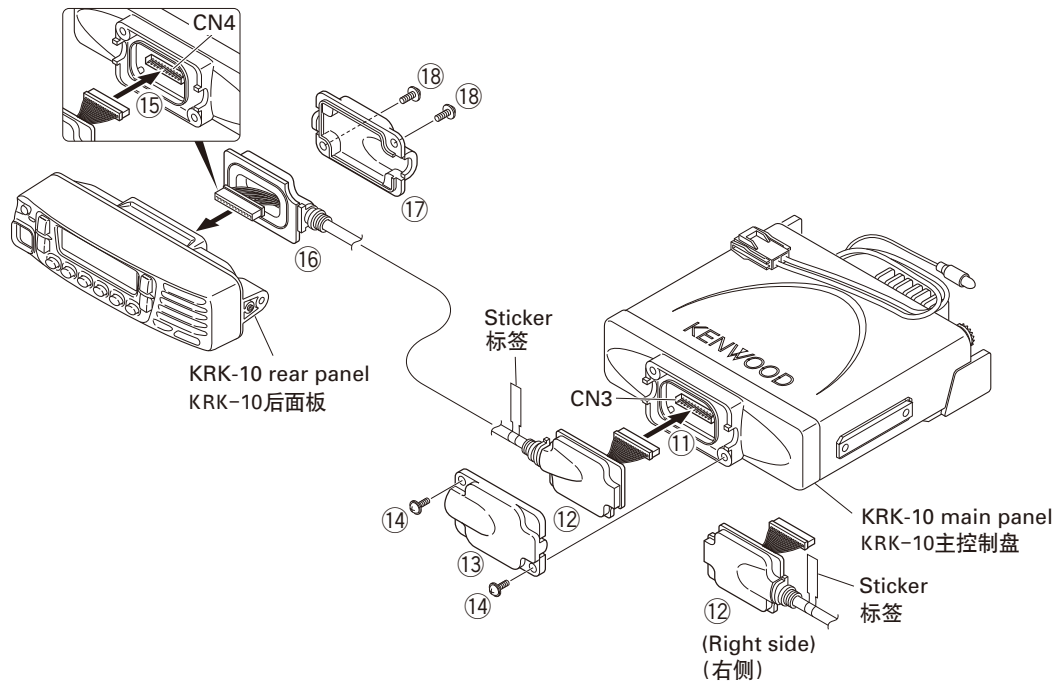

Fig. 3-5 / 图 3-5

INSTALLATION / 安装

4. Voice Guide & Storage Unit (VGS-1: Option)

4-1. Installing the VGS-1 unit in the transceiver

1. Remove the cabinet, top packing and shielding plate of the transceiver.
2. Attach two cushions to VGS-1 as shown in Figure 4. (①)
Note: Be sure not to cover the connector with the bottom cushion.
3. Insert the VGS-1 connector (CN1) into the TX-RX unit (A/2) connector (CN595). (②)

Note: You must setup using the KPG-111D(C).

4. 语言指导及存储单元 (VGS-1: 可选项)

4-1. 在车载对讲机中安装 VGS-1 单元

1. 取下车载对讲机的机壳、顶盖和屏蔽板。
2. 如图 4 所示，将两块缓冲垫安装到 VGS-1。(①)
注意: 请勿将底部缓冲垫盖住连接器。
3. 将 VGS-1 连接器 (CN1) 插入 TX-RX 单元 (A/2) 连接器 (CN595)。(②)

注意: 必须使用 KPG-111D(C) 进行设置。

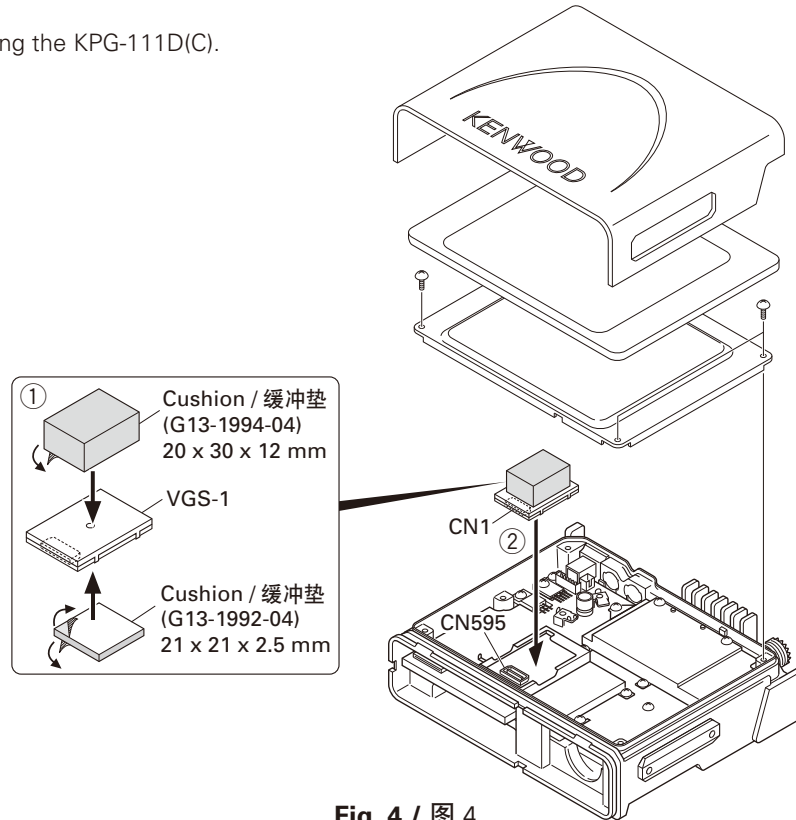

Fig. 4 / 图 4

5. External Speaker (Option)

5-1. KES-3

The KES-3 is an external speaker for the 3.5-mm-diameter speaker jack.

■ Connection Procedure

1. Connect the KES-3 to the 3.5-mm-diameter speaker jack on the rear of the transceiver.

5. 外部扬声器 (可选项)

5-1. KES-3

KES-3 是用于直径 3.5 mm 扬声器插孔的外部扬声器。

■ 连接操作

1. 将 KES-3 连接到车载对讲机后部的直径 3.5mm 扬声器插孔。

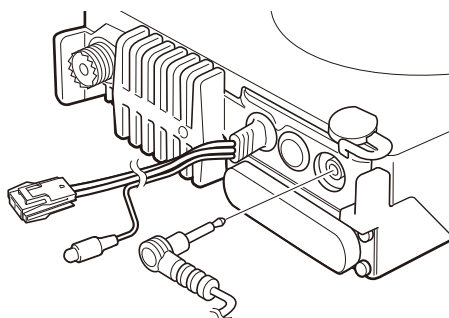

Fig. 5-1 / 图 5-1

INSTALLATION / 安装

5-2. KES-5 or KES-6

External speaker KES-5 or KES-6 can be installed for KAP-2. If KES-5 or KES-6 is installed, it can be set by changing the CN1 short pin from pins 4 and 5 to pins 5 and 6 on the KAP-2.

KAP-2 CN1 Connect	Set Up
4-5	INT. SP or KES-3
5-6	KES-5 or KES-6

When you use the KES-5 or KES-6, plug the short pin to pins 5 and 6 on the KAP-2.

When you use the INT. SP or KES-3, plug the short pin to pins 4 and 5 on the KAP-2.

■ Connection Procedure

Insert the crimp terminal into the Square plug supplied with the KAP-2.

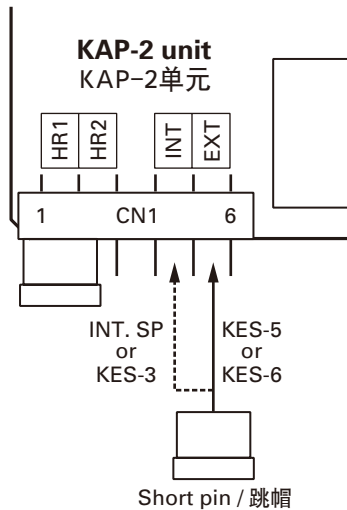
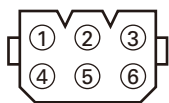

Fig. 5-2 / 图 5-2

■ KAP-2 Cable (E37-1113-25) 6-pin Connector



Pin No.	Color	Name
1	Red	HR2
2	Blue	GND
3	Yellow	OSP
4	Green	ESP
5	Brown	GND
6	Black	HR1

5-2. KES-5 或 KES-6

KAP-2 可以安装外部扬声器 KES-5 或 KES-6。如果安装了 KES-5 或 KES-6，则可以通过将 KAP-2 上的 CN1 跳帽从引脚 4 和 5 更改为引脚 5 和 6 来进行设置。

KAP-2 CN1 连接	设置
4-5	INT. SP 或 KES-3
5-6	KES-5 或 KES-6

使用 KES-5 或 KES-6 时，请将跳帽插入 KAP-2 的引脚 5 和引脚 6。

使用 INT. SP 或 KES-3 时，请将跳帽插入 KAP-2 的引脚 4 和引脚 5。

■ 连接操作

将压接式端子插入 KAP-2 附带的方形插头。

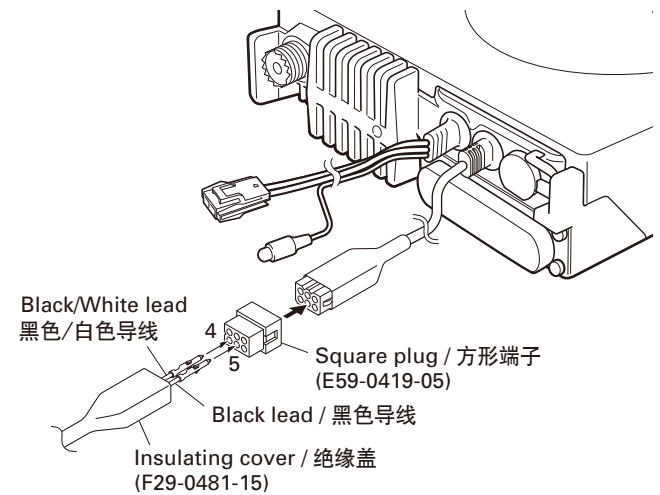
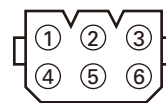

Fig. 5-3 / 图 5-3

■ KAP-2 电缆 (E37-1113-25) 6 针连接器



针编号	颜色	名称
1	红色	HR2
2	青色	GND
3	黄色	OSP
4	绿色	ESP
5	茶色	GND
6	黑色	HR1

INSTALLATION / 安装

6. GPS Receiver Connection

6-1. Installing the GPS receiver

1. Remove the cabinet, top packing and shielding plate of the transceiver.
2. Remove the front panel from the transceiver.
3. Attach two cushions to the top of the GPS receiver.
4. Attach the GPS receiver to the shield case with two cushions as shown in Figure 6-2.
5. Solder each lead of the GPS receiver to a necessary location of each landing on the component side of the TX-RX unit (A/2).
6. Place the GPS antenna cable in the hollow at the rear of the chassis. (Fig. 6-2 ①)

Note: If the GPS receiver is installed, cut the base of the convex tab of the top packing with a pair of nippers, or similar tool. (Fig. 6-3 ②)

If the convex tab of the top packing is cut off, the water proofing property is no longer guaranteed.

Note: You must setup using the KPG-111D(C).

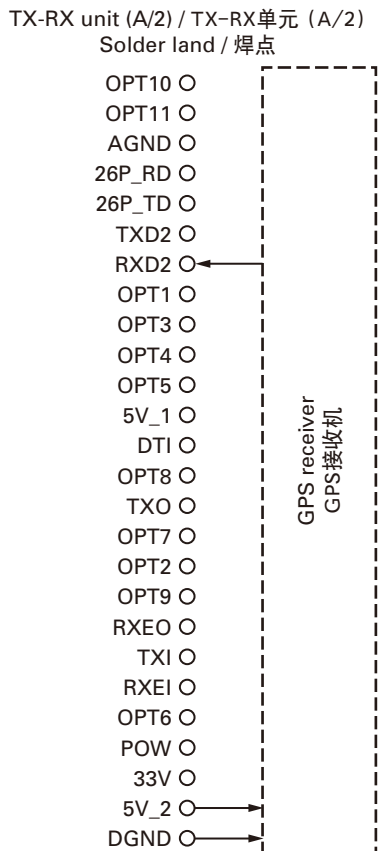

Fig. 6-1 / 图 6-1

6. GPS 接收机连接

6-1. 安装 GPS 接收机

1. 取下车载对讲机的机壳、顶盖和屏蔽板。
2. 从车载对讲机取下前面板。
3. 将两块缓冲垫安装到 GPS 接收机顶部。
4. 如图 6-2 所示，用两块缓冲垫将 GPS 接收机安装到屏蔽罩。
5. 将 GPS 接收机各个导线焊接到 TX-RX 单元 (A/2) 元件侧每个落点的必要位置。
6. 将 GPS 天线放入底座后部的凹槽。(图 6-2 ①)

注意: 如果安装了 GPS 接收机，请用镊子或类似工具剪断顶盖凸起的底部。(图 6-3 ②)
如果剪断顶盖凸起，则无法保证防水性。

注意: 必须使用 KPG-111D(C) 进行设置。

3M Double coated cushion / 3M 双面缓冲垫
No. 4016 (or No. 4416) / No. 4016 (或No.4416)
30 x 25 mm

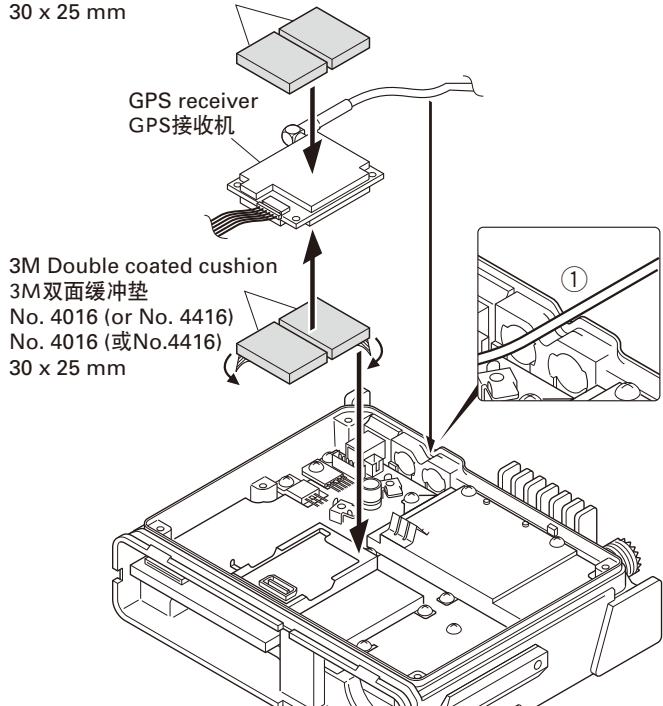

Fig. 6-2 / 图 6-2

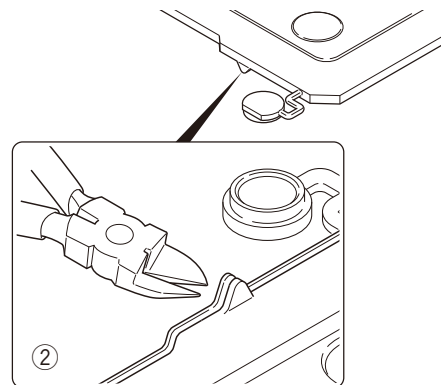

Fig. 6-3 / 图 6-3

INSTALLATION / 安装

6-2. Installing the GPS receiver together with the VGS-1

1. Remove the cabinet, top packing and shielding plate of the transceiver.
 2. Remove the front panel from the transceiver.
 3. Attach a cushion to the bottom of the VGS-1 as shown in Figure 6-5.
- Note:** Be sure not to cover the connector with the cushion.
4. Insert the VGS-1 connector (CN1) into the TX-RX unit (A/2) connector (CN595).
 5. Perform step 3 to 6 of "6-1. Installing the GPS receiver" described on page 20.

Note: You must setup using the KPG-111D(C).

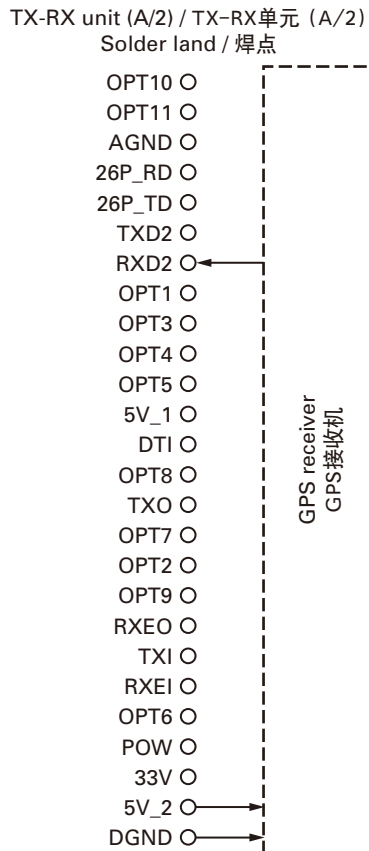

Fig. 6-4 / 图 6-4

6-2. 同时安装 GPS 接收机和 VGS-1

1. 取下车载对讲机的机壳、顶盖和屏蔽板。
2. 从车载对讲机取下前面板。
3. 如图 6-5 所示，将缓冲垫安装到 VGS-1 底部。
注意：请勿将缓冲垫盖住连接器。
4. 将 VGS-1 连接器 (CN1) 插入 TX-RX 单元 (A/2) 连接器 (CN595)。
5. 如第 20 页所述，执行“6-1. 安装 GPS 接收机”的步骤 3 到 6。

注意：必须使用 KPG-111D(C) 进行设置。

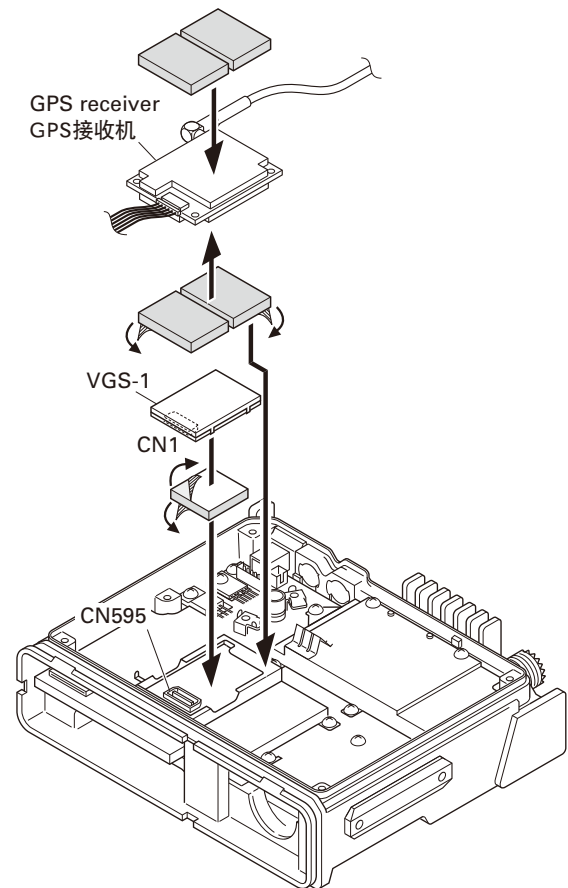

Fig. 6-5 / 图 6-5

DISASSEMBLY FOR REPAIR / 维修拆卸

1. Precautions on Disassembly

■ TX-RX PCB (TX-RX unit A/2) Disassembly

1. Remove all screws and antenna terminals on the TX-RX PCB.
2. Rotate the bush of the power supply cable 90 degrees counterclockwise as viewed from the rear of the chassis (①) and remove the power supply cable from the chassis (②).
3. When the speaker phone jack is pushed up, using your finger, from the rear of the chassis (③), the TX-RX PCB is removed from the chassis.

Note: The TX-RX PCB and D-sub PCB (TX-RX unit B/2) are connected with a flat cable. Remove them carefully.

4. Turn the TX-RX PCB over and remove the flat cable from the connector (CN600). (④)
5. Remove the TX-RX PCB from the chassis.

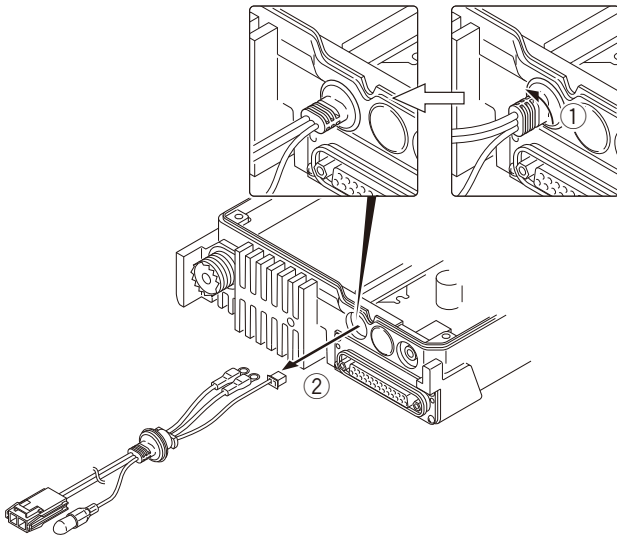

Fig. 1-1 / 图 1-1

■ Removing the speaker hardware fixture (J21-8481-03) and holder (J19-5485-12)

1. Remove the speaker lead from the holder hook. (①)
2. Remove the speaker connector from the display unit connector (CN902). (②)
3. When removing the speaker hardware fixture, insert a flat-head screwdriver at the position shown in Figure 2-1 and tilt it in the direction shown by the arrow. (③)
4. To remove the holder, insert a flat-head screwdriver into tab of the holder and tilt it in the direction shown by the arrow. (④)

1. 拆卸注意事项

■ TX-RX PCB (TX-RX 单元 A/2) 拆卸

1. 取下 TX-RX PCB 上的所有螺丝和天线端子。
2. 从底座后部方向上看，逆时针 90 度转动电缆的套管 (①)，然后从底座取下电源线 (②)。
3. 用手指从底座 (③) 后部将扬声器插孔提起时，TX-RX PCB 即可从底座取下。
注意：TX-RX PCB 和 D-sub PCB (TX-RX 单元 B/2) 通过带状电缆连接。取下时请小心。
4. 翻转 TX-RX PCB 并从连接器 (CN600) 取下带状电缆。(④)
5. 从底座取下 TX-RX PCB。

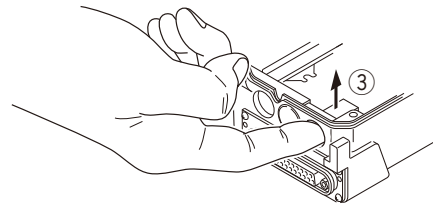

Fig. 1-2 / 图 1-2

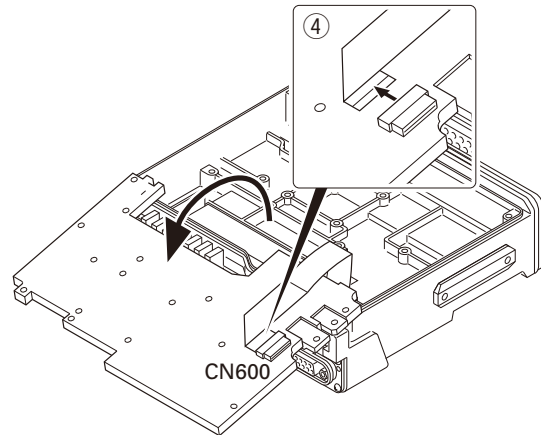

Fig. 1-3 / 图 1-3

■ 取下扬声器硬件夹具 (J21-8481-03) 和扬声器座 (J19-5485-12)

1. 从扬声器座挂钩取下扬声器导线。(①)
2. 从显示单元连接器 (CN902) 取下扬声器连接器。(②)
3. 取下扬声器硬件夹具时，请在图 2-1 所示位置插入平头螺丝刀并按箭头方向将其翘起。(③)
4. 如需取下扬声器座，请将平头螺丝刀插入扬声器座的凸起并按箭头方向将其翘起。(④)

DISASSEMBLY FOR REPAIR / 维修拆卸

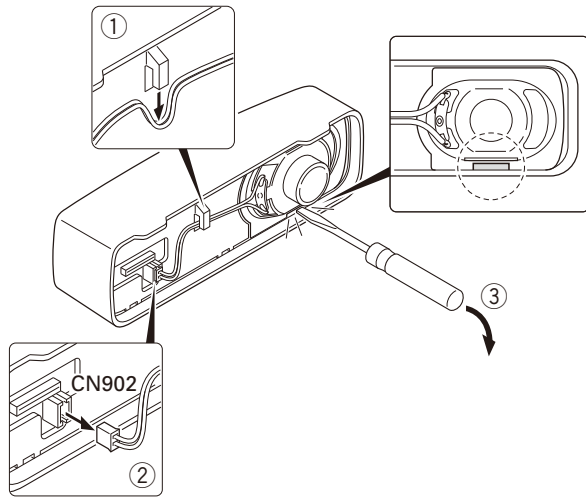

Fig. 2-1 / 图 2-1

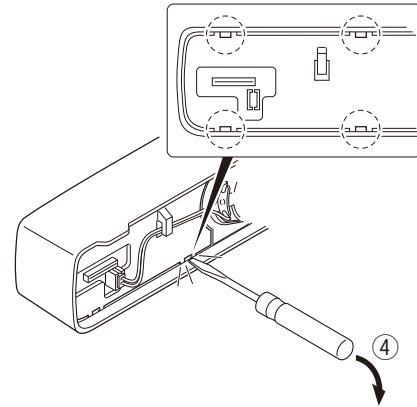

Fig. 2-2 / 图 2-2

2. Precautions on Reassembly

■ TX-RX PCB (TX-RX unit A/2) Reassembly

1. With the TX-RX PCB turned over, insert the flat cable from the D-sub PCB (TX-RX unit B/2) into the connector (CN600) on the TX-RX PCB.
2. Place the TX-RX PCB at its original position, tilt the TX-RX PCB and install the chassis as shown in Figure 3.

2. 重新组装注意事项

■ TX-RX PCB (TX-RX 单元 A/2) 重新组装

1. 翻转 TX-RX PCB，然后将 D-sub PCB (TX-RX 单元 B/2) 的带状电缆插入 TX-RX PCB 上的连接器 (CN600)。
2. 如图 3 所示，将 TX-RX PCB 放置在原来的位置，然后翘起 TX-RX PCB 并安装底座。

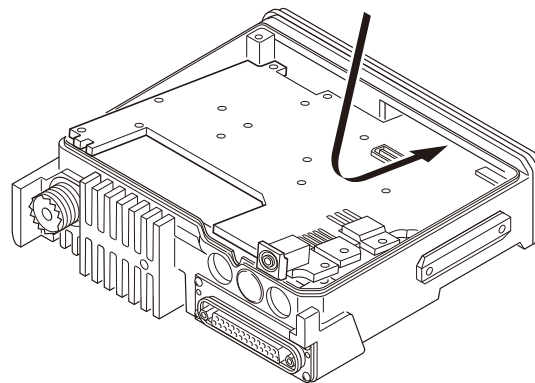

Fig. 3 / 图 3

■ FINAL shield case (F10-2489-13) installation procedure

1. Place the shield case on the final section of the TX-RX unit (A/2).
2. The shield case is installed on the positioning boss of the chassis by pushing down on "PUSH2" (on the shield case) while pushing "PUSH1" (stamped on two parts on the shield case) to the right.

■ 末级屏蔽罩 (F10-2489-13) 安装操作

1. 将屏蔽罩放置在 TX-RX 单元 (A/2) 的最外层。
2. 向右按压 "PUSH1" (印制在屏蔽罩的两个部分上) 的同时按压 (屏蔽罩上的) "PUSH2", 将屏蔽罩安装在底座的定位凸起上。

DISASSEMBLY FOR REPAIR / 维修拆卸

■ Power supply cable installation procedure

1. Pass the power supply cable through the chassis hole (①) as shown in Figure 4-1 and insert the bush into the chassis hole.
2. Rotate the bush of the power supply cable 90 degrees clockwise as viewed from the rear of the chassis. (②)
3. Align the ignition sense connector (yellow) of the power supply cable around the chemical capacitor (C401) and connect it to the TX-RX unit (A/2) connector (CN403).
4. Align the + (positive) terminal of the power supply cable (red) as shown in Figure 4-2 and fix it to the terminal strip with a screw.
5. Align the - (negative) terminal of the power supply cable (black) as shown in Figure 4-2 and fix it to the terminal strip with a screw.

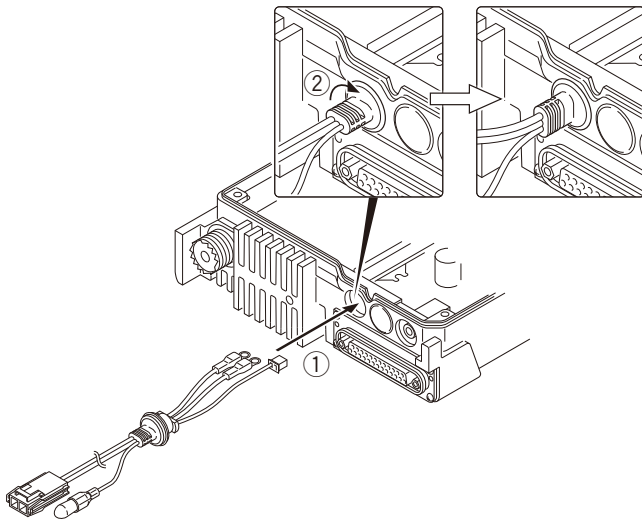

Fig. 4-1 / 图 4-1

■ 电源线安装操作

1. 如图 4-1 所示，将电源线穿过底座孔 (①)，然后将套管插入底座孔。
2. 从底座后部方向上看，顺时针 90 度转动电源线的套管。(②)
3. 将电源线的点火感应连接器 (黄色) 绕过电解质电容器 (C401)，然后将其连接到 TX-RX 单元 (A/2) 连接器 (CN403)。
4. 如图 4-2 所示，对准电源线 (红色) + (正极) 端子，然后用螺丝将其固定到端子板。
5. 如图 4-2 所示，对准电源线 (黑色) - (负极) 端子，然后用螺丝将其固定到端子板。

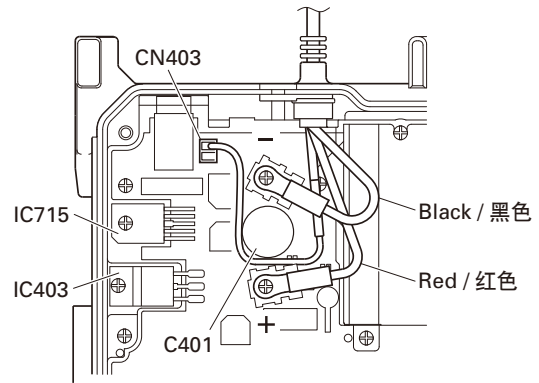

Fig. 4-2 / 图 4-2

■ Top packing installation procedure

1. Place the top packing over the shielding plate.
2. Fit the convex tab of the top packing into the hollow of the chassis. (①)
3. Fit the chassis into the groove of the top packing. (②)
Verify that the top packing is in close contact with the chassis.

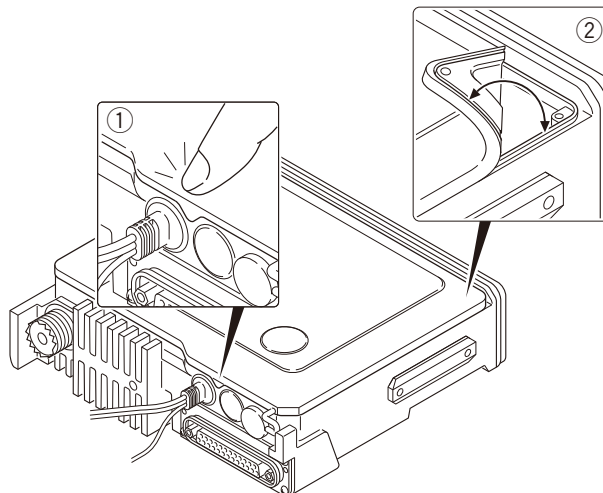

Fig. 5 / 图 5

■ 顶盖安装操作

1. 将顶盖放置在屏蔽板上。
2. 将顶盖凸起卡入底座凹槽。(①)
3. 将底座卡入顶盖凹槽。(②)
请确保顶盖与底座紧密接触。

DISASSEMBLY FOR REPAIR / 维修拆卸

■ D-sub cap installation procedure

To improve water resistance, fit the D-sub cap into the D-sub terminal hardware fixture of the transceiver in the following order:

1. Fit the left side (①) of the D-sub cap into the hardware fixture.
 2. Fit the right side (②) of the D-sub cap into the hardware fixture.
 3. Fit the center (③) of the D-sub cap into the hardware fixture.
- Verify that the D-sub cap is in close contact with the hardware fixture.

■ D-sub 盖安装操作

如需提高防水性能，请按照以下顺序将 D-sub 盖卡入车载对讲机的 D-sub 端子硬件夹具。

1. 将 D-sub 盖的左侧 (①) 卡入硬件夹具。
2. 将 D-sub 盖的右侧 (②) 卡入硬件夹具。
3. 将 D-sub 盖的中央 (③) 卡入硬件夹具。
请确保 D-sub 盖与硬件夹具紧密接触。

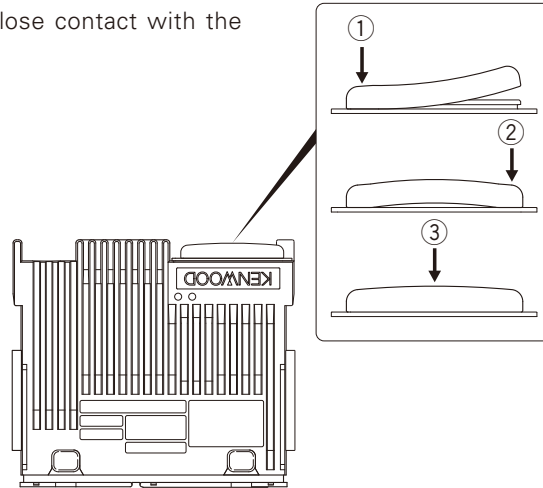

Fig. 6 / 图 6

■ Installing the holder (J19-5485-12) and speaker hardware fixture (J21-8481-03)

1. Insert two tabs of the holder (J19-5485-12) into the hollows in the top of the panel. (①)
2. Push the two tabs of the holder in on the opposite side of those in step 1 above and fit them into the hollow in the bottom of the panel. (②)
Note: Push in the holder until it snaps in place.
3. Install the speaker holder onto the panel. (③)
Note: To improve water resistance, fit the panel into the groove of the holder.
4. Place the speaker into the speaker holder.
Note: The speaker must not ride on the holder rib.
5. Place the spacer on the speaker.
6. Insert the hardware fixture (J21-8481-03) into the hollow of the panel as shown in Figure 7-3, then push two parts of the hardware fixture and fit it into the hollow of the top of the panel. (Fig. 7-3 ④)
Note: Push in the hardware fixture until it snaps in place.
7. Insert the speaker connector into the display unit connector (CN902).
8. Place the speaker lead on the holder hook.

■ 安装扬声器座 (J19-5485-12) 和扬声器硬件夹具 (J21-8481-03)

1. 将扬声器座 (J19-5485-12) 的两个凸起插入面板顶部凹槽。(①)
2. 按入步骤 1 相反方向的两个扬声器座凸起，然后将其卡入面板底部凹槽。(②)
注意: 按入扬声器座，直到其咬接到位。
3. 将扬声器座安装到面板上。(③)
注意: 如需提高防水性能，请将面板卡入扬声器座的凹槽。
4. 将扬声器放入扬声器座。
注意: 扬声器不能倚靠扬声器座的凸缘。
5. 将垫圈放置在扬声器上。
6. 如图 7-3 所示，将硬件夹具 (J21-8481-03) 插入面板凹槽，然后推动硬件夹具的两个部分并将其卡入面板顶部的凹槽。(图 7-3 ④)
注意: 按入硬件夹具，直到其咬接到位。
7. 将扬声器连接器插入显示单元连接器 (CN902)。
8. 将扬声器导线放置在扬声器座挂钩上。

DISASSEMBLY FOR REPAIR / 维修拆卸

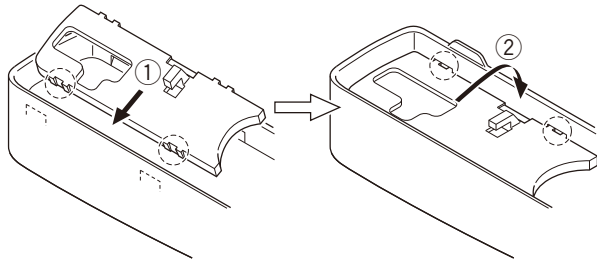

Fig. 7-1 / 图 7-1

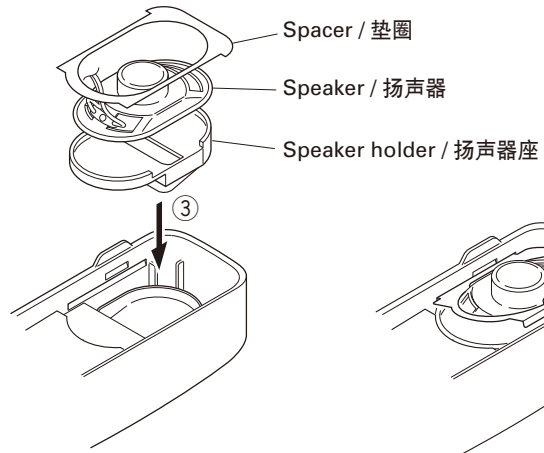

Fig. 7-2 / 图 7-2

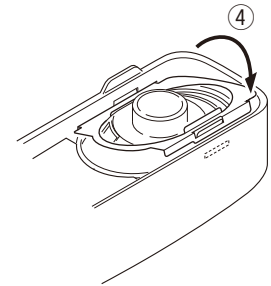

Fig. 7-3 / 图 7-3

■ Removing the lithium cell (W09-0971-05)

Insert a non-conductive screwdriver to groove of one side of the socket (CN405) and pry the lithium cell up from the socket.

■ 取出锂电池 (W09-0971-05)

将不导电的螺丝刀插入电池座 (CN405) 的一侧，从电池座中撬起锂电池。

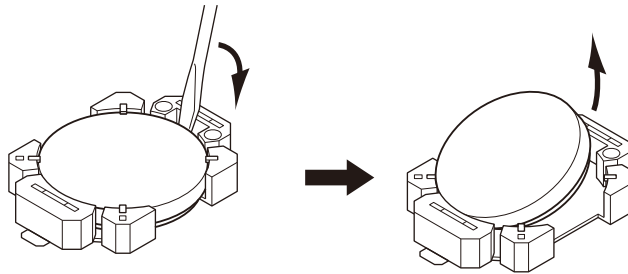

Fig. 8 / 图 8

■ Installing the lithium cell (W09-0971-05)

Insert a lithium cell into one side of the socket (CN405). Push the lithium cell to insert the lithium cell into the socket.

■ 安装锂电池 (W09-0971-05)

将锂电池插入电池座 (CN405) 的一侧。推动锂电池，将其插入电池座中。



Fig. 9 / 图 9

CIRCUIT DESCRIPTION / 电路说明

1. Overview

NX-700 is a VHF Mobile transceiver designed to operate in the frequency range of 136 to 174MHz. The unit consists of receiver, transmitter, phase-locked loop (PLL) frequency synthesizer, base band parts, power supply, and control circuits.

2. Frequency Configuration

The receiver is a double-conversion super heterodyne using first intermediate frequency (IF) of 58.05MHz and second IF of 450kHz. Incoming signals from the antenna are mixed with the local signal from the PLL circuit to produce the first IF of 58.05MHz. This is then mixed with the 57.6MHz second local oscillator output to produce the 450kHz second IF. The transmit signal frequency is generated by the PLL VCO, and modulated by the signal from the DSP. It is then amplified and fed to the antenna.

1. 概述

NX-700 为 VHF 便携式车载对讲机，设计用于 136 至 174MHz 的频率范围。该设备由接收机、发射机、锁相环 (PLL) 频率合成器、基带部分、电源和控制电路组成。

2. 频率构成

接收机为二次变频超外差方式，使用的第一中频 (IF) 为 58.05MHz，第二中频为 450kHz。天线接收到的信号与 PLL 电路的本振信号混频，从而产生第一个 58.05MHz 的中频。然后与第二个 57.6MHz 的本地振荡器输出信号混频，进而产生第二个 450kHz 的中频。发射的信号频率由 PLL VCO 生成，并经 DSP 信号调制。最后，该信号频率经过放大并发送到天线。

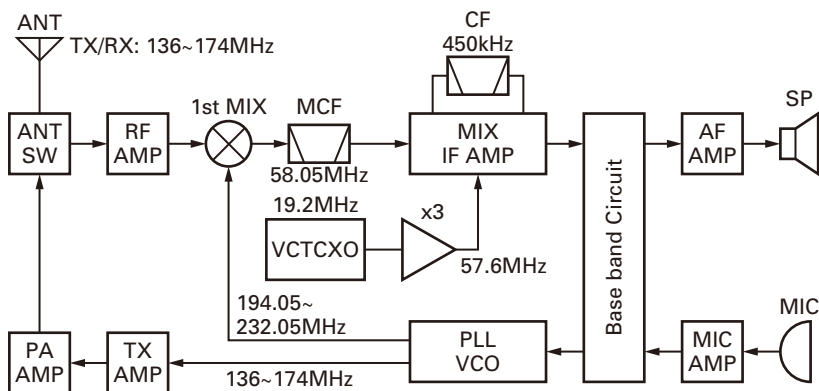

Fig. 1 Frequency configuration / 图 1 频率构成

3. Receiver System

3-1. RF circuit

The front-end circuit consists of former BPF (D213, D216, D217, D218), RF amplifier Q210, and latter BPF (D207, D208, D209 and D210).

The BPF covers frequency ranges 136 to 174MHz.

The latter BPF (D207, D208, D209 and D210) attenuates the unwanted signals, and sends only the necessary signal to the first mixer.

3-2. First Mixer

The signal from the BPF is heterodyned with the first local oscillator signal from the PLL frequency synthesizer circuit at the first mixer DBM (IC204) to become a 58.05MHz first intermediate frequency (IF) signal.

The first IF signal is fed through a monolithic crystal filter (XF202) to further remove spurious signals.

3. 接收部系统

3-1. RF 电路

前端电路由前级 BPF (D213、D216、D217 和 D218)、RF 放大器 Q210 和末级 BPF (D207、D208、D209 和 D210) 组成。

BPF 覆盖的频率范围为 136 ~ 174MHz。

末级 BPF (D207、D208、D209 和 D210) 衰减不需要的信号，然后仅将必要的信号发送给第一混频器。

3-2. 第一个混频器

BPF 的信号与 PLL 频率合成器电路的第一本地振荡器信号在第一混频器 DBM (IC204) 进行外差，成为 58.05MHz 的第一中频 (IF) 信号。

第一 IF 信号经由单片晶体滤波器 (XF202) 馈通以进一步消除杂散信号。

CIRCUIT DESCRIPTION / 电路说明

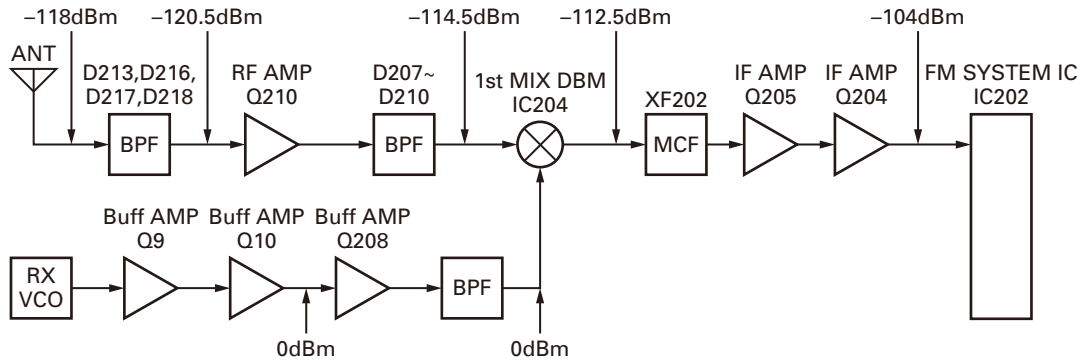

Fig. 2 / 图 2

3-3. IF circuit

The first IF signal is passed through a four-pole monolithic crystal filter (XF202) to reject adjacent channel signal. The filtered first IF signal is amplified by the first IF amplifier (Q204, Q205) and then applied to the IF system IC (IC202). The IF system IC provides a second mixer, AGC amplifier, and RSSI (Received Signal Strength Indicator).

The second mixer mixes the first IF signal with the 57.6MHz of second local oscillator output and produces the second IF signal of 450kHz.

The second IF signal is passed through the ceramic filter (CF201, CF202) to reject the adjacent channel signal. The filtered second IF signal is amplified by AGC amplifier.

The signal from AGC amplifier is input to A/D converter (IC510) through ceramic filter (CF203) and operational amplifier (IC201 and IC704).

3-3. 中频电路

第一中频信号经过一个四极的单片晶体滤波器 (XF202) 以消除临近信道的信号。滤波后的第一中频信号经过第一中频放大器 (Q204、Q205) 的放大后, 加到中频系统 IC (IC202) 上。中频系统 IC 提供一个第二混频器、AGC 放大器和 RSSI (接收信号强度指示器)。

第二混频器混合第一中频信号及 57.6MHz 的第二本地振荡器输出, 生成 450kHz 的第二中频信号。第二中频信号通过陶瓷滤波器 (CF201、CF202) 以消除临近信道的信号。滤波后的信号由 AGC 放大器进行放大。

AGC 放大器的信号通过陶瓷滤波器 (CF203) 和运算放大器 (IC201 和 IC704) 输入 A/D 转换器 (IC510)。

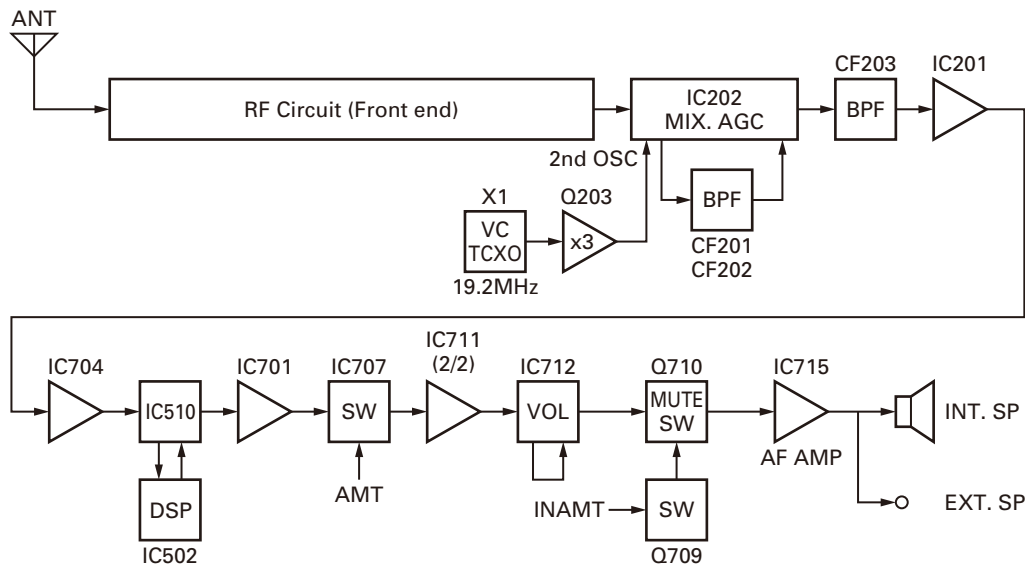

Fig. 3 / 图 3

CIRCUIT DESCRIPTION / 电路说明

3-4. Audio amplifier circuit

Audio processing (high-pass filter, low-pass filter, de-emphasized and so on) at FM mode and decoding at NXDN mode are processed by DSP. Audio signal from IC510, IC502 goes through the amplifier (IC701). The signal then goes through mute switch (IC707), amplifier (IC711), and electronic volume control (IC712).

While busy, INAMT becomes High, turn switch (Q709) on and Mute switch (Q710) off, and signal is fed to AF Power Amp (IC715). While Non-busy, INAMT is become Low, turn switch (Q709) off and Mute switch (Q710) on, then there is not AF output.

3-5. Squelch Circuit

It amplifies the demodulated noise signal from IC202 after filtering through BPF circuit. Then, the amplified signal is converted to DC signal by the detection circuit. The converted signal is fed back to IC510.

3-4. 音频放大器电路

FM 模式的音频处理（高通滤波器、低通滤波器、去加重等）和 NXDN 模式的解码由 DSP 进行处理。IC510、IC502 的音频信号通过放大器 (IC701)。然后，信号通过静音开关 (IC707)、放大器 (IC711) 和电子音量控制 (IC712)。

繁忙时，INAMT 变高，打开开关 (Q709) 并关闭静音开关 (Q710)，信号被送入 AF 功率放大器 (IC715)。不繁忙时，INAMT 变低，关闭开关 (Q709) 并打开静音开关 (Q710)，此时没有 AF 输出。

3-5. 静噪电路

通过 BPF 电路滤波后，该电路放大 IC202 的已解调噪声信号。随后，放大的信号由检测电路转换为 DC 信号。转换的信号被反馈给 IC510。

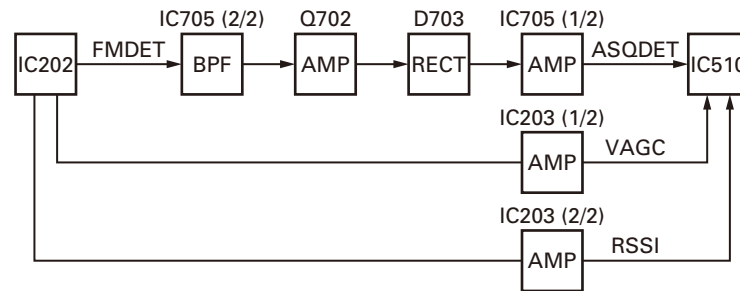

Fig. 4 / 图 4

4. Transmitter System

4-1. Audio Band Circuit

The signal from the microphone goes through the mute switch (Q706), the Mic-Mute signal (MM) becomes Low, then mute switch (Q706) is turned off. The signal from microphone goes through Mic-AGC (Q704, Q705, D704, D705), and goes through switch IC (IC708), and amplified by Mic-Amp IC706 (1/2), LPF IC706 (2/2) works as anti-aliasing filter.

If an optional scrambler board is installed, the switch (IC708) adjusts the signal path so that the audio signal is input to the scrambler board.

4-2. Base Band Circuit

The audio signal output from the base band circuit is converted to digital data of a sampling frequency of 48kHz.

This digital data is sent to the DSP (IC502), and voice signals of 300Hz or lower and frequencies of 3kHz or higher are cut off and an audio range 300Hz to 3kHz is extracted. The audio signal is then pre-emphasized in FM mode and synthesized with the signals, such as QT and DQT, as required, and is then output from the IC510. In Digital mode, the audio signal is converted to the 4-Level FSK base band signal and output from the IC510. The DTMF and MSK base band signals are also generated by the DSP and output by the IC510.

4. 发射机系统

4-1. 音频频带电路

麦克风的信号通过静音开关 (Q706)，麦克风静音信号 (MM) 变低，然后静音开关 (Q706) 被关闭。麦克风的信号通过 Mic-AGC (Q704、Q705、D704、D705)，然后通过开关 IC (IC708)，由麦克风放大器 IC706 (1/2) 放大，LPF IC706 (2/2) 用作抗混叠滤波器。

如果装有语音扰频器板，则开关 (IC708) 将对信号路径进行调整，使信号输入语音扰频器板。

4-2. 基带电路

从基带电路输出的音频信号被转换为取样频率为 48kHz 的数字信号。

该数字信号被发送给 DSP (IC502)，300Hz 或更低的语音信号和 3kHz 或更高的频率被截止，并选取 300Hz 至 3kHz 的音频范围。然后，音频信号以 FM 模式预加重，并与所需的 QT 和 DQT 等信号合成，然后从 IC510 输出。在数字模式下，音频信号被转换为 4 级 FSK 基带信号，从 IC510 输出。DTMF 和 MSK 基带信号也由 DSP 生成并由 IC510 输出。

CIRCUIT DESCRIPTION / 电路说明

LPF (IC702) works as smoothing filter. The DAC (IC712) assigns the base band signal to the VCO and VCTCXO (X1). At this time, the level output according to the transmit carrier is fine-adjusted according to each modulation method.

LPF (IC702) 用作平滑滤波器。DAC (IC712) 将基带信号分配到 VCO 和 VCTCXO (X1)。此时，将按照各自的调制方式对按照发射载波输出的电平进行微调。

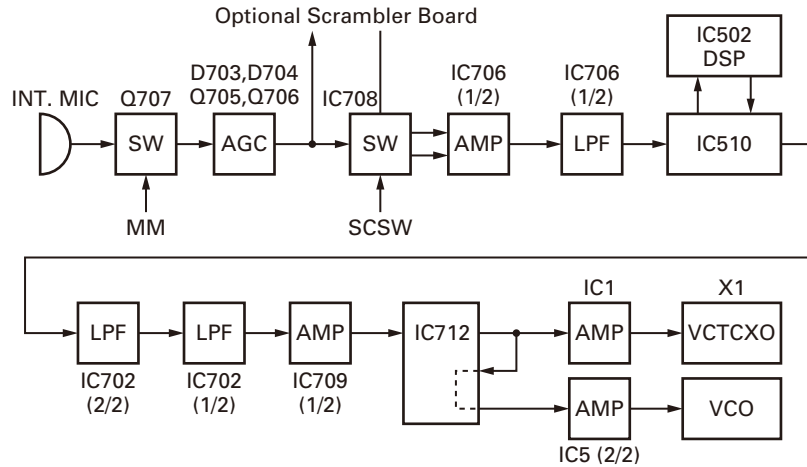

Fig. 5 / 图 5

4-3. Drive and Final amplifier

The transmit signal obtained from the TX VCO buffer amplifier Q13, is amplified to approximately +17dBm by the driver amplifiers Q14, Q101 and Q102.

This amplified signal is passed to the power amplifier module (power module) IC102, which consists of a MOS-FET amplifier and capable of transmission output power.

4-3. 驱动及末级功率放大器电路

驱动放大器 Q14、Q101 和 Q102 将从 TX VCO 缓冲放大器 Q13 获得的发射信号放大 +17dBm 左右。

放大后的信号转到功率放大器模块（功率模块）IC102（由单个 MOS-FET 放大器组成并能发射输出功率）。

4-4. APC circuit

The Automatic transmission power control (APC) circuit stabilizes the transmitter output power at a predetermined level by detecting the power module output with a diodes D107, D108 and D109. Diodes D107, D108 and D109 apply a voltage to DC amplifier IC103 (1/2).

IC103 (2/2) compares the APC control voltage (PC) generated by MCU IC510 and DC amplifier IC101 (1/2, 2/2) with the detection output voltage from IC103 (1/2) to control the Vgg Pin of IC102, and stabilizes transmission output.

The APC circuit is configured to protect over-current of the power module due to fluctuations of the load at the antenna end and to stabilize transmission output at voltage and temperature variations.

4-4. APC 电路

通过使用二极管 D107、D108 和 D109 检测功率模块输出，自动发射功率控制（APC）电路将发射器输出功率稳定在预定电平。二极管 D107、D108 和 D109 对直流放大器 IC103 (1/2) 施加电压。

IC103 (2/2) 将 MCU IC510 和直流放大器 IC101 (1/2, 2/2) 生成的 APC 控制电压 (PC) 与 IC103 (1/2) 的检测输出电压进行比较，从而达到控制 IC102 Vgg 引脚并稳定发射输出的目的。

配置 APC 电路是为了保护因天线端负载波动而引起的功率模块过流，以及在电压和温度变化时稳定发射输出。

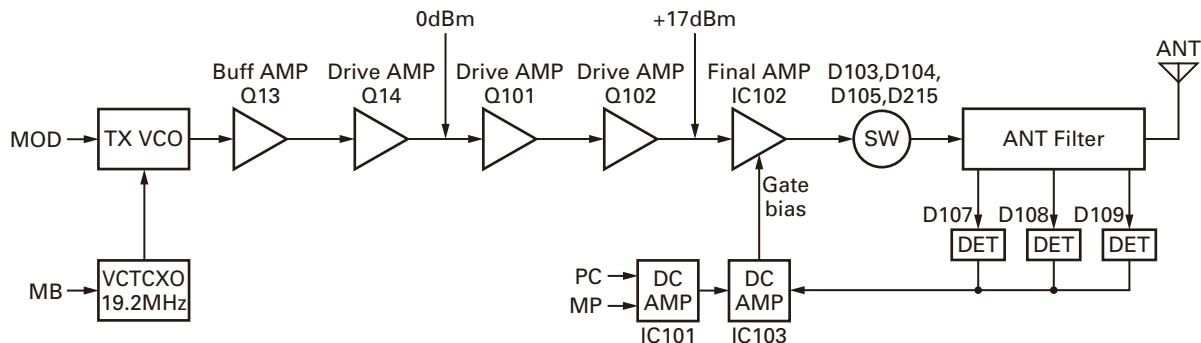

Fig. 6 / 图 6

CIRCUIT DESCRIPTION / 电路说明

5. PLL Frequency Synthesizer

5-1. VCTCXO (X1)

VCTCXO (X1) generates a reference frequency of 19.2MHz for the PLL frequency synthesizer. This reference frequency is applied to pin 9 of the PLL IC (IC3) and connected to IF circuit as a 2nd local signal through Tripler. The VCTCXO oscillation frequency is determined by DC voltage of VC terminal. The VC voltage is fixed to 1.65V by R1 and R2, and supplied to VC terminal through IC1. Modulation signal is also fed to VC terminal through IC1.

The frequency adjustment is achieved by switching the ratio of dividing frequency that is not adjusted by the DC voltage impressed to VC. The resolution of adjusting frequency is approximately 8Hz. Because twice the VCO output are input as for the input frequency of PLL IC, the sending and receiving frequency can be adjusted by approximately 4Hz resolution.

5-2. VCO

There is a RX VCO and a TX VCO.

The TX VCO (Q10) generates a transmit carrier and the RX VCO (Q9) generates a 1st local signal. For the VCO oscillation frequency, the transmit carrier is 136 to 174MHz and the 1st local receive signal is 194.05 to 232.05MHz.

The VCO oscillation frequency is determined by one system of operation switching terminal "T/R" and two systems of voltage control terminals "C/V" and "V-assist".

The operation switching terminal, "T/R", is controlled by the control line (/T_R) output from the MCU (IC510). When the /T_R logic is low, the VCO outputs the transmit carrier and when it is high, it outputs a 1st local receive signal.

The voltage control terminals, "CV" and "V-assist", are controlled by the PLL IC (IC3) and MCU (IC510) and the output frequency changes continuously according to the applied voltage. For the modulation input terminal, "VCO MOD", the output frequency changes according to the applied voltage. This is used to modulate the VCO output. "VCO MOD" works only when "/T_R" is low.

5-3. PLL IC (IC3)

PLL IC compares the differences in phases of the VCO oscillation frequency and the VCTCXO reference frequency, returns the difference to the VCO CV terminal and realizes the "Phase Locked Loop" for the return control. This allows the VCO oscillation frequency to accurately match (lock) the desired frequency.

When the frequency is controlled by the PLL, the frequency convergence time increases as the frequency difference increases when the set frequency is changed. To supplement this, the MCU is used before control by the PLL IC to bring the VCO oscillation frequency close to the desired frequency. As a result, the VCO CV voltage does not change and is always stable at approx. 3.0V.

The desired frequency is set for the PLL IC by the MCU (IC510) through the 3-line "SD01", "SCK1", "PCS_RF" serial bus. Whether the PLL IC is locked or not is monitored by the MCU through the "PLD" signal line. If the VCO is not the desired frequency (unlock), the "PLD" logic is low.

5. PLL 频率合成器

5-1. VCTCXO (X1)

VCTCXO (X1) 为 PLL 频率合成器产生 19.2MHz 的基准频率。该基准频率被施加到 PLL IC (IC3) 的第 9 针, 作为第 2 本振信号通过三倍频器后送到 IF 电路。VCTCXO 振荡频率由 VC 端子的 DC 电压决定。VC 电压由 R1 和 R2 固定为 1.65V, 通过 IC1 施加于 VC 端子。调制信号也通过 IC1 送入 VC 端子。

通过切换未经外加到 VC 的 DC 电压调整的分割频率的比率, 实现频率调整。调整频率的分辨率约为 8Hz。由于 PLL IC 的输入频率输入两倍的 VCO 输出, 发送频率和接收频率可按照约 4Hz 的分辨率进行调整。

5-2. VCO

有一个 RX VCO 和一个 TX VCO。

TX VCO (Q10) 生成发射载波, RX VCO (Q9) 生成第 1 本振信号。对于 VCO 震荡频率, 发射载波为 136 到 174MHz, 第 1 本振信号为 194.05 到 232.05MHz。

VCO 震荡频率由一个操作切换端子 "T/R" 系统和两个电压控制端子 "C/V" 和 "V-assist" 系统决定。

操作切换端子 "T/R" 由 MCU (IC510) 输出的控制线路 (/T_R) 进行控制。/T_R 逻辑较低时, VCO 输出发射载波, 较高时, 输出第 1 本地接收信号。

电压控制端子 "CV" 和 "V-assist" 由 PLL IC (IC3) 和 MCU (IC510) 控制, 输出频率根据施加的电压持续改变。对于调制输入端子 "VCO_MOD", 输出频率根据施加的电压改变。籍此调制 VCO 输出。"VCO_MOD" 仅在 "/T_R" 低时工作。

5-3. PLL IC (IC3)

PLL IC 对比 VCO 震荡频率和 VCTCXO 基准频率的相位差, 将相位差返回 VCO CV 端子, 实现返回控制的 "锁相环路"。这可以使 VCO 震荡频率与所需的频率精确匹配 (锁定)。

频率由 PLL 控制时, 频率锁定时间将随着设定频率改变时频率差的增大而增加。为对此进行补充, 在由 PLL IC 控制之前使用 MCU 以使 VCO 震荡频率接近所需的频率。因此, VCO CV 的电压不变, 始终稳定在约 3.0V。

PLL IC 的所需电压由 MCU (IC510) 通过 3 线路 "SD01"、"SCK1"、"PCS_RF" 串行总线进行设置。PLL IC 是否锁定由 MCU 通过 "PLD" 信号线路进行监测。如果 VCO 不是所需的频率 (失锁), 则 "PLD" 逻辑较低。

CIRCUIT DESCRIPTION / 电路说明

5-4. Doubler (Q6)

The doubler (Q6) extracts the twice harmonic component from the signal from the VCO. This twice harmonic component is then fed into PLL (IC3) through band pass filter.

Band pass filter consists of two filters. One is for TX (L7, L15, L18) and pass band is 272.0 to 348.0MHz. The other is for RX 1st Local (L8, L12, L16) and pass band is 388.1 to 464.1MHz.

5-5. Local Switch (D101, D205)

The connection destination of the signal output from the buffer amplifier (Q14) is changed with the diode switch (D101) that is controlled by the transmission power supply, 80T, and the diode switch (D205) that is controlled by the receive power supply, 50R. If the 80T logic is high, it is connected to a send-side pre-drive (Q101). If the 80T logic is low, it is connected to a local amplifier (Q208).

5-4. 倍频器 (Q6)

倍频器 (Q6) 从 VCO 的信号当中选取两倍的谐波成分。然后，这两倍的谐波成份通过带通滤波器送入 PLL (IC3)。

带通滤波器由两个滤波器组成。一个用于 TX (L7, L15, L18)，通频带为 272.0 到 348.0MHz。另一个用于 RX 第 1 本地 (L8, L12, L16)，通频带为 388.1 到 464.1MHz。

5-5. 本地开关 (D101、D205)

缓冲放大器 (Q14) 输出信号的连接目标由二极管开关 (D101) (由发射电源 80T 控制) 和二极管开关 (D205) (由接收电源 50R 控制) 进行改变。如果 80T 逻辑高，则它被连接到发送侧预驱动 (Q101)。如果 80T 逻辑低，则它被连接到接收侧混频器 (Q208)。

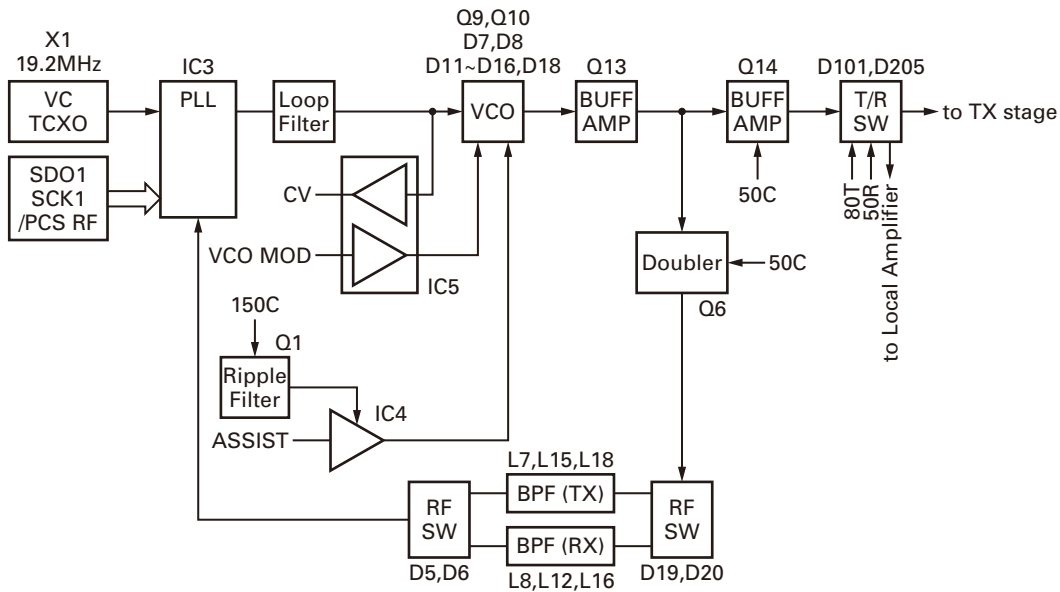

Fig. 7 / 图 7

6. Control Circuit

The control circuit consists of MCU (IC510) and its peripheral circuits. IC510 mainly performs the following;

- 1) Switching between transmission and reception by PTT signal input.
- 2) Reading system, zone, frequency, and program data from the memory circuit.
- 3) Sending frequency program data to the PLL.
- 4) Controlling squelch on/off by the DC voltage from the squelch circuit.
- 5) Controlling the audio mute circuit by decode data input.

6. 控制电路

控制电路由 MCU (IC510) 和外围电路组成。IC510 主要有以下功能：

- 1) 由输入的 PTT 信号切换发射和接收。
- 2) 从存储电路读取系统、区域、频率和编程数据。
- 3) 将频率数据发送到 PLL。
- 4) 由静音电路的 DC 电压控制静音的开 / 关。
- 5) 由输入的解码数据控制音频静音电路。

CIRCUIT DESCRIPTION / 电路说明

6-1. MCU

The MCU (IC510) is 32bit RISC processor, equipped with peripheral function and ADC/DAC.

This MCU operates at 18.432MHz clock and 3.3V /1.5V DC. Controls the flash memory, SRAM, DSP, the receive circuit, the transmitter circuit, the control circuit, and the display circuit and transfers data to or from an external device.

6-2. Memory Circuit

Memory circuit consists of the MCU (IC510) and the SRAM (IC503), the flash memory (IC501). The flash memory has capacity of 32Mbit that contains the transceiver control program for the MCU and stores the data. It also stores the data for transceiver channels and operating parameter that are written by the FPU. This program can be easily written from external devices. The SRAM has capacity of 1Mbit that contains work area and data area.

■ Flash memory

Note: The flash memory stores the data that is written by the FPU (KPG-111D(C)), tuning data (Deviation, Squelch, etc.), and firmware program.

■ SRAM (static memory)

Note: The SRAM has temporary data area and work area.

When the power supply is off, it is backed up by an internal secondary lithium battery. Therefore, the saved data is not lost.

■ Real-time clock

The clock function is based on real-time clock IC (IC504). When the power supply is off, it is backed up by an internal secondary lithium battery

6-3. Display Unit

The display unit is composed of the MCU (IC911) and the memory IC (IC913), and the LCD & Key backlight etc.

The LCD Ass'y (with LCD Driver) is controlled using the bus lines on the connector (CN905) of the display unit. It corrects the LCD contrast voltage using IC909.

6-4. Key Detection Circuit

Keys are detected using Key scan circuit in IC911. The /KI* and KO* signals that are normally pulled up go low when any key is pressed.

6-5. DSP

The DSP circuit consists of a DSP (IC502) and processes the base band signal. The DSP operates on an external clock of 18.432MHz (the same as the IC510), the I/O section operates at 3.3V and the core section operates at 1.5V. The DSP carries out the following processes:

- 4Level FSK processing
- Analog FM pre-emphasis/de-emphasis
- Vocoder processing between audio codec and modulation/demodulation
- CAI processing, such as error correction encoding
- QT/DQT encoding/decoding

6-1. MCU

MCU (IC510) 是一个 32 位 RISC 处理器，具备外围功能和 ADC/DAC。

该 MCU 以 18.432MHz 时钟和 3.3V/1.5V DC 运行。它控制闪存、SRAM、DSP、接收电路、发射机电路、控制电路以及显示电路，并与外部设备双向传输数据。

6-2. 存储电路

存储电路由 MCU (IC510)、SRAM (IC503) 和闪存 (IC501) 组成。闪存具有 32M 位的容量，包含 MCU 的车载对讲机控制程序并储存数据。它也保存车载对讲机信道的数据和由 FPU 写入的操作参数。此程序很容易从外部设备写入。SRAM 具有 1M 位的容量，包含工作区和数据区。

■ 闪存

注意：闪存可储存由 FPU (KPG-111D(C)) 写入的数据、调谐数据（频偏、静噪等）以及固件程序（用户模式、测试模式、调谐模式等）。更换闪存后，此数据必须重写。

■ SRAM (静态存储器)

注意：SRAM 含有临时数据区和工作区。
当电源关闭时，则以内部二次锂电池作为后备电源。因此，保存的数据不会丢失。

■ 实时时钟

时钟功能以实时时钟 IC (IC504) 为基础。当电源关闭时，则以内部二次锂电池作为后备电源。

6-3. 显示单元

显示单元由 MCU (IC911) 和存储 IC (IC913)、以及 LCD 和按键背光等部分组成。

LCD ASSY (包括 LCD 驱动) 由显示单元的连接器 (CN905) 上的总线线路进行控制。它使用 IC909 校正 LCD 电压差异。

6-4. 按键检测电路

用 IC911 中的按键扫描电路对按键进行检测。按任意按键时，通常提升的 /KI* 和 KO* 信号会降低。

6-5. DSP

DSP 电路由 DSP (IC502) 组成，可处理基带信号。DSP 在 18.432MHz 的外部时钟上运行（与 IC510 相同），I/O 部分以 3.3V 运行，核心部分以 1.5V 运行。DSP 执行以下处理：

- 4 级 FSK 处理
- 模拟 FM 预加重 / 去加重
- 音频编解码器和调制 / 解调之间的声码器处理
- CAI 处理，例如纠错编码
- QT/DQT 编码 / 解码

CIRCUIT DESCRIPTION / 电路说明

33M and 15M provide the power to MCU, DSP, and Flash memory. At this time MCU starts working. Voltage detector IC (IC401) watches +B voltage. If +B voltage is higher than 8.6V, IC401 (/BINT) outputs High. If the /BINT signal is high, Q404 (SB SW) is turned on by SBC signal from MCU. (High: SB=ON, Low: SB=OFF). When the SB is turned on, IC403 (80C), IC404 (50C), IC406 (33C), IC407 (33GPS) and IC410 (150C) start working. Q416 and Q412 are controlled by SBC signal. If the SBC signal becomes High, Q416 (33A-2) operates and Q412 (50MC SW) are turned on.

The MCU controls the TXC signal to High during transmission to supply power (80T) for transmission circuit. The MCU controls the signals (RXC) to High during reception to supply power (80R, 50R) for reception circuit.

When the MCU detects the PSW (Power switch) signal, IGN (Ignition sense) signal or /BINT signal, it controls the SBC signal to Low, and turns the transceiver power (SB) off. When D401 and Q401 detect over-voltage condition, they turns Q404 (SB SW) off. But the MCU still works.

If +B is not provided to the transceiver, the power is provided to SRAM and RTC through the secondary battery connected with CN405.

8. Signaling Circuit

8-1. Encode (QT/DQT/LTR/DTMF/2-tone/MSK)

Each signaling data signal of QT, DQT, LTR, DTMF, 2-tone and MSK is generated by the DSP circuit, superposed on a modulation signal and output from IC510. The modulation balance of the QT/DQT/LTR signal is adjusted by the D/A converter (IC712) and the resulting signal is routed to the modulation input of the VCO and VCTCX0 (X1). The each deviation of the TX QT, DQT, LTR, DTMF, 2-tone and MSK tone is adjusted by changing the output level of the IC510 and the resulting signal is routed to VCO and VCX0. The RX DTMF tone is routed to the receive audio signal system, and is output from the speaker.

8-2. Decode (QT/DQT/LTR/DTMF/2-tone/MSK)

The audio signal is removed from the FM detection signal sent to the DSP circuit and the resulting signal is decoded.

9. Comander Circuit

The term "comander" means compressor and expander. The comander reduces noise by utilizing a compressor and an expander. The transceiver contains DSP (IC502) to perform this operation. The transceiver comander can be turned on or off using the FPU.

33M 和 15M 对 MCU、DSP 和闪存供电。此时 MCU 开始工作。电压检测 IC (IC401) 观测 +B 电压。如果 +B 电压高于 8.6V, 则 IC401 (/BINT) 输出高。如果 /BINT 信号高, 则 Q404 (SB SW) 由 MCU 的 SBC 信号开启。(高: SB=ON, 低: SB=OFF)。SB 开启时, IC403 (80C)、IC404 (50C)、IC406 (33C)、IC407 (33GPS) 和 IC410 (150C) 开始工作。Q416 和 Q412 由 SBC 信号控制。如果 SBC 信号变高, Q416 (33A-2) 运行, 并开启 Q412 (50MC SW)。

发射期间, MCU 将 TXC 信号控制为高, 为发射电路供电 (80T)。接收期间, MCU 将信号 (RXC) 控制为高, 为接收电路供电 (80R、50R)。

当 MCU 检测 PSW (电源开关) 信号、IGN (点火感应) 信号或 /BINT 信号时, 它将 SBC 信号控制为低, 关闭车载对讲机电源 (SB)。当 D401 和 Q401 检测到过电压情况时, 它们将关闭 Q404 (SB SW)。

但 MCU 仍然工作。如果没有对车载对讲机提供 +B, 则通过与 CN405 相连的备用电池对 SRAM 和 RTC 供电。

8. 信令电路

8-1. 编码 (QT/DQT/LTR/DTMF/2 音 /MSK)

QT、DQT、LTR、DTMF、2 音和 MSK 的各信令信号由 DSP 电路产生, 叠加到调制信号上并从 IC510 输出。QT/DQT/LTR 信号的调制平衡由 D/A 转换器 (IC712) 进行调整, 产生的信号送入 VCO 和 VCTCX0 (X1) 的调制输入。TX QT、DQT、LTR、DTMF、2 音和 MSK 音各自的频偏通过 IC510 输出电平的变化进行调整, 产生的信号被送入 VCO 和 VCX0。RX DTMF 音被送入接收音频信号系统, 从扬声器输出。

8-2. 解码 (QT/DQT/LTR/DTMF/2 音 /MSK)

音频信号从发送到 DSP 电路的 FM 检测信号中移除, 产生的信号被解码。

9. 压扩器电路

"comander" 一词表示压缩器和扩展器。压扩器利用压缩器和扩展器减低噪音。车载对讲机含有 DSP (IC102), 用以执行此操作。可用 FPU 打开或关闭车载对讲机的压扩器。

COMPONENTS DESCRIPTION / 元件说明

Display unit (X54-3680-10)

Ref. No.	Part Name	Description
IC901	IC	AFO/BLC SW
IC902	IC	AF Buffer AMP (AFO)
IC903	IC	Voltage Regulator (5C)
IC904	IC	Voltage Regulator (33C)
IC905	IC	Bus Buffer (TXD0)
IC906	IC	DC/DC Converter (N100C)
IC907	IC	Dual Bus Buffer (RXD0/RXD1)
IC908	IC	AND Gate (TXD1/RXD0)
IC909	IC	Buffer AMP (LCD Contrast ADJ)
IC910	IC	Bus Buffer (D0-D7)
IC911	IC	MCU
IC912	IC	Bus Buffer (A1-A2)
IC913	IC	FLASH ROM
Q901	FET	AFO SW
Q902	Transistor	HK/RXD0 SW
Q904	Transistor	HK/RXD0 SW
Q905	Transistor	TX/RX LED (TX)
Q906	Transistor	TX/RX LED (BUSY)
Q908	Transistor	LCD Backlight SW
Q909	Transistor	Dimmer SW (LCD Backlight)
Q910	Transistor	LCD Backlight SW
Q911	FET	Dimmer SW (LCD Backlight)
Q913	FET	LCD Reset SW
D901	Varistor	Surge Absorption (DM/KVL)
D902	Varistor	Surge Absorption (HK/RXD)
D903	Zener Diode	Over DC Supply Protection
D904	Varistor	Surge Absorption (BLC/AFO)
D906	Varistor	Line Protection (SB)
D907	Zener Diode	Over DC Supply Protection
D908	Diode	KEY Matrix
D910	Diode	Reverse Current Prevention (HK/RXD)
D911,912	Diode	KEY Matrix
D913	Diode	Line Protection (PTT/TXDO)
D914	LED	TX/RX LED
D915~926	LED	LCD Backlight
D927~936	LED	KEY Backlight
D937	Diode	Level Shift (PRST)

TX-RX unit (X57-7742-71)

Ref. No.	Part Name	Description
IC1	IC	Buffer AMP (TCXO modulation)
IC2	IC	Temp Sensor
IC3	IC	PLL IC

显示单元 (X54-3680-10)

有关号码	零件名称	说明
IC901	IC	AFO/BLC 开关
IC902	IC	AF 缓冲 AMP (AFO)
IC903	IC	稳压器 (5C)
IC904	IC	稳压器 (33C)
IC905	IC	总线缓冲器 (TXD0)
IC906	IC	DC/DC 转换器 (N100C)
IC907	IC	双总线缓冲器 (RXD0/RXD1)
IC908	IC	AND 栅 (TXD1/RXD0)
IC909	IC	缓冲 AMP (LCD 对比度调整)
IC910	IC	总线缓冲器 (D0-D7)
IC911	IC	MCU
IC912	IC	总线缓冲器 (A1-A2)
IC913	IC	FLASH ROM
Q901	场效应管	AFO 开关
Q902	晶体管	HK/RXD0 开关
Q904	晶体管	HK/RXD0 开关
Q905	晶体管	TX/RX LED (TX)
Q906	晶体管	TX/RX LED (BUSY)
Q908	晶体管	LCD 背光开关
Q909	晶体管	调光器开关 (LCD 背光)
Q910	晶体管	LCD 背光开关
Q911	场效应管	调光器开关 (LCD 背光)
Q913	场效应管	LCD 复位开关
D901	变阻器	电涌吸收 (DM/KVL)
D902	变阻器	电涌吸收 (HK/RXD)
D903	稳压二极管	DC 供电过高保护
D904	变阻器	电涌吸收 (BLC/AFO)
D906	变阻器	线路保护 (SB)
D907	稳压二极管	DC 供电过高保护
D908	二极管	KEY 矩阵
D910	二极管	逆向电流预防 (HK/RXD)
D911, 912	二极管	KEY 矩阵
D913	二极管	线路保护 (PTT/TXDO)
D914	LED	TX/RX LED
D915~926	LED	LCD 背光
D927~936	LED	KEY 背光
D937	二极管	电平位移 (PRST)

TX-RX 单元 (X57-7742-71)

有关号码	零件名称	说明
IC1	IC	缓冲 AMP (TCXO 调制)
IC2	IC	温度传感器
IC3	IC	PLL IC

COMPONENTS DESCRIPTION / 元件说明

Ref. No.	Part Name	Description
IC4	IC	Buffer AMP (VCO tune)
IC5	IC	VCO Modulation/Buffer AMP (CV)
IC101	IC	Auto Power Control
IC102	IC	Final AMP (RF Power Module)
IC103	IC	Auto Power Control
IC201	IC	Buffer AMP (2nd IF DET)
IC202	IC	IF IC
IC203	IC	Buffer AMP (RSSI/VAGC)
IC204	IC	1st Mixer
IC205,206	IC	Buffer AMP (BPF tune)
IC401	IC	Voltage Detector (BINT)
IC402	IC	Voltage Regulator (33M)
IC403	IC	Voltage Regulator (80C)
IC404	IC	Voltage Regulator (50C)
IC405	IC	DC/DC Converter (50M)
IC406	IC	Voltage Regulator (33C)
IC407	IC	Voltage Regulator (33GPS)
IC408	IC	Voltage Regulator (33A)
IC409	IC	Voltage Regulator (15M)
IC410	IC	DC/DC Converter (150C)
IC501	IC	FLASH ROM
IC502	IC	DSP (BGA)
IC503	IC	SRAM (BGA)
IC504	IC	RTC
IC505	IC	Delay
IC506	IC	Reset (MCU)
IC507	IC	Bus Buffer (BFSX2)
IC508	IC	Buffer AMP (18.432MHz)
IC509	IC	Bus Buffer (BER CLK/BER DATA)
IC510	IC	MCU (BGA)
IC511	IC	AND (PCS_RF/HD2)
IC512	IC	Level Shift (AND ITXD1/SCTXD)
IC513	IC	Buffer AMP (TXD2)
IC514	IC	Level Shift (I2CCK/I2CDT)
IC515	IC	Level Shift (TXDO/RTSO)
IC516	IC	Level Shift (RXDO/CTSO)
IC517	IC	I/O Expander
IC518	IC	RS-232C Driver
IC701	IC	LPF (RXAF)
IC702	IC	LPF (MOD)
IC703	IC	LPF (APC/DEO)
IC704	IC	Buffer AMP (2nd IF DET)
IC705	IC	BRF/Buffer AMP (SQ)
IC706	IC	LPF/SUM AMP
IC707	IC	RXAF/RXEI SW

有关号码	零件名称	说明
IC4	IC	缓冲 AMP (VCO 调谐)
IC5	IC	VCO 调制 / 缓冲 AMP (CV)
IC101	IC	自动电源控制
IC102	IC	末级 AMP (RF 功率模块)
IC103	IC	自动电源控制
IC201	IC	缓冲 AMP (第 2 IF DET)
IC202	IC	IF IC
IC203	IC	缓冲 AMP (RSSI/VAGC)
IC204	IC	第 1 混频器
IC205, 206	IC	缓冲 AMP (BPF 调谐)
IC401	IC	电压检测器 (BINT)
IC402	IC	稳压器 (33M)
IC403	IC	稳压器 (80C)
IC404	IC	稳压器 (50C)
IC405	IC	DC/DC 转换器 (50M)
IC406	IC	稳压器 (33C)
IC407	IC	稳压器 (33GPS)
IC408	IC	稳压器 (33A)
IC409	IC	稳压器 (15M)
IC410	IC	DC/DC 转换器 (150C)
IC501	IC	FLASH ROM
IC502	IC	DSP (BGA)
IC503	IC	SRAM (BGA)
IC504	IC	RTC
IC505	IC	延迟
IC506	IC	复位 (MCU)
IC507	IC	总线缓冲器 (BFSX2)
IC508	IC	缓冲 AMP (18.432MHz)
IC509	IC	总线缓冲器 (BER CLK/BER DATA)
IC510	IC	MCU (BGA)
IC511	IC	AND (PCS_RF/HD2)
IC512	IC	电平位移 (AND ITXD1/SCTXD)
IC513	IC	缓冲 AMP (TXD2)
IC514	IC	电平位移 (I2CCK/I2CDT)
IC515	IC	电平位移 (TXDO/RTSO)
IC516	IC	电平位移 (RXDO/CTSO)
IC517	IC	I/O 扩展器
IC518	IC	RS-232C 驱动器
IC701	IC	LPF (RXAF)
IC702	IC	LPF (MOD)
IC703	IC	LPF (APC/DEO)
IC704	IC	缓冲 AMP (第 2 IF DET)
IC705	IC	BRF/ 缓冲 AMP (SQ)
IC706	IC	LPF/SUM AMP
IC707	IC	RXAF/RXEI 开关

COMPONENTS DESCRIPTION / 元件说明

Ref. No.	Part Name	Description
IC708	IC	AF SW (TXO/TXI)
IC709	IC	SUM AMP (AI/TONE/MI1 MI2) / (MOD/DI)
IC710	IC	AF SW (AI TONE OPT9/VREF)
IC711	IC	SUM AMP (AF) / VREF
IC712	IC	DAC
IC713	IC	AO SW
IC714	IC	AFO Buffer
IC715	IC	AF Power AMP
Q1	Transistor	Ripple Filter
Q2	Transistor	PLL Fin T/R SW
Q3	FET	PLL Fin T/R SW
Q5	Transistor	PLL Fin T/R SW
Q6	Transistor	Buffer AMP (PLL Fin)
Q7	Transistor	Ripple Filter
Q9,10	FET	VCO
Q11,12	FET	T/R SW (VCO)
Q13	Transistor	Buffer AMP (VCO)
Q14	Transistor	Buffer AMP (RF)
Q15	FET	Buffer AMP (19.2MHz)
Q101	Transistor	RF Pre-Drive AMP
Q102	Transistor	RF Drive AMP
Q105	Transistor	SW (RF Power H/L)
Q106	FET	SW (RF Power H/L)
Q201,202	Transistor	SW (W/N)
Q203	Transistor	2nd Local buffer AMP (X3)
Q204,205	Transistor	1st IF AMP
Q208	Transistor	Buffer AMP (Local)
Q210	Transistor	LNA
Q212	Transistor	SW (W/N)
Q401	Transistor	SW (Over DC Supply Protection)
Q402	Transistor	DC SW (SB)
Q403	Transistor	DC SW (IGN)
Q404	FET	DC SW (SB)
Q405	Transistor	DC SW (SCTAM1)
Q406	FET	DC SW (33BU)
Q407	Transistor	DC SW (80T)
Q408	Transistor	DC SW (80R)
Q409	Transistor	DC SW (50R)
Q410	FET	DC SW (50MC)
Q411	Transistor	DC SW (33BU)
Q412	Transistor	DC SW (50MC)
Q413	Transistor	DC SW (80T)
Q414	Transistor	DC SW (80R)
Q415	Transistor	DC SW (50R)
Q416	FET	DC SW (33A-2)

有关号码	零件名称	说明
IC708	IC	AF 开关 (TXO/TXI)
IC709	IC	SUM AMP (AI/TONE/MI1 MI2) / (MOD/DI)
IC710	IC	AF 开关 (AI TONE OPT9/VREF)
IC711	IC	SUM AMP (AF) /VREF
IC712	IC	DAC
IC713	IC	A0 开关
IC714	IC	AFO 缓冲
IC715	IC	AF 功率 AMP
Q1	晶体管	纹波滤波器
Q2	晶体管	PLL Fin T/R 开关
Q3	场效应管	PLL Fin T/R 开关
Q5	晶体管	PLL Fin T/R 开关
Q6	晶体管	缓冲 AMP (PLL Fin)
Q7	晶体管	纹波滤波器
Q9, 10	场效应管	VCO
Q11, 12	场效应管	T/R 开关 (VCO)
Q13	晶体管	缓冲 AMP (VCO)
Q14	晶体管	缓冲 AMP (RF)
Q15	场效应管	缓冲 AMP (19.2MHz)
Q101	晶体管	RF 预驱动 AMP
Q102	晶体管	RF 驱动 AMP
Q105	晶体管	开关 (RF 功率 H/L)
Q106	场效应管	开关 (RF 功率 H/L)
Q201, 202	晶体管	开关 (W/N)
Q203	晶体管	第 2 本地缓冲 AMP (X3)
Q204, 205	晶体管	第 1 IF AMP
Q208	晶体管	缓冲 AMP (本地)
Q210	晶体管	LNA
Q212	晶体管	开关 (W/N)
Q401	晶体管	开关 (DC 供电过高保护)
Q402	晶体管	DC 开关 (SB)
Q403	晶体管	DC 开关 (IGN)
Q404	场效应管	DC 开关 (SB)
Q405	晶体管	DC 开关 (SCTAM1)
Q406	场效应管	DC 开关 (33BU)
Q407	晶体管	DC 开关 (80T)
Q408	晶体管	DC 开关 (80R)
Q409	晶体管	DC 开关 (50R)
Q410	场效应管	DC 开关 (50MC)
Q411	晶体管	DC 开关 (33BU)
Q412	晶体管	DC 开关 (50MC)
Q413	晶体管	DC 开关 (80T)
Q414	晶体管	DC 开关 (80R)
Q415	晶体管	DC 开关 (50R)
Q416	场效应管	DC 开关 (33A-2)

COMPONENTS DESCRIPTION / 元件说明

Ref. No.	Part Name	Description
Q417	FET	DC SW
Q501	FET	DC SW
Q701	FET	SW (W/N)
Q702	Transistor	Noise AMP
Q703	FET	TONE SW
Q704,705	Transistor	Limit
Q706	FET	Mute (MI1)
Q707	FET	Mute (MI2)
Q708	Transistor	OPT10 SW
Q709	Transistor	DC SW
Q710	Transistor	AF Mute
Q901,902	Transistor	DC SW (AUXO1, AUXO2)
D3	Diode	Bypass Diode
D5,6	Diode	PLL Fin T/R SW
D7,8	Variable Capacitance Diode	Frequency Control
D11~16	Variable Capacitance Diode	Frequency Control
D18	Variable Capacitance Diode	TX Modulation
D19,20	Diode	PLL Fin T/R SW
D21	Diode	2nd Local SW
D101	Diode	T/R SW
D102	Zener Diode	PM Drain Bias Protection
D103~105	Diode	Antenna Switch
D107~109	Diode	Power Det
D201,202	Diode	CF SW (W/N)
D205	Diode	T/R SW
D207~210	Variable Capacitance Diode	Vari-Cap Tune
D213	Variable Capacitance Diode	Vari-Cap Tune
D215	Diode	Antenna Switch
D216~218	Variable Capacitance Diode	Vari-Cap Tune
D401	Zener Diode	Over DC Supply Protection
D403	Diode	Reverse Current Prevention
D404	Varistor	Surge Absorption
D405	Diode	Reverse Protection
D406	Diode	Reverse Current Prevention (BLVL)
D407	Diode	DC/DC Converter (50M)
D408	Diode	Reverse Current Prevention (OR 33M/SBC_2)
D409	Diode	DC/DC Converter (50M)
D410	Diode	Reverse Current Prevention (Backup Battery)
D411	Diode	Reverse Current Prevention (33BU)

有关号码	零件名称	说明
Q417	场效应管	DC 开关
Q501	场效应管	DC 开关
Q701	场效应管	开关 (W/N)
Q702	晶体管	噪音 AMP
Q703	场效应管	TONE 开关
Q704, 705	晶体管	限幅
Q706	场效应管	静音 (MI1)
Q707	场效应管	静音 (MI2)
Q708	晶体管	OPT10 开关
Q709	晶体管	DC 开关
Q710	晶体管	AF 静音
Q901, 902	晶体管	DC 开关 (AUXO1, AUXO2)
D3	二极管	旁路二极管
D5, 6	二极管	PLL Fin T/R 开关
D7, 8	可变电容二极管	频率控制
D11~16	可变电容二极管	频率控制
D18	可变电容二极管	TX 调制
D19, 20	二极管	PLL Fin T/R 开关
D21	二极管	第 2 本地开关
D101	二极管	T/R 开关
D102	稳压二极管	PM 漏偏压保护
D103~105	二极管	天线开关
D107~109	二极管	功率检测器
D201, 202	二极管	CF 开关 (W/N)
D205	二极管	T/R 开关
D207~210	可变电容二极管	变容二极管调谐
D213	可变电容二极管	变容二极管调谐
D215	二极管	天线开关
D216~218	可变电容二极管	变容二极管调谐
D401	稳压二极管	DC 供电过高保护
D403	二极管	逆向电流预防
D404	变阻器	电涌吸收
D405	二极管	逆向保护
D406	二极管	逆向电流预防 (BLVL)
D407	二极管	DC/DC 转换器 (50M)
D408	二极管	逆向电流预防 (OR 33M/SBC_2)
D409	二极管	DC/DC 转换器 (50M)
D410	二极管	逆向电流预防 (备用电池)
D411	二极管	逆向电流预防 (33BU)

COMPONENTS DESCRIPTION / 元件说明

Ref. No.	Part Name	Description
D412	Diode	Discharge (33A, 33M, CE)
D501,502	Diode	Line Protection
D503	Diode	Reverse Current Prevention (PCS_RF)
D504	Diode	Reverse Current Prevention (RXD)
D506	Diode	Reverse Current Prevention (OR G_RXD2)
D507	Diode	Reverse Current Prevention (OR RXD2)
D508	Diode	Line Protection
D509,510	Diode	Reverse Current Prevention
D511	Diode	Line Protection (RXD2)
D512	Diode	Line Protection (AUXIO9)
D702	Diode	SQ Voltage Control
D703	Diode	Noise Detector (SQ)
D704,705	Diode	AF Detector (LIMIT)
D706	Zener Diode	Line Protection (DI)
D707	Zener Diode	Line Protection (DEO)
D901	Diode	Line Protection (BER CK)
D902	Diode	Line Protection (BER DT)
D903	Diode	Line Protection (AUXIO1)
D904	Diode	Line Protection (AUXIO2)
D905,906	Zener Diode	Over DC Supply Protection
D907	Diode	Line Protection (AUXIO3)
D908	Diode	Line Protection (AUXIO4)
D909	Diode	Reverse Current Prevention (SB)
D910	Zener Diode	Over DC Supply Protection
D911	Diode	Line Protection (AUXIO8)
D912	Diode	Line Protection (AUXIO5)
D913	Diode	Reverse Current Prevention (SB)
D914	Zener Diode	Over DC Supply Protection

有关号码	零件名称	说明
D412	二极管	放电 (33A, 33M, CE)
D501, 502	二极管	线路保护
D503	二极管	逆向电流预防 (PCS_RF)
D504	二极管	逆向电流预防 (RXD)
D506	二极管	逆向电流预防 (OR G_RXD2)
D507	二极管	逆向电流预防 (OR RXD2)
D508	二极管	线路保护
D509, 510	二极管	逆向电流预防
D511	二极管	线路保护 (RXD2)
D512	二极管	线路保护 (AUXIO9)
D702	二极管	SQ 电压控制
D703	二极管	噪音检测器 (SQ)
D704, 705	二极管	AF 检测器 (LIMIT)
D706	稳压二极管	线路保护 (DI)
D707	稳压二极管	线路保护 (DEO)
D901	二极管	线路保护 (BER CK)
D902	二极管	线路保护 (BER DT)
D903	二极管	线路保护 (AUXIO1)
D904	二极管	线路保护 (AUXIO2)
D905, 906	稳压二极管	DC 供电过高保护
D907	二极管	线路保护 (AUXIO3)
D908	二极管	线路保护 (AUXIO4)
D909	二极管	逆向电流预防 (SB)
D910	稳压二极管	DC 供电过高保护
D911	二极管	线路保护 (AUXIO8)
D912	二极管	线路保护 (AUXIO5)
D913	二极管	逆向电流预防 (SB)
D914	稳压二极管	DC 供电过高保护

PARTS LIST / 零件表

CAPACITORS

CC 45 TH 1H 220 J
 1 2 3 4 5 6

- 1 = Type ... ceramic, electrolytic, etc.
- 2 = Shape ... round, square, etc.
- 3 = Temp. coefficient
- 4 = Voltage rating
- 5 = Value
- 6 = Tolerance

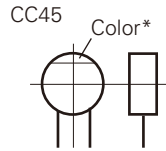

• Capacitor value

- 010 = 1pF
- 100 = 10pF
- 101 = 100pF
- 102 = 1000pF = 0.001μF
- 103 = 0.01μF

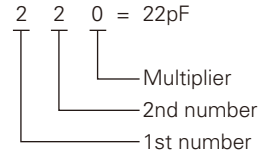

• Temperature coefficient

1st Word	C	L	P	R	S	T	U
Color*	Black	Red	Orange	Yellow	Green	Blue	Violet
ppm/°C	0	-80	-150	-220	-330	-470	-750

2nd Word	G	H	J	K	L
ppm/°C	±30	±60	±120	±250	±500

Example : CC45TH = -470±60ppm/°C

• Tolerance (More than 10pF)

Code	C	D	G	J	K	M	X	Z	P	No code
(%)	±0.25	±0.5	±2	±5	±10	±20	+40 -20	+80 -20	+100 -0	More than 10μF : -10~+50 Less than 4.7μF : -10~+75

(Less than 10pF)

Code	B	C	D	F	G
(pF)	±0.1	±0.25	±0.5	±1	±2

• Voltage rating

2nd word	A	B	C	D	E	F	G	H	J	K	V	
1st word	0	1.0	1.25	1.6	2.0	2.5	3.15	4.0	5.0	6.3	8.0	-
1	10	12.5	16	20	25	31.5	40	50	63	80	35	
2	100	125	160	200	250	315	400	500	630	800	-	
3	1000	1250	1600	2000	2500	2150	4000	5000	6300	8000	-	

• Chip capacitors

- (EX) CC 73 F SL 1H 000 J
 1 2 3 4 5 6 7
- (Chip) (CH, RH, UJ, SL)
- (EX) CK 73 F F 1H 000 Z
 1 2 3 4 5 6 7
- (Chip) (B, F)
- Refer to the table above.
- 1 = Type
 - 2 = Shape
 - 3 = Dimension
 - 4 = Temp. coefficient
 - 5 = Voltage rating
 - 6 = Value
 - 7 = Tolerance

• Dimension

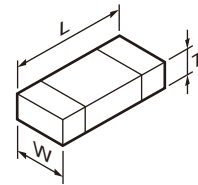

Chip capacitor

Code	L	W	T
Empty	5.6±0.5	5.0±0.5	Less than 2.0
A	4.5±0.5	3.2±0.4	Less than 2.0
B	4.5±0.5	2.0±0.3	Less than 2.0
C	4.5±0.5	1.25±0.2	Less than 1.25
D	3.2±0.4	2.5±0.3	Less than 1.5
E	3.2±0.2	1.6±0.2	Less than 1.25
F	2.0±0.3	1.25±0.2	Less than 1.25
G	1.6±0.2	0.8±0.2	Less than 1.0
H	1.0±0.05	0.5±0.05	0.5±0.05

Chip resistor

Code	L	W	T
E	3.2±0.2	1.6±0.2	1.0
F	2.0±0.3	1.25±0.2	1.0
G	1.6±0.2	0.8±0.2	0.5±0.1
H	1.0±0.05	0.5±0.05	0.35±0.05

• Rating wattage

Code	Wattage	Code	Wattage	Code	Wattage
1J	1/16W	2C	1/6W	3A	1W
2A	1/10W	2E	1/4W	3D	2W
2B	1/8W	2H	1/2W		

RESISTORS

• Chip resistor (Carbon)

- (EX) RD 73 E B 2B 000 J
 1 2 3 4 5 6 7
- (Chip) (B, F)

• Carbon resistor (Normal type)

- (EX) RD 14 B B 2C 000 J
 1 2 3 4 5 6 7

- 1 = Type
- 2 = Shape
- 3 = Dimension
- 4 = Temp. coefficient
- 5 = Rating wattage
- 6 = Value
- 7 = Tolerance

NX-700

PARTS LIST / 零件表

* New Parts. Δ indicates safety critical components.

Parts without **Parts No.** are not supplied.

Les articles non mentionnés dans le **Parts No.** ne sont pas fournis.

Teile ohne **Parts No.** werden nicht geliefert.

L : Scandinavia

Y : PX (Far East, Hawaii)

C : China

K : USA

T : England

X : Australia

P : Canada

E : Europe

M : Other Areas

NX-700

DISPLAY UNIT (X54-3680-10)

Ref. No.	Address	New parts	Parts No.	Description	Destination
NX-700					
1	1B		A01-2194-11	METALLIC CABINET	
2	3A		A62-1162-12	PANEL ASSY	
4	2A		B09-0681-03	CAP (KAP-2)	
5	3B	*	B11-1871-04	FILTER (LCD)	
6	3B	*	B38-0922-15	LCD ASSY	
7	3A		B42-7417-04	STICKER (NEXEDGE)	
8	1D	*	B62-2190-10	INSTRUCTION MANUAL	
10	2B		E04-0167-15	RF COAXIAL RECEPTACLE (M)	
11	2B		E30-7520-25	DC CORD (PIG TAIL)	
12	2C		E30-7523-55	DC CORD ASSY ACCESSORY	
13	1A		E37-1118-05	SHORT PLUG	
14	3B		E37-1124-05	LEAD WIRE WITH CONNECTOR (2P/SP)	
15	2A		E37-1448-05	FLAT CABLE (30P/D-SUB)	
16	2A		E37-1449-05	FLAT CABLE (30P/PANEL)	
18	2B		F10-2488-12	SHIELDING PLATE (CHASSIS)	
20	1A		F10-2490-13	SHIELDING CASE (VCO)	
21	1A		F10-3032-14	SHIELDING CASE ASSY (FINAL)	
22	1A		F10-3112-03	SHIELDING CASE (POWER MODULE)	
23	2C		F52-0024-05	FUSE (BLADE TYPE) 15A 32V	
-			G10-1322-04	FIBROUS SHEET (PANEL-SP)	
27	3B		G10-1342-04	FIBROUS SHEET	
28	3B		G10-1802-04	FIBROUS SHEET (LCD)	
-			G11-4336-04	SHEET (PANEL-FG)	
30	1B		G11-4343-04	SHEET (STEP)	
31	1A		G13-2018-04	CUSHION (FINAL)	
32	2B		G13-2047-04	CUSHION (DC SCREW)	
34	1B		G13-2101-04	CONDUCTIVE CUSHION (PM BOTTOM)	
35	1A		G13-2102-04	CONDUCTIVE CUSHION (PM TOP)	
36	2B		G13-2279-04	CUSHION (FFC)	
37	1B		G53-1613-11	PACKING (SHIELD PLATE)	
38	1A		G53-1616-03	PACKING (PHONE JACK)	
39	2B		G53-1626-03	PACKING (D-SUB OUTER)	
40	2B		G53-1643-04	PACKING (DC CORD)	
41	2B		G53-1645-03	PACKING (D-SUB INNER)	
42	2A		G53-1662-04	PACKING (ANT)	
43	3A		G53-1676-03	PACKING (CHASSIS)	
50	3B		J19-5464-13	HOLDER (SPEAKER)	
51	3B		J19-5485-12	HOLDER (PANEL)	
52	3B		J19-5502-03	HOLDER (LCD)	
53	2B		J21-8479-02	MOUNTING HARDWARE (D-SUB)	
54	3B		J21-8481-03	MOUNTING HARDWARE (SPEAKER)	
55	3B		J21-8569-03	MOUNTING HARDWARE (LCD)	
56	2C		J29-0726-03	BRACKET ACCESSORY	
57	3B		J30-1289-04	SPACER (SP-SHEET)	
59	3A		K29-9401-03	KEY TOP	
A	2B		N09-2292-05	HEXAGON HEAD SCREW	
B	1A		N67-3008-48	PAN HEAD SEMS SCREW	
C	1A,2B		N87-2606-43	BRAZIER HEAD TAPTITE SCREW	
D	1A,2A,2B		N87-2608-48	BRAZIER HEAD TAPTITE SCREW	
61	2C		N99-2039-05	SCREW SET ACCESSORY	
63	3B		T07-0757-15	SPEAKER	

Ref. No.	Address	New parts	Parts No.	Description	Destination
-			X57-7742-72	SERVICE TX-RX UNIT	
DISPLAY UNIT (X54-3680-10)					
D914			B30-2304-05	LED (RED/GREEN)	
D915-926			B30-2281-05	LED (Y)	
D927-936			B30-2282-05	LED (Y)	
C903			CK73HB1E103K	CHIP C 0.010UF K	
C905			CK73HB1A104K	CHIP C 0.10UF K	
C906			CK73HB1H222K	CHIP C 2200PF K	
C907-909			CK73HB1H102K	CHIP C 1000PF K	
C910-912			CC73HCH1H101J	CHIP C 100PF J	
C913			CK73HB1A104K	CHIP C 0.10UF K	
C914			CK73HB1H102K	CHIP C 1000PF K	
C915			CK73FB1E475K	CHIP C 4.7UF K	
C916			CK73GB1E105K	CHIP C 1.0UF K	
C917,918			CK73HB1A104K	CHIP C 0.10UF K	
C919			CK73HB1H102K	CHIP C 1000PF K	
C920			CC73HCH1H121J	CHIP C 120PF J	
C921			CK73HB1A104K	CHIP C 0.10UF K	
C922-925			CK73HB1H102K	CHIP C 1000PF K	
C926-929			CK73HB1A104K	CHIP C 0.10UF K	
C930			CK73GB1E105K	CHIP C 1.0UF K	
C931,932			CK73HB1H102K	CHIP C 1000PF K	
C933			CK73GB1E105K	CHIP C 1.0UF K	
C934			CK73HB1H102K	CHIP C 1000PF K	
C935			CS77BA1E4R7M	CHIP TNTL 4.7UF 25WV	
C936			CC73HCH1H100D	CHIP C 10PF D	
C938			CC73HCH1H100D	CHIP C 10PF D	
C939			CK73GB1C104K	CHIP C 0.10UF K	
C940			CK73FB1A106K	CHIP C 10UF K	
C941,942			CK73HB1H102K	CHIP C 1000PF K	
C943,944			CS77BA1E4R7M	CHIP TNTL 4.7UF 25WV	
C945			CK73GB1H103K	CHIP C 0.010UF K	
C946			CC73HCH1H101J	CHIP C 100PF J	
C947			CK73HB1A104K	CHIP C 0.10UF K	
C948			CC73HCH1H101J	CHIP C 100PF J	
C949-954			CK73GB1E105K	CHIP C 1.0UF K	
C955			CC73HCH1H101J	CHIP C 100PF J	
C956,957			CK73HB1E103K	CHIP C 0.010UF K	
C958			CK73HB1H102K	CHIP C 1000PF K	
C959,960			CK73HB1E103K	CHIP C 0.010UF K	
C961			CK73HB0J105K	CHIP C 1.0UF K	
C962			CK73HB1A104K	CHIP C 0.10UF K	
C963			CC73HCH1H101J	CHIP C 100PF J	
C964			CK73GB1E105K	CHIP C 1.0UF K	
C965			CK73HB1A104K	CHIP C 0.10UF K	
C966,967			CK73HB1H102K	CHIP C 1000PF K	
CN901			E40-6559-05	FLAT CABLE CONNECTOR	
CN902			E41-2671-05	PIN ASSY	
CN905			E40-6557-05	FLAT CABLE CONNECTOR	
J901			E58-0522-05	MODULAR JACK	
-			J31-0551-05	COLLAR	

PARTS LIST / 零件表

DISPLAY UNIT (X54-3680-10)

TX-RX UNIT (X57-7742-71)

Ref. No.	Address	New parts	Parts No.	Description	Desti-nation	Ref. No.	Address	New parts	Parts No.	Description	Desti-nation
L901,902			L41-1095-39	SMALL FIXED INDUCTOR (1.0UH)		R965,966			RK73GB2A821J	CHIP R 820 J 1/10W	
L903-905			L92-0140-05	CHIP FERRITE		R967-974			RK73HB1J103J	CHIP R 10K J 1/16W	
L906			L92-0163-05	BEADS CORE		R976			RK73HB1J000J	CHIP R 0.0 J 1/16W	
L907			L92-0140-05	CHIP FERRITE		R977-979			RK73HB1J473J	CHIP R 47K J 1/16W	
L908			L92-0163-05	BEADS CORE		R981,982			RK73HB1J103J	CHIP R 10K J 1/16W	
X901			L77-1950-05	CRYSTAL RESONATOR (11.0592MHZ)		R986			RK73HB1J103J	CHIP R 10K J 1/16W	
CP907,908			RK75HA1JR00J	CHIP-COM 0.00 J 1/16W		R988			RK73HB1J473J	CHIP R 47K J 1/16W	
CP909			RK74HA1J104J	CHIP-COM 100K J 1/16W		R989			RK73HB1J474J	CHIP R 470K J 1/16W	
CP910			RK74HA1J101J	CHIP-COM 100 J 1/16W		R990			RK73HB1J472J	CHIP R 4.7K J 1/16W	
CP912			RK74HA1J101J	CHIP-COM 100 J 1/16W		R991			RK73HB1J474J	CHIP R 470K J 1/16W	
CP917			RK74HA1J104J	CHIP-COM 100K J 1/16W		R992			RK73HB1J000J	CHIP R 0.0 J 1/16W	
R900			RK73HB1J000J	CHIP R 0.0 J 1/16W		R996			RK73HB1J472J	CHIP R 4.7K J 1/16W	
R901			RK73GB2A000J	CHIP R 0.0 J 1/10W		R997			RK73GB2A000J	CHIP R 0.0 J 1/10W	
R902			RK73HB1J102J	CHIP R 1.0K J 1/16W		R998			RK73HB1J000J	CHIP R 0.0 J 1/16W	
R904			RK73HB1J101J	CHIP R 100 J 1/16W		R999			RK73HB1J101J	CHIP R 100 J 1/16W	
R905			RK73HB1J102J	CHIP R 1.0K J 1/16W		D901,902			AVRM16080MAAB	VARISTOR	
R906			RK73HB1J331J	CHIP R 330 J 1/16W		D903			02DZ18F-X	ZENER DIODE	
R907			RK73HB1J104J	CHIP R 100K J 1/16W		D904			AVRM16080MAAB	VARISTOR	
R908			RK73HB1J473J	CHIP R 47K J 1/16W		D906			MINISMDC020F	VARISTOR	
R909			RK73HB1J104J	CHIP R 100K J 1/16W		D907			02DZ18F-X	ZENER DIODE	
R911			RK73HB1J472J	CHIP R 4.7K J 1/16W		D908			HSC119	DIODE	
R912			RK73HB1J333J	CHIP R 33K J 1/16W		D910			1SS416	DIODE	
R913			RK73HB1J823J	CHIP R 82K J 1/16W		D911,912			HSC119	DIODE	
R914			RK73HB1J104J	CHIP R 100K J 1/16W		D913			DA204U	DIODE	
R915			RK73HB1J473J	CHIP R 47K J 1/16W		D937			1SS416	DIODE	
R916,917			RK73HB1J103J	CHIP R 10K J 1/16W		IC901			TC7W66FK-F	MOS-IC	
R918			RK73GB2A100J	CHIP R 10 J 1/10W		IC902			TC7S51FE(F)	MOS-IC	
R919			RK73HB1J103J	CHIP R 10K J 1/16W		IC903			XC6209B502PR	MOS-IC	
R920,921			RK73HB1J101J	CHIP R 100 J 1/16W		IC904			XC6204B332M	MOS-IC	
R922-925			RK73HB1J102J	CHIP R 1.0K J 1/16W		IC905			TC7SH126FU-F	MOS-IC	
R926			RK73HB1J103J	CHIP R 10K J 1/16W		IC906			LM2682MMX	MOS-IC	
R927			RK73HB1J473J	CHIP R 47K J 1/16W		IC907			TC7WH126FU-F	MOS-IC	
R928			RK73HB1J103J	CHIP R 10K J 1/16W		IC908			TC7SH08FU-F	MOS-IC	
R929			RK73HB1J474J	CHIP R 470K J 1/16W		IC909			LMC7101BIM5	MOS-IC	
R930			RK73HB1J103J	CHIP R 10K J 1/16W		IC910			TC74LCX245FK	MOS-IC	
R931			RK73FB2B561J	CHIP R 560 J 1/8W		IC911			30620SPGPU3C	MICROPROCESSOR IC	
R932			RK73FB2B471J	CHIP R 470 J 1/8W		IC912			TC7WZ245FK-F	MOS-IC	
R933			RK73HB1J101J	CHIP R 100 J 1/16W		IC913	*		29AL16D7KCCB	ROM IC	
R934-937			RK73HB1J473J	CHIP R 47K J 1/16W		Q901			SSM3K15TE(F)	FET	
R938,939			RK73HB1J103J	CHIP R 10K J 1/16W		Q902			RT1N441U-T111	TRANSISTOR	
R940			RK73HB1J274J	CHIP R 270K J 1/16W		Q904			RT1N441U-T111	TRANSISTOR	
R941			RK73HB1J124J	CHIP R 120K J 1/16W		Q905,906			RT1N141U-T111	TRANSISTOR	
R942			RK73HB1J000J	CHIP R 0.0 J 1/16W		Q908,909			RT1N141U-T111	TRANSISTOR	
R943			RK73HB1J102J	CHIP R 1.0K J 1/16W		Q910			12A02CH	TRANSISTOR	
R944			RK73HB1J104J	CHIP R 100K J 1/16W		Q911			SSM3K15TE(F)	FET	
R945,946			RK73HB1J000J	CHIP R 0.0 J 1/16W		Q913			UPA672T-A	FET	
R947			RK73HB1J474J	CHIP R 470K J 1/16W		TH901			ERTJ0EV104H	THERMISTOR	
R948			RK73HB1J103J	CHIP R 10K J 1/16W		TX-RX UNIT (X57-7742-71)					
R949			RK73HB1J102J	CHIP R 1.0K J 1/16W		C1			CK73HB1A104K	CHIP C 0.10UF K	
R950			RK73HB1J473J	CHIP R 47K J 1/16W		C2			CK73HB1H471K	CHIP C 470PF K	
R952			RK73HB1J000J	CHIP R 0.0 J 1/16W		C3			CK73HB1A104K	CHIP C 0.10UF K	
R953			RK73GB2A271J	CHIP R 270 J 1/10W		C6			CK73HB1E103K	CHIP C 0.010UF K	
R954			RK73GB2A470J	CHIP R 47 J 1/10W		C7			CC73HCH1H470J	CHIP C 47PF J	
R955			RK73GB2A271J	CHIP R 270 J 1/10W		C8			CC73HCH1H180J	CHIP C 18PF J	
R956			RK73GB2A101J	CHIP R 100 J 1/10W		C9			CK73FB1A106K	CHIP C 10UF K	
R957,958			RK73GB2A271J	CHIP R 270 J 1/10W		C11			CC73HCH1H390J	CHIP C 39PF J	
R960			RK73HB1J000J	CHIP R 0.0 J 1/16W		C12			CK73HB0J105K	CHIP C 1.0UF K	
R962			RK73HB1J000J	CHIP R 0.0 J 1/16W							
R963,964			RK73GB2A391J	CHIP R 390 J 1/10W							

PARTS LIST / 零件表

TX-RX UNIT (X57-7742-71)

Ref. No.	Address	New parts	Parts No.	Description	Destination	Ref. No.	Address	New parts	Parts No.	Description	Destination
C13			CK73HB1E103K	CHIP C 0.010UF K		C97			CK73HB1A104K	CHIP C 0.10UF K	
C14			CC73HCH1H101J	CHIP C 100PF J		C98			CC73HCH1H100C	CHIP C 10PF C	
C15,16			CK73HB1E103K	CHIP C 0.010UF K		C101			CK73HB1H471K	CHIP C 470PF K	
C17			CC73HCH1H101J	CHIP C 100PF J		C102			CK73HB1H102K	CHIP C 1000PF K	
C18			CK73GB1E105K	CHIP C 1.0UF K		C103			CK73HB1E103K	CHIP C 0.010UF K	
C19-23			CC73HCH1H101J	CHIP C 100PF J		C104-107			CK73HB1H471K	CHIP C 470PF K	
C24			CK73HB1A104K	CHIP C 0.10UF K		C108			CK73FB1E475K	CHIP C 4.7UF K	
C25,26			CC73HCH1H101J	CHIP C 100PF J		C109			CC73HCH1H330J	CHIP C 33PF J	
C27			CK73HB1A104K	CHIP C 0.10UF K		C110-112			CK73HB1H471K	CHIP C 470PF K	
C28,29			CC73HCH1H101J	CHIP C 100PF J		C115-117			CK73HB1H471K	CHIP C 470PF K	
C31			CC73HCH1H101J	CHIP C 100PF J		C118			CC73HCH1H560J	CHIP C 56PF J	
C32			CS77CA1VR15M	CHIP TNTL 0.15UF 35WV		C119			CK73HB1H471K	CHIP C 470PF K	
C33			CC73HCH1H330J	CHIP C 33PF J		C120			CC73HCH1H220J	CHIP C 22PF J	
C34			CS77BA1D100M	CHIP TNTL 10UF 20WV		C121			CC73HCH1H090B	CHIP C 9.0PF B	
C35			C92-0863-05	CHIP TNTL 0.047UF 35WV		C122			CC73HCH1H220J	CHIP C 22PF J	
C36			CK73HB1H102K	CHIP C 1000PF K		C123			CC73HCH1H330J	CHIP C 33PF J	
C37			C93-0787-05	CHIP C 0.1UF J		C124			CK73HB1H471K	CHIP C 470PF K	
C38			CK73HB1H102K	CHIP C 1000PF K		C125			CC73HCH1H220J	CHIP C 22PF J	
C39			CK73HB1H471K	CHIP C 470PF K		C126			CK73HB1H471K	CHIP C 470PF K	
C41			CK73HB1H471K	CHIP C 470PF K		C127			CC73HCH1H470J	CHIP C 47PF J	
C42,43			CC73HCH1H101J	CHIP C 100PF J		C128			CC73HCH1H330J	CHIP C 33PF J	
C44,45			CK73HB1H471K	CHIP C 470PF K		C130			CC73HCH1H101J	CHIP C 100PF J	
C46			CC73HCH1H470J	CHIP C 47PF J		C132-134			CK73HB1H471K	CHIP C 470PF K	
C47			CK73HB0J105K	CHIP C 1.0UF K		C135			CK73FB1H471K	CHIP C 470PF K	
C48-51			CK73HB1H471K	CHIP C 470PF K		C136			CC73HCH1H101J	CHIP C 100PF J	
C52			CC73HCH1H390G	CHIP C 39PF G		C137			CC73FCH1H180J	CHIP C 18PF J	
C53			CC73HCH1H180G	CHIP C 18PF G		C139			CS77BA1E4R7M	CHIP TNTL 4.7UF 25WV	
C54			CK73HB0J105K	CHIP C 1.0UF K		C141			CC73HCH1H220J	CHIP C 22PF J	
C55			CK73HB1A104K	CHIP C 0.10UF K		C145			CC73HCH1H470J	CHIP C 47PF J	
C56			CC73HCH1H030B	CHIP C 3.0PF B		C148			CC73HCH1H101J	CHIP C 100PF J	
C57			CC73HCH1H020B	CHIP C 2.0PF B		C149			CK73HB1H471K	CHIP C 470PF K	
C61			CC73HCH1H220G	CHIP C 22PF G		C151			C92-0875-05	ELECTRO 47UF 25WV	
C62			CC73HCH1H390G	CHIP C 39PF G		C154-156			CC73HCH1H101J	CHIP C 100PF J	
C63			CK73HB1H471K	CHIP C 470PF K		C157-159			CK73HB1H471K	CHIP C 470PF K	
C64			CC73HCH1H560J	CHIP C 56PF J		C163			CM73F2H090D	CHIP C 9.0PF D	
C65,66			CK73HB1H471K	CHIP C 470PF K		C164			CC73FCH1H120J	CHIP C 12PF J	
C67			CC73HCH1H330G	CHIP C 33PF G		C165			CM73F2H121J	CHIP C 120PF J	
C68			CK73HB1H102K	CHIP C 1000PF K		C167			CM73F2H270J	CHIP C 27PF J	
C69			CK73HB1H471K	CHIP C 470PF K		C169			CC73GCH1H040B	CHIP C 4.0PF B	
C70			CC73HCH1H070B	CHIP C 7.0PF B		C170			CK73HB1H471K	CHIP C 470PF K	
C71			CK73HB1H471K	CHIP C 470PF K		C171			CC73GCH1H0R3B	CHIP C 0.3PF B	
C72			CC73HCH1H100B	CHIP C 10PF B		C172			CK73HB1H471K	CHIP C 470PF K	
C73			CK73HB1H471K	CHIP C 470PF K		C173			CM73F2H220J	CHIP C 22PF J	
C75			CK73FB1A106K	CHIP C 10UF K		C174			CM73F2H180J	CHIP C 18PF J	
C76			CC73HCH1HR75B	CHIP C 0.75PF B		C176			CC73GCH1H030B	CHIP C 3.0PF B	
C77,78			CK73HB1H471K	CHIP C 470PF K		C177			CC73GCH1H0R3B	CHIP C 0.3PF B	
C79,80			CC73HCH1H080B	CHIP C 8.0PF B		C178			CK73HB1H471K	CHIP C 470PF K	
C81			CC73HCH1H090B	CHIP C 9.0PF B		C179			CM73F2H360J	CHIP C 36PF J	
C82			CC73HCH1H080B	CHIP C 8.0PF B		C182			CM73F2H270J	CHIP C 27PF J	
C83			CK73GB1E105K	CHIP C 1.0UF K		C183			CK73HB1H471K	CHIP C 470PF K	
C84,85			CK73GB1H103K	CHIP C 0.010UF K		C184			CC73GCH1H040B	CHIP C 4.0PF B	
C86			CK73HB1H471K	CHIP C 470PF K		C186			CC73GCH1H0R5B	CHIP C 0.5PF B	
C87,88			CC73HCH1H0R5B	CHIP C 0.5PF B		C188			CM73F2H150J	CHIP C 15PF J	
C89			CK73HB1H102K	CHIP C 1000PF K		C190			CK73HB1E103K	CHIP C 0.010UF K	
C90			CK73HB1H471K	CHIP C 470PF K		C193-195			CK73HB1E103K	CHIP C 0.010UF K	
C91			CC73HCH1H220J	CHIP C 22PF J		C197			CK73HB1H102K	CHIP C 1000PF K	
C92			CK73HB1H102K	CHIP C 1000PF K		C198			CK73HB1H471K	CHIP C 470PF K	
C93			CC73HCH1H050B	CHIP C 5.0PF B		C201			CK73HB1E103K	CHIP C 0.010UF K	
C94			CC73HCH1H150J	CHIP C 15PF J		C202-205			CK73HB1A104K	CHIP C 0.10UF K	
C95,96			CK73HB1H102K	CHIP C 1000PF K		C206			CC73HCH1H100B	CHIP C 10PF B	

PARTS LIST / 零件表

TX-RX UNIT (X57-7742-71)

Ref. No.	Address	New parts	Parts No.	Description	Desti-nation	Ref. No.	Address	New parts	Parts No.	Description	Desti-nation
C207,208			CK73HB1E103K	CHIP C 0.010UF K		C297			CC73GCH1H150G	CHIP C 15PF G	
C210			CC73HCH1H100B	CHIP C 10PF B		C298			CK73GB1H104K	CHIP C 0.10UF K	
C211			CC73HCH1H680J	CHIP C 68PF J		C299-301			CK73HB1H102K	CHIP C 1000PF K	
C212-214			CK73HB1A104K	CHIP C 0.10UF K		C302			CC73HCH1H120G	CHIP C 12PF G	
C215			CC73HCH1H101J	CHIP C 100PF J		C304			CK73HB1H102K	CHIP C 1000PF K	
C216			CC73HCH1H680J	CHIP C 68PF J		C307			CK73HB1H102K	CHIP C 1000PF K	
C217			CC73HCH1H470J	CHIP C 47PF J		C308			CK73HB1A104K	CHIP C 0.10UF K	
C218			CK73HB1A104K	CHIP C 0.10UF K		C315			CC73HCH1H330G	CHIP C 33PF G	
C219,220			CK73GB0J475K	CHIP C 4.7UF K		C316			CC73GCH1H180G	CHIP C 18PF G	
C221			CK73FB1A106K	CHIP C 10UF K		C325			C93-0955-05	CHIP C 68PF G	
C222,223			CK73HB1E103K	CHIP C 0.010UF K		C328			C93-0955-05	CHIP C 68PF G	
C224			CK73HB1A104K	CHIP C 0.10UF K		C329			CK73HB1H102K	CHIP C 1000PF K	
C225			CK73FB1A106K	CHIP C 10UF K		C330-334			CK73HB1A104K	CHIP C 0.10UF K	
C226			CC73HCH1H820J	CHIP C 82PF J		C335			CC73HCH1H090B	CHIP C 9.0PF B	
C227			CK73HB1A104K	CHIP C 0.10UF K		C336			CK73HB1E103K	CHIP C 0.010UF K	
C228			CK73HB1E103K	CHIP C 0.010UF K		C337,338			CC73HCH1H220G	CHIP C 22PF G	
C229			CK73HB1A104K	CHIP C 0.10UF K		C341,342			CK73HB1H102K	CHIP C 1000PF K	
C230			CK73HB1E103K	CHIP C 0.010UF K		C348			CK73HB1E103K	CHIP C 0.010UF K	
C231,232			CK73HB1A104K	CHIP C 0.10UF K		C351			CK73GB0J105K	CHIP C 1.0UF K	
C233			CK73HB0J105K	CHIP C 1.0UF K		C352,353			CK73HB1A104K	CHIP C 0.10UF K	
C234			CK73HB1E103K	CHIP C 0.010UF K		C354			CK73FB1A106K	CHIP C 10UF K	
C235			CC73HCH1H470J	CHIP C 47PF J		C355			CK73HB1A104K	CHIP C 0.10UF K	
C237			CK73HB1E103K	CHIP C 0.010UF K		C356			CK73HB1H471K	CHIP C 470PF K	
C238			CK73HB1H471K	CHIP C 470PF K		C357			CK73HB1E103K	CHIP C 0.010UF K	
C239,240			CK73HB1E103K	CHIP C 0.010UF K		C358			CK73HB1H102K	CHIP C 1000PF K	
C242			CK73HB1H471K	CHIP C 470PF K		C359			CK73HB1H471K	CHIP C 470PF K	
C243			CK73HB1E103K	CHIP C 0.010UF K		C364-366			CK73HB1H102K	CHIP C 1000PF K	
C244			CC73HCH1H470J	CHIP C 47PF J		C401			C92-0777-05	ELECTRO 1000UF 25WV	
C245,246			CK73HB1E103K	CHIP C 0.010UF K		C403			CK73HB1H471K	CHIP C 470PF K	
C247			CK73HB1A104K	CHIP C 0.10UF K		C405			CK73HB1H471K	CHIP C 470PF K	
C252			CC73HCH1H010B	CHIP C 1.0PF B		C406			CK73HB1H102K	CHIP C 1000PF K	
C256			CC73HCH1H010B	CHIP C 1.0PF B		C409			CK73HB1E103K	CHIP C 0.010UF K	
C259			CK73HB1E103K	CHIP C 0.010UF K		C410			CK73GB1H103K	CHIP C 0.010UF K	
C260,261			CK73HB1H471K	CHIP C 470PF K		C411			CK73HB1H471K	CHIP C 470PF K	
C262,263			CK73HB1E103K	CHIP C 0.010UF K		C413			CK73GB1E105K	CHIP C 1.0UF K	
C264			CK73HB1H471K	CHIP C 470PF K		C415			CK73HB1H471K	CHIP C 470PF K	
C265			CK73HB1E103K	CHIP C 0.010UF K		C417			CK73HB1H471K	CHIP C 470PF K	
C266			CK73HB1H102K	CHIP C 1000PF K		C419			CK73HB1H102K	CHIP C 1000PF K	
C267			CK73HB1H471K	CHIP C 470PF K		C420			CK73HB1A104K	CHIP C 0.10UF K	
C268			CK73HB1H102K	CHIP C 1000PF K		C421			CK73GB1H473K	CHIP C 0.047UF K	
C269			CC73HCH1H100C	CHIP C 10PF C		C422			CK73FB1E475K	CHIP C 4.7UF K	
C270			CK73HB1H471K	CHIP C 470PF K		C424			CK73GB1E105K	CHIP C 1.0UF K	
C272			CC73HCH1H180G	CHIP C 18PF G		C425			CK73GB1H104K	CHIP C 0.10UF K	
C275			CC73HCH1H270G	CHIP C 27PF G		C426			CK73HB1E103K	CHIP C 0.010UF K	
C276			CK73HB1H471K	CHIP C 470PF K		C427			CK73HB1H471K	CHIP C 470PF K	
C279			CK73HB1H102K	CHIP C 1000PF K		C428			CC73HCH1H101J	CHIP C 100PF J	
C280			CC73HCH1H180G	CHIP C 18PF G		C429			CK73GB1H104K	CHIP C 0.10UF K	
C282			CK73HB1H102K	CHIP C 1000PF K		C430,431			CK73FB1E475K	CHIP C 4.7UF K	
C283			CK73HB1H471K	CHIP C 470PF K		C432			C92-0875-05	ELECTRO 47UF 25WV	
C284			CK73HB1H102K	CHIP C 1000PF K		C433			CK73GB1H104K	CHIP C 0.10UF K	
C285			CC73HCH1H120G	CHIP C 12PF G		C434			CK73HB1H102K	CHIP C 1000PF K	
C286			CK73HB1H102K	CHIP C 1000PF K		C435			CK73FB1A106K	CHIP C 10UF K	
C287			CC73GCH1H150G	CHIP C 15PF G		C436			CS77BA1A100M	CHIP TNL 10UF 10WV	
C288			CK73HB1H102K	CHIP C 1000PF K		C437			CK73HB1A224K	CHIP C 0.22UF K	
C289			CK73GB1H104K	CHIP C 0.10UF K		C438			CK73FB1A106K	CHIP C 10UF K	
C290			CK73HB1H102K	CHIP C 1000PF K		C439			CK73HB1E103K	CHIP C 0.010UF K	
C291			CC73HCH1H120G	CHIP C 12PF G		C440			CK73GB1E105K	CHIP C 1.0UF K	
C293,294			CK73HB1H102K	CHIP C 1000PF K		C441,442			CK73HB1E103K	CHIP C 0.010UF K	
C295			CC73HCH1H120G	CHIP C 12PF G		C443,444			CK73GB1E105K	CHIP C 1.0UF K	
C296			CK73HB1H102K	CHIP C 1000PF K		C445			CK73FB1A106K	CHIP C 10UF K	

PARTS LIST / 零件表

TX-RX UNIT (X57-7742-71)

Ref. No.	Address	New parts	Parts No.	Description	Destination	Ref. No.	Address	New parts	Parts No.	Description	Destination
C446			C92-0765-05	CHIP TNTL 4.7UF 16WV		C568-578			CC73HCH1H101J	CHIP C 100PF J	
C447			CK73HB1A224K	CHIP C 0.22UF K		C579			CK73HB1H102K	CHIP C 1000PF K	
C448			CK73HB1E103K	CHIP C 0.010UF K		C580			CC73HCH1H101J	CHIP C 100PF J	
C449			CK73GB1C225K	CHIP C 2.2UF K		C581-583			CK73HB1H102K	CHIP C 1000PF K	
C450			CK73HB1E103K	CHIP C 0.010UF K		C584,585			CC73HCH1H101J	CHIP C 100PF J	
C451			CK73GB1C225K	CHIP C 2.2UF K		C586			CK73HB1E103K	CHIP C 0.010UF K	
C452			CK73HB0J105K	CHIP C 1.0UF K		C587-589			CK73HB1H102K	CHIP C 1000PF K	
C453			CK73GB1E105K	CHIP C 1.0UF K		C590,591			CK73HB1E103K	CHIP C 0.010UF K	
C454			CK73HB1H471K	CHIP C 470PF K		C592,593			CC73HCH1H101J	CHIP C 100PF J	
C455,456			CK73HB1E103K	CHIP C 0.010UF K		C594,595			CK73HB1E103K	CHIP C 0.010UF K	
C457,458			CK73GB1E105K	CHIP C 1.0UF K		C596			CK73HB1A104K	CHIP C 0.10UF K	
C459			C92-0765-05	CHIP TNTL 4.7UF 16WV		C597-607			CK73HB1H102K	CHIP C 1000PF K	
C460			CK73HB1A104K	CHIP C 0.10UF K		C608			CC73HCH1H101J	CHIP C 100PF J	
C461			CC73HCH1H181J	CHIP C 180PF J		C609			CK73HB1H102K	CHIP C 1000PF K	
C462			CK73HB1H471K	CHIP C 470PF K		C610			CC73HCH1H101J	CHIP C 100PF J	
C463			CK73HB0J105K	CHIP C 1.0UF K		C611			CK73HB1H102K	CHIP C 1000PF K	
C464			CC73HCH1H220J	CHIP C 22PF J		C612			CK73GB1H103K	CHIP C 0.010UF K	
C465-467			CK73GB1E105K	CHIP C 1.0UF K		C613-616			CK73GB1E105K	CHIP C 1.0UF K	
C468			CK73HB1E103K	CHIP C 0.010UF K		C618			CK73HB1E103K	CHIP C 0.010UF K	
C471			CK73HB0J105K	CHIP C 1.0UF K		C620,621			CK73HB1E103K	CHIP C 0.010UF K	
C473			CS77BA1E4R7M	CHIP TNTL 4.7UF 25WV		C622			CK73HB1H102K	CHIP C 1000PF K	
C474			CK73HB1E103K	CHIP C 0.010UF K		C623-629			CK73HB1E103K	CHIP C 0.010UF K	
C475			CK73FB1A106K	CHIP C 10UF K		C702			CK73HB0J105K	CHIP C 1.0UF K	
C476			CK73HB1H102K	CHIP C 1000PF K		C704			CC73HCH1H030B	CHIP C 3.0PF B	
C477			CC73HCH1H101J	CHIP C 100PF J		C705			CK73HB1H122K	CHIP C 1200PF K	
C478-483			CK73HB1H102K	CHIP C 1000PF K		C706			CK73HB1H331K	CHIP C 330PF K	
C501,502			CK73HB0J105K	CHIP C 1.0UF K		C707			CK73HB1A104K	CHIP C 0.10UF K	
C503-507			CK73HB1A104K	CHIP C 0.10UF K		C708			CK73HB1H122K	CHIP C 1200PF K	
C508			CK73HB1H102K	CHIP C 1000PF K		C709			CC73HCH1H221J	CHIP C 220PF J	
C509			CK73HB1A104K	CHIP C 0.10UF K		C710			CK73HB1E103K	CHIP C 0.010UF K	
C511-514			CK73HB1A104K	CHIP C 0.10UF K		C711			CC73HCH1H181J	CHIP C 180PF J	
C515			CK73HB0J105K	CHIP C 1.0UF K		C712			CC73HCH1H680J	CHIP C 68PF J	
C516,517			CK73HB1A104K	CHIP C 0.10UF K		C714			CK73HB1E103K	CHIP C 0.010UF K	
C518			CK73GB1E105K	CHIP C 1.0UF K		C715			CK73HB1H122K	CHIP C 1200PF K	
C520-523			CK73HB1E103K	CHIP C 0.010UF K		C716			CC73HCH1H221J	CHIP C 220PF J	
C527			CK73HB1E103K	CHIP C 0.010UF K		C717			CK73HB1A104K	CHIP C 0.10UF K	
C528			CK73HB1A104K	CHIP C 0.10UF K		C718			CC73HCH1H221J	CHIP C 220PF J	
C529,530			CK73HB1E103K	CHIP C 0.010UF K		C719,720			CK73HB1A104K	CHIP C 0.10UF K	
C531			CK73HB1A104K	CHIP C 0.10UF K		C721			CC73HCH1H221J	CHIP C 220PF J	
C532			CK73HB1E103K	CHIP C 0.010UF K		C722			CC73HCH1H470J	CHIP C 47PF J	
C533			CK73HB1A104K	CHIP C 0.10UF K		C723,724			CK73HB1A104K	CHIP C 0.10UF K	
C534			CC73HCH1H101J	CHIP C 100PF J		C725			CK73HB1E103K	CHIP C 0.010UF K	
C535			CS77CP0J100M	CHIP TNTL 10UF 6.3WV		C726			CK73HB1A104K	CHIP C 0.10UF K	
C536			CK73HB1E103K	CHIP C 0.010UF K		C727			CC73HCH1H820J	CHIP C 82PF J	
C537,538			CK73HB1A104K	CHIP C 0.10UF K		C729			CK73HB1A104K	CHIP C 0.10UF K	
C539			CK73HB1E103K	CHIP C 0.010UF K		C730			CK73HB1H561K	CHIP C 560PF K	
C540			CK73HB0J105K	CHIP C 1.0UF K		C731			CK73HB1A104K	CHIP C 0.10UF K	
C541			CK73HB1A104K	CHIP C 0.10UF K		C732			CK73HB1E103K	CHIP C 0.010UF K	
C542			CS77CP0J100M	CHIP TNTL 10UF 6.3WV		C734			CK73HB1E103K	CHIP C 0.010UF K	
C543-546			CC73HCH1H101J	CHIP C 100PF J		C735			CK73FB1E475K	CHIP C 4.7UF K	
C547-550			CK73HB1A104K	CHIP C 0.10UF K		C736			CC73HCH1H101J	CHIP C 100PF J	
C551			CK73HB1E103K	CHIP C 0.010UF K		C737			CK73HB1A104K	CHIP C 0.10UF K	
C552			CK73HB0J105K	CHIP C 1.0UF K		C738			CK73HB1H102K	CHIP C 1000PF K	
C553			CC73HCH1H101J	CHIP C 100PF J		C740			CK73HB1H472K	CHIP C 4700PF K	
C554-558			CK73HB1A104K	CHIP C 0.10UF K		C741			CK73HB1A154K	CHIP C 0.15UF K	
C559			CK73HB1E103K	CHIP C 0.010UF K		C742			CK73HB1A104K	CHIP C 0.10UF K	
C560			CK73HB0J105K	CHIP C 1.0UF K		C743			CK73HB1E103K	CHIP C 0.010UF K	
C561-563			CC73HCH1H101J	CHIP C 100PF J		C744			CK73HB1A104K	CHIP C 0.10UF K	
C565,566			CC73HCH1H101J	CHIP C 100PF J		C745-747			CK73HB1E103K	CHIP C 0.010UF K	
C567			CK73HB1H102K	CHIP C 1000PF K		C748-751			CK73HB1A104K	CHIP C 0.10UF K	

PARTS LIST / 零件表

TX-RX UNIT (X57-7742-71)

Ref. No.	Address	New parts	Parts No.	Description	Destination	Ref. No.	Address	New parts	Parts No.	Description	Destination
C752,753			CK73HB1E103K	CHIP C 0.010UF K		CN549			E40-6720-05	SOCKET FOR PIN ASSY	
C754			CK73HB1H102K	CHIP C 1000PF K		CN595			E40-6361-05	PIN ASSY	
C757			CC73HCH1H150J	CHIP C 15PF J		CN597			E40-6558-05	FLAT CABLE CONNECTOR	
C761			CK73HB1E103K	CHIP C 0.010UF K		CN600			E40-6560-05	FLAT CABLE CONNECTOR	
C762,763			CK73HB1A104K	CHIP C 0.10UF K		CN611,612			E23-1278-05	TERMINAL	
C764			CC73HCH1H220J	CHIP C 22PF J		CN614			E23-1278-05	TERMINAL	
C765,766			CK73GB1E105K	CHIP C 1.0UF K		CN705			E40-6582-05	PIN ASSY	
C767			CK73HB1A104K	CHIP C 0.10UF K		CN901			E40-6560-05	FLAT CABLE CONNECTOR	
C768,769			CK73HB1E103K	CHIP C 0.010UF K		J701			E11-0425-05	3.5D PHONE JACK (3P)	
C770			CK73HB1A104K	CHIP C 0.10UF K		J901			E58-0521-05	SUB SOCKET (D)	
C773			CK73HB1A104K	CHIP C 0.10UF K		F401			F53-0328-05	FUSE (5A)	
C774			CK73HB1H102K	CHIP C 1000PF K		F501			F53-0352-05	FUSE (2A)	
C775			CK73HB1A104K	CHIP C 0.10UF K		CN405			J19-5386-05	HOLDER (LITHIUM CELL)	
C776			CK73HBQJ105K	CHIP C 1.0UF K		CD201			L79-1850-05	TUNING COIL	
C777			CK73HB1H102K	CHIP C 1000PF K		CF201			L72-1027-05	CERAMIC FILTER	
C778			CK73HB1A104K	CHIP C 0.10UF K		CF202			L72-1041-05	CERAMIC FILTER	
C779			CC73HCH1H680J	CHIP C 68PF J		CF203			L72-1020-05	CERAMIC FILTER	
C782-786			CK73HB1A104K	CHIP C 0.10UF K		L1			L41-4795-39	SMALL FIXED INDUCTOR (4.7UH)	
C787			CK73FB1A106K	CHIP C 10UF K		L2			L92-0163-05	BEADS CORE	
C788			CK73HB1A104K	CHIP C 0.10UF K		L3,4			L40-1001-86	SMALL FIXED INDUCTOR (10UH)	
C789			CK73FB1E475K	CHIP C 4.7UF K		L7,8			L40-5667-92	SMALL FIXED INDUCTOR (5.6NH)	
C790			CK73FB1A106K	CHIP C 10UF K		L10,11			L40-2285-92	SMALL FIXED INDUCTOR (220NH)	
C791			CK73HB1H102K	CHIP C 1000PF K		L12			L40-6875-92	SMALL FIXED INDUCTOR (68NH)	
C792			CC73HCH1H470J	CHIP C 47PF J		L13,14			L40-2285-92	SMALL FIXED INDUCTOR (220NH)	
C793			CK73HB1H102K	CHIP C 1000PF K		L15			L40-8275-92	SMALL FIXED INDUCTOR (82NH)	
C794,795			CK73FB1A106K	CHIP C 10UF K		L16			L40-5667-92	SMALL FIXED INDUCTOR (5.6NH)	
C796-799			CK73HB1A104K	CHIP C 0.10UF K		L17			L40-2285-92	SMALL FIXED INDUCTOR (220NH)	
C801,802			CK73GB1E105K	CHIP C 1.0UF K		L18			L40-5667-92	SMALL FIXED INDUCTOR (5.6NH)	
C803-805			CK73HB1H102K	CHIP C 1000PF K		L19			L40-2285-92	SMALL FIXED INDUCTOR (220NH)	
C806			C92-0906-05	ELECTRO 330UF 16WV		L20			L40-3975-92	SMALL FIXED INDUCTOR (39NH)	
C807			C92-0875-05	ELECTRO 47UF 25WV		L22			L34-4610-15	AIR-CORE COIL	
C809			CK73HB1H102K	CHIP C 1000PF K		L23			L34-4607-15	AIR-CORE COIL	
C810			CK73HB1H471K	CHIP C 470PF K		L24			L92-0446-05	BEADS CORE	
C811			CK73HB1H102K	CHIP C 1000PF K		L25,26			L40-3391-86	SMALL FIXED INDUCTOR (3.3UH)	
C813			CK73FB1A106K	CHIP C 10UF K		L27			L40-1085-71	SMALL FIXED INDUCTOR (100NH)	
C814			CK73HB1H471K	CHIP C 470PF K		L28			L40-1085-92	SMALL FIXED INDUCTOR (100NH)	
C815,816			CK73FB1A106K	CHIP C 10UF K		L31-36			L92-0163-05	BEADS CORE	
C817			CK73HB1E103K	CHIP C 0.010UF K		L40,41			L92-0163-05	BEADS CORE	
C818			CK73HBQJ105K	CHIP C 1.0UF K		L101			L40-8275-92	SMALL FIXED INDUCTOR (82NH)	
C820			CK73GB1E105K	CHIP C 1.0UF K		L102			L40-6875-92	SMALL FIXED INDUCTOR (68NH)	
C821			CK73HB1H102K	CHIP C 1000PF K		L103			L92-0140-05	CHIP FERRITE	
C824			CK73HB1H102K	CHIP C 1000PF K		L104			L40-3375-92	SMALL FIXED INDUCTOR (33NH)	
C825			CC73HCH1H101J	CHIP C 100PF J		L105			L40-3975-92	SMALL FIXED INDUCTOR (39NH)	
C826			CK73HB1H102K	CHIP C 1000PF K		L106			L92-0140-05	CHIP FERRITE	
C901			CC73HCH1H101J	CHIP C 100PF J		L107-109			L92-0179-05	CHIP FERRITE	
C902			CK73HB1H102K	CHIP C 1000PF K		L110			L34-4638-05	AIR-CORE COIL	
C903-906			CC73HCH1H101J	CHIP C 100PF J		L111			L34-4744-05	AIR-CORE COIL	
C907			CK73HB1H102K	CHIP C 1000PF K		L112-115			L34-4742-05	AIR-CORE COIL	
C908-921			CC73HCH1H101J	CHIP C 100PF J		L116			L34-4848-05	AIR-CORE COIL	
C922,923			CK73HB1H102K	CHIP C 1000PF K		L117-119			L92-0163-05	BEADS CORE	
C928			CK73HB1E103K	CHIP C 0.010UF K		L201			L40-1085-71	SMALL FIXED INDUCTOR (100NH)	
CN401,402			E23-1260-04	TERMINAL		L202			L40-5681-86	SMALL FIXED INDUCTOR (0.56UH)	
CN403			E41-1682-05	PIN ASSY		L204			L41-4778-45	SMALL FIXED INDUCTOR (47NH)	
CN502-513			E23-1278-05	TERMINAL		L205			L40-5681-86	SMALL FIXED INDUCTOR (0.56UH)	
CN516,517			E23-1278-05	TERMINAL		L206			L92-0138-05	CHIP FERRITE	
CN520			E23-1278-05	TERMINAL		L207			L40-5681-86	SMALL FIXED INDUCTOR (0.56UH)	
CN527			E23-1278-05	TERMINAL		L208			L92-0138-05	CHIP FERRITE	
CN540			E23-1278-05	TERMINAL		L209			L39-1498-05	TOROIDAL COIL	
CN542,543			E23-1278-05	TERMINAL							

PARTS LIST / 零件表

TX-RX UNIT (X57-7742-71)

Ref. No.	Address	New parts	Parts No.	Description	Destination	Ref. No.	Address	New parts	Parts No.	Description	Destination
L210			L92-0138-05	CHIP FERRITE		R44			RK73HB1J104J	CHIP R 100K J 1/16W	
L211			L40-1085-92	SMALL FIXED INDUCTOR (100NH)		R45,46			RK73HB1J223J	CHIP R 22K J 1/16W	
L212			L39-1498-05	TOROIDAL COIL		R47			RK73HB1J000J	CHIP R 0.0 J 1/16W	
L213			L40-4775-92	SMALL FIXED INDUCTOR (47NH)		R48			RK73HB1J104J	CHIP R 100K J 1/16W	
L214			L39-1498-05	TOROIDAL COIL		R49			RK73HB1J123J	CHIP R 12K J 1/16W	
L215			L40-4775-92	SMALL FIXED INDUCTOR (47NH)		R51			RK73HB1J473J	CHIP R 47K J 1/16W	
L217-219			L34-4566-05	AIR-CORE COIL		R52			RK73HB1J683J	CHIP R 68K J 1/16W	
L220			L92-0138-05	CHIP FERRITE		R56			RK73HB1J331J	CHIP R 330 J 1/16W	
L221			L34-4566-05	AIR-CORE COIL		R57			RK73HB1J472J	CHIP R 4.7K J 1/16W	
L222			L41-1085-14	SMALL FIXED INDUCTOR (100NH)		R59			RK73HB1J223J	CHIP R 22K J 1/16W	
L223			L40-1585-92	SMALL FIXED INDUCTOR (150NH)		R60			RK73HB1J563J	CHIP R 56K J 1/16W	
L229,230			L34-4567-05	AIR-CORE COIL		R61			RK73HB1J223J	CHIP R 22K J 1/16W	
L240			L40-1575-92	SMALL FIXED INDUCTOR (15NH)		R62			RK73HB1J474J	CHIP R 470K J 1/16W	
L401-403			L92-0179-05	CHIP FERRITE		R63			RK73HB1J472J	CHIP R 4.7K J 1/16W	
L404			L92-0639-05	CHIP FERRITE		R64,65			RK73HB1J271D	CHIP R 270 D 1/16W	
L405			L33-1496-05	SMALL FIXED INDUCTOR		R66			RK73HB1J121J	CHIP R 120 J 1/16W	
L406			L33-1462-05	SMALL FIXED INDUCTOR		R67			RK73HB1J151J	CHIP R 150 J 1/16W	
L501-503			L92-0138-05	CHIP FERRITE		R68			RK73HB1J102J	CHIP R 1.0K J 1/16W	
L506-511			L92-0138-05	CHIP FERRITE		R69			RK73HB1J473J	CHIP R 47K J 1/16W	
L512			L92-0140-05	CHIP FERRITE		R70			RK73HB1J154J	CHIP R 150K J 1/16W	
L517,518			L92-0138-05	CHIP FERRITE		R71			RK73HB1J101J	CHIP R 100 J 1/16W	
L521-523			L92-0162-05	BEADS CORE		R72			RK73HB1J332J	CHIP R 3.3K J 1/16W	
L901,902			L92-0140-05	CHIP FERRITE		R73			RK73HB1J103J	CHIP R 10K J 1/16W	
L903-905			L92-0162-05	BEADS CORE		R74			RK73HB1J271J	CHIP R 270 J 1/16W	
X1			L77-3014-05	TCXO (19.2MHZ)		R75			RK73HB1J222J	CHIP R 2.2K J 1/16W	
X501			L77-1802-05	CRYSTAL RESONATOR (32768HZ)		R76			RK73HB1J470J	CHIP R 47 J 1/16W	
X502			L77-3015-05	TCXO (18.432MHZ)		R77			RK73HB1J000J	CHIP R 0.0 J 1/16W	
XF202			L71-0649-05	MCF (58.05MHZ)		R78			RK73HB1J472J	CHIP R 4.7K J 1/16W	
R1,2			RK73HB1J223D	CHIP R 22K D 1/16W		R79			RK73HB1J560J	CHIP R 56 J 1/16W	
R3			RK73HB1J274J	CHIP R 270K J 1/16W		R80			RK73HB1J183J	CHIP R 18K J 1/16W	
R4			RK73HB1J224J	CHIP R 220K J 1/16W		R82			RK73HB1J102J	CHIP R 1.0K J 1/16W	
R5			RK73HB1J101J	CHIP R 100 J 1/16W		R83			RK73GB2A272J	CHIP R 2.7K J 1/10W	
R6,7			RK73HB1J472J	CHIP R 4.7K J 1/16W		R84			RK73HB1J221J	CHIP R 220 J 1/16W	
R9			RK73HB1J472J	CHIP R 4.7K J 1/16W		R85			RK73HB1J474J	CHIP R 470K J 1/16W	
R10			RK73HB1J000J	CHIP R 0.0 J 1/16W		R86			RK73HB1J101J	CHIP R 100 J 1/16W	
R11,12			RK73HB1J100J	CHIP R 10 J 1/16W		R88,89			RK73HB1J000J	CHIP R 0.0 J 1/16W	
R13			RK73HB1J103J	CHIP R 10K J 1/16W		R90,91			RK73GB2A000J	CHIP R 0.0 J 1/10W	
R14,15			RK73HB1J100J	CHIP R 10 J 1/16W		R92,93			RK73HB1J000J	CHIP R 0.0 J 1/16W	
R17			RK73HB1J000J	CHIP R 0.0 J 1/16W		R101			RK73HB1J332J	CHIP R 3.3K J 1/16W	
R18			RK73HB1J100J	CHIP R 10 J 1/16W		R102			RK73HB1J271J	CHIP R 270 J 1/16W	
R20			RK73HB1J102J	CHIP R 1.0K J 1/16W		R103			RK73HB1J180J	CHIP R 18 J 1/16W	
R21			RK73HB1J100J	CHIP R 10 J 1/16W		R104			RK73HB1J271J	CHIP R 270 J 1/16W	
R22			RK73HB1J473J	CHIP R 47K J 1/16W		R105			RK73HB1J333J	CHIP R 33K J 1/16W	
R23			RK73HB1J102J	CHIP R 1.0K J 1/16W		R106			RK73HB1J103J	CHIP R 10K J 1/16W	
R25			RK73HB1J000J	CHIP R 0.0 J 1/16W		R107			RK73HB1J181J	CHIP R 180 J 1/16W	
R26			RK73HB1J474J	CHIP R 470K J 1/16W		R108			RK73GB2A101J	CHIP R 100 J 1/10W	
R27			RK73HB1J104J	CHIP R 100K J 1/16W		R109			RK73HB1J471J	CHIP R 470 J 1/16W	
R28			RK73HB1J473J	CHIP R 47K J 1/16W		R110			RK73GB2A220J	CHIP R 22 J 1/10W	
R29			RK73HB1J683J	CHIP R 68K J 1/16W		R111			RK73HB1J272J	CHIP R 2.7K J 1/16W	
R30			RK73HB1J000J	CHIP R 0.0 J 1/16W		R112			RK73HB1J182J	CHIP R 1.8K J 1/16W	
R31			RK73HB1J151J	CHIP R 150 J 1/16W		R113			RK73GB2A220J	CHIP R 22 J 1/10W	
R33			RK73HB1J184J	CHIP R 180K J 1/16W		R114			RK73HB1J331J	CHIP R 330 J 1/16W	
R34			RK73HB1J473J	CHIP R 47K J 1/16W		R115			RK73HB1J473J	CHIP R 47K J 1/16W	
R35			RK73HB1J102J	CHIP R 1.0K J 1/16W		R116			RK73HB1J223J	CHIP R 22K J 1/16W	
R36			RK73HB1J391D	CHIP R 390 D 1/16W		R117			RK73HB1J000J	CHIP R 0.0 J 1/16W	
R37			RK73HB1J103J	CHIP R 10K J 1/16W		R119			RK73HB1J103J	CHIP R 10K J 1/16W	
R38			RK73HB1J106J	CHIP R 10M J 1/16W		R120			RK73HB1J473J	CHIP R 47K J 1/16W	
R39			RK73HB1J472J	CHIP R 4.7K J 1/16W		R121			RK73HB1J104J	CHIP R 100K J 1/16W	
R42,43			RK73HB1J000J	CHIP R 0.0 J 1/16W		R122			RK73HB1J332J	CHIP R 3.3K J 1/16W	
						R123			RK73FB2B221J	CHIP R 220 J 1/8W	

PARTS LIST / 零件表

TX-RX UNIT (X57-7742-71)

Ref. No.	Address	New parts	Parts No.	Description	Destination	Ref. No.	Address	New parts	Parts No.	Description	Destination
R124,125			RK73FB2B470J	CHIP R 47 J 1/8W		R248			RK73HB1J474J	CHIP R 470K J 1/16W	
R126			RK73HB1J104J	CHIP R 100K J 1/16W		R250			RK73HB1J000J	CHIP R 0.0 J 1/16W	
R127			RK73FB2B221J	CHIP R 220 J 1/8W		R256			RK73HB1J181J	CHIP R 180 J 1/16W	
R130			RK73HB1J104J	CHIP R 100K J 1/16W		R257			RK73HB1J000J	CHIP R 0.0 J 1/16W	
R131			RK73HB1J221J	CHIP R 220 J 1/16W		R261			RK73HB1J000J	CHIP R 0.0 J 1/16W	
R132			RK73HB1J154J	CHIP R 150K J 1/16W		R263			RK73HB1J470J	CHIP R 47 J 1/16W	
R134			RK73HB1J104J	CHIP R 100K J 1/16W		R264			RK73HB1J472J	CHIP R 4.7K J 1/16W	
R135			RK73HB1J334J	CHIP R 330K J 1/16W		R265			RK73HB1J332J	CHIP R 3.3K J 1/16W	
R137			RK73EB2E241J	CHIP R 240 J 1/4W		R266			RK73HB1J103J	CHIP R 10K J 1/16W	
R138			RK73HB1J104J	CHIP R 100K J 1/16W		R267			RK73HB1J222J	CHIP R 2.2K J 1/16W	
R139			RK73HB1J124J	CHIP R 120K J 1/16W		R268			RK73HB1J271J	CHIP R 270 J 1/16W	
R140			RK73HB1J104J	CHIP R 100K J 1/16W		R269			RK73HB1J470J	CHIP R 47 J 1/16W	
R141			RK73GB2A000J	CHIP R 0.0 J 1/10W		R270			RK73HB1J330J	CHIP R 33 J 1/16W	
R142			RK73HB1J104J	CHIP R 100K J 1/16W		R271			RK73HB1J222J	CHIP R 2.2K J 1/16W	
R143			RK73HB1J823J	CHIP R 82K J 1/16W		R273			RK73HB1J000J	CHIP R 0.0 J 1/16W	
R144,145			RK73HB1J104J	CHIP R 100K J 1/16W		R274			RK73HB1J102J	CHIP R 1.0K J 1/16W	
R146			RK73HB1J124J	CHIP R 120K J 1/16W		R276			RK73GB2A000J	CHIP R 0.0 J 1/10W	
R147			RK73HB1J822J	CHIP R 8.2K J 1/16W		R277			RK73HB1J121J	CHIP R 120 J 1/16W	
R148			RK73HB1J473J	CHIP R 47K J 1/16W		R279			RK73HB1J470J	CHIP R 47 J 1/16W	
R149			RK73HB1J154J	CHIP R 150K J 1/16W		R280			RK73HB1J102J	CHIP R 1.0K J 1/16W	
R150			R92-1061-05	JUMPER REST 0 OHM		R281			RK73HB1J121J	CHIP R 120 J 1/16W	
R154			RK73EB2E241J	CHIP R 240 J 1/4W		R282,283			RK73HB1J104J	CHIP R 100K J 1/16W	
R156			RK73HB1J000J	CHIP R 0.0 J 1/16W		R284			RK73HB1J103J	CHIP R 10K J 1/16W	
R161			RK73HB1J332J	CHIP R 3.3K J 1/16W		R285			RK73HB1J000J	CHIP R 0.0 J 1/16W	
R201			RK73HB1J222J	CHIP R 2.2K J 1/16W		R286			RK73HB1J104J	CHIP R 100K J 1/16W	
R202			RK73HB1J470J	CHIP R 47 J 1/16W		R287			RK73HB1J274J	CHIP R 270K J 1/16W	
R203,204			RK73HB1J223J	CHIP R 22K J 1/16W		R288			RK73HB1J104J	CHIP R 100K J 1/16W	
R205			RK73HB1J334J	CHIP R 330K J 1/16W		R290,291			RK73HB1J104J	CHIP R 100K J 1/16W	
R206,207			RK73HB1J223J	CHIP R 22K J 1/16W		R292			RK73HB1J103J	CHIP R 10K J 1/16W	
R208			RK73HB1J153J	CHIP R 15K J 1/16W		R294			RK73HB1J100J	CHIP R 10 J 1/16W	
R209,210			RK73HB1J100J	CHIP R 10 J 1/16W		R296			RK73HB1J274J	CHIP R 270K J 1/16W	
R211			RK73HB1J102J	CHIP R 1.0K J 1/16W		R297			RK73HB1J104J	CHIP R 100K J 1/16W	
R212			RK73HB1J000J	CHIP R 0.0 J 1/16W		R298			RK73HB1J680J	CHIP R 68 J 1/16W	
R213			RK73HB1J102J	CHIP R 1.0K J 1/16W		R299			RK73HB1J104J	CHIP R 100K J 1/16W	
R215			RK73HB1J332J	CHIP R 3.3K J 1/16W		R300			RK73HB1J680J	CHIP R 68 J 1/16W	
R216			RK73HB1J000J	CHIP R 0.0 J 1/16W		R301			RK73HB1J101J	CHIP R 100 J 1/16W	
R218,219			RK73HB1J103J	CHIP R 10K J 1/16W		R302			RK73HB1J000J	CHIP R 0.0 J 1/16W	
R220			RK73HB1J473J	CHIP R 47K J 1/16W		R303			RK73HB1J104J	CHIP R 100K J 1/16W	
R221			RK73HB1J183J	CHIP R 18K J 1/16W		R305			RK73HB1J000J	CHIP R 0.0 J 1/16W	
R222			RK73HB1J222J	CHIP R 2.2K J 1/16W		R306			RK73HB1J472J	CHIP R 4.7K J 1/16W	
R223			RK73HB1J274J	CHIP R 270K J 1/16W		R307			RK73HB1J222J	CHIP R 2.2K J 1/16W	
R224			RK73HB1J103J	CHIP R 10K J 1/16W		R310			RK73HB1J000J	CHIP R 0.0 J 1/16W	
R225			RK73HB1J153J	CHIP R 15K J 1/16W		R313-315			RK73HB1J000J	CHIP R 0.0 J 1/16W	
R226			RK73HB1J223J	CHIP R 22K J 1/16W		R319			RK73HB1J104J	CHIP R 100K J 1/16W	
R227			RK73HB1J473J	CHIP R 47K J 1/16W		R320-322			RK73HB1J000J	CHIP R 0.0 J 1/16W	
R228			RK73HB1J104J	CHIP R 100K J 1/16W		R326			RK73HB1J122J	CHIP R 1.2K J 1/16W	
R229			RK73HB1J102J	CHIP R 1.0K J 1/16W		R328			RK73HB1J102J	CHIP R 1.0K J 1/16W	
R231			RK73HB1J222J	CHIP R 2.2K J 1/16W		R329			RK73HB1J682J	CHIP R 6.8K J 1/16W	
R232			RK73HB1J103J	CHIP R 10K J 1/16W		R330			RK73GB2A100J	CHIP R 10 J 1/10W	
R234			RK73HB1J221J	CHIP R 220 J 1/16W		R331			RK73HB1J473J	CHIP R 47K J 1/16W	
R235			RK73HB1J101J	CHIP R 100 J 1/16W		R332			RK73HB1J000J	CHIP R 0.0 J 1/16W	
R236			RK73HB1J104J	CHIP R 100K J 1/16W		R333			RK73HB1J102J	CHIP R 1.0K J 1/16W	
R238			RK73HB1J000J	CHIP R 0.0 J 1/16W		R334			RK73HB1J000J	CHIP R 0.0 J 1/16W	
R239			RK73HB1J103J	CHIP R 10K J 1/16W		R338			RK73HB1J000J	CHIP R 0.0 J 1/16W	
R240			RK73HB1J104J	CHIP R 100K J 1/16W		R342,343			RK73HB1J000J	CHIP R 0.0 J 1/16W	
R242			RK73HB1J221J	CHIP R 220 J 1/16W		R346			RK73HB1J223J	CHIP R 22K J 1/16W	
R243			RK73HB1J101J	CHIP R 100 J 1/16W		R352,353			RK73HB1J000J	CHIP R 0.0 J 1/16W	
R244			RK73HB1J000J	CHIP R 0.0 J 1/16W		R401			RK73HH1J105D	CHIP R 1.0M D 1/16W	
R245			RK73HB1J104J	CHIP R 100K J 1/16W		R402			RK73HB1J471J	CHIP R 470 J 1/16W	
R247			RK73HB1J104J	CHIP R 100K J 1/16W		R403			RK73HH1J104D	CHIP R 100K D 1/16W	

PARTS LIST / 零件表

TX-RX UNIT (X57-7742-71)

Ref. No.	Address	New parts	Parts No.	Description	Destination	Ref. No.	Address	New parts	Parts No.	Description	Destination
R404			RK73HB1J103J	CHIP R 10K J 1/16W		R538			RK73HB1J101J	CHIP R 100 J 1/16W	
R405			RK73HH1J274D	CHIP R 270K D 1/16W		R539			RK73HB1J000J	CHIP R 0.0 J 1/16W	
R406			RK73HH1J104D	CHIP R 100K D 1/16W		R540,541			RK73HB1J101J	CHIP R 100 J 1/16W	
R407			RK73HB1J473J	CHIP R 47K J 1/16W		R542			RK73HB1J104J	CHIP R 100K J 1/16W	
R408			RK73HB1J103J	CHIP R 10K J 1/16W		R543			RK73HB1J000J	CHIP R 0.0 J 1/16W	
R409			RK73HB1J683J	CHIP R 68K J 1/16W		R544			RK73HB1J104J	CHIP R 100K J 1/16W	
R410			RK73HB1J684J	CHIP R 680K J 1/16W		R545			RK73HB1J000J	CHIP R 0.0 J 1/16W	
R411			RK73HB1J104J	CHIP R 100K J 1/16W		R548			RK73GB2A000J	CHIP R 0.0 J 1/10W	
R413			RK73HB1J474J	CHIP R 470K J 1/16W		R551			RK73HB1J101J	CHIP R 100 J 1/16W	
R415			RK73HB1J332J	CHIP R 3.3K J 1/16W		R552-554			RK73HB1J104J	CHIP R 100K J 1/16W	
R417			RK73HB1J473J	CHIP R 47K J 1/16W		R556-558			RK73HB1J104J	CHIP R 100K J 1/16W	
R418,419			RK73HB1J103J	CHIP R 10K J 1/16W		R560			RK73HB1J000J	CHIP R 0.0 J 1/16W	
R420			RK73HB1J473J	CHIP R 47K J 1/16W		R561			RK73HB1J473J	CHIP R 47K J 1/16W	
R421			RK73HB1J474J	CHIP R 470K J 1/16W		R562			RK73GB2A000J	CHIP R 0.0 J 1/10W	
R422			RK73HB1J103J	CHIP R 10K J 1/16W		R565			RK73GB2A000J	CHIP R 0.0 J 1/10W	
R423-425			RK73GB2A472J	CHIP R 4.7K J 1/10W		R567			RK73HB1J151J	CHIP R 150 J 1/16W	
R426			RK73HB1J474J	CHIP R 470K J 1/16W		R568			RK73HB1J102J	CHIP R 1.0K J 1/16W	
R428,429			RK73HB1J103J	CHIP R 10K J 1/16W		R569			RK73HB1J220J	CHIP R 22 J 1/16W	
R430			RK73HH1J124D	CHIP R 120K D 1/16W		R572			RK73HB1J220J	CHIP R 22 J 1/16W	
R431			RK73HH1J183D	CHIP R 18K D 1/16W		R574			RK73GB2A000J	CHIP R 0.0 J 1/10W	
R432			RK73HH1J223D	CHIP R 22K D 1/16W		R575			RK73HB1J103J	CHIP R 10K J 1/16W	
R433			RK73HB1J102J	CHIP R 1.0K J 1/16W		R576			RK73HB1J000J	CHIP R 0.0 J 1/16W	
R434			RK73HB1J330J	CHIP R 33 J 1/16W		R577			RK73HB1J102J	CHIP R 1.0K J 1/16W	
R435			RK73GB2A100J	CHIP R 10 J 1/10W		R578-580			RK73HB1J000J	CHIP R 0.0 J 1/16W	
R436			RK73HB1J000J	CHIP R 0.0 J 1/16W		R581			RK73HB1J474J	CHIP R 470K J 1/16W	
R437			RK73HB1J474J	CHIP R 470K J 1/16W		R582-586			RK73HB1J000J	CHIP R 0.0 J 1/16W	
R438			RK73HB1J154J	CHIP R 150K J 1/16W		R587			RK73HB1J102J	CHIP R 1.0K J 1/16W	
R440			RK73HB1J102J	CHIP R 1.0K J 1/16W		R588-590			RK73HB1J000J	CHIP R 0.0 J 1/16W	
R441			RK73HB1J123J	CHIP R 12K J 1/16W		R591			RK73HB1J102J	CHIP R 1.0K J 1/16W	
R442			RK73HH1J334D	CHIP R 330K D 1/16W		R592,593			RK73HB1J000J	CHIP R 0.0 J 1/16W	
R443			RK73HH1J223D	CHIP R 22K D 1/16W		R594			RK73HB1J102J	CHIP R 1.0K J 1/16W	
R444			RK73HB1J272J	CHIP R 2.7K J 1/16W		R595			RK73HB1J000J	CHIP R 0.0 J 1/16W	
R445			RK73HB1J473J	CHIP R 47K J 1/16W		R596			RK73HB1J104J	CHIP R 100K J 1/16W	
R446			RK73GB2A100J	CHIP R 10 J 1/10W		R597			RK73HB1J102J	CHIP R 1.0K J 1/16W	
R447			RK73HB1J473J	CHIP R 47K J 1/16W		R598-601			RK73FB2B102J	CHIP R 1.0K J 1/8W	
R448			RK73HB1J000J	CHIP R 0.0 J 1/16W		R602			RK73HB1J102J	CHIP R 1.0K J 1/16W	
R449			RK73GB2A220J	CHIP R 22 J 1/10W		R603,604			RK73HB1J000J	CHIP R 0.0 J 1/16W	
R450			RK73HB1J000J	CHIP R 0.0 J 1/16W		R605			RK73HB1J102J	CHIP R 1.0K J 1/16W	
R501			RK73HB1J104J	CHIP R 100K J 1/16W		R606			RK73HB1J103J	CHIP R 10K J 1/16W	
R503			RK73HB1J102J	CHIP R 1.0K J 1/16W		R607,608			RK73HB1J102J	CHIP R 1.0K J 1/16W	
R504			RK73HB1J104J	CHIP R 100K J 1/16W		R610			RK73HB1J102J	CHIP R 1.0K J 1/16W	
R506			RK73HB1J474J	CHIP R 470K J 1/16W		R611,612			RK73HB1J105J	CHIP R 1.0M J 1/16W	
R507			RK73HB1J000J	CHIP R 0.0 J 1/16W		R614			RK73HB1J474J	CHIP R 470K J 1/16W	
R509			RK73HB1J000J	CHIP R 0.0 J 1/16W		R615,616			RK73HB1J000J	CHIP R 0.0 J 1/16W	
R510			RK73HB1J474J	CHIP R 470K J 1/16W		R617-620			RK73HB1J102J	CHIP R 1.0K J 1/16W	
R511			RK73HB1J220J	CHIP R 22 J 1/16W		R621			RK73HB1J000J	CHIP R 0.0 J 1/16W	
R512			RK73HB1J104J	CHIP R 100K J 1/16W		R622			RK73HB1J102J	CHIP R 1.0K J 1/16W	
R514			RK73HB1J000J	CHIP R 0.0 J 1/16W		R623-625			RK73HB1J104J	CHIP R 100K J 1/16W	
R515,516			RK73HB1J104J	CHIP R 100K J 1/16W		R627,628			RK73HB1J104J	CHIP R 100K J 1/16W	
R520,521			RK73HB1J473J	CHIP R 47K J 1/16W		R629			RK73HB1J105J	CHIP R 1.0M J 1/16W	
R522			RK73HB1J474J	CHIP R 470K J 1/16W		R630			RK73HB1J102J	CHIP R 1.0K J 1/16W	
R523			RK73HB1J473J	CHIP R 47K J 1/16W		R632			RK73HB1J103J	CHIP R 10K J 1/16W	
R524			RK73HB1J000J	CHIP R 0.0 J 1/16W		R633			RK73HB1J000J	CHIP R 0.0 J 1/16W	
R525			RK73HB1J104J	CHIP R 100K J 1/16W		R634			RK73HB1J103J	CHIP R 10K J 1/16W	
R527			RK73HB1J104J	CHIP R 100K J 1/16W		R636			RK73HB1J000J	CHIP R 0.0 J 1/16W	
R528,529			RK73HB1J000J	CHIP R 0.0 J 1/16W		R637			RK73HB1J103J	CHIP R 10K J 1/16W	
R531			RK73HB1J104J	CHIP R 100K J 1/16W		R638			RK73HB1J104J	CHIP R 100K J 1/16W	
R532			RK73HB1J101J	CHIP R 100 J 1/16W		R639			RK73HB1J102J	CHIP R 1.0K J 1/16W	
R533,534			RK73HB1J000J	CHIP R 0.0 J 1/16W		R640			RK73HB1J103J	CHIP R 10K J 1/16W	
R536,537			RK73HB1J000J	CHIP R 0.0 J 1/16W		R641,642			RK73HB1J104J	CHIP R 100K J 1/16W	

PARTS LIST / 零件表

TX-RX UNIT (X57-7742-71)

Ref. No.	Address	New parts	Parts No.	Description	Destination	Ref. No.	Address	New parts	Parts No.	Description	Destination
R644			RK73GB2A000J	CHIP R 0.0 J 1/10W		R749			RK73HB1J823J	CHIP R 82K J 1/16W	
R646			RK73HB1J682J	CHIP R 6.8K J 1/16W		R750			RK73HB1J332J	CHIP R 3.3K J 1/16W	
R648			RK73HB1J682J	CHIP R 6.8K J 1/16W		R751			RK73HB1J271J	CHIP R 270 J 1/16W	
R650			RK73GB2A000J	CHIP R 0.0 J 1/10W		R752			RK73HB1J102J	CHIP R 1.0K J 1/16W	
R651			RK73FB2B102J	CHIP R 1.0K J 1/8W		R753			RK73HB1J563J	CHIP R 56K J 1/16W	
R652			RK73HB1J104J	CHIP R 100K J 1/16W		R755			RK73HB1J103J	CHIP R 10K J 1/16W	
R654			RK73GB2A000J	CHIP R 0.0 J 1/10W		R756			RK73HB1J153J	CHIP R 15K J 1/16W	
R656			RK73HB1J471J	CHIP R 470 J 1/16W		R758			RK73HB1J103J	CHIP R 10K J 1/16W	
R658			RK73GB2A000J	CHIP R 0.0 J 1/10W		R759			RK73HB1J104J	CHIP R 100K J 1/16W	
R659-661			RK73HB1J104J	CHIP R 100K J 1/16W		R760			RK73HB1J152J	CHIP R 1.5K J 1/16W	
R662,663			RK73HB1J474J	CHIP R 470K J 1/16W		R761			RK73HB1J563J	CHIP R 56K J 1/16W	
R664-674			RK73HB1J104J	CHIP R 100K J 1/16W		R762			RK73HB1J684J	CHIP R 680K J 1/16W	
R676			RK73HB1J104J	CHIP R 100K J 1/16W		R763			RK73HB1J183J	CHIP R 18K J 1/16W	
R677			RK73HB1J474J	CHIP R 470K J 1/16W		R764			RK73HB1J124J	CHIP R 120K J 1/16W	
R678			RK73HB1J104J	CHIP R 100K J 1/16W		R765			RK73HB1J102J	CHIP R 1.0K J 1/16W	
R680-683			RK73HB1J102J	CHIP R 1.0K J 1/16W		R766			RK73HB1J104J	CHIP R 100K J 1/16W	
R684-686			RK73HB1J104J	CHIP R 100K J 1/16W		R767,768			RK73HB1J473J	CHIP R 47K J 1/16W	
R687,688			RK73HB1J472J	CHIP R 4.7K J 1/16W		R769			RK73HB1J472J	CHIP R 4.7K J 1/16W	
R689,690			RK73HB1J474J	CHIP R 470K J 1/16W		R770			RK73HB1J563J	CHIP R 56K J 1/16W	
R691-696			RK73HB1J104J	CHIP R 100K J 1/16W		R771			RK73HB1J104J	CHIP R 100K J 1/16W	
R697,698			RK73HB1J000J	CHIP R 0.0 J 1/16W		R772			RK73HB1J123J	CHIP R 12K J 1/16W	
R701			RK73HB1J104J	CHIP R 100K J 1/16W		R773			RK73HB1J684J	CHIP R 680K J 1/16W	
R703			RK73HB1J103J	CHIP R 10K J 1/16W		R774			RK73HB1J474J	CHIP R 470K J 1/16W	
R704			RK73HB1J563J	CHIP R 56K J 1/16W		R775			RK73HB1J823J	CHIP R 82K J 1/16W	
R705			RK73HB1J104J	CHIP R 100K J 1/16W		R776			RK73HB1J334J	CHIP R 330K J 1/16W	
R706			RK73HB1J683J	CHIP R 68K J 1/16W		R777			RK73HB1J154J	CHIP R 150K J 1/16W	
R707			RK73HB1J153J	CHIP R 15K J 1/16W		R778			RK73HB1J394J	CHIP R 390K J 1/16W	
R708			RK73HB1J683J	CHIP R 68K J 1/16W		R779			RK73HB1J474J	CHIP R 470K J 1/16W	
R709			RK73HB1J822J	CHIP R 8.2K J 1/16W		R782			RK73HB1J153J	CHIP R 15K J 1/16W	
R710			RK73HB1J104J	CHIP R 100K J 1/16W		R783			RK73HB1J000J	CHIP R 0.0 J 1/16W	
R712			RK73HB1J683J	CHIP R 68K J 1/16W		R784			RK73HB1J154J	CHIP R 150K J 1/16W	
R713			RK73HB1J563J	CHIP R 56K J 1/16W		R785			RK73HB1J103J	CHIP R 10K J 1/16W	
R714			RK73HB1J104J	CHIP R 100K J 1/16W		R786			RK73HB1J393J	CHIP R 39K J 1/16W	
R715			RK73HB1J473J	CHIP R 47K J 1/16W		R787			RK73HB1J274J	CHIP R 270K J 1/16W	
R716			RK73HB1J000J	CHIP R 0.0 J 1/16W		R788			RK73HB1J223J	CHIP R 22K J 1/16W	
R717			RK73HB1J393J	CHIP R 39K J 1/16W		R789			RK73HB1J000J	CHIP R 0.0 J 1/16W	
R718			RK73HB1J000J	CHIP R 0.0 J 1/16W		R790			RK73HB1J224J	CHIP R 220K J 1/16W	
R720			RK73HB1J104J	CHIP R 100K J 1/16W		R791			RK73HB1J564J	CHIP R 560K J 1/16W	
R721			RK73HB1J222J	CHIP R 2.2K J 1/16W		R792			RK73HB1J102J	CHIP R 1.0K J 1/16W	
R722			RK73HB1J683J	CHIP R 68K J 1/16W		R793,794			RK73HB1J000J	CHIP R 0.0 J 1/16W	
R724			RK73HB1J563J	CHIP R 56K J 1/16W		R795			RK73HB1J224J	CHIP R 220K J 1/16W	
R725			RK73HB1J683J	CHIP R 68K J 1/16W		R796			RK73HB1J103J	CHIP R 10K J 1/16W	
R726			RK73HB1J100J	CHIP R 10 J 1/16W		R797			RK73HB1J334J	CHIP R 330K J 1/16W	
R727			RK73HB1J274J	CHIP R 270K J 1/16W		R798			RK73HB1J684J	CHIP R 680K J 1/16W	
R728			RK73HB1J000J	CHIP R 0.0 J 1/16W		R799			RK73HB1J563J	CHIP R 56K J 1/16W	
R729			RK73HB1J104J	CHIP R 100K J 1/16W		R800			RK73HB1J472J	CHIP R 4.7K J 1/16W	
R730			RK73HB1J103J	CHIP R 10K J 1/16W		R801			RK73HB1J104J	CHIP R 100K J 1/16W	
R731			RK73HB1J000J	CHIP R 0.0 J 1/16W		R802			RK73HB1J273J	CHIP R 27K J 1/16W	
R732			RK73HB1J473J	CHIP R 47K J 1/16W		R803			RK73HB1J153J	CHIP R 15K J 1/16W	
R733			RK73HB1J333J	CHIP R 33K J 1/16W		R804			RK73HB1J681J	CHIP R 680 J 1/16W	
R734			RK73HB1J223J	CHIP R 22K J 1/16W		R805			RK73HB1J823J	CHIP R 82K J 1/16W	
R737			RK73HB1J473J	CHIP R 47K J 1/16W		R806			RK73HB1J562J	CHIP R 5.6K J 1/16W	
R738			RK73HB1J102J	CHIP R 1.0K J 1/16W		R807,808			RK73HB1J103J	CHIP R 10K J 1/16W	
R739			RK73HB1J000J	CHIP R 0.0 J 1/16W		R809			RK73HB1J104J	CHIP R 100K J 1/16W	
R740,741			RK73HB1J104J	CHIP R 100K J 1/16W		R810			RK73HB1J102J	CHIP R 1.0K J 1/16W	
R744			RK73HB1J473J	CHIP R 47K J 1/16W		R812,813			RK73HB1J472J	CHIP R 4.7K J 1/16W	
R745			RK73HB1J104J	CHIP R 100K J 1/16W		R814-816			RK73HB1J104J	CHIP R 100K J 1/16W	
R746			RK73HB1J103J	CHIP R 10K J 1/16W		R817			RK73HB1J473J	CHIP R 47K J 1/16W	
R747			RK73HB1J334J	CHIP R 330K J 1/16W		R818			RK73HB1J333J	CHIP R 33K J 1/16W	
R748			RK73HB1J000J	CHIP R 0.0 J 1/16W		R819			RK73HB1J000J	CHIP R 0.0 J 1/16W	

PARTS LIST / 零件表

TX-RX UNIT (X57-7742-71)

Ref. No.	Address	New parts	Parts No.	Description	Destination	Ref. No.	Address	New parts	Parts No.	Description	Destination
R820			RK73HB1J474J	CHIP R 470K J 1/16W		D703-705			RB706F-40	DIODE	
R821			RK73HB1J000J	CHIP R 0.0 J 1/16W		D706,707			EMZ6.8N	ZENER DIODE	
R822			RK73HB1J101J	CHIP R 100 J 1/16W		D901-904			DA204U	DIODE	
R823			RK73HB1J472J	CHIP R 4.7K J 1/16W		D905,906			02DZ18F-X	ZENER DIODE	
R825,826			RK73HB1J103J	CHIP R 10K J 1/16W		D907,908			DA204U	DIODE	
R827			RK73HB1J332J	CHIP R 3.3K J 1/16W		D909			1SS355	DIODE	
R828			RK73HB1J000J	CHIP R 0.0 J 1/16W		D910			02DZ18F-X	ZENER DIODE	
R831			RK73HB1J000J	CHIP R 0.0 J 1/16W		D911,912			DA204U	DIODE	
R833-835			RK73HB1J101J	CHIP R 100 J 1/16W		D913			1SS355	DIODE	
R836			RK73HB1J000J	CHIP R 0.0 J 1/16W		D914			02DZ18F-X	ZENER DIODE	
R837			RK73HB1J472J	CHIP R 4.7K J 1/16W		IC1			LMC7101BIM5	MOS-IC	
R838			RK73HB1J000J	CHIP R 0.0 J 1/16W		IC2			LM73CIMKX-0	MOS-IC	
R841			RK73HB1J000J	CHIP R 0.0 J 1/16W		IC3			SKY72300-362	MOS-IC	
R842			RK73FB2B102J	CHIP R 1.0K J 1/8W		IC4			LMC7101BIM5	MOS-IC	
R843			RK73HB1J471J	CHIP R 470 J 1/16W		IC5			TC75W51FK(F)	MOS-IC	
R845			RK73HB1J102J	CHIP R 1.0K J 1/16W		IC101			TA75W01FUJ	MOS-IC	
R846			RK73HB1J332J	CHIP R 3.3K J 1/16W		IC102	2A		RA60H13171123	MOS-IC	
R847			RK73HB1J000J	CHIP R 0.0 J 1/16W		IC103			TA75W01FUJ	MOS-IC	
R850			RK73GB2A000J	CHIP R 0.0 J 1/10W		IC201			MCP6021-E/OT	MOS-IC	
R901			RK73GB2A471J	CHIP R 470 J 1/10W		IC202			TK10931VTL-G	ANALOGUE IC	
R902,903			RK73HB1J101J	CHIP R 100 J 1/16W		IC203			TC75W51FK(F)	MOS-IC	
R904-913			RK73HB1J471J	CHIP R 470 J 1/16W		IC204			SPM5001	MOS-IC	
R914			RK73GB2A471J	CHIP R 470 J 1/10W		IC205,206			LMC7101BIM5	MOS-IC	
R915			RK73HB1J000J	CHIP R 0.0 J 1/16W		IC401			XC6108C23CMN	MOS-IC	
R918-920			RK73HB1J000J	CHIP R 0.0 J 1/16W		IC402			XC6204B332P1	ANALOGUE IC	
R921			RK73HB1J474J	CHIP R 470K J 1/16W		IC403	2A		NJM78M08FA-ZB	ANALOGUE IC	
R923			RK73HB1J473J	CHIP R 47K J 1/16W		IC404			TA7805FQ	MOS-IC	
D3			DA221	DIODE		IC405			LT1616ES6-PBF	ANALOGUE IC	
D5,6			HVC131	DIODE		IC406			TK71733S	BI-POLAR IC	
D7,8			1SV325F	VARIABLE CAPACITANCE DIODE		IC407,408			XC6204B332M	MOS-IC	
D11-16			1SV282-F	VARIABLE CAPACITANCE DIODE		IC409			XC6205B152PRN	ANALOGUE IC	
D18			1SV278F	VARIABLE CAPACITANCE DIODE		IC410			XC9101D09AKR	ANALOGUE IC	
D19-21			HVC131	DIODE		IC501			Note 1 (BGA)	ROM IC	
D101			HVC131	DIODE		IC502			Note 1 (BGA)	MICROPROCESSOR IC	
D102			02DZ5.6F-X,Y	ZENER DIODE		IC503			Note 1 (BGA)	SRAM IC	
D103,104			L407CDB	DIODE (50V/1W)		IC504			RV5C386A	MOS-IC	
D105			L7091CER	DIODE		IC505			TC7SH08FU-F	MOS-IC	
D107-109			HSM88AS-E	DIODE		IC506			XC6109C29ANN	ANALOGUE IC	
D201,202			DAN235E	DIODE		IC507			TC7SH126FU-F	MOS-IC	
D205			HVC131	DIODE		IC508			SM5023CNDH-G	MOS-IC	
D207-210			1SV283F	VARIABLE CAPACITANCE DIODE		IC509			TC7WT125FUJ	MOS-IC	
D213			1SV325F	VARIABLE CAPACITANCE DIODE		IC510			Note 1 (BGA)	MOS-IC	
D215			HVC131	DIODE		IC511			TC7SH08FU-F	MOS-IC	
D216-218			1SV325F	VARIABLE CAPACITANCE DIODE		IC512,513			TC7SET08FU-F	MOS-IC	
D401			02DZ18F-X	ZENER DIODE		IC514			TC7WBD125AFK	MOS-IC	
D403			1SS416	DIODE		IC515			TC7WT126FU-F	MOS-IC	
D404			22ZR-10D	SURGE ABSORBER		IC516			TC7WH126FU-F	MOS-IC	
D405			DSA3A1	DIODE		IC517			PCA9535RGE	MOS-IC	
D406			HSC119	DIODE		IC518			ADM202EARNZ	MOS-IC	
D407			CRS02-Q	DIODE		IC701			TC75S51FE(F)	MOS-IC	
D408			1SS301F	DIODE		IC702,703			TC75W51FK(F)	MOS-IC	
D409-412			1SS388F	DIODE		IC704			MCP6021-E/OT	MOS-IC	
D501,502			1SS388F	DIODE		IC705,706			TC75W51FK(F)	MOS-IC	
D503,504			1SS416	DIODE		IC707,708			TC7W53FK(F)	MOS-IC	
D506,507			1SS416	DIODE		IC709			TC75W51FK(F)	MOS-IC	
D508			DA204U	DIODE		IC710			TC7W53FK(F)	MOS-IC	
D509,510			1SS416	DIODE		IC711			TC75W51FK(F)	MOS-IC	
D511,512			DA204U	DIODE		IC712			M62364FP-F	MOS-IC	
D702			HSC119	DIODE		IC713			TC7W53FK(F)	MOS-IC	
						IC714			TC75S51FE(F)	MOS-IC	

PARTS LIST / 零件表

TX-RX UNIT (X57-7742-71)

Ref. No.	Address	New parts	Parts No.	Description	Destination	Ref. No.	Address	New parts	Parts No.	Description	Destination
IC715	2A		LA4425A	MOS-IC							
Q1			2SC5383-T111	TRANSISTOR							
Q2			RT1P144U-T111	TRANSISTOR							
Q3			SSM3K15TE(F)	FET							
Q5			EMD9	TRANSISTOR							
Q6			2SC5636	TRANSISTOR							
Q7			2SC5383-T111	TRANSISTOR							
Q9,10			2SK508NV(K52)	FET							
Q11			SSM6L05FU-F	FET							
Q12			SSM3J05FU-F	FET							
Q13,14			2SC5636	TRANSISTOR							
Q15			2SK1215-E(E)	FET							
Q101			2SC5108(Y)F	TRANSISTOR							
Q102			2SC5455-A	TRANSISTOR							
Q105			RT1N141U-T111	TRANSISTOR							
Q106			2SK1830F	FET							
Q201			RT1P141U-T111	TRANSISTOR							
Q202			RT1N441U-T111	TRANSISTOR							
Q203			2SC5636	TRANSISTOR							
Q204,205			2SC3356(R23)	TRANSISTOR							
Q208			2SC5636	TRANSISTOR							
Q210			2SC3357-A	TRANSISTOR							
Q212			EMD9	TRANSISTOR							
Q401,402			RT1N141U-T111	TRANSISTOR							
Q403			RT1N140U-T111	TRANSISTOR							
Q404			2SJ645	FET							
Q405			2SA1955A-F	TRANSISTOR							
Q406			UPA672T-A	FET							
Q407-409			12A02CH	TRANSISTOR							
Q410			SSM3K15TE(F)	FET							
Q411,412			2SA1955A-F	TRANSISTOR							
Q413-415			RT1N141U-T111	TRANSISTOR							
Q416			SSM6L05FU-F	FET							
Q417			SSM5H01TU-F	FET							
Q501			UPA672T-A	FET							
Q701			SSM3K15TE(F)	FET							
Q702			2SC4617(Q)	TRANSISTOR							
Q703			SSM3K15TE(F)	FET							
Q704			2SC4738(GR)F	TRANSISTOR							
Q705			2SA1832(GR)F	TRANSISTOR							
Q706,707			2SJ243-A	FET							
Q708			2SA1832(GR)F	TRANSISTOR							
Q709			RT1N141U-T111	TRANSISTOR							
Q710			DTC363EU	DIGITAL TRANSISTOR							
Q901,902			Q5X6	TRANSISTOR							
TH101,102			ERTJ0EV104H	THERMISTOR							
TH701			ERTJ0EV104H	THERMISTOR							
101	2A		W09-0971-05	LITHIUM CELL							

If a part reference number is listed in a shaded box, that part does not come with the PCB.

NX-700

EXPLODED VIEW / 部件分解图

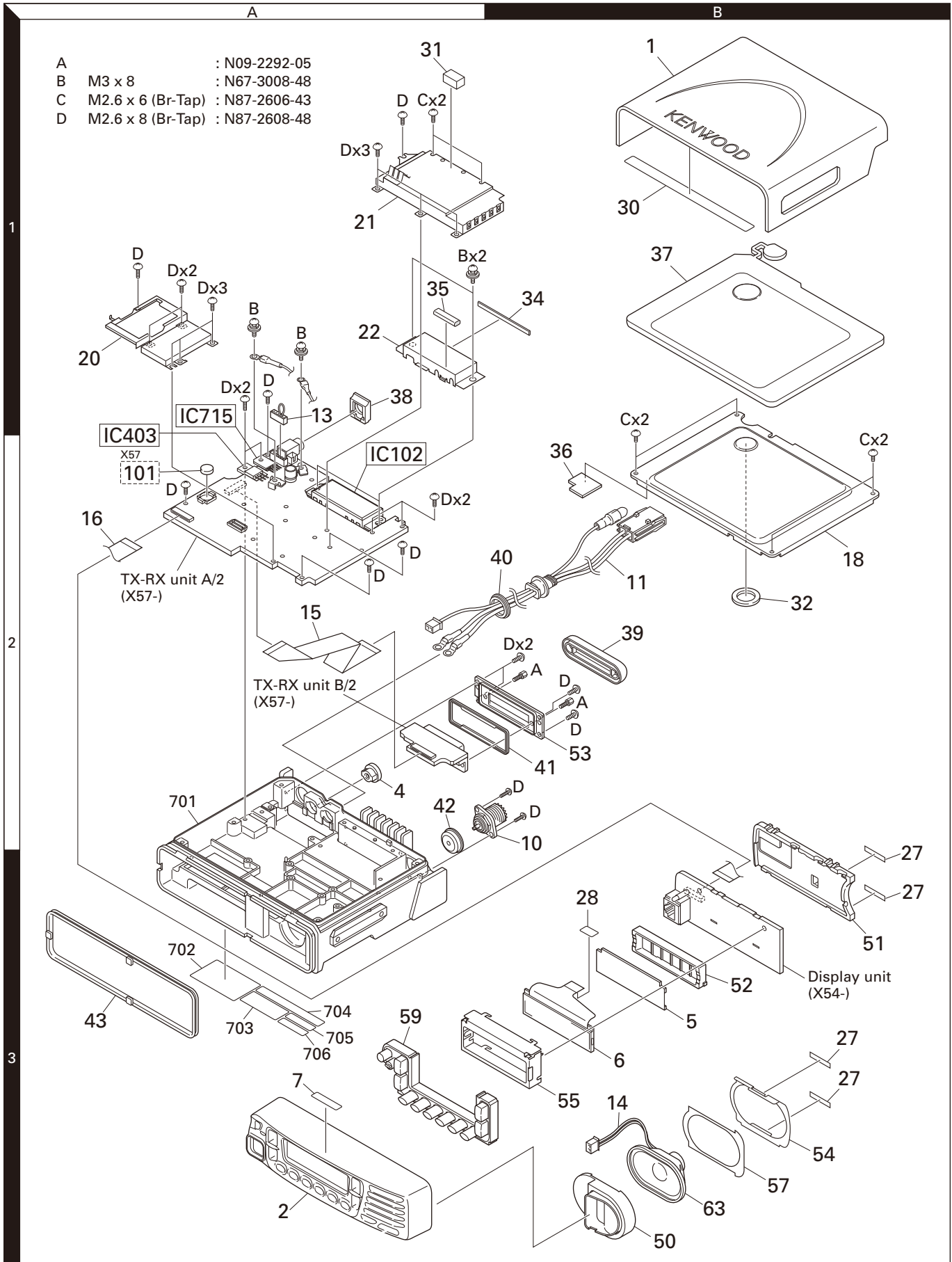

54 Parts with the exploded numbers larger than 700 are not supplied.
 If a part reference number is listed in a box on the exploded view of the PCB, that part does not come with the PCB.
 These parts must be ordered separately.

PACKING / 包装

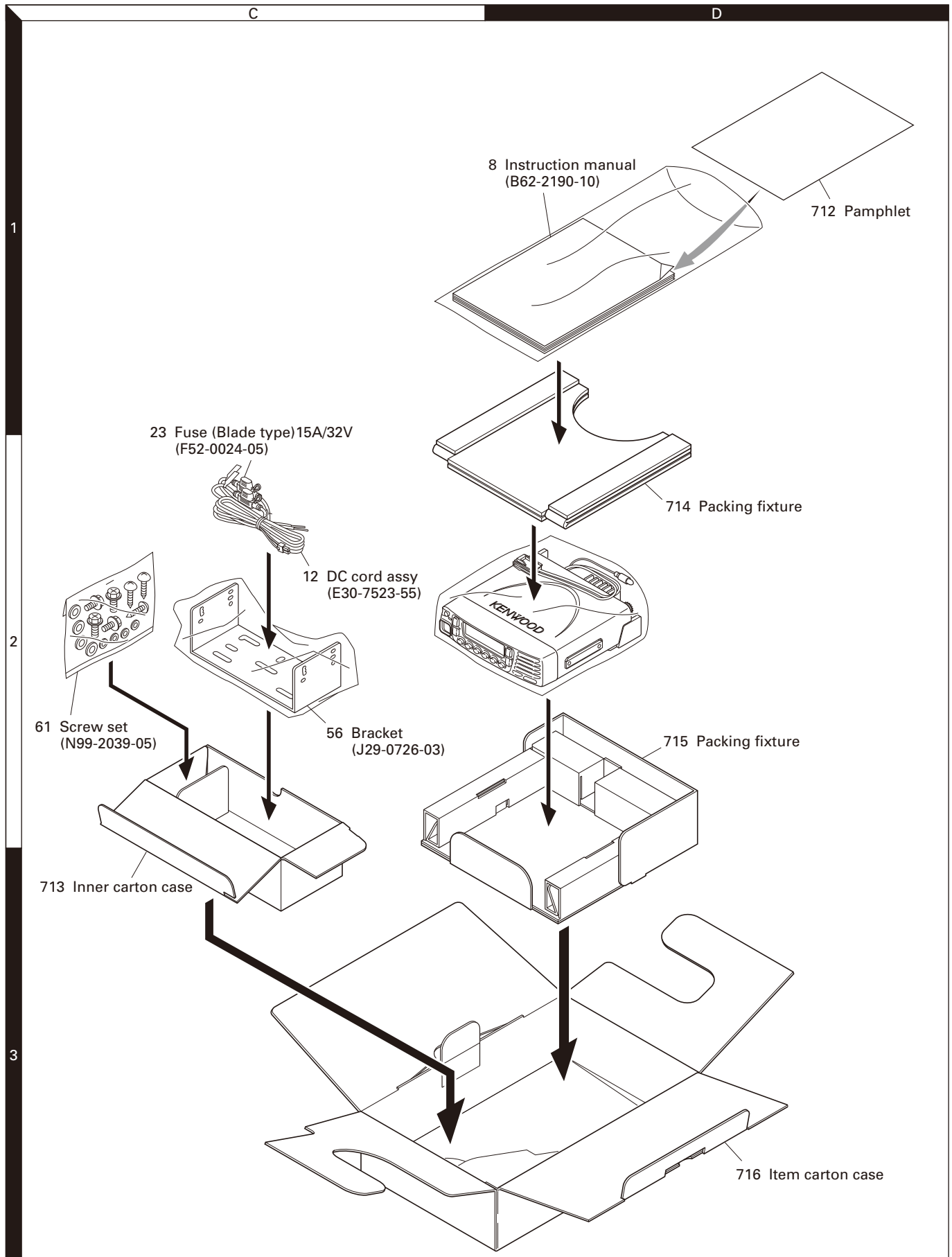

Parts with the exploded numbers larger than 700 are not supplied.

TROUBLE SHOOTING

Fault diagnosis of the BGA (Ball Grid Array) IC

Overview: A flowchart for determining whether or not the transceiver can be powered on (the LCD does not function even if the power switch is turned on) due to broken BGA parts.

BGA parts: ASIC (IC510), DSP (IC502), FLASH (IC501), SRAM (IC503)

When the BGA IC is problematic, please bring the printed circuit board (X57-7742-71) in for service. Various ESN/default adjustment values are written on the printed circuit board for service. Additionally various ESN stickers are included. The power module (RA60H13171123), short connector (E37-1180-05) and button type lithium battery (W09-0971-05) do not belong to the printed circuit board for service. Please use the part which has been attached to the printed circuit board. After the printed circuit board has been readjusted, please attach any ESN stickers to the chassis. When "ESN Validation" is used with NXDN Trunking, you must modify the ESN register.

● Checking power supply voltage

Checking voltage	
Points to be checked	Normal voltage
33M IC402 (5 pin)	3.3V
15M IC409 (5 pin)	1.5V
33A IC408 (5 pin)	3.3V
33BU D411 (Cathode side)	3.3V
Power supply of each device is connected through the coil. [ASIC] 33M: L903, 15M: L511, 33A: R603 [DSP] 33M: L503, 15M: L502 [FLASH] 33M: L501 [SRAM] 33BU: L522	

When an abnormal value is confirmed.

Checking for an abnormal point	
33M has an abnormal voltage. [ASIC] Remove L508 to check the voltage of the 33M. If the voltage becomes normal, the ASIC is broken. [DSP] Remove L503 to check the voltage of the 33M. If the voltage becomes normal, the DSP is broken. [FLASH] Remove L501 to check the voltage of the 33M. If the voltage becomes normal, the FLASH is broken.	
15M has an abnormal voltage. [ASIC] Remove L511 to check the voltage of the 15M. If the voltage becomes normal, the ASIC is broken. [DSP] Remove L502 to check the voltage of the 15M. If the voltage becomes normal, the DSP is broken.	
33A has an abnormal voltage. [ASIC] Remove R603 to check the voltage of the 33A. If the voltage becomes normal, the ASIC is broken.	
33BU has an abnormal voltage. [SRAM] Remove L522 to check the voltage of the 33BU. If the voltage becomes normal, the SRAM is broken.	
If the voltage is not corrected, there is a problem other than the BGA parts.	

● Checking the clock

Checking the clock	
Points to be checked	Normal voltage (3.3V)
18.432MHz ASIC side R569	18.432MHz
DSP side R511	18.432MHz
32.768kHz IC504 (1 pin) or R545	32.768kHz

When a normal value is confirmed.

When an abnormal value is confirmed.

● Checking the Reset/Control signal

Checking the control signal input to the ASIC	
Points to be checked	Normal voltage
RST (RESET) IC506 (4 pin)	3.3V
/BINT IC401 (1 pin)	3.3V
/OVRB D403 (Cathode side)	3.3V

When a normal value is confirmed.

When an abnormal value is confirmed.

Checking the ASIC input switch signal	
*Each signal is not masked by the setting of the FPU. The POWER key is pressed and held.	
Points to be checked	Confirmed voltage
/PSW (R619) The ignition key is kept ON.	0V
/IGN (R618)	0V

When a normal value is confirmed.

When an abnormal value is confirmed.

● Checking the output signal from the ASIC

Points to be checked	Normal voltage
/FRST R509	3.3V

When a normal value is confirmed.

When an abnormal value is confirmed.

Remove the R569, R511 and R545. If it oscillates normally, the DSP and ASIC may be broken.

The BGA parts are not broken.

If the /FRST is always 0V, the ASIC is broken.
If the /FRST repeats 3.3V and 0V at intervals, the ASIC, FLASH and SRAM may be broken.

故障排除

BGA(球状矩阵排列)IC的故障诊断

概述：用于确定对讲机因BGA部分损坏时是否可以开启电源（即使打开电源开关LCD也不工作）的流程。

BGA部分：ASIC(IC510)、DSP(IC502)、FLASH(IC501)、SRAM(IC503)

BGA IC出现问题时，请带印刷电路板(X57-7742-71)进行维修。各种ESN/默认调整值写在用于维修的印刷电路板上。此外还包括各种ESN标签。功率模块(RA60H13171123)、短路连接器(E37-1180-05)和纽扣式锂电池(W09-0971-05)不属于用于维修的印刷电路板。请使用已经安装在印刷电路板上的部分。印刷电路板经过重新调整后，请将ESN标签贴到底座上。“ESN验证”用于NXDN集群时，必须修改ESN寄存器。

● 检查电源电压

检查电压	
检查点	正常电压
33M IC402 (5针)	3.3V
15M IC409 (5针)	1.5V
33A IC408 (5针)	3.3V
33BU D411 (阴极侧)	3.3V
各装置的电源连通线圈	
[ASIC]	
33M: L903, 15M: L511, 33A: R603	
[DSP]	
33M: L503, 15M: L502	
[FLASH]	
33M: L501	
[SRAM]	
33BU: L522	

● 检查时钟

检查时钟	
检查点	正常电压 (3.3V)
18.432MHz ASIC侧R569	18.432MHz
DSP侧R511	18.432MHz
32.768kHz IC504 (1针)或R545	32.768kHz

● 检查复位/控制信号

检查输入到ASIC的控制信号	
检查点	正常电压
RST (RESET) IC506 (4针)	3.3V
/BINT IC401 (1针)	3.3V
/OVRB D403 (阴极侧)	3.3V

检查ASIC输入开关信号	
*各信号未被FPU的设置屏蔽	
按住POWER键	
检查点	确认的电压
/PSW (R619)	0V
点火钥匙保持ON	
检查点	确认的电压
/IGN (R618)	0V

● 检查ASIC的输出信号

检查点	
/FRST R509	正常电压
	3.3V

检查异常点

33M有异常电压
[ASIC]
取出L508检查33M的电压。
如果电压变正常，则ASIC已损坏。
[DSP]
取出L503检查33M的电压。
如果电压变正常，则DSP已损坏。
[FLASH]
取出L501检查33M的电压。
如果电压变正常，则FLASH已损坏。

15M有异常电压
[ASIC]
取出L511检查15M的电压。
如果电压变正常，则ASIC已损坏。
[DSP]
取出L502检查15M的电压。
如果电压变正常，则DSP已损坏。

33A有异常电压
[ASIC]
取出R603检查33A的电压。
如果电压变正常，则ASIC已损坏。

33BU有异常电压
[SRAM]
取出L522检查33BU的电压。
如果电压变正常，则SRAM已损坏。

如果电压无法纠正，则是BGA部分之外的其他部分的问题。

取下R569、R511和R545。如果它正常振荡，则DSP和ASIC可能已损坏。

BGA部分未损坏。

如果 /FRST始终为0V，则ASIC已损坏。
如果 /FRST交替重复3.3V和0V，则ASIC、FLASH和SRAM可能已损坏。

TROUBLE SHOOTING

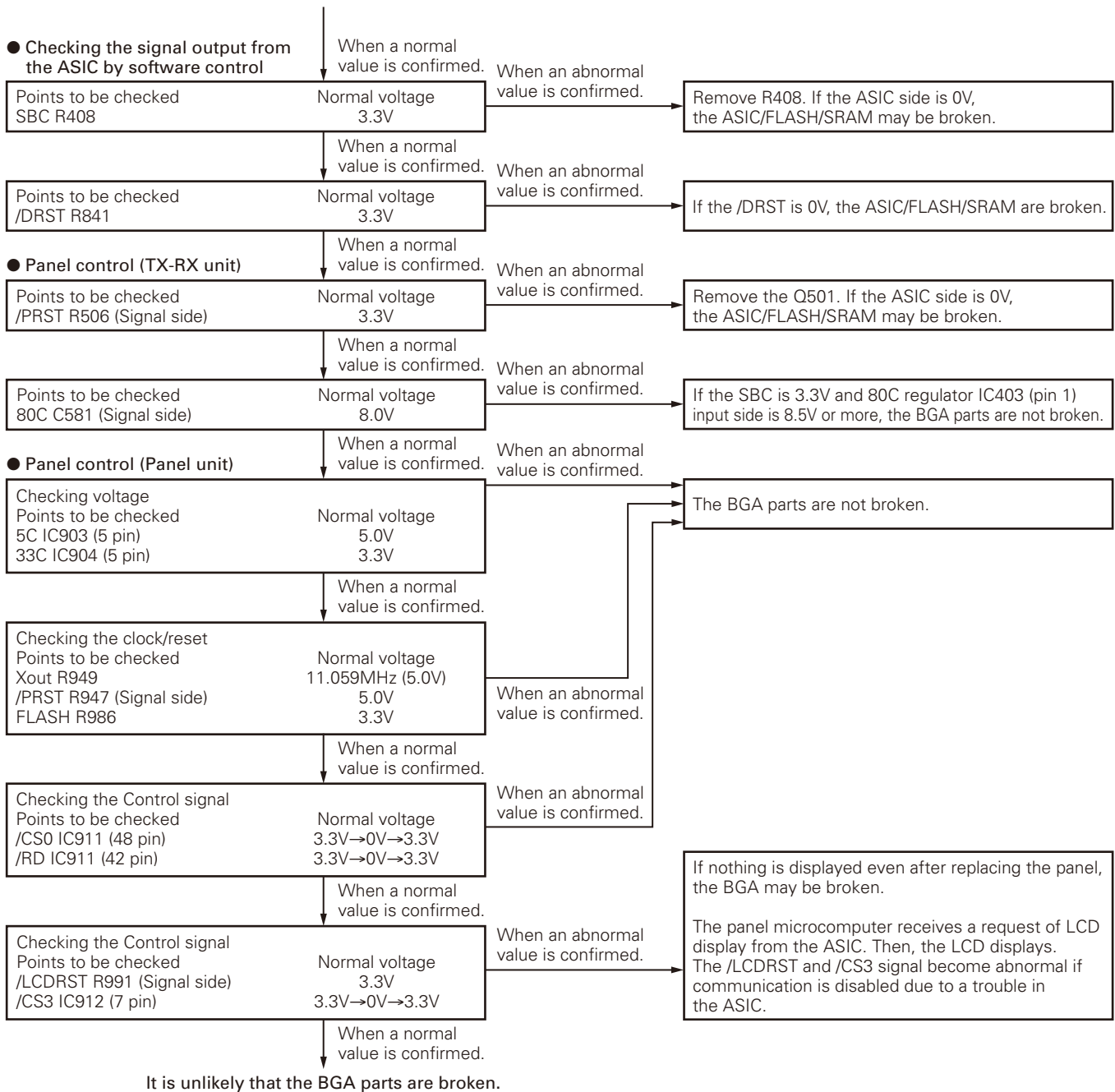

● **When an error display appears on the LCD.**

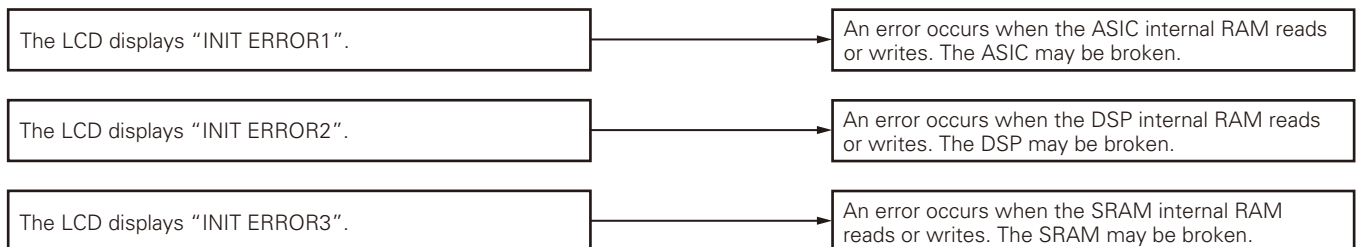

故障排除

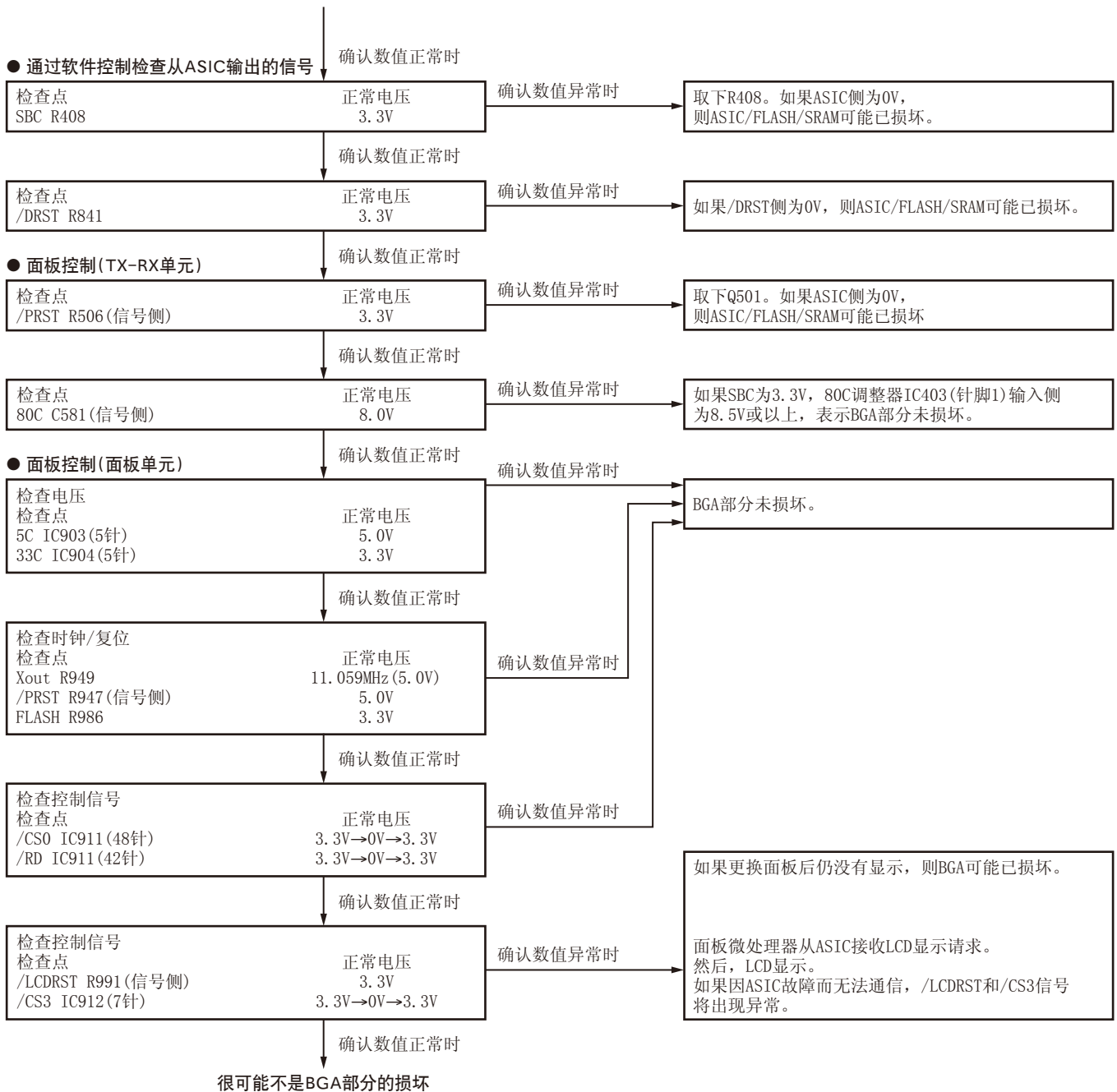

● LCD上出现错误显示时

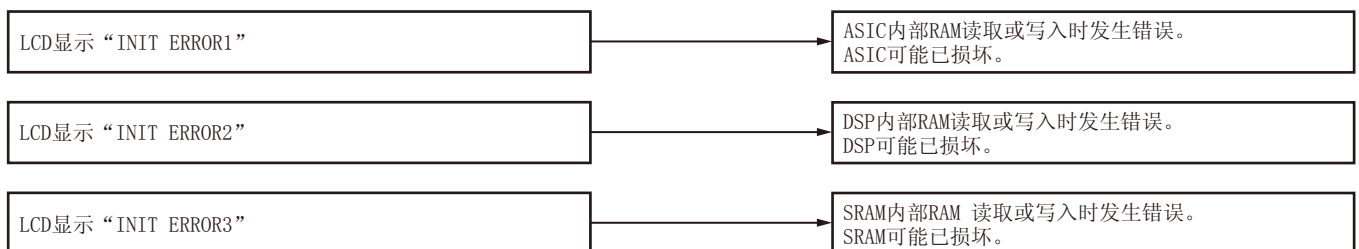

Replacing TX-RX Unit

■ TX-RX Unit Information

Model Name	Original TX-RX Unit Number	For Service TX-RX Unit Number
NX-700 (C)	X57-7742-71	X57-7742-72

■ Method of confirming "Original TX-RX unit" and "Service TX-RX Unit"

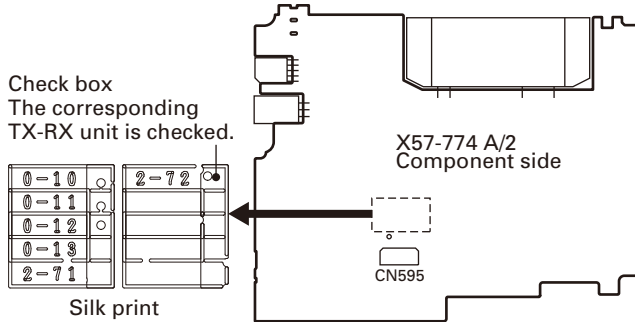

■ Supplied Accessories of "Service TX-RX Unit"

Item (Including Parts Number)	Quantity
TX-RX Unit	1
Kenwood ESN Label	1
NXDN ESN Label	1
Product Number Label	1
MPT ESN Label	1
Addendum (B59-2576-XX)	1

■ "Service TX-RX Unit" Data

The following data is written on the service unit:

- Firmware
- FPU Data
- Various Adjustment Data
- Kenwood ESN ("S" is given after the model name.)
- NXDN ESN / Product number

■ Printed Circuit Board Data

The following data is written on the printed circuit board:

Data Type	Description
Firmware	NX-700 Firmware.
FPU Data (PC programming mode)	X57-774 (NX-700) Ex type data.
Various Adjustment Data (PC Test mode)	General adjustment values for the X57-774 (NX-700).
Kenwood ESN	Model Name: [X57-774] NX-700S Type: Ex The same number as the Kenwood ESN label is written.
NXDN ESN/ MPT ESN/ Product number	The same number as the NXDN ESN/ MPT ESN/ Product Number label is written.

更换 TX-RX 单元

■ TX-RX 单元信息

型号名称	原始 TX-RX 单元编号	维修 TX-RX 单元编号
NX-700 (C)	X57-7742-71	X57-7742-72

■ "原始 TX-RX 单元" 和 "维修 TX-RX 单元" 的确认方法

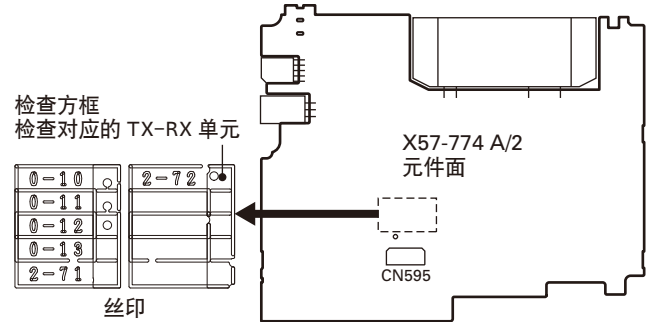

■ "维修 TX-RX 单元" 的附件

项目 (包括零件号)	数量
TX-RX 单元	1
Kenwood ESN 标签	1
NXDN ESN 标签	1
产品编号标签	1
MPT ESN 标签	1
附加物 (B59-2576-XX)	1

■ "维修 TX-RX 单元" 数据

维修单元上写有以下数据：

- 固件
- FPU 数据
- 各种调整数据
- Kenwood ESN (型号名称后有固定的 "S")
- NXDN ESN/ 产品编号

■ 印刷电路板数据

印刷电路板上写有以下数据：

数据类型	说明
固件	NX-700 固件
FPU 数据 (PC 编程模式)	X57-774 (NX-700) Ex 型数据
各种调整数据 (PC 测试模式)	X57-774 (NX-700) 的一般调整值
Kenwood ESN	型号名称：[X57-774] NX-700S 型式：Ex 写有与 Kenwood ESN 标签相同的编号。
NXDN ESN/MPT ESN/ 产品编号	写有与 NXDN ESN/MPT ESN/ 产品编号标签相同的编号。

TROUBLE SHOOTING / 故障排除

■ After Changing the PCB

1. After changing the printed circuit board, write the up-to-date Firmware following the instructions in the "REALIGNMENT - 6.Firmware Programming Mode".
2. Using the KPG-111D(C), select your desired item (Model Name and Frequency) from the Model → Product Information menu, then use Program → Write Data to the Transceiver to write the FPU data (PC Programming mode).
3. Enter Program → Test Mode, then adjust the various adjustment data (PC Test Mode) as described in the "ADJUSTMENT".
4. Attach the new labels corresponding to the new printed circuit board. (Refer to the images below for label placement.)
5. If necessary, write the FPU data used by the customer with the KPG-111D(C).

Note:

- When using the ESN Validation function of NXDN Trunking, the NXDN ESN number changes when the circuit board is changed (the number is written on the circuit board); the NXDN Trunking System cannot be accessed. Use the KPG-110SM on the NXDN Trunking System side to reprogram the NXDN ESN number.
- When a new printed circuit board is used, the Kenwood ESN changes, as does the Transceiver information display of the KPG-111D(C), but this does not have any effect on the operation of the transceiver.
- If changing to the original Kenwood ESN and NXDN ESN, please contact our service center.

■ ESN Label Layout

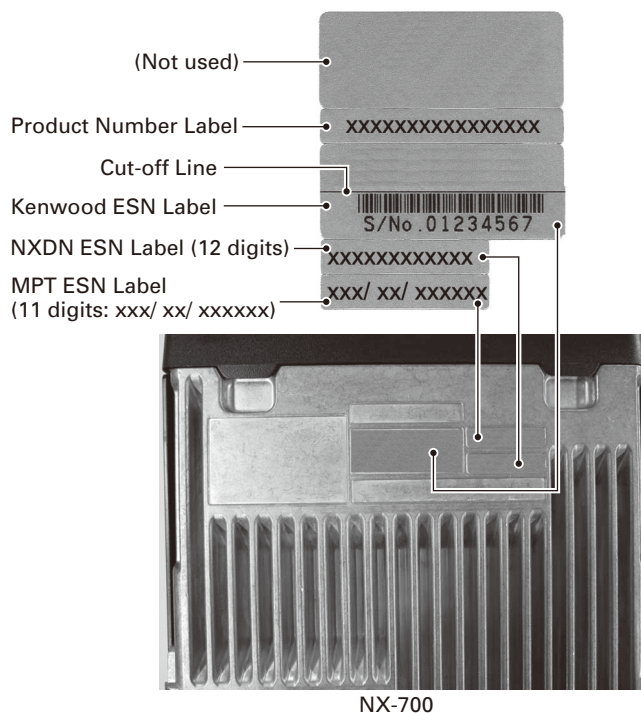

Note: A UPC code and UPC barcode is not printed on the Kenwood ESN Label. If necessary, cut the label at the cut-off line and attach only the serial number.

■ 更换 PCB 后

1. 更换印刷电路板之后，按照“模式组合 - 6. 固件编程模式”的说明写入最新的固件。
2. 使用 KPG-111D(C)，从 Model → Product Information 菜单中选择所需的项目（型号名称和频率），然后用 Program → Write Data to the Transceiver 写入 FPU 数据（PC 编程模式）。
3. 进入 Program → Test Mode，然后按照“调整”中的说明调整各项调整数据（PC 测试模式）。
4. 贴上与新印刷电路板对应的新标签。（关于标签位置，请参见下图。）
5. 如有必要，使用 KPG-111D(C) 写入用户使用的 FPU 数据。

注意：

- 使用 NXDN 集群的 ESN 验证功能时，因 NXDN ESN 编号在更换电路板时发生改变（该编号写在电路板上），所以无法接入 NXDN 系统。可使用 NXDN 系统侧的 KPG-110SM 重新编制 NXDN ESN 编号。
- 使用新印刷电路板时，Kenwood ESN 会改变，KPG-111D(C) 的车载对讲机信息显示也会改变，但这并不影响车载对讲机的操作。
- 若要改为原来的 Kenwood ESN 和 NXDN ESN，请与我方的维修中心联系。

■ ESN 标签布局

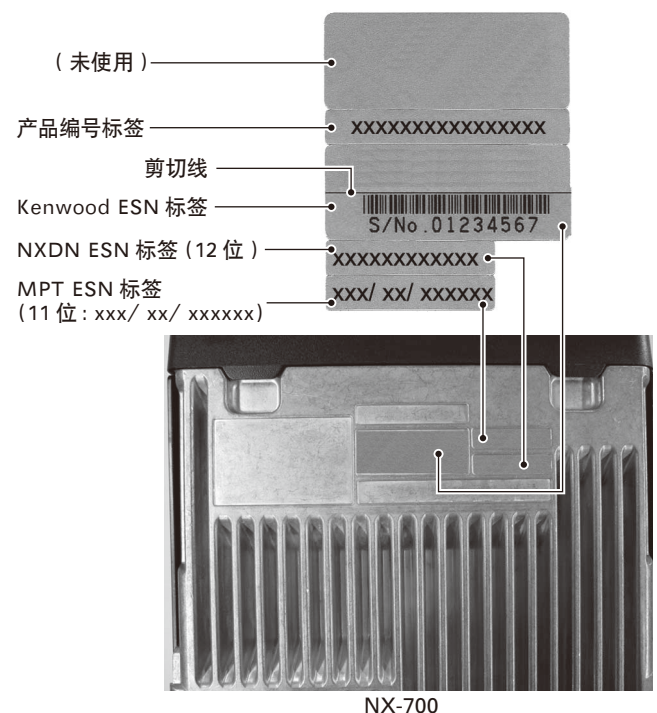

注意： Kenwood ESN 标签上未印制 UPC 代码和 UPC 条码。如有必要，可在剪切线处切断标签，仅贴上序列号。

ADJUSTMENT / 调整

Controls

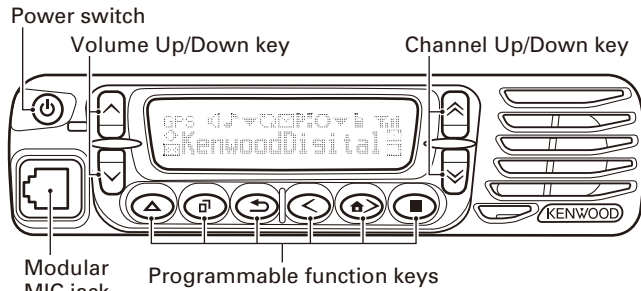

KMC-36

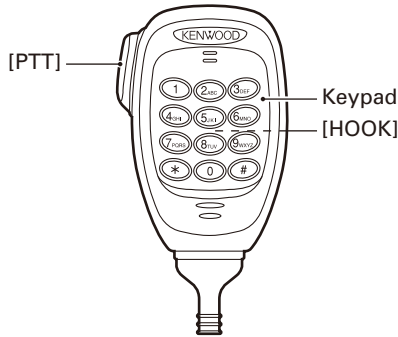

控制

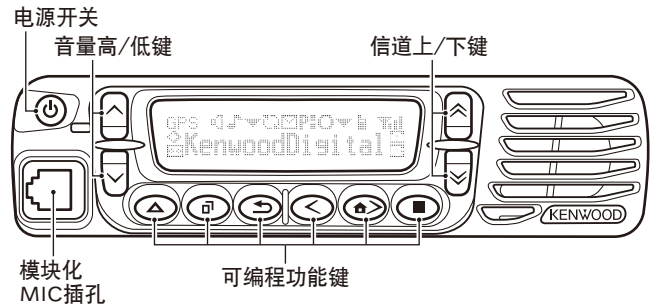

KMC-36

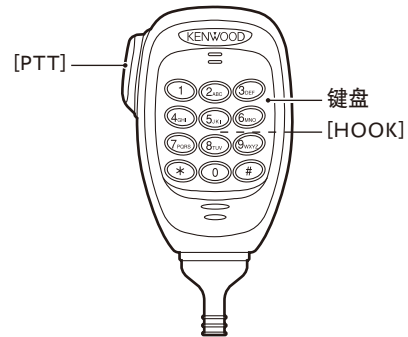

Panel Test Mode

■ Test mode operation features

This transceiver has a test mode. **To enter test mode, press and hold the [↵] key while turning the transceiver power ON. Before the transceiver enters test mode, the frequency version information appears on the LCD momentarily.** Test mode can be inhibited by programming. To exit test mode, turn the transceiver power OFF. The following functions are available in test mode.

■ Key operation

Key	"FNC" not appears on the sub LCD display	
	Function	Display
[↗]/[↘]	Test CH up/down	Channel No.
[^]/[v]	Volume up/down	-
[▲]	Push: Squelch level up Hold: Squelch off	Squelch level Squelch off: 📻 icon appears
[■]	Wide/Narrow/Very narrow	Wide: "w" Narrow: "n" Very narrow: "v"
[📻]	Shift to panel tuning mode	-
[↵]	Function on	"FNC" appears on the sub LCD display
[<]	MSK 1200bps and 2400bps	2400bps: 📻 icon appears
[↗]	Test signaling CH up	Signaling No.

面板测试模式

■ 测试模式操作功能

本车载对讲机有测试模式。要进入测试模式，打开车载对讲机电源时，按住 [↵] 键。车载对讲机进入测试模式之前，LCD 上短时间出现频率版本信息。

可以通过编程禁用测试模式。如需退出测试模式，请关闭车载对讲机电源。在测试模式可以使用下列功能。

■ 键操作

键	副 LCD 显示上不出现 "FNC"	
	功能	显示
[↗]/[↘]	测试信道递增 / 递减	信道号
[^]/[v]	音量升高 / 降低	-
[▲]	按下：静噪电平递增 按住：静噪关	静噪电平 静噪关：📻图标出现
[■]	宽 / 窄 / 超窄	宽：“w” 窄：“n” 超窄：“v”
[📻]	换到面板调谐模式	-
[↵]	功能开	副 LCD 显示上出现 "FNC"
[<]	MSK 1200bps 和 2400bps	2400bps: 📻图标出现
[↗]	测试信令信道递增	信令号

ADJUSTMENT / 调整

Key	"FNC" not appears on the sub LCD display	
	Function	Display
Microphone key		
[PTT]	Transmit	-
[0] to [9] and [A] to [D], [#], [*]	Use as the DTMF keypad. If a key is pressed during transmission, the DTMF corresponding to the key that was presses is sent.	-

键	副 LCD 显示上不出现 "FNC"	
	功能	显示
麦克风键		
[PTT]	发射	-
[0] 至 [9] 和 [A] 至 [D], [#], [*]	用作 DTMF 键盘。如果在发射时按下某个键, 则发送与按下的键对应的 DTMF。	-

Key	"FNC" appears on the sub LCD display	
	Function	Display
[↖]	-	-
[↙]	Analog/NXDN	Analog: "A" NXDN: "N"
[↗]/[↘]	Function off	-
[▲]	-	-
[■]	LCD all lights	LCD all point appears
[▣]	High power/Low power	Low: [▣] icon appears
[↵]	Function off	-
[<]	Compander on/off	On: [🔊] icon appears
[▶]	Beat shift on/off	On: [🌀] icon appears
Microphone key		
[PTT]	Transmit	-
[0] to [9] and [A] to [D], [#], [*]	Function off	-

键	副 LCD 显示上出现 "FNC"	
	功能	显示
[↖]	-	-
[↙]	模拟 /NXDN	模拟: "A" NXDN: "N"
[↗]/[↘]	功能关	-
[▲]	-	-
[■]	LCD 全亮	LCD 全点显示
[▣]	高功率 / 低功率	低: [▣] 图标出现
[↵]	功能关	-
[<]	压扩器打开 / 关闭	开: [🔊] 图标出现
[▶]	拍频偏移打开 / 关闭	开: [🌀] 图标出现
麦克风键		
[PTT]	发射	-
[0] 至 [9] 和 [A] 至 [D], [#], [*]	功能关	-

• LED indicator

Red LED Lights during transmission.
Green LED Lights when there is carrier.

• LED 指示灯

红色 LED 发射时点亮。
绿色 LED 有载波时点亮。

• Sub LCD indicator

"FNC" Appears at function on.

• 副 LCD 指示

"FNC" 功能开启时出现。

• LCD display in panel test mode

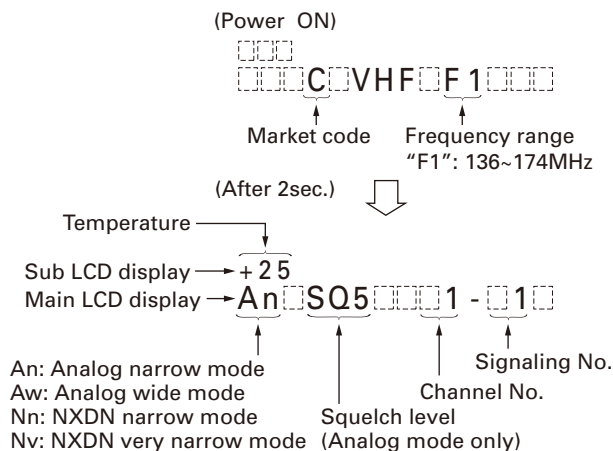

• 面板测试模式时的 LCD 显示

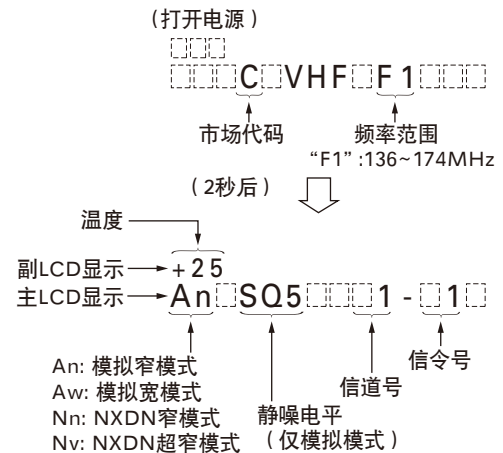

ADJUSTMENT / 调整

■ Frequency and Signaling

The transceiver has been adjusted for the frequencies shown in the following table. When required, readjust them following the adjustment procedure to obtain the frequencies you want in actual operation.

• Test frequency

CH	RX (MHz)	TX (MHz)
1	155.05000	155.10000
2	136.05000	136.10000
3	173.95000	173.90000
4	155.00000	155.00000
5	155.20000	155.20000
6	155.40000	155.40000
7~16	-	-

• Analog mode signaling

No.	RX	TX
1	None	None
2	None	100Hz Square Wave
3	LTR Data : AREA=0, GOTO=12 HOME=12 ID=47, FREE=25	LTR Data : AREA=0, GOTO=12 HOME=12 ID=47, FREE=25
4	QT: 67.0Hz	QT: 67.0Hz
5	QT: 151.4Hz	QT: 151.4Hz
6	QT: 210.7Hz	QT: 210.7Hz
7	QT: 254.1Hz	QT: 254.1Hz
8	DQT: D023N	DQT: D023N
9	DQT: D754I	DQT: D754I
10	DTMF: 159D	DTMF: 159D
11	None	DTMF Code 9
12	2-tone : A: 304.7Hz B: 3106.0Hz	2-tone : A: 304.7Hz B: 3106.0Hz
13	Single Tone: 979.9Hz	Single Tone: 979.9Hz
14	None	Single Tone: 1000Hz
15	None	MSK
16	MSK	MSK

• NXDN mode signaling

No.	RX	TX
1	RAN1	RAN1
2	None	PN9
3	RAN1	Maximum deviation pattern
7	None	FSW+PN9

RAN: Radio Access Number

PN9: Pseudo-Random Pattern (For production only)

■ 频率和信令

已经根据下表所示的频率调整了设置。需要时，按调整步骤重新调整，以获得实际操作时想要的频率。

• 测试频率

信道	接收 (MHz)	发射 (MHz)
1	155.05000	155.10000
2	136.05000	136.10000
3	173.95000	173.90000
4	155.00000	155.00000
5	155.20000	155.20000
6	155.40000	155.40000
7~16	-	-

• 模拟模式信令

号	接收	发射
1	无	无
2	无	100Hz 方波
3	LTR 数据 : AREA=0, GOTO=12 HOME=12 ID=47, FREE=25	LTR 数据 : AREA=0, GOTO=12 HOME=12 ID=47, FREE=25
4	QT: 67.0Hz	QT: 67.0Hz
5	QT: 151.4Hz	QT: 151.4Hz
6	QT: 210.7Hz	QT: 210.7Hz
7	QT: 254.1Hz	QT: 254.1Hz
8	DQT: D023N	DQT: D023N
9	DQT: D754I	DQT: D754I
10	DTMF: 159D	DTMF: 159D
11	无	DTMF 代码 9
12	2-音 : A: 304.7Hz B: 3106.0Hz	2-音 : A: 304.7Hz B: 3106.0Hz
13	单音 : 979.9Hz	单音 : 979.9Hz
14	无	单音 : 1000Hz
15	无	MSK
16	MSK	MSK

• NXDN 模式信令

号	接收	发射
1	RAN1	RAN1
2	无	PN9
3	RAN1	最大频偏模式
7	无	FSW+PN9

RAN: 无线接入编号

PN9: 伪随机模式 (仅用于生产)

ADJUSTMENT / 调整

Panel Tuning Mode

■ Preparations for tuning the transceiver

Before attempting to tune the transceiver, connect the unit to a suitable power supply.

Whenever the transmitter is turned, the unit must be connected to a suitable dummy load (i.e. power meter).

The speaker output connector must be terminated with a 4Ω dummy load and connected to an AC voltmeter and an audio distortion meter or a SINAD measurement meter at all times during tuning.

■ Transceiver tuning (To enter tuning mode)

To enter tuning mode, press the [⇐] key while the transceiver is in test mode. Use the [←] key to write tuning data through tuning modes, and the [↗]/[↘] key to adjust tuning requirements (1 to 4096 appears on the LCD).

Use the [▶] key to select the adjustment item through tuning modes. Use the [↵] key to adjust 5 reference level adjustments, and use the [■] key to switch between Wide/Narrow/Very narrow.

• LCD display in panel tuning mode

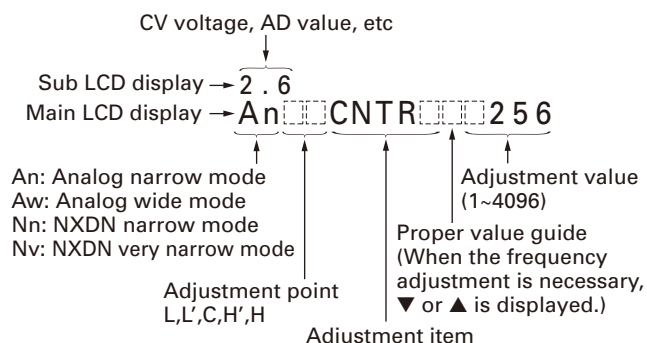

■ Key operation

Key	Function	
	Push	Hold (1 second)
[↗]/[↘]	Adjustment value up/down	Continuation up/down
[^]/[v]	Volume up/down	Continuation up/down
[▲]	Auto adjustment start	-
[■]	Wide/Narrow/Very narrow	-
[⇐]	Shift to panel test mode	-
[↵]	To enter 5 reference level adjustments L/L'/C/H'/H	-
[←]	Writes the adjustment value	-
[▶]	Go to next adjustment item	Back to last adjustment item
Microphone key		
[PTT]	Transmit	-
[0] to [9] and [A] to [D], [#], [*]	-	-

面板调谐模式

■ 调谐车载对讲机的准备

在尝试调谐车载对讲机前，请将车载对讲机连接到合适的电源上。

发射打开时，车载对讲机必须连接到合适的等效负载上（如功率表）。

扬声器输出连接器必须端接 4Ω 的等效负载，调谐期间，必须始终连接到交流电压表和音频失真仪或 SINAD 测量仪表上。

■ 车载对讲机调谐（进入调谐模式）

要进入调谐模式，请在车载对讲机处于测试模式时按 [⇐] 键。用 [←] 键写入调谐模式的调谐数据，用 [↗]/[↘] 键调整调谐要求（LCD 上出现 1 到 4096）。

用 [▶] 键选择调谐模式的调整项目。用 [↵] 键调整 5 点基准电平调整，然后用 [■] 键切换宽/窄/超窄。

• 面板调谐模式时的 LCD 显示

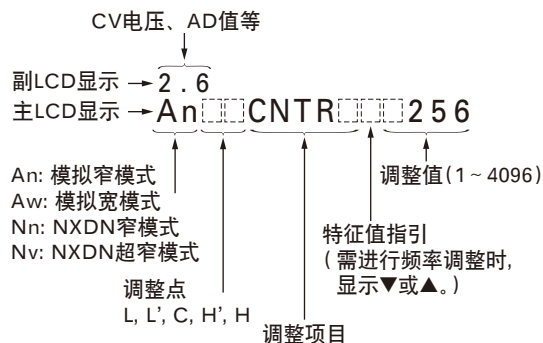

■ 键操作

键	功 能	
	按下	按住 (1 秒钟)
[↗]/[↘]	调整值递增 / 递减	连续增加 / 减小
[^]/[v]	音量升高 / 降低	连续升高 / 降低
[▲]	自动调整开始	-
[■]	宽 / 窄 / 超窄	-
[⇐]	换到面板测试模式	-
[↵]	进入 5 点基准电平调整 调整点 L/L'/C/H'/H	-
[←]	写入调整值	-
[▶]	转到下一调整项目	返回到最后调整的项目
麦克风键		
[PTT]	发射	-
[0] 至 [9] 和 [A] 至 [D], [#], [*]	-	-

ADJUSTMENT

■ 5 reference level adjustments frequency

Tuning point	RX (MHz)	TX (MHz)
Low	136.05000	136.10000
Low'	145.55000	145.60000
Center	155.05000	155.10000
High'	164.55000	164.60000
High	173.95000	173.90000

■ Adjustment item supplement

Adjustment Item	Description
LCD contrast	The contrast of LCD display can be changed.
Receive Assist	The lock voltage of VCO (Receive) is adjusted. This item must be adjusted before all adjustment items for receiver section are adjusted.
Transmit Assist	The lock voltage of VCO (Transmit) is adjusted. This item must be adjusted before all adjustment items for transmitter section are adjusted.
RTC	Real Time Clock (RTC) is adjusted. This item uses the internal clock. (Any measurement equipment is not required.)
Frequency	Frequency stability is adjusted under receiving condition with SSG. The SSG needs 0.003ppm accuracy so please use a standard oscillator if necessary. This item can be adjusted only in PC Test Mode so that the adjustment value is not changed easily.
High Transmit Power Limit	The limit value of the High Transmit Power output is adjusted.
Low Transmit Power Limit	The limit value of the Low Transmit Power output is adjusted.
High Transmit Power	High Transmit Power is adjusted.
Low Transmit Power	Low Transmit Power is adjusted.
Balance	The transmit audio frequency response is adjusted. This item is adjusted so that the deviation of 2kHz becomes the same deviation of 20Hz. This item must be adjusted before all adjustment items for deviations are adjusted.
Maximum Deviation (NXDN Narrow/Very Narrow)	Maximum Deviation of NXDN (Narrow/Very Narrow) is adjusted.
Maximum Deviation (Analog Wide/Narrow)	Maximum Deviation of Analog (Wide/Narrow) is adjusted. This item must be adjusted before all adjustment items for tone deviations are adjusted. Note: "Maximum Deviation (Analog Narrow)" must be adjusted before "CWID Deviation (NXDN Very Narrow)" is adjusted.
QT Deviation	QT tone deviation is adjusted.
DQT Deviation	DQT tone deviation is adjusted.
LTR Deviation	LTR tone deviation is adjusted.
DTMF Deviation	DTMF tone deviation is adjusted.
Single Tone Deviation	The deviation of Single Tone used in "2-tone" is adjusted.
MSK Deviation	MSK tone deviation is adjusted.
CWID Deviation	CWID tone deviation is adjusted. CWID is used to inform the others who is transmitting on a 6.25-kHz spacing channel. (In FCC rule, Analog mode or CWID is required for each channel-spacing.)
Sensitivity 1	Sensitivity 1 allows a service engineer to improve the intermodulation rejection, receiver spurious response, and receiver sensitivity characteristics by changing the voltage of Variable-Capacitor Tune in the receiver front-end circuit of the primary band-pass filter to optimize the characteristics at five frequency spots.
Sensitivity 2	Sensitivity 2 allows a service engineer to improve the intermodulation rejection, receiver spurious response, and receiver sensitivity characteristics by changing the voltage of Variable-Capacitor Tune in the receiver front-end circuit of the secondary band-pass filter to optimize the characteristics at five frequency spots.
RSSI Reference	The minimum RSSI level for scan stop is adjusted.
Open Squelch	The squelch level at level "5" is adjusted.

调 整

■ 5 点基准电平调整频率

调谐点	接收 (MHz)	发射 (MHz)
低	136.05000	136.10000
低'	145.55000	145.60000
中心	155.05000	155.10000
高'	164.55000	164.60000
高	173.95000	173.90000

■ 调整项目补充

调整项目	说明
LCD 对比度	可更改 LCD 显示的对比度。
接收辅助	调整 VCO (接收) 的锁定电压。 必须在调整接收机部分的所有调整项目之前调整此项。
发射辅助	调整 VCO (发射) 的锁定电压。 必须在调整发射机部分的所有调整项目之前调整此项。
RTC	调整实时时钟 (RTC)。 此项使用内部时钟。 (无须使用任何测量设备。)
频率	调整 SSG 接收条件下的频率稳定性。 SSG 需要 0.003ppm 的精度, 因此, 必要时请使用标准振荡器。 此项只能在 PC 测试模式下进行调整, 以使调整值不易改变。
高发射功率限制	调整高发射功率输出的极限值。
低发射功率限制	调整低发射功率输出的极限值。
高发射功率	调整高发射功率。
低发射功率	调整低发射功率。
平衡	调整发射音频频率响应。 通过调整此项, 使 2kHz 的频偏变成 20Hz 的相同频偏。 必须在调整频偏的所有调整项目之前调整此项。
最大频偏 (NXDN 窄 / 超窄)	调整 NXDN 最大频偏 (窄 / 超窄)。
最大频偏 (模拟宽 / 窄)	调整模拟最大频偏 (宽 / 窄)。 必须在调整音调频偏的所有调整项目之前调整此项。 注意: 必须在调整“CWID 频偏 (NXDN 超窄)”之前调整“最大频偏 (模拟窄)”。
QT 频偏	调整 QT 音调频偏。
DQT 频偏	调整 DQT 音调频偏。
LTR 频偏	调整 LTR 音调频偏。
DTMF 频偏	调整 DTMF 音调频偏。
单音频偏	调整“2 音”中使用的单音频偏。
MSK 频偏	调整 MSK 音调频偏。
CWID 频偏	调整 CWID 音调频偏。 CWID 用于通知在 6.25-kHz 间隔信道上发射的其他人。 (按照 FCC 规则, 各信道间隔须使用模拟模式或 CWID。)
灵敏度 1	灵敏度 1 可让维修工程师通过改变初级带通滤波器的接收机前端电路中可变电容器调谐的电压, 改善互调抗干扰、接收机杂散响应和接收机灵敏度特性, 从而使五个频率点的特性得到优化。
灵敏度 2	灵敏度 2 可让维修工程师通过改变次级带通滤波器的接收机前端电路中可变电容器调谐的电压, 改善互调抗干扰、接收机杂散响应和接收机灵敏度特性, 从而使五个频率点的特性得到优化。
RSSI 基准	调整扫描停止的最低 RSSI 电平。
静噪开	调整“5”级的静噪电平。

ADJUSTMENT

Adjustment Item	Description
Low RSSI	RSSI display level “  <h3>■ Adjustment item and Display</h3>

Order	Adjustment item	Main LCD display	Sub-LCD display	Aw	An (Analog	Nn (NXDN	Nv (NXDN	Adjust item Number
				(Analog Wide)	Narrow)	Narrow)	Very Narrow)	
				Adjustment range				
1	LCD contrast	CNTR	-	1 point ADJ				Common Section 2
				1~256				
2	Receive Assist	RAST	(CV voltage)	5 point ADJ				Common Section 3
				1~4096				
3	Transmit Assist	TAST	(CV voltage)	5 point ADJ				Common Section 3
				1~4096				
4	RTC (Real-time clock)	RTC	-	1 point ADJ				Common Section 4
				-62~-1/0/+1~+62				
5	High Transmit Power Limit	HILMT	-	-	5	-	-	Transmitter Section 1
				1~256				
6	Low Transmit Power Limit	LOLMT	-	-	5	-	-	Transmitter Section 2
				1~256				
7	High Transmit Power	HIPWR	-	-	5	-	-	Transmitter Section 3
				1~1024				
8	Low Transmit Power	LOPWR	-	-	5	-	-	Transmitter Section 4
				1~1024				
9	Balance	BAL	(Encode frequency)	-	5	-	-	Transmitter Section 5
				1~256				
10	Maximum Deviation (NXDN)	NDEV	-	-	-	5	5	Transmitter Section 6
				1~1024				
11	Maximum Deviation (Analog)	ADEV	-	5	5	-	-	Transmitter Section 7
				1~1024				
12	QT Deviation	QT	-	1	1	-	-	Transmitter Section 8
				1~1024				
13	DQT Deviation	DQT	-	1	1	-	-	Transmitter Section 9
				1~1024				
14	LTR Deviation	LTR	-	1	1	-	-	Transmitter Section 10
				1~1024				
15	DTMF Deviation	DTMF	-	1	1	-	-	Transmitter Section 11
				1~1024				
16	Single Tone Deviation	TONE	-	1	1	-	-	Transmitter Section 12
				1~1024				
17	MSK Deviation	MSK	-	1	1	-	-	Transmitter Section 13
				1~1024				
18	CWID Deviation	CWID	-	-	-	-	1	Transmitter Section 14
				1~1024				

调 整

调整项目	说 明
低 RSSI	调整 RSSI 显示电平“9”。“低 RSSI”和“高 RSSI”都必须调整。 (应用 RSSI 电平的曲线数据。)
高 RSSI	
深静噪	调整电平“9”的静噪电平。

■ 调整项目和显示

顺序	调整项目	主 LCD 显示	副 LCD 显示	Aw (模拟宽)	An (模拟窄)	Nn (NXDN 窄)	Nv (NXDN 超窄)	调整项目编号
				调整范围				
1	LCD 对比度	CNTR	-	1 点调整				共通部分 2
				1~256				
2	接收辅助	RAST	(CV 电压)	5 点调整				共通部分 3
				1~4096				
3	发射辅助	TAST	(CV 电压)	5 点调整				共通部分 3
				1~4096				
4	RTC(实时时钟)	RTC	-	1 点调整				共通部分 4
				-62~-1/0/+1~+62				
5	高发射功率限制	HILMT	-	-	5	-	-	发射机部分 1
				1~256				
6	低发射功率限制	LOLMT	-	-	5	-	-	发射机部分 2
				1~256				
7	高发射功率	HIPWR	-	-	5	-	-	发射机部分 3
				1~1024				
8	低发射功率	LOPWR	-	-	5	-	-	发射机部分 4
				1~1024				
9	平衡	BAL	(编码频率)	-	5	-	-	发射机部分 5
				1~256				
10	最大频偏(NXDN)	NDEV	-	-	-	5	5	发射机部分 6
				1~1024				
11	最大频偏(模拟)	ADEV	-	5	5	-	-	发射机部分 7
				1~1024				
12	QT 频偏	QT	-	1	1	-	-	发射机部分 8
				1~1024				
13	DQT 频偏	DQT	-	1	1	-	-	发射机部分 9
				1~1024				
14	LTR 频偏	LTR	-	1	1	-	-	发射机部分 10
				1~1024				
15	DTMF 频偏	DTMF	-	1	1	-	-	发射机部分 11
				1~1024				
16	单音频偏	TONE	-	1	1	-	-	发射机部分 12
				1~1024				
17	MSK 频偏	MSK	-	1	1	-	-	发射机部分 13
				1~1024				
18	CWID 频偏	CWID	-	-	-	-	1	发射机部分 14
				1~1024				

ADJUSTMENT

Order	Adjustment item	Main LCD display	Sub-LCD display	Aw (Analog Wide)	An (Analog Narrow)	Nn (NXDN Narrow)	Nv (NXDN Very Narrow)	Adjust item Number
				Adjustment range				
19	Sensitivity 1	SENS1	(RSSI measurement value)	-	5	-	-	Receive Section 2
				1~256				
20	Sensitivity 2	SENS2	(RSSI measurement value)	-	5	-	-	Receive Section 3
				1~256				
21	RSSI Reference	RRSSI	(RSSI measurement value)	5	5	- *1	5	Receive Section 4
				1~256				
22	Open Squelch	SQL	(ASQDET measurement value)	5	5	- *1	5	Receive Section 5
				1~256				
23	Low RSSI	LRSSI	(RSSI measurement value)	5	5	- *1	5	Receive Section 6
				1~256				
24	High RSSI	HRSSI	(RSSI measurement value)	5	5	- *1	5	Receive Section 7
				1~256				
25	Tight Squelch	SQLT	(ASQDET measurement value)	5	5	-	-	Receive Section 8
				1~256				

*1: Because NXDN Narrow adjusted by adjusting Analog Narrow, it is not necessary to adjust NXDN Narrow.

■ Panel tuning mode flow chart

Note: In this Panel tuning mode flow chart, the Adjustment item name is modified.

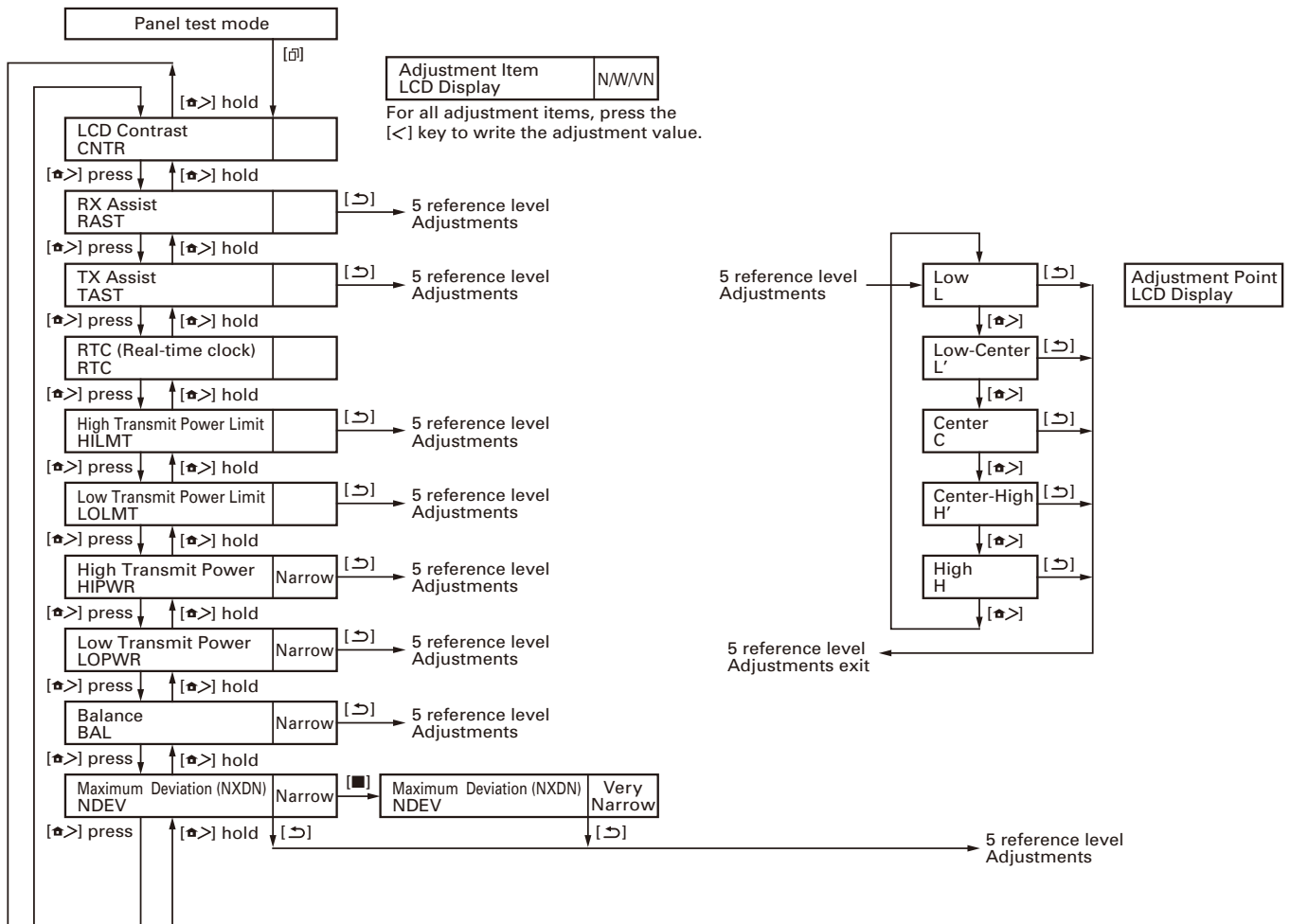

调 整

顺序	调整项目	主 LCD 显示	副 LCD 显示	Aw	An	Nn	Nv	调整项目编号
				(模拟宽)	(模拟窄)	(NXDN 窄)	(NXDN 超窄)	
				调整范围				
19	灵敏度 1	SENS1	(RSSI 测量值)	-	5	-	-	接收机部分 2
				1~256				
20	灵敏度 2	SENS2	(RSSI 测量值)	-	5	-	-	接收机部分 3
				1~256				
21	RSSI 基准	RRSSI	(RSSI 测量值)	5	5	- *1	5	接收机部分 4
				1~256				
22	静噪开	SQL	(ASQDET 测量值)	5	5	- *1	5	接收机部分 5
				1~256				
23	低 RSSI	LRSSI	(RSSI 测量值)	5	5	- *1	5	接收机部分 6
				1~256				
24	高 RSSI	HRSSI	(RSSI 测量值)	5	5	- *1	5	接收机部分 7
				1~256				
25	深静噪	SQLT	(ASQDET 测量值)	5	5	-	-	接收机部分 8
				1~256				

*1: 由于 NXDN 窄通过调整模拟窄进行调整, 因此不需要调整 NXDN 窄。

■ 面板调谐模式流程图

注意: 在此面板调谐模式流程图中, 调整项目的名称作了修改。

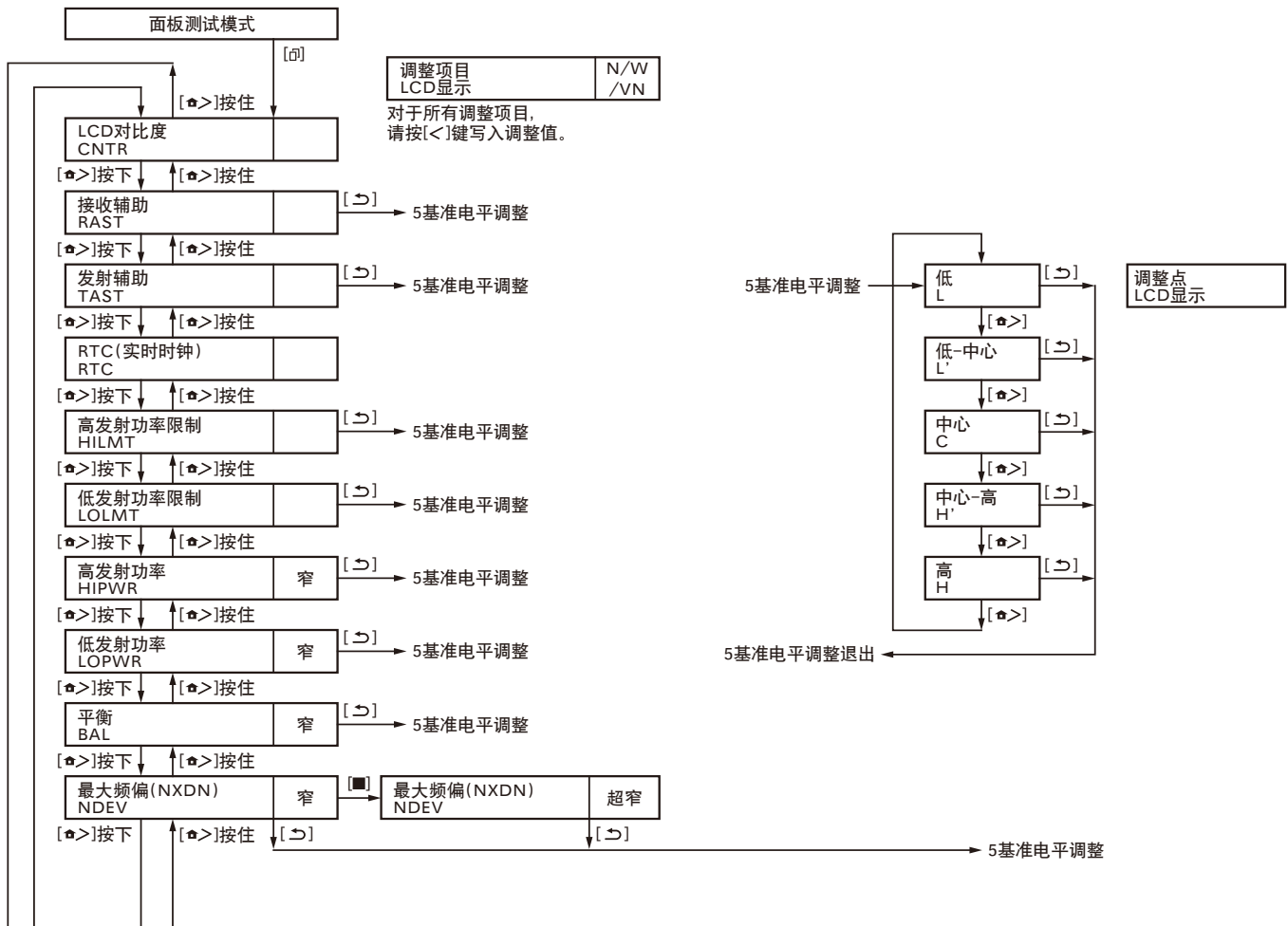

ADJUSTMENT

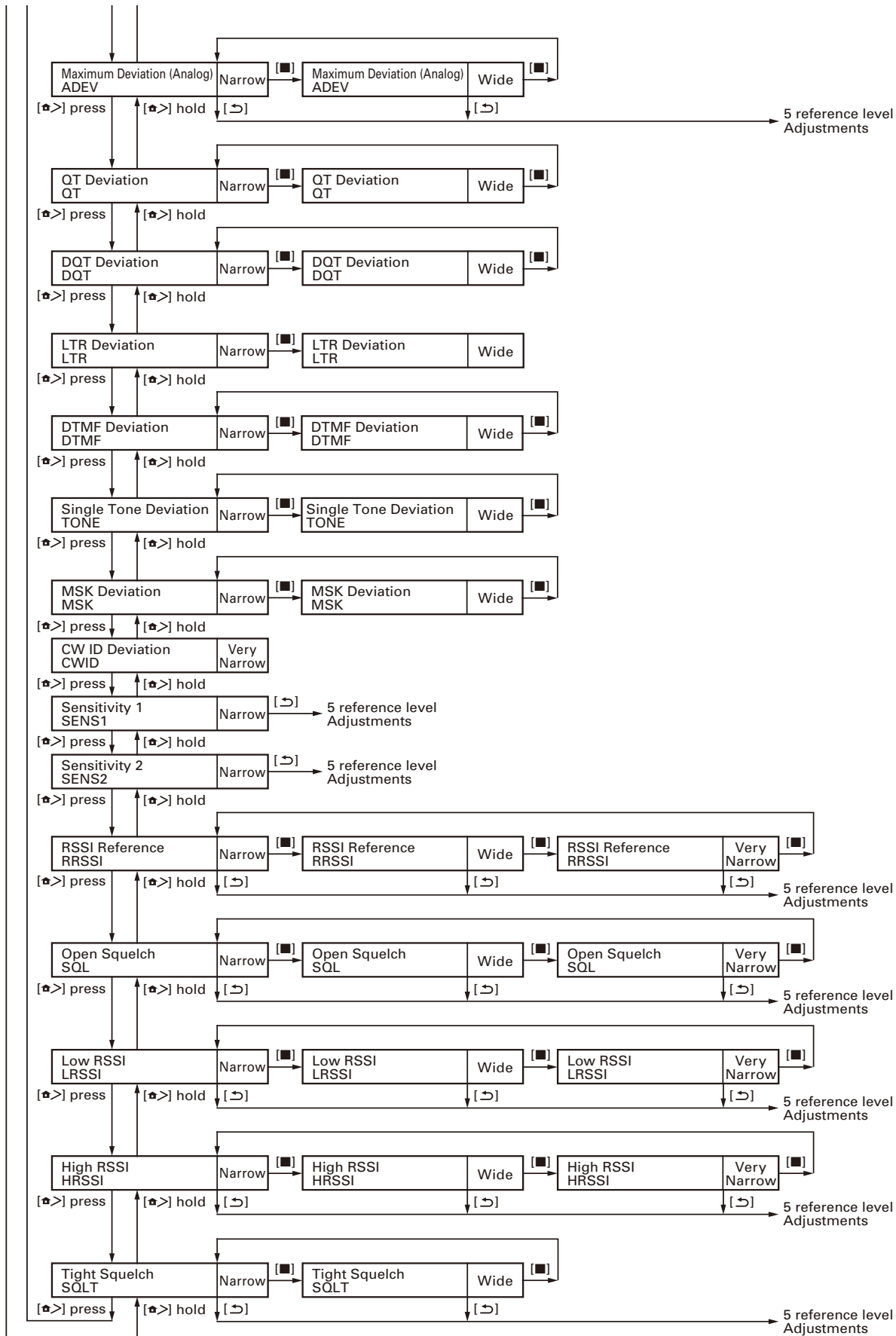

调整

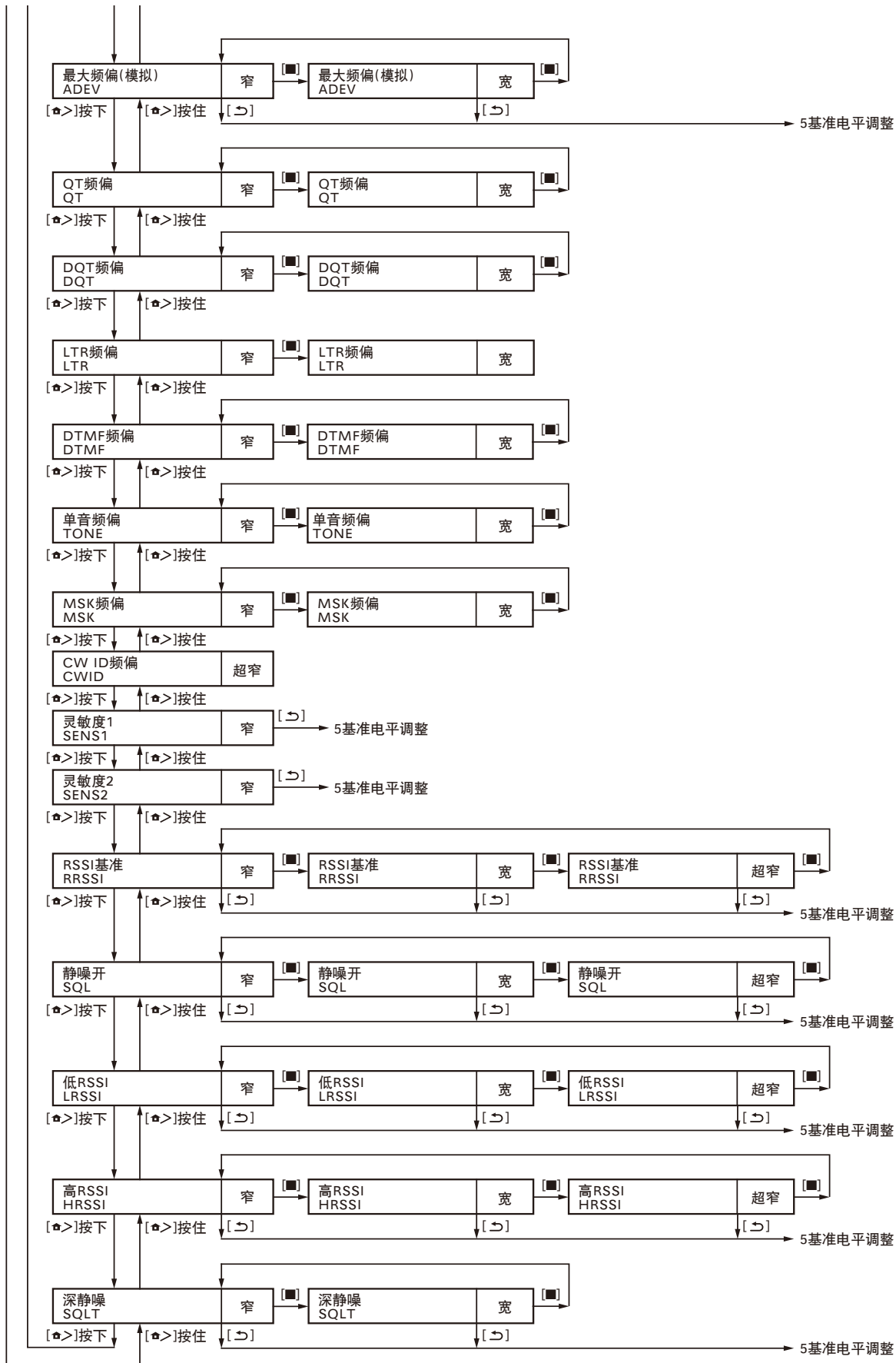

ADJUSTMENT

Test Equipment Required for Alignment

Test Equipment	Major Specifications	
1. Standard Signal Generator (SSG)	Frequency Range Modulation Output When performing the Frequency adjustment, the following accuracy is necessary. • 0.003ppm Use a standard oscillator for adjustments, if necessary.	Operational frequency range of the transceiver Frequency modulation and external modulation -127dBm/0.1μV to greater than -20dBm/22.4mV
2. RF Power Meter	Input Impedance Operation Frequency Measurement Capability	50Ω Operational frequency range of the transceiver Vicinity of 100W
3. Deviation Meter	Frequency Range	Operational frequency range of the transceiver
4. Digital Volt Meter (DVM)	Measuring Range Input Impedance	10mV to 20V DC High input impedance for minimum circuit loading
5. Oscilloscope		DC through 30MHz
6. High Sensitivity Frequency Counter	Frequency Range Frequency Stability	10Hz to 1000MHz 0.01ppm or less
7. DC Ammeter		20A or more
8. AF Volt Meter (AF VTVM)	Frequency Range Voltage Range	50Hz to 10kHz 1mV to 10V
9. Audio Generator (AG)	Frequency Range Output	50Hz to 5kHz or more 0 to 1V
10. Distortion Meter	Capability Input Level	3% or less at 1kHz 50mV to 10Vrms
11. 4Ω Dummy Load		Approx. 4Ω, 20W
12. Regulated Power Supply		13.6V, approx. 20A (adjustable from 9V to 20V) Useful if ammeter equipped
13. Spectrum Analyzer	Frequency Range Input Level Input Sensitivity Resolution Bandwidth Video Bandwidth	40MHz to 520MHz Up to +20dBm -100dBm 100Hz 100Hz
14. Tracking Generator	Frequency Range Output Level	40MHz to 520MHz -30dBm to 0dBm

Test cable for microphone input (E30-3360-08)

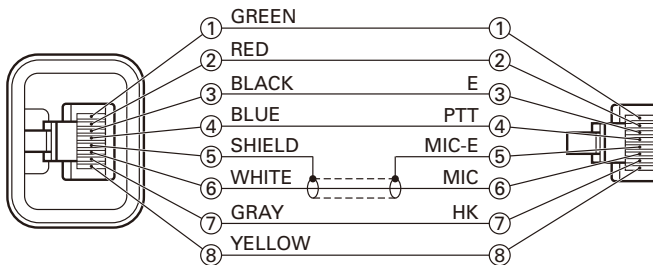

Tuning cable (E30-3383-05)

Adapter cable (E30-3383-05) is required for injecting an audio if PC tuning is used. See "PC Mode" section for the connection.

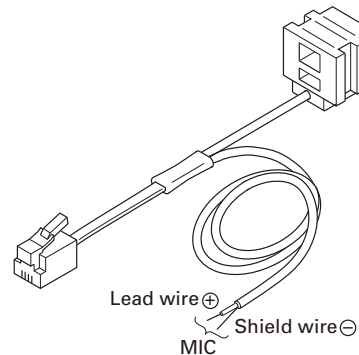

MIC connector (Front panel view)

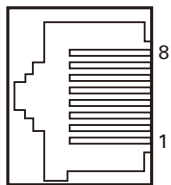

- 1 : BLC/AFO
- 2 : +B
- 3 : GND
- 4 : PTT/TXD (PC serial data from radio)
- 5 : MICE
- 6 : MIC
- 7 : HOOK/RXD (PC serial data to radio)
- 8 : DM/KVL

调 整

所需的用于调整的测试设备

测 试 设 备	主 要 规 格
1. 标准信号发生器 (SSG)	频率范围 调制 输出 进行频率调整时，需要以下精度。 • 0.003ppm 如有必要，请使用标准振荡器进行调整。
2. RF 功率计	输入阻抗 操作频率 测量范围
3. 频偏仪	频率范围
4. 数字电压表 (DVM)	测量范围 输入阻抗
5. 示波器	直流到 30MHz
6. 高灵敏度频率计数器	频率范围 频率稳定性
7. 直流电流表	20A 或更高
8. 音频电压表 (AF VTVM)	频率范围 电压范围
9. 音频发生器 (AG)	频率范围 输出
10. 失真测试仪	能力 输入电平
11. 4Ω 假负载	大约 4Ω, 20W
12. 电可调电源	13.6V, 大约 20A (可调 9 到 20V) 最好具备电流表
13. 频谱分析仪	频率范围 输入电平 输入灵敏度 分辨率带宽 视频带宽
14. 轨迹发生器	频率范围 输出电平

用于麦克风输入的测试电缆 (E30-3360-08)

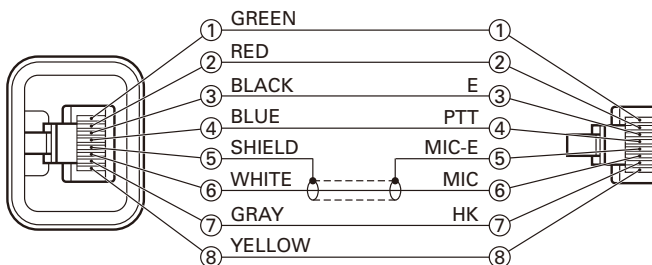

调谐电缆 (E30-3383-05)

如果使用 PC 调谐，则输入音频需要适配器电缆 (E30-3383-05)。

有关连接详情，请参看“PC 模式”。

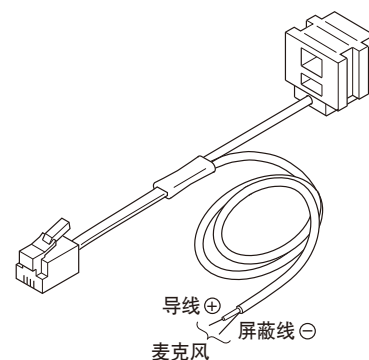

MIC 连接器 (前面板视图)

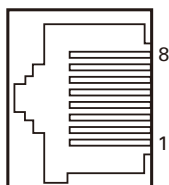

- 1: BLC/AFO
- 2: +B
- 3: GND
- 4: PTT/TXD (来自车载对讲机的 PC 串行数据)
- 5: MICE
- 6: MIC
- 7: HOOK/RXD (送到车载对讲机的 PC 串行数据)
- 8: DM/KVL

ADJUSTMENT

Radio Check Section

Item	Condition		Measurement			Adjustment		Specifications / Remarks	
	Panel test mode	PC test mode	Test-equipment	Unit	Terminal	Unit	Parts		Method
1. Frequency check	1) CH-Sig: 1-1 PTT: ON	1) Test Channel Channel: 1 Test Signaling Mode: Analog Signaling: 1 PTT: Press [Transmit] button.	f. counter	Panel	ANT			Check an internal temperature of radio within 25°C ± 2°C.	±0.5ppm -77.55Hz~ +77.55Hz @155.1MHz
2. High power check	1) CH-Sig: 1-1 PTT: ON	1) Test Channel Channel: 1 Test Signaling Mode: Analog Signaling: 1 PTT: Press [Transmit] button.	Power meter Ammeter					Check	21W~29W 9.0A or less
	2) CH-Sig: 2-1 PTT: ON	2) Test Channel Channel: 2 Test Signaling Mode: Analog Signaling: 1 PTT: Press [Transmit] button.							
	3) CH-Sig: 3-1 PTT: ON	3) Test Channel Channel: 3 Test Signaling Mode: Analog Signaling: 1 PTT: Press [Transmit] button.							
3. Low power check	1) CH-Sig: 1-1 PTT: ON	1) Test Channel Channel: 1 Test Signaling Mode: Analog Signaling: 1 PTT: Press [Transmit] button.							3.5W~6.5W 5.0A or less
	2) CH-Sig: 2-1 PTT: ON	2) Test Channel Channel: 2 Test Signaling Mode: Analog Signaling: 1 PTT: Press [Transmit] button.							
	3) CH-Sig: 3-1 PTT: ON	3) Test Channel Channel: 3 Test Signaling Mode: Analog Signaling: 1 PTT: Press [Transmit] button.							
4. MIC sensitivity check	1) CH-Sig: 1-1 AG: 1kHz PTT: ON	1) Test Channel Channel: 1 Test Signaling Mode: Analog Signaling: 1 AG: 1kHz PTT: Press [Transmit] button.	Deviation meter Oscilloscope AG AF VTVM					Adjust AG input to get a standard MOD.	Dev: 3kHz at 5mV±1mV

调 整

通信机检查部分

项 目	条 件		测 量			调 整			规格 / 备注
	面板测试模式	PC 测试模式	测量装置	单元	端子	单元	部件	方 法	
1. 频率检查	1)CH-Sig:1-1 PTT: 开启	1) 测试信道 信道 :1 测试信令 模式 : 模拟 信令 :1 PTT: 按 [Transmit] 按钮。	频率计数器	面板	天线			确认车载对讲机的内部温度在25℃ ±2℃范围内。	± 0.5ppm -77.55Hz~ +77.55Hz @155.1MHz
2. 高功率检查	1)CH-Sig:1-1 PTT: 开启	1) 测试信道 信道 :1 测试信令 模式 : 模拟 信令 :1 PTT: 按 [Transmit] 按钮。	功率计 电流表					检查	21W~29W 9.0A 或更低
	2)CH-Sig:2-1 PTT: 开启	2) 测试信道 信道 :2 测试信令 模式 : 模拟 信令 :1 PTT: 按 [Transmit] 按钮。							
	3)CH-Sig:3-1 PTT: 开启	3) 测试信道 信道 :3 测试信令 模式 : 模拟 信令 :1 PTT: 按 [Transmit] 按钮。							
3. 低功率检查	1)CH-Sig:1-1 PTT: 开启	1) 测试信道 信道 :1 测试信令 模式 : 模拟 信令 :1 PTT: 按 [Transmit] 按钮。							3.5W~6.5W 5.0A 或更低
	2)CH-Sig: 2-1 PTT: ON	2) 测试信道 信道 :2 测试信令 模式 : 模拟 信令 :1 PTT: 按 [Transmit] 按钮。							
	3)CH-Sig:3-1 PTT: 开启	3) 测试信道 信道 :3 测试信令 模式 : 模拟 信令 :1 PTT: 按 [Transmit] 按钮。							
4. 麦克风灵敏度检查	1)CH-Sig:1-1 AG:1kHz PTT: 开启	1) 测试信道 信道 :1 测试信令 模式 : 模拟 信令 :1 AG:1kHz PTT: 按 [Transmit] 按钮。	频偏仪 示波器 AG AF VTVM					调整 AG 输入以获得标准 MOD。	频偏 :5mV±1mV 时 3kHz

ADJUSTMENT

Item	Condition		Measurement			Adjustment			Specifications / Remarks
	Panel test mode	PC test mode	Test-equipment	Unit	Terminal	Unit	Parts	Method	
5. Sensitivity check	1) CH-Sig : 1-1 SSG output Wide: -117dBm (0.32μV) (MOD: 1kHz/±3kHz) Narrow: -117dBm (0.32μV) (MOD: 1kHz, Dev: ±1.5kHz)	1) Test Channel Channel: 1 Test Signaling Mode: Analog Signaling: 1 SSG output Wide: -117dBm (0.32μV) (MOD: 1kHz/±3kHz) Narrow: -117dBm (0.32μV) (MOD: 1kHz, Dev : ±1.5kHz)	SSG AF VTVM Oscilloscope Distortion meter		ANT EXT SP connec- tor			Check	12dB SINAD or more

Common Section

Item	Condition		Measurement			Adjustment			Specifications / Remarks
	Panel tuning mode	PC test mode	Test-equipment	Unit	Terminal	Unit	Parts	Method	
1. Setting	1) DC voltage: 13.6V 2) SSG standard modulation [Wide] MOD: 1kHz, DEV: 3kHz [Narrow] MOD: 1kHz, DEV: 1.5kHz								
2. LCD contrast	1) Adj item: [CNTR] Adjst: [***] Press [◀] key to store the adjustment value.	1) Adj item: [LCD Con- trast] Press [Apply] but- ton to store the adjustment value.					[Panel tuning mode] [↵],[↶]	Adjust the LCD contrast by looking.	After replacing the LCD align contrast.
3. Receive Assist	1) Adj item: [RAST] Adjst: [***] 2) Adj item: [L RAST]→ [L' RAST]→[C RAST]→ [H' RAST]→[H RAST] Adjst: [***] Press [◀] key to store the adjustment value.	1) Adj item: [Receive Assist] 2) Adj item: [Low], [Low'], [Center], [High'], [High] Press [Apply All] button to store the adjustment value.					[PC test mode] [◀],[▶]	The sub LCD display and [V] indicator on the PC window shows VCO lock voltage. Change the adjustment value to get VCO lock voltage within the limit of the specified voltage.	3.0V±0.1V [PC test mode] Press [Apply All] button to store the adjustment value after all adjustment point was adjusted.
Transmit Assist	1) Adj item: [TAST] Adjst: [***] 2) Adj item: [L TAST]→ [L' TAST]→[C TAST]→ [H' TAST]→[H TAST] Adjst: [***] PTT : ON Press [◀] key to store the adjustment value.	1) Adj item: [Transmit Assist] 2) Adj item: [Low], [Low'], [Center], [High'], [High] PTT: Press [Transmit] button. Press [Apply All] button to store the adjustment value.						Note: Confirm the VCO lock voltage approximately 3 seconds after the adjustment value is changed.	

调 整

项 目	条 件		测 量			调 整			规格 / 备注
	面板测试模式	PC 测试模式	测量装置	单元	端子	单元	部件	方 法	
5. 灵敏度检查	1) CH-Sig: 1-1 SSG 输出 宽 : -117dBm (0.32μV) (MOD: 1kHz/±3kHz) 窄 : -117dBm (0.32μV) (MOD: 1kHz, 频偏 : ±1.5kHz)	1) 测试信道 信道 : 1 测试信令 模式 : 模拟 信令 : 1 SSG 输出 宽 : -117dBm (0.32μV) (MOD: 1kHz/±3kHz) 窄 : -117dBm (0.32μV) (MOD: 1kHz, 频偏 : ±1.5kHz)	SSG AF VTVM 示波器 失真测试仪		天线 外部 SP 连接器			检查	12dB SINAD 或更高

共通部分

项 目	条 件		测 量			调 整			规格 / 备注
	面板调谐模式	PC 测试模式	测量装置	单元	端子	单元	部件	方 法	
1. 设置	1) DC 电压 : 13.6V 2) SSG 标准调制 [宽] MOD: 1kHz, DEV: 3kHz [窄] MOD: 1kHz, DEV: 1.5kHz								
2. LCD 对比度	1) 调整项目 : [CNTR] 调整 : [***] 按 [<] 键储存调整值。	1) 调整项目 : [LCD Contrast] 按 [Apply] 按钮储存调整值。					[面板调谐模式] [↵],[⇩] [PC 测试模式] [◀],[▶]	通过观察调整 LCD 对比度。	更换 LCD 后校正对比度。
3. 接收辅助	1) 调整项目 : [RAST] 调整 : [***] 2) 调整项目 : [L RAST] → [L' RAST] → [C RAST] → [H' RAST] → [H RAST] 调整 : [***] 按 [<] 键储存调整值。	1) 调整项目 : [Receive Assist] 2) 调整项目 : [Low], [Low'], [Center], [High'], [High] 按 [Apply All] 按钮储存调整值。						副 LCD 显示和 PC 窗口上的 [V] 指示显示了 VCO 锁定电压。更改调整值, 以获得指定电压范围内的 VCO 锁定电压。 注意: 在更改调整值约 3 秒后确认 VCO 锁定电压。	3.0V ± 0.1V [PC 测试模式] 调整所有调整点之后, 按 [Apply All] 按钮储存调整值。
发射辅助	1) 调整项目 : [TAST] 调整 : [***] 2) 调整项目 : [L TAST] → [L' TAST] → [C TAST] → [H' TAST] → [H TAST] 调整 : [***] PTT: 开启 按 [<] 键储存调整值。	1) 调整项目 : [Transmit Assist] 2) 调整项目 : [Low], [Low'], [Center], [High'], [High] PTT: 按 [Transmit] 按钮。 按 [Apply All] 按钮储存调整值。							

ADJUSTMENT

Item	Condition		Measurement			Adjustment			Specifications / Remarks
	Panel tuning mode	PC test mode	Test-equipment	Unit	Terminal	Unit	Parts	Method	
4. RTC oscillation frequency adjust	1) Adj item: [RTC] Adjust: [***]	1) Adj item: [RTC] (Real-time clock)					[Δ]	<p>[Panel tuning mode] Press [Δ] key. After automatic adjustment adjusted value is displayed on LCD. Press [◀] key to store the adjustment value.</p> <p>[PC test mode] Press [Start] button of "Auto Tuning". Press [Apply] button to store the adjustment value after the automatic adjustment was finished.</p>	Adjustment of the transceiver's internal clock.
5. Frequency adjust	* The Frequency adjustment can be performed only in PC test mode.	1) Adj item: [Frequency] 2) CH-Sig: 1-1 SSG output: -20dBm (CW (without modulation)) Caution: Perform the frequency adjustment under the following conditions. <ul style="list-style-type: none"> • Temperature range of +23°C to +27°C (+73.4°F to +80.6°F). (The temperature is displayed on the Frequency adjustment screen of the KPG-111D(C) and the LCD of the transceiver.) • Use an accuracy of 0.003ppm for the SSG. (Use a standard oscillator if necessary.) 	SSG		ANT		[Δ]	<p>[PC test mode] Press [Start] button of "Auto Tuning". Press [Apply] button to store the adjustment value after the automatic adjustment was finished.</p>	<p>[PC test mode] "IF20" value = Within 0±12 digits. The value of "IF20" will become around "0" after the adjustment was finished. Frequency is adjusted under receiving condition with SSG.</p>

调 整

项 目	条 件		测 量			调 整			规格 / 备注
	面板调谐模式	PC 测试模式	测量装置	单元	端子	单元	部件	方 法	
4. RTC 振荡 频率调整	1) 调整项目 : [RTC] 调整 : [***]	1) 调整项目 : [RTC (Real-time clock)]					[▲]	<p>[面板调谐模式] 按 [▲] 键。自动调整的调整值显示在 LCD 上之后。按 [<] 键储存调整值。</p> <p>[PC 测试模式] 按 “Auto Tuning” 的 [Start] 按钮。自动调整完成之后，按 [Apply] 按钮储存调整值。</p>	车载对讲机内部时钟的调整。
5. 频率调整	* 频率调整只能在 PC 测试模式中进行。	1) 调整项目 : [Frequency] 2) CH-Sig: 1-1 SSG 输出 : -20dBm (CW (无调制)) 注意 : 在下列条件下进行频率调整。 <ul style="list-style-type: none"> • 温度范围 +23°C 至 +27°C。 (KPG-111D (C) 的频率调整画面和车载对讲机的 LCD 上显示频率。) • 使用 0.003ppm 的 SSG 精度。 (如有必要，请使用标准振荡器。) 	SSG		天线		[▲]	<p>[PC 测试模式] 按 “Auto Tuning” 的 [Start] 按钮。自动调整完成之后，按 [Apply] 按钮储存调整值。</p>	<p>[PC 测试模式] “ IF20 ” 值 = 0 ± 12 位以内调整结束后，“ IF20 ” 的值将变成 “ 0 ” 左右。在 SSG 接收条件下调整频率。</p>

ADJUSTMENT

Transmitter Section

Item	Condition		Measurement			Adjustment			Specifications / Remarks
	Panel tuning mode	PC test mode	Test-equipment	Unit	Terminal	Unit	Parts	Method	
1. High Transmit Power Limit adjust	1) Adj item: [HILMT] Adjust: [****] 2) Adj item: [L HILMT]→ [L' HILMT]→ [C HILMT]→ [H' HILMT]→ [H HILMT] Adjust: [****] PTT: ON Press [◀] key to store the adjustment value.	1) Adj item: [High Transmit Power Limit] 2) Adj item: [Low], [Low'], [Center], [High'], [High] PTT: Press [Transmit] button. Press [Apply All] button to store the adjustment value.	Power meter Ammeter		ANT		[Panel tuning mode] [↶],[↷] [PC test mode] [◀],[▶]	28.0W	±3.0W [PC test mode] Press [Apply All] button to store the adjustment value after all adjustment point was adjusted. CAUTION! Do not attempt to adjust the transceiver's transmit output power beyond its specifications. If the transceiver is adjusted beyond the specifications, it may cause deterioration of the parts reliability and the output power may be lowered suddenly and unstable. The transceiver may be also extremely hot.
2. Low Transmit Power Limit adjust	1) Adj item: [LOLMT] Adjust: [****] 2) Adj item: [L LOLMT]→ [L' LOLMT]→ [C LOLMT]→ [H' LOLMT]→ [H LOLMT] Adjust: [****] PTT: ON Press [◀] key to store the adjustment value.	1) Adj item: [Low Transmit Power Limit] 2) Adj item: [Low], [Low'], [Center], [High'], [High] PTT: Press [Transmit] button. Press [Apply All] button to store the adjustment value.						10.0W	±1.0W [PC test mode] Press [Apply All] button to store the adjustment value after all adjustment point was adjusted. CAUTION! Do not attempt to adjust the transceiver's transmit output power beyond its specifications. If the transceiver is adjusted beyond the specifications, it may cause deterioration of the parts reliability and the output power may be lowered suddenly and unstable. The transceiver may be also extremely hot.

调 整

发射机部分

项 目	条 件		测 量			调 整			规格 / 备注
	面板调谐模式	PC 测试模式	测量装置	单元	端子	单元	部件	方 法	
1. 高发射功率限制调整	1) 调整项目:[HILMT] 调整:[****] 2) 调整项目: [L HILMT]→ [L' HILMT]→ [C HILMT]→ [H' HILMT]→ [H HILMT] 调整:[****] PTT: 开启 按 [<] 键储存调整值。	1) 调整项目:[High Transmit Power Limit] 2) 调整项目:[Low], [Low'], [Center], [High'], [High] PTT: 按 [Transmit] 按钮。 按 [Apply All] 按钮储存调整值。	功率计 电流表		天线		[面板调谐模式] [↵],[⏏] [PC 测试模式] [◀],[▶]	28.0W	±3.0W [PC 测试模式] 调整所有调整点之后, 按 [Apply All] 按钮储存调整值。 注意! 请勿尝试调节车载对讲机规格范围之外的发射输出功率。如果车载对讲机调节超出其规格, 则可能导致部件可靠性降低以及输出功率可能突然降低且不稳定。 车载对讲机也可能极热。
2. 低发射功率限制调整	1) 调整项目:[LOLMT] 调整:[****] 2) 调整项目: [L LOLMT]→ [L' LOLMT]→ [C LOLMT]→ [H' LOLMT]→ [H LOLMT] 调整:[****] PTT: 开启 按 [<] 键储存调整值。	1) 调整项目:[Low Transmit Power Limit] 2) 调整项目:[Low], [Low'], [Center], [High'], [High] PTT: 按 [Transmit] 按钮。 按 [Apply All] 按钮储存调整值。						10.0W	±1.0W [PC 测试模式] 调整所有调整点之后, 按 [Apply All] 按钮储存调整值。 注意! 请勿尝试调节车载对讲机规格范围之外的发射输出功率。如果车载对讲机调节超出其规格, 则可能导致部件可靠性降低以及输出功率可能突然降低且不稳定。 车载对讲机也可能极热。

ADJUSTMENT

Item	Condition		Measurement			Adjustment			Specifications / Remarks
	Panel tuning mode	PC test mode	Test-equipment	Unit	Terminal	Unit	Parts	Method	
3. High Transmit Power adjust	1) Adj item: [HIPWR] Adjust: [****] 2) Adj item: [L HIPWR]→ [L' HIPWR]→ [C HIPWR]→ [H' HIPWR]→ [H HIPWR] Adjust: [****] PTT: ON Press [◀] key to store the adjustment value.	1) Adj item: [High Transmit Power] 2) Adj item: [Low], [Low'], [Center], [High'], [High] PTT: Press [Transmit] button. Press [Apply All] button to store the adjustment value.	Power meter Ammeter		ANT		[Panel tuning mode] [↵],[↶] [PC test mode] [◀],[▶]	25.0W	±1.0W 9.0A or less [PC test mode] Press [Apply All] button to store the adjustment value after all adjustment point was adjusted.
4. Low Transmit Power adjust	1) Adj item: [LOPWR] Adjust: [****] 2) Adj item: [L LOPWR]→ [L' LOPWR]→ [C LOPWR]→ [H' LOPWR]→ [H LOPWR] Adjust: [****] PTT: ON Press [◀] key to store the adjustment value.	1) Adj item: [Low Transmit Power] 2) Adj item: [Low], [Low'], [Center], [High'], [High] PTT: Press [Transmit] button. Press [Apply All] button to store the adjustment value.						5.0W	±0.5W 5.0A or less [PC test mode] Press [Apply All] button to store the adjustment value after all adjustment point was adjusted.
5. Balance adjust *2	1) Adj item: [BAL] Adjust: [***] Deviation meter LPF: 3kHz HPF: OFF 2) Adj item: [L BAL]→ [L' BAL]→[C BAL]→ [H' BAL]→[H BAL] Adjust: [***] PTT: ON Press [◀] key to store the adjustment value. Sub LCD: Tone frequency [▲] key: Press while transmitting to change 20Hz and 2kHz.	1) Adj item: [Balance] Deviation meter LPF : 3kHz HPF : OFF 2) Adj item: [Low], [Low'], [Center], [High'], [High] PTT: Press [Transmit] button. Press [Apply All] button to store the adjustment value. [2kHz Sine Wave Check box]: Check while transmitting change to 2kHz.	Deviation meter Oscilloscope					The Deviation of 20Hz frequency is fixed. Change the 2kHz adjustment value to become the same deviation of 20Hz within the specified range.	2kHz Tone deviation is within ±1.0% of 20Hz tone deviation. [PC test mode] Press [Apply All] button to store the adjustment value after all adjustment point was adjusted.
*2: Refer to the "Necessary Deviation adjustment item for each signaling and mode" table on page 92. Balance adjustment is common with the adjustment of all signaling deviation.									
6. Maximum Deviation (NXDN) adjust *3 [Narrow]	1) Adj item: [Nn NDEV] Adjust: [****] Deviation meter LPF: 3kHz HPF: OFF 2) Adj item: [NnL NDEV]→ [NnL' NDEV]→ [NnC NDEV]→ [NnH' NDEV]→ [NnH NDEV] Adjust: [****] PTT: ON Press [◀] key to store the adjustment value.	1) Adj item: [Maximum Deviation (NXDN Narrow)] Deviation meter LPF: 3kHz HPF: OFF 2) Adj item: [Low], [Low'], [Center], [High'], [High] PTT: Press [Transmit] button. Press [Apply All] button to store the adjustment value.	Deviation meter Oscilloscope		ANT		[Panel tuning mode] [↵],[↶] [PC test mode] [◀],[▶]	3056Hz	±50Hz [PC test mode] Press [Apply All] button to store the adjustment value after all adjustment point was adjusted.

调 整

项 目	条 件		测 量			调 整			规格 / 备注
	面板调谐模式	PC 测试模式	测量装置	单元	端子	单元	部件	方 法	
3. 高发射功率调整	1) 调整项目:[HIPWR] 调整:[*****] 2) 调整项目: [L HIPWR]→ [L' HIPWR]→ [C HIPWR]→ [H' HIPWR]→ [H HIPWR] 调整:[*****] PTT: 开启 按[<]键储存调整值。	1) 调整项目:[High Transmit Power] 2) 调整项目:[Low], [Low'], [Center], [High'], [High] PTT: 按[Transmit]按钮。 按[Apply All]按钮储存调整值。	功率计 电流表		天线		[面板调谐模式] [↔],[↔] [PC 测试模式] [◀],[▶]	25.0W	±1.0W 9.0A 或更低 [PC 测试模式] 调整所有调整点之后, 按[Apply All]按钮储存调整值。
4. 低发射功率调整	1) 调整项目:[LOPWR] 调整:[*****] 2) 调整项目: [L LOPWR]→ [L' LOPWR]→ [C LOPWR]→ [H' LOPWR]→ [H LOPWR] 调整:[*****] PTT: 开启 按[<]键储存调整值。	1) 调整项目:[Low Transmit Power] 2) 调整项目:[Low], [Low'], [Center], [High'], [High] PTT: 按[Transmit]按钮。 按[Apply All]按钮储存调整值。						5.0W	±0.5W 5.0A 或更低 [PC 测试模式] 调整所有调整点之后, 按[Apply All]按钮储存调整值。
5. 平衡调整 *2	1) 调整项目:[BAL] 调整:[*****] 频偏仪 LPF: 3kHz HPF: 关闭 2) 调整项目:[L BAL] → [L' BAL] → [C BAL] → [H' BAL] → [H BAL] 调整:[*****] PTT: 开启 按[<]键储存调整值。 副 LCD: 单音频率 [▲]键: 发射时按此键更改 20Hz 和 2kHz。	1) 调整项目:[Balance] 频偏仪 LPF: 3kHz HPF: 关闭 2) 调整项目:[Low], [Low'], [Center], [High'], [High] PTT: 按[Transmit]按钮。 按[Apply All]按钮储存调整值。 [2kHz Sine Wave Check box]: 发射时复选此项改为 2kHz。	频偏仪 示波器					20Hz 频率的频偏固定。 更改 2kHz 调整值, 变成指定范围内 20Hz 的相同频偏。	2kHz 音调频偏在 20Hz 音调频偏的 ±1.0% 以内。 [PC 测试模式] 调整所有调整点之后, 按[Apply All]按钮储存调整值。
*2: 请参阅第 93 页的“各信令和模式所需的频偏调整项目”表。 所有信令频偏的平衡调整共用。									
6. 最大频偏 (NXDN) 调整 *3 [窄]	1) 调整项目:[Nn NDEV] 调整:[*****] 频偏仪 LPF: 3kHz HPF: 关闭 2) 调整项目: [NnL NDEV]→ [NnL' NDEV]→ [NnC NDEV]→ [NnH' NDEV]→ [NnH NDEV] 调整:[*****] PTT: 开启 按[<]键储存调整值。	1) 调整项目:[Maximum Deviation (NXDN Narrow)] 频偏仪 LPF: 3kHz HPF: 关闭 2) 调整项目:[Low], [Low'], [Center], [High'], [High] PTT: 按[Transmit]按钮。 按[Apply All]按钮储存调整值。	频偏仪 示波器		天线		[面板调谐模式] [↔],[↔] [PC 测试模式] [◀],[▶]	3056Hz	±50Hz [PC 测试模式] 调整所有调整点之后, 按[Apply All]按钮储存调整值。

ADJUSTMENT

Item	Condition		Measurement			Adjustment			Specifications / Remarks
	Panel tuning mode	PC test mode	Test-equipment	Unit	Terminal	Unit	Parts	Method	
[Very Narrow]	1) Adj item: [Nv NDEV] Adjust: [****] 2) Adj item: [NvL NDEV]→ [NvL' NDEV]→ [NvC NDEV]→ [NvH' NDEV]→ [NvH NDEV] Adjust: [****] PTT: ON Press [◀] key to store the adjustment value.	1) Adj item: [Maximum Deviation (NXDN Very Narrow)] 2) Adj item: [Low], [Low'], [Center], [High'], [High] PTT: Press [Transmit] button. Press [Apply All] button to store the adjustment value.	Deviation meter Oscilloscope		ANT		[Panel tuning mode] [↶],[↷] [PC test mode] [◀],[▶]	1337Hz	±50Hz [PC test mode] Press [Apply All] button to store the adjustment value after all adjustment point was adjusted.
7. Maximum Deviation (Analog) adjust *3 [Narrow]	1) Adj item: [An ADEV] Adjust: [****] Deviation meter LPF: 15kHz HPF: OFF 2) Adj item: [AnL ADEV]→ [AnL' ADEV]→ [AnC ADEV]→ [AnH' ADEV]→ [AnH ADEV] Adjust: [****] PTT: ON Press [◀] key to store the adjustment value.	1) Adj item: [Maximum Deviation (Analog Narrow)] Deviation meter LPF: 15kHz HPF: OFF 2) Adj item: [Low], [Low'], [Center], [High'], [High] PTT: Press [Transmit] button. Press [Apply All] button to store the adjustment value.						Write the same adjustment value of "NXDN Deviation [Narrow]" for each adjustment point. Transmit at each adjustment point and check that the Analog deviation is between 2050Hz and 2150Hz. Deviation meter LPF: 15kHz HPF: OFF [Panel tuning mode] PTT: ON [PC test mode] PTT: Press [Transmit] button	2050~2150Hz [PC test mode] Press [Apply All] button to store the adjustment value after all adjustment point was adjusted.
[Wide]	1) Adj item: [Aw ADEV] Adjust: [****] 2) Adj item: [AwL ADEV]→ [AwL' ADEV]→ [AwC ADEV]→ [AwH' NDEV]→ [AwH NDEV] Adjust: [****] PTT: ON Press [◀] key to store the adjustment value.	1) Adj item: [Maximum Deviation (Analog Wide)] 2) Adj item: [Low], [Low'], [Center], [High'], [High] PTT: Press [Transmit] button. Press [Apply All] button to store the adjustment value.						Write the same adjustment value of "NXDN Deviation [Narrow]" for each adjustment point. Transmit at each adjustment point and check that the Analog deviation is between 4150Hz and 4250Hz. Deviation meter LPF: 15kHz HPF: OFF [Panel tuning mode] PTT: ON [PC test mode] PTT: Press [Transmit] button	4150~4250Hz [PC test mode] Press [Apply All] button to store the adjustment value after all adjustment point was adjusted.

*3: Refer to the "Necessary Deviation adjustment item for each signaling and mode" table on page 92.
Analog deviation adjustment (Narrow/Wide) is common with the adjustment of all analog signaling.

调 整

项 目	条 件		测 量			调 整			规格 / 备注
	面板调谐模式	PC 测试模式	测量装置	单元	端子	单元	部件	方 法	
[超窄]	1) 调整项目： [Nv NDEV] 调整：[*****] 2) 调整项目： [NvL NDEV]→ [NvL' NDEV]→ [NvC NDEV]→ [NvH' NDEV]→ [NvH NDEV] 调整：[*****] PTT: 开启 按 [<] 键储存调整值。	1) 调整项目： [Maximum Deviation (NXDN Very Narrow)] 2) 调整项目：[Low], [Low'], [Center], [High'], [High] PTT: 按 [Transmit] 按钮。 按 [Apply All] 按钮储存调整值。	频偏仪 示波器		天线		[面板调谐模式] [↵],[⏏] [PC 测试模式] [←],[→]	1337Hz	±50Hz [PC 测试模式] 调整所有调整点之后，按 [Apply All] 按钮储存调整值。
7. 最大频偏 (模拟) 调整 *3 [窄]	1) 调整项目： [An ADEV] 调整：[*****] 频偏仪 LPF: 15kHz HPF: 关闭 2) 调整项目： [AnL ADEV]→ [AnL' ADEV]→ [AnC ADEV]→ [AnH' ADEV]→ [AnH ADEV] 调整：[*****] PTT: 开启 按 [<] 键储存调整值。	1) 调整项目： [Maximum Deviation (Analog Narrow)] 频偏仪 LPF: 15kHz HPF: 关闭 2) 调整项目：[Low], [Low'], [Center], [High'], [High] PTT: 按 [Transmit] 按钮。 按 [Apply All] 按钮储存调整值。					为每个调整点 写入相同的 “NXDN Deviation [Narrow]”调整值。 在每个调整点发射， 检查模拟频偏是否在 2050Hz 和 2150Hz 之间。 频偏仪 LPF: 15kHz HPF: 关闭 [面板调谐模式] PTT: 开启 [PC 测试模式] PTT: 按 [Transmit] 按钮。	2050~2150Hz	[PC 测试模式] 调整所有调整点之后，按 [Apply All] 按钮储存调整值。
[宽]	1) 调整项目： [Aw ADEV] 调整：[*****] 2) 调整项目： [AwL ADEV]→ [AwL' ADEV]→ [AwC ADEV]→ [AwH' NDEV]→ [AwH NDEV] 调整：[*****] PTT: 开启 按 [<] 键储存调整值。	1) 调整项目： [Maximum Deviation (Analog Wide)] 2) 调整项目：[Low], [Low'], [Center], [High'], [High] PTT: 按 [Transmit] 按钮。 按 [Apply All] 按钮储存调整值。					为每个调整点 写入相同的 “NXDN Deviation [Narrow]”调整值。 在每个调整点发射， 检查模拟频偏是否在 4150Hz 和 4250Hz 之间。 频偏仪 LPF: 15kHz HPF: 关闭 [面板调谐模式] PTT: 开启 [PC 测试模式] PTT: 按 [Transmit] 按钮。	4150~4250Hz	[PC 测试模式] 调整所有调整点之后，按 [Apply All] 按钮储存调整值。

*3: 请参阅第 93 页的“各信令和模式所需的频偏调整项目”表。
模拟频偏调整(窄/宽)与所有模拟信令的调整共用。

ADJUSTMENT

Item	Condition		Measurement			Adjustment			Specifications / Remarks
	Panel tuning mode	PC test mode	Test-equipment	Unit	Terminal	Unit	Parts	Method	
8. QT Deviation adjust *4 [Narrow]	1) Adj item: [An QT] Adjust: [****] Deviation meter LPF: 3kHz HPF: OFF PTT: ON Press [◀] key to store the adjustment value.	1) Adj item: [QT Deviation (Narrow)] Deviation meter LPF: 3kHz HPF: OFF PTT: Press [Transmit] button. Press [Apply] button to store the adjustment value.	Deviation meter Oscilloscope		ANT		[Panel tuning mode] [↶],[↷] [PC test mode] [◀],[▶]	Write the value as followings. 513 (Reference value)	0.30~0.40kHz
	[Wide]	1) Adj item: [Aw QT] Adjust: [****] PTT: ON Press [◀] key to store the adjustment value.							1) Adj item: [QT Deviation (Wide)] PTT: Press [Transmit] button. Press [Apply] button to store the adjustment value.
9. DQT Deviation adjust *4 [Narrow]	1) Adj item: [An DQT] Adjust: [****] Deviation meter LPF: 3kHz HPF: OFF PTT: ON Press [◀] key to store the adjustment value.	1) Adj item: [DQT Deviation (Narrow)] Deviation meter LPF: 3kHz HPF: OFF PTT: Press [Transmit] button. Press [Apply] button to store the adjustment value.						Write the value as followings. 430 (Reference value)	0.30~0.40kHz
	[Wide]	1) Adj item: [Aw DQT] Adjust: [****] PTT: ON Press [◀] key to store the adjustment value.							1) Adj item: [DQT Deviation (Wide)] PTT: Press [Transmit] button. Press [Apply] button to store the adjustment value.
10. LTR Deviation adjust *4 [Narrow]	1) Adj item: [An LTR] Adjust: [****] Deviation meter LPF: 3kHz HPF: OFF PTT: ON Press [◀] key to store the adjustment value.	1) Adj item: [LTR Deviation (Narrow)] Deviation meter LPF: 3kHz HPF: OFF PTT: Press [Transmit] button. Press [Apply] button to store the adjustment value.						Write the value as followings. 465 (Reference value)	0.70~0.80kHz
	[Wide]	1) Adj item: [Aw LTR] Adjust: [****] PTT: ON Press [◀] key to store the adjustment value.							1) Adj item: [LTR Deviation (Wide)] PTT: Press [Transmit] button. Press [Apply] button to store the adjustment value.

调 整

项 目	条 件		测 量			调 整			规格 / 备注
	面板调谐模式	PC 测试模式	测量装置	单元	端子	单元	部件	方 法	
8. QT 频偏调整 *4 [窄]	1) 调整项目 : [An QT] 调整 : [*****] 频偏仪 LPF: 3kHz HPF: 关闭 PTT: 开启 按 [<] 键储存调整值。	1) 调整项目 : [QT Deviation (Narrow)] 频偏仪 LPF: 3kHz HPF: 关闭 PTT: 按 [Transmit] 按钮。 按 [Apply] 按钮储存调整值。	频偏仪示波器		天线		[面板调谐模式] [PC 测试模式]	写入以下值。 513 (基准值)	0.30~0.40kHz
	[宽]	1) 调整项目 : [Aw QT] 调整 : [*****] PTT: 开启 按 [<] 键储存调整值。							1) 调整项目 : [QT Deviation (Wide)] PTT: 按 [Transmit] 按钮。 按 [Apply] 按钮储存调整值。
9. DQT 频偏调整 *4 [窄]	1) 调整项目 : [An DQT] 调整 : [*****] 频偏仪 LPF: 3kHz HPF: 关闭 PTT: 开启 按 [<] 键储存调整值。	1) 调整项目 : [DQT Deviation (Narrow)] 频偏仪 LPF: 3kHz HPF: 关闭 PTT: 按 [Transmit] 按钮。 按 [Apply] 按钮储存调整值。						写入以下值。 430 (基准值)	0.30~0.40kHz
	[宽]	1) 调整项目 : [Aw DQT] 调整 : [*****] PTT: 开启 按 [<] 键储存调整值。							1) 调整项目 : [DQT Deviation (Wide)] PTT: 按 [Transmit] 按钮。 按 [Apply] 按钮储存调整值。
10. LTR 频偏调整 *4 [窄]	1) 调整项目 : [An LTR] 调整 : [*****] 频偏仪 LPF: 3kHz HPF: 关闭 PTT: 开启 按 [<] 键储存调整值。	1) 调整项目 : [LTR Deviation (Narrow)] 频偏仪 LPF: 3kHz HPF: 关闭 PTT: 按 [Transmit] 按钮。 按 [Apply] 按钮储存调整值。						写入以下值。 465 (基准值)	0.70~0.80kHz
	[宽]	1) 调整项目 : [Aw LTR] 调整 : [*****] PTT: 开启 按 [<] 键储存调整值。							1) 调整项目 : [LTR Deviation (Wide)] PTT: 按 [Transmit] 按钮。 按 [Apply] 按钮储存调整值。

ADJUSTMENT

Item	Condition		Measurement			Adjustment		Specifications / Remarks	
	Panel tuning mode	PC test mode	Test-equipment	Unit	Terminal	Unit	Parts		Method
11. DTMF Deviation adjust *4 [Narrow]	1) Adj item: [An DTMF] Adjust: [****] Deviation meter LPF: 15kHz HPF: OFF PTT: ON Press [◀] key to store the adjustment value.	1) Adj item: [DTMF Deviation (Narrow)] Deviation meter LPF: 15kHz HPF: OFF PTT: Press [Transmit] button. Press [Apply] button to store the adjustment value.	Deviation meter Oscilloscope		ANT		[Panel tuning mode] [↵],[↶] [PC test mode] [◀],[▶]	Write the value as followings. 650 (Reference value)	1.45~1.55kHz
	[Wide]	1) Adj item: [Aw DTMF] Adjust: [****] PTT: ON Press [◀] key to store the adjustment value.							1) Adj item: [DTMF Deviation (Wide)] PTT: Press [Transmit] button. Press [Apply] button to store the adjustment value.
12. Single Tone Deviation (2-tone deviation adjust) adjust *4 [Narrow]	1) Adj item: [An TONE] Adjust: [****] Deviation meter LPF: 15kHz HPF: OFF PTT: ON Press [◀] key to store the adjustment value.	1) Adj item: [Single Tone Deviation (Narrow)] Deviation meter LPF: 15kHz HPF: OFF PTT: Press [Transmit] button. Press [Apply] button to store the adjustment value.						Write the value as followings. 513 (Reference value)	1.45~1.55kHz
	[Wide]	1) Adj item: [Aw TONE] Adjust: [****] PTT: ON Press [◀] key to store the adjustment value.							1) Adj item: [Single Tone Deviation (Wide)] PTT: Press [Transmit] button. Press [Apply] button to store the adjustment value.
13. MSK Deviation adjust *4 [Narrow]	1) Adj item: [An MSK] Adjust: [****] Deviation meter LPF: 15kHz HPF: OFF PTT: ON Press [◀] key to store the adjustment value.	1) Adj item: [MSK Deviation (Narrow)] Deviation meter LPF: 15kHz HPF: OFF PTT: Press [Transmit] button. Press [Apply] button to store the adjustment value.						Write the value as followings. 513 (Reference value)	1.45~1.55kHz
	[Wide]	1) Adj item: [Aw MSK] Adjust: [****] PTT: ON Press [◀] key to store the adjustment value.							1) Adj item: [MSK Deviation (Wide)] PTT: Press [Transmit] button. Press [Apply] button to store the adjustment value.

调 整

项 目	条 件		测 量			调 整			规格 / 备注	
	面板调谐模式	PC 测试模式	测量装置	单元	端子	单元	部件	方 法		
11. DTMF 频偏调整 *4 [窄]	1) 调整项目： [An DTMF] 调整：[*****] 频偏仪 LPF:15kHz HPF: 关闭 PTT: 开启 按 [<] 键储存调整值。	1) 调整项目： [DTMF Deviation (Narrow)] 频偏仪 LPF:15kHz HPF: 关闭 PTT: 按 [Transmit] 按钮。 按 [Apply] 按钮储存调整值。	频偏仪示波器		天线		[面板调谐模式] [<],[>] [PC 测试模式] [<],[>]	写入以下值。 650(基准值)	1.45~1.55kHz	
	[宽]	1) 调整项目： [Aw DTMF] 调整：[*****] PTT: 开启 按 [<] 键储存调整值。							1) 调整项目： [DTMF Deviation (Wide)] PTT: 按 [Transmit] 按钮。 按 [Apply] 按钮储存调整值。	2.95~3.05kHz
12. 单音频偏 (2 音频偏调整) 调整 *4 [窄]	1) 调整项目： [An TONE] 调整：[*****] 频偏仪 LPF:15kHz HPF: 关闭 PTT: 开启 按 [<] 键储存调整值。	1) 调整项目：[Single Tone Deviation (Narrow)] 频偏仪 LPF:15kHz HPF: 关闭 PTT: 按 [Transmit] 按钮。 按 [Apply] 按钮储存调整值。						513(基准值)	1.45~1.55kHz	
	[宽]	1) 调整项目： [Aw TONE] 调整：[*****] PTT: 开启 按 [<] 键储存调整值。							1) 调整项目：[Single Tone Deviation (Wide)] PTT: 按 [Transmit] 按钮。 按 [Apply] 按钮储存调整值。	2.95~3.05kHz
13. MSK 频偏调整 *4 [窄]	1) 调整项目： [An MSK] 调整：[*****] 频偏仪 LPF:15kHz HPF: 关闭 PTT: 开启 按 [<] 键储存调整值。	1) 调整项目： [MSK Deviation (Narrow)] 频偏仪 LPF:15kHz HPF: 关闭 PTT: 按 [Transmit] 按钮。 按 [Apply] 按钮储存调整值。							513(基准值)	1.45~1.55kHz
	[宽]	1) 调整项目： [Aw MSK] 调整：[*****] PTT: 开启 按 [<] 键储存调整值。								1) 调整项目： [MSK Deviation (Wide)] PTT: 按 [Transmit] 按钮。 按 [Apply] 按钮储存调整值。

ADJUSTMENT

Item	Condition		Measurement			Adjustment			Specifications / Remarks
	Panel tuning mode	PC test mode	Test-equipment	Unit	Terminal	Unit	Parts	Method	
14. CWID Deviation adjust *4 [Very Narrow]	1) Adj item: [Nv CWID] Adjust: [****] Deviation meter LPF: 3kHz HPF: OFF PTT: ON Press [◀] key to store the adjustment value.	1) Adj item: [CWID Deviation] Deviation meter LPF: 3kHz HPF: OFF PTT: Press [Transmit] button. Press [Apply] button to store the adjustment value.	Deviation meter Oscilloscope		ANT		[Panel tuning mode] [↖],[↗] [PC test mode] [◀],[▶]	Write the value as followings. 375 (Reference value)	0.90~1.10kHz
*4: Refer to the "Necessary Deviation adjustment item for each signaling and mode" table on page 92.									

■ Necessary Deviation adjustment for each signaling and mode

The following shows the necessary adjustment items for each signaling deviation. Please read the following table like the following example. In the case of the signaling "QT (Wide)", this signaling is composed of three elements [Balance, Maximum Deviation (Analog Wide) and QT Deviation (Wide)]. Please adjust Balance and Maximum Deviation (Analog Wide) before adjusting QT Deviation (Wide).

Mode	Signaling	Necessary adjustment and order		
		Wide	Narrow	Very Narrow
Analog	Audio	Step1. Balance adjust Step2. Maximum Deviation (Analog Wide)	Step1. Balance adjust Step2. Maximum Deviation (Analog Narrow)	-
	QT	Step1. Balance adjust Step2. Maximum Deviation (Analog Wide) Step3. QT Deviation (Wide)	Step1. Balance adjust Step2. Maximum Deviation (Analog Narrow) Step3. QT Deviation (Narrow)	-
	DQT	Step1. Balance adjust Step2. Maximum Deviation (Analog Wide) Step3. DQT Deviation (Wide)	Step1. Balance adjust Step2. Maximum Deviation (Analog Narrow) Step3. DQT Deviation (Narrow)	-
	LTR	Step1. Balance adjust Step2. Maximum Deviation (Analog Wide) Step3. LTR Deviation (Wide)	Step1. Balance adjust Step2. Maximum Deviation (Analog Narrow) Step3. LTR Deviation (Narrow)	-
	DTMF	Step1. Balance adjust Step2. Maximum Deviation (Analog Wide) Step3. DTMF Deviation (Wide)	Step1. Balance adjust Step2. Maximum Deviation (Analog Narrow) Step3. DTMF Deviation (Narrow)	-
	2-tone	Step1. Balance adjust Step2. Maximum Deviation (Analog Wide) Step3. Single Tone Deviation (Analog Wide)	Step1. Balance adjust Step2. Maximum Deviation (Analog Narrow) Step3. Single Tone Deviation (Analog Narrow)	-
	MSK (FleetSync)	Step1. Balance adjust Step2. Maximum Deviation (Analog Wide) Step3. MSK Deviation (Analog Wide)	Step1. Balance adjust Step2. Maximum Deviation (Analog Narrow) Step3. MSK Deviation (Analog Narrow)	-
NXDN	Audio	-	Step1. Balance adjust Step2. Maximum Deviation (NXDN Narrow)	Step1. Balance adjust Step2. Maximum Deviation (NXDN Very Narrow)
	CWID	-	-	Step1. Balance adjust Step2. Maximum Deviation (Analog Narrow) Step3. CWID Deviation (NXDN Very Narrow)

Balance is common with all the above deviation adjustments. If Balance (Transmitter Section 5) has already adjusted, please skip Step1 and adjust from Step2. Maximum Deviation (Analog Wide/Narrow) is common with all the analog signaling deviations and CWID Deviation (NXDN Very Narrow). If Balance and Maximum Deviation (Analog Wide/Narrow) (Transmitter Section 7) have already adjusted, please skip Step2 and adjust from Step3.

调 整

项 目	条 件		测 量			调 整			规格 / 备注
	面板调谐模式	PC 测试模式	测量装置	单元	端子	单元	部件	方 法	
14. CWID 频偏调整 *4 [超窄]	1) 调整项目： [Nv CWID] 调整：[*****] 频偏仪 LPF: 3kHz HPF: 关闭 PTT: 开启 按 [<] 键储存调整值。	1) 调整项目：[CWID Deviation] 频偏仪 LPF: 3kHz HPF: 关闭 PTT: 按 [Transmit] 按钮。 按 [Apply] 按钮储存调整值。	频偏仪示波器		天线		[面板调谐模式] [↵],[⏏] [PC 测试模式] [◀],[▶]	写入以下值。 375 (基准值)	0.90~1.10kHz
*4: 请参阅第 93 页的“各信令和模式所需的频偏调整项目”表。									

■ 各信令和模式所需的频偏调整项目

下表显示了各信令频偏所需的调整项目。请按照以下示例阅读下表。对于信令“QT(宽)”，该信令包含三个组成部分 [平衡、最大频偏(模拟宽)和 QT 频偏(宽)]。请在调整 QT 频偏(宽)之前调整平衡和最大频偏(模拟宽)。

模式	信 令	所 需 的 调 整 和 顺 序		
		宽	窄	超 窄
模拟	音频	步骤 1. 平衡调整 步骤 2. 最大频偏 (模拟宽)	步骤 1. 平衡调整 步骤 2. 最大频偏 (模拟窄)	-
	QT	步骤 1. 平衡调整 步骤 2. 最大频偏 (模拟宽) 步骤 3. QT 频偏 (宽)	步骤 1. 平衡调整 步骤 2. 最大频偏 (模拟窄) 步骤 3. QT 频偏 (窄)	-
	DQT	步骤 1. 平衡调整 步骤 2. 最大频偏 (模拟宽) 步骤 3. DQT 频偏 (宽)	步骤 1. 平衡调整 步骤 2. 最大频偏 (模拟窄) 步骤 3. DQT 频偏 (窄)	-
	LTR	步骤 1. 平衡调整 步骤 2. 最大频偏 (模拟宽) 步骤 3. LTR 频偏 (宽)	步骤 1. 平衡调整 步骤 2. 最大频偏 (模拟窄) 步骤 3. LTR 频偏 (窄)	-
	DTMF	步骤 1. 平衡调整 步骤 2. 最大频偏 (模拟宽) 步骤 3. DTMF 频偏 (宽)	步骤 1. 平衡调整 步骤 2. 最大频偏 (模拟窄) 步骤 3. DTMF 频偏 (窄)	-
	2 音	步骤 1. 平衡调整 步骤 2. 最大频偏 (模拟宽) 步骤 3. 单音频偏 (模拟宽)	步骤 1. 平衡调整 步骤 2. 最大频偏 (模拟窄) 步骤 3. 单音频偏 (模拟窄)	-
	MSK (FleetSync)	步骤 1. 平衡调整 步骤 2. 最大频偏 (模拟宽) 步骤 3. MSK 频偏 (模拟宽)	步骤 1. 平衡调整 步骤 2. 最大频偏 (模拟窄) 步骤 3. MSK 频偏 (模拟窄)	-
NXDN	音频	-	步骤 1. 平衡调整 步骤 2. 最大频偏 (NXDN 窄)	步骤 1. 平衡调整 步骤 2. 最大频偏 (NXDN 超窄)
	CWID	-	-	步骤 1. 平衡调整 步骤 2. 最大频偏 (模拟窄) 步骤 3. CWID 频偏 (NXDN 超窄)

上述所有频偏调整的平衡共用。如果已经调整了平衡(发射机部分 5)，请跳过步骤 1，从步骤 2 开始调整。

对于所有的模拟信令频偏和 CWID 频偏(NXDN 超窄)，最大频偏(模拟宽/窄)共用。

如果已经调整了平衡和最大频偏(模拟宽/窄)(发射机部分 7)，请跳过步骤 2，从步骤 3 开始调整。

ADJUSTMENT

Receiver Section

Item	Condition		Measurement			Adjustment		Specifications / Remarks	
	Panel tuning mode	PC test mode	Test-equipment	Unit	Terminal	Unit	Parts		Method
1. AF level setting	[Panel test mode] 1) CH-Sig: 1-1 SSG output: -47dBm (1mV) (MOD: 1kHz, Dev: ±1.5kHz)	1) Test Channel Channel: 1 Test Signaling Mode: Analog Signaling: 1 SSG output: -47dBm (1mV) (MOD: 1kHz, Dev: ±1.5kHz)	SSG DVM AF VTVM Dummy load (4Ω)		ANT Ext.SP connec- tor		[Panel tuning mode] [↵],[↶] [PC test mode] [◀],[▶] (Volume Button in PC test mode screen)	Volume Up/Down knob to obtain 2.83V AF output. (2.0W @ 4Ω load)	2.83V±0.3V
2. Sensitivity 1 Adjust (BPF adjust)	1) Adj item: [SENS1] Adjust: [***] 2) Adj item: [L SENS1]→ [L' SENS1]→ [C SENS1]→ [H' SENS1]→ [H SENS1] Adjust: [***] Press [◀] key to store the adjustment value.	1) Adj item: [Sensitiv- ity 1] 2) Adj item: [Low], [Low'], [Center], [High'], [High] Press [Apply All] button to store the adjustment value.					[Panel tuning mode] [↵],[↶] [PC test mode] [◀],[▶]	Write the value as followings [L SENS1] / [Low] : 85 [L' SENS1] / [Low'] : 105 [C SENS1] / [Center] : 127 [H' SENS1] / [High'] : 165 [H SENS1] / [High] : 200	Variable-Capacitor Tune voltage is adjusted. (Output voltage ad- justment of IC206)
3. Sensitivity 2 Adjust (BPF adjust)	1) Adj item: [SENS2] Adjust: [***] 2) Adj item: [L SENS2]→ [L' SENS2]→ [C SENS2]→ [H' SENS2]→ [H SENS2] Adjust: [***] Press [◀] key to store the adjustment value.	1) Adj item: [Sensitiv- ity 2] 2) Adj item: [Low], [Low'], [Center], [High'], [High] Press [Apply All] button to store the adjustment value.						Write the value as followings [L SENS2] / [Low] : 98 [L' SENS2] / [Low'] : 114 [C SENS2] / [Center] : 120 [H' SENS2] / [High'] : 160 [H SENS2] / [High] : 195	Variable-Capacitor Tune voltage is adjusted. (Output voltage ad- justment of IC205)
4. RSSI reference adjust *5 [Analog Narrow]	1) Adj item: [An RRSSI] Adjust: [***] 2) Adj item: [AnL RRSSI]→ [AnL' RRSSI]→ [AnC RRSSI]→ [AnH' RRSSI]→ [AnH RRSSI] SSG output: 12dB SINAD level -3dB (MOD: 1kHz, Dev: ±1.5kHz)	1) Adj item: [RSSI Reference (Narrow)] 2) Adj item: [Low], [Low'], [Center], [High'], [High] SSG output: 12dB SINAD level -3dB (MOD: 1kHz, Dev: ±1.5kHz)	SSG AF VTVM Oscilloscope Distortion meter Dummy load					[Panel tuning mode] After input signal from SSG, press [◀] key to store the adjustment value. [PC test mode] After input signal from SSG, press [Apply] button to store the adjust- ment value.	
[Analog Wide]	1) Adj item: [Aw RRSSI] Adjust: [***] 2) Adj item: [AwL RRSSI]→ [AwL' RRSSI]→ [AwC RRSSI]→ [AwH' RRSSI]→ [AwH RRSSI] SSG output: 12dB SINAD level -3dB (MOD: 1kHz, Dev: ±3kHz)	1) Adj item: [RSSI Reference (Wide)] 2) Adj item: [Low], [Low'], [Center], [High'], [High] SSG output: 12dB SINAD level -3dB (MOD: 1kHz, Dev: ±3kHz)							

调 整

接收机部分

项 目	条 件		测 量			调 整			规格 / 备注
	面板调谐模式	PC 测试模式	测量装置	单元	端子	单元	部件	方 法	
1. AF 电平设置	[面板测试模式] 1) CH-Sig:1-1 SSG 输出 : -47dBm(1mV) (MOD:1kHz, 频偏 :±1.5kHz)	1) 测试信道 信道 :1 测试信令 模式 : 模拟 信令 :1 SSG 输出 : -47dBm(1mV) (MOD:1kHz, 频偏 :±1.5kHz)	SSG DVM AF VTVM 假负载 (4Ω)		天线 外部 SP 连接器		[面板调谐模式] [↵],[⏏] [PC 测试模式] [◀],[▶] (PC 测试模式画面中的音量按钮)	上 / 下调整音量旋钮以获得 2.83V AF 输出。 (2.0W @ 4Ω 负载)	2.83V±0.3V
2. 灵敏度 1 调整 (BPF 调整)	1) 调整项目 :[SENS1] 调整 :[***] 2) 调整项目 : [L SENS1]→ [L' SENS1]→ [C SENS1]→ [H' SENS1]→ [H SENS1] 调整 :[***] 按 [<] 键储存调整值。	1) 调整项目 : [Sensitivity 1] 2) 调整项目 :[Low], [Low'], [Center], [High'], [High] 按 [Apply All] 按钮储存调整值。					[面板调谐模式] [↵],[⏏] [PC 测试模式] [◀],[▶]	写入以下值。 [L SENS1]/[Low] :85 [L' SENS1]/[Low'] :105 [C SENS1]/[Center] :127 [H' SENS1]/[High'] :165 [H SENS1]/[High] :200	可变电容器调整调谐电压。 (IC206 的输出电压调整)
3. 灵敏度 2 调整 (BPF 调整)	1) 调整项目 :[SENS2] 调整 :[***] 2) 调整项目 : [L SENS2]→ [L' SENS2]→ [C SENS2]→ [H' SENS2]→ [H SENS2] 调整 :[***] 按 [<] 键储存调整值。	1) 调整项目 : [Sensitivity 2] 2) 调整项目 :[Low], [Low'], [Center], [High'], [High] 按 [Apply All] 按钮储存调整值。					写入以下值。 [L SENS2]/[Low] :98 [L' SENS2]/[Low'] :114 [C SENS2]/[Center] :120 [H' SENS2]/[High'] :160 [H SENS2]/[High] :195	可变电容器调整调谐电压。 (IC205 的输出电压调整)	
4. RSSI 基准调整 *5 [模拟窄]	1) 调整项目 :[An RRSSI] 调整 :[***] 2) 调整项目 : [AnL RRSSI]→ [AnL' RRSSI]→ [AnC RRSSI]→ [AnH' RRSSI]→ [AnH RRSSI] SSG 输出 :12dB SINAD 电平 -3dB (MOD:1kHz, 频偏 :±1.5kHz)	1) 调整项目 :[RSSI Reference(Narrow)] 2) 调整项目 :[Low], [Low'], [Center], [High'], [High] SSG 输出 :12dB SINAD 电平 -3dB (MOD:1kHz, 频偏 :±1.5kHz)	SSG AF VTVM 示波器 失真测试仪 假负载				[面板调谐模式] 从 SSG 输入信号之后, 按 [<] 键储存调整值。 [PC 测试模式] 从 SSG 输入信号之后, 按 [Apply] 按钮储存调整值。		
[模拟宽]	1) 调整项目 :[Aw RRSSI] 调整 :[***] 2) 调整项目 : [AwL RRSSI]→ [AwL' RRSSI]→ [AwC RRSSI]→ [AwH' RRSSI]→ [AwH RRSSI] SSG 输出 :12dB SINAD 电平 -3dB (MOD:1kHz, 频偏 :±3kHz)	1) 调整项目 :[RSSI Reference(Wide)] 2) 调整项目 :[Low], [Low'], [Center], [High'], [High] SSG 输出 :12dB SINAD 电平 -3dB (MOD:1kHz, 频偏 :±3kHz)							

ADJUSTMENT

Item	Condition		Measurement			Adjustment			Specifications / Remarks
	Panel tuning mode	PC test mode	Test-equipment	Unit	Terminal	Unit	Parts	Method	
[NXDN Very Narrow]	1) Adj item: [Nv RRSSI] Adjust: [***] 2) Adj item: [NvL RRSSI]→ [NvL' RRSSI]→ [NvC RRSSI]→ [NvH' RRSSI]→ [NvH RRSSI] SSG output: 12dB SINAD level -3dB (MOD: 1kHz, Dev: ±1.5kHz)	1) Adj item: [RSSI Reference (Very Narrow)] 2) Adj item: [Low], [Low'], [Center], [High'], [High] SSG output: 12dB SINAD level -3dB (MOD: 1kHz, Dev: ±1.5kHz)	SSG AF VTVM Oscilloscope Distortion meter Dummy load		ANT Ext.SP connector		[Panel tuning mode] [↵],[↶] [PC test mode] [←],[→]	[Panel tuning mode] After input signal from SSG, press [←] key to store the adjustment value. [PC test mode] After input signal from SSG, press [Apply] button to store the adjustment value.	Adjust with the analog signal.
*5: Because "RSSI reference adjust" of NXDN Narrow is adjusted by adjusting "RSSI reference adjust [Analog Narrow]", it is not necessary to adjust "RSSI reference adjust" of NXDN Narrow.									
5. Open Squelch adjust *6 (Squelch level 5 adjust) [Analog Narrow]	1) Adj item: [An SQL] Adjust: [***] 2) Adj item: [AnL SQL]→ [AnL' SQL]→ [AnC SQL]→ [AnH' SQL]→ [AnH SQL] SSG output: 12dB SINAD level +1dB (MOD: 1kHz, Dev: ±1.5kHz)	1) Adj item: [Open Squelch (Narrow)] 2) Adj item: [Low], [Low'], [Center], [High'], [High] SSG output: 12dB SINAD level +1dB (MOD: 1kHz, Dev: ±1.5kHz)	SSG AF VTVM Oscilloscope Distortion meter Dummy load		ANT Ext.SP connector		[Panel tuning mode] [↵],[↶] [PC test mode] [←],[→]	[Panel tuning mode] After input signal from SSG, press [←] key to store the adjustment value. [PC test mode] After input signal from SSG, press [Apply] button to store the adjustment value.	"Open Squelch" will not be adjusted correctly if MOD and Deviation are wrong.
[Analog Wide]	1) Adj item: [Aw SQL] Adjust: [***] 2) Adj item: [AwL SQL]→ [AwL' SQL]→ [AwC SQL]→ [AwH' SQL]→ [AwH SQL] SSG output: 12dB SINAD level +1dB (MOD: 1kHz, Dev: ±3kHz)	1) Adj item: [Open Squelch (Wide)] 2) Adj item: [Low], [Low'], [Center], [High'], [High] SSG output: 12dB SINAD level +1dB (MOD: 1kHz, Dev: ±3kHz)							
[NXDN Very Narrow]	1) Adj item: [Nv SQL] Adjust: [***] 2) Adj item: [NvL SQL]→ [NvL' SQL]→ [NvC SQL]→ [NvH' SQL]→ [NvH SQL] SSG output: 12dB SINAD level -2dB (MOD: non)	1) Adj item: [Open Squelch (Very Narrow)] 2) Adj item: [Low], [Low'], [Center], [High'], [High] SSG output: 12dB SINAD level -2dB (MOD: non)							Adjust with the analog signal. This item is adjusted under the condition that MOD is "non" due to the circuit configuration.
*6: Because "Squelch (Open) adjust" of NXDN Narrow is adjusted by adjusting "Squelch (Open) adjust [Analog Narrow]", it is not necessary to adjust "Squelch (Open) adjust" of NXDN Narrow.									

调 整

项 目	条 件		测 量			调 整			规格 / 备注
	面板调谐模式	PC 测试模式	测量装置	单元	端子	单元	部件	方 法	
[NXDN 超窄]	1) 调整项目： [Nv RRSSI] 调整：[***] 2) 调整项目： [NvL RRSSI]→ [NvL' RRSSI]→ [NvC RRSSI]→ [NvH' RRSSI]→ [NvH RRSSI] SSG 输出：12dB SINAD 电平 -3dB (MOD:1kHz, 频偏：±1.5kHz)	1) 调整项目：[RSSI Reference (Very Narrow)] 2) 调整项目：[Low], [Low'], [Center], [High'], [High] SSG 输出：12dB SINAD 电平 -3dB (MOD:1kHz, 频偏：±1.5kHz)	SSG AF VTVM 示波器 失真测试仪 假负载		天线 外部 SP 连接器		[面板调谐模式] [↵],[⏏] [PC 测试模式] [◀],[▶]	[面板调谐模式] 从 SSG 输入信号之后，按 [<] 键储存调整值。 [PC 测试模式] 从 SSG 输入信号之后，按 [Apply] 按钮储存调整值。	用模拟信号进行调整。
*5: 由于 NXDN 窄的“RSSI 基准调整”通过调整“RSSI 基准调整 [模拟窄]”进行调整，因此不需要调整 NXDN 窄的“RSSI 基准调整”。									
5. 静音开调整 *6 (静音电平 5 调整) [模拟窄]	1) 调整项目： [An SQL] 调整：[***] 2) 调整项目： [AnL SQL]→ [AnL' SQL]→ [AnC SQL]→ [AnH' SQL]→ [AnH SQL] SSG 输出：12dB SINAD 电平 +1dB (MOD:1kHz, 频偏：±1.5kHz)	1) 调整项目：[Open Squelch (Narrow)] 2) 调整项目：[Low], [Low'], [Center], [High'], [High] SSG 输出：12dB SINAD 电平 +1dB (MOD:1kHz, 频偏：±1.5kHz)	SSG AF VTVM 示波器 失真测试仪 假负载		天线 外部 SP 连接器		[面板调谐模式] [↵],[⏏] [PC 测试模式] [◀],[▶]	[面板调谐模式] 从 SSG 输入信号之后，按 [<] 键储存调整值。 [PC 测试模式] 从 SSG 输入信号之后，按 [Apply] 按钮储存调整值。	如果 MOD 和频偏错误，则不能正确调整“Open Squelch”。
[模拟宽]	1) 调整项目： [Aw SQL] 调整：[***] 2) 调整项目： [AwL SQL]→ [AwL' SQL]→ [AwC SQL]→ [AwH' SQL]→ [AwH SQL] SSG 输出：12dB SINAD 电平 +1dB (MOD:1kHz, 频偏：±3kHz)	1) 调整项目：[Open Squelch (Wide)] 2) 调整项目：[Low], [Low'], [Center], [High'], [High] SSG 输出：12dB SINAD 电平 +1dB (MOD:1kHz, 频偏：±3kHz)							
[NXDN 超窄]	1) 调整项目： [Nv SQL] 调整：[***] 2) 调整项目： [NvL SQL]→ [NvL' SQL]→ [NvC SQL]→ [NvH' SQL]→ [NvH SQL] SSG 输出：12dB SINAD 电平 -2dB (MOD: 无)	1) 调整项目：[Open Squelch (Very Narrow)] 2) 调整项目：[Low], [Low'], [Center], [High'], [High] SSG 输出：12dB SINAD 电平 -2dB (MOD: 无)							用模拟信号进行调整。 由于电路结构，此项在 MOD 为“无”的条件下进行调整。
*6: 由于 NXDN 窄的“静音 (开) 调整”通过调整“静音 (开) 调整 [模拟窄]”进行调整，因此不需要调整 NXDN 窄的“静音 (开) 调整”。									

ADJUSTMENT

Item	Condition		Measurement			Adjustment			Specifications / Remarks
	Panel tuning mode	PC test mode	Test-equipment	Unit	Terminal	Unit	Parts	Method	
6. Low RSSI at -118dBm adjust *7 [Analog Narrow]	1) Adj item: [An LRSSI] Adjust: [***] 2) Adj item: [AnL LRSSI]→ [AnL' LRSSI]→ [AnC LRSSI]→ [AnH' LRSSI]→ [AnH LRSSI] SSG output: -118dBm (0.28μV) (MOD: 1kHz, Dev: ±1.5kHz)	1) Adj item: [Low RSSI (Narrow)] 2) Adj item: [Low], [Low'], [Center], [High'], [High] SSG output: -118dBm (0.28μV) (MOD: 1kHz, Dev: ±1.5kHz)	SSG		ANT Ext.SP connector			[Panel tuning mode] After input signal from SSG, press [<] key to store the adjustment value. [PC test mode] After input signal from SSG, press [Apply] button to store the adjustment value.	Adjust with the analog signal.
[Analog Wide]	1) Adj item: [Aw LRSSI] Adjust: [***] 2) Adj item: [AwL LRSSI]→ [AwL' LRSSI]→ [AwC LRSSI]→ [AwH' LRSSI]→ [AwH LRSSI] SSG output: -118dBm (0.28μV) (MOD: 1kHz, Dev: ±3kHz)	1) Adj item: [Low RSSI (Wide)] 2) Adj item: [Low], [Low'], [Center], [High'], [High] SSG output: -118dBm (0.28μV) (MOD: 1kHz, Dev: ±3kHz)							
[NXDN Very Narrow]	1) Adj item: [Nv LRSSI] Adjust: [***] 2) Adj item: [NvL LRSSI]→ [NvL' LRSSI]→ [NvC LRSSI]→ [NvH' LRSSI]→ [NvH LRSSI] SSG output: -118dBm (0.28μV) (MOD: 1kHz, Dev: ±1.5kHz)	1) Adj item: [Low RSSI (Very Narrow)] 2) Adj item: [Low], [Low'], [Center], [High'], [High] SSG output: -118dBm (0.28μV) (MOD: 1kHz, Dev: ±1.5kHz)							
*7: Because "RSSI at -118dBm adjust" of NXDN Narrow is adjusted by adjusting "RSSI at -118dBm adjust [Analog Narrow]", it is not necessary to adjust "RSSI at -118dBm adjust" of NXDN Narrow.									
7. High RSSI at -80dBm adjust *8 [Analog Narrow]	1) Adj item: [An HRSSI] Adjust: [***] 2) Adj item: [AnL HRSSI]→ [AnL' HRSSI]→ [AnC HRSSI]→ [AnH' HRSSI]→ [AnH HRSSI] SSG output: -80dBm (22.4μV) (MOD: 1kHz, Dev: ±1.5kHz)	1) Adj item: [High RSSI (Narrow)] 2) Adj item: [Low], [Low'], [Center], [High'], [High] SSG output: -80dBm (22.4μV) (MOD: 1kHz, Dev: ±1.5kHz)	SSG		ANT Ext.SP connector			[Panel tuning mode] After input signal from SSG, press [<] key to store the adjustment value. [PC test mode] After input signal from SSG, press [Apply] button to store the adjustment value.	

调 整

项 目	条 件		测 量			调 整			规格 / 备注
	面板调谐模式	PC 测试模式	测量装置	单元	端子	单元	部件	方 法	
6. -118dBm 低 RSSI 调整 *7 [模拟窄]	1) 调整项目： [An LRSSI] 调整：[***] 2) 调整项目： [AnL LRSSI]→ [AnL' LRSSI]→ [AnC LRSSI]→ [AnH' LRSSI]→ [AnH LRSSI] SSG 输出： -118dBm (0.28μV) (MOD:1kHz, 频偏：±1.5kHz)	1) 调整项目：[Low RSSI (Narrow)] 2) 调整项目：[Low], [Low'], [Center], [High'], [High] SSG 输出： -118dBm (0.28μV) (MOD:1kHz, 频偏：±1.5kHz)	SSG		天线 外部 SP 连接器			[面板调谐模式] 从 SSG 输入信号之后，按 [<] 键储存调整值。 [PC 测试模式] 从 SSG 输入信号之后，按 [Apply] 按钮储存调整值。	
[模拟宽]	1) 调整项目： [Aw LRSSI] 调整：[***] 2) 调整项目： [AwL LRSSI]→ [AwL' LRSSI]→ [AwC LRSSI]→ [AwH' LRSSI]→ [AwH LRSSI] SSG 输出： -118dBm (0.28μV) (MOD:1kHz, 频偏：±3kHz)	1) 调整项目：[Low RSSI (Wide)] 2) 调整项目：[Low], [Low'], [Center], [High'], [High] SSG 输出： -118dBm (0.28μV) (MOD:1kHz, 频偏：±3kHz)							
[NXDN 超窄]	1) 调整项目： [Nv LRSSI] 调整：[***] 2) 调整项目： [NvL LRSSI]→ [NvL' LRSSI]→ [NvC LRSSI]→ [NvH' LRSSI]→ [NvH LRSSI] SSG 输出： -118dBm (0.28μV) (MOD:1kHz, 频偏：±1.5kHz)	1) 调整项目：[Low RSSI (Very Narrow)] 2) 调整项目：[Low], [Low'], [Center], [High'], [High] SSG 输出： -118dBm (0.28μV) (MOD:1kHz, 频偏：±1.5kHz)							用模拟信号进行调整。
*7: 由于 NXDN 窄的“-118dBm 的 RSSI 调整”通过调整“-118dBm 的 RSSI 调整 [模拟窄]”进行调整，因此不需要调整 NXDN 窄的“-118dBm 的 RSSI 调整”。									
7. -80dBm 高 RSSI 调整 *8 [模拟窄]	1) 调整项目： [An HRSSI] 调整：[***] 2) 调整项目： [AnL HRSSI]→ [AnL' HRSSI]→ [AnC HRSSI]→ [AnH' HRSSI]→ [AnH HRSSI] SSG 输出： -80dBm (22.4μV) (MOD:1kHz, 频偏：±1.5kHz)	1) 调整项目：[High RSSI (Narrow)] 2) 调整项目：[Low], [Low'], [Center], [High'], [High] SSG 输出： -80dBm (22.4μV) (MOD:1kHz, 频偏：±1.5kHz)	SSG		天线 外部 SP 连接器			[面板调谐模式] 从 SSG 输入信号之后，按 [<] 键储存调整值。 [PC 测试模式] 从 SSG 输入信号之后，按 [Apply] 按钮储存调整值。	

ADJUSTMENT

Item	Condition		Measurement			Adjustment			Specifications / Remarks
	Panel tuning mode	PC test mode	Test-equipment	Unit	Terminal	Unit	Parts	Method	
[Analog Wide]	1) Adj item: [Aw HRSSI] Adjust: [***] 2) Adj item: [AwL HRSSI]→ [AwL' HRSSI]→ [AwC HRSSI]→ [AwH' HRSSI]→ [AwH HRSSI] SSG output: -80dBm (22.4μV) (MOD: 1kHz, Dev: ±3kHz)	1) Adj item: [High RSSI (Wide)] 2) Adj item: [Low], [Low'], [Center], [High'], [High] SSG output: -80dBm (22.4μV) (MOD: 1kHz, Dev: ±3kHz)	SSG		ANT Ext.SP connector			[Panel tuning mode] After input signal from SSG, press [<] key to store the adjustment value. [PC test mode] After input signal from SSG, press [Apply] button to store the adjustment value.	Adjust with the analog signal.
[NXDN Very Narrow]	1) Adj item: [Nv HRSSI] Adjust: [***] 2) Adj item: [NvL HRSSI]→ [NvL' HRSSI]→ [NvC HRSSI]→ [NvH' HRSSI]→ [NvH HRSSI] SSG output: -80dBm (22.4μV) (MOD: 1kHz, Dev: ±1.5kHz)	1) Adj item: [High RSSI (Very Narrow)] 2) Adj item: [Low], [Low'], [Center], [High'], [High] SSG output: -80dBm (22.4μV) (MOD: 1kHz, Dev: ±1.5kHz)							
*8: Because "RSSI at -80dBm adjust" of NXDN Narrow is adjusted by adjusting "RSSI at -80dBm adjust [Analog Narrow]", it is not necessary to adjust "RSSI at -80dBm adjust" of NXDN Narrow.									
8. Tight Squelch adjust (Squelch level 9 adjust) [Analog Narrow]	1) Adj item: [An SQLT] Adjust: [***] 2) Adj item: [AnL SQLT]→ [AnL' SQLT]→ [AnC SQLT]→ [AnH' SQLT]→ [AnH SQLT] SSG output: 12dB SINAD level +6dB (MOD: 1kHz, Dev: ±1.5kHz)	1) Adj item: [Tight Squelch (Narrow)] 2) Adj item: [Low], [Low'], [Center], [High'], [High] SSG output: 12dB SINAD level +6dB (MOD: 1kHz, Dev: ±1.5kHz)	SSG AF VTVM Oscilloscope Distortion meter Dummy load		ANT Ext.SP connector			[Panel tuning mode] After input signal from SSG, press [<] key to store the adjustment value. [PC test mode] After input signal from SSG, press [Apply] button to store the adjustment value.	
[Analog Wide]	1) Adj item: [Aw SQLT] Adjust: [***] 2) Adj item: [AwL SQLT]→ [AwL' SQLT]→ [AwC SQLT]→ [AwH' SQLT]→ [AwH SQLT] SSG output: 12dB SINAD level +6dB (MOD: 1kHz, Dev: ±3kHz)	1) Adj item: [Tight Squelch (Wide)] 2) Adj item: [Low], [Low'], [Center], [High'], [High] SSG output: 12dB SINAD level +6dB (MOD: 1kHz, Dev: ±3kHz)							

调 整

项 目	条 件		测 量			调 整			规格 / 备注
	面板调谐模式	PC 测试模式	测量装置	单元	端子	单元	部件	方 法	
[模拟宽]	1) 调整项目： [Aw HRSSI] 调整：[***] 2) 调整项目： [AwL HRSSI]→ [AwL' HRSSI]→ [AwC HRSSI]→ [AwH' HRSSI]→ [AwH HRSSI] SSG 输出： -80dBm (22.4μV) (MOD:1kHz, 频偏：±3kHz)	1) 调整项目：[High RSSI (Wide)] 2) 调整项目：[Low], [Low'], [Center], [High'], [High] SSG 输出： -80dBm (22.4μV) (MOD:1kHz, 频偏：±3kHz)	SSG		天线 外部 SP 连接器			[面板调谐模式] 从 SSG 输入信号之 后，按 [<] 键储存 调整值。 [PC 测试模式] 从 SSG 输入信号之 后，按 [Apply] 按 钮储存调整值。	
[NXDN 超 窄]	1) 调整项目： [Nv HRSSI] 调整：[***] 2) 调整项目： [NvL HRSSI]→ [NvL' HRSSI]→ [NvC HRSSI]→ [NvH' HRSSI]→ [NvH HRSSI] SSG 输出： -80dBm (22.4μV) (MOD:1kHz, 频偏：±1.5kHz)	1) 调整项目：[High RSSI (Very Narrow)] 2) 调整项目：[Low], [Low'], [Center], [High'], [High] SSG 输出： -80dBm (22.4μV) (MOD:1kHz, 频偏：±1.5kHz)							用模拟信号进行调 整。
*8: 由于 NXDN 窄的“-80dBm 的 RSSI 调整”通过调整“-80dBm 的 RSSI 调整 [模拟窄]”进行调整,因此不需要调整 NXDN 窄的“-80dBm 的 RSSI 调整”。									
8. 静噪深调 整 (静噪 电平 9 调 整) [模拟窄]	1) 调整项目： [An SQLT] 调整：[***] 2) 调整项目： [AnL SQLT]→ [AnL' SQLT]→ [AnC SQLT]→ [AnH' SQLT]→ [AnH SQLT] SSG 输出：12dB SINAD 电平 +6dB (MOD:1kHz, 频偏：±1.5kHz)	1) 调整项目：[Tight Squelch (Narrow)] 2) 调整项目：[Low], [Low'], [Center], [High'], [High] SSG 输出：12dB SINAD 电平 +6dB (MOD:1kHz, 频偏：±1.5kHz)	SSG AF VTVM 示波器 失真测试 仪 假负载		天线 外部 SP 连接器			[面板调谐模式] 从 SSG 输入信号之 后，按 [<] 键储存 调整值。 [PC 测试模式] 从 SSG 输入信号之 后，按 [Apply] 按 钮储存调整值。	
[模拟宽]	1) 调整项目： [Aw SQLT] 调整：[***] 2) 调整项目： [AwL SQLT]→ [AwL' SQLT]→ [AwC SQLT]→ [AwH' SQLT]→ [AwH SQLT] SSG 输出：12dB SINAD 电平 +6dB (MOD:1kHz, 频偏：±3kHz)	1) 调整项目：[Tight Squelch (Wide)] 2) 调整项目：[Low], [Low'], [Center], [High'], [High] SSG 输出：12dB SINAD 电平 +6dB (MOD:1kHz, 频偏：±3kHz)							

TERMINAL FUNCTION

Display unit (X54-3680-10)

Pin No.	Name	Function
CN901 (to TX-RX unit A/2 CN597)		
1~6	SPO	Speaker input.
7	GND	Ground.
8	80C	8V input.
9,10	SB	Power input of switched power supply.
11	NC	No connection.
12	/PSW	Detection signal output of power switch.
13,14	GND	Ground.
15	MIC	MIC signal output.
16	ME	MIC ground.
17	GND	Ground.
18	AFO	RX filtered AF signal input.
19	/PRST	Display MCU reset signal input.
20~23	GND	Ground.
24	SHIFT	Control signal input of Beat-shift function.
25	NC	No connection.
26	5C	5V output.
27	TXD	Serial data signal input.
28	RXD	Serial data signal output.
29,30	GND	Ground.
CN902 (to internal speaker)		
1	GND	Ground.
2	SPO	Speaker output.
CN905 (to LCD ASSY)		
1	V5	LCD Drive voltage output.
2	V4	LCD Drive voltage output.
3	V3	LCD Drive voltage output.
4	V2	LCD Drive voltage output.
5	V1	LCD Drive voltage output.
6	Vdd	LCD Driver DC power supply.
7	Vss	LCD Driver Ground.
8	Vdd	LCD Driver DC power supply.
9	D7	LCD Driver data output.
10	D6	LCD Driver data output.
11	D5	LCD Driver data output.
12	D4	LCD Driver data output.
13	D3	LCD Driver data output.
14	D2	LCD Driver data output.
15	D1	LCD Driver data output.
16	D0	LCD Driver data output.
17	/WR	LCD Driver WR signal output.
18	A0	LCD Driver address output.
19	/RES	LCD Driver Reset signal output.
20	/CS	LCD Driver Chip-select signal output.

Pin No.	Name	Function
J901 (MIC jack)		
1	BLC	MIC key backlight control.
2	SB	Power output of switched power supply. DC13.6V±15%, 200mA typ.
3	E	Ground.
4	PTT/TXD	PTT: PTT input, TXD: Serial data output.
5	ME	MIC ground.
6	MIC	MIC signal input.
7	HOOK/RXD	HOOK: Hook detection, RXD: Serial data input.
8	DM	MIC data detection.

TX-RX unit (X57-7742-71) (A/2)

Pin No.	Name	Function
CN595 (to Option board)		
1	OPT1	Refer to "CN595 26-pin connector specification" described on page 110 to 116.
2	OPT3	
3	26P_RD	
4	26P_TD	
5	NC	
6	OPT4	
7	OPT10	
8	OPT5	
9	DGND	
10	AGND	
11	AI	
12	AO	
13	AGND	
14	50C	
15	OPT9	
16	DTI	
17	OPT8	
18	OPT11	
19	OPT7	
20	OPT2	
21	TXO	
22	RXEO	
23	RXEI	
24	TXI	
25	OPT6	
26	80C	
CN597 (to Display Unit CN901)		
1,2	GND	Ground
3	RXD	Serial data signal input
4	TXD	Serial data signal output

端子功能

显示单元 (X54-3680-10)

号码	名称	功能
CN901(至 TX-RX 单元 A/2 CN597)		
1~6	SPO	扬声器输入
7	GND	接地
8	80C	8V 输入
9, 10	SB	开关式电源的电源输入
11	NC	未连接
12	/PSW	电源开关的检测信号输出
13, 14	GND	接地
15	MIC	MIC 信号输出
16	ME	MIC 接地
17	GND	接地
18	AFO	RX 滤波 AF 信号输入
19	/PRST	显示 MCU 复位信号输入
20~23	GND	接地
24	SHIFT	拍频偏移功能的控制信号输入
25	NC	未连接
26	5C	5V 输出
27	TXD	串行数据信号输入
28	RXD	串行数据信号输出
29, 30	GND	接地
CN902(至内部扬声器)		
1	GND	接地
2	SPO	扬声器输出
CN905(至 LCD ASSY)		
1	V5	LCD 驱动电压输出
2	V4	LCD 驱动电压输出
3	V3	LCD 驱动电压输出
4	V2	LCD 驱动电压输出
5	V1	LCD 驱动电压输出
6	Vdd	LCD 驱动器 DC 电源
7	Vss	LCD 驱动器接地
8	Vdd	LCD 驱动器 DC 电源
9	D7	LCD 驱动器数据输出
10	D6	LCD 驱动器数据输出
11	D5	LCD 驱动器数据输出
12	D4	LCD 驱动器数据输出
13	D3	LCD 驱动器数据输出
14	D2	LCD 驱动器数据输出
15	D1	LCD 驱动器数据输出
16	D0	LCD 驱动器数据输出
17	/WR	LCD 驱动器 WR 信号输出
18	A0	LCD 驱动器地址输出
19	/RES	LCD 驱动器复位信号输出
20	/CS	LCD 驱动器芯片选择信号输出

号码	名称	功能
J901(MIC 插孔)		
1	BLC	MIC 键背光控制
2	SB	开关式电源的电源输出 DC13.6V±15%, 标准 200mA
3	E	接地
4	PTT/TXD	PTT:PTT 输入, TXD: 串行数据输出
5	ME	MIC 接地
6	MIC	MIC 信号输入
7	HOOK/RXD	HOOK: 挂钩检测, RXD: 串行数据输入
8	DM	MIC 数据检测

TX-RX 单元 (X57-7742-71) (A/2)

号码	名称	功能
CN595(至可选板)		
1	OPT1	请参阅第 111 至 117 页介绍的“CN595 26 针连接器规格”。
2	OPT3	
3	26P_RD	
4	26P_TD	
5	NC	
6	OPT4	
7	OPT10	
8	OPT5	
9	DGND	
10	AGND	
11	AI	
12	A0	
13	AGND	
14	50C	
15	OPT9	
16	DTI	
17	OPT8	
18	OPT11	
19	OPT7	
20	OPT2	
21	TX0	
22	RXE0	
23	RXEI	
24	TXI	
25	OPT6	
26	80C	
CN597(至显示单元 CN901)		
1, 2	GND	接地
3	RXD	串行数据信号输入
4	TXD	串行数据信号输出

TERMINAL FUNCTION

Pin No.	Name	Function
5	NC	No connection
6	50C	5V output.
7	SHIFT	Control signal output of Beat-shift function
8~11	GND	Ground
12	/PRST	Display MCU reset signal output
13	AFO	RX filtered AF signal output
14	GND	Ground
15	ME	MIC ground
16	MIC	MIC signal input
17,18	GND	Ground
19	/PSW	Detection signal input of power switch
20	NC	No connection
21,22	SB	Power output of switched power supply
23	80C	8V output
24	GND	Ground
25~30	SPO	Speaker output
CN600 (to TX-RX unit B/2 CN901)		
1	NC	No connection.
2~7	SB	Power output of switched power supply.
8	AFO	RX filtered AF signal output.
9	DI	Data signal input.
10	50C	5V output.
11	GND	Ground.
12	DEO	RX Detected signal output.
13	MI2	External MIC signal input.
14	ME	MIC ground.
15	GND	Ground.
16	RXD0	Serial data input 0.
17	AUXO2	AUX output 2.
18	TXD0	Serial data output 0.
19	AUXO1	AUX output 1.
20	AUXIO9	AUX input/output 9.
21	AUXIO5	AUX input/output 5.
22	AUXIO8	AUX input/output 8.
23	AUXIO4	AUX input/output 4.
24	TXD2	Serial data output 2.
25	AUXIO3	AUX input/output 3.
26	RXD2	Serial data input 2.
27	AUXIO2	AUX input/output 2.
28	AUXIO1	AUX input/output 1.
29	AUXIO7	AUX input/output 7.
30	AUXIO6	AUX input/output 6.
CN705		
1	SB	Power output of switched power supply.
2	SPI	Speaker output.

Pin No.	Name	Function
3	SPO	Speaker input.
4	PA	Control signal output of PA function.
5	HOR	Control signal output of Horn alert function.
6	GND	Ground.
CN403		
1	IGN	Ignition sense input.
2	GND	Ground.

TX-RX unit (X57-7742-71) (B/2)

Pin No.	Name	Function
CN901 (to TX-RX unit A/2 CN600)		
1	AUXIO6	AUX input/output 6.
2	AUXIO7	AUX input/output 7.
3	AUXIO1	AUX input/output 1.
4	AUXIO2	AUX input/output 2.
5	RXD2	Serial data output 2.
6	AUXIO3	AUX input/output 3.
7	TXD2	Serial data input 2.
8	AUXIO4	AUX input/output 4.
9	AUXIO8	AUX input/output 8.
10	AUXIO5	AUX input/output 5.
11	AUXIO9	AUX input/output 9.
12	AUXO1	AUX input 1.
13	TXD0	Serial data input 0.
14	AUXO2	AUX input 2.
15	RXD0	Serial data output 0.
16	GND	Ground.
17	ME	MIC ground.
18	MI2	External MIC signal output.
19	DEO	RX Detected signal input.
20	GND	Ground.
21	50C	5V input.
22	DI	Data signal output.
23	AFO	RX filtered AF signal input.
24	SB	Power input of switched power supply.
25	SB	Power input of switched power supply.
26	SB	Power input of switched power supply.
27	SB	Power input of switched power supply.
28	SB	Power input of switched power supply.
29	SB	Power input of switched power supply.
30	NC	No connection.
J901 (ACC. D-Sub 25pin)		
1	NC	Refer to "D-sub 25-pin connector specification" described on page 116 to 120.
2	RXD1	
3	TXD1	

端子功能

号码	名称	功能
5	NC	未连接
6	50C	5V 输出
7	SHIFT	频偏移功能的控制信号输出
8~11	GND	接地
12	/PRST	显示 MCU 复位信号输出
13	AFO	RX 滤波 AF 信号输出
14	GND	接地
15	ME	MIC 接地
16	MIC	MIC 信号输入
17, 18	GND	接地
19	/PSW	电源开关的检测信号输入
20	NC	未连接
21, 22	SB	开关式电源的电源输出
23	80C	8V 输出
24	GND	接地
25~30	SPO	扬声器输出
CN600 (至 TX-RX 单元 B/2 CN901)		
1	NC	未连接
2~7	SB	开关式电源的电源输出
8	AFO	RX 滤波 AF 信号输出
9	DI	数据信号输入
10	50C	5V 输出
11	GND	接地
12	DEO	RX 检测信号输出
13	MI2	外部 MIC 信号输入
14	ME	MIC 接地
15	GND	接地
16	RXD0	串行数据输入 0
17	AUX02	AUX 输出 2
18	TXD0	串行数据输出 0
19	AUX01	AUX 输出 1
20	AUXI09	AUX 输入 / 输出 9
21	AUXI05	AUX 输入 / 输出 5
22	AUXI08	AUX 输入 / 输出 8
23	AUXI04	AUX 输入 / 输出 4
24	TXD2	串行数据输出 2
25	AUXI03	AUX 输入 / 输出 3
26	RXD2	串行数据输入 2
27	AUXI02	AUX 输入 / 输出 2
28	AUXI01	AUX 输入 / 输出 1
29	AUXI07	AUX 输入 / 输出 7
30	AUXI06	AUX 输入 / 输出 6
CN705		
1	SB	电源开关后的电源输出
2	SPI	扬声器输出

号码	名称	功能
3	SPO	扬声器输入
4	PA	PA 功能的控制信号输出
5	HOR	喇叭提示功能的控制信号输出
6	GND	接地
CN403		
1	IGN	点火感应输入
2	GND	接地

TX-RX 单元 (X57-7742-71) (B/2)

号码	名称	功能
CN901 (至 TX-RX 单元 A/2 CN600)		
1	AUXI06	AUX 输入 / 输出 6
2	AUXI07	AUX 输入 / 输出 7
3	AUXI01	AUX 输入 / 输出 1
4	AUXI02	AUX 输入 / 输出 2
5	RXD2	串行数据输出 2
6	AUXI03	AUX 输入 / 输出 3
7	TXD2	串行数据输入 2
8	AUXI04	AUX 输入 / 输出 4
9	AUXI08	AUX 输入 / 输出 8
10	AUXI05	AUX 输入 / 输出 5
11	AUXI09	AUX 输入 / 输出 9
12	AUX01	AUX 输入 1
13	TXD0	串行数据输入 0
14	AUX02	AUX 输入 2
15	RXD0	串行数据输出 0
16	GND	接地
17	ME	MIC 接地
18	MI2	外部 MIC 信号输出
19	DEO	RX 检测信号输入
20	GND	接地
21	50C	5V 输入
22	DI	数据信号输出
23	AFO	RX 滤波 AF 信号输入
24	SB	开关式电源的电源输入
25	SB	开关式电源的电源输入
26	SB	开关式电源的电源输入
27	SB	开关式电源的电源输入
28	SB	开关式电源的电源输入
29	SB	开关式电源的电源输入
30	NC	未连接
J901 (ACC. D-Sub 25 针)		
1	NC	请参阅第 117 至 121 页介绍的“D-sub 25 针连接器规格”。
2	RXD1	
3	TXD1	

TERMINAL FUNCTION

Pin No.	Name	Function
4	AUXIO9	Refer to "D-sub 25-pin connector specification" described on page 116 to 120.
5	DI	
6	MI2	
7	GND	
8	AUXIO8	
9	TXD2	
10	RXD2	
11	GND	
12	AUXIO7	
13	AUXIO6	
14	SB	
15	AUXO2	
16	AUXO1	
17	AFO	
18	GND	

Pin No.	Name	Function
19	DEO	Refer to "D-sub 25-pin connector specification" described on page 116 to 120.
20	AUXIO5	
21	AUXIO4	
22	AUXIO3	
23	AUXIO2	
24	AUXIO1	
25	ME	

Solder Land

Name	Description
to GPS receiver	
DGND	Ground
RXD2	Data input
5V_2	5V power supply

Solder Pad Interface Description

Pin Name	I/O	Signal Type	Rating and Condition				
			Parameter	Min	Typ	Max	Unit
OPT1	I/O	Digital/CMOS Out/CMOS In with Interrupt	VIH	2.7	-	3.5	V
			VIL	-0.3	-	0.7	V
			VOH (Io=-2mA)	2.8	-	3.4	V
			VOL (Io=2mA)	-	-	0.7	V
OPT3	I/O	Digital/CMOS Out/CMOS In with Interrupt	VIH	2.7	-	3.5	V
			VIL	-0.3	-	0.7	V
			VOH (Io=-2mA)	2.8	-	3.4	V
			VOL (Io=2mA)	-	-	0.7	V
26P_RD	I	Digital/CMOS In with Interrupt	VIH	2.7	-	3.5	V
			VIL	-0.3	-	0.7	V
			Baud Rate	-	-	19200	bps
26P_TD	O	Digital/CMOS Out	VOH (Io=-2mA)	2.8	-	3.4	V
			VOL (Io=2mA)	-	-	0.7	V
			Baud Rate	-	-	19200	bps
OPT4	I/O	Digital/CMOS Out/CMOS In	VIH	2.7	-	3.5	V
			VIL	-0.3	-	0.7	V
			VOH (Io=-2mA)	2.8	-	3.4	V
			VOL (Io=2mA)	-	-	0.7	V
OPT10 (USEL)	O	Digital/Analog	Output Amplitude	-	0.28	-	Vp-p
			Coupling Capacitor		0.1		μF
			Allowable Load	100	-	-	kΩ
			Pull Down Resistor	-	470	-	kΩ

端子功能

号码	名称	功能
4	AUXIO9	请参阅第 117 至 121 页介绍的“D-sub 25 针连接器规格”。
5	DI	
6	MI2	
7	GND	
8	AUXIO8	
9	TXD2	
10	RXD2	
11	GND	
12	AUXIO7	
13	AUXIO6	
14	SB	
15	AUXO2	
16	AUXO1	
17	AFO	
18	GND	

号码	名称	功能
19	DE0	请参阅第 117 至 121 页介绍的“D-sub 25 针连接器规格”。
20	AUXIO5	
21	AUXIO4	
22	AUXIO3	
23	AUXIO2	
24	AUXIO1	
25	ME	

焊点

名称	说明
至 GPS 接收机	
DGND	接地
RXD2	数据输入
5V_2	5V 电源

焊盘接口说明

名称	I/O	信号类型	额定值和条件				
			参数	最小	标准	最大	单位
OPT1	I/O	有中断的数字 /CMOS 输出 /CMOS 输入	VIH	2.7	-	3.5	V
			VIL	-0.3	-	0.7	V
			VOH (Io=-2mA)	2.8	-	3.4	V
			VOL (Io=2mA)	-	-	0.7	V
OPT3	I/O	有中断的数字 /CMOS 输出 /CMOS 输入	VIH	2.7	-	3.5	V
			VIL	-0.3	-	0.7	V
			VOH (Io=-2mA)	2.8	-	3.4	V
			VOL (Io=2mA)	-	-	0.7	V
26P_RD	I	有中断的数字 /CMOS 输入	VIH	2.7	-	3.5	V
			VIL	-0.3	-	0.7	V
			波特率	-	-	19200	bps
26P_TD	O	数字 /CMOS 输出	VOH (Io=-2mA)	2.8	-	3.4	V
			VOL (Io=2mA)	-	-	0.7	V
			波特率	-	-	19200	bps
OPT4	I/O	数字 /CMOS 输出 /CMOS 输入	VIH	2.7	-	3.5	V
			VIL	-0.3	-	0.7	V
			VOH (Io=-2mA)	2.8	-	3.4	V
			VOL (Io=2mA)	-	-	0.7	V
OPT10 (USEL)	O	数字 / 模拟	输出振幅	-	0.28	-	Vp-p
			耦合电容	-	0.1	-	μF
			容许负载	100	-	-	k Ω
			下拉电阻	-	470	-	k Ω

TERMINAL FUNCTION

Pin Name	I/O	Signal Type	Rating and Condition				
			Parameter	Min	Typ	Max	Unit
OPT5	I/O	Digital/CMOS Out/CMOS In	VIH	2.7	-	3.5	V
			VIL	-0.3	-	0.7	V
			VOH (Io=-2mA)	2.8	-	3.4	V
			VOL (Io=2mA)	-	-	0.7	V
DGND	-	-					
AGND	-	-					
OPT9 (STON)	I	Analog	Input Level	-	3.3	-	Vp-p
			Coupling Capacitor	-	0.01	-	μF
			Input Impedance	22	-	-	kΩ
DTI	I	Analog	Input Level	-	0.6	-	Vp-p
			Coupling Capacitor	-	0.1	-	uF
			Input Impedance	22	-	-	kΩ
OPT8	I/O	Digital/CMOS Out/CMOS In with Interrupt	VIH	2.7	-	3.5	V
			VIL	-0.3	-	0.7	V
			VOH (Io=-2mA)	2.8	-	3.4	V
			VOL (Io=2mA)	-	-	0.7	V
OPT11	I/O	Digital/CMOS Out/CMOS In	VIH	2.7	-	3.5	V
			VIL	-0.3	-	0.7	V
			VOH (Io=-2mA)	2.8	-	3.4	V
			VOL (Io=2mA)	-	-	0.7	V
OPT7	I/O	Digital/CMOS Out/CMOS In with Interrupt	VIH	2.7	-	3.5	V
			VIL	-0.3	-	0.7	V
			VOH (Io=-2mA)	2.8	-	3.4	V
			VOL (Io=2mA)	-	-	0.7	V
OPT2	I/O	Digital/CMOS Out/CMOS In with Interrupt	VIH	2.7	-	3.5	V
			VIL	-0.3	-	0.7	V
			VOH (Io=-2mA)	2.8	-	3.4	V
			VOL (Io=2mA)	-	-	0.7	V
TXO	O	Analog	Output Level	-	130	-	mVp-p
			Coupling Capacitor	-	0.1	-	μF
			Allowable Load	100	-	-	kΩ
RXEO	O	Analog	Output Level	-	640	-	mVp-p
			Coupling Capacitor	-	0.1	-	μF
			Allowable Load	100	-	-	kΩ
RXEI	I	Analog	Input Level	-	640	-	mVp-p
			Coupling Capacitor		0.1		μF
			Input Impedance	22	-	-	kΩ
TXI	I	Analog	Input Level	-	130	-	mVp-p
			Coupling Capacitor		0.1		μF
			Input Impedance	22	-	-	kΩ
OPT6	I/O	Digital/CMOS Out/CMOS In	VIH	2.7	-	3.5	V
			VIL	-0.3	-	0.7	V
			VOH (Io=-2mA)	2.8	-	3.4	V
			VOL (Io=2mA)	-	-	0.7	V

端子功能

名称	I/O	信号类型	额定值和条件				
			参数	最小	标准	最大	单位
OPT5	I/O	数字 /CMOS 输出 /CMOS 输入	VIH	2.7	-	3.5	V
			VIL	-0.3	-	0.7	V
			VOH (Io=-2mA)	2.8	-	3.4	V
			VOL (Io=2mA)	-	-	0.7	V
DGND	-	-					
AGND	-	-					
OPT9 (STON)	I	模拟	输入电平	-	3.3	-	Vp-p
			耦合电容	-	0.01	-	μF
			输入阻抗	22	-	-	kΩ
DTI	I	模拟	输入电平	-	0.6	-	Vp-p
			耦合电容	-	0.1	-	μF
			输入阻抗	22	-	-	kΩ
OPT8	I/O	有中断的数字 /CMOS 输出 /CMOS 输入	VIH	2.7	-	3.5	V
			VIL	-0.3	-	0.7	V
			VOH (Io=-2mA)	2.8	-	3.4	V
			VOL (Io=2mA)	-	-	0.7	V
OPT11	I/O	数字 /CMOS 输出 /CMOS 输入	VIH	2.7	-	3.5	V
			VIL	-0.3	-	0.7	V
			VOH (Io=-2mA)	2.8	-	3.4	V
			VOL (Io=2mA)	-	-	0.7	V
OPT7	I/O	有中断的数字 /CMOS 输出 /CMOS 输入	VIH	2.7	-	3.5	V
			VIL	-0.3	-	0.7	V
			VOH (Io=-2mA)	2.8	-	3.4	V
			VOL (Io=2mA)	-	-	0.7	V
OPT2	I/O	有中断的数字 /CMOS 输出 /CMOS 输入	VIH	2.7	-	3.5	V
			VIL	-0.3	-	0.7	V
			VOH (Io=-2mA)	2.8	-	3.4	V
			VOL (Io=2mA)	-	-	0.7	V
TX0	O	模拟	输出电平	-	130	-	mVp-p
			耦合电容	-	0.1	-	μF
			容许负载	100	-	-	kΩ
RXE0	O	模拟	输出电平	-	640	-	mVp-p
			耦合电容	-	0.1	-	μF
			容许负载	100	-	-	kΩ
RXE1	I	模拟	输入电平	-	640	-	mVp-p
			耦合电容	-	0.1	-	μF
			输入阻抗	22	-	-	kΩ
TX1	I	模拟	输入电平	-	130	-	mVp-p
			耦合电容	-	0.1	-	μF
			输入阻抗	22	-	-	kΩ
OPT6	I/O	数字 /CMOS 输出 /CMOS 输入	VIH	2.7	-	3.5	V
			VIL	-0.3	-	0.7	V
			VOH (Io=-2mA)	2.8	-	3.4	V
			VOL (Io=2mA)	-	-	0.7	V

TERMINAL FUNCTION

Pin Name	I/O	Signal Type	Rating and Condition				
			Parameter	Min	Typ	Max	Unit
POW	-	Power	Output Voltage (Iout=100mA)	7.6	8.0	8.4	V
			Output Current	-	-	100	mA
RXD2	I	Digital/CMOS In with Interrupt	VIH	2.7	-	25	V
			VIL	-10	-	0.6	V
			Baud Rate	-	-	19200	bps
TXD2	O	Digital/CMOS Out	VOH(Io=-8mA)	4.3	-	5.2	V
			VOL(Io=8mA)	-	-	0.5	
			Baud Rate	-	-	19200	bps
5V_2	-	Power	Output Voltage (Iout=100mA)	4.65	5.0	5.2	V
			Output Current	-	-	100	mA
33V	-	Power	Output Voltage (Iout=100mA)	3.2	3.3	3.4	V
			Output Current	-	-	100	mA

CN595 26-pin connector specification (Rating/Condition)

Pin No.	Pin Name	I/O	Signal Type	Rating and Condition				
				Parameter	Min	Typ	Max	Unit
1	OPT1	I/O	Digital/CMOS Out/CMOS In with Interrupt	VIH	2.7	-	3.5	V
				VIL	-0.3	-	0.7	V
				VOH (Io=-2mA)	2.8	-	3.4	V
				VOL (Io=2mA)	-	-	0.7	V
2	OPT3	I/O	Digital/CMOS Out/CMOS In with Interrupt	VIH	2.7	-	3.5	V
				VIL	-0.3	-	0.7	V
				VOH (Io=-2mA)	2.8	-	3.4	V
				VOL (Io=2mA)	-	-	0.7	V
3	26P_RD	I	Digital/CMOS In with Interrupt	VIH	2.7	-	3.5	V
				VIL	-0.3	-	0.7	V
				Baud Rate		19200		bps
4	26P_TD	O	Digital/CMOS Out	VOH (Io=-2mA)	2.8	-	3.4	V
				VOL (Io=2mA)	-	-	0.7	V
				Baud Rate		19200		bps
5	NC	-	-					
6	OPT4	I/O	Digital/CMOS Out/CMOS In	VIH	2.7	-	3.5	V
				VIL	-0.3	-	0.7	V
				VOH (Io=-2mA)	2.8	-	3.4	V
				VOL (Io=2mA)	-	-	0.7	V
7	OPT10 (USEL)	O	Digital/Analog	Output Amplitude	-	0.28	-	Vp-p
				Coupling Capacitor		0.1		μF
				Allowable Load	100	-	-	kΩ
				Pull Down Resistor	-	470	-	kΩ
8	OPT5	I/O	Digital/CMOS Out/CMOS In	VIH	2.7	-	3.5	V
				VIL	-0.3	-	0.7	V
				VOH (Io=-2mA)	2.8	-	3.4	V
				VOL (Io=2mA)	-	-	0.7	V

端子功能

名称	I/O	信号类型	额定值和条件				
			参数	最小	标准	最大	单位
POW	-	电源	输出电压 (I _{out} =100mA)	7.6	8.0	8.4	V
			输出电流	-	-	100	mA
RXD2	I	有中断的数字 /CMOS 输入	V _{IH}	2.7	-	25	V
			V _{IL}	-10	-	0.6	V
			波特率	-	-	19200	bps
TXD2	O	数字 /CMOS 输出	V _{OH} (I _o =-8mA)	4.3	-	5.2	V
			V _{OL} (I _o =8mA)	-	-	0.5	
			波特率	-	-	19200	bps
5V_2	-	电源	输出电压 (I _{out} =100mA)	4.65	5.0	5.2	V
			输出电流	-	-	100	mA
33V	-	电源	输出电压 (I _{out} =100mA)	3.2	3.3	3.4	V
			输出电流	-	-	100	mA

CN595 26 针连接器规格 (额定值 / 条件)

号码	名称	I/O	信号类型	额定值和条件				
				参数	最小	标准	最大	单位
1	OPT1	I/O	有中断的数字 /CMOS 输出 /CMOS 输入	V _{IH}	2.7	-	3.5	V
				V _{IL}	-0.3	-	0.7	V
				V _{OH} (I _o =-2mA)	2.8	-	3.4	V
				V _{OL} (I _o =2mA)	-	-	0.7	V
2	OPT3	I/O	有中断的数字 /CMOS 输出 /CMOS 输入	V _{IH}	2.7	-	3.5	V
				V _{IL}	-0.3	-	0.7	V
				V _{OH} (I _o =-2mA)	2.8	-	3.4	V
				V _{OL} (I _o =2mA)	-	-	0.7	V
3	26P_RD	I	有中断的数字 /CMOS 输入	V _{IH}	2.7	-	3.5	V
				V _{IL}	-0.3	-	0.7	V
				波特率		19200		bps
4	26P_TD	O	数字 /CMOS 输出	V _{OH} (I _o =-2mA)	2.8	-	3.4	V
				V _{OL} (I _o =2mA)	-	-	0.7	V
				波特率		19200		bps
5	NC	-	-					
6	OPT4	I/O	数字 /CMOS 输出 /CMOS 输入	V _{IH}	2.7	-	3.5	V
				V _{IL}	-0.3	-	0.7	V
				V _{OH} (I _o =-2mA)	2.8	-	3.4	V
				V _{OL} (I _o =2mA)	-	-	0.7	V
7	OPT10 (USEL)	O	数字 / 模拟	输出振幅	-	0.28	-	V _{p-p}
				耦合电容		0.1		μF
				容许负载	100	-	-	kΩ
				下拉电阻	-	470	-	kΩ
8	OPT5	I/O	数字 /CMOS 输出 /CMOS 输入	V _{IH}	2.7	-	3.5	V
				V _{IL}	-0.3	-	0.7	V
				V _{OH} (I _o =-2mA)	2.8	-	3.4	V
				V _{OL} (I _o =2mA)	-	-	0.7	V

TERMINAL FUNCTION

Pin No.	Pin Name	I/O	Signal Type	Rating and Condition				
				Parameter	Min	Typ	Max	Unit
9	DGND	-	-					
10	AGND	-	-					
11	AI	-	Analog	Input Amplitude	-	0.5	-	V _{p-p}
				Coupling Capacitor	-	0.1	-	μF
				Input Impedance	22	-	-	kΩ
12	AO	O	Analog	Output Amplitude	-	50.0	-	mV _{p-p}
				Coupling Capacitor	-	0.1	-	μF
				Allowable Load	220	-	-	kΩ
13	AGND	-	-					
14	50C	-	Power	Output Voltage (I _{out} =200mA)	4.7	5.0	5.1	V
				Output Current	-	-	100	mA
15	OPT9 (STON)	I	Analog	Input Level	-	3.3	-	V _{p-p}
				Coupling Capacitor	-	0.01	-	μF
				Input Impedance	22	-	-	kΩ
16	DTI	I	Analog	Input Level	-	0.6	-	V _{p-p}
				Coupling Capacitor	-	0.1	-	μF
				Input Impedance	22	-	-	kΩ
17	OPT8	I/O	Digital/CMOS Out/CMOS In with Interrupt	V _{IH}	2.7	-	3.5	V
				V _{IL}	-0.3	-	0.7	V
				V _{OH} (I _o =-2mA)	2.8	-	3.4	V
				V _{OL} (I _o =2mA)	-	-	0.7	V
18	OPT11	I/O	Digital/CMOS Out/CMOS In	V _{IH}	2.7	-	3.5	V
				V _{IL}	-0.3	-	0.7	V
				V _{OH} (I _o =-2mA)	2.8	-	3.4	V
				V _{OL} (I _o =2mA)	-	-	0.7	V
19	OPT7	I/O	Digital/CMOS Out/CMOS In with Interrupt	V _{IH}	2.7	-	3.5	V
				V _{IL}	-0.3	-	0.7	V
				V _{OH} (I _o =-2mA)	2.8	-	3.4	V
				V _{OL} (I _o =2mA)	-	-	0.7	V
20	OPT2	I/O	Digital/CMOS Out/CMOS In with Interrupt	V _{IH}	2.7	-	3.5	V
				V _{IL}	-0.3	-	0.7	V
				V _{OH} (I _o =-2mA)	2.8	-	3.4	V
				V _{OL} (I _o =2mA)	-	-	0.7	V
21	TXO	O	Analog	Output Level	-	130	-	mV _{p-p}
				Coupling Capacitor	-	0.1	-	μF
				Allowable Load	100	-	-	kΩ
22	RXEO	O	Analog	Output Level	-	640	-	mV _{p-p}
				Coupling Capacitor	-	0.1	-	μF
				Allowable Load	100	-	-	kΩ
23	RXEI	I	Analog	Input Level	-	640	-	mV _{p-p}
				Coupling Capacitor	-	0.1	-	μF
				Input Impedance	22	-	-	kΩ

端子功能

号码	名称	I/O	信号类型	额定值和条件				
				参数	最小	标准	最大	单位
9	DGND	-	-					
10	AGND	-	-					
11	AI	-	模拟	输入振幅	-	0.5	-	V _{p-p}
				耦合电容	-	0.1	-	μF
				输入阻抗	22	-	-	kΩ
12	AO	0	模拟	输出振幅	-	50.0	-	mV _{p-p}
				耦合电容	-	0.1	-	μF
				容许负载	220	-	-	kΩ
13	AGND	-	-					
14	50C	-	电源	输出电压 (I _{out} =200mA)	4.7	5.0	5.1	V
				输出电流	-	-	100	mA
15	OPT9 (STON)	I	模拟	输入电平	-	3.3	-	V _{p-p}
				耦合电容	-	0.01	-	μF
				输入阻抗	22	-	-	kΩ
16	DTI	I	模拟	输入电平	-	0.6	-	V _{p-p}
				耦合电容	-	0.1	-	μF
				输入阻抗	22	-	-	kΩ
17	OPT8	I/O	有中断的数字 /CMOS 输出 /CMOS 输入	V _{IH}	2.7	-	3.5	V
				V _{IL}	-0.3	-	0.7	V
				V _{OH} (I _o =-2mA)	2.8	-	3.4	V
				V _{OL} (I _o =2mA)	-	-	0.7	V
18	OPT11	I/O	数字 /CMOS 输出 /CMOS 输入	V _{IH}	2.7	-	3.5	V
				V _{IL}	-0.3	-	0.7	V
				V _{OH} (I _o =-2mA)	2.8	-	3.4	V
				V _{OL} (I _o =2mA)	-	-	0.7	V
19	OPT7	I/O	有中断的数字 /CMOS 输出 /CMOS 输入	V _{IH}	2.7	-	3.5	V
				V _{IL}	-0.3	-	0.7	V
				V _{OH} (I _o =-2mA)	2.8	-	3.4	V
				V _{OL} (I _o =2mA)	-	-	0.7	V
20	OPT2	I/O	有中断的数字 /CMOS 输出 /CMOS 输入	V _{IH}	2.7	-	3.5	V
				V _{IL}	-0.3	-	0.7	V
				V _{OH} (I _o =-2mA)	2.8	-	3.4	V
				V _{OL} (I _o =2mA)	-	-	0.7	V
21	TX0	0	模拟	输出电平	-	130	-	mV _{p-p}
				耦合电容	-	0.1	-	μF
				容许负载	100	-	-	kΩ
22	RXEO	0	模拟	输出电平	-	640	-	mV _{p-p}
				耦合电容	-	0.1	-	μF
				容许负载	100	-	-	kΩ
23	RXEI	I	模拟	输入电平	-	640	-	mV _{p-p}
				耦合电容	-	0.1	-	μF
				输入阻抗	22	-	-	kΩ

TERMINAL FUNCTION

Pin No.	Pin Name	I/O	Signal Type	Rating and Condition				
				Parameter	Min	Typ	Max	Unit
24	TXI	I	Analog	Input Level	-	130	-	mVp-p
				Coupling Capacitor		0.1		μF
				Input Impedance	22	-	-	kΩ
25	OPT6	I/O	Digital/CMOS Out/CMOS In	VIH	2.7	-	3.5	V
				VIL	-0.3	-	0.7	V
				VOH (I _o =-2mA)	2.8	-	3.4	V
				VOL (I _o =2mA)	-	-	0.7	V
26	80C	-	Power	Output Voltage (I _{out} =100mA)	7.6	8.0	8.4	V
				Output Current	-	-	100	mA

CN595 26-pin connector specification (Function)

Pin No.	Pin Name	Device	I/O	Connection	Description/Function
1	OPT1	ANI board	O	AUX INPUT	[COR] Conv/LTR L: Activity receiving H: Not activity receiving [TOR] Conv/LTR L: Activity receiving H: Not activity receiving [LOK] Conv L: TX Complete H: TX not complete LTR L: TX Link complete (Until TX finishes) H: TX Link not complete
		VGS-1	I	BUSY	BUSY indication
2	OPT3	ANI board	I	KEY	TX requirement input
		VGS-1	I	PLAY	PLAY indication
3	26P_RD	ANI board	-	-	-
		VGS-1	I	SO	Serial data input
4	26P_TD	ANI board	-	-	-
		VGS-1	O	SI	Serial data output
5	NC	-	-	-	-
6	OPT4	ANI board	O	PTT	PTT signal output
		VGS-1	O	EN	Enable signal output
7	OPT10 (USEL)	ANI board	-	-	-
		VGS-1	O	USEL	UART speed select signal output
8	OPT5	ANI board	O	Emergency	Emergency signal output
		VGS-1	O	RST	Reset signal output
9	DGND	ANI board	-	A-	GND
		VGS-1	-	DGND	DGND
10	AGND	ANI board	-	A-	GND
		VGS-1	-	AGND	AGND

端子功能

号码	名称	I/O	信号类型	额定值和条件				
				参数	最小	标准	最大	单位
24	TXI	I	模拟	输入电平	-	130	-	mVp-p
				耦合电容		0.1		μF
				输入阻抗	22	-	-	kΩ
25	OPT6	I/O	数字 /CMOS 输出 /CMOS 输入	VIH	2.7	-	3.5	V
				VIL	-0.3	-	0.7	V
				VOH (Io=-2mA)	2.8	-	3.4	V
				VOL (Io=2mA)	-	-	0.7	V
26	80C	-	电源	输出电压 (Iout=100mA)	7.6	8.0	8.4	V
				输出电流	-	-	100	mA

CN595 26 针连接器规格 (功能)

号码	名称	装置	I/O	连接	说明 / 功能
1	OPT1	ANI 板	0	AUX INPUT	[COR] 常规 /LTR L: 接收 H: 无接收 [TOR] 常规 /LTR L: 接收 H: 无接收 [LOK] 常规 L: 发射 H: 未发射 LTR L: 发射链接中 (直至发射结束) H: 非发射链接
		VGS-1	I	BUSY	繁忙指示
2	OPT3	ANI 板	I	KEY	发射要求输入
		VGS-1	I	PLAY	播放指示
3	26P_RD	ANI 板	-	-	-
		VGS-1	I	SO	串行数据输入
4	26P_TD	ANI 板	-	-	-
		VGS-1	0	SI	串行数据输出
5	NC	-	-	-	-
6	OPT4	ANI 板	0	PTT	PTT 信号输出
		VGS-1	0	EN	启用信号输出
7	OPT10 (USEL)	ANI 板	-	-	-
		VGS-1	0	USEL	UART 速度选择信号输出
8	OPT5	ANI 板	0	紧急报警	紧急报警信号输出
		VGS-1	0	RST	复位信号输出
9	DGND	ANI 板	-	A-	GND
		VGS-1	-	DGND	DGND
10	AGND	ANI 板	-	A-	GND
		VGS-1	-	AGND	AGND

TERMINAL FUNCTION

Pin No.	Pin Name	Device	I/O	Connection	Description/Function
11	AI	ANI board	-	-	-
		VGS-1	I	AO	VGS Audio signal input
12	AO	ANI board	-	-	-
		VGS-1	O	AI	VGS Audio signal output
13	AGND	ANI board	-	A-	GND
		VGS-1	-	AGND	AGND
14	50C	ANI board	-	-	Note: 80C and 50C can not be used simultaneously.
		VGS-1	O	5C	5V power supply
15	OPT9 (STON)	ANI board	I	SIDETONE	Side tone signal input
		VGS-1	-	-	-
16	DTI	ANI board	I	DATA OUT	Data signal input
		VGS-1	-	-	-
17	OPT8	ANI board	I	TONE CONTROL	Speaker mute signal input
		VGS-1	-	-	-
18	OPT11	ANI board	O	MAN-DOWN	Man-Down signal output
		VGS-1	-	-	-
19	OPT7	ANI board	I	MIC MUTE	MIC mute signal input
		VGS-1	-	-	-
20	OPT2	ANI board	I	AUX OUTPUT	Emergency signal input
		VGS-1	-	-	-
21	TXO	ANI board	-	-	-
		VGS-1	-	-	-
22	RXEO	ANI board	-	-	-
		VGS-1	-	-	-
23	RXEI	ANI board	-	-	-
		VGS-1	-	-	-
24	TXI	ANI board	-	-	-
		VGS-1	-	-	-
25	OPT6	ANI board	-	-	-
		VGS-1	-	-	-
26	80C	ANI board	O	A+	8V power supply
		VGS-1	-	-	Note: 80C and 50C can not be used simultaneously.

D-sub 25-pin connector specification

Pin No.	Pin Name	I/O	A/D	Rating and Condition				
				Parameter	Min	Typ	Max	Unit
1	NC (No connection)	-	-		-			
2	RXD1 Serial data input 1. RS-232C level.	I	Digital	Input Voltage Range	-30		30	V
				Threshold Low	0.5	1.3		V
				Threshold High		1.75	2.6	V
				Baud Rate		11520		bps
				CL		100		pF

端子功能

号码	名称	装置	I/O	连接	说明 / 功能
11	AI	ANI 板	-	-	-
		VGS-1	I	A0	VGS 音频信号输入
12	AO	ANI 板	-	-	-
		VGS-1	O	AI	VGS 音频信号输出
13	AGND	ANI 板	-	A-	GND
		VGS-1	-	AGND	AGND
14	50C	ANI 板	-	-	注意 :80C 和 50C 不能同时使用
		VGS-1	O	5C	5V 电源
15	OPT9 (STON)	ANI 板	I	SIDETONE	侧音信号输入
		VGS-1	-	-	-
16	DTI	ANI 板	I	DATA OUT	数据信号输入
		VGS-1	-	-	-
17	OPT8	ANI 板	I	TONE CONTROL	扬声器静音信号输入
		VGS-1	-	-	-
18	OPT11	ANI 板	O	MAN-DOWN	人员事故信号输出
		VGS-1	-	-	-
19	OPT7	ANI 板	I	MIC MUTE	麦克风静音信号输入
		VGS-1	-	-	-
20	OPT2	ANI 板	I	AUX OUTPUT	紧急报警信号输入
		VGS-1	-	-	-
21	TX0	ANI 板	-	-	-
		VGS-1	-	-	-
22	RXEO	ANI 板	-	-	-
		VGS-1	-	-	-
23	RXEI	ANI 板	-	-	-
		VGS-1	-	-	-
24	TXI	ANI 板	-	-	-
		VGS-1	-	-	-
25	OPT6	ANI 板	-	-	-
		VGS-1	-	-	-
26	80C	ANI 板	O	A+	8V 电源
		VGS-1	-	-	注意 :80C 和 50C 不能同时使用

D-sub 25 针连接器规格

号码	名称	I/O	A/D	额定值和条件				
				参数	最小	标准	最大	单位
1	NC (未连接)	-	-		-			
2	RXD1 串行数据输入 1 RS-232C 电平	I	数字	输入电压范围	-30		30	V
				阈值低	0.5	1.3		V
				阈值高		1.75	2.6	V
				波特率		11520		bps
				CL		100		pF

TERMINAL FUNCTION

Pin No.	Pin Name	I/O	A/D	Rating and Condition				
				Parameter	Min	Typ	Max	Unit
3	TXD1 Serial data output 1. RS-232C level.	O	Digital	Voltage Swing (3kΩ Load)	±5	±9		V
				Baud Rate		11520		bps
				CL		100		pF
4	AUXIO9 AUX input/output 9.	I/O	Digital	VIH	4	-	5.2	V
				VIL	-0.5	-	1	V
				VOH (I _o =-1.5mA)	4	-	5.2	V
				VOL (I _o =1.5mA)	-	-	1.1	V
5	DI Data signal input.	I	Analog	Input Voltage range (STD Deviation)	-	0.5	-	V _{p-p}
				Freq Response (STD Dev.) 20~9600Hz	-3		3	dB
6	MI2 External MIC input.	I	Analog	Audio Level (STD Deviation)	-	5	-	mV _{rms}
				Allowable Freq	300		3000	Hz
				Input Impedance	-	600	-	Ω
7	GND (Ground)	-	GND					
8	AUXIO8 AUX input/output 8.	I/O	Digital	VIH	4	-	5.2	V
				VIL	-0.5	-	1	V
				VOH (I _o =-1.5mA)	4	-	5.2	V
				VOL (I _o =1.5mA)	-	-	1.1	V
9	TXD2 Serial data output 2. TTL level.	O	Digital	VOH (I _o =-1.5mA)	3.7	-	5.2	V
				VOL (I _o =1.5mA)	-	-	1.1	V
				CL		100		pF
10	RXD2 Serial data input 2. TTL level.	I	Digital	VIH	2.8	-	5.2	V
				VIL	-	-	0.65	V
				CL		100		pF
11	GND (Ground)	-	GND					
12	AUXIO7/ BER_DATA AUX input/output 7. BER data input.	I/O	Digital	VIH	4	-	5.2	V
				VIL	-0.5	-	1	V
				VOH (I _o =-1.5mA)	3.7	-	5.2	V
				VOL (I _o =1.5mA)	-	-	1.1	V
13	AUXIO6/ BER_CLK AUX input/output 6. BER CLK input.	I/O	Digital	VIH	4	-	5.2	V
				VIL	-0.5	-	1	V
				VOH (I _o =-1.5mA)	3.7	-	5.2	V
				VOL (I _o =1.5mA)	-	-	1.1	V
14	SB Power output after power switch.	-	Power	Voltage	This parameter depends on Battery Voltage			
				Supply Current	-	-	2	A
15	AUXO2 AUX output 2.	O	Digital	The type of this port is open collector.				
				VOL			0.4	V
				IOL			-500	mA
16	AUXO1 AUX output 1.	O	Digital	The type of this port is open collector.				
				VOL			0.4	V
				IOL			-500	mA
17	AFO RX filtered audio output.	O	Analog	Output Level		0.7		V _{p-p}
				Coupling Capacitor		0.1		μF
				Allowable Load	100	-	-	kΩ
				Allowable freq	300		3000	Hz

端子功能

号码	名称	I/O	A/D	额定值和条件				
				参数	最小	标准	最大	单位
3	TXD1 串行数据输出 1 RS-232C 电平	0	数字	电压摆动 (3k Ω 负载)	± 5	± 9		V
				波特率		11520		bps
				CL		100		pF
4	AUXIO9 AUX 输入 / 输出 9	I/O	数字	VIH	4	-	5.2	V
				VIL	-0.5	-	1	V
				VOH (I _O =-1.5mA)	4	-	5.2	V
				VOL (I _O =1.5mA)	-	-	1.1	V
5	DI 数据信号输入	I	模拟	输入电压范围 (STD 频偏)	-	0.5	-	V _{p-p}
				频率响应 (STD 频偏) 20~9600Hz	-3		3	dB
6	MI2 外部 MIC 输入	I	模拟	音频电平 (STD 频偏)	-	5	-	mV _{rms}
				容许频率	300		3000	Hz
				输入阻抗	-	600	-	Ω
7	GND(接地)	-	GND					
8	AUXIO8 AUX 输入 / 输出 8	I/O	数字	VIH	4	-	5.2	V
				VIL	-0.5	-	1	V
				VOH (I _O =-1.5mA)	4	-	5.2	V
				VOL (I _O =1.5mA)	-	-	1.1	V
9	TXD2 串行数据输出 2 TTL 电平	0	数字	VOH (I _O =-1.5mA)	3.7	-	5.2	V
				VOL (I _O =1.5mA)	-	-	1.1	V
				CL		100		pF
10	RXD2 串行数据输入 2 TTL 电平	I	数字	VIH	2.8	-	5.2	V
				VIL	-	-	0.65	V
				CL		100		pF
11	GND(接地)	-	GND					
12	AUXIO7/ BER_DATA AUX 输入 / 输出 7 BER 数据输入	I/O	数字	VIH	4	-	5.2	V
				VIL	-0.5	-	1	V
				VOH (I _O =-1.5mA)	3.7	-	5.2	V
				VOL (I _O =1.5mA)	-	-	1.1	V
13	AUXIO6/ BER_CLK AUX 输入 / 输出 6 BER_CLK 输入	I/O	数字	VIH	4	-	5.2	V
				VIL	-0.5	-	1	V
				VOH (I _O =-1.5mA)	3.7	-	5.2	V
				VOL (I _O =1.5mA)	-	-	1.1	V
14	SB 电源开关后的 电源输出	-	电源	电压	该参数取决于电池电压			
				供电电流	-	-	2	A
15	AUXO2 AUX 输出 2	0	数字	该端口的类型为开放式集电极				
				VOL			0.4	V
				IOL			-500	mA
16	AUXO1 AUX 输出 1	0	数字	该端口的类型为开放式集电极				
				VOL			0.4	V
				IOL			-500	mA
17	AFO RX 滤波音频输出	0	模拟	输出电平		0.7		V _{p-p}
				耦合电容		0.1		μ F
				容许负载	100	-	-	k Ω
				容许频率	300		3000	Hz

TERMINAL FUNCTION

Pin No.	Pin Name	I/O	A/D	Rating and Condition				
				Parameter	Min	Typ	Max	Unit
18	GND (Ground)	-	GND					
19	DEO Detected signal output.	O	Analog	Output Level	-	0.28	-	V _{p-p}
				Coupling Capacitor	-	4.7	-	μF
				Allowable Load	47	-	-	kΩ
				Freq. Response (STD Dev) Wide; 20~4800Hz	-6		1	dB
				Freq. Response (STD Dev) Wide; 4800~7200Hz	-24		1	dB
				Freq. Response (STD Dev) Narrow; 20~4800Hz	-15		1	dB
20	AUXIO5 AUX input/output 5.	I/O	Digital	VIH	4	-	5.2	V
				VIL	-0.5	-	1	V
				VOH (I _o =-1.5mA)	4	-	5.2	V
				VOL (I _o =1.5mA)	-	-	1.1	V
21	AUXIO4 AUX input/output 4.	I/O	Digital	VIH	4	-	5.2	V
				VIL	-0.5	-	1	V
				VOH (I _o =-1.5mA)	4	-	5.2	V
				VOL (I _o =1.5mA)	-	-	1.1	V
22	AUXIO3 AUX input/output 3.	I/O	Digital	VIH	4	-	5.2	V
				VIL	-0.5	-	1	V
				VOH (I _o =-1.5mA)	4	-	5.2	V
				VOL (I _o =1.5mA)	-	-	1.1	V
23	AUXIO2 AUX input/output 2.	I/O	Digital	VIH	4	-	5.2	V
				VIL	-0.5	-	1	V
				VOH (I _o =-1.5mA)	4	-	5.2	V
				VOL (I _o =1.5mA)	-	-	1.1	V
24	AUXIO1 AUX input/output 1.	I/O	Digital	VIH	4	-	5.2	V
				VIL	-0.5	-	1	V
				VOH (I _o =-1.5mA)	4	-	5.2	V
				VOL (I _o =1.5mA)	-	-	1.1	V
25	ME (Mic ground)	-	Analog	This is GND port for Microphone.				

端子功能

号码	名称	I/O	A/D	额定值和条件				
				参数	最小	标准	最大	单位
18	GND(接地)	-	GND					
19	DE0 检测信号输出	0	模拟	输出电平	-	0.28	-	V _{p-p}
				耦合电容	-	4.7	-	μF
				容许负载	47	-	-	kΩ
				频率响应(STD频偏)宽; 20~4800Hz	-6		1	dB
				频率响应(STD频偏)宽; 4800~7200Hz	-24		1	dB
				频率响应(STD频偏)窄; 20~4800Hz	-15		1	dB
20	AUXIO5 AUX输入/输出5	I/O	数字	VIH	4	-	5.2	V
				VIL	-0.5	-	1	V
				VOH(I _o =-1.5mA)	4	-	5.2	V
				VOL(I _o =1.5mA)	-	-	1.1	V
21	AUXIO4 AUX输入/输出4	I/O	数字	VIH	4	-	5.2	V
				VIL	-0.5	-	1	V
				VOH(I _o =-1.5mA)	4	-	5.2	V
				VOL(I _o =1.5mA)	-	-	1.1	V
22	AUXIO3 AUX输入/输出3	I/O	数字	VIH	4	-	5.2	V
				VIL	-0.5	-	1	V
				VOH(I _o =-1.5mA)	4	-	5.2	V
				VOL(I _o =1.5mA)	-	-	1.1	V
23	AUXIO2 AUX输入/输出2	I/O	数字	VIH	4	-	5.2	V
				VIL	-0.5	-	1	V
				VOH(I _o =-1.5mA)	4	-	5.2	V
				VOL(I _o =1.5mA)	-	-	1.1	V
24	AUXIO1 AUX输入/输出1	I/O	数字	VIH	4	-	5.2	V
				VIL	-0.5	-	1	V
				VOH(I _o =-1.5mA)	4	-	5.2	V
				VOL(I _o =1.5mA)	-	-	1.1	V
25	ME(麦克风接地)	-	模拟	这是麦克风GND端口				

NX-700 PC BOARD / PC板

DISPLAY UNIT (X54-3680-10) Component side view (J79-0157-39)

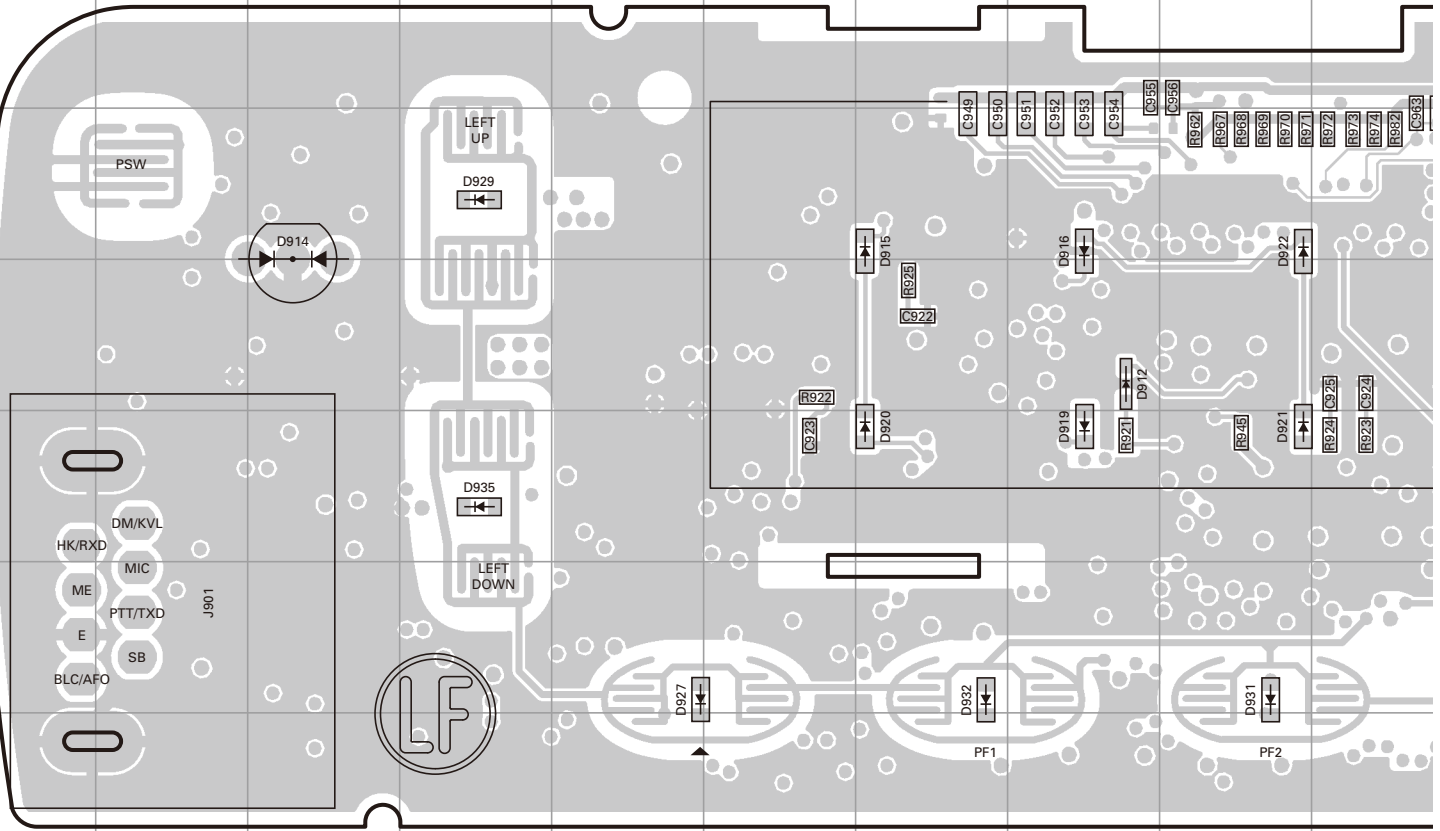

DISPLAY UNIT (X54-3680-10) Foil side view (J79-0157-39)

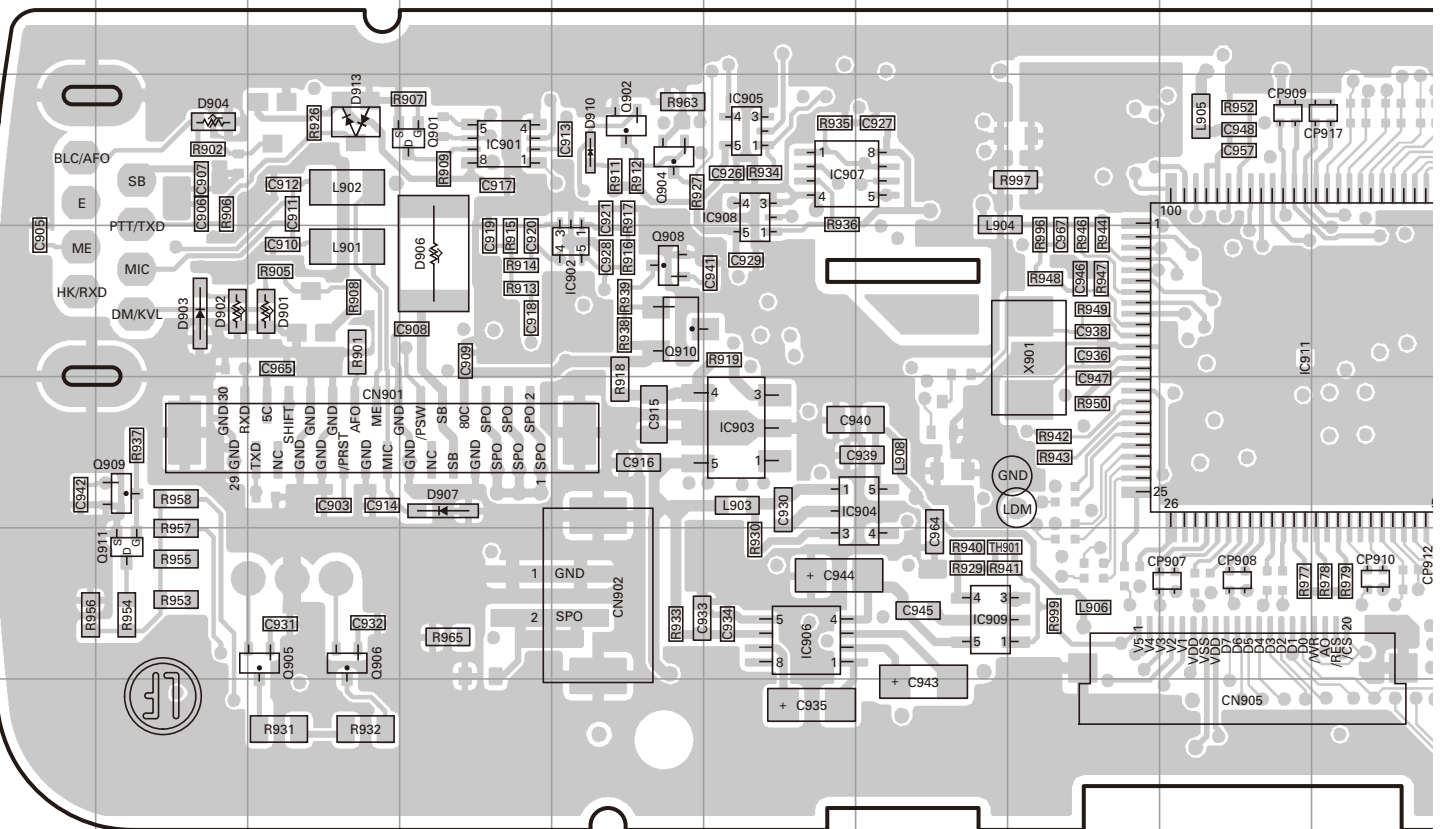

PC BOARD / PC板 NX-700

DISPLAY UNIT (X54-3680-10) Component side view (J79-0157-39)

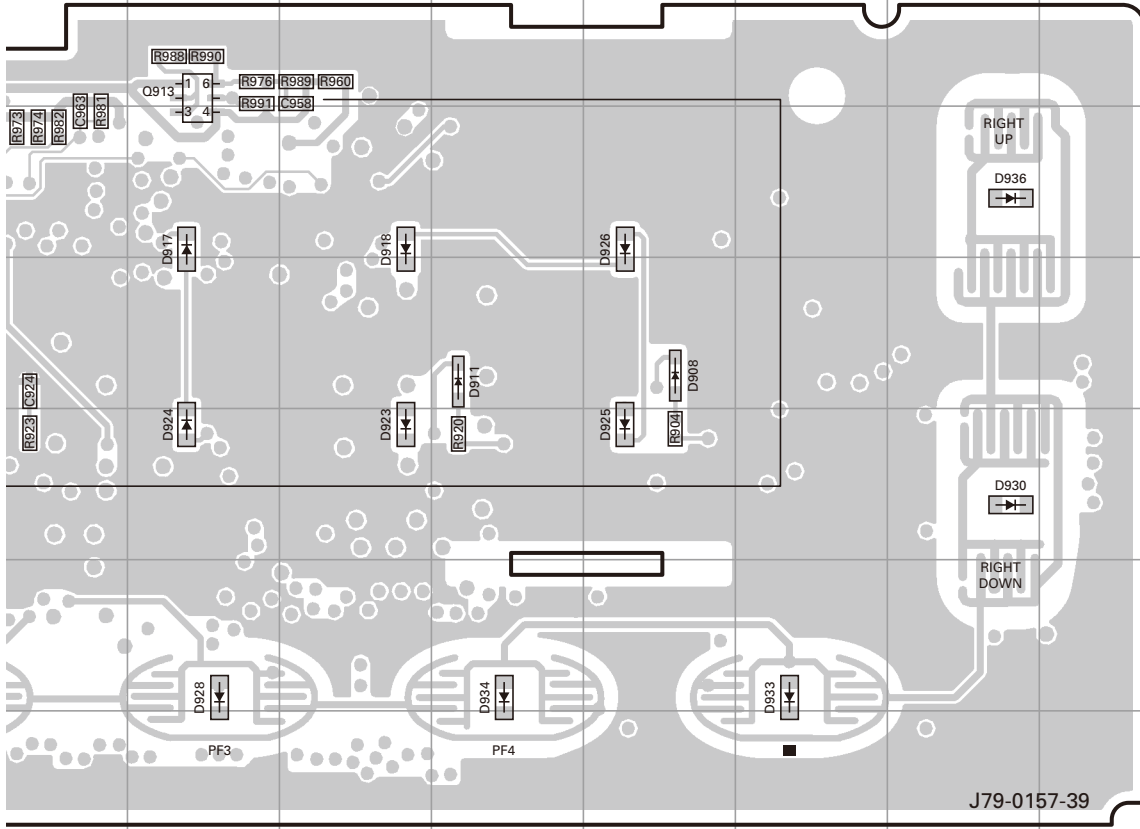

Ref. No.	Address	Ref. No.	Address
Q913	2K	D924	5K
D908	4N	D925	5N
D911	4M	D926	3M
D912	4H	D927	6E
D914	3C	D928	6K
D915	3G	D929	3D
D916	3H	D930	5P
D917	3K	D931	6I
D918	3L	D932	6G
D919	5H	D933	6O
D920	5G	D934	6M
D921	5I	D935	5D
D922	3I	D936	3P
D923	5L		

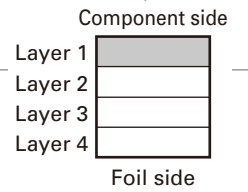

DISPLAY UNIT (X54-3680-10) Foil side view (J79-0157-39)

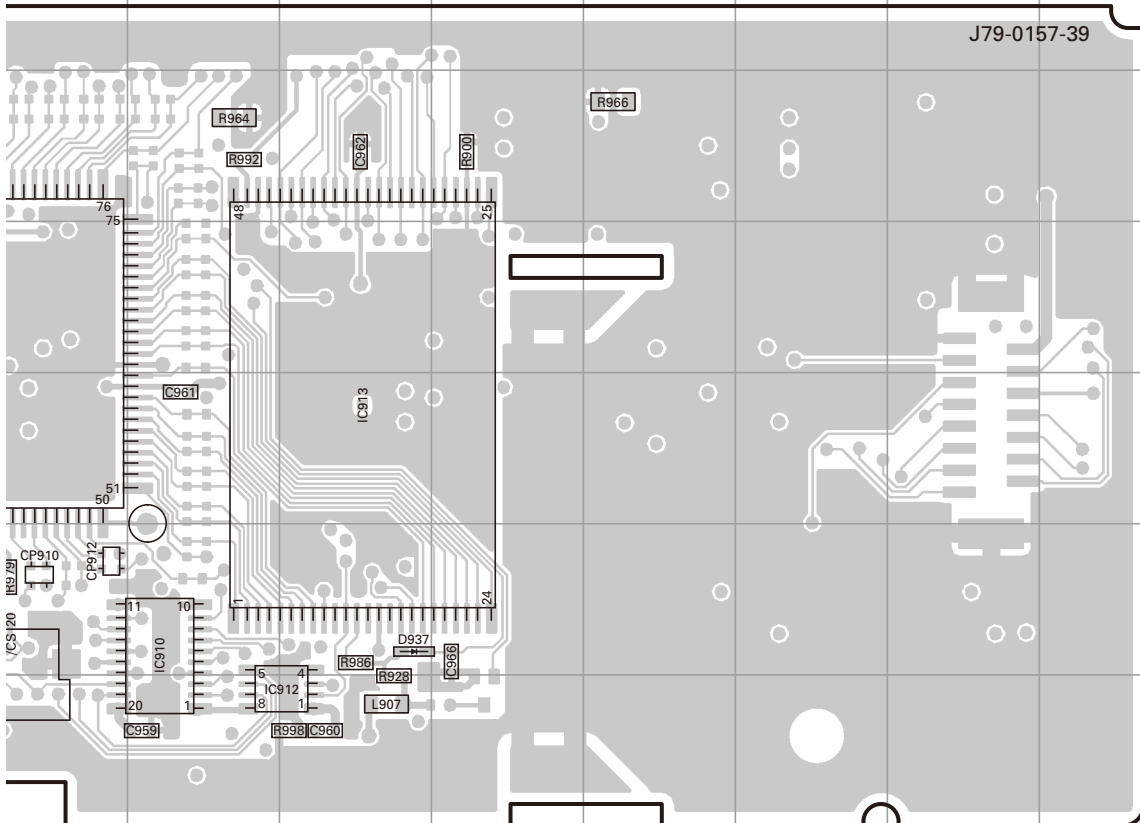

Ref. No.	Address	Ref. No.	Address
IC901	9D	Q905	12C
IC902	10E	Q906	12C
IC903	11F	Q908	10E
IC904	11G	Q909	11B
IC905	9F	Q910	10E
IC906	12F	Q911	12B
IC907	9F	D901	10C
IC908	9F	D902	10B
IC909	12G	D903	10B
IC910	12K	D904	9B
IC911	10I	D906	10D
IC912	13L	D907	11D
IC913	11L	D910	9E
Q901	9D	D913	9C
Q902	9E	D937	12L
Q904	9E		

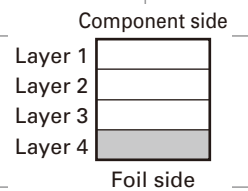

PC BOARD / PC板 NX-700

TX-RX UNIT (X57-7742-71) (A/2) Component side view (J79-0207-19 A/2)

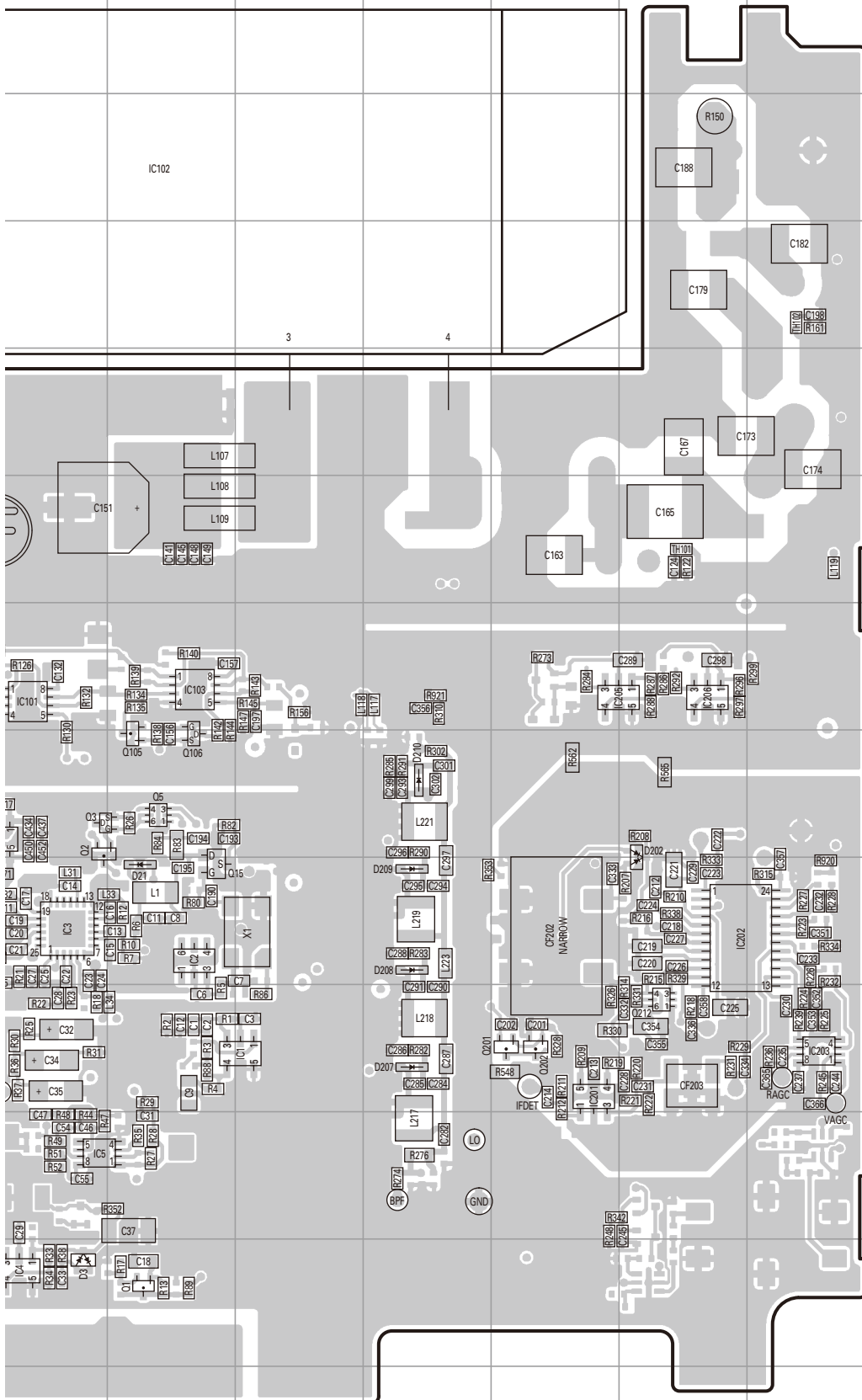

Ref. No.	Address	Ref. No.	Address
IC1	10L	Q106	8K
IC2	9K	Q201	10N
IC3	9J	Q202	10N
IC4	12J	Q212	10O
IC5	11J	Q403	2E
IC101	7J	Q405	9B
IC102	3K	Q406	9B
IC103	7K	Q411	10B
IC201	10N	Q501	11C
IC202	9O	Q709	5D
IC203	10P	D3	12J
IC205	7N	D21	9K
IC206	7O	D102	5I
IC403	5B	D202	8O
IC406	8J	D207	10M
IC407	12H	D208	9M
IC507	10C	D209	9M
IC512	12B	D210	8M
IC513	8B	D404	6F
IC514	9D	D405	6G
IC515	8D	D408	5G
IC516	8D	D410	10B
IC517	9C	D411	10B
IC518	7D	D504	13B
IC715	4B	D506	8C
Q1	12K	D507	8C
Q2	8J	D508	8B
Q3	8J	D509	9D
Q5	8K	D510	8D
Q15	9K	D511	8C
Q105	8K	D512	9B

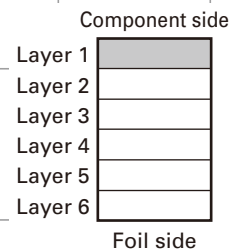

NX-700 PC BOARD / PC板

TX-RX UNIT (X57-7742-71) (A/2) Foil side view (J79-0207-19 A/2)

Ref. No.	Address	Ref. No.	Address	Ref. No.	Address
IC204	11F	Q12	10J	D12	11J
IC401	7M	Q13	10I	D13	11H
IC402	6N	Q14	10I	D14	11I
IC404	6P	Q101	7I	D15	11J
IC405	5N	Q102	7J	D16	11I
IC408	5M	Q203	8E	D18	11J
IC409	7N	Q204	9D	D19	9I
IC410	12J	Q205	10D	D20	9I
IC501	12P	Q208	10G	D101	9H
IC502	10Q	Q210	7G	D103	5F
IC503	12Q	Q401	3P	D104	6F
IC504	10N	Q402	4P	D105	6E
IC505	10P	Q404	4P	D107	6D
IC506	13P	Q407	5P	D108	5D
IC508	10O	Q408	5P	D109	4D
IC509	9P	Q409	7O	D201	10E
IC510	12O	Q410	7N	D205	9H
IC511	9O	Q412	6N	D213	7E
IC701	12M	Q413	5P	D215	7D
IC702	8N	Q414	5P	D216	7E
IC703	12L	Q415	7O	D217	7F
IC704	10M	Q416	5N	D218	7E
IC705	12L	Q417	12I	D401	3O
IC706	8M	Q701	12K	D403	4P
IC707	12M	Q702	11L	D406	3P
IC708	8N	Q703	12M	D407	4N
IC709	8O	Q704	7P	D409	4N
IC710	11M	Q705	8P	D412	5N
IC711	11L	Q706	8R	D501	13O
IC712	9L	Q707	8R	D502	13O
IC713	11K	Q708	10L	D503	9O
IC714	11L	Q710	5Q	D702	11L
Q6	9I	D5	9J	D703	11L
Q7	9K	D6	9J	D704	7O
Q9	10I	D7	11I	D705	8O
Q10	10J	D8	11J	D706	9L
Q11	10K	D11	11H	D707	9M

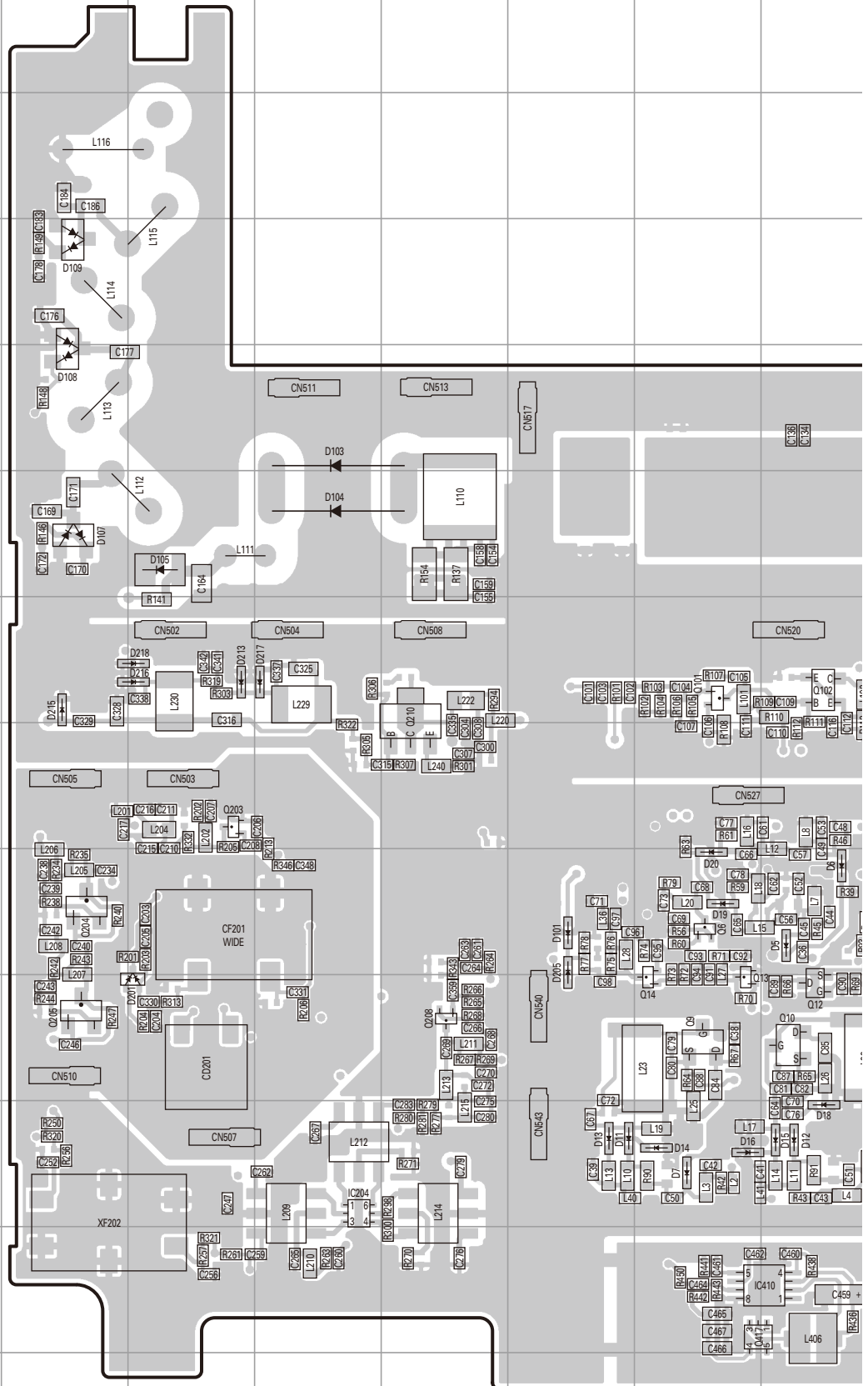

PC BOARD / PC板 NX-700

TX-RX UNIT (X57-7742-71) (A/2)
Foil side view (J79-0207-19 A/2)

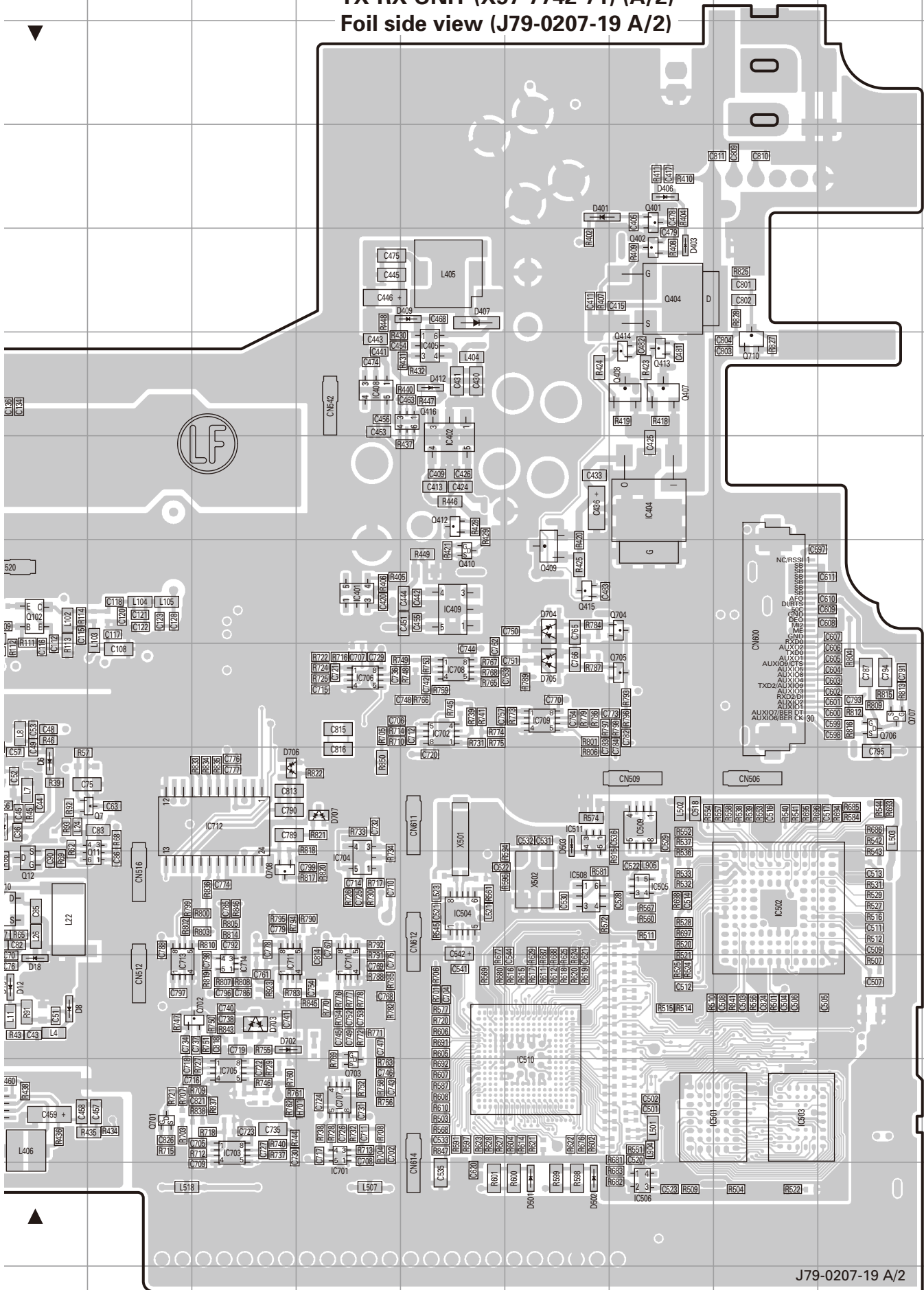

J79-0207-19 A/2

NX-700 PC BOARD / PC板

TX-RX UNIT (X57-7742-71) (B/2) Component side view (J79-0207-19 B/2)

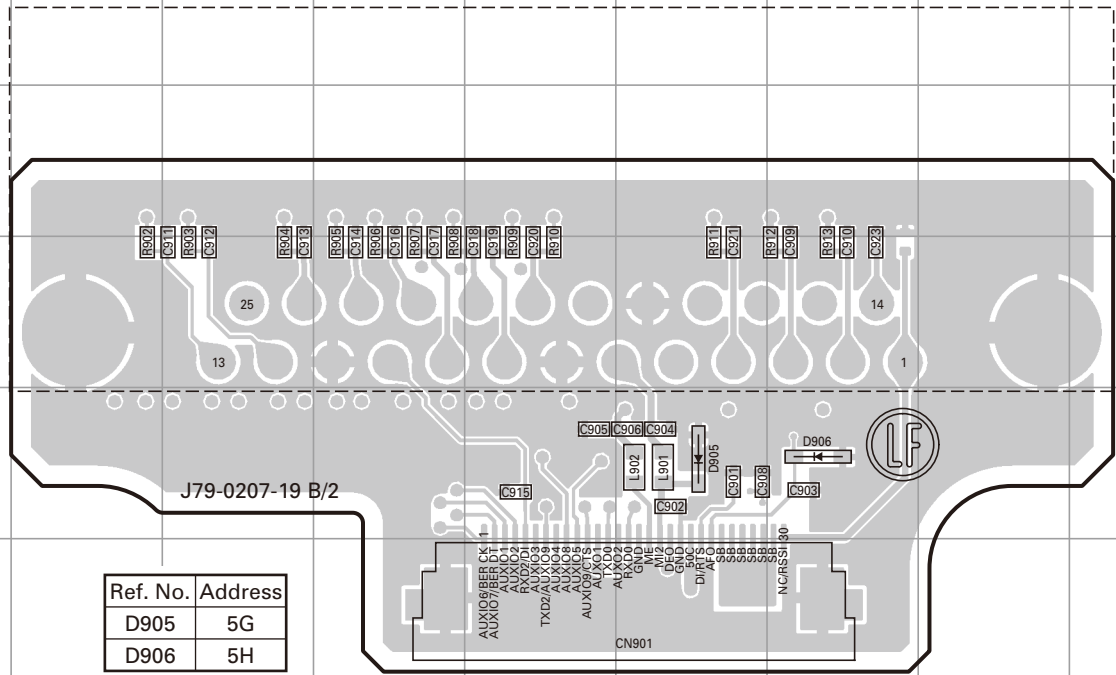

TX-RX UNIT (X57-7742-71) (B/2) Foil side view (J79-0207-19 B/2)

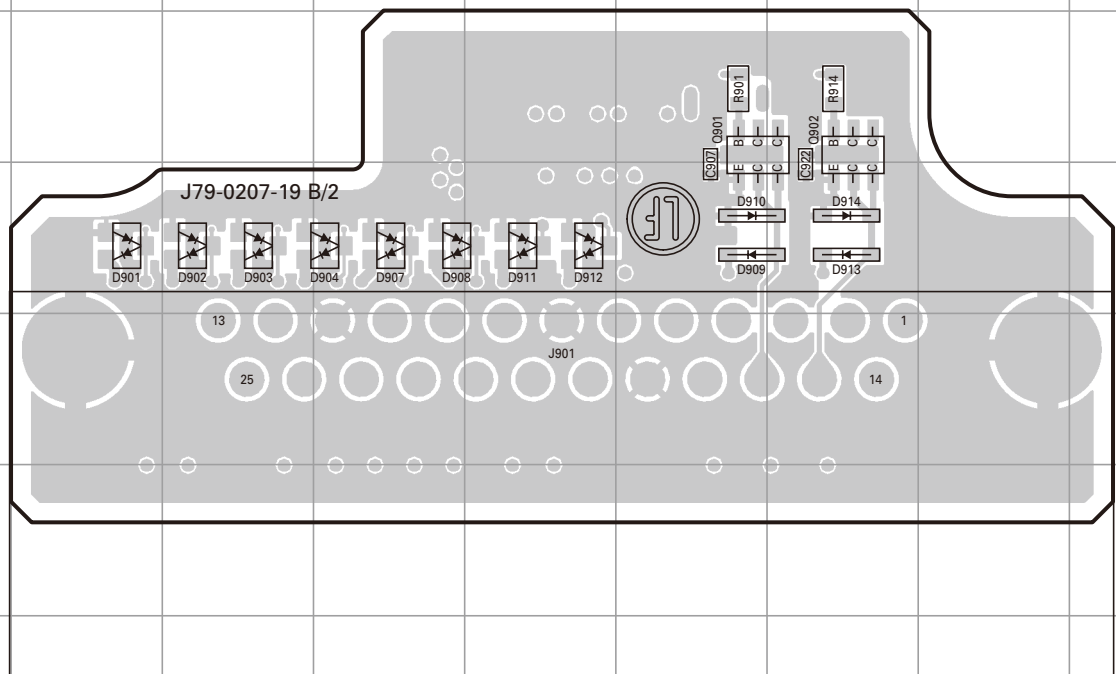

INTERCONNECTION DIAGRAM / 互连图

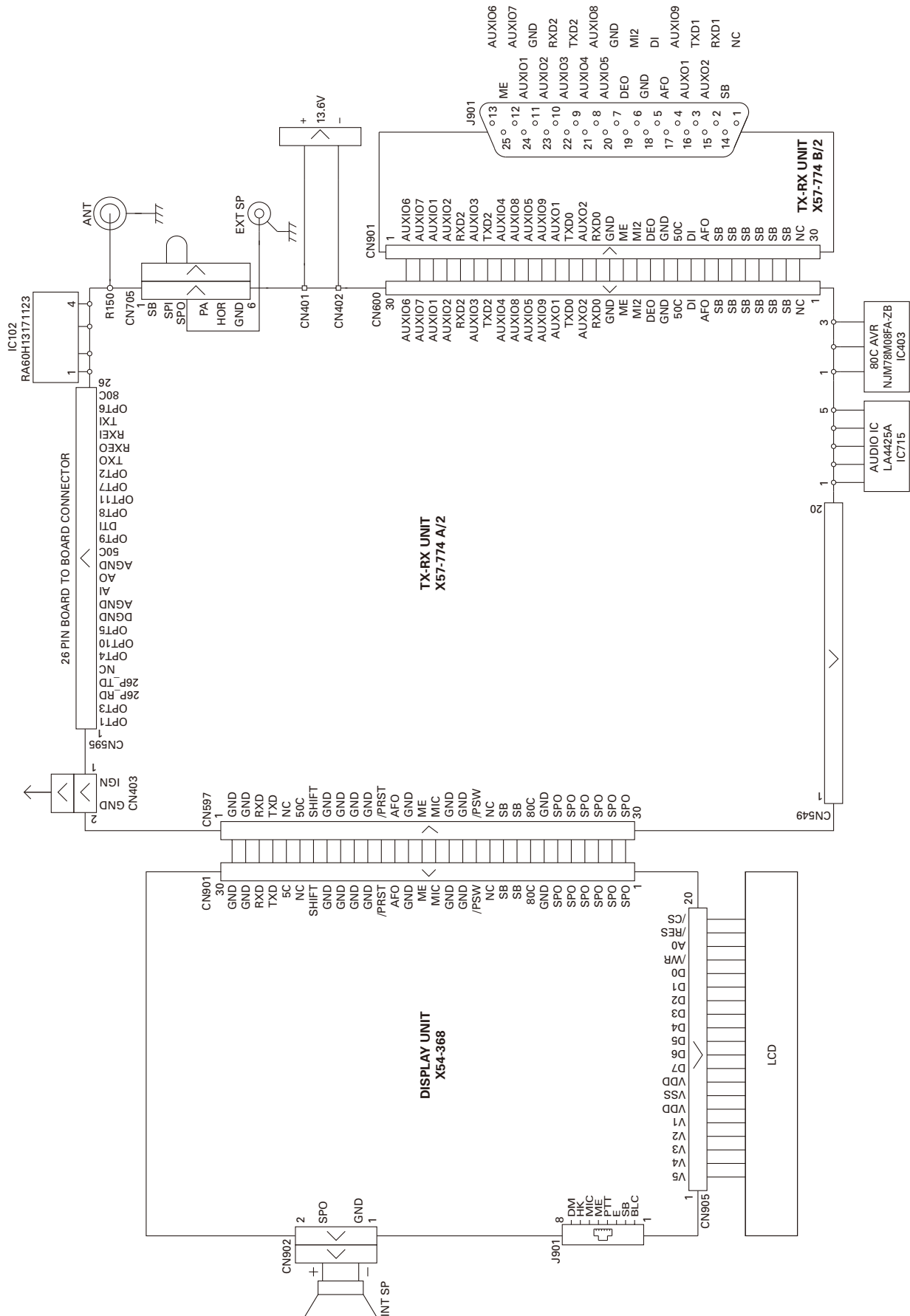

NX-700 SCHEMATIC DIAGRAM / 原理图

TX-RX UNIT (X57-7742-71) (A/2)

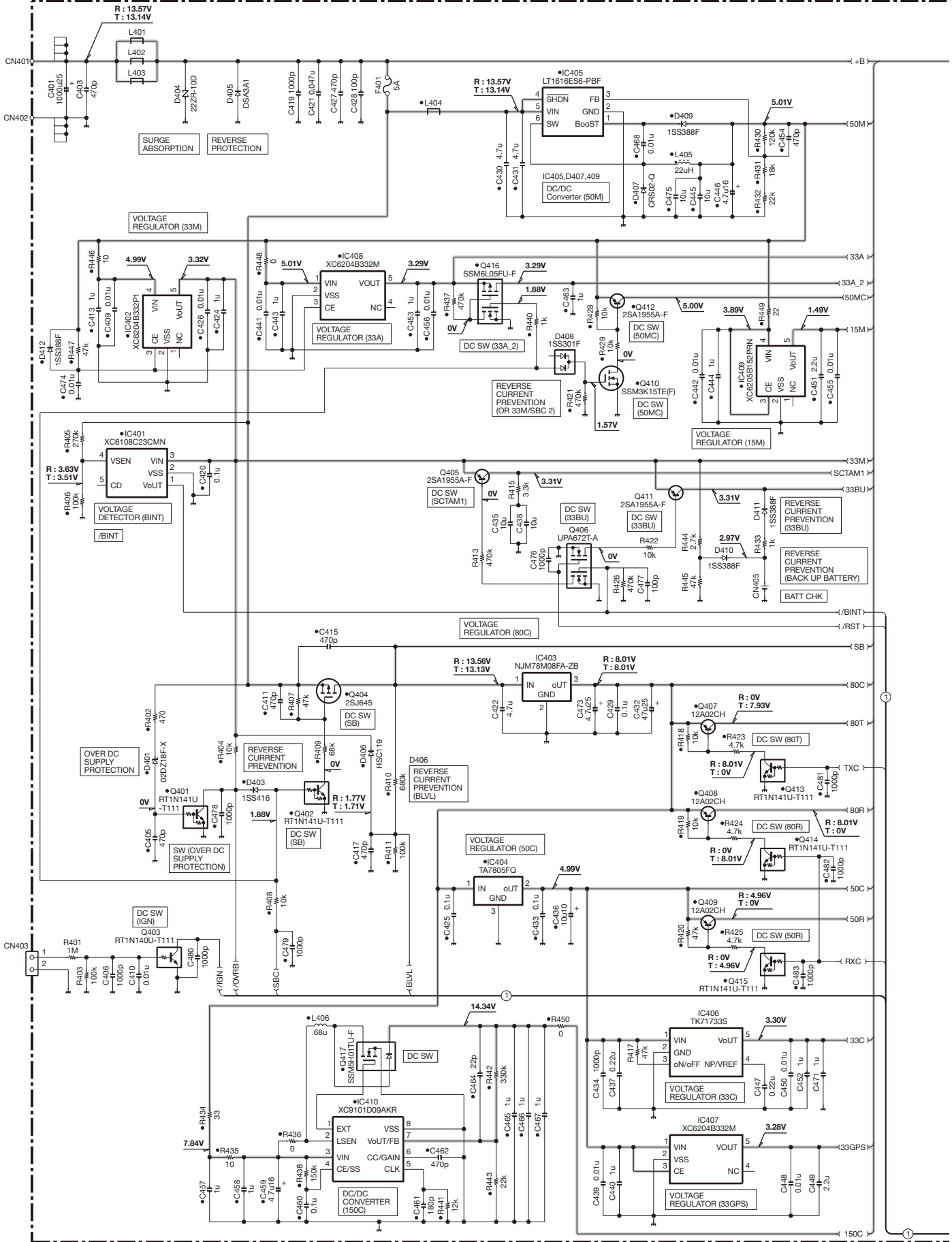

SCHEMATIC DIAGRAM / 原理图 NX-700

TX-RX UNIT (X57-7742-71) (A/2)

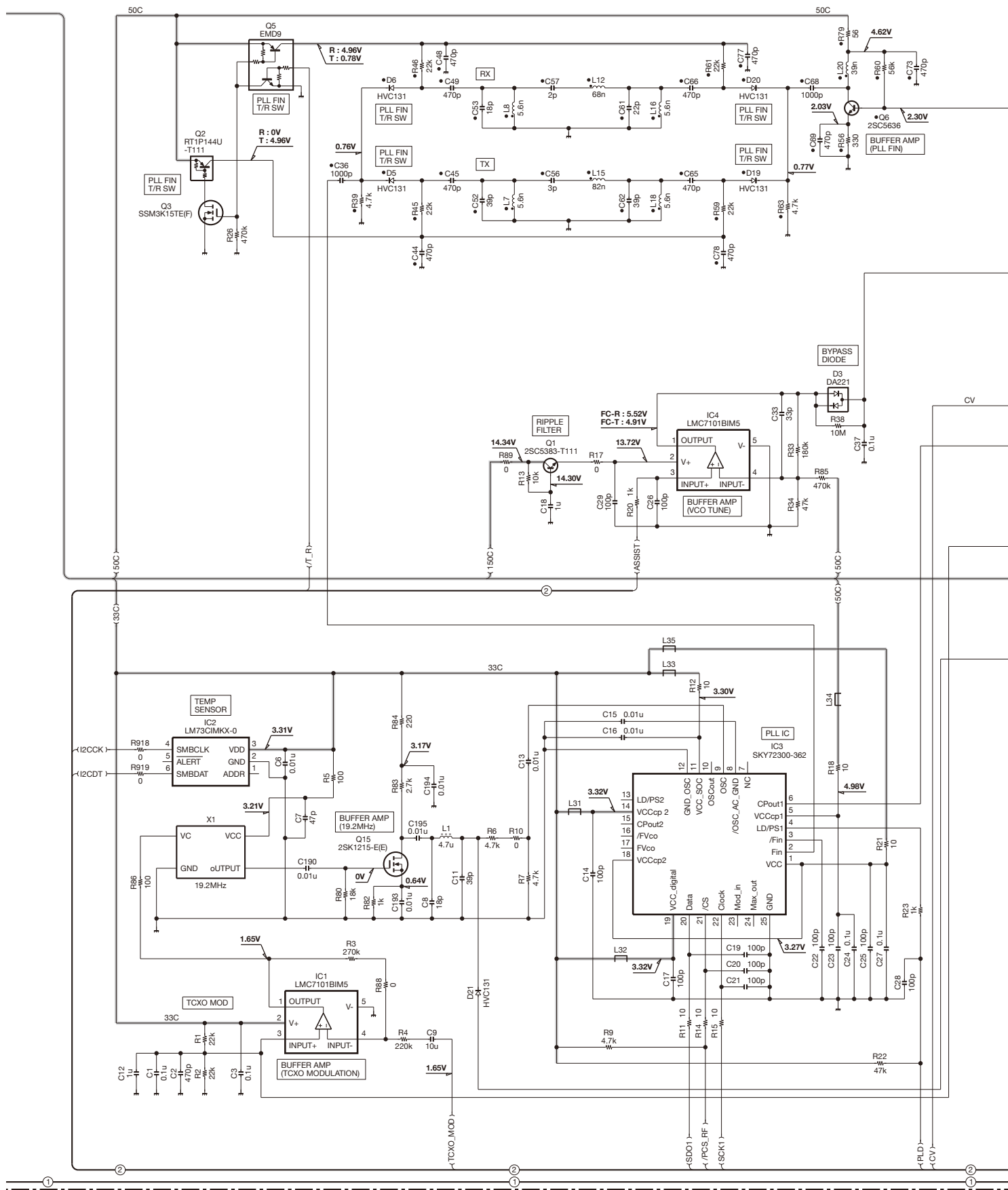

NX-700 SCHEMATIC DIAGRAM / 原理图

TX-RX UNIT (X57-7742-71) (A/2)

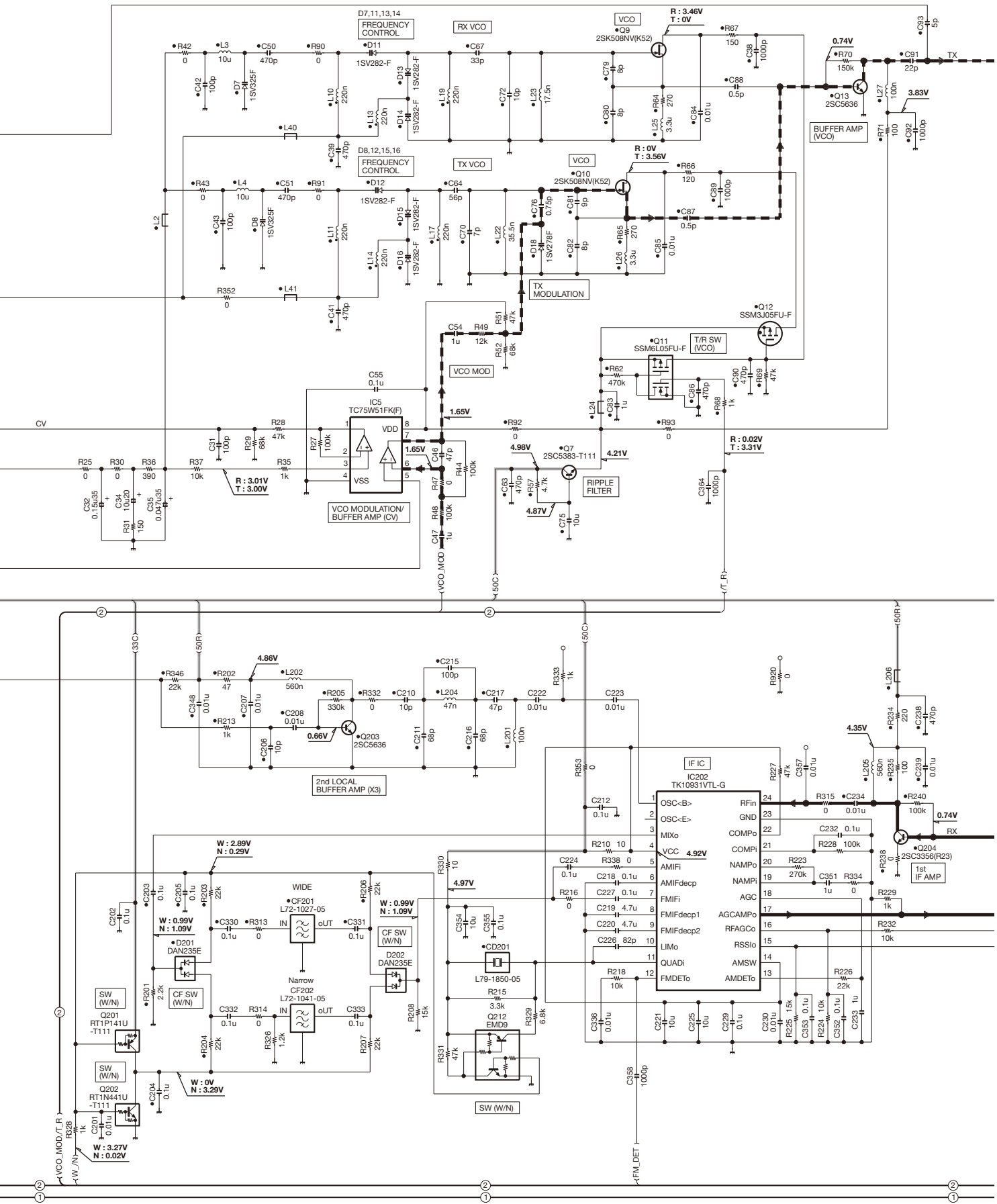

SCHEMATIC DIAGRAM / 原理图 NX-700

TX-RX UNIT (X57-7742-71) (A/2)

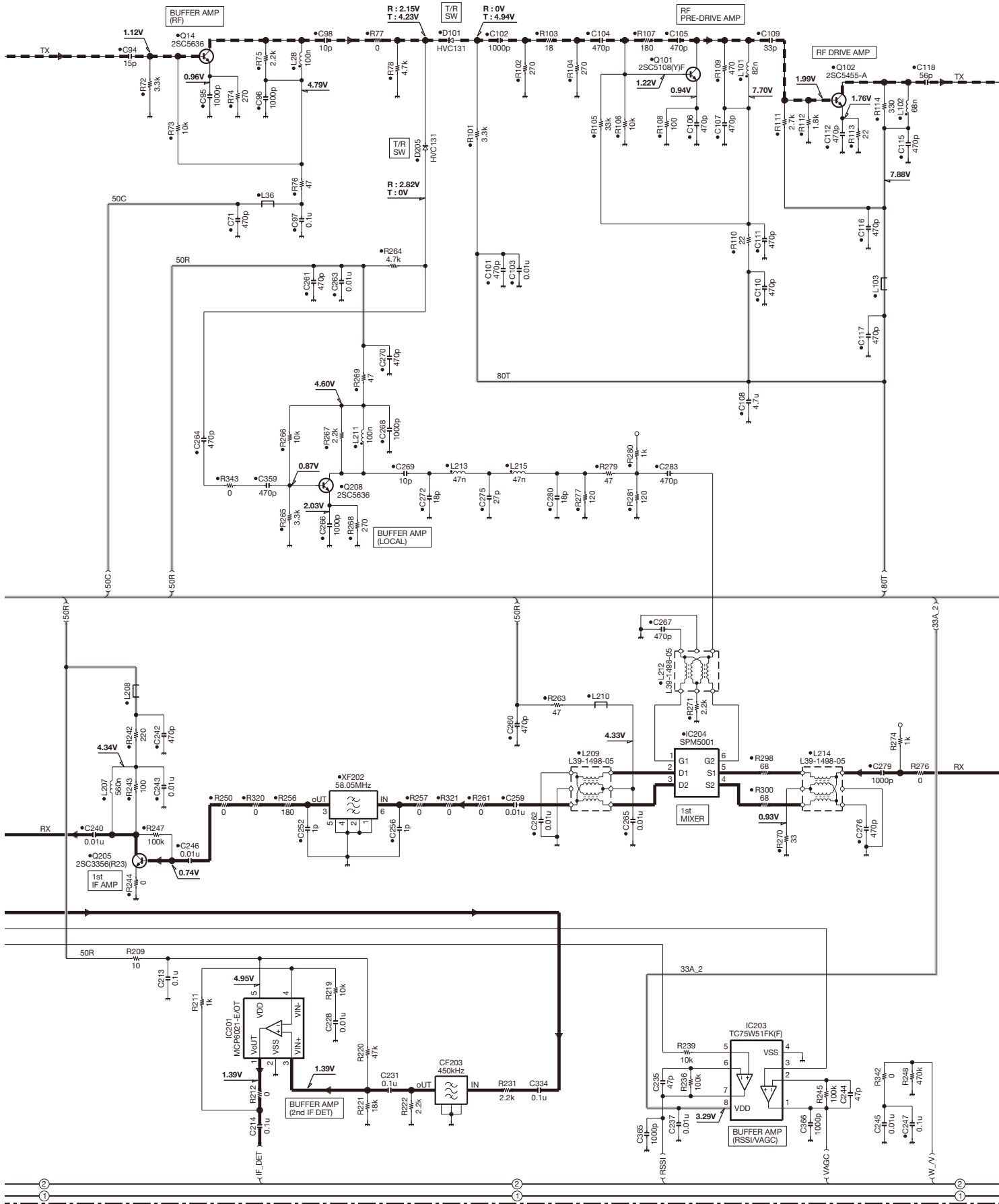

NX-700 SCHEMATIC DIAGRAM / 原理图

TX-RX UNIT (X57-7742-71) (A/2)

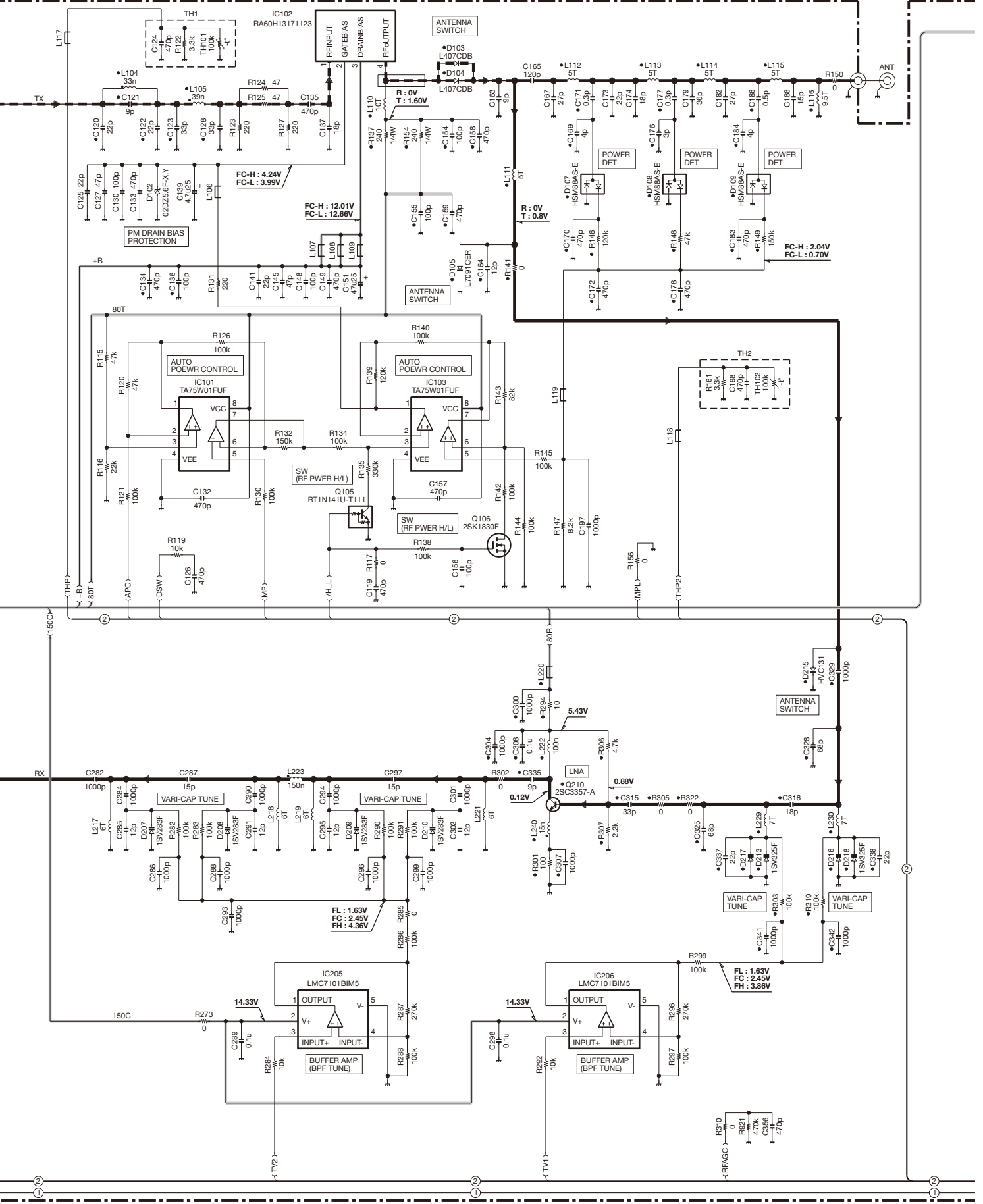

SCHEMATIC DIAGRAM / 原理图 NX-700

TX-RX UNIT (X57-7742-71) (A/2)

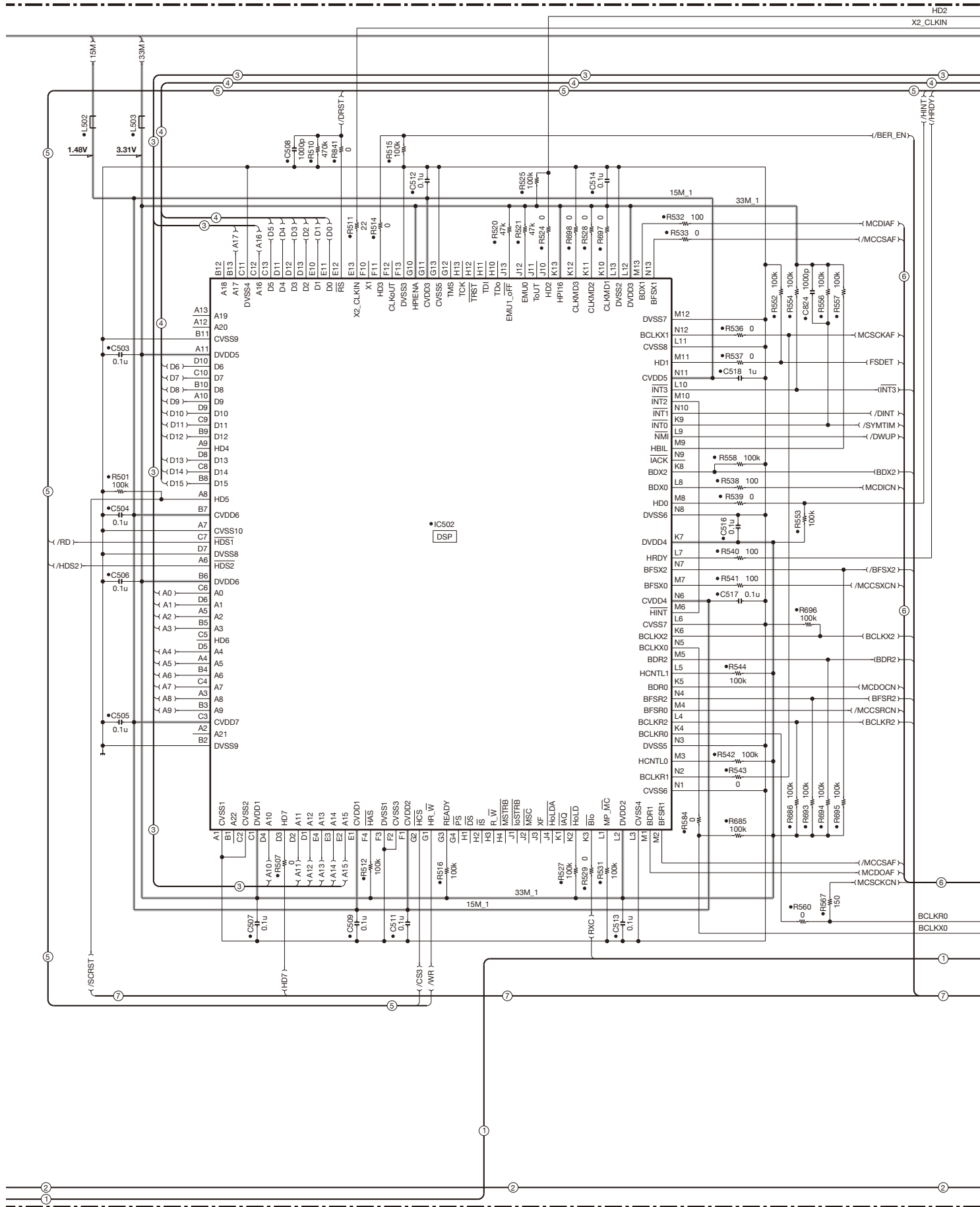

NX-700 SCHEMATIC DIAGRAM / 原理图

TX-RX UNIT (X57-7742-71) (A/2)

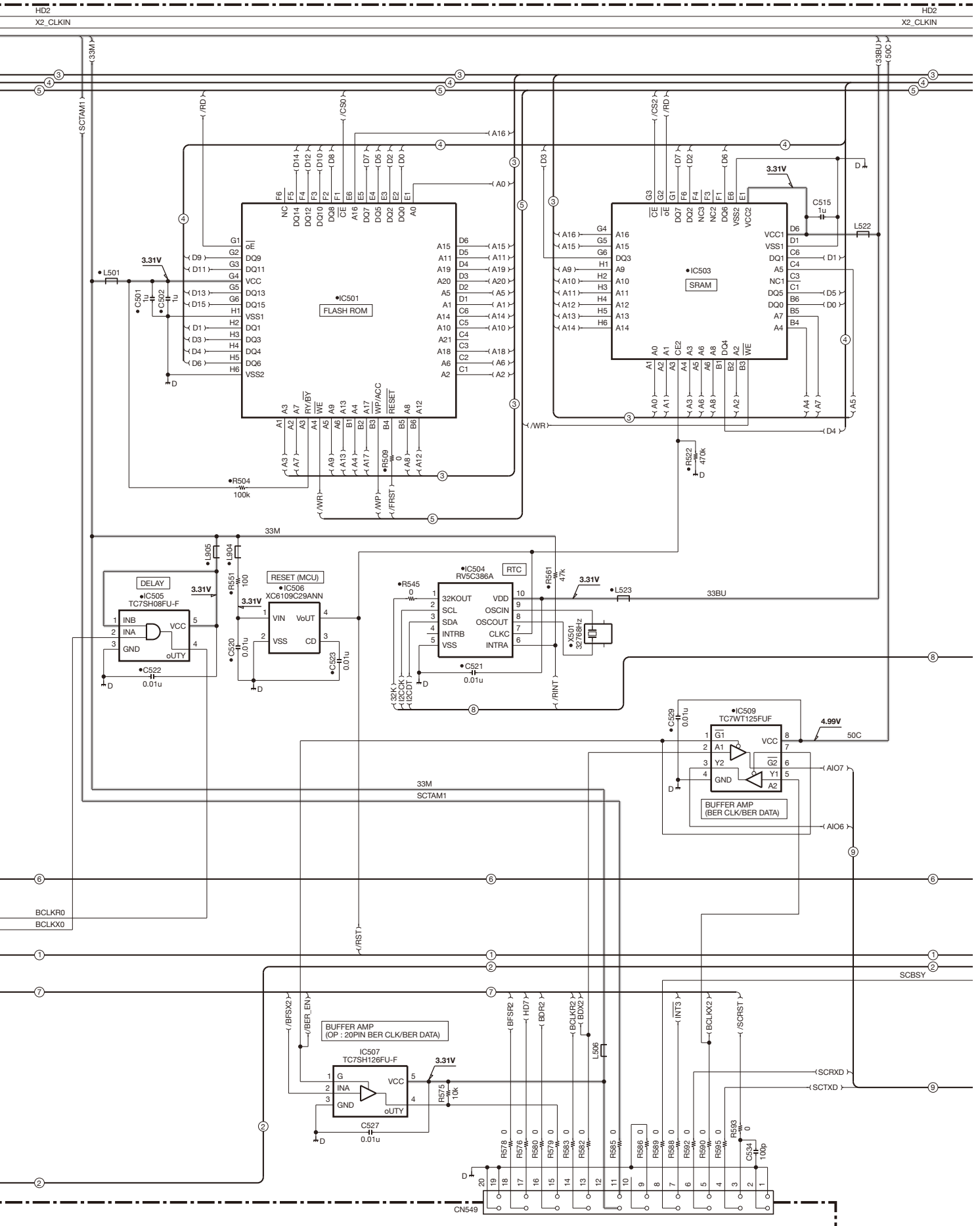

SCHEMATIC DIAGRAM / 原理图 NX-700

TX-RX UNIT (X57-7742-71) (A/2)

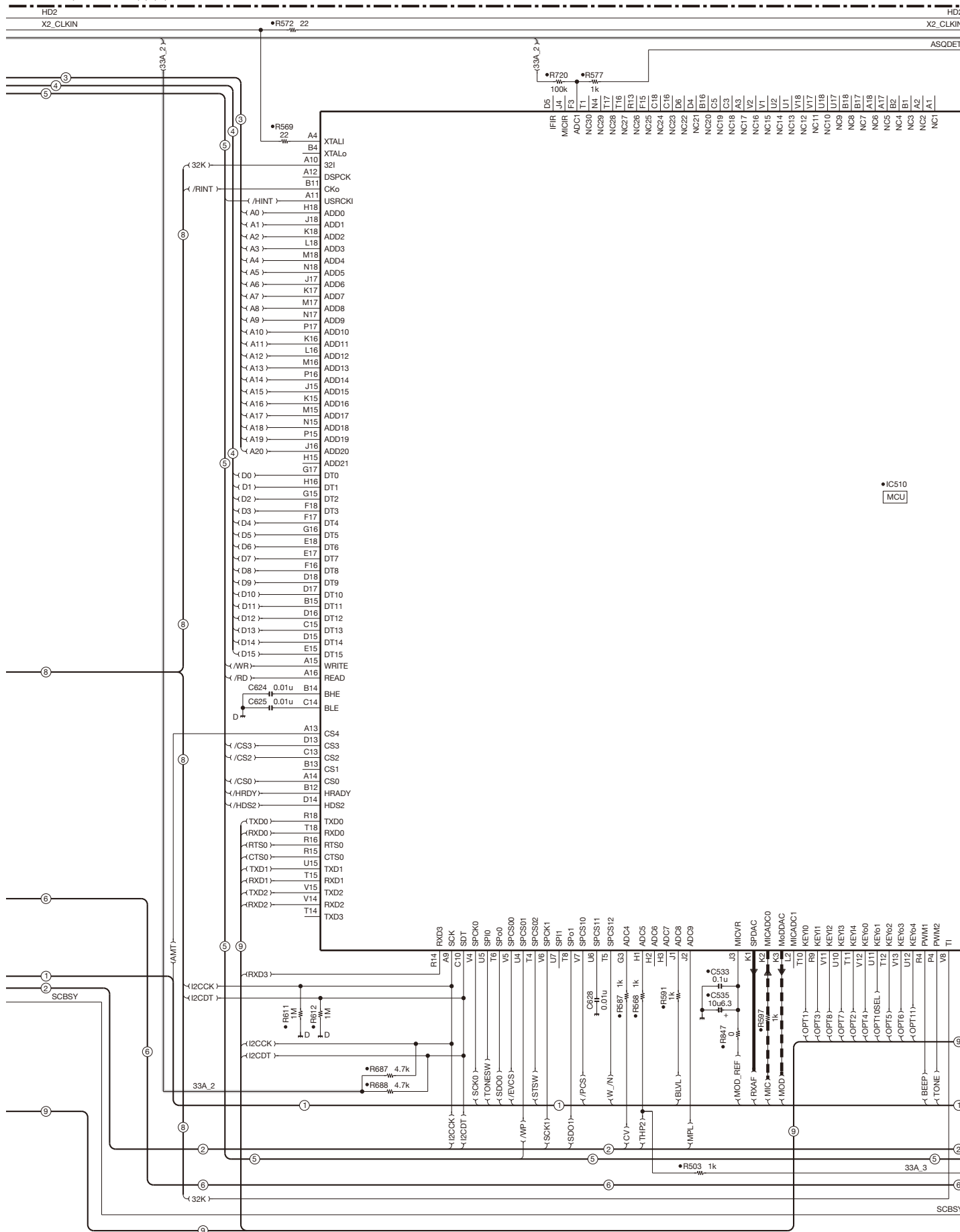

NX-700 SCHEMATIC DIAGRAM / 原理图

TX-RX UNIT (X57-7742-71) (A/2)

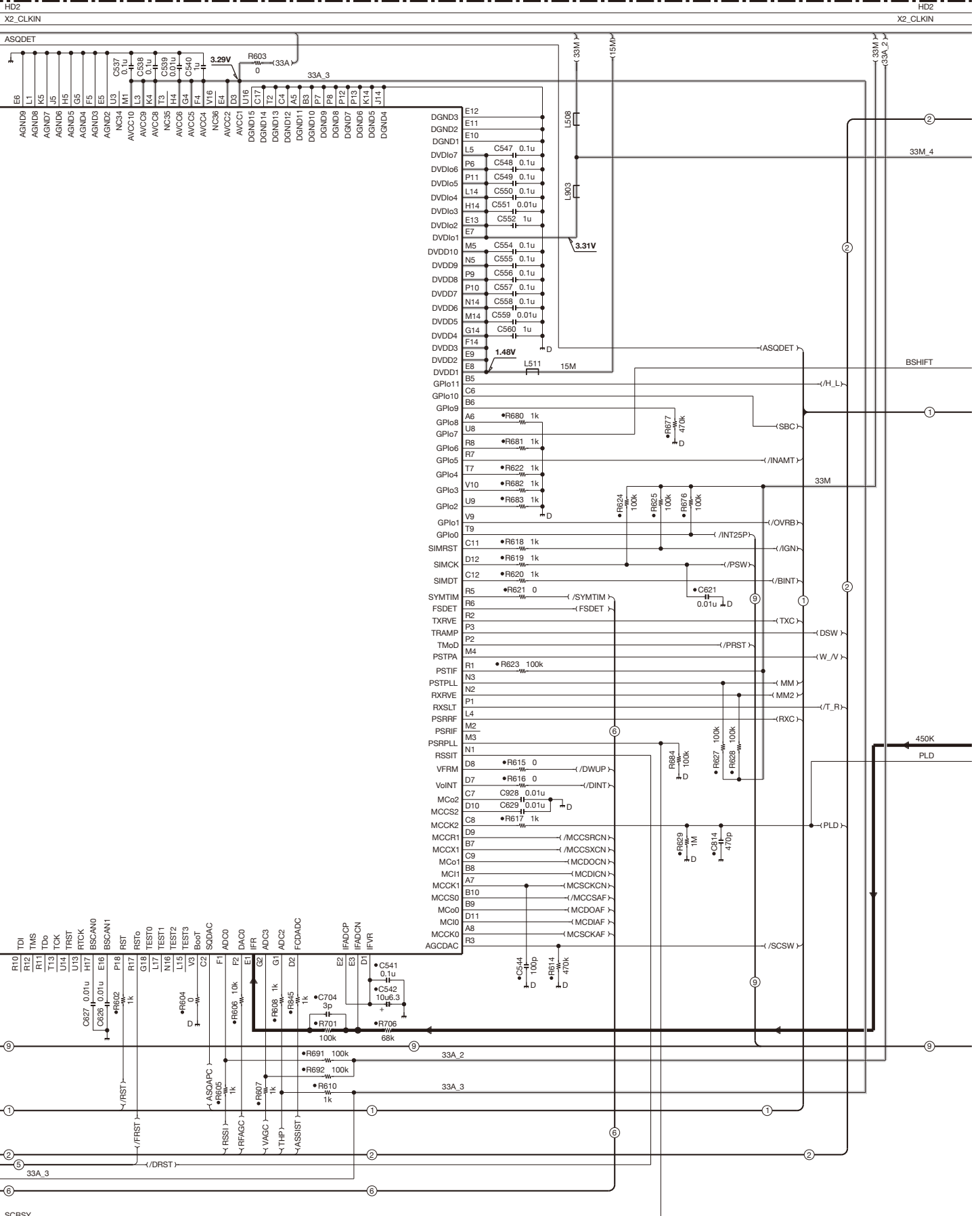

SCHEMATIC DIAGRAM / 原理图 NX-700

TX-RX UNIT (X57-7742-71) (A/2)

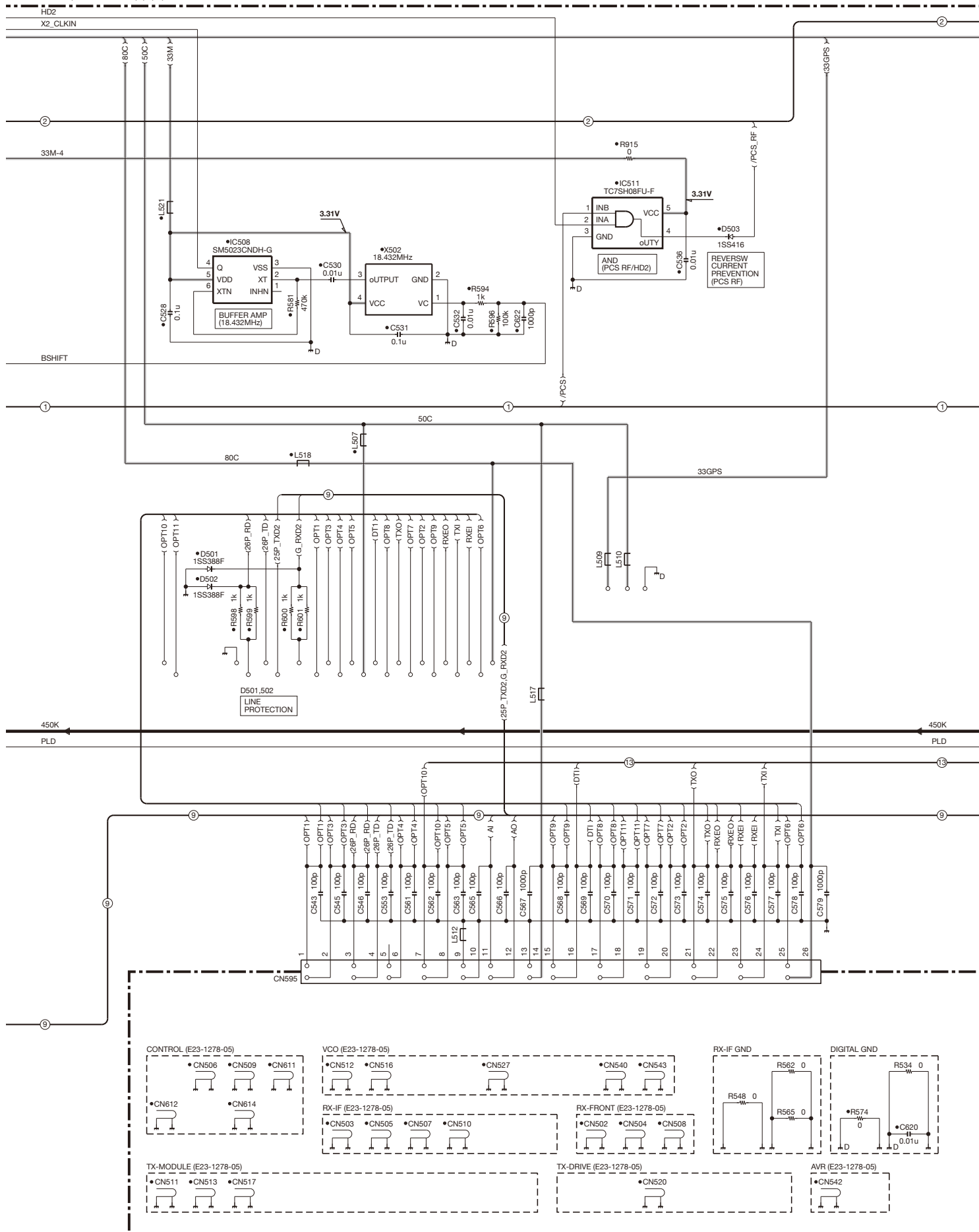

NX-700 SCHEMATIC DIAGRAM / 原理图

TX-RX UNIT (X57-7742-71) (A/2)

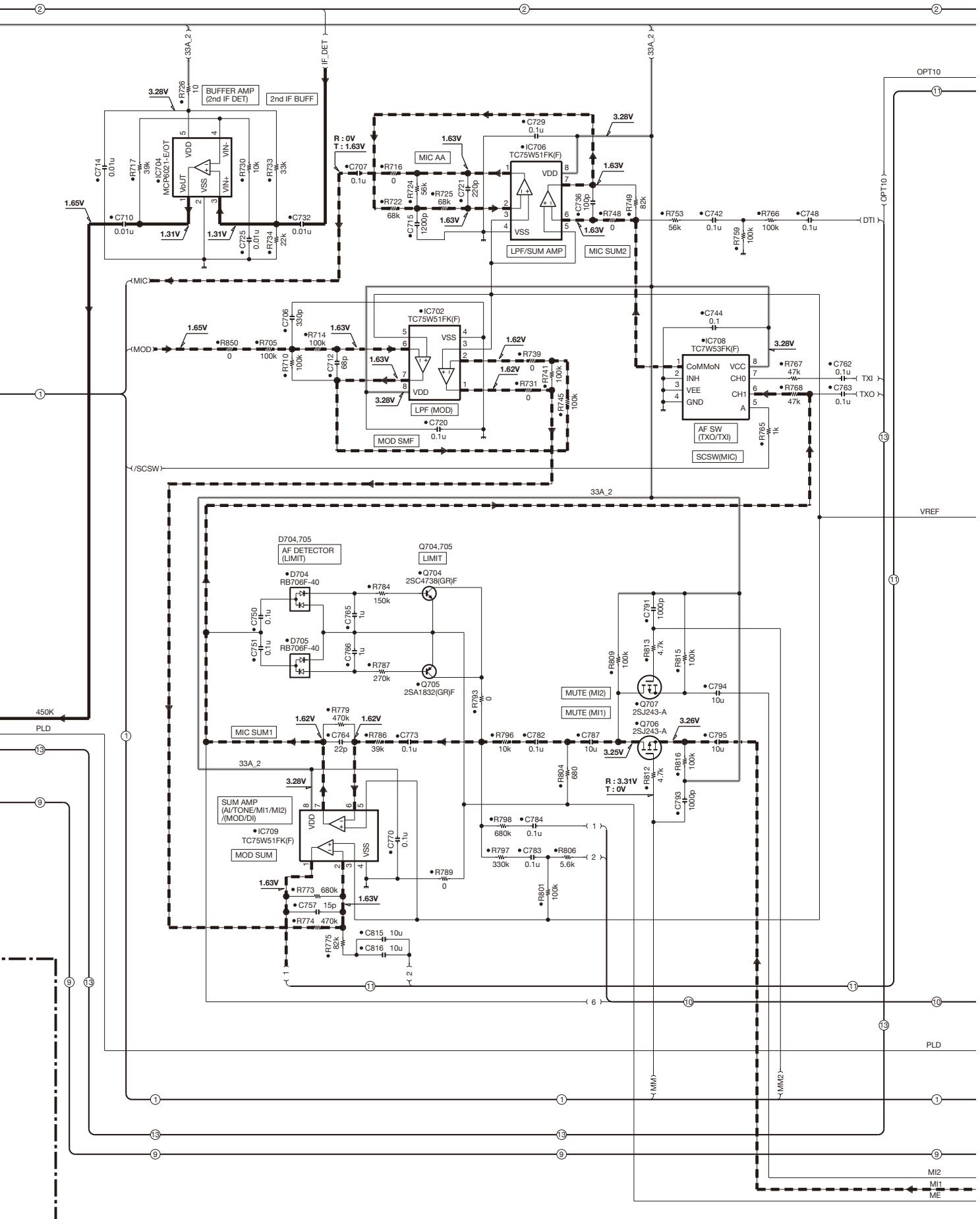

SCHEMATIC DIAGRAM / 原理图 NX-700

TX-RX UNIT (X57-7742-71) (A/2)

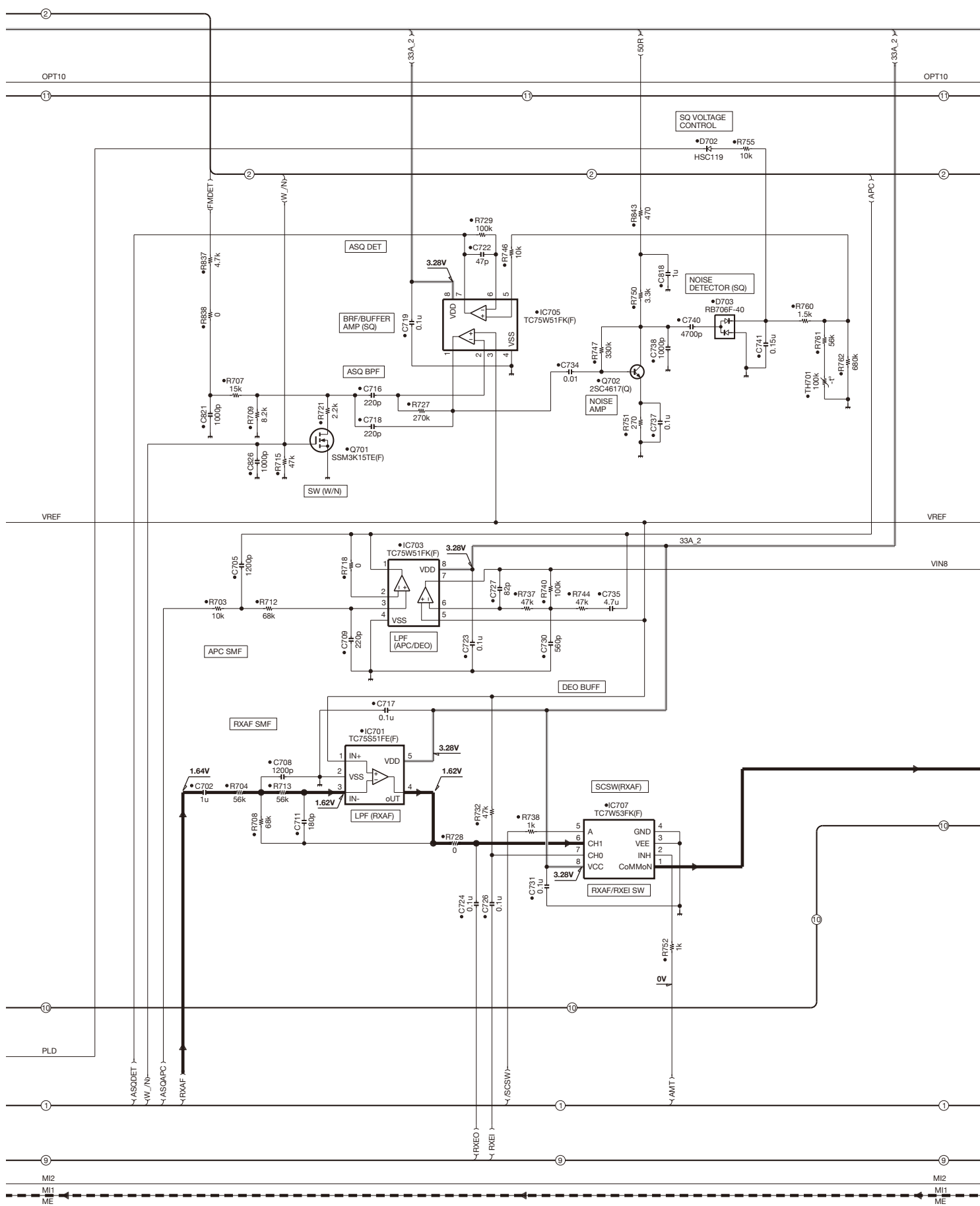

NX-700 SCHEMATIC DIAGRAM / 原理图

TX-RX UNIT (X57-7742-71) (A/2)

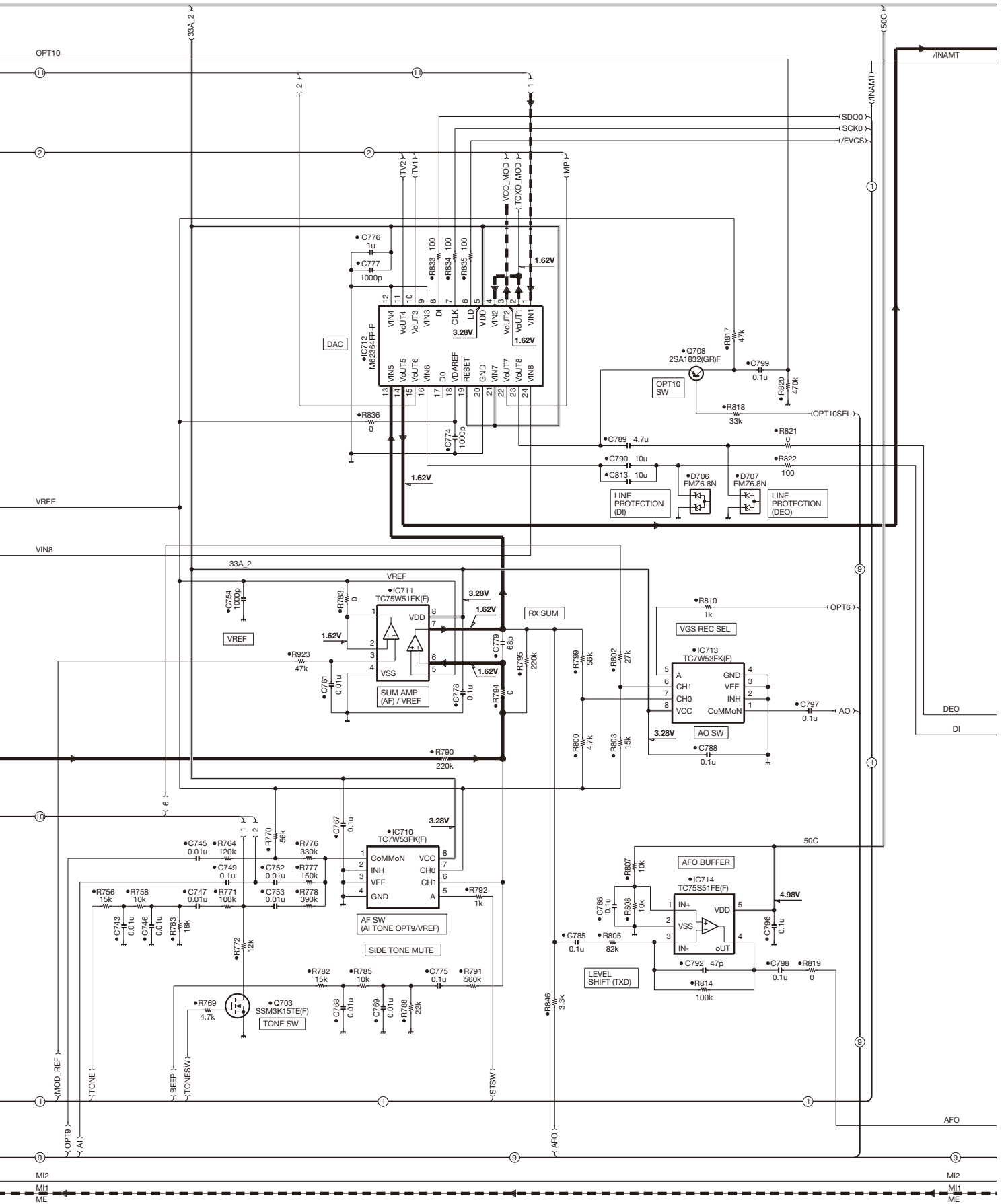

SCHEMATIC DIAGRAM / 原理图 NX-700

TX-RX UNIT (X57-7742-71) (A/2)

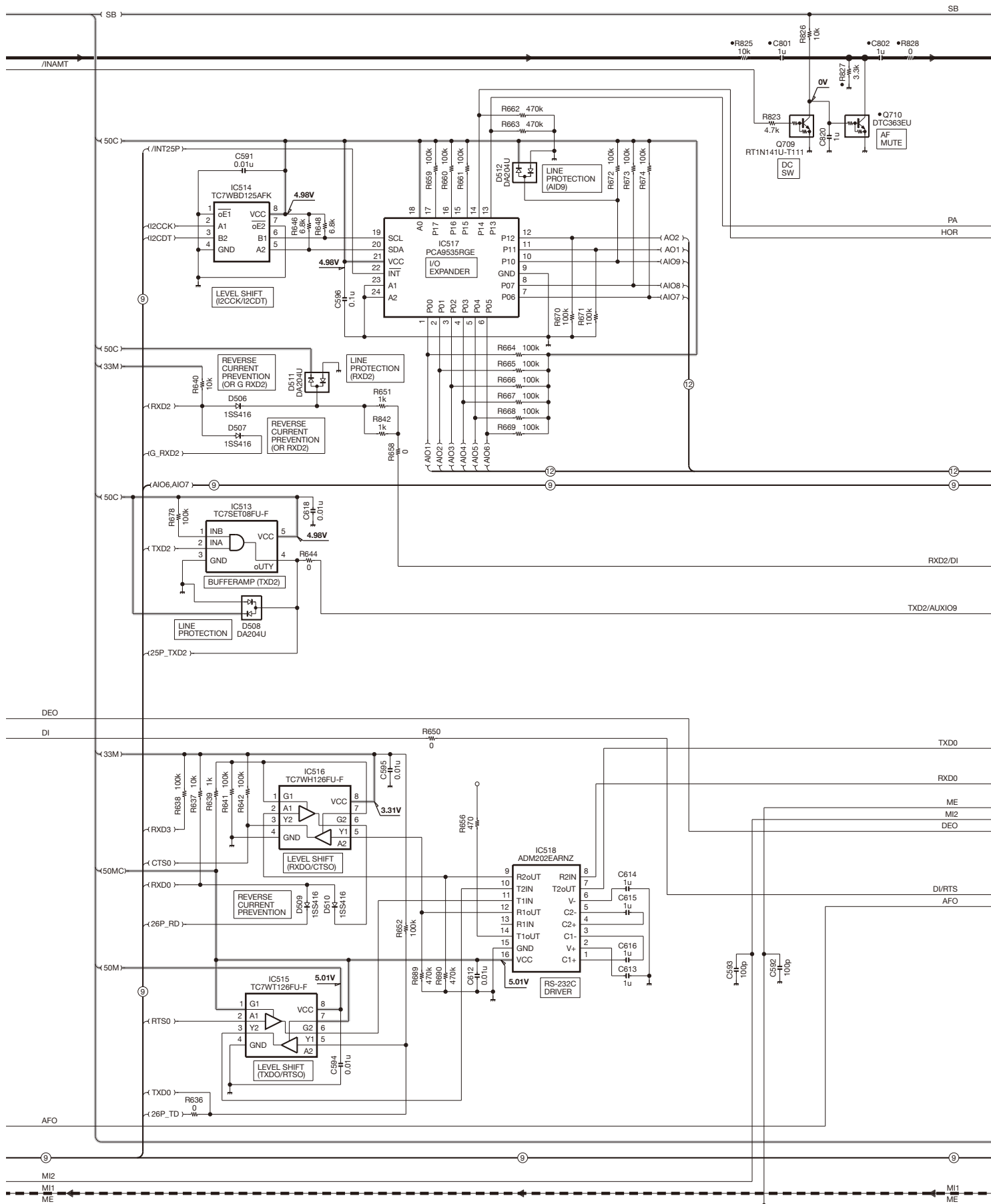

NX-700 SCHEMATIC DIAGRAM / 原理图

TX-RX UNIT (X57-7742-71) (A/2)

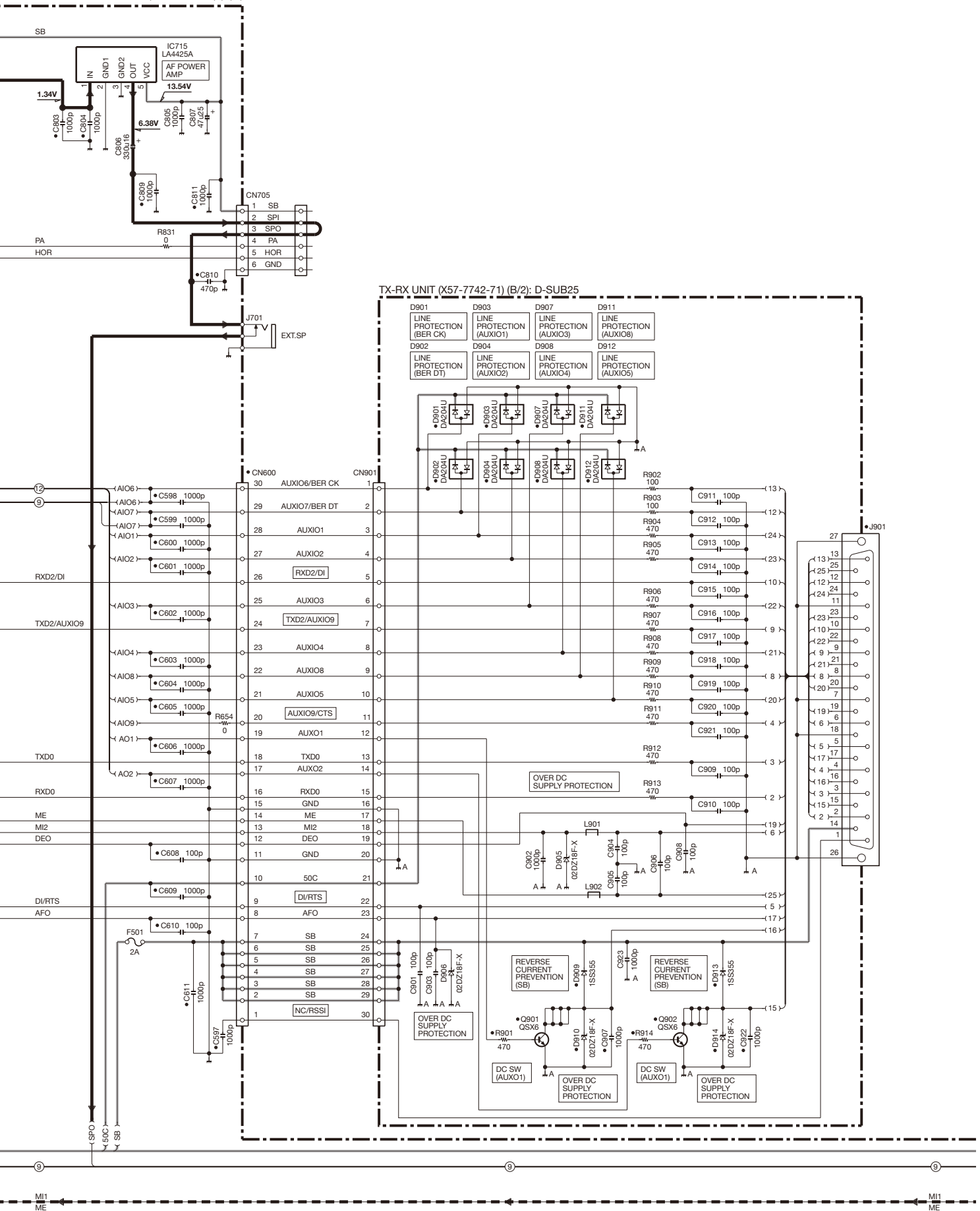

SCHEMATIC DIAGRAM / 原理图 NX-700

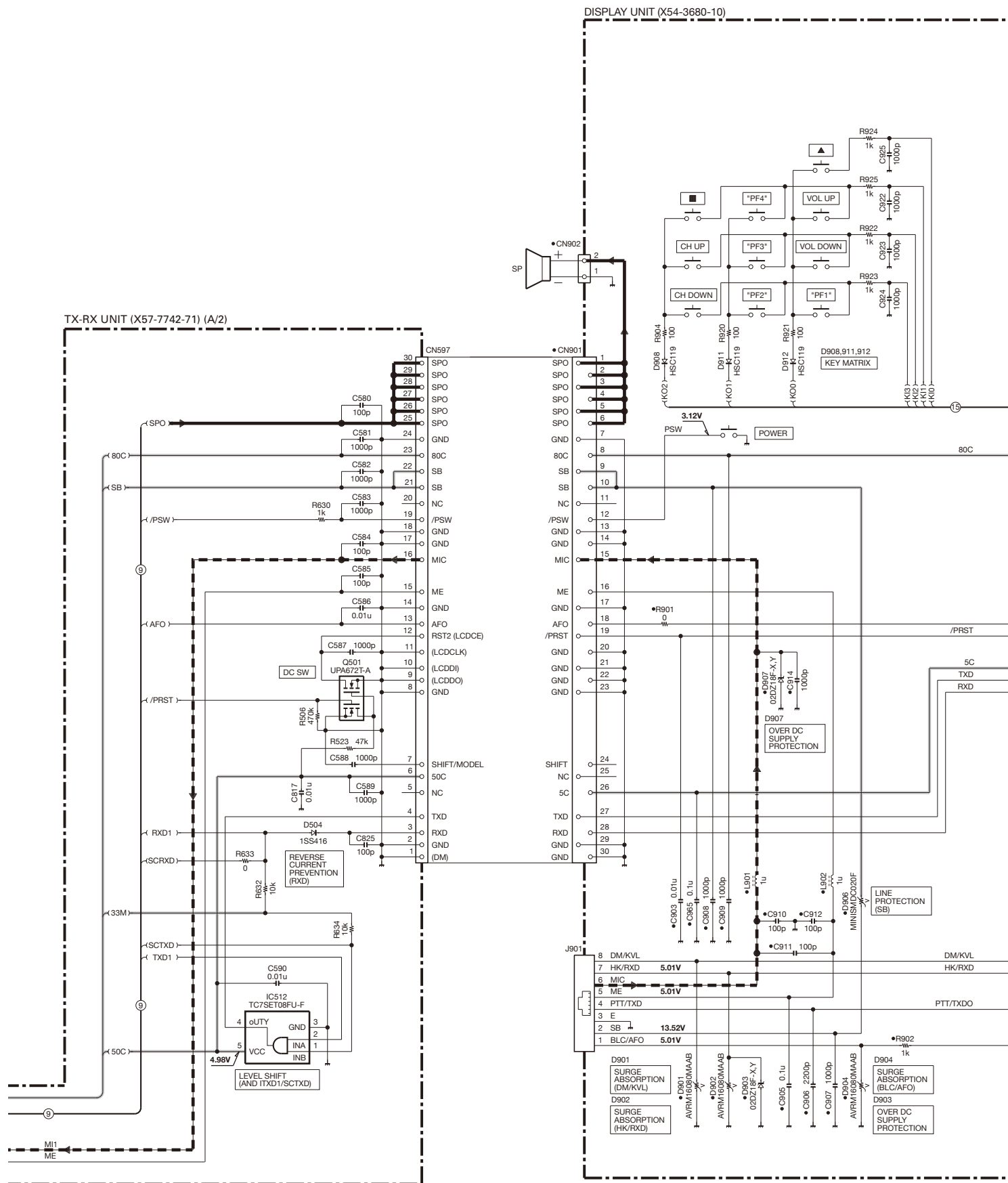

NX-700 SCHEMATIC DIAGRAM / 原理图

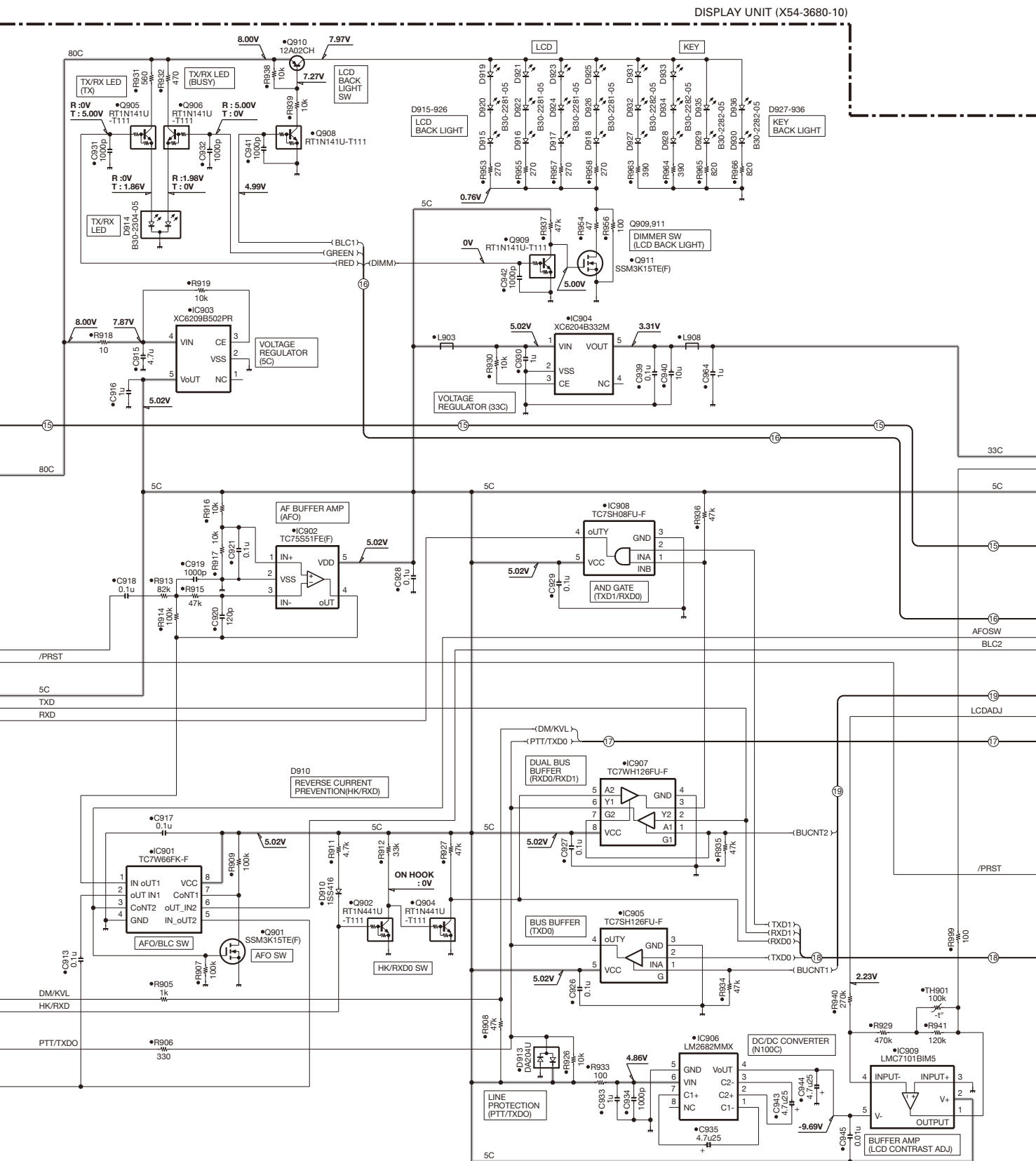

SCHEMATIC DIAGRAM / 原理图 NX-700

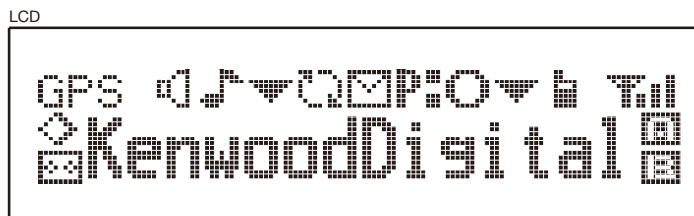

DISPLAY UNIT (X54-3680-10)

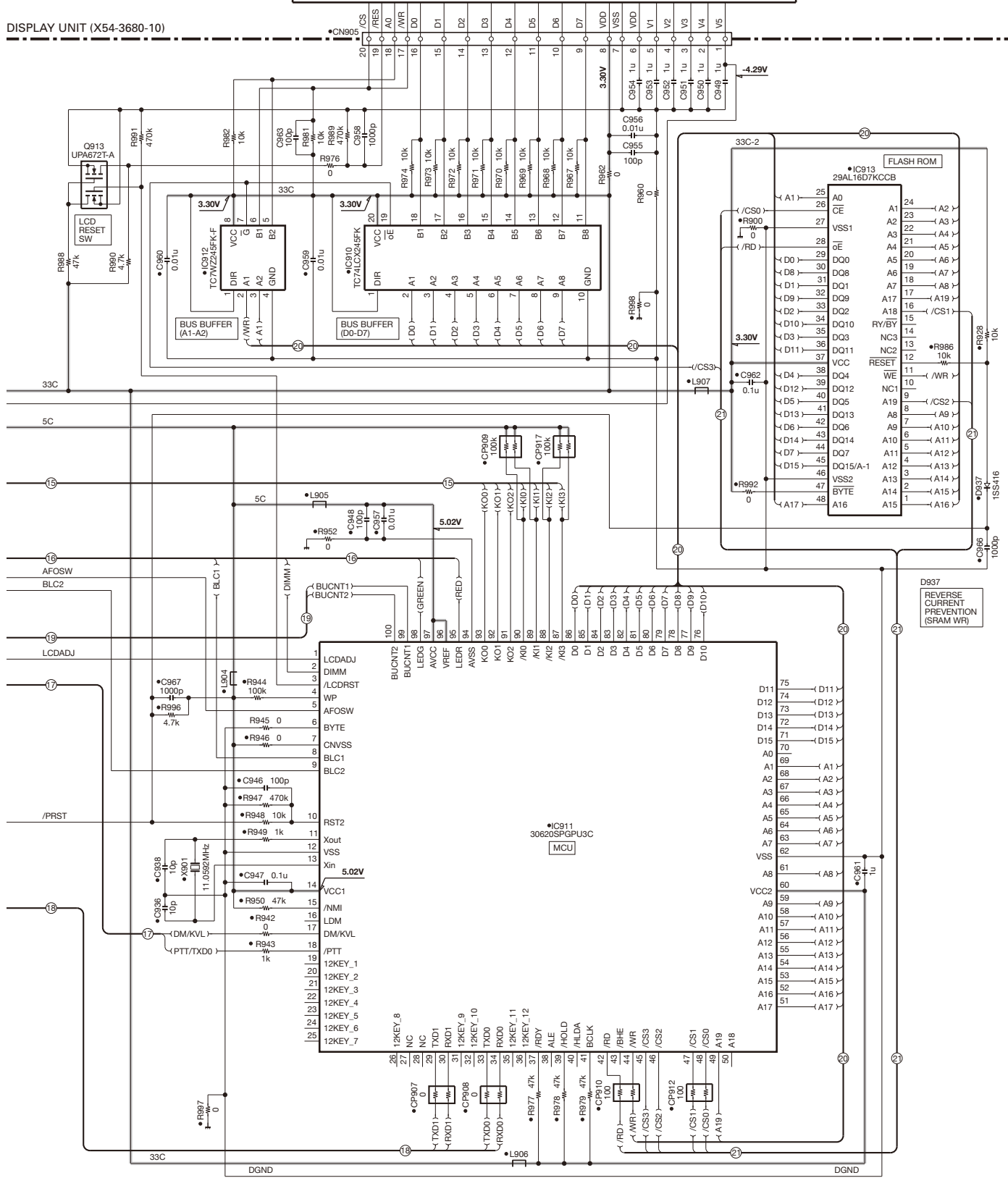

Note : The components marked with a dot (•) are parts of foil side.

LEVEL DIAGRAM / 电平图

Receiver Section / 接收部分

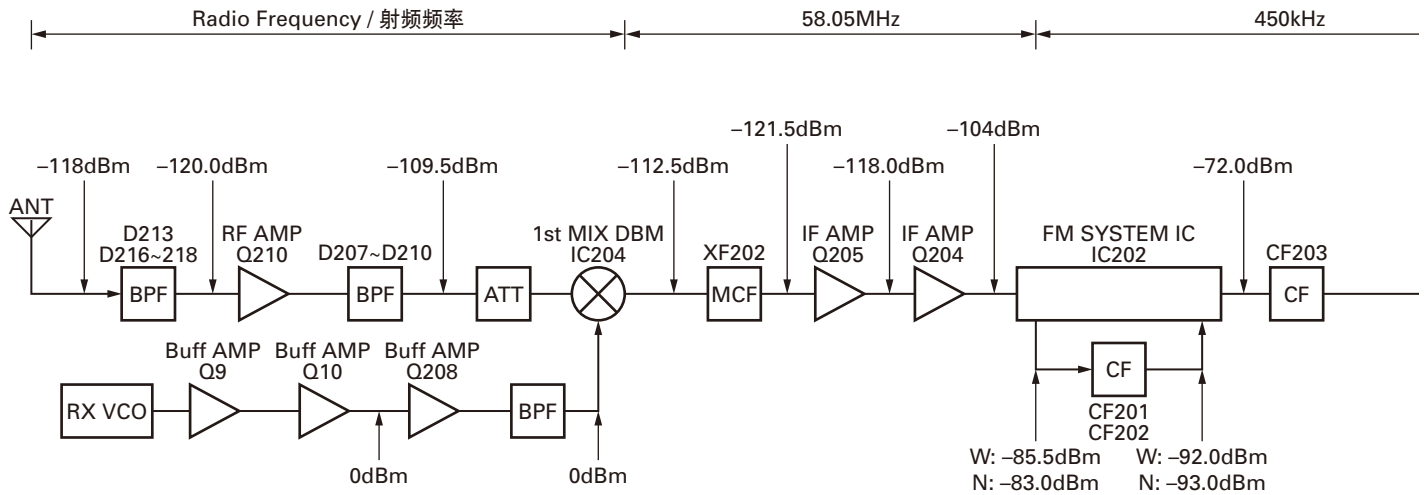

SSG input level for 12dB SINAD are obtained Measured by connecting SSG to each point via a 0.01 μ F capacitor.

获得12dB SINAD的SSG输入电平。
将SSG连接到通过0.01 μ F电容器的每个点后测得。

Transmitter Section / 发射部分

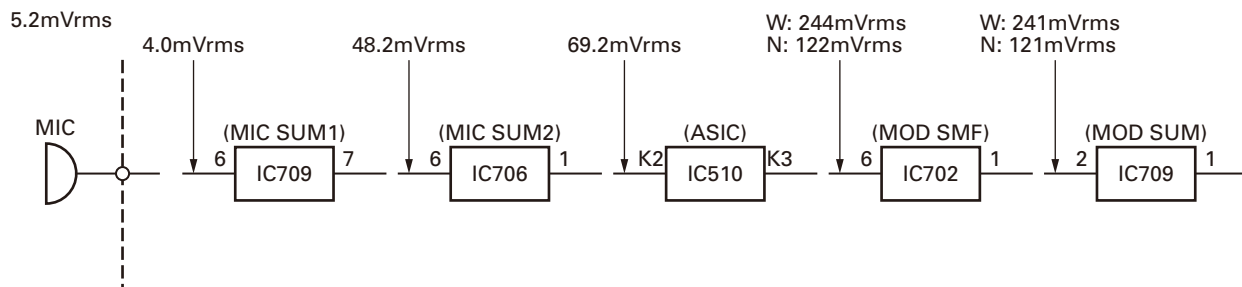

MIC input : 3kHz DEV. (Wide), 1.5kHz DEV. (Narrow) at 1kHz MOD.
Transmitting frequency : Center frequency

麦克风输入: 3kHz DEV. (宽), 1.5kHz DEV. (窄) (1kHz MOD时)
发射频率: 中心频率

W: Wide / 宽
N: Narrow / 窄

LEVEL DIAGRAM / 电平图

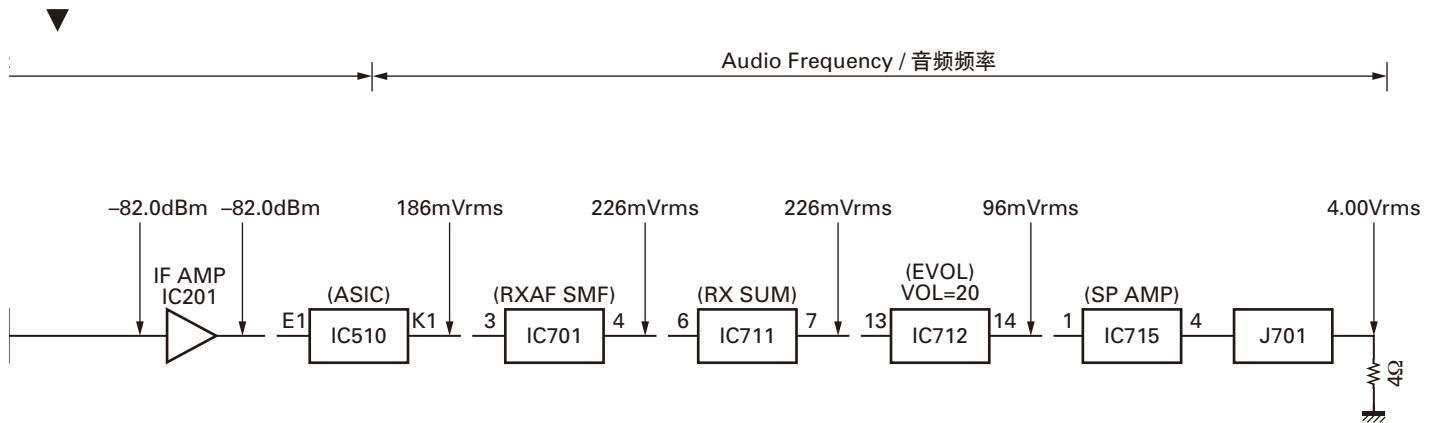

AF VTVM

AF level obtained when the AF output level is adjusted for 4.00V/4Ω with the front panel AF VOL control. Measured with AF voltmeter connected to the external speaker jack, receiving a -53dBm SSG signal modulated at 1kHz, DEV (Wide 3kHz, Narrow 1.5kHz).

用前面板AF VOL控制器将AF输出电平调整为4.00V/4Ω时获得的AF电平。将AF电压表连接到外部扬声器插孔，正在接收调制为1kHz,DEV(宽3kHz,窄1.5kHz)的-53dBm SSG信号时测得。

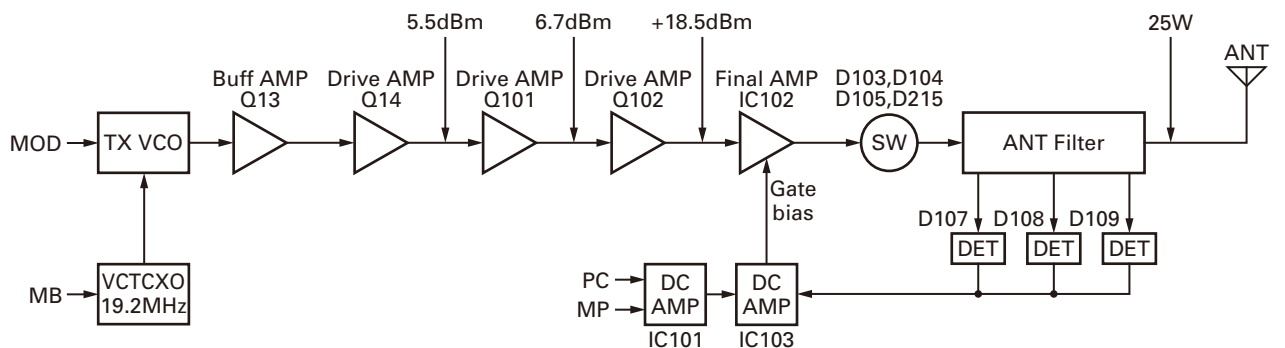
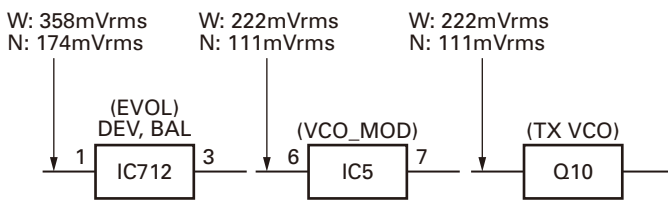

NX-700 BLOCK DIAGRAM / 方块图

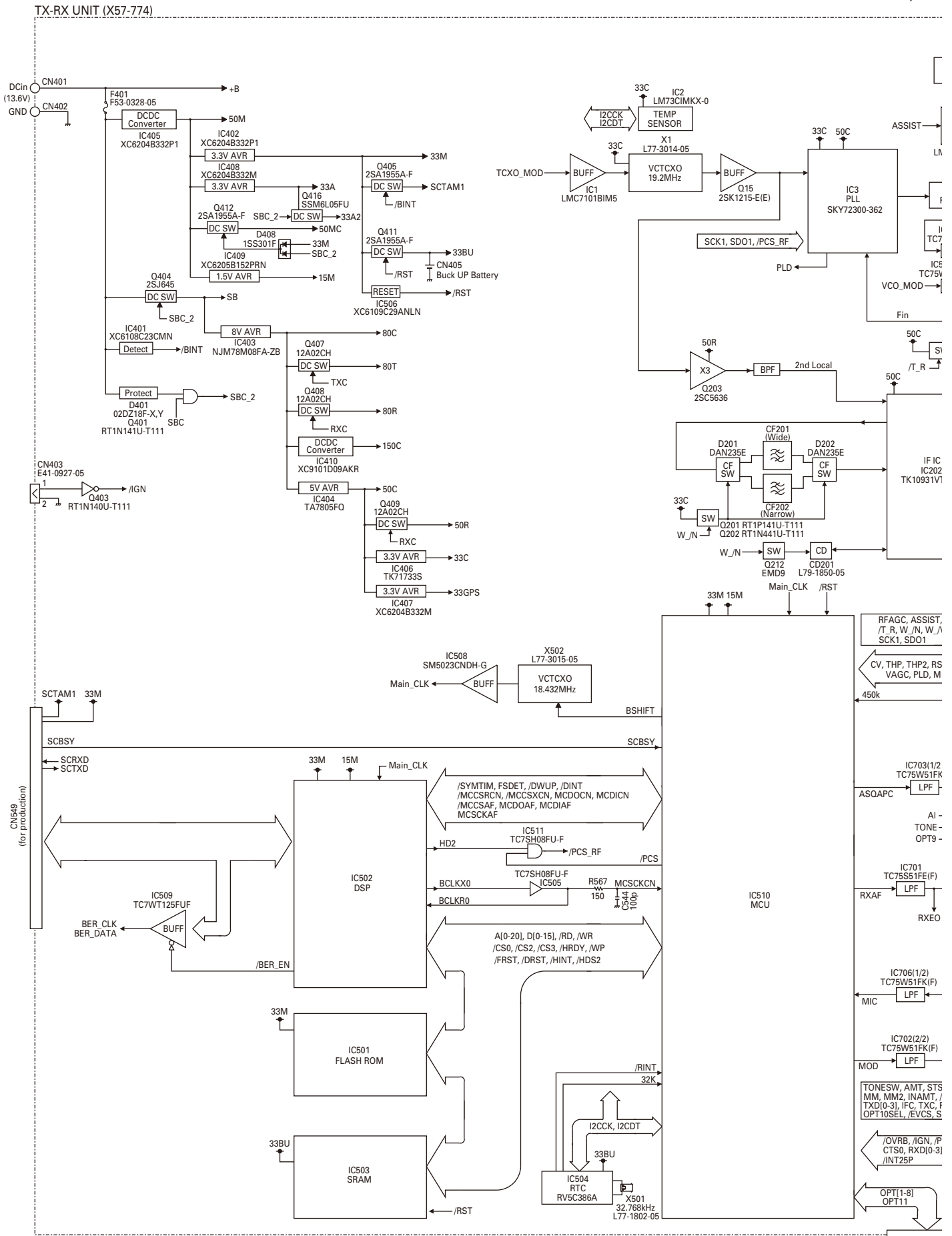

BLOCK DIAGRAM / 方块图 NX-700

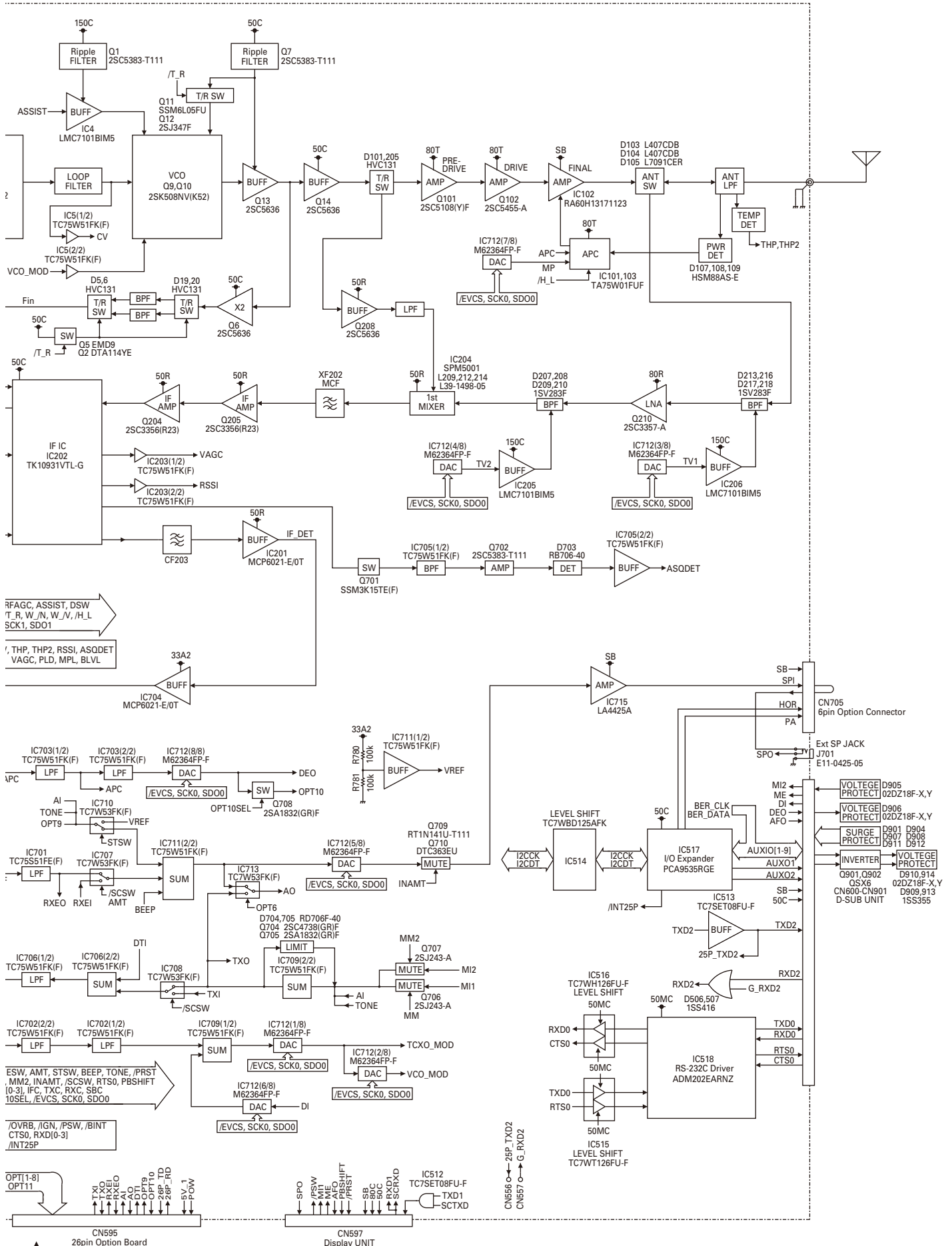

BLOCK DIAGRAM / 方块图

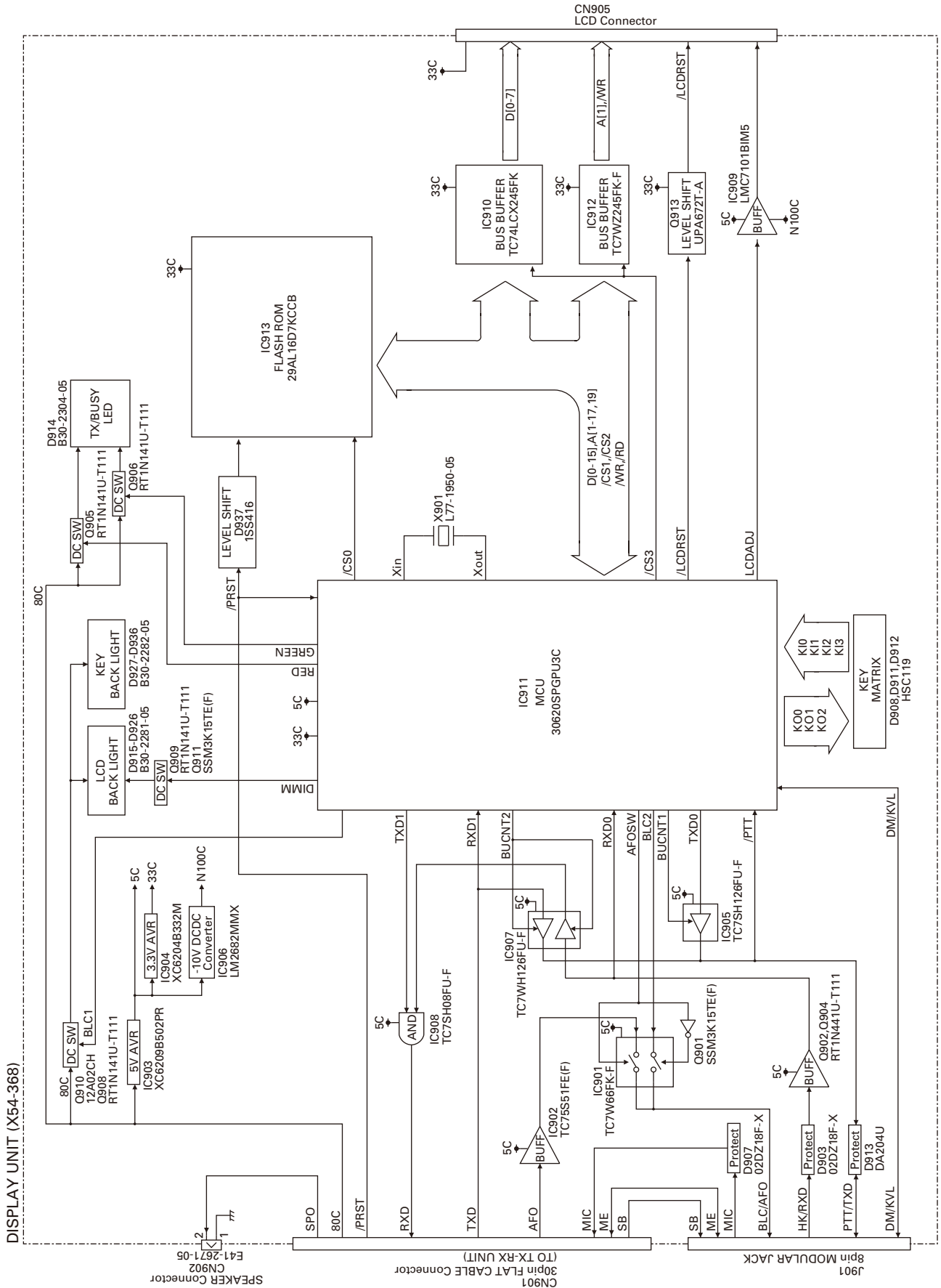

SPECIFICATIONS

GENERAL

Frequency Range.....	136~174MHz
Number of Channels.....	512
Zones.....	128
Max. Channels per Zone.....	250
Channel Spacing.....	Analog: 12.5/25 kHz Digital: 6.25/12.5 kHz
Operating Voltage.....	13.6V DC (10.8~15.6V DC)
Operating Temperature Range.....	-30°C~+60°C
Frequency Stability.....	±2.0ppm
Antenna Impedance.....	50Ω
Dimensions (W x H x D).....	160 x 45 x 157 mm
(Projections not included)	
Weight.....	1.38kg

RECEIVER

Sensitivity.....	Digital @6.25kHz (3% BER): 0.20μV
	Digital @12.5kHz (3% BER): 0.28μV
	Analog @12.5kHz (12dB SINAD): 0.25μV
	Analog @25kHz (12dB SINAD): 0.25μV
Adjacent Channel Selectivity (Analog).....	25kHz: 80dB 12.5kHz: 70dB
Intermodulation (Analog).....	75dB
Spurious Response Rejection (Analog).....	90dB
Audio Distortion.....	Less than 3%
Audio Output.....	4W/4Ω

TRANSMITTER

RF Power Output.....	1~25W
Modulation Limiting (Analog).....	±5.0kHz (25kHz) ±2.5kHz (12.5kHz)
Spurious Emission.....	-36dBm ≤ 1GHz, -30dBm > 1GHz
FM Noise (Analog).....	25kHz: 50dB 12.5kHz: 45dB
Modulation Distortion.....	Less than 3%
Modulation.....	Analog @25kHz: 16K0F3E Analog @12.5kHz: 8K50F3E
	Digital @12.5kHz: 8K30F1E Digital @6.25kHz: 4K00F1E

Analog measurements made per TIA/EIA603 and specifications shown are typical.
 KENWOOD reserves the right to change specifications without prior notice or obligation.

NX-700

规 格

通 用

频率范围.....	136~174MHz
信道数量.....	512
区域分区数量.....	128
每区域最大信道数量.....	250
信道间隔.....	模拟 : 12.5/25 kHz 数字 : 6.25/12.5 kHz
工作电源电压.....	13.6V DC (10.8~15.6V DC)
工作温度范围.....	-30°C ~ +60°C
频率稳定度.....	±2.0ppm
天线阻抗.....	50 Ω
外型尺寸 (宽 × 高 × 长).....	160 × 45 × 157 mm (未包括凸起部分)
重量.....	1.38kg

接 收

接收灵敏度.....	数字 @6.25kHz (3% 误码率) : 0.20μV 数字 @12.5kHz (3% 误码率) : 0.28μV 模拟 @12.5kHz (12dB SINAD) : 0.25μV 模拟 @25kHz (12dB SINAD) : 0.25μV
邻道选择性 (模拟).....	25kHz : 80dB 12.5kHz : 70dB
互调抑制 (模拟).....	75dB
杂散响应 (模拟).....	90dB
音频失真.....	3% 以下
音频输出功率.....	4W (4 Ω 时)

发 射

发射功率.....	1~25W
调制限制 (模拟).....	±5.0kHz (25kHz 信道) ±2.5kHz (12.5kHz 信道)
杂散抑制.....	-36dBm ≦ 1GHz, -30dBm > 1GHz
调频噪声 (模拟).....	25kHz : 50dB 12.5kHz : 45dB
调制失真.....	3% 以下
电波类型.....	模拟 @25kHz : 16K0F3E 模拟 @12.5kHz : 8K50F3E 数字 @12.5kHz : 8K30F1E 数字 @6.25kHz : 4K00F1E

依据 TIA/EIA603 获得的模拟测量值和所示规格均为典型值。
建伍公司有权变更技术规格，恕不预先通知。

Kenwood Corporation

2967-3, Ishikawa-machi, Hachioji-shi, Tokyo, 192-8525 Japan

Kenwood U.S.A. Corporation

P.O. BOX 22745, 2201 East Dominguez Street, Long Beach, CA 90801-5745, U.S.A.

Kenwood Electronics Canada Inc.

6070 Kestrel Road, Mississauga, Ontario, Canada L5T 1S8

Kenwood Electronics Deutschland GmbH

Rembrücker Str. 15, 63150 Heusenstamm, Germany

Kenwood Electronics Belgium N.V.

Leuvensesteenweg 248 J, 1800 Vilvoorde, Belgium

Kenwood Electronics France S.A.

L'Etoile Paris Nord 2, 50 Allée des Impressionnistes, Bp 58416 Villepinte, 95944 Roissy Ch De Gaulle Cedex

Kenwood Electronics UK Limited

KENWOOD House, Dwight Road, Watford, Herts., WD18 9EB United Kingdom

Kenwood Electronics Europe B.V.

Amsterdamseweg 37, 1422 AC Uithoorn, The Netherlands

Kenwood Electronics Italia S.p.A.

Via G. Sirtori, 7/9 20129 Milano, Italy

Kenwood Ibérica, S.A.

Bolivia, 239-08020 Barcelona, Spain

Kenwood Electronics Australia Pty. Ltd.

Talavera Business Park Building A, 4 Talavera Road, North Ryde NSW 2113 Australia

Kenwood Electronics (Hong Kong) Ltd.

Unit 3712-3724, Level 37, Tower one Metroplaza, 223 Hing Fong Road, Kwai Fong, N.T., Hong Kong

Kenwood Electronics Singapore Pte Ltd

1 Ang Mo Kio Street 63, Singapore 569110

NX-700 PC BOARD / PC板

TX-RX UNIT (X57-7742-71) (A/2)
Foil side view (J79-0207-19 A/2)

PC BOARD / PC板 NX-700

TX-RX UNIT (X57-7742-71) (A/2)
Foil side view (J79-0207-19 A/2)

Ref. No.	Address	Ref. No.	Address	Ref. No.	Address
IC204	11F	Q12	10J	D12	11J
IC401	7M	Q13	10I	D13	11H
IC402	6N	Q14	10I	D14	11I
IC404	6P	Q101	7I	D15	11J
IC405	5N	Q102	7J	D16	11I
IC408	5M	Q203	8E	D18	11J
IC409	7N	Q204	9D	D19	9I
IC410	12J	Q205	10D	D20	9I
IC501	12P	Q208	10G	D101	9H
IC502	10Q	Q210	7G	D103	5F
IC503	12Q	Q401	3P	D104	6F
IC504	10N	Q402	4P	D105	6E
IC505	10P	Q404	4P	D107	6D
IC506	13P	Q407	5P	D108	5D
IC508	10Q	Q408	5P	D109	4D
IC509	9P	Q409	7O	D201	10E
IC510	12Q	Q410	7N	D205	9H
IC511	9Q	Q412	6N	D213	7E
IC701	12M	Q413	5P	D215	7D
IC702	8N	Q414	5P	D216	7E
IC703	12L	Q415	7O	D217	7F
IC704	10M	Q416	5N	D218	7E
IC705	12L	Q417	12I	D401	3O
IC706	8M	Q701	12K	D403	4P
IC707	12M	Q702	11L	D406	3P
IC708	8N	Q703	12M	D407	4N
IC709	8O	Q704	7P	D409	4N
IC710	11M	Q705	8P	D412	5N
IC711	11L	Q706	8R	D501	13O
IC712	9L	Q707	8R	D502	13O
IC713	11K	Q708	10L	D503	9O
IC714	11L	Q710	5Q	D702	11L
Q6	9I	D5	9J	D703	11L
Q7	9K	D6	9J	D704	7O
Q9	10I	D7	11I	D705	8O
Q10	10J	D8	11J	D706	9L
Q11	10K	D11	11H	D707	9M

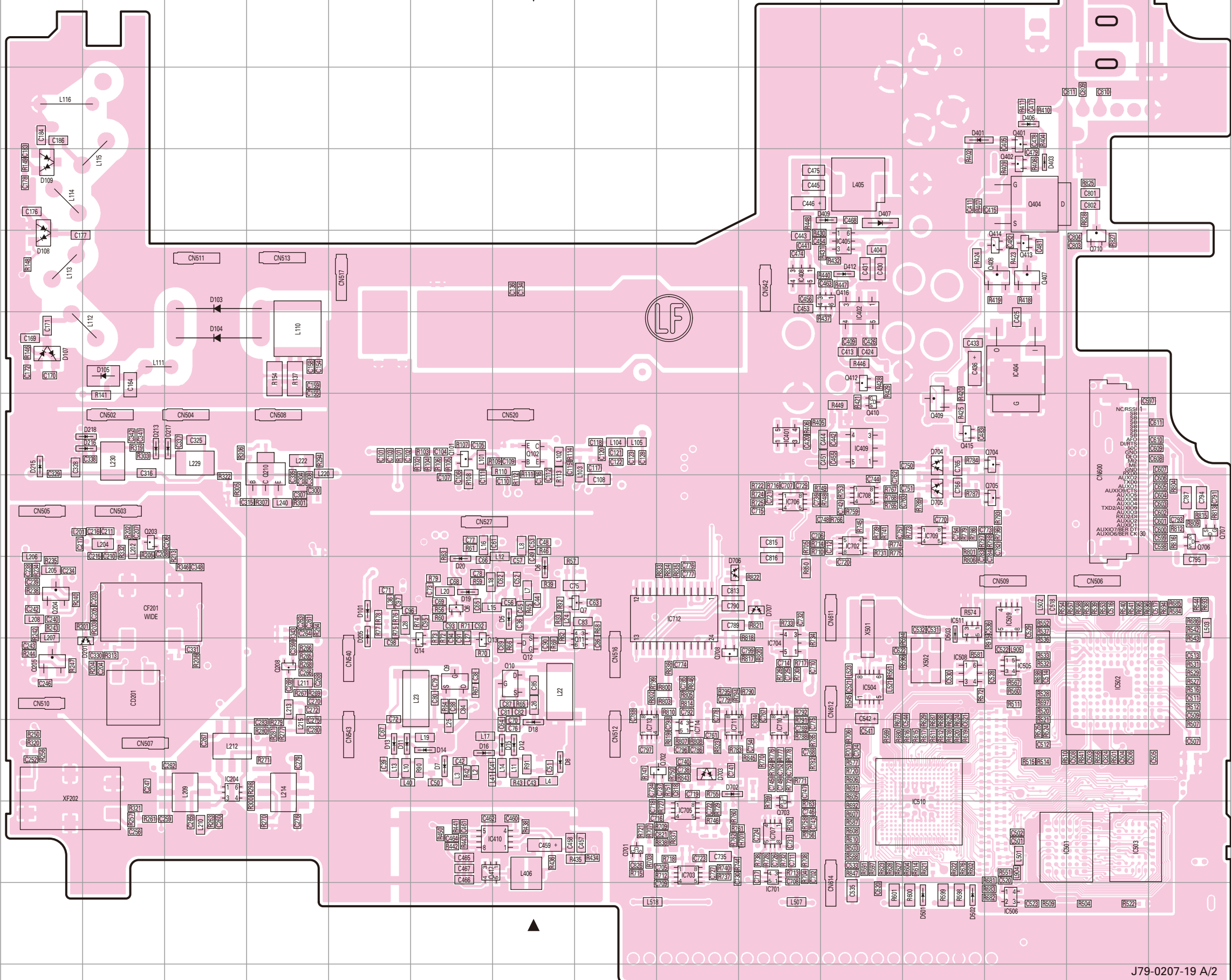
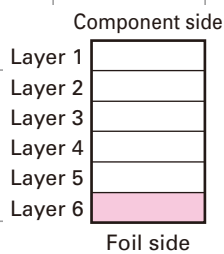

NX-700 PC BOARD / PC板

TX-RX UNIT (X57-7742-71) (B/2) Component side view (J79-0207-19 B/2)

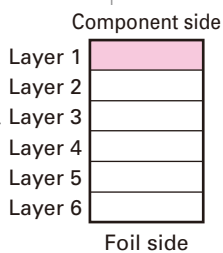
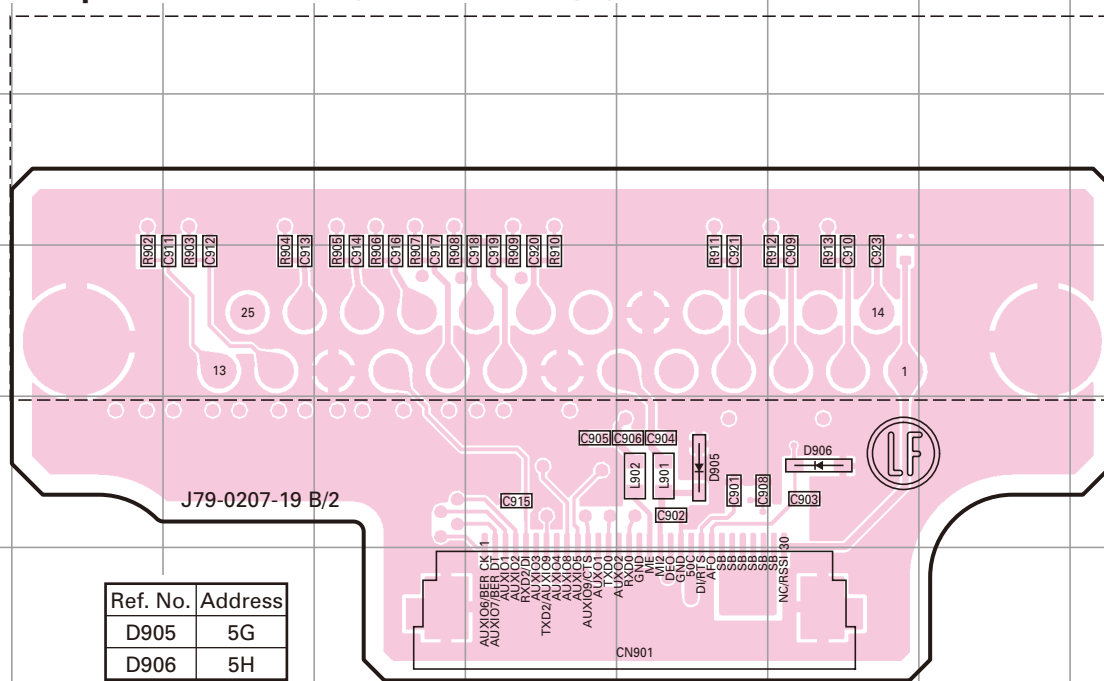

Ref. No.	Address
D905	5G
D906	5H

TX-RX UNIT (X57-7742-71) (B/2) Foil side view (J79-0207-19 B/2)

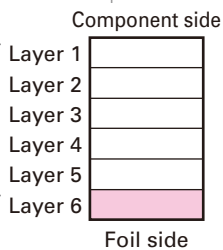
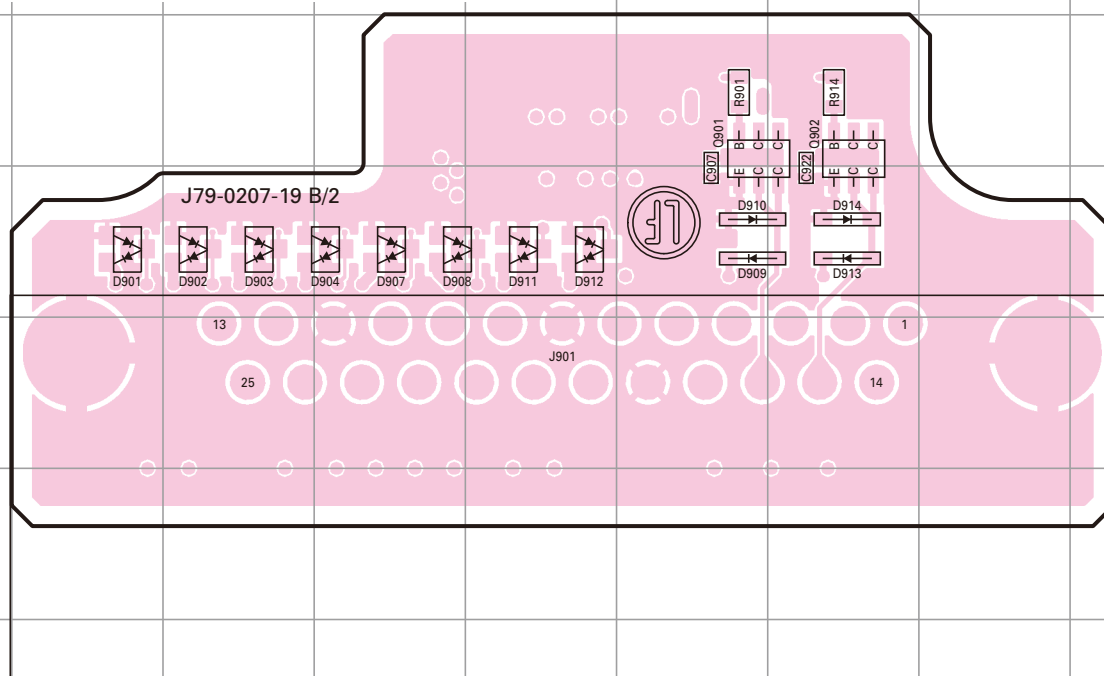

Ref. No.	Address	Ref. No.	Address	Ref. No.	Address
Q901	8G	D904	9E	D911	9F
Q902	8H	D907	9E	D912	9F
D901	9C	D908	9E	D913	9H
D902	9D	D909	9G	D914	9H
D903	9D	D910	9G		



TX-RX UNIT (X57-774)

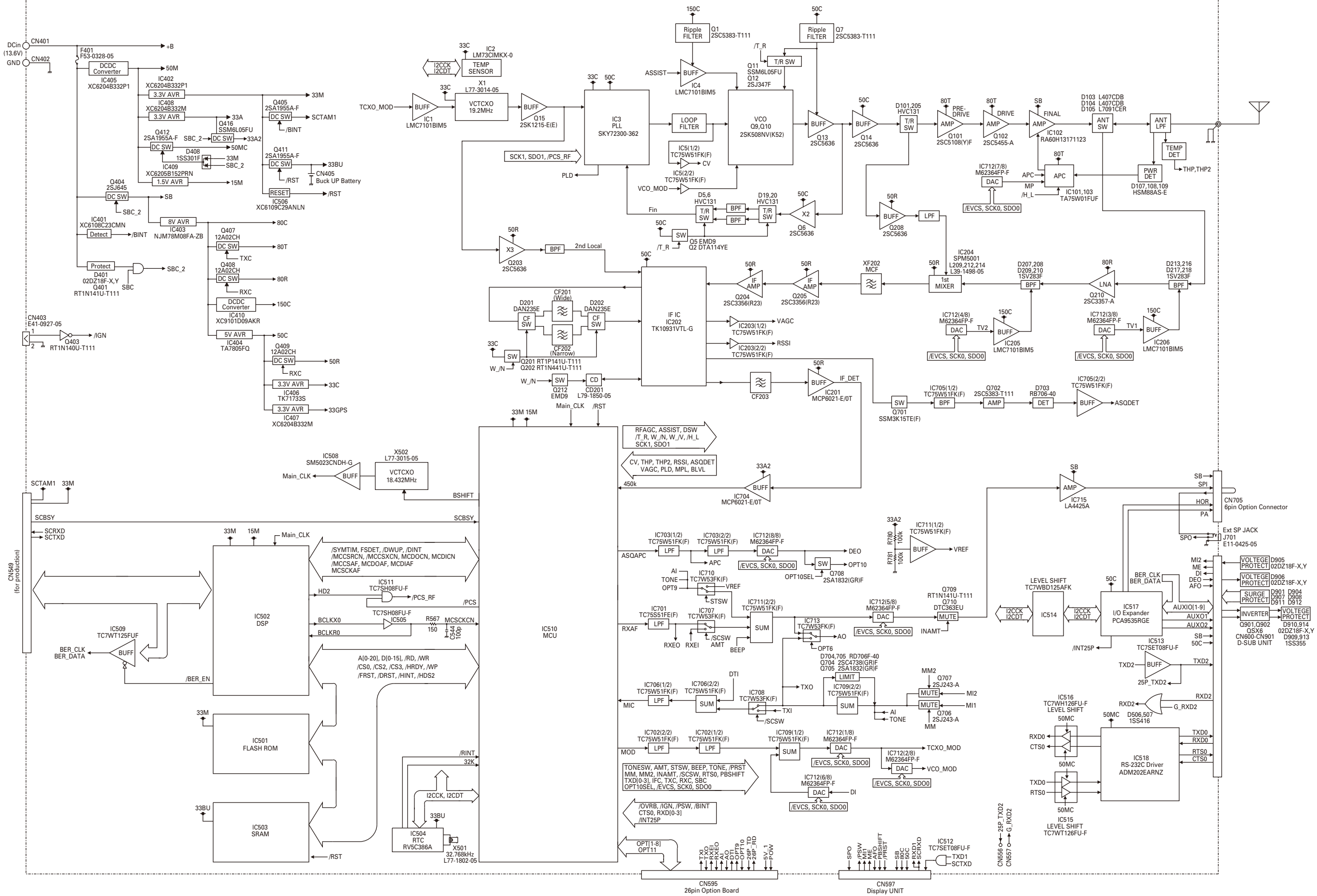

Receiver Section / 接收部分

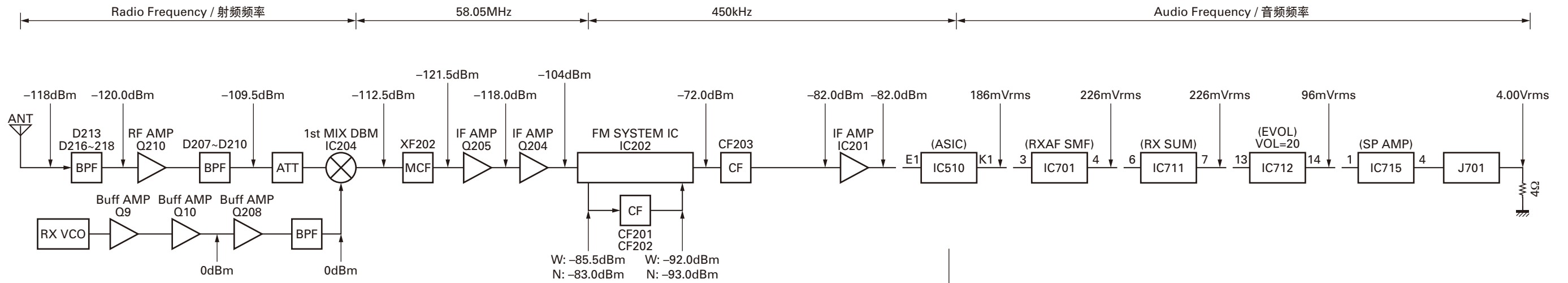

SSG input level for 12dB SINAD are obtained Measured by connecting SSG to each point via a 0.01 μ F capacitor.

获得12dB SINAD的SSG输入电平。
将SSG连接到通过0.01 μ F电容器的每个点后测得。

AF VTVM

AF level obtained when the AF output level is adjusted for 4.00V/4 Ω with the front panel AF VOL control. Measured with AF voltmeter connected to the external speaker jack, receiving a -53dBm SSG signal modulated at 1kHz, DEV (Wide 3kHz, Narrow 1.5kHz).

用前面板AF VOL控制器将AF输出电平调整为4.00V/4 Ω 时获得的AF电平。
将AF电压表连接到外部扬声器插孔, 正在接收调制为1kHz,DEV(宽3kHz, 窄1.5kHz)的-53dBm SSG信号时测得。

Transmitter Section / 发射部分

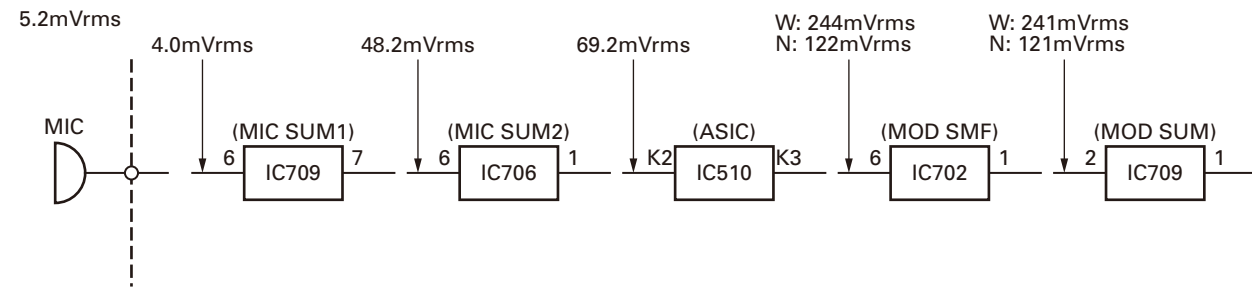

MIC input : 3kHz DEV. (Wide), 1.5kHz DEV. (Narrow) at 1kHz MOD.
Transmitting frequency : Center frequency

麦克风输入: 3kHz DEV. (宽), 1.5kHz DEV. (窄) (1kHz MOD时)
发射频率: 中心频率

W: Wide / 宽
N: Narrow / 窄

