

# NX-720

## SERVICE MANUAL / 维修手册

### C version / C 版本

# KENWOOD

JVCKENWOOD Corporation

© 2012-11 PRINTED IN CHINA  
B53-7045-00 (Y)

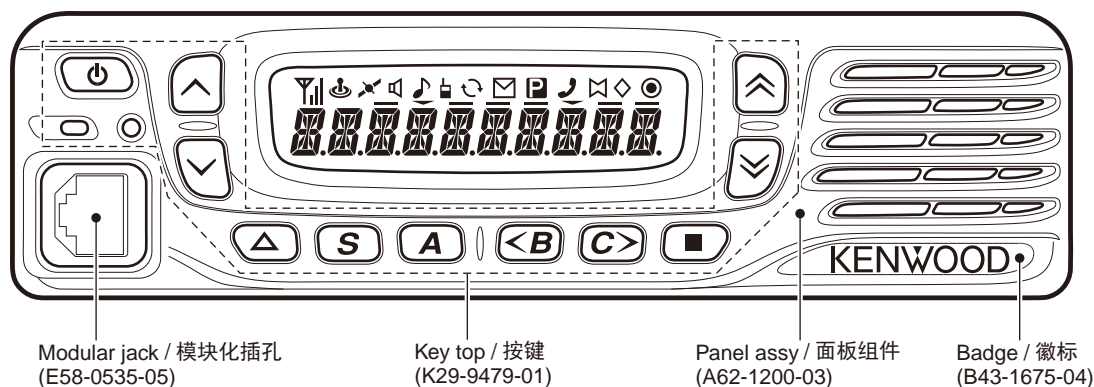

## 无铅焊接通信产品

### 保护环境建伍领先

⚠ 注意：本产品是无铅化焊接产品  
在维修时请使用无铅焊锡  
和相应的焊接工具  
详细事项请访问如下网址了解：  
<http://www.kenwoodhk.com.hk/>



<b>GENERAL</b> .....	<b>3</b>	概 述 .....	3
<b>SYSTEM SET-UP</b> .....	<b>5</b>	系统体系 .....	5
<b>REALIGNMENT</b> .....	<b>6</b>	模式组合 .....	6
<b>INSTALLATION</b> .....	<b>11</b>	安 装 .....	11
<b>DISASSEMBLY FOR REPAIR</b> .....	<b>15</b>	维修拆卸 .....	15
<b>CIRCUIT DESCRIPTION</b> .....	<b>19</b>	电路说明 .....	19
<b>COMPONENTS DESCRIPTION</b> .....	<b>28</b>	元件说明 .....	28
<b>PARTS LIST</b> .....	<b>32</b>	零 件 表 .....	32
<b>EXPLODED VIEW</b> .....	<b>43</b>	部件分解图 .....	43
<b>TROUBLE SHOOTING</b> .....	<b>44</b>	故障排除 .....	45
<b>ADJUSTMENT</b> .....	<b>50</b>	调 整 .....	51
<b>TERMINAL FUNCTION</b> .....	<b>90</b>	端子功能 .....	90
<b>PC BOARD</b>		印刷电路板	
<b>DISPLAY UNIT (X54-3830-10)</b> .....	<b>98</b>	显示单元 (X54-3830-10) .....	98
<b>TX-RX UNIT (X57-8230-11)</b> .....	<b>100</b>	收发单元 (X57-8230-11) .....	100
<b>INTERCONNECTION DIAGRAM</b> .....	<b>104</b>	互 连 图 .....	104
<b>SCHEMATIC DIAGRAM</b> .....	<b>105</b>	原 理 图 .....	105
<b>BLOCK DIAGRAM</b> .....	<b>116</b>	方 块 图 .....	116
<b>LEVEL DIAGRAM</b> .....	<b>119</b>	电 平 图 .....	119
<b>SPECIFICATIONS</b> .....	<b>120</b>	规 格 .....	121

### Document Copyrights

Copyright 2012 by JVC KENWOOD Corporation. All rights reserved.

No part of this manual may be reproduced, translated, distributed, or transmitted in any form or by any means, electronic, mechanical, photocopying, recording, or otherwise, for any purpose without the prior written permission of JVC KENWOOD Corporation.

### Disclaimer

While every precaution has been taken in the preparation of this manual, JVC KENWOOD Corporation assumes no responsibility for errors or omissions. Neither is any liability assumed for damages resulting from the use of the information contained herein. JVC KENWOOD Corporation reserves the right to make changes to any products herein at any time for improvement purposes.

### 文档版权信息

JVC 建伍株式会社拥有版权 2012。保留所有权利。

未经 JVC 建伍株式会社预先书面同意, 无论出于何种目的, 均不得以任何形式或任何方式包括电子、机械、影印、录音或其他方式复制、翻译、分发或传播本手册的任何部分。

### 免责声明

JVC 建伍株式会社在准备本文档时已采取所有必要的预防措施, 恕不对错误或疏漏承担任何责任, 也不对因使用本文中所含的信息而导致的损害负责。JVC 建伍株式会社保留出于改进的需要而随时对文中的产品信息做出更改的权利。

# GENERAL / 概述

## INTRODUCTION

### SCOPE OF THIS MANUAL

This manual is intended for use by experienced technicians familiar with similar types of commercial grade communications equipment. It contains all required service information for the equipment and is current as of the publication date. Changes which may occur after publication are covered by either Service Bulletins or Manual Revisions. These are issued as required.

## ORDERING REPLACEMENT PARTS

When ordering replacement parts or equipment information, the full part identification number should be included. This applies to all parts : components, kits, or chassis. If the part number is not known, include the chassis or kit number of which it is a part, and a sufficient description of the required component for proper identification.

## PERSONAL SAFETY

The following precautions are recommended for personal safety:

- DO NOT transmit if someone is within two feet (0.6 meter) of the antenna.
- DO NOT transmit until all RF connectors are secure and any open connectors are properly terminated.
- SHUT OFF this equipment when near electrical blasting caps or while in an explosive atmosphere.
- All equipment should be properly grounded before powerup for safe operation.
- This equipment should be serviced by only qualified technicians.

## PRE-INSTALLATION CONSIDERATIONS

### 1. UNPACKING

Unpack the radio from its shipping container and check for accessory items. If any item is missing, please contact KENWOOD immediately.

### 2. PRE-INSTALLATION CHECKOUT

#### 2-1. Introduction

Each radio is adjusted and tested before shipment. However, it is recommended that receiver and transmitter operation be checked for proper operation before installation.

#### 2-2. Testing

The radio should be tested complete with all cabling and accessories as they will be connected in the final installation. Transmitter frequency, deviation, and power output should be checked, as should receiver sensitivity, squelch operation, and audio output. Signalling equipment operation should be verified.

## 引言

### 本手册的范围

本手册是提供给熟悉通信专业并且具有维修经验的技术人员使用的。它包括了维修该设备所需要的全部资料和现行出版日期。在出版后可能发生变动，如果需要，可以参照《维修通报》或《手册修订本》进行补充。

## 替换零件的订购

当订购替换零件或设备资料时，应注意完整的零件识别号码。所有的零件均有识别号码：元件，组件或机壳。如果不知道零件的号码，为了正确地识别，必须注明此元件所属的机壳或组件的号码，并对元件进行充分的说明。

## 个人安全

为了个人的安全，请注意下列事项：

- 如果有人在天线两英尺（0.6米）范围之内时，不要进行发射。
- 在没有认真核实所有射频插头之前或有任何一个脱开的插头没有连接到相应端口上的情况下均不要发射。
- 在电爆管附近或在易燃性气体环境中，必须关闭电源，不要操作本设备。
- 为了操作的安全，在接通电源之前所有设备应该连接地线。
- 本设备只应该由有资格的技术人员进行维修。

## 安装前条件

### 1. 开箱

从运输包装中取出本无线电设备并检查附件。如果有任何组件遗失，请立即与 KENWOOD 联系。

### 2. 安装前检查

#### 2-1. 说明

在运输之前每一台无线电设备均已调整和测试过。但是，在安装之前最好检查接收和发射以便操作正确。

#### 2-2. 测试

无线电设备应该按照电缆和附件最终安装时的连接进行完整的测试。应该检查发射频率，频偏和输出功率，同样应该检查接收灵敏度，静噪和音频输出。应该检验信令操作。

### 3. PLANNING THE INSTALLATION

#### 3-1. General

Inspect the vehicle and determine how and where the radio antenna and accessories will be mounted.

Plan cable runs for protection against pinching or crushing wiring, and radio installation to prevent overheating.

#### 3-2. Antenna

The favored location for an antenna is in the center of a large, flat conductive area, usually at the roof center. The trunk lid is preferred, bond the trunk lid and vehicle chassis using ground straps to ensure the lid is at chassis ground.

#### 3-3. Radio

The universal mount bracket allows the radio to be mounted in a variety of ways. Be sure the mounting surface is adequate to support the radio's weight. Allow sufficient space around the radio for air cooling. Position the radio close enough to the vehicle operator to permit easy access to the controls when driving.

#### 3-4. DC Power and wiring

1. This radio may be installed in negative ground electrical systems only. Reverse polarity will cause the cable fuse to blow. Check the vehicle ground polarity before installation to prevent wasted time and effort.
2. Connect the positive power lead directly to the vehicle battery positive terminal. Connecting the Positive lead to any other positive voltage source in the vehicle is not recommended.
3. Connect the ground lead directly to the battery negative terminal.
4. The cable provided with the radio is sufficient to handle the maximum radio current demand. If the cable must be extended, be sure the additional wire is sufficient for the current to be carried and length of the added lead.

### 4. INSTALLATION PLANNING – CONTROL STATIONS

#### 4-1. Antenna system

The antenna system selection depends on many factors and is beyond the scope of this manual. Your KENWOOD dealer can help you select an antenna system that will best serve your particular needs.

#### 4-2. Radio location

Select a convenient location for your control station radio which is as close as practical to the antenna cable entry point. Secondly, use your system's power supply (which supplies the voltage and current required for your system). Make sure sufficient air can flow around the radio and power supply to allow adequate cooling.

## SERVICE

This radio is designed for easy servicing. Refer to the schematic diagrams, printed circuit board views, and alignment procedures contained in this manual.

### 3. 安装步骤

#### 3-1. 概述

检查车辆并确认如何以及在何处安装无线电天线和附件。

安排好电缆的位置，避免挤压或碾碎布线，同时无线电设备避免过热。

#### 3-2. 天线

天线的最佳位置应该在一个宽阔，平整导电区域的中心，通常在车顶的中心。行李箱的盖子更好，将地线黏结在行李箱的盖子和车辆的外壳上确保行李箱盖子接地。

#### 3-3. 无线电设备

通用安装托架允许以多种方法安装无线电设备。确认安装的表面足以支撑无线电设备的重量。无线电设备的周围留出适当的空间进行散热。将无线电设备尽可能的安装在靠近车辆操作者的位置上，以便在驾驶时易于控制。

#### 3-4. 直流电源和布线

1. 本无线电设备只能被安装在负极接地电子系统中。反向极性将导致电缆保险丝熔断。在安装之前检查车辆的接地极性，避免工作效率低以及浪费时间。
2. 将电源的正极引线直接连接到车载电池的正极端点上。不要将正极引线与其他正极电压连接。
3. 将接地引线直接与电池的负极连接。
4. 与无线电设备一起提供的电缆适用于所需的最大无线电流。如果电缆必须加长，要确认附加的电线适用于所载的电流和添加引线的长度。

### 4. 安装步骤 - 基站

#### 4-1. 天线系统

天线系统的选择取决于许多因素和本手册的范围。用户的KENWOOD销售商可以帮助用户选择最能满足用户特殊要求的天线系统。

#### 4-2. 无线电位置

为用户的基站无线电设备选择一个方便的位置，此位置应尽量靠近天线电缆输入点。其次，使用用户系统的电源（为用户的系统提供所需的电压和电流）。确认无线电设备周围的空气流通顺畅并且足以使电源冷却。

## 维修服务

为了便于维修本设备，建立了完整的维修服务体系，提供了包括原理图，印刷电路板图和调整步骤在内的资料供参考。

## GENERAL / 概述

### NOTE

If you do not intend to use the speaker 3.5-mm jack and the D-sub 15-pin connector, fit the supplied speaker-jack cap and ACC cap to stop dust and sand from getting in.

### 注意

如果不打算使用 3.5mm 扬声器插孔和 15 针 D-sub 连接器，请装上附带的扬声器插孔盖和 ACC 盖，防止灰尘和沙粒进入。

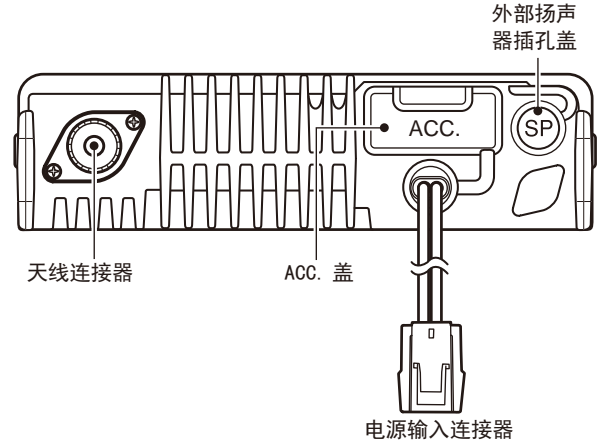
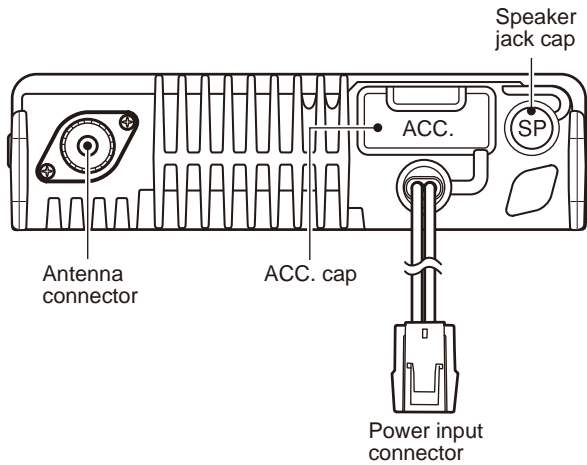

## SYSTEM SET-UP / 系统体系

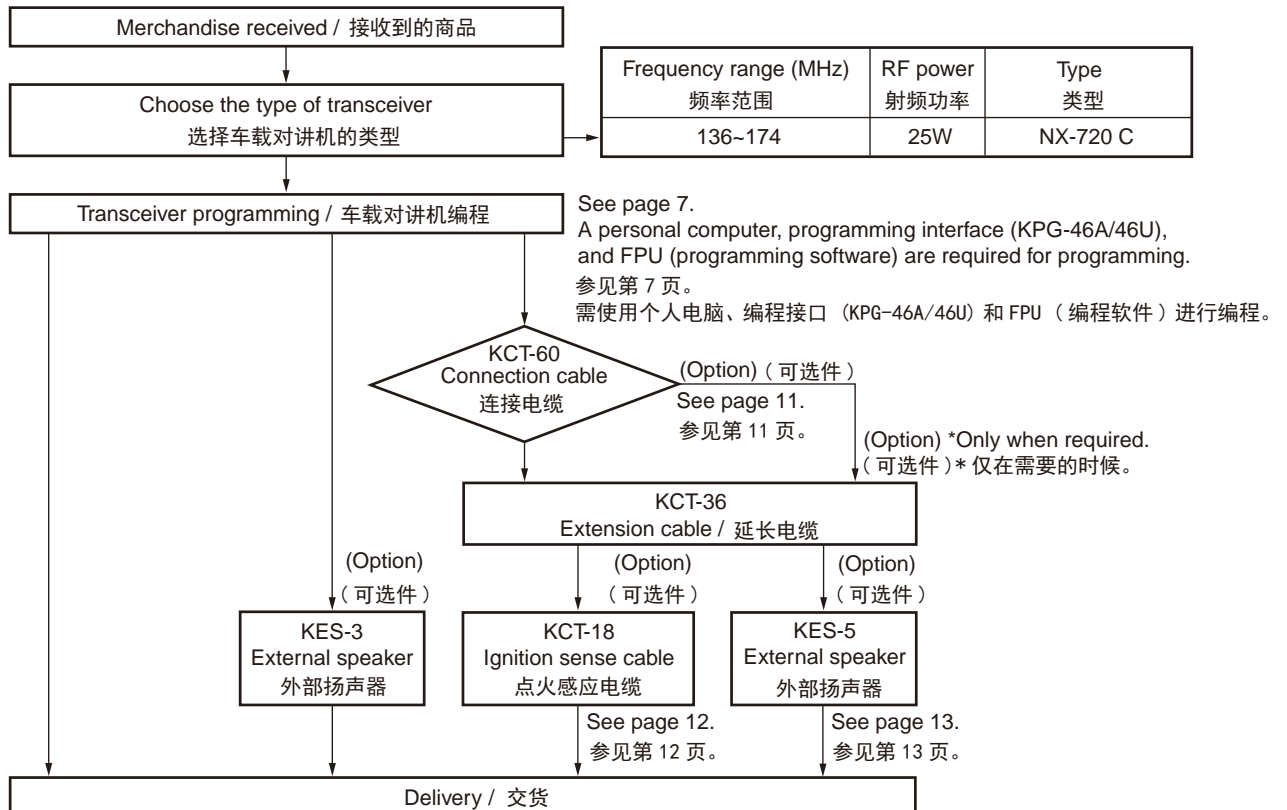

## REALIGNMENT / 模式组合

### 1. Modes

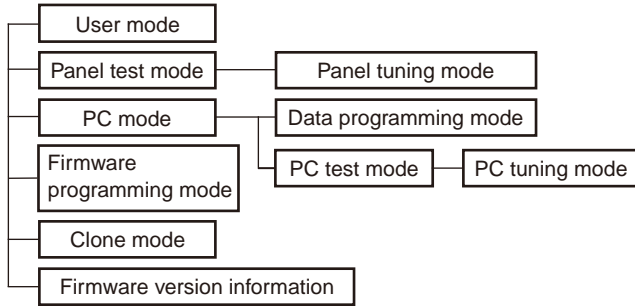

Mode	Function
User mode	For normal use.
Panel test mode	Use by the dealer to check the fundamental characteristics.
Panel tuning mode	Used by the dealer to tune the transceiver.
PC mode	Used for communication between the transceiver and PC.
Data programming mode	Used to read and write frequency data and other features to and from the transceiver.
PC test mode	Used to check the transceiver using the PC. This feature is included in the FPU.
PC tuning mode	Used to tune the transceiver using the PC.
Firmware programming mode	Used when changing the main program of the flash memory.
Clone mode	Used to transfer programming data from one transceiver to another.
Firmware version information	Used to confirm the internal firmware version.

### 2. How to Enter Each Mode

Mode	Operation
User mode	Power ON
Panel test mode	[A] + Power ON
Panel tuning mode	Panel test mode + [s]
PC mode	Received commands from PC
Firmware programming mode	[Δ] + Power ON
Clone mode	[<B] + Power ON (One second)
Firmware version information	[s] + Power ON

### 3. Panel Test Mode

Setting method refer to ADJUSTMENT.

### 4. Panel Tuning Mode

Setting method refer to ADJUSTMENT.

### 1. 模式

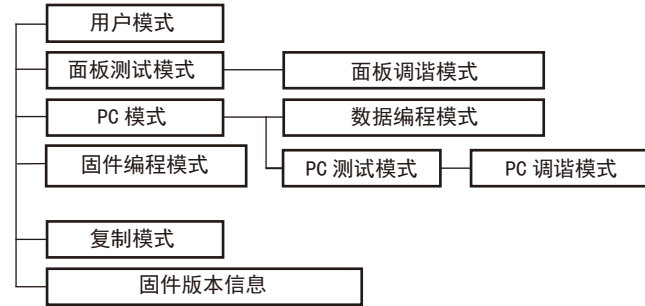

模式	功能
用户模式	一般使用。
面板测试模式	用于经销商检查基本功能。
面板调谐模式	用于经销商调整车载对讲机指标。
PC 模式	用于车载对讲机与 PC 之间的通信。
数据编程模式	用于阅读和写入频率数据以及其他功能。
PC 测试模式	用于通过 PC 检查车载对讲机。该功能内置于 FPU 中。
PC 调谐模式	用于通过 PC 调谐车载对讲机。
固件编程模式	当改变闪存中操作主程序时使用。
复制模式	用于将一台车载对讲机的编程数据传送到另一台。
固件版本信息	用于确认内部固件版本。

### 2. 如何进入每一种模式

模式	操作
用户模式	接通电源
面板测试模式	[A] + 接通电源
面板调谐模式	面板测试模式 + [S]
PC 模式	从 PC 接收指令
固件编程模式	[Δ] + 接通电源
复制模式	[<B] + 接通电源 (1 秒钟)
固件版本信息	[S] + 接通电源

### 3. 关于面板测试模式

关于设定方式，参见调整。

### 4. 关于面板调谐模式

关于设定方式，参见调整。

# REALIGNMENT / 模式组合

## 5. PC Mode

### 5-1. Preface

The transceiver is programmed using a personal computer, a programming interface (KPG-46A/46U) and FPU (programming software).

The programming software can be used with a PC. Figure 1 shows the setup of a PC for programming.

### 5-2. Connection procedure

1. Connect the transceiver to the computer using the interface cable.

#### Note:

- You must install the KPG-46U driver in the computer to use the USB programming interface cable (KPG-46U).

2. When the Power is switched on, user mode can be entered immediately. When the PC sends a command, the transceiver enters PC mode, and "PROGRAM" is displayed on the LCD.

When data is transmitting from the transceiver, the red LED blinks.

When data is receiving by the transceiver, the green LED blinks.

#### Note:

The data stored in the computer must match the "Model Name" when it is written into the flash memory.

### 5-3. KPG-46A description

#### (PC programming interface cable: Option)

The KPG-46A is required to interface the transceiver to the computer. It has a circuit in its D-sub connector case that converts the RS-232C logic level to the TTL level.

The KPG-46A connects the 8-pin microphone connector of the transceiver to the RS-232C serial port of the computer.

### 5-4. KPG-46U description

#### (USB programming interface cable: Option)

The KPG-46U is a cable which connects to a USB port on a computer.

When using the KPG-46U, install the supplied CD-ROM (with driver software) in the computer. The KPG-46U driver runs under Windows XP, Vista or 7.

The latest version of the USB driver is available for download from the following URL:

<http://www.kenwood.com/usb-com/>

(This URL may change without notice.)

### 5-5. Programming Software : KPG-141D(C)

#### (ver.3.00 or later) description

The FPU is the programming software for the transceiver supplied on a CD-ROM. This software runs under Windows XP, Vista or 7 on a PC.

The data can be input to or read from the transceiver and edited on the screen. The programmed or edited data can be printed out. It is also possible to tune the transceiver.

## 5. PC 模式

### 5-1. 前言

车载对讲机采用个人电脑、编程接口 (KPG-46A/46U) 和 FPU (编程软件) 进行编程。

编程软件可在 PC 上使用。图 1 说明了 PC 进行编程的设置。

### 5-2. 连接操作

1. 用接口电缆将车载对讲机连接到电脑。

#### 注意：

- 必须在电脑上安装 KPG-46U 驱动程序才能使用 USB 编程接口电缆 (KPG-46U)。

2. 电源打开时，可以立即进入用户模式。PC 发出命令时，车载对讲机进入 PC 模式，LCD 上显示 "PROGRAM"。车载对讲机发送数据时，红色 LED 闪烁。车载对讲机接收数据时，绿色 LED 闪烁。

#### 注意：

电脑保存的数据写入闪存时，必须与 "型号名称" 相符。

### 5-3. KPG-46A 说明 (PC 编程接口电缆：选购件)

将车载对讲机连接到电脑需要 KPG-46A。该电缆的 D-sub 连接器盒具有将 RS-232C 逻辑电平转换为 TTL 电平的电路。

KPG-46A 将车载对讲机的 8 针麦克风连接器连接到电脑的 RS-232C 串行端口。

### 5-4. KPG-46U 说明 (USB 编程接口电缆：选购件)

KPG-46U 是连接到电脑 USB 端口的电缆。

使用 KPG-46U 时，请在电脑上安装附带的 CD-ROM (带有驱动程序)。KPG-46U 驱动程序可以在 Windows XP、Vista 或 7 下运行。

最新版的 USB 驱动程序可以从下列的 URL 下载。

<http://www.kenwood.com/usb-com/>

(URL 会有没有预告发生变更的情况。)

### 5-5. 编程软件：KPG-141D(C) (ver. 3.00 或更高版本)

#### 说明

FPU 是 CD-ROM 附带的用于车载对讲机的编程软件。该软件在 PC 的 Windows XP、Vista 或 7 下运行。

可在车载对讲机上写入或读取数据，并可在电脑屏幕上进行编辑。可以打印编程或编辑的数据。此外，还可调谐车载对讲机。

## REALIGNMENT / 模式组合

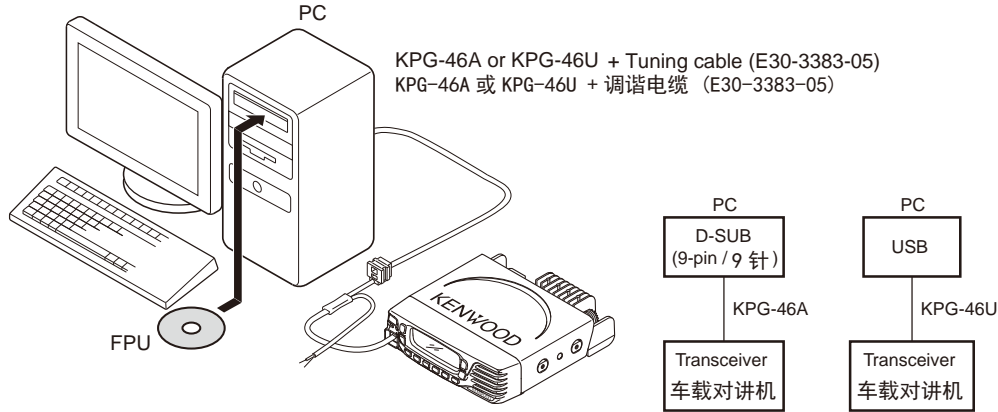

Fig. 1 / 图 1

### 6. Firmware Programming Mode

#### 6-1. Preface

Flash memory is mounted on the transceiver. This allows the transceiver to be upgraded when new features are released in the future. (For details on how to obtain the firmware, contact Customer Service.)

#### 6-2. Connection procedure

Connect the transceiver to the personal computer using the interface cable (KPG-46A/46U). (Connection is the same as in the PC Mode.)

#### 6-3. Programming

1. Start up the firmware programming software (Fpro.exe (ver. 6.1 or later)). The Fpro.exe exists in the KPG-141D(C) installed folder.
2. Set the communications speed (normally, 115200 bps) and communications port in the configuration item.
3. Set the firmware to be updated by File name item.
4. Press and hold the [Δ] key while turning the transceiver power ON. Then, the orange LED on the transceiver lights and "FIRM PRG" is displayed.
5. Check the connection between the transceiver and the personal computer, and make sure that the transceiver is in the Program mode.
6. Press "write" button in the window. When the transceiver starts to receive data, the "LOADING" display lights.
7. If writing ends successfully, the checksum is calculated and a result is displayed.
8. If you want to continue programming other transceivers, repeat steps 4 to 7.

#### 6-4. Function

If you press the [Δ] key while "FIRM PRG" is displayed, the checksum is calculated, and a result is displayed. If you press the [Δ] key again while the checksum is displayed, "FIRM PRG" is redisplayed.

##### Note:

- This mode cannot be entered if the Firmware Programming mode is set to Disable in the Programming software.
- Normally, write in the high-speed mode.

### 6. 固件编程模式

#### 6-1. 前言

闪存安装在车载对讲机上。将来发布新功能时，可以使车载对讲机进行升级。（有关如何获得固件的详情，请咨询客户服务机构。）

#### 6-2. 连接操作

用接口电缆（KPG-46A/46U）将车载对讲机连接到个人电脑。（连接方式与 PC 模式下相同。）

#### 6-3. 编程

1. 启动固件编程软件（Fpro.exe（ver. 6.1 或更高版本））。Fpro.exe 存在于 KPG-141D(C) 安装文件夹内。
2. 在配置项中设置通信速度（通常为 115200 bps）和通信端口。
3. 通过文件名项目设置要更新的固件。
4. 打开车载对讲机电源时，按住 [Δ] 键。然后，车载对讲机上的橙色 LED 点亮，并显示 "FIRM PRG"。
5. 检查车载对讲机与个人电脑之间的连接，确认车载对讲机处于编程模式。
6. 按窗口中的 "write" 按钮。车载对讲机开始接收数据时，显示 "LOADING"。
7. 如果写入操作成功完成，则计算校验和并显示结果。
8. 若要继续为其他车载对讲机编程，请重复步骤 4 至 7。

#### 6-4. 功能

如果在显示 "FIRM PRG" 时按 [Δ] 键，则计算校验和并显示结果。如果在显示校验和时再次按 [Δ] 键，则重新显示 "FIRM PRG"。

##### 注意：

- 如果车载对讲机的固件编程模式设为禁用，则无法进入此模式。
- 通常以高速模式写入。



## REALIGNMENT / 模式组合

### 7. Clone Mode

Programming data can be transferred from one transceiver to another by connecting them via their modular microphone jacks. The operation is as follows (the transmit transceiver is the source and the receive transceiver is a target). Clone mode should be enabled.

The following data cannot be cloned.

- Tuning data
- Embedded message with password
- Model name data
- ESN (Electronic Serial Number) data

#### Note:

The following data can be cloned.

- Fleet (own)/ID (own) for FleetSync
- Unit ID (own) for NXDN
- ID (own) for MDC-1200

1. Turn the source transceiver power ON with the [**B**] key held down (1 second), "CLONE MODE" is displayed on the LCD.
2. Power on the target transceiver.
3. Connect the cloning cable (No. E30-3382-05) to the modular microphone jacks on the source and target.
4. Press the [**s**] key on the source transceiver.  
The data of the source is sent to the target. While the source is sending data, red LED blinked. While the target is receiving the data, "PROGRAM" is displayed and green LED blinked. When cloning of data is completed, the source displays "END", and the source red LED turned off, and the target automatically operates in the User mode. The target can then be operated by the same program as the source.
5. The other target can be continuously cloned. Carry out the operation in step 2 to 4.

### 7. 复制模式

通过模块化麦克风插孔连接车载对讲机，可以将编程数据从一台传输到另一台。具体操作如下（发射车载对讲机是主机，接收车载对讲机是子机）。应当启用复制模式。

不能复制以下数据。

- 调谐数据
- 带密码的嵌入信息
- 机型数据
- ESN(电子序列号)数据

注意：

可以复制以下数据。

- FleetSync 的 Fleet(自身)/ID(自身)
- NXDN 的 Unit ID(自身)
- MDC-1200 的 ID(自身)

1. 按住 [**B**] 键 (1 秒) 打开主机的电源, LCD 上显示 "CLONE MODE"。
2. 打开子机的电源。
3. 将复制电缆 (编号 :E30-3382-05) 连接到主机和子机上的模块化麦克风插孔。
4. 按主机上的 [**s**] 键。  
主机的数据便被发送到子机。主机发送数据时, 红色 LED 将会闪烁。子机接收数据时, 将显示 "PROGRAM" 且绿色 LED 闪烁。数据复制完成后, 主机显示 "END", 主机的红色 LED 熄灭, 子机自动以用户模式运行。然后子机就可以按与主机相同的程序操作。
5. 可以继续对另一台子机进行复制。执行步骤 2 至 4 的操作。

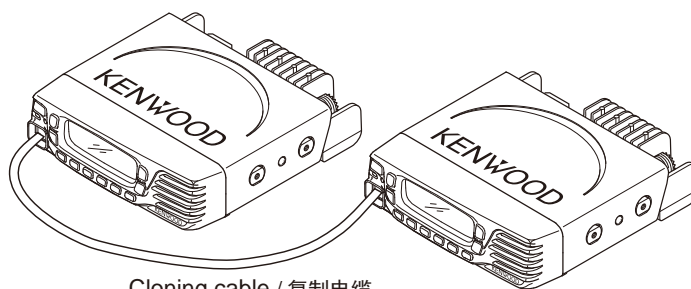

Cloning cable / 复制电缆  
(E30-3382-05)

Fig. 2 / 图 2

#### 7-1. How to enter the data password

If the read authorization password is set in the optional feature menu, you must enter the password (Source transceiver) to activate a clone mode.

You can use 0~9 to configure the password. The maximum length of the password is 6 digits.

#### 7-1. 如何输入数据密码

如果在可选功能菜单中设置了读取授权密码, 则您必须输入密码 (主机) 方可激活复制模式。

可使用 0~9 设置密码。密码最大长度为 6 位。

## REALIGNMENT / 模式组合

1. [**B**]+Power ON.
2. "CLONE LOCK" is displayed on the LCD.
3. If the [↵] and [≡] keys is pressed while "CLONE LOCK" is displayed, numbers (0 to 9) are displayed flashing. When you press the [s] key, the currently selected number is determined. If you press the [s] key after entering the password in this procedure, "CLONE MODE" is displayed if the entered password is correct. If the password is incorrect, "CLONE LOCK" is redisplayed.

1. [**B**] + 接通电源。
2. LCD 上显示 "CLONE LOCK"。
3. 如果在显示 "CLONE LOCK" 时按 [↵] 和 [≡] 键，数字 (0 到 9) 闪烁显示。按 [s] 键即可确定当前选择的数字。在此步骤中输入密码后按 [s] 键，如果输入的密码正确，则显示 "CLONE MODE"。如果密码不正确，则重新显示 "CLONE LOCK"。

### 7-2. Flow chart (Source transceiver)

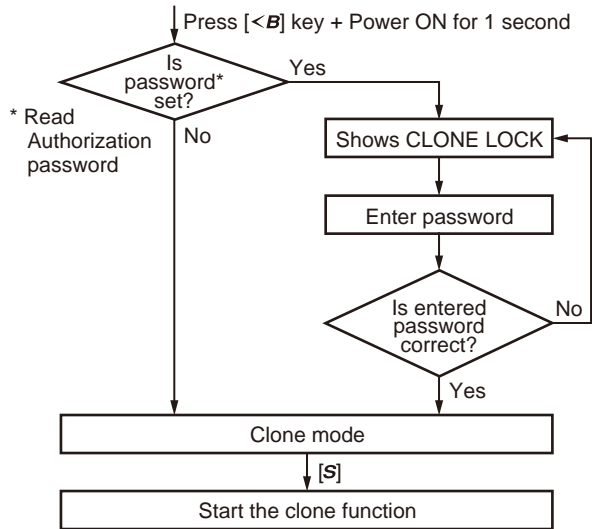

### 7-2. 流程图（主车载对讲机）

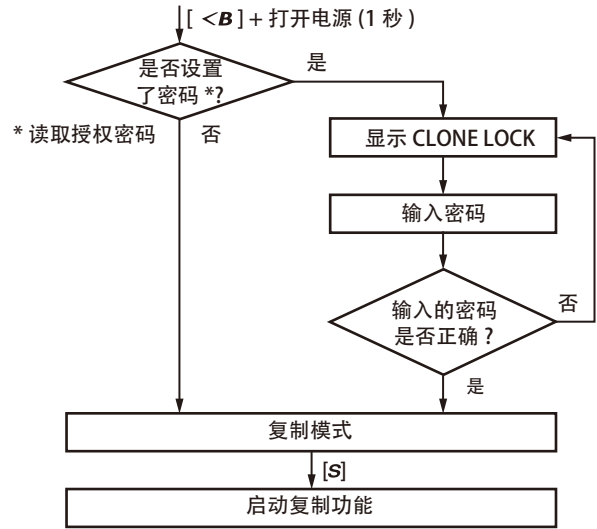

### 8. Firmware Version Information

Press and hold the [s] key while turning the transceiver power ON and then keep pressing and holding the [s] key, the firmware version information appears on the LCD.

### 8. 固件版本信息

打开车载对讲机电源时按住 [s] 键，然后一直按住 [s] 键，LCD 上便出现固件版本信息。

## INSTALLATION / 安装

### 1. Connection Cable (KCT-60: Option)

The KCT-60 connection cable kit is used to connect the transceiver to a Horn alert cable, KCT-18 (Ignition sense cable), KES-5 (External speaker), or through the KCT-36 extension cable.

#### 1-1. Installing the KCT-60 (Connection cable) in the transceiver

1. Remove the ACC. cap on the rear of the transceiver.
2. Connect the D-sub connector of the KCT-60 to the D-sub 15-pin terminal of the transceiver.
3. Connect the 15-pin connector of the KCT-60 to a Horn alert cable, KCT-18, KES-5, or through a KCT-36 extension cable.

**Note:** You must setup using the KPG-141D(C).

### 1. 连接电缆 (KCT-60: 选购件)

KCT-60 连接电缆组件用于将车载对讲机连接到喇叭提示电缆、KCT-18 (点火感应电缆)、KES-5 (外部扬声器), 或通过 KCT-36 延长电缆连接。

#### 1-1. 在车载对讲机上安装 KCT-60 (连接电缆)

1. 拆下车载对讲机后部的 ACC. 盖。
2. 将 KCT-60 的 D-sub 连接器连接到车载对讲机的 D-sub 15 针端子。
3. 将 KCT-60 的 15 针连接器连接到喇叭提示电缆、KCT-18、KES-5, 或通过 KCT-36 延长电缆。

**注意:** 必须使用 KPG-141D(C) 进行设置。

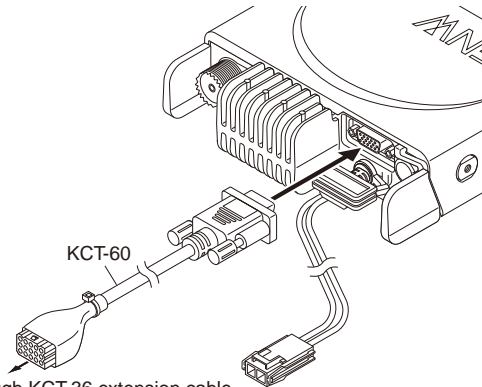

Horn alert cable, KCT-18, KES-5 or through KCT-36 extension cable  
喇叭提示电缆、KCT-18、KES-5 或通过 KCT-36 延长电缆

#### 1-2. Terminal function

D-sub 15-pin Pin No.	Name	Molex 15-pin Pin No.
1	SB	1
2	IGN	2
3	PA or EXT-SP	12
4	DO	4
5	DI	5
6	FNC1	9
7	FNC2	11
8	FNC3	7
9	FNC4	6
10	FNC5	8
11	FNC6	10
12	5C	-
13	HR1	13
14	HR2	14
15	GND	3

#### 1-2. 端子功能

D-sub 15 针脚号	名称	Molex 15 针脚号
1	SB	1
2	IGN	2
3	PA 或 EXT-SP	12
4	DO	4
5	DI	5
6	FNC1	9
7	FNC2	11
8	FNC3	7
9	FNC4	6
10	FNC5	8
11	FNC6	10
12	5C	-
13	HR1	13
14	HR2	14
15	GND	3

### 2. Horn Alert Function

The Horn alert function (max. 2A drive) is enabled by installing the KCT-60 in the transceiver.

#### 2-1. Installation Procedure

1. Remove the ACC. cap on the rear of the transceiver.
2. Connect the D-sub connector of the KCT-60 to the D-sub 15-pin terminal of the transceiver.
3. Insert the two crimp terminals of the Horn alert cable to pins 13 and 14 of the square plug.
4. Connect the square plug to the 15-pin connector of the KCT-60.
5. Connect the remaining two Horn alert cables to your car Horn alert signal control. The internal FET switch can be controlled by turning the HA function on/off and by using a signaling decode output. The maximum current of HA is 2A. This switch is the FET switch of P-channel type. Therefore, a DC power supply is necessary to use the HR1. The voltage range is from 5V to 16V.

**Note:** You must setup using the KPG-141D(C).

### 2. 喇叭提示功能

在车载对讲机上安装 KCT-60，可使用喇叭提示功能（最大 2A 驱动）。

#### 2-1. 安装步骤

1. 拆下车载对讲机后部的 ACC. 盖。
2. 将 KCT-60 的 D-sub 连接器连接到车载对讲机的 D-sub 15 针端子。
3. 将喇叭提示电缆的两个压接式端子插入方形插头的针脚 13 和 14。
4. 将方形插头连接到 KCT-60 的 15 针连接器。
5. 将剩下的两条喇叭提示电缆连接到汽车的喇叭提示信号控制。  
内部 FET 开关可通过打开 / 关闭 HA 功能和使用信令解码输出进行控制。HA 的最大电流为 2A。这个开关是 P 通道类型的 FET 开关。因此，需 DC 电源方可使用 HR1。电压范围为 5V 至 16V。

**注意：**必须使用 KPG-141D(C) 进行设置。

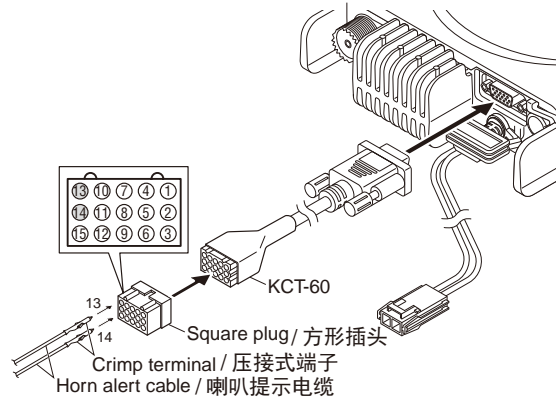
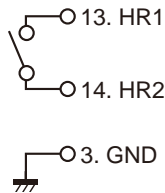

### 3. Ignition Sense Cable (KCT-18: Option)

The KCT-18 is an optional cable for enabling the ignition function. The ignition function lets you turn the transceiver power on and off with the car ignition key.

#### 3-1. Installing the KCT-18 (Ignition sense cable) in the transceiver

### 3. 点火感应电缆 (KCT-18: 选购件)

KCT-18 为用于启用点火功能的选购电缆。点火功能让您能够通过汽车点火钥匙打开和关闭车载对讲机的电源。

#### 3-1. 在车载对讲机上安装 KCT-18 (点火感应电缆)

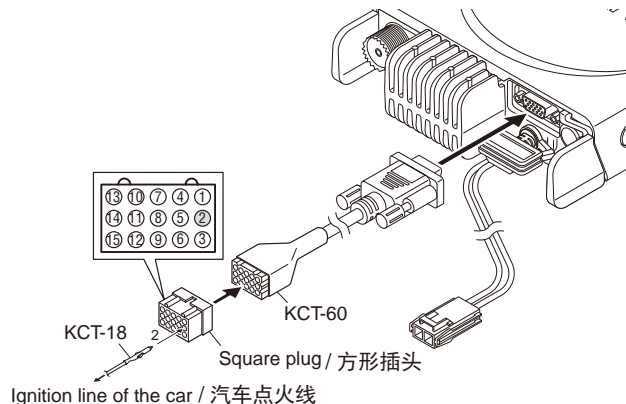

## INSTALLATION / 安装

### 4. External Speaker (Option)

#### 4-1. KES-5

External speaker KES-5 can be installed for KCT-60.

#### ■ Connection procedure

1. Remove the ACC. cap on the rear of the transceiver.
2. Connect the D-sub connector of the KCT-60 to the D-sub 15-pin terminal of the transceiver.
3. Insert the two crimp terminals of the KES-5 to pins 3 and 12 of the square plug.
4. Connect the square plug to the 15-pin connector of the KCT-60.

#### Note:

You must set up using the KPG-141D(C).  
Before the external speaker can be used, you must assign one of the keys as "External Speaker", using the KPG-141D(C).

### 4. 外部扬声器（选配件）

#### 4-1. KES-5

外部扬声器 KES-5 可安装于 KCT-60。

#### ■ 连接步骤

1. 拆下车载对讲机后部的 ACC. 盖。
2. 将 KCT-60 的 D-sub 连接器连接到车载对讲机的 D-sub 15 针端子。
3. 将 KES-5 的两个压接式端子插入方形插头的针脚 3 和 12。
4. 将方形插头连接到 KCT-60 的 15 针连接器。

#### 注意：

必须使用 KPG-141D(C) 进行设置。  
必须使用 KPG-141D(C) 将某个键指定为“外部扬声器”，方可使用外部扬声器。

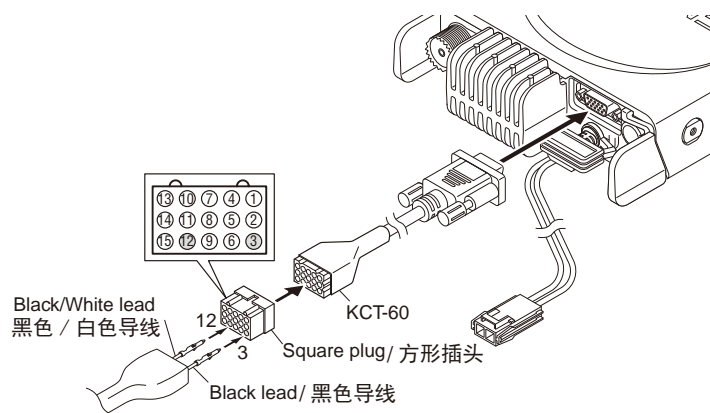

### 5. Changing Serial Port Level

#### 5-1. Change FNC1 (TXD) and FNC2 (RXD) of D-SUB 15-pin connector from TTL level to RS-232C level

FNC1 (TXD /6pin ) and FNC2 (RXD /7pin ) of D-SUB 15-pin connector are configured at the TTL level as the default value. But you can change these serial port level to RS-232C level through the RS-232C level converter IC (IC516) by configuring the port.

Remove the R664, R635 and R662 chip jumpers and solder the chip jumpers to R666, R633 and R665.

#### 5-2. Change FNC1 (TXD), FNC2 (RXD), FNC3 (RTS) and FNC4 (CTS) of D-SUB 15-pin connector from TTL level to RS-232C level

FNC1 (TXD/6pin), FNC2 (RXD/7pin), FNC3 (RTS/8pin) and FNC4 (CTS/9pin) of D-SUB 15-pin connector are configured at the TTL level as the default value. But you can change these serial port level to RS-232C level through the RS-232C level converter IC (IC516) by configuring the port.

Remove the R664, R635, R662, R659, R658 and R632 chip jumpers and solder the chip jumpers to R666, R633, R665, R663, R660 and R630.

### 5. 改变串行接口电平

#### 5-1. 将 FNC1 (TXD) 和 FNC2 (RXD) 的 D-SUB 15 针连接器从 TTL 电平转换到 RS-232C 电平

FNC1 (TXD/6 针) 和 FNC2 (RXD/7 针) 的 D-SUB 15 针连接器被默认设置在 TTL 电平。但可以通过端口设置将这些串行端口电平通过 RS-232C 档位转换器 IC (IC516) 转换至 RS-232C 电平。

从 R664, R635 和 R662 跳线至 R666, R633 和 R665。

#### 5-2. 将 D-SUB 15 针连接器的 FNC1 (TXD), FNC2 (RXD), FNC3 (RTS) 和 FNC4 (CTS) 从 TTL 电平转换到 RS-232C 电平

D-SUB 15 针连接器的 FNC1 (TXD/6 针), FNC2 (RXD/7 针), FNC3 (RTS/8 针) 和 FNC4 (CTS/9 针) 默认设置在 TTL 电平。但可以通过端口设置将这些串行端口电平通过 RS-232C 档位转换器 IC (IC516) 转换至 RS-232C 电平。

从 R664, R635, R662, R659, R658 和 R632 跳线至 R666, R633, R665, R663, R660 和 R630。

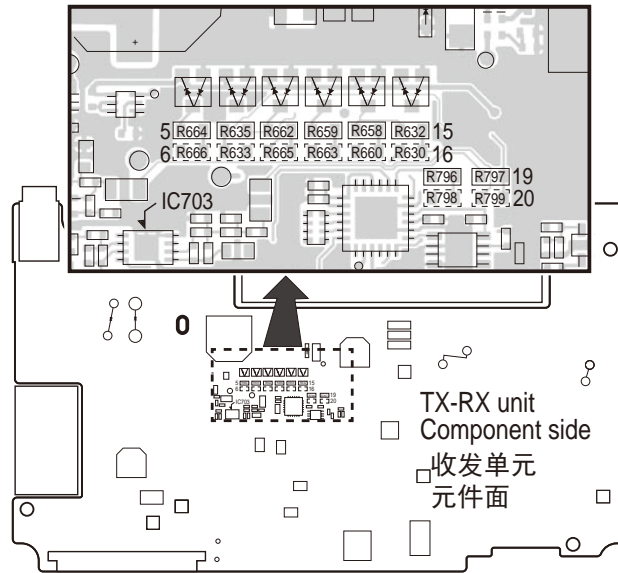

### ■ In the case of 5-1.

[TTL level]

R664, R635 and R662: 0Ω chip jumper.  
R666, R633 and R665: open.

[RS-232C level]

R666, R633 and R665: 0Ω chip jumper.  
R664, R635 and R662: open.

### ■ In the case of 5-2.

[TTL level]

R664, R635, R662, R659, R658 and R632: 0Ω chip jumper.  
R666, R633, R665, R663, R660 and R630: open.

[RS-232C level]

R666, R633, R665, R663, R660 and R630: 0Ω chip jumper.  
R664, R635, R662, R659, R658 and R632: open.

### ■ 5-1 の場合

[TTL 电平]

R664, R635 和 R662: 0Ω 贴片电阻。  
R666, R633 和 R665: 断开。

[RS-232C 电平]

R666, R633 和 R665: 0Ω 贴片电阻。  
R664, R635 和 R662: 断开。

### ■ 5-2 の場合

[TTL 电平]

R664, R635, R662, R659, R658 和 R632: 0Ω 贴片电阻。  
R666, R633, R665, R663, R660 和 R630: 断开。

[RS-232C 电平]

R666, R633, R665, R663, R660 和 R630: 0Ω 贴片电阻。  
R664, R635, R662, R659, R658 和 R632: 断开。

## 6. Changing of Signal Type

### 6-1. Change signal output of D-SUB connector from DE0 to AFO

The output (4pin) of D-SUB 15-pin connector is configured at the DE0 as the default value.

Remove the R796 chip jumper and solder the clip jumper to R798.

### 6-2. Change signal input of D-SUB connector from DI to MI2

The input (5pin) of D-SUB 15-pin connector is configured at the DI as the default value.

Remove the R797 chip jumper and solder the chip jumper to R799.

## 6. 改变信号类型

6-1. 请将 D-SUB 连接器的信号输出从 DE0 变更到 AFO。  
D-SUB 15 针连接器的输出 (4 针), 作为默认值形成 DE0。  
从 R796 跳线至 R798。

6-2. 请将 D-SUB 连接器的信号输入从 DI 变更到 MI2。  
D-SUB 15 针连接器的输入 (5 针), 作为默认值形成 DI。  
从 R797 跳线至 R799。

## DISASSEMBLY FOR REPAIR / 维修拆卸

### 1. Disassembly Procedure

1. Remove the cabinet, top packing and shielding plate of the transceiver.

### 1. 拆卸步骤

1. 取下车载对讲机的机壳、顶盖和屏蔽板。

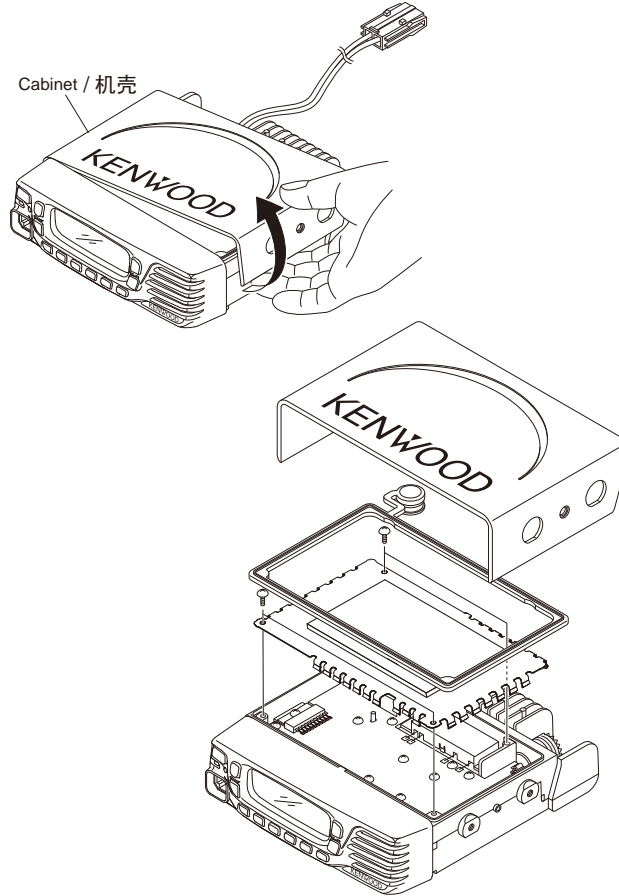

2. To remove the panel assembly, first turn the transceiver upside down. Then, insert a flat-head screwdriver into the holes of the chassis and tilt it in the direction as shown by the arrow.

2. 要拆卸面板组件，应先将车载对讲机颠倒放置。然后，将一字螺丝刀插入底座的孔内，使其按箭头所示的方向倾斜。

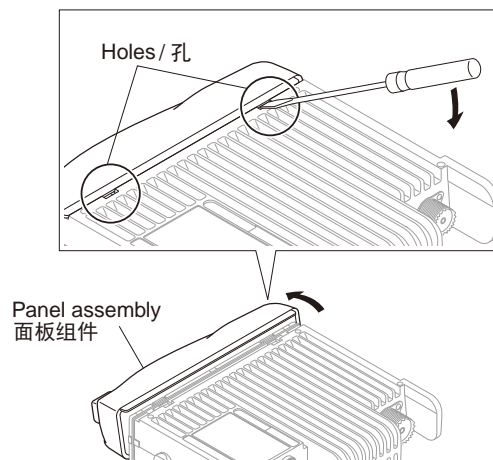

## DISASSEMBLY FOR REPAIR / 维修拆卸

3. Disconnect the flat cable from connector of the panel assembly.

3. 从面板组件的连接器断开带状电缆。

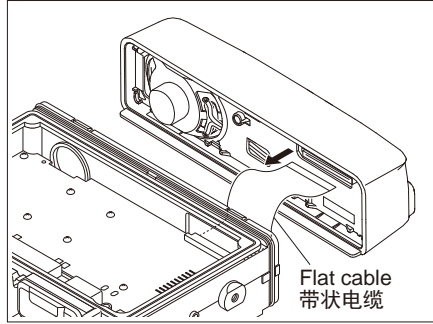

4. Hook the finger to hole and while pulling the speaker holder to this side, expand the panel side of ① to ③, and remove the speaker holder from the front panel.

4. 拇指放入如图所示的洞孔中，然后同时拉起扬声器座和拉开面板的①到③处，就可以从面板上卸下扬声器座。

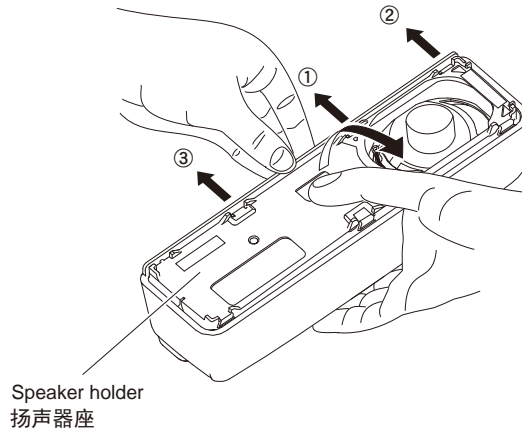

5. When removing the TX-RX PCB, first remove the top packing. Then, remove the solder of the antenna hot pin and positive terminal of the DC cord. Remove the 16 screws from the TX-RX PCB, power module, and audio amp.

5. 拆卸收发 PCB 时，应先拆下顶盖。然后，除去天线热端和直流电源线的正极端子的焊锡。拆下收发 PCB、功率模块和音频放大器上的 16 颗螺丝。

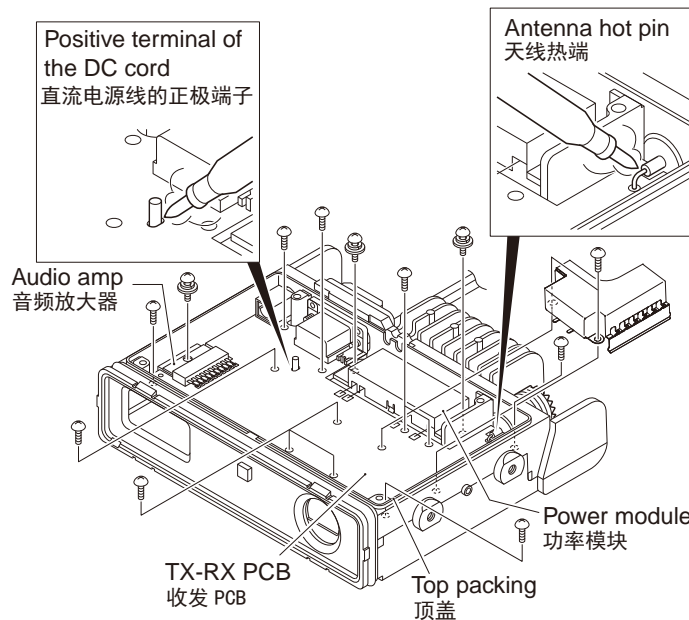



## DISASSEMBLY FOR REPAIR / 维修拆卸

### Note:

When you supply power to the TX-RX PCB after removing the TX-RX PCB from the chassis, solder the positive and ground terminals of the DC cord (Recommendation: E30-3448-25) to the + and GND terminals of the TX-RX PCB.

### 注意：

从底座上拆下收发 PCB 之后对收发 PCB 供电时，将直流电源线（推荐：E30-3448-25）的正极和接地端子焊接到收发 PCB 的 + 和 GND 端子。

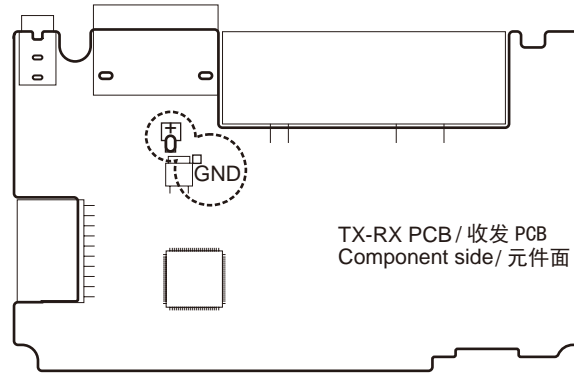

- Pull it out behind the chassis by rotating the bush ③ of the DC cord 90 degrees in the direction of the arrow after the screw ① in the negative terminal is removed, and the positive terminal ② is removed from the chassis.

- 拆下负极端子的螺丝①，并从底座上拆下正极端子②之后，将直流电源线的套管③以箭头方向旋转 90 度，将其拉出至底座后面。

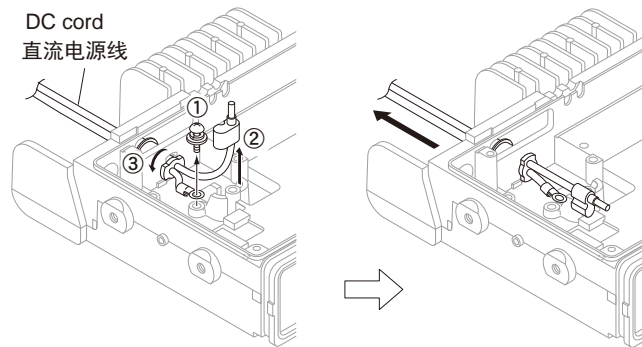

## 2. Precautions for Reassembly

- The tab from ① to ③ is applied the front panel first. And, ④ to ⑥ tabs inside the front panel is pushed.

## 2. 重新组装注意事项

- 首先放下①到③的凸起部，然后再按住④到⑥的凸起部。

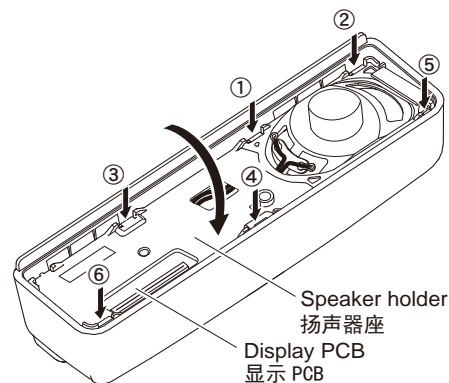

# NX-720

## DISASSEMBLY FOR REPAIR / 维修拆卸

- When mounting the panel assembly, pass the flat cable through the hole of the chassis as shown below then connect the flat cable to connector of the panel assembly.

- 安装面板组件时，如下图所示将带状电缆穿过底座的孔，然后将带状电缆连接到面板组件的连接器。

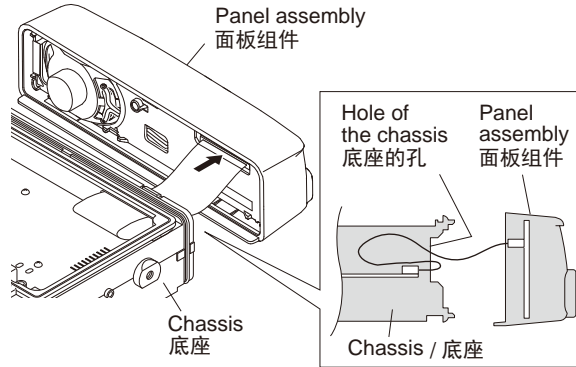

- Fit the panel assembly into the two tabs of the chassis top side first. Then, fit the panel assembly into the two tabs of the chassis bottom side by turning the panel assembly.

- 先将面板组件装配到底座顶侧的两个凸起内。然后，再通过转动面板组件，将面板组件装配到底座底侧的两个凸起内。

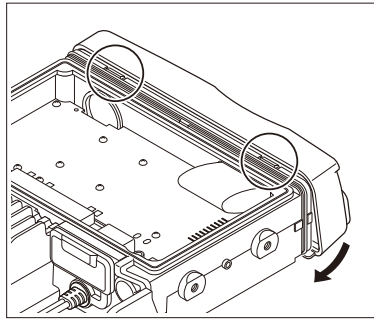

### 3. Correspondence when replacing the LED (D22 and D23)

When replacing the LED (D22 and D23), it makes it to length.

### 3. 更换 LED (D22 和 D23) 时的相应操作

更换 LED (D22 和 D23) 时，将 LED 的引线截到如下图所的尺寸。

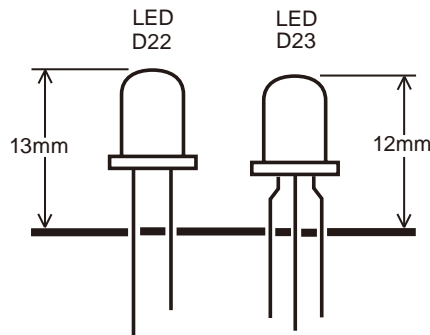

# CIRCUIT DESCRIPTION / 电路说明

## 1. Overview

The NX-720 is a VHF Mobile transceiver designed to operate in the frequency range of 136 to 174MHz. The unit consists of a receiver, transmitter, phase-locked loop (PLL) frequency synthesizer, baseband parts, power supply, and control circuits.

## 2. Frequency Configuration

The receiver is a double-conversion super-heterodyne using the first intermediate frequency (IF) of 49.95MHz and the second IF of 450kHz. Incoming signals from the antenna are mixed with the local signal from the PLL circuit to produce the first IF of 49.95MHz. This is then mixed with the 50.4MHz second local oscillator output to produce the 450kHz second IF. The transmit signal frequency is generated by the PLL VCO, and modulated by the signal from the DSP. It is then amplified and fed to the antenna.

## 1. 概述

NX-720 为 VHF 车载对讲机，设计用于 136 至 174MHz 的频率范围。该设备由接收机、发射机、锁相环 (PLL) 频率合成器、基带部件、电源和控制电路组成。

## 2. 频率构成

接收机为二次变频超外差方式，使用的第一中频 (IF) 为 49.95MHz，第二中频为 450kHz。天线接收到的信号与 PLL 电路的本振信号混频，从而产生第一个 49.95MHz 的中频。然后与第二个 50.4MHz 的本地振荡器输出信号混频，进而产生第二个 450kHz 的中频。发射的信号频率由 PLL VCO 生成，并经 DSP 信号调制。最后，该信号频率经过放大并发送到天线。

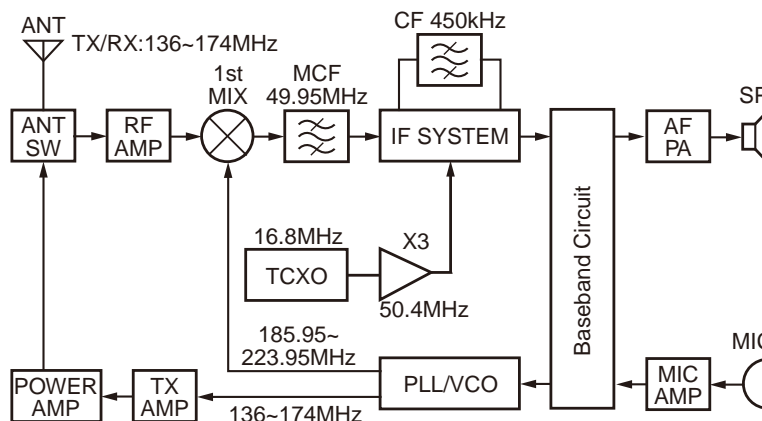

Fig.1 Frequency configuration / 图 1 频率构成

## 3. Receiver System

### 3-1. RF circuit

An incoming RF signal from the antenna terminal is passed through the antenna switch (D110, 111 and 107) and then the bandpass filter (L215, 216). The bandpass filter is adjusted by a variable capacitor. The input voltage to the variable capacitor is regulated by the voltage output from the D/A converter (IC712). The signal is amplified by an RF amplifier (Q202), and passed through the bandpass filter (L207, 209, 210 and 220). The resulting signal is applied to the first mixer (Q201) where it is mixed with the first local oscillator signal output from the frequency synthesizer to produce the first IF (49.95MHz).

### 3-2. IF circuit

The first IF signal is passed through a four-pole monolithic crystal filter (XF1) to reject the adjacent channel signal. The filtered first IF signal is amplified by the first IF amplifier (Q305) and then applied to the IF system IC (IC303). The IF system IC provides a second mixer, AGC amplifier, and RSSI (Received Signal Strength Indicator).

## 3. 接收部系统

### 3-1. RF 电路

天线端子接收到的 RF 输入信号依次通过天线开关 (D110、111 和 107) 和带通滤波器 (L215、216)。带通滤波器经由可变电容器的输入电压经由数模转换器 (IC712) 的输出电压进行调整。随后，信号被 RF 放大器 (Q202) 放大，然后通过带通滤波器 (L207、209、210 和 220)。最终的信号被运用到第一混频器 (Q201)。在该混频器中，信号与频率合成器输出的第一本地振荡器信号混频，从而产生第一中频 (49.95MHz)。

### 3-2. 中频电路

第一中频信号经过一个四极单片晶体滤波器 (XF1) 以消除临近信道的信号。滤波后的第一中频信号经过第一中频放大器 (Q305) 的放大后，加载到中频系统 IC (IC303) 上。中频系统 IC 提供一个第二混频器、AGC 放大器和 RSSI (接收信号强度指示器)。

## CIRCUIT DESCRIPTION / 电路说明

The second mixer mixes the first IF signal with the 50.4MHz of the second local oscillator output and produces the second IF signal of 450kHz.

The second IF signal is passed through the ceramic filter (CF1) to reject the adjacent channel signal. The filtered second IF signal is amplified by the AGC amplifier.

The signal from the AGC amplifier is input to the ASIC (IC507) through the ceramic filter (CF2).

第二混频器混合第一中频信号及 50.4MHz 的第二本地振荡器输出，生成 450kHz 的第二中频信号。

第二中频信号通过陶瓷滤波器 (CF1) 以消除临近信道的信号。滤波后的信号由 AGC 放大器进行放大。

AGC 放大器的信号通过陶瓷滤波器 (CF2) 被输入 ASIC (IC507)。

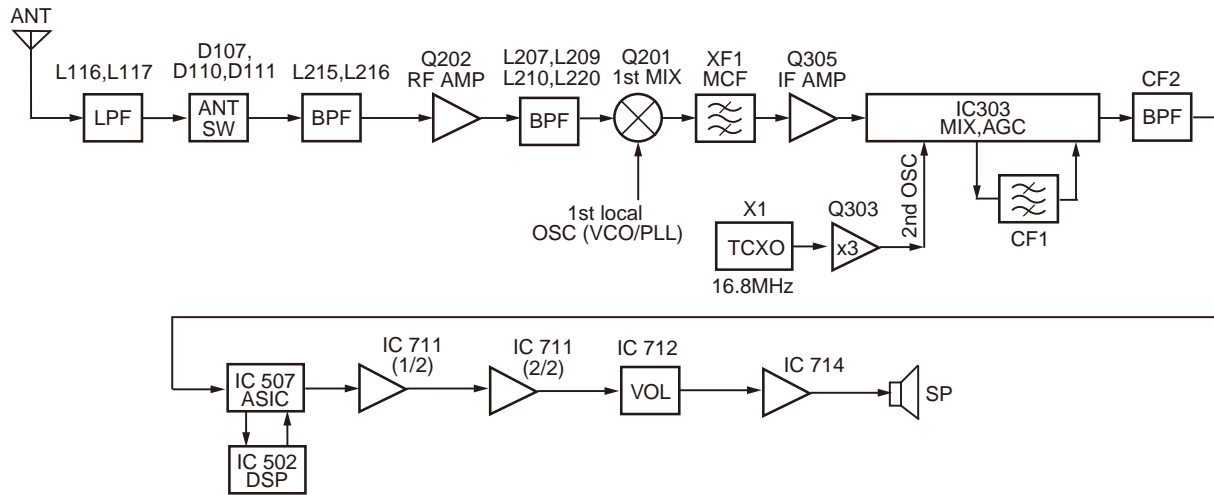

Fig.2 Receiver System / 图 2 接收机系统

### 3-3. Audio amplifier circuit

Audio processing (high-pass filter, low-pass filter, de-emphasized and so on) in FM mode and decoding in NXDN mode are processed by the DSP (IC502). Audio signals from the ASIC (IC507), IC502 goes through the amplifier (IC711). The signal then goes through the D/A converter (IC712) and an amplifier (IC714).

### 3-3. 音频放大器电路

FM 模式的音频处理 (高通滤波器、低通滤波器、去加重等) 和 NXDN 模式的解码由 DSP (IC502) 进行处理。ASIC (IC507) 和 IC502 的音频信号通过放大器 (IC711)。然后信号通过数模转换器 (IC712) 和放大器 (IC714)。

### 3-4. Squelch Circuit

It amplifies the demodulated noise signal from ASIC (IC507) after filtering through the LPF and HPF circuit. The amplified signal is then converted to a DC signal by the detection circuit. The converted signal is fed back to IC507.

### 3-4. 静噪电路

通过 LPF 和 HPF 电路滤波后，该电路放大 ASIC (IC507) 的已解调噪声信号。随后，放大的信号由检测电路转换为 DC 信号。转换的信号被反馈给 IC507。

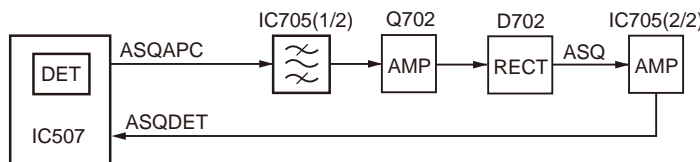

Fig. 3 Squelch Circuit / 图 3 静噪电路

## CIRCUIT DESCRIPTION / 电路说明

## 4. Transmitter System

## 4. 发射机系统

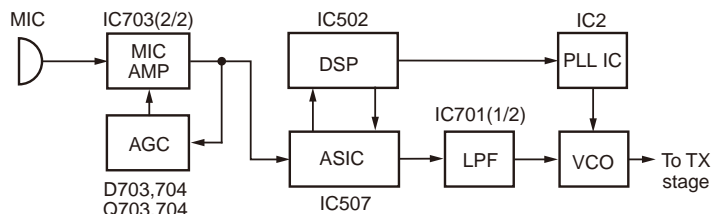

Fig. 4 Transmitter System / 图 4 发射机系统

## 4-1. Audio Band Circuit

The signal from the microphone is amplified by IC703 (1/2) and limited by the AGC circuit composed of D703, D704, Q703 and Q704. IC703 (2/2) works as an anti-aliasing LPF filter.

## 4-2. Baseband Circuit

The audio signal output from the Audio band circuit is converted to digital data with a sampling frequency of 48 kHz. This digital data is sent to the DSP (IC502), and voice signals of 300Hz or lower and frequencies of 3kHz or higher are cut off so that an audio range 300Hz to 3kHz is extracted. The audio signal is then pre-emphasized in FM mode and synthesized with the signals, such as QT and DQT, as required, and is then output from the ASIC (IC507). In Digital mode, the audio signal is converted to the 4-Level FSK baseband signal and is output from IC507. The DTMF and MSK baseband signals are also generated by the DSP and output from IC507.

LPF (IC701) works as smoothing filter. The output level according to the transmit carrier is fine-adjusted according to each modulation method.

## 4-3. Drive and Final amplifier

The signal from the T/R switch (D17 is on) is amplified by the drive amplifier (Q102) to 16~17dBm. The output of the drive amplifier is amplified by the final amplifier module (IC102) to 25W (5.0W when the power is low). The output of the final amplifier module is then passed through the harmonic filter (LPF) and antenna switch (D110, D111 are on) and directional coupler and is applied to the antenna terminal.

## 4-4. APC circuit

The Automatic transmission power control (APC) circuit stabilizes the transmitter output power at a predetermined level by detecting the power module output with the directional coupler and diode detector (D104 and D105). The diode detector (D104 and D105) applies the detected voltage to the DC amplifier IC103 (2/2).

The APC circuit is configured to protect over-current of the power module due to fluctuations of the load at the antenna end and to stabilize transmission output at voltage and temperature variations.

## 4-1. 音频频带电路

麦克风信号被 IC703 (1/2) 放大并被 D703、D704、Q703 和 Q704 组成的 AGC 电路所限制。IC703 (2/2) 用作抗混叠 LPF 滤波器。

## 4-2. 基带电路

从音频频带电路输出的音频信号被转换为取样频率为 48kHz 的数字数据。该数字数据被发送给 DSP (IC502)，300Hz 或更低的语音信号以及 3kHz 或更高的频率被截止，并选取 300Hz 至 3kHz 的音频范围。然后，音频信号以 FM 模式预加重，并与所需的 QT 和 DQT 等信号合成，然后从 ASIC (IC507) 输出。在数字模式下，音频信号被转换为 4 级 FSK 基带信号并从 IC507 输出。DTMF 和 MSK 基带信号也由 DSP 生成并由 IC507 输出。

LPF (IC701) 用作平滑滤波器。根据各自的调制方式对按照发射载波输出的电平进行微调。

## 4-3. 驱动器和末级放大器

T/R 开关 (D17 开启) 的信号由驱动放大器 (Q102) 放大到 16~17dBm。驱动放大器的输出信号由末级放大器模块 (IC102) 放大到 25W (当功率低为 5.0W 时)。末级放大器模块的输出信号随即通过谐波滤波器 (LPF) 及天线开关 (D110、D111 开启) 及方向性耦合器，然后加载到天线端子上。

## 4-4. APC 电路

通过使用方向性耦合器和二极管 (D104 和 D105) 检测功率模块输出，自动发射功率控制 (APC) 电路将发射器输出功率稳定在预定电平。二极管 (D104 和 D105) 对直流感放大器 IC103 (2/2) 施加电压。

配置 APC 电路是为了保护因天线端负载波动而引起的功率模块过流，以及在电压和温度变化时稳定发射输出。

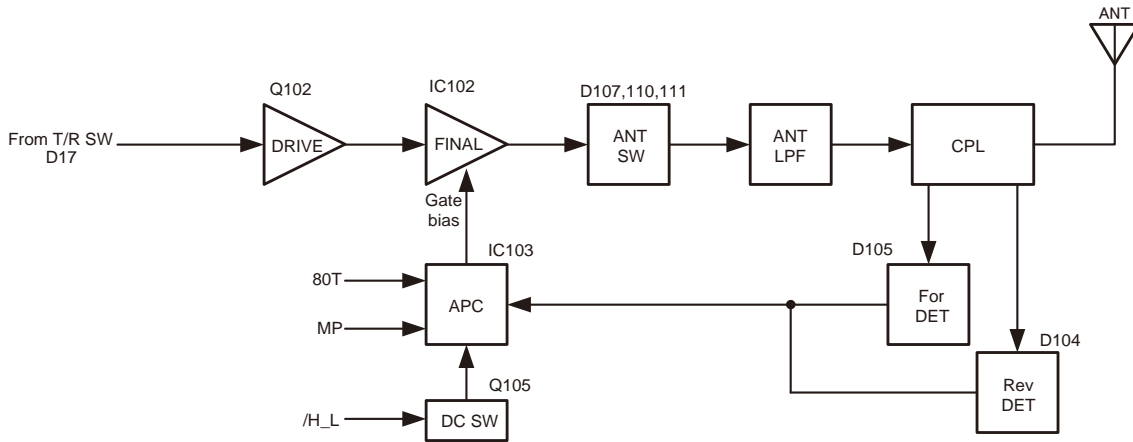

Fig. 5 APC Circuit / 图 5 APC 电路

### 5. PLL Frequency Synthesizer

#### 5-1. TCXO (X1)

The TCXO (X1) generates a reference frequency of 16.8MHz for the PLL frequency synthesizer. This reference frequency is applied to pin 9 of the PLL IC (IC2) and is connected to the IF circuit as a 2nd local signal through the Tripler.

The frequency adjustment is achieved by switching the ratio of the dividing frequency. The resolution of the adjusting frequency is approximately 4Hz.

#### 5-2. VCO

There is an RX VCO and a TX VCO.

The TX VCO (Q7) generates a transmit carrier and the RX VCO (Q6) generates the 1st local signal. For the VCO oscillation frequency, the transmit carrier is 136 to 174MHz and the 1st local signal is 185.95 to 223.95MHz.

The VCO oscillation frequency is determined by one system of operation switching terminal "T/R" and two systems of voltage control terminals "CV" and "ASSIST".

The operation switching terminal, "T/R", is controlled by the control line (/T\_R) output from the ASIC (IC507). When the /T\_R logic is low, the VCO outputs the transmit carrier and when it is high, it outputs the 1st local receive signal.

The voltage control terminals, "CV" and "ASSIST", are controlled by the PLL IC (IC2) and ASIC (IC507) and the output frequency changes continuously according to the applied voltage. For the modulation input terminal, "VCO\_MOD", the output frequency changes according to the applied voltage. This is used to modulate the VCO output. "VCO\_MOD" works only when "/T\_R" is low.

#### 5-3. PLL IC (IC2)

The PLL IC compares the differences in phases of the VCO oscillation frequency and the TCXO reference frequency, returns the difference to the VCO CV terminal and realizes the "Phase Locked Loop" for the return control. This allows the VCO oscillation frequency to accurately match (lock) the desired frequency.

### 5. PLL 频率合成器

#### 5-1. TCXO (X1)

TCXO (X1) 生成 16.8MHz PLL 频率合成器的基准频率。该基准频率作为第 2 本振信号通过三倍频器，被加载到 PLL IC (IC2) 的第 9 脚并送至 IF 电路。

通过切换分频比进行频率调整。调整频率的分辨率约为 4Hz。

#### 5-2. VCO

设有一个 RX VCO 和一个 TX VCO。

TX VCO (Q7) 生成发射载波，RX VCO (Q6) 生成第 1 本振信号。对于 VCO 振荡频率，发射载波为 136 至 174MHz，第 1 本振信号为 185.95 至 223.95MHz。

VCO 振荡频率由一个操作切换端子 "T/R" 系统和两个电压控制端子 "CV" 和 "ASSIST" 系统确定。

操作切换端子 "T/R" 由 ASIC (IC507) 控制线路 (/T\_R) 的输出信号进行控制。/T\_R 逻辑低时，VCO 输出发射载波；高时，输出第 1 本振接收信号。

电压控制端子 "CV" 和 "ASSIST" 由 PLL IC (IC2) 和 ASIC (IC507) 控制，输出频率根据加载的电压持续改变。对于调制输入端子 "VCO\_MOD"，输出频率根据加载的电压改变。籍此调制 VCO 输出。"VCO\_MOD" 仅在 "/T\_R" 低时工作。

#### 5-3. PLL IC (IC2)

PLL IC 对比 VCO 振荡频率和 TCXO 基准频率的相位差，将相位差返回至 VCO CV 端子，从而实现反馈控制的 "锁相环路"。这样可以使 VCO 振荡频率与所需的频率精确匹配 (锁定)。

## CIRCUIT DESCRIPTION / 电路说明

When the frequency is controlled by the PLL, the frequency convergence time increases as the frequency difference increases when the set frequency is changed. To supplement this, the ASIC (IC507) is used before control by the PLL IC to bring the VCO oscillation frequency close to the desired frequency. As a result, the VCO CV voltage does not change and is always stable at approximately 2.5V.

The desired frequency is set for the PLL IC by the ASIC (IC507) through the 3-line "SDO1", "P\_SCK1", "/PCS\_RF" serial bus. Whether the PLL IC is locked or not is monitored by the ASIC through the "PLD" signal line. If the VCO is not the desired frequency (unlocked), the "PLD" logic is low.

The modulation signal of the Low-speed-Data is applied to pin 23 of the PLL IC (IC2).

The modulation signal that is digital data of a sampling frequency of 96 kHz is set for the PLL IC by the DSP (IC502) through the "PLL\_MOD" line.

### 5-4. Local Switch (D16, D17)

The connection destination of the signal output from the buffer amplifier (Q11) is changed with the diode switch (D17) that is controlled by the transmission power supply, HSW, and the diode switch (D16) that is controlled by the reception power supply, 50R. If the HSW logic is high, it is connected to a transmit-side drive (Q102). If the HSW logic is low, it is connected to a receive-side mixer (Q202).

频率由 PLL 控制时，频率锁定时间将随着设定频率改变时频率差的增大而增加。为对此进行补充，在由 PLL IC 控制之前使用 ASIC (IC507) 以使 VCO 振荡频率接近所需的频率。因此，VCO CV 的电压不变，始终稳定在约 2.5V。

PLL IC 的所需频率由 ASIC (IC507) 通过 3 线 "SDO1"、"P\_SCK1"、"/PCS\_RF" 串行总线进行设置。PLL IC 是否锁定由 ASIC 通过 "PLD" 信号线路进行监测。如果 VCO 不是所需的频率 (失锁)，则 "PLD" 逻辑变低。

低速数据调制信号被加载到 PLL IC (IC2) 的第 23 脚。

调制信号是 DSP (IC502) 通过 "PLL\_MOD" 线路为 PLL IC 设置的 96kHz 采样频率的数字数据。

### 5-4. 本振开关 (D16, D17)

缓冲放大器 (Q11) 输出信号的连接目标由发射电源 HSW 控制的二极管开关 (D17) 和接收电源 50R 控制的二极管开关 (D16) 进行切换。如果 HSW 逻辑为高，则被连接到发送侧驱动器 (Q102)。如果 HSW 逻辑为低，则被连接到接收侧混频器 (Q202)。

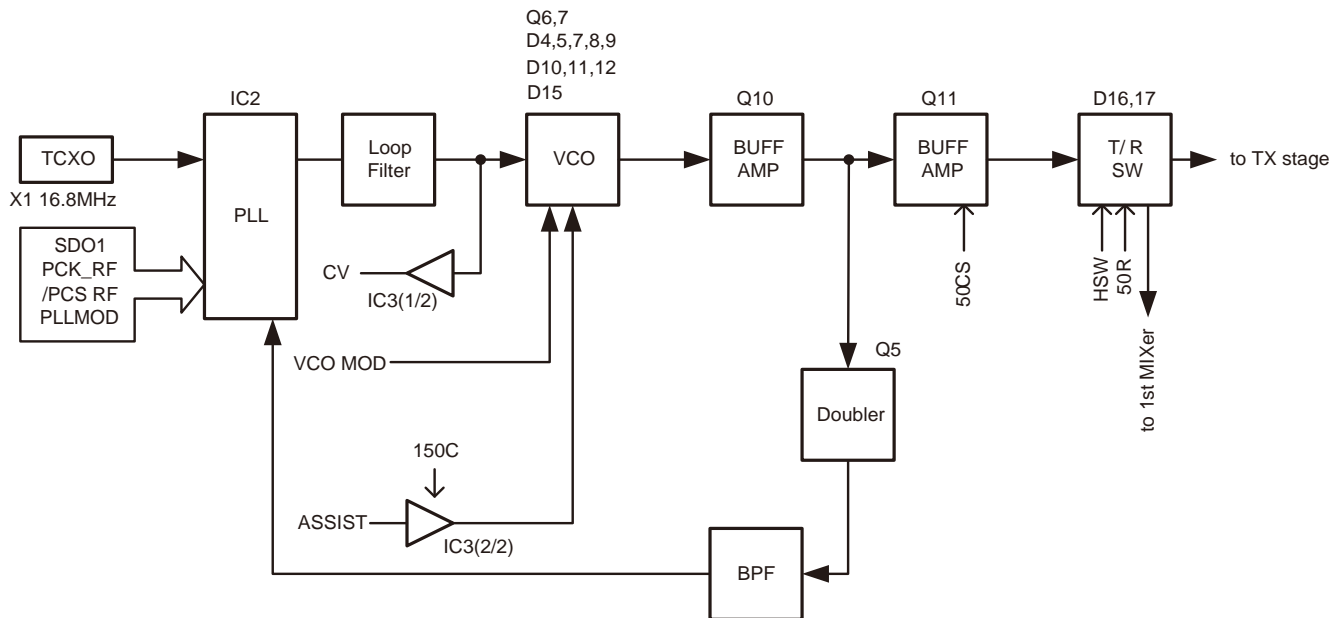

Fig. 6 PLL circuit / 图 6 PLL 电路

### 6. Control Circuit

The control circuit consists of the ASIC (IC507) and its peripheral circuits. IC507 mainly performs the following:

- 1) Switching between transmission and reception via the PTT signal input.
- 2) Reading system, zone, frequency, and program data from the memory circuit.
- 3) Sending frequency program data to the PLL.
- 4) Controlling the squelch on/off using the DC voltage from the squelch circuit.
- 5) Controlling the audio mute circuit using the decode data input.

#### 6-1. ASIC

The ASIC (IC507) is a 32bit RISC processor, equipped with a peripheral function and ADC/DAC.

This ASIC operates at 18.432MHz clock and 3.3V/1.5V DC. It controls the flash memory, SRAM, DSP, the receive circuit, the transmitter circuit, the control circuit, and the display circuit and transfers data to or from an external device.

#### 6-2. Memory Circuit

The memory circuit consists of the ASIC (IC507), the SRAM (IC503) and the flash memory (IC501). The flash memory has a capacity of 32Mbit which contains the transceiver control program for the ASIC and stores the data. It also stores the data for the transceiver channels and operating parameters that are written by the FPU. This program can be easily written from external devices. The SRAM has a capacity of 1Mbit which contains the work area and data area.

#### ■ Flash memory

**Note:** The flash memory stores the data that is written by the FPU (KPG-141D(C)), tuning data (Deviation, Squelch, etc.) and firmware program (User mode, Test mode, Tuning mode, etc.).

#### ■ SRAM (static memory)

**Note:** The SRAM has a temporary data area and work area.

#### 6-3. Display Unit

The display unit is composed of the LCD driver IC (IC1), the LCD & Key backlight, etc.

The LCD is controlled using the 4 serial lines (LCDDI, LCDCE, LCDCL, LCDDO) from the ASIC (IC507).

#### 6-4. Key Detection Circuit

The keys are detected using an LCD driver IC (IC1). If a pressed key is detected by IC1, the information is passed to IC507 through the serial line.

### 6. 控制电路

控制电路由 ASIC (IC507) 和外围电路组成。IC507 主要执行以下功能：

- 1) 由输入的 PTT 信号切换发射和接收。
- 2) 从存储电路读取系统、区域、频率和编程数据。
- 3) 将频率数据发送到 PLL。
- 4) 由静噪电路的 DC 电压控制静噪的开 / 关。
- 5) 由输入的解码数据控制音频静音电路。

#### 6-1. ASIC

ASIC (IC507) 是 32 位 RISC 处理器，具备外围功能和 ADC/DAC。

该 ASIC 以 18.432MHz 时钟和 3.3V/1.5V DC 运行。用以控制闪存、SRAM、DSP、接收电路、发射电路、控制电路以及显示电路，并与外部设备双向传输数据。

#### 6-2. 存储电路

存储电路由 ASIC (IC507)、SRAM (IC503) 和闪存 (IC501) 组成。闪存具有 32M 位的容量，包含 ASIC 的车载对讲机控制程序并储存数据。同时还保存车载对讲机信道的数据及 FPU 写入的运行参数。可以轻松通过外部设备写入此程序。SRAM 具有 1M 位的容量，包含工作区和数据区。

#### ■ 闪存

**注意：**闪存可储存 FPU (KPG-141D(C)) 写入的数据、调谐数据（频偏、静噪等）以及固件程序（用户模式、测试模式、调谐模式等）。

#### ■ SRAM（静态存储器）

**注意：**SRAM 设有临时数据区和工作区。

#### 6-3. 显示单元

显示单元由 LCD 驱动 IC (IC1)、以及 LCD 和按键背光等部分组成。

LCD 通过 ASIC (IC507) 的 4 条串行控制线 (LCDDI、LCDCE、LCDCL、LCDDO) 进行控制。

#### 6-4. 按键检测电路

使用 LCD 驱动 IC (IC1) 检测按键。如果 IC1 检测到已有按键按下，则会通过串行线路通知 IC507。



## CIRCUIT DESCRIPTION / 电路说明

### 6-5. DSP

The DSP circuit consists of a DSP (IC502) and processes the baseband signal. The DSP operates on an external clock of 18.432MHz (the same as the IC507), the I/O section operates at 3.3V and the core section operates at 1.5V. The DSP carries out the following processes:

- 4 level FSK processing
- Analog FM pre-emphasis/de-emphasis
- Vocoder processing between the audio codec and modulation/demodulation
- CAI processing, such as error correction encoding
- QT/DQT encoding/decoding
- DTMF encoding/decoding
- MSK encoding/decoding
- 2-tone encoding/decoding
- Compressor/expander processing
- Voice scrambler processing
- Transmit/receive audio filtering processing
- Microphone amplifier AGC processing
- Audio mute processing
- Modulation level processing

## 7. Power Supply Circuit

+B is connected to the Final amplifier and the DC/DC converter IC (IC405). IC405 regulates the +B voltage to 5.0V (50M). 50M operates whenever +B is supplied. IC401 (33M) and IC408 (15M) are enabled while the 50M is operating.

33M and 15M provide the power to the ASIC (IC507), DSP (IC502), and Flash memory. At this time the ASIC starts working. The voltage detector IC (IC402) watches the +B voltage. If the +B voltage is higher than 8.6V, IC402 (/BINT) outputs High. If the /BINT signal is high, Q403 (SB SW) is turned on by the SBC signal from the ASIC. (High : SBC=ON, Low : SBC=OFF). When the SB is turned on, IC1 (80C), IC404 (50C), Q402 (80ANT), Q404 (80T), Q415, 416 (150C), Q417 (50R) and Q408 (50CS) start working. IC409, Q409 and Q410 are controlled by the SBC signal. If the SBC signal becomes High, IC409 (33C) operates, and Q409 (33A\_2) and Q410 (50MC SW) turn on.

The ASIC sets the TXC signal to High during transmission to the supply power (80T) for the transmission circuit. The ASIC sets the signals (RXC) to High during reception to the supply power (50R) for the reception circuit.

When the ASIC detects the PSW (Power switch) signal, IGN (Ignition sense) signal or /BINT signal, it sets the SBC signal to Low, and turns the transceiver power (SB) off. When D401 and Q401 detect an over-voltage condition, they turn Q403 (SB SW) off, but the ASIC continues to function.

### 6-5. DSP

DSP 电路由 DSP (IC502) 组成, 用以处理基带信号。DSP 在 18.432MHz 的外部时钟上运行 (与 IC507 相同), I/O 部分以 3.3V 运行, 核心部分以 1.5V 运行。DSP 进行以下处理:

- 4 级 FSK 处理
- 模拟 FM 预加重 / 去加重
- 音频编解码器和调制 / 解调之间的声码器处理
- CAI 处理, 例如纠错编码
- QT/DQT 编码 / 解码
- DTMF 编码 / 解码
- MSK 编码 / 解码
- 2 音编码 / 解码
- 压缩器 / 扩展器处理
- 语音扰频器处理
- 发射 / 接收音频滤波处理
- 麦克风放大器 AGC 处理
- 音频静音处理
- 调制电平处理

## 7. 电源电路

+B 连接至末级放大器和 DC/DC 转换器 IC (IC405)。IC405 将 +B 电压调整至 5.0V (50M)。提供 +B 时, 50M 运行。50M 运行时, IC401 (33M) 和 IC408 (15M) 启用。

33M 和 15M 对 ASIC (IC507)、DSP (IC502) 和闪存供电。此时 ASIC 开始工作。电压检测 IC (IC402) 观测 +B 电压。如果 +B 电压高于 8.6V, 则 IC402 (/BINT) 输出高。如果 /BINT 信号高, 则 Q403 (SB SW) 由 ASIC 的 SBC 信号开启。(高 : SBC=ON, 低 : SBC=OFF)。SB 开启时, IC1 (80C)、IC404 (50C)、Q402 (80ANT)、Q404 (80T)、Q415、416 (150C)、Q417 (50R) 和 Q408 (50CS) 开始工作。IC409、Q409 和 Q410 由 SBC 信号控制。如果 SBC 信号变高, IC409 (33C) 运行, 并开启 Q409 (33A\_2) 和 Q410 (50MC SW)。

发射期间, ASIC 将 TXC 信号控制为高, 为发射电路供电 (80T)。接收期间, ASIC 将信号 (RXC) 控制为高, 为接收电路供电 (50R)。

当 ASIC 检测 PSW (电源开关) 信号、IGN (点火感应) 信号或 /BINT 信号时, 它将 SBC 信号控制为低, 关闭车载对讲机电源 (SB)。当 D401 和 Q401 检测到过电压情况时, 它们将关闭 Q403 (SB SW)。但 ASIC 仍然工作。

## CIRCUIT DESCRIPTION / 电路说明

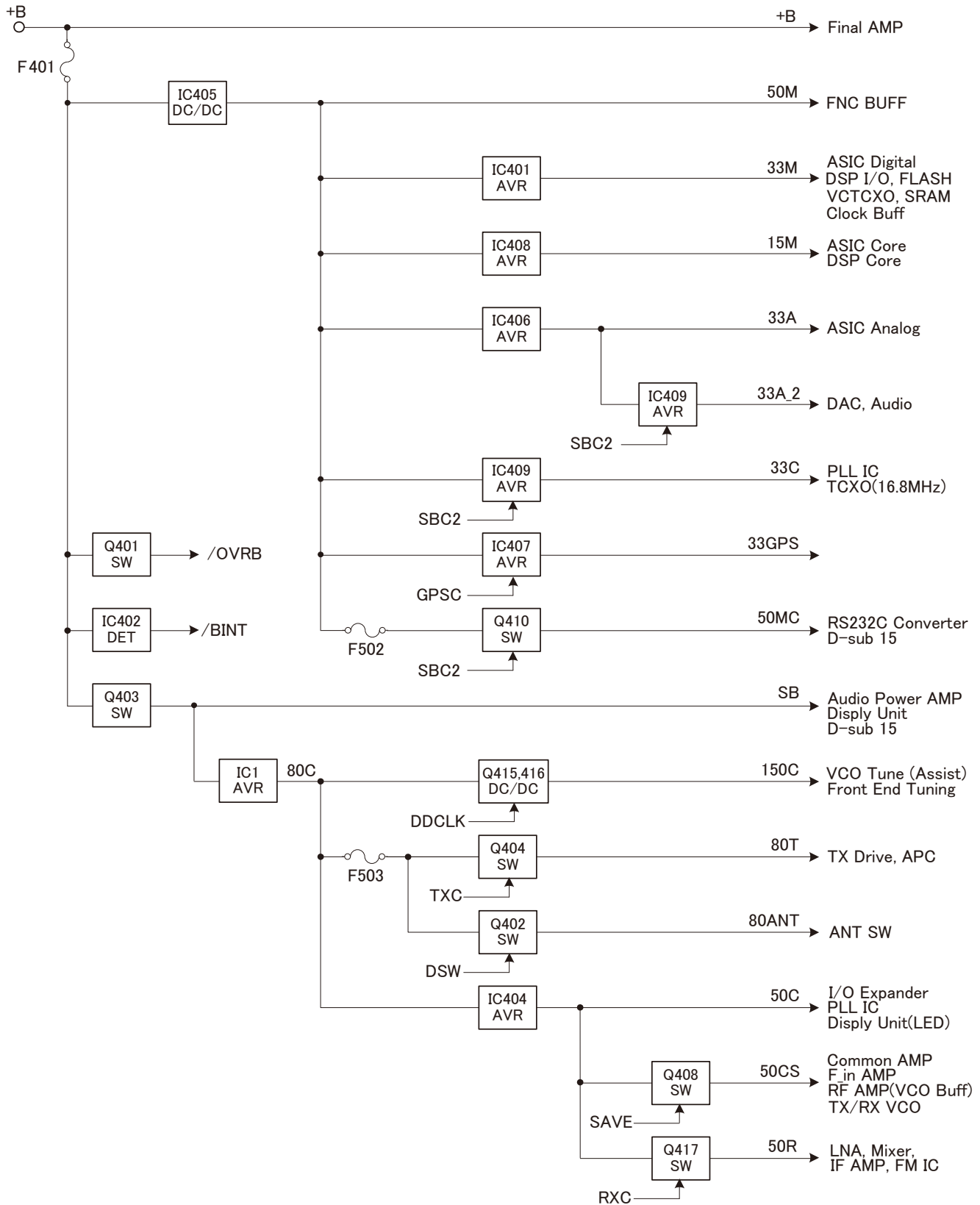

Fig. 7 Power supply circuit / 图7 电源电路

## CIRCUIT DESCRIPTION / 电路说明

### 8. Signaling Circuit

#### 8-1. Encode (QT/DQT/DTMF/2-tone/MSK)

Each signaling data signal of the QT, DQT, DTMF, 2-tone and MSK is generated by the DSP circuit, superposed on a modulation signal and output from the ASIC (IC507). Each deviation of the TX QT, DQT, DTMF, 2-tone and MSK tones are adjusted by changing the output level of the DSP (IC502) and the resulting signal is routed to the VCO and PLL.

#### 8-2. Decode (QT/DQT/DTMF/2-tone/MSK)

The audio signal is removed from the FM detection signal sent to the DSP circuit and the resulting signal is decoded by the DSP.

### 9. Compander Circuit

The term “compander” means compressor and expander. The compander reduces noise by utilizing a compressor and an expander. The DSP (IC502) performs this operation. The Compander can be turned on or off using the FPU.

### 8. 信令电路

#### 8-1. 编码 (QT/DQT/DTMF/2音/MSK)

DSP 电路生成 QT、DQT、DTMF、2 音和 MSK 的各信令信号，这些信号被叠加到调制信号上并从 ASIC (IC507) 输出。TX QT、DQT、DTMF、2 音和 MSK 音各自的频偏通过改变 DSP (IC502) 的输出电平进行调整，产生的信号被送至 VCO 和 PLL。

#### 8-2. 解码 (QT/DQT/DTMF/2音/MSK)

音频信号从发送到 DSP 电路的 FM 检测信号中提取，产生的信号由 DSP 解码。

### 9. 压扩器电路

“Compander” 一词表示压缩器和扩展器。压扩器利用压缩器和扩展器减低噪音。DSP (IC502) 用以执行此操作。可用 FPU 开启或关闭压扩器。

## COMPONENTS DESCRIPTION / 元件说明

### Display unit (X54-3830-10)

Ref. No.	Part Name	Description
IC1	IC	LCD driver
Q3	Transistor	TX/Busy LED switch
Q6	Transistor	TX/Busy LED switch
Q8	Transistor	LCD backlight switch
Q9	Transistor	Backlight switch
Q10	Transistor	Status LED switch
Q11	Transistor	Backlight switch
D2	Diode	Line protection
D5-9	LED	Key backlight
D11-21	LED	LCD backlight
D22	LED	Status LED
D23	LED	TX/Busy LED
D24	LED	LCD backlight
D25	Varistor	Line protection
D26	Diode	Key control
D27	Zener diode	Over DC supply protection

### 显示单元 (X54-3830-10)

有关号码	零件名称	说明
IC1	IC	LCD 驱动
Q3	晶体管	LED 开关 (TX/BUSY)
Q6	晶体管	LED 开关 (TX/BUSY)
Q8	晶体管	LCD 背光开关
Q9	晶体管	背光开关
Q10	晶体管	LED 开关 (状态)
Q11	晶体管	背光开关
D2	二极管	线路保护
D5-9	LED	键背光
D11-21	LED	LCD 背光
D22	LED	状态 LED
D23	LED	TX/BUSY LED
D24	LED	LCD 背光
D25	变阻器	线路保护
D26	二极管	键控制
D27	稳压二极管	DC 供电过高保护

### TX-RX unit (X57-8230-11)

Ref. No.	Part Name	Description
IC1	IC	AVR (80C)
IC2	IC	PLL system
IC3	IC	DC AMP (CV/Assist)
IC102	IC	TX power module
IC103	IC	OP AMP (APC)
IC201	IC	DC AMP (BPF)
IC301	IC	AND gate
IC303	IC	FM system
IC304	IC	DC AMP (RSSI)
IC401	IC	AVR (33M)
IC402	IC	Voltage detector (BINT)
IC404	IC	AVR (50C)
IC405	IC	DC/DC converter (50M)
IC406	IC	AVR (33A)
IC407	IC	AVR (33GPS)
IC408	IC	AVR (15M)
IC409	IC	AVR (33C)
IC501	IC	Flash memory
IC502	IC	DSP
IC503	IC	SRAM
IC504	IC	Reset
IC506	IC	Buffer AMP (Clock)

### 收发单元 (X57-8230-11)

有关号码	零件名称	说明
IC1	IC	稳压器 (80C)
IC2	IC	PLL 系统
IC3	IC	直流放大器 (CV/ 辅助)
IC102	IC	功率模块
IC103	IC	OP 放大器 (APC)
IC201	IC	直流放大器 (BPF)
IC301	IC	AND 栅
IC303	IC	FM 系统
IC304	IC	直流放大器 (RSSI)
IC401	IC	稳压器 (33M)
IC402	IC	电压检测器 (BINT)
IC404	IC	稳压器 (50C)
IC405	IC	DC/DC 转换器 (50M)
IC406	IC	稳压器 (33A)
IC407	IC	稳压器 (33GPS)
IC408	IC	稳压器 (15M)
IC409	IC	稳压器 (33C)
IC501	IC	闪存
IC502	IC	DSP
IC503	IC	SRAM
IC504	IC	复位
IC506	IC	射频缓冲放大器 (时钟)

## COMPONENTS DESCRIPTION / 元件说明

Ref. No.	Part Name	Description
IC507	IC	ASIC
IC508	IC	AND gate
IC509	IC	Dual BUS buffer (HOOK/RXD/MKEY1)
IC511	IC	BUS buffer
IC512	IC	Level shift
IC513	IC	Dual BUS buffer (FNC3/FNC1)
IC514	IC	Dual BUS buffer (FNC2/FNC4)
IC515	IC	I/O expander
IC516	IC	RS-232C driver
IC701	IC	VCO MOD/VREF
IC702	IC	LPF (APC/DMO)
IC703	IC	MIC SUM AMP/LPF (DI)
IC705	IC	BPF/Buffer AMP (SQ)
IC711	IC	RX SUM AMP/LPF (RX AF)
IC712	IC	D/A converter
IC713	IC	MIC/RX selector
IC714	IC	AF power AMP
IC716	IC	Dual BUS buffer (TXD1/MKEO)
IC801	IC	Dual BUS buffer (TXD2/RXD2)
Q1	Transistor	DC switch (Assist)
Q2	FET	DC switch (Assist)
Q4	Transistor	Ripple filter
Q5	Transistor	Buffer AMP (PLL fin)
Q6	FET	RX VCO
Q7	FET	TX VCO
Q8,9	FET	T/R VCO switch
Q10,11	Transistor	Buffer AMP
Q102	Transistor	TX drive AMP
Q105	FET	DC switch (H/L power)
Q106	Transistor	DC switch (50C)
Q201	FET	RX 1st mixer
Q202	Transistor	LNA
Q303	Transistor	Tripler
Q305	Transistor	1st IF AMP
Q401	Transistor	DC switch (Over DC supply protection)
Q402	Transistor	DC switch (80ANT)
Q403	FET	DC switch (SB)
Q404	Transistor	DC switch (80T)
Q405	Transistor	DC switch (80ANT)
Q407	Transistor	DC switch (50MC)
Q408	Transistor	DC switch (50CS)
Q409	FET	DC switch (33A_2)
Q410	Transistor	DC switch (50MC)

有关号码	零件名称	说 明
IC507	IC	ASIC
IC508	IC	AND 栅
IC509	IC	双总线缓冲器 (HOOK/RXD/MKEY1)
IC511	IC	总线缓冲器
IC512	IC	电平位移
IC513	IC	双总线缓冲器 (FNC3/FNC1)
IC514	IC	双总线缓冲器 (FNC2/FNC4)
IC515	IC	I/O 扩展器
IC516	IC	RS-232C 驱动
IC701	IC	VCO 调制 /VREF
IC702	IC	LPF (APC/DMO)
IC703	IC	麦克风 SUM 放大器 /LPF (DI)
IC705	IC	BPF/ 射频缓冲放大器 (SQ)
IC711	IC	RX SUM 放大器 /LPF (RX AF)
IC712	IC	D/A 转换器
IC713	IC	麦克风 /RX 选择器
IC714	IC	AF 功率放大器
IC716	IC	双总线缓冲器 (TXD1/MKEO)
IC801	IC	双总线缓冲器 (TXD2/RXD2)
Q1	晶体管	直流开关 ( 辅助 )
Q2	场效应管	直流开关 ( 辅助 )
Q4	晶体管	纹波滤波器
Q5	晶体管	射频缓冲放大器 (PLL fin)
Q6	场效应管	RX VCO 振荡器
Q7	场效应管	TX VCO 振荡器
Q8, 9	场效应管	收发 VCO 直流开关
Q10, 11	晶体管	射频缓冲放大器
Q102	晶体管	驱动放大器
Q105	场效应管	直流开关 ( 高 / 低功率 )
Q106	晶体管	直流开关 (50C)
Q201	场效应管	第一混频器
Q202	晶体管	LNA
Q303	晶体管	三倍频器
Q305	晶体管	第一 IF 放大器
Q401	晶体管	直流开关 (DC 供电过高保护)
Q402	晶体管	直流开关 (80ANT)
Q403	场效应管	直流开关 (SB)
Q404	晶体管	直流开关 (80T)
Q405	晶体管	直流开关 (80ANT)
Q407	晶体管	直流开关 (50MC)
Q408	晶体管	直流开关 (50CS)
Q409	场效应管	直流开关 (33A_2)
Q410	晶体管	直流开关 (50MC)

## COMPONENTS DESCRIPTION / 元件说明

Ref. No.	Part Name	Description
Q411	Transistor	DC switch (80T)
Q412	Transistor	DC switch (80ANT)
Q414	Transistor	DC switch (150C)
Q415,416	Transistor	DC/DC converter
Q417	Transistor	DC switch (50R)
Q418	FET	DC switch (SB)
Q501	FET	DC switch (System)
Q502	Transistor	DC switch (Horn alert)
Q503	FET	DC switch (Horn alert)
Q504	Transistor	DC switch (IGN)
Q701	FET	SQL noise BW switch
Q702	Transistor	Noise AMP
Q703,704	Transistor	MIC AGC
Q705	FET	Mute (MI1)
Q706	FET	Mute (MI2)
Q708	Transistor	Pop noise prevention switch
Q709	FET	AF mute switch
D2	Zener diode	Over voltage protection
D4	Variable capacitance diode	RX VCO frequency control
D5	Variable capacitance diode	TX VCO frequency control
D6	Variable capacitance diode	PLL f-in BPF tune
D7	Variable capacitance diode	RX VCO assist tune
D8	Variable capacitance diode	TX VCO assist tune
D9,10	Variable capacitance diode	RX VCO assist tune
D11	Variable capacitance diode	TX VCO assist tune
D13	Variable capacitance diode	PLL f-in BPF tune
D14	Diode	Speed up
D15	Variable capacitance diode	FM modulation
D16,17	Diode	T/R switch
D101	Zener diode	Over voltage protection
D102	Diode	Transient voltage limiter
D103	Diode	Reverse current prevention
D104,105	Diode	TX power detection
D106	Diode	Voltage limiter
D107	Diode	Antenna switch
D108,109	Diode	Over DC supply protection
D110,110	Diode	Antenna switch
D112-114	Diode	Over DC supply protection
D202-207	Variable capacitance diode	RX BPF tune

有关号码	零件名称	说明
Q411	晶体管	直流开关 (80T)
Q412	晶体管	直流开关 (80ANT)
Q414	晶体管	直流开关 (150C)
Q415, 416	晶体管	DC/DC 转换器
Q417	晶体管	直流开关 (50R)
Q418	场效应管	直流开关 (SB)
Q501	场效应管	直流开关 (系统)
Q502	晶体管	直流开关 (喇叭提示)
Q503	场效应管	直流开关 (喇叭提示)
Q504	晶体管	直流开关 (IGN)
Q701	场效应管	静噪噪声开关
Q702	晶体管	噪声放大器
Q703, 704	晶体管	麦克风 AGC
Q705	场效应管	静音 (MI1)
Q706	场效应管	静音 (MI2)
Q708	晶体管	噪声预防开关
Q709	场效应管	AF 静音开关
D2	稳压二极管	过电压防护
D4	可变电容二极管	频率控制 /RX VCO
D5	可变电容二极管	频率控制 /TX VCO
D6	可变电容二极管	PLL f-in BPF 调谐
D7	可变电容二极管	RX VCO 辅助调谐
D8	可变电容二极管	TX VCO 辅助调谐
D9, 10	可变电容二极管	RX VCO 辅助调谐
D11	可变电容二极管	TX VCO 辅助调谐
D13	可变电容二极管	PLL f-in BPF 调谐
D14	二极管	加速
D15	可变电容二极管	FM 调制器
D16, 17	二极管	收发开关
D101	稳压二极管	过电压防护
D102	二极管	过渡电压限制器
D103	二极管	逆向电流保护
D104, 105	二极管	功率检测器
D106	二极管	电压限制器
D107	二极管	天线开关
D108, 109	二极管	DC 供电过高保护
D110, 110	二极管	天线开关
D112-114	二极管	DC 供电过高保护
D202-207	可变电容二极管	RX BPF 调谐

## COMPONENTS DESCRIPTION / 元件说明

Ref. No.	Part Name	Description
D401	Zener diode	Over DC supply protection
D403,404	Diode	Reverse current prevention
D405	Diode	Discharge
D406	Diode	DC/DC converter
D407	Diode	DC/DC converter (50M)
D408,409	Diode	DC/DC converter
D410	Surge absorption	Surge protection
D411	Diode	Reverse current prevention
D502	Diode	Reverse current prevention
D504	Diode	Reverse current prevention
D505-510	Diode	Line protection
D511-513	Diode	Reverse current prevention
D601	Diode	Line protection
D701	Diode	Reverse current prevention
D702	Diode	Noise detector
D703,704	Diode	AF detector
D705,706	Diode	Line protection
D801,802	Diode	Over DC supply protection

有关号码	零件名称	说 明
D401	稳压二极管	DC 供电过高保护
D403, 404	二极管	逆向电流保护
D405	二极管	放电
D406	二极管	DC/DC 转换器
D407	二极管	DC/DC 转换器 (50M)
D408, 409	二极管	DC/DC 转换器
D410	电涌吸收	电涌保护
D411	二极管	逆向电流保护
D502	二极管	逆向电流保护
D504	二极管	逆向电流保护
D505-510	二极管	线路保护
D511-513	二极管	逆向电流保护
D601	二极管	线路保护
D701	二极管	逆向电流保护
D702	二极管	噪声检测
D703, 704	二极管	AF 检测
D705, 706	二极管	线路保护
D801, 802	二极管	DC 供电过高保护

## PARTS LIST / 零件表

### CAPACITORS

$\frac{C}{1} \frac{C}{2} \frac{45}{3} \frac{TH}{4} \frac{1H}{5} \frac{220}{6} \frac{J}{6}$

- 1 = Type ... ceramic, electrolytic, etc.
- 2 = Shape ... round, square, etc.
- 3 = Temp. coefficient

- 4 = Voltage rating
- 5 = Value
- 6 = Tolerance

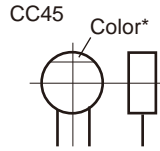

#### • Capacitor value

- 010 = 1pF
- 100 = 10pF
- 101 = 100pF
- 102 = 1000pF = 0.001μF
- 103 = 0.01μF

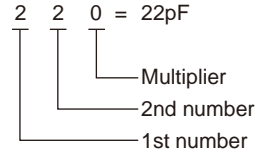

#### • Temperature coefficient

1st Word	C	L	P	R	S	T	U
Color*	Black	Red	Orange	Yellow	Green	Blue	Violet
ppm/°C	0	-80	-150	-220	-330	-470	-750

2nd Word	G	H	J	K	L
ppm/°C	±30	±60	±120	±250	±500

Example : CC45TH = -470±60ppm/°C

#### • Tolerance (More than 10pF)

Code	C	D	G	J	K	M	X	Z	P	No code
(%)	±0.25	±0.5	±2	±5	±10	±20	+40 -20	+80 -20	+100 -0	More than 10μF : -10~+50 Less than 4.7μF : -10~+75

#### (Less than 10pF)

Code	B	C	D	F	G
(pF)	±0.1	±0.25	±0.5	±1	±2

#### • Voltage rating

2nd word 1st word	A	B	C	D	E	F	G	H	J	K	V
0	1.0	1.25	1.6	2.0	2.5	3.15	4.0	5.0	6.3	8.0	-
1	10	12.5	16	20	25	31.5	40	50	63	80	35
2	100	125	160	200	250	315	400	500	630	800	-
3	1000	1250	1600	2000	2500	2150	4000	5000	6300	8000	-

#### • Chip capacitors

(EX)  $\frac{C}{1} \frac{C}{2} \frac{73}{3} \frac{F}{4} \frac{SL}{5} \frac{1H}{6} \frac{000}{7} \frac{J}{7}$   
(Chip) (CH, RH, UJ, SL)

(EX)  $\frac{C}{1} \frac{K}{2} \frac{73}{3} \frac{F}{4} \frac{F}{5} \frac{1H}{6} \frac{000}{7} \frac{Z}{7}$   
(Chip) (B, F)

Refer to the table above.

- 1 = Type
- 2 = Shape
- 3 = Dimension
- 4 = Temp. coefficient
- 5 = Voltage rating
- 6 = Value
- 7 = Tolerance

#### • Dimension

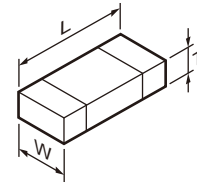

#### Chip capacitor

Code	L	W	T
Empty	5.6±0.5	5.0±0.5	Less than 2.0
A	4.5±0.5	3.2±0.4	Less than 2.0
B	4.5±0.5	2.0±0.3	Less than 2.0
C	4.5±0.5	1.25±0.2	Less than 1.25
D	3.2±0.4	2.5±0.3	Less than 1.5
E	3.2±0.2	1.6±0.2	Less than 1.25
F	2.0±0.3	1.25±0.2	Less than 1.25
G	1.6±0.2	0.8±0.2	Less than 1.0
H	1.0±0.05	0.5±0.05	0.5±0.05

#### Chip resistor

Code	L	W	T
E	3.2±0.2	1.6±0.2	1.0
F	2.0±0.3	1.25±0.2	1.0
G	1.6±0.2	0.8±0.2	0.5±0.1
H	1.0±0.05	0.5±0.05	0.35±0.05

### RESISTORS

#### • Chip resistor (Carbon)

(EX)  $\frac{R}{1} \frac{D}{2} \frac{73}{3} \frac{E}{4} \frac{B}{5} \frac{2B}{6} \frac{000}{7} \frac{J}{7}$   
(Chip) (B, F)

#### • Carbon resistor (Normal type)

(EX)  $\frac{R}{1} \frac{D}{2} \frac{14}{3} \frac{B}{4} \frac{B}{5} \frac{2C}{6} \frac{000}{7} \frac{J}{7}$

- 1 = Type
- 2 = Shape
- 3 = Dimension
- 4 = Temp. coefficient
- 5 = Rating wattage
- 6 = Value
- 7 = Tolerance

#### • Rating wattage

Code	Wattage	Code	Wattage	Code	Wattage
1J	1/16W	2C	1/6W	3A	1W
2A	1/10W	2E	1/4W	3D	2W
2B	1/8W	2H	1/2W		



## PARTS LIST / 零件表

\* New Parts. △ indicates safety critical components.  
 Parts without **Parts No.** are not supplied.  
 \* 新零件。△代表对安全至关重要的零件。  
 我们不会提供没有零件号的零件。

L : Scandinavia      K : USA      P : Canada  
 Y : PX (Far East, Hawaii)      T : England      E : Europe  
 C : China      X : Australia      M : Other Areas

NX-720  
 DISPLAY UNIT (X54-3830-10)

Ref. No.	Address	New parts	Parts No.	Description	Desti-nation	Ref. No.	Address	New parts	Parts No.	Description	Desti-nation
<b>NX-720</b>						<b>DISPLAY UNIT (X54-3830-10)</b>					
1	1B		A02-4073-21	PLASTIC CABINET		101	2A		B11-1885-03	ILLUMINATION GUIDE	
2	2B		A10-4161-01	CHASSIS		102	2A		B38-0936-05	LCD	
3	3A		A62-1200-03	PANEL ASSY		D5 -9			B30-2337-05	LED(YELLOW)	
5	2B		B09-0732-03	CAP(D-SUB)		D11 -21			B30-2337-05	LED(YELLOW)	
7	3A		B43-1675-04	BADGE		D22	3A		B30-2321-05	LED(BLUE LED)	
9	2B		E04-0167-15	RF COAXIAL RECEPTACLE(M)		D23	3A		B30-2151-05	LED(RED/GREEN)	
11	2A		E29-1244-14	RELAY HARDWARE(CHASSIS)		D24			B30-2337-05	LED(YELLOW)	
12	2B	*	E30-7686-15	DC CORD		C1			CC73HCH1H101J	CHIP C    100PF    J	
13	2A		E37-1461-05	FLAT CABLE(30P)		C2 ,3			CC73HCH1H221J	CHIP C    220PF    J	
15	2B		F10-3183-03	SHIELDING CASE(POWER MODULE)		C4			CC73HCH1H101J	CHIP C    100PF    J	
16	1B		F10-3184-03	SHIELDING COVER(TOP)		C5			CC73HCH1H221J	CHIP C    220PF    J	
17	1B		F10-3203-02	SHIELDING CASE(LPF)		C6			CK73HB1H471K	CHIP C    470PF    K	
18	2B		F51-0079-05	FUSE(15A)		C7			CK73HB1H102K	CHIP C    1000PF    K	
19	1A		G11-4353-04	SHEET(SHIELDING/BOTTOM)		C10			CK73HB1H102K	CHIP C    1000PF    K	
20	2B		G11-4578-04	SHEET		C11			CC73HCH1H221J	CHIP C    220PF    J	
21	1B		G11-4611-04	SHEET(D-SUB)		C12			CC73HCH1H101J	CHIP C    100PF    J	
22	1B		G13-2102-04	CONDUCTIVE CUSHION		C13			CK73HB1E103K	CHIP C    0.010UF    K	
23	3B		G13-2363-04	CUSHION(PANELHOLDER)		C14 ,15			CK73HB1H102K	CHIP C    1000PF    K	
24	1B		G13-2389-04	CUSHION(SHIELDING/TOP)		C21			CK73HB1E103K	CHIP C    0.010UF    K	
25	2B		G13-2395-04	CUSHION(X57)		C23			CK73HB1H102K	CHIP C    1000PF    K	
26	2B		G53-1643-04	PACKING(DC CORD)		C24 ,25			CK73HB1E103K	CHIP C    0.010UF    K	
27	2B		G53-1662-04	PACKING(M/ANT)		C27			CK73HB1A105K	CHIP C    1.0UF    K	
31	1B		G53-1819-21	PACKING(CHASSIS)		C31			CK73HB1H102K	CHIP C    1000PF    K	
32	3A		G53-1820-03	PACKING(PANEL)		C32 ,33			CK73HB1C473K	CHIP C    0.047UF    K	
33	3A		G53-1858-03	PACKING(SP)		C34			CC73HCH1H470J	CHIP C    47PF    J	
35	3A	*	J19-5542-12	HOLDER(PANEL)		C35 ,36			CC73HCH1H221J	CHIP C    220PF    J	
36	3A		K29-9479-01	KEY TOP		103	2A		E29-1231-15	INTER CONNECTOR	
A	2A,2B		N67-3008-48	PAN HEAD SEMS SCREW		CN1			E40-6924-05	FLAT CABLE CONNECTOR(30P)	
B	1A,2B		N87-2608-48	BRAZIER HEAD TAPTITE SCREW		J1	3A		E58-0535-05	MODULAR JACK(MIC)	
37	3A		T07-0785-15	SPEAKER		104	2A		J21-8629-03	MOUNTING HARDWARE(LCD)	
						L1			L92-0138-05	CHIP FERRITE	
						L2 ,3			L92-0140-05	CHIP FERRITE	
						CP1			RK74HB1J101J	CHIP-COM    100    J    1/16W	
						R1			RK73HB1J101J	CHIP R    100    J    1/16W	
						R2 -4			RK73HB1J103J	CHIP R    10K    J    1/16W	
						R5			RK73HB1J102J	CHIP R    1.0K    J    1/16W	
						R7			RK73HB1J000J	CHIP R    0    J    1/16W	
						R9			RK73HB1J000J	CHIP R    0    J    1/16W	
						R12			RK73HB1J101J	CHIP R    100    J    1/16W	
						R14			RK73HB1J122J	CHIP R    1.2K    J    1/16W	
						R15			RK73HB1J000J	CHIP R    0    J    1/16W	
						R17			RK73HB1J000J	CHIP R    0    J    1/16W	
						R18			RK73GB2A331J	CHIP R    330    J    1/10W	
						R19			RK73GB2A221J	CHIP R    220    J    1/10W	
						R20			RK73HB1J000J	CHIP R    0    J    1/16W	
						R22			RK73HB1J000J	CHIP R    0    J    1/16W	
						R23			RK73HB1J473J	CHIP R    47K    J    1/16W	
						R24 ,25			RK73HB1J332J	CHIP R    3.3K    J    1/16W	
						R26			RK73HB1J472J	CHIP R    4.7K    J    1/16W	
						R28			RK73FB2B121J	CHIP R    120    J    1/8W	
						R29			RK73FB2B221J	CHIP R    220    J    1/8W	
						R34 -37			RK73GB2A271J	CHIP R    270    J    1/10W	
				<b>ACCESSORY</b>							
		*	B62-2448-00	INSTRUCTION MANUAL	ACCESSORY						
			E30-3339-15	DC CORD	ACCESSORY						
			F51-0079-05	FUSE(15A)	ACCESSORY						
			J29-0726-03	BRACKET	ACCESSORY						
			N99-2039-05	SCREW SET	ACCESSORY						
			X57-8230-13	TX-RX UNIT(FOR SERVICE)							

## PARTS LIST / 零件表

DISPLAY UNIT (X54-3830-10)

TX-RX UNIT (X57-8230-11)

Ref. No.	Address	New parts	Parts No.	Description	Destination	Ref. No.	Address	New parts	Parts No.	Description	Destination
R38 -40			RK73HB1J472J	CHIP R 4.7K J 1/16W		C57			CC73HCH1H040B	CHIP C 4.0PF B	
R41			RK73HB1J101J	CHIP R 100 J 1/16W		C58			CK73HB1H471K	CHIP C 470PF K	
R42			RK73HB1J272J	CHIP R 2.7K J 1/16W		C59 ,60			CC73HCH1H040B	CHIP C 4.0PF B	
R43			RK73HB1J103J	CHIP R 10K J 1/16W		C61			CK73HB1H471K	CHIP C 470PF K	
R44			RK73HB1J222J	CHIP R 2.2K J 1/16W		C63			CC73HCH1HR75B	CHIP C 0.75PF B	
R45			RK73HB1J472J	CHIP R 4.7K J 1/16W		C64			CK73FB1A106K	CHIP C 10UF K	
D1			DZ2J062(M)	ZENER DIODE		C66			CC73HCH1H100B	CHIP C 10PF B	
D2			DA3S101F	DIODE		C67			CC73HCH1H060B	CHIP C 6.0PF B	
D25			MINISMDC020F	VARISTOR		C68			CC73HCH1H100B	CHIP C 10PF B	
D26			HN2S03FE	DIODE		C69			CC73HCH1H080B	CHIP C 8.0PF B	
D27			DZ2J062(M)	ZENER DIODE		C70			CK73GB1E105K	CHIP C 1.0UF K	
IC1			LC75857W-E	MOS-IC		C71			CC73HCH1H471J	CHIP C 470PF J	
Q3			KTC4075E(Y,GR)	TRANSISTOR		C73 ,74			CK73HB1H103K	CHIP C 0.010UF K	
Q6			KTC4075E(Y,GR)	TRANSISTOR		C76 ,77			CC73HCH1H0R5B	CHIP C 0.5PF B	
Q8			KTC4075E(Y,GR)	TRANSISTOR		C78 ,79			CK73HB1H102K	CHIP C 1000PF K	
Q9			QST7	TRANSISTOR		C80			CK73HB1H471K	CHIP C 470PF K	
Q10			LTC014EEBFS8	TRANSISTOR		C81			CC73HCH1H220J	CHIP C 22PF J	
Q11			KTC4075E(Y,GR)	TRANSISTOR		C82			CK73HB1H102K	CHIP C 1000PF K	
<b>TX-RX UNIT (X57-8230-11)</b>						C83			CC73HCH1H050B	CHIP C 5.0PF B	
C1			CK73HB1E103K	CHIP C 0.010UF K		C84			CC73HCH1H150J	CHIP C 15PF J	
C2			CC73HCH1H101J	CHIP C 100PF J		C85			CK73HB1H102K	CHIP C 1000PF K	
C3 ,4			CK73HB1H103K	CHIP C 0.010UF K		C86			CK73HB1H471K	CHIP C 470PF K	
C5 ,6			CC73HCH1H100B	CHIP C 10PF B		C87			CK73HB1H102K	CHIP C 1000PF K	
C7			CK73HB1H103K	CHIP C 0.010UF K		C88			CK73HB1A104K	CHIP C 0.10UF K	
C9			CC73HCH1H100B	CHIP C 10PF B		C89			CC73HCH1H150G	CHIP C 15PF G	
C10 ,11			CK73HB1H103K	CHIP C 0.010UF K		C91			C93-0787-05	CHIP C 0.1UF J	
C16 -21			CC73HCH1H101J	CHIP C 100PF J		C101			CK73HB1H102K	CHIP C 1000PF K	
C22			CK73HB1A104K	CHIP C 0.10UF K		C102			CK73HB1H471K	CHIP C 470PF K	
C23			CC73HCH1H101J	CHIP C 100PF J		C103			CK73HB1H103K	CHIP C 0.010UF K	
C24			CK73HB1A104K	CHIP C 0.10UF K		C104			CK73HB1H102K	CHIP C 1000PF K	
C25 ,26			CC73HCH1H101J	CHIP C 100PF J		C108			CK73FB1E475K	CHIP C 4.7UF K	
C28			CC73HCH1H101J	CHIP C 100PF J		C111			CK73HB1H471K	CHIP C 470PF K	
C29			CS77MA1VR15M	CHIP TNL 0.15UF 35WV		C113			CK73HB1H471K	CHIP C 470PF K	
C30			CK73GB1E105K	CHIP C 1.0UF K		C116-118			CK73HB1H471K	CHIP C 470PF K	
C31			CC73HCH1H101J	CHIP C 100PF J		C119			CC73HCH1H270J	CHIP C 27PF J	
C32			CS77BA1D100M	CHIP TNL 10UF 20WV		C120			CC73HCH1H220J	CHIP C 22PF J	
C33			CK73HB1H103K	CHIP C 0.010UF K		C121			CC73HCH1H060B	CHIP C 6.0PF B	
C34			C93-1906-05	CHIP FILM 0.047UF 35WV		C123			CC73HCH1H220J	CHIP C 22PF J	
C35			CC73HCH1H060B	CHIP C 6.0PF B		C124			CC73HCH1H330J	CHIP C 33PF J	
C36			CC73HCH1H101J	CHIP C 100PF J		C125			CK73HB1H471K	CHIP C 470PF K	
C37			CC73HCH1H080B	CHIP C 8.0PF B		C127			CC73HCH1H220J	CHIP C 22PF J	
C39			CC73HCH1H330J	CHIP C 33PF J		C128			CC73HCH1H470J	CHIP C 47PF J	
C40			CC73HCH1H080B	CHIP C 8.0PF B		C129			CC73HCH1H330J	CHIP C 33PF J	
C41 -44			CC73HCH1H101J	CHIP C 100PF J		C131			CC73HCH1H101J	CHIP C 100PF J	
C45			CC73HCH1H331J	CHIP C 330PF J		C133			CC73HCH1H221J	CHIP C 220PF J	
C46			CC73HCH1H100B	CHIP C 10PF B		C134,135			CK73HB1H471K	CHIP C 470PF K	
C49			CC73HCH1H221J	CHIP C 220PF J		C136			CK73FB1H471K	CHIP C 470PF K	
C50			CC73HCH1H070B	CHIP C 7.0PF B		C137			CC73HCH1H101J	CHIP C 100PF J	
C51			CK73HB1A105K	CHIP C 1.0UF K		C140			CS77LA1C4R7M	CHIP TNL 4.7UF 16WV	
C52			CK73HB1H471K	CHIP C 470PF K		C142			CC73HCH1H220J	CHIP C 22PF J	
C53			CC73HCH1H221J	CHIP C 220PF J		C144			CC73HCH1H470J	CHIP C 47PF J	
C54			CC73HCH1H181J	CHIP C 180PF J		C145			CK73HB1A104K	CHIP C 0.10UF K	
C55			CC73HCH1H390G	CHIP C 39PF G		C146			C93-0561-05	CHIP C 12PF J	
C56			CC73HCH1H080B	CHIP C 8.0PF B		C148			CC73HCH1H101J	CHIP C 100PF J	
						C149			CK73HB1H471K	CHIP C 470PF K	
						C151			C93-0563-05	CHIP C 18PF J	
						C152			C92-0875-05	ELECTRO 47UF 25WV	
						C154			CK73HB1E223K	CHIP C 0.022UF K	
						C155			CK73HB1H471K	CHIP C 470PF K	
						C156			CC73HCH1H101J	CHIP C 100PF J	

## PARTS LIST / 零件表

TX-RX UNIT (X57-8230-11)

Ref. No.	Address	New parts	Parts No.	Description	Desti-nation	Ref. No.	Address	New parts	Parts No.	Description	Desti-nation
C157			CK73HB1H102K	CHIP C 1000PF K		C293			CK73HB1H471K	CHIP C 470PF K	
C158			CK73HB1H471K	CHIP C 470PF K		C306			CK73HB1E103K	CHIP C 0.010UF K	
C161			CC73GCH1H040C	CHIP C 4.0PF C		C307			CK73HB1A104K	CHIP C 0.10UF K	
C163			CC73GCH1H220J	CHIP C 22PF J		C309			CC73HCH1H100B	CHIP C 10PF B	
C165			CK73HB1H471K	CHIP C 470PF K		C312			CK73HB1H103K	CHIP C 0.010UF K	
C167			CC73GCH1H150J	CHIP C 15PF J		C313			CK73HB1A104K	CHIP C 0.10UF K	
C168			CK73HB1H471K	CHIP C 470PF K		C315			CK73HB1E103K	CHIP C 0.010UF K	
C171			CC73HCH1H101J	CHIP C 100PF J		C316			CC73HCH1H100B	CHIP C 10PF B	
C172,173			CK73HB1H471K	CHIP C 470PF K		C317			CC73HCH1H101J	CHIP C 100PF J	
C175			CC73FCH1H390J	CHIP C 39PF J		C322			CC73HCH1H101J	CHIP C 100PF J	
C176			C93-0564-05	CHIP C 22PF J		C323			CC73HCH1H151J	CHIP C 150PF J	
C177,178			C93-1871-05	CHIP C 100PF J		C324			CC73HCH1H330G	CHIP C 33PF G	
C179			C93-0559-05	CHIP C 9.0PF D		C325			CC73HCH1H680G	CHIP C 68PF G	
C182			C93-1866-05	CHIP C 27PF G		C326			CC73HCH1H100B	CHIP C 10PF B	
C184			C93-0564-05	CHIP C 22PF J		C327			CK73HB1A104K	CHIP C 0.10UF K	
C187,188			CK73HB1H102K	CHIP C 1000PF K		C330			CK73HB1A104K	CHIP C 0.10UF K	
C191			CC73GCH1H151J	CHIP C 150PF J		C332-335			CK73HB1A104K	CHIP C 0.10UF K	
C192			CC73GCH1H100C	CHIP C 10PF C		C336			CK73FB1A106K	CHIP C 10UF K	
C193			CC73GCH1H101J	CHIP C 100PF J		C337			CK73HB1A104K	CHIP C 0.10UF K	
C194			CC73HCH1H050B	CHIP C 5.0PF B		C338			CK73FB1A106K	CHIP C 10UF K	
C201			CK73HB1H103K	CHIP C 0.010UF K		C339			CK73HB1A104K	CHIP C 0.10UF K	
C202			CK73HB1E103K	CHIP C 0.010UF K		C340			CK73HB1H103K	CHIP C 0.010UF K	
C203			CK73HB1H471K	CHIP C 470PF K		C341			CK73HB1A104K	CHIP C 0.10UF K	
C204			CK73FB1E475K	CHIP C 4.7UF K		C342			CK73HB1A105K	CHIP C 1.0UF K	
C205			CK73HB1H471K	CHIP C 470PF K		C343-345			CK73HB1A104K	CHIP C 0.10UF K	
C207			CK73HB1H102K	CHIP C 1000PF K		C346			CK73HB1A105K	CHIP C 1.0UF K	
C208,209			CC73HCH1H120G	CHIP C 12PF G		C347			CK73HB1H103K	CHIP C 0.010UF K	
C210			CK73HB1H103K	CHIP C 0.010UF K		C348			CC73HCH1H470J	CHIP C 47PF J	
C211			CC73GCH1H060B	CHIP C 6.0PF B		C350			CK73HB1H103K	CHIP C 0.010UF K	
C212			CC73HCH1H220G	CHIP C 22PF G		C351			CC73HCH1H101J	CHIP C 100PF J	
C213			CC73HCH1H030B	CHIP C 3.0PF B		C357			CC73HCH1H0R5B	CHIP C 0.5PF B	
C214			CC73HCH1H150G	CHIP C 15PF G		C358			CC73HCH1H100B	CHIP C 10PF B	
C215,216			CK73HB1H102K	CHIP C 1000PF K		C359-361			CK73HB1E103K	CHIP C 0.010UF K	
C217			CC73HCH1H040B	CHIP C 4.0PF B		C366			CK73HB1E103K	CHIP C 0.010UF K	
C218			CC73HCH1H020B	CHIP C 2.0PF B		C367			CK73HB1H103K	CHIP C 0.010UF K	
C223			CK73HB1H102K	CHIP C 1000PF K		C368			CK73HB1H471K	CHIP C 470PF K	
C224			CC73HCH1H220G	CHIP C 22PF G		C369			CK73HB1H103K	CHIP C 0.010UF K	
C225			CK73HB1H102K	CHIP C 1000PF K		C370			CC73HCH1H220G	CHIP C 22PF G	
C227			CK73HB1H102K	CHIP C 1000PF K		C371			CK73HB1H103K	CHIP C 0.010UF K	
C229			CK73HB1H102K	CHIP C 1000PF K		C401			C92-0968-05	ELECTRO 470UF 25WV	
C231			CC73GCH1H060B	CHIP C 6.0PF B		C403			CK73HB1H471K	CHIP C 470PF K	
C232			CC73HCH1H220J	CHIP C 22PF J		C405			CK73HB1H103K	CHIP C 0.010UF K	
C233			CC73GCH1H060B	CHIP C 6.0PF B		C408,409			CK73HB1H103K	CHIP C 0.010UF K	
C234			CC73HCH1H390J	CHIP C 39PF J		C410			CK73GB1C225K	CHIP C 2.2UF K	
C235			CC73HCH1H270G	CHIP C 27PF G		C411			CK73GB1H104K	CHIP C 0.10UF K	
C239			CK73GB1H104K	CHIP C 0.10UF K		C413			CC73HCH1H101J	CHIP C 100PF J	
C240			CK73GB1E105K	CHIP C 1.0UF K		C416			CK73HB1H103K	CHIP C 0.010UF K	
C246,247			CK73HB1H102K	CHIP C 1000PF K		C417			CC73HCH1H101J	CHIP C 100PF J	
C250			CK73HB1A104K	CHIP C 0.10UF K		C420			CK73GB1E105K	CHIP C 1.0UF K	
C251			CC73HCH1H050B	CHIP C 5.0PF B		C422			CK73HB1H102K	CHIP C 1000PF K	
C253			CK73HB1H102K	CHIP C 1000PF K		C423,424			CC73HCH1H101J	CHIP C 100PF J	
C254			CC73HCH1H120G	CHIP C 12PF G		C425			CK73HB1H103K	CHIP C 0.010UF K	
C255			CC73HCH1H470J	CHIP C 47PF J		C427			CK73GB1H473K	CHIP C 0.047UF K	
C256			CC73HCH1H180G	CHIP C 18PF G		C428			CK73HB1A104K	CHIP C 0.10UF K	
C257			CK73HB1H102K	CHIP C 1000PF K		C429			CK73HB1H471K	CHIP C 470PF K	
C258			CC73HCH1H150G	CHIP C 15PF G		C430			CK73FB1E475K	CHIP C 4.7UF K	
C259			CK73HB1H102K	CHIP C 1000PF K		C431			CC73HCH1H101J	CHIP C 100PF J	
C260			CC73HCH1H180G	CHIP C 18PF G		C432			CK73GB1H104K	CHIP C 0.10UF K	
C261			CC73HCH1H560J	CHIP C 56PF J		C433,434			CK73FB1E475K	CHIP C 4.7UF K	
C262			CK73HB1H102K	CHIP C 1000PF K		C435			CK73GB1C225K	CHIP C 2.2UF K	

## PARTS LIST / 零件表

### TX-RX UNIT (X57-8230-11)

Ref. No.	Address	New parts	Parts No.	Description	Destination	Ref. No.	Address	New parts	Parts No.	Description	Destination
C436			CK73HB1H103K	CHIP C 0.010UF K		C559			CK73FB1A106K	CHIP C 10UF K	
C437			CK73FB1E475K	CHIP C 4.7UF K		C560			CC73HCH1H030B	CHIP C 3.0PF B	
C438,439			CK73GB1H104K	CHIP C 0.10UF K		C563			CC73HCH1H101J	CHIP C 100PF J	
C440			C92-0875-05	ELECTRO 47UF 25WV		C565-568			CK73HB1A104K	CHIP C 0.10UF K	
C441			CK73GB1C225K	CHIP C 2.2UF K		C569			CK73HB1H103K	CHIP C 0.010UF K	
C442			CK73HB1H103K	CHIP C 0.010UF K		C570			CK73HB1A105K	CHIP C 1.0UF K	
C443			CK73GB1E105K	CHIP C 1.0UF K		C572-576			CK73HB1A104K	CHIP C 0.10UF K	
C445,446			CK73HB1H103K	CHIP C 0.010UF K		C577			CK73HB1H103K	CHIP C 0.010UF K	
C447			CK73GB1E105K	CHIP C 1.0UF K		C578			CK73HB1A105K	CHIP C 1.0UF K	
C448			CK73HB1H103K	CHIP C 0.010UF K		C579-581			CK73HB1H103K	CHIP C 0.010UF K	
C449			CK73GB1E105K	CHIP C 1.0UF K		C602			CK73HB1H103K	CHIP C 0.010UF K	
C450,451			CK73FB1A106K	CHIP C 10UF K		C603			CC73HCH1H101J	CHIP C 100PF J	
C452			CS77LA1C4R7M	CHIP TNL 4.7UF 16WV		C604			CK73HB1H102K	CHIP C 1000PF K	
C453			CK73HB1H103K	CHIP C 0.010UF K		C605			CC73HCH1H101J	CHIP C 100PF J	
C454,455			CK73GB1C225K	CHIP C 2.2UF K		C607			CC73HCH1H101J	CHIP C 100PF J	
C456			CK73HB1H103K	CHIP C 0.010UF K		C609-611			CC73HCH1H470J	CHIP C 47PF J	
C457,458			CC73HCH1H101J	CHIP C 100PF J		C612			CC73HCH1H101J	CHIP C 100PF J	
C460			CC73HCH1H101J	CHIP C 100PF J		C613			CK73HB1H103K	CHIP C 0.010UF K	
C461			CK73HB1A105K	CHIP C 1.0UF K		C614-618			CC73HCH1H101J	CHIP C 100PF J	
C462			CK73GB1E105K	CHIP C 1.0UF K		C620			CC73HCH1H101J	CHIP C 100PF J	
C463			CC73HCH1H101J	CHIP C 100PF J		C621			CK73HB1H102K	CHIP C 1000PF K	
C464			CK73HB1A105K	CHIP C 1.0UF K		C622-624			CK73HB1H103K	CHIP C 0.010UF K	
C465,466			CK73GB1E105K	CHIP C 1.0UF K		C625			CK73HB1A104K	CHIP C 0.10UF K	
C468			CK73HB1H103K	CHIP C 0.010UF K		C626			CK73GB1H103K	CHIP C 0.010UF K	
C469			CK73HB1A105K	CHIP C 1.0UF K		C627-630			CK73GB1E105K	CHIP C 1.0UF K	
C471			CC73HCH1H101J	CHIP C 100PF J		C632			CK73HB1H102K	CHIP C 1000PF K	
C472			CK73HB1H102K	CHIP C 1000PF K		C633-642			CC73HCH1H101J	CHIP C 100PF J	
C475			CK73GB1E105K	CHIP C 1.0UF K		C643			CK73HB1E223K	CHIP C 0.022UF K	
C476			CK73HB1A104K	CHIP C 0.10UF K		C644			CC73HCH1H101J	CHIP C 100PF J	
C477			CK73GB1H104K	CHIP C 0.10UF K		C645			CK73GB1H103K	CHIP C 0.010UF K	
C501-504			CK73HB1A104K	CHIP C 0.10UF K		C646			CC73HCH1H101J	CHIP C 100PF J	
C505-507			CK73GB0J106K	CHIP C 10UF K		C647			CK73HB1H103K	CHIP C 0.010UF K	
C508,509			CK73HB1A105K	CHIP C 1.0UF K		C648			CK73GB1H104K	CHIP C 0.10UF K	
C510			CK73HB1A104K	CHIP C 0.10UF K		C650-652			CK73HB1A104K	CHIP C 0.10UF K	
C512			CK73HB1A104K	CHIP C 0.10UF K		C660			CC73HCH1H101J	CHIP C 100PF J	
C514-516			CK73HB1A104K	CHIP C 0.10UF K		C661			CC73HCH1H470J	CHIP C 47PF J	
C518-520			CK73HB1A104K	CHIP C 0.10UF K		C680			CK73HB1A104K	CHIP C 0.10UF K	
C521			CC73HCH1H101J	CHIP C 100PF J		C701			CK73HB1H682K	CHIP C 6800PF K	
C522,523			CK73HB1A104K	CHIP C 0.10UF K		C702			CK73HB1H102K	CHIP C 1000PF K	
C524			CK73HB1A105K	CHIP C 1.0UF K		C704			CK73HB1A105K	CHIP C 1.0UF K	
C525-531			CK73HB1A104K	CHIP C 0.10UF K		C705			CC73HCH1H470J	CHIP C 47PF J	
C532			CK73HB1H103K	CHIP C 0.010UF K		C706			CK73HB1A104K	CHIP C 0.10UF K	
C533			CK73GB0J106K	CHIP C 10UF K		C707			CK73HB1H681K	CHIP C 680PF K	
C534			CK73HB1A104K	CHIP C 0.10UF K		C708			CK73HB1H102K	CHIP C 1000PF K	
C535			CK73HB1H272K	CHIP C 2700PF K		C709			CC73HCH1H270J	CHIP C 27PF J	
C536			CK73HB1A104K	CHIP C 0.10UF K		C711			CC73HCH1H331J	CHIP C 330PF J	
C537			CK73HB1H102K	CHIP C 1000PF K		C712			CC73HCH1H181J	CHIP C 180PF J	
C541			CK73HB1A104K	CHIP C 0.10UF K		C714			CC73HCH1H680J	CHIP C 68PF J	
C542			CK73HB1H103K	CHIP C 0.010UF K		C716			CC73HCH1H101J	CHIP C 100PF J	
C543,544			CK73HB1A104K	CHIP C 0.10UF K		C718			CK73HB1A104K	CHIP C 0.10UF K	
C545			CK73FB1A106K	CHIP C 10UF K		C719			CC73HCH1H101J	CHIP C 100PF J	
C546			CK73HB1H103K	CHIP C 0.010UF K		C720			CK73HB1A104K	CHIP C 0.10UF K	
C547			CC73HCH1H101J	CHIP C 100PF J		C722			CK73HB1A104K	CHIP C 0.10UF K	
C548			CK73HB1H103K	CHIP C 0.010UF K		C723			CC73HCH1H470J	CHIP C 47PF J	
C549			CK73HB1A104K	CHIP C 0.10UF K		C725			CC73HCH1H121J	CHIP C 120PF J	
C551			CK73HB1A104K	CHIP C 0.10UF K		C728			CK73HB1H821K	CHIP C 820PF K	
C552			CK73HB1H103K	CHIP C 0.010UF K		C729			CK73HB1H681K	CHIP C 680PF K	
C553			CK73HB1A105K	CHIP C 1.0UF K		C732			CK73HB1H102K	CHIP C 1000PF K	
C555,556			CK73HB1H103K	CHIP C 0.010UF K		C733			CK73FB1E475K	CHIP C 4.7UF K	
C558			CK73HB1A104K	CHIP C 0.10UF K		C734			CK73HB1H472K	CHIP C 4700PF K	

## PARTS LIST / 零件表

TX-RX UNIT (X57-8230-11)

Ref. No.	Address	New parts	Parts No.	Description	Desti-nation	Ref. No.	Address	New parts	Parts No.	Description	Desti-nation
C735			CK73GB0J106K	CHIP C 10UF K		L2			L41-4795-39	SMALL FIXED INDUCTOR(4.7UH)	
C738			CK73HB1A104K	CHIP C 0.10UF K		L3			L92-0163-05	BEADS CORE	
C739			CK73HB1A105K	CHIP C 1.0UF K		L4			L40-1075-71	SMALL FIXED INDUCTOR(10NH)	
C740			CK73HB1H102K	CHIP C 1000PF K		L5			L92-0163-05	BEADS CORE	
C741			CK73HB1A224K	CHIP C 0.22UF K		L6 ,7			L40-1001-86	SMALL FIXED INDUCTOR(10UH)	
C743			CC73HCH1H470J	CHIP C 47PF J		L10			L40-5663-71	SMALL FIXED INDUCTOR(5.6NH)	
C744			CK73HB1A224K	CHIP C 0.22UF K		L11			L40-2285-92	SMALL FIXED INDUCTOR(220NH)	
C746			CK73HB1A104K	CHIP C 0.10UF K		L12			L40-3391-86	SMALL FIXED INDUCTOR(3.3UH)	
C747			CC73HCH1H221J	CHIP C 220PF J		L13			L40-2285-92	SMALL FIXED INDUCTOR(220NH)	
C749			CK73HB1H102K	CHIP C 1000PF K		L14			L40-3391-86	SMALL FIXED INDUCTOR(3.3UH)	
C752,753			CK73HB1A104K	CHIP C 0.10UF K		L15 ,16			L40-1885-92	SMALL FIXED INDUCTOR(180NH)	
C758			CC73HCH1H101J	CHIP C 100PF J		L17			L40-6865-71	SMALL FIXED INDUCTOR(6.8NH)	
C762			CK73HB1H103K	CHIP C 0.010UF K		L18			L34-4611-15	AIR-CORE COIL(10T)	
C765			CC73HCH1H220J	CHIP C 22PF J		L19			L92-0163-05	BEADS CORE	
C766,767			CK73GB0J475K	CHIP C 4.7UF K		L20			L34-4609-15	AIR-CORE COIL(8T)	
C769			CK73HB1E103K	CHIP C 0.010UF K		L21			L40-4775-92	SMALL FIXED INDUCTOR(47NH)	
C770			CK73HB1A104K	CHIP C 0.10UF K		L22			L92-0446-05	BEADS CORE	
C771			CK73HB1H122K	CHIP C 1200PF K		L23 ,24			L40-3391-86	SMALL FIXED INDUCTOR(3.3UH)	
C773			CK73HB1E103K	CHIP C 0.010UF K		L25			L40-1285-71	SMALL FIXED INDUCTOR(120NH)	
C774			CK73HB1A104K	CHIP C 0.10UF K		L26			L92-0163-05	BEADS CORE	
C775			CC73HCH1H101J	CHIP C 100PF J		L27			L40-1085-92	SMALL FIXED INDUCTOR(100NH)	
C776			CK73HB1A393K	CHIP C 0.039UF K		L102			L40-6875-92	SMALL FIXED INDUCTOR(68NH)	
C777			CK73HB1A104K	CHIP C 0.10UF K		L103			L92-0140-05	CHIP FERRITE	
C778			CK73HB1A105K	CHIP C 1.0UF K		L104			L40-3375-92	SMALL FIXED INDUCTOR(33NH)	
C779,780			CC73HCH1H101J	CHIP C 100PF J		L105			L92-0163-05	BEADS CORE	
C782			CK73HB1A104K	CHIP C 0.10UF K		L106			L40-3975-92	SMALL FIXED INDUCTOR(39NH)	
C784			CK73FB1A106K	CHIP C 10UF K		L107			L92-0140-05	CHIP FERRITE	
C786			CK73HB1A104K	CHIP C 0.10UF K		L108-110			L92-0179-05	CHIP FERRITE	
C788			CK73FB1E475K	CHIP C 4.7UF K		L111			L92-0163-05	BEADS CORE	
C790,791			CK73FB1A106K	CHIP C 10UF K		L112			L34-4478-15	AIR-CORE COIL(9.5T)	
C796			CK73GB1E105K	CHIP C 1.0UF K		L113			L34-4909-05	AIR-CORE COIL(5T)	
C797,798			CK73GB1C224K	CHIP C 0.22UF K		L114			L34-4478-15	AIR-CORE COIL(9.5T)	
C801			C92-0875-05	ELECTRO 47UF 25WV		L115			L34-4670-05	AIR-CORE COIL(5T)	
C802			CK73HB1H102K	CHIP C 1000PF K		L116			L34-4481-15	AIR-CORE COIL(6T)	
C803,804			C92-0906-05	ELECTRO 330UF 16WV		L117			L34-4736-05	AIR-CORE COIL(5T)	
C805			CK73HB1H102K	CHIP C 1000PF K		L118			L40-6875-92	SMALL FIXED INDUCTOR(68NH)	
C806			CK73GB1E105K	CHIP C 1.0UF K		L130			L40-5675-71	SMALL FIXED INDUCTOR(56NH)	
C807			CK73HB1C473K	CHIP C 0.047UF K		L201			L92-0138-05	CHIP FERRITE	
C808			CK73HB1A683K	CHIP C 0.068UF K		L202			L41-5685-39	SMALL FIXED INDUCTOR(0.56UH)	
C810			CK73FB1E475K	CHIP C 4.7UF K		L203			L41-2785-39	SMALL FIXED INDUCTOR(0.27UH)	
C811			CK73HB1H102K	CHIP C 1000PF K		L204			L40-3375-71	SMALL FIXED INDUCTOR(33NH)	
C812			CK73FB1A106K	CHIP C 10UF K		L205			L40-3975-71	SMALL FIXED INDUCTOR(39NH)	
C813			CK73GB0J106K	CHIP C 10UF K		L206			L40-1085-71	SMALL FIXED INDUCTOR(100NH)	
C829			CK73GB0J106K	CHIP C 10UF K		L207			L41-2285-14	SMALL FIXED INDUCTOR(220NH)	
C830,831			CK73HB1A104K	CHIP C 0.10UF K		L209,210			L41-2778-14	SMALL FIXED INDUCTOR(27NH)	
C832,833			CK73HB1H102K	CHIP C 1000PF K		L212			L92-0138-05	CHIP FERRITE	
CN10-15			E23-1278-05	TERMINAL(2P)		L213			L41-1085-14	SMALL FIXED INDUCTOR(100NH)	
CN203-206			E23-1278-05	TERMINAL(2P)		L214			L40-1275-92	SMALL FIXED INDUCTOR(12NH)	
CN514			E40-6847-05	FLAT CABLE CONNECTOR(30P)		L215,216			L41-3378-14	SMALL FIXED INDUCTOR(33NH)	
J501	1B		E58-0536-05	D-SUB SOCKET(15P)		L220			L40-2785-92	SMALL FIXED INDUCTOR(270NH)	
J701	2B		E11-0425-05	3.5D PHONE JACK(3P)		L221			L40-5663-71	SMALL FIXED INDUCTOR(5.6NH)	
F401			F53-0328-15	FUSE(5A)		L232,233			L41-3978-14	SMALL FIXED INDUCTOR(39NH)	
F501			F53-0324-15	FUSE(2.5A)		L301			L41-1585-14	SMALL FIXED INDUCTOR(150NH)	
F502			F53-0315-15	FUSE(250MA)		L302			L40-5681-86	SMALL FIXED INDUCTOR(0.56UH)	
F503			F53-0316-15	FUSE(375MA)		L304			L40-5675-92	SMALL FIXED INDUCTOR(56NH)	
F701			F53-0324-15	FUSE(2.5A)		L307			L40-2291-86	SMALL FIXED INDUCTOR(2.2UH)	
CF1			L72-1017-05	CERAMIC FILTER(450KHZ)		L309			L40-1085-57	SMALL FIXED INDUCTOR(100NH)	
CF2			L72-1040-05	CERAMIC FILTER(450KHZ)		L310			L92-0138-05	CHIP FERRITE	
L1			L92-0163-05	BEADS CORE		L317			L41-3985-39	SMALL FIXED INDUCTOR(0.39UH)	
						L319			L41-1885-39	SMALL FIXED INDUCTOR(0.18UH)	

## PARTS LIST / 零件表

### TX-RX UNIT (X57-8230-11)

Ref. No.	Address	New parts	Parts No.	Description	Destination	Ref. No.	Address	New parts	Parts No.	Description	Destination
L404			L92-0639-05	CHIP FERRITE		R54			RN73HH1J331D	CHIP R 330 D	1/16W
L405			L33-1496-05	SMALL FIXED INDUCTOR(22UH)		R55			RN73HH1J221D	CHIP R 220 D	1/16W
L501			L92-0138-05	CHIP FERRITE		R56			RK73HB1J000J	CHIP R 0 J	1/16W
L503			L92-0138-05	CHIP FERRITE		R57, 58			RN73HH1J220D	CHIP R 22 D	1/16W
L504-506			L92-0162-05	BEADS CORE		R59			RK73HB1J102J	CHIP R 1.0K J	1/16W
L508			L92-0138-05	CHIP FERRITE		R60			RK73HB1J473J	CHIP R 47K J	1/16W
L510			L92-0138-05	CHIP FERRITE		R61			RK73HB1J154J	CHIP R 150K J	1/16W
X1			L77-3073-05	TCXO(16.8MHZ)		R62			RK73HB1J101J	CHIP R 100 J	1/16W
X501			L77-3015-05	TCXO(18.432MHZ)		R63			RK73HB1J103J	CHIP R 10K J	1/16W
XF1			L71-0678-05	MCF(49.95MHZ)		R64			RK73HB1J822J	CHIP R 8.2K J	1/16W
CP1			RK74HB1J100J	CHIP-COM 10 J 1/16W		R65-67			RK73HB1J101J	CHIP R 100 J	1/16W
CP501			RK74HB1J104J	CHIP-COM 100K J 1/16W		R69			RK73HB1J472J	CHIP R 4.7K J	1/16W
CP502			RK74HA1J104J	CHIP-COM 100K J 1/16W		R70			RK73HB1J474J	CHIP R 470K J	1/16W
CP503			RK74HB1J104J	CHIP-COM 100K J 1/16W		R71			RK73HB1J101J	CHIP R 100 J	1/16W
CP504			RK74HA1J101J	CHIP-COM 100 J 1/16W		R72			RK73HB1J102J	CHIP R 1.0K J	1/16W
CP505			RK74HA1J104J	CHIP-COM 100K J 1/16W		R73			RK73GB2A000J	CHIP R 0 J	1/10W
CP506-508			RK74HB1J104J	CHIP-COM 100K J 1/16W		R75			RK73HB1J100J	CHIP R 10 J	1/16W
CP510			RK74HA1J104J	CHIP-COM 100K J 1/16W		R76			RK73HB1J000J	CHIP R 0 J	1/16W
CP511			RK74HA1J101J	CHIP-COM 100 J 1/16W		R80-83			RK73GB2A000J	CHIP R 0 J	1/10W
CP512			RK74HA1J104J	CHIP-COM 100K J 1/16W		R86-88			RK73HB1J000J	CHIP R 0 J	1/16W
CP513			RK74HB1J104J	CHIP-COM 100K J 1/16W		R101			RK73HB1J332J	CHIP R 3.3K J	1/16W
CP514			RK74HA1J104J	CHIP-COM 100K J 1/16W		R103			RK73HB1J000J	CHIP R 0 J	1/16W
CP515			RK74HA1J101J	CHIP-COM 100 J 1/16W		R111			RK73HB1J272J	CHIP R 2.7K J	1/16W
CP516			RK74HB1J101J	CHIP-COM 100 J 1/16W		R112			RK73HB1J182J	CHIP R 1.8K J	1/16W
CP701			RK74HB1J101J	CHIP-COM 100 J 1/16W		R113			RK73GB2A680J	CHIP R 68 J	1/10W
CP703,704			RK74HB1J104J	CHIP-COM 100K J 1/16W		R114			RK73HB1J331J	CHIP R 330 J	1/16W
CP705,706			RK74HA1J104J	CHIP-COM 100K J 1/16W		R115			RK73GB2A680J	CHIP R 68 J	1/10W
CP707			RK74HB1J102J	CHIP-COM 1.0K J 1/16W		R120			RK73HB1J153J	CHIP R 15K J	1/16W
R1			RK73HB1J000J	CHIP R 0 J 1/16W		R121			RK73FB2B471J	CHIP R 470 J	1/8W
R10			RK73HB1J100J	CHIP R 10 J 1/16W		R122,123			RK73FB2B220J	CHIP R 22 J	1/8W
R12			RK73HB1J683J	CHIP R 68K J 1/16W		R125			RK73FB2B471J	CHIP R 470 J	1/8W
R13,14			RK73HB1J473J	CHIP R 47K J 1/16W		R128			RK73HB1J471J	CHIP R 470 J	1/16W
R15			RK73HB1J100J	CHIP R 10 J 1/16W		R130			RK73HB1J273J	CHIP R 27K J	1/16W
R16			RK73HB1J102J	CHIP R 1.0K J 1/16W		R131			RK73HB1J103J	CHIP R 10K J	1/16W
R17			RK73HB1J104J	CHIP R 100K J 1/16W		R133			RK73HB1J153J	CHIP R 15K J	1/16W
R18			RK73HB1J102J	CHIP R 1.0K J 1/16W		R134			RK73GB2A181J	CHIP R 180 J	1/10W
R19,20			RK73HB1J000J	CHIP R 0 J 1/16W		R135			RK73HB1J104J	CHIP R 100K J	1/16W
R21			RK73HB1J470J	CHIP R 47 J 1/16W		R136			RK73GB2A181J	CHIP R 180 J	1/10W
R22			RK73HB1J121J	CHIP R 120 J 1/16W		R137			RK73HB1J104J	CHIP R 100K J	1/16W
R23			RK73HB1J100J	CHIP R 10 J 1/16W		R138			RK73HB1J103J	CHIP R 10K J	1/16W
R24			RK73HH1J391D	CHIP R 390 D 1/16W		R139			RK73GH2A101D	CHIP R 100 D	1/10W
R25			RK73HB1J104J	CHIP R 100K J 1/16W		R141			RK73HB1J333J	CHIP R 33K J	1/16W
R26			RK73HB1J102J	CHIP R 1.0K J 1/16W		R142			RK73HB1J000J	CHIP R 0 J	1/16W
R27			RK73HB1J103J	CHIP R 10K J 1/16W		R143			RK73HB1J104J	CHIP R 100K J	1/16W
R28			RK73HB1J106J	CHIP R 10M J 1/16W		R145			RK73GB2A000J	CHIP R 0 J	1/10W
R29			RK73HB1J470J	CHIP R 47 J 1/16W		R146			RK73HB1J393J	CHIP R 39K J	1/16W
R30			RK73HB1J184J	CHIP R 180K J 1/16W		R147			RK73HB1J124J	CHIP R 120K J	1/16W
R31			RK73HB1J473J	CHIP R 47K J 1/16W		R148			RK73HB1J000J	CHIP R 0 J	1/16W
R33			RK73HB1J472J	CHIP R 4.7K J 1/16W		R149			RK73HB1J103J	CHIP R 10K J	1/16W
R34			RK73HB1J182J	CHIP R 1.8K J 1/16W		R150			RK73HB1J124J	CHIP R 120K J	1/16W
R35-38			RK73HB1J000J	CHIP R 0 J 1/16W		R152			RK73HB1J102J	CHIP R 1.0K J	1/16W
R39			RK73HB1J103J	CHIP R 10K J 1/16W		R154			RK73HB1J000J	CHIP R 0 J	1/16W
R42,43			RK73HB1J104J	CHIP R 100K J 1/16W		R155			RK73HB1J223J	CHIP R 22K J	1/16W
R44			RK73HB1J273J	CHIP R 27K J 1/16W		R157,158			RK73HB1J333J	CHIP R 33K J	1/16W
R45,46			RK73HB1J473J	CHIP R 47K J 1/16W		R159,160			RK73HB1J000J	CHIP R 0 J	1/16W
R48			RK73HB1J472J	CHIP R 4.7K J 1/16W		R161			RK73HB1J104J	CHIP R 100K J	1/16W
R50			RK73HB1J560J	CHIP R 56 J 1/16W		R167			RK73HB1J153J	CHIP R 15K J	1/16W
R51			RK73HB1J561J	CHIP R 560 J 1/16W		R168,169			RK73EB2E241J	CHIP R 240 J	1/4W
R52			RK73HB1J474J	CHIP R 470K J 1/16W		R171	2B		R92-1061-05	JUMPER REST 0 OHM	
R53			RK73HB1J563J	CHIP R 56K J 1/16W		R176			RK73GB2A471J	CHIP R 470 J	1/10W

## PARTS LIST / 零件表

TX-RX UNIT (X57-8230-11)

Ref. No.	Address	New parts	Parts No.	Description	Desti-nation	Ref. No.	Address	New parts	Parts No.	Description	Desti-nation
R177,178			RK73HB1J000J	CHIP R 0 J 1/16W		R390			RK73HB1J103J	CHIP R 10K J 1/16W	
R179,180			RK73HB1J333J	CHIP R 33K J 1/16W		R394			RK73HB1J181J	CHIP R 180 J 1/16W	
R181			RK73HB1J000J	CHIP R 0 J 1/16W		R401			RK73HB1J471J	CHIP R 470 J 1/16W	
R183			RK73HB1J103J	CHIP R 10K J 1/16W		R402			RK73HB1J103J	CHIP R 10K J 1/16W	
R184			RK73HB1J473J	CHIP R 47K J 1/16W		R403			RK73HH1J274D	CHIP R 270K D 1/16W	
R201			RK73HB1J470J	CHIP R 47 J 1/16W		R404			RK73HH1J104D	CHIP R 100K D 1/16W	
R203			RK73HB1J681J	CHIP R 680 J 1/16W		R405,406			RK73HB1J103J	CHIP R 10K J 1/16W	
R204			RK73HB1J472J	CHIP R 4.7K J 1/16W		R407			RK73HB1J472J	CHIP R 4.7K J 1/16W	
R205			RK73HB1J151J	CHIP R 150 J 1/16W		R408			RK73HB1J684J	CHIP R 680K J 1/16W	
R207			RK73HB1J104J	CHIP R 100K J 1/16W		R409			RK73HB1J104J	CHIP R 100K J 1/16W	
R208			RK73HB1J184J	CHIP R 180K J 1/16W		R410			RK73GB2A4R7J	CHIP R 4.7 J 1/10W	
R209			RK73HB1J104J	CHIP R 100K J 1/16W		R411			RK73HB1J473J	CHIP R 47K J 1/16W	
R210			RK73HB1J224J	CHIP R 220K J 1/16W		R412,413			RK73GB2A100J	CHIP R 10 J 1/10W	
R212			RK73HB1J104J	CHIP R 100K J 1/16W		R414,415			RK73HB1J103J	CHIP R 10K J 1/16W	
R223			RK73HB1J000J	CHIP R 0 J 1/16W		R417			RK73HB1J104J	CHIP R 100K J 1/16W	
R230			RK73HB1J000J	CHIP R 0 J 1/16W		R418			RK73HB1J000J	CHIP R 0 J 1/16W	
R233			RK73HB1J274J	CHIP R 270K J 1/16W		R419			RK73HB1J272J	CHIP R 2.7K J 1/16W	
R234			RK73HB1J104J	CHIP R 100K J 1/16W		R421			RK73HB1J472J	CHIP R 4.7K J 1/16W	
R235			RK73HB1J103J	CHIP R 10K J 1/16W		R422			RK73HB1J474J	CHIP R 470K J 1/16W	
R237			RK73HB1J104J	CHIP R 100K J 1/16W		R423			RK73HB1J472J	CHIP R 4.7K J 1/16W	
R241			RK73HB1J103J	CHIP R 10K J 1/16W		R424			RK73HB1J103J	CHIP R 10K J 1/16W	
R242			RK73HB1J154J	CHIP R 150K J 1/16W		R425			RK73HH1J124D	CHIP R 120K D 1/16W	
R243			RK73HB1J104J	CHIP R 100K J 1/16W		R426			RK73HH1J183D	CHIP R 18K D 1/16W	
R245			RK73HB1J102J	CHIP R 1.0K J 1/16W		R427			RK73HH1J223D	CHIP R 22K D 1/16W	
R246			RK73HB1J100J	CHIP R 10 J 1/16W		R428			RK73HB1J102J	CHIP R 1.0K J 1/16W	
R247			RK73HB1J390J	CHIP R 39 J 1/16W		R429			RK73HB1J000J	CHIP R 0 J 1/16W	
R249			RK73HB1J472J	CHIP R 4.7K J 1/16W		R430			RK73HB1J102J	CHIP R 1.0K J 1/16W	
R250			RK73HB1J222J	CHIP R 2.2K J 1/16W		R431			RK73HB1J000J	CHIP R 0 J 1/16W	
R255-258			RK73HB1J104J	CHIP R 100K J 1/16W		R432			RK73HB1J103J	CHIP R 10K J 1/16W	
R259			RK73HB1J000J	CHIP R 0 J 1/16W		R433			RK73HB1J274J	CHIP R 270K J 1/16W	
R303-305			RK73HB1J102J	CHIP R 1.0K J 1/16W		R434			RK73HB1J103J	CHIP R 10K J 1/16W	
R306			RK73HB1J334J	CHIP R 330K J 1/16W		R435			RK73HB1J000J	CHIP R 0 J 1/16W	
R307			RK73HB1J561J	CHIP R 560 J 1/16W		R438			RK73GB2A100J	CHIP R 10 J 1/10W	
R308			RK73HB1J000J	CHIP R 0 J 1/16W		R439			RK73HB1J474J	CHIP R 470K J 1/16W	
R315			RK73HB1J000J	CHIP R 0 J 1/16W		R440			RK73HB1J000J	CHIP R 0 J 1/16W	
R316			RK73HB1J332J	CHIP R 3.3K J 1/16W		R441			RK73HB1J272J	CHIP R 2.7K J 1/16W	
R323			RK73HB1J000J	CHIP R 0 J 1/16W		R501			RK73HB1J220J	CHIP R 22 J 1/16W	
R324			RK73HB1J183J	CHIP R 18K J 1/16W		R503,504			RK73HB1J104J	CHIP R 100K J 1/16W	
R326			RK73GB2A331J	CHIP R 330 J 1/10W		R505,506			RK73GB2A000J	CHIP R 0 J 1/10W	
R328			RK73HB1J183J	CHIP R 18K J 1/16W		R508-511			RK73HB1J101J	CHIP R 100 J 1/16W	
R329			RK73HB1J100J	CHIP R 10 J 1/16W		R512			RK73HB1J104J	CHIP R 100K J 1/16W	
R332			RK73HB1J000J	CHIP R 0 J 1/16W		R513			RK73HB1J000J	CHIP R 0 J 1/16W	
R336,337			RK73HB1J102J	CHIP R 1.0K J 1/16W		R515-517			RK73HB1J000J	CHIP R 0 J 1/16W	
R338			RK73HB1J473J	CHIP R 47K J 1/16W		R518			RK73HB1J101J	CHIP R 100 J 1/16W	
R339			RK73HB1J153J	CHIP R 15K J 1/16W		R519			RK73HB1J000J	CHIP R 0 J 1/16W	
R340			RK73HB1J274J	CHIP R 270K J 1/16W		R521,522			RK73HB1J104J	CHIP R 100K J 1/16W	
R341			RK73HB1J103J	CHIP R 10K J 1/16W		R524			RK73HB1J000J	CHIP R 0 J 1/16W	
R342			RK73HB1J104J	CHIP R 100K J 1/16W		R525			RK73HB1J474J	CHIP R 470K J 1/16W	
R343			RK73HB1J223J	CHIP R 22K J 1/16W		R526			RK73HB1J104J	CHIP R 100K J 1/16W	
R344			RK73HB1J272J	CHIP R 2.7K J 1/16W		R531			RK73HB1J104J	CHIP R 100K J 1/16W	
R345			RK73HB1J000J	CHIP R 0 J 1/16W		R532			RK73HB1J000J	CHIP R 0 J 1/16W	
R350			RK73HB1J103J	CHIP R 10K J 1/16W		R533,534			RK73HB1J473J	CHIP R 47K J 1/16W	
R351			RK73HB1J104J	CHIP R 100K J 1/16W		R536			RK73HB1J000J	CHIP R 0 J 1/16W	
R355			RK73HB1J000J	CHIP R 0 J 1/16W		R541			RK73HB1J101J	CHIP R 100 J 1/16W	
R357			RK73HB1J124J	CHIP R 120K J 1/16W		R546			RK73HB1J000J	CHIP R 0 J 1/16W	
R358			RK73HB1J333J	CHIP R 33K J 1/16W		R549			RK73HB1J103J	CHIP R 10K J 1/16W	
R368			RK73HB1J221J	CHIP R 220 J 1/16W		R550			RK73HB1J104J	CHIP R 100K J 1/16W	
R378			RK73HB1J394J	CHIP R 390K J 1/16W		R552,553			RK73HB1J472J	CHIP R 4.7K J 1/16W	
R379			RK73HB1J222J	CHIP R 2.2K J 1/16W		R554			RK73HB1J332J	CHIP R 3.3K J 1/16W	
R381			RK73HB1J221J	CHIP R 220 J 1/16W		R555			RK73HB1J102J	CHIP R 1.0K J 1/16W	

## PARTS LIST / 零件表

### TX-RX UNIT (X57-8230-11)

Ref. No.	Address	New parts	Parts No.	Description	Destination	Ref. No.	Address	New parts	Parts No.	Description	Destination
R556			RK73HB1J220J	CHIP R 22 J 1/16W		R703			RK73HB1J563J	CHIP R 56K J 1/16W	
R557			RK73HB1J153J	CHIP R 15K J 1/16W		R704			RK73HB1J153J	CHIP R 15K J 1/16W	
R558			RK73HB1J220J	CHIP R 22 J 1/16W		R705			RK73HB1J683J	CHIP R 68K J 1/16W	
R559			RK73HB1J392J	CHIP R 3.9K J 1/16W		R706			RK73HB1J823J	CHIP R 82K J 1/16W	
R560			RK73HB1J474J	CHIP R 470K J 1/16W		R707			RK73HB1J182J	CHIP R 1.8K J 1/16W	
R566			RK73HB1J474J	CHIP R 470K J 1/16W		R708			RK73HB1J333J	CHIP R 33K J 1/16W	
R567			RK73HB1J102J	CHIP R 1.0K J 1/16W		R709			RK73HB1J104J	CHIP R 100K J 1/16W	
R568,569			RK73HB1J000J	CHIP R 0 J 1/16W		R710			RK73HB1J563J	CHIP R 56K J 1/16W	
R571,572			RK73HB1J000J	CHIP R 0 J 1/16W		R711			RK73HB1J104J	CHIP R 100K J 1/16W	
R580			RK73HB1J332J	CHIP R 3.3K J 1/16W		R712			RK73HB1J473J	CHIP R 47K J 1/16W	
R581			RK73HB1J104J	CHIP R 100K J 1/16W		R713			RK73HB1J223J	CHIP R 22K J 1/16W	
R583			RK73HB1J104D	CHIP R 100K D 1/16W		R716			RK73HB1J104J	CHIP R 100K J 1/16W	
R584			RK73HB1J473J	CHIP R 47K J 1/16W		R720			RK73HB1J334J	CHIP R 330K J 1/16W	
R599			RK73HB1J104J	CHIP R 100K J 1/16W		R722			RK73HB1J104J	CHIP R 100K J 1/16W	
R603			RK73HB1J474J	CHIP R 470K J 1/16W		R724			RK73HB1J473J	CHIP R 47K J 1/16W	
R606			RK73HB1J105J	CHIP R 1.0M J 1/16W		R728			RK73HB1J393J	CHIP R 39K J 1/16W	
R610			RK73HB1J474J	CHIP R 470K J 1/16W		R730			RK73HB1J473J	CHIP R 47K J 1/16W	
R611			RK73HB1J103J	CHIP R 10K J 1/16W		R738			RK73HB1J103J	CHIP R 10K J 1/16W	
R612			RK73HB1J102J	CHIP R 1.0K J 1/16W		R739			RK73HB1J334J	CHIP R 330K J 1/16W	
R613			RK73HB1J103J	CHIP R 10K J 1/16W		R741			RK73HB1J470J	CHIP R 47 J 1/16W	
R614			RK73HB1J000J	CHIP R 0 J 1/16W		R742			RK73HB1J332J	CHIP R 3.3K J 1/16W	
R615			RK73HB1J472J	CHIP R 4.7K J 1/16W		R743			RK73HB1J471J	CHIP R 470 J 1/16W	
R616			RK73HB1J474J	CHIP R 470K J 1/16W		R745			RK73HB1J104J	CHIP R 100K J 1/16W	
R617			RK73HB1J000J	CHIP R 0 J 1/16W		R746			RK73HB1J103J	CHIP R 10K J 1/16W	
R620			RK73HB1J103J	CHIP R 10K J 1/16W		R748,749			RK73HB1J104J	CHIP R 100K J 1/16W	
R621-624			RK73HB1J104J	CHIP R 100K J 1/16W		R750			RK73HB1J393J	CHIP R 39K J 1/16W	
R626			RK73HB1J101J	CHIP R 100 J 1/16W		R751			RK73HB1J104J	CHIP R 100K J 1/16W	
R627,628			RK73HB1J682J	CHIP R 6.8K J 1/16W		R752			RK73HB1J394J	CHIP R 390K J 1/16W	
R629			RK73HB1J104J	CHIP R 100K J 1/16W		R754			RK73HB1J563J	CHIP R 56K J 1/16W	
R631			RK73HB1J104J	CHIP R 100K J 1/16W		R755			RK73HB1J224J	CHIP R 220K J 1/16W	
R632			RK73GB2A000J	CHIP R 0 J 1/10W		R756			RK73HB1J102J	CHIP R 1.0K J 1/16W	
R634			RK73HB1J101J	CHIP R 100 J 1/16W		R769			RK73HB1J684J	CHIP R 680K J 1/16W	
R635			RK73GB2A000J	CHIP R 0 J 1/10W		R770,771			RK73HB1J473J	CHIP R 47K J 1/16W	
R636			RK73HB1J474J	CHIP R 470K J 1/16W		R772			RK73HB1J153J	CHIP R 15K J 1/16W	
R637,638			RK73FB2B102J	CHIP R 1.0K J 1/8W		R773			RK73HB1J000J	CHIP R 0 J 1/16W	
R639			RK73HB1J471J	CHIP R 470 J 1/16W		R775			RK73HB1J562J	CHIP R 5.6K J 1/16W	
R641			RK73GB2A000J	CHIP R 0 J 1/10W		R776,777			RK73HB1J103J	CHIP R 10K J 1/16W	
R643			RK73GB2A000J	CHIP R 0 J 1/10W		R778			RK73HB1J273J	CHIP R 27K J 1/16W	
R657			RK73HB1J472J	CHIP R 4.7K J 1/16W		R779			RK73HB1J223J	CHIP R 22K J 1/16W	
R658,659			RK73GB2A000J	CHIP R 0 J 1/10W		R783			RK73HB1J154J	CHIP R 150K J 1/16W	
R661			RK73HB1J473J	CHIP R 47K J 1/16W		R785			RK73HB1J000J	CHIP R 0 J 1/16W	
R662			RK73GB2A000J	CHIP R 0 J 1/10W		R786			RK73HB1J563J	CHIP R 56K J 1/16W	
R664			RK73GB2A000J	CHIP R 0 J 1/10W		R787			RK73HB1J123J	CHIP R 12K J 1/16W	
R667			RK73GB2A101J	CHIP R 100 J 1/10W		R796,797			RK73GB2A000J	CHIP R 0 J 1/10W	
R668			RK73HB1J471J	CHIP R 470 J 1/16W		R800			RK73HB1J104J	CHIP R 100K J 1/16W	
R669-671			RK73HB1J101J	CHIP R 100 J 1/16W		R801			RK73HB1J102J	CHIP R 1.0K J 1/16W	
R672			RK73GB2A471J	CHIP R 470 J 1/10W		R803,804			RK73HB1J472J	CHIP R 4.7K J 1/16W	
R673			RK73HB1J104J	CHIP R 100K J 1/16W		R805,806			RK73HB1J102J	CHIP R 1.0K J 1/16W	
R674			RK73HB1J105J	CHIP R 1.0M J 1/16W		R810			RK73HB1J123J	CHIP R 12K J 1/16W	
R677-680			RK73GB2A000J	CHIP R 0 J 1/10W		R811			RK73HB1J103J	CHIP R 10K J 1/16W	
R681			RK73HB1J000J	CHIP R 0 J 1/16W		R813			RK73HB1J102J	CHIP R 1.0K J 1/16W	
R682,683			RK73GB2A000J	CHIP R 0 J 1/10W		R814			RK73HB1J391J	CHIP R 390 J 1/16W	
R684			RK73HB1J473J	CHIP R 47K J 1/16W		R816			RK73HB1J123J	CHIP R 12K J 1/16W	
R685			RK73HB1J103J	CHIP R 10K J 1/16W		R818			RK73HB1J332J	CHIP R 3.3K J 1/16W	
R686			RK73HB1J223J	CHIP R 22K J 1/16W		R819,820			RK73HB1J222J	CHIP R 2.2K J 1/16W	
R687			RK73HB1J103J	CHIP R 10K J 1/16W		R821,822			RK73GB2A000J	CHIP R 0 J 1/10W	
R688			RK73HB1J102J	CHIP R 1.0K J 1/16W		R823			RK73HB1J123J	CHIP R 12K J 1/16W	
R690			RK73HB1J102J	CHIP R 1.0K J 1/16W		R824			RK73HB1J332J	CHIP R 3.3K J 1/16W	
R701			RK73HB1J103J	CHIP R 10K J 1/16W		R825			RK73HB1J000J	CHIP R 0 J 1/16W	
R702			RK73HB1J222J	CHIP R 2.2K J 1/16W		R826			RK73HB1J103J	CHIP R 10K J 1/16W	



## PARTS LIST / 零件表

TX-RX UNIT (X57-8230-11)

Ref. No.	Address	New parts	Parts No.	Description	Desti-nation	Ref. No.	Address	New parts	Parts No.	Description	Desti-nation
R827			RK73HB1J823J	CHIP R 82K J 1/16W		IC407			NJM2878F4-33	BI-POLAR IC	
R831,832			RK73HB1J683J	CHIP R 68K J 1/16W		IC408			XC6205B152P-G	MOS-IC	
R833			RK73HB1J101J	CHIP R 100 J 1/16W		IC409			NJM2878F4-33	BI-POLAR IC	
R834			RK73HB1J102J	CHIP R 1.0K J 1/16W		IC501			<b>Note1(BGA)</b>	ROM IC	
R837			RK73HB1J562J	CHIP R 5.6K J 1/16W		IC502			<b>Note1(BGA)</b>	DSP IC	
R838			RK73HB1J332J	CHIP R 3.3K J 1/16W		IC503			<b>Note1(BGA)</b>	SRAM IC	
R845			RK73HB1J101J	CHIP R 100 J 1/16W		IC504			BD5329FVE	MOS-IC	
R846,847			RK73HB1J223J	CHIP R 22K J 1/16W		IC506			SM5023CNDH-G	MOS-IC	
D2			DZ2J091(M)	ZENER DIODE		IC507			<b>Note1(BGA)</b>	MOS-IC	
D4 ,5			1SV325F	VARIABLE CAPACITANCE DIODE		IC508			TC7SH08FU-F	MOS-IC	
D6			1SV305F	VARIABLE CAPACITANCE DIODE		IC509			TC7WH126FU-F	MOS-IC	
D7 -12			1SV282-F	VARIABLE CAPACITANCE DIODE		IC511			TC74VHCT244AFK	MOS-IC	
D13			1SV305F	VARIABLE CAPACITANCE DIODE		IC512			TC7WBD125AFK	MOS-IC	
D14			DA2S101	DIODE		IC513			TC7WT126FU-F	MOS-IC	
D15			1SV278F	VARIABLE CAPACITANCE DIODE		IC514			TC7WH126FU-F	MOS-IC	
D16 ,17			RKS151KJ	DIODE		IC515			PCA9535BS	MOS-IC	
D101			DZ2J056(M)	ZENER DIODE		IC516			ADM202EARNZ	MOS-IC	
D102			DA3S101F	DIODE		IC701			BU7462NUX	MOS-IC	
D103			RKS151KJ	DIODE		IC702			BU7242NUX	MOS-IC	
D104,105			HSB88AS-E	DIODE		IC703			BU7462NUX	MOS-IC	
D106			DZ2J056(M)	ZENER DIODE		IC705			BU7242NUX	MOS-IC	
D107			RKP351KW-1P2	DIODE		IC711			BU7462NUX	MOS-IC	
D108,109			RB520SM-30	DIODE		IC712			R2A20178NP	DAC IC	
D110,111			L407CDB	DIODE		IC713			TC7W53FK(F)	MOS-IC	
D112-114			RN142S	DIODE		<b>IC714</b>	2A		LA4600	BI-POLAR IC	
D202,203			1SV283F	VARIABLE CAPACITANCE DIODE		IC716			TC7WT126FU-F	MOS-IC	
D204-207			1SV325F	VARIABLE CAPACITANCE DIODE		Q1			LTC014EEBFS8	TRANSISTOR	
D401			DZ2J180(M)	ZENER DIODE		Q2			2SJ648-A	FET	
D403			RB520SM-30	DIODE		Q4			2SC5383-T111	TRANSISTOR	
D404			DA2S101	DIODE		Q5			2SC5108(Y)F	TRANSISTOR	
D405			DB2S310	DIODE		Q6 ,7			MCH3914(7)-H	FET	
D406			DB22306	DIODE		Q8			EM6M1	FET	
D407			RB520SM-30	DIODE		Q9			SSM3J15FS	FET	
D408,409			DB2S310	DIODE		Q10 ,11			2SC5108(Y)F	TRANSISTOR	
D410			22ZR-10D	SURGE ABSORBER		Q102			2SC3357-A	TRANSISTOR	
D411			DSA3A1	DIODE		Q105			FK330301	FET	
D502			DB2S310	DIODE		Q106			EMD5	TRANSISTOR	
D504			DB2S310	DIODE		Q201			3SK318	FET	
D505-510			MC2850	DIODE		Q202			NESG240034	TRANSISTOR	
D511-513			DB2S310	DIODE		Q303			2SC5108(Y)F	TRANSISTOR	
D601			DB2S310	DIODE		Q305			2SC4215-F(Y)	TRANSISTOR	
D701			DA2S101	DIODE		Q401			LTC014EEBFS8	TRANSISTOR	
D702			1SS422	DIODE		Q402			2SA1955A-F	TRANSISTOR	
D703,704			DA3S101F	DIODE		Q403			MTM981400BF	FET	
D705,706			EMZ6.8N	ZENER DIODE		Q404			2SA1955A-F	TRANSISTOR	
IC1			TA7808F-NQ	ANALOGUE IC		Q405			LTC014EEBFS8	TRANSISTOR	
IC2			SKY72310-362	MOS-IC		Q407			FK330301	FET	
IC3			BD7542FVM	MOS-IC		Q408			EMD5	TRANSISTOR	
IC103			NJM12904RB1	MOS-IC		Q409			EM6M1	FET	
<b>IC102</b>	2B		RA60H1317M1A	IC(POWER MODULE)		Q410			2SA1955A-F	TRANSISTOR	
IC201			BD7542FVM	MOS-IC		Q411,412			LTC014EEBFS8	TRANSISTOR	
IC301			TC7SH08FU-F	MOS-IC		Q414			EMD9	TRANSISTOR	
IC303			TK10931VTL-G	ANALOGUE IC		Q415			2SC4738(GR)F	TRANSISTOR	
IC304			BU7445HFV	MOS-IC		Q416			2SA1832(GR)F	TRANSISTOR	
IC401			XC6209B332M-G	MOS-IC		Q417			EMD5	TRANSISTOR	
IC402			XC6118C23CMR	MOS-IC		Q418			LTC014EEBFS8	TRANSISTOR	
IC404			XC6209B502P-G	MOS-IC		Q501			FK330301	FET	
IC405			LT1616ES6-PBF	ANALOGUE IC		Q502			LTC014TEBFS8	TRANSISTOR	
IC406			XC6209B332M-G	MOS-IC		Q503			MTM981400BF	FET	
						Q504			LTC014TEBFS8	TRANSISTOR	

If a part reference number is listed in a shaded box, that part does not come with the PCB.

**Note 1: This part cannot be replaced. Therefore, this part is not supplied as a service part.**

维修部件的 PCB 板里不含阴影显示文字的零件。 注意 1: 该零件不可以替换。所以, 对该零件不能供应它的维修零件。

# NX-720

## PARTS LIST / 零件表

TX-RX UNIT (X57-8230-11)

Ref. No.	Address	New parts	Parts No.	Description	Destination	Ref. No.	Address	New parts	Parts No.	Description	Destination
Q701			FK330301	FET							
Q702			KTC4075E(Y,GR)	TRANSISTOR							
Q703			2SA1832(GR)F	TRANSISTOR							
Q704			2SC4738(GR)F	TRANSISTOR							
Q705,706			SSM3J15FS	FET							
Q708			LTC014EEBFS8	TRANSISTOR							
Q709			SSM6N37FE	FET							
TH1			ERTJ0EV104H	THERMISTOR							
TH101			ERTJ0EV104H	THERMISTOR							
TH103			ERTJ0EV104H	THERMISTOR							
TH701			ERTJ0EV104H	THERMISTOR							

## EXPLODED VIEW / 部件分解图

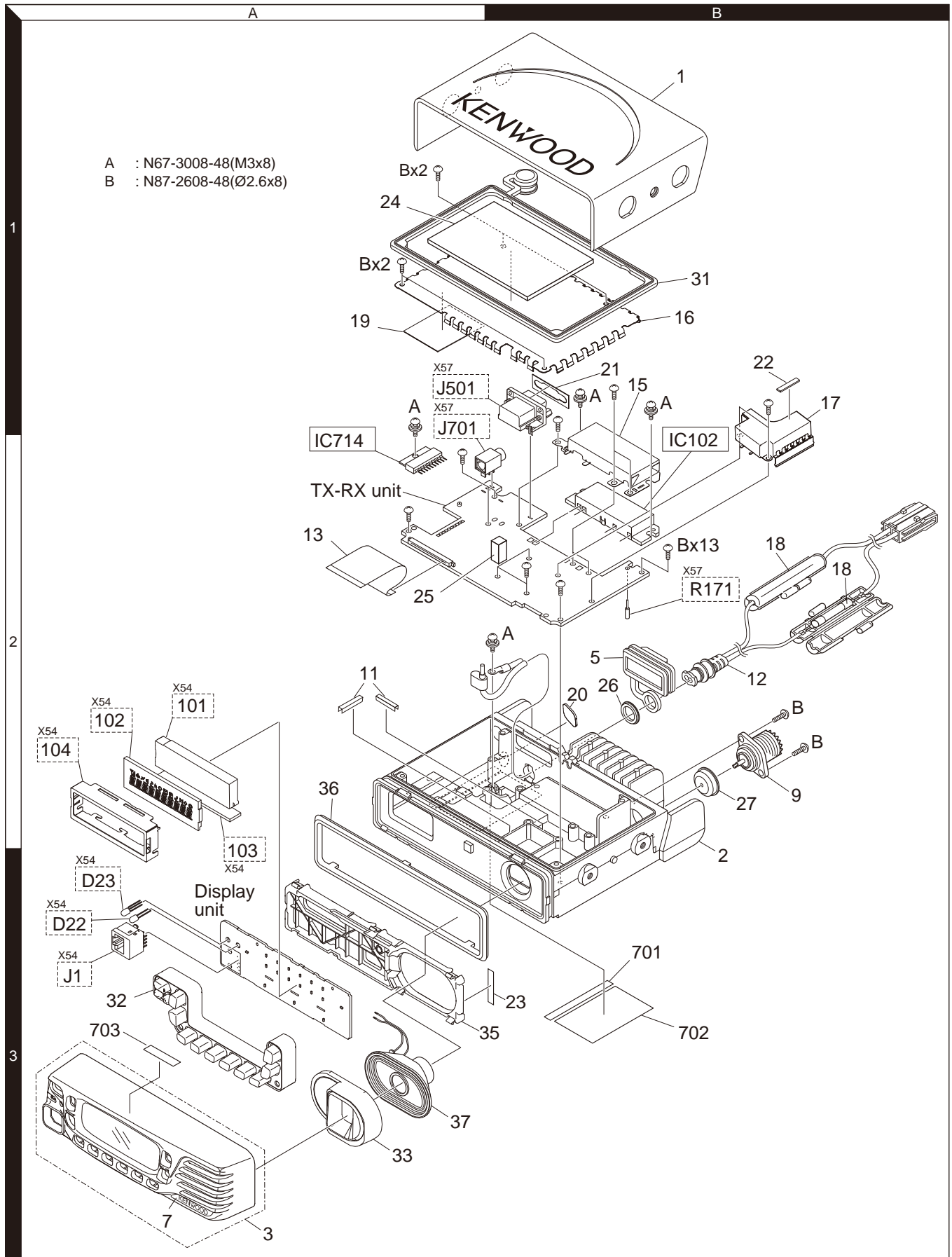

Parts with the exploded numbers larger than 700 are not supplied. / 编号大于 700 的零件未提供分解图。  
 If a part reference number is listed in a box on the exploded view of the PCB, that part does not come with the PCB.  
 These parts must be ordered separately. / 维修部件的 PCB 板里不含方里的文字所表示的零件。这些零件必需另外购买。

## TROUBLE SHOOTING

### Fault Diagnosis of the BGA (Ball Grid Array) IC

#### ■ Overview

A flowchart for determining whether or not the transceiver can be powered on (the LCD does not function even if the power switch is turned on) due to broken BGA parts.

#### ■ BGA parts

ASIC (IC507), DSP (IC502), FLASH (IC501), SRAM (IC503)

When the BGA IC is problematic, please bring the printed circuit board (X57-8230-13) in for service. Various ESN/default adjustment values are written on the printed circuit board for service.

Additionally various ESN stickers are included.

After the printed circuit board has been readjusted, please attach any ESN stickers to the chassis. When "ESN Validation" is used with Trunking, you must modify the ESN register.

#### ● Checking power supply voltage

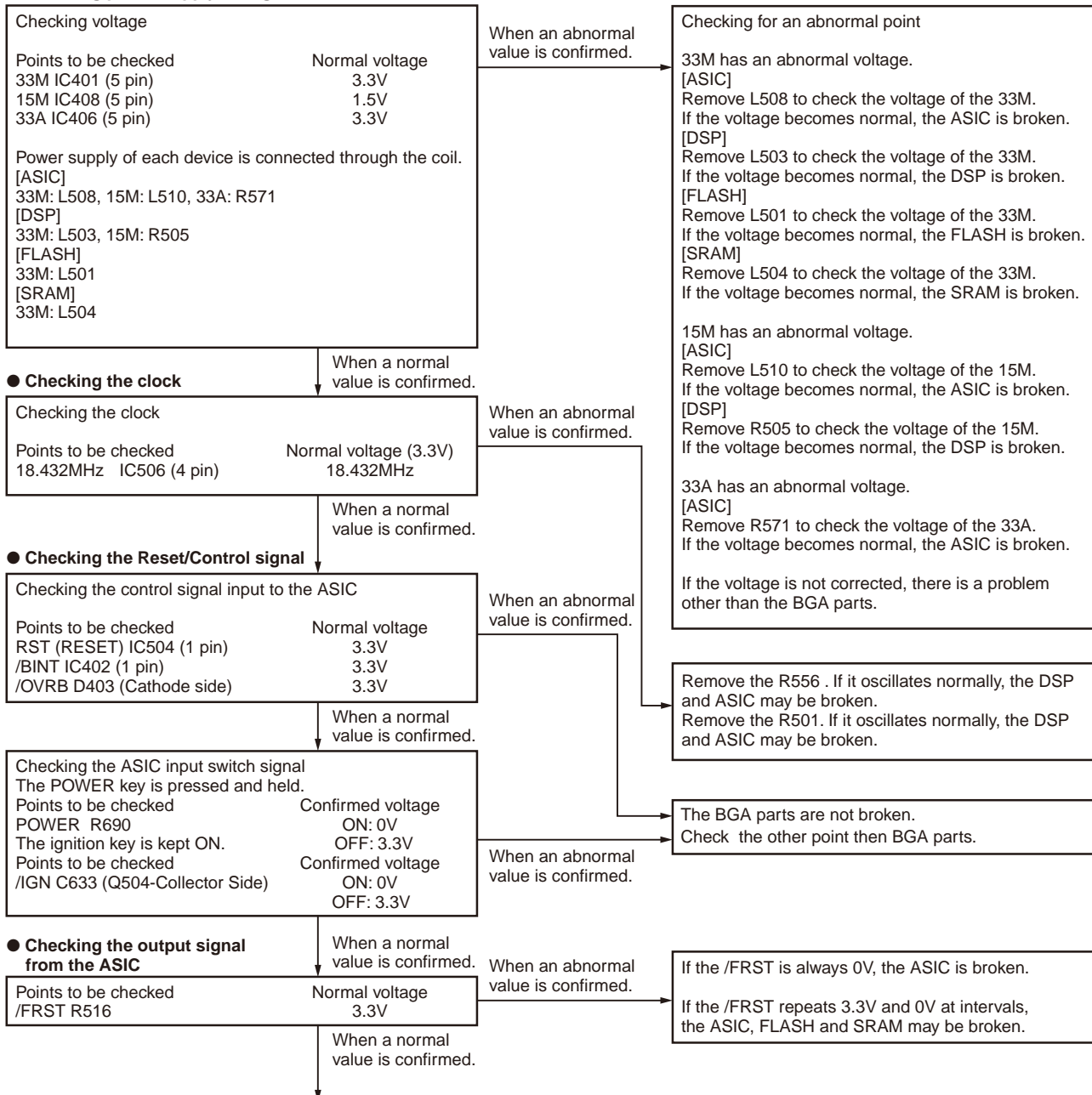

## 故障排除

### BGA（球状矩阵排列）IC 的故障诊断

#### ■ 概述

用于确定车载对讲机因 BGA 部分损坏时是否可以开启电源（即使打开电源开关 LCD 也不工作）的流程。

#### ■ BGA 部分

ASIC (IC507), DSP (IC502), FLASH (IC501), SRAM (IC503)

BGA IC 出现问题时, 请带印刷电路板 (X57-8230-13) 进行维修。各种 ESN/ 默认调整值写在用于维修的印刷电路板上。此外还包括各种 ESN 标签。

印刷电路板经过重新调整后, 请将 ESN 标签贴到底座上。“ESN 验证”用于集群时, 必须修改 ESN 登记。

#### ● 检查电源电压

检查电压	
检查点	正常电压
33M IC401 (5 针)	3.3V
15M IC408 (5 针)	1.5V
33A IC406 (5 针)	3.3V
各装置的电源连通线圈。	
[ASIC]	
33M: L508, 15M: L510, 33A: R571	
[DSP]	
33M: L503, 15M: R505	
[FLASH]	
33M: L501	
[SRAM]	
33M: L504	

确认数值异常时

检查异常点	
33M 有异常电压。	
[ASIC]	
取出 L508 检查 33M 的电压。	
如果电压变正常, 则 ASIC 已损坏。	
[DSP]	
取出 L503 检查 33M 的电压。	
如果电压变正常, 则 DSP 已损坏。	
[FLASH]	
取出 L501 检查 33M 的电压。	
如果电压变正常, 则 FLASH 已损坏。	
[SRAM]	
取出 L504 检查 33M 的电压。	
如果电压变正常, 则 SRAM 已损坏。	
15M 有异常电压	
[ASIC]	
取出 L510 检查 15M 的电压。	
如果电压变正常, 则 ASIC 已损坏。	
[DSP]	
取出 R505 检查 15M 的电压。	
如果电压变正常, 则 DSP 已损坏。	
33A 有异常电压	
[ASIC]	
取出 R571 检查 33A 的电压。	
如果电压变正常, 则 ASIC 已损坏。	
如果电压无法纠正, 则是 BGA 部分之外的其他部分的问题。	

确认数值正常时

#### ● 检查时钟

检查时钟	
检查点	正常电压(3.3V)
18.432MHz IC506 (4 针)	18.432MHz

确认数值异常时

#### ● 检查复位/控制信号

检查输入到 ASIC 的控制信号	
检查点	正常电压
RST(RESET) IC504 (1 针)	3.3V
/BINT IC402 (1 针)	3.3V
/OVRB D403 (阴极侧)	3.3V

确认数值异常时

确认数值正常时

检查 ASIC 输入开关信号	
按住 POWER 键	
检查点	确认的电压
POWER R690	ON: 0V
点火钥匙保持 ON	OFF: 3.3V
检查点	确认的电压
/IGN C633 (Q504 集电极侧)	ON: 0V
	OFF: 3.3V

确认数值异常时

#### ● 检查 ASIC 的输出信号

检查点	
/FRST R516	正常电压
	3.3V

确认数值异常时

确认数值正常时

取下 R556。如果它正常振荡, 则 DSP 和 ASIC 可能已损坏。
取下 R501。如果它正常振荡, 则 DSP 和 ASIC 可能已损坏。

BGA 部分未损坏。
除 BGA 部分外请检查其他的点。

如果 /FRST 始终为 0V, 则 ASIC 已损坏。
如果 /FRST 交替重复 3.3V 和 0V, 则 ASIC、FLASH 和 SRAM 可能已损坏。

## TROUBLE SHOOTING

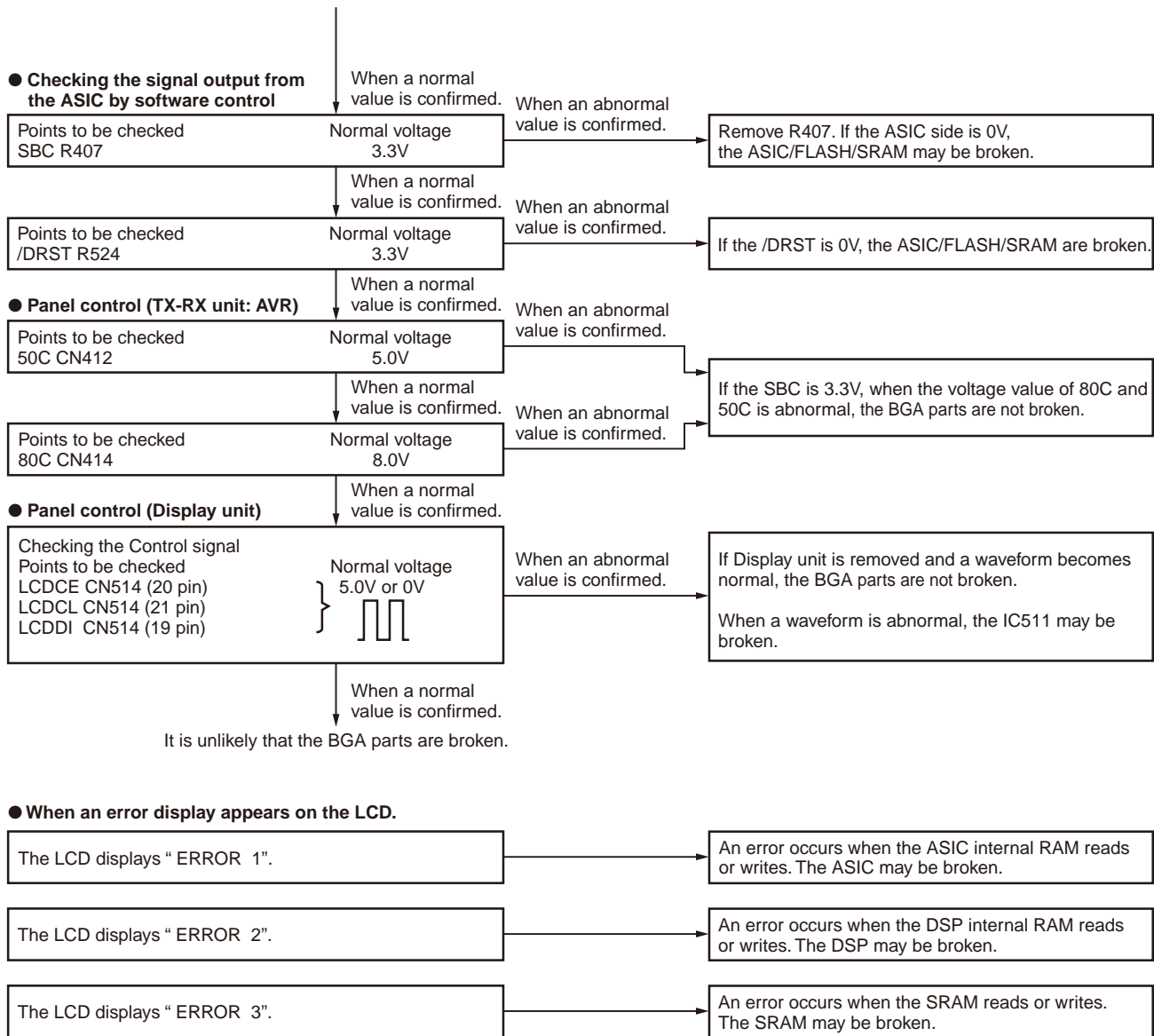

## 故障排除

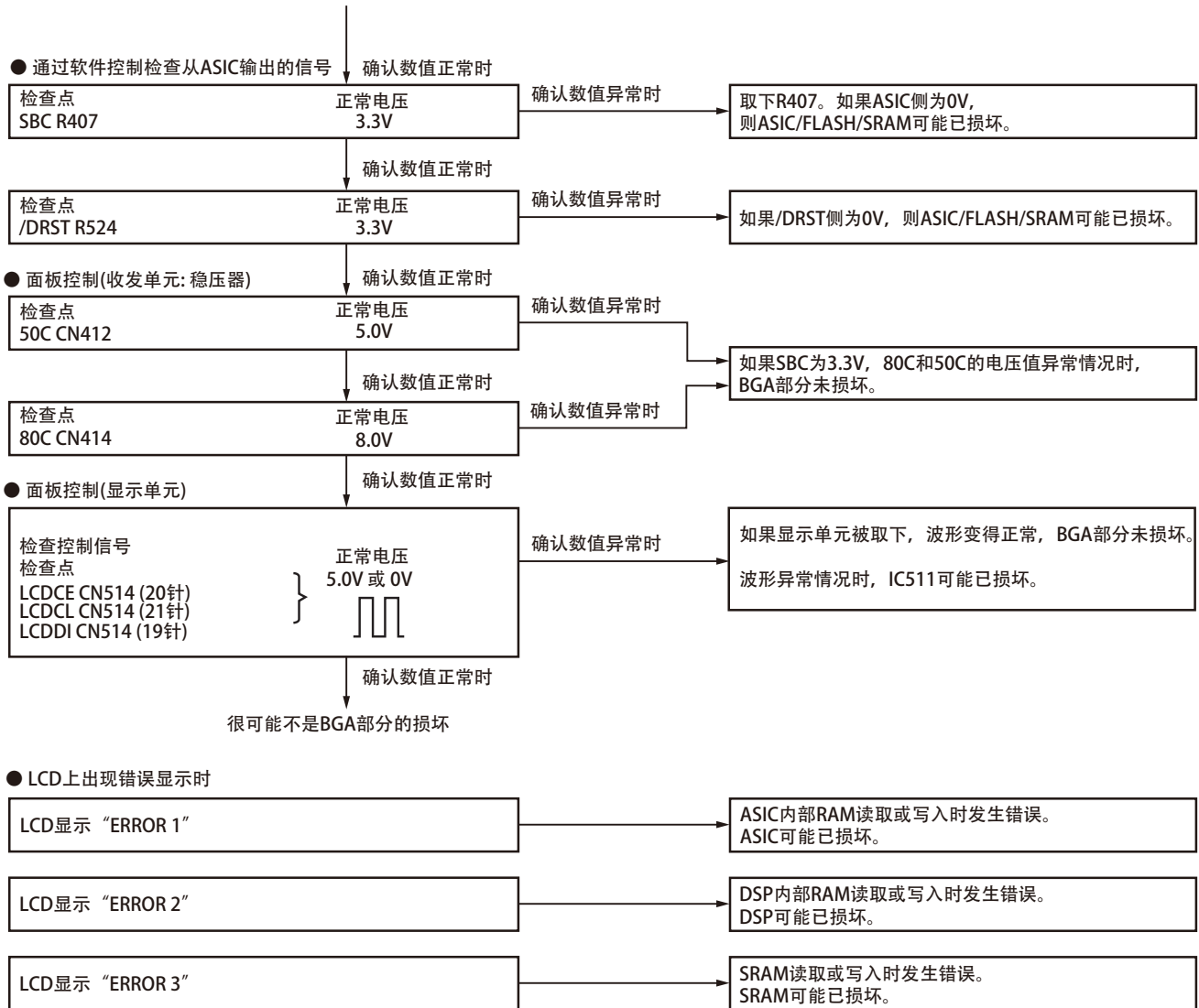

## TROUBLE SHOOTING

### Replacing TX-RX Unit

Model Name	Original TX-RX unit Number	For Service TX-RX unit Number
NX-720	X57-8230-11	X57-8230-13

#### Method of confirming “Original TX-RX unit” and “Service TX-RX unit”

#### SUPPLIED ACCESSORIES

ESN Label .....	1
• KENWOOD ESN	
• NXDN ESN	
• MPT ESN	
Addendum .....	1

#### PRINTED CIRCUIT BOARD DATA

The following data is written on the printed circuit board:

Data Type	Description
Firmware	NX-720/820 K type firmware
FPU Data (PC programming mode)	X57-823: NX-720 Kx type data
	X57-824: NX-820 Kx type data
Voice Language	English
Various Adjustment Data (PC Test mode)	General adjustment values for the X57-823 (NX-720), and X57-824 (NX-820).
KENWOOD ESN	Model Name: • [X57-823] NX-720HS • [X57-824] NX-820HS Type : Kx The same number as the KENWOOD ESN label is written.
NXDN ESN/MPT ESN	The same number as the NXDN ESN/MPT ESN label is written.

#### AFTER CHANGING THE PCB

- After changing the printed circuit board, write the up-to-date Firmware following the instructions in the “REALIGNMENT- 6. Firmware Programming Mode”.
  - Write the Firmware in accordance to the Market. If you write different Market Firmware, there are times communication with the FPU is not possible.
- Using the KPG-141D(C), select your desired item (Model Name and Frequency) from the Model > Product Information menu, then use Program > Write Data to the Transceiver to write the FPU data (PC Programming mode). When writing to the transceiver, a Warning Message, corresponding to the item selected, appears. Click [OK] to continue writing the data.
- Enter Program > Test Mode, then adjust the various adjustment data (PC Test mode) as described in the “ADJUSTMENT”.
- Attach the new labels corresponding to the new printed circuit board. (Refer to the images below for label placement.)
- If necessary, write the FPU data used by the customer with the KPG-141D(C).

#### Note:

- When using the ESN Validation function of Trunking, the ESN number changes when the circuit board is changed (the number is written on the circuit board); the Trunking system cannot be accessed. Maintain the ESN data of the Trunking System following the new ESN.
- When a new printed circuit board is used, the KENWOOD ESN changes, as does the Transceiver Information display of the KPG-141D(C), but this does not have any effect on the operation of the transceiver.
- If changing to the original ESN, please contact our service center.

### ATTACHING THE ESN LABEL

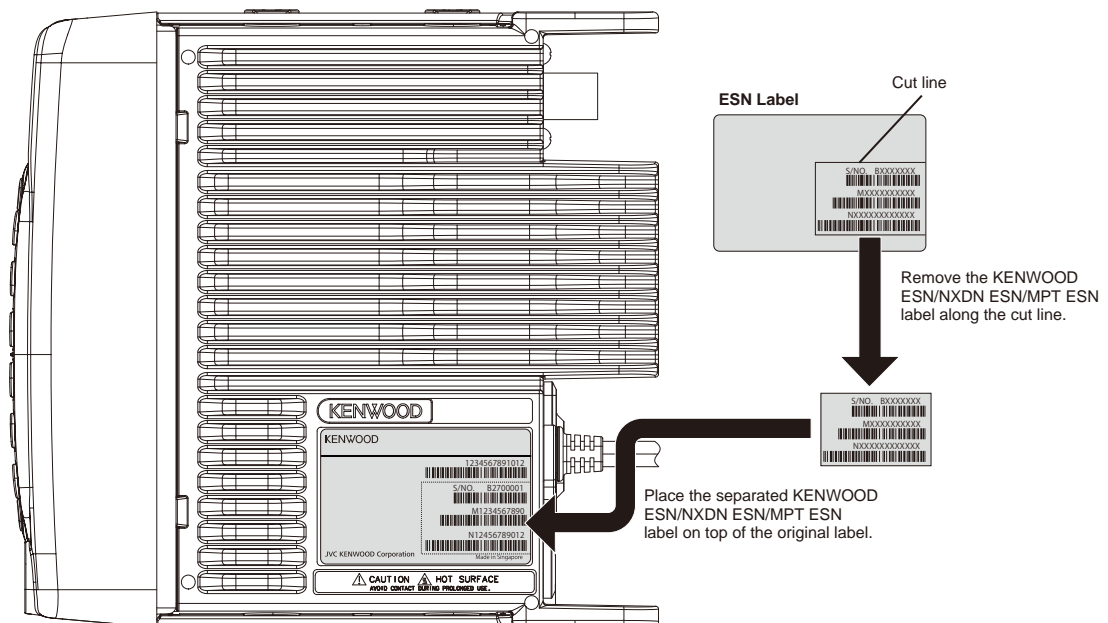



## 故障排除

### 更换收发单元

型号名称	原始收发单元编号	维修收发单元编号
NX-720	X57-8230-11	X57-8230-13

#### ■ “原始收发单元”和“维修收发单元”的确认方法

##### 附件

ESN 标签 .....	1
• KENWOOD ESN	
• NXDN ESN	
• MPT ESN	
附加物 .....	1

#### ■ 印刷电路板数据

印刷电路板上写有以下数据：

数据类型	说 明
固件	NX-720/820 K 型固件
FPU 数据 (PC 编程模式)	X57-823: NX-720 Kx 型数据。 X57-824: NX-820 Kx 型数据。
音声语言	英语
各种调整数据 (PC 测试模式)	X57-823 (NX-720) 和 X57-824 (NX-820) 的一般调整值。
KENWOOD ESN	型号名称： • [X57-823] NX-720HS • [X57-824] NX-820HS 型式：Kx 写有与 KENWOOD ESN 标签相同的编号。
NXDN ESN/MPT ESN	写有与 NXDN ESN/MPT ESN 标签相同的编号。

#### ■ 更换 PCB 后

1. 更换印刷电路板之后，按照“模式组合 -6. 固件编程模式”的说明写入最新的固件。
  - 根据市场写入固件。如果写入不同的市场固件，则无法与 FPU 进行通信。
2. 使用 KPG-141D (C)，从机型 > 产品信息菜单中选择所需的项目（型号名称和频率），然后用编程 > 向通信机写入数据写入 FPU 数据（PC 编程模式）。写入车载对讲机时，会出现与所选项目对应的警告讯息。单击 [OK] 继续写入数据。
3. 进入编程 > 测试模式，然后按照“调整”中的说明调整各项调整数据（PC 测试模式）。
4. 贴上与新印刷电路板对应的新标签。（关于标签位置，请参见下图。）
5. 如有必要，可使用 KPG-141D (C) 写入用户使用的 FPU 数据。

##### 注意：

- 使用集群通信的 ESN 验证功能时，ESN 编号会在更换电路板时发生改变（该编号写在电路板上）；无法访问集群通信系统。根据新的 ESN 保持集群通信系统的 ESN 数据。
- 使用新印刷电路板时，KENWOOD ESN 会改变，就像 KPG-141D (C) 的车载对讲机信息显示一样，但这并不影响车载对讲机的操作。
- 若要改为原来的 ESN，请与本公司的服务中心联系。贴 ESN 标签

### 贴 ESN 标签

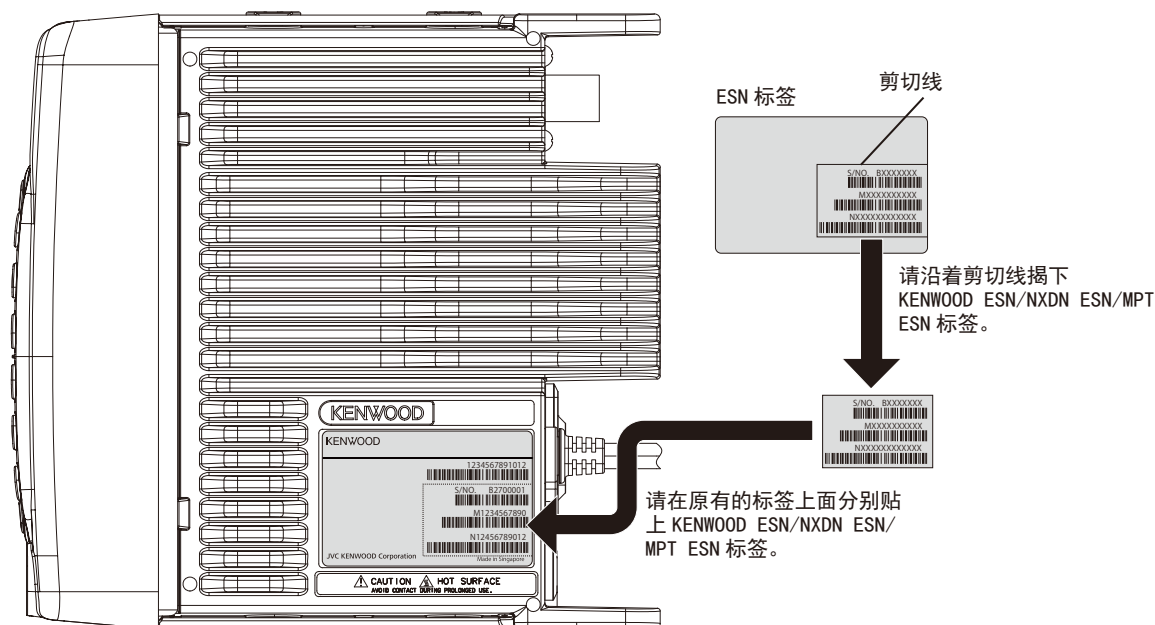

## ADJUSTMENT

### Controls

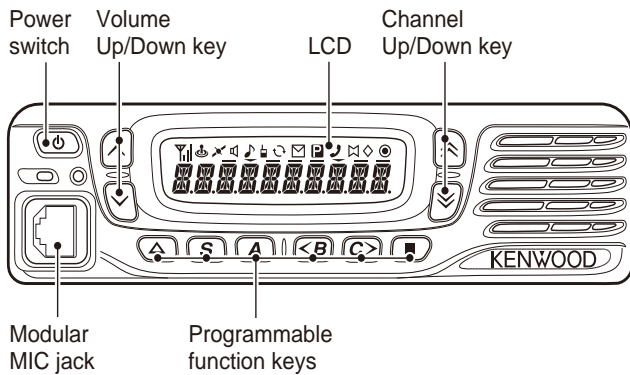

### KMC-36 (OPTION)

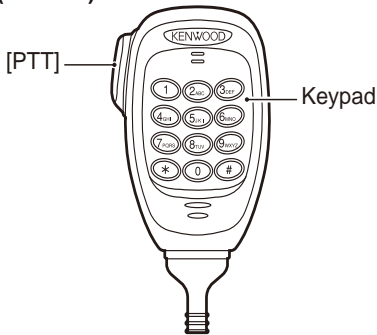

### ■ Preparations for checking/tuning the transceiver

Before attempting to check/tune the transceiver, connect the unit to a suitable power supply.

Whenever the transmitter is turned on, the unit must be connected to a suitable dummy load (i.e. power meter).

The speaker output connector must be terminated with a 4Ω dummy load and connected to an AC voltmeter and an audio distortion meter or a SINAD measurement meter at all times during checking/tuning.

### Panel Test Mode

#### ■ Test mode operation features

This transceiver has a test mode. To enter test mode, press and hold the [A] key while turning the transceiver power ON. Before the transceiver enters test mode, the frequency version information appears on the LCD momentarily. Test mode can be inhibited by programming. To exit test mode, turn the transceiver power OFF. The following functions are available in test mode.

### ■ Key operation

Key	“—” not appears on the LCD display	
	Function	Display
[^]/[v]	Test channel up/down	Channel No.
[Δ]	Push: Squelch level up Hold: Squelch off	Squelch level Squelch off: [icon] icon appears
[■]	Wide/Narrow/Very narrow	Wide: “W” Narrow: “N” Very narrow: “V”
[S]	Shift to panel tuning mode	-
[A]	Function on	“—” appears on the LCD display
[<B]	MSK 1200bps and 2400bps	2400bps: [icon] icon appears
[C>]	Push: Test signaling up Hold: Test signaling up continuously	Signaling No.
[^]/[v]	Volume level up/down	
[PTT] (MIC)	Transmit	-
[0] to [9] and [#], [*] (MIC)	Use as the DTMF keypad. If a key is pressed during transmission, the DTMF corresponding to the key that was presses is sent.	-

Key	“—” appears on the LCD display	
	Function	Display
[^]	Function off	-
[v]	Analog /NXDN	Analog: “A”, NXDN: “N”
[Δ]	Function off	-
[■]	LCD all lights	LCD all point appears
[S]	High/Low power	High: icon not appears Low: “— —” icon appears
[A]	Function off	-
[<B]	Compander on/off	On: [icon] icon appears
[C>]	Beat shift on/off	On: [icon] icon appears
[^]/[v]	Volume level up/down	
[PTT] (MIC)	Transmit	-
[0] to [9] and [#], [*] (MIC)	Function off	-

## 调 整

### 控制

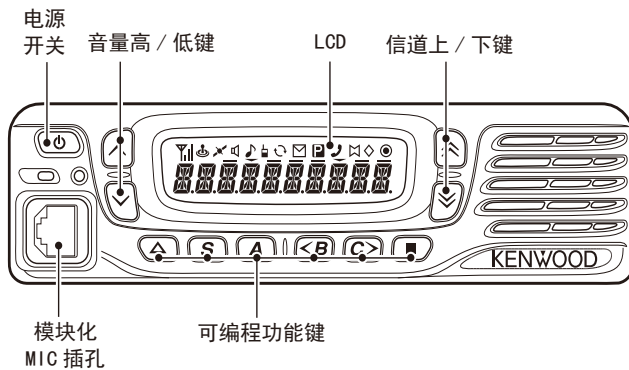

KMC-36 (可选件)

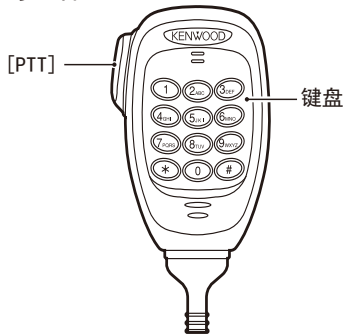

#### ■ 准备检查和调谐车载对讲机的

在尝试调谐车载对讲机前，请将车载对讲机连接到合适的电源上。

发射打开时，车载对讲机必须连接到合适的等效负载上（如功率表）。

扬声器输出连接器必须端接 4Ω 的等效负载，调谐期间，必须始终连接到交流电压表和音频失真仪或 SINAD 测量仪表上。

### 面板测试模式

#### ■ 测试模式操作功能

本对讲机有测试模式。如需进入测试模式，请在打开对讲机电源的同时按住 [A] 键。对讲机进入测试模式之前，LCD 上短时间出现频率版本信息。可以通过编程禁用测试模式。如需退出测试模式，请关闭对讲机电源。在测试模式可以使用下列功能。

#### ■ 键操作

键	LCD 显示上不出现 “—”	
	功 能	显 示
[↖]/[↙]	测试信道递增 / 递减	信道号
[△]	按下：静噪电平递增 按住：静噪关	静噪电平 静噪关：🔊 图标出现
[■]	宽带 / 窄带 / 甚窄带	宽带：“W” 窄带：“N” 甚窄带：“V”
[S]	换到面板调谐模式	-
[A]	功能开	LCD 显示上出现 “—”
[<B]	MSK 1200bps 和 2400bps	2400bps: ☑ 图标出现
[C>]	按下：测试信令递增 按住：测试信令持续递增	信令号
[^]/[v]	音量电平升高 / 降低	
[PTT] (麦克风)	发射	-
[0] 至 [9] 和 [#], [*] (麦克风)	用作 DTMF 键盘。 如果在发射时按下某个键， 则发送与按下的键对应的 DTMF。	-

键	LCD 显示上出现 “—”	
	功 能	显 示
[↖]	功能关	-
[↙]	模拟 / NXDN	模拟：“A”，NXDN：“N”
[△]	功能关	-
[■]	LCD 全亮	LCD 全点显示
[S]	高 / 低功率	高：图标不出现 低：“— —” 图标出现
[A]	功能关	-
[<B]	压扩器打开 / 关闭	开：🔊 图标出现
[C>]	拍频偏移打开 / 关闭	开：◇ 图标出现
[^]/[v]	音量电平升高 / 降低	
[PTT] (麦克风)	发射	-
[0] 至 [9] 和 [#], [*] (麦克风)	功能关	-

## ADJUSTMENT

### • LED indicator

- Red LED Lights during transmission.
- Green LED Lights when there is carrier.

### • LCD display in panel test mode

(Power ON)

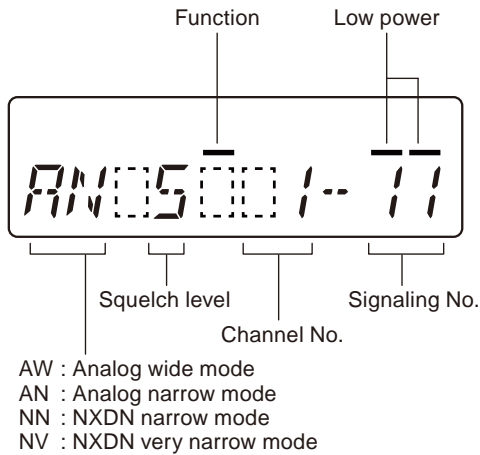
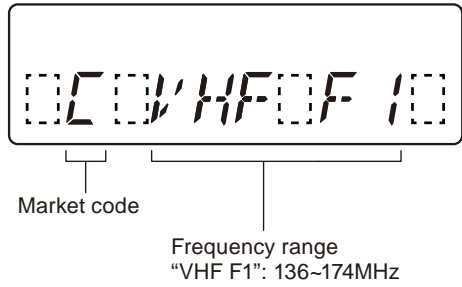

### ■ Frequency and Signaling

The transceiver has been adjusted for the frequencies shown in the following table. When required, readjust them following the adjustment procedure to obtain the frequencies you want in actual operation.

### • Test frequency

CH	RX (MHz)	TX (MHz)
1	155.05000	155.10000
2	136.05000	136.10000
3	173.95000	173.90000
4	155.00000	155.00000
5	155.20000	155.20000
6	155.40000	155.40000
7-16	-	-

### • Analog mode signaling

No.	RX	TX
1	None	None
2	None	100Hz Square Wave
3	LTR Data: AREA=0, GOTO=12 HOME=12 ID=47, FREE=25	LTR Data: AREA=0, GOTO=12 HOME=12 ID=47, FREE=25
4	QT: 67.0Hz	QT: 67.0Hz
5	QT: 151.4Hz	QT: 151.4Hz
6	QT: 210.7Hz	QT: 210.7Hz
7	QT: 254.1Hz	QT: 254.1Hz
8	DQT: D023N	DQT: D023N
9	DQT: D754I	DQT: D754I
10	DTMF: 159D	DTMF: 159D
11	None	DTMF Code 9
12	2-tone: A: 304.7Hz, B: 3106.0Hz	2-tone: A: 304.7Hz, B: 3106.0Hz
13	Single Tone: 979.9Hz	Single Tone: 979.9Hz
14	None	Single Tone: 1000Hz
15	None	MSK PN9
16	MSK	MSK

## 调 整

- LED 指示灯  
 红色 LED 发射时点亮。  
 绿色 LED 有载波时点亮。
- 面板测试模式时的 LCD 显示

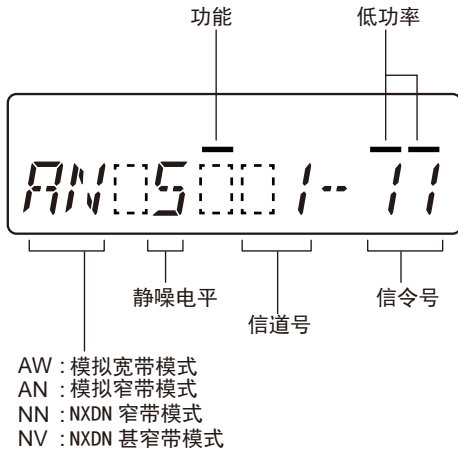
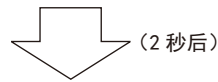
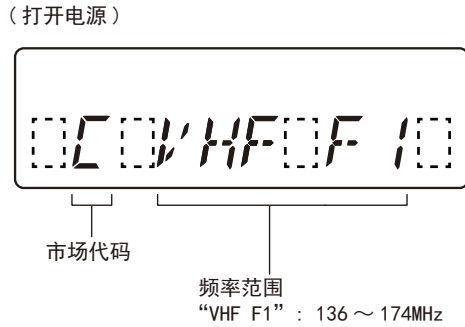

### ■ 频率和信令

已经根据下表所示的频率调整了设置。需要时，按调整步骤重新调整，以获得实际操作时想要的频率。

#### • 测试频率

信道	接收 (MHz)	发射 (MHz)
1	155.05000	155.10000
2	136.05000	136.10000
3	173.95000	173.90000
4	155.00000	155.00000
5	155.20000	155.20000
6	155.40000	155.40000
7 ~ 16	-	-

#### • 模拟模式信令

编号	接 收	发 射
1	无	无
2	无	100Hz 方波
3	LTR 数据 : AREA=0, GOTO=12 HOME=12 ID=47, FREE=25	LTR 数据 : AREA=0, GOTO=12 HOME=12 ID=47, FREE=25
4	QT: 67.0Hz	QT: 67.0Hz
5	QT: 151.4Hz	QT: 151.4Hz
6	QT: 210.7Hz	QT: 210.7Hz
7	QT: 254.1Hz	QT: 254.1Hz
8	DQT: D023N	DQT: D023N
9	DQT: D754I	DQT: D754I
10	DTMF: 159D	DTMF: 159D
11	无	DTMF 代码 9
12	2-音 : A: 304.7Hz, B: 3106.0Hz	2-音 : A: 304.7Hz, B: 3106.0Hz
13	单音 : 979.9Hz	单音 : 979.9Hz
14	无	单音 : 1000Hz
15	无	MSK PN9
16	MSK	MSK

## ADJUSTMENT

### • NXDN mode signaling

No.	RX	TX
1	RAN1	RAN1
2	None	PN9
3	RAN1	Maximum Deviation Pattern
7	None	FSW+PN9 (PC test mode only)
9	Tone Pattern (1031Hz) (Simple BER Measurement)	Tone Pattern (1031Hz)

RAN: Radio Access Number

PN9: Pseudo-Random Pattern (for production only)

No.9 Item: PC test mode only

### Panel Tuning Mode

#### ■ Transceiver tuning (To enter tuning mode)

To enter tuning mode, press the [S] key while the transceiver is in test mode. Use the [<B] key to write tuning data through tuning modes, and the [↔]/[↔] to adjust tuning requirements (1 to 4096 appears on the LCD).

Use the [C>] key to select the adjustment item through tuning modes. Use the [A] key to adjust 5 reference level adjustments, and use the [■] key to switch between Wide/Narrow/Very narrow.

#### • LCD display in panel tuning mode

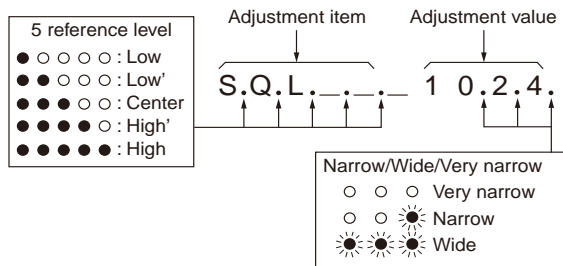

### ■ Key operation

Key	Function	
	Push	Hold (1 second)
[↔]/[↔]	Adjustment value up/down	
[Δ]	20Hz/2kHz (During transmission in balance adjustment)	-
[■]	Wide/Narrow/Very narrow	-
[S]	Shift to panel test mode	-
[A]	To enter 5 reference level adjustments	-
[<B]	Writes the adjustment value	-
[C>]	Go to next adjustment item	Back to last adjustment item
[^]/[v]	Volume level up/down	
[PTT]	Transmit	
[0] to [9] and [#], [*]	-	

#### ■ 5 reference level adjustments frequency

Tuning point	RX (MHz)	TX (MHz)
Low	136.05000	136.10000
Low'	145.55000	145.60000
Center	155.05000	155.10000
High'	164.55000	164.60000
High	173.95000	173.90000

#### ■ 9 reference level adjustments frequency

Tuning point	RX (MHz)	TX (MHz)
Low1	136.05000	136.10000
Low2	140.80000	140.85000
Low3	145.55000	145.60000
Center1	150.30000	150.35000
Center2	155.05000	155.10000
Center3	159.80000	159.85000
High1	164.55000	164.60000
High2	169.30000	169.35000
High3	173.95000	173.90000

## 调 整

### • NXDN 模式信令

编号	接 收	发 射
1	RAN1	RAN1
2	无	PN9
3	RAN1	最大频偏模式
7	无	FSW+PN9 (仅限 PC 测试模式)
9	音模式 (1031Hz) (简易 BER 测量)	音模式 (1031Hz)

RAN: 无线接入编号  
 PN9: 伪随机模式 (仅限用于生产)  
 号码 9 项: 仅限 PC 测试模式

### 面板调谐模式

#### ■ 车载对讲机调谐 (进入调谐模式)

要进入调谐模式, 请在车载对讲机处于测试模式时按 [S] 键。用 [<B] 键写入调谐模式的调谐数据, 用 [^]/[v] 键调整调谐要求 (LCD 上出现 1 到 4096)。

用 [C>] 键选择调谐模式的调整项目。用 [A] 键调整 5 点基准电平调整, 然后用 [■] 键切换宽带 / 窄带 / 甚窄带。

#### • 面板调谐模式时的 LCD 显示

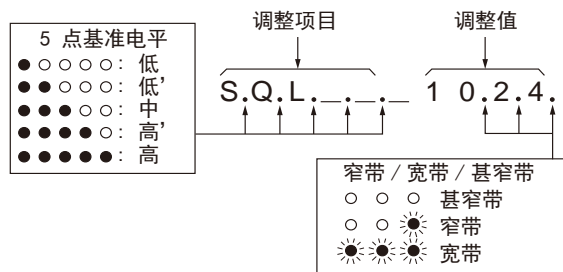

### ■ 键操作

键	功 能	
	按 下	按住 (1 秒钟)
[^]/[v]	调整值增大 / 减小	
[Δ]	20Hz/2kHz (在平衡调整的发射期间)	-
[■]	宽带 / 窄带 / 甚窄带	-
[S]	换到面板测试模式	-
[A]	进入 5 点基准电平调节	-
[<B]	写入调整值	-
[C>]	转到下一调整项目	返回到最后调整的项目
[^]/[v]	音量升高 / 降低	
[PTT]	发射	
[0] 至 [9] 和 [#], [*]	-	

### ■ 5 点基准电平调整频率

调谐点	接收 (MHz)	发射 (MHz)
低	136.05000	136.10000
低'	145.55000	145.60000
中	155.05000	155.10000
高'	164.55000	164.60000
高	173.95000	173.90000

### ■ 9 点基准电平调整频率

调谐点	接收 (MHz)	发射 (MHz)
低 1	136.05000	136.10000
低 2	140.80000	140.85000
低 3	145.55000	145.60000
中 1	150.30000	150.35000
中 2	155.05000	155.10000
中 3	159.80000	159.85000
高 1	164.55000	164.60000
高 2	169.30000	169.35000
高 3	173.95000	173.90000

## ADJUSTMENT

### ■ Adjustment item supplement

Adjustment Item	Description
Receive Assist	The lock voltage of VCO (Receive) is adjusted. This item must be adjusted before all adjustment items for receiver section are adjusted. This item can be adjusted only in PC Test Mode.
Transmit Assist	The lock voltage of VCO (Transmit) is adjusted. This item must be adjusted before all adjustment items for transmitter section are adjusted. This item can be adjusted only in PC Test Mode.
Frequency	Frequency stability is adjusted under receiving condition with SSG. The SSG needs 0.003ppm accuracy so please use a standard oscillator if necessary. This item can be adjusted only in PC Test Mode so that the adjustment value is not changed easily.
High Transmit Power Limit	High Transmit Power Limit is adjusted.
Low Transmit Power Limit	Low Transmit Power Limit is adjusted.
High Transmit Power	High Transmit Power is adjusted.
Low Transmit Power	Low Transmit Power is adjusted.
Balance	The transmit audio frequency response is adjusted. This item is adjusted so that the deviation of 2kHz becomes the same deviation of 20Hz. This item must be adjusted before all adjustment items for deviations are adjusted.
Maximum Deviation (NXDN Narrow/Very Narrow)	Maximum Deviation of NXDN (Narrow/Very Narrow) is adjusted.
Maximum Deviation (Analog Wide/Narrow)	Maximum Deviation of Analog (Wide/Narrow) is adjusted. This item must be adjusted before all adjustment items for tone deviations are adjusted. Note: "Maximum Deviation (Analog Narrow)" must be adjusted before "CW ID Deviation (NXDN Very Narrow)" is adjusted.
QT Deviation	QT tone deviation is adjusted.
DQT Deviation	DQT tone deviation is adjusted.
LTR Deviation	LTR tone deviation is adjusted.
DTMF Deviation	DTMF tone deviation is adjusted.
Single Tone Deviation	The deviation of Single Tone used in "2-tone" is adjusted.
MSK Deviation	MSK tone deviation is adjusted.
CW ID Deviation	CW ID tone deviation is adjusted. CW ID is used to inform the others who is transmitting on a 6.25 kHz spacing channel. (In FCC rule, Analog mode or CW ID is required for each channel-spacing.)
Sensitivity 1	Band-Pass Filter is adjusted. The performance of Receive Sensitivity and unwanted signal rejection are improved. This item can be adjusted only in PC Test Mode.
Sensitivity 2	Band-Pass Filter is adjusted. The performance of Receive Sensitivity and unwanted signal rejection are improved. This item can be adjusted only in PC Test Mode.
RSSI Reference	The minimum RSSI level for scan stop is adjusted.
Open Squelch	The squelch level at level "5" is adjusted.
Low RSSI	RSSI display level "V" is adjusted.
High RSSI	Both "Low RSSI" and "High RSSI" must be adjusted. (The curve data of RSSI level is applied.)
Tight Squelch	The squelch level at level "9" is adjusted.



## 调 整

## ■ 调整项目补充

调整项目	说 明
接收辅助	调整 VCO（接收）的锁定电压。 必须在调整接收机部分的所有调整项目之前调整此项。 此项只能在 PC 测试模式下进行调整。
发射辅助	调整 VCO（发射）的锁定电压。 必须在调整发射机部分的所有调整项目之前调整此项。 此项只能在 PC 测试模式下进行调整。
频率	调整 SSG 接收条件下的频率稳定性。 SSG 需要 0.003ppm 的精度，因此，必要时请使用标准振荡器。 此项只能在 PC 测试模式下进行调整，以使调整值不易改变。
高发射功率限制	调整高发射功率限制。
低发射功率限制	调整低发射功率限制。
高发射功率	调整高发射功率。
低发射功率	调整低发射功率。
平衡	调整发射音频频率响应。 通过调整此项，使 2kHz 的频偏变成 20Hz 的相同频偏。 必须在调整频偏的所有调整项目之前调整此项。
最大频偏（NXDN 窄带 / 甚窄带）	调整 NXDN 最大频偏（窄带 / 甚窄带）。
最大频偏（模拟宽带 / 窄带）	调整模拟最大频偏（宽带 / 窄带）。 必须在调整音调频偏的所有调整项目之前调整此项。 注意：必须在调整“CW ID 频偏（NXDN 甚窄带）”之前调整“最大频偏（模拟窄带）”。
QT 频偏	调整 QT 音调频偏。
DQT 频偏	调整 DQT 音调频偏。
LTR 频偏	调整 LTR 音调频偏。
DTMF 频偏	调整 DTMF 音调频偏。
单音频偏	调整“2 音”中使用的单音频偏。
MSK 频偏	调整 MSK 音调频偏。
CW ID 频偏	调整 CW ID 音调频偏。 CW ID 用于通知在 6.25kHz 间隔信道上发射的其他人。 (按照 FCC 规则，各信道间隔须使用模拟模式或 CW ID。)
灵敏度 1	调整带通滤波器。 提高接收灵敏度的性能。 仅可在 PC 测试模式中调整此项。
灵敏度 2	调整带通滤波器。 提高接收灵敏度的性能。 仅可在 PC 测试模式中调整此项。
RSSI 参考	调整扫描停止的最低 RSSI 电平。
静噪（浅）	调整“5”级的静噪电平。
低 RSSI	调整 RSSI 显示电平“ $\nabla$ ”。
高 RSSI	“低 RSSI”和“高 RSSI”都必须调整。 (应用 RSSI 电平的曲线数据。)
静噪（深）	调整电平“9”的静噪电平。

## ADJUSTMENT

### ■ Adjustment item and Adjustment range

Order	Adjustment item	Panel tuning	PC test	AW (Analog Wide)	AN (Analog Narrow)	NN (NXDN Narrow)	NV (NXDN Very Narrow)	Adjust item Number
				Adjustment range				
1	Receive Assist		✓	9 point ADJ				Common Section 2
				1~4096				
2	Transmit Assist		✓	9 point ADJ				Common Section 3
				1~4096				
3	Frequency		✓	1 point ADJ				Common Section 4
				1~4096				
4	High Transmit Power Limit	✓	✓	-	5	-	-	Transmitter Section 1
				1~256				
5	Low Transmit Power Limit	✓	✓	-	5	-	-	Transmitter Section 1
				1~256				
6	High Transmit Power	✓	✓	-	5	-	-	Transmitter Section 2
				1~1024				
7	Low Transmit Power	✓	✓	-	5	-	-	Transmitter Section 2
				1~1024				
8	Balance	✓	✓	-	5	-	-	Transmitter Section 2
				1~1024				
9	Maximum Deviation (NXDN)	✓	✓	-	-	5	5	Transmitter Section 4
				1~1024				
10	Maximum Deviation (Analog)	✓	✓	5	5	-	-	Transmitter Section 5
				1~1024				
11	QT Deviation	✓	✓	1	1	-	-	Transmitter Section 6
				1~1024				
12	DQT Deviation	✓	✓	1	1	-	-	Transmitter Section 7
				1~1024				
13	LTR Deviation	✓	✓	1	1	-	-	Transmitter Section 8
				1~1024				
14	DTMF Deviation	✓	✓	1	1	-	-	Transmitter Section 9
				1~1024				
15	Single Tone Deviation	✓	✓	1	1	-	-	Transmitter Section 10
				1~1024				
16	MSK Deviation	✓	✓	1	1	-	-	Transmitter Section 11
				1~1024				
17	CW ID Deviation	✓	✓	-	-	-	1	Transmitter Section 12
				1~1024				
18	Sensitivity 1		✓	-	5	-	-	Receiver Section 2
				1~256				
19	Sensitivity 2		✓	-	5	-	-	Receiver Section 3
				1~256				

## 调 整

## ■ 调整项目和调整范围

项目	调整项目	面板 调谐	PC 测试	AW (模拟宽带)	AN (模拟窄带)	NN (NXDN 窄带)	NV (NXDN 甚窄带)	调整项目编号
				调整范围				
1	接收辅助		✓	9点调整				共通部分 2
				1 ~ 4096				
2	发射辅助		✓	9点调整				共通部分 3
				1 ~ 4096				
3	频率		✓	1点调整				共通部分 4
				1 ~ 4096				
4	高发射功率限制	✓	✓	-	5	-	-	发射部分 1
				1 ~ 256				
5	低发射功率限制	✓	✓	-	5	-	-	发射部分 1
				1 ~ 256				
6	高发射功率	✓	✓	-	5	-	-	发射部分 2
				1 ~ 1024				
7	低发射功率	✓	✓	-	5	-	-	发射部分 2
				1 ~ 1024				
8	平衡	✓	✓	-	5	-	-	发射部分 3
				1 ~ 1024				
9	最大频偏 (NXDN)	✓	✓	-	-	5	5	发射部分 4
				1 ~ 1024				
10	最大频偏 (模拟)	✓	✓	5	5	-	-	发射部分 5
				1 ~ 1024				
11	QT 频偏	✓	✓	1	1	-	-	发射部分 6
				1 ~ 1024				
12	DQT 频偏	✓	✓	1	1	-	-	发射部分 7
				1 ~ 1024				
13	LTR 频偏	✓	✓	1	1	-	-	发射部分 8
				1 ~ 1024				
14	DTMF 频偏	✓	✓	1	1	-	-	发射部分 9
				1 ~ 1024				
15	单音频偏	✓	✓	1	1	-	-	发射部分 10
				1 ~ 1024				
16	MSK 频偏	✓	✓	1	1	-	-	发射部分 11
				1 ~ 1024				
17	CW ID 频偏	✓	✓	-	-	-	1	发射部分 12
				1 ~ 1024				
18	灵敏度 1		✓	-	5	-	-	接收部分 2
				1 ~ 256				
19	灵敏度 2		✓	-	5	-	-	接收部分 3
				1 ~ 256				

## ADJUSTMENT

Order	Adjustment item	Panel tuning	PC test	AW (Analog Wide)	AN (Analog Narrow)	NN (NXDN Narrow)	NV (NXDN Very Narrow)	Adjust item Number
				Adjustment range				
20	RSSI Reference	✓	✓	5	5	- *1	5	Receiver Section 4
				1~256				
21	Open Squelch	✓	✓	5	5	- *1	5	Receiver Section 5
				1~256				
22	Low RSSI	✓	✓	5	5	- *1	5	Receiver Section 6
				1~256				
23	High RSSI	✓	✓	5	5	- *1	5	Receiver Section 7
				1~256				
24	Tight Squelch	✓	✓	5	5	-	-	Receiver Section 8
				1~256				

\*1: Because NXDN Narrow is adjusted by adjusting Analog Narrow, it is not necessary to adjust NXDN Narrow.

### ■ Panel tuning mode flow chart

**Note:** In this Panel tuning mode flow chart, the Adjustment item name is modified.

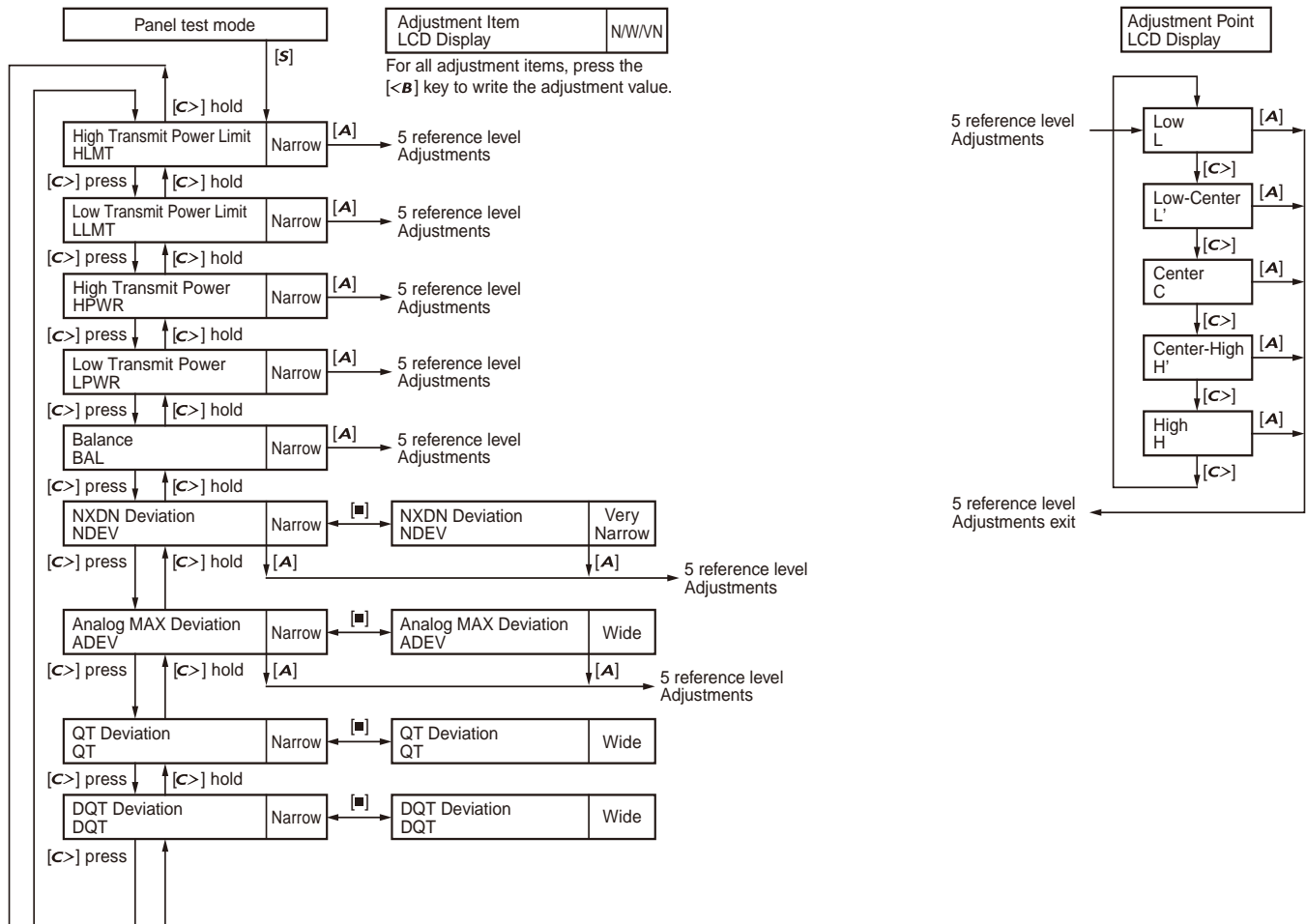

## 调 整

项目	调整项目	面板调谐	PC测试	AW (模拟宽带)	AN (模拟窄带)	NN (NXDN 窄带)	NV (NXDN 甚窄带)	调整项目编号
				调整范围				
20	RSSI 参考	✓	✓	5	5	- *1	5	接收部分 4
				1 ~ 256				
21	静噪 (浅)	✓	✓	5	5	- *1	5	接收部分 5
				1 ~ 256				
22	低 RSSI	✓	✓	5	5	- *1	5	接收部分 6
				1 ~ 256				
23	高 RSSI	✓	✓	5	5	- *1	5	接收部分 7
				1 ~ 256				
24	静噪 (深)	✓	✓	5	5	-	-	接收部分 8
				1 ~ 256				

\*1: 由于 NXDN 窄带通过调整模拟窄带进行调整, 因此不需要调整 NXDN 窄带。

### ■ 面板调谐模式流程图

注意: 在此面板调谐模式流程图中, 调整项目的名称作了修改。

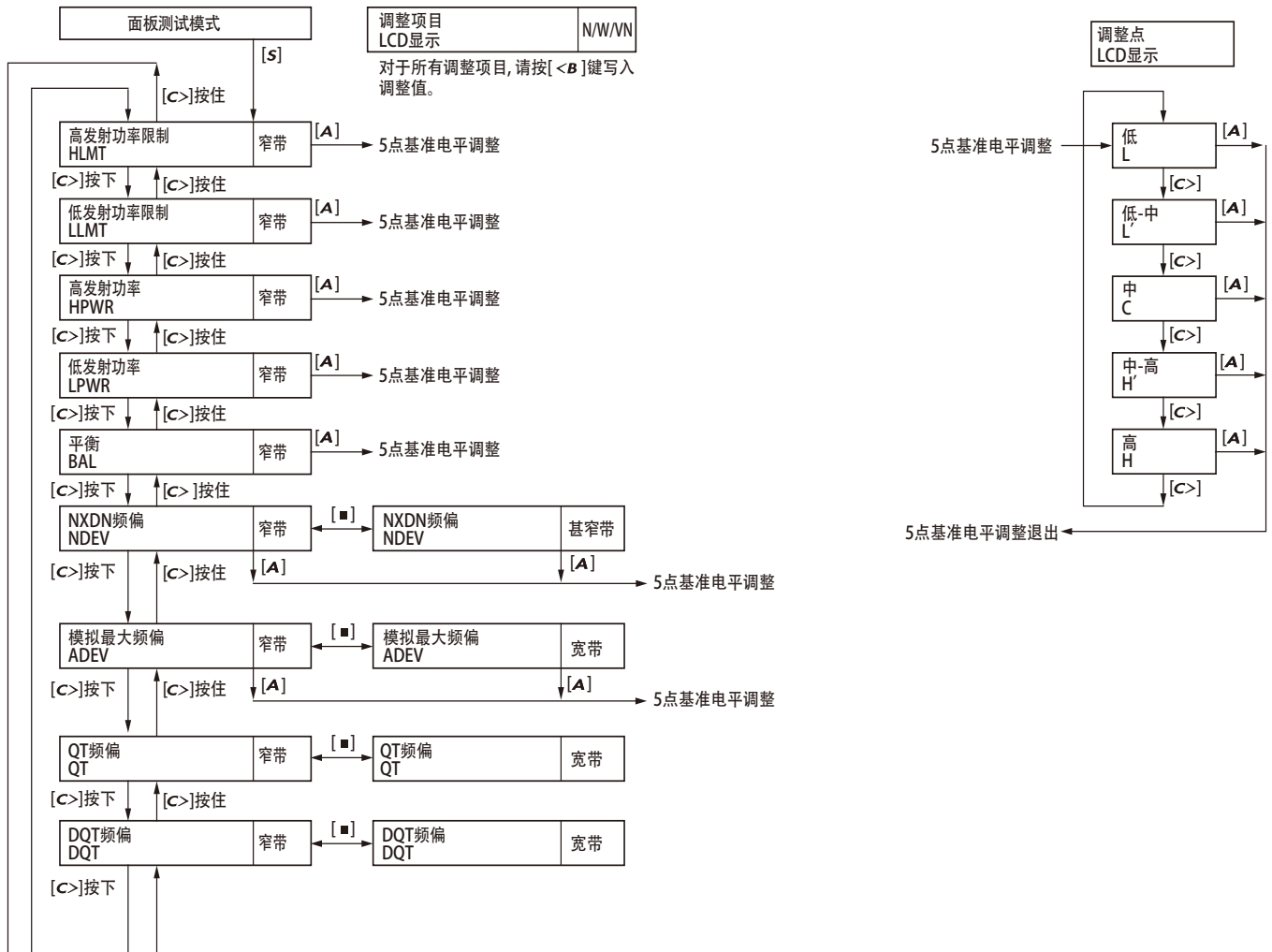

## ADJUSTMENT

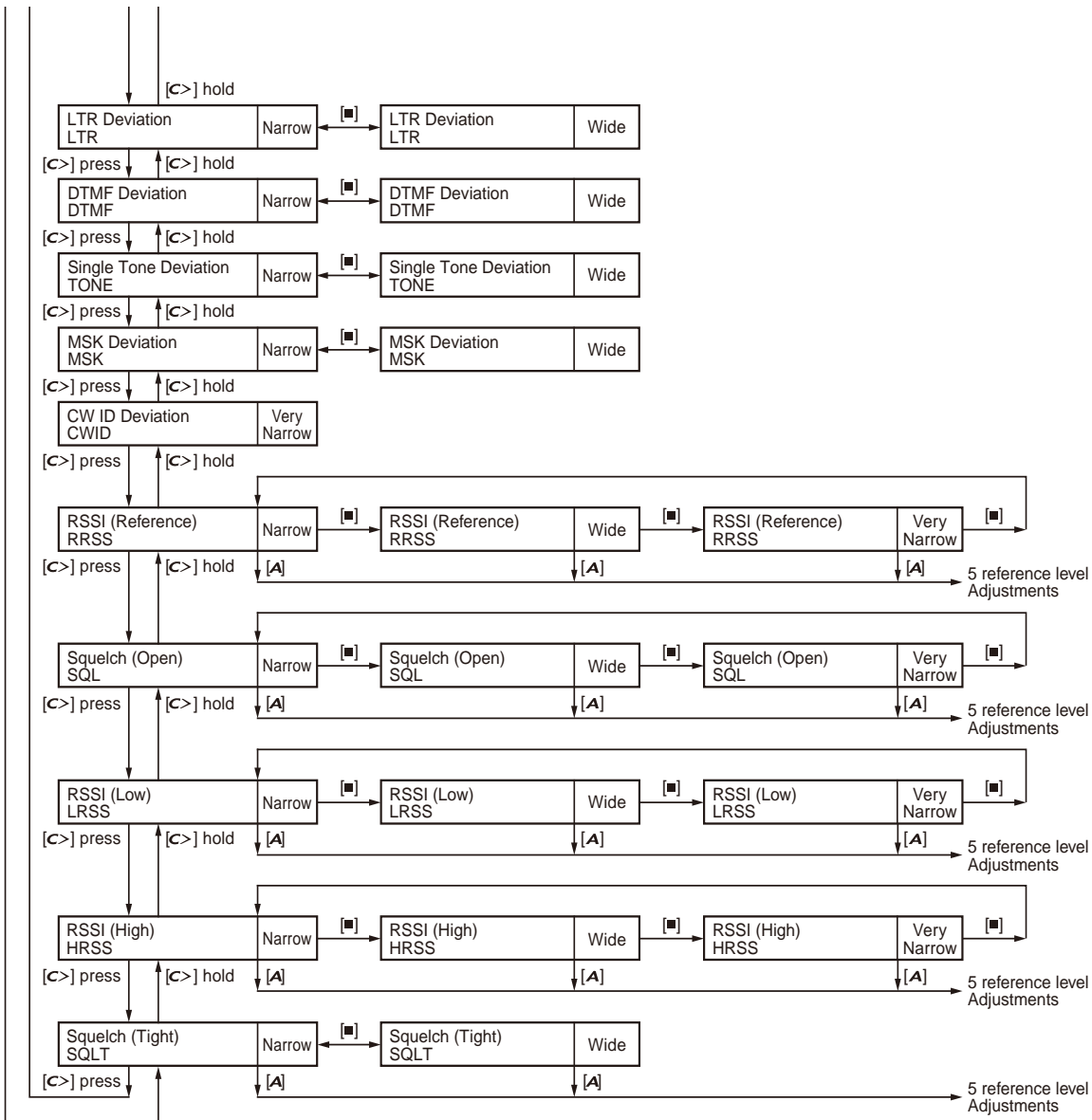

## 调整

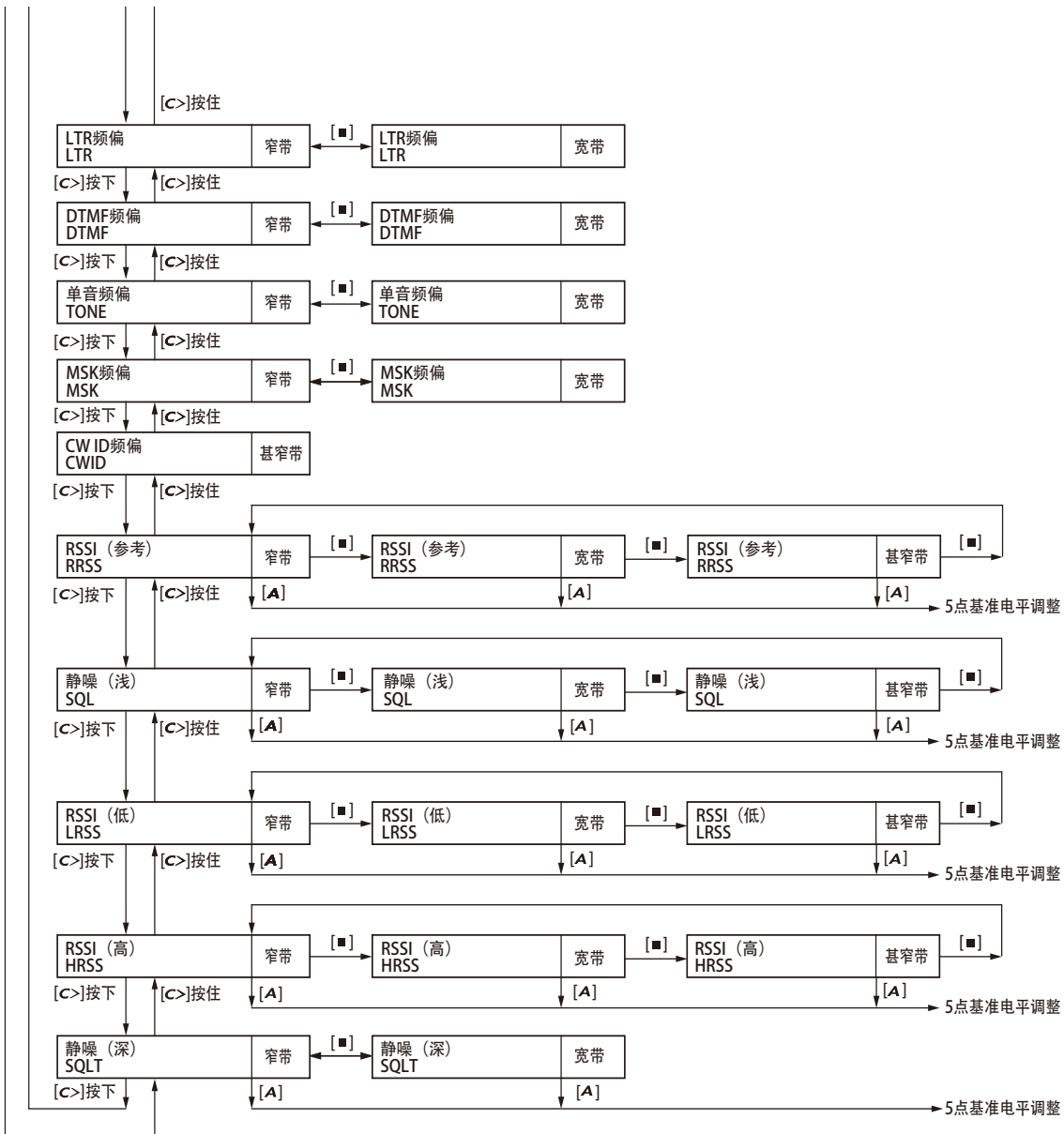

## Test Equipment Required for Alignment

Test Equipment	Major Specifications	
1. Standard Signal Generator (SSG)	Frequency Range Modulation Output When performing the Frequency adjustment, the following accuracy is necessary. • 0.003ppm Use a standard oscillator for adjustments, if necessary.	100 to 520MHz Frequency modulation and external modulation -127dBm/0.1μV to greater than -20dBm/22.4mV
2. Power Meter	Input Impedance Operation Frequency Measurement Capability	50Ω 100 to 520MHz Vicinity of 100W
3. Deviation Meter	Frequency Range	100 to 520MHz
4. Digital Volt Meter (DVM)	Measuring Range Input Impedance	10mV to 20V DC High input impedance for minimum circuit loading
5. Oscilloscope		DC through 30MHz
6. High Sensitivity Frequency Counter	Frequency Range Frequency Stability	10Hz to 1000MHz 0.01ppm or less
7. Ammeter		20A or more
8. AF Volt Meter (AF VM)	Frequency Range Voltage Range	50Hz to 10kHz 1mV to 10V
9. Audio Generator (AG)	Frequency Range Output	50Hz to 5kHz or more 0 to 1V
10. Distortion Meter	Capability Input Level	3% or less at 1kHz 50mV to 10Vrms
11. 4Ω Dummy Load		Approx. 4Ω, 10W
12. Regulated Power Supply		13.6V, approx.20A (adjustable from 9V to 17V) Useful if ammeter equipped
13. Spectrum Analyzer	Frequency Range Input Level Input Sensitivity Resolution Bandwidth Video Bandwidth	40MHz to 520MHz Up to +20dBm -100dBm 100Hz 100Hz
14. Tracking Generator	Frequency Range Output Level	40MHz to 520MHz -30dBm to 0dBm

\*The test equipment which is not used for adjustment is contained in this table.

### ■ Test cable for microphone input (E30-3360-28)

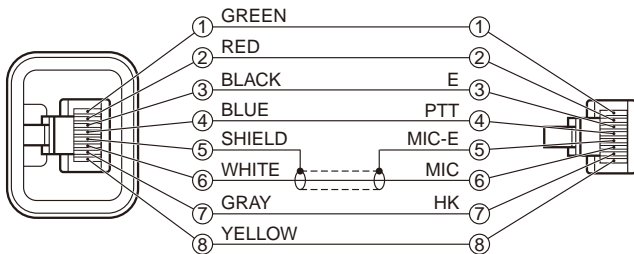

### ■ MIC connector (Front panel view)

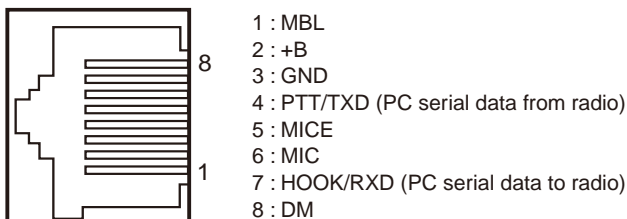

### ■ Tuning cable (E30-3383-05 or E30-7754-05)

Adapter cable (E30-3383-05 or E30-7754-05) is required for injecting an audio if PC tuning is used. See "PC Mode" section for the connection.

Illust is E30-3383-05.

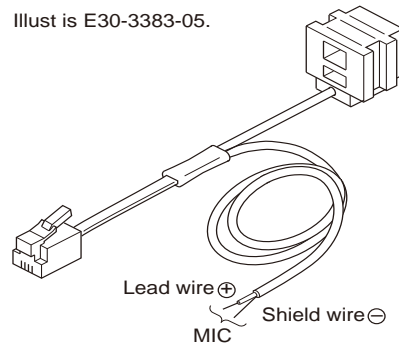



## 调整

### 调整所需的测试设备

测试设备	主要规格
1. 标准信号发生器 (SSG)	频率范围 100 到 520MHz 调制 调频和外部调制 输出 -127dBm/0.1 μV 到大于 -20dBm/22.4mV 进行频率调整时, 需要以下精度。 • 0.003ppm 如有必要, 请使用标准振荡器进行调整。
2. 功率计	输入阻抗 50Ω 操作频率 100 到 520MHz 测量范围 100W 左右
3. 频偏仪	频率范围 100 到 520MHz
4. 数字电压表 (DVM)	测量范围 直流 10mV 到 20V 输入阻抗 为最小电路负载高输入阻抗
5. 示波器	直流到 30MHz
6. 高灵敏度频率计数器	频率范围 10Hz 到 1000MHz 频率稳定性 0.01ppm 或更低
7. 电流表	20A 或更高
8. 音频电压表 (AF VM)	频率范围 50Hz 到 10kHz 电压范围 1mV 到 10V
9. 音频发生器 (AG)	频率范围 50Hz 到 5kHz 或更高 输出 0 到 1V
10. 失真测试仪	能力 在 1kHz 时 3% 或更低 输入电平 50mV 到 10Vrms
11. 4Ω 假负载	大约 4Ω, 10W
12. 电可调电源	13.6V, 大约 20A (可调 9 到 17V) 配备了电流表时更好
13. 频谱分析仪	频率范围 40MHz 到 520MHz 输入电平 最高 +20dBm 输入灵敏度 -100dBm 分辨率带宽 100Hz 视频带宽 100Hz
14. 轨迹发生器	频率范围 40MHz 到 520MHz 输出电平 -30dBm 到 0dBm

\* 这张表包括调整时不使用的测试设备。

#### ■ 用于麦克风输入的测试电缆 (E30-3360-28)

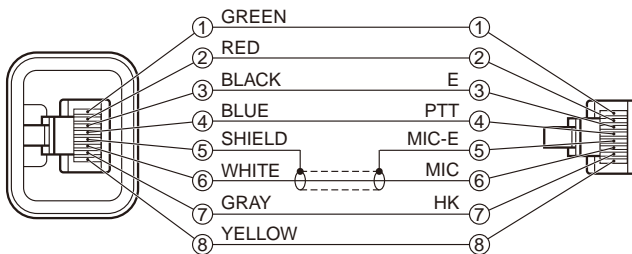

#### ■ MIC 连接器 (前面板视图)

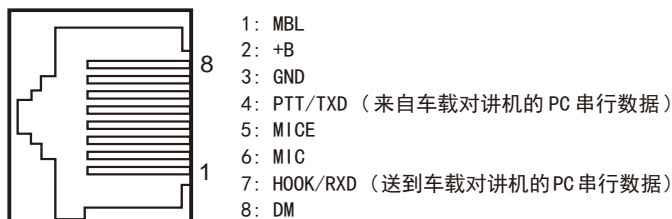

#### ■ 调谐电缆 (E30-3383-05 或 E30-7754-05)

如果使用 PC 调谐, 则输入音频需要适配器电缆 (E30-3383-05 或 E30-7754-05)。

有关连接详情, 请参看“PC 模式”。

插图是 E30-3383-05。

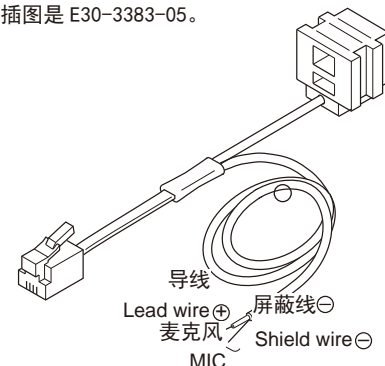

## ADJUSTMENT

### Radio check Section

Item	Condition		Measurement			Adjustment			Specifications/ Remarks
	Panel test mode	PC test mode	Test-equipment	Unit	Terminal	Unit	Parts	Method	
1. Frequency check	1) CH-Sig : 1-1 PTT : ON	1) Test Channel Channel: 1 Test Signaling Mode: Analog Signaling: 1 PTT: Press [Transmit] button.	f. counter		ANT			Check an internal temperature of radio from 20°C to 26°C.	+/-0.25ppm +/-38.0Hz @155.1MHz
2. High power check	1) CH-Sig : 1-1 PTT : ON	1) Test Channel Channel: 1 Test Signaling Mode: Analog Signaling: 1 PTT: Press [Transmit] button.	Power meter Ammeter					Check	23W~29W 10A or less
	2) CH-Sig : 2-1 PTT : ON	2) Test Channel Channel: 2 Test Signaling Mode: Analog Signaling: 1 PTT: Press [Transmit] button.							
	3) CH-Sig : 3-1 PTT : ON	3) Test Channel Channel: 3 Test Signaling Mode: Analog Signaling: 1 PTT: Press [Transmit] button.							
3. Low power check	1) CH-Sig : 1-1 PTT : ON	1) Test Channel Channel: 1 Test Signaling Mode: Analog Signaling: 1 PTT: Press [Transmit] button.							3.5W~6.5W 7A or less
	2) CH-Sig : 2-1 PTT : ON	2) Test Channel Channel: 2 Test Signaling Mode: Analog Signaling: 1 PTT: Press [Transmit] button.							
	3) CH-Sig : 3-1 PTT : ON	3) Test Channel Channel: 3 Test Signaling Mode: Analog Signaling: 1 PTT: Press [Transmit] button.							
4. MIC sensitivity check	1) CH-Sig: 1-1 AG: 1kHz PTT: ON	1) Test Channel Channel: 1 Test Signaling Mode: Analog Signaling: 1 AG: 1kHz PTT: Press [Transmit] button.	Deviation meter Oscilloscope AG AF VM					Adjust AG input to get a standard MOD.	Dev 1.5kHz at 5mV±1.0mV

## 调 整

## 通信机检查部分

项 目	条 件		测 量			调 整			规格 / 备注
	面板测试模式	PC 测试模式	测量装置	单元	端子	单元	部件	方 法	
1. 频率检查	1) CH-Sig: 1-1 PTT: 开启	1) 测试信道 信道: 1 测试信令 模式: 模拟 信令: 1 PTT: 按 [ 发射 ] 按钮。	频率计数器		天线			确认车载对讲机的内部温度在 20°C 至 26°C 范围内。	+/-0.25ppm +/-38.0Hz @ 155.1MHz
2. 高功率检查	1) CH-Sig: 1-1 PTT: 开启	1) 测试信道 信道: 1 测试信令 模式: 模拟 信令: 1 PTT: 按 [ 发射 ] 按钮。	功率计 电流表					检查	23W ~ 29W 10A 或更低
	2) CH-Sig: 2-1 PTT: 开启	2) 测试信道 信道: 2 测试信令 模式: 模拟 信令: 1 PTT: 按 [ 发射 ] 按钮。							
	3) CH-Sig: 3-1 PTT: 开启	3) 测试信道 信道: 3 测试信令 模式: 模拟 信令: 1 PTT: 按 [ 发射 ] 按钮。							
3. 低功率检查	1) CH-Sig: 1-1 PTT: 开启	1) 测试信道 信道: 1 测试信令 模式: 模拟 信令: 1 PTT: 按 [ 发射 ] 按钮。							3.5W ~ 6.5W 7A 或更低
	2) CH-Sig: 2-1 PTT: 开启	2) 测试信道 信道: 2 测试信令 模式: 模拟 信令: 1 PTT: 按 [ 发射 ] 按钮。							
	3) CH-Sig: 3-1 PTT: 开启	3) 测试信道 信道: 3 测试信令 模式: 模拟 信令: 1 PTT: 按 [ 发射 ] 按钮。							
4. 麦克风灵敏度检查	1) CH-Sig: 1-1 AG: 1kHz PTT: 开启	1) 测试信道 信道: 1 测试信令 模式: 模拟 信令: 1 AG: 1kHz PTT: 按 [ 发射 ] 按钮。	频偏仪 示波器 AG AF VM					调整 AG 输入以获得标准 MOD。	频偏: 5mV ± 1mV 时 1.5kHz

## ADJUSTMENT

Item	Condition		Measurement			Adjustment			Specifications/ Remarks
	Panel test mode	PC test mode	Test-equipment	Unit	Terminal	Unit	Parts	Method	
5. Sensitivity check	1) CH-Sig: 1-1 SSG output Wide: -117dBm (0.32μV) (MOD: 1kHz/±3kHz) Narrow: -117dBm (0.32μV) (MOD: 1kHz/±1.5kHz)	1) Test Channel Channel: 1 Test Signaling Mode: Analog Signaling: 1 SSG output Wide: -117dBm (0.32μV) (MOD: 1kHz/±3kHz) Narrow: -117dBm (0.32μV) (MOD: 1kHz/±1.5kHz)	SSG AF VM Oscilloscope Distortion meter 4Ω Dummy load		ANT Ext.SP connector			Check	12dB SINAD or more

### Common Section

Item	Condition		Measurement			Adjustment			Specifications/ Remarks
	Panel tuning mode	PC test mode	Test-equipment	Unit	Terminal	Unit	Parts	Method	
1. Setting	1) DC voltage: 13.6V 2) SSG standard modulation [Wide] MOD: 1kHz, DEV: 3kHz [Narrow] MOD: 1kHz, DEV: 1.5kHz								
2. Receive Assist	* This adjustment can be performed only PC test mode.	1) Adj item: [Receive Assist] 2) Adj item: [Low1], [Low2], [Low3], [Center1], [Center2], [Center3], [High1], [High2], [High3] Press [Apply All] button to store the adjustment value.					[PC test mode] [◀], [▶]	[PC test mode] [Automatic Adjustment] Press [Tune Assist Voltage] button. Press [Apply All] button to store the adjustment value after the automatic adjustment has finished. [Manual Adjustment] [V] indicator on the PC window shows VCO lock voltage. Change the adjustment value to get VCO lock voltage within the limit of the specified voltage.	2.5V±0.1V  [PC test mode] Press [Apply All] button to store the adjustment value after all adjustment point was adjusted.  <b>Check!</b> The assist adjustment value must be between from 340 to 3550.
3. Transmit Assist	* This adjustment can be performed only PC test mode.	1) Adj item: [Transmit Assist] 2) Adj item: [Low1], [Low2], [Low3], [Center1], [Center2], [Center3], [High1], [High2], [High3] PTT: Press [Transmit] button. Press [Apply All] button to store the adjustment value.						<b>Note:</b> Confirm the VCO lock voltage approximately 3 seconds after the adjustment value is changed.	

## 调 整

项 目	条 件		测 量			调 整			规格 / 备注
	面板测试模式	PC 测试模式	测量装置	单元	端子	单元	部件	方 法	
5. 灵敏度检查	1) CH-Sig: 1-1 SSG 输出 宽带： -117dBm (0.32 μV) (MOD: 1kHz/±3kHz) 窄带： -117dBm (0.32 μV) (MOD: 1kHz/±1.5kHz)	1) 测试信道 信道：1 测试信令 模式：模拟 信令：1 SSG 输出 宽带： -117dBm (0.32 μV) (MOD: 1kHz/±3kHz) 窄带： -117dBm (0.32 μV) (MOD: 1kHz/±1.5kHz)	SSG AF VM 示波器 失真测试仪 4Ω 假负载		天线 外部 SP 连接器			检查	12dB SINAD 或更高



### 共通部分

项 目	条 件		测 量			调 整			规格 / 备注
	面板调谐模式	PC 测试模式	测量装置	单元	端子	单元	部件	方 法	
1. 设置	1) DC 电压 : 13.6V 2) SSG 标准调制 [宽]MOD: 1kHz, DEV: 3kHz [窄]MOD: 1kHz, DEV: 1.5kHz								
2. 接收辅助	* 仅可在 PC 测试模式 中进行调整。	1) 调整项目： [接收辅助] 2) 调整项目： [低 1], [低 2], [低 3], [中 1], [中 2], [中 3], [高 1], [高 2], [高 3]  按 [全部应用] 按 钮储存调整值。					[PC 测 试模式] [自动调整] [◀], [▶]	[PC 测试模式] [自动调整] 按 [调整辅助电 压] 按钮。 自动调整完成后, 按 [全部应用] 按 钮储存调整值。  [手动调整] PC 窗口上的 [V] 指 示显示 VCO 锁定电 压。更改调整值, 以获得指定电压范 围内的 VCO 锁定电 压。  注意： 在更改调整值约 3 秒后确认 VCO 锁定 电压。	2.5V±0.1V  [PC 测试模式] 在所有调整点调整之 后, 按 [全部应用] 按钮储存调整值。  检查： 辅助调整值必须介于 340 至 3550 之间。
3. 发射辅助	* 仅可在 PC 测试模式 中进行调整。	1) 调整项目： [发射辅助] 2) 调整项目： [低 1], [低 2], [低 3], [中 1], [中 2], [中 3], [高 1], [高 2], [高 3]  PTT: 按 [发射] 按 钮。 按 [全部应用] 按 钮储存调整值。							

## ADJUSTMENT

Item	Condition		Measurement			Adjustment			Specifications/ Remarks
	Panel tuning mode	PC test mode	Test-equipment	Unit	Terminal	Unit	Parts	Method	
4. Frequency	* The Frequency adjustment can be performed only in PC test mode.	1) Adj item: [Frequency] SSG output :-20dBm (22.4mV) (CW (without modulation))  <b>Caution:</b> Perform the frequency adjustment under the following conditions. <ul style="list-style-type: none"> <li>Temperature range of +20°C to +26°C. (The temperature is displayed on the Frequency adjustment screen of the KPG-141D(C) and the LCD of the transceiver.)</li> <li>Use an accuracy of 0.003ppm for the SSG. (Use a standard oscillator if necessary.)</li> </ul>	SSG		ANT			<b>[PC test mode]</b> Press [Start] button of "Auto Tuning". Press [Apply] button to store the adjustment value after the automatic adjustment was finished.	<b>[PC test mode]</b> The value of "IF20" will become around "0" (Target: ±12digit) after the adjustment was finished.  <b>Remark:</b> "Frequency" is adjusted under receiving condition with SSG.





### Transmitter Section

Item	Condition		Measurement			Adjustment			Specifications/ Remarks
	Panel tuning mode	PC test mode	Test-equipment	Unit	Terminal	Unit	Parts	Method	
1. High Transmit power Limit	1) Adj item: [HLMT] Adjust: [****] 2) Adj item: [H.LMT_]→ [H.L.MT_]→ [H.L.M.T_]→ [H.L.M.T._]→ [H.L.M.T._.] PTT : ON Press [<B] key to store the adjustment value	1) TEST CH: Low, Low', Center, High', High (5 point) 2) Transmit Press [Apply All] button to store the adjustment value.	Power meter Ammeter		ANT		<b>[Panel tuning mode]</b>   <b>[PC test mode]</b> 	28W	±2.0W
Low Transmit power Limit	1) Adj item: [LLMT] Adjust: [****] 2) Adj item: [L.LMT_]→ [L.L.MT_]→ [L.L.M.T_]→ [L.L.M.T._]→ [L.L.M.T._.] PTT : ON Press [<B] key to store the adjustment value	1) TEST CH: Low, Low', Center, High', High (5 point) 2) Transmit Press [Apply All] button to store the adjustment value.					10W	<b>[PC test mode]</b> Press [Apply All] button to store the adjustment value after all adjustment point was adjusted.	

## 调 整

项 目	条 件		测 量			调 整			规格 / 备注
	面板调谐模式	PC 测试模式	测量装置	单元	端子	单元	部件	方 法	
4. 频率	* 仅在 PC 测试模式中进行调整。	1) 调整项目：[频率] SSG 输出： -20dBm (22.4mV) (CW (无调制))  注意： 在下述条件下进行频率调整。 • 温度范围 +20°C 至 +26°C。 (KPG-141D(C) 的频率调整画面和车载对讲机的 LCD 上显示频率。) • 使用 0.003ppm 的 SSG 精度。(如有必要, 请使用标准振荡器。)	SSG		天线			[PC 测试模式] 按“自动调整”的 [开始] 按钮。 自动调整完成之后, 按 [应用] 按钮储存调整值。	[PC 测试模式] 调整结束后, “IF20” 的值将变成 “0” 左右 (目标值: ±12)。  备注： 在 SSG 接收条件下调整 “频率”。

### 发射部分

项 目	条 件		测 量			调 整			规格 / 备注
	面板调谐模式	PC 测试模式	测量装置	单元	端子	单元	部件	方 法	
1. 高发射功率限制	1) 调整项目：[HLMT] 调整：[****] 2) 调整项目： [H. LMT_] → [H. L. MT_] → [H. L. M. T_] → [H. L. M. T. _] → [H. L. M. T. _.] PTT: 开启 按 [ <B ] 键储存调整值。	1) 测试信道： 低, 低', 中, 高', 高 (5 点) 2) 发射 按 [全部应用] 按钮储存调整值。	功率计 电流表		天线		[面板调谐模式] [  ], [  ]  [PC 测试模式] [  ], [  ]	28W	±2.0W  [PC 测试模式] 调整所有调整点之后, 按 [全部应用] 按钮储存调整值。
低发射功率限制	1) 调整项目：[LLMT] 调整：[****] 2) Adj item: [L. LMT_] → [L. L. MT_] → [L. L. M. T_] → [L. L. M. T. _] → [L. L. M. T. _.] PTT: 开启 按 [ <B ] 键储存调整值。	1) 测试信道： 低, 低', 中, 高', 高 (5 点) 2) 发射 按 [全部应用] 按钮储存调整值。						10W	

## ADJUSTMENT







Item	Condition		Measurement			Adjustment			Specifications/ Remarks
	Panel tuning mode	PC test mode	Test-equipment	Unit	Terminal	Unit	Parts	Method	
2. High Transmit Power	1) Adj item: [HPWR] Adjust: [****] 2) Adj item: [H.PWR_]→ [H.P.WR_]→ [H.P.W.R_]→ [H.P.W.R_]→ [H.P.W.R_]→ PTT : ON Press [ <b>B</b> ] key to store the adjustment value	1) TEST CH: Low, Low', Center, High', High (5 point) 2) Transmit Press [Apply All] button to store the adjustment value.	Power meter Ammeter		ANT		[Panel tuning mode] [↕], [↖]  [PC test mode] [◀], [▶]	25.0W	±1.0W 10.0A or less  [PC test mode] Press [Apply All] button to store the adjustment value after all adjustment point was adjusted.
Low Transmit power	1) Adj item: [LPWR] Adjust: [****] 2) Adj item: [L.PWR_]→ [L.P.WR_]→ [L.P.W.R_]→ [L.P.W.R_]→ [L.P.W.R_]→ PTT : ON Press [ <b>B</b> ] key to store the adjustment value	1) TEST CH: Low, Low', Center, High', High (5 point) 2) Transmit Press [Apply All] button to store the adjustment value.						5.0W	±0.2W 7.0A or less  [PC test mode] Press [Apply All] button to store the adjustment value after all adjustment point was adjusted.
3. Balance *2	1) Adj item: [BAL] Adjust: [***] Deviation meter LPF: 3kHz HPF: OFF 2) Adj item: [B.AL_]→ [B.A.L_]→ [B.A.L_]→ [B.A.L_]→ [B.A.L_]→ Adjust: [***] PTT: ON Press [ <b>B</b> ] key to store the adjustment value.	1) Adj item: [Balance] Deviation meter LPF: 3kHz HPF: OFF 2) Adj item: [Low], [Low'], [Center], [High'], [High] PTT: Press [Transmit] button. Press [Apply All] button to store the adjustment value. [2kHz Sine Wave Check box]: Check while transmitting change to 2kHz.	Deviation meter Oscilloscope		ANT		[Panel tuning mode] [↕], [↖]  [PC test mode] [◀], [▶]	The Deviation of 20Hz frequency is fixed. Change the 2kHz adjustment value to become the same deviation of 20Hz within the specified range.	2kHz Tone deviation is within ±1.0% of 20Hz tone deviation.  [PC test mode] Press [Apply All] button to store the adjustment value after all adjustment point was adjusted.
*2: Refer to the "Necessary Deviation adjustment item for each signaling and mode" table on page 80. Balance adjustment is common with the adjustment of all signaling deviations.									
4. Maximum Deviation (NXDN) *3  [Narrow]	1) Adj item: [NDEV] Adjust: [****] Deviation meter LPF: 3kHz HPF: OFF PTT: ON Press [ <b>B</b> ] key to store the adjustment value.	1) Adj item: [Maximum Deviation (NXDN Narrow)] Deviation meter LPF: 3kHz HPF: OFF PTT: Press [Transmit] button. Press [Apply All] button to store the adjustment value.	Deviation meter Oscilloscope		ANT		[Panel tuning mode] [↕], [↖]  [PC test mode] [◀], [▶]	Write Reference value "513" for each adjustment point. Transmit at each adjustment point and check that the Analog deviation is between 2995Hz and 3117Hz.	2995~3117Hz  [PC test mode] Press [Apply All] button to store the adjustment value after all adjustment point was adjusted.



## 调 整

项 目	条 件		测 量			调 整			规格 / 备注
	面板调谐模式	PC 测试模式	测量装置	单元	端子	单元	部件	方 法	
2. 高发射功率	1) 调整项目:[HPWR] 调整:[****] 2) 调整项目: [H.PWR_]→ [H.P.WR_]→ [H.P.W.R_]→ [H.P.W.R._]→ [H.P.W.R._.] PTT: 开启 按 [ <B ] 键储存调整值。	1) 测试信道: 低, 低', 中, 高', 高 (5 点) 2) 发射 按 [ 全部应用 ] 按钮储存调整值。	功率计 电流表		天线		[ 面板调谐模式 ] [ < > ], [ < > ]  [PC 测试模式] [ < > ], [ < > ]	25.0W	±1.0W 10.0A 或更低  [PC 测试模式] 调整所有调整点之后, 按 [ 全部应用 ] 按钮储存调整值。
低发射功率	1) 调整项目:[LPWR] 调整:[****] 2) 调整项目: [L.PWR_]→ [L.P.WR_]→ [L.P.W.R_]→ [L.P.W.R._]→ [L.P.W.R._.] PTT: 开启 按 [ <B ] 键储存调整值。	1) 测试信道: 低, 低', 中, 高', 高 (5 点) 2) 发射 按 [ 全部应用 ] 按钮储存调整值。						5.0W	±0.2W 7.0A 或更低  [PC 测试模式] 调整所有调整点之后, 按 [ 全部应用 ] 按钮储存调整值。
3. 平衡 *2	1) 调整项目:[BAL] 调整:[***] 频偏仪 LPF: 3kHz HPF: 关闭 2) 调整项目: [B.AL_]→ [B.A.L_]→ [B.A.L._]→ [B.A.L._.] 调整:[***] PTT: 开启 按 [ <B ] 键储存调整值。	1) 调整项目:[平衡] 频偏仪 LPF: 3kHz HPF: 关闭 2) 调整项目: [低], [低'], [中], [高'], [高] PTT: 按 [ 发射 ] 按钮。 按 [ 全部应用 ] 按钮储存调整值。 [2kHz 弦波波] 复选框: 发射时复选此项改为 2kHz。	频偏仪 示波器		天线		[ 面板调谐模式 ] [ < > ], [ < > ]  [PC 测试模式] [ < > ], [ < > ]	20Hz 频率的频偏固定。 更改 2kHz 调整值, 变成指定范围内 20Hz 的相同频偏。	2kHz 音调频偏在 20Hz 音调频偏的 ±1.0% 以内。  [PC 测试模式] 调整所有调整点之后, 按 [ 全部应用 ] 按钮储存调整值。
*2: 请参阅第 81 页的“各信令和模式所需的频偏调整项目”表。 所有信令频偏的平衡调整共用。									
4. 最大频偏 (NXDN) *3 [ 窄带 ]	1) 调整项目:[NDEV] 调整:[****.] 频偏仪 LPF: 3kHz HPF: 关闭 PTT: 开启 按 [ <B ] 键储存调整值。	1) 调整项目:[最大频偏 (NXDN 窄带)] 频偏仪 LPF: 3kHz HPF: 关闭 PTT: 按 [ 发射 ] 按钮。 按 [ 全部应用 ] 按钮储存调整值。	频偏仪 示波器		天线		[ 面板调谐模式 ] [ < > ], [ < > ]  [PC 测试模式] [ < > ], [ < > ]	写基准值 "513" 到每个调整点。 在每个调整点发射, 检查模拟频偏是否在 2995Hz 和 3117Hz 之间。	2995 ~ 3117Hz  [PC 测试模式] 调整所有调整点之后, 按 [ 全部应用 ] 按钮储存调整值。







## ADJUSTMENT

Item	Condition		Measurement			Adjustment			Specifications/ Remarks
	Panel tuning mode	PC test mode	Test-equipment	Unit	Terminal	Unit	Parts	Method	
4. Maximum Deviation (NXDN) *3  [Very Narrow]	1) Adj item: [NDEV] Adjust: [****] PTT : ON Press [ <b>B</b> ] key to store the adjustment value.	1) Adj item: [Maximum Deviation (NXDN Very Narrow)] PTT: Press [Transmit] button. Press [Apply All] button to store the adjustment value.	Deviation meter Oscilloscope		ANT		[Panel tuning mode]  [PC test mode] 	Write Reference value "513" for each adjustment point. Transmit at each adjustment point and check that the Analog deviation is between 1311Hz and 1363Hz.	1311~1363Hz  [PC test mode] Press [Apply All] button to store the adjustment value after all adjustment point was adjusted.
5. Maximum Deviation (Analog) *3  [Narrow]	1) Adj item: [ADEV] Adjust: [****.] Deviation meter LPF: 15kHz HPF: OFF PTT: ON Press [ <b>B</b> ] key to store the adjustment value.	1) Adj item: [Maximum Deviation (Analog Narrow)] Deviation meter LPF: 15kHz HPF: OFF PTT: Press [Transmit] button. Press [Apply All] button to store the adjustment value.	Deviation meter Oscilloscope		ANT		[Panel tuning mode]  [PC test mode] 	Write Reference value "513" for each adjustment point. Transmit at each adjustment point and check that the Analog deviation is between 2050Hz and 2150Hz.	2050~2150Hz  [PC test mode] Press [Apply All] button to store the adjustment value after all adjustment point was adjusted.
[Wide]	1) Adj item: [ADEV] Adjust: [**.*.*.]. PTT: ON Press [ <b>B</b> ] key to store the adjustment value.	1) Adj item: [Maximum Deviation (Analog Wide)] PTT: Press [Transmit] button. Press [Apply All] button to store the adjustment value.						Write Reference value "513" for each adjustment point. Transmit at each adjustment point and check that the Analog deviation is between 4150Hz and 4250Hz.	4150~4250Hz  [PC test mode] Press [Apply All] button to store the adjustment value after all adjustment point was adjusted.
*3: Refer to the "Necessary Deviation adjustment item for each signaling and mode" table on page 80. Regarding Maximum Deviation (Analog), it is common with the adjustment of all analog signalings.									
6. QT Deviation *4  [Narrow]	1) Adj item: [QT] Adjust: [****.] Deviation meter LPF: 3kHz HPF: OFF PTT: ON Press [ <b>B</b> ] key to store the adjustment value.	1) Adj item: [QT Deviation (Analog Narrow)] Deviation meter LPF: 3kHz HPF: OFF PTT: Press [Transmit] button. Press [Apply] button to store the adjustment value.	Deviation meter Oscilloscope		ANT		[Panel tuning mode]  [PC test mode] 	Write the value 513 (Reference value)	0.35kHz±0.05kHz

## 调 整

项 目	条 件		测 量			调 整			规格 / 备注
	面板调谐模式	PC 测试模式	测量装置	单元	端子	单元	部件	方 法	
4. 最大频偏 (NXDN) *3 [ 甚窄带 ]	1) 调整项目: [NDEV] 调整: [****] PTT: 开启 按 [ <B ] 键储存调整值。	1) 调整项目: [最大频偏 (NXDN 甚窄带)] PTT: 按 [ 发射 ] 按钮。 按 [ 全部应用 ] 按钮储存调整值。	频偏仪示波器		天线		[ 面板调谐模式 ] [ < > ], [ < > ]  [ PC 测试模式 ] [ < > ], [ < > ]	写基准值 "513" 到每个调整点。 在每个调整点发射, 检查模拟频偏是否在 1311Hz 和 1363Hz 之间。	1311 ~ 1363Hz  [ PC 测试模式 ] 调整所有调整点之后, 按 [ 全部应用 ] 按钮储存调整值。
5. 最大频偏 (模拟) *3 [ 窄带 ]	1) 调整项目: [ADEV] 调整: [****.] 频偏仪 LPF: 15kHz HPF: 关闭 PTT: 开启 按 [ <B ] 键储存调整值。	1) 调整项目: [最大频偏 (模拟窄带)] 频偏仪 LPF: 15kHz HPF: 关闭 PTT: 按 [ 发射 ] 按钮。 按 [ 全部应用 ] 按钮储存调整值。	频偏仪示波器		天线		[ 面板调谐模式 ] [ < > ], [ < > ]  [ PC 测试模式 ] [ < > ], [ < > ]	写基准值 "513" 到每个调整点。 在每个调整点发射, 检查模拟频偏是否在 2050Hz 和 2150Hz 之间。	2050 ~ 2150Hz  [ PC 测试模式 ] 调整所有调整点之后, 按 [ 全部应用 ] 按钮储存调整值。
[ 宽带 ]	1) 调整项目: [ADEV] 调整: [*. *. *. ] PTT: 开启 按 [ <B ] 键储存调整值。	1) 调整项目: [最大频偏 (模拟宽带)] PTT: 按 [ 发射 ] 按钮。 按 [ 全部应用 ] 按钮储存调整值。						写基准值 "513" 到每个调整点。 在每个调整点发射, 检查模拟频偏是否在 4150Hz 和 4250Hz 之间。	4150 ~ 4250Hz  [ PC 测试模式 ] 调整所有调整点之后, 按 [ 全部应用 ] 按钮储存调整值。
*3: 请参阅第 81 页的“各信令和模式所需的频偏调整项目”表。 对于最大频偏 (模拟), 所有模拟信令的调整共用。									
6. QT 频偏 *4 [ 窄带 ]	1) 调整项目: [QT] 调整: [****.] 频偏仪 LPF: 3kHz HPF: 关闭 PTT: 开启 按 [ <B ] 键储存调整值。	1) 调整项目: [QT 频偏 (模拟窄带)] 频偏仪 LPF: 3kHz HPF: 关闭 PTT: 按 [ 发射 ] 按钮。 按 [ 应用 ] 按钮储存调整值。	频偏仪示波器		天线		[ 面板调谐模式 ] [ < > ], [ < > ]  [ PC 测试模式 ] [ < > ], [ < > ]	写入以下值。 513 (基准值)	0.35kHz ± 0.05kHz

## ADJUSTMENT

Item	Condition		Measurement			Adjustment			Specifications/ Remarks
	Panel tuning mode	PC test mode	Test-equipment	Unit	Terminal	Unit	Parts	Method	
6. QT Deviation *4  [Wide]	1) Adj item: [QT] Adjust: [**.*.*.] PTT: ON Press [ <b>B</b> ] key to store the adjustment value.	1) Adj item: [QT Deviation (Analog Wide)] Deviation meter LPF: 3kHz HPF: OFF PTT: Press [Transmit] button. Press [Apply] button to store the adjustment value.	Deviation meter Oscilloscope		ANT		[Panel tuning mode]   [PC test mode] 	Write the value 513 (Reference value)	0.75kHz±0.05kHz
7. DQT Deviation *4  [Narrow]	1) Adj item: [DQT] Adjust: [****.] Deviation meter LPF: 3kHz HPF: OFF PTT: ON Press [ <b>B</b> ] key to store the adjustment value.	1) Adj item: [DQT Deviation (Analog Narrow)] Deviation meter LPF: 3kHz HPF: OFF PTT: Press [Transmit] button. Press [Apply] button to store the adjustment value.	Deviation meter Oscilloscope		ANT		[Panel tuning mode]   [PC test mode] 	Write the value 430 (Reference value)	0.35kHz±0.05kHz
[Wide]	1) Adj item: [DQT] Adjust: [**.*.*.] PTT: ON Press [ <b>B</b> ] key to store the adjustment value.	1) Adj item: [DQT Deviation (Analog Wide)] PTT: Press [Transmit] button. Press [Apply] button to store the adjustment value.						Write the value 430 (Reference value)	0.75kHz±0.05kHz
8. LTR Deviation *4  [Narrow]	1) Adj item: [LTR] Adjust: [****.] Deviation meter LPF: 3kHz HPF: OFF PTT: ON Press [ <b>B</b> ] key to store the adjustment value.	1) Adj item: [LTR Deviation (Analog Narrow)] Deviation meter LPF: 3kHz HPF: OFF PTT: Press [Transmit] button. Press [Apply] button to store the adjustment value.	Deviation meter Oscilloscope		ANT		[Panel tuning mode]   [PC test mode] 	Write the value 465 (Reference value)	0.75kHz±0.05kHz
[Wide]	1) Adj item: [LTR] Adjust: [**.*.*.] PTT: ON Press [ <b>B</b> ] key to store the adjustment value.	1) Adj item: [LTR Deviation (Analog Wide)] PTT: Press [Transmit] button. Press [Apply] button to store the adjustment value.						Write the value 465 (Reference value)	1.00kHz±0.05kHz

## 调 整

项 目	条 件		测 量			调 整			规格 / 备注
	面板调谐模式	PC 测试模式	测量装置	单元	端子	单元	部件	方 法	
6. QT 频偏 *4 [ 宽带 ]	1) 调整项目 : [QT] 调整 : [**. *.* .] PTT : 开启 按 [ <B ] 键储存调整值。	1) 调整项目 : [QT 频偏 (模拟宽带)] PTT : 按 [ 发射 ] 按钮。 按 [ 应用 ] 按钮储存调整值。	频偏仪 示波器		天线		[ 面板调谐模式 ] [ < > ], [ < > ]  [ PC 测试模式 ] [ < > ], [ < > ]	写入以下值。 513 (基准值)	0.75kHz ± 0.05kHz
7. DQT 频偏 *4 [ 窄带 ]	1) 调整项目 : [DQT] 调整 : [****.] 频偏仪 LPF : 3kHz HPF : 关闭 PTT : 开启 按 [ <B ] 键储存调整值	1) 调整项目 : [DQT 频偏 (模拟窄带)] 频偏仪 LPF : 3kHz HPF : 关闭 PTT : 按 [ 发射 ] 按钮。 按 [ 应用 ] 按钮储存调整值。	频偏仪 示波器		天线		[ 面板调谐模式 ] [ < > ], [ < > ]  [ PC 测试模式 ] [ < > ], [ < > ]	写入以下值。 430 (基准值)	0.35kHz ± 0.05kHz
[ 宽带 ]	1) 调整项目 : [DQT] 调整 : [**. *.* .] PTT : 开启 按 [ <B ] 键储存调整值。	1) 调整项目 : [DQT 频偏 (模拟宽带)] PTT : 按 [ 发射 ] 按钮。 按 [ 应用 ] 按钮储存调整值。						写入以下值。 430 (基准值)	0.75kHz ± 0.05kHz
8. LTR 频偏 *4 [ 窄带 ]	1) 调整项目 : [LTR] 调整 : [****.] 频偏仪 LPF : 3kHz HPF : 关闭 PTT : 开启 按 [ <B ] 键储存调整值。	1) 调整项目 : [LTR 频偏 (模拟窄带)] 频偏仪 LPF : 3kHz HPF : 关闭 PTT : 按 [ 发射 ] 按钮。 按 [ 应用 ] 按钮储存调整值。	频偏仪 示波器		天线		[ 面板调谐模式 ] [ < > ], [ < > ]  [ PC 测试模式 ] [ < > ], [ < > ]	写入以下值。 465 (基准值)	0.75kHz ± 0.05kHz
[ 宽带 ]	1) 调整项目 : [LTR] 调整 : [**. *.* .] PTT : 开启 按 [ <B ] 键储存调整值。	1) 调整项目 : [LTR 频偏 (模拟宽带)] PTT : 按 [ 发射 ] 按钮。 按 [ 应用 ] 按钮储存调整值。						写入以下值。 465 (基准值)	1.00kHz ± 0.05kHz

## ADJUSTMENT

Item	Condition		Measurement			Adjustment			Specifications/ Remarks
	Panel tuning mode	PC test mode	Test-equipment	Unit	Terminal	Unit	Parts	Method	
9. DTMF Deviation *4 [Narrow]	1) Adj item: [DTMF] Adjust: [****.] Deviation meter LPF : 15kHz HPF : OFF PTT: ON Press [ <b>B</b> ] key to store the adjustment value.	1) Adj item: [DTMF Deviation (Analog Narrow)] Deviation meter LPF: 15kHz HPF: OFF PTT: Press [Transmit] button. Press [Apply] button to store the adjustment value.	Deviation meter Oscilloscope		ANT		[Panel tuning mode] [↕], [↖]  [PC test mode] [◀], [▶]	Write the value 648 (Reference value)	1.50kHz±0.05kHz
	[Wide]	1) Adj item: [DTMF] Adjust: [***.*.] PTT: ON Press [ <b>B</b> ] key to store the adjustment value.						1) Adj item: [DTMF Deviation (Analog Wide)] PTT: Press [Transmit] button. Press [Apply] button to store the adjustment value.	Write the value 648 (Reference value)
10. Single Tone Deviation *4 [Narrow]	1) Adj item: [TONE] Adjust: [****.] Deviation meter LPF: 15kHz HPF: OFF PTT: ON Press [ <b>B</b> ] key to store the adjustment value.	1) Adj item: [Single Tone Deviation (Analog Narrow)] Deviation meter LPF: 15kHz HPF: OFF PTT: Press [Transmit] button. Press [Apply] button to store the adjustment value.	Deviation meter Oscilloscope		ANT		[Panel tuning mode] [↕], [↖]  [PC test mode] [◀], [▶]	Write the value 513 (Reference value)	1.50kHz±0.05kHz
	[Wide]	1) Adj item: [TONE] Adjust: [***.*.] PTT: ON Press [ <b>B</b> ] key to store the adjustment value.						1) Adj item: [Single Tone Deviation (Analog Wide)] PTT: Press [Transmit] button. Press [Apply] button to store the adjustment value.	Write the value 513 (Reference value)
11. MSK Deviation *4 [Narrow]	1) Adj item: [MSK] Adjust: [****.] Deviation meter LPF: 15kHz HPF: OFF PTT: ON Press [ <b>B</b> ] key to store the adjustment value.	1) Adj item: [MSK Deviation (Analog Narrow)] Deviation meter LPF: 15kHz HPF: OFF PTT: Press [Transmit] button. Press [Apply] button to store the adjustment value.	Deviation meter Oscilloscope		ANT		[Panel tuning mode] [↕], [↖]  [PC test mode] [◀], [▶]	Write the value 513 (Reference value)	1.50kHz±0.05kHz
	[Wide]	1) Adj item: [MSK] Adjust: [***.*.] PTT: ON Press [ <b>B</b> ] key to store the adjustment value.						1) Adj item: [MSK Deviation (Analog Wide)] PTT: Press [Transmit] button. Press [Apply] button to store the adjustment value.	Write the value 513 (Reference value)

## 调 整

项 目	条 件		测 量			调 整			规格 / 备注
	面板调谐模式	PC 测试模式	测量装置	单元	端子	单元	部件	方 法	
9. DTMF 频偏 *4  [窄带]	1) 调整项目: [DTMF] 调整: [****.] 频偏仪 LPF: 15kHz HPF: 关闭 PTT: 开启 按 [ <B ] 键储存调整值。	1) 调整项目: [DTMF] 频偏 (模拟窄带)] 频偏仪 LPF: 15kHz HPF: 关闭 PTT: 按 [发射] 按钮。 按 [应用] 按钮储存调整值。	频偏仪 示波器		天线		[面板调 谐模式] [ < > ], [ < > ]  [PC 测 试模式] [ < > ], [ < > ]	写入以下值。 648 (基准值)	1.50kHz ± 0.05kHz
	[宽带]	1) 调整项目: [DTMF] 调整: [**.*.*] PTT: 开启 按 [ <B ] 键储存调整值。						1) 调整项目: [DTMF] 频偏 (模拟宽带)] PTT: 按 [发射] 按钮。 按 [应用] 按钮储存调整值。	
10. 单音频偏 *4  [窄带]	1) 调整项目: [TONE] 调整: [****.] 频偏仪 LPF: 15kHz HPF: 关闭 PTT: 开启 按 [ <B ] 键储存调整值。	1) 调整项目: [单音 频偏 (模拟窄带)] 频偏仪 LPF: 15kHz HPF: 关闭 PTT: 按 [发射] 按钮。 按 [应用] 按钮储存调整值。	频偏仪 示波器		天线		[面板调 谐模式] [ < > ], [ < > ]  [PC 测 试模式] [ < > ], [ < > ]	写入以下值。 513 (基准值)	1.50kHz ± 0.05kHz
	[宽带]	1) 调整项目: [TONE] 调整: [**.*.*] PTT: 开启 按 [ <B ] 键储存调整值。						1) 调整项目: [单音 频偏 (模拟宽带)] PTT: 按 [发射] 按钮。 按 [应用] 按钮储存调整值。	
11. MSK 频偏 *4  [窄带]	1) 调整项目: [MSK] 调整: [****.] 频偏仪 LPF: 15kHz HPF: 关闭 PTT: 开启 按 [ <B ] 键储存调整值。	1) 调整项目: [MSK] 频偏 (模拟窄带)] 频偏仪 LPF: 15kHz HPF: 关闭 PTT: 按 [发射] 按钮。 按 [应用] 按钮储存调整值。	频偏仪 示波器		天线		[面板调 谐模式] [ < > ], [ < > ]  [PC 测 试模式] [ < > ], [ < > ]	写入以下值。 513 (基准值)	1.50kHz ± 0.05kHz
	[宽带]	1) 调整项目: [MSK] 调整: [**.*.*] PTT: 开启 按 [ <B ] 键储存调整值。						1) 调整项目: [MSK] 频偏 (模拟宽带)] PTT: 按 [发射] 按钮。 按 [应用] 按钮储存调整值。	

## ADJUSTMENT

Item	Condition		Measurement			Adjustment			Specifications/ Remarks
	Panel tuning mode	PC test mode	Test-equipment	Unit	Terminal	Unit	Parts	Method	
12. CW ID Deviation *4  [Very Narrow]	1) Adj item: [CWID] Adjust: [****] Deviation meter LPF: 15kHz HPF: OFF PTT: ON Press [←B] key to store the adjustment value.	1) Adj item: [CW ID Deviation (NXDN Very Narrow)] Deviation meter LPF: 15kHz HPF: OFF PTT: Press [Transmit] button. Press [Apply] button to store the adjustment value.	Deviation meter Oscilloscope		ANT		[Panel tuning mode] [↕], [↕]  [PC test mode] [←], [→]	Write the value 376 (Reference value)	1.00kHz±0.10kHz
*4: Refer to the “Necessary Deviation adjustment item for each signaling and mode” table on page 80.									

### ■ Necessary Deviation adjustment item for each signaling and mode

The following shows the necessary adjustment items for each signaling deviation. Please read the following table like the following example. In the case of the signaling “QT (Wide)”, this signaling is composed of three elements [Balance, Maximum Deviation (Analog Wide) and QT Deviation (Wide)]. Please adjust Balance and Maximum Deviation (Analog Wide) before adjusting QT Deviation (Wide).

Mode	Signaling	Necessary adjustment and order		
		Wide	Narrow	Very Narrow
Analog	Audio	1. Balance adjust 2. Maximum Deviation (Analog Wide)	1. Balance adjust 2. Maximum Deviation (Analog Narrow)	-
	QT	1. Balance adjust 2. Maximum Deviation (Analog Wide) 3. QT Deviation (Wide)	1. Balance adjust 2. Maximum Deviation (Analog Narrow) 3. QT Deviation (Narrow)	-
	DQT	1. Balance adjust 2. Maximum Deviation (Analog Wide) 3. DQT Deviation (Wide)	1. Balance adjust 2. Maximum Deviation (Analog Narrow) 3. DQT Deviation (Narrow)	-
	LTR	1. Balance adjust 2. Maximum Deviation (Analog Wide) 3. LTR Deviation (Wide)	1. Balance adjust 2. Maximum Deviation (Analog Narrow) 3. LTR Deviation (Narrow)	-
	DTMF	1. Balance adjust 2. Maximum Deviation (Analog Wide) 3. DTMF Deviation [(Wide)	1. Balance adjust 2. Maximum Deviation (Analog Narrow) 3. DTMF Deviation (Narrow)	-
	2TONE	1. Balance adjust 2. Maximum Deviation (Analog Wide) 3. Single TONE Deviation (Analog Wide)	1. Balance adjust 2. Maximum Deviation (Analog Narrow) 3. Single TONE Deviation (Analog Narrow)	-
	MSK (FleetSync)	1. Balance adjust 2. Maximum Deviation (Analog Wide) 3. MSK Deviation (Analog Wide)	1. Balance adjust 2. Maximum Deviation (Analog Narrow) 3. MSK Deviation (Analog Narrow)	-
NXDN	Audio	-	1. Balance adjust 2. Maximum Deviation (NXDN Narrow)	1. Balance adjust 2. Maximum Deviation (NXDN Very Narrow)
	CW ID	-	-	1. Balance adjust 2. Maximum Deviation (Analog Narrow) 3. CW ID Deviation (NXDN Very Narrow)



## 调 整

项 目	条 件		测 量			调 整			规格 / 备注
	面板调谐模式	PC 测试模式	测量装置	单元	端子	单元	部件	方 法	
12. CW ID 频偏 *4 [ 甚窄带 ]	1) 调整项目: [CWID] 调整: [****] 频偏仪 LPF: 15kHz HPF: 关闭 PTT: 开启 按 [ <B ] 键储存调整值。	1) 调整项目: [CW ID 频偏 (NXDN 甚窄带)] 频偏仪 LPF: 15kHz HPF: 关闭 PTT: 按 [ 发射 ] 按钮。 按 [ 应用 ] 按钮储存调整值。	频偏仪 示波器		天线		[ 面板调谐模式 ] [ < > ], [ < > ]  [ PC 测试模式 ] [ < > ], [ < > ]	写入以下值。 376 (基准值)	1.00kHz ± 0.10kHz
*4: 请参阅第 81 页的“各信令和模式所需的频偏调整项目”表。									

### ■ 各信令和模式所需的频偏调整项目

下表显示了各信令频偏所需的调整项目。请按照以下示例阅读下表。对于信令“QT (宽带)”，该信令包含三个组成部分 [ 平衡, 最大频偏 (模拟宽带) 和 QT 频偏 (宽带) ]。请在调整 QT 频偏 (宽带) 之前调整平衡和最大频偏 (模拟宽带)。

模式	信令	所需的调整和顺序		
		宽 带	窄 带	甚 窄 带
模拟	音频	1. 平衡调整 2. 最大频偏 (模拟宽带)	1. 平衡调整 2. 最大频偏 (模拟窄带)	-
	QT	1. 平衡调整 2. 最大频偏 (模拟宽带) 3. QT 频偏 (宽带)	1. 平衡调整 2. 最大频偏 (模拟窄带) 3. QT 频偏 (窄带)	-
	DQT	1. 平衡调整 2. 最大频偏 (模拟宽带) 3. DQT 频偏 (宽带)	1. 平衡调整 2. 最大频偏 (模拟窄带) 3. DQT 频偏 (窄带)	-
	LTR	1. 平衡调整 2. 最大频偏 (模拟宽带) 3. LTR 频偏 (宽带)	1. 平衡调整 2. 最大频偏 (模拟窄带) 3. LTR 频偏 (窄带)	-
	DTMF	1. 平衡调整 2. 最大频偏 (模拟宽带) 3. DTMF 频偏 (宽带)	1. 平衡调整 2. 最大频偏 (模拟窄带) 3. DTMF 频偏 (窄带)	-
	2 音	1. 平衡调整 2. 最大频偏 (模拟宽带) 3. 单音频偏 (模拟宽带)	1. 平衡调整 2. 最大频偏 (模拟窄带) 3. 单音频偏 (模拟窄带)	-
	MSK (FleetSync)	1. 平衡调整 2. 最大频偏 (模拟宽带) 3. MSK 频偏 (模拟宽带)	1. 平衡调整 2. 最大频偏 (模拟窄带) 3. MSK 频偏 (模拟窄带)	-
NXDN	音频	-	1. 平衡调整 2. 最大频偏 (NXDN 窄带)	1. 平衡调整 2. 最大频偏 (NXDN 甚窄带)
	CWID	-	-	1. 平衡调整 2. 最大频偏 (模拟窄带) 3. CW ID 频偏 (NXDN 甚窄带)

## ADJUSTMENT

### Receiver Section

Item	Condition		Measurement			Adjustment			Specifications/ Remarks
	Panel tuning mode	PC test mode	Test-equipment	Unit	Terminal	Unit	Parts	Method	
1.AF level setting	<b>[Panel test mode]</b> 1) CH-Sig: 1-1 SSG output: -47dBm (1mV) (MOD: 1kHz/±1.5kHz) Wide 5k/Narrow: Narrow Beat Shift: Uncheck Compander: Uncheck	1) Test Channel Channel: 1 Test Signaling Mode: Analog Signaling: 1 Wide 5k/Narrow: Narrow Beat Shift: Uncheck Compander: Uncheck SSG output: -47dBm (1mV) (MOD: 1kHz/±1.5kHz)	SSG DVM AF VM 4Ω Dummy load Oscillo-scope		ANT Ext.SP con- nector		<b>[Panel tuning mode]</b> [^], [v]  <b>[PC test mode]</b> [◀], [▶]	Volume Up/Down Key to obtain 2.83V AF output. (2.0W @ 4Ω load)	2.83V±0.3V (Volume Button in PC test mode screen)
2. Sensitivity 1	* This adjustment can be performed only PC test mode.	1) Adj item: [Sensitivity 1] 2) Adj item: [Low], [Low'], [Center], [High'], [High] Press [Apply All] button to store the adjustment value.	SSG AF VM 4Ω Dummy load Distortion meter Oscillo- scope		ANT Ext.SP con- nector		<b>[PC test mode]</b> [◀], [▶]	Write the value as followings, [Low]: 61 (Preset) [Low']: 85 (Preset) [Center]: 103 (Preset) [High']: 122 (Preset) [High]: 152 (Preset)	Increase the adjust- ment value from the preset value to get 12dB SINAD. SSG output: -119dBm (0.25uV) (Mod: 1kHz/±1.5kHz) <b>Note:</b> The fixed value of Sensitivity 2 must be written before adjust- ing Sensitivity 1.
3. Sensitivity 2	* This adjustment can be performed only PC test mode.	1) Adj item: [Sensitivity 2] 2) Adj item: [Low], [Low'], [Center], [High'], [High] Press [Apply All] button to store the adjustment value.	SSG AF VM 4Ω Dummy load Distortion meter Oscillo- scope		ANT Ext.SP con- nector		<b>[PC test mode]</b> [◀], [▶]	Write the value as followings, [Low]: 48 (Fixed) [Low']: 75 (Fixed) [Center]: 104 (Fixed) [High']: 132 (Fixed) [High]: 187 (Fixed)	
4. RSSI reference *5  [Analog Narrow]	1) Adj item: [RRSS] Adjust: [***. ] 2) Adj item: [R.RSS]→ [R.R.SS]→ [R.R.S.S]→ [R.R.S.S.]→ [R.R.S.S._] SSG output: 12dB SINAD level -3dB (MOD: 1kHz/±1.5kHz)	1) Adj item: [RSSI Reference (Analog Narrow)] 2) Adj item: [Low], [Low'], [Center], [High'], [High] SSG output: 12dB SINAD level -3dB (MOD: 1kHz/±1.5kHz)	SSG AF VM 4Ω Dummy load Distortion meter Oscillo- scope		ANT Ext.SP con- nector		<b>[Panel tuning mode]</b> After input signal from SSG, press [<B>] key to store the adjustment value.  <b>[PC test mode]</b> After input signal from SSG, press [Apply] button to store the adjust- ment value.		

## 调 整

### 接收部分

项 目	条 件		测 量			调 整			规 格 / 备 注
	面板调谐模式	PC 测试模式	测量装置	单元	端子	单元	部件	方 法	
1. AF 电平设置	[ 面板测试模式 ] 1) CH-Sig: 1-1 SSG 输出: -47dBm (1mV) (MOD: 1kHz/±1.5kHz) 宽带 / 窄带: 窄带 拍频偏移: 不选 压缩扩展器: 不选	1) 测试信道 信道: 1 测试信令 模式: 模拟 信令: 1 宽带 / 窄带: 窄带 拍频偏移: 不选 压缩扩展器: 不选 SSG 输出: -47dBm (1mV) (MOD: 1kHz/±1.5kHz)	SSG DVM AF VM 4Ω 假负载 示波器		天线 外部 SP 连接器		[ 面板调谐模式 ] [ ^ ], [ v ]  [ PC 测试模式 ] [ ◀ ], [ ▶ ]	上 / 下调整音量旋钮以获得 2.83V AF 输出。(2.0W @ 4Ω 负载)	2.83V±0.3V (在 PC 测试模式画面的音量按钮)
2. 灵敏度 1	* 仅在 PC 测试模式中进行调整。	1) 调整项目: [ 灵敏度 1 ] 2) 调整项目: [ 低 ], [ 低 ' ], [ 中 ], [ 高 ' ], [ 高 ] 按 [ 全部应用 ] 按钮储存调整值。	SSG AF VM 4Ω 假负载 失真测试仪		天线 外部 SP 连接器		[ PC 测试模式 ] [ ◀ ], [ ▶ ]	写入以下值。 [ 低 ]: 61 (预设) [ 低 ' ]: 85 (预设) [ 中 ]: 103 (预设) [ 高 ' ]: 122 (预设) [ 高 ]: 152 (预设)	增大预设值的调整值以获得 12dB SINAD。 SSG 输出: -119dBm (0.25 μV) (MOD: 1kHz/±1.5kHz) 注意: 在调整灵敏度 1 之前, 必须写入灵敏度 2 的预设值。
3. 灵敏度 2	* 仅在 PC 测试模式中进行调整。	1) 调整项目: [ 灵敏度 2 ] 2) 调整项目: [ 低 ], [ 低 ' ], [ 中 ], [ 高 ' ], [ 高 ] 按 [ 全部应用 ] 按钮储存调整值。	SSG AF VM 4Ω 假负载 示波器 失真测试仪		天线 外部 SP 连接器		[ PC 测试模式 ] [ ◀ ], [ ▶ ]	写入以下值。 [ 低 ]: 48 (固定) [ 低 ' ]: 75 (固定) [ 中 ]: 104 (固定) [ 高 ' ]: 132 (固定) [ 高 ]: 187 (固定)	
4. RSSI 参考 *5 [ 模拟窄带 ]	1) 调整项目: [RRSS] 调整: [***.] 2) 调整项目: [R. RSS_]→ [R. R. SS_]→ [R. R. S. S_]→ [R. R. S. S. _]→ [R. R. S. S. _.] SSG 输出: 12dB SINAD 电平 -3dB (MOD: 1kHz/±1.5kHz)	1) 调整项目: [RSSI 参考 (模拟窄带)] 2) 调整项目: [ 低 ], [ 低 ' ], [ 中 ], [ 高 ' ], [ 高 ] SSG 输出: 12dB SINAD 电平 -3dB (MOD: 1kHz/±1.5kHz)	SSG AF VM 4Ω 假负载 示波器 失真测试仪		天线 外部 SP 连接器		[ 面板调谐模式 ] 从 SSG 输入信号之后, 按 [ <B ] 键储存调整值。  [ PC 测试模式 ] 从 SSG 输入信号之后, 按 [ 应用 ] 按钮储存调整值。		

## ADJUSTMENT

Item	Condition		Measurement			Adjustment			Specifications/ Remarks
	Panel tuning mode	PC test mode	Test-equipment	Unit	Terminal	Unit	Parts	Method	
4. RSSI reference *5  [Analog Wide]	1) Adj item: [RRSS] Adjust: [* . * . ] 2) Adj item: [R.RSS]→ [R.R.SS]→ [R.R.S.S.]→ [R.R.S.S.]→ [R.R.S.S._.] SSG output: 12dB SINAD level -3dB (MOD: 1kHz±3kHz)	1) Adj item: [RSSI Reference (Analog Wide)] 2) Adj item: [Low], [Low'], [Center], [High'], [High] SSG output: 12dB SINAD level -3dB (MOD: 1kHz±3kHz)	SSG AF VM 4Ω Dummy load Distortion meter Oscillo- scope		ANT Ext.SP con- nector			<b>[Panel tuning mode]</b> After input signal from SSG, press [<B>] key to store the adjustment value.  <b>[PC test mode]</b> After input signal from SSG, press [Apply] button to store the adjust- ment value.	Adjust with the ana- log signal.
[NXDN Very Narrow]	1) Adj item: [RRSS] Adjust: [***] 2) Adj item: [R.RSS]→ [R.R.SS]→ [R.R.S.S.]→ [R.R.S.S.]→ [R.R.S.S._.] SSG output: 12dB SINAD level for Analog Narrow -3dB (MOD: 1kHz±1.5kHz)	1) Adj item: [RSSI Reference (NXDN Very Nar- row)] 2) Adj item: [Low], [Low'], [Center], [High'], [High] SSG output: 12dB SINAD level for Analog Narrow -3dB (MOD: 1kHz±1.5kHz)							
*5: Because RSSI Reference (NXDN Narrow) is adjusted by adjusting RSSI Reference (Analog Narrow), it is not necessary to adjust RSSI Reference (NXDN Narrow).									
5. Open Squelch *6 (Squelch level 5)  [Analog Narrow]	1) Adj item: [SQL] Adjust: [***.] 2) Adj item: [S.QL]→ [S.Q.L]→ [S.Q.L.]→ [S.Q.L._.]→ [S.Q.L._. _.] SSG output: 12dB SINAD level (MOD: 1kHz±1.5kHz)	1) Adj item: [Open Squelch (Analog Narrow)] 2) Adj item: [Low], [Low'], [Center], [High'], [High] SSG output: 12dB SINAD level (MOD: 1kHz±1.5kHz)	SSG AF VM 4Ω Dummy load Distortion meter Oscillo- scope		ANT Ext.SP con- nector			<b>[Panel tuning mode]</b> After input signal from SSG, press [<B>] key to store the adjustment value.  <b>[PC test mode]</b> After input signal from SSG, press [Apply] button to store the adjust- ment value.	“Open Squelch” will not be adjusted correctly if MOD and Deviation are wrong.  <b>Remark:</b> During production, a fixed value is writ- ten. 138 (Fixed)
[Analog Wide]	1) Adj item: [SQL] Adjust: [***.] 2) Adj item: [S.QL]→ [S.Q.L]→ [S.Q.L.]→ [S.Q.L._.]→ [S.Q.L._. _.] SSG output: 12dB SINAD level (MOD: 1kHz±3kHz)	1) Adj item: [Open Squelch (Analog Wide)] 2) Adj item: [Low], [Low'], [Center], [High'], [High] SSG output: 12dB SINAD level (MOD: 1kHz±3kHz)							

## 调 整

项 目	条 件		测 量			调 整			规格 / 备注
	面板调谐模式	PC 测试模式	测量装置	单元	端子	单元	部件	方 法	
4. RSSI 参考 *5 [模拟宽带]	1) 调整项目: [RRSS] 调整: [*.*.*] 2) 调整项目: [R. RSS_]→ [R. R. SS_]→ [R. R. S. S_]→ [R. R. S. S. _]→ [R. R. S. S. _] SSG 输出: 12dB SINAD 电平 -3dB (MOD: 1kHz/±3kHz)	1) 调整项目: [RSSI 参考 (模拟宽带)] 2) 调整项目: [低], [低'], [中], [高'], [高] SSG 输出: 12dB SINAD 电平 -3dB (MOD: 1kHz/±3kHz)	SSG AF VM 4Ω 假负载 示波器 失真测试仪		天线 外部 SP 连接器			[面板调谐模式] 从 SSG 输入信号之 后, 按 [ <B ] 键 储存调整值。  [PC 测试模式] 从 SSG 输入信号之 后, 按 [应用] 按 钮储存调整值。	
[NXDN 甚窄带]	1) 调整项目: [RRSS] 调整: [***] 2) 调整项目: [R. RSS_]→ [R. R. SS_]→ [R. R. S. S_]→ [R. R. S. S. _]→ [R. R. S. S. _] SSG 输出: 模拟窄 的 12dB SINAD 电 平 -3dB (MOD: 1kHz/±1.5kHz)	1) 调整项目: [RSSI 参考 (NXDN 甚窄 带)] 2) 调整项目: [低], [低'], [中], [高'], [高] SSG 输出: 模拟窄 的 12dB SINAD 电 平 -3dB (MOD: 1kHz/±1.5kHz)						用模拟信号进行调 整。	
*5: 由于 RSSI 参考 (NXDN 窄带) 通过调整 RSSI 参考 (模拟窄带) 进行调整, 因此不需要调整 RSSI 参考 (NXDN 窄带)。									
5. 静噪 (浅) *6 (静噪电 平 5 调整) [模拟窄带]	1) 调整项目: [SQL] 调整: [***] 2) 调整项目: [S. QL_]→ [S. Q. L_]→ [S. Q. L. _]→ [S. Q. L. _]→ [S. Q. L. _] SSG 输出: 12dB SINAD 电平 (MOD: 1kHz/±1.5kHz)	1) 调整项目: [静噪 (浅) (模拟窄带)] 2) 调整项目: [低], [低'], [中], [高'], [高] SSG 输出: 12dB SINAD 电平 +1dB (MOD: 1kHz/±1.5kHz)	SSG AF VM 4Ω 假负载 示波器 失真测试仪		天线 外部 SP 连接器			[面板调谐模式] 从 SSG 输入信号之 后, 按 [ <B ] 键 储存调整值。  [PC 测试模式] 从 SSG 输入信号之 后, 按 [应用] 按 钮储存调整值。	注意: 如果 MOD 和频偏错 误, 则不能正确调整 “静噪 (浅)”。  备注: 在生产过程中, 写入 固定值。 138 (固定)
[模拟宽带]	1) 调整项目: [SQL] 调整: [*.*.*] 2) 调整项目: [S. QL_]→ [S. Q. L_]→ [S. Q. L. _]→ [S. Q. L. _]→ [S. Q. L. _] SSG 输出: 12dB SINAD 电平 (MOD: 1kHz/±3kHz)	1) 调整项目: [静噪 (浅) (模拟宽带)] 2) 调整项目: [低], [低'], [中], [高'], [高] SSG 输出: 12dB SINAD 电平 (MOD: 1kHz/±3kHz)							

## ADJUSTMENT

Item	Condition		Measurement			Adjustment			Specifications/ Remarks
	Panel tuning mode	PC test mode	Test-equipment	Unit	Terminal	Unit	Parts	Method	
5. Open Squelch *6 (Squelch level 5)  [NXDN Very Narrow]	1) Adj item: [SQL] Adjust: [***] 2) Adj item: [S.QL]→ [S.Q.L]→ [S.Q.L.]→ [S.Q.L._]→ [S.Q.L._.] SSG output: 12dB SINAD level for Analog Narrow -4dB (MOD: 400Hz±1.1kHz)	1) Adj item: [Open Squelch (NXDN Very Narrow)] 2) Adj item: [Low],[Low'], [Center], [High'], [High] SSG output: 12dB SINAD level for Analog Narrow -4dB (MOD: 400Hz±1.1kHz)	SSG AF VM 4Ω Dummy load Distortion meter Oscilloscope		ANT Ext.SP connector			<b>[Panel tuning mode]</b> After input signal from SSG, press [ <b>&lt;B</b> ] key to store the adjustment value.  <b>[PC test mode]</b> After input signal from SSG, press [Apply] button to store the adjustment value.	Adjust with the analog signal. This item is adjusted under the condition that MOD is "400Hz" and Deviation is "±1.1kHz" due to the circuit configuration.  <b>Remark:</b> During production, a fixed value is written. 171 (Fixed)
*6: Because Open Squelch (NXDN Narrow) is adjusted by adjusting Open Squelch (Analog Narrow), it is not necessary to adjust Open Squelch (NXDN Narrow).									
6. Low RSSI at -118dBm *7  [Analog Narrow]	1) Adj item: [LRSS] Adjust: [***. ] 2) Adj item: [L.RSS]→ [L.R.SS]→ [L.R.S.S]→ [L.R.S.S.]→ [L.R.S.S._] SSG output: -118dBm (0.28uV) (MOD: 1kHz±1.5kHz)	1) Adj item: [Low RSSI (Analog Narrow)] 2) Adj item: [Low], [Low'], [Center], [High'], [High] SSG output: -118dBm (0.28μV) (MOD: 1kHz±1.5kHz)	SSG		ANT Ext.SP connector			<b>[Panel tuning mode]</b> After input signal from SSG, press [ <b>&lt;B</b> ] key to store the adjustment value.  <b>[PC test mode]</b> After input signal from SSG, press [Apply] button to store the adjustment value.	
[Analog Wide]	1) Adj item: [LRSS] Adjust: [* . * . ] 2) Adj item: [L.RSS]→ [L.R.SS]→ [L.R.S.S]→ [L.R.S.S.]→ [L.R.S.S._] SSG output: -118dBm (0.28uV) (MOD: 1kHz±3kHz)	1) Adj item: [Low RSSI (Analog Wide)] 2) Adj item: [Low], [Low'], [Center], [High'], [High] SSG output: -118dBm (0.28μV) (MOD: 1kHz±3kHz)							
[NXDN Very Narrow]	1) Adj item: [LRSS] Adjust: [***] 2) Adj item: [L.RSS]→ [L.R.SS]→ [L.R.S.S]→ [L.R.S.S.]→ [L.R.S.S._] SSG output: -118dBm (0.28uV) (MOD: 1kHz±1.5kHz)	1) Adj item: [Low RSSI (NXDN Very Narrow)] 2) Adj item: [Low], [Low'], [Center], [High'], [High] SSG output: -118dBm (0.28μV) (MOD: 1kHz±1.5kHz)							Adjust with the analog signal.
*7: Because Low RSSI at -118dBm (NXDN Narrow) is adjusted by adjusting Low RSSI at -118dBm (Analog Narrow), it is not necessary to adjust Low RSSI at -118dBm (NXDN Narrow).									

## 调 整

项 目	条 件		测 量			调 整			规格 / 备注
	面板调谐模式	PC 测试模式	测量装置	单元	端子	单元	部件	方 法	
5. 静噪 (浅) *6 (静噪电 平 5 调整)  [NXDN 甚窄带]	1) 调整项目: [SQL] 调整: [***] 2) 调整项目: [S. QL_ ]→ [S. Q. L_ ]→ [S. Q. L. _ ]→ [S. Q. L. _ ]→ [S. Q. L. _ ]→ SSG 输出: 模拟窄 的 12dB SINAD 电平 -4dB (MOD: 400Hz/±1.1kHz)	1) 调整项目: [静噪 (浅) (NXDN 甚窄 带)] 2) 调整项目: [低], [低'], [中], [高'], [高] SSG 输出: 模拟窄 的 12dB SINAD 电平 -4dB (MOD: 400Hz/±1.1kHz)	SSG AF VM 4Ω 假负载 示波器 失真测试 仪		天线 外部 SP 连接器			[ 面板调谐模式 ] 从 SSG 输入信号之 后, 按 [ <B ] 键 储存调整值。  [PC 测试模式] 从 SSG 输入信号之 后, 按 [ 应用 ] 按 钮储存调整值。	用模拟信号进行调 整。 由于电路结构, 此项在 MOD 为 “400Hz” 和频偏为 “±1.1kHz” 的条 件下进行调整。  备注: 在生产过程中, 写入 固定值。 171 (固定)
*6: 由于静噪 (浅) (NXDN 窄带) 通过调整静噪 (浅) (模拟窄带) 进行调整, 因此不需要调整静噪 (浅) (NXDN 窄带)。									
6. -118dBm 低 RSSI *7  [ 模拟窄带]	1) 调整项目: [LRSS] 调整: [***.] 2) 调整项目: [L. RSS_ ]→ [L. R. SS_ ]→ [L. R. S. S_ ]→ [L. R. S. S. _ ]→ SSG 输出: -118dBm (0.28 μV) (MOD: 1kHz/±1.5kHz)	1) 调整项目: [低 RSSI (模拟窄带)] 2) 调整项目: [低], [低'], [中], [高'], [高] SSG 输出: -118dBm (0.28 μV) (MOD: 1kHz/±1.5kHz)	SSG		天线 外部 SP 连接器			[ 面板调谐模式 ] 从 SSG 输入信号之 后, 按 [ <B ] 键 储存调整值。  [PC 测试模式] 从 SSG 输入信号之 后, 按 [ 应用 ] 按 钮储存调整值。	
[ 模拟宽带]	1) 调整项目: [LRSS] 调整: [*.*.*.] 2) 调整项目: [L. RSS_ ]→ [L. R. SS_ ]→ [L. R. S. S_ ]→ [L. R. S. S. _ ]→ SSG 输出: -118dBm (0.28 μV) (MOD: 1kHz/±3kHz)	1) 调整项目: 低 RSSI (模拟宽带)] 2) 调整项目: [低], [低'], [中], [高'], [高] SSG 输出: -118dBm (0.28 μV) (MOD: 1kHz/±3kHz)							
[NXDN 甚窄带]	1) 调整项目: [LRSS] 调整: [***] 2) 调整项目: [L. RSS_ ]→ [L. R. SS_ ]→ [L. R. S. S_ ]→ [L. R. S. S. _ ]→ SSG 输出: -118dBm (0.28 μV) (MOD: 1kHz/±1.5kHz)	1) 调整项目: [低 RSSI (NXDN 甚窄 带)] 2) 调整项目: [低], [低'], [中], [高'], [高] SSG 输出: -118dBm (0.28 μV) (MOD: 1kHz/±1.5kHz)							用模拟信号进行调 整。
*7: 由于 -118dBm 低 RSSI (NXDN 窄带) 通过调整 -118dBm 低 RSSI (模拟窄带) 进行调整, 因此不需要调整 -118dBm 低 RSSI (NXDN 窄带)。									

## ADJUSTMENT

Item	Condition		Measurement			Adjustment			Specifications/ Remarks
	Panel tuning mode	PC test mode	Test-equipment	Unit	Terminal	Unit	Parts	Method	
7.High RSSI at -80dBm *8  [Analog Narrow]	1) Adj item: [HRSS] Adjust: [***. ] 2) Adj item: [H.RSS]→ [H.R.SS]→ [H.R.S.S]→ [H.R.S.S.]→ [H.R.S.S._.] SSG output: -80dBm (22.4uV) (MOD: 1kHz/±1.5kHz)	1) Adj item: [High RSSI (Analog Narrow)] 2) Adj item: [Low], [Low'], [Center], [High'], [High] SSG output: -80dBm (22.4μV) (MOD: 1kHz/±1.5kHz)	SSG		ANT Ext.SP connector			<b>[Panel tuning mode]</b> After input signal from SSG, press [ <b>&lt;B</b> ] key to store the adjustment value.  <b>[PC test mode]</b> After input signal from SSG, press [Apply] button to store the adjustment value.	
[Analog Wide]	1) Adj item: [HRSS] Adjust: [*. *.*.] 2) Adj item: [H.RSS]→ [H.R.SS]→ [H.R.S.S]→ [H.R.S.S.]→ [H.R.S.S._.] SSG output : -80dBm (22.4uV) (MOD: 1kHz/±3kHz)	1) Adj item: [High RSSI (Analog Wide)] 2) Adj item: [Low], [Low'], [Center], [High'], [High] SSG output: -80dBm (22.4μV) (MOD: 1kHz/±3kHz)							
[NXDN Very Narrow]	1) Adj item: [HRSS] Adjust: [***] 2) Adj item: [H.RSS]→ [H.R.SS]→ [H.R.S.S]→ [H.R.S.S.]→ [H.R.S.S._.] SSG output : -80dBm (22.4uV) (MOD: 1kHz/±1.5kHz)	1) Adj item: [High RSSI (NXDN Very Narrow)] 2) Adj item: [Low], [Low'], [Center], [High'], [High] SSG output: -80dBm (22.4μV) (MOD: 1kHz/±1.5kHz)							Adjust with the analog signal.
*8: Because "RSSI at -80dBm adjust" of NXDN Narrow is adjusted by adjusting "RSSI at -80dBm adjust [Analog Narrow]", it is not necessary to adjust "RSSI at -80dBm adjust" of NXDN Narrow.									
8. Squelch (Tight)  [Analog Narrow]	1) Adj item: [SQLT] Adjust: [***.] 2) Adj item: [S.QLT]→ [S.Q.LT]→ [S.Q.L.T.]→ [S.Q.L.T.]→ [S.Q.L.T._.] SSG output: 12dB SINAD level + 4dB (MOD: 1kHz/±1.5kHz)	1) Adj item: [Tight Squelch (Analog Narrow)] 2) Adj item: [Low], [Low'], [Center], [High'], [High] SSG output: 12dB SINAD level + 4dB (MOD: 1kHz/±1.5kHz)	SSG AF VM 4Ω Dummy load Distortion meter Oscilloscope		ANT Ext.SP connector			<b>[Panel tuning mode]</b> After input signal from SSG, press [ <b>&lt;B</b> ] key to store the adjustment value.  <b>[PC test mode]</b> After input signal from SSG, press [Apply] button to store the adjustment value.	"Squelch (Tight)" will not be adjusted correctly if MOD or Deviation is wrong.  <b>Remark:</b> During production, a fixed value is written.  -Analog Narrow [S.QLT]→ 248 [S.Q.LT]→ 248 [S.Q.L.T.]→ 248 [S.Q.L.T._.]→ 248  -Analog Wide [S.QLT]→ 255 [S.Q.LT]→ 255 [S.Q.L.T.]→ 255 [S.Q.L.T._.]→ 255
[Analog Wide]	1) Adj item: [SQLT] Adjust: [*. *.*.] 2) Adj item: [S.QLT]→ [S.Q.LT]→ [S.Q.L.T.]→ [S.Q.L.T.]→ [S.Q.L.T._.] SSG output: 12dB SINAD level + 4dB (MOD: 1kHz/±3kHz)	1) Adj item: [Tight Squelch (Analog Wide)] 2) Adj item: [Low], [Low'], [Center], [High'], [High] SSG output: 12dB SINAD level + 4dB (MOD: 1kHz/±3kHz)							



## 调 整

项 目	条 件		测 量			调 整			规格 / 备注
	面板调谐模式	PC 测试模式	测量装置	单元	端子	单元	部件	方 法	
7. -80dBm 高 RSSI *8 [模拟窄带]	1) 调整项目: [HRSS] 调整: [***.] 2) 调整项目: [H. RSS_]→ [H. R. SS_]→ [H. R. S. S_]→ [H. R. S. S. _]→ [H. R. S. S. _.] SSG 输出: -80dBm (22.4 μV) (MOD: 1kHz/±1.5kHz)	1) 调整项目: [高 RSSI (模拟窄带)] 2) 调整项目: [低], [低'], [中], [高'], [高] SSG 输出: -80dBm (22.4 μV) (MOD: 1kHz/±1.5kHz)	SSG		天线外部 SP 连接器			[面板调谐模式] 从 SSG 输入信号之后, 按 [ <B > ] 键 储存调整值。  [PC 测试模式] 从 SSG 输入信号之后, 按 [ 应用 ] 按钮 储存调整值。	
[模拟宽带]	1) 调整项目: [HRSS] 调整: [*.*.*.] 2) 调整项目: [H. RSS_]→ [H. R. SS_]→ [H. R. S. S_]→ [H. R. S. S. _]→ [H. R. S. S. _.] SSG 输出: -80dBm (22.4 μV) (MOD: 1kHz/±3kHz)	1) 调整项目: [高 RSSI (模拟宽带)] 2) 调整项目: [低], [低'], [中], [高'], [高] SSG 输出: -80dBm (22.4 μV) (MOD: 1kHz/±3kHz)							
[NXDN 甚窄带]	1) 调整项目: [HRSS] 调整: [***] 2) 调整项目: [H. RSS_]→ [H. R. SS_]→ [H. R. S. S_]→ [H. R. S. S. _]→ [H. R. S. S. _.] SSG 输出: -80dBm (22.4 μV) (MOD: 1kHz/±1.5kHz)	1) 调整项目: [高 RSSI (NXDN 甚窄带)] 2) 调整项目: [低], [低'], [中], [高'], [高] SSG 输出: -80dBm (22.4 μV) (MOD: 1kHz/±1.5kHz)							用模拟信号进行调整。
*8: 由于 -80dBm 高 RSSI (NXDN 窄带) 通过调整 -80dBm 高 RSSI (模拟窄带) 进行调整, 因此不需要调整 -80dBm 高 RSSI (NXDN 窄带)。									
8. 静噪 (深) [模拟窄带]	1) 调整项目: [SQLT] 调整: [***.] 2) 调整项目: [S. QLT_]→ [S. Q. LT_]→ [S. Q. L. T_]→ [S. Q. L. T. _]→ [S. Q. L. T. _.] SSG 输出: 12dB SINAD 电平 +4dB (MOD: 1kHz/±1.5kHz)	1) 调整项目: [静噪 (深) (模拟窄带)] 2) 调整项目: [低], [低'], [中], [高'], [高] SSG 输出: 12dB SINAD 电平 +4dB (MOD: 1kHz/±1.5kHz)	SSG AF VM 4Ω 假负载 示波器 失真测试仪		天线外部 SP 连接器			[面板调谐模式] 从 SSG 输入信号之后, 按 [ <B > ] 键 储存调整值。  [PC 测试模式] 从 SSG 输入信号之后, 按 [ 应用 ] 按钮 储存调整值。	如果 MOD 和频偏错误, 则不能正确调整“静噪 (深)”。  备注: 在生产过程中, 写入固定值。  • 模拟窄带 [S. QLT]→ 248 [S. Q. LT]→ 248 [S. Q. L. T]→ 248 [S. Q. L. T. _]→ 248 [S. Q. L. T. _.]→ 248  • 模拟宽带 [S. QLT]→ 255 [S. Q. LT]→ 255 [S. Q. L. T]→ 255 [S. Q. L. T. _]→ 255 [S. Q. L. T. _.]→ 255
[模拟宽带]	1) 调整项目: [SQLT] 调整: [*.*.*.] 2) 调整项目: [S. QLT_]→ [S. Q. LT_]→ [S. Q. L. T_]→ [S. Q. L. T. _]→ [S. Q. L. T. _.] SSG 输出: 12dB SINAD 电平 +4dB (MOD: 1kHz/±3kHz)	1) 调整项目: [静噪 (深) (模拟宽带)] 2) 调整项目: [低], [低'], [中], [高'], [高] SSG 输出: 12dB SINAD 电平 +4dB (MOD: 1kHz/±3kHz)							

## TERMINAL FUNCTION / 端子功能

### Display unit (X54-3830-10)

Pin No.	Name	I/O	Function
<b>CN1 (to TX-RX unit CN514)</b>			
1	SB	I	Battery voltage DC supply
2	SB	I	Battery voltage DC supply
3	SP-	I	Speaker input -
4	SP-	I	Speaker input -
5	SP+	I	Speaker input +
6	SP+	I	Speaker input +
7	BLC	I	LCD backlight control signal input
8	MBL	I	MIC backlight control signal input
9	RLED	I	Red LED control signal input
10	GLED	I	Green LED control signal input
11	BLED	I	Blue LED control signal input
12	GND	-	Ground
13	GND	-	Ground
14	GND	-	Ground
15	EMG	O	Emergency key detection
16	GND	-	Ground
17	NC	-	No connection
18	50C	I	5V DC power supply
19	LCDDI	I	LCD data input
20	LCDCE	I	LCD enable input
21	LCDCL	I	LCD clock input
22	LCDDO	O	LCD data output
23	GND	-	Ground
24	GND	-	Ground
25	MIC	O	MIC signal output
26	ME	-	MIC ground
27	HOOK/RXD	O	HOOK/PC serial data
28	PTT/TXD	I/O	PTT/PC serial data
29	MKEY	I/O	MIC data detection
30	POWER	O	Detection output of power switch
<b>J1 (MIC jack)</b>			
1	MBL	O	MIC backlight control
2	SB	O	Battery voltage DC supply
3	GND	-	Ground
4	PTT	I/O	PTT/ PC serial data from radio
5	ME	-	MIC ground
6	MIC	I	MIC signal input
7	HOOK	I	HOOK/ PC serial data to radio
8	DM	I/O	MIC data detection

### 显示单元 (X54-3830-10)

管脚号码	名称	输入 / 输出	功能
<b>CN1 (至收发单元 CN514)</b>			
1	SB	输入	电池电压 DC 电源
2	SB	输入	电池电压 DC 电源
3	SP -	输入	扬声器 -
4	SP -	输入	扬声器 -
5	SP+	输入	扬声器 +
6	SP+	输入	扬声器 +
7	BLC	输入	LCD 背光控制信号
8	MBL	输入	MIC 背光控制信号
9	RLED	输入	红色 LED 控制信号
10	GLED	输入	绿色 LED 控制信号
11	BLED	输入	蓝色 LED 控制信号
12	GND	-	接地
13	GND	-	接地
14	GND	-	接地
15	EMG	输出	EMG 键
16	GND	-	接地
17	NC	-	未连接
18	50C	输入	5V DC 电源
19	LCDDI	输入	LCD 数据
20	LCDCE	输入	LCD 启用
21	LCDCL	输入	LCD 时钟
22	LCDDO	输出	LCD 数据
23	GND	-	接地
24	GND	-	接地
25	MIC	输出	MIC 信号
26	ME	-	MIC 接地
27	HOOK/RXD	输出	HOOK/PC 串行数据
28	PTT/TXD	输入 / 输出	PTT/PC 串行数据
29	MKEY	输入 / 输出	MIC 数据检测
30	POWER	输出	电源开关的检测
<b>J1 (MIC 插孔)</b>			
1	MBL	输出	MIC 背光控制
2	SB	输出	电池电压 DC 电源
3	GND	-	接地
4	PTT	输入 / 输出	来自通信机的 PTT/PC 串行数据
5	ME	-	MIC 接地
6	MIC	输入	MIC 信号
7	HOOK	输入	送到通信机的 HOOK/PC 串行数据
8	DM	输入 / 输出	MIC 数据检测

# TERMINAL FUNCTION / 端子功能

## TX-RX unit (X57-8230-11)

Pin No.	Name	I/O	Function
<b>CN514 (to Display unit CN1)</b>			
1	SB	O	Battery voltage DC supply
2	SB	O	Battery voltage DC supply
3	SP-	O	Speaker output -
4	SP-	O	Speaker output -
5	SP+	O	Speaker output +
6	SP+	O	Speaker output +
7	BLC	O	LCD backlight control signal output
8	MBL	O	MIC backlight control signal output
9	RLED	O	Red LED control signal output
10	GLED	O	Green LED control signal output
11	BLED	O	Blue LED control signal output
12	GND	-	Ground
13	GND	-	Ground
14	GND	-	Ground
15	EMG	I	Emergency key detection
16	GND	-	Ground
17	NC	-	No connection
18	50C	O	5V DC power supply
19	LCDDI	O	LCD data output
20	LCDCE	O	LCD enable output
21	LCDCL	O	LCD clock output
22	LCDDO	I	LCD data input
23	GND	-	Ground
24	GND	-	Ground
25	MIC	I	MIC signal input
26	ME	-	MIC ground
27	HOOK/RXD	I	HOOK/PC serial data
28	PTT/TXD	I/O	PTT/PC serial data
29	MKEY	I/O	MIC data detection
30	POWER	I	Detection input of power switch

## 收发单元 (X57-8230-11)

管脚号码	名称	输入 / 输出	功能
<b>CN514 (至显示单元 CN1)</b>			
1	SB	输出	电池电压 DC 电源
2	SB	输出	电池电压 DC 电源
3	SP -	输出	扬声器 -
4	SP -	输出	扬声器 -
5	SP+	输出	扬声器 +
6	SP+	输出	扬声器 +
7	BLC	输出	LCD 背光控制信号
8	MBL	输出	MIC 背光控制信号
9	RLED	输出	红色 LED 控制信号
10	GLED	输出	绿色 LED 控制信号
11	BLED	输出	蓝色 LED 控制信号
12	GND	-	接地
13	GND	-	接地
14	GND	-	接地
15	EMG	输入	EMG 键
16	GND	-	接地
17	NC	-	未连接
18	50C	输出	5V DC 电源
19	LCDDI	输出	LCD 数据
20	LCDCE	输出	LCD 启用
21	LCDCL	输出	LCD 时钟
22	LCDDO	输入	LCD 数据
23	GND	-	接地
24	GND	-	接地
25	MIC	输入	MIC 信号
26	ME	-	MIC 接地
27	HOOK/RXD	输入	HOOK/PC 串行数据
28	PTT/TXD	输入 / 输出	PTT/PC 串行数据
29	MKEY	输入 / 输出	MIC 数据检测
30	POWER	输入	电源开关的检测

## TERMINAL FUNCTION

### 8pin Modular Connector Specification

Pin No.	Pin Name	I/O	Signal Type	Description/port type	Item and Condition	Min	Typ	Max	Unit	Note
1	MBL	O	Digital	CMOS output	VOH	4.2		5.2	V	
					VOL	-		0.8	V	
2	SB	O	Power	Switched B output	Output Voltage	This parameter depends on Battery voltage.				
					Output Current			200	mA	
3	GND	-	GND	Ground	Allowable current value			200	mA	
4	PTT	I	Digital	CMOS input (Pull Up: 5.0V/10kΩ)	VIH	4.2		5.0	V	
					VIL	0		0.8	V	
	TXD	O	Digital	CMOS 3-State Buffer output (Pull Up: 5.0V/10kΩ)	VOH	4.2		5.2	V	
					VOL	-		0.8	V	
					Baud rate	-		19200	bps	
5	ME	-	GND	MIC Ground	MIC Ground	This is ground port for Microphone.				
6	MIC	I	Analog	Audio input	Output Amplitude (1kHz, 60% deviation)	-	5	-	mVrms	
					Coupling Capacitor	-	10	-	uF	
					Input impedance	-	600	-	Ω	
					Allowable Frequency	300		3000	Hz	
7	HOOK/ RXD	I	Digital	DTC144EE input (Pull Up: 5.0V/4.7kΩ)	VIH	4.2		5.0	V	
					VIL	0		0.8	V	
					Baud rate	-		115200	bps	
8	DM	I	Digital	CMOS input/output (Pull Up: 5.0V/47kΩ)	VIH	4.2		5.0	V	
					VIL	0		0.8	V	
		O	Digital		VOL	-		0.8	V	

### 15pin D-sub Connector Specification

Pin No.	Pin Name	I/O	Signal Type	Description	Item and Condition	Min	Typ	Max	Unit	Note
1	SB	-	Power	Switched B output	Voltage	This parameter depends on Battery voltage.				
					Supply Current	-	-	2.0	A	
					(with KCT-60)	-	-	0.5	A	
2	IGN	I	Digital	Ignition sense input	Input Voltage	10.8	-	16	V	
3	SP2/PA	O	Analog	Speaker output	Audio output	3	4	-	W	at 4Ω, 10% Distortion
					Coupling Capacitor	-	330	-	uF	
					RL	4	-	-	Ω	
					Allowable Frequency	300	-	3000	Hz	

## 端子功能

## 8 针模块化连接器规格

管脚号码	名称	输入/输出	信号类型	说明	项目和条件	最小	标准	最大	单位	注意
1	MBL	输出	数字	CMOS 输出	VOH	4.2		5.2	V	
					VOL	-		0.8	V	
2	SB	输出	电源	开关 B 输出	输出电压	这个参数源于电池电压。				
					输出电流			200	mA	
3	GND	-	接地	接地	容许电流值			200	mA	
4	PTT	输入	数字	CMOS 输入 (上拉: 5.0V/10kΩ)	VIH	4.2		5.0	V	
					VIL	0		0.8	V	
	TXD	输出	数字	CMOS 3 态缓冲器输出 (上拉: 5.0V/10kΩ)	VOH	4.2		5.2	V	
					VOL	-		0.8	V	
				波特率	-		19200	bps		
5	ME	-	接地	MIC 接地	MIC 接地	这是为了麦克风的接地端口。				
6	MIC	输入	模拟	音频输入	输出振幅 (1kHz, 60% 频偏)	-	5	-	mVrms	
					耦合电容	-	10	-	uF	
					输入阻抗	-	600	-	Ω	
					容许频率	300		3000	Hz	
7	HOOK/RXD	输入	数字	DTC144EE 输入 (上拉: 5.0V/4.7kΩ)	VIH	4.2		5.0	V	
					VIL	0		0.8	V	
					波特率	-		115200	bps	
8	DM	输入	数字	CMOS 输入 / 输出 (上拉: 5.0V/47kΩ)	VIH	4.2		5.0	V	
					VIL	0		0.8	V	
		输出	数字		VOL	-		0.8	V	

## 15 针 D-sub 针连接器规格

管脚号码	名称	输入/输出	信号类型	说明	项目和条件	最小	标准	最大	单位	注意
1	SB	-	电源	开关 B 输出	电压	这个参数源于电池电压。				
					提供电流	-	-	2	A	
					(KCT-60 时)	-	-	0.5	A	
2	IGN	输入	数字	点火感应输入	输入电压	10.8	-	16	V	
3	SP2/PA	输出	模拟	扬声器输出	音频输出	3	4	-	W	4Ω, 10% 失真时
					耦合电容	-	330	-	uF	
					RL	4	-	-	Ω	
					容许频率	300	-	3000	Hz	

## TERMINAL FUNCTION

Pin No.	Pin Name	I/O	Signal Type	Description	Item and Condition	Min	Typ	Max	Unit	Note
4	DETO	O	Analog	FM detector output	Output Level	-	0.28	-	Vp-p	
					Coupling Capacitor	-	4.7	-	uF	
					Allowable Load	600	-	-	Ω	
	AFO	O	Analog	RX Audio output	Output Level	-	0.24	-	Vp-p	
					Coupling Capacitor	-	4.7	-	uF	
					Allowable Load	600	-	-	Ω	
5	DATAI	I	Analog	External Modulation input	Input Voltage Range	-	0.5	1.98	Vp-p	Standard deviation
					Input Impedance	-	100	-	kΩ	
	MI2	I	Analog	External MIC AF Input	Input Voltage Range	-	5	-	mVrms	
					Allowable Frequency	300	-	3000	Hz	
					Input Impedance	-	600	-	Ω	
6	FNC1/ TXD	I/O	Digital	Programmable I/O	VIH	4.0	-	5.2	V	
					VIL	-0.5	-	1.0	V	
					VOH (Io=-1.5mA)	4.0	-	5.2	V	
					VOL (Io=1.5mA)	-	-	1.1	V	
	TXD (RS-232C)	O	Digital	RS-232C Serial port (TXD)	Voltage Swing	±5	±9	-	V	3kΩ Load
					Baud Rate	1200	-	19200	bps	
					CL		100		pF	
7	FNC2/ RXD	I/O	Digital	Programmable I/O	VIH	4.0	-	5.2	V	
					VIL	-0.5	-	1.0	V	
					VOH (Io=-1.5mA)	4.0	-	5.2	V	
					VOL (Io=1.5mA)	-	-	1.1	V	
	RXD (RS-232C)	I	Digital	RS-232C Serial port (RXD)	Input Voltage Range	-30	-	30	V	
					Threshold Low	0.5	1.3	-	V	
					Threshold High	-	1.75	2.6	V	
					Baud Rate	1200	-	19200	bps	
8	FNC3	I/O	Digital	Programmable I/O	VIH	4.0	-	5.2	V	
					VIL	-0.5	-	1.0	V	
					VOH (Io=-1.5mA)	4.0	-	5.2	V	
					VOL (Io=1.5mA)	-	-	1.1	V	
	RTS (RS-232C)	O	Digital	RS-232C Serial port (RTS)	Voltage Swing	±5	±9	-	V	3kΩ Load
9	FNC4	I/O	Digital	Programmable I/O	VIH	4.0	-	5.2	V	
					VOH	-0.5	-	1.0	V	
					VOH (Io=-1.5mA)	4.0	-	5.2	V	
					VOL (Io=1.5mA)	-	-	1.1	V	
	CTS (RS-232C)	I	Digital	RS-232C Serial port (CTS)	Input Voltage Range	-30	-	30	V	
					Threshold Low	0.5	1.3	-	V	
					Threshold High	-	1.75	2.6	V	
10	FNC5	I/O	Digital	Programmable I/O	VIH	4.0	-	5.2	V	
					VOH	-0.5	-	1.0	V	
					VOH (Io=-1.5mA)	4.0	-	5.2	V	
					VOL (Io=1.5mA)	-	-	1.1	V	

## 端子功能

管脚号码	名称	输入/输出	信号类型	说明	项目和条件	最小	标准	最大	单位	注意
4	DETO	输出	模拟	FM 检测输出	输出电平	-	0.28	-	Vp-p	
					耦合电容	-	4.7	-	uF	
					容许负载	600	-	-	Ω	
	AFO	输出		RX 音频输出	输出电平	-	0.24	-	Vp-p	
					耦合电容	-	4.7	-	uF	
					容许负载	600	-	-	Ω	
5	DATA1	输入	模拟	外部调制输入	输入电压范围	-	0.5	1.98	Vp-p	标准频偏
					输入阻抗	-	100	-	kΩ	
	MI2	输入		外部 MIC AF 输入	输入电压范围	-	5	-	mVrms	
					容许频率	300	-	3000	Hz	
					输入阻抗	-	600	-	Ω	
6	FNC1/TXD	输入/输出	数字	可编程输入/输出	VIH	4.0	-	5.2	V	
					VIL	-0.5	-	1.0	V	
					VOH (Io=-1.5mA)	4.0	-	5.2	V	
					VOL (Io=1.5mA)	-	-	1.1	V	
	TXD (RS-232C)	输出	数字	RS-232C 串行端口 (TXD)	电压振幅	±5	±9	-	V	3kΩ 负载
					波特率	1200	-	19200	bps	
					GL		100		pF	
7	FNC2/RXD	输入/输出	数字	可编程输入/输出	VIH	4.0	-	5.2	V	
					VIL	-0.5	-	1.0	V	
					VOH (Io=-1.5mA)	4.0	-	5.2	V	
					VOL (Io=1.5mA)	-	-	1.1	V	
	RXD (RS-232C)	输入	数字	RS-232C 串行端口 (RXD)	输入电压范围	-30	-	30	V	
					阈值低	0.5	1.3	-	V	
					阈值高	-	1.75	2.6	V	
					波特率	1200	-	19200	bps	
8	FNC3	输入/输出	数字	可编程输入/输出	VIH	4.0	-	5.2	V	
					VIL	-0.5	-	1.0	V	
					VOH (Io=-1.5mA)	4.0	-	5.2	V	
					VOL (Io=1.5mA)	-	-	1.1	V	
	RTS (RS-232C)	输出	数字	RS-232C 串行端口 (RTS)	电压振幅	±5	±9	-	V	3kΩ 负载
9	FNC4	输入/输出	数字	可编程输入/输出	VIH	4.0	-	5.2	V	
					VIL	-0.5	-	1.0	V	
					VOH (Io=-1.5mA)	4.0	-	5.2	V	
					VOL (Io=1.5mA)	-	-	1.1	V	
	CTS (RS-232C)	输入	数字	RS-232C 串行端口 (CTS)	输入电压范围	-30	-	30	V	
					阈值低	0.5	1.3	-	V	
					阈值高	-	1.75	2.6	V	
10	FNC5	输入/输出	数字	可编程输入/输出	VIH	4.0	-	5.2	V	
					VIL	-0.5	-	1.0	V	
					VOH (Io=-1.5mA)	4.0	-	5.2	V	
					VOL (Io=1.5mA)	-	-	1.1	V	

## TERMINAL FUNCTION

Pin No.	Pin Name	I/O	Signal Type	Description	Item and Condition	Min	Typ	Max	Unit	Note
11	FNC6	I/O	Digital	Programmable I/O	VIH	4.0	-	5.2	V	
					VIL	-0.5	-	1.0	V	
					VOH (Io=-1.5mA)	4.0	-	5.2	V	
					VOL (Io=1.5mA)	-	-	1.1	V	
12	50MC	O	Power	5V DC Power supply	Output Voltage	4.5	5.0	5.25	V	
					Output Current	-	-	100	mA	
13	HR1	I	Analog	Horn alert signal input	Input Voltage	5	-	16	V	
					Input Current	-	-	2.0	A	
					Rds (ON)	-	55	108	mΩ	
14	HR2	O	Analog	Horn alert signal output	Output Voltage	-	-	16	V	
					Output Current	-	-	2.0	A	
15	GND	-	GND	Ground					-	



## 端子功能

管脚 号码	名称	输入/ 输出	信号 类型	说 明	项目和条件	最小	标准	最大	单位	注 意
11	FNC6	输入/ 输出	数字	可编程输入 / 输出	VIH	4.0	-	5.2	V	
					VIL	-0.5	-	1.0	V	
					VOH (Io=-1.5mA)	4.0	-	5.2	V	
					VOL (Io=1.5mA)	-	-	1.1	V	
12	50MC	输出	电源	5V DC 电源	输出电压	4.5	5.0	5.25	V	
					输出电流	-	-	100	mA	
13	HR1	输入	模拟	喇叭提示信号输入	输入电压	5.0	-	16	V	
					输入电流	-	-	2.0	A	
					Rds (ON)	-	55	108	mΩ	
14	HR2	输出	模拟	喇叭提示信号输出	输出电压	-	-	16	V	
					输出电流	-	-	2.0	A	
15	GND	-	GND	接地					-	

# NX-720 PC BOARD / 印刷电路板

## DISPLAY UNIT (X54-3830-10) Component side view (J79-0345-09)

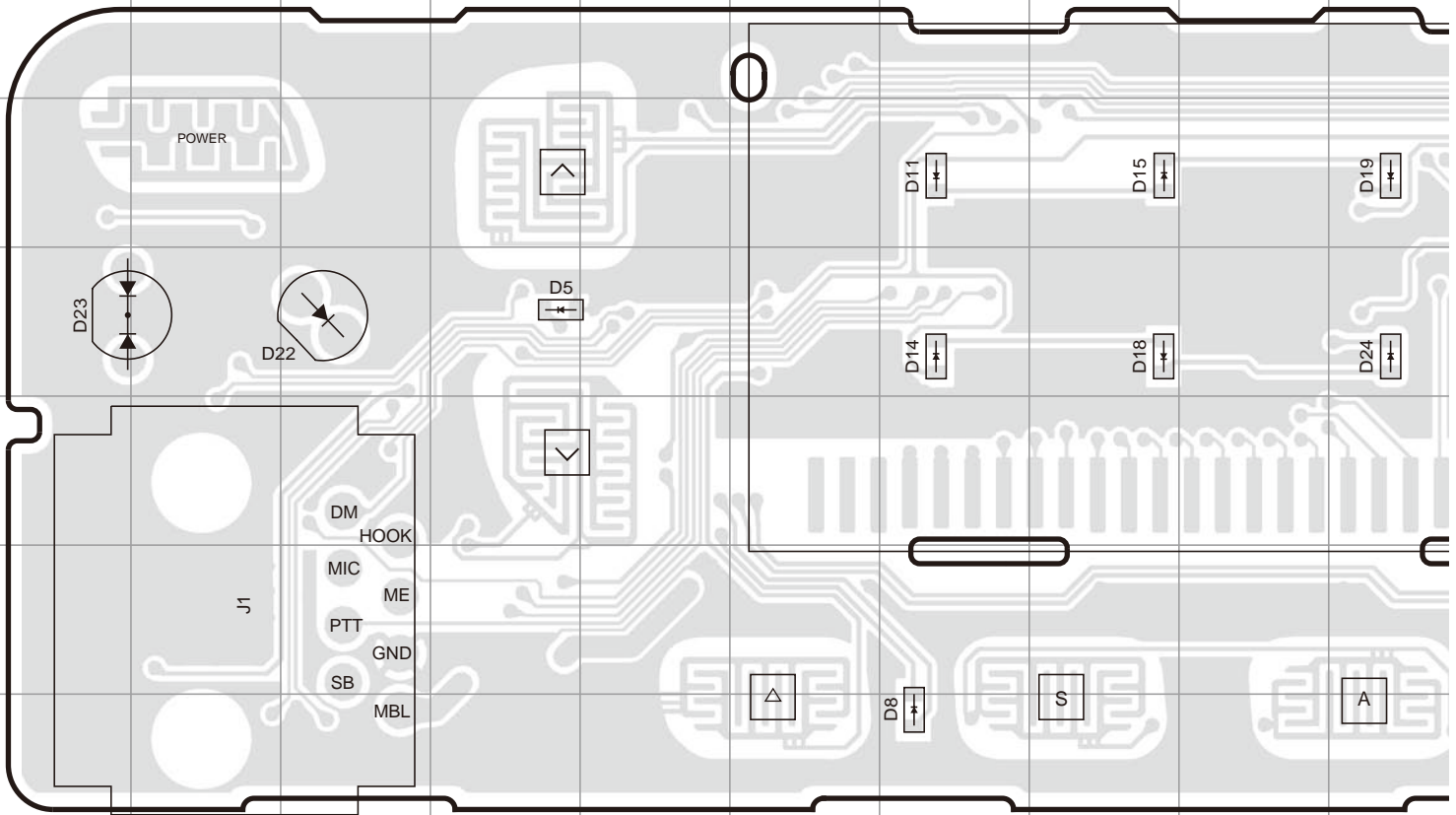

## DISPLAY UNIT (X54-3830-10) Foil side view (J79-0345-09)

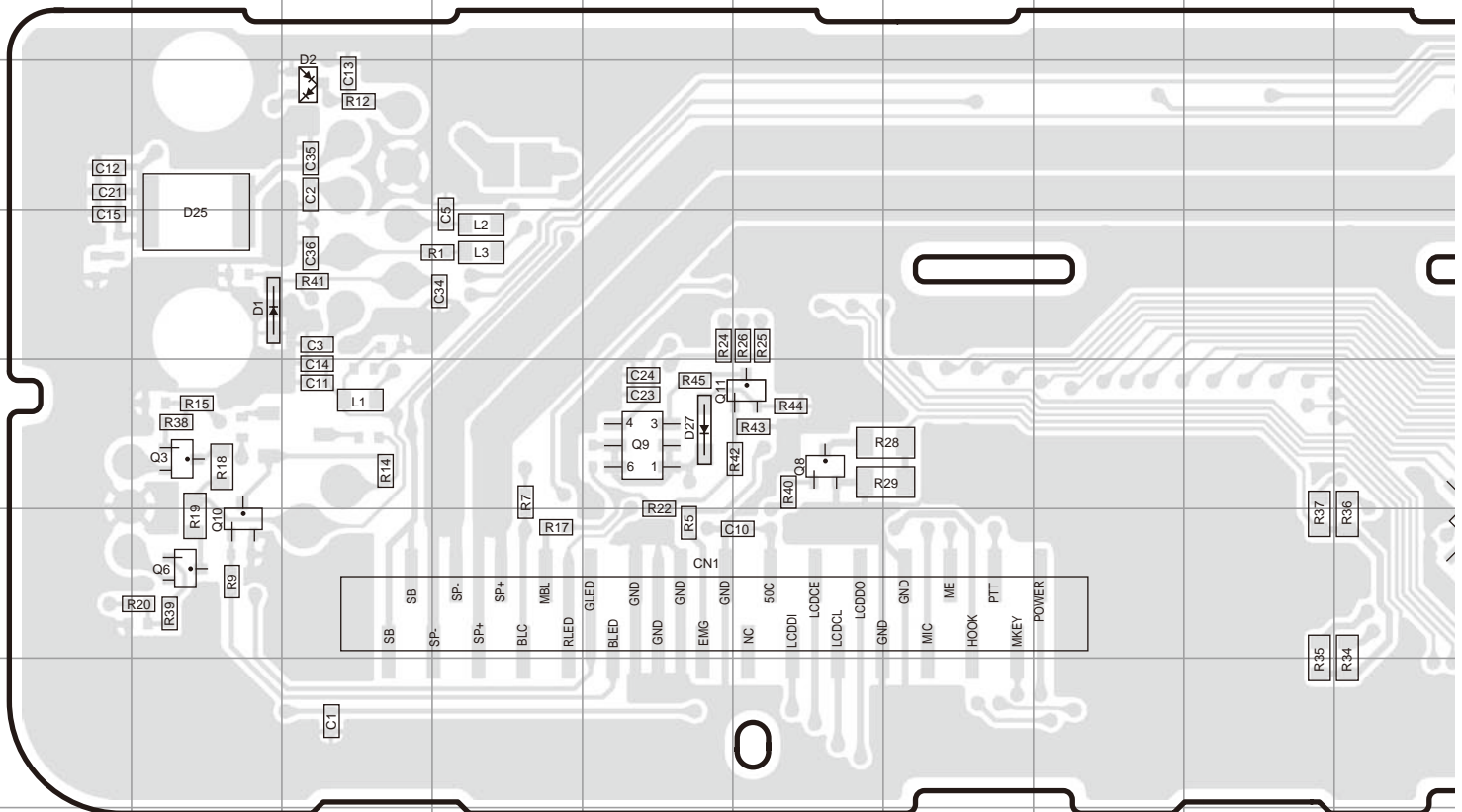

# PC BOARD / 印刷电路板 NX-720

## DISPLAY UNIT (X54-3830-10) Component side view (J79-0345-09)

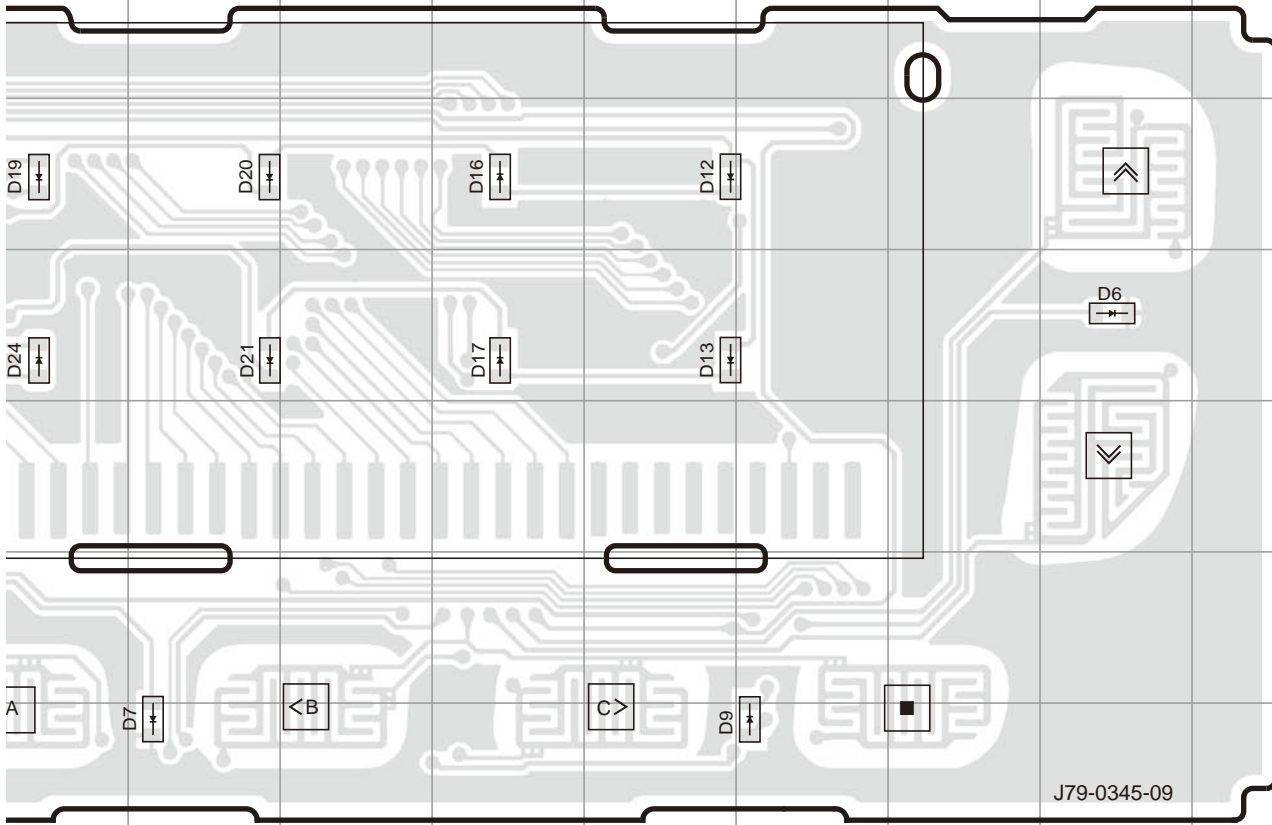

Ref. No.	Address
D5	4D
D7	7K
D8	7G
D9	7O
D11	3G
D12	3N
D13	4N
D14	4G
D15	3H
D17	4M
D16	3M
D18	4H
D19	3J
D21	4K
D20	3K
D22	4C
D23	4B

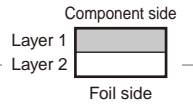

J79-0345-09

## DISPLAY UNIT (X54-3830-10) Foil side view (J79-0345-09)

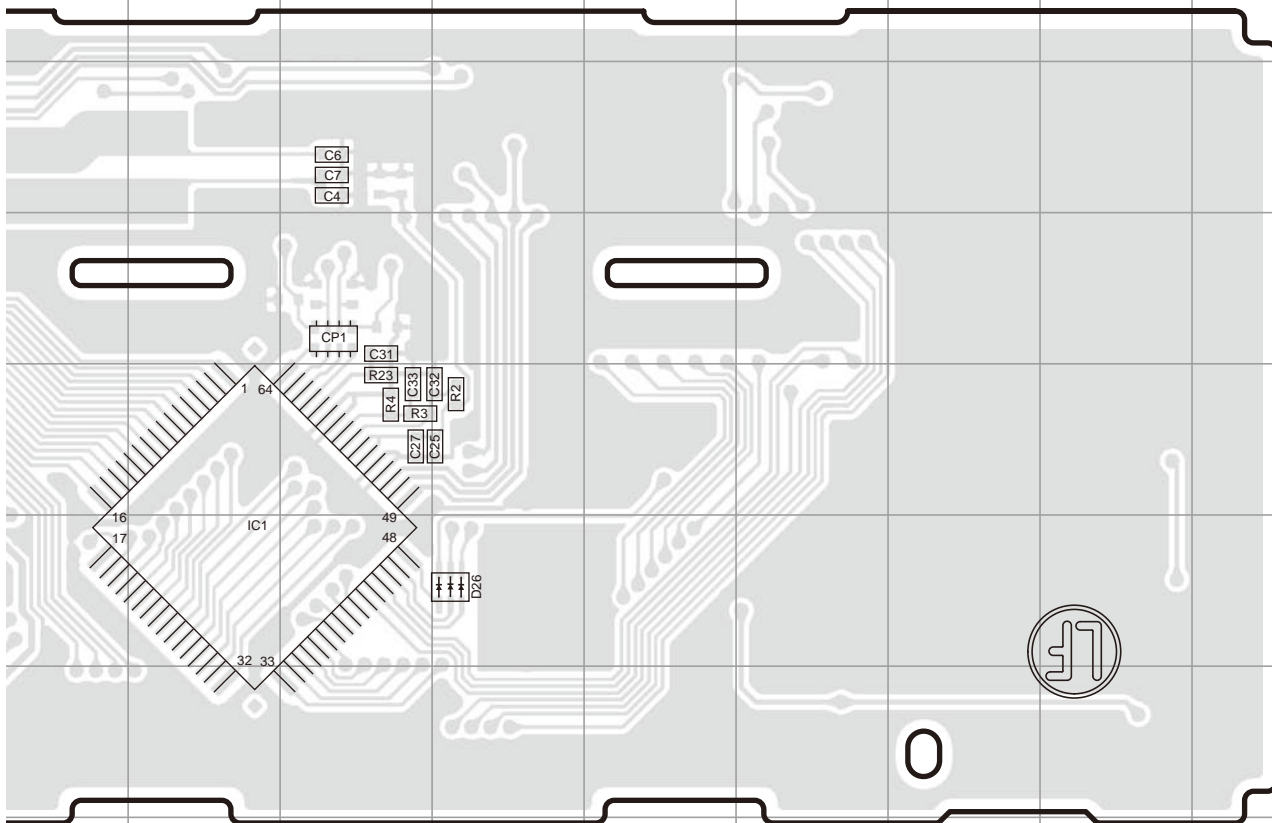

Ref. No.	Address
IC1	12K
Q3	11B
Q6	12B
Q8	11F
Q9	11E
Q10	12B
Q11	11F
D1	10B
D2	9C
D25	10B
D26	12M
D27	11E

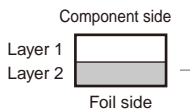

# NX-720 PC BOARD / 印刷电路板

## TX-RX UNIT (X57-8230-11) Component side view (J79-0343-09)

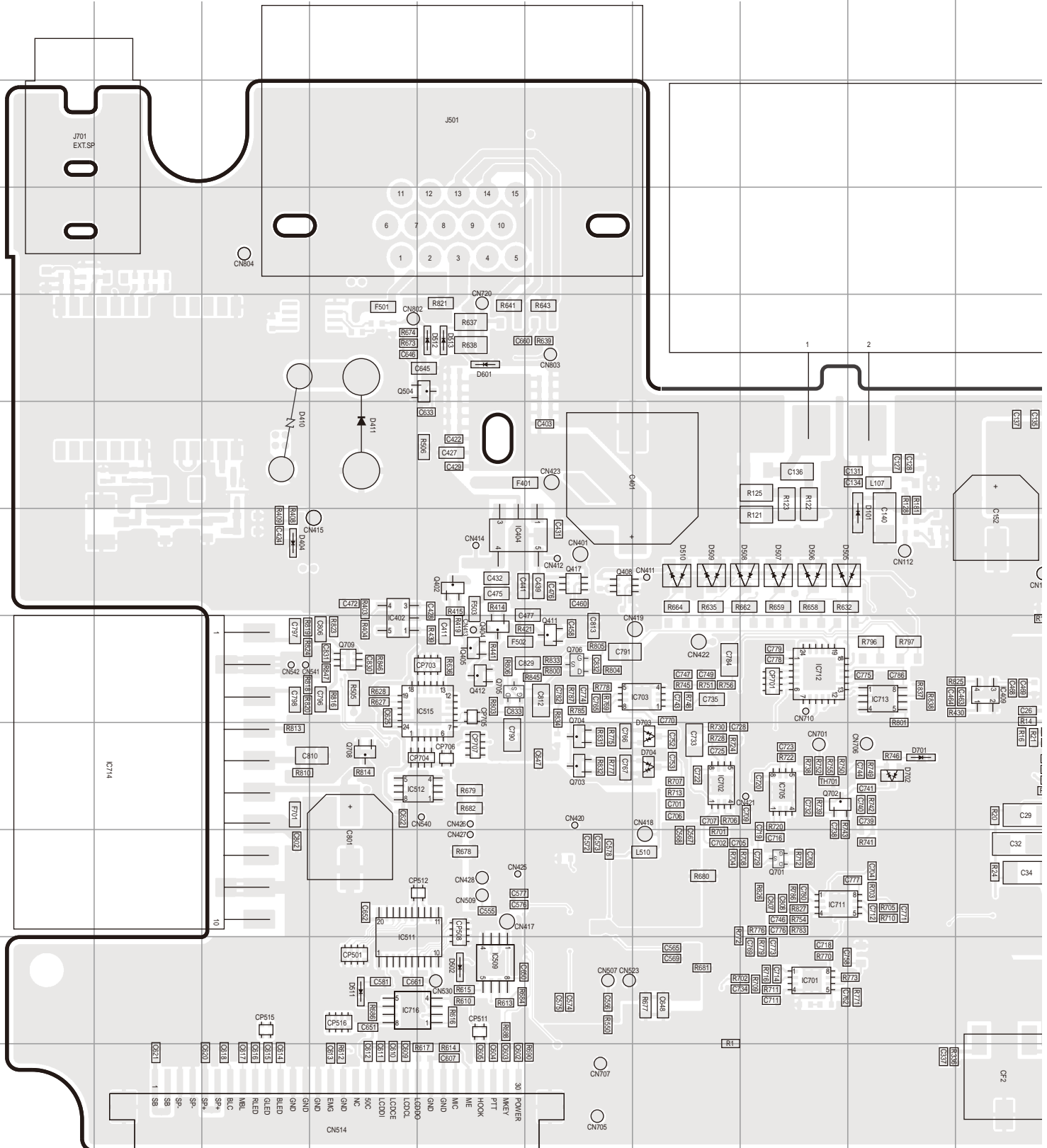

# PC BOARD / 印刷电路板 NX-720

## TX-RX UNIT (X57-8230-11) Component side view (J79-0343-09)

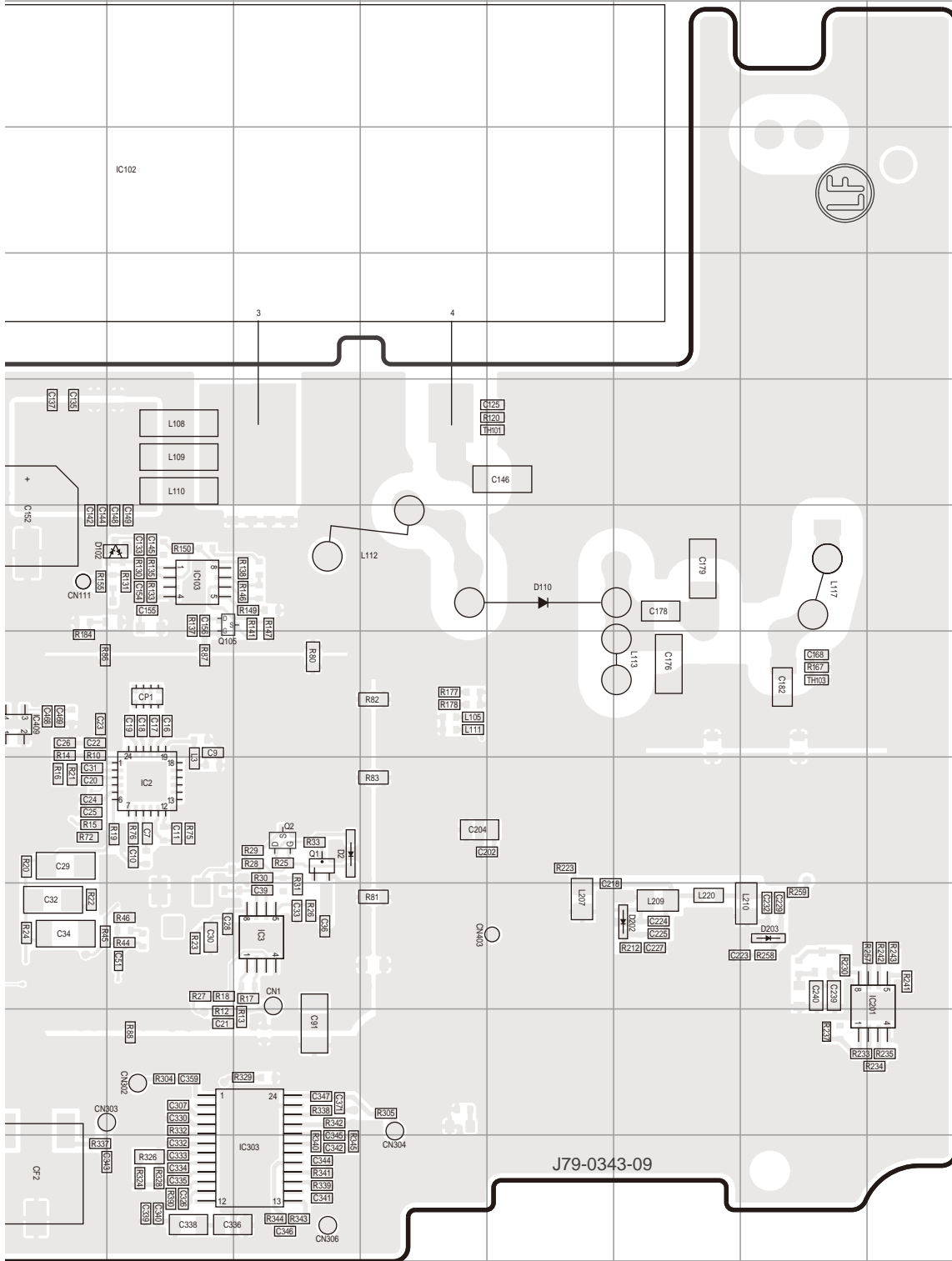

Ref. No.	Address	Ref. No.	Address
IC2	9K	Q702	9H
IC3	10L	Q703	9F
IC103	7K	Q704	9F
IC201	10Q	Q705	8E
IC303	11L	Q706	8F
IC402	8D	Q708	9D
IC404	7E	Q709	8D
IC409	8J	D2	9L
IC509	11E	D101	7I
IC511	10D	D102	7K
IC512	9E	D110	7N
IC515	8E	D202	10O
IC701	11H	D203	10P
IC702	9G	D404	7C
IC703	8G	D410	6C
IC705	9H	D411	6D
IC711	10H	D502	11E
IC712	8H	D505	7H
IC713	8I	D506	7H
IC716	11D	D507	7H
Q1	9L	D508	7H
Q2	9L	D509	7G
Q105	7K	D510	7G
Q402	7E	D511	11D
Q404	8E	D512	5E
Q405	8E	D513	5E
Q408	7F	D601	5E
Q411	8F	D701	9I
Q412	8E	D702	9I
Q417	7F	D703	9G
Q504	5E	D704	9G
Q701	10H		

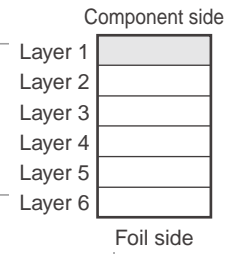

# NX-720 PC BOARD / 印刷电路板

## TX-RX UNIT (X57-8230-11) Foil side view (J79-0343-09)

Ref. No.	Address	Ref. No.	Address
IC1	7R	Q502	3O
IC301	11M	Q503	3N
IC304	12H	D4	10H
IC401	8M	D5	10I
IC405	7O	D6	8I
IC406	9M	D7	10H
IC407	8P	D8	10J
IC408	8N	D9	10H
IC501	11P	D10	10H
IC502	9P	D11	10J
IC503	11Q	D12	10I
IC504	12Q	D13	8I
IC506	9N	D14	9J
IC507	10N	D15	10J
IC508	11M	D16	8H
IC513	8L	D17	8H
IC514	8L	D103	6E
IC516	7M	D104	5C
Q4	9J	D105	6E
Q5	8I	D106	6E
Q6	9I	D107	8E
Q7	9J	D108	10L
Q8	9I	D109	10L
Q9	9I	D111	7F
Q10	9H	D112	8F
Q11	8H	D113	8F
Q102	7K	D114	8F
Q106	7I	D204	9D
Q201	10G	D205	9E
Q202	9D	D206	9E
Q303	10K	D207	9E
Q401	6Q	D403	6P
Q403	5R	D405	9M
Q407	8O	D406	7N
Q409	9L	D407	7O
Q410	8O	D408	11L
Q414	11L	D409	11L
Q415	11L	D504	8L
Q416	11L	D705	5N
Q418	5Q	D706	5N
Q501	11M		

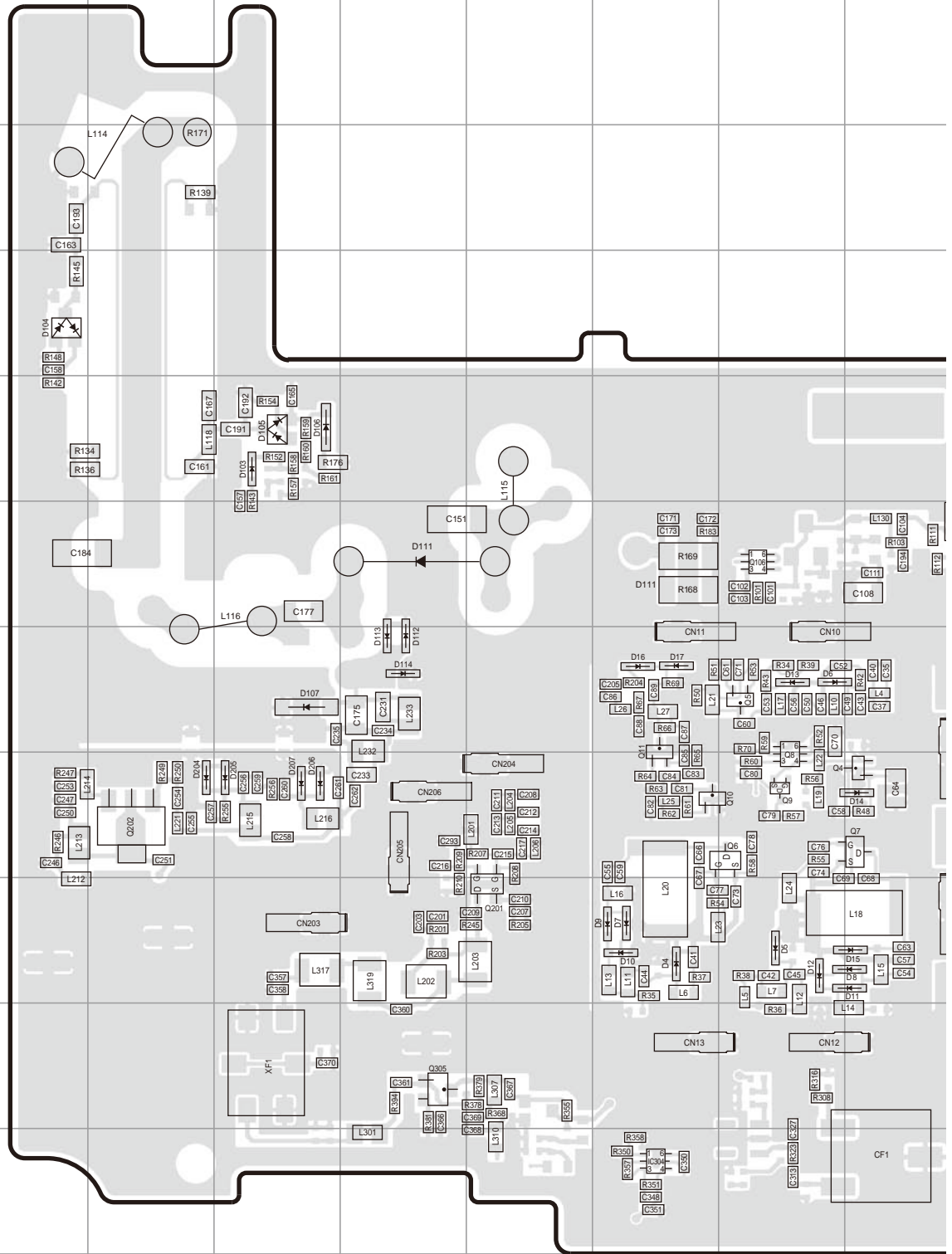

Component side

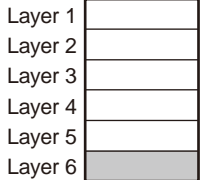

Foil side

# PC BOARD / 印刷电路板 NX-720

## TX-RX UNIT (X57-8230-11) Foil side view (J79-0343-09)

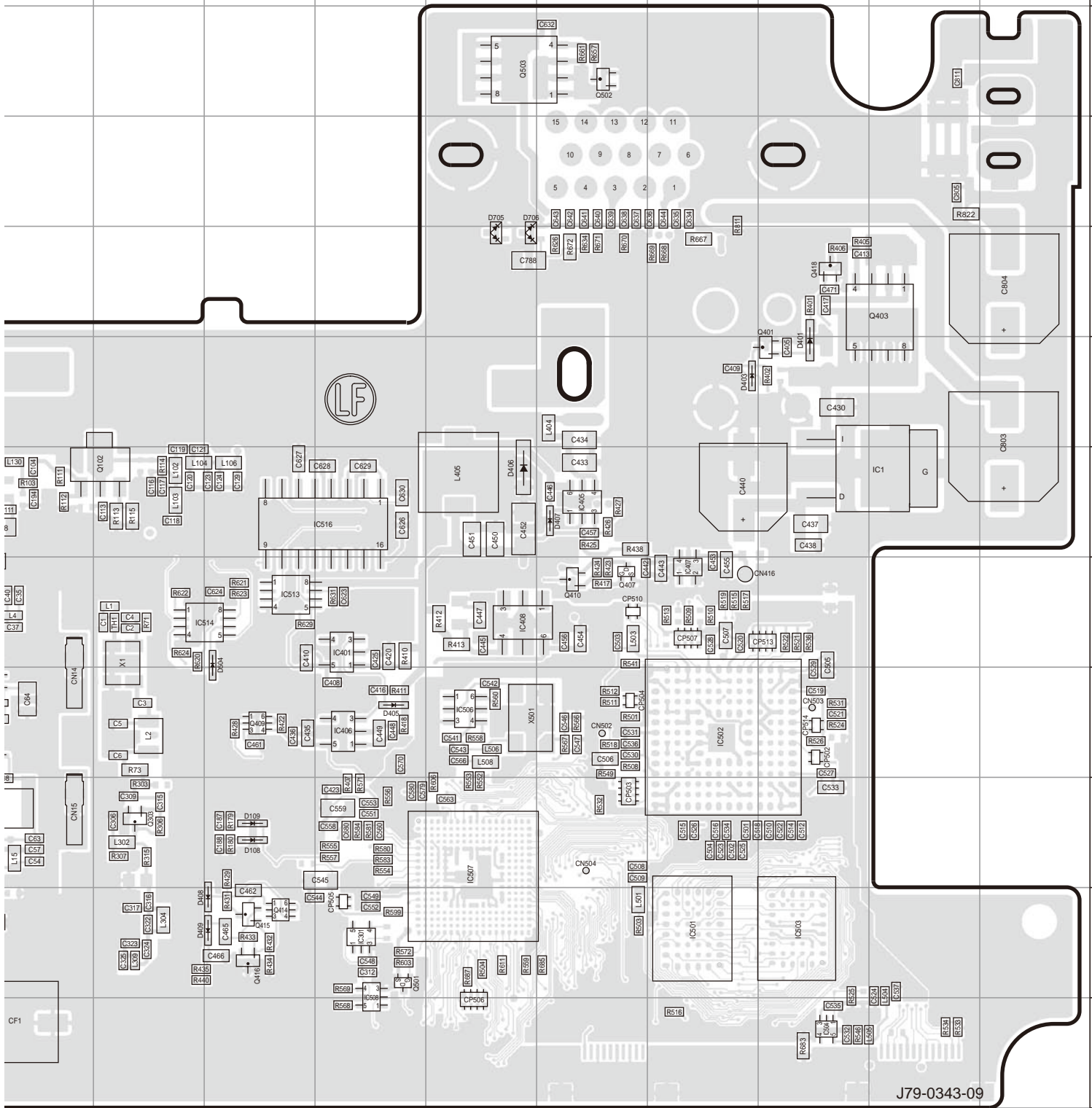

J79-0343-09

## INTERCONNECTION DIAGRAM / 互连图

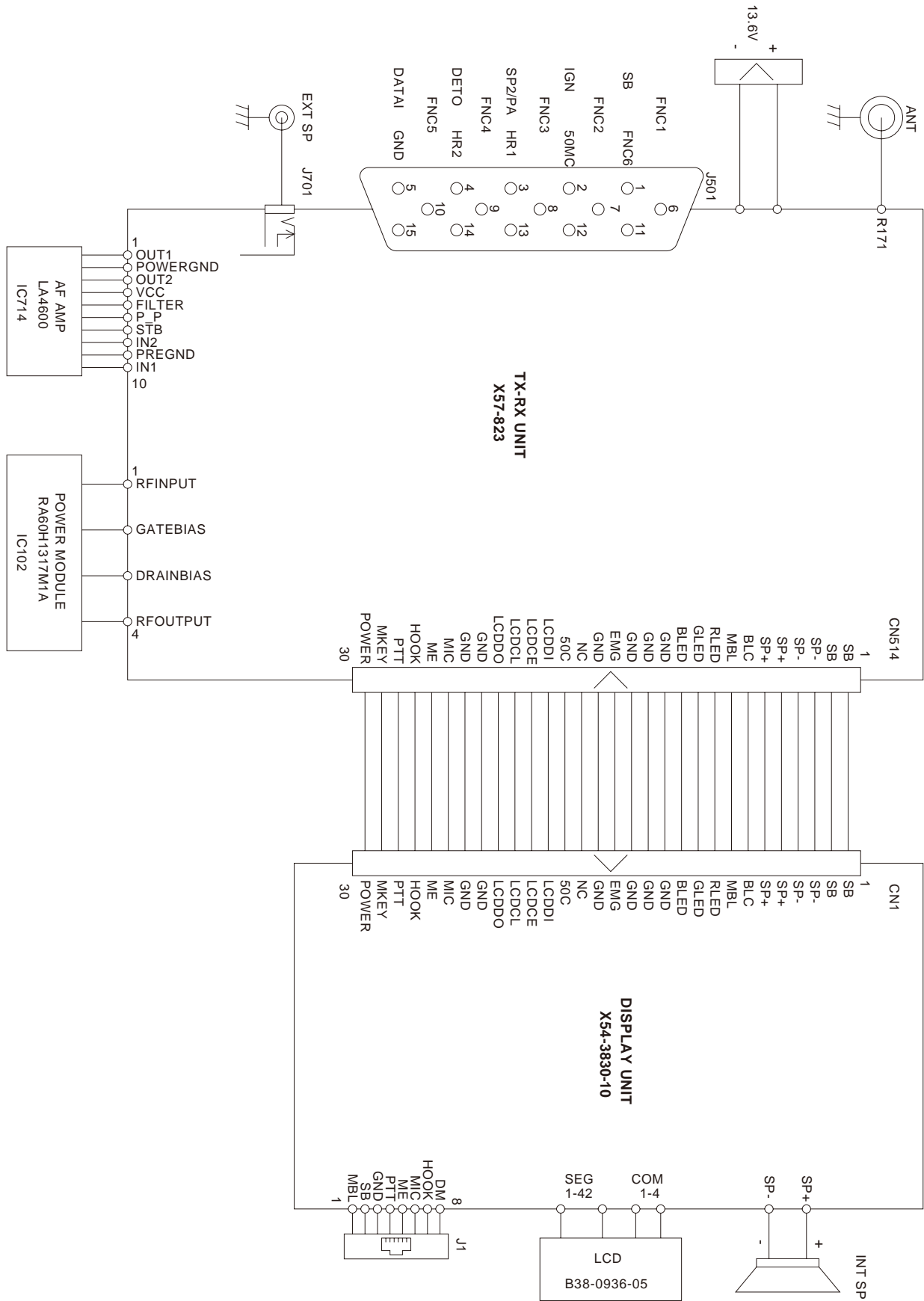



# SCHEMATIC DIAGRAM / 原理图

# NX-720

TX-RX UNIT(X57-8230-11)

1  
2  
3  
4  
5  
6  
7

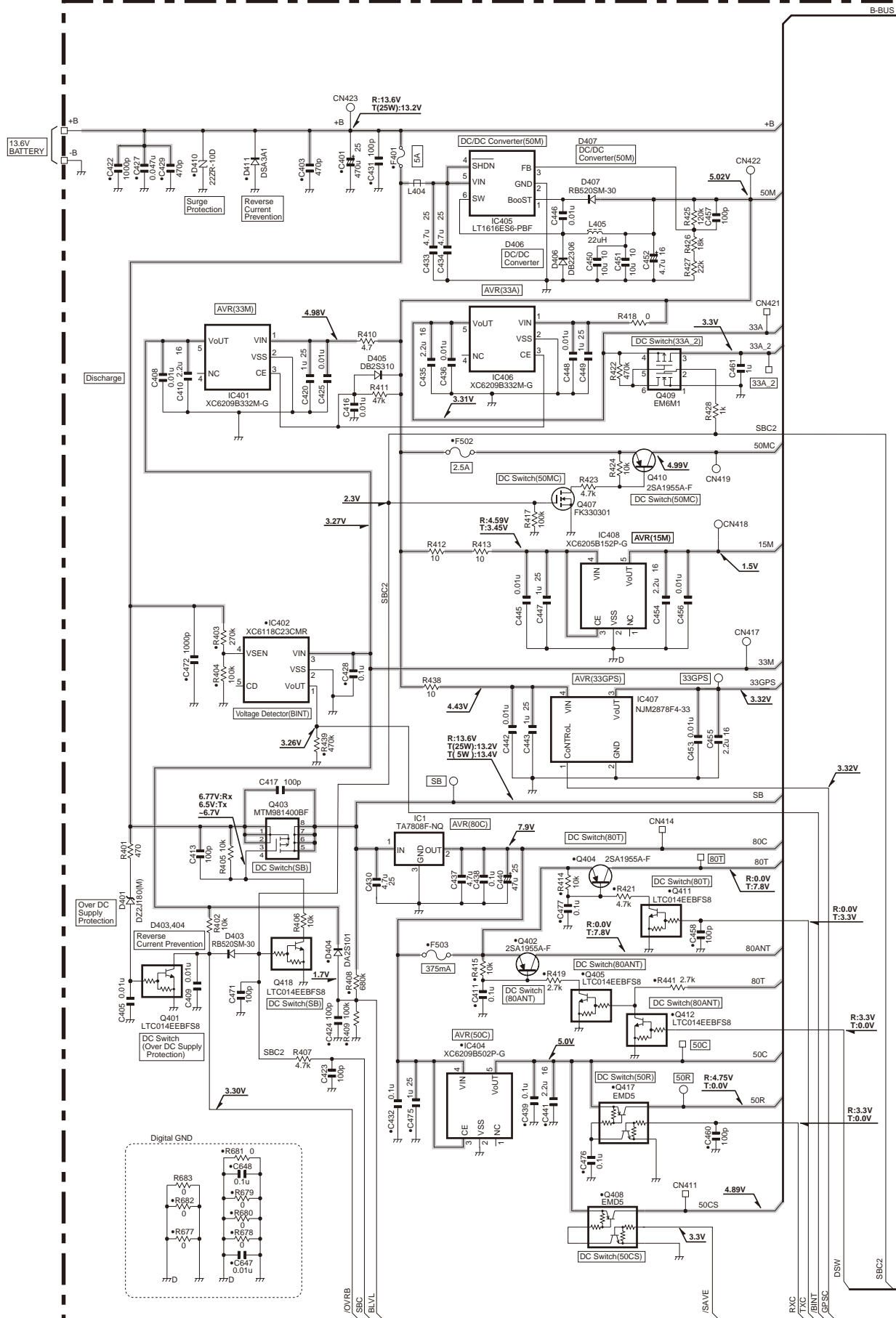

# NX-720 SCHEMATIC DIAGRAM / 原理图

TX-RX UNIT (X57-8230-11)

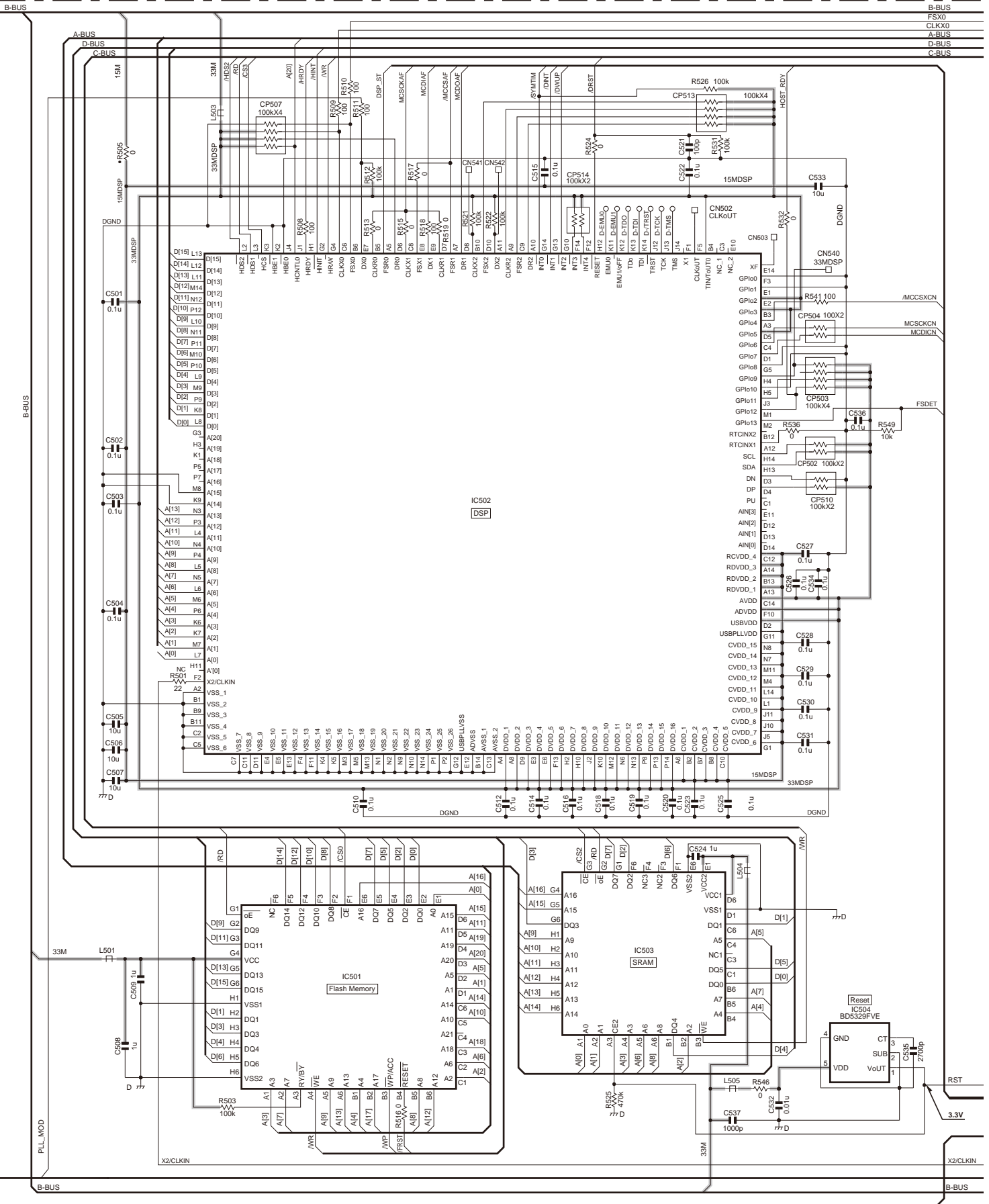

# SCHEMATIC DIAGRAM / 原理图 NX-720

TX-RX UNIT (X57-8230-11)

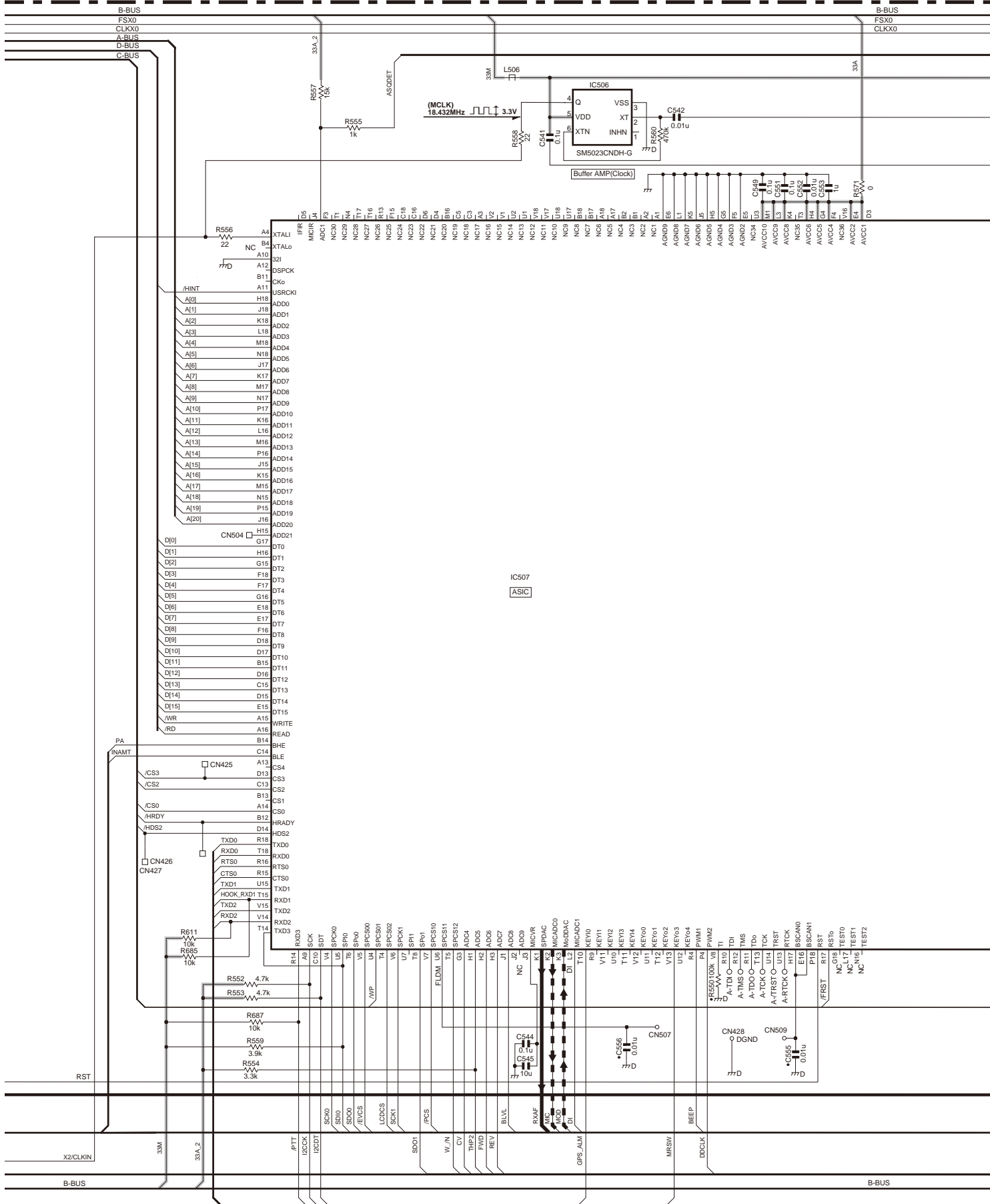

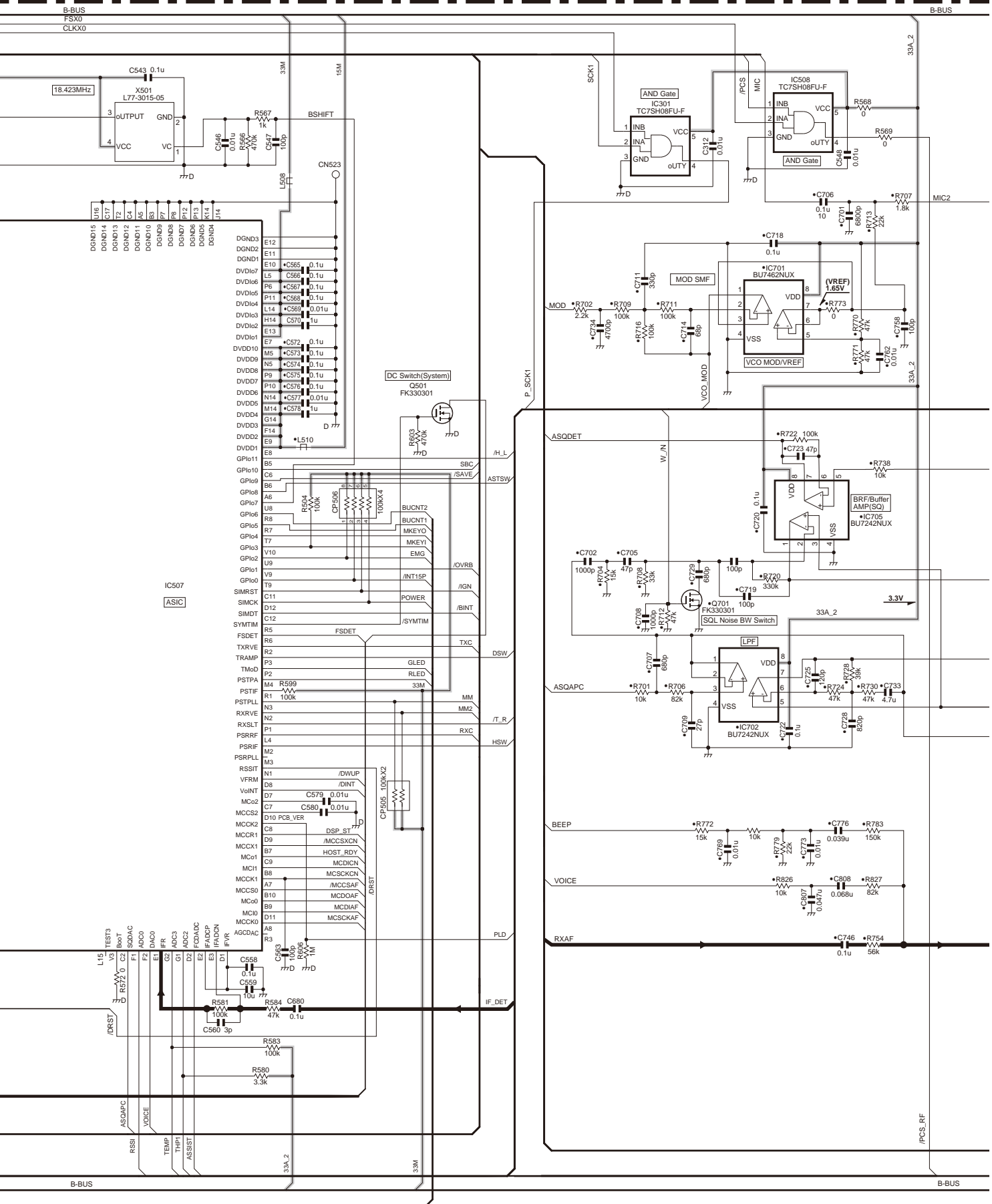

# SCHEMATIC DIAGRAM / 原理图

# NX-720

TX-RX UNIT (X57-8230-11)

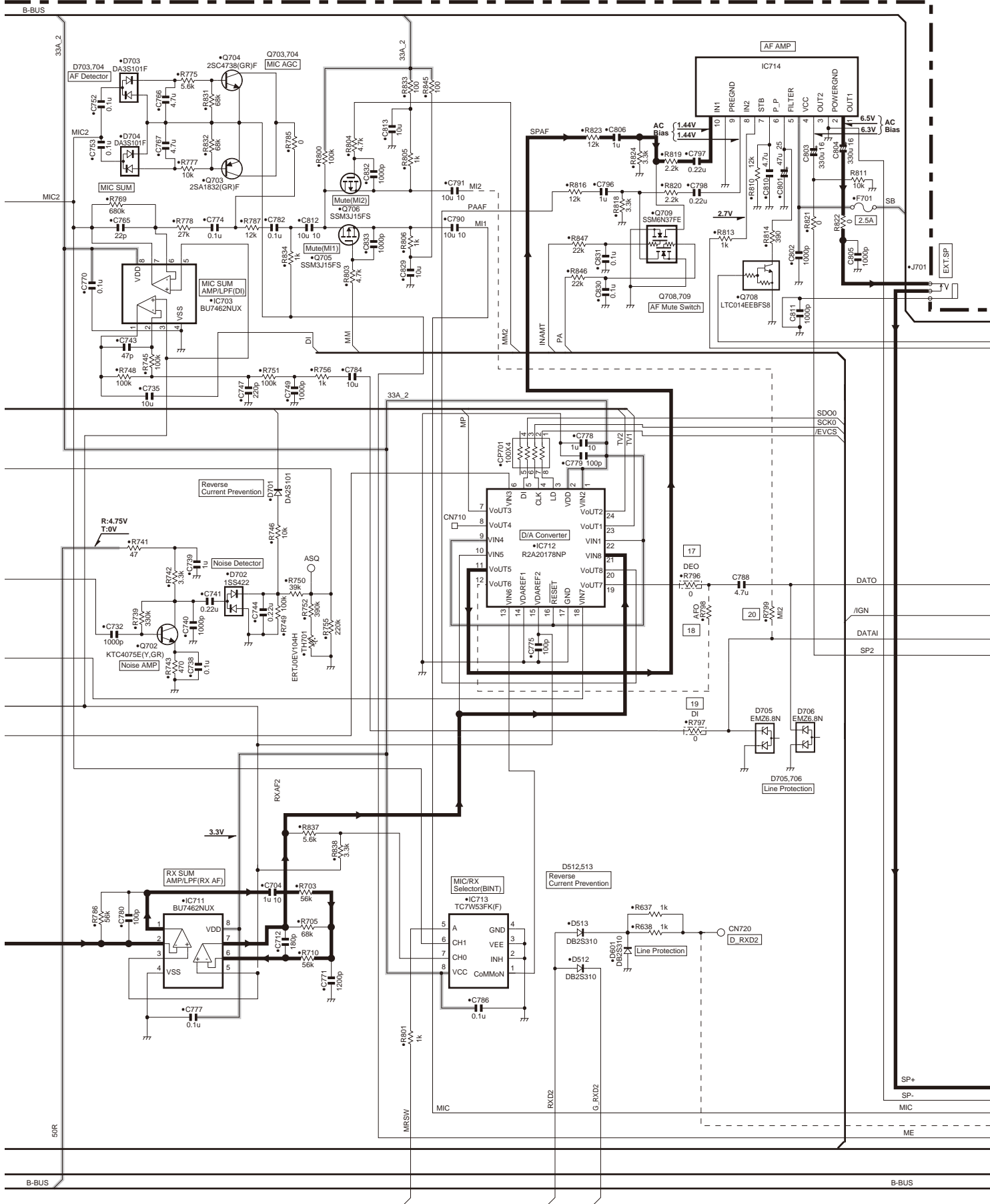

# NX-720 SCHEMATIC DIAGRAM / 原理图

TX-RX UNIT (X57-8230-11)

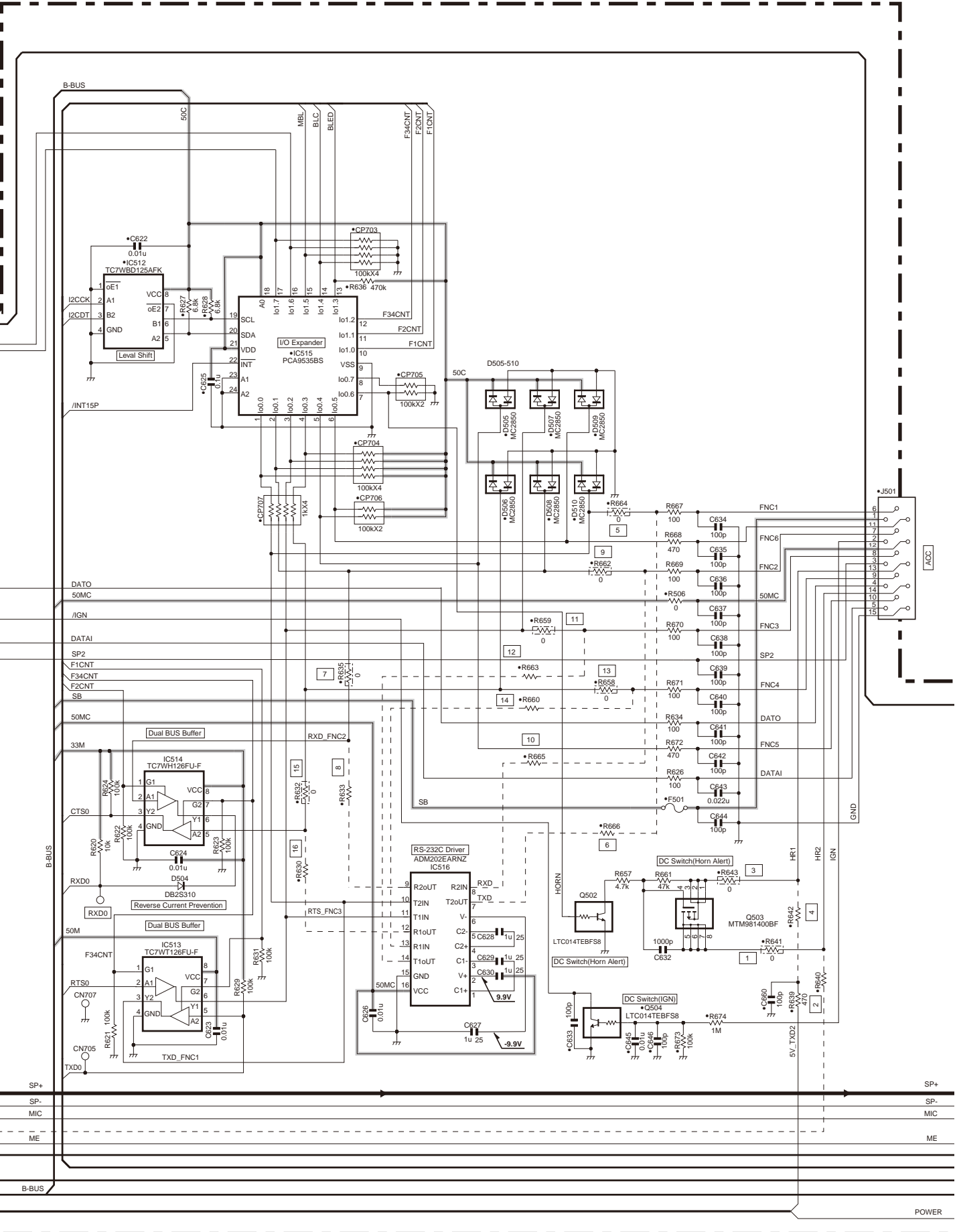

# SCHEMATIC DIAGRAM / 原理图 NX-720

TX-RX UNIT (X57-8230-11)

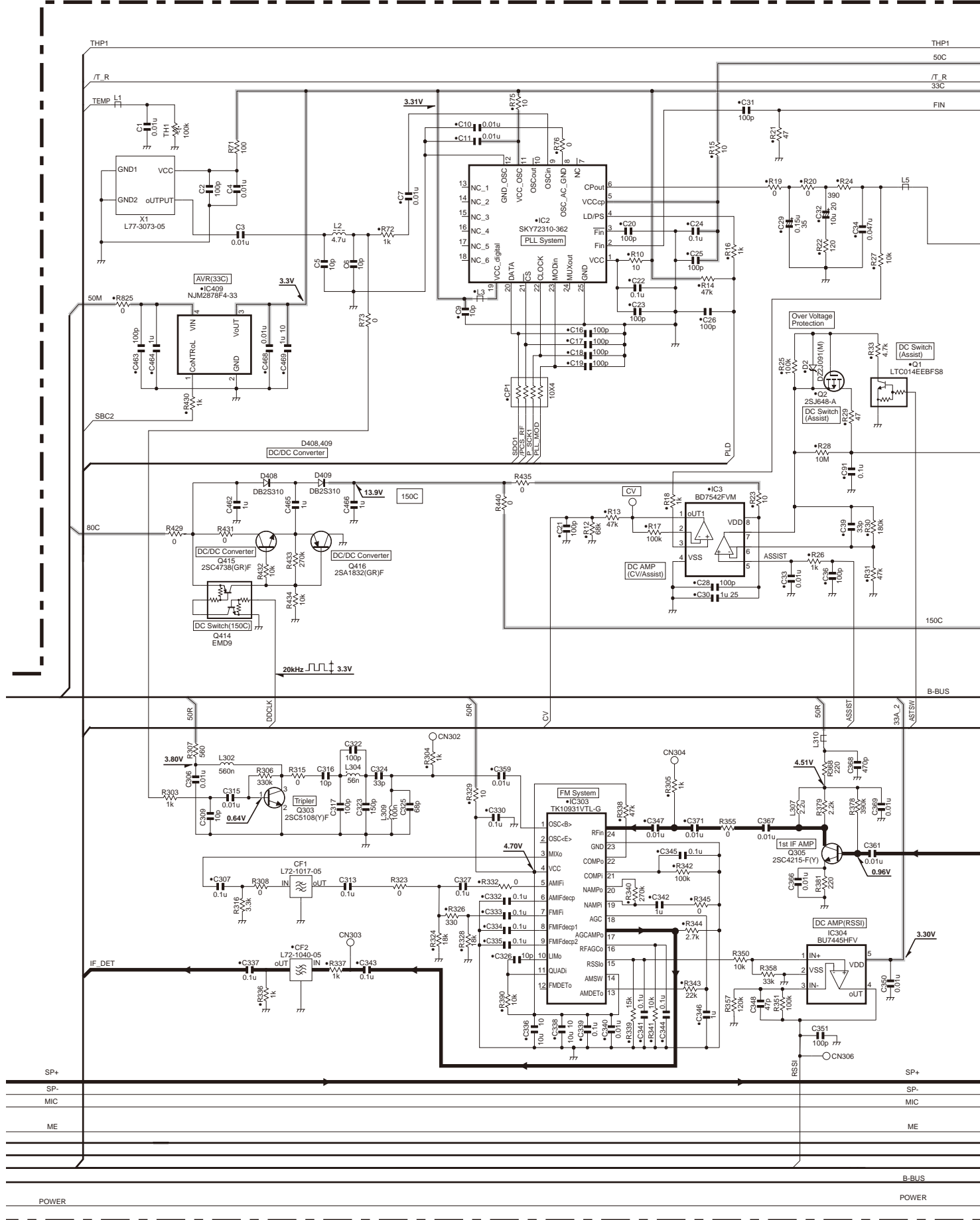

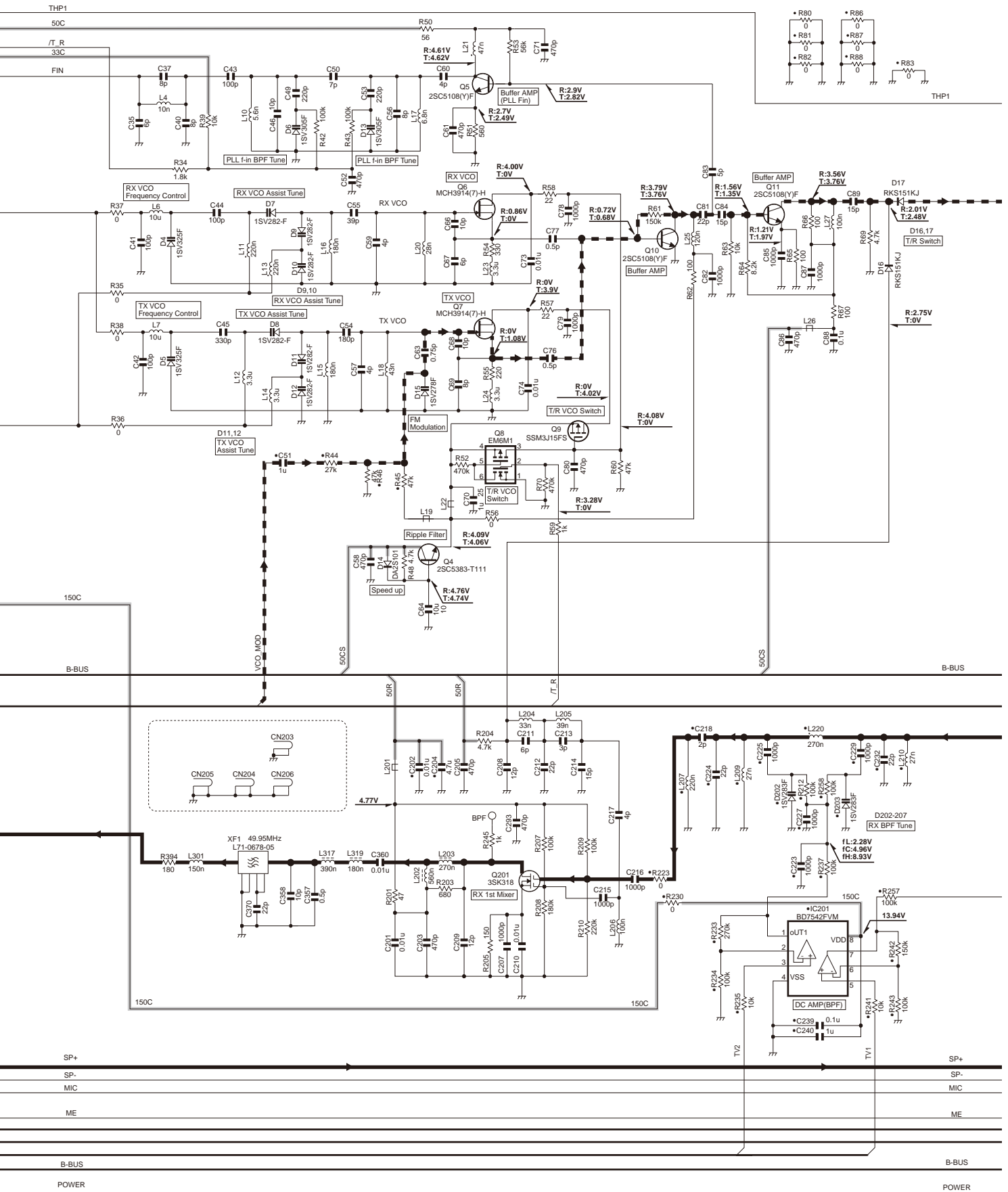



# SCHEMATIC DIAGRAM / 原理图 NX-720

TX-RX UNIT (X57-8230-11)

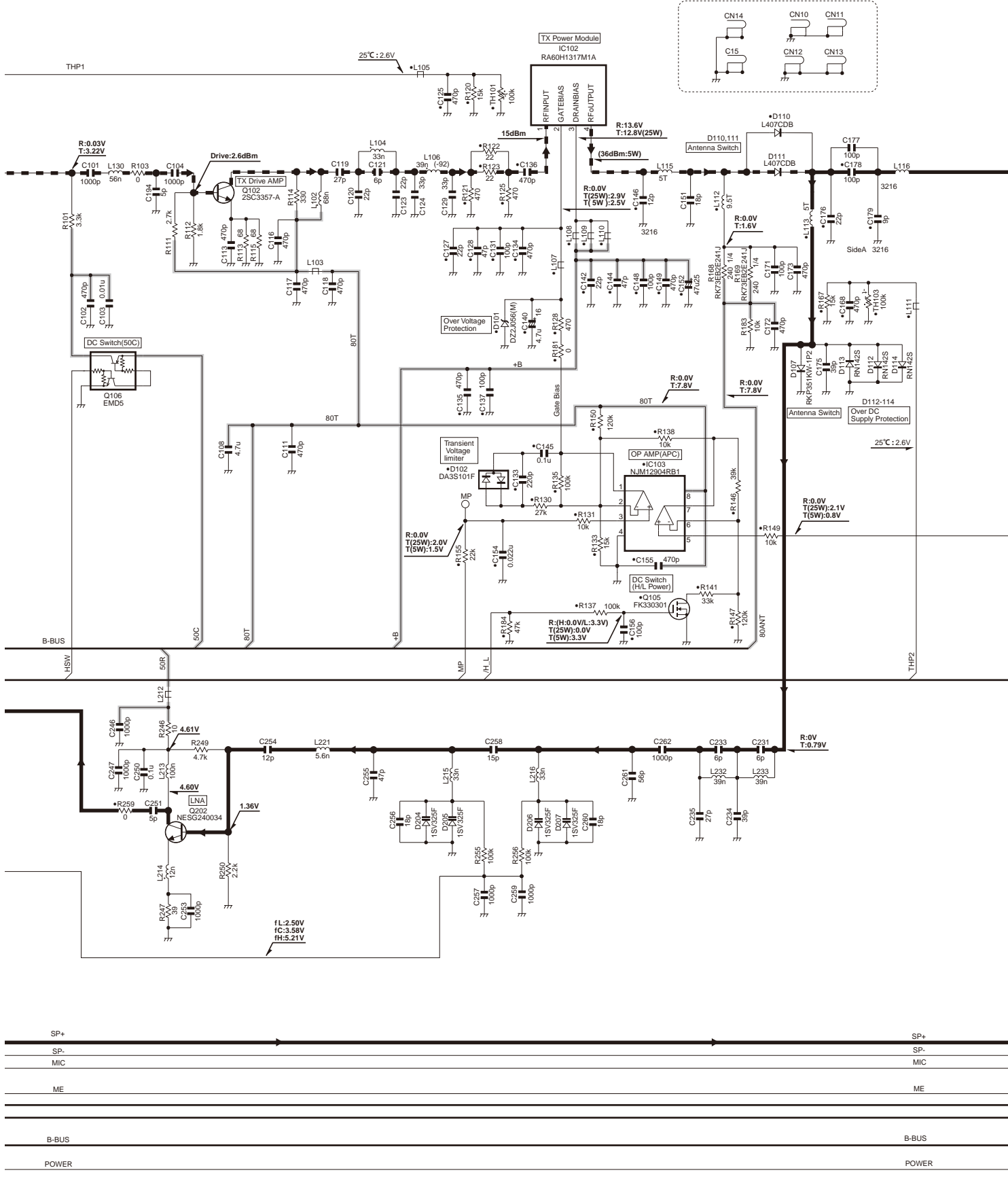

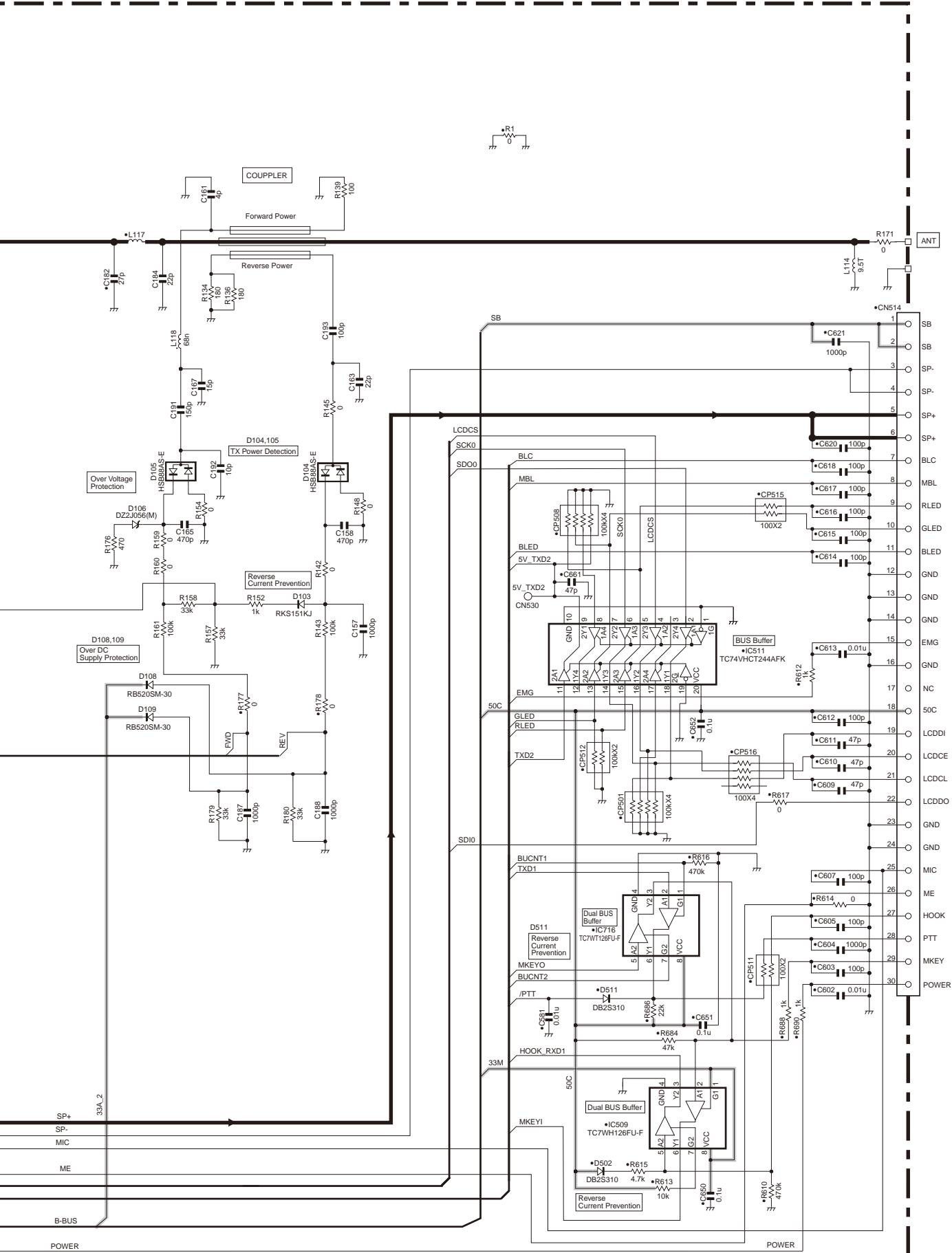

# SCHEMATIC DIAGRAM / 原理图 NX-720

DISPLAY UNIT (X54-3830-10)

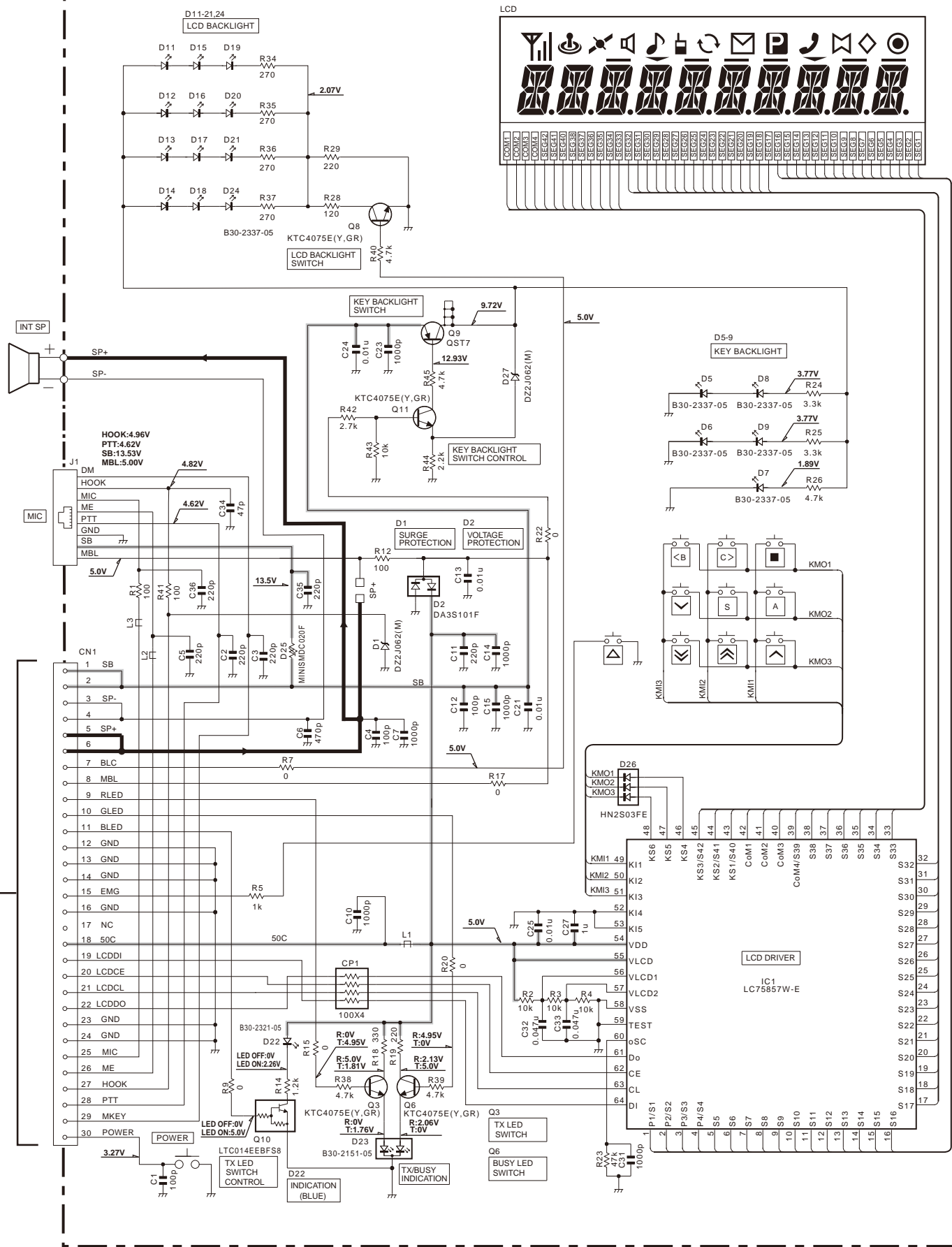



## BLOCK DIAGRAM / 方块图

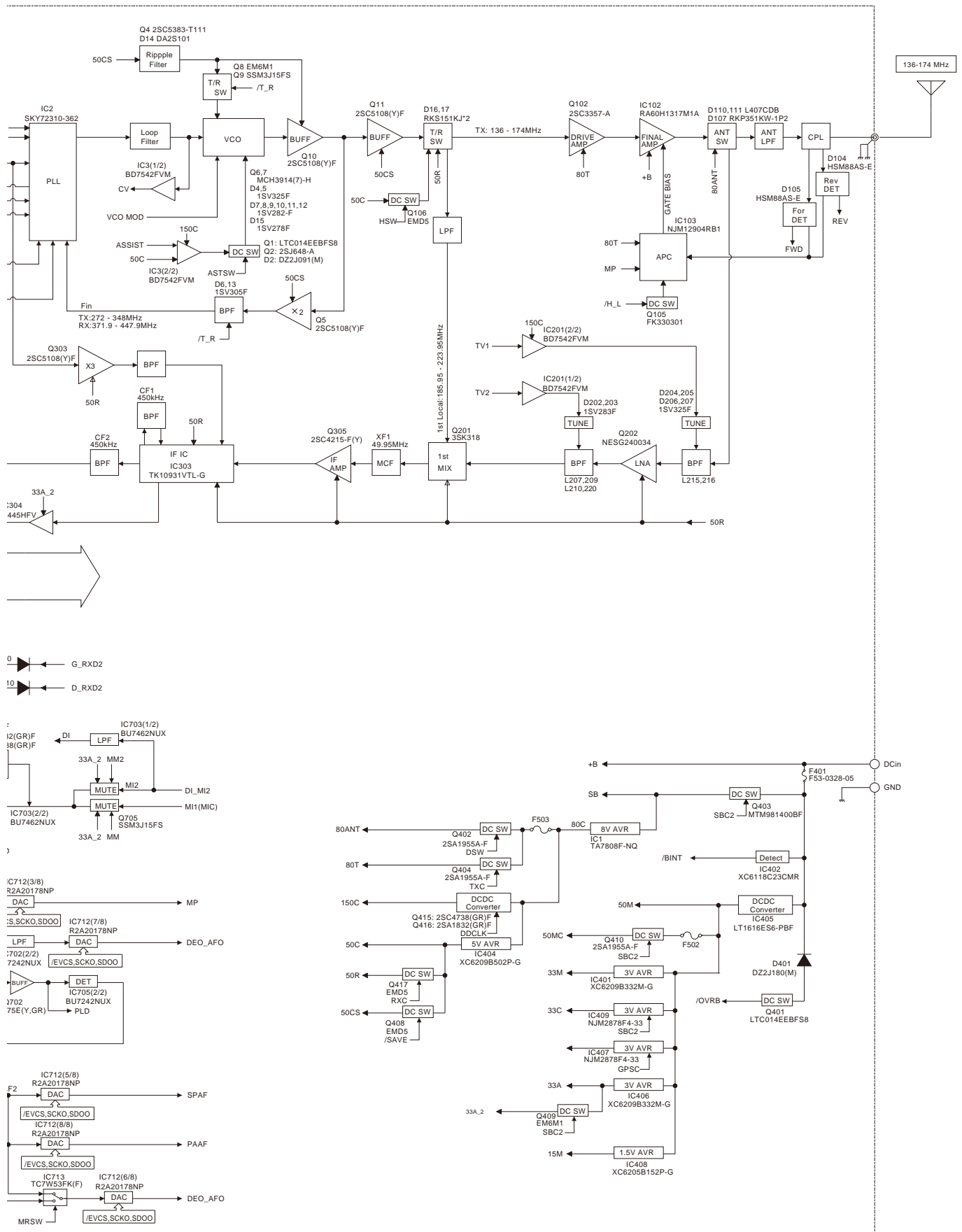

## BLOCK DIAGRAM / 方块图

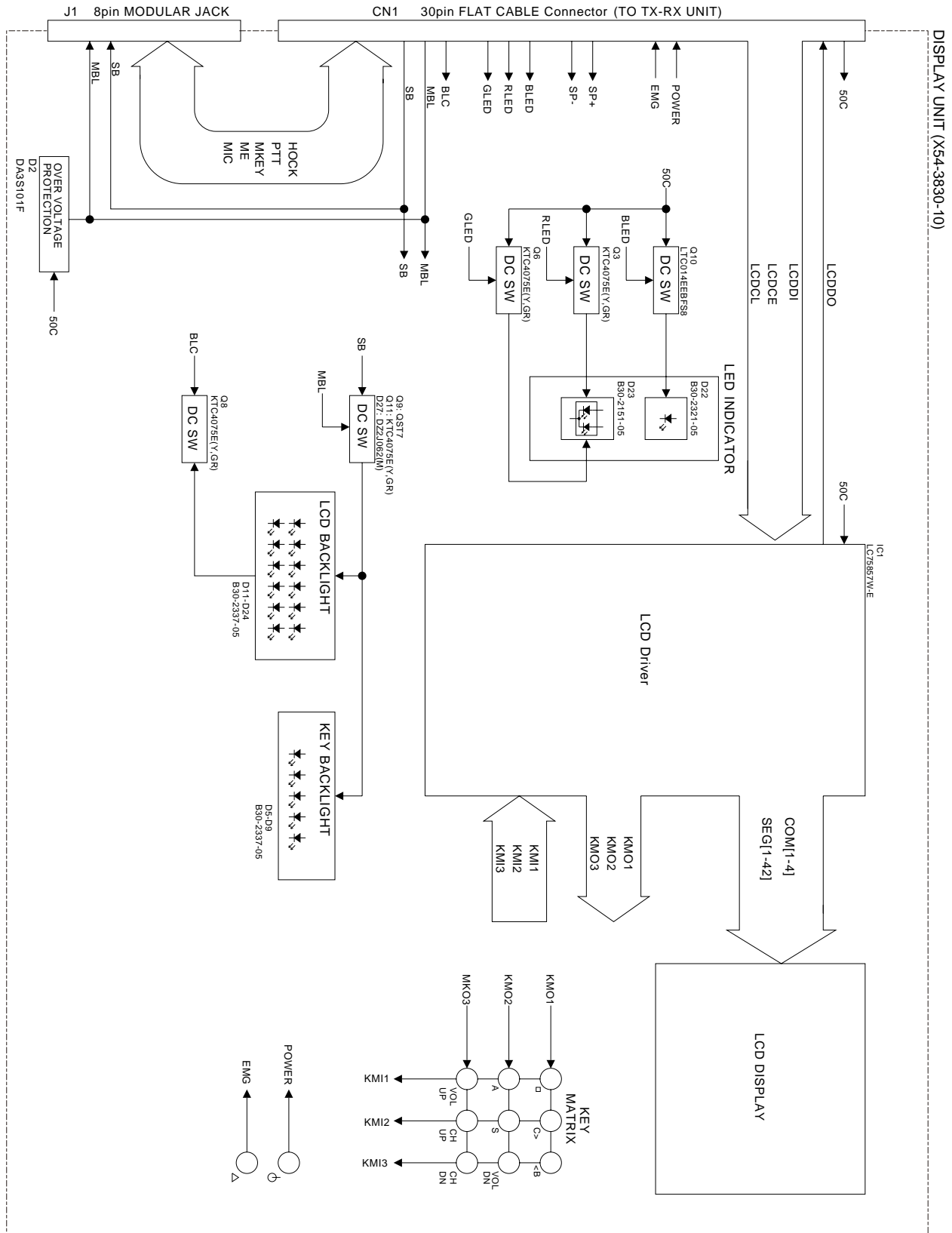

## LEVEL DIAGRAM / 电平图

### Receiver Section / 接收部分

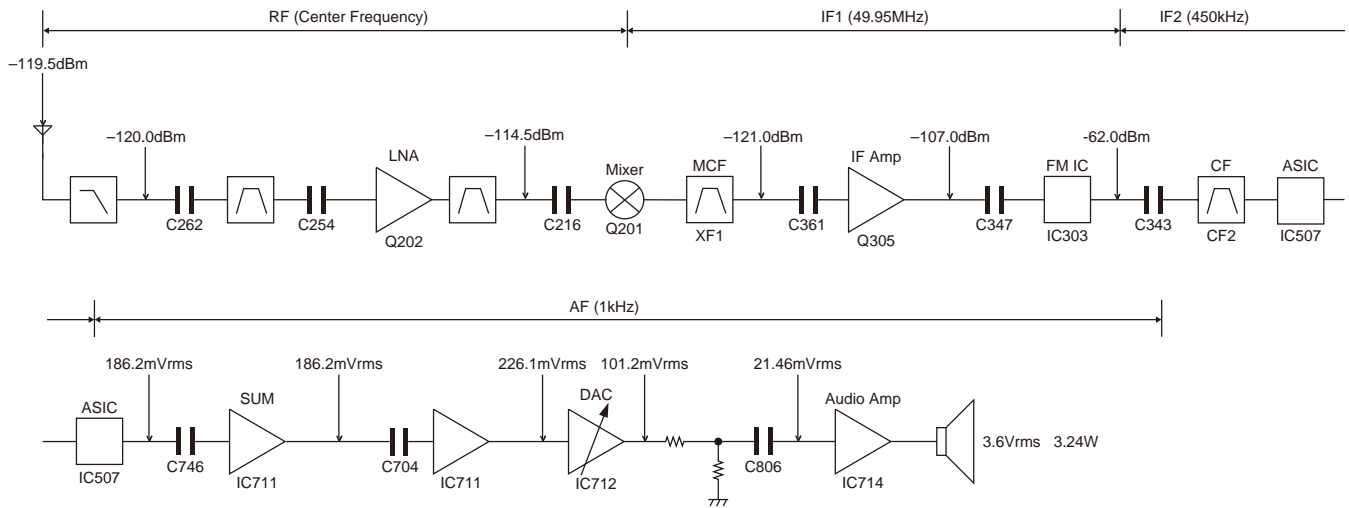

To make measurements in the AF section, connect the AC level meter. (ANT input: -53dBm, 1kHz FM, 3kHz DEV (Wide))

In the RF section, use a 1000pF coupling capacitor.

(The display shows the SSG input value required to obtain 12dB SINAD without local level.)

如要在 AF 部测量, 则连接 AC 电平表。(天线输入: -53dBm, 1kHz FM, 3kHz DEV (宽带))

如要在 RF 部测量, 请使用 1000pF 耦合电容器。

(图中显示了获得 12dB SINAD 所需的 SSG 输入值, 没有本振电平。)

### Transmitter Section / 发射部分

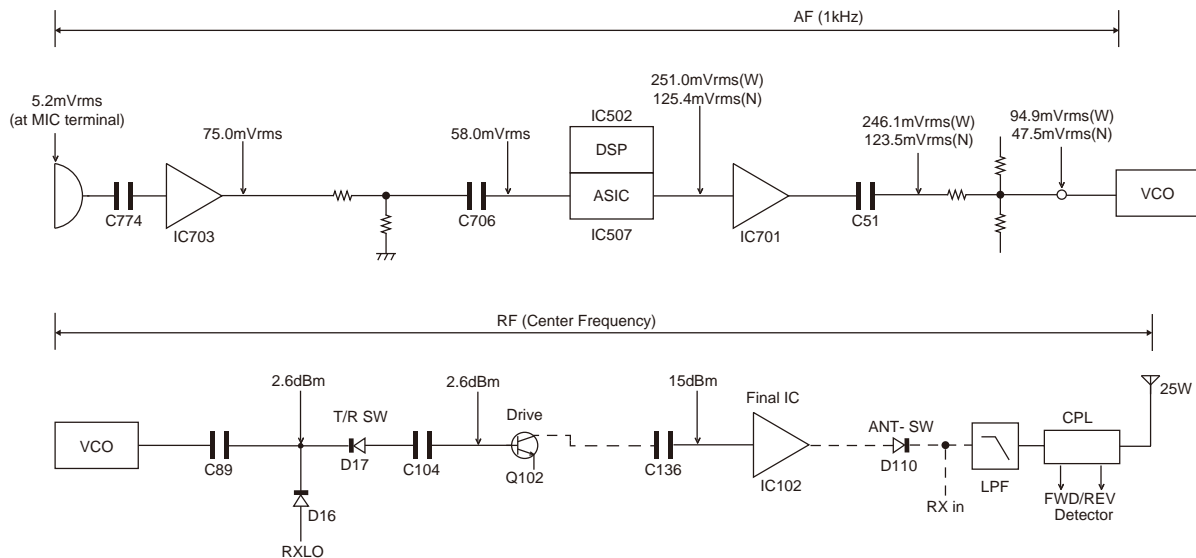

MIC input : 3kHz DEV.(Wide), 1.5kHz DEV.(Narrow) at 1kHz MOD.

Transmitting frequency : Center frequency

麦克风输入 : 3kHz DEV. (宽), 1.5kHz DEV. (窄) (1kHz MOD 时)

发射频率 : 中心频率

## SPECIFICATIONS

### GENERAL

Frequency Range .....	136~174MHz
Number of Channels.....	260
Zones.....	128
Max. Channels per Zone .....	250
Channel Spacing .....	Analog: 12.5/25 kHz    Digital: 6.25/12.5 kHz
Operating Voltage .....	13.6V DC $\pm$ 15%
Operating Temperature Range .....	-30°C~+60°C
Frequency Stability .....	$\pm$ 1.0ppm
Antenna Impedance .....	50 $\Omega$
Dimensions (W x H x D) .....	160 x 43 x 136 mm (Projections not included)
Weight .....	1.3 kg

### RECEIVER

Sensitivity .....	Digital @6.25kHz (1% BER): 0.28 $\mu$ V    Digital @12.5kHz (1% BER): 0.4 $\mu$ V Analog EIA 12dB SINAD: 0.25 $\mu$ V Analog EN 20dB SINAD: -3dB $\mu$ V
Adjacent Channel Selectivity .....	Analog @25kHz: 80dB    Analog @12.5kHz: 70dB
Intermodulation Distortion .....	Analog: 65dB
Spurious Response .....	Analog: 80dB
Audio Distortion .....	Less than 3%
Audio Output .....	4W/4 $\Omega$

### TRANSMITTER

RF Power Output.....	5~25W
Spurious Response .....	-36dBm $\leq$ 1GHz, -30dBm > 1GHz
FM Noise (EIA).....	Analog @25kHz: 50dB    Analog @12.5kHz: 45dB
Modulation .....	16K0F3E, 14K0F2D, 8K50F3E, 7K50F2D, 8K30F1E, 8K30F1D, 8K30F7W, 4K00F1E, 4K00F1D, 4K00F7W, 4K00F2D

Analog measurements made per EN standards or TIA/EIA 603 and specifications shown are typical.

JVC KENWOOD Corporation reserves the right to change specifications without prior notice or obligation.



## 规格

## 概 述

频率范围 .....	136 ~ 174MHz
信道数量 .....	260
区域数量 .....	128
每区域最大信道数量 .....	250
信道间隔 .....	模拟 : 12.5/25kHz      数字 : 6.25/12.5kHz
工作电源电压 .....	13.6V DC ±15%
工作温度范围 .....	-30°C ~ +60°C
频率稳定度 .....	±1.0ppm
天线阻抗 .....	50Ω
外型尺寸 (宽 × 高 × 长) .....	160 x 43 x 136 mm (未包括凸起部分)
重量 .....	1.3 kg

## 接 收

接收灵敏度 .....	数字 @6.25kHz (1% 误码率): 0.28 μV      数字 @12.5kHz (1% 误码率): 0.4 μV 模拟 EIA 12dB SINAD: 0.25 μV 模拟 EN 20dB SINAD: -3dB μV
邻道选择性 .....	模拟 @25kHz: 80dB      模拟 @12.5kHz: 70dB
互调抑制 .....	模拟: 65dB
杂散响应 .....	模拟: 80dB
音频失真 .....	小于 3%
音频输出功率 .....	4W/4Ω

## 发 射

发射功率输出 .....	5 ~ 25W
杂散发射 .....	-36dBm ≤ 1GHz, -30dBm > 1GHz
调频噪声 (EIA) .....	模拟 @25kHz: 50dB      模拟 @12.5kHz: 45dB
电波类型 .....	16K0F3E, 14K0F2D, 8K50F3E, 7K50F2D, 8K30F1E, 8K30F1D, 8K30F7W, 4K00F1E, 4K00F1D, 4K00F7W, 4K00F2D

依据 EN 标准或 TIA/EIA 603 获得的模拟测量值和所示规格均为典型值。

JVC 建伍株式会社有权变更技术规格，恕不预先通知。

# NX-720

## **JVCKENWOOD Corporation**

3-12, Moriyacho, Kanagawa-ku, Yokohama-shi,  
Kanagawa, 221-0022 Japan

### **Kenwood U.S.A. Corporation**

P.O. BOX 22745, 2201 East Dominguez Street, Long Beach,  
CA 90801-5745, U.S.A.

### **Kenwood Electronics Canada Inc.**

6070 Kestrel Road, Mississauga, Ontario, Canada L5T 1S8

### **Kenwood Electronics Deutschland GmbH**

Rembrücker Str. 15, 63150 Heusenstamm, Germany

### **Kenwood Electronics Belgium N.V.**

Leuvensesteenweg 248 J, 1800 Vilvoorde, Belgium

### **Kenwood Electronics France S.A.**

L'Etoile Paris Nord 2, 50 Allée des Impressionnistes,  
Bp 58416 Villepinte, 95944 Roissy Ch De Gaulle Cedex

### **Kenwood Electronics UK Limited**

Kenwood House, Dwight Road, Watford, Herts.,  
WD18 9EB United Kingdom

### **Kenwood Electronics Europe B.V.**

Amsterdamseweg 37, 1422 AC Uithoorn, The Netherlands

### **Kenwood Electronics Italia S.p.A.**

Via G. Sirtori, 7/9 20129 Milano, Italy

### **Kenwood Ibérica, S.A.**

Carretera de Rubi, 88 Planta 1 A 08174 Sant Cugat del Vallès  
Barcelona, Spain

### **JVCKENWOOD Australia Pty. Ltd.**

Talavera Business Park Building A, 4 Talavera Road,  
North Ryde NSW 2113 Australia

### **Kenwood Electronics (Hong Kong) Ltd.**

Suite 2504, 25/F, Tower 2, Nina Tower, No. 8 Yeung Uk Road,  
Tsuen Wan, New Territories, Hong Kong

### **Kenwood Electronics Singapore Pte Ltd**

1 Ang Mo Kio Street 63, Singapore 569110

# NX-720 PC BOARD / 印刷电路板

# PC BOARD / 印刷电路板 NX-720

DISPLAY UNIT (X54-3830-10) Component side view (J79-0345-09)

DISPLAY UNIT (X54-3830-10) Component side view (J79-0345-09)

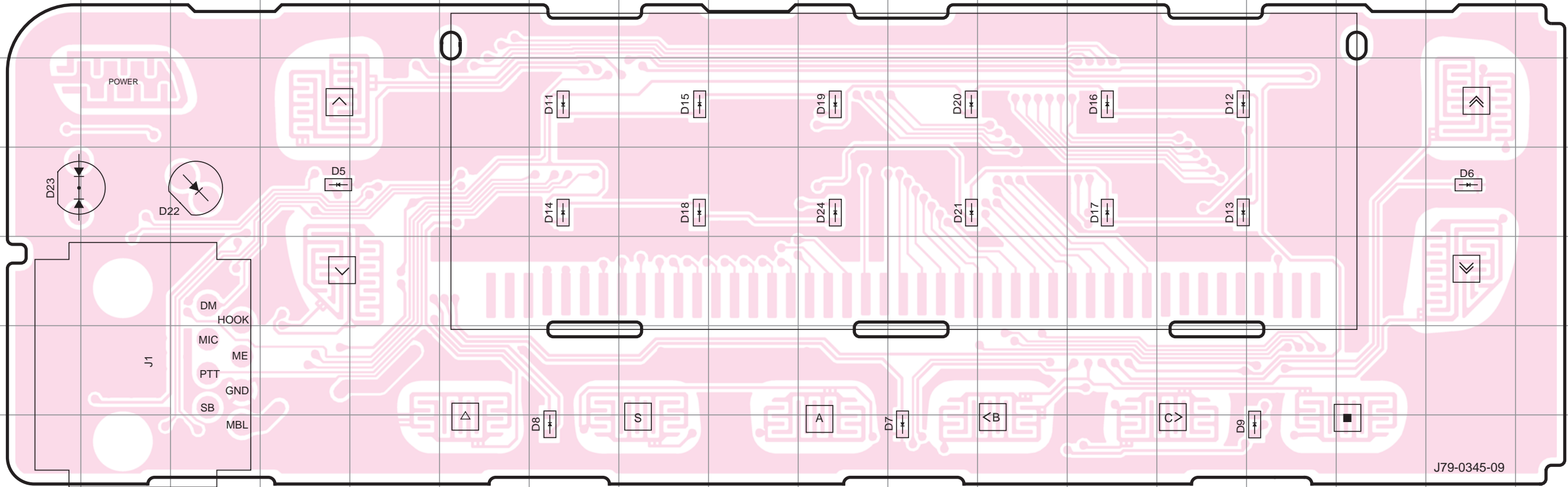

Ref. No.	Address
D5	4D
D7	7K
D8	7G
D9	7O
D11	3G
D12	3N
D13	4N
D14	4G
D15	3H
D17	4M
D16	3M
D18	4H
D19	3J
D21	4K
D20	3K
D22	4C
D23	4B

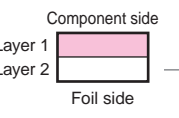

DISPLAY UNIT (X54-3830-10) Foil side view (J79-0345-09)

DISPLAY UNIT (X54-3830-10) Foil side view (J79-0345-09)

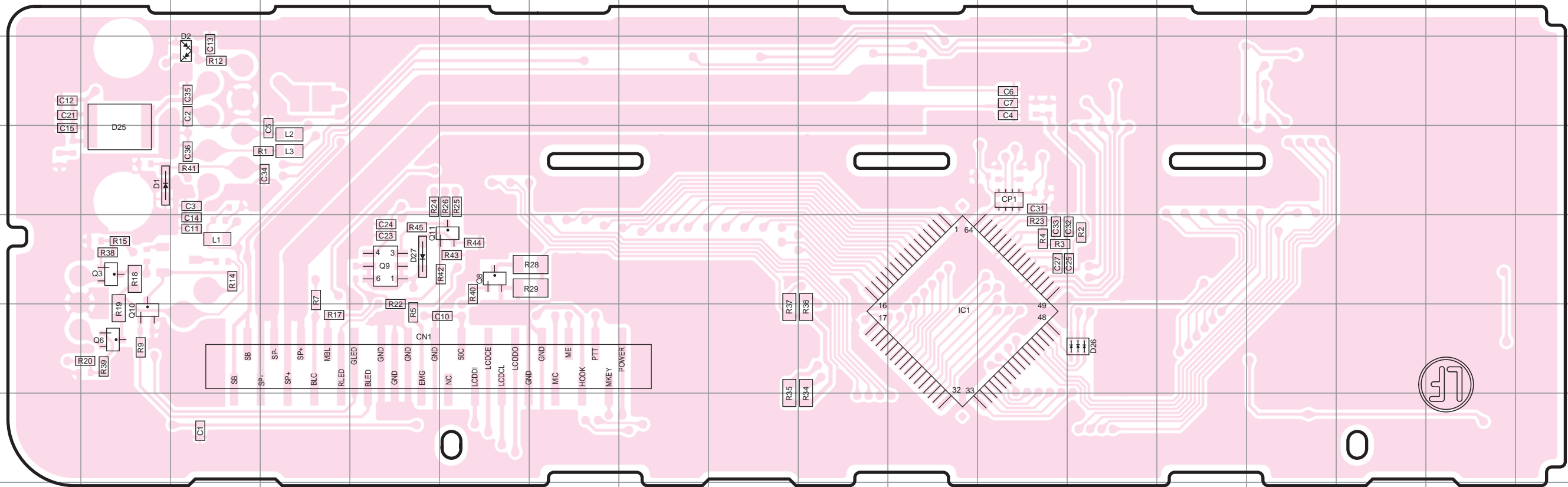

Ref. No.	Address
IC1	12K
Q3	11B
Q6	12B
Q8	11F
Q9	11E
Q10	12B
Q11	11F
D1	10B
D2	9C
D25	10B
D26	12M
D27	11E

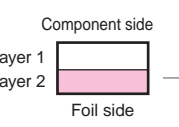

# NX-720 PC BOARD / 印刷电路板

# PC BOARD / 印刷电路板 NX-720

TX-RX UNIT (X57-8230-11) Component side view (J79-0343-09)

TX-RX UNIT (X57-8230-11) Component side view (J79-0343-09)

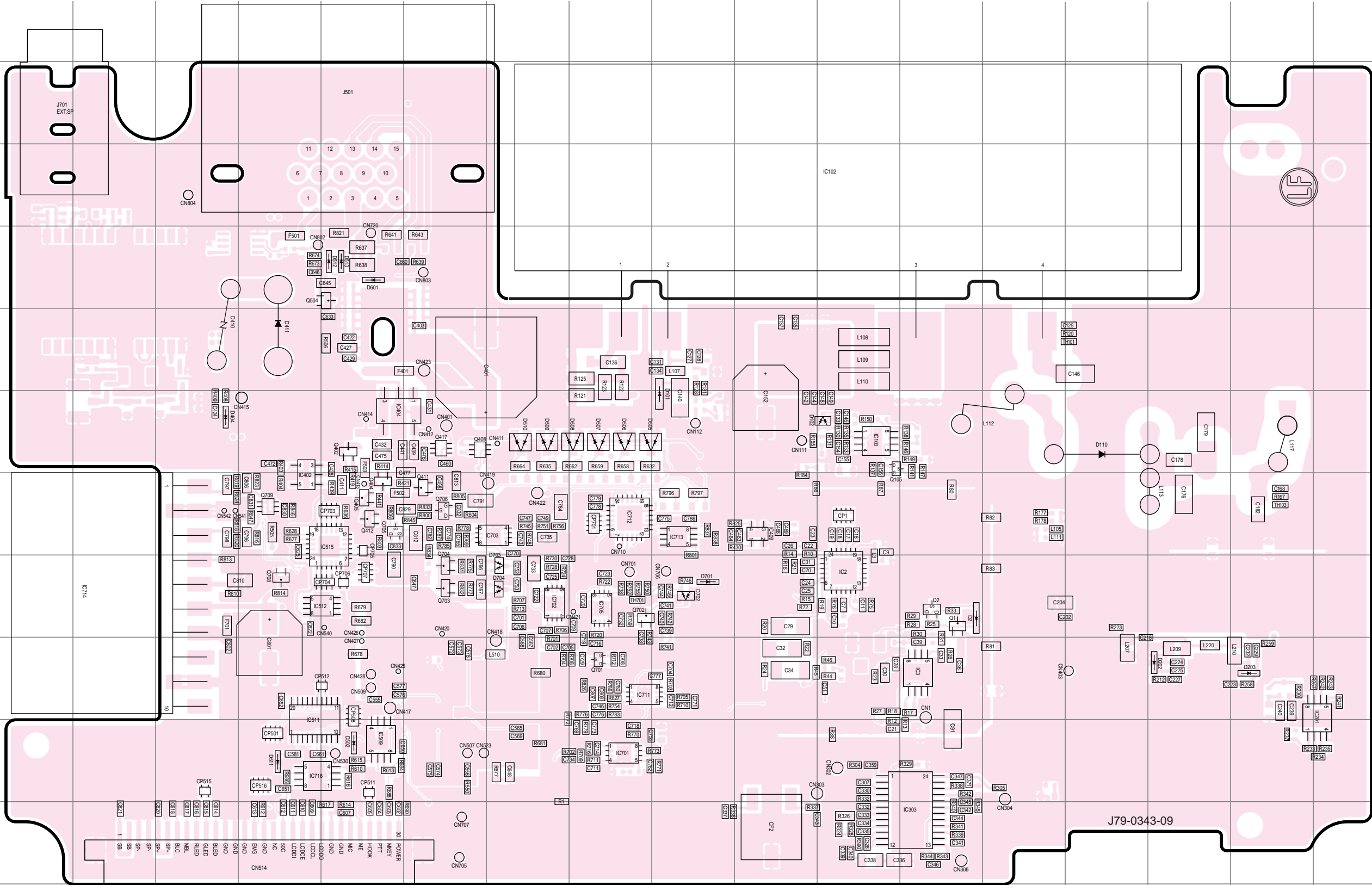

Ref. No.	Address	Ref. No.	Address
IC2	9K	Q702	9H
IC3	10L	Q703	9F
IC103	7K	Q704	9F
IC201	10Q	Q705	8E
IC303	11L	Q706	8F
IC402	8D	Q708	9D
IC404	7E	Q709	8D
IC409	8J	D2	9L
IC509	11E	D101	7I
IC511	10D	D102	7K
IC512	9E	D110	7N
IC515	8E	D202	10O
IC701	11H	D203	10P
IC702	9G	D404	7C
IC703	8G	D410	6C
IC705	9H	D411	6D
IC711	10H	D502	11E
IC712	8H	D505	7H
IC713	8I	D506	7H
IC716	11D	D507	7H
Q1	9L	D508	7H
Q2	9L	D509	7G
Q105	7K	D510	7G
Q402	7E	D511	11D
Q404	8E	D512	5E
Q405	8E	D513	5E
Q408	7F	D601	5E
Q411	8F	D701	9I
Q412	8E	D702	9I
Q417	7F	D703	9G
Q504	5E	D704	9G
Q701	10H		

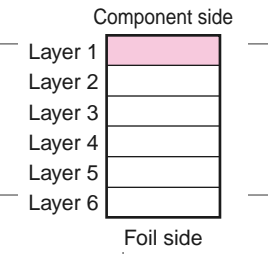

# NX-720 PC BOARD / 印刷电路板

# PC BOARD / 印刷电路板 NX-720

TX-RX UNIT (X57-8230-11) Foil side view (J79-0343-09)

TX-RX UNIT (X57-8230-11) Foil side view (J79-0343-09)

Ref. No.	Address	Ref. No.	Address
IC1	7R	Q502	3O
IC301	11M	Q503	3N
IC304	12H	D4	10H
IC401	8M	D5	10I
IC405	7O	D6	8I
IC406	9M	D7	10H
IC407	8P	D8	10J
IC408	8N	D9	10H
IC501	11P	D10	10H
IC502	9P	D11	10J
IC503	11Q	D12	10I
IC504	12Q	D13	8I
IC506	9N	D14	9J
IC507	10N	D15	10J
IC508	11M	D16	8H
IC513	8L	D17	8H
IC514	8L	D103	6E
IC516	7M	D104	5C
Q4	9J	D105	6E
Q5	8I	D106	6E
Q6	9I	D107	8E
Q7	9J	D108	10L
Q8	9I	D109	10L
Q9	9I	D111	7F
Q10	9H	D112	8F
Q11	8H	D113	8F
Q102	7K	D114	8F
Q106	7I	D204	9D
Q201	10G	D205	9E
Q202	9D	D206	9E
Q303	10K	D207	9E
Q305	11F	D401	6Q
Q401	6Q	D403	6P
Q403	5R	D405	9M
Q407	8O	D406	7N
Q409	9L	D407	7O
Q410	8O	D408	11L
Q414	11L	D409	11L
Q415	11L	D504	8L
Q416	11L	D705	5N
Q418	5Q	D706	5N
Q501	11M		

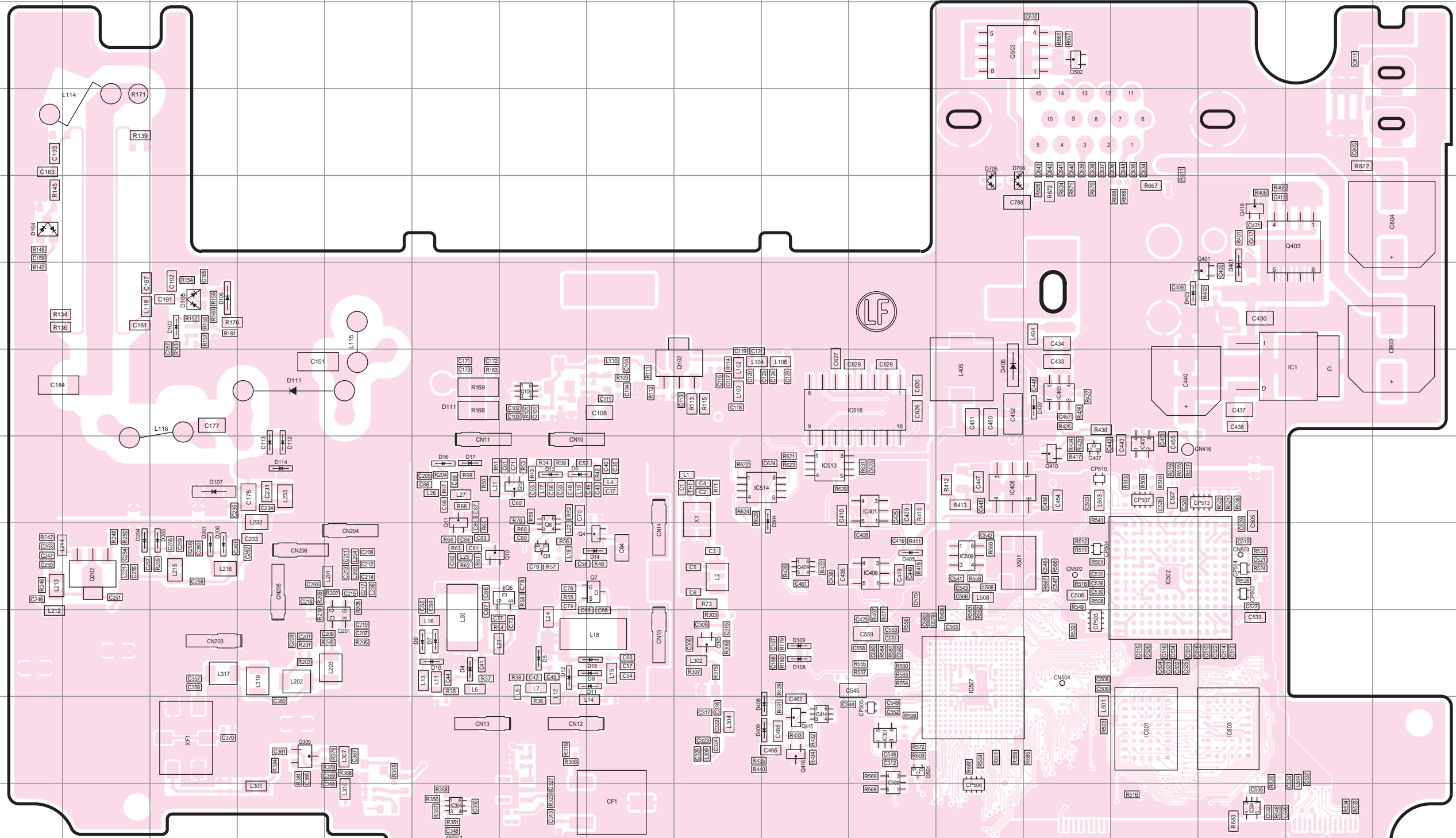

Component side

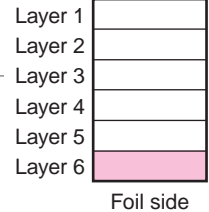

J79-0343-09

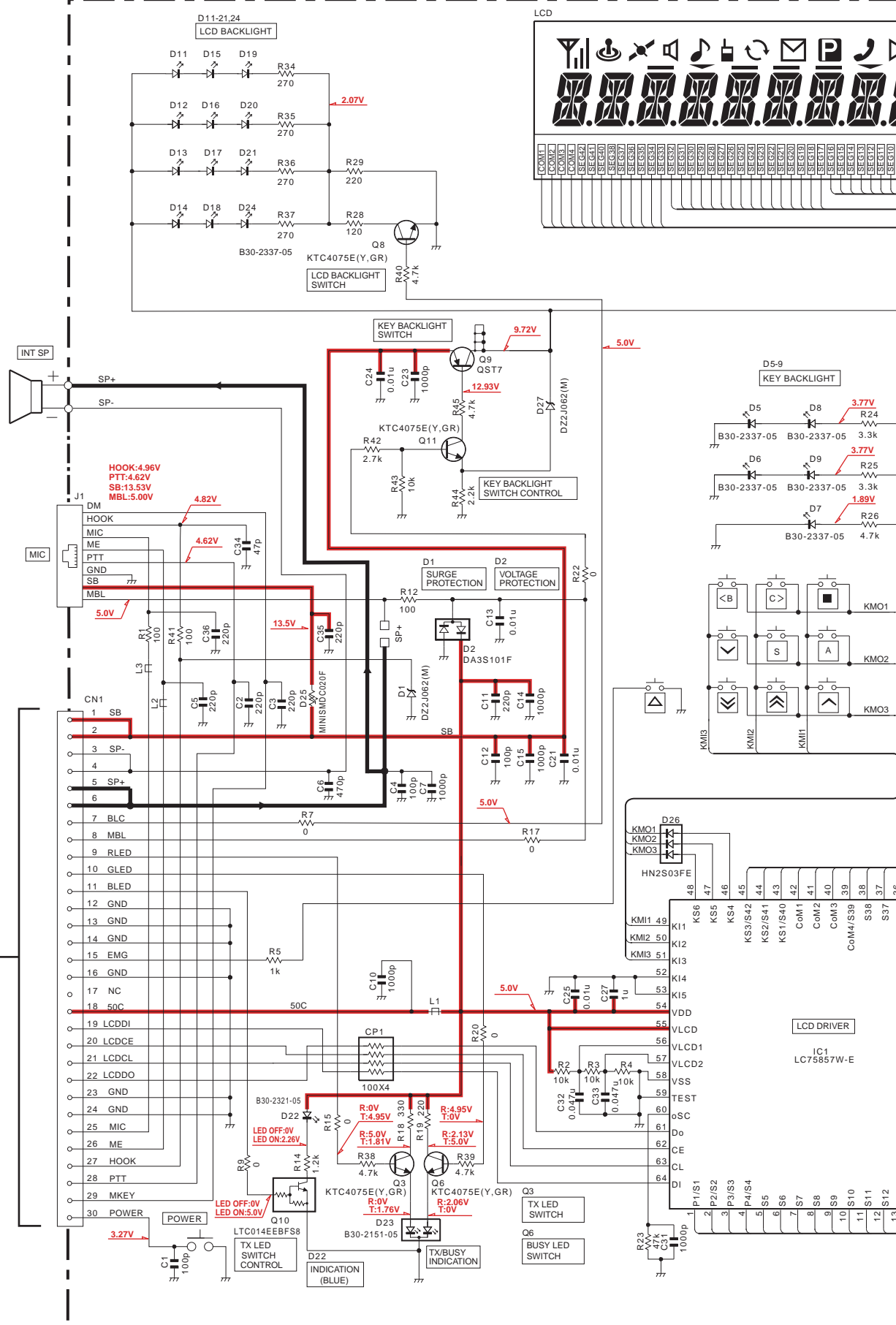


# TX-RX UNIT (X57-8230-11)

