

# KENWOOD

## SERVICE MANUAL

UHF DIGITAL TRANSCEIVER

### NX-840H, NX-840H(U), NX-840

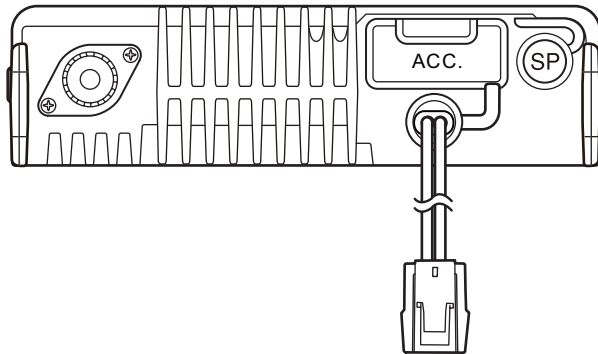
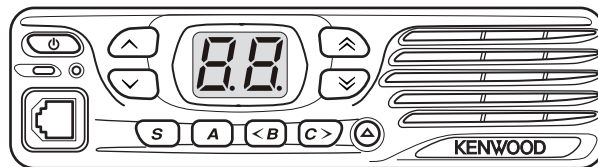

**Note :**

Lead free solder used in the board (material : Sn, Ag, In, Bi, melting point : 227 Centigrade)

### TABLE OF CONTENTS

1	PRECAUTION.....	1-4
2	SPECIFIC SERVICE INSTRUCTIONS.....	1-4
3	DISASSEMBLY .....	1-21
4	ADJUSTMENT .....	1-23
5	TROUBLESHOOTING .....	1-29

This product complies with the RoHS directive for the European market.



This product uses Lead Free solder.

## Document Copyrights

Copyright 2014 by JVC KENWOOD Corporation. All rights reserved.

No part of this manual may be reproduced, translated, distributed, or transmitted in any form or by any means, electronic, mechanical, photocopying, recording, or otherwise, for any purpose without the prior written permission of JVC KENWOOD Corporation.

## Disclaimer

While every precaution has been taken in the preparation of this manual, JVC KENWOOD Corporation assumes no responsibility for errors or omissions. Neither is any liability assumed for damages resulting from the use of the information contained herein. JVC KENWOOD Corporation reserves the right to make changes to any products herein at any time for improvement purposes.

## Firmware Copyrights

The title to and ownership of copyrights for firmware embedded in KENWOOD product memories are reserved for JVC KENWOOD Corporation. Any modifying, reverse engineering, copy, reproducing or disclosing on an Internet website of the firmware is strictly prohibited without prior written consent of JVC KENWOOD Corporation. Furthermore, any reselling, assigning or transferring of the firmware is also strictly prohibited without embedding the firmware in KENWOOD product memories.

Transceivers containing AMBE+2™ Vocoder:

The AMBE+2™ voice coding technology is embedded in the firmware under the license of Digital Voice Systems, Inc.

## SPECIFICATION

<b>GENERAL</b>		
Frequency Range		450 ~ 520MHz
Number of Channels		Max. 32ch
Number of Zones		2 zones (Max. 16ch per Zone)
Channel Spacing	Analog	12.5kHz
	Digital	6.25kHz
Operating Voltage		13.6V DC $\pm$ 15%
Operating Temperature Range		-22°F ~ +140°F (-30°C ~ +60°C)
Frequency Stability		$\pm$ 1.0ppm
Antenna Impedance		50 $\Omega$
Dimensions (W x H x D) (Projections not included)		160 x 43 x 122.6 mm (6.29 x 1.69 x 4.82 in)
Weight (net)	Radio only	1.10 kg (2.42 lb)
<b>RECEIVER</b>		
Sensitivity	Digital	0.28 $\mu$ V
	Analog (12dB SINAD)	0.28 $\mu$ V
Selectivity	Analog	65dB
Intermodulation Distortion	Analog	65dB
Spurious Response	Analog	75dB
Audio Output (4 $\Omega$ impedance)		4W with less than 5% distortion
<b>TRANSMITTER</b>		
RF Power Output		5W ~ 45W (NX-840H) 5W ~ 25W (NX-840)
Spurious Response		70dB
FM Hum & Noise	Analog	40dB
Audio Distortion		Less than 5%
Modulation		11K0F3E, 4K00F1E, 4K00F1D, 4K00F7W, 4K00F2D

Measurements made per TIA/EIA-603 and specifications shown are typical.

JVC KENWOOD Corporation reserves the right to change specifications without prior notice or obligation.

# SECTION 1 PRECAUTION

This service manual does not describe PRECAUTION.

## SECTION 2 SPECIFIC SERVICE INSTRUCTIONS

### 2.1 SYSTEM SET-UP

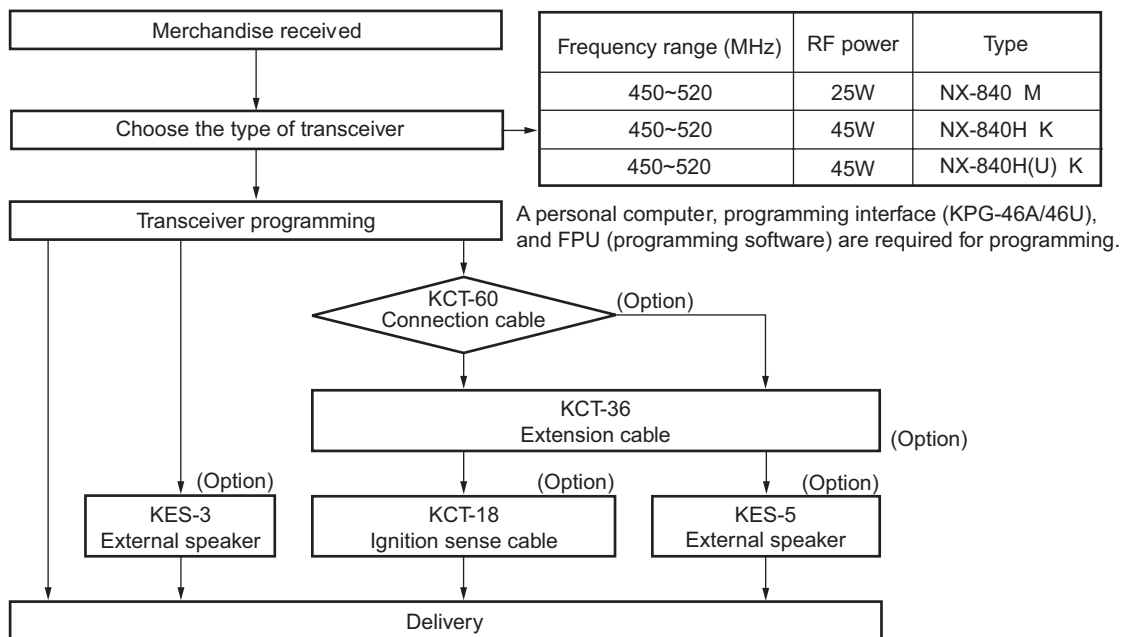

### 2.2 REALIGNMENT

#### 2.2.1 Modes

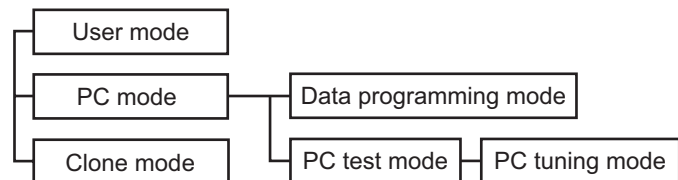

#### 2.2.2 How to Enter Each Mode

Mode	Function
User mode	Power ON
PC mode	Received commands from PC
Clone mode	[⏏] + Power ON (Two seconds)

Mode	Function
User mode	For normal use.
PC mode	Used for communication between the transceiver and PC (IBM compatible).
PC programming mode	Used to read and write frequency data and other features to and from the transceiver.
PC test mode	Used to check the transceiver using the PC. This feature is included in the FPU.
PC tuning mode	Used to tune the transceiver using the PC.
Clone mode	Used to transfer programming data from one transceiver to another.

## 2.2.3 PC Mode

### 2.2.3.1 Preface

The transceiver is programmed using a personal computer, a programming interface (KPG-46A/46U) and FPU (programming software).

The programming software can be used with a PC. Figure 1 shows the setup of a PC for programming.

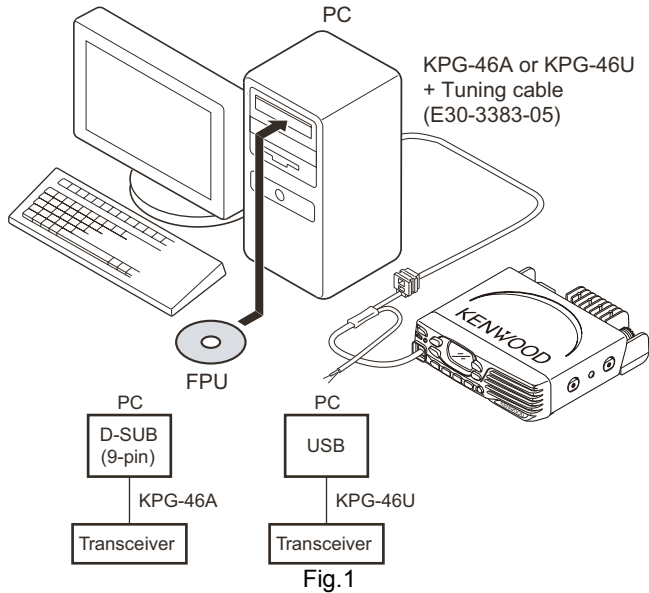

### 2.2.3.2 Connection procedure

- (1) Connect the transceiver to the computer using the interface cable.

#### Note:

- (2) You must install the KPG-46U driver in the computer to use the USB programming interface cable (KPG-46U).
- (2) When the Power is switched on, you can immediately enter user mode. When the PC sends a command, the transceiver enters PC mode, and "Pc" is displayed on the LED. When data is transmitting from the transceiver, the red LED blinks. When data is receiving by the transceiver, the green LED blinks.

#### Note:

The data stored in the computer must match the "Model Name" when it is written into the EEPROM.

### 2.2.3.3 KPG-46A description

#### (PC programming interface cable: Option)

The KPG-46A is required to interface the transceiver to the computer. It has a circuit in its D-sub connector (KPG-46A: 9-pin) case that converts the RS-232C logic level to the TTL level. The KPG-46A connects the 8-pin microphone connector of the transceiver to the RS-232C serial port of the computer.

### 2.2.3.4 KPG-46U description

#### (USB programming interface cable: Option)

The KPG-46U is a cable which connects to a USB port on a computer.

When using the KPG-46U, install the supplied CD (with driver software) in the computer. The KPG-46U driver runs under Windows XP, Vista, 7 or 8.

The latest version of the USB driver is available for download from the following URL:

<http://www.kenwood.com/usb-com/>

(This URL may change without notice.)

### 2.2.3.5 Programming Software: KPG-175D description

The FPU is the programming software for the transceiver supplied on a CD. This software runs under Windows XP, Vista, 7 or 8 on a PC.

The data can be input to or read from the transceiver and edited on the screen. The programmed or edited data can be printed out. It is also possible to tune the transceiver.

## 2.2.4 Clone Mode

Programming data can be transferred from one transceiver to another by connecting them via their cloning cable. The operation is as follows (the transmit transceiver is the source and the receive transceiver is a target).

#### Note:

Clone mode should be enabled.

- (1) Turn the source transceiver power ON with the [M] key held down (2 seconds), "cL" is displayed on the LED.
- (2) Power on the target transceiver.
- (3) Connect the cloning cable (No. E30-3382-05) to the modular microphone jacks on the source and target.
- (4) Press the [S] key on the source transceiver.

The data of the source is sent to the target. While the source is sending data, red LED blinks.

While the target is receiving the data, "Pc" is displayed and green LED blinks. When cloning of data is completed, the source displays "En", and the source red LED turned off, and the target automatically operates in the User mode. The target can then be operated by the same program as the source.

- (5) The other target can be continuously cloned. Carry out the operation in step 2 to 4.

### 2.2.4.1 Adding the data password.

If the data password is set in the optional feature menu, you must enter the password (Source transceiver) to activate a clone mode.

You can use 0~9 to configure the password. The maximum length of the password is 6 digits.

- (1) [M] + Power ON.
- (2) "PS" is displayed on the LED.
- (3) If the [A] and [M] keys is pressed while "PS" is displayed, numbers (0 to 9) are displayed flashing. When you press the [C>] key, the currently selected number is determined. If you press the [S] key after entering the password in this procedure, "cL" is displayed if the entered password is correct. If the password is incorrect, "PS" is redisplayed.

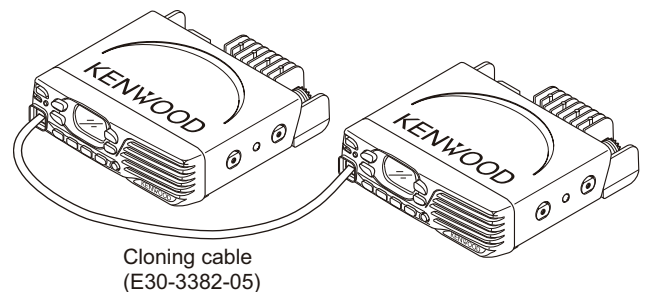

### 2.2.4.2 Flow chart (Source transceiver)

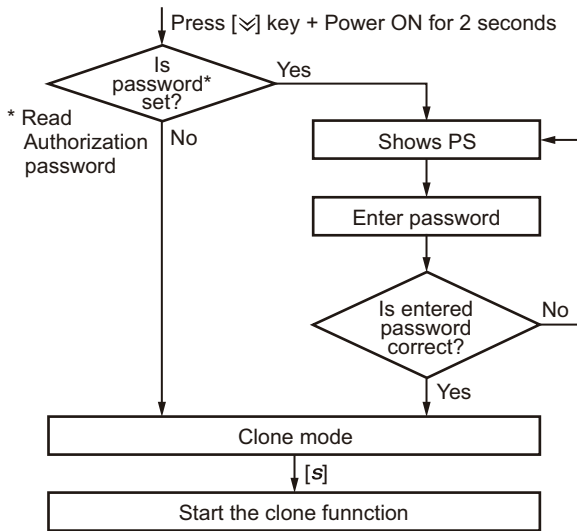

## 2.3 INSTALLATION

### 2.3.1 Connection Cable (KCT-60: Option)

The KCT-60 connection cable kit is used to connect the transceiver to a Horn alert cable, KCT-18 (Ignition sense cable), KES-5 (External speaker), or through the KCT-36 extension cable.

#### 2.3.1.1 Installing the KCT-60 (Connection cable) in the transceiver

- (1) Remove the ACC. cap on the rear of the transceiver.
- (2) Connect the D-sub connector of the KCT-60 to the D-sub 15-pin terminal of the transceiver.
- (3) Connect the 15-pin connector of the KCT-60 to a Horn alert cable, KCT-18, KES-5, or through a KCT-36 extension cable.

#### Note:

You must set up using the KPG-175D.

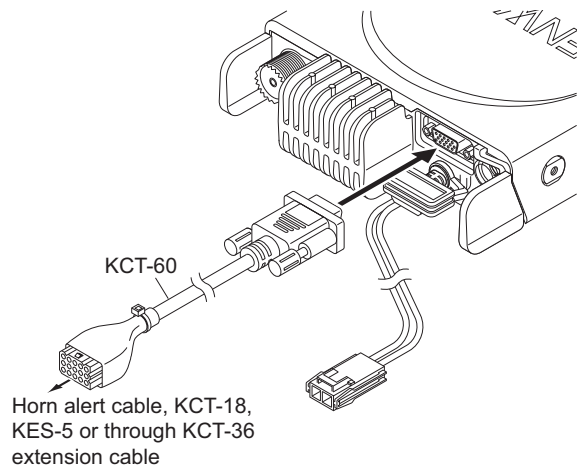

#### 2.3.1.2 Terminal function

D-sub 15-pin Pin No.	Name	Molex 15-pin Pin No.
1	SB	1
2	IGN	2
3	PA or External SP	12
4	DETO	4
5	DATAI	5

D-sub 15-pin Pin No.	Name	Molex 15-pin Pin No.
6	FNC1	9
7	FNC2	11
8	FNC3	7
9	FNC4	6
10	FNC5	8
11	FNC6	10
12	5MS	NC
13	HR1	13
14	HR2	14
15	GND	3

### 2.3.2 Horn Alert Function

The Horn alert function (max. 2A drive) is enabled by installing the KCT-60 in the transceiver.

#### 2.3.2.1 Installation Procedure

- (1) Remove the ACC. cap on the rear of the transceiver.
- (2) Connect the D-sub connector of the KCT-60 to the D-sub 15-pin terminal of the transceiver.
- (3) Insert the two crimp terminals of the Horn alert cable to pins 13 and 14 of the square plug.
- (4) Connect the square plug to the 15-pin connector of the KCT-60.
- (5) Connect the remaining two Horn alert cables to your car Horn alert signal control.

The internal FET switch can be controlled by turning the HA function on/off and by using a signaling decode output. The maximum current of HA is 2A. This FET switch is the open drain circuit. Therefore, a DC power supply is necessary to use the HR1. The voltage range is from 5V to 16V.

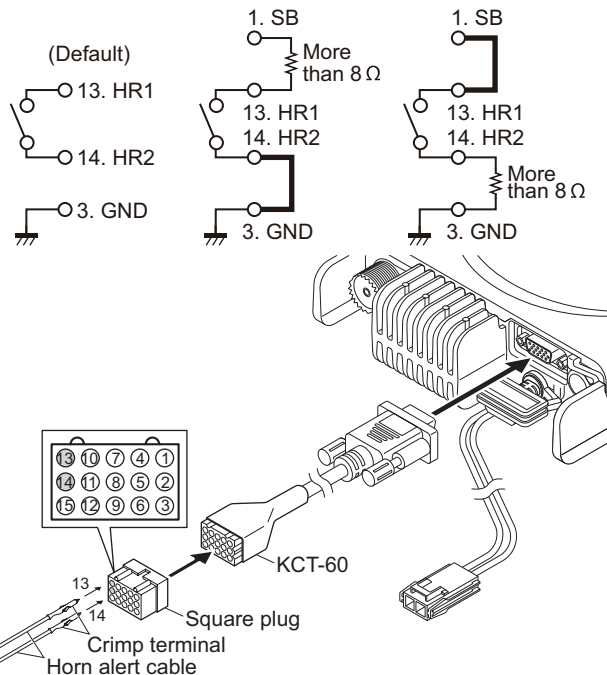

### 2.3.3 Ignition Sense Cable (KCT-18: Option)

The KCT-18 is an optional cable for enabling the ignition function. The ignition function lets you turn the transceiver power on and off with the car ignition key.

#### 2.3.3.1 Installing the KCT-18 (Ignition sense cable) in the transceiver

- (1) The KCT-18 can be installed in the transceiver by the following two methods (Method A, Method B).

**Method A:** The KCT-18 is soldered to the "IGN" pad on the TX-RX unit.

**Method B:** The KCT-18 is connected to the 15-pin connector of the KCT-60 connected to the transceiver.

#### ■Installation Procedure: Method A

- (1) Remove the two screws on both the right and left sides of the transceiver, then remove the cabinet and top packing from the transceiver.
- (2) Cut the crimp terminal side of the KCT-18 using a pair of nippers or similar tool.

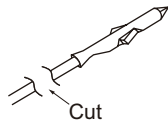

- (3) Solder the cable side cut in the above step 3 to the "IGN" pad on the TX-RX unit.

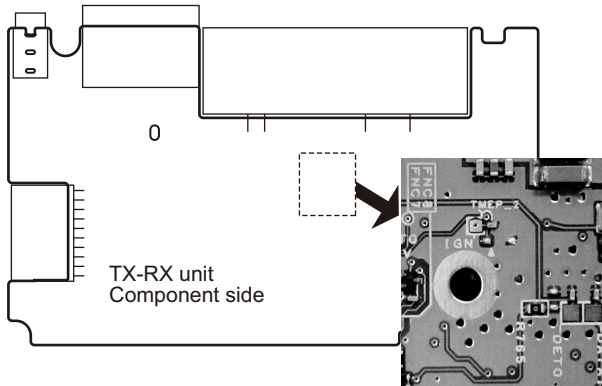

- (4) Dress the KCT-18 cable as shown in the figure. The KCT-18 cable needs to pass through one of two indentations located on the rear panel of the transceiver.
- (5) Cut off the projection of the top packing using a pair of nippers or similar tool.

If the KCT-18 cable is dressed to be routed through the indentations on the right side in step 5, the right side of the projection needs to be cut off. If the KCT-18 cable is dressed to be routed through the indentations on the left side, the left side of the projection needs to be cut off. Following is a figure presenting an example for when the right side of the projection is cut off.

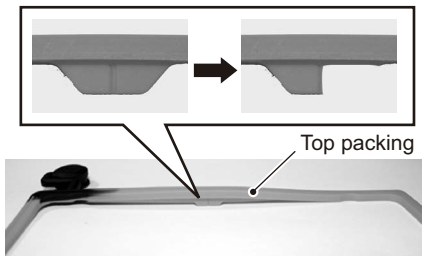

- (6) Reinstall the top packing. Check the correct fitting of the top packing, then reinstall the cabinet and two screws for the right and left sides.
- (7) Connect the other side of the KCT-18 to the ignition line of the car.

#### ■Installation Procedure: Method B

- (1) Remove the ACC. cap on the rear of the transceiver.
- (2) Connect the D-sub connector of the KCT-60 to the D-sub 15-pin terminal of the transceiver.
- (3) Insert the crimp terminal side of the KCT-18 to pin 2 of the square plug.
- (4) Connect the square plug to the 15-pin connector of the KCT-60.
- (5) Connect the other side of the KCT-18 to the ignition line of the car.

#### Note:

You must set up using the KPG-175D.

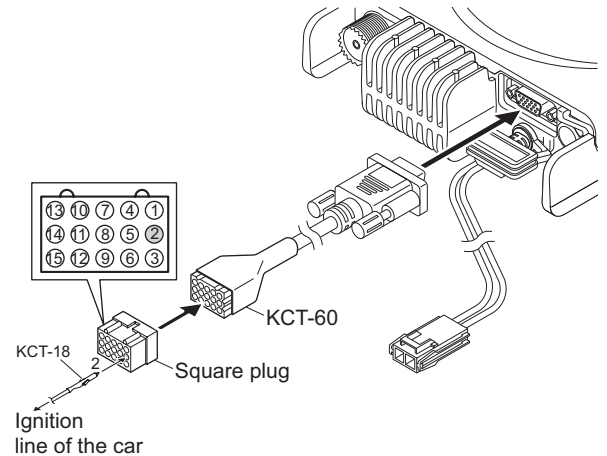

### 2.3.4 External Speaker (Option)

#### 2.3.4.1 KES-3

The KES-3 is an external speaker for the 3.5-mm-diameter speaker jack.

#### ■Connection procedure

- (1) Remove the speaker-jack cap on the rear of the transceiver.
- (2) Connect the KES-3 to the 3.5-mm-diameter speaker jack on the rear of the transceiver.

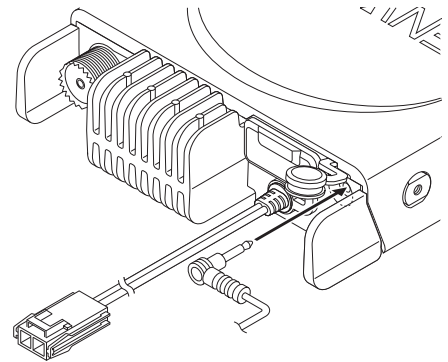



### 2.3.4.2 KES-5

External speaker KES-5 can be installed for KCT-60.

#### ■Connection procedure

- (1) Remove the ACC. cap on the rear of the transceiver.
- (2) Connect the D-sub connector of the KCT-60 to the D-sub 15-pin terminal of the transceiver.
- (3) Insert the two crimp terminals of the KES-5 to pins 3 and 12 of the square plug.
- (4) Connect the square plug to the 15-pin connector of the KCT-60.

#### Note:

- You must set up using the KPG-175D.  
Before the external speaker can be used, you must assign one of the keys as “External Speaker”, using the KPG-175D.
- This also applicable to public address provide you must assign one of the keys as “Public Address”, using the KPG-175D.

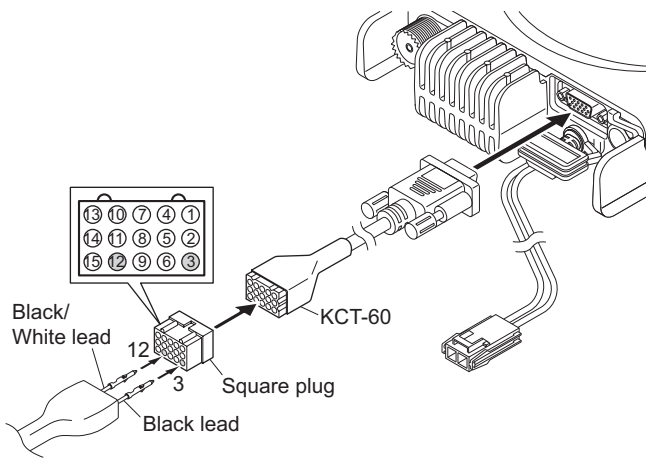

### 2.3.5 GPS Receiver Connection

#### 2.3.5.1 Connecting the GPS receiver

- (1) Soldering position

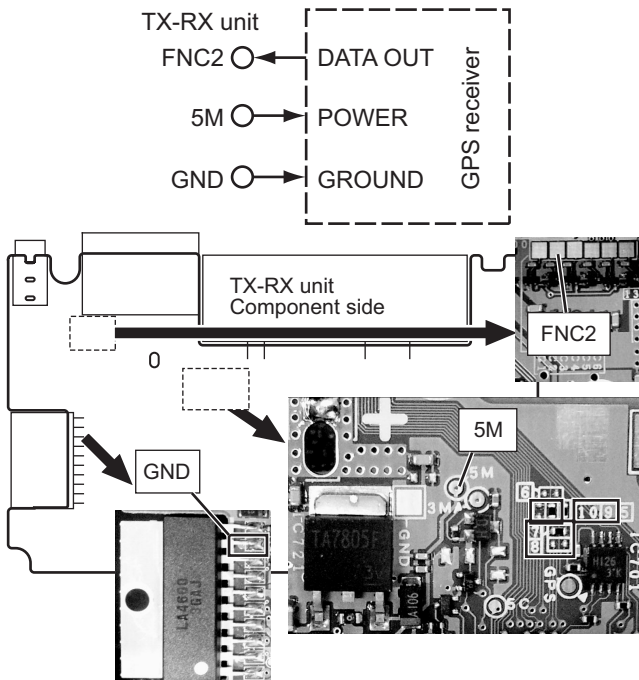

- (2) Refer to FNC2 (RXD) of “2.3.7 Changing Serial Port Level”.

### 2.3.6 Extended Function: COM Port 0 and COM Port 1

Location of COM Port 0 and COM Port 1 of the transceiver is shown below.

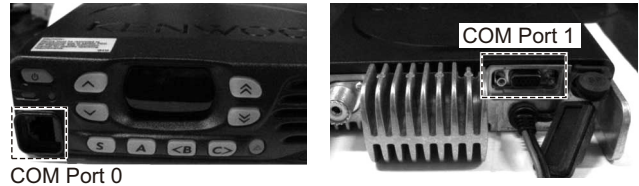

You must configure the transceiver COM Port 0 and COM Port 1 using the KPG-175D.

When you set as “Data”, the Function port 1 and 2 will be automatically fixed as Input ports.

The reason for this is because function port 1 (TXD) and 2 (RXD) share the same circuit path of TXD and RXD line.

### 2.3.7 Changing Serial Port Level

#### 2.3.7.1 Change FNC1 (TXD) and FNC2 (RXD) of D-SUB 15-pin connector from TTL level to RS-232C level

FNC1 (TXD /6pin) and FNC2 (RXD /7pin) of D-SUB 15-pin connector are configured at the TTL level as the default value. But you can change these serial port level to RS-232C level through the RS-232C level converter IC (IC704) by configuring the port.

#### ■FNC1 (TXD)

Remove the R761 chip jumper and solder the clip jumper to R767.

	TTL level	RS-232C level
R761[5] *1	0Ω chip jumper.	open
R767[6] *1	open	0Ω chip jumper.

#### ■FNC2 (RXD)

Remove the R724 and R762 chip jumpers and solder the chip jumpers to R725 and R756.

	TTL level	RS-232C level
R724[7], R762[9] *1	0Ω chip jumper.	open
R725[8], R756[10] *1	open	0Ω chip jumper.

\*1: The value in square bracket [ ] is the silk print number on the TX-RX unit.

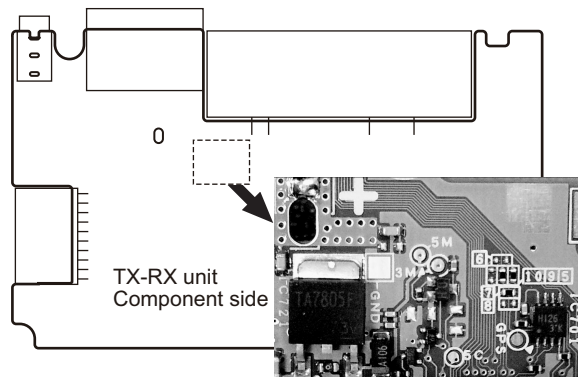



### 2.3.8 Changing of Signal Type

#### 2.3.8.1 Change signal input of D-SUB connector from DI to MIC

The input (5pin) of D-SUB 15-pin connector is configured at the DI as the default value.  
Remove the R737 chip jumper and solder the chip jumper to R735.

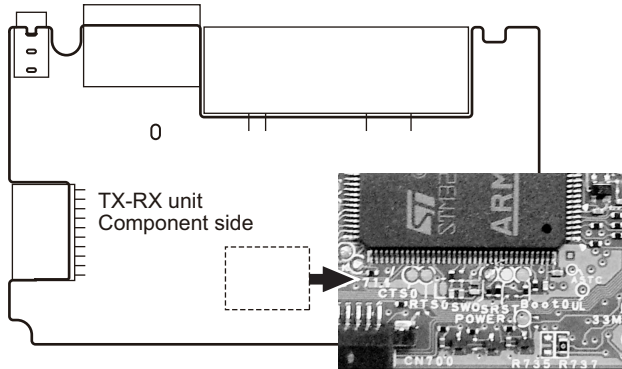

### 2.3.9 Emergency MIC

#### 2.3.9.1 Installation Procedure

- (1) Remove the two screws on both the right and left sides of the transceiver, then remove the cabinet and top packing from the transceiver.
- (2) solder the MIC connection cable as below
  - a) solder the MIC +ve cable (signal line) to EMGMIC solder pad
  - b) solder the -ve cable (GND) to GND solder pad

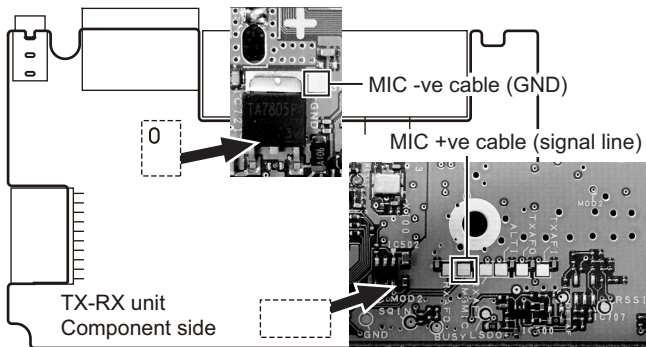

**Note:**

You must set up using the KPG-175D.

- (3) Dress the cable as shown in the figure. The cable needs to pass through one of two indentations located on the rear panel of the transceiver.

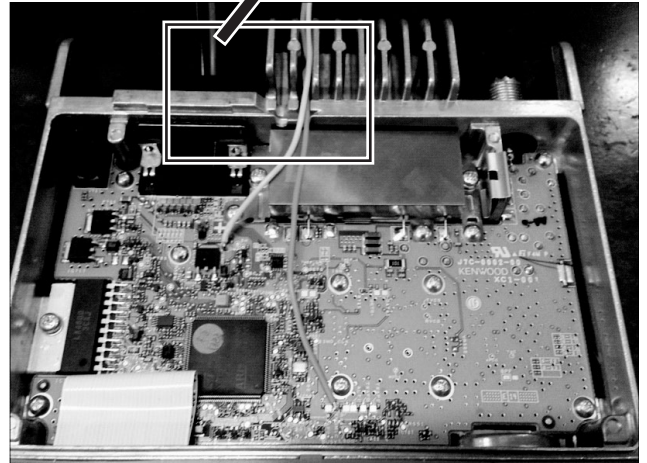
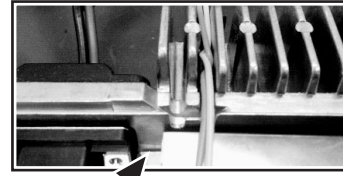

- (4) Cut off the projection of the top packing using a pair of nippers or similar tool.  
If the cable is dressed to be routed through the indentations on the right side in step 4, the right side of the projection needs to be cut off.  
If the cable is dressed to be routed through the indentations on the left side, the left side of the projection needs to be cut off.  
Following is a figure presenting an example for when the right side of the projection is cut off.

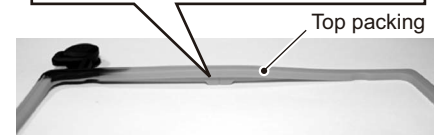
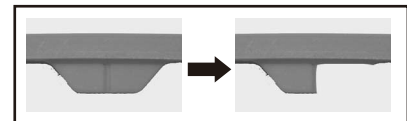

- (5) Reinstall the top packing. Check the correct fitting of the top packing, then reinstall the cabinet and two screws for the right and left sides.

## 2.4 CIRCUIT DESCRIPTION

### 2.4.1 Frequency Configuration

The receiver utilizes double conversion. The first IF is 49.95MHz and the second IF is 450kHz. The first local oscillator signal is supplied from the PLL circuit.

The PLL circuit in the transmitter generates the necessary frequencies. Figure 1 shows the frequencies.

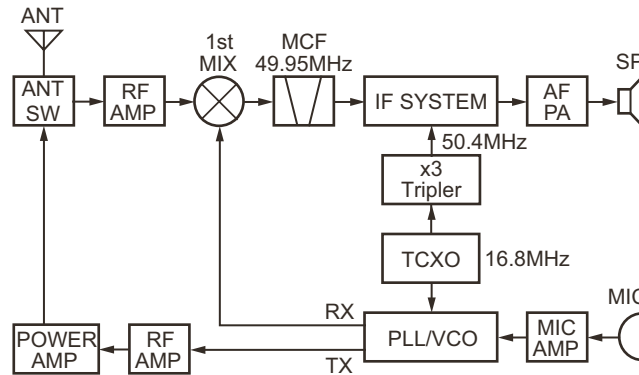

Fig.1 Frequency configuration

### 2.4.2 Receiver System

The receiver is double conversion superheterodyne.

The frequency configuration is shown in Figure 1.

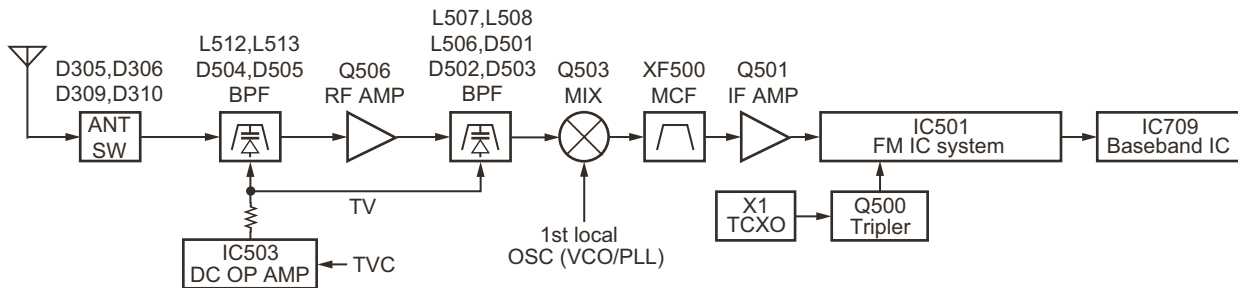

Fig.2 Receiver system

#### 2.4.2.1 Front-end RF Amplifier

An incoming signal from the antenna is applied to an RF amplifier (Q506) after passing through a transmit/receive switch circuit (D305, D306, D309 and D310), BPF (L512, L513, and varactor diodes: D504, D505).

After the signal is amplified (Q506), the signal is filtered by a BPF (L506, L507, L508 and varactor diodes: D501, D502, D503) to eliminate unwanted signals before it is passed to the first mixer.

The voltage of these diodes are controlled by the TVC according to the channel frequency. (See Figure 2)

#### 2.4.2.2 First Mixer

The signal from the RF amplifier is heterodyned with the first local oscillator signal from the PLL frequency synthesizer circuit at the first mixer (Q503) to create a 49.95MHz first intermediate frequency (1st IF) signal. The first IF signal is then fed through one pair of monolithic crystal filter (MCF: XF500) to further remove spurious signals.

#### 2.4.2.3 IF Amplifier Circuit

The first IF signal is amplified by Q501, and enters IC501 (FM processing IC). The signal is heterodyned again with a second local oscillator signal within IC501 to create a 450kHz second IF signal. The second IF signal is fed through a 450 kHz filter in IC501 to further eliminate unwanted signals before it is amplified and FM detected in IC501.

### 2.4.2.4 AF Signal System

The detection signal from FM IC (IC501) goes to the baseband IC (IC709) DISC input (pin 16) after pass through IC500 for characterizing the signal.

- **Analog signal**

The demodulated AF signal pass through IC709 with the signal processing and output at AUDIO (pin26) to the E-Vol before the Audio amplifier (IC719). The AF signal from IC719 switches between the internal speaker and speaker jack (J701) output.

- **NXDN (Digital signal)**

The recovered 4L-FSK signal obtained from IC501 is decoded in the baseband IC (IC709).

Decoded signal is fed into microprocessor (IC714) and converted to PCM audio signal, and return to baseband IC (IC709) for converting to audio signal.

This audio signal will output at AUDIO (pin26) to the E-Vol before the Audio amplifier (IC719).

The AF signal from IC719 switches between the internal speaker and speaker jack (J701) output.

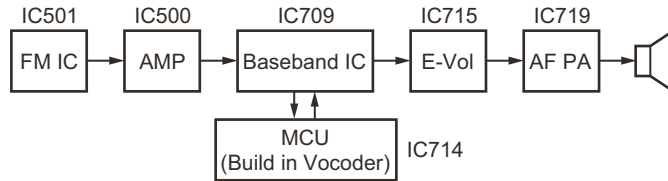

Fig.3 AF signal system

### 2.4.2.5 Squelch Circuit

Part of the AF signal goes a rectifier circuit to produce a DC voltage corresponding to the noise level after filtering and amplification. This DC voltage send to MCU (IC714) SQIN input pin.

The MCU controls squelch according to the voltage (SQIN) level.

The signal from the RSSI pin of IC501 is monitored. The electric field strength of the receive signal can be known before the SQIN voltage is input to the MCU, and the scan stop speed is improved.

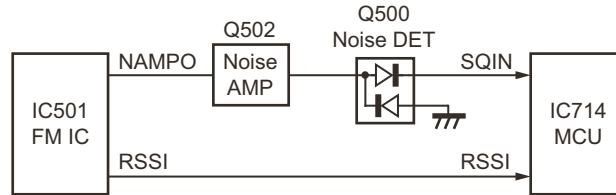

Fig.4 Squelch circuit

## 2.4.3 Transmitter System

### 2.4.3.1 Outline

The transmitter circuit produces and amplifies the desired frequency directly. It FM-modulates the carrier signal by means of a varicap diode.

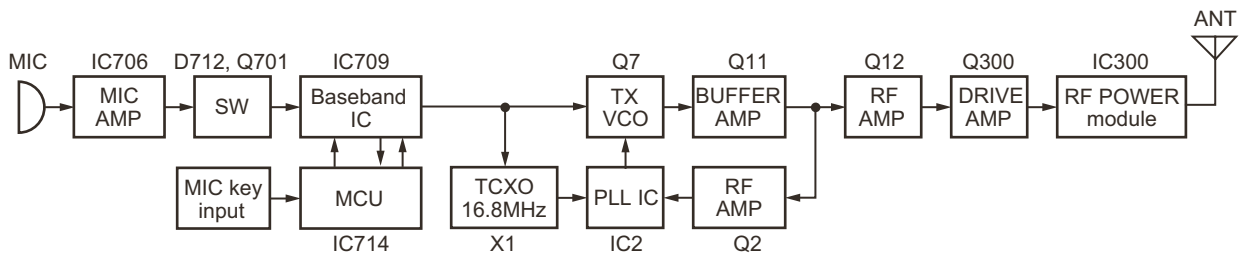

Fig.5 Transmitter system

### 2.4.3.2 Power Amplifier Circuit

The transmit output signal from the VCO passes through the transmission/reception selection diode (D16) and amplified by Q300. The amplified signal goes to the RF power module (IC300) through a low-pass filter.

The lowpass filter removes unwanted high-frequency harmonic components, and the resulting signal is goes the antenna terminal.

### 2.4.3.3 APC Circuit

The automatic transmission power control (APC) circuit detects part of a final amplifier output with a coupler circuit and applies a voltage to IC301.

IC301 compares the APC control voltage (APCC) generated by the baseband IC (IC709) and DC amplifier (IC503) with the detection output voltage.

IC301 generates the voltage to control IC300 and stabilizes transmission output.

The APC circuit is configured to protect over current of Q300 and IC300 due to fluctuations of the load at the antenna end and to stabilize transmission output at voltage and temperature variations.

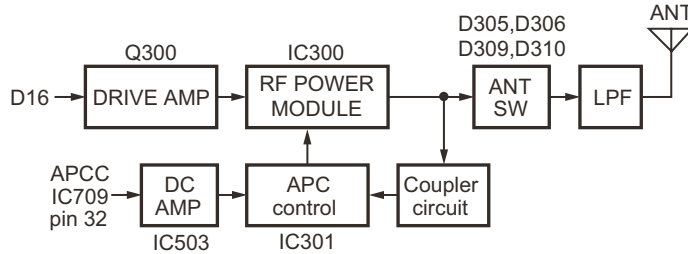

Fig.6 APC circuit and Power amplifier circuit

### 2.4.4 PLL Frequency Synthesizer

The PLL circuit generates the first local oscillator signal for reception and the RF signal for transmission.

#### 2.4.4.1 PLL Circuit

The frequency step of the PLL is 2.5, 5.0, 6.25 or 7.5 kHz. A 16.8MHz reference signal is divided at IC2 by a fixed counter to produce the reference frequency.

The voltage controlled oscillator (VCO) feedback output is divided by a programmable counter in IC2.

The 2 signals are phase compared, filtered through a low pass filter and passed to VCO to control the oscillator frequency.

#### 2.4.4.2 VCO Circuit

The operating frequency is generated by Q7 in transmit mode and Q5 in receive mode.

The oscillator frequency is controlled by applying the control voltage, which is obtained from the phase comparator, to varactor diodes (D5, D6, D9, D10, D11 in transmit mode and D7, D8, D12, D13, D14 in receive mode).

The TX/RX pin is set "High" in receive mode causing turn on Q9. And T/R pin is set "Low" in transmit mode causing turn on Q6.

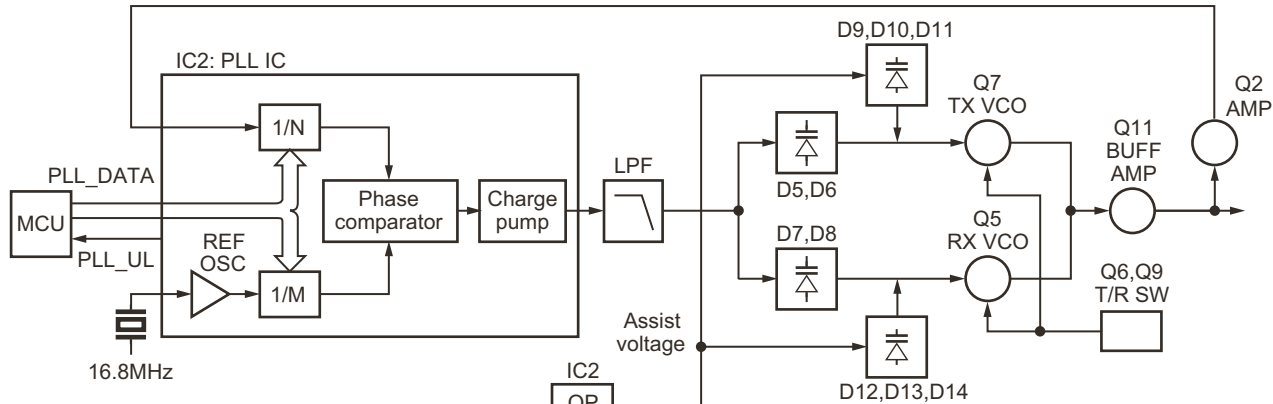

Fig.7 PLL and VCO circuit

#### 2.4.4.3 Unlock Circuit

If low level appears at the "LD" pin of IC2, then PLL an unlock condition occurs.

It causes the voltage applied to the "PLL\_UL" pin of the microprocessor to go low.

When the microprocessor detects this condition, the transmitter is disabled by ignoring the push-to-talk switch input signal.

### 2.4.5 Control Circuit

The MCU carries out the following tasks:

- (1) Controls the FM IC (IC501).
- (2) Controls the baseband IC (IC709).
- (3) Controls the PLL (IC2) & TX/RX outputs.
- (4) Controls IO expender through I2C level converter.
- (5) Controls the display unit.

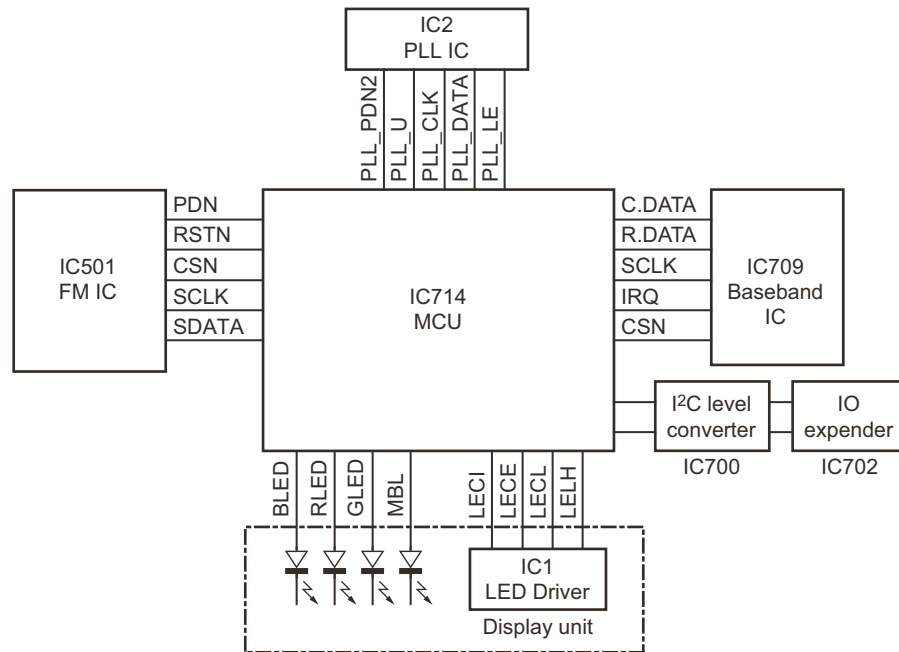

Fig.8 Control circuit

#### 2.4.5.1 Memory Circuit

The transceiver has an 256k-bit EEPROM (IC716). The EEPROM contains adjustment data. The MCU (IC714) controls the EEPROM through three serial data lines.

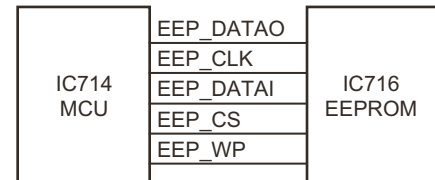

Fig.9 Memory circuit

#### 2.4.5.2 Display Circuit

The MCU (IC714) controls the Display 7-segment LED and LEDs.

When power is on, the MCU will use the MBL line to control the key backlight LEDs.

When the transceiver is busy, the GLED line goes high, Q1 turns on and the green LED (D23) lights after Q4 turn on. In transmit mode, the RLED line goes high, Q2 and Q8 turns on and the red LED (D23) lights.

BLED will be set high when the function select (FPU setting) is on, Q6 turn on and the blue LED (D22) lights.

The dimmer function is controlled by the switch Q5. The LED driver (IC1) controls the functions of the 7-segment LED through the LEDI, LECE, LECL, LELH lines from the MCU.

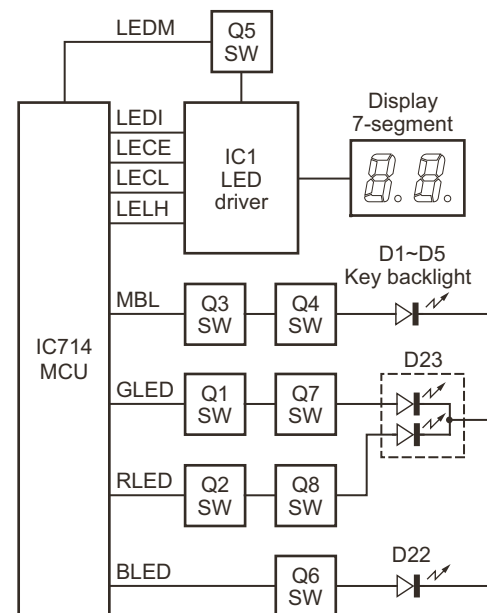

Fig.10 Display circuit

### 2.4.5.3 Key Matrix Circuit

The front panel has function keys. Each of them is connected to a cross point of a matrix of the KMI1 to KMO3 ports of the micro-processor.

The KMO1 to KMO3 ports are always high, while the KMI1 to KMI3 ports are always low.

The microprocessor monitors the status of the KMI1 to KMO3 ports. If the state of one of the ports changes, the microprocessor assumes that the key at the matrix point corresponding to that port has been pressed.

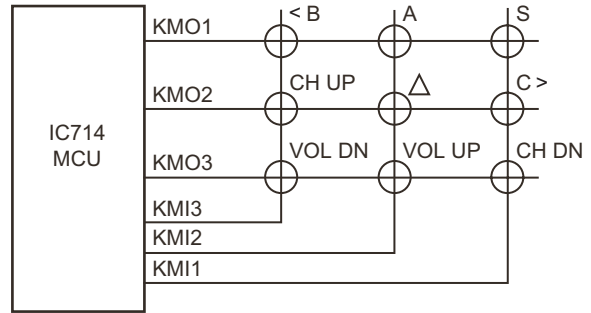

Fig.11 Key matrix circuit

### 2.4.6 Signaling Circuit

#### 2.4.6.1 Encode

##### (1) Low-speed data (QT, DQT)

Low-speed data is output from pin 40 (LSDO) of the MCU (IC714).

The signal passes through a low-pass CR filter. The signal is mixed with the audio signal and goes to the VCO and TCXO (X1) modulation input after signal processing in the baseband IC (IC709).

##### (2) High-speed data (2-tone)

High-speed data (HSD) is output from pin 41 (HSDO) of the MCU.

The signal passes through a low-pass CR filter. TX deviation making an adjustment by microprocessor is applied to the baseband IC (IC709).

The signal is mixed with the audio signal and goes to the VCO and TCXO.

The side tone is audio output of baseband IC(IC709) at the same time to audio power amplifier and then to the speaker.

##### (3) MSK / DTMF

MSK and DTMF signal is self generated by the baseband IC (IC709).

The TX deviation adjustment is done by the output gain of baseband IC (IC709), and is routed to the VCO.

When encoding MSK/DTMF, the microphone-input signal is muted.

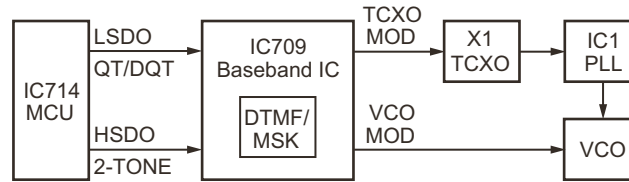

Fig.12 Encode

#### 2.4.6.2 Decode

##### (1) Low-speed data (QT, DQT)

The demodulated signal from the FM IC (IC501) will input to baseband IC(IC701) to remove frequency above 300Hz.

The signal is input to pin 26 (LSDI) of the MCU.

The MCU digitizes this signal, performs processing such as DC restoration, and decodes the signal.

##### (2) High-speed data (2-tone)

The demodulated signal from the FM IC (IC501) is amplified by baseband IC and passes through a band-pass filter in IC709 to remove frequency of 3kHz or above and 300Hz or below.

The MCU digitizes this signal and decodes the signal after receive the signal at pin 27(HSDI).

##### (3) MSK / DTMF

The demodulated signal from the FM IC(IC501) will input to baseband IC(IC709), then the baseband IC will decode and send the decode information to MCU by the data line.

The MCU then processes the decoded information.

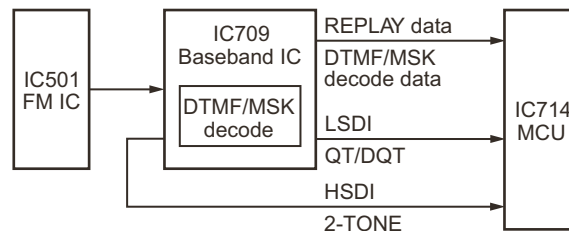

Fig.13 Decode

### 2.4.6.3 NXDN Receiving

- For Digital Data Mode:  
The demodulated signal from IC501 (Pin13) feed into baseband IC (Pin 16) for NXDN decoding.  
The decoded digital data will pass to MCU through C-BUS. MCU determines whether or not to output sound from speaker by checking if the data match.
- For Digital Voice Mode:  
If the digital data match in MCU, the digital voice payload data will goes into Vocoder in MCU for conversion to PCM.  
The PCM data will go to baseband IC through SPI input, where it will be converted to analog by DAC.  
Analog voice will be filtered and finally send to audio amplifier.

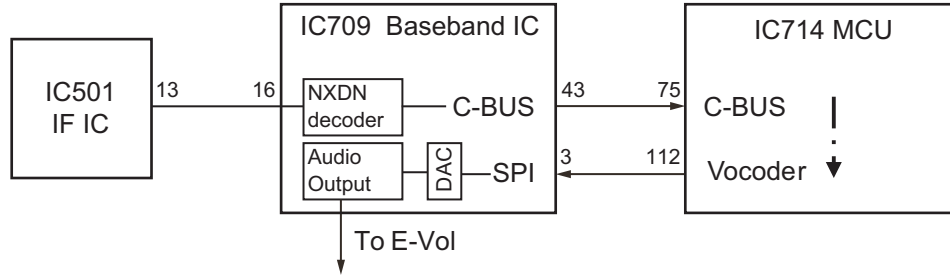

Fig.14 NXDN receiver system

### 2.4.6.4 NXDN Transmitting

- For Digital Data Mode:  
The digital data will be generated by MCU, where it will be pass to baseband IC, through C-BUS for encoding process. The encoded data finally will transmit through TCXO and VCO modulation.
- For Digital Voice Mode:  
The analog voice from mic will go to ADC (after audio filter) to convert to PCM data.  
The PCM data will send to Vocoder through SPI output.  
Vocoder will convert the PCM to NXDN protocol, where it will be sent to baseband through C-BUS.  
In baseband IC, the data will be encoded and finally transmit through TCXO and VCO modulation.

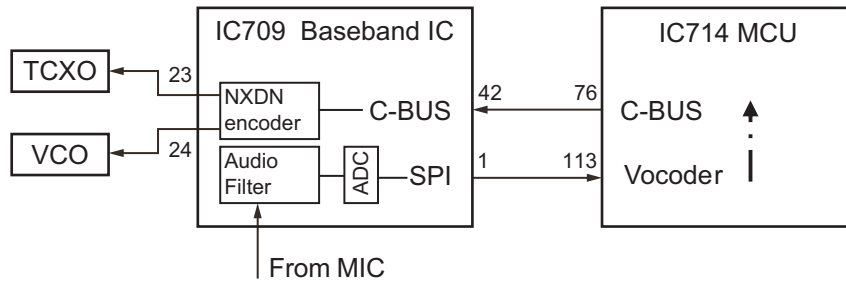

Fig.15 NXDN transmit system



## 2.4.7 Power Supply Circuit

- When the power switch on the display unit is pressed, the power port on the display unit which is connected pin 140 (POWKEY), goes low, then pin88 (SBC) goes high, Q718 turns on, SB SW (Q719) turns on and power (SB) is supplied to the transceiver.
- When the DC power supplied to the transceiver, the voltage regulator IC (IC720 & IC718) and supply into the MCU VDD and reset voltage detect IC (IC723). IC723 will generate signal (RESET) into the reset terminal on the MCU (IC714) to carry out a power on reset.
- When the DC power voltage decreases from normal voltage, the INT voltage detector IC (IC722) will set to high on MCU port 141 (BATT\_INT). If B line becomes less than about 8.5V, MCU will send the backup data to EEPROM (IC716) and go into STOP mode. This circuit has an overvoltage protection circuit. If a DC voltage of 18V or higher is applied to the base of Q712, this voltage turns Q712 on and sets port 141 (BATT\_INT) to low. As a result port 88 (SBC) is low, and turns Q719 and Q720 (SB) off.

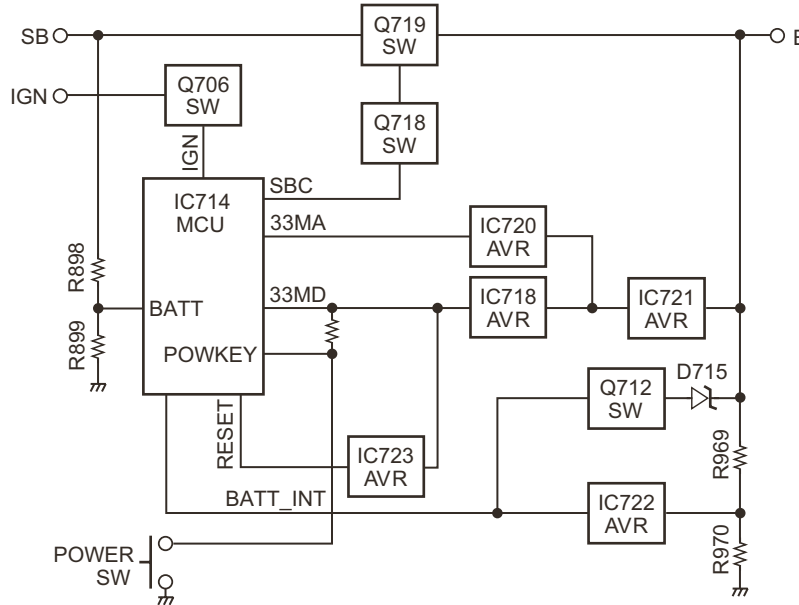

Fig.16 Power supply circuit

## 2.5 SEMICONDUCTOR DATA

### 2.5.1 MCU: 2F405ZGT6KFKA (TX-RX unit IC714)

Pin No.	Port Name	I/O	Function
1	LEDI	O	LED Data
2	LECE	O	LED Enable
3	LECL	O	LED Clock
4	LELH	O	LED Latch
5	LERE	O	LED Reset
6	VBAT	-	3.3V
7	ACR_SW	O	ACR switch for HSDO(D/A) port
8	NC	I	No connection
9	NC	I	No connection
10	I2CDT	I/O	Function P8/I/O Expander I2C Data
11	I2CCK	I/O	Function P7/I/O Expander I2C Data
12	EVOL_DACCE	O	Function P6CE for EVOL
13	EVOL_SCLK	O	Function P5CLK for EVOL
14	EVOL_DATA	O	Function P4DATA for EVOL
15	/INT15P	I/O	Function P3/I/O Expander Interrupt
16	VSS	-	GND
17	VDD	-	33MD
18	BEEP	O	Beep for Side Tone
19	NC	I	No connection

Pin No.	Port Name	I/O	Function
20	PCBVER	I	PCB version identification
21	IFDET	I	IFDET for ACR improvement
22	DISC_DC (optional)	I	for Discriminator DC Level Adjustment
23	XIN	I	Crystal (19.2MHz)
24	NC	I	No connection
25	RESET	I	MCU Reset pin
26	LSDI	I	Low-Speed Data Input
27	HSDI	I	High-Speed Data Input
28	TEMP_1	I	Temperature 1
29	TEMP_2	I	Temperature 2
30	VDD	-	33MD
31	VSSA	-	GND
32	VREF+	-	33MA
33	VDDA	-	33MA
34	TEST_TX	I/O	UART_TX for Debug
35	TEST_RX	I/O	UART_RX for Debug
36	FNC_1(TXD0)	I/O	Function P1(TXD)
37	FNC_2(RXD0)	I/O	Function P2(RXD)
38	VSS	-	GND

Pin No.	Port Name	I/O	Function
39	VDD	-	33MD
40	LSDO	O	Low-Speed Data Output
41	HSDO	O	High-Speed Data Output
42	3CC	O	33C Control
43	5CC	O	5C Control
44	SQIN	I	Squelch Input
45	RSSI	I	RSSI Input
46	BATT	I	Battery Voltage
47	CVIN	I	VCO Lock Voltage
48	BOOT_1	I	Test Point to enable Bootloader
49	TEST_1	I/O	Test Point 1 for Debug
50	TEST_2	I/O	Test Point 2 for Debug
51	VSS	-	GND
52	VDD	-	33MD
53	PLL_DATA	O	PLL IC Data
54	PLL_LE	O	PLL IC Enable
55	PLL_CLK	O	PLL IC Clock
56	PLL_PDN2	O	PLL IC Power Down
57	PA	O	Public Address
58	AMP_SW	O	AF amplifier
59	9TC	O	9T Control
60	BSFT	O	Beat Shift
61	VSS	-	GND
62	VDD	-	33MD
63	KMO3	O	Key Matrix Output 3
64	KMO2	O	Key Matrix Output 2
65	KMO1	O	Key Matrix Output 1
66	KMI1	I	Key Matrix Input 1
67	KMI2	I	Key Matrix Input 2
68	KMI3	I	Key Matrix Input 3
69	TXD2	O	2nd UART for DE15
70	RXD2	I	2nd UART for DE15
71	VCAP_1	-	2.2uF
72	VDD	-	33MD
73	CML_CSN	O	C-BUS Chip Select
74	CML_SCLK	O	C-BUS Clock
75	CML_RDATA	I	C-BUS Reply Data
76	CML_CDATA	O	C-BUS Command Data
77	EEP_DATAO	O	EEPROM Data Out
78	EEP_DATAI	I	EEPROM Data In
79	EEP_SCLK	O	EEPROM Clock
80	EEP_CS	O	EEPROM Chip Select
81	EEP_WP	O	EEPROM Write Protect
82	BUCNT1	O	PTT/TXD buffer control
83	VSS	-	GND

Pin No.	Port Name	I/O	Function
84	VDD	-	33MD
85	MKEYI	I	DTMF MIC key input
86	BUCNT2	O	DTMF MIC buffer control
87	PLL_UL	I	PLL Unlock Detect
88	SBC	O	SB Control
89	MKEYO	O	DTMF MIC Key output
90	9RC	O	9R Control
91	PTT	I	PTT
92	HOOK	I	Hook
93	ASTSW	O	Assist Speed-up Switch
94	VSS	-	GND
95	VDD	-	33MD
96	FM_SDATA	O	FM IC Data In/Out
97	FM_RSTN	O	FM IC Hardware Reset
98	FM_SCLK	O	FM IC Clock
99	FM_CSN	O	FM IC Chip Select
100	FM_PDN	O	FM IC Power Down
101	TXD	O	Serial Data to Mic Jack
102	RXD	I	Serial Data from Mic Jack
103	TXRX	O	TX / RX Switch
104	HORN	O	Horn Alert
105	SWDIO	I/O	SWDIO for SWD
106	VCAP2	-	2.2uF
107	VSS	-	GND
108	VDD	-	33MD
109	SWCLK	I/O	SWCLK for SWD
110	CML_SSOUT	I	Audio Codec Chip Select
111	CML_EPSCLK	I	Audio Codec Clock
112	CML_EPSO	O	Audio Codec Data Out
113	CML_EPSI	I	Audio Codec Data In
114	NC	I	No connection
115	LEDM	O	LED Dimmer
116	MBL	O	Panel and Mic Key Backlight
117	FNC_4 (CTS0)	I	Function P4(CTS)
118	FNC_3(RTS0)	O	Function P3(RTS)
119	NC	I	No connection
120	VSS	-	GND
121	VDD	-	33MD
122	33BC	O	BB IC power supply control
123	MIC1MUTE	O	Internal Mic Mute
124	MIC2MUTE	O	External Mic Mute
125	SP_MUTE	O	Speaker Mute
126	SIM1	I	Shimuke port 1
127	SIM2	I	Shimuke port 2
128	NC	O	No connection

Pin No.	Port Name	I/O	Function
129	NC	O	No connection
130	VSS	-	GND
131	VDD	-	33MD
132	NC	O	No connection
133	SWO	O	SWO for SWD
134	SRST	O	SRST for SWD
135	BLULED	O	Blue LED
136	GRNLED	O	Green LED
137	REDLED	O	Red LED
138	BOOT_0		Test Point to enable Bootloader
139	IGN	I	Ignition Sense
140	POWKEY	I	Power Key Input
141	BATT_INT	I	MCU Stop
142	CML_IRQ	I	Baseband IC IRQ (CML_pin8)
143	Power On Reset	I	33MD
144	VDD	-	33MD

## 2.6 COMPONENTS DESCRIPTION

### 2.6.1 Display Unit (X54-3890-20)

Ref. No.	Part Name	Description
IC1	IC	LED driver
Q1, Q2	Transistor	TX/RX indication LED switch
Q3, Q4	Transistor	KEY backlight control switch
Q5, Q9	Transistor	LED dimmer control switch
Q6	Transistor	Indication LED switch
Q7, Q8	Transistor	TX/Busy indication LED switch
D1~D5	LED	KEY backlight
D20	Diode	Voltage protection
D22	LED	Indication
D23	LED	TX/Busy indication
D33	Zener diode	Surge protection
D37	LED	LED display

### 2.6.2 TX-RX Unit (XC1-0010-XX)

Ref. No.	Part Name	Description
IC2	IC	PLL IC
IC3	IC	Assist Filter
IC301	IC	APC DC amplifier
IC500	IC	DETAFA amplifier
IC501	IC	FM IC
IC502	IC	Voltage regulator (33MS)
IC503	IC	RF BPF DC amplifier
IC700	IC	I2C level shifter
IC701	IC	3.3V level shifter (RXDO/CTSO)
IC702	IC	IO expander

Ref. No.	Part Name	Description
IC703	IC	5V level shifter (TXDO/RTSO)
IC704	IC	RS-232C driver
IC705	IC	5V level shifter (TXD2)
IC706	IC	MIC/AFO amplifier
IC709	IC	Baseband IC
IC710	IC	Voltage regulator (33BD)
IC713	IC	19.2MHz amplifier
IC714	IC	MCU
IC715	IC	Evo/DAC
IC716	IC	EEPROM
IC717	IC	Voltage regulator (9R)
IC718	IC	Voltage regulator (33MD)
IC720	IC	Voltage regulator (33MA)
IC721	IC	Voltage regulator (5M)
IC722	IC	Voltage detection (INT)
IC723	IC	Voltage detection (Reset)
IC724	IC	5V level shifter (MKEY/PTT)
IC725	IC	3.3V level shifter (MKEY/PTT)
IC726	IC	Voltage regulator (33C)
Q2	Transistor	PLL Fin amplifier
Q3, Q4	FET	Assist filter control switch
Q5	FET	RX VCO
Q6	FET	TX/RX VCO switch
Q7	FET	TX VCO
Q9	Transistor	TX/RX VCO switch
Q10	Transistor	Ripple filter
Q11	Transistor	VCO buffer amp
Q12	Transistor	VCO common amp
Q300	FET	Drive amp
Q500	Transistor	RX 2nd local amp
Q501	Transistor	1st IF amp
Q502	Transistor	Squelch amp
Q503	FET	Mixer
Q504	Transistor	Squelch input switch
Q505	Transistor	Squelch input control switch
Q506	FET	Front-end LNA
Q700	FET	MIC mute switch
Q701	Transistor	MIC mute switch
Q702	Transistor	Horn alert control switch
Q703	FET	Horn alert switch
Q704	Transistor	DETO amp
Q705	FET	MOD2 switch
Q706	Transistor	Ignition sense control switch
Q707	Transistor	9R control switch
Q708	Transistor	9T control switch
Q709	Transistor	9R switch

Ref. No.	Part Name	Description
Q710	Transistor	9T switch
Q711	Transistor	5C control switch
Q712	Transistor	Overvoltage detect
Q713	Transistor	Overvoltage detect
Q714, Q715	FET	Speaker mute switch
Q716	Transistor	5C switch
Q717	FET	33BA switch
Q718	Transistor	SB control switch
Q719	FET	SB switch
Q720	Transistor	AF amp switch
Q721	FET	5MS switch
Q722	Transistor	5MS control switch
Q723	Transistor	33BA control switch
D5	Variable Capacitance Diode	TX VCO tune
D6	Variable Capacitance Diode	TX VCO tune
D7	Variable Capacitance Diode	RX VCO tune
D8	Variable Capacitance Diode	RX VCO tune
D9	Variable Capacitance Diode	TX VCO tune
D10	Variable Capacitance Diode	TX VCO tune
D11	Variable Capacitance Diode	TX VCO tune
D12	Variable Capacitance Diode	RX VCO tune
D13	Variable Capacitance Diode	RX VCO tune
D14	Variable Capacitance Diode	RX VCO tune
D15	Variable Capacitance Diode	Modulation Control (TX VCO)
D16, D17	Diode	TX/RX band switch
D300	Zener Diode	Voltage Protection
D301	Diode	TX power control
D304	Diode	Reverse power rectifier
D305, D306	Diode	ANT switch
D307, D308	Diode	Power rectifier
D309, D310	Diode	ANT switch
D500	Diode	Squelch voltage rectifier
D502~ D505	Variable Capacitance Diode	RF BPF tuning
D700~ D702	Diode	Surge protection

Ref. No.	Part Name	Description
D704~ D711	Diode	Surge protection
D712, D713	Diode	MIC AGC detection
D714, D715	Diode	RXD2 level shifter
D717	Zener Diode	Voltage Protection
D718	Diode	5M stabilize
D719	Surge Absorber	Voltage Protection
D720	Diode	PTT
D721	Diode	Hook

## 2.7 TERMINAL FUNCTION

### 2.7.1 Display unit (X54-3890-20)

Pin No.	Name	I/O	Function
<b>CN1</b>			
1	POWER	O	Detection output of power switch
2	MKEY	I/O	MIC data detection
3	PTT/TXD	I/O	PTT/PC serial data
4	HOOK/RXD	I/O	HOOK/PC serial data
5	ME	-	MIC ground
6	MIC	O	MIC signal output
7	GND	-	Ground
8	NC	-	-
9	LELH	I	LED latch input
10	LECL	I	LED clock input
11	LECE	I	LED enable input
12	LEDI	I	LED data input
13	5C	I	5V DC power supply
14	KMI3	O	Key matrix output 3
15	KMI2	O	Key matrix output 2
16	KMI1	O	Key matrix output 1
17	KMO3	I	Key matrix input 3
18	KMO2	I	Key matrix input 2
19	KMO1	I	Key matrix input 1
20	BLED	I	Blue LED control signal input
21	GLED	I	Green LED control signal input
22	RLED	I	Red LED control signal input
23	MBL	I	MIC backlight control signal input
24	LEDM	I	LED dimmer input
25	SP-	I	Speaker input -
26	SP-	I	Speaker input -
27	SP+	I	Speaker input +
28	SP+	I	Speaker input +
29	SB	I	Battery voltage DC supply
30	SB	I	Battery voltage DC supply

Pin No.	Name	I/O	Function
<b>J1(MIC Jack)</b>			
1	MBL	O	Backlight of Microphone
2	SB	O	Battery voltage DC supply
3	GND	-	Ground
4	PTT	I	PTT/ PC serial data from radio
5	ME	-	MIC ground
6	MIC	I	MIC signal input
7	HOOK	I	HOOK/ PC serial data to radio
8	DM	I/O	MIC data detection

### 2.7.2 TX-RX unit (XC1-0010-XX)

Pin No.	Name	I/O	Function
<b>CN700</b>			
1	SB	O	Battery voltage DC supply
2	SB	O	Battery voltage DC supply
3	SP-	O	Speaker input -
4	SP-	O	Speaker input -
5	SP+	O	Speaker input +
6	SP+	O	Speaker input +
7	LEDM	O	LED dimmer output
8	MBL	O	MIC backlight control signal output
9	RLED	O	Red LED control signal output
10	GLED	O	Green LED control signal output
11	BLED	O	Blue LED control signal output
12	KMO1	O	Key matrix output 1
13	KMO2	O	Key matrix output 2
14	KMO3	O	Key matrix output 3
15	KMI1	I	Key matrix input 1
16	KMI2	I	Key matrix input 2
17	KMI3	I	Key matrix input 3
18	5MS	O	5V DC power supply
19	LEDI	O	LED data output
20	LECE	O	LED enable output
21	LECL	O	LED clock output
22	LELH	O	LED latch output
23	LERE	O	LED reset output
24	GND	-	Ground
25	MIC	I	MIC signal input
26	ME	-	MIC ground
27	HOOK/RXD	I/O	HOOK/PC serial data
28	PTT/TXD	I/O	PTT/PC serial data
29	MKEY	I/O	MIC data detection
30	POWER	I	Detection input of power switch

Pin No.	Name	I/O	Function
<b>J700 (D-SUB 15pin)</b>			
1	SB	O	Battery voltage DC supply DC 13.6V±15%,1.0A max
2	IGN	I	Ignition sens input,16.0V max
3	SP2	O	Speaker output
4	DETO	O	FM detector output, 500mVp-p
5	DATAI	I	External transmit signal input 200±50mVp-p
6	FNC1	I/O	Programable I/O (programmed by FPU) 1.0mA max.
7	FNC2	I/O	Programable I/O (programmed by FPU) 1.0mA max.
8	FNC3	I/O	Programable I/O (programmed by FPU) 1.0mA max.
9	FNC4	I/O	Programable I/O (programmed by FPU) 1.0mA max.
10	FNC5	I/O	Programable I/O (programmed by FPU) 1.0mA max.
11	FNC6	I/O	Programable I/O (programmed by FPU) 1.0mA max.
12	5MS	O	5V DC power supply, 100mA max
13	HR1	O	Horn alert signal output,16.0V/ 2.0A max.
14	HR2	O	Horn alert signal output,16.0V/ 2.0A max.
15	GND	-	Ground

### 2.7.3 Function Port Assignment

	GPS (NMEA)	
	Name	I/O
FNC1	None	O
FNC2	GPS (NMEA Input)	I
FNC3	-	-
FNC4	-	-
FNC5	-	-
FNC6	-	-
FNC7	-	-
FNC8	-	-

## SECTION 3 DISASSEMBLY

### 3.1 Disassembly Procedure

- (1) When removing the cabinet, first remove the two screws from the right and left with a phillips screwdriver. Then, hook your finger on the edge of the cabinet and pull it out until it is over the chassis protrusion. Remove the cabinet by prying the cabinet as shown below.

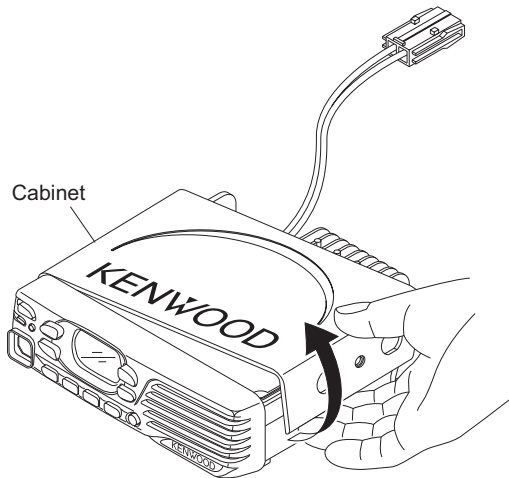

- (2) To remove the panel assembly, first turn the transceiver upside down. Then, insert a flat-head screwdriver into the holes of the chassis and tilt it in the direction as shown by the arrow.

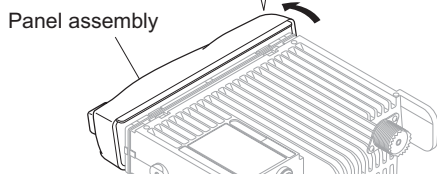
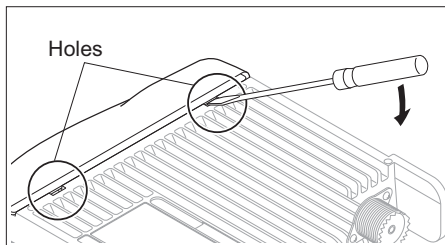

- (3) Disconnect the flat cable from connector of the panel assembly.

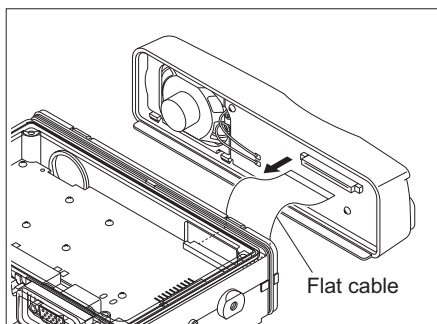

- (4) To remove the speaker holder, first remove the two screws from the display PCB using a phillips screwdriver. Then, insert a flat-head screwdriver under the tabs of the speaker holder and tilt it in the direction shown by the arrow.

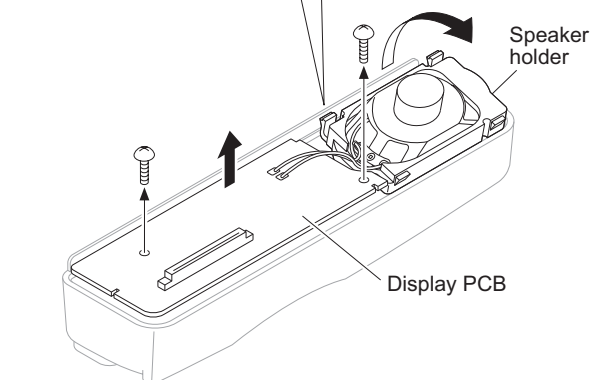
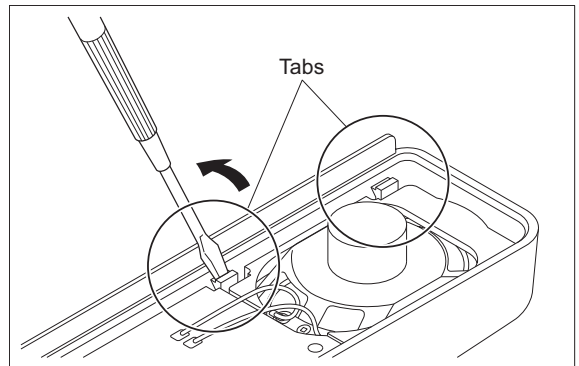

- (5) When removing the TX-RX PCB, first remove the top packing. Then, remove the solder of the antenna hot pin and positive terminal of the DC cord. Remove the 15 screws from the TX-RX PCB, power module, and audio amp.

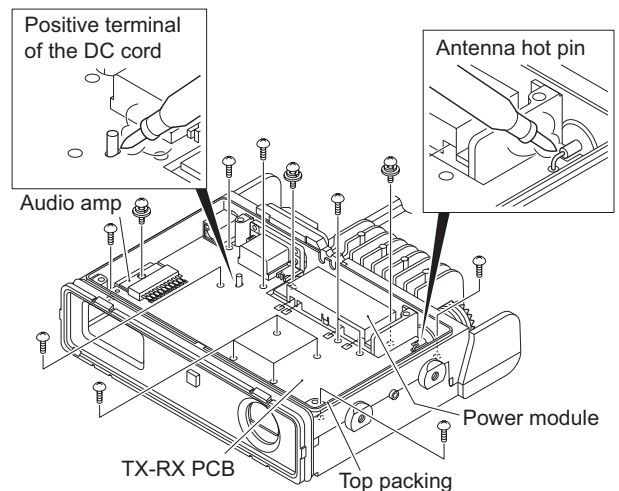

**Note:**

When you supply power to the TX-RX PCB after removing the TX-RX PCB from the chassis, solder the positive and ground terminals of the DC cord (Recommendation: E30-3448-25) to the + and GND terminals of the TX-RX PCB.

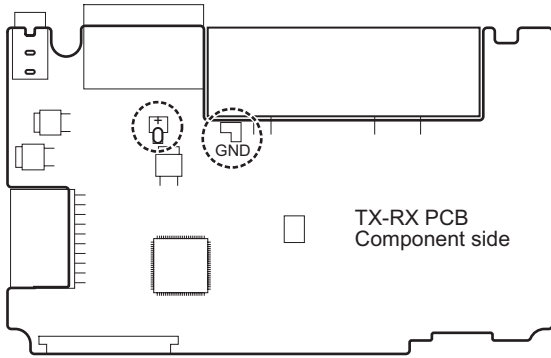

- (6) Pull it out behind the chassis by rotating the bush [3] of the DC cord 90 degrees in the direction of the arrow after the screw [1] in the negative terminal is removed, and the positive terminal [2] is removed from the chassis.

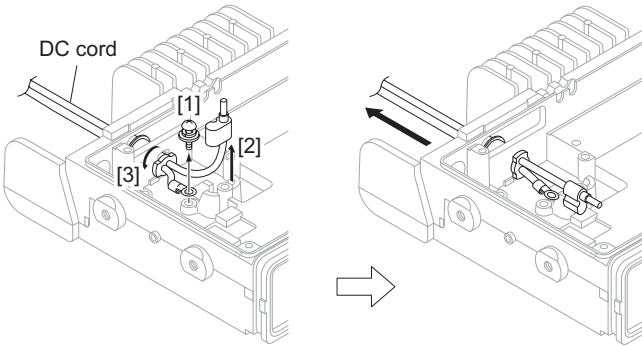

**3.2 Precautions for Reassembly**

- (1) When mounting the speaker holder, while suppressing the speaker rear part (shaded area), fix the four tabs of the speaker holder into the hollows of the front panel in order ([1], [2], [3], and [4]). Then, tighten the two screws of the display PCB.

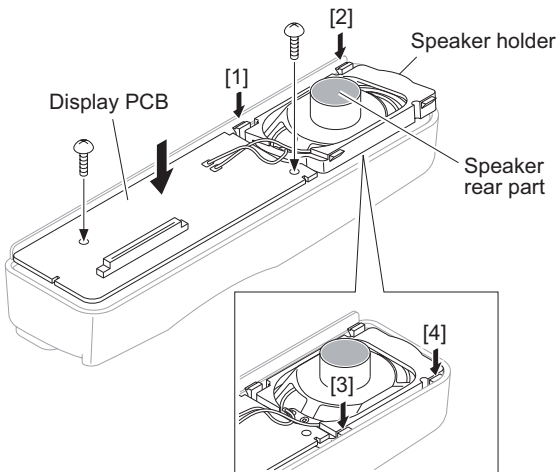

- (2) When mounting the panel assembly, pass the flat cable through the hole of the chassis as shown below then connect the flat cable to connector of the panel assembly.

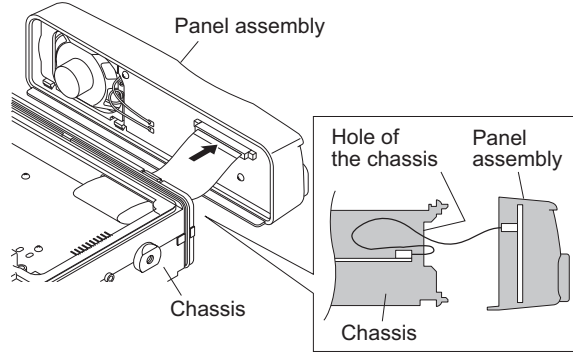

- (3) Fit the panel assembly into the two tabs of the chassis top side first. Then, fit the panel assembly into the two tabs of the chassis bottom side by turning the panel assembly.

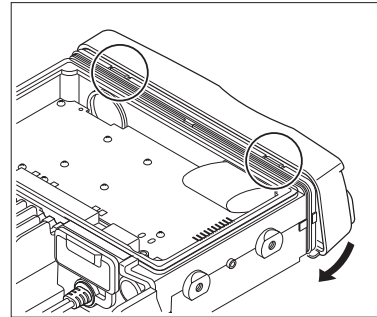

**3.3 Correspondence when replacing the LED (B30-2321-05)**

When replacing the LED (B30-2321-05), cut the leg of the LED to 4mm (0.16 inch) after installing the Collar (J31-0565-15).

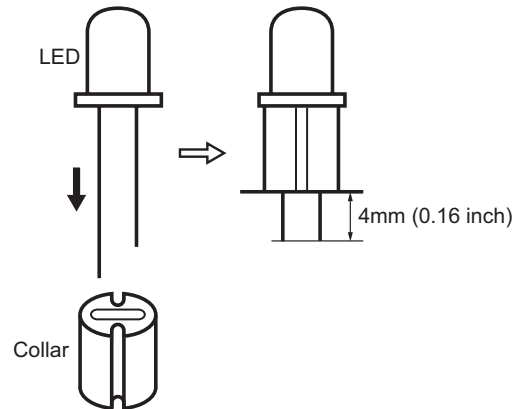



# SECTION 4 ADJUSTMENT

## 4.1 Test Equipment Required for Alignment

Test Equipment	Major Specifications	
1. Standard Signal Generator (SSG)	Frequency Range	100 to 520MHz
	Modulation	Frequency modulation and external modulation
	Output	-127dBm/0.1μV to greater than -7dBm/100mV
2. Power Meter	Input Impedance	50Ω
	Operation Frequency	100 to 520MHz
	Measuring Range	Vicinity of 100W
3. Deviation Meter	Frequency Range	100 to 520MHz
4. Digital Volt Meter (DVM)	Measuring Range	1V to 20V DC
	Input Impedance	High input impedance for minimum circuit loading
5. Oscilloscope		DC through 30MHz
6. High Sensitivity Frequency Counter	Frequency Range	10Hz to 1000MHz
	Frequency Stability	0.2ppm or less
7. Ammeter		20A
8. AF Volt Meter (AF VM)	Frequency Range	50Hz to 10kHz
	Voltage Range	1mV to 3V
9. Audio Generator (AG)	Frequency Range	20Hz to 20kHz or more
	Output	0 to 1V
10. Distortion Meter	Capability	3% or less at 1kHz
	Input Level	50mV to 10Vrms
11. 4Ω Dummy Load		Approx. 4Ω, 10W or more
12. Regulated Power Supply		13.6V, approx. 20A (adjusted from 9 to 17V) Useful if ammeter equipped

### ■ Test cable for microphone input (E30-3360-28)

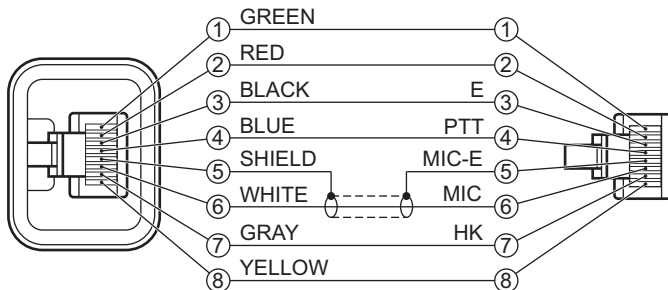

### ■ MIC connector (Front panel view)

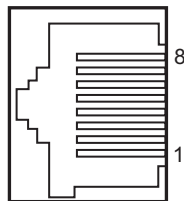

- 1 : MBL
- 2 : SB
- 3 : GND
- 4 : PTT
- 5 : ME
- 6 : MIC
- 7 : HOOK
- 8 : DM

### ■ Tuning cable (E30-3383-05)

Adapter cable (E30-3383-05) is required for injecting an audio if PC tuning is used.  
See "PC Mode" section for the connection.

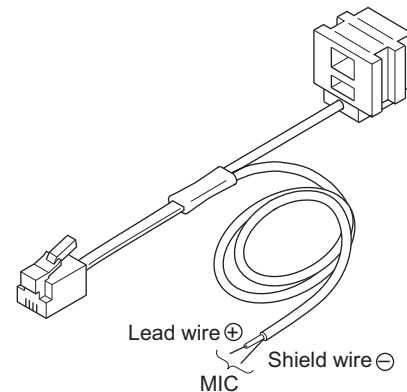

## 4.2 Frequency and Signaling

The transceiver has been adjusted for the frequencies shown in the following table. When required, re-adjust them following the adjustment procedure to obtain the frequencies you want in actual operation.

### ■Test frequency

Channel No.	RX (MHz)	TX (MHz)
1	485.05000	485.10000
2	450.05000	450.10000
3	519.85000	519.90000
4	485.00000	485.00000
5	485.20000	485.20000
6	485.40000	485.40000
7~16	-	-

### ■Analog Signaling

Signaling No.	RX (Decode)	TX (Encode)
1	None	None
2	None	20Hz Square wave
3	QT 67.0Hz	QT 67.0Hz
4	QT 151.4Hz	QT 151.4Hz
5	QT 210.7Hz	QT 210.7Hz
6	QT 254.1Hz	QT 254.1Hz
7	DQT D023N	DQT D023N
8	DQT D754I	DQT D754I
9	DTMF Decode (Code: 159D)	DTMF Encode (Code: 159D)
10	None	DTMF (Code: 9)
11	None	MSK (1010)
12	FleetSync (100-1000)	FleetSync (100-1000)
13	None	Single Tone (1000Hz)
14	2-tone Decode A: 304.7Hz B: 3106.0Hz	2-tone Encode A: 304.7Hz B: 3106.0Hz
15	None	DTMF Tone (1477Hz)
16	Single Tone (979.9Hz)	Single Tone (979.9Hz)
17	None	MSK PN9
18	None	DTMF (Code: 3)

### ■Digital Signaling

Signaling No.	RX (Decode)	TX (Encode)
1	RAN 1	RAN 1
2	None	PN9
3	RAN 1	Maximum Deviation pattern
4	FSW +PN9	MOD Set-up *1
5	Tone Pattern (1031Hz)	Tone Pattern (1031Hz)

RAN: Radio Access Number

PN9: Pseudo-Random Pattern (for production only)

\*1: To output 150Hz square wave (for production only)

## 4.3 Preparations for Tuning the Transceiver

Before attempting to tune the transceiver, connect the unit to a suitable power supply.

Whenever the transmitter is tuned, the unit must be connected to a suitable dummy load (i.e. power meter).

The speaker output connector must be terminated with a 4Ω dummy load and connected to an AC voltmeter and an audio distortion meter or a SINAD measurement meter at all times during tuning.

### ■5 reference level adjustments frequency

TEST CH	RX (MHz)	TX (MHz)
Low	450.05000	450.10000
Low'	467.55000	467.60000
Center	485.05000	485.10000
High'	502.55000	502.60000
High	519.95000	519.90000

#### 4.4 Common Section

Item	Condition	Measurement			Adjustment			Specifications /Remarks
		Test-equipment	Unit	Terminal	Unit	Parts	Method	
1. Setting	1) Power supply voltage DC power supply terminal : 13.6V							
2. Receive Assist voltage	1) Select each tab CH : Low CH : Low' CH : Center CH : High' CH : High * Note 1					FPU	Voltage level indicated in PC window show VCO Lock voltage.  Change the adjustment to get the VCO Lock Voltage within the limit of the specified voltage.	2.5 ±0.1V
3. Transmit Assist voltage	1) Select each tab CH : Low CH : Low' CH : Center CH : High' CH : High * Note 1							

**\*Note 1:**

Click [Tune Assist Voltage] button on Test Mode dialog box, these adjustment can be done by automatic.

When automatic adjustment is done, Lock Voltage can not be confirmed on the window.

If you would like to confirm it, please check the lock voltage on Receive Assist Voltage adjustment window and Transmit Assist Voltage adjustment window.

#### 4.5 Transmitter Section

Item	Condition	Measurement			Adjustment			Specifications /Remarks
		Test-equipment	Unit	Terminal	Unit	Parts	Method	
1. Frequency	1) Test CH : Center ( 1 point ) PTT ON ( Transmit )	Frequency counter		ANT	TX-RX	FPU	485.100MHz	±50Hz
2. High Transmit Power	<b>NX-840HK</b> 1) Test CH : Low, Low', Center, High', High ( 5 point ) 2) Battery Terminal voltage : 13.6V 3) PTT ON ( Transmit )	Power meter Ammeter		ANT		FPU	45.0W	±2.0W 14.0A or less
	<b>NX-840</b> 1) Test CH : Low, Low', Center, High', High ( 5 point ) 2) Battery Terminal voltage : 13.6V 3) PTT ON ( Transmit )	Power meter Ammeter		ANT		FPU	25.0W	±1.0W 8.0A or less
3. Mid Transmit Power	<b>NX-840HK</b> 1) Test CH : Low, Low', Center, High', High ( 5 point ) 2) Battery Terminal voltage : 13.6V 3) PTT ON ( Transmit )	Power meter Ammeter		ANT		FPU	25.0W	±1.0W 8.0A or less

Item	Condition	Measurement			Adjustment			Specifications /Remarks
		Test-equipment	Unit	Terminal	Unit	Parts	Method	
4. Low Transmit Power	1) Test CH : Low, Low', Center, High', High ( 5 point ) 2) Battery Terminal voltage : 13.6V 3) PTT ON ( Transmit )	Power meter Ammeter		ANT		FPU	5.0W	±0.1W 4.0A or less
5. DQT Balance *Note 2	<b>DQT Balance 1</b> 1) Test CH : Low, Low', Center, High', High ( 5 point ) 2) Deviation meter filter LPF : 15kHz HPF : OFF 3) PTT ON ( Transmit )	Deviation Meter Oscilloscope		ANT		FPU	Make the demodulation wave into square wave	
	<b>DQT Balance 2</b> 1) Test CH : Low, Low', Center, High', High ( 5 point ) 2) Deviation meter filter LPF : 3kHz HPF : OFF 3) PTT ON ( Transmit )	Deviation Meter Oscilloscope		ANT		FPU	The Deviation of 20Hz frequency is fixed. Change the 1kHz adjustment value to become the same deviation of 20Hz within the specified range.	±15Hz
6. Maximum Deviation (Analog Narrow)	1) Test CH : Low, Low', Center, High', High ( 5 point ) 2) Deviation meter filter LPF : 15kHz HPF : OFF 3) PTT ON ( Transmit )	Deviation Meter Oscilloscope		ANT		FPU	2.0kHz (According to larger +, -)	±50Hz  Note : FPU auto input 1kHz / 150mV
7. Maximum Deviation (NXDN Very Narrow) *Note 3	1) Test CH : Low, Low', Center, High', High ( 5 point ) 2) Deviation meter filter LPF : 15kHz HPF : OFF 3) PTT ON ( Transmit )	Deviation Meter Oscilloscope		ANT		FPU	1.337kHz	±50Hz
8. CW ID Deviation (NXDN Very Narrow) *Note 3	1) Test CH : Center ( 1 point ) 2) Deviation meter filter LPF : 15kHz HPF : OFF 3) PTT ON ( Transmit )	Deviation Meter Oscilloscope		ANT		FPU	1.00kHz	±100Hz
9. DQT Deviation (Analog Narrow)	1) Test CH : Center ( 1 point ) 2) Deviation meter filter LPF : 3kHz HPF : OFF 3) PTT ON ( Transmit )	Deviation Meter Oscilloscope		ANT		FPU	0.35kHz	±40Hz
10. QT Deviation (Analog Narrow)	1) Test CH : Center ( 1 point ) 2) Deviation meter filter LPF : 3kHz HPF : OFF 3) PTT ON ( Transmit )	Deviation Meter Oscilloscope		ANT		FPU	0.35kHz	±40Hz
11. DTMF Deviation (Analog Narrow)	1) Test CH : Center ( 1 point ) 2) Deviation meter filter LPF : 15kHz HPF : OFF 3) PTT ON ( Transmit )	Deviation Meter Oscilloscope		ANT		FPU	1.5kHz	±50Hz

Item	Condition	Measurement			Adjustment			Specifications /Remarks
		Test-equipment	Unit	Terminal	Unit	Parts	Method	
12. MSK Deviation (Analog Narrow)	1) Test CH : Center ( 1 point ) 2) Deviation meter filter LPF : 15kHz HPF : OFF 3) PTT ON ( Transmit )	Deviation Meter Oscilloscope		ANT		FPU	1.5kHz	±50Hz

**\*Note 2:**

Only 1 DQT Balance need to align(either DQT Balance1 or DQT Balance2)

**\*Note 3:**

(for the NXDN Very Narrow Maximum Deviation and CW ID Deviation alignment)

**Must** do the NXDN Very Narrow Maximum Deviation and CW ID Deviation alignment after the DQT Balance alignment and Maximum Deviation alignment (Analog).

**4.6 Receiver Section**

Item	Condition	Measurement			Adjustment			Specifications /Remarks
		Test-equipment	Unit	Terminal	Unit	Parts	Method	
1. Receive Sensitivity [Semiautomatic]	1) Test CH : Low, Low', Center, High', High ( 5 point ) 2) SSG output : -90dBm AF Freq : 1kHz Mod Dev : ±1.5kHz	SSG Oscilloscope Audio Analyzer		ANT		FPU	Press [Start], [Auto tuning]	
2. Open Squelch (5)	<b>[Analog Narrow]</b> 1) Test CH : Low, Low', Center, High', High ( 5 point ) 2) SSG output : -120dBm AF Freq : 1kHz Mod Dev : ±1.5kHz	SSG Oscilloscope Audio Analyzer		ANT		FPU	Press [Start], [Auto tuning]	
	<b>[NXDN Very Narrow]</b> 1) Test CH : Low, Low', Center, High', High ( 5 point ) 2) SSG output : -124dBm AF Freq : 400Hz Mod Dev : ±1.1kHz	SSG Oscilloscope Audio Analyzer		ANT		FPU	Press [Start], [Auto tuning]	
3. Tight Squelch	<b>[Analog Narrow]</b> 1) Test CH : Low, Low', Center, High', High ( 5 point ) 2) SSG output : -116dBm AF Freq : 1kHz Mod Dev : ±1.5kHz	SSG Oscilloscope Audio Analyzer		ANT		FPU	Press [Start], [Auto tuning]	
4. Low RSSI *Note 4	<b>[Analog Narrow]</b> 1) Test CH : Low, Low', Center, High', High ( 5 point ) 2) SSG output : -120dBm AF Freq : 1kHz Mod Dev : ±1.5kHz	SSG Oscilloscope Audio Analyzer		ANT		FPU	Press [Start], [Auto tuning]	
	<b>[NXDN Very Narrow]</b> 1) Test CH : Low, Low', Center, High', High ( 5 point ) 2) SSG output : -120dBm AF Freq : 1kHz Mod Dev : ±1.5kHz	SSG Oscilloscope Audio Analyzer		ANT		FPU	Press [Start], [Auto tuning]	

Item	Condition	Measurement			Adjustment			Specifications /Remarks
		Test-equipment	Unit	Terminal	Unit	Parts	Method	
5. High RSSI *Note 4	<b>[Analog Narrow]</b> 1) Test CH : Low, Low', Center, High', High ( 5 point ) 2) SSG output : -80dBm AF Freq : 1kHz Mod Dev : ±1.5kHz	SSG Oscilloscope Audio Analyzer		ANT		FPU	Press [Start], [Auto tuning]	
	<b>[NXDN Very Narrow]</b> 1) Test CH : Low, Low', Center, High', High ( 5 point ) 2) SSG output : -80dBm AF Freq : 1kHz Mod Dev : ±1.5kHz	SSG Oscilloscope Audio Analyzer		ANT		FPU	Press [Start], [Auto tuning]	

**\*Note 4:**

- (1) If NXDN Very Narrow RSSI tuning is selected, it will align for the NXDN Very Narrow band only.
- (2) If Analog Narrow Band RSSI tuning is selected, Analog Narrow band and NXDN Very Narrow will be align with same tuning value.

# SECTION 5 TROUBLESHOOTING

## 5.1 Replacing TX-RX Unit

### ■TX-RX unit Information

Model Name	Original TX-RX unit Number	For Service TX-RX unit Number
NX-840H K	XC1-0010-11	XC2-0020-10
NX-840HU K	XC1-0010-11	XC2-0020-11
NX-840 M	XC1-0010-22	XC2-0020-21

### ■Supplied Accessories of "Service TX-RX unit"

Item (Including Parts Number)	Quantity
TX-RX Unit (XC2-002)	1
Model Name Plate	1

### ■"Service TX-RX unit" Data

The following data is written on the service TX-RX unit:

Data Type	Description
Firmware	NX-740H/840H Firmware.
FPU Data (PC programming mode)	XC2-002 (NX-840H/840HU) K type data. XC2-002 (NX-840) M type data.
KENWOOD ESN	Model name: NX-840H, NX-840HU or NX-840 Type: K or M The same number as the Model Name Plate label is written.
NXDN ESN	The same number as the Model Name Plate label is written.

### ■Model Name Plate Label Layout

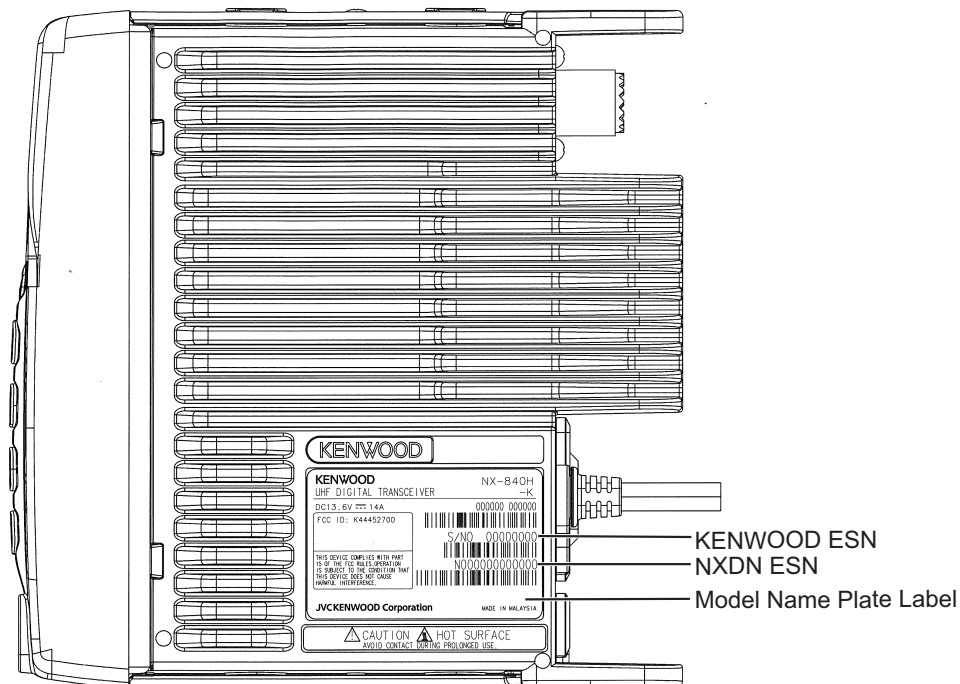

### ■After Changing the PCB

- (1) Using the KPG-175D, select your desired item (Model Name and Frequency) from the Model> Product Information menu, then use Program> Write Data to the Transceiver to write the FPU data (PC Programming mode). When writing to the transceiver, a Warning Message, corresponding to the item selected, appears. Click [OK] to continue writing the data.
- (2) Enter Program> Test Mode, then adjust the various adjustment data (PC Test Mode) as described in the "SECTION 4 ADJUSTMENT"
- (3) Attach the new labels corresponding to the new printed circuit board. (Refer to the images right for label placement.)
- (4) If necessary, write the FPU data used by the customer with the KPG-175D.

### Note:

- When a new printed circuit board is used, the KENWOOD ESN changes, as does the Transceiver Information display of the KPG-175D, but this does not have any effect on the operation of the transceiver.
- If changing to the original ESN, please contact our service center.



# MEMO

# PRINTED CIRCUIT BOARD

■ TX-RX UNIT (XC1-0010-11 (NX-840H(K), NX-840H(U)(K)), XC1-0010-22 (NX-840(M)))

--- Component side view (J7C-0002-10) ---

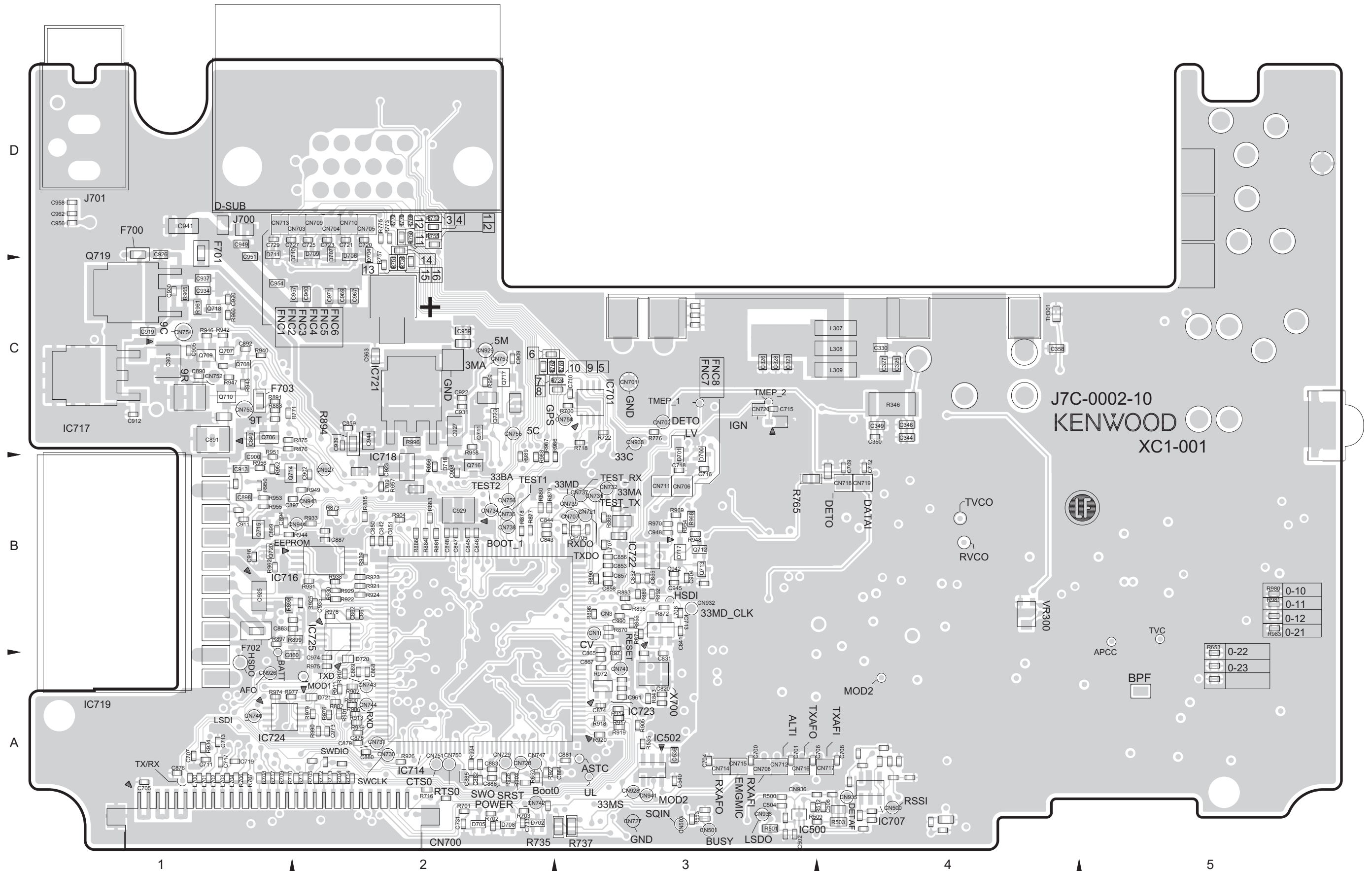

■ TX-RX UNIT (XC1-0010-11 (NX-840H(K), NX-840H(U)(K)), XC1-0010-22 (NX-840(M))

--- Foil side view (J7C-0002-10) ---

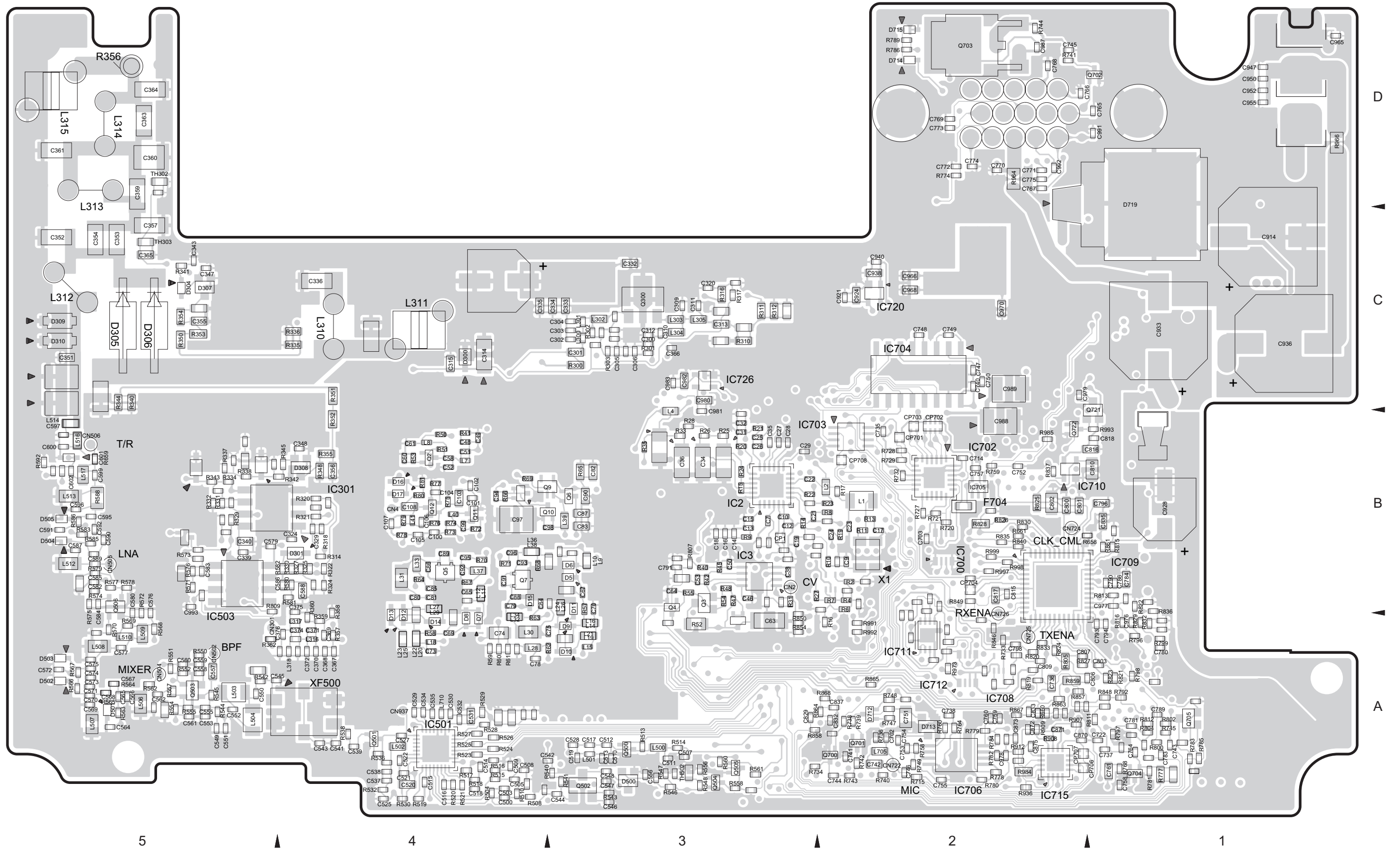





# ■ DISPLAY UNIT (X54-3890-20)

--- Component side view (J79-0249-29) ---

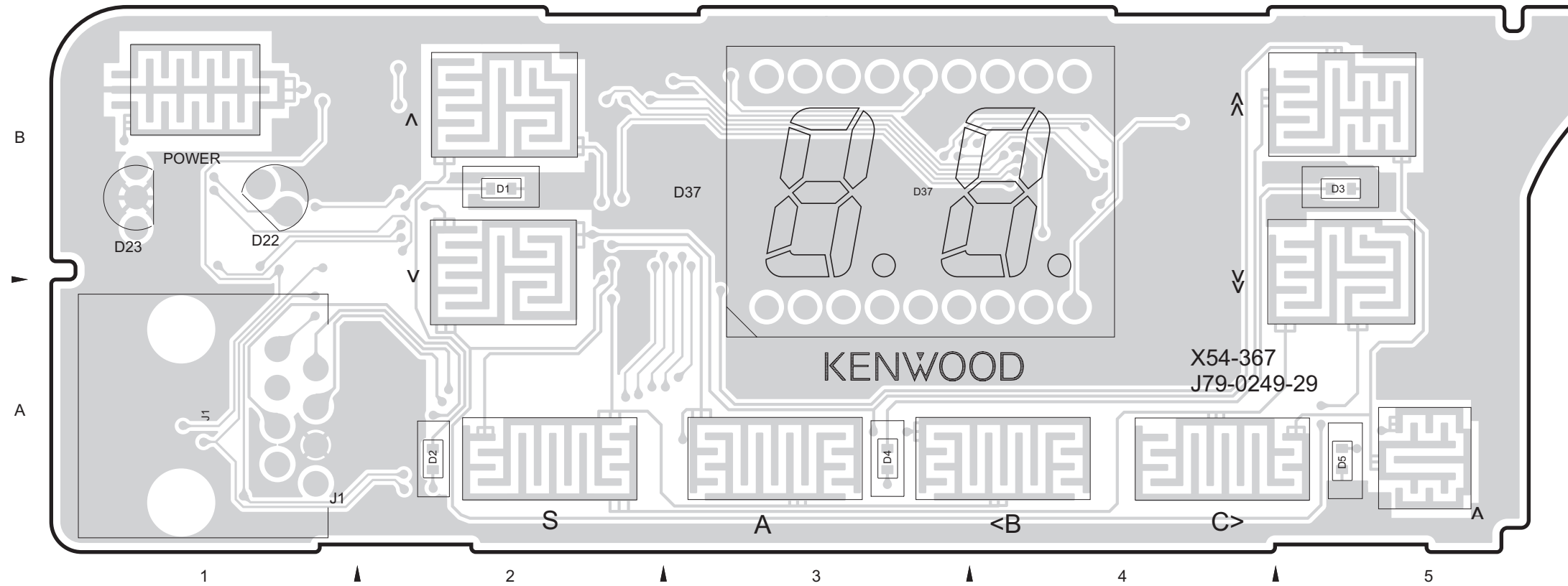

## ● ADDRESS TABLE OF BOARD PARTS

Each address may have an address error by one interval.

REF.NO.	LOCATION	REF.NO.	LOCATION	REF.NO.	LOCATION
<b>IC</b>		R8	B- 2B	C30	B- 1A
IC1	B- 4B	R10	B- 2A	C31	B- 4B
		R11	B- 2A	C32	B- 4B
<b>TRANSISTOR</b>		R12	B- 2A	C33	B- 4B
Q1	B- 1B	R21	B- 1B	C34	B- 3B
Q2	B- 1B	R22	B- 1B	C35	B- 4B
Q3	B- 2A	R23	B- 1B	C36	B- 2A
Q4	B- 2A	R26	B- 1A	C38	B- 1A
Q5	B- 3B	R27	B- 1B	C39	B- 1A
Q6	B- 1B	R28	B- 1B	C40	B- 4A
Q7	B- 1B	R29	B- 1B	C41	B- 4A
Q8	B- 1B	R34	B- 3B	C42	B- 2A
Q9	B- 1B	R35	B- 4B	C43	B- 4A
		R36	B- 4B	C44	B- 4A
<b>DIODE</b>		R37	B- 3B	C45	B- 1A
D20	B- 1A	R38	B- 4A	C46	B- 1B
D22	B- 1B	R39	B- 1A	C47	B- 1B
D23	B- 1B	R40	B- 1B		
D33	B- 1A	R41	B- 1B	<b>OTHER</b>	
D37	A- 3B	R42	B- 1B	CN1	B- 2B
				CN2	B- 5B
<b>RESISTOR</b>		<b>CAPACITOR</b>		CP1	B- 4B
R1	B- 1A	C1	B- 1A		
R2	B- 1A	C8	B- 1A	J1	A- 1A
R3	B- 2B	C9	B- 1A		
R4	B- 2B	C10	B- 1A	L1	B- 1B
R5	B- 2B	C16	B- 4B		
R6	B- 2B	C27	B- 1B		
R7	B- 2B	C29	B- 1A		

--- Foil side view (J79-0249-29) ---

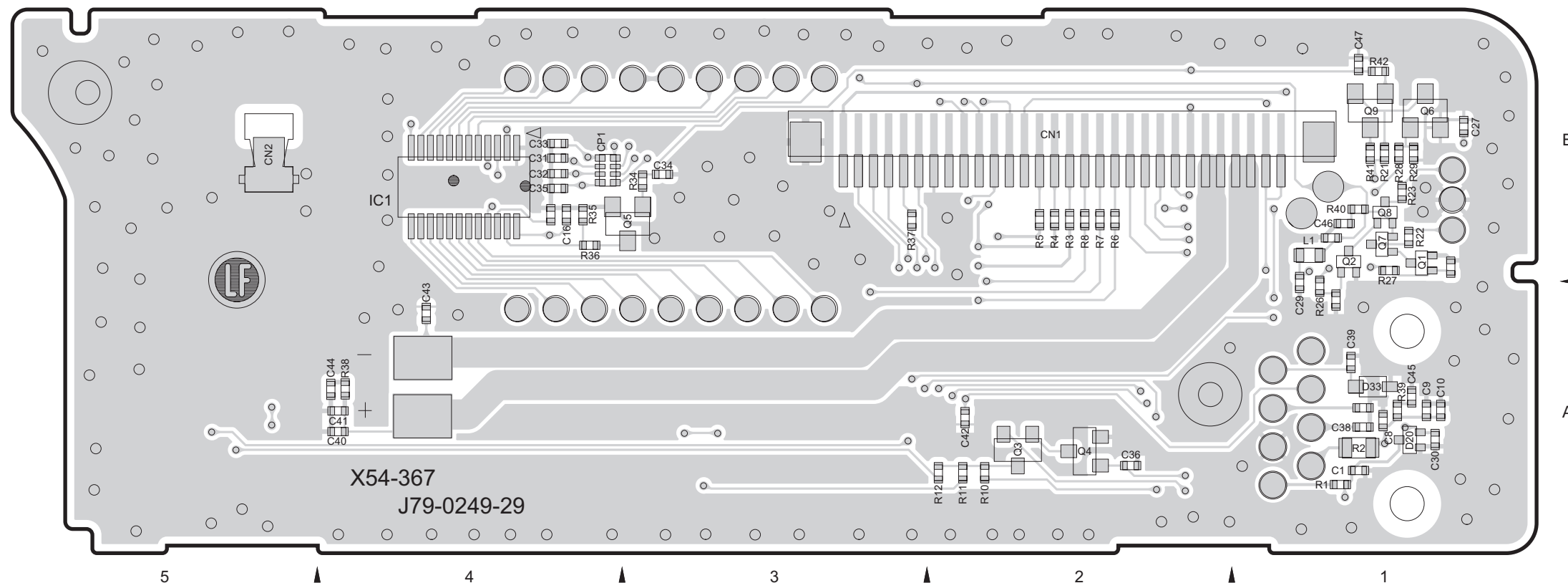

# SCHEMATIC DIAGRAM

## TX-RX UNIT (1/2) (XC1-0010-11 (NX-840H(K), NX-840H(U)(K)), XC1-0010-22 (NX-840(M)))

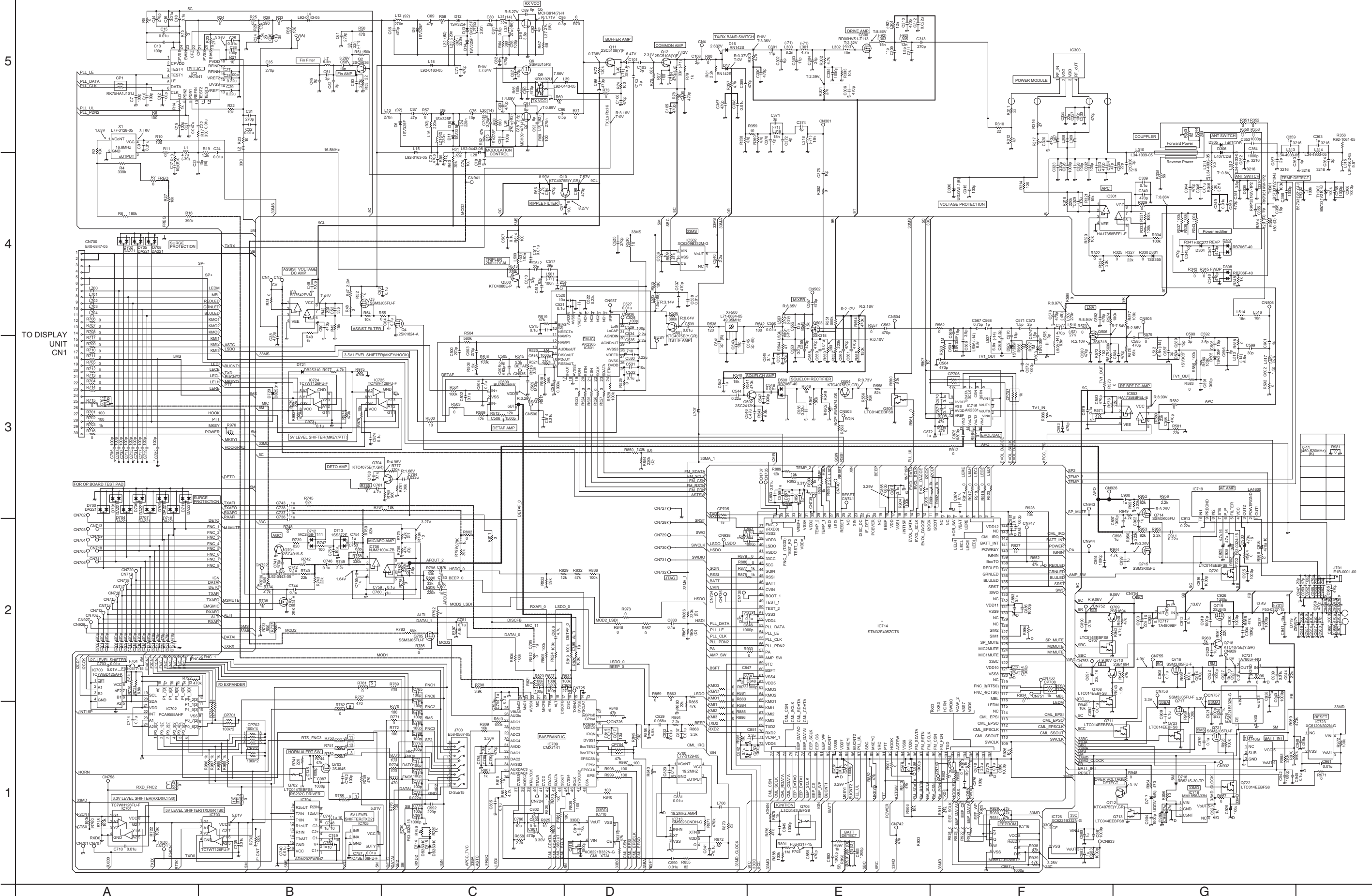





■ DISPLAY UNIT (X54-3890-20)

5

4

3

2

1

TO TX-RX  
UNIT 1/2  
CN700

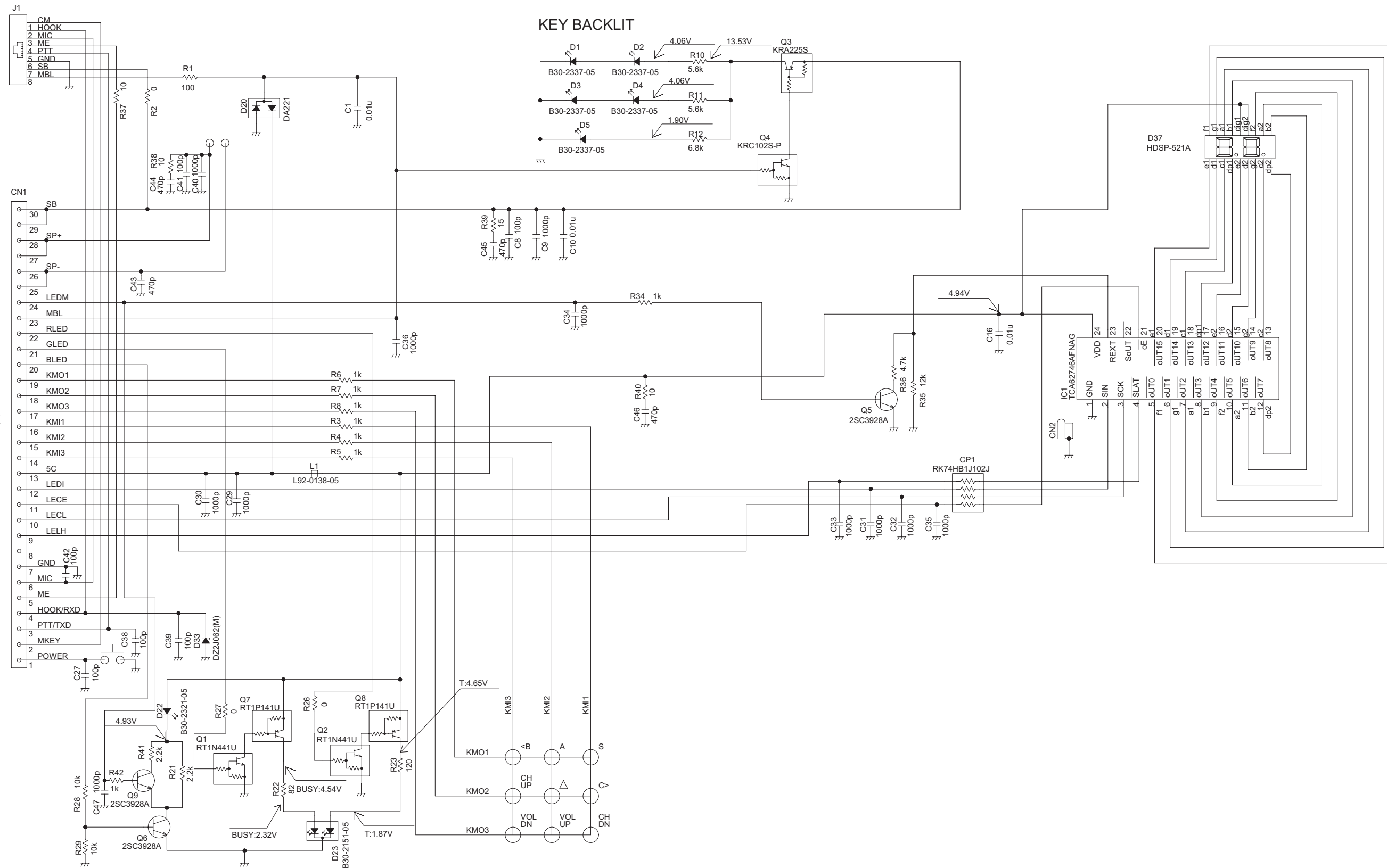

# LEVEL DIAGRAM

## Receiver Section

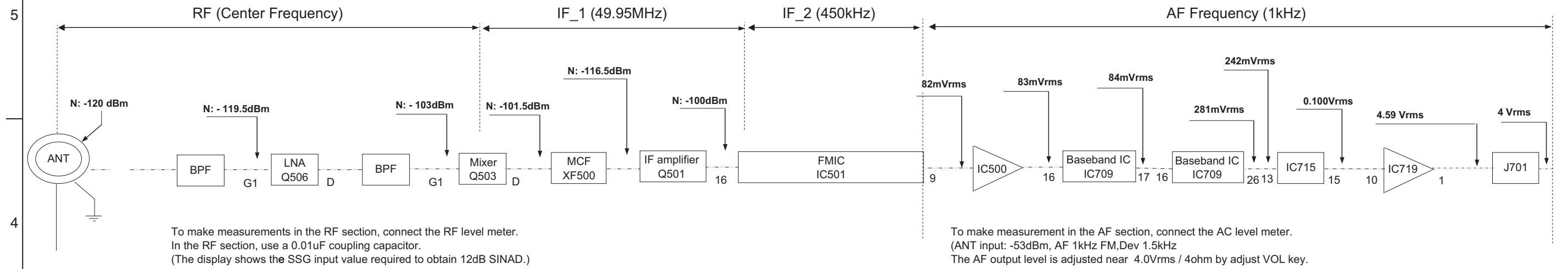

## Transmitter Section

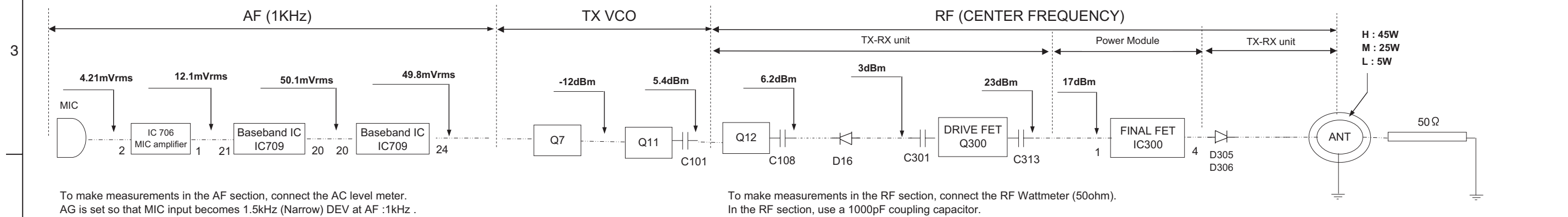

# BLOCK DIAGRAM

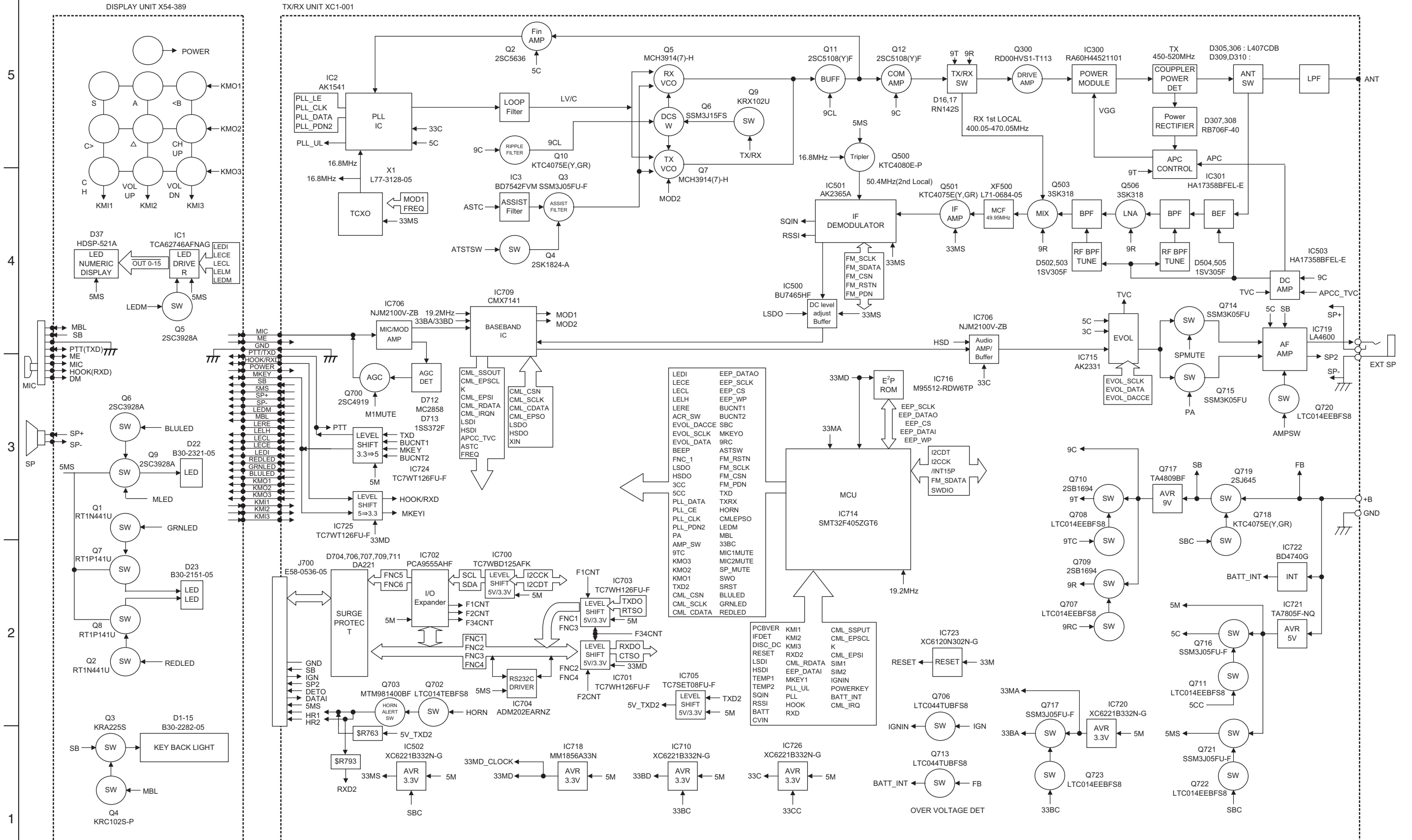

MEMO

# PARTS LIST

[NX-840H,NX-840H(U),NX-840]

\* SAFETY PRECAUTION

Parts identified by the ⚠ symbol are critical for safety. Replace only with specified part numbers.

\* BEWARE OF BOGUS PARTS

Parts that do not meet specifications may cause trouble in regard to safety and performance. We recommend that genuine parts be used.

\* (x\_) in a description column shows the number of the used part.

- Contents -

Exploded view of general assembly and parts list .....	3-2
Electrical parts list .....	3-4
Packing materials and accessories parts list .....	3-12

# Exploded view of general assembly and parts list

Block No.M1MM

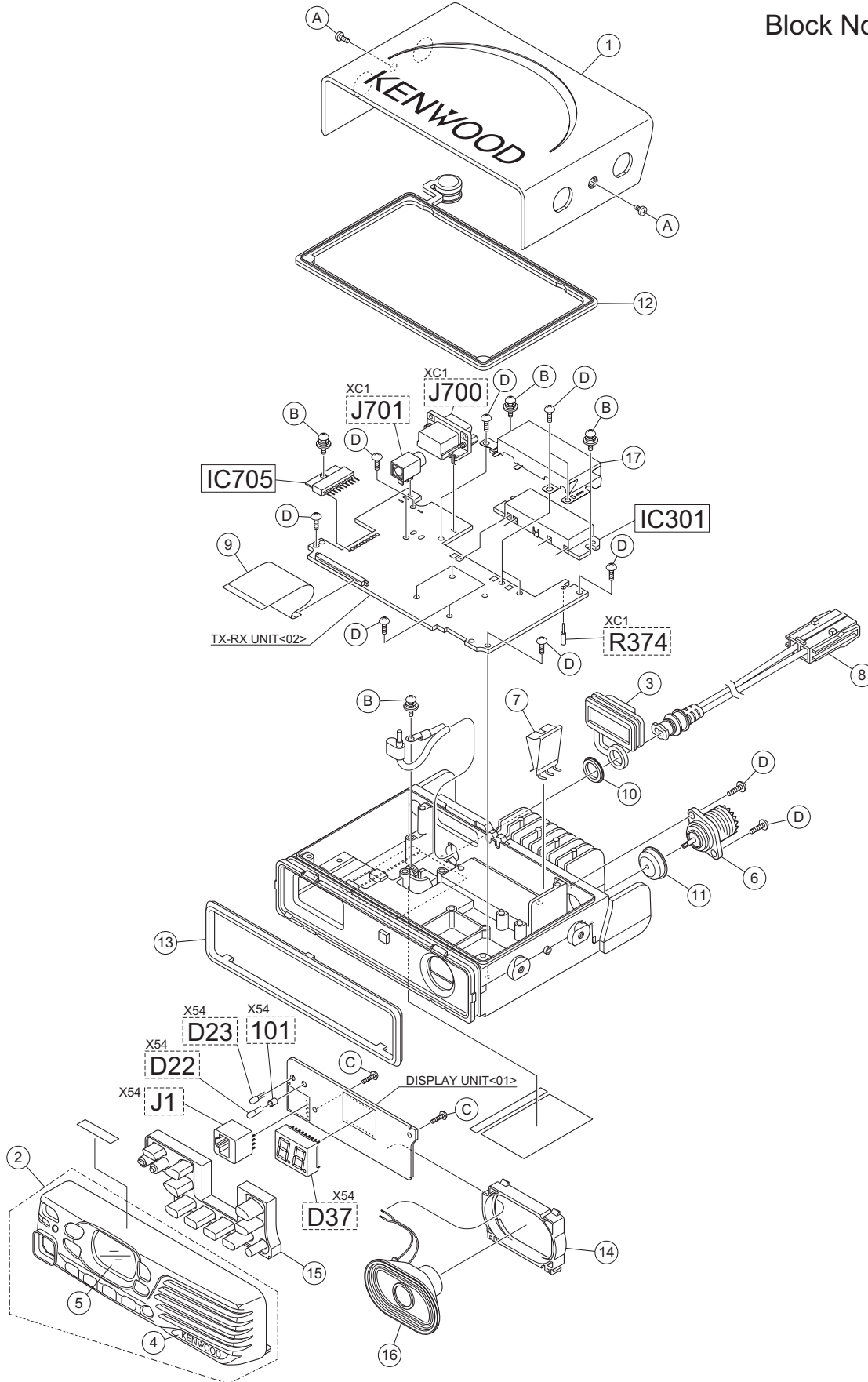

# General assembly

Block No. [M][1][M][M]

△ Symbol No.	Part No.	Part Name	Description	Local
1	A02-4073-21	PLASTIC CABINET		
2	A6A-0004-00	PANEL ASSY		
3	B09-0732-03	CAP(D-SUB)		
4	B4D-0003-00	BADGE		
5	B10-2794-03	FRONT GLASS		
6	E04-0167-15	RF COAXIAL RECEPTACLE(M)		
7	E23-1346-04	GROUND TERMINAL		
8	E30-7684-25	DC CORD		
9	E37-1461-05	FLAT CABLE(30P PANEL)		
10	G53-1643-04	PACKING(DC CORD)		
11	G53-1662-04	PACKING(RECEPTACLE)		
12	G53-1819-21	PACKING(CHASSIS)		
13	G53-1820-03	PACKING(PANEL)		
14	J19-5528-03	HOLDER(SPEAKER)		
15	K29-9448-01	KEY TOP		
16	T07-0785-15	SPEAKER		
17	F10-3140-13	SHIELD CASE		
A	N35-2604-43	BINDING HEAD MACHINE SCREW	(x2)	
B	N67-3008-48	PAN HEAD SEMS SCREW	(x4)	
C	N80-2008-48	PAN HEAD TAPTITE SCREW	(x2)	
D	N87-2608-48	BRAZIER HEAD TAPTITE SCREW	(x14)	
-	XC2-0020-10	SERVICE TX-RX UNIT		HK
-	XC2-0020-11	SERVICE TX-RX UNIT		HUK
-	XC2-0020-21	SERVICE TX-RX UNIT		M

# Electrical parts list

## DISPLAY UNIT

X54-3890-20

Block No. [0][1]

△ Symbol No.	Part No.	Part Name	Description	Local
IC1	TC62D748CFNAG	MOS-IC		
Q1	LTC044EEBFS8	TRANSISTOR		
Q2	LTC044EEBFS8	TRANSISTOR		
Q3	KRA225S	TRANSISTOR		
Q4	KRC102S-P	TRANSISTOR		
Q5	2SC3928A	TRANSISTOR		
Q6	2SC3928A	TRANSISTOR		
Q7	LTA014EEBFS8	TRANSISTOR		
Q8	LTA014EEBFS8	TRANSISTOR		
Q9	2SC3928A	TRANSISTOR		
D1	B30-2337-05	LED	(YELLOW)	
D2	B30-2337-05	LED	(YELLOW)	
D3	B30-2337-05	LED	(YELLOW)	
D4	B30-2337-05	LED	(YELLOW)	
D5	B30-2337-05	LED	(YELLOW)	
D20	DA221	DIODE		
D22	B30-2321-05	LED	(BLUE LED)	
D23	B30-2151-05	LED	(RED/GREEN)	
D33	DZ2J062(M)	ZENER DIODE		
D37	HDSP-521A	LED		
C1	CK73HB1E103K	C CAPACITOR	0.010UF K	
C8	CC73HCH1H101J	C CAPACITOR	100PF J	
C9	CK73HB1H102K	C CAPACITOR	1000PF K	
C10	CK73HB1E103K	C CAPACITOR	0.010UF K	
C16	CK73HB1E103K	C CAPACITOR	0.010UF K	
C27	CC73HCH1H101J	C CAPACITOR	100PF J	
C29	CK73HB1H102K	C CAPACITOR	1000PF K	
C30	CK73HB1H102K	C CAPACITOR	1000PF K	
C31	CK73HB1H102K	C CAPACITOR	1000PF K	
C32	CK73HB1H102K	C CAPACITOR	1000PF K	
C33	CK73HB1H102K	C CAPACITOR	1000PF K	
C34	CK73HB1H102K	C CAPACITOR	1000PF K	
C35	CK73HB1H102K	C CAPACITOR	1000PF K	
C36	CK73HB1H102K	C CAPACITOR	1000PF K	
C38	CC73HCH1H101J	C CAPACITOR	100PF J	
C39	CC73HCH1H101J	C CAPACITOR	100PF J	
C40	CK73HB1H102K	C CAPACITOR	1000PF K	
C41	CC73HCH1H101J	C CAPACITOR	100PF J	
C42	CC73HCH1H101J	C CAPACITOR	100PF J	
C43	CK73HB1H471K	C CAPACITOR	470PF K	
C44	CK73HB1H471K	C CAPACITOR	470PF K	
C45	CK73HB1H471K	C CAPACITOR	470PF K	
C46	CK73HB1H471K	C CAPACITOR	470PF K	
C47	CK73HB1H102K	C CAPACITOR	1000PF K	
R1	RK73HB1J101J	MG RESISTOR	100 J 1/16W	
R2	RK73FB2B000J	MG RESISTOR	0.0 J 1/8W	
R3	RK73HB1J102J	MG RESISTOR	1.0K J 1/16W	
R4	RK73HB1J102J	MG RESISTOR	1.0K J 1/16W	
R5	RK73HB1J102J	MG RESISTOR	1.0K J 1/16W	
R6	RK73HB1J102J	MG RESISTOR	1.0K J 1/16W	
R7	RK73HB1J102J	MG RESISTOR	1.0K J 1/16W	
R8	RK73HB1J102J	MG RESISTOR	1.0K J 1/16W	
R10	RK73HB1J562J	MG RESISTOR	5.6K J 1/16W	
R11	RK73HB1J562J	MG RESISTOR	5.6K J 1/16W	
R12	RK73HB1J682J	MG RESISTOR	6.8K J 1/16W	
R21	RK73HB1J222J	MG RESISTOR	2.2K J 1/16W	
R22	RK73HB1J820J	MG RESISTOR	82 J 1/16W	
R23	RK73HB1J121J	MG RESISTOR	120 J 1/16W	
R26	RK73HB1J000J	MG RESISTOR	0.0 J 1/16W	
R27	RK73HB1J000J	MG RESISTOR	0.0 J 1/16W	
R28	RK73HB1J103J	MG RESISTOR	10K J 1/16W	
R29	RK73HB1J103J	MG RESISTOR	10K J 1/16W	
R34	RK73HB1J102J	MG RESISTOR	1.0K J 1/16W	
R35	RK73HB1J123J	MG RESISTOR	12K J 1/16W	
R36	RK73HB1J472J	MG RESISTOR	4.7K J 1/16W	
R37	RK73HB1J100J	MG RESISTOR	10 J 1/16W	

△ Symbol No.	Part No.	Part Name	Description	Local
R38	RK73HB1J100J	MG RESISTOR	10 J 1/16W	
R39	RK73HB1J150J	MG RESISTOR	15 J 1/16W	
R40	RK73HB1J100J	MG RESISTOR	10 J 1/16W	
R41	RK73HB1J222J	MG RESISTOR	2.2K J 1/16W	
R42	RK73HB1J102J	MG RESISTOR	1.0K J 1/16W	
L1	L92-0138-05	CHIP FERRITE		
101	J31-0565-15	COLLAR		
CN1	E40-6851-05	FLAT CABLE CONNECTOR		
CN2	E23-1262-05	TERMINAL		
CP1	RK74HB1J102J	CHIP-COM	1.0K J 1/16W	
J1	J1	MODULAR JACK		

## TX-RX UNIT

XC1-0010-11 (NX-840H(K), NX-840H(U)(K))

XC1-0010-22 (NX-840(M))

Block No. [0][2]

△ Symbol No.	Part No.	Part Name	Description	Local
IC2	AK1541	MOS-IC		
IC3	BD7542FVM	MOS-IC		
IC300	RA60H44521101	MOS-IC	(POWER MODULE)	
IC301	HA17358BFEL-E	MOS-IC		
IC500	BU7465HFV	MOS-IC		
IC501	AK2365A	FM-IC		
IC502	XC6209B332M-G	MOS-IC		
IC503	HA17358BFEL-E	MOS-IC		
IC700	TC7WBD125AFK	MOS-IC		
IC701	TC7WH126FU-F	MOS-IC		
IC702	PCA9555AHF	MOS-IC		
IC703	TC7WT126FU-F	MOS-IC		
IC704	ADM202EARNZ	MOS-IC		
IC705	TC7SET08FU-F	MOS-IC		
IC706	NJM2100V-ZB	BI-POLAR IC		
IC709	CMX7141	MOS-IC		
IC710	XC6221B332N-G	MOS-IC		
IC713	SM5023CNDH-G	MOS-IC		
IC714	2F4052GT6KFKA	MCU		
IC715	AK2331	MOS-IC		
IC716	M95512-RDW6TP	ROM IC		
IC717	TA4809BF	ANALOGUE IC		
IC718	MM1856A33N	BI-POLAR IC		
IC719	LA4600	BI-POLAR IC		
IC720	XC6221B332N-G	MOS-IC		
IC721	TA7805F-NQ	MOS-IC		
IC722	BD4740G	MOS-IC		
IC723	XC6120N302N-G	MOS-IC		
IC724	TC7WT126FU-F	MOS-IC		
IC725	TC7WH126FU-F	MOS-IC		
IC726	XC6221B332N-G	MOS-IC		
Q2	2SC5636	TRANSISTOR		
Q3	SSM3J05FU-F	FET		
Q4	2SK1824-A	FET		
Q5	MCH3914(7)-H	FET		
Q6	SSM3J15FS	FET		
Q7	MCH3914(7)-H	FET		
Q9	KRX102U	TRANSISTOR		
Q10	KTC4075E(Y,GR)	TRANSISTOR		
Q11	2SC5108(Y)F	TRANSISTOR		
Q12	2SC5108(Y)F	TRANSISTOR		
Q300	RD00HVS1-T113	FET		
Q500	KTC4080E-P	TRANSISTOR		
Q501	KTC4075E(Y,GR)	TRANSISTOR		
Q502	2SC2412K	TRANSISTOR		
Q503	3SK318	FET		
Q504	KTC4075E(Y,GR)	TRANSISTOR		
Q505	LTC014EEBFS8	TRANSISTOR		



△ Symbol No.	Part No.	Part Name	Description	Local	△ Symbol No.	Part No.	Part Name	Description	Local
Q506	3SK318	FET			C14	CK73HB1H271K	C CAPACITOR	270PF K	
Q700	2SK1824-A	FET			C15	CK73HB1H103K	C CAPACITOR	0.010UF K	
Q701	2SC4919-S	TRANSISTOR			C16	CK73HB1E103K	C CAPACITOR	0.010UF K	
Q702	LTC014TEBFS8	TRANSISTOR			C17	CC73HCH1H100B	C CAPACITOR	10PF B	
Q703	2SJ645	FET			C18	CK73HB1A104K	C CAPACITOR	0.10UF K	
Q704	KTC4075E(Y,GR)	TRANSISTOR			C19	CC73HCH1H101J	C CAPACITOR	100PF J	
Q705	SSM3J05FU-F	FET			C21	CK73HB1A473K	C CAPACITOR	0.047UF K	
Q706	LTC044TUBFS8	TRANSISTOR			C22	CK73HB1E103K	C CAPACITOR	0.010UF K	
Q707	LTC014EEBFS8	TRANSISTOR			C23	CC73HCH1H100B	C CAPACITOR	10PF B	
Q708	LTC014EEBFS8	TRANSISTOR			C24	CK73HB1E103K	C CAPACITOR	0.010UF K	
Q709	2SB1694	TRANSISTOR			C25	CK73HB1E103K	C CAPACITOR	0.010UF K	
Q710	2SB1694	TRANSISTOR			C26	CC73HCH1H101J	C CAPACITOR	100PF J	
Q711	LTC014EEBFS8	TRANSISTOR			C27	CC73HCH1H101J	C CAPACITOR	100PF J	
Q712	KTC4075E(Y,GR)	TRANSISTOR			C28	CK73HB1A224K	C CAPACITOR	0.22UF K	
Q713	LTC044EEBFS8	TRANSISTOR			C29	CK73HB1A224K	C CAPACITOR	0.22UF K	
Q714	SSM3K05FU	FET			C31	CK73HB1H271K	C CAPACITOR	270PF K	
Q715	SSM3K05FU	FET			C32	CK73HB1E103K	C CAPACITOR	0.010UF K	
Q716	SSM3J05FU-F	FET			C34	CS77MA1D1R5M	TA E CAPACITOR	1.5UF 20WV	
Q717	SSM3J05FU-F	FET			C35	CK73HB1H271K	C CAPACITOR	270PF K	
Q718	KTC4075E(Y,GR)	TRANSISTOR			C36	CS77MA1V0R1M	TA E CAPACITOR	0.1UF 35WV	
Q719	2SJ645	FET			C38	CK73HB1H471K	C CAPACITOR	470PF K	
Q720	LTC014EEBFS8	TRANSISTOR			C46	CC73HCH1H101J	C CAPACITOR	100PF J	
Q721	SSM3J05FU-F	FET			C49	CC73HCH1H080B	C CAPACITOR	8.0PF B	
Q722	LTC014EEBFS8	TRANSISTOR			C50	CK73HB1H471K	C CAPACITOR	470PF K	
Q723	LTC014EEBFS8	TRANSISTOR			C51	CC73HCH1H030B	C CAPACITOR	3.0PF B	
D6	1SV325F	VARIABLE CAPACITANCE DIODE			C52	CC73HCH1H080B	C CAPACITOR	8.0PF B	
D8	1SV325F	VARIABLE CAPACITANCE DIODE			C53	CC73HCH1H330J	C CAPACITOR	33PF J	
D9	1SV325F	VARIABLE CAPACITANCE DIODE			C58	CC73HCH1H100B	C CAPACITOR	10PF B	
D10	1SV325F	VARIABLE CAPACITANCE DIODE			C60	CK73HB1H271K	C CAPACITOR	270PF K	
D11	1SV325F	VARIABLE CAPACITANCE DIODE			C61	CK73HB1H271K	C CAPACITOR	270PF K	
D12	1SV325F	VARIABLE CAPACITANCE DIODE			C63	C93-0787-05	C CAPACITOR	0.1UF J	
D13	1SV325F	VARIABLE CAPACITANCE DIODE			C64	CK73HB1A104K	C CAPACITOR	0.10UF K	
D14	1SV325F	VARIABLE CAPACITANCE DIODE			C65	CK73HB1H471K	C CAPACITOR	470PF K	
D15	1SV278F	VARIABLE CAPACITANCE DIODE			C67	CC73HCH1H470J	C CAPACITOR	47PF J	
D16	RN142S	DIODE			C69	CC73HCH1H470J	C CAPACITOR	47PF J	
D17	RN142S	DIODE			C70	CK73HB1H471K	C CAPACITOR	470PF K	
D300	UDZW5.1(B)	ZENER DIODE			C73	CK73HB1H471K	C CAPACITOR	470PF K	
D301	1SS355	DIODE			C74	CK73FB0J106K	C CAPACITOR	10UF K	
D304	HSC277	DIODE			C75	CC73HCH1H100C	C CAPACITOR	10PF C	
D305	L407CDB	DIODE	(50V/1W)		C78	CC73HCH1H101J	C CAPACITOR	100PF J	
D306	L407CDB	DIODE	(50V/1W)		C79	CC73HCH1HR75B	C CAPACITOR	0.75PF B	
D307	RB706F-40	DIODE			C80	CC73HCH1H200J	C CAPACITOR	20PF J	
D308	RB706F-40	DIODE			C81	CC73HCH1H0R5B	C CAPACITOR	0.5PF B	
D309	RKP351KW-1P2	DIODE			C82	CK73GB1H471K	C CAPACITOR	470PF K	
D310	RKP351KW-1P2	DIODE			C83	CK73GB1H471K	C CAPACITOR	470PF K	
D500	RB706F-40	DIODE			C84	CC73HCH1H101J	C CAPACITOR	100PF J	
D501	1SV305F	VARIABLE CAPACITANCE DIODE			C85	CC73HCH1H101J	C CAPACITOR	100PF J	
D502	1SV305F	VARIABLE CAPACITANCE DIODE			C86	CC73HCH1H3R5B	C CAPACITOR	3.5PF B	
D503	1SV305F	VARIABLE CAPACITANCE DIODE			C87	CK73GB1H471K	C CAPACITOR	470PF K	
D504	1SV305F	VARIABLE CAPACITANCE DIODE			C88	CC73HCH1H2R5B	C CAPACITOR	2.5PF B	
D505	1SV305F	VARIABLE CAPACITANCE DIODE			C89	CC73HCH1H060B	C CAPACITOR	6.0PF B	
D700	DA221	DIODE			C90	CK73GB1H471K	C CAPACITOR	470PF K	
D701	DA221	DIODE			C91	CC73HCH1H080B	C CAPACITOR	8.0PF B	
D702	DA221	DIODE			C92	CC73HCH1H040B	C CAPACITOR	4.0PF B	
D704	DA221	DIODE			C93	CC73HCH1H060B	C CAPACITOR	6.0PF B	
D705	DA221	DIODE			C94	CK73HB1H471K	C CAPACITOR	470PF K	
D706	DA221	DIODE			C95	CC73HCH1H0R3B	C CAPACITOR	0.3PF B	
D707	DA221	DIODE			C96	CC73HCH1H0R5B	C CAPACITOR	0.5PF B	
D708	DA221	DIODE			C97	CS77BB21C100M	TA E CAPACITOR	10UF 16WV	
D709	DA221	DIODE			C98	CK73HB1H471K	C CAPACITOR	470PF K	
D710	DA221	DIODE			C99	CK73HB1H471K	C CAPACITOR	470PF K	
D711	DA221	DIODE			C100	CK73HB1H471K	C CAPACITOR	470PF K	
D712	MC2858-T111	DIODE			C101	CC73HCH1H040B	C CAPACITOR	4.0PF B	
D713	1SS372F	DIODE			C102	CC73HCH1H020B	C CAPACITOR	2.0PF B	
D714	DB2S310	DIODE			C103	CC73GCH1H020B	C CAPACITOR	2.0PF B	
D715	DB2S310	DIODE			C104	CK73HB1H471K	C CAPACITOR	470PF K	
D717	UDZW18(B)	ZENER DIODE			C105	CK73HB1H471K	C CAPACITOR	470PF K	
D718	RB521S-30-TP	DIODE			C106	CK73HB1H471K	C CAPACITOR	470PF K	
D719	Z5W27V	SURGE ABSORBER			C108	CC73GCH1H020B	C CAPACITOR	2.0PF B	
D720	DB2S310	DIODE			C300	CK73HB1H471K	C CAPACITOR	470PF K	
D721	DB2S310	DIODE			C301	CC73GCH1H110J	C CAPACITOR	11PF J	
C7	CC73HCH1H101J	C CAPACITOR	100PF J		C302	CC73HCH1H060B	C CAPACITOR	6.0PF B	
C9	CK73HB1E103K	C CAPACITOR	0.010UF K		C303	CC73HCH1H110J	C CAPACITOR	11PF J	
C10	CC73HCH1H101J	C CAPACITOR	100PF J		C304	CC73HCH1H240J	C CAPACITOR	24PF J	
C12	CC73HCH1H101J	C CAPACITOR	100PF J		C305	CK73HB1H102K	C CAPACITOR	1000PF K	
C13	CC73HCH1H101J	C CAPACITOR	100PF J		C306	CK73HB1H471K	C CAPACITOR	470PF K	
					C309	CC73HCH1H110J	C CAPACITOR	11PF J	
					C310	CK73HB1H471K	C CAPACITOR	470PF K	

△ Symbol No.	Part No.	Part Name	Description	Local	△ Symbol No.	Part No.	Part Name	Description	Local
C311	CC73HCH1H1R5B	C CAPACITOR	1.5PF B		C535	CK73HB0J225K	C CAPACITOR	2.2UF K	
C312	CK73HB1E223K	C CAPACITOR	0.022UF K		C536	CK73GB1A105K	C CAPACITOR	1.0UF K	
C313	CC73GCH1H271J	C CAPACITOR	270PF J		C537	CK73HB1H471K	C CAPACITOR	470PF K	
C315	CC73GCH1H101J	C CAPACITOR	100PF J		C538	CK73HB1E103K	C CAPACITOR	0.010UF K	
C320	CK73HB1H471K	C CAPACITOR	470PF K		C539	CK73HB1E103K	C CAPACITOR	0.010UF K	
C323	CK73GB1H221K	C CAPACITOR	220PF K		C540	CK73HB0J225K	C CAPACITOR	2.2UF K	
C325	CC73GCH1H220J	C CAPACITOR	22PF J		C541	CC73HCH1H020B	C CAPACITOR	2.0PF B	
C326	CK73GB1H102K	C CAPACITOR	1000PF K		C542	CK73HB1A105K	C CAPACITOR	1.0UF K	
C327	CC73GCH1H101J	C CAPACITOR	100PF J		C543	CC73HCH1H100C	C CAPACITOR	10PF C	
C328	CC73GCH1H101J	C CAPACITOR	100PF J		C544	CK73HB1A224K	C CAPACITOR	0.22UF K	
C329	CK73HB1A154K	C CAPACITOR	0.15UF K		C545	CC73HCH1H020B	C CAPACITOR	2.0PF B	
C330	CK73GB1H471K	C CAPACITOR	470PF K		C546	CK73HB1A474K	C CAPACITOR	0.47UF K	
C332	CC73GCH1H101J	C CAPACITOR	100PF J		C547	CK73HB1H102K	C CAPACITOR	1000PF K	
C333	CK73GB1H471K	C CAPACITOR	470PF K		C548	CK73HB1E103K	C CAPACITOR	0.010UF K	
C334	CC73GCH1H470J	C CAPACITOR	47PF J		C549	CK73HB1A104K	C CAPACITOR	0.10UF K	
C335	CC73GCH1H220J	C CAPACITOR	22PF J		C550	CK73HB1E103K	C CAPACITOR	0.010UF K	
C336	C93-0553-05	C CAPACITOR	3.0PF C		C551	CK73HB1H471K	C CAPACITOR	470PF K	
C339	CK73HB1A104K	C CAPACITOR	0.10UF K		C552	CC73HCH1H130J	C CAPACITOR	13PF J	
C340	CK73GB1H471K	C CAPACITOR	470PF K		C553	CK73HB1E103K	C CAPACITOR	0.010UF K	
C343	CK73HB1H471K	C CAPACITOR	470PF K		C555	CK73HB1H471K	C CAPACITOR	470PF K	
C344	CK73GB1H471K	C CAPACITOR	470PF K		C556	CK73HB0J224K	C CAPACITOR	0.22UF K	
C346	CK73GB1H103K	C CAPACITOR	0.010UF K		C557	CK73GB1H471K	C CAPACITOR	470PF K	
C347	CK73HB1H471K	C CAPACITOR	470PF K		C558	CK73HB1H471K	C CAPACITOR	470PF K	
C348	CK73HB1H471K	C CAPACITOR	470PF K		C559	CK73HB1E103K	C CAPACITOR	0.010UF K	
C349	CK73GB1H103K	C CAPACITOR	0.010UF K		C560	CK73HB1H471K	C CAPACITOR	470PF K	
C350	CK73HB1H471K	C CAPACITOR	470PF K		C561	CK73HB1H471K	C CAPACITOR	470PF K	
C351	CC73GCH1H3R5B	C CAPACITOR	3.5PF B		C562	CK73HB1H471K	C CAPACITOR	470PF K	
C352	C93-0550-05	C CAPACITOR	1.0PF C		C564	CK73HB1H471K	C CAPACITOR	470PF K	
C353	C93-0603-05	C CAPACITOR	1000PF K		C565	CC73HCH1H150J	C CAPACITOR	15PF J	
C354	C93-0603-05	C CAPACITOR	1000PF K		C566	CC73HCH1H3R5B	C CAPACITOR	3.5PF B	
C355	CC73GCH1H090B	C CAPACITOR	9.0PF B		C567	CC73HCH1HR75B	C CAPACITOR	0.75PF B	
C356	CC73GCH1H150J	C CAPACITOR	15PF J		C568	CC73HCH1H010B	C CAPACITOR	1.0PF B	
C357	C93-0552-05	C CAPACITOR	2.0PF C		C569	CC73HCH1H4R5B	C CAPACITOR	4.5PF B	
C358	CK73GB1H102K	C CAPACITOR	1000PF K		C570	CC73HCH1H150J	C CAPACITOR	15PF J	
C359	C93-0550-05	C CAPACITOR	1.0PF C		C571	CC73HCH1H1R5B	C CAPACITOR	1.5PF B	
C360	CM73F2H040D	C CAPACITOR	4.0PF D		C572	CK73HB1H102K	C CAPACITOR	1000PF K	
C363	C93-0550-05	C CAPACITOR	1.0PF C		C573	CC73HCH1H020B	C CAPACITOR	2.0PF B	
C364	C93-0553-05	C CAPACITOR	3.0PF C		C574	CC73HCH1H150J	C CAPACITOR	15PF J	
C365	CK73GB1H102K	C CAPACITOR	1000PF K		C575	CC73HCH1H030B	C CAPACITOR	3.0PF B	
C366	CK73HB1H102K	C CAPACITOR	1000PF K		C576	CK73HB1H471K	C CAPACITOR	470PF K	
C367	CK73HB1H471K	C CAPACITOR	470PF K		C577	CK73HB1H471K	C CAPACITOR	470PF K	
C368	CK73HB1E103K	C CAPACITOR	0.010UF K		C579	CK73HB1A104K	C CAPACITOR	0.10UF K	
C369	CK73HB1H471K	C CAPACITOR	470PF K		C580	CK73HB1H471K	C CAPACITOR	470PF K	
C370	CC73HCH1H100D	C CAPACITOR	10PF D		C582	CK73HB1H471K	C CAPACITOR	470PF K	
C371	CC73HCH1H030B	C CAPACITOR	3.0PF B		C583	CK73HB1H471K	C CAPACITOR	470PF K	
C372	CC73HCH1H040B	C CAPACITOR	4.0PF B		C584	CK73HB1H471K	C CAPACITOR	470PF K	
C374	CC73HCH1H040B	C CAPACITOR	4.0PF B		C585	CK73HB1H471K	C CAPACITOR	470PF K	
C376	CC73HCH1H100C	C CAPACITOR	10PF C		C586	CK73HB1H471K	C CAPACITOR	470PF K	
C500	CK73HB1H271K	C CAPACITOR	270PF K		C587	CC73HCH1H020B	C CAPACITOR	2.0PF B	
C502	CK73HB1A104K	C CAPACITOR	0.10UF K		C589	CC73HCH1H150J	C CAPACITOR	15PF J	
C503	CK73HB1H271K	C CAPACITOR	270PF K		C590	CC73HCH1H030B	C CAPACITOR	3.0PF B	
C504	CK73HB1A104K	C CAPACITOR	0.10UF K		C591	CK73HB1H102K	C CAPACITOR	1000PF K	
C505	CC73HCH1H560J	C CAPACITOR	56PF J		C592	CC73HCH1H3R5B	C CAPACITOR	3.5PF B	
C506	CK73HB1H152K	C CAPACITOR	1500PF K		C595	CC73HCH1H150J	C CAPACITOR	15PF J	
C507	CK73HB1A104K	C CAPACITOR	0.10UF K		C596	CC73HCH1H050B	C CAPACITOR	5.0PF B	
C508	CK73HB1H681K	C CAPACITOR	680PF K		C599	CC73HCH1H300J	C CAPACITOR	30PF J	
C509	CK73HB1H182K	C CAPACITOR	1800PF K		C601	CC73HCH1H040B	C CAPACITOR	4.0PF B	
C510	CC73HCH1H330J	C CAPACITOR	33PF J		C602	CC73HCH1H1R5B	C CAPACITOR	1.5PF B	
C511	CK73HB1E103K	C CAPACITOR	0.010UF K		C700	CK73HB1H471K	C CAPACITOR	470PF K	
C512	CC73HCH1H220J	C CAPACITOR	22PF J		C701	CK73HB1H471K	C CAPACITOR	470PF K	
C513	CC73HCH1H820J	C CAPACITOR	82PF J		C702	CC73HCH1H101J	C CAPACITOR	100PF J	
C514	CK73HB1E103K	C CAPACITOR	0.010UF K		C703	CK73HB1H103K	C CAPACITOR	0.010UF K	
C515	CK73HB1A104K	C CAPACITOR	0.10UF K		C704	CK73HB1H471K	C CAPACITOR	470PF K	
C516	CK73HB1H102K	C CAPACITOR	1000PF K		C705	CC73HCH1H101J	C CAPACITOR	100PF J	
C517	CC73HCH1H390J	C CAPACITOR	39PF J		C706	CK73HB1H471K	C CAPACITOR	470PF K	
C518	CK73HB1A333K	C CAPACITOR	0.033UF K		C707	CC73HCH1H101J	C CAPACITOR	100PF J	
C519	CC73HCH1H820J	C CAPACITOR	82PF J		C708	CK73HB1H471K	C CAPACITOR	470PF K	
C520	CK73GB0J106K	C CAPACITOR	10UF K		C709	CK73HB1H471K	C CAPACITOR	470PF K	
C521	CK73HB1A104K	C CAPACITOR	0.10UF K		C710	CK73HB1H103K	C CAPACITOR	0.010UF K	
C522	CK73HB1A224K	C CAPACITOR	0.22UF K		C711	CC73HCH1H101J	C CAPACITOR	100PF J	
C525	CK73HB1H271K	C CAPACITOR	270PF K		C712	CK73HB1H471K	C CAPACITOR	470PF K	
C527	CK73HB1E103K	C CAPACITOR	0.010UF K		C713	CC73HCH1H101J	C CAPACITOR	100PF J	
C528	CC73HCH1H101J	C CAPACITOR	100PF J		C714	CK73HB1A104K	C CAPACITOR	0.10UF K	
C529	CC73HCH1H101J	C CAPACITOR	100PF J		C715	CK73HB1H471K	C CAPACITOR	470PF K	
C530	CK73HB1A224K	C CAPACITOR	0.22UF K		C716	CK73HB1H471K	C CAPACITOR	470PF K	
C531	CK73GB0J106K	C CAPACITOR	10UF K		C717	CC73HCH1H101J	C CAPACITOR	100PF J	
C532	CK73HB1A104K	C CAPACITOR	0.10UF K		C718	CK73HB1H471K	C CAPACITOR	470PF K	
C534	CK73HB0J225K	C CAPACITOR	2.2UF K		C719	CC73HCH1H101J	C CAPACITOR	100PF J	

△ Symbol No.	Part No.	Part Name	Description	Local	△ Symbol No.	Part No.	Part Name	Description	Local
C720	CK73HB1H471K	C CAPACITOR	470PF K		C843	CK73HB1A104K	C CAPACITOR	0.10UF K	
C721	CK73HB1H471K	C CAPACITOR	470PF K		C844	CK73HB1H102K	C CAPACITOR	1000PF K	
C722	CC73HCH1H101J	C CAPACITOR	100PF J		C845	CK73HB1A104K	C CAPACITOR	0.10UF K	
C723	CK73HB1H471K	C CAPACITOR	470PF K		C846	CK73HB1H102K	C CAPACITOR	1000PF K	
C725	CK73HB1H471K	C CAPACITOR	470PF K		C847	CK73HB1A104K	C CAPACITOR	0.10UF K	
C727	CK73HB1H471K	C CAPACITOR	470PF K		C848	CK73HB1H102K	C CAPACITOR	1000PF K	
C729	CK73HB1H471K	C CAPACITOR	470PF K		C849	CK73GB1H102K	C CAPACITOR	1000PF K	
C731	CC73HCH1H101J	C CAPACITOR	100PF J		C850	CK73HB1H102K	C CAPACITOR	1000PF K	
C733	CC73HCH1H101J	C CAPACITOR	100PF J		C851	CK73HB0J225K	C CAPACITOR	2.2UF K	
C735	CK73HB1H103K	C CAPACITOR	0.010UF K		C853	CK73HB1H103K	C CAPACITOR	0.010UF K	
C736	CK73GB1A105K	C CAPACITOR	1.0UF K		C856	CK73HB0J105K	C CAPACITOR	1.0UF K	
C737	CK73HB0J105K	C CAPACITOR	1.0UF K		C857	CK73HB1H103K	C CAPACITOR	0.010UF K	
C738	CK73HB0J105K	C CAPACITOR	1.0UF K		C858	CK73HB0J105K	C CAPACITOR	1.0UF K	
C740	CK73HB1H103K	C CAPACITOR	0.010UF K		C859	CK73HB1H471K	C CAPACITOR	470PF K	
C741	CK73HB1H471K	C CAPACITOR	470PF K		C860	CK73GB1H102K	C CAPACITOR	1000PF K	
C742	CK73GB1C104K	C CAPACITOR	0.10UF K		C861	CK73HB1A104K	C CAPACITOR	0.10UF K	
C743	CK73HB0J105K	C CAPACITOR	1.0UF K		C862	CK73HB1H102K	C CAPACITOR	1000PF K	
C744	CK73HB1A104K	C CAPACITOR	0.10UF K		C863	CK73HB1H102K	C CAPACITOR	1000PF K	
C745	CK73HB1H102K	C CAPACITOR	1000PF K		C865	CK73HB1H102K	C CAPACITOR	1000PF K	
C746	CK73HB1A104K	C CAPACITOR	0.10UF K		C867	CK73HB1A104K	C CAPACITOR	0.10UF K	
C747	CK73HB1A105K	C CAPACITOR	1.0UF K		C868	CK73HB1A104K	C CAPACITOR	0.10UF K	
C748	CK73HB1A105K	C CAPACITOR	1.0UF K		C869	CK73HB1H102K	C CAPACITOR	1000PF K	
C749	CK73HB1A105K	C CAPACITOR	1.0UF K		C870	CK73HB1A104K	C CAPACITOR	0.10UF K	
C750	CK73HB1A105K	C CAPACITOR	1.0UF K		C871	CK73HB1A104K	C CAPACITOR	0.10UF K	
C751	CK73FB0J106K	C CAPACITOR	10UF K		C872	CK73HB0J105K	C CAPACITOR	1.0UF K	
C752	CC73HCH1H101J	C CAPACITOR	100PF J		C874	CK73HB1A104K	C CAPACITOR	0.10UF K	
C753	CC73HCH1H680J	C CAPACITOR	68PF J		C875	CK73HB1H682K	C CAPACITOR	6800PF K	
C754	CK73HB0J105K	C CAPACITOR	1.0UF K		C876	CC73HCH1H101J	C CAPACITOR	100PF J	
C755	CK73HB0J105K	C CAPACITOR	1.0UF K		C878	CK73HB0J225K	C CAPACITOR	2.2UF K	
C757	CK73HB1H103K	C CAPACITOR	0.010UF K		C879	CK73HB1A104K	C CAPACITOR	0.10UF K	
C758	CK73HB1A104K	C CAPACITOR	0.10UF K		C880	CK73HB1H102K	C CAPACITOR	1000PF K	
C759	CK73HB1A104K	C CAPACITOR	0.10UF K		C881	CK73HB1A104K	C CAPACITOR	0.10UF K	
C760	CK73HB0J105K	C CAPACITOR	1.0UF K		C882	CK73HB1A104K	C CAPACITOR	0.10UF K	
C761	CK73GB0J475K	C CAPACITOR	4.7UF K		C883	CK73HB1A104K	C CAPACITOR	0.10UF K	
C764	CK73HB1C333K	C CAPACITOR	0.033UF K		C884	CK73HB1H102K	C CAPACITOR	1000PF K	
C765	CC73HCH1H101J	C CAPACITOR	100PF J		C885	CK73HB1H102K	C CAPACITOR	1000PF K	
C766	CC73HCH1H101J	C CAPACITOR	100PF J		C886	CK73HB1H102K	C CAPACITOR	1000PF K	
C767	CC73HCH1H101J	C CAPACITOR	100PF J		C887	CK73HB1H102K	C CAPACITOR	1000PF K	
C768	CC73HCH1H101J	C CAPACITOR	100PF J		C890	CK73HB1A104K	C CAPACITOR	0.10UF K	
C769	CC73HCH1H101J	C CAPACITOR	100PF J		C891	CS77BB21C220M	TA E CAPACITOR	22UF 16WV	
C770	CC73HCH1H101J	C CAPACITOR	100PF J		C892	CK73HB1E103K	C CAPACITOR	0.010UF K	
C771	CC73HCH1H101J	C CAPACITOR	100PF J		C894	CK73HB1H102K	C CAPACITOR	1000PF K	
C772	CC73HCH1H101J	C CAPACITOR	100PF J		C897	CK73HB1H102K	C CAPACITOR	1000PF K	
C773	CC73HCH1H101J	C CAPACITOR	100PF J		C898	CK73GB1A105K	C CAPACITOR	1.0UF K	
C774	CK73HB1E223K	C CAPACITOR	0.022UF K		C899	CK73HB0J105K	C CAPACITOR	1.0UF K	
C775	CC73HCH1H101J	C CAPACITOR	100PF J		C900	CK73GB1A105K	C CAPACITOR	1.0UF K	
C780	CK73HB0J105K	C CAPACITOR	1.0UF K		C902	CK73HB0J105K	C CAPACITOR	1.0UF K	
C781	CK73HB1A104K	C CAPACITOR	0.10UF K		C903	CS77BB21C220M	TA E CAPACITOR	22UF 16WV	
C783	CK73HB1A104K	C CAPACITOR	0.10UF K		C904	CK73HB1H102K	C CAPACITOR	1000PF K	
C784	CK73GB0J106K	C CAPACITOR	10UF K		C905	CK73HB1A104K	C CAPACITOR	0.10UF K	
C786	CK73HB1A104K	C CAPACITOR	0.10UF K		C908	CK73HB1A104K	C CAPACITOR	0.10UF K	
C789	CK73HB0J105K	C CAPACITOR	1.0UF K		C909	CK73HB1A104K	C CAPACITOR	0.10UF K	
C790	CK73HB1H471K	C CAPACITOR	470PF K		C911	CK73HB1A224K	C CAPACITOR	0.22UF K	
C793	CK73HB0J105K	C CAPACITOR	1.0UF K		C912	CK73HB1A104K	C CAPACITOR	0.10UF K	
C794	CK73HB1A104K	C CAPACITOR	0.10UF K		C913	CK73GB1C224K	C CAPACITOR	0.22UF K	
C796	CK73GB0J106K	C CAPACITOR	10UF K		C914	CE32BM1C471M	E CAPACITOR	470UF 16WV	
C798	CK73HB0J105K	C CAPACITOR	1.0UF K		C916	CK73HB1H102K	C CAPACITOR	1000PF K	
C800	CK73GB1C104K	C CAPACITOR	0.10UF K		C919	CK73GB1H102K	C CAPACITOR	1000PF K	
C801	CK73GB1H471K	C CAPACITOR	470PF K		C920	CK73HB0J105K	C CAPACITOR	1.0UF K	
C802	CK73FB0J106K	C CAPACITOR	10UF K		C921	CK73HB1H102K	C CAPACITOR	1000PF K	
C803	CC73HCH1H101J	C CAPACITOR	100PF J		C922	CK73HB1H102K	C CAPACITOR	1000PF K	
C806	CK73HB0J475M	C CAPACITOR	4.7UF M		C923	CK73HB1A105K	C CAPACITOR	1.0UF K	
C807	CC73HCH1H101J	C CAPACITOR	100PF J		C924	CK73GB1A105K	C CAPACITOR	1.0UF K	
C809	CK73HB1H271K	C CAPACITOR	270PF K		C925	CS77BA1C4R7M	TA E CAPACITOR	4.7UF 16WV	
C810	CK73FB0J106K	C CAPACITOR	10UF K		C926	CK73GB1H102K	C CAPACITOR	1000PF K	
C815	CK73HB1E103K	C CAPACITOR	0.010UF K		C927	CS77BA1A100M	TA E CAPACITOR	10UF 10WV	
C816	CK73GB1A105K	C CAPACITOR	1.0UF K		C928	CE32CL1C470M	E CAPACITOR	47UF 16WV	
C817	CK73GB0J106K	C CAPACITOR	10UF K		C929	CS77MB20J101M	TA E CAPACITOR	100UF 6.3WV	
C818	CK73HB1H102K	C CAPACITOR	1000PF K		C930	CK73HB1H102K	C CAPACITOR	1000PF K	
C820	CK73HB1H103K	C CAPACITOR	0.010UF K		C931	CK73HB1E103K	C CAPACITOR	0.010UF K	
C829	CK73HB1A683K	C CAPACITOR	0.068UF K		C933	CE32BD1C471M	E CAPACITOR	470UF 16WV	
C831	CK73HB1H103K	C CAPACITOR	0.010UF K		C934	CK73GB1H102K	C CAPACITOR	1000PF K	
C832	CK73HB1E103K	C CAPACITOR	0.010UF K		C935	CK73HB1H102K	C CAPACITOR	1000PF K	
C833	CK73HB1A104K	C CAPACITOR	0.10UF K		C936	CE32BD1C471M	E CAPACITOR	470UF 16WV	
C835	CK73GB1H104K	C CAPACITOR	0.10UF K		C937	CK73GB1H102K	C CAPACITOR	1000PF K	
C837	CK73HB1E103K	C CAPACITOR	0.010UF K		C938	CK73GB1A105K	C CAPACITOR	1.0UF K	
C841	CK73HB1A104K	C CAPACITOR	0.10UF K		C939	CK73HB1E103K	C CAPACITOR	0.010UF K	
C842	CK73HB1A104K	C CAPACITOR	0.10UF K		C940	CK73HB1H102K	C CAPACITOR	1000PF K	

△ Symbol No.	Part No.	Part Name	Description	Local	△ Symbol No.	Part No.	Part Name	Description	Local
C941	CK73EB1E106K	C CAPACITOR	10UF K		R52	RK73FB2B102J	MG RESISTOR	1.0K J 1/8W	
C942	CK73HB1H102K	C CAPACITOR	1000PF K		R53	RK73HB1J220J	MG RESISTOR	22 J 1/16W	
C944	CK73FB1E225K	C CAPACITOR	2.2UF K		R54	RK73HB1J103J	MG RESISTOR	10K J 1/16W	
C945	CK73HB1A104K	C CAPACITOR	0.10UF K		R55	RK73HB1J000J	MG RESISTOR	0.0 J 1/16W	
C947	CC73HCH1H220J	C CAPACITOR	22PF J		R57	RK73HB1J000J	MG RESISTOR	0.0 J 1/16W	
C948	CK73HB1A393K	C CAPACITOR	0.039UF K		R58	RK73HB1J000J	MG RESISTOR	0.0 J 1/16W	
C949	CK73GB1H102K	C CAPACITOR	1000PF K		R59	RK73HB1J473J	MG RESISTOR	47K J 1/16W	
C950	CC73HCH1H470J	C CAPACITOR	47PF J		R60	RK73HB1J393J	MG RESISTOR	39K J 1/16W	
C951	CK73GB1H221K	C CAPACITOR	220PF K		R61	RK73HB1J393J	MG RESISTOR	39K J 1/16W	
C952	CC73HCH1H101J	C CAPACITOR	100PF J		R62	RK73HB1J473J	MG RESISTOR	47K J 1/16W	
C954	CK73GB1H471K	C CAPACITOR	470PF K		R63	RN73HH1J561D	MG RESISTOR	560 D 1/16W	
C955	CK73HB1H471K	C CAPACITOR	470PF K		R64	RN73HH1J391D	MG RESISTOR	390 D 1/16W	
C956	CC73HCH1H220J	C CAPACITOR	22PF J		R65	RK73GB2A104J	MG RESISTOR	100K J 1/10W	
C957	CC73GCH1H220J	C CAPACITOR	22PF J		R66	RK73HB1J472J	MG RESISTOR	4.7K J 1/16W	
C958	CK73HB1H471K	C CAPACITOR	470PF K		R67	RN73HH1J680D	MG RESISTOR	68 D 1/16W	
C959	CK73GB1H471K	C CAPACITOR	470PF K		R68	RN73HH1J101D	MG RESISTOR	100 D 1/16W	
C960	CC73GCH1H470J	C CAPACITOR	47PF J		R69	RK73HB1J102J	MG RESISTOR	1.0K J 1/16W	
C961	CK73HB1E103K	C CAPACITOR	0.010UF K		R70	RK73HB1J000J	MG RESISTOR	0.0 J 1/16W	
C962	CC73HCH1H220J	C CAPACITOR	22PF J		R71	RK73HB1J000J	MG RESISTOR	0.0 J 1/16W	
C963	CK73GB1H471K	C CAPACITOR	470PF K		R72	RK73HB1J124J	MG RESISTOR	120K J 1/16W	
C965	CK73HB1H471K	C CAPACITOR	470PF K		R73	RK73HB1J000J	MG RESISTOR	0.0 J 1/16W	
C966	CC73GCH1H101J	C CAPACITOR	100PF J		R74	RK73HB1J101J	MG RESISTOR	100 J 1/16W	
C967	CK73GB1H102K	C CAPACITOR	1000PF K		R76	RK73HB1J683J	MG RESISTOR	68K J 1/16W	
C968	CC73GCH1H470J	C CAPACITOR	47PF J		R77	RK73HB1J101J	MG RESISTOR	100 J 1/16W	
C969	CK73GB1H471K	C CAPACITOR	470PF K		R78	RK73HB1J101J	MG RESISTOR	100 J 1/16W	
C970	CK73GB1H471K	C CAPACITOR	470PF K		R79	RK73HB1J102J	MG RESISTOR	1.0K J 1/16W	
C971	CK73GB1H221K	C CAPACITOR	220PF K		R80	RK73HB1J000J	MG RESISTOR	0.0 J 1/16W	
C973	CK73HB1A104K	C CAPACITOR	0.10UF K		R81	RK73HB1J222J	MG RESISTOR	2.2K J 1/16W	
C974	CK73HB1A104K	C CAPACITOR	0.10UF K		R300	RK73GB2A472J	MG RESISTOR	4.7K J 1/10W	
C976	CK73HB0J105K	C CAPACITOR	1.0UF K		R301	RK73HB1J273J	MG RESISTOR	27K J 1/16W	
C977	CK73HB0J105K	C CAPACITOR	1.0UF K		R302	RK73HB1J472J	MG RESISTOR	4.7K J 1/16W	
C978	CC73HCH1H560J	C CAPACITOR	56PF J		R303	RK73HB1J103J	MG RESISTOR	10K J 1/16W	
C979	CK73HB1A104K	C CAPACITOR	0.10UF K		R310	RK73GB2A220J	MG RESISTOR	22 J 1/10W	
C980	CK73GB1A105K	C CAPACITOR	1.0UF K		R311	RK73GB2A220J	MG RESISTOR	22 J 1/10W	
C981	CK73HB1H102K	C CAPACITOR	1000PF K		R312	RK73GB2A470J	MG RESISTOR	47 J 1/10W	
C982	CK73GB1A105K	C CAPACITOR	1.0UF K		R314	RK73HB1J101J	MG RESISTOR	100 J 1/16W	
C983	CK73HB1H102K	C CAPACITOR	1000PF K		R316	RK73GB2A470J	MG RESISTOR	47 J 1/10W	
C987	CK73HB1H102K	C CAPACITOR	1000PF K		R317	RK73HB1J000J	MG RESISTOR	0.0 J 1/16W	
C988	CS77BB21A470M	TA E CAPACITOR	47UF 10WV		R318	RK73HB1J224J	MG RESISTOR	220K J 1/16W	
C989	CS77BB21A470M	TA E CAPACITOR	47UF 10WV		R320	RK73HB1J103J	MG RESISTOR	10K J 1/16W	
C990	CK73HB1E103K	C CAPACITOR	0.010UF K		R321	RK73HB1J103J	MG RESISTOR	10K J 1/16W	
C991	CK73HB1H102K	C CAPACITOR	1000PF K		R322	RK73HB1J000J	MG RESISTOR	0.0 J 1/16W	
C992	CC73HCH1H221J	C CAPACITOR	220PF J		R324	RK73HB1J333J	MG RESISTOR	33K J 1/16W	
C993	CK73HB1H471K	C CAPACITOR	470PF K		R325	RK73HB1J000J	MG RESISTOR	0.0 J 1/16W	
					R327	RK73HB1J223J	MG RESISTOR	22K J 1/16W	
R2	RK73HB1J103J	MG RESISTOR	10K J 1/16W		R329	RK73HB1J000J	MG RESISTOR	0.0 J 1/16W	
R4	RK73HB1J334J	MG RESISTOR	330K J 1/16W		R330	RK73HB1J000J	MG RESISTOR	0.0 J 1/16W	
R6	RK73HB1J184J	MG RESISTOR	180K J 1/16W		R331	RK73HB1J104J	MG RESISTOR	100K J 1/16W	
R7	RK73HB1J000J	MG RESISTOR	0.0 J 1/16W		R332	RK73HB1J104J	MG RESISTOR	100K J 1/16W	
R8	RK73HB1J101J	MG RESISTOR	100 J 1/16W		R334	RK73HB1J104J	MG RESISTOR	100K J 1/16W	
R9	RK73HB1J100J	MG RESISTOR	10 J 1/16W		R335	RK73GH2A560D	MG RESISTOR	56 D 1/10W	
R10	RK73HB1J101J	MG RESISTOR	100 J 1/16W		R337	RK73HB1J104J	MG RESISTOR	100K J 1/16W	
R11	RK73HB1J000J	MG RESISTOR	0.0 J 1/16W		R338	RK73HB1J104J	MG RESISTOR	100K J 1/16W	
R13	RK73HB1J000J	MG RESISTOR	0.0 J 1/16W		R340	RK73GH2A820D	MG RESISTOR	82 D 1/10W	
R14	RK73HB1J102J	MG RESISTOR	1.0K J 1/16W		R341	RK73HB1J000J	MG RESISTOR	0.0 J 1/16W	
R15	RK73HB1J000J	MG RESISTOR	0.0 J 1/16W		R342	RK73HB1J000J	MG RESISTOR	0.0 J 1/16W	
R16	RK73HB1J394J	MG RESISTOR	390K J 1/16W		R343	RK73HB1J104J	MG RESISTOR	100K J 1/16W	
R17	RK73HB1J331J	MG RESISTOR	330 J 1/16W		R344	RK73GH2A201D	MG RESISTOR	200 D 1/10W	
R19	RK73HB1J122J	MG RESISTOR	1.2K J 1/16W		R345	RK73HB1J000J	MG RESISTOR	0.0 J 1/16W	
R20	RK73HB1J273J	MG RESISTOR	27K J 1/16W		R346	RK73RB2H101J	MG RESISTOR	100 J 1/2W	
R21	RK73HB1J100J	MG RESISTOR	10 J 1/16W		R348	RK73GB2A102J	MG RESISTOR	1.0K J 1/10W	
R22	RK73HB1J103J	MG RESISTOR	10K J 1/16W		R350	RK73GB2A000J	MG RESISTOR	0.0 J 1/10W	
R23	RK73HB1J100J	MG RESISTOR	10 J 1/16W		R351	RK73GB2A000J	MG RESISTOR	0.0 J 1/10W	
R24	RK73HB1J000J	MG RESISTOR	0.0 J 1/16W		R352	RK73GB2A000J	MG RESISTOR	0.0 J 1/10W	
R25	RK73HB1J000J	MG RESISTOR	0.0 J 1/16W		R353	RK73GB2A000J	MG RESISTOR	0.0 J 1/10W	
R26	RK73HB1J152J	MG RESISTOR	1.5K J 1/16W		R354	RK73GH2A121D	MG RESISTOR	120 D 1/10W	
R27	RK73HB1J183J	MG RESISTOR	18K J 1/16W		R355	RK73GH2A181D	MG RESISTOR	180 D 1/10W	
R28	RK73HB1J391J	MG RESISTOR	390 J 1/16W		R356	R92-1061-05	JUMPER REST	0 OHM	
R31	RK73HB1J000J	MG RESISTOR	0.0 J 1/16W		R357	RK73HB1J472J	MG RESISTOR	4.7K J 1/16W	
R33	RK73HB1J000J	MG RESISTOR	0.0 J 1/16W		R358	RK73HB1J471J	MG RESISTOR	470 J 1/16W	
R35	RK73HB1J103J	MG RESISTOR	10K J 1/16W		R359	RK73HB1J100J	MG RESISTOR	10 J 1/16W	
R40	RK73HB1J102J	MG RESISTOR	1.0K J 1/16W		R360	RK73HB1J471J	MG RESISTOR	470 J 1/16W	
R42	RK73HB1J223J	MG RESISTOR	22K J 1/16W		R362	RK73HB1J000J	MG RESISTOR	0.0 J 1/16W	
R45	RK73HB1J153J	MG RESISTOR	15K J 1/16W		R500	RK73HB1J100J	MG RESISTOR	10 J 1/16W	
R47	RK73HB1J225J	MG RESISTOR	2.2M J 1/16W		R501	RK73GB2A104J	MG RESISTOR	100K J 1/10W	
R48	RK73HB1J000J	MG RESISTOR	0.0 J 1/16W		R503	RK73GB2A000J	MG RESISTOR	0.0 J 1/10W	
R50	RK73HB1J471J	MG RESISTOR	470 J 1/16W		R504	RK73HB1J564J	MG RESISTOR	560K J 1/16W	
R51	RK73HB1J154J	MG RESISTOR	150K J 1/16W		R508	RK73HB1J152J	MG RESISTOR	1.5K J 1/16W	

△ Symbol No.	Part No.	Part Name	Description	Local	△ Symbol No.	Part No.	Part Name	Description	Local
R509	RK73HB1J123J	MG RESISTOR	12K J 1/16W		R704	RK73HB1J000J	MG RESISTOR	0.0 J 1/16W	
R510	RK73HB1J104J	MG RESISTOR	100K J 1/16W		R705	RK73HB1J000J	MG RESISTOR	0.0 J 1/16W	
R512	RK73HB1J123J	MG RESISTOR	12K J 1/16W		R706	RK73HB1J000J	MG RESISTOR	0.0 J 1/16W	
R513	RK73HB1J334J	MG RESISTOR	330K J 1/16W		R707	RK73HB1J000J	MG RESISTOR	0.0 J 1/16W	
R514	RK73HB1J101J	MG RESISTOR	100 J 1/16W		R708	RK73HB1J000J	MG RESISTOR	0.0 J 1/16W	
R515	RK73HB1J332J	MG RESISTOR	3.3K J 1/16W		R709	RK73HB1J000J	MG RESISTOR	0.0 J 1/16W	
R516	RK73HB1J332J	MG RESISTOR	3.3K J 1/16W		R710	RK73HB1J000J	MG RESISTOR	0.0 J 1/16W	
R517	RK73HB1J000J	MG RESISTOR	0.0 J 1/16W		R711	RK73HB1J000J	MG RESISTOR	0.0 J 1/16W	
R518	RK73HB1J563J	MG RESISTOR	56K J 1/16W		R712	RK73HB1J000J	MG RESISTOR	0.0 J 1/16W	
R519	RK73HH1J473D	MG RESISTOR	47K D 1/16W		R713	RK73HB1J000J	MG RESISTOR	0.0 J 1/16W	
R520	RK73HB1J105J	MG RESISTOR	1.0M J 1/16W		R714	RK73HB1J000J	MG RESISTOR	0.0 J 1/16W	
R521	RK73HB1J224J	MG RESISTOR	220K J 1/16W		R715	RK73HB1J000J	MG RESISTOR	0.0 J 1/16W	
R523	RK73HB1J000J	MG RESISTOR	0.0 J 1/16W		R716	RK73HB1J000J	MG RESISTOR	0.0 J 1/16W	
R524	RK73HB1J000J	MG RESISTOR	0.0 J 1/16W		R717	RK73HB1J000J	MG RESISTOR	0.0 J 1/16W	
R525	RK73HB1J000J	MG RESISTOR	0.0 J 1/16W		R718	RK73HB1J104J	MG RESISTOR	100K J 1/16W	
R526	RK73HB1J000J	MG RESISTOR	0.0 J 1/16W		R720	RK73HB1J682J	MG RESISTOR	6.8K J 1/16W	
R527	RK73HB1J000J	MG RESISTOR	0.0 J 1/16W		R721	RK73HB1J682J	MG RESISTOR	6.8K J 1/16W	
R528	RK73HB1J104J	MG RESISTOR	100K J 1/16W		R722	RK73HB1J104J	MG RESISTOR	100K J 1/16W	
R529	RK73HB1J000J	MG RESISTOR	0.0 J 1/16W		R724	RK73HB1J000J	MG RESISTOR	0.0 J 1/16W	
R530	RK73HB1J100J	MG RESISTOR	10 J 1/16W		R727	RK73HB1J474J	MG RESISTOR	470K J 1/16W	
R532	RK73HB1J101J	MG RESISTOR	100 J 1/16W		R728	RK73HB1J102J	MG RESISTOR	1.0K J 1/16W	
R535	RK73HB1J473J	MG RESISTOR	47K J 1/16W		R729	RK73HB1J102J	MG RESISTOR	1.0K J 1/16W	
R536	RK73HB1J394J	MG RESISTOR	390K J 1/16W		R730	RK73HB1J000J	MG RESISTOR	0.0 J 1/16W	
R538	RK73HB1J121J	MG RESISTOR	120 J 1/16W		R732	RK73HB1J104J	MG RESISTOR	100K J 1/16W	
R540	RK73HB1J183J	MG RESISTOR	18K J 1/16W		R733	RK73HB1J561J	MG RESISTOR	560 J 1/16W	
R541	RK73HB1J474J	MG RESISTOR	470K J 1/16W		R734	RK73HB1J472J	MG RESISTOR	4.7K J 1/16W	
R542	RK73HB1J101J	MG RESISTOR	100 J 1/16W		R736	RK73HB1J681J	MG RESISTOR	680 J 1/16W	
R543	RK73HB1J682J	MG RESISTOR	6.8K J 1/16W		R737	RK73GB2A000J	MG RESISTOR	0.0 J 1/10W	
R544	RK73HB1J470J	MG RESISTOR	47 J 1/16W		R738	RK73HB1J102J	MG RESISTOR	1.0K J 1/16W	
R545	RK73HB1J152J	MG RESISTOR	1.5K J 1/16W		R739	RK73HB1J821J	MG RESISTOR	820 J 1/16W	
R546	RK73HB1J102J	MG RESISTOR	1.0K J 1/16W		R740	RK73HB1J223J	MG RESISTOR	22K J 1/16W	
R547	RK73HB1J104J	MG RESISTOR	100K J 1/16W		R741	RK73HB1J221J	MG RESISTOR	220 J 1/16W	
R548	RK73HB1J274J	MG RESISTOR	270K J 1/16W		R742	RK73HB1J000J	MG RESISTOR	0.0 J 1/16W	
R550	RK73HB1J391J	MG RESISTOR	390 J 1/16W		R743	RK73HB1J223J	MG RESISTOR	22K J 1/16W	
R551	RK73HB1J684J	MG RESISTOR	680K J 1/16W		R744	RK73HB1J473J	MG RESISTOR	47K J 1/16W	
R552	RK73HB1J224J	MG RESISTOR	220K J 1/16W		R745	RK73HB1J823J	MG RESISTOR	82K J 1/16W	
R553	RK73HB1J000J	MG RESISTOR	0.0 J 1/16W		R747	RK73HB1J101J	MG RESISTOR	100 J 1/16W	
R554	RK73HB1J474J	MG RESISTOR	470K J 1/16W		R748	RK73HB1J000J	MG RESISTOR	0.0 J 1/16W	
R555	RK73HB1J154J	MG RESISTOR	150K J 1/16W		R749	RK73HB1J222J	MG RESISTOR	2.2K J 1/16W	
R556	RK73HB1J823J	MG RESISTOR	82K J 1/16W		R750	RK73HB1J000J	MG RESISTOR	0.0 J 1/16W	
R557	RK73HB1J000J	MG RESISTOR	0.0 J 1/16W		R751	RK73HB1J000J	MG RESISTOR	0.0 J 1/16W	
R558	RK73HB1J823J	MG RESISTOR	82K J 1/16W		R752	RK73HB1J000J	MG RESISTOR	0.0 J 1/16W	
R560	RK73HB1J823J	MG RESISTOR	82K J 1/16W		R755	RK73HB1J000J	MG RESISTOR	0.0 J 1/16W	
R561	RK73HB1J000J	MG RESISTOR	0.0 J 1/16W		R757	RK73HB1J471J	MG RESISTOR	470 J 1/16W	
R562	RK73HB1J000J	MG RESISTOR	0.0 J 1/16W		R758	RK73HB1J334J	MG RESISTOR	330K J 1/16W	
R563	RK73HB1J105J	MG RESISTOR	1.0M J 1/16W		R759	RK73HB1J471J	MG RESISTOR	470 J 1/16W	
R566	RK73HB1J105J	MG RESISTOR	1.0M J 1/16W		R760	RK73HB1J823J	MG RESISTOR	82K J 1/16W	
R567	RK73HB1J105J	MG RESISTOR	1.0M J 1/16W		R761	RK73HB1J000J	MG RESISTOR	0.0 J 1/16W	
R568	RK73HB1J000J	MG RESISTOR	0.0 J 1/16W		R762	RK73HB1J000J	MG RESISTOR	0.0 J 1/16W	
R570	RK73HB1J000J	MG RESISTOR	0.0 J 1/16W		R764	RK73HB1J183J	MG RESISTOR	18K J 1/16W	
R571	RK73HB1J473J	MG RESISTOR	47K J 1/16W		R765	RK73GB2A000J	MG RESISTOR	0.0 J 1/10W	
R572	RK73HB1J151J	MG RESISTOR	150 J 1/16W		R768	RK73HB1J561J	MG RESISTOR	560 J 1/16W	
R573	RK73HB1J000J	MG RESISTOR	0.0 J 1/16W		R769	RK73HB1J101J	MG RESISTOR	100 J 1/16W	
R574	RK73HB1J104J	MG RESISTOR	100K J 1/16W		R770	RK73HB1J101J	MG RESISTOR	100 J 1/16W	
R575	RK73HB1J564J	MG RESISTOR	560K J 1/16W		R771	RK73HB1J000J	MG RESISTOR	0.0 J 1/16W	
R576	RK73HB1J223J	MG RESISTOR	22K J 1/16W		R772	RK73HB1J101J	MG RESISTOR	100 J 1/16W	
R577	RK73HB1J104J	MG RESISTOR	100K J 1/16W		R773	RK73HB1J101J	MG RESISTOR	100 J 1/16W	
R578	RK73HB1J683J	MG RESISTOR	68K J 1/16W		R774	RK73HB1J101J	MG RESISTOR	100 J 1/16W	
R579	RK73HB1J000J	MG RESISTOR	0.0 J 1/16W		R775	RK73HB1J471J	MG RESISTOR	470 J 1/16W	
R580	RK73HB1J223J	MG RESISTOR	22K J 1/16W		R776	RK73HB1J101J	MG RESISTOR	100 J 1/16W	
R581	RK73HB1J223J	MG RESISTOR	22K J 1/16W		R777	RK73GB2A124J	MG RESISTOR	120K J 1/10W	
R582	RK73HB1J000J	MG RESISTOR	0.0 J 1/16W		R778	RK73HB1J000J	MG RESISTOR	0.0 J 1/16W	
R583	RK73HB1J000J	MG RESISTOR	0.0 J 1/16W		R779	RK73HH1J473D	MG RESISTOR	47K D 1/16W	
R585	RK73HB1J104J	MG RESISTOR	100K J 1/16W		R780	RK73HH1J473D	MG RESISTOR	47K D 1/16W	
R586	RK73HB1J104J	MG RESISTOR	100K J 1/16W		R781	RK73HB1J104J	MG RESISTOR	100K J 1/16W	
R588	RK73FB2B000J	MG RESISTOR	0.0 J 1/8W		R782	RK73HB1J224J	MG RESISTOR	220K J 1/16W	
R592	RK73HB1J000J	MG RESISTOR	0.0 J 1/16W		R783	RK73HB1J683J	MG RESISTOR	68K J 1/16W	
R652	RK73HB1J473J	MG RESISTOR	47K J 1/16W		R784	RK73HB1J100J	MG RESISTOR	10 J 1/16W	
R653	RK73HB1J000J	MG RESISTOR	0.0 J 1/16W	M	R785	RK73HB1J000J	MG RESISTOR	0.0 J 1/16W	
R656	RK73HB1J100J	MG RESISTOR	10 J 1/16W		R786	RK73HB1J102J	MG RESISTOR	1.0K J 1/16W	
R657	RK73HB1J000J	MG RESISTOR	0.0 J 1/16W		R789	RK73HB1J102J	MG RESISTOR	1.0K J 1/16W	
R658	RK73HB1J222J	MG RESISTOR	2.2K J 1/16W		R792	RK73HB1J000J	MG RESISTOR	0.0 J 1/16W	
R660	RK73HB1J223J	MG RESISTOR	22K J 1/16W		R796	RK73HB1J333J	MG RESISTOR	33K J 1/16W	
R661	RK73HB1J101J	MG RESISTOR	100 J 1/16W		R797	RK73HB1J562J	MG RESISTOR	5.6K J 1/16W	
R700	RK73HB1J104J	MG RESISTOR	100K J 1/16W		R798	RK73HB1J392J	MG RESISTOR	3.9K J 1/16W	
R701	RK73HB1J101J	MG RESISTOR	100 J 1/16W		R799	RK73HB1J393J	MG RESISTOR	39K J 1/16W	
R702	RK73HB1J101J	MG RESISTOR	100 J 1/16W		R800	RK73HB1J333J	MG RESISTOR	33K J 1/16W	
R703	RK73HB1J102J	MG RESISTOR	1.0K J 1/16W		R802	RK73HB1J000J	MG RESISTOR	0.0 J 1/16W	

△ Symbol No.	Part No.	Part Name	Description	Local	△ Symbol No.	Part No.	Part Name	Description	Local
R804	RK73HB1J104J	MG RESISTOR	100K J 1/16W		R907	RK73HB1J100J	MG RESISTOR	10 J 1/16W	
R805	RK73GB2A104J	MG RESISTOR	100K J 1/10W		R908	RK73HB1J473J	MG RESISTOR	47K J 1/16W	
R807	RK73HB1J102J	MG RESISTOR	1.0K J 1/16W		R909	RK73HB1J473J	MG RESISTOR	47K J 1/16W	
R809	RK73HB1J103J	MG RESISTOR	10K J 1/16W		R910	RK73HB1J473J	MG RESISTOR	47K J 1/16W	
R811	RK73HB1J000J	MG RESISTOR	0.0 J 1/16W		R911	RK73HB1J473J	MG RESISTOR	47K J 1/16W	
R812	RK73HB1J000J	MG RESISTOR	0.0 J 1/16W		R912	RK73HB1J000J	MG RESISTOR	0.0 J 1/16W	
R813	RK73HB1J104J	MG RESISTOR	100K J 1/16W		R913	RK73HB1J102J	MG RESISTOR	1.0K J 1/16W	
R815	RK73HB1J102J	MG RESISTOR	1.0K J 1/16W		R914	RK73HB1J000J	MG RESISTOR	0.0 J 1/16W	
R816	RK73HB1J224J	MG RESISTOR	220K J 1/16W		R916	RK73HB1J000J	MG RESISTOR	0.0 J 1/16W	
R819	RK73HB1J104J	MG RESISTOR	100K J 1/16W		R917	RK73HB1J000J	MG RESISTOR	0.0 J 1/16W	
R820	RK73HB1J104J	MG RESISTOR	100K J 1/16W		R918	RK73HB1J000J	MG RESISTOR	0.0 J 1/16W	
R821	RK73HB1J000J	MG RESISTOR	0.0 J 1/16W		R919	RK73HB1J000J	MG RESISTOR	0.0 J 1/16W	
R822	RK73HB1J393J	MG RESISTOR	39K J 1/16W		R920	RK73HB1J000J	MG RESISTOR	0.0 J 1/16W	
R823	RK73HB1J104J	MG RESISTOR	100K J 1/16W		R921	RK73HB1J000J	MG RESISTOR	0.0 J 1/16W	
R824	RK73HB1J104J	MG RESISTOR	100K J 1/16W		R922	RK73HB1J000J	MG RESISTOR	0.0 J 1/16W	
R825	RK73GB2A100J	MG RESISTOR	10 J 1/10W		R923	RK73HB1J000J	MG RESISTOR	0.0 J 1/16W	
R826	RK73HB1J101J	MG RESISTOR	100 J 1/16W		R924	RK73HB1J000J	MG RESISTOR	0.0 J 1/16W	
R827	RK73HB1J104J	MG RESISTOR	100K J 1/16W		R925	RK73HB1J000J	MG RESISTOR	0.0 J 1/16W	
R828	RK73GB2A000J	MG RESISTOR	0.0 J 1/10W		R926	RK73HB1J103J	MG RESISTOR	10K J 1/16W	
R829	RK73HB1J123J	MG RESISTOR	12K J 1/16W		R927	RK73HB1J102J	MG RESISTOR	1.0K J 1/16W	
R830	RK73HB1J101J	MG RESISTOR	100 J 1/16W		R928	RK73HB1J103J	MG RESISTOR	10K J 1/16W	
R832	RK73HB1J473J	MG RESISTOR	47K J 1/16W		R929	RK73HB1J473J	MG RESISTOR	47K J 1/16W	
R833	RK73HB1J104J	MG RESISTOR	100K J 1/16W		R930	RK73HB1J473J	MG RESISTOR	47K J 1/16W	
R835	RK73HB1J101J	MG RESISTOR	100 J 1/16W		R931	RK73HB1J473J	MG RESISTOR	47K J 1/16W	
R836	RK73HB1J104J	MG RESISTOR	100K J 1/16W		R933	RK73HB1J000J	MG RESISTOR	0.0 J 1/16W	
R837	RK73HB1J473J	MG RESISTOR	47K J 1/16W		R934	RK73HB1J000J	MG RESISTOR	0.0 J 1/16W	
R840	RK73HB1J101J	MG RESISTOR	100 J 1/16W		R936	RK73HB1J000J	MG RESISTOR	0.0 J 1/16W	
R843	RK73HB1J000J	MG RESISTOR	0.0 J 1/16W		R938	RK73HB1J473J	MG RESISTOR	47K J 1/16W	
R846	RK73HB1J473J	MG RESISTOR	47K J 1/16W		R939	RK73HB1J473J	MG RESISTOR	47K J 1/16W	
R848	RK73HB1J000J	MG RESISTOR	0.0 J 1/16W		R940	RK73HB1J103J	MG RESISTOR	10K J 1/16W	
R849	RK73HB1J103J	MG RESISTOR	10K J 1/16W		R942	RK73HB1J472J	MG RESISTOR	4.7K J 1/16W	
R850	RK73HH1J124D	MG RESISTOR	120K D 1/16W		R943	RK73HB1J152J	MG RESISTOR	1.5K J 1/16W	
R854	RK73HH1J224D	MG RESISTOR	220K D 1/16W		R944	RK73HB1J472J	MG RESISTOR	4.7K J 1/16W	
R855	RK73HB1J820J	MG RESISTOR	82 J 1/16W		R946	RK73HB1J473J	MG RESISTOR	47K J 1/16W	
R857	RK73HB1J000J	MG RESISTOR	0.0 J 1/16W		R947	RK73HB1J473J	MG RESISTOR	47K J 1/16W	
R858	RK73HB1J682J	MG RESISTOR	6.8K J 1/16W		R948	RK73HB1J000J	MG RESISTOR	0.0 J 1/16W	
R859	RK73GB2A000J	MG RESISTOR	0.0 J 1/10W		R949	RK73HB1J472J	MG RESISTOR	4.7K J 1/16W	
R861	RK73HB1J472J	MG RESISTOR	4.7K J 1/16W		R950	RK73HB1J224J	MG RESISTOR	220K J 1/16W	
R863	RK73HB1J000J	MG RESISTOR	0.0 J 1/16W		R951	RK73HB1J224J	MG RESISTOR	220K J 1/16W	
R864	RK73HB1J222J	MG RESISTOR	2.2K J 1/16W		R952	RK73HB1J823J	MG RESISTOR	82K J 1/16W	
R865	RK73HB1J473J	MG RESISTOR	47K J 1/16W		R953	RK73HB1J823J	MG RESISTOR	82K J 1/16W	
R866	RK73HH1J334D	MG RESISTOR	330K D 1/16W		R954	RK73HB1J471J	MG RESISTOR	470 J 1/16W	
R867	RK73HH1J154D	MG RESISTOR	150K D 1/16W		R955	RK73HB1J222J	MG RESISTOR	2.2K J 1/16W	
R868	RK73HB1J332J	MG RESISTOR	3.3K J 1/16W		R956	RK73HB1J222J	MG RESISTOR	2.2K J 1/16W	
R870	RK73HB1J220J	MG RESISTOR	22 J 1/16W		R958	RK73HB1J104J	MG RESISTOR	100K J 1/16W	
R871	RK73HB1J474J	MG RESISTOR	470K J 1/16W		R959	RK73HB1J104J	MG RESISTOR	100K J 1/16W	
R872	RK73HB1J820J	MG RESISTOR	82 J 1/16W		R960	RK73HB1J102J	MG RESISTOR	1.0K J 1/16W	
R873	RK73HB1J000J	MG RESISTOR	0.0 J 1/16W		R961	RK73GB2A221J	MG RESISTOR	220 J 1/10W	
R875	RK73HB1J102J	MG RESISTOR	1.0K J 1/16W		R962	RK73HB1J391J	MG RESISTOR	390 J 1/16W	
R876	RK73HB1J473J	MG RESISTOR	47K J 1/16W		R964	RK73FB2B000J	MG RESISTOR	0.0 J 1/8W	
R877	RK73HB1J102J	MG RESISTOR	1.0K J 1/16W		R965	RK73GB2A473J	MG RESISTOR	47K J 1/10W	
R878	RK73HB1J102J	MG RESISTOR	1.0K J 1/16W		R966	RK73FB2B000J	MG RESISTOR	0.0 J 1/8W	
R879	RK73HB1J000J	MG RESISTOR	0.0 J 1/16W		R968	RK73GB2A334J	MG RESISTOR	330K J 1/10W	
R880	RK73HB1J000J	MG RESISTOR	0.0 J 1/16W		R969	RK73HB1J474J	MG RESISTOR	470K J 1/16W	
R881	RK73HB1J000J	MG RESISTOR	0.0 J 1/16W		R970	RK73HB1J564J	MG RESISTOR	560K J 1/16W	
R882	RK73HB1J473J	MG RESISTOR	47K J 1/16W		R971	RK73HB1J000J	MG RESISTOR	0.0 J 1/16W	
R883	RK73HB1J000J	MG RESISTOR	0.0 J 1/16W		R972	RK73HB1J104J	MG RESISTOR	100K J 1/16W	
R884	RK73HB1J000J	MG RESISTOR	0.0 J 1/16W		R973	RK73HB1J000J	MG RESISTOR	0.0 J 1/16W	
R885	RK73HB1J000J	MG RESISTOR	0.0 J 1/16W		R974	RK73HB1J474J	MG RESISTOR	470K J 1/16W	
R886	RK73HB1J000J	MG RESISTOR	0.0 J 1/16W		R975	RK73HB1J474J	MG RESISTOR	470K J 1/16W	
R888	RK73HB1J104J	MG RESISTOR	100K J 1/16W		R976	RK73HB1J473J	MG RESISTOR	47K J 1/16W	
R889	RK73HB1J123J	MG RESISTOR	12K J 1/16W		R977	RK73HB1J472J	MG RESISTOR	4.7K J 1/16W	
R890	RK73HB1J000J	MG RESISTOR	0.0 J 1/16W		R978	RK73HB1J103J	MG RESISTOR	10K J 1/16W	
R891	RK73HB1J105J	MG RESISTOR	1.0M J 1/16W		R979	RK73HB1J223J	MG RESISTOR	22K J 1/16W	
R892	RK73HB1J153J	MG RESISTOR	15K J 1/16W		R981	RK73HB1J000J	MG RESISTOR	0.0 J 1/16W	HK,HUK
R893	RK73HB1J102J	MG RESISTOR	1.0K J 1/16W		R984	RK73GB2A000J	MG RESISTOR	0.0 J 1/10W	
R895	RK73HB1J102J	MG RESISTOR	1.0K J 1/16W		R985	RK73HB1J103J	MG RESISTOR	10K J 1/16W	
R896	RK73HB1J222J	MG RESISTOR	2.2K J 1/16W		R986	RK73HB1J102J	MG RESISTOR	1.0K J 1/16W	
R897	RK73HB1J102J	MG RESISTOR	1.0K J 1/16W		R987	RK73HB1J102J	MG RESISTOR	1.0K J 1/16W	
R898	RK73GH2A134D	MG RESISTOR	130K D 1/10W		R988	RK73HB1J102J	MG RESISTOR	1.0K J 1/16W	
R899	RK73GH2A123D	MG RESISTOR	12K D 1/10W		R989	RK73HB1J102J	MG RESISTOR	1.0K J 1/16W	
R900	RK73HB1J000J	MG RESISTOR	0.0 J 1/16W		R990	RK73HB1J474J	MG RESISTOR	470K J 1/16W	
R901	RK73HB1J000J	MG RESISTOR	0.0 J 1/16W		R991	RK73HB1J472J	MG RESISTOR	4.7K J 1/16W	
R902	RK73HB1J000J	MG RESISTOR	0.0 J 1/16W		R992	RK73HB1J472J	MG RESISTOR	4.7K J 1/16W	
R903	RK73HB1J473J	MG RESISTOR	47K J 1/16W		R993	RK73HB1J104J	MG RESISTOR	100K J 1/16W	
R904	RK73HB1J104J	MG RESISTOR	100K J 1/16W		R994	RK73HB1J000J	MG RESISTOR	0.0 J 1/16W	HK,HUK
R905	RK73HB1J102J	MG RESISTOR	1.0K J 1/16W		R996	RK73GB2A000J	MG RESISTOR	0.0 J 1/10W	
R906	RK73HB1J103J	MG RESISTOR	10K J 1/16W		R997	RK73HB1J101J	MG RESISTOR	100 J 1/16W	

△ Symbol No.	Part No.	Part Name	Description	Local	△ Symbol No.	Part No.	Part Name	Description	Local
R998	RK73HB1J101J	MG RESISTOR	100 J 1/16W		CP707	RK75HA1J102J	CHIP-COM	1.0K J 1/16W	
R999	RK73HB1J101J	MG RESISTOR	100 J 1/16W		CP708	RK74HA1J102J	CHIP-COM	1.0K J 1/16W	
L1	L41-4795-39	SMALL FIXED INDUCTOR (4.7U)			F700	F53-0324-15	FUSE	(2.5A)	
L2	L92-0442-05	CHIP FERRITE			F701	F53-0327-15	FUSE	(4A)	
L4	L92-0443-05	CHIP FERRITE			F702	F53-0324-15	FUSE	(2.5A)	
L7	L40-6865-71	SMALL FIXED INDUCTOR (6.8NH)			F703	F53-0317-15	FUSE	(500MA)	
L8	L40-2275-71	SMALL FIXED INDUCTOR (22NH)			F704	F53-0317-15	FUSE	(500MA)	
L10	L40-2785-92	SMALL FIXED INDUCTOR (270NH)			J700	E58-0567-05	SUB SOCKET(D)		
L12	L40-2785-92	SMALL FIXED INDUCTOR (270NH)			J701	E1B-0001-00	3.5D PHONE JACK		
L15	L92-0163-05	BEADS CORE			TH301	B57331V2104J	THERMISTOR		
L16	L40-2285-92	SMALL FIXED INDUCTOR (220NH)			TH302	B57331V2104J	THERMISTOR		
L18	L92-0163-05	BEADS CORE			TH303	B57331V2104J	THERMISTOR		
L21	L40-2285-92	SMALL FIXED INDUCTOR (220NH)			TH502	NCP18WM474J0S	THERMISTOR		
L22	L40-2285-92	SMALL FIXED INDUCTOR (220NH)			X1	L77-3128-05	TCXO	(16.8MHZ)	
L23	L40-2285-92	SMALL FIXED INDUCTOR (220NH)			X700	L77-3129-05	TCXO	(19.2MHZ)	
L24	L40-2285-92	SMALL FIXED INDUCTOR (220NH)			XF500	L71-0684-05	MCF	(49.95MHZ)	
L27	L40-2285-92	SMALL FIXED INDUCTOR (220NH)							
L28	L92-0443-05	CHIP FERRITE							
L30	L41-2278-14	SMALL FIXED INDUCTOR (22NH)							
L31	L41-2278-14	SMALL FIXED INDUCTOR (22NH)							
L33	L40-2702-86	SMALL FIXED INDUCTOR (27UH)							
L34	L40-2785-92	SMALL FIXED INDUCTOR (270NH)							
L36	L40-2785-92	SMALL FIXED INDUCTOR (270NH)							
L37	L40-2702-86	SMALL FIXED INDUCTOR (27UH)							
L39	L92-0443-05	CHIP FERRITE							
L40	L40-3375-71	SMALL FIXED INDUCTOR (33NH)							
L41	L40-3375-71	SMALL FIXED INDUCTOR (33NH)							
L300	L40-8265-71	SMALL FIXED INDUCTOR (8.2NH)							
L301	L40-4763-71	SMALL FIXED INDUCTOR (4.7NH)							
L302	L40-1075-92	SMALL FIXED INDUCTOR (10NH)							
L303	L40-1575-92	SMALL FIXED INDUCTOR (15NH)							
L304	L40-1275-92	SMALL FIXED INDUCTOR (12NH)							
L305	L40-1275-92	SMALL FIXED INDUCTOR (12NH)							
L307	L92-0179-05	CHIP FERRITE							
L308	L92-0179-05	CHIP FERRITE							
L309	L92-0179-05	CHIP FERRITE							
L310	L34-1039-05	AIR-CORE COIL							
L311	L34-4902-05	AIR-CORE COIL							
L312	L34-1039-05	AIR-CORE COIL							
L313	L34-1113-05	AIR-CORE COIL							
L314	L34-1113-05	AIR-CORE COIL							
L315	L34-4902-05	AIR-CORE COIL							
L316	L40-1875-71	SMALL FIXED INDUCTOR (18NH)							
L318	L40-1875-71	SMALL FIXED INDUCTOR (18NH)							
L500	L41-1885-53	SMALL FIXED INDUCTOR (0.18UH)							
L501	L40-1085-71	SMALL FIXED INDUCTOR (100NH)							
L502	L40-1591-86	SMALL FIXED INDUCTOR (1.5UH)							
L503	L41-2785-39	SMALL FIXED INDUCTOR (0.27U)							
L504	L41-6885-39	SMALL FIXED INDUCTOR (0.68U)							
L506	L41-6868-14	SMALL FIXED INDUCTOR (6.8NH)							
L507	L41-6868-14	SMALL FIXED INDUCTOR (6.8NH)							
L508	L41-6868-14	SMALL FIXED INDUCTOR (6.8NH)							
L509	L41-2788-45	SMALL FIXED INDUCTOR (270NH)							
L510	L40-2775-92	SMALL FIXED INDUCTOR (27NH)							
L512	L41-6868-14	SMALL FIXED INDUCTOR (6.8NH)							
L513	L41-6868-14	SMALL FIXED INDUCTOR (6.8NH)							
L514	L40-1875-92	SMALL FIXED INDUCTOR (18NH)							
L516	L40-1875-92	SMALL FIXED INDUCTOR (18NH)							
L517	L41-8275-45	SMALL FIXED INDUCTOR (82NH)							
L700	L92-0163-05	BEADS CORE							
L701	L92-0163-05	BEADS CORE							
L702	L92-0163-05	BEADS CORE							
L703	L92-0163-05	BEADS CORE							
L704	L92-0163-05	BEADS CORE							
L705	L92-0443-05	CHIP FERRITE							
L706	L92-0163-05	BEADS CORE							
L707	L92-0163-05	BEADS CORE							
L710	L92-0161-05	BEADS CORE							
CN700	E40-6847-05	FLAT CABLE CONNECTOR							
CP1	RK75HA1J101J	CHIP-COM	100 J 1/16W						
CP701	RK74HA1J104J	CHIP-COM	100K J 1/16W						
CP702	RK74HB1J104J	CHIP-COM	100K J 1/16W						
CP703	RK74HA1J104J	CHIP-COM	100K J 1/16W						
CP704	RK75HA1J473J	CHIP-COM	47K J 1/16W						
CP705	RK74HA1J102J	CHIP-COM	1.0K J 1/16W						
CP706	RK75HA1J473J	CHIP-COM	47K J 1/16W						

# Packing materials and accessories parts list

Block No.M2MM

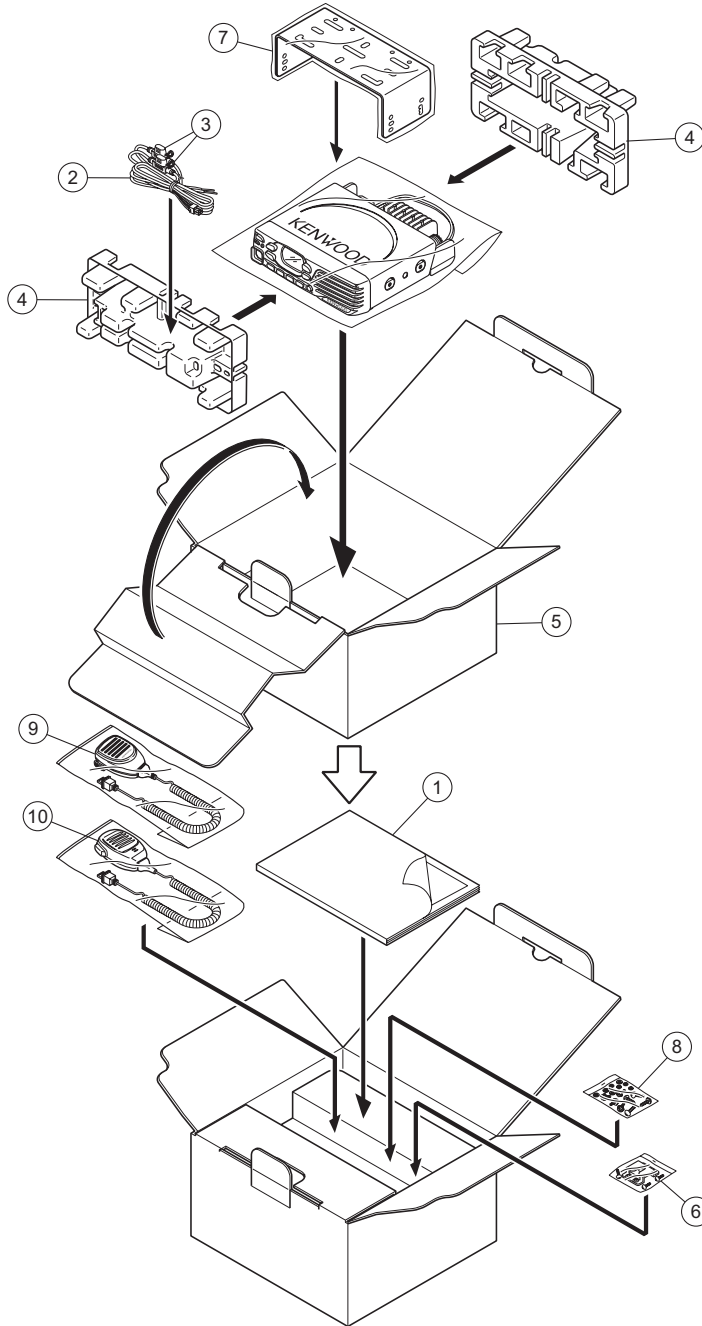

## Packing and accessories

Block No. [M][2][M][M]  
Local

Symbol No.	Part No.	Part Name	Description	Local
1	B5A-0031-10	INSTRUCTION MANUAL		HK,HUK
1	B5A-0030-10	INSTRUCTION MANUAL		M
2	E30-7523-55	DC CORD ASSY ACCESSORY		
3	F52-0024-05	FUSE(BLADE TYPE)15A ACCESSORY	(x2)	HK,HUK
3	F52-0023-05	FUSE(BLADE TYPE)10A ACCESSORY	(x2)	M
4	H12-3178-05	PACKING FIXTURE	(x2)	
5	H52-2674-02	ITEM CARTON CASE		
6	J19-1584-15	HOLDER(MIC HANGER)		HK,HUK
7	J29-0726-03	BRACKET ACCESSORY		
8	N99-2039-05	SCREW SET		
9	T91-0624-65	MICROPHONE(KMC-30) ACCESSORY		HK
10	T91-0639-65	MICROPHONE(KMC-35) ACCESSORY		HUK



# MEMO



# KENWOOD

JVC KENWOOD Corporation  
Communications Equipment Div

---

(No.RA011<Rev.001>)

Printed in Japan  
VSE