

NXR-700

SERVICE MANUAL

E version

KENWOOD

Kenwood Corporation

© 2009-4 PRINTED IN JAPAN
B51-8853-00 (N) 114

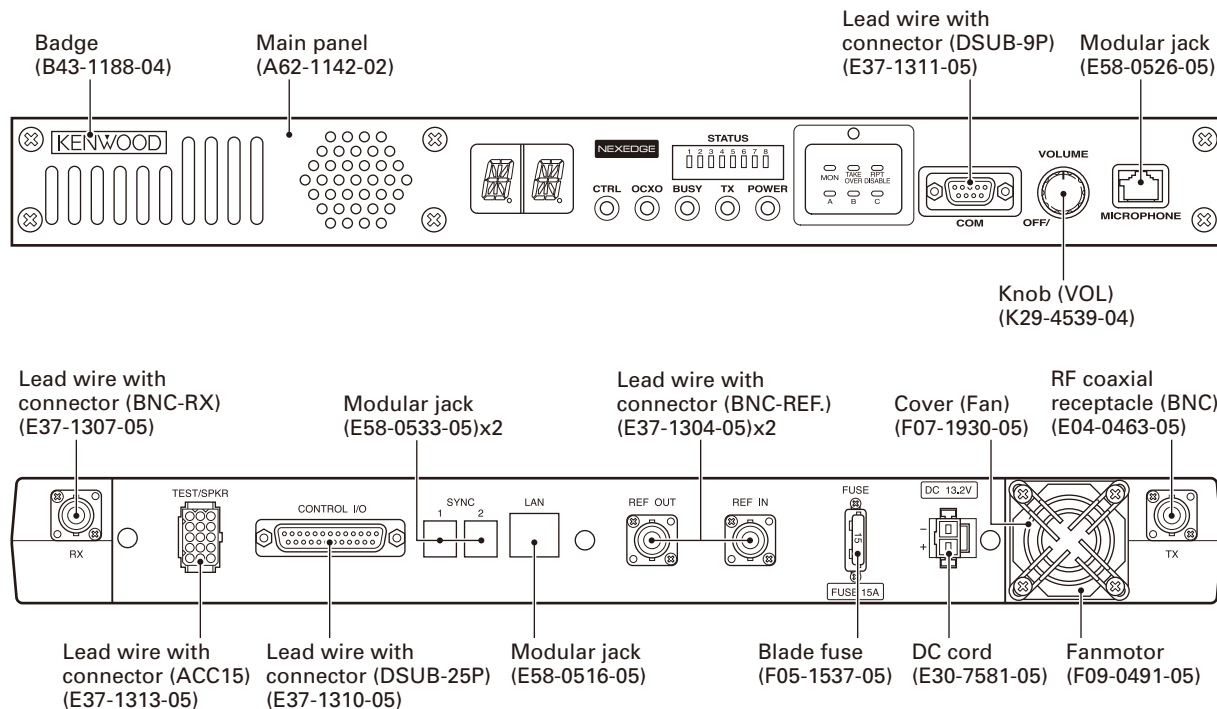

CONTENTS

GENERAL	2	PACKING	70
SYSTEM SET-UP	3	TROUBLE SHOOTING	71
REALIGNMENT	3	ADJUSTMENT	79
OPERATING FEATURES	5	PC BOARD	92
INSTALLATION	6	BLOCK DIAGRAM	114
CIRCUIT DESCRIPTION	8	INTERCONNECTION DIAGRAM	118
COMPONENTS DESCRIPTION	24	SCHEMATIC DIAGRAM	122
TERMINAL FUNCTION	28	OPTIONAL ACCESSORIES	146
PARTS LIST	39	SPECIFICATIONS	BACK COVER
EXPLODED VIEW	68		



NXR-700

Document Copyrights

Copyright 2009 by Kenwood Corporation. All rights reserved.

No part of this manual may be reproduced, translated, distributed, or transmitted in any form or by any means, electronic, mechanical, photocopying, recording, or otherwise, for any purpose without the prior written permission of Kenwood.

Disclaimer

While every precaution has been taken in the preparation of this manual, Kenwood assumes no responsibility for errors or omissions. Neither is any liability assumed for damages resulting from the use of the information contained herein. Kenwood reserves the right to make changes to any products herein at any time for improvement purposes.

Firmware Copyrights

The title to and ownership of copyrights for firmware embedded in Kenwood product memories are reserved for Kenwood Corporation. Any modifying, reverse engineering, copy, reproducing or disclosing on an Internet website of the firmware is strictly prohibited without prior written consent of Kenwood Corporation. Furthermore, any reselling, assigning or transferring of the firmware is also strictly prohibited without embedding the firmware in Kenwood product memories.

NXDN Transceivers:

The AMBE+2(TM) voice coding technology is embedded in the firmware under the license of Digital Voice Systems, Inc.

GENERAL

INTRODUCTION

SCOPE OF THIS MANUAL

This manual is intended for use by experienced technicians familiar with similar types of commercial grade communications equipment. It contains all required service information for the equipment and is current as of the publication date. Changes which may occur after publication are covered by either Service Bulletins or Manual Revisions. These are issued as required.

ORDERING REPLACEMENT PARTS

When ordering replacement parts or equipment information, the full part identification number should be included. This applies to all parts : components, kits, or chassis. If the part number is not known, include the chassis or kit number of which it is a part, and a sufficient description of the required component for proper identification.

PERSONAL SAFETY

The following precautions are recommended for personal safety :

- DONOT transmit if someone is within two feet (0.6 meter) of the antenna.
- DONOT transmit until all RF connectors are secure and any open connectors are properly terminated.
- SHUT OFF this equipment when near electrical blasting caps or while in an explosive atmosphere.
- All equipment should be properly grounded before powerup for safe operation.
- This equipment should be serviced by only qualified technicians.

SERVICE

This transceiver is designed for easy servicing. Refer to the schematic diagrams, printed circuit board views, and alignment procedures contained within.

SYSTEM SET-UP

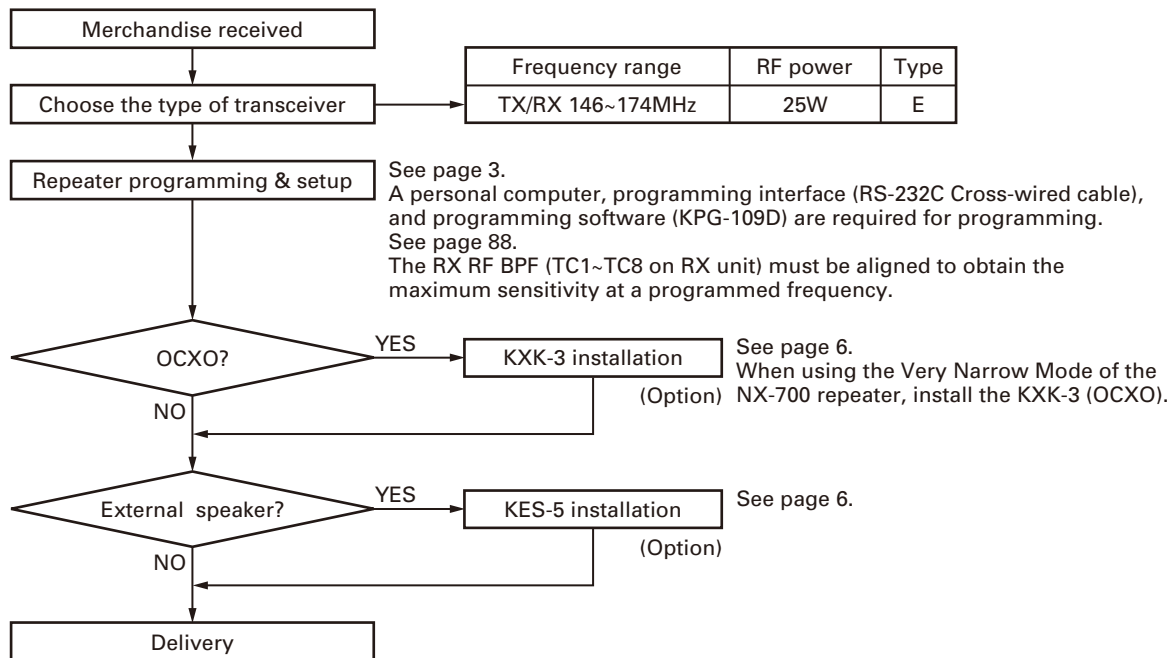

REALIGNMENT

1. Modes

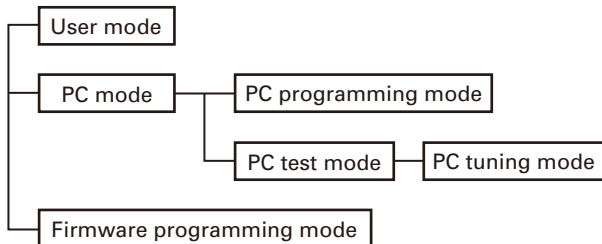

Mode	Function
User mode	Use this mode for normal operation.
PC mode	Use this mode to make various settings by means of the FPU through the RS-232C port.
PC programming mode	Use to read and write frequency data and other features to and from the repeater.
PC test mode	Use to check the repeater using the PC. This feature is included in the FPU.
Firmware programming mode	Use when changing the firmware program of the flash memory.

2. How to Enter Each Mode

Mode	Operation
User mode	Power on.
PC mode	Received commands from PC.
Firmware programming mode	Received commands from PC.

3. PC Mode

3-1. Preface

The NXR-700 repeater is programmed by using a personal computer, programming interface and KPG-109D software.

3-2. Connection Procedure

1. Connect the NXR-700 to the personal computer with the interface cable.
2. When power is applied, the user mode is entered immediately. When the PC sends a command, the repeater enters the PC mode and displays "PC" on the 17-segment LED. When data is being transmitted to the PC from the repeater, the TX LED flashes. The BUSY LED flashes when data from the PC is being received by the repeater.

Note:

- The data stored in the personal computer must match the model type, when it is written into the flash memory.
- Change the NXR-700 to PC mode, then attach the RS-232C Cross-wired cable.

NXR-700

REALIGNMENT

3-3. KCT-53U Description (USB adapter: Option)

The KCT-53U is cable which connects the RS-232C Cross-wired cable to a USB port on a computer.

When using the KCT-53U, install the supplied CD-ROM (with driver software) in the computer. The KCT-53U driver runs under Windows 2000, XP or Vista (32-bit).

3-4. Programming Software Description

The KPG-109D is the programming software for NXR-700 supplied on a CD-ROM. This software runs under Windows 2000, XP or Vista on a PC.

The data can be input to or read from NXR-700 and edited on the screen. The programmed or edited data can be printed out. It is also possible to tune the transceiver.

3-5. Programming With PC

Data can be programmed into the flash memory in RS-232C format via the COM connector.

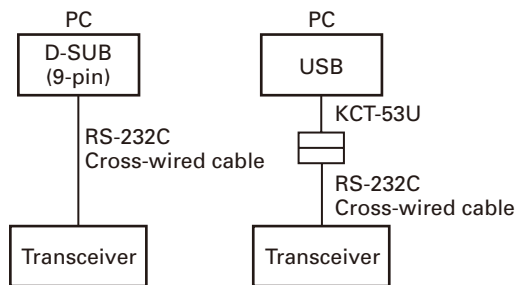
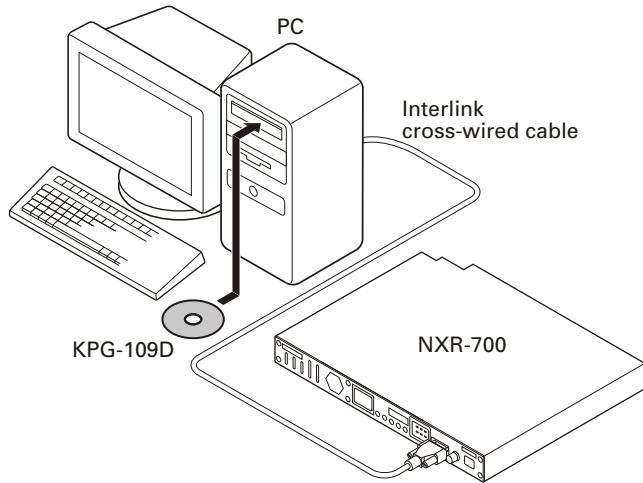

Fig. 1

4. Firmware Programming Mode

4-1. Preface

The NXR-700 uses flash memory to allow it to be easily upgraded when new features are released in the future.

4-2. Connection Procedure

Connect the NXR-700 to the personal computer with the RS-232C Cross-wired cable. (Connection is the same as in the PC mode.)

Note:

You can only program firmware from the DB-9 COM connector on the front panel. Using the 25-pin logic interface on the rear panel will not work.

4-3. Programming

1. Start up the programming software (Fpro. exe).
The Fpro. exe exists in the KPG-109D installed holder.
2. Set the communications speed (normally, 115200 bps) and communications port in the configuration item.
3. Set the firmware to be updated by file name item.
4. Turn the NXR-700 power on.
5. Check the connection between the NXR-700 and the personal computer, and make sure that the NXR-700 is in the program mode.
6. Press write button in the window. A window opens on the display to indicate progress of writing.
7. If writing ends successfully, the NXR-700 restarts.
8. If you want to continue programming other NXR-700s, repeat steps 3 to 6.

Note:

It automatically enters the firmware program mode by the writing request from the programming software (KPG-109D).

4-4. Function

Baud rate is decided automatically with setting of programming software.

Note:

Normally, write in the high-speed mode (115200 bps).

■ Cross-wired cable

There are a few types of null modem cable available in the market. Make sure to use one of the following null modem cables that meets the following specifications.

Cable Specification: Null modem cable with full handshaking (cross-wired) or InterLink cable that is usually used to transfer files between PCs.

Connector Specification (both cable ends): DB-9 female

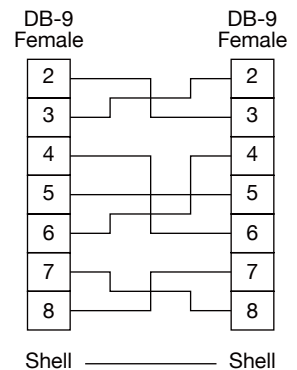
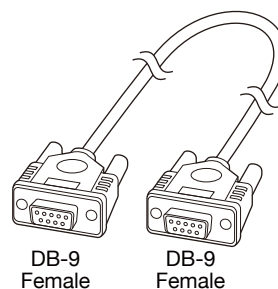

OPERATING FEATURES

1. Two 17-segment LED Displays

- Channel display (1~30): While operating normally in user mode.

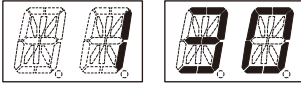

- When the displayed channel is contained in scan sequence, the right side decimal point is displayed.



- When the displayed channel is the priority channel, the left side decimal point is displayed.

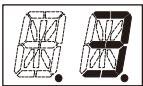

- "PC" is displayed while in PC mode.



- "PG" is displayed while in firmware programming mode.



- "E1" is displayed when FPU data is not written.

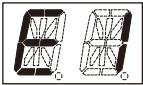

- "E2" is displayed when the channel data is not written.



- "E3" is displayed when PLL is unlocked.
Receiver PLL unlocked = BUSY LED blinks.
Transmitter PLL unlocked = TX LED blinks.



- "E4" is displayed when PTT is attempted on a channel number that has no frequency data programmed.



- "E5" is displayed when IP address configuration is error.



- "E7" is displayed when the thermal protection occurs.



- "SC" is displayed while in scan mode.

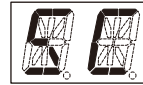

All segments ON

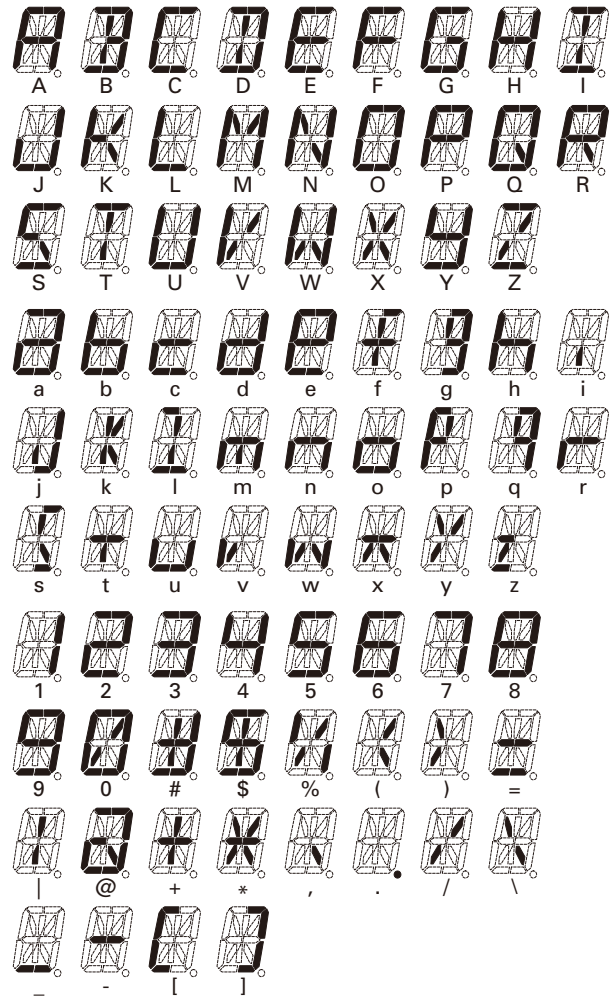

INSTALLATION

1. OCXO (KXK-3)

1. Before installing the KXK-3, be sure to turn the power off.
2. Remove the top cover of the TX unit.
3. Mount the KXK-3 using the 5 screws.
4. Carefully connect and lock the flat cable to CN1 and CN803, with the conductor side facing in.
5. Connect the coaxial cable to CN2 and CN407.
6. Connect the 2-pin cable to CN3 and CN807.

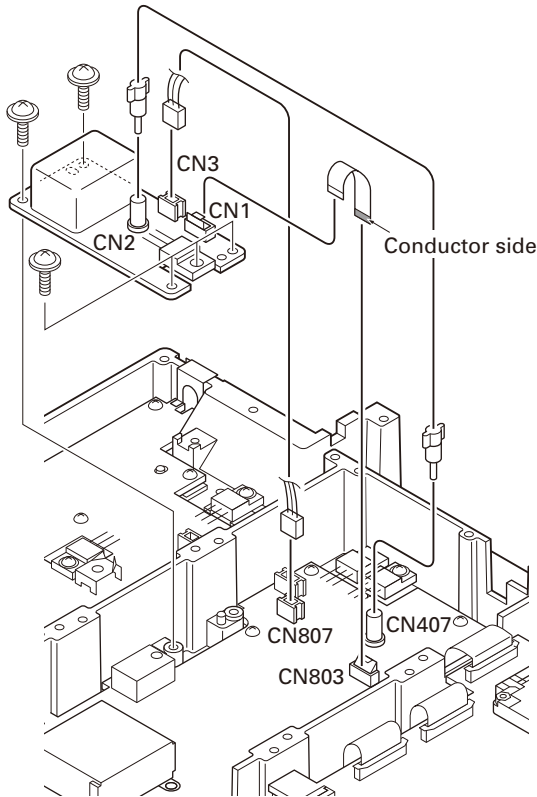

Fig. 1

2. External Speaker (KES-5)

The NXR-700 has a internal built-in speaker, and the external speaker output from the TEST/SPKR connector (15-pin) on the rear of the radio is 3W/4Ω. Use external speaker KES-5.

2-1. Connection for the KES-5 With the NXR-700

■ When taking the AF output from the TEST/SPKR connector (15-pin) on the rear of the radio

The following tools are required for changing the connector.

• Extracting tool

The following extracting tool is recommended:
Molex Inc. Order No.: 11-03-0002 (W05-0878-00)

1. Remove the connector with jumper from the external speaker connector on the rear panel of the radio. (Fig. 2-1)
Note: Save the jumper, which is required when the radio is used without the external speaker.
2. Remove the terminals with the jumper from the connector housing holes number 9 and 12 using the extracting tool.

Removing the jumper lead (Fig. 2-2)

- 1) Insert the extracting tool (11-03-0002) into the connector while pushing the jumper lead in the direction of (a).
- 2) Push the extracting tool into collapse the barbs of the crimp terminal.
- 3) Pull out the lead while continuing to push the extracting tool in the direction (b).
3. Reinsert the terminal with the black and white stripe lead into hole number 12, and the terminal with the black lead into hole number 6. (Fig. 2-3)
4. Attach the connector to the external speaker connector on the radio.

Note:

- Relationship between TEST/SPKR connector (15-pin) connection and speaker output.
- When pins 9 and 12 are shorted: Built-in internal speaker is used.
- When pins 9 and 12 are open and output is from pins 6 and 12: KES-5 is used.

Square-type plug
(E31-3228-05)
Accessory

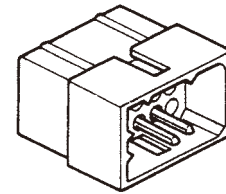

Fig. 2-1

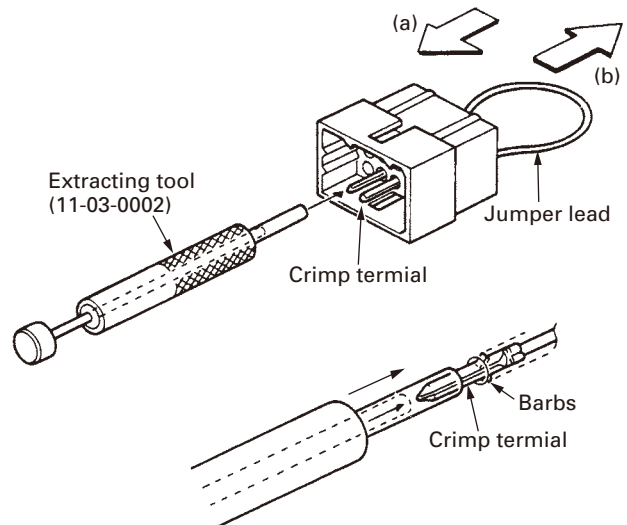

Fig. 2-2

INSTALLATION

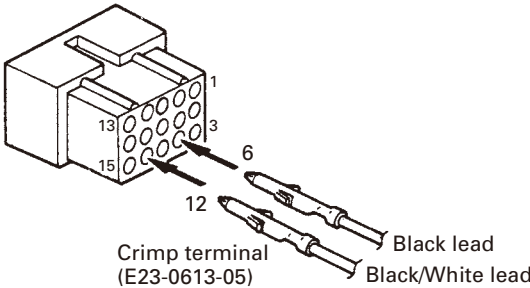

Fig. 2-3

3. How to Attach the Supplied Accessories

- 1. Attach the front glass to the front panel with the supplied screw. (①)
- 2. To attach the handles on the both sides of the chassis, refer to illustration. (②)

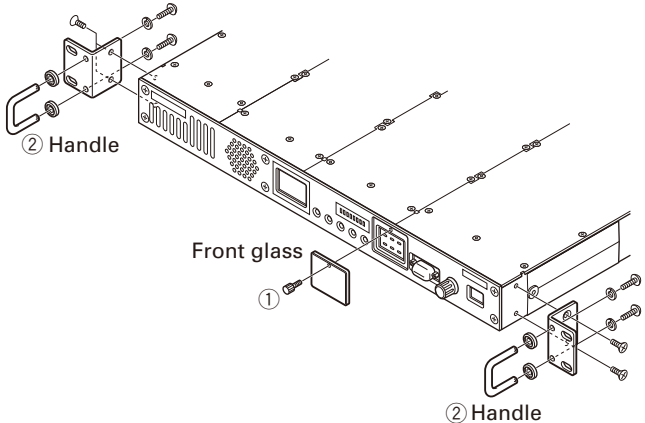

Fig. 3

CIRCUIT DESCRIPTION

1. Outline

The NXR-700 is a VHF repeater operating in the 146~174MHz frequency range.

2. Transmitter unit

The transmitter unit (X56-311 A/3) consists of the following circuit.

- (1) Internal/external reference circuit
- (2) Transmitter reference 19.2MHz PLL circuit
- (3) Transmitter Modulation 19.2MHz PLL circuit
- (4) Transmitter DDS circuit
- (5) Transmitter main PLL circuit
- (6) Driver circuit
- (7) Modulation level adjustment circuit
- (8) AVR circuit
- (9) Other circuits

2-1. Internal/external reference circuit

The internal/external reference circuit automatically

switches signals used as reference signals among the 5.99MHz internal DDS, the 10MHz external reference signal and the 10MHz OCXO unit.

If no OCXO unit is installed, and there is no external reference signal, the 5.99MHz internal DDS (IC601) is selected as the reference signal.

If the OCXO unit is installed and there is no external reference signal, the 10MHz OCXO unit is selected as the reference signal.

If an external reference signal (CN408/ 10MHz/ 0dBm or higher/ $Z_{in}=50\Omega$) is input, the external reference signal is selected as the reference signal irrespective of an existing OCXO unit.

The internal/external reference circuit consists of Q419, Q418, D401, D403, D404, Q430, Q422, D601 and IC407.

The DDS circuit consists of X601, IC602, IC601, Q606, CF601, Q603 and D602.

If either the OCXO 10MHz or external reference 10MHz is selected as the reference signal, the reference output terminal outputs the reference signal (CN403/ 10MHz/ +9dBm/ $Z_{out}=50\Omega$). This circuit consists of Q431, Q420 and Q425.

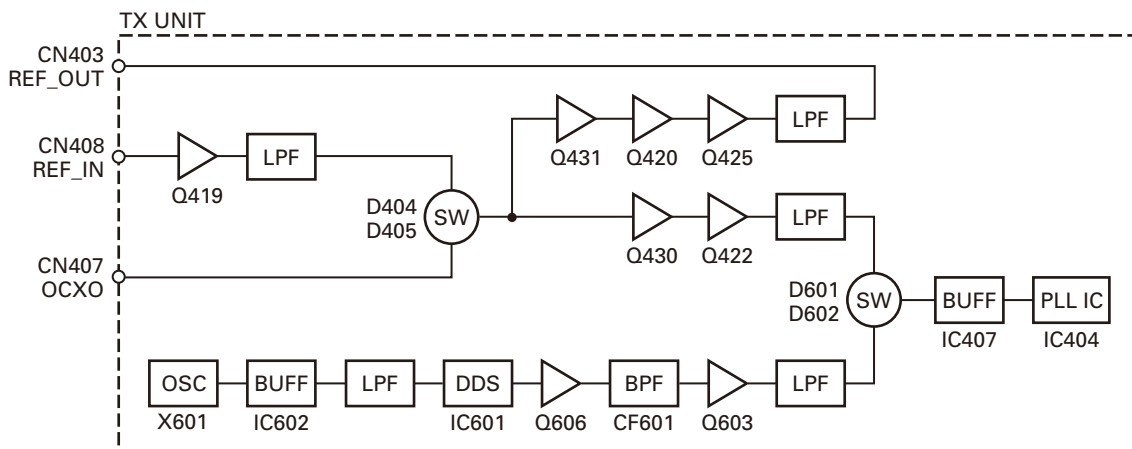

Fig. 1 Internal/external reference circuit

2-2. Transmitter reference 19.2MHz PLL circuit

The transmitter reference 19.2MHz PLL circuit produces a reference frequency signal for the transmitter modulation 19.2MHz PLL circuit, the Receiver unit (X55-309) Receiver DDS circuit and the Control Unit (X53-414) DSP IC.

This circuit consists of Q401, Q402, Q412, Q415, Q416, Q417, X401, IC404, and IC407.

The 5.99MHz or 10MHz signal produced by the internal/external reference circuit is amplified by IC407 and supplied to the PLL IC (IC404) reference signal pin.

The VCXO (X401) signal enters buffer amp Q417 and is amplified by Q415. The higher harmonic wave is attenuated by LPF and returns to IC404. Its phase is compared with that of the reference frequency 10kHz.

The phase difference signal produced by the comparing phase is converted to a DC voltage by a lag-lead type loop filter. This DC voltage is input to the X401 control voltage terminal for controlling the VCXO oscillating frequency.

The DC voltage passes through the IC401 operational amplifier, and is output as a voltage signal (CVT-REF) for monitoring the reference 19.2MHz PLL circuit lock voltage.

The stabilized 19.2MHz reference oscillating signal enters the Q417 buffer amplifier and is amplified by Q412 and Q416. The higher harmonic wave is attenuated by LPF, fed to IC302 and used as the reference frequency signal for the transmitter modulation 19.2MHz PLL circuit.

The 19.2MHz reference oscillating signal is also used as the reference signal for the receiver unit (X55-309) and control unit (X53-414).

It enters the Q417 buffer amplifier for the receiver unit (X55-309) and is amplified by Q401. The higher harmonic wave is attenuated by LPF and is output from CN406.

It enters the Q417 buffer amplifier for the control unit (X53-414) and is amplified by Q402. The higher harmonic wave is attenuated by LPF and is output from CN405.

CIRCUIT DESCRIPTION

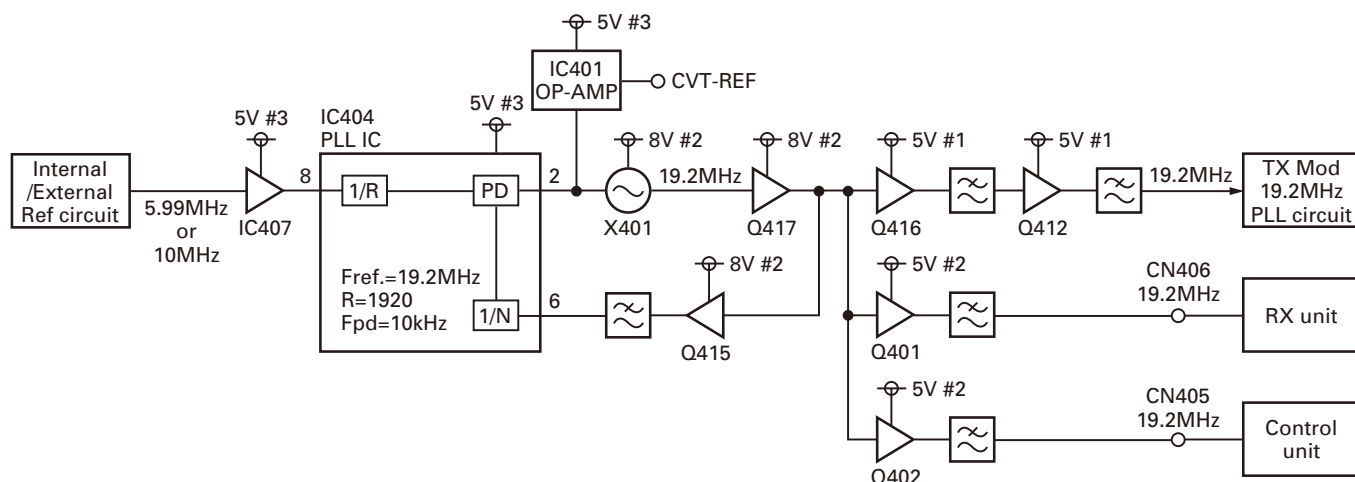

Fig. 2 Transmitter reference 19.2MHz PLL circuit

2-3. Transmitter modulation 19.2MHz PLL circuit

The transmitter modulation 19.2MHz PLL circuit produces the reference frequency signal for the Transmitter DDS circuit and modulates the low-frequency components.

The circuit consists of IC302, IC303, IC305, X301, Q304, Q305, and Q307.

The signal generated by the VCXO (X301) is fed to the buffer amplifier Q307.

The VCXO (X301) signal enters buffer amplifier Q307 and is amplified by Q305. The higher harmonic wave is attenuated by the LPF and returns to IC303. Its phase is compared with that of the reference frequency 5kHz.

The phase difference signal produced by the comparing

phase is converted to a DC voltage by a lag-lead type loop filter. This DC voltage is input to the IC305 invert amplifier (B/2) and is synthesized with the modulating signal. This DC voltage is input to the X301 control voltage terminal for controlling the VCXO oscillating frequency 19.2MHz.

The DC voltage passes through the IC306 operational amplifier, and is output as a voltage signal (CVT-MOD) for monitoring the modulating 19.2MHz PLL circuit lock voltage.

The 19.2MHz oscillating signal is fed to the Q307 buffer amplifier and is amplified by Q304. The higher harmonic wave is attenuated by the LPF, fed to IC307, and is used as the reference frequency signal of the transmitter DDS circuit.

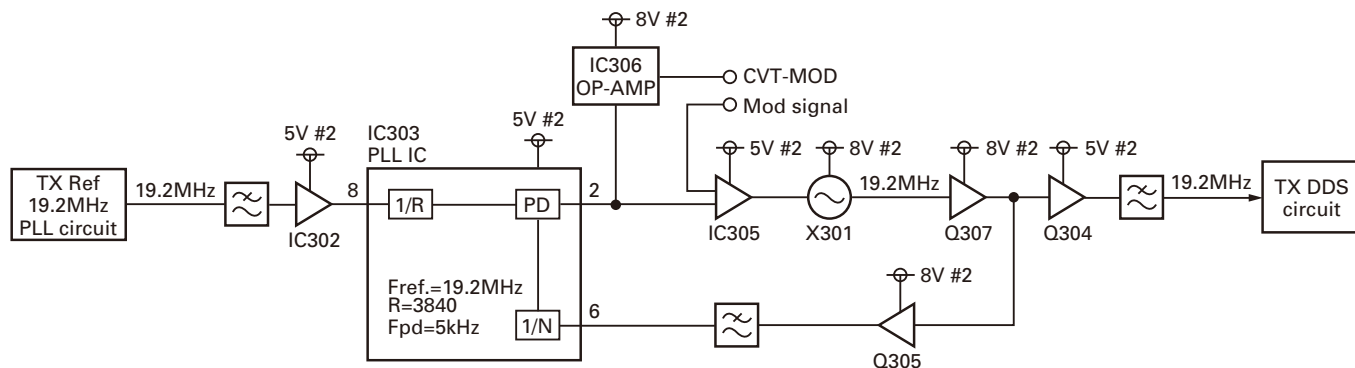

Fig. 3 Transmitter modulation 19.2MHz PLL circuit

CIRCUIT DESCRIPTION

2-4. Transmitter DDS circuit

The transmitter DDS circuit produces the transmitter main PLL reference frequency signal 4.5MHz.

This circuit consists of IC307, IC202, CF201, Q210, Q211, Q212 and Q213.

The 19.2MHz signal from the transmitter modulation 19.2MHz PLL circuit is amplified by IC307 and supplied to the IC202 reference signal pin.

IC202 produces the transmitter main PLL 4.5MHz refer-

ence frequency signal based on 19.2MHz on signal.

The spurious output by IC202 is attenuated by CF201 and LPF, 4.5MHz reference frequency signal is amplified by Q211, Q212, and Q213, and fed to the transmitter main PLL.

The comparison frequency of the transmitter main PLL is 100kHz and the PLL frequency step is 100kHz.

However, minute frequency step such as 2.5kHz and 3.125kHz because the DDS output frequency is variable.

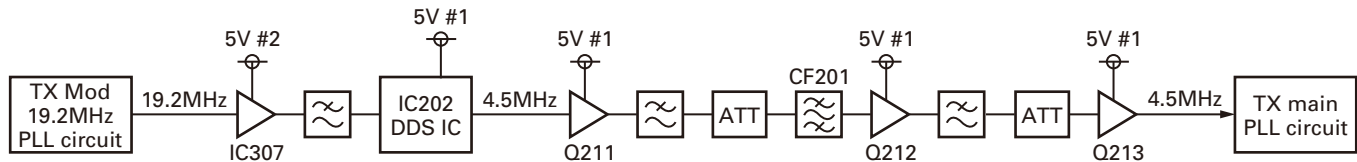

Fig. 4 Transmitter DDS circuit

2-5. Transmitter main PLL circuit

The transmitter main PLL circuit consists of the VCO (Q102 and Q103), PLL IC (IC101) and divide-by-2 circuit (IC811) and produces the transmitter frequency signal.

The VCO Q102 produces transmitter frequencies from 146.000MHz to 159.995MHz. (The transmitter frequency of the VCO is from 292.000MHz to 319.990MHz.)

The VCO Q103 produces transmitter frequencies from 160.000MHz to 174.000MHz. (The transmitter frequency of the VCO is from 320.000MHz to 348.000MHz.)

The signal produced by the VCO (Q102 or Q103) is fed to the buffer amplifier and is amplified by Q106. The higher harmonic wave is attenuated by LPF and returns to the PLL IC (IC101).

IC101 divides the VCO oscillating frequency signal and

transmitter PLL reference signal (4.5MHz), and compares the phase with the 100kHz comparison frequency.

The phase difference signal produced by the comparing phase is converted to a DC voltage by a lag-lead type loop filter.

The DC signal is applied to varicaps D101, D102, D107, and D108 to lock the VCO oscillator frequency with the desired oscillator frequency.

At the same time, the DC signal passes through the IC102 operational amplifier for monitoring the transmitter main PLL lock voltage.

The output from the VCO passes through the buffer amplifier Q104. The divide-by-2 circuit (IC811) divides the frequency and produces the transmitter frequency. The output level of IC811 is about +6dBm (4mW).

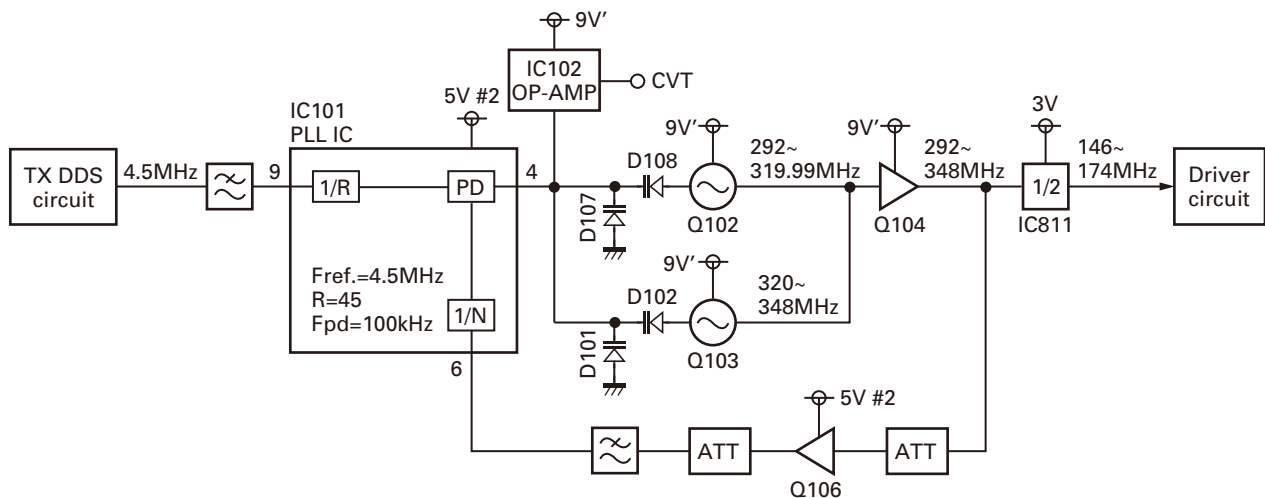

Fig. 5 Transmitter main PLL circuit

CIRCUIT DESCRIPTION

2-6. Driver circuit

The driver circuit amplifies the transmitter frequency signal to the level required for input to the Final Unit (X45-385 A/5).

This circuit consists of RF amplifiers Q202 and Q203, switches Q204, Q205 and Q206, and operating amplifier IC201.

DC switches Q204, Q205, and Q206 turns the power supply voltage of RF amplifiers Q202, and Q203 on and off.

The output of the divide-by-2 IC (IC811) is attenuated by attenuators R209, R210 and R211, by approximately 10dB. So, the transmitter signal input level to Q202 is approximately -4dBm (0.4mW).

Q202 amplifies it by approximately 15dB. So, the output level is approximately $+11\text{dBm}$ (12.6mW).

The output from Q202 is attenuated by attenuators R217, R218 and R219, by approximately 3dB, and amplified by Q203 approximately by 12dB. So, the output from Q203 is approximately $+20\text{dBm}$ (100mW). This output level is output from the driver output connector CN802 and connected to the Final Unit (X45-385 A/5).

Q203 has an AGC (Auto Gain Control) circuit. D201 rectifies a part of the Q203 output and converts it into DC voltage. It is compared with the control voltage (D_PC) by the operation amplifier IC201. The Q203 Gate terminal voltage is controlled for the stabilizing Q203 output ($+20\text{dBm}$).

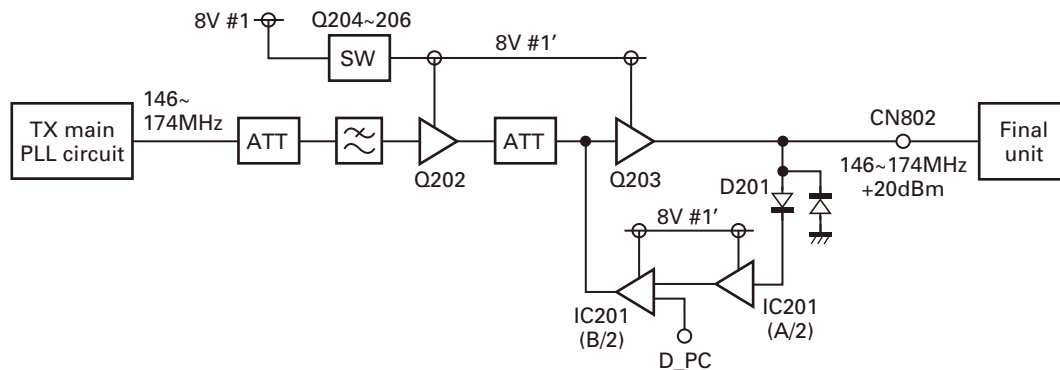

Fig. 6 Driver circuit

2-7. Modulation level adjustment circuit

The level adjustment circuit adjusts the modulation signal level to provide the required level of modulation. This circuit consists of IC301, IC304, IC305, and IC308.

The audio signal comes from the Control Unit (X53-413) through pin 4. The modulating signal is input to IC304 from this.

IC304 is an electronic volume control IC.

The modulation waveform balance adjustment, maximum AF Dev. change, and adjustment are performed according to data from the MPU using the FPU.

The modulation signal is produced by the modulating low-pitched tone to the transmitter modulation 19.2MHz PLL circuit and adds the high-pitched modulation to the transmitter main PLL.

IC305 is an inverting amplifier (B/2) for inverting the amplification (A/2) of the modulating signal and synthesizing the VCXO (X301) control voltage and modulating signal.

IC301 is a reference voltage generator (A/2) in modulating level adjusting circuit and non-inverting amplification of modulating signal with a cutoff signal of approximately 9kHz (B/2).

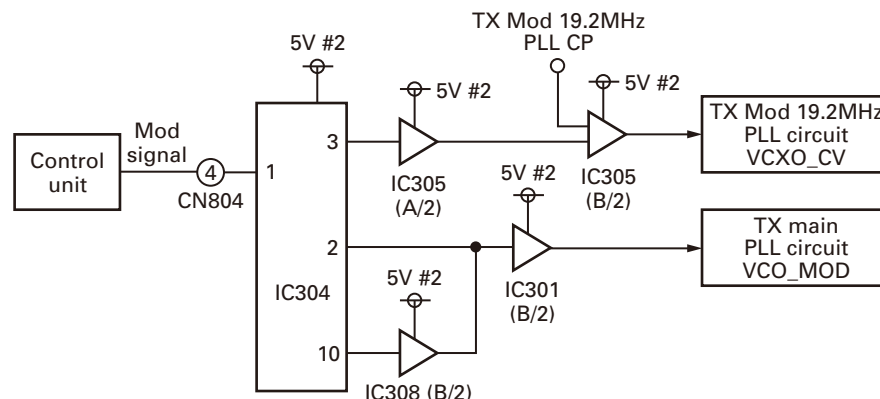

Fig. 7 Modulation level adjustment circuit

CIRCUIT DESCRIPTION

2-8. AVR circuit

IC104, IC603, IC704, IC705, IC706, IC807, IC808 and IC809 are AVR ICs.

Each circuit contains its own power regulator IC to maintain isolation between circuits.

2-9. Other circuits

In addition, IC702 is an EEPROM. The transmitter adjustment data adjusted for each unit is written into the EEPROM. If the unit is installed in another set, it is not necessary to adjust it again from the beginning, but only fine-tuning is necessary for each unit.

The temperature sensor (IC804) monitors the temperature of the transmitter unit (X56-311 A/3).

The D/A converters (IC701 and IC802) converts the AGC setting (D_PC) of the driver circuit and control voltage value (PWR_CONT, PWR_PRT) of the Final Unit (X45-385 A/5).

The A/D converter (IC803) converts the transmitter unit (X56-311 A/3) temperature, VCO & VCXO control voltage (CVT, CVT-REF and CVT-MOD), Final Unit (X45-385 A/5) PA current (PA_CURR), fan current (FAN_CURR), detection voltage (FWD_PWR, RFL_PWR), etc.

The shift register (IC703) controls each part of the transmitter unit (X56-311 A/3) based on serial data of the Control Unit (X53-413).

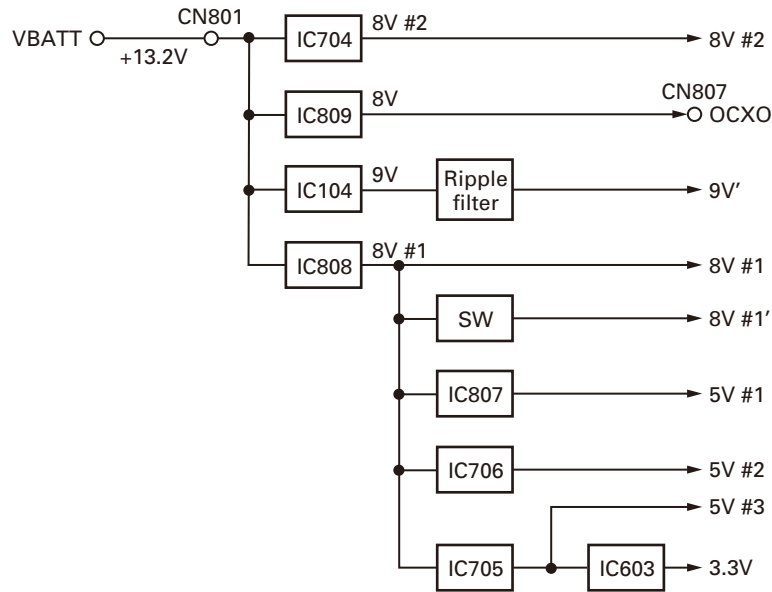

Fig. 8 AVR circuit

3. Final unit

The RF final amplifier unit (X45-385 A/5) amplifies the transmitter power to a specified level.

This unit consists of the following circuits:

- (1) Transmitter power module
- (2) High pass filter
- (3) Forward/Reflect power detector circuit
- (4) Antenna switch
- (5) Harmonic filter circuit
- (6) APC circuit
- (7) High temperature detector circuit
- (8) FAN action control circuit
- (9) Current detector circuit
- (10) AVR Circuit
- (11) Other Circuits

3-1. Transmitter power module

The power module IC10 uses power module RA60H1317 1123 to improve its efficiency. The driver output of the transmitter unit passes through an attenuator and enters the power module IC10 pin 1. Power module IC10 amplifies the RF power according to the voltage at the amplification control pin 2 (VGG) and outputs it through pin 4 (Pout).



Fig. 9 Transmitter power module

3-2. High pass fileter

The T type single stage high pass filter prevents the Power Amplifier Module from being broken by static electricity.

CIRCUIT DESCRIPTION

3-3. Forward/Reflect power detector circuit

The forward / Reflect power detector circuit consists of a CM coupling type detection circuit formed by a Micro strip line and the differential amplifier IC4.

A part of the transmitter power is detected by diodes D9 and D10 and is converted into DC voltage.

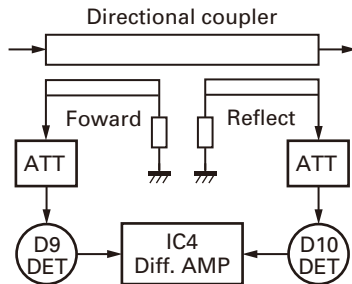

Fig. 10 Forward/Reflect power detector circuit

3-4. Harmonic filter circuit

The harmonic filter circuit uses a three-stage "pi" type Chebyshev type LPF.

This circuit removes harmonics from the transmitter output and sends the filtered signal to the antenna connector (CN22).

3-5. APC circuit

The APC circuit stabilizes the transmitter power so that the output power specified by the Control Voltage from the MPU is obtained. It consists of a Forward/Reflect power detector circuit and Differential amplifiers (IC2 and IC5).

It compares the voltage detected by the Forward/Reflect power detector circuit (voltage detected by the Forward Power) and the Control Voltage (PWR_CONT) from the MPU (IC802: X56-311 A/3). It stabilizes the output power by changing pin 2 (Vgg).

The voltage detected (that detected Reflect Power) by the Forward/Reflect power detector circuit is compared to the Control Voltage (PWR_PRT) from the MPU (IC802: X56-311 A/3). When a load V.S.W.R. is connected to the Antenna Connector and is more than 1.5, it functions so that the output power gets smaller as the detection voltage (that detected Reflect Power) gets larger.

3-6. High temperature detector circuit

The high temperature detector circuit consists of a thermal switch IC (IC7) and a switching FET (Q2).

This circuit lowers the transmitter power when the final unit temperature is too high (83°C or higher).

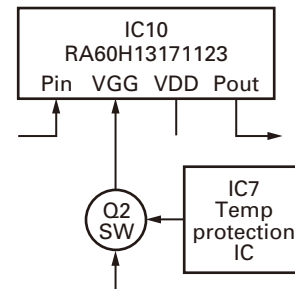

Fig. 12 High temperature detector circuit

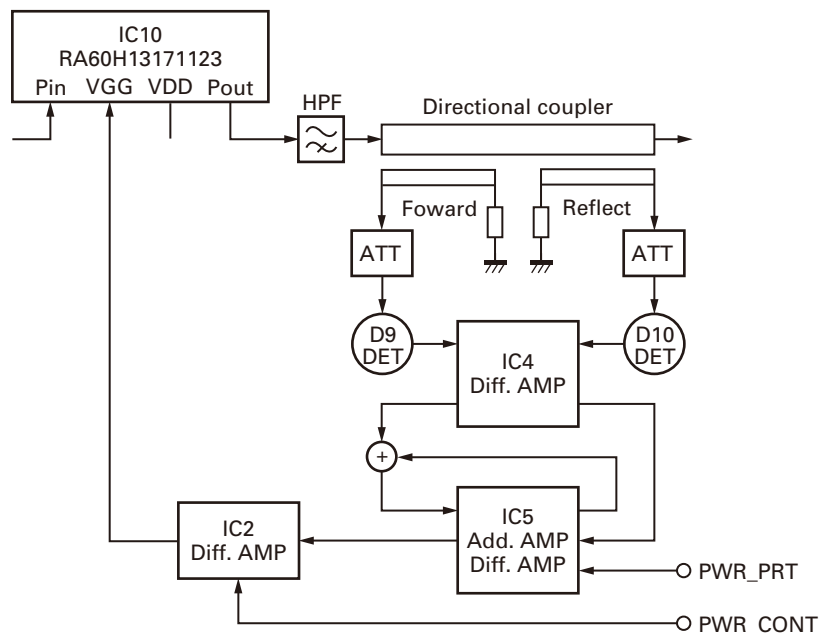

Fig. 11 APC circuit

CIRCUIT DESCRIPTION

3-7. FAN action control circuit

The FAN action control circuit consists of a FAN and a AVR (IC12)

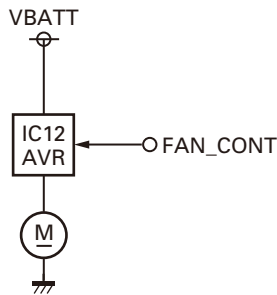

Fig. 13 FAN action control circuit

3-8. Current detector circuit

The current detector circuit monitors the current of the Power Amplifier Module. It consists of a current detection resistance (R4) and a current detection IC (IC1). It detects the normal and abnormal state of the Power Amplifier Module by monitoring the current of the Power Amplifier Module. If a failure occurs, it stops operation.

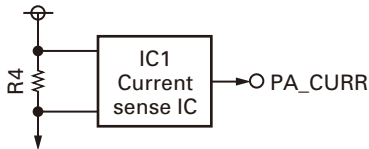

Fig. 14 Current detector circuit

3-9. AVR circuit

IC3, IC11 and IC12 are AVR ICs.

They maintain isolation of each power supply.

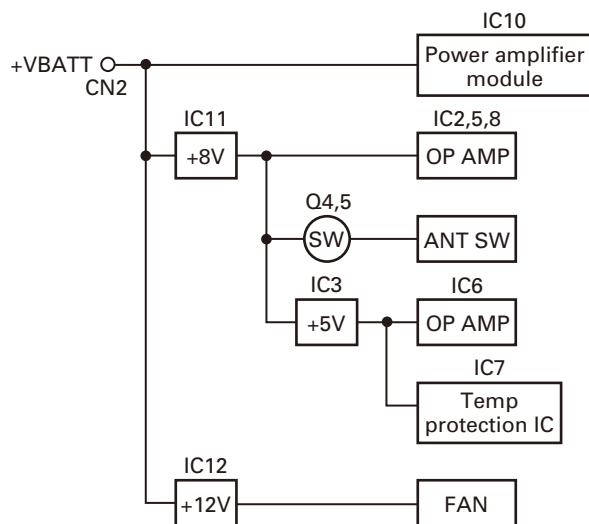

Fig. 15 AVR circuit

3-10. Other circuits

Circuit IC9 saves various adjustment values of the Final Unit in the EEPROM.

4. Receiver Unit

The receiver unit (X55-309) consists of the following circuits:

- (1) Front-end circuit
- (2) 1st-Mixer circuit
- (3) 1st-IF circuits
- (4) Demodulator circuits
- (5) Squelch circuit
- (6) Receiver DDS circuit
- (7) Receiver PLL circuits
- (8) AVR circuit
- (9) Other circuits

There are five modulating modes that can receive demodulate, including Analog_Wide_5k, Analog_Wide_4k, Analog_Narrow, NXDN_Narrow, and NXDN_Very-Narrow.

4-1. Front-end circuit

The front-end circuit consists of L132, L133, L134, and L135 coils, tetra polar BPF synchronizing TC1, TC2, TC3 and TC4 variable trimming capacitors, Q1 Low Noise Amplifier (LNA), L136, L137, L138, L139 coils, and tetra polar BPF synchronizing TC5, TC6, TC7, and TC8 variable trimming capacitors.

Adjusting eight variable trimming capacitors forms the BPF having a pass band width of 3MHz with a center frequency from 146 to 174MHz.

+9V is applied to the Q1 collector power supply. -3V produced by IC701, IC702 and IC703 mounted on a negative power unit (X45-385 D/5) is applied to the emitter power supply. The collector current is monitored by the IC4 current detection circuit. Detected DC voltage is input to pin 15 of IC30 (ADC).

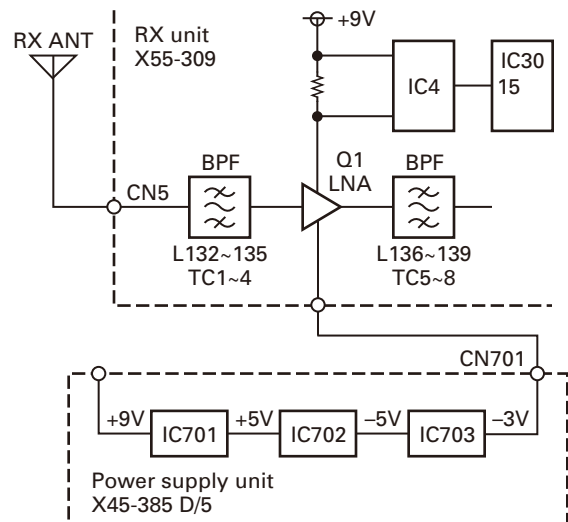

Fig. 16 Front-end circuit

CIRCUIT DESCRIPTION

4-2. 1st-Mixer circuit

The unwanted out-of-band RF components produced by Q1 are attenuated by the BPF. Only the desired signal is transmitted to the A1 Double Balanced Mixer (DBM). Here, the desired signal is mixed with the first hetero signal. 49.95MHz is produced as the 1st Intermediate Frequency (IF1).

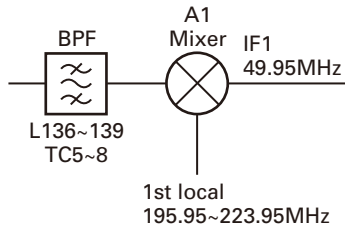

Fig. 17 1st-Mixer circuit

4-3. 1st-IF circuits

The IF1 signal produced by the 1st-Mixer circuit is transmitted through either one of two 1st-IF circuits with different bandwidth. The signal passes through the WIDE band consisting of D9, XF1, Q19, XF3, Q28 and D13 only in Analog_Wide_5k/4k mode. Meanwhile, the signal passes through the NARROW band consisting of D10, XF2, Q20, XF4, Q29, and D14 only in Analog_Narrow, NXDN_Narrow or NXDN_Very-Narrow mode.

XF1 and XF2 is 2 pole and XF3 and XF4 are 4 pole Monolithic Crystal Filters (MCF). They are BPF for removing spurious noise occurring close to the desired signal. The DC switch consists of Q31, Q32, Q26 and Q25, switches the WIDE (5k/4k) and NARROW bands of the 1st-IF circuits.

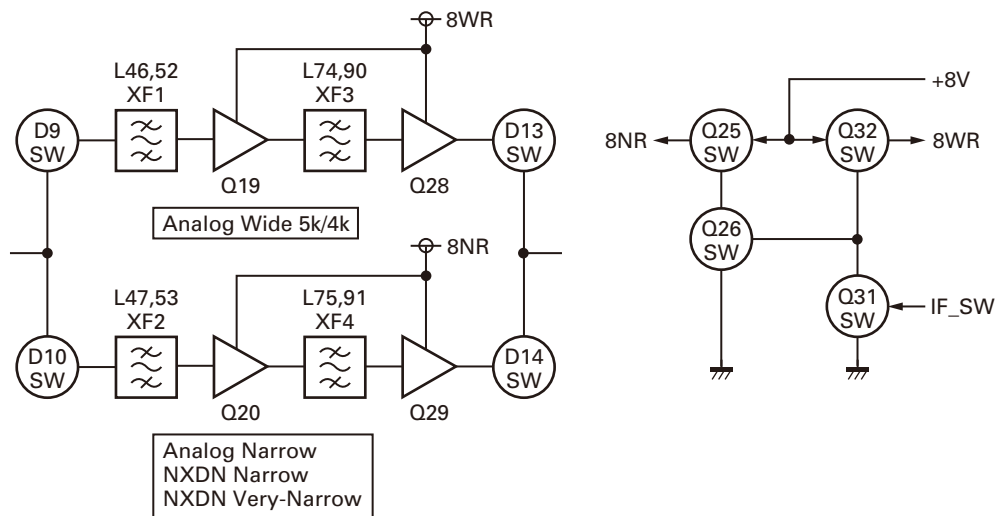

Fig. 18 1st-IF circuits

4-4. Demodulator circuits

The desired signal that passed through the 1st-IF circuits passes through the distributor consisting of LC parts and is fed to the IF system IC12, IC13. The signal in Analog_Wide_5k/4k or Analog_Narrow mode is mixed with the second local oscillator hetero signal by the mixer in IC12. 450kHz is produced as the 2nd Intermediate Frequency (IF2).

It passes through D15, CF2, D16, D19, CF5 and D20 path if the modulation mode is Analog_Wide_5k/4k. It passes through D15, CF3, D16 and D19, CF7 and D20 path if the modulation mode is Analog_Narrow. The base band signal FM-detected by the quadrature detection circuit consisting of L128, Q57, and Q58 and is amplified to a signal level of

approximately 100mVrms by IC20 and is then transmitted to the control unit (X53-413) from CN42 (pin12).

The signal in NXDN_Narrow or NXDN_Very-Narrow mode is mixed with the second local oscillator hetero signal by the mixer in IC13. 450kHz is produced as the 2nd Intermediate Frequency (IF2). Here, irrespective of modulation modes, it passes through the CF4 and CF6 path. It is transmitted as the base band signal via IC14 to the CN43 control unit, X53-414.

CF2, CF3, CF4, CF5, CF6 and CF7 are hexode Ceramic Filters. They are BPF for removing spurious noise occurring close to the desired signal.

CIRCUIT DESCRIPTION

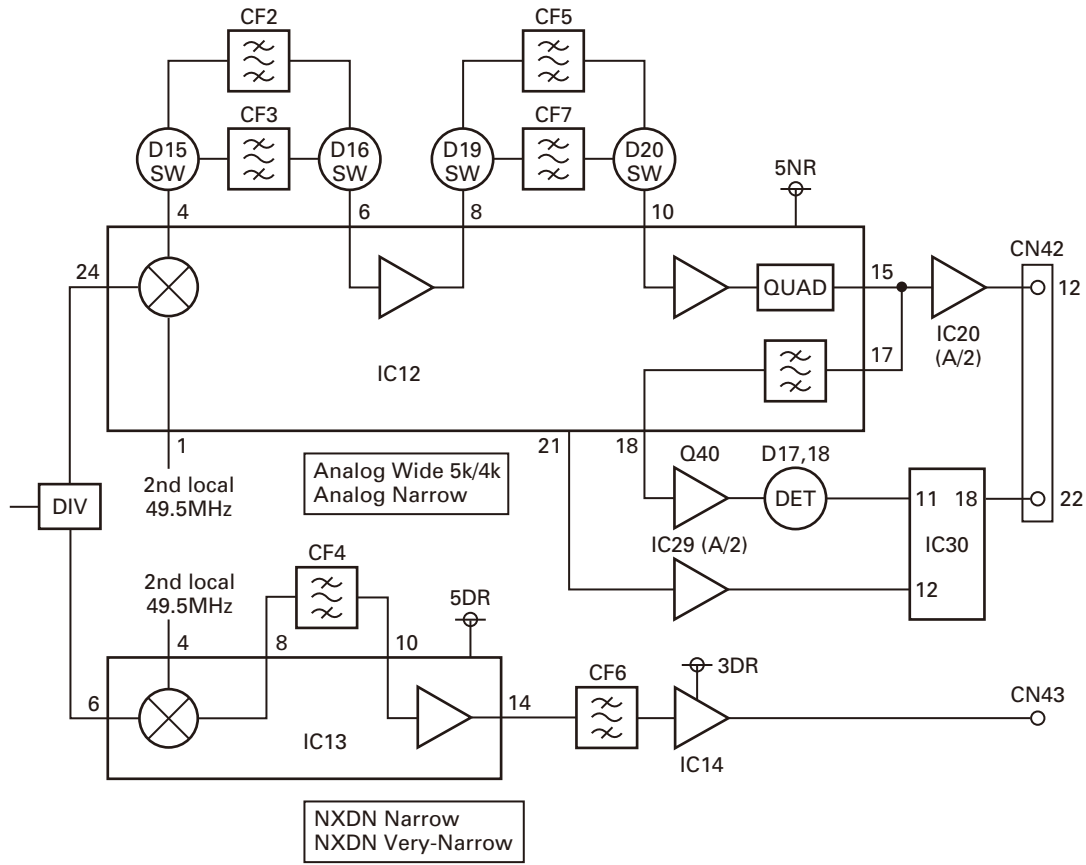

Fig. 19 Demodulator circuits

4-5. Squelch circuit

The desired noise of the noise component output from IF system IC_{IC12} (pin18) is extracted by the BPF. After passing through Q40, it is DC-detected as the squelch voltage by D17, D18 and input to ADC_{IC30} (pin11).

The MPU mounted in the control unit (X53-413) compares it with a predetermined reference voltage and turns the Audio signal on and off. The strength of the receiver signal input from CN5 is output as the RSSI voltage from IF system IC_{IC12} (pin21), and is input to IC_{IC30} (ADC) pin12 via IC_{IC29} A/2.

4-6. Receiver DDS circuit

The 19.2MHz Internal reference clock produced by transmitter unit (X56-311 A/3) is distributed to CN45 of the receiver unit (X55-309). It passes through Q39, Q30, and IC8, and is input to IC7 (DDS-IC) pin6 as the Master clock. Approximately 6MHz signal is generated as the 1st-PLL Reference clock.

IC7 has a resolution of 32 bits for realizing the frequency step minters than the 1st-PLL comparison frequency. The generated Reference clock is output via Q12, CF1, and Q5. CF1 is a Ceramic Filter. It is the BPF for removing unnecessary spurious noise included in the generated Reference clock.

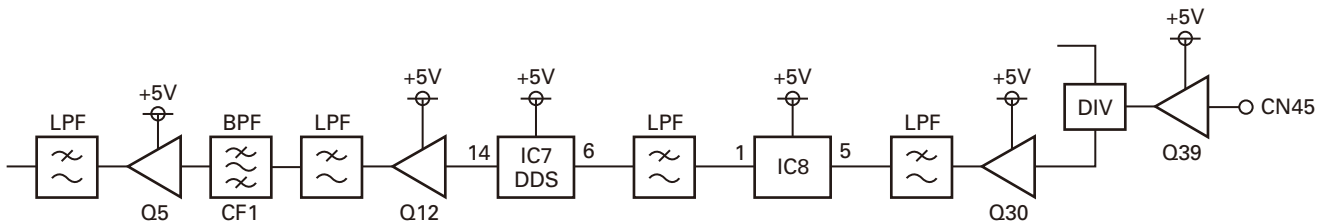

Fig. 20 Receiver DDS circuit

CIRCUIT DESCRIPTION

4-7. Receiver PLL circuits

The receiver unit (X55-309) has the 1st-PLL circuit for controlling the VCO that generates the hetero signal to the first local oscillator, and the 2nd-PLL circuit for controlling the VCO that generates the hetero signal to the second local oscillator.

The 1st-PLL circuit consists of the VCO (Q7 and Q8), the Buffer amplifier (Q17), the RF amplifiers (Q16 and Q3), the PLL-IC (IC5), the Active loop filters (Q2 and Q4) and the Band switches (Q14, Q10, Q11 and Q59). The signal in the 195.95 through 209.95MHz band generated by VCO Q7 and the 209.95 through 223.95MHz band generated by VCO Q8 is input to IC5 (pin5) via Q17 and Q16 as the Fin signal. The 6MHz reference signal generated by the DDS-IC (IC7) is input to IC5 (pin8) via Q3. Two signals, Fin and REFin, are phase-compared as the 100kHz comparison frequency by each frequency divider. The VCO output with the frequency synchronized is input to the 1st-Mixer as the first local oscillator Upper hetero signal approximately

+17dBm via Q17, Q23, and Q18. The control voltage is input to IC30 (ADC) pin16 via IC6.

Meanwhile, the 2nd-PLL circuit consists of the VCO (Q24), the Buffer amplifier (Q33), the RF amplifier (Q38, Q22), and the PLL-IC (IC11). The 99.0MHz signal generated by Q24 is input to IC11 (pin5) as the Fin signal via Q38. The 19.2MHz Internal reference clock distributed by the transmitter unit (X56-311) is input as the REFin signal to IC11 (pin8) via Q22. Two signals, Fin and REFin, are phase-compared by each frequency divider as the comparison frequency of 200kHz. The VCO output with the frequency synchronized is input to IC9 (prescaler IC) pin2 via Q33 and Q21. The 49.5MHz signal is frequency-divided into halves by IC9 and is excited by Q53 and distributed. One is input to IC12 (pin1) via Buffer amplifier_Q35. The other is input to IC13 (pin4) via Buffer amplifier_Q36. Both are input as approximately -16dBm for the second local oscillator Lower hetero signal. The control voltage at this point is input to IC30 (ADC) pin10 via IC33.

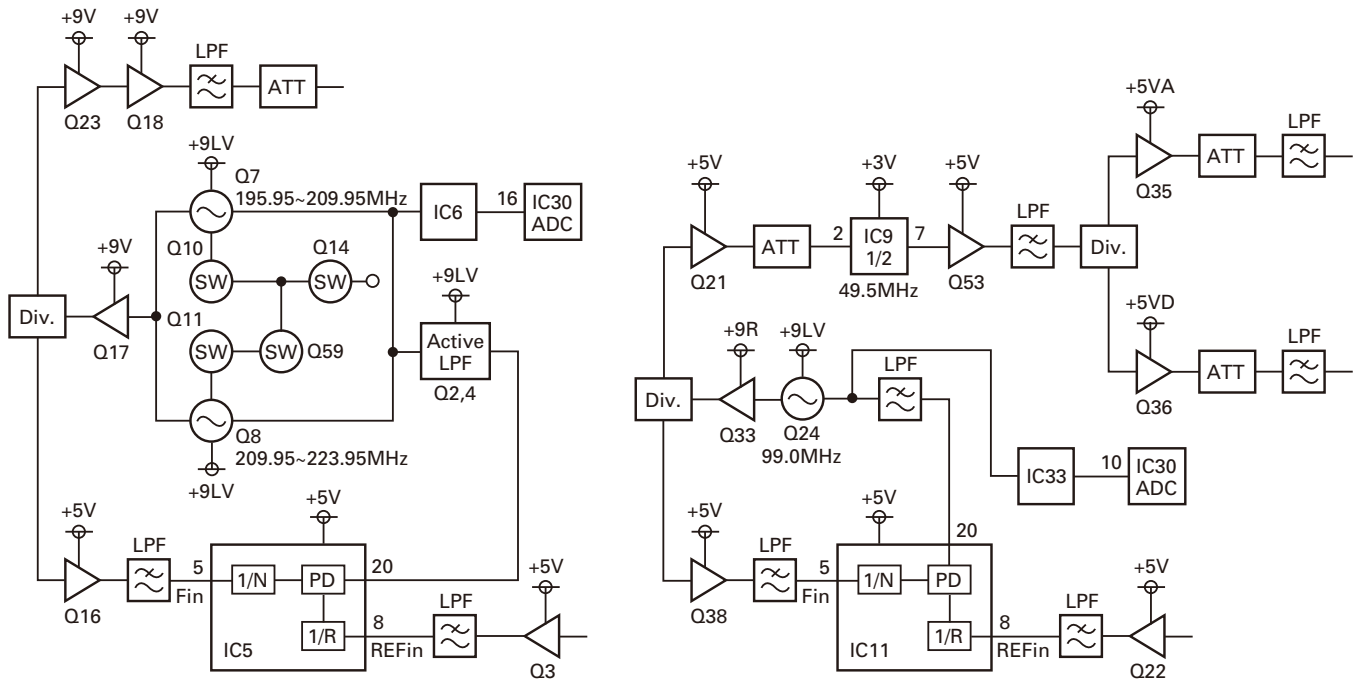

Fig. 21 Receiver PLL circuits

4-8. AVR circuit

The power supply voltage supplied from the power unit (X45-385 C/5) is distributed from the receiver unit (X55-309) CN44 to IC24 (8V), IC25 (8V), IC26 (9V), and IC27 (9V) via the Q52 DC switch. The output of IC24 is supplied to the 1st-IF circuits, the 1st-Local amplifiers and the IF system IC_IC12 via IC15 (5V). Further, the output of IC25 is distributed to IC16 (5V), IC17 (5V), IC18 (5V) and IC19 (5V). The output

of IC16 is supplied to IF system IC_IC13. The output of IC17 is supplied to the 2nd-Local amplifiers. The output of IC18 is supplied to the 1st-PLL and the 2nd-PLL. The output of IC19 is supplied to the DDS circuit. The output of IC26 is supplied to LNA_Q1. The output of IC27 is supplied to the VCO buffer amplifiers_Q17, Q33, the 1st-VCO and the 2nd-VCO via Active ripple filters_Q9, Q27, and to the Active loop filter_Q2, Q4 via the Active ripple filters_Q6.

CIRCUIT DESCRIPTION

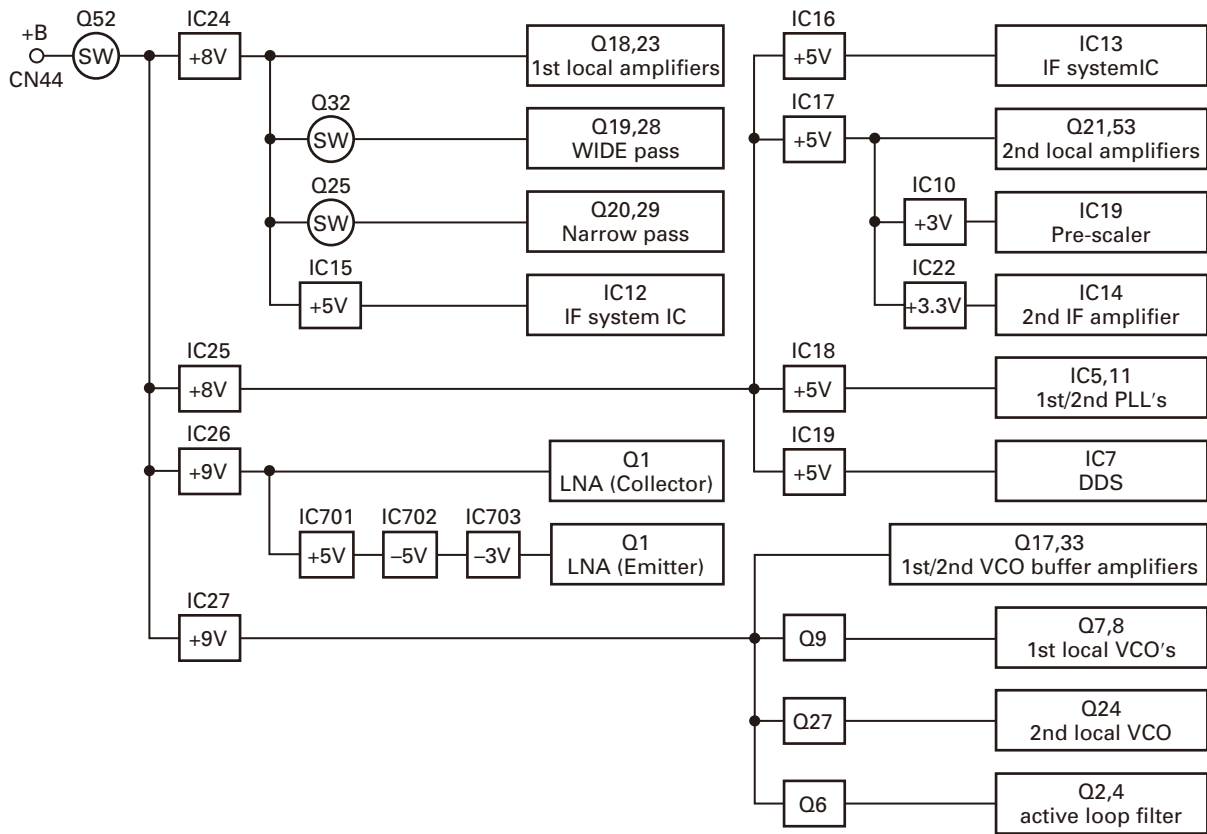

Fig. 22 AVR circuit

4-9. Other circuits

Other circuits include the EEPROM (IC31), the temperature sensor IC (IC35), the DAC (IC23) and the ADC (IC30). IC31 saves various adjustment values of the receiver unit. IC35 is built-in for detecting changes in temperature. IC23 offsets the RSSI voltage (pin1) (detected by the IF system IC (IC12)) and the 1st-VCO_A, VCO_B control voltage (pin2, pin3).

IC30 monitors the 1st-VCO control voltage (pin16), the LNA current detection value (pin15), the temperature detected by the temperature sensor IC (IC35 pin14), the RSSI voltage detected by the IF system IC (IC12 pin12), the squelch voltage detected by the IF system IC (IC12 pin11), and the control voltage of the 2nd-VCO (pin10), and outputs each state in serial data (IC30 pin18), sends the signal from CN42 (pin22) to the control unit (X53-413). The signal is processed by the MPU.

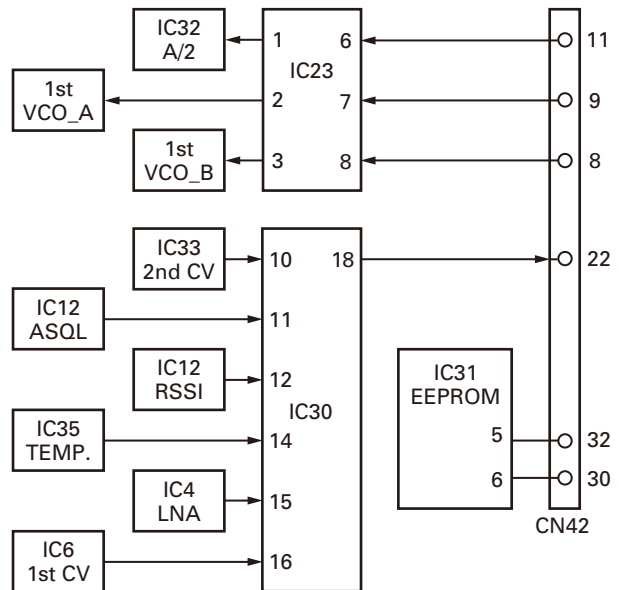

Fig. 23 Other circuits

CIRCUIT DESCRIPTION

5. Base-Band Signal Processing Part

The base-band circuit is located on unit X53-413. This circuit enables the selection of the Analog Signal Processing mode and the Digital Signal Processing mode, and adjusts the level of the base-band signals in each mode. This circuit consists of IC2, IC3, IC5, IC8, IC9, IC12, IC14, IC19, IC20 and IC21.

The type of input modulation signals are local microphone terminal, low-speed data (LSD), high-speed data (HSD), external audio input (TA), and external data input (TD), and also the type of output demodulation signals are receiving audio output (RA), and receiving data output (RD).

The multiplexer (IC2, IC3, IC14) selects the signal path, the electronic volume (IC8) adjusts the signal level, and the operational amplifiers (IC5, IC9, IC12, IC19, IC20, and IC21) amplify and sum various signals.

5-1. Demodulation circuit (Analog/NXDN signal processing)

In case of the Analog Signal Processing mode, the detected audio signal obtained from the IF SYSTEM IC (X55-307 IC8) is amplified by IC5 (A/2), input into the AINR terminal of CODEC IC (IC4), and then processed as an audio signal by the DSP (IC37). The processed audio signal from the AOUTR terminal of IC4 is amplified to a sufficient level by IC12 (A/2), and is then passed through the anti-aliasing filter at IC12 (B/2).

In case of the NXDN Signal Processing mode, the detected audio/data signal obtained from the IF SYSTEM IC (X55-307 IC7) is input into the ADC (X53-414 IC312). Receiving signal processing is performed by RX_DSP (X53-414 IC323), and voice decode processing is performed by TX_VOCODER DSP (X53-414 IC324). The processed audio signal from the AOUTL terminal of CODEC IC (X53-414 IC309) is amplified to a sufficient level by IC20 (D/4), and is then passed through the anti-aliasing filter at IC20 (C/4).

The audio signal path is selected by multiplexer (IC14) depending on the Analog mode (IC14 is setting $Y=Y0$) or the NXDN mode (IC14 is setting $Y=Y1$). The audio signal is then routed through an electronic volume (IC8) V3/V4 to multiplexer IC (IC25), and is amplified to a sufficient level to drive the loudspeaker using an audio power amplifier (IC29).

5-2. Audio amplifier circuit

The audio amplifier circuit is located in the control section of the Control unit (X53-413).

The 3W output audio power is available from the pin15 test connector "SPO, SPG" on the rear panel to the external speaker in the case of a 13.2V power supply voltage and 4 ohm load.

5-3. Microphone circuit

The signal from the microphone is passed through the AGC circuit located in the DISPLAY circuit (X56-311 B/3) so that it may not saturate. This circuit consists of IC926, D933, D934 Q931, and Q932. The AGC controls the amplifier gains using the detected audio signal depending on the positive and negative peaks of the signal amplitude. The audio signal goes to the control section of the Control unit

(X53-413) from the DISPLAY circuit (X56-311 B/3).

5-4. Modulation circuit (Analog/NXDN signal processing)

The transmitting audio signal goes to the input terminal of the multiplexer IC (IC3) for microphone muting.

In case of the Analog Signal Processing mode (multiplexer IC3 is setting $X=X0$), the audio signal is amplified by IC9 (A/4), input to the AINL terminal of the CODEC IC (IC4), and audio processed by the DSP (IC37). The processed audio signal from the AOUTL terminal of IC4 is amplified to a sufficient level by IC9 (B/4), and is then passed through an anti-aliasing filter at IC9 (C/4), and amplified by the summing (TD) amplifier IC9 (D/4).

On the other hand, in the case of the NXDN Signal Processing mode (multiplexer IC3 is setting $X=X1$), the audio signal is amplified by IC20 (A/4), input to the AINL terminal of the CODEC IC (X53-414 IC309), and processed by the TX_VOCODER DSP (X53-414 IC324). The processed audio signal from the AOUTR terminal of IC309 passes through the anti-aliasing filter at IC19 (B/2).

6. Control Circuit

The control circuit consists of two units, X53-413 and X53-414.

Unit X53-413 mainly has the power supply circuit, base-band signal path selection circuit (level adjustment is included), analog mode voice codec circuit, and RF controller circuit.

Unit X53-414 has the mode selection (analog or NXDN) circuit, NXDN mode communication processing circuit, LAN interface circuit, and Compact Flash interface circuit.

6-1. X53-413

■ RF control MPU

The IC34 RF control MPU is a 16-bit single chip microprocessor incorporating 256Kb of ROM and 20Kb of RAM.

This MPU controls the Flash ROM, DSP, receiver unit, transmitter unit, and EEPROM of each unit, and the display circuit, and has communication I/F with external devices.

■ DSP

The DSP circuit is in charge of the filtering of transmitting and receiving signals, and the encoding and decoding of sub-audible signals (encode: QT, DQT, DTMF, decode: QT, DQT, DTMF).

This circuit consists of IC37, IC30, IC31, IC4, IC5, IC9, and IC12.

The receiving signal, DET is converted from analog to digital by IC4 with a sampling frequency of 16.128kHz. The digitized audio signal is sent to the DSP (IC37) to process the sub-audible signal and audio signal. The processed digital audio signal is applied to CODEC IC4, and is converted from digital to analog. The analog signal is output from pin16 (AOUTR). The audio signal is then amplified by IC12 (A/2), passes through the low-pass filter at IC12 (B/2), is selected by the multiplexer IC14 ($Y0=Y$) and is then input into an electronic volume IC8.

CIRCUIT DESCRIPTION

On the other hand, the transmitting audio signal output from IC3 is amplified by IC9 (A/4), applied to pin 3 (AINL) of CODEC IC4, and is then converted from analog to digital at a sampling frequency of 16.128kHz. The digitized transmitting audio signal is AGC-processed, pre-emphasized and filtered, except for the 300Hz to 3kHz range, by DSP IC37, and is then feed back to CODEC IC4, converted from

digital to analog, and the analog signal is output from pin15 (AOUTL). The transmitting signal from the AOUTL is amplified by IC9 (B/4), passed through the IC9 (C/4) low-pass filter, and sent to the IC9 (D/4) summing amplifier.

IC31 is a counter IC. The clock required for the CODEC and DSP is generated by dividing the 16.515072MHz clock signal supplied by the DSP IC37.

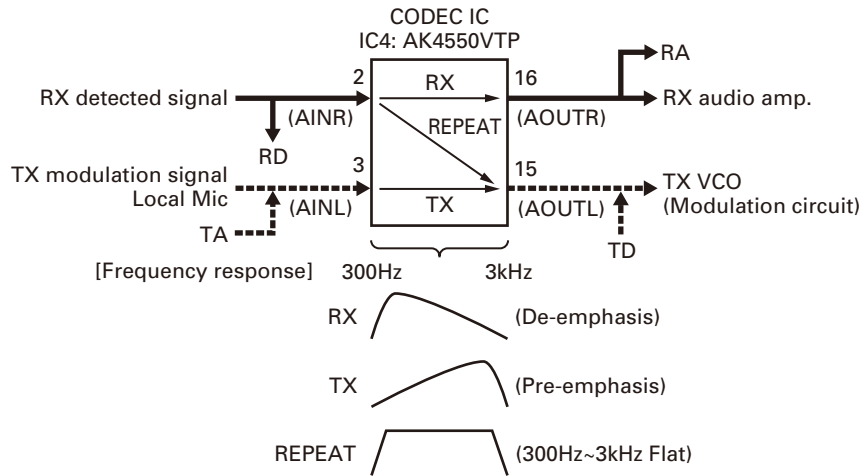

Fig. 24 An audio signal course and the frequency characteristic

■ Shift register circuit

The MPU (IC34) transmits serial data to shift registers IC923 from IC923 to IC960 and from IC960 to IC963 in the display circuit (X56-311 B/3, C/3).

Additionally, it transmit serial data to the control unit (X53-413) IC1 and IC22 and the transmitter unit (X56-311) IC703. This serial data can control various functions of each unit.

■ Power supply circuit

This circuit consists of X53-413 IC6, IC10, IC11, IC15, IC16 and 18, and X53-414 IC305, IC306, IC307 and IC329.

IC11 is a DC/DC converter that converts 13.2V to 5.0V. IC10 is a DC/DC converter that converts 13.2V to 8.0V. IC16 is the 5.0V AVR and connected to IC10. IC6, IC15, IC305 and IC329 is the 3.3V AVR. IC18 is the 1.8V AVR. IC306 is the 1.5V AVR. IC18 and IC306 is connected to IC329.

■ Flash ROM (RF control MPU)

IC17 is an 8M bit Flash ROM and contains MPU firmware for controlling the RF.

■ EEPROMs circuit

The EEPROM is a built in receiver unit (X55-309), transmitter unit (X56-311) and Final unit (X45-385).

The RF control MPU controls these EEPROMs by the IIC bus.

6-2. X53-414

■ Main MPU

The Main MPU (IC703) is a 32-bit RISC microprocessor incorporating a 16K bite cache memory.

The main MPU controls the Flash ROM, SDRAM, SRAM, LAN IC, RS-232C driver, receiver and real-time clock (RTC) IC besides RF control MPU and UART communication with modem control MPU.

■ LAN interface

NXR-700 is equipped with a 100Base-TX or 10Base-T LAN interface. This circuit consists of IC719, IC720 and J700. IC719 is a control IC. IC720 is a EEPROM, and saves the MAC address.

■ Real time clock (RTC) circuit

This circuit consists of IC710 and X701. IC710 is a Real Time Clock. X701 is a crystal oscillator. IC710 is connected to IC703 (Main MPU) via the IIC bus. The oscillating frequency of X701 is 32.768kHz. It is backed up by a rechargeable lithium battery (BA300). The IC710 clock data is used after resetting the backup.

■ RS-232C circuit

NXR-700 is equipped with a RS-232C interface. It is connected to a PC with pin9 female RS-232C cross-wired cable. It uses the FPU and writes the firmware. IC705 is a RS-232C driver receiver IC, and interfaces at the TTL232C level.

CIRCUIT DESCRIPTION

Modem control MPU

Modem control MPU (IC325) is 16-bit single chip micro-processor incorporating 256Kbytes of ROM and 20Kbytes of RAM.

This MPU controls the Flash Rom, two DSPs, the OCXO unit in the transmitter unit (X42-328) and the PLL circuit.

It also monitors the external power supply voltage. If the voltage is abnormal, it stops the system.

RX DSP (IC323)

In NXDN mode, the IF signal input from the ADC (IC312) to the RX DSP is limited to a narrow band or a very narrow band. So, it passes through the IF band limitation band.

This signal is demodulated by the wave detection processing part. The demodulated wave is made to pass through the base band limitation filter (root nyquist cosine filter and 1/sinc filter).

This signal is symbol-detected and bit-judged, and is then converted to NXDN data. Its frame timing is detected and decoded for CAI (Common Air Interface: NXDN format) data error correction.

Audio data is vocoder decode processed by the IC324 TX_Vocoder_DSP. It is then converted into the PCM signal. It is analog-output as an audio signal by the DAC part of the Audio codec IC (IC309 AOUTL terminal).

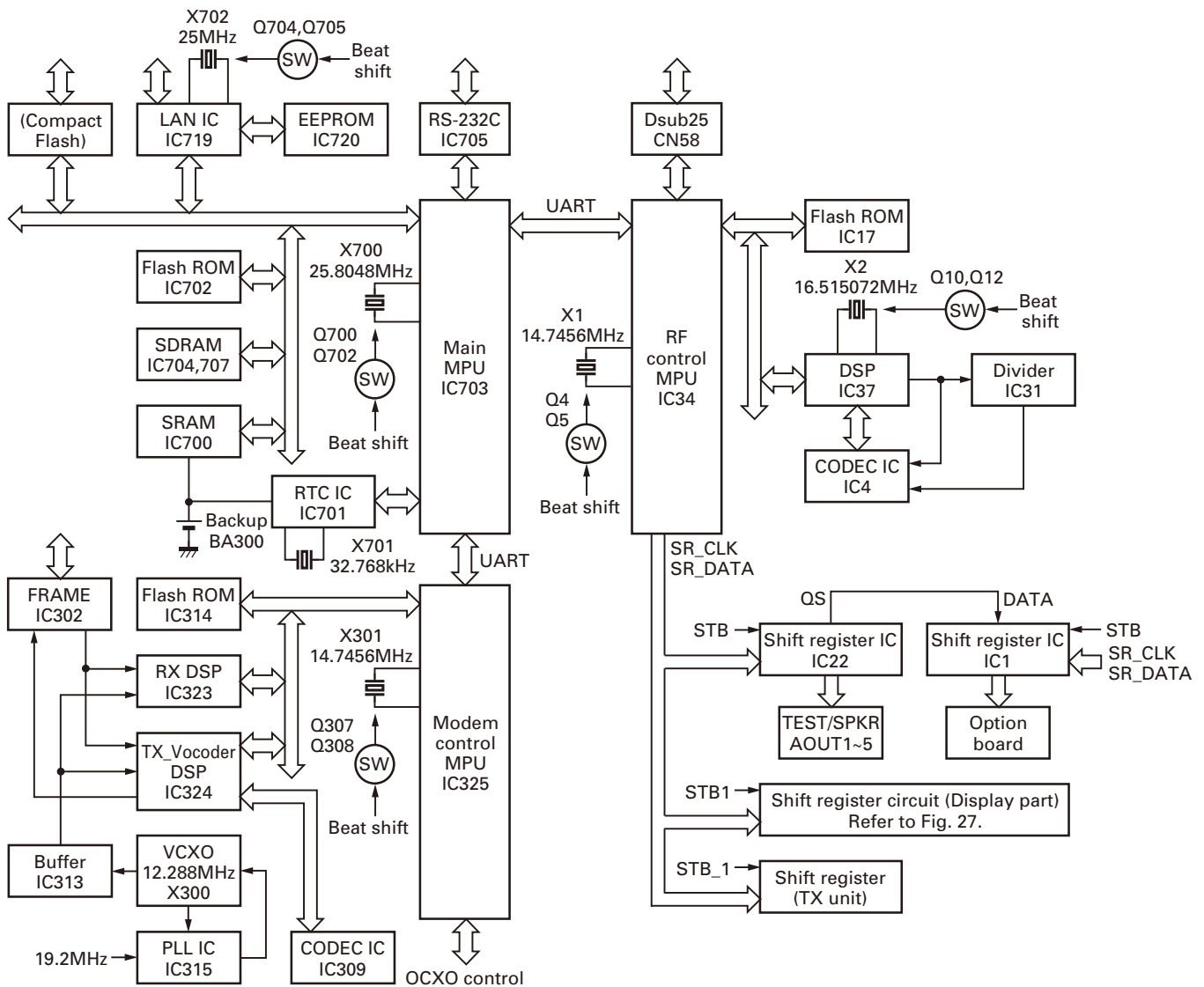

Fig. 25 Control circuit

CIRCUIT DESCRIPTION

■ TX_Vocoder DSP

In NXDN mode, the AMBE+2 (TM) vocoder processing is performed by the IC324 TX_Vocoder_DSP.

Audio signal input from the Audio codec IC ADC part (IC309 AINL) terminal is vocoder encode processed and converted to audio data.

CAI data is encoded for correcting errors and converted to transmitter data.

This data is framed, converted to symbol values and made to pass the base band limitation filter (root nyquist cosine filter and sinc filter). The passed signal turns into a modulating signal. It is output as an analog signal by the Audio codec IC DAC part (IC309 AOUTR terminal).

■ Power supply voltage monitoring circuit

This circuit always monitors the external power supply voltage assuming that the abnormal power supply voltage is applied. This circuit consists of X53-413 R67, R68, R71, and R79 and IC7, and X53-414 IC308. If the voltage is reduced, these circuits interrupt the Modem control MPU (IC325) and NXR-700 rapidly shift to the power down state. The IC325 A/D converter (pin124) monitors the voltage. It detects the voltage rises and returns to the normal voltage range.

■ Reset circuit

Reset system diagrams of each device of NXR-700 are attached. With regard to the priority of the reset signal of each device, IC303 that prepares the reset signal of IC325 has the highest priority. Software of IC325 can activate devices including IC323, IC324, IC703, IC700, IC719, IC34, and IC17. Software of IC703 can activate the reset of IC325.

■ Clock shift circuit

NXR-700 control unit has a crystal oscillation circuit shown below.

X53-4132-71:

14.7456MHz (IC34 and X1)

16.515072MHz (IC37 and X2)

X53-4140-10:

14.7456MHz (IC325 and X301)

25.8048MHz (IC37 and X2)

25MHz (IC719 and X702)

Each oscillation circuit turns on the NPN transistor "2SC4738(GR)F" and staggers the oscillating frequency by approximately -70ppm . This may prevent interference against transmitter and receiver frequencies. Each transistor is turned on and off by the FPU.

■ Flash ROM (Main MPU)

IC702 is a 128M bit Flash ROM and contains the firmware of the Main MPU.

■ Flash ROM (Modem control MPU)

IC314 is an 8M bit Flash ROM and contains the firmware of the Modem control MPU, RX DSP, and TX_Vocoder_DSP.

■ SDRAM

IC704 and IC707 are program execution 128M bit memory used by the Main MPU.

■ SRAM

IC700 is a memory backed up by a lithium battery (BA300). The memory size is 16M bits. It contains data required for the system backup.

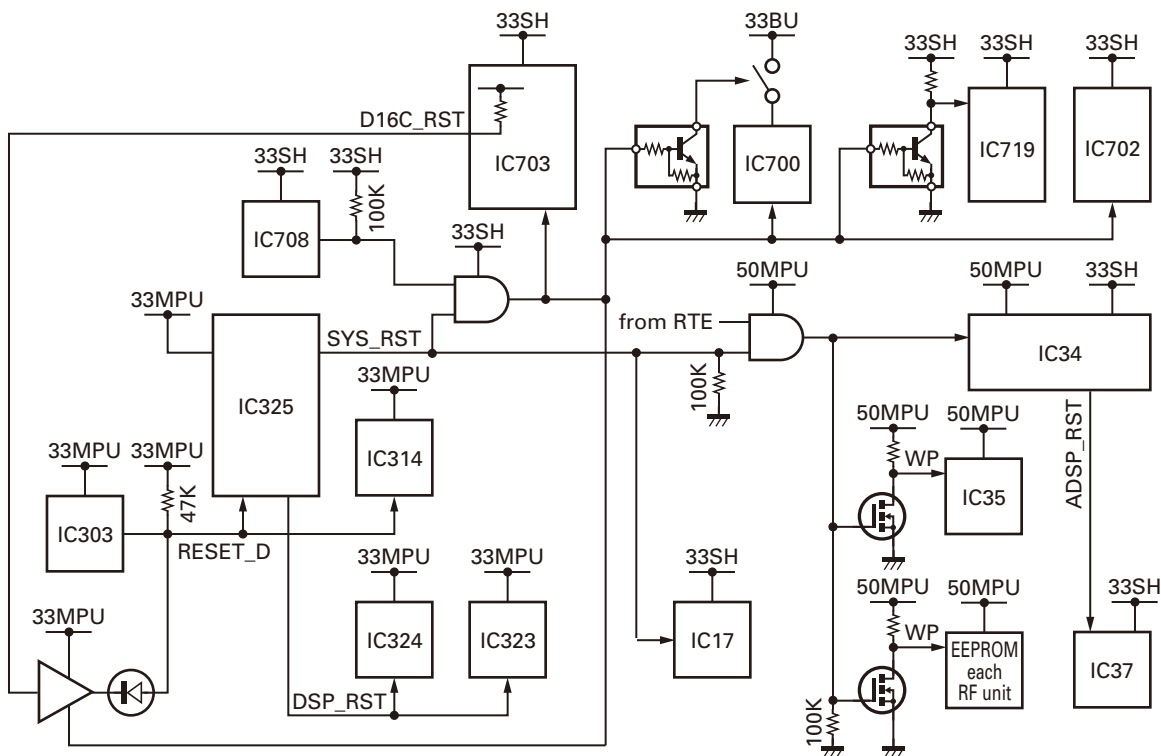

Fig. 26 Reset circuit

CIRCUIT DESCRIPTION

■ Frame synchronizing signal transmitter and receiver circuit

J702 and J703 are connectors for synchronizing with other repeaters in NXDN trunking mode. The differential rectangular wave that conforms to RS-485, 12.5Hz or 25Hz is input to and output from this connector for synchronizing multiple repeaters.

In the repeater system, any given repeater outputs a synchronizing signal and that synchronous signal is input to other remaining repeaters.

With regards to the output of the synchronous signal, the frame signal generated by TX_Vocoder_DSP (IC324) is differentially output by IC302.

With regards to the input of the synchronous signal, IC302 receives a differential signal, and is input to the interruption of the RX DSP (IC323) and TX_Vocoder_DSP (IC324).

■ 12.288MHz clock PLL circuit

The PLL circuit is installed in the control unit (X53-414) for operating the RX DSP and TX_Vocoder DSP.

The PLL circuit consists of X300 (12.288MHz VCXO), IC315 (PLL IC), Q300, Q304, Q305, and IC313.

The purpose of this PLL circuit is to synchronize with the 19.2MHz reference signal controlled by the 10MHz OCXO (deviation \pm 0.4ppm) in the transmitter unit (X56-311).

So, two DSPs can be executed by a \pm 0.4ppm clock deviation.

Q300 is a 19.2MHz buffer amp signal input from the transmitter unit (X56-311).

The signal from the transmitter unit is supplied to IC315 pin8 (reference signal input).

12.288MHz from X300 is amplified by Q304 and dis-

tributed to two routes. One is amplified by Q305 and input to IC315 pin6 (RF signal input). The other is amplified by IC313 and becomes a clock for the RX DSP and TX_Vocoder DSP.

IC315 compares the reference signal and RF signal and detects their phase errors.

This phase error signal is output from pin2 charge pump (CP), passed through the LPF and is supplied to X300 voltage control pin1.

7. Display Circuit

7-1. Display circuit

The display circuit (X56-311 B/3,C/3) consists of various types of LEDs, 17-segment type D960, D961 (red), D921 (red: transmission), two-color type D920 (green: busy), D922 (green: power on, red blinking: abnormal voltage), D923 (green: CTRL), two-color type D924 (red: OCXO error, green: OCXO normality, orange: external reference signal), 8-bit status LEDs D925 to D932, and LEDs with built in switches S920 to S925.

IC920 to IC925 and IC960 to IC963 are in charge of displaying present channels and states on the front panel. IC923 to IC925 and IC960 to IC963 are shift registers that convert the MPU serial data to parallel data and turn on LEDs.

7-2. Key switches circuit

The logic signals from the front panel key and channel switches (channel selector) are entered directly into the RF MPU (IC34).

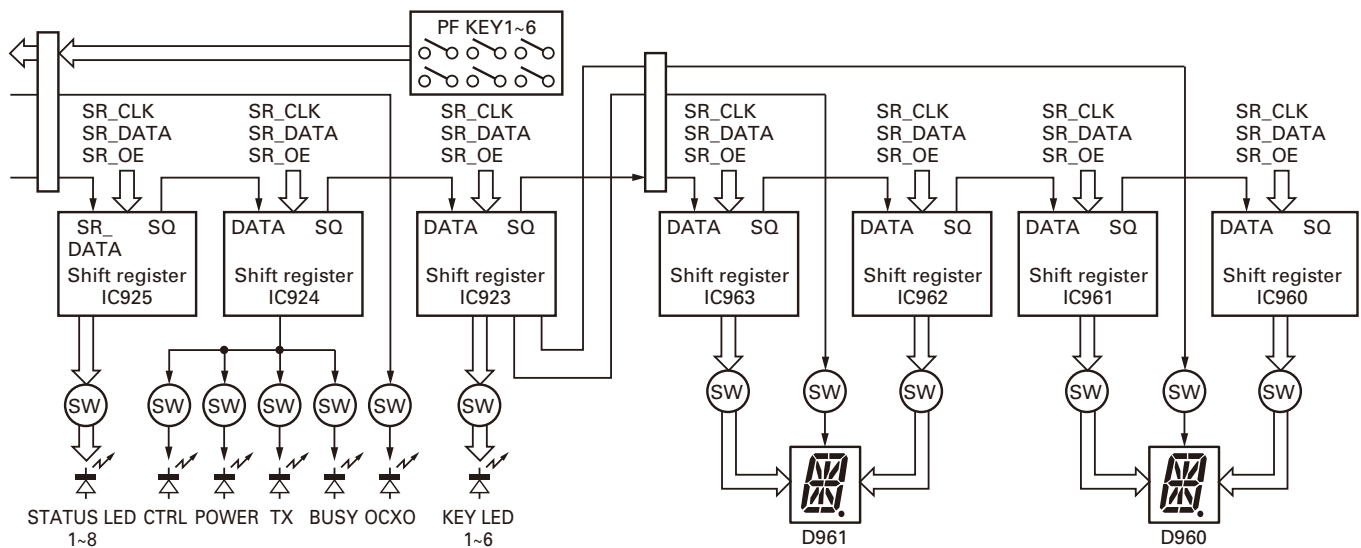

Fig. 27 Shift register circuit (Display part)

COMPONENTS DESCRIPTION

FINAL UNIT (X45-3852-70)

Ref. No.	Part Name	Description
IC1	Analogue IC	Current monitor
IC2	Analogue IC	OP AMP
IC3	MOS-IC	Voltage regulator
IC4~6	Analogue IC	OP AMP
IC7	MOS-IC	Temperature sensor
IC8	Analogue IC	OP AMP
IC9	ROM IC	E2PROM
IC10	MOS-IC	Power module
IC11,12	Bi-polar IC	Voltage regulator
IC701	Bi-polar IC	Voltage regulator
IC702	MOS-IC	DC/DC converter
IC703	Bi-polar IC	Voltage regulator
Q2	FET	DC switch
Q4~6,8	FET	DC switch
D4	Surge absorber	Surge protection
D5,6	Diode	Surge protection
D7	Zener diode	Overvoltage protection
D9,10	Diode	Detector
D11,14~16	Diode	RF switch
D19	Zener diode	Overvoltage protection
D902	Varistor	Surge protection

CONTROL UNIT (X53-4132-71)

Ref. No.	Part Name	Description
IC1	MOS-IC	Shift register
IC2,3	MOS-IC	Multiplexer
IC4	MOS-IC	CODEC
IC5	Bi-polar IC	OP AMP
IC6	MOS-IC	Voltage regulator
IC7	MOS-IC	OP AMP
IC8	MOS-IC	D/A converter
IC9	Bi-polar IC	OP AMP
IC10,11	MOS-IC	DC/DC converter control
IC12	Bi-polar IC	OP AMP
IC14	MOS-IC	Multiplexer
IC15,16	MOS-IC	Voltage regulator
IC17	ROM IC	Flash memory
IC18	MOS-IC	Voltage regulator
IC19~21	Bi-polar IC	OP AMP
IC22	MOS-IC	Shift register

Ref. No.	Part Name	Description
IC23	MOS-IC	Nand gate
IC25	MOS-IC	Analog switch
IC27,28	MOS-IC	Buffer
IC29	MOS-IC	AF PA
IC30	MOS-IC	Nand gate
IC31	MOS-IC	Divider
IC32,33	MOS-IC	Buffer
IC34	Microprocessor IC	MPU
IC35	ROM IC	ROM-IC
IC36	MOS-IC	Buffer
IC37	Microprocessor IC	DSP
IC38	MOS-IC	And gate
IC39,40	MOS-IC	Buffer
IC41,50	MOS-IC	And gate
Q1	Transistor	Inverter
Q2,3	FET	DC/DC converter
Q4,5	Transistor	Clock shift switch
Q6,7	Transistor	AF mute switch
Q8	Transistor	Power switch
Q9	FET	Power switch
Q10	Transistor	Clock shift switch
Q11	Transistor	Buffer AMPlifier
Q12	Transistor	Clock shift switch
Q13	Transistor	Buffer AMPlifier
Q14~17	Transistor	DC/DC converter
Q18	FET	Inverter
Q19	FET	Pull up switch
Q20~23	Transistor	Power switch
Q25	Transistor	OP CONT switch
Q26	Transistor	AF mute switch
Q27~29	Transistor	Buffer AMPlifier
D1,2	Diode	DC/DC converter
D3~5	Diode	Surge protector
D6	Zener diode	Surge protector
D7~12	Diode	Surge protector
D13	Zener diode	Surge protector
D14~18,20,23	Diode	Surge protector
D24,25	Varistor	Current protector
D26	Diode	Diode switch
D28	Diode	Surge protector
D29	Zener diode	Surge protector

COMPONENTS DESCRIPTION

Ref. No.	Part Name	Description
D30	Diode	Surge protector
D31	Zener diode	Surge protector
D32	Diode	Surge protector
D33	Zener diode	Surge protector
D36,37	Diode	Surge protector
D38,39	Diode	Diode switch

CONTROL UNIT (X53-4140-10)

Ref. No.	Part Name	Description
IC300,301	MOS-IC	Buffer
IC302	MOS-IC	RS-485 driver/reciever
IC303	MOS-IC	Voltage detector
IC304	MOS-IC	Buffer
IC305~307	MOS-IC	Voltage regulator
IC308	MOS-IC	Voltage detector
IC309	MOS-IC	CODEC
IC312	MOS-IC	A/D converter
IC313	MOS-IC	Inverter
IC314	ROM IC	Flash memory
IC315	MOS-IC	12.288MHz PLL
IC318~321	MOS-IC	Buffer
IC323,324	Microprocessor IC	DSP
IC325	Microprocessor IC	MPU
IC327	MOS-IC	And gate
IC329	MOS-IC	Voltage regulator
IC330	MOS-IC	Buffer
IC700	SRAM IC	SRAM
IC701	MOS-IC	RTC IC
IC702	ROM IC	Flash memory
IC703	Microprocessor IC	MPU
IC704	DRAM IC	SDRAM
IC705	MOS-IC	RS-232C driver/reciever
IC707	DRAM IC	SDRAM
IC708	MOS-IC	Voltage detector
IC709	MOS-IC	Buffer
IC710,711	MOS-IC	Nand gate
IC712,713	MOS-IC	Or gate
IC714~718	MOS-IC	Octal buffer
IC719	MOS-IC	LAN IC
IC720	ROM IC	EEPROM
IC721	MOS-IC	And gate

Ref. No.	Part Name	Description
IC722	MOS-IC	Or gate
IC723	MOS-IC	Nand gate
IC724,725	MOS-IC	Buffer
IC726	MOS-IC	And gate
IC727,728	MOS-IC	Buffer
Q300	Transistor	Reference AMP
Q301	Transistor	DC switch
Q302	Transistor	Power switch
Q303	Transistor	Control switch
Q304,305	Transistor	Reference AMP
Q307,308	Transistor	Clock shift switch
Q309	FET	Switch
Q700,702 Q704,705	Transistor	Clock shift switch
Q706	Transistor	Control switch
Q707	Transistor	MIC switch
D300	Diode	DC Switch
D701	Diode	Switch
D702	Diode	Voltage protector

RX UNIT (X55-3092-71)

Ref. No.	Part Name	Description
IC4	MOS-IC	OP AMP
IC5	MOS-IC	Frequency PLL
IC6	MOS-IC	OP AMP
IC7	MOS-IC	DDS
IC8	MOS-IC	Buffer AMP
IC9	Bi-polar IC	1/2 divider
IC10	Bi-polar IC	Voltage regulator
IC11	MOS-IC	Frequency PLL
IC12	MOS-IC	IF system
IC13	Bi-polar IC	IF system
IC14	Analogue IC	OP AMP
IC15,16	Bi-polar IC	Voltage regulator
IC17~19	Analogue IC	Voltage regulator
IC20	Analogue IC	OP AMP
IC22	MOS-IC	Voltage regulator
IC23	Analogue IC	DAC
IC24,25	Bi-polar IC	Voltage regulator
IC26~28	Analogue IC	Voltage regulator
IC29	Bi-polar IC	OP AMP

COMPONENTS DESCRIPTION

Ref. No.	Part Name	Description
IC30	MOS-IC	ADC
IC31	ROM IC	EEPROM
IC32	Bi-polar IC	OP AMP
IC33	MOS-IC	OP AMP
IC35	MOS-IC	Temperature sensor
Q1	Transistor	LNA
Q2	Transistor	PLL active filter AMP
Q3	Transistor	RF AMP
Q4	Transistor	PLL active filter AMP
Q5	Transistor	RF AMP
Q6	Transistor	Ripple filter AMP
Q7,8	FET	Oscillator
Q9	Transistor	Ripple filter AMP
Q10,11	Transistor	DC switch
Q12	Transistor	RF AMP
Q13	Transistor	DC switch
Q14,15	FET	DC switch
Q16,17	Transistor	RF AMP
Q18~20	FET	RF AMP
Q21~23	Transistor	RF AMP
Q24	FET	Oscillator
Q25,26	FET	DC switch
Q27	Transistor	Ripple filter AMP
Q28,29	FET	RF AMP
Q30	Transistor	RF AMP
Q31,32	FET	DC switch
Q33	Transistor	RF AMP
Q34	Transistor	DC switch
Q35,36	Transistor	RF AMP
Q37	FET	DC switch
Q38~40	Transistor	RF AMP
Q50~52	FET	DC switch
Q53	Transistor	RF AMP
Q56	FET	DC switch
Q57	Transistor	DC switch
Q58~61	FET	DC switch
D1,2	Diode	Surge protection
D3~8	Variable capacitance diode	Frequency control
D9,10	Diode	RF switch
D11,12	Variable capacitance diode	Frequency control

Ref. No.	Part Name	Description
D13~16	Diode	RF switch
D17,18	Diode	Detector
D19,20	Diode	RF switch
D21	LED	PLL indicator
D22,23	Variable capacitance diode	Frequency control

TX UNIT (X56-3112-71)

Ref. No.	Part Name	Description
IC101	Analogue IC	RF PLL
IC102	MOS-IC	OP AMP
IC104	Analogue IC	Voltage regulator
IC201	Analogue IC	APC AMP
IC202	MOS-IC	4.5MHz DDS
IC301	BI-POLAR IC	OP AMP
IC302	MOS-IC	Buffer AMP
IC303	MOS-IC	PLL
IC304	MOS-IC	Digital potentiometer
IC305	Bi-polar IC	Summing AMP
IC306	MOS-IC	OP AMP
IC307	MOS-IC	Buffer AMP
IC308	Bi-polar IC	OP AMP
IC401	MOS-IC	OP AMP
IC404	MOS-IC	19.2MHz PLL
IC405,406	MOS-IC	Comparator
IC407	MOS-IC	Buffer AMP
IC408,409	Bi-polar IC	OP AMP
IC601	MOS-IC	5.99MHz DDS
IC602	MOS-IC	Buffer AMP
IC603	MOS-IC	Voltage regulator
IC701	Analogue IC	DAC
IC702	ROM IC	EEPROM
IC703	MOS-IC	Shift register
IC704~706	Analogue IC	Voltage regulator
IC801	Analogue IC	Voltage reference
IC802	MOS-IC	DAC
IC803	MOS-IC	ADC
IC804	MOS-IC	Temperature sensor
IC805,806	MOS-IC	3-state buffer
IC807~810	Analogue IC	Voltage regulator
IC811	MOS-IC	Prescaler

COMPONENTS DESCRIPTION

Ref. No.	Part Name	Description
IC920~922	MOS-IC	3-state buffer
IC923~925	MOS-IC	Shift register
IC926	Bi-polar IC	OP AMP
IC960	MOS-IC	Shift register
IC961~963	MOS-IC	Shift register
Q101	FET	DC switch
Q102,103	FET	RF VCO
Q104	Transistor	RF AMP
Q105	Transistor	Ripple filter AMP
Q106	Transistor	RF AMP
Q107~109	Transistor	DC switch
Q110	FET	DC switch
Q202	Transistor	RF AMP
Q203	FET	RF driver AMP
Q204~206,210	FET	DC switch
Q211~213	Transistor	RF AMP
Q301,302	FET	DC switch
Q303	Transistor	DC switch
Q304,305,307 Q401,402	Transistor	RF AMP
Q405,407~409	FET	DC switch
Q410	Transistor	DC switch
Q412	Transistor	RF AMP
Q413,414	FET	DC switch
Q415~419	Transistor	RF AMP
Q420	FET	RF AMP
Q421	FET	DC switch
Q422	FET	RF AMP
Q423,424	FET	DC switch
Q425	FET	RF AMP
Q426,428,429	FET	DC switch
Q430,431	FET	RF AMP
Q601,602	FET	DC switch

Ref. No.	Part Name	Description
Q603	Transistor	RF AMP
Q604,605	FET	DC switch
Q606	Transistor	RF AMP
Q607~609 Q701,702	FET	DC switch
Q920~930	Transistor	DC switch
Q931,932	Transistor	Audio level limiter
Q960~976	Transistor	DC switch
D101,102	Variable Capacitance diode	Frequency control
D106	Variable Capacitance diode	Moduration control
D107,108	Variable Capacitance diode	Frequency control
D112	Variable Capacitance diode	Moduration control
D201	Diode	Detector
D202	LED	Output indicator
D301	LED	PLL indicator
D401~403	Diode	Detector
D404~407	Diode	RF switch
D408	Diode	Detector
D409	Surge absorber	Ref signal output
D601,602	Diode	RF switch
D603~606	Zener diode	Limiter
D920	LED	BUSY
D921	LED	TX
D922	LED	POWER
D923	LED	CTRL
D924	LED	OXC0
D925~932	LED	Status 8~Status 1
D933,934	Diode	Audio level limiter
D935,936	Diode	Surge protection
D960,961	LED	17-segment

TERMINAL FUNCTION

Final Unit (X45-3852-70) (A/5)

Pin No.	Name	I/O	Function
CN1 (To X56-311 A/3 CN802)			
1	TX SIGNAL	I	Tx driver input signal (Coaxial)
CN2 (To X45-385 C/5 CN29)			
1	SB	I	Power supply input
CN8			
1	-	O	5V supply output for FAN
2	-	-	Ground
CN19			
1	MONITOR	O	Receive signal input (Coaxial)
CN20 (To X56-311 A/3 CN806)			
1	GND	-	Ground
2	GND	-	Ground
3	NC	-	No connection
4	GND	-	Ground
5	PA_CURR	O	Power module current monitor
6	GND	-	Ground
7	FAN_CURR	O	FAN current monitor
8	GND	-	Ground
9	FWD_PWR	O	TX Forward power detection
10	GND	-	Ground
11	RFL_PWR	O	TX Reflect power detection
12	GND	-	Ground
13	PWR_PRT	I	TX power protection
14	GND	-	Ground
15	PWR_CONT	I	TX power control
16	GND	-	Ground
17	FAN_CONT	I	FAN1 control
18	GND	-	Ground
19	FAN_CONT2	I	FAN2 control
20	GND	-	Ground
21	TEMP_RST	I	Reset input for temperature detect IC
22	GND	-	Ground
23	ANT_SW	I	Antenna switch
24	GND	-	Ground
25	TEMP_PRT	O	High temperature detect
26	D_GND	-	Digital ground
27	CONT_5.0V	I	Switched 5V supply
28	D_GND	-	Digital ground
29	SCL	I	Clock input for E2PROM
30	D_GND	-	Digital ground
31	SDA	I/O	Data input/output for E2PROM

Pin No.	Name	I/O	Function
32	D_GND	-	Digital ground
33	GND	-	Ground
34	WP	I	Write protection input for E2PROM
35	GND	-	Ground
36	GND	-	Ground
CN21 (To X45-385 C/5 CN30)			
1	E	-	Ground

Final Unit (X45-3852-70) (C/5)

Pin No.	Name	I/O	Function
CN11 (To X53-413 CN4)			
1	E	-	Ground
2	-	-	No connection
3	SB	O	Power supply output
4	SB	O	Power supply output
CN12 (To X56-311 CN801)			
1	E	-	Ground
2	SB	O	Power supply output
3	SB	O	Power supply output
CN15 (To X55-309 CN44)			
1	E	-	Ground
2	SB	O	Power supply output
3	SB	O	Power supply output

Final Unit (X45-3852-70) (D/5)

Pin No.	Name	I/O	Function
CN701 (To X55-309 CN6/CN36)			
1	-	I	9V supply input
2	-	-	Ground
3	-	O	-3V supply output
4	-	-	Ground

Final Unit (X45-3852-70) (E/5)

Pin No.	Name	I/O	Function
CN905 (To X56-311 B/3 CN923)			
1	VOLUME_IN	O	Volume control output for AF signal
2	33MPU	I	3.3V constant voltage
3	GND	-	Ground
4	33AUD	I	3.3V constant voltage
5	SB	I	Power supply input
6	SCM_EN	-	No connection
7	GND	-	Ground

TERMINAL FUNCTION

Pin No.	Name	I/O	Function
8	PTT_TXD_SCM	O	PTT output
9	HOOK_RXD_SCM	O	Hook detection output
10	MIG	-	MIC ground
11	MIC	O	MIC signal output

Control Unit (X53-4132-71)

Pin No.	Name	I/O	Function
CN1 (To X53-414 CN401)			
1	PTT_TXD_SCM	-	No connection
2	GND	-	Ground
3	LO_VOL_DET	O	Low voltage detection signal
4	NC	-	No connection
5	TD_SW	I	TD terminal input signal mute switch
6	MICAD_SW	I	Microphone input signal switch, changed to analog modulation or NXDN modulation
7	MIC_SW	I	Microphone mute switch
8	RXAD_SW	I	Speaker signal switch, changed to analog reception signal or NXDN reception signal
9	PATH_SW	I	Analog or NXDN modulation route selector switch
10	BEEP_SW	I	Beep sound mute switch
11	TA_SW	I	TA input mute switch
12	TAAD_SW	I	TA input signal, changed to analog modulation or NXDN modulation
13	EVOL_LD	I	Load for electronic volume
14	GND	-	Ground
15	EVOL_CLK	I	Clock for electronic volume
16	PTT_AM16C	O	PTT signal
17	EVOL_DATA	I	Data for electronic volume
18	INSP_SW	-	No connection
19	AF_MUTE	I	Speaker output mute switch
20	SCM_EN	-	No connection
21	AMP_SW	I	Speaker amplifier power ON/OFF switch
22	HOOK_RXD_SCM	-	No connection
23	NC	-	No connection
24	INRA_SW	-	No connection
25	MIC_D_IN	O	NXDN transmission signal output
26	BEEP	I	Beep sound signal input
27	RX_AUDIO_D	I	NXDN reception signal input
28	GND	-	Ground
29	MOD_D_OUT	I	NXDN modulation signal input
30	PWR_ST_R	I	Switch for red LED (Power source)

Pin No.	Name	I/O	Function
31	VOLUME_IN	O	Volume control input for AF signal
32	OCXO_ST_G	I	Switch for green LED (OCXO)
33	OCXO_ST_R	I	Switch for red LED (OCXO)
34	RX_POWER_SAVE	I	RX unit power saving signal
35	GND	-	Ground
36	GND	-	Ground
CN2 (To X53-414 CN402)			
1	SYS_RST	I	System reset signal from modem control MPU
2	GND	-	Ground
3	BER_CLK	I	Serial clock for measurement bit error rate
4	BER_DAT	I	Serial data for measurement bit error rate
5	A16C_CK_SFT	I	"Frequency shift" signal to RF control MPU
6	TRUNKING	O	"Trunking mode" signal to Main MPU
7	ADSP_CK_SFT	I	"Frequency shift" signal to Analog mode DSP
8	GND	-	Ground
9	RADIO_ERR	O	"Detect accident of RF block" signal to Main MPU
10	QT_DQT	O	"Detect QT or DQT" signal to Main MPU
11	TX_STATE	O	"During the transmission" signal to Main MPU
12	RF_PTT	O	"Press-to-talk-switch" signal to Main MPU
13	GND	-	Ground
14	STXO_ARXO	I	UART signal from Main CPU to RF control MPU
15	SRXO_ATXO	O	UART signal from RF control MPU to Main MPU
16	GND	-	Ground
17	SC_SH	O	"Squelch control" signal to Main MPU
18	E_PTT_SH	O	"External press-to-talk-switch" signal to Main MPU
19	NC	-	No connection
20	50MPU_CONT	I	5V regulator control
21	33SH	I	3.3V constant voltage
22	33MPU_A	O	3.3V constant voltage
23	50MPU_A	O	5V constant voltage
24	33MPU_A_GND	-	Ground
25	33MPU	O	3.3V constant voltage
26	33MPU	O	3.3V constant voltage
27	33MPU_A_GND	-	Ground
28	DC50	O	5V constant voltage
29	DC50	O	5V constant voltage
30	DC50	O	5V constant voltage
31	DC50	O	5V constant voltage

TERMINAL FUNCTION

Pin No.	Name	I/O	Function
32	50MPU_A_GND	-	Ground
33	50MPU	O	5V constant voltage
34	50MPU_A_GND	-	Ground
35	GND	-	Ground
36	HI_VOL_DET	O	Voltage monitor
CN3 (To X56-311 B/3 CN921)			
1	DC8	O	8V constant voltage
2	GND	-	Ground
3	DC8	O	8V constant voltage
4	DC8	O	8V constant voltage
5	50MPU	O	5V constant voltage
6	50MPU	O	5V constant voltage
7	GND	-	Ground
8	DC8	O	8V constant voltage
9	K5	O	Key Scan
10	K4	O	Key Scan
11	K3	I	Key Scan
12	K2	I	Key Scan
13	K1	I	Key Scan
14	GND	-	Ground
15	STB1	O	Shift Register Strobe
16	GND	-	Ground
17	SR_DATA	O	Shift Register Data
18	GND	-	Ground
19	SR_CLK	O	Shift Register Clock
20	GND	-	Ground
21	SR_OE	O	Shift Register Output Enable
22	GND	-	Ground
23	PTT_TXD_SCM	I	MIC PTT
24	SCM_EN	-	No connection
25	HOOK_RXD_SCM	I	HOOK detect input
26	GND	-	Ground
27	OCXO_ST_G	O	OCXO Green LED Switch
28	PWR_ST_R	O	POWER Red LED Switch
29	OCXO_ST_R	O	OCXO Red LED Switch
30	SB	O	Power supply output
31	VOLUME_IN	I	Volume control input for AF signal
32	33AUD	O	3.3V constant voltage
33	33MPU	O	3.3V constant voltage
34	MIC	I	MIC Signal Input
35	GND	-	Ground
36	MIG	-	MIC Ground

Pin No.	Name	I/O	Function
CN4 (To X45-385 C/5 CN11)			
1	E	-	Earth
2	NC	-	No connection
3	SB	I	Power supply input
4	SB	I	Power supply input
CN56 (To X56-311 A/3 CN804)			
1	GND	-	Ground
2	GND	-	Ground
3	PAG	O	POCSAG Switch
4	GND	-	Ground
5	CONT_5.0V	O	5V constant voltage
6	D_GND	-	Ground
7	CONT_5.0V	O	5V constant voltage
8	D_GND	-	Ground
9	SDA	I/O	EEPROM Data
10	D_GND	-	Ground
11	SCK	O	EEPROM Clock
12	TEMP_PRT	I	Temperature Sensor Protection Signal
13	ANT_SW	O	Transmission antenna switch
14	DDS_EN	O	Enable for DDS
15	VR_EN	O	Enable for electronic volume
16	440_EN	O	Enable for PLL
17	132_EN	O	Enable for PLL
18	440_CE	O	PLL chip select
19	132_CE	O	PLL chip select
20	LDT	I	PLL lock detection
21	2DA_EN	O	Enable for 2ch DAC
22	3DA_EN	O	Enable for 3ch DAC
23	2DA_CE	O	Chip select for 2ch DAC
24	SR_OE	O	Shift Register Output Enable
25	8AD_EN	O	Enable for 8ch DC
26	SR_EN	O	Shift Register Strobe
27	SDI1	I	Analog data of 8ch ADC
28	SDO0	O	Data for 3 line serial
29	SCLK1	O	Clock 1 for 3 line serial
30	SCLK0	O	Clock for 3 line serial
31	SDO1	O	Data 1 for 3 line serial
32	GND	-	Ground
33	MOD	O	Modulating signal
34	WP	O	Write protection of EEPROM
35	GND	-	Ground
36	GND	-	Ground

TERMINAL FUNCTION

Pin No.	Name	I/O	Function
CN57 (To X55-309 CN42)			
1	GND	-	Ground
2	GND	-	Ground
3	WP	O	Write protection of EEPROM
4	D_GND	-	Digital Ground
5	E2PROM_SDA	I/O	Data of EEPROM
6	CONT_5.0V	-	5V constant voltage
7	E2PROM_SCL	O	Clock of EEPROM
8	D_GND	-	Digital Ground
9	AD_CS	O	Enable for 8ch DAC
10	IF_BW_SW	O	IF_bandwidth switch
11	AD_DAT_WRITE	O	Data 0 for 3 line serial
12	NC (IF_NW_SW)	-	No connection
13	AD_CLK	O	Clock 0 for 3 line serial
14	GND	-	Ground
15	AD_DAT_READ	I	Analog data of 8ch ADC
16	NC	-	No connection
17	CONT_5.0V	-	5V constant voltage
18	PLL_LOCK_DET	I	PLL1,2 lock detection
19	AGC_RSSI	-	No connection
20	PLL2_EN	O	PLL 2 enabling signal
21	FM_RSSI	I	RSSI signal input
22	NC	-	No connection
23	GND	-	Ground
24	PLL_PWR_SAVE	O	PLL1,2 chip selection signal
25	RX_AUDIO	I	Reception audio signal
26	SIF_DAT	O	Data 0 for 3 line serial
27	GND	-	Ground
28	SIF_CLK	O	Clock 0 for 3 line serial
29	3DA_EN	O	Enable for 3ch DAC
30	PLL1_EN	O	PLL 1 enabling signal
31	VCO_BAND_SW	O	VCO bandwidth switch
32	DDS_EN	O	Enable for DDS
33	RX_POWER_SAVE	O	Power saving signal of RX unit
34	NC	-	No connection
35	GND	-	Ground
36	GND	-	Ground
CN58 (To CONTROL I/O 25pin D-sub Connector)			
1	NC	-	No connection
2	NC	-	No connection
3	NC	-	No connection
4	NC (RSSI)	-	No connection (RSSI)

Pin No.	Name	I/O	Function
5	BER_CLK	O	for Bit Error Rate Clock
6	NC	-	No connection
7	EMON	I	External monitor switch input "L"=Monitor on, "H"=Monitor off
8	NC	-	No connection
9	EPTT	I	External press-to-talk switch input "L"=PTT on, "H"=PTT off
10	AI1	I	Programmable function input 1
11	SC	O	Squelch control output "L"=Busy, "H"=Not busy
12	AI2	I	Programmable function input 2
13	BER_DAT	O	for Bit Error Rate Data
14	AI3	I	Programmable function input 3
15	TXG	-	TX signal ground for TA,TD
16	DG	-	Control line ground
17	IO1	I/O	Programmable function input/output 1
18	TD	I	TX-DATA input (data or Signaling) Input impedance=600Ω Coupling=AC coupling Deviation=0.75kHz (Wide)/ 0.75kHz (Narrow) at 100Hz 0.5Vpp input
19	IO2		Programmable function input/output 2
20	TA	I	TX audio input (voice) Input impedance=600Ω Coupling=AC coupling Frequency response=Pre-emphasis curve Deviation=60% deviation at 1kHz 280mVrms±25mV input
21	IO3	I/O	Programmable function input/output 3
22	RD	O	RX-DATA output (data or Signaling) output impedance=1kΩ or less Coupling=AC coupling Non-squelched Frequency responses=±2.5dB at 10~3000Hz Output level=70~90mVrms (standard modulation)
23	IO4		Programmable function input/output 4
24	RA	O	RX-Audio output (voice) output impedance=1kΩ or less Coupling=AC coupling Squelched Frequency responses=De-emphasis curve Output level=360~440mVrms (standard modulation)
25	IO5	I/O	Programmable function input/output 5
26	RXG	-	RX signal ground for RA, RD
27	IO6	I/O	Programmable function input/output 6
28	SPM	I	Speaker mute signal input. "L"=Mute on
29	NC	-	No connection

TERMINAL FUNCTION

Pin No.	Name	I/O	Function
30	NC	-	No connection
CN59 (To TEST/SPKR 15pin Connector)			
1	AO5	O	Auxiliary output 5
2	AO4	O	Auxiliary output 4
3	AO3	O	Auxiliary output 3
4	SPO	O	Speaker AF output
5	AO2	O	Auxiliary output 2
6	SPO	O	Speaker AF output
7	AO1	O	Auxiliary output 1
8	SPI	I	Internal speaker AF input
9	RSSI	O	RSSI output (Analog signal output)
10	RD	O	RX-DATA output (Equal to D-sub connector terminal No22)
11	GND	-	Ground
12	SPG	-	Speaker ground
13	GND	-	Ground
14	SPG	-	Speaker ground
15	NC	-	No connection
16	NC	-	No connection
17	SB	O	Power supply output
18	NC	-	No connection
19	SB	O	Power supply output
20	NC	-	No connection
CN60 (To Internal Speaker)			
1	SPO	O	Internal speaker AF output
2	SPG	-	Internal speaker ground

Control Unit (X53-4140-10)

Serial data inable signal to potentiometer of OCXO unit

Pin No.	Name	I/O	Function
CN300 (To X55-309 CN43)			
	RX_IF_VN	I	2nd IF signal (450 kHz) of NXDN mode
CN302 (To X56-311 A/3 CN405)			
	REF2 (19.2MHz)	I	19.2MHz reference clock input from TX unit
CN400 (To X56-311 A/3 CN805)			
1	GND	-	Ground
2	GND	-	Ground
3	REF_SW2	O	Control signal for reference clock change circuit
4	WP	O	Write protection signal to EEPROM
5	REF_SW	O	Control signal for reference clock change circuit
6	OX_SCL	O	ADC of OCXO unit (for electric current detection) to serial clock

Pin No.	Name	I/O	Function
7	EXT_EXIST	I	External reference clock detection signal
8	OX_SDA	I/O	ADC of OCXO unit (for electric current detection) to serial data input/output
9	REF_EXIST	I	Reference clock detection signal
10	IMP_H_L	-	No connection
11	REF_IN_OUT	O	Control signal for reference clock change circuit
12	GND	-	Ground
13	OX_SDI2	I	Serial data input from potentiometer of OCXO unit
14	GND	-	Ground
15	OCXO_VR_EN	O	Serial data enable signal to potentiometer of OCXO unit
16	GND	-	Ground
17	OCXO_ON	O	Power source control of OCXO unit
18	GND	-	Ground
19	OCXO_CURR	I	Monitor of the voltage which detects current of OCXO unit
20	GND	-	Ground
21	OCXO_EXIST	I	Detection signal of OCXO unit presence
22	GND	-	Ground
23	VCXO_DA_EN	O	DDS (5.99MHz) to serial data enabling signal
24	GND	-	Ground
25	REF_LDT	I	Lock detection signal from PLL (19.2MHz)
26	GND	-	Ground
27	PLL_19_EN	O	Serial data enabling signal to PLL (19.2MHz)
28	GND	-	Ground
29	PLL_19_CE	-	No connection
30	GND	-	Ground
31	OX_SDO2	O	DAC of OCXO unit to serial data output
32	GND	-	Ground
33	OX_SCLK2	O	DAC of OCXO unit to serial clock output
34	33MPU	O	3.3V constant voltage
35	GND	-	Ground
36	GND	-	Ground
CN401 (To X53-413 CN1)			
1	GND	-	Ground
2	GND	-	Ground
3	RX_POWER_SAVE	O	Power saving signal of RX unit
4	OCXO_ST_R	O	OCXO LED red control
5	OCXO_ST_G	O	OCXO LED green control
6	VOLUME_IN	I	Voltage monitor for audio level control
7	PWR_ST_R	O	POWER LED red control

TERMINAL FUNCTION

Pin No.	Name	I/O	Function
8	MOD_D_OUT	O	Transmission modulating signal of NXDN mode
9	GND	-	Ground
10	RX_AUDIO_D	O	Reception demodulating signal of NXDN mode
11	BEEP	O	Beep sound signal output
12	MIC_D_IN	I	Audio signal before the transmission compressing of the NXDN mode
13	INRA_SW	-	No connection
14	NC	-	No connection
15	HOOK_RXD_SCM	I	Hook detection input
16	AMP_SW	O	Power source control of audio power amplifier
17	SCM_EN	-	No connection
18	AF_MUTE	O	Audio mute control
19	INSP_SW	-	No connection
20	EVOL_DATA	O	Serial data to DAC (for audio level adjustment)
21	PTT_AM16C	I	"Press-to-talk-switch" signal to Main MPU
22	EVOL_CLK	O	Serial clock to DAC (for audio level adjustment)
23	GND	-	Ground
24	EVOL_LD	O	Serial load to DAC (for audio level adjustment)
25	TAAD_SW	O	Route formation signal of audio circuit
26	TA_SW	O	Route formation signal of audio circuit
27	BEEP_SW	O	Route formation signal of audio circuit
28	PATH_SW	O	Route formation signal of audio circuit
29	RXAD_SW	O	Route formation signal of audio circuit
30	MIC_SW	O	Route formation signal of audio circuit
31	MICAD_SW	O	Route formation signal of audio circuit
32	TD_SW	O	Route formation signal of audio circuit
33	NC	-	No connection
34	LO_VOL_DET	I	Detection of voltage for low voltage state
35	GND	-	Ground
36	PTT_TXD_SCM	-	No connection
CN402 (To X53-413 CN2)			
1	HI_VOL_DET	I	Voltage monitor
2	GND	-	Ground
3	50MPU_A_GND	-	Ground
4	50MPU	I	5V constant voltage
5	50MPU_A_GND	-	Ground
6	DC50	I	5V constant voltage
7	DC50	I	5V constant voltage
8	DC50	I	5V constant voltage

Pin No.	Name	I/O	Function
9	DC50	I	5V constant voltage
10	33MPU_A_GND	-	Ground
11	33MPU	I	3.3V constant voltage
12	33MPU	I	3.3V constant voltage
13	33MPU_A_GND	-	Ground
14	50MPU_A	I	5V constant voltage
15	33MPU_A	I	3.3V constant voltage
16	33SH	O	3.3V constant voltage
17	50MPU_CONT	O	5V regulator control
18	NC	-	No connection
19	E_PTT_SH	I	"External press-to-talk-switch" signal to Main MPU
20	SC_SH	I	"Squelch control" signal to Main MPU
21	GND	-	Ground
22	SRXD_ATXO	O	UART signal from RF control MPU to Main MPU
23	STXO_ARXO	I	UART signal from Main MPU to RF control MPU
24	GND	-	Ground
25	RF_PTT	I	"Press-to-talk-switch" signal to Main MPU
26	TX_STATE	I	"During the transmission" signal to Main MPU
27	QT_DQT	I	"Detect QT or DQT" signal to Main MPU
28	RADIO_EER	I	"Detect accident of RF block" signal to Main MPU
29	GND	-	Ground
30	ADSP_CK_SFT	O	"Frequency shift" signal to Analog mode DSP
31	TRUKING	I	"Trunking mode" signal to Main MPU
32	A16C_CK_SFT	O	"Frequency shift" signal to RF control MPU
33	BER_DAT	O	Serial data for measurement bit error rate
34	BER_CLK	O	Serial clock for measurement bit error rate
35	GND	-	Ground
36	SYS_RST	O	System reset signal from modem control MPU
CN713 (To COM DSUB9 connector)			
1	CD	-	No connection
2	DSR	I	Data Set Ready
3	RD	I	Receive Data
4	RTS	O	Request to Send
5	SD	O	Send Data
6	CTS	I	Clear to Send
7	DTR	O	Data Terminal Ready
8	RI	-	No connection
9	GND	-	Ground

TERMINAL FUNCTION

RX Unit (X55-3092-71)

Pin No.	Name	I/O	Function
CN5 (To RX ANT)			
1	RX_SIGNAL	I	Receive signal input (Coaxial)
CN6 (To X45-385 D/5 CN701)			
1	-	O	9V output
2	-	-	Ground
CN36 (To X45-385 D/5 CN701)			
1	-	I	-3V input
2	-	-	Ground
CN41			
1	MONITOR_PORT	O	Use for RX BPF tuning (Coaxial)
CN42 (To X53-413 CN57)			
1	GND	-	Ground
2	GND	-	Ground
3	NC	-	No connection
4	RX_POWER_SAVE	I	RX power save
5	DDS_EN	I	Enable input for DDS
6	VCO_BAND_SW	I	VCO band switch
7	PLL1_EN	I	Enable input for PLL1
8	DA_EN	I	Enable input for DA
9	SIF_CLK	I	Clock input for PLL1/PLL2/DDS/DA
10	GND	-	Ground
11	SIF_DAT	I	Data input for PLL1/PLL2/DDS/DA
12	RX_AUDIO	O	RX audio output
13	PLL_PWR_SAVE	I	Enable input for PLL1/PLL2
14	GND	-	Ground
15	NC	-	No connection
16	FM_RSSI	O	FM RSSI output
17	PLL2_EN	I	Enable input for PLL2
18	NC (AGC_RSSI)	-	No connection
19	PLL_LOCK_DET	O	PLL1/PLL2 lock detect output
20	CONT_5.0V	I	Switched 5V supply
21	NC	-	No connection
22	AD_CLK	O	AD logic data output
23	GND	-	Ground
24	AD_CLK	I	Clock input for AD
25	NC (IF_NW_SW)	-	No connection
26	AD_DAT_WRITE	I	Serial data input for AD
27	IF_BW_SW	I	IF bandwidth switch input
28	AD_CS	I	Enable input for AD
29	D_GND	-	Ground
30	E2PROM_SCL	I	Clock input for E2PROM

Pin No.	Name	I/O	Function
31	CONT_5.0V	I	Switched 5V supply
32	E2PROM_SDA	I/O	Data input/output for E2PROM
33	D_GND	-	Digital ground
34	WP	I	Write protection input for E2PROM
35	GND	-	Ground
36	GND	-	Ground
CN43 (To X53-414 CN300)			
1	RX_IF_VN	O	RX NXDN detection output
CN44 (To X45-385 C/5 CN15)			
1	E	-	Ground
2	B	I	Power supply input
3	B	I	Power supply input
CN45 (To X56-311 A/3 CN406)			
1	REF1	I	Reference signal input
CN46			
1	-	I	Use for RX MCF tuning
2	GND	-	Ground
CN47			
1	-	O	Use for RX MCF tuning
2	-	-	Ground

TX Unit (X56-3112-71) (A/3)

Pin No.	Name	I/O	Function
CN403			
1	REF_OUT (10MHz)	O	Reference signal distribution (coaxial)
CN405 (To X53-414 CN302)			
1	REF2 (19.2MHz)	O	DSP reference signal output (coaxial)
CN406 (To X55-309 CN45)			
1	REF1 (19.2MHz)	O	Rx reference signal output (coaxial)
CN407 (To X42-328 CN2: OCXO Optional unit)			
1	OCXO	I	OCXO (Optional unit) reference signal input (coaxial)
CN408			
1	REF_IN (10MHz)	I	External reference signal input (coaxial)
CN801 (To X45-385 C/5 CN12)			
1	E	-	Ground
2	B	I	Power supply (Vcc)
3	B	I	Power supply (Vcc)
CN802 (To X45-385 A/5 CN1)			
1	TX OUT	O	Tx driver output signal (coaxial)
CN803 (To X42-328 CN1: OCXO Optional unit)			
1	33MPU	O	Switched 3.3V power supply

TERMINAL FUNCTION

Pin No.	Name	I/O	Function
2	GND	-	Ground
3	OX_SDA	I/O	OCXO EEPROM serial data
4	OX_SCL	O	OCXO EEPROM serial clock
5	OCXO_VR_EN	O	Enable output for OCXO IC3 (potentiometer)
6	OCXO_ON	O	OCXO power on signal
7	OX_SCLK2	O	Serial clock output for OCXO IC3 (potentiometer)
8	OCXO_CURR	I	OCXO current detection signal
9	OX_SDI2	I	Serial data input for OCXO IC3 (potentiometer)
10	OCXO_EXIST	I	OCXO detection signal
11	OX_SDO2	O	Serial data output for OCXO IC3 (potentiometer)
12	GND	-	Ground
13	REF_SW2	O	OCXO reference signal output switch
CN804 (To X53-413 CN56)			
1	GND	-	Ground
2	GND	-	Ground
3	WP	I	EEPROM write protect signal input
4	MOD	I	Modulation signal input
5	GND	-	Ground
6	SDO1	I	Serial data input for IC101, IC202, IC303, IC802, IC803
7	SCLK0	I	Serial clock input for IC703
8	SCLK1	I	Serial clock input for IC101, IC202, IC303, IC802, IC803
9	SDO0	I	Serial data input for IC701, IC703
10	SDI1	O	Serial data output for IC803
11	SR_EN	I	Enable input for IC701, IC703
12	8AD_EN	I	Enable input for IC803
13	SR_OE	I	Enable input for IC703
14	2DA_CE	I	Chip enable input for IC802
15	3DA_EN	I	Enable input for IC701
16	2DA_EN	I	Enable input for IC802
17	LDT	O	RF PLL lock detect output
18	132_CE	I	Chip enable input for IC303
19	440_CE	I	Chip enable input for IC101
20	132_EN	I	Load enable input for IC303
21	440_EN	I	Load enable input for IC101
22	VR_EN	I	Load enable input for IC304
23	DDS_EN	I	Load enable input for IC202
24	ANT_SW	I	TX antenna switch input
25	TEMP_PRT	O	Temp protection signal output
26	SCK	I	EEPROM Clock

Pin No.	Name	I/O	Function
27	D_GND	-	Ground
28	SDA	I/O	EEPROM Data
29	D_GND	-	Ground
30	CONT_5.0V	I	Switched 5V power supply
31	D_GND	-	Ground
32	CONT_5.0V	I	Switched 5V power supply
33	GND	-	Ground
34	PAG	I	POCSAG Switch
35	GND	-	Ground
36	GND	-	Ground
CN805 (To X53-414 CN400)			
1	GND	-	Ground
2	GND	-	Ground
3	33MPU	I	Switched 3.3V power supply
4	OX_SCLK2	I	Serial clock input for IC601, IC404
5	GND	-	Ground
6	OX_SDO2	I	Serial data input for IC601, IC404
7	GND	-	Ground
8	PLL_19_CE	I	100kohm load
9	GND	-	Ground
10	PLL_19_EN	I	Enable input for IC404
11	GND	-	Ground
12	REF_LDT	O	19.2MHz PLL lock detect output
13	GND	-	Ground
14	VCXO_DA_EN	I	Enable input for IC601
15	GND	-	Ground
16	OCXO_EXIST	O	OCXO detection signal
17	GND	-	Ground
18	OCXO_CURR	O	OCXO current detection signal
19	GND	-	Ground
20	OCXO_ON	I	OCXO power on signal
21	GND	-	Ground
22	OCXO_VR_EN	I	Enable input for OCXO IC3 (potentiometer)
23	GND	-	Ground
24	OX_SDI2	O	Serial data output for OCXO IC3 (potentiometer)
25	GND	-	Ground
26	REF_IN_OUT	I	Reference clock switched signal input
27	IMP_H_L	I	100kohm load
28	REF_EXIST	O	Reference detector signal output
29	OX_SDA	I/O	OCXO EEPROM serial data
30	EXT_EXIST	O	External reference detector signal output

TERMINAL FUNCTION

Pin No.	Name	I/O	Function
31	OX_SCL	I	OCXO EEPROM serial clock
32	REF_SW	I	Reference signal output switch
33	WP	I	EEPROM write protect signal input
34	REF_SW2	I	OCXO reference signal output switch
35	GND	-	Ground
36	GND	-	Ground
CN806 (To X45-385 A/5 CN20)			
1	GND	-	Ground
2	GND	-	Ground
3	WP	O	EEPROM write potect signal output
4	GND	-	Ground
5	D_GND	-	Ground
6	SDA	I/O	EEPROM Data
7	D_GND	-	Ground
8	SCK	O	EEPROM Clock
9	D_GND	-	Ground
10	CONT_5.0V	O	Switched 5V power supply
11	D_GND	-	Ground
12	TEMP_PRT	I	Temp protection signal input
13	GND	-	Ground
14	ANT_SW	O	TX antenna switch output
15	GND	-	Ground
16	TEMP_RST	O	Tempereture sensor reset signal output
17	GND	-	Ground
18	FAN_CONT2	O	FAN2 control signal output
19	GND	-	Ground
20	FAN_CONT	O	FAN1 control signal output
21	GND	-	Ground
22	PWR_CONT	O	Power control signal output
23	GND	-	Ground
24	PWR_PRT	O	Power protection signal output
25	GND	-	Ground
26	RFL_PWR	I	Reflect power signal input
27	GND	-	Ground
28	FWD_PWR	I	Forward power signal input
29	GND	-	Ground
30	FAN_CURR	I	Fan current monitor signal input
31	GND	-	Ground
32	PA_CURR	I	PA current monitor signal input
33	GND	-	Ground
34	NC	-	No connection
35	GND	-	Ground

Pin No.	Name	I/O	Function
36	GND	-	Ground
CN807 (To X42-328 CN3: OCXO Optional unit)			
1	8OCXO	O	OCXO power supply 8V
2	GND	-	Ground

TX Unit (X56-3112-71) (B/3)

Pin No.	Name	I/O	Function
CN920 (To X56-311 C/3 CN960)			
1	DC8	O	8V Power supply
2	GND	-	Ground
3	50MPU	O	Switched 5V power supply
4	STB	O	Shift Register Strobe
5	SR_OE	O	Shift Register Output Enable
6	SR_CLK	O	Shift Register Clock
7	SR_DATA	O	Shift Register Data
8	LED1	O	D960 segment "F" control
9	GND	-	Ground
10	LED10	O	D961 segment "F" control
CN921 (To X53-413 CN3)			
1	MIG	-	MIC Ground
2	GND	-	Ground
3	MIC	O	MIC Signal Input
4	33MPU	I	Switched 3.3V power supply
5	33AUD	I	Switched 3.3V power supply
6	VOLUME_IN	O	Volume control output for AF signal
7	SB	I	Power supply output
8	OCXO_ST_R	I	OCXO Red LED Switch
9	PWR_ST_R	I	POWER Red LED Switch
10	OCXO_ST_G	I	OCXO Green LED Switch
11	GND	-	Ground
12	HOOK_RXD_SCM	O	HOOK detect signal
13	SCM_EN	-	No connection
14	PTT_TXD_SCM	O	MIC PTT
15	GND	-	Ground
16	SR_OE	I	Shift Register Output Enable
17	GND	-	Ground
18	SR_CLK	I	Shift Register Clock
19	GND	-	Ground
20	SR_DATA	I	Shift Register Data
21	GND	-	Ground
22	STB1	I	Shift Register Strobe
23	GND	-	Ground

TERMINAL FUNCTION

Pin No.	Name	I/O	Function
24	K1	O	Key Scan
25	K2	O	Key Scan
26	K3	O	Key Scan
27	K4	I	Key Scan
28	K5	I	Key Scan
29	DC8	I	8V Power supply
30	GND	-	Ground
31	50MPU	I	Switched 5V power supply
32	50MPU	I	Switched 5V power supply
33	DC8	I	8V Power supply
34	DC8	I	8V Power supply
35	GND	-	Ground
36	DC8	I	8V Power supply
CN923 (To X45-385 E/5 CN905)			
1	VOLUME_IN	I	Volume control input for AF signal
2	33MPU	O	Switched 3.3V power supply
3	GND	-	Ground
4	33AUD	O	Switched 3.3V power supply
5	SB	O	Power supply output
6	SCM_EN	-	No connection
7	GND	-	Ground
8	PTT_TXD_SCM	I	MIC PTT
9	HOOK_RXD_SCM	I	HOOK detect signal
10	MIG	-	MIC ground
11	MIC	I	MIC signal input

TX Unit (X56-3112-71) (C/3)

Pin No.	Name	I/O	Function
CN960 (To X56-311 B/3 CN920)			
1	DC8	I	8V Power supply
2	GND	-	Ground
3	50MPU	I	Switched 5V power supply
4	STB	I	Shift Register Strobe
5	SR_OE	I	Shift Register Output Enable
6	SR_CLK	I	Shift Register Clock
7	SR_DATA	I	Shift Register Data
8	LED1	I	D960 segment "F" control
9	GND	-	Ground
10	LED10	I	D961 segment "F" control

CONTROL I/O 25 pin D-sub Connector

Pin No.	Pin Name	I/O	Signal Type	Modification	Description/ Port Type
1	NC	-	-	Default	-
		O	Digital	Land short	RSSI
2	NC	-	-	No	-
3	NC	-	-	No	-
4	AI1	I	Digital	No	Programmable Function Input 1/ CMOS
5	AI2	I	Digital	No	Programmable Function Input 2/ CMOS
6	AI3	I	Digital	No	Programmable Function Input 3/ CMOS
7	DG	-	GND	No	Digital GND
8	TD	I	Analog	No	TX Data Input (signaling)
9	TA	I	Analog	No	TX Audio Input (voice)
10	RD	O	Analog	No	RX Data Output (signaling)
11	RA	O	Analog	No	RX Audio Output (voice)
12	RXG	-	GND	No	RX Signal GND
13	SPM	I	Digital	No	Speaker Mute/ CMOS
14	BER_CLK	O	Digital	No	for Bit Error Rate Clock
15	EMON	I	Digital	No	External Monitor Switch
16	EPTT	I	Digital	No	External PTT Switch
17	SC	O	Digital	No	Squelch Control
18	BER_DAT	O	Digital	No	for Bit Error Rate Data
19	TXG	-	GND	No	TX Signal GND
20	IO1	I/O	Digital	No	Programmable Function I/O 1
21	IO2	I/O	Digital	No	Programmable Function I/O 2
22	IO3	I/O	Digital	No	Programmable Function I/O 3
23	IO4	I/O	Digital	No	Programmable Function I/O 4
24	IO5	I/O	Digital	No	Programmable Function I/O 5
25	IO6	I/O	Digital	No	Programmable Function I/O 6

LAN

Pin No.	Pin Name	I/O	Signal Type	Modification	Description/ Port Type
1	TD+	O	Analog	No	TX Signal +
2	TD-	O	Analog	No	TX Signal -
3	RD+	I	Analog	No	RX Signal +
4	NC	-	-	No	-
5	NC	-	-	No	-
6	RD-	I	Analog	No	RX Signal -
7	NC	-	-	No	-
8	NC	-	-	No	-

TERMINAL FUNCTION

COM DSUB9 Connector

Pin No.	Pin Name	I/O	Signal Type	Modification	Description/ Port Type
1	CD	I	Digital	No	Carrier Detect
2	RD	I	Digital	No	Receive Data
3	SD	O	Digital	No	Send Data
4	DTR	O	Digital	No	Data Terminal Ready
5	SG	-	GND	No	Signal GND
6	DSR	I	Digital	No	Data Set Ready
7	RTS	O	Digital	No	Request to Send
8	CTS	I	Digital	No	Clear to Send
9	CI	I	Digital	No	Ringer DET

TEST/SPKR 15 pin Connector

Pin No.	Pin Name	I/O	Signal Type	Modification	Description/ Port Type
1	SB	-	Power	No	Power Supply
2	SB	-	Power	No	Power Supply
3	NC	-	-	No	-
4	GND	-	GND	No	Digital GND
5	GND	-	GND	No	Digital GND
6	SPG	-	GND	No	Speaker GND
7	RD	O	Analog	No	RX Data Output (Equal to D-sub CN.#10)
8	RSSI	O	Analog	No	RSSI Output
9	SPI	I	Analog	No	Internal Speaker Input
10	AO1	O	Digital	default	Auxiliary Output 1 Open collector
				\$R520=47k D5=delete	Auxiliary Output 1 CMOS
11	AO2	O	Digital	default	Auxiliary Output 2 Open collector
				\$R519=47k D5=delete	Auxiliary Output 2 CMOS
12	SPO	O	Analog	No	External Speaker Output
13	AO3	O	Digital	default	Auxiliary Output 3 Open collector
				\$R518=47k D5=delete	Auxiliary Output 3 CMOS
14	AO4	O	Digital	default	Auxiliary Output 4 Open collector
				\$R517=47k D5=delete	Auxiliary Output 4 CMOS
15	AO5	O	Digital	default	Auxiliary Output 5 Open collector
				\$R516=47k D5=delete	Auxiliary Output 5 CMOS

Microphone Connector

(Left =1...Right=8, Front Panel View)

Pin No.	Pin Name	I/O	Signal Type	Modification	Description/ Port Type
1	NC	-	-	No	-
2	SB	-	Power	No	Power
3	GND	-	GND	No	Digital GND
4	PTT	I	Digital	No	PTT Signal/ CMOS Active Lo
5	MIG	-	-	No	MIC GND
6	MIC	I	Analog	No	MIC Input
7	HOOK	I	Digital	No	HOOK Detect Signal CMOS, Active Lo
8	NC	-	-	No	-

Frame Synchronous Connector

(Left =1...Right=4, Rear Panel View)

There are two connectors at the rear panel, these are the same function.

Pin No.	Pin Name	I/O	Signal Type	Modification	Description/ Port Type
1	FRMA	I/O	-	No	RS-485 Differential Signal A
2	NC	-	-	No	-
3	NC	-	-	No	-
4	FRMB	I/O	-	No	RS-485 Differential Signal B

PARTS LIST

CAPACITORS

$\frac{C}{1} \frac{C}{2} \frac{45}{3} \frac{TH}{4} \frac{1H}{5} \frac{220}{6} \frac{J}{7}$

- 1 = Type ... ceramic, electrolytic, etc.
- 2 = Shape ... round, square, etc.
- 3 = Temp. coefficient
- 4 = Voltage rating
- 5 = Value
- 6 = Tolerance

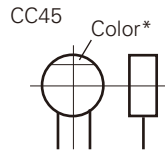

• Capacitor value

- 010 = 1pF
- 100 = 10pF
- 101 = 100pF
- 102 = 1000pF = 0.001μF
- 103 = 0.01μF

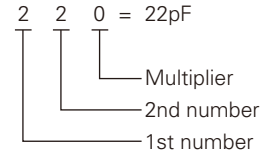

• Temperature coefficient

1st Word	C	L	P	R	S	T	U
Color*	Black	Red	Orange	Yellow	Green	Blue	Violet
ppm/°C	0	-80	-150	-220	-330	-470	-750

2nd Word	G	H	J	K	L
ppm/°C	±30	±60	±120	±250	±500

Example : CC45TH = -470±60ppm/°C

• Tolerance (More than 10pF)

Code	C	D	G	J	K	M	X	Z	P	No code
(%)	±0.25	±0.5	±2	±5	±10	±20	+40 -20	+80 -20	+100 -0	More than 10μF : -10~+50 Less than 4.7μF : -10~+75

(Less than 10pF)

Code	B	C	D	F	G
(pF)	±0.1	±0.25	±0.5	±1	±2

• Voltage rating

2nd word	A	B	C	D	E	F	G	H	J	K	V	
1st word	0	1.0	1.25	1.6	2.0	2.5	3.15	4.0	5.0	6.3	8.0	-
1	10	12.5	16	20	25	31.5	40	50	63	80	35	
2	100	125	160	200	250	315	400	500	630	800	-	
3	1000	1250	1600	2000	2500	2150	4000	5000	6300	8000	-	

• Chip capacitors

- (EX) $\frac{C}{1} \frac{C}{2} \frac{73}{3} \frac{F}{4} \frac{SL}{5} \frac{1H}{6} \frac{000}{7} \frac{J}{8}$ → Refer to the table above.
- 1 = Type
 - 2 = Shape
 - 3 = Dimension
 - 4 = Temp. coefficient
 - 5 = Voltage rating
 - 6 = Value
 - 7 = Tolerance
- (Chip) (CH, RH, UJ, SL)
- (EX) $\frac{C}{1} \frac{K}{2} \frac{73}{3} \frac{F}{4} \frac{F}{5} \frac{1H}{6} \frac{000}{7} \frac{Z}{8}$
- (Chip) (B, F)

• Dimension

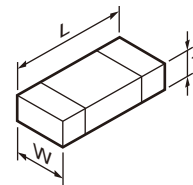

Chip capacitor

Code	L	W	T
Empty	5.6±0.5	5.0±0.5	Less than 2.0
A	4.5±0.5	3.2±0.4	Less than 2.0
B	4.5±0.5	2.0±0.3	Less than 2.0
C	4.5±0.5	1.25±0.2	Less than 1.25
D	3.2±0.4	2.5±0.3	Less than 1.5
E	3.2±0.2	1.6±0.2	Less than 1.25
F	2.0±0.3	1.25±0.2	Less than 1.25
G	1.6±0.2	0.8±0.2	Less than 1.0
H	1.0±0.05	0.5±0.05	0.5±0.05

Chip resistor

Code	L	W	T
E	3.2±0.2	1.6±0.2	1.0
F	2.0±0.3	1.25±0.2	1.0
G	1.6±0.2	0.8±0.2	0.5±0.1
H	1.0±0.05	0.5±0.05	0.35±0.05

RESISTORS

• Chip resistor (Carbon)

- (EX) $\frac{R}{1} \frac{D}{2} \frac{73}{3} \frac{E}{4} \frac{B}{5} \frac{2B}{6} \frac{000}{7} \frac{J}{8}$
- (Chip) (B, F)

• Carbon resistor (Normal type)

- (EX) $\frac{R}{1} \frac{D}{2} \frac{14}{3} \frac{B}{4} \frac{B}{5} \frac{2C}{6} \frac{000}{7} \frac{J}{8}$

- 1 = Type
- 2 = Shape
- 3 = Dimension
- 4 = Temp. coefficient
- 5 = Rating wattage
- 6 = Value
- 7 = Tolerance

• Rating wattage

Code	Wattage	Code	Wattage	Code	Wattage
1J	1/16W	2C	1/6W	3A	1W
2A	1/10W	2E	1/4W	3D	2W
2B	1/8W	2H	1/2W		

NXR-700

PARTS LIST

* New Parts. Δ indicates safety critical components.

Parts without **Parts No.** are not supplied.

Les articles non mentionnés dans le **Parts No.** ne sont pas fournis.

Teile ohne **Parts No.** werden nicht geliefert.

L : Scandinavia

Y : PX (Far East, Hawaii)

Y : AAFES (Europe)

K : USA

T : England

X : Australia

P : Canada

E : Europe

M : Other Areas

NXR-700 (Y54-3242-71)

FINAL UNIT (X45-3852-70)

Ref. No.	Address	New parts	Parts No.	Description	Destination
NXR-700					
1	3A		A62-1142-02	MAIN PANEL	
3	1E		B10-2781-04	FRONT GLASS ACCESSORY	
4	3A		B11-1841-04	FILTER (PF)	
5	3A		B11-1842-04	FILTER (17SEG)	
6	3A		B11-1843-04	FILTER (LED)	
7	3A		B11-1844-04	FILTER (STATUS)	
8	3A		B42-7296-04	STICKER (NEXEDGE)	
9	3A		B43-1188-04	BADGE	
10	1F		B62-2114-00	INSTRUCTION MANUAL	
12	2B		E04-0463-05	RF COAXIAL RECEPTACLE (BNC)	
13	1F		E30-3344-25	DC CORD ACCESSORY	
14	1B		E30-7581-05	DC CORD	
15	2C		E30-7582-05	TRUNK CABLE	
16	1B,2C		E30-7583-05	TRUNK CABLE	
17	1B,1C		E37-1295-05	FLAT CABLE (36P)	
18	1B		E37-1299-05	LEAD WIRE WITH TERMINAL (FUSE-DC+)	
19	1B		E37-1300-05	LEAD WIRE WITH TERMINAL (FUSE-DC-)	
20	1B		E37-1301-05	LEAD WIRE WITH TERMINAL (DC-PA+)	
21	1B		E37-1302-05	LEAD WIRE WITH TERMINAL (DC-PA-)	
22	2C		E37-1303-05	LEAD WIRE WITH CONNECTOR (BNC-RX)	
23	1D		E37-1304-05	LEAD WIRE WITH CONNECTOR (BN-REF)	
24	1B		E37-1305-05	LEAD WIRE WITH CONNECTOR (DC-TX)	
25	1C		E37-1306-05	LEAD WIRE WITH CONNECTOR (DC-CONT)	
26	2C		E37-1307-05	LEAD WIRE WITH CONNECTOR (DC-RX)	
27	2D		E37-1308-05	LEAD WIRE WITH CONNECTOR (RX-DCDC)	
28	1D		E37-1310-05	LEAD WIRE WITH CONNECTOR (DSUB-25P)	
29	3B		E37-1311-05	LEAD WIRE WITH CONNECTOR (DSUB-9P)	
30	2D		E37-1313-05	LEAD WIRE WITH CONNECTOR (ACC15)	
31	3B		E37-1314-05	LEAD WIRE WITH CONNECTOR (DISP-MIC)	
32	3B		E37-1315-05	LEAD WIRE WITH CONNECTOR (DISP-17SEG)	
33	2B		E37-1316-05	LEAD WIRE WITH CONNECTOR (SP)	
34	1E		E37-1381-05	15P PLUG ACCESSORY	
36	1D,1E		F05-1537-05	BLADE FUSE (15A/32V) ACCESSORY	
37	2A		F07-1930-05	COVER (FAN)	
38	1D		F09-0445-05	CAP (25P)	
39	3B		F09-0484-05	CAP (9P)	
40	2A		F09-0491-05	FANMOTOR	
42	3A		G10-1343-04	FIBROUS SHEET (FRONT PANEL)	
44	3C	*	G10-1396-04	FIBROUS SHEET (SHIELDING COVER)	
45	2B		G11-4408-04	RUBBER SHEET (CONT-TR)	
47	3A		G13-2163-04	CUSHION (PF)	
52	3B		J19-5496-02	HOLDER (DISP)	
54	1E		J29-0725-04	BRACKET (SIDE)	
55	3A		J39-0655-03	SPACER (SP)	
56	2D		J61-0307-05	BAND (DC)	
58	1E		K01-0421-05	HANDLE ACCESSORY	
59	3A		K29-4539-04	KNOB (VOLUME)	
61	1F		L79-1419-05	LINE FILTER (DC)	
A	1E		N08-0563-04	DRESSED SCREW (FRONT GLASS)	
B	3B,1D		N09-2292-05	HEXAGON HEAD SCREW (DSUB)	
D	2C,1D		N30-2606-48	PAN HEAD MACHINE SCREW (BNC)	

Ref. No.	Address	New parts	Parts No.	Description	Destination
E	2A		N30-3035-43	PAN HEAD MACHINE SCREW (FAN)	
F	2D,3D		N32-3006-43	FLAT HEAD MACHINE SCREW (TOP,REAR)	
G	3A,1E		N32-4008-43	FLAT HEAD MACHINE SCREW (PANEL)	
H	1B,1C		N67-3008-48	PAN HEAD SEMS SCREW (AVR)	
J	3B		N80-2006-43	PAN HEAD TAPTITE SCREW (DISP)	
K	1D		N80-2608-43	PAN HEAD TAPTITE SCREW (FUSE)	
L	1B,2C		N87-2608-48	BRAZIER HEAD TAPTITE SCREW (PCB)	
64	3A		T07-0347-15	SPEAKER	
-			490-0174-05	ADHESIVE TAPE	
FINAL UNIT (X45-3852-70)					
C1,2			CD04BD1H101M	ELECTRO 100UF 50WV	
C7,8			CE32BM1V220M	CHIP EL 22UF 35WV	
C10,11			CK73GB1H102K	CHIP C 1000PF K	
C15-17			CK73GB1H103K	CHIP C 0.010UF K	
C21			CK73GB1H102K	CHIP C 1000PF K	
C22			C93-0564-05	CHIP C 22PF J	
C25,26			CK73GB1H103K	CHIP C 0.010UF K	
C29,30			CK73GB1H102K	CHIP C 1000PF K	
C32,33			CE32BM1V220M	CHIP EL 22UF 35WV	
C36			CK73GB1H102K	CHIP C 1000PF K	
C37			CK73GB1H103K	CHIP C 0.010UF K	
C38			CE32BM1V220M	CHIP EL 22UF 35WV	
C39			CK73GB1H102K	CHIP C 1000PF K	
C40			CK73GB1H103K	CHIP C 0.010UF K	
C41,42			CK73GB1H102K	CHIP C 1000PF K	
C44			CE32CL1V100M	CHIP EL 10UF 35WV	
C46			CK73GB1H102K	CHIP C 1000PF K	
C47			CK73GB1H103K	CHIP C 0.010UF K	
C49			CK73GB1H473K	CHIP C 0.047UF K	
C50-52			CK73GB1H102K	CHIP C 1000PF K	
C53			CK73GB1H103K	CHIP C 0.010UF K	
C59			CK73GB1H103K	CHIP C 0.010UF K	
C60			C93-0573-05	CHIP C 120PF J	
C61			CK73GB1H102K	CHIP C 1000PF K	
C62			CK73GB1H103K	CHIP C 0.010UF K	
C63-65			CK73GB1H102K	CHIP C 1000PF K	
C67			CK73GB1H102K	CHIP C 1000PF K	
C68			CE32CL1V100M	CHIP EL 10UF 35WV	
C70			CK73GB1H103K	CHIP C 0.010UF K	
C71-75			CK73GB1H102K	CHIP C 1000PF K	
C77,78			CK73GB1H102K	CHIP C 1000PF K	
C80			CK73GB1H103K	CHIP C 0.010UF K	
C82			CK73GB1H104K	CHIP C 0.10UF K	
C83			CK73GB1H102K	CHIP C 1000PF K	
C85			CC73GCH1H330J	CHIP C 33PF J	

PARTS LIST

FINAL UNIT (X45-3852-70)

Ref. No.	Address	New parts	Parts No.	Description	Desti-nation	Ref. No.	Address	New parts	Parts No.	Description	Desti-nation
C86			CK73GB1H103K	CHIP C 0.010UF K		CN1			E04-0193-05	PIN SOCKET	
C87			CC73GCH1H330J	CHIP C 33PF J		CN2			E23-0902-05	TERMINAL	
C88-90			CK73GB1H102K	CHIP C 1000PF K		CN8			E41-2671-05	PIN ASSY	
C95-102			CK73GB1H102K	CHIP C 1000PF K		CN11			E41-2673-05	PIN ASSY	
C104			CK73GB1H102K	CHIP C 1000PF K		CN12			E41-2672-05	PIN ASSY	
C105			C93-0603-05	CHIP C 1000PF K		CN15			E41-2672-05	PIN ASSY	
C106			CK73GB1H102K	CHIP C 1000PF K		CN19			E04-0193-05	PIN SOCKET	
C108,109			CK73GB1H102K	CHIP C 1000PF K		CN20			E40-6656-05	PIN ASSY	
C112			CK73GB1H102K	CHIP C 1000PF K		CN701			E41-2741-05	PIN ASSY	
C113,114			CK73GB1H472K	CHIP C 4700PF K		CN905			E41-1483-05	PIN ASSY	
C115			CK73GB1H102K	CHIP C 1000PF K		J901			E58-0526-05	MODULAR JACK	
C116			C93-0554-05	CHIP C 4.0PF C		CN4			J13-0071-05	FUSE HOLDER	
C117			CK73GB1H103K	CHIP C 0.010UF K		L1,2			L92-0179-05	CHIP FERRITE	
C119			CC73GCH1H060D	CHIP C 6.0PF D		L3			L79-1938-05	FILTER	
C122,123			C93-0568-05	CHIP C 47PF J		L4			L92-0131-05	CHIP FERRITE	
C124			CK73GB1H102K	CHIP C 1000PF K		L5			L34-4522-05	AIR-CORE COIL	
C126			C93-0563-05	CHIP C 18PF J		L6			L34-4519-05	AIR-CORE COIL	
C127,128			CK73GB1H102K	CHIP C 1000PF K		L7			L34-4521-05	AIR-CORE COIL	
C130			C93-0552-05	CHIP C 2.0PF C		L9			L34-4638-05	AIR-CORE COIL	
C131			C93-0566-05	CHIP C 33PF J		L10			L34-4614-05	AIR-CORE COIL	
C132			C93-0557-05	CHIP C 7.0PF D		L12			L34-4522-05	AIR-CORE COIL	
C133,134			CK73GB1H102K	CHIP C 1000PF K		L13-15			L34-4521-05	AIR-CORE COIL	
C138			CE32CL1V100M	CHIP EL 10UF 35WV		L17			L34-4523-05	AIR-CORE COIL	
C141			C93-0573-05	CHIP C 120PF J		L18			L41-3378-14	SMALL FIXED INDUCTOR (33NH)	
C147			C93-0565-05	CHIP C 27PF J		L19			L41-2278-14	SMALL FIXED INDUCTOR (22NH)	
C149			C93-0558-05	CHIP C 8.0PF D		L701,702			L41-4705-33	SMALL FIXED INDUCTOR (47UH)	
C158			C93-0564-05	CHIP C 22PF J		L703,704			L41-1095-33	SMALL FIXED INDUCTOR (1.0UH)	
C159			C93-0553-05	CHIP C 3.0PF C		L900			L92-0447-05	BEADS CORE	
C161			CC73GCH1H150J	CHIP C 15PF J		CP1			RK75GB1J103J	CHIP-COM 10K J 1/16W	
C162			CK73GB1H104K	CHIP C 0.10UF K		R1			RK73FB2B271J	CHIP R 270 J 1/8W	
C187,188			C92-0905-05	OS-CON 47UF 35WV		R2			RK73FB2B180J	CHIP R 18 J 1/8W	
C189			CK73GB1H103K	CHIP C 0.010UF K		R3			RK73FB2B271J	CHIP R 270 J 1/8W	
C190			CK73GB1H102K	CHIP C 1000PF K		R4			R92-3627-05	CHIP R 0.005 D 1.0W	
C191			CK73GB1E105K	CHIP C 1.0UF K		R9			RK73GB2A101J	CHIP R 100 J 1/10W	
C701			CK73GB1E105K	CHIP C 1.0UF K		R12,13			RK73GB2A473J	CHIP R 47K J 1/10W	
C702,703			CK73GB1H102K	CHIP C 1000PF K		R15			RK73GB2A332J	CHIP R 3.3K J 1/10W	
C704			CE32AU1E100M	CHIP EL 10UF 25WV		R17			RK73GB2A103J	CHIP R 10K J 1/10W	
C705			CK73GB1E105K	CHIP C 1.0UF K		R20			RK73GB2A104J	CHIP R 100K J 1/10W	
C706,707			CK73GB1H102K	CHIP C 1000PF K		R21,22			RK73GB2A824J	CHIP R 820K J 1/10W	
C708			CE32CL1V100M	CHIP EL 10UF 35WV		R25			RK73GB2A104J	CHIP R 100K J 1/10W	
C709			CE32AU1C330M	CHIP EL 33UF 16WV		R26			RK73EB2E101J	CHIP R 100 J 1/4W	
C710			CK73GB1H104K	CHIP C 0.10UF K		R27			RK73GB2A224J	CHIP R 220K J 1/10W	
C711			CS77CB21C100M	CHIP TMTL 10UF 16WV		R28			RK73GB2A474J	CHIP R 470K J 1/10W	
C712			CE32AU1C330M	CHIP EL 33UF 16WV		R29,30			RK73GB2A103J	CHIP R 10K J 1/10W	
C713,714			CK73GB1H104K	CHIP C 0.10UF K		R31,32			RK73GB2A104J	CHIP R 100K J 1/10W	
C715			CE32AU1C330M	CHIP EL 33UF 16WV		R33			RK73GB2A824J	CHIP R 820K J 1/10W	
C716			CK73GB1H104K	CHIP C 0.10UF K		R34			RK73FB2B8R2J	CHIP R 8.2 J 1/8W	
C717,718			CK73GB1H102K	CHIP C 1000PF K		R35,36			RK73GB2A823J	CHIP R 82K J 1/10W	
C900			CK73GB1H104K	CHIP C 0.10UF K		R37			RK73GB2A824J	CHIP R 820K J 1/10W	
C901			CK73GB1H102K	CHIP C 1000PF K		R38			RK73FB2B151J	CHIP R 150 J 1/8W	
C902			CC73GCH1H101J	CHIP C 100PF J		R39,40			RK73GB2A684J	CHIP R 680K J 1/10W	
C904			CC73GCH1H101J	CHIP C 100PF J		R41			RK73GB2A000J	CHIP R 0.0 J 1/10W	
C905			CK73FB0J106K	CHIP C 10UF K		R42			RK73FB2B8R2J	CHIP R 8.2 J 1/8W	
C906-908			CK73GB1H102K	CHIP C 1000PF K		R44			RK73FB2B8R2J	CHIP R 8.2 J 1/8W	
C909,910			CC73GCH1H101J	CHIP C 100PF J		R45,46			RK73GB2A000J	CHIP R 0.0 J 1/10W	
C912,913			CC73GCH1H101J	CHIP C 100PF J		R47			RK73FB2B151J	CHIP R 150 J 1/8W	
C914			CK73GB1H104K	CHIP C 0.10UF K		R49			RK73GB2A000J	CHIP R 0.0 J 1/10W	
C915			CC73GCH1H101J	CHIP C 100PF J		R50,51			RK73GB2A104J	CHIP R 100K J 1/10W	
C916			CK73GB1H102K	CHIP C 1000PF K							

PARTS LIST

FINAL UNIT (X45-3852-70)

CONTROL UNIT (X53-4132-72)

Ref. No.	Address	New parts	Parts No.	Description	Destination
R52			RK73FB2B8R2J	CHIP R 8.2 J 1/8W	
R53,54			RK73GB2A154J	CHIP R 150K J 1/10W	
R55-58			RK73GB2A104J	CHIP R 100K J 1/10W	
R59,60			RK73GB2A103J	CHIP R 10K J 1/10W	
R61			RK73EB2E101J	CHIP R 100 J 1/4W	
R62			RK73GH2A513D	CHIP R 51K D 1/10W	
R63			RK73GH2A333D	CHIP R 33K D 1/10W	
R64			RK73GB2A474J	CHIP R 470K J 1/10W	
R65			RK73GB2A473J	CHIP R 47K J 1/10W	
R66			RK73GB2A100J	CHIP R 10 J 1/10W	
R67			RS14DB3D560J	FL-PROOF RS 56 J 2W	
R68			RK73GB2A104J	CHIP R 100K J 1/10W	
R69			RK73GB2A103J	CHIP R 10K J 1/10W	
R70-72			RK73GB2A000J	CHIP R 0.0 J 1/10W	
R75,76			RK73GB2A472J	CHIP R 4.7K J 1/10W	
R78			RK73GB2A104J	CHIP R 100K J 1/10W	
R89			RK73GB2A000J	CHIP R 0.0 J 1/10W	
R92			RK73GB2A104J	CHIP R 100K J 1/10W	
R102			RK73GH2A101D	CHIP R 100 D 1/10W	
R104			RK73GB2A393J	CHIP R 39K J 1/10W	
R121			RK73GH2A103D	CHIP R 10K D 1/10W	
R123			RK73GB2A103J	CHIP R 10K J 1/10W	
R124			RK73FB2B220J	CHIP R 22 J 1/8W	
R125			R92-1061-05	JUMPER REST 0 OHM	
R140			RK73GB2A103J	CHIP R 10K J 1/10W	
R142			RK73GB2A000J	CHIP R 0.0 J 1/10W	
R146			RK73GB2A000J	CHIP R 0.0 J 1/10W	
R150			RK73GB2A000J	CHIP R 0.0 J 1/10W	
R900			RK73GB2A000J	CHIP R 0.0 J 1/10W	
R901			RK73GB2A182J	CHIP R 1.8K J 1/10W	
R902			RK73GB2A000J	CHIP R 0.0 J 1/10W	
R903			RK73GB2A681J	CHIP R 680 J 1/10W	
R905,906			RK73GB2A000J	CHIP R 0.0 J 1/10W	
R907			RK73GH2A153D	CHIP R 15K D 1/10W	
R909			RK73GB2A000J	CHIP R 0.0 J 1/10W	
R910			RK73GB2A182J	CHIP R 1.8K J 1/10W	
R911,912			RK73GB2A000J	CHIP R 0.0 J 1/10W	
R914			RK73GB2A222J	CHIP R 2.2K J 1/10W	
VR1			R32-0744-05	SEMI FIXED VARIABLE RESISTOR	
VR2			R32-0754-05	SEMI FIXED VARIABLE RESISTOR	
VR902			R31-0668-05	VARIABLE RESISTOR	
D4			Z5W27V	SURGE ABSORBER	
D5			DSA3A1-FK	DIODE	
D6			1SS355	DIODE	
D7			O2C25.6(Y)F	ZENER DIODE	
D9,10			HSB88WS	DIODE	
D11			L7091CER	DIODE	
D14-16			L7091CER	DIODE	
D902			AVRM16270MABB	VARIATOR	
IC1			LTC6101BIS5-F	ANALOGUE IC	
IC2			NJM2904E-ZB	ANALOGUE IC	
IC3			TA78L05FF	MOS-IC	
IC4-6			NJM2904E-ZB	ANALOGUE IC	
IC7			S-8130AC	MOS-IC	
IC8			NJM2904E-ZB	ANALOGUE IC	
IC9			S24CS02AFJTBG	ROM IC	
IC10	1A		RA60H13171123	MOS-IC	
IC11	1B		NJM7808FA-ZB	BI-POLAR IC	
IC12	1B		NJM2388F12-ZB	BI-POLAR IC	

Ref. No.	Address	New parts	Parts No.	Description	Destination
IC701			NJM78L05UA-ZB	BI-POLAR IC	
IC702			LTC1046IS8	MOS-IC	
IC703			TK72130CS	BI-POLAR IC	
Q2			SSM3K15TE(F)	FET	
Q4			2SJ506-E(S)	FET	
Q5,6			SSM3K15TE(F)	FET	
Q8			SSM3K15TE(F)	FET	
CONTROL UNIT (X53-4132-72 for service)					
C1-5			CK73GB1H102K	CHIP C 1000PF	K
C6			CC73GCH1H101J	CHIP C 100PF	J
C7			CK73GB1H102K	CHIP C 1000PF	K
C8			CC73GCH1H101J	CHIP C 100PF	J
C9			CK73GB1H102K	CHIP C 1000PF	K
C10			CC73GCH1H101J	CHIP C 100PF	J
C12-16			CK73GB1H102K	CHIP C 1000PF	K
C18-28			CK73GB1H102K	CHIP C 1000PF	K
C29			CC73GCH1H101J	CHIP C 100PF	J
C30-33			CK73GB1H102K	CHIP C 1000PF	K
C34			CC73GCH1H101J	CHIP C 100PF	J
C35			CK73GB1H102K	CHIP C 1000PF	K
C36			CC73GCH1H101J	CHIP C 100PF	J
C37			CK73GB1H104K	CHIP C 0.10UF	K
C39-47			CK73GB1H102K	CHIP C 1000PF	K
C49			CC73GCH1H101J	CHIP C 100PF	J
C50-53			CK73GB1H102K	CHIP C 1000PF	K
C54			CC73GCH1H101J	CHIP C 100PF	J
C55			CK73GB1H102K	CHIP C 1000PF	K
C56			CC73GCH1H101J	CHIP C 100PF	J
C57			CK73GB1H102K	CHIP C 1000PF	K
C58			CC73GCH1H101J	CHIP C 100PF	J
C60-62			CK73GB1H102K	CHIP C 1000PF	K
C63			CK73GB1H104K	CHIP C 0.10UF	K
C64			CK73GB1H102K	CHIP C 1000PF	K
C65			CK73FB0J106K	CHIP C 10UF	K
C66			CK73GB1H102K	CHIP C 1000PF	K
C67			CK73FB0J106K	CHIP C 10UF	K
C68			CK73GB1H102K	CHIP C 1000PF	K
C69			CK73GB1H104K	CHIP C 0.10UF	K
C70			CK73GB1H102K	CHIP C 1000PF	K
C71			CK73FB0J106K	CHIP C 10UF	K
C72			CK73GB1E105K	CHIP C 1.0UF	K
C73			CC73GCH1H101J	CHIP C 100PF	J
C74			CK73GB1H104K	CHIP C 0.10UF	K
C75			CC73GCH1H101J	CHIP C 100PF	J
C76			CK73GB1H102K	CHIP C 1000PF	K
C77			C93-0912-05	CHIP C 100UF	M
C78			CK73FB0J106K	CHIP C 10UF	K
C79-82			CK73GB1H104K	CHIP C 0.10UF	K
C83-86			CK73FB0J106K	CHIP C 10UF	K
C87			C93-0912-05	CHIP C 100UF	M
C88			CK73GB1H103K	CHIP C 0.010UF	K
C89,90			CC73GCH1H221J	CHIP C 220PF	J
C92			CC73GCH1H100D	CHIP C 10PF	D
C95			C93-0912-05	CHIP C 100UF	M
C96			CC73GCH1H101J	CHIP C 100PF	J
C97			CK73GB1H104K	CHIP C 0.10UF	K
C98			CK73FB0J106K	CHIP C 10UF	K

PARTS LIST

CONTROL UNIT (X53-4132-72)

Ref. No.	Address	New parts	Parts No.	Description	Destination	Ref. No.	Address	New parts	Parts No.	Description	Destination
C99			CK73GB1H102K	CHIP C 1000PF K		C210			CK73GB1E105K	CHIP C 1.0UF K	
C102			CC73GCH1H150J	CHIP C 15PF J		C211			CK73GB1H392K	CHIP C 3900PF K	
C103			CC73GCH1H101J	CHIP C 100PF J		C212			CC73GCH1H120J	CHIP C 12PF J	
C104-106			CD04BD1H221M	ELECTRO 220UF 50WV		C213,214			CK73GB1H103K	CHIP C 0.010UF K	
C107			CK73GB1H102K	CHIP C 1000PF K		C215			CK73GB1H104K	CHIP C 0.10UF K	
C108			CK73GB1H104K	CHIP C 0.10UF K		C216			CC73GCH1H100D	CHIP C 10PF D	
C109			CK73GB1H102K	CHIP C 1000PF K		C217			CK73GB1H103K	CHIP C 0.010UF K	
C110			C93-0912-05	CHIP C 100UF M		C218			CC73GCH1H471J	CHIP C 470PF J	
C111			CK73GB1H104K	CHIP C 0.10UF K		C219			CC73GCH1H100D	CHIP C 10PF D	
C119			CC73GCH1H181J	CHIP C 180PF J		C220			CK73GB1H103K	CHIP C 0.010UF K	
C120			CK73GB1H102K	CHIP C 1000PF K		C222			CC73GCH1H150J	CHIP C 15PF J	
C121			CK73FBJ106K	CHIP C 10UF K		C223			CK73GB1H103K	CHIP C 0.010UF K	
C122			CC73GCH1H101J	CHIP C 100PF J		C224			CK73GB1E105K	CHIP C 1.0UF K	
C123			CK73GB1H472K	CHIP C 4700PF K		C225			CK73GB1H104K	CHIP C 0.10UF K	
C125			CK73GB1H472K	CHIP C 4700PF K		C226			CK73FBJ106K	CHIP C 10UF K	
C127			CK73GB1H182K	CHIP C 1800PF K		C227			CK73GB1H102K	CHIP C 1000PF K	
C128			CC73GCH1H101J	CHIP C 100PF J		C228			CK73GB1H104K	CHIP C 0.10UF K	
C130			CD04BD1H221M	ELECTRO 220UF 50WV		C229			CC73GCH1H101J	CHIP C 100PF J	
C131			CE32AU1C330M	CHIP EL 33UF 16WV		C230			CK73GB1E105K	CHIP C 1.0UF K	
C133			CD04BD1H221M	ELECTRO 220UF 50WV		C231			CK73GB1H104K	CHIP C 0.10UF K	
C134			CK73GB1H104K	CHIP C 0.10UF K		C233			CK73GB1H103K	CHIP C 0.010UF K	
C137,138			CK73GB1H102K	CHIP C 1000PF K		C234,235			CK73GB1H104K	CHIP C 0.10UF K	
C139,140			CE32AU1C330M	CHIP EL 33UF 16WV		C236			C90-4120-05	ELECTRO 470UF 35WV	
C141			CK73GB1H102K	CHIP C 1000PF K		C237			CK73GB1H104K	CHIP C 0.10UF K	
C144			CE32AU1C330M	CHIP EL 33UF 16WV		C238			CK73GB1H102K	CHIP C 1000PF K	
C145			CK73GB1H182K	CHIP C 1800PF K		C239			C92-0777-05	ELECTRO 1000UF 25WV	
C146			CK73GB1H104K	CHIP C 0.10UF K		C241			CK73GB1H103K	CHIP C 0.010UF K	
C152			CK73GB1H102K	CHIP C 1000PF K		C243			CK73GB1H103K	CHIP C 0.010UF K	
C155			CC73GCH1H181J	CHIP C 180PF J		C244			CK73GB1H104K	CHIP C 0.10UF K	
C157			CE32AU1C330M	CHIP EL 33UF 16WV		C245			CK73FBJ106K	CHIP C 10UF K	
C159			CK73GB1H102K	CHIP C 1000PF K		C246,247			CK73GB1H102K	CHIP C 1000PF K	
C161			CK73GB1H102K	CHIP C 1000PF K		C248,249			CK73GB1H104K	CHIP C 0.10UF K	
C162			CE32AU1C330M	CHIP EL 33UF 16WV		C250			CK73FBJ106K	CHIP C 10UF K	
C165			CK73GB1H102K	CHIP C 1000PF K		C251			CK73GB1H102K	CHIP C 1000PF K	
C166			CE32AU1C330M	CHIP EL 33UF 16WV		C252			CK73FBJ106K	CHIP C 10UF K	
C169			CK73FBJ106K	CHIP C 10UF K		C253-255			CK73GB1H103K	CHIP C 0.010UF K	
C170			CK73GB1H102K	CHIP C 1000PF K		C256			CK73GB1H104K	CHIP C 0.10UF K	
C172			CK73FBJ106K	CHIP C 10UF K		C257			CK73FBJ106K	CHIP C 10UF K	
C173			CC73GCH1H101J	CHIP C 100PF J		C258			CK73GB1H103K	CHIP C 0.010UF K	
C174			CK73GB1H102K	CHIP C 1000PF K		C262			CK73FBJ106K	CHIP C 10UF K	
C175			CC73GCH1H391J	CHIP C 390PF J		C263			CK73GB1H102K	CHIP C 1000PF K	
C177			CC73GCH1H101J	CHIP C 100PF J		C265			CK73GB1H104K	CHIP C 0.10UF K	
C178			CK73FBJ106K	CHIP C 10UF K		C266-270			CK73GB1H103K	CHIP C 0.010UF K	
C188,189			CK73GB1H104K	CHIP C 0.10UF K		C271			CK73FBJ106K	CHIP C 10UF K	
C190			CK73GB1E105K	CHIP C 1.0UF K		C272,273			CK73GB1H103K	CHIP C 0.010UF K	
C192,193			CK73GB1E105K	CHIP C 1.0UF K		C274			CK73GB1H472K	CHIP C 4700PF K	
C194			CC73GCH1H560J	CHIP C 56PF J		C275			CC73GCH1H120J	CHIP C 12PF J	
C195			CC73GCH1H181J	CHIP C 180PF J		C276			CC73GCH1H100D	CHIP C 10PF D	
C196			CC73GCH1H101J	CHIP C 100PF J		C277			CK73GB1H103K	CHIP C 0.010UF K	
C197			CC73GCH1H330J	CHIP C 33PF J		C278			CK73FBJ106K	CHIP C 10UF K	
C199			C93-0912-05	CHIP C 100UF M		C279			CK73GB1H103K	CHIP C 0.010UF K	
C200			CK73FBJ106K	CHIP C 10UF K		C280			CC73GCH1H100D	CHIP C 10PF D	
C202			CK73GB1E105K	CHIP C 1.0UF K		C281			CC73GCH1H150J	CHIP C 15PF J	
C203			CC73GCH1H101J	CHIP C 100PF J		C282			CK73GB1H103K	CHIP C 0.010UF K	
C204			CC73GCH1H121J	CHIP C 120PF J		C283			CK73GB1H104K	CHIP C 0.10UF K	
C205			CK73GB1H182K	CHIP C 1800PF K		C284-288			CK73GB1H103K	CHIP C 0.010UF K	
C206			C93-0912-05	CHIP C 100UF M		C289			CK73GB1H102K	CHIP C 1000PF K	
C207			CK73GB1H102K	CHIP C 1000PF K		C290-297			CK73GB1H103K	CHIP C 0.010UF K	
C208			CK73FBJ106K	CHIP C 10UF K		C299,300			CK73GB1H103K	CHIP C 0.010UF K	
C209			CK73GB1H103K	CHIP C 0.010UF K		C302			CK73GB1H103K	CHIP C 0.010UF K	

PARTS LIST

CONTROL UNIT (X53-4132-72)

Ref. No.	Address	New parts	Parts No.	Description	Destination	Ref. No.	Address	New parts	Parts No.	Description	Destination
C304			CC73GCH1H101J	CHIP C 100PF J		C400,401			CE32AU1C330M	CHIP EL 33UF 16WV	
C305,306			CK73GB1H102K	CHIP C 1000PF K		C403			CK73GB1E105K	CHIP C 1.0UF K	
C307-310			CC73GCH1H101J	CHIP C 100PF J		C404			CK73FB0J106K	CHIP C 10UF K	
C311,312			CK73GB1H102K	CHIP C 1000PF K		C405,406			CC73GCH1H101J	CHIP C 100PF J	
C313			CC73GCH1H101J	CHIP C 100PF J		C407			CK73GB1H102K	CHIP C 1000PF K	
C314			CK73GB1H102K	CHIP C 1000PF K		C408-410			CK73GB1E105K	CHIP C 1.0UF K	
C315			CC73GCH1H101J	CHIP C 100PF J		C413			CK73GB1H104K	CHIP C 0.10UF K	
C316			CK73GB1H102K	CHIP C 1000PF K		C414			CK73GB1H103K	CHIP C 0.010UF K	
C317			CK73GB1H103K	CHIP C 0.010UF K		C415			CK73GB1H104K	CHIP C 0.10UF K	
C318			CC73GCH1H101J	CHIP C 100PF J		C416			CK73GB1H103K	CHIP C 0.010UF K	
C319			CK73GB1H102K	CHIP C 1000PF K		C417			CK73GB1E105K	CHIP C 1.0UF K	
C320			CK73GB1H103K	CHIP C 0.010UF K		C418-420			CK73GB1H102K	CHIP C 1000PF K	
C321			CC73GCH1H101J	CHIP C 100PF J		C421			CC73GCH1H101J	CHIP C 100PF J	
C322,323			CK73GB1H102K	CHIP C 1000PF K		C422-424			CK73GB1H102K	CHIP C 1000PF K	
C324			CK73GB1H103K	CHIP C 0.010UF K		C425,426			CC73GCH1H101J	CHIP C 100PF J	
C325			CC73GCH1H101J	CHIP C 100PF J		C427-435			CK73GB1H102K	CHIP C 1000PF K	
C326,327			CK73GB1H102K	CHIP C 1000PF K		C436			CK73GB1E105K	CHIP C 1.0UF K	
C328			CK73GB1H103K	CHIP C 0.010UF K		C437,438			CC73GCH1H101J	CHIP C 100PF J	
C329-331			CK73GB1H102K	CHIP C 1000PF K		C440			CK73GB1H102K	CHIP C 1000PF K	
C332			CK73GB1H103K	CHIP C 0.010UF K		C442			CC73GCH1H101J	CHIP C 100PF J	
C333-339			CK73GB1H102K	CHIP C 1000PF K		C444			CK73GB1H102K	CHIP C 1000PF K	
C340			CK73GB1H103K	CHIP C 0.010UF K		C445			CK73GB1H104K	CHIP C 0.10UF K	
C342,343			CK73GB1H102K	CHIP C 1000PF K		C446			CC73GCH1H391J	CHIP C 390PF J	
C344			CK73GB1H103K	CHIP C 0.010UF K		C447			CC73GCH1H101J	CHIP C 100PF J	
C345			CK73GB1H104K	CHIP C 0.10UF K		C448,449			CK73GB1H102K	CHIP C 1000PF K	
C346,347			CK73GB1H102K	CHIP C 1000PF K		C450			CC73GCH1H101J	CHIP C 100PF J	
C348			CK73GB1H103K	CHIP C 0.010UF K		C452,453			CK73GB1H102K	CHIP C 1000PF K	
C350			CK73GB1H102K	CHIP C 1000PF K		C456,457			CK73GB1H102K	CHIP C 1000PF K	
C351			CK73GB1H103K	CHIP C 0.010UF K		C463			CK73GB1H104K	CHIP C 0.10UF K	
C352,353			CK73GB1H102K	CHIP C 1000PF K		C467,468			CK73GB1H102K	CHIP C 1000PF K	
C354			CK73GB1H103K	CHIP C 0.010UF K		C469,470			CC73GCH1H101J	CHIP C 100PF J	
C355			CC73GCH1H101J	CHIP C 100PF J		C471			CK73GB1H102K	CHIP C 1000PF K	
C356			CK73GB1H102K	CHIP C 1000PF K		C473-475			CK73GB1H102K	CHIP C 1000PF K	
C357			CK73GB1H103K	CHIP C 0.010UF K		C477			CK73GB1E105K	CHIP C 1.0UF K	
C358			CK73GB1H102K	CHIP C 1000PF K		C499			C92-0905-05	OS-CON 47UF 35WV	
C359			CC73GCH1H101J	CHIP C 100PF J		C500			CK73GB1H104K	CHIP C 0.10UF K	
C360			CK73GB1H102K	CHIP C 1000PF K		C510			CK73FB0J106K	CHIP C 10UF K	
C361			CK73GB1H103K	CHIP C 0.010UF K		CN1-3			E40-6656-05	PIN ASSY	
C362			CK73GB1H102K	CHIP C 1000PF K		CN4			E41-2673-05	PIN ASSY	
C363			CC73GCH1H101J	CHIP C 100PF J		CN56,57			E40-6656-05	PIN ASSY	
C364			CK73GB1H102K	CHIP C 1000PF K		CN58			E40-5960-05	PIN ASSY	
C365			CK73GB1H103K	CHIP C 0.010UF K		CN59			E40-6102-05	PIN ASSY	
C366-368			CK73GB1H102K	CHIP C 1000PF K		CN60			E41-2735-05	PIN ASSY	
C369			CK73GB1H103K	CHIP C 0.010UF K		F1,2			F53-0315-05	FUSE	
C370-372			CK73GB1H102K	CHIP C 1000PF K		F3			F53-0328-05	FUSE	
C373			CC73GCH1H101J	CHIP C 100PF J		L3-14			L92-0447-05	BEADS CORE	
C374			CK73GB1H103K	CHIP C 0.010UF K		L15			L33-1476-05	SMALL FIXED INDUCTOR	
C375,376			CK73GB1H102K	CHIP C 1000PF K		L16			L33-1475-05	SMALL FIXED INDUCTOR	
C377			CC73GCH1H101J	CHIP C 100PF J		L17,18			L92-0447-05	BEADS CORE	
C379,380			CK73GB1H102K	CHIP C 1000PF K		L19			L33-1475-05	SMALL FIXED INDUCTOR	
C381			CC73GCH1H101J	CHIP C 100PF J		L20-22			L92-0447-05	BEADS CORE	
C382			CK73GB1H103K	CHIP C 0.010UF K		L32-40			L92-0447-05	BEADS CORE	
C383,384			CK73GB1H102K	CHIP C 1000PF K		L43			L92-0447-05	BEADS CORE	
C385			CC73GCH1H101J	CHIP C 100PF J		L44-49			L92-0467-05	CHIP FERRITE	
C386,387			CK73GB1H102K	CHIP C 1000PF K		X1			L77-1984-05	CRYSTAL RESONATOR (14.7456MHZ)	
C388			CC73GCH1H101J	CHIP C 100PF J		X2			L77-1987-05	CRYSTAL RESONATOR (16.515072MHZ)	
C389,390			CK73GB1H102K	CHIP C 1000PF K		CP8			RK75GB1JR00	CHIP-COM 0.00 1/16W	
C394			C92-0905-05	OS-CON 47UF 35WV							
C395			CK73GB1H103K	CHIP C 0.010UF K							
C396-399			CK73GB1H102K	CHIP C 1000PF K							

PARTS LIST

CONTROL UNIT (X53-4132-72)

Ref. No.	Address	New parts	Parts No.	Description	Desti-nation	Ref. No.	Address	New parts	Parts No.	Description	Desti-nation
CP10			RK75GB1JR00	CHIP-COM 0.00 1/16W		R149			RK73GB2A333J	CHIP R 33K J 1/10W	
CP13			RK75GB1JR00	CHIP-COM 0.00 1/16W		R150			RK73GB2A563J	CHIP R 56K J 1/10W	
CP19			RK75GB1JR00	CHIP-COM 0.00 1/16W		R151			RK73GB2A124J	CHIP R 120K J 1/10W	
CP25,26			RK75GB1JR00	CHIP-COM 0.00 1/16W		R152			RK73GB2A104J	CHIP R 100K J 1/10W	
R1,2			RK73GB2A000J	CHIP R 0.0 J 1/10W		R153			RK73GB2A000J	CHIP R 0.0 J 1/10W	
R6			RK73GB2A101J	CHIP R 100 J 1/10W		R154,155			RK73GB2A333J	CHIP R 33K J 1/10W	
R7-17			RK73GB2A000J	CHIP R 0.0 J 1/10W		R156,157			RK73GH2A104D	CHIP R 100K D 1/10W	
R18,19			RK73GB2A101J	CHIP R 100 J 1/10W		R158			RK73GB2A333J	CHIP R 33K J 1/10W	
R21-45			RK73GB2A000J	CHIP R 0.0 J 1/10W		R159			RK73GB2A000J	CHIP R 0.0 J 1/10W	
R47-49			RK73GB2A000J	CHIP R 0.0 J 1/10W		R160,161			RK73GB2A563J	CHIP R 56K J 1/10W	
R51-61			RK73GB2A000J	CHIP R 0.0 J 1/10W		R162			RK73GB2A224J	CHIP R 220K J 1/10W	
R62			RK73GB2A101J	CHIP R 100 J 1/10W		R163			RK73GB2A000J	CHIP R 0.0 J 1/10W	
R63,64			RK73GB2A332J	CHIP R 3.3K J 1/10W		R165			RK73GB2A104J	CHIP R 100K J 1/10W	
R65			RK73GB2A123J	CHIP R 12K J 1/10W		R166			RK73GB2A333J	CHIP R 33K J 1/10W	
R66			RK73GB2A683J	CHIP R 68K J 1/10W		R167			RK73GB2A473J	CHIP R 47K J 1/10W	
R67			RK73GH2A822D	CHIP R 8.2K D 1/10W		R168			RK73GB2A563J	CHIP R 56K J 1/10W	
R68			RK73GH2A332D	CHIP R 3.3K D 1/10W		R169			RK73GB2A333J	CHIP R 33K J 1/10W	
R69,70			RK73GB2A000J	CHIP R 0.0 J 1/10W		R171			RK73GB2A183J	CHIP R 18K J 1/10W	
R71			RK73GH2A473D	CHIP R 47K D 1/10W		R172,173			RK73GB2A473J	CHIP R 47K J 1/10W	
R72-76			RK73GB2A000J	CHIP R 0.0 J 1/10W		R174			RK73GB2A683J	CHIP R 68K J 1/10W	
R77			RK73GH2A104D	CHIP R 100K D 1/10W		R175			RK73GB2A393J	CHIP R 39K J 1/10W	
R78			RK73GB2A104J	CHIP R 100K J 1/10W		R176			RK73GB2A473J	CHIP R 47K J 1/10W	
R79			RK73GH2A332D	CHIP R 3.3K D 1/10W		R177,178			RK73GB2A000J	CHIP R 0.0 J 1/10W	
R80			RK73GB2A123J	CHIP R 12K J 1/10W		R179			RK73GB2A473J	CHIP R 47K J 1/10W	
R81,82			RK73GB2A563J	CHIP R 56K J 1/10W		R180			RK73GB2A223J	CHIP R 22K J 1/10W	
R83			RK73GB2A124J	CHIP R 120K J 1/10W		R181,182			RK73GB2A103J	CHIP R 10K J 1/10W	
R84			RK73GB2A473J	CHIP R 47K J 1/10W		R183			RK73GB2A000J	CHIP R 0.0 J 1/10W	
R85			RK73GB2A000J	CHIP R 0.0 J 1/10W		R184			RK73GB2A473J	CHIP R 47K J 1/10W	
R86			RK73GB2A473J	CHIP R 47K J 1/10W		R185			RK73GB2A103J	CHIP R 10K J 1/10W	
R87			RK73GB2A223J	CHIP R 22K J 1/10W		R186			RK73GB2A563J	CHIP R 56K J 1/10W	
R88			RK73GB2A000J	CHIP R 0.0 J 1/10W		R187			RK73GB2A223J	CHIP R 22K J 1/10W	
R89			RK73GB2A103J	CHIP R 10K J 1/10W		R190			RK73GB2A393J	CHIP R 39K J 1/10W	
R90			RK73GB2A153J	CHIP R 15K J 1/10W		R191			RK73GB2A000J	CHIP R 0.0 J 1/10W	
R91			RK73GB2A472J	CHIP R 4.7K J 1/10W		R192			RK73GB2A154J	CHIP R 150K J 1/10W	
R92			RK73GB2A562J	CHIP R 5.6K J 1/10W		R193			RK73GB2A103J	CHIP R 10K J 1/10W	
R93,94			RK73GB2A000J	CHIP R 0.0 J 1/10W		R194			RK73GB2A473J	CHIP R 47K J 1/10W	
R95			RK73GB2A470J	CHIP R 47 J 1/10W		R195,196			RK73GB2A000J	CHIP R 0.0 J 1/10W	
R96			RK73GB2A223J	CHIP R 22K J 1/10W		R197			RK73GB2A103J	CHIP R 10K J 1/10W	
R98			RK73GB2A103J	CHIP R 10K J 1/10W		R198			RK73GB2A473J	CHIP R 47K J 1/10W	
R100			RK73GB2A473J	CHIP R 47K J 1/10W		R199			RK73GB2A103J	CHIP R 10K J 1/10W	
R101			RK73GB2A000J	CHIP R 0.0 J 1/10W		R200,201			RK73GB2A000J	CHIP R 0.0 J 1/10W	
R102			RK73GB2A123J	CHIP R 12K J 1/10W		R202			RK73GB2A473J	CHIP R 47K J 1/10W	
R103-105			RK73GB2A473J	CHIP R 47K J 1/10W		R203			RK73GB2A104J	CHIP R 100K J 1/10W	
R106-108			RK73GB2A000J	CHIP R 0.0 J 1/10W		R204			RK73GB2A473J	CHIP R 47K J 1/10W	
R109			RK73GB2A153J	CHIP R 15K J 1/10W		R205			RK73GB2A104J	CHIP R 100K J 1/10W	
R111			RK73GB2A823J	CHIP R 82K J 1/10W		R206			RK73GB2A122J	CHIP R 1.2K J 1/10W	
R112			RK73GB2A123J	CHIP R 12K J 1/10W		R207,208			RK73GB2A473J	CHIP R 47K J 1/10W	
R113			RK73GB2A823J	CHIP R 82K J 1/10W		R209			RK73GB2A103J	CHIP R 10K J 1/10W	
R114			RK73GB2A223J	CHIP R 22K J 1/10W		R210			RK73GB2A000J	CHIP R 0.0 J 1/10W	
R115			RK73GB2A154J	CHIP R 150K J 1/10W		R211,212			RK73GB2A473J	CHIP R 47K J 1/10W	
R116			RK73GB2A223J	CHIP R 22K J 1/10W		R213			RK73GB2A102J	CHIP R 1.0K J 1/10W	
R127			RK73GB2A473J	CHIP R 47K J 1/10W		R214			RK73GB2A824J	CHIP R 820K J 1/10W	
R128-130			RK73GB2A000J	CHIP R 0.0 J 1/10W		R215			RK73GB2A473J	CHIP R 47K J 1/10W	
R131-133			RK73GB2A473J	CHIP R 47K J 1/10W		R216,217			RK73GB2A000J	CHIP R 0.0 J 1/10W	
R135			RK73GB2A000J	CHIP R 0.0 J 1/10W		R218,219			RK73GB2A473J	CHIP R 47K J 1/10W	
R137			RK73GB2A102J	CHIP R 1.0K J 1/10W		R220,221			RK73GB2A000J	CHIP R 0.0 J 1/10W	
R138			RK73GB2A473J	CHIP R 47K J 1/10W		R222			RK73GB2A473J	CHIP R 47K J 1/10W	
R141-144			RK73GB2A000J	CHIP R 0.0 J 1/10W		R223			RK73GB2A103J	CHIP R 10K J 1/10W	
R145			RK73GB2A104J	CHIP R 100K J 1/10W		R224			RK73GB2A222J	CHIP R 2.2K J 1/10W	
R146-148			RK73GB2A000J	CHIP R 0.0 J 1/10W		R225			RK73GB2A103J	CHIP R 10K J 1/10W	

PARTS LIST

CONTROL UNIT (X53-4132-72)

Ref. No.	Address	New parts	Parts No.	Description	Destination	Ref. No.	Address	New parts	Parts No.	Description	Destination
R226			RK73GB2A822J	CHIP R 8.2K J 1/10W		R457			RK73GB2A473J	CHIP R 47K J 1/10W	
R228,229			RK73GB2A824J	CHIP R 820K J 1/10W		R458,459			RK73GB2A104J	CHIP R 100K J 1/10W	
R230,231			RK73GB2A473J	CHIP R 47K J 1/10W		R460,461			RK73GB2A103J	CHIP R 10K J 1/10W	
R232			RK73GB2A102J	CHIP R 1.0K J 1/10W		R467,468			RK73GB2A000J	CHIP R 0.0 J 1/10W	
R233			RK73GB2A000J	CHIP R 0.0 J 1/10W		R469			RK73GB2A103J	CHIP R 10K J 1/10W	
R234,235			RK73GB2A473J	CHIP R 47K J 1/10W		R470			RK73GB2A000J	CHIP R 0.0 J 1/10W	
R237			RK73GB2A473J	CHIP R 47K J 1/10W		R471-473			RK73GB2A104J	CHIP R 100K J 1/10W	
R240-243			RK73GB2A473J	CHIP R 47K J 1/10W		R474			RK73GB2A000J	CHIP R 0.0 J 1/10W	
R245,246			RK73GB2A472J	CHIP R 4.7K J 1/10W		R475			RK73GB2A104J	CHIP R 100K J 1/10W	
R247			RK73GB2A473J	CHIP R 47K J 1/10W		R477			RK73GB2A104J	CHIP R 100K J 1/10W	
R249,250			RK73GB2A000J	CHIP R 0.0 J 1/10W		R478			RK73GB2A103J	CHIP R 10K J 1/10W	
R251			RK73GB2A473J	CHIP R 47K J 1/10W		R479			RK73GB2A000J	CHIP R 0.0 J 1/10W	
R254			RK73GB2A473J	CHIP R 47K J 1/10W		R482			RK73GB2A000J	CHIP R 0.0 J 1/10W	
R261,262			RK73GB2A473J	CHIP R 47K J 1/10W		R484			RK73GB2A000J	CHIP R 0.0 J 1/10W	
R267-271			RK73GB2A473J	CHIP R 47K J 1/10W		R491-495			RK73GB2A000J	CHIP R 0.0 J 1/10W	
R273			RK73GB2A473J	CHIP R 47K J 1/10W		R501			RK73GB2A000J	CHIP R 0.0 J 1/10W	
R275			RK73GB2A473J	CHIP R 47K J 1/10W		R502			RK73GB2A183J	CHIP R 18K J 1/10W	
R277			RK73GB2A473J	CHIP R 47K J 1/10W		R507-510			RK73GB2A183J	CHIP R 18K J 1/10W	
R279			RK73GB2A103J	CHIP R 10K J 1/10W		R511-515			RK73GB2A123J	CHIP R 12K J 1/10W	
R281			RK73GB2A103J	CHIP R 10K J 1/10W		R522,523			RK73GB2A000J	CHIP R 0.0 J 1/10W	
R283			RK73GB2A000J	CHIP R 0.0 J 1/10W		R524,525			RK73GB2A473J	CHIP R 47K J 1/10W	
R286-288			RK73GB2A000J	CHIP R 0.0 J 1/10W		R526,527			RK73GB2A121J	CHIP R 120 J 1/10W	
R289			RK73GB2A473J	CHIP R 47K J 1/10W		R528-535			RK73GB2A000J	CHIP R 0.0 J 1/10W	
R290			RK73GB2A000J	CHIP R 0.0 J 1/10W		R536			RK73GB2A104J	CHIP R 100K J 1/10W	
R292-294			RK73GB2A000J	CHIP R 0.0 J 1/10W		R540			RK73GB2A222J	CHIP R 2.2K J 1/10W	
R296,297			RK73GB2A473J	CHIP R 47K J 1/10W		R541			RK73GB2A123J	CHIP R 12K J 1/10W	
R299,300			RK73GB2A103J	CHIP R 10K J 1/10W		R552			RK73GB2A000J	CHIP R 0.0 J 1/10W	
R301,302			RK73GB2A104J	CHIP R 100K J 1/10W		R553			RK73GB2A000J	CHIP R 0.0 J 1/10W	
R303-315			RK73GB2A473J	CHIP R 47K J 1/10W		D1,2			CMS05-Q	DIODE	
R316-338			RK73GB2A000J	CHIP R 0.0 J 1/10W		D3,4			DA204U	DIODE	
R340			RK73GB2A102J	CHIP R 1.0K J 1/10W		D5			1SS355	DIODE	
R342-351			RK73GB2A102J	CHIP R 1.0K J 1/10W		D6	*		02DZ18F-X	ZENER DIODE	
R352			RK73GB2A471J	CHIP R 470 J 1/10W		D7-11			DA204U	DIODE	
R353-357			RK73GB2A102J	CHIP R 1.0K J 1/10W		D12			1SS355	DIODE	
R358			RK73GB2A122J	CHIP R 1.2K J 1/10W		D13	*		02DZ18F-X	ZENER DIODE	
R359			RK73GB2A000J	CHIP R 0.0 J 1/10W		D14-18			DA204U	DIODE	
R360			RK73GB2A122J	CHIP R 1.2K J 1/10W		D20			DA204U	DIODE	
R361-377			RK73GB2A000J	CHIP R 0.0 J 1/10W		D23			DA204U	DIODE	
R378,379			RK73GB2A122J	CHIP R 1.2K J 1/10W		D24			SMD185F-2	VARISTOR	
R380			RK73GB2A000J	CHIP R 0.0 J 1/10W		D25			MINISMD C020F	VARISTOR	
R389-396			RK73GB2A000J	CHIP R 0.0 J 1/10W		D26			1SS388F	DIODE	
R398-404			RK73GB2A000J	CHIP R 0.0 J 1/10W		D28			1SS355	DIODE	
R406-409			RK73GB2A000J	CHIP R 0.0 J 1/10W		D29	*		02DZ18F-X	ZENER DIODE	
R410			RK73GB2A684J	CHIP R 680K J 1/10W		D30			1SS355	DIODE	
R411			RK73GB2A224J	CHIP R 220K J 1/10W		D31	*		02DZ18F-X	ZENER DIODE	
R412			RK73GB2A103J	CHIP R 10K J 1/10W		D32			1SS355	DIODE	
R413			RK73GB2A104J	CHIP R 100K J 1/10W		D33	*		02DZ18F-X	ZENER DIODE	
R414			RK73GB2A000J	CHIP R 0.0 J 1/10W		D36,37			DA204U	DIODE	
R415-418			RK73GB2A104J	CHIP R 100K J 1/10W		D38,39			1SS388F	DIODE	
R419,420			RK73GB2A000J	CHIP R 0.0 J 1/10W		IC1			BU4094BCFV	MOS-IC	
R426			RS14KB3D220J	FL-PROOF RS 22 J 2W		IC2,3			BU4053BCFV	MOS-IC	
R427			RK73GB2A223J	CHIP R 22K J 1/10W		IC4			AK4550VTP	MOS-IC	
R428-430			RK73GB2A000J	CHIP R 0.0 J 1/10W		IC5			NJM2732V	BI-POLAR IC	
R432			RK73GB2A470J	CHIP R 47 J 1/10W		IC6			XC6209B332PPR	MOS-IC	
R433			RK73GB2A473J	CHIP R 47K J 1/10W		IC7			TA75S01F-F	MOS-IC	
R434			RK73GB2A470J	CHIP R 47 J 1/10W		IC8			M62364FP-F	MOS-IC	
R435			RK73GB2A473J	CHIP R 47K J 1/10W		IC9	*		NJM2734V	BI-POLAR IC	
R436-446			RK73GB2A000J	CHIP R 0.0 J 1/10W		IC10,11			NJM2340RB1	MOS-IC	
R448-454			RK73GB2A000J	CHIP R 0.0 J 1/10W		IC12			NJM2732V	BI-POLAR IC	
R455			RK73GB2A104J	CHIP R 100K J 1/10W							

PARTS LIST

CONTROL UNIT (X53-4132-72)
CONTROL UNIT (X53-4140-11)

Ref. No.	Address	New parts	Parts No.	Description	Desti-nation	Ref. No.	Address	New parts	Parts No.	Description	Desti-nation
IC14			BU4053BCFV	MOS-IC		C322,323			CK73HB1H102K	CHIP C	1000PF K
IC15			BA33BC0FP	MOS-IC		C324			CC73HCH1H101J	CHIP C	100PF J
IC16			XC6209B502PR	MOS-IC		C326-329			CK73HB1H102K	CHIP C	1000PF K
IC17		*	Note 1 (BGA)	ROM IC		C331			CK73HB1H102K	CHIP C	1000PF K
IC18			XC6201P182MR	MOS-IC		C333-335			CK73HB1H102K	CHIP C	1000PF K
IC19			NJM2732V	BI-POLAR IC		C337			CK73HB1H102K	CHIP C	1000PF K
IC20,21		*	NJM2734V	BI-POLAR IC		C339			CC73HCH1H101J	CHIP C	100PF J
IC22			BU4094BCFV	MOS-IC		C341,342			CK73HB1H102K	CHIP C	1000PF K
IC23			TC7SH00FU-F	MOS-IC		C343			CC73HCH1H101J	CHIP C	100PF J
IC25			TC7S66FUF	MOS-IC		C344			CK73HB1H102K	CHIP C	1000PF K
IC26		*	NJM2734V	BI-POLAR IC		C345			CC73HCH1H101J	CHIP C	100PF J
IC27			TC7SET126FU-F	MOS-IC		C346-348			CK73HB1H102K	CHIP C	1000PF K
IC28			TC7SH126FU-F	MOS-IC		C349			CC73HCH1H101J	CHIP C	100PF J
IC29	2C		LA4425A	MOS-IC		C350			CK73HB1H102K	CHIP C	1000PF K
IC30			TC7SH00FU-F	MOS-IC		C352			CK73HB1H102K	CHIP C	1000PF K
IC31			TC7MH4040FK-F	MOS-IC		C353			CC73HCH1H101J	CHIP C	100PF J
IC32,33			TC7SH126FU-F	MOS-IC		C354			CK73HB1H102K	CHIP C	1000PF K
IC34			3625MGP396GP	MICRO CONTROL UNIT		C355			CK73HB1E103K	CHIP C	0.010UF K
IC35			S24CS02AFJTBG	ROM IC		C356			CC73HCH1H101J	CHIP C	100PF J
IC36			TC7MET541AFK	MOS-IC		C357,358			CK73HB1H102K	CHIP C	1000PF K
IC37			320VC5402PGE	MICRO CONTROL UNIT		C359,360			CK73HB1A104K	CHIP C	0.10UF K
IC38			TC7SET08FU-F	MOS-IC		C361			CK73HB1H102K	CHIP C	1000PF K
IC39			TC7SH125FU-F	MOS-IC		C362			CK73HB1E103K	CHIP C	0.010UF K
IC40			TC7SH126FU-F	MOS-IC		C364-366			CK73HB1H102K	CHIP C	1000PF K
IC41			TC7SH08FU-F	MOS-IC		C369,370			CK73HB1H102K	CHIP C	1000PF K
IC50			TC7SH08FU-F	MOS-IC		C371			CK73HB1A104K	CHIP C	0.10UF K
Q1			DTC114EUA	DIGITAL TRANSISTOR		C373,374			CK73HB1H102K	CHIP C	1000PF K
Q2,3			2SJ506-E(S)	FET		C376-378			CK73HB1H102K	CHIP C	1000PF K
Q4,5		*	2SC4738F	TRANSISTOR		C379			CK73HB1A104K	CHIP C	0.10UF K
Q6			DTC363EU	DIGITAL TRANSISTOR		C380,381			CK73HB1H102K	CHIP C	1000PF K
Q7,8			DTC114EUA	DIGITAL TRANSISTOR		C383-386			CK73HB1H102K	CHIP C	1000PF K
Q9			2SJ506-E(S)	FET		C387			CK73GB1H103K	CHIP C	0.010UF K
Q10		*	2SC4738F	TRANSISTOR		C388-390			CK73HB1H102K	CHIP C	1000PF K
Q11			2SD2114K(W)	TRANSISTOR		C391			CK73GB1E105K	CHIP C	1.0UF K
Q12		*	2SC4738F	TRANSISTOR		C393-395			CK73HB1H102K	CHIP C	1000PF K
Q13			2SD2114K(W)	TRANSISTOR		C396			CK73GB1H103K	CHIP C	0.010UF K
Q14			2SC4116(Y)F	TRANSISTOR		C397,398			CK73HB1H102K	CHIP C	1000PF K
Q15			2SA1586(Y)F	TRANSISTOR		C399			CK73GB1H104K	CHIP C	0.10UF K
Q16			2SC4116(Y)F	TRANSISTOR		C401			CC73HCH1H101J	CHIP C	100PF J
Q17			2SA1586(Y)F	TRANSISTOR		C402			CK73HB1H102K	CHIP C	1000PF K
Q18			2SK1830F	FET		C403			CC73HCH1H101J	CHIP C	100PF J
Q19			HN1LQ2FU(F)	FET		C405,406			CK73HB1H102K	CHIP C	1000PF K
Q20			2SA1955A-F	TRANSISTOR		C409			CK73HB1H102K	CHIP C	1000PF K
Q21			DTC144EUA	DIGITAL TRANSISTOR		C410			CC73HCH1H101J	CHIP C	100PF J
Q22			2SA1955A-F	TRANSISTOR		C412-415			CK73HB1H102K	CHIP C	1000PF K
Q23			DTC144EUA	DIGITAL TRANSISTOR		C416			CC73HCH1H101J	CHIP C	100PF J
Q25,26			DTC144EUA	DIGITAL TRANSISTOR		C417,418			CE32AU1C330M	CHIP EL	33UF 16WV
Q27-29			2SD2114K(W)	TRANSISTOR		C419			CC73HCH1H101J	CHIP C	100PF J
CONTROL UNIT (X53-4140-11 for service)						C420			CK73HB1A104K	CHIP C	0.10UF K
C302			CC73HCH1H101J	CHIP C	100PF J	C421			CK73HB1H102K	CHIP C	1000PF K
C303			CK73HB1H102K	CHIP C	1000PF K	C422			CE32AU1C330M	CHIP EL	33UF 16WV
C305			CK73HB1A104K	CHIP C	0.10UF K	C423			CC73HCH1H101J	CHIP C	100PF J
C306			CK73HB1H102K	CHIP C	1000PF K	C424			CK73HB1H102K	CHIP C	1000PF K
C308,309			CK73HB1H102K	CHIP C	1000PF K	C426-430			CK73HB1H102K	CHIP C	1000PF K
C311			CK73HB1A104K	CHIP C	0.10UF K	C432			CC73HCH1H101J	CHIP C	100PF J
C312-317			CK73HB1H102K	CHIP C	1000PF K	C433			CK73HB1H102K	CHIP C	1000PF K
C320			CC73HCH1H101J	CHIP C	100PF J	C435-437			CK73HB1H102K	CHIP C	1000PF K
						C438			CK73GB1H103K	CHIP C	0.010UF K
						C439			CE32AU1C330M	CHIP EL	33UF 16WV
						C440-442			CK73HB1H102K	CHIP C	1000PF K

Note 1 : This part cannot be replaced. Therefore, this part is not supplied as a service part.

PARTS LIST

CONTROL UNIT (X53-4140-11)

Ref. No.	Address	New parts	Parts No.	Description	Destination	Ref. No.	Address	New parts	Parts No.	Description	Destination
C443,444			CE32AU1C330M	CHIP EL 33UF 16WV		C565			CK73FB0J106K	CHIP C 10UF K	
C445			CK73HB1A104K	CHIP C 0.10UF K		C566			CK73HB1H102K	CHIP C 1000PF K	
C446			CK73FB1H102K	CHIP C 1000PF K		C567			CK73HB1E103K	CHIP C 0.010UF K	
C447			CK73HB1A104K	CHIP C 0.10UF K		C569			CE32AU1C330M	CHIP EL 33UF 16WV	
C448			CE32AU1C330M	CHIP EL 33UF 16WV		C570,571			CK73HB1H102K	CHIP C 1000PF K	
C449,450			CK73HB1A104K	CHIP C 0.10UF K		C572			CE32BM1E470M	CHIP EL 47UF 25WV	
C453			CK73GB1H103K	CHIP C 0.010UF K		C574			CK73HB1H102K	CHIP C 1000PF K	
C461			CK73GB1H103K	CHIP C 0.010UF K		C575-588			CK73HB1E103K	CHIP C 0.010UF K	
C462			CK73HB1E103K	CHIP C 0.010UF K		C590-601			CK73HB1E103K	CHIP C 0.010UF K	
C463			CC73HCH1H100D	CHIP C 10PF D		C700			CK73HB1E103K	CHIP C 0.010UF K	
C465			CK73GB1H103K	CHIP C 0.010UF K		C701			CK73HB1A104K	CHIP C 0.10UF K	
C466			CK73GB1H104K	CHIP C 0.10UF K		C702			CK73HB1H102K	CHIP C 1000PF K	
C467			CK73GB1H103K	CHIP C 0.010UF K		C703			CC73HCH1H150J	CHIP C 15PF J	
C468			CK73GB1H104K	CHIP C 0.10UF K		C704,705			CK73FB0J106K	CHIP C 10UF K	
C469			CC73GCH1H121J	CHIP C 120PF J		C706			CK73HB1H102K	CHIP C 1000PF K	
C471			CK73HB1H102K	CHIP C 1000PF K		C707			CC73HCH1H070D	CHIP C 7.0PF D	
C474			CK73HB1H392K	CHIP C 3900PF K		C708			CK73HB1A104K	CHIP C 0.10UF K	
C475			CK73FB0J106K	CHIP C 10UF K		C709			CK73FB0J106K	CHIP C 10UF K	
C476			CK73HB1A104K	CHIP C 0.10UF K		C710			CK73HB1E103K	CHIP C 0.010UF K	
C477			CC73GCH1H121J	CHIP C 120PF J		C711			CK73FB0J106K	CHIP C 10UF K	
C478			CK73HB1H102K	CHIP C 1000PF K		C712			CK73HB1H102K	CHIP C 1000PF K	
C479			CC73GCH1H121J	CHIP C 120PF J		C713			CK73HB1A104K	CHIP C 0.10UF K	
C480			CK73FB0J106K	CHIP C 10UF K		C714			CK73FB0J106K	CHIP C 10UF K	
C482			CK73HB1A104K	CHIP C 0.10UF K		C715			CK73HB1A104K	CHIP C 0.10UF K	
C484			CS77BA1C010M	CHIP TNL 1.0UF 16WV		C716			CK73HB1H102K	CHIP C 1000PF K	
C485			CK73GB1H103K	CHIP C 0.010UF K		C717			CK73HB1A104K	CHIP C 0.10UF K	
C486			CC73GCH1H121J	CHIP C 120PF J		C718			CC73HCH1H070D	CHIP C 7.0PF D	
C487			CK73HB1H102K	CHIP C 1000PF K		C719			CK73FB0J106K	CHIP C 10UF K	
C491			CK73FB0J106K	CHIP C 10UF K		C720			CK73HB1A104K	CHIP C 0.10UF K	
C493,494			CK73HB1A104K	CHIP C 0.10UF K		C721			CC73HCH1H100D	CHIP C 10PF D	
C495			CK73GB1E105K	CHIP C 1.0UF K		C722,723			CK73HB1H102K	CHIP C 1000PF K	
C496			CK73HB1C822K	CHIP C 8200PF K		C724			CK73HB1A104K	CHIP C 0.10UF K	
C501			CK73HB1A104K	CHIP C 0.10UF K		C725			CK73HB1H102K	CHIP C 1000PF K	
C504			CK73HB1A104K	CHIP C 0.10UF K		C726			CK73FB0J106K	CHIP C 10UF K	
C506			CK73HB1H472K	CHIP C 4700PF K		C727			CC73HCH1H020B	CHIP C 2.0PF B	
C507			CK73HB1E103K	CHIP C 0.010UF K		C728			CK73HB1E103K	CHIP C 0.010UF K	
C508			CK73HB1A104K	CHIP C 0.10UF K		C729			CC73HCH1H020B	CHIP C 2.0PF B	
C509			CK73GB1E105K	CHIP C 1.0UF K		C730			CK73HB1A104K	CHIP C 0.10UF K	
C515			CK73GB1E105K	CHIP C 1.0UF K		C732			CK73HB1H102K	CHIP C 1000PF K	
C516			CK73HB1H102K	CHIP C 1000PF K		C733-741			CK73HB1A104K	CHIP C 0.10UF K	
C517			CK73HB1A104K	CHIP C 0.10UF K		C742			CK73FB0J106K	CHIP C 10UF K	
C519			CK73HB1C473K	CHIP C 0.047UF K		C743,744			CK73HB1A104K	CHIP C 0.10UF K	
C520			CK73GB1E105K	CHIP C 1.0UF K		C746-750			CK73GB1E105K	CHIP C 1.0UF K	
C521			CK73HB1E103K	CHIP C 0.010UF K		C751			CK73HB1E103K	CHIP C 0.010UF K	
C522-525			CK73HB1A104K	CHIP C 0.10UF K		C754-758			CK73HB1A104K	CHIP C 0.10UF K	
C526-529			CK73FB0J106K	CHIP C 10UF K		C767,768			CK73HB1H102K	CHIP C 1000PF K	
C531			CK73HB1H102K	CHIP C 1000PF K		C769			CK73FB0J106K	CHIP C 10UF K	
C532			CK73HB1A104K	CHIP C 0.10UF K		C770-773			CK73HB1A104K	CHIP C 0.10UF K	
C533-536			CK73HB1H102K	CHIP C 1000PF K		C775			CK73HB1H102K	CHIP C 1000PF K	
C537			CK73FB0J106K	CHIP C 10UF K		C776-780			CK73HB1E103K	CHIP C 0.010UF K	
C538,539			CK73HB1H102K	CHIP C 1000PF K		C781			CK73HB1A104K	CHIP C 0.10UF K	
C543			CK73FB0J106K	CHIP C 10UF K		C782			CC73HCH1H120G	CHIP C 12PF G	
C544-546			CK73HB1H102K	CHIP C 1000PF K		C783			CC73HCH1H100D	CHIP C 10PF D	
C547			CK73FB0J106K	CHIP C 10UF K		C784,785			CK73HB1A104K	CHIP C 0.10UF K	
C548			CK73HB1E103K	CHIP C 0.010UF K		C786			CC73HCH1H150J	CHIP C 15PF J	
C549			CC73HCH1H120G	CHIP C 12PF G		C787			CC73HCH1H100D	CHIP C 10PF D	
C550,551			CC73HCH1H100D	CHIP C 10PF D		C788			CK73FB0J106K	CHIP C 10UF K	
C552			CC73HCH1H150J	CHIP C 15PF J		C789-793			CK73HB1A104K	CHIP C 0.10UF K	
C553			CK73HB1E103K	CHIP C 0.010UF K		C794			CK73FB0J106K	CHIP C 10UF K	
C557			CK73HB1H102K	CHIP C 1000PF K		C795			CK73HB1A104K	CHIP C 0.10UF K	

PARTS LIST

CONTROL UNIT (X53-4140-11)

Ref. No.	Address	New parts	Parts No.	Description	Destination	Ref. No.	Address	New parts	Parts No.	Description	Destination
C796,797			CK73HB1E103K	CHIP C 0.010UF K		CP747			RK75HA1JR00J	CHIP-COM 0.00 J 1/16W	
C798			CK73HB1A104K	CHIP C 0.10UF K		CP750			RK75HA1JR00J	CHIP-COM 0.00 J 1/16W	
C799,800			CK73HB1E103K	CHIP C 0.010UF K		CP760			RK75HA1JR00J	CHIP-COM 0.00 J 1/16W	
C801			CK73HB1H102K	CHIP C 1000PF K		CP762			RK75HA1JR00J	CHIP-COM 0.00 J 1/16W	
C802,803			CK73HB1A104K	CHIP C 0.10UF K		CP768			RK75HA1JR00J	CHIP-COM 0.00 J 1/16W	
C804			CK73FB0J106K	CHIP C 10UF K		CP775-778			RK75HA1JR00J	CHIP-COM 0.00 J 1/16W	
C805-807			CK73HB1E103K	CHIP C 0.010UF K		CP783-798			RK75HA1J390J	CHIP-COM 39 J 1/16W	
C808			CK73HB1H102K	CHIP C 1000PF K		CP807-811			RK75HA1J104J	CHIP-COM 100K J 1/16W	
C809			CK73HB1A104K	CHIP C 0.10UF K		CP813			RK75HA1J104J	CHIP-COM 100K J 1/16W	
C812			CK73HB1A104K	CHIP C 0.10UF K		CP814,815			RK75HA1JR00J	CHIP-COM 0.00 J 1/16W	
C813-815			CK73HB1H102K	CHIP C 1000PF K		R300,301			RK73GB2A000J	CHIP R 0.0 J 1/10W	
C816-818			CK73HB1A104K	CHIP C 0.10UF K		R302			RK73HB1J000J	CHIP R 0.0 J 1/16W	
C819			CK73HB1H102K	CHIP C 1000PF K		R303			RK73GB2A000J	CHIP R 0.0 J 1/10W	
C820,821			CK73HB1A104K	CHIP C 0.10UF K		R309			RK73HB1J000J	CHIP R 0.0 J 1/16W	
C822			CK73HB1H102K	CHIP C 1000PF K		R311-317			RK73HB1J000J	CHIP R 0.0 J 1/16W	
C825			CK73HB1H102K	CHIP C 1000PF K		R318,319			RK73HB1J101J	CHIP R 100 J 1/16W	
C826,827			CC73HCH1H101J	CHIP C 100PF J		R320-337			RK73HB1J000J	CHIP R 0.0 J 1/16W	
C828			CK73HB1H102K	CHIP C 1000PF K		R339			RK73HB1J473J	CHIP R 47K J 1/16W	
C829			CC73HCH1H101J	CHIP C 100PF J		R340-350			RK73HB1J000J	CHIP R 0.0 J 1/16W	
C830			CK73HB1H102K	CHIP C 1000PF K		R352-354			RK73HB1J000J	CHIP R 0.0 J 1/16W	
C831			CC73HCH1H101J	CHIP C 100PF J		R356-360			RK73HB1J000J	CHIP R 0.0 J 1/16W	
C832			CK73HB1H102K	CHIP C 1000PF K		R361			RK73GB2A104J	CHIP R 100K J 1/10W	
C833,834			CK73HB1A104K	CHIP C 0.10UF K		R362			RK73GB2A681J	CHIP R 680 J 1/10W	
C835-837			CK73HB1H102K	CHIP C 1000PF K		R363-386			RK73HB1J000J	CHIP R 0.0 J 1/16W	
C838,839			CC73HCH1H101J	CHIP C 100PF J		R387			RK73HB1J104J	CHIP R 100K J 1/16W	
C841-848			CC73GCH1H470J	CHIP C 47PF J		R388-390			RK73GB2A000J	CHIP R 0.0 J 1/10W	
C850			CC73GCH1H470J	CHIP C 47PF J		R391			RK73GB2A100J	CHIP R 10 J 1/10W	
C851-869			CC73HCH1H470J	CHIP C 47PF J		R392			RK73HB1J103J	CHIP R 10K J 1/16W	
C870-873			CK73HB1H102K	CHIP C 1000PF K		R393-397			RK73HB1J000J	CHIP R 0.0 J 1/16W	
						R398			RK73HB1J104J	CHIP R 100K J 1/16W	
CN300			E04-0193-05	PIN SOCKET		R399			RK73HB1J151J	CHIP R 150 J 1/16W	
CN302			E04-0193-05	PIN SOCKET		R401			RK73HB1J000J	CHIP R 0.0 J 1/16W	
CN400-402			E40-6656-05	PIN ASSY		R403			RK73GB2A000J	CHIP R 0.0 J 1/10W	
CN713			E41-2263-05	PIN ASSY		R404,405			RK73HB1J000J	CHIP R 0.0 J 1/16W	
J700			E58-0516-05	MODULAR JACK		R406			RK73GB2A000J	CHIP R 0.0 J 1/10W	
J701			E58-0515-05	RECTANGULAR RECEPTACLE		R408,409			RK73HB1J000J	CHIP R 0.0 J 1/16W	
J702,703			E58-0533-05	MODULAR JACK		R410			RK73GB2A103J	CHIP R 10K J 1/10W	
53	1C		J19-5497-05	HOLDER (COMPACT FLASH)		R411			RK73GB2A472J	CHIP R 4.7K J 1/10W	
L300-307			L92-0447-05	BEADS CORE		R413			RK73GB2A103J	CHIP R 10K J 1/10W	
L308,309			L41-8285-33	SMALL FIXED INDUCTOR (0.82UH)		R414			RK73HB1J000J	CHIP R 0.0 J 1/16W	
L310			L41-1005-33	SMALL FIXED INDUCTOR (10UH)		R415			RK73HB1J100J	CHIP R 10 J 1/16W	
L311,312			L41-1595-33	SMALL FIXED INDUCTOR (1.5UH)		R416			RK73HB1J104J	CHIP R 100K J 1/16W	
L313-316			L92-0447-05	BEADS CORE		R417			RK73HB1J000J	CHIP R 0.0 J 1/16W	
L317,318			L33-1500-05	CHOKE COIL		R418,419			RK73GB2A104J	CHIP R 100K J 1/10W	
L319-325			L92-0447-05	BEADS CORE		R420			RK73HB1J000J	CHIP R 0.0 J 1/16W	
L326-329			L92-0467-05	CHIP FERRITE		R421			RK73HB1J100J	CHIP R 10 J 1/16W	
X300			L77-1988-05	VCXO (12.288MHZ)		R423			RK73HB1J000J	CHIP R 0.0 J 1/16W	
X301			L77-1984-05	CRYSTAL RESONATOR (14.7456MHZ)		R424			RK73GB2A681J	CHIP R 680 J 1/10W	
X700			L77-1985-05	CRYSTAL RESONATOR (25.8048MHZ)		R425			RK73HB1J000J	CHIP R 0.0 J 1/16W	
X701			L77-1802-05	CRYSTAL RESONATOR (32768HZ)		R428			RK73GB2A100J	CHIP R 10 J 1/10W	
X702			L77-1986-05	CRYSTAL RESONATOR (25MHZ)		R429			RK73GB2A471J	CHIP R 470 J 1/10W	
C	1C		N30-2008-43	PAN HEAD MACHINE SCREW (COMPACT FLASH)		R431			RK73HB1J000J	CHIP R 0.0 J 1/16W	
CP716			RK75HA1JR00J	CHIP-COM 0.00 J 1/16W		R432			RK73GB2A220J	CHIP R 22 J 1/10W	
CP718			RK75HA1JR00J	CHIP-COM 0.00 J 1/16W		R433			RK73HB1J105J	CHIP R 1.0M J 1/16W	
CP720			RK75HA1JR00J	CHIP-COM 0.00 J 1/16W		R438			RK73GB2A100J	CHIP R 10 J 1/10W	
CP737			RK75HA1JR00J	CHIP-COM 0.00 J 1/16W		R439,440			RK73GB2A220J	CHIP R 22 J 1/10W	
CP739			RK75HA1JR00J	CHIP-COM 0.00 J 1/16W		R441			RK73HB1J823J	CHIP R 82K J 1/16W	
CP743			RK75HA1JR00J	CHIP-COM 0.00 J 1/16W		R442			RK73HB1J683J	CHIP R 68K J 1/16W	
						R445			RK73HB1J393J	CHIP R 39K J 1/16W	
						R446,447			RK73HB1J000J	CHIP R 0.0 J 1/16W	

PARTS LIST

CONTROL UNIT (X53-4140-11)

Ref. No.	Address	New parts	Parts No.	Description	Destination	Ref. No.	Address	New parts	Parts No.	Description	Destination
R448			RK73GB2A221J	CHIP R 220 J 1/10W		R602			RK73HB1J103J	CHIP R 10K J 1/16W	
R449			RK73HB1J683J	CHIP R 68K J 1/16W		R604			RK73HB1J103J	CHIP R 10K J 1/16W	
R451			RK73HB1J473J	CHIP R 47K J 1/16W		R605-610			RK73HB1J000J	CHIP R 0.0 J 1/16W	
R452-454			RK73HB1J100J	CHIP R 10 J 1/16W		R612-616			RK73HB1J000J	CHIP R 0.0 J 1/16W	
R457-461			RK73HB1J473J	CHIP R 47K J 1/16W		R620-623			RK73HB1J000J	CHIP R 0.0 J 1/16W	
R464			RK73HB1J472J	CHIP R 4.7K J 1/16W		R624			RK73HB1J473J	CHIP R 47K J 1/16W	
R469			RK73HB1J470J	CHIP R 47 J 1/16W		R626			RK73HB1J473J	CHIP R 47K J 1/16W	
R470			RK73HB1J102J	CHIP R 1.0K J 1/16W		R627			RK73HB1J000J	CHIP R 0.0 J 1/16W	
R474			RK73HB1J100J	CHIP R 10 J 1/16W		R629-631			RK73HB1J000J	CHIP R 0.0 J 1/16W	
R478			RK73HB1J100J	CHIP R 10 J 1/16W		R632			RK73HB1J101J	CHIP R 100 J 1/16W	
R479			RK73HB1J102J	CHIP R 1.0K J 1/16W		R634			RK73HB1J473J	CHIP R 47K J 1/16W	
R480			RK73HB1J100J	CHIP R 10 J 1/16W		R635,636			RK73HB1J000J	CHIP R 0.0 J 1/16W	
R481			RK73HB1J473J	CHIP R 47K J 1/16W		R637-640			RK73HB1J473J	CHIP R 47K J 1/16W	
R483			RK73HB1J104J	CHIP R 100K J 1/16W		R641			RK73HB1J000J	CHIP R 0.0 J 1/16W	
R484			RK73HB1J000J	CHIP R 0.0 J 1/16W		R642			RK73HB1J101J	CHIP R 100 J 1/16W	
R485			RK73HB1J100J	CHIP R 10 J 1/16W		R643			RK73HB1J473J	CHIP R 47K J 1/16W	
R486-489			RK73HB1J000J	CHIP R 0.0 J 1/16W		R644			RK73HB1J000J	CHIP R 0.0 J 1/16W	
R491-505			RK73HB1J000J	CHIP R 0.0 J 1/16W		R646			RK73HB1J473J	CHIP R 47K J 1/16W	
R516-518			RK73HB1J473J	CHIP R 47K J 1/16W		R648			RK73HB1J000J	CHIP R 0.0 J 1/16W	
R521			RK73HB1J000J	CHIP R 0.0 J 1/16W		R649			RK73HB1J101J	CHIP R 100 J 1/16W	
R522			RK73HB1J473J	CHIP R 47K J 1/16W		R650			RK73HB1J473J	CHIP R 47K J 1/16W	
R526			RK73HB1J000J	CHIP R 0.0 J 1/16W		R651-653			RK73HB1J000J	CHIP R 0.0 J 1/16W	
R527			RK73HB1J473J	CHIP R 47K J 1/16W		R656,657			RK73HB1J000J	CHIP R 0.0 J 1/16W	
R528,529			RK73HB1J000J	CHIP R 0.0 J 1/16W		R660-664			RK73HB1J000J	CHIP R 0.0 J 1/16W	
R530			RK73HB1J473J	CHIP R 47K J 1/16W		R667,668			RK73HB1J000J	CHIP R 0.0 J 1/16W	
R531,532			RK73HB1J000J	CHIP R 0.0 J 1/16W		R672-674			RK73HB1J473J	CHIP R 47K J 1/16W	
R533,534			RK73HB1J473J	CHIP R 47K J 1/16W		R678,679			RK73HB1J000J	CHIP R 0.0 J 1/16W	
R535-539			RK73HB1J000J	CHIP R 0.0 J 1/16W		R680			RK73HB1J473J	CHIP R 47K J 1/16W	
R540-542			RK73HB1J473J	CHIP R 47K J 1/16W		R685-687			RK73HB1J000J	CHIP R 0.0 J 1/16W	
R543			RK73HB1J000J	CHIP R 0.0 J 1/16W		R690			RK73HB1J000J	CHIP R 0.0 J 1/16W	
R546			RK73HB1J000J	CHIP R 0.0 J 1/16W		R700,701			RK73HB1J103J	CHIP R 10K J 1/16W	
R547,548			RK73HB1J473J	CHIP R 47K J 1/16W		R702,703			RK73HB1J473J	CHIP R 47K J 1/16W	
R549			RK73HB1J000J	CHIP R 0.0 J 1/16W		R709,710			RK73HB1J104J	CHIP R 100K J 1/16W	
R550			RK73HB1J473J	CHIP R 47K J 1/16W		R711			RK73GB2A000J	CHIP R 0.0 J 1/10W	
R551,552			RK73HB1J000J	CHIP R 0.0 J 1/16W		R712-714			RK73HB1J100J	CHIP R 10 J 1/16W	
R553-555			RK73HB1J473J	CHIP R 47K J 1/16W		R715			RK73GB2A000J	CHIP R 0.0 J 1/10W	
R556,557			RK73HB1J000J	CHIP R 0.0 J 1/16W		R716			RK73HB1J000J	CHIP R 0.0 J 1/16W	
R559			RK73HB1J102J	CHIP R 1.0K J 1/16W		R718			RK73HB1J104J	CHIP R 100K J 1/16W	
R560			RK73HB1J103J	CHIP R 10K J 1/16W		R719			RK73HB1J472J	CHIP R 4.7K J 1/16W	
R561			RK73HB1J000J	CHIP R 0.0 J 1/16W		R720			RK73HB1J100J	CHIP R 10 J 1/16W	
R562			RK73HB1J103J	CHIP R 10K J 1/16W		R721			RK73GB2A000J	CHIP R 0.0 J 1/10W	
R564-566			RK73HB1J000J	CHIP R 0.0 J 1/16W		R722			RK73HB1J472J	CHIP R 4.7K J 1/16W	
R567			RK73HB1J473J	CHIP R 47K J 1/16W		R725,726			RK73HB1J000J	CHIP R 0.0 J 1/16W	
R568			RK73HB1J000J	CHIP R 0.0 J 1/16W		R727			RK73HB1J103J	CHIP R 10K J 1/16W	
R569			RK73HB1J224J	CHIP R 220K J 1/16W		R729,730			RK73HB1J000J	CHIP R 0.0 J 1/16W	
R570			RK73HB1J000J	CHIP R 0.0 J 1/16W		R731			RK73HB1J103J	CHIP R 10K J 1/16W	
R573-576			RK73HB1J000J	CHIP R 0.0 J 1/16W		R732			RK73HB1J390J	CHIP R 39 J 1/16W	
R577,578			RK73HB1J473J	CHIP R 47K J 1/16W		R733			RK73HB1J104J	CHIP R 100K J 1/16W	
R579			RK73HB1J000J	CHIP R 0.0 J 1/16W		R734			RK73HB1J102J	CHIP R 1.0K J 1/16W	
R581			RK73HB1J000J	CHIP R 0.0 J 1/16W		R735,736			RK73HB1J000J	CHIP R 0.0 J 1/16W	
R582			RK73HB1J473J	CHIP R 47K J 1/16W		R738			RK73HB1J104J	CHIP R 100K J 1/16W	
R583			RK73HB1J000J	CHIP R 0.0 J 1/16W		R742			RK73HB1J104J	CHIP R 100K J 1/16W	
R584			RK73HB1J473J	CHIP R 47K J 1/16W		R743,744			RK73HB1J153J	CHIP R 15K J 1/16W	
R585,586			RK73HB1J000J	CHIP R 0.0 J 1/16W		R745			RK73HB1J104J	CHIP R 100K J 1/16W	
R587			RK73HB1J473J	CHIP R 47K J 1/16W		R751			RK73HB1J000J	CHIP R 0.0 J 1/16W	
R588			RK73HB1J000J	CHIP R 0.0 J 1/16W		R754			RK73HB1J103J	CHIP R 10K J 1/16W	
R589			RK73HB1J473J	CHIP R 47K J 1/16W		R756			RK73HB1J000J	CHIP R 0.0 J 1/16W	
R590			RK73HB1J000J	CHIP R 0.0 J 1/16W		R758			RK73HB1J103J	CHIP R 10K J 1/16W	
R591			RK73HB1J223J	CHIP R 22K J 1/16W		R759			RK73HB1J000J	CHIP R 0.0 J 1/16W	
R592-600			RK73HB1J000J	CHIP R 0.0 J 1/16W		R760			RK73HB1J103J	CHIP R 10K J 1/16W	

PARTS LIST

CONTROL UNIT (X53-4140-11)

Ref. No.	Address	New parts	Parts No.	Description	Destination	Ref. No.	Address	New parts	Parts No.	Description	Destination
R761-765			RK73GB2A000J	CHIP R 0.0 J 1/10W		R910			RK73HB1J473J	CHIP R 47K J 1/16W	
R766			RK73HB1J000J	CHIP R 0.0 J 1/16W		R911			RK73HB1J000J	CHIP R 0.0 J 1/16W	
R767			RK73HB1J102J	CHIP R 1.0K J 1/16W		R912			RK73HB1J473J	CHIP R 47K J 1/16W	
R768-770			RK73HB1J000J	CHIP R 0.0 J 1/16W		R913,914			RK73HB1J000J	CHIP R 0.0 J 1/16W	
R772-777			RK73HB1J104J	CHIP R 100K J 1/16W		R915			RK73HB1J473J	CHIP R 47K J 1/16W	
R778			RK73HB1J000J	CHIP R 0.0 J 1/16W		R916-923			RK73HB1J000J	CHIP R 0.0 J 1/16W	
R779			RK73HB1J104J	CHIP R 100K J 1/16W		R924			RK73HB1J104J	CHIP R 100K J 1/16W	
R780			RK73HB1J000J	CHIP R 0.0 J 1/16W		R926			RK73HB1J473J	CHIP R 47K J 1/16W	
R781-784			RK73HB1J104J	CHIP R 100K J 1/16W		R927-933			RK73HB1J000J	CHIP R 0.0 J 1/16W	
R785			RK73HB1J272J	CHIP R 2.7K J 1/16W		R934,935			RK73HB1J474J	CHIP R 470K J 1/16W	
R786-788			RK73HB1J104J	CHIP R 100K J 1/16W		R936			RK73HB1J104J	CHIP R 100K J 1/16W	
R794			RK73HB1J104J	CHIP R 100K J 1/16W		R942			RK73HB1J104J	CHIP R 100K J 1/16W	
R796			RK73HB1J104J	CHIP R 100K J 1/16W		R943			RK73HB1J000J	CHIP R 0.0 J 1/16W	
R799-803			RK73HB1J104J	CHIP R 100K J 1/16W		R945-950			RK73HB1J000J	CHIP R 0.0 J 1/16W	
R805-808			RK73HB1J103J	CHIP R 10K J 1/16W		R951			RK73HB1J104J	CHIP R 100K J 1/16W	
R816			RK73HB1J105J	CHIP R 1.0M J 1/16W		R952,953			RK73HB1J000J	CHIP R 0.0 J 1/16W	
R817			RK73HB1J821J	CHIP R 820 J 1/16W		R954-957			RK73GB2A000J	CHIP R 0.0 J 1/10W	
R818			RK73HB1J104J	CHIP R 100K J 1/16W		R960			RK73GB2A000J	CHIP R 0.0 J 1/10W	
R819			RK73GB2A000J	CHIP R 0.0 J 1/10W		R961			RK73GB2A000J	CHIP R 0.0 J 1/10W	
R820			RK73HB1J103J	CHIP R 10K J 1/16W		S700			S79-0473-05	DIP SWITCHES	
R821			RK73HB1J000J	CHIP R 0.0 J 1/16W		D300			1SS388F	DIODE	
R822			RK73HB1J103J	CHIP R 10K J 1/16W		D701			1SS388F	DIODE	
R824			RK73HB1J103J	CHIP R 10K J 1/16W		D702			1SS355	DIODE	
R826			RK73HB1J103J	CHIP R 10K J 1/16W		IC300,301			TC7SET126FU-F	MOS-IC	
R827			RK73GB2A000J	CHIP R 0.0 J 1/10W		IC302			SN65HVD485EDR	MOS-IC	
R828			RK73HB1J104J	CHIP R 100K J 1/16W		IC303			BU4829FVE	MOS-IC	
R829			RK73HH1J113D	CHIP R 11K D 1/16W		IC304			TC7SH125FU-F	MOS-IC	
R830			RK73HB1J104J	CHIP R 100K J 1/16W		IC305			XC6209B332PR	MOS-IC	
R832			RK73HB1J104J	CHIP R 100K J 1/16W		IC306			BA15BC0FP	MOS-IC	
R833			RK73HB1J000J	CHIP R 0.0 J 1/16W		IC307			XC6201P152PR	MOS-IC	
R834			RK73HB1J104J	CHIP R 100K J 1/16W		IC308			XC61CN2702N	MOS-IC	
R835			RK73HB1J000J	CHIP R 0.0 J 1/16W		IC309			AK4550VTP	MOS-IC	
R837			RK73GH2A49R9D	CHIP R 49.9 D 1/10W		IC312			ADCS7476AIMF	MOS-IC	
R839			RK73GB2A000J	CHIP R 0.0 J 1/10W		IC313			TC7WU04FK-F	MOS-IC	
R840			RK73GH2A49R9D	CHIP R 49.9 D 1/10W		IC314		*	Note 1 (BGA)	ROM IC	
R842-845			RK73HB1J104J	CHIP R 100K J 1/16W		IC315			ADF4001BRUZ	MOS-IC	
R867,868			RK73GH2A24R9D	CHIP R 24.9 D 1/10W		IC318			TC7SH126FU-F	MOS-IC	
R869			RK73HB1J331J	CHIP R 330 J 1/16W		IC319-321			TC7SET126FU-F	MOS-IC	
R870			RK73HB1J000J	CHIP R 0.0 J 1/16W		IC323,324			Note 1 (BGA)	MICRO CONTORL UNIT	
R871-873			RK73HB1J103J	CHIP R 10K J 1/16W		IC325			3625MGP396GP	MICRO CONTORL UNIT	
R874			RK73HB1J000J	CHIP R 0.0 J 1/16W		IC327			TC7SH08FU-F	MOS-IC	
R875,876			RK73GH2A24R9D	CHIP R 24.9 D 1/10W		IC329	1C		BA33DD0WT	MOS-IC	
R877,878			RK73HB1J103J	CHIP R 10K J 1/16W		IC330			TC7SH126FU-F	MOS-IC	
R879			RK73GB2A000J	CHIP R 0.0 J 1/10W		IC700			62167DV30LL55	SRAM IC	
R880,881			RK73HB1J104J	CHIP R 100K J 1/16W		IC701			RV5C386A	MOS-IC	
R883-885			RK73HB1J000J	CHIP R 0.0 J 1/16W		IC702		*	29PL127JKDCD	ROM IC	
R886			RK73HB1J221J	CHIP R 220 J 1/16W		IC703		*	Note 1 (BGA)	MICRO CONTORL UNIT	
R887			RK73HB1J000J	CHIP R 0.0 J 1/16W		IC704			48LC8M16A2P75I	DRAM IC	
R888			RK73HB1J221J	CHIP R 220 J 1/16W		IC705			ADM3202ARUZ	MOS-IC	
R889			RK73HB1J103J	CHIP R 10K J 1/16W		IC707			48LC8M16A2P75I	DRAM IC	
R890			RK73HB1J000J	CHIP R 0.0 J 1/16W		IC708			BU4829FVE	MOS-IC	
R891			RK73HB1J104J	CHIP R 100K J 1/16W		IC709			TC7SH126FU-F	MOS-IC	
R892,893			RK73HB1J000J	CHIP R 0.0 J 1/16W		IC710,711			TC7SH00FU-F	MOS-IC	
R894			RK73HB1J103J	CHIP R 10K J 1/16W		IC712,713			TC7SH32FU-F	MOS-IC	
R895			RK73HB1J151J	CHIP R 150 J 1/16W		IC714-716			TC7MA244FK	MOS-IC	
R896			RK73HB1J101J	CHIP R 100 J 1/16W		IC717,718			TC7MA245FK	MOS-IC	
R897			RK73HB1J104J	CHIP R 100K J 1/16W		IC719			LAN91C1111-NU	MOS-IC	
R902,903			RK73HB1J000J	CHIP R 0.0 J 1/16W		IC720			AT93C4610SU.1.8	ROM IC	
R907			RK73HB1J000J	CHIP R 0.0 J 1/16W		IC721			TC7SH08FU-F	MOS-IC	
R909			RK73HB1J000J	CHIP R 0.0 J 1/16W							

Note 1 : This part cannot be replaced. Therefore, this part is not supplied as a service part.

PARTS LIST

CONTROL UNIT (X53-4140-11)

RX UNIT (X55-3092-71)

Ref. No.	Address	New parts	Parts No.	Description	Destination	Ref. No.	Address	New parts	Parts No.	Description	Destination
IC722			TC7SH32FU-F	MOS-IC		C67		*	CS77CB21A470M	CHIP TNTL 47UF 10WV	
IC723			TC7SH00FU-F	MOS-IC		C68			CC73GCH1H101J	CHIP C 100PF J	
IC724			TC7SH125FU-F	MOS-IC		C69			CK73GB1H102K	CHIP C 1000PF K	
IC725			TC7SH126FU-F	MOS-IC		C70			CS77CC1C330M	CHIP TNTL 33UF 16WV	
IC726			TC7SH08FU-F	MOS-IC		C74			CC73GCH1H100C	CHIP C 10PF C	
IC727,728			TC7SH126FU-F	MOS-IC		C75			CS77CC1C330M	CHIP TNTL 33UF 16WV	
Q300			2SC4738F	TRANSISTOR		C76			CC73GCH1H330J	CHIP C 33PF J	
Q301			DTC114EUA	DIGITAL TRANSISTOR		C77			CK73GB1H104K	CHIP C 0.10UF K	
Q302			2SA1955A-F	TRANSISTOR		C79			CS77BA1E010M	CHIP TNTL 1.0UF 25WV	
Q303			DTA144EUA	DIGITAL TRANSISTOR		C81			CK73GB1H104K	CHIP C 0.10UF K	
Q304,305			2SC4738F	TRANSISTOR		C83-85			CK73GB1H102K	CHIP C 1000PF K	
Q307,308			2SC4738F	TRANSISTOR		C86			CC73GCH1H100C	CHIP C 10PF C	
Q309			SSM6N16FE-F	FET		C87			CK73GB1H104K	CHIP C 0.10UF K	
Q700			2SC4738F	TRANSISTOR		C88			CK73GB1H103K	CHIP C 0.010UF K	
Q702			2SC4738F	TRANSISTOR		C89			CC73GCH1H070B	CHIP C 7.0PF B	
Q704,705			2SC4738F	TRANSISTOR		C90			CK73GB1H103K	CHIP C 0.010UF K	
Q706			DTC114EUA	DIGITAL TRANSISTOR		C91			CC73GCH1H050B	CHIP C 5.0PF B	
Q707			DTC144EUA	DIGITAL TRANSISTOR		C92			CC73GCH1H070B	CHIP C 7.0PF B	
BA300			W09-1004-05	LITHIUM CELL		C93			CC73GCH1H060B	CHIP C 6.0PF B	
						C94			CC73GCH1H050B	CHIP C 5.0PF B	
						C95			CC73GCH1H080B	CHIP C 8.0PF B	
						C96			CE32BM1E470M	CHIP EL 47UF 25WV	
						C97			CK73GB1H104K	CHIP C 0.10UF K	
						C98,99			CK73GB1H102K	CHIP C 1000PF K	
						C100			CK73GB1H103K	CHIP C 0.010UF K	
RX UNIT (X55-3092-71)											
D21			B30-2230-05	LED (1608/YG/8)		C102			CK73GB1H102K	CHIP C 1000PF K	
C10			CK73GB1H102K	CHIP C 1000PF K		C103			CC73GCH1H120J	CHIP C 12PF J	
C12			CC73GCH1H080D	CHIP C 8.0PF D		C104			CK73GB1H102K	CHIP C 1000PF K	
C14			CK73GB1H102K	CHIP C 1000PF K		C105			CC73GCH1H060B	CHIP C 6.0PF B	
C15			CK73GB1H104K	CHIP C 0.10UF K		C106			CC73GCH1H050B	CHIP C 5.0PF B	
C17			CK73GB1H102K	CHIP C 1000PF K		C107			CC73GCH1H330J	CHIP C 33PF J	
C18			CK73GB1H104K	CHIP C 0.10UF K		C108			CC73GCH1H560J	CHIP C 56PF J	
C19			CK73GB1H102K	CHIP C 1000PF K		C109,110			CK73GB1H103K	CHIP C 0.010UF K	
C25			CK73GB1H104K	CHIP C 0.10UF K		C112			CC73GCH1H220J	CHIP C 22PF J	
C26			CK73GB1H471K	CHIP C 470PF K		C113			CC73GCH1H070B	CHIP C 7.0PF B	
C27			CK73GB1H102K	CHIP C 1000PF K		C114			CC73GCH1H060B	CHIP C 6.0PF B	
C31			CS77BA1E010M	CHIP TNTL 1.0UF 25WV		C115			CC73GCH1H150J	CHIP C 15PF J	
C32			CC73GCH1H151J	CHIP C 150PF J		C116			CC73GCH1H560J	CHIP C 56PF J	
C33			CC73GCH1H271J	CHIP C 270PF J		C117			CC73GCH1H121J	CHIP C 120PF J	
C35			CK73GB1H471K	CHIP C 470PF K		C118-120			CK73GB1H102K	CHIP C 1000PF K	
C36			CK73GB1H102K	CHIP C 1000PF K		C122			CC73GCH1H150J	CHIP C 15PF J	
C37			CK73FB1E224K	CHIP C 0.22UF K		C123			CC73GCH1H080B	CHIP C 8.0PF B	
C38			CS77CA1VR33M	CHIP TNTL 0.33UF 35WV		C124			CC73GCH1H070B	CHIP C 7.0PF B	
C39			CC73GCH1H271J	CHIP C 270PF J		C125			CC73GCH1H180J	CHIP C 18PF J	
C41,42			CK73GB1H102K	CHIP C 1000PF K		C126			CK73GB1H104K	CHIP C 0.10UF K	
C43			CC73GCH1H561J	CHIP C 560PF J		C128			CC73GCH1H560J	CHIP C 56PF J	
C44			CK73GB1H103K	CHIP C 0.010UF K		C129,130			CK73GB1H103K	CHIP C 0.010UF K	
C45			CK73GB1H104K	CHIP C 0.10UF K		C131			CS77CC1C330M	CHIP TNTL 33UF 16WV	
C46			CC73GCH1H561J	CHIP C 560PF J		C132-134			CK73GB1H102K	CHIP C 1000PF K	
C47			CK73GB1H102K	CHIP C 1000PF K		C137			CC73GCH1H120J	CHIP C 12PF J	
C48			CK73GB1H104K	CHIP C 0.10UF K		C138			CC73GCH1H330J	CHIP C 33PF J	
C50			CE32BM1E470M	CHIP EL 47UF 25WV		C139			CE32BM1E470M	CHIP EL 47UF 25WV	
C51			CK73GB1H104K	CHIP C 0.10UF K		C140,141			CK73GB1H103K	CHIP C 0.010UF K	
C53			CC73GCH1H271J	CHIP C 270PF J		C142,143			CC73FCH1H0R5B	CHIP C 0.5PF B	
C54			CC73GCH1H101J	CHIP C 100PF J		C144-146			CK73GB1H104K	CHIP C 0.10UF K	
C55			CC73GCH1H120J	CHIP C 12PF J		C147			CS77CC1C330M	CHIP TNTL 33UF 16WV	
C56			CC73GCH1H271J	CHIP C 270PF J		C149-151			CC73GCH1H180J	CHIP C 18PF J	
C58		*	CS77CB21A470M	CHIP TNTL 47UF 10WV		C152			CC73GCH1H030C	CHIP C 3.0PF C	
C59			CK73GB1H104K	CHIP C 0.10UF K		C153			CC73GCH1H060D	CHIP C 6.0PF D	
C60,61			CK73GB1H102K	CHIP C 1000PF K		C154,155			CK73GB1H104K	CHIP C 0.10UF K	
C62-66			CK73GB1H104K	CHIP C 0.10UF K							

PARTS LIST

RX UNIT (X55-3092-71)

Ref. No.	Address	New parts	Parts No.	Description	Desti-nation	Ref. No.	Address	New parts	Parts No.	Description	Desti-nation
C156			CC73GCH1H150J	CHIP C 15PF J		C252			CC73GCH1H151J	CHIP C 150PF J	
C157,158			CK73GB1H102K	CHIP C 1000PF K		C253			CC73GCH1H010C	CHIP C 1.0PF C	
C159,160			CK73GB1H104K	CHIP C 0.10UF K		C254			CC73GCH1H030C	CHIP C 3.0PF C	
C161			CC73GCH1H030C	CHIP C 3.0PF C		C255			CK73GB1H104K	CHIP C 0.10UF K	
C162			CC73GCH1H060D	CHIP C 6.0PF D		C256			CK73GB1H102K	CHIP C 1000PF K	
C164			CK73GB1H104K	CHIP C 0.10UF K		C257			CK73GB1H103K	CHIP C 0.010UF K	
C165			CS77CB21C100M	CHIP TNTL 10UF 16WV		C258			CK73GB1H473K	CHIP C 0.047UF K	
C166,167			CC73GCH1H180J	CHIP C 18PF J		C260			CK73GB1H102K	CHIP C 1000PF K	
C168			CK73GB1H102K	CHIP C 1000PF K		C261			CK73GB1H103K	CHIP C 0.010UF K	
C169			CC73GCH1H270J	CHIP C 27PF J		C262,263			CK73GB1H102K	CHIP C 1000PF K	
C170,171			CK73GB1H104K	CHIP C 0.10UF K		C264			CS77CA1ER47M	CHIP TNTL 0.47UF 25WV	
C172			CK73GB1H473K	CHIP C 0.047UF K		C265			CC73GCH1H470J	CHIP C 47PF J	
C173,174			CK73GB1H103K	CHIP C 0.010UF K		C266,267			CK73GB1H102K	CHIP C 1000PF K	
C175			CC73GCH1H101J	CHIP C 100PF J		C268,269			CK73GB1H473K	CHIP C 0.047UF K	
C176			CK73GB1H104K	CHIP C 0.10UF K		C270			CS77CA1DR68M	CHIP TNTL 0.68UF 20WV	
C177-179			CK73GB1H102K	CHIP C 1000PF K		C271			CK73GB1H102K	CHIP C 1000PF K	
C180			CK73GB1H104K	CHIP C 0.10UF K		C272			CK73GB1H104K	CHIP C 0.10UF K	
C183			CE32AU1E100M	CHIP EL 10UF 25WV		C273			CC73GCH1H220J	CHIP C 22PF J	
C185,186			CK73GB1H102K	CHIP C 1000PF K		C274			CK73GB1H473K	CHIP C 0.047UF K	
C187			CC73GCH1H150J	CHIP C 15PF J		C277			CK73GB1H102K	CHIP C 1000PF K	
C188			CK73GB1H103K	CHIP C 0.010UF K		C278			CC73GCH1H080D	CHIP C 8.0PF D	
C192			CK73GB1H102K	CHIP C 1000PF K		C279			CK73GB1H473K	CHIP C 0.047UF K	
C193			CK73GB1H104K	CHIP C 0.10UF K		C280			CC73GCH1H080B	CHIP C 8.0PF B	
C194			CC73GCH1H180J	CHIP C 18PF J		C281			CC73GCH1H030B	CHIP C 3.0PF B	
C195			CK73GB1H102K	CHIP C 1000PF K		C282			CS77CB21C150M	CHIP TNTL 15UF 16WV	
C196,197			CK73GB1H103K	CHIP C 0.010UF K		C284			CK73GB1H473K	CHIP C 0.047UF K	
C198			CK73GB1H102K	CHIP C 1000PF K		C285			CC73GCH1H180J	CHIP C 18PF J	
C199			CK73GB1H103K	CHIP C 0.010UF K		C287			CC73GCH1H390J	CHIP C 39PF J	
C203-205			CK73GB1H102K	CHIP C 1000PF K		C288,289			CC73GCH1H150J	CHIP C 15PF J	
C206			CC73GCH1H150J	CHIP C 15PF J		C290,291			CK73GB1H473K	CHIP C 0.047UF K	
C211,212			CK73GB1H103K	CHIP C 0.010UF K		C292			CE32CL1V100M	CHIP EL 10UF 35WV	
C213			CK73GB1H473K	CHIP C 0.047UF K		C295			CK73GB1H102K	CHIP C 1000PF K	
C214			CC73GCH1H090D	CHIP C 9.0PF D		C296			CS77CA1DR68M	CHIP TNTL 0.68UF 20WV	
C215			CK73GB1H103K	CHIP C 0.010UF K		C297			CC73GCH1H120J	CHIP C 12PF J	
C216			CK73GB1H473K	CHIP C 0.047UF K		C298			CK73GB1H102K	CHIP C 1000PF K	
C217			CK73GB1H104K	CHIP C 0.10UF K		C300			CC73GCH1H220G	CHIP C 22PF G	
C218			CK73GB1H473K	CHIP C 0.047UF K		C301			CK73GB1H473K	CHIP C 0.047UF K	
C220			CC73GCH1H090D	CHIP C 9.0PF D		C303,304			CK73GB1H473K	CHIP C 0.047UF K	
C221,222			CK73GB1H104K	CHIP C 0.10UF K		C306			CK73GB1H102K	CHIP C 1000PF K	
C223			CK73GB1H103K	CHIP C 0.010UF K		C307,308			CK73GB1H103K	CHIP C 0.010UF K	
C224			CK73GB1H104K	CHIP C 0.10UF K		C309			CK73GB1H471K	CHIP C 470PF K	
C225			CK73GB1H473K	CHIP C 0.047UF K		C310			CK73GB1H102K	CHIP C 1000PF K	
C227			CK73GB1H102K	CHIP C 1000PF K		C311			CC73GCH1H080D	CHIP C 8.0PF D	
C228,229			CK73FB1E474K	CHIP C 0.47UF K		C314			CK73GB1H104K	CHIP C 0.10UF K	
C230			CC73GCH1H820J	CHIP C 82PF J		C315			CC73GCH1H270G	CHIP C 27PF G	
C231			CK73GB1H473K	CHIP C 0.047UF K		C316			CK73GB1H473K	CHIP C 0.047UF K	
C232			CC73GCH1H101J	CHIP C 100PF J		C317			CC73GCH1H151J	CHIP C 150PF J	
C233			CK73GB1H473K	CHIP C 0.047UF K		C318,319			CK73GB1H103K	CHIP C 0.010UF K	
C234,235			CC73GCH1H270J	CHIP C 27PF J		C320			CE32BM1E470M	CHIP EL 47UF 25WV	
C236			CK73GB1H104K	CHIP C 0.10UF K		C324			CK73GB1H102K	CHIP C 1000PF K	
C237			CK73GB1H102K	CHIP C 1000PF K		C325			CC73GCH1H270G	CHIP C 27PF G	
C239			CE32AU1C330M	CHIP EL 33UF 16WV		C326			CC73GCH1H151J	CHIP C 150PF J	
C240			CS77CB21C100M	CHIP TNTL 10UF 16WV		C327			CK73GB1H102K	CHIP C 1000PF K	
C241,242			CC73GCH1H150J	CHIP C 15PF J		C329			CK73GB1H103K	CHIP C 0.010UF K	
C243			CC73GCH1H820J	CHIP C 82PF J		C330			CK73GB1H102K	CHIP C 1000PF K	
C244			CC73GCH1H270J	CHIP C 27PF J		C331			CC73GCH1H020B	CHIP C 2.0PF B	
C245			CK73GB1H102K	CHIP C 1000PF K		C332			CK73GB1H104K	CHIP C 0.10UF K	
C248			CK73GB1H102K	CHIP C 1000PF K		C333			CC73GCH1H151J	CHIP C 150PF J	
C249			CC73GCH1H150J	CHIP C 15PF J		C334,335			CK73GB1H103K	CHIP C 0.010UF K	
C250,251			CK73GB1H104K	CHIP C 0.10UF K		C336			CK73GB1H102K	CHIP C 1000PF K	

PARTS LIST

RX UNIT (X55-3092-71)

Ref. No.	Address	New parts	Parts No.	Description	Destination	Ref. No.	Address	New parts	Parts No.	Description	Destination
C337			CC73GCH1H560J	CHIP C 56PF J		C430			CK73GB1H102K	CHIP C 1000PF K	
C340			CS77CC1C330M	CHIP TNTL 33UF 16WV		C431			CK73GB1H473K	CHIP C 0.047UF K	
C341,342			CK73GB1H473K	CHIP C 0.047UF K		C432			CK73GB1H102K	CHIP C 1000PF K	
C343			CC73GCH1H220J	CHIP C 22PF J		C434,435			CK73GB1H473K	CHIP C 0.047UF K	
C347,348			CK73GB1H103K	CHIP C 0.010UF K		C437			CK73GB1H102K	CHIP C 1000PF K	
C349			CC73GCH1H680J	CHIP C 68PF J		C438			CK73GB1H473K	CHIP C 0.047UF K	
C350			CS77CC1C330M	CHIP TNTL 33UF 16WV		C439			CK73GB1H104K	CHIP C 0.10UF K	
C351			CK73GB1H102K	CHIP C 1000PF K		C440-442			CK73FB1E474K	CHIP C 0.47UF K	
C352			CK73GB1H473K	CHIP C 0.047UF K		C443,444			CK73GB1H473K	CHIP C 0.047UF K	
C353			CK73GB1H102K	CHIP C 1000PF K		C446			CE32AU1E100M	CHIP EL 10UF 25WV	
C355			CK73GB1H103K	CHIP C 0.010UF K		C447			CK73FB1E474K	CHIP C 0.47UF K	
C356			CK73GB1H473K	CHIP C 0.047UF K		C448			CK73GB1H104K	CHIP C 0.10UF K	
C357			CK73GB1H103K	CHIP C 0.010UF K		C449			CK73GB1H473K	CHIP C 0.047UF K	
C358			CK73GB1H473K	CHIP C 0.047UF K		C450,451			CK73FB1E474K	CHIP C 0.47UF K	
C359-361			CK73GB1H102K	CHIP C 1000PF K		C452,453			CK73GB1H104K	CHIP C 0.10UF K	
C362			CC73GCH1H270J	CHIP C 27PF J		C454,455			CK73FB1E474K	CHIP C 0.47UF K	
C363			CK73GB1H473K	CHIP C 0.047UF K		C456			CK73GB1H473K	CHIP C 0.047UF K	
C365,366			CK73GB1H104K	CHIP C 0.10UF K		C458			CK73GB1H104K	CHIP C 0.10UF K	
C367,368			CC73GCH1H330J	CHIP C 33PF J		C459			CC73GCH1H221J	CHIP C 220PF J	
C369,370			CK73FB1E474K	CHIP C 0.47UF K		C460			CK73FB1E474K	CHIP C 0.47UF K	
C371			CK73GB1H102K	CHIP C 1000PF K		C461			CC73GCH1H221J	CHIP C 220PF J	
C372			CK73GB1H473K	CHIP C 0.047UF K		C462			CK73GB1H104K	CHIP C 0.10UF K	
C373			CK73GB1H103K	CHIP C 0.010UF K		C463-465			CK73FB1E474K	CHIP C 0.47UF K	
C375			CK73GB1H103K	CHIP C 0.010UF K		C466			CK73GB1H473K	CHIP C 0.047UF K	
C377			CK73GB1H103K	CHIP C 0.010UF K		C467			CK73GB1H102K	CHIP C 1000PF K	
C379			CC73GCH1H121J	CHIP C 120PF J		C468			CK73GB1H104K	CHIP C 0.10UF K	
C380			CC73GCH1H560J	CHIP C 56PF J		C469			CK73GB1H473K	CHIP C 0.047UF K	
C381			CE32BM1E470M	CHIP EL 47UF 25WV		C470			CK73GB1H471K	CHIP C 470PF K	
C382,383			CK73GB1H104K	CHIP C 0.10UF K		C471,472			CK73GB1H104K	CHIP C 0.10UF K	
C385,386			CK73GB1H104K	CHIP C 0.10UF K		C473			CC73GCH1H270J	CHIP C 27PF J	
C387			CC73GCH1H270J	CHIP C 27PF J		C474			CK73FB1E474K	CHIP C 0.47UF K	
C388			CC73GCH1H820J	CHIP C 82PF J		C476			CE32AU1E100M	CHIP EL 10UF 25WV	
C389			CK73GB1H473K	CHIP C 0.047UF K		C477			CK73GB1H104K	CHIP C 0.10UF K	
C390			CK73GB1H104K	CHIP C 0.10UF K		C478			CK73FB1E474K	CHIP C 0.47UF K	
C391,392			CK73GB1H103K	CHIP C 0.010UF K		C480-482			CE32CL1V100M	CHIP EL 10UF 35WV	
C394,395			CK73GB1H102K	CHIP C 1000PF K		C484-489			CK73GB1H102K	CHIP C 1000PF K	
C396-398			CK73GB1H104K	CHIP C 0.10UF K		C491			CK73GB1H104K	CHIP C 0.10UF K	
C400			CC73GCH1H220J	CHIP C 22PF J		C492			C93-0912-05	CHIP C 100UF M	
C401			CK73GB1H473K	CHIP C 0.047UF K		C493			CK73GB1H473K	CHIP C 0.047UF K	
C402			CC73GCH1H560J	CHIP C 56PF J		C494			CK73FB0J106K	CHIP C 10UF K	
C403			CK73GB1H104K	CHIP C 0.10UF K		C495			CK73GB1H104K	CHIP C 0.10UF K	
C405			CK73GB1H102K	CHIP C 1000PF K		C498			CC73GCH1H470J	CHIP C 47PF J	
C406			CK73GB1H103K	CHIP C 0.010UF K		C499			CK73FB0J106K	CHIP C 10UF K	
C407			CC73GCH1H560J	CHIP C 56PF J		C500-504			CK73GB1H102K	CHIP C 1000PF K	
C408			CC73GCH1H220J	CHIP C 22PF J		C505			CK73FB0J106K	CHIP C 10UF K	
C409			CK73GB1H102K	CHIP C 1000PF K		C506			CK73GB1H102K	CHIP C 1000PF K	
C410			CK73GB1H104K	CHIP C 0.10UF K		C507			CK73GB1H104K	CHIP C 0.10UF K	
C411			CC73GCH1H121J	CHIP C 120PF J		C508			CK73FB0J106K	CHIP C 10UF K	
C412			CK73GB1H104K	CHIP C 0.10UF K		C509			CC73GCH1H101J	CHIP C 100PF J	
C413			CK73GB1H103K	CHIP C 0.010UF K		C510			CK73GB1H104K	CHIP C 0.10UF K	
C414			CK73GB1H104K	CHIP C 0.10UF K		C516			CK73GB1H473K	CHIP C 0.047UF K	
C415,416			CK73GB1H103K	CHIP C 0.010UF K		C517			CK73FB0J106K	CHIP C 10UF K	
C417			CK73GB1H104K	CHIP C 0.10UF K		C518			CK73GB1H104K	CHIP C 0.10UF K	
C418,419			CK73GB1H103K	CHIP C 0.010UF K		C519			CK73GB1H102K	CHIP C 1000PF K	
C420			CK73GB1H102K	CHIP C 1000PF K		C520			CK73GB1H103K	CHIP C 0.010UF K	
C421,422			CK73GB1H473K	CHIP C 0.047UF K		C521			CK73GB1H104K	CHIP C 0.10UF K	
C423,424			CK73GB1H103K	CHIP C 0.010UF K		C522			CK73GB1H103K	CHIP C 0.010UF K	
C425			CK73GB1H104K	CHIP C 0.10UF K		C523			CK73GB1H104K	CHIP C 0.10UF K	
C427			CK73FB1E474K	CHIP C 0.47UF K		C524			CK73FB1H333K	CHIP C 0.033UF K	
C428,429			CC73GCH1H560J	CHIP C 56PF J		C527			CK73GB1H104K	CHIP C 0.10UF K	

PARTS LIST

RX UNIT (X55-3092-71)

Ref. No.	Address	New parts	Parts No.	Description	Destination	Ref. No.	Address	New parts	Parts No.	Description	Destination
C532			CK73GB1H104K	CHIP C 0.10UF K		C660			CC73GCH1H050C	CHIP C 5.0PF C	
C533-536			CE32CL1V100M	CHIP EL 10UF 35WV		C661			CK73GB1H104K	CHIP C 0.10UF K	
C537-540			CK73GB1H102K	CHIP C 1000PF K		C662			CC73GCH1H070B	CHIP C 7.0PF B	
C541,542			CK73GB1H104K	CHIP C 0.10UF K		C663			CC73GCH1H080B	CHIP C 8.0PF B	
C543			CK73GB1H473K	CHIP C 0.047UF K		C664			CC73GCH1H060B	CHIP C 6.0PF B	
C544			CC73GCH1H470J	CHIP C 47PF J		C665			CC73GCH1H080B	CHIP C 8.0PF B	
C545-548			CK73GB1H102K	CHIP C 1000PF K		C666,667			CK73GB1H102K	CHIP C 1000PF K	
C549			CC73GCH1H470J	CHIP C 47PF J		C668			CC73GCH1H080B	CHIP C 8.0PF B	
C550-553			CK73GB1H103K	CHIP C 0.010UF K		C669			CC73GCH1H070B	CHIP C 7.0PF B	
C554			CK73GB1H473K	CHIP C 0.047UF K		C670			CC73GCH1H050B	CHIP C 5.0PF B	
C555			CE32BM1V220M	CHIP EL 22UF 35WV		C671			CK73GB1H104K	CHIP C 0.10UF K	
C556			CK73GB1H102K	CHIP C 1000PF K		C673-675			CE32BM1E470M	CHIP EL 47UF 25WV	
C557			CK73GB1H473K	CHIP C 0.047UF K		C677			CK73GB1H104K	CHIP C 0.10UF K	
C558			CK73GB1H102K	CHIP C 1000PF K		TC1-8			C05-0301-05	CERAMIC TRIMMER CAPACITOR (7PF)	
C559			CK73GB1H104K	CHIP C 0.10UF K		CN1-4			E23-1280-05	TERMINAL	
C560,561			CK73GB1H102K	CHIP C 1000PF K		CN5			E04-0460-05	RF COAXIAL RECEPTACLE (SMB)	
C562			CK73GB1H473K	CHIP C 0.047UF K		CN6			E41-2735-05	PIN ASSY	
C563			CK73GB1H102K	CHIP C 1000PF K		CN8-35			E23-1280-05	TERMINAL	
C564			CK73GB1H103K	CHIP C 0.010UF K		CN36			E41-2735-05	PIN ASSY	
C565			CK73GB1H102K	CHIP C 1000PF K		CN38,39			E23-1280-05	TERMINAL	
C566			CK73GB1H473K	CHIP C 0.047UF K		CN41			E04-0154-05	PIN SOCKET	
C567			CE32CL1V100M	CHIP EL 10UF 35WV		CN42			E40-6656-05	PIN ASSY	
C568			CC73GCH1H470J	CHIP C 47PF J		CN43			E04-0193-05	PIN SOCKET	
C569			CK73GB1H102K	CHIP C 1000PF K		CN44			E41-2672-05	PIN ASSY	
C570			CC73GCH1H470J	CHIP C 47PF J		CN45			E04-0193-05	PIN SOCKET	
C571			C92-0904-05	OS-CON		CN46,47			E41-2735-05	PIN ASSY	
C572,573			CK73GB1H103K	CHIP C 0.010UF K		CN61,62			E23-1280-05	TERMINAL	
C574-576			CK73GB1H104K	CHIP C 0.10UF K		CN69			E23-1330-05	TERMINAL	
C577			CK73GB1H103K	CHIP C 0.010UF K		E1			F10-2379-04	SHIELDING CASE	
C578			CC73GCH1H151J	CHIP C 150PF J		E2			F10-2409-04	SHIELDING CASE	
C579			CC73GCH1H560J	CHIP C 56PF J		E3			F10-3080-04	SHIELDING CASE	
C580-582			CK73GB1H103K	CHIP C 0.010UF K		CF1			L72-1019-05	CERAMIC FILTER	
C583			CK73GB1H102K	CHIP C 1000PF K		CF2			L72-1028-05	CERAMIC FILTER	
C584			CK73GB1H103K	CHIP C 0.010UF K		CF3,4			L72-1027-05	CERAMIC FILTER	
C585			CC73GCH1H102J	CHIP C 1000PF J		CF5,6			L72-1028-05	CERAMIC FILTER	
C586			CC73GCH1H470J	CHIP C 47PF J		CF7			L72-1027-05	CERAMIC FILTER	
C587-590			CK73FB1E474K	CHIP C 0.47UF K		L2			L34-4616-05	AIR-CORE COIL	
C591			CK73GB1H102K	CHIP C 1000PF K		L5			L41-2275-33	SMALL FIXED INDUCTOR (0.022UH)	
C618			CC73GCH1H101J	CHIP C 100PF J		L8,9			L41-1875-33	SMALL FIXED INDUCTOR (0.018UH)	
C619			CK73GB1H104K	CHIP C 0.10UF K		L10			L41-6885-33	SMALL FIXED INDUCTOR (0.68UH)	
C620			CK73GB1H102K	CHIP C 1000PF K		L11			L41-1295-33	SMALL FIXED INDUCTOR (1.2UH)	
C621,622			CK73GB1H104K	CHIP C 0.10UF K		L12			L41-6875-33	SMALL FIXED INDUCTOR (0.068UH)	
C624			CC73GCH1H390J	CHIP C 39PF J		L13			L41-1295-33	SMALL FIXED INDUCTOR (1.2UH)	
C625,626			CC73GCH1H050C	CHIP C 5.0PF C		L14			L41-1805-33	SMALL FIXED INDUCTOR (18UH)	
C627			CC73GCH1H060D	CHIP C 6.0PF D		L16			L41-2705-33	SMALL FIXED INDUCTOR (27UH)	
C628			CC73GCH1H390J	CHIP C 39PF J		L17,18			L41-1005-33	SMALL FIXED INDUCTOR (10UH)	
C629			CC73GCH1H060D	CHIP C 6.0PF D		L20			L41-2705-33	SMALL FIXED INDUCTOR (27UH)	
C631,632			CC73GCH1H050C	CHIP C 5.0PF C		L21,22			L41-1005-33	SMALL FIXED INDUCTOR (10UH)	
C633			CC73GCH1H060D	CHIP C 6.0PF D		L23			L41-2705-33	SMALL FIXED INDUCTOR (27UH)	
C634			CC73GCH1H390J	CHIP C 39PF J		L24,25			L41-1005-33	SMALL FIXED INDUCTOR (10UH)	
C635-646			CC73GCH1HR75B	CHIP C 0.75PF B		L26			L41-1095-33	SMALL FIXED INDUCTOR (1.0UH)	
C647			CK73GB1H102K	CHIP C 1000PF K		L27			L41-1005-33	SMALL FIXED INDUCTOR (10UH)	
C648,649			CC73GCH1H120J	CHIP C 12PF J		L28			L34-4586-05	AIR-CORE COIL	
C650			CC73GCH1H390J	CHIP C 39PF J		L29			L41-1005-33	SMALL FIXED INDUCTOR (10UH)	
C651			CE32BM1E470M	CHIP EL 47UF 25WV		L30			L34-4586-05	AIR-CORE COIL	
C652-654			CK73GB1H104K	CHIP C 0.10UF K		L31			L41-3375-33	SMALL FIXED INDUCTOR (0.033UH)	
C655			CK73FBOJ106K	CHIP C 10UF K		L32			L41-8275-33	SMALL FIXED INDUCTOR (0.082UH)	
C657			CC73GCH1H270J	CHIP C 27PF J		L33			L41-2785-33	SMALL FIXED INDUCTOR (0.27UH)	
C658			CK73FB1E474K	CHIP C 0.47UF K		L34			L41-1205-33	SMALL FIXED INDUCTOR (12UH)	
C659			CC73GCH1H060D	CHIP C 6.0PF D							

PARTS LIST

RX UNIT (X55-3092-71)

Ref. No.	Address	New parts	Parts No.	Description	Destination	Ref. No.	Address	New parts	Parts No.	Description	Destination
L35			L41-3395-33	SMALL FIXED INDUCTOR (3.3UH)		L115			L41-8275-33	SMALL FIXED INDUCTOR (0.082UH)	
L36			L41-3375-33	SMALL FIXED INDUCTOR (0.033UH)		L116,117			L41-1585-33	SMALL FIXED INDUCTOR (0.15UH)	
L37			L41-1205-33	SMALL FIXED INDUCTOR (12UH)		L118			L41-6875-33	SMALL FIXED INDUCTOR (0.068UH)	
L38			L41-1095-33	SMALL FIXED INDUCTOR (1.0UH)		L119			L41-2285-33	SMALL FIXED INDUCTOR (0.22UH)	
L39			L41-3375-33	SMALL FIXED INDUCTOR (0.033UH)		L120			L41-8295-33	SMALL FIXED INDUCTOR (8.2UH)	
L40,41			L41-1005-33	SMALL FIXED INDUCTOR (10UH)		L121			L41-1595-33	SMALL FIXED INDUCTOR (1.5UH)	
L42			L41-3375-33	SMALL FIXED INDUCTOR (0.033UH)		L122			L41-1585-33	SMALL FIXED INDUCTOR (0.15UH)	
L43,44			L41-3395-33	SMALL FIXED INDUCTOR (3.3UH)		L123			L41-3395-33	SMALL FIXED INDUCTOR (3.3UH)	
L45			L41-3375-33	SMALL FIXED INDUCTOR (0.033UH)		L124-126			L41-1585-33	SMALL FIXED INDUCTOR (0.15UH)	
L46,47			L34-4749-05	COIL		L127			L41-8295-33	SMALL FIXED INDUCTOR (8.2UH)	
L48			L41-1095-33	SMALL FIXED INDUCTOR (1.0UH)		L128			L34-4725-05	COIL	
L49			L41-2705-33	SMALL FIXED INDUCTOR (27UH)		L129,130			L41-1005-33	SMALL FIXED INDUCTOR (10UH)	
L50			L41-4775-33	SMALL FIXED INDUCTOR (0.047UH)		L131			L41-5685-33	SMALL FIXED INDUCTOR (0.56UH)	
L51			L92-0140-05	CHIP FERRITE		L132-139			L34-4614-05	AIR-CORE COIL	
L52,53			L34-4749-05	COIL		L140,141			L41-3985-33	SMALL FIXED INDUCTOR (0.39UH)	
L54			L41-1075-33	SMALL FIXED INDUCTOR (0.01UH)		XF1			L71-0646-15	MCF (49.95MHZ)	
L55			L41-1085-33	SMALL FIXED INDUCTOR (0.1UH)		XF2			L71-0645-15	MCF (49.95MHZ)	
L56			L41-8295-33	SMALL FIXED INDUCTOR (8.2UH)		XF3			L71-0648-05	MCF (49.95MHZ)	
L57			L41-4775-33	SMALL FIXED INDUCTOR (0.047UH)		XF4			L71-0647-05	MCF (49.95MHZ)	
L58,59			L41-1885-33	SMALL FIXED INDUCTOR (0.18UH)		R1			RK73GB2A332J	CHIP R 3.3K J 1/10W	
L60,61			L41-4775-33	SMALL FIXED INDUCTOR (0.047UH)		R2			RK73GB2A182J	CHIP R 1.8K J 1/10W	
L62			L41-1075-33	SMALL FIXED INDUCTOR (0.01UH)		R4			RK73FB2B121J	CHIP R 120 J 1/8W	
L66,67			L41-8275-33	SMALL FIXED INDUCTOR (0.082UH)		R8			RK73GB2A000J	CHIP R 0.0 J 1/10W	
L68			L41-8295-33	SMALL FIXED INDUCTOR (8.2UH)		R9			RK73GB2A332J	CHIP R 3.3K J 1/10W	
L69			L41-1595-33	SMALL FIXED INDUCTOR (1.5UH)		R11,12			RK73GB2A681J	CHIP R 680 J 1/10W	
L70			L41-3985-33	SMALL FIXED INDUCTOR (0.39UH)		R13			RK73GB2A682J	CHIP R 6.8K J 1/10W	
L71			L41-1595-33	SMALL FIXED INDUCTOR (1.5UH)		R14			RK73FB2B100J	CHIP R 10 J 1/8W	
L72			L41-3985-33	SMALL FIXED INDUCTOR (0.39UH)		R15,16			RK73GB2A000J	CHIP R 0.0 J 1/10W	
L73			L41-2285-33	SMALL FIXED INDUCTOR (0.22UH)		R17			RK73GB2A181J	CHIP R 180 J 1/10W	
L74,75			L34-4748-05	COIL		R19,20			RK73GB2A104J	CHIP R 100K J 1/10W	
L76			L41-3375-33	SMALL FIXED INDUCTOR (0.033UH)		R21			RK73GB2A684J	CHIP R 680K J 1/10W	
L77			L92-0140-05	CHIP FERRITE		R22			RK73GB2A474J	CHIP R 470K J 1/10W	
L78			L41-1005-33	SMALL FIXED INDUCTOR (10UH)		R23			RK73GB2A000J	CHIP R 0.0 J 1/10W	
L79			L41-1095-33	SMALL FIXED INDUCTOR (1.0UH)		R24			RK73GB2A100J	CHIP R 10 J 1/10W	
L80			L41-3975-33	SMALL FIXED INDUCTOR (0.039UH)		R25			RK73GB2A561J	CHIP R 560 J 1/10W	
L81			L41-8285-33	SMALL FIXED INDUCTOR (0.82UH)		R26,27			RK73GB2A000J	CHIP R 0.0 J 1/10W	
L82			L41-1005-33	SMALL FIXED INDUCTOR (10UH)		R28			RK73GB2A100J	CHIP R 10 J 1/10W	
L83			L41-6895-33	SMALL FIXED INDUCTOR (6.8UH)		R29			RK73GB2A152J	CHIP R 1.5K J 1/10W	
L86			L41-1585-33	SMALL FIXED INDUCTOR (0.15UH)		R30			RK73GB2A684J	CHIP R 680K J 1/10W	
L87			L41-1005-33	SMALL FIXED INDUCTOR (10UH)		R31			RK73GB2A181J	CHIP R 180 J 1/10W	
L88			L41-8295-33	SMALL FIXED INDUCTOR (8.2UH)		R32			RK73GB2A104J	CHIP R 100K J 1/10W	
L89			L41-6895-33	SMALL FIXED INDUCTOR (6.8UH)		R33			RK73GB2A102J	CHIP R 1.0K J 1/10W	
L90,91			L34-4748-05	COIL		R34			RK73GB2A471J	CHIP R 470 J 1/10W	
L92			L41-5675-33	SMALL FIXED INDUCTOR (0.056UH)		R36			RK73GB2A103J	CHIP R 10K J 1/10W	
L93			L41-1085-33	SMALL FIXED INDUCTOR (0.1UH)		R37			RK73GB2A123J	CHIP R 12K J 1/10W	
L94,95			L39-1476-05	TOROIDAL COIL		R38			RK73GB2A101J	CHIP R 100 J 1/10W	
L96			L41-6895-33	SMALL FIXED INDUCTOR (6.8UH)		R39			RK73GB2A000J	CHIP R 0.0 J 1/10W	
L97			L41-1005-33	SMALL FIXED INDUCTOR (10UH)		R40			RK73GB2A102J	CHIP R 1.0K J 1/10W	
L98,99			L41-1895-33	SMALL FIXED INDUCTOR (1.8UH)		R42-44			RK73GB2A000J	CHIP R 0.0 J 1/10W	
L100			L41-3985-33	SMALL FIXED INDUCTOR (0.39UH)		R45			RK73GB2A471J	CHIP R 470 J 1/10W	
L101			L41-1595-33	SMALL FIXED INDUCTOR (1.5UH)		R46			RK73GB2A330J	CHIP R 33 J 1/10W	
L102			L41-1005-33	SMALL FIXED INDUCTOR (10UH)		R47			RK73GB2A102J	CHIP R 1.0K J 1/10W	
L103			L41-3985-33	SMALL FIXED INDUCTOR (0.39UH)		R48			RK73FB2B271J	CHIP R 270 J 1/8W	
L106			L41-1585-33	SMALL FIXED INDUCTOR (0.15UH)		R50			RK73FB2B180J	CHIP R 18 J 1/8W	
L107			L41-6895-33	SMALL FIXED INDUCTOR (6.8UH)		R52			RK73GB2A100J	CHIP R 10 J 1/10W	
L108,109			L41-4775-33	SMALL FIXED INDUCTOR (0.047UH)		R53,54			RK73GB2A000J	CHIP R 0.0 J 1/10W	
L110			L41-1585-33	SMALL FIXED INDUCTOR (0.15UH)		R55			RK73FB2B271J	CHIP R 270 J 1/8W	
L111			L41-1595-33	SMALL FIXED INDUCTOR (1.5UH)		R56			RK73GB2A100J	CHIP R 10 J 1/10W	
L112,113			L39-1476-05	TOROIDAL COIL		R57			RK73GB2A470J	CHIP R 47 J 1/10W	
L114			L41-6875-33	SMALL FIXED INDUCTOR (0.068UH)							

PARTS LIST

RX UNIT (X55-3092-71)

Ref. No.	Address	New parts	Parts No.	Description	Desti-nation	Ref. No.	Address	New parts	Parts No.	Description	Desti-nation
R60			RK73GB2A100J	CHIP R 10 J 1/10W		R143			RK73FB2B471J	CHIP R 470 J 1/8W	
R61			RK73GB2A470J	CHIP R 47 J 1/10W		R145			RK73GB2A100J	CHIP R 10 J 1/10W	
R62,63			RK73GB2A102J	CHIP R 1.0K J 1/10W		R146			RK73GB2A101J	CHIP R 100 J 1/10W	
R64			RK73GB2A000J	CHIP R 0.0 J 1/10W		R147			RK73GB2A271J	CHIP R 270 J 1/10W	
R65			RK73GB2A472J	CHIP R 4.7K J 1/10W		R148			RK73GB2A561J	CHIP R 560 J 1/10W	
R66,67			RN73GE1J391D	CHIP R 330 D 1/16W		R149			RK73GB2A821J	CHIP R 820 J 1/10W	
R68			RK73GB2A392J	CHIP R 3.9K J 1/10W		R150			RK73FB2B101J	CHIP R 100 J 1/8W	
R69-71			RK73GB2A102J	CHIP R 1.0K J 1/10W		R151			RK73GB2A000J	CHIP R 0.0 J 1/10W	
R72			RK73GB2A2R2J	CHIP R 2.2 J 1/10W		R152			RK73GB2A102J	CHIP R 1.0K J 1/10W	
R73			RK73GB2A104J	CHIP R 100K J 1/10W		R153			RK73GB2A101J	CHIP R 100 J 1/10W	
R75,76			RK73GB2A103J	CHIP R 10K J 1/10W		R154			RK73GB2A000J	CHIP R 0.0 J 1/10W	
R77,78			RK73FB2B470J	CHIP R 47 J 1/8W		R155			RK73GB2A472J	CHIP R 4.7K J 1/10W	
R79			RK73GB2A100J	CHIP R 10 J 1/10W		R156			RK73GB2A680J	CHIP R 68 J 1/10W	
R80			RK73GB2A271J	CHIP R 270 J 1/10W		R157			RK73GB2A151J	CHIP R 150 J 1/10W	
R81			RK73FB2B000J	CHIP R 0.0 J 1/8W		R158			RK73GB2A101J	CHIP R 100 J 1/10W	
R82			RK73GB2A102J	CHIP R 1.0K J 1/10W		R159			RK73GB2A000J	CHIP R 0.0 J 1/10W	
R83,84			RK73GB2A472J	CHIP R 4.7K J 1/10W		R160			RK73GB2A3R3J	CHIP R 3.3 J 1/10W	
R85			RK73GB2A333J	CHIP R 33K J 1/10W		R161			RK73GB2A000J	CHIP R 0.0 J 1/10W	
R86			RK73GB2A104J	CHIP R 100K J 1/10W		R163			RK73GB2A102J	CHIP R 1.0K J 1/10W	
R88			RK73GB2A103J	CHIP R 10K J 1/10W		R164			RK73GB2A104J	CHIP R 100K J 1/10W	
R89			RK73GB2A100J	CHIP R 10 J 1/10W		R165,166			RK73GB2A273J	CHIP R 27K J 1/10W	
R90			RK73GB2A330J	CHIP R 33 J 1/10W		R167			RK73GB2A000J	CHIP R 0.0 J 1/10W	
R91			RK73GB2A101J	CHIP R 100 J 1/10W		R169			RK73GB2A103J	CHIP R 10K J 1/10W	
R92			RK73GB2A104J	CHIP R 100K J 1/10W		R171			RK73GB2A103J	CHIP R 10K J 1/10W	
R93			RK73GB2A105J	CHIP R 1.0M J 1/10W		R172			RK73GB2A100J	CHIP R 10 J 1/10W	
R94			RK73GB2A682J	CHIP R 6.8K J 1/10W		R173			RN73GE1J271D	CHIP R 270 D 1/16	
R95			RK73GB2A152J	CHIP R 1.5K J 1/10W		R174,175			RK73GB2A153J	CHIP R 15K J 1/10W	
R96			RK73GB2A470J	CHIP R 47 J 1/10W		R176			RK73GB2A100J	CHIP R 10 J 1/10W	
R97			RK73GB2A100J	CHIP R 10 J 1/10W		R177			RK73GB2A470J	CHIP R 47 J 1/10W	
R98			RK73GB2A221J	CHIP R 220 J 1/10W		R178,179			RK73GB2A103J	CHIP R 10K J 1/10W	
R99			RK73GB2A331J	CHIP R 330 J 1/10W		R180			RK73GB2A100J	CHIP R 10 J 1/10W	
R100			RK73GB2A000J	CHIP R 0.0 J 1/10W		R181			RK73GB2A102J	CHIP R 1.0K J 1/10W	
R101			RK73FB2B100J	CHIP R 10 J 1/8W		R183			RK73GB2A102J	CHIP R 1.0K J 1/10W	
R102			RK73GB2A181J	CHIP R 180 J 1/10W		R184			RK73GB2A000J	CHIP R 0.0 J 1/10W	
R103			RK73GB2A682J	CHIP R 6.8K J 1/10W		R185			RK73GB2A100J	CHIP R 10 J 1/10W	
R104,105			RK73GB2A123J	CHIP R 12K J 1/10W		R186,187			RK73GB2A104J	CHIP R 100K J 1/10W	
R106			RK73GB2A105J	CHIP R 1.0M J 1/10W		R189,190			RK73FB2B101J	CHIP R 100 J 1/8W	
R107,108			RK73GB2A103J	CHIP R 10K J 1/10W		R191,192			RK73FB2B271J	CHIP R 270 J 1/8W	
R110			RK73GB2A332J	CHIP R 3.3K J 1/10W		R193			RK73GB2A102J	CHIP R 1.0K J 1/10W	
R112			RK73GB2A102J	CHIP R 1.0K J 1/10W		R194			RK73GB2A472J	CHIP R 4.7K J 1/10W	
R114			RK73GB2A102J	CHIP R 1.0K J 1/10W		R195			RK73GB2A181J	CHIP R 180 J 1/10W	
R115			RK73FB2B220J	CHIP R 22 J 1/8W		R196,197			RK73FB2B100J	CHIP R 10 J 1/8W	
R116			RK73GB2A101J	CHIP R 100 J 1/10W		R198,199			RK73GB2A102J	CHIP R 1.0K J 1/10W	
R117,118			RK73FB2B220J	CHIP R 22 J 1/8W		R200			RK73GB2A682J	CHIP R 6.8K J 1/10W	
R119,120			RK73GB2A103J	CHIP R 10K J 1/10W		R201			RK73GB2A330J	CHIP R 33 J 1/10W	
R122			RK73GB2A101J	CHIP R 100 J 1/10W		R202			RK73GB2A2R2J	CHIP R 2.2 J 1/10W	
R123			RK73GB2A153J	CHIP R 15K J 1/10W		R203			RK73GB2A104J	CHIP R 100K J 1/10W	
R124			RK73GB2A392J	CHIP R 3.9K J 1/10W		R204			RK73GB2A332J	CHIP R 3.3K J 1/10W	
R125			RK73GB2A102J	CHIP R 1.0K J 1/10W		R205			RK73GB2A682J	CHIP R 6.8K J 1/10W	
R128			RK73GB2A101J	CHIP R 100 J 1/10W		R206			RK73GB2A152J	CHIP R 1.5K J 1/10W	
R129			RK73GB2A102J	CHIP R 1.0K J 1/10W		R207			RK73GB2A470J	CHIP R 47 J 1/10W	
R130,131			RK73FB2B100J	CHIP R 10 J 1/8W		R209			RK73GB2A101J	CHIP R 100 J 1/10W	
R132			RK73GB2A102J	CHIP R 1.0K J 1/10W		R210			RK73GB2A100J	CHIP R 10 J 1/10W	
R133			RK73GB2A153J	CHIP R 15K J 1/10W		R211			RK73GB2A104J	CHIP R 100K J 1/10W	
R134			RK73GB2A104J	CHIP R 100K J 1/10W		R212			RK73GB2A100J	CHIP R 10 J 1/10W	
R135,136			RK73GB2A332J	CHIP R 3.3K J 1/10W		R213,214			RK73GB2A563J	CHIP R 56K J 1/10W	
R137			RK73GB2A101J	CHIP R 100 J 1/10W		R215			RK73GB2A181J	CHIP R 180 J 1/10W	
R138,139			RK73GB2A682J	CHIP R 6.8K J 1/10W		R217			RK73GB2A104J	CHIP R 100K J 1/10W	
R140,141			RK73GB2A181J	CHIP R 180 J 1/10W		R218,219			RK73GB2A180J	CHIP R 18 J 1/10W	
R142			RK73FB2B100J	CHIP R 10 J 1/8W		R220			RK73GB2A102J	CHIP R 1.0K J 1/10W	

PARTS LIST

RX UNIT (X55-3092-71)

Ref. No.	Address	New parts	Parts No.	Description	Destination	Ref. No.	Address	New parts	Parts No.	Description	Destination
R221,222			RK73GB2A471J	CHIP R 470 J 1/10W		R311			RK73GB2A474J	CHIP R 470K J 1/10W	
R223			RK73GB2A180J	CHIP R 18 J 1/10W		R317-319			RK73GB2A100J	CHIP R 10 J 1/10W	
R224			RK73GB2A100J	CHIP R 10 J 1/10W		R321			RK73GB2A104J	CHIP R 100K J 1/10W	
R225			RK73GB2A180J	CHIP R 18 J 1/10W		R323			RK73GB2A000J	CHIP R 0.0 J 1/10W	
R226			RK73GB2A101J	CHIP R 100 J 1/10W		R324,325			RK73GB2A104J	CHIP R 100K J 1/10W	
R229			RK73GB2A101J	CHIP R 100 J 1/10W		R326			RK73GB2A100J	CHIP R 10 J 1/10W	
R230			RK73GB2A100J	CHIP R 10 J 1/10W		R328			RK73GB2A000J	CHIP R 0.0 J 1/10W	
R231			RK73GB2A680J	CHIP R 68 J 1/10W		R330			RK73GB2A104J	CHIP R 100K J 1/10W	
R232			RK73GB2A100J	CHIP R 10 J 1/10W		R332			RK73GB2A101J	CHIP R 100 J 1/10W	
R233			RK73GB2A000J	CHIP R 0.0 J 1/10W		R333			RK73GB2A104J	CHIP R 100K J 1/10W	
R234			RK73GB2A101J	CHIP R 100 J 1/10W		R334			RK73GB2A101J	CHIP R 100 J 1/10W	
R236,237			RK73GB2A180J	CHIP R 18 J 1/10W		R335			RK73GB2A104J	CHIP R 100K J 1/10W	
R238			RK73GB2A181J	CHIP R 180 J 1/10W		R337			RK73GB2A102J	CHIP R 1.0K J 1/10W	
R239			RK73GB2A100J	CHIP R 10 J 1/10W		R338			RK73GB2A472J	CHIP R 4.7K J 1/10W	
R240			RK73GB2A471J	CHIP R 470 J 1/10W		R340-342			RK73GB2A102J	CHIP R 1.0K J 1/10W	
R241			RK73GB2A103J	CHIP R 10K J 1/10W		R343			RK73GB2A104J	CHIP R 100K J 1/10W	
R242,243			RK73GB2A470J	CHIP R 47 J 1/10W		R344			RK73GB2A473J	CHIP R 47K J 1/10W	
R244			RK73GB2A682J	CHIP R 6.8K J 1/10W		R345,346			RK73GB2A472J	CHIP R 4.7K J 1/10W	
R245			RK73GB2A473J	CHIP R 47K J 1/10W		R347,348			RK73GB2A101J	CHIP R 100 J 1/10W	
R248			RK73GB2A332J	CHIP R 3.3K J 1/10W		R349			RK73GB2A470J	CHIP R 47 J 1/10W	
R249,250			RK73GB2A272J	CHIP R 2.7K J 1/10W		R350,351			RK73GB2A221J	CHIP R 220 J 1/10W	
R254			RK73GB2A331J	CHIP R 330 J 1/10W		R352			RK73GB2A473J	CHIP R 47K J 1/10W	
R255			RK73GB2A391J	CHIP R 390 J 1/10W		R353			RK73GB2A470J	CHIP R 47 J 1/10W	
R256			RK73GB2A152J	CHIP R 1.5K J 1/10W		R357			RK73GB2A471J	CHIP R 470 J 1/10W	
R257			RK73GB2A331J	CHIP R 330 J 1/10W		R358			RK73GB2A100J	CHIP R 10 J 1/10W	
R258			RK73GB2A391J	CHIP R 390 J 1/10W		R359			RK73GB2A221J	CHIP R 220 J 1/10W	
R259,260			RK73GB2A272J	CHIP R 2.7K J 1/10W		R360			RK73GB2A682J	CHIP R 6.8K J 1/10W	
R261			RK73GB2A123J	CHIP R 12K J 1/10W		R361			RK73GB2A332J	CHIP R 3.3K J 1/10W	
R262			RK73GB2A472J	CHIP R 4.7K J 1/10W		R362			RK73GB2A101J	CHIP R 100 J 1/10W	
R263			RK73GB2A183J	CHIP R 18K J 1/10W		R363			RK73GB2A100J	CHIP R 10 J 1/10W	
R264			RK73GB2A152J	CHIP R 1.5K J 1/10W		R364			RK73GB2A470J	CHIP R 47 J 1/10W	
R265			RK73GB2A181J	CHIP R 180 J 1/10W		R366,367			RK73GB2A331J	CHIP R 330 J 1/10W	
R266			RK73GB2A332J	CHIP R 3.3K J 1/10W		R368-370			RK73GB2A272J	CHIP R 2.7K J 1/10W	
R267			RK73GB2A103J	CHIP R 10K J 1/10W		R371,372			RK73GB2A391J	CHIP R 390 J 1/10W	
R268			RK73GB2A154J	CHIP R 150K J 1/10W		R373			RK73GB2A272J	CHIP R 2.7K J 1/10W	
R269			RK73GB2A470J	CHIP R 47 J 1/10W		R375,376			RK73GB2A105J	CHIP R 1.0M J 1/10W	
R270,271			RK73GB2A103J	CHIP R 10K J 1/10W		R377			RK73GB2A000J	CHIP R 0.0 J 1/10W	
R272			RK73GB2A104J	CHIP R 100K J 1/10W		R379			RK73GB2A101J	CHIP R 100 J 1/10W	
R273			RK73GB2A152J	CHIP R 1.5K J 1/10W		R380			RK73GB2A104J	CHIP R 100K J 1/10W	
R274			RK73GB2A153J	CHIP R 15K J 1/10W		R381			RK73GB2A223J	CHIP R 22K J 1/10W	
R275			RK73GB2A223J	CHIP R 22K J 1/10W		R382-384			RK73GB2A104J	CHIP R 100K J 1/10W	
R276			RK73GB2A183J	CHIP R 18K J 1/10W		R385			RK73GB2A101J	CHIP R 100 J 1/10W	
R277			RK73GB2A103J	CHIP R 10K J 1/10W		R388			RK73GB2A000J	CHIP R 0.0 J 1/10W	
R278,279			RK73GB2A152J	CHIP R 1.5K J 1/10W		R390			RK73GB2A471J	CHIP R 470 J 1/10W	
R280,281			RK73GB2A103J	CHIP R 10K J 1/10W		R391,392			RK73GB2A000J	CHIP R 0.0 J 1/10W	
R284			RK73GB2A471J	CHIP R 470 J 1/10W		R395			RK73GB2A101J	CHIP R 100 J 1/10W	
R285			RK73GB2A334J	CHIP R 330K J 1/10W		R400,401			RK73GB2A000J	CHIP R 0.0 J 1/10W	
R286			RK73GB2A183J	CHIP R 18K J 1/10W		R403			RK73GB2A000J	CHIP R 0.0 J 1/10W	
R287			RK73GB2A273J	CHIP R 27K J 1/10W		R405			RK73GB2A153J	CHIP R 15K J 1/10W	
R288			RK73GB2A560J	CHIP R 56 J 1/10W		R406			RK73GB2A682J	CHIP R 6.8K J 1/10W	
R290			RK73GB2A332J	CHIP R 3.3K J 1/10W		R417			RK73GB2A000J	CHIP R 0.0 J 1/10W	
R291			RK73GB2A122J	CHIP R 1.2K J 1/10W		R432			RK73GB2A103J	CHIP R 10K J 1/10W	
R292			RK73GB2A000J	CHIP R 0.0 J 1/10W		R433,434			RN73GE1J151D	CHIP R 150 D 1/16	
R293			RK73GB2A183J	CHIP R 18K J 1/10W		R435			RK73GB2A473J	CHIP R 47K J 1/10W	
R294			RK73GB2A223J	CHIP R 22K J 1/10W		R436			RK73GB2A682J	CHIP R 6.8K J 1/10W	
R295			RK73GB2A104J	CHIP R 100K J 1/10W		R437			RK73GB2A000J	CHIP R 0.0 J 1/10W	
R296-298			RK73GB2A473J	CHIP R 47K J 1/10W		R452			RK73GB2A000J	CHIP R 0.0 J 1/10W	
R300			RK73GB2A000J	CHIP R 0.0 J 1/10W		R455			RK73GB2A104J	CHIP R 100K J 1/10W	
R306			RK73GB2A473J	CHIP R 47K J 1/10W		R459			RK73GB2A000J	CHIP R 0.0 J 1/10W	
R307-310			RK73GB2A000J	CHIP R 0.0 J 1/10W		R462			RK73GB2A000J	CHIP R 0.0 J 1/10W	

PARTS LIST

RX UNIT (X55-3092-71)
TX UNIT (X56-3112-71)

Ref. No.	Address	New parts	Parts No.	Description	Destination	Ref. No.	Address	New parts	Parts No.	Description	Destination
D1,2			HSC119	DIODE		Q34			2SA1832F	TRANSISTOR	
D3-8			1SV283F	VARIABLE CAPACITANCE DIODE		Q35,36			2SC4725	TRANSISTOR	
D9,10			JDP4P02U	DIODE		Q37			SSM3K15TE(F)	FET	
D11			KV1470-G	VARIABLE CAPACITANCE DIODE		Q38			2SC4725	TRANSISTOR	
D12			1SV283F	VARIABLE CAPACITANCE DIODE		Q39			2SC4617(R)	TRANSISTOR	
D13,14			JDP4P02U	DIODE		Q40			2SC4617(S)	TRANSISTOR	
D15,16			DAN235E	DIODE		Q50,51			SSM3K15TE(F)	FET	
D17,18			MA3J742	DIODE		Q52			2SJ484	FET	
D19,20			DAN235E	DIODE		Q53			2SC4725	TRANSISTOR	
D22,23			1SV283F	VARIABLE CAPACITANCE DIODE		Q56			SSM3K15TE(F)	FET	
IC4			TA75S01F-F	MOS-IC		Q57			DTA144EE	DIGITAL TRANSISTOR	
IC5			ADF4111BCP7	MOS-IC		Q58-61			SSM3K15TE(F)	FET	
IC6			LMC7101BIM5	MOS-IC		TH2,3			157-103-53007	THERMISTOR	
IC7			AD9835BRUZ	MOS-IC		A1			W02-1940-05	DBM	
IC8			NJU6368PF1	MOS-IC		TX UNIT (X56-3112-71)					
IC9			UPB1509GV	BI-POLAR IC		D202			B30-2230-05	LED (YG)	
IC10			TK11230CMCL-G	BI-POLAR IC		D301			B30-2230-05	LED (YG)	
IC11			ADF4111BCP7	MOS-IC		D920-924			B30-2265-05	LED (BR/PG)	
IC12			TA31137FNG	MOS-IC		D925-932			B30-2171-05	LED (D)	
IC13			AD607Z	BI-POLAR IC		C102			CK73GB1E105K	CHIP C	1.0UF K
IC14			AD8051ART	ANALOGUE IC		C103-105			CC73GCH1H471J	CHIP C	470PF J
IC15,16			NJM78L05UA-ZB	BI-POLAR IC		C106,107			CK73GB1H103K	CHIP C	0.010UF K
IC17-19		*	NJM78M05DL1AZB	ANALOGUE IC		C108			CC73GCH1H471J	CHIP C	470PF J
IC20			NJM4558E-ZB	ANALOGUE IC		C109			CK73GB1H104K	CHIP C	0.10UF K
IC22			XC6204B332M	MOS-IC		C110			CC73GCH1H471J	CHIP C	470PF J
IC23			BH2220FVM	ANALOGUE IC		C111,112			CK73GB1H104K	CHIP C	0.10UF K
IC24,25	2D		NJM7808FA-ZB	BI-POLAR IC		C113			CC73GCH1H471J	CHIP C	470PF J
IC26,27			NJM2386ADL3-09	ANALOGUE IC		C114			CK73GB1H104K	CHIP C	0.10UF K
IC28			AD1582	ANALOGUE IC		C115-117			CC73GCH1H471J	CHIP C	470PF J
IC29			NJM2732V	BI-POLAR IC		C120			CK73GB1H103K	CHIP C	0.010UF K
IC30			AD7908BRU	MOS-IC		C122			CC73GCH1H471J	CHIP C	470PF J
IC31			S24CS02AFJTBG	ROM IC		C123			CS77CA1ER47M	CHIP TNTL	0.47UF 25WV
IC32			NJM2732V	BI-POLAR IC		C126			CC73GCH1H471J	CHIP C	470PF J
IC33			LMC7101BIM5	MOS-IC		C133			CC73GCH1H120J	CHIP C	12PF J
IC35			LM50BIM3/NOPB	MOS-IC		C135			CC73GCH1H471J	CHIP C	470PF J
Q1			2SC5337	TRANSISTOR		C136			CC73GCH1H070B	CHIP C	7.0PF B
Q2			2SC4116(BLJF)	TRANSISTOR		C137			CK73GB1H103K	CHIP C	0.010UF K
Q3			2SC4617(R)	TRANSISTOR		C138,139			CC73GCH1H020B	CHIP C	2.0PF B
Q4			2SC4116(BLJF)	TRANSISTOR		C140,141			CC73GCH1H471J	CHIP C	470PF J
Q5			2SC4617(R)	TRANSISTOR		C142			CC73GCH1H080B	CHIP C	8.0PF B
Q6			2SC4116(BLJF)	TRANSISTOR		C143			CC73GCH1H090D	CHIP C	9.0PF D
Q7,8			2SK508NV(K53)	FET		C145			CC73GCH1H080B	CHIP C	8.0PF B
Q9-11			2SC4116(BLJF)	TRANSISTOR		C146			CC73GCH1H471J	CHIP C	470PF J
Q12			2SC4617(R)	TRANSISTOR		C147			CC73GCH1HR75B	CHIP C	0.75PF B
Q13			2SA1832F	TRANSISTOR		C148			CC73GCH1H150J	CHIP C	15PF J
Q14,15			SSM3K15TE(F)	FET		C149			CK73GB1H103K	CHIP C	0.010UF K
Q16,17			2SC3356-A(R24)	TRANSISTOR		C151			CE32CL1V100M	CHIP EL	10UF 35WV
Q18-20			RD01MUS1-T113	FET		C152			CC73GCH1H471J	CHIP C	470PF J
Q21			2SC4725	TRANSISTOR		C153			CC73GCH1H090D	CHIP C	9.0PF D
Q22			2SC4617(R)	TRANSISTOR		C154			CS77CC1C330M	CHIP TNTL	33UF 16WV
Q23			2SC3356-A(R24)	TRANSISTOR		C156,157			CC73GCH1H471J	CHIP C	470PF J
Q24			2SK508NV(K52)	FET		C158			CS77CC1C330M	CHIP TNTL	33UF 16WV
Q25			SSM3J01F	FET		C160			CC73GCH1H471J	CHIP C	470PF J
Q26			SSM3K15TE(F)	FET		C161			CE32BM1E470M	CHIP EL	47UF 25WV
Q27			2SC4116(BLJF)	TRANSISTOR		C162,163			CC73GCH1H471J	CHIP C	470PF J
Q28,29			3SK317-E	FET		C164			CC73GCH1H470J	CHIP C	47PF J
Q30			2SC4617(R)	TRANSISTOR							
Q31			SSM3K15TE(F)	FET							
Q32			SSM3J01F	FET							
Q33			2SC4725	TRANSISTOR							

If a part reference number is listed in a shaded box, that part does not come with the PCB.

PARTS LIST

TX UNIT (X56-3112-71)

Ref. No.	Address	New parts	Parts No.	Description	Destination	Ref. No.	Address	New parts	Parts No.	Description	Destination
C166			CC73GCH1H120J	CHIP C 12PF J		C263			CC73GCH1H390J	CHIP C 39PF J	
C167			CC73GCH1H100D	CHIP C 10PF D		C265			CC73GCH1H680J	CHIP C 68PF J	
C168			CC73GCH1H120J	CHIP C 12PF J		C267			CC73GCH1H390J	CHIP C 39PF J	
C169,170			CC73GCH1H471J	CHIP C 470PF J		C269-272			CK73GB1H104K	CHIP C 0.10UF K	
C171			CK73GB1H103K	CHIP C 0.010UF K		C275			CC73GCH1H471J	CHIP C 470PF J	
C172-174			CC73GCH1H471J	CHIP C 470PF J		C276			CC73GCH1H271J	CHIP C 270PF J	
C175			CC73GCH1H100D	CHIP C 10PF D		C277			CC73GCH1H471J	CHIP C 470PF J	
C176			CC73GCH1H471J	CHIP C 470PF J		C278			CC73GCH1H391J	CHIP C 390PF J	
C177-180			CK73GB1H104K	CHIP C 0.10UF K		C279			CC73GCH1H471J	CHIP C 470PF J	
C181			CC73GCH1H471J	CHIP C 470PF J		C280			CC73GCH1H271J	CHIP C 270PF J	
C182			CC73GCH1H180J	CHIP C 18PF J		C281			CC73GCH1H471J	CHIP C 470PF J	
C183			CC73GCH1H020B	CHIP C 2.0PF B		C282-285			CK73GB1H104K	CHIP C 0.10UF K	
C186			CC73GCH1H1R5B	CHIP C 1.5PF B		C286			CK73GB1H103K	CHIP C 0.010UF K	
C187			C93-0912-05	CHIP C 100UF M		C287			CK73GB1H104K	CHIP C 0.10UF K	
C188			CC73GCH1H471J	CHIP C 470PF J		C288			CS77CA1C2R2M	CHIP TNL 2.2UF 16WV	
C189			CC73GCH1H080B	CHIP C 8.0PF B		C290			CS77CB21A470M	CHIP TNL 47UF 10WV	
C190,191			CC73GCH1H020B	CHIP C 2.0PF B		C292			CS77BA1C4R7M	CHIP TNL 4.7UF 16WV	
C192			CC73GCH1H471J	CHIP C 470PF J		C301			CS77CA1C2R2M	CHIP TNL 2.2UF 16WV	
C193,194			CC73GCH1H100C	CHIP C 10PF C		C302			CC73GCH1H100D	CHIP C 10PF D	
C195			CC73GCH1HR75B	CHIP C 0.75PF B		C303			CK73GB1H103K	CHIP C 0.010UF K	
C196-198			CC73GCH1H471J	CHIP C 470PF J		C304			CC73GCH1H331J	CHIP C 330PF J	
C201			CC73GCH1H471J	CHIP C 470PF J		C305			CC73GCH1H180J	CHIP C 18PF J	
C209			CK73GB1H102K	CHIP C 1000PF K		C306			CK73FB0J106K	CHIP C 10UF K	
C210			CC73GCH1H180J	CHIP C 18PF J		C307			CK73GB1H104K	CHIP C 0.10UF K	
C211			CC73GCH1H100C	CHIP C 10PF C		C308			CC73GCH1H471J	CHIP C 470PF J	
C212,213			CK73GB1H102K	CHIP C 1000PF K		C309			CC73GCH1H331J	CHIP C 330PF J	
C214			CC73GCH1H330J	CHIP C 33PF J		C310			CK73FB0J106K	CHIP C 10UF K	
C215			CK73GB1H102K	CHIP C 1000PF K		C311			C93-0912-05	CHIP C 100UF M	
C216			CK73GB1H103K	CHIP C 0.010UF K		C312			CK73GB1H103K	CHIP C 0.010UF K	
C217			CC73GCH1H102J	CHIP C 1000PF J		C313			CC73GCH1H121J	CHIP C 120PF J	
C218			CC73GCH1H180J	CHIP C 18PF J		C314,315			CK73GB1H103K	CHIP C 0.010UF K	
C219			CK73GB1H102K	CHIP C 1000PF K		C316			CC73GCH1H100D	CHIP C 10PF D	
C220			CK73GB1H104K	CHIP C 0.10UF K		C317			CK73GB1H104K	CHIP C 0.10UF K	
C221			CK73GB1H102K	CHIP C 1000PF K		C318			CE32BM1E470M	CHIP EL 47UF 25WV	
C223			CK73GB1H102K	CHIP C 1000PF K		C319			CK73GB1H104K	CHIP C 0.10UF K	
C224			CK73GB1H473K	CHIP C 0.047UF K		C320			CK73GB1H103K	CHIP C 0.010UF K	
C225,226			CK73GB1H102K	CHIP C 1000PF K		C321			CC73GCH1H471J	CHIP C 470PF J	
C227			CK73GB1H103K	CHIP C 0.010UF K		C323-326			CK73GB1H103K	CHIP C 0.010UF K	
C228			CK73GB1H102K	CHIP C 1000PF K		C327			CC73GCH1H181J	CHIP C 180PF J	
C229			CC73GCH1H020C	CHIP C 2.0PF C		C328,329			C93-0912-05	CHIP C 100UF M	
C230			CC73GCH1H120J	CHIP C 12PF J		C330			CC73GCH1H470J	CHIP C 47PF J	
C231			CK73GB1H103K	CHIP C 0.010UF K		C331			CK73GB1H104K	CHIP C 0.10UF K	
C233			CC73GCH1H010C	CHIP C 1.0PF C		C332			CC73GCH1H331J	CHIP C 330PF J	
C234			CK73GB1H102K	CHIP C 1000PF K		C333			CS77CC1C100M	CHIP TNL 10UF 16WV	
C235			CK73GB1H103K	CHIP C 0.010UF K		C334			CK73GB1H103K	CHIP C 0.010UF K	
C237			CK73GB1H102K	CHIP C 1000PF K		C335			CK73GB1H102K	CHIP C 1000PF K	
C240			CC73GCH1H221J	CHIP C 220PF J		C336			CC73GCH1H180J	CHIP C 18PF J	
C241			CC73GCH1H820J	CHIP C 82PF J		C337			CK73GB1H103K	CHIP C 0.010UF K	
C242			CC73GCH1H330J	CHIP C 33PF J		C338			CS77CB21A470M	CHIP TNL 47UF 10WV	
C243,244			CC73GCH1H471J	CHIP C 470PF J		C339			CC73GCH1H221J	CHIP C 220PF J	
C245			CC73GCH1H470J	CHIP C 47PF J		C340			CK73GB1H103K	CHIP C 0.010UF K	
C246,247			CC73GCH1H471J	CHIP C 470PF J		C341			CK73GB1H104K	CHIP C 0.10UF K	
C248			CC73GCH1H151J	CHIP C 150PF J		C342			CS77CB21A470M	CHIP TNL 47UF 10WV	
C249			CE32CL1V100M	CHIP EL 10UF 35WV		C343,344			CK73GB1H103K	CHIP C 0.010UF K	
C250			CK73GB1H104K	CHIP C 0.10UF K		C345			CK73GB1H104K	CHIP C 0.10UF K	
C251,252			CK73GB1H103K	CHIP C 0.010UF K		C346,347			CK73GB1H103K	CHIP C 0.010UF K	
C253			CE32CL1V100M	CHIP EL 10UF 35WV		C348			CC73GCH1H221J	CHIP C 220PF J	
C254			CK73GB1H104K	CHIP C 0.10UF K		C349,350			CC73GCH1H100D	CHIP C 10PF D	
C255,256			CK73GB1H103K	CHIP C 0.010UF K		C351			CS77CC1C100M	CHIP TNL 10UF 16WV	
C257-260			CK73GB1H104K	CHIP C 0.10UF K		C352			CC73GCH1H180J	CHIP C 18PF J	

PARTS LIST

TX UNIT (X56-3112-71)

Ref. No.	Address	New parts	Parts No.	Description	Desti-nation	Ref. No.	Address	New parts	Parts No.	Description	Desti-nation
C353			CK73GB1H103K	CHIP C 0.010UF K		C454			CC73GCH1H470J	CHIP C 47PF J	
C354			CC73GCH1H331J	CHIP C 330PF J		C455			CK73GB1H103K	CHIP C 0.010UF K	
C355			CC73GCH1H470J	CHIP C 47PF J		C456			CC73GCH1H331J	CHIP C 330PF J	
C356			CK73GB1H103K	CHIP C 0.010UF K		C457			CC73GCH1H181J	CHIP C 180PF J	
C357			CC73GCH1H181J	CHIP C 180PF J		C458			CC73GCH1H470J	CHIP C 47PF J	
C358			CK73GB1H104K	CHIP C 0.10UF K		C459			CC73GCH1H180J	CHIP C 18PF J	
C359			CC73GCH1H100D	CHIP C 10PF D		C460			CC73GCH1H331J	CHIP C 330PF J	
C360			CK73GB1H103K	CHIP C 0.010UF K		C461			CC73GCH1H221J	CHIP C 220PF J	
C361			CK73GB1H104K	CHIP C 0.10UF K		C462			CC73GCH1H180J	CHIP C 18PF J	
C362			CC73GCH1H471J	CHIP C 470PF J		C463			CK73GB1H104K	CHIP C 0.10UF K	
C363,364			CK73GB1H103K	CHIP C 0.010UF K		C464,465			CK73GB1H103K	CHIP C 0.010UF K	
C365			CC73GCH1H471J	CHIP C 470PF J		C466			CC73GCH1H221J	CHIP C 220PF J	
C366			CC73GCH1H100D	CHIP C 10PF D		C467			CK73FB1C105K	CHIP C 1.0UF K	
C367			CK73GB1H103K	CHIP C 0.010UF K		C468,469			CK73GB1H103K	CHIP C 0.010UF K	
C369,370			CK73GB1H103K	CHIP C 0.010UF K		C470			CK73GB1H104K	CHIP C 0.10UF K	
C372			CC73GCH1H180J	CHIP C 18PF J		C471-482			CK73GB1H103K	CHIP C 0.010UF K	
C373			CC73GCH1H470J	CHIP C 47PF J		C483-486			CK73GB1H104K	CHIP C 0.10UF K	
C375			CK73GB1H103K	CHIP C 0.010UF K		C487			CK73GB1H103K	CHIP C 0.010UF K	
C376			CC73GCH1H471J	CHIP C 470PF J		C488-490			CK73GB1H104K	CHIP C 0.10UF K	
C378			CK73FB1C105K	CHIP C 1.0UF K		C491			CC73GCH1H470J	CHIP C 47PF J	
C379			CK73GB1H103K	CHIP C 0.010UF K		C492-495			CK73GB1H104K	CHIP C 0.10UF K	
C381			CK73GB1H103K	CHIP C 0.010UF K		C496			CC73GCH1H221J	CHIP C 220PF J	
C382			CC73GCH1H221J	CHIP C 220PF J		C497			CK73GB1H104K	CHIP C 0.10UF K	
C383			CC73GCH1H331J	CHIP C 330PF J		C498			CC73GCH1H121J	CHIP C 120PF J	
C384			CC73GCH1H181J	CHIP C 180PF J		C499			CK73GB1H104K	CHIP C 0.10UF K	
C386			CE32CL1V100M	CHIP EL 10UF 35WV		C500			CC73GCH1H471J	CHIP C 470PF J	
C387			CK73GB1H104K	CHIP C 0.10UF K		C501,502			CK73GB1H104K	CHIP C 0.10UF K	
C388			CC73GCH1H471J	CHIP C 470PF J		C503			CC73GCH1H470J	CHIP C 47PF J	
C389			CK73GB1H102K	CHIP C 1000PF K		C504			CC73GCH1H010C	CHIP C 1.0PF C	
C390			CK73GB1H222K	CHIP C 2200PF K		C505,506			CK73GB1H104K	CHIP C 0.10UF K	
C391			C93-0912-05	CHIP C 100UF M		C507,508			CC73GCH1H331J	CHIP C 330PF J	
C392,393			CC73GCH1H100D	CHIP C 10PF D		C509,510			CK73GB1H104K	CHIP C 0.10UF K	
C401			CK73GB1H103K	CHIP C 0.010UF K		C511			CC73GCH1H470J	CHIP C 47PF J	
C402,403			CK73GB1H104K	CHIP C 0.10UF K		C512			CC73GCH1H471J	CHIP C 470PF J	
C404			CK73GB1H103K	CHIP C 0.010UF K		C513			CC73GCH1H010C	CHIP C 1.0PF C	
C405			CC73GCH1H471J	CHIP C 470PF J		C514			CC73GCH1H121J	CHIP C 120PF J	
C406-412			CK73GB1H103K	CHIP C 0.010UF K		C515			CC73GCH1H030C	CHIP C 3.0PF C	
C413			CC73GCH1H471J	CHIP C 470PF J		C516,517			CK73GB1H104K	CHIP C 0.10UF K	
C414-416			CK73GB1H103K	CHIP C 0.010UF K		C519			CK73GB1H104K	CHIP C 0.10UF K	
C419			CK73FB0J106K	CHIP C 10UF K		C520			CC73GCH1H221J	CHIP C 220PF J	
C420			CK73GB1H103K	CHIP C 0.010UF K		C521-527			CK73GB1H104K	CHIP C 0.10UF K	
C422			CK73GB1H103K	CHIP C 0.010UF K		C529-532			CK73GB1H104K	CHIP C 0.10UF K	
C423			CE32BM1E470M	CHIP EL 47UF 25WV		C533			CC73GCH1H471J	CHIP C 470PF J	
C425			CC73GCH1H181J	CHIP C 180PF J		C534-537			CK73GB1H104K	CHIP C 0.10UF K	
C427			CC73GCH1H470J	CHIP C 47PF J		C538			CC73GCH1H471J	CHIP C 470PF J	
C429			CC73GCH1H331J	CHIP C 330PF J		C539			CK73GB1H104K	CHIP C 0.10UF K	
C430			CC73GCH1H180J	CHIP C 18PF J		C541,542			CC73GCH1H100D	CHIP C 10PF D	
C433			CC73GCH1H221J	CHIP C 220PF J		C543-547			CK73GB1H104K	CHIP C 0.10UF K	
C435			CK73GB1H104K	CHIP C 0.10UF K		C548			CC73GCH1H471J	CHIP C 470PF J	
C436			CS77BA1E010M	CHIP TNTL 0.1UF 50WV		C549-552			CK73GB1H104K	CHIP C 0.10UF K	
C437			CK73GB1H103K	CHIP C 0.010UF K		C554-556			CK73GB1H104K	CHIP C 0.10UF K	
C439-443			CK73GB1H103K	CHIP C 0.010UF K		C557			CC73GCH1H030C	CHIP C 3.0PF C	
C445			CS77CA1V0R1M	CHIP TNTL 0.1UF 35WV		C558,559			CK73GB1H104K	CHIP C 0.10UF K	
C446			CK73FB1E473K	CHIP C 0.047UF K		C562			CK73GB1H104K	CHIP C 0.10UF K	
C447			CK73FB0J106K	CHIP C 10UF K		C563			CC73GCH1H121J	CHIP C 120PF J	
C448			CK73GB1H104K	CHIP C 0.10UF K		C564			CC73GCH1H470J	CHIP C 47PF J	
C449			CK73GB1H103K	CHIP C 0.010UF K		C565			CK73GB1H104K	CHIP C 0.10UF K	
C451			CK73GB1H104K	CHIP C 0.10UF K		C568			CC73GCH1H221J	CHIP C 220PF J	
C452			CK73FB0J106K	CHIP C 10UF K		C569			CC73GCH1H471J	CHIP C 470PF J	
C453			CC73GCH1H181J	CHIP C 180PF J		C570			CC73GCH1H010C	CHIP C 1.0PF C	

PARTS LIST

TX UNIT (X56-3112-71)

Ref. No.	Address	New parts	Parts No.	Description	Destination	Ref. No.	Address	New parts	Parts No.	Description	Destination
C571			CC73GCH1H331J	CHIP C 330PF J		C820,821			CK73GB1H104K	CHIP C 0.10UF K	
C573,574			CC73GCH1H331J	CHIP C 330PF J		C822			CK73GB1H103K	CHIP C 0.010UF K	
C575,576			CC73GCH1H180J	CHIP C 18PF J		C823,824			CC73GCH1H471J	CHIP C 470PF J	
C577,578			CC73GCH1H331J	CHIP C 330PF J		C825			CK73GB1H103K	CHIP C 0.010UF K	
C601-605			CK73GB1H104K	CHIP C 0.10UF K		C826			CC73GCH1H471J	CHIP C 470PF J	
C610			CK73GB1H104K	CHIP C 0.10UF K		C827			CK73GB1H103K	CHIP C 0.010UF K	
C612,613			CK73GB1H104K	CHIP C 0.10UF K		C848			C92-0904-05	OS-CON 22UF 35WV	
C614			CC73GCH1H100D	CHIP C 10PF D		C850			CK73GB1H103K	CHIP C 0.010UF K	
C616			CC73GCH1H270J	CHIP C 27PF J		C856			CE32AU1E100M	CHIP EL 10UF 25WV	
C619			CC73GCH1H100D	CHIP C 10PF D		C857			CK73GB1H103K	CHIP C 0.010UF K	
C620-623			CK73GB1H104K	CHIP C 0.10UF K		C858,859			CC73GCH1H471J	CHIP C 470PF J	
C624-627			CC73GCH1H560J	CHIP C 56PF J		C860			CK73GB1H103K	CHIP C 0.010UF K	
C628-631			CK73GB1H104K	CHIP C 0.10UF K		C871-873			CK73GB1H102K	CHIP C 1000PF K	
C632-634			CK73GB1H103K	CHIP C 0.010UF K		C874			CK73GB1H103K	CHIP C 0.010UF K	
C635,636			CK73GB1H104K	CHIP C 0.10UF K		C875			CK73GB1H104K	CHIP C 0.10UF K	
C637			CK73GB1H103K	CHIP C 0.010UF K		C876-878			CC73GCH1H471J	CHIP C 470PF J	
C638			CC73GCH1H470J	CHIP C 47PF J		C879			CE32CL1V100M	CHIP EL 10UF 35WV	
C639			CC73GCH1H180J	CHIP C 18PF J		C882			CC73GCH1H180J	CHIP C 18PF J	
C640			CC73GCH1H181J	CHIP C 180PF J		C883			CC73GCH1H330J	CHIP C 33PF J	
C641			CC73GCH1H331J	CHIP C 330PF J		C884			CC73GCH1H180J	CHIP C 18PF J	
C642			CC73GCH1H221J	CHIP C 220PF J		C885			CK73GB1H104K	CHIP C 0.10UF K	
C643			CC73GCH1H471J	CHIP C 470PF J		C886			CC73GCH1H270J	CHIP C 27PF J	
C645			CC73GCH1H471J	CHIP C 470PF J		C887			CC73GCH1H100D	CHIP C 10PF D	
C656,657			CK73GB1H103K	CHIP C 0.010UF K		C888			CC73GCH1H270J	CHIP C 27PF J	
C658			CK73GB1H104K	CHIP C 0.10UF K		C889			CK73GB1H104K	CHIP C 0.10UF K	
C659,660			CK73GB1H103K	CHIP C 0.010UF K		C894,895			CK73GB1H103K	CHIP C 0.010UF K	
C661			CK73FB0J106K	CHIP C 10UF K		C896			CC73GCH1H100D	CHIP C 10PF D	
C662,663			CK73GB1H104K	CHIP C 0.10UF K		C920-925			CK73GB1H104K	CHIP C 0.10UF K	
C703			CK73GB1H104K	CHIP C 0.10UF K		C926			CK73GB1H102K	CHIP C 1000PF K	
C704			CK73FB0J106K	CHIP C 10UF K		C928,929			CK73GB1H104K	CHIP C 0.10UF K	
C707			CK73GB1H102K	CHIP C 1000PF K		C930,931			CK73GB1E105K	CHIP C 1.0UF K	
C708			CK73GB1H104K	CHIP C 0.10UF K		C932			CC73GCH1H470J	CHIP C 47PF J	
C709			CE32CL1V100M	CHIP EL 10UF 35WV		C933,934		*	CS77CA1A1R5M	CHIP TNTL 1.5UF 10WV	
C710			CK73GB1H104K	CHIP C 0.10UF K		C935,936			CK73GB1H104K	CHIP C 0.10UF K	
C711			CK73GB1H103K	CHIP C 0.010UF K		C937			CK73GB1H103K	CHIP C 0.010UF K	
C712,713			CC73GCH1H471J	CHIP C 470PF J		C938			CK73FB0J106K	CHIP C 10UF K	
C714			CK73GB1H103K	CHIP C 0.010UF K		C939			CK73GB1H102K	CHIP C 1000PF K	
C715			CE32CL1V100M	CHIP EL 10UF 35WV		C941			CK73GB1H102K	CHIP C 1000PF K	
C716			CK73GB1H103K	CHIP C 0.010UF K		C943			CK73GB1H104K	CHIP C 0.10UF K	
C717,718			CC73GCH1H471J	CHIP C 470PF J		C960-965			CK73GB1H104K	CHIP C 0.10UF K	
C719			CK73GB1H103K	CHIP C 0.010UF K		CN102-121			E23-1280-05	TERMINAL	
C720,721			CE32CL1V100M	CHIP EL 10UF 35WV		CN403			E04-0193-05	PIN SOCKET	
C722			CK73GB1H103K	CHIP C 0.010UF K		CN405,406			E04-0193-05	PIN SOCKET	
C723,724			CC73GCH1H471J	CHIP C 470PF J		CN407			E04-0154-05	PIN SOCKET	
C725			CK73GB1H103K	CHIP C 0.010UF K		CN408			E04-0193-05	PIN SOCKET	
C801-803			CK73GB1H104K	CHIP C 0.10UF K		CN801			E41-2672-05	PIN ASSY	
C804			CC73GCH1H471J	CHIP C 470PF J		CN802			E04-0193-05	PIN SOCKET	
C805			CK73GB1H104K	CHIP C 0.10UF K		CN803			E40-6822-05	FLAT CABLE CONNECTOR	
C806			CE32CL1V100M	CHIP EL 10UF 35WV		CN804-806			E40-6656-05	PIN ASSY	
C807			CK73FB1C105K	CHIP C 1.0UF K		CN807			E41-2671-05	PIN ASSY	
C808,809			CK73GB1H104K	CHIP C 0.10UF K		CN920			E41-1493-05	PIN ASSY	
C810			CC73GCH1H471J	CHIP C 470PF J		CN921			E40-6656-05	PIN ASSY	
C811			CK73GB1H104K	CHIP C 0.10UF K		CN923			E41-1483-05	PIN ASSY	
C812			CK73GB1H103K	CHIP C 0.010UF K		CN960			E41-1493-05	PIN ASSY	
C813			CC73GCH1H471J	CHIP C 470PF J		E100			F10-3081-04	SHIELDING CASE	
C814			CK73GB1H104K	CHIP C 0.10UF K		CF201			L72-1029-05	CERAMIC FILTER	
C816			CE32CL1V100M	CHIP EL 10UF 35WV		CF601			L72-1019-05	CERAMIC FILTER	
C817			CK73GB1H103K	CHIP C 0.010UF K		L105,106			L41-1595-33	SMALL FIXED INDUCTOR (1.5UH)	
C818			CE32CL1V100M	CHIP EL 10UF 35WV		L108			L34-4871-05	AIR-CORE COIL	
C819			CK73GB1H102K	CHIP C 1000PF K							

PARTS LIST

TX UNIT (X56-3112-71)

Ref. No.	Address	New parts	Parts No.	Description	Destination	Ref. No.	Address	New parts	Parts No.	Description	Destination
L109-111			L41-1595-33	SMALL FIXED INDUCTOR (1.5UH)		L606,607			L41-1205-33	SMALL FIXED INDUCTOR (12UH)	
L112,113			L41-2775-33	SMALL FIXED INDUCTOR (0.027UH)		L608			L41-1005-33	SMALL FIXED INDUCTOR (10UH)	
L116-118			L41-2775-33	SMALL FIXED INDUCTOR (0.027UH)		L609			L92-0140-05	CHIP FERRITE	
L119			L41-1575-33	SMALL FIXED INDUCTOR (0.015UH)		L610			L41-1005-33	SMALL FIXED INDUCTOR (10UH)	
L120			L41-2275-33	SMALL FIXED INDUCTOR (0.022UH)		L611			L92-0140-05	CHIP FERRITE	
L121-124			L41-1005-33	SMALL FIXED INDUCTOR (10UH)		L612			L41-3385-33	SMALL FIXED INDUCTOR (0.33UH)	
L125,126			L41-1595-33	SMALL FIXED INDUCTOR (1.5UH)		L613			L41-3985-33	SMALL FIXED INDUCTOR (0.39UH)	
L128			L34-4871-05	AIR-CORE COIL		L614			L41-1005-33	SMALL FIXED INDUCTOR (10UH)	
L129-131			L41-1595-33	SMALL FIXED INDUCTOR (1.5UH)		L801			L41-1095-33	SMALL FIXED INDUCTOR (1.0UH)	
L203			L41-3375-33	SMALL FIXED INDUCTOR (0.033UH)		L810,811			L41-5675-33	SMALL FIXED INDUCTOR (0.056UH)	
L204,205			L41-5675-33	SMALL FIXED INDUCTOR (0.056UH)		L812			L41-1005-33	SMALL FIXED INDUCTOR (10UH)	
L207			L41-1085-33	SMALL FIXED INDUCTOR (0.1UH)		X301			L77-1981-05	VCXO (19.2MHZ)	
L208			L41-6875-33	SMALL FIXED INDUCTOR (0.068UH)		X401			L77-1981-05	VCXO (19.2MHZ)	
L210			L41-1595-33	SMALL FIXED INDUCTOR (1.5UH)		X601			L77-3034-05	TCXO (19.2M/4P/12)	
L211			L41-1895-33	SMALL FIXED INDUCTOR (1.8UH)		CP920			RK74GB1J102J	CHIP-COM 1.0K J 1/16W	
L212,213			L41-1005-33	SMALL FIXED INDUCTOR (10UH)		CP923			RK74GB1J102J	CHIP-COM 1.0K J 1/16W	
L214,215			L41-4705-33	SMALL FIXED INDUCTOR (47UH)		CP924			RK75GB1JR00	CHIP-COM 0.00 1/16W	
L216,217			L41-2295-33	SMALL FIXED INDUCTOR (2.2UH)		CP926			RK74GB1J681J	CHIP-COM 680 J 1/16W	
L218			L41-6885-33	SMALL FIXED INDUCTOR (0.68UH)		CP928			RK74GB1J681J	CHIP-COM 680 J 1/16W	
L219			L41-6895-33	SMALL FIXED INDUCTOR (6.8UH)		CP961,962			RK74GB1J102J	CHIP-COM 1.0K J 1/16W	
L301			L41-3985-33	SMALL FIXED INDUCTOR (0.39UH)		CP965,966			RK74GB1J102J	CHIP-COM 1.0K J 1/16W	
L302			L41-1005-33	SMALL FIXED INDUCTOR (10UH)		CP970,971			RK74GB1J102J	CHIP-COM 1.0K J 1/16W	
L303			L41-1095-33	SMALL FIXED INDUCTOR (1.0UH)		CP973,974			RK74GB1J102J	CHIP-COM 1.0K J 1/16W	
L304			L41-1005-33	SMALL FIXED INDUCTOR (10UH)		R101			RK73GB2A000J	CHIP R 0.0 J 1/10W	
L305			L41-3385-33	SMALL FIXED INDUCTOR (0.33UH)		R118			RK73GB2A000J	CHIP R 0.0 J 1/10W	
L306			L41-1095-33	SMALL FIXED INDUCTOR (1.0UH)		R120			RK73GB2A100J	CHIP R 10 J 1/10W	
L307,308			L41-3985-33	SMALL FIXED INDUCTOR (0.39UH)		R123			RK73GB2A000J	CHIP R 0.0 J 1/10W	
L309			L41-1095-33	SMALL FIXED INDUCTOR (1.0UH)		R124,125			RK73GB2A105J	CHIP R 1.0M J 1/10W	
L310			L41-3385-33	SMALL FIXED INDUCTOR (0.33UH)		R129			RK73GB2A101J	CHIP R 100 J 1/10W	
L311			L41-3985-33	SMALL FIXED INDUCTOR (0.39UH)		R131			RN73GE1J101D	CHIP R 100 D 1/16W	
L312			L41-3385-33	SMALL FIXED INDUCTOR (0.33UH)		R132			RN73GE1J271D	CHIP R 270 D 1/16W	
L313			L41-1095-33	SMALL FIXED INDUCTOR (1.0UH)		R133			RK73GB2A470J	CHIP R 47 J 1/10W	
L314			L41-1005-33	SMALL FIXED INDUCTOR (10UH)		R134			RK73GB2A220J	CHIP R 22 J 1/10W	
L401-403			L41-1095-33	SMALL FIXED INDUCTOR (1.0UH)		R135			RK73GB2A472J	CHIP R 4.7K J 1/10W	
L404			L41-1005-33	SMALL FIXED INDUCTOR (10UH)		R137			RK73GB2A102J	CHIP R 1.0K J 1/10W	
L405			L41-3385-33	SMALL FIXED INDUCTOR (0.33UH)		R138			RK73GB2A103J	CHIP R 10K J 1/10W	
L406			L41-1005-33	SMALL FIXED INDUCTOR (10UH)		R139			RK73GB2A102J	CHIP R 1.0K J 1/10W	
L407			L41-3985-33	SMALL FIXED INDUCTOR (0.39UH)		R141			RK73GB2A101J	CHIP R 100 J 1/10W	
L408			L41-1095-33	SMALL FIXED INDUCTOR (1.0UH)		R142			RK73GB2A221J	CHIP R 220 J 1/10W	
L409,410			L41-3385-33	SMALL FIXED INDUCTOR (0.33UH)		R144,145			RK73GB2A000J	CHIP R 0.0 J 1/10W	
L411			L41-3985-33	SMALL FIXED INDUCTOR (0.39UH)		R146			RK73GB2A121J	CHIP R 120 J 1/10W	
L412			L41-1095-33	SMALL FIXED INDUCTOR (1.0UH)		R147			RK73GB2A470J	CHIP R 47 J 1/10W	
L413			L41-3985-33	SMALL FIXED INDUCTOR (0.39UH)		R148			RK73GB2A121J	CHIP R 120 J 1/10W	
L414,415			L41-1095-33	SMALL FIXED INDUCTOR (1.0UH)		R149			RK73GB2A221J	CHIP R 220 J 1/10W	
L416,417			L41-1005-33	SMALL FIXED INDUCTOR (10UH)		R150			RK73GB2A820J	CHIP R 82 J 1/10W	
L418			L41-5685-33	SMALL FIXED INDUCTOR (0.56UH)		R151			RK73GB2A101J	CHIP R 100 J 1/10W	
L419,420			L41-6885-33	SMALL FIXED INDUCTOR (0.68UH)		R152			RK73GB2A000J	CHIP R 0.0 J 1/10W	
L421			L41-5685-33	SMALL FIXED INDUCTOR (0.56UH)		R153			RK73GB2A271J	CHIP R 270 J 1/10W	
L422			L39-1517-05	TOROIDAL COIL		R154			RK73GB2A180J	CHIP R 18 J 1/10W	
L423			L41-3305-33	SMALL FIXED INDUCTOR (33UH)		R155			RK73GB2A682J	CHIP R 6.8K J 1/10W	
L424			L39-1517-05	TOROIDAL COIL		R156			RK73GB2A332J	CHIP R 3.3K J 1/10W	
L425			L41-3305-33	SMALL FIXED INDUCTOR (33UH)		R157			RK73GB2A271J	CHIP R 270 J 1/10W	
L426,427			L39-1517-05	TOROIDAL COIL		R158			RK73GB2A103J	CHIP R 10K J 1/10W	
L430			L41-5685-33	SMALL FIXED INDUCTOR (0.56UH)		R159-161			RK73GB2A104J	CHIP R 100K J 1/10W	
L431			L41-6885-33	SMALL FIXED INDUCTOR (0.68UH)		R164			RK73GB2A104J	CHIP R 100K J 1/10W	
L433,434			L41-3985-33	SMALL FIXED INDUCTOR (0.39UH)		R165-168			RK73GB2A102J	CHIP R 1.0K J 1/10W	
L435			L41-2205-33	SMALL FIXED INDUCTOR (22UH)		R170			RK73GB2A000J	CHIP R 0.0 J 1/10W	
L601,602			L41-3305-33	SMALL FIXED INDUCTOR (33UH)		R171,172			RK73GB2A470J	CHIP R 47 J 1/10W	
L603,604			L41-4705-33	SMALL FIXED INDUCTOR (47UH)		R173,174			RK73GB2A102J	CHIP R 1.0K J 1/10W	
L605			L41-2205-33	SMALL FIXED INDUCTOR (22UH)							

PARTS LIST

TX UNIT (X56-3112-71)

Ref. No.	Address	New parts	Parts No.	Description	Destination	Ref. No.	Address	New parts	Parts No.	Description	Destination
R176			RK73GB2A000J	CHIP R 0.0 J 1/10W		R270,271			RK73GB2A472J	CHIP R 4.7K J 1/10W	
R178			RK73GB2A000J	CHIP R 0.0 J 1/10W		R272			RK73GB2A100J	CHIP R 10 J 1/10W	
R179			RK73GB2A224J	CHIP R 220K J 1/10W		R274			RK73GB2A331J	CHIP R 330 J 1/10W	
R180			RK73GB2A101J	CHIP R 100 J 1/10W		R276			RK73GB2A000J	CHIP R 0.0 J 1/10W	
R181			RK73GB2A104J	CHIP R 100K J 1/10W		R301,302			RK73GB2A473J	CHIP R 47K J 1/10W	
R182			RN73GE1J101D	CHIP R 100 D 1/16W		R303			RK73GB2A000J	CHIP R 0.0 J 1/10W	
R183			RN73GE1J271D	CHIP R 270 D 1/16W		R304			RK73GB2A471J	CHIP R 470 J 1/10W	
R184			RK73GB2A470J	CHIP R 47 J 1/10W		R305			RK73GB2A104J	CHIP R 100K J 1/10W	
R185,186			RK73GB2A103J	CHIP R 10K J 1/10W		R306-309			RK73GB2A102J	CHIP R 1.0K J 1/10W	
R187,188			RK73GB2A000J	CHIP R 0.0 J 1/10W		R310,311			RK73GB2A104J	CHIP R 100K J 1/10W	
R189-191			RK73GB2A103J	CHIP R 10K J 1/10W		R312			RK73GB2A154J	CHIP R 150K J 1/10W	
R202			RK73GB2A000J	CHIP R 0.0 J 1/10W		R313			RK73GB2A2R2J	CHIP R 2.2 J 1/10W	
R209			RK73GB2A101J	CHIP R 100 J 1/10W		R314			RK73GB2A000J	CHIP R 0.0 J 1/10W	
R210			RK73GB2A680J	CHIP R 68 J 1/10W		R316			RK73GB2A683J	CHIP R 68K J 1/10W	
R211			RK73GB2A101J	CHIP R 100 J 1/10W		R317			RK73GB2A104J	CHIP R 100K J 1/10W	
R212			RK73GB2A562J	CHIP R 5.6K J 1/10W		R318			RK73GB2A472J	CHIP R 4.7K J 1/10W	
R213			RK73GB2A222J	CHIP R 2.2K J 1/10W		R319			RK73GB2A104J	CHIP R 100K J 1/10W	
R214			RK73GB2A221J	CHIP R 220 J 1/10W		R320			RK73GB2A470J	CHIP R 47 J 1/10W	
R215			RK73GB2A000J	CHIP R 0.0 J 1/10W		R321-323			RK73GB2A100J	CHIP R 10 J 1/10W	
R216			RK73GB2A470J	CHIP R 47 J 1/10W		R324			RK73GB2A682J	CHIP R 6.8K J 1/10W	
R217			RK73GB2A271J	CHIP R 270 J 1/10W		R325			RK73GB2A332J	CHIP R 3.3K J 1/10W	
R218			RK73GB2A180J	CHIP R 18 J 1/10W		R326			RK73GB2A100J	CHIP R 10 J 1/10W	
R219			RK73GB2A271J	CHIP R 270 J 1/10W		R327,328			RK73GB2A000J	CHIP R 0.0 J 1/10W	
R220			RK73GB2A560J	CHIP R 56 J 1/10W		R329,330			RK73GB2A104J	CHIP R 100K J 1/10W	
R221			RK73GB2A103J	CHIP R 10K J 1/10W		R331,332			RK73GB2A471J	CHIP R 470 J 1/10W	
R222			RK73GB2A000J	CHIP R 0.0 J 1/10W		R333			RK73GB2A000J	CHIP R 0.0 J 1/10W	
R223			RK73GB2A123J	CHIP R 12K J 1/10W		R334			RK73GB2A473J	CHIP R 47K J 1/10W	
R224			RK73GB2A102J	CHIP R 1.0K J 1/10W		R335			RK73GB2A223J	CHIP R 22K J 1/10W	
R225			RK73GB2A474J	CHIP R 470K J 1/10W		R336			RK73GB2A334J	CHIP R 330K J 1/10W	
R226,227			RK73GB2A000J	CHIP R 0.0 J 1/10W		R337			RK73GB2A273J	CHIP R 27K J 1/10W	
R229			RK73GB2A563J	CHIP R 56K J 1/10W		R338			RK73GB2A105J	CHIP R 1.0M J 1/10W	
R230			RK73FB2B4R7J	CHIP R 4.7 J 1/8W		R339			RK73GB2A104J	CHIP R 100K J 1/10W	
R231,232			RK73GB2A000J	CHIP R 0.0 J 1/10W		R340			RK73GB2A101J	CHIP R 100 J 1/10W	
R233			RK73GB2A104J	CHIP R 100K J 1/10W		R341			RK73GB2A221J	CHIP R 220 J 1/10W	
R234,235			RK73GB2A474J	CHIP R 470K J 1/10W		R342			RK73GB2A470J	CHIP R 47 J 1/10W	
R236			RK73GB2A821J	CHIP R 820 J 1/10W		R343			RK73GB2A000J	CHIP R 0.0 J 1/10W	
R241			RK73GB2A000J	CHIP R 0.0 J 1/10W		R344-351			RK73GB2A104J	CHIP R 100K J 1/10W	
R242			RK73GB2A474J	CHIP R 470K J 1/10W		R352			RK73GB2A123J	CHIP R 12K J 1/10W	
R243			RK73GB2A392J	CHIP R 3.9K J 1/10W		R353			RK73GB2A332J	CHIP R 3.3K J 1/10W	
R244-246			RK73GB2A102J	CHIP R 1.0K J 1/10W		R355			RK73GB2A221J	CHIP R 220 J 1/10W	
R247-249			RK73GB2A104J	CHIP R 100K J 1/10W		R356			RK73GB2A100J	CHIP R 10 J 1/10W	
R250			RK73GB2A473J	CHIP R 47K J 1/10W		R357			RK73GB2A101J	CHIP R 100 J 1/10W	
R251			RK73GB2A100J	CHIP R 10 J 1/10W		R358			RK73GB2A105J	CHIP R 1.0M J 1/10W	
R252			RK73GB2A104J	CHIP R 100K J 1/10W		R360			RK73GB2A104J	CHIP R 100K J 1/10W	
R253			RK73GB2A331J	CHIP R 330 J 1/10W		R362			RK73GB2A100J	CHIP R 10 J 1/10W	
R254			RK73GB2A100J	CHIP R 10 J 1/10W		R363			RK73GB2A471J	CHIP R 470 J 1/10W	
R255			RK73GB2A274J	CHIP R 270K J 1/10W		R364			RK73GB2A104J	CHIP R 100K J 1/10W	
R256			RK73GB2A102J	CHIP R 1.0K J 1/10W		R367			RK73GB2A104J	CHIP R 100K J 1/10W	
R257,258			RK73GB2A000J	CHIP R 0.0 J 1/10W		R368			RK73GB2A822J	CHIP R 8.2K J 1/10W	
R259			RK73GB2A562J	CHIP R 5.6K J 1/10W		R369			RK73GB2A000J	CHIP R 0.0 J 1/10W	
R260			RK73GB2A331J	CHIP R 330 J 1/10W		R370			RK73GB2A182J	CHIP R 1.8K J 1/10W	
R261			RK73GB2A562J	CHIP R 5.6K J 1/10W		R371			RK73GB2A2R2J	CHIP R 2.2 J 1/10W	
R262			RK73GB2A102J	CHIP R 1.0K J 1/10W		R374			RK73GB2A000J	CHIP R 0.0 J 1/10W	
R263			RK73GB2A563J	CHIP R 56K J 1/10W		R375,376			RK73GB2A563J	CHIP R 56K J 1/10W	
R264			RK73GB2A100J	CHIP R 10 J 1/10W		R377,378			RK73GB2A104J	CHIP R 100K J 1/10W	
R265			RK73GB2A471J	CHIP R 470 J 1/10W		R379			RK73GB2A000J	CHIP R 0.0 J 1/10W	
R266			RK73GB2A000J	CHIP R 0.0 J 1/10W		R380			RK73GB2A470J	CHIP R 47 J 1/10W	
R267			RK73GB2A271J	CHIP R 270 J 1/10W		R381			RK73GB2A104J	CHIP R 100K J 1/10W	
R268			RK73GB2A180J	CHIP R 18 J 1/10W		R401			RK73GB2A000J	CHIP R 0.0 J 1/10W	
R269			RK73GB2A271J	CHIP R 270 J 1/10W		R402			RK73GB2A474J	CHIP R 470K J 1/10W	

PARTS LIST

TX UNIT (X56-3112-71)

Ref. No.	Address	New parts	Parts No.	Description	Destination	Ref. No.	Address	New parts	Parts No.	Description	Destination
R403,404			RK73GB2A102J	CHIP R 1.0K J 1/10W		R500			RK73GB2A332J	CHIP R 3.3K J 1/10W	
R406-408			RK73GB2A100J	CHIP R 10 J 1/10W		R501			RK73GB2A221J	CHIP R 220 J 1/10W	
R409			RK73GB2A000J	CHIP R 0.0 J 1/10W		R502			RK73GB2A000J	CHIP R 0.0 J 1/10W	
R410			RK73GB2A331J	CHIP R 330 J 1/10W		R503			RK73GB2A100J	CHIP R 10 J 1/10W	
R411			RK73GB2A000J	CHIP R 0.0 J 1/10W		R504			RK73GB2A104J	CHIP R 100K J 1/10W	
R412			RK73GB2A331J	CHIP R 330 J 1/10W		R505			RK73GB2A000J	CHIP R 0.0 J 1/10W	
R413			RK73GB2A123J	CHIP R 12K J 1/10W		R506			RK73GB2A101J	CHIP R 100 J 1/10W	
R414			RK73GB2A562J	CHIP R 5.6K J 1/10W		R507			RK73GB2A100J	CHIP R 10 J 1/10W	
R415			RK73GB2A123J	CHIP R 12K J 1/10W		R508-510			RK73GB2A000J	CHIP R 0.0 J 1/10W	
R416			RK73GB2A562J	CHIP R 5.6K J 1/10W		R511			RK73GB2A102J	CHIP R 1.0K J 1/10W	
R417,418			RK73GB2A000J	CHIP R 0.0 J 1/10W		R512			RK73GB2A181J	CHIP R 180 J 1/10W	
R422-424			RK73GB2A474J	CHIP R 470K J 1/10W		R513			RK73GB2A471J	CHIP R 470 J 1/10W	
R425			RK73GB2A104J	CHIP R 100K J 1/10W		R514			RK73GB2A100J	CHIP R 10 J 1/10W	
R427			RK73GB2A100J	CHIP R 10 J 1/10W		R515			RK73GB2A470J	CHIP R 47 J 1/10W	
R430,431			RK73GB2A100J	CHIP R 10 J 1/10W		R518			RK73GB2A104J	CHIP R 100K J 1/10W	
R433			RK73GB2A102J	CHIP R 1.0K J 1/10W		R519			RK73GB2A124J	CHIP R 120K J 1/10W	
R434			RK73GB2A000J	CHIP R 0.0 J 1/10W		R521			RK73GB2A223J	CHIP R 22K J 1/10W	
R435			RK73GB2A104J	CHIP R 100K J 1/10W		R522			RK73GB2A822J	CHIP R 8.2K J 1/10W	
R436,437			RK73GB2A102J	CHIP R 1.0K J 1/10W		R523,524			RK73GB2A221J	CHIP R 220 J 1/10W	
R438			RK73GB2A104J	CHIP R 100K J 1/10W		R525			RK73GB2A471J	CHIP R 470 J 1/10W	
R439			RK73GB2A2R2J	CHIP R 2.2 J 1/10W		R526			RK73GB2A473J	CHIP R 47K J 1/10W	
R440			RK73GB2A103J	CHIP R 10K J 1/10W		R527			RK73GB2A271J	CHIP R 270 J 1/10W	
R442			RK73GB2A470J	CHIP R 47 J 1/10W		R528			RK73GB2A152J	CHIP R 1.5K J 1/10W	
R447			RK73GB2A000J	CHIP R 0.0 J 1/10W		R529			RK73GB2A153J	CHIP R 15K J 1/10W	
R452,453			RK73GB2A000J	CHIP R 0.0 J 1/10W		R530			RK73GB2A120J	CHIP R 12 J 1/10W	
R454,455			RK73GB2A105J	CHIP R 1.0M J 1/10W		R531			RK73GB2A474J	CHIP R 470K J 1/10W	
R457			RK73GB2A333J	CHIP R 33K J 1/10W		R532			RK73GB2A271J	CHIP R 270 J 1/10W	
R458			RK73GB2A104J	CHIP R 100K J 1/10W		R533			RK73GB2A104J	CHIP R 100K J 1/10W	
R459			RK73GB2A472J	CHIP R 4.7K J 1/10W		R534			RK73GB2A221J	CHIP R 220 J 1/10W	
R460			RK73GB2A183J	CHIP R 18K J 1/10W		R535			RK73GB2A104J	CHIP R 100K J 1/10W	
R461			RK73GB2A000J	CHIP R 0.0 J 1/10W		R536			RK73GB2A102J	CHIP R 1.0K J 1/10W	
R463			RK73GB2A000J	CHIP R 0.0 J 1/10W		R538			RK73GB2A102J	CHIP R 1.0K J 1/10W	
R464			RK73GB2A221J	CHIP R 220 J 1/10W		R539			RK73GB2A100J	CHIP R 10 J 1/10W	
R465			RK73GB2A000J	CHIP R 0.0 J 1/10W		R540			RK73GB2A474J	CHIP R 470K J 1/10W	
R466			RK73GB2A470J	CHIP R 47 J 1/10W		R541			RK73FB2B1R0J	CHIP R 1.0 J 1/8W	
R469,470			RK73GB2A000J	CHIP R 0.0 J 1/10W		R542			RK73GB2A102J	CHIP R 1.0K J 1/10W	
R471			RK73GB2A102J	CHIP R 1.0K J 1/10W		R543			RK73GB2A220J	CHIP R 22 J 1/10W	
R474			RK73GB2A682J	CHIP R 6.8K J 1/10W		R544			RK73GB2A104J	CHIP R 100K J 1/10W	
R475			RK73GB2A332J	CHIP R 3.3K J 1/10W		R545			RK73GB2A470J	CHIP R 47 J 1/10W	
R476,477			RK73GB2A000J	CHIP R 0.0 J 1/10W		R547			RK73GB2A472J	CHIP R 4.7K J 1/10W	
R478			RK73GB2A153J	CHIP R 15K J 1/10W		R548			RK73GB2A473J	CHIP R 47K J 1/10W	
R479			RK73GB2A2R2J	CHIP R 2.2 J 1/10W		R549			RK73GB2A331J	CHIP R 330 J 1/10W	
R480			RK73GB2A682J	CHIP R 6.8K J 1/10W		R550			RK73GB2A104J	CHIP R 100K J 1/10W	
R481			RK73GB2A182J	CHIP R 1.8K J 1/10W		R551			RK73GB2A473J	CHIP R 47K J 1/10W	
R482			RK73GB2A103J	CHIP R 10K J 1/10W		R552			RK73GB2A104J	CHIP R 100K J 1/10W	
R483			RK73GB2A562J	CHIP R 5.6K J 1/10W		R553			RK73GB2A223J	CHIP R 22K J 1/10W	
R484			RK73GB2A101J	CHIP R 100 J 1/10W		R554			RK73GB2A180J	CHIP R 18 J 1/10W	
R485			RK73GB2A392J	CHIP R 3.9K J 1/10W		R555			RK73GB2A102J	CHIP R 1.0K J 1/10W	
R486			RK73GB2A221J	CHIP R 220 J 1/10W		R556			RK73GB2A122J	CHIP R 1.2K J 1/10W	
R487			RK73GB2A102J	CHIP R 1.0K J 1/10W		R557			RK73GB2A473J	CHIP R 47K J 1/10W	
R488			RK73GB2A822J	CHIP R 8.2K J 1/10W		R558			RK73GB2A331J	CHIP R 330 J 1/10W	
R489			RK73GB2A272J	CHIP R 2.7K J 1/10W		R560			RK73GB2A000J	CHIP R 0.0 J 1/10W	
R490			RK73GB2A470J	CHIP R 47 J 1/10W		R561			RK73GB2A102J	CHIP R 1.0K J 1/10W	
R492			RK73GB2A471J	CHIP R 470 J 1/10W		R562			RK73GB2A104J	CHIP R 100K J 1/10W	
R493			RK73GB2A104J	CHIP R 100K J 1/10W		R563			RK73GB2A473J	CHIP R 47K J 1/10W	
R494			RK73GB2A123J	CHIP R 12K J 1/10W		R564			RK73GB2A223J	CHIP R 22K J 1/10W	
R495			RK73GB2A332J	CHIP R 3.3K J 1/10W		R566			RK73GB2A473J	CHIP R 47K J 1/10W	
R496,497			RK73GB2A100J	CHIP R 10 J 1/10W		R567			RK73GB2A472J	CHIP R 4.7K J 1/10W	
R498			RK73GB2A471J	CHIP R 470 J 1/10W		R568			RK73GB2A224J	CHIP R 220K J 1/10W	
R499			RK73GB2A682J	CHIP R 6.8K J 1/10W		R569			RK73GB2A561J	CHIP R 560 J 1/10W	

PARTS LIST

TX UNIT (X56-3112-71)

Ref. No.	Address	New parts	Parts No.	Description	Destination	Ref. No.	Address	New parts	Parts No.	Description	Destination
R570			RK73GB2A473J	CHIP R 47K J 1/10W		R802,803			RK73GB2A104J	CHIP R 100K J 1/10W	
R571			RK73GB2A100J	CHIP R 10 J 1/10W		R804-807			RK73GB2A100J	CHIP R 10 J 1/10W	
R573			RK73GB2A104J	CHIP R 100K J 1/10W		R812-824			RK73GB2A000J	CHIP R 0.0 J 1/10W	
R575			RK73GB2A472J	CHIP R 4.7K J 1/10W		R830-837			RK73GB2A000J	CHIP R 0.0 J 1/10W	
R576			RK73FB2B1R0J	CHIP R 1.0 J 1/8W		R840			RK73GB2A000J	CHIP R 0.0 J 1/10W	
R577			RK73GB2A104J	CHIP R 100K J 1/10W		R845			RK73GB2A000J	CHIP R 0.0 J 1/10W	
R578			RK73GB2A000J	CHIP R 0.0 J 1/10W		R855			RK73GB2A560J	CHIP R 56 J 1/10W	
R580			RK73GB2A220J	CHIP R 22 J 1/10W		R856			RK73GB2A220J	CHIP R 22 J 1/10W	
R581			RK73GB2A104J	CHIP R 100K J 1/10W		R865			RK73GB2A104J	CHIP R 100K J 1/10W	
R582			RK73GB2A474J	CHIP R 470K J 1/10W		R866,867			RK73GB2A000J	CHIP R 0.0 J 1/10W	
R583			RK73GB2A221J	CHIP R 220 J 1/10W		R869			RK73GB2A104J	CHIP R 100K J 1/10W	
R586			RK73GB2A104J	CHIP R 100K J 1/10W		R870			RK73GB2A101J	CHIP R 100 J 1/10W	
R588			RK73GB2A103J	CHIP R 10K J 1/10W		R871,872			RK73GB2A104J	CHIP R 100K J 1/10W	
R591			RK73FB2B271J	CHIP R 270 J 1/8W		R873			RK73GB2A103J	CHIP R 10K J 1/10W	
R592			RK73GB2A273J	CHIP R 27K J 1/10W		R877			RK73GB2A104J	CHIP R 100K J 1/10W	
R593			RK73FB2B120J	CHIP R 12 J 1/8W		R878			RK73GB2A000J	CHIP R 0.0 J 1/10W	
R594			RK73FB2B271J	CHIP R 270 J 1/8W		R879			RK73GB2A104J	CHIP R 100K J 1/10W	
R595			RK73GB2A102J	CHIP R 1.0K J 1/10W		R883			RK73GB2A000J	CHIP R 0.0 J 1/10W	
R601			RK73GB2A103J	CHIP R 10K J 1/10W		R887-889			RK73GB2A102J	CHIP R 1.0K J 1/10W	
R602			RK73GB2A104J	CHIP R 100K J 1/10W		R891			RK73GB2A102J	CHIP R 1.0K J 1/10W	
R603			RK73GB2A222J	CHIP R 2.2K J 1/10W		R920-932			RK73GB2A000J	CHIP R 0.0 J 1/10W	
R604			RK73GB2A473J	CHIP R 47K J 1/10W		R933			RK73GB2A821J	CHIP R 820 J 1/10W	
R605			RK73GB2A153J	CHIP R 15K J 1/10W		R934,935			RK73GB2A000J	CHIP R 0.0 J 1/10W	
R606			RK73GB2A181J	CHIP R 180 J 1/10W		R936,937			RK73GB2A122J	CHIP R 1.2K J 1/10W	
R607			RK73GB2A470J	CHIP R 47 J 1/10W		R938,939			RK73GB2A821J	CHIP R 820 J 1/10W	
R608			RK73GB2A222J	CHIP R 2.2K J 1/10W		R940			RK73GB2A122J	CHIP R 1.2K J 1/10W	
R610			RK73GB2A104J	CHIP R 100K J 1/10W		R941			RK73GB2A821J	CHIP R 820 J 1/10W	
R611			RK73GB2A100J	CHIP R 10 J 1/10W		R942			RK73GB2A000J	CHIP R 0.0 J 1/10W	
R612			RK73GB2A471J	CHIP R 470 J 1/10W		R943			RK73GH2A224D	CHIP R 220K D 1/10W	
R613			RK73GB2A682J	CHIP R 6.8K J 1/10W		R944,945			RK73GB2A102J	CHIP R 1.0K J 1/10W	
R614			RK73GB2A332J	CHIP R 3.3K J 1/10W		R946			RK73GB2A103J	CHIP R 10K J 1/10W	
R615			RK73GB2A471J	CHIP R 470 J 1/10W		R947			RK73GB2A000J	CHIP R 0.0 J 1/10W	
R616			RK73GB2A000J	CHIP R 0.0 J 1/10W		R948,949			RK73GH2A104D	CHIP R 100K D 1/10W	
R617			RK73GB2A471J	CHIP R 470 J 1/10W		R950			RK73GH2A822D	CHIP R 8.2K D 1/10W	
R618			RK73GB2A104J	CHIP R 100K J 1/10W		R951			RK73GB2A122J	CHIP R 1.2K J 1/10W	
R619			RK73GB2A100J	CHIP R 10 J 1/10W		R960-965			RK73GB2A000J	CHIP R 0.0 J 1/10W	
R620			RK73GB2A104J	CHIP R 100K J 1/10W		R966,967			RK73GB2A102J	CHIP R 1.0K J 1/10W	
R621			RK73GB2A471J	CHIP R 470 J 1/10W		VR401,402			R32-0754-05	SEMI FIXED VARIABLE RESISTOR	
R622			RK73GB2A331J	CHIP R 330 J 1/10W		S920-925			S70-0502-05	TACT SWITCH	
R623			RK73GB2A392J	CHIP R 3.9K J 1/10W		D101,102			1SV283F	VARIABLE CAPACITANCE DIODE	
R624			RK73GB2A474J	CHIP R 470K J 1/10W		D106			1SV278F	VARIABLE CAPACITANCE DIODE	
R625			RK73GB2A000J	CHIP R 0.0 J 1/10W		D107,108			1SV283F	VARIABLE CAPACITANCE DIODE	
R626-628			RK73GB2A102J	CHIP R 1.0K J 1/10W		D112			1SV278F	VARIABLE CAPACITANCE DIODE	
R629			RK73GB2A101J	CHIP R 100 J 1/10W		D201			HSM88AS-E	DIODE	
R630			RK73GB2A102J	CHIP R 1.0K J 1/10W		D401-403			HSM88AS-E	DIODE	
R631			RK73GB2A561J	CHIP R 560 J 1/10W		D404,405			JDP4P02U	DIODE	
R637,638			RK73GB2A472J	CHIP R 4.7K J 1/10W		D406,407			HSC119	DIODE	
R639,640			RK73GH2A104D	CHIP R 100K D 1/10W		D408			HSM88AS-E	DIODE	
R705			RK73GB2A2R2J	CHIP R 2.2 J 1/10W		D409			CSA70-401L	SURGE ABSORBER	
R706-708			RK73GB2A100J	CHIP R 10 J 1/10W		D601,602			JDP4P02U	DIODE	
R709			RK73GB2A474J	CHIP R 470K J 1/10W		D603-606			UDZS3.0B	ZENER DIODE	
R711			RK73GB2A104J	CHIP R 100K J 1/10W		D933,934			HSM88AS-E	DIODE	
R712,713			RK73GB2A472J	CHIP R 4.7K J 1/10W		D935,936			1SS355	DIODE	
R714			RK73GB2A104J	CHIP R 100K J 1/10W		D960,961		*	PSA05-11SRWA	LED	
R715			RK73GB2A474J	CHIP R 470K J 1/10W		IC101			LMX2352TMX/NP	ANALOGUE IC	
R716-718			RK73GB2A100J	CHIP R 10 J 1/10W		IC102			LMC7101BIM5	MOS-IC	
R719,720			RK73GB2A104J	CHIP R 100K J 1/10W		IC104			NJM2386ADL3-09	ANALOGUE IC	
R721			RK73GB2A100J	CHIP R 10 J 1/10W		IC201			NJM2904E-ZB	ANALOGUE IC	
R722			RK73GB2A474J	CHIP R 470K J 1/10W		IC202			AD9835BRUZ	MOS-IC	
R801			RK73GB2A102J	CHIP R 1.0K J 1/10W							

PARTS LIST

TX UNIT (X56-3112-71)

Ref. No.	Address	New parts	Parts No.	Description	Destination	Ref. No.	Address	New parts	Parts No.	Description	Destination
IC301			NJM2732V	BI-POLAR IC		Q420			3SK317-E	FET	
IC302			NJU6368PF1	MOS-IC		Q421			SSM6L05FU-F	FET	
IC303			ADF4001BRUZ	MOS-IC		Q422			RD01MUS1-T113	FET	
IC304			M62364FP-F	MOS-IC		Q423			SSM6L05FU-F	FET	
IC305			NJM2732V	BI-POLAR IC		Q424			SSM3K15TE(F)	FET	
IC306			LMC7101BIM5	MOS-IC		Q425			RD01MUS1-T113	FET	
IC307			NJU6368PF1	MOS-IC		Q426			SSM3J01F	FET	
IC308			NJM2732V	BI-POLAR IC		Q428,429			SSM3K15TE(F)	FET	
IC401			LMC7101BIM5	MOS-IC		Q430,431			3SK317-E	FET	
IC404			ADF4001BRUZ	MOS-IC		Q601			SSM3J01F	FET	
IC405,406			TC75S59F-F	MOS-IC		Q602			SSM3K15TE(F)	FET	
IC407			NJU6368PF1	MOS-IC		Q603			2SC4617(R)	TRANSISTOR	
IC408,409			TA75S01F-F	MOS-IC		Q604			SSM3K15TE(F)	FET	
IC601			AD9835BRUZ	MOS-IC		Q605			SSM3J01F	FET	
IC602			NJU6368PF1	MOS-IC		Q606			2SC4617(R)	TRANSISTOR	
IC603			XC6204B332M	MOS-IC		Q607-609			SSM3K15TE(F)	FET	
IC701			BH2220FVM	ANALOGUE IC		Q701,702			SSM3K15TE(F)	FET	
IC702			S24CS02AFJTBG	ROM IC		Q920-930			UMG1N	TRANSISTOR	
IC703			BU4094BCFV	MOS-IC		Q931			2SC4116(Y)F	TRANSISTOR	
IC704		*	NJM78M08DL1AZB	ANALOGUE IC		Q932			2SA1586(Y)F	TRANSISTOR	
IC705,706			NJM78M05DL1AZB	ANALOGUE IC		Q960-976			UMG1N	TRANSISTOR	
IC801			AD1582	ANALOGUE IC		TH101,102			157-302-65801	THERMISTOR	
IC802			AD5312BRM	MOS-IC							
IC803			AD7908BRU	MOS-IC							
IC804			LM50BIM3/NOPB	MOS-IC							
IC805,806			TC7SET126FU-F	MOS-IC							
IC807			NJM78M05DL1AZB	ANALOGUE IC							
IC808,809	1B		NJM7808FA-ZB	BI-POLAR IC							
IC810			TK11230CMCL-G	BI-POLAR IC							
IC811			PE3511-52	MOS-IC							
IC920-922			TC7SET126FU-F	MOS-IC							
IC923-925			BU4094BCFV	MOS-IC							
IC926			NJM2732V	BI-POLAR IC							
IC960-963			BU4094BCFV	MOS-IC							
Q101			SSM3K15TE(F)	FET							
Q102,103			2SK508NV(K52)	FET							
Q104			2SC3356-A(R24)	TRANSISTOR							
Q105			2SC4116(BL)F	TRANSISTOR							
Q106			2SC3356-A(R24)	TRANSISTOR							
Q107,108			2SC4116(BL)F	TRANSISTOR							
Q109			2SA1832F	TRANSISTOR							
Q110			SSM3K15TE(F)	FET							
Q202			2SC5337	TRANSISTOR							
Q203			RD01MUS1-T113	FET							
Q204			SSM3K15TE(F)	FET							
Q205			SSM3J01F	FET							
Q206			SSM3K15TE(F)	FET							
Q210			SSM3K15TE(F)	FET							
Q211-213			2SC4617(R)	TRANSISTOR							
Q301,302			SSM3K15TE(F)	FET							
Q303			2SA1832F	TRANSISTOR							
Q304,305			2SC4617(R)	TRANSISTOR							
Q307			2SC4617(R)	TRANSISTOR							
Q401,402			2SC4617(R)	TRANSISTOR							
Q405			SSM3K15TE(F)	FET							
Q407-409			SSM3K15TE(F)	FET							
Q410			2SA1832F	TRANSISTOR							
Q412			2SC4617(R)	TRANSISTOR							
Q413,414			SSM3K15TE(F)	FET							
Q415-419			2SC4617(R)	TRANSISTOR							

If a part reference number is listed in a shaded box, that part does not come with the PCB.

NXR-700

EXPLODED VIEW

B	:	N09-2292-05
C	M2 x 8	: N30-2008-43
D	M2.6 x 6	: N30-2606-48
E	M3 x 35	: N30-3035-43
F	M3 x 6 (F)	: N32-3006-43
G	M4 x 8 (F)	: N32-4008-43
H	:	N67-3008-48
J	:	N80-2006-43
K	:	N80-2608-43
L	M2.6 x 8 (Br-Tap)	: N87-2608-48

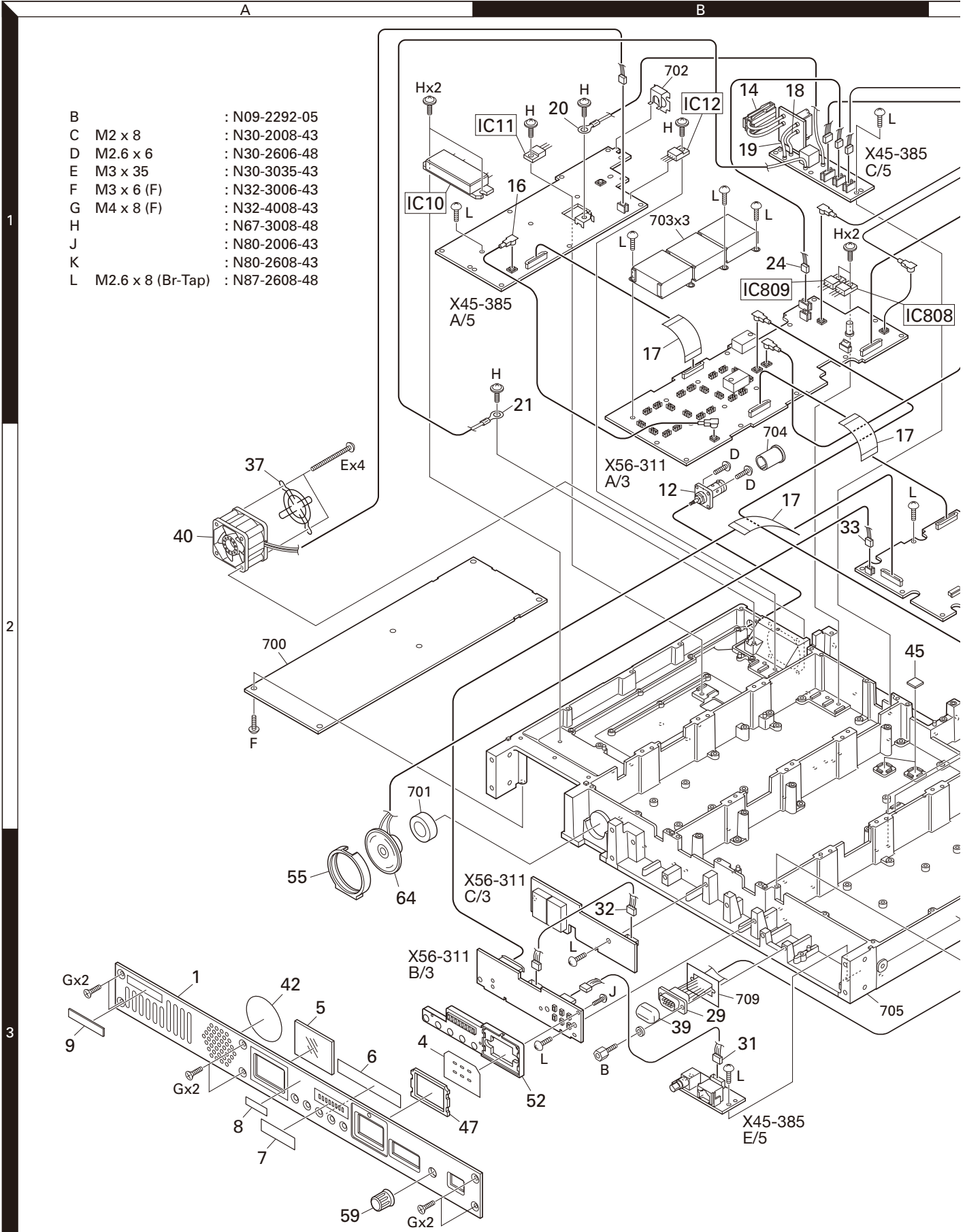

68 Parts with the exploded numbers larger than 700 are not supplied.
 If a part reference number is listed in a box on the exploded view of the PCB, that part does not come with the PCB.
 These parts must be ordered separately.

EXPLODED VIEW

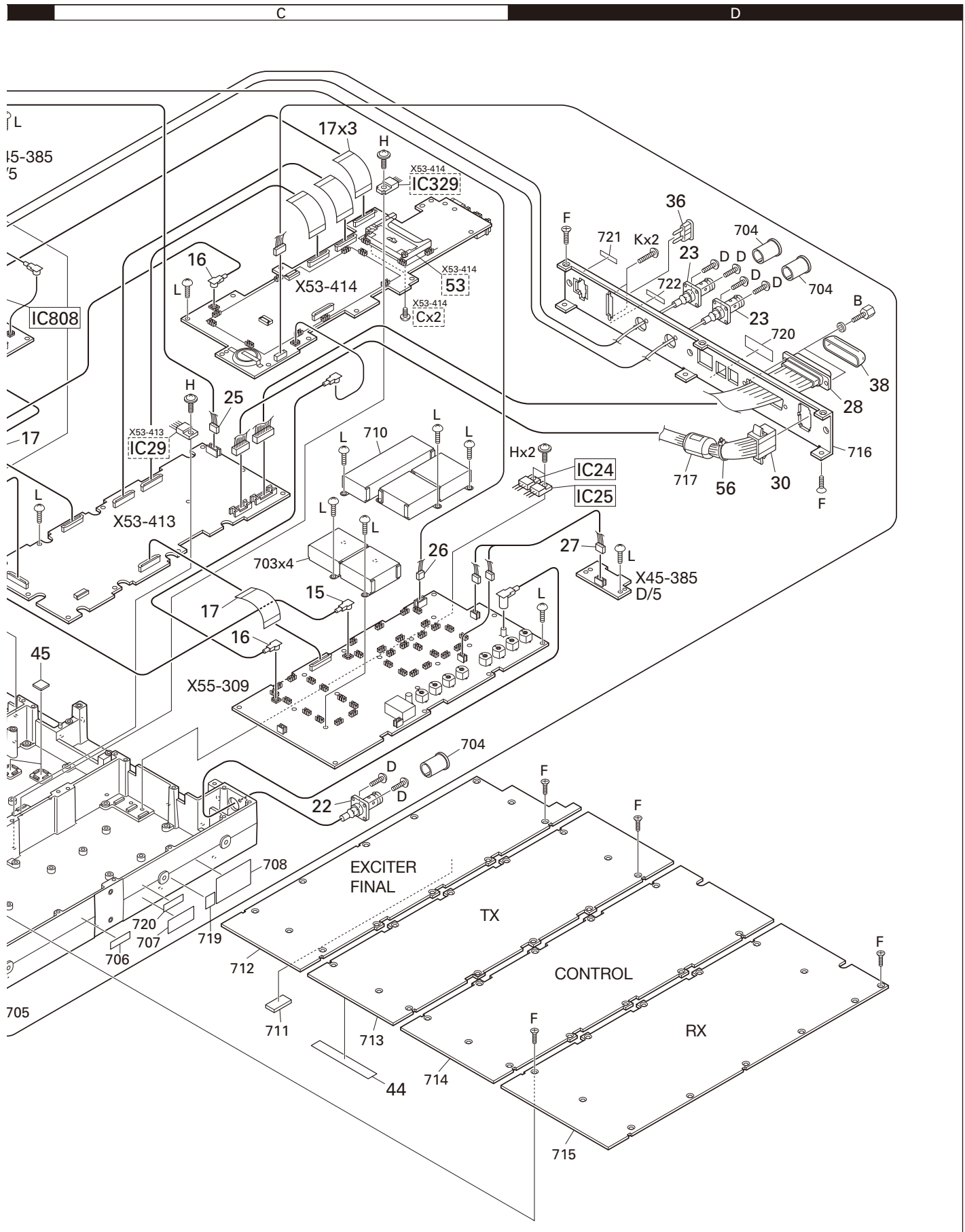

Parts with the exploded numbers larger than 700 are not supplied.

If a part reference number is listed in a box on the exploded view of the PCB, that part does not come with the PCB. These parts must be ordered separately.

PACKING

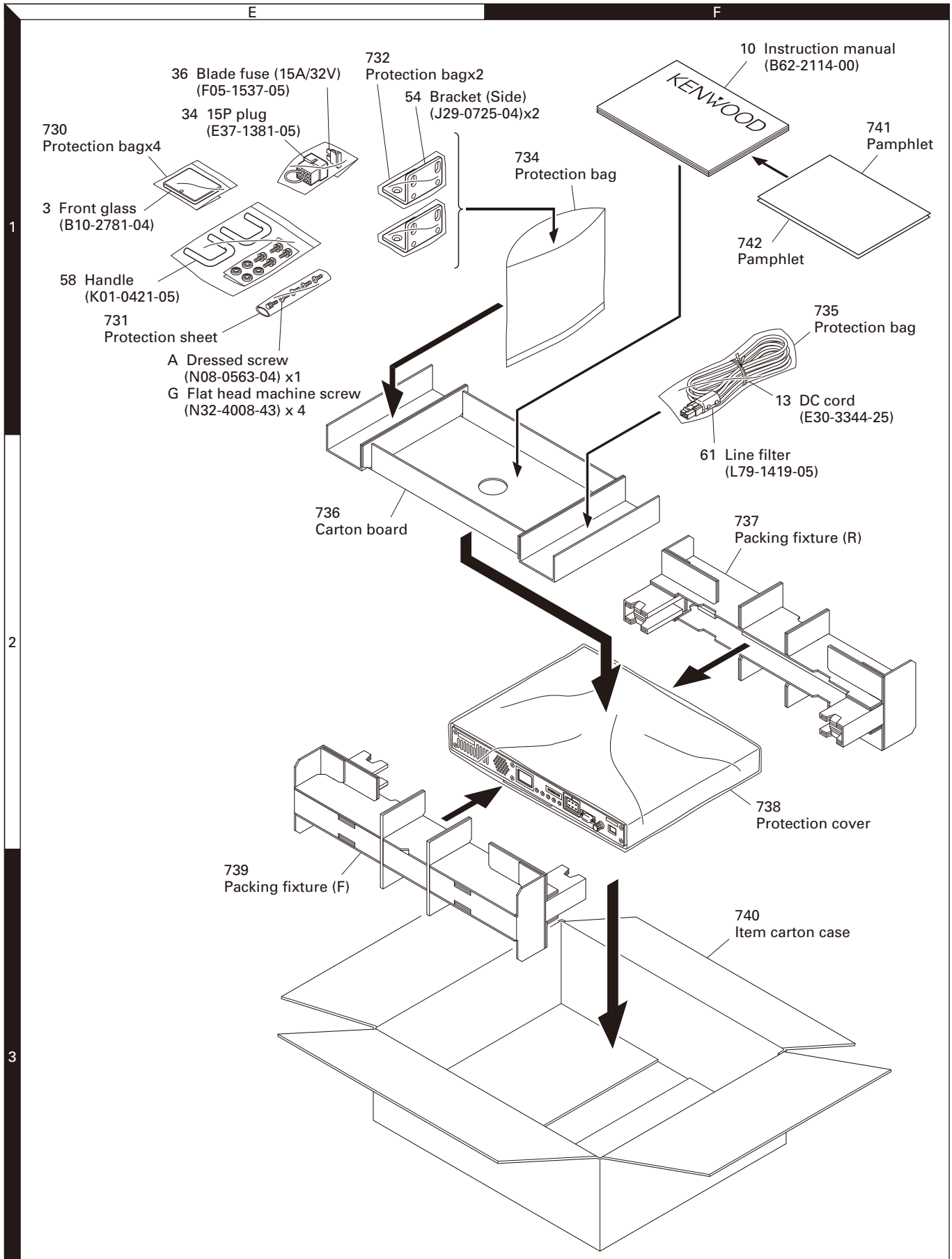

TROUBLE SHOOTING

Procedure for Traceability of BGA Package and How to Replace Control Unit

This clause is procedure when you replace Control unit on you repair. Implement traceability of BGA package in order to make sure BGA failure in prior to replace Control Unit. You choose appropriate procedure accordingly.

1. Traceability of BGA Package ICs in Control Unit

The control unit (X53-414) of NXR-700 series have BGA package ICs. BGA package IC is difficult to trace whether it be broken. So, control unit is difficult to confirm whether it has a problem. This document shows a simple method by PC to confirm the control unit has problem. The two methods for traceability in BGA packages IC are provided as below.

1-1. Simplified traceability

- Open the top cover of control unit.
- Slide the tab on DIP_SW4 (Ref No. S700) to the ON position. (See Fig 1.)
- Connect a cross-wired RS232C cable to COM port on the front panel of NXR-700. Plug the other end of the cable to PC. (See Fig 2.)
- Run a communication software, example a Hyper Terminal in Windows, and set the following parameters.
- COM port: COM port of NXR-700 used in step c.

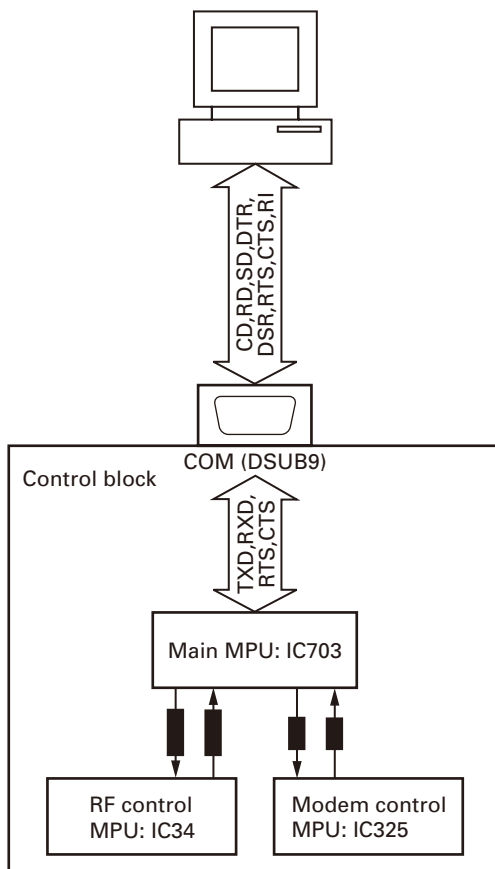

Configuration in communication port

Communication speed: 115200bps
 Data Length: 8-bit
 Parity: None
 Stop bits: 1
 Flow control: Hardware

- Apply 13.2VDC to NXR-700. When BGA ICs mounted in this control unit works correctly, the following messages appears on the screen of communication software. If the software doesn't show below messages, it's supposed that BGA package IC is broken.

```
NEXEDGE IPL 1.00 *1
COPYRIGHT KENWOOD CORPORATION
2007 ALL RIGHTS RESERVED
CPU[R] Version 1.00 *2
CPU[M] Version 1.00 *3
```

- *1: Appearing this information means the boot program in Main MPU (IC703) is correctly working.
- *2: ppearing this information means the boot program at the RF control MPU (IC34) is correctly working.
- *3: Appearing this information means the boot program at the Modem control in MPU(IC325) is correctly working.

Note: IPL and CPU[R], CPU[M] version will be updated by any modification or improvement in future.

- After that slide the tab on DIP_SW4 to OFF position, before close the top cover of control unit.

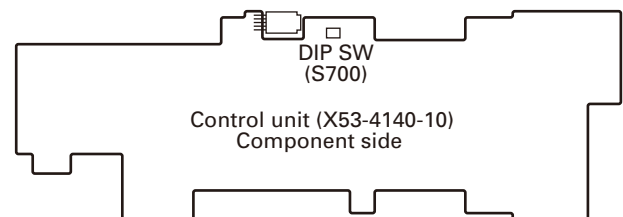

Fig. 1

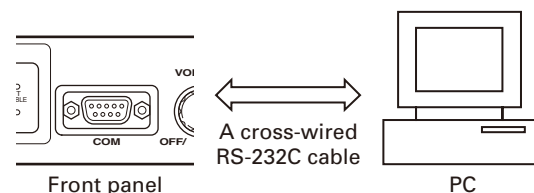
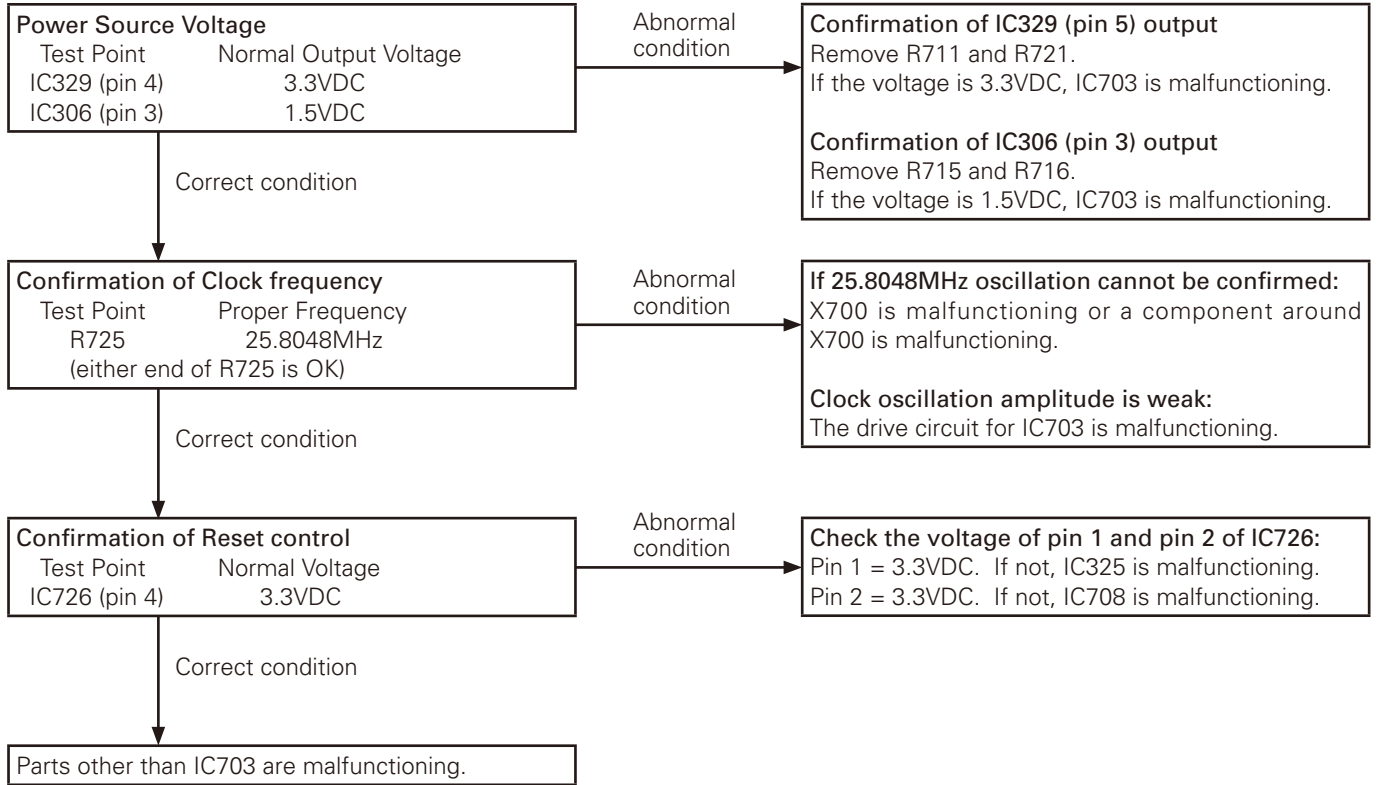

Fig. 2

TROUBLE SHOOTING

1-2. Hardware Traceability (Method1)

■ Procedure for IC703 (Main MPU) traceability



■ Traceability Procedure of IC324 (TX Vocoder_DSP)

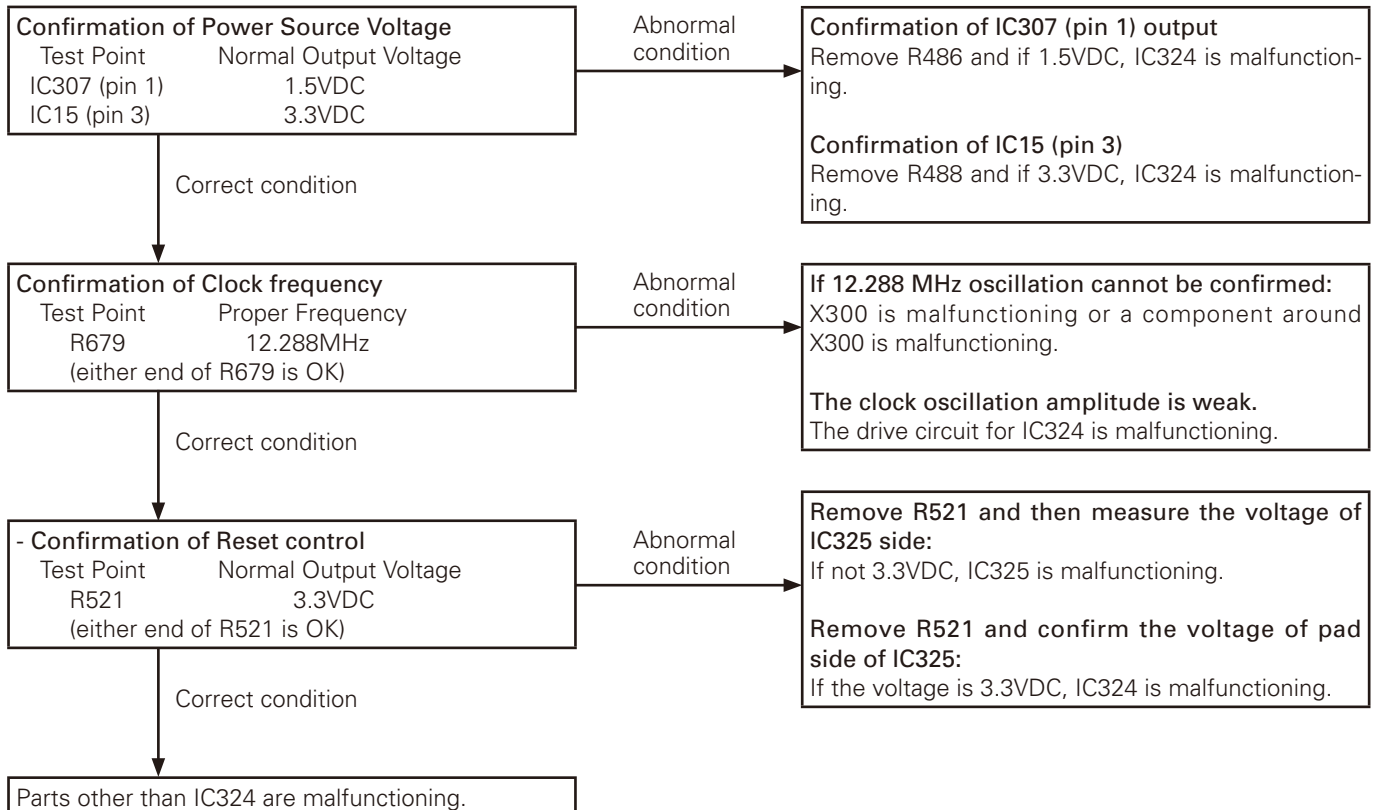

TROUBLE SHOOTING

■ Traceability Procedure of IC323 (RX_DSP)

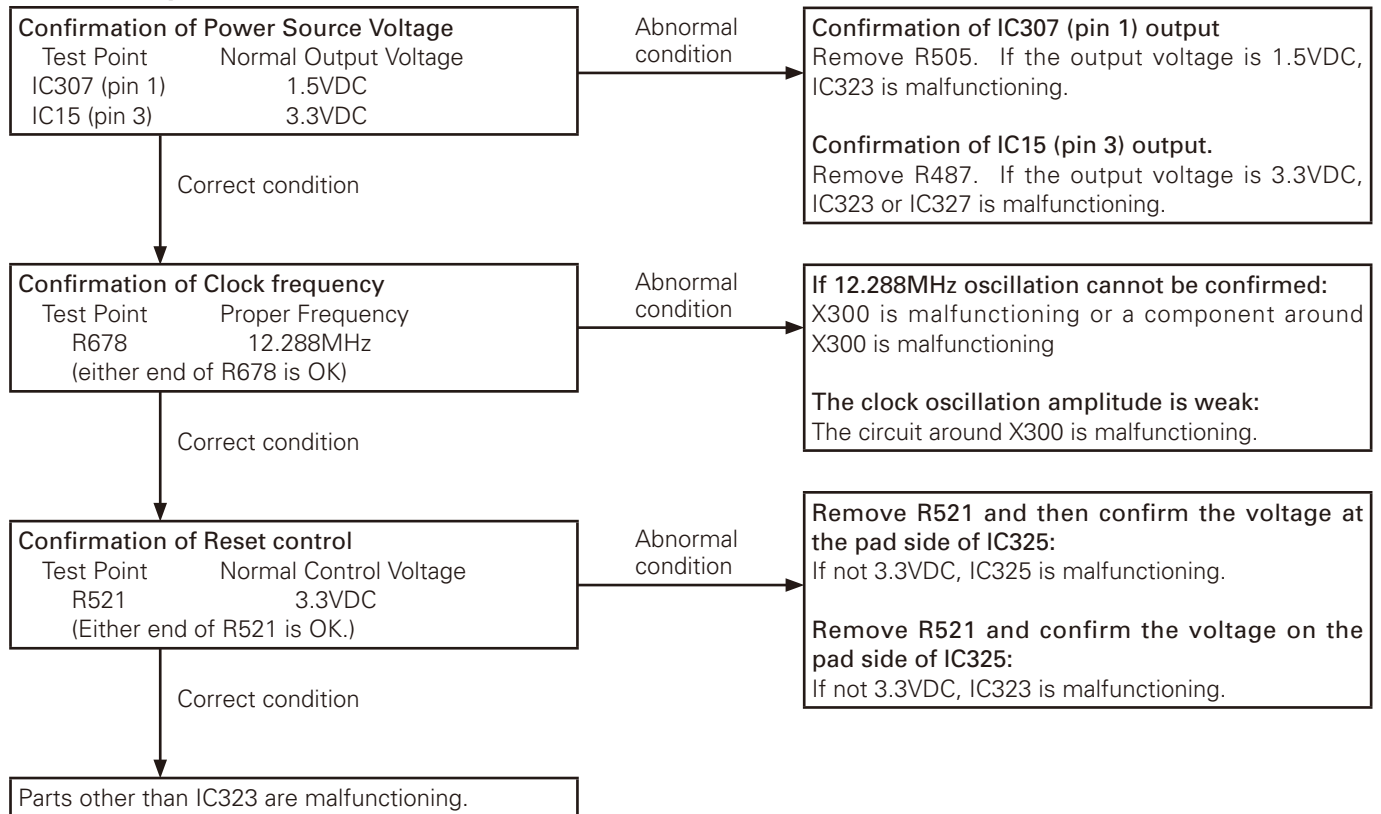

■ Traceability Procedure of IC314 (Flash Memory of modem control MPU)

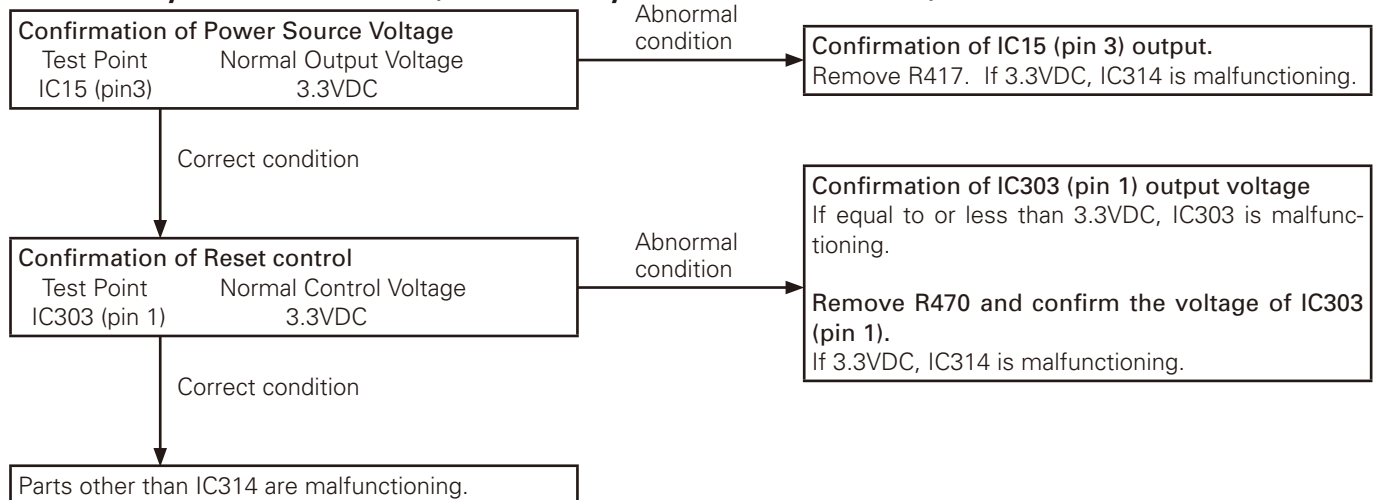

TROUBLE SHOOTING

■ Traceability Procedure of IC17 (Flash Memory of RF control MPU)

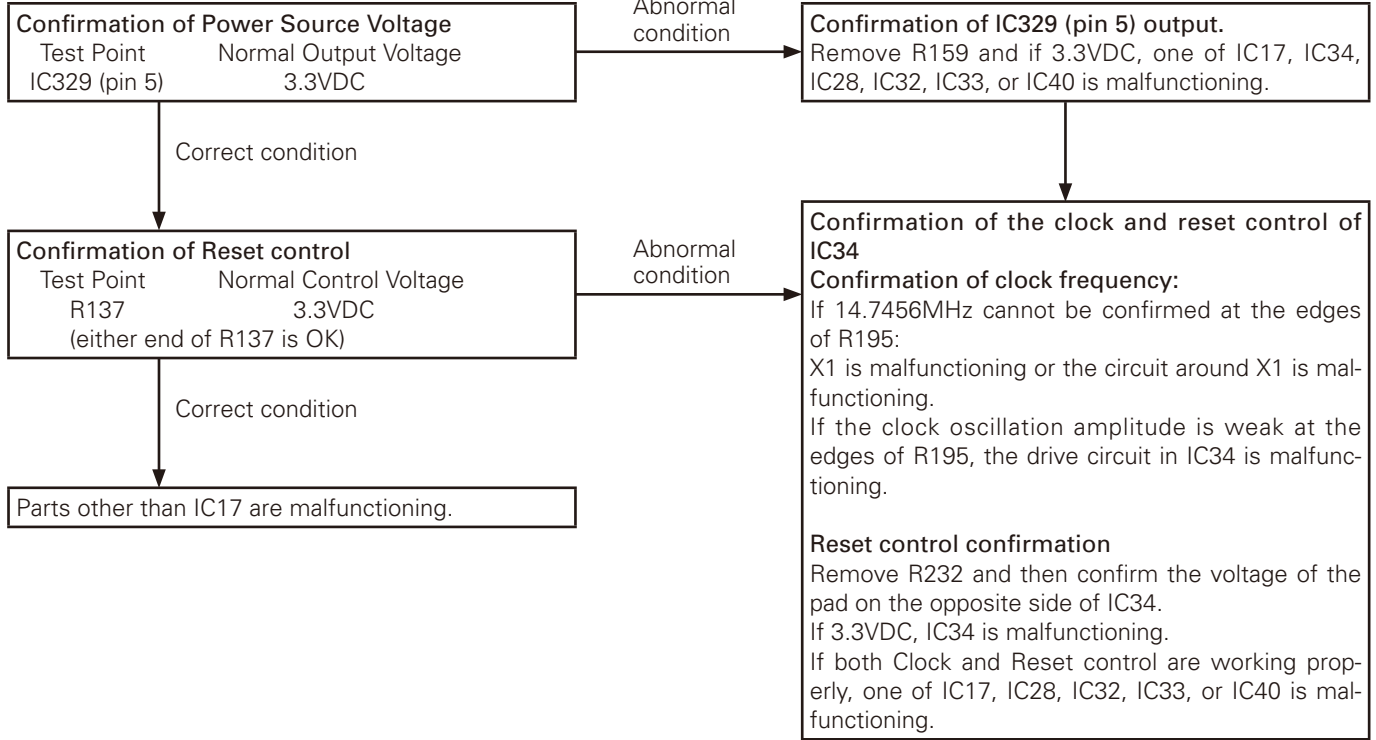

■ Traceability Procedure of IC325 (The Modem control MPU)

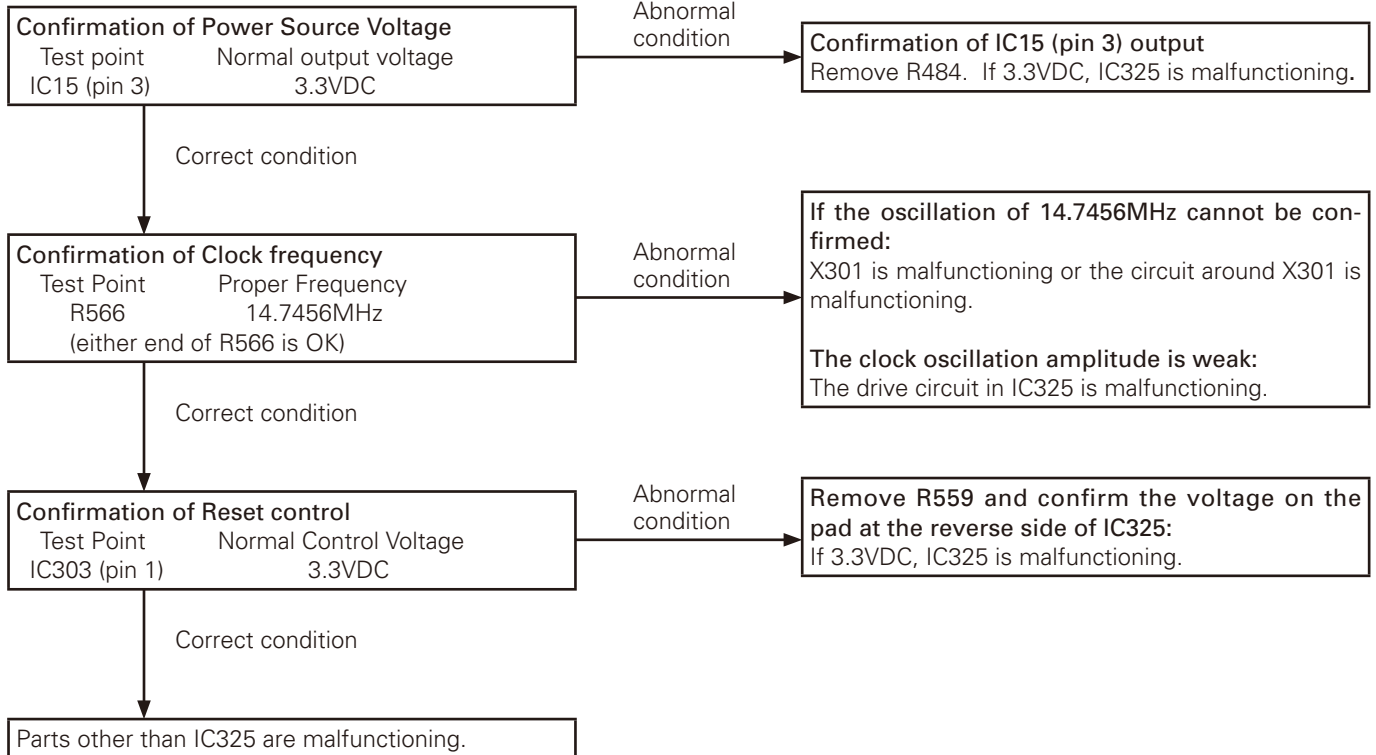

TROUBLE SHOOTING

■ Traceability Procedure of IC34 (The RF control MPU)

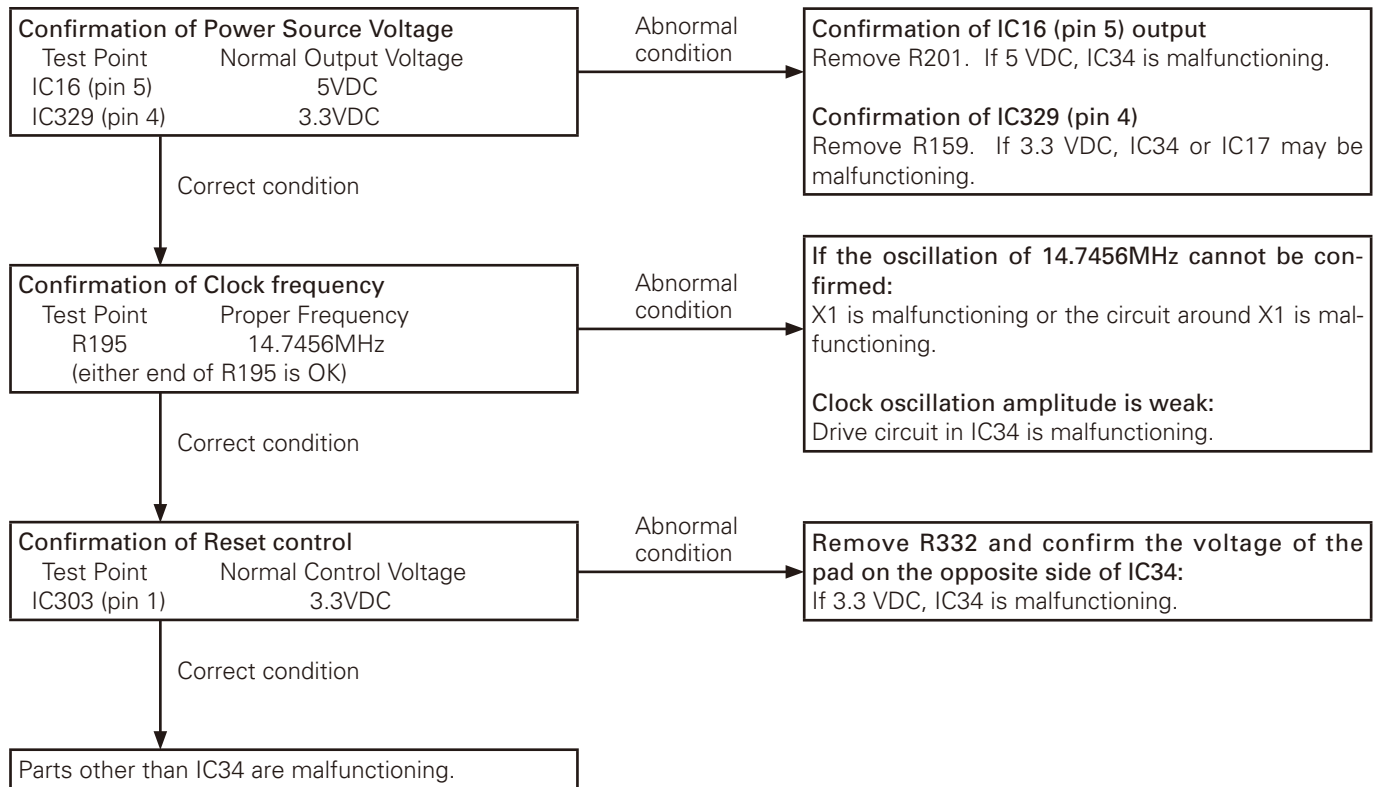

1-3. Hardware traceability (Method 2)

The NXR-700 control circuit executes the following procedures when the system starts up.

1. An external DC 13.2V power source is applied to the NXR-700 terminal.
2. The Modem control MPU (IC325) starts up.
3. The Modem control MPU (IC325) initiates all circuit blocks.
4. The Main MPU (IC703) and the RF control MPU (IC34) start up.
5. The Main MPU (IC703) confirms the operational status of the Modem control MPU (IC325) and the RF control MPU (IC34) by using 115.2kbps UART communications and then the operation transfer commands will be exchanged in order to integrate all hardware blocks.

The above steps 1 to 5 will be executed as follows.

TROUBLE SHOOTING

External DC 13.2V Power Source applied to the NXR-700 Terminal

Refer to the power supply diagram sequence below.

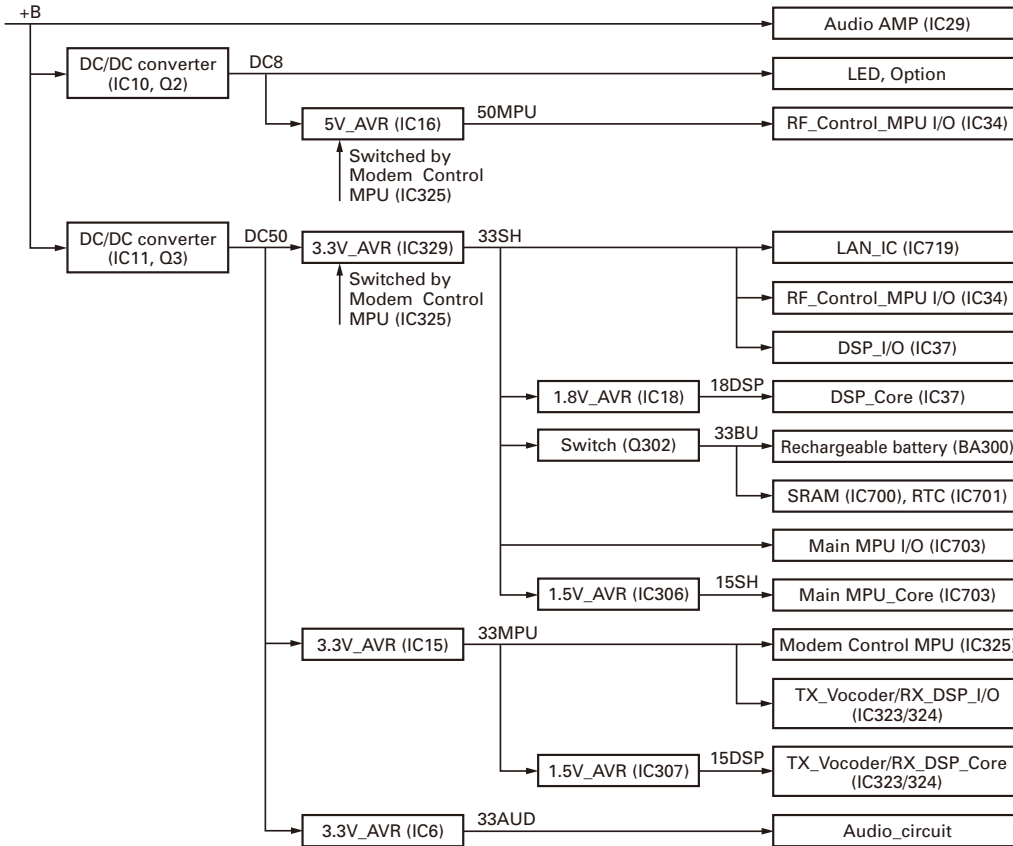

Initialization of the Modem control MPU (IC325) (normal oscillation of X301 and normal reset-unlock of IC303)

Refer to Traceability procedure for IC325.

Unlocking "SYS_RST" Signal on the Modem control MPU (IC325) starts Up all Hardware Blocks

Refer to the Reset circuit below.

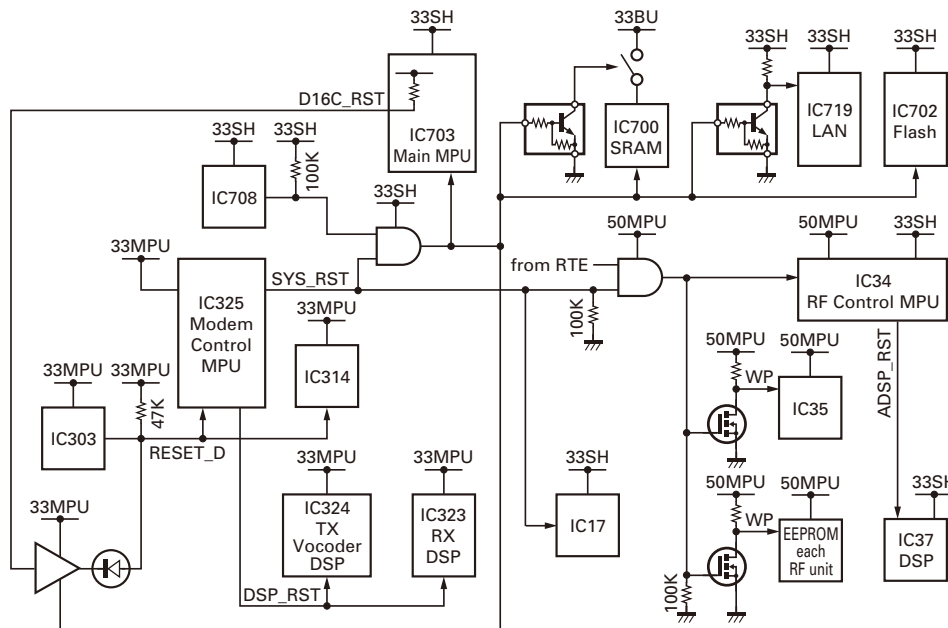

Reset circuit

TROUBLE SHOOTING

■ Start-up of each Control Block

• Main MPU Block

- Component elements:
- Main MPU: IC703
 - Flash Memory: IC702
 - SD RAM: IC704 and IC707
 - LAN IC: IC719
 - RTC: IC701

Overview of Start-up Operation:

When MPU reset line logic switches as high, the MPU starts reading the program from the flash memory and expands the program to SDRAM. Linux OS begins operation on the SDRAM after main MPU transfers the program. Main MPU works usage of Linux OS codes. The other higher-level applications software to the Linux OS will also be expanded in SDRAM. On starting up, main MPU verify the status of the registers in LAN IC except SDRAM which is purpose of backup data even if abnormal symptom detects in either LAN IC or SDRAM, the start-up process is not affected by this error; main MPU behaves operation as if it works properly. To express another word, either Flash memory or SDRAM has defective, a circuit behaves as if main MPU happens malfunction. After executing all initialization routines, the Main MPU verifies the operational status of each MPU then transmits/ receives the operation transfer command set to from the Modem control MPU (IC325) and the RF control MPU (IC34) using 115.2kbps UART communications.

• RF Control MPU Block

- Component elements:
- RF control MPU: IC34
 - Flash memory: IC17
 - DSP: IC37

Overview of Start-up Operation:

When the RF control MPU (IC34) reset line logic switches as high, this MPU reads the boot program from the internal ROM of MPU and then initializes the peripheral devices. After this boot process completes, the MPU starts working with the programs (application programs) stored in flash memory (IC17) to process the preprogrammed tasks. During the process, the MPU transfers the program to the DSP IC (IC37). It also verifies the operating status of DSP at certain interval.

After a series of processes completes, the RF control MPU verifies the operational status and then transmits and receives the operation transfer command set to/from Main MPU (IC703) using 115200bps UART communications.

• Modem Control MPU Block

- Component elements:
- Modem control MPU: IC325
 - Flash memory: IC314
 - RX DSP: IC323
 - TS Vocoder DSP: IC324

Overview of Start-up Operation

When the Modem control MPU (IC325) reset line logic switches as high, the MPU reads the boot program from the internal ROM of MPU and then initializes the peripheral devices. After this boot-up process completes, the MPU starts working with the programs (application programs) stored in flash memory (IC314) to process the preprogrammed tasks. During the process, the MPU transfers the program to the RX DSP IC (IC323) and TX Vocoder DSP IC (IC324). It also confirms the operating status of these DSP ICs. After a series of processes completes, the Modem control MPU confirms the operational status and then transmits and receives the operation transfer command set to/from Main MPU (IC703) using 115200 bps UART communications.

• Possible Symptoms if the Block (mainly BGA IC) Malfunctions

Ref. No.	Element of Block	Presumption Symptoms
IC703	Main MPU	<ul style="list-style-type: none"> • Since the boot program cannot be executed at all, the LEDs do not light or flash. • The operations that should be executed by IC703 are not processed. • Runaway of IC703.
IC17	Flash Memory on RF control MPU block	<ul style="list-style-type: none"> • Migrated to the programming mode (Write). ("PG" appears on the 17-segment LED display.) • The operations that should be executed by IC34 are not processed. • Runaway of IC34.
IC314	Flash Memory on Modem control block	<ul style="list-style-type: none"> • Migrated to the programming mode (Write). ("PG" appears on the 17-segment LED display.) • The operations that should be executed by IC325 are not processed. • Runaway of IC325.
IC323	RX DSP	<ul style="list-style-type: none"> • While the boot program is executed, the operation stops (the status LED is flashing). • The operations that should be executed by IC323 are not processed. • Runaway of IC323.
IC324	TX Vocoder DSP	<ul style="list-style-type: none"> • While the boot program is executed, the operation stops (the status LED is flashing). • The operations that should be executed by IC324 are not processed. • Runaway of IC324.

TROUBLE SHOOTING

2. Replacing control Unit

2-1. Control Unit information

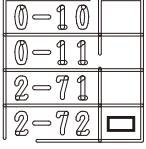
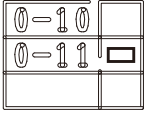
Original Control Unit	Control Unit (Service unit)	Difference between original unit and Service Unit
X53-4132-71	X53-4132-72	Mounted chip at 2-72 location for Service Unit. 
X53-4140-10	X53-4140-11	Mounted chip at 0-11 location for Service Unit. 

Rear View

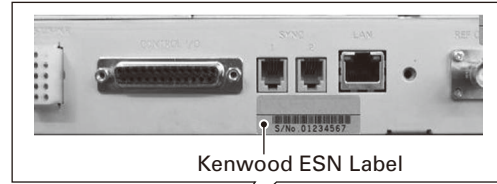

Kenwood ESN Label

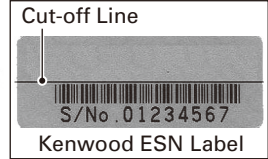

Cut-off Line

Kenwood ESN Label

Side View



Kenwood ESN Label
NXDN ESN Label (12 digits)

2-2. Supplied Accessories

Item (Including Part Number)	Quantity	
	X53-413	X53-414
Control Unit (X53-413)	1	-
Control Unit (X53-414)	-	1
Kenwood ESN Label	-	2
NXDN ESN Label	-	1
Addendum (B59-2536-XX)	1	1

2-3. Printed Circuit Board DATA

The following data is written on the circuit board:

Data Type	Description
Firmware	NXR-700/800 Firmware
FPU Data (PC programming mode)	NXR-700 E type data.
Various Adjustment Data (PC test mode)	General adjustment values for the NXR-700/800.
Kenwood ESN (X53-414 only)	Model Name: NXR-700/800S Type: E The same number as the Kenwood ESN label is written.
NXDN ESN (X53-414 only)	The same number as the NXDN ESN label is written.

Note: For the X53-414, a UPC code and UPC barcode is not printed on the Kenwood ESN Label. If necessary, cut the label at the cut-off line and attach only the serial number.

2-4. After Changing the PCB

1. After changing the printed circuit board, write the up-to-date Firmware following the instructions in the "REALIGNMENT 4. Firmware Programming Mode".
2. Using the KPG-109D, select your desired item (Model Name and Frequency) from the Model > Product Information menu, then use Program > Write Data to the repeater to write the FPU data (PC Programming mode). When writing to the repeater, a Warning Message, corresponding to the item selected, appears. Click [OK] to continue writing the data.
3. Enter Program > Test mode, then adjust the various adjustment data (PC Test mode) as described in the "ADJUSTMENT".
4. For the X53-414, attach the new labels corresponding to the new printed circuit board. (Refer to the images below for label placement.)
5. If necessary, write the FPU data used by the customer with the KPG-109D or KPG-110SM.

Note:

- When a new printed circuit board is used, the Kenwood ESN changes, as does the Repeater Information display of the KPG-109D, but this does not have any effect on the operation of the transceiver.
- If changing to the original Kenwood ESN and NXDN ESN, please contact our service center.
- Re-installing other parts from original unit to Service unit is not required after changing to Service unit.

ADJUSTMENT

Test Equipment Required for Alignment

Test Equipment	Major Specifications	
1. Standard Signal Generator (SSG)	Frequency Range Modulation Output	136 to 174MHz Frequency modulation and external modulation 0.1μV to greater than 1mV
2. FR Power Meter	Input Impedance Operation Frequency Measurement Capability	50Ω 136 to 174MHz or more Vicinity of 100W
3. Deviation Meter	Frequency Range	136 to 174MHz
4. Digital Volt Meter (DVM)	Measuring Range Input Impedance	1V to 20V DC High input impedance for minimum circuit loading
5. Oscilloscope		DC through 30MHz
6. High Sensitivity Frequency Counter	Frequency Range Frequency Stability	10Hz to 600MHz 0.2ppm or less
7. DC Ammeter		15A or more
8. AF Volt Meter (AF V.M)	Frequency Range Voltage Range	50Hz to 10kHz 3mV to 3V
9. Audio Generator (AG)	Frequency Range Output	50Hz to 5kHz 0 to 1V
10. Distortion Meter	Capability Input Level	1% or less at 1kHz 50mV to 10Vrms
11. Voltmeter	Measuring Range Input Impedance	10V to 1.5V DC or less 50kΩ/V or greater
12. 4Ω Dummy Load		Approx. 4Ω, 5W
13. Spectrum Analyzer	Frequency Range Input Level Input Sensitivity Resolution Bandwidth Video Bandwidth	40MHz to 520MHz Up to +20dBm -100dBm 100Hz 100Hz
14. Tracking Generator	Frequency Range Output Level	40MHz to 520MHz -30dBm to 0dBm

MIC connector (Front panel view)

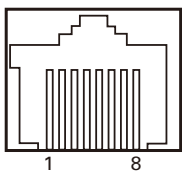

- 1: NC
- 2: SB
- 3: GND
- 4: PTT
- 5: MIG
- 6: MIC
- 7: HOOK
- 8: NC

Jig for MCF adjustment (W05-1000-00)

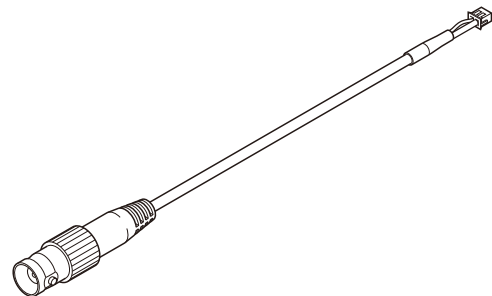

Test cable for microphone input (E30-3360-18)

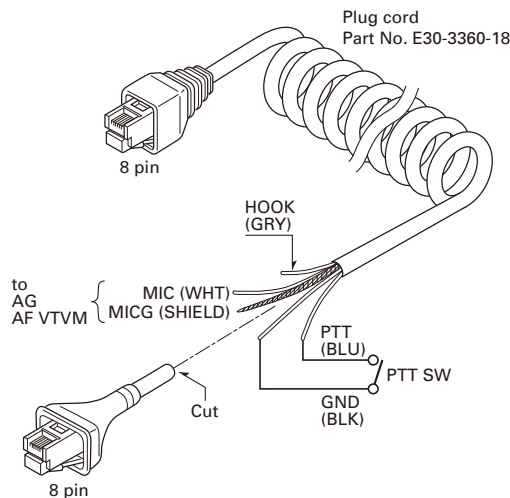

Jig for Drive AMP adjustment (E30-3228-15 or E37-1304-05)

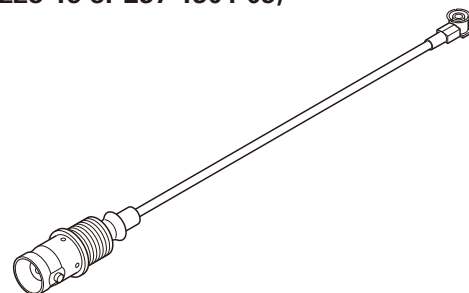

ADJUSTMENT

Flat cable (36-pin) about 256mm (E37-0979-05)

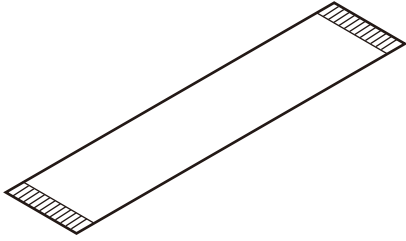

ANT Jig for BPF adjustment (E30-3418-08)

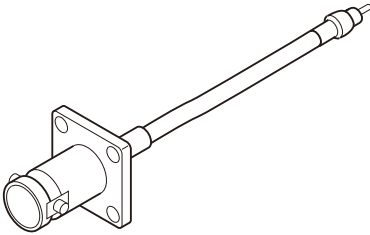

Test Signaling

■ Analog

No.	Decode tone	Encode tone
1	None	None
2	None	100Hz square wave
3	QT 67.0Hz	QT 67.0Hz
4	QT 151.4Hz	QT 151.4Hz
5	QT 210.7Hz	QT 210.7Hz
6	QT 254.1Hz	1QT 254.1Hz
7	DQT D023N	DQT D023N
8	DQT D754I	DQT D754I
9	None	CWID encode (ID: VVV)
10	None	Single tone
11	DTMF decode (Code: 159D)	DTMF encode (Code: 159D)
12	None	DTMF encode (Code: 9)
13	None	Courtesy tone

■ NXDN

No.	Decode tone	Encode tone
1	RAN1	RAN1
2	RAN1	PN9
3	RAN1	Maximum deviation pattern

- Signaling number 1 is used for link test with voice.
- Signaling number 2 is used for TX modulation signal quality test. i.e, TX adjacent channel power, FSK error, Occupied bandwidth, Emission mask, etc.
- Signaling number 3 is used for TX deviation test. If the modulation mode is very narrow, the modulation frequency is 600Hz. If the modulation mode is narrow, the modulation frequency is 1200Hz.

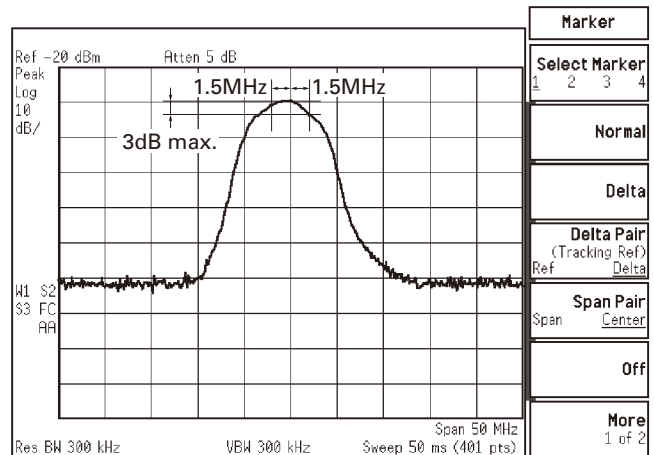

BPF center frequency (Production default)
E: 160.1MHz
Pass bandwidth: ± 1.5 MHz at 3dB

Fig. 1

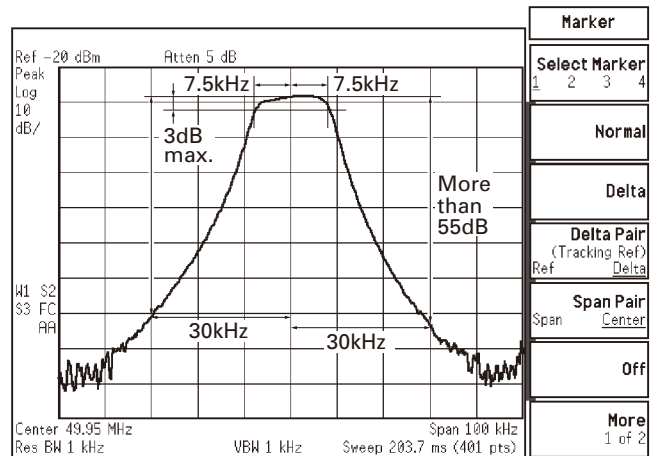

Center frequency: 49.95MHz
Pass bandwidth: ± 7.5 MHz at 3dB

Fig. 2

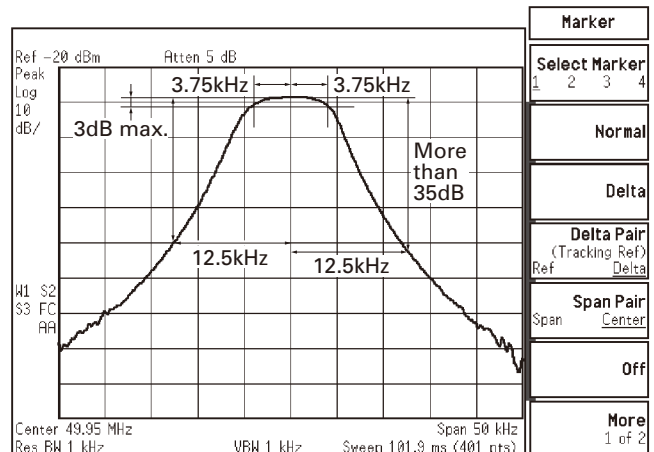

Center frequency: 49.95MHz
Pass bandwidth: ± 3.75 MHz at 3dB

Fig. 3

ADJUSTMENT

Adjustment Points

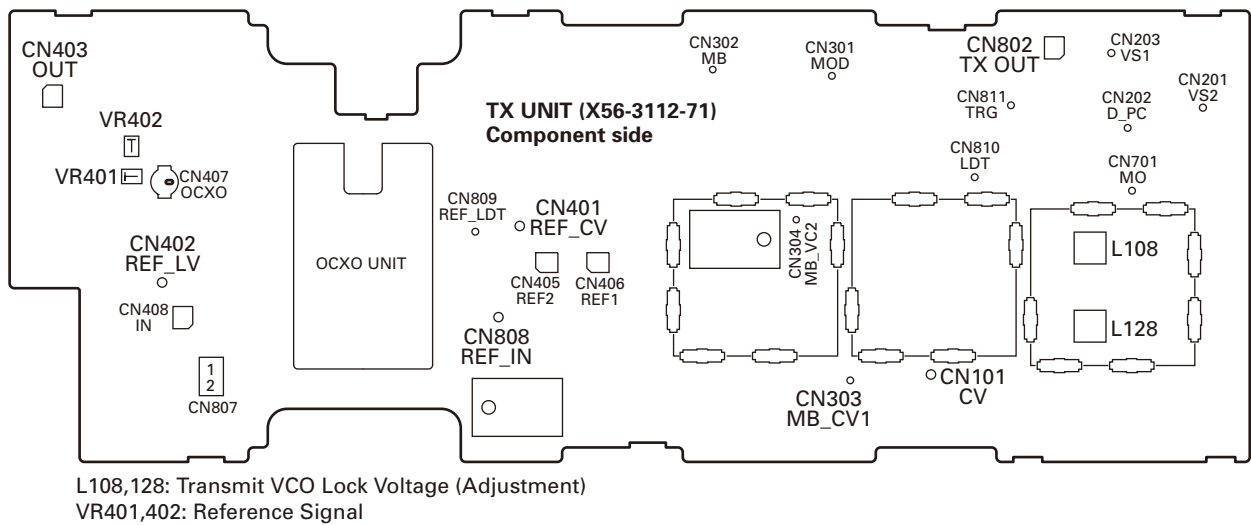
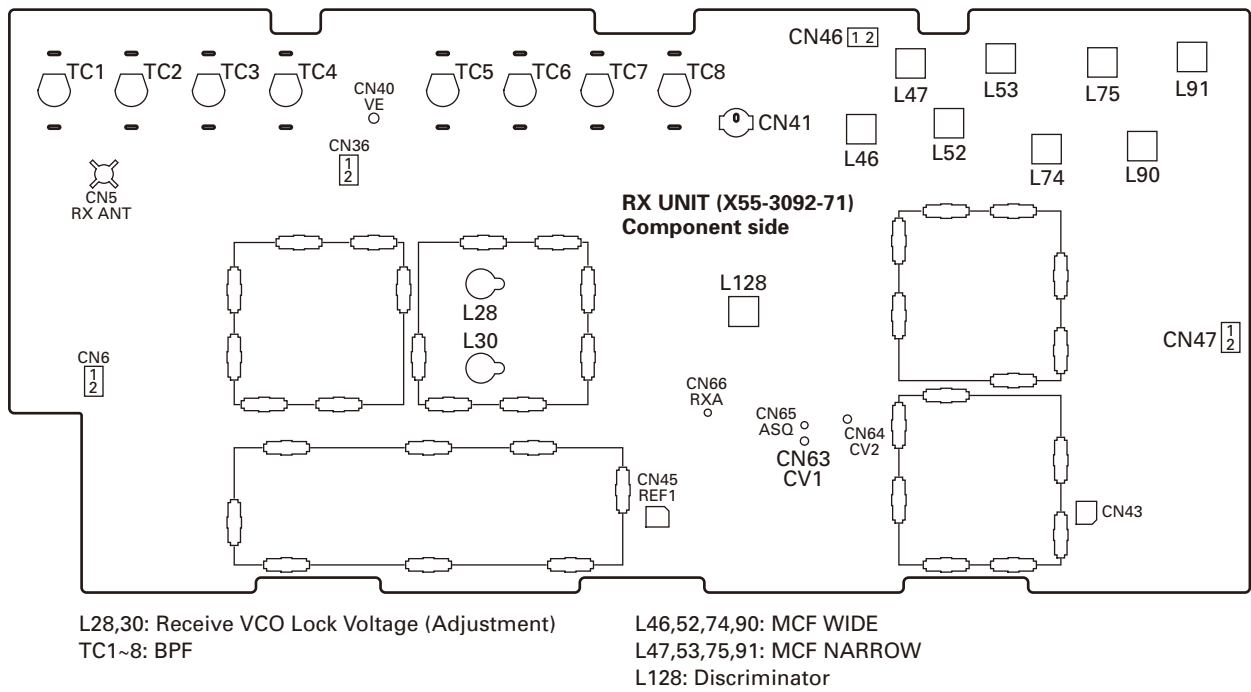
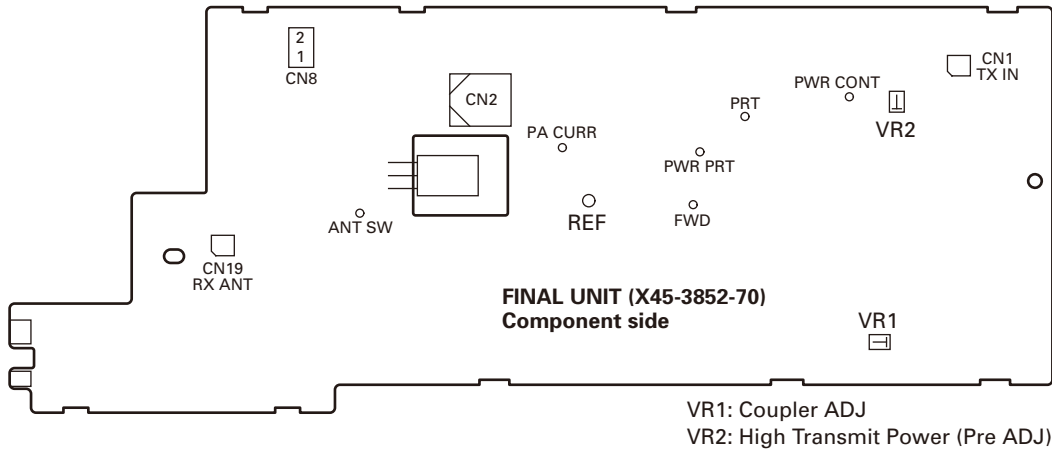

NXR-700

ADJUSTMENT

Alignment

Item	Condition	Measurement			Adjustment			Specifications / Remarks
		Test-equipment	Unit	Terminal	Unit	Parts	Method	
1. Setting	1) Connect the DC power output to the rear panel DC terminal (13.2V). 2) Connect the front panel COM port (D-sub 9 connector) to the PC serial port with a cross-wired cable. 3) Activate the FPU to go to the test mode.							
2. Temperature Sensor	1) Receive unit (Celsius or Fahrenheit)	Thermometer		Room temperature	RX	PC ADJ	Measuring room temperature, write the value with PC.	
	2) Transmit unit (Celsius or Fahrenheit)				TX			
3. Driver Amplifier Power (Pre ADJ)	1) Low 2) High					PC ADJ	Value: 1	Fixed value writing
4. RF Power Down Detection	1) High 2) Low					PC ADJ	Value: 1	Fixed value writing
5. VCO Lock Voltage	1) REF Low SSG frequency: 10MHz -10ppm (9.99999MHz) SSG output: 0dBm	SSG DVM	TX	REF IN REF CV (CN401)			Check	1.5V or more
	2) REF High SSG frequency: 10MHz +10ppm (10.00001MHz) SSG output: 0dBm							3.5V or less
	3) MOD Low SSG frequency: 10MHz -10ppm (9.99999MHz) SSG output: 0dBm							1.5V or more
	4) MOD High SSG frequency: 10MHz +10ppm (10.00001MHz) SSG output: 0dBm							3.5V or less
6. Transmit VCO Lock Voltage (Adjustment)	1) A: Low	DVM	TX	CV	TX	L128	Adjust the interval of the L128. 1.30V	±0.05V
	2) B: Low							L108
7. Receive VCO Lock Voltage (Adjustment) Pre ADJ	1) A: Low	DVM	RX	CV1	RX	L28	Adjust the interval of the L28. 1.3V	±0.05V
	2) B: Low							L30
8. Fixation of Oscillation Coil	1) Apply the high-frequency varnish to the adjusted Transmit VCO coil (L128, L108) and cover it with a shield cover. 2) Apply the high-frequency varnish to the adjusted Receive VCO coil (L28, L30) and cover it with a shield cover.							

ADJUSTMENT

Item	Condition	Measurement			Adjustment			Specifications / Remarks
		Test-equipment	Unit	Terminal	Unit	Parts	Method	
9. Transmit VCO Lock Voltage (Check)	1) A: Low	DVM	TX	CV			Check	1.0V or more
	2) A: High							4.4V or less
	3) B: Low							1.0V or more
	4) B: High							4.4V or less
10. Receive VCO Lock Voltage (Adjustment & Check)	1) A: Low	DVM PC	RX	CV1		PC ADJ	0.8V	+0.15V, -0.05V
	2) A: High						Check	4.2V or less
	3) B: Low					PC ADJ	0.8V	+0.15V, -0.05V
	4) B: High						Check	4.2V or less
11. Reference Signal The switching circuit to switch the OCXO and the internal reference oscillation	1) Connecting SSG to REF IN and 50Ω-load parallel. SSG frequency: 10MHz SSG output: +0dBm (224mV)	SSG Spectrum analyzer	Rear TX	REF IN REF OUT	TX	VR402	+8~-+9dBm	The OCXO LED (orange) lights.
	2) SSG frequency: 10MHz SSG output: +0dBm (224mV)		SSG Oscilloscope	Rear TX			REF IN REF_LV	VR401
	3) SSG frequency: 10MHz SSG output: +10dBm (708mV)	SSG Spectrum analyzer	Rear TX	REF IN REF OUT			Check	REF OUT: +10dBm or less The OCXO LED (orange) lights.
	4) SSG frequency: 10MHz SSG output: -7dBm (99.9mV)							REF OUT: -50dBm or less The OCXO LED goes off.
12. VCXO	1) Confirm that there is no OCXO and external reference input.	F. counter PC	TX	REF_IN		PC ADJ	5.99MHz+0.3ppm	±0.15ppm (5.99000270~5.99000090MHz) It takes a time from movement of adjustment value to stability.
13. Maximum Deviation (NXDN)	1) NXDN Narrow					PC ADJ	Value: 22800	Fixed value writing
	2) NXDN Very Narrow						Value: 10000	
14. Driver Amplifier Power	Disconnect the cable from TX OUT and insert a cable from power meter. After the adjustment, connect the cable to TX OUT. 1) Low 2) Center 3) High	Power meter	TX	TX OUT (CN802)		PC ADJ	+20.0dBm (100mW)	±0.1dB Disconnect the cable from TX OUT and insert a cable from power meter. After the adjustment, connect the cable to TX OUT.

ADJUSTMENT

Item	Condition	Measurement			Adjustment			Specifications / Remarks
		Test-equipment	Unit	Terminal	Unit	Parts	Method	
15. High Transmit Power (Pre ADJ)	1) Center	Power meter PC	Rear	TX ANT		PC ADJ	Value: 1024	Fixed value writing
					Final	VR2	25W	±0.5W
16. Coupler ADJ	1) Center	DVM Power meter	Final	REF	Final	VR1	Adjust to the minimum value.	
17. High Transmit Power (Max power limit ADJ)	1) Center	Power meter PC	Rear	TX ANT		PC ADJ	Value: 1024	Fixed value writing
					Final	VR2	30.0W	±1.0W
18. High Transmit Power	Frequency 1) Low 2) Center 3) High Attach the EXCITER/FINAL shield cover.	Power meter Ammeter	Rear	TX ANT		PC ADJ	25.0W	±0.5W 10.0A or less
							5.0W	±0.1W 5.5A or less
19. Low Transmit Power	Frequency 1) Low 2) Center 3) High Attach the EXCITER/FINAL shield cover.							
20. Deviation (The transmission VCO band is separated into A and B. 3-points for each, i.e., total of 6-points shall be adjusted.)	Modulation pattern : 100Hz square signal Connect the deviation meter to the TX ANT end via the ATT. Deviation meter setting HPF: OFF LPF: 15kHz De-emp: OFF Detector: (p-p)/2 1) A: Low 2) A: Center 3) A: High 4) B: Low 5) B: Center 6) B: High	Deviation meter Oscilloscope PC	Rear	TX ANT		PC ADJ	±1.10kHz Adjust it into clean square wave with changing "Sub-audible Gain" and "Audible Gain".	±0.05kHz Connect the deviation meter to the TX ANT end via the ATT.
							Check	±3.06kHz±0.20kHz Clean sine wave.

ADJUSTMENT

Item	Condition	Measurement			Adjustment			Specifications / Remarks
		Test-equipment	Unit	Terminal	Unit	Parts	Method	
21. Maximum Deviation (Analog)	1) Channel: 3 (Center) Wide/Narrow: Analog Wide 5k Connect the deviation meter to the TX ANT end via the ATT. Deviation meter setting HPF: OFF LPF: 15kHz De-emp: OFF Detector: +peak, -peak AG setting: 1kHz/45mVrms (Sine wave, Terminal load)	Deviation meter AG DVM	Rear Front	TX ANT MIC		PC ADJ	±4.1kHz	±0.2kHz Connect the deviation meter to the TX ANT end via the ATT.
	±3.20kHz						±0.2kHz	
	±1.7kHz						±0.1kHz	
22. Standard Modulation Check	1) Channel: 3 (Center) Wide/Narrow: Analog Wide 5k Connect the deviation meter to the TX ANT end via the ATT. Deviation meter setting HPF: OFF LPF: 15kHz De-emp: OFF Detector: (p-p)/2 AG setting : 1kHz/±3kHz DEV (Sine wave, Terminal load)					Check	4.5mV±1.5mV Connect the deviation meter to the TX ANT end via the ATT.	
	2) Channel: 3 (Center) Wide/Narrow: Analog Narrow Connect the deviation meter to the TX ANT end via the ATT. AG setting : 1kHz/±1.5kHz DEV (Sine wave, Terminal load)						5.5mV±1.5mV	
23. QT Deviation	1) Channel: 3 (Center) Wide/Narrow: Analog Wide 5k Connect the deviation meter to the TX ANT end via the ATT. Deviation meter setting HPF: OFF LPF: 3kHz De-emp: OFF Detector: p-p/2	Deviation meter	Rear	TX ANT		PC ADJ	±0.75kHz ±0.05kHz Connect the deviation meter to the TX ANT end via the ATT.	

ADJUSTMENT

Item	Condition	Measurement			Adjustment			Specifications / Remarks
		Test-equipment	Unit	Terminal	Unit	Parts	Method	
23. QT Deviation	2) Channel: 3 (Center) Wide/Narrow: Analog Wide 4k	Deviation meter	Rear	TX ANT		PC ADJ	±0.6kHz	±0.05kHz
	3) Channel: 3 (Center) Wide/Narrow: Analog Narrow						±0.35kHz	±0.05kHz
24. DQT Deviation	1) Channel: 3 (Center) Wide/Narrow: Analog Wide 5k Connect the deviation meter to the TX ANT end via the ATT. Deviation meter setting HPF: OFF LPF: 3kHz De-emp: OFF Detector: Peak hold	Deviation meter	Rear	TX ANT		PC ADJ	±0.75kHz	±0.05kHz Connect the deviation meter to the TX ANT end via the ATT.
	2) Channel: 3 (Center) Wide/Narrow: Analog Wide 4k						±0.6kHz	±0.05kHz
	3) Channel: 3 (Center) Wide/Narrow: Analog Narrow						±0.35kHz	±0.05kHz
25. CW ID Deviation	1) Channel: 3 (Center) Wide/Narrow: Analog Wide 5k Connect the deviation meter to the TX ANT end via the ATT. Deviation meter setting HPF: OFF LPF: 15kHz De-emp: OFF Detector: +peak, -peak	Deviation meter	Rear	TX ANT		PC ADJ	±2.00kHz	±0.05kHz Connect the deviation meter to the TX ANT end via the ATT.
	2) Channel: 3 (Center) Wide/Narrow: Analog Wide 4k						±1.6kHz	±0.05kHz
	3) Channel: 3 (Center) Wide/Narrow: Analog Narrow						±1.00kHz	±0.05kHz
26. Test Tone Deviation	1) Channel: 3 (Center) Wide/Narrow: Analog Wide 5k Connect the deviation meter to the TX ANT end via the ATT. Deviation meter setting HPF: OFF, LPF: 15kHz De-emp: OFF Detector: (p-p)/2	Deviation meter	Rear	TX ANT		PC ADJ	±3.00kHz	±0.05kHz Connect the deviation meter to the TX ANT end via the ATT.
	2) Channel: 3 (Center) Wide/Narrow: Analog Wide 4k						±2.4kHz	±0.05kHz
	3) Channel: 3 (Center) Wide/Narrow: Analog Narrow						±1.50kHz	±0.05kHz

ADJUSTMENT

Item	Condition	Measurement			Adjustment			Specifications / Remarks
		Test-equipment	Unit	Terminal	Unit	Parts	Method	
27. DTMF Deviation	1) Channel: 3 (Center) Wide/Narrow: Analog Wide 5k Connect the deviation meter to the TX ANT end via the ATT. Deviation meter setting HPF: OFF, LPF: 15kHz De-emp: OFF Detector: (p-p)/2	Deviation meter	Rear	TX ANT		PC ADJ	±2.85kHz	±0.05kHz Connect the deviation meter to the TX ANT end via the ATT.
	±2.4kHz						±0.05kHz	
	±1.50kHz						±0.05kHz	
28. Courtesy Tone Deviation	1) Channel: 3 (Center) Wide/Narrow: Analog Wide 5k Connect the deviation meter to the TX ANT end via the ATT. Deviation meter setting HPF: OFF, LPF: 15kHz De-emp: OFF Detector: (p-p)/2	Deviation meter	Rear	TX ANT		PC ADJ	±1.00kHz	±0.05kHz Connect the deviation meter to the TX ANT end via the ATT.
	±0.8kHz						±0.05kHz	
	±0.50kHz						±0.05kHz	
29. TD Deviation	1) Channel: 3 (Center) Wide/Narrow: Analog Wide 5k Connect the deviation meter to the TX ANT end via the ATT. Deviation meter setting HPF: OFF, LPF: 3kHz De-emp: OFF Detector: +peak, -peak AG setting : 0.1kHz/0.5Vp-p (177mVrms)	Deviation meter AG DVM	Rear	TX ANT CONTROL I/O jack TD (pin 8)		PC ADJ	±0.75kHz	±0.02kHz Connect the deviation meter to the TX ANT end via the ATT.
	±0.75kHz						±0.02kHz	
	±0.75kHz						±0.02kHz	
30. Transmit Audio Input (TA)	1) Channel: 3 (Center) Wide/Narrow: Analog Wide 5k Connect the deviation meter to the TX ANT end via the ATT. Deviation meter setting HPF: OFF, LPF: 15kHz De-emp: OFF Detector: +peak, -peak AG setting : 1kHz/280mVrms	Deviation meter AG DVM	Rear	TX ANT CONTROL I/O jack TA (pin 9)		PC ADJ	±3.00kHz	±0.03kHz Connect the deviation meter to the TX ANT end via the ATT.

ADJUSTMENT

Item	Condition	Measurement			Adjustment			Specifications / Remarks
		Test-equipment	Unit	Terminal	Unit	Parts	Method	
30. Transmit Audio Input (TA)	2) Channel: 3 (Center) Wide/Narrow: Analog Wide 4k	Deviation meter AG DVM	Rear	TX ANT CONTROL I/O jack TA (pin 9)		PC ADJ	±2.4kHz	±0.03kHz
	3) Channel: 3 (Center) Wide/Narrow: Analog Narrow						±1.50kHz	±0.02kHz
31. BPF	1) Tracking generator Output: -20dBm Spectrum analyzer Frequency: Desired frequency Span: 50MHz	Tracking generator Spectrum analyzer	Rear RX	RX ANT CN41	RX	TC1~ TC8	Adjust it by the programmed frequency to look like the wave in figure 1.	Refer to Fig. 1. (Page 80)
32. MCF	1) Wide Tracking generator Output: -20dBm Spectrum analyzer Frequency: 49.95MHz Span: 100kHz	Tracking generator Spectrum analyzer	Rear RX	CN46 CN47	RX	L46 L52 L74 L90	Adjust it to look like the wave in figure 2.	Refer to Fig. 2. (Page 80)
	2) Narrow Spectrum analyzer Span: 50kHz			L47 L53 L75 L91		Adjust it to look like the wave in figure 3.	Refer to Fig. 3. (Page 80)	
33. Discriminator	1) Narrow Frequency: Desired frequency SSG output: -53dBm (501µV) SSG MOD: 1kHz SSG DEV: 1.5kHz AF output: 2V/4Ω	SSG AF V.M	Rear	RX ANT TEST/ SPKR jack SPO (pin 12) 4Ω load	RX	L128	Adjust AF output max.	
34. RD Level	1) Wide/Narrow: Analog Wide 5k Connect the SSG to the RX ANT. SSG setting Frequency: Desired frequency Output: -53dBm (501µV) MOD: 1kHz DEV: ±3.0kHz	SSG AF V.M	Rear	RX ANT CONTROL I/O jack RD (pin 10)		PC ADJ	80mV	±5mV
	2) Wide/Narrow: Analog Wide 4k SSG setting DEV: ±2.4kHz							
	3) Wide/Narrow: Analog Narrow SSG setting DEV: ±1.5kHz							
35. RA Level	1) Wide/Narrow: Analog Wide 5k Connect the SSG to the RX ANT. SSG setting Frequency: Desired frequency Output: -53dBm (501µV) MOD: 1kHz DEV: ±3.0kHz	SSG AF V.M	Rear	RX ANT CONTROL I/O jack RA (pin 11)		PC ADJ	400mV	±20mV

ADJUSTMENT

Item	Condition	Measurement			Adjustment			Specifications / Remarks	
		Test-equipment	Unit	Terminal	Unit	Parts	Method		
35. RA Level	2) Wide/Narrow: Analog Wide 4k SSG setting DEV: $\pm 2.4\text{kHz}$	SSG AF V.M	Rear	RX ANT CONTROL I/O jack RA (pin 11)		PC ADJ	400mV	$\pm 20\text{mV}$	
	3) Wide/Narrow: Analog Narrow SSG setting DEV: $\pm 1.5\text{kHz}$								
36. Receiver Sensitivity Check	1) Wide/Narrow: Analog Wide 5k Connect the SSG to the RX ANT. SSG setting Frequency: Desired frequency MOD: 1kHz DEV: $\pm 3.0\text{kHz}$ AF: $0.45\text{V}/4\Omega$	SSG Distortion meter	Rear	RX ANT TEST/ SPKR jack SPO (pin 12) 4Ω load			Check	-115dBm ($0.4\mu\text{V}$) or less	
	2) Wide/Narrow: Analog Wide 4k SSG setting DEV: $\pm 2.4\text{kHz}$								
	3) Wide/Narrow: Analog Narrow SSG setting DEV: $\pm 1.5\text{kHz}$								
37. Tight Squelch	1) Wide/Narrow: Analog Wide 5k Connect the SSG to the RX ANT. SSG setting Frequency: Desired frequency Output: 12dB SINAD level +7dB MOD: 1kHz DEV: $\pm 3.0\text{kHz}$	SSG Oscilloscope Audio analyzer	Rear	RX ANT TEST/ SPKR jack SPO (pin 12) 4Ω load		PC ADJ	Adjust it to the level to open the squelch.		
	2) SSG output: OFF							Check	The squelch shall be closed.
	3) Wide/Narrow: Analog Wide 4k SSG setting DEV: $\pm 2.4\text{kHz}$						PC ADJ	Adjust it to the level to open the squelch.	
	4) SSG output: OFF							Check	The squelch shall be closed.
	5) Wide/Narrow: Analog Narrow SSG setting DEV: $\pm 1.5\text{kHz}$						PC ADJ	Adjust it to the level to open the squelch.	
	6) SSG output: OFF							Check	The squelch shall be closed.
38. Open Squelch	1) Wide/Narrow: Analog Wide 5k Connect the SSG to the RX ANT. SSG setting Frequency: Desired frequency Output: 12dB SINAD level -2dB MOD: 1kHz DEV: $\pm 3.0\text{kHz}$	SSG Oscilloscope Audio analyzer	Rear	RX ANT TEST/ SPKR jack SPO (pin 12) 4Ω load		PC ADJ	Adjust it to the level to open the squelch.		

ADJUSTMENT

Item	Condition	Measurement			Adjustment			Specifications / Remarks	
		Test-equipment	Unit	Terminal	Unit	Parts	Method		
38. Open Squelch	2) SSG output: OFF	SSG Oscilloscope Audio analyzer	Rear	RX ANT TEST/ SPKR jack SPO (pin 12) 4Ω load			Check	The squelch shall be closed.	
	3) Wide/Narrow: Analog Wide 4k SSG setting DEV: ±2.4kHz						PC ADJ	Adjust it to the level to open the squelch.	
	4) SSG output: OFF							Check	The squelch shall be closed.
	5) Wide/Narrow: Analog Narrow SSG setting DEV: ±1.5kHz						PC ADJ	Adjust it to the level to open the squelch.	
	6) SSG output: OFF							Check	The squelch shall be closed.
39. RSSI	Wide/Narrow: Analog Narrow Connect the SSG to the RX ANT. SSG setting Frequency: Desired frequency MOD: 1kHz DEV: ±1.5kHz 1) SSG output: -53dBm (501μV)	SSG AF V.M	Rear	RX ANT TEST/ SPKR jack RSSI (pin 8)		PC ADJ	3.5V	±0.1V	
	2) Point: High Level SSG output : 12dB SINAD level +7dB						PC ADJ (Vin4)	Apply the value (Vin4)	
	3) Point: Low Level SSG output : 12dB SINAD level -2dB								
40. Repeater Gain	1) Wide/Narrow: Analog Wide 5k Connect the SSG to the RX ANT. SSG setting Frequency: Desired frequency Output: -53dBm (501μV) MOD: 1.0kHz DEV: ±1.0kHz Connect the deviation meter to the TX ANT end via the ATT. Deviation meter setting HPF: OFF LPF: 15kHz De-emp: OFF Detector: +peak, -peak	SSG Deviation meter	Rear	RX ANT TX ANT		PC ADJ	±1.00kHz	±0.10kHz	
	2) Wide/Narrow: Analog Wide 4k							±1.00kHz	±0.10kHz
	3) Wide/Narrow: Analog Narrow							±1.00kHz	±0.10kHz

ADJUSTMENT

Adjustment for KXK-3 (OCXO unit)

We recommend that the frequency adjustment be checked each time the radio is serviced, or at least once per year. Maintenance should only be performed under normal temperatures.

■ Test Equipment Required for Alignment

Test Equipment	Major Specifications	
1. Frequency Counter	Frequency Range	Up to 50MHz
	Resolution	9 digits
	Reference Frequency Accuracy	Smaller than 0.01ppm
	Input level	Up to 5Vpp

■ Adjustment Setup

The KXK-3 OCXO unit must be mounted on the NXR-700 or NXR-800 repeater. Adjustment setup is shown as follows.

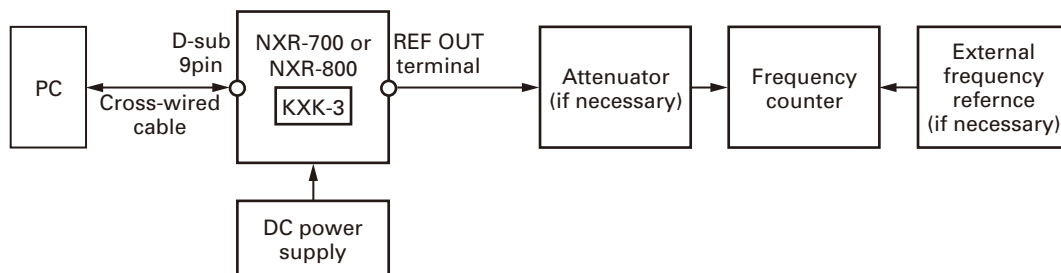

To adjust the KXK-3 OCXO unit, some preparations are required.

1. The NXR-700 or NXR-800 with the KXK-3 OCXO unit must be warmed up at least 24 hours before the adjustment is made. The environment temperature must be stable.
2. The frequency counter (or reference oscillator) must be warmed up as defined by the equipment manufacturer.

■ Adjustment

Item	Condition	Measurement			Adjustment			Specifications / Remarks
		Test-equipment	Unit	Terminal	Unit	Parts	Method	
1. Setting	1) Connect the DC power output to the rear panel DC terminal (13.2V). 2) Connect the "REF OUT" terminal to the frequency counter. 3) Warm-up the equipment and KXK-3 properly. 4) Connect the front panel COM port (D-sub 9 connector) to the PC serial port with a cross-wired cable. 5) Activate the FPU to go to the test mode.							
2. OCXO frequency adjustment		f. counter	Rear	REF OUT		PC ADJ		±0.15ppm 9.9999850MHz~ 10.00000150MHz

Note:

Adjusted data is stored in the KXK-3 internal memory, therefore no re-adjustment is required when the adjusted KXK-3 is moved to another NXR-700 or NXR-800.

NXR-700 PC BOARD

FINAL UNIT (X45-3852-70) Component side view (J79-0218-19)

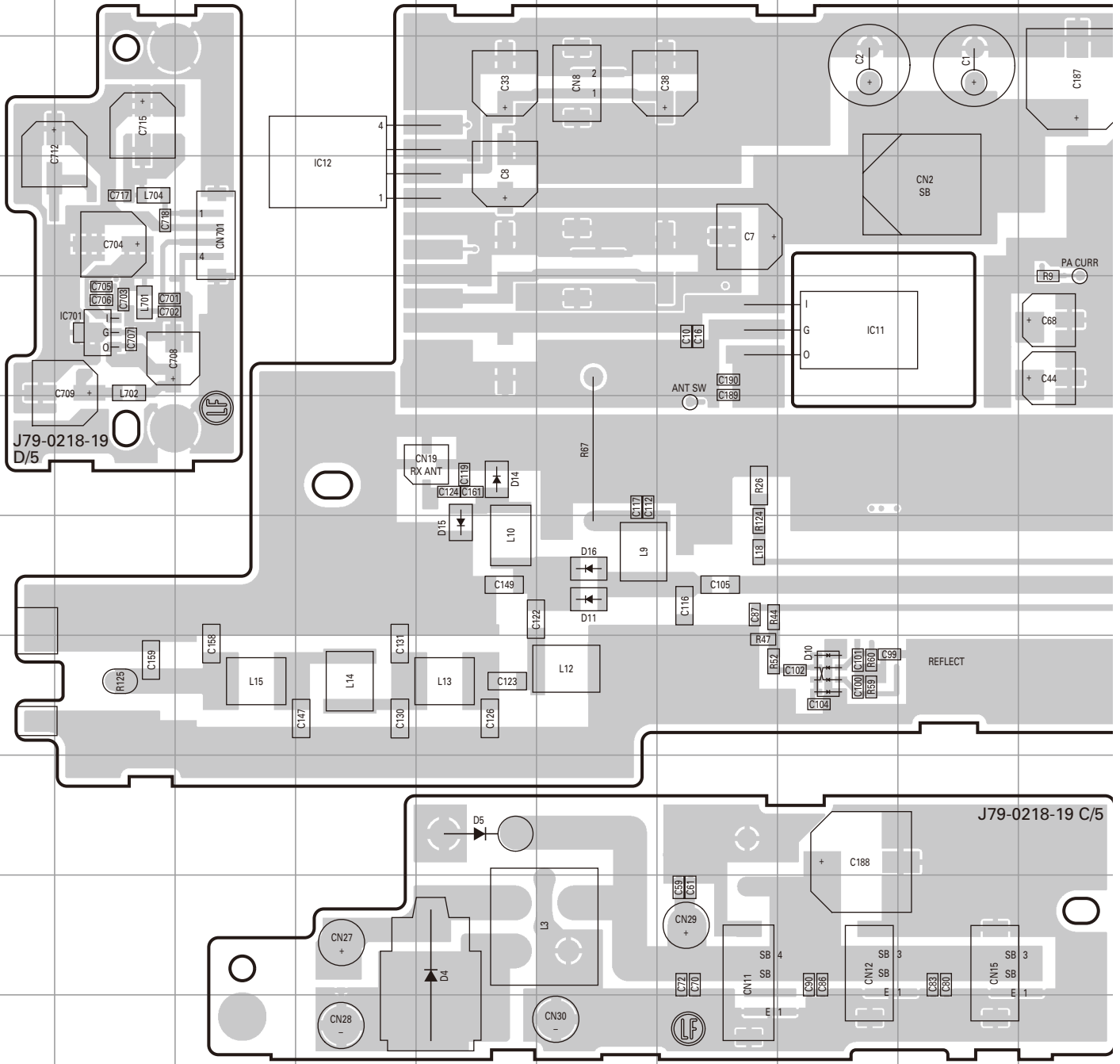

Ref. No.	Address	Ref. No.	Address	Ref. No.	Address	Ref. No.	Address	Ref. No.	Address
IC2	4O	IC8	5M	IC701	5B	D5	9E	D14	6E
IC4	5K	IC9	3M	Q2	4Q	D7	4Q	D15	7E
IC5	4M	IC10	5R	Q6	3N	D9	6O	D16	7F
IC6	4K	IC11	5H	Q8	5N	D10	8H		
IC7	5N	IC12	4D	D4	10E	D11	7F		

PC BOARD NXR-700

FINAL UNIT (X45-3852-70) Component side view (J79-0218-19)

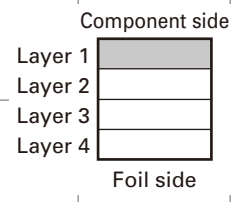
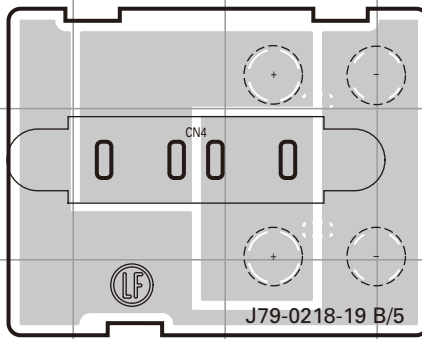
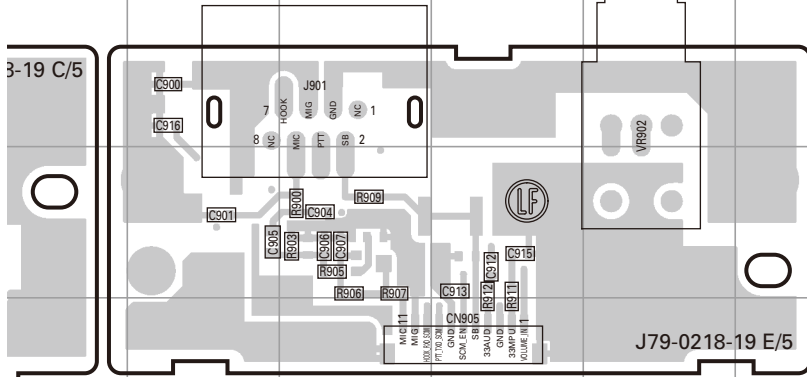
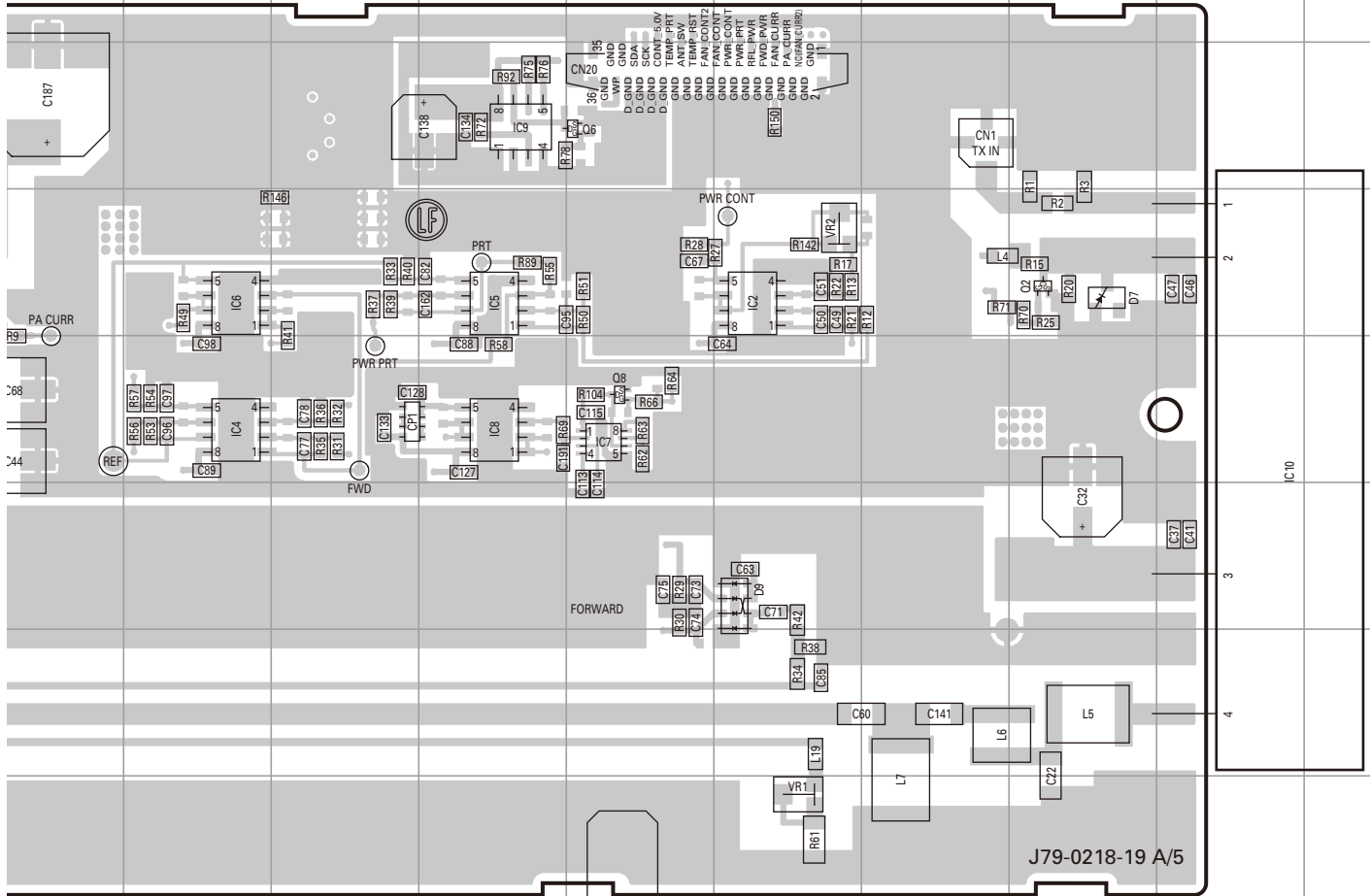

NXR-700 PC BOARD

FINAL UNIT (X45-3852-70)
Foil side view (J79-0218-19)

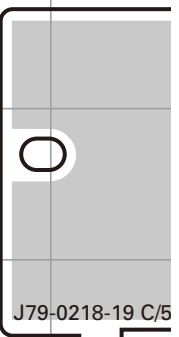
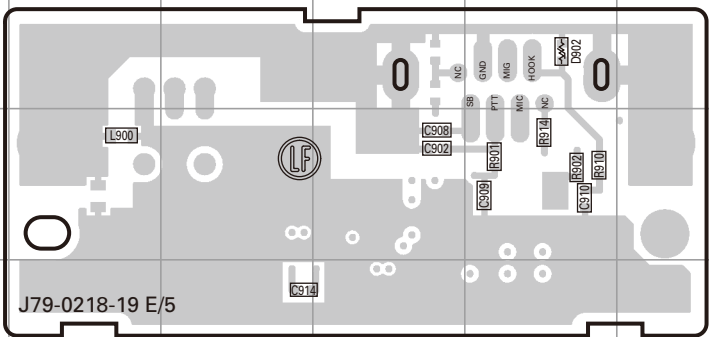
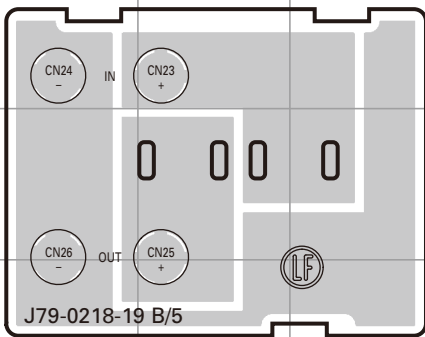
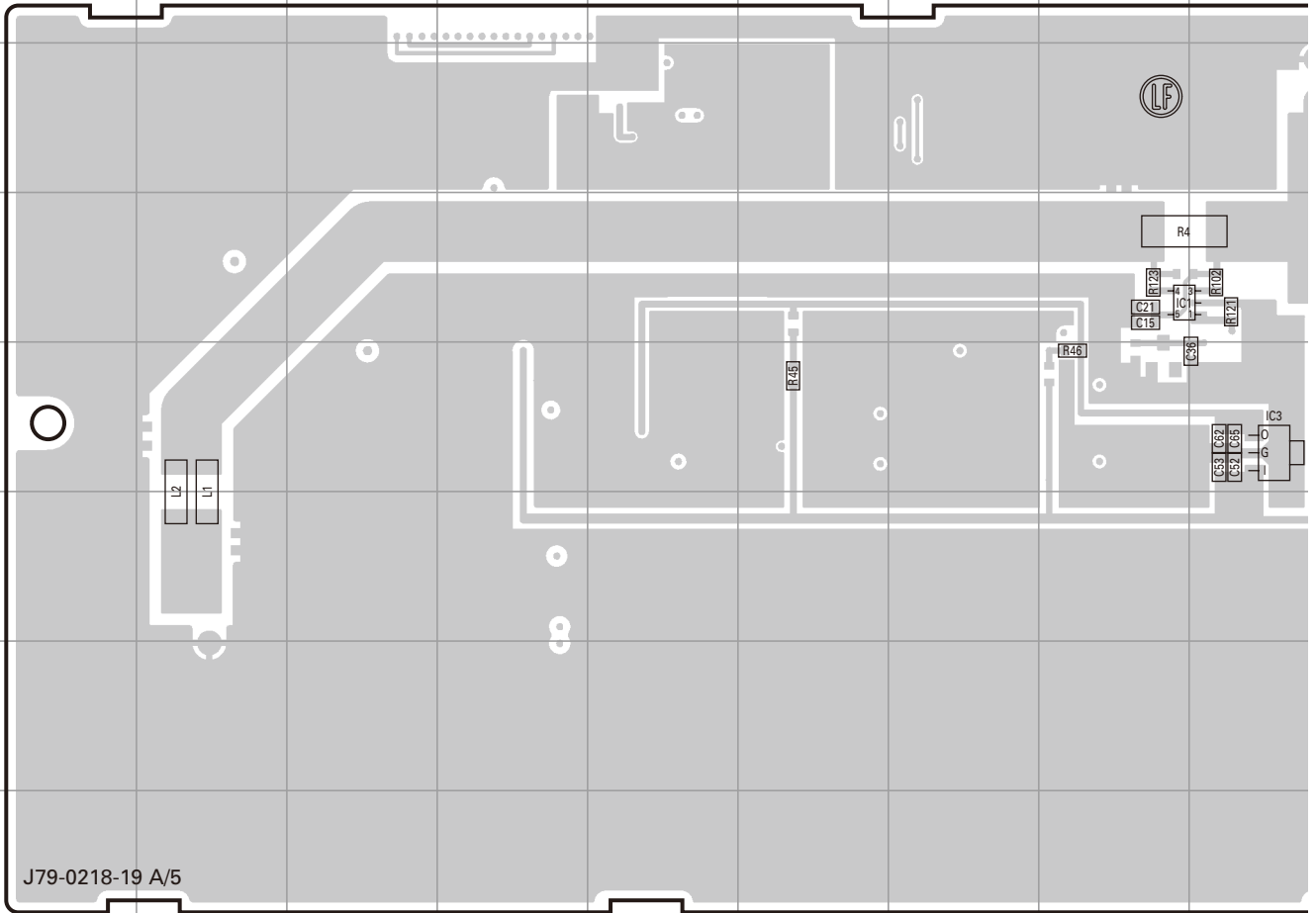

Ref. No.	Address	Ref. No.	Address
IC1	4I	Q4	5M
IC3	5J	Q5	5L
IC702	5Q	D6	3M
IC703	4Q	D902	9H

NXR-700 PC BOARD

RX UNIT (X55-3092-71)

Component side view (J79-0220-09)

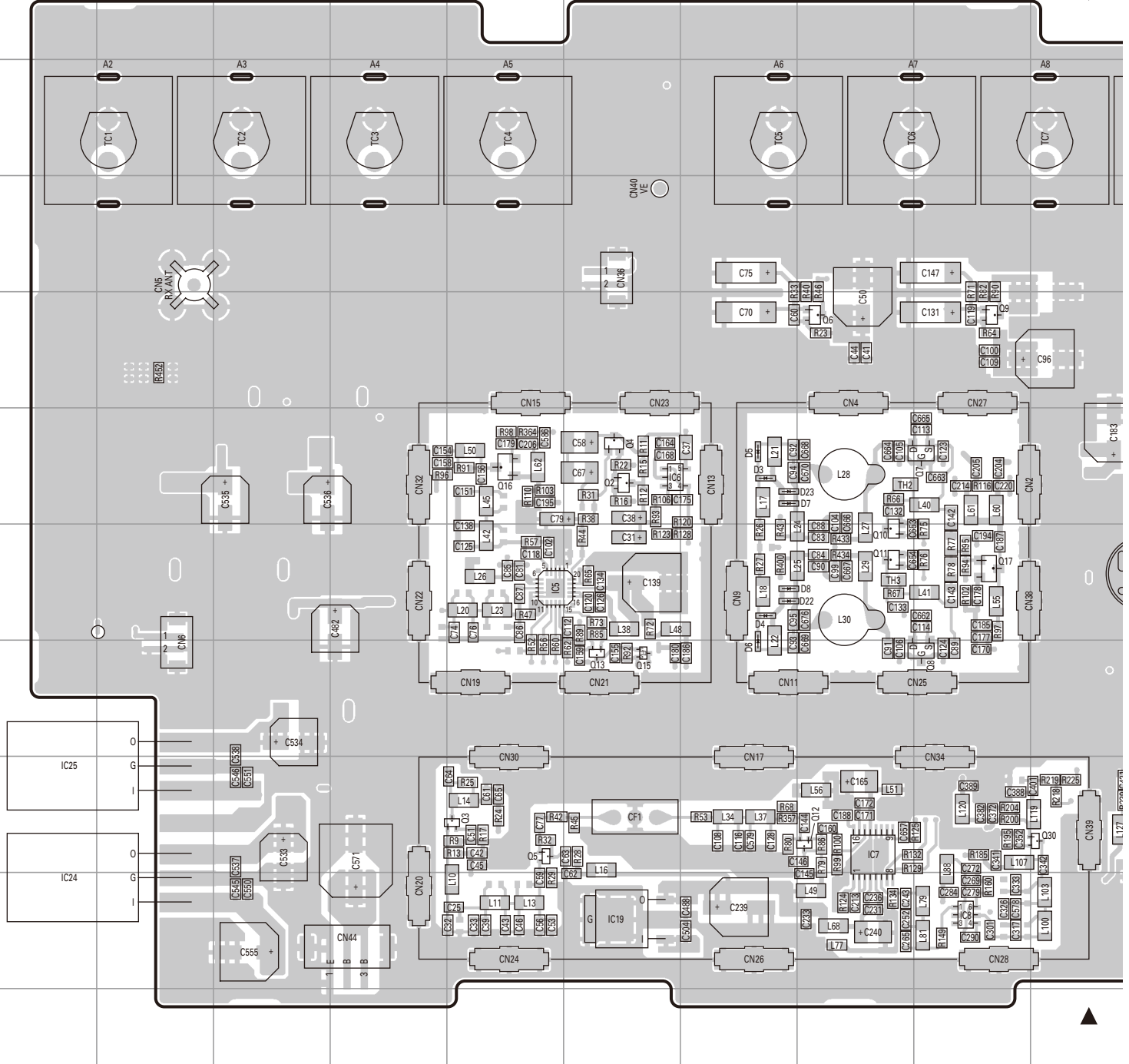

Ref. No.	Address	Ref. No.	Address	Ref. No.	Address	Ref. No.	Address	Ref. No.	Address	Ref. No.	Address	Ref. No.	Address	Ref. No.	Address
IC5	7E	IC15	5K	IC30	8M	Q7	6I	Q17	7I	Q35	6N	D5	6G	D16	6M
IC6	6F	IC19	10F	IC31	9M	Q8	8I	Q22	6O	Q37	7N	D6	8G	D17	8M
IC7	9H	IC20	8K	IC32	8L	Q9	5I	Q24	10O	Q38	6P	D7	6G	D18	8M
IC8	10I	IC22	10Q	IC35	8M	Q10	7H	Q27	9P	Q39	9J	D8	7G	D19	6L
IC10	9Q	IC23	9K	Q2	6F	Q11	7H	Q28	6Q	Q40	7M	D11	8N	D20	6L
IC11	6O	IC24	10A	Q3	9E	Q12	9H	Q29	5S	Q51	10M	D12	9N	D21	9L
IC12	7M	IC25	9A	Q4	6F	Q13	8F	Q30	9J	Q56	10L	D13	7R	D22	7G
IC13	9S	IC28	8N	Q5	9E	Q15	8F	Q33	9P	D3	6G	D14	6R	D23	6G
IC14	9R	IC29	8L	Q6	5H	Q16	6E	Q34	7N	D4	7G	D15	6M		

PC BOARD NXR-700

RX UNIT (X55-3092-71)

Component side view (J79-0220-09)

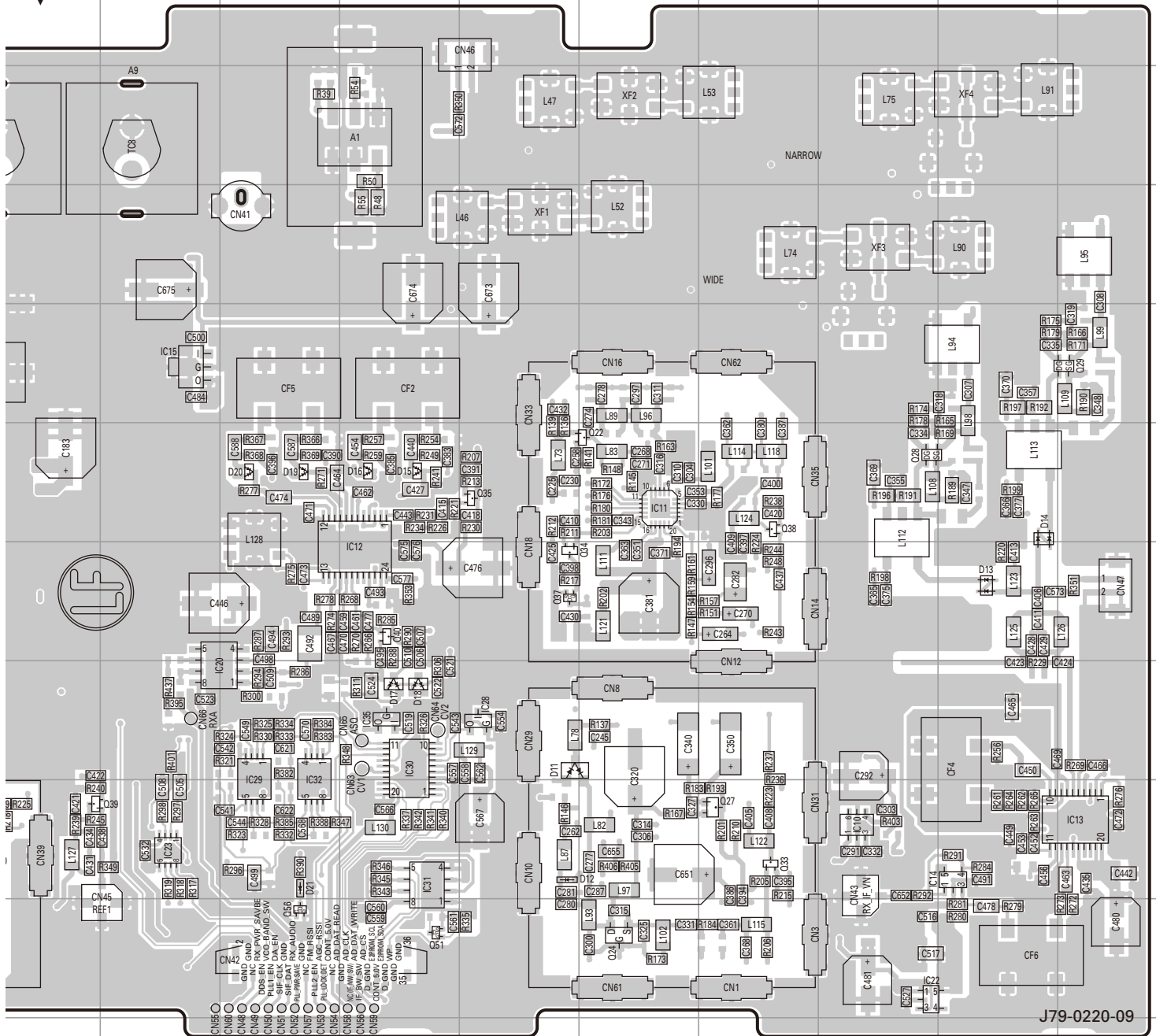

J79-0220-09

Component side

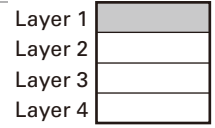

NXR-700 PC BOARD

RX UNIT (X55-3092-71)
Foil side view (J79-0220-09)

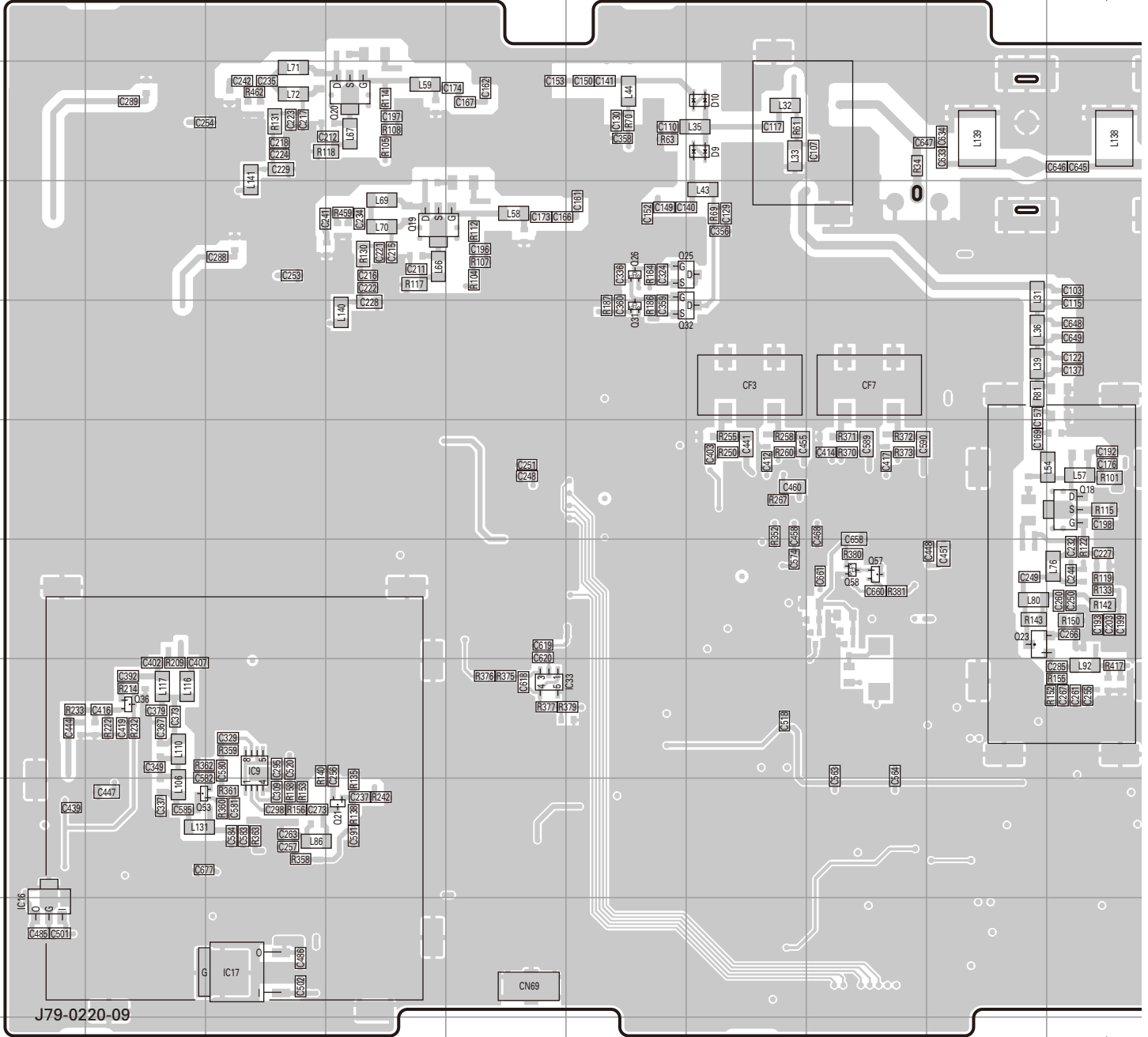

Ref. No.	Address	Ref. No.	Address	Ref. No.	Address	Ref. No.	Address
IC4	4M	Q14	7L	Q32	5G	Q61	7N
IC9	8C	Q18	6J	Q36	8B	D1	4N
IC16	10A	Q19	4D	Q50	10Q	D2	4N
IC17	10C	Q20	3D	Q52	10Q	D9	3G
IC18	8P	Q21	9D	Q53	9B	D10	3G
IC26	7Q	Q23	7I	Q57	7H		
IC27	7P	Q25	4G	Q58	7H		
IC33	8E	Q26	4F	Q59	7L		
Q1	3N	Q31	5F	Q60	7N		

PC BOARD NXR-700

RX UNIT (X55-3092-71)
Foil side view (J79-0220-09)

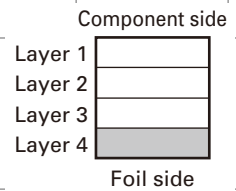
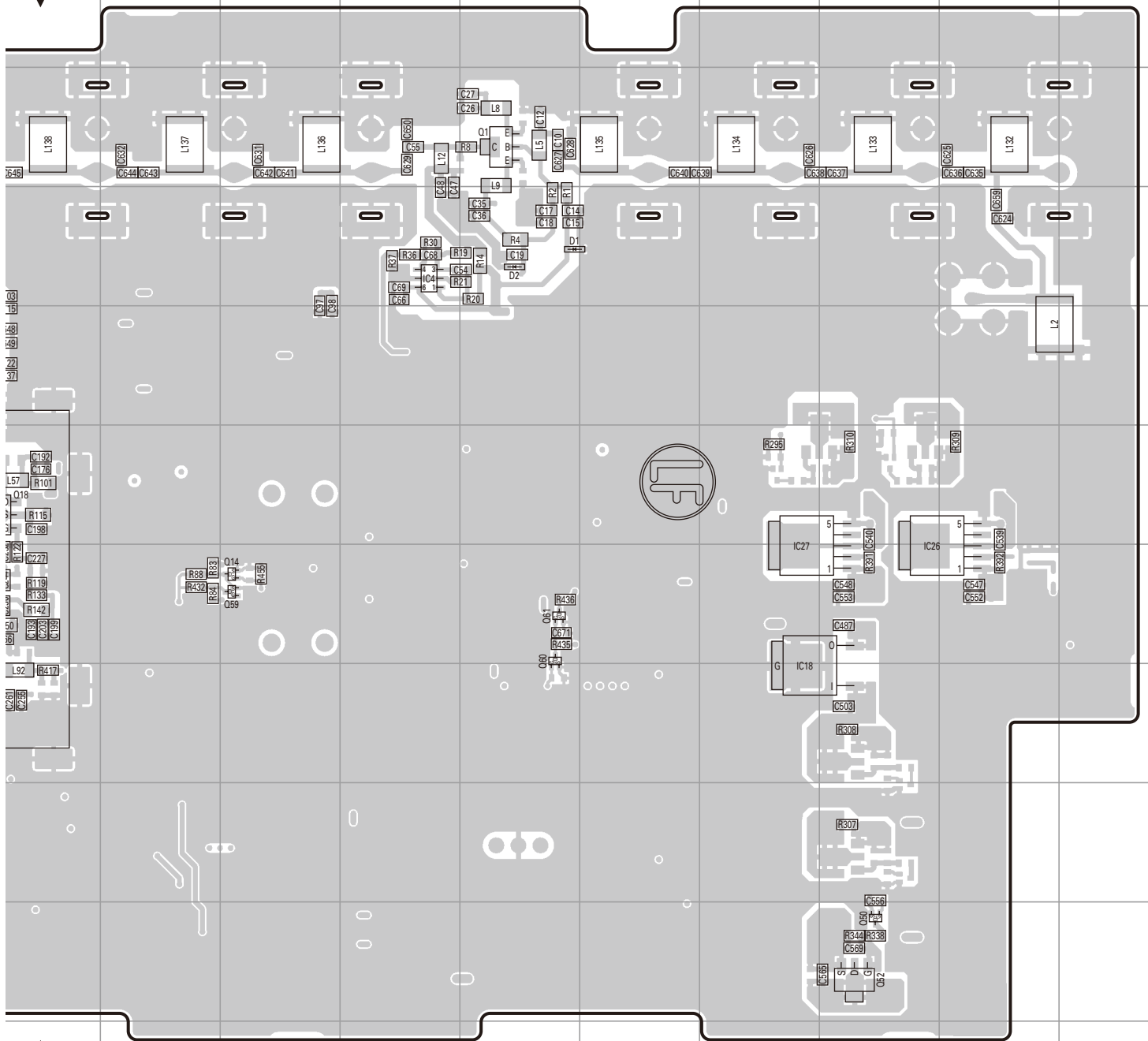

NXR-700 PC BOARD

TX UNIT (X56-3112-71) Component side view (J79-0152-09)

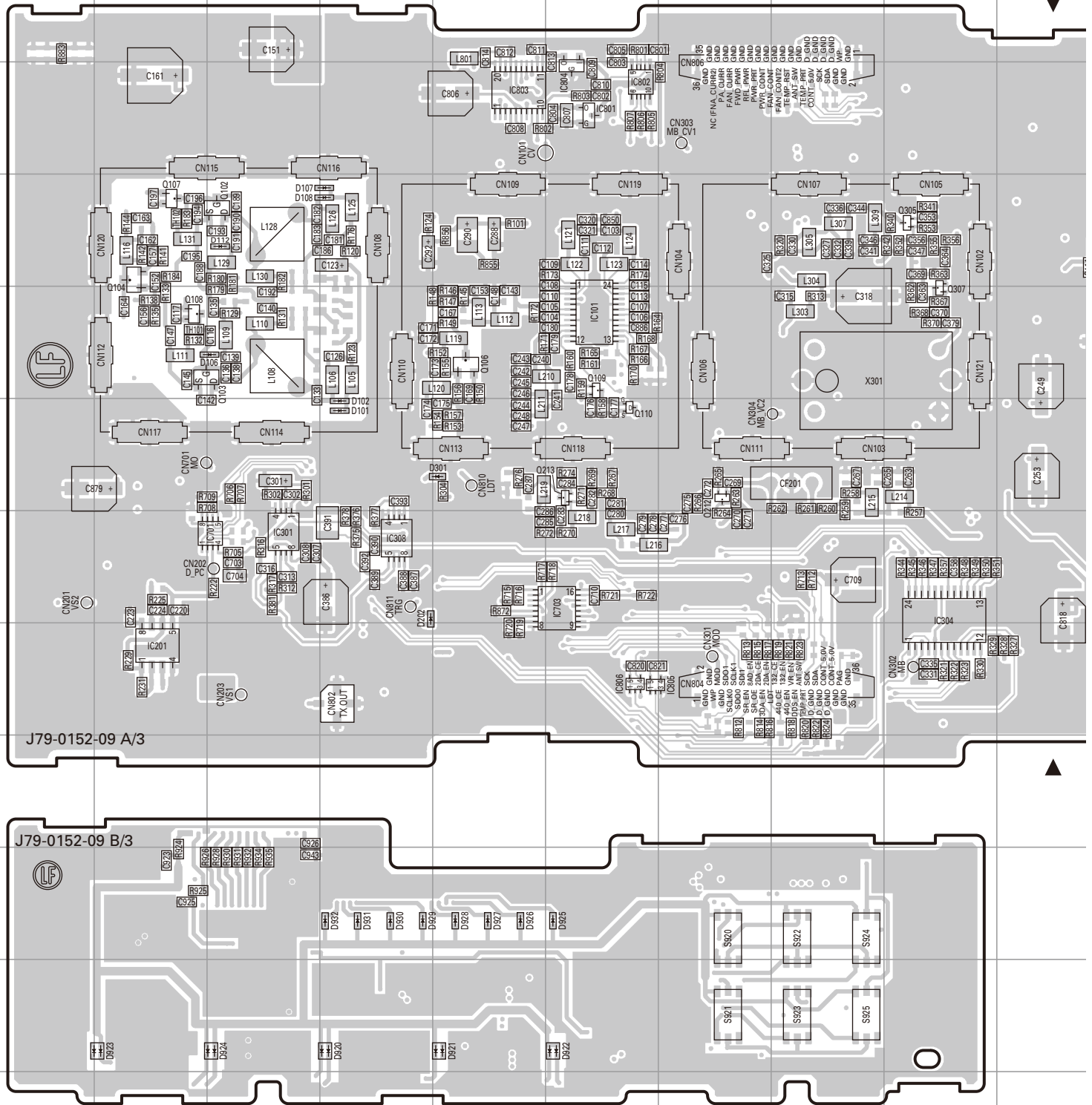

Ref. No.	Address	Ref. No.	Address	Ref. No.	Address	Ref. No.	Address	Ref. No.	Address	Ref. No.	Address	Ref. No.	Address	Ref. No.	Address
IC101	5F	IC706	6K	IC807	8K	Q104	4B	Q213	6F	Q964	11O	D107	4D	D922	11F
IC201	8B	IC801	3F	IC808	4S	Q106	5E	Q305	4I	Q965	11P	D108	4D	D923	11B
IC301	7C	IC802	3F	IC809	3S	Q107	4B	Q307	5I	Q966	11Q	D112	4C	D924	11C
IC304	7I	IC803	3E	IC960	11R	Q108	5B	Q401	4K	Q967	11Q	D202	7D	D925	10F
IC308	7D	IC804	3F	IC961	11P	Q109	5F	Q402	4K	D101	6D	D301	6E	D926	10E
IC701	7C	IC805	8F	Q102	4C	Q110	6F	Q962	11R	D102	6D	D920	11D	D927	10E
IC703	7F	IC806	8F	Q103	5C	Q212	6G	Q963	11R	D106	5C	D921	11E	D928	10E

PC BOARD NXR-700

TX UNIT (X56-3112-71)

Component side view (J79-0152-09)

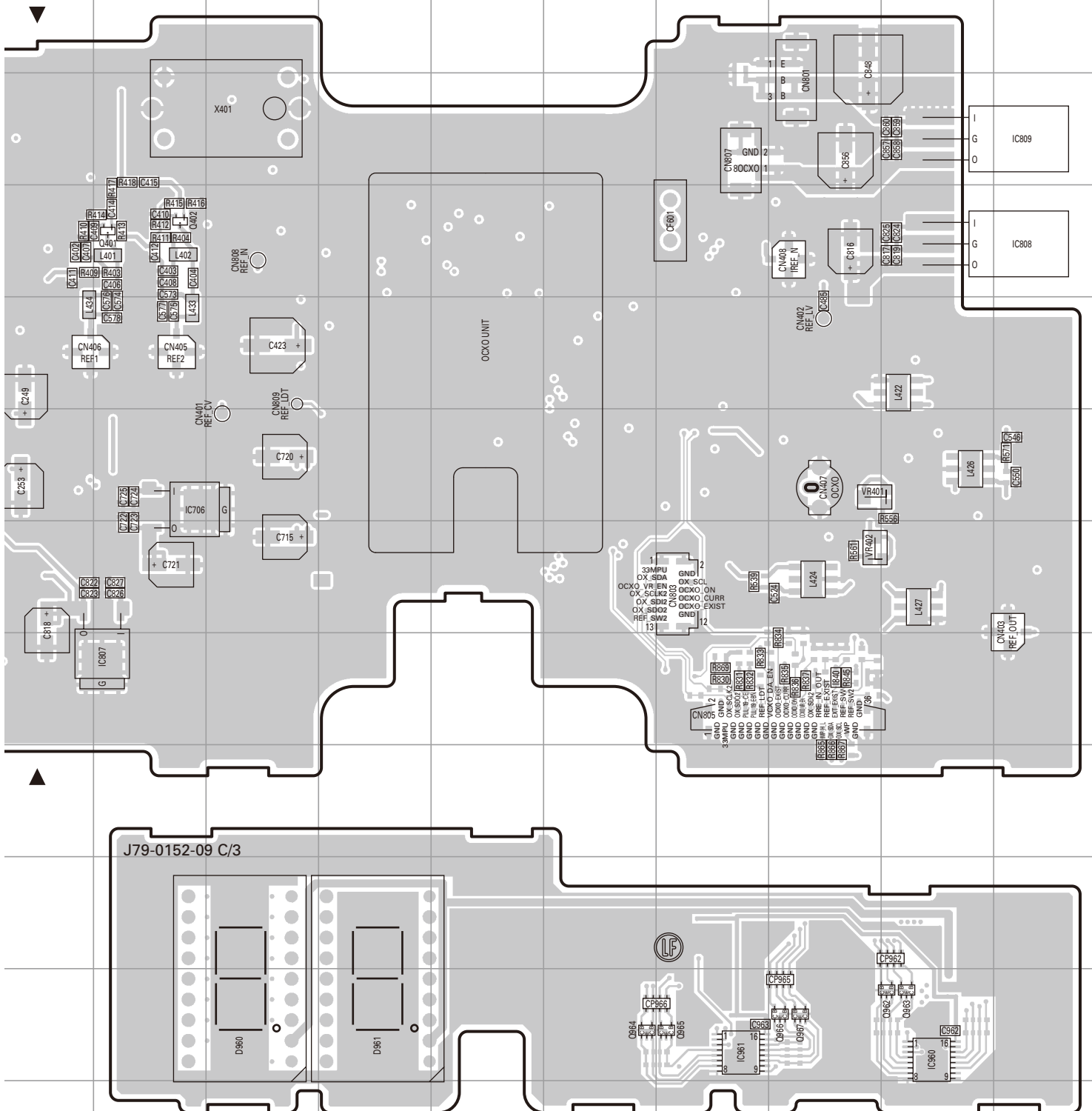

No.	Address
29	10D
30	10D
31	10D
32	10D
60	11L
61	11M

Component side

Layer 1	
Layer 2	
Layer 3	
Layer 4	

Foil side

NXR-700 PC BOARD

TX UNIT (X56-3112-71)
Foil side view (J79-0152-09)

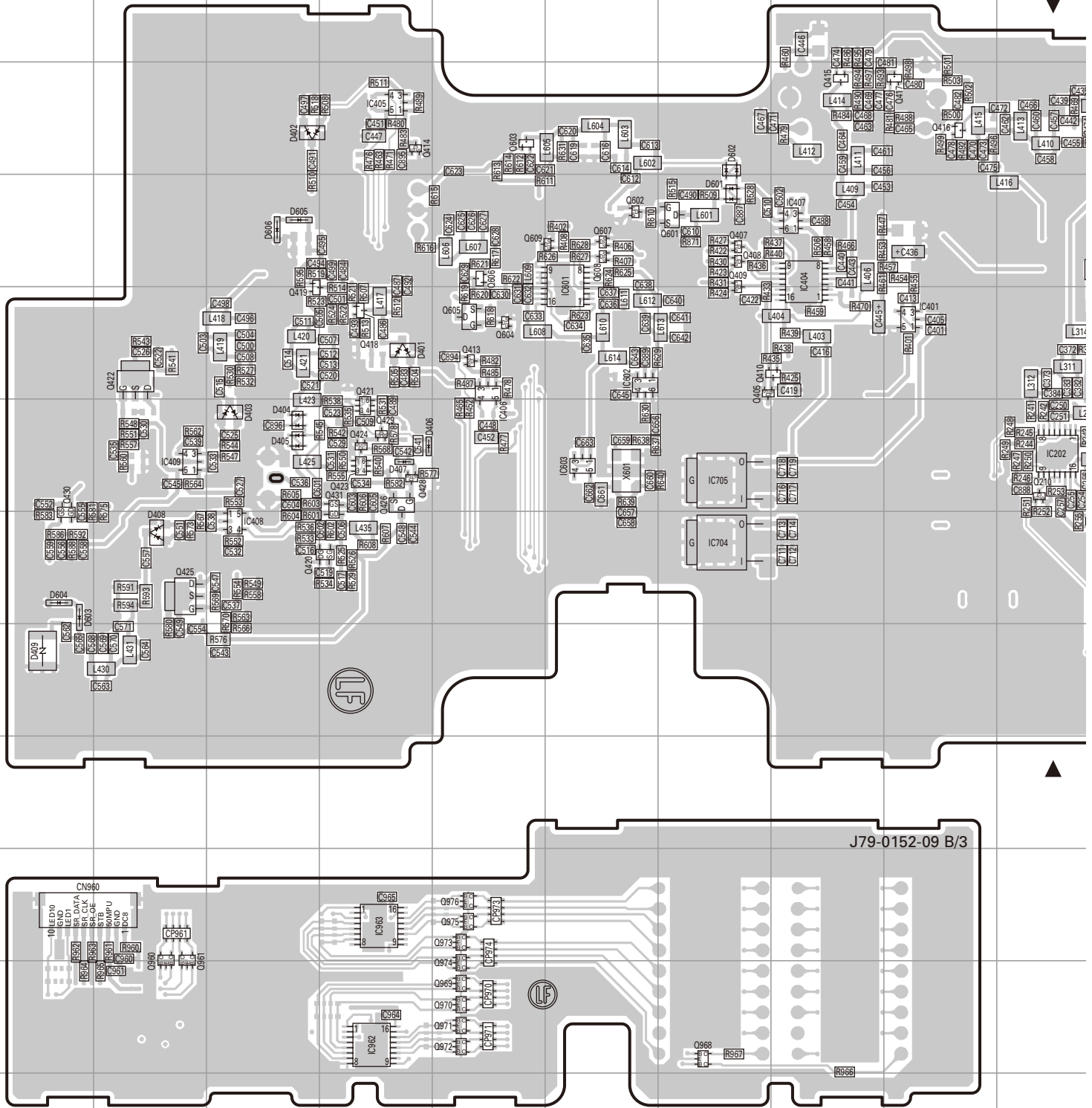

J79-0152-09 B/3

Ref. No.	Address	Ref. No.	Address	Ref. No.	Address	Ref. No.	Address	Ref. No.	Address	Ref. No.	Address	Ref. No.	Address	Ref. No.	Address		
IC102	4O	IC404	4H	IC702	7L	IC924	11Q	Q204	7P	Q405	5G	Q416	3I	Q425	7B	Q604	5E
IC104	2Q	IC405	3D	IC704	7G	IC925	11P	Q205	8P	Q407	4G	Q417	3I	Q426	6D	Q605	5E
IC202	6J	IC406	5E	IC705	6G	IC926	11L	Q206	7P	Q408	4G	Q418	5D	Q428	6D	Q606	4E
IC302	4M	IC407	4H	IC810	6R	IC962	11D	Q210	6J	Q409	4G	Q419	5C	Q429	6D	Q607	4F
IC303	4L	IC408	7C	IC811	6R	IC963	10D	Q211	7J	Q410	5H	Q420	7D	Q430	6A	Q608	4F
IC305	5M	IC409	6B	IC920	11O	Q101	4R	Q301	5L	Q412	3J	Q421	6D	Q431	6D	Q609	4F
IC306	4M	IC601	4F	IC921	11O	Q105	3R	Q302	6O	Q413	5E	Q422	5B	Q601	4G	Q701	8L
IC307	5K	IC602	5F	IC922	11O	Q202	7S	Q303	4L	Q414	3D	Q423	6D	Q602	4F	Q702	4R
IC401	5H	IC603	6F	IC923	11N	Q203	8Q	Q304	4K	Q415	3H	Q424	6D	Q603	3E	Q920	11N

PC BOARD NXR-700

TX UNIT (X56-3112-71)

Foil side view (J79-0152-09)

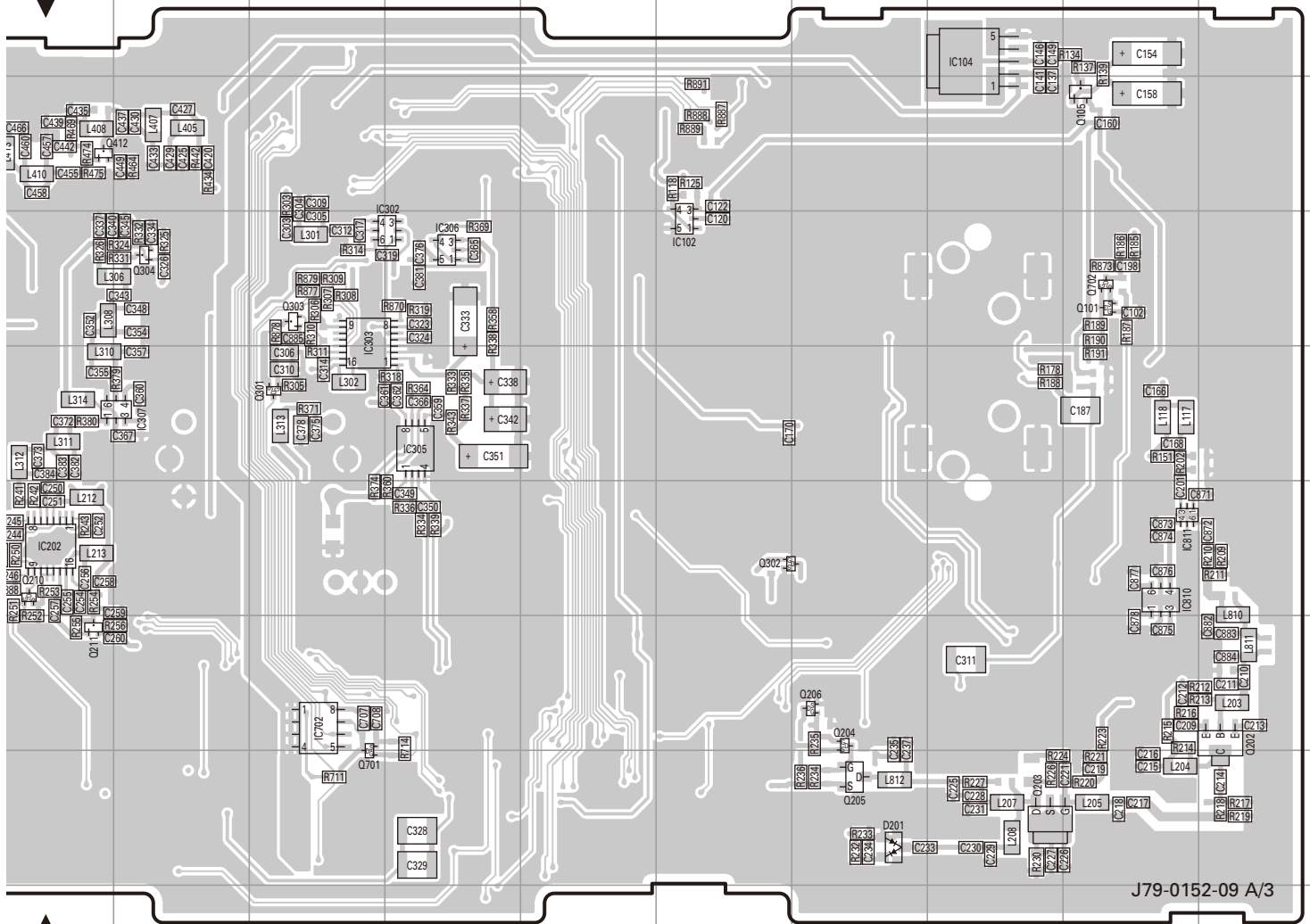

J79-0152-09 A/3

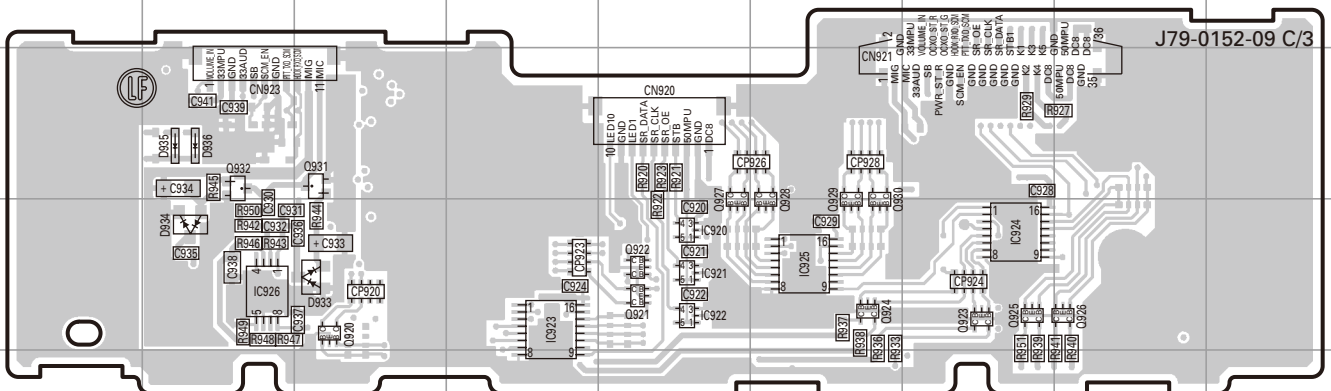

J79-0152-09 C/3

No.	Address	Ref. No.	Address	Ref. No.	Address	Ref. No.	Address	Ref. No.	Address	Ref. No.	Address
04	5E	Q921	11O	Q930	11P	Q972	11E	D404	6C	D604	7A
05	5E	Q922	11O	Q931	10M	Q973	10E	D405	6C	D605	4C
06	4E	Q923	11Q	Q932	10L	Q974	11E	D406	6D	D606	4C
07	4F	Q924	11P	Q960	10B	Q975	10E	D407	6D	D933	11M
08	4F	Q925	11Q	Q961	10B	Q976	10E	D408	7B	D934	11L
09	4F	Q926	11R	Q968	11G	D201	8P	D409	8A	D935	10L
01	8L	Q927	11O	Q969	11E	D401	5D	D601	4G	D936	10L
02	4R	Q928	11P	Q970	11E	D402	3C	D602	3G		
20	11M	Q929	11P	Q971	11E	D403	6C	D603	7A		

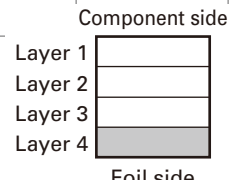

NXR-700 PC BOARD

CONTROL UNIT (X53-4132-XX) -71 : E -72 : For service
Component side view (J79-0011-19)

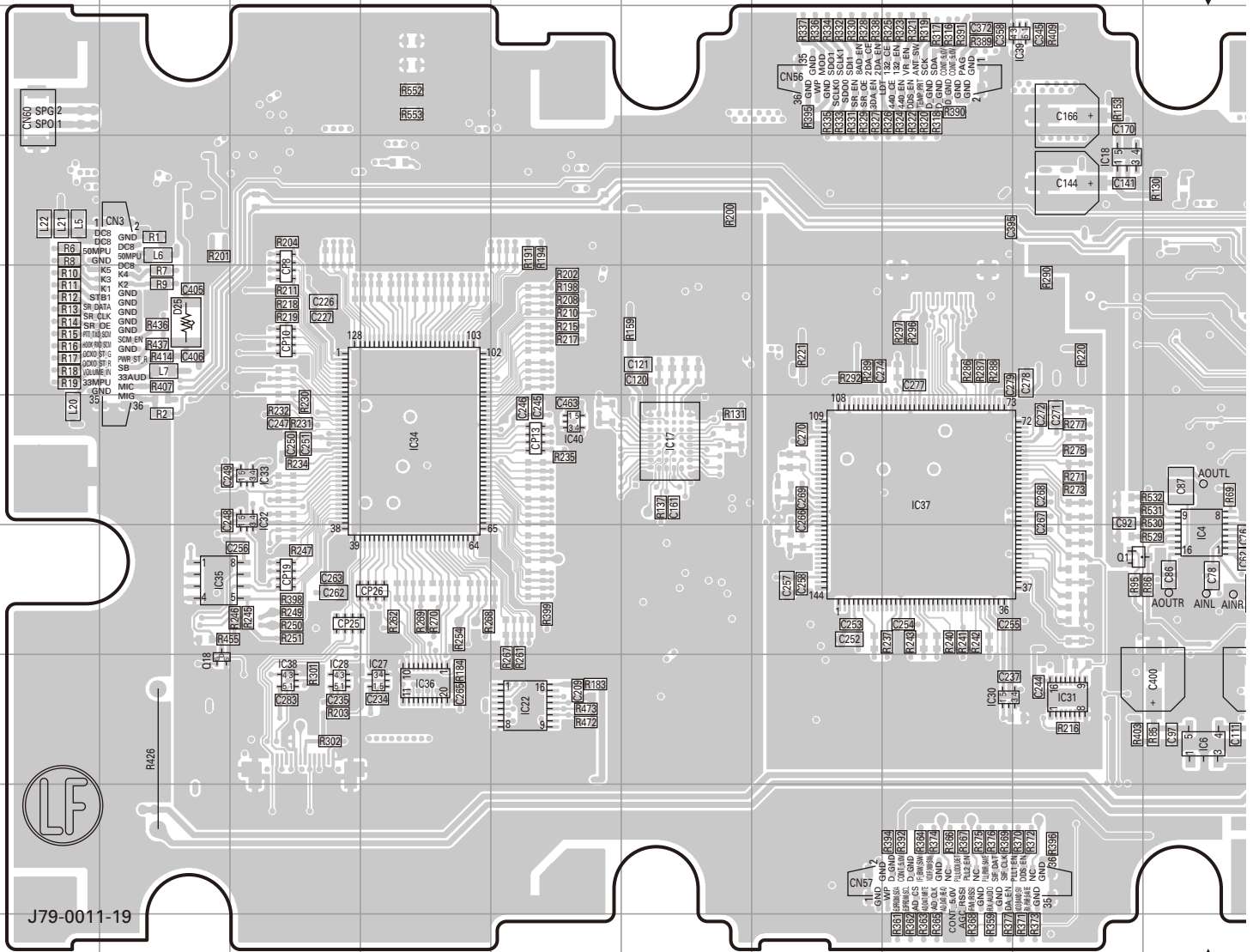

Ref. No.	Address	Ref. No.	Address	Ref. No.	Address	Ref. No.	Address
IC4	7J	IC22	8E	IC33	6C	Q1	7I
IC6	8J	IC23	9N	IC34	6D	Q6	9N
IC7	5S	IC25	9N	IC35	7B	Q7	9N
IC10	6Q	IC27	8D	IC36	8D	Q18	8B
IC11	4P	IC28	8C	IC37	6H	Q26	8N
IC15	8Q	IC29	9K	IC38	8C	D1	6R
IC16	8R	IC30	8H	IC39	3I	D2	4Q
IC17	6F	IC31	8I	IC40	6E	D20	10S
IC18	4I	IC32	6C	IC41	9N	D25	5B

PC BOARD NXR-700

CONTROL UNIT (X53-4132-XX) -71 : E -72 : For service
Component side view (J79-0011-19)

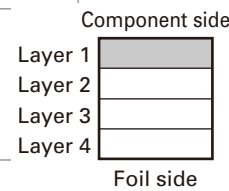
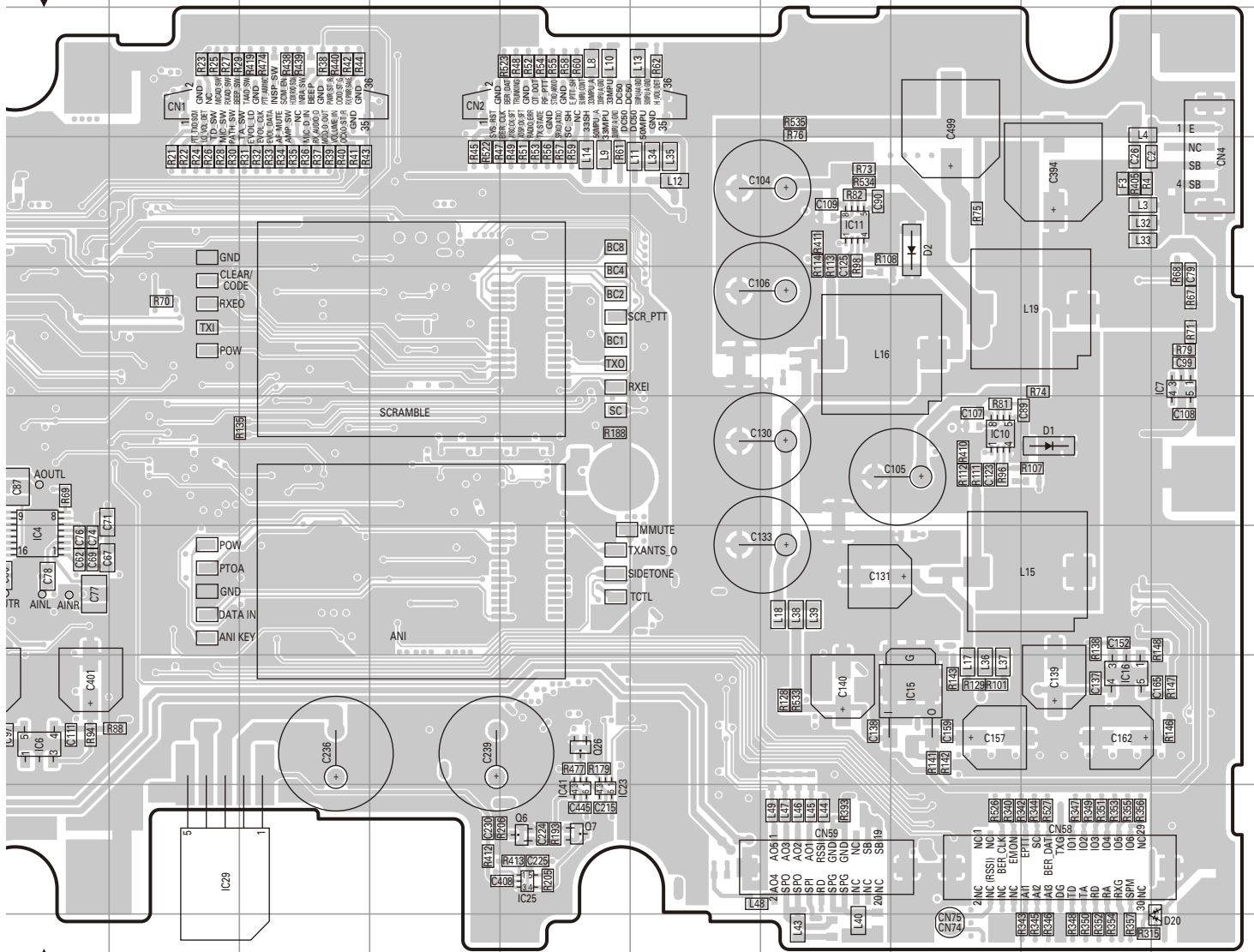

NXR-700 PC BOARD

CONTROL UNIT (X53-4132-XX) -71 : E -72 : For service
Foil side view (J79-0011-19)

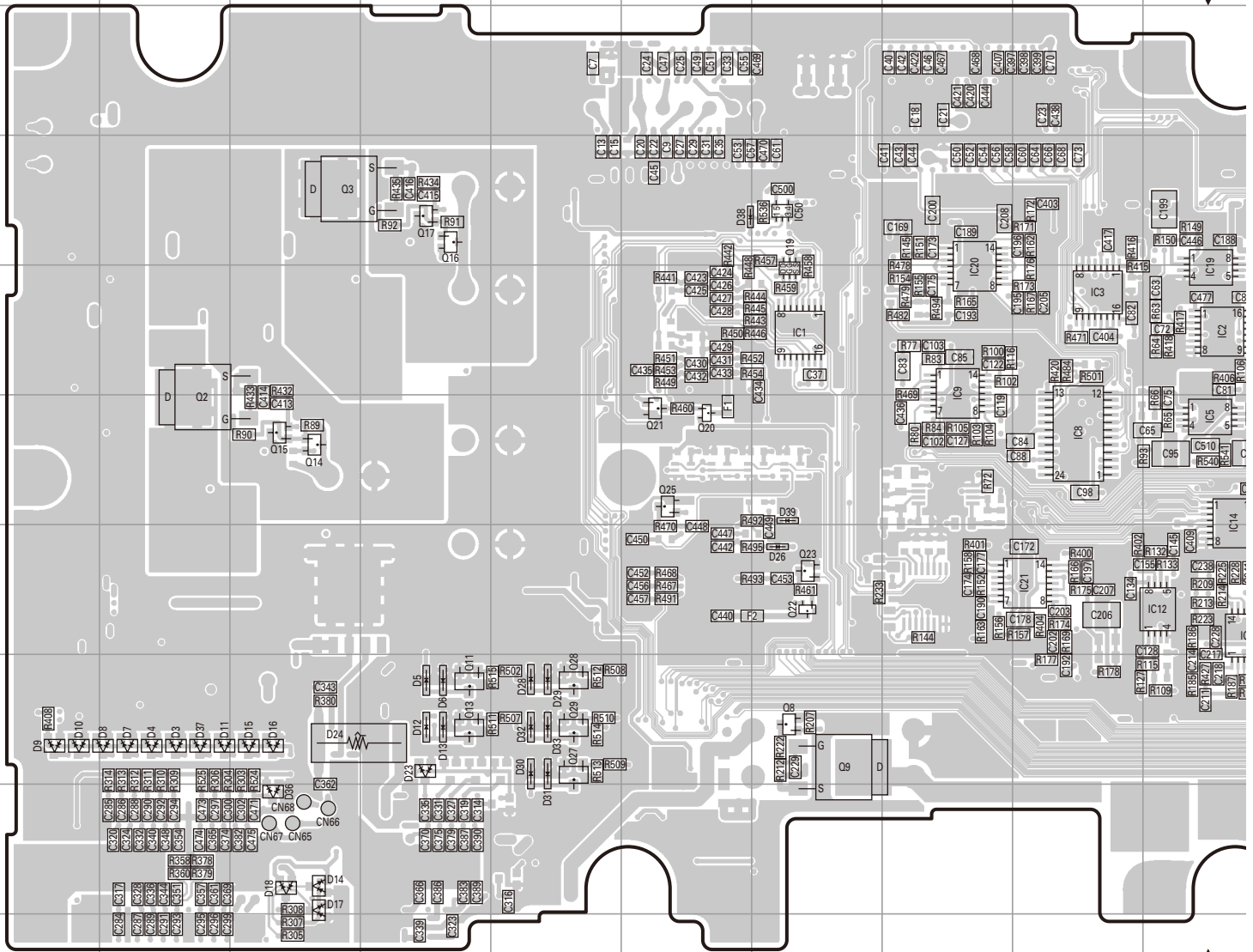

Ref. No.	Address	Ref. No.	Address	Ref. No.	Address	Ref. No.	Address	Ref. No.	Address
IC1	5G	Q2	6B	Q17	4D	D6	8D	D23	8D
IC2	5J	Q3	4C	Q19	5G	D7	8B	D24	8C
IC3	5I	Q4	6P	Q20	6F	D8	8B	D26	7G
IC5	6J	Q5	6P	Q21	6F	D9	8A	D28	8E
IC8	6I	Q8	8G	Q22	7G	D10	8A	D29	8E
IC9	5H	Q9	8G	Q23	7G	D11	8B	D30	8E
IC12	7J	Q10	6M	Q25	6F	D12	8D	D31	8E
IC14	6J	Q11	8D	Q27	8E	D13	8D	D32	8E
IC19	5J	Q12	6L	Q28	8E	D14	9C	D33	8E
IC20	5H	Q13	8D	Q29	8E	D15	8C	D36	9C
IC21	7I	Q14	6C	D3	8B	D16	8C	D37	8B
IC26	7J	Q15	6C	D4	8B	D17	9C	D38	4F
IC50	4G	Q16	4D	D5	8D	D18	9C	D39	6G

PC BOARD NXR-700

CONTROL UNIT (X53-4132-XX) -71 : E -72 : For service
Foil side view (J79-0011-19)

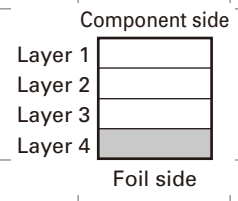
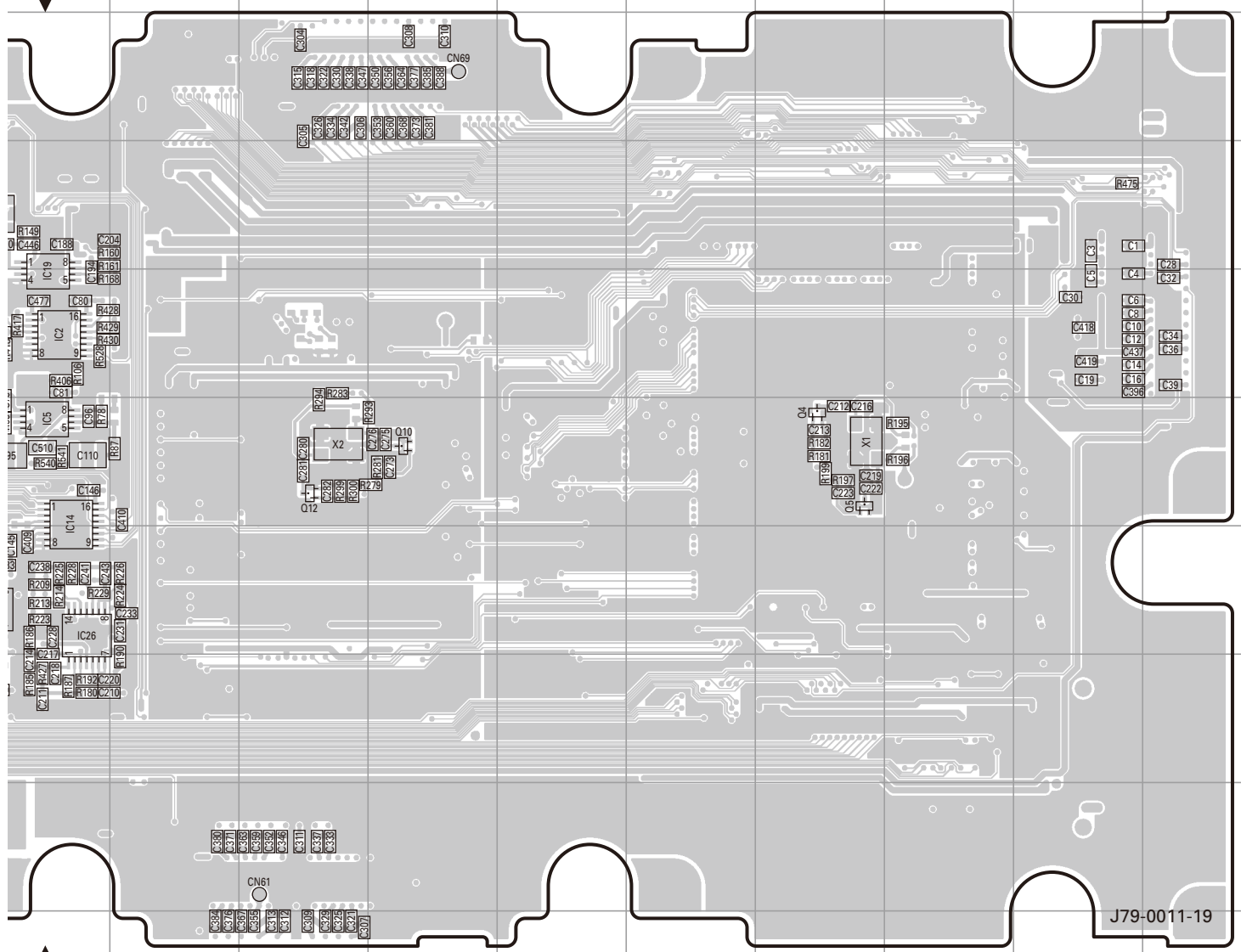

PC BOARD NXR-700

CONTROL UNIT (X53-4140-XX) -10 : E -11 : For service
Component side view (J79-0012-09)

CONTROL UNIT (X53-4140-XX) -10 : E -11 : For service
Component side view (J79-0012-09)

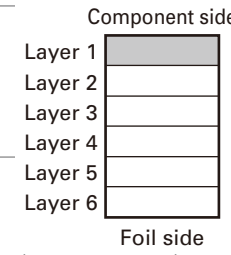
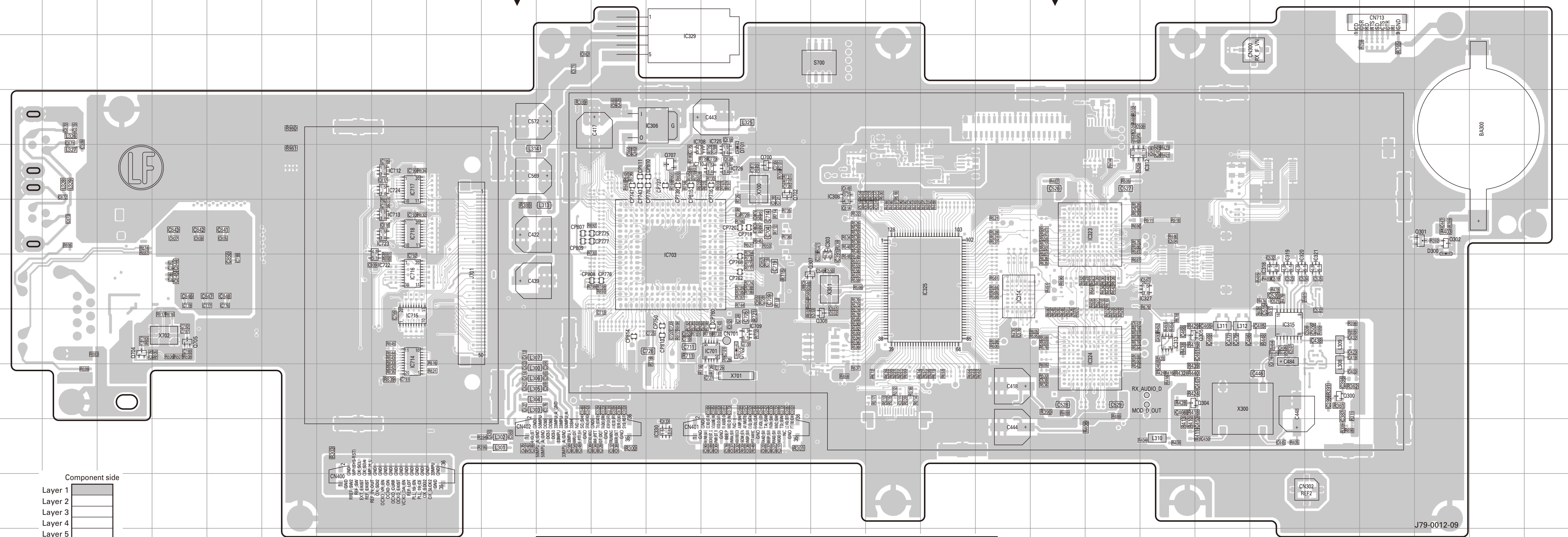

Ref. No.	Address	Ref. No.	Address	Ref. No.	Address	Ref. No.	Address	Ref. No.	Address	Ref. No.	Address	Ref. No.	Address
IC303	7P	IC318	7X	IC327	7V	IC710	5N	IC718	6H	Q301	6AA	Q702	5O
IC306	4M	IC319	7X	IC329	3M	IC712	5H	IC722	7H	Q302	6AA	Q704	8C
IC308	5P	IC320	7X	IC330	10M	IC713	6H	IC723	6H	Q304	9V	Q705	8D
IC312	5U	IC321	7Y	IC701	8N	IC714	8H	IC724	5H	Q305	8V	Q707	5M
IC313	8V	IC323	6U	IC703	7M	IC715	8H	IC725	5N	Q307	7O	D300	6AA
IC314	7S	IC324	8U	IC708	5M	IC716	7H	IC726	5N	Q308	8P	D701	5N
IC315	8X	IC325	7R	IC709	8N	IC717	5H	Q300	9Y	Q700	5O	D702	8N

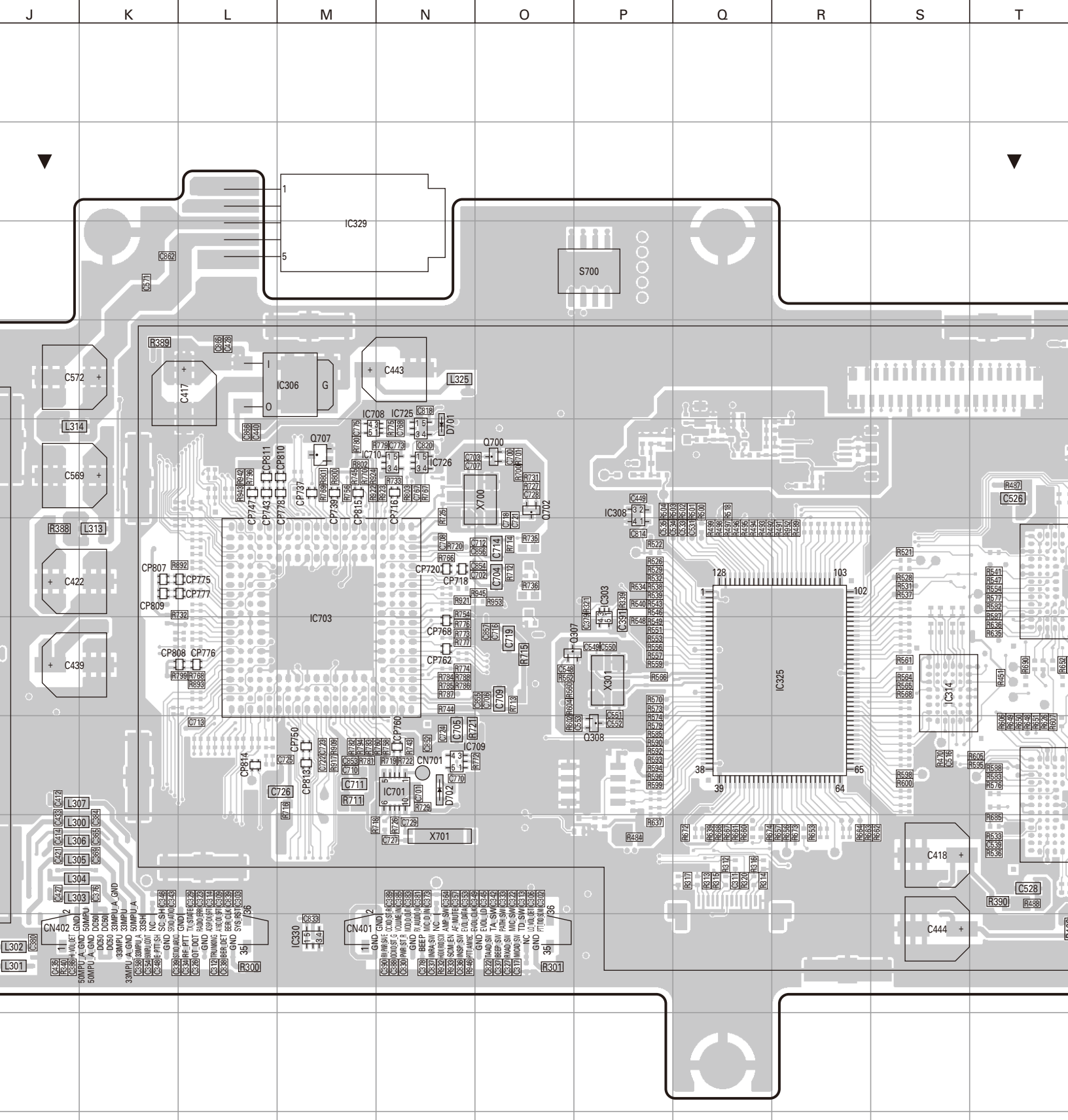

Ref. No.	Address	Ref. No.	Address	Ref. No.	Address	Ref. No.	Address	Ref. No.	Address	Ref. No.	Address	Ref. No.	Address
IC303	7P	IC318	7X	IC327	7V	IC710	5N	IC718	6H	Q301	6AA	Q702	5O
IC306	4M	IC319	7X	IC329	3M	IC712	5H	IC722	7H	Q302	6AA	Q704	8C
IC308	5P	IC320	7X	IC330	10M	IC713	6H	IC723	6H	Q304	9V	Q705	8D
IC312	5U	IC321	7Y	IC701	8N	IC714	8H	IC724	5H	Q305	8V	Q707	5M
IC313	8V	IC323	6U	IC703	7M	IC715	8H	IC725	5N	Q307	7O	D300	6AA
IC314	7S	IC324	8U	IC708	5M	IC716	7H	IC726	5N	Q308	8P	D701	5N
IC315	8X	IC325	7R	IC709	8N	IC717	5H	Q300	9Y	Q700	5O	D702	8N

PC BOARD NXR-700

CONTROL UNIT (X53-4140-XX) -10 : E -11 : For service
Component side view (J79-0012-09)

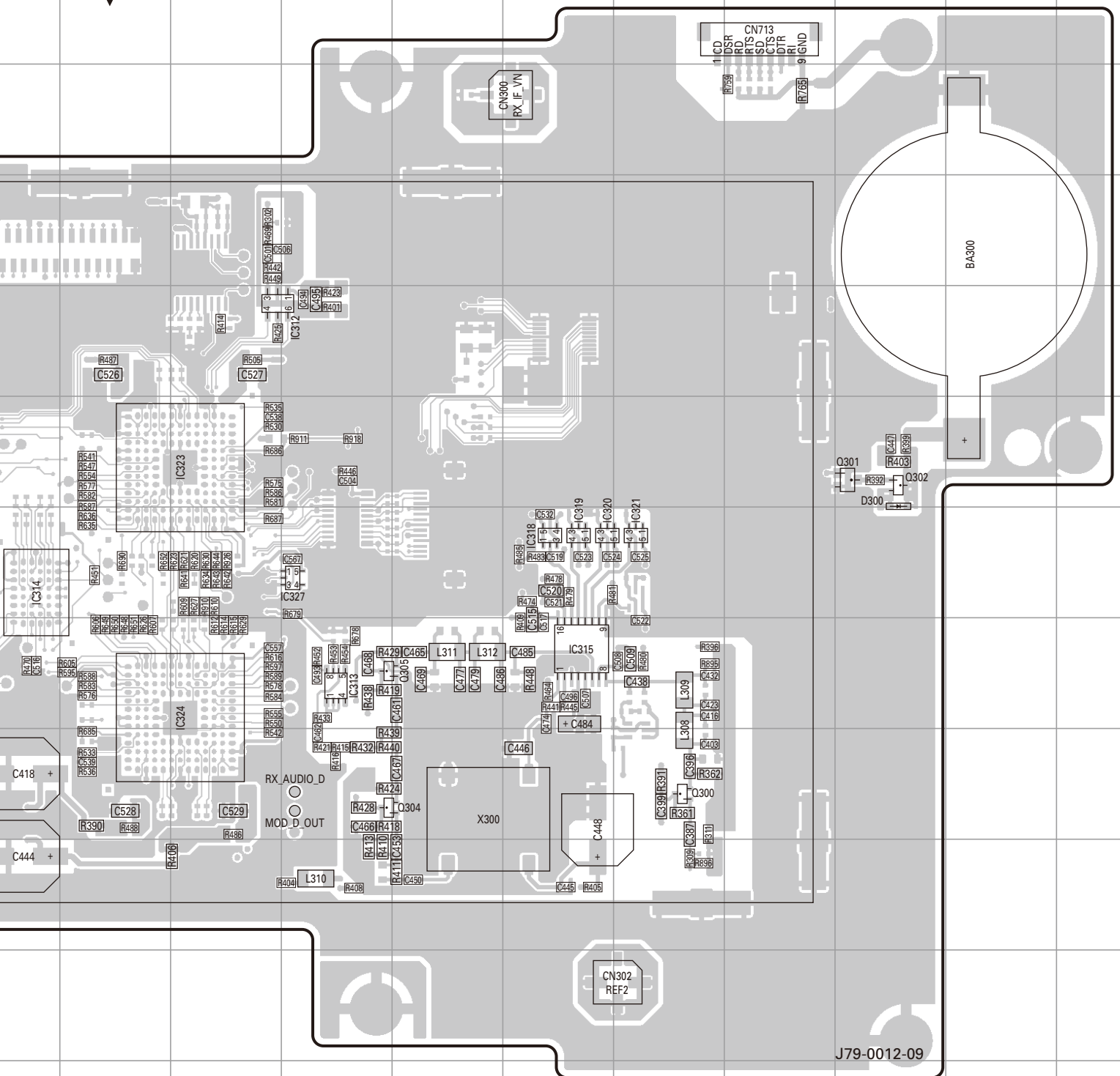

NXR-700 PC BOARD

CONTROL UNIT (X53-4140-XX) -10 : E -11 : For service
Foil side view (J79-0012-09)

CONTROL UNIT (X53-4140-XX) -10 : E -11 : For service
Foil side view (J79-0012-09)

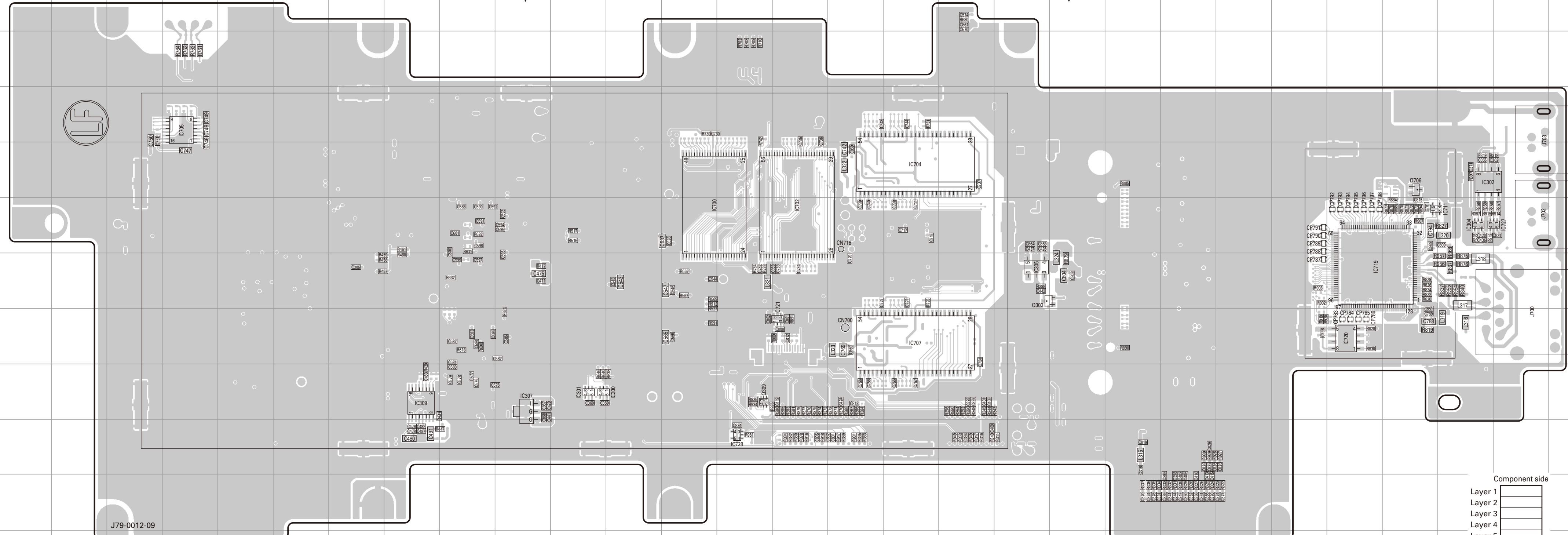

J79-0012-09

Ref. No.	Address	Ref. No.	Address	Ref. No.	Address
IC300	9K	IC700	6M	IC720	8Y
IC301	9K	IC702	6O	IC721	8O
IC302	5AA	IC704	5Q	IC727	6AB
IC304	6AA	IC705	4D	IC728	10N
IC305	7S	IC707	8Q	Q303	7S
IC307	9J	IC711	6Z	Q309	9N
IC309	9H	IC719	7Y	Q706	5Z

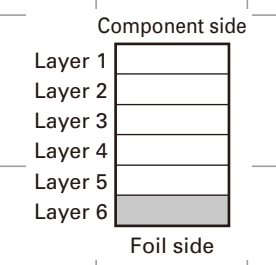

NXR-700 PC BOARD

CONTROL UNIT (X53-4140-XX) -10 : E -11 : For service
Foil side view (J79-0012-09)

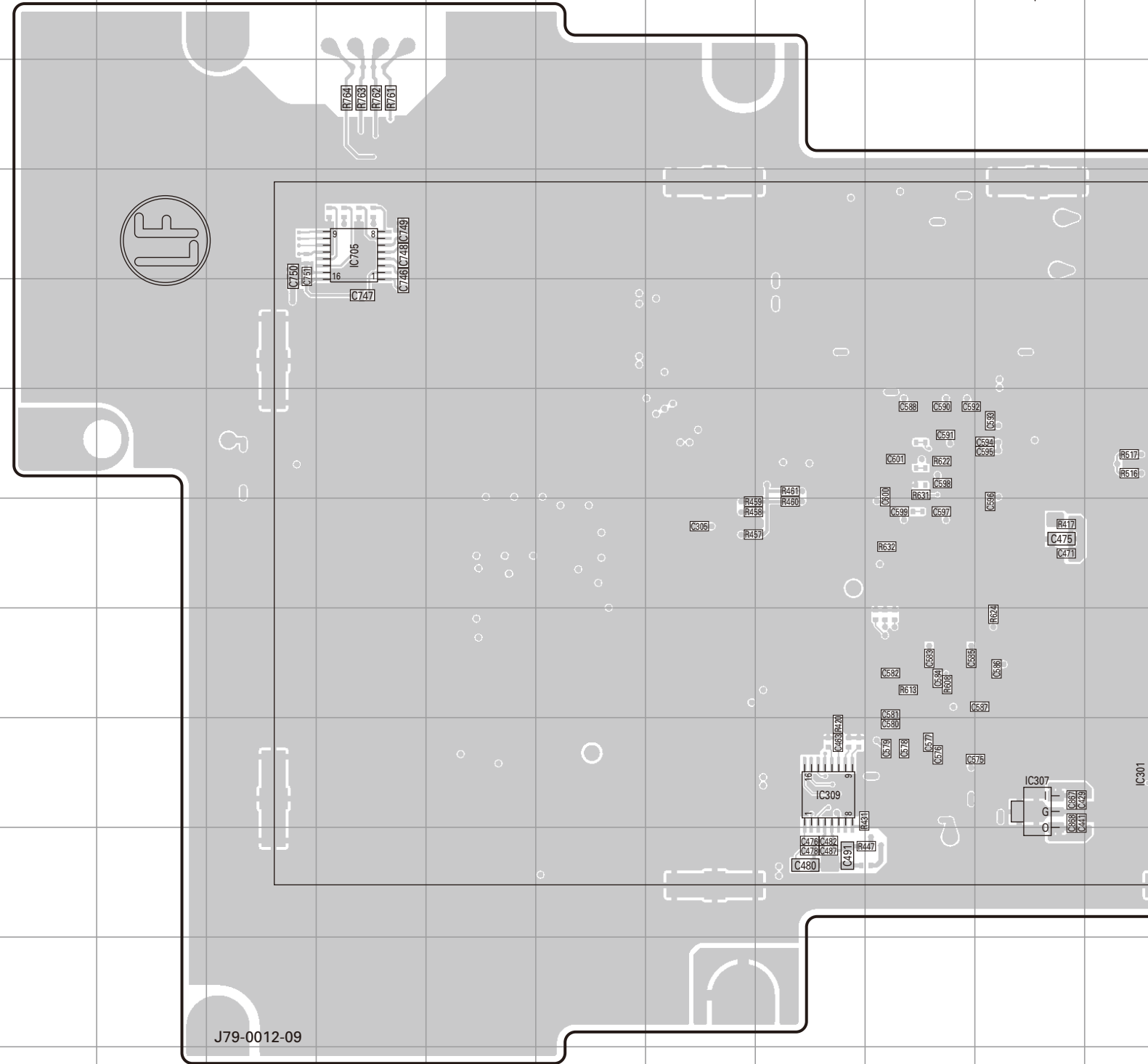

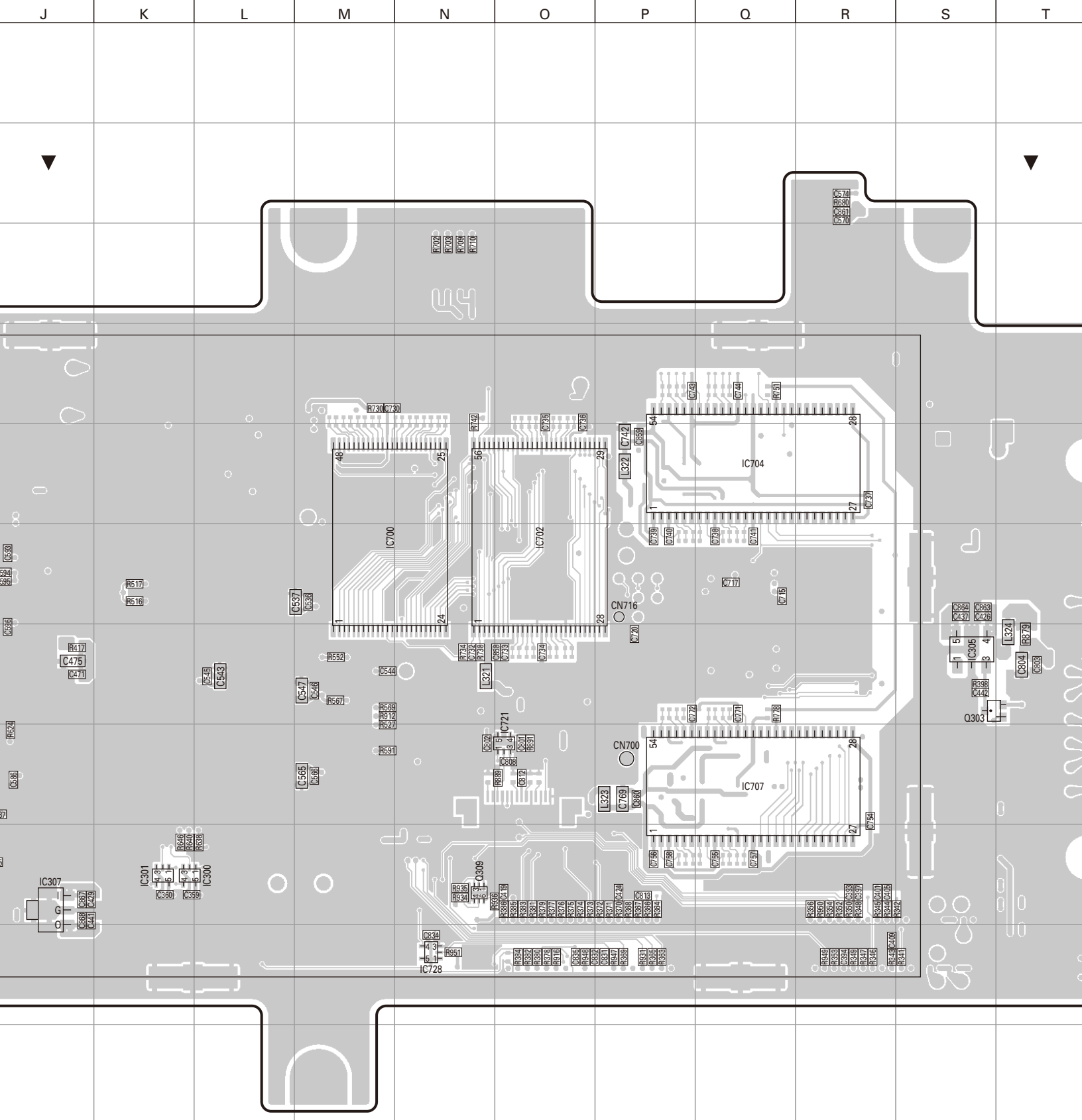

Ref. No.	Address	Ref. No.	Address	Ref. No.	Address
IC300	9K	IC700	6M	IC720	8Y
IC301	9K	IC702	6O	IC721	8O
IC302	5AA	IC704	5Q	IC727	6AB
IC304	6AA	IC705	4D	IC728	10N
IC305	7S	IC707	8Q	Q303	7S
IC307	9J	IC711	6Z	Q309	9N
IC309	9H	IC719	7Y	Q706	5Z

CONTROL UNIT (X53-4140-XX) -10 : E -11 : For service
Foil side view (J79-0012-09)

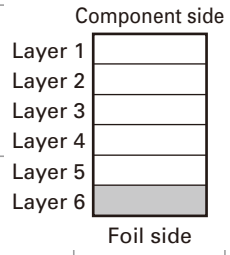
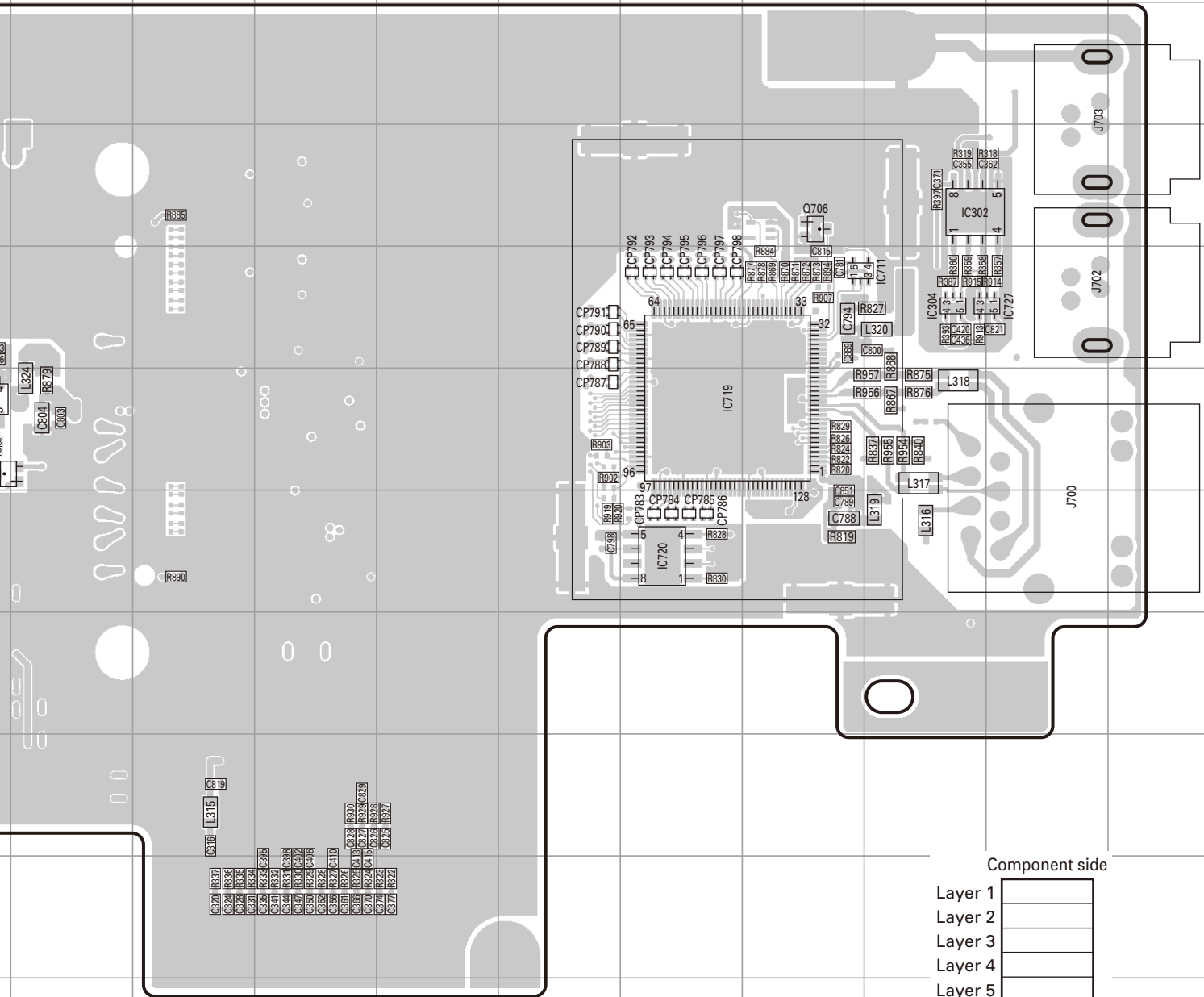

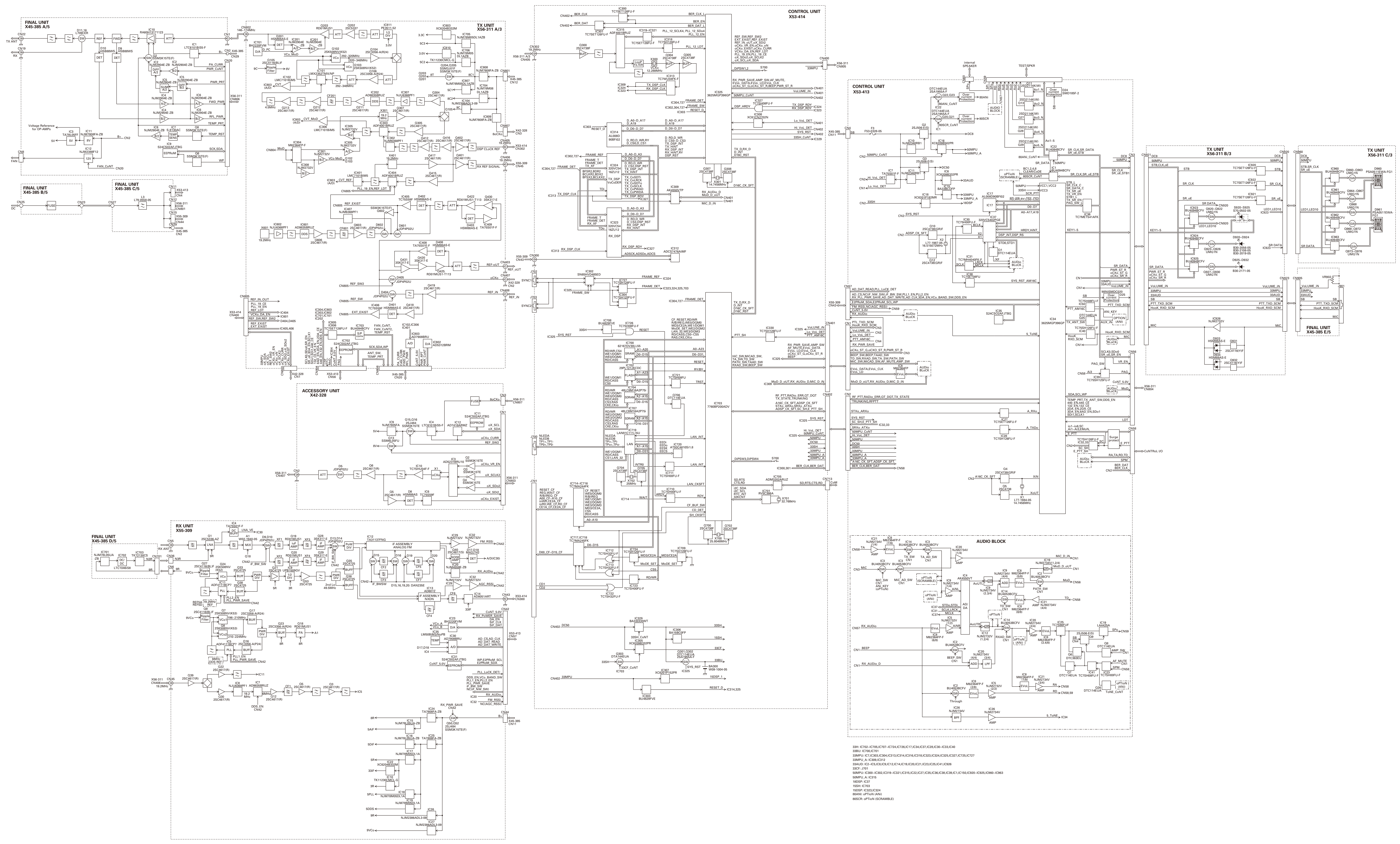

- 388: IC705, IC706, IC707, IC708, IC709, IC710, IC711, IC712, IC713, IC714, IC715, IC716, IC717, IC718, IC719, IC720
- 389: IC721, IC722, IC723, IC724, IC725, IC726, IC727, IC728, IC729, IC730, IC731, IC732, IC733, IC734, IC735, IC736, IC737, IC738, IC739, IC740
- 390: IC741, IC742, IC743, IC744, IC745, IC746, IC747, IC748, IC749, IC750, IC751, IC752, IC753, IC754, IC755, IC756, IC757, IC758, IC759, IC760
- 391: IC761, IC762, IC763, IC764, IC765, IC766, IC767, IC768, IC769, IC770, IC771, IC772, IC773, IC774, IC775, IC776, IC777, IC778, IC779, IC780
- 392: IC781, IC782, IC783, IC784, IC785, IC786, IC787, IC788, IC789, IC790, IC791, IC792, IC793, IC794, IC795, IC796, IC797, IC798, IC799, IC800
- 393: IC801, IC802, IC803, IC804, IC805, IC806, IC807, IC808, IC809, IC810, IC811, IC812, IC813, IC814, IC815, IC816, IC817, IC818, IC819, IC820
- 394: IC821, IC822, IC823, IC824, IC825, IC826, IC827, IC828, IC829, IC830, IC831, IC832, IC833, IC834, IC835, IC836, IC837, IC838, IC839, IC840
- 395: IC841, IC842, IC843, IC844, IC845, IC846, IC847, IC848, IC849, IC850, IC851, IC852, IC853, IC854, IC855, IC856, IC857, IC858, IC859, IC860
- 396: IC861, IC862, IC863, IC864, IC865, IC866, IC867, IC868, IC869, IC870, IC871, IC872, IC873, IC874, IC875, IC876, IC877, IC878, IC879, IC880
- 397: IC881, IC882, IC883, IC884, IC885, IC886, IC887, IC888, IC889, IC890, IC891, IC892, IC893, IC894, IC895, IC896, IC897, IC898, IC899, IC900
- 398: IC901, IC902, IC903, IC904, IC905, IC906, IC907, IC908, IC909, IC910, IC911, IC912, IC913, IC914, IC915, IC916, IC917, IC918, IC919, IC920
- 399: IC921, IC922, IC923, IC924, IC925, IC926, IC927, IC928, IC929, IC930, IC931, IC932, IC933, IC934, IC935, IC936, IC937, IC938, IC939, IC940
- 400: IC941, IC942, IC943, IC944, IC945, IC946, IC947, IC948, IC949, IC950, IC951, IC952, IC953, IC954, IC955, IC956, IC957, IC958, IC959, IC960

BLOCK DIAGRAM NXR-700

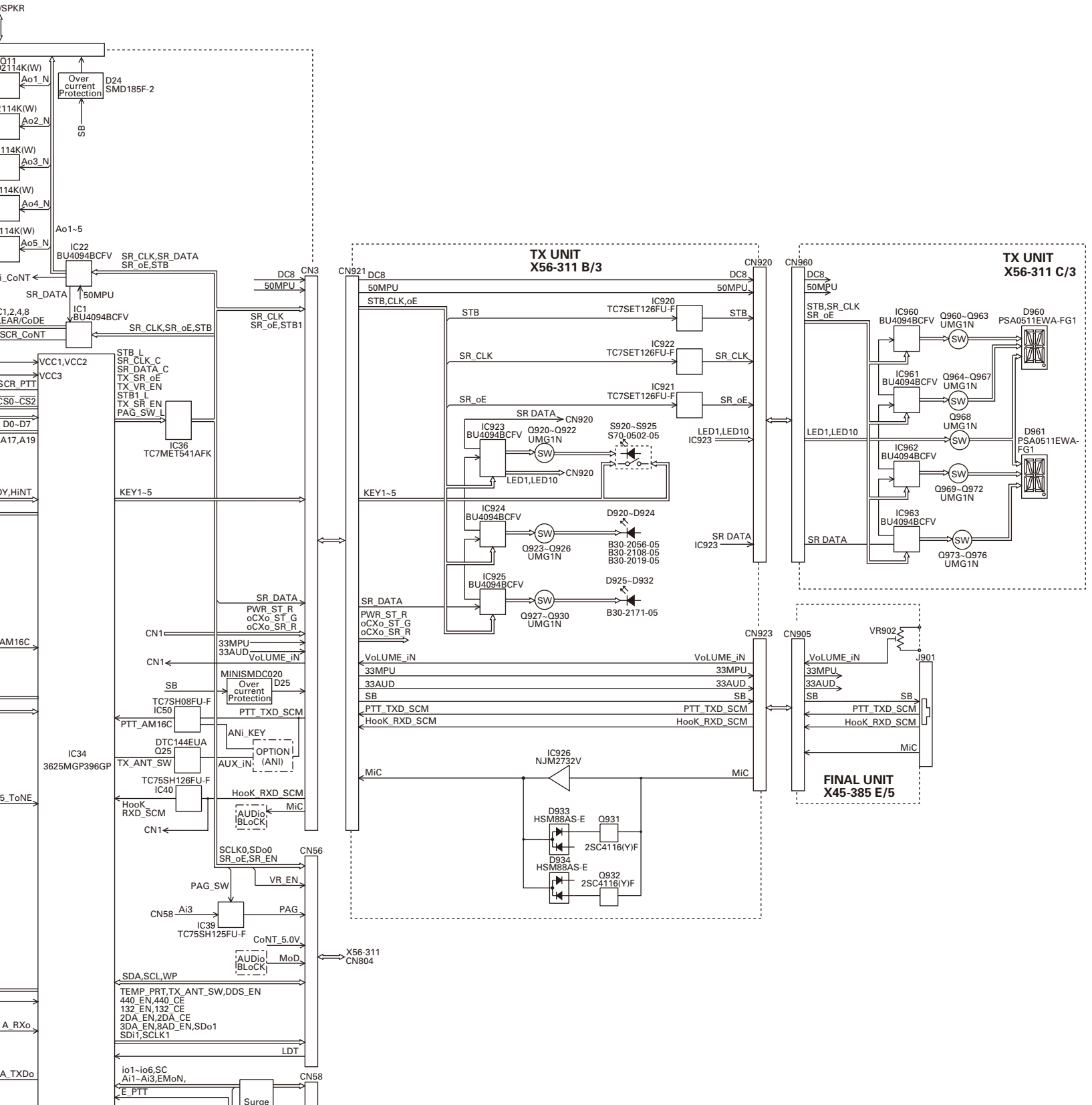

**FINAL UNIT
X45-385 D/5**

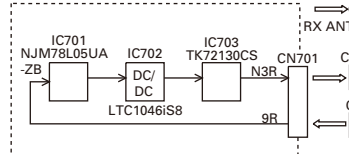

**RX UNIT
X55-309**

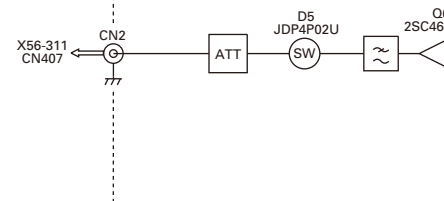
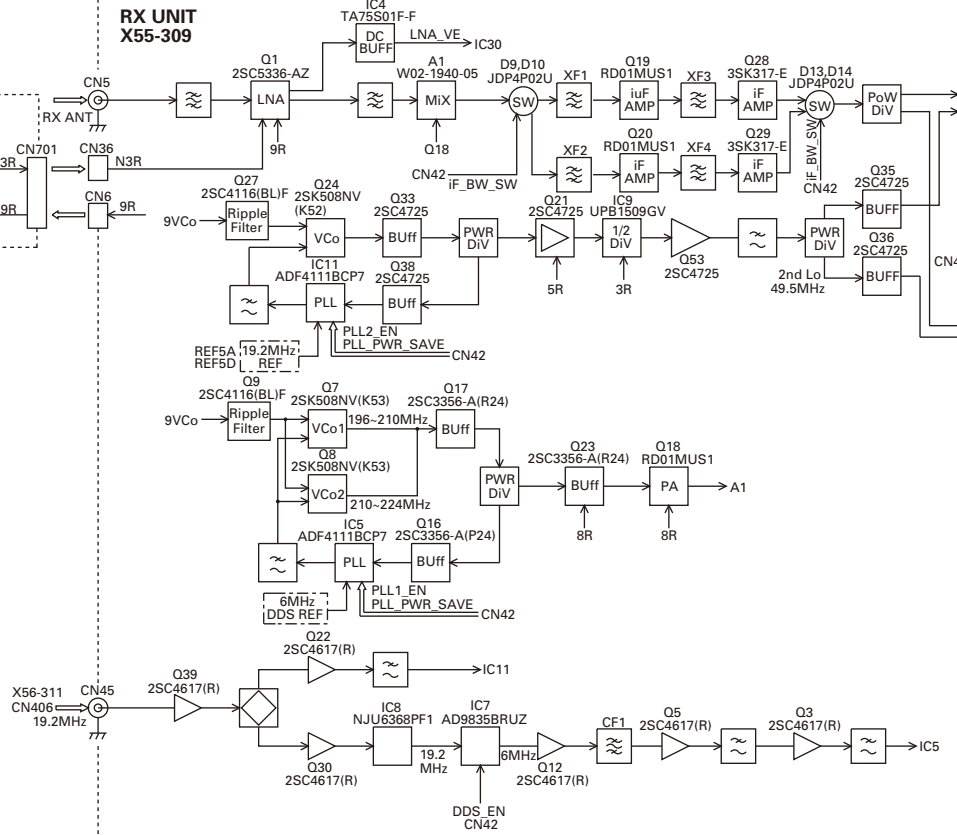

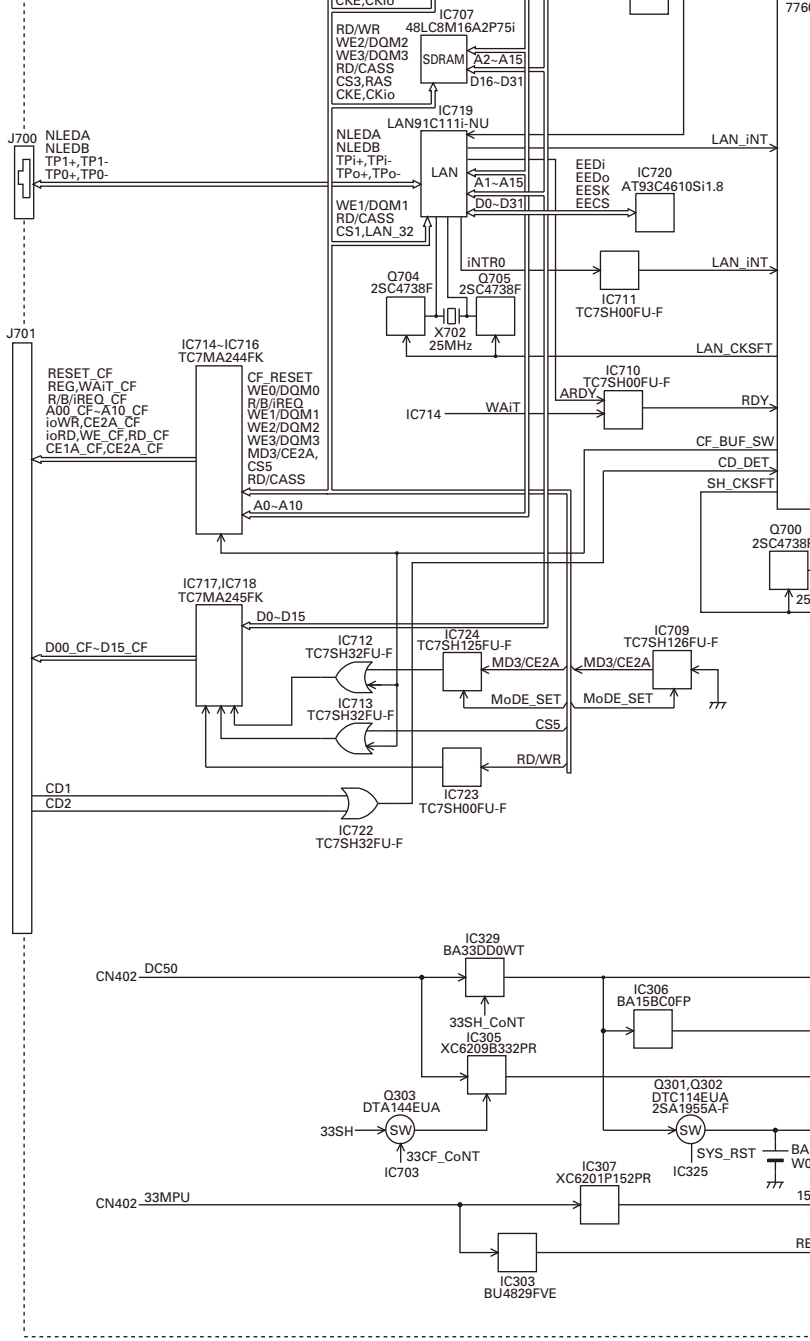
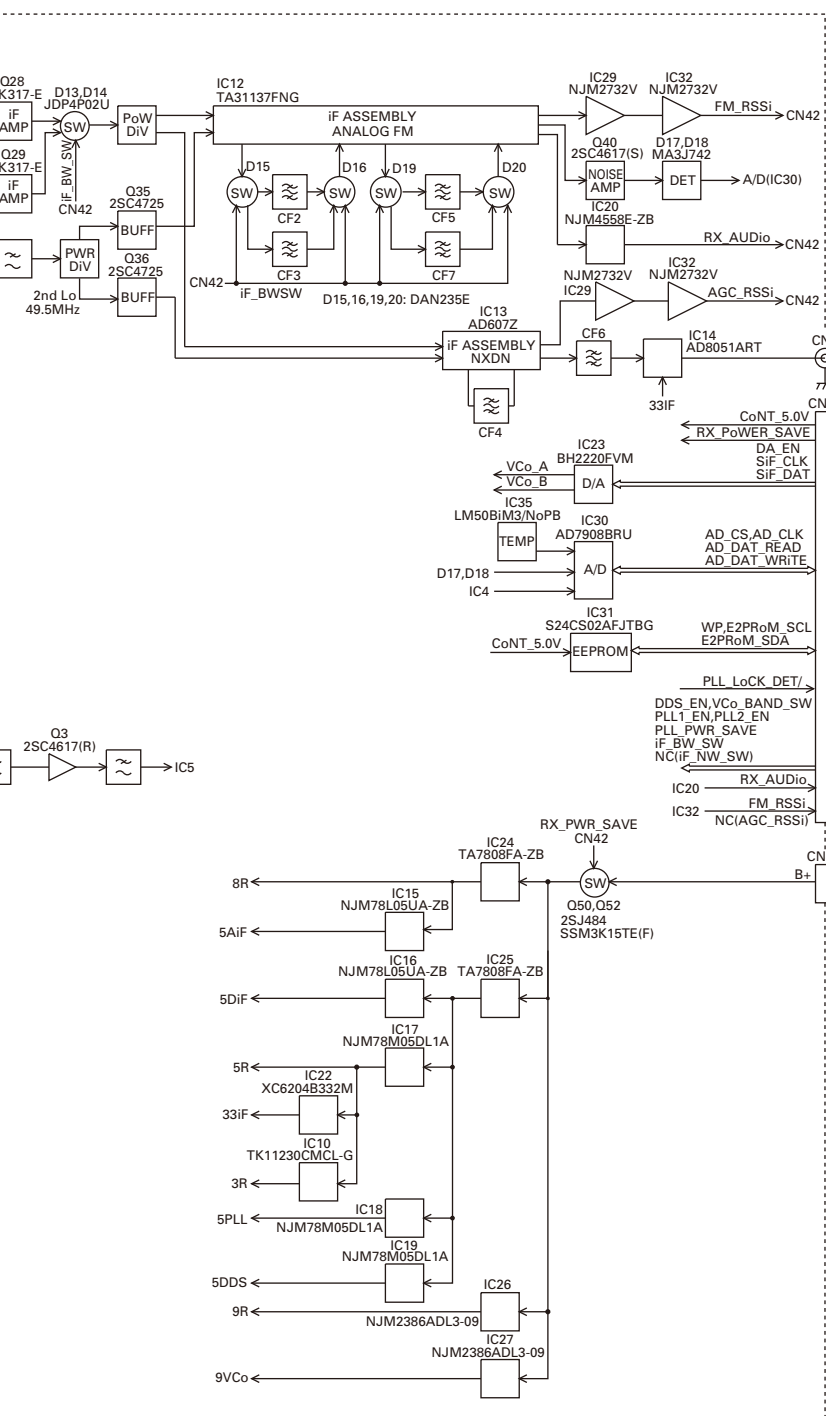
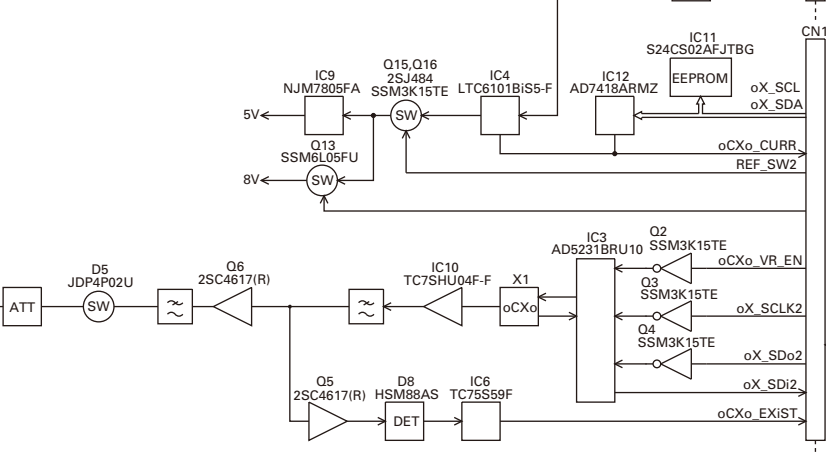

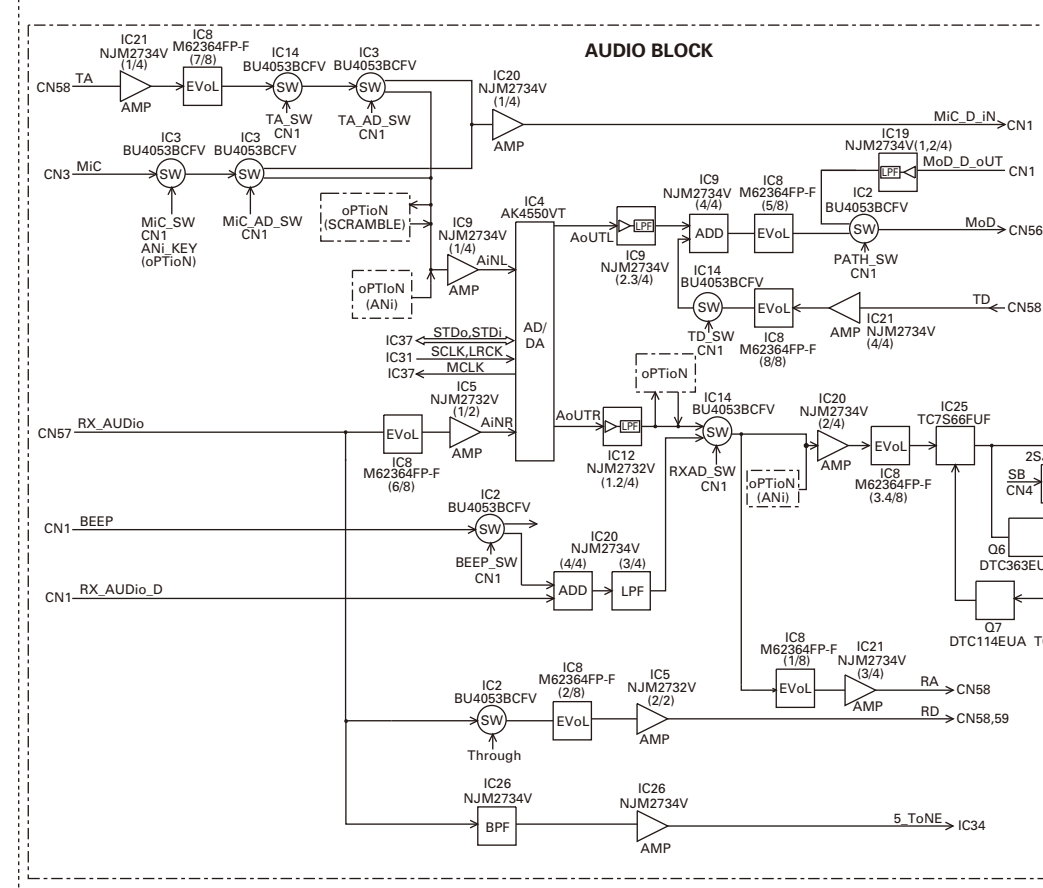
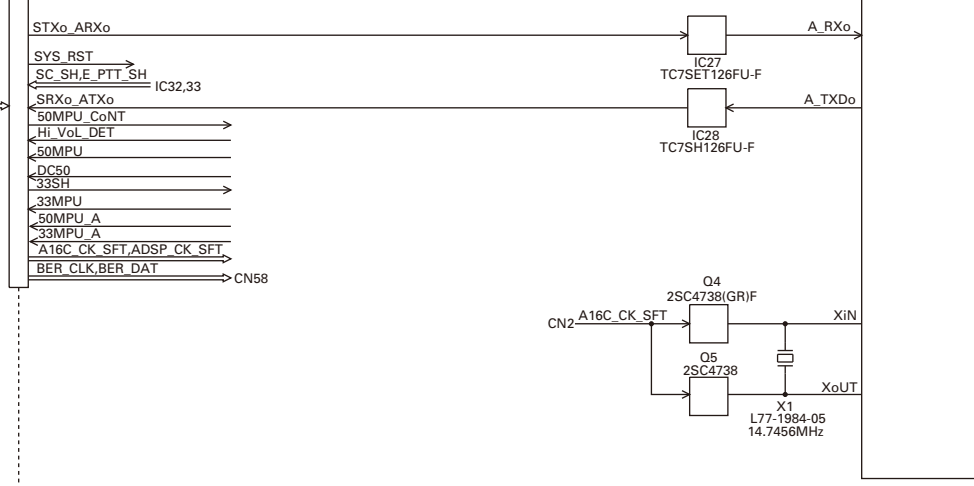
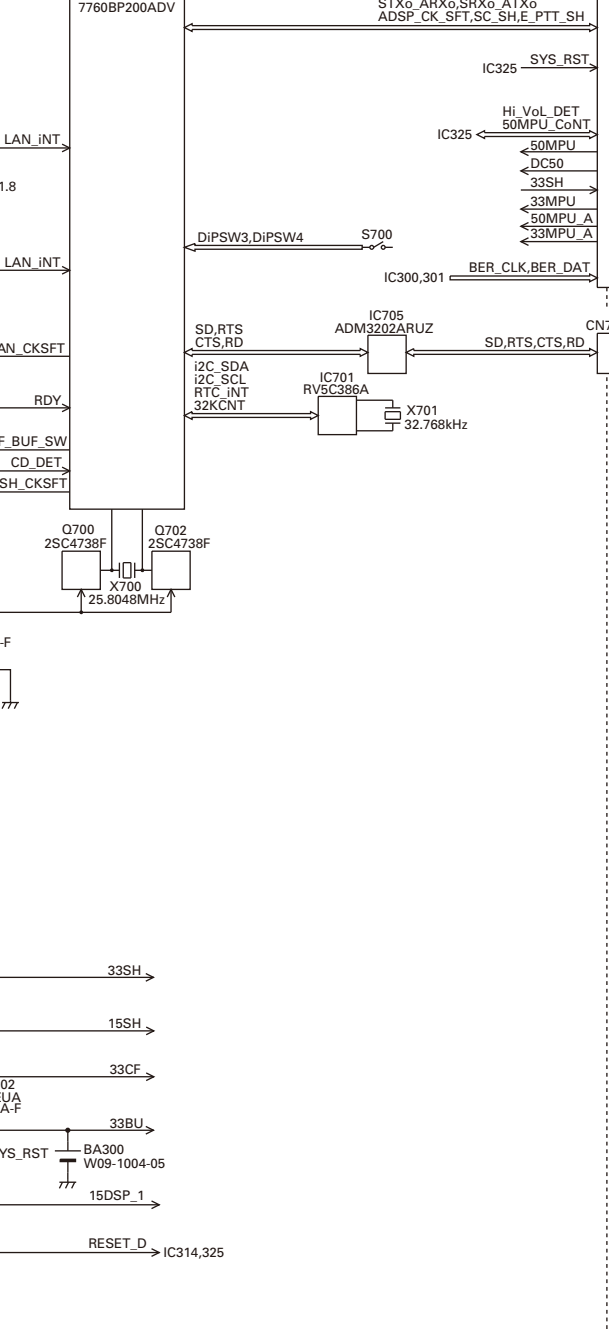

- 33H: IC702-IC705, IC707-IC724, IC726, IC17, IC34, IC37, IC28, IC30-IC33, IC40
- 33BU: IC700, IC701
- 33MPU: IC7, IC303, IC304, IC313, IC314, IC316, IC318, IC323, IC324, IC325, IC327, IC725, IC727
- 33MPU_A: IC309, IC312
- 33AUD: IC2-IC5, IC8, IC9, IC12, IC14, IC19, IC20, IC21, IC23, IC25, IC41, IC926
- 33CF: J701
- 50MPU: IC300-IC302, IC319-IC321, IC315, IC22, IC27, IC35, IC36, IC38, IC39, IC1, IC150, IC920-IC925, IC960-IC963
- 50MPU_A: IC315
- 18DSP: IC37
- 15SH: IC703
- 15DSP: IC323, IC324
- 80ANI: oPTioN (ANI)
- 80SCR: oPTioN (SCRAMBLE)

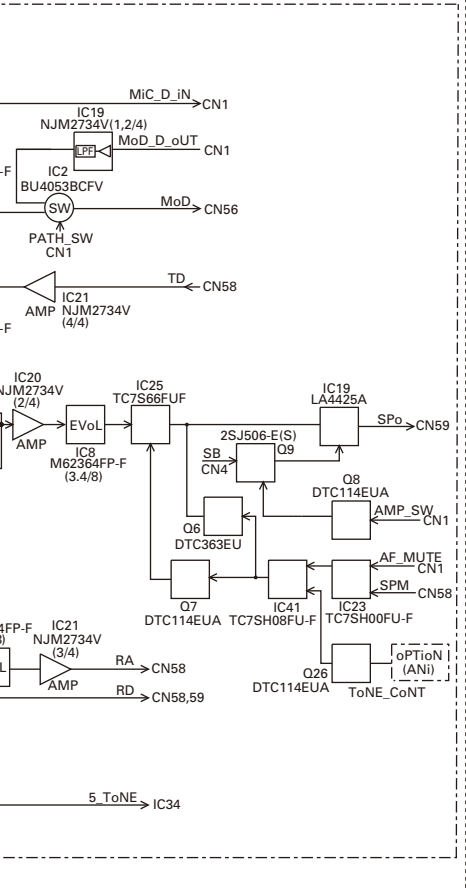
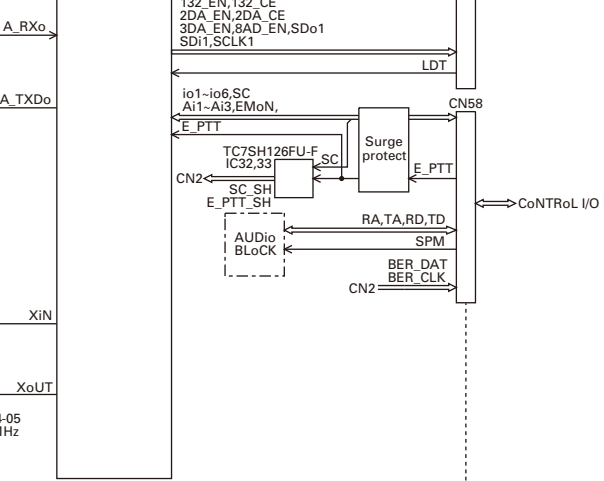

NXR-700 INTERCONNECTION DIAGRAM

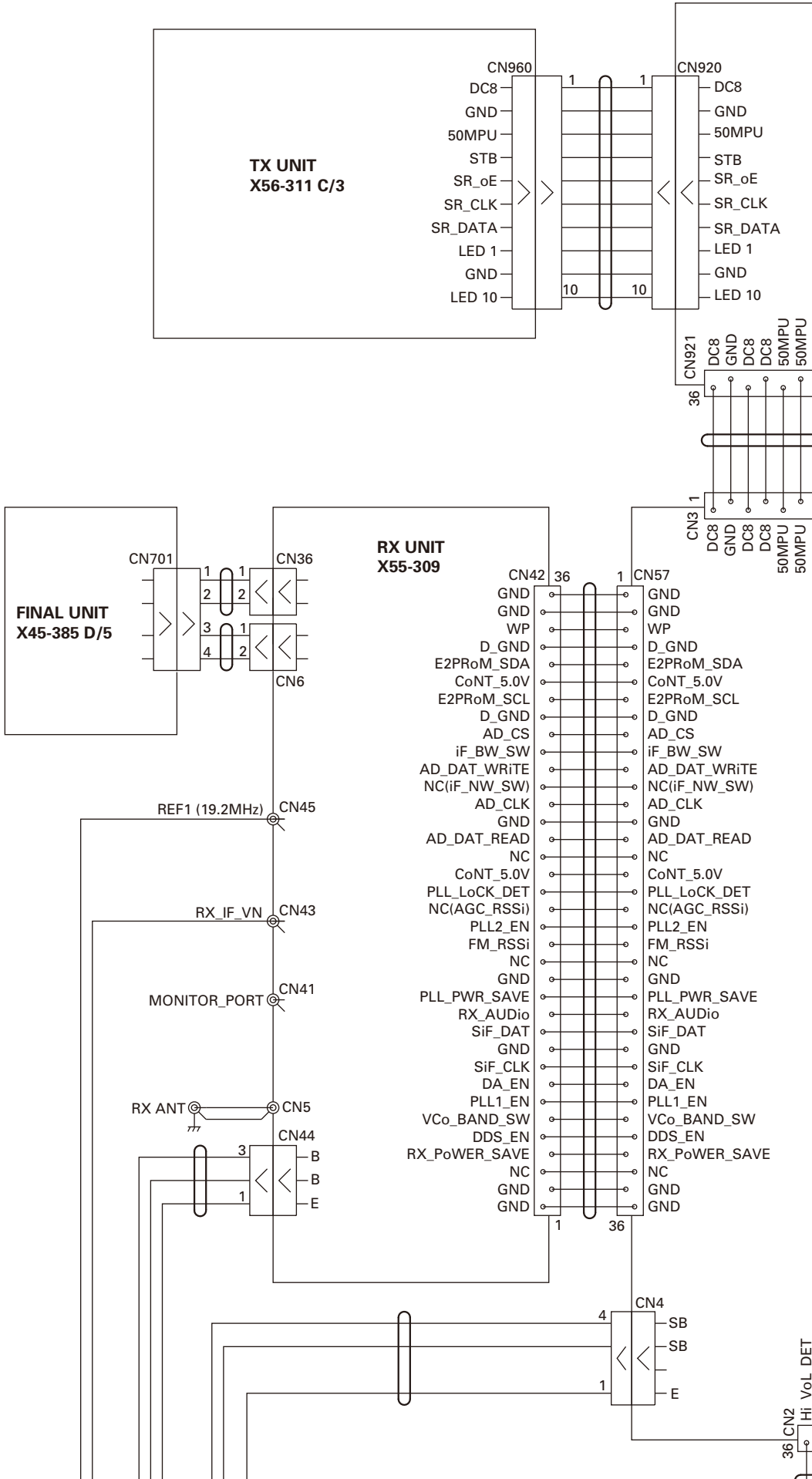

PANEL VIEW

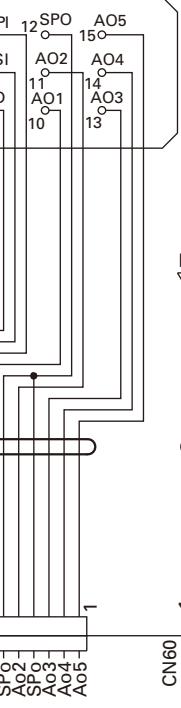

CONTROL I/O (PANEL VIEW)

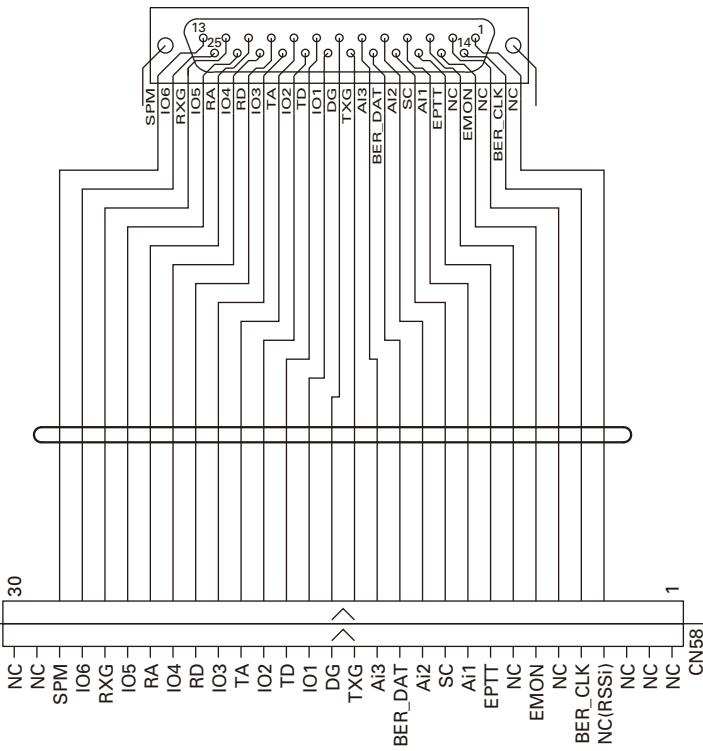

OPTION (OCXO) KXK-3

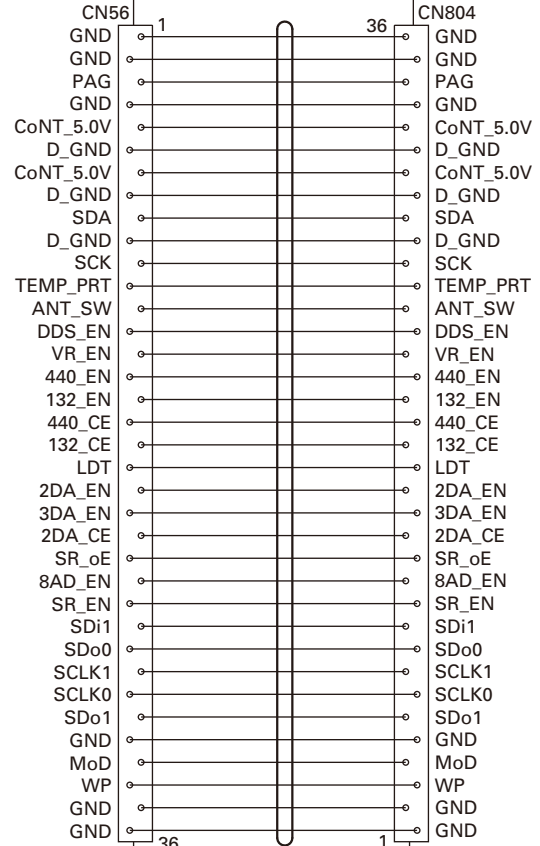
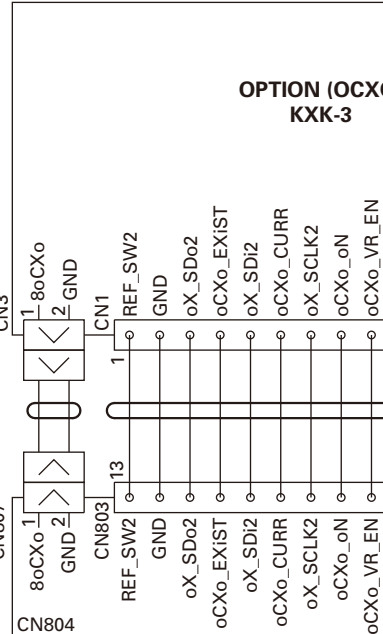

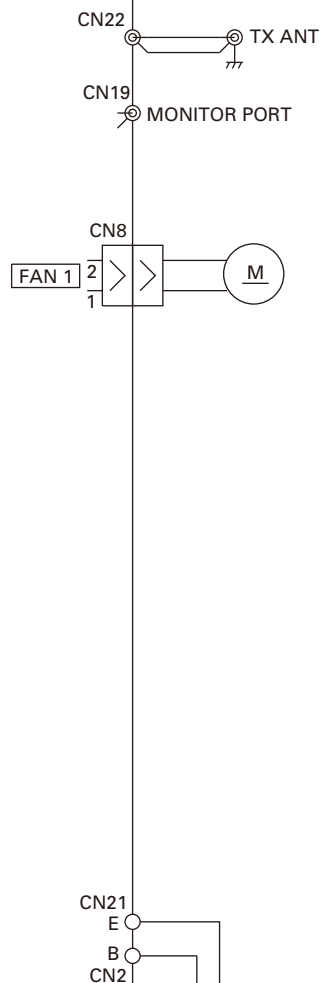
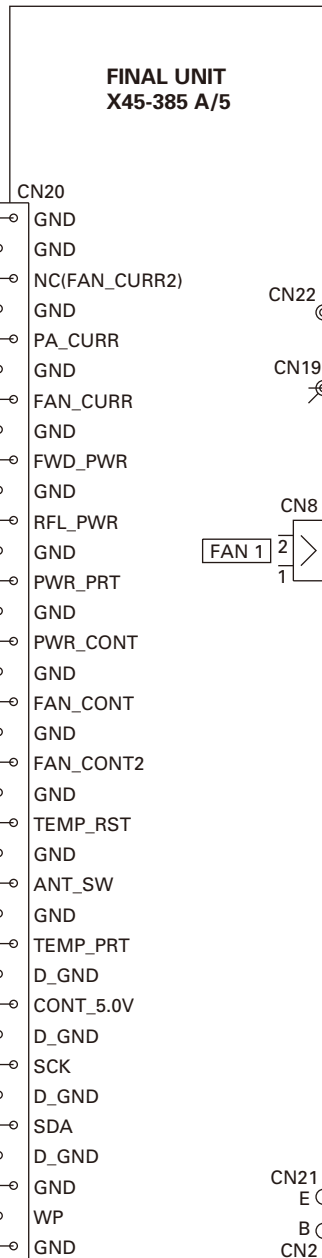
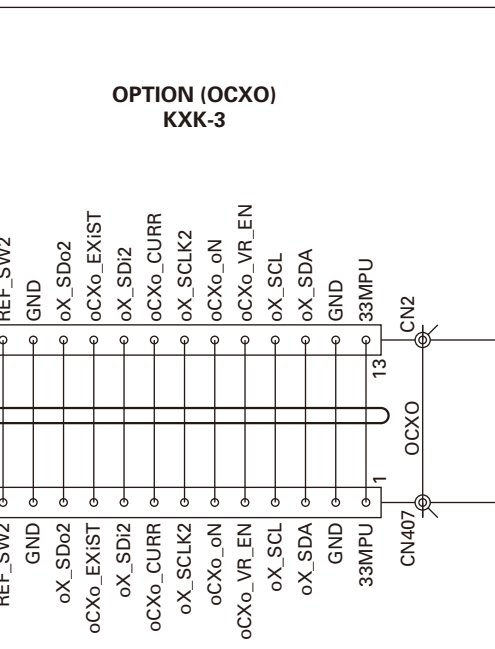

**TX UNIT
X56-311 A/3**



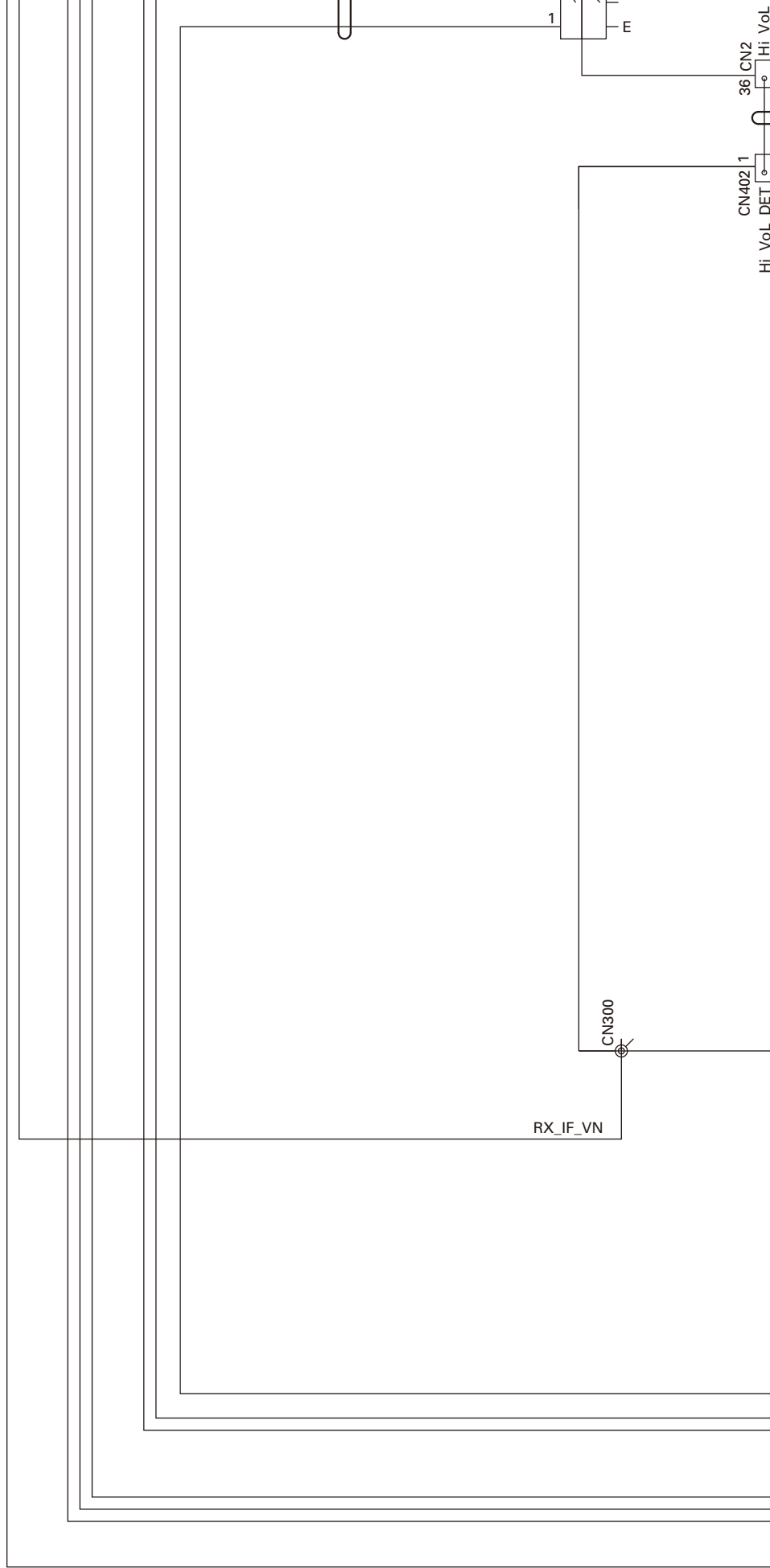

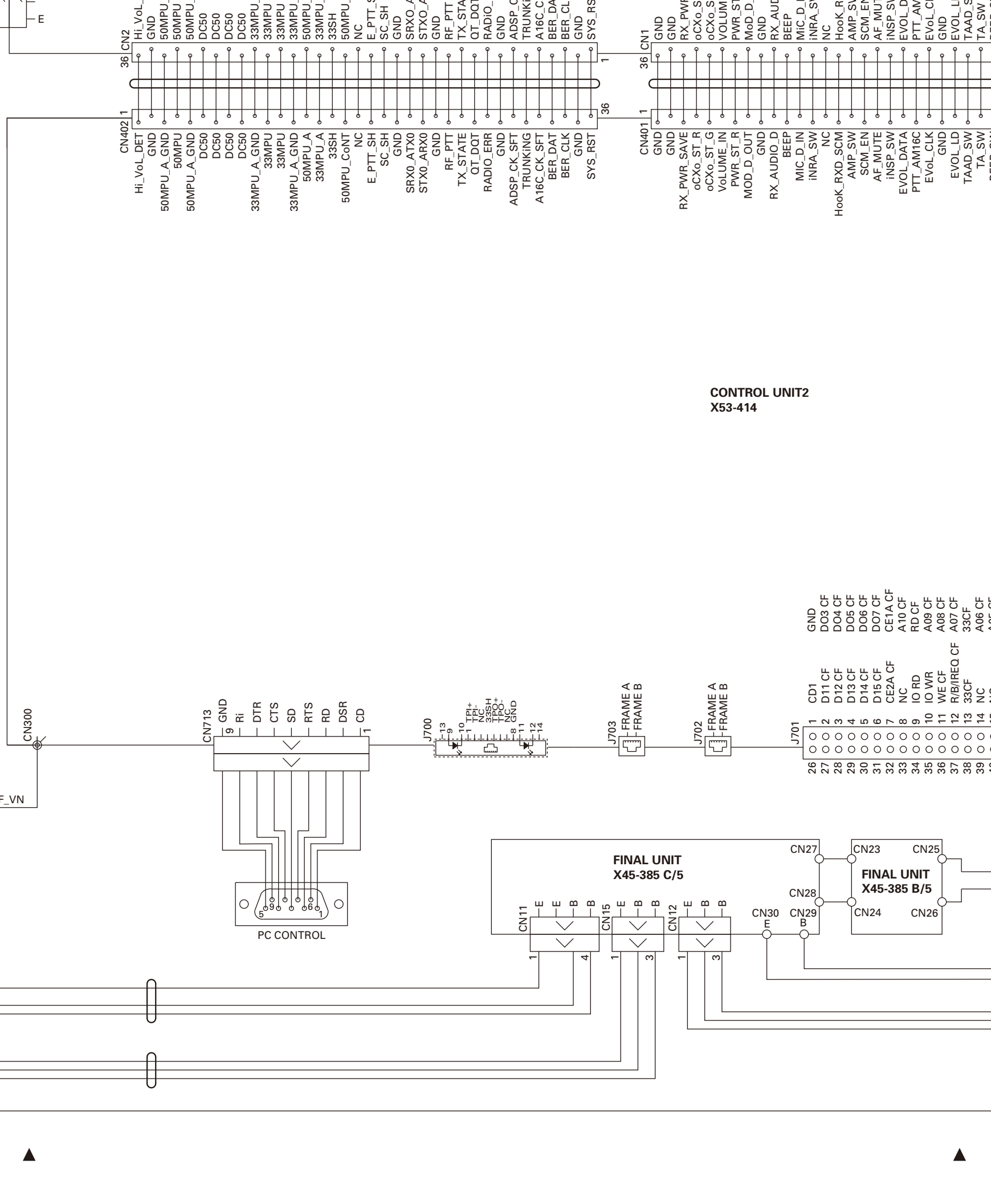

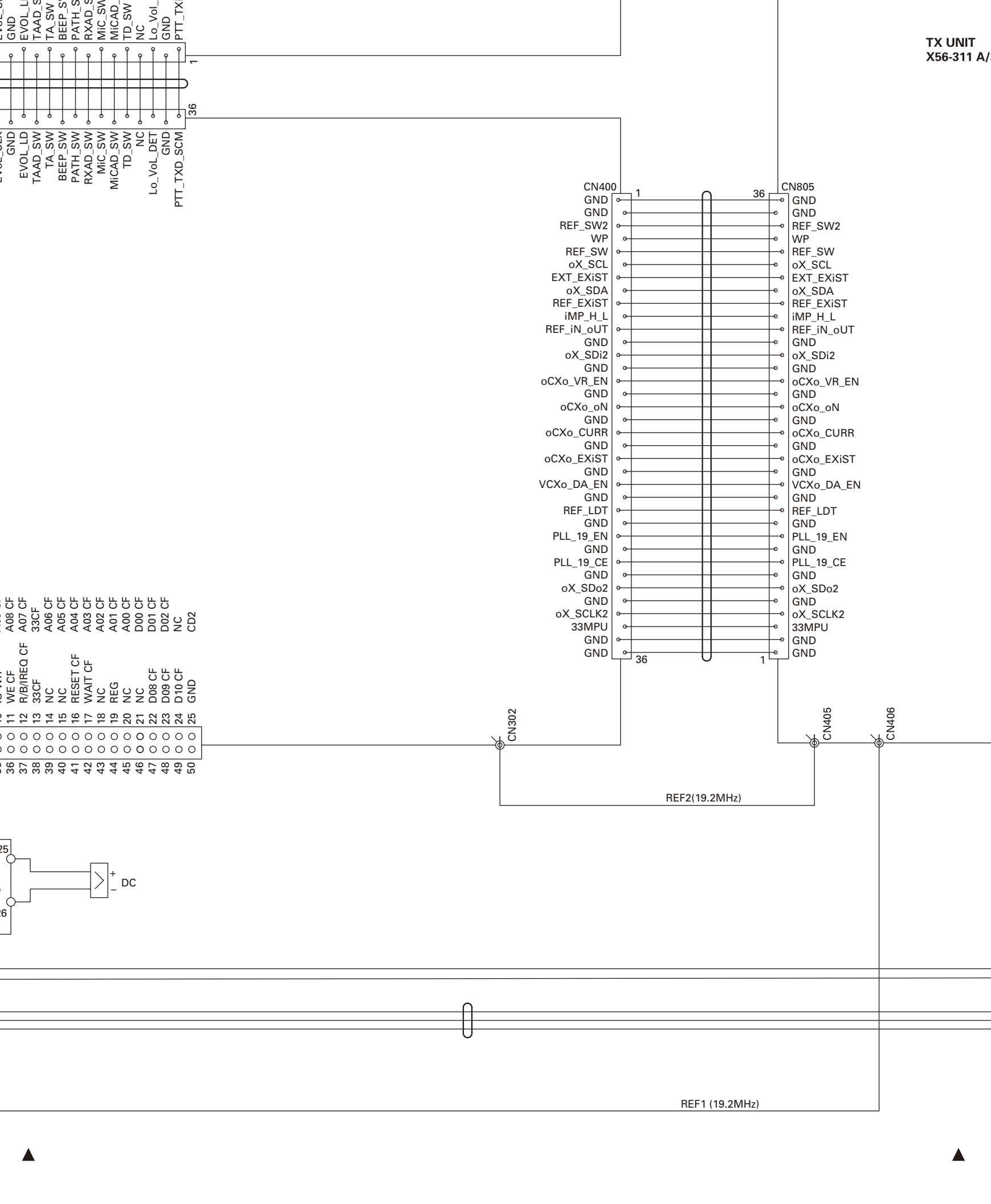

TX UNIT
X56-311 A/3

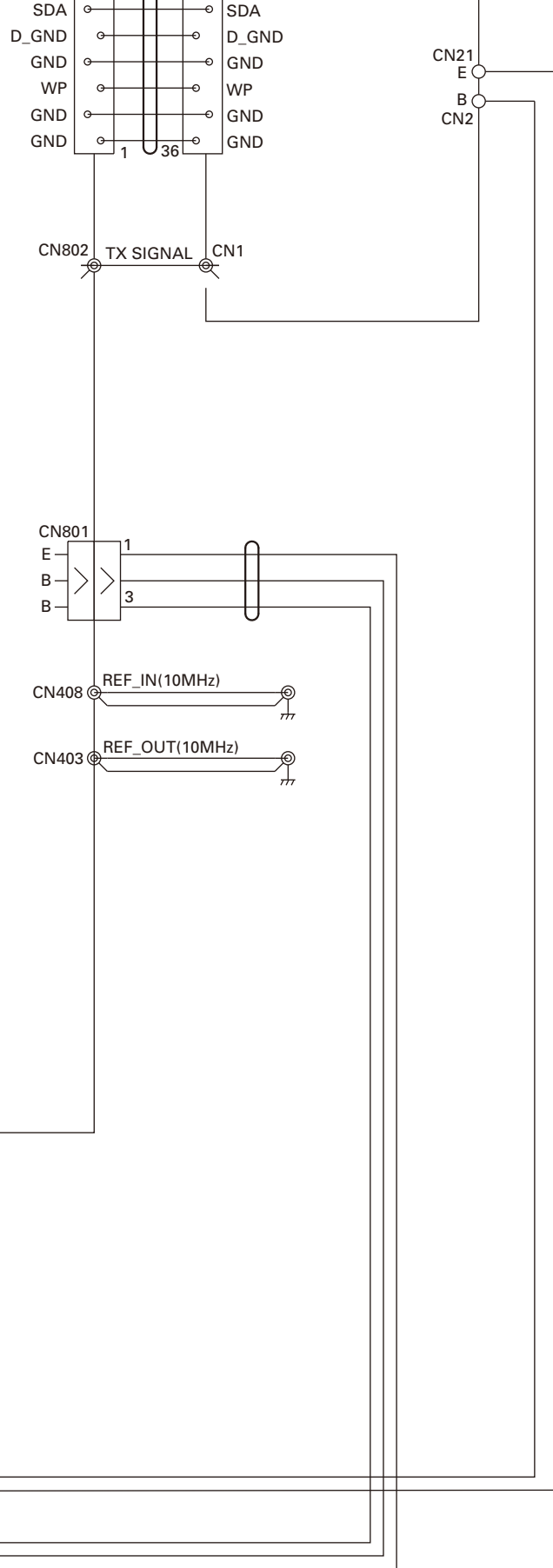

NXR-700 SCHEMATIC DIAGRAM

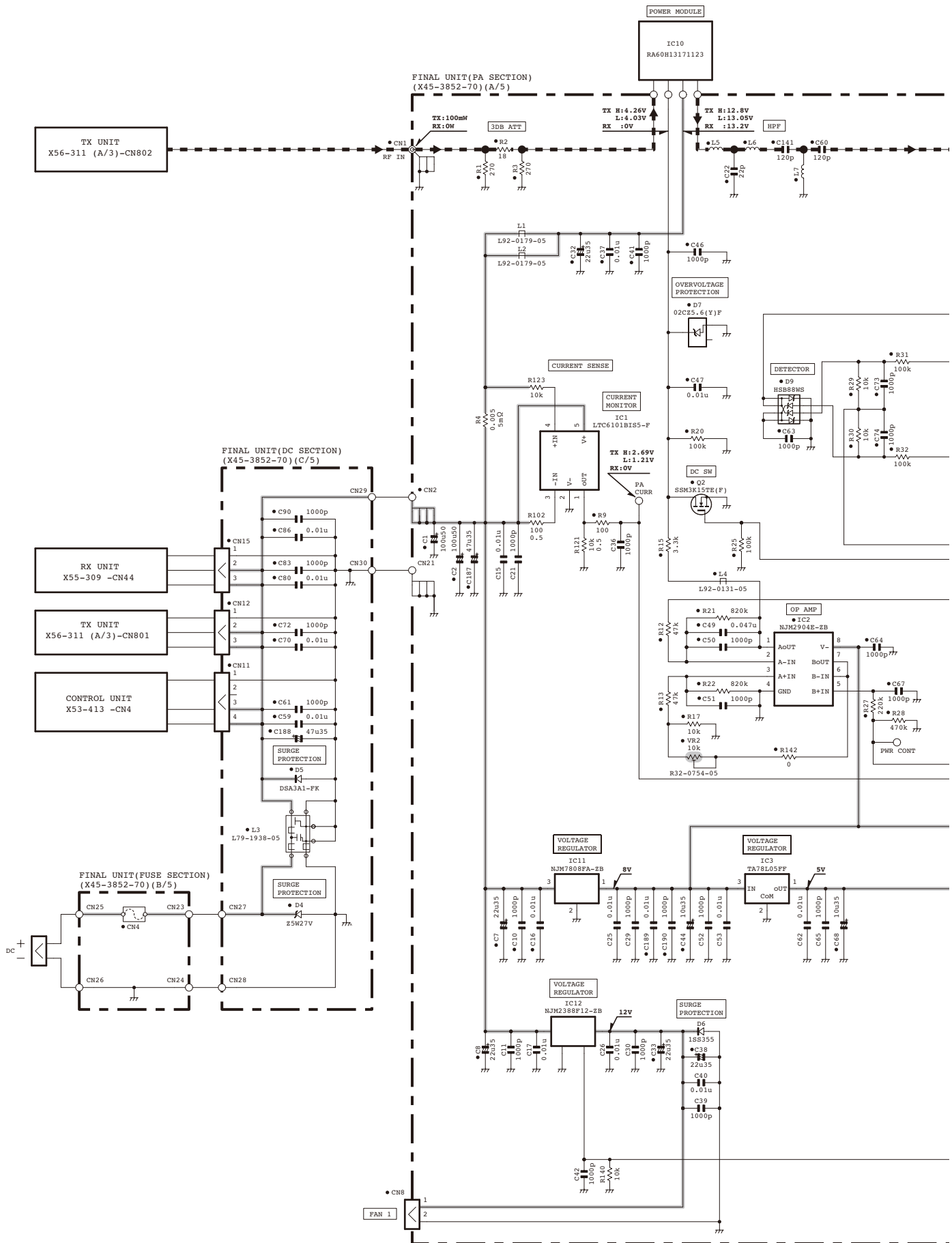

SCHEMATIC DIAGRAM NXR-700

FINAL UNIT (PA SECTION)
[X45-3852-70] (A/5)

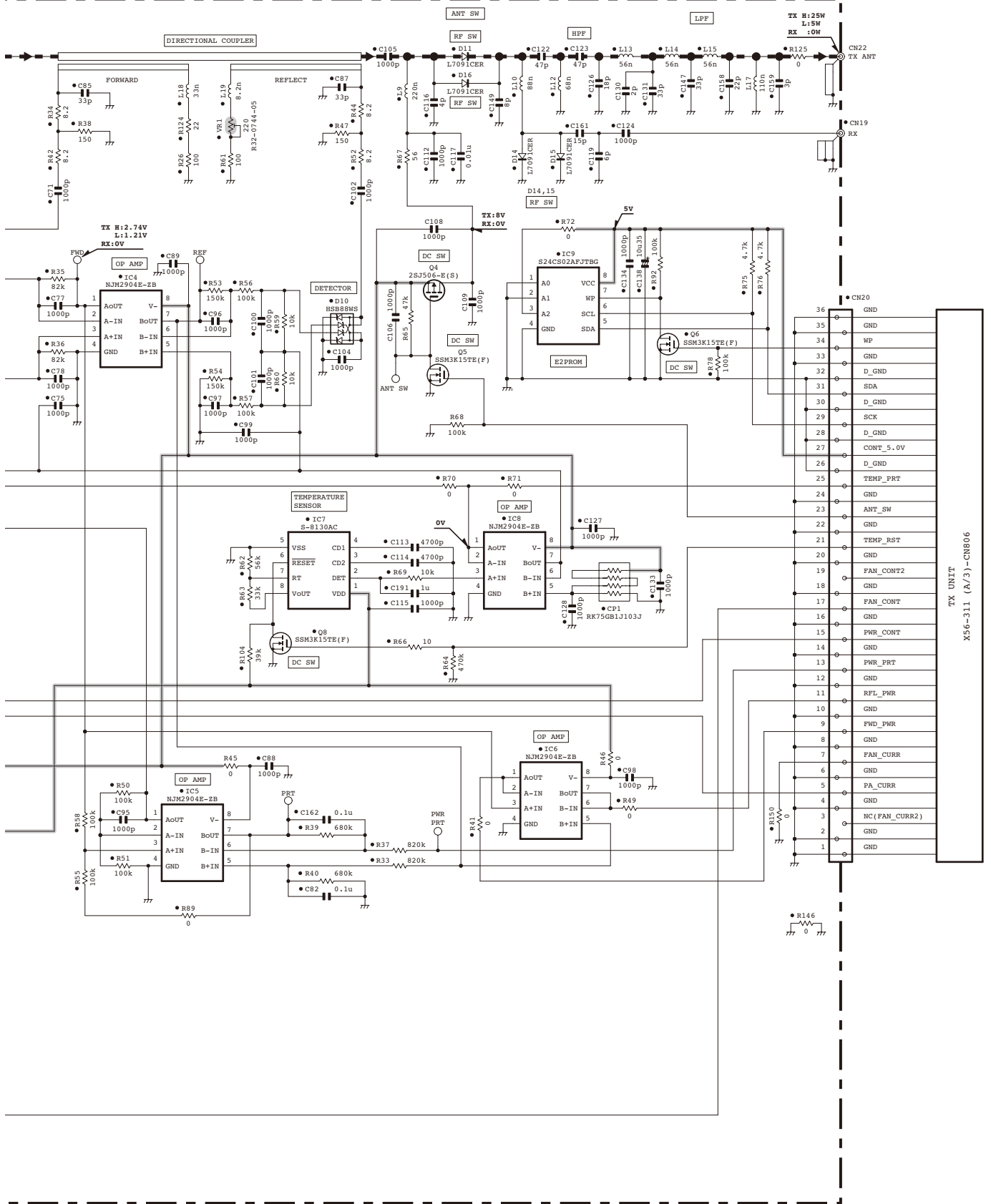

Note : The components marked with a dot (•) are parts of layer 1.

NXR-700 SCHEMATIC DIAGRAM

RX UNIT (X55-3092-71)

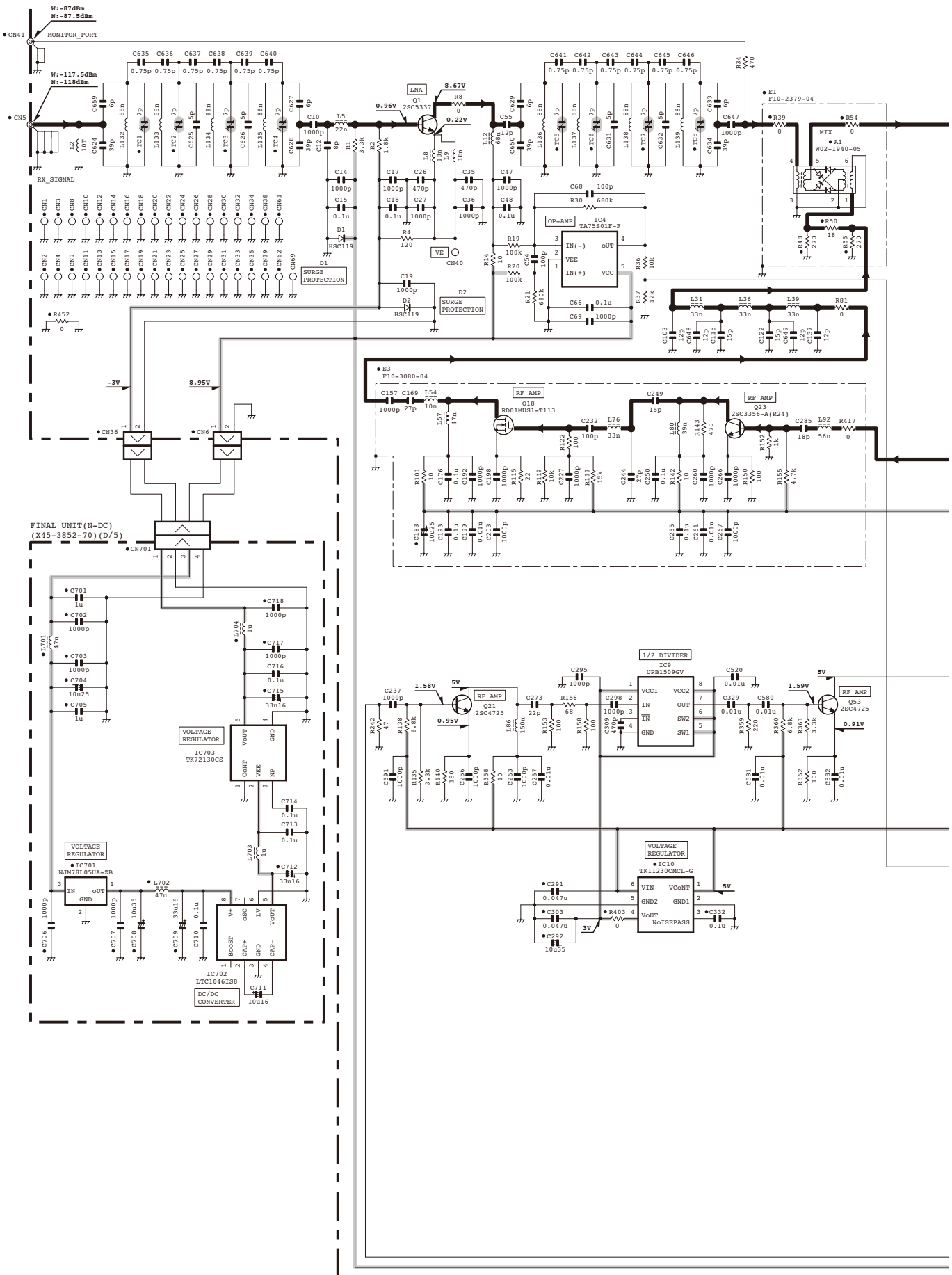

SCHEMATIC DIAGRAM NXR-700

RX UNIT (X55-3092-71)

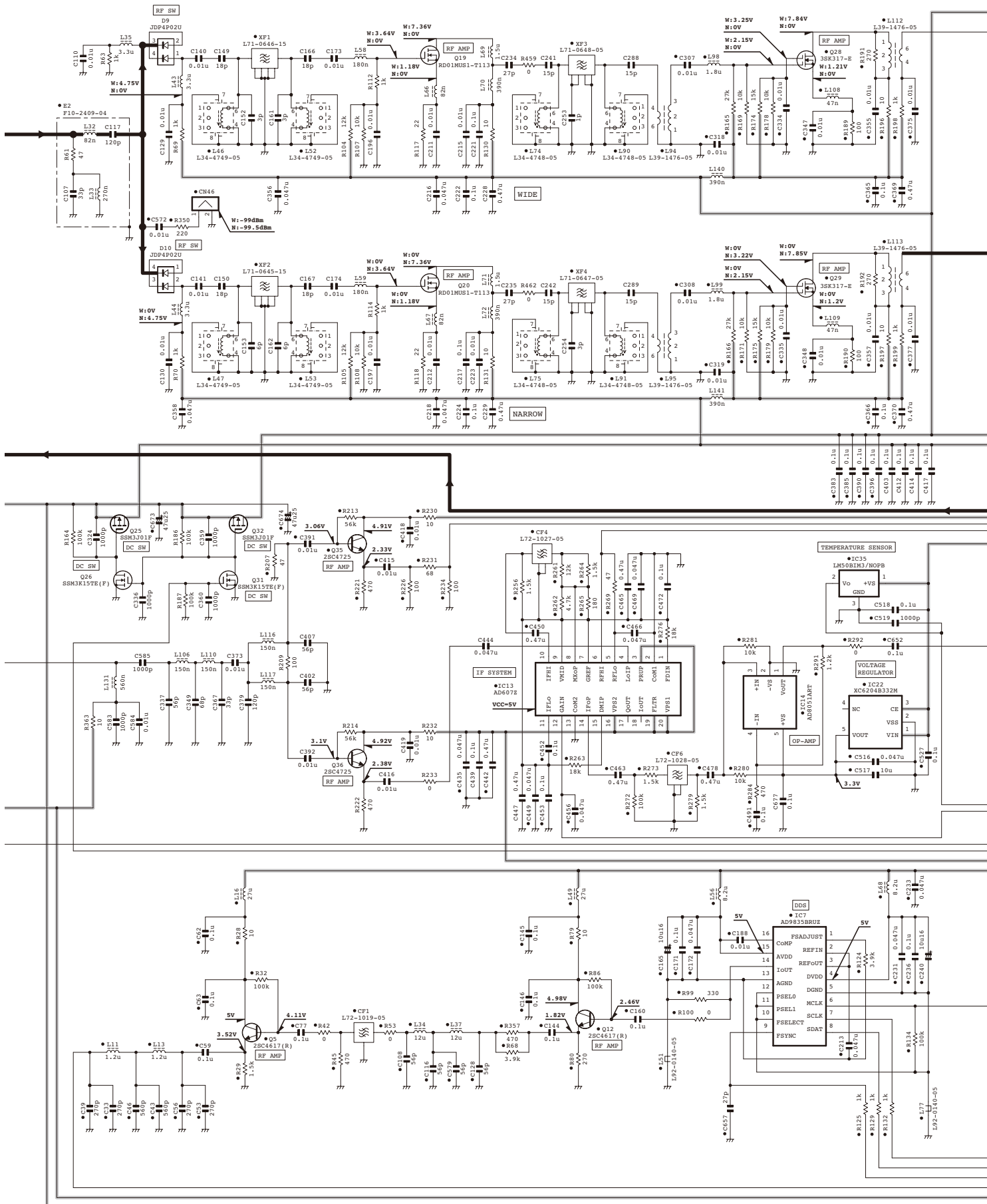

NXR-700 SCHEMATIC DIAGRAM

RX UNIT (X55-3092-71)

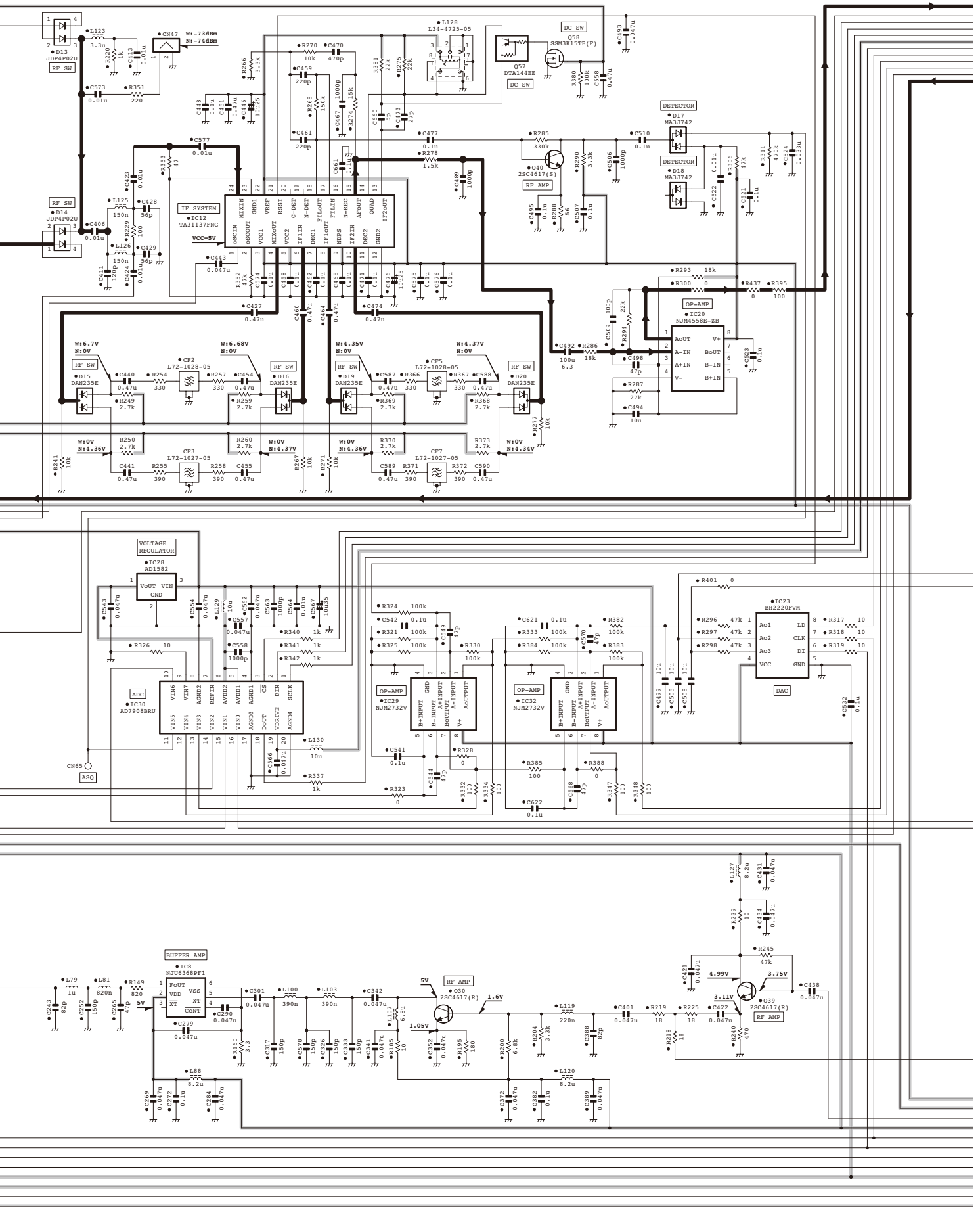

SCHEMATIC DIAGRAM NXR-700

RX UNIT (X55-3092-71)

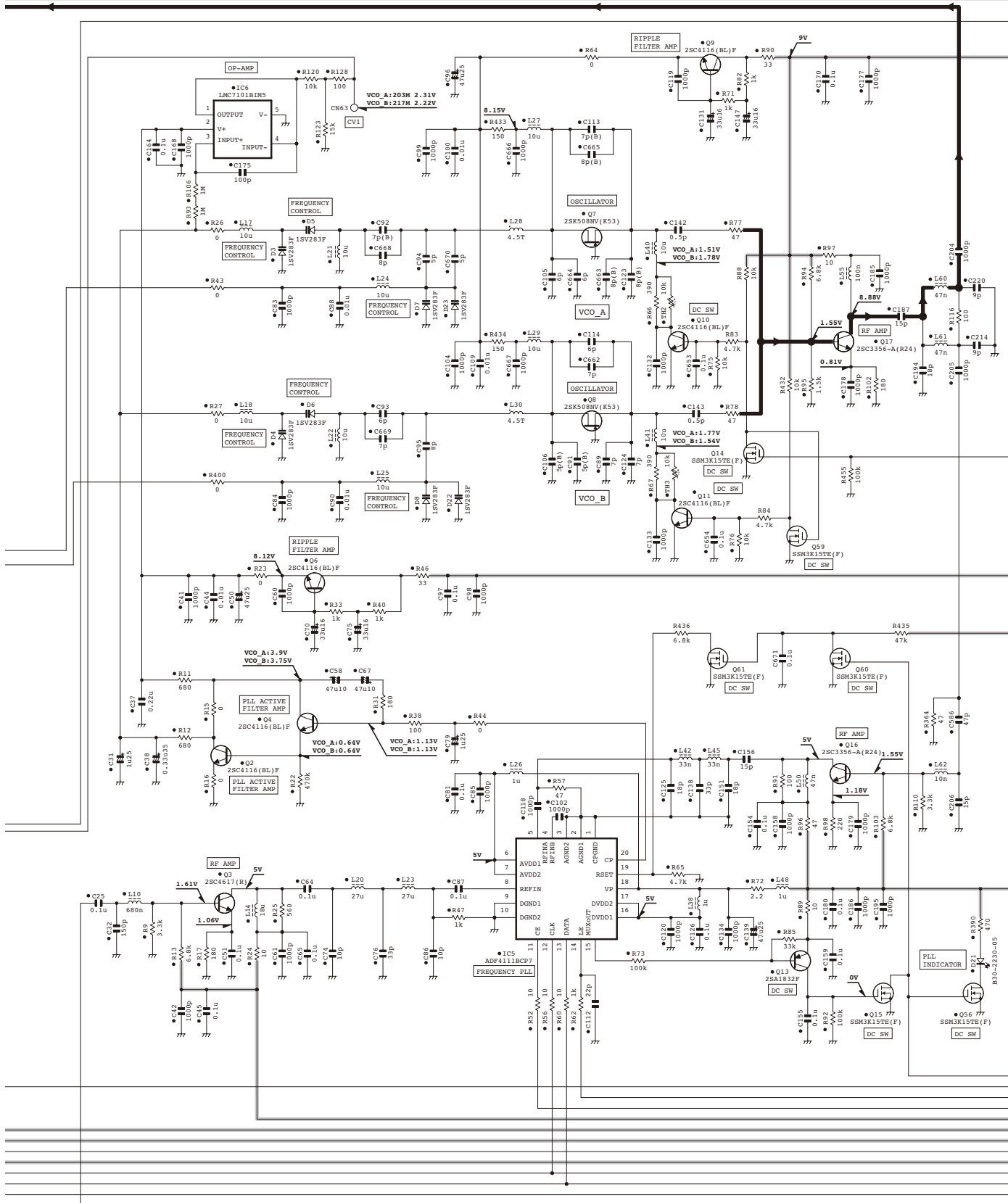

NXR-700 SCHEMATIC DIAGRAM

RX UNIT (X55-3092-71)

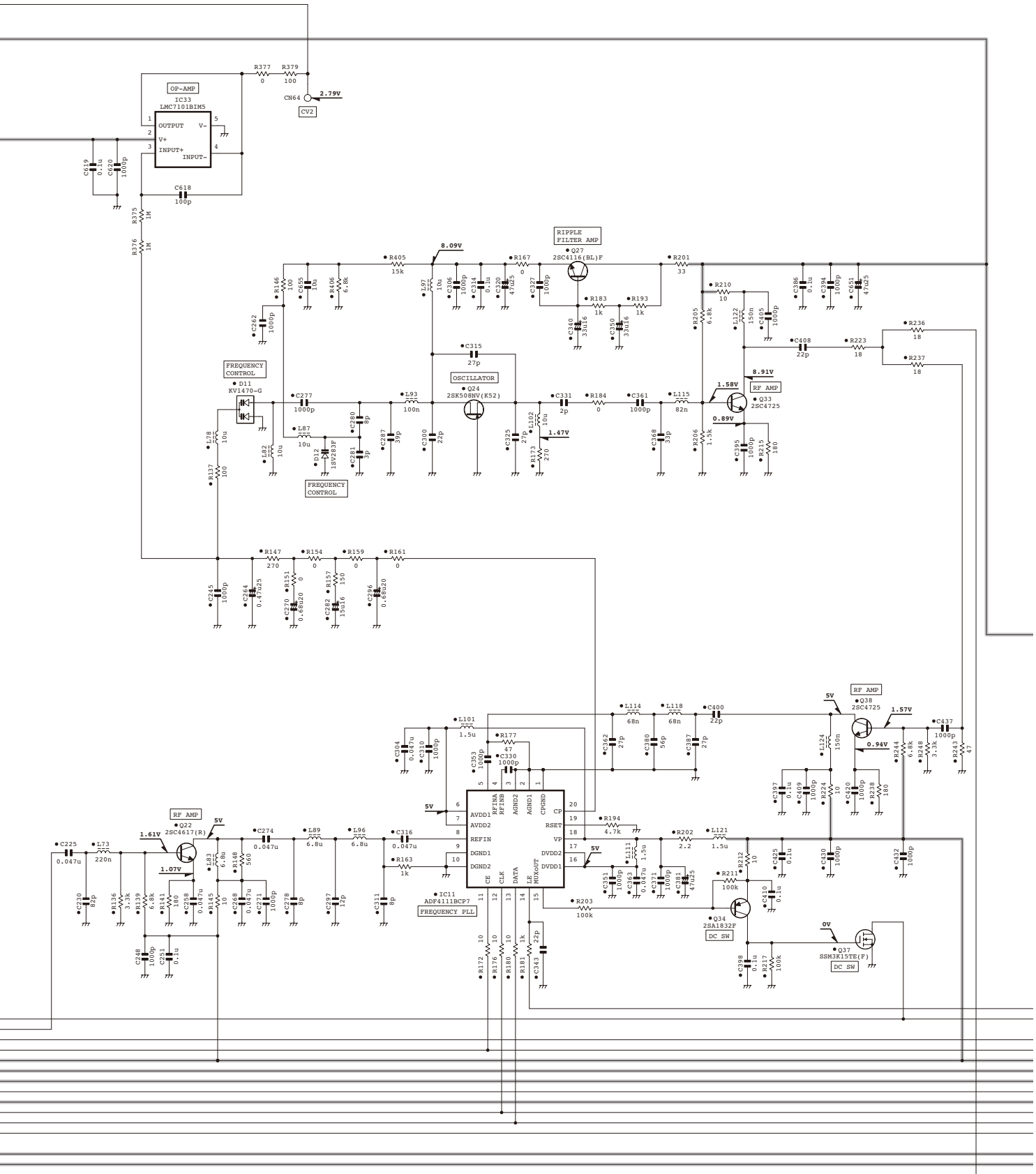

SCHEMATIC DIAGRAM NXR-700

RX UNIT (X55-3092-71)

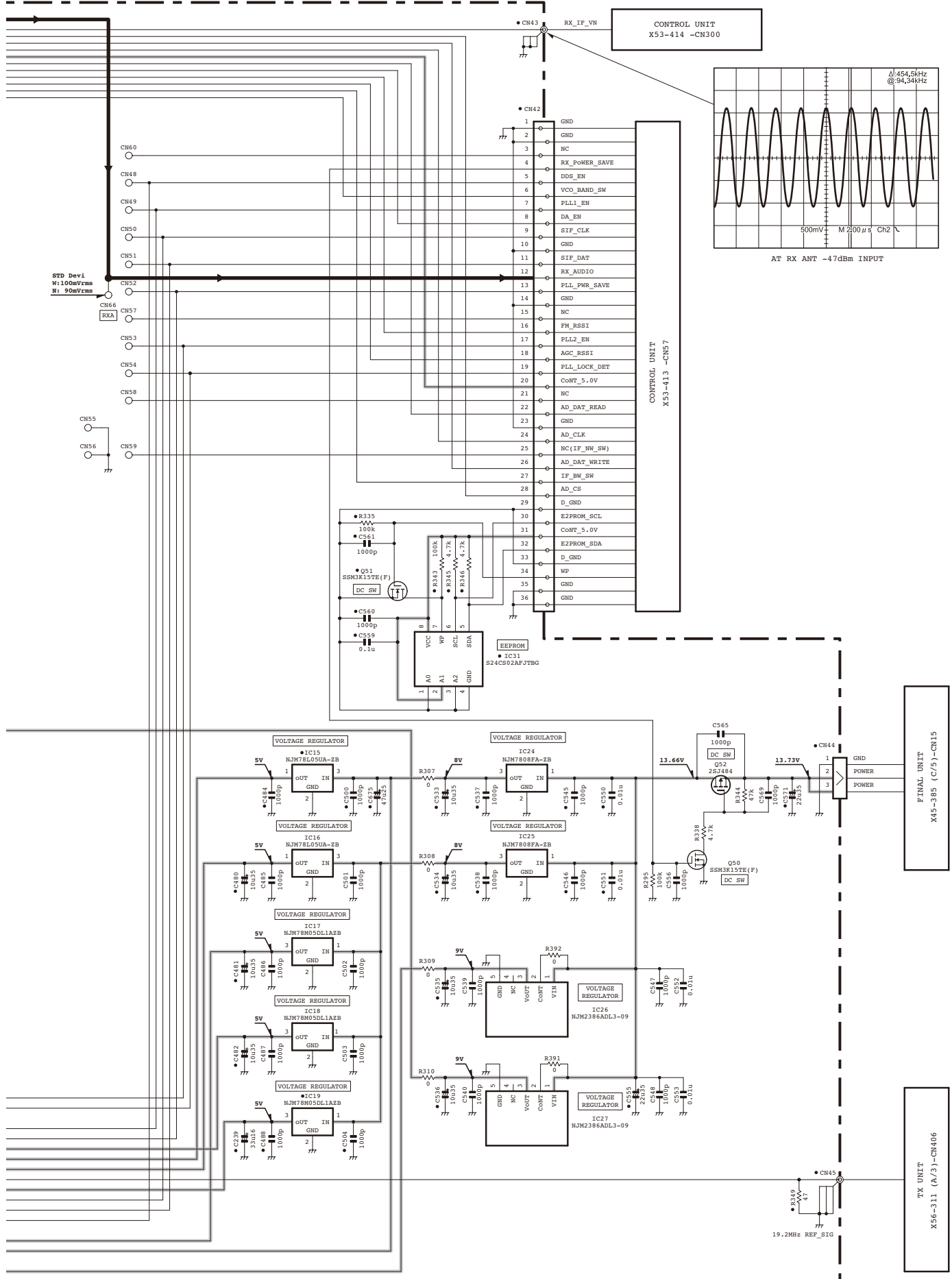

Note : The components marked with a dot (•) are parts of layer 1.

NXR-700 SCHEMATIC DIAGRAM

TX UNIT(X56-3112-71) (A/3)

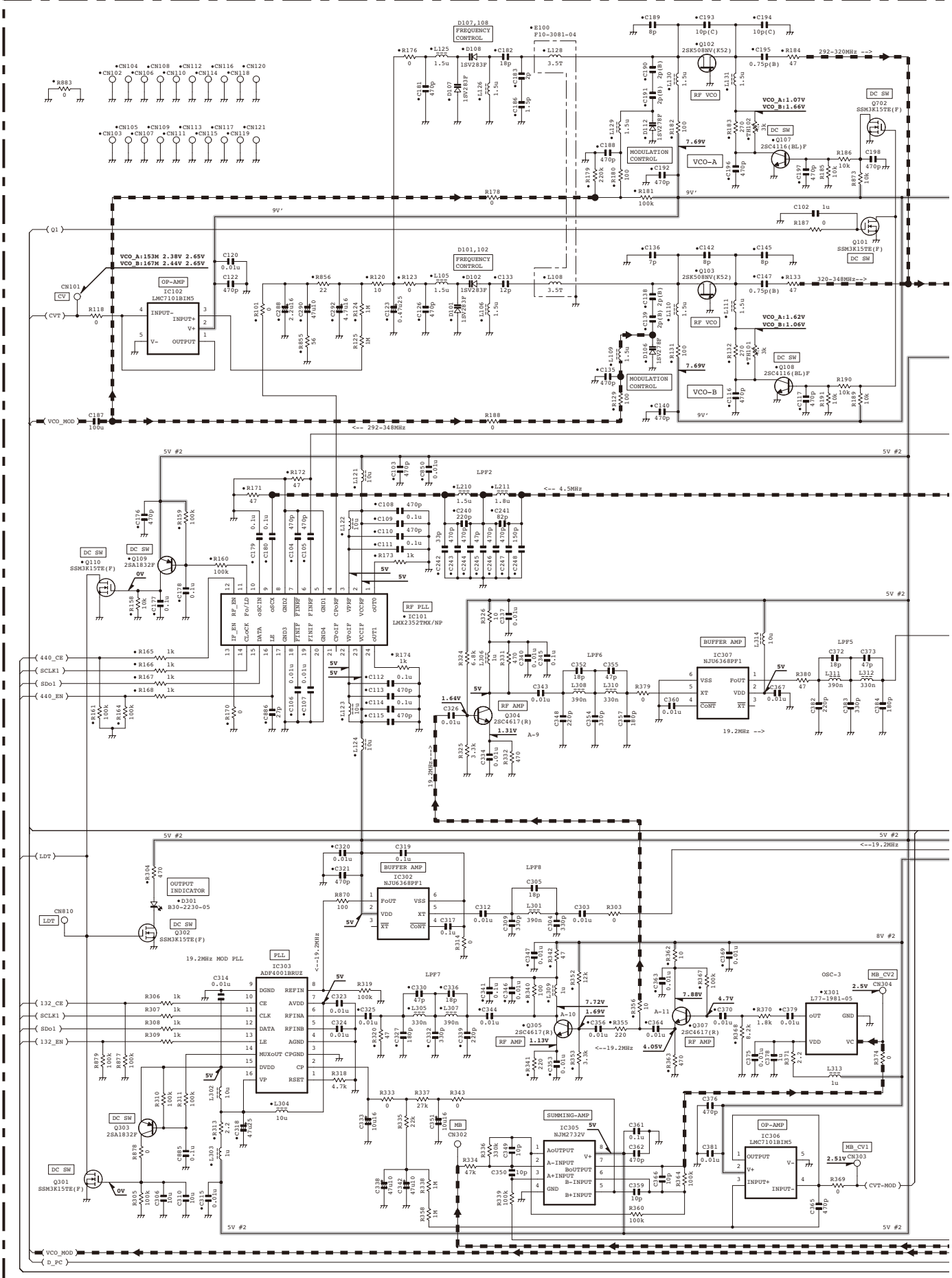

SCHEMATIC DIAGRAM NXR-700

TX UNIT (X56-3112-71) (A/3)

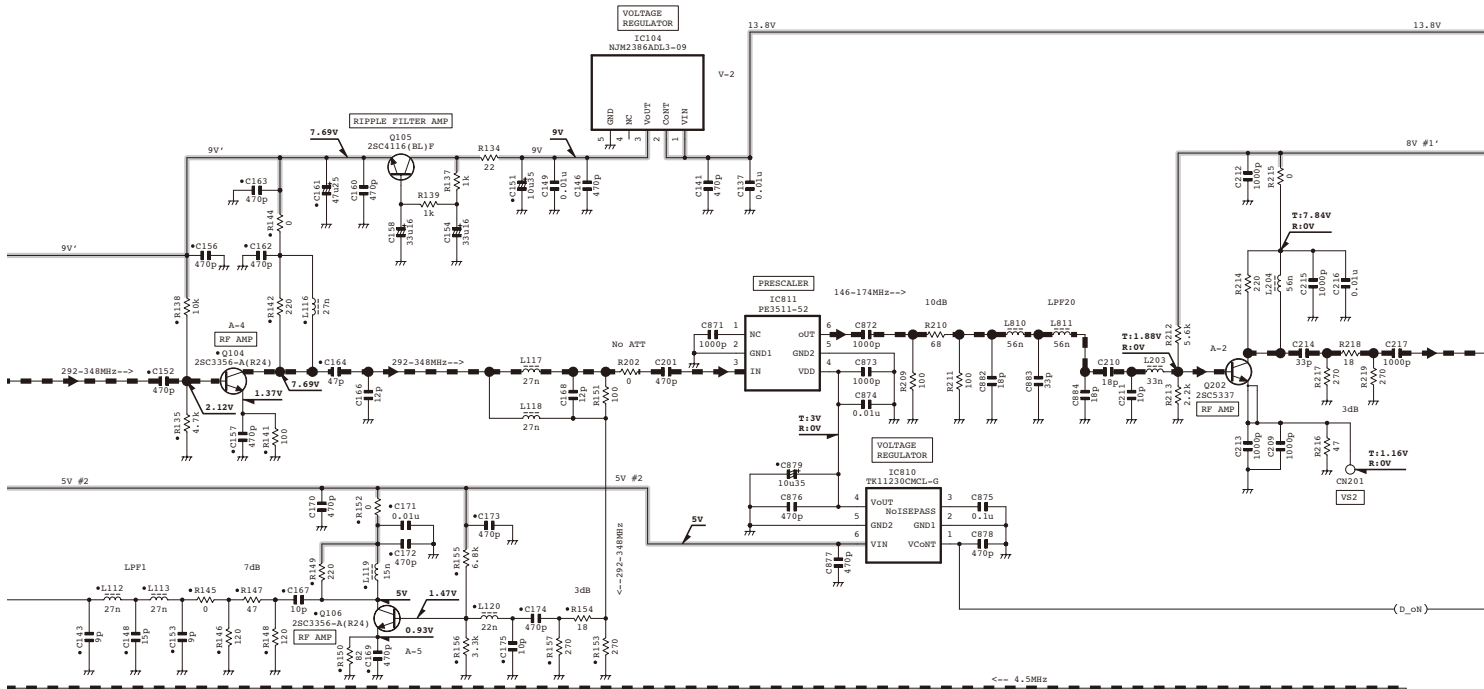

NXR-700 SCHEMATIC DIAGRAM

TX UNIT (X56-311-71) (A/3)

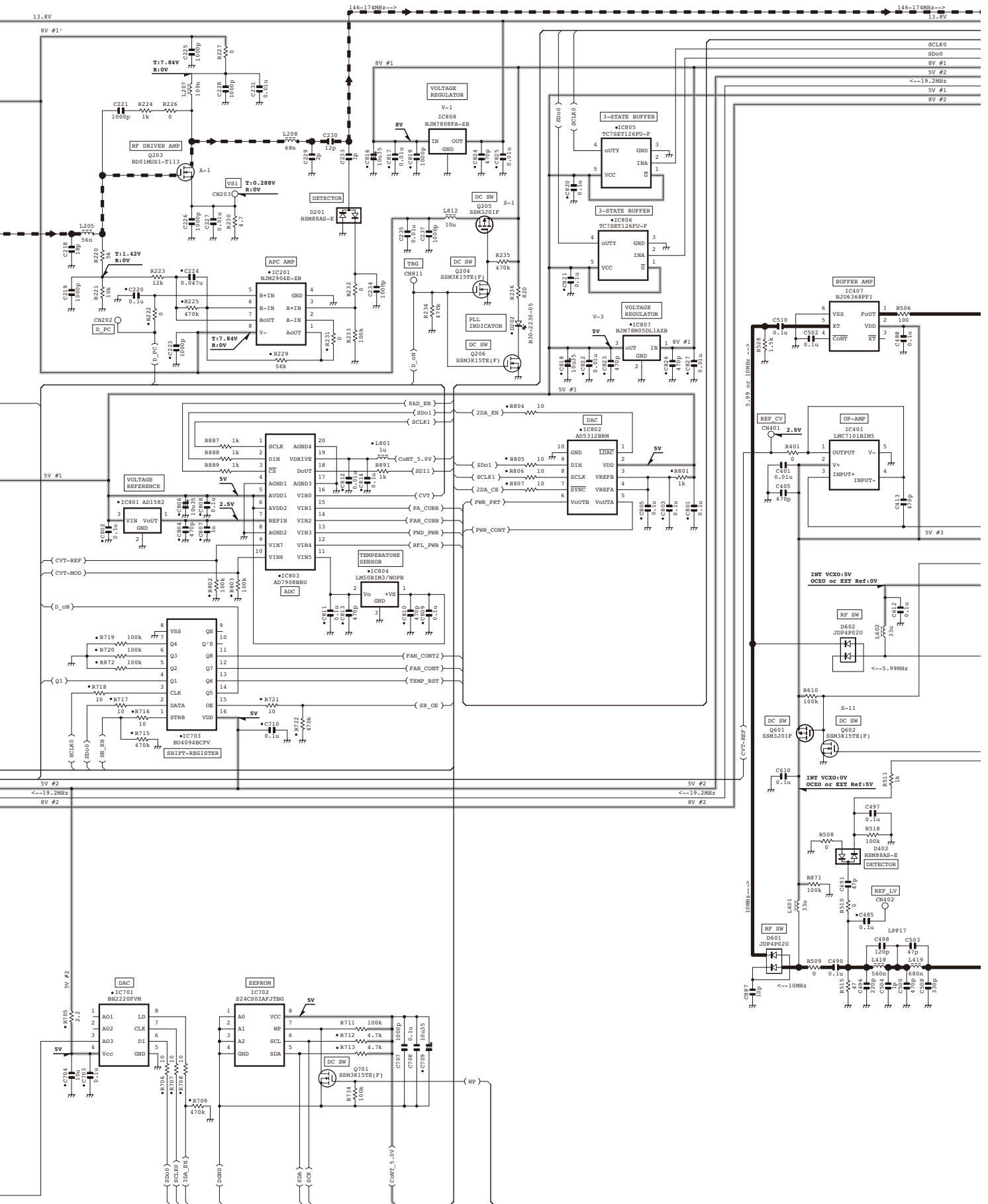

SCHEMATIC DIAGRAM NXR-700

TX UNIT (X56-3112-71) (A/3)

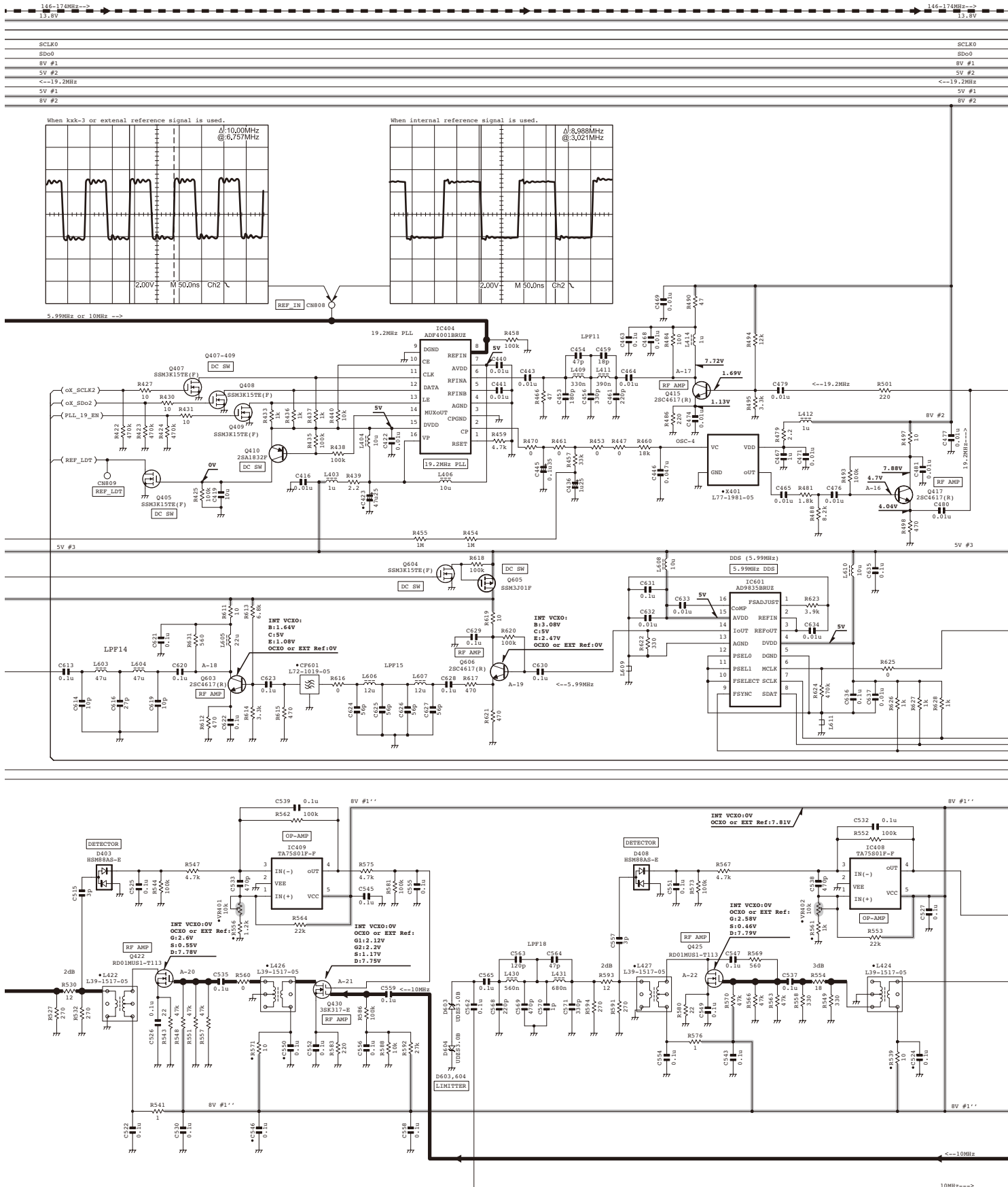

NXR-700 SCHEMATIC DIAGRAM

TX UNIT (X56-311-71) (A/3)

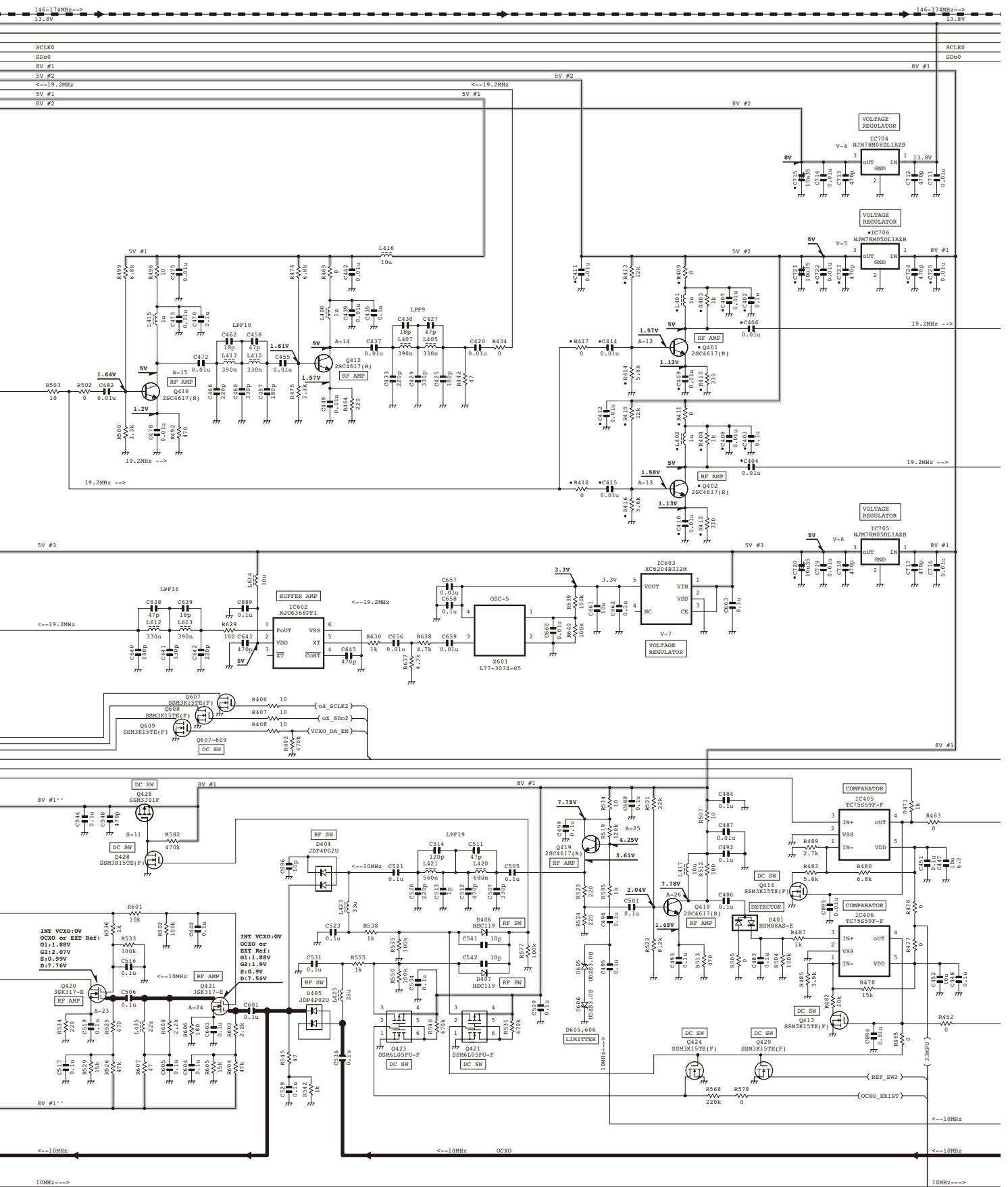

SCHEMATIC DIAGRAM NXR-700

TX UNIT (X56-3112-71) (A/3)

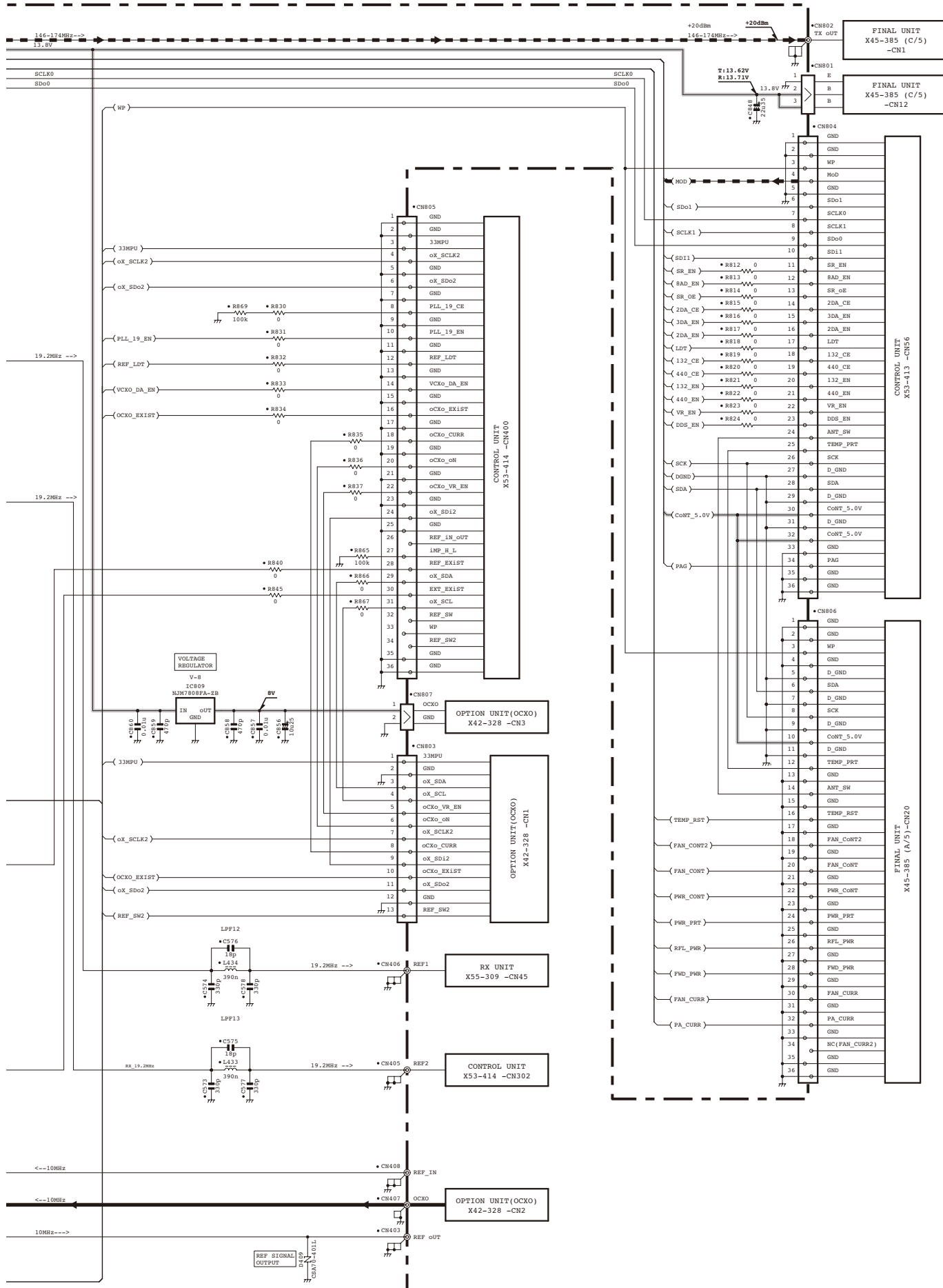

Note : The components marked with a dot (•) are parts of layer 1.

NXR-700 SCHEMATIC DIAGRAM

TX UNIT (17SEG)
(X56-3112-71)

TX UNIT (LED)
(X56-3112-71)

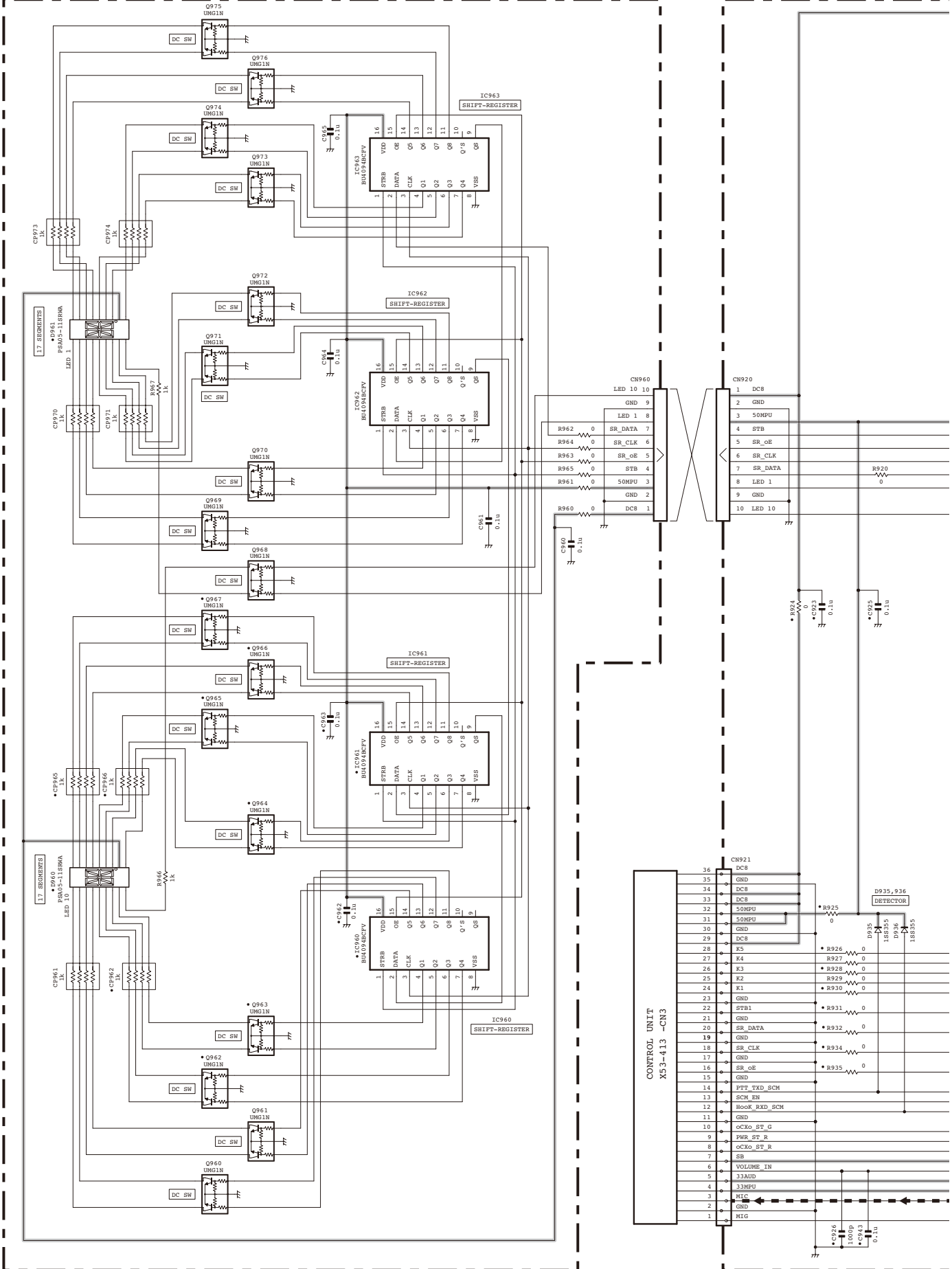

SCHEMATIC DIAGRAM NXR-700

TX UNIT (LED)
(X56-3112-71) (B/3)

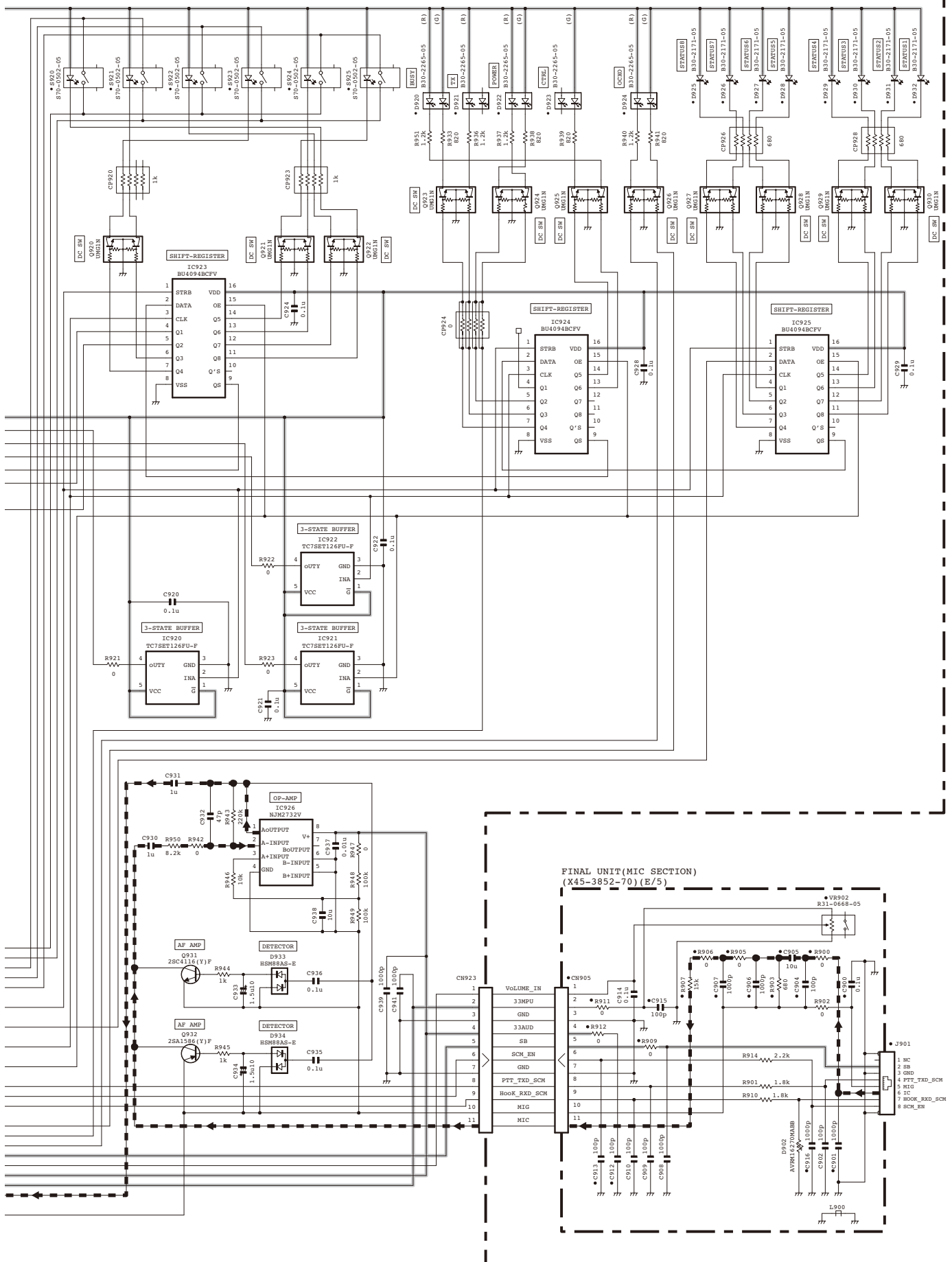

Note : The components marked with a dot (•) are parts of layer 1.

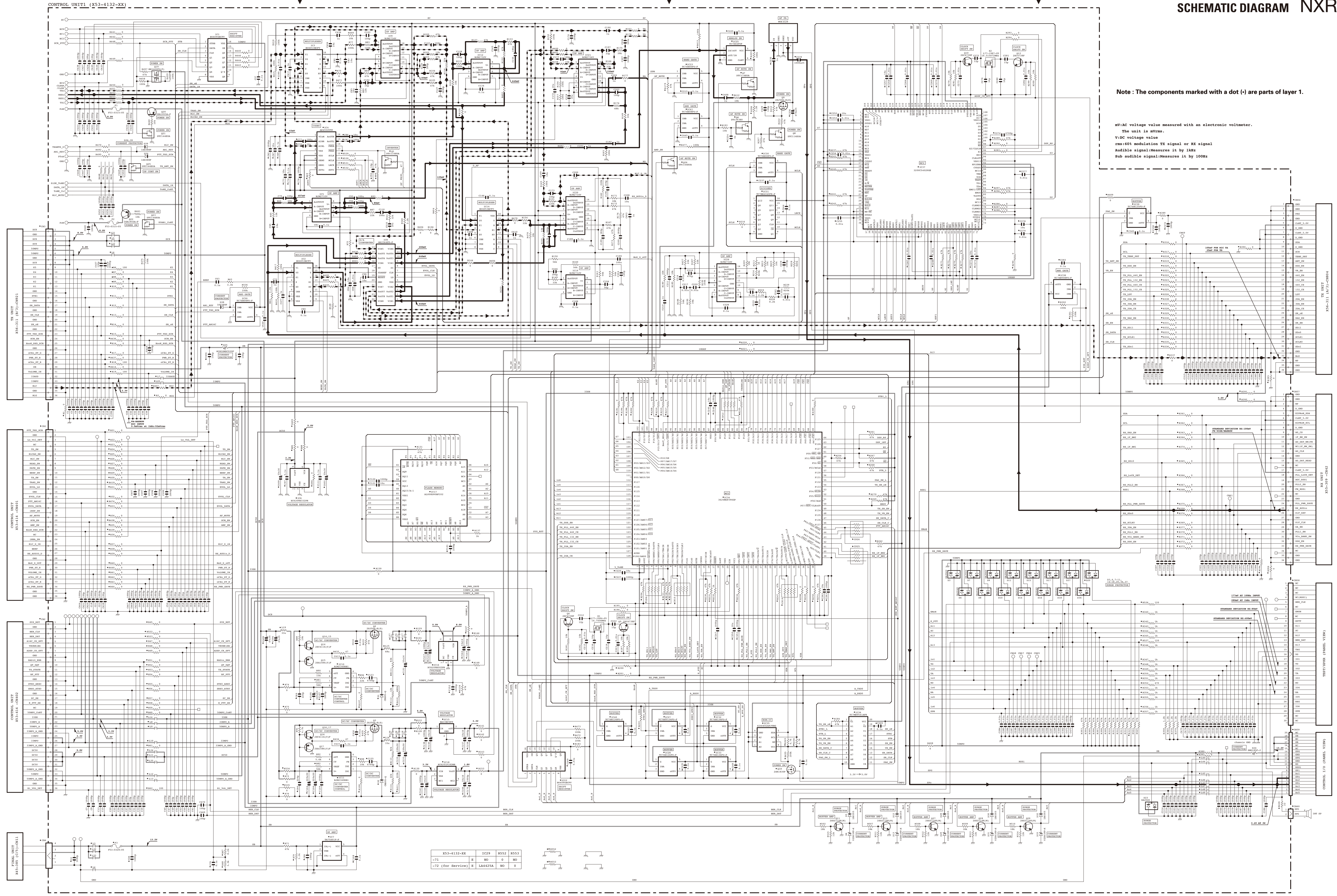

Note : The components marked with a dot (•) are parts of layer 1.

v:AC voltage value measured with an electronic voltmeter.
 The unit is mVrms.
 V:DC voltage value
 rms:60i modulation TX signal or RX signal
 Audible signal:Measures it by 1kHz
 Sub audible signal:Measures it by 100Hz

X53-4132-XX				
-71	(For Service)	IC29	8552	8553
			LA443A	80 0

CONTROL UNIT1 (X53-4132-XX)

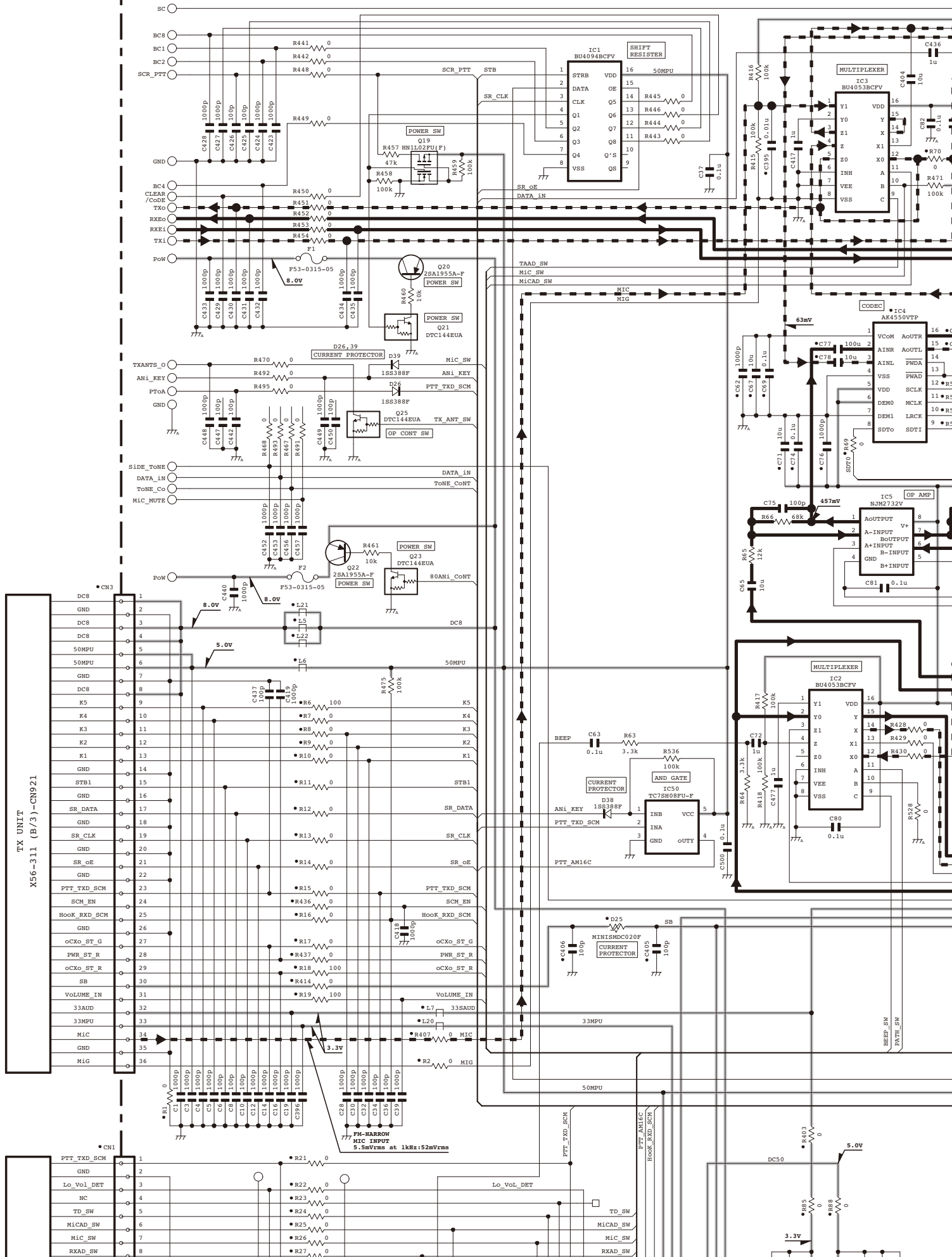

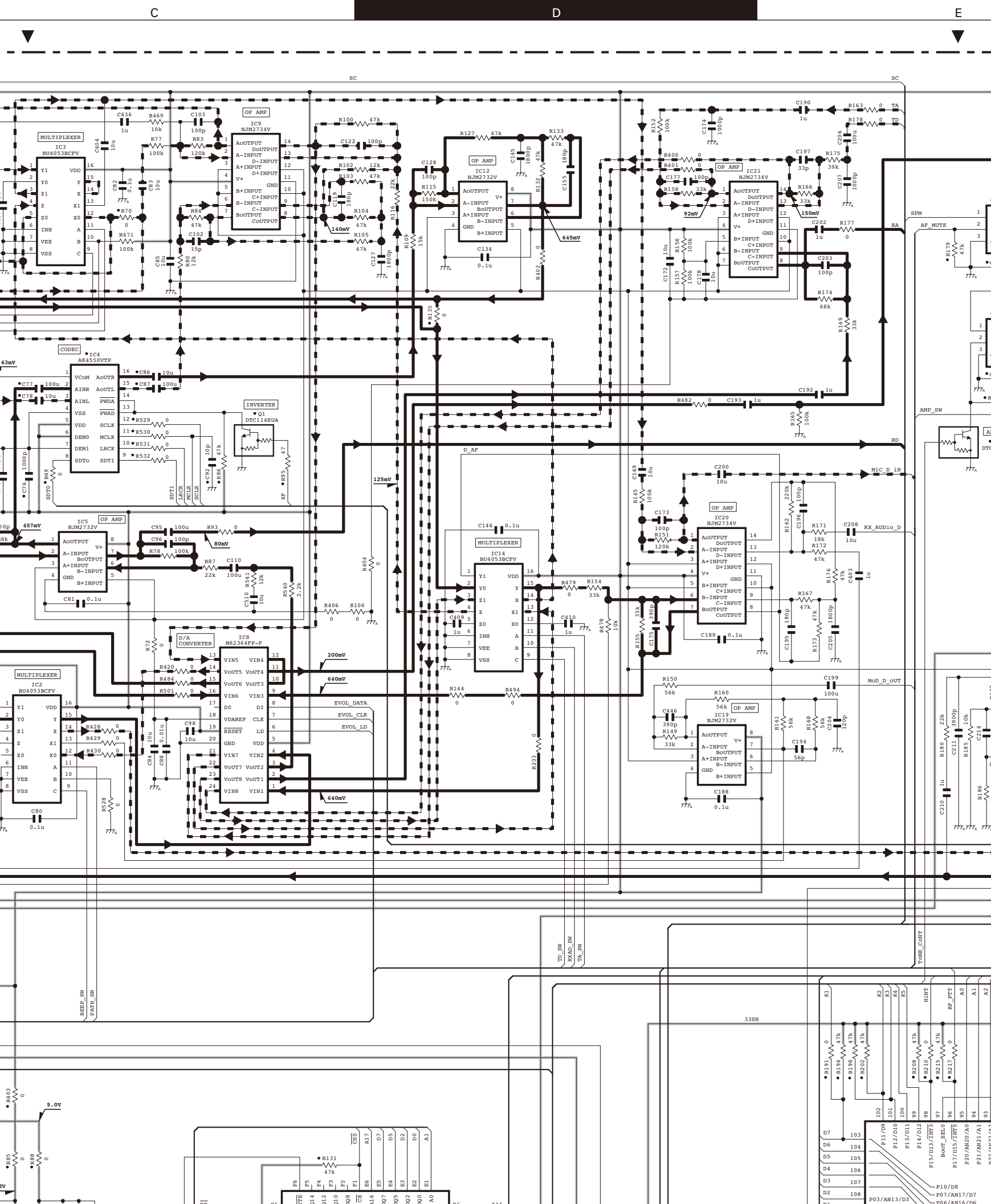

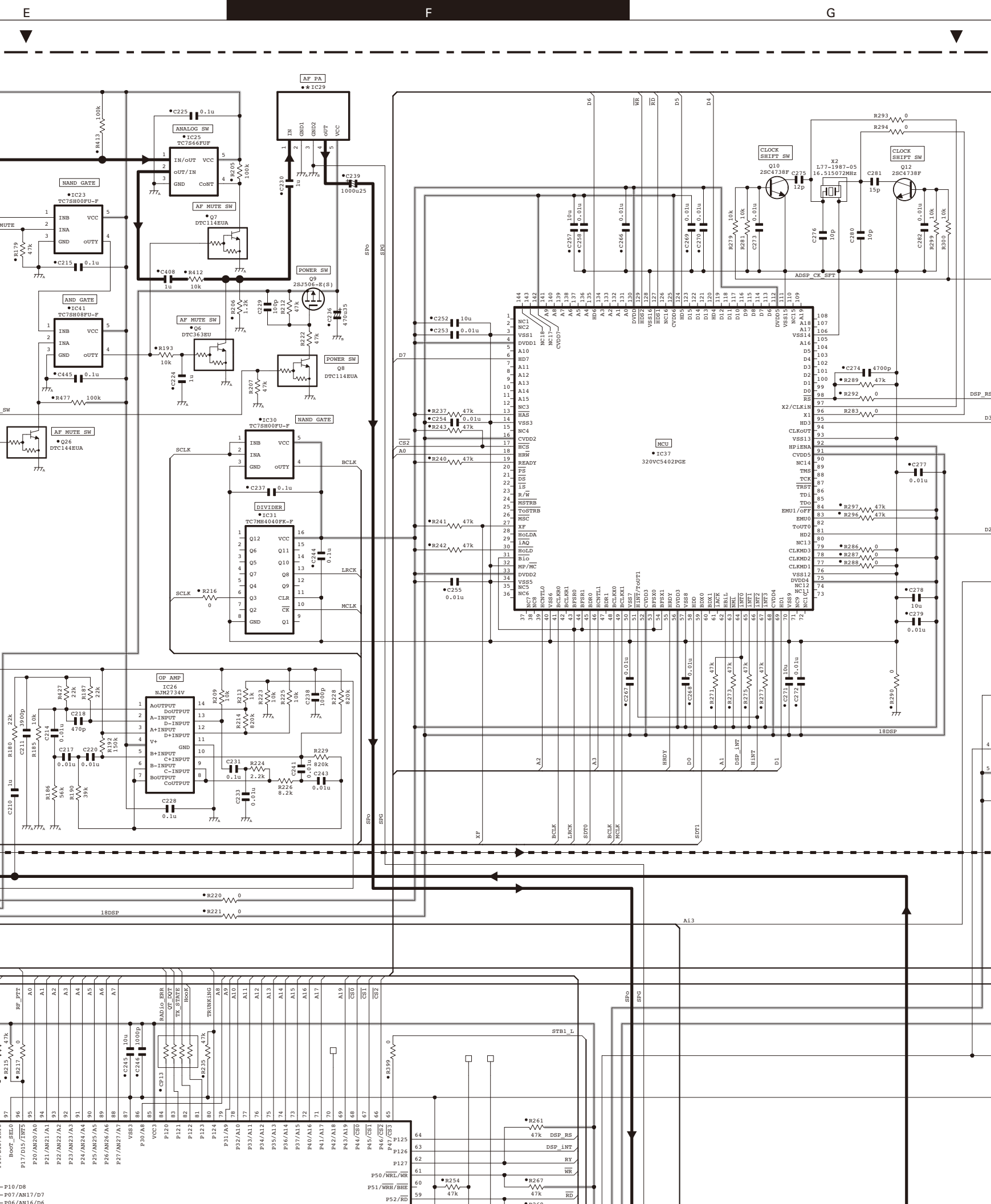

SCHEMATIC DIAGRAM NXR-700

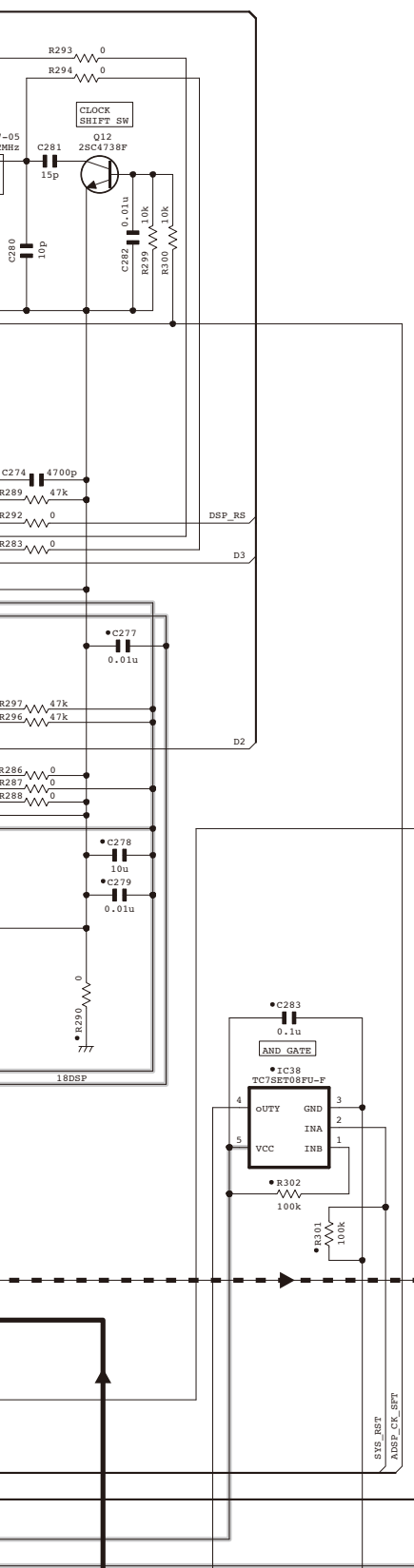

Note : The components marked with a dot (•) are parts of layer 1.

mV:AC voltage value measured with an electronic voltmeter.

The unit is mVrms.

V:DC voltage value

rms:60% modulation TX signal or RX signal

Audible signal:Measures it by 1kHz

Sub audible signal:Measures it by 100Hz

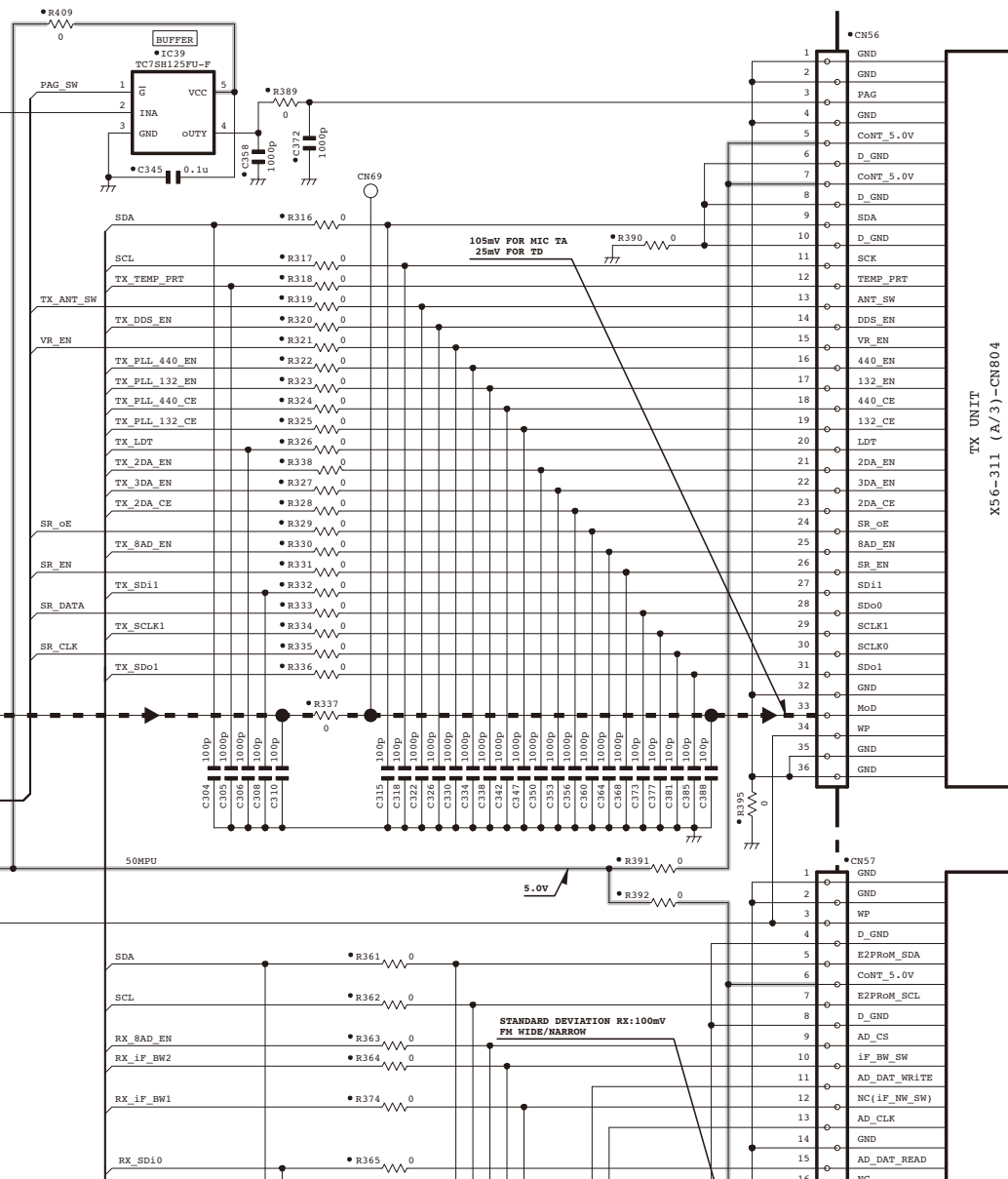

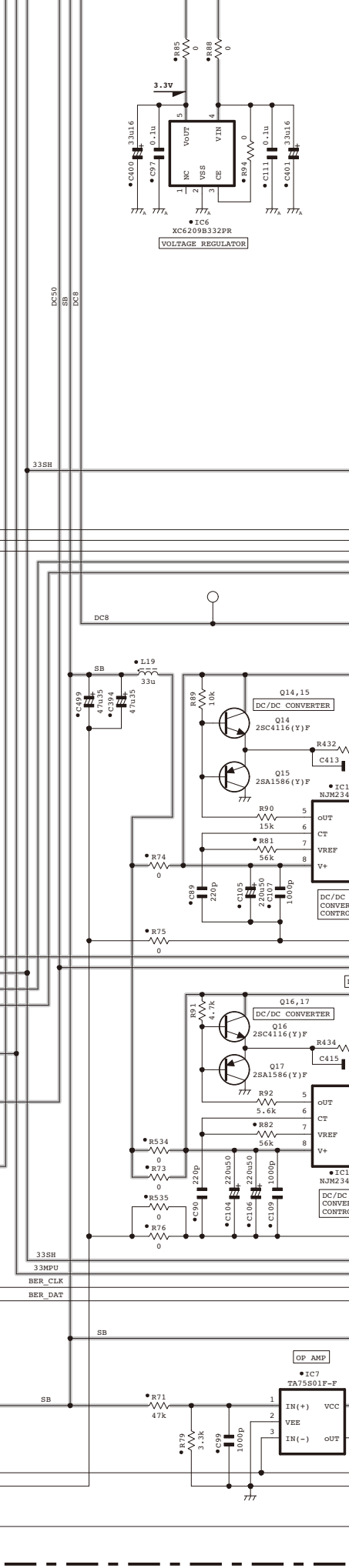
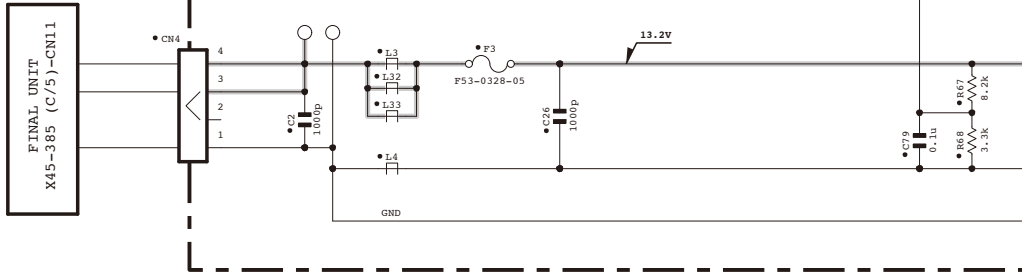
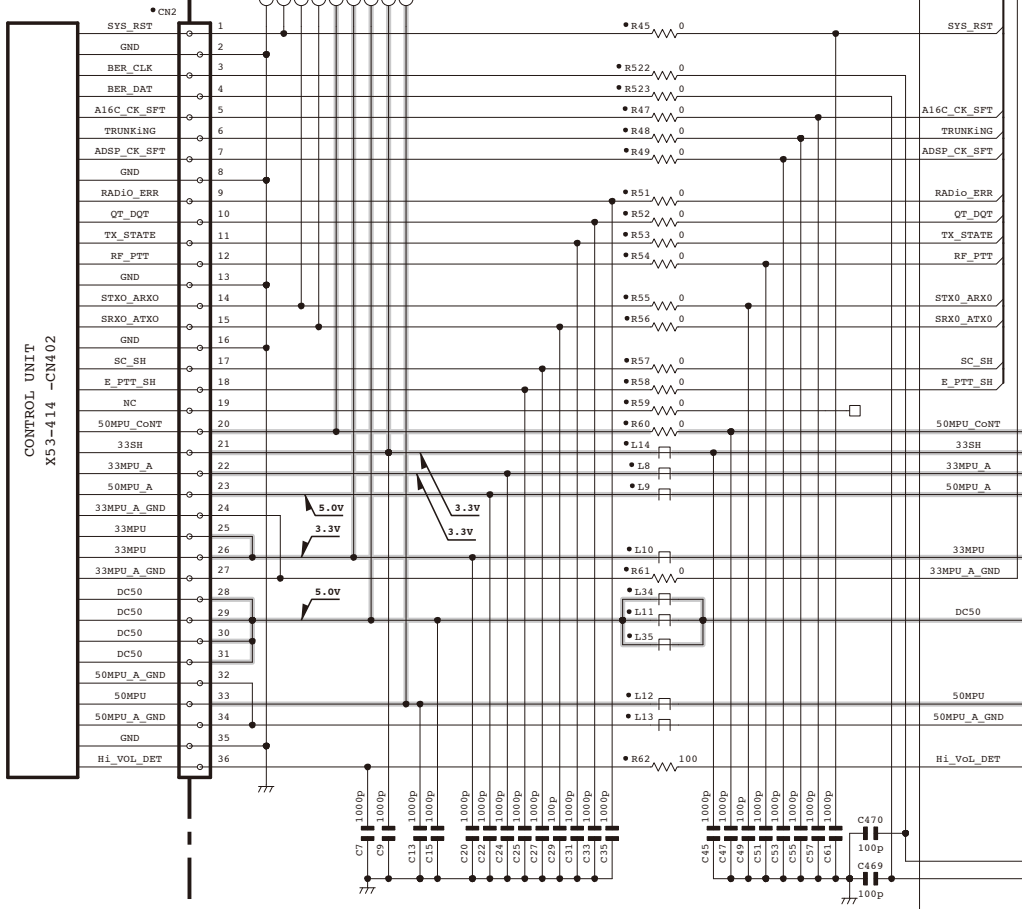
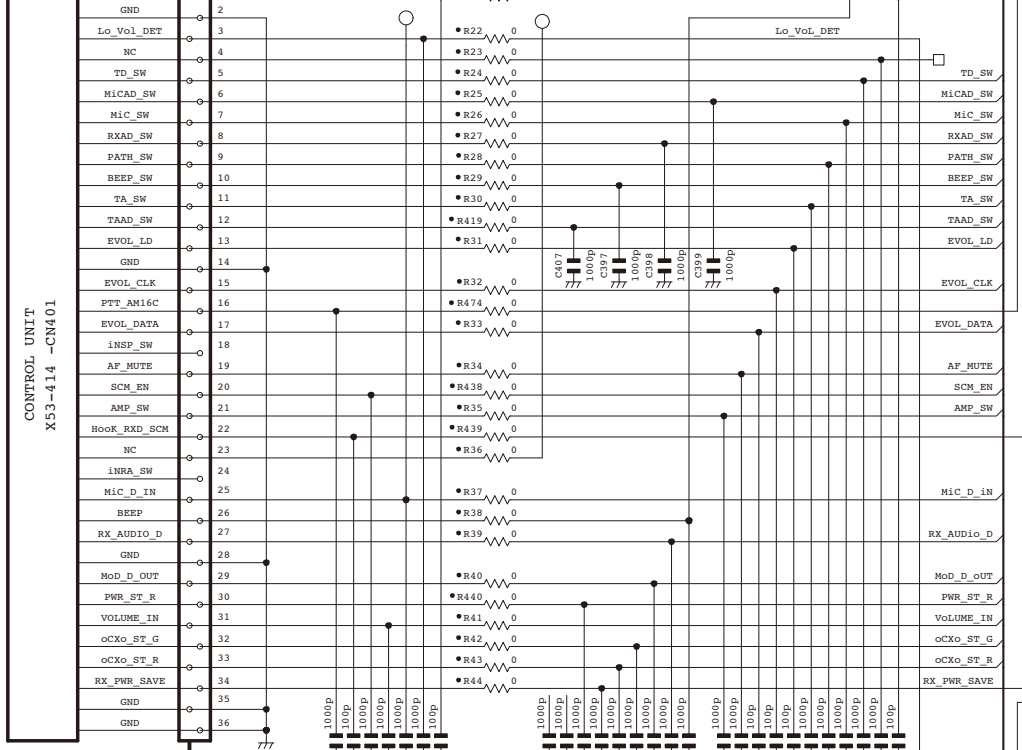

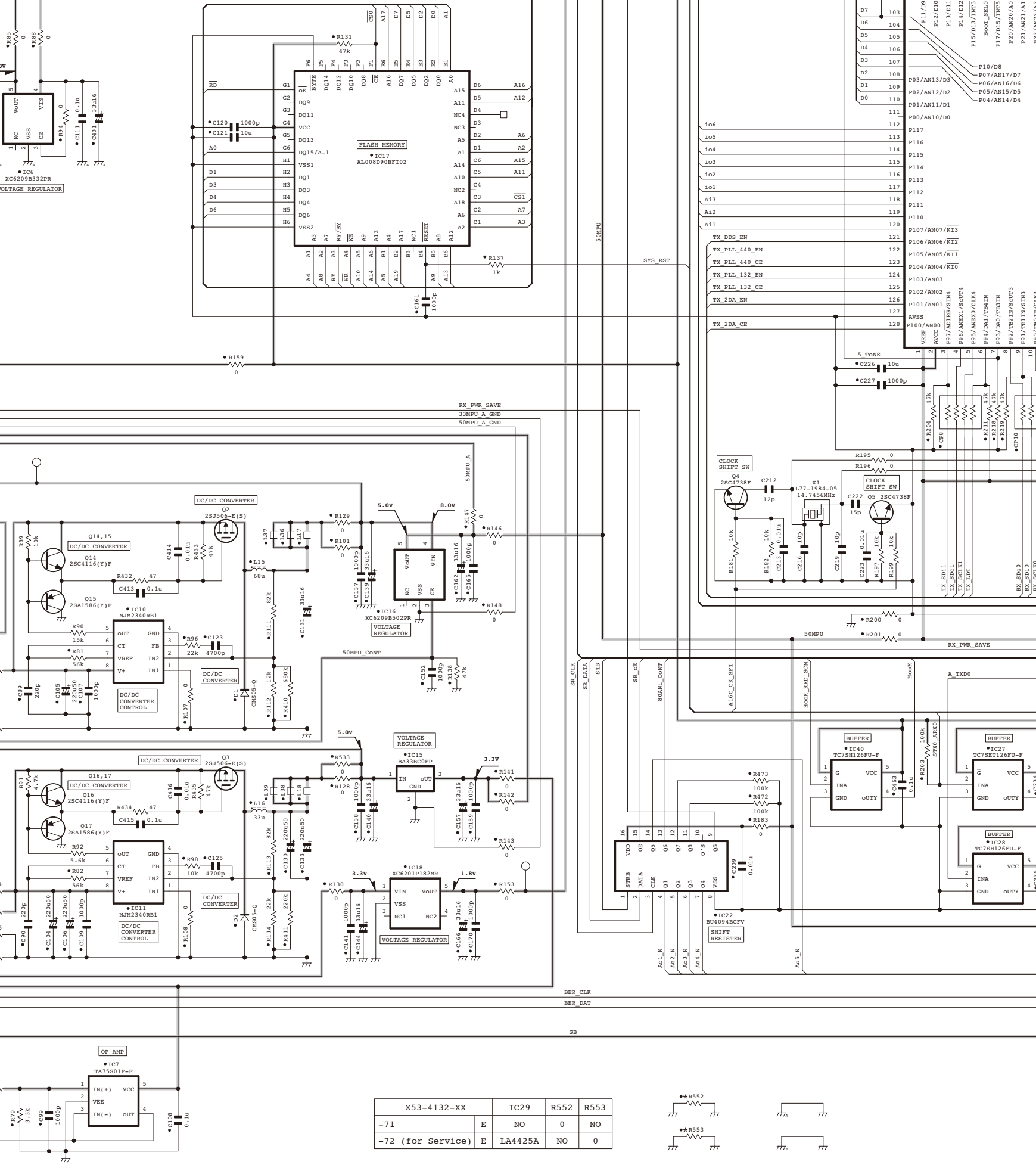

X53-4132-XX	IC29	R552	R553
-71	E	NO	0
-72 (for Service)	E	LA4425A	0



GND

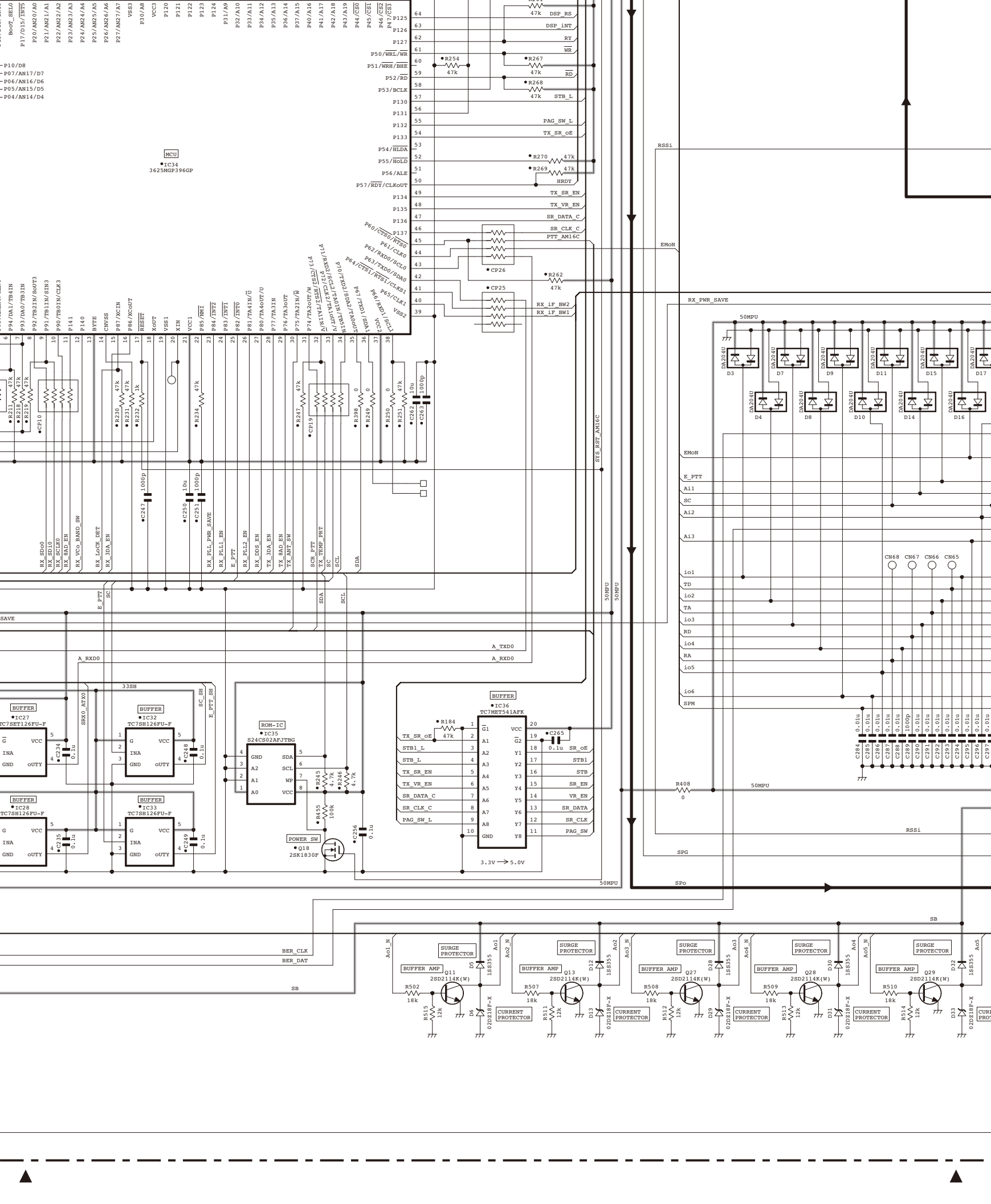

IC34
3625MGF396GP

IC35
S24CS02AFJTBG

IC36
TC7MET341AFK

IC32
TC7SH126FU-F

IC33
TC7SH126FU-F

IC27
TC7SET126FU-F

IC28
TC7SH126FU-F

3.3V → 5.0V

Q11
2SD2114K(W)

Q13
2SD2114K(W)

Q27
2SD2114K(W)

Q28
2SD2114K(W)

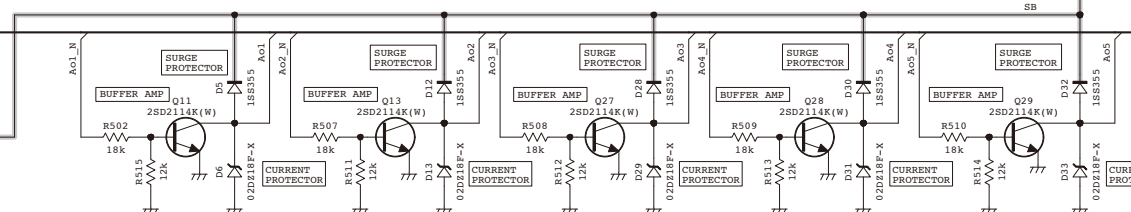
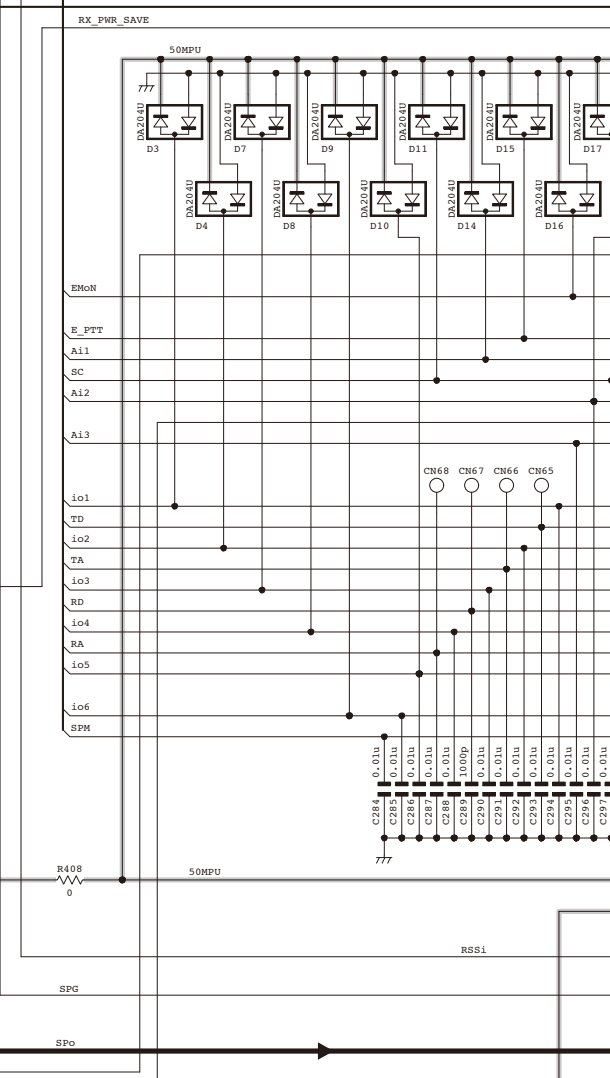
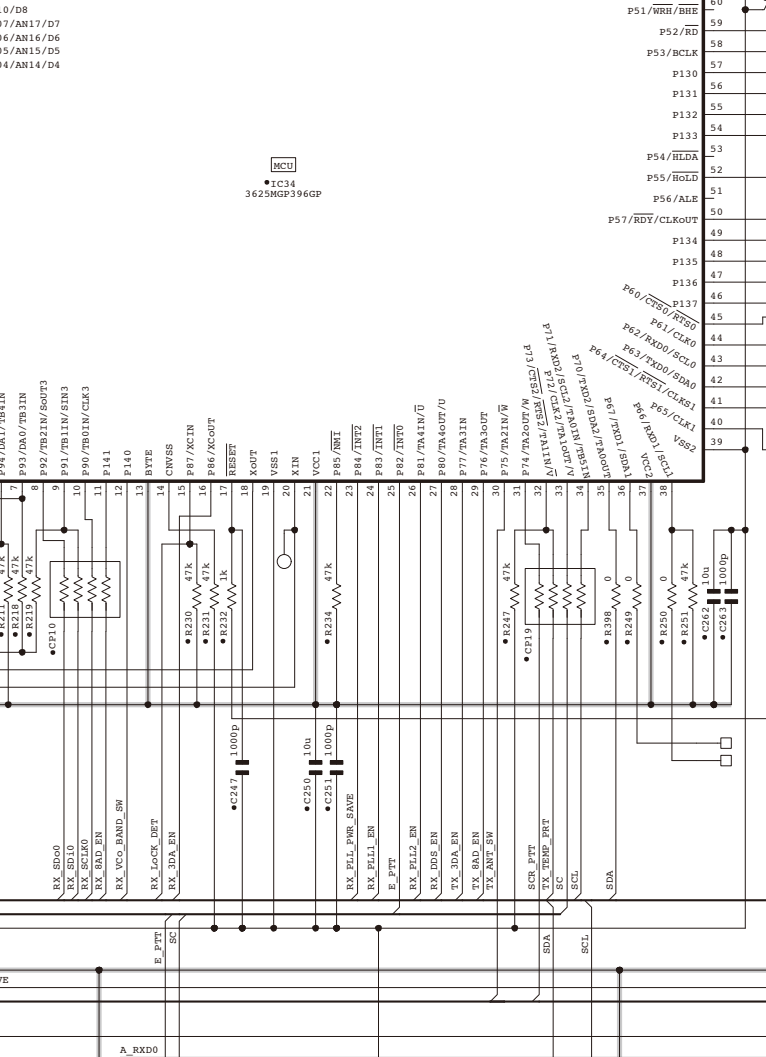

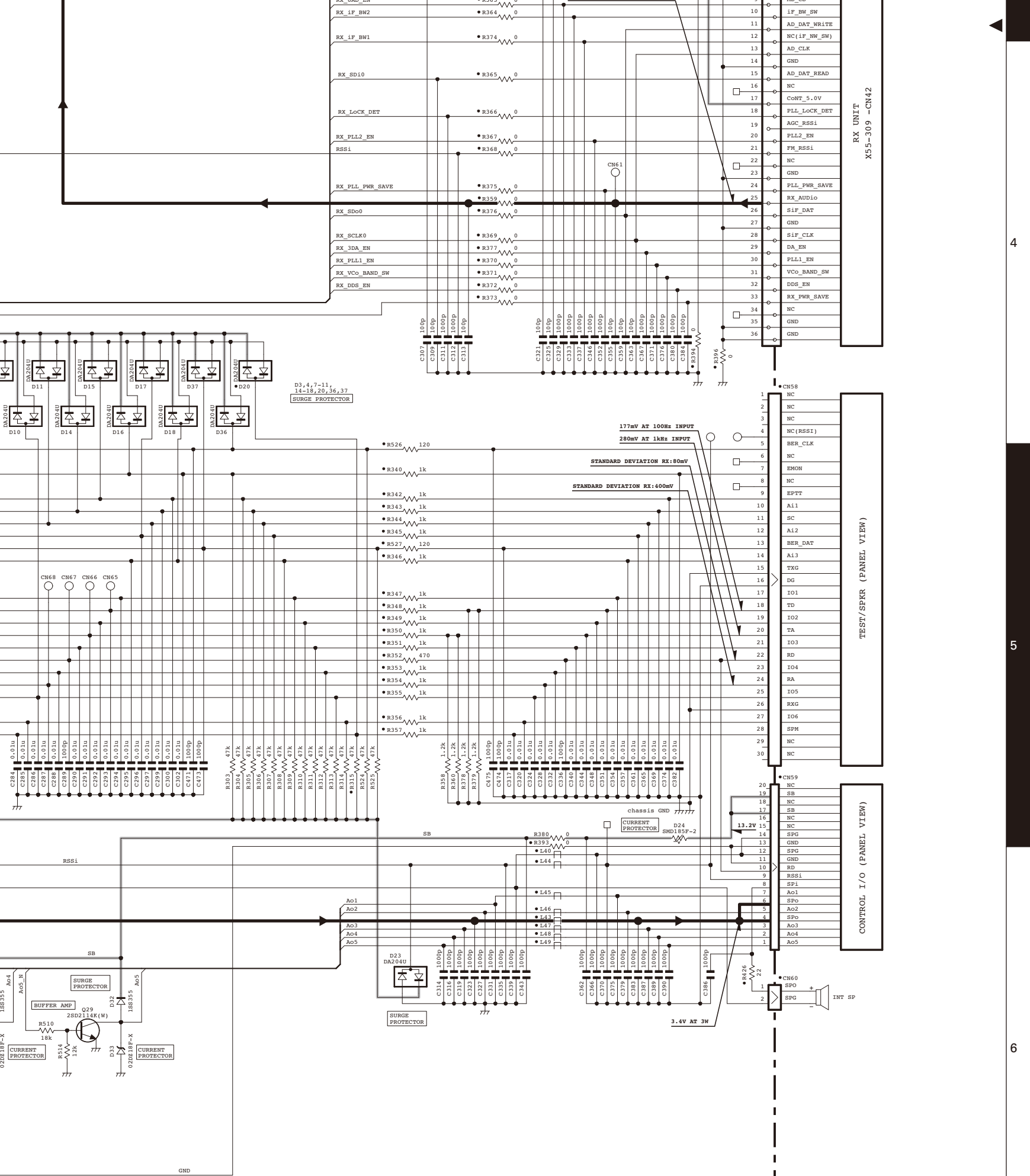

RX UNIT
X55-309 -CN42

TEST/SPKR (PANEL VIEW)

CONTROL I/O (PANEL VIEW)

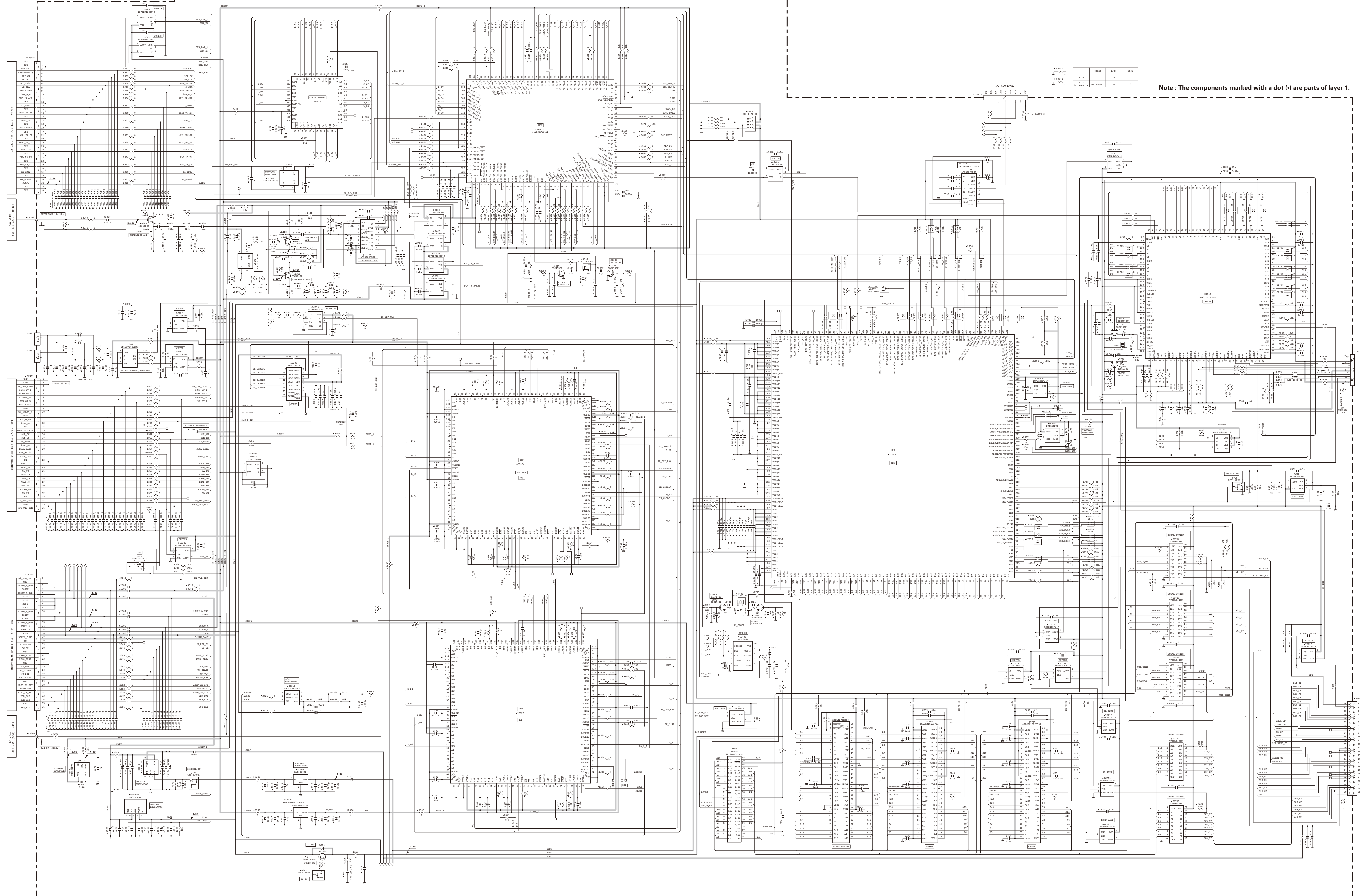

Symbol	Value
[Symbol]	10K
[Symbol]	100K
[Symbol]	1M
[Symbol]	100n
[Symbol]	10n
[Symbol]	1n

Note: The components marked with a dot (+) are parts of layer 1.

NXR-700 SCHEMATIC DIAGRAM

CONTROL UNIT2 (X53-4140-XX)

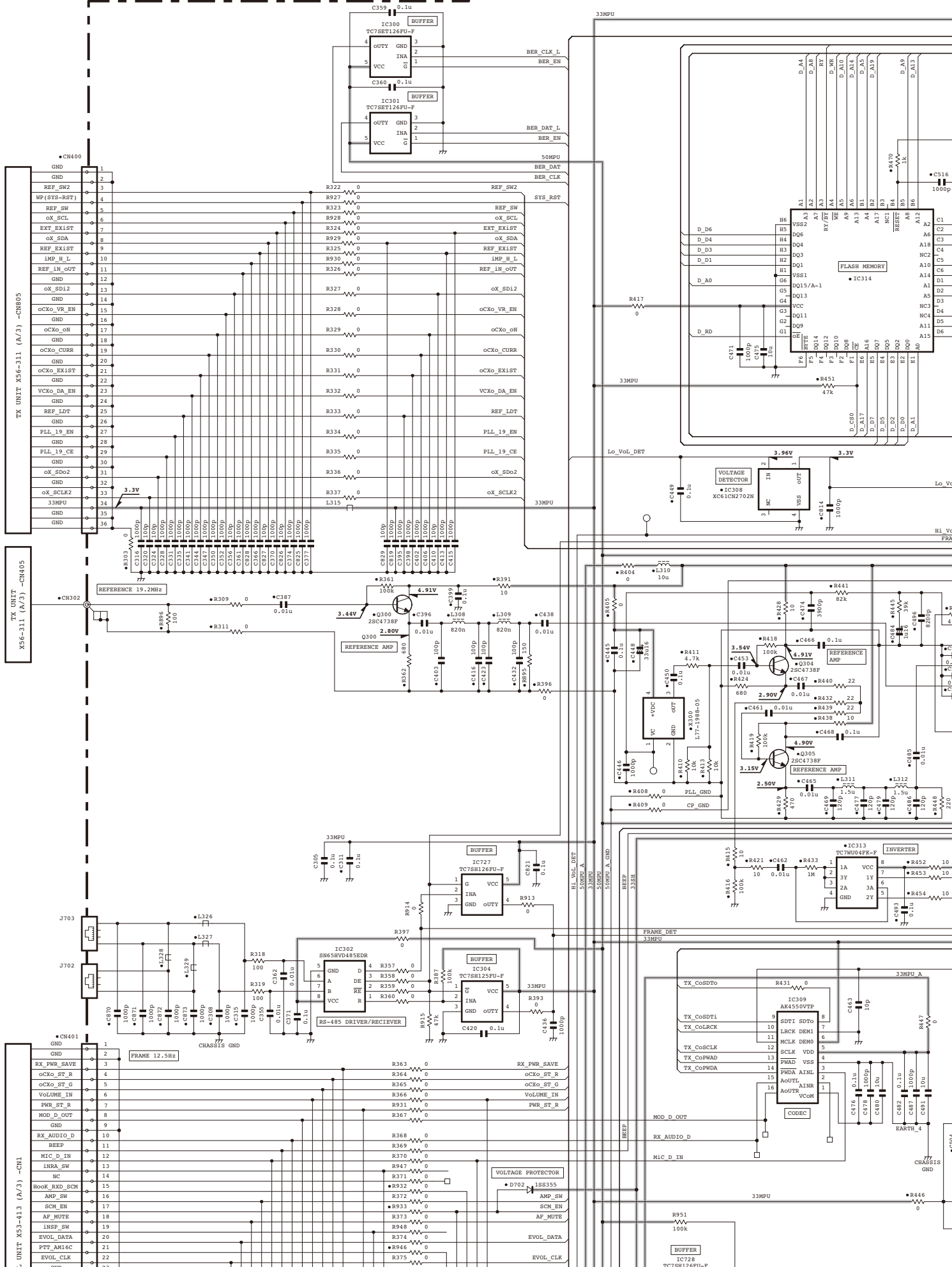

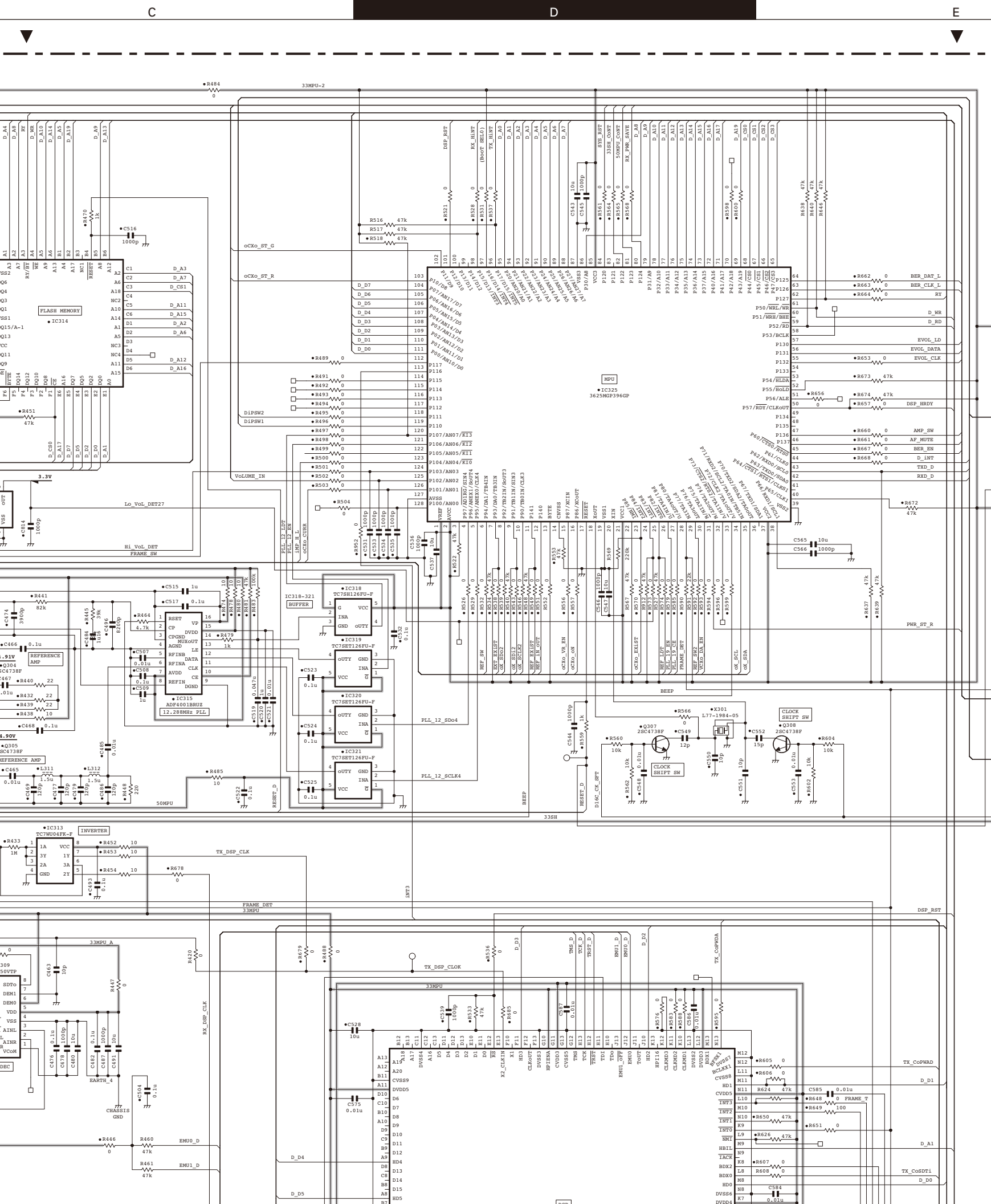



	IC329	R960	R961
	0-10	0	-
	0-11 for service	BA33DD0WT	0

Note : The components marked with a dot (•) are parts of layer 1.

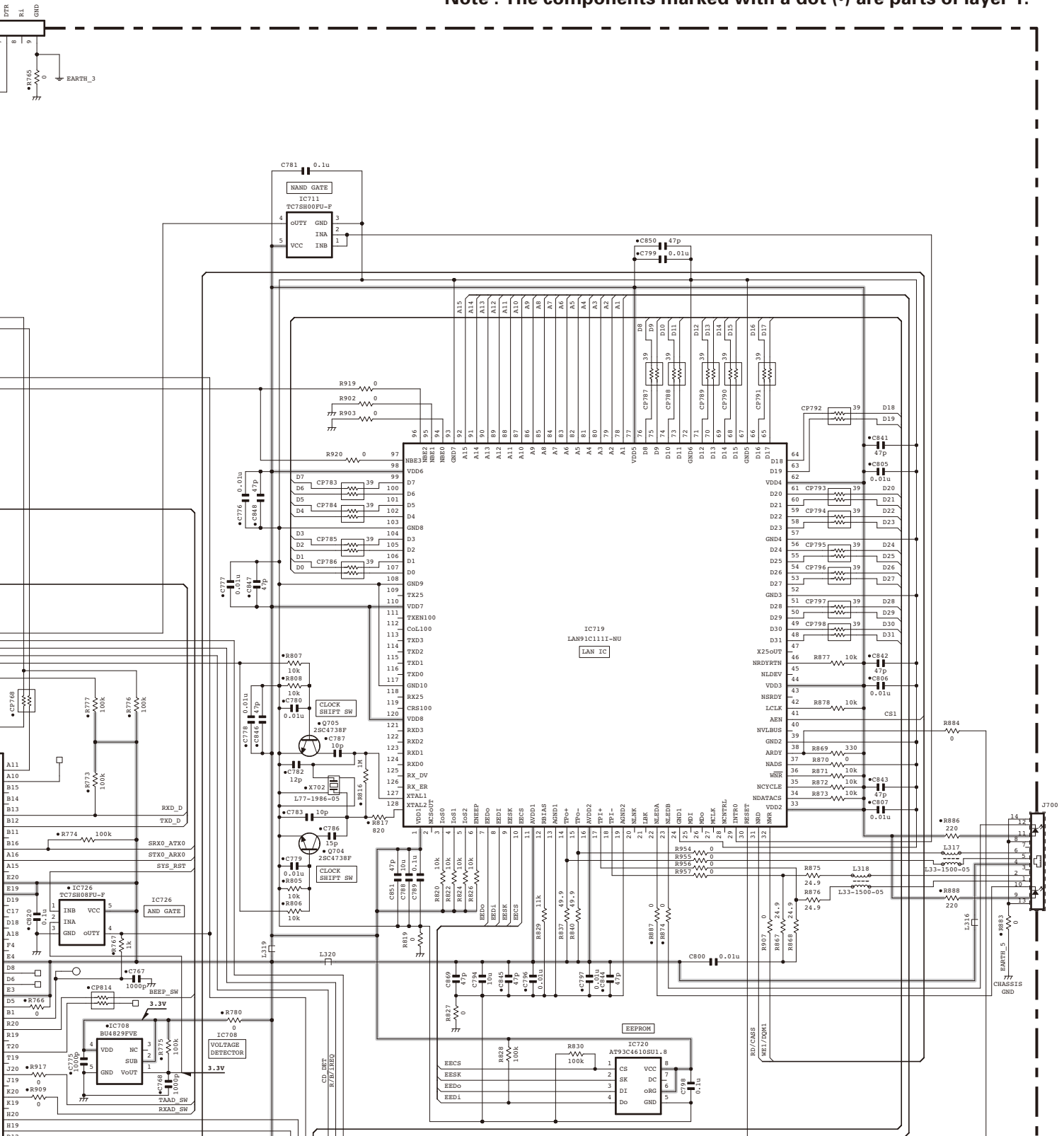

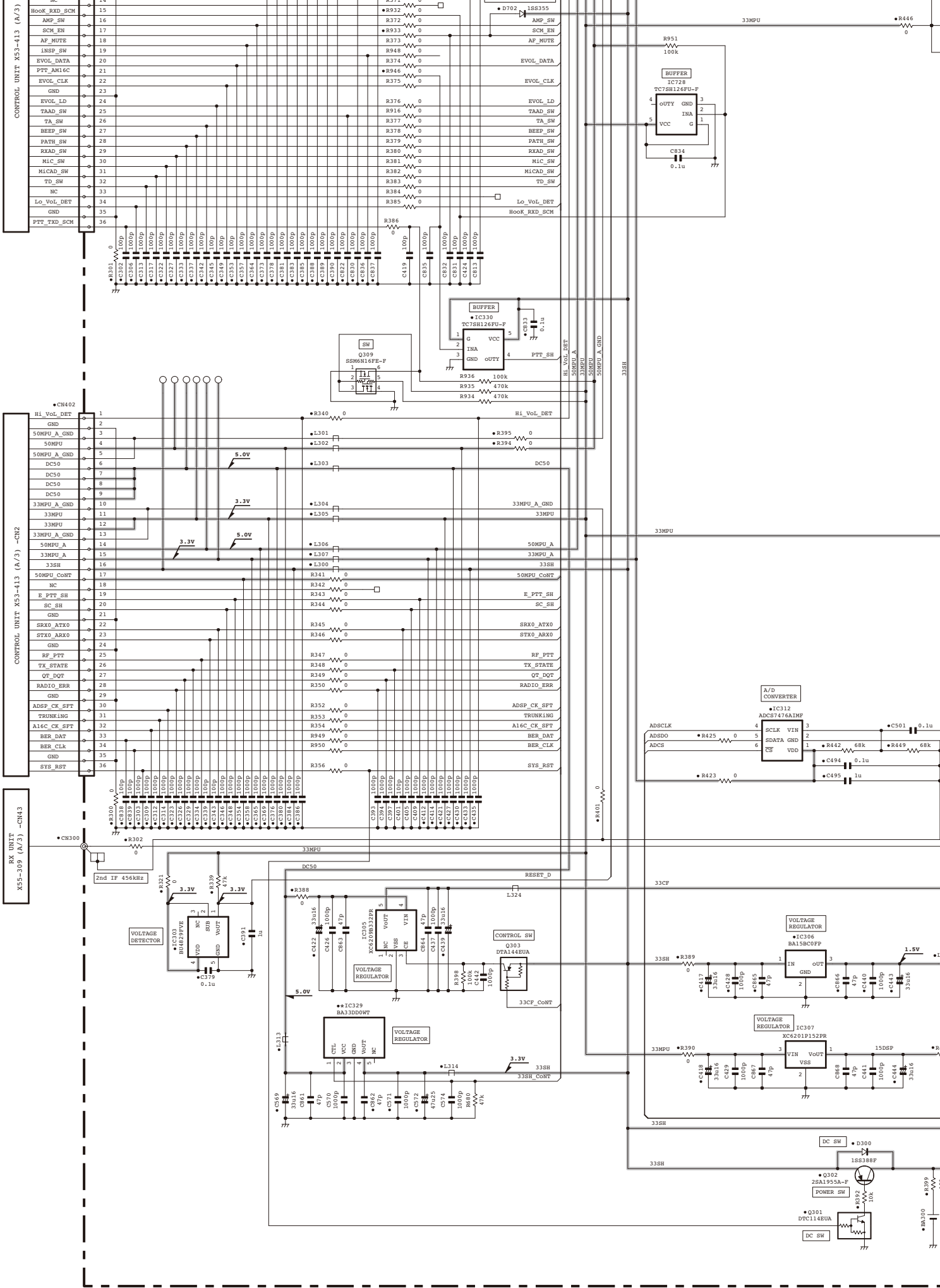

4

5

6

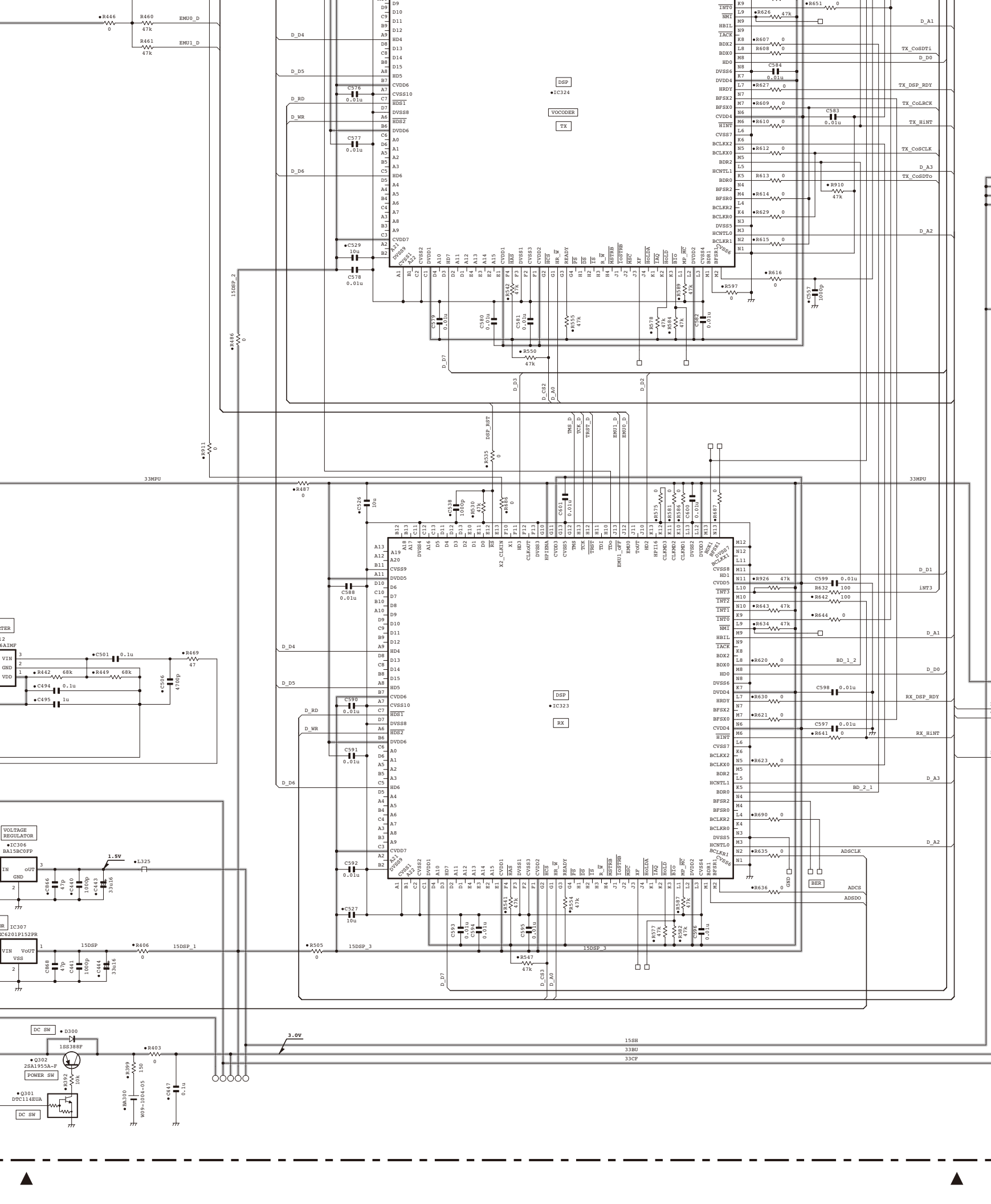

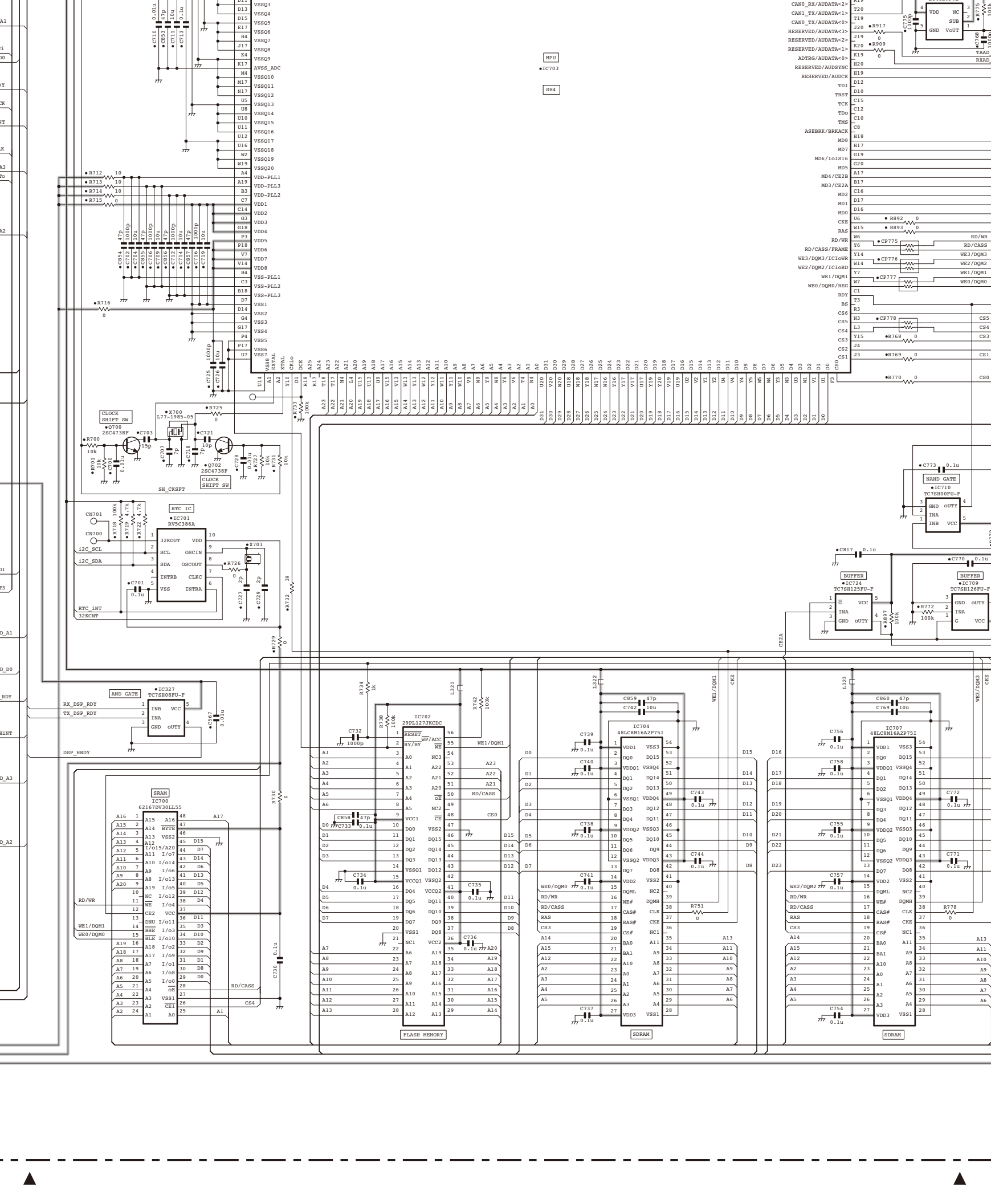

MPU
•IC703

SB4

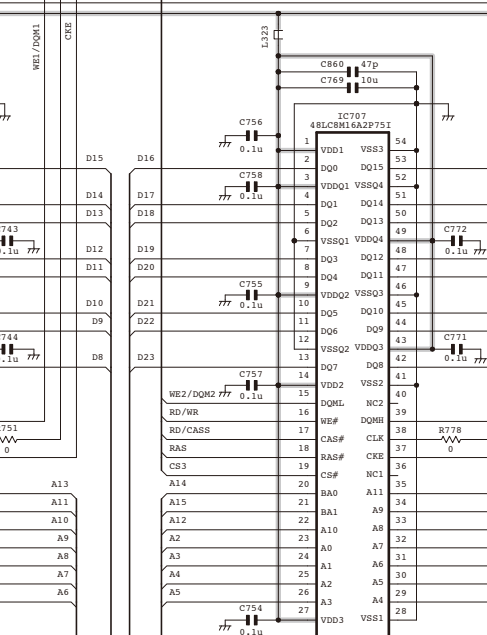
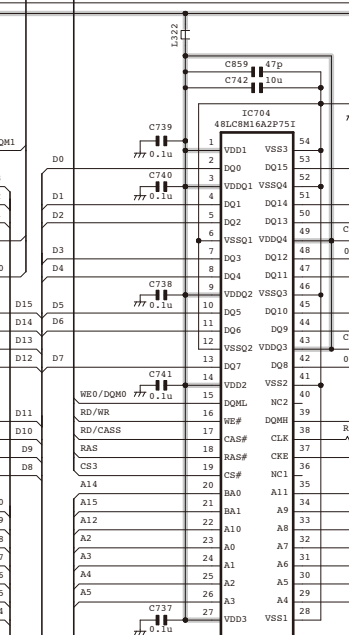
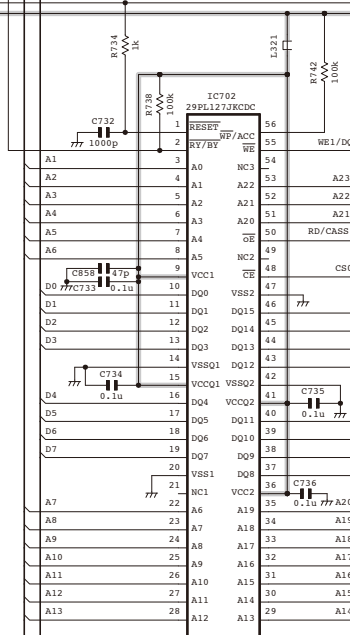
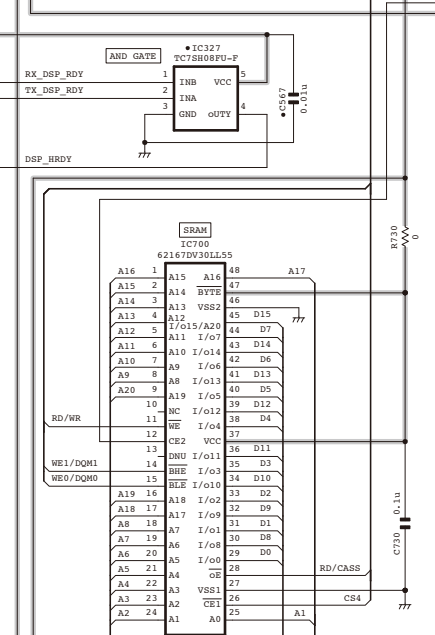
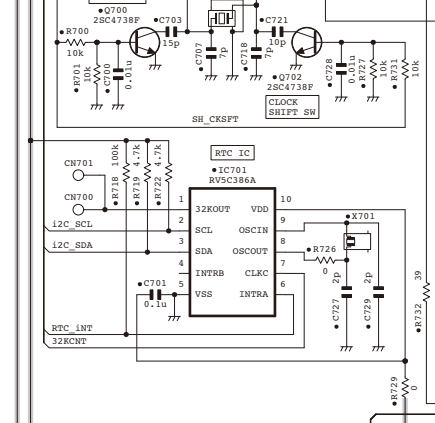
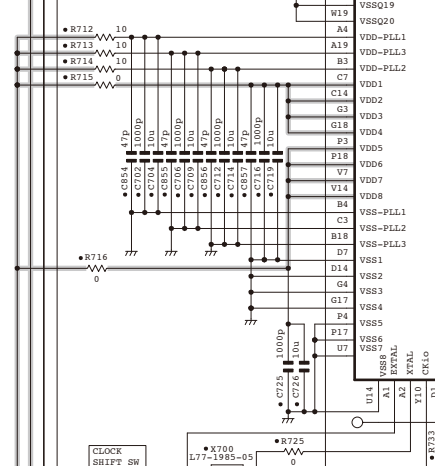
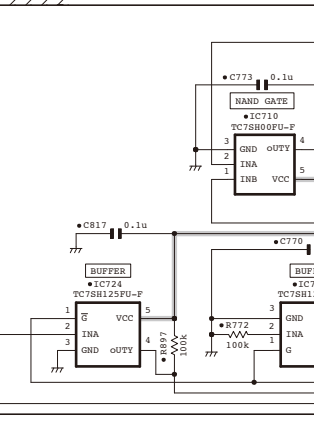
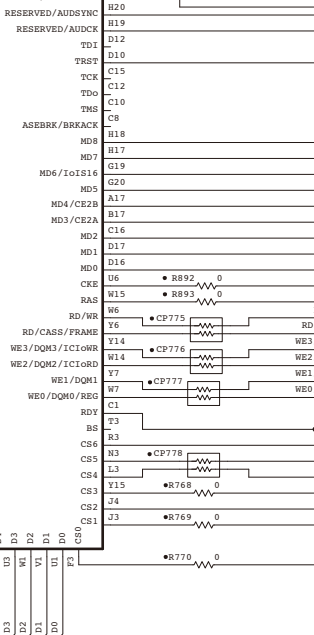
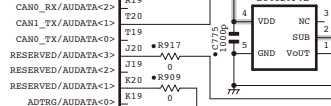

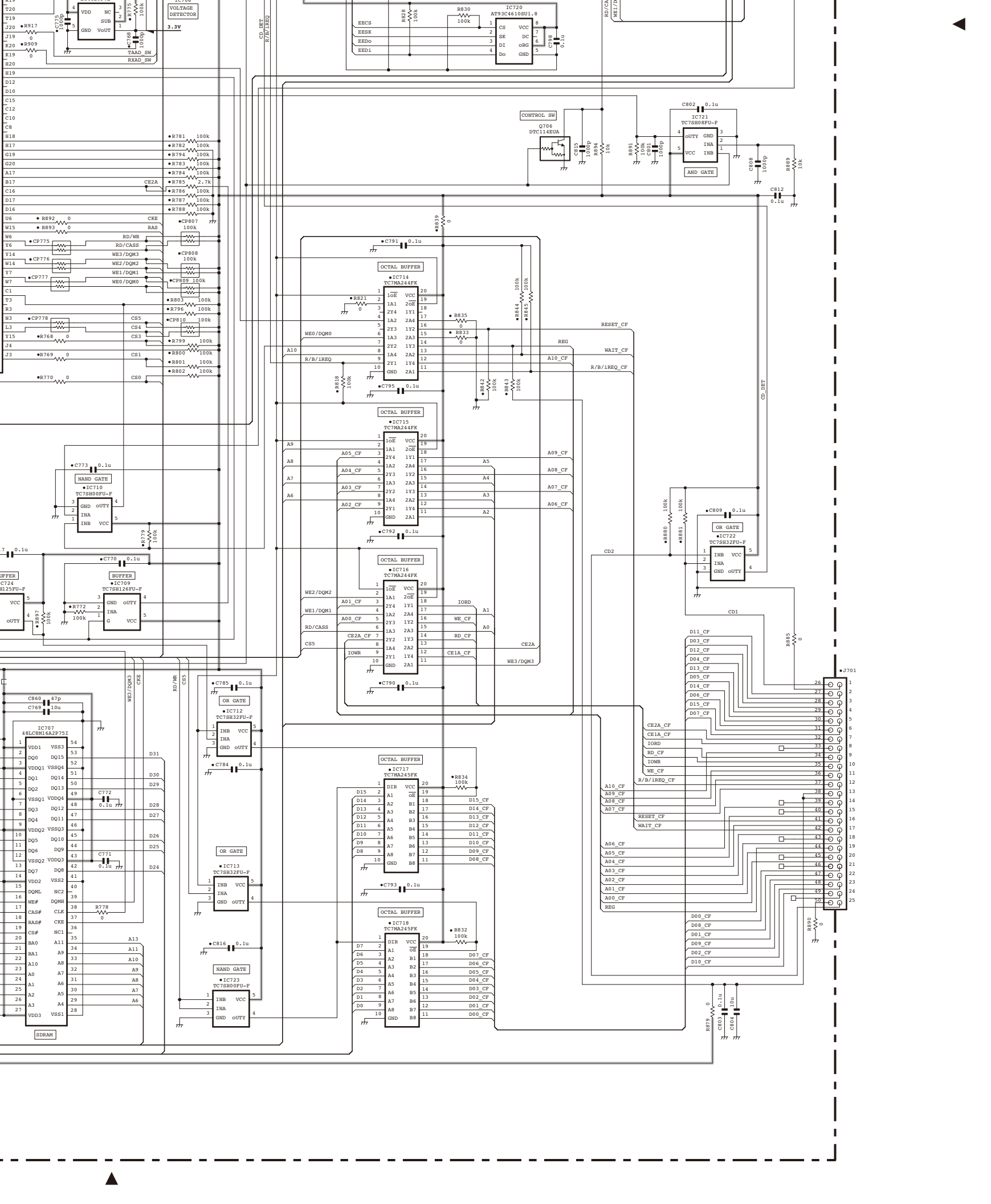

OPTIONAL ACCESSORIES: KES-5 (EXTERNAL SPEAKER)

When Using an External Speaker

1. Make sure the unit's power is tuned off.
2. When using the external speaker, remove the jumper lead from the connector, and attach the speaker cable.
3. When not using the external speaker, replace the jumper lead and insert the connector into the speaker jack (pin9 and 12).

Specifications

Maximum input power	40W
Impedance	4Ω
Dimensions (W x H x D) projection not included	129 x 129 x 77 mm (5-1/16 x 5-1/16 x 3 inches)
Weight	820g / 1.81 lbs

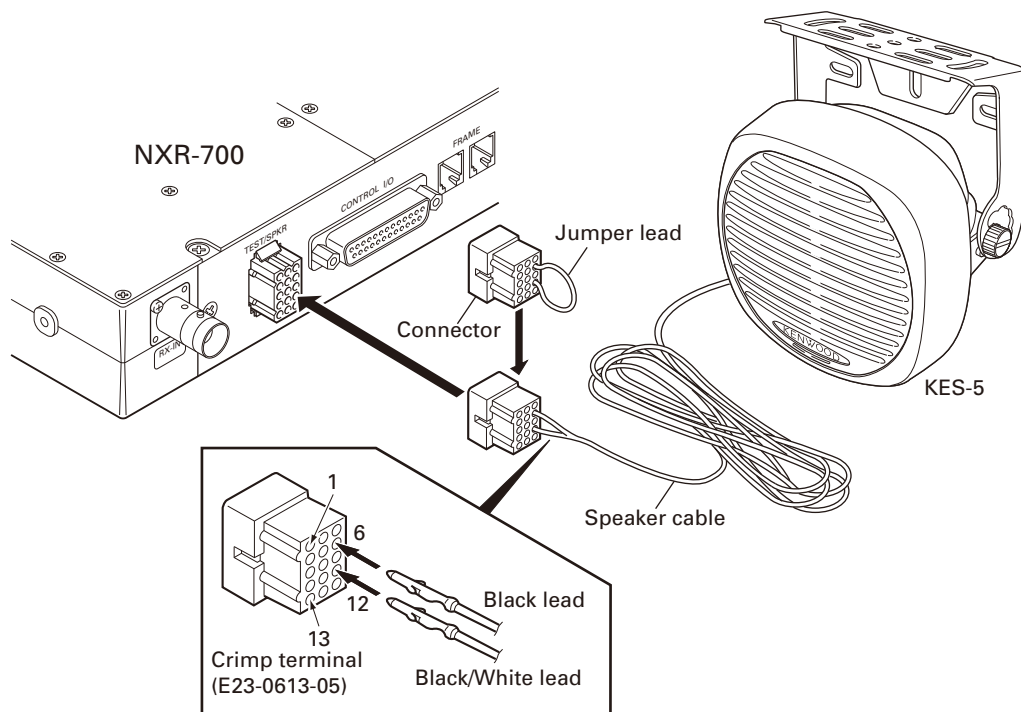

NXR-700

OPTIONAL ACCESSORIES: KXK-3 (OCXO UNIT)

Components Description

■ ACCESSORY UNIT (X42-3280-20)

Ref. No.	Part Name	Description
IC3	MOS-IC	Digitl potentiometer
IC4	Analogue IC	OP AMP
IC6	MOS-IC	OP AMP
IC9	Bi-polar IC	Voltage regulator
IC10	MOS-IC	Inverter
IC11	ROM IC	EEPROM
IC12	Analogue IC	ADC
Q2~4	FET	DC switch
Q5,6	Transistor	RF AMP
Q13~17	FET	DC switch
D5	Diode	DC switch
D8	Diode	Detector

Parts List

Y60-4120-XX -20: M -21: M2

* New Parts.

Ref. No.	Address	New parts	Parts No.	Description	Desti-nation
KXK-3					
		*	B62-2022-00	INSTRUCTION MANUAL	M
		*	B62-2162-00	INSTRUCTION MANUAL	M2
			E31-3269-05	LEAD WIRE WITH MINIPIN PLUG	
		*	E37-1405-05	FLAT CABLE	
		*	E37-1406-05	LEAD WIRE WITH CONNECTOR	
			N67-3008-48	PAN HEAD SEMS SCREW	
ACCESSORY UNIT (X42-3280-20)					
C1-4			CK73GB1H471K	CHIP C 470PF K	
C5			CK73GB1H104K	CHIP C 0.10UF K	
C6			CK73GB1H471K	CHIP C 470PF K	
C7			CK73GB1H102K	CHIP C 1000PF K	
C8			CK73GB1H471K	CHIP C 470PF K	
C10			CK73GB1H471K	CHIP C 470PF K	
C12			CK73GB1H103K	CHIP C 0.010UF K	
C13			CK73GB1H104K	CHIP C 0.10UF K	
C14			CC73GCH1H090B	CHIP C 9.0PF B	
C16-19			CK73GB1H104K	CHIP C 0.10UF K	
C20			CK73GB1H471K	CHIP C 470PF K	
C21,22			CK73GB1H104K	CHIP C 0.10UF K	
C24			CC73GCH1H030B	CHIP C 3.0PF B	
C26			CK73GB1H471K	CHIP C 470PF K	
C27			CK73GB1H103K	CHIP C 0.010UF K	
C28			CK73GB1H104K	CHIP C 0.10UF K	
C29			CC73GCH1H060B	CHIP C 6.0PF B	
C30		*	CE32AU1C330M	CHIP EL 33UF 16WV	
C31			CK73GB1H104K	CHIP C 0.10UF K	
C33			CK73GB1H104K	CHIP C 0.10UF K	

Ref. No.	Address	New parts	Parts No.	Description	Desti-nation
C35			CK73GB1H104K	CHIP C 0.10UF K	
C36-39			CK73GB1H471K	CHIP C 470PF K	
C46			CC73GCH1H820J	CHIP C 82PF J	
C47			CK73GB1H104K	CHIP C 0.10UF K	
C54			CK73GB1H104K	CHIP C 0.10UF K	
C56			CK73GB1H104K	CHIP C 0.10UF K	
C59			CK73GB1H104K	CHIP C 0.10UF K	
C61			CC73GCH1H560J	CHIP C 56PF J	
C62			CK73GB1H104K	CHIP C 0.10UF K	
C63			CC73GCH1H391J	CHIP C 390PF J	
C64			CK73GB1H104K	CHIP C 0.10UF K	
C71			CC73GCH1H101J	CHIP C 100PF J	
C72			CC73GCH1H270J	CHIP C 27PF J	
C73			CC73GCH1H101J	CHIP C 100PF J	
C80			CK73GB1H104K	CHIP C 0.10UF K	
C81			CC73GCH1H050B	CHIP C 5.0PF B	
C82			CC73GCH1H1R5B	CHIP C 1.5PF B	
C84			CC73GCH1H220J	CHIP C 22PF J	
C86			CK73GB1E105K	CHIP C 1.0UF K	
C87,88			CK73GB1H471K	CHIP C 470PF K	
C89			CC73GCH1H101J	CHIP C 100PF J	
C90			CK73GB1H104K	CHIP C 0.10UF K	
C91			CK73GB1H103K	CHIP C 0.010UF K	
C93			CK73GB1H104K	CHIP C 0.10UF K	
C94			CK73GB1H103K	CHIP C 0.010UF K	
C95,96		*	CS77CC1C100M	CHIP TNTL 10UF 16WV	
C97			CK73GB1H104K	CHIP C 0.10UF K	
C99			CK73GB1H103K	CHIP C 0.010UF K	
C100,101			CK73GB1H104K	CHIP C 0.10UF K	
C102,103			CK73GB1H471K	CHIP C 470PF K	
C104			CK73GB1H103K	CHIP C 0.010UF K	
C105			CK73GB1H104K	CHIP C 0.10UF K	
CN1		*	E40-6822-05	FLAT CABLE CONNECTOR	
CN2			E04-0154-05	PIN SOCKET	
CN3			E41-2671-05	PIN ASSY	
F1			F53-0324-05	FUSE (2.5A)	
L4			L41-2205-33	SMALL FIXED INDUCTOR (22UH)	
L5		*	L41-1205-33	SMALL FIXED INDUCTOR (12UH)	
L6			L41-1505-33	SMALL FIXED INDUCTOR (15UH)	
L8			L41-2205-33	SMALL FIXED INDUCTOR (22UH)	
L10			L41-3305-33	SMALL FIXED INDUCTOR (33UH)	
L15			L41-3305-33	SMALL FIXED INDUCTOR (33UH)	
L17		*	L41-2292-28	SMALL FIXED INDUCTOR (2.2UH)	
L19			L41-2295-33	SMALL FIXED INDUCTOR (2.2UH)	
L20			L41-6885-33	SMALL FIXED INDUCTOR (0.68UH)	
L21			L41-5685-33	SMALL FIXED INDUCTOR (0.56UH)	
X1		*	L77-1977-05	OCXO (10MHZ)	M
X1		*	L77-3045-05	OCXO (10MHZ)	M2
R1-3			RK73GB2A474J	CHIP R 470K J 1/10W	
R4-6			RK73GB2A471J	CHIP R 470 J 1/10W	
R10			RK73GB2A102J	CHIP R 1.0K J 1/10W	
R12,13			RK73GB2A102J	CHIP R 1.0K J 1/10W	
R15			RK73GB2A104J	CHIP R 100K J 1/10W	
R16			RK73GB2A000J	CHIP R 0.0 J 1/10W	
R17			RK73GB2A474J	CHIP R 470K J 1/10W	
R18,19			RK73GB2A221J	CHIP R 220 J 1/10W	
R20			RK73GB2A101J	CHIP R 100 J 1/10W	
R21			RK73GB2A103J	CHIP R 10K J 1/10W	

OPTIONAL ACCESSORIES: KXK-3 (OCXO UNIT)

Ref. No.	Address	New parts	Parts No.	Description	Destination
R22			RK73GB2A562J	CHIP R 5.6K J 1/10W	
R23			RK73GB2A470J	CHIP R 47 J 1/10W	
R24			RK73GB2A102J	CHIP R 1.0K J 1/10W	
R25			RK73GB2A331J	CHIP R 330 J 1/10W	
R26			R92-3475-05	CHIP R 0.27 F 1/2W	
R27			RK73GB2A105J	CHIP R 1.0M J 1/10W	
R28			RK73GB2A101J	CHIP R 100 J 1/10W	
R29			RK73GB2A103J	CHIP R 10K J 1/10W	
R30			RK73GB2A181J	CHIP R 180 J 1/10W	
R31			RK73GB2A102J	CHIP R 1.0K J 1/10W	
R32			RK73GB2A104J	CHIP R 100K J 1/10W	
R33			RK73GB2A473J	CHIP R 47K J 1/10W	
R34			RK73GB2A153J	CHIP R 15K J 1/10W	
R36			RK73GB2A102J	CHIP R 1.0K J 1/10W	
R43			RK73GB2A332J	CHIP R 3.3K J 1/10W	
R55			RK73GB2A180J	CHIP R 18 J 1/10W	
R59,60			RK73GB2A821J	CHIP R 820 J 1/10W	
R62			RK73GB2A332J	CHIP R 3.3K J 1/10W	
R63,64			RK73GB2A331J	CHIP R 330 J 1/10W	
R67			RK73GB2A101J	CHIP R 100 J 1/10W	
R68			RK73GB2A103J	CHIP R 10K J 1/10W	
R69			RK73GB2A102J	CHIP R 1.0K J 1/10W	
R72			RK73GB2A472J	CHIP R 4.7K J 1/10W	
R73			RK73GB2A102J	CHIP R 1.0K J 1/10W	
R74			RK73GB2A104J	CHIP R 100K J 1/10W	
R75			RK73GB2A223J	CHIP R 22K J 1/10W	
R76			RK73GB2A471J	CHIP R 470 J 1/10W	
R77			RK73GB2A470J	CHIP R 47 J 1/10W	
R78,79			RK73GB2A104J	CHIP R 100K J 1/10W	
R80			RK73GB2A471J	CHIP R 470 J 1/10W	

ACCESSORY UNIT (X42-3280-20)

Ref. No.	Address	New parts	Parts No.	Description	Destination
R81			RK73GB2A000J	CHIP R 0.0 J 1/10W	
R82,83			RK73GB2A104J	CHIP R 100K J 1/10W	
R84			RK73GB2A472J	CHIP R 4.7K J 1/10W	
R85			RK73GB2A000J	CHIP R 0.0 J 1/10W	
R86			RK73GB2A104J	CHIP R 100K J 1/10W	
R87			RK73GB2A100J	CHIP R 10 J 1/10W	
R88,89			RK73GB2A102J	CHIP R 1.0K J 1/10W	
R90-92			RK73GB2A000J	CHIP R 0.0 J 1/10W	
R93-95			RK73GB2A102J	CHIP R 1.0K J 1/10W	
R96,97			RK73GB2A103J	CHIP R 10K J 1/10W	
R98,99			RK73GB2A561J	CHIP R 560 J 1/10W	
D5		*	JDP4P02U	DIODE	
D8			HSM88AS-E	DIODE	
IC3		*	AD5231BRU10	MOS-IC	
IC4		*	LTC6101BIS5-F	ANALOGUE IC	
IC6		*	TC75S59F-F	MOS-IC	
IC9			NJM7805FA-ZB	BI-POLAR IC	
IC10			TC7SHU04F-F	MOS-IC	
IC11			S24CS02AFJTBG	ROM IC	
IC12		*	AD7418ARMZ	ANALOGUE IC	
Q2-4			SSM3K15TE(F)	FET	
Q5,6			2SC4617(R)	TRANSISTOR	
Q13			SSM6L05FU-F	FET	
Q14			SSM3K15TE(F)	FET	
Q15			2SJ484	FET	
Q16,17			SSM3K15TE(F)	FET	

If a part reference number is listed in a shaded box, that part does not come with the PCB.

NXR-700 OPTIONAL ACCESSORIES: KXK-3 (OCXO UNIT)

PC Board

ACCESSORY UNIT (X42-3280-20) Component side view (J79-0004-09)

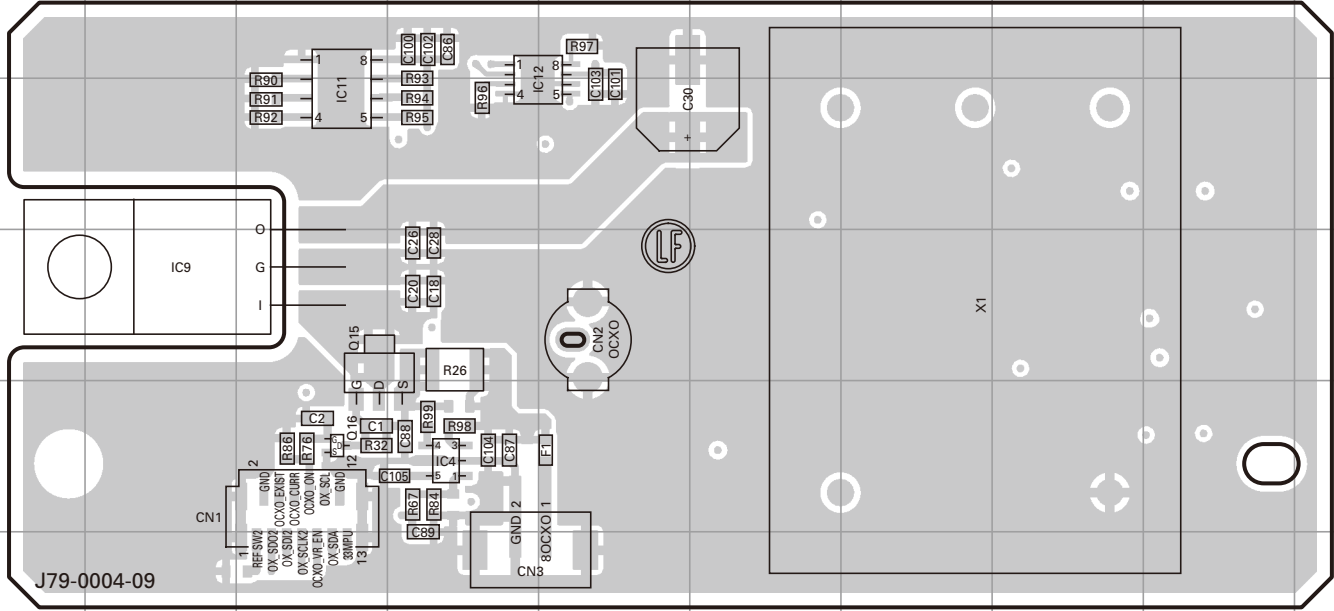

Ref. No.	Address	Ref. No.	Address
IC4	5D	Q15	4C
IC11	3C	Q16	5C
IC12	3D		

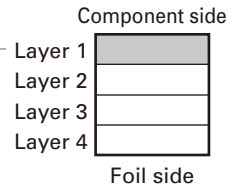

ACCESSORY UNIT (X42-3280-20) Foil side view (J79-0004-09)

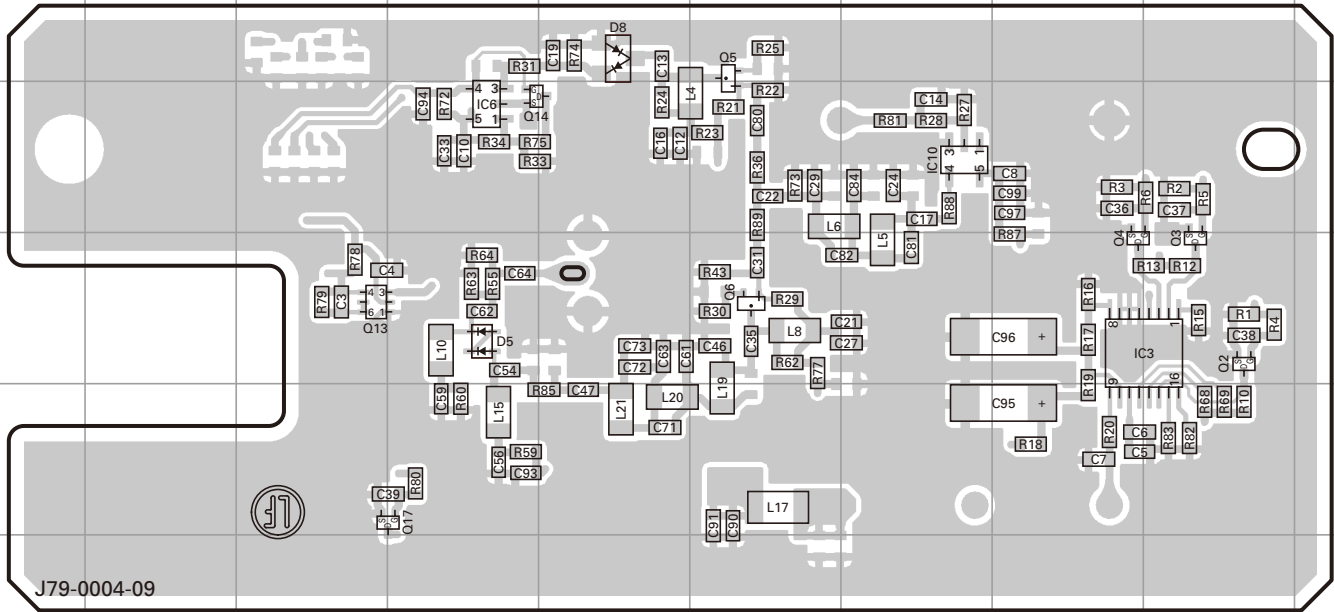

Ref. No.	Address	Ref. No.	Address	Ref. No.	Address	Ref. No.	Address
IC3	10I	Q3	10I	Q13	10C	D8	8E
IC6	9D	Q4	10H	Q14	9D		
IC10	9G	Q5	8F	Q17	11D		
Q2	10I	Q6	10F	D5	10D		

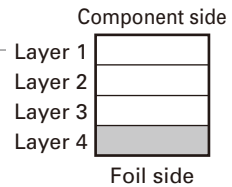

OPTIONAL ACCESSORIES: KXK-3 (OCXO UNIT) NXR-700

Schematic Diagram

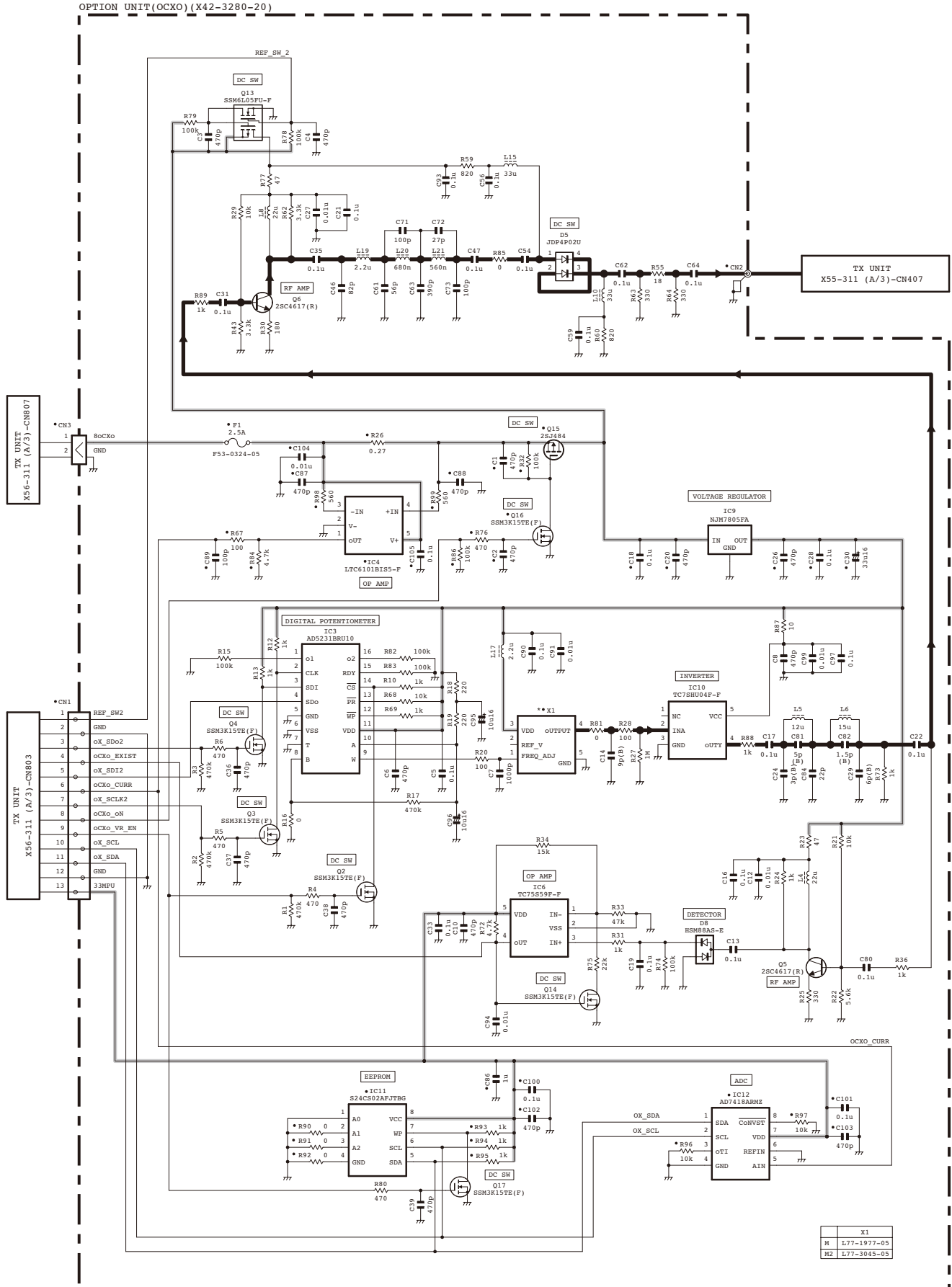

Note : The components marked with a dot (•) are parts of layer 1.

NXR-700

SPECIFICATIONS

General

Frequency Range	146~174MHz
Channel Spacing	
Wide 5k	25kHz
Wide 4k	20kHz
Narrow	12.5kHz
VN	6.25kHz
PLL Channel Step	2.5/ 3.125/ 5/ 6.25kHz
Frequency Stability	±1.5ppm
with OCXO unit	±1.0ppm
Operating Voltage	10.8~15.6V DC
Operating Temperature Range	-30°C~+60°C
Antenna Impedance	50Ω
Dimensions (W x H x D) (Projections not included)	
	483 x 44 x 331 mm
Weight	5kg

Transmitter

RF Power Output	5~25W
Spurious Emission	-36dBm≤1GHz, -30dBm>1GHz
FM Hum & Noise (EIA)	
Wide 5k/Wide 4k	55dB
Narrow	50dB
Modulation	16K0F3E, 14K0F3E, 14K0F2D, 12K0F2D, 8K50F3E, 7K50F2D, 8K30F1E, 8K30F1D, 8K30F7W, 4K00F1E, 4K00F1D, 4K00F7W, 4K00F2D

Receiver

Sensitivity (Analogue)	
EIA 12dB SINAD	0.30μV
EN 20dB SINAD	0dBμV (0.50μV)
Sensitivity (Digital)	
3% BER	12.5kHz: 0.33μV, 6.25kHz: 0.27μV
1% BER	
.....12.5kHz: -1dBμV (0.45μV), 6.25kHz: -3dBμV (0.35μV)	
Adjacent Channel Selectivity	
Analogue Wide 5k *1 (±25kHz)	90dB
Analogue Wide 4k *1 (±20kHz)	87dB
Analogue Narrow *1 (±12.5kHz)	82dB
Intermodulation (Analogue)	72dB
Spurious Respons Rejection (Analogue)	95dB
Audio Distortion	Less than 2%
Audio Output (EXT. SP)	3W/4Ω

*1: Analogue measurements made per TIA/EIA 603, EN300-086.

Without *1: Analogue measurements made per TIA/EIA 603A.

KENWOOD reserves the right to change specifications without prior notice or obligation.

Kenwood Corporation

2967-3, Ishikawa-machi, Hachioji-shi, Tokyo, 192-8525 Japan

Kenwood U.S.A. Corporation

P.O. BOX 22745, 2201 East Dominguez Street, Long Beach, CA 90801-5745, U.S.A.

Kenwood Electronics Canada Inc.

6070 Kestrel Road, Mississauga, Ontario, Canada L5T 1S8

Kenwood Electronics Deutschland GmbH

Rembrücker Str. 15, 63150 Heusenstamm, Germany

Kenwood Electronics Belgium N.V.

Leuvensesteenweg 248 J, 1800 Vilvoorde, Belgium

Kenwood Electronics France S.A.

L'Etoile Paris Nord 2, 50 Allée des Impressionnistes, Bp 58416 Villepinte, 95944 Roissy Ch De Gaulle Cedex

Kenwood Electronics UK Limited

KENWOOD House, Dwight Road, Watford, Herts., WD18 9EB United Kingdom

Kenwood Electronics Europe B.V.

Amsterdamseweg 37, 1422 AC Uithoorn, The Netherlands

Kenwood Electronics Italia S.p.A.

Via G. Sirtori, 7/9 20129 Milano, Italy

Kenwood Ibérica, S.A.

Bolivia, 239-08020 Barcelona, Spain

Kenwood Electronics Australia Pty. Ltd.

(A.C.N. 001 499 074)

16 Giffnock Avenue, Centrecourt Estate, North Ryde, N.S.W. 2113 Australia

Kenwood Electronics (Hong Kong) Ltd.

Unit 3712-3724, Level 37, Tower one Metroplaza, 223 Hing Fong Road, Kwai Fong, N.T., Hong Kong

Kenwood Electronics Singapore Pte Ltd

1 Ang Mo Kio Street 63, Singapore 569110

NXR-700 PC BOARD

PC BOARD NXR-700

FINAL UNIT (X45-3852-70)
Component side view (J79-0218-19)

FINAL UNIT (X45-3852-70)
Component side view (J79-0218-19)

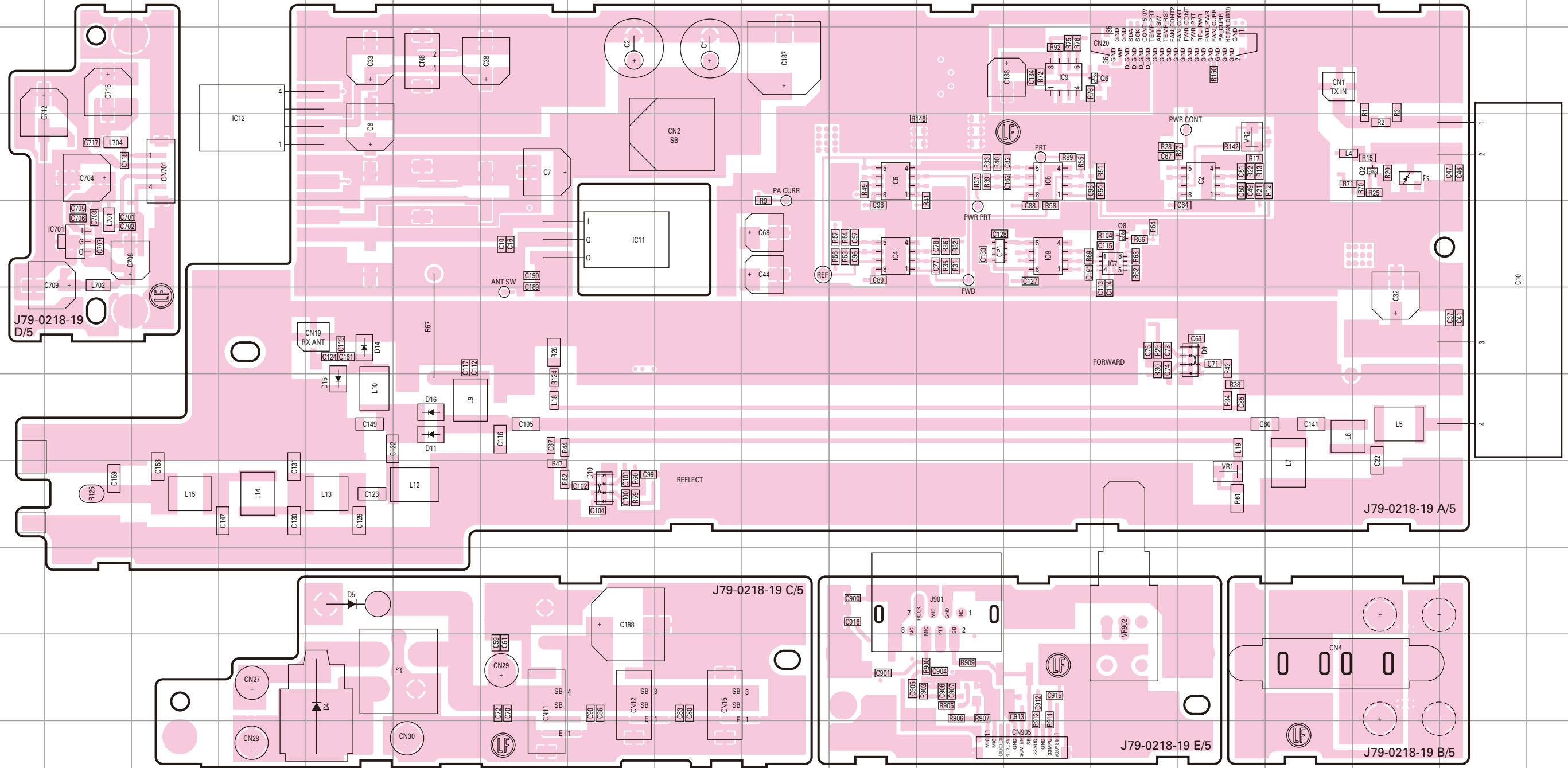

Ref. No.	Address	Ref. No.	Address	Ref. No.	Address	Ref. No.	Address	Ref. No.	Address
IC2	4O	IC8	5M	IC701	5B	D5	9E	D14	6E
IC4	5K	IC9	3M	Q2	4Q	D7	4Q	D15	7E
IC5	4M	IC10	5R	Q6	3N	D9	6O	D16	7F
IC6	4K	IC11	5H	Q8	5N	D10	8H		
IC7	5N	IC12	4D	D4	10E	D11	7F		

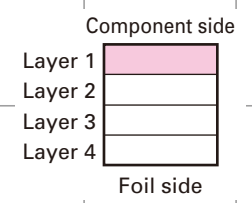

NXR-700 PC BOARD

PC BOARD NXR-700

RX UNIT (X55-3092-71)
Component side view (J79-0220-09)

RX UNIT (X55-3092-71)
Component side view (J79-0220-09)

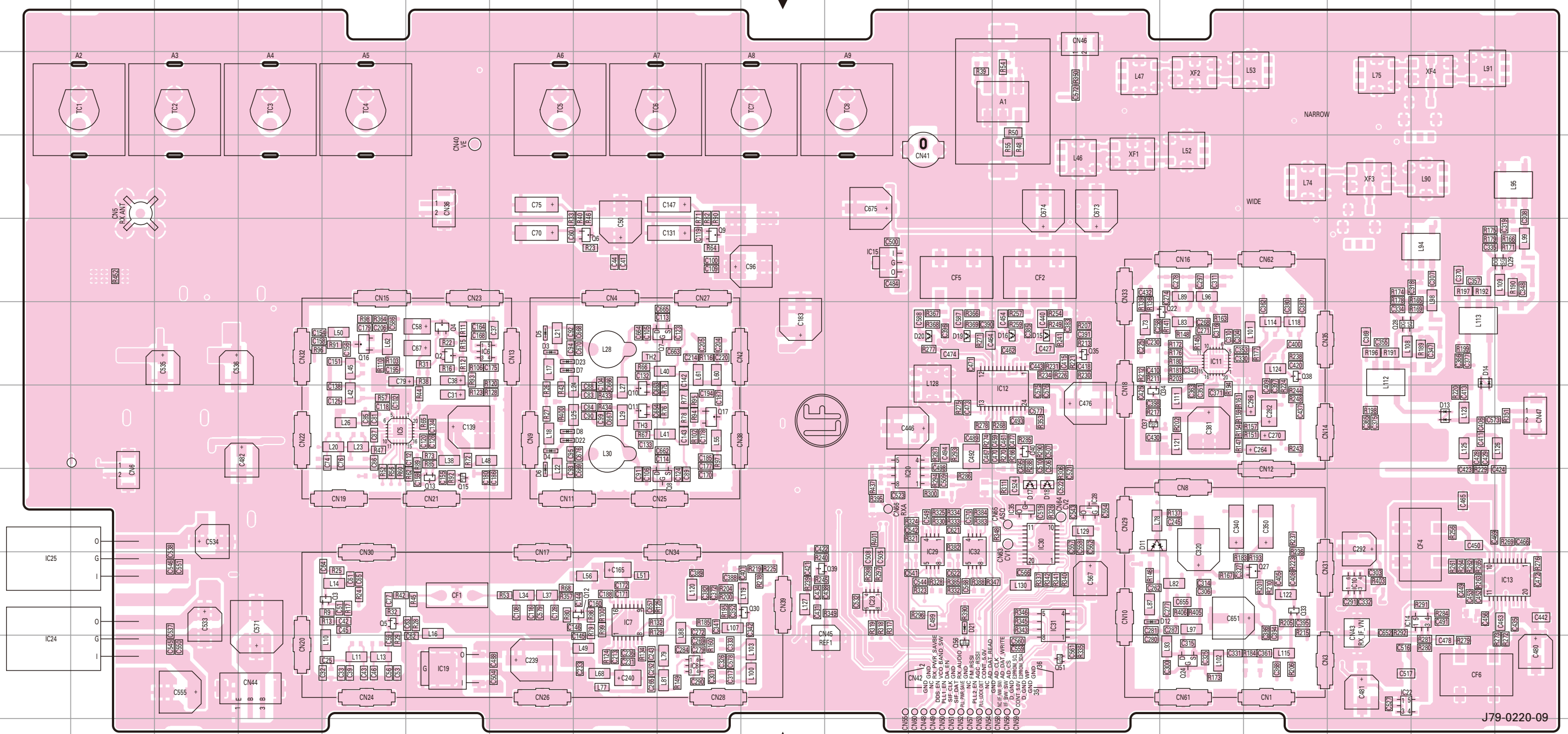

Ref. No.	Address	Ref. No.	Address	Ref. No.	Address	Ref. No.	Address	Ref. No.	Address	Ref. No.	Address	Ref. No.	Address	Ref. No.	Address
IC5	7E	IC15	5K	IC30	8M	Q7	6I	Q17	7I	Q35	6N	D5	6G	D16	6M
IC6	6F	IC19	10F	IC31	9M	Q8	8I	Q22	6O	Q37	7N	D6	8G	D17	8M
IC7	9H	IC20	8K	IC32	8L	Q9	5I	Q24	10O	Q38	6P	D7	6G	D18	8M
IC8	10I	IC22	10Q	IC35	8M	Q10	7H	Q27	9P	Q39	9J	D8	7G	D19	6L
IC10	9Q	IC23	9K	Q2	6F	Q11	7H	Q28	6Q	Q40	7M	D11	8N	D20	6L
IC11	6O	IC24	10A	Q3	9E	Q12	9H	Q29	5S	Q51	10M	D12	9N	D21	9L
IC12	7M	IC25	9A	Q4	6F	Q13	8F	Q30	9J	Q56	10L	D13	7R	D22	7G
IC13	9S	IC28	8N	Q5	9E	Q15	8F	Q33	9P	D3	6G	D14	6R	D23	6G
IC14	9R	IC29	8L	Q6	5H	Q16	6E	Q34	7N	D4	7G	D15	6M		

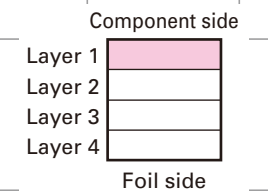

NXR-700 PC BOARD

PC BOARD NXR-700

RX UNIT (X55-3092-71)
Foil side view (J79-0220-09)

RX UNIT (X55-3092-71)
Foil side view (J79-0220-09)



Ref. No.	Address	Ref. No.	Address	Ref. No.	Address	Ref. No.	Address
IC4	4M	Q14	7L	Q32	5G	Q61	7N
IC9	8C	Q18	6J	Q36	8B	D1	4N
IC16	10A	Q19	4D	Q50	10Q	D2	4N
IC17	10C	Q20	3D	Q52	10Q	D9	3G
IC18	8P	Q21	9D	Q53	9B	D10	3G
IC26	7Q	Q23	7I	Q57	7H		
IC27	7P	Q25	4G	Q58	7H		
IC33	8E	Q26	4F	Q59	7L		
Q1	3N	Q31	5F	Q60	7N		

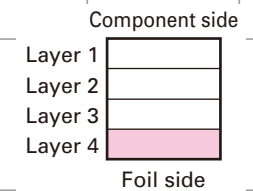

NXR-700 PC BOARD

PC BOARD NXR-700

TX UNIT (X56-3112-71)
Component side view (J79-0152-09)

TX UNIT (X56-3112-71)
Component side view (J79-0152-09)

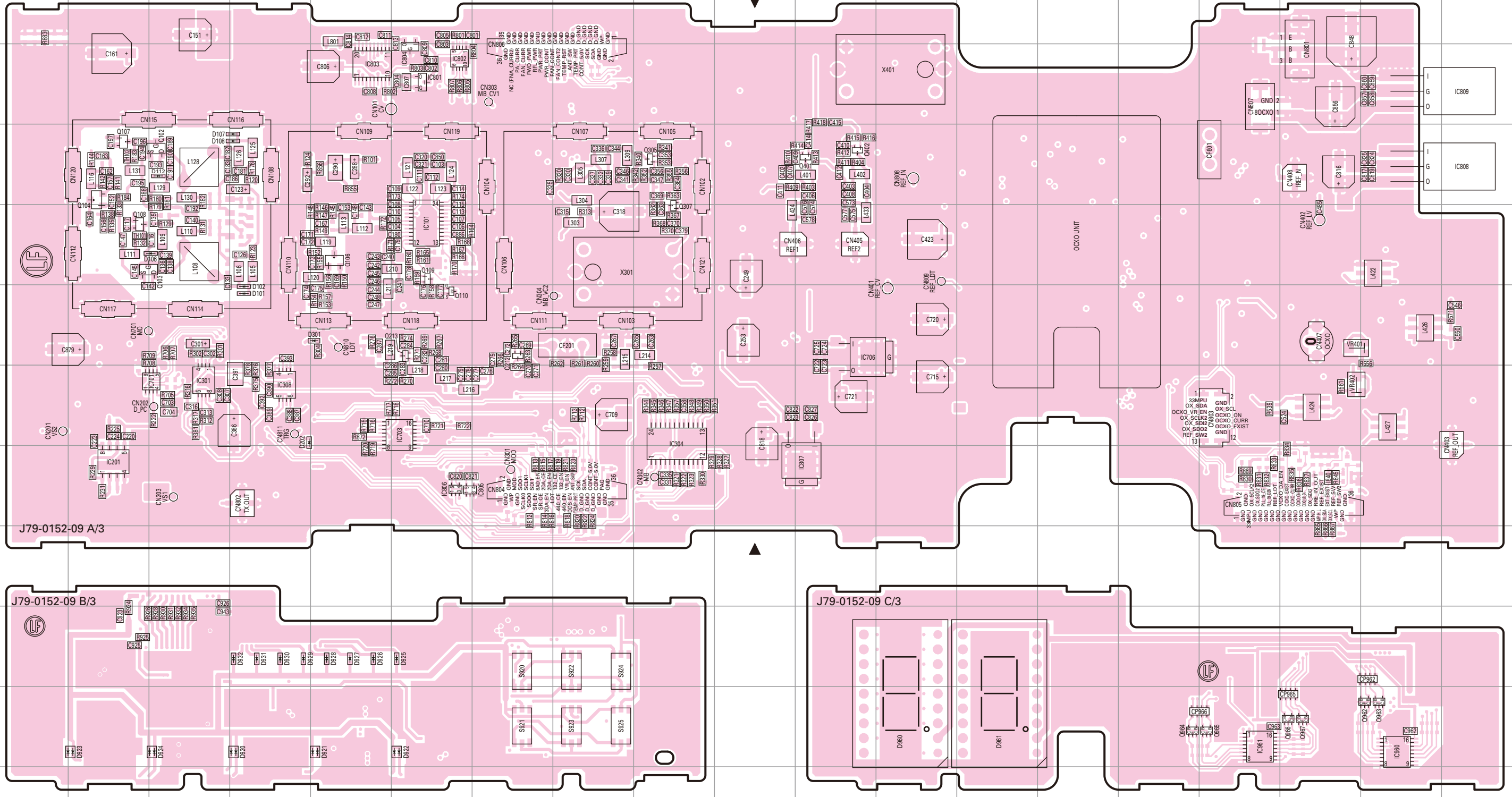

Ref. No.	Address	Ref. No.	Address	Ref. No.	Address	Ref. No.	Address	Ref. No.	Address	Ref. No.	Address	Ref. No.	Address	Ref. No.	Address
IC101	5F	IC706	6K	IC807	8K	Q104	4B	Q213	6F	Q964	11O	D107	4D	D922	11F
IC201	8B	IC801	3F	IC808	4S	Q106	5E	Q305	4I	Q965	11P	D108	4D	D923	11B
IC301	7C	IC802	3F	IC809	3S	Q107	4B	Q307	5I	Q966	11Q	D112	4C	D924	11C
IC304	7I	IC803	3E	IC901	11R	Q108	5B	Q401	4K	Q967	11Q	D202	7D	D925	10F
IC308	7D	IC804	3F	IC902	11P	Q109	5F	Q402	4K	D101	6D	D301	6E	D926	10E
IC701	7C	IC805	8F	Q102	4C	Q110	6F	Q962	11R	D102	6D	D920	11D	D927	10E
IC703	7F	IC806	8F	Q103	5C	Q212	6G	Q963	11R	D106	5C	D921	11E	D928	10E

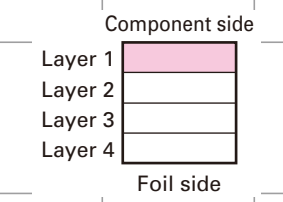

NXR-700 PC BOARD

PC BOARD NXR-700

TX UNIT (X56-3112-71)
Foil side view (J79-0152-09)

TX UNIT (X56-3112-71)
Foil side view (J79-0152-09)

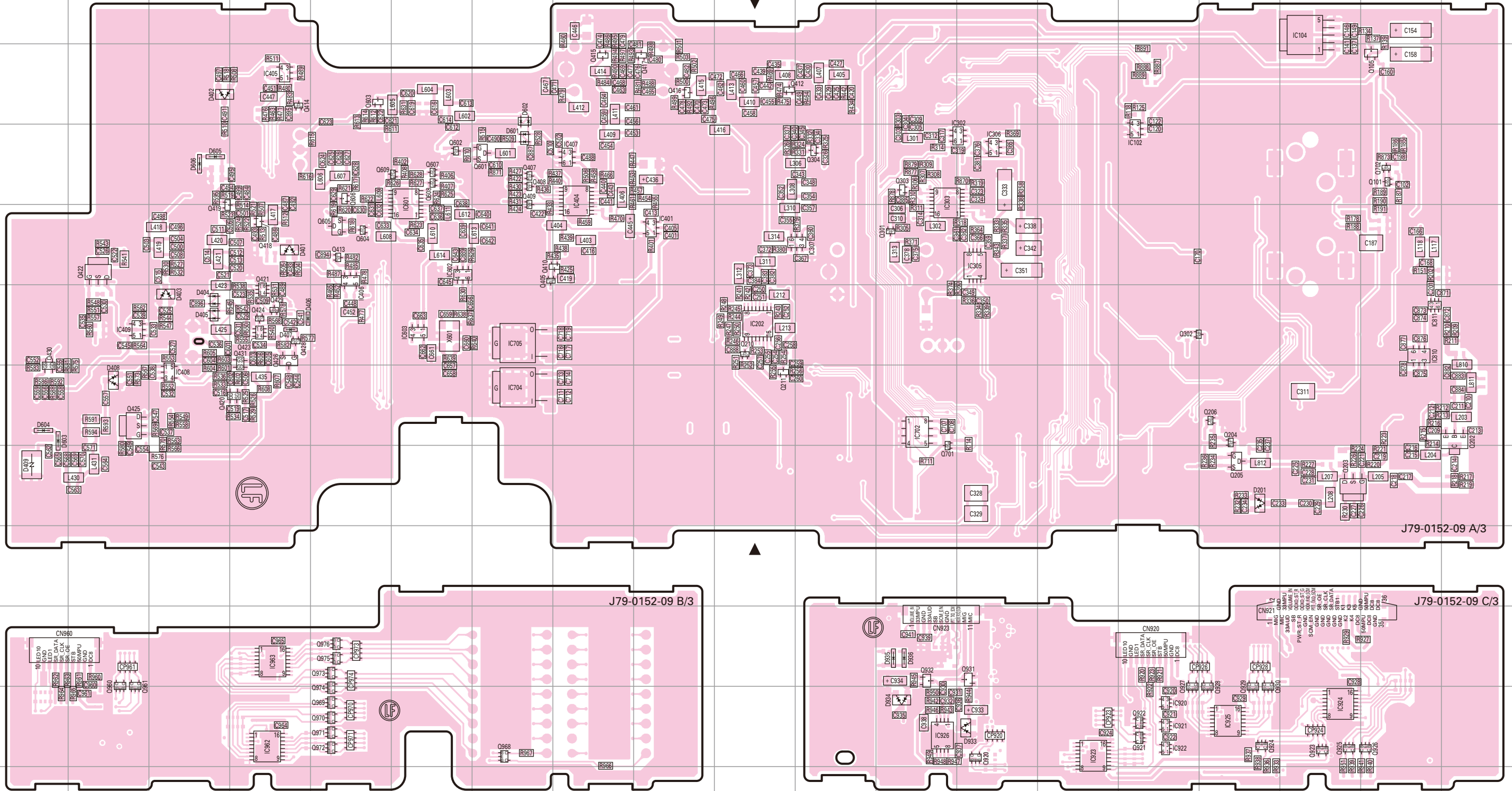

Ref. No.	Address	Ref. No.	Address	Ref. No.	Address	Ref. No.	Address	Ref. No.	Address	Ref. No.	Address	Ref. No.	Address	Ref. No.	Address	Ref. No.	Address	Ref. No.	Address	Ref. No.	Address	Ref. No.	Address	Ref. No.	Address		
IC102	4O	IC404	4H	IC702	7L	IC924	11Q	Q204	7P	Q405	5G	Q416	3I	Q425	7B	Q604	5E	Q921	11O	Q930	11P	Q972	11E	D404	6C	D604	7A
IC104	2Q	IC405	3D	IC704	7G	IC925	11P	Q205	8P	Q407	4G	Q417	3I	Q426	6D	Q605	5E	Q922	11O	Q931	10M	Q973	10E	D405	6C	D605	4C
IC202	6J	IC406	5E	IC705	6G	IC926	11L	Q206	7P	Q408	4G	Q418	5D	Q428	6D	Q606	4E	Q923	11Q	Q932	10L	Q974	11E	D406	6D	D606	4C
IC302	4M	IC407	4H	IC810	6R	IC962	11D	Q210	6J	Q409	4G	Q419	5C	Q429	6D	Q607	4F	Q924	11P	Q960	10B	Q975	10E	D407	6D	D933	11M
IC303	4L	IC408	7C	IC811	6R	IC963	10D	Q211	7J	Q410	5H	Q420	7D	Q430	6A	Q608	4F	Q925	11Q	Q961	10B	Q976	10E	D408	7B	D934	11L
IC305	5M	IC409	6B	IC920	11O	Q101	4R	Q301	5L	Q412	3J	Q421	6D	Q431	6D	Q609	4F	Q926	11R	Q968	11G	D201	8P	D409	8A	D935	10L
IC306	4M	IC601	4F	IC921	11O	Q105	3R	Q302	6O	Q413	5E	Q422	5B	Q601	4G	Q701	8L	Q927	11O	Q969	11E	D401	5D	D601	4G	D936	10L
IC307	5K	IC602	5F	IC922	11O	Q202	7S	Q303	4L	Q414	3D	Q423	6D	Q602	4F	Q702	4R	Q928	11P	Q970	11E	D402	3C	D602	3G		
IC401	5H	IC603	6F	IC923	11N	Q203	8Q	Q304	4K	Q415	3H	Q424	6D	Q603	3E	Q920	11M	Q971	11E	D403	6C	D603	7A				

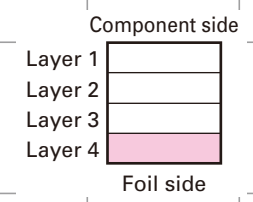

NXR-700 PC BOARD

PC BOARD NXR-700

CONTROL UNIT (X53-4132-XX) -71 : E -72 : For service
Component side view (J79-0011-19)

CONTROL UNIT (X53-4132-XX) -71 : E -72 : For service
Component side view (J79-0011-19)

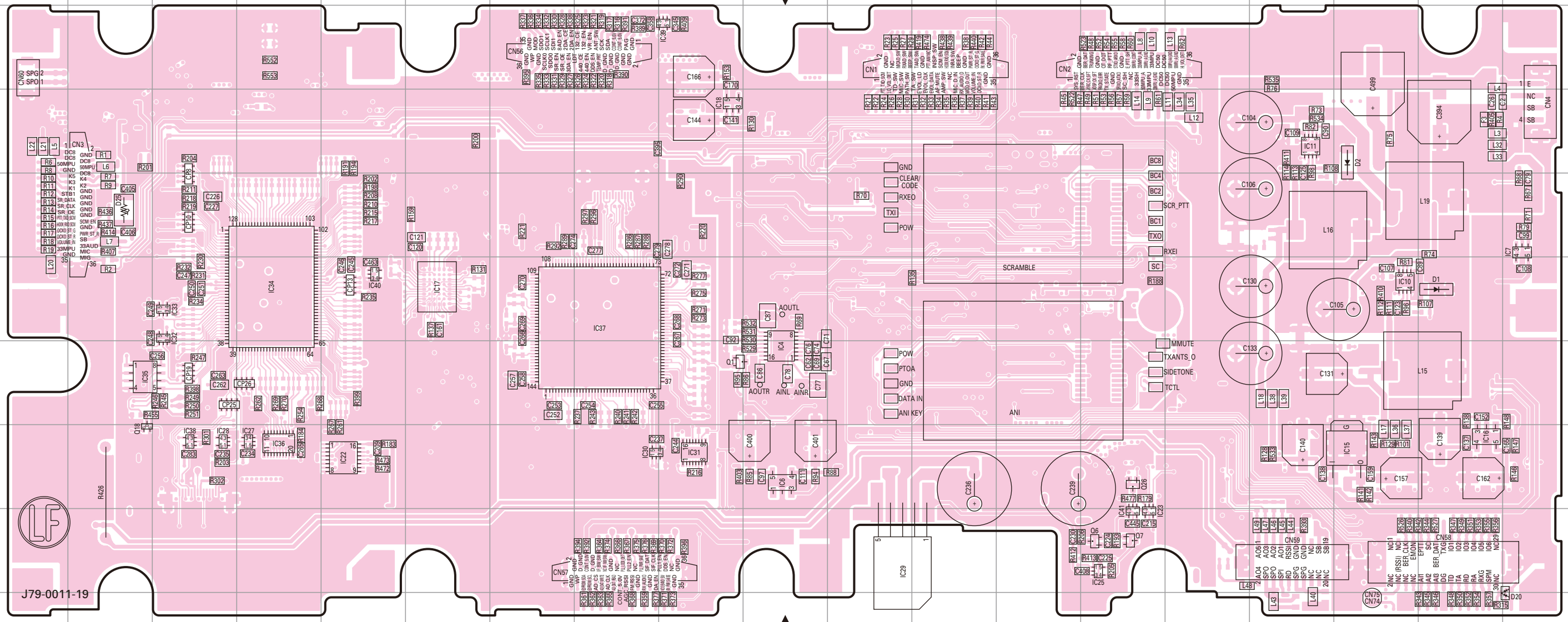

Ref. No.	Address	Ref. No.	Address	Ref. No.	Address	Ref. No.	Address
IC4	7J	IC22	8E	IC33	6C	Q1	7I
IC6	8J	IC23	9N	IC34	6D	Q6	9N
IC7	5S	IC25	9N	IC35	7B	Q7	9N
IC10	6Q	IC27	8D	IC36	8D	Q18	8B
IC11	4P	IC28	8C	IC37	6H	Q26	8N
IC15	8Q	IC29	9K	IC38	8C	D1	6R
IC16	8R	IC30	8H	IC39	3I	D2	4Q
IC17	6F	IC31	8I	IC40	6E	D20	10S
IC18	4I	IC32	6C	IC41	9N	D25	5B

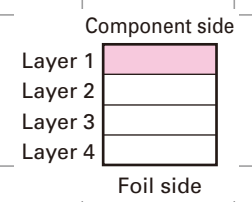

J79-0011-19



NXR-700 PC BOARD

PC BOARD NXR-700

CONTROL UNIT (X53-4132-XX) -71 : E -72 : For service
Foil side view (J79-0011-19)

CONTROL UNIT (X53-4132-XX) -71 : E -72 : For service
Foil side view (J79-0011-19)

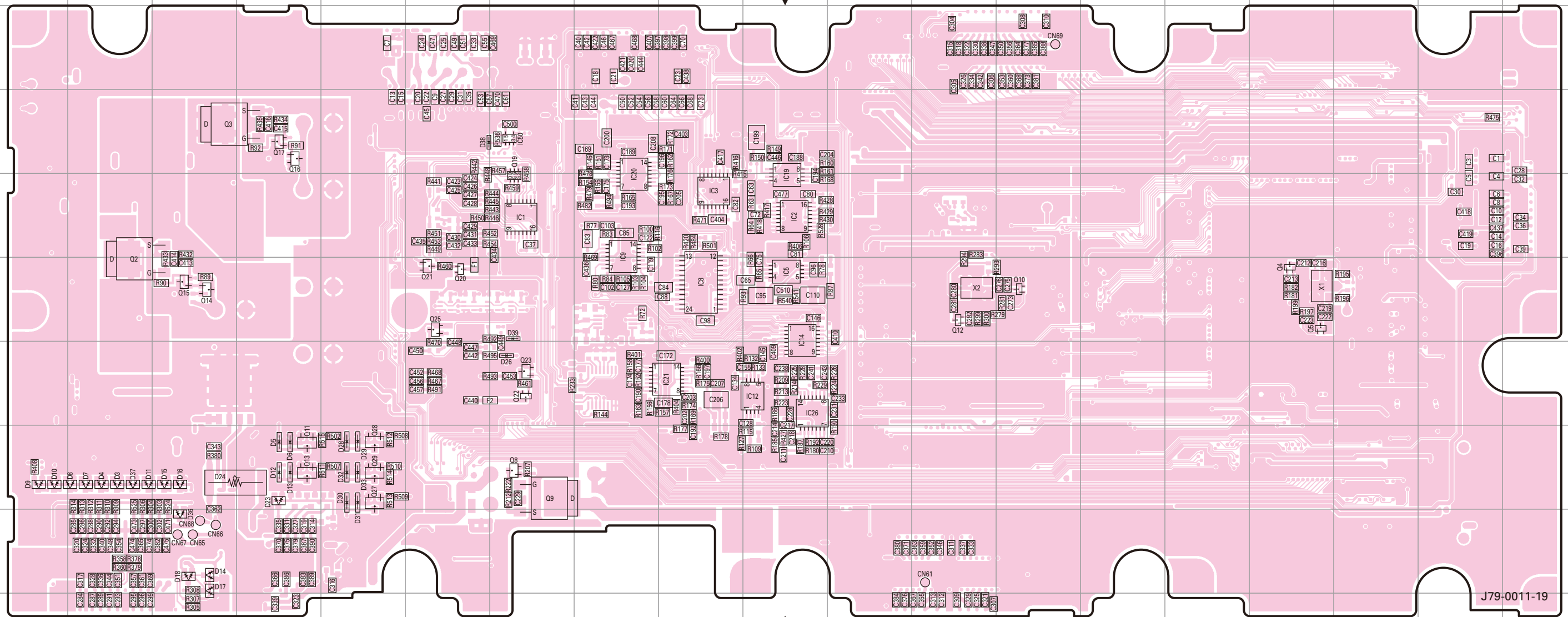

J79-0011-19

Ref. No.	Address	Ref. No.	Address	Ref. No.	Address	Ref. No.	Address	Ref. No.	Address
IC1	5G	Q2	6B	Q17	4D	D6	8D	D23	8D
IC2	5J	Q3	4C	Q19	5G	D7	8B	D24	8C
IC3	5I	Q4	6P	Q20	6F	D8	8B	D26	7G
IC5	6J	Q5	6P	Q21	6F	D9	8A	D28	8E
IC8	6I	Q8	8G	Q22	7G	D10	8A	D29	8E
IC9	5H	Q9	8G	Q23	7G	D11	8B	D30	8E
IC12	7J	Q10	6M	Q25	6F	D12	8D	D31	8E
IC14	6J	Q11	8D	Q27	8E	D13	8D	D32	8E
IC19	5J	Q12	6L	Q28	8E	D14	9C	D33	8E
IC20	5H	Q13	8D	Q29	8E	D15	8C	D36	9C
IC21	7I	Q14	6C	D3	8B	D16	8C	D37	8B
IC26	7J	Q15	6C	D4	8B	D17	9C	D38	4F
IC50	4G	Q16	4D	D5	8D	D18	9C	D39	6G

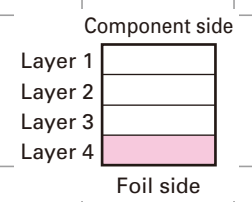

PC BOARD NXR-700

CONTROL UNIT (X53-4140-XX) -10 : E -11 : For service
Component side view (J79-0012-09)

CONTROL UNIT (X53-4140-XX) -10 : E -11 : For service
Component side view (J79-0012-09)

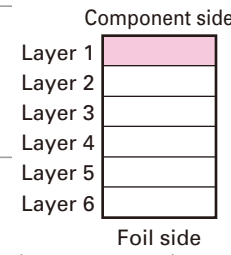
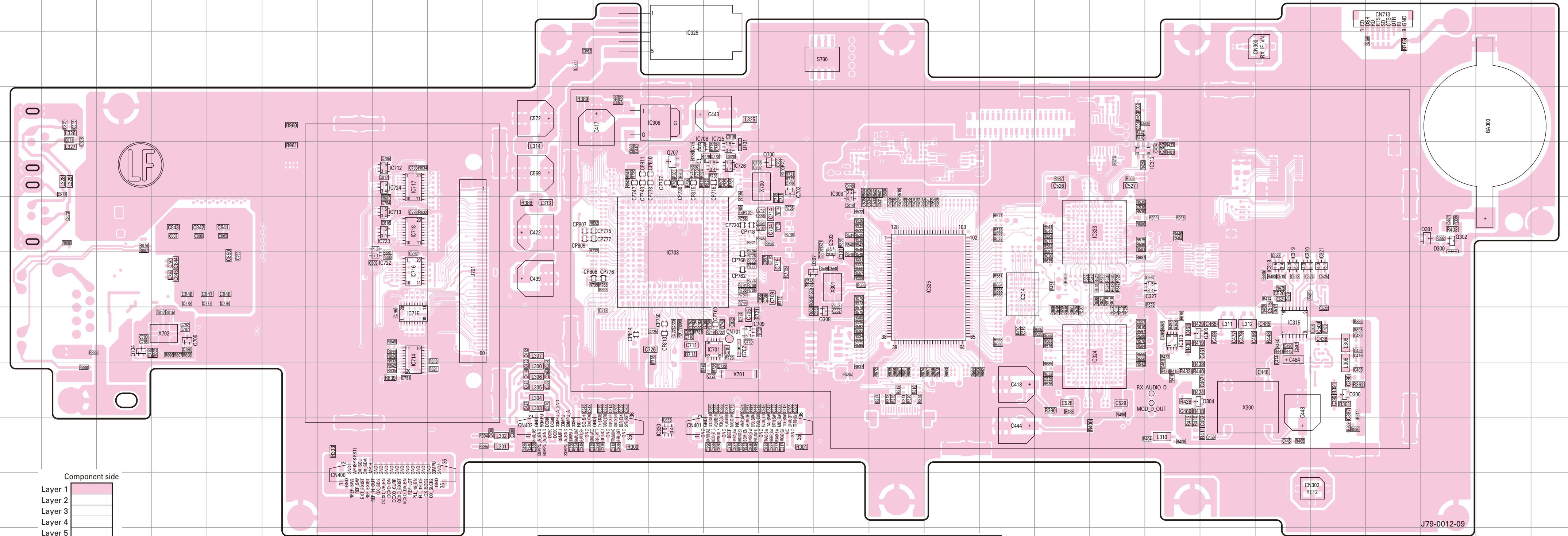

Ref. No.	Address	Ref. No.	Address	Ref. No.	Address	Ref. No.	Address	Ref. No.	Address	Ref. No.	Address	Ref. No.	Address
IC303	7P	IC318	7X	IC327	7V	IC710	5N	IC718	6H	Q301	6AA	Q702	5O
IC306	4M	IC319	7X	IC329	3M	IC712	5H	IC722	7H	Q302	6AA	Q704	8C
IC308	5P	IC320	7X	IC330	10M	IC713	6H	IC723	6H	Q304	9V	Q705	8D
IC312	5U	IC321	7Y	IC701	8N	IC714	8H	IC724	5H	Q305	8V	Q707	5M
IC313	8V	IC323	6U	IC703	7M	IC715	8H	IC725	5N	Q307	7O	D300	6AA
IC314	7S	IC324	8U	IC708	5M	IC716	7H	IC726	5N	Q308	8P	D701	5N
IC315	8X	IC325	7R	IC709	8N	IC717	5H	Q300	9Y	Q700	5O	D702	8N

NXR-700 PC BOARD

CONTROL UNIT (X53-4140-XX) -10 : E -11 : For service
Foil side view (J79-0012-09)

CONTROL UNIT (X53-4140-XX) -10 : E -11 : For service
Foil side view (J79-0012-09)

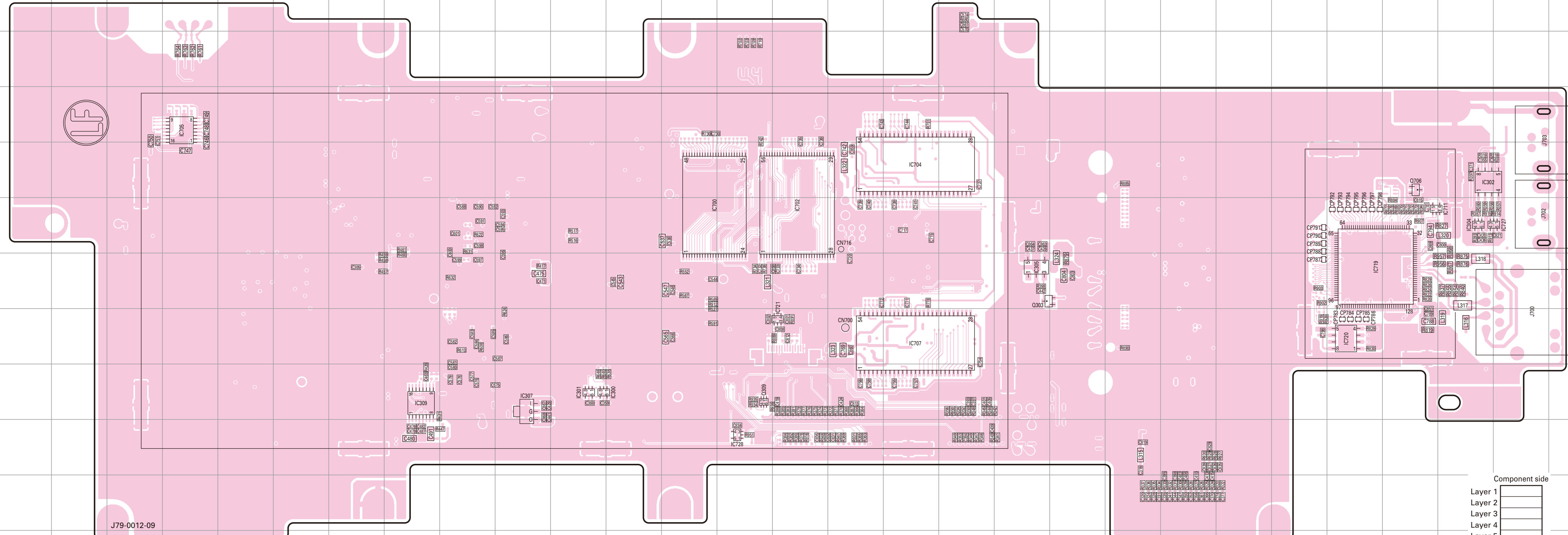

Ref. No.	Address	Ref. No.	Address	Ref. No.	Address
IC300	9K	IC700	6M	IC720	8Y
IC301	9K	IC702	6O	IC721	8O
IC302	5AA	IC704	5Q	IC727	6AB
IC304	6AA	IC705	4D	IC728	10N
IC305	7S	IC707	8Q	Q303	7S
IC307	9J	IC711	6Z	Q309	9N
IC309	9H	IC719	7Y	Q706	5Z

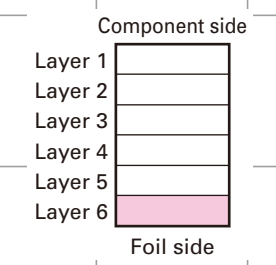

NXR-700 OPTIONAL ACCESSORIES: KXK-3 (OCXO UNIT)

PC Board

ACCESSORY UNIT (X42-3280-20) Component side view (J79-0004-09)

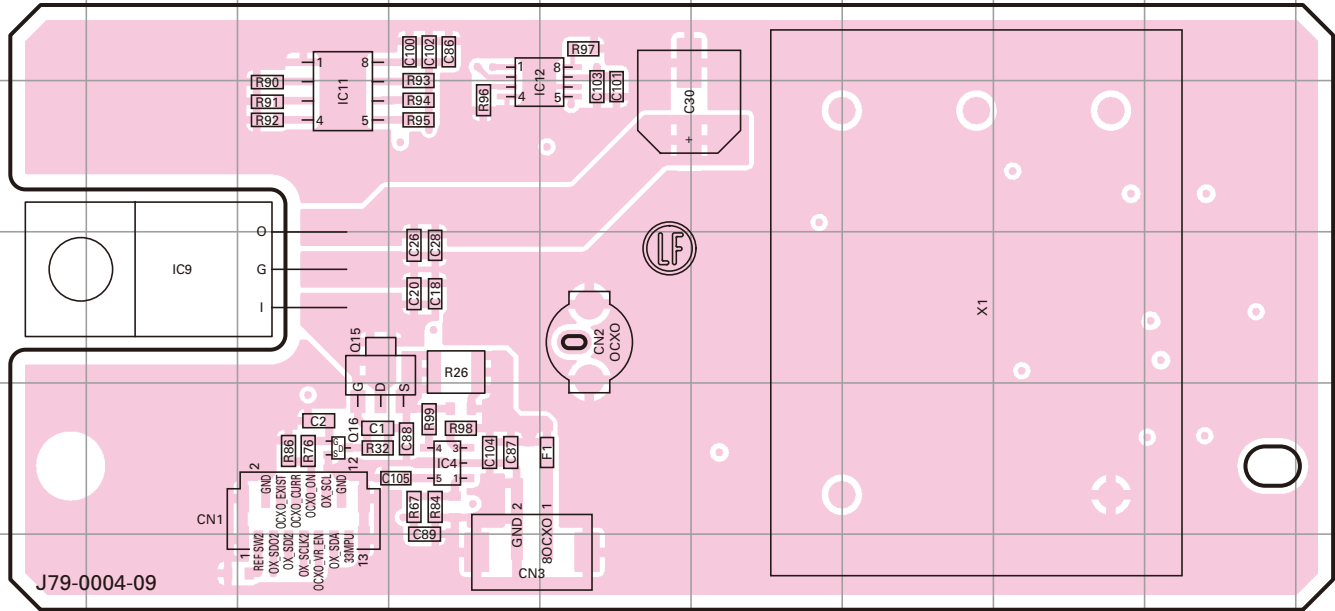

Ref. No.	Address	Ref. No.	Address
IC4	5D	Q15	4C
IC11	3C	Q16	5C
IC12	3D		

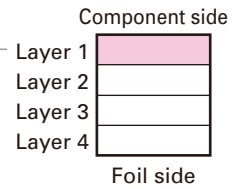

ACCESSORY UNIT (X42-3280-20) Foil side view (J79-0004-09)

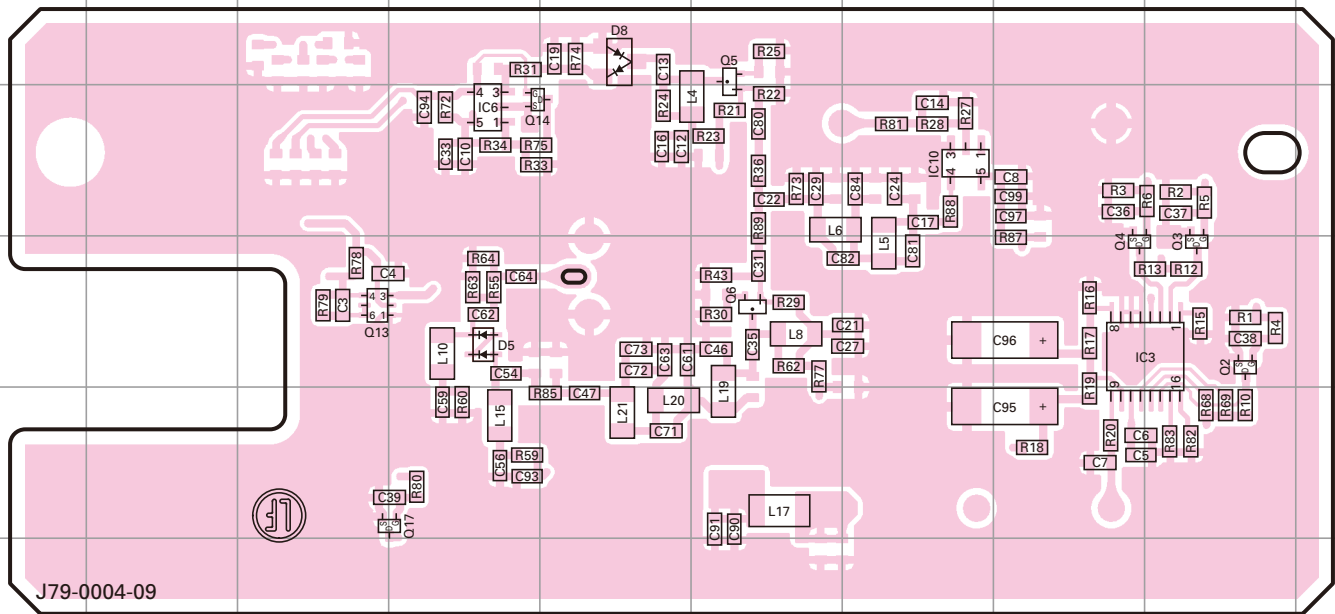

Ref. No.	Address	Ref. No.	Address	Ref. No.	Address	Ref. No.	Address
IC3	10I	Q3	10I	Q13	10C	D8	8E
IC6	9D	Q4	10H	Q14	9D		
IC10	9G	Q5	8F	Q17	11D		
Q2	10I	Q6	10F	D5	10D		

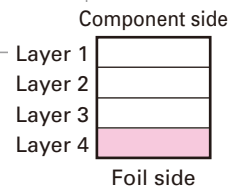

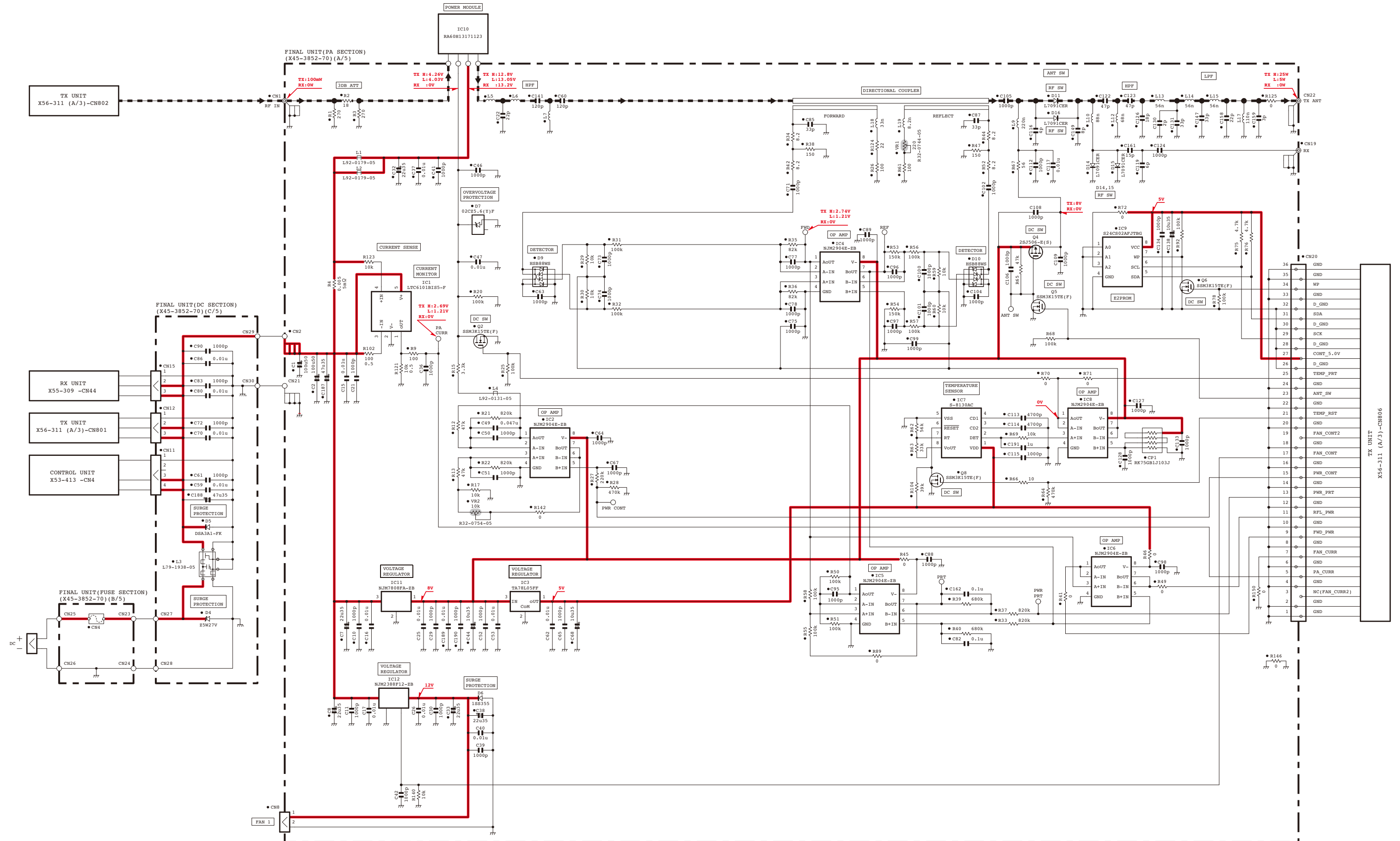

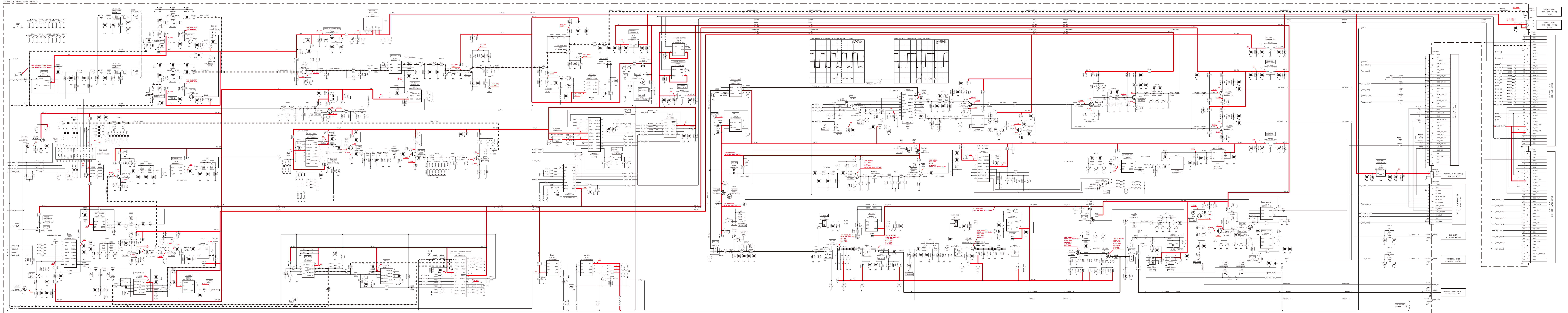

TX UNIT(17SEG)
(X56-3112-71)

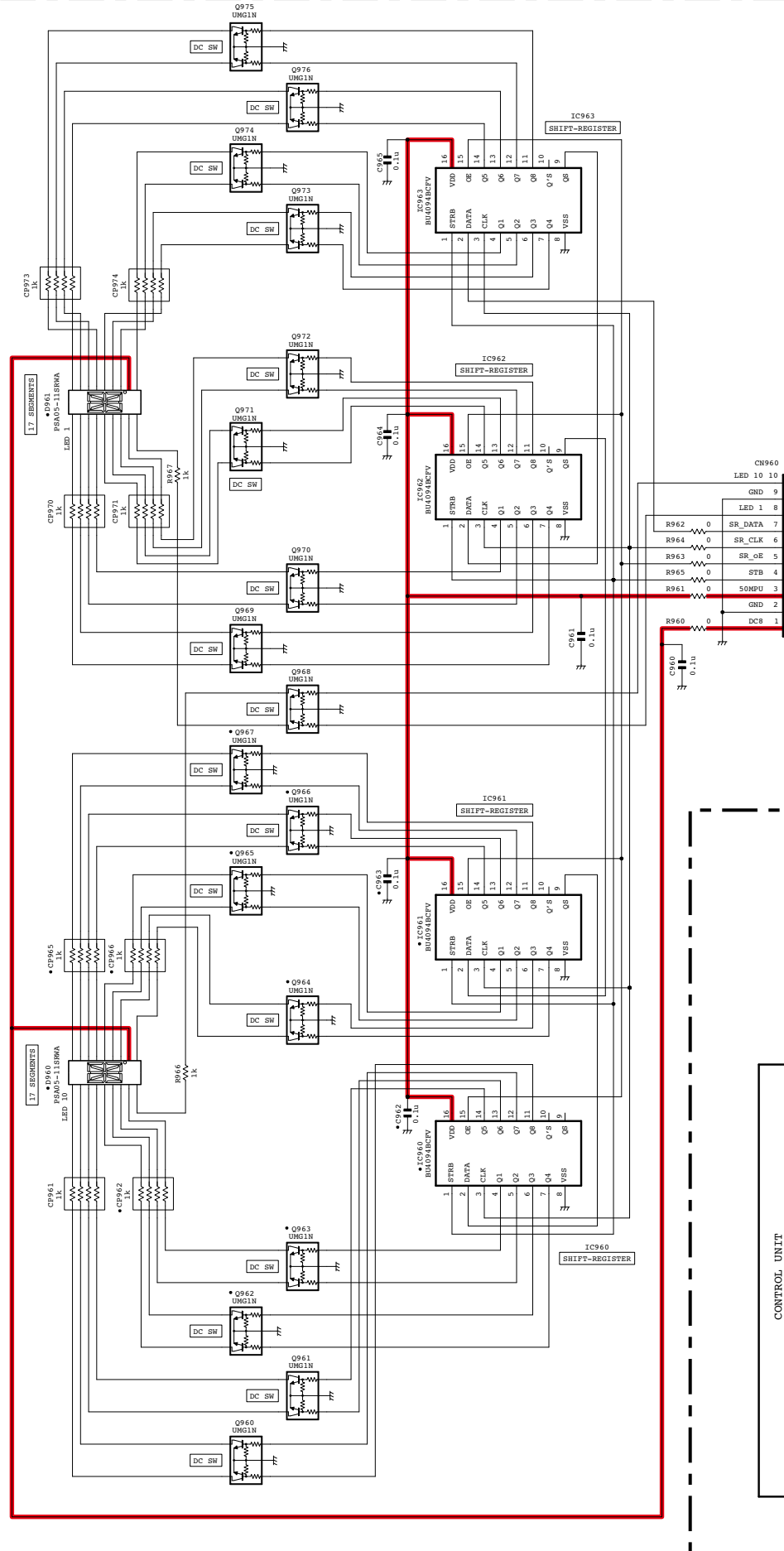

TX UNIT(LED)
(X56-3112-71)

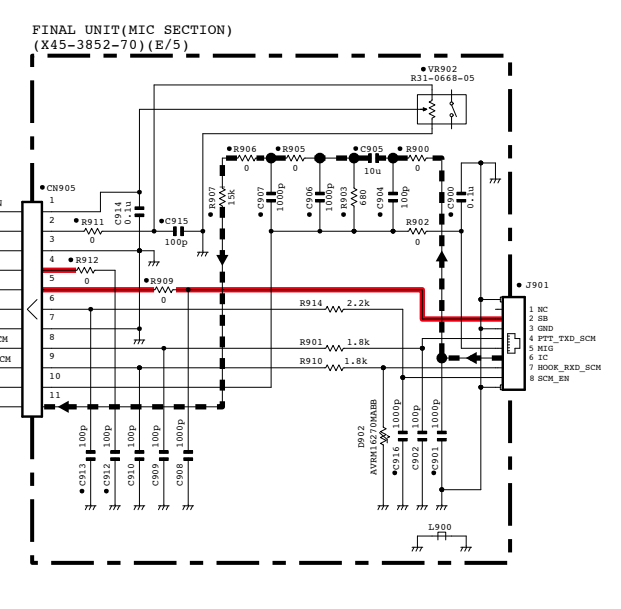
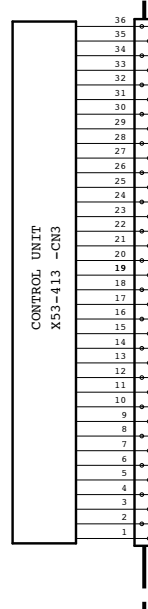
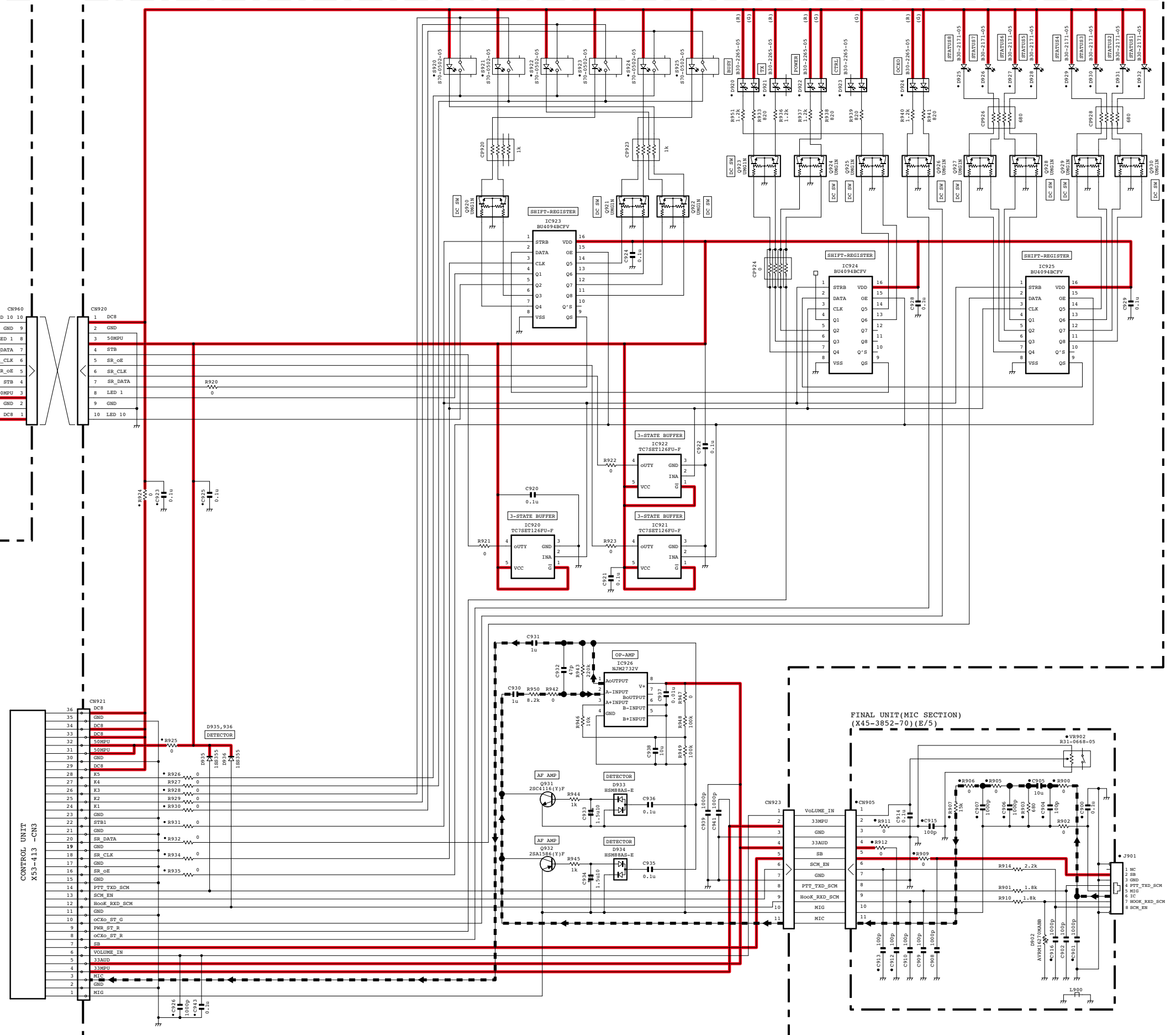

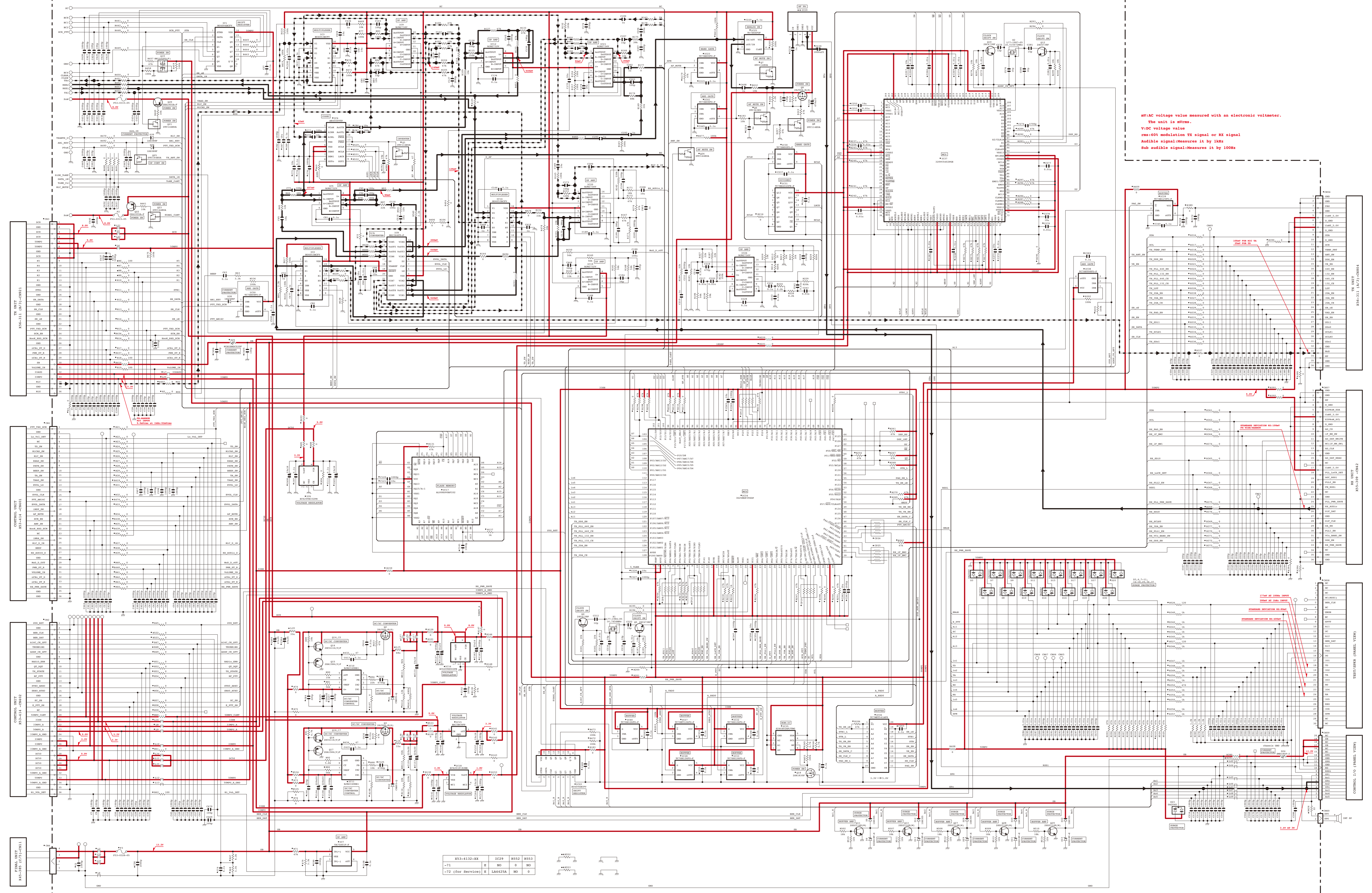

mV:AC voltage value measured with an electronic voltmeter.
 The unit is mVrms.
 V:DC voltage value
 rms:60 modulation TX signal or RX signal
 Audible signal:Measures it by kHz
 Sub audible signal:Measures it by 100Hz

X53-4132-XX	IC29	R552	R553
-71	E	NO	0
-72 (for Service)	E	LA4425A	NO

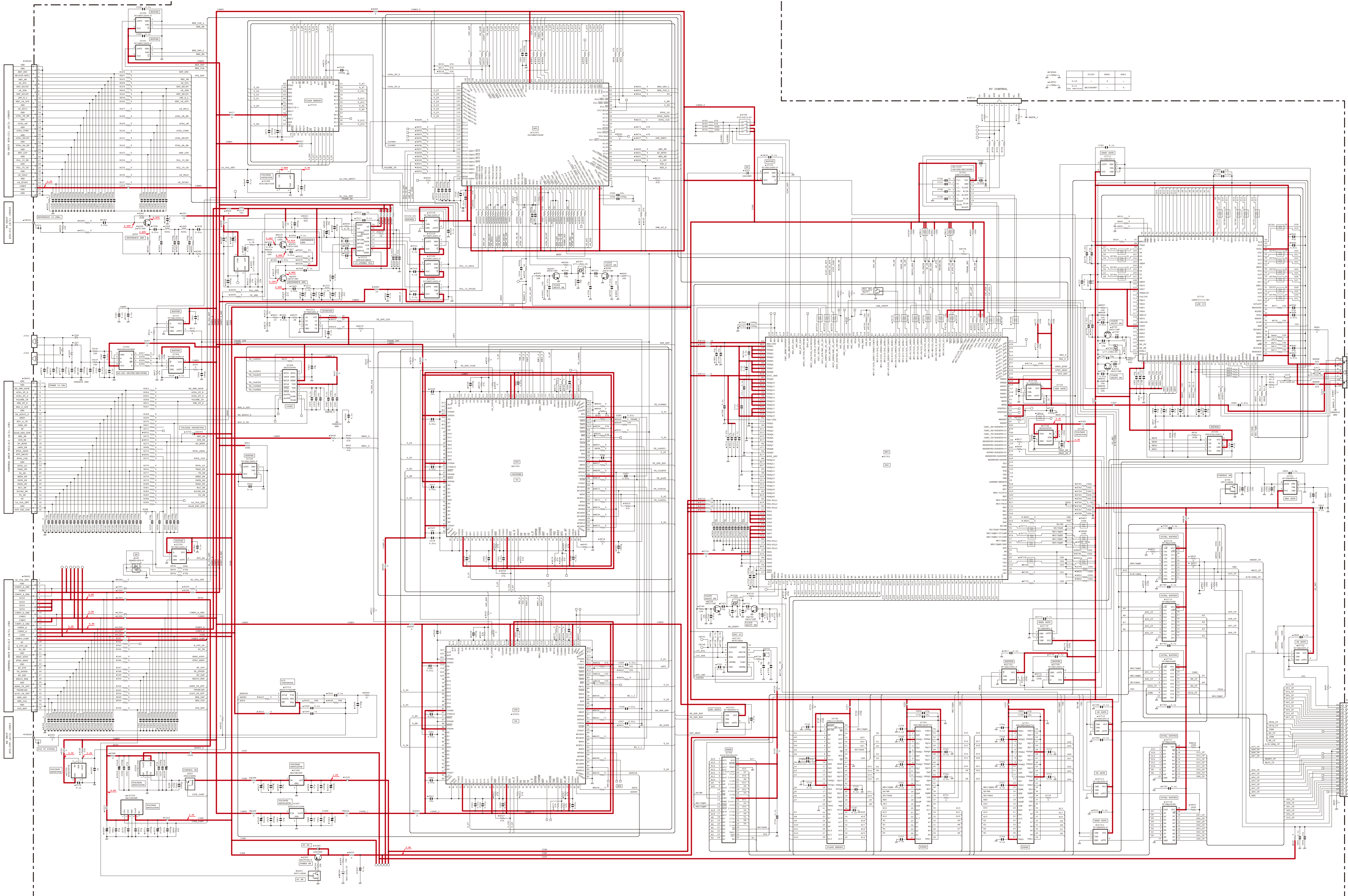

OPTION UNIT (OCXO) (X42-3280-20)

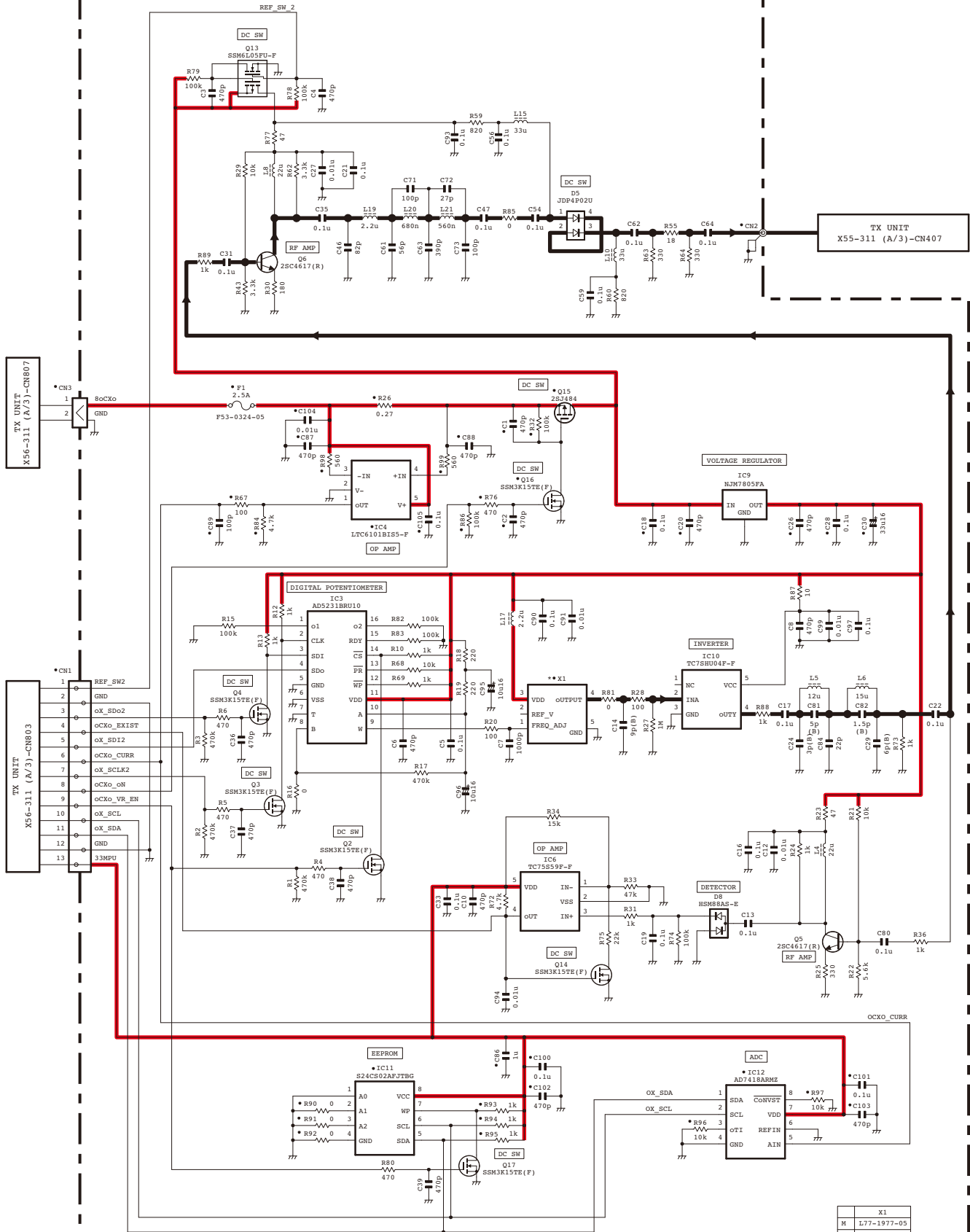

X1	
M	L77-1977-05
M2	L77-3045-05

- | | | |
|---|-------------------|---------------|
| B | : | N09-2292-05 |
| C | M2 x 8 | : N30-2008-43 |
| D | M2.6 x 6 | : N30-2606-48 |
| E | M3 x 35 | : N30-3035-43 |
| F | M3 x 6 (F) | : N32-3006-43 |
| G | M4 x 8 (F) | : N32-4008-43 |
| H | : | N67-3008-48 |
| J | : | N80-2006-43 |
| K | : | N80-2608-43 |
| L | M2.6 x 8 (Br-Tap) | : N87-2608-48 |

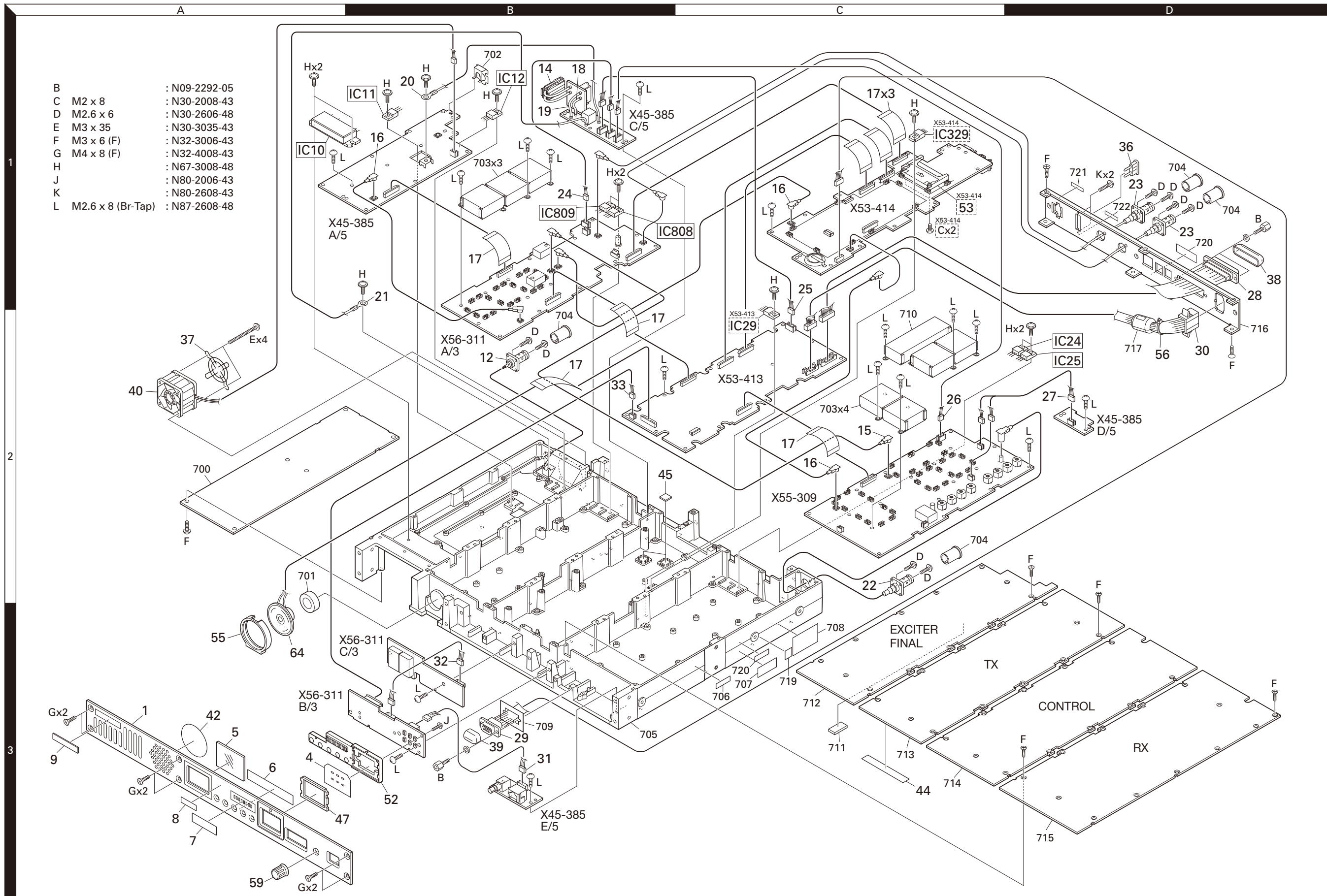

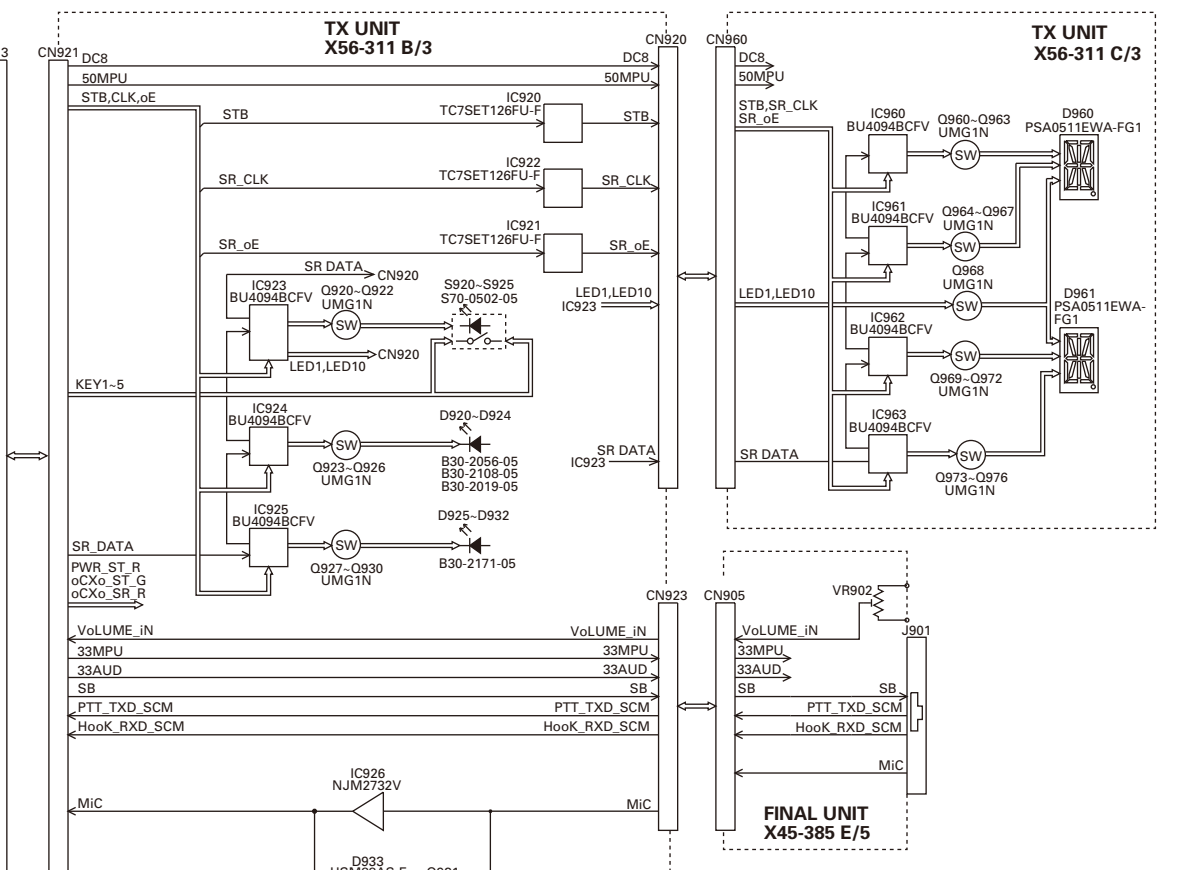
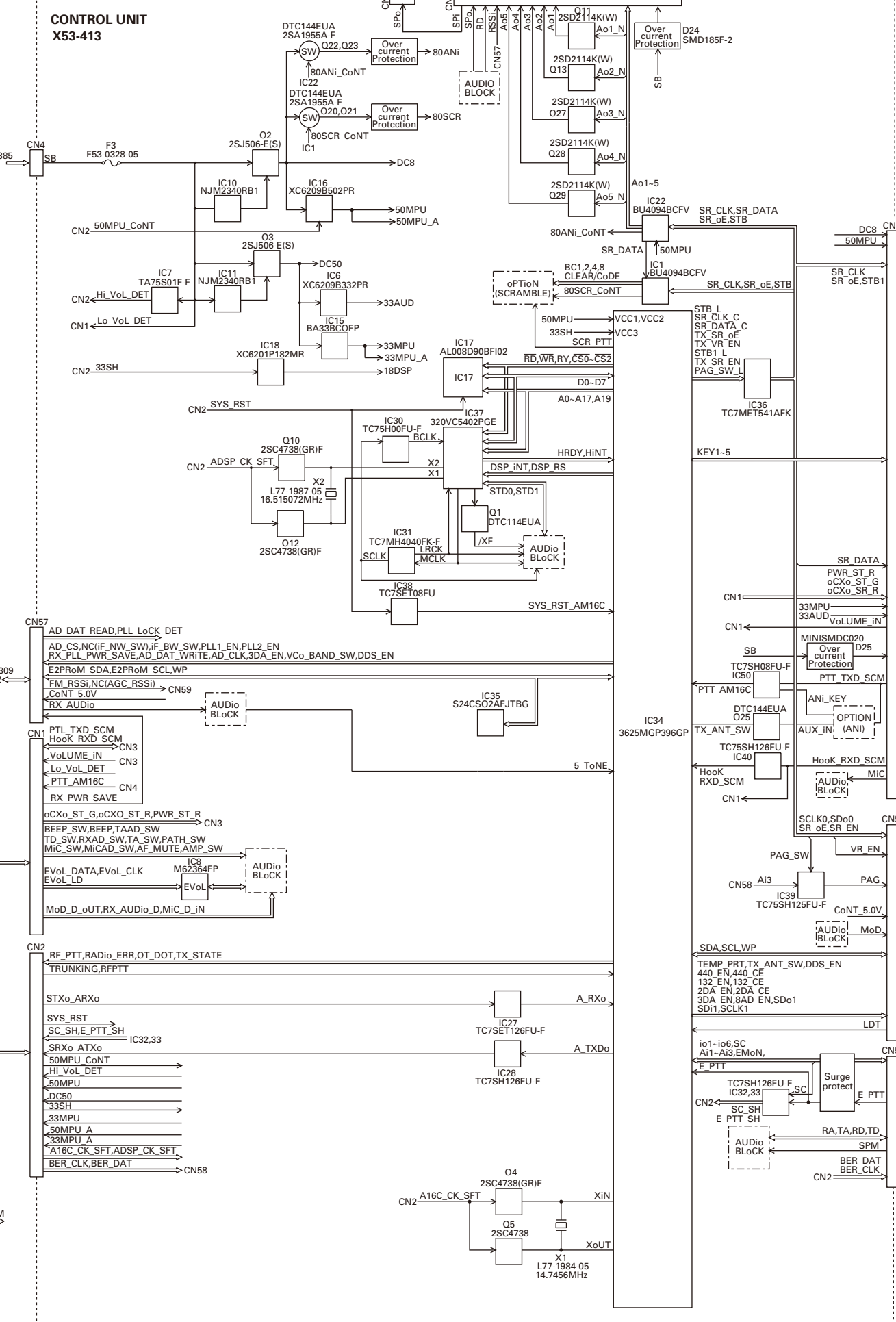
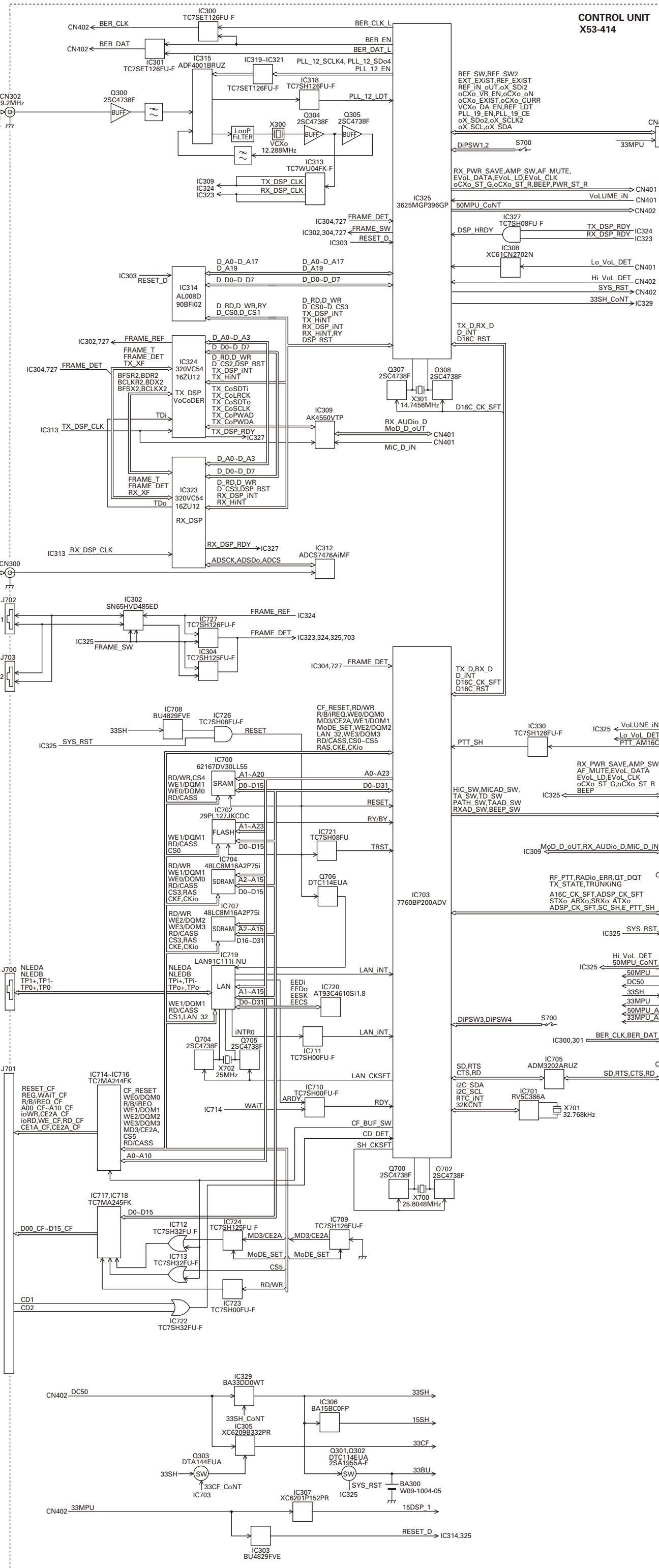
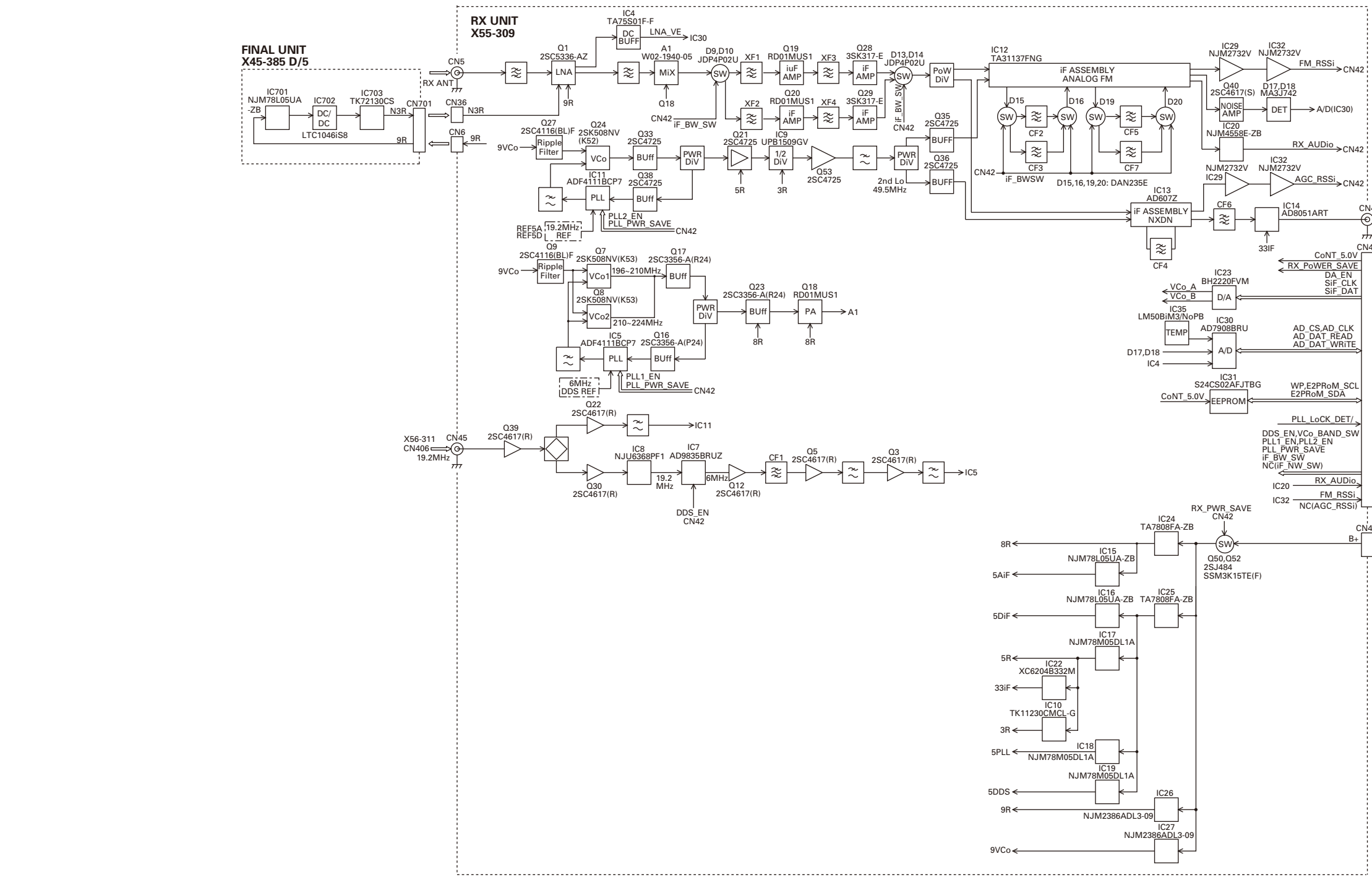
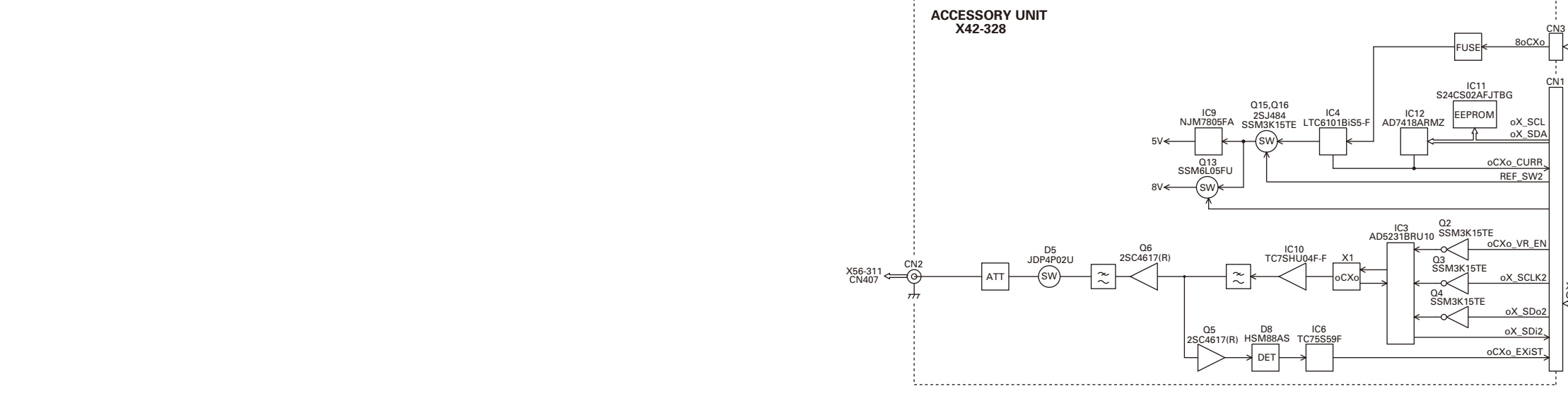
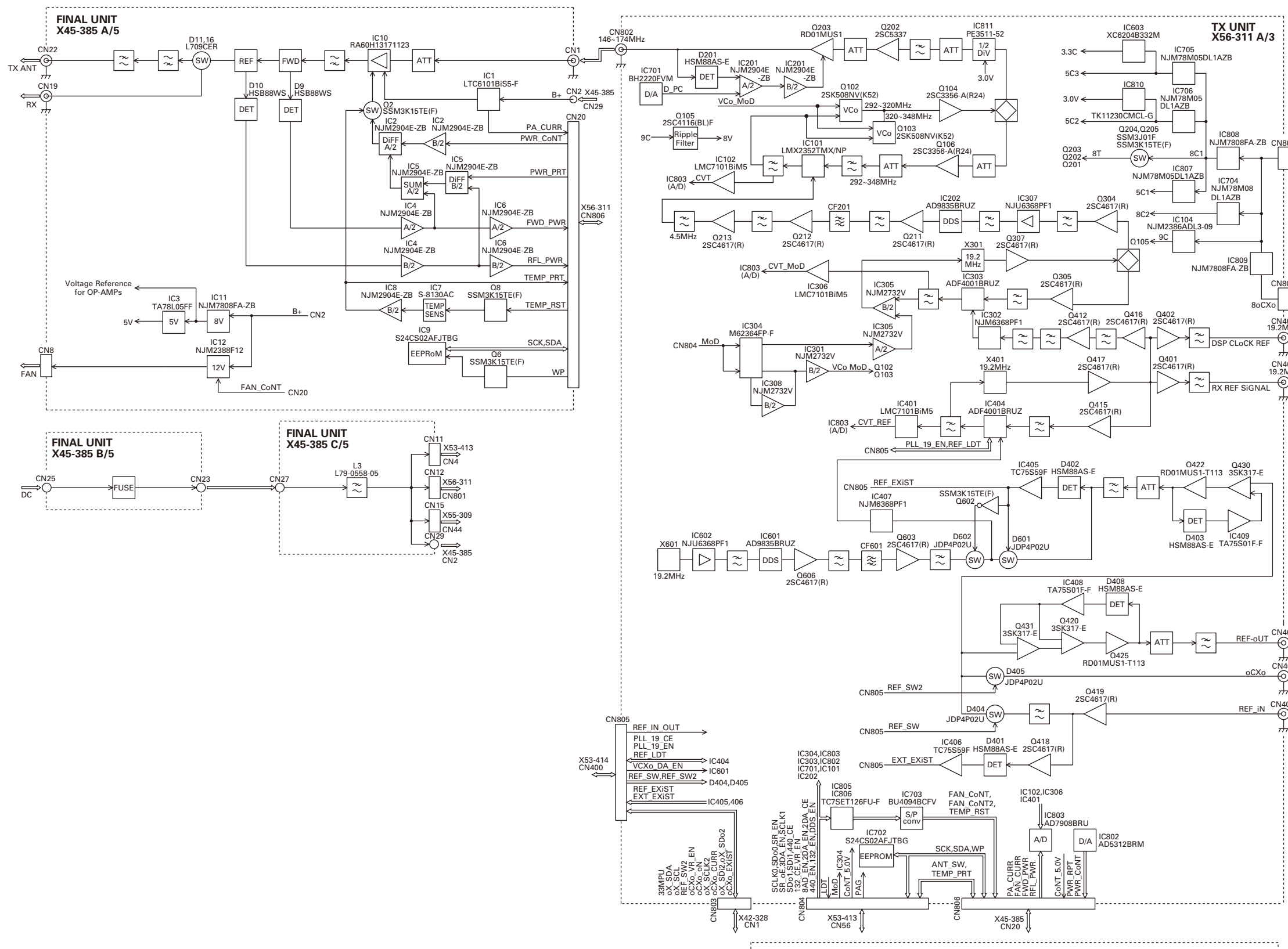

- 33H IC702-IC709, IC747, IC747A, IC747B, IC747C, IC747D, IC747E, IC747F, IC747G, IC747H, IC747I
- 33BU IC701, IC702
- 33BU IC703, IC704, IC705, IC706, IC707, IC708, IC709, IC710, IC711, IC712, IC713, IC714, IC715, IC716, IC717, IC718, IC719, IC720, IC721, IC722, IC723, IC724, IC725, IC726, IC727, IC728, IC729
- 33MPU A IC208, IC210, IC211, IC212, IC213, IC214, IC215, IC216, IC217, IC218, IC219, IC220, IC221, IC222, IC223, IC224, IC225, IC226, IC227, IC228, IC229, IC230
- 33AUD IC231, IC232, IC233, IC234, IC235, IC236, IC237, IC238, IC239, IC240, IC241, IC242, IC243, IC244, IC245, IC246, IC247, IC248, IC249, IC250
- 33CF IC251
- 33MPU IC300, IC301, IC302, IC303, IC304, IC305, IC306, IC307, IC308, IC309, IC310, IC311, IC312, IC313, IC314, IC315, IC316, IC317, IC318, IC319, IC320, IC321, IC322, IC323, IC324, IC325, IC326, IC327, IC328, IC329, IC330
- 5MPU A IC315
- 15SH IC703
- 15SP IC231, IC232, IC233, IC234
- 15BNC IC208, IC209, IC210, IC211, IC212, IC213, IC214, IC215, IC216, IC217, IC218, IC219, IC220, IC221, IC222, IC223, IC224, IC225, IC226, IC227, IC228, IC229, IC230
- 15OCR IC208, IC209, IC210, IC211, IC212, IC213, IC214, IC215, IC216, IC217, IC218, IC219, IC220, IC221, IC222, IC223, IC224, IC225, IC226, IC227, IC228, IC229, IC230

