

# NXR-810

## SERVICE MANUAL

# KENWOOD

Kenwood Corporation

© 2009-12 PRINTED IN JAPAN  
B51-8902-00 (N) 427

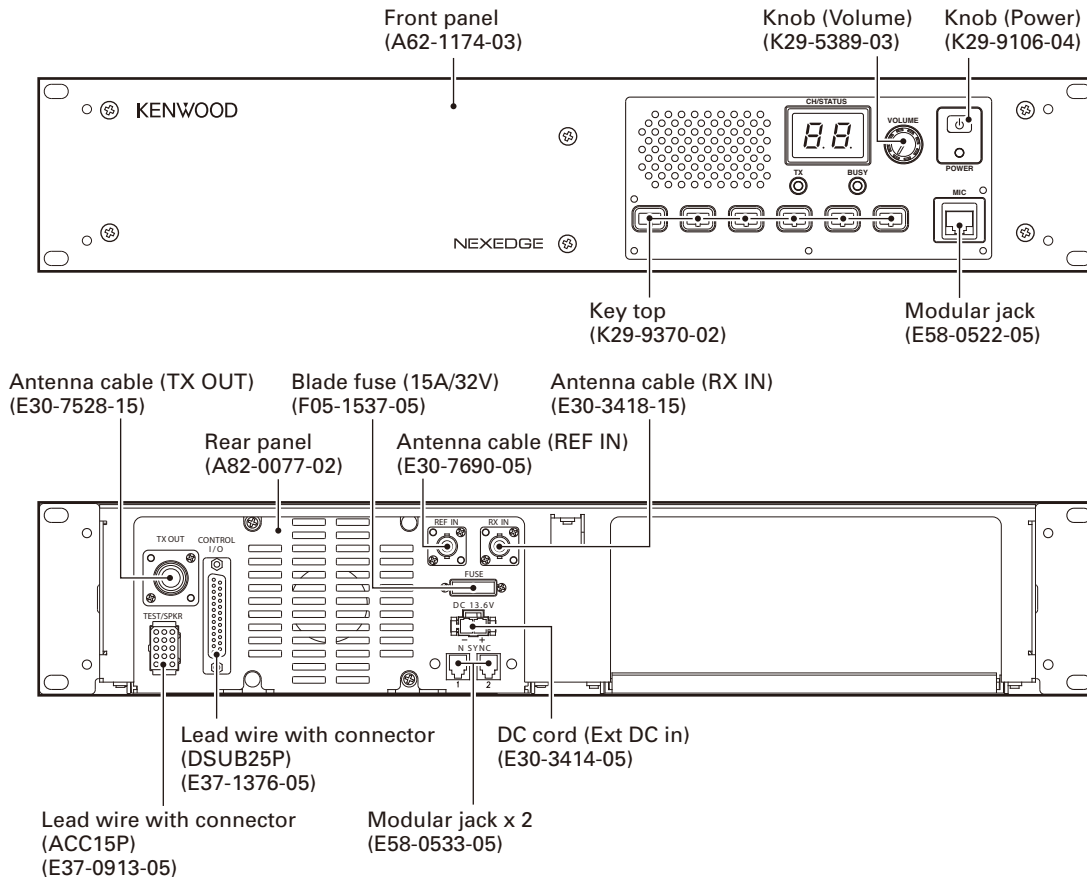

## CONTENTS

GENERAL.....	2
SYSTEM SET-UP .....	3
REALIGNMENT .....	3
OPERATING FEATURES .....	5
INSTALLATION.....	6
MODIFICATION .....	8
DISASSEMBLY FOR REPAIR .....	8
CIRCUIT DESCRIPTION .....	9
COMPONENTS DESCRIPTION.....	18
PARTS LIST .....	20
EXPLODED VIEW .....	36
PACKING.....	38
ADJUSTMENT .....	39
TERMINAL FUNCTION .....	53

PC BOARD	
FINAL UNIT (X45-3930-10) .....	58
CONTROL UNIT (X53-4490-10) .....	62
DISPLAY UNIT (X54-3580-20) .....	66
TX-RX UNIT (X57-7950-10).....	70
RX VCO/PLL UNIT (X58-5090-10) .....	74
TX VCO/PLL UNIT (X58-5100-10) .....	75
INTERCONNECTION DIAGRAM .....	76
SCHEMATIC DIAGRAM .....	78
BLOCK DIAGRAM .....	96
OPTIONAL ACCESSORIES	
KES-5 (EXTERNAL SPEAKER) .....	99
SPECIFICATIONS .....	BACK COVER



# NXR-810

## Document Copyrights

Copyright 2009 by Kenwood Corporation. All rights reserved.

No part of this manual may be reproduced, translated, distributed, or transmitted in any form or by any means, electronic, mechanical, photocopying, recording, or otherwise, for any purpose without the prior written permission of Kenwood.

## Disclaimer

While every precaution has been taken in the preparation of this manual, Kenwood assumes no responsibility for errors or omissions. Neither is any liability assumed for damages resulting from the use of the information contained herein. Kenwood reserves the right to make changes to any products herein at any time for improvement purposes.

## Firmware Copyrights

The title to and ownership of copyrights for firmware embedded in Kenwood product memories are reserved for Kenwood Corporation. Any modifying, reverse engineering, copy, reproducing or disclosing on an Internet website of the firmware is strictly prohibited without prior written consent of Kenwood Corporation. Furthermore, any reselling, assigning or transferring of the firmware is also strictly prohibited without embedding the firmware in Kenwood product memories.

Transceivers containing AMBE+2™ Vocoder:

The AMBE+2™ voice coding technology is embedded in the firmware under the license of Digital Voice Systems, Inc.

# GENERAL

## INTRODUCTION

### SCOPE OF THIS MANUAL

This manual is intended for use by experienced technicians familiar with similar types of commercial grade communications equipment. It contains all required service information for the equipment and is current as of the publication date. Changes which may occur after publication are covered by either Service Bulletins or Manual Revisions. These are issued as required.

### ORDERING REPLACEMENT PARTS

When ordering replacement parts or equipment information, the full part identification number should be included. This applies to all parts: components, kits, or chassis. If the part number is not known, include the chassis or kit number of which it is a part, and a sufficient description of the required component for proper identification.

## PERSONAL SAFETY

The following precautions are recommended for personal safety:

- DO NOT transmit if someone is within two feet (0.6 meter) of the antenna.
- DO NOT transmit until all RF connectors are secure and any open connectors are properly terminated.
- SHUT OFF this equipment when near electrical blasting caps or while in an explosive atmosphere.
- All equipment should be properly grounded before powerup for safe operation.
- This equipment should be serviced by only qualified technicians.

## SERVICE

This transceiver is designed for easy servicing. Refer to the schematic diagrams, printed circuit board views, and alignment procedures contained within.

## SYSTEM SET-UP

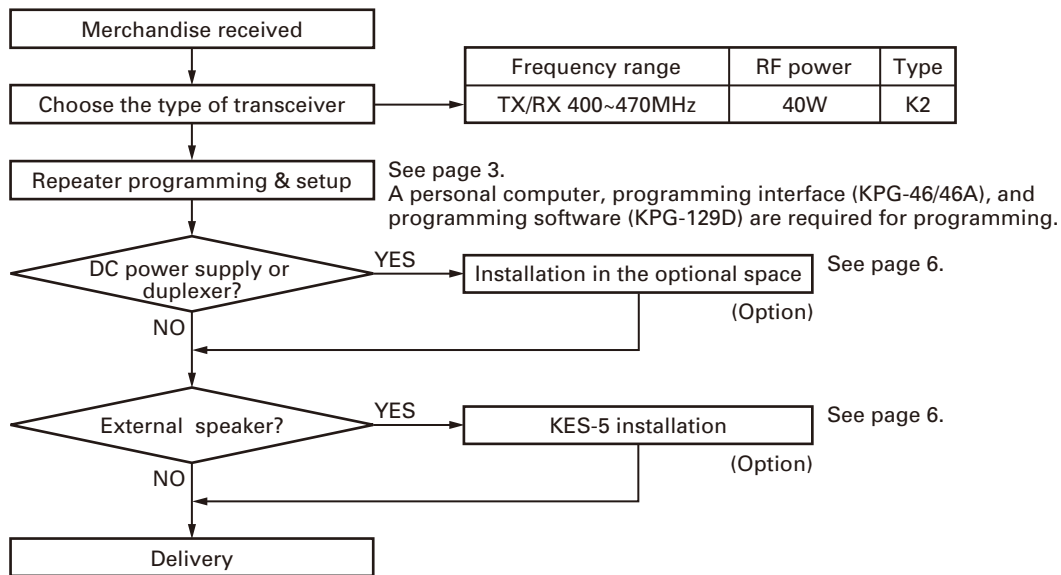

## REALIGNMENT

### 1. Modes

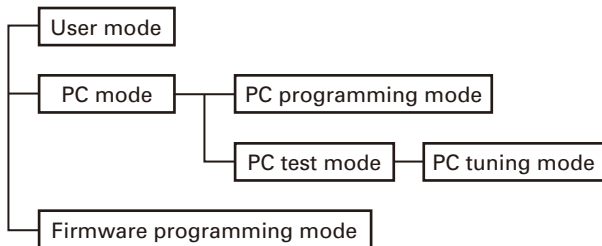

Mode	Function
User mode	Use this mode for normal operation.
PC mode	Use this mode to make various settings by means of the FPU through the RS-232C port.
PC programming mode	Use to read and write frequency data and other features to and from the repeater.
PC test mode	Use to check the repeater using the PC. This feature is included in the FPU.
Firmware programming mode	Use when changing the firmware program of the flash memory.

### 2. How to Enter Each Mode

Mode	Operation
User mode	Power on.
PC mode	Received commands from PC.
Firmware programming mode	[PF1] + Power on (one second)

### 3. PC Mode

#### 3-1. Preface

The NXR-810 is programmed by using a personal computer, programming interface (KPG-46/46A) and programming software (KPG-129D).

The programming software can be used with a PC. Figure 1 shows the setup of a PC for programming.

#### 3-2. Connection Procedure

1. Connect the NXR-810 to the computer using the interface cable and USB adapter (When the interface cable is KPG-46A, the KCT-53U can be used.).

#### Note:

- You must install the KCT-53U driver in the computer to use the USB adapter (KCT-53U).
- When using the USB adapter (KCT-53U) for the first time, plug the KCT-53U into a USB port on the computer with the computer power ON.

2. When power is applied, the user mode is entered immediately. When the PC sends a command, the repeater enters the PC mode and displays "PC" on the 7-segment LED. When data is being transmitted to the PC from the repeater, the TX LED flashes. The BUSY LED flashes when data from the PC is being received by the repeater.

#### Note:

- The data stored in the personal computer must match the model type, when it is written into the flash memory.
- Change the NXR-810 to PC mode, then attach the interface cable.

## REALIGNMENT

### 3-3. KPG-46/KPG-46A Description

#### (PC programming interface cable: Option)

The KPG-46/46A is required to interface the NXR-810 to the computer. It has a circuit in its D-sub connector (KPG-46: 25-pin, KPG-46A: 9-pin) case that converts the RS-232C logic level to the TTL level.

The KPG-46/46A connects the 8-pin microphone connector of the NXR-810 to the RS-232C serial port of the computer.

### 3-4. KCT-53U Description (USB adapter: Option)

The KCT-53U is a cable which connects the KPG-46A to a USB port on a computer.

When using the KCT-53U, install the supplied CD-ROM (with driver software) in the computer. The KCT-53U driver runs under Windows 2000, XP or Vista (32-bit).

### 3-5. Programming Software KPG-129D Description

The KPG-129D is the programming software for the transceiver supplied on a CD-ROM. This software runs under Windows XP, Vista or 7 on a PC.

The data can be input to or read from the NXR-810 and edited on the screen. The programmed or edited data can be printed out. It is also possible to tune the NXR-810.

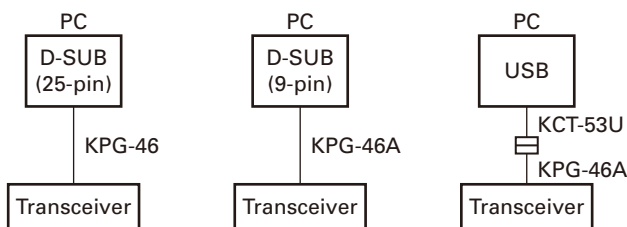
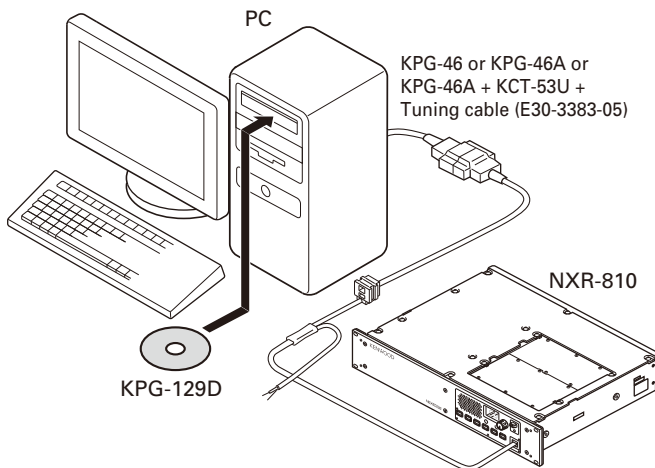

Fig. 1

## 4. Firmware Programming Mode

### 4-1. Preface

The NXR-810 uses flash memory to allow it to be easily upgraded when new features are released in the future.

### 4-2. Connection Procedure

Connect the NXR-810 to the personal computer using the interface cable (KPG-46/46A) and USB adapter (KCT-53U: when the interface cable is KPG-46A, the KCT-53U can be used.). (Connection is the same as in the PC Mode.)

#### Note:

You can only program firmware from the 8-pin microphone connector on the front panel. Using the 25-pin logic interface on the rear panel will not work.

### 4-3. Programming

1. Start up the firmware programming software (Fpro.exe (ver. 4.1 or later)). The Fpro.exe exists in the KPG-129D installed folder.
2. Set the communications speed (normally, 115200 bps) and communications port in the configuration item.
3. Set the firmware to be updated by File name item.
4. Turn the NXR-810 power ON with the [PF1] key held down. Then, "P.G." is displayed.
5. Check the connection between the NXR-810 and the personal computer, and make sure that the NXR-810 is in the Program mode.
6. Press write button in the window. When the NXR-810 starts to receive data.
7. If writing ends successfully, the TX LED on the NXR-810 lights.
8. If you want to continue programming other NXR-810s, repeat steps 4 to 7.

#### Note:

This mode cannot be entered if the Firmware Programming mode is set to Disable in the Programming software.

### 4-4. Function

If you press the [PF6] key while "P.G." is displayed, the display changes to "PG" to indicate that the write speed is low speed (38400 bps). If you press the [PF6] key again while "PG" is displayed, the display changes to "P.G." to indicate that the write speed is mid speed (57600 bps). If you press the [PF6] key again while "P.G." is displayed, the display changes to "P.G." to indicate that the write speed is high speed (115200 bps).

#### Note:

Normally, write in the high-speed mode.

## OPERATING FEATURES

### 1. Two 7-segment LED Displays

- Channel display (1~30): While operating normally in user mode.

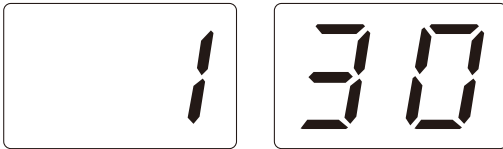

- When the displayed channel is contained in scan sequence, the right side decimal point is displayed.



- When the displayed channel is the priority channel, the left side decimal point is displayed.



- "PC" is displayed while in PC mode.



- "PG" is displayed while in firmware programming mode.  
2 decimal points displayed = 115,200 bps  
1 decimal point displayed = 57,600 bps  
No decimal = 38,400 bps

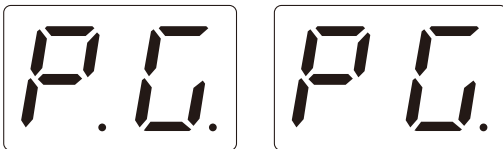

- "E1" is displayed when FPU data is not written.



- "E2" is displayed when the channel data is not written.



- "E3" is displayed when PLL is unlocked.  
Receiver PLL unlocked = BUSY LED blinks.  
Transmitter PLL unlocked = TX LED blinks.



- "E4" is displayed when PTT is attempted on a channel number that has no TX frequency data programmed.



- "SC" is displayed while in scan mode.



- "E5" is ESN blank error.



- "E.6." is MCU internal RAM error.



- "E6." is DSP RAM error.



- "E6" is MCU External RAM error.



## INSTALLATION

### 1. External Speaker (KES-5)

The NXR-810 has a built-in speaker (5W/8Ω), and the external speaker output from the TEST/SPKR connector (15-pin) on the rear of the radio is 4W/4Ω. Use external speaker KES-5.

#### 1-1. Connection for the KES-5 with the NXR-810

##### ■ When taking the AF output from the TEST/SPKR connector (15-pin) on the rear of the radio

The following tools are required for changing the connector.

##### • Extracting tool

The following extracting tool is recommended:  
Molex Inc. Order No.: J5800-002 (W05-0878-00)

1. Remove the connector with jumper from the external speaker connector on the rear panel of the radio. (Fig. 1-1)  
**Note:** Save the jumper, which is required when the radio is used without the external speaker.
2. Remove the terminals with the jumper from the connector housing holes number 9 and 12 using the extracting tool.

##### Removing the jumper lead (Fig. 1-2)

- 1) Insert the extracting tool (J5800-002) into the connector while pushing the jumper lead in the direction of (a).
- 2) Push the extracting tool in to collapse the barbs of the crimp terminal.
- 3) Pull out the lead while continuing to push the extracting tool in the direction (b).
3. Reinsert the terminal with the black and white stripe lead into hole number 12, and the terminal with the black lead into hole number 6. (Fig. 1-3)
4. Attach the connector to the external speaker connector on the radio.

##### Note:

Relationship between the TEST/SPKR connector (15-pin) connection and speaker output:

- When pins 9 and 12 are shorted: The built-in speaker is used.
- When pins 9 and 12 are open and output is from pins 6 and 12: KES-5 is used.

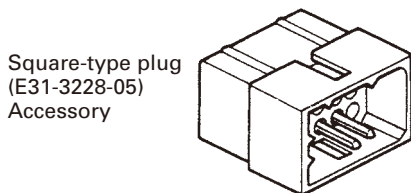

Fig. 1-1

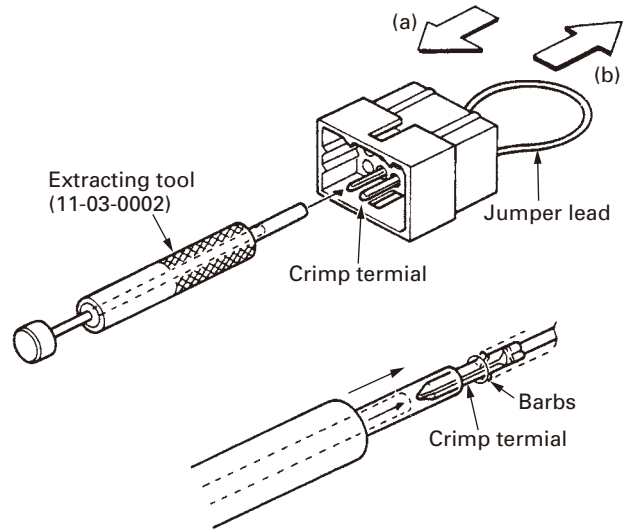

Fig. 1-2

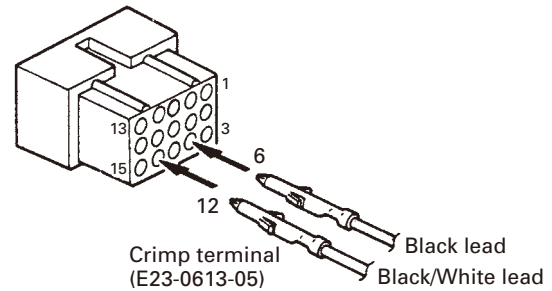

Fig. 1-3

### 2. Accessory Cabinet

You can install optional accessories, such as a DC power supply or duplexers, in the accessory cabinet.

1. Place the optional accessory in the cabinet as shown below.
2. If necessary, attach cushions (G13-1801-04 and/or G13-1802-04) to the top plate (J21-8559-04) in order to adjust the space between the cabinet and the top plate. Then, insert the 3 tabs of the plate into the slots in the side of the cabinet. High, middle, or low positions are available. To affix the plate, inset and tighten the 2 screws on the other side of the plate.

You can also flip the top plate upside-down to adjust the height of the cabinet space.

## INSTALLATION

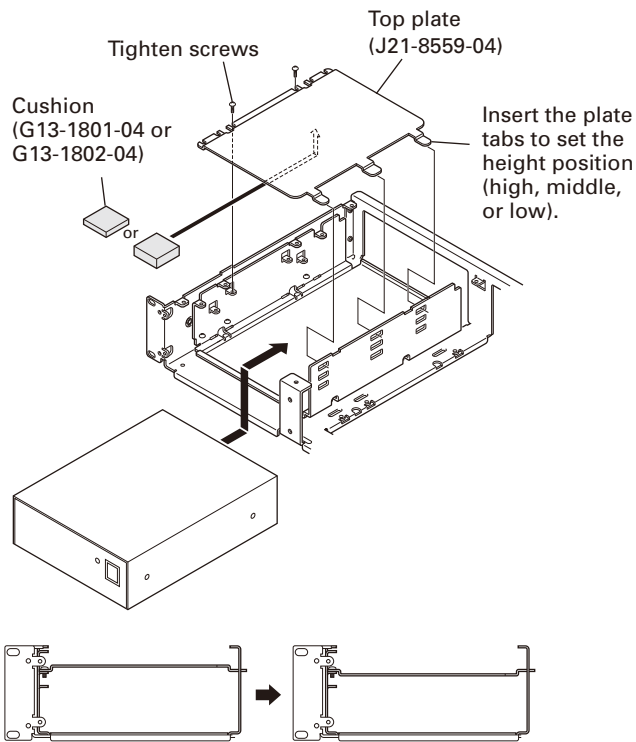

The top plate can be inverted to adjust the height of the cabinet space.

**Fig. 2**

### 3. Key Cover

To avoid accidentally pressing the keys, you can install the key cover.

1. Install and fix the key protector using the 5 supplied screws (N35-3006-43).

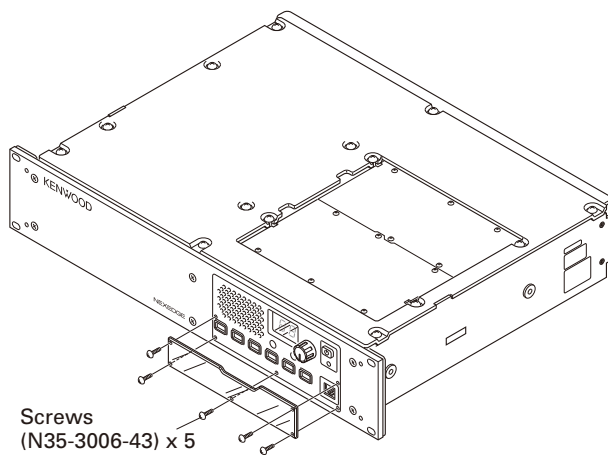

**Fig. 3**

### 4. Desktop Repeater

When you use the repeater on a desktop, attach the 4 spacers to the base of the repeater as shown in the figure. With these spacers attached, the front panel will not touch the desk surface.

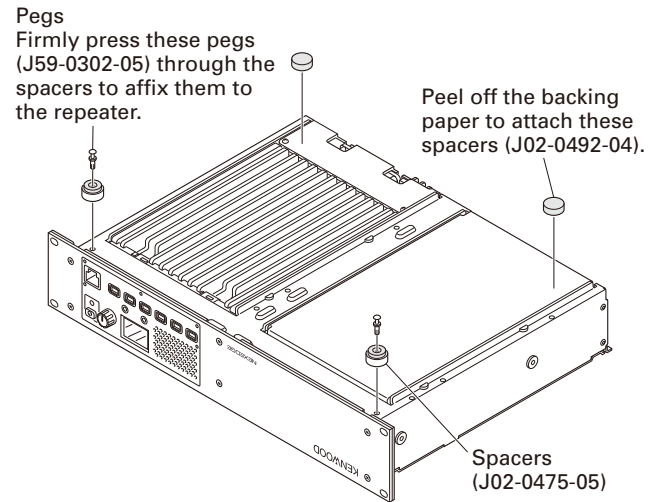
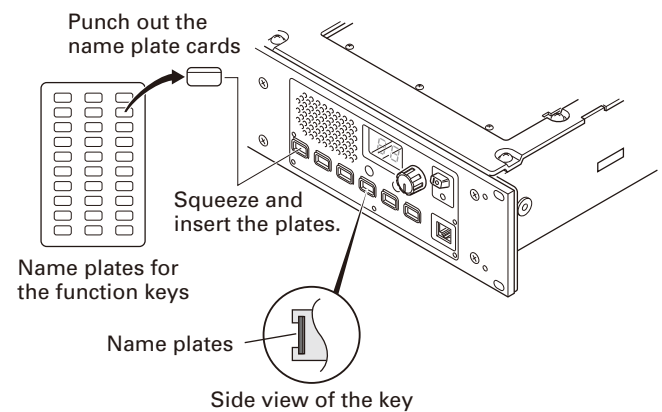

**Fig. 4**

### 5. Installing Name Plates

Punch out the name plate card. Then insert the plates onto the relative function keys.

You can reconfigure the name plates at any time.



**Fig. 5**



## MODIFICATION

### 1. DC Source Switch

To prevent the power supply from turning off due to misoperation of the DC source switch on the front panel or accidents (tampering) after installation, the main unit can be kept on regardless of the on/off setting of the DC source switch on the front panel.

Using solder, short the PSW land near the CN40 connector.

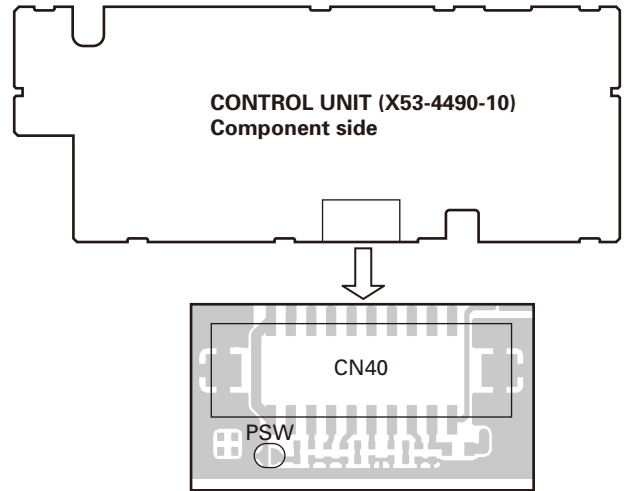

## DISASSEMBLY FOR REPAIR

### 1. How to Remove the Panel Assy (ABS)

**Note:** You can remove the panel assembly (ABS) without removing the top panel (A62-1148-03).

1. To remove the panel (TX-RX, ②), loosen the 6 screws (①).
2. To remove the panel assembly (Front, ④), loosen the 6 screws (③).
3. The panel assembly (ABS) is securely fastened by 4 tabs (⑤) on the top and bottom. You can remove the panel assembly by pulling to the front while you are pulling up the tabs.

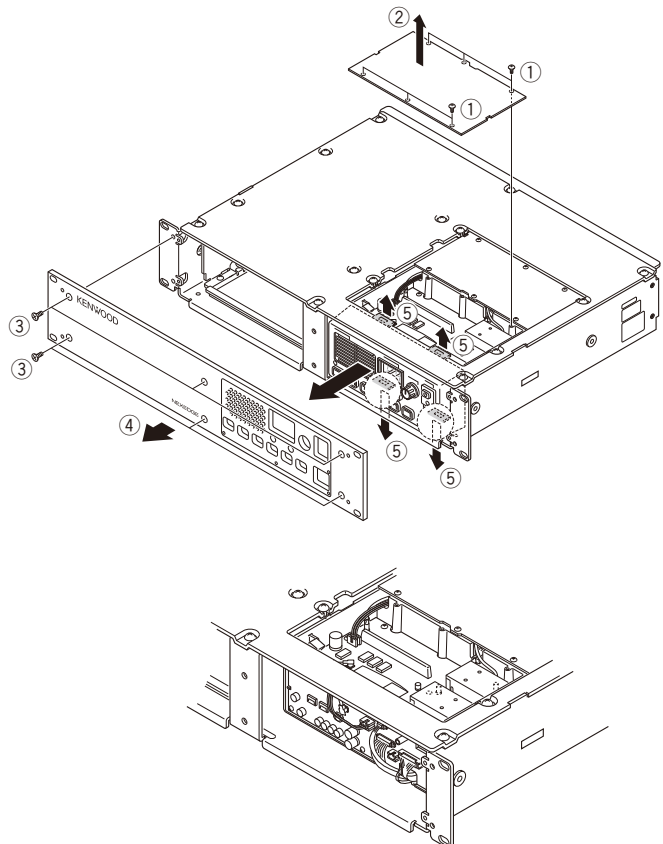



## CIRCUIT DESCRIPTION

### 1. Outline

The NXR-810 is a UHF repeater operating in the 400~470MHz frequency range.

### 2. TX-RX unit

TX-RX unit (X57-7950-10) consists of the following circuit.

- (1) Internal/external reference circuit
- (2) Transmitter reference 16.8MHz PLL circuit
- (3) Transmitter main PLL circuit
- (4) Modulation level adjustment circuit
- (5) Front-end circuit
- (6) 1st-Mixer circuit
- (7) IF circuit
- (8) Receiver PLL circuits
- (9) AVR circuits
- (10) Other circuits

#### 2-1. Internal/External reference circuit

The internal reference circuit consists of X500, Q502, Q504 and D505. The output of 19.2MHz VCTCXO (X500) is fed to buffer amplifier Q502. The higher harmonic wave is attenuated by the LPF. This reference signal is fed to IF IC (IC304) as the 2nd Local signal through the Tripler.

The internal reference signal is amplified by Q504 to achieve the needed level for PLL ICs. That signal is divided

by a Wilkinson divider. The divided signal is fed to the PLL IC for the receiver. Another signal is fed to the transmitter reference 16.8MHz PLL IC through PIN diode switch (D505) which switches the Internal or external reference.

The external reference circuit consists of CN500, Q501, Q503, IC500, IC501, D503 and D504. The external reference signal (10MHz/0dBm) input from CN500 is fed to buffer amplifier Q501 and is amplified by Q503. Q503 is a dual gate MOS-FET. The output of amplifier (Q503) is detected by D503 and that DC voltage is amplified by IC500 (B/2). The amplified DC voltage is compared to the reference voltage by IC500 (A/2). The difference of voltages is amplified by IC500 (A/2) and is fed to the gate-2 terminal of Q503. The voltage of the Q503 gate-2 terminal is controlled automatically to constantly maintain the power output of amplifier (Q503). The output of amplifier (Q503) is fed to the transmitter reference 16.8MHz PLL IC through the PIN diode switch (D504) which switches the Internal or External reference.

The PIN diode switches (D504, D505) are controlled by the I/O expander IC (IC805 Pin15). The I/O expander IC is controlled by the MCU which is in the Control unit (X53-449). If internal reference is selected by the FPU, the I/O expander IC outputs an "H" status. This signal sets power switch Q506 to ON. Then D505 is activated.

If external reference is selected, the I/O expander IC outputs an "L" status. This signal sets power switch Q500 to ON. Then D504 is activated.

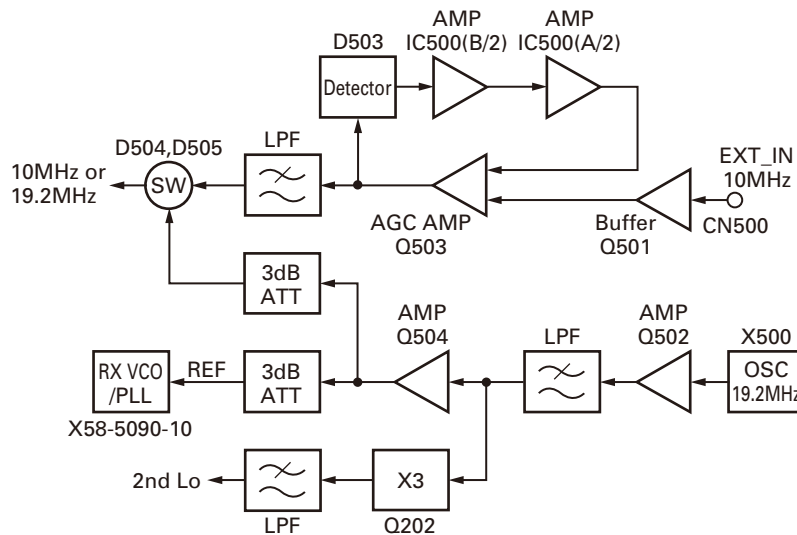

**Fig. 1 Internal/external reference circuit**

#### 2-2. Transmitter reference 16.8MHz PLL circuit

The transmitter reference 16.8MHz PLL circuit produces the reference frequency signal for the Transmitter Main PLL circuit and modulates the low-frequency components.

The circuit consists of IC600, IC601, IC602, IC603, IC604, Q601, Q602, Q603, and X600.

The VCXO (X600) signal enters the buffer amplifier Q601 and is amplified by Q602. The higher harmonic wave is attenuated by the LPF and returns to IC602. Its phase is compared with that of the reference frequency 5kHz.

The phase difference signal produced by the comparing phase is converted to a DC voltage by a lag-lead type loop filter. This DC voltage is input to the IC604 invert amplifier and is synthesized with the modulating signal. This DC voltage is input to the X600 control voltage terminal for controlling the VCXO oscillating frequency 16.8MHz.

The 16.8MHz oscillating signal is fed to the Q603 buffer amplifier. The output signal of the buffer amplifier is used as the reference frequency signal of the transmitter main PLL circuit.

## CIRCUIT DESCRIPTION

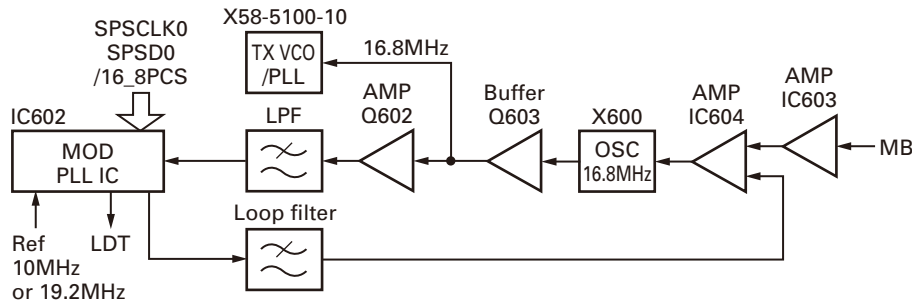

**Fig. 2 Transmitter reference 16.8MHz PLL circuit**

### 2-3. Transmitter Main PLL circuit (SUB unit)

#### ■ VCO

The TX VCO circuit consists of two VCOs (VCO A X58-510: Q352, VCO B X58-510: Q353). Those VCOs generate a transmit carrier. VCO A Q352 produces a transmitter frequency from 400.000MHz to 434.995MHz. VCO B Q353 produces a transmitter frequency from 435.000MHz to 470.000MHz.

Those VCO oscillation frequencies are determined by two systems of voltage control terminals: "CV" and "TXASSIST".

The voltage control terminals, "CV" and "TXASSIST", are controlled by the PLL IC (X58-510: IC300) and MCU (X53-449: IC20) and the output frequency changes continuously according to the applied voltage. For the modulation input terminal, "MO", the output frequency changes according to the applied voltage.

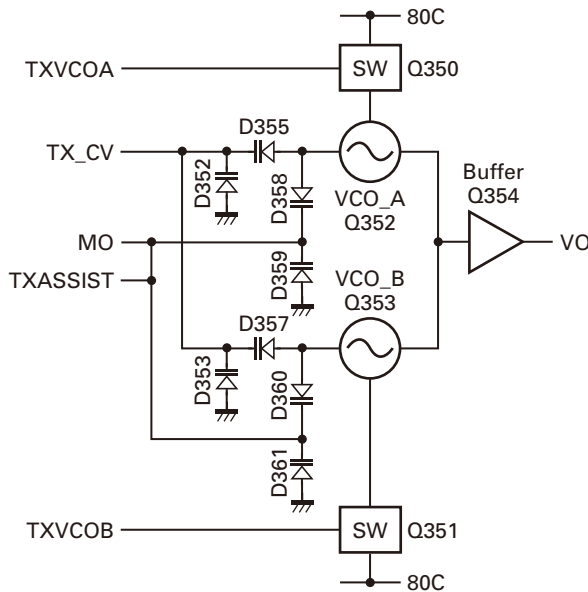

**Fig. 3 Transmitter VCO circuit**

#### ■ PLL IC (X58-510: IC300)

The PLL IC compares the differences in phases of the VCO oscillation frequency and the transmitter PLL reference signal (16.8MHz), returns the difference to the VCO CV ter-

terminal and realizes the "Phase Locked Loop" for the return control. This allows the VCO oscillation frequency to accurately match (lock) the desired frequency.

When the frequency is controlled by the PLL, the frequency convergence time increases as the frequency difference increases when the set frequency is changed. To supplement this, the MCU is used before control by the PLL IC to bring the VCO oscillation frequency close to the desired frequency. As a result, the VCO CV voltage does not change and is always stable at approx. 3.0V.

The desired frequency is set for the PLL IC by the MCU (X53-449: IC20) through the 3-line "SPSD0", "SPSCLK0", "/TXPCS" serial bus. Whether the PLL IC is locked or not is monitored by the MCU through the "LDT" signal line. If the VCO is not the desired frequency (unlock), the "LDT" logic is low.

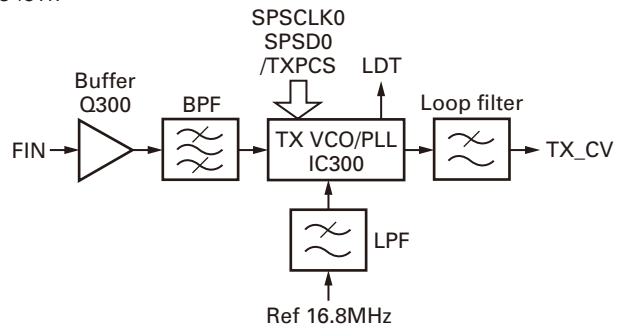

**Fig. 4 Transmitter Main PLL IC circuit**

### 2-4. Modulation level adjustment circuit

The Modulation level adjustment circuit adjusts the modulation waveform balance. This circuit consists of IC804, IC603, IC604, IC605 and IC606.

The modulating signal comes from the Control unit (X53-449) through the interface connector (CN800 Pin14). The modulating signal is produced by the modulation low-pitched tone to the transmitter modulation 16.8MHz PLL circuit and adds the high-pitched modulation to the transmitter main PLL.

IC804 is an electronic volume control IC. It has 8 electronic volume control circuits. The modulation level adjustment circuit uses 2 electronic volume control circuits in IC804. The 1st electronic volume control circuit adjusts the modulating signal and is fed to IC603 and the 2nd electronic

## CIRCUIT DESCRIPTION

volume control circuit. The 2nd electronic volume control circuit adjusts the modulating signal and is fed to IC606.

IC603 is an inverting amplifier for inverting the amplification of the modulating signal. The output of IC603 and the charge pump output of IC602 (Transmitter modulation 16.8MHz PLL IC) are synthesized by IC604 and is fed to VCXO (X600).

IC606 is a non-inverting amplifier. The output of the 2nd electronic volume control circuit is amplified by IC606 and is fed to the transmitter main PLL circuit.

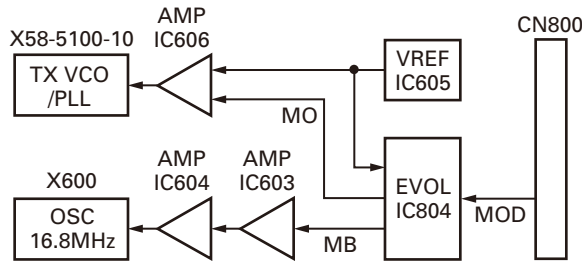
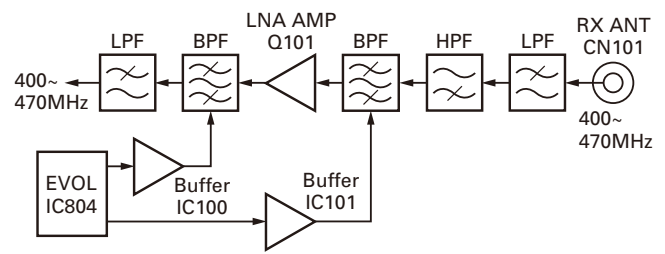

**Fig. 5 Modulation level adjustment circuit**

### 2-5. Front-end circuit

The front-end circuit consists of former LPF, former BPF (D105, D106, D107 and D108), RF Low Noise Amplifier (Q101), latter BPF (D100, D101, D103 and D104), and latter LPF. The BPF covers frequency ranges 400 to 470MHz.

The former LPF, former BPF, latter BPF, and latter LPF attenuate the unwanted signals and send only the necessary signal to the first mixer.



**Fig. 6 Front-end circuit**

### 2-6. 1st-Mixer circuit

The filtered signal from the front-end circuit is heterodyned with the first local oscillator signal from the PLL frequency synthesizer circuit at the first mixer (IC300) to become a 58.05MHz first intermediate frequency (IF) signal.

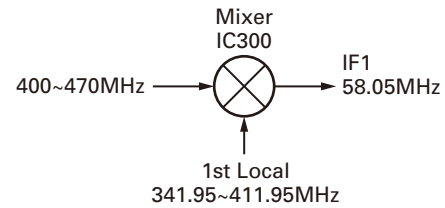

**Fig. 7 1st-Mixer circuit**

### 2-7. IF circuit

The first IF signal is amplified by the IF Post Amp (Q301) and passed through a four-pole monolithic crystal filter (XF300) to reject adjacent channel signal. The filtered first IF signal is amplified by the IF AGC amplifier (Q300) and then applied to the IF system IC (IC403). The IF system IC

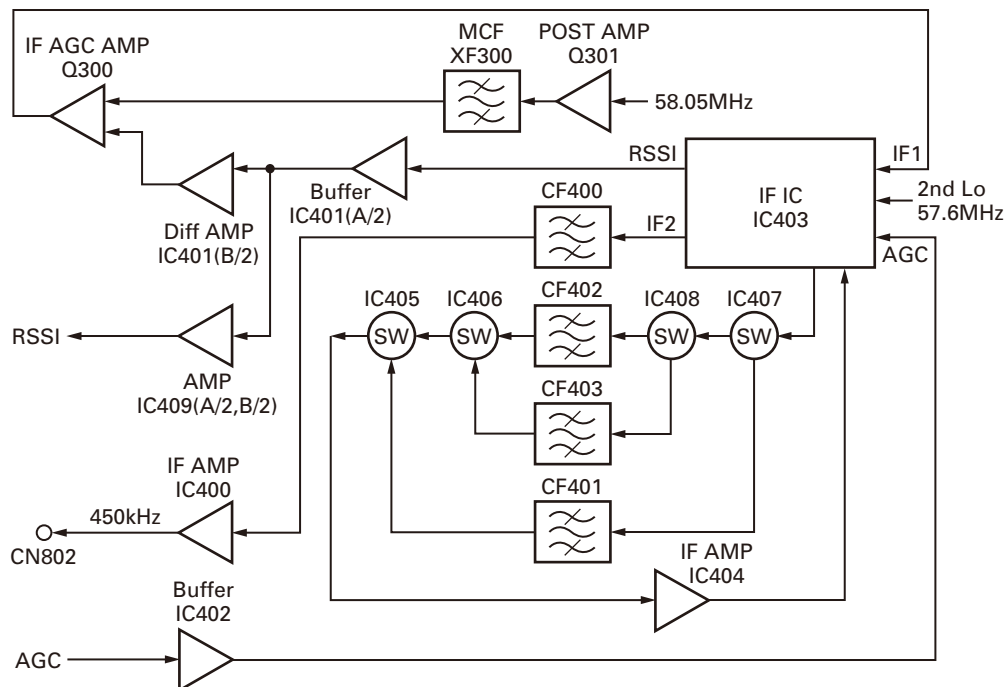

**Fig. 8 IF circuit**

## CIRCUIT DESCRIPTION

provides a second mixer, AGC amplifier, and RSSI (Received Signal Strength Indicator).

The second mixer mixes the first IF signal with the 57.6 MHz of the second local oscillator output and produces the second IF signal of 450kHz.

The second IF signal is passed through the ceramic filter (CF401, CF402 and CF403) to reject the adjacent channel signals. The filtered second IF signal is amplified by the second IF amplifier (IC404) and AGC amplifier (IC403).

The signal from the AGC amplifier is input to the AD converter (X53-449: IC20) through the ceramic filter (CF400) and operational amplifier (IC400 and X53-449: IC20).

### 2-8. Receiver PLL circuit (SUB unit)

#### ■ VCO

RX VCO circuit consists of two VCOs (VCO A X58-509: Q352, VCO B X58-509: Q353). Those VCOs generate a 1st local signal. For the VCO oscillation frequency, the 1st local signal is 341.95 to 411.95MHz. (VCO A: 341.95~376.95MHz, VCO B: 376.95~411.95MHz)

Those VCO oscillation frequency is determined by two systems of voltage control terminals "CV" and "RXASSIST".

The voltage control terminals, "CV" and "RXASSIST", are controlled by the PLL IC (X58-509: IC300) and the MCU (X53-449: IC20) and the output frequency changes continuously according to the applied voltage.

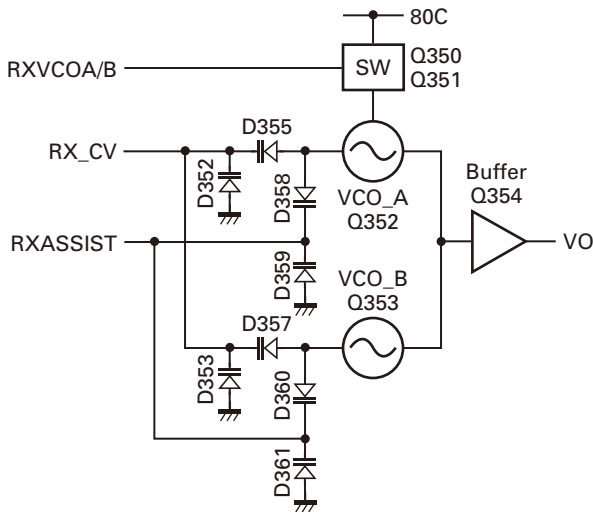

Fig. 9 Receiver VCO circuit

#### ■ PLL IC (X58-509: IC300)

PLL IC compares the differences in phases of the VCO oscillation frequency and the VCTCXO reference frequency, returns the difference to the VCO CV terminal and realizes the "Phase Locked Loop" for the return control. This allows the VCO oscillation frequency to accurately match (lock) the desired frequency.

When the frequency is controlled by the PLL, the frequency convergence time increases as the frequency difference increases when the set frequency is changed. To supplement this, the MCU is used before control by the PLL IC to bring the VCO oscillation frequency close to the desired frequency. As a result, the VCO CV voltage does not change and is always stable at approx. 3.0V.

The desired frequency is set for the PLL IC by the MCU (X53-449: IC20) through the 3-line "SPSD0", "SPSCLK0", "/RXPCS\_TR" serial bus. Whether the PLL IC is locked or not is monitored by the MCU through the "LDR" signal line. If the VCO is not the desired frequency (unlock), the "LDR" logic is low.

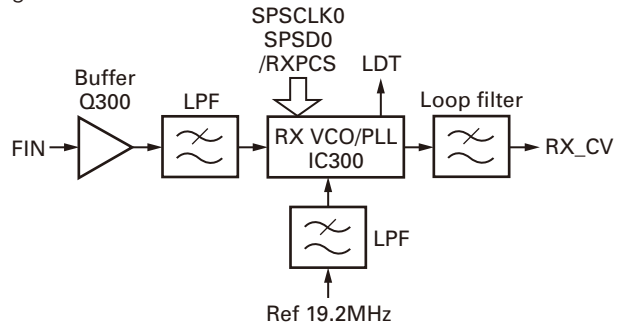

Fig. 10 Receiver PLL circuit

### 2-9. AVR circuit

The 13.6V Power Source (+B) is provided through the Connector (CN701) from the Final unit (X45-393). +B is connected to the FET switch (Q702, Q703) and CN700. Q702 and Q703 are controlled by the "SBC" signal from the MCU which is in the Control unit (X53-449). If "SBC" logic is high, Q702 and Q703 turn on. The 13.6V power source (SB) which is turned on by Q702 and Q703 is provided to the 8V AVR IC (IC702) and CN700. CN700 is connected to the Control unit (X53-449) to provide the +B power source and the SB power source.

IC702 supplies 8V to the VCO, 15V DC/DC converter IC (IC701), AVR IC (IC700) and FET switches (Q700, Q701). IC701 is a step-up switching regulator. IC701 regulates 8V to 15V and supplies the 15V power source to the "assist circuit" and "front-end BPF tuning circuit". The FET switches (Q700, Q701) are controlled by the I/O expander IC (IC805). When Q700 and Q701 turn on, the 8V power source is provided to the receiver section.

IC700 regulates 5V to 8V. The output of IC700 is provided to the FET switches (Q705, Q706) and AVR IC (IC703). The FET switches (Q705, Q706) are controlled by the I/O expander IC (IC805). When Q705 and Q706 turn on, the 5V power source is provided to the receiver section, IF section and IC704. IC704 regulates 5V to 3V. The 3V power source is provided to the Mixer IC (IC300). IC703 regulates 5V to 3.3V. The output of IC703 is provided to the IF section.

## CIRCUIT DESCRIPTION

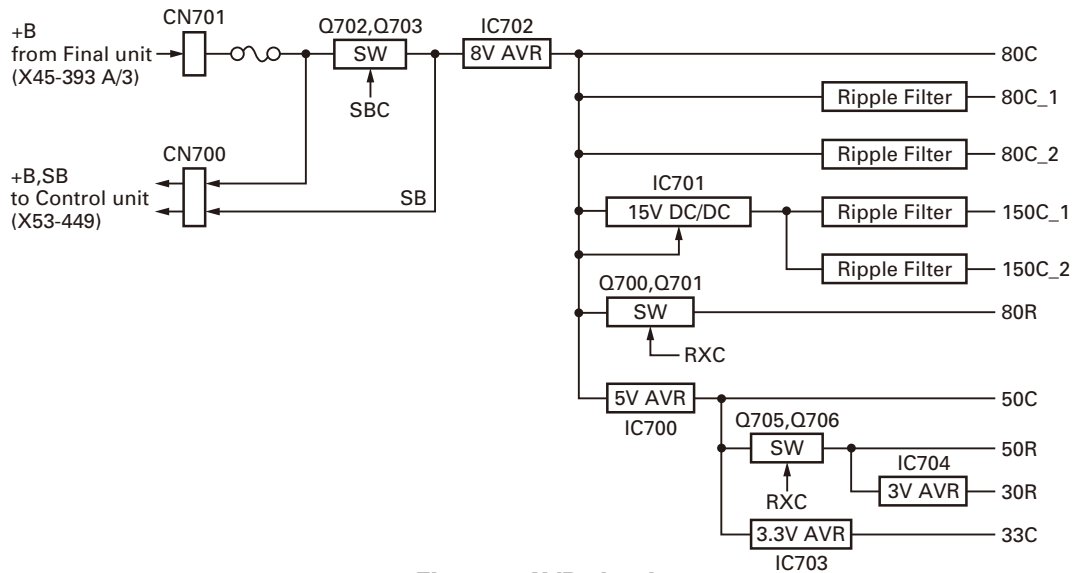

Fig. 11 AVR circuit

### 2-10. Other circuit

#### ■ EEPROM

The EEPROM (IC802) has a data capacity of 2Kbit. It stores the tuning data in frequency adjustment.

#### ■ Temperature sensor

The temperature sensor (IC800) monitors temperature around the VCTCXO (X500).

#### ■ I/O expander

The I/O expander IC (IC805) controls the power sources, fan, analogue switches, and the transmit power control circuit. IC805 is controlled by the MCU which is in the Control unit (X53-449).

#### ■ Electronic volume control IC

The Electronic volume control IC (IC804) adjusts the modulating signal, center frequency of the front-end BPF, and the power of the RF final amplifier. IC804 is controlled by the MCU which is in the Control unit.

### 3. Final unit

The RF final amplifier unit (X45-3930-10) amplifies the transmitter power to a specified level.

This unit consists of the following circuits:

- (1) Driver and Final power amplifier circuit
- (2) CM coupler circuit
- (3) Filter circuit
- (4) APC circuit
- (5) High temperature detector circuit
- (6) FAN action control circuit
- (7) AVR circuit

#### 3-1. Driver and Final power amplifier circuit

The transmit signal from the TX IN terminal CN1 of the Final unit (X45-393) is amplified by Q1, Q2 and Q3, and is passed to the final stage Q4. The signal amplified by the final stage Q4 passes through the CM coupler circuit and filter circuit, and is then fed to the antenna.

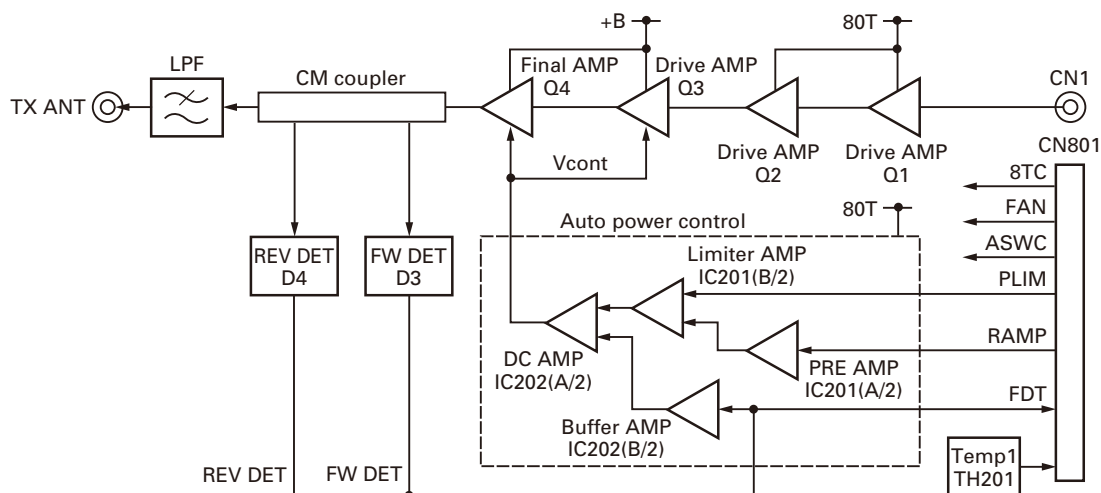

Fig. 12 Driver and Final power amplifier circuit

## CIRCUIT DESCRIPTION

### 3-2. CM coupler circuit

The CM coupler circuit is a line for detecting forward wave and reflected wave. Forward wave is detected by D1, and is converted into DC voltage. If an abnormal antenna load is connected, reflected wave is detected by D3 and converted into DC voltage.

### 3-3. Filter circuit

This circuit removes harmonics from the transmitter output and sends filtered signals to the antenna.

### 3-4. APC circuit

The automatic transmission power control (APC) circuit stabilizes the transmitter output power at a pre-determined level. DC voltage from the CM coupler circuit is amplified by the DC amplifier IC202 (1/2). IC202 (2/2) compares the APC control voltage (RAMP) generated by the MCU (X53-449) and the DC amplifier IC201 (1/2, 2/2) with the output voltage from IC202 (1/2) to control the gate voltage for amplifier Q2, Q3 and final amplifier Q4.

### 3-5. High temperature detector circuit

To prevent thermal destruction of amplifier Q3 and final amplifier Q4, this circuit reduces the APC control voltage (RAMP) when the temperature of the amplifier Q3 and final amplifier Q4 rises. The MCU detects the temperature with the thermistor (TH201) and controls the APC voltage (RAMP).

### 3-6. FAN action control circuit

The FAN action control circuit consists of the FAN and switching transistor Q207. It is controlled by the MCU (X53-449). If the FAN action is set to "Temperature", the cooling fan is turned ON or OFF according to the temperature. If the FAN action is set to "Continuous", the cooling fan operates continuously, but Q207 stays ON.

### 3-7. AVR circuit

The 13.6V power source (+B) is provided through connector CN201 to the Final unit (X45-393 A/3). +B is connected to CN203 to supply the 13.6V power source for the TX-RX unit (X57-795). +B is a power source for the "final amplifier", "drive amplifier" and fan. IC203 regulates the +B voltage to 8V. This 8V power source is connected to the FET switches Q203, Q204, Q205, and Q206. Q204 and Q206 are controlled by the "8TC" signal from the I/O expander IC which is in the TX-RX unit (X57-795). If "8TC" logic is high, Q204 and Q206 turn on and supply the 8V power source to the APC circuit and pre drive amplifiers. Q203 and Q205 are controlled by the "ASWC" signal from the I/O expander IC which is in the TX-RX unit (X57-795). If "ASWC" logic is high, Q203 and Q205 turn on and supply the 8V power source to the antenna switch circuit.

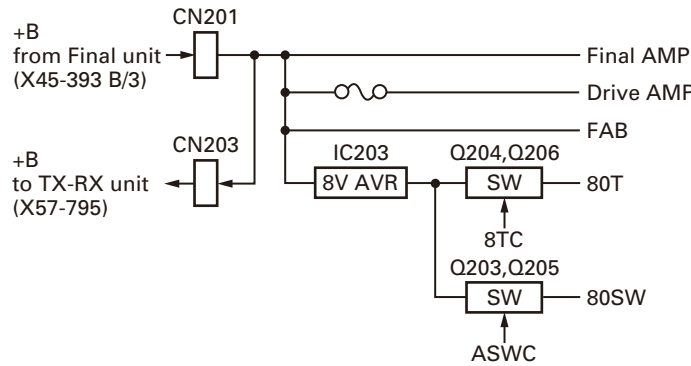

Fig. 13 AVR circuit

## 4. Control unit

The Control unit (X53-4490-10) consists of the following circuits:

- (1) MCU circuit
- (2) Memory circuit
- (3) DSP circuit
- (4) Squelch circuit
- (5) Power supply circuit
- (6) Power Supply Voltage Monitoring Circuit
- (7) 18.432MHz clock circuit
- (8) Audio circuit
- (9) Other circuit

### 4-1. MCU circuit

The MCU (IC20) is a 32bit RISC processor, equipped with a peripheral function and ADC/DAC.

This MCU operates at a 18.432MHz clock and 3.3V/1.5V DC.

It controls the flash memory, SRAM, DSP, receive circuit, transmitter circuit, and control circuit.



## CIRCUIT DESCRIPTION

### 4-2. Memory circuit

The Memory circuit consists of the MCU (IC20), the SRAM (IC9), and the flash memory (IC3).

The flash memory has a capacity of 32Mbit that contains the transceiver control program for the MCU and stores the data. It also stores the data for transceiver channels and operating parameters that are written by the FPU. This program can be easily written from external devices.

The SRAM has a capacity of 1Mbit that contains work area and data area.

#### ■ Flash memory

**Note:** The flash memory stores the data that is written by the FPU, tuning data (Deviation, Squelch, etc.), and firmware program.

#### ■ SRAM (static memory)

**Note:** The SRAM has a temporary data area and work area. When the power supply is off, it is backed up by an internal secondary lithium battery. Therefore, the saved data is not lost.

### 4-3. DSP circuit

The DSP circuit consists of a DSP (IC6) and processes the base band signal. The DSP operates on an external clock of 18.432MHz (the same as IC20). The I/O section operates at 3.3V and the core section operates at 1.6V. The DSP carries out the following processes:

#### ■ Digital processing

- 4Level FSK and Baseband filter processing
- Vocoder processing between audio codec and modulation/demodulation
- CAI processing, such as error correction encoding/decoding and interleaving
- AFC loop control
- Frame synchronization and Time tracking
- Data scrambling

#### ■ Analog FM processing

- Pre-emphasis/De-emphasis
- QT/DQT encoding/decoding
- DTMF encoding/decoding
- Compressor/Expander processing
- Voice scrambler processing

#### ■ Audio or Modulation function

- Transmit/Receive audio filtering processing
- Microphone amplifier AGC processing
- Audio soft mute processing
- Modulation level processing
- Squelch Filtering

#### ■ Other function

- Voting tone
- CWID
- Courtesy tone
- Repeater operating
- Analog/Digital Mixed mode

### 4-4. Squelch circuit

The Squelch circuit amplifies the demodulated noise signal from IC6 after filtering through the BPF circuit. The processed digital noise signal is applied to CODEC IC14, and is converted from digital to analog. The amplified signal is then converted to a DC signal by the detection circuit. The converted signal is fed back to IC20.

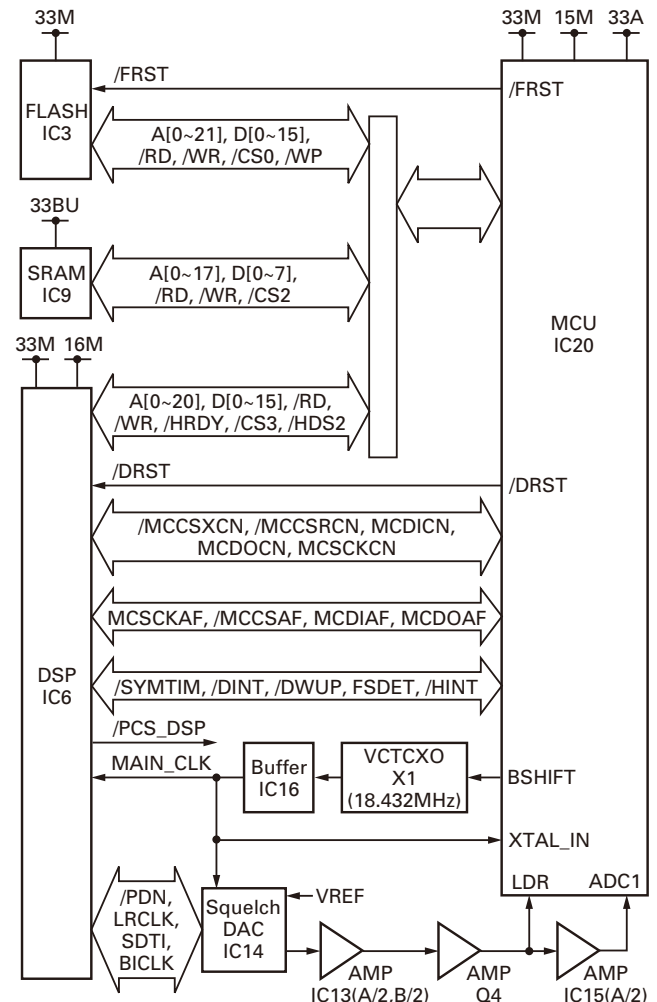

Fig. 14 Control circuit

### 4-5. Power supply circuit

The X53-449 circuit consists of IC301, IC302, IC303, IC304, IC305 and IC306.

IC301 is a DC/DC converter that converts 13.6V to 6.0V. This 13.6V voltage is supplied from TX-RX unit (X57-795).

IC302 is connected to IC301 and regulates the voltage to 5.0V. IC303, IC304, IC305 and IC306 are connected to IC301. IC303 and IC306 are 3.3V voltage regulators. IC304 is a 1.5V regulator IC, and IC305 is a 1.6V regulator IC.

CN302 is the connector for the lithium battery. The lithium battery is used to back up the SRAM and RTC data when no external DC power source is available.



## CIRCUIT DESCRIPTION

### 4-6. Power supply voltage monitoring circuit

The X53-449 circuit consists of IC307, IC308, D303 and Q301.

IC308 is a voltage detect IC and is used to generate the "/RST" signal for the MCU (IC20).

This "/RST" signal is connected to the hardware reset pin of MCU (IC20).

IC307 is a voltage detect IC and is used to generate the "/BINT" signal for the MCU (IC20).

This "/BINT" signal is connected to the hardware interrupt pin of MCU (IC20). The software of the MCU (IC20) runs to the sleep-mode to use the "/BINT" signal.

D303 and Q301 are used to generate the "OVRB" signal for the MCU (IC20). The software of the MCU (IC20) runs to the sleep-mode to use the "OVRB" signal.

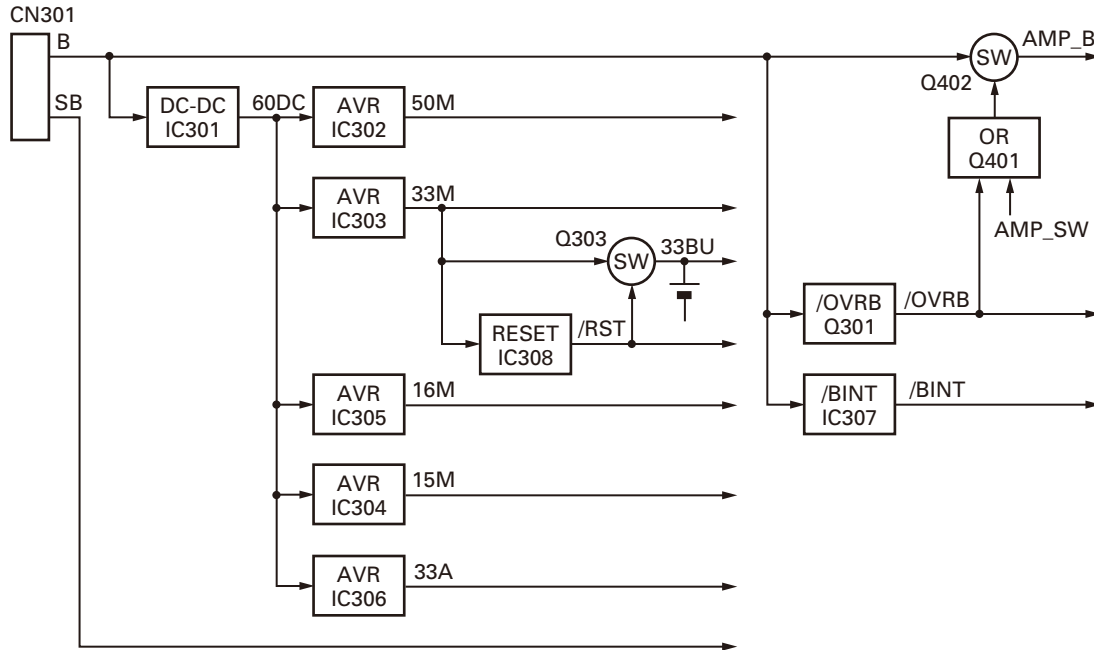

Fig. 15 Power supply circuit

### 4-7. 18.432MHz clock circuit

The 18.432MHz clock is provided to the MCU (IC20), DSP (IC6), and DAC (IC14) of the Squelch circuit.

### 4-8. Audio circuit

#### ■ Audio amplifier circuit

The audio amplifier circuit is located in the control section of the Control unit (X53-449). The 4W output audio power is available from the pin 15 TEST/SPKR connector "SPO", "SPG" on the rear panel to the external speaker in the case of a power supply voltage of 13.6V and a 4Ω load.

#### ■ Microphone circuit

The signal from the microphone is passed through the AGC circuit located in the Display unit (X54-358 A/2) so that it may not saturate. This circuit consists of IC501, D501, D502 Q501, and Q502. The AGC controls the amplifier gains using the detected audio signal depending on the positive and negative peaks of the signal amplitude. The audio signal goes to the control section of the Control unit (X53-449) from the Display unit (X54-358 A/2).

#### ■ Modulation circuit (Analog/Digital signal processing)

In the case of the Analog Signal Processing mode, the transmitting audio signal is amplified by IC405 (C/4), input to the MICADCO terminal of the MCU (IC20), and audio processed by DSP (IC6). The processed audio signal from the MODDAC terminal of IC20 is passed through an anti-aliasing filter at IC404 (A/2), and is then amplified to a sufficient level by IC404 (B/2), and amplified by the summing (TD) amplifier. The Digital Signal Processing mode is the same as the Analog Signal Processing mode.

### 4-9. Other circuit

#### ■ Real-time clock

The clock function is based on a real-time clock IC (IC17). When the power supply is off, it is backed up by an internal secondary lithium battery.

## CIRCUIT DESCRIPTION

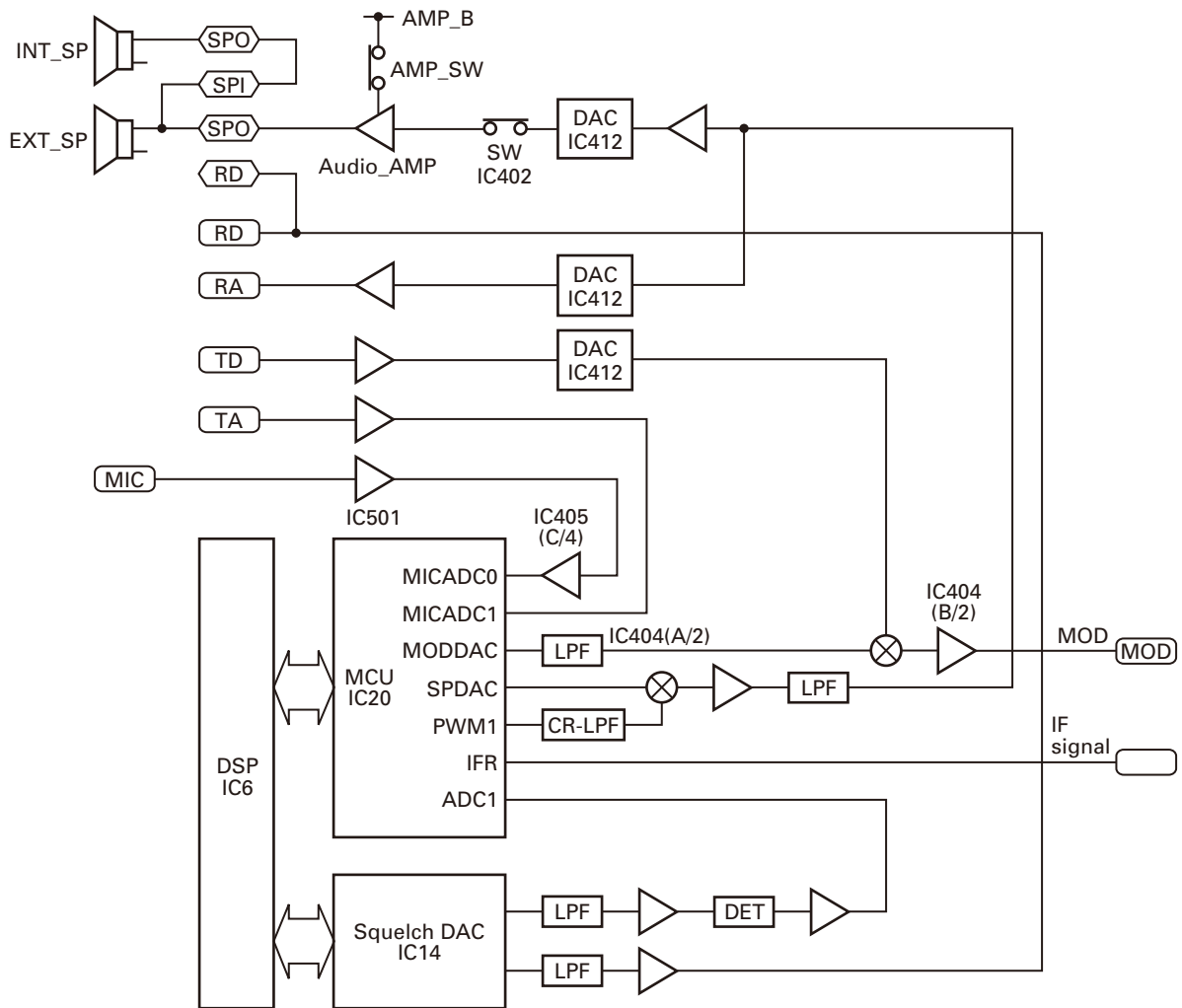

**Fig. 16 Modulation circuit (Analog/Digital signal processing)**

### 5. Display unit

The Display unit (X54-3580-20) is the same circuit as X54-3580-20, used in TKR-750/850/751/851.

The Display unit (X54-3580-20) consists of the following circuits:

- (1) LED circuit
- (2) Key switch circuit

#### 5-1. LED circuit

The display circuit consists of various types of LEDs: 7-segment type D506 and D507 (red), D503 (red: transmission), D504 (green: busy), D505 (green: power on).

IC502 to IC505 are shift registers that convert MCU serial data to parallel data and turn on the LEDs.

#### 5-2. Key switch circuit

There are PF key 1 to PF key 6 on the Display unit. Using these key switches, mode settings are available.

The logic signals pushing these key switches are entered directly into the MCU (IC20).

## COMPONENTS DESCRIPTION

### FINAL UNIT (X45-3930-10)

Ref. No.	Part Name	Description
IC201,202	MOS-IC	DC amplifier
IC203	Analogue IC	Voltage regulator
Q1	Transistor	RF amplifier
Q2	FET	RF amplifier
Q3	FET	TX drive amplifier
Q4	FET	Final amplifier
Q203~206	FET	DC switch
Q207	Transistor	DC switch
D1~3	Diode	RF detector
D6,7	Diode	RF switch
D8	Surge absorber	Surge protection
D201	Zener diode	Voltage reference
D202	Surge absorber	Surge protector
D203	Diode	Surge protector
D301	Diode	Protect of reverse connection

### CONTROL UNIT (X53-4490-10)

Ref. No.	Part Name	Description
IC3	ROM IC	Flash memory
IC4,5	MOS-IC	RS-485 transceiver
IC6	Microprocessor IC	DSP
IC7,8	MOS-IC	Buffer
IC9	SRAM IC	SRAM
IC10,11	MOS-IC	Buffer
IC12	MOS-IC	AND gate
IC13	MOS-IC	AF amplifier
IC14	MOS-IC	CODEC
IC15	MOS-IC	AF amplifier
IC16	MOS-IC	Buffer amplifier
IC17	MOS-IC	RTC IC
IC18,19	MOS-IC	Buffer
IC20	MOS-IC	MCU
IC21	MOS-IC	RS-232C driver/receiver
IC22	MOS-IC	I/O expander
IC23	MOS-IC	NAND gate
IC24	MOS-IC	AND gate
IC25	MOS-IC	OR gate
IC26	MOS-IC	AND gate
IC27,28	MOS-IC	AF amplifier
IC301	Analogue IC	DC/DC converter
IC302	MOS-IC	Voltage regulator
IC303~306	Analogue IC	Voltage regulator
IC307	MOS-IC	Voltage regulator
IC308	Analogue IC	Voltage regulator
IC401	MOS-IC	NAND gate

Ref. No.	Part Name	Description
IC402	MOS-IC	Analog switch
IC403	Bi-polar IC	AF power amplifier
IC404~406	Bi-polar IC	OP AMP
IC407	MOS-IC	Analog switch
IC411	Bi-polar IC	OP AMP
IC412	MOS-IC	DC/AC converter
Q4	Transistor	DC switch
Q5	FET	DC switch
Q6~10	Transistor	Buffer amplifier
Q301	Transistor	DC switch
Q302	FET	DC switch
Q303	Transistor	Power switch
Q401	Transistor	Power switch
Q402	FET	Power switch
Q403	Transistor	Power switch
Q404,405	Transistor	AF mute switch
D1,2	Diode	Detector
D3~12	Diode	Surge protector
D13	Zener diode	Surge protector
D14~16	Diode	Surge protector
D18	Diode	Surge protector
D20	Diode	Surge protector
D22,23	Diode	Surge protector
D24	Zener diode	Surge protector
D26	Diode	Surge protector
D28,29	Diode	Surge protector
D30	Zener diode	Surge protector
D31	Diode	Surge protector
D32	Zener diode	Surge protector
D35	Diode	Surge protector
D36	Zener diode	Surge protector
D37	Varistor	Current protector
D301,302	Diode	Surge protector
D303	Zener diode	Voltage reference
D304,305	Diode	Surge protector
D401	Diode	Diode switch

### DISPLAY UNIT (X54-3580-20)

Ref. No.	Part Name	Description
IC501	MOS IC	MIC amplifier
IC502~505	MOS IC	Shift register
IC506,507	MOS IC	Voltage regulator
Q501,502	Transistor	Level controller
Q503,504	FET	DC switch
Q506	Transistor	DC switch
Q507	FET	DC switch

## COMPONENTS DESCRIPTION

Ref. No.	Part Name	Description
Q508~511	Transistor	DC switch
Q512~514	FET	DC switch
Q516~519	FET	DC switch
Q521~525	FET	DC switch
D501,502	Diode	AF detector
D503~507	LED	LED
D508~514	Diode	Surge absorption
D601,602	Diode	Surge absorption
D603	Varistor	Current protector

### TX-RX UNIT (X57-7950-10)

Ref. No.	Part Name	Description
IC100,101	MOS-IC	OP AMP
IC200,201	MOS-IC	OP AMP
IC203	MOS-IC	Buffer
IC300	MOS-IC	Mixer
IC400	MOS-IC	IF amplifier
IC401	MOS-IC	Buffer amplifier
IC402	MOS-IC	OP AMP
IC403	MOS-IC	IF system
IC404	MOS-IC	IF amplifier
IC405~408	MOS-IC	Analog switch
IC409	MOS-IC	Buffer amplifier
IC500	MOS-IC	Buffer amplifier
IC501	MOS-IC	OP AMP
IC600,601	MOS-IC	Buffer
IC602	MOS-IC	16.8MHz PLL
IC603~607	MOS-IC	OP AMP
IC608	MOS-IC	AF amplifier
IC700~702	Analogue IC	Voltage regulator
IC703,704	Bi-polar IC	Voltage regulator
IC800	MOS-IC	Temperature sensor
IC801	MOS-IC	OP AMP
IC802	ROM IC	EEPROM
IC803	MOS-IC	Buffer amplifier
IC804	MOS-IC	Digital potentiometer
IC805	MOS-IC	I/O expander
IC806	MOS-IC	Analog switch
Q100	Transistor	DC switch
Q101	Transistor	RF amplifier
Q200,201	Transistor	DC switch
Q202,203	Transistor	RF amplifier
Q300	FET	RF amplifier
Q301	Transistor	RF amplifier
Q500	FET	DC switch

Ref. No.	Part Name	Description
Q501	Transistor	RF amplifier
Q502,503	FET	RF amplifier
Q504	Transistor	RF amplifier
Q505~507	FET	DC switch
Q600	FET	DC switch
Q601	Transistor	DC switch
Q602,603	Transistor	RF amplifier
Q604,605	Transistor	DC switch
Q606	Transistor	RF amplifier
Q607	FET	DC switch
Q700~702	FET	DC switch
Q703	Transistor	DC switch
Q704~706	FET	DC switch
Q800	FET	DC switch
D100,101	Varicap	Frequency control
D103~108	Varicap	Frequency control
D200	Diode	DC switch
D500,501	Zener diode	Limiter
D503	Diode	Detector
D504,505	Diode	RF switch
D600	Diode	DC switch
D601	Diode	RF switch
D801	Diode	DC switch

### RX VCO/PLL UNIT (X58-5090-10)

Ref. No.	Part Name	Description
IC300	IC	PLL
Q300	Transistor	Buffer amplifier
Q350,351	FET	DC switch
Q352,353	FET	VCO OSC
Q354	Transistor	Buffer amplifier
D352,353	Varicap	Frequency control
D355	Varicap	Frequency control
D357~361	Varicap	Frequency control

### TX VCO/PLL UNIT (X58-5100-10)

Ref. No.	Part Name	Description
IC300	IC	PLL
Q300	Transistor	Buffer amplifier
Q350,351	FET	DC switch
Q352,353	FET	VCO OSC
Q354	Transistor	Buffer amplifier
D352,353	Varicap	Frequency control
D355	Varicap	Frequency control
D357~361	Varicap	Frequency control

# NXR-810

## PARTS LIST

\* New Parts. Δ indicates safety critical components.

Parts without **Parts No.** are not supplied.

Les articles non mentionnés dans le **Parts No.** ne sont pas fournis.

Teile ohne **Parts No.** werden nicht geliefert.

L : Scandinavia

Y : PX (Far East, Hawaii)

C : China

K : USA

T : England

X : Australia

P : Canada

E : Europe

M : Other Areas

### NXR-810

#### FINAL UNIT (X45-3930-10)

Ref. No.	Address	New parts	Parts No.	Description	Destination
<b>NXR-810</b>					
1	3A	*	A62-0933-23	PANEL ASSY (INNER)	
2	1A		A62-1146-04	PANEL (TX-RX)	
3	1B		A62-1147-04	PANEL (FINAL)	
4	1D		A62-1148-03	PANEL (OUTER)	
5	3C	*	A62-1174-03	PANEL ASSY	
6	2C	*	A82-0077-02	REAR PANEL	
8	1F		B10-2635-04	FRONT GLASS ACCESSORY	
9	1F		B11-1259-04	FILTER ACCESSORY	
10	1F	*	B62-2199-00	INSTRUCTION MANUAL	
11	2C,3D	*	B72-2602-04	MODEL NAME-PLATE	
13	1B		E30-3414-05	DC CORD (EXT DC IN)	
14	1C		E30-3418-15	ANTENNA CABLE (RX IN)	
15	1E		E30-3427-35	DC CORD ACCESSORY	
16	1D		E30-7528-15	ANTENNA CABLE (TX OUT)	
17	1A	*	E30-7689-05	TRUNK CABLE (X57-X53)	
18	1C	*	E30-7690-05	ANTENNA CABLE (REF IN)	
19	1E		E31-3228-05	15P PLUG ACCESSORY	
20	1B	*	E37-0902-15	LEAD WIRE WITH TERMINAL (DC+)	
21	1B	*	E37-0903-15	LEAD WIRE WITH TERMINAL (DC-)	
22	3A		E37-0905-15	LEAD WIRE WITH CONNECTOR (SP)	
23	3A		E37-0906-05	LEAD WIRE WITH CONNECTOR (X53-X54)	
24	3A,2B		E37-0908-05	LEAD WIRE WITH CONNECTOR (11P)	
25	3A,1B		E37-0911-05	LEAD WIRE WITH CONNECTOR (3P)	
26	2B	*	E37-0912-15	LEAD WIRE WITH MINIPIN PLUG	
27	2C		E37-0913-05	LEAD WIRE WITH CONNECTOR (ACC15P)	
28	2A		E37-1340-15	FLAT CABLE	
29	2C		E37-1376-05	LEAD WIRE WITH CONNECTOR (DSUB25P)	
32	1C,1E		F05-1537-05	BLADE FUSE (15A/32V) ACCESSORY	
33	2C		F09-0445-05	CAP (DSUB)	
34	1C		F09-0471-15	FANMOTOR	
36	1B	*	F10-3129-03	SHIELDING CASE (X45 FINAL PCB)	
38	2A,2B		G02-0576-14	FLAT SPRING	
39	2B		G02-0829-14	FLAT SPRING (RX VCO)	
40	3A		G02-0885-13	EARTH SPRING (X54 DISPLAY PCB)	
41	1B		G02-0894-04	EARTH SPRING (X45:FINAL FET)	
42	2B		G02-1831-04	EARTH SPRING (REAR BOTTOM)	
43	1C		G02-1832-04	EARTH SPRING (REAR TOP)	
44	1B	*	G02-1855-04	FLAT SPRING (X45:AVR)	
46	2B,3B		G10-1263-04	FIBROUS SHEET (CHASSIS)	
47	3C,2D		G10-1264-04	FIBROUS SHEET (PANEL ASSY)	
48	3B		G10-1344-04	FIBROUS SHEET (EARTH SPRING,SHORT)	
49	3B		G10-1345-04	FIBROUS SHEET (EARTH SPRING,LONG)	
50	1F		G13-1801-04	CUSHION (40X40X5) ACCESSORY	
51	1F		G13-1802-04	CUSHION (40X40X10) ACCESSORY	
52	2B		G13-1886-04	CUSHION (BNC)	
54	1E		H25-0029-04	PROTECTION BAG (60/110/0.07)	
55	1F		H25-0747-04	PROTECTION BAG (250X350)	
56	1E		H25-0762-04	PROTECTION BAG (120X300)	
57	1F		H25-2328-04	PROTECTION BAG (80/250/0.07)	
58	1F	*	H52-2335-02	ITEM CARTON CASE	
60	1E		J02-0475-05	FOOT ACCESSORY	
61	1E		J02-0492-04	FOOT (RUBBER) ACCESSORY	

Ref. No.	Address	New parts	Parts No.	Description	Destination
62	2B	*	J19-5540-03	HOLDER (TRUNK CABLE)	
63	1B		J21-8467-04	MOUNTING HARDWARE (X45:DRIVE FET)	
64	1F		J21-8559-04	MOUNTING HARDWARE ACCESSORY	
66	1E		J59-0302-05	GROMMET ACCESSORY	
67	1B,1E		J61-0307-05	BAND	
69	1E		K01-0418-15	HANDLE ACCESSORY	
70	3A		K29-5389-03	KNOB (VOLUME)	
71	3A		K29-9106-04	KNOB (POWER)	
72	3A		K29-9370-02	KEY TOP	
74	1E		L79-1419-05	LINE FILTER (ACCESSORY DC CORD)	
75	1B		L79-1854-05	LINE FILTER (DC CORD:EXT DC IN)	
76	1B		L79-1855-05	LINE FILTER (DC+,DC-)	
A	2C		N09-2292-05	HEXAGON HEAD SCREW (DSUB)	
B	1C,2C,2D		N30-2606-48	PAN HEAD MACHINE SCREW (ANT)	
C	2A,1E		N30-4006-48	PAN HEAD MACHINE SCREW (CHAS,ACC)	
D	2B,2C		N30-4014-48	PAN HEAD MACHINE SCREW (CHASSIS)	
E	1C		N30-4020-43	PAN HEAD MACHINE SCREW (FAN)	
F	1C,2C		N32-3006-48	FLAT HEAD MACHINE SCREW (R PANEL)	
G	3B		N32-4008-43	FLAT HEAD MACHINE SCREW (F PANEL)	
H	1A,1B,1E		N35-3006-43	BINDING HEAD MACHINE SCREW (TOP,ACC)	
J	1C		N35-4006-43	BINDING HEAD MACHINE SCREW (TOP)	
K	1B,3B		N67-3008-48	PAN HEAD SEMS SCREW (X53:AUDIO IC)	
L	1C,2C		N80-2608-43	PAN HEAD TAPTITE SCREW (FUSE)	
M	3A		N87-3005-43	BRAZIER HEAD TAPTITE SCREW (SP)	
N	3A,1B,2B		N87-3006-48	BRAZIER HEAD TAPTITE SCREW (PCB)	
78	3A		T07-0770-35	SPEAKER	
80	3A		W09-0971-05	LITHIUM CELL	
-			490-0174-05	ADHESIVE TAPE	

#### FINAL UNIT (X45-3930-10)

C1			CK73GB1H471K	CHIP C	470PF	K
C2			CC73GCH1H060D	CHIP C	6.0PF	D
C3			CK73GB1H471K	CHIP C	470PF	K
C4			CK73GB1H104K	CHIP C	0.10UF	K
C5,6			CK73GB1H471K	CHIP C	470PF	K
C8			CK73GB1H471K	CHIP C	470PF	K
C9			CC73GCH1H080D	CHIP C	8.0PF	D
C10			CC73GCH1H120J	CHIP C	12PF	J
C12			CK73GB1H471K	CHIP C	470PF	K
C13,14			CK73GB1H104K	CHIP C	0.10UF	K
C16-18			CK73GB1H471K	CHIP C	470PF	K
C20			CK73FB1H471K	CHIP C	470PF	K
C22			CC73FCH1H120J	CHIP C	12PF	J
C23			CK73FB1H471K	CHIP C	470PF	K
C27,28			CC73FCH1H060B	CHIP C	6.0PF	B
C29			C93-0566-05	CHIP C	33PF	J
C31			C93-0599-05	CHIP C	470PF	K
C32			CK73GB1H471K	CHIP C	470PF	K
C33			C93-0599-05	CHIP C	470PF	K
C34			CC73GCH1H101J	CHIP C	100PF	J
C36		*	C93-1792-05	CHIP C	39PF	500WV
C37			CK73GB1H104K	CHIP C	0.10UF	K

## PARTS LIST

FINAL UNIT (X45-3930-10)

Ref. No.	Address	New parts	Parts No.	Description	Destination	Ref. No.	Address	New parts	Parts No.	Description	Destination
C40			CK73GB1H471K	CHIP C 470PF K		CN3			E23-1262-05	TERMINAL	
C41			CC73GCH1H220J	CHIP C 22PF J		CN4-7			E23-1330-05	TERMINAL	
C42		*	C93-1792-05	CHIP C 39PF 500WV		CN8-10			E23-1262-05	TERMINAL	
C43			C93-0599-05	CHIP C 470PF K		CN11			E23-1330-05	TERMINAL	
C44			CC73GCH1H820J	CHIP C 82PF J		CN201,202			E23-0462-05	TERMINAL	
C45		*	C93-1792-05	CHIP C 39PF 500WV		CN203			E41-2672-05	PIN ASSY	
C48		*	C93-1789-05	CHIP C 30PF 500WV		CN204			E41-2743-05	PIN ASSY	
C49			CC73GCH1H101J	CHIP C 100PF J		CN205			E41-1682-05	PIN ASSY	
C50			C93-0599-05	CHIP C 470PF K		J401,402			E58-0533-05	MODULAR JACK	
C51		*	C93-1788-05	CHIP C 27PF 500WV		101	2C	*	E37-1473-05	LEAD WIRE WITH CONNECTOR (X45-X53)	
C52			CK73GB1H104K	CHIP C 0.10UF K		F1			F53-0392-05	FUSE (3A)	
C54		*	C93-1782-05	CHIP C 15PF 500WV		102	1B	*	G02-1856-04	EARTH SPRING (FUSE)	
C56		*	C93-1778-05	CHIP C 10PF 500WV		CN301			J13-0071-05	FUSE HOLDER	
C57			CC73GCH1H220J	CHIP C 22PF J		103	2C	*	J21-8616-04	MOUNTING HARDWARE (MODULAR)	
C58		*	C93-1768-05	CHIP C 6PF 500WV		L1			L41-1578-14	SMALL FIXED INDUCTOR (15NH)	
C60			CC73GCH1H820J	CHIP C 82PF J		L2			L41-8268-14	SMALL FIXED INDUCTOR (8.2NH)	
C61			C93-0572-05	CHIP C 100PF J		L3			L41-1578-14	SMALL FIXED INDUCTOR (15NH)	
C62			CK73GB1H471K	CHIP C 470PF K		L4			L34-4604-15	AIR-CORE COIL	
C67			C93-0599-05	CHIP C 470PF K		L5			L34-4556-05	AIR-CORE COIL	
C68			CK73GB1H471K	CHIP C 470PF K		L6			L34-4520-05	AIR-CORE COIL	
C74			CK73GB1H471K	CHIP C 470PF K		L7,8			L41-1085-14	SMALL FIXED INDUCTOR (100NH)	
C76			C93-0572-05	CHIP C 100PF J		L9			L34-4667-05	AIR-CORE COIL	
C77			CC73FCH1H030B	CHIP C 3.0PF B		L10			L34-4758-05	AIR-CORE COIL	
C79			C93-0553-05	CHIP C 3.0PF C		L11-13			L34-4517-05	AIR-CORE COIL	
C82			C93-0554-05	CHIP C 4.0PF C		L14			L41-4763-14	SMALL FIXED INDUCTOR (4.7NH)	
C83			CC73FCH1H030B	CHIP C 3.0PF B		R1			RK73GB2A181J	CHIP R 180 J 1/10W	
C86		*	C93-1776-05	CHIP C 9PF 500WV		R2			RK73GB2A270J	CHIP R 27 J 1/10W	
C87			CK73GB1H471K	CHIP C 470PF K		R3			RK73GB2A181J	CHIP R 180 J 1/10W	
C89		*	C93-1778-05	CHIP C 10PF 500WV		R4			RK73FB2B151J	CHIP R 150 J 1/8W	
C91			C93-0553-05	CHIP C 3.0PF C		R5			RK73GB2A392J	CHIP R 3.9K J 1/10W	
C92			C93-0562-05	CHIP C 15PF J		R6			RK73GB2A332J	CHIP R 3.3K J 1/10W	
C201			CK73GB1H471K	CHIP C 470PF K		R7			RK73GB2A221J	CHIP R 220 J 1/10W	
C204			CK73GB1H471K	CHIP C 470PF K		R8			RK73GB2A180J	CHIP R 18 J 1/10W	
C206			CK73GB1H104K	CHIP C 0.10UF K		R10			RK73GB2A123J	CHIP R 12K J 1/10W	
C207			CK73GB1H471K	CHIP C 470PF K		R11			RK73FB2B221J	CHIP R 220 J 1/8W	
C213			CK73GB1H471K	CHIP C 470PF K		R12			RK73GB2A103J	CHIP R 10K J 1/10W	
C215			CK73GB1H104K	CHIP C 0.10UF K		R13			RK73RB2H100J	CHIP R 10 J 1/2W	
C216			CK73GB1H471K	CHIP C 470PF K		R14			RK73FB2B221J	CHIP R 220 J 1/8W	
C217		*	CD04AZ1V100M	ELECTRO 10UF 35WV		R16			RK73RB2H821J	CHIP R 820 J 1/2W	
C218,219			CK73GB1H471K	CHIP C 470PF K		R17			RK73RB2H5R6J	CHIP R 5.6 J 1/2W	
C220			CD04AZ1V102M	ELECTRO 1000UF 35WV		R18			RK73RB2H821J	CHIP R 820 J 1/2W	
C221			CK73GB1H471K	CHIP C 470PF K		R19			RK73FB2B103J	CHIP R 10K J 1/8W	
C222			CK73GB1H104K	CHIP C 0.10UF K		R20			RK73EB2E221J	CHIP R 220 J 1/4W	
C223			CK73GB1H471K	CHIP C 470PF K		R21			RK73FB2B123J	CHIP R 12K J 1/8W	
C224			CK73GB1H104K	CHIP C 0.10UF K		R22-25			RK73GB2A000J	CHIP R 0.0 J 1/10W	
C225-233			CK73GB1H471K	CHIP C 470PF K		R26			RK73FB2B103J	CHIP R 10K J 1/8W	
C234			CD04BD1H101M	ELECTRO 100UF 50WV		R27			RK73RB2H101J	CHIP R 100 J 1/2W	
C235			CC73GCH1H220J	CHIP C 22PF J		R28			RK73FB2B103J	CHIP R 10K J 1/8W	
C236			CC73GCH1H101J	CHIP C 100PF J		R29			RK73FB2B000J	CHIP R 0.0 J 1/8W	
C237,238			CK73GB1H471K	CHIP C 470PF K		R30			RK73FB2B750J	CHIP R 75 J 1/8W	
C239			CC73GCH1H220J	CHIP C 22PF J		R31			RK73GB2A000J	CHIP R 0.0 J 1/10W	
C240			CK73GB1H104K	CHIP C 0.10UF K		R32			RK73FB2B181J	CHIP R 180 J 1/8W	
C241,242			CK73GB1H471K	CHIP C 470PF K		R33			RK73GB2A274J	CHIP R 270K J 1/10W	
C244-247			CK73GB1H471K	CHIP C 470PF K		R34,35			RK73GB2A000J	CHIP R 0.0 J 1/10W	
C301			CC73GCH1H470J	CHIP C 47PF J		R36,37			RK73FB2B000J	CHIP R 0.0 J 1/8W	
C302			CC73GCH1H220J	CHIP C 22PF J		R38			RK73FB2B820J	CHIP R 82 J 1/8W	
C303			CC73GCH1H150J	CHIP C 15PF J		R39		*	RK73PB2H121J	CHIP R 120 J 1/2W	
C304			CC73GCH1H101J	CHIP C 100PF J							
CN1			E04-0154-05	PIN SOCKET							

## PARTS LIST

FINAL UNIT (X45-3930-10)

CONTROL UNIT (X53-4490-10)

Ref. No.	Address	New parts	Parts No.	Description	Destination	Ref. No.	Address	New parts	Parts No.	Description	Destination
R40			RK73GB2A000J	CHIP R 0.0 J 1/10W		C39			CK73HB1A104K	CHIP C 0.10UF K	
R41			RK73FB2B224J	CHIP R 220K J 1/8W		C40			CK73HB1A105K	CHIP C 1.0UF K	
R201			RK73GB2A273J	CHIP R 27K J 1/10W		C41-45			CK73HB1A104K	CHIP C 0.10UF K	
R202			RK73GB2A104J	CHIP R 100K J 1/10W		C46			CK73HB1A105K	CHIP C 1.0UF K	
R203			RK73GB2A683J	CHIP R 68K J 1/10W		C47			CK73HB1H102K	CHIP C 1000PF K	
R204			RK73GB2A473J	CHIP R 47K J 1/10W		C49			CK73HB1A105K	CHIP C 1.0UF K	
R205,206			RK73GB2A104J	CHIP R 100K J 1/10W		C50			CK73HB1A104K	CHIP C 0.10UF K	
R207			RK73GB2A154J	CHIP R 150K J 1/10W		C51			CK73HB1A105K	CHIP C 1.0UF K	
R209			RK73GB2A104J	CHIP R 100K J 1/10W		C52			CC73HCH1H270J	CHIP C 27PF J	
R211			RK73GB2A101J	CHIP R 100 J 1/10W		C56,57			CK73HB1A104K	CHIP C 0.10UF K	
R213			RK73GB2A334J	CHIP R 330K J 1/10W		C58			CK73HB1H681K	CHIP C 680PF K	
R215			RK73GB2A332J	CHIP R 3.3K J 1/10W		C60,61			CK73HB1H102K	CHIP C 1000PF K	
R217			RK73GB2A333J	CHIP R 33K J 1/10W		C62,63			CK73FB0J106K	CHIP C 10UF K	
R218,219			RK73GB2A104J	CHIP R 100K J 1/10W		C64			CK73HB1A105K	CHIP C 1.0UF K	
R220			RK73GB2A224J	CHIP R 220K J 1/10W		C65			CK73HB1H102K	CHIP C 1000PF K	
R222			RK73GB2A473J	CHIP R 47K J 1/10W		C66			CK73HB1E103K	CHIP C 0.010UF K	
R225			RK73GB2A000J	CHIP R 0.0 J 1/10W		C67			CK73HB1A104K	CHIP C 0.10UF K	
R226			RK73GB2A332J	CHIP R 3.3K J 1/10W		C68			CK73HB1E103K	CHIP C 0.010UF K	
R228,229			RK73GB2A473J	CHIP R 47K J 1/10W		C69			CK73HB1H102K	CHIP C 1000PF K	
R230,231			RK73GB2A472J	CHIP R 4.7K J 1/10W		C70			CK73HB1A224K	CHIP C 0.22UF K	
R232,233			RK73GB2A474J	CHIP R 470K J 1/10W		C72			CK73HB1A224K	CHIP C 0.22UF K	
R235,236			RK73PB2H100J	CHIP R 10 J 1/2W		C73			CC73HCH1H470J	CHIP C 47PF J	
R237			RK73GB2A274J	CHIP R 270K J 1/10W		C74			CC73HCH1H101J	CHIP C 100PF J	
R351			RK73GB2A000J	CHIP R 0.0 J 1/10W		C75			CK73GB1C104K	CHIP C 0.10UF K	
R355			RK73GB2A000J	CHIP R 0.0 J 1/10W		C76			CC73HCH1H470J	CHIP C 47PF J	
D1			HSM88AS-E	DIODE		C77			CK73HB1A104K	CHIP C 0.10UF K	
D2			MA2S111-F	DIODE		C79,80			CK73HB1E103K	CHIP C 0.010UF K	
D3			HSM88AS-E	DIODE		C81			CK73HB1H102K	CHIP C 1000PF K	
D6,7			L7091CER	DIODE		C82,83			CC73HCH1H101J	CHIP C 100PF J	
D8			CSA70-401L	SURGE ABSORBER		C84-86			CK73HB1H682K	CHIP C 6800PF K	
D201			02DZ6.2F-Y	ZENER DIODE		C87			CK73HB1H102K	CHIP C 1000PF K	
D202			22ZR-10D	SURGE ABSORBER		C88			CK73GB1C104K	CHIP C 0.10UF K	
D203			1SS355	DIODE		C89			CK73HB1H102K	CHIP C 1000PF K	
D301			DSA3A1	DIODE		C90			CK73GB1C104K	CHIP C 0.10UF K	
IC201,202			TA75W01FUF	MOS-IC		C91			CK73HB1A104K	CHIP C 0.10UF K	
IC203			NJM78M08FA-ZB	ANALOGUE IC		C92			CK73HB1E103K	CHIP C 0.010UF K	
Q1			2SC5092-F	TRANSISTOR		C93			CS77CPOJ100M	CHIP TINTL 10UF 6.3WV	
Q2			RD01MUS1-T113	FET		C94			CK73HB1A104K	CHIP C 0.10UF K	
Q3	2B		PD55008S-E	FET		C95,96			CC73HCH1H020C	CHIP C 2.0PF C	
Q4	2B		RD60HUF1-101	FET		C97			CK73HB1H102K	CHIP C 1000PF K	
Q203,204			2SJ484	FET		C98-100			CK73HB1A104K	CHIP C 0.10UF K	
Q205,206			SSM3K15TE(F)	FET		C101			CK73HB1E103K	CHIP C 0.010UF K	
Q207			DTD123EK	DIGITAL TRANSISTOR		C102			CK73HB1A105K	CHIP C 1.0UF K	
TH201			S1R103J440H	THERMISTOR		C103			CK73HB1H102K	CHIP C 1000PF K	
						C104-107			CK73GB1C104K	CHIP C 0.10UF K	
<b>CONTROL UNIT (X53-4490-10)</b>						C108			CC73HCH1H020C	CHIP C 2.0PF C	
C7-10			CC73HCH1H101J	CHIP C 100PF J		C109			CS77CPOJ100M	CHIP TINTL 10UF 6.3WV	
C11			CK73HB1A105K	CHIP C 1.0UF K		C110,111			CC73HCH1H101J	CHIP C 100PF J	
C12-15			CC73HCH1H101J	CHIP C 100PF J		C112			CK73HB1A104K	CHIP C 0.10UF K	
C18,19			CK73GB1C104K	CHIP C 0.10UF K		C114			CC73HCH1H101J	CHIP C 100PF J	
C20			CK73HB1A105K	CHIP C 1.0UF K		C115-119			CK73HB1A104K	CHIP C 0.10UF K	
C21,22			CK73GB1C104K	CHIP C 0.10UF K		C120			CK73HB1A105K	CHIP C 1.0UF K	
C23-30			CK73HB1A104K	CHIP C 0.10UF K		C121			CK73HB1H102K	CHIP C 1000PF K	
C31			CK73HB1H102K	CHIP C 1000PF K		C122-126			CK73HB1A104K	CHIP C 0.10UF K	
C32,33			CK73HB1A104K	CHIP C 0.10UF K		C127			CK73HB1E103K	CHIP C 0.010UF K	
C34			CK73HB1A105K	CHIP C 1.0UF K		C128			CK73HB1A105K	CHIP C 1.0UF K	
C35,36			CK73GB1C104K	CHIP C 0.10UF K		C129			CK73HB1H102K	CHIP C 1000PF K	
C38			CK73HB1H102K	CHIP C 1000PF K		C130,131			CK73HB1A104K	CHIP C 0.10UF K	
						C132			CK73HB1E103K	CHIP C 0.010UF K	
						C133			CK73HB1H102K	CHIP C 1000PF K	



## PARTS LIST

### CONTROL UNIT (X53-4490-10)

Ref. No.	Address	New parts	Parts No.	Description	Desti-nation	Ref. No.	Address	New parts	Parts No.	Description	Desti-nation
C134			CK73HB1E103K	CHIP C 0.010UF K		C237			CC73HCH1H101J	CHIP C 100PF J	
C135,136			CK73HB1H102K	CHIP C 1000PF K		C239			CC73HCH1H101J	CHIP C 100PF J	
C137			CK73HB1E103K	CHIP C 0.010UF K		C240-242			CK73HB1H102K	CHIP C 1000PF K	
C138			CC73HCH1H101J	CHIP C 100PF J		C243			CC73HCH1H101J	CHIP C 100PF J	
C139			CK73HB1E103K	CHIP C 0.010UF K		C244			CK73HB1H102K	CHIP C 1000PF K	
C140			CK73GB1C104K	CHIP C 0.10UF K		C245,246			CC73HCH1H101J	CHIP C 100PF J	
C141,142			CK73HB1H102K	CHIP C 1000PF K		C247			CK73HB1H102K	CHIP C 1000PF K	
C143			CK73HB1E103K	CHIP C 0.010UF K		C249			CK73HB1H102K	CHIP C 1000PF K	
C144-146			CK73HB1H102K	CHIP C 1000PF K		C250			CC73HCH1H101J	CHIP C 100PF J	
C147			CK73HB1E103K	CHIP C 0.010UF K		C252			CK73HB1H102K	CHIP C 1000PF K	
C148			CK73HB1H122K	CHIP C 1200PF K		C254			CC73HCH1H101J	CHIP C 100PF J	
C149			CK73HB1H102K	CHIP C 1000PF K		C256			CC73HCH1H101J	CHIP C 100PF J	
C150			CK73HB1E103K	CHIP C 0.010UF K		C257			CK73HB1H102K	CHIP C 1000PF K	
C151-155			CK73HB1H102K	CHIP C 1000PF K		C258			CC73HCH1H101J	CHIP C 100PF J	
C156			CC73HCH1H221J	CHIP C 220PF J		C259,260			CK73HB1A104K	CHIP C 0.10UF K	
C157			CK73HB1H102K	CHIP C 1000PF K		C301,302			C92-0905-05	OS-CON 47UF 35WV	
C158			CK73HB1A104K	CHIP C 0.10UF K		C303,304	*		C93-1810-05	CHIP C 4.7UF 50WV	
C159			CK73HB1E103K	CHIP C 0.010UF K		C306			CK73HB1H471K	CHIP C 470PF K	
C160			CC73HCH1H101J	CHIP C 100PF J		C308			CK73EB1H474K	CHIP C 0.47UF K	
C161			CK73HB1H102K	CHIP C 1000PF K		C310,311			CE32AU1C330M	CHIP EL 33UF 16WV	
C162			CC73HCH1H101J	CHIP C 100PF J		C312			CE32BM1E470M	CHIP EL 47UF 25WV	
C164			CK73HB1H102K	CHIP C 1000PF K		C313			CK73HB1E223K	CHIP C 0.022UF K	
C166			CK73HB1E103K	CHIP C 0.010UF K		C314			CK73HB1H102K	CHIP C 1000PF K	
C167			CC73HCH1H101J	CHIP C 100PF J		C315-317			CE32BM1E470M	CHIP EL 47UF 25WV	
C170,171			CK73HB1H102K	CHIP C 1000PF K		C318-321			CK73HB1H102K	CHIP C 1000PF K	
C175,176			CK73HB1H102K	CHIP C 1000PF K		C322			CE32BM1E470M	CHIP EL 47UF 25WV	
C179,180			CK73HB1H102K	CHIP C 1000PF K		C323			CK73HB1H102K	CHIP C 1000PF K	
C182			CK73HB1H102K	CHIP C 1000PF K		C324			CE32BM1E470M	CHIP EL 47UF 25WV	
C184,185			CK73HB1H102K	CHIP C 1000PF K		C325,326			CK73HB1H102K	CHIP C 1000PF K	
C186			CC73HCH1H101J	CHIP C 100PF J		C327-329			CE32BM1E470M	CHIP EL 47UF 25WV	
C187			CK73HB1H102K	CHIP C 1000PF K		C330,331			CK73HB1H102K	CHIP C 1000PF K	
C188			CC73HCH1H101J	CHIP C 100PF J		C332			CE32BM1E470M	CHIP EL 47UF 25WV	
C189			CK73HB1H102K	CHIP C 1000PF K		C333			CK73HB1A104K	CHIP C 0.10UF K	
C190			CC73HCH1H101J	CHIP C 100PF J		C334			CK73HB1E103K	CHIP C 0.010UF K	
C191			CK73HB1H102K	CHIP C 1000PF K		C335			CK73HB1H471K	CHIP C 470PF K	
C192			CK73HB1E103K	CHIP C 0.010UF K		C336			CK73HB1E103K	CHIP C 0.010UF K	
C193			CC73HCH1H101J	CHIP C 100PF J		C337			CK73HB1H102K	CHIP C 1000PF K	
C194-197			CK73HB1H102K	CHIP C 1000PF K		C401			CK73HB1E103K	CHIP C 0.010UF K	
C198			CC73HCH1H101J	CHIP C 100PF J		C402			CC73HCH1H101J	CHIP C 100PF J	
C199			CK73HB1E103K	CHIP C 0.010UF K		C403			CK73HB1A105K	CHIP C 1.0UF K	
C200			CC73HCH1H101J	CHIP C 100PF J		C404			C90-4120-05	ELECTRO 470UF 35WV	
C201			CK73HB1H102K	CHIP C 1000PF K		C405			CK73HB1A104K	CHIP C 0.10UF K	
C202			CC73HCH1H101J	CHIP C 100PF J		C406,407			CK73HB1A105K	CHIP C 1.0UF K	
C203			CK73HB1H102K	CHIP C 1000PF K		C408,409			C93-0912-05	CHIP C 100UF M	
C205			CK73HB1H102K	CHIP C 1000PF K		C410			CK73HB1A105K	CHIP C 1.0UF K	
C206			CC73HCH1H101J	CHIP C 100PF J		C412			CK73FB0J106K	CHIP C 10UF K	
C207			CK73HB1E103K	CHIP C 0.010UF K		C413			CK73HB1H102K	CHIP C 1000PF K	
C209-212			CK73HB1H102K	CHIP C 1000PF K		C414			CK73HB1A105K	CHIP C 1.0UF K	
C213			CK73HB1E103K	CHIP C 0.010UF K		C415			CD04AY1E470M	ELECTRO 47UF 25WV	
C215,216			CK73HB1H102K	CHIP C 1000PF K		C416			CK73HB1H102K	CHIP C 1000PF K	
C218			CC73HCH1H101J	CHIP C 100PF J		C417			CK73HB1H222K	CHIP C 2200PF K	
C219-223			CK73HB1H102K	CHIP C 1000PF K		C418			CC73HCH1H391J	CHIP C 390PF J	
C224			CC73HCH1H101J	CHIP C 100PF J		C419			CK73HB1H152K	CHIP C 1500PF K	
C225,226			CK73HB1H102K	CHIP C 1000PF K		C420			CC73HCH1H221J	CHIP C 220PF J	
C227			CC73HCH1H101J	CHIP C 100PF J		C421			CK73FB0J106K	CHIP C 10UF K	
C228,229			CK73HB1H102K	CHIP C 1000PF K		C422			CD04AY1E470M	ELECTRO 47UF 25WV	
C230			CC73HCH1H101J	CHIP C 100PF J		C423			CK73HB1H471K	CHIP C 470PF K	
C232			CK73HB1H102K	CHIP C 1000PF K		C424			CC73HCH1H331J	CHIP C 330PF J	
C233			CC73HCH1H101J	CHIP C 100PF J		C425			CD04AY1E470M	ELECTRO 47UF 25WV	
C235			CK73HB1E103K	CHIP C 0.010UF K		C426			CK73HB1A104K	CHIP C 0.10UF K	

## PARTS LIST

### CONTROL UNIT (X53-4490-10)

Ref. No.	Address	New parts	Parts No.	Description	Destination	Ref. No.	Address	New parts	Parts No.	Description	Destination
C427			CK73HB1H471K	CHIP C 470PF K		R3-9			RK73HB1J104J	CHIP R 100K J 1/16W	
C428			CK73HB1A105K	CHIP C 1.0UF K		R10-13			RK73EB2E101J	CHIP R 100 J 1/4W	
C429			CK73HB1A104K	CHIP C 0.10UF K		R14			RK73HB1J000J	CHIP R 0.0 J 1/16W	
C430			C92-0777-05	ELECTRO 1000UF 25WV		R15			RK73HB1J104J	CHIP R 100K J 1/16W	
C432			CK73HB1A104K	CHIP C 0.10UF K		R18			RK73HB1J104J	CHIP R 100K J 1/16W	
C433			CC73HCH1H181J	CHIP C 180PF J		R22,23			RK73HB1J104J	CHIP R 100K J 1/16W	
C434,435			CC73HCH1H101J	CHIP C 100PF J		R24			RK73HB1J000J	CHIP R 0.0 J 1/16W	
C436			CC73HCH1H221J	CHIP C 220PF J		R25,26			RK73HB1J103J	CHIP R 10K J 1/16W	
C438			C93-0912-05	CHIP C 100UF M		R27,28			RK73HB1J473J	CHIP R 47K J 1/16W	
C441			C93-0912-05	CHIP C 100UF M		R29			RK73HB1J000J	CHIP R 0.0 J 1/16W	
C442			CK73HB1A105K	CHIP C 1.0UF K		R30			RK73HB1J474J	CHIP R 470K J 1/16W	
C443			CK73HB1A104K	CHIP C 0.10UF K		R32,33			RK73HB1J472J	CHIP R 4.7K J 1/16W	
C445			CK73HB1A105K	CHIP C 1.0UF K		R34-36			RK73HB1J104J	CHIP R 100K J 1/16W	
C446			CK73HB1A104K	CHIP C 0.10UF K		R37			RK73HB1J103J	CHIP R 10K J 1/16W	
C450,451			CK73HB1A105K	CHIP C 1.0UF K		R38			RK73HB1J104J	CHIP R 100K J 1/16W	
C455			CC73HCH1H101J	CHIP C 100PF J		R40-42			RK73HB1J104J	CHIP R 100K J 1/16W	
C456			CC73HCH1H221J	CHIP C 220PF J		R43-50			RK73HB1J000J	CHIP R 0.0 J 1/16W	
C457			CK73HB1A105K	CHIP C 1.0UF K		R51			RK73HB1J104J	CHIP R 100K J 1/16W	
C459			CC73HCH1H221J	CHIP C 220PF J		R52			RK73HB1J220J	CHIP R 22 J 1/16W	
C460-462			CK73HB1A104K	CHIP C 0.10UF K		R53-57			RK73HB1J104J	CHIP R 100K J 1/16W	
C463			CC73HCH1H331J	CHIP C 330PF J		R58			RK73HB1J101J	CHIP R 100 J 1/16W	
C464			CC73HCH1H101J	CHIP C 100PF J		R59-61			RK73HB1J000J	CHIP R 0.0 J 1/16W	
C465			CK73HB1H152K	CHIP C 1500PF K		R62			RK73HB1J101J	CHIP R 100 J 1/16W	
C466			CK73HB1A105K	CHIP C 1.0UF K		R63			RK73HB1J000J	CHIP R 0.0 J 1/16W	
C469			CK73HB1A105K	CHIP C 1.0UF K		R64,65			RK73HB1J101J	CHIP R 100 J 1/16W	
C470,471			CK73HB1H102K	CHIP C 1000PF K		R66-73			RK73HB1J000J	CHIP R 0.0 J 1/16W	
C472,473			CK73HB1E103K	CHIP C 0.010UF K		R74,75			RK73HB1J104J	CHIP R 100K J 1/16W	
CN5			E41-1481-05	PIN ASSY		R77			RK73HB1J151J	CHIP R 150 J 1/16W	
CN38			E40-6656-05	PIN ASSY		R78			RK73HB1J102J	CHIP R 1.0K J 1/16W	
CN39			E04-0193-05	PIN SOCKET		R79			RK73HB1J000J	CHIP R 0.0 J 1/16W	
CN40			E40-6102-05	PIN ASSY		R80			RK73HB1J823J	CHIP R 82K J 1/16W	
CN41		*	E41-3086-05	PIN ASSY		R81-83			RK73HB1J104J	CHIP R 100K J 1/16W	
CN42		*	E41-3090-05	PIN ASSY		R85			RK73HB1J103J	CHIP R 10K J 1/16W	
CN43			E41-2671-05	PIN ASSY		R87			RK73HB1J334J	CHIP R 330K J 1/16W	
CN44			E40-5960-05	PIN ASSY		R88			RK73HB1J100J	CHIP R 10 J 1/16W	
CN301			E41-2672-05	PIN ASSY		R89			RK73HB1J332J	CHIP R 3.3K J 1/16W	
CN302			J19-5386-05	HOLDER (LITHIUM CELL)		R90			RK73HB1J471J	CHIP R 470 J 1/16W	
L1			L92-0467-05	CHIP FERRITE		R92-94			RK73HB1J104J	CHIP R 100K J 1/16W	
L2,3			L33-1500-05	CHOKE COIL		R95			RK73HB1J220J	CHIP R 22 J 1/16W	
L4			L92-0467-05	CHIP FERRITE		R99,100			RK73HB1J104J	CHIP R 100K J 1/16W	
L5-7			L92-0162-05	BEADS CORE		R101			RK73HB1J103J	CHIP R 10K J 1/16W	
L8			L92-0639-05	CHIP FERRITE		R102,103			RK73HB1J104J	CHIP R 100K J 1/16W	
L9-11			L92-0467-05	CHIP FERRITE		R104			RK73HB1J393J	CHIP R 39K J 1/16W	
L14-16			L92-0467-05	CHIP FERRITE		R105			RK73HB1J334J	CHIP R 330K J 1/16W	
L17			L92-0639-05	CHIP FERRITE		R106			RK73HB1J100J	CHIP R 10 J 1/16W	
L18			L92-0162-05	BEADS CORE		R107			RK73HB1J103J	CHIP R 10K J 1/16W	
L20			L92-0162-05	BEADS CORE		R108			RK73HB1J184J	CHIP R 180K J 1/16W	
L22,23		*	L92-0171-05	BEADS CORE		R109			RK73HB1J104J	CHIP R 100K J 1/16W	
L301-304			L92-0639-05	CHIP FERRITE		R110			RK73HB1J682J	CHIP R 6.8K J 1/16W	
L305		*	L33-1541-05	SMALL FIXED INDUCTOR		R111,112			RK73HB1J104J	CHIP R 100K J 1/16W	
L306-309			L92-0467-05	CHIP FERRITE		R113			RK73HB1J102J	CHIP R 1.0K J 1/16W	
L311			L92-0162-05	BEADS CORE		R114,115			RK73HB1J220J	CHIP R 22 J 1/16W	
L312			L92-0467-05	CHIP FERRITE		R116,117			RK73HB1J472J	CHIP R 4.7K J 1/16W	
L313,314			L92-0639-05	CHIP FERRITE		R118			RK73HB1J000J	CHIP R 0.0 J 1/16W	
L315-317			L92-0467-05	CHIP FERRITE		R119			RK73HB1J474J	CHIP R 470K J 1/16W	
X1			L77-3015-05	TCXO (18.432MHZ)		R121			RK73HB1J104J	CHIP R 100K J 1/16W	
X2			L77-1802-05	CRYSTAL RESONATOR (32768HZ)		R122			RK73HB1J103J	CHIP R 10K J 1/16W	
CP1-8		*	RK74HB1J334J	CHIP-COM 330K J 1/16W		R123			RK73HB1J473J	CHIP R 47K J 1/16W	
						R124			RK73HB1J103J	CHIP R 10K J 1/16W	
						R126			RK73HB1J104J	CHIP R 100K J 1/16W	

## PARTS LIST

CONTROL UNIT (X53-4490-10)

Ref. No.	Address	New parts	Parts No.	Description	Destination	Ref. No.	Address	New parts	Parts No.	Description	Destination
R127			RK73HB1J102J	CHIP R 1.0K J 1/16W		R255-262			RK73HB1J000J	CHIP R 0.0 J 1/16W	
R128			RK73HB1J104J	CHIP R 100K J 1/16W		R263			RK73HB1J103J	CHIP R 10K J 1/16W	
R129,130			RK73HB1J101J	CHIP R 100 J 1/16W		R265,266			RK73HB1J471J	CHIP R 470 J 1/16W	
R131			RK73HB1J472J	CHIP R 4.7K J 1/16W		R267			RK73HB1J103J	CHIP R 10K J 1/16W	
R132			RK73HB1J102J	CHIP R 1.0K J 1/16W		R268			RK73HB1J000J	CHIP R 0.0 J 1/16W	
R133			RK73HB1J472J	CHIP R 4.7K J 1/16W		R269			RK73HB1J103J	CHIP R 10K J 1/16W	
R135			RK73HB1J104J	CHIP R 100K J 1/16W		R270-275			RK73HB1J101J	CHIP R 100 J 1/16W	
R137,138			RK73HB1J104J	CHIP R 100K J 1/16W		R276			RK73HB1J471J	CHIP R 470 J 1/16W	
R141,142			RK73HB1J104J	CHIP R 100K J 1/16W		R277			RK73HB1J101J	CHIP R 100 J 1/16W	
R143,144			RK73HB1J000J	CHIP R 0.0 J 1/16W		R278,279			RK73HB1J471J	CHIP R 470 J 1/16W	
R145			RK73HB1J104J	CHIP R 100K J 1/16W		R280			RK73HB1J101J	CHIP R 100 J 1/16W	
R146,147			RK73HB1J101J	CHIP R 100 J 1/16W		R281			RS14KB3D5R6J	FL-PROOF RS 5.6 J 2W	
R148			RK73HB1J563J	CHIP R 56K J 1/16W		R282			RK73HB1J104J	CHIP R 100K J 1/16W	
R149-151			RK73HB1J104J	CHIP R 100K J 1/16W		R301,302			RK73HB1J000J	CHIP R 0.0 J 1/16W	
R152			RK73HB1J102J	CHIP R 1.0K J 1/16W		R303			RK73HB1J104J	CHIP R 100K J 1/16W	
R153			RK73HB1J473J	CHIP R 47K J 1/16W		R304			RK73HB1J223J	CHIP R 22K J 1/16W	
R154,155			RK73HB1J104J	CHIP R 100K J 1/16W		R305			RK73HB1J183J	CHIP R 18K J 1/16W	
R156,157			RK73HB1J474J	CHIP R 470K J 1/16W		R306			RK73HB1J184D	CHIP R 180K D 1/16W	
R159			RK73HB1J103J	CHIP R 10K J 1/16W		R307			RK73HB1J273D	CHIP R 27K D 1/16W	
R160			RK73HB1J101J	CHIP R 100 J 1/16W		R308			RK73HB1J473J	CHIP R 47K J 1/16W	
R161			RK73HB1J103J	CHIP R 10K J 1/16W		R309			RK73PB2H220J	CHIP R 22 J 1/2W	
R162			RK73HB1J104J	CHIP R 100K J 1/16W		R310			RK73GB2A220J	CHIP R 22 J 1/10W	
R163			RK73HH1J334D	CHIP R 330K D 1/16W		R312			RK73HB1J104J	CHIP R 100K J 1/16W	
R164			RK73HH1J104D	CHIP R 100K D 1/16W		R313			RK73HH1J822D	CHIP R 8.2K D 1/16W	
R165,166			RK73HB1J104J	CHIP R 100K J 1/16W		R314			RK73HH1J332D	CHIP R 3.3K D 1/16W	
R167-169			RK73HB1J473J	CHIP R 47K J 1/16W		R315			RK73HB1J471J	CHIP R 470 J 1/16W	
R170			RK73HH1J124D	CHIP R 120K D 1/16W		R316			RK73HB1J000J	CHIP R 0.0 J 1/16W	
R171			RK73HB1J473J	CHIP R 47K J 1/16W		R317,318			RK73HB1J472J	CHIP R 4.7K J 1/16W	
R172			RK73HB1J103J	CHIP R 10K J 1/16W		R319			RK73HB1J103J	CHIP R 10K J 1/16W	
R173,174			RK73HB1J473J	CHIP R 47K J 1/16W		R320			RK73HB1J101J	CHIP R 100 J 1/16W	
R175			RK73HB1J683J	CHIP R 68K J 1/16W		R321			RK73HH1J272D	CHIP R 2.7K D 1/16W	
R176-178			RK73HB1J473J	CHIP R 47K J 1/16W		R322			RK73HH1J473D	CHIP R 47K D 1/16W	
R179			RK73HB1J000J	CHIP R 0.0 J 1/16W		R323			RK73HB1J102J	CHIP R 1.0K J 1/16W	
R180-183			RK73HB1J473J	CHIP R 47K J 1/16W		R324			RK73GB2A000J	CHIP R 0.0 J 1/10W	
R184			RK73HB1J000J	CHIP R 0.0 J 1/16W		R401			RK73HB1J473J	CHIP R 47K J 1/16W	
R185			RK73HB1J473J	CHIP R 47K J 1/16W		R402			RK73HB1J472J	CHIP R 4.7K J 1/16W	
R186			RK73HB1J103J	CHIP R 10K J 1/16W		R403			RK73HB1J473J	CHIP R 47K J 1/16W	
R187			RK73HB1J473J	CHIP R 47K J 1/16W		R404			RK73HB1J472J	CHIP R 4.7K J 1/16W	
R190			RK73HB1J000J	CHIP R 0.0 J 1/16W		R405			RK73HB1J473J	CHIP R 47K J 1/16W	
R191			RK73HB1J474J	CHIP R 470K J 1/16W		R406,407			RK73HB1J104J	CHIP R 100K J 1/16W	
R194			RK73HB1J103J	CHIP R 10K J 1/16W		R408,409			RK73HB1J103J	CHIP R 10K J 1/16W	
R196,197			RK73HB1J103J	CHIP R 10K J 1/16W		R410			RK73HB1J104J	CHIP R 100K J 1/16W	
R199			RK73HB1J103J	CHIP R 10K J 1/16W		R411			RK73HB1J472J	CHIP R 4.7K J 1/16W	
R204			RK73HB1J103J	CHIP R 10K J 1/16W		R412			RK73HB1J123J	CHIP R 12K J 1/16W	
R205-208			RK73HB1J102J	CHIP R 1.0K J 1/16W		R413			RK73HB1J223J	CHIP R 22K J 1/16W	
R209			RK73HB1J121J	CHIP R 120 J 1/16W		R414			RK73HB1J153J	CHIP R 15K J 1/16W	
R210			RK73HB1J102J	CHIP R 1.0K J 1/16W		R415			RK73HB1J123J	CHIP R 12K J 1/16W	
R211,212			RK73HB1J101J	CHIP R 100 J 1/16W		R416			RK73HB1J224J	CHIP R 220K J 1/16W	
R213-219			RK73HB1J102J	CHIP R 1.0K J 1/16W		R417,418			RK73HB1J104J	CHIP R 100K J 1/16W	
R220			RK73HB1J471J	CHIP R 470 J 1/16W		R419			RK73HB1J105J	CHIP R 1.0M J 1/16W	
R221			RK73HB1J102J	CHIP R 1.0K J 1/16W		R420			RK73HB1J000J	CHIP R 0.0 J 1/16W	
R222			RK73HB1J101J	CHIP R 100 J 1/16W		R421			RK73HB1J393J	CHIP R 39K J 1/16W	
R223			RK73HB1J102J	CHIP R 1.0K J 1/16W		R422			RK73HB1J223J	CHIP R 22K J 1/16W	
R224			RK73HB1J121J	CHIP R 120 J 1/16W		R423			RK73HB1J471J	CHIP R 470 J 1/16W	
R225			RK73HB1J102J	CHIP R 1.0K J 1/16W		R424			RK73HB1J153J	CHIP R 15K J 1/16W	
R226			RK73HB1J103J	CHIP R 10K J 1/16W		R425			RK73HB1J223J	CHIP R 22K J 1/16W	
R227-230			RK73HB1J122J	CHIP R 1.2K J 1/16W		R426			RK73HB1J103J	CHIP R 10K J 1/16W	
R231-238			RK73HB1J000J	CHIP R 0.0 J 1/16W		R430			RK73HB1J2R7J	CHIP R 2.7 J 1/16W	
R241-253			RK73HB1J000J	CHIP R 0.0 J 1/16W		R431			RK73HB1J000J	CHIP R 0.0 J 1/16W	
R254			RK73HB1J103J	CHIP R 10K J 1/16W		R432			RK73HB1J333J	CHIP R 33K J 1/16W	



## PARTS LIST

DISPLAY UNIT (X54-3580-20)

TX-RX UNIT (X57-7950-10)

Ref. No.	Address	New parts	Parts No.	Description	Desti-nation
C523			CK73FB1E334K	CHIP C 0.33UF K	
C524			CS77AA1A100M	CHIP TNTL 10UF 10WV	
C525			CK73GB1C104K	CHIP C 0.10UF K	
C526			CK73FB1E334K	CHIP C 0.33UF K	
C601			CC73GCH1H101J	CHIP C 100PF J	
C602			CK73GB1H102K	CHIP C 1000PF K	
C603			CC73GCH1H101J	CHIP C 100PF J	
C606			CC73GCH1H101J	CHIP C 100PF J	
C607			CK73GB1C104K	CHIP C 0.10UF K	
CN501			E41-2743-05	PIN ASSY	
CN502			E40-6102-05	PIN ASSY	
CN601			E41-2751-05	PIN ASSY	
J601			E58-0522-05	MODULAR JACK	
-			J31-0543-05	COLLAR (LH-5-1.5)	
CP501-504			RK75GB1J471J	CHIP-COM 470 J 1/16W	
R502,503			RK73GB2A000J	CHIP R 0.0 J 1/10W	
R505			RK73GB2A683J	CHIP R 68K J 1/10W	
R506			RK73GB2A103J	CHIP R 10K J 1/10W	
R507			RK73GB2A682J	CHIP R 6.8K J 1/10W	
R508			RK73GB2A102J	CHIP R 1.0K J 1/10W	
R509			RK73GB2A103J	CHIP R 10K J 1/10W	
R510			RK73GB2A224J	CHIP R 220K J 1/10W	
R511,512			RK73GB2A103J	CHIP R 10K J 1/10W	
R513			RK73GB2A104J	CHIP R 100K J 1/10W	
R514			RK73GB2A154J	CHIP R 150K J 1/10W	
R516			RK73PB2H102J	CHIP R 1.0K J 1/2W	
R517			RK73PB2H821J	CHIP R 820 J 1/2W	
R518,519			RK73PB2H102J	CHIP R 1.0K J 1/2W	
R520-526			RK73PB2H821J	CHIP R 820 J 1/2W	
R529-540			RK73GB2A102J	CHIP R 1.0K J 1/10W	
R541-544			RK73GB2A103J	CHIP R 10K J 1/10W	
R601			RK73GB2A681J	CHIP R 680 J 1/10W	
R604,605			RK73GB2A102J	CHIP R 1.0K J 1/10W	
R606			RK73GB2A473J	CHIP R 47K J 1/10W	
VR501			R32-0689-05	SEMI FIXED VARIABLE RESISTOR (10K)	
VR601			R31-0630-05	VARIABLE RESISTOR	
S501-506			S70-0502-05	TACT SWITCH	
S507			S68-0410-05	PUSH SWITCH	
D501,502			HSM88AS-E	DIODE	
D506,507			LA-501DD	LED	
D508-514			DA204U	DIODE	
D601,602			DA204U	DIODE	
D603			MINISMDC020F	VARISTOR	
IC501			NJM4558E-ZB	ANALOGUE IC	
IC502-505			BU4094BCFV	MOS-IC	
IC506,507			TA78L05FF	MOS-IC	
Q501			2SC4116(Y)F	TRANSISTOR	
Q502			2SA1586(Y,GR)F	TRANSISTOR	
Q503,504			UPA672T-A	FET	
Q506		*	RT1P141M-T111	TRANSISTOR	
Q507			UPA672T-A	FET	
Q508-511		*	RT1P141M-T111	TRANSISTOR	
Q512-514			UPA672T-A	FET	
Q516-519			UPA672T-A	FET	
Q521-524			UPA672T-A	FET	
Q525			2SK1824-A	FET	

Ref. No.	Address	New parts	Parts No.	Description	Desti-nation
<b>TX-RX UNIT (X57-7950-10)</b>					
C100			CC73HCH1H050B	CHIP C 5.0PF B	
C101			CC73HCH1H560J	CHIP C 56PF J	
C102			CC73HCH1H060B	CHIP C 6.0PF B	
C103			CC73HCH1H150G	CHIP C 15PF G	
C104			CK73HB1H471K	CHIP C 470PF K	
C105			CC73HCH1H090B	CHIP C 9.0PF B	
C106			CK73HB1H471K	CHIP C 470PF K	
C107,108			CC73HCH1H120G	CHIP C 12PF G	
C109			CK73HB1H471K	CHIP C 470PF K	
C110		*	CS77CA1V2R2M	CHIP TNTL 2.2UF 35WV	
C111			CC73HCH1H090B	CHIP C 9.0PF B	
C112			CC73HCH1H180G	CHIP C 18PF G	
C113			CC73HCH1H100B	CHIP C 10PF B	
C114			CK73HB1H471K	CHIP C 470PF K	
C115			CC73HCH1H090B	CHIP C 9.0PF B	
C116			CK73HB1H471K	CHIP C 470PF K	
C117			CC73HCH1H050B	CHIP C 5.0PF B	
C118			CC73HCH1H120G	CHIP C 12PF G	
C119		*	CK73HB1E104K	CHIP C 0.10UF K	
C120			CK73HB1H471K	CHIP C 470PF K	
C121			CC73HCH1H060B	CHIP C 6.0PF B	
C122			CK73HB1H471K	CHIP C 470PF K	
C123		*	CK73HB1E104K	CHIP C 0.10UF K	
C124			CC73HCH1H080B	CHIP C 8.0PF B	
C125			CK73HB1H471K	CHIP C 470PF K	
C126		*	CK73HB1E104K	CHIP C 0.10UF K	
C127			CK73HB1H471K	CHIP C 470PF K	
C129			CC73HCH1H080B	CHIP C 8.0PF B	
C130			CC73HCH1H100B	CHIP C 10PF B	
C131		*	CK73HB1E104K	CHIP C 0.10UF K	
C134			CK73HB1H471K	CHIP C 470PF K	
C135			CC73HCH1H050B	CHIP C 5.0PF B	
C136			CC73HCH1H120G	CHIP C 12PF G	
C137			CK73HB1H471K	CHIP C 470PF K	
C138			CC73HCH1H090B	CHIP C 9.0PF B	
C139			CK73HB1H471K	CHIP C 470PF K	
C140			CC73HCH1H180G	CHIP C 18PF G	
C141			CC73HCH1H100B	CHIP C 10PF B	
C142			CK73HB1H471K	CHIP C 470PF K	
C143			CC73HCH1H090B	CHIP C 9.0PF B	
C144			CC73HCH1H100C	CHIP C 10PF C	
C145			CC73HCH1H120G	CHIP C 12PF G	
C146			CK73HB1H471K	CHIP C 470PF K	
C147			CC73HCH1H090B	CHIP C 9.0PF B	
C148			CK73HB1H471K	CHIP C 470PF K	
C149			CC73HCH1H040B	CHIP C 4.0PF B	
C150			CC73HCH1H150G	CHIP C 15PF G	
C151,152			CC73HCH1H050B	CHIP C 5.0PF B	
C154			CC73HCH1H050B	CHIP C 5.0PF B	
C155			CC73HCH1H010B	CHIP C 1.0PF B	
C156			CC73HCH1H050B	CHIP C 5.0PF B	
C157			CC73HCH1H560J	CHIP C 56PF J	
C158			CC73HCH1H080B	CHIP C 8.0PF B	
C159			CC73HCH1H060B	CHIP C 6.0PF B	
C160			CK73HB1H471K	CHIP C 470PF K	
C161			CK73HB1H561K	CHIP C 560PF K	
C162,163			CC73HCH1H050B	CHIP C 5.0PF B	
C164			CC73HCH1H060B	CHIP C 6.0PF B	

## PARTS LIST

### TX-RX UNIT (X57-7950-10)

Ref. No.	Address	New parts	Parts No.	Description	Destination	Ref. No.	Address	New parts	Parts No.	Description	Destination
C165,166			CC73HCH1H050B	CHIP C 5.0PF B		C337,338		*	CK73HB1H103K	CHIP C 0.010UF K	
C167-169			CC73HCH1H060B	CHIP C 6.0PF B		C339			CC73HCH1H471J	CHIP C 470PF J	
C170			CC73HCH1H560J	CHIP C 56PF J		C341		*	CK73HB1H103K	CHIP C 0.010UF K	
C171,172			CC73HCH1H060B	CHIP C 6.0PF B		C342			CC73HCH1H180J	CHIP C 18PF J	
C173			CC73HCH1H030B	CHIP C 3.0PF B		C343,344		*	CK73HB1H103K	CHIP C 0.010UF K	
C174			CC73HCH1H040B	CHIP C 4.0PF B		C345			CK73HB1H471K	CHIP C 470PF K	
C175			CC73HCH1H050B	CHIP C 5.0PF B		C346			CC73HCH1H180J	CHIP C 18PF J	
C176			CK73GB1H471K	CHIP C 470PF K		C347			CC73HCH1H150G	CHIP C 15PF G	
C200,201		*	CS77CA1V2R2M	CHIP TNTL 2.2UF 35WV		C349		*	CK73HB1H103K	CHIP C 0.010UF K	
C202			CC73HCH1H100D	CHIP C 10PF D		C350		*	CK73HB1E104K	CHIP C 0.10UF K	
C203			CK73HB1H471K	CHIP C 470PF K		C352			CC73HCH1H100D	CHIP C 10PF D	
C204			CC73HCH1H101J	CHIP C 100PF J		C353			CC73HCH1H180J	CHIP C 18PF J	
C205		*	CK73HB1E104K	CHIP C 0.10UF K		C354			CC73HCH1H090B	CHIP C 9.0PF B	
C206			CC73HCH1H470J	CHIP C 47PF J		C356			CC73HCH1H100D	CHIP C 10PF D	
C207,208			CS77BA1D100M	CHIP TNTL 10UF 20WV		C358			CC73HCH1H100D	CHIP C 10PF D	
C209			CK73HB1H471K	CHIP C 470PF K		C400-403		*	CK73HB1E104K	CHIP C 0.10UF K	
C210			CE32CL1V100M	CHIP EL 10UF 35WV		C404			CC73HCH1H100D	CHIP C 10PF D	
C211			CK73HB1H471K	CHIP C 470PF K		C405,406		*	CK73HB1E104K	CHIP C 0.10UF K	
C212		*	CK73HB1H103K	CHIP C 0.010UF K		C407			CK73HB1H471K	CHIP C 470PF K	
C213			CC73HCH1H100B	CHIP C 10PF B		C408		*	CK73HB1E104K	CHIP C 0.10UF K	
C214			CC73HCH1H050B	CHIP C 5.0PF B		C410			CK73HB1H471K	CHIP C 470PF K	
C216			CC73HCH1H050B	CHIP C 5.0PF B		C411			CK73GB1E105K	CHIP C 1.0UF K	
C219			CC73HCH1H100D	CHIP C 10PF D		C412			CK73HB1H471K	CHIP C 470PF K	
C220-223		*	CK73HB1H103K	CHIP C 0.010UF K		C413			CK73GB1E105K	CHIP C 1.0UF K	
C224			CK73HB1H471K	CHIP C 470PF K		C414			CK73HB1H471K	CHIP C 470PF K	
C225			CC73HCH1H100D	CHIP C 10PF D		C415		*	CK73HB1E104K	CHIP C 0.10UF K	
C226			CC73HCH1H680J	CHIP C 68PF J		C416		*	CK73HB1H103K	CHIP C 0.010UF K	
C227		*	CK73HB1E104K	CHIP C 0.10UF K		C417		*	CK73HB1E104K	CHIP C 0.10UF K	
C228			CC73HCH1H101J	CHIP C 100PF J		C418			CK73HB1H102K	CHIP C 1000PF K	
C229			CK73HB1H471K	CHIP C 470PF K		C419			CK73HB1H471K	CHIP C 470PF K	
C230			CC73HCH1H680J	CHIP C 68PF J		C421			CK73HB1H102K	CHIP C 1000PF K	
C231			CK73HB1H471K	CHIP C 470PF K		C422		*	CK73HB1E104K	CHIP C 0.10UF K	
C233,234			CC73HCH1H470J	CHIP C 47PF J		C423		*	CK73HB1H103K	CHIP C 0.010UF K	
C235,236			CK73HB1H471K	CHIP C 470PF K		C424-430		*	CK73HB1E104K	CHIP C 0.10UF K	
C237			CC73HCH1H080B	CHIP C 8.0PF B		C437-440		*	CK73HB1E104K	CHIP C 0.10UF K	
C240			CK73HB1H471K	CHIP C 470PF K		C500-503		*	CK73HB1E104K	CHIP C 0.10UF K	
C241			CC73HCH1H080B	CHIP C 8.0PF B		C504			CK73HB1H471K	CHIP C 470PF K	
C242			CC73HCH1H020B	CHIP C 2.0PF B		C505-507		*	CK73HB1E104K	CHIP C 0.10UF K	
C243			CC73HCH1H120J	CHIP C 12PF J		C508		*	CK73HB1H103K	CHIP C 0.010UF K	
C244			CC73HCH1H010B	CHIP C 1.0PF B		C509-512		*	CK73HB1E104K	CHIP C 0.10UF K	
C245			CC73HCH1H060D	CHIP C 6.0PF D		C514		*	CK73HB1H103K	CHIP C 0.010UF K	
C246		*	CK73HB1H103K	CHIP C 0.010UF K		C515		*	CK73HB1E104K	CHIP C 0.10UF K	
C247			CK73HB1H471K	CHIP C 470PF K		C517		*	CK73HB1H103K	CHIP C 0.010UF K	
C300			CC73HCH1H270J	CHIP C 27PF J		C518		*	CK73HB1E104K	CHIP C 0.10UF K	
C301			CK73HB1H471K	CHIP C 470PF K		C519		*	CK73HB1H103K	CHIP C 0.010UF K	
C302-305		*	CK73HB1H103K	CHIP C 0.010UF K		C520		*	CK73HB1E104K	CHIP C 0.10UF K	
C306			CC73HCH1H020B	CHIP C 2.0PF B		C521			CC73HCH1H180J	CHIP C 18PF J	
C318			CC73HCH1H270G	CHIP C 27PF G		C522			CC73HCH1H101J	CHIP C 100PF J	
C322			CK73HB1H471K	CHIP C 470PF K		C523			CC73HCH1H331J	CHIP C 330PF J	
C323			CE32CL1E4R7M	CHIP EL 4.7UF 25WV		C524			CC73HCH1H180J	CHIP C 18PF J	
C325		*	CK73HB1E104K	CHIP C 0.10UF K		C525			CC73HCH1H470J	CHIP C 47PF J	
C326			CC73HCH1H330G	CHIP C 33PF G		C526			CC73HCH1H471J	CHIP C 470PF J	
C328			CC73HCH1H020B	CHIP C 2.0PF B		C528			CC73HCH1H121J	CHIP C 120PF J	
C329		*	CK73HB1H103K	CHIP C 0.010UF K		C529			CC73HCH1H221J	CHIP C 220PF J	
C331			CK73HB1H471K	CHIP C 470PF K		C530-533		*	CK73HB1E104K	CHIP C 0.10UF K	
C332			CC73HCH1H150J	CHIP C 15PF J		C534			CC73HCH1H050C	CHIP C 5.0PF C	
C333			CC73HCH1H120J	CHIP C 12PF J		C535		*	CK73HB1H103K	CHIP C 0.010UF K	
C334		*	CK73HB1H103K	CHIP C 0.010UF K		C536,537		*	CK73HB1E104K	CHIP C 0.10UF K	
C335			CC73HCH1H820J	CHIP C 82PF J		C538		*	CK73HB1H103K	CHIP C 0.010UF K	
C336			CC73HCH1H270J	CHIP C 27PF J		C539			CC73HCH1H820J	CHIP C 82PF J	

## PARTS LIST

TX-RX UNIT (X57-7950-10)

Ref. No.	Address	New parts	Parts No.	Description	Desti-nation	Ref. No.	Address	New parts	Parts No.	Description	Desti-nation
C540		*	CK73HB1H103K	CHIP C 0.010UF K		C679,680			CK73HB1H471K	CHIP C 470PF K	
C541		*	CK73HB1E104K	CHIP C 0.10UF K		C683-688			CK73HB1H471K	CHIP C 470PF K	
C542			CK73FB1A106K	CHIP C 10UF K		C700	*		CK73HB1H103K	CHIP C 0.010UF K	
C543-545		*	CK73HB1E104K	CHIP C 0.10UF K		C701			C92-0905-05	OS-CON 47UF 35WV	
C546			CC73HCH1H390J	CHIP C 39PF J		C702			CK73GB1E105K	CHIP C 1.0UF K	
C547,548			CC73HCH1H100D	CHIP C 10PF D		C703			CK73HB1H471K	CHIP C 470PF K	
C549		*	CK73HB1E104K	CHIP C 0.10UF K		C704			CK73GB1E105K	CHIP C 1.0UF K	
C550		*	CK73HB1H103K	CHIP C 0.010UF K		C705			CK73HB1H471K	CHIP C 470PF K	
C600,601			CK73FB1A106K	CHIP C 10UF K		C706			C92-0765-05	CHIP TNL 4.7UF 16WV	
C602-604		*	CK73HB1E104K	CHIP C 0.10UF K		C707			CE32CL1V100M	CHIP EL 10UF 35WV	
C605		*	CK73HB1H103K	CHIP C 0.010UF K		C708	*		CK73HB1E104K	CHIP C 0.10UF K	
C606,607			CK73FB1A106K	CHIP C 10UF K		C709	*		CK73HB1H103K	CHIP C 0.010UF K	
C608		*	CK73HB1H103K	CHIP C 0.010UF K		C710,711			CK73HB1H471K	CHIP C 470PF K	
C610-613		*	CK73HB1H103K	CHIP C 0.010UF K		C712			CK73GB1E105K	CHIP C 1.0UF K	
C614			CS77BA1D100M	CHIP TNL 10UF 20WV		C713			CK73HB1H471K	CHIP C 470PF K	
C615			CC73HCH1H181J	CHIP C 180PF J		C714			CC73HCH1H181J	CHIP C 180PF J	
C616			CC73HCH1H470J	CHIP C 47PF J		C715			CK73HB1H471K	CHIP C 470PF K	
C618			CS77CB21A470M	CHIP TNL 47UF 10WV		C716			CE32CL1V100M	CHIP EL 10UF 35WV	
C619			CC73HCH1H331J	CHIP C 330PF J		C717			CC73HCH1H220J	CHIP C 22PF J	
C620			CC73HCH1H180J	CHIP C 18PF J		C718			CK73HB1H471K	CHIP C 470PF K	
C621			CS77CB21A470M	CHIP TNL 47UF 10WV		C719			CK73GB1E105K	CHIP C 1.0UF K	
C622			CC73HCH1H221J	CHIP C 220PF J		C720	*		CK73HB1E104K	CHIP C 0.10UF K	
C623		*	CK73HB1H103K	CHIP C 0.010UF K		C721			CK73GB1E105K	CHIP C 1.0UF K	
C624		*	CK73HB1E104K	CHIP C 0.10UF K		C722,723	*		CK73HB1E104K	CHIP C 0.10UF K	
C625		*	CK73HB1H103K	CHIP C 0.010UF K		C724,725			CK73GB1E105K	CHIP C 1.0UF K	
C626			CS77BA1D100M	CHIP TNL 10UF 20WV		C726	*		CK73HB1H103K	CHIP C 0.010UF K	
C627		*	CK73HB1H103K	CHIP C 0.010UF K		C727			CK73GB1E105K	CHIP C 1.0UF K	
C628			CC73HCH1H100D	CHIP C 10PF D		C728,729			CK73HB1H471K	CHIP C 470PF K	
C629,630		*	CK73HB1H103K	CHIP C 0.010UF K		C814			CC73HCH1H101J	CHIP C 100PF J	
C631			CC73HCH1H100D	CHIP C 10PF D		C815	*		CK73HB1H103K	CHIP C 0.010UF K	
C632		*	CK73HB1E104K	CHIP C 0.10UF K		C817,818	*		CK73HB1E104K	CHIP C 0.10UF K	
C633,634		*	CK73HB1H103K	CHIP C 0.010UF K		C819	*		CK73HB1H103K	CHIP C 0.010UF K	
C635			CC73HCH1H100D	CHIP C 10PF D		C820			CK73HB1H471K	CHIP C 470PF K	
C636,637		*	CK73HB1H103K	CHIP C 0.010UF K		C821	*		CK73HB1E104K	CHIP C 0.10UF K	
C638			CK73GB1E105K	CHIP C 1.0UF K		C822			CC73HCH1H100D	CHIP C 10PF D	
C639		*	CK73HB1H103K	CHIP C 0.010UF K		C823	*		CK73HB1E104K	CHIP C 0.10UF K	
C641		*	CK73HB1H103K	CHIP C 0.010UF K		C825			C93-0912-05	CHIP C 100UF M	
C642		*	CK73HB1E104K	CHIP C 0.10UF K		C826			CK73GB1E105K	CHIP C 1.0UF K	
C643			CS77BA1D100M	CHIP TNL 10UF 20WV		C827			CK73HB1H471K	CHIP C 470PF K	
C644			CC73HCH1H100D	CHIP C 10PF D		C828	*		CK73HB1E104K	CHIP C 0.10UF K	
C645			CK73GB1E105K	CHIP C 1.0UF K		C831	*		CK73HB1E104K	CHIP C 0.10UF K	
C647,648		*	CS77CA1V2R2M	CHIP TNL 2.2UF 35WV		C832			CC73HCH1H050B	CHIP C 5.0PF B	
C649		*	CK73HB1E104K	CHIP C 0.10UF K		CN101			E04-0154-05	PIN SOCKET	
C650			CK73HB1H471K	CHIP C 470PF K		CN102			E23-1330-05	TERMINAL	
C651			CC73HCH1H101J	CHIP C 100PF J		CN106			E23-1330-05	TERMINAL	
C652			CC73HCH1H100D	CHIP C 10PF D		CN500			E04-0154-05	PIN SOCKET	
C653,654			CS77BA1D100M	CHIP TNL 10UF 20WV		CN610			E04-0154-05	PIN SOCKET	
C655			CK73HB1H471K	CHIP C 470PF K		CN700,701			E41-2672-05	PIN ASSY	
C656			CE32CL1V100M	CHIP EL 10UF 35WV		CN800			E40-6656-05	PIN ASSY	
C657			CC73HCH1H330J	CHIP C 33PF J		CN801			E41-2743-05	PIN ASSY	
C658			CK73HB1H471K	CHIP C 470PF K		CN802			E04-0193-05	PIN SOCKET	
C660			CC73HCH1H100D	CHIP C 10PF D		CN807-809			E23-1278-05	TERMINAL	
C661		*	CK73HB1E104K	CHIP C 0.10UF K		CN811-813			E23-1278-05	TERMINAL	
C662			CC73HCH1H070B	CHIP C 7.0PF B		-			F10-2409-04	SHIELDING CASE	
C663		*	CK73HB1H103K	CHIP C 0.010UF K		F700			F53-0328-15	FUSE	
C664			CC73HCH1H3R5B	CHIP C 3.5PF B		CF400,401			L72-1028-05	CERAMIC FILTER	
C671			CC73HCH1H040B	CHIP C 4.0PF B		CF402			L72-1027-05	CERAMIC FILTER	
C672,673			CK73HB1H471K	CHIP C 470PF K		CF403			L72-1041-05	CERAMIC FILTER	
C674			CC73HCH1H040B	CHIP C 4.0PF B							
C677			CC73HCH1H060B	CHIP C 6.0PF B							



## PARTS LIST

### TX-RX UNIT (X57-7950-10)

Ref. No.	Address	New parts	Parts No.	Description	Destination	Ref. No.	Address	New parts	Parts No.	Description	Destination
L100,101			L34-4565-05	AIR-CORE COIL		XF300			L71-0649-05	MCF (58.05MHZ)	
L103,104			L34-4565-05	AIR-CORE COIL		R100			RK73GB2A102J	CHIP R 1.0K J 1/10W	
L106			L92-0467-05	CHIP FERRITE		R101			RK73HB1J000J	CHIP R 0.0 J 1/16W	
L107			L41-1278-14	SMALL FIXED INDUCTOR (12NH)		R105,106			RK73HB1J104J	CHIP R 100K J 1/16W	
L109			L41-6868-14	SMALL FIXED INDUCTOR (6.8NH)		R107			RK73HB1J103J	CHIP R 10K J 1/16W	
L111,112			L34-4565-05	AIR-CORE COIL		R109,110			RK73HB1J104J	CHIP R 100K J 1/16W	
L114-118			L34-4565-05	AIR-CORE COIL		R111			RK73HB1J101J	CHIP R 100 J 1/16W	
L119			L34-4616-05	AIR-CORE COIL		R112			RK73HB1J104J	CHIP R 100K J 1/16W	
L120,121			L41-1878-14	SMALL FIXED INDUCTOR (18NH)		R113			RK73HB1J103J	CHIP R 10K J 1/16W	
L200,201			L41-2778-14	SMALL FIXED INDUCTOR (27NH)		R114			RK73HB1J101J	CHIP R 100 J 1/16W	
L203			L41-5685-14	SMALL FIXED INDUCTOR (560NH)		R115			RK73FB2B121J	CHIP R 120 J 1/8W	
L205			L41-4778-14	SMALL FIXED INDUCTOR (47NH)		R116			RK73HB1J103J	CHIP R 10K J 1/16W	
L206			L41-1085-33	SMALL FIXED INDUCTOR (0.1UH)		R117			RK73HB1J100J	CHIP R 10 J 1/16W	
L207			L41-2278-14	SMALL FIXED INDUCTOR (22NH)		R118			RK73HB1J274J	CHIP R 270K J 1/16W	
L209			L41-1575-33	SMALL FIXED INDUCTOR (0.015UH)		R119			RK73HB1J393J	CHIP R 39K J 1/16W	
L210			L41-1875-33	SMALL FIXED INDUCTOR (0.018UH)		R120			RK73HB1J122J	CHIP R 1.2K J 1/16W	
L211			L41-3378-14	SMALL FIXED INDUCTOR (33NH)		R121			RK73HB1J102J	CHIP R 1.0K J 1/16W	
L212			L92-0467-05	CHIP FERRITE		R122			RK73HB1J221J	CHIP R 220 J 1/16W	
L214			L92-0467-05	CHIP FERRITE		R125			RK73HB1J000J	CHIP R 0.0 J 1/16W	
L300			L92-0467-05	CHIP FERRITE		R126			RK73HB1J103J	CHIP R 10K J 1/16W	
L301			L40-3381-86	SMALL FIXED INDUCTOR (330NH)		R128,129			RK73HB1J000J	CHIP R 0.0 J 1/16W	
L302		*	L41-5685-47	SMALL FIXED INDUCTOR (560NH)		R130			RK73HB1J274J	CHIP R 270K J 1/16W	
L303		*	L41-3385-47	SMALL FIXED INDUCTOR (330NH)		R131			RK73HB1J393J	CHIP R 39K J 1/16W	
L304,305			L41-1578-14	SMALL FIXED INDUCTOR (15NH)		R132-136			RK73HB1J104J	CHIP R 100K J 1/16W	
L308			L41-2278-14	SMALL FIXED INDUCTOR (22NH)		R137			RK73HB1J4R7J	CHIP R 4.7 J 1/16W	
L309			L41-6878-14	SMALL FIXED INDUCTOR (68NH)		R138,139			RK73HB1J000J	CHIP R 0.0 J 1/16W	
L310			L41-3385-47	SMALL FIXED INDUCTOR (330NH)		R140			RK73HB1J220J	CHIP R 22 J 1/16W	
L312			L41-1078-14	SMALL FIXED INDUCTOR (10NH)		R200			RK73HB1J223J	CHIP R 22K J 1/16W	
L313			L40-8275-92	SMALL FIXED INDUCTOR (82NH)		R201,202			RK73HB1J103J	CHIP R 10K J 1/16W	
L315			L41-1078-14	SMALL FIXED INDUCTOR (10NH)		R203			RK73HB1J000J	CHIP R 0.0 J 1/16W	
L316			L40-2785-92	SMALL FIXED INDUCTOR (270NH)		R204			RK73HB1J224J	CHIP R 220K J 1/16W	
L317			L41-1095-33	SMALL FIXED INDUCTOR (1.0UH)		R205			RK73HB1J102J	CHIP R 1.0K J 1/16W	
L320			L40-1885-92	SMALL FIXED INDUCTOR (180NH)		R206			RK73HB1J334J	CHIP R 330K J 1/16W	
L500			L41-3395-33	SMALL FIXED INDUCTOR (3.3UH)		R207			RK73HB1J393J	CHIP R 39K J 1/16W	
L501			L41-4795-33	SMALL FIXED INDUCTOR (4.7UH)		R208			RK73HB1J000J	CHIP R 0.0 J 1/16W	
L502			L41-6885-33	SMALL FIXED INDUCTOR (0.68UH)		R209			RK73HB1J102J	CHIP R 1.0K J 1/16W	
L503			L41-5685-33	SMALL FIXED INDUCTOR (0.56UH)		R210			RK73HB1J124J	CHIP R 120K J 1/16W	
L504			L41-2295-33	SMALL FIXED INDUCTOR (2.2UH)		R211			RK73HB1J333J	CHIP R 33K J 1/16W	
L505,506			L41-1295-33	SMALL FIXED INDUCTOR (1.2UH)		R212			RK73HB1J394J	CHIP R 390K J 1/16W	
L507,508			L41-3305-33	SMALL FIXED INDUCTOR (33UH)		R213			RK73HB1J106J	CHIP R 10M J 1/16W	
L600,601			L41-1005-33	SMALL FIXED INDUCTOR (10UH)		R214			RK73HB1J000J	CHIP R 0.0 J 1/16W	
L602			L92-0467-05	CHIP FERRITE		R215,216			RK73HB1J102J	CHIP R 1.0K J 1/16W	
L603			L41-1005-33	SMALL FIXED INDUCTOR (10UH)		R217			RK73HB1J000J	CHIP R 0.0 J 1/16W	
L604			L41-3385-39	SMALL FIXED INDUCTOR (0.33UH)		R220,221			RK73HB1J101J	CHIP R 100 J 1/16W	
L605			L41-3985-39	SMALL FIXED INDUCTOR (0.39UH)		R223			RK73HB1J331J	CHIP R 330 J 1/16W	
L606			L41-1095-39	SMALL FIXED INDUCTOR (1.0UH)		R224			RK73HB1J220J	CHIP R 22 J 1/16W	
L607,608			L41-1878-14	SMALL FIXED INDUCTOR (18NH)		R225			RK73HB1J334J	CHIP R 330K J 1/16W	
L609			L41-1278-14	SMALL FIXED INDUCTOR (12NH)		R227			RK73HB1J220J	CHIP R 22 J 1/16W	
L610			L41-2778-14	SMALL FIXED INDUCTOR (27NH)		R228,229			RK73HB1J000J	CHIP R 0.0 J 1/16W	
L611			L41-1578-14	SMALL FIXED INDUCTOR (15NH)		R230			RK73HB1J271J	CHIP R 270 J 1/16W	
L613,614			L92-0639-05	CHIP FERRITE		R231			RK73HB1J180J	CHIP R 18 J 1/16W	
L615-617			L92-0467-05	CHIP FERRITE		R232			RK73HB1J271J	CHIP R 270 J 1/16W	
L700			L33-1462-05	SMALL FIXED INDUCTOR (68UH)		R233			RK73HB1J472J	CHIP R 4.7K J 1/16W	
L701,702			L41-1005-33	SMALL FIXED INDUCTOR (10UH)		R234			RK73HB1J182J	CHIP R 1.8K J 1/16W	
L800,801			L92-0467-05	CHIP FERRITE		R235			RK73HB1J220J	CHIP R 22 J 1/16W	
L803			L92-0162-05	BEADS CORE		R236			RK73HB1J102J	CHIP R 1.0K J 1/16W	
L804			L41-1285-14	SMALL FIXED INDUCTOR (120NH)		R237			RK73HB1J680J	CHIP R 68 J 1/16W	
L805,806			L92-0467-05	CHIP FERRITE		R238,239			RK73HB1J000J	CHIP R 0.0 J 1/16W	
X500		*	L77-3056-05	TCXO (19.2MHZ)		R243			RK73HB1J271J	CHIP R 270 J 1/16W	
X600		*	L77-1960-15	VCXO (16.8MHZ)							

## PARTS LIST

TX-RX UNIT (X57-7950-10)

Ref. No.	Address	New parts	Parts No.	Description	Desti-nation	Ref. No.	Address	New parts	Parts No.	Description	Desti-nation
R244			RK73HB1J180J	CHIP R 18 J 1/16W		R505			RK73HB1J124J	CHIP R 120K J 1/16W	
R245			RK73HB1J271J	CHIP R 270 J 1/16W		R506			RK73HB1J471J	CHIP R 470 J 1/16W	
R246			RK73HB1J221J	CHIP R 220 J 1/16W		R507			RK73HB1J220J	CHIP R 22 J 1/16W	
R247			RK73HB1J103J	CHIP R 10K J 1/16W		R509			RK73HB1J183J	CHIP R 18K J 1/16W	
R300			RK73HB1J331J	CHIP R 330 J 1/16W		R510			RK73HB1J223J	CHIP R 22K J 1/16W	
R301			RK73HB1J101J	CHIP R 100 J 1/16W		R511			RK73HB1J220J	CHIP R 22 J 1/16W	
R302			RK73HB1J473J	CHIP R 47K J 1/16W		R512			RK73HB1J223J	CHIP R 22K J 1/16W	
R303			RK73HB1J220J	CHIP R 22 J 1/16W		R513			RK73HB1J471J	CHIP R 470 J 1/16W	
R304			RK73HB1J104J	CHIP R 100K J 1/16W		R514			RK73HB1J220J	CHIP R 22 J 1/16W	
R305			RK73HB1J123J	CHIP R 12K J 1/16W		R515			RK73HB1J272J	CHIP R 2.7K J 1/16W	
R306			RK73HB1J103J	CHIP R 10K J 1/16W		R516			RK73HB1J000J	CHIP R 0.0 J 1/16W	
R310			RK73HB1J122J	CHIP R 1.2K J 1/16W		R518			RK73HB1J102J	CHIP R 1.0K J 1/16W	
R311			RK73GB2A100J	CHIP R 10 J 1/10W		R519			RK73HB1J181J	CHIP R 180 J 1/16W	
R312			RK73HB1J100J	CHIP R 10 J 1/16W		R520			RK73HB1J394J	CHIP R 390K J 1/16W	
R313			RK73HB1J272J	CHIP R 2.7K J 1/16W		R521			RK73HB1J154J	CHIP R 150K J 1/16W	
R314			RK73HB1J103J	CHIP R 10K J 1/16W		R522			RK73HB1J333J	CHIP R 33K J 1/16W	
R315			RK73GB2A101J	CHIP R 100 J 1/10W		R523			RK73HB1J000J	CHIP R 0.0 J 1/16W	
R316			RK73GB2A100J	CHIP R 10 J 1/10W		R524			RK73HB1J104J	CHIP R 100K J 1/16W	
R318			RK73HB1J220J	CHIP R 22 J 1/16W		R525			RK73HB1J000J	CHIP R 0.0 J 1/16W	
R320			RK73HB1J100J	CHIP R 10 J 1/16W		R527			RK73HB1J104J	CHIP R 100K J 1/16W	
R323			RK73HB1J151J	CHIP R 150 J 1/16W		R528			RK73HB1J224J	CHIP R 220K J 1/16W	
R332			RK73HB1J470J	CHIP R 47 J 1/16W		R529			RK73HB1J104J	CHIP R 100K J 1/16W	
R400			RK73HB1J224J	CHIP R 220K J 1/16W		R530			RK73HB1J471J	CHIP R 470 J 1/16W	
R401			RK73HB1J220J	CHIP R 22 J 1/16W		R531,532			RK73HB1J103J	CHIP R 10K J 1/16W	
R402			RK73HB1J101J	CHIP R 100 J 1/16W		R533			RK73HB1J220J	CHIP R 22 J 1/16W	
R403			RK73HB1J682J	CHIP R 6.8K J 1/16W		R534			RK73HB1J682J	CHIP R 6.8K J 1/16W	
R404			RK73HB1J000J	CHIP R 0.0 J 1/16W		R535			RK73HB1J104J	CHIP R 100K J 1/16W	
R405			RK73HB1J103J	CHIP R 10K J 1/16W		R536			RK73HB1J272J	CHIP R 2.7K J 1/16W	
R406			RK73HB1J220J	CHIP R 22 J 1/16W		R537			RK73HB1J102J	CHIP R 1.0K J 1/16W	
R407			RK73HB1J474J	CHIP R 470K J 1/16W		R538			RK73HB1J221J	CHIP R 220 J 1/16W	
R408			RK73HB1J103J	CHIP R 10K J 1/16W		R539,540			RK73HB1J104J	CHIP R 100K J 1/16W	
R409-411			RK73HB1J473J	CHIP R 47K J 1/16W		R541			RK73HB1J101J	CHIP R 100 J 1/16W	
R412			RK73HB1J101J	CHIP R 100 J 1/16W		R542			RK73HB1J104J	CHIP R 100K J 1/16W	
R413			RK73HB1J000J	CHIP R 0.0 J 1/16W		R543			RK73HB1J221J	CHIP R 220 J 1/16W	
R415			RK73HB1J000J	CHIP R 0.0 J 1/16W		R544			RK73HB1J104J	CHIP R 100K J 1/16W	
R416			RK73HB1J222J	CHIP R 2.2K J 1/16W		R545,546			RK73HB1J120J	CHIP R 12 J 1/16W	
R417,418			RK73HB1J220J	CHIP R 22 J 1/16W		R547-550			RK73HB1J182J	CHIP R 1.8K J 1/16W	
R420			RK73HB1J470J	CHIP R 47 J 1/16W		R551			RK73HB1J101J	CHIP R 100 J 1/16W	
R421			RK73HB1J182J	CHIP R 1.8K J 1/16W		R552			RK73HB1J102J	CHIP R 1.0K J 1/16W	
R422			RK73HB1J101J	CHIP R 100 J 1/16W		R602			RK73HB1J101J	CHIP R 100 J 1/16W	
R425			RK73HB1J183J	CHIP R 18K J 1/16W		R604			RK73HB1J104J	CHIP R 100K J 1/16W	
R426			RK73HB1J822J	CHIP R 8.2K J 1/16W		R605			RK73HB1J000J	CHIP R 0.0 J 1/16W	
R427,428			RK73HB1J473J	CHIP R 47K J 1/16W		R606-608			RK73HB1J104J	CHIP R 100K J 1/16W	
R429			RK73HB1J220J	CHIP R 22 J 1/16W		R609			RK73HB1J472J	CHIP R 4.7K J 1/16W	
R431			RK73HB1J000J	CHIP R 0.0 J 1/16W		R610			RK73HB1J000J	CHIP R 0.0 J 1/16W	
R433-435			RK73HB1J000J	CHIP R 0.0 J 1/16W		R611			RK73HB1J101J	CHIP R 100 J 1/16W	
R436-438			RK73HB1J152J	CHIP R 1.5K J 1/16W		R612			RK73HB1J470J	CHIP R 47 J 1/16W	
R442			RK73HB1J821J	CHIP R 820 J 1/16W		R613			RK73HB1J000J	CHIP R 0.0 J 1/16W	
R443			RK73HB1J821J	CHIP R 820 J 1/16W		R614			RK73HB1J223J	CHIP R 22K J 1/16W	
R444			RK73HB1J122J	CHIP R 1.2K J 1/16W		R615			RK73HB1J273J	CHIP R 27K J 1/16W	
R447			RK73HB1J000J	CHIP R 0.0 J 1/16W		R616			RK73HB1J103J	CHIP R 10K J 1/16W	
R448,449			RK73HB1J334J	CHIP R 330K J 1/16W		R617			RK73HB1J154J	CHIP R 150K J 1/16W	
R450			RK73HB1J563J	CHIP R 56K J 1/16W		R618			RK73HB1J101J	CHIP R 100 J 1/16W	
R451			RK73HB1J104J	CHIP R 100K J 1/16W		R619			RK73HB1J221J	CHIP R 220 J 1/16W	
R452			RK73HB1J224J	CHIP R 220K J 1/16W		R620			RK73HB1J000J	CHIP R 0.0 J 1/16W	
R453			RK73HB1J220J	CHIP R 22 J 1/16W		R621			RK73HB1J220J	CHIP R 22 J 1/16W	
R500			RK73HB1J104J	CHIP R 100K J 1/16W		R622			RK73HB1J103J	CHIP R 10K J 1/16W	
R501,502			RK73HB1J104D	CHIP R 100K D 1/16W		R623			RK73HB1J562J	CHIP R 5.6K J 1/16W	
R503			RK73HB1J101J	CHIP R 100 J 1/16W		R624			RK73HB1J104J	CHIP R 100K J 1/16W	
R504			RK73HB1J220J	CHIP R 22 J 1/16W		R625			RK73HB1J221J	CHIP R 220 J 1/16W	

## PARTS LIST

### TX-RX UNIT (X57-7950-10)

Ref. No.	Address	New parts	Parts No.	Description	Destination	Ref. No.	Address	New parts	Parts No.	Description	Destination
R626			RK73HB1J472J	CHIP R 4.7K J 1/16W		R715-717			RK73HB1J000J	CHIP R 0.0 J 1/16W	
R627			RK73HB1J220J	CHIP R 22 J 1/16W		R800-803			RK73HB1J000J	CHIP R 0.0 J 1/16W	
R628			RK73HB1J471J	CHIP R 470 J 1/16W		R806-815			RK73HB1J000J	CHIP R 0.0 J 1/16W	
R629,630			RK73HB1J104J	CHIP R 100K J 1/16W		R816,817			RK73HB1J101J	CHIP R 100 J 1/16W	
R631			RK73HB1J822J	CHIP R 8.2K J 1/16W		R818			RK73HB1J102J	CHIP R 1.0K J 1/16W	
R632			RK73HB1J182J	CHIP R 1.8K J 1/16W		R819			RK73HB1J683J	CHIP R 68K J 1/16W	
R633			RK73HB1J220J	CHIP R 22 J 1/16W		R820			RK73HB1J473J	CHIP R 47K J 1/16W	
R634			RK73HB1J473J	CHIP R 47K J 1/16W		R821			RK73HB1J394J	CHIP R 390K J 1/16W	
R635			RK73GB2A2R2J	CHIP R 2.2 J 1/10W		R822			RK73HB1J104J	CHIP R 100K J 1/16W	
R636			RK73HB1J104J	CHIP R 100K J 1/16W		R824,825			RK73HB1J101J	CHIP R 100 J 1/16W	
R637			RK73HB1J473J	CHIP R 47K J 1/16W		R826			RK73HB1J562J	CHIP R 5.6K J 1/16W	
R638			RK73HB1J220J	CHIP R 22 J 1/16W		R827			RK73HB1J103J	CHIP R 10K J 1/16W	
R639			RK73HB1J000J	CHIP R 0.0 J 1/16W		R828			RK73HB1J224J	CHIP R 220K J 1/16W	
R640			RK73HB1J102J	CHIP R 1.0K J 1/16W		R829			RK73HB1J220J	CHIP R 22 J 1/16W	
R641			RK73HB1J000J	CHIP R 0.0 J 1/16W		R830			RK73HB1J334J	CHIP R 330K J 1/16W	
R642,643			RK73HB1J104J	CHIP R 100K J 1/16W		R831			RK73HB1J563J	CHIP R 56K J 1/16W	
R644			RK73HB1J103J	CHIP R 10K J 1/16W		R832			RK73HB1J683J	CHIP R 68K J 1/16W	
R645			RK73HB1J220J	CHIP R 22 J 1/16W		R833-835			RK73HB1J101J	CHIP R 100 J 1/16W	
R646			RK73HB1J000J	CHIP R 0.0 J 1/16W		R837			RK73HB1J000J	CHIP R 0.0 J 1/16W	
R647			RK73HB1J102J	CHIP R 1.0K J 1/16W		R838			RK73HB1J101J	CHIP R 100 J 1/16W	
R648			RK73HB1J274J	CHIP R 270K J 1/16W		R840,841			RK73HB1J101J	CHIP R 100 J 1/16W	
R649			RK73HB1J000J	CHIP R 0.0 J 1/16W		R842-849			RK73HB1J104J	CHIP R 100K J 1/16W	
R650-652			RK73HB1J102J	CHIP R 1.0K J 1/16W		R850,851			RK73HB1J000J	CHIP R 0.0 J 1/16W	
R653			RK73HB1J124J	CHIP R 120K J 1/16W		R853			RK73HB1J000J	CHIP R 0.0 J 1/16W	
R654			RK73HB1J333J	CHIP R 33K J 1/16W		R855			RK73HB1J000J	CHIP R 0.0 J 1/16W	
R655			RK73HB1J394J	CHIP R 390K J 1/16W		R856			RK73GB2A220J	CHIP R 22 J 1/10W	
R656			RK73HB1J106J	CHIP R 10M J 1/16W		R860,861			RK73HB1J000J	CHIP R 0.0 J 1/16W	
R657			RK73HB1J223J	CHIP R 22K J 1/16W		D100,101			1SV283F	VARIABLE CAPACITANCE DIODE	
R658			RK73HB1J103J	CHIP R 10K J 1/16W		D103-108			1SV283F	VARIABLE CAPACITANCE DIODE	
R659			RK73HB1J224J	CHIP R 220K J 1/16W		D200			DA221	DIODE	
R660			RK73HB1J334J	CHIP R 330K J 1/16W		D500,501			UDZS3.0B	ZENER DIODE	
R661			RK73HB1J393J	CHIP R 39K J 1/16W		D503			HSM88AS-E	DIODE	
R663			RK73HB1J000J	CHIP R 0.0 J 1/16W		D504,505	*		JDP4P02AT	DIODE	
R665			RK73HB1J000J	CHIP R 0.0 J 1/16W		D600			DA221	DIODE	
R666			RK73HB1J101J	CHIP R 100 J 1/16W		D601			HVC131	DIODE	
R668			RK73HB1J472J	CHIP R 4.7K J 1/16W		D801			1SS388F	DIODE	
R669			RK73HB1J182J	CHIP R 1.8K J 1/16W		IC100,101			LMC7101BIM5	MOS-IC	
R670			RK73HB1J181J	CHIP R 180 J 1/16W		IC200			TC75W51FK(F)	MOS-IC	
R671			RK73HB1J220J	CHIP R 22 J 1/16W		IC201			LMC7101BIM5	MOS-IC	
R680			RK73HB1J821J	CHIP R 820 J 1/16W		IC203			TC7SH126FU-F	MOS-IC	
R681			RK73HB1J5R6J	CHIP R 5.6 J 1/16W		IC300	*		ADL5350ACPZ	MOS-IC	
R682			RK73HB1J821J	CHIP R 820 J 1/16W		IC400			AD8051ART	ANALOGUE IC	
R683-685			RK73HB1J000J	CHIP R 0.0 J 1/16W		IC401			TC75W51FK(F)	MOS-IC	
R686,687			RK73HB1J472J	CHIP R 4.7K J 1/16W		IC402			LMC7101BIM5	MOS-IC	
R688			RK73HB1J330J	CHIP R 33 J 1/16W		IC403	*		NJM2287V	MOS-IC	
R689,690			RK73HB1J181J	CHIP R 180 J 1/16W		IC404			MCP6021-E/OT	MOS-IC	
R700			RK73HB1J330J	CHIP R 33 J 1/16W		IC405-408			TC7W53FK(F)	MOS-IC	
R701			RK73HB1J100J	CHIP R 10 J 1/16W		IC409			TC75W51FK(F)	MOS-IC	
R702			RK73HB1J473J	CHIP R 47K J 1/16W		IC500			TC75W51FK(F)	MOS-IC	
R703			RK73HB1J000J	CHIP R 0.0 J 1/16W		IC501			TC75S59F-F	MOS-IC	
R704			RK73HB1J472J	CHIP R 4.7K J 1/16W		IC600,601			TC7WH126FU-F	MOS-IC	
R705			RK73HB1J104J	CHIP R 100K J 1/16W		IC602			ADF4001BRUZ	MOS-IC	
R706			RK73HB1J102J	CHIP R 1.0K J 1/16W		IC603			TC75S51FE(F)	MOS-IC	
R707			RK73HB1J154J	CHIP R 150K J 1/16W		IC604			LMC7101BIM5	MOS-IC	
R708,709			RK73HB1J473J	CHIP R 47K J 1/16W		IC605			TC75S51FE(F)	MOS-IC	
R710			RK73HB1J472J	CHIP R 4.7K J 1/16W		IC606,607			LMC7101BIM5	MOS-IC	
R711			RK73HB1J123J	CHIP R 12K J 1/16W		IC608			TC75W51FK(F)	MOS-IC	
R712			RK73HB1J474J	CHIP R 470K J 1/16W		IC700			NJM78M05DL1AZB	ANALOGUE IC	
R713			RK73HH1J334D	CHIP R 330K D 1/16W		IC701			XC9101D09AKR	ANALOGUE IC	
R714			RK73HH1J223D	CHIP R 22K D 1/16W							

## PARTS LIST

**TX-RX UNIT (X57-7950-10)**  
**RX VCO/PLL UNIT (X58-5090-10)**

Ref. No.	Address	New parts	Parts No.	Description	Desti-nation	Ref. No.	Address	New parts	Parts No.	Description	Desti-nation
IC702			NJM78M08FA-ZB	ANALOGUE IC		C329			CK73HB1H471K	CHIP C 470PF K	
IC703			TK71733S	BI-POLAR IC		C330			CC73HCH1H040B	CHIP C 4.0PF B	
IC704			TK11230CMCL-G	BI-POLAR IC		C331			CK73HB1H471K	CHIP C 470PF K	
IC800			LM73CIMKX-0	MOS-IC		C332			CC73HCH1H100C	CHIP C 10PF C	
IC801			TC75S51FE(F)	MOS-IC		C333			CK73HB1E103K	CHIP C 0.010UF K	
IC802		*	M24C02-RMN6TP	ROM IC		C335			CC73HCH1H101J	CHIP C 100PF J	
IC803			TC75W51FK(F)	MOS-IC		C352,353			CC73HCH1H101J	CHIP C 100PF J	
IC804			M62364FP-F	MOS-IC		C354,355			CC73GCH1H390J	CHIP C 39PF J	
IC805		*	MCP23S08TE/ML	MOS-IC		C356,357			CK73HB1H471K	CHIP C 470PF K	
IC806			TC7W53FK(F)	MOS-IC		C358,359			CK73HB1E103K	CHIP C 0.010UF K	
Q100			2SC5383-T111	TRANSISTOR		C360,361			CK73HB1H471K	CHIP C 470PF K	
Q101			2SC5337	TRANSISTOR		C362			CC73GCH1H270G	CHIP C 27PF G	
Q200,201			2SC5383-T111	TRANSISTOR		C363			CC73GCH1H180G	CHIP C 18PF G	
Q202,203			2SC5636	TRANSISTOR		C364			CC73GCH1H060B	CHIP C 6.0PF B	
Q300			3SK294-FP	FET		C365			CC73GCH1H040B	CHIP C 4.0PF B	
Q301			2SC5337	TRANSISTOR		C366,367			CK73HB1H471K	CHIP C 470PF K	
Q500			SSM6L05FU-F	FET		C368			CC73GCH1H100C	CHIP C 10PF C	
Q501			2SC4617(R)	TRANSISTOR		C369			CC73GCH1H080B	CHIP C 8.0PF B	
Q502		*	2SK3737-5	FET		C370			CC73GCH1H060B	CHIP C 6.0PF B	
Q503			3SK294-FP	FET		C371			CC73GCH1H050B	CHIP C 5.0PF B	
Q504			2SC4617(R)	TRANSISTOR		C372			CC73GCH1H040B	CHIP C 4.0PF B	
Q505			SSM3K15TE(F)	FET		C373			CC73GCH1H030B	CHIP C 3.0PF B	
Q506			SSM6L05FU-F	FET		C374,375			CC73GCH1H0R5B	CHIP C 0.5PF B	
Q507			UPA672T-A	FET		C376,377			CK73HB1H471K	CHIP C 470PF K	
Q600			SSM3K15TE(F)	FET		C378			CC73HCH1H040C	CHIP C 4.0PF C	
Q601			2SA1832(GR)F	TRANSISTOR		C379			C93-0787-05	CHIP C 0.1UF J	
Q602,603			2SC4617(R)	TRANSISTOR		C380,381			CC73GCH1H020B	CHIP C 2.0PF B	
Q604,605			2SC5383-T111	TRANSISTOR		C382,383			CC73GCH1H050B	CHIP C 5.0PF B	
Q606			2SC5636	TRANSISTOR		CN303		*	E40-5816-05	PIN ASSY	
Q607			SSM3K15TE(F)	FET		CN350			E40-6860-05	PIN ASSY	
Q700			CPH3317	FET		CN351			E40-6098-05	PIN ASSY	
Q701			SSM3K15TE(F)	FET		-			F10-2377-04	SHIELDING CASE	
Q702			2SJ506-E(S)	FET		L300			L92-0163-05	BEADS CORE	
Q703			RT1N141M-T111	TRANSISTOR		L303			L41-1295-33	SMALL FIXED INDUCTOR (1.2UH)	
Q704			SSM5H01TU-F	FET		L305,306			L92-0163-05	BEADS CORE	
Q705			CPH3317	FET		L309			L41-2278-14	SMALL FIXED INDUCTOR (22NH)	
Q706			SSM3K15TE(F)	FET		L310			L92-0163-05	BEADS CORE	
Q800			SSM3K15TE(F)	FET		L312,313			L92-0163-05	BEADS CORE	
<b>RX VCO/PLL UNIT (X58-5090-10)</b>						L315			L41-3378-14	SMALL FIXED INDUCTOR (33NH)	
C300			CS77CA1VR15M	CHIP TNL 0.15UF 35WV		L316			L41-2278-14	SMALL FIXED INDUCTOR (22NH)	
C303			CS77BA1D100M	CHIP TNL 10UF 20WV		L350-357			L41-1095-33	SMALL FIXED INDUCTOR (1.0UH)	
C304			CC73GCH1H100C	CHIP C 10PF C		L358,359			L34-4607-15	AIR-CORE COIL	
C306			CC73GCH1H100C	CHIP C 10PF C		L360,361			L41-1098-40	SMALL FIXED INDUCTOR (1000NH)	
C307			CS77CA1V0R1M	CHIP TNL 0.1UF 35WV		L362,363			L41-1095-33	SMALL FIXED INDUCTOR (1.0UH)	
C308-310			CK73HB1E103K	CHIP C 0.010UF K		L364			L41-2275-33	SMALL FIXED INDUCTOR (0.022UH)	
C311			CK73HB1H471K	CHIP C 470PF K		R301			RK73GB2A391J	CHIP R 390 J 1/10W	
C312			CC73GCH1H070B	CHIP C 7.0PF B		R302			RK73GB2A151J	CHIP R 150 J 1/10W	
C313			CC73HCH1H101J	CHIP C 100PF J		R303			RK73GB2A000J	CHIP R 0.0 J 1/10W	
C314			CS77BA1E010M	CHIP TNL 1.0UF 25WV		R304			RK73HB1J472J	CHIP R 4.7K J 1/16W	
C315,316			CC73HCH1H101J	CHIP C 100PF J		R305			RK73GB2A000J	CHIP R 0.0 J 1/10W	
C317			CK73HB1E103K	CHIP C 0.010UF K		R306			RK73HB1J100J	CHIP R 10 J 1/16W	
C318			CC73HCH1H101J	CHIP C 100PF J		R307			RK73HB1J470J	CHIP R 47 J 1/16W	
C320-322			CC73GCH1H101J	CHIP C 100PF J		R308			RK73HB1J100J	CHIP R 10 J 1/16W	
C324			CC73HCH1H101J	CHIP C 100PF J		R310			RK73HB1J102J	CHIP R 1.0K J 1/16W	
C325			CC73GCH1H120G	CHIP C 12PF G		R311			RK73HB1J100J	CHIP R 10 J 1/16W	
C326			CC73HCH1H101J	CHIP C 100PF J		R312			RK73HB1J330J	CHIP R 33 J 1/16W	
C328			CC73GCH1H070B	CHIP C 7.0PF B		R313			RK73HB1J103J	CHIP R 10K J 1/16W	
						R314			RK73HB1J472J	CHIP R 4.7K J 1/16W	

## PARTS LIST

### RX VCO/PLL UNIT (X58-5090-10)

### TX VCO/PLL UNIT (X58-5100-10)

Ref. No.	Address	New parts	Parts No.	Description	Destination	Ref. No.	Address	New parts	Parts No.	Description	Destination
R315			RK73HB1J101J	CHIP R 100 J 1/16W		C330			CC73HCH1H3R5B	CHIP C 3.5PF B	
R316			RK73HB1J100J	CHIP R 10 J 1/16W		C331,332			CK73HB1H471K	CHIP C 470PF K	
R317			RK73HB1J101J	CHIP R 100 J 1/16W		C333			CK73HB1E103K	CHIP C 0.010UF K	
R318			RK73HB1J121J	CHIP R 120 J 1/16W		C335			CC73HCH1H101J	CHIP C 100PF J	
R319			RK73HB1J151J	CHIP R 150 J 1/16W		C350			C93-0787-05	CHIP C 0.1UF J	
R320			RK73HB1J223J	CHIP R 22K J 1/16W		C354,355			CK73GB1H471K	CHIP C 470PF K	
R321			RK73HB1J103J	CHIP R 10K J 1/16W		C356,357			CK73HB1H471K	CHIP C 470PF K	
R322			RK73HB1J8R2J	CHIP R 8.2 J 1/16W		C358,359			CK73HB1E103K	CHIP C 0.010UF K	
R323			RK73HB1J151J	CHIP R 150 J 1/16W		C360,361			CK73HB1H471K	CHIP C 470PF K	
R324			RK73HB1J8R2J	CHIP R 8.2 J 1/16W		C362,363			CC73GCH1H120J	CHIP C 12PF J	
R325			RK73GB2A000J	CHIP R 0.0 J 1/10W		C364			CC73GCH1H0R5B	CHIP C 0.5PF B	
R327			RK73GB2A000J	CHIP R 0.0 J 1/10W		C365			CC73GCH1H010B	CHIP C 1.0PF B	
R331			RK73GB2A000J	CHIP R 0.0 J 1/10W		C366,367			CK73HB1H471K	CHIP C 470PF K	
R333			RK73HB1J000J	CHIP R 0.0 J 1/16W		C368			CC73GCH1H060B	CHIP C 6.0PF B	
R350,351			RK73HB1J474J	CHIP R 470K J 1/16W		C369-373			CC73GCH1H050B	CHIP C 5.0PF B	
R352			RK73HB1J000J	CHIP R 0.0 J 1/16W		C374,375			CC73GCH1H0R5B	CHIP C 0.5PF B	
R354			RK73HB1J474J	CHIP R 470K J 1/16W		C376,377			CK73HB1H471K	CHIP C 470PF K	
R357-360			RK73HB1J000J	CHIP R 0.0 J 1/16W		C378			CC73HCH1H040C	CHIP C 4.0UF C	
R361,362		*	RN73GH1J330D	CHIP R 33 D 1/16W		C379			C93-0787-05	CHIP C 0.1UF J	
R363,364			RN73GH1J271D	CHIP R 270 D 1/16W		C382			CC73GCH1H050B	CHIP C 5.0PF B	
R365,366			RN73GH1J470D	CHIP R 47 D 1/16W		C383			CC73GCH1H030B	CHIP C 3.0PF B	
R367			RK73HB1J330J	CHIP R 33 J 1/16W		CN303			E40-5816-05	PIN ASSY	
R368			RN73GH1J333D	CHIP R 33K D 1/16W		CN350		*	E40-6860-05	PIN ASSY	
R369			RN73GH1J103D	CHIP R 10K D 1/16W		CN351			E40-6098-05	PIN ASSY	
R370			RK73HB1J101J	CHIP R 100 J 1/16W		-			F10-2377-04	SHIELDING CASE	
R372			RK73HB1J000J	CHIP R 0.0 J 1/16W		L300			L92-0163-05	BEADS CORE	
R374			RK73GB2A000J	CHIP R 0.0 J 1/10W		L303			L41-1295-33	SMALL FIXED INDUCTOR (1.2UH)	
R377			RK73GB2A000J	CHIP R 0.0 J 1/10W		L305,306			L92-0163-05	BEADS CORE	
R379			RK73HB1J000J	CHIP R 0.0 J 1/16W		L307			L41-1078-14	SMALL FIXED INDUCTOR (10NH)	
D352,353			1SV325F	VARIABLE CAPACITANCE DIODE		L309			L41-4778-14	SMALL FIXED INDUCTOR (47NH)	
D355			1SV282-F	VARIABLE CAPACITANCE DIODE		L310			L92-0163-05	BEADS CORE	
D357-361			1SV282-F	VARIABLE CAPACITANCE DIODE		L312,313			L92-0163-05	BEADS CORE	
IC300			SKY72300-362	MOS-IC		L314			L41-1078-14	SMALL FIXED INDUCTOR (10NH)	
Q300			2SC5636	TRANSISTOR		L315			L41-3978-14	SMALL FIXED INDUCTOR (39NH)	
Q350,351			SSM6L05FU-F	FET		L350-357			L41-1095-33	SMALL FIXED INDUCTOR (1.0UH)	
Q352,353		*	MCH3914(8)-H	FET		L358			L34-4608-15	AIR-CORE COIL	
Q354			2SC5636	TRANSISTOR		L359			L34-4607-15	AIR-CORE COIL	
<b>TX VCO/PLL UNIT (X58-5100-10)</b>						L360,361			L41-1005-33	SMALL FIXED INDUCTOR (10UH)	
C300			C92-0863-05	CHIP TNTL 0.047UF 35WV		L362,363			L41-1095-33	SMALL FIXED INDUCTOR (1.0UH)	
C303			CS77BA1D100M	CHIP TNTL 10UF 20WV		L364			L41-1875-33	SMALL FIXED INDUCTOR (0.018UH)	
C304			CC73GCH1H100C	CHIP C 10PF C		R301			RK73GB2A391J	CHIP R 390 J 1/10W	
C306			CC73GCH1H100C	CHIP C 10PF C		R302			RK73GB2A151J	CHIP R 150 J 1/10W	
C307			CS77CA1VR15M	CHIP TNTL 0.15UF 35WV		R303			RK73GB2A000J	CHIP R 0.0 J 1/10W	
C308-310			CK73HB1E103K	CHIP C 0.010UF K		R305			RK73GB2A000J	CHIP R 0.0 J 1/10W	
C311			CK73HB1H471K	CHIP C 470PF K		R306			RK73HB1J100J	CHIP R 10 J 1/16W	
C312			CC73GCH1H120G	CHIP C 12PF G		R307			RK73HB1J560J	CHIP R 56 J 1/16W	
C313			CC73HCH1H101J	CHIP C 100PF J		R308			RK73HB1J100J	CHIP R 10 J 1/16W	
C314			CS77BA1E010M	CHIP TNTL 1.0UF 25WV		R310			RK73HB1J102J	CHIP R 1.0K J 1/16W	
C315,316			CC73HCH1H101J	CHIP C 100PF J		R311			RK73HB1J100J	CHIP R 10 J 1/16W	
C317			CK73HB1E103K	CHIP C 0.010UF K		R312			RK73HB1J470J	CHIP R 47 J 1/16W	
C318			CC73HCH1H101J	CHIP C 100PF J		R313			RK73HB1J473J	CHIP R 47K J 1/16W	
C320-322			CC73HCH1H101J	CHIP C 100PF J		R315			RK73HB1J101J	CHIP R 100 J 1/16W	
C323			CC73GCH1H030B	CHIP C 3.0PF B		R316			RK73HB1J100J	CHIP R 10 J 1/16W	
C324			CC73HCH1H101J	CHIP C 100PF J		R317			RK73HB1J101J	CHIP R 100 J 1/16W	
C326			CC73HCH1H101J	CHIP C 100PF J		R318			RK73HB1J222J	CHIP R 2.2K J 1/16W	
C328			CC73GCH1H120G	CHIP C 12PF G		R319			RK73HB1J391J	CHIP R 390 J 1/16W	
C329			CK73HB1H471K	CHIP C 470PF K		R320			RK73HB1J103J	CHIP R 10K J 1/16W	
						R321			RK73HB1J562J	CHIP R 5.6K J 1/16W	

## PARTS LIST

TX VCO/PLL UNIT (X58-5100-10)

Ref. No.	Address	New parts	Parts No.	Description	Destination	Ref. No.	Address	New parts	Parts No.	Description	Destination
R322			RK73HB1J220J	CHIP R 22 J 1/16W							
R323			RK73HB1J470J	CHIP R 47 J 1/16W							
R324			RK73HB1J220J	CHIP R 22 J 1/16W							
R325			RK73GB2A000J	CHIP R 0.0 J 1/10W							
R327			RK73GB2A000J	CHIP R 0.0 J 1/10W							
R331			RK73GB2A000J	CHIP R 0.0 J 1/10W							
R333			RK73HB1J000J	CHIP R 0.0 J 1/16W							
R350,351			RK73HB1J474J	CHIP R 470K J 1/16W							
R353			RK73HB1J000J	CHIP R 0.0 J 1/16W							
R354			RK73HB1J474J	CHIP R 470K J 1/16W							
R355			RK73HB1J103J	CHIP R 10K J 1/16W							
R356			RK73HB1J180J	CHIP R 18 J 1/16W							
R357-360			RK73HB1J000J	CHIP R 0.0 J 1/16W							
R361,362		*	RN73GH1J330D	CHIP R 33 D 1/16W							
R363,364			RN73GH1J271D	CHIP R 270 D 1/16W							
R365,366			RN73GH1J470D	CHIP R 47 D 1/16W							
R367			RK73HB1J330J	CHIP R 33 J 1/16W							
R368			RN73GH1J333D	CHIP R 33K D 1/16W							
R369			RN73GH1J103D	CHIP R 10K D 1/16W							
R370			RK73HB1J820J	CHIP R 82 J 1/16W							
R372			RK73HB1J000J	CHIP R 0.0 J 1/16W							
R373			RK73HB1J474J	CHIP R 470K J 1/16W							
R374			RK73GB2A000J	CHIP R 0.0 J 1/10W							
R377			RK73GB2A000J	CHIP R 0.0 J 1/10W							
R379			RK73HB1J000J	CHIP R 0.0 J 1/16W							
D352,353			1SV278F	VARIABLE CAPACITANCE DIODE							
D355			1SV282-F	VARIABLE CAPACITANCE DIODE							
D357			1SV282-F	VARIABLE CAPACITANCE DIODE							
D358-361			1SV278F	VARIABLE CAPACITANCE DIODE							
IC300			SKY72300-362	MOS-IC							
Q300			2SC5636	TRANSISTOR							
Q350,351			SSM6L05FU-F	FET							
Q352,353		*	MCH3914(8)-H	FET							
Q354			2SC5636	TRANSISTOR							







## EXPLODED VIEW

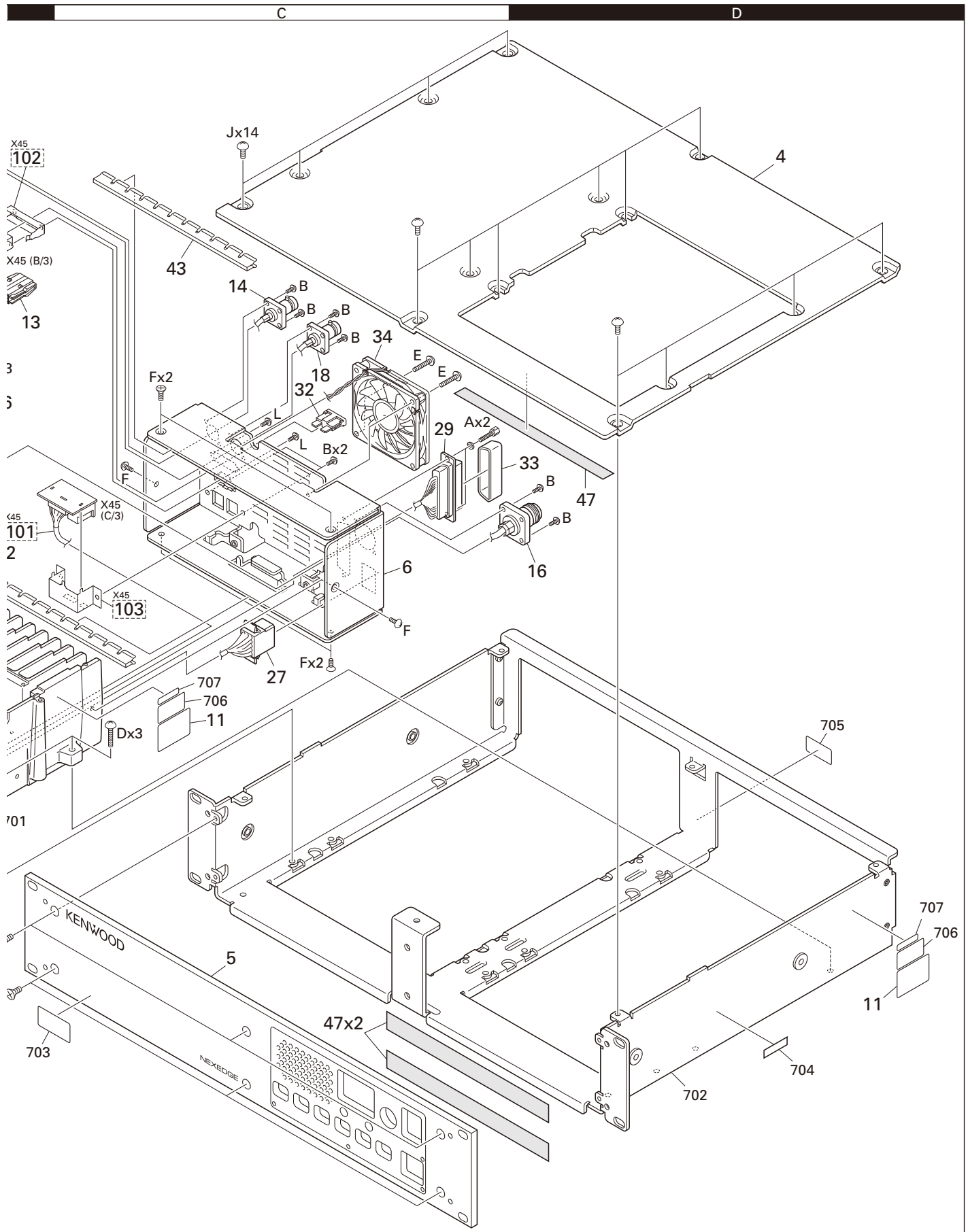

Parts with the exploded numbers larger than 700 are not supplied.  
 If a part reference number is listed in a box on the exploded view of the PCB, that part does not come with the PCB.  
 These parts must be ordered separately.

## PACKING

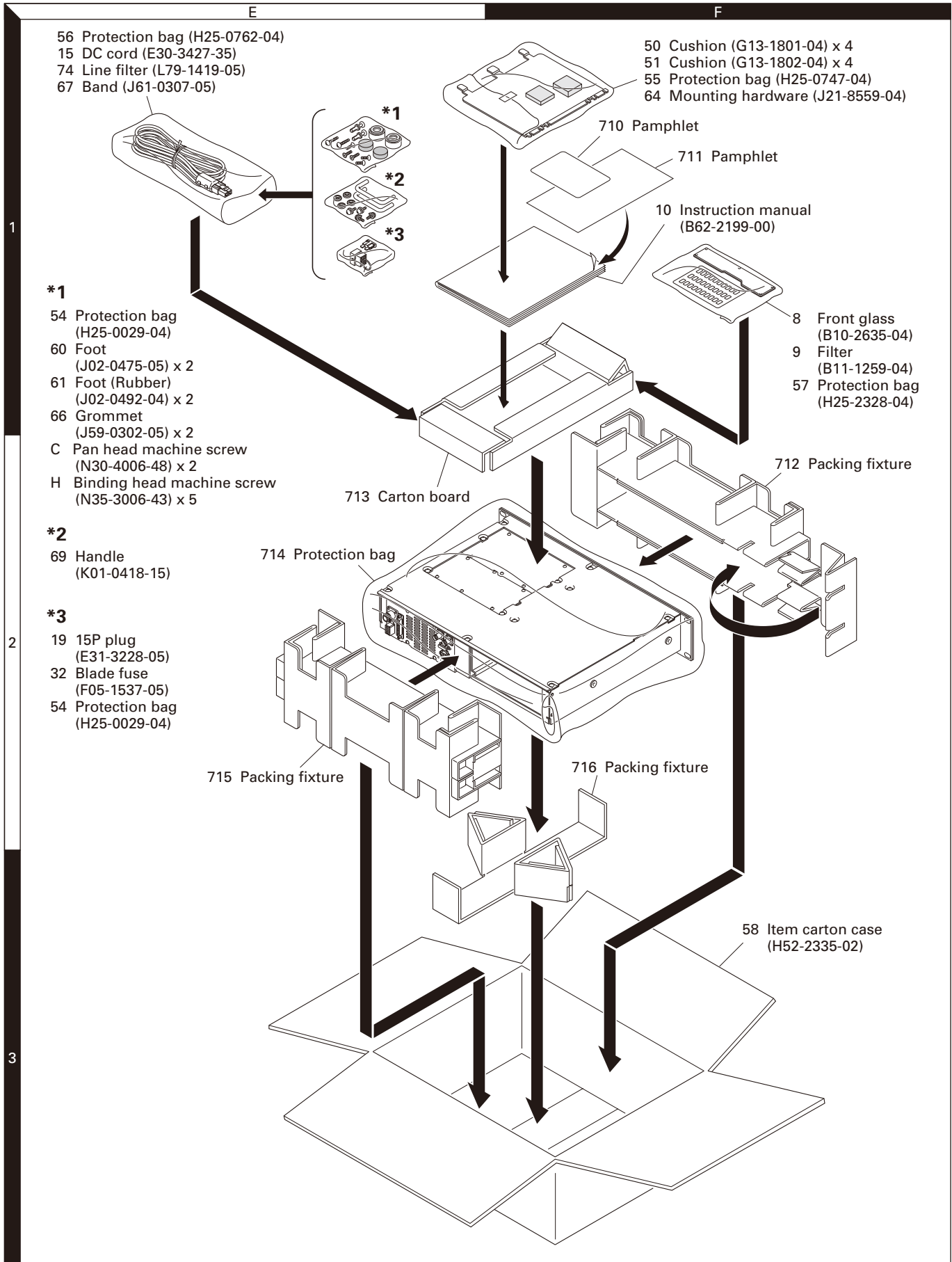

## ADJUSTMENT

### Test Equipment Required for Alignment

Test Equipment	Major Specifications	
1. Standard Signal Generator (SSG)	Frequency Range Modulation Output When performing the Frequency adjustment, the following accuracy is necessary. • 0.001ppm Use a standard oscillator for adjustments, if necessary.	400 to 470MHz Frequency modulation and external modulation -127dBm/0.1μV to greater than -20dBm/22.4mV
2. Power Meter	Input Impedance Operation Frequency Measurement Capability	50Ω 400 to 470MHz or more Vicinity of 100W
3. Deviation Meter	Frequency Range	400 to 470MHz
4. Digital Volt Meter (DVM)	Measuring Range Input Impedance	1V to 20V DC High input impedance for minimum circuit loading
5. Oscilloscope		DC through 30MHz
6. High Sensitivity Frequency Counter	Frequency Range Frequency Stability	10Hz to 600MHz 0.2ppm or less
7. Ammeter		15A or more
8. AF Volt Meter (AF V.M)	Frequency Range Voltage Range	50Hz to 10kHz 3mV to 3V
9. Audio Generator (AG)	Frequency Range Output	50Hz to 5kHz 0 to 1V
10. Distortion Meter	Capability Input Level	3% or less at 1kHz 50mV to 10Vrms
11. Voltmeter	Measuring Range Input Impedance	10V to 1.5V DC or less 50kΩ/V or greater
12. 4Ω Dummy Load		Approx. 4Ω, 5W

### Test cable for microphone input (E30-3360-28)

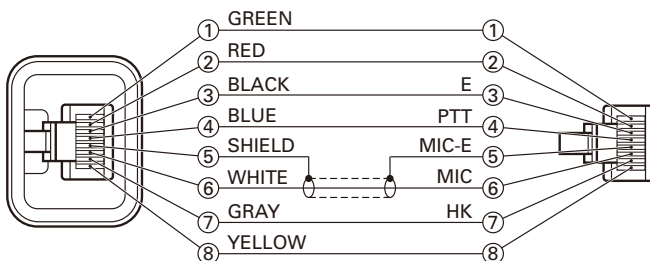

### Tuning cable (E30-3383-05)

Adapter cable (E30-3383-05) is required for injecting an audio if PC tuning is used. See "PC Mode" section for the connection.

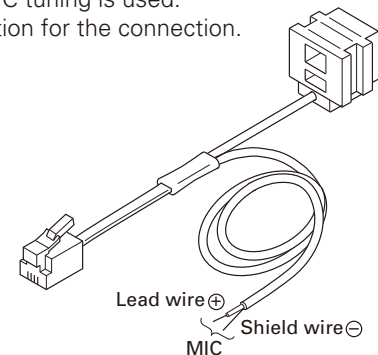

### MIC connector (Front panel view)

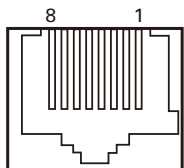

- 1: NC
- 2: SB
- 3: GND
- 4: PTT/TXD  
(PC serial data from transceiver)
- 5: MIC GND
- 6: MIC
- 7: HOOK/RXD  
(PC serial data to transceiver)
- 8: NC

### Flat cable (36-pin) about 256mm

To connect the Control unit (CN38) to the TX-RX unit (CN800) while in servicing, you can use the 36-pin flat cable, E37-0979-05, which is available from the KENWOOD parts center.

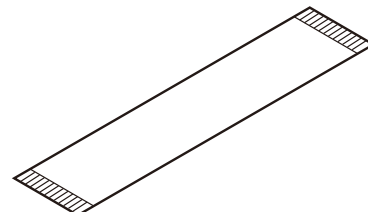

## ADJUSTMENT

### Test Channel

No.	RX	TX
1	435.050000MHz	435.100000MHz
2	400.050000MHz	400.100000MHz
3	469.950000MHz	469.900000MHz
4	435.000000MHz	435.000000MHz
5	435.200000MHz	435.200000MHz
6	435.400000MHz	435.400000MHz
7~16	Blank	Blank

### Test Signaling (Analog)

No.	RX (Decode Signaling)	TX (Encode Signaling)
1	None	None
2	None	100Hz Square Wave
3	QT 67.0Hz	QT 67.0Hz
4	QT 151.4Hz	QT 151.4Hz
5	QT 210.7Hz	QT 210.7Hz
6	QT 254.1Hz	QT 254.1Hz
7	DQT D023N	DQT D023N
8	DQT D754I	DQT D754I
9	None	CWID Encode (ID: VVV)
10	None	Single Tone
11	DTMF Decode (CODE: 159D)	DTMF Encode (CODE: 159D)
12	None	DTMF Encode (CODE: 9)
13	None	Courtesy Tone

### Test Signaling (NXDN)

No.	RX (Decode Signaling)	TX (Encode Signaling)
1	RAN 1	RAN 1
2	RAN 1	PN 9
3	RAN 1	Maximum Deviation Pattern

- Signaling number 1 is used for link test.
- Signaling number 2 is used for TX modulation signal quality test. i.e, TX adjacent channel power, FSK error, Occupied bandwidth, Emission mask, etc.
- Signaling number 3 is used for TX deviation test. If the modulation mode is very narrow, the modulation frequency is 600Hz. If the modulation mode is narrow, the modulation frequency is 1200Hz.

### Adjustment Points

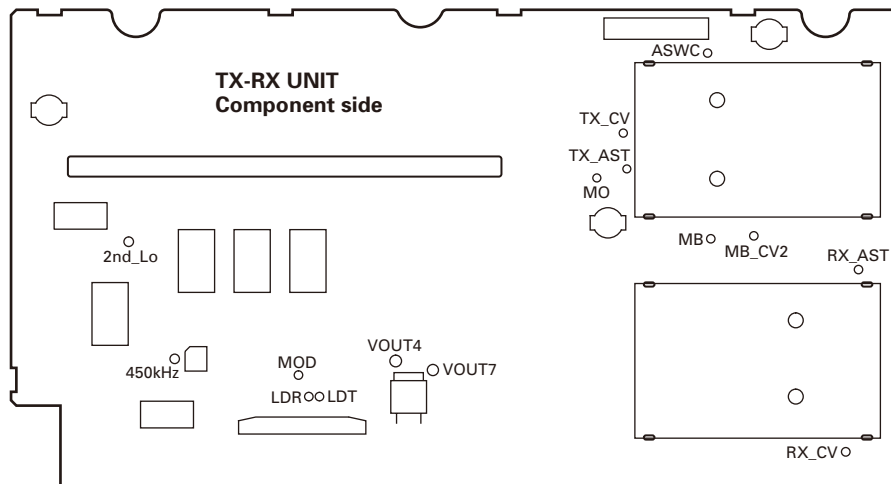

## ADJUSTMENT

### Common Section

Item	Condition	Measurement			Adjustment			Specifications / Remarks
		Test-equipment	Unit	Terminal	Unit	Parts	Method	
1. Setting	1) Connect the unit to a suitable power supply (13.6V). 2) Turn the power switch on after connecting a PC and FPU cable to the radio. 3) Start up the program for the adjustment.							
2. RX Assist voltage Adjust	FPU Test mode 1) Adjust Item: [Receive Assist] 2) Adjust Item: [A: Low], [A: Center], [A: High], [B: Low], [B: Center], [B: High]					PC ADJ	3.0V	$\pm 0.1V$  [V] indicator on the PC window shows "VCO lock voltage". Change the adjustment value to get "VCO lock voltage" within the limit of the specified voltage.  Press [Apply All] button to store the adjustment value.  Confirm the VCO lock voltage approximately 3 seconds after the adjustment value is changed.
	3) Adjust Item: [A: Low], [A: Center], [A: High], [B: Low], [B: Center], [B: High]	DVM	TX-RX	RX_CV			Check	$3.0V \pm 0.1V$
3. TX Assist voltage Adjust	FPU Test mode 1) Adjust Item: [Transmit Assist] 2) Adjust Item: [A: Low], [A: Center], [A: High], [B: Low], [B: Center], [B: High] Press [Transmit] button.					PC ADJ	3.0V	$\pm 0.1V$  [V] indicator on the PC window shows "VCO lock voltage". Change the adjustment value to get "VCO lock voltage" within the limit of the specified voltage.  Press [Apply All] button to store the adjustment value.  Confirm the VCO lock voltage approximately 3 seconds after the adjustment value is changed.
	3) Adjust Item: [A: Low], [A: Center], [A: High], [B: Low], [B: Center], [B: High] Press [Transmit] button.	DVM	TX-RX	TX_CV			Check	$3.0V \pm 0.1V$
4. Sensitivity 1 Adjust BPF Adjust	FPU Test mode 1) Adjust Item: [Sensitivity 1] 2) Adjust Item: [Low], [Low'], [Center], [High'], [High]					PC ADJ	Write the value as followings (typical value) [Low] = 25 [Low'] = 70 [Center] = 100 [High'] = 145 [High] = 205	Press [Apply All] button to store the adjustment value.  Variable-Capacitor Tune voltage is adjusted. (Output voltage is adjustment of BPF)

## ADJUSTMENT

Item	Condition	Measurement			Adjustment			Specifications / Remarks
		Test-equipment	Unit	Terminal	Unit	Parts	Method	
5. Sensitivity 2 Adjust BPF Adjust	FPU Test mode 1) Adjust Item: [Sensitivity 2] 2) Adjust Item: [Low], [Low'], [Center], [High'], [High]					PC ADJ	Write the value as followings (typical value) [Low] = 25 [Low'] = 70 [Center] = 100 [High'] = 145 [High] = 205	Press [Apply All] button to store the adjustment value.  Variable-Capacitor Tune voltage is adjusted. (Output voltage is adjustment of BPF)
6. AGC Target Level adjust	FPU Test mode 1) Adjust Item: [AGC Target Level Adjustment]						Write the value as followings (typical value) [AGC Target Level Adjustment] = -18	Press [Apply] button to store the adjustment value.
7. AGC adjustment [Analog Narrow]	FPU Test mode 1) Adjust Item: [AGC Adjustment (Analog Narrow)] 2) Adjust Item: [Low], [Low'], [Center], [High'], [High]						Write the value as followings (typical value) [Low] = 256 [Low'] = 256 [Center] = 256 [High'] = 256 [High] = 256	Press [Apply All] button to store the adjustment value.
8. AGC adjustment [Analog Wide]	FPU Test mode 1) Adjust Item: [AGC Adjustment (Analog Wide)] 2) Adjust Item: [Low], [Low'], [Center], [High'], [High]							
9. AGC adjustment [NXDN Very Narrow]	FPU Test mode 1) Adjust Item: [AGC Adjustment (NXDN Very Narrow)] 2) Adjust Item: [Low], [Low'], [Center], [High'], [High]							
10. Frequency Adjust	FPU Test mode 1) Adjust Item: [Frequency] Connect the SSG to the RX ANT. CH: 1 (Analog Narrow) SSG Output: -47dBm (1mV) (CW (without modulation)) <b>Caution:</b> Perform the frequency adjustment under the following condition. • Temperature range of +23°C to +27°C (+73.4°F to +80.6°F). (The temperature is displayed on the frequency adjustment screen of the KPG-129D.) • Use an accuracy of 0.001ppm for the SSG. (Use a standard oscillator if necessary.)	SSG	Rear	RX ANT		PC ADJ		Press [Start] button of [Auto Tuning]. Press [Apply] Button to store the adjustment value after the automatic adjustment was finished.

## ADJUSTMENT

### Receiver Section

Item	Condition	Measurement			Adjustment			Specifications / Remarks
		Test-equipment	Unit	Terminal	Unit	Parts	Method	
1. RD Output level Adjust [Analog Wide]	FPU Test mode 1) Adjust Item: [RD Level (Analog Wide)] Connect the SSG to the RX ANT. SSG setting Frequency: Desired Frequency Output: -53dBm (501μV) MOD: 1.0kHz DEV: ±3.0kHz	SSG	Rear	RX ANT		PC ADJ	80mV	±5mV  Press [Apply] button to store the adjustment value.
		AF VTVM		Control I/O Jack RD (Pin No.10)				
2. RD Output level Adjust [Analog Narrow]	FPU Test mode 1) Adjust Item: [RD Level (Analog Narrow)] Connect the SSG to the RX ANT. SSG setting Frequency: Desired Frequency Output: -53dBm (501μV) MOD: 1.0kHz DEV: ±1.5kHz							
3. RA Output level Adjust [Analog Wide]	FPU Test mode 1) Adjust Item: [RA Level (Analog Wide)] Connect the SSG to the RX ANT. SSG setting Frequency: Desired Frequency Output: -53dBm (501μV) MOD: 1.0kHz DEV: ±3.0kHz	SSG	Rear	RX ANT		PC ADJ	400mV	±20mV  Press [Apply] button to store the adjustment value.
		AF VTVM		Control I/O Jack RA (Pin No.11)				
4. RA Output level Adjust [Analog Narrow]	FPU Test mode 1) Adjust Item: [RA Level (Analog Narrow)] Connect the SSG to the RX ANT. SSG setting Frequency: Desired Frequency Output: -53dBm (501μV) MOD: 1.0kHz DEV: ±1.5kHz							
5. Open Squelch Adjust [Analog Wide]	FPU Test mode 1) Adjust Item: [Open Squelch (Analog Wide)] Connect the SSG to the RX ANT. SSG setting Frequency: [Low], [Low'], [Center], [High'], [High] Output : 12dB SINAD level -1dB MOD: 1.0kHz DEV: ±3.0kHz	SSG	Rear	RX ANT		PC ADJ		Press [Apply] button to store the adjustment value.  <b>Note:</b> Write the fixed value of "33" when the adjustment value is 27 or less.
		Audio analyzer Oscilloscope					Check	



## ADJUSTMENT

Item	Condition	Measurement			Adjustment			Specifications / Remarks
		Test-equipment	Unit	Terminal	Unit	Parts	Method	
6. Open Squelch Adjust [Analog Narrow]	FPU Test mode 1) Adjust Item: [Open Squelch (Analog Narrow)] Connect the SSG to the RX ANT. SSG setting Frequency: [Low], [Low'], [Center], [High'], [High] Output : 12dB SINAD level -1dB MOD: 1.0kHz DEV: ±1.5kHz	SSG Audio analyzer Oscilloscope	Rear	RX ANT		PC ADJ		Press [Apply] button to store the adjustment value.  <b>Note:</b> Write the fixed value of "30" when the adjustment value is 24 or less.
	2) SSG output: OFF							
7. Open Squelch Adjust [NXDN Very Narrow]	FPU Test mode 1) Adjust Item: [Open Squelch (NXDN Very Narrow)] Connect the SSG to the RX ANT. SSG setting Frequency: [Low], [Low'], [Center], [High'], [High] Output: 12dB SINAD level of Analog Narrow -4dB MOD: OFF				PC ADJ		Press [Apply] button to store the adjustment value.	
8. Tight Squelch Adjust [Analog Wide]	FPU Test mode 1) Adjust Item: [Tight Squelch (Analog Wide)] Connect the SSG to the RX ANT. SSG setting Frequency: [Low], [Low'], [Center], [High'], [High] Output : 12dB SINAD level +6dB MOD: 1.0kHz DEV: ±3.0kHz				PC ADJ		Press [Apply] button to store the adjustment value.	
	2) SSG output: OFF					Check	The squelch shall be closed.	
9. Tight Squelch Adjust [Analog Narrow]	FPU Test mode 1) Adjust Item [Tight Squelch (Analog Narrow)] Connect the SSG to the RX ANT. SSG setting Frequency: [Low], [Low'], [Center], [High'], [High] Output : 12dB SINAD level +8dB MOD: 1.0kHz DEV: ±1.5kHz				PC ADJ		Press [Apply] button to store the adjustment value.	
	2) SSG output: OFF					Check	The squelch shall be closed.	

## ADJUSTMENT

Item	Condition	Measurement			Adjustment			Specifications / Remarks
		Test-equipment	Unit	Terminal	Unit	Parts	Method	
10. RSSI Reference Adjust [Analog Wide]	FPU Test mode 1) Adjust Item [RSSI Ref (Analog Wide)] Connect the SSG to the RX ANT. SSG setting Frequency: [Low], [Low'] [Center], [High'], [High] Output : 12dB SINAD level -1dB MOD: 1.0kHz DEV: ±3.0kHz	SSG Audio analyzer	Rear	RX ANT		PC ADJ		Press [Apply] button to store the adjustment value.
11. RSSI Reference Adjust [Analog Narrow]	FPU Test mode 1) Adjust Item [RSSI Ref (Analog Narrow)] Connect the SSG to the RX ANT. SSG setting Frequency: [Low], [Low'] [Center], [High'], [High] Output : 12dB SINAD level -1dB MOD: 1.0kHz DEV: ±1.5kHz							
12. RSSI Reference Adjust [NXDN Very Narrow]	FPU Test mode 1) Adjust Item [RSSI Ref (NXDN Very Narrow)] Connect the SSG to the RX ANT. SSG setting Frequency: [Low], [Low'] [Center], [High'], [High] Output : 12dB SINAD level -1dB MOD: OFF							
13. Low RSSI Adjust [Analog Wide]	FPU Test mode 1) Adjust Item [Low RSSI (Analog Wide)] Connect the SSG to the RX ANT. SSG setting Frequency: [Low], [Low'] [Center], [High'], [High] Output: -118dBm (0.28µV) MOD: 1.0kHz DEV: ±3.0kHz	SSG	Rear	RX ANT		PC ADJ		Press [Apply] button to store the adjustment value.
14. Low RSSI Adjust [Analog Narrow]	FPU Test mode 1) Adjust Item [Low RSSI (Analog Narrow)] Connect the SSG to the RX ANT. SSG setting Frequency: [Low], [Low'] [Center], [High'], [High] Output: -118dBm (0.28µV) MOD: 1.0kHz DEV: ±1.5kHz							

## ADJUSTMENT

Item	Condition	Measurement			Adjustment			Specifications / Remarks
		Test-equipment	Unit	Terminal	Unit	Parts	Method	
15. Low RSSI Adjust [NXDN Very Narrow]	FPU Test mode 1) Adjust Item [Low RSSI (NXDN Very Narrow)] Connect the SSG to the RX ANT. SSG setting Frequency: [Low], [Low'] [Center], [High'], [High] Output: -118dBm (0.28μV) MOD: OFF	SSG	Rear	RX ANT		PC ADJ		Press [Apply] button to store the adjustment value.
16. High RSSI Adjust [Analog Wide]	FPU Test mode 1) Adjust Item [High RSSI (Analog Wide)] Connect the SSG to the RX ANT. SSG setting Frequency: [Low], [Low'] [Center], [High'], [High] Output: -70dBm (70.7μV) MOD: 1.0kHz DEV: ±3.0kHz	SSG	Rear	RX ANT		PC ADJ		Press [Apply] button to store the adjustment value.
17. High RSSI Adjust [Analog Narrow]	FPU Test mode 1) Adjust Item [High RSSI (Analog Narrow)] Connect the SSG to the RX ANT. SSG setting Frequency: [Low], [Low'] [Center], [High'], [High] Output: -70dBm (70.7μV) MOD: 1.0kHz DEV: ±1.5kHz							
18. High RSSI Adjust [NXDN Very Narrow]	FPU Test mode 1) Adjust Item [High RSSI (NXDN Very Narrow)] Connect the SSG to the RX ANT. SSG setting Frequency: [Low], [Low'] [Center], [High'], [High] Output: -70dBm (70.7μV) MOD: OFF							
19. Receiver Sensitivity Check [Analog Wide]	1) Connect the SSG to the RX ANT. SSG setting Frequency: Desired Frequency Output: -53dBm (501μV) MOD = 1.0kHz DEV: ±3.0kHz AF: 0.45V/4Ω	SSG Audio analyzer	Rear	RX ANT			Check	-115dBm (0.4μV) or Less
[Analog Narrow]	2) SSG setting DEV: ±1.5kHz	Oscilloscope		TEST/ SPKR Jack pin 12 4Ω load				

## ADJUSTMENT

### Transmitter Section

Item	Condition	Measurement			Adjustment			Specifications / Remarks
		Test-equipment	Unit	Terminal	Unit	Parts	Method	
1. High Transmit Power Limit Adjust	FPU Test mode 1) Adjust Item: [High Transmit Power Limit Adjust] Frequency: [Low], [Low'], [Center], [High'], [High] Press [Transmit] button.	Power meter	Rear	TX ANT		PC ADJ	43W±1.5W	Press [Apply] button to store the adjustment value.
2. High Transmit Power Adjust	FPU Test mode 1) Adjust Item: [High Transmit Power ] Frequency: [Low], [Low'], [Center], [High'], [High] Press [Transmit] button.						40W±0.5W	
3. Low Transmit Power Limit Adjust	FPU Test mode 1) Adjust Item: [Low Transmit Power Limit Adjust ] Frequency: [Low], [Low'], [Center], [High'], [High] Press [Transmit] button.						28W±1.5W	
4. Low Transmit Power Adjust	FPU Test mode 1) Adjust Item: [High Transmit Power Adjust ] Frequency: [Low], [Low'], [Center], [High'], [High] Press [Transmit] button.						25W±0.5W	
5. Maximum Deviation Adjust [NXDN Narrow]	FPU Test mode 1) Adjust Item: [Maximum Deviation (NXDN Narrow)]					PC ADJ	Write the value as followings (typical value) [Maximum Deviation (NXDN Narrow)] = 530	Press [Apply] button to store the adjustment value.
6. Maximum Deviation Adjust [NXDN Very Narrow]	FPU Test mode 1) Adjust Item: [Maximum Deviation (NXDN Very Narrow)]						Write the value as followings (typical value) [Maximum Deviation (NXDN Very Narrow)] = 530	
7. Maximum Deviation Adjust [Analog Wide]	FPU Test mode 1) Adjust Item: [Maximum Deviation (Analog Wide)]						Write the value as followings (typical value) [Maximum Deviation (Analog Wide)] = 530	
8. Maximum Deviation Adjust [Analog Narrow]	FPU Test mode 1) Adjust Item: [Maximum Deviation (Analog Narrow)]						Write the value as followings (typical value) [Maximum Deviation (Analog Narrow)] = 530	

## ADJUSTMENT

Item	Condition	Measurement			Adjustment			Specifications / Remarks
		Test-equipment	Unit	Terminal	Unit	Parts	Method	
9. Balance Adjust [20Hz Adjustment]	FPU Test mode 1) Adjust Item: [Balance] Connect the Deviation Meter to the TX ANT end via the ATT. Deviation Meter setting LPF: 3kHz HPF: OFF De-emphasis: OFF 2) Adjust Item: [A: Low], [A: Center], [A: High], [B: Low], [B: Center], [B: High] Press [Transmit] button. 20Hz is transmitted.	Deviation meter Oscilloscope	Rear	TX ANT		PC ADJ	The Deviation of 20Hz frequency is fixed to 2.05kHz Deviation. Change the 2kHz adjustment value to become the same deviation to 20Hz within the specified range.	2kHz Tone deviation is within $\pm 1.0\%$ of 20Hz tone deviation.  Press [Apply All] button to store the adjustment value after all adjustment point was adjusted.
[2.0kHz Adjustment]	FPU Test mode 1) Adjust Item: [Balance] [2kHz Sine Wave] check box is checked. 2) Adjust Item: [A: Low], [A: Center], [A: High], [B: Low], [B: Center], [B: High] Press [Transmit] button. Check while transmitting change to 2kHz.							
10. Standard Modulation Check [Analog Wide ]	1) Connect the Deviation Meter to the TX ANT end via the ATT. Deviation Meter setting LPF: 15kHz HPF: OFF De-emphasis: OFF Detector: (p-p)/2 2) Connect the AG to the MIC Terminal of MIC connector. AG Frequency : 1kHz (Sine Wave) AG Output level: Adjust to become the 3kHz Deviation.	Deviation meter Oscilloscope AG DVM	Rear Front	TX ANT MIC			Check	5.0mV $\pm$ 1.5mV
[Analog Narrow ]	1) Connect the Deviation Meter to the TX ANT end via the ATT. Deviation Meter setting LPF: 15kHz HPF: OFF De-emphasis: OFF Detector: (p-p)/2 2) Connect the AG to the MIC Terminal of MIC connector. AG Frequency : 1kHz (Sine Wave) AG Output level: Adjust to become the 1.5kHz Deviation.							

## ADJUSTMENT

Item	Condition	Measurement			Adjustment			Specifications / Remarks
		Test-equipment	Unit	Terminal	Unit	Parts	Method	
11. TD Deviation adjust [Analog Wide]	FPU Test mode 1) Adjust Item: [TD Deviation (Analog Wide)] Connect the Deviation Meter to the TX ANT end via the ATT. Deviation Meter setting LPF: 3kHz, HPF: OFF De-emphasis: OFF 2) Connect the AG to the TD Terminal of Control I/O Jack. AG Frequency : 100Hz (Sine Wave) AG Output level : 0.5Vpp (177mVrms) Press [Transmit] button.	Deviation meter Oscilloscope AG AF VTVM	Rear	TX ANT  Control I/O Jack TD (Pin No.8)		PC ADJ	0.75kHz Deviation	±0.1kHz  Press [Apply] button to store the adjustment value.
12. TD Deviation adjust [Analog Narrow]	FPU Test mode 1) Adjust Item: [TD Deviation (Analog Narrow)] Connect the Deviation Meter to the TX ANT end via the ATT. Deviation Meter setting LPF: 3kHz, HPF: OFF De-emphasis: OFF 2) Connect the AG to the TD Terminal of Control I/O Jack. AG Frequency : 100Hz (Sine Wave) AG Output level : 0.5Vpp (177mVrms) Press [Transmit] button.							
13. Transmit Audio Input (TA) adjust [Analog Wide]	FPU Test mode 1) Adjust Item: [Transmit Audio Input (TA) (Analog Wide)] Connect the Deviation Meter to the TX ANT end via the ATT. Deviation Meter setting LPF: 15kHz, HPF: OFF De-emphasis: OFF 2) Connect the AG to the TA Terminal of Control I/O Jack. AG Frequency : 1kHz (Sine Wave) AG Output level: 280mVrms Press [Transmit] button.	Deviation meter Oscilloscope AG AF VTVM	Rear	TX ANT  Control I/O Jack TA (Pin No.9)		PC ADJ	3.0kHz Deviation	±0.1kHz  Press [Apply] button to store the adjustment value.
14. Transmit Audio Input (TA) adjust [Analog Narrow]	FPU Test mode 1) Adjust Item: [Transmit Audio Input (TA) (Analog Narrow)] Connect the Deviation Meter to the TX ANT end via the ATT. Deviation Meter setting LPF: 15kHz, HPF: OFF De-emphasis: OFF 2) Connect the AG to the TA Terminal of Control I/O Jack. AG Frequency : 1kHz (Sine Wave) AG Output level: 280mVrms Press [Transmit] button.						1.5kHz Deviation	±0.05kHz  Press [Apply] button to store the adjustment value.

## ADJUSTMENT

Item	Condition	Measurement			Adjustment			Specifications / Remarks
		Test-equipment	Unit	Terminal	Unit	Parts	Method	
15. QT Deviation adjust [Analog Wide]	FPU Test mode 1) Adjust Item: [QT Deviation (Analog Wide)] Connect the Deviation Meter to the TX ANT end via the ATT. Deviation Meter setting LPF: 3kHz, HPF: OFF De-emphasis: OFF Detector: p-p/2 Press [Transmit] button.	Deviation meter Oscilloscope	Rear	TX ANT		PC ADJ	0.75kHz Deviation	±0.05kHz  Press [Apply] button to store the adjustment value.
16. QT Deviation adjust [Analog Narrow]	FPU Test mode 1) Adjust Item: [QT Deviation (Analog Narrow)] Connect the Deviation Meter to the TX ANT end via the ATT. Deviation Meter setting LPF: 3kHz, HPF: OFF De-emphasis: OFF Detector: p-p/2 Press [Transmit] button.						0.35kHz Deviation	±0.05kHz  Press [Apply] button to store the adjustment value.
17. DQT Deviation adjust [Analog Wide]	FPU Test mode 1) Adjust Item: [DQT Deviation (Analog Wide)] Connect the Deviation Meter to the TX ANT end via the ATT. Deviation Meter setting LPF: 3kHz, HPF: OFF De-emphasis: OFF Detector: Peak hold Press [Transmit] button.						0.75kHz Deviation	±0.05kHz  Press [Apply] button to store the adjustment value.
18. DQT Deviation adjust [Analog Narrow]	FPU Test mode 1) Adjust Item: [DQT Deviation (Analog Narrow)] Connect the Deviation Meter to the TX ANT end via the ATT. Deviation Meter setting LPF: 3kHz, HPF: OFF De-emphasis: OFF Detector: Peak hold Press [Transmit] button.						0.35kHz Deviation	±0.05kHz  Press [Apply] button to store the adjustment value.
19. DTMF Deviation adjust [Analog Wide]	FPU Test mode 1) Adjust Item: [DTMF Deviation (Analog Wide)] Connect the Deviation Meter to the TX ANT end via the ATT. Deviation Meter setting LPF: 15kHz, HPF: OFF De-emphasis: OFF Press [Transmit] button.	Deviation meter Oscilloscope	Rear	TX ANT		PC ADJ	3.0kHz Deviation	±0.1kHz  Press [Apply] button to store the adjustment value.
20. DTMF Deviation adjust [Analog Narrow]	FPU Test mode 1) Adjust Item: [DTMF Deviation (Analog Narrow)] Connect the Deviation Meter to the TX ANT end via the ATT. Deviation Meter setting LPF: 15kHz, HPF: OFF De-emphasis: OFF Press [Transmit] button.						1.5kHz Deviation	±0.05kHz  Press [Apply] button to store the adjustment value.



## ADJUSTMENT

Item	Condition	Measurement			Adjustment			Specifications / Remarks
		Test-equipment	Unit	Terminal	Unit	Parts	Method	
21. Test Tone Deviation adjust [Analog Wide]	FPU Test mode 1) Adjust Item: [Test Tone Deviation (Analog Wide)] Connect the Deviation Meter to the TX ANT end via the ATT. Deviation Meter setting LPF: 15kHz HPF: OFF De-emphasis: OFF Press [Transmit] button.	Deviation meter Oscilloscope	Rear	TX ANT		PC ADJ	3.0kHz Deviation	±0.1kHz  Press [Apply] button to store the adjustment value.
22. Test Tone Deviation adjust [Analog Narrow]	FPU Test mode 1) Adjust Item: [Test Tone Deviation (Analog Narrow)] Connect the Deviation Meter to the TX ANT end via the ATT. Deviation Meter setting LPF: 15kHz HPF: OFF De-emphasis: OFF Press [Transmit] button.						1.5kHz Deviation	±0.05kHz  Press [Apply] button to store the adjustment value.
23. CW ID Deviation adjust [Analog Wide]	FPU Test mode 1) Adjust Item: [CW ID Deviation (Analog Wide)] Connect the Deviation Meter to the TX ANT end via the ATT. Deviation Meter setting LPF: 15kHz HPF: OFF De-emphasis: OFF Press [Transmit] button.						2.0kHz Deviation	±0.1kHz  Press [Apply] button to store the adjustment value.
24. CW ID Deviation adjust [Analog Narrow]	FPU Test mode 1) Adjust Item: [CW ID Deviation (Analog Narrow)] Connect the Deviation Meter to the TX ANT end via the ATT. Deviation Meter setting LPF: 15kHz HPF: OFF De-emphasis: OFF Press [Transmit] button.						1.0kHz Deviation	±0.05kHz  Press [Apply] button to store the adjustment value.
25. Courtesy Tone Deviation adjust [Analog Wide]	FPU Test mode 1) Adjust Item: [Courtesy Tone Deviation (Analog Wide)] Connect the Deviation Meter to the TX ANT end via the ATT. Deviation Meter setting LPF: 15kHz HPF: OFF De-emphasis: OFF Press [Transmit] button.						1.0kHz Deviation	±0.05kHz  Press [Apply] button to store the adjustment value.
26. Courtesy Tone Deviation adjust [Analog Narrow]	FPU Test mode 1) Adjust Item: [Courtesy Tone Deviation (Analog Narrow)] Connect the Deviation Meter to the TX ANT end via the ATT. Deviation Meter setting LPF: 15kHz HPF: OFF De-emphasis: OFF Press [Transmit] button.						0.5kHz Deviation	±0.05kHz  Press [Apply] button to store the adjustment value.

## ADJUSTMENT

Item	Condition	Measurement			Adjustment			Specifications / Remarks
		Test-equipment	Unit	Terminal	Unit	Parts	Method	
27. Repeat Gain adjust [Analog Wide]	FPU Test mode 1) Adjust Item: [Repeat Gain (Analog Wide)] Connect the Deviation Meter to the TX ANT end via the ATT. Deviation Meter setting LPF: 15kHz HPF: OFF De-emphasis: OFF 2) Connect the SSG to the RX ANT. SSG setting Frequency: Desired Frequency Output: -53dBm (501μV) MOD: 1.0kHz DEV: ±1.0kHz	Deviation meter Oscilloscope SSG	Rear	TX ANT  RX ANT		PC ADJ	1.0kHz Deviation	±0.1kHz  Press [Apply] button to store the adjustment value.
28. Repeat Gain adjust [Analog Narrow]	FPU Test mode 1) Adjust Item: [Repeat Gain (Analog Narrow)] Connect the Deviation Meter to the TX ANT end via the ATT. Deviation Meter setting LPF: 15kHz HPF: OFF De-emphasis: OFF 2) Connect the SSG to the RX ANT. SSG setting Frequency: Desired Frequency Output: -53dBm (501μV) MOD: 1.0kHz DEV: ±1.0kHz							

### Confirmation and Alignment of Set-up to Prevent Receiver Desensitization

#### 1. Confirmation of Duplexer alignment

The duplexer allows the Repeater to simultaneously transmit and receive. To accomplish this, in the programmed receive frequency, the transmit frequency must be notched or suppressed by 75dB or more. Additionally, on the programmed transmit frequency, the receive frequency must be notched or suppressed by 75dB or more. The following figures are examples of Duplexer alignment using a spectrum analyzer.

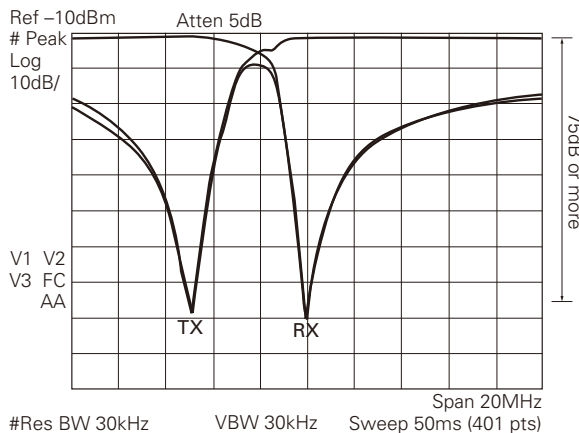

#### 2. Confirmation of Repeater Desensitization

The following figure is a Test set-up for Repeater Desensitization.

After this Test set-up is completed, confirm the Repeater Desensitization as mentioned below.

- 1) Disable the repeater mode.
- 2) Adjust the level of the RF generator until 12dB SINAD is reached.
- 3) Increase the output of the RF generator by 1dB. (This increases the SINAD.)
- 4) Enable the repeater mode.
- 5) Read the SINAD level. It should not drop below 12dB SINAD. If the SINAD is less than 12dB, check the tightness of the connectors and the tuning of duplexer.

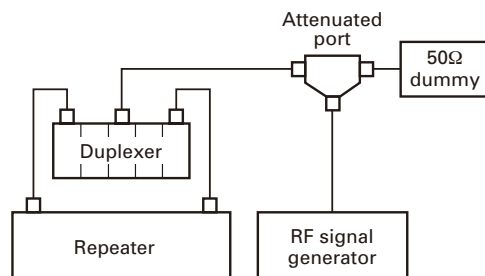

## TERMINAL FUNCTION

### Final Unit (X45-3930-10) (A/3)

Pin No.	Name	I/O	Function
<b>CN1 (To X57-795 CN610)</b>			
1	TX IN	I	TX driver input signal (Coaxial)
<b>CN201 (To X45-393 B/3 +B)</b>			
1	+B	I	Power supply input
<b>CN202 (To X45-393 B/3 GND)</b>			
1	GND	-	Ground
<b>CN203 (To X57-795 CN701)</b>			
1	GND	-	Ground
2	+B	O	Power supply output
3	+B	O	Power supply output
<b>CN204 (To X57-795 CN801)</b>			
1	GND	-	Ground
2	8TC	I	8V power supply control
3	RAMP	I	RF power control voltage
4	ASWC	I	ANT switch control
5	FAN	I	FAN control
6	FDT	O	Coupler input voltage
7	TMP2	O	Temperature of X45 Final unit
8	TMP1	O	Temperature of X45 Final unit
9	PLIM	I	Power limit control
10	H/L	I	Power control
11	HVV2	O	Hardware version detect
<b>CN205 (To FAN)</b>			
1	FAB	O	FAN power supply
2	FAG	-	FAN ground

### Final Unit (X45-3930-10) (B/3)

Pin No.	Name	I/O	Function
<b>+B (To X45-393 A/3 CN201)</b>			
1	+B	O	Power supply output
<b>GND (To X45-393 A/3 CN202)</b>			
1	GND	-	Ground
<b>+B1 (To DC 13.6V)</b>			
1	+B	I	Power supply input
<b>GND (To DC 13.6V)</b>			
1	GND	-	Ground

### Final Unit (X45-3930-10) (C/3)

Pin No.	Name	I/O	Function
<b>N_SYNC1, 2 (To X53-449 CN5)</b>			
1	N_SYNC1_B	I/O	RS-485 differential signal 1-B
2	N_SYNC1_A	I/O	RS-485 differential signal 1-A
3	N_SYNC2_B	I/O	RS-485 differential signal 2-B
4	N_SYNC2_A	I/O	RS-485 differential signal 2-A
5	N_SYNC1_B	I/O	RS-485 differential signal 1-B

Pin No.	Name	I/O	Function
6	N_SYNC1_A	I/O	RS-485 differential signal 1-A
7	N_SYNC2_B	I/O	RS-485 differential signal 2-B
8	N_SYNC2_A	I/O	RS-485 differential signal 2-A
<b>J401, 402 (N_SYNC1, 2 jack)</b>			
1	N_SYNC1_B	I/O	RS-485 differential signal 1-B
2	N_SYNC1_A	I/O	RS-485 differential signal 1-A
3	N_SYNC2_B	I/O	RS-485 differential signal 2-B
4	N_SYNC2_A	I/O	RS-485 differential signal 2-A

### Control Unit (X53-4490-10)

Pin No.	Name	I/O	Function
<b>CN5 (To X45-393 C/3)</b>			
1	N_SYNC1_B	I/O	RS-485 differential signal 1-B
2	N_SYNC1_A	I/O	RS-485 differential signal 1-A
3	N_SYNC2_B	I/O	RS-485 differential signal 2-B
4	N_SYNC2_A	I/O	RS-485 differential signal 2-A
5	N_SYNC1_B	I/O	RS-485 differential signal 1-B
6	N_SYNC1_A	I/O	RS-485 differential signal 1-A
7	N_SYNC2_B	I/O	RS-485 differential signal 2-B
8	N_SYNC2_A	I/O	RS-485 differential signal 2-A
<b>CN38 (To X57-795 CN800)</b>			
1	TMP1	I	Temperature of X45 Final unit
2	TMP2	I	Temperature of X45 Final unit
3	RAMP	O	RF power control voltage
4	FWD	I	RF power monitor voltage
5	TXASSIST	O	TX PLL assist voltage
6	RXASSIST	O	RX PLL assist voltage
7	TX_CV	I	TX VCO lock voltage
8	RX_CV	I	RX VCO lock voltage
9	GND	-	Ground
10	GND	-	Ground
11	TXVCOB	O	TX VCO B control signal
12	RXVCOA/B	O	RX VCO control signal to A or B
13	TXVCOA	O	TX VCO A control signal
14	/RXPCS_TR	O	RX PLL chip select signal
15	LDT	I	TX PLL lock detect signal
16	/16_8PCS	O	Reference clock PLL chip select signal
17	LDR	I	RX PLL lock detect signal
18	/TXPCS	O	TX PLL chip select signal
19	SPSCLK0	O	Serial clock
20	SPSD0	O	Serial data
21	SBC	O	Switched +B control signal
22	GND	-	Ground
23	MOD	O	Audio signal for TX modulation
24	GND	-	Ground
25	RSSI	I	RSSI voltage

## TERMINAL FUNCTION

Pin No.	Name	I/O	Function
26	AGC	O	Auto gain control voltage
27	33A	O	3.3V voltage
28	/EWP	O	EEPROM write control signal
29	HVV1	I	Hardware version signal
30	I2CCK	O	Serial clock
31	SPSCLK1	O	Serial clock
32	I2CDA	I/O	Serial data
33	SPSD1	O	Serial data
34	/IOCS	I	IO expander chip select signal
35	/EVCS	O	DA converter chip select signal
36	NC	-	No connection
<b>CN39</b>			
IN	IF_SIG	I	450kHz IF signal
OUT	GND	-	Ground
<b>CN40 (To X54-358 CN502)</b>			
1	SB	O	Power supply input
2	SB	O	Power supply input
3	GND	-	Ground
4	NC	-	No connection
5	DAT	O	Serial data
6	PSW	I	Power switch signal
7	STB1	O	Data latch signal
8	CLK	O	Serial clock
9	SOE	O	Output enable signal
10	TXD1	I/O	MIC PTT, UART TX data
11	K1	I	Key scan input
12	RXD1	I	Hook detect signal, UART TX data
13	K2	I	Key scan input
14	K3	I	Key scan input
15	K4	O	Key scan output
16	K5	O	Key scan output
17	VLI	I	Speaker audio level control voltage
18	5C	O	5V voltage
19	MIG	-	MIC ground
20	MIC	I	MIC signal
<b>CN41 (To TEST/SPKR 15pin Connector)</b>			
1	SB	O	Power supply output
2	SB	O	Power supply input
3	GND	-	Ground
4	GND	-	Ground
<b>CN42 (To TEST/SPKR 15pin Connector)</b>			
1	AO5	O	Auxiliary output 5
2	AO4	O	Auxiliary output 4
3	AO3	O	Auxiliary output 3
4	SPO	O	Speaker AF output
5	SPO	O	Speaker AF output

Pin No.	Name	I/O	Function
6	AO2	O	Auxiliary output 2
7	AO1	O	Auxiliary output 1
8	SPI	I	Internal speaker AF input
9	RSI	O	RSSI voltage
10	RD	O	RX data output
11	SPG	-	Speaker ground
12	SPG	-	Speaker ground
<b>CN43 (To INT SPKR )</b>			
1	SPO	O	Internal speaker AF output
2	SPG	-	Speaker ground
<b>CN44 (To Control I/O 25pin D-sub Connector)</b>			
1	NC	-	No connection
2	NC	-	No connection
3	SPM_D25	I	Speaker mute signal input
4	IO6_D25	I/O	Programmable function input/output 6
5	RXG	-	RX signal ground for RA,RD
6	IO5_D25	I/O	Programmable function input/output 5
7	RA_D25	O	RX-Audio output (voice)
8	IO4_D25	I/O	Programmable function input/output 4
9	RD_D25	O	RX-DATA output (data or signaling)
10	IO3_D25	I/O	Programmable function input/output 3
11	TA_D25	I	TX audio input (voice)
12	IO2_D25	I/O	Programmable function input/output 2
13	TD_D25	I	TX-DATA input (data or signaling)
14	IO1_D25	I/O	Programmable function input/output 1
15	DG	-	Control line ground
16	TXG	-	TX signal ground for TA,TD
17	AI3_D25	I	Programmable function input 3
18	BER_DATA_D25	O	Bit error rate data
19	AI2_D25	I	Programmable function input 2
20	SC_D25	O	Squelch control output
21	AI1_D25	I	Programmable function input 1
22	/EPTT_D25	I	External PTT
23	TXD0_D25	O	UART TX data
24	EXT_MON_D25	I	External monitor signal
25	RXD0_D25	I	UART RX data
26	BER_CLK_D25	O	Bit error rate clock
27	NC (RSSI)		No connection (RSSI)
28	NC	-	No connection
29	NC	-	No connection
30	NC	-	No connection
<b>CN301 (To X57-795 CN700)</b>			
1	GND	-	Ground
2	+B	I	Power supply input
3	SB	I	Power supply input

## TERMINAL FUNCTION

### Display Unit (X54-3580-20) (A/2)

Pin No.	Name	I/O	Function
<b>CN501 (To X54-358 B/2 CN601)</b>			
1	HK	I	Hook detection input/ RXD input
2	MIC	I	MIC signal input
3	MIG	-	MIC ground
4	PTT	I/O	PTT input/ TDX output
5	GND	-	Ground
6	NC	-	No connection
7	SB	O	Power supply output after power switch
8	NC	-	No connection
9	GND	-	Ground
10	5M	O	Common 5V output
11	VLI	I	Volume control input for AF signal
<b>CN502 (To X53-449 CN40)</b>			
1	MIG	-	MIC ground
2	MIC	O	MIC signal output
3	VLI	O	Volume control output for AF signal
4	5C	I	Common 5V output
5	K4	I	KEY input 4
6	K5	I	KEY input 5
7	K2	O	KEY input 2
8	K3	O	KEY input 3
9	K1	O	KEY input 1
10	HK/RXD	O	Hook detection output/ RXD input
11	SOE	I	Output enable for shift register
12	PTT/TXD	I/O	PTT output/ TDX input
13	STB1	I	Strobe data for shift register
14	CLK	I	Clock data input
15	DAT	I	Serial data input
16	PSW	O	Power switch output
17	GND	-	Ground
18	NC	-	No connection
19	SB	I	Power supply output after power switch
20	SB	I	Power supply output after power switch

### Display Unit (X54-3580-20) (B/2)

Pin No.	Name	I/O	Function
<b>CN601 (To X54-358 A/2 CN501)</b>			
1	VLI	O	Volume control output for AF signal
2	5M	I	Common 5V input
3	GND	-	Ground
4	NC	-	No connection
5	SB	I	Power supply output after power switch
6	NC	-	No connection
7	GND	-	Ground
8	PTT	I/O	PTT output/ TDX input

Pin No.	Name	I/O	Function
9	MIG	-	MIC ground
10	MIC	O	MIC signal output
11	HK	O	Hook detection output/ RXD output
<b>J601 (MIC jack)</b>			
1	NC	-	No connection
2	SB	O	Power supply output after power switch
3	GND	-	Ground
4	PTT/TXD	I/O	PTT input/ TDX output
5	MIG	-	MIC ground
6	MIC	I	MIC signal input
7	HOOK/RXD	I	Hook detection input/ RXD input
8	NC	-	No connection

### TX-RX Unit (X57-7950-10)

Pin No.	Name	I/O	Function
<b>CN101 (To RX ANT)</b>			
1	RX_SIGNAL	I	Receive signal input (Coaxial)
<b>CN202 (To X58-509 CN350)</b>			
1	GND	-	Ground
2	NC	-	No connection
3	80C_2	O	8V power supply
4	RXVCOA/B	O	VCO select
5	RX_CV	I	Control voltage input
6	NC	-	No connection
7	RXASSIST	O	Assist voltage output
<b>CN203 (To X58-509 CN351)</b>			
1	VO	I	VCO input
2	GND	-	Ground
<b>CN204 (To X58-509 CN303)</b>			
1	FIN	O	VCO output
2	SPSCLK0	O	PLL clock output
3	/RXPCS_TR	O	PLL chip select output
4	SPSD0	O	PLL data output
5	33C	O	3.3V power supply
6	50C	O	5V power supply
7	LDR	I	PLL lock detect input
8	REF	O	19.2MHz reference clock output
<b>CN500 (To Ext IN)</b>			
1	REF IN	I	External reference input (Coaxial)
<b>CN605 (To X58-510 CN350)</b>			
1	GND	-	Ground
2	TXVCOB	O	VCOB select
3	80C_1	O	8V power supply
4	TXVCOA	O	VCOA select
5	TX_CV	I	Control voltage input
6	MO	O	Modulation output

## TERMINAL FUNCTION

Pin No.	Name	I/O	Function
7	TXASSIST	O	Assist voltage output
<b>CN608 (To X58-510 CN351)</b>			
1	VO	I	VCO input
2	GND	-	Ground
<b>CN609 (To X58-510 CN303)</b>			
1	FIN	O	VCO output
2	SPSCLK0	O	PLL clock output
3	/TXPCS	O	PLL chip select output
4	SPSD0	O	PLL data output
5	33C	O	3.3V power supply
6	50C	O	5V power supply
7	LDT	I	PLL lock detect input
8	REF	O	16.8MHz reference clock output
<b>CN610 (To X45-393 A/3 CN1)</b>			
1	TX OUT	O	TX driver output signal (Coaxial)
<b>CN700 (To X53-449 CN301)</b>			
1	GND	-	Ground
2	+B	O	Power supply output
3	SB	O	Power supply output
<b>CN701 (To X45-393 A/3 CN203)</b>			
1	GND	-	Ground
2	+B	I	Power supply input
3	+B	I	Power supply input
<b>CN800 (To X53-449 CN38)</b>			
1	NC	-	No connection
2	/EVCS	I	DA converter chip select signal
3	/IOCS	O	IO expander chip select signal
4	SPSD1	I	Serial data
5	I2CDA	I/O	Serial data
6	SPSCLK1	I	Serial clock
7	I2CCK	I	Serial clock
8	HWV1	O	Hardware version signal
9	/EWP	I	EEPROM write control signal
10	33A	I	3.3V voltage
11	AGC	I	Auto gain control voltage
12	RSSI	O	RSSI voltage
13	GND	-	Ground
14	MOD	I	Audio signal for TX modulation
15	GND	-	Ground
16	SBC	I	Switched +B control signal
17	SPSD0	I	Serial data
18	SPSCLK0	I	Serial clock
19	/TXPCS	I	TX PLL chip select signal
20	LDR	O	RX PLL lock detect signal
21	/16_8PCS	I	Reference clock PLL chip select signal
22	LDT	O	TX PLL lock detect signal

Pin No.	Name	I/O	Function
23	/RXPCS_TR	I	RX PLL chip select signal
24	TXVCOA	I	TX VCO A control signal
25	RXVCOA/B	I	RX VCO control signal to A or B
26	TXVCOB	I	TX VCO B control signal
27	GND	-	Ground
28	GND	-	Ground
29	RX_CV	O	RX VCO lock voltage
30	TX_CV	O	TX VCO lock voltage
31	RXASSIST	I	RX PLL assist voltage
32	TXASSIST	I	TX PLL assist voltage
33	FWD	O	RF power monitor voltage
34	RAMP	I	RF power control voltage
35	TMP2	O	Temperature of X45 Final unit
36	TMP1	O	Temperature of X45 Final unit
<b>CN801 (To X45-393 A/3 CN204)</b>			
1	HWV2	I	Hardware version detect
2	H/L	O	Power control
3	PLIM	O	Power limit control
4	TMP1	I	Temperature of X45 Final unit
5	TMP2	I	Temperature of X45 Final unit
6	FDT	I	Coupler input voltage
7	FAN	O	FAN control
8	ASWC	O	ANT switch control
9	RAMP	O	RF power control voltage
10	8TC	O	8V power supply control
11	GND	-	Ground
<b>CN802 (To X53-449 CN39)</b>			
1	IF_SIG	O	450kHz IF signal (Coaxial)

### RX VCO/PLL Unit (X58-5090-10)

Pin No.	Name	I/O	Function
<b>CN303 (To X57-795 CN204)</b>			
1	FIN	I	VCO input
2	SPSCLK0	I	PLL clock input
3	/RXPCS_TR	I	PLL chip select input
4	SPSD0	I	PLL data input
5	33C	I	3.3V power supply
6	50C	I	5V power supply
7	LDR	O	PLL Lock detect output
8	REF	I	19.2MHz reference clock input
<b>CN350 (To X57-795 CN202)</b>			
1	GND	-	Ground
2	NC	-	No connection
3	80C_2	I	8V power supply
4	RXVCOA/B	I	VCO select
5	RX_CV	O	Control voltage output

## TERMINAL FUNCTION

Pin No.	Name	I/O	Function
6	NC	-	No connection
7	RXASSIST	I	Assist voltage input
<b>CN351 (To X57-795 CN203)</b>			
1	VO	O	VCO output
2	GND	-	Ground

### TX VCO/PLL Unit (X58-5100-10)

Pin No.	Name	I/O	Function
<b>CN303 (To X57-795 CN609)</b>			
1	FIN	I	VCO input
2	SPSCLK0	I	PLL clock input
3	/TXPCS	I	PLL chip select input
4	SPSD0	I	PLL data input
5	33C	I	3.3V power supply
6	50C	I	5V power supply
7	LDT	O	PLL lock detect output
8	REF	I	16.8MHz reference clock input
<b>CN350 (To X57-795 CN605)</b>			
1	GND	-	Ground
2	TXVCOB	I	VCOB select
3	80C_1	I	8V power supply
4	TXVCOA	I	VCOA select
5	TX_CV	O	Control voltage output
6	MO	I	Modulation input
7	TXASSIST	I	Assist voltage input
<b>CN351 (To X57-795 CN608)</b>			
1	VO	O	VCO output
2	GND	-	Ground

### CONTROL I/O 25 pin D-sub Connector

Pin No.	Pin Name	I/O	Signal Type	Modification	Description/ Port Type
1	NC	-	-	-	Land short
2	RXD2	I	Digital	No	Asynchronous Receive Data
3	TXD2	O	Digital	No	Asynchronous Send Data
4	AI1	I	Digital	No	Programmable Function Input 1/ CMOS
5	AI2	I	Digital	No	Programmable Function Input 2/ CMOS
6	AI3	I	Digital	No	Programmable Function Input 3/ CMOS
7	DG	-	GND	No	Digital GND
8	TD	I	Analog	No	TX Data Input (signaling)
9	TA	I	Analog	No	TX Audio Input (voice)
10	RD	O	Analog	No	RX Data Output (signaling) Not Squelched
11	RA	O	Analog	No	RX Audio Output (voice) Squelched

Pin No.	Pin Name	I/O	Signal Type	Modification	Description/ Port Type
12	RXG	-	GND	No	RX Signal GND
13	SPM	I	Digital	No	Speaker Mute/ CMOS
14	BER_CLK	O	Digital	No	for Bit Error Rate Clock
15	EMON	I	Digital	No	External Monitor Switch
16	EPTT	I	Digital	No	External PTT Switch
17	SC	O	Digital	No	Squelch Control
18	BER_DAT	O	Digital	No	for Bit Error Rate Data
19	TXG	-	GND	No	TX Signal GND
20	IO1	I/O	Digital	No	Programmable Function I/O 1
21	IO2	I/O	Digital	No	Programmable Function I/O 2
22	IO3	I/O	Digital	No	Programmable Function I/O 3
23	IO4	I/O	Digital	No	Programmable Function I/O 4
24	IO5	I/O	Digital	No	Programmable Function I/O 5
25	IO6	I/O	Digital	No	Programmable Function I/O 6

### TEST/SPKR 15 pin Connector

Pin No.	Pin Name	I/O	Signal Type	Modification	Description/ Port Type
1	SB	-	Power	No	Power Supply
2	SB	-	Power	No	Power Supply
3	NC	-	-	No	-
4	GND	-	GND	No	Digital GND
5	GND	-	GND	No	Digital GND
6	SPG	-	GND	No	Speaker GND
7	RD	O	Analog	No	RX Data Output (signaling) Not Squelched
8	RSSI	O	Analog	No	RSSI Output
9	SPI	I	Analog	No	Internal Speaker Input
10	AO1	O	Digital	Default	Auxiliary Output 1 Open collector
				\$R203=47k D23=delete	Auxiliary Output 1 Open collector with PU
11	AO2	O	Digital	Default	Auxiliary Output 2 Open collector
				\$R202=47k D29=delete	Auxiliary Output 2 Open collector with PU
12	SPO	O	Analog	No	External Speaker Output
13	AO3	O	Digital	Default	Auxiliary Output 3 Open collector
				\$R201=47k D31=delete	Auxiliary Output 3 Open collector with PU
14	AO4	O	Digital	Default	Auxiliary Output 4 Open collector
				\$R200=47k D35=delete	Auxiliary Output 4 Open collector with PU
15	AO5	O	Digital	Default	Auxiliary Output 5 Open collector
				\$R198=47k D12=delete	Auxiliary Output 5 Open collector with PU



# NXR-810 PC BOARD

## FINAL UNIT (X45-3930-10) Component side view (J79-0264-09)

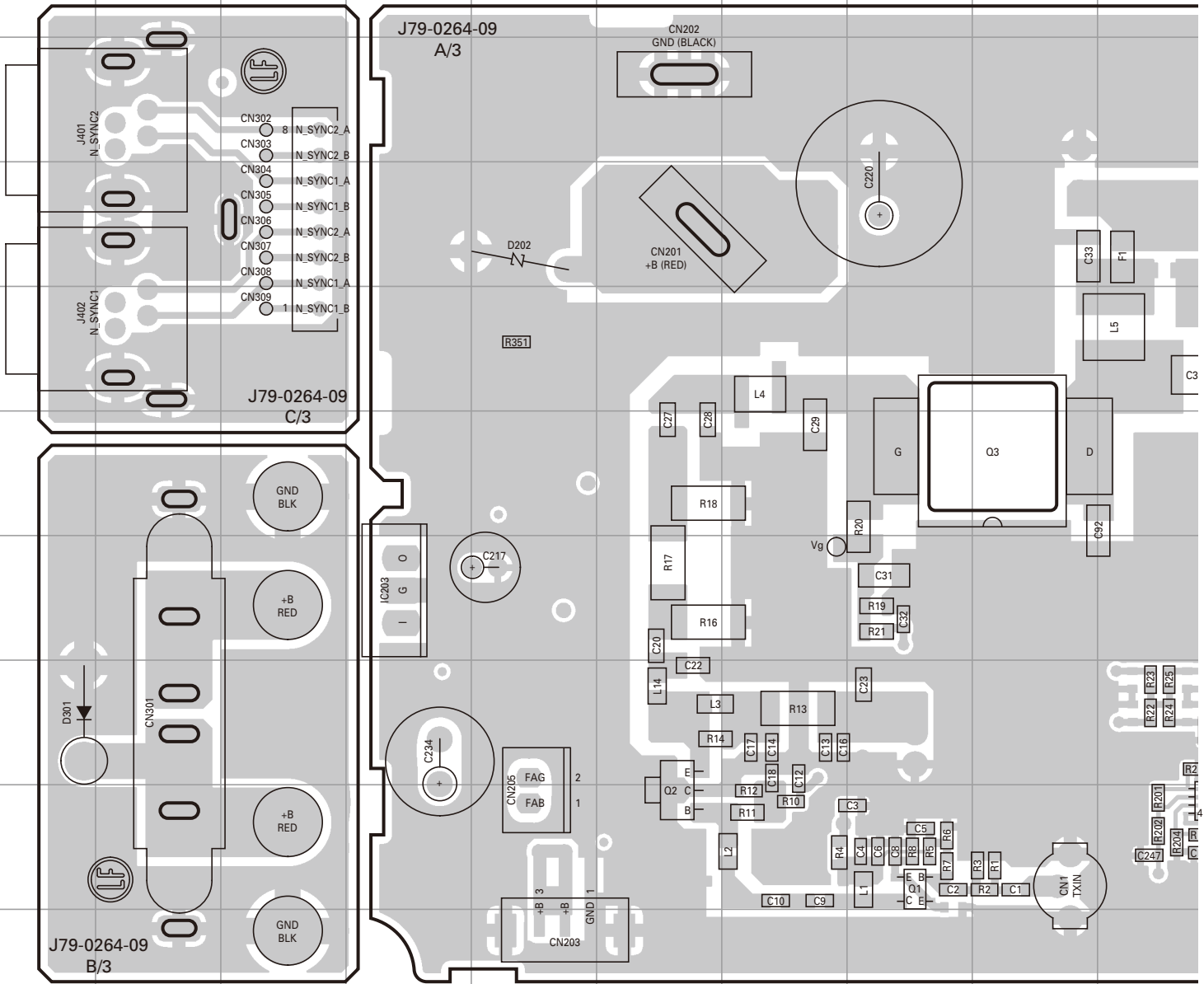

Ref. No.	Address	Ref. No.	Address
IC201	9J	D1	8Q
IC202	8L	D2	8M
IC203	7D	D3	9Q
Q1	9H	D8	4Q
Q2	9F	D201	8K
Q3	6I	D202	4E
Q4	5L	D301	8A



# NXR-810 PC BOARD

FINAL UNIT (X45-3930-10)  
Foil side view (J79-0264-09)

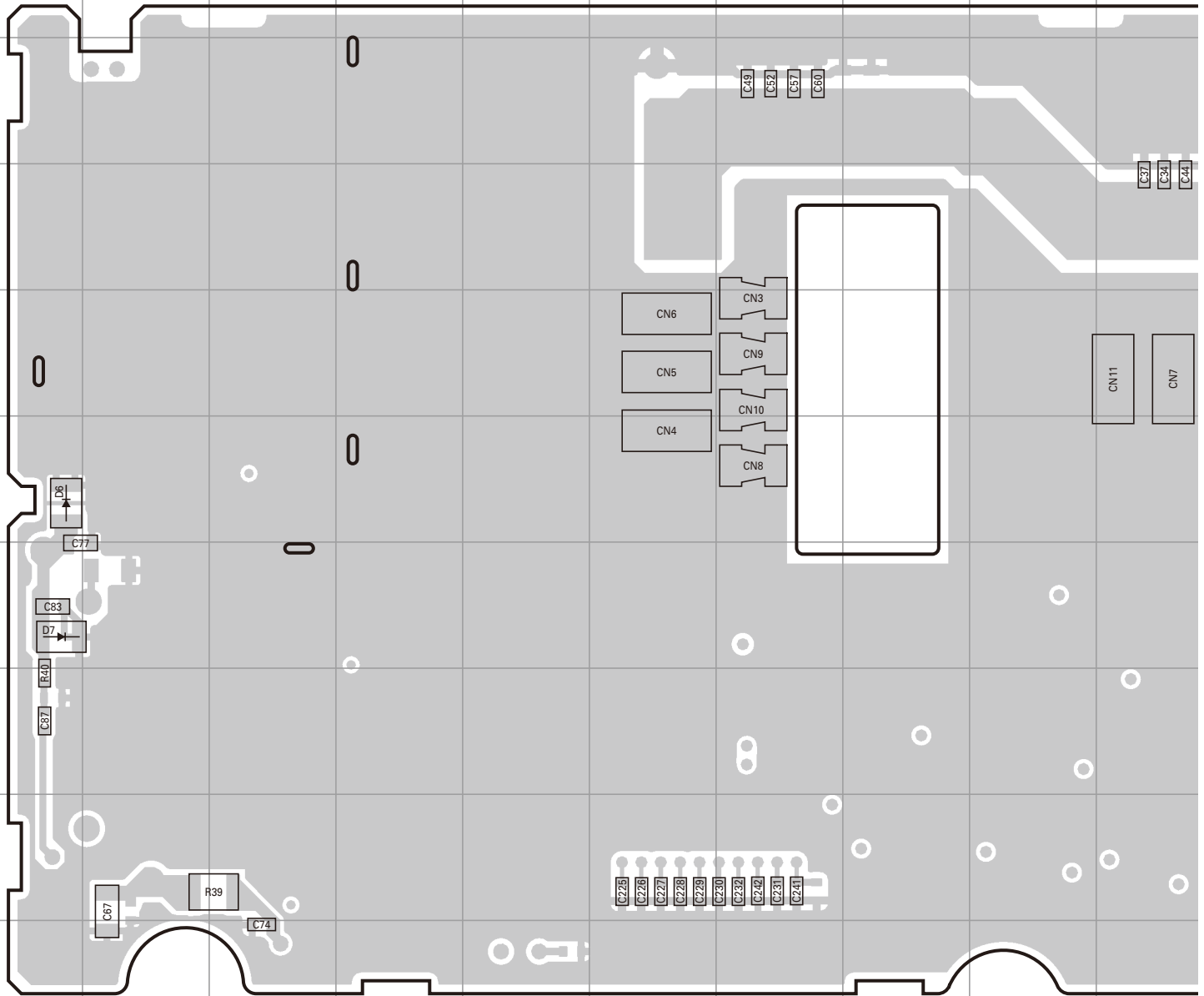

Ref. No.	Address
Q203	70
Q204	60
Q205	7P
Q206	6P
Q207	90
D6	6A
D7	7A
D203	90



# NXR-810 PC BOARD

## CONTROL UNIT (X53-4490-10) Component side view (J79-0277-09)

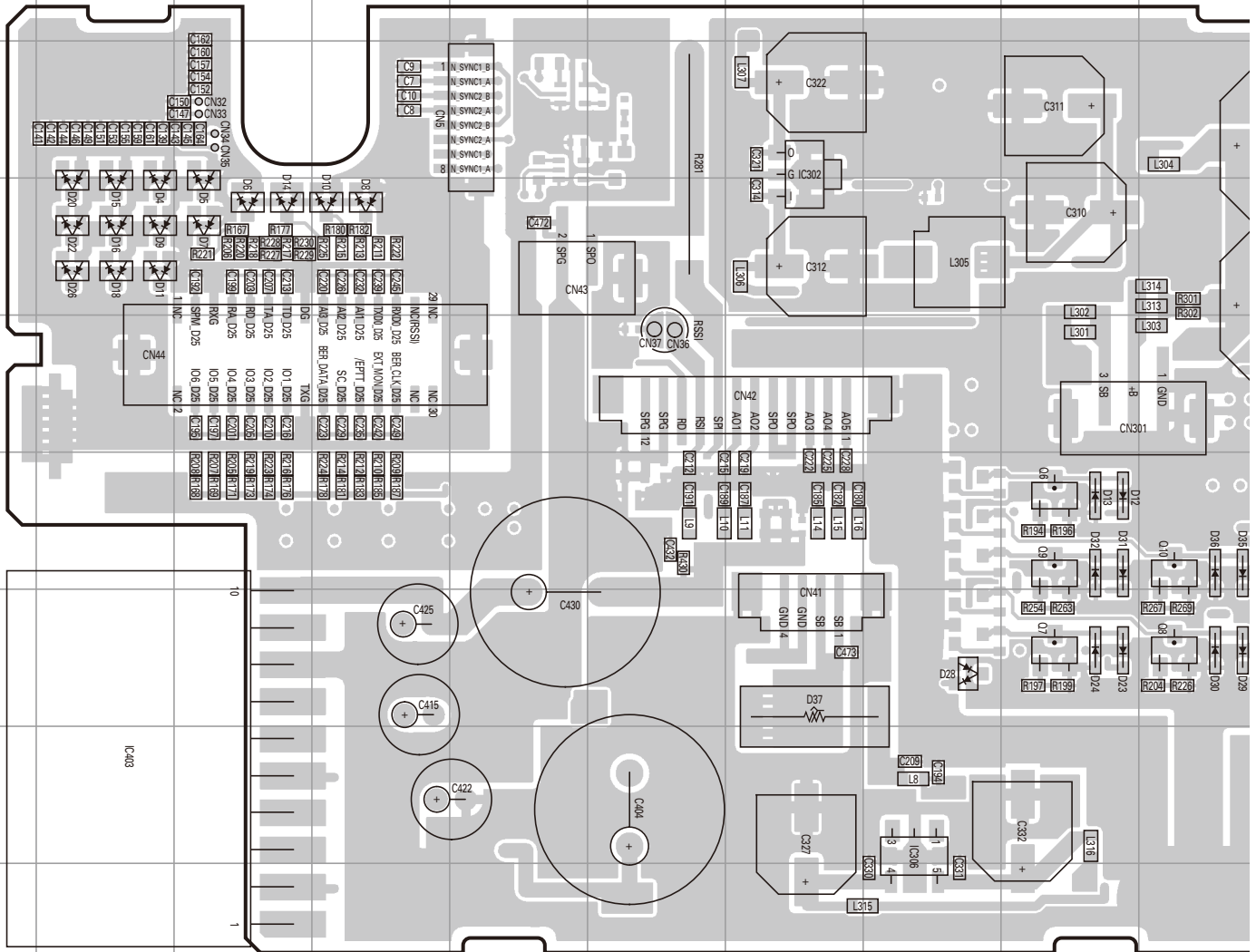

Ref. No.	Address	Ref. No.	Address	Ref. No.	Address	Ref. No.	Address	Ref. No.	Address
IC25	8N	Q6	6I	D7	4C	D18	4B	D32	6I
IC26	8N	Q7	7I	D8	4D	D20	4B	D35	6J
IC27	8M	Q8	7J	D9	4B	D22	4B	D36	6J
IC28	8M	Q9	6I	D10	4D	D23	7I	D37	7G
IC302	3G	Q10	6J	D11	4B	D24	7I	D302	4N
IC303	4M	Q302	5L	D12	6I	D26	4B	D304	5L
IC304	4N	Q303	5L	D13	6I	D28	7H	D305	5L
IC305	4R	D4	4B	D14	4C	D29	7J		
IC306	8H	D5	4C	D15	4B	D30	7J		
IC403	8B	D6	4C	D16	4B	D31	6I		



# NXR-810 PC BOARD

## CONTROL UNIT (X53-4490-10) Foil side view (J79-0277-09)

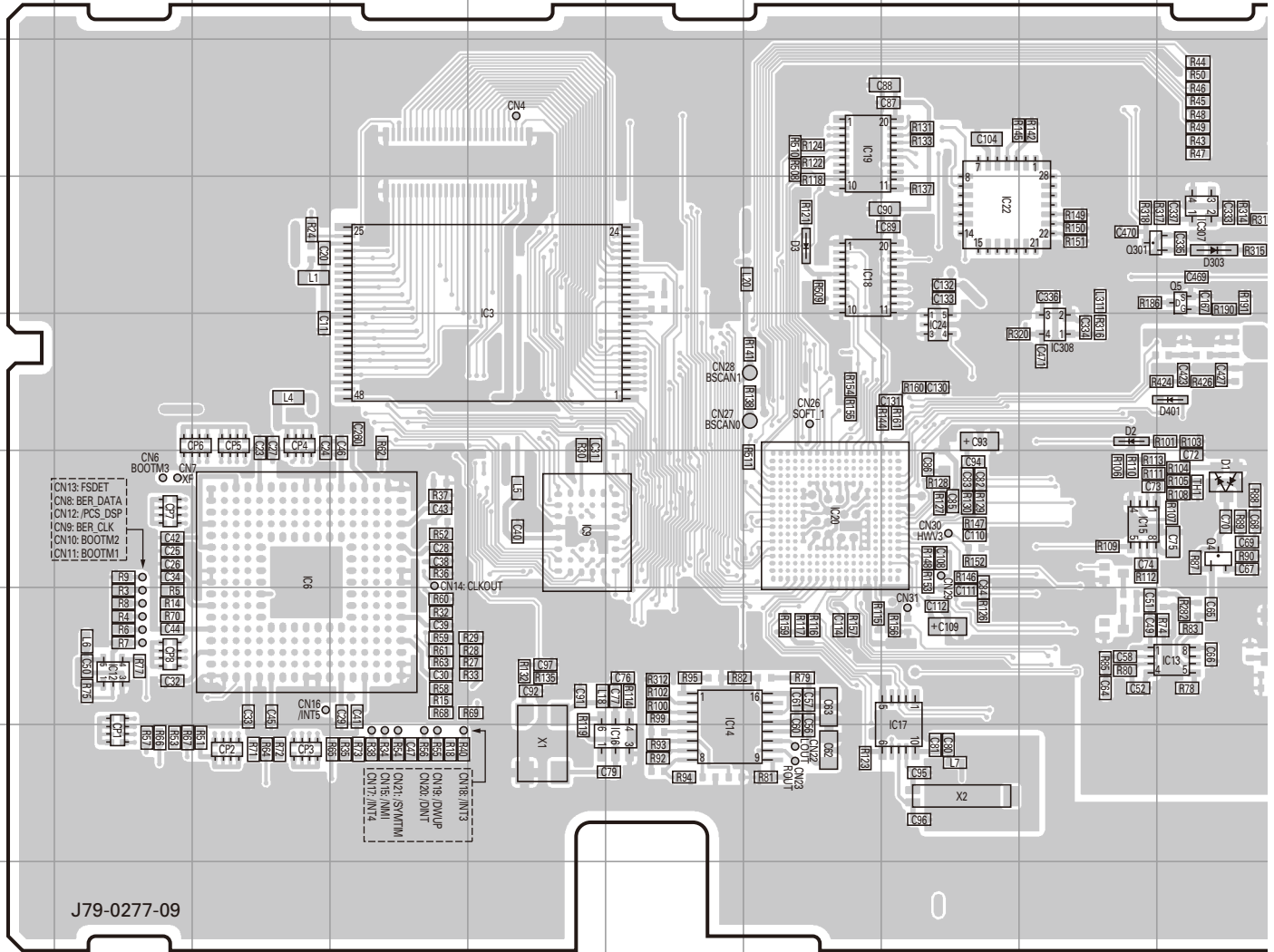

Ref. No.	Address	Ref. No.	Address	Ref. No.	Address	Ref. No.	Address	Ref. No.	Address
IC3	4E	IC13	7J	IC23	5K	IC407	7M	Q405	8Q
IC4	3O	IC14	8F	IC24	5H	IC411	6M	D1	6J
IC5	4O	IC15	6I	IC301	3L	IC412	5O	D2	5I
IC6	6C	IC16	8F	IC307	4J	Q4	6J	D3	4G
IC7	3N	IC17	8H	IC308	5I	Q5	4J	D301	4M
IC8	4N	IC18	4G	IC401	7N	Q301	4I	D303	4J
IC9	6E	IC19	3G	IC402	7N	Q401	7O	D401	5J
IC10	3M	IC20	6G	IC404	7L	Q402	8O		
IC11	4M	IC21	5K	IC405	5Q	Q403	8P		
IC12	7B	IC22	4H	IC406	5M	Q404	8N		





# NXR-810 PC BOARD

## DISPLAY UNIT (X54-3580-20) Component side view (J79-0035-09)

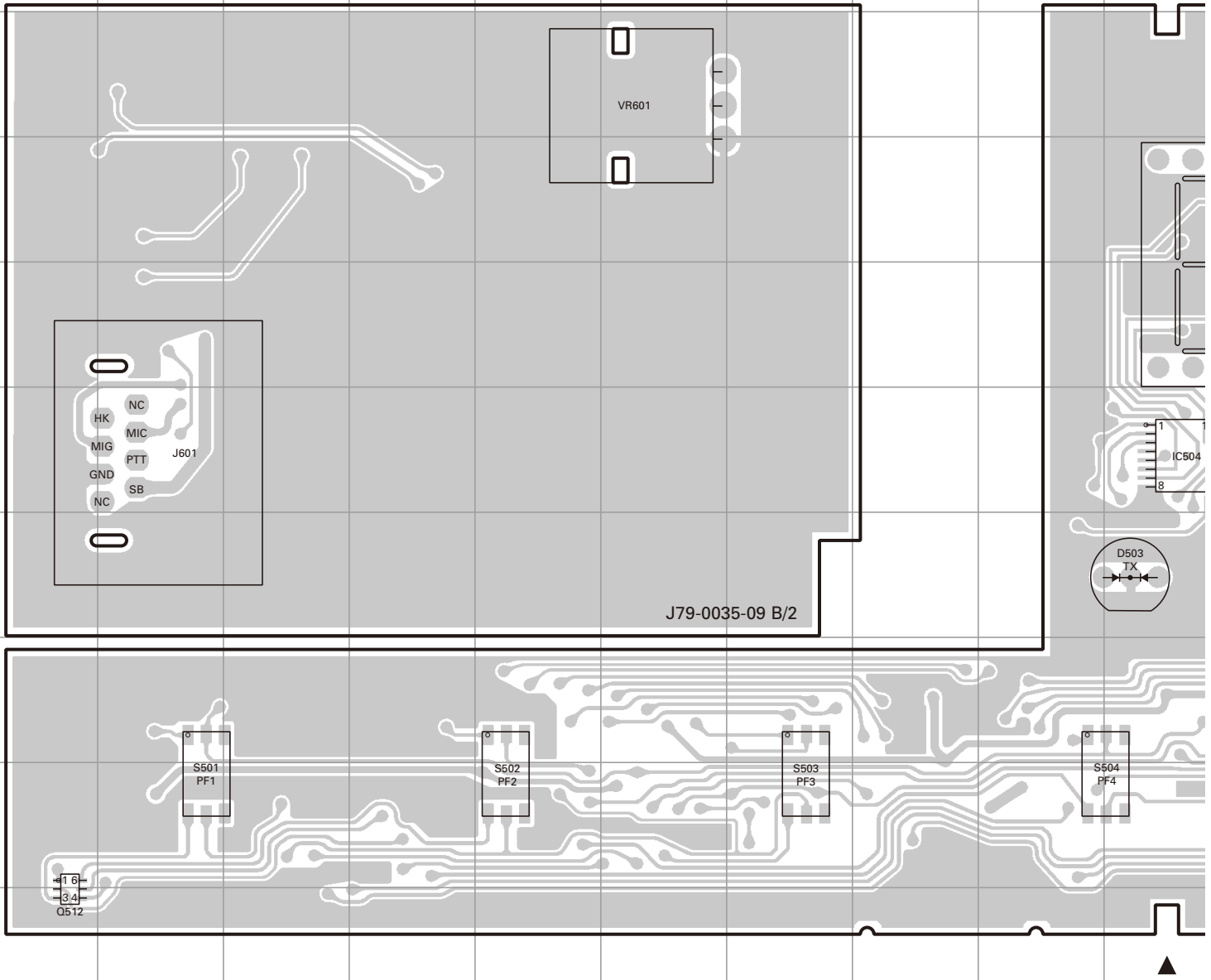

# PC BOARD NXR-810

## DISPLAY UNIT (X54-3580-20) Component side view (J79-0035-09)

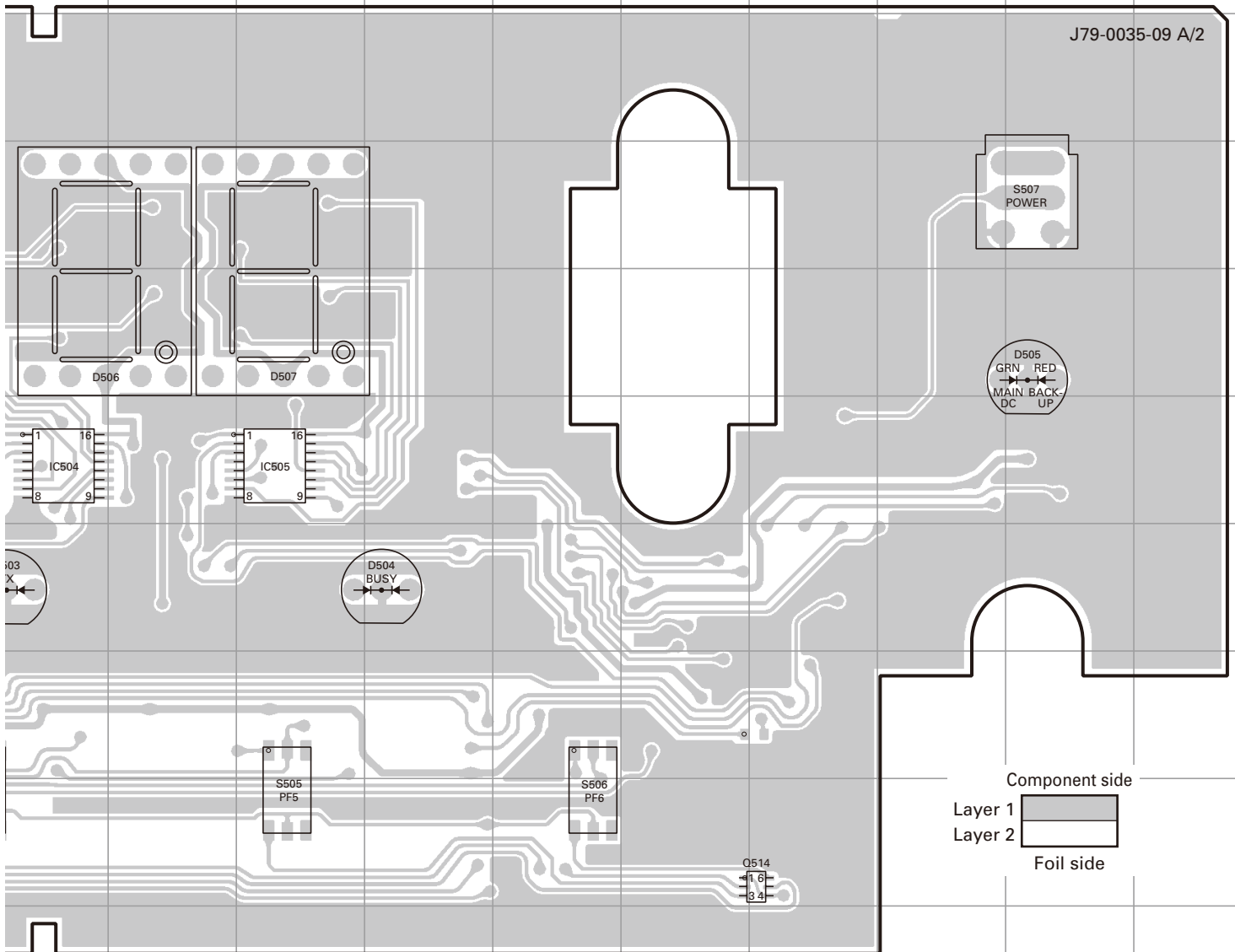

Ref. No.	Address
IC504	6J
IC505	6L
Q512	10A
Q514	9P
D503	7J
D504	7M
D505	5R
D506	5J
D507	5L

# NXR-810 PC BOARD

## DISPLAY UNIT (X54-3580-20) Foil side view (J79-0035-09)

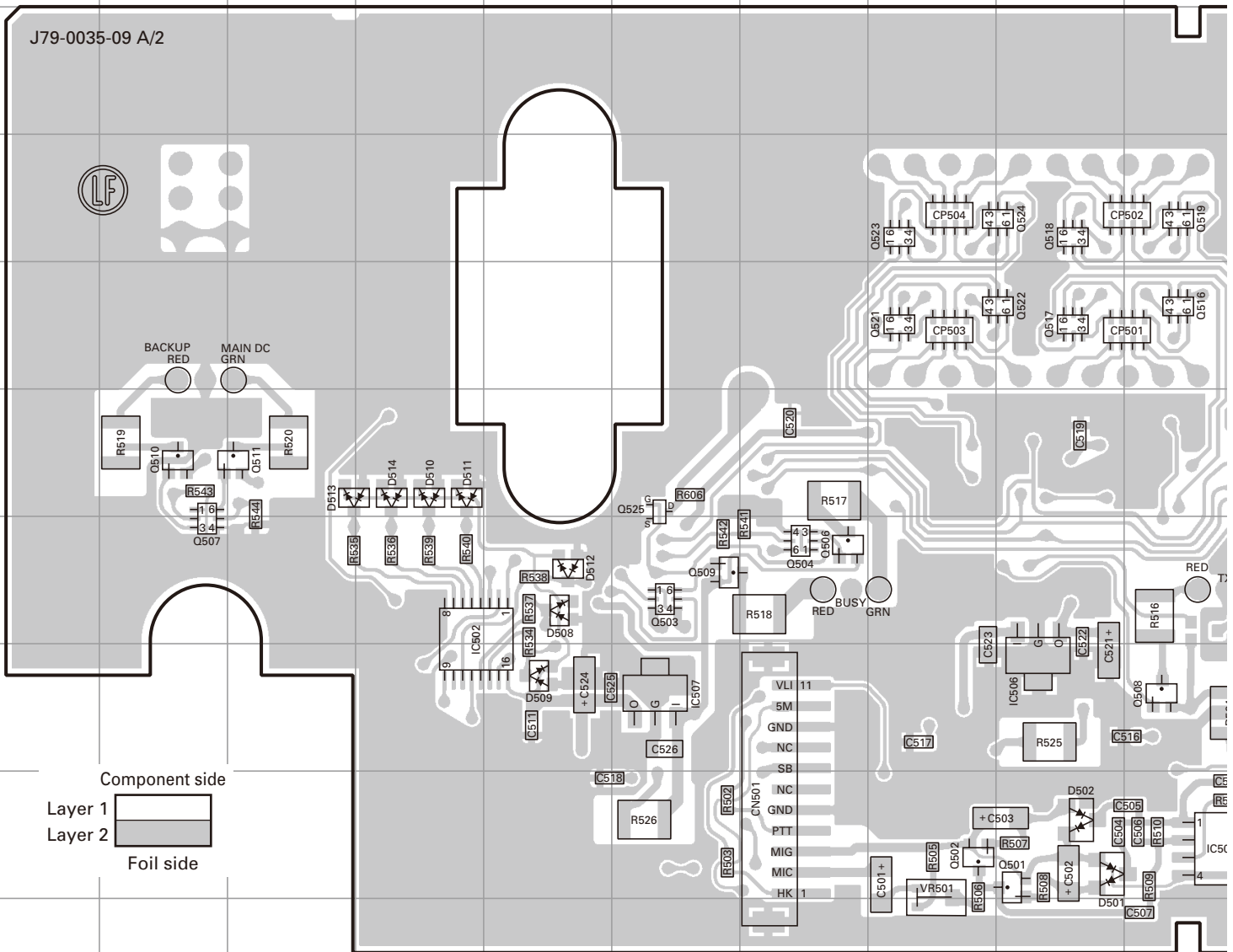

Ref. No.	Address	Ref. No.	Address	Ref. No.	Address	Ref. No.	Address
IC501	9J	Q507	7B	Q521	5H	D511	6D
IC502	7D	Q508	8J	Q522	5I	D512	7E
IC503	9P	Q509	7F	Q523	4H	D513	6C
IC506	8I	Q510	6B	Q524	4I	D514	6D
IC507	8F	Q511	6C	Q525	6F	D601	5R
Q501	9I	Q513	9N	D501	9I	D602	4R
Q502	9H	Q516	5J	D502	9I	D603	4R
Q503	7F	Q517	5I	D508	7E		
Q504	7G	Q518	4I	D509	8E		
Q506	7G	Q519	4J	D510	6D		

# PC BOARD NXR-810

## DISPLAY UNIT (X54-3580-20) Foil side view (J79-0035-09)

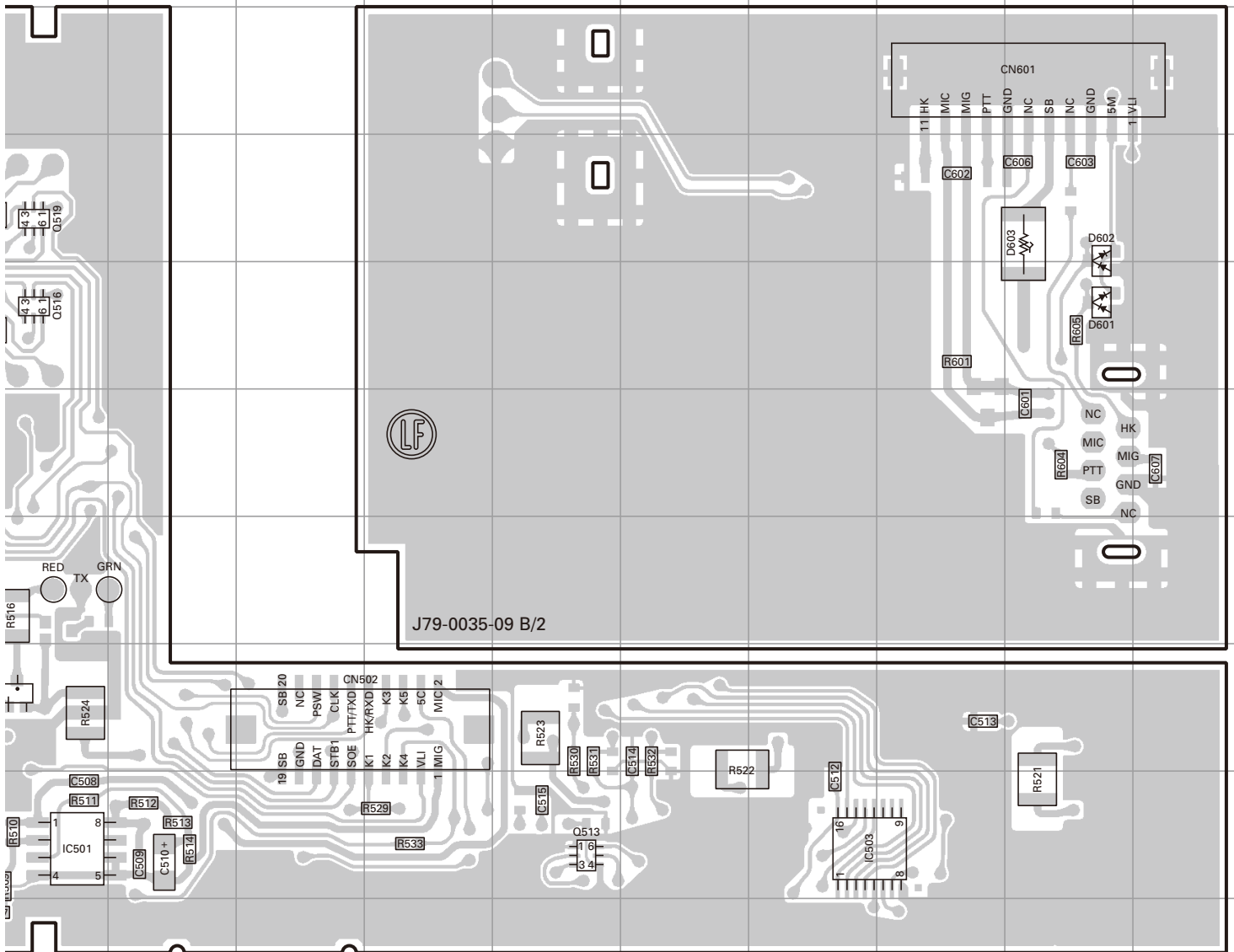







# NXR-810 PC BOARD

TX-RX UNIT (X57-7950-10)  
Foil side view (J79-0266-09)

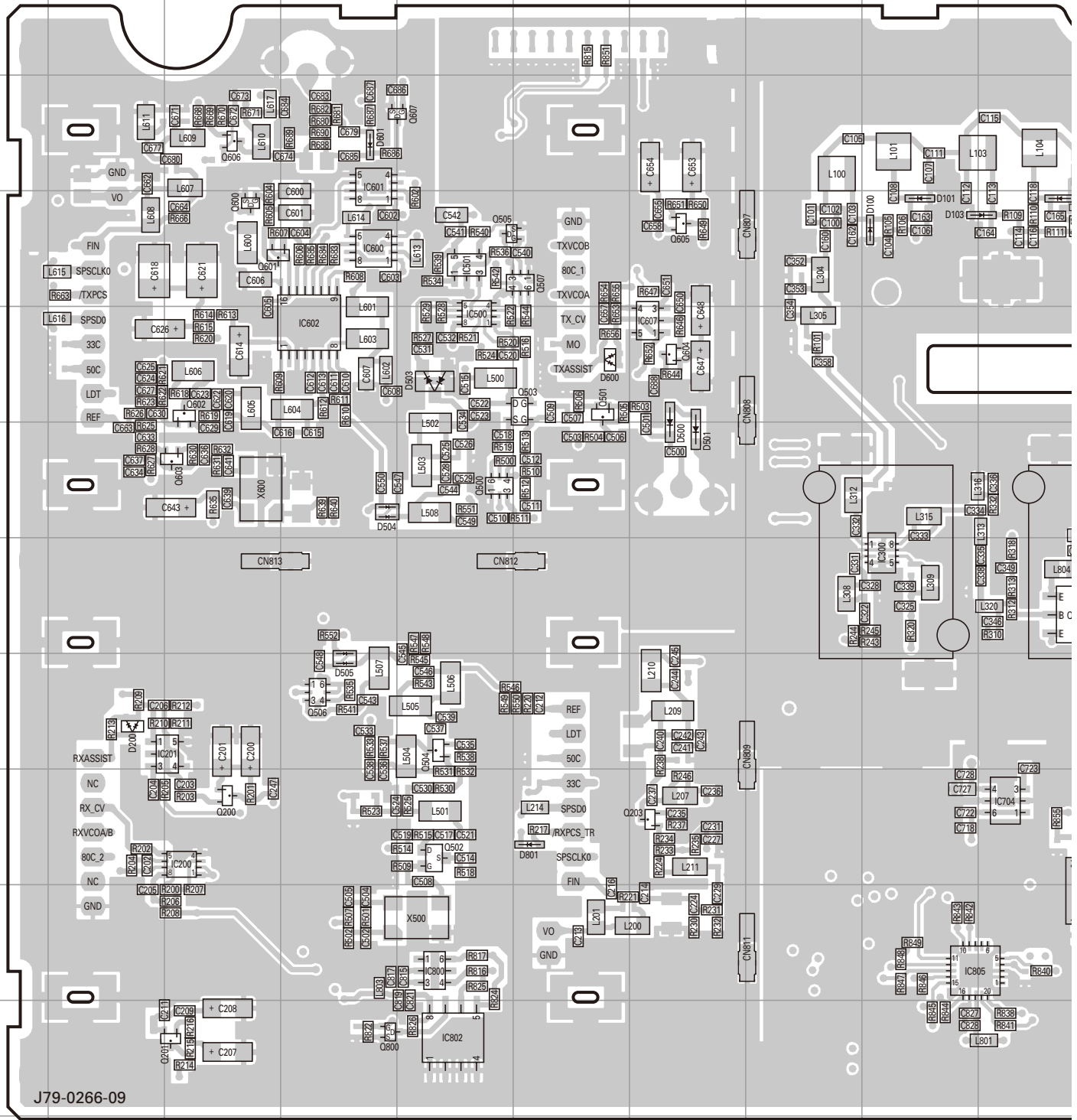

Ref. No.	Address	Ref. No.	Address	Ref. No.	Address	Ref. No.	Address	Ref. No.	Address	Ref. No.	Address	Ref. No.	Address	Ref. No.	Address
IC100	4P	IC402	8P	IC600	4D	IC802	11E	Q200	9C	Q500	6E	Q506	8D	Q604	
IC101	4O	IC403	7P	IC601	3D	IC803	10L	Q201	11C	Q501	5F	Q507	4F	Q605	
IC200	9C	IC404	8O	IC602	5D	IC804	10K	Q202	6P	Q502	9E	Q600	4C	Q606	
IC201	8C	IC409	7Q	IC607	5G	IC805	10I	Q203	9G	Q503	5F	Q601	4C	Q607	
IC300	7I	IC500	5E	IC704	9J	Q100	4Q	Q300	7O	Q504	8E	Q602	5C	Q702	
IC401	8Q	IC501	4E	IC800	10E	Q101	3K	Q301	7J	Q505	4E	Q603	6C	Q703	

# PC BOARD NXR-810

TX-RX UNIT (X57-7950-10)  
Foil side view (J79-0266-09)

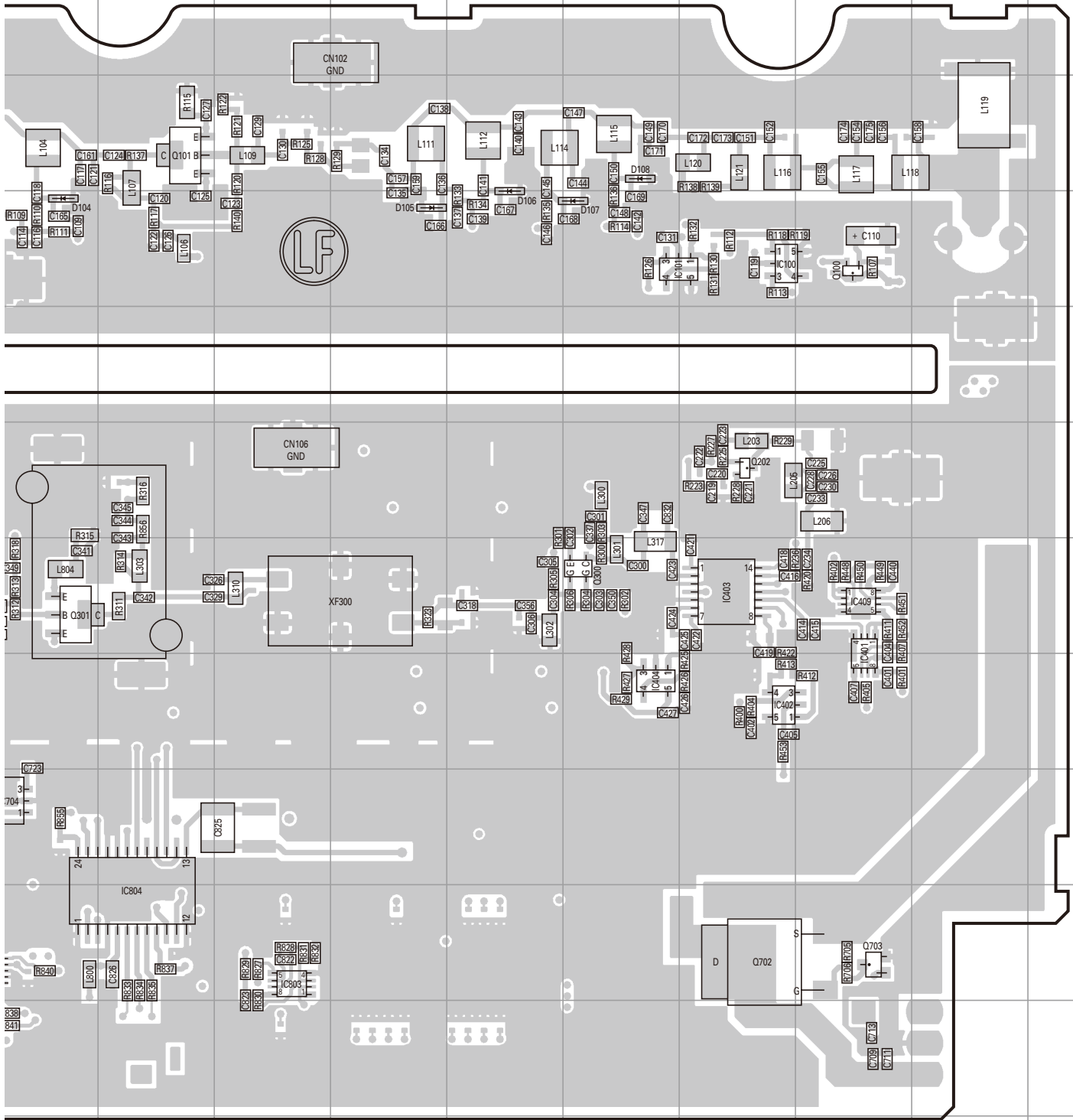

Ref. No.	Address	Ref. No.	Address	Ref. No.	Address	Ref. No.	Address
Q604	5G	Q800	11D	D106	4N	D503	5E
Q605	4G	D100	4I	D107	4O	D504	6D
Q606	3C	D101	4I	D108	3O	D505	8D
Q607	3E	D103	4I	D200	8B	D600	5F
Q702	10P	D104	4J	D500	6G	D601	3D
Q703	10Q	D105	4M	D501	6G	D801	9F

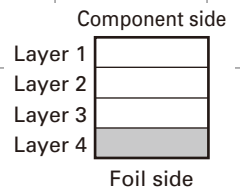



# PC BOARD NXR-810

**TX VCO/PLL UNIT (X58-5100-10)**  
**Component side view (J79-0270-09)**

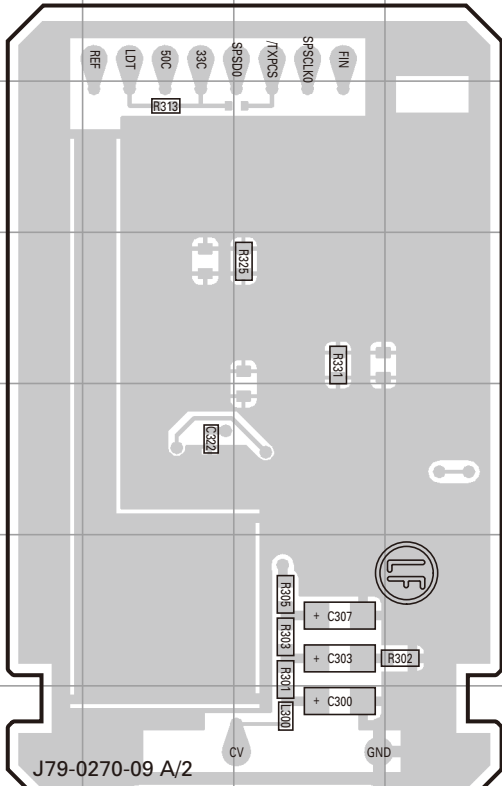

**TX VCO/PLL UNIT (X58-5100-10)**  
**Foil side view (J79-0270-09)**

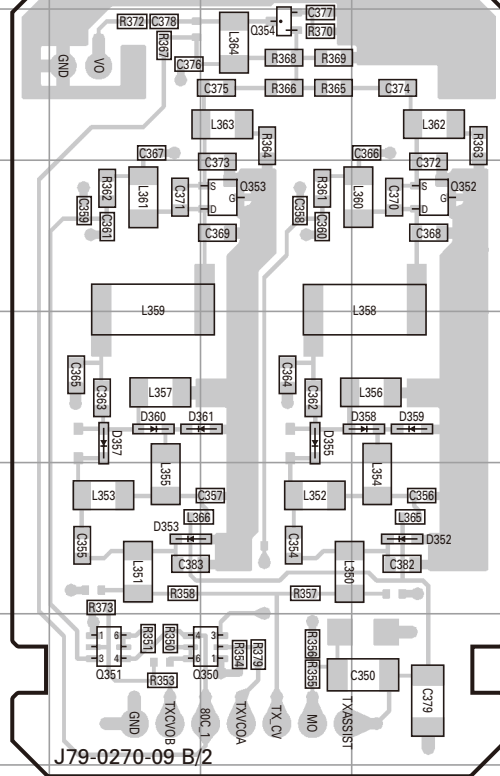
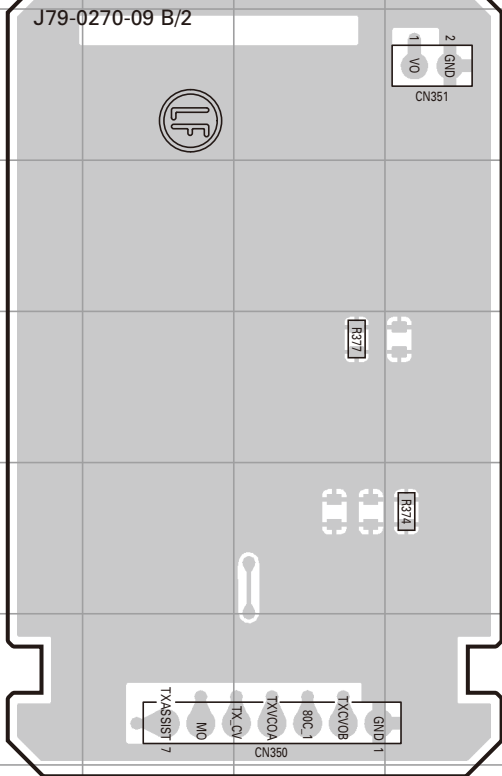
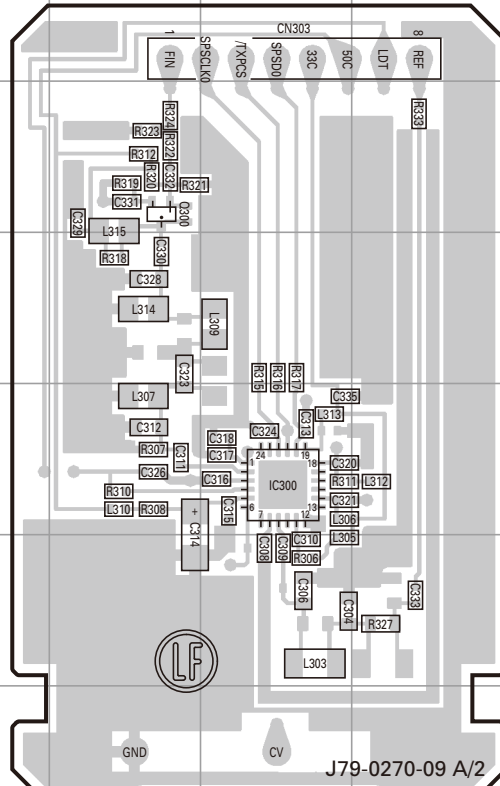

Ref. No.	Address
IC300	5G
Q300	3F
Q350	12G
Q351	12F
Q352	9H
Q353	9G
Q354	8G
D352	11H
D353	11F
D355	10G
D357	10F
D358	10H
D359	10H
D360	10F
D361	10G

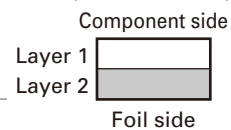
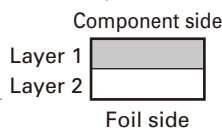

# NXR-810 INTERCONNECTION DIAGRAM

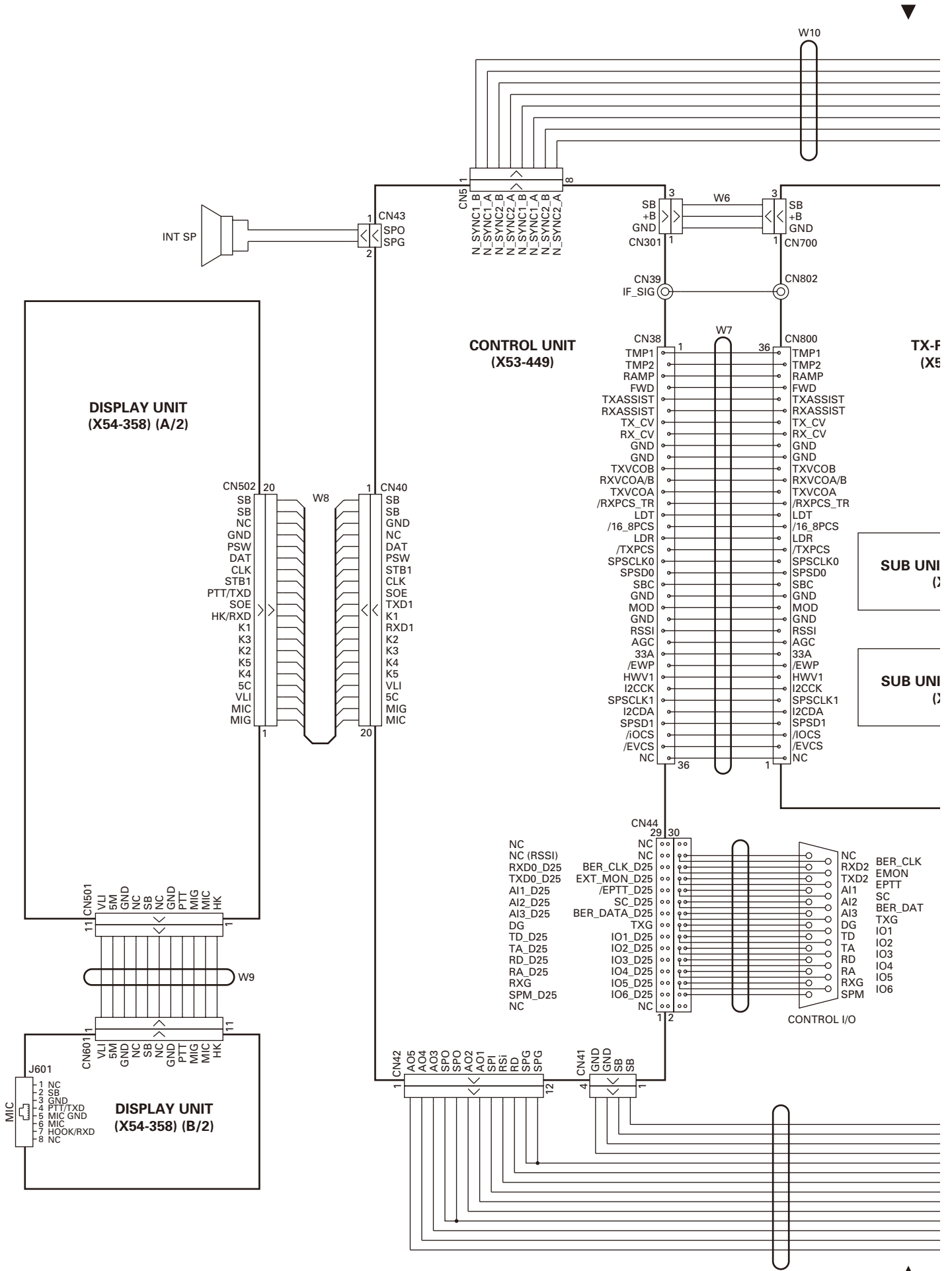

# INTERCONNECTION DIAGRAM NXR-810

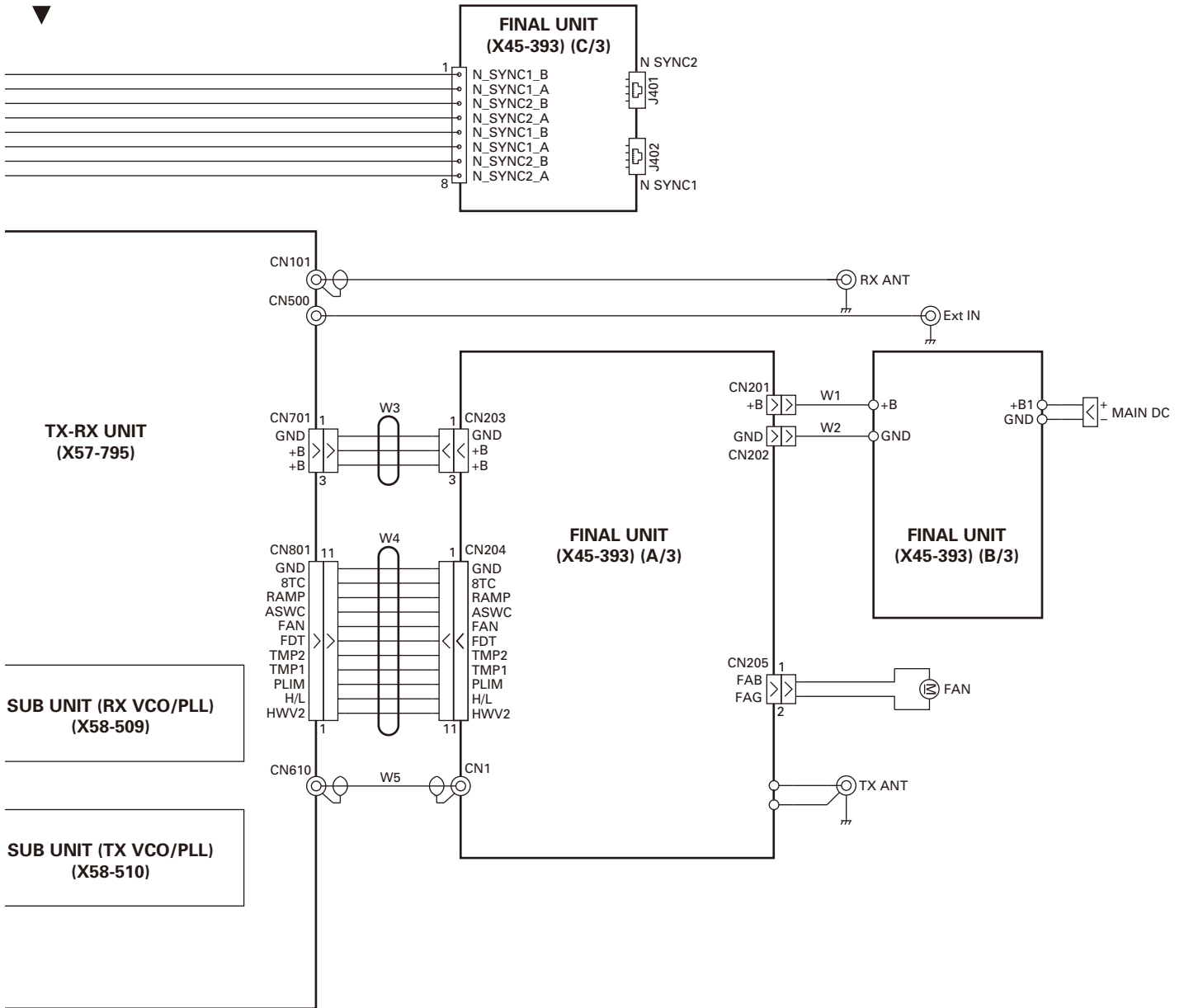

- 3ER\_CLK
- MON
- PTT
- 3C
- 3ER\_DAT
- TXG
- O1
- O2
- O3
- O4
- O5
- O6

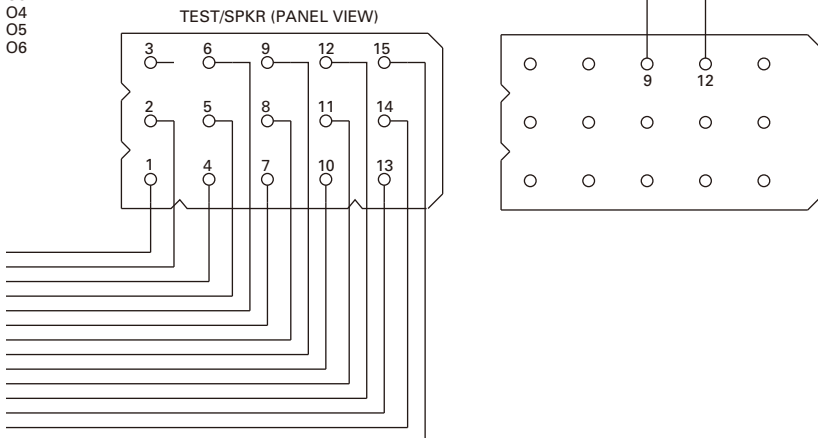

# NXR-810 SCHEMATIC DIAGRAM

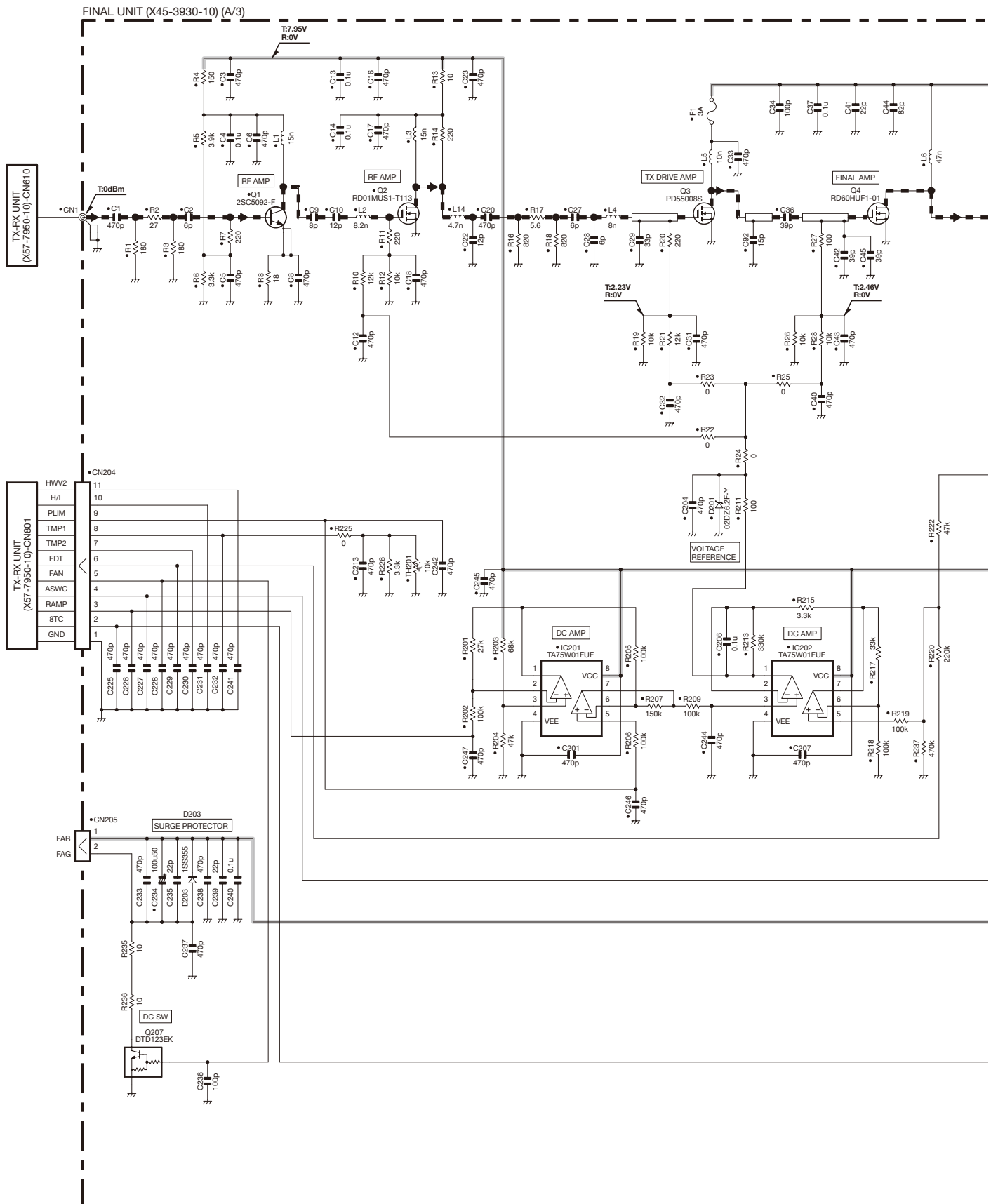





# NXR-810 SCHEMATIC DIAGRAM

CONTROL UNIT (X53-4490-10)

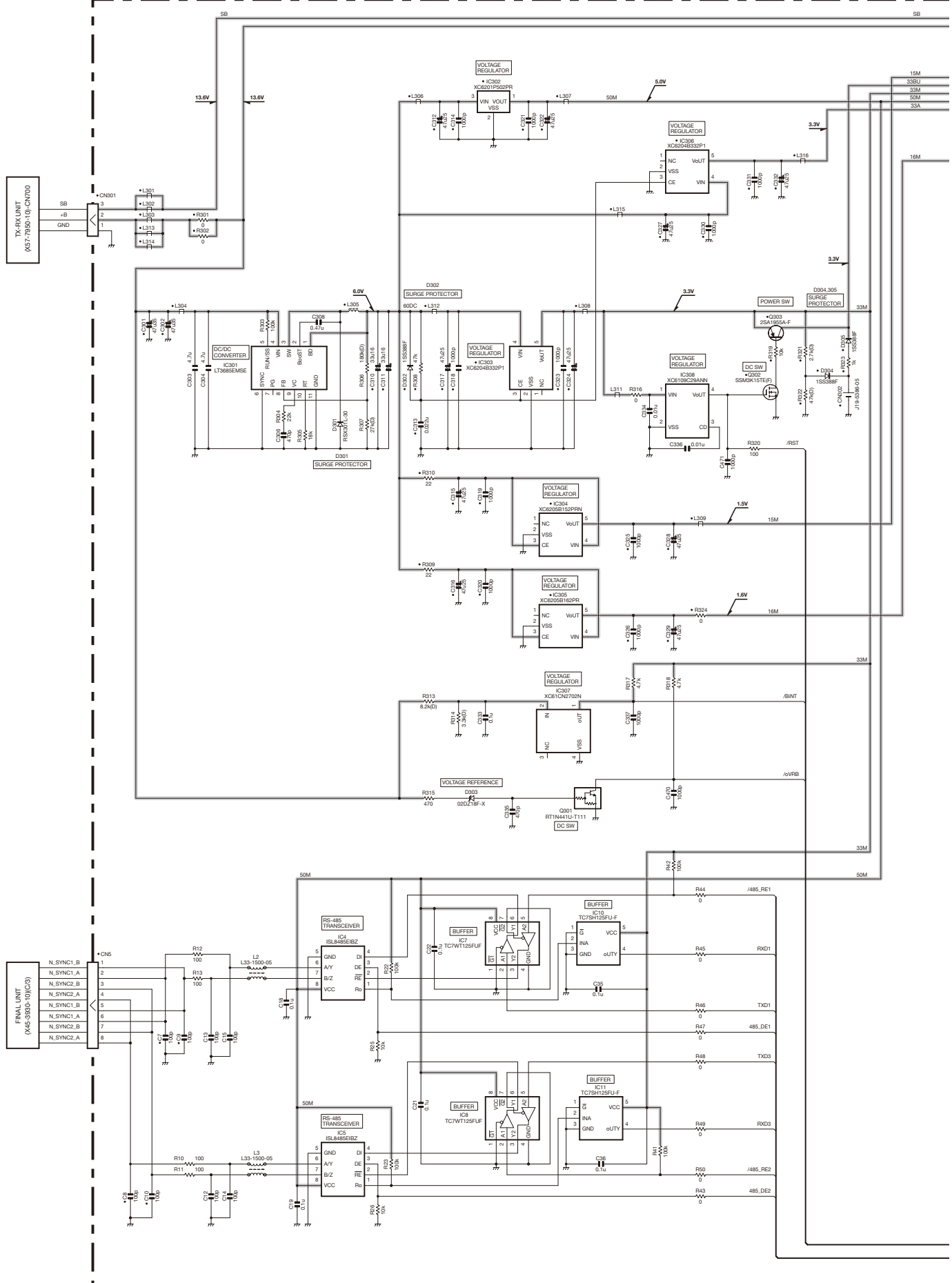

# SCHEMATIC DIAGRAM NXR-810

CONTROL UNIT (X53-4490-10)

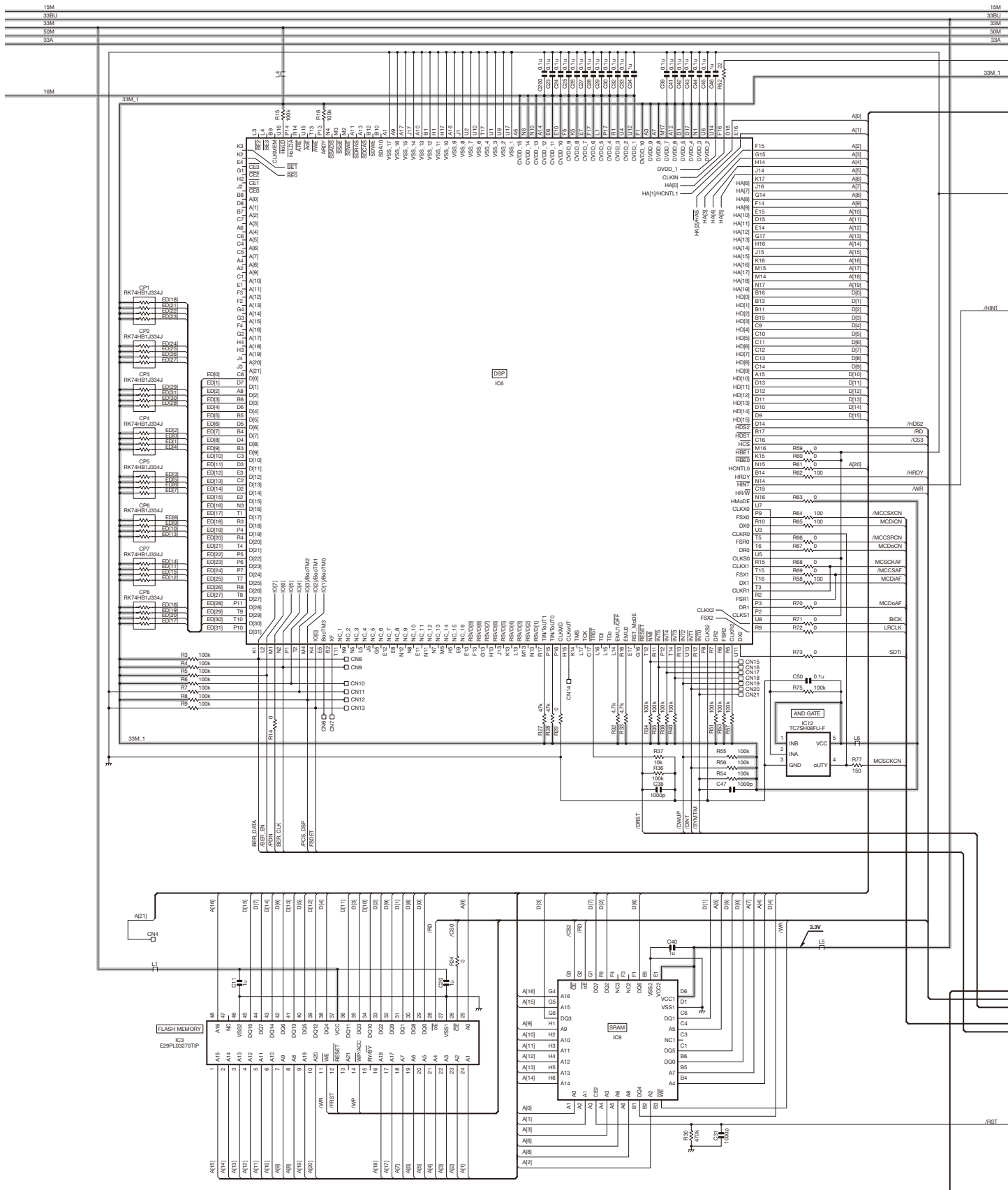





# NXR-810 SCHEMATIC DIAGRAM

CONTROL UNIT (X53-4490-10)

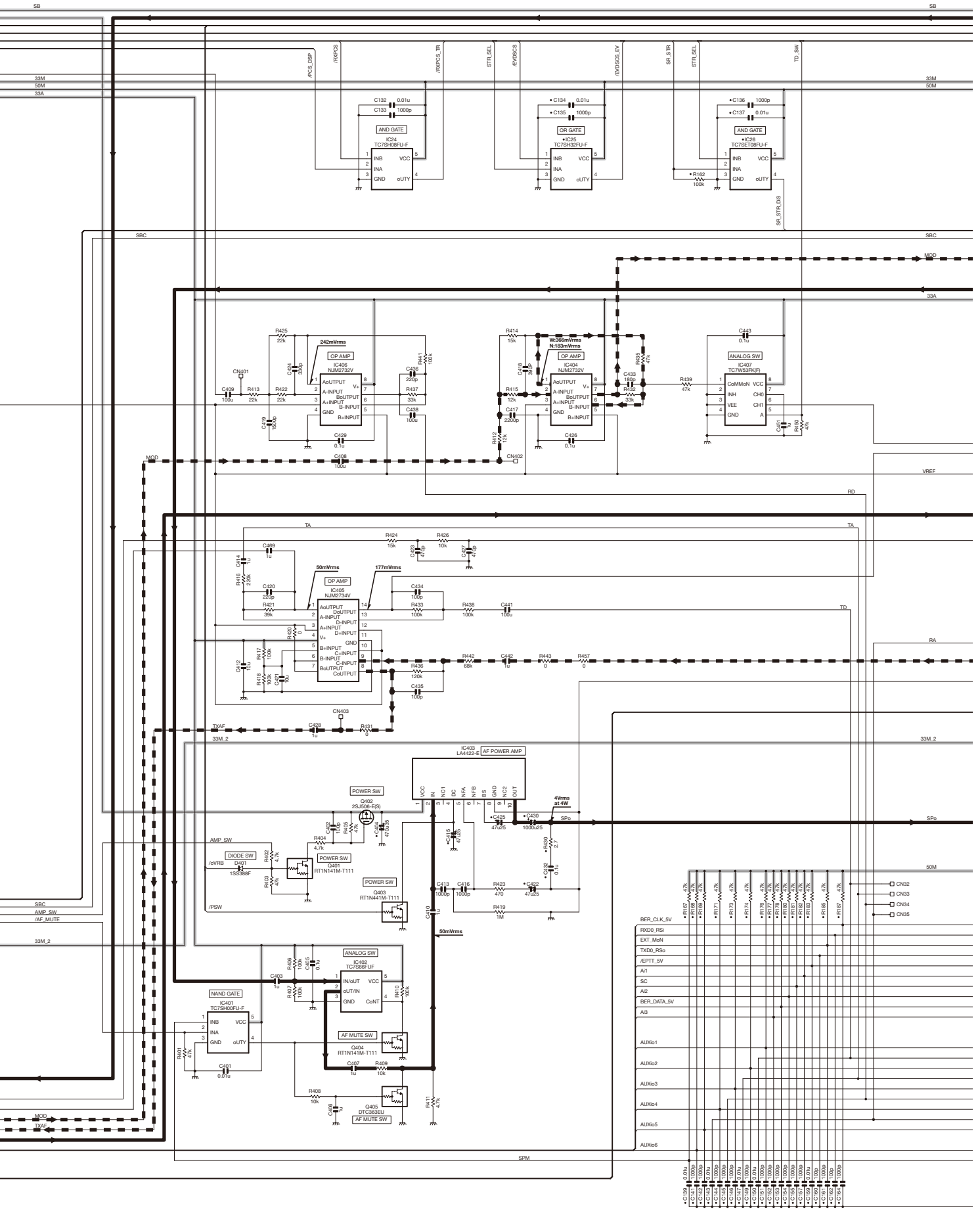

# SCHEMATIC DIAGRAM NXR-810

CONTROL UNIT (X53-4490-10)

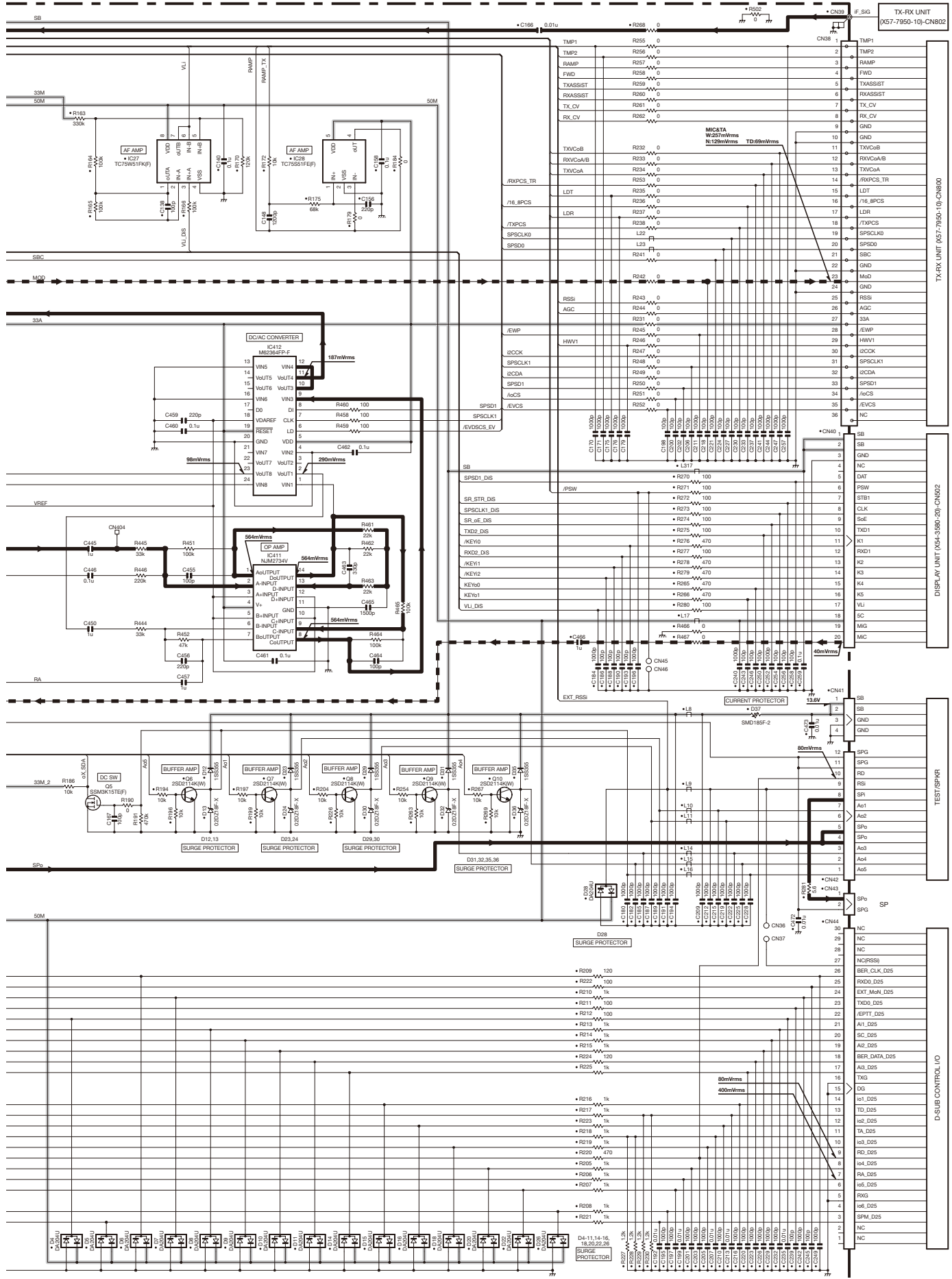

Note : The components marked with a dot (•) are parts of layer 1.



# NXR-810 SCHEMATIC DIAGRAM

DISPLAY UNIT (X54-3580-20) (A/2)

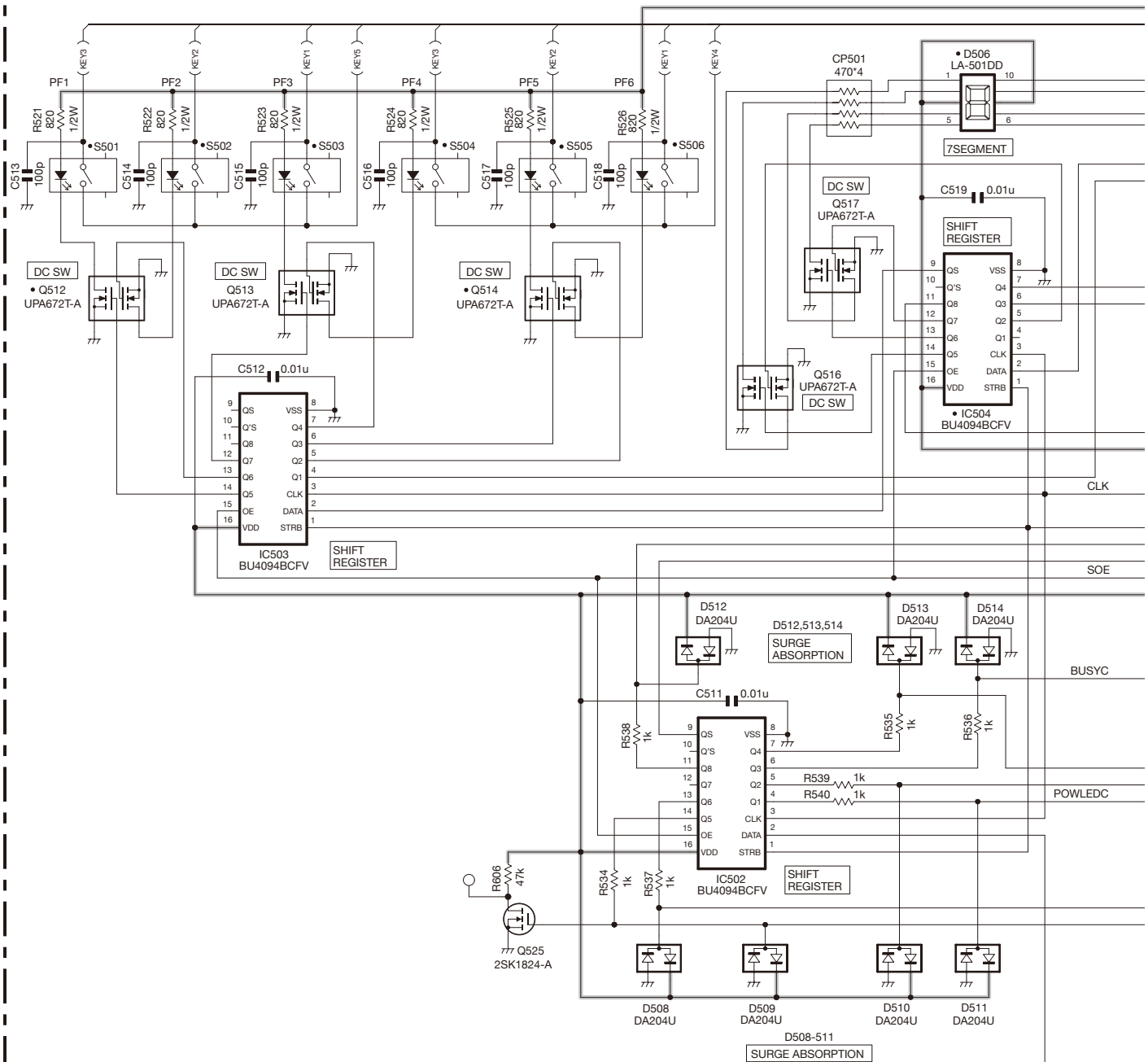

DISPLAY UNIT (X54-3580-20) (B/2)

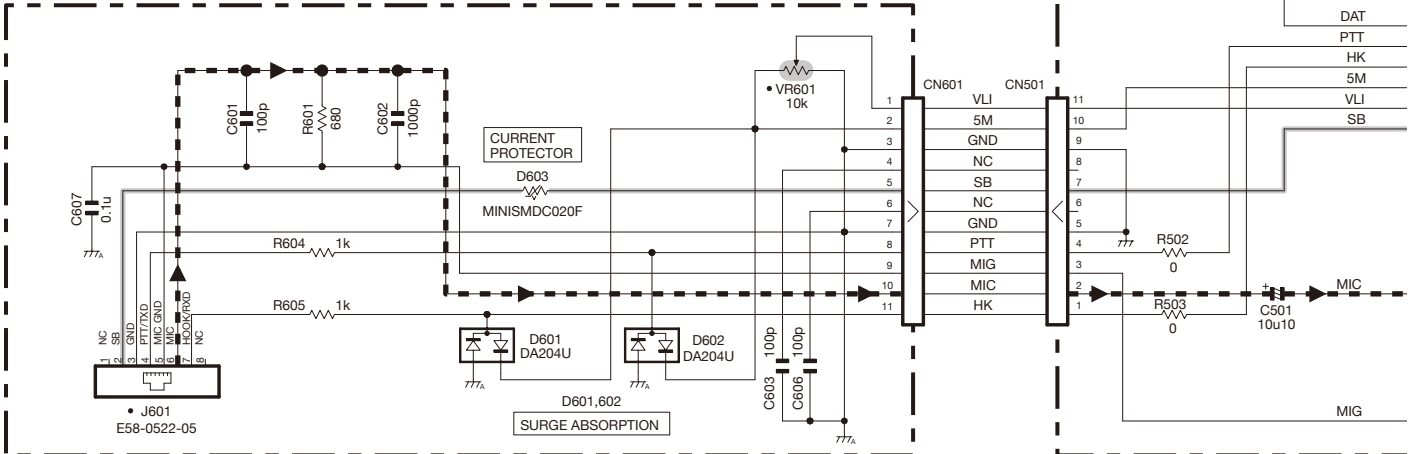

# SCHEMATIC DIAGRAM NXR-810

DISPLAY UNIT (X54-3580-20) (A/2)

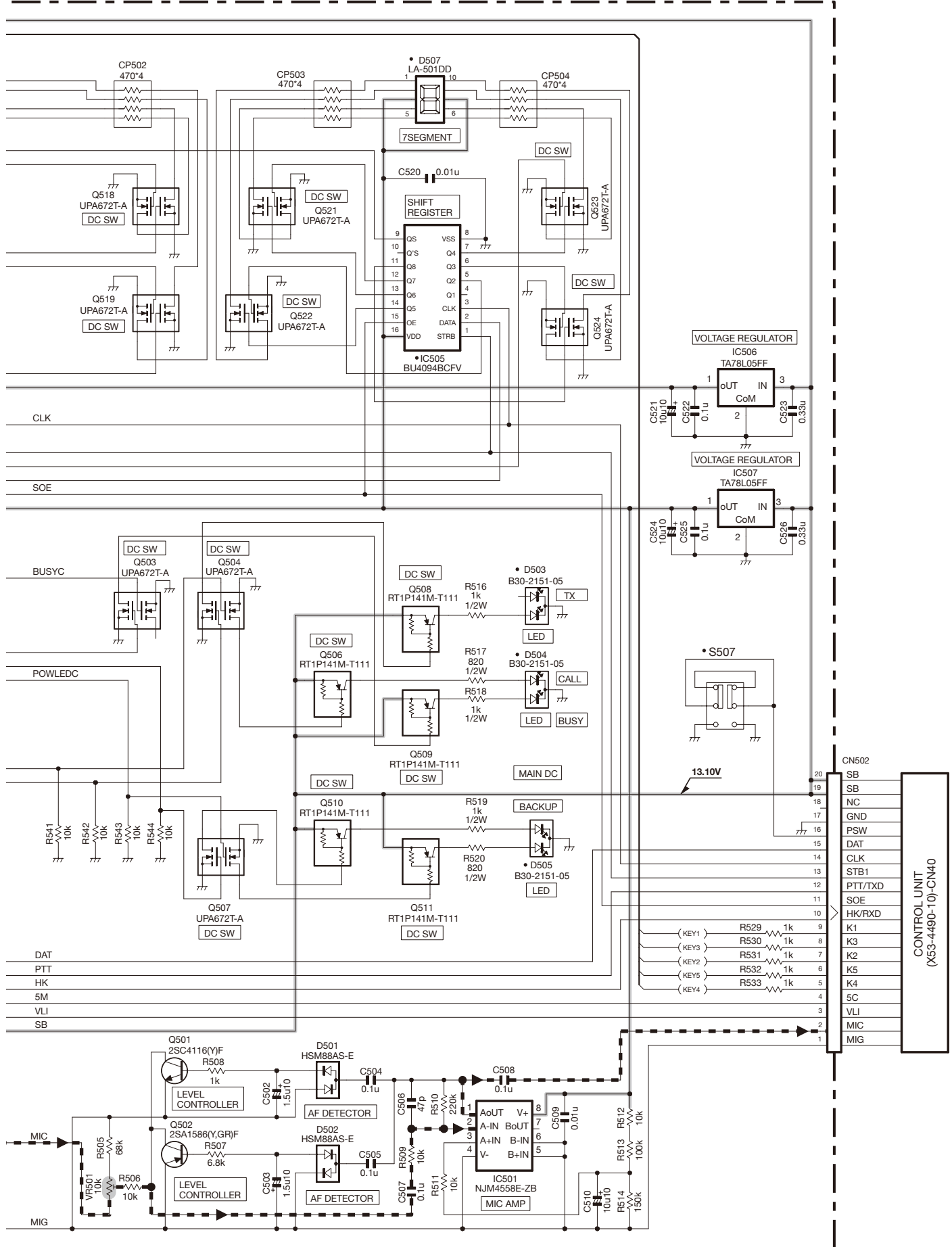

**Note :** The components marked with a dot (•) are parts of layer 1.

# NXR-810 SCHEMATIC DIAGRAM

TX-RX UNIT (X57-7950-10)

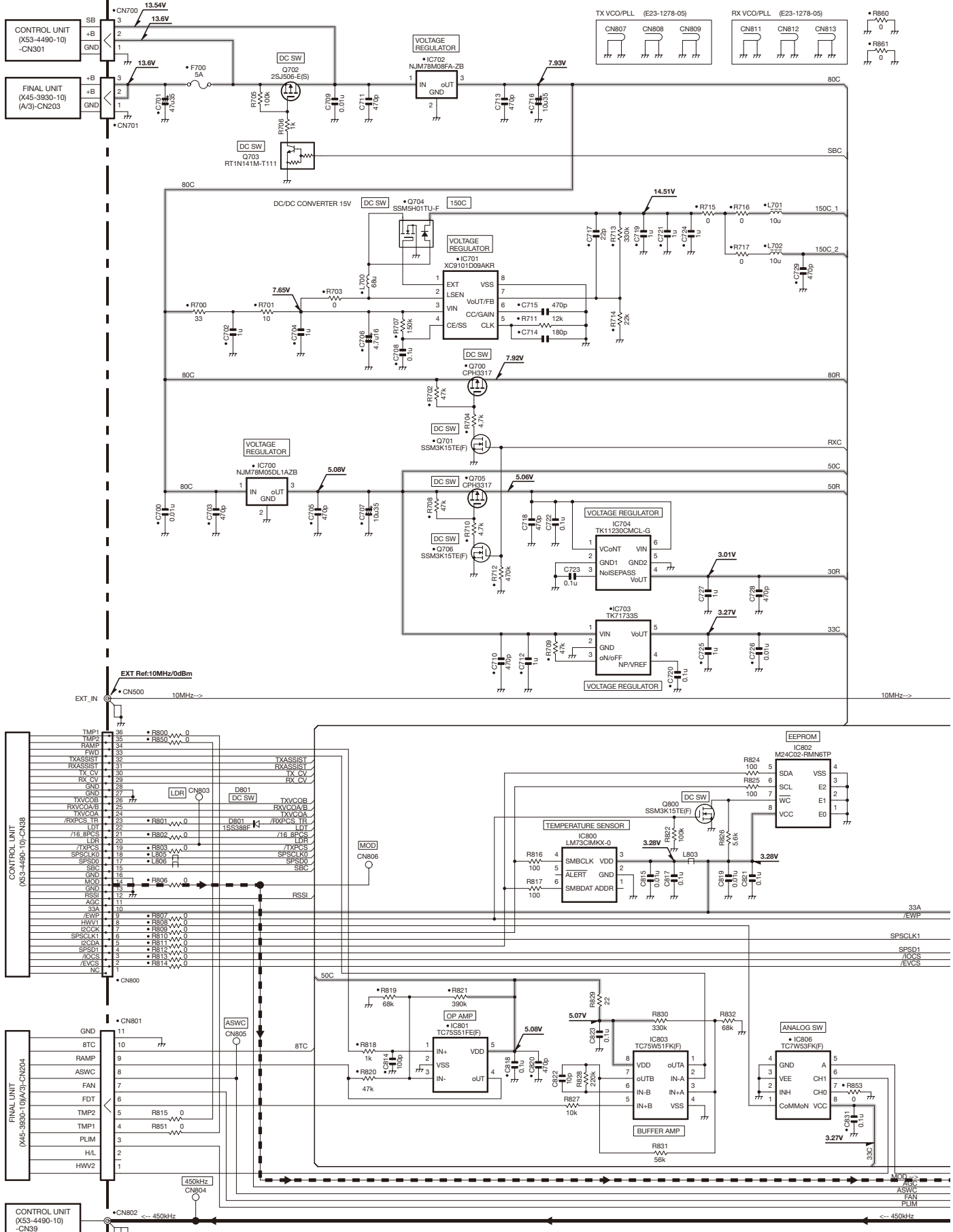

# SCHEMATIC DIAGRAM NXR-810

TX-RX UNIT (X57-7950-10)

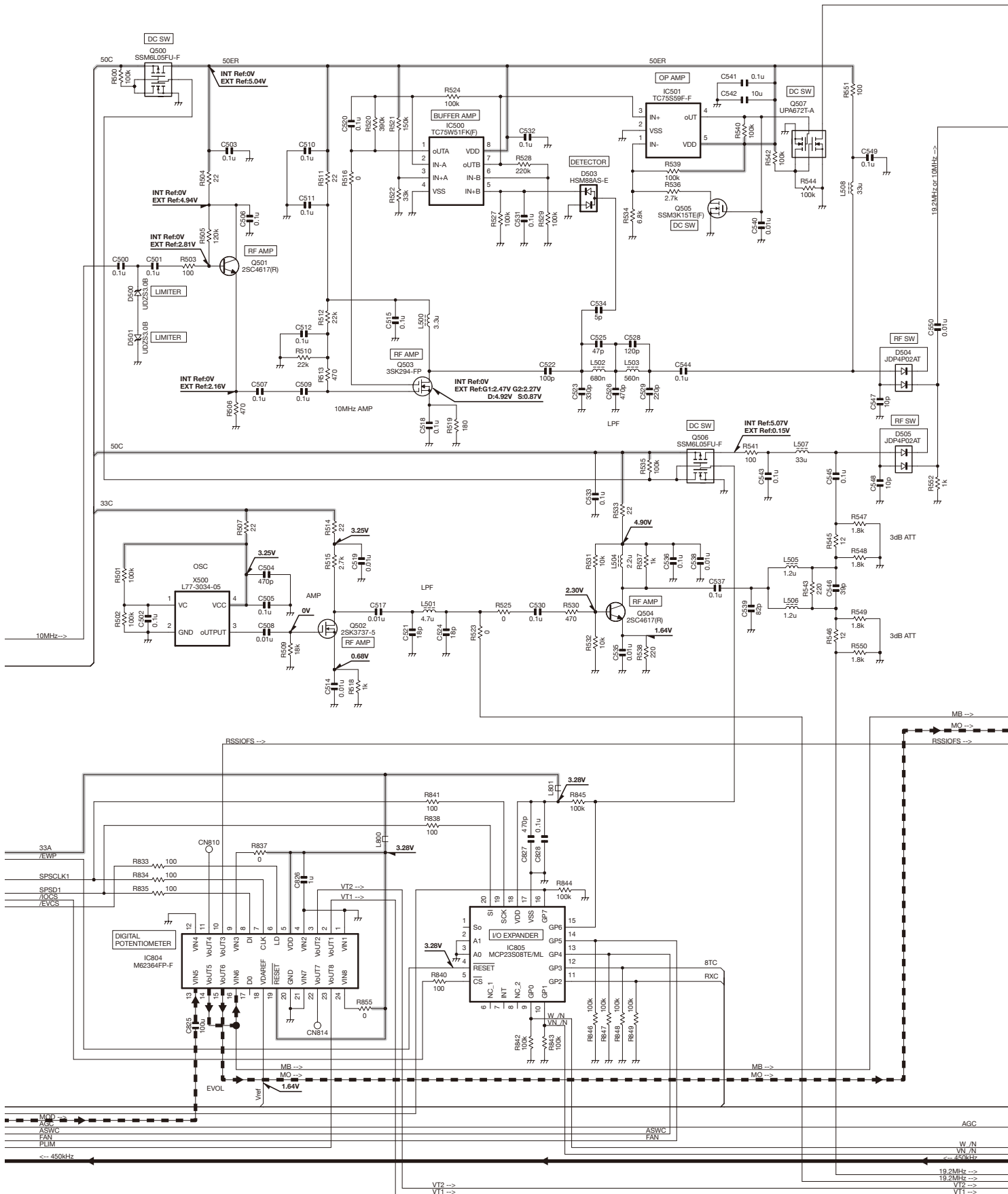

# NXR-810 SCHEMATIC DIAGRAM

TX-RX UNIT (X57-7950-10)

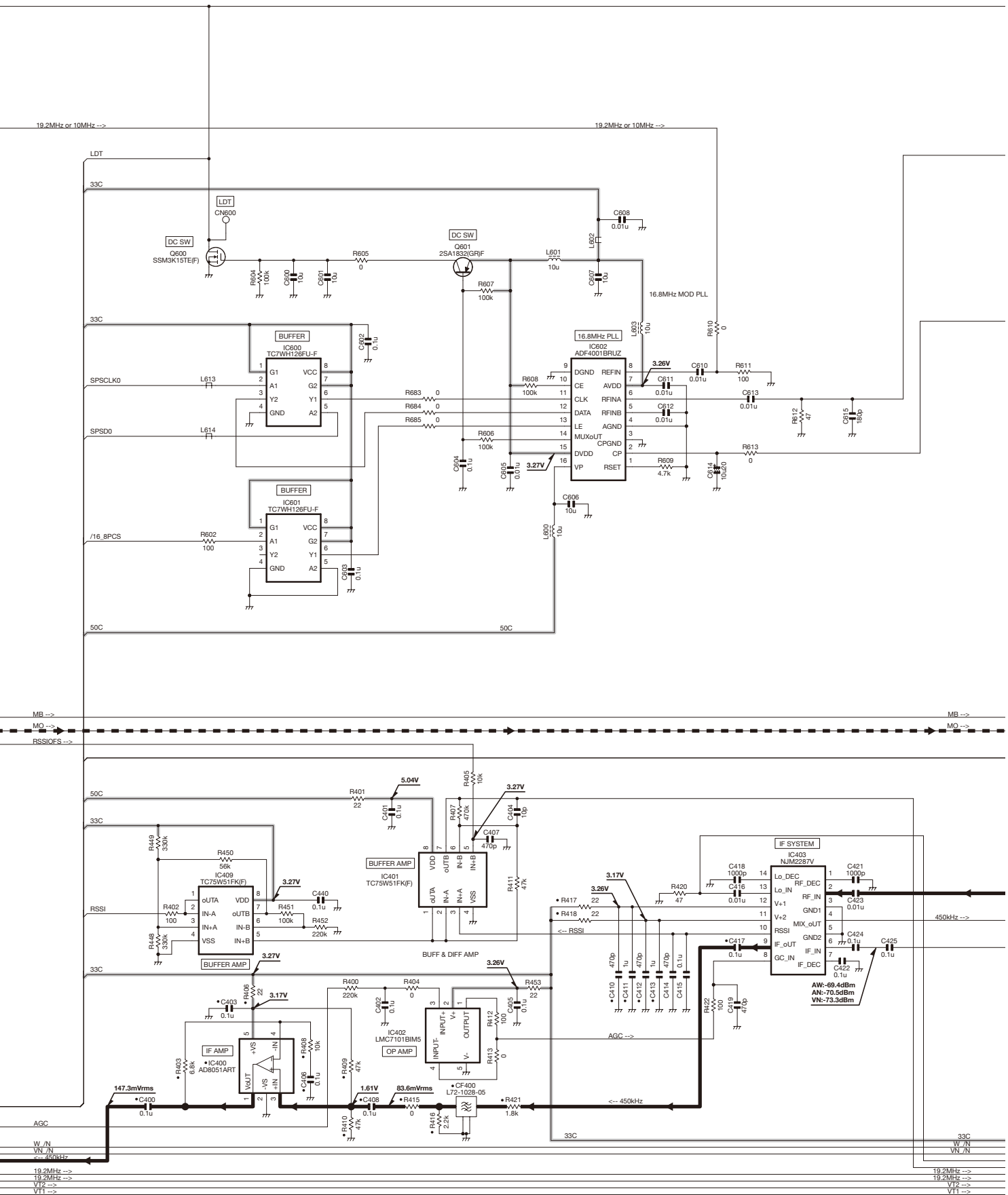









# NXR-810 SCHEMATIC DIAGRAM

TX-RX UNIT (X57-7950-10)

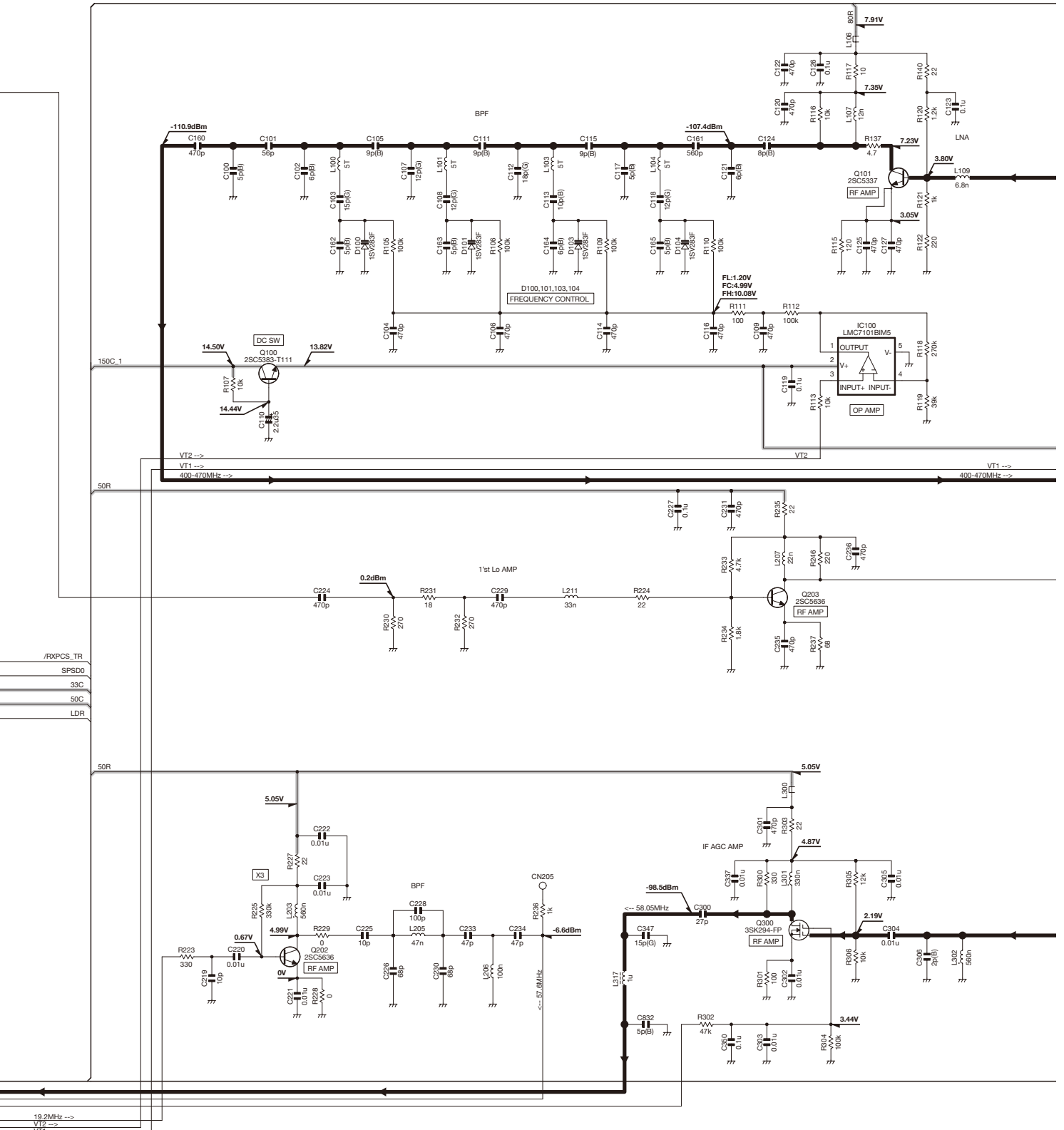

## SCHEMATIC DIAGRAM NXR-810

TX-RX UNIT (X57-7950-10)

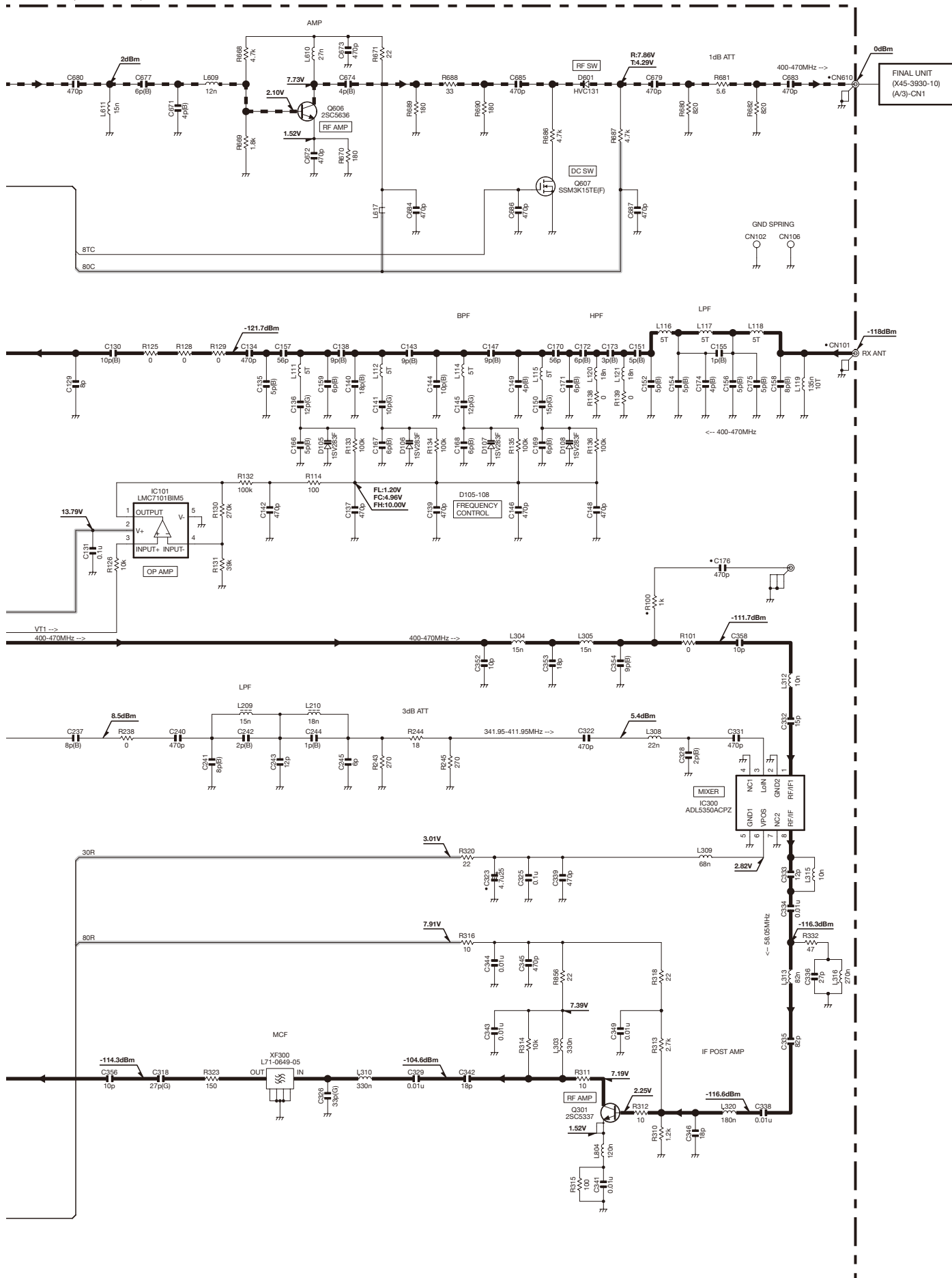

# NXR-810 BLOCK DIAGRAM

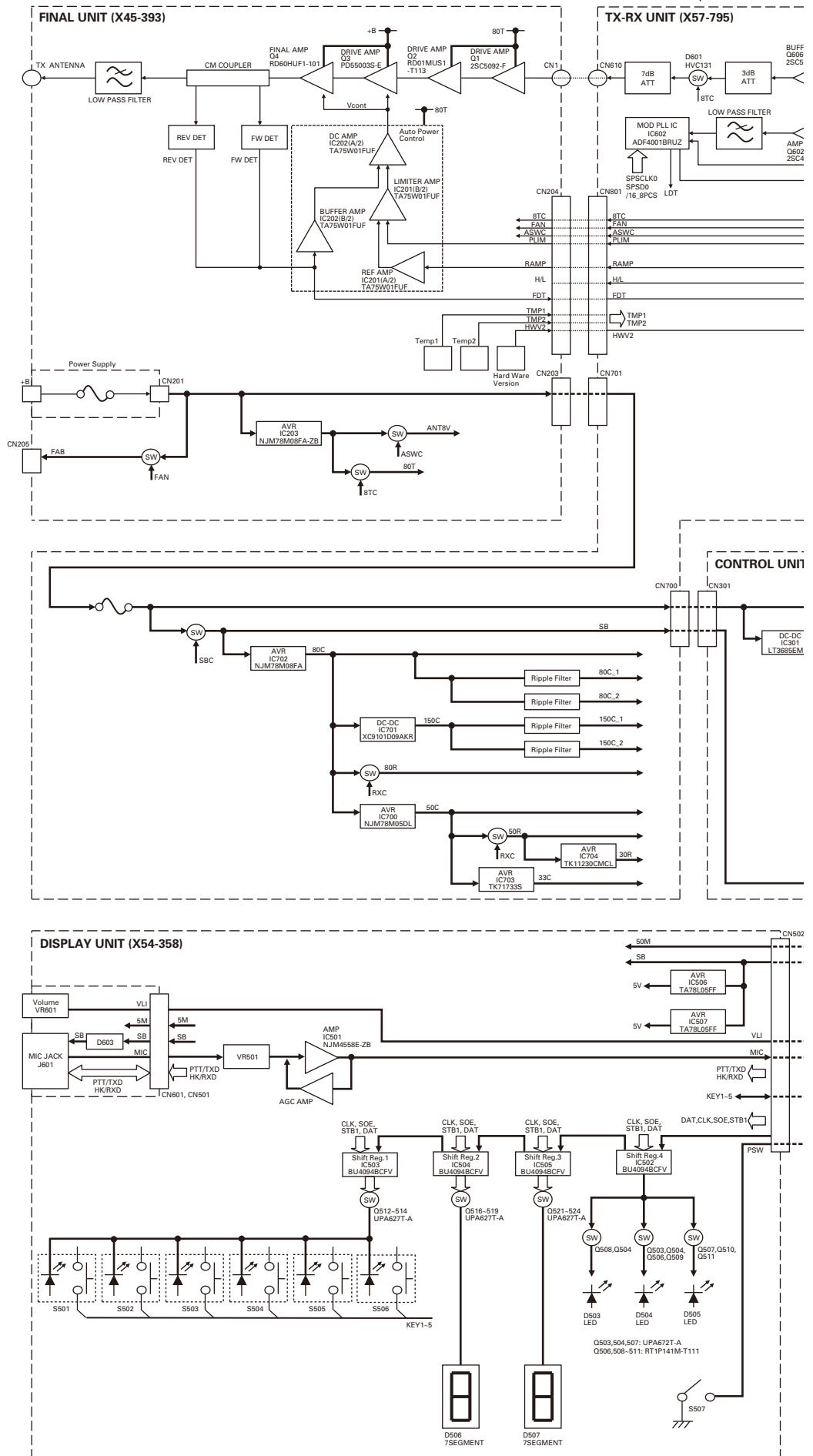

# BLOCK DIAGRAM NXR-810

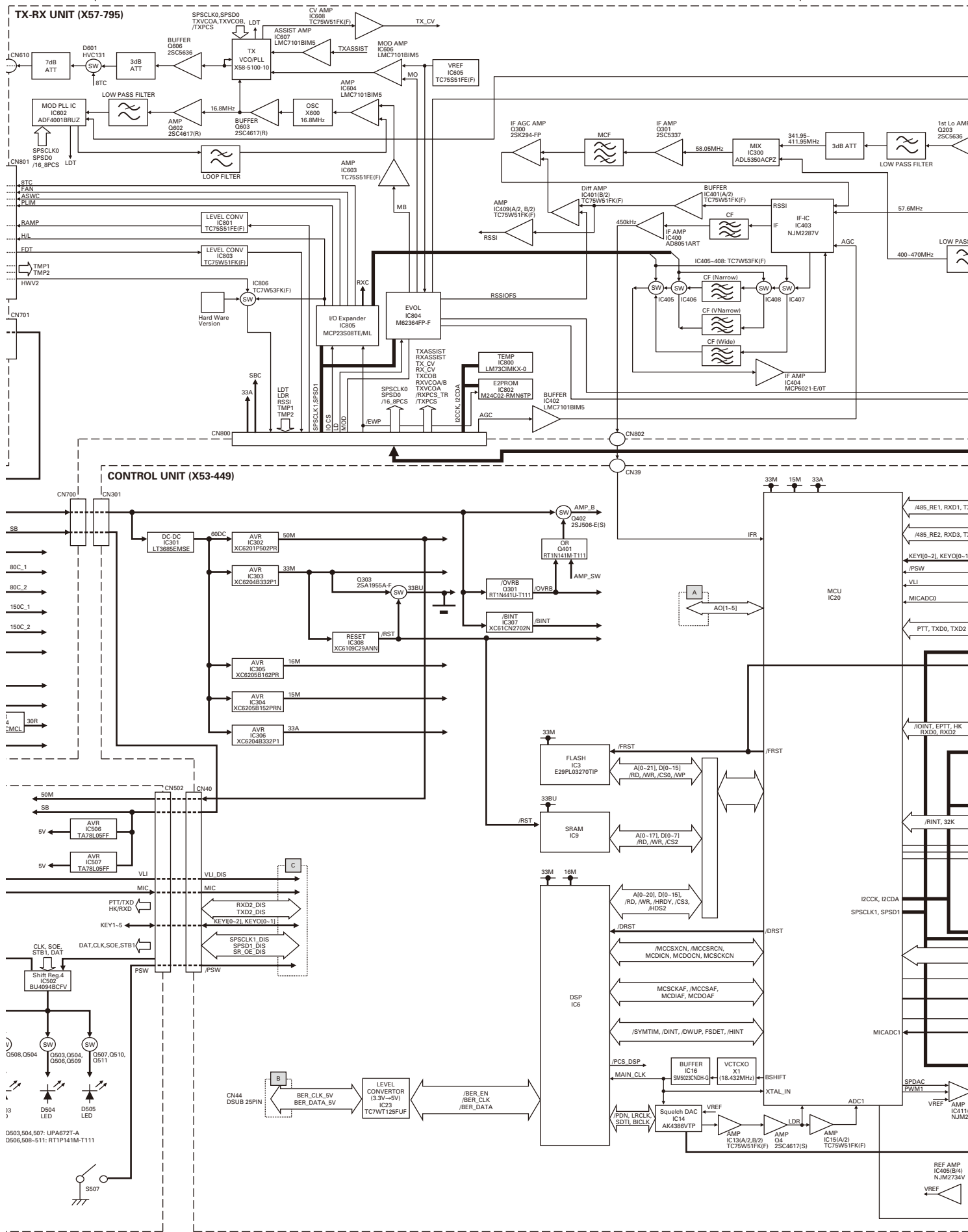



## OPTIONAL ACCESSORIES: KES-5 (EXTERNAL SPEAKER)

### When Using an External Speaker

1. Make sure the unit's power is tuned off.
2. When using the external speaker, remove the jumper lead from the connector, and attach the speaker cable.
3. When not using the external speaker, replace the jumper lead and insert the connector into the speaker jack (pin 9 and 12).

### Specifications

Maximum input power .....	40W
Impedance .....	4Ω
Dimensions (W x H x D) projection not included .....	129 x 129 x 77 mm (5-1/16 x 5-1/16 x 3 inches)
Weight .....	820g / 1.81 lbs

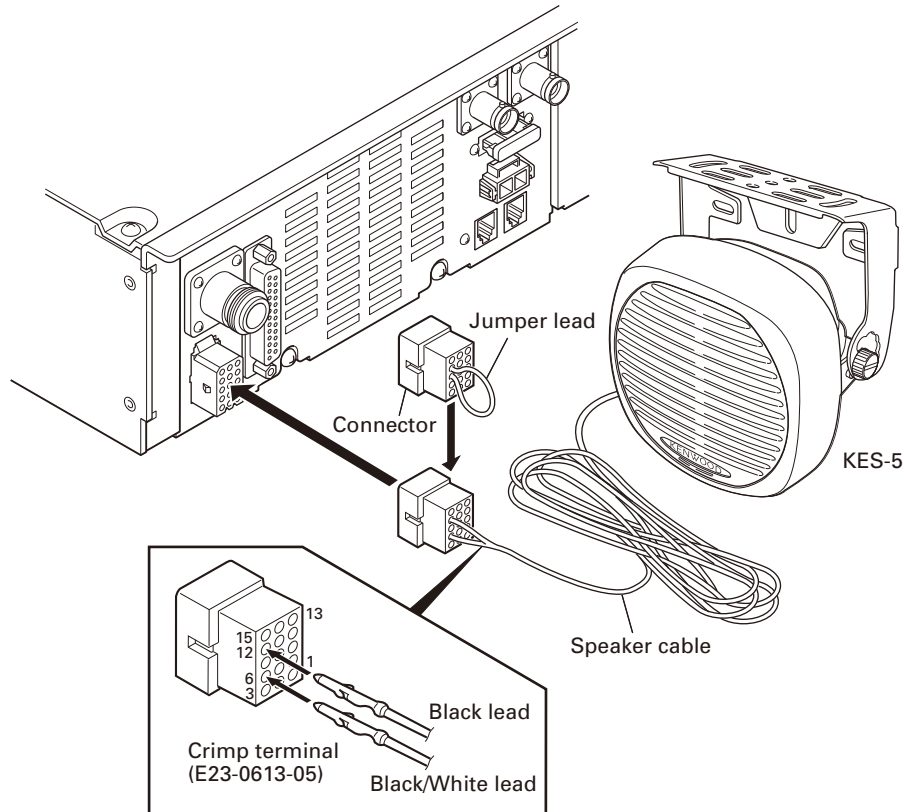

# NXR-810

## SPECIFICATIONS

### General

Frequency Ranges.....	400~470MHz
Number of Channels.....	30
Channel Spacing	
Analog.....	12.5/ 25kHz
Digital.....	6.25/ 12.5kHz
PLL Channel Step.....	3.125/ 5kHz
Antenna Impedance.....	50Ω
Operating Voltage.....	10.8~15.6V DC
Current Drain	
Standby.....	0.5A
Receive.....	1.0A
Transmit.....	11.0A
TX Power	
50% Duty.....	40W
100% Duty.....	25W
Operating Temperature Range	
.....	-22°F~+140°F (-30°C~+60°C)
Frequency Stability.....	±0.5ppm
Dimension (W x H x D) (Projections not included)	
.....	19.00 x 3.46 x 13.39 inches (482.6 x 88 x 340 mm)
Weight (net).....	21.4 lbs (9.7kg)

### Receiver

Sensitivity	
Digital@6.25kHz (3% BER).....	0.22μV
Digital@12.5kHz (3% BER).....	0.28μV
Analog (12dB SINAD).....	0.28μV
Sensitivity	
Analog@25kHz.....	80dB
Analog@12.5kHz.....	74dB
FM Hum & Noise	
Analog@25kHz.....	55dB
Analog@12.5kHz.....	50dB
Intermodulation Distortion.....	80dB
Spurious Response.....	90dB
Audio Distortion (Ext. SP).....	Less than 2.5% at 1000Hz
Audio Output (Ext. SP)....	4W (at 4Ω, less than 5% distortion)

### Transmitter

RF Power Output.....	25~40W
Spurious & Harmonics.....	80dB
FM Hum & Noise	
Analog@25kHz.....	55dB
Analog@12.5kHz.....	50dB
Audio Distortion.....	Less than 1% at 1000Hz
Modulation.....	16K0F3E, 11K0F3E, 8K30F1E, 8K30F1D, 8K30F7W, 4K00F1E, 4K00F1D, 4K00F7W, 4K00F2D

Analog measurements made per TIA/EIA 603 and specifications shown are typical.

KENWOOD reserves the right to change specifications without prior notice or obligation.

## Kenwood Corporation

2967-3, Ishikawa-machi, Hachioji-shi, Tokyo, 192-8525 Japan

### Kenwood U.S.A. Corporation

P.O. BOX 22745, 2201 East Dominguez Street, Long Beach, CA 90801-5745, U.S.A.

### Kenwood Electronics Canada Inc.

6070 Kestrel Road, Mississauga, Ontario, Canada L5T 1S8

### Kenwood Electronics Deutschland GmbH

Rembrücker Str. 15, 63150 Heusenstamm, Germany

### Kenwood Electronics Belgium N.V.

Leuvensesteenweg 248 J, 1800 Vilvoorde, Belgium

### Kenwood Electronics France S.A.

L'Etoile Paris Nord 2, 50 Allée des Impressionnistes, Bp 58416 Villepinte, 95944 Roissy Ch De Gaulle Cedex

### Kenwood Electronics UK Limited

KENWOOD House, Dwight Road, Watford, Herts., WD18 9EB United Kingdom

### Kenwood Electronics Europe B.V.

Amsterdamsseweg 37, 1422 AC Uithoorn, The Netherlands

### Kenwood Electronics Italia S.p.A.

Via G. Sirtori, 7/9 20129 Milano, Italy

### Kenwood Ibérica, S.A.

Bolivia, 239-08020 Barcelona, Spain

### Kenwood Electronics Australia Pty. Ltd.

Talavera Business Park Building A, 4 Talavera Road, North Ryde NSW 2113 Australia

### Kenwood Electronics (Hong Kong) Ltd.

Unit 3712-3724, Level 37, Tower one Metroplaza, 223 Hing Fong Road, Kwai Fong, N.T., Hong Kong

### Kenwood Electronics Singapore Pte Ltd

1 Ang Mo Kio Street 63, Singapore 569110





# NXR-810 PC BOARD

# PC BOARD NXR-810

**FINAL UNIT (X45-3930-10)**  
**Component side view (J79-0264-09)**

**FINAL UNIT (X45-3930-10)**  
**Component side view (J79-0264-09)**

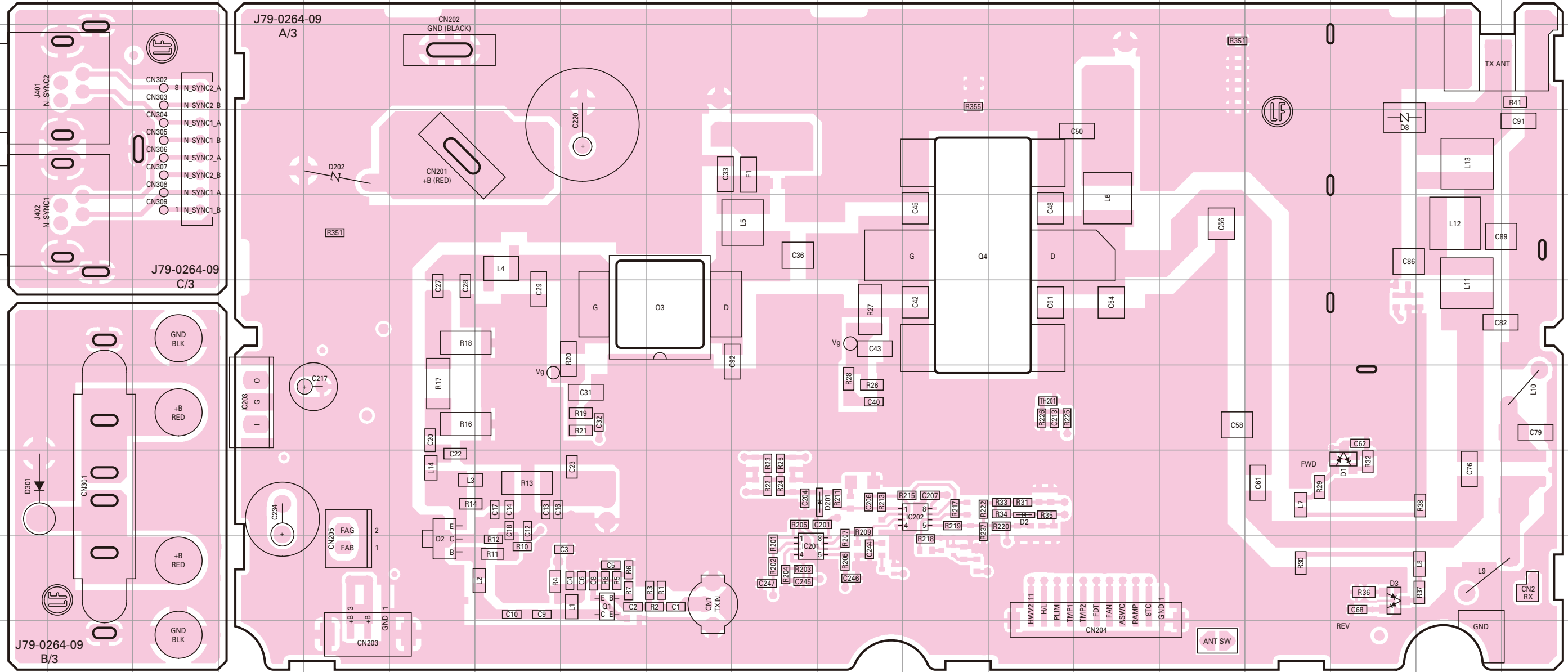

Ref. No.	Address	Ref. No.	Address
IC201	9J	D1	8Q
IC202	8L	D2	8M
IC203	7D	D3	9Q
Q1	9H	D8	4Q
Q2	9F	D201	8K
Q3	6I	D202	4E
Q4	5L	D301	8A

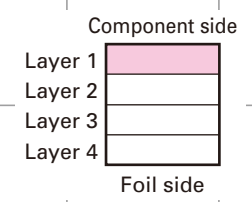

# NXR-810 PC BOARD

# PC BOARD NXR-810

FINAL UNIT (X45-3930-10)  
Foil side view (J79-0264-09)

FINAL UNIT (X45-3930-10)  
Foil side view (J79-0264-09)

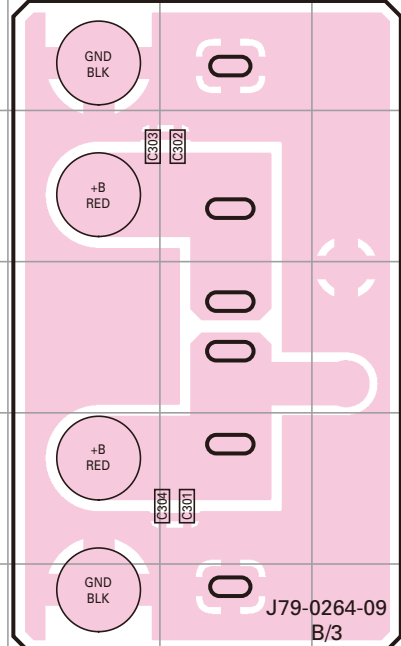
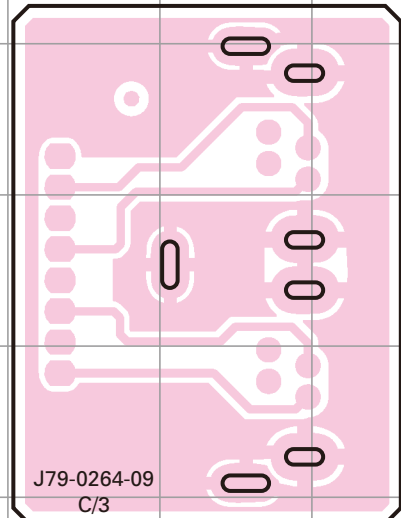
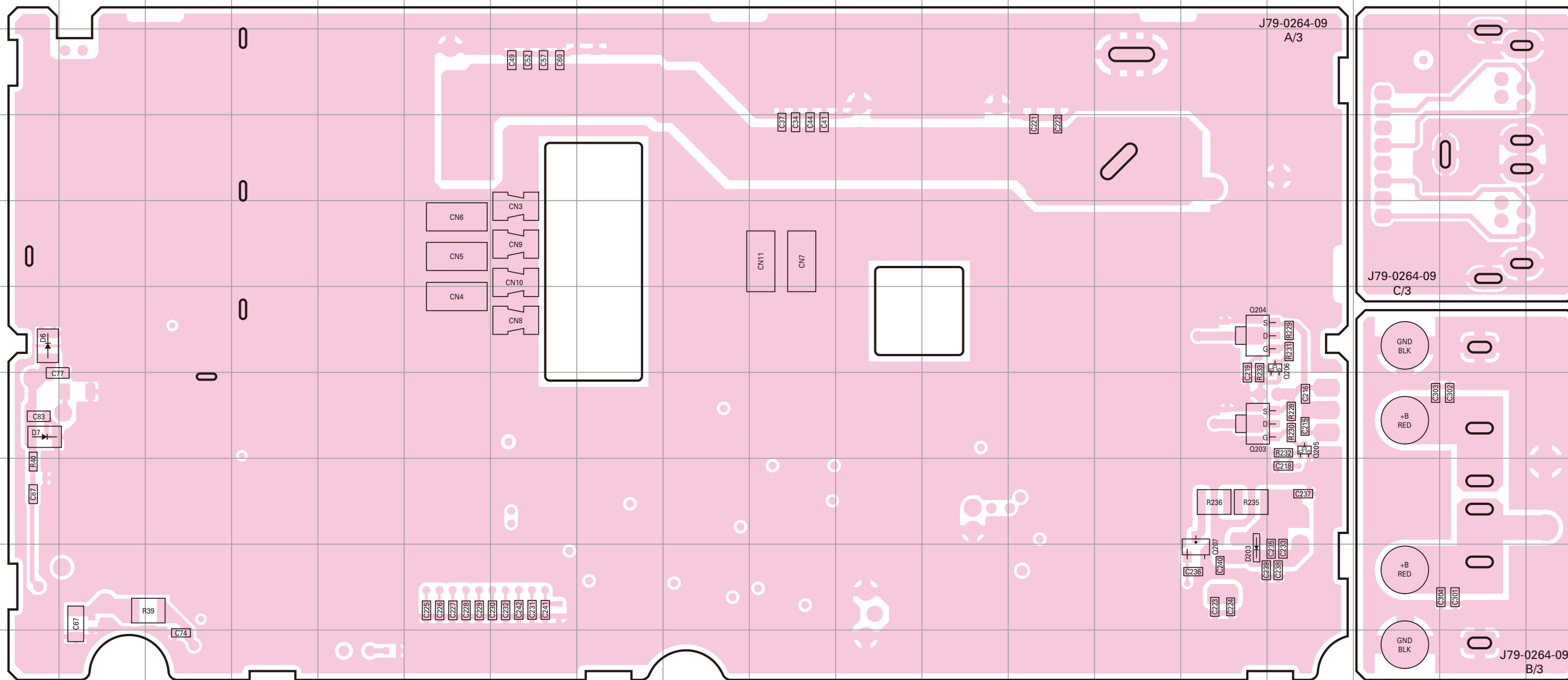

Ref. No.	Address
Q203	70
Q204	60
Q205	7P
Q206	6P
Q207	90
D6	6A
D7	7A
D203	90

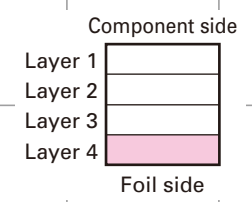

# NXR-810 PC BOARD

# PC BOARD NXR-810

**CONTROL UNIT (X53-4490-10)**  
**Component side view (J79-0277-09)**

**CONTROL UNIT (X53-4490-10)**  
**Component side view (J79-0277-09)**

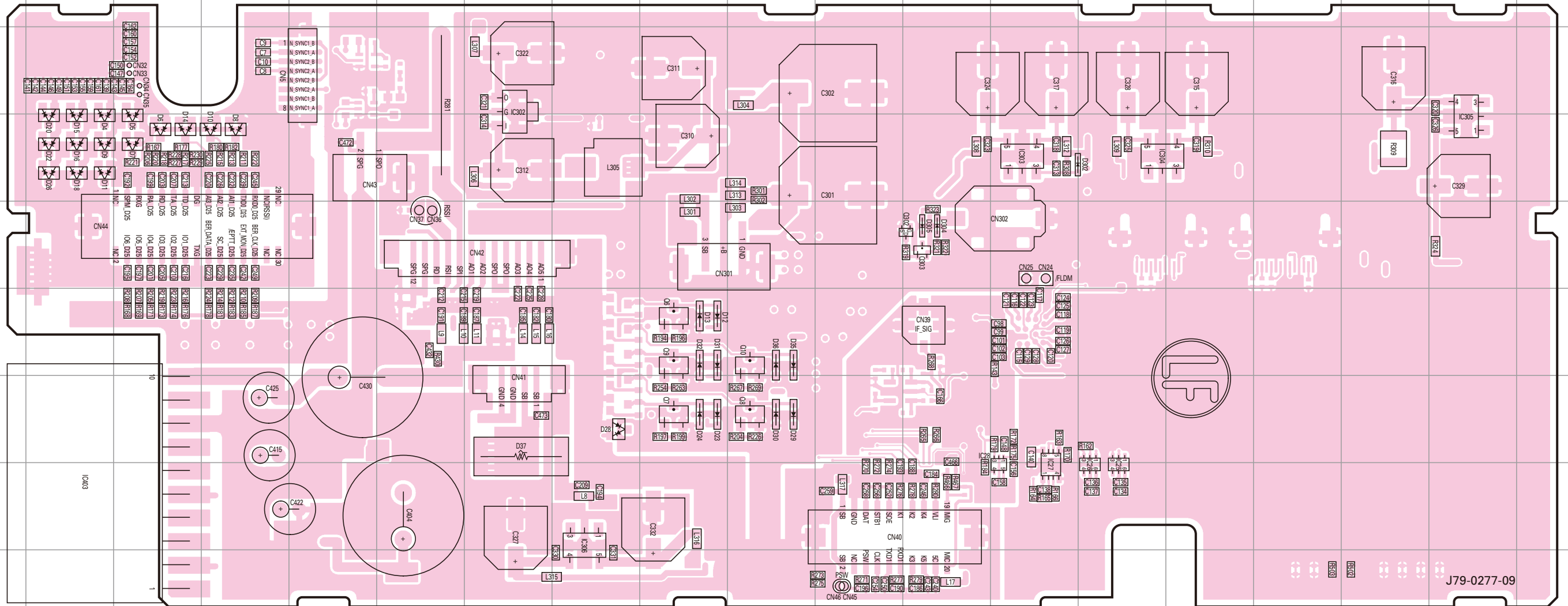

Ref. No.	Address	Ref. No.	Address	Ref. No.	Address	Ref. No.	Address	Ref. No.	Address
IC25	8N	Q6	6I	D7	4C	D18	4B	D32	6I
IC26	8N	Q7	7I	D8	4D	D20	4B	D35	6J
IC27	8M	Q8	7J	D9	4B	D22	4B	D36	6J
IC28	8M	Q9	6I	D10	4D	D23	7I	D37	7G
IC302	3G	Q10	6J	D11	4B	D24	7I	D302	4N
IC303	4M	Q302	5L	D12	6I	D26	4B	D304	5L
IC304	4N	Q303	5L	D13	6I	D28	7H	D305	5L
IC305	4R	D4	4B	D14	4C	D29	7J		
IC306	8H	D5	4C	D15	4B	D30	7J		
IC403	8B	D6	4C	D16	4B	D31	6I		

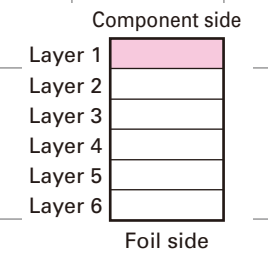

# NXR-810 PC BOARD

# PC BOARD NXR-810

**CONTROL UNIT (X53-4490-10)**  
Foil side view (J79-0277-09)

**CONTROL UNIT (X53-4490-10)**  
Foil side view (J79-0277-09)

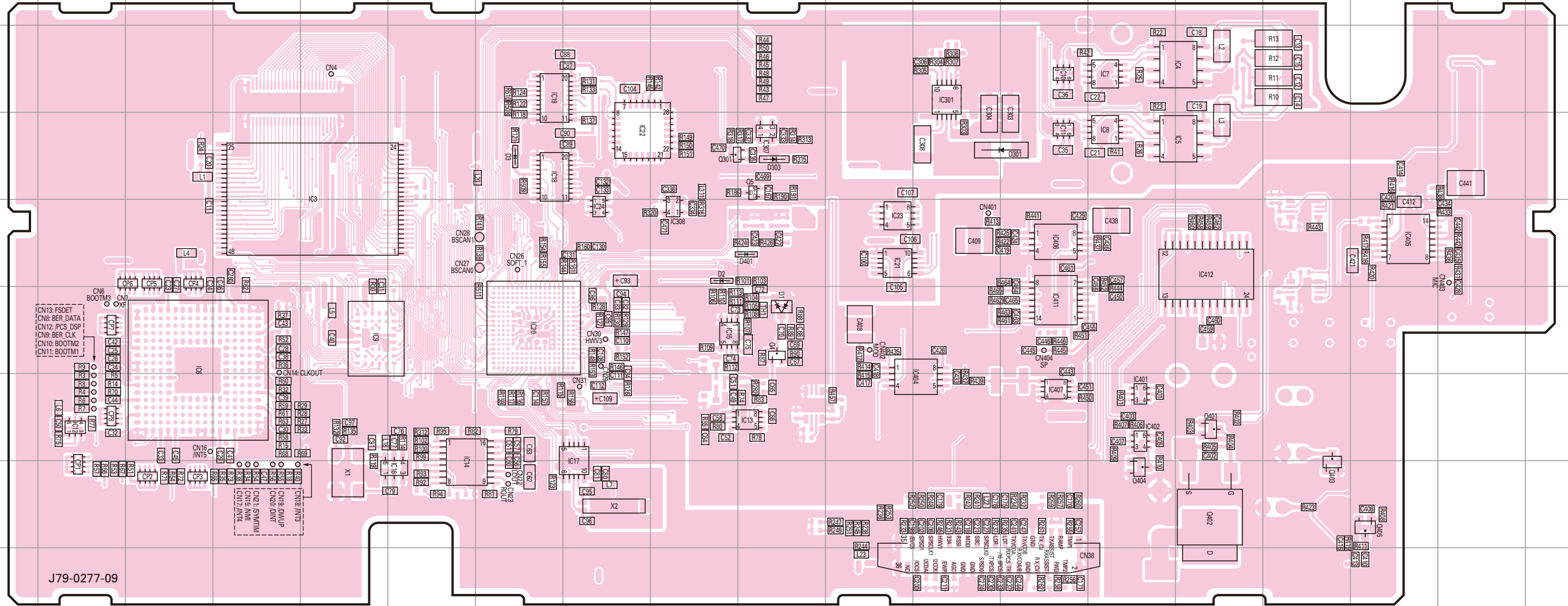

Ref. No.	Address	Ref. No.	Address	Ref. No.	Address	Ref. No.	Address	Ref. No.	Address
IC3	4E	IC13	7J	IC23	5K	IC407	7M	Q405	8Q
IC4	3O	IC14	8F	IC24	5H	IC411	6M	D1	6J
IC5	4O	IC15	6I	IC301	3L	IC412	5O	D2	5I
IC6	6C	IC16	8F	IC307	4J	Q4	6J	D3	4G
IC7	3N	IC17	8H	IC308	5I	Q5	4J	D301	4M
IC8	4N	IC18	4G	IC401	7N	Q301	4I	D303	4J
IC9	6E	IC19	3G	IC402	7N	Q401	7O	D401	5J
IC10	3M	IC20	6G	IC404	7L	Q402	8O		
IC11	4M	IC21	5K	IC405	5Q	Q403	8P		
IC12	7B	IC22	4H	IC406	5M	Q404	8N		

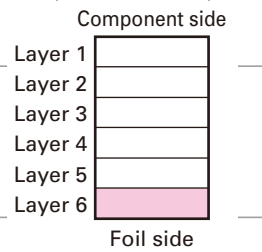

# NXR-810 PC BOARD

# PC BOARD NXR-810

DISPLAY UNIT (X54-3580-20) Component side view (J79-0035-09)

DISPLAY UNIT (X54-3580-20) Component side view (J79-0035-09)

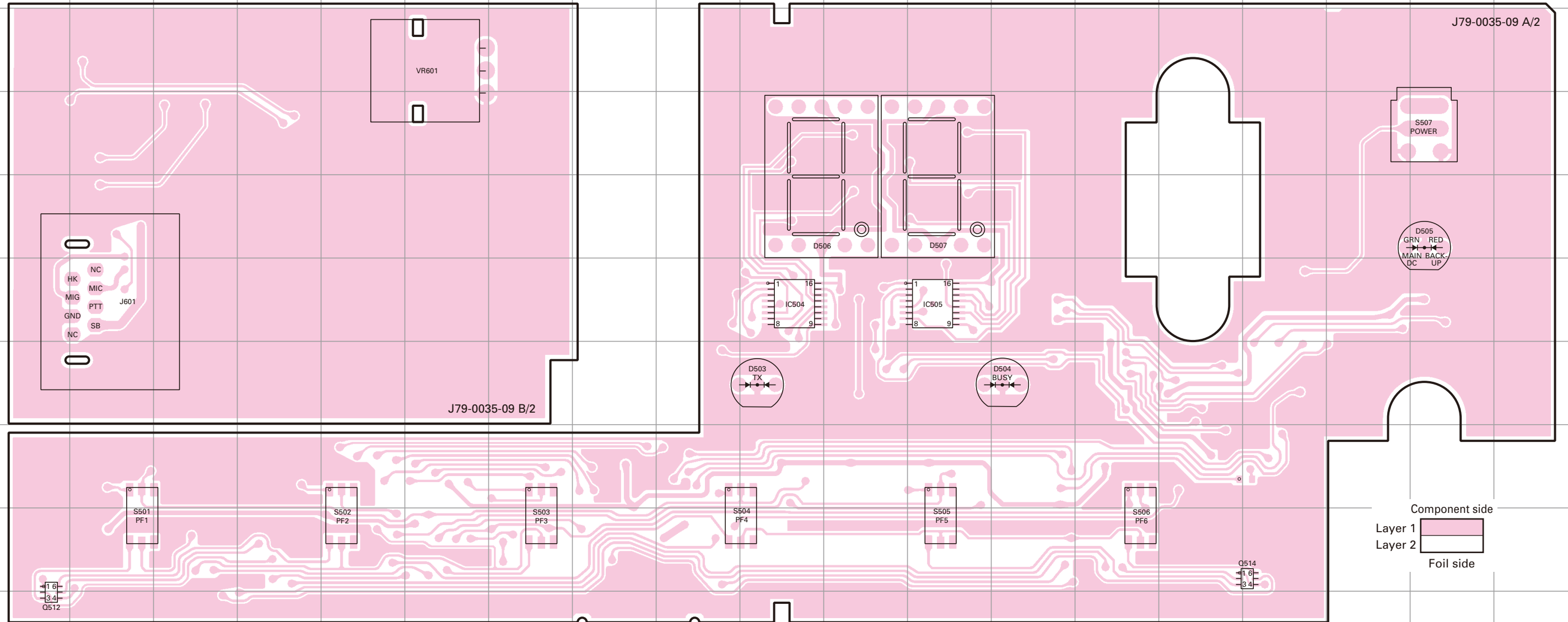

Ref. No.	Address
IC504	6J
IC505	6L
Q512	10A
Q514	10P
D503	7J
D504	7M
D505	5R
D506	5J
D507	5L

# NXR-810 PC BOARD

# PC BOARD NXR-810

DISPLAY UNIT (X54-3580-20) Foil side view (J79-0035-09)

DISPLAY UNIT (X54-3580-20) Foil side view (J79-0035-09)

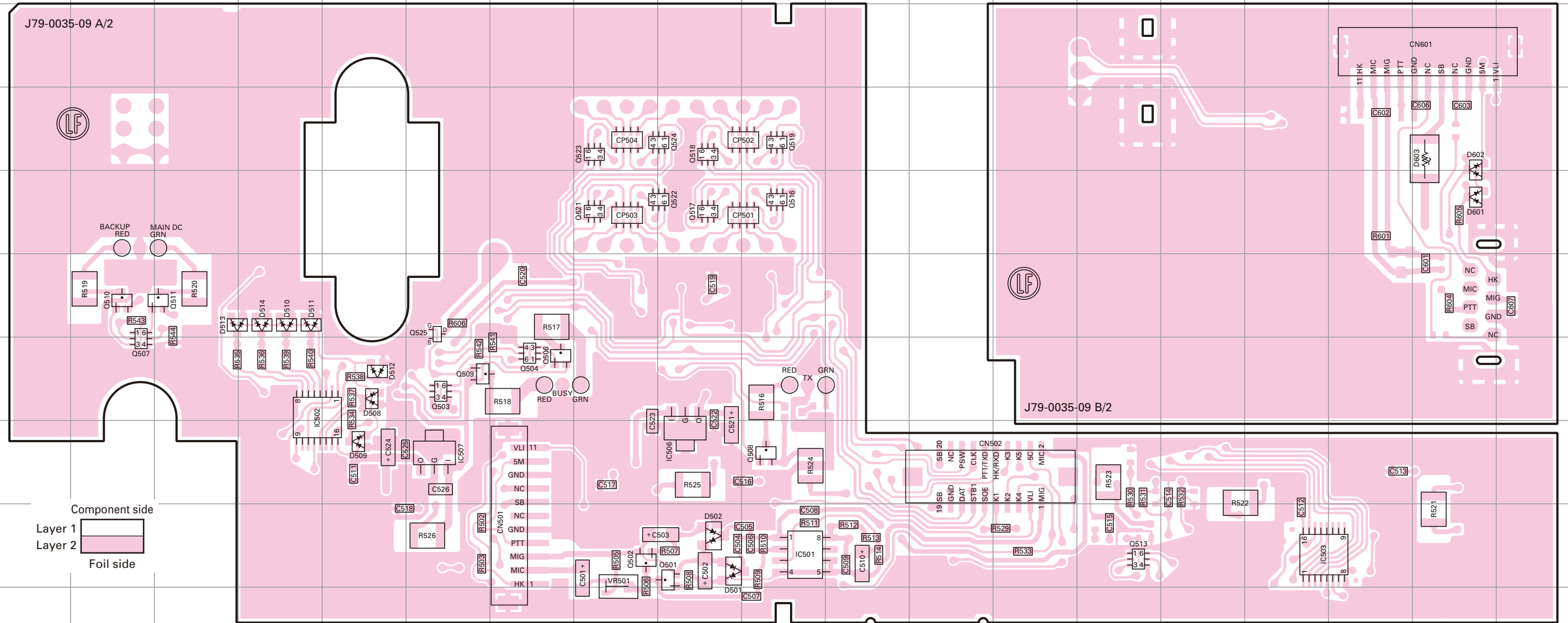

Ref. No.	Address	Ref. No.	Address	Ref. No.	Address	Ref. No.	Address
IC501	9J	Q507	7B	Q521	5H	D511	6D
IC502	7D	Q508	8J	Q522	5I	D512	7E
IC503	9P	Q509	7F	Q523	4H	D513	6C
IC506	8I	Q510	6B	Q524	4I	D514	6D
IC507	8F	Q511	6C	Q525	6F	D601	5R
Q501	9I	Q513	9N	D501	9I	D602	4R
Q502	9H	Q516	5J	D502	9I	D603	4R
Q503	7F	Q517	5I	D508	7E		
Q504	7G	Q518	4I	D509	8E		
Q506	7G	Q519	4J	D510	6D		





# NXR-810 PC BOARD

# PC BOARD NXR-810

TX-RX UNIT (X57-7950-10)  
Foil side view (J79-0266-09)

TX-RX UNIT (X57-7950-10)  
Foil side view (J79-0266-09)

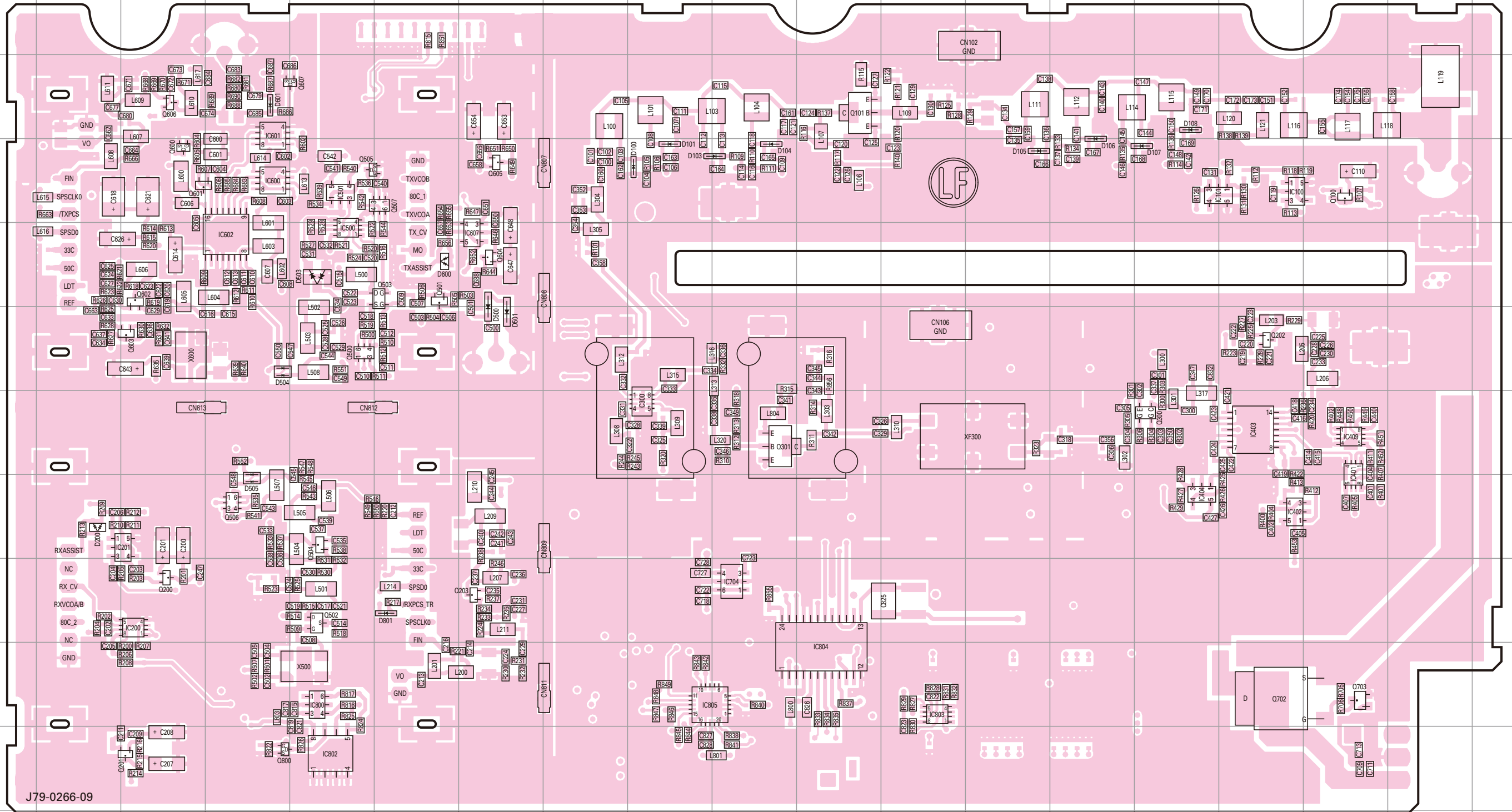

J79-0266-09

Ref. No.	Address	Ref. No.	Address	Ref. No.	Address	Ref. No.	Address	Ref. No.	Address	Ref. No.	Address	Ref. No.	Address	Ref. No.	Address	Ref. No.	Address	Ref. No.	Address		
IC100	4P	IC402	8P	IC600	4D	IC802	11E	Q200	9C	Q500	6E	Q506	8D	Q604	5G	Q800	11D	D106	4N	D503	5E
IC101	4O	IC403	7P	IC601	3D	IC803	10L	Q201	11C	Q501	5F	Q507	4F	Q605	4G	D100	4I	D107	4O	D504	6D
IC200	9C	IC404	8O	IC602	5D	IC804	10K	Q202	6P	Q502	9E	Q600	4C	Q606	3C	D101	4I	D108	3O	D505	8D
IC201	8C	IC409	7Q	IC607	5G	IC805	10I	Q203	9G	Q503	5F	Q601	4C	Q607	3E	D103	4I	D200	8B	D600	5F
IC300	7I	IC500	5E	IC704	9J	Q100	4Q	Q300	7O	Q504	8E	Q602	5C	Q702	10P	D104	4J	D500	6G	D601	3D
IC401	8Q	IC501	4E	IC800	10E	Q101	3K	Q301	7J	Q505	4E	Q603	6C	Q703	10Q	D105	4M	D501	6G	D801	9F

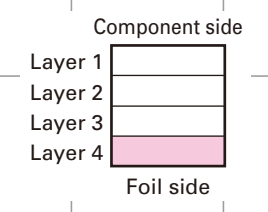



# NXR-810 PC BOARD

**RX VCO/PLL UNIT (X58-5090-10)**  
**Component side view (J79-0269-09)**

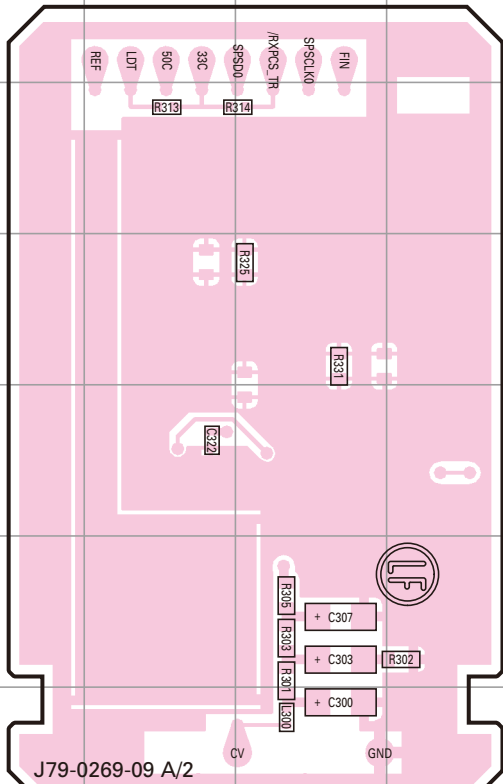

**RX VCO/PLL UNIT (X58-5090-10)**  
**Foil side view (J79-0269-09)**

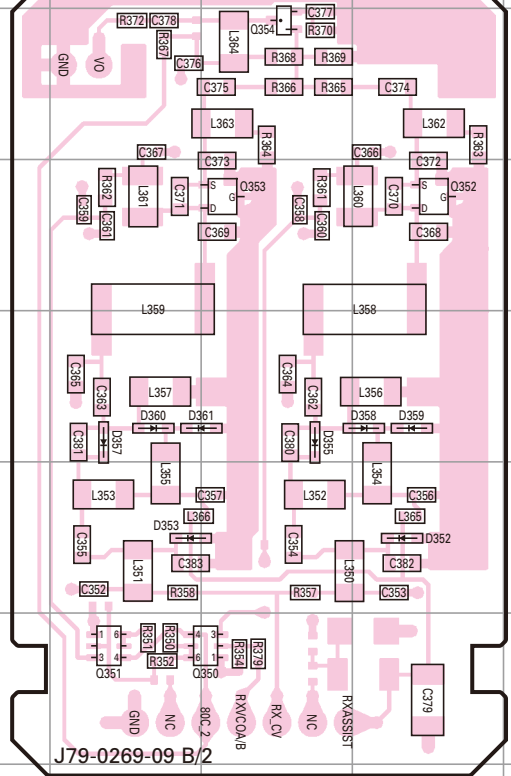
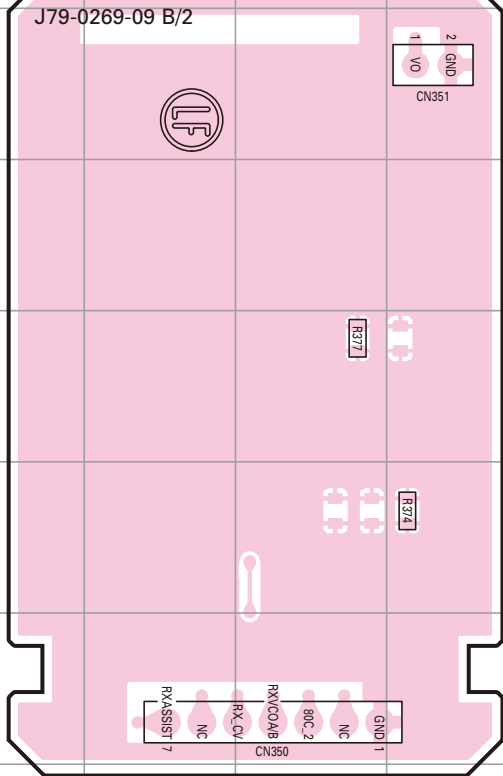
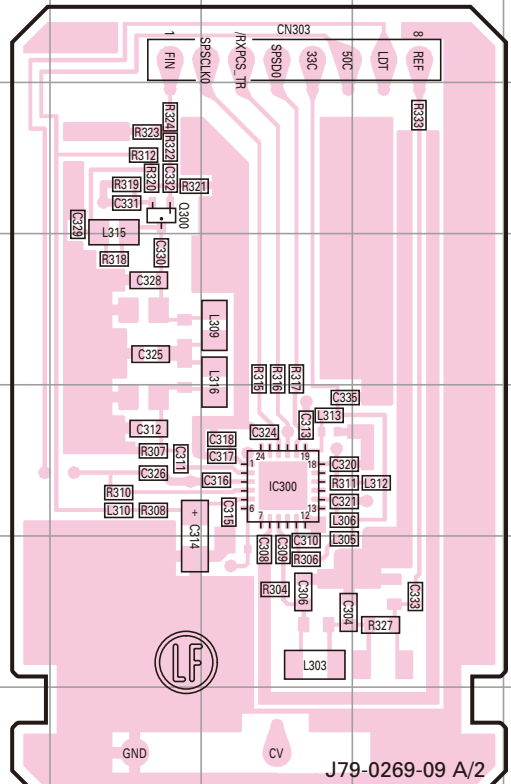

Ref. No.	Address
IC300	5G
Q300	3F
Q350	12G
Q351	12F
Q352	9H
Q353	9G
Q354	8G
D352	11H
D353	11F
D355	10G
D357	10F
D358	10H
D359	10H
D360	10F
D361	10G

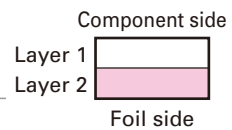
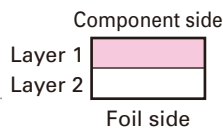



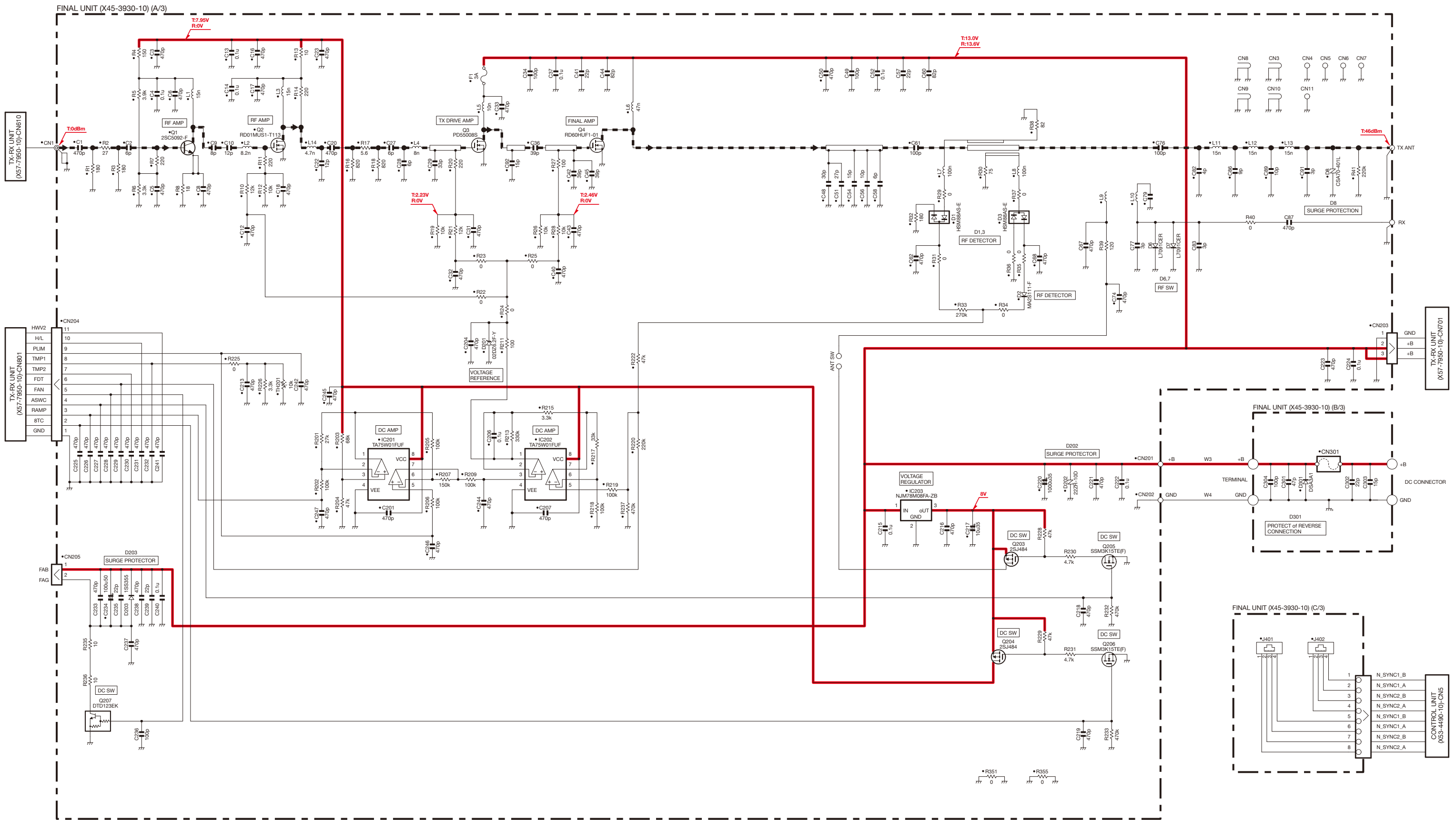

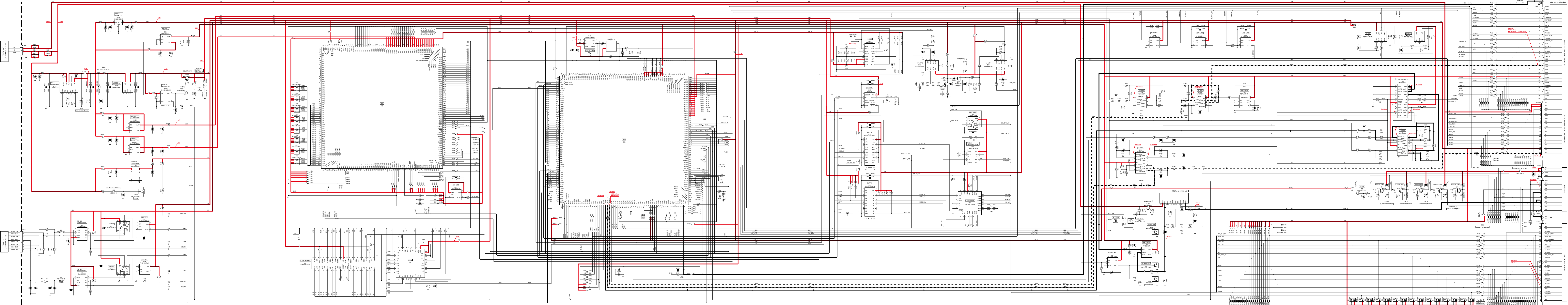

Terminal	Signal Name	Notes
1	100V AC	AC Input
2	0V	Ground
3	100V AC	AC Input
4	0V	Ground
5	100V AC	AC Input
6	0V	Ground
7	100V AC	AC Input
8	0V	Ground
9	100V AC	AC Input
10	0V	Ground
11	100V AC	AC Input
12	0V	Ground
13	100V AC	AC Input
14	0V	Ground
15	100V AC	AC Input
16	0V	Ground
17	100V AC	AC Input
18	0V	Ground
19	100V AC	AC Input
20	0V	Ground
21	100V AC	AC Input
22	0V	Ground
23	100V AC	AC Input
24	0V	Ground
25	100V AC	AC Input
26	0V	Ground
27	100V AC	AC Input
28	0V	Ground
29	100V AC	AC Input
30	0V	Ground
31	100V AC	AC Input
32	0V	Ground
33	100V AC	AC Input
34	0V	Ground
35	100V AC	AC Input
36	0V	Ground
37	100V AC	AC Input
38	0V	Ground
39	100V AC	AC Input
40	0V	Ground
41	100V AC	AC Input
42	0V	Ground
43	100V AC	AC Input
44	0V	Ground
45	100V AC	AC Input
46	0V	Ground
47	100V AC	AC Input
48	0V	Ground
49	100V AC	AC Input
50	0V	Ground



DISPLAY UNIT (X54-3580-20) (A/2)

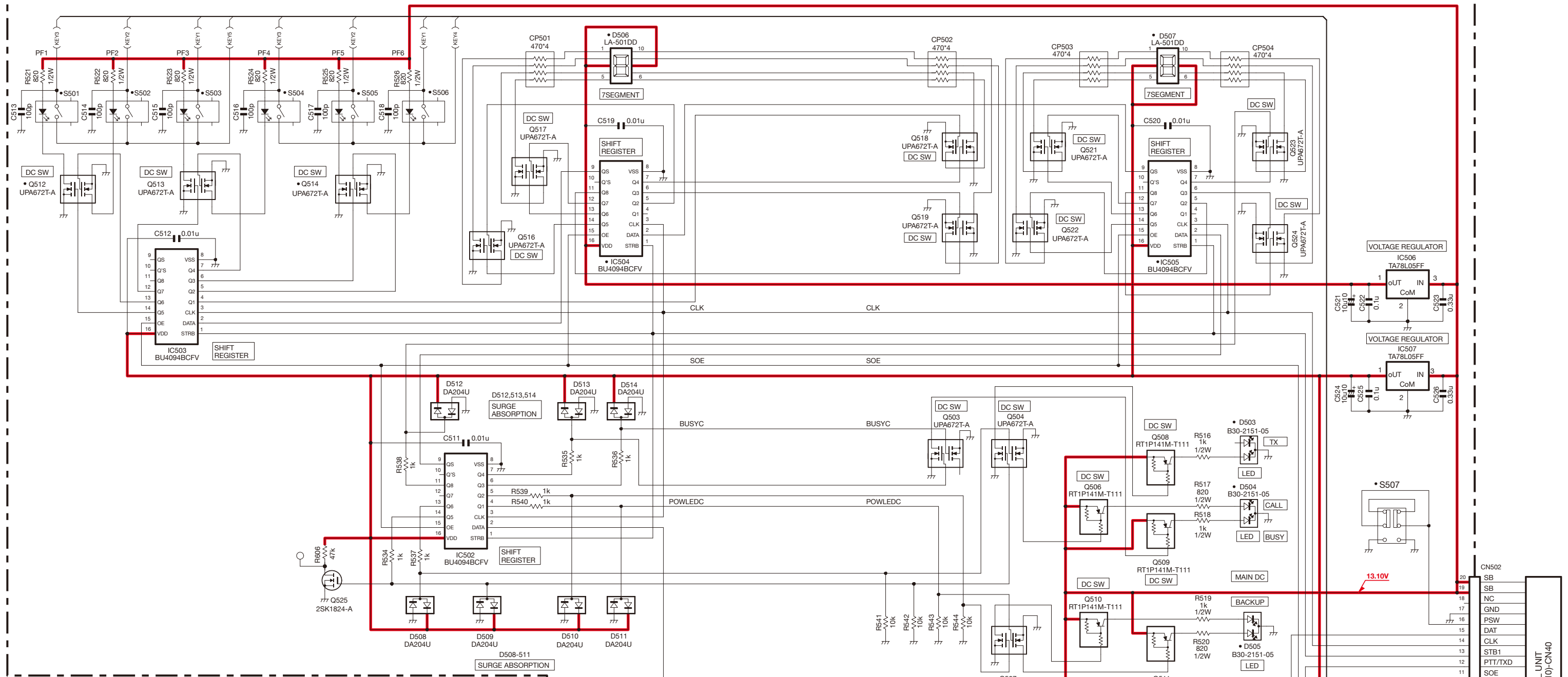

DISPLAY UNIT (X54-3580-20) (B/2)

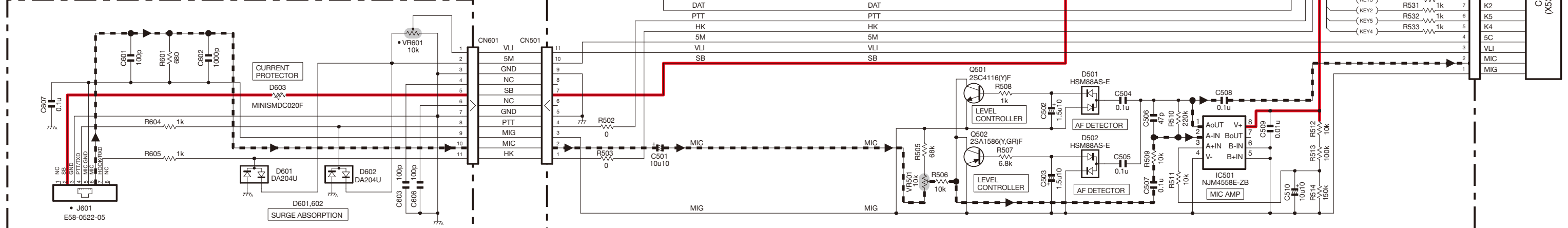





- |   |                 |               |
|---|-----------------|---------------|
| A | :               | N09-2292-05   |
| B | M2.6 x 6        | : N30-2606-48 |
| C | M4 x 6          | : N30-4006-48 |
| D | M4 x 14         | : N30-4014-48 |
| E | M4 x 20         | : N30-4020-43 |
| F | M3 x 6 (F)      | : N32-3006-48 |
| G | M4 x 8 (F)      | : N32-4008-43 |
| H | M3 x 6 (Bi)     | : N35-3006-43 |
| J | M4 x 6 (Bi)     | : N35-4006-43 |
| K | M3 x 8          | : N67-3008-48 |
| L | M2.6 x 8        | : N80-2608-43 |
| M | M3 x 5 (Br-Tap) | : N87-3005-43 |
| N | M3 x 6 (Br-Tap) | : N87-3006-48 |

