

KENWOOD

Document Copyrights

Copyright 2006 by Kenwood Corporation. All rights reserved.

No part of this manual may be reproduced, translated, distributed, or transmitted in any form or by any means, electronic, mechanical, photocopying, recording, or otherwise, for any purpose without the prior written permission of Kenwood.

Disclaimer

While every precaution has been taken in the preparation of this manual, Kenwood assumes no responsibility for errors or omissions. Neither is any liability assumed for damages resulting from the use of the information contained herein. Kenwood reserves the right to make changes to any products herein at any time for improvement purposes.

MOBILE CONTROLLER
RC-2000
 SERVICE MANUAL

KENWOOD

© 2001-2 PRINTED IN JAPAN
 B51-8571-00 (N) 697

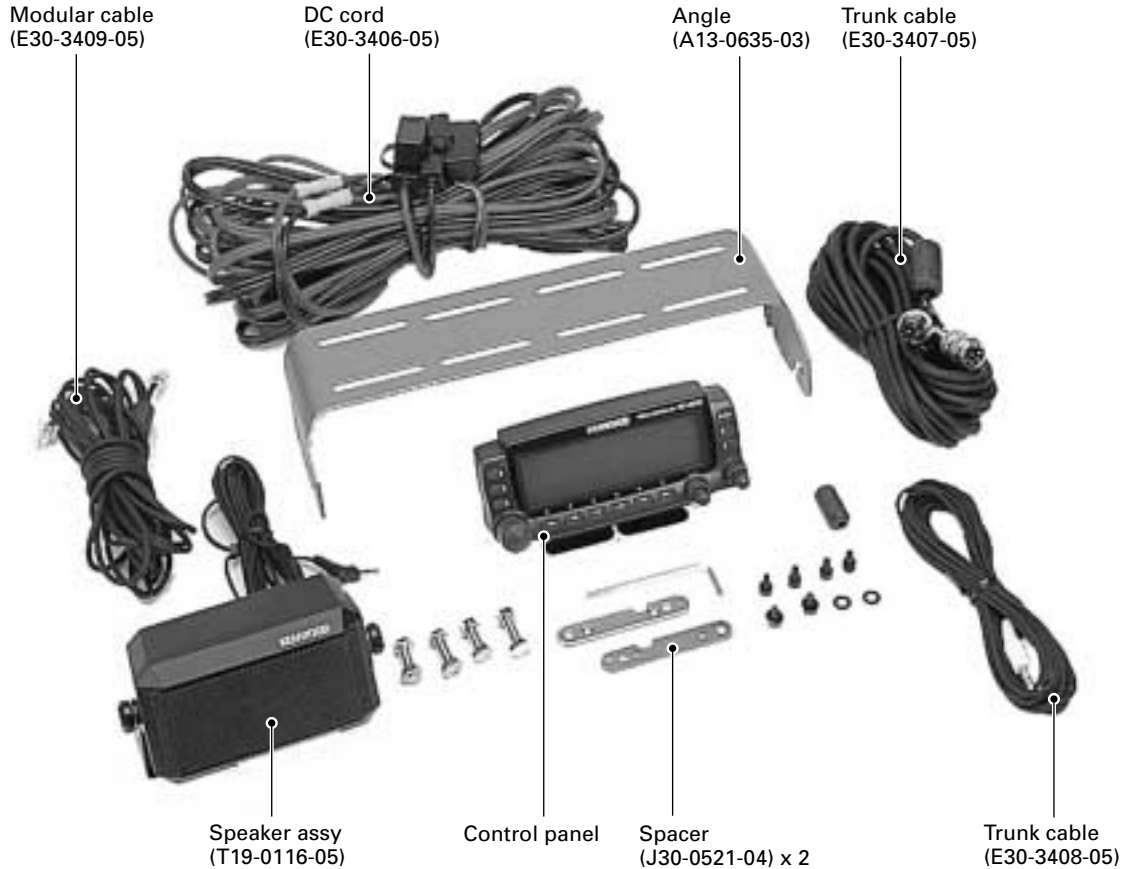

CONTENTS

CIRCUIT DESCRIPTION	2	PACKING	7
SEMICONDUCTOR DATA	3	PC BOARD VIEWS	
DESCRIPTION OF COMPONENTS	4	DISPLAY UNIT (X54-3290-00)	9
TERMINAL FUNCTION	4	SCHEMATIC DIAGRAM	13
PARTS LIST	5	BLOCK DIAGRAM	15
EXPLODED VIEW	6	SPECIFICATIONS	BACK COVER

CIRCUIT DESCRIPTION

Panel Section (LCD ASSY : B38-0829-05)

The panel section controls serial communications with the main unit control section, the key input circuit, the display circuit, and the dimmer circuit through the microprocessor (IC4).

Serial communications circuit

A buffer amp is inserted in order to protect the microprocessor ports.

Key, Volume input circuit

Circuits to operate the panel section keys are connected to each microprocessor port. The PSW key is pulled up and the other keys are pulled up with software within the microprocessor. Rotary encoder operating circuits are connected directly to the microprocessor. The control divides the power supply voltage, reads the A/D port of the microprocessor, and transfers that data to the main unit.

Display circuit

Display section is a 188 x 54-dot full-dot matrix LCD controlled by two LCD. As shown in Figure 1, the master IC (IC2) side is connected to 22 common dots and 88 segment dots and the slave IC (IC1) side is connected to 33 common dots and 100 segment dots. The LCD drive voltage is obtained by raising the power supply voltage (5V) within the IC.

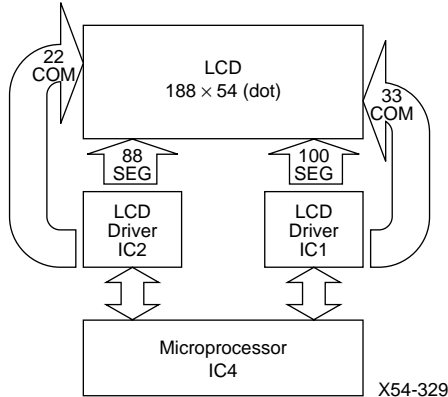

Fig. 1 Display circuit

Dimmer circuit

The dimmer circuit switches the lamp brightness to one of four levels or OFF (See table1). The current flowing to the LEDs is varied by selecting resistors from R8 to R14.

Dimmer level	DIM 0	DIM 1	DIM 2	DIM 3
1	H	L	L	L
2	L	H	L	L
3	L	L	H	L
4	L	L	L	H
OFF	L	L	L	L

Table 1 Port logic

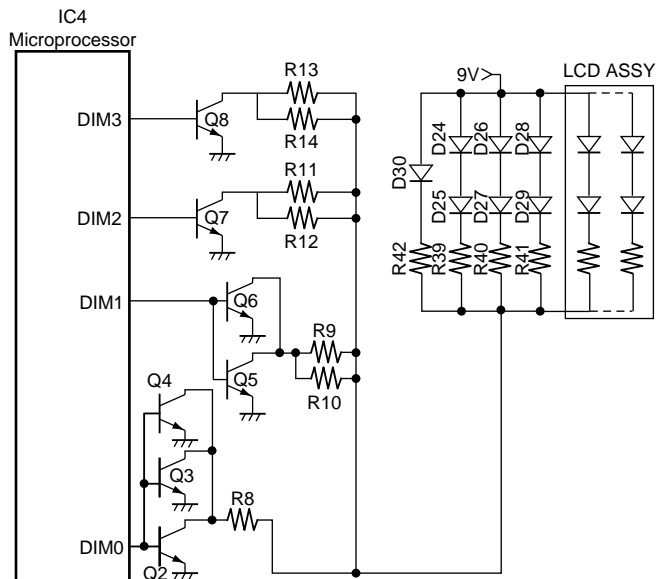

Fig. 2 Dimmer circuit

SEMICONDUCTOR DATA

CPU : 30622M8759GP (Display Unit IC4)

Pin No.	Port name	I/O	Function	Active level
1	KYCALL	I	[AT] key input	L
2	KYVFO	I	[Q. IN] key input	L
3	KYMR	I	[EASY] key input	L
4	KYPM	I	[PM] key input	L
5	KYMNU	I	[RIT] key input	L
6	BYTE	I	Select 8-bit data bus (5C)	
7	CNVSS	I	Select memory expansion mode	
8	FUNC	I	[F1] key input	L
9	KYF1	I	[F2] key input	L
10	RESET	I	Reset	
11	XOUT	O	Clock output	
12	VSS	-	GND	
13	XIN	I	Clock input	
14	VCC	-	Power input	
15	NMI	(I)	Not used	
16	INT2	I	Interrupt from serial input port	
17	INT1	I	Encoder pulse 1 input	
18	INT0	I	Encoder pulse 2 input	
19	KYF2	I	[F3] key input	L
20	KYF3	I	[F4] key input	L
21	NC	I	Not used (VCC)	
22	NC	I	Not used (VCC)	
23~26	DIM3~0	O	Dimmer output	
27	PSW	O	Power SW control output	
28	BS	O	Beat shift output	
29	NC	I	Not used (VCC)	
30	NC	I	Not used (VCC)	
31	KYF4	I	[F5] key input	L
32	KYF5	I	[F6] key input	L
33	TXD0	O	Serial port for connecting to TX-RX uint	
34	RXD0	I	Serial port for connecting to TX-RX uint	
35	NC	I	Not used (VCC)	
36	NC	I	Not used (VCC)	
37~41	NC	I	Not used	
42	RD	-	Read signal	
43	NC	-	Not used	
44	WR	-	Write signal	
45	LCDA0	O	LCD address 0	
46	LCDCD2	O	LCD chip select 2	
47	LCDCD1	O	LCD chip select 1	
48	CS0	-	Flash ROM chip select signal	
49	A19	-	Not used (Open)	
50~59	A18~9	-	Address bus 18~9	
60	VCC	-	Power input	
61	A8	-	Address bus 8	
62	VSS	-	GND	
63~70	A7~0	-	Address bus 7~0	
71~78	LCDD7~0	I/O	LCD data bus 7~0	
79~86	D7~0	-	Data bus 7~0	
87	LCDRD	O	LCD read terminal	
88	LCDWR	O	LCD write terminal	
89	LCDRES	O	LCD reset	
90	POWER	I	[Ⓞ] key input (key interrupt)	L
91	B-AFVR	I	Sub band R AF VOL (A/D)	
92	B-SQVR	I	Sub band R SQ VOL (A/D)	
93	A-AFVR	I	Main band L AF VOL (A/D)	
94	AVSS	-	Analog power input (GND)	
95	A-SQVR	I	Main band L SQ VOL (A/D)	
96	VREF	-	A/D reference voltage input	
97	AVCC	-	Analog power input (5C)	
98	MHz	I	[TUNING CONTROL] key input	L
99	B_KEY	I	[SUB AF CONTROL] key input	L
100	A_KEY	I	[MAIN AF CONTROL] key input	L

RC-2000

DESCRIPTION OF COMPONENTS / TERMINAL FUNCTION

Display Unit (X54-3290-00)

Ref. No.	Application/Function	Operation/Condition/Compatibility
IC1	Serial transmission buffer	
IC2	Serial transmission buffer	
IC3	AVR with reset function	
IC4	Control microcomputer	
IC5	ROM	
Q1	Power switch	
Q2~4,6, 7,9,10	Dimmer	
D1	Reverse flow prevention	
D2	Reset circuit	
D3-23	Over-voltage prevention (Surge elimination)	
D24~30	Key illumination	

Display Unit (X54-3290-00)

CN No.	Pin No.	Name	Function
CN1	1	D7	LCD driver data
	2	D6	LCD driver data
	3	D5	LCD driver data
	4	D4	LCD driver data
	5	D3	LCD driver data
	6	D2	LCD driver data
	7	D1	LCD driver data
	8	D0	LCD driver data
	9	RD	LCD driver RD
	10	WR	LCD driver WR
	11	A0	LCD driver A0
	12	GND	GND
	13	CS2	LCD driver chip select
	14	CS1	LCD driver chip select
	15	RES	LCD driver reset
	16	VDD	LCD driver VDD
	17	VL	Illumination LED control
	18	VL	Illumination LED control
	19	PB	Illumination LED power
	20	PB	Illumination LED power
CN2	1		GND
CN3	2		VR power
	3		switch
	4		VR voltage
	5		SQL voltage

PARTS LIST

* New Parts. Δ indicates safety critical components.
 Parts without **Parts No.** are not supplied.
 Les articles non mentionnés dans le **Parts No.** ne sont pas fournis.
 Teile ohne **Parts No.** werden nicht geliefert.

L : Scandinavia **K** : USA **P** : Canada
Y : PX (Far East, Hawaii) **T** : England **E** : Europe
Y : AAFES (Europe) **X** : Australia **M** : Other Areas

RC-2000 DISPLAY UNIT (X54-3290-00)

Ref. No.	Address	New parts	Parts No.	Description	Desti-nation	Ref. No.	Address	New parts	Parts No.	Description	Desti-nation
RC-2000						C7,8			CK73GB1H102K	CHIP C 1000PF	K
1	2D		A13-0635-03	ANGLE (TS-2000 (X)/TS-B2000)		C9,10			CC73GCH1H220J	CHIP C 22PF	J
2	2A		A62-0775-03	PANEL (PANEL)		C11			CK73GB1H103K	CHIP C 0.010UF	K
3	1C		A82-0040-01	REAR PANEL (PANEL)		C12			CK73GB1H102K	CHIP C 1000PF	K
5	2A	*	B10-2628-02	FRONT GLASS (PANEL)		C13,14			CK73GB1H472K	CHIP C 4700PF	K
6	1B		B38-0829-05	LCD ASSY (PANEL)		C15			CK73GB1H103K	CHIP C 0.010UF	K
7	2D		B42-7003-04	RATING LABEL (DC CORD)		C16			CK73GB1H102K	CHIP C 1000PF	K
8	2A		B43-1222-04	BADGE (PANEL)		C17-23			CK73GB1H103K	CHIP C 0.010UF	K
9	2G		B46-0310-03	WARRANTY CARD (EUROPEAN COUNTRIES)		C24			CK73FB1C105K	CHIP C 1.0UF	K
10	2G		B46-0469-10	WARRANTY CARD (U.S.A. AND CANADA)		C25			CK73GB1H472K	CHIP C 4700PF	K
11	2G	*	B62-1292-00	INSTRUCTION MANUAL		CN1			E40-5852-05	FLAT CABLE CONNECTOR (20P)	
12	1F	*	B72-1754-04	MODEL NAME PLATE		CN2,3			E40-5392-05	PIN ASSY (5P)	
14	1D	*	E30-3406-05	DC CORD		CN4,5			E40-5409-05	PIN ASSY (5P)	
15	2E	*	E30-3407-05	TRUNK CABLE (MIC)		J1			E58-0457-05	MODULAR JACK	
16	2E	*	E30-3408-05	TRUNK CABLE (SP)		L1-7			L92-0140-05	FERRITE CHIP	
17	2E	*	E30-3409-05	MODULAR CABLE		L9			L92-0140-05	FERRITE CHIP	
18	1B		E37-0835-05	FLAT CABLE (PANEL)		X1			L77-1814-05	CRYSTAL RESONATOR (11.0592MHZ)	
21	3F		F05-2531-05	FUSE (BLADE) 25A/32V		CP1-15			R90-0741-05	MULTIPLE RESISTOR 1K X2	
23	1C		G10-1257-04	FIBROUS SHEET (PANEL)		R2			RK73GB1J473J	CHIP R 47K J 1/16W	
24	1C		G11-2600-14	SHEET (PANEL)		R3			RK73GB1J103J	CHIP R 10K J 1/16W	
25	2A		G11-2611-04	SHEET (PANEL)		R4			RK73GB1J331J	CHIP R 330 J 1/16W	
26	2B		G11-2612-14	SHEET (PANEL)		R5,6			RK73GB1J473J	CHIP R 47K J 1/16W	
27	2A		G13-1753-04	CUSHION (PANEL)		R8			R92-0670-05	CHIP R 0 OHM	
28	1E		G13-1757-04	CUSHION (BRACKET)		R9,10			RK73FB2A560J	CHIP R 56 J 1/10W	
29	1B		G13-1784-04	CUSHION (PANEL)		R11,12			RK73FB2A181J	CHIP R 180 J 1/10W	
31	3E	*	H52-1596-02	ITEM CARTON CASE		R13,14			RK73FB2A271J	CHIP R 270 J 1/10W	
33	1E		J29-0663-03	BRACKET		R15			R92-1252-05	CHIP R 0 OHM	
34	3F		J29-0664-13	BRACKET		R17-22			RK73GB1J102J	CHIP R 1.0K J 1/16W	
35	1E		J30-0521-04	SPACER (ANGLE)		R25			RK73GB1J103J	CHIP R 10K J 1/16W	
36	1E		J61-0307-05	BAND (MIC)		R27-29			RK73GB1J102J	CHIP R 1.0K J 1/16W	
38	2A		K29-5222-03	KNOB (PANEL)		R30-32			RK73GB1J473J	CHIP R 47K J 1/16W	
39	2A		K29-5223-03	KNOB (PANEL)		R33			RK73GB1J102J	CHIP R 1.0K J 1/16W	
40	2A		K29-5381-03	KNOB (PANEL)		R34-38			RK73GB1J473J	CHIP R 47K J 1/16W	
41	2B	*	K29-9129-01	BUTTON KNOB (PANEL)		R39-41			RK73FB2A391J	CHIP R 390 J 1/10W	
43	1E		L79-1417-05	LINE FILTER (PANEL,SP)		R42			RK73FB2A471J	CHIP R 470 J 1/10W	
44	1E		L79-1419-05	LINE FILTER (MIC)		R43			R92-1252-05	CHIP R 0 OHM	
A	2A		N14-0569-04	CIRCULAR NUT (PANEL)		R44			R92-0679-05	CHIP R 0 OHM	
B	1C		N80-2010-45	PAN HEAD TAPTITE SCREW (PANEL)		VR1,2	2B,2C		R31-0629-05	VARIABLE RESISTOR 50K	
46	1E		N99-2014-05	SCREW SET (BRACKET)		S1-12			S70-0439-05	TACT SWITCH	
47	1E	*	N99-2017-05	SCREW SET (SPEAKER ASSY,ANGLE)		D1			LFB01	DIODE	
48	1E		N99-2024-05	SCREW SET (ANGLE)		D2			MA2S111	DIODE	
50	1F	*	T19-0116-05	SPEAKER ASSY		D3-23			DA221	DIODE	
DISPLAY UNIT (X54-3290-00)						IC1,2			TC4S81F	IC (SERIAL TRANSMISSION BUFFER)	
D24-30			B30-2215-05	LED		IC3			L78LR05B-FA	IC (AVR WITH RESET FUNCTION)	
C1			CK73GB1C104K	CHIP C 0.10UF	K	IC4			30622M8759GP	IC (CONTROL MICROCOMPUTER)	
C2,3			CC73GCH1H101J	CHIP C 100PF	J	IC5			AT29C020-90TI	IC (ROM)	
C4			C92-0512-05	CHIP-TAN 1.0UF	16WV	Q1			2SA1162(Y)	TRANSISTOR	
C5			CK73GB1C104K	CHIP C 0.10UF	K	Q2-4			DTC143EKA	DIGITAL TRANSISTOR	
C6			C92-0698-05	ELECTRO 47UF	16WV	Q6,7			DTC143EKA	DIGITAL TRANSISTOR	
C9,10						Q9,10			DTC143EKA	DIGITAL TRANSISTOR	
C11						S13	1B		W02-1978-05	ENCODER	

RC-2000

EXPLODED VIEW

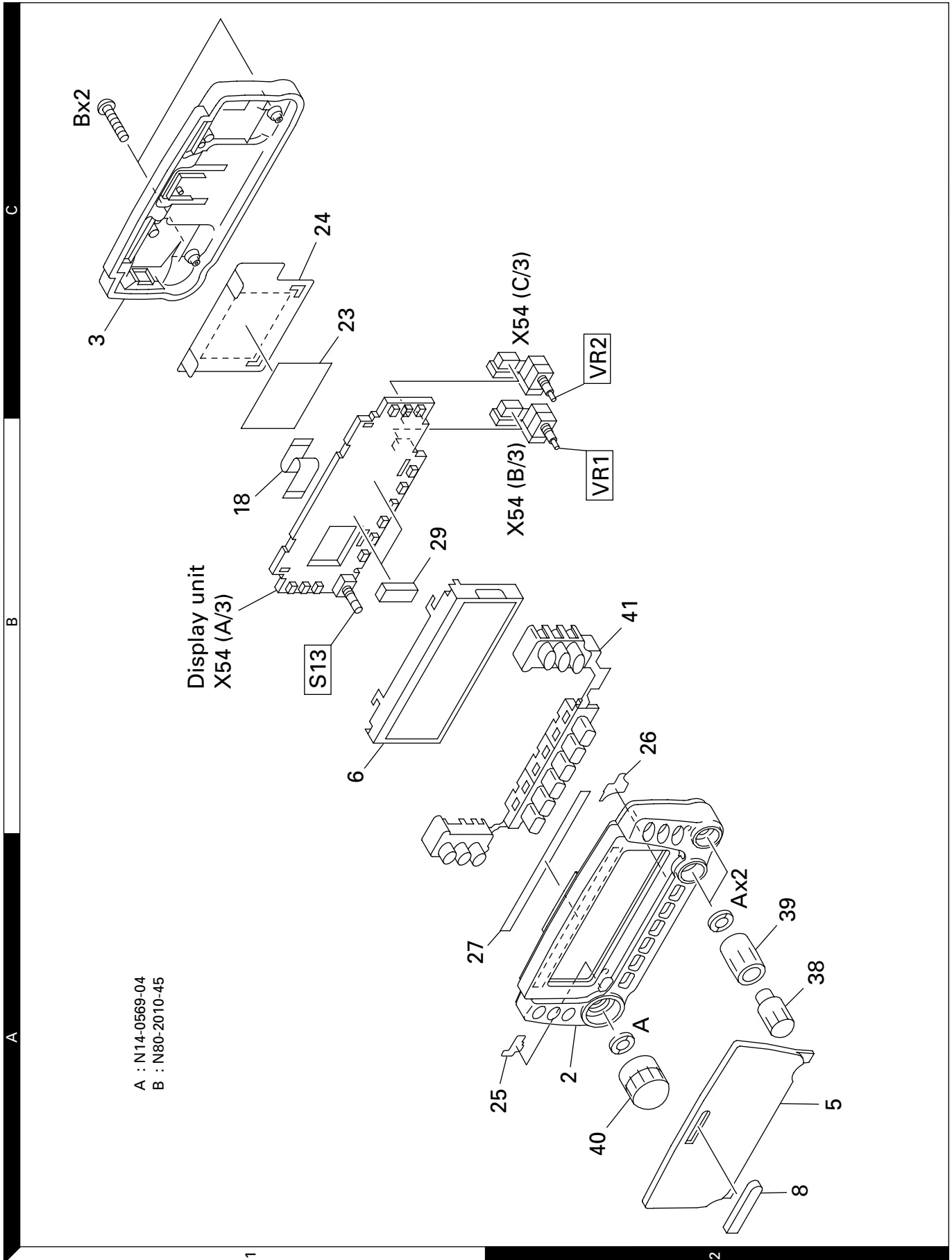

PACKING

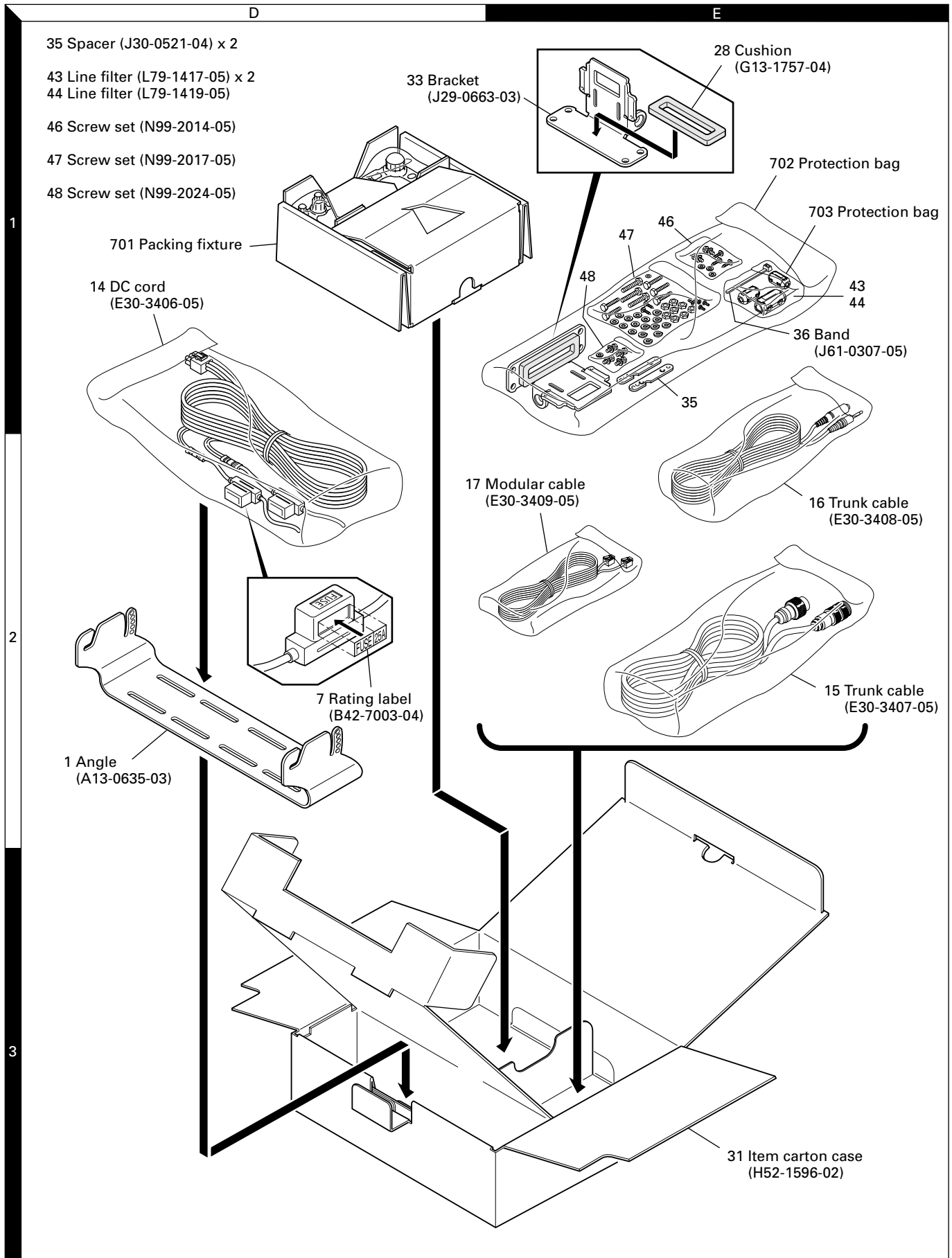

Parts with the exploded numbers larger than 700 are not supplied.

PACKING

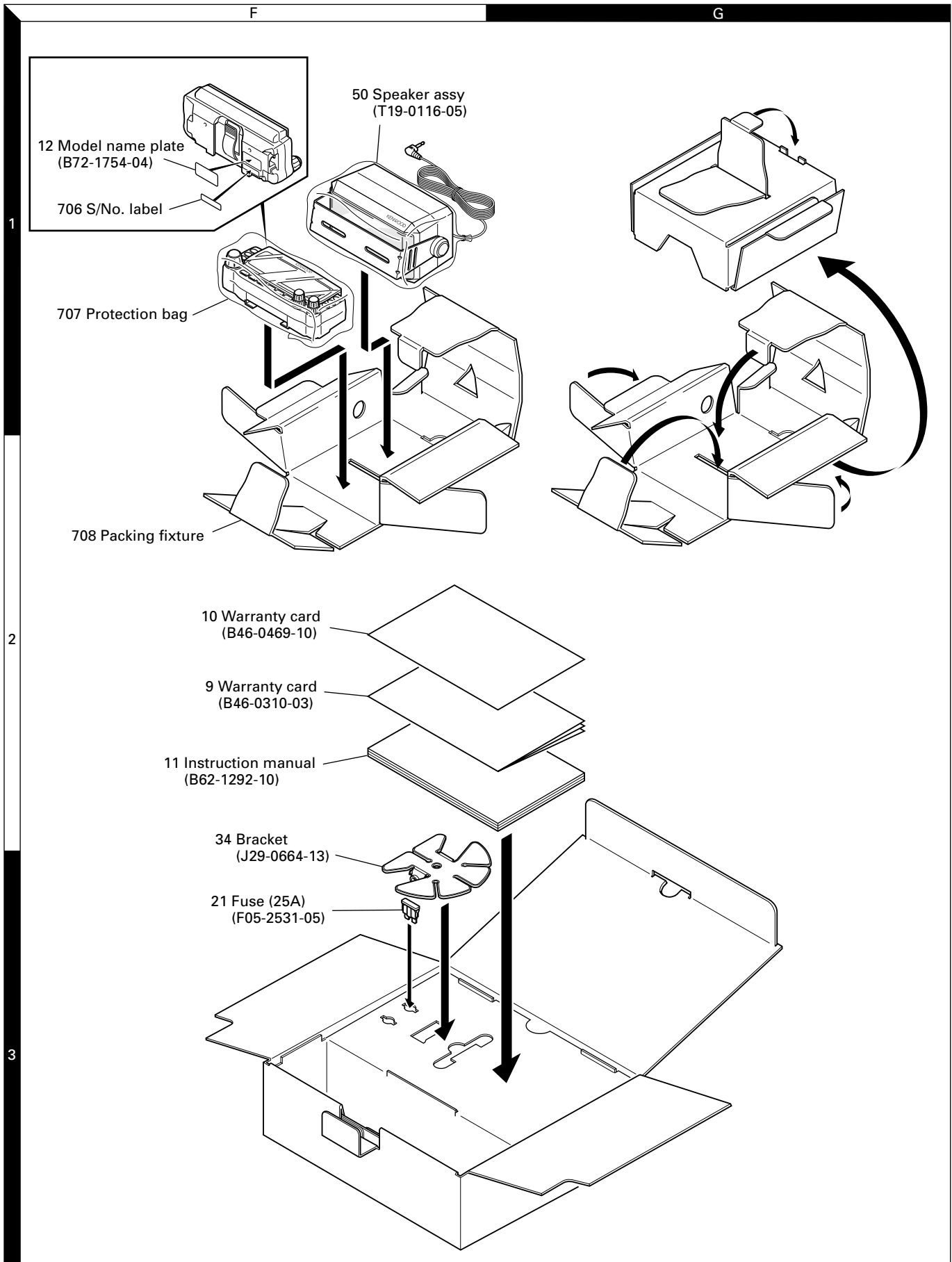

DISPLAY UNIT (X54-3290-00) Component side view

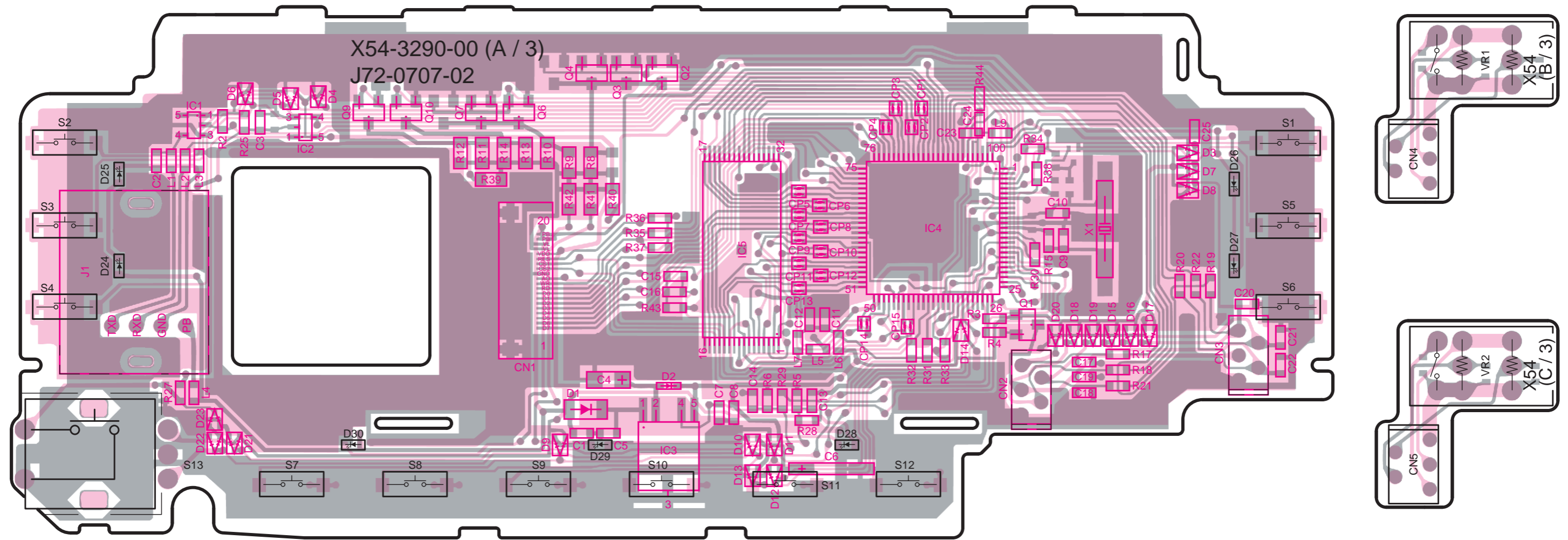

Component side
 Foil side

2SA1162

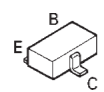

DTC143EKA

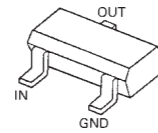

L78LR05B-FA

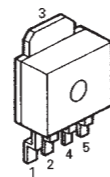

DA221



TC4S81F

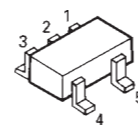

30622M8759GP

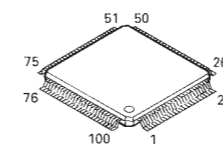

AT29C020-90TI

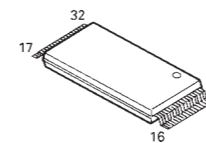

RC-2000 PC BOARD VIEWS

DISPLAY UNIT (X54-3290-00) Foil side view

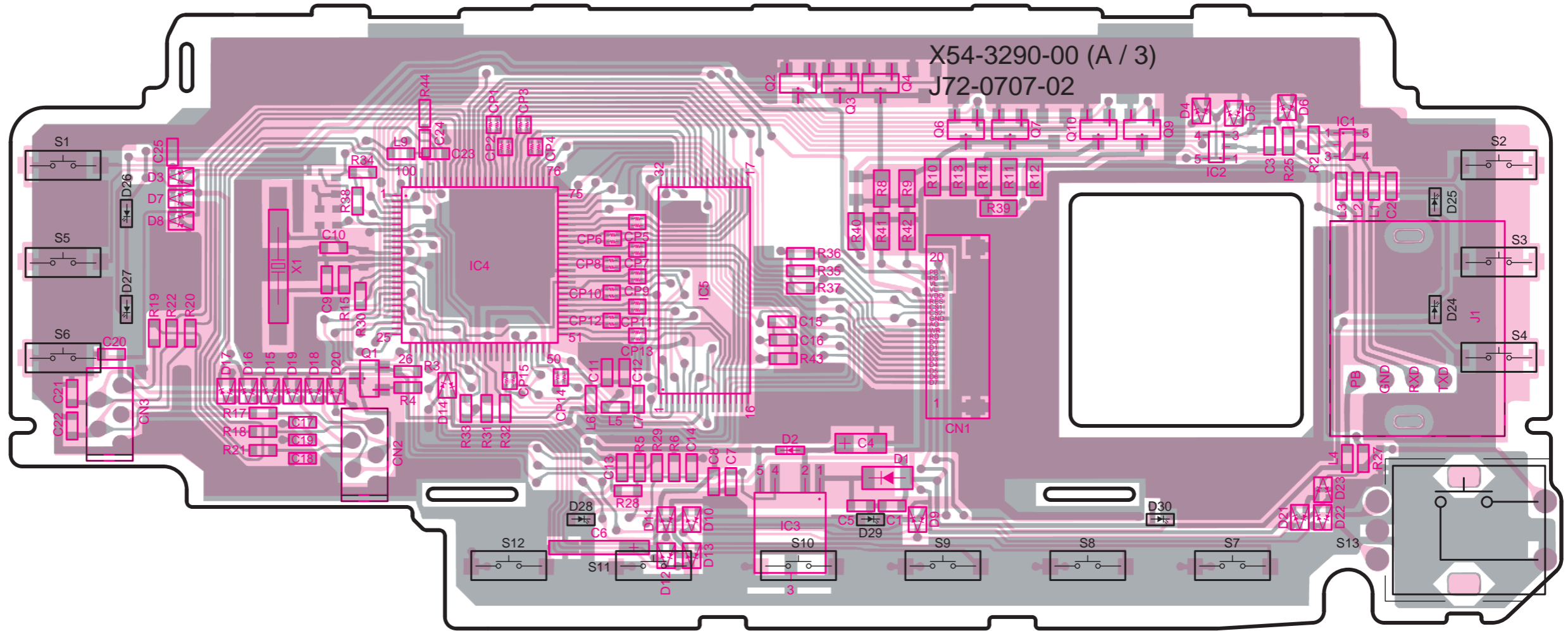
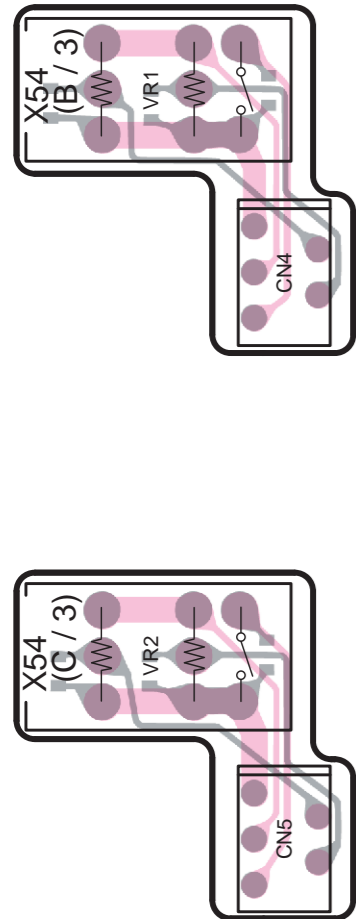

Component side
 Foil side

SCHEMATIC DIAGRAM RC-2000

LCD ASSY

X54-3290-00 A/3 DISPLAY UNIT

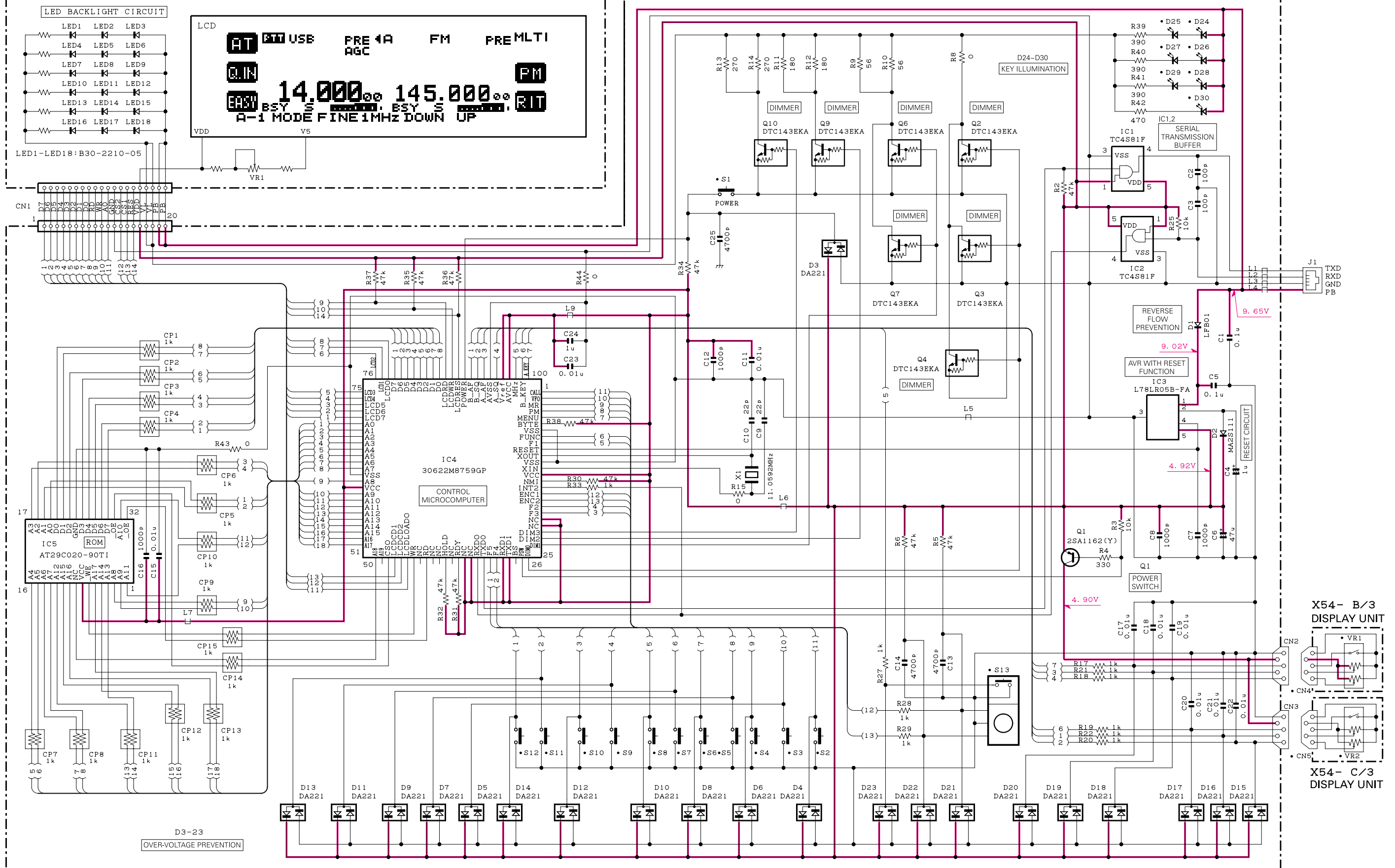

D1	:LFB01	IC1, 2	:TC4S81F	Q1	:2SA1162(Y)
D2	:MA2S111	IC3	:L78LR05B-FA	Q2-4, 6, 7, 9, 10	:DTC143EKA
D3-23	:DA221	IC4	:30622M8759GP		
D24-30	:B30-2215-05	IC5	:AT29C020-90TI		

BLOCK DIAGRAM

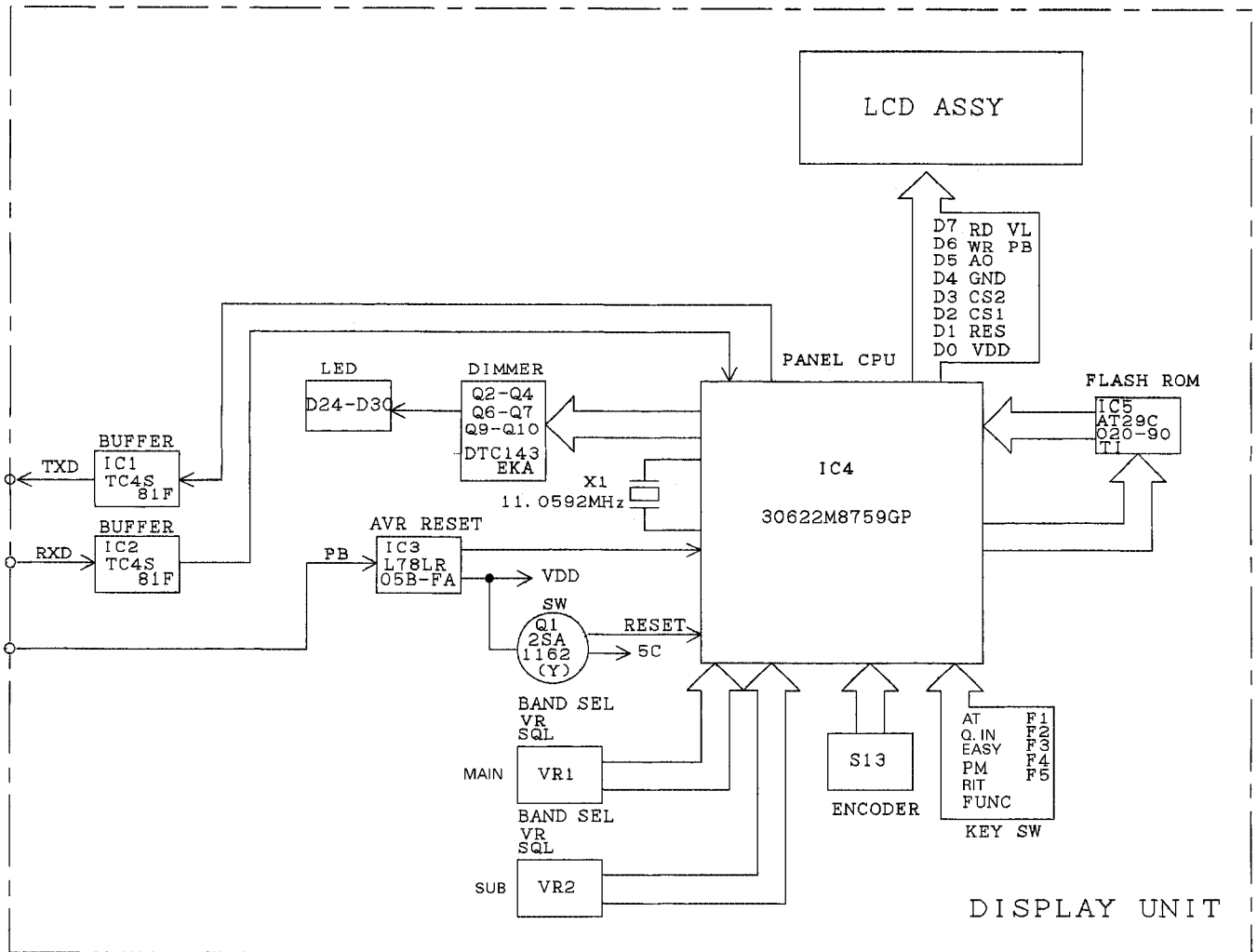

X54-3290-00

RC-2000

SPECIFICATIONS

Control Panel

Usable temperature range	-20°C to +60°C (-4°F to +140°F)
Supply voltage	9.5V DC \pm 0.5V
Current	Less than 200mA
Dimensions (W x H x D, Projections included)	140 (5.5) x 60 (2.4) x 49.3 (2.0) mm (inch)
Weight	Approx. 180g (0.4 lbs)

External Speaker

Speaker impedance	4 Ω \pm 15%
Output audio level	85 \pm 2dB/W
Frequency response	300 to 9000Hz
Input power	3W (Nominal), 5W (Maximum)
Dimensions (W x H x D)	113 (4.5) x 66 (2.6) x 58.5 (2.3) mm (inch)
Weight	Approx. 360g (0.79 lbs)

KENWOOD CORPORATION

14-6, Dogenzaka 1-chome, Shibuya-ku, Tokyo 150-8501, Japan

KENWOOD SERVICE CORPORATION

P.O. BOX 22745, 2201 East Dominguez Street, Long Beach, CA 90801-5745, U.S.A.

KENWOOD ELECTRONICS CANADA INC.

6070 Kestrel Road, Mississauga, Ontario, Canada L5T 1S8

KENWOOD ELECTRONICS DEUTSCHLAND GMBH

Rembrücker Str. 15, 63150 Heusenstamm, Germany

KENWOOD ELECTRONICS BELGIUM N.V.

Mechelsesteenweg 418 B-1930 Zaventem, Belgium

KENWOOD ELECTRONICS FRANCE S.A.

13, Boulevard Ney, 75018 Paris, France

KENWOOD ELECTRONICS U.K. LIMITED

KENWOOD House, Dwight Road, Watford, Herts., WD1 8EB United Kingdom

KENWOOD ELECTRONICS EUROPE B.V.

Amsterdamseweg 37, 1422 AC Uithoorn, The Netherlands

KENWOOD ELECTRONICS ITALIA S.p.A.

Via G. Sirtori, 7/9 20129 Milano, Italy

KENWOOD IBERICA S.A.

Bolivia, 239-08020 Barcelona, Spain

KENWOOD ELECTRONICS AUSTRALIA PTY. LTD.

(A.C.N. 001 499 074)

16 Giffnock Avenue, Centrecourt Estate, North Ryde, N.S.W. 2113 Australia

KENWOOD ELECTRONICS (HONG KONG) LTD.

Unit 3712-3724, Level 37, Tower one Metroplaza, 223 Hing Fong Road, Kwai Fong, N.T., Hong Kong

KENWOOD ELECTRONICS TECHNOLOGIES(S) PTE LTD.

Sales Marketing Division

1 Ang Mo Kio Street 63, Singapore 569110