

VHF FM TRANSCEIVER

TK-2160

SERVICE MANUAL

E version

KENWOOD

© 2004-1 PRINTED IN JAPAN
B51-8673-00 (S) 559



Does not come with antenna.
Antenna is available as an option.

CONTENTS

GENERAL	2
SYSTEM SET-UP	2
REALIGNMENT	3
DISASSEMBLY FOR REPAIR	4
CIRCUIT DESCRIPTION	6
INSTALLATION	10
TERMINAL FUNCTION	11
SEMICONDUCTOR DATA	12
COMPONENTS DESCRIPTION	13
PARTS LIST	14
EXPLODED VIEW	21
PACKING	22
ADJUSTMENT	23
PC BOARD	
TX-RX UNIT (X57-6722-71)	28
SCHEMATIC DIAGRAM	32
BLOCK DIAGRAM	36
LEVEL DIAGRAM	38
KSC-30	39
SPECIFICATIONS	BACK COVER

TK-2160

GENERAL / SYSTEM SET-UP

INTRODUCTION

SCOPE OF THIS MANUAL

This manual is intended for use by experienced technicians familiar with similar types of commercial grade communications equipment. It contains all required service information for the equipment and is current as of the publication date. Changes which may occur after publication are covered by either Service Bulletins or Manual Revisions. These are issued as required.

ORDERING REPLACEMENT PARTS

When ordering replacement parts or equipment information, the full part identification number should be included. This applies to all parts, components, kits, or chassis. If the part number is not known, include the chassis or kit number of which it is a part, and a sufficient description of the required component for proper identification.

Unit		TX-RX Unit	Frequency range	Remarks
Model & destination				
TK-2160	E	X57-6722-71	136~174MHz	IF1 : 49.95MHz LOC : 50.4MHz

PERSONAL SAFETY

The following precautions are recommended for personal safety:

- DO NOT transmit until all RF connectors are verified secure and any open connectors are properly terminated.
- SHUT OFF and DO NOT operate this equipment near electrical blasting caps or in an explosive atmosphere.
- This equipment should be serviced by a qualified technician only.

SERVICE

This radio is designed for easy servicing. Refer to the schematic diagrams, printed circuit board views, and alignment procedures contained within.

SYSTEM SET-UP

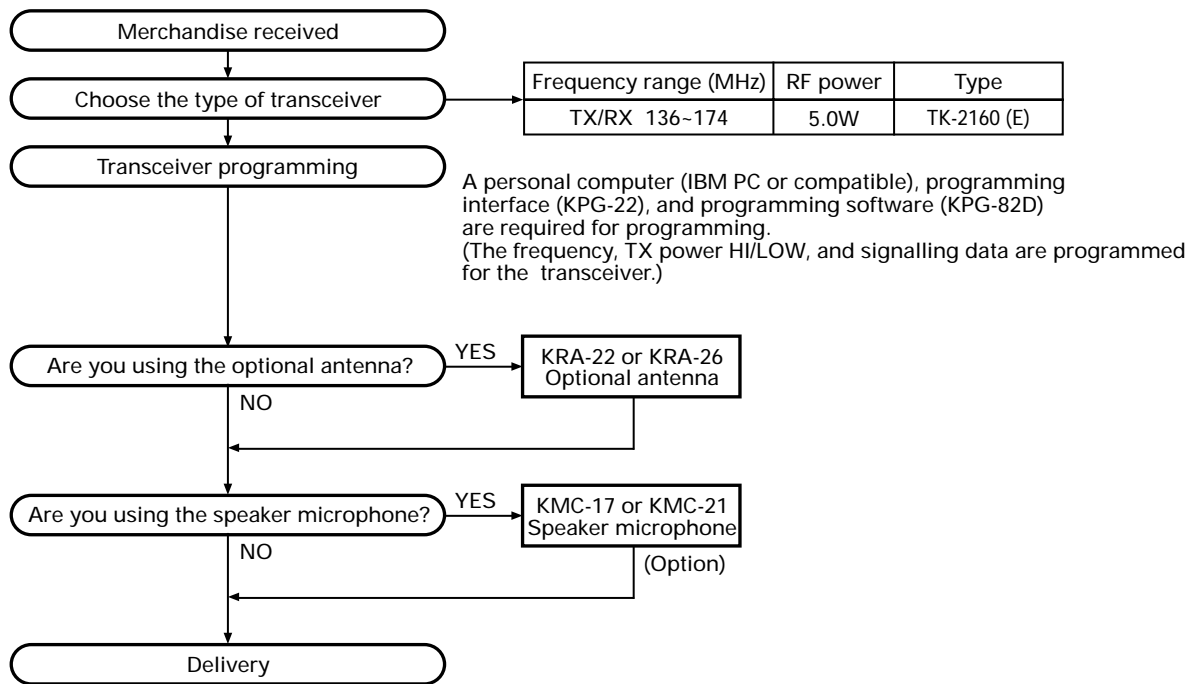

REALIGNMENT

REALIGNMENT

1. Modes

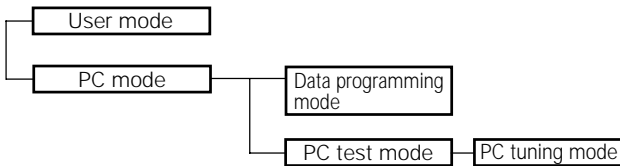

Mode	Function
User mode	For normal use.
PC mode	Used for communication between the radio and PC (IBM compatible).
Data programming mode	Used to read and write frequency data and other features to and from the radio.
PC test mode	Used to check the radio using the PC. This feature is included in the KPG-82D.

2. How to Enter Each Mode

Mode	Operation
User mode	Power ON
PC mode	Received commands from PC

3. PC Mode

3-1. Preface

The TK-2160 transceiver is programmed using a personal computer, a programming interface (KPG-22) and programming software (KPG-82D).

The programming software can be used with an IBM PC or compatible. Figure 1 shows the setup of an IBM PC for programming.

3-2. Connection procedure

1. Connect the TK-2160 to the personal computer with the interface cable.
2. When the POWER is switched on, user mode can be entered immediately. When the PC sends a command, the radio enters PC mode.
When data is transmitting from the transceiver, the red LED lights.
When data is received by the transceiver, the green LED lights.

Notes:

- The data stored in the personal computer must match the model type when it is written into the EEPROM.
- Change the TK-2160 to PC mode, then attach the interface cable.

3-3. KPG-22 description

(PC programming interface cable: Option)

The KPG-22 is required to interface the TK-2160 with the computer. It has a circuit in its D-subconnector (25-pin) case

that converts the RS-232C logic level to the TTL level.

The KPG-22 connects the SP/MIC connector of the TK-2160 to the computer's RS-232C serial port.

3-4. Programming software description

KPG-82D is the programming software for TK-2160 supplied on a CD-ROM. This software runs under Windows 98, ME, Windows 2000 or XP on an IBM-PC or compatible machine.

The data can be input to or read from TK-2160 and edited on the screen. The programmed or edited data can be printed out. It is also possible to tune the transceiver.

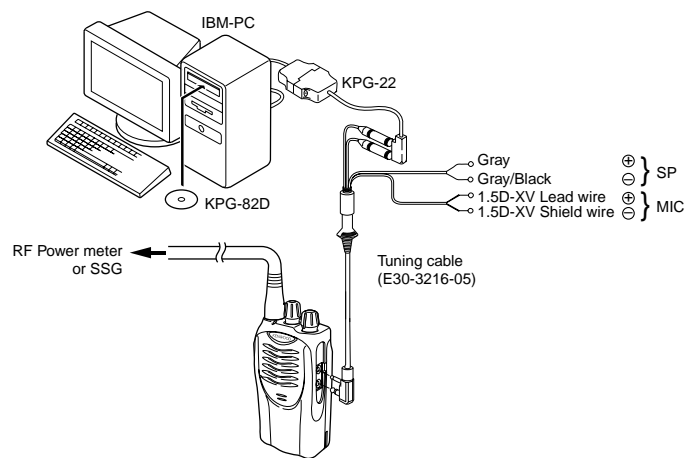

Fig. 1

TK-2160

DISASSEMBLY FOR REPAIR

1. Separating the case assembly from the chassis.

1. Remove the volume knob ①.
2. Remove the two screws ②.
3. Lift the chassis ③, and remove it from the case assembly.

Note: After separating the case assembly from the chassis, remove the channel knob.

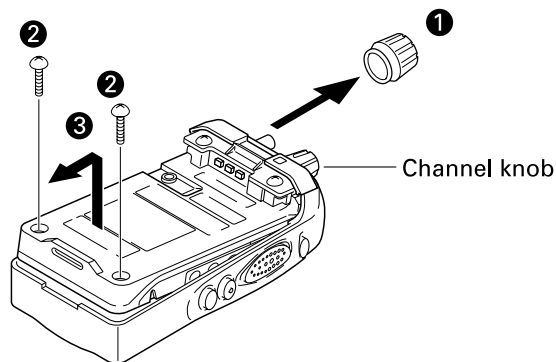

3. How to remove the battery terminal block.

1. Remove the two screws ⑩, then pull out the back cover ⑪.
2. Remove the screw ⑫.

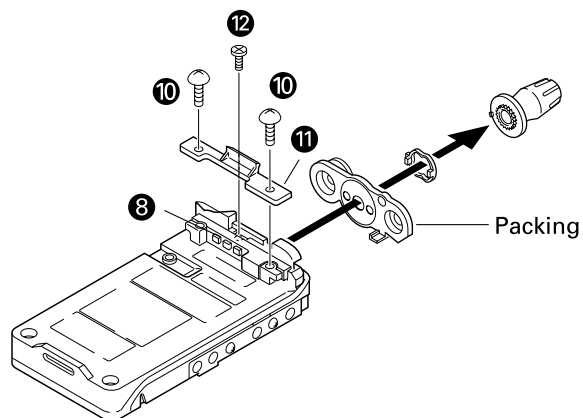

2. Separating the chassis from the TX/RX unit.

1. Remove the two screws ④ fixing the TX/RX unit B/2.
2. Remove the twelve screws ⑤ and two screws ⑥ fixing the TX/RX unit A/2.
3. Remove the solder from the antenna terminal using a soldering iron ⑦, then lift the unit off.

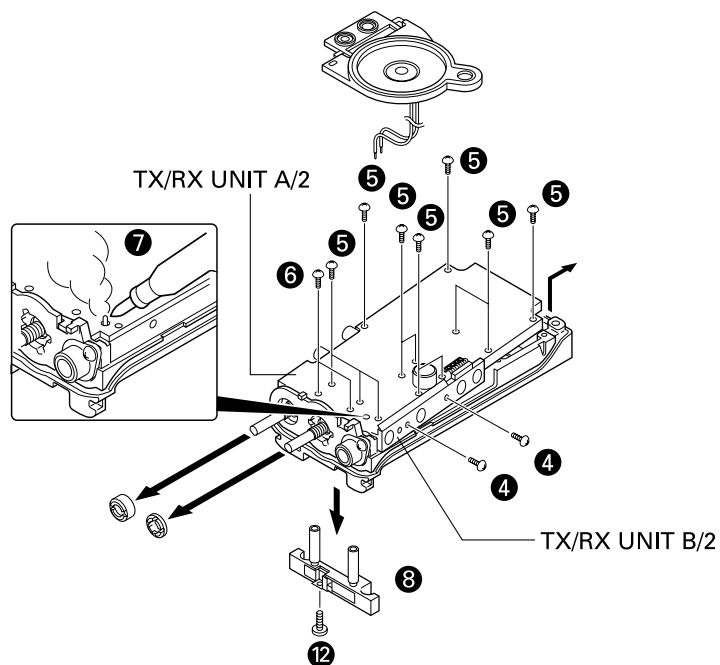

Note: The two screws ⑥ of TX/RX unit A/2 are fixing the battery terminal block ⑧.

DISASSEMBLY FOR REPAIR

Assembling

- Installation of battery terminal block and packing

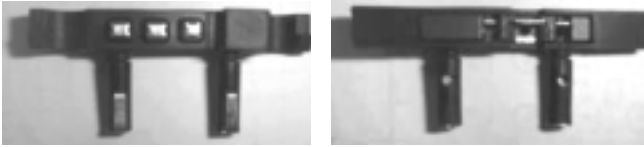

Install them so that no distortion or deformation occurs.

- Installation of speakers and cushion, and wire styling of speakers

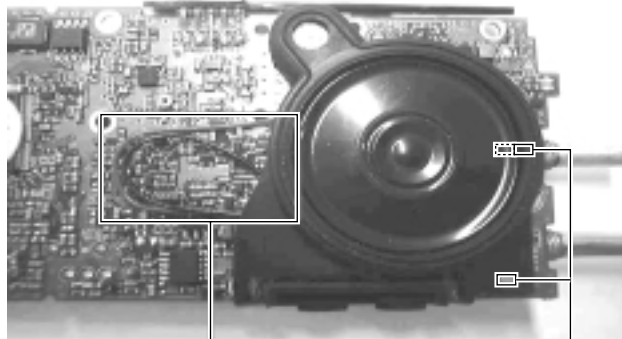

Wire Styling

Install the cushion according to the guide.

Install the speakers so that they do not protrude from the cushion. Perform the wire styling of speakers as shown in a photograph.

- Attaching the cushion

Attach the cushion as shown in Fig. 1.

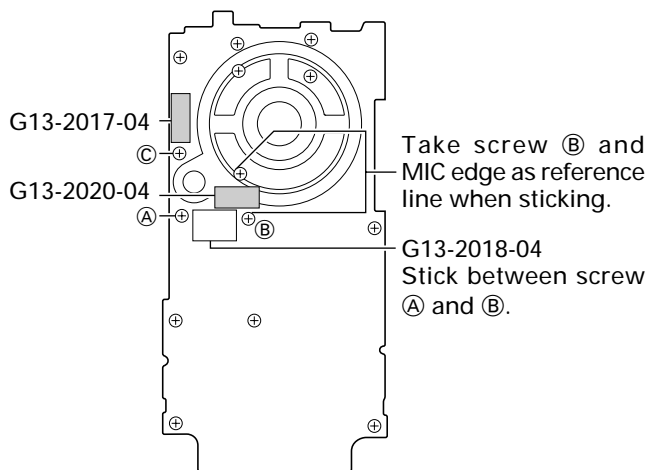

Fig. 1

Note: Cushion must not cover the screws ①, ② and ③.

- Installation of chassis and cabinet assy

Do not press this area, top packing easily deform.



First, mount the set to the cabinet assy.



Second, press down the Chassis to the cabinet assy as shown in the diagram.

Good Condition

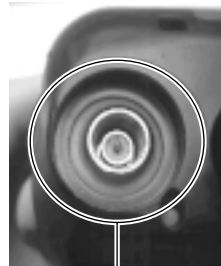

After mount, packing should be in this condition.

NG Condition



Packing deform.

Packing protruded out.



Note:

- Take care that the packing does not protrude from the chassis or case.
- Replace the protruded or deformed packing with a new one.

CIRCUIT DESCRIPTION

1. Frequency Configuration

The receiver utilizes double conversion. The first IF is 49.95 MHz and the second IF is 450 kHz. The first local oscillator signal is supplied from the PLL circuit.

The PLL circuit in the transmitter generates the necessary frequencies. Fig. 1 shows the frequencies.

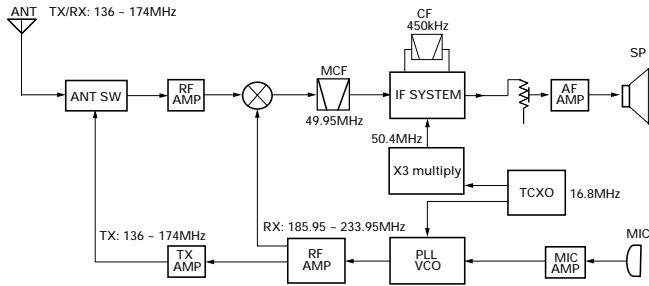

Fig. 1 Frequency configuration

2. Receiver

The frequency configuration of the receiver is shown in Fig. 2.

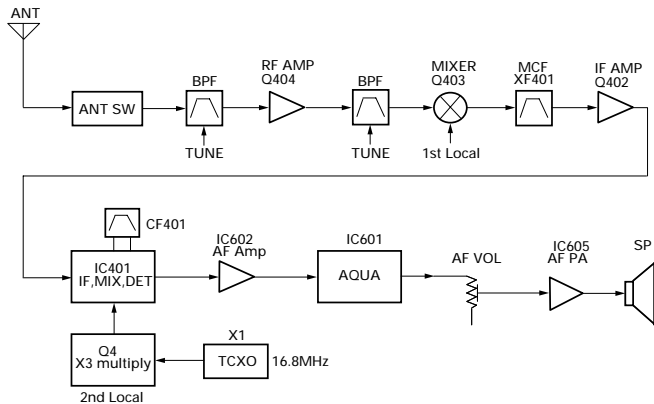

Fig. 2 Receiver section

1) Front End (RF AMP)

The signal coming from the antenna passes through the transmit/receive switching diode circuit, (D204, D206, D208 and D212) passes through a BPF (L411 and L412), and is amplified by the RF amplifier (Q404).

The resulting signal passes through a BPF (L407 and L409) and goes to the mixer. These BPFs are adjusted by variable capacitors (D402, D403, D404 and D405). The input voltage to the variable capacitor is regulated by voltage output from the microprocessor (IC805).

2) First Mixer

The signal from the front end is mixed with the first local oscillator signal generated in the PLL circuit by Q403 to produce a first IF frequency of 49.95 MHz.

The resulting signal passes through the XF401 MCF to cut the adjacent spurious and provide the optimum characteristics, such as adjacent frequency selectivity.

3) IF Amplifier Circuit

The first IF signal is passed through a four-pole monolithic crystal filter (XF401) to remove the adjacent channel signal. The filtered first IF signal is amplified by the first IF amplifier (Q402) and then applied to the IF system IC (IC401). The IF system IC provides a second mixer, second local oscillator, limiting amplifier, quadrature detector and RSSI (Received Signal Strength Indicator). The second mixer mixes the first IF signal with the 50.4 MHz of the second local oscillator output (TCXO X1) and produces the second IF signal of 450 kHz.

The second IF signal is passed through the ceramic filter (CF401) to remove the adjacent channel signal. The filtered second IF signal is amplified by the limiting amplifier and demodulated by the quadrature detector with the ceramic discriminator (CD401). The demodulated signal is routed to the audio circuit.

4) Wide/Narrow Switching Circuit

Narrow and Wide settings can be made for each channel by switching the demodulation level.

The WIDE (low level) and NARROW (high level) data is output from IC805, pin 54.

When a WIDE (low level) data is received, Q401 turn on. When a NARROW (high level) data is received, Q401 turn off.

Q401 turns on/off with the Wide/Narrow data and the IC401 detector output level is switched to maintain a constant output level during wide or narrow signals.

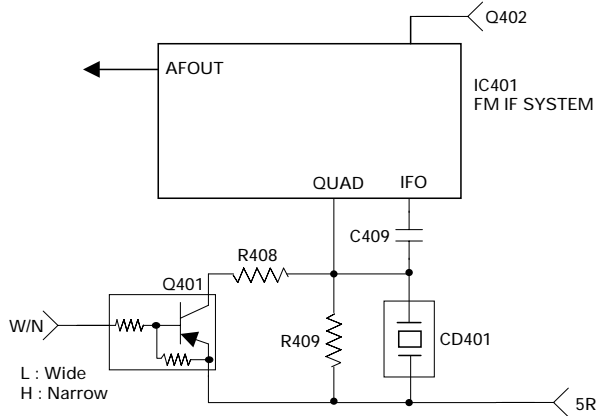

Fig. 3 Wide/Narrow switching circuit

5) Audio Amplifier Circuit

The demodulated signal from IC401 is amplified by IC602, and goes to AF amplifier through IC601.

The signal then goes through an AF volume control (VR801), and is routed to an audio power amplifier (IC605) where it is amplified and output to the speaker.

CIRCUIT DESCRIPTION

6) Tone Volume Fixed Circuit

This function generates a TONE signal sound even if the AF volume of the transceiver is the minimum. A TONE signal is sent through Q602 to the AF amplifier when, in the FPU, "TONE Volume Fixed" is set to ON.

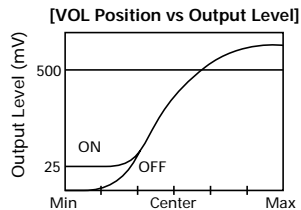
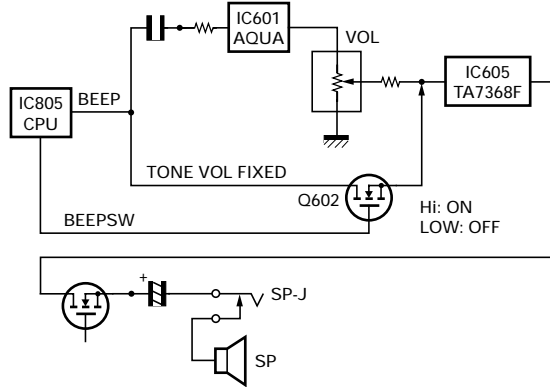

Fig. 4 Tone volume fixed circuit

7) Squelch

Part of the AF signal from the IC enters the FM IC (IC401) again, and the noise component is amplified and rectified by a filter and an amplifier to produce a DC voltage corresponding to the noise level.

The DC signal from the FM IC goes to the analog port of the microprocessor (IC805). IC805 determines whether to output sounds from the speaker by checking whether the input voltage is higher or lower than the preset value. To output sounds from the speaker, IC805 sends a high signal to the SP MUTE line and turns IC605 on through Q603, Q604, Q607 and Q608. (See Fig. 5)

8) Receive Signalling

(1) QT/DQT

The output signal from IF IC (IC401) enters the microprocessor (IC805) through IC601. IC805 determines whether the QT or DQT matches the preset value, and controls the SP MUTE and the speaker output sounds according to the squelch results.

(2) 5-TONE

Part of the received AF signal output from the AF amplifier IC602, and then passes through an audio processor (IC601), goes to the other AF amplifier IC603, is compared, and then goes to IC805. IC805 checks whether 5-TONE data is necessary. If it matches, IC805 carries out a specified operation, such as turning the speaker on. (See Fig. 5)

(3) MSK (Fleet Sync)

Fleet Sync utilizes 1200bps and 2400bps MSK signal is output from pin 6 of IC601. And is routed to the VCO. When encoding MSK, the microphone input signal is muted.

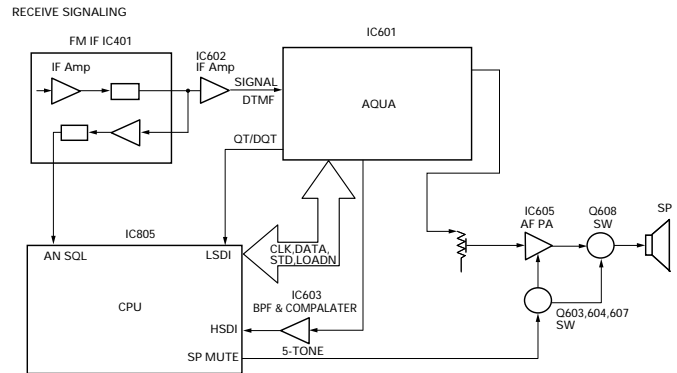

Fig. 5 AF amplifier and squelch

(4) DTMF

The DTMF input signal from the IF IC (IC401) is amplified by IC602 and goes to IC601. The decoded information is then processed by the CPU.

3. PLL Frequency Synthesizer

The PLL circuit generates the first local oscillator signal for reception and the RF signal for transmission.

1) PLL

The frequency step of the PLL circuit is K:2.5,5,6.25 or 7.5kHz, M:6 or 6.25kHz.

A 16.8MHz reference oscillator signal is divided at IC1 by a fixed counter to produce an oscillator (VCO) output signal which is buffer amplified by Q9 then divided in IC1 by a dual-module programmable counter. The divided signal is compared in phase with the 5 or 6.25kHz reference signal from the phase comparator in IC1. The output signal from the phase comparator is filtered through a low-pass filter and passed to the VCO to control the oscillator frequency. (See Fig. 6)

2) VCO

The operating frequency is generated by Q6 in transmit mode and Q5 in receive mode. The oscillator frequency is controlled by applying the VCO control voltage, obtained from the phase comparator, to the varactor diodes (D3, D5, D7 and D8 in transmit mode and D4, D6, D9 and D10 in receive mode). The RX pin is set high in receive mode causing Q8 and Q12 to turn Q6 off and Q5 on.

The TX pin is set high in transmit mode. The outputs from Q5 and Q6 are amplified by Q9 and sent to the RF amplifiers.

CIRCUIT DESCRIPTION

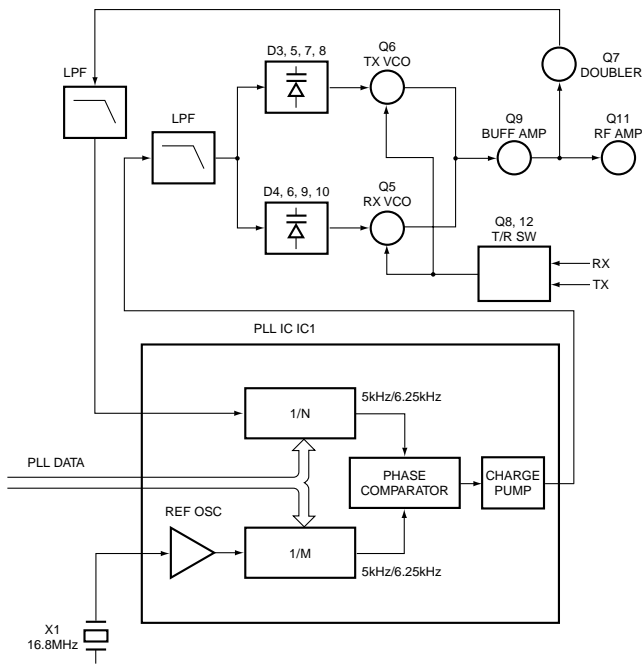

Fig. 6 PLL circuit

3) Unlock Detector

If a pulse signal appears at the LD pin of IC1, an unlock condition occurs, and the DC voltage obtained from C19, R6 and Q1 causes the voltage applied to the microprocessor to go high. When the microprocessor detects this condition, the transmitter is disabled, ignoring the push-to-talk switch input signal. (See Fig. 7)

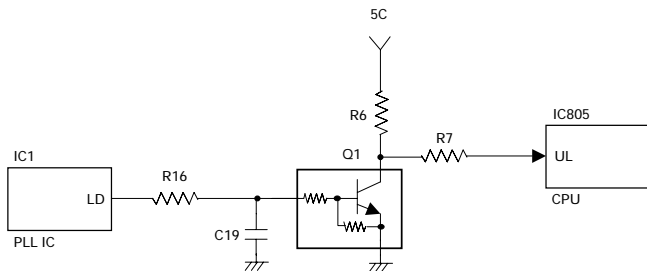

Fig. 7 Unlock detector circuit

4. Transmitter System

1) Microphone Amplifier

The signal from the microphone passes through the IC601. When encoding DTMF, it is turned OFF for muting the microphone input signal by IC601. The signal passes through the Audio processor (IC601) for the maximum deviation adjustment, and goes to the VCXO modulation input.

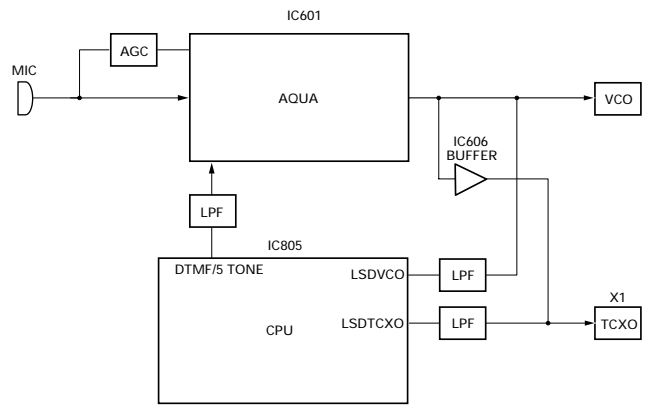

Fig. 8 Microphone amplifier

2) Drive and Final Amplifier

The signal from the T/R switch (D201 is on) is amplified by the drive amplifier (Q207) to 50mW.

The output of the drive amplifier is amplified by the RF power amplifier (Q211) to 5.0W (1W when the power is low). The RF power amplifier consists of two MOS FET stages. The output of the RF power amplifier is then passed through the harmonic filter (LPF) and antenna switch (D204 and D206) and applied to the antenna terminal.

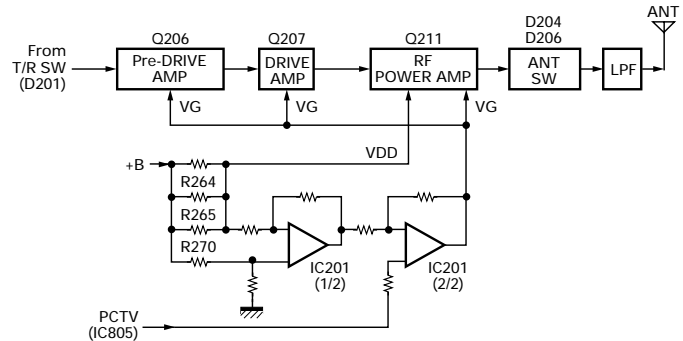

Fig. 9 Drive and final amplifier and APC circuit

3) APC Circuit

The APC circuit always monitors the current flowing through the RF power amplifier (Q211) and keeps a constant current. The voltage drop at R264, R265 and R270 is caused by the current flowing through the RF power amplifier and this voltage is applied to the differential amplifier IC201(1/2). IC201(2/2) compares the output voltage of IC201(1/2) with the reference voltage from IC805. The output of IC201(2/2) controls the VG of the RF power amplifier, drive amplifier and pre-drive amplifier to make both voltages the same. The change of power high/low is carried out by the change of the reference voltage.

4) Encode Signalling

(1) QT/DQT

QT, DQT data of the LSDTCXO Line is output from pin 22 of the CPU. The signal passes through a low-pass CR filter and goes to the TCXO(X1).

The QT, DQT data of the LSDVCO Line is output from pin

CIRCUIT DESCRIPTION

20 of the CPU. The signal passes through a low pass CR filter, mixes with the audio signal, and goes to the VCO modulation input. TX deviation is adjusted by the CPU.

(2) DTMF/5-TONE

High-speed data is output from pin 2 of the CPU. The signal passes through a low-pass CR filter, and provides a TX and SP out tone, and is then applied to the audio processor (IC601). The signal is mixed with the audio signal and goes to the VCO.

TX deviation is adjusted by the CPU.

(3) MSK (Fleet Sync)

The MSK input signal from the IF IC is amplified by IC602 (1/2) and goes to pin 31 of IC 601. The signal is demodulated by MSK demodulator in IC 601. The demodulated data goes to the CPU for processing.

5. Power Supply

There are 3.5V power supply for PLL circuit and five 5V power supplies for the microprocessor: 5M,5MS,5C,5R, and 5T. 5M is always output while the power is on. 5M is always output, but turns off when the power is turned off to prevent malfunction of the microprocessor.

5C is a common 5V and is output when SAVE is not set to OFF.

5R is 5V for reception and output during reception.

5T is 5V for transmission and output during transmission.

6. Control Circuit

The control circuit consists of a microprocessor (IC805) and its peripheral circuits. It controls the TX-RX unit. IC805 mainly performs the following:

- (1) Switching between transmission and reception by the PTT signal input.
- (2) Reading system, group, frequency, and program data from the memory circuit.
- (3) Sending frequency program data to the PLL.
- (4) Controlling squelch on/off by the DC voltage from the squelch circuit.
- (5) Controlling the audio mute circuit by the decode data input.
- (6) Transmitting tone and encode data.

1) Frequency Shift Circuit

The microprocessor (IC805) operates at a clock of 7.3728MHz. This oscillator has a circuit that shifts the frequency by BEAT SHIFT SW (Q810).

A beat sound may be able to be evaded from generation if "Beat Shift" is set to ON when it is generated in the internal spurious transmission modulated sound of a transceiver.

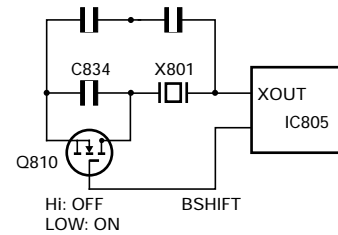

Fig. 10 Frequency shift circuit

2) Memory Circuit

Memory circuit consists of the CPU (IC805) and an EEPROM (IC804). An EEPROM has a capacity of 64k bits that contains the transceiver control program for the CPU and data such as transceiver channels and operating features.

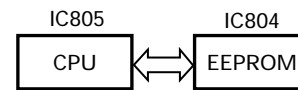

Fig. 11 Memory circuit

3) Low Battery Warning

The battery voltage is checked using by the microprocessor. The transceiver generates a warning tone when it falls below the warning voltage shown in the table.

- (1) The red LED blinks when the battery voltage falls below the voltage (1) shown in the table during transmission.
- (2) The red LED blinks when the battery voltage falls below the voltage (2) shown in the table during transmission.

Note:

The transceiver checks the battery voltage during reception even when, in the FPU, the Battery Warning status function is set to "On TX" (default setting).

However, the LED does not blink during reception. During transmission, the LED blinks to generate the warning tone of a low battery voltage.

- (3) The transceiver immediately stops transmission when the battery voltage falls below the voltage (3) shown in the table. A message tone beeps while the PTT switch is released.

	Battery Case	Li-ion Battery	Ni-Cd Battery	Ni-MH Battery
(1)	6.2[V]	6.5[V]	6.2[V]	6.2[V]
(2)	7.6[V]	7.1[V]	6.8[V]	7.0[V]
(3)	5.9[V]	6.2[V]	5.9[V]	5.9[V]

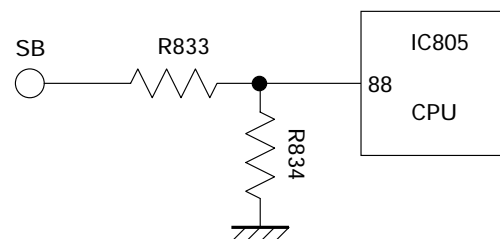

Fig. 12 Low battery warning

TK-2160

CIRCUIT DESCRIPTION / INSTALLATION

4) Battery Type Detection

The transceiver automatically detects the battery type, measuring the resistance between the S-terminal and + terminal on the battery pack and changes the supplied voltage to the S-terminal as below. The microprocessor then detects the battery type.

Resistor value	Battery type	Input voltage of S-terminal
1.8MΩ	Li-ion	0.3~1.3V
560kΩ	Ni-Cd	1.3~2.6V
220kΩ	Ni-MH	2.6~5.0V
OPEN	Battery case	0~0.3V

7. Control System

Keys and channel selector circuit.

The signal from the keys and channel selector are directly input to the microprocessor, as shown in fig. 13.

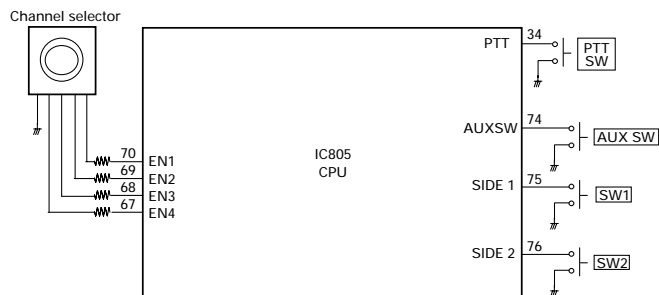

Fig. 13 Control system

INSTALLATION

1. Optional Board

Remove the TX/RX unit from the radio before installing the optional board in the radio.

The procedure for removing the TX/RX unit is described in the DISASSEMBLY FOR REPAIR section in the Service Manual.

Install the optional board on the back of the TX/RX unit.

For details on installation of the optional board, refer to Installation Information supplied with the optional board.

When installing the optional board, also refer to the chart in TERMINAL FUNCTION section (page 12) given in the Service Manual.

Note: To install and use the Scrambler Board, remove "R601" and "R647" from the front of the TX/RX unit.

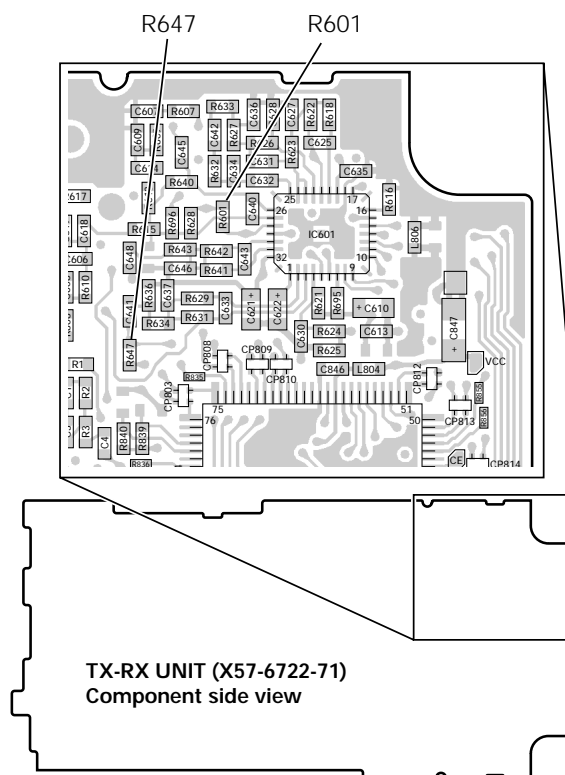

TERMINAL FUNCTION

■ Solder point connection

Designation	Function	Condition	Value
MIC_I	Mic input	Input sensitivity/Impedance (1kHz std. dev.)	7±3mVrms @22kΩ Load
MIC_O	Mic o utput	Output voltage/Impedance (1kHz 15mVrms mic input)	2.6±1.0mVrms @2.2kΩ Load
		Output voltage/Impedance (1kHz 100mVrms mic input)	90±20mVrms @100kΩ Load
RA_I	Receiver AF input	Input sensitivity/Impedance (1kHz rated AF power/Vol. MAX)	75±20mVrms @22kΩ Load
RA_O	Receiver AF output	Output voltage/Impedance (1kHz std. mod.)	150±50mVrms @2.2kΩ Load
		Output voltage/Impedance (1kHz system mod.)	290±50mVrms @100kΩ Load
A1	AUX1	Load >100kΩ	(Low) Vss ~ 0.4V (High) Vdd-0.8V ~ Vdd
A2	AUX2	Load >100kΩ	(Low) Vss ~ 0.4V (High) Vdd-0.8V ~ Vdd
A3	AUX3	Load >100kΩ	(Low) Vss ~ 0.4V (High) Vdd-0.8V ~ Vdd
A4	AUX4	Load >100kΩ	(Low) Vss ~ 0.4V (High) Vdd-0.8V ~ Vdd
A5	AUX5	Load >100kΩ	(Low) Vss ~ 0.4V (High) Vdd-0.8V ~ Vdd
A6	AUX6	Load >100kΩ	(Low) Vss ~ 0.4V (High) Vdd-0.8V ~ Vdd
SB	Switched B	Output Voltage/7mA load	DC (Battery terminal) ±0.5V
GND	GND		Vss
5C	DC 5V	Output Voltage/10mA load	5.0±0.5V
TXAFI	Transmit AF input	Input sensitivity/Impedance (1kHz std. dev.)	280±50mVrms @22kΩ Load
DEO	Discriminator signal output	Output voltage/Impedance (1kHz std. mod.)	280±50mVrms @2.2kΩ Load
LSDFO	Received sub-tone output	Output voltage/Impedance (150Hz 15% mod.)	180±50mVrms @2.2kΩ Load
ALT	Sidetone input	Input sensitivity/Impedance (1kHz rated AF power/Vol. MAX)	7±3mVrms @22kΩ Load

SEMICONDUCTOR DATA

Microprocessor : M30622MCA8C1GP (TX-RX UNIT : IC805)

■ Pin function

Pin No.	Port Name	I/O	Function
1	PCTV	O	APC/BPF control data output.
2	DTMF	O	DTMF, 5TONE.
3	HSDI	I	High speed data input (5TONE).
4	EEPDAT	I/O	EEPROM data input/output.
5	EEPCLK	O	EEPROM Clock
6	BYTE	I	GND.
7	CNVSS	I	GND.
8	AUX5	O	Option Board 5
9	AUX6	O	Option Board 6
10	RESET	I	CPU reset.
11	XOUT	O	CPU clock.
12	VSS	-	GND.
13	XIN	I	CPU clock.
14	VCC	-	+5V.
15	NC	I	NC
16	INT	I	Battery voltage monitor input Low battery : L
17	RDF/FD	I	Base Band IC Data input
18	TCLK/ DTRDI	I	Base Band IC Data input
19	NC	-	NC
20	LSDVCO	O	Low speed data output (VCO).
21	NC	I	NC
22	LSDTCXO	O	Low speed data output (TCXO).
23	NC	I	NC
24	BEEP	O	Beep output.
25	OPTDET	I	Option detect input
26	NC	-	NC
27	NC	-	NC
28	NC	-	NC
29	AUX4	O	Option board port 4
30	AUX2	I/O	Option board port 2
31	NC	-	NC
32	NC	-	NC
33	TXD	I/O	Serial data.
34	PTT/RXD	I	PTT on : L/Serial data.
35	STD	I	Base Band IC Data input
36	BBDIR	O	Base Band IC Data output
37	BBCLK	O	Base Band IC clock output
38	BBDI/O	I/O	Base Band IC Data input/output
39	NC	-	NC
40	TDATA/ DTRCLK	O	Base Band IC Data output
41	DTRLOADN	O	Base Band IC Data output
42	AUX3	O	Option board port 3
43	AUX1	O	Option board port 1
44	NC	-	NC
45	NC	-	NC
46	DSW	O	APC voltage discharge Switch
47	BEEPSW	O	Beep switch.
48	AFCOUT	O	AF amp power supply control
49	AFMUTE	O	RX audio mute
50	NC	-	NC
51	TX	O	TX VCO power supply switch TX:L
52	RX	O	RX VCO power supply switch RX:L

Pin No.	Port Name	I/O	Function
53	BSHIFT	O	Beet shift switch.
54	W/N	O	W/N switch Wide:L
55	NC	-	NC
56	APCSW	O	APC switch output.
57	SAVE	O	Battery save output.
58	5TC	O	5T control output.
59	5RC	O	5R control output.
60	VCC	-	+5V.
61	5MSC	O	5M control output.
62	VSS	-	GND.
63	NC	-	NC
64	NC	-	NC
65	NC	-	NC
66	NC	-	NC
67	EN4	I	CH selector input 4.
68	EN3	I	CH selector input 3.
69	EN2	I	CH selector input 2.
70	EN1	I	CH selector input 1.
71	NC	-	NC
72	LEDTX	O	RED LED lights control output
73	LEDRX	O	GREEN LED lights control output
74	AUXSW	I	Key input (Emergency).
75	SIDE1	I	Side key 1 input.
76	SIDE2	I	Side key 2 input.
77	NC	-	NC
78	NC	-	NC
79	SIM1	I	Destination select 1.
80	SIM2	I	Destination select 2.
81	NC	-	NC
82	PLLUL	I	PLL unlock detect input. unlock : L
83	RFCLK	O	PLL clock output. Latch : L
84	RFDAT	O	PLL data output.
85	PS	O	PLL power save output.
86	PLLSTB	O	PLL strobe output.
87	BATTSEL	I	Battery distinction input.
88	BATT	I	Battery voltage input.
89	VOX	I	VOX input.
90	RSSQL	I	Received signal strength indicator input.
91	ANSQL	I	Squelch level input.
92	LSDI	I	Low speed data input (QT/DQT).
93	THM	I	Thermistor input.
94	AVSS	-	GND.
95	NC	-	NC
96	VREF	-	+5V.
97	AVCC	-	+5V.
98	NC	-	NC
99	NC	-	NC
100	NC	-	NC

COMPONENTS DESCRIPTION

TX-RX UNIT (X57-672X-XX)

Ref. No.	Use/Function	Operation/Condition
IC1	IC	PLL system
IC201	IC	Comparator (APC)
IC401	IC	FM IF system
IC601	IC	Audio processor
IC602	IC	AF AMP
IC603(1/2)	IC	HSD AMP
IC603(2/2)	IC	HSD AMP
IC604	IC	VOX AMP
IC605	IC	AF Power AMP
IC606	IC	AF AMP
IC801	IC	Voltage regulator / 5V
IC802	IC	Voltage detector / Reset
IC803	IC	Voltage detector / INT
IC804	IC	EEPROM
IC805	IC	Microprocessor
IC806	IC	Flip Flop
Q1	Transistor	Level shift
Q2	Transistor	Level shift
Q3	Transistor	Level shift
Q4	Transistor	Tripler
Q5	FET	VCO / RX
Q6	FET	VCO / TX
Q7	Transistor	Doubler
Q8	FET	DC switch / TX VCO
Q9	Transistor	RF Buffer AMP
Q10	Transistor	Ripple filter
Q11	Transistor	RF AMP
Q12	FET	DC switch / RX VCO
Q206	FET	Pre-drive AMP
Q207	FET	TX Drive AMP
Q208	Transistor	APC switch
Q209	FET	APC switch
Q210	Transistor	APC switch
Q211	FET	TX Final AMP
Q212	FET	APC switch
Q213	Transistor	APC switch
Q400	FET	W/N switch / TX
Q401	Transistor	W/N switch / RX
Q402	Transistor	IF AMP
Q403	FET	Mixer
Q404	FET	RF AMP
Q601	FET	AF Mute
Q602	FET	Beep switch
Q603	Transistor	DC switch / SP Mute
Q604	Transistor	DC switch
Q605	Transistor	MIC AGC
Q606	Transistor	MIC AGC
Q607	Transistor	DC switch / SP Mute
Q608	FET	SP Mute switch
Q801	Transistor	5T switch
Q802(1/2)	FET	5TC switch
Q802(2/2)	FET	SAVE switch
Q803(1/2)	Transistor	AVR / 5C
Q803(2/2)	Transistor	AVR / 5T

Ref. No.	Use/Function	Operation/Condition
Q804	Transistor	5C switch
Q805(1/2)	Transistor	LED switch / Green
Q805(2/2)	Transistor	LED switch / Red
Q806	Transistor	AVR / PLLB
Q807	Transistor	PLLB switch
Q808	Transistor	5MS switch
Q809	Transistor	5R switch
Q810	FET	Beet shift switch
D2	diode	Shift switch
D3	Variable capacitance diode	Frequency control / TX VCO
D4	Variable capacitance diode	Frequency control / RX VCO
D5	Variable capacitance diode	Frequency control / TX VCO
D6	Variable capacitance diode	Frequency control / RX VCO
D7	Variable capacitance diode	Frequency control / TX VCO
D8	Variable capacitance diode	Frequency control / TX VCO
D9	Variable capacitance diode	Frequency control / RX VCO
D10	Variable capacitance diode	Frequency control / RX VCO
D11	Diode	Shift switch
D12	Variable capacitance diode	Modulator
D13	Diode	Current steering
D14	Diode	Shift switch
D201	Diode	TX/RX RF switch
D203	Zener diode	APC protect
D204	Diode	ANT switch
D206	Diode	ANT switch
D208	Diode	ANT switch
D212	Diode	ANT switch
D401	Diode	TX/RX RF switch
D402	Variable capacitance diode	RF BPF tuning
D403	Variable capacitance diode	RF BPF tuning
D404	Variable capacitance diode	RF BPF tuning
D405	Variable capacitance diode	RF BPF tuning
D603	Diode	Limiter
D604	Diode	Detector
D605	Diode	Detector
D606	Diode	Detector
D801	Diode	5M protector
D802	LED	LED / Red
D803	LED	LED / Green
D805	Diode	Reverse protection

TK-2160

PARTS LIST

* New Parts. △ indicates safety critical components.
 Parts without **Parts No.** are not supplied.
 Les articles non mentionnés dans le **Parts No.** ne sont pas fournis.
 Teile ohne **Parts No.** werden nicht geliefert.

L: Scandinavia K: USA P: Canada
 Y: PX (Far East, Hawaii) T: England E: Europe
 Y: AAFES (Europe) X: Australia M: Other Areas

TK-2160 (Y50-5782-71) TX-RX UNIT (X57-6722-71)

Ref. No.	Address	New parts	Parts No.	Description	Destination
TK-2160					
1	1B	*	A02-3826-43	CABINET ASSY	
2	2B	*	A10-4068-31	CHASSIS	
3	3A	*	A82-0054-02	REAR PANEL	
4	3A	*	B01-0694-03	ESCUTCHEON	
5	2D	*	B09-0676-13	CAP ACCESSORY	
6	1C	*	B62-1788-00	INSTRUCTION MANUAL	
7	3B	*	B72-2250-04	MODEL NAME PLATE	
8	3A	*	E04-0446-05	RF COAXIAL RECEPTACLE(SMA)	
10	2A	*	E37-1101-05	SPEAKER WIRE(RED)	
11	2A	*	E37-1102-05	SPEAKER WIRE(BLACK)	
12	3A	*	E72-0416-23	BATT TERMINAL BLOCK	
13	2B		G11-4090-04	SHEET(FINAL FET)	
14	3B	*	G11-4254-04	SHEET(PTT)	
15	3A	*	G11-4287-04	SHEET(BATT TERMINAL BLOCK)	
16	3A	*	G11-4289-04	SHEET(CHASSIS)	
17	3B	*	G11-4293-04	SHEET	
18	2A	*	G11-4294-04	SHEET	
19	3B	*	G11-4295-04	SHEET	
20	1A	*	G11-4306-04	SHEET	
21	2A	*	G11-4312-04	SHEET	
22	2B	*	G13-2001-04	CUSHION(CHASSIS)	
23	2B	*	G13-2014-04	CUSHION(CHASSIS BOTTOM)	
24	2B	*	G13-2017-04	CUSHION	
25	2B	*	G13-2018-04	CUSHION	
26	3A	*	G13-2019-04	CUSHION	
27	2B	*	G13-2020-04	CUSHION	
28	3A	*	G13-2026-04	CUSHION	
29		*	G13-2027-04	CUSHION	
30	2B	*	G53-1580-03	PACKING(CHASSIS)	
31	1B	*	G53-1581-12	PACKING(SPEAKER)	
32	3B	*	G53-1582-03	PACKING(BATT TERMINAL BLOCK)	
33	3A	*	G53-1641-02	PACKING	
34	3C	*	H12-3150-02	PACKING FIXTURE	
35		*	H25-2345-04	PROTECTION BAG	
36	1D	*	H52-1981-02	ITEM CARTON CASE	
37	2A	*	J19-5454-03	HOLDER	
38	2D	*	J21-8464-04	HARDWARE FIXTURE ACCESSORY	
39	2C		J29-0701-05	HOOK ACCESSORY	
40	3A	*	J30-1275-04	SPACER(CH KNOB)	
41	1A	*	K29-9278-13	KNOB(VOLUME)	
42	3A	*	K29-9280-13	KNOB(CH SELECTOR)	
43	1B	*	K29-9332-03	KNOB(PTT)	
A	3A		N14-0583-04	CIRCULAR NUT(CH)	
B	3A		N14-0805-04	CIRCULAR NUT(VOLUME)	
C	3A		N30-2604-46	PAN HEAD MACHINE SCREW	
D	3B		N30-2612-46	PAN HEAD MACHINE SCREW	
E	3A,3B		N30-3006-45	PAN HEAD MACHINE SCREW	
F	2D		N35-3004-45	BINDING HEAD MACHINE SCREW	
G	3A,3B	*	N78-2040-46	PAN HEAD TAPTITE SCREW	
H	2A,2B		N83-2005-46	PAN HEAD TAPTITE SCREW	

Ref. No.	Address	New parts	Parts No.	Description	Destination
44	2A	*	R31-0650-05	VARIABLE RESISTOR	
45	2A		S60-0420-05	ROTARY SWITCH	
46	1B		T07-0369-05	SPEAKER	
TX-RX UNIT (X57-6722-71)					
D802			B30-2156-05	LED(RED)	
D803			B30-2157-05	LED(YELLOW)	
C1			CK73GB1H822K	CHIP C 8200PF K	
C2			CK73GB1H102K	CHIP C 1000PF K	
C3			CK73GB1E123K	CHIP C 0.012UF K	
C4			CK73GB0J225K	CHIP C 2.2UF K	
C5			CK73GB1H102K	CHIP C 1000PF K	
C6			CK73GB1H103K	CHIP C 0.010UF K	
C7			CK73GB1H102K	CHIP C 1000PF K	
C8			CC73GCH1H100D	CHIP C 10PF D	
C9			CK73GB1H103K	CHIP C 0.010UF K	
C10			CC73GCH1H100D	CHIP C 10PF D	
C11-13			CC73GCH1H101J	CHIP C 100PF J	
C14			C92-0713-05	CHIP-TAN 10UF 6.3WV	
C15			CK73GB1H102K	CHIP C 1000PF K	
C16			CC73GCH1H470J	CHIP C 47PF J	
C18,19			CK73GB1C104K	CHIP C 0.10UF K	
C22			CK73GB1C104K	CHIP C 0.10UF K	
C23			CK73GB0J225K	CHIP C 2.2UF K	
C24			C92-0713-05	CHIP-TAN 10UF 6.3WV	
C25			CK73GB1H102K	CHIP C 1000PF K	
C27			CK73GB1H102K	CHIP C 1000PF K	
C28			CC73GCH1H560J	CHIP C 56PF J	
C30			CC73GCH1H220J	CHIP C 22PF J	
C31			CC73GCH1H560J	CHIP C 56PF J	
C32			C92-0002-05	CHIP-TAN 0.22UF 35WV	
C33			CC73GCH1H470J	CHIP C 47PF J	
C34			CK73GB1H102K	CHIP C 1000PF K	
C35			CC73GCH1H680J	CHIP C 68PF J	
C36			C92-0560-05	CHIP-TAN 10UF 6.3WV	
C37			CK73GB1H102K	CHIP C 1000PF K	
C38,39			C92-0504-05	CHIP-TAN 0.68UF 20WV	
C40			CK73GB1H471K	CHIP C 470PF K	
C41			CK73GB1H103K	CHIP C 0.010UF K	
C42			CK73GB1H183K	CHIP C 0.018UF K	
C43			CK73GB1A105K	CHIP C 1.0UF K	
C44			CK73FB1A225K	CHIP C 2.2UF K	
C45			CC73GCH1H120J	CHIP C 12PF J	
C46			CC73GCH1H090B	CHIP C 9.0PF B	
C47			CC73GCH1H040B	CHIP C 4.0PF B	
C48			CK73HB1C103K	CHIP C 0.010UF K	
C49			CK73HB1H102K	CHIP C 1000PF K	
C50			CC73GCH1H120J	CHIP C 12PF J	
C52			CC73GCH1H050B	CHIP C 5.0PF B	
C53			CC73HCH1H560J	CHIP C 56PF J	
C54			CC73HCH1H220J	CHIP C 22PF J	
C55			CC73GCH1H050B	CHIP C 5.0PF B	

PARTS LIST

TX-RX UNIT (X57-6722-71)

Ref. No.	Address	New parts	Parts No.	Description	Destination	Ref. No.	Address	New parts	Parts No.	Description	Destination
C56,57			CC73HCH1H270J	CHIP C 27PF J		C320			CC73GCH1H220J	CHIP C 22PF J	
C58			CC73GCH1H150J	CHIP C 15PF J		C326			CC73GCH1H220J	CHIP C 22PF J	
C59			CC73HCH1HR75C	CHIP C 0.75PF C		C329			CK73GB1H102K	CHIP C 1000PF K	
C60			CC73GCH1H070B	CHIP C 7.0PF B		C333			CC73GCH1H120J	CHIP C 12PF J	
C61			CC73HCH1H070B	CHIP C 7.0PF B		C338			CC73GCH1H220J	CHIP C 22PF J	
C62			CK73GB1E103K	CHIP C 0.010UF K		C341			CC73GCH1H100D	CHIP C 10PF D	
C63			CC73GCH1H220J	CHIP C 22PF J		C344			CC73GCH1H820J	CHIP C 82PF J	
C64			CC73GCH1H4R5B	CHIP C 4.5PF B		C349			CC73GCH1H030B	CHIP C 3.0PF B	
C65			CC73HCH1H120J	CHIP C 12PF J		C351			CK73GB1H102K	CHIP C 1000PF K	
C66			CK73GB1H102K	CHIP C 1000PF K		C352			CC73GCH1H270G	CHIP C 27PF G	
C67			CK73HB1C103K	CHIP C 0.010UF K		C353			CC73GCH1H270J	CHIP C 27PF J	
C69			CK73GB1E103K	CHIP C 0.010UF K		C355			CK73GB1H102K	CHIP C 1000PF K	
C70			C92-0714-05	CHIP-TAN 4.7UF 6.3WV		C356			CC73GCH1H060D	CHIP C 6.0PF D	
C71			CC73HCH1H0R5B	CHIP C 0.5PF B		C358			CC73GCH1H100D	CHIP C 10PF D	
C72			CC73HCH1H040B	CHIP C 4.0PF B		C359			CC73GCH1H240J	CHIP C 24PF J	
C73			CK73GB1H102K	CHIP C 1000PF K		C360			CC73GCH1H120J	CHIP C 12PF J	
C74			CC73HCH1H0R5B	CHIP C 0.5PF B		C362			CC73GCH1H110J	CHIP C 11PF J	
C75,76			CK73HB1H102K	CHIP C 1000PF K		C363			CC73GCH1H070D	CHIP C 7.0PF D	
C77			C92-0713-05	CHIP-TAN 10UF 6.3WV		C365			CC73GCH1H330J	CHIP C 33PF J	
C78			CK73HB1H102K	CHIP C 1000PF K		C368			CC73GCH1H030C	CHIP C 3.0PF C	
C80			CC73HCH1H330J	CHIP C 33PF J		C400			CK73GB0J225K	CHIP C 2.2UF K	
C81			CC73HCH1H150J	CHIP C 15PF J		C401			CK73GB1H182K	CHIP C 1800PF K	
C82-84			CK73HB1H102K	CHIP C 1000PF K		C402,403			CC73GCH1H271J	CHIP C 270PF J	
C85			CC73HCH1H100D	CHIP C 10PF D		C405			CC73GCH1H390J	CHIP C 39PF J	
C86			CC73GCH1H090D	CHIP C 9.0PF D		C406			C92-0713-05	CHIP-TAN 10UF 6.3WV	
C87			CC73GCH1H060B	CHIP C 6.0PF B		C407			CK73GB1H103K	CHIP C 0.010UF K	
C89			CK73HB1C103K	CHIP C 0.010UF K		C408			CK73GB1C104K	CHIP C 0.10UF K	
C201,202			CK73GB1H102K	CHIP C 1000PF K		C409			CC73GCH1H680J	CHIP C 68PF J	
C203			CC73GCH1H470J	CHIP C 47PF J		C410			CK73GB1H102K	CHIP C 1000PF K	
C212			CK73GB1H102K	CHIP C 1000PF K		C411-413			CK73GB1C104K	CHIP C 0.10UF K	
C241			CK73GB1H102K	CHIP C 1000PF K		C414			CC73GCH1H330J	CHIP C 33PF J	
C242			CC73GCH1H390J	CHIP C 39PF J		C415			CK73GB1H102K	CHIP C 1000PF K	
C243			CK73GB1C104K	CHIP C 0.10UF K		C416,417			CK73GB1H103K	CHIP C 0.010UF K	
C246			CK73GB1H102K	CHIP C 1000PF K		C418			CK73GB1H102K	CHIP C 1000PF K	
C248			CK73GB1H102K	CHIP C 1000PF K		C419			CC73GCH1H010B	CHIP C 1.0PF B	
C249			CC73GCH1H100D	CHIP C 10PF D		C420			CK73GB1C104K	CHIP C 0.10UF K	
C255			CK73GB1H102K	CHIP C 1000PF K		C421			CC73GCH1H080B	CHIP C 8.0PF B	
C258			CK73GB1C104K	CHIP C 0.10UF K		C422			CK73GB1H103K	CHIP C 0.010UF K	
C265			CC73GCH1H220J	CHIP C 22PF J		C424			CK73GB1H103K	CHIP C 0.010UF K	
C273			CC73GCH1H101J	CHIP C 100PF J		C425			CC73GCH1H150J	CHIP C 15PF J	
C277			CC73GCH1H270J	CHIP C 27PF J		C426			CC73GCH1H020B	CHIP C 2.0PF B	
C280			CK73GB1H102K	CHIP C 1000PF K		C427			CK73GB1H103K	CHIP C 0.010UF K	
C282			CC73GCH1H100D	CHIP C 10PF D		C428			CC73GCH1H150J	CHIP C 15PF J	
C285			C92-0565-05	CHIP-TAN 6.8UF 10WV		C429			CK73GB1H102K	CHIP C 1000PF K	
C286			CK73GB1A105K	CHIP C 1.0UF K		C430			CC73GCH1H180J	CHIP C 18PF J	
C288			CK73GB1H102K	CHIP C 1000PF K		C432			CK73GB1H102K	CHIP C 1000PF K	
C290,291			CK73GB1H102K	CHIP C 1000PF K		C434			CK73GB1H103K	CHIP C 0.010UF K	
C292			CC73GCH1H101J	CHIP C 100PF J		C435			CK73GB1H102K	CHIP C 1000PF K	
C293			CK73GB1H102K	CHIP C 1000PF K		C436			CC73GCH1H050B	CHIP C 5.0PF B	
C295,296			CC73GCH1H050B	CHIP C 5.0PF B		C437			CC73GCH1H020B	CHIP C 2.0PF B	
C297			CK73GB1H102K	CHIP C 1000PF K		C438			CC73GCH1H090B	CHIP C 9.0PF B	
C298			CK73GB1H103K	CHIP C 0.010UF K		C439			CK73GB1H102K	CHIP C 1000PF K	
C299			CK73GB1C104K	CHIP C 0.10UF K		C440			CK73HB1H102K	CHIP C 1000PF K	
C300			CK73GB1A105K	CHIP C 1.0UF K		C441			CK73GB1H102K	CHIP C 1000PF K	
C301			CK73GB1H102K	CHIP C 1000PF K		C442			CK73HB1A104K	CHIP C 0.10UF K	
C302			CC73GCH1H180J	CHIP C 18PF J		C443			CK73GB1A105K	CHIP C 1.0UF K	
C308			CK73GB1H103K	CHIP C 0.010UF K		C444			CC73GCH1H040B	CHIP C 4.0PF B	
C309			CC73GCH1H100D	CHIP C 10PF D		C445			CC73GCH1H020B	CHIP C 2.0PF B	
C312			CC73GCH1H820J	CHIP C 82PF J		C446			CC73GCH1H010C	CHIP C 1.0PF C	
C317			CC73GCH1H100D	CHIP C 10PF D		C447			CC73GCH1H390J	CHIP C 39PF J	

PARTS LIST

TX-RX UNIT (X57-6722-71)

Ref. No.	Address	New parts	Parts No.	Description	Destination	Ref. No.	Address	New parts	Parts No.	Description	Destination
C448			CK73GB1H102K	CHIP C 1000PF K		C653			CK73GB1A224K	CHIP C 0.22UF K	
C456			C92-0714-05	CHIP-TAN 4.7UF 6.3WV		C654			CK73GB1H103K	CHIP C 0.010UF K	
C462			CK73HB1H102K	CHIP C 1000PF K		C655			CK73GB1E223J	CHIP C 0.022UF J	
C463			CC73GCH1H050B	CHIP C 5.0PF B		C656			CK73GB1C104K	CHIP C 0.10UF K	
C464			CC73GCH1H040B	CHIP C 4.0PF B		C657			CC73GCH1H470J	CHIP C 47PF J	
C465,466			CK73GB1H102K	CHIP C 1000PF K		C658			CK73GB1C104K	CHIP C 0.10UF K	
C467			CC73GCH1H270J	CHIP C 27PF J		C659			CK73GB1H103K	CHIP C 0.010UF K	
C468			CC73GCH1H010B	CHIP C 1.0PF B		C660			CK73GB1A105K	CHIP C 1.0UF K	
C469			CK73GB1H102K	CHIP C 1000PF K		C661			CK73GB1H471K	CHIP C 470PF K	
C472			CK73GB1H102K	CHIP C 1000PF K		C662,663			CK73GB1C104K	CHIP C 0.10UF K	
C474			CK73GB1H102K	CHIP C 1000PF K		C664			CK73GB1H102K	CHIP C 1000PF K	
C475			CC73GCH1H4R5B	CHIP C 4.5PF B		C667			CK73GB1H102K	CHIP C 1000PF K	
C476			CC73GCH1H0R5B	CHIP C 0.5PF B		C668			CK73GB1H103K	CHIP C 0.010UF K	
C477			CC73GCH1H330J	CHIP C 33PF J		C669			CK73GB1H102K	CHIP C 1000PF K	
C478			CK73GB1H102K	CHIP C 1000PF K		C671			CK73GB1C104K	CHIP C 0.10UF K	
C479			CC73GCH1H040B	CHIP C 4.0PF B		C672,673			CK73GB1H472K	CHIP C 4700PF K	
C480			CK73GB1H102K	CHIP C 1000PF K		C674			CC73GCH1H221J	CHIP C 220PF J	
C481			CC73GCH1H220J	CHIP C 22PF J		C675,676			C92-0804-05	CHIP-TAN 1.5UF 15WV	
C483			CC73GCH1H100D	CHIP C 10PF D		C677			CK73GB1H332K	CHIP C 3300PF K	
C484			CC73GCH1H040B	CHIP C 4.0PF B		C678			CK73FB1C474K	CHIP C 0.47UF K	
C485			CK73GB1H471K	CHIP C 470PF K		C679			CC73GCH1H101J	CHIP C 100PF J	
C486			CC73GCH1H050B	CHIP C 5.0PF B		C680			C92-0560-05	CHIP-TAN 10UF 6.3WV	
C487			CK73HB1A104K	CHIP C 0.10UF K		C681			CK73GB1C683K	CHIP C 0.068UF K	
C602			CK73GB1A224K	CHIP C 0.22UF K		C684			CK73GB1C104K	CHIP C 0.10UF K	
C604			CK73GB1C104K	CHIP C 0.10UF K		C686			CK73GB1C473K	CHIP C 0.047UF K	
C605			C92-0632-05	CHIP-TAN 6.8UF 6.3WV		C687			C92-0560-05	CHIP-TAN 10UF 6.3WV	
C606			CK73GB1H332K	CHIP C 3300PF K		C688			CC73GCH1H221J	CHIP C 220PF J	
C607			CK73GB1H103K	CHIP C 0.010UF K		C689			CK73GB1C223K	CHIP C 0.022UF K	
C608			CK73GB1H392K	CHIP C 3900PF K		C690			CK73GB1H102K	CHIP C 1000PF K	
C609			CK73GB1H103K	CHIP C 0.010UF K		C691			C92-0665-05	TANTAL 100UF 6.3WV	
C610			C92-0714-05	CHIP-TAN 4.7UF 6.3WV		C692			CC73GCH1H221J	CHIP C 220PF J	
C611			CK73GB0J105K	CHIP C 1.0UF K		C693			CK73GB1H471K	CHIP C 470PF K	
C613-615			CK73GB1C104K	CHIP C 0.10UF K		C695			CK73GB1H102K	CHIP C 1000PF K	
C618			CK73GB1C104K	CHIP C 0.10UF K		C696			CK73GB1A224K	CHIP C 0.22UF K	
C619			CK73GB1H472K	CHIP C 4700PF K		C801			CK73GB1A105K	CHIP C 1.0UF K	
C621,622			C92-0714-05	CHIP-TAN 4.7UF 6.3WV		C802			CK73GB1H103K	CHIP C 0.010UF K	
C624			CK73GB1C104K	CHIP C 0.10UF K		C803,804			CK73GB1A105K	CHIP C 1.0UF K	
C625			CC73GCH1H680J	CHIP C 68PF J		C805			CK73GB1H102K	CHIP C 1000PF K	
C627			CK73GB1E123K	CHIP C 0.012UF K		C807			CK73GB1H102K	CHIP C 1000PF K	
C628			CK73GB1H222K	CHIP C 2200PF K		C809			CK73GB1A105K	CHIP C 1.0UF K	
C629			CK73GB1H103K	CHIP C 0.010UF K		C811			CK73GB1C104K	CHIP C 0.10UF K	
C630			CC73GCH1H101J	CHIP C 100PF J		C812			CK73GB1H103K	CHIP C 0.010UF K	
C631			CK73GB1E123K	CHIP C 0.012UF K		C814			CK73GB1H103K	CHIP C 0.010UF K	
C632			CK73GB1C104K	CHIP C 0.10UF K		C815			CK73GB1A105K	CHIP C 1.0UF K	
C633			CC73GCH1H020B	CHIP C 2.0PF B		C816,817			CK73GB1H102K	CHIP C 1000PF K	
C634			CK73GB1H102K	CHIP C 1000PF K		C818			CK73GB1H103K	CHIP C 0.010UF K	
C635			CK73GB1C104K	CHIP C 0.10UF K		C819			CK73GB1H102K	CHIP C 1000PF K	
C636			CK73GB1C683K	CHIP C 0.068UF K		C820,821			CK73GB1A105K	CHIP C 1.0UF K	
C637			CC73GCH1H101J	CHIP C 100PF J		C822			CK73GB1H102K	CHIP C 1000PF K	
C638			CK73GB1H102K	CHIP C 1000PF K		C823			CK73GB1H103K	CHIP C 0.010UF K	
C639			CC73GCH1H470J	CHIP C 47PF J		C825			C92-0713-05	CHIP-TAN 10UF 6.3WV	
C640			CC73GCH1H101J	CHIP C 100PF J		C828			CK73GB1H102K	CHIP C 1000PF K	
C641,642			CK73GB1C104K	CHIP C 0.10UF K		C830			CK73GB1C104K	CHIP C 0.10UF K	
C643			CC73GCH1H680J	CHIP C 68PF J		C833			CK73GB1A105K	CHIP C 1.0UF K	
C645			CK73GB0J225K	CHIP C 2.2UF K		C834			CK73GB1C104K	CHIP C 0.10UF K	
C646			CK73GB1H821K	CHIP C 820PF K		C835,836			CK73GB1A105K	CHIP C 1.0UF K	
C647			CK73GB1H102K	CHIP C 1000PF K		C837			CK73GB1H102K	CHIP C 1000PF K	
C648,649			CK73GB1C104K	CHIP C 0.10UF K		C840			CK73GB1H102K	CHIP C 1000PF K	
C650			C92-0713-05	CHIP-TAN 10UF 6.3WV		C841			CK73GB1H103K	CHIP C 0.010UF K	
C652			CK73GB1H102K	CHIP C 1000PF K		C842			CC73GCH1H150J	CHIP C 15PF J	

PARTS LIST

TX-RX UNIT (X57-6722-71)

Ref. No.	Address	New parts	Parts No.	Description	Destination	Ref. No.	Address	New parts	Parts No.	Description	Destination
C843			CC73GCH1H030C	CHIP C 3.0PF C		L401			L92-0138-05	FERRITE CHIP	
C845			CC73GCH1H150J	CHIP C 15PF J		L402			L40-3975-92	SMALL FIXED INDUCTOR(39NH)	
C846			CK73GB1H103K	CHIP C 0.010UF K		L403			L40-5685-85	SMALL FIXED INDUCTOR(0.56UH)	
C847			C92-0712-05	CHIP-TAN 22UF 6.3WV		L404			L40-1885-92	SMALL FIXED INDUCTOR(180NH)	
C848			CC73GCH1H101J	CHIP C 100PF J		L405			L40-1285-92	SMALL FIXED INDUCTOR(120NH)	
C849			CK73GB1H471K	CHIP C 470PF K		L406			L40-2785-92	SMALL FIXED INDUCTOR(270NH)	
C850			CK73GB1H103K	CHIP C 0.010UF K		L407			L41-6878-14	SMALL FIXED INDUCTOR	
C852,853			CK73GB1H102K	CHIP C 1000PF K		L408			L92-0138-05	FERRITE CHIP	
C854			CK73GB1H103K	CHIP C 0.010UF K		L409			L41-6878-14	SMALL FIXED INDUCTOR	
C861			CK73FB1A475K	CHIP C 4.7UF K		L411			L41-6878-14	SMALL FIXED INDUCTOR	
CTC1,2			C05-0384-05	CERAMIC TRIMMER (10PF)		L412			L41-5678-14	SMALL FIXED INDUCTOR	
J601			E11-0457-05	PHONE JACK (2.5/3.5)		L413			L40-3975-92	SMALL FIXED INDUCTOR(39NH)	
9	3B	*	E37-1085-05	FLAT CABLE		L416			L40-5681-86	SMALL FIXED INDUCTOR(0.56UH)	
F801		*	F20-3352-04	INSULATING SHEET		L601			L92-0140-05	FERRITE CHIP	
		*	F53-0190-05	FUSE		L602			L92-0149-05	FERRITE CHIP	
		*	G11-4300-04	RUBBER CUSHION		L801			L92-0149-05	FERRITE CHIP	
		*	J99-0374-04	ADHESIVE TAPE		L802			L92-0140-05	FERRITE CHIP	
CD401			L79-1582-05	TUNING COIL		L803-807			L92-0138-05	FERRITE CHIP	
CF401		*	L72-1015-05	CERAMIC FILTER		X1			L77-1932-05	TCXO (16.8MHZ)	
L1			L40-4795-85	SMALL FIXED INDUCTOR(4.7UH)		X801			L77-1933-05	CRYSTAL RESONATOR(7.3728MHZ)	
L3			L40-1581-86	SMALL FIXED INDUCTOR(0.15UH)		XF401			L71-0617-15	MCF (49.95MHZ)	
L5			L92-0138-05	FERRITE CHIP		RCP1,2			RK75HA1J473J	CHIP-COM 47K J 1/16W	
L6			L40-1085-92	SMALL FIXED INDUCTOR(100NH)		RCP3,4			RK75HA1J102J	CHIP-COM 1.0K J 1/16W	
L7			L92-0141-05	FERRITE CHIP		RCP801,802			RK75HA1J473J	CHIP-COM 47K J 1/16W	
L8			L40-1075-92	SMALL FIXED INDUCTOR(10NH)		RCP803-805			RK75HA1J102J	CHIP-COM 1.0K J 1/16W	
L9			L40-1001-86	SMALL FIXED INDUCTOR(10UH)		RCP806			RK75HA1J473J	CHIP-COM 47K J 1/16W	
L10			L40-1802-86	SMALL FIXED INDUCTOR(18UH)		RCP807			RK75HA1J102J	CHIP-COM 1.0K J 1/16W	
L11			L40-2775-92	SMALL FIXED INDUCTOR(27NH)		RCP808			RK75HA1J472J	CHIP-COM 4.7K J 1/16W	
L12			L40-1502-86	SMALL FIXED INDUCTOR(15UH)		RCP809-818			RK75HA1J102J	CHIP-COM 1.0K J 1/16W	
L14			L40-1502-86	SMALL FIXED INDUCTOR(15UH)		R1			RK73GB1J223J	CHIP R 22K J 1/16W	
L16			L41-3378-14	SMALL FIXED INDUCTOR		R2			RK73GB1J103J	CHIP R 10K J 1/16W	
L17			L41-2278-14	SMALL FIXED INDUCTOR		R3			RK73GB1J473J	CHIP R 47K J 1/16W	
L18			L40-2275-92	SMALL FIXED INDUCTOR(22NH)		R4			R92-1252-05	CHIP R 0 OHM J 1/16W	
L19,20			L40-1001-86	SMALL FIXED INDUCTOR(10UH)		R5			RK73GB1J224J	CHIP R 220K J 1/16W	
L21			L40-2785-92	SMALL FIXED INDUCTOR(270NH)		R6			RK73GB1J473J	CHIP R 47K J 1/16W	
L23			L92-0138-05	FERRITE CHIP		R7			R92-1252-05	CHIP R 0 OHM J 1/16W	
L24,25			L40-1085-92	SMALL FIXED INDUCTOR(100NH)		R9			RK73GB1J393J	CHIP R 39K J 1/16W	
L208			L40-1085-92	SMALL FIXED INDUCTOR(100NH)		R12			RK73GB1J101J	CHIP R 100 J 1/16W	
L209			L92-0138-05	FERRITE CHIP		R13			R92-1252-05	CHIP R 0 OHM J 1/16W	
L213			L40-2775-92	SMALL FIXED INDUCTOR(27NH)		R14			RK73GB1J222J	CHIP R 2.2K J 1/16W	
L214			L40-4775-92	SMALL FIXED INDUCTOR(47NH)		R15			R92-1252-05	CHIP R 0 OHM J 1/16W	
L216			L40-1585-54	SMALL FIXED INDUCTOR(150NH)		R16			RK73GB1J102J	CHIP R 1.0K J 1/16W	
L217			L92-0149-05	FERRITE CHIP		R17			RK73GB1J101J	CHIP R 100 J 1/16W	
L218			L40-2775-54	SMALL FIXED INDUCTOR(27NH)		R18			RK73GB1J474J	CHIP R 470K J 1/16W	
L219			L34-4577-05	AIR-CORE COIL		R19			RK73GB1J100J	CHIP R 10 J 1/16W	
L220			L92-0149-05	FERRITE CHIP		R20,21			R92-1252-05	CHIP R 0 OHM J 1/16W	
L221			L34-4563-05	AIR-CORE COIL		R22			RK73GB1J561J	CHIP R 560 J 1/16W	
L222			L34-4573-05	AIR-CORE COIL		R23			RK73GB1J121J	CHIP R 120 J 1/16W	
L223			L34-4563-05	AIR-CORE COIL		R24			RK73GB1J471J	CHIP R 470 J 1/16W	
L224			L40-2295-85	SMALL FIXED INDUCTOR(2.2UH)		R25			RK73GB1J103J	CHIP R 10K J 1/16W	
L225			L34-4576-05	AIR-CORE COIL		R26			RK73GB1J223J	CHIP R 22K J 1/16W	
L226			L34-4575-05	AIR-CORE COIL		R27			RK73GB1J103J	CHIP R 10K J 1/16W	
L227			L34-4567-05	AIR-CORE COIL		R28			RK73GB1J472J	CHIP R 4.7K J 1/16W	
L228			L40-5675-92	SMALL FIXED INDUCTOR(56NH)		R29			RK73GB1J103J	CHIP R 10K J 1/16W	
L229			L34-4566-05	AIR-CORE COIL		R30			RK73GB1J393J	CHIP R 39K J 1/16W	
L230			L40-1092-81	SMALL FIXED INDUCTOR		R31			RK73GB1J472J	CHIP R 4.7K J 1/16W	
						R32			RK73GB1J104J	CHIP R 100K J 1/16W	
						R33			RK73HB1J103J	CHIP R 10K J 1/16W	
						R35			RK73HB1J223J	CHIP R 22K J 1/16W	

PARTS LIST

TX-RX UNIT (X57-6722-71)

Ref. No.	Address	New parts	Parts No.	Description	Destination	Ref. No.	Address	New parts	Parts No.	Description	Destination
R37			RK73HB1J274J	CHIP R 270K J 1/16W		R419			RK73GB1J151J	CHIP R 150 J 1/16W	
R38			RK73HB1J271J	CHIP R 270 J 1/16W		R421-424			RK73GB1J823J	CHIP R 82K J 1/16W	
R39			RK73GB1J220J	CHIP R 22 J 1/16W		R425			R92-1252-05	CHIP R 0 OHM J 1/16W	
R40			RK73HB1J221J	CHIP R 220 J 1/16W		R427			RK73GB1J105J	CHIP R 1.0M J 1/16W	
R41			RK73GB1J331J	CHIP R 330 J 1/16W		R428,429			RK73HB1J562J	CHIP R 5.6K J 1/16W	
R42			RK73GB1J683J	CHIP R 68K J 1/16W		R431			RK73GB1J105J	CHIP R 1.0M J 1/16W	
R43,44			RK73HB1J220J	CHIP R 22 J 1/16W		R433			R92-1252-05	CHIP R 0 OHM J 1/16W	
R46			RK73HB1J154J	CHIP R 150K J 1/16W		R434			RK73HB1J103J	CHIP R 10K J 1/16W	
R47			RK73HB1J472J	CHIP R 4.7K J 1/16W		R435			RK73HB1J224J	CHIP R 220K J 1/16W	
R49			RK73HB1J101J	CHIP R 100 J 1/16W		R436			RK73HB1J473J	CHIP R 47K J 1/16W	
R50			RK73HB1J332J	CHIP R 3.3K J 1/16W		R437			RK73HB1J224J	CHIP R 220K J 1/16W	
R51			RK73HB1J103J	CHIP R 10K J 1/16W		R438			RK73GB1J391J	CHIP R 390 J 1/16W	
R55			RK73GJ1J333D	CHIP R 33K D 1/16W		R440			RK73GB1J470J	CHIP R 47 J 1/16W	
R56			RK73HB1J331J	CHIP R 330 J 1/16W		R441			RK73GB1J181J	CHIP R 180 J 1/16W	
R57			RK73GJ1J104D	CHIP R 100K D 1/16W		R443			RK73HB1J224J	CHIP R 220K J 1/16W	
R58			RK73HB1J222J	CHIP R 2.2K J 1/16W		R457			RK73HB1J104J	CHIP R 100K J 1/16W	
R59			RK73HB1J470J	CHIP R 47 J 1/16W		R459			RK73GB1J184J	CHIP R 180K J 1/16W	
R60			RK73GB1J472J	CHIP R 4.7K J 1/16W		R460			RK73GB1J124J	CHIP R 120K J 1/16W	
R61			RK73GB1J103J	CHIP R 10K J 1/16W		R461			RK73GB1J101J	CHIP R 100 J 1/16W	
R201			RK73GB1J101J	CHIP R 100 J 1/16W		R462			R92-1252-05	CHIP R 0 OHM J 1/16W	
R202			RK73GB1J472J	CHIP R 4.7K J 1/16W		R463			RK73GB1J105J	CHIP R 1.0M J 1/16W	
R203			R92-1252-05	CHIP R 0 OHM J 1/16W		R465			RK73GB1J105J	CHIP R 1.0M J 1/16W	
R214			RK73GB1J223J	CHIP R 22K J 1/16W		R466,467			R92-0670-05	CHIP R 0 OHM	
R215			RK73GB1J103J	CHIP R 10K J 1/16W		R468			RK73GB1J332J	CHIP R 3.3K J 1/16W	
R252			RK73GB1J331J	CHIP R 330 J 1/16W		R469			RK73GB1J221J	CHIP R 220 J 1/16W	
R254			R92-1252-05	CHIP R 0 OHM J 1/16W		R601			R92-1252-05	CHIP R 0 OHM J 1/16W	
R256			RK73GB1J683J	CHIP R 68K J 1/16W		R602			RK73GB1J184J	CHIP R 180K J 1/16W	
R257			RK73GB1J473J	CHIP R 47K J 1/16W		R603			R92-1252-05	CHIP R 0 OHM J 1/16W	
R258			R92-1252-05	CHIP R 0 OHM J 1/16W		R604			RK73GB1J184J	CHIP R 180K J 1/16W	
R259			RK73GB1J150J	CHIP R 15 J 1/16W		R607-609			RK73GB1J103J	CHIP R 10K J 1/16W	
R260			RK73GB1J331J	CHIP R 330 J 1/16W		R610			RK73GB1J472J	CHIP R 4.7K J 1/16W	
R261-263			R92-1252-05	CHIP R 0 OHM J 1/16W		R612			RK73GB1J682J	CHIP R 6.8K J 1/16W	
R264,265			RK73EB2ER39K	CHIP R 0.39 K 1/4W		R613			RK73GB1J824J	CHIP R 820K J 1/16W	
R267			RK73GB1J123J	CHIP R 12K J 1/16W		R615			RK73GB1J334J	CHIP R 330K J 1/16W	
R268			RK73GB1J820J	CHIP R 82 J 1/16W		R616			R92-1252-05	CHIP R 0 OHM J 1/16W	
R269			RK73GB1J473J	CHIP R 47K J 1/16W		R617			RK73GB1J103J	CHIP R 10K J 1/16W	
R270			RK73EB2ER39K	CHIP R 0.39 K 1/4W		R618			RK73GJ1J364D	CHIP R 360K D 1/16W	
R272-277			RK73GH1J154D	CHIP R 150K D 1/16W		R621			RK73GB1J473J	CHIP R 47K J 1/16W	
R278			RK73GB1J103J	CHIP R 10K J 1/16W		R622			RK73GB1J684J	CHIP R 680K J 1/16W	
R279			RK73GB1J473J	CHIP R 47K J 1/16W		R623			RK73GB1J274G	CHIP R 270K G 1/16W	
R280			R92-1252-05	CHIP R 0 OHM J 1/16W		R624			RK73GB1J822J	CHIP R 8.2K J 1/16W	
R281			RK73GB1J222J	CHIP R 2.2K J 1/16W		R625			RK73GB1J563J	CHIP R 56K J 1/16W	
R282			RK73GB1J105J	CHIP R 1.0M J 1/16W		R626,627			RK73GB1J184J	CHIP R 180K J 1/16W	
R283,284			RK73GB1J104J	CHIP R 100K J 1/16W		R628			RK73GB1J224J	CHIP R 220K J 1/16W	
R285,286			RK73GB1J271J	CHIP R 270 J 1/16W		R629			RK73GB1J394J	CHIP R 390K J 1/16W	
R287			R92-1252-05	CHIP R 0 OHM J 1/16W		R630			RK73GB1J684J	CHIP R 680K J 1/16W	
R401			RK73GB1J100J	CHIP R 10 J 1/16W		R631			RK73GB1J394J	CHIP R 390K J 1/16W	
R403			RK73GB1J102J	CHIP R 1.0K J 1/16W		R632			RK73GB1J823J	CHIP R 82K J 1/16W	
R404			RK73GB1J334J	CHIP R 330K J 1/16W		R633			RK73GB1J223J	CHIP R 22K J 1/16W	
R406			RK73GB1J332J	CHIP R 3.3K J 1/16W		R634			RK73GB1J103J	CHIP R 10K J 1/16W	
R407			RK73GB1J474J	CHIP R 470K J 1/16W		R636			RK73GB1J474J	CHIP R 470K J 1/16W	
R408			RK73GB1J332J	CHIP R 3.3K J 1/16W		R637			RK73GB1J394J	CHIP R 390K J 1/16W	
R409			RK73GB1J392J	CHIP R 3.9K J 1/16W		R639			RK73GB1J393J	CHIP R 39K J 1/16W	
R412			RK73GB1J122J	CHIP R 1.2K J 1/16W		R640			RK73GB1J184J	CHIP R 180K J 1/16W	
R413			RK73GB1J124J	CHIP R 120K J 1/16W		R641,642			RK73GB1J124J	CHIP R 120K J 1/16W	
R414			RK73GB1J331J	CHIP R 330 J 1/16W		R643			RK73GB1J154J	CHIP R 150K J 1/16W	
R415			RK73GB1J472J	CHIP R 4.7K J 1/16W		R644,645			RK73GB1J472J	CHIP R 4.7K J 1/16W	
R416			RK73GB1J331J	CHIP R 330 J 1/16W		R646			RK73GB1J223J	CHIP R 22K J 1/16W	
R417			R92-1252-05	CHIP R 0 OHM J 1/16W		R647			R92-1252-05	CHIP R 0 OHM J 1/16W	
R418			RK73GB1J122J	CHIP R 1.2K J 1/16W		R648			RK73GB1J103J	CHIP R 10K J 1/16W	

PARTS LIST

TX-RX UNIT (X57-6722-71)

Ref. No.	Address	New parts	Parts No.	Description	Destination	Ref. No.	Address	New parts	Parts No.	Description	Destination
R649			RK73GB1J104J	CHIP R 100K J 1/16W		R828			RK73GB1J332J	CHIP R 3.3K J 1/16W	
R650			RK73GB1J102J	CHIP R 1.0K J 1/16W		R829			RK73GB1J272J	CHIP R 2.7K J 1/16W	
R651			R92-1252-05	CHIP R 0 OHM J 1/16W		R830			RK73GB1J821J	CHIP R 820 J 1/16W	
R652			RK73GB1J273J	CHIP R 27K J 1/16W		R833,834			RK73GH1J474D	CHIP R 470K D 1/16W	
R653			RK73GB1J392J	CHIP R 3.9K J 1/16W		R835,836			RK73HB1J102J	CHIP R 1.0K J 1/16W	
R654			RK73GB1J103J	CHIP R 10K J 1/16W		R839,840			RK73GB1J473J	CHIP R 47K J 1/16W	
R655,656			RK73GB1J105J	CHIP R 1.0M J 1/16W		R841			R92-1252-05	CHIP R 0 OHM J 1/16W	
R657			RK73GB1J332J	CHIP R 3.3K J 1/16W		R842			R92-1368-05	CHIP R 0 OHM	
R658			RK73GB1J103J	CHIP R 10K J 1/16W		R844			RK73GB1J473J	CHIP R 47K J 1/16W	
R660			RK73GB1J154J	CHIP R 150K J 1/16W		R845			R92-1368-05	CHIP R 0 OHM	
R661			RK73GB1J684J	CHIP R 680K J 1/16W		R847,848			RK73GB1J102J	CHIP R 1.0K J 1/16W	
R665			R92-1252-05	CHIP R 0 OHM J 1/16W		R849			R92-1252-05	CHIP R 0 OHM J 1/16W	
R666			RK73GB1J822J	CHIP R 8.2K J 1/16W		R851			R92-1368-05	CHIP R 0 OHM	
R667			RK73GB1J104J	CHIP R 100K J 1/16W		R852			RK73HB1J473J	CHIP R 47K J 1/16W	
R668			RK73GB1J473J	CHIP R 47K J 1/16W		R854			RK73GB1J680J	CHIP R 68 J 1/16W	
R669			RK73GB1J222J	CHIP R 2.2K J 1/16W		R855-857			RK73HB1J102J	CHIP R 1.0K J 1/16W	
R670			RK73GB1J102J	CHIP R 1.0K J 1/16W		R858			R92-1368-05	CHIP R 0 OHM	
R671			RK73GB1J683J	CHIP R 68K J 1/16W		R859			RK73GB1J104J	CHIP R 100K J 1/16W	
R672			RK73GB1J102J	CHIP R 1.0K J 1/16W		R860			RK73GB1J223J	CHIP R 22K J 1/16W	
R673			RK73GB1J272J	CHIP R 2.7K J 1/16W		VR1			R12-7491-05	TRIMMING POT.(68K)	
R674			R92-1252-05	CHIP R 0 OHM J 1/16W		S802-805			S70-0457-05	TACT SWITCH	
R675			RK73GB1J103J	CHIP R 10K J 1/16W		MIC60			T91-0543-05	MIC ELEMENT	
R676			RK73GB1J151J	CHIP R 150 J 1/16W		D2			HSC277	DIODE	
R677-679			R92-1252-05	CHIP R 0 OHM J 1/16W		D3-10			1SV325	VARIABLE CAPACITANCE DIODE	
R681			RK73GB1J222J	CHIP R 2.2K J 1/16W		D11			HSC277	DIODE	
R682			RK73GB1J100J	CHIP R 10 J 1/16W		D12			1SV278	VARIABLE CAPACITANCE DIODE	
R683			RK73GB1J474J	CHIP R 470K J 1/16W		D13			MA2S111	DIODE	
R684			RK73GB1J182J	CHIP R 1.8K J 1/16W		D14			HSC277	DIODE	
R686			RK73GB1J471J	CHIP R 470 J 1/16W		D201			HSC277	DIODE	
R687			RK73GB1J102J	CHIP R 1.0K J 1/16W		D203			HZU5CLL	ZENER DIODE	
R688,689			RK73GB1J101J	CHIP R 100 J 1/16W		D204			HVC131	DIODE	
R691			RK73GB1J333J	CHIP R 33K J 1/16W		D206			HVC131	DIODE	
R692			R92-1252-05	CHIP R 0 OHM J 1/16W		D208			HVC131	DIODE	
R693			RK73GB1J273J	CHIP R 27K J 1/16W		D212			HVC131	DIODE	
R694,695			R92-1252-05	CHIP R 0 OHM J 1/16W		D401			HSC277	DIODE	
R696			RK73GB1J103J	CHIP R 10K J 1/16W		D402-405			1SV305	VARIABLE CAPACITANCE DIODE	
R697			R92-1252-05	CHIP R 0 OHM J 1/16W		D603-606			RB706F-40	DIODE	
R698			RK73GB1J152J	CHIP R 1.5K J 1/16W		D801			RB521S-30	DIODE	
R802			RK73GB1J101J	CHIP R 100 J 1/16W		D805			1SR154-400	DIODE	
R803,804			R92-1252-05	CHIP R 0 OHM J 1/16W		IC1			MB15E03SL	MOS IC	
R805			RK73GB1J153J	CHIP R 15K J 1/16W		IC201			TA75W01FU	MOS IC	
R807			RK73GB1J103J	CHIP R 10K J 1/16W		IC401			TA31136FN	MOS IC	
R808			RK73GB1J102J	CHIP R 1.0K J 1/16W		IC601			AQUA	MOS IC	
R809			RK73GB1J272J	CHIP R 2.7K J 1/16W		IC602			TC75S51FE	MOS IC	
R810			RK73GB1J334J	CHIP R 330K J 1/16W		IC603			TC75W51FU	MOS IC	
R811			RK73GB1J332J	CHIP R 3.3K J 1/16W		IC604			TC75S51FE	MOS IC	
R812			RK73GB1J334J	CHIP R 330K J 1/16W		IC605			TA7368F	MOS IC	
R813			RK73GB1J332J	CHIP R 3.3K J 1/16W		IC606			TC75S51FE	MOS IC	
R814			RK73GB1J153J	CHIP R 15K J 1/16W		IC801			XC6204B502MR	MOS IC	
R815			R92-1252-05	CHIP R 0 OHM J 1/16W		IC802	*		PST9134NR	MOS IC	
R816			RK73GB1J224J	CHIP R 220K J 1/16W		IC803			XC61CN5002NR	MOS IC	
R817			RK73GB1J272J	CHIP R 2.7K J 1/16W		IC804	*		CAT24WC64JI	ROM IC	
R818			RK73GB1J821J	CHIP R 820 J 1/16W		IC805	*		30622MCA-8C1GP	MPU	
R819			RK73GB1J103J	CHIP R 10K J 1/16W		IC806			TC7W74FU	MOS IC	
R820			RK73GB1J561J	CHIP R 560 J 1/16W		Q1			DTC144EE	DIGITAL TRANSISTOR	
R821			RK73GB1J331J	CHIP R 330 J 1/16W		Q2,3			UMG9N	TRANSISTOR	
R823			RK73GB1J102J	CHIP R 1.0K J 1/16W		Q4			KTC4082	TRANSISTOR	
R824			RK73GB1J183J	CHIP R 18K J 1/16W							
R825			RK73GB1J473J	CHIP R 47K J 1/16W							
R827			RK73GB1J102J	CHIP R 1.0K J 1/16W							

TK-2160

PARTS LIST

TX-RX UNIT (X57-6722-71)

Ref. No.	Address	New parts	Parts No.	Description	Destination	Ref. No.	Address	New parts	Parts No.	Description	Destination
05,6			2SK508NV(K52)	FET							
07			2SC5108(Y)	TRANSISTOR							
08			2SJ347	FET							
09			2SC5108(Y)	TRANSISTOR							
010			2SC4617(S)	TRANSISTOR							
011			2SC5108(Y)	TRANSISTOR							
012			2SJ347	FET							
0206		*	2SK3077	FET							
0207			2SK2596	FET							
0208			DTC114EE	DIGITAL TRANSISTOR							
0209			2SK879(GR)	FET							
0210			DTC114EE	DIGITAL TRANSISTOR							
0211			2SK2595	FET							
0212			2SK1824	FET							
0213			DTA144EE	DIGITAL TRANSISTOR							
0400			2SK1824	FET							
0401			DTA144EE	DIGITAL TRANSISTOR							
0402			2SC4649(N,P)	TRANSISTOR							
0403			3SK318	FET							
0404		*	3SK294	FET							
0601,602			2SK1824	FET							
0603			DTC144EE	DIGITAL TRANSISTOR							
0604			2SA1362(GR)	TRANSISTOR							
0605			2SC4116(Y)	TRANSISTOR							
0606			2SA1586(Y,GR)	TRANSISTOR							
0607			DTC144EE	DIGITAL TRANSISTOR							
0608			2SK1588	FET							
0801			UMG3N	TRANSISTOR							
0802			UPA672T	FET							
0803			FP210	TRANSISTOR							
0804			UMG3N	TRANSISTOR							
0805			UMG9N	TRANSISTOR							
0806			KTA1298(Y)	TRANSISTOR							
0807			UMG3N	TRANSISTOR							
0808,809			DTA123JE	DIGITAL TRANSISTOR							
0810			2SK1824	FET							
TH1,2			B57331V2104J	THERMISTOR							

EXPLODED VIEW

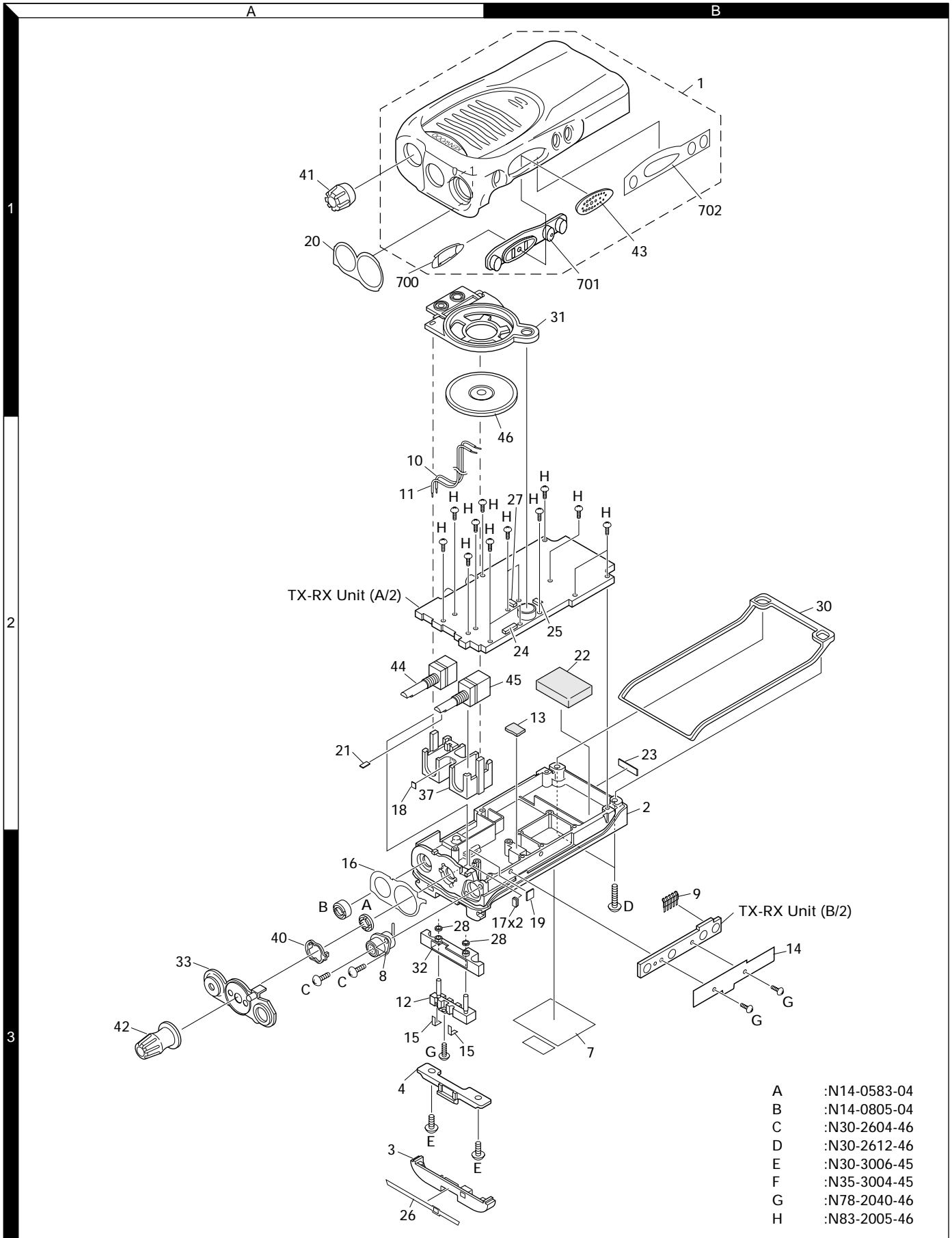

- A :N14-0583-04
- B :N14-0805-04
- C :N30-2604-46
- D :N30-2612-46
- E :N30-3006-45
- F :N35-3004-45
- G :N78-2040-46
- H :N83-2005-46

PACKING

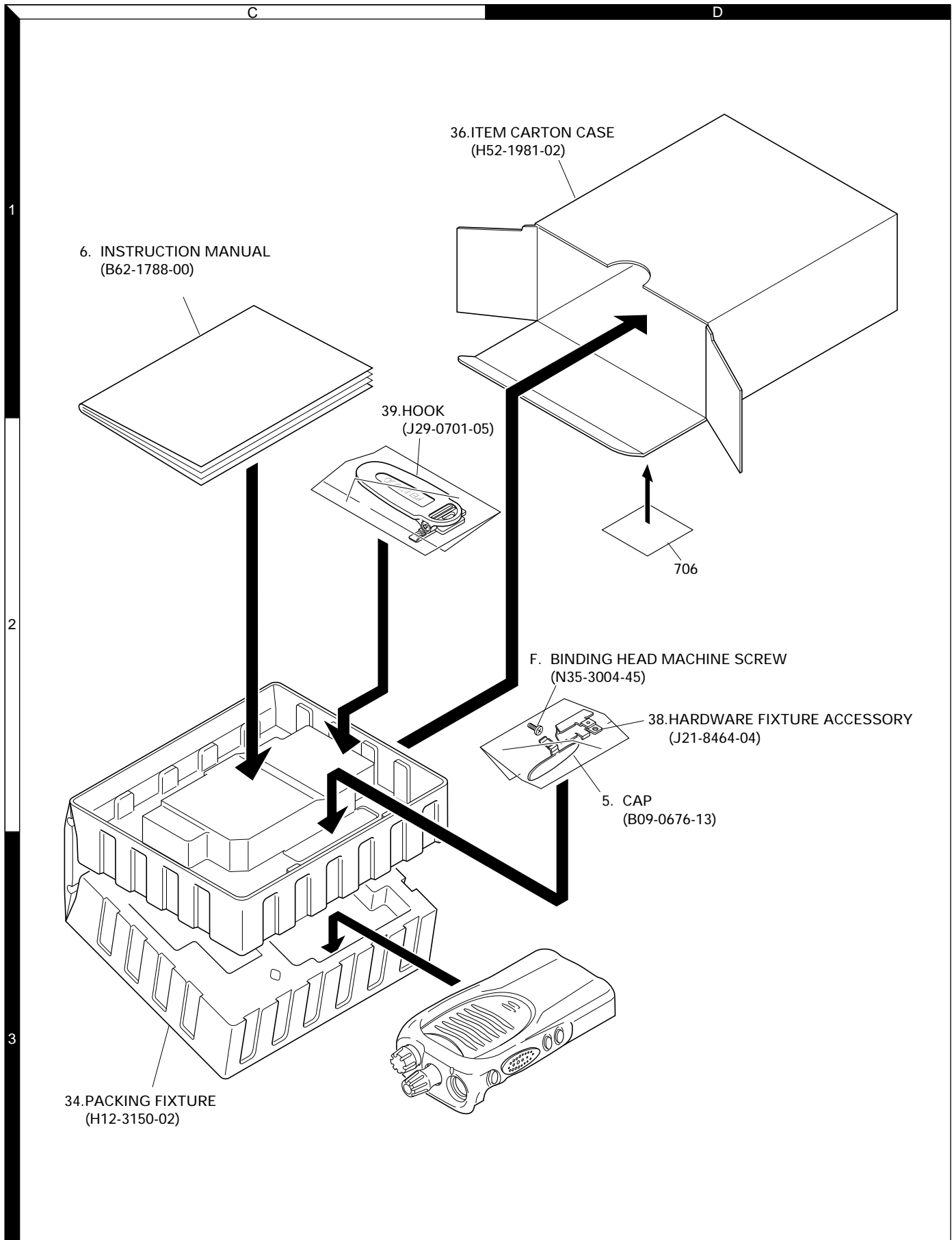

ADJUSTMENT

Test Equipment Required for Alignment

Test Equipment	Major Specifications	
1. Standard Signal Generator (SSG)	Frequency Range Modulation Output	136 to 174MHz. Frequency modulation and external modulation. -127dBm/0.1 μ V to greater than -47dBm/1mV
2. Power Meter	Input Impedance Operation Frequency Measurement Range	50 Ω . 136 to 174MHz. Vicinity of 10W
3. Deviation Meter	Frequency Range	136 to 174MHz.
4. Digital Volt Meter (DVM)	Measuring Range Input Impedance	10mV to 10V DC High input impedance for minimum circuit loading.
5. Oscilloscope		DC through 30MHz.
6. High Sensitivity Frequency Counter	Frequency Range Frequency Stability	10Hz to 1000MHz. 0.2ppm or less.
7. Ammeter		5A.
8. AF Volt Meter (AF VTVM)	Frequency Range Voltage Range	50Hz to 10kHz. 1mV to 10V.
9. Audio Generator (AG)	Frequency Range Output	50Hz to 5kHz or more. 0 to 1V.
10. Distortion Meter	Capability Input Level	3% or less at 1kHz. 50mV to 10Vrms.
11. 8 Ω Dummy Load		Approx. 8 Ω , 3W.
12. Regulated Power Supply		5V to 10V, approx. 3A Useful if ammeter equipped.

■ The following parts are required for adjustment

1. Antenna connector adapter

The antenna connector of this radio uses an SMA terminal. Use an antenna connector adapter [SMA(f) – BNC(f) or SMA(f) – N(f)] for adjustment. (The adapter is not provided as an option, so buy a commercially-available one.)

2. Repair Jig (Chassis)

Use jig (part No.: A10-4082-02) for repairing the TK-2160. Place the TX-RX unit on the jig and fit it with screws.

The jig facilitates the voltage check and protects the final amplifier FET when the voltage on the flow side of the TX-RX unit is checked during repairs.

3. Battery Jig (W05-0909-00)

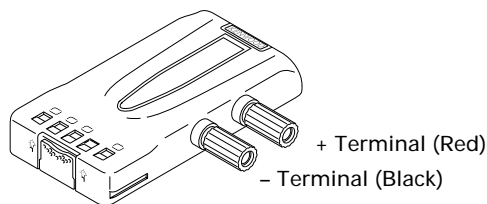

Connect the power cable properly between the battery jig installed in the transceiver and the power supply, and be sure output voltage and the power supply polarity prior to switching the power supply ON, otherwise over voltage and reverse connection may damage the transceiver, or the power supply or both.

When using the battery jig in user mode, the transceiver assumes that a lithium-ion battery pack is attached to the transceiver. In adjustment mode, battery type detection is not performed. Refer to page 10 for details.

Note: When using the battery jig, you must measure the voltage at the terminals of the battery jig. Otherwise, a slight voltage drop may occur within the power cable, between the power supply and the battery jig, especially while the transceiver transmits.

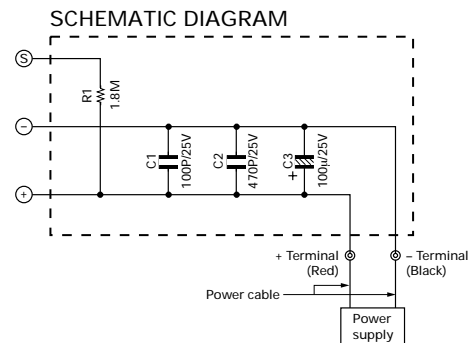

ADJUSTMENT

Adjustment points TX-RX unit (X57-672) Component side view

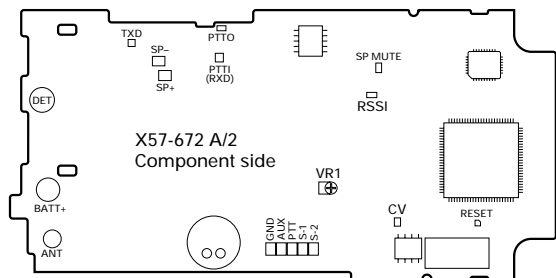

VR1 : Frequency adjustment
RSSI : Band-pass wave form test point

Foil Side View

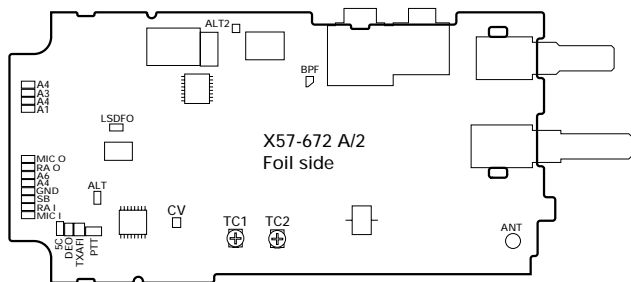

TC1 : Transmit lock voltage adjustment
TC2 : Receive lock voltage adjustment
CV : Lock voltage adjustment terminal.

Fig. 1 Adjustment points

■ Frequency and signalling

The set has been adjusted for the frequencies shown in the following table. When required, re-adjust them following the adjustment procedure to obtain the frequencies you want in actual operation.

Frequency (MHz) E type

Channel No.	RX Frequency	TX Frequency
1	155.050	155.100
2	136.050	136.100
3	173.950	173.900
4	155.000	155.000
5	155.200	155.200
6	155.400	155.400
7~16	—	—

Signalling

Signalling No.	RX	TX
1	None	None
2	None	100Hz Square Wave
3	QT 67.0Hz	QT 67.0Hz
4	QT 151.4Hz	QT 151.4Hz
5	QT 210.7Hz	QT 210.7Hz
6	QT 254.1Hz	QT 254.1Hz
7	DQT D023N	DQT D023N
8	DQT D754I	DQT D754I
9	DTMF 159D	DTMF 159D
10	None	DTMF tone 9
11	5 Tone: CCIR 1,2,3,4,5	5 Tone: CCIR 1,2,3,4,5
12	None	Single Tone:1000Hz
13	None	MSK
14	MSK Code	MSK Code

• Preparations for tuning the transceiver

Before attempting to tune the transceiver, connect the unit to a suitable power supply.

Whenever the transmitter is tuned, the unit must be connected to a suitable dummy load (i.e. power meter).

The speaker output connector must be terminated with a 8W dummy load and connected to an AC voltmeter and an audio distortion meter or a SINAD measurement meter at all times during tuning.

Adjustment Frequency

TEST CH	E	
	RX	TX
Center	155.050MHz	155.100MHz
Low	136.050MHz	136.100MHz
High	173.950MHz	173.900MHz
Low'	145.550MHz	145.600MHz
High'	164.550MHz	164.600MHz
	155.000MHz	155.000MHz
	155.200MHz	155.200MHz
	155.400MHz	155.400MHz

ADJUSTMENT

Common Section

Item	Condition	Measurement		Adjustment		Specifications/ Remark
		Test equipment	Terminal	Parts	Method	
1.Setting	1) BATT terminal vorage:7.5V 2) SSG standard modulation [Wide5k] MOD:1kHz,DEV:3kHz [Wide4k] MOD:1kHz,DEV:2.4kHz [Narrow] MOD:1kHz,DEV:1.5kHz					
2.VCO lock voltage RX	1) CH:High	Power meter DVM	ANT CV	TC2	ADJ	3.8V ±0.2V
	2) CH:Low				Check	0.6V or more
3.VCO lock voltage TX	3) CH:High PTT:ON			TC1	ADJ	3.8V ±0.2V
	4) CH:Low PTT:ON				Check	0.6V or more

Transmitter Section

Item	Condition	Measurement		Adjustment		Specifications/ Remark	
		Test equipment	Terminal	Parts	Method		
1.Frequency Adjust [Wide 5k]	1) CH:Center 2) PTT:ON	Frequency counter	ANT	VR1		Center frequency ±50Hz	
2.High power Adjust [Wide 5k]	TEST CH: Low Low' Center High' High (5 points) BATT terminal voltage:7.5V PTT:ON	Power meter Ampere meter		Programming Software:KPG-82D		4.8W ±0.1W 2.0 A or less	
3.Low power Adjust [Wide 5k]	TEST CH: Low Low' Center High' High (5 points) BATT terminal voltage:7.5V PTT:ON					1.0W ±0.1W 1.0 A or less	
4.Max deviation Adjust [Wide 5k]	TEST CH: Low Center High (3 points) AG:1kHz/150mV Dev meter filter LPF:15kHz HPF:OFF PTT:ON	Power meter Dev meter Oscilloscope AG AF VTVM	ANT SP/MIC connector		4.2kHz (According to the lager +,-)	±50Hz	
						3.4kHz (According to the lager +,-)	±50Hz
						2.1kHz (According to the lager +,-)	±50Hz
[Wide 4k]	TEST CH: Center PTT:ON						
[Narrow]							
5.VOX 1 Writing [Wide 5k]	TEST CH: Center AG:1KHz/60mV	Power meter Dev meter Oscilloscope AG AF VTVM					
6.VOX 10 Writing [Wide 5k]	TEST CH: Center AG:1KHz/4.0mV						

ADJUSTMENT

Item	Condition	Measurement		Adjustment		Specifications/ Remark
		Test equipment	Terminal	Parts	Method	
7.DQT TCXO Balance Writing [Wide 5k] [Wide 4k] [Narrow]	TEST CH: Center	Power mete Dev meter Oscilloscope AG AF VTVM	ANT	Programming Software:KPG-82D	Write	230 hex (Wide 5k, Wide 4k, Narrow)
8.DQT VCO Balance Adjust [Wide 5k] [Wide 4k] [Narrow]	TEST CH: Low Center High (3 points) LPF:3kHz HPF:OFF PTT:ON				Make the demodulation wave into square waves	
	TEST CH: Center PTT:ON				0.8kHz	±40Hz
9.QT Deviation Adjust [Wide 5k] [Wide 4k] [Narrow]	TEST CH: Low Center High (3 points) LPF:3kHz HPF:OFF PTT:ON				0.6kHz	±40Hz
	TEST CH:Center PTT:ON				0.4kHz	±40Hz
10.DQT Deviation Adjust [Wide 5k] [Wide 4k] [Narrow]	TEST CH: Low Center High (3 points) LPF:3kHz HPF:OFF PTT:ON				0.75kHz	±40Hz
	TEST CH: Center PTT:ON				0.6kHz	±40Hz
					0.35kHz	±40Hz
11.Tone Deviation Adjust [Wide 5k] [Wide 4k] [Narrow]	TEST CH: Center LPF:15kHz HPF:OFF PTT:ON				3.0kHz	±100Hz
	TEST CH: Center PTT:ON				2.4kHz	±100Hz
					1.5kHz	±100Hz
12.DTMF Deviation Adjust [Wide 5k] [Wide 4k] [Narrow]	TEST CH: Center LPF:15kHz HPF:OFF PTT:ON				3.0kHz	±100Hz
	TEST CH: Center PTT:ON				2.4kHz	±100Hz
					1.5kHz	±100Hz
13.MSK Deviation Adjust [Wide 5k] [Wide 4k] [Narrow]	TEST CH: Low Center High (3 points) LPF:15kHz HPF:OFF PTT:ON	3.0kHz	±100Hz			
	TEST CH: Center PTT:ON	2.4kHz	±100Hz			
		1.5kHz	±100Hz			
14.BATT Detection Writing [Wide 5k]	BATT terminal voltage:5.9V PTT:ON	Power meter DVM	ANT BATT terminal	Write	BATT terminal voltage:5.9V	

ADJUSTMENT

Item	Condition	Measurement		Adjustment		Specifications/ Remark
		Test equipment	Terminal	Parts	Method	
15.BATT Detection Check	1) BATT terminal voltage:5.5V PTT:ON	Power meter DVM	ANT BATT terminal		Check	LED blinks
	2) BATT terminal voltage:7.5V PTT:ON					LED does not blink

Receiver Section

Item	Condition	Measurement		Adjustment		Specifications/ Remark		
		Test equipment	Terminal	Parts	Method			
1.BPF Wave form ADJ [Wide 5k]	TEST CH:Low Low' Center High' High (5 points) SSG otuput:-103 dBm(1.58μV)	SSG DVM Oscilloscope AF VTVM	ANT RSSI	Programming Software:KPG-82D	RSSI MAX			
	2.Sesitivity check [Wide 5k]					ANT	Check	12dB SINAD or more
	[Wide 4k]							12dB SINAD or more
[Narrow]	12dB SINAD or more							
3.Squelch tight writing [Wide 5k]	TEST CH:Center SSG otuput:-117 dBm(0.3μV) SSG MOD:3.0kHz			Programming Software:KPG-82D		Squelch open		
	[Wide 4k]					Squelch open		
	[Narrow]					Squelch open		
4. Squelch threshold writing [Wide 5k]	TEST CH:Center SSG otuput:-122 dBm(0.18μV) SSG MOD:3.0kHz					Squelch open		
	[Wide 4k]					Squelch open		
	[Narrow]					Squelch open		
5.RSSI writing [Wide 5k]	TEST CH:Center SSG otuput:-123 dBm(0.16μV) SSG MOD:off							
	[Wide 4k]							
	[Narrow]							
	TEST CH:Center SSG otuput:-122 dBm(0.18μV) SSG MOD:off							

PC BOARD TK-2160

TX-RX UNIT (X57-6722-71) Component side view (J72-0895-09)

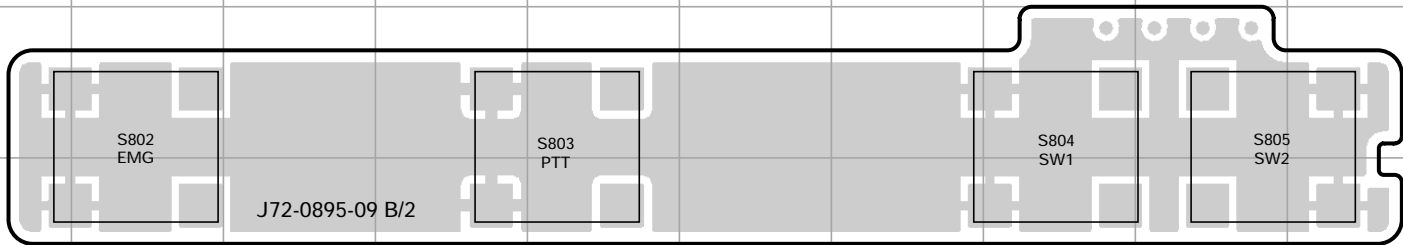
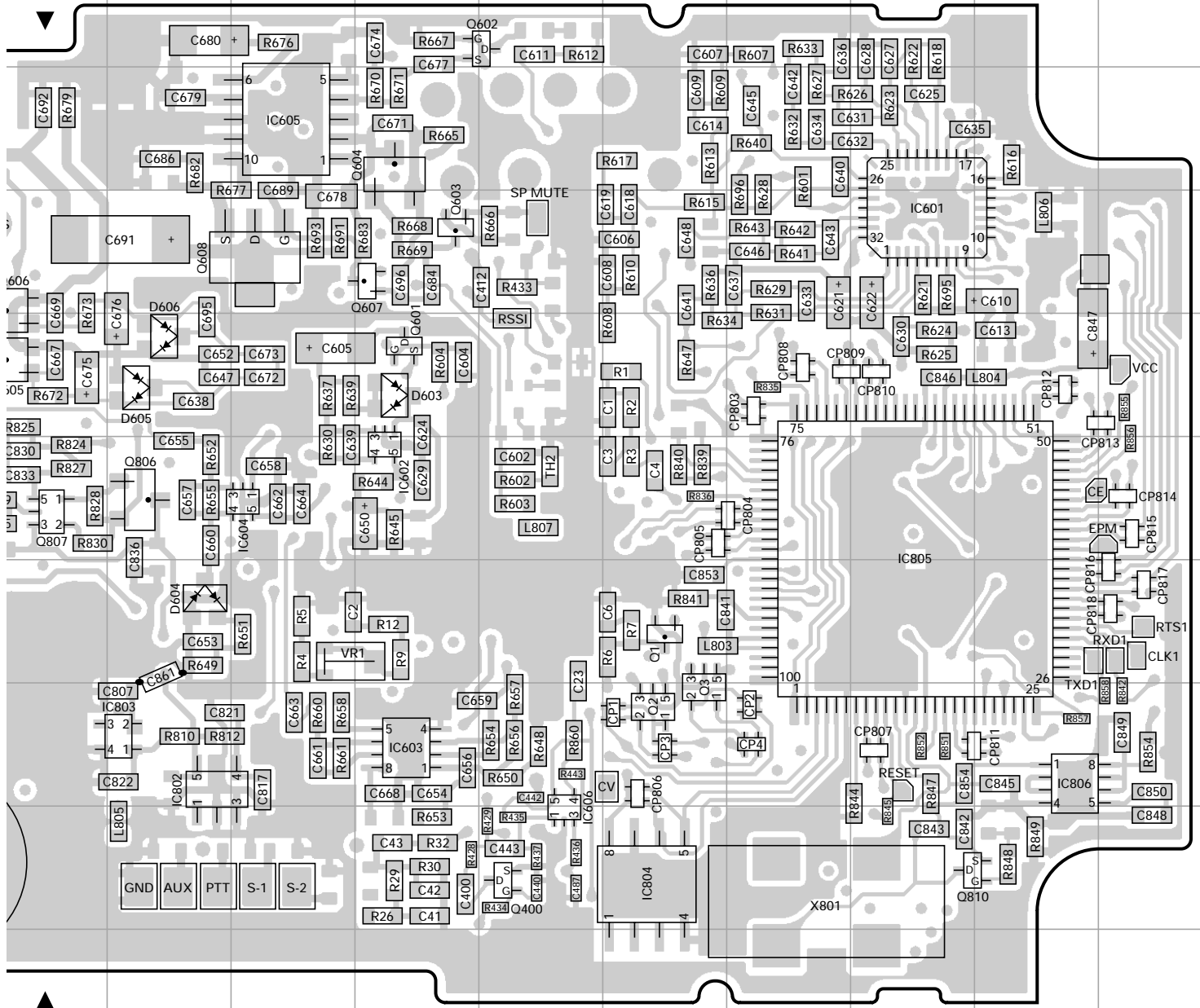

TK-2160 PC BOARD

TX-RX UNIT (X57-6722-71) Foil side view (J72-0895-09)

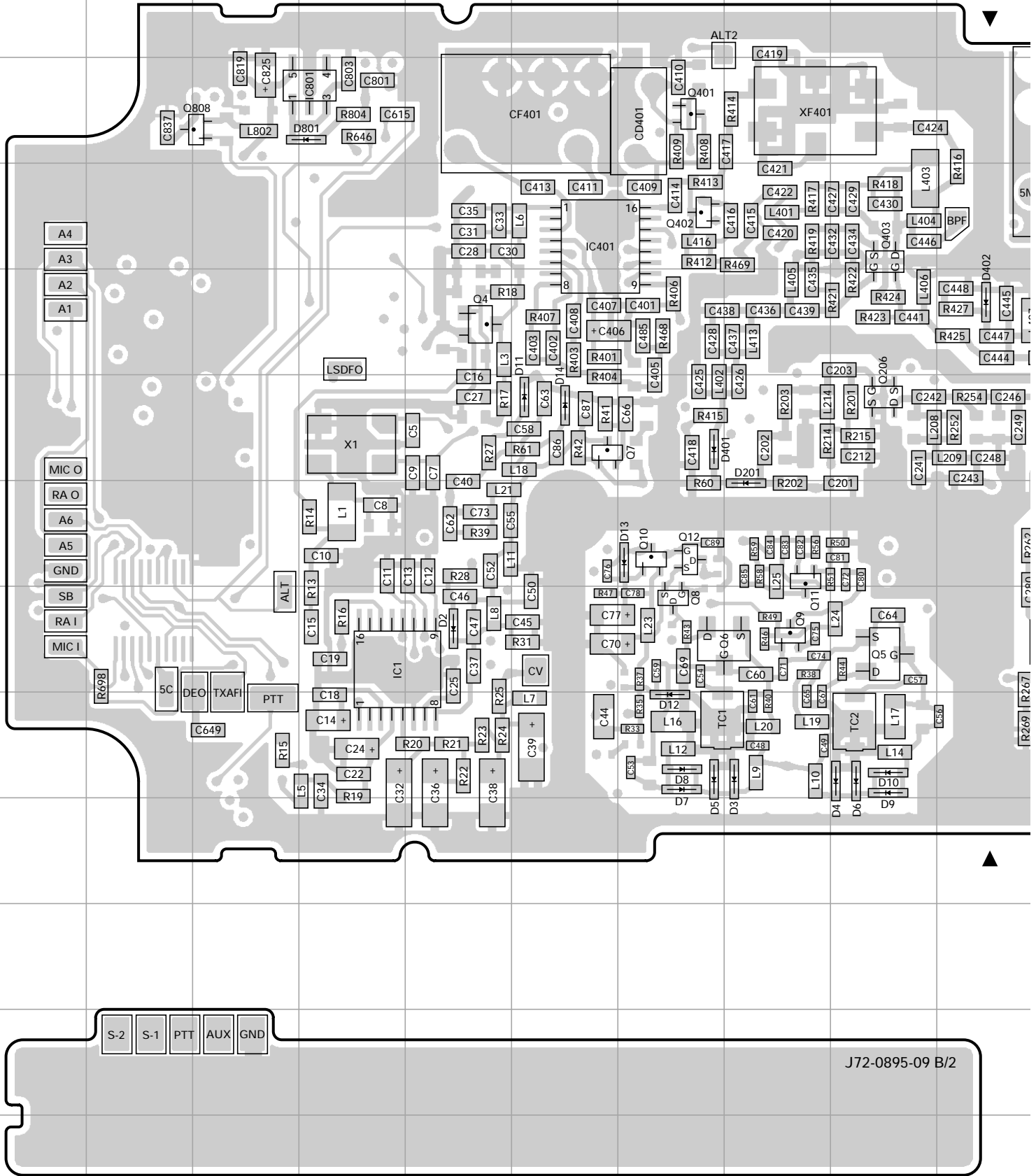

PC BOARD TK-2160

TX-RX UNIT (X57-6722-71) Foil side view (J72-0895-09)

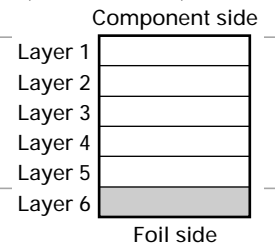
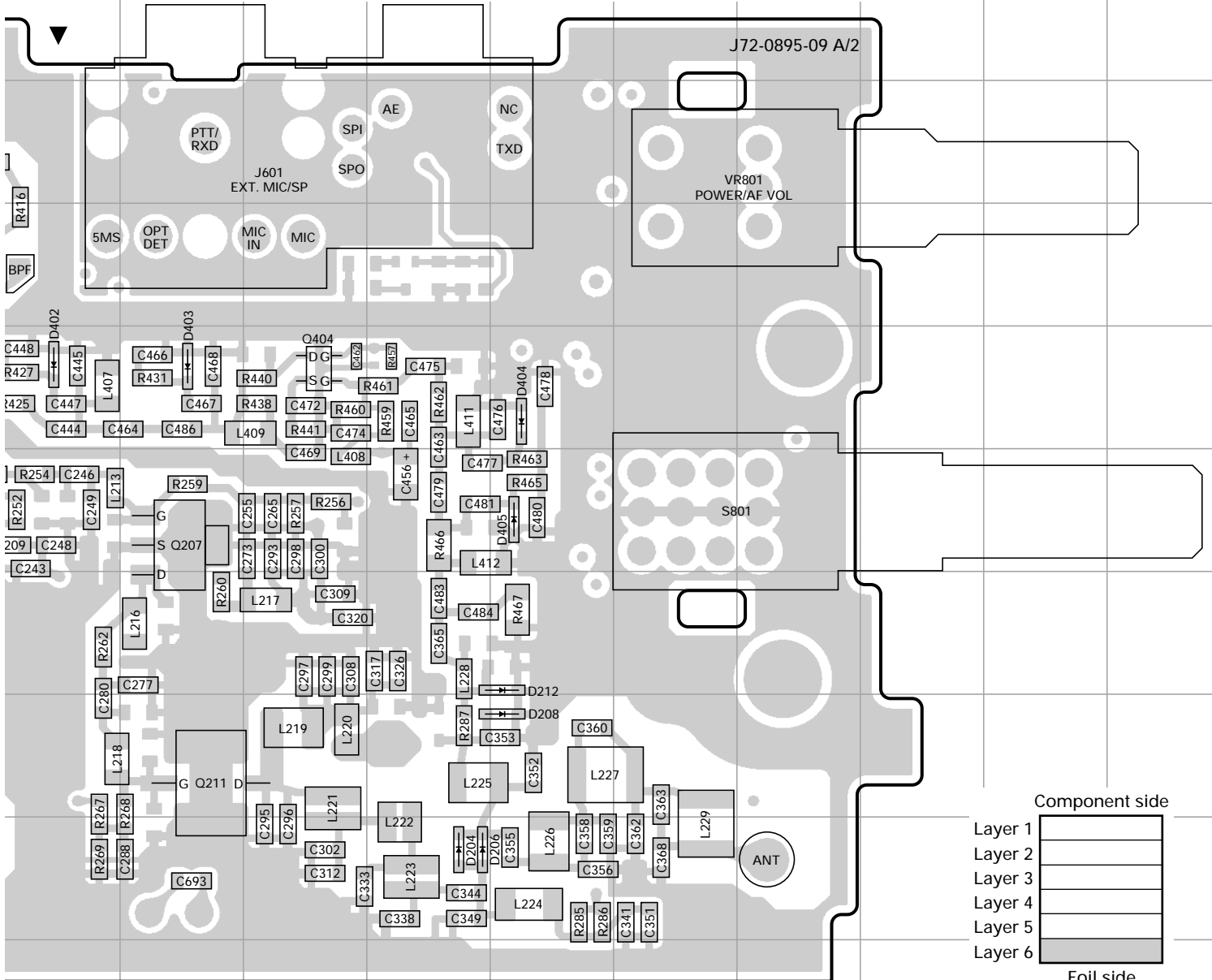

TX-RX UNIT (X57-6722-71)

Ref. NO.	Address
IC1	8D
IC401	4F
IC801	3D
Q4	5E
Q5	8I
Q6	8G
Q7	6F
Q8	8G
Q9	8H
Q10	7G
Q11	7H
Q12	7G
Q206	6I
Q207	6K
Q211	8K
Q401	3G

Ref. NO.	Address
Q402	4G
Q403	4I
Q404	5L
Q808	3C
D2	8E
D3	9H
D4	9I
D5	9G
D6	9I
D7	9G
D8	9G
D9	9I
D10	9I
D11	6F
D12	9G
D13	7G

Ref. NO.	Address
D14	6F
D201	7H
D204	9M
D206	9M
D208	8N
D212	7N
D401	6G
D402	5J
D403	5K
D404	5N
D405	6N
D801	3D

TX-RX UNIT (X57-6722-71)

Ref. NO.	Address
IC201	9G
IC601	4Q
IC602	6M
IC603	8M
IC604	6L
IC605	3L
IC802	8K
IC803	8K
IC804	9O
IC805	7Q
IC806	8R
Q1	7O
Q2	8O
Q3	8O
Q208	8H
Q209	7H
Q210	9G
Q212	9F
Q213	9H
Q400	9N
Q601	5M
Q602	2N
Q603	4M
Q604	3M
Q605	5J
Q606	4J
Q607	4M
Q608	4L
Q801	4G
Q802	6I
Q803	4F
Q804	3G
Q805	7D
Q806	6K
Q807	6J
Q809	3E
Q810	9R
D203	8H
D603	5M
D604	7K
D605	5K
D802	8C
D803	8C
D805	9E

TX-RX UNIT (X57-6722-71) Component side view (J72-0895-09)

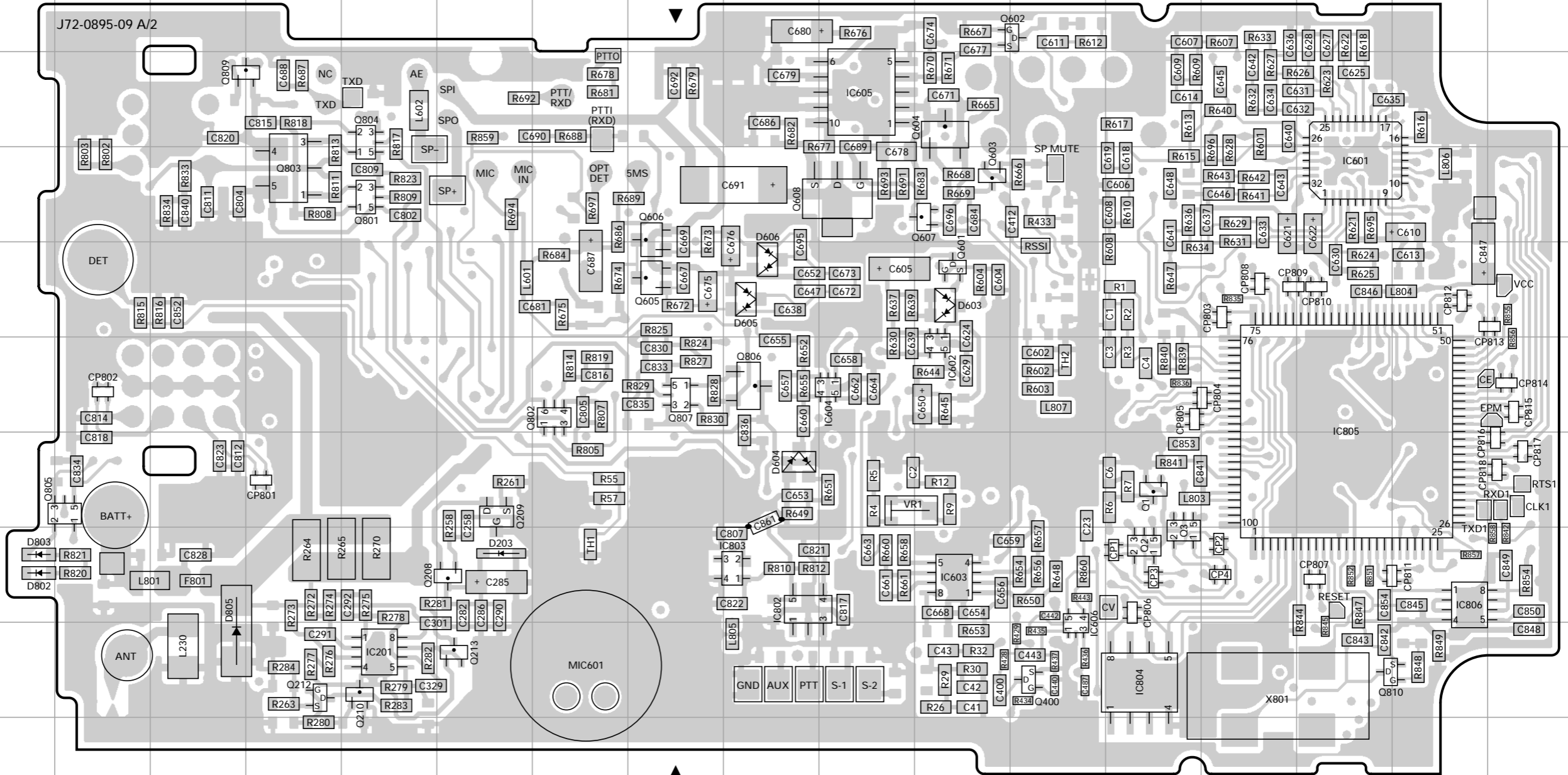

TX-RX UNIT (X57-6722-71) Component side view (J72-0895-09)

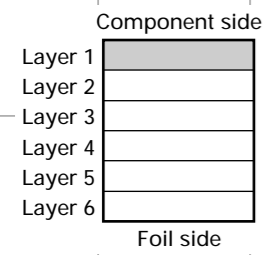
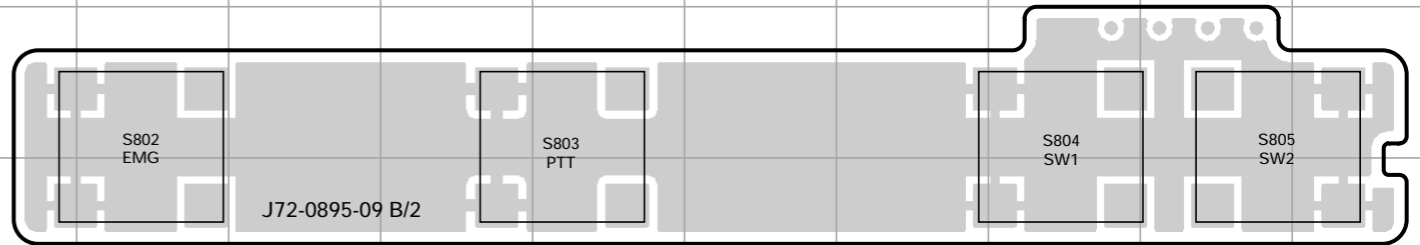

TX-RX UNIT (X57-6722-71) Foil side view (J72-0895-09)

TX-RX UNIT (X57-6722-71) Foil side view (J72-0895-09)

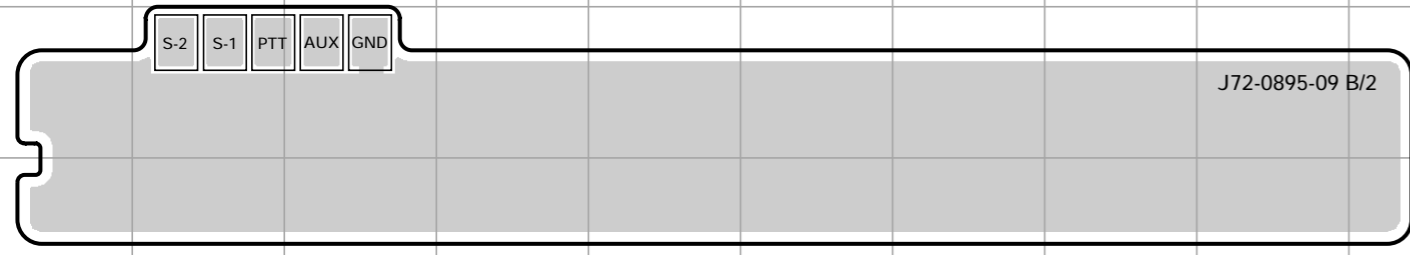
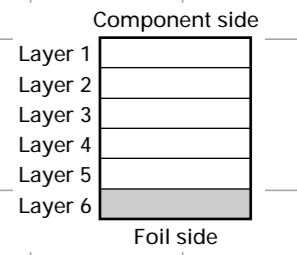
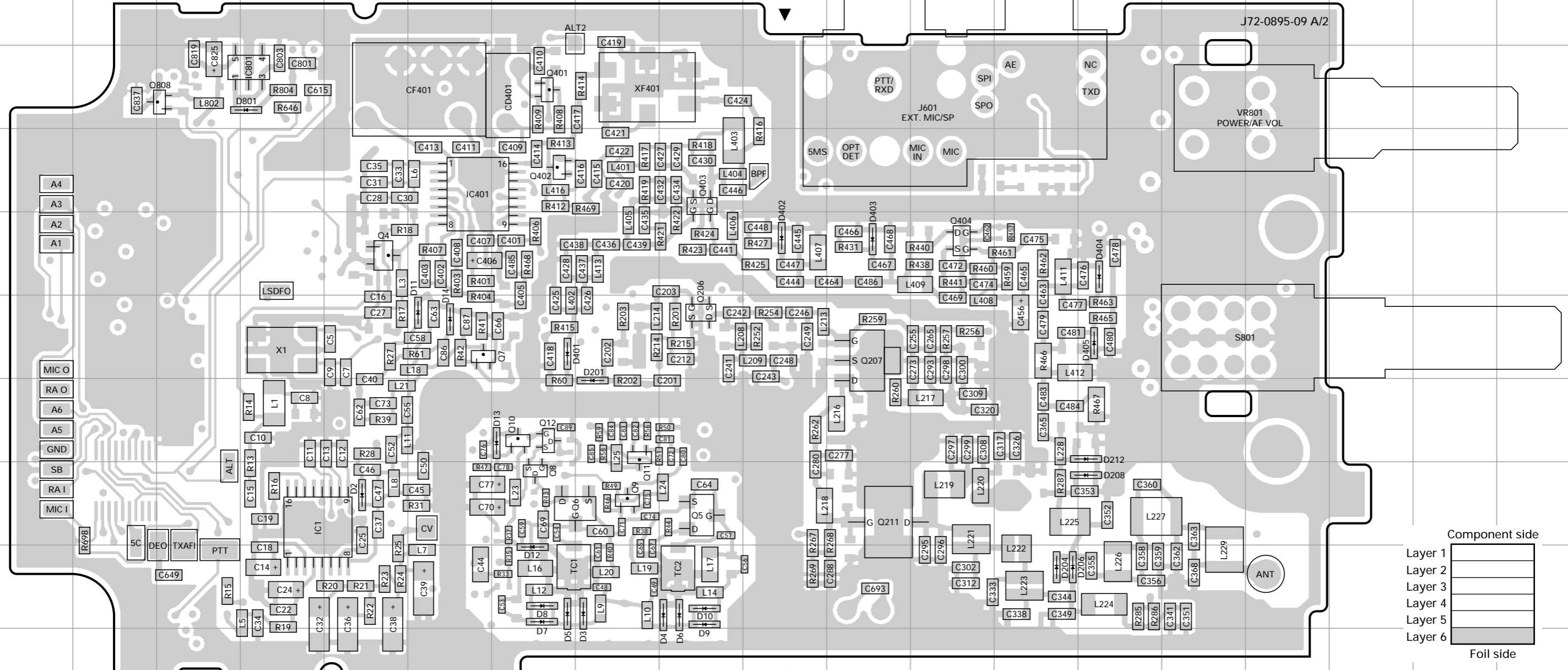

TX-RX UNIT (X57-6722-71)

Ref. NO.	Address	Ref. NO.	Address	Ref. NO.	Address
IC1	8D	Q402	4G	D14	6F
IC401	4F	Q403	4I	D201	7H
IC801	3D	Q404	5L	D204	9M
Q4	5E	Q808	3C	D206	9M
Q5	8I	D2	8E	D208	8N
Q6	8G	D3	9H	D212	7N
Q7	6F	D4	9I	D401	6G
Q8	8G	D5	9G	D402	5J
Q9	8H	D6	9I	D403	5K
Q10	7G	D7	9G	D404	5N
Q11	7H	D8	9G	D405	6N
Q12	7G	D9	9I	D801	3D
Q206	6I	D10	9I		
Q207	6K	D11	6F		
Q211	8K	D12	9G		
Q401	3G	D13	7G		

TK-2160 SCHEMATIC DIAGRAM

TX-RX UNIT (X57-6722-71)

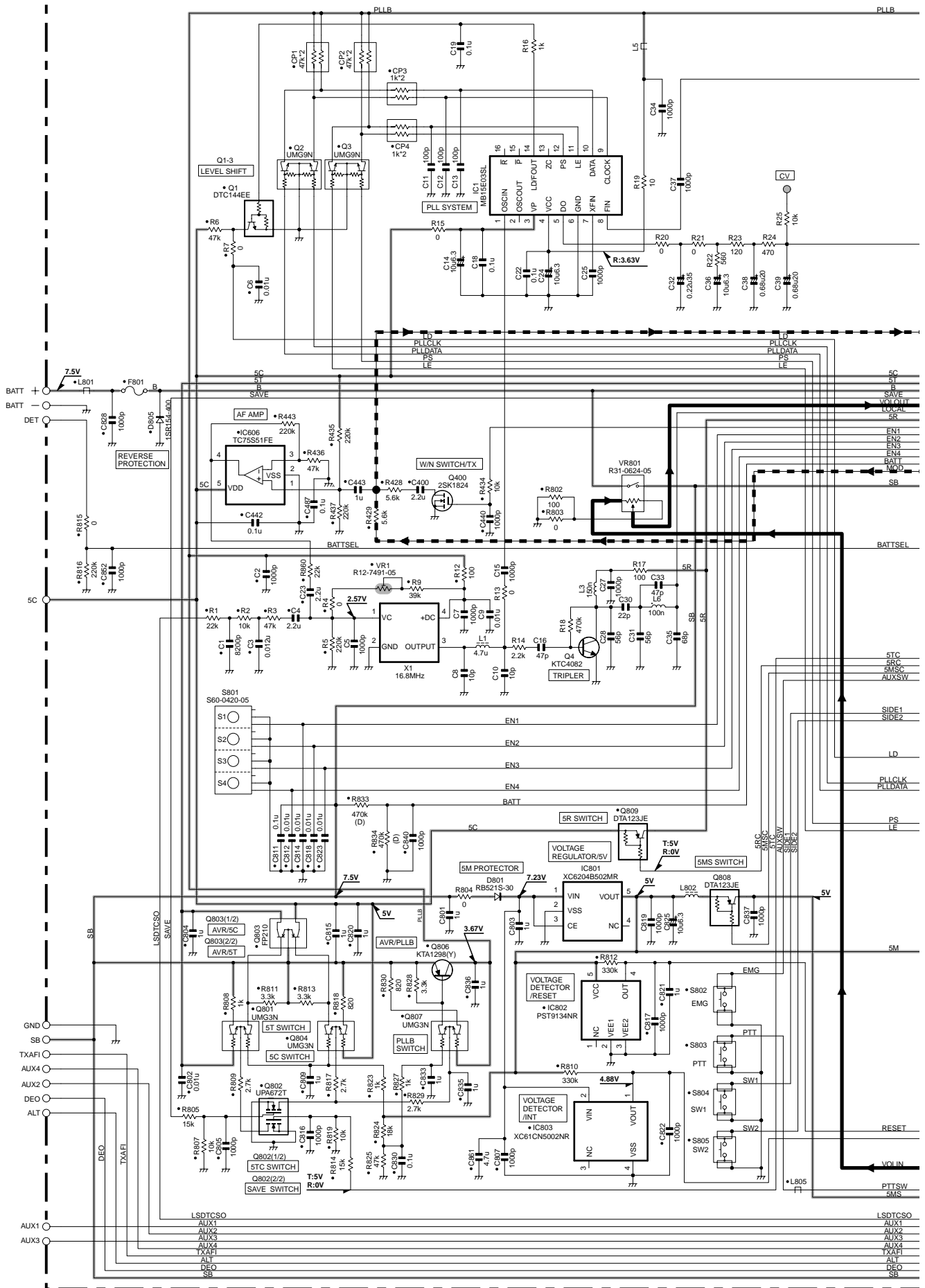

SCHEMATIC DIAGRAM TK-2160

TX-RX UNIT (X57-6722-71)

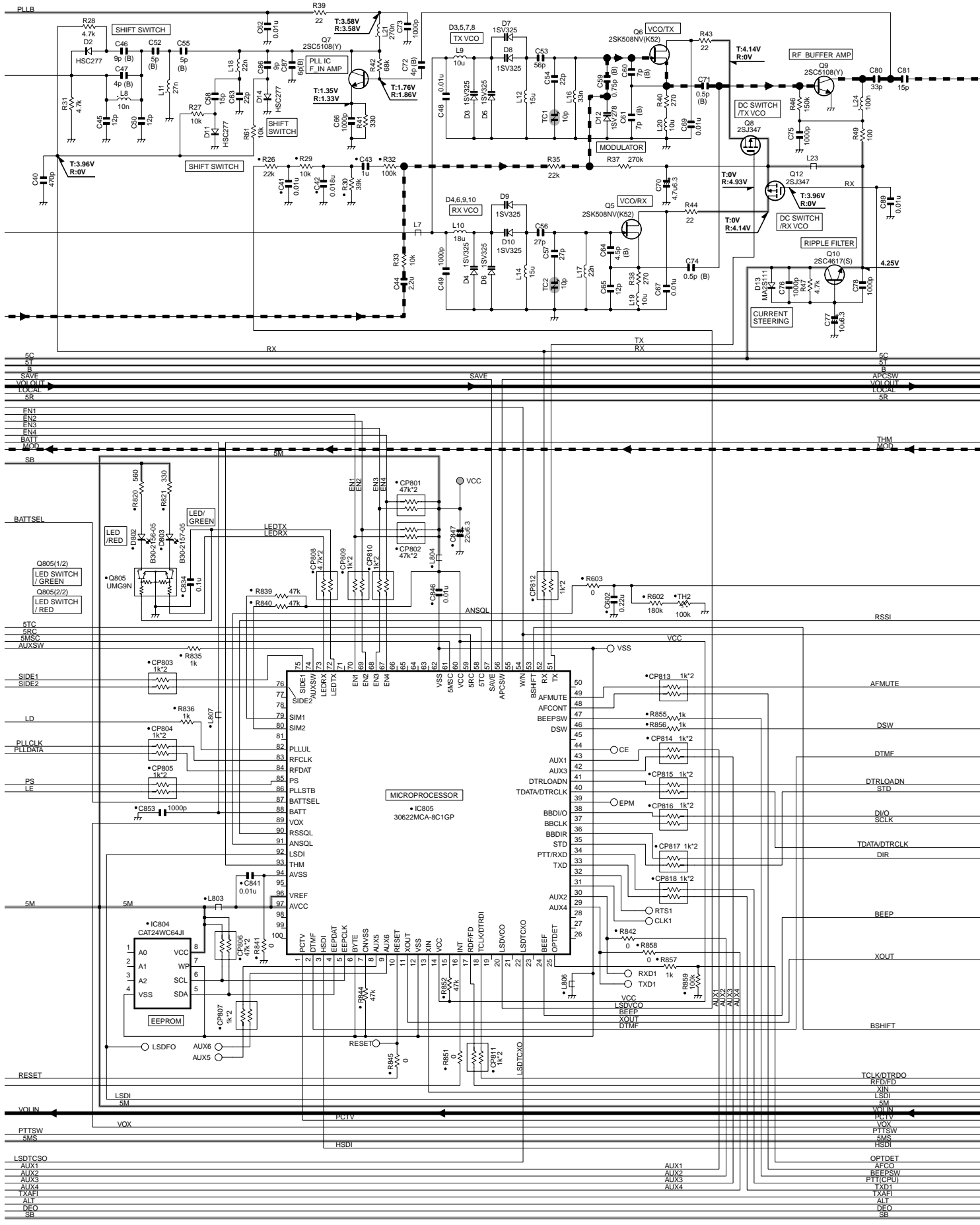

TK-2160 SCHEMATIC DIAGRAM

TX-RX UNIT (X57-6722-71)

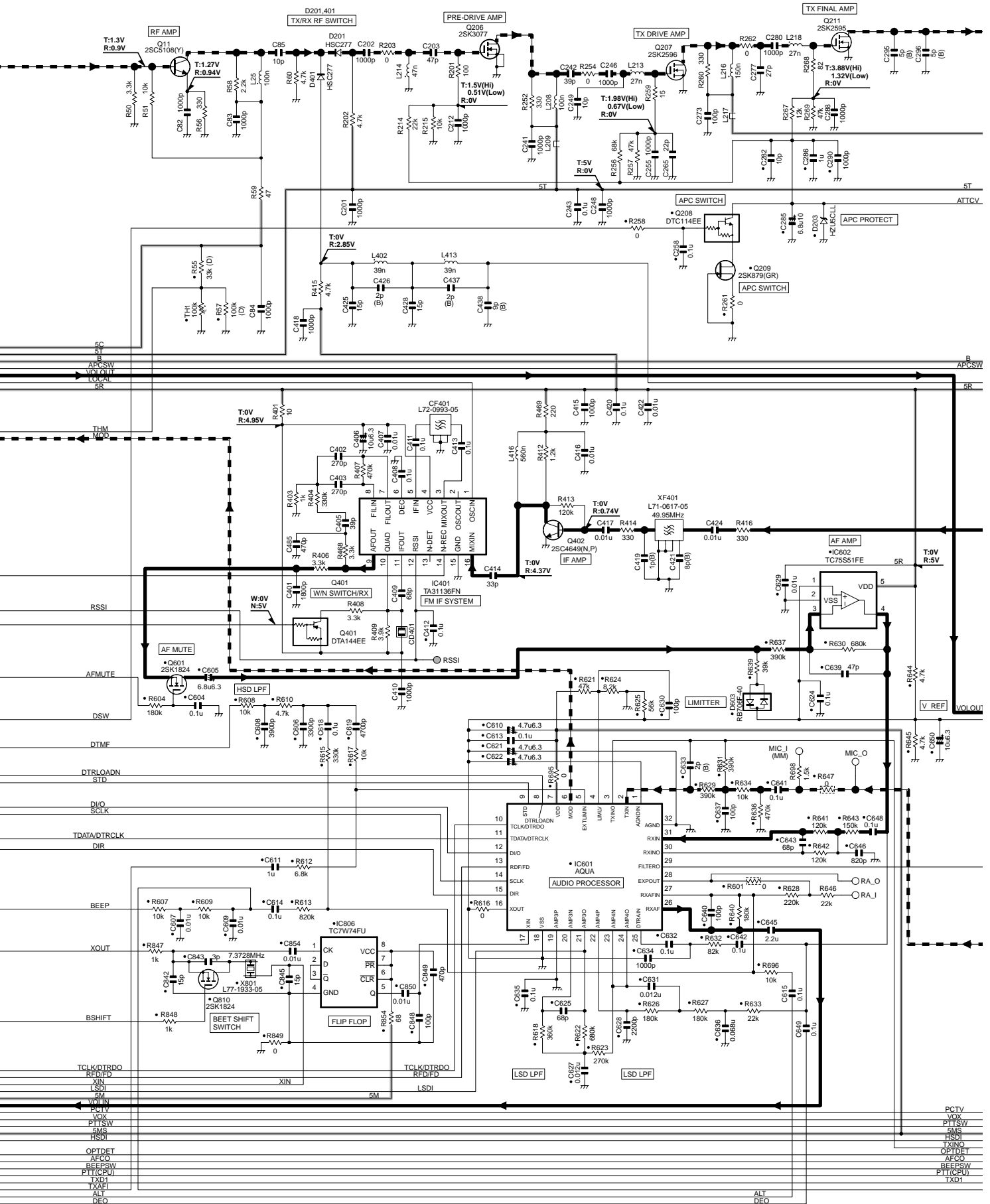

SCHEMATIC DIAGRAM TK-2160

TX-RX UNIT (X57-6722-71)

Note : The components marked with a dot (●) are parts of layer1.

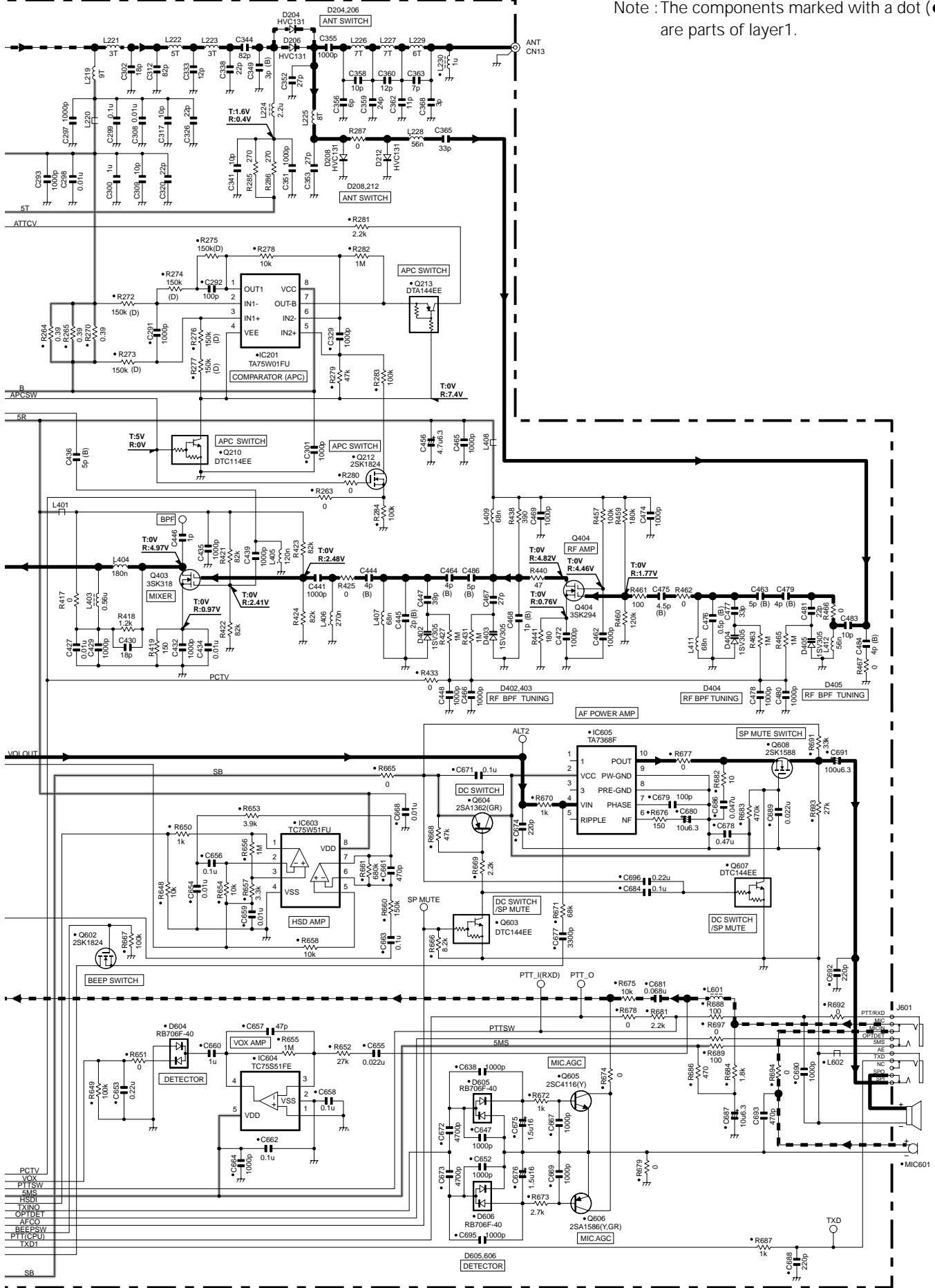

1
2
3
4
5
6
7

TK-2160 SCHEMATIC DIAGRAM

TX-RX UNIT (X57-6722-71)

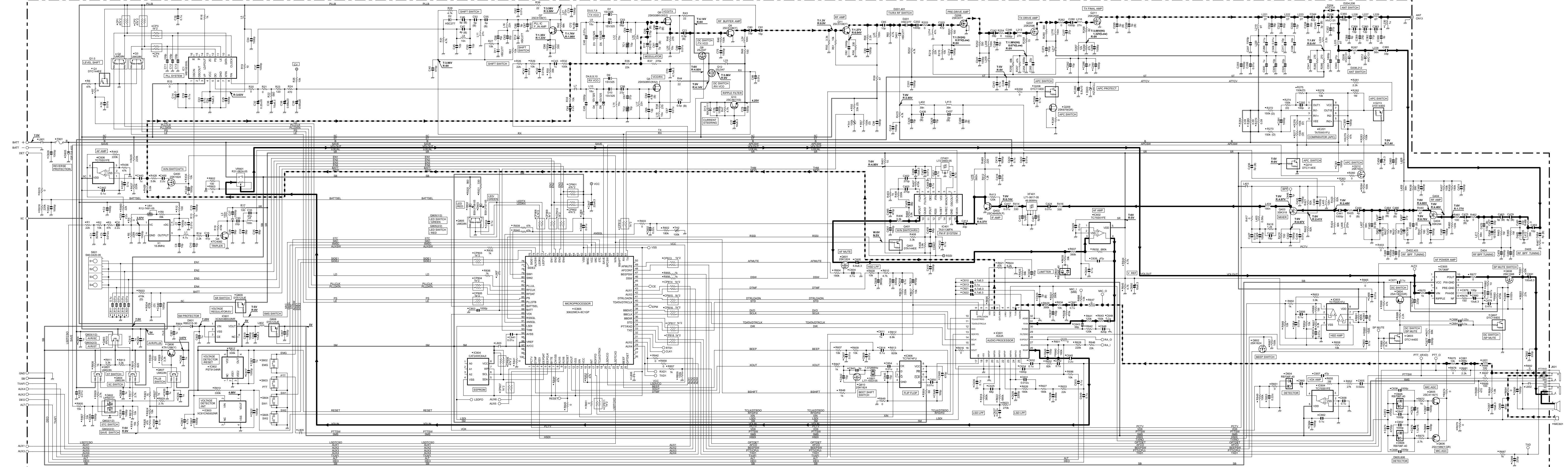

BLOCK DIAGRAM

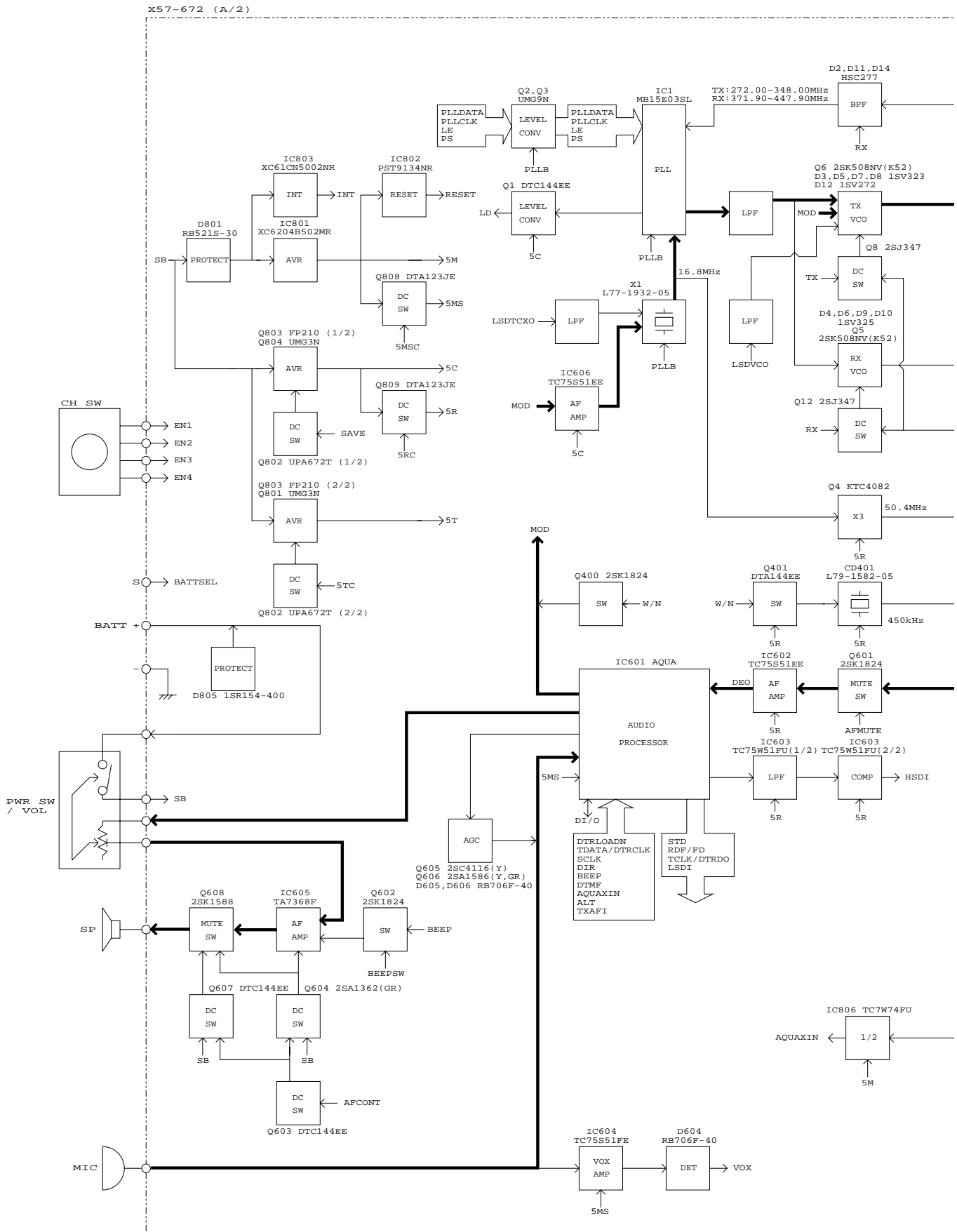

BLOCK DIAGRAM

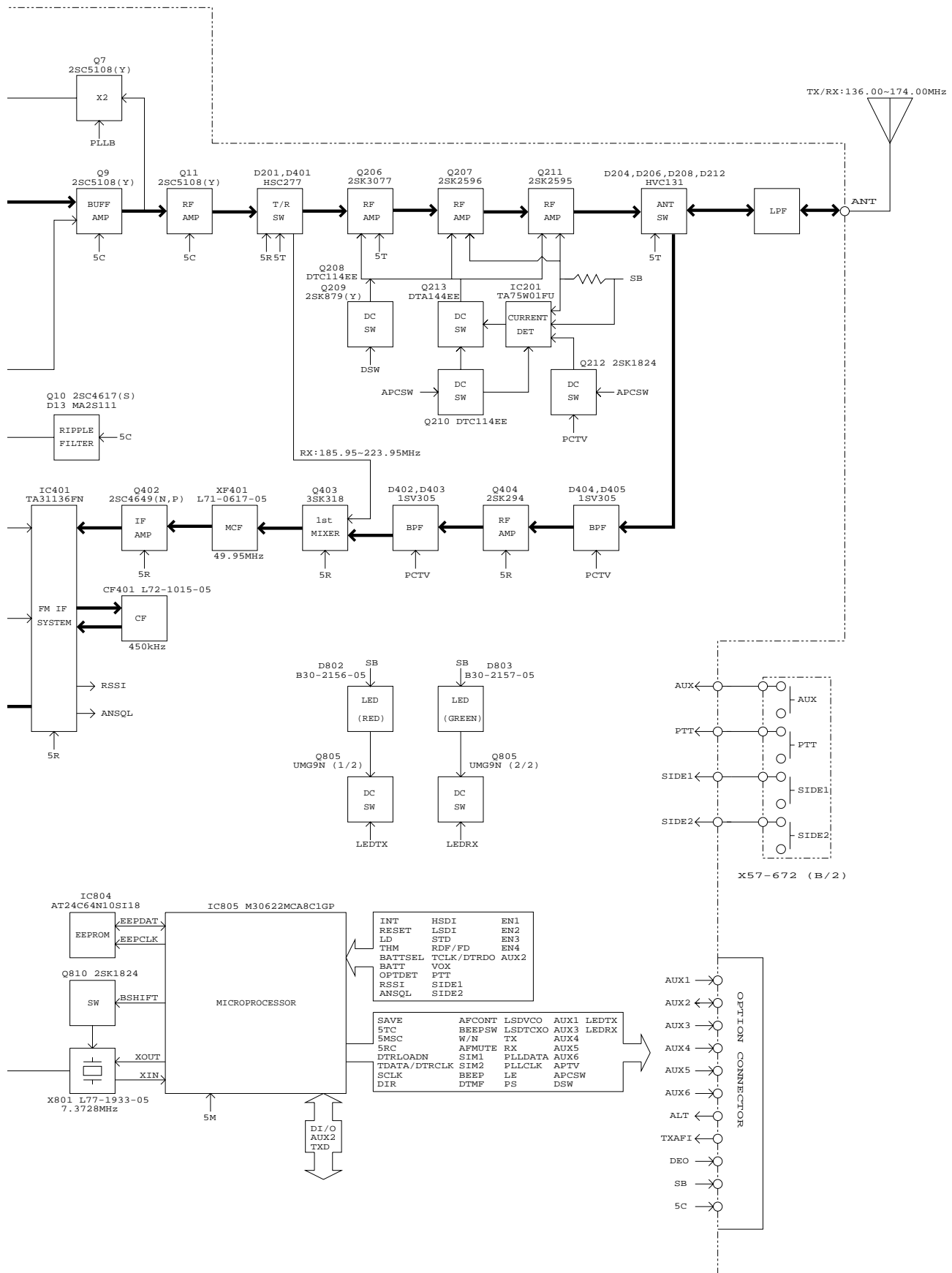

LEVEL DIAGRAM

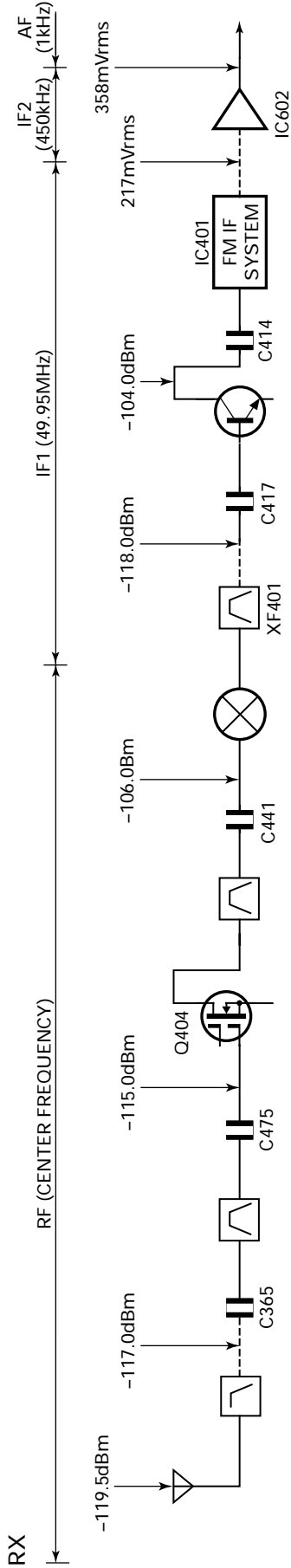

To make measurements in the AF section, connect the AC level meter. (ANT input : -53dBm, 1kHz FM, 3kHz DEV(WIDE).)

In the RF section, use a 100pF coupling capacitor. (The display shows the SSG input value required to obtain 12dB SINAD Without Local Level.)

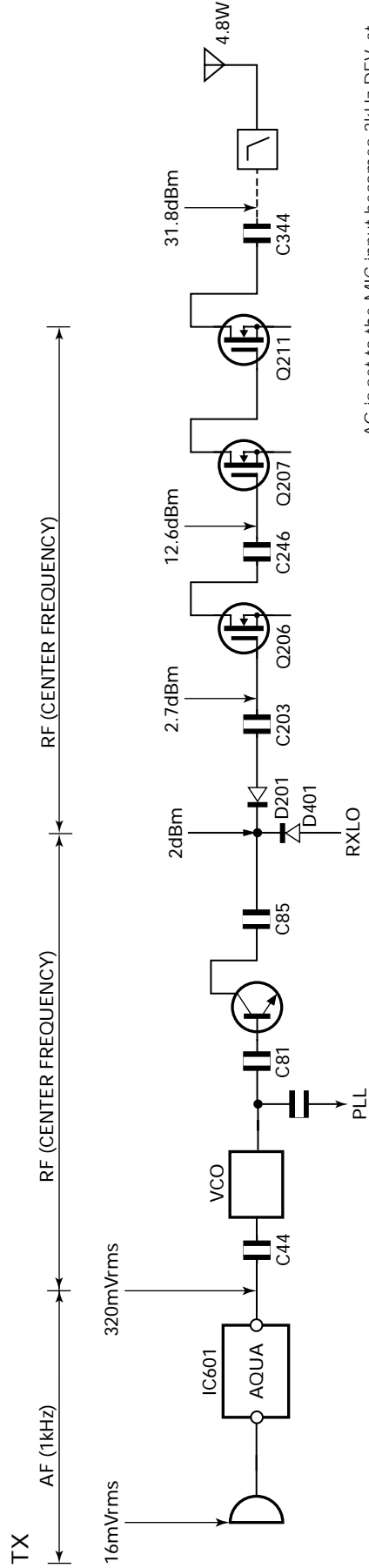
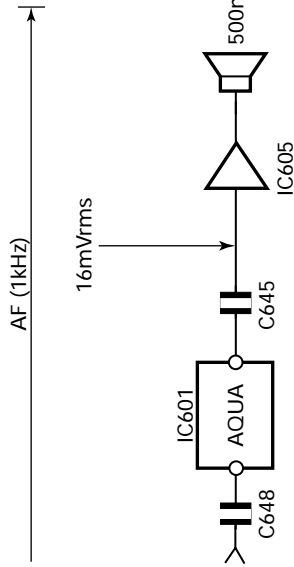

AG is set to the MIC input becomes 3kHz DEV. at 1kHz MOD. (WIDE)

To make measurements in the AF section, connect the AC level meter.

In the RF section, use a 100pF coupling capacitor.

KSC-30



Operating flow chart

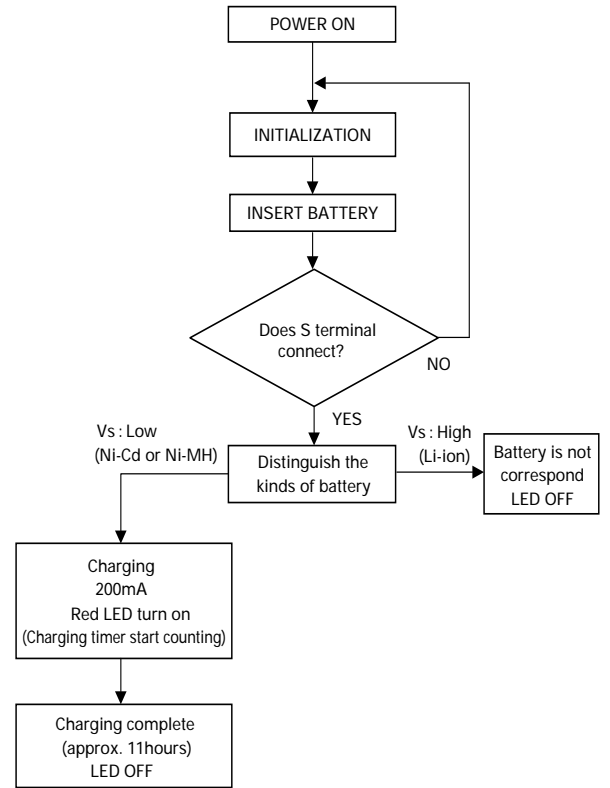

Ref. No.	Address	New parts	Parts No.	Description	Destination
KSC-30					
		*	A02-3656-08	CABINET BOTTOM	
		*	A02-3841-08	CABINET UPPER	
		*	B43-1151-08	BADGE	K,T E
		*	B62-1754-08	INSTRUCTION MANUAL	
		*	B62-1755-08	INSTRUCTION MANUAL	
		*	B72-2209-08	MODEL NAME PLATE	
		*	E03-0453-08	DC JACK	
			E23-1190-08	RELAY TERMINAL	
			G13-1547-08	CUSHION	
			N83-2610-45	PAN HEAD TAPTITE SCREW	
		*	W02-3671-08	ELECTRIC CIRCUIT MODULE	K T E
			W08-0479-05	AC ADAPTER 120V AC 60HZ	
			W08-0513-05	AC ADAPTER 230V AC 50HZ	
			W08-0558-15	AC ADAPTER 230V AC 50HZ	

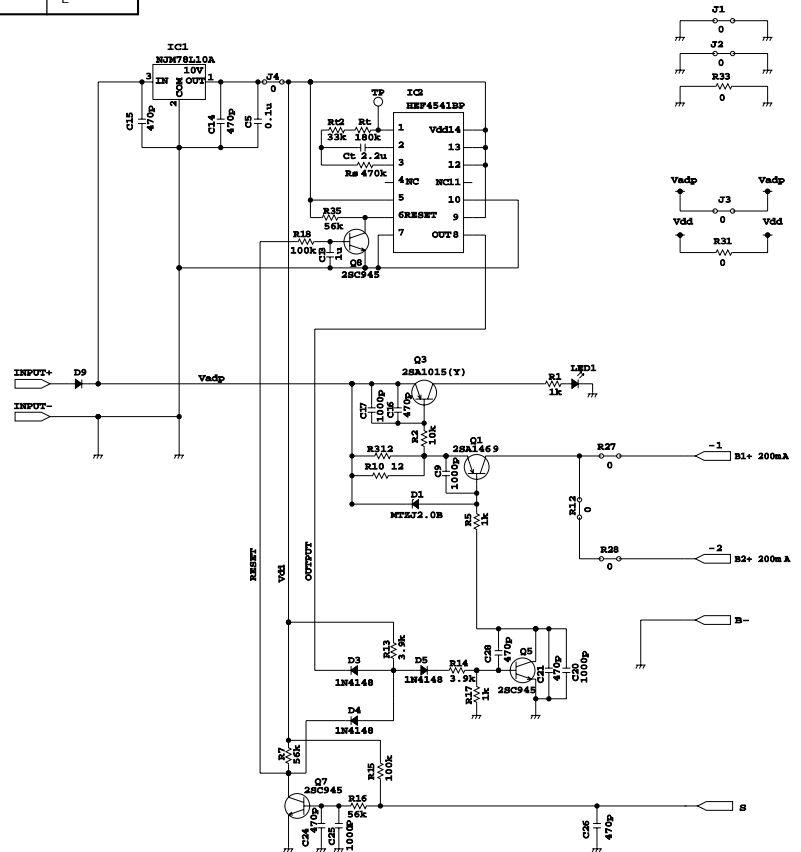

TK-2160

SPECIFICATIONS

E TYPE

General

Frequency Range	136~174MHz (E)
Number of channels	Max. 16
Number of groups	Max. 16
Channel Spacing	20kHz, 25kHz (Wide) 12.5kHz (Narrow)
PLL Channel Stepping	5kHz, 6.25kHz
Operating Voltage	7.5 VDC±20%
Battery Life	More than 9 hours at 5 watts (5-5-90 duty cycle with KNB-24L battery)
Operating Temperature range	-30°C to +60°C (-22 °F to +140 °F)
Dimensions and Weight	
With KNB-24L (1400mAh battery)	56 (2-3/16) W x 109.3 (4-5/16) H x 34.5 (1-3/8) D mm (in) 290g (0.64lbs)
With KNB-25A (1200mAh battery)	56 (2-3/16) W x 109.3 (4-5/16) H x 40.7 (1-5/8) D mm (in) 355g (0.78lbs)
With KNB-26N (2000mAh battery)	56 (2-3/16) W x 109.3 (4-5/16) H x 40.7 (1-5/8) D mm (in) 400g (0.88lbs)

Receiver (Measurements made per EIA standard EIA-603, EN300 086, EN300 113)

Sensitivity	
EIA 12dB SINAD	0.25µV (Wide)/0.32µV (Narrow)
EN 20dB SINAD	-4dBµV (Wide)/-3dBµV (Narrow)
Selectivity (Wide 5k/Wide 4k/Narrow)	70dB/70dB/62dB
Inter modulation	65dB
Spurious response	70dB
Audio Power Output	500mW/8Ω
Frequency Stability	±2.5ppm
Channel Frequency Spread	38MHz

Transmitter (Measurements made per EIA standard EIA-603, EN300 086, EN300 113)

RF Power Output	5W/1W
Spurious and Harmonics	-36dBm 1GHz, -30dBm > 1GHz
Modulation Limiting (Wide 5k/Wide 4k/Narrow)	±5.0kHz/±4.0kHz/±2.5kHz
FM Noise (EIA) (Wide 5k/Wide 4k/Narrow)	45dB/43dB/43dB
Audio Distortion	Less than 5%
Frequency Stability	±2.5ppm
Channel Frequency Spread	38MHz

KENWOOD CORPORATION

2967-3, Ishikawa-machi, Hachioji-shi, Tokyo 192-8525, Japan

KENWOOD U.S.A. CORPORATION

P.O. BOX 22745, 2201 East Dominguez Street, Long Beach, CA 90801-5745, U.S.A.

KENWOOD ELECTRONICS CANADA INC.

6070 Kestrel Road, Mississauga, Ontario, Canada L5T 1S8

KENWOOD ELECTRONICS DEUTSCHLAND GMBH

Rembrücker Str. 15, 63150 Heusenstamm, Germany

KENWOOD ELECTRONICS BELGIUM N.V.

Leuvensesteenweg 248 J, 1800 Vilvoorde, Belgium

KENWOOD ELECTRONICS FRANCE S.A.

13, Boulevard Ney, 75018 Paris, France

KENWOOD ELECTRONICS U.K. LIMITED

KENWOOD House, Dwight Road, Watford, Herts., WD18 9EB, United Kingdom

KENWOOD ELECTRONICS EUROPE B.V.

Amsterdamseweg 37, 1422 AC Uithoorn, The Netherlands

KENWOOD ELECTRONICS ITALIA S.p.A.

Via G. Sirtori, 7/9 20129 Milano, Italy

KENWOOD IBERICA S.A.

Bolivia, 239-08020 Barcelona, Spain

KENWOOD ELECTRONICS AUSTRALIA PTY. LTD.

(A.C.N. 001 499 074)

16 Giffnock Avenue, Centrecourt Estate, North Ryde, N.S.W. 2113, Australia

KENWOOD ELECTRONICS (HONG KONG) LTD.

Unit 3712-3724, Level 37, Tower one Metroplaza, 223 Hing Fong Road, Kwai Fong, N.T., Hong Kong

KENWOOD ELECTRONICS SINGAPORE PTE LTD.

1 Genting Lane #07-00 Kenwood Building, Singapore 349544

