

KENWOOD

INSTRUCTION MANUAL
MODE D'EMPLOI
MANUAL DE INSTRUCCIONES
MANUALE DI ISTRUZIONI
BEDIENUNGSANLEITUNG
GEBRUIKSAANWIJZING



TK-2160/ TK-3160

VHF FM TRANSCEIVER/
UHF FM TRANSCEIVER

ÉMETTEUR-RÉCEPTEUR FM VHF/
ÉMETTEUR-RÉCEPTEUR FM UHF

TRANSCEPTOR DE FM VHF/
TRANSCEPTOR DE FM UHF

RICETRASMETTITORE FM VHF/
RICETRASMETTITORE FM UHF

VHF-FM-TRANSCEIVER/
UHF-FM-TRANSCEIVER

VHF FM ZENDONTVANGER/
UHF FM ZENDONTVANGER

KENWOOD CORPORATION

© B62-1788-00 (E, E3)
09 08 07 06 05 04 03 02 01 00

TK-2160/ TK-3160

VHF FM TRANSCEIVER/
UHF FM TRANSCEIVER
INSTRUCTION MANUAL

ENGLISH

THANK YOU

We are grateful you chose **KENWOOD** for your land mobile radio applications. We believe this easy-to-use transceiver will provide dependable communications to keep personnel operating at peak efficiency.

KENWOOD transceivers incorporate the latest in advanced technology. As a result, we feel strongly that you will be pleased with the quality and features of this product.

MODELS COVERED BY THIS MANUAL

- **TK-2160:** VHF FM Transceiver
- **TK-3160:** UHF FM Transceiver

NOTICES TO THE USER

- ◆ Government law prohibits the operation of unlicensed radio transmitters within the territories under government control.
- ◆ Illegal operation is punishable by fine or imprisonment or both.
- ◆ Refer service to qualified technicians only.

Safety: It is important that the operator is aware of and understands hazards common to the operation of any transceiver.



EXPLOSIVE ATMOSPHERES (GASES, DUST, FUMES, etc.)

Turn off your transceiver while taking on fuel, or while parked in gasoline service stations.

PRECAUTIONS

Observe the following precautions to prevent fire, personal injury, and transceiver damage.

- Do not modify this transceiver for any reason.
- Do not expose the transceiver to long periods of direct sunlight, nor place it close to heating appliances.
- Do not place the transceiver in excessively dusty, humid, and/or wet areas, nor on unstable surfaces.
- If an abnormal odor or smoke is detected coming from the transceiver, switch OFF the power immediately and remove the optional battery pack from the transceiver. Contact your **KENWOOD** dealer.

CONTENTS

UNPACKING AND CHECKING EQUIPMENT	1
SUPPLIED ACCESSORIES	1
PREPARATION	2
BATTERY PACK PRECAUTIONS	2
INSTALLING/ REMOVING THE (OPTIONAL) RECHARGEABLE BATTERY PACK OR ALKALINE BATTERY CASE	7
INSTALLING/ REMOVING ALKALINE BATTERIES	8
INSTALLING THE (OPTIONAL) ANTENNA	9
INSTALLING THE BELT CLIP	9
INSTALLING THE COVER OVER THE SPEAKER/ MICROPHONE JACKS	10
INSTALLING THE (OPTIONAL) SPEAKER/ MICROPHONE	10
GETTING ACQUAINTED	11
PROGRAMMABLE AUXILIARY FUNCTIONS	14
OPERATING BASICS	15
SWITCHING POWER ON/ OFF	15
ADJUSTING THE VOLUME	15
SELECTING A CHANNEL	15
MAKING A CALL	16
RECEIVING A CALL	16
SCAN	17
PRIORITY SCAN	17
CHANNEL LOCKOUT	18
REVERT CHANNEL	18
5-TONE SIGNALLING	19
RECEIVING	19
TRANSMITTING	19

(CONTENTS CONTINUED...)

DTMF SIGNALLING	20
FleetSync OPERATION	21
CALL TYPES	21
QUIET TALK (QT)/ DIGITAL QUIET TALK (DQT)	22
SCRAMBLER	23
VOX OPERATION	24
EMERGENCY CALLS	26
ADVANCED OPERATIONS	27
SELECTING AN OUTPUT POWER	27
MONITOR/ SQUELCH OFF	27
BACKGROUND OPERATIONS	28
TIME-OUT TIMER (TOT)	28
BATTERY SAVE	28
LOW BATTERY WARNING	29
BUSY CHANNEL LOCKOUT (BCL)	29
STUN	29
BEGINNING/ END OF TRANSMISSION (TX) SIGNAL	29

UNPACKING AND CHECKING EQUIPMENT

Note: The following unpacking instructions are for use by your **KENWOOD** dealer, an authorized **KENWOOD** service facility, or the factory.

Carefully unpack the transceiver. We recommend that you identify the items listed in the following table before discarding the packing material. If any items are missing or have been damaged during shipment, file a claim with the carrier immediately.

SUPPLIED ACCESSORIES

Item	Part number	Quantity
Belt clip	J29-0701-XX	1
Speaker/ microphone locking bracket	J21-8464-XX	1
Speaker/ microphone jacks cap	B09-0676-XX	1
Binding machine screw	N35-3004-XX	1
Instruction manual	B62-1788-XX	1

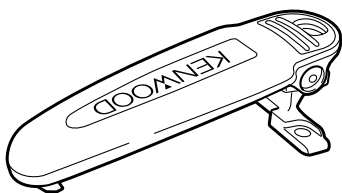

Belt clip

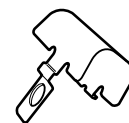

Speaker/ microphone locking bracket

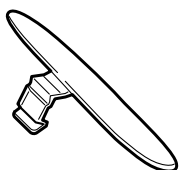

Speaker/ microphone jacks cap



Binding machine screw

PREPARATION

BATTERY PACK PRECAUTIONS



CAUTION

- ◆ Do not recharge the battery pack if it is already fully charged. Doing so may cause the life of the battery pack to shorten or the battery pack may be damaged.
- ◆ After recharging the battery pack, disconnect it from the charger. If the charger power is reset (turned ON after being turned OFF), recharging will start again and the battery pack will become overcharged.
- ◆ Do not use the transceiver while charging the battery pack. We recommend you switch the transceiver power OFF while charging is taking place.
- ◆ Do not short the battery terminals or dispose of the battery by fire.
- ◆ Never attempt to remove the casing from the battery pack.

Information concerning the (optional) Li-ion battery pack:

The battery pack includes flammable objects such as organic solvent. Mishandling may cause the battery to rupture producing flames or extreme heat, deteriorate, or cause other forms of damage to the battery. Please observe the following prohibitive matters.



DANGER

- **Do not disassemble or reconstruct battery!**
The battery pack has a safety function and protection circuit to avoid danger. If they suffer serious damage, the battery may generate heat or smoke, rupture, or burst into flame.
- **Do not short-circuit the battery!**
Do not join the + and – terminals using any form of metal (such as a paper clip or wire). Do not carry or store the battery pack in containers holding metal objects (such as wires, chain-necklace or hairpins). If the battery pack is short-circuited, excessive current will flow and the battery may generate heat or smoke, rupture, or burst into flame. It will also cause metal objects to heat up.

- **Do not incinerate or apply heat to the battery!**

If the insulator is melted, the gas release vent or safety function is damaged, or the electrolyte is ignited, the battery may generate heat or smoke, rupture, or burst into flame.

- **Do not use or leave the battery near fires, stoves, or other heat generators (areas reaching over 80°C/ 176°F)!**

If the polymer separator is melted due to high temperature, an internal short-circuit may occur in the individual cells and the battery may generate heat or smoke, rupture, or burst into flame.

- **Do not immerse the battery in water or get it wet by other means!**

If the battery's protection circuit is damaged, the battery may charge at extreme current (or voltage) and an abnormal chemical reaction may occur. The battery may generate heat or smoke, rupture, or burst into flame.

- **Do not charge the battery near fires or under direct sunlight!**

If the battery's protection circuit is damaged, the battery may charge at extreme current (or voltage) and an abnormal chemical reaction may occur. The battery may generate heat or smoke, rupture, or burst into flame.

- **Use only the specified charger and observe charging requirements!**

If the battery is charged in unspecified conditions (under high temperature over the regulated value, excessive high voltage or current over regulated value, or with a remodelled charger), it may overcharge or an abnormal chemical reaction may occur. The battery may generate heat or smoke, rupture, or burst into flame.

- **Do not pierce the battery with any object, strike it with an instrument, or step on it!**

This may break or deform the battery, causing a short-circuited. The battery may generate heat or smoke, rupture, or burst into flame.

- **Do not jar or throw the battery!**

An impact may cause the battery to leak, generate heat or smoke, rupture, and/or burst into flame. If the battery's protection circuit is damaged, the battery may charge at an abnormal current (or voltage), and an abnormal chemical reaction may occur. The battery may generate heat or smoke, rupture, or burst into flame.

- **Do not use the battery pack if it is damaged in any way!**
The battery may generate heat or smoke, rupture, or burst into flame.
- **Do not solder directly onto the battery!**
If the insulator is melted or the gas release vent or safety function is damaged, the battery may generate heat or smoke, rupture, or burst into flame.
- **Do not reverse the battery polarity (and terminals)!**
When charging a reversed battery, an abnormal chemical reaction may occur. In some cases, an unexpected large amount of current may flow upon discharging. The battery may generate heat or smoke, rupture, or burst into flame.
- **Do not reverse-charge or reverse-connect the battery!**
The battery pack has positive and negative poles. If the battery pack does not smoothly connect with a charger or operating equipment, do not force it; check the polarity of the battery. If the battery pack is reverse-connected to the charger, it will be reverse-charged and an abnormal chemical reaction may occur. The battery may generate heat or smoke, rupture, or burst into flame.
- **Do not touch a ruptured and leaking battery!**
If the electrolyte liquid from the battery gets into your eyes, wash your eyes out with fresh water as soon as possible, without rubbing your eyes. Go to the hospital immediately. If left untreated, it may cause eye-problems.



WARNING

- **Do not charge the battery for longer than the specified time!**
If the battery pack has not finished charging even after the regulated time has passed, stop it. The battery may generate heat or smoke, rupture, or burst into flame.
- **Do not place the battery pack into a microwave or high pressure container!**
The battery may generate heat or smoke, rupture, or burst into flame.
- **Keep ruptured and leaking battery packs away from fire!**
If the battery pack is leaking (or the battery emits a bad odor), immediately remove it from flammable areas. Electrolyte leaking from battery can easily catch on fire and may cause the battery to generate smoke or burst into flame.
- **Do not use an abnormal battery!**
If the battery pack emits a bad odor, appears to have different coloring, is deformed, or seems abnormal for any other reason, remove it from the charger or operating equipment and do not use it. The battery may generate heat or smoke, rupture, or burst into flame.

■ **Using the Li-ion Battery Pack**

- Charge the battery pack before using it.
- To keep the battery discharge at a minimum, remove the battery pack from the equipment when it is not in use. Store the battery pack in a cool and dry location.
- When storing the battery pack for a long period:
 - 1 Remove the battery pack from the equipment.
 - 2 Discharge the battery pack, if possible.
 - 3 Store the battery pack in a cool (below 25°C/ 77°F) and dry location.

■ Characteristics of the Li-ion Battery Pack

- As the battery pack is charged and discharged repeatedly, the battery capacity decreases.
- Even if the battery pack is unused, the battery pack degrades.
- It takes a longer time to charge the battery pack in cooler areas.
- The life of battery pack is shortened when it is charged and discharged in hotter areas. When the battery pack is stored in a hot location, the battery pack degrades quicker. Do not leave the battery pack in vehicles or near heating appliances.
- When the battery pack operating time becomes short, even if it is fully charged, replace the battery pack. Continuing to charge and discharge the battery pack may result in electrolyte leakage.

■ Charging the Li-ion Battery Pack

When charging a transceiver with a KNB-24L battery pack, the safety catch of the battery pack may stick out past the battery. When inserting the transceiver with the battery pack into the charger, the safety catch will touch the metal contacts of the charger and the charger LED will momentarily light red. Be sure to push the transceiver fully into the battery pack slot so the safety catch no longer touches the charger terminals. Once in place, the battery pack will begin charging.

For charging procedures, refer to the KSC-25 Instruction Manual.

INSTALLING/ REMOVING THE (OPTIONAL) RECHARGEABLE BATTERY PACK OR ALKALINE BATTERY CASE

1 Match the guides of the battery pack with the corresponding grooves on the upper rear of the transceiver, then firmly press the battery pack to lock it in place.

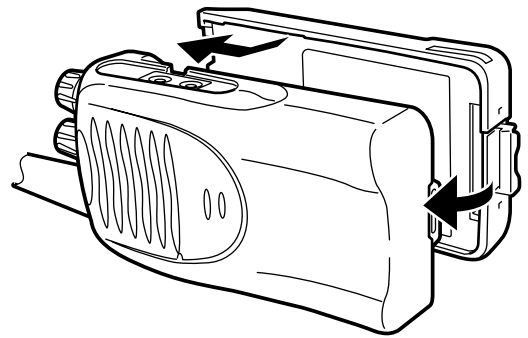

2 Flip the safety catch into place to prevent accidentally pressing the release latch and removing the battery.

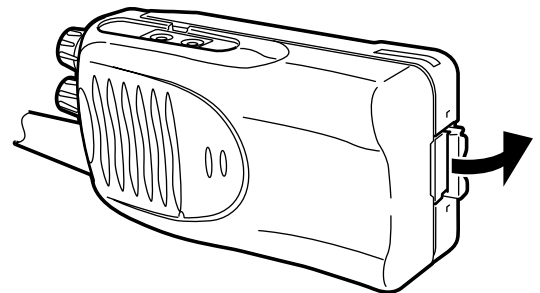

3 To remove the battery pack, lift the safety catch, press the release latch, then pull the battery pack away from the transceiver.

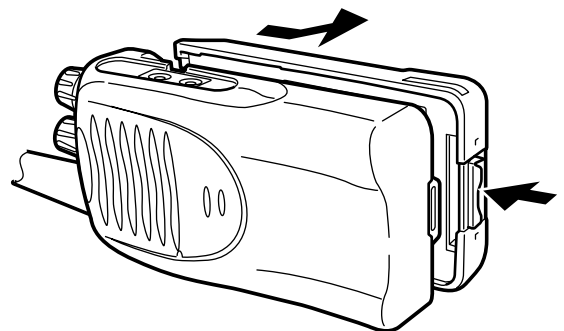

Note:

- ◆ To lift the battery pack safety catch, use a piece of hardened plastic or metal, such as a screwdriver, that is no more than 6 mm wide and 1 mm thick. It is imperative that you place the implement under only the lip of the safety catch so that you do not damage the release latch.
 - ◆ Before charging a battery pack that is attached to the transceiver, ensure that the safety catch is firmly closed.
 - ◆ While operating the transceiver using a Li-ion or Ni-MH battery pack in areas with an ambient temperature of -10°C / $+14^{\circ}\text{F}$ and lower, operating time may be shortened.
-

INSTALLING/ REMOVING ALKALINE BATTERIES



WARNING

- ◆ Do not install batteries in a hazardous environment where sparks could cause an explosion.
- ◆ Never discard old batteries in fire; extremely high temperatures can cause batteries to explode.
- ◆ Do not short circuit the battery case terminals.
- ◆ Do not use commercially available rechargeable batteries.

Note:

- ◆ If you do not plan to use the transceiver for a long period, remove the batteries from the battery case.
- ◆ This battery case has been designed for transmitting at a power of approximately 1 W (the low power setting on your transceiver). If you want to transmit a stronger signal (using the high power setting on your transceiver), use an optional rechargeable battery pack.

1 To open the battery case, press on the 2 tabs on the upper rear of the case then pull the 2 halves apart.

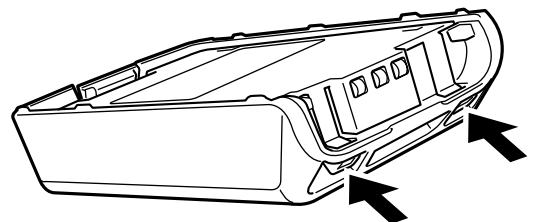

2 Insert 6 AA (LR 6) alkaline batteries into the battery case.

- Be sure to match the polarities with those marked in the bottom of the battery case.

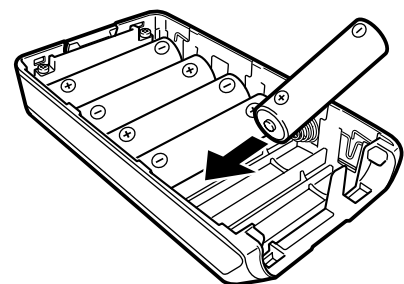

3 Align the tabs of the cover with the base, then push down on the cover until it locks in place.

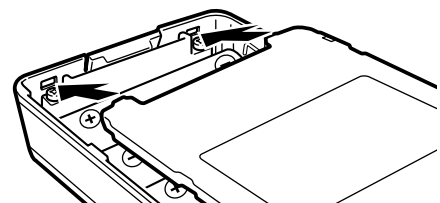

INSTALLING THE (OPTIONAL) ANTENNA

Screw the antenna into the connector on the top of the transceiver by holding the antenna at its base and turning it clockwise until secure.

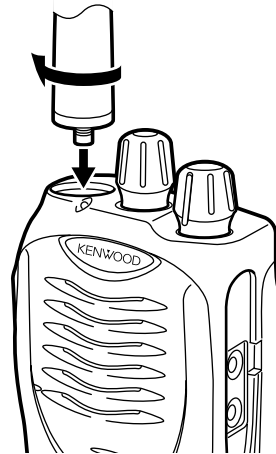

INSTALLING THE BELT CLIP

Note: When installing the belt clip, you must remove the battery pack from the rear of the transceiver.

- 1 Remove the 2 screws from the rear of the transceiver, then remove the small, plastic black covering that was held in place.
- 2 Insert the belt clip mount into the space on the rear of the transceiver.
- 3 Using the 2 screws, affix the belt clip in place.

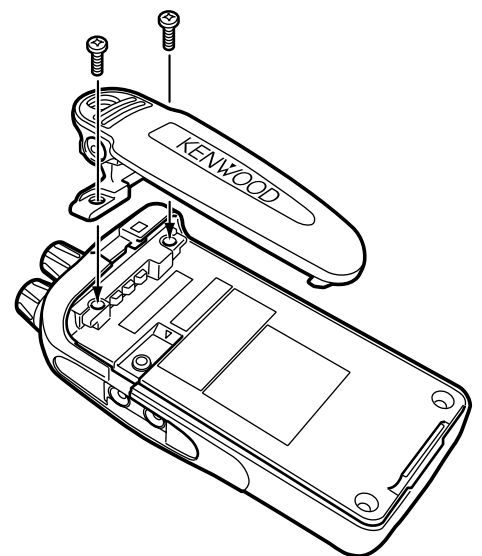
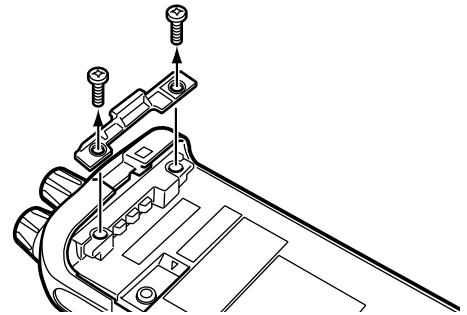

Note: Do not dispose of the plastic black covering! If you remove the belt clip, replace the covering into the space on the rear of the transceiver. Either this covering or the belt clip must be in place, otherwise the battery pack may not remain installed properly.

INSTALLING THE COVER OVER THE SPEAKER/ MICROPHONE JACKS

Note: When installing the speaker/ microphone jack cover, you must remove the battery pack from the rear of the transceiver.

If you are not using a speaker/ microphone, install the cover over the speaker/ microphone jacks by sliding the cover's tab into the slot on the side of the transceiver until it snaps in place.

Note: To keep the transceiver water resistant, you must cover the speaker/ microphone jacks with the supplied cover.

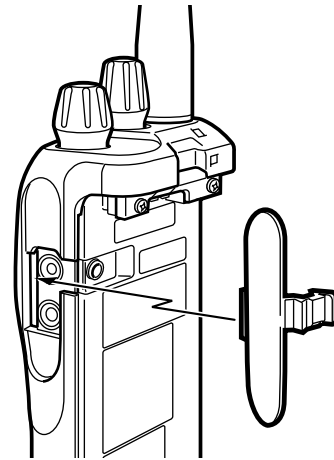

INSTALLING THE (OPTIONAL) SPEAKER/ MICROPHONE

Note: When installing the optional speaker/ microphone and its locking bracket, you must remove the battery pack from the rear of the transceiver.

- 1 Insert the speaker/ microphone plugs into the speaker/ microphone jacks.
- 2 Attach the locking bracket using the supplied screw.

Note: To lift the locking bracket after it has been installed, use a piece of hardened plastic or metal, such as a small screwdriver. Lift the bracket by its tab, beside the screwhole, taking care not to damage the bracket.

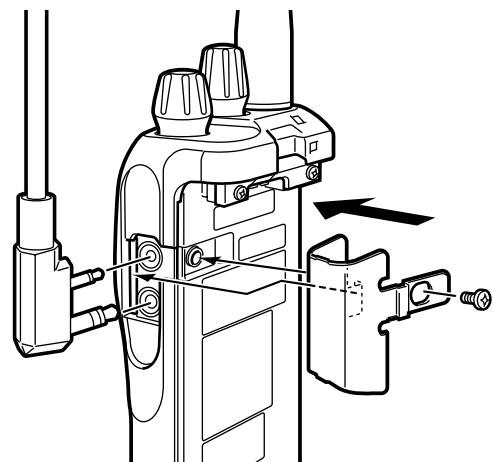

GETTING ACQUAINTED

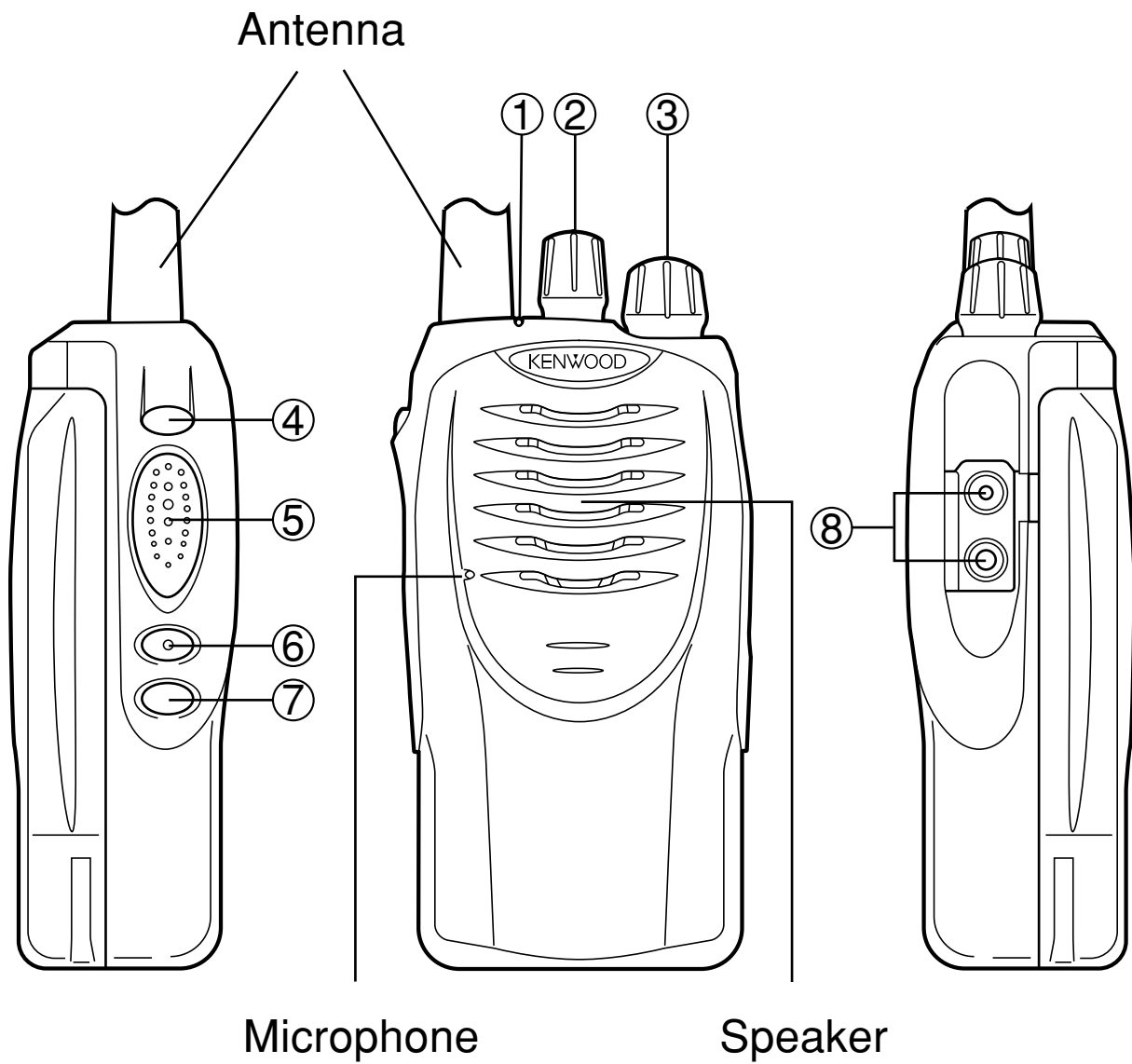

① LED indicator

LED Color	Continuously Lit	Flashing
Red	While transmitting	Battery power low
Green	While receiving	While scanning
Orange	<ul style="list-style-type: none"> While monitoring (on transceivers set up for 5-Tone Signalling only). When testing the VOX Gain sensitivity level. 	<p><i>1 second:</i> While receiving an encoded call that matches the code set up in your transceiver.</p> <p><i>2 seconds:</i> After the Auto Reset Timer of the 5-Tone call activates (if it has been activated by your dealer).</p>
Red/ Orange	—	The selected channel has not been programmed and cannot be used.
Green/ Orange	—	While pressing the PTT switch when stun is activated.
Red/ Green	—	The transceiver is in VOX Gain adjustment mode.

② Channel Switch

Rotate to select a channel from 1 to 16.

③ **Power switch/ Volume control**

Turn clockwise to switch ON the transceiver. Rotate to adjust the volume. To switch OFF the transceiver, turn counterclockwise fully.

④ **AUX key**

This is a PF (Programmable Function) key. Press it to activate its auxiliary function (page 14). The default setting for this key is None.

⑤ **PTT (Push-to-Talk) switch**

Press this switch, then speak into the microphone to call a station.

⑥ **Side 1 key**

This is a PF (Programmable Function) key. Press it to activate its auxiliary function (page 14). The default setting for this key is Call1.

⑦ **Side 2 key**

This is a PF (Programmable Function) key. Press it to activate its auxiliary function (page 14). The default setting for this key is Monitor Toggle.

⑧ **Speaker/ Microphone jacks**

Connect an optional speaker/ microphone here.

PROGRAMMABLE AUXILIARY FUNCTIONS

The **AUX**, **Side 1**, and **Side 2** keys can be programmed with the auxiliary functions listed below:

- Call1 ¹
- Call2 ¹
- Emergency ²
- Monitor Momentary
- Monitor Toggle
- None
- RF Power Low
- Scan
- Scan Temporary Delete
- Scrambler
- Squelch Off Momentary
- Squelch Off Toggle

¹ These functions are only available on transceivers set up for 5-Tone signalling.

² This function can be programmed only on the AUX key.

OPERATING BASICS

SWITCHING POWER ON/ OFF

Turn the **Power** switch/ **Volume** control clockwise to switch the transceiver ON.

Turn the **Power** switch/ **Volume** control counterclockwise to switch the transceiver OFF.

ADJUSTING THE VOLUME

Rotate the **Power** switch/ **Volume** control to adjust the volume. Clockwise increases the volume and counterclockwise decreases it.

- You may need to adjust the volume more precisely while communicating with other parties.

Note: If your dealer programmed **Squelch Off Momentary** or **Squelch Off Toggle** onto a PF key, you can press that key to hear background noise while adjusting the volume level (refer to “MONITOR” on page 27).

SELECTING A CHANNEL

Rotate the **Channel** switch to choose your desired channel from 1 to 16. Clockwise increases the number and counterclockwise decreases it.

- If a channel has not been programmed, it cannot be used. When a non-programmed channel is selected, the LED indicator flashes red and orange and an alert tone sounds.

MAKING A CALL

- 1** Make sure no parties are currently transmitting on your selected channel.
- 2** Press the **PTT** switch and speak into the microphone in your normal speaking voice.
 - For best sound quality at the receiving station, hold the microphone approximately 1.5 inches (3 ~ 4 cm) from your mouth.
- 3** Release the **PTT** switch to receive.

RECEIVING A CALL

Your dealer may have programmed QT or DQT signalling on your transceiver. If your selected channel is programmed with one of these features, you will hear calls only when another party in your system makes a call. All other calls will not be heard.

If your selected channel is not set up with QT or DQT, you will hear calls made by any party (not just those in your system).

SCAN

Scan is useful for monitoring signals on the transceiver channels. When scanning, the transceiver checks for a signal on each channel and only stops if a signal is present.

The transceiver will remain on a busy channel until the signal is no longer present. Your dealer programs the delay time between signal drop-out and Scan resumption. If a signal is received during the delay time, the transceiver will remain on the same channel.

Note:

- ◆ You can only use Scan if your dealer has programmed at least 2 channels on the transceiver. Also, there must be at least 2 channels not locked out of Scan.
 - ◆ Ask your dealer for an explanation on how Channel Scan functions when using 5-Tone or DTMF signalling.
-

To start scanning, press the key programmed as **Scan**.

- Scanning starts from the current channel and ascends through the channel numbers.
- The LED flashes green.
- When a signal is received on a channel and signalling matches, the LED indicator lights green.

To end Scan, press the **Scan** key again.

PRIORITY SCAN

If your dealer set up a Priority channel on your transceiver, the transceiver will automatically change to the Priority channel when a call is received on it, even if a call is being received on a regular channel.

The transceiver will remain on the Priority channel until the signal drops out. Your dealer programs the delay time between signal drop-out and Scan resumption.

TEMPORARY CHANNEL LOCKOUT

During Scan, if a key is programmed with the Scan Temporary Delete function, you can temporarily remove specific channels from the scanning sequence. When Scan stops at a channel, you can remove that channel from the scanning sequence by pressing the **Scan Temporary Delete** key.

- To add the channel back into the Scan list, simply exit Scan mode or switch the transceiver OFF and then ON again.

REVERT CHANNEL

During Scan, pressing the **PTT** switch to transmit will cause the transceiver to select the revert channel. Your dealer can program the revert channel using one of the following methods:

- **Last Called:** The last channel received is assigned as the new revert channel.
- **Last Used:** The last channel responded to is assigned as the new revert channel.
- **Selected:** The last channel selected is assigned as the new revert channel.
- **Selected + Talkback:** If the channel has been changed during Scan, the newly selected channel is assigned as the new revert channel. However, the transceiver also transmits on the channel where Scan is currently paused.
- **Priority:** If your dealer has programmed a Priority channel, it is the revert channel.
- **Priority + Talkback:** If your dealer has programmed a Priority channel, it is the revert channel. However, the transceiver also transmits on the channel where Scan is currently paused.

5-TONE SIGNALLING

5-Tone Signalling is enabled or disabled by your dealer. This function opens the squelch only when the transceiver receives the 5 tones programmed in your transceiver, in succession. Transceivers that do not transmit the correct tones will not be heard.

Your dealer may also activate Group Call for your transceiver.

RECEIVING

When you receive a signal containing the correct tones, squelch opens and you will hear the call.

- The LED indicator flashes orange.
- The LED remains lit after pressing any key.
- To mute the speaker after squelch opens, press the key programmed as **Monitor Momentary** or **Monitor Toggle**.
- Your dealer can program the squelch to close again after a specific time period elapses. The LED indicator flashes orange (2 seconds) at this time.
- If Transpond for 5-Tone Signalling is programmed, an acknowledgment signal is returned to the calling station.
- If Tone Alert for 5-Tone Signalling is programmed, an alert tone will sound when the correct tones are received.

TRANSMITTING

To transmit a 5-Tone signal, simply press the **PTT** switch and make the call. If the selected channel has been programmed with a 5-Tone signal, it will be transmitted when the call is made.

DTMF SIGNALLING

DTMF Signalling is either enabled or disabled by your dealer. This function opens the squelch only when the transceiver receives the DTMF code (3 to 10 digits) programmed in your transceiver. Each transceiver is normally programmed with a unique code. You will not hear calls from transceivers that are not programmed with a matching code.

Your dealer may also program a Group Code in your transceiver. Ask your dealer for further details.

When you receive a signal containing the correct tones, squelch opens and you will hear the call.

- The LED indicator flashes orange.
- To mute the speaker after squelch opens, press the key programmed as **Monitor Momentary** or **Monitor Toggle**.
- Your dealer can program the squelch to close again after a specific time period elapses.
- If Transpond for DTMF Signalling is programmed, an acknowledgment signal is returned to the calling station.
- If Tone Alert for DTMF Signalling is programmed, an alert tone will sound when the correct tones are received.

FleetSync OPERATION

FleetSync is a protocol owned by **KENWOOD** Corporation and is enabled or disabled by your dealer. This function opens the squelch only when the transceiver receives the Fleet code and ID code programmed in your transceiver. Calls that do not contain the correct codes will not be heard.

RECEIVING

When you receive a signal containing both your Fleet code and your ID code, squelch opens and you will hear the call.

- An alert tone will sound.
- The LED indicator flashes orange.
- To mute the speaker after squelch opens, press the key programmed as **Monitor Momentary** or **Monitor Toggle**.

TRANSMITTING

To transmit a FleetSync signal, simply press the **PTT** switch and make the call. If the selected channel has been programmed with a FleetSync PTT ID, it will be transmitted when the call is made.

QUIET TALK (QT)/ DIGITAL QUIET TALK (DQT)

Your dealer may have programmed QT or DQT signalling on your transceiver channels. A QT tone/DQT code is a sub-audible tone/code which allows you to ignore (not hear) calls from other parties who are using the same channel.

When a channel is set up with a QT tone or DQT code, squelch will only open when a call containing a matching tone or code is received. Likewise, signals that you transmit will only be heard by parties whose QT/DQT signalling matches your transceiver.

If a call containing a different tone or code is made on the same channel you are using, squelch will not open and you will not hear the call. This allows you to ignore (not hear) these calls. Although it may seem like you have your own private channel while using QT/DQT, other parties can still hear your calls if they set up their transceiver with the same tone or code.

SCRAMBLER

Whereas the Quiet Talk and Digital Quiet Talk functions (page 22) allow you to ignore unwanted calls, Scrambler allows you to hold a conversation in complete privacy. When activated, any other party listening in on your channel will be unable to understand your conversation. The transceiver scrambles your voice so that anybody listening to your conversation will not be able to understand what you are saying.

In order for members of your own group to understand your call while you are using the Scrambler, all other members must also activate the Scrambler on their transceivers. This scrambles everybody's voice while transmitting and descrambles the voice message on your own transceiver when you receive the message.

To activate the Scrambler, press the key programmed as **Scrambler**.

To deactivate the Scrambler, press the **Scrambler** key again.

Note: There are 2 options for using the Scrambler. Your dealer can activate or deactivate the built-in Scrambler function of the transceiver, or he/she can add a more secure optional scrambler board to your transceiver. Ask your dealer for details.

VOX OPERATION

VOX can be activated or deactivated by your dealer.

VOX operation allows you to transmit hands-free. This feature can only be used if you are using a supported headset.

When operating VOX, you must set a VOX Gain level. This setting allows the transceiver to recognize sound levels. If the microphone is too sensitive, it will begin transmitting when there is noise in the background. If it is not sensitive enough, it will not pick up your voice when you begin speaking. Be sure to adjust the VOX Gain level to an appropriate sensitivity to allow smooth transmission.

To activate VOX and set the VOX Gain level, perform the following steps:

- 1** Connect the headset to the transceiver.
 - The VOX function does not activate when a headset is not connected to the accessory terminal of the transceiver.
- 2** With the transceiver power OFF, press and hold the **Side 1** key for 2 seconds while turning the transceiver power ON.
 - The LED flashes red and green.
- 3** Press the **Side 1** key to increase the VOX Gain level and the **Side 2** key to decrease the level.
 - The VOX Gain can be adjusted from levels 1 to 10 and OFF.
- 4** While adjusting the gain level, speak into the headset microphone as you would while under normal operation, to test the sensitivity level.
 - When the microphone recognizes a sound, the LED lights orange. This allows you to determine a suitable level where background noise will not activate VOX operation while speaking into the microphone will.
 - The transceiver does not transmit your voice during this test procedure.

- 5 Turn the transceiver power OFF and then ON again to save the setting and activate VOX.

To turn VOX operation OFF, enter the VOX Gain level setting (step 2, above) and press the **PTT** switch, then turn the transceiver power OFF and then ON again.

Note:

- ◆ If a speaker/ microphone is connected to the transceiver while the VOX function is switched ON and the VOX Gain Level is configured to a higher, more sensitive level, louder received signals may cause the transceiver to start transmission.
 - ◆ When you operate the VOX function, you must use an optional KHS-1 or KHS-2 accessory.
-

EMERGENCY CALLS

If your transceiver has been programmed with the Emergency function, you can make emergency calls.

Note: Only the AUX key can be programmed with the Emergency function.

- 1 Press and hold the key programmed as **Emergency**.
 - Depending on the delay time programmed into your transceiver, the length of time you must hold the **Emergency** key will vary.
 - When the transceiver enters Emergency mode, a tone will sound and the transceiver will change to the emergency channel and begin transmitting based on how the transceiver is set up by your dealer.
 - When transmission ends, a second tone will sound. The transceiver will henceforth periodically transmit with tones sounding when it starts and stops. Transmission periods are set by your dealer.
- 2 To exit Emergency mode, press and hold the **Emergency** key again.
 - If the Emergency mode completes the preset number of cycles, Emergency mode will automatically end and the transceiver will return to the channel that was in use before Emergency mode was entered.

Note: Your dealer can set the transceiver to emit tones and received signals as normal or mute the speaker during Emergency operation.

ADVANCED OPERATIONS

SELECTING AN OUTPUT POWER

Each channel is programmed with either high or low output power by your dealer. You can change the output power of only channels programmed as high.

When you can reliably communicate with other parties without using high power, select low power by pressing the key programmed as **RF Power Low**. Each time you press **RF Power Low**, the output power toggles between high and low.

- Using low power conserves battery power and reduces the risk of interfering with other communications.

Note:

- ◆ Pressing **RF Power Low** while using a channel programmed with low power causes an error tone to sound.
 - ◆ When changing a channel from high power to low power, all channels programmed with high power are changed to low.
-

MONITOR/ SQUELCH OFF

You can use the **Monitor/ Squelch Off** key to listen to weak signals that you cannot hear during normal operation and to adjust the volume when no signals are present on your selected channel.

Your dealer can program a key with one of 4 functions:

- **Squelch Off Momentary:** Press and hold to hear background noise. Release the key to return to normal operation.
- **Squelch Off Toggle:** Momentarily press to hear background noise. Press the key again to return to normal operation.
- **Monitor Momentary:** Press and hold to deactivate QT, DQT, or 5-Tone Signalling. Release the key to return to normal operation.
- **Monitor Toggle:** Momentarily press to deactivate QT, DQT, or 5-Tone Signalling. Press the key again to return to normal operation.

BACKGROUND OPERATIONS

Your dealer can activate a variety of transceiver functions to perform without any additional operation on your part.

TIME-OUT TIMER (TOT)

The Time-out Timer is used to prevent any caller from using a channel for an extended period of time.

If you continuously transmit for a period of time that exceeds the programmed time (default = 60 seconds), the transceiver will stop transmitting and an alert tone will sound. To stop the tone, release the **PTT** switch.

If programmed by your dealer, a pre-alert tone will sound before the timer expires. Also, if programmed by your dealer, you may have to wait for a short duration before you can continue to transmit. If you press the **PTT** switch before the timer has been reset, an alert tone will sound and the transceiver will not enter transmit mode.

BATTERY SAVE

The Battery Save function decreases the amount of power used when a signal is not being received and no operations are being performed (no keys are being pressed and no switches are being turned).

While the channel is not busy and no operation is performed for 10 seconds, Battery Save activates. When a signal is received or an operation is performed, Battery Save is disabled.

LOW BATTERY WARNING

Low Battery Warning alerts you when the battery needs to be recharged or replaced. While transmitting or receiving, the LED will blink red when the battery power is low. If programmed by your dealer, a tone may also sound.

BUSY CHANNEL LOCKOUT (BCL)

When activated, BCL prevents you from interfering with other parties who may be using the same channel that you selected. Pressing the **PTT** switch while the channel is in use will cause your transceiver to emit an alert tone and transmission will be inhibited (you cannot transmit). Release the **PTT** switch to stop the tone and return to receive mode.

STUN

When the transceiver receives a call containing a stun code, either transmit mode will be disabled, or both receive mode and transmit mode will be disabled (default). (This function is used when a transceiver is stolen or lost.) Stun is cancelled when the transceiver receives a call with a revive code.

BEGINNING/ END OF TRANSMISSION (TX) SIGNAL

The Beginning of TX and End of TX identification signals are used to access and release some repeaters and telephone systems.

If Beginning of TX is set, the ID signal is transmitted when you press the **PTT** switch.

If End of TX is set, the ID signal is transmitted when you release the **PTT** switch.

If both are set, the ID signal is transmitted when you press and release the **PTT** switch.

KENWOOD

CE 0168 