

KENWOOD

Document Copyrights

Copyright 2006 by Kenwood Corporation. All rights reserved.

No part of this manual may be reproduced, translated, distributed, or transmitted in any form or by any means, electronic, mechanical, photocopying, recording, or otherwise, for any purpose without the prior written permission of Kenwood.

Disclaimer

While every precaution has been taken in the preparation of this manual, Kenwood assumes no responsibility for errors or omissions. Neither is any liability assumed for damages resulting from the use of the information contained herein. Kenwood reserves the right to make changes to any products herein at any time for improvement purposes.

TK-2170

SERVICE MANUAL

TK-2170 K2

TK-2170 K

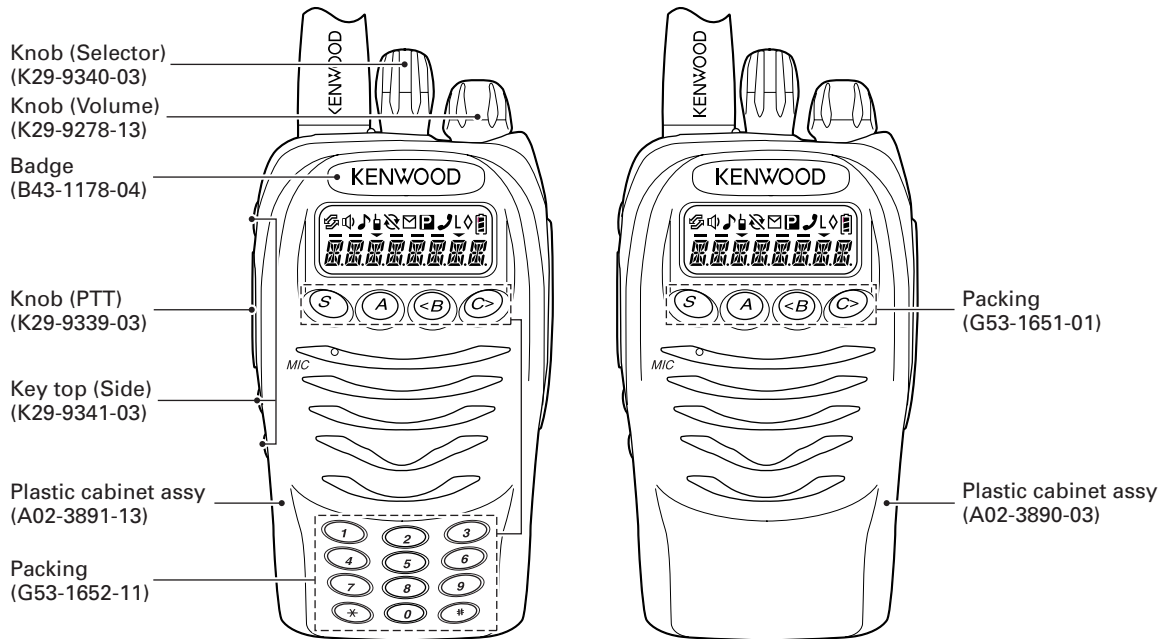

Does not come with antenna.
Antenna is available as an option.

CONTENTS

GENERAL	2	ADJUSTMENT	41
SYSTEM SET-UP	2	TERMINAL FUNCTION	49
REALIGNMENT	3	PC BOARD	
DISASSEMBLY FOR REPAIR	21	TX-RX UNIT (X57-7000-XX) (A/4)	50
CIRCUIT DESCRIPTION	23	TX-RX UNIT (X57-7000-XX) (B,C,D/4)	52
SEMICONDUCTOR DATA	28	SCHEMATIC DIAGRAM	56
COMPONENTS DESCRIPTION	29	BLOCK DIAGRAM	64
PARTS LIST	31	LEVEL DIAGRAM	66
EXPLODED VIEW	39	KSC-30 (RAPID CHARGER)	67
PACKING	40	SPECIFICATIONS	BACK COVER



GENERAL / SYSTEM SET-UP

INTRODUCTION

SCOPE OF THIS MANUAL

This manual is intended for use by experienced technicians familiar with similar types of commercial grade communications equipment. It contains all required service information for the equipment and is current as of the publication date. Changes which may occur after publication are covered by either Service Bulletins or Manual Revisions. These are issued as required.

ORDERING REPLACEMENT PARTS

When ordering replacement parts or equipment information, the full part identification number should be included. This applies to all parts : components, kits, or chassis. If the part number is not known, include the chassis or kit number of which it is a part, and a sufficient description of the required component for proper identification.

PERSONAL SAFETY

The following precautions are recommended for personal safety:

- DO NOT transmit until all RF connectors are verified secure and any open connectors are properly terminated.
- SHUT OFF and DO NOT operate this equipment near electrical blasting caps or in an explosive atmosphere.
- This equipment should be serviced by a qualified technician only.

SERVICE

This radio is designed for easy servicing. Refer to the schematic diagrams, printed circuit board views, and alignment procedures contained within.

SYSTEM SET-UP

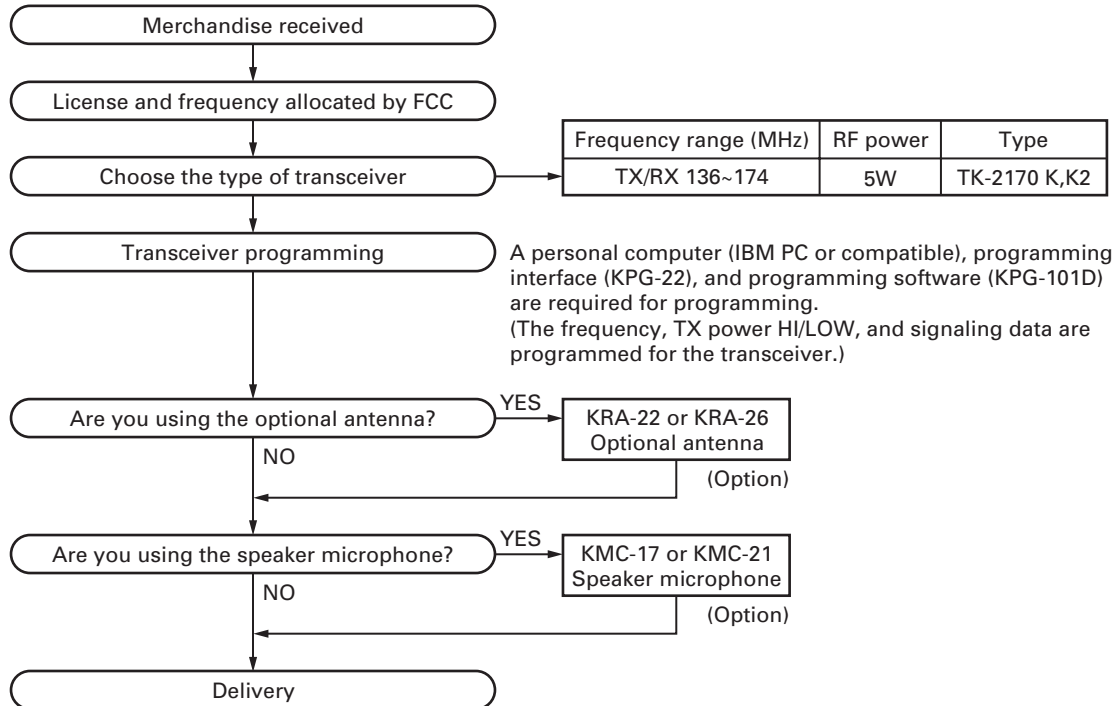

REALIGNMENT

1. Modes

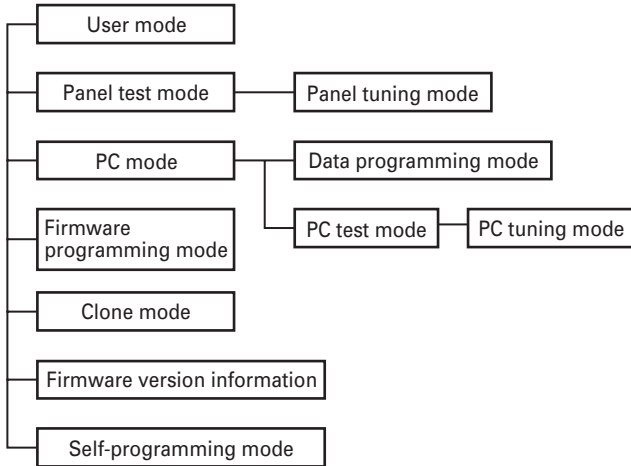

Mode	Function
User mode	For normal use.
Panel test mode	Used by the dealer to check the fundamental characteristics.
Panel tuning mode	Used by the dealer to tune the radio.
PC mode	Used for communication between the radio and PC (IBM compatible).
Data programming mode	Used to read and write frequency data and other features to and from the radio.
PC test mode	Used to check the radio using the PC. This feature is included in the FPU. See panel tuning.
Firmware programming mode	Used when changing the main program of the flash memory.
Clone mode	Used to transfer programming data from one radio to another.
Firmware version information	Used to confirm the internal firmware version.
Self-programming mode	You can program the frequency signaling and other function using only the radio.

2. How to Enter Each Mode

Mode	Operation
User mode	Power ON
Panel test mode	[A] + Power ON
PC mode	Received commands from PC
Panel tuning mode	[Panel test mode] + [S]
Firmware programming mode	[Side2] + Power ON
Clone mode	[B] + Power ON
Firmware version information	[Side1] + Power ON
Self-programming mode	[C] + Power ON

3. Panel Test Mode

Setting method refer to ADJUSTMENT.

4. Panel Tuning Mode

Setting method refer to ADJUSTMENT.

5. PC Mode

5-1. Preface

The transceiver is programmed by using a personal computer, programming interface (KPG-22) and programming software (KPG-101D).

The programming software can be used with an IBM PC or compatible. Figure 1 shows the setup of an IBM PC for programming.

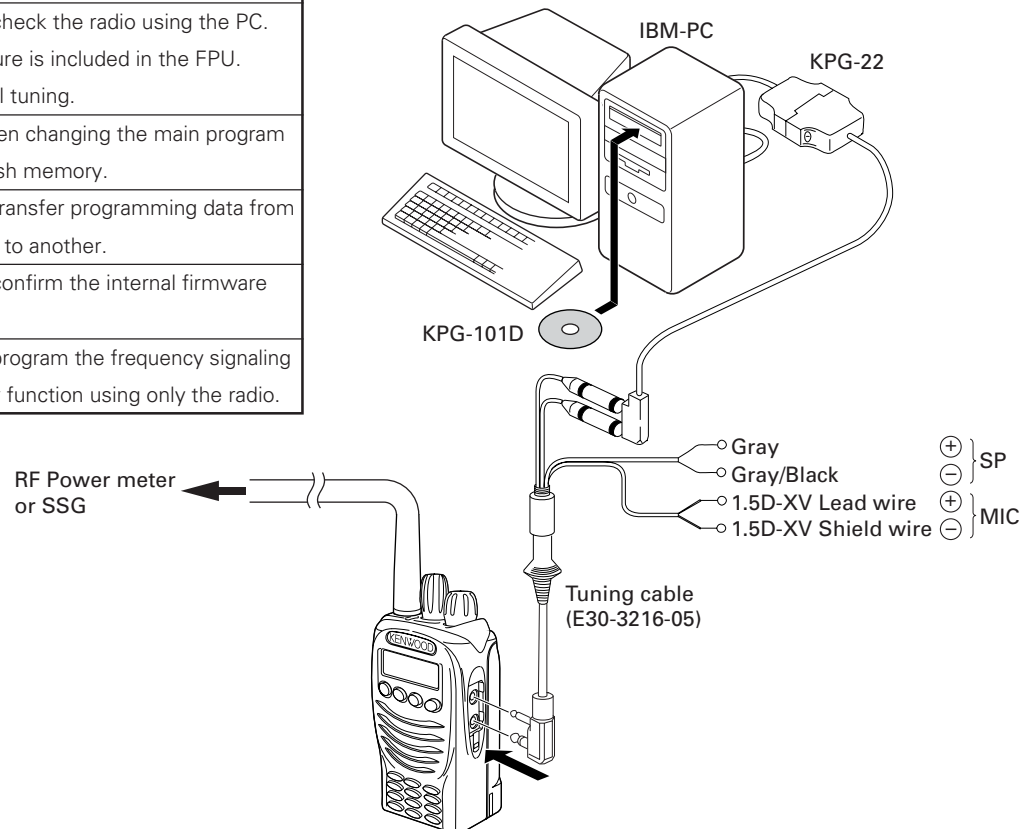

Fig. 1

REALIGNMENT

5-2. Connection Procedure

1. Connect the transceiver to the personal computer with the interface cable.
2. When the POWER switch on, user mode can be entered immediately. When PC sends command the radio enter PC mode, and "PROGRAM" is displayed on the LCD. When data transmitting from transceiver, the red LED is lights. When data receiving to transceiver, the green LED is lights.

Note:

- The data stored in the personal computer must match model type, when it is written into the flash memory.

5-3. KPG-22 Description

(PC programming interface cable: Option)

The KPG-22 is required to interface the transceiver to the computer. It has a circuit in its D-subconnector (25-pin) case that converts the RS-232C logic level to the TTL level.

The KPG-22 connects the SP/MIC connector of the transceiver to the computers RS-232C serial port.

5-4. Programming Software KPG-101D Description

The KPG-101D is the programming software for the transceiver supplied on a CD-ROM. This software runs under MS-Windows 98, ME, Windows 2000 or XP on an IBM-PC or compatible machine.

The data can be input to or read from the transceiver and edited on the screen. The programmed or edited data can be printed out. It is also possible to tune the transceiver.

6. Firmware Programming Mode

6-1. Preface

Flash memory is mounted on the transceiver. This allows the transceiver to be upgraded when new features are released in the future. (For details on how to obtain the firmware, contact Customer Service.)

6-2. Connection Procedure

Connect the transceiver to the personal computer (IBM PC or compatible) with the interface cable (KPG-22). (Connection is the same as in the PC Mode.)

6-3. Programming

1. Start up the firmware programming software (Fpro.exe).
2. Set the communications speed (normally, 115200 bps) and communications port in the configuration item.
3. Set the firmware to be updated by File name item.
4. Turn the transceiver power ON with the [Side2] key held down. Then, the orange LED on the transceiver lights and "PROG 1152" is displayed.
5. Check the connection between the transceiver and the personal computer, and make sure that the transceiver is in the Program mode.
6. Press write button in the window. When the transceiver starts to receive data, the "LOADING" is displayed.

7. If writing ends successfully, the checksum is calculated and a result is displayed.
8. If you want to continue programming other transceivers, repeat steps 4 to 7.

Notes:

- This mode cannot be entered if the Firmware Programming mode is set to Disable in the Programming software.
- When programming the firmware, it is recommend to copy the data from the floppy disk to your hard disk before update the radio firmware. Directly copying from the floppy disk to the radio may not work because the access speed is too slow.

6-4. Function

1. If you press the [Side2] key while "PROG 1152" is displayed, the display changes to "PROG 192" to indicate that the write speed is low speed (19200 bps). If you press the [Side2] key again while "PROG 192" is displayed, the display changes to "PROG 384". If you press the [Side2] key again while "PROG 384" is displayed, the display changes to "PROG 576". If you press the [Side2] key again while "PROG 576" is displayed, the display returns to "PROG 1152".
2. If you press the [Side1] key while "PROG 1152" is displayed, the checksum is calculated, and a result is displayed. If you press the [Side1] key again while the checksum is displayed, "PROG 1152" is redisplayed.

Note:

Normally, write in the high-speed mode.

7. Clone Mode

Programming data can be transferred from one radio to another by connecting them via their SP/MIC connectors. The operation is as follows (the transmit radio is the master and the receive radio is a slave).

The following data cannot be cloned.

- Tuning data
- Embedded message with password
- Serial number

The "password" of description by explanation of 1. to 7. are "Read Authorization Password".

1. Turn the master transceiver power ON with the [B] key held down. If the Data password is set to the transceiver, the transceiver displays "CLN LOCK". If the password is not set, the transceiver displays "CLONE".
2. When you enter the correct password, and "CLONE" is displayed, the transceiver can be used as the cloning master. The following describes how to enter the password.
3. **How to enter the password with the keypad;** If you press a key while "CLN LOCK" is displayed, the number that was pressed is displayed on the transceiver. Each press of the key shifts the display in order to the left. When you enter the password and press the [*] or [S] key, "CLONE" is displayed if the entered password is correct. If the password is incorrect, "CLN LOCK" is redisplayed.

REALIGNMENT

How to enter the password with the selector;

If the selector is rotated while "CLN LOCK" is displayed, numbers (0 to 9) are displayed flashing. When you press the [C] key, the currently selected number is determined. If you press the [S] key after entering the password in this procedure, "CLONE" is displayed if the entered password is correct. If the password is incorrect, "CLN LOCK" is redisplayed.

4. Power on the slave transceiver.
5. Connect the cloning cable (part No. E30-3410-05) to the SP/MIC connectors on the master and slave.
6. Press the [S] key on the master while the master displays "CLONE". The data of the master is sent to the slave. While the slave is receiving the data, "PROGRAM" is displayed. When cloning of data is completed, the master displays "END", and the slave automatically operates in the User mode. The slave can then be operated by the same program as the master.
7. The other slave can be continuously cloned. When the [S] key on the master is pressed while the master displays "END", the master displays "CLONE". Carry out the operation in step 4 to 6.

Notes:

Cannot be cloned if the password (over write password) is programmed to the slave.

Only the same models can be cloned together.

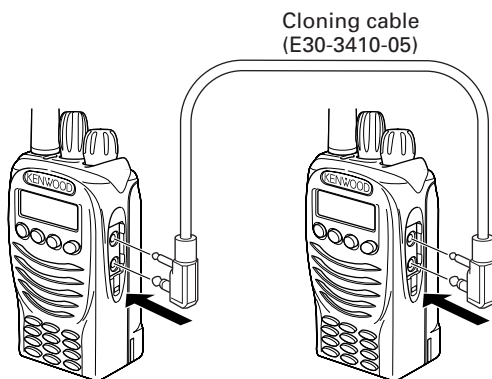

Fig. 2

8. Self-Programming Mode

This mode allows you to write the frequency data and signaling, etc. to the equipment. This mode is to be used ONLY by authorized service personnel who are maintaining the user's equipment. After programming, reset the FPU to disable "Self- Programming" mode. Radios CANNOT be delivered to the end-user with self-programming mode enabled.

8-1. Entering Self-Programming Mode

Remove D14 on the control unit (X57 B/4) first.

1. Press and hold the [C] key for 2 seconds while turning the power on.
2. When self-programming mode is enabled, " SELF " appears on the display.

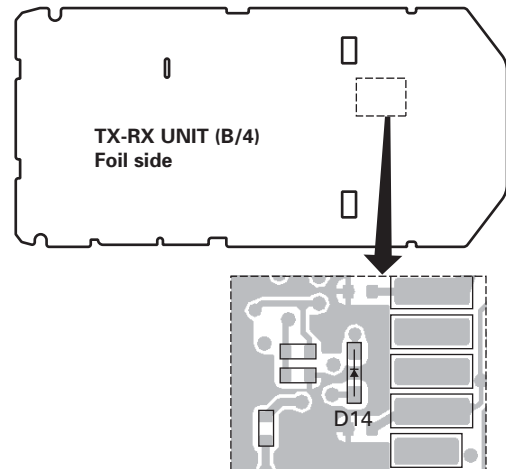

Fig. 3

8-2. Adding a Data Password

If a data password is set in the optional feature menu, you must enter the password to activate self-programming mode.

The password can consist of 6 digits, ranging from 0~9.

■ To enter the password using the keypad:

1. Press a key while "SLF.LOCK.R" or "SLF.LOCK.W" is displayed. The number that was pressed will appear on the display.
2. Each press of the key shifts the display in order to the left.
3. When you have entered the entire password, press the [*] or [S] key. "SELF" appears on the display if the entered password is correct. If the password is incorrect, "SLF.LOCK.R" or "SLF.LOCK.W" is redisplayed.

■ To enter the password using the selector:

1. Rotate the selector while "SLF.LOCK.R" or "SLF.LOCK.W" is displayed. A number (0 to 9) will appear on the display and flash.
2. Press the [C] key. The currently selected number is set.
3. When you have entered the entire password, press the [S] key. "SELF" appears on the display if the entered password is correct. If the password is incorrect, "SLF.LOCK.R" or "SLF.LOCK.W" is redisplayed.

Note:

- Self-programming mode cannot be set when it has been disabled by the FPU.

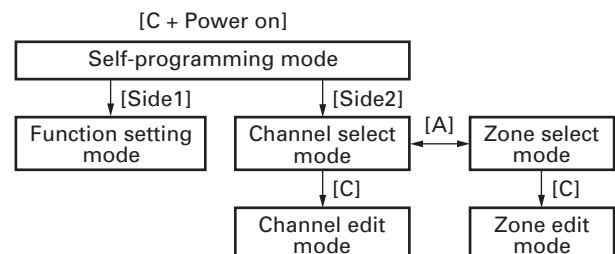

REALIGNMENT

8-3. Zone/Channel Select Mode

■ To enable Zone/Channel select mode

1. Press the [Side2] key when "SELF" is displayed. The transceiver enters Channel Select Mode. On the left half of the display, the zone number is displayed. On the right half of the display, the channel number is displayed.
2. Each press of the [A] key changes the position of the "▼" indicator between the zone select (left side) and the channel select (right side).
3. Rotate the selector to set the zone or channel number, depending on the location of the "▼" indicator.

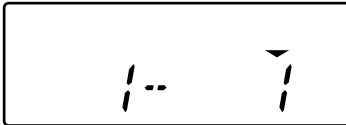

■ Channel edit mode

1. Press the [A] key so that the "▼" indicator is located on the right side, above the channel number.
2. Rotate the selector select your desired channel number.
3. Press the [C] key to enter Channel Edit Mode.
4. Press the [C] key again to select the setting you wish to modify.
5. Rotate the selector to select the desired value.
6. Press the [B] key to store the value in memory and advance to the next setting.
7. Press the [C] key to skip any settings you do not wish to modify.
8. Press the [S] key to exit. "SELF" appears on the display.

No.	Function	Choices	Display	Remarks	
Zone/Channel Setting Mode					
	Select Channel	1-128	▼ 1 - 1	[A] : Zone Selection/Channel Selection change	
			▼ 1 - 1 2 8		
	Select Zone	1-128	▼ 1 - 1		
			▼ 1 2 8 - 1		
Channel Edit					
1	RX Frequency	Step 2.5kHz	S T P _ _ 2 5 0	Display when an item is selected or when a step is changed (about 0.5 seconds) [A] : Step change Default=6.25kHz	
		Step 5.0kHz	S T P _ _ 5 0 0		
		Step 6.25kHz	S T P _ _ 6 2 5		
		Step 7.5kHz	S T P _ _ 7 5 0		
		Step 1MHz	S T P _ _ _ 1 M		
		Blank	R. - - - - -		[Side1] : Freq On/Blank switching
		100.0000~280.0000MHz	R.1 5 0.0 0 0 0		The rightmost dot indicates 50Hz digit (On=5; Off=0)
2	RX Signaling	OFF	- - - - -	[Side1] : Off/QT/DQT switching	
		QT 67.0~250.3Hz (EIA Mode)	Q T _ _ 6 7.0 _	[A] : Mode switching	
			Q T _ 2 5 0.3 _	[Side2] : Normal/Inverse switching	
		QT 67.0~254.1Hz (0.1Hz Step Mode)	Q T _ _ 6 7.0 *	Default=OFF	
			Q T _ 2 5 4.1 *		
		DQT 023~754 Normal (Standard Table Mode)	D Q T 0 2 3 N _		
			D Q T 7 5 4 N _		
DQT 000~777 Normal (1 Step Mode)	D Q T 0 0 0 N *				
	D Q T 7 7 7 N *				

REALIGNMENT

No.	Function	Choices	Display	Remarks
		DQT 023~754 Inverse (Standard Table Mode)	DQT 0 2 3 I _ DQT 7 5 4 I _	
		DQT 000~777 Inverse (1 Step Mode)	DQT 0 0 0 I * DQT 7 7 7 I *	
3	TX Frequency	Step 2.5kHz	S T P _ _ 2 5 0	Same as RX frequency
		Step 5.0kHz	S T P _ _ 5 0 0	
		Step 6.25kHz	S T P _ _ 6 2 5	
		Step 7.5kHz	S T P _ _ 7 5 0	
		Step 1MHz	S T P _ _ _ 1 M	
		Blank	T. - - - - -	Same as RX frequency
		100.0000~280.0000MHz	T.1 5 0.0 0 0 0	Same as RX frequency
4	TX Signaling	OFF	- - - - -	Same as RX signaling
		QT 67.0~250.3Hz (EIA Mode)	Q T _ _ 6 7.0 _ Q T _ 2 5 0.3 _	
		QT 67.0~254.1Hz (0.1Hz Step Mode)	Q T _ _ 6 7.0 * Q T _ 2 5 4.1 *	
		DQT 023~754 Normal (Standard Table Mode)	D Q T 0 2 3 N _ D Q T 7 5 4 N _	
		DQT 000~777 Normal (1 Step Mode)	D Q T 0 0 0 N * D Q T 7 7 7 N *	
		DQT 023~754 Inverse (Standard Table Mode)	D Q T 0 2 3 I _ D Q T 7 5 4 I _	
		DQT 000~777 Inverse (1 Step Mode)	D Q T 0 0 0 I * D Q T 7 7 7 I *	
5	Option Signaling	OFF	OP _ _ OFF _	←Default
		DTMF	OP _ _ D T M F	
		2-tone	OP _ 2 T O N 1 OP _ 2 T O N 2 OP _ 2 T O N 3	
		FleetSync	OP _ F L S Y _	
6	ID	DTMF Signaling = Code SQ 000~9999999999	_ _ _ I D _ _ _	Display when an item is selected (about 0.5 seconds)
		DTMF Signaling = Selective Call 000~9999	1 2 3 4 5 6 7 8	Display of the current setting (If it is 8 or more digits, scroll it)
			- - - - - 1 2 3	Display when a code is input (Input it with DTMF key)
		Code Default	_ _ _ _ _ 0 0 0	[Side1] : Data clear
7	Transmit Power	High Transmit Power	P W R _ H _ _ _	←Default
		Low Transmit Power	P W R _ L _ _ _	

REALIGNMENT

No.	Function	Choices	Display	Remarks
8	Wide/Narrow	Wide	W I D E _ _ _ _	←Default
		Narrow	N A R R O W _ _	
9	Busy Channel Lockout	No	B C L _ N O _ _	←Default
		QT/DQT Tone	B C L _ Q T _ _	
		Option Signaling	B C L _ O P T _	
		Carrier Only	B C L _ C A R R	
10	Scan Delete/Add	Add	S C A N _ A D D	←Default
		Delete	S C A N _ D E L	
11	Beat Shift	NO	S H F T _ N O _	←Default
		YES	S H F T _ Y E S	
12	Compander	NO	C O M P _ N O _	←Default
		YES	C O M P _ Y E S	
13	Priority Channel	NO	P R C H _ N O _	←Default
		YES	P R C H _ Y E S	
14	Home Channel	NO	H M C H _ N O _	Current zone outside cannot be set up Default=NO
		YES	H M C H _ Y E S	
15	Direct Channel	NO	D I R C T _ N O	Default=NO
		1~4	D I R C T _ _ 1	
16	PTT ID	OFF	P I D _ O F F _	Default=NO
		Beginning of Transmit	P I D _ B O T _	
		End of Transmit	P I D _ E O T _	
		Both	P I D _ B O T H	
17	Beginning of Transmit	Code which it can input, 0~9, A~D, * and #, maximum of 16 digits.	B O T _ I D _ _	Not display if Dial ID =Uncheck and PTT ID=OFF, or EOT is set
			1 2 3 4 5 6 7 8	Display of the current setting (If it is 8 or more digits, scroll it)
			- - - - - 9 8 7	Display when a code is input (Input it with DTMF key)
		Blank	- - - - - - - -	[Side1] : Data clear
18	End of Transmit	Code which it can input, 0~9, A~D, * and #, maximum of 16 digits.	E O T _ I D _ _	Not display if Dial ID =Uncheck and PTT ID=OFF, or EOT is set
			1 2 3 4 5 6 7 8	Display of the current setting (If it is 8 or more digits, scroll it)
			- - - - - 9 8 7	Display when a code is input (Input it with DTMF key)
		Blank	- - - - - - - -	[Side1] : Data clear

REALIGNMENT

■ Channel edit mode flow chart

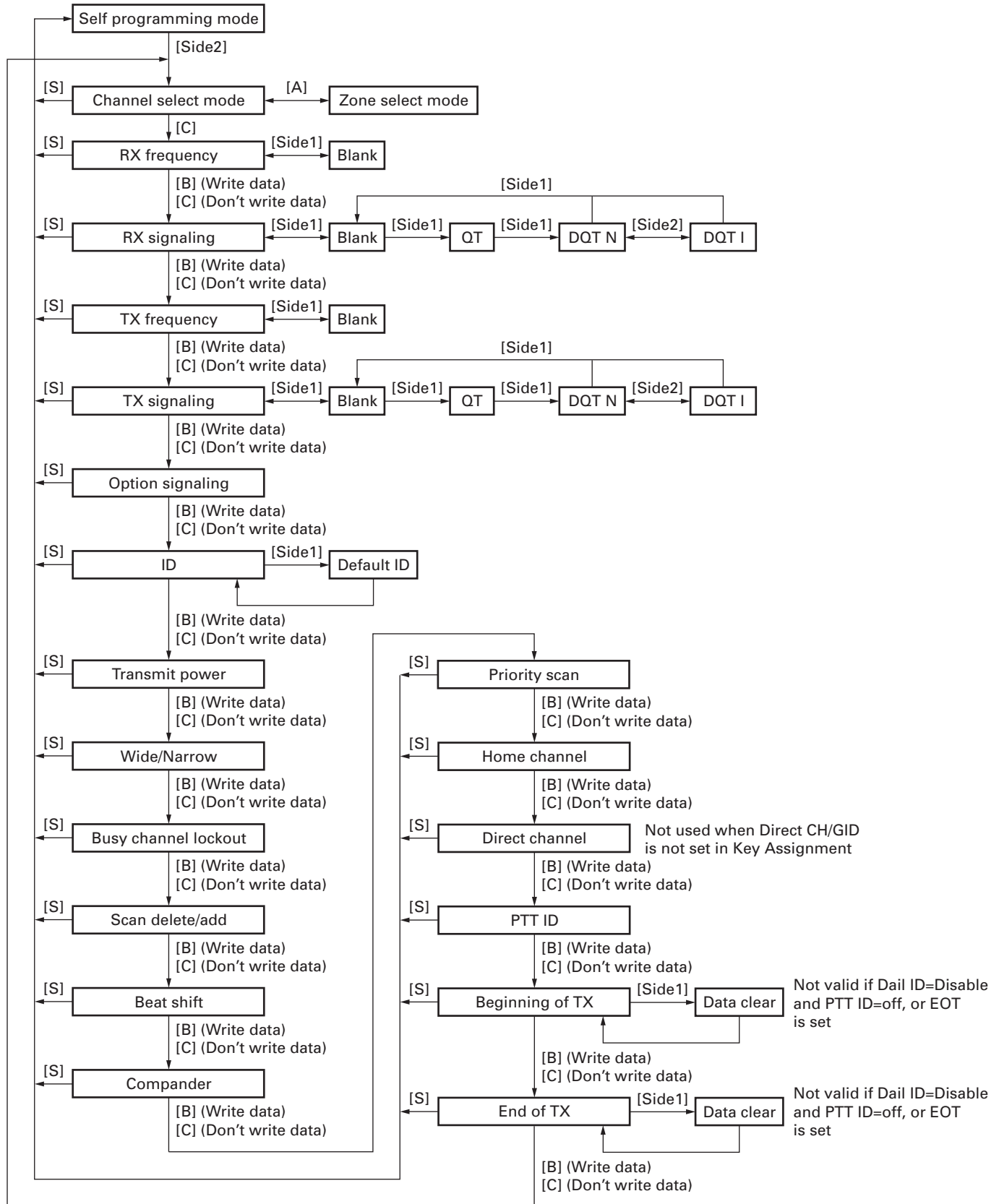

REALIGNMENT

■ Zone edit mode

1. Press the [A] key so that the “▼” indicator is located on the left side, above the zone number.
2. Rotate the selector select your desired zone number.
3. Press the [C] key to enter Zone Edit Mode.
4. Press the [C] key again to select the setting you wish to modify.
5. Rotate the selector to select the desired value.
6. Press the [B] key to store the value in memory and advance to the next setting.
7. Press the [C] key to skip any settings you do not wish to modify.
Press the [S] key to exit. “SELF” appears on the display.

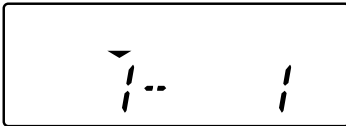

■ Zone edit mode flow chart

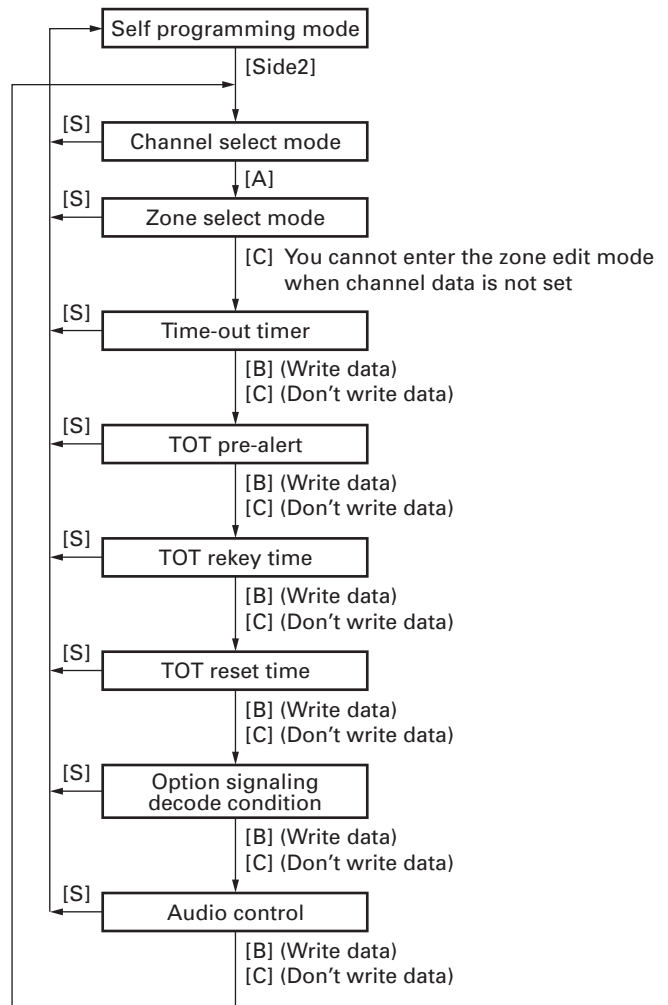

No.	Function	Choices	Display	Remarks
Zone Edit				
1	Time-out Timer	15~1200/15s	TOT _ _ _ 6 0	Default=60
2	TOT Pre-alert	Off, 1~10/1s	TOT P _ OFF	Default=Off
3	TOT Rekey Time	Off, 1~60/1s	TOT K _ OFF	Default=Off
4	TOT Reset Time	Off, 1~15/1s	TOT S _ OFF	Default=Off
5	Option Signaling Decode Condition	QT/DQT	OPDC _ QT _	←Default
		Carrier	OPDC _ CR _	
6	Audio Control	QT/DQT	ADC _ QT _ _	←Default
		QT/DQT and Option Signaling	ADC _ AND _	
		QT/DQT or Option Signaling	ADC _ OR _ _	

REALIGNMENT

8-4. Function Setting Mode

1. Press the [Side1] key when "SELF" is displayed. The transceiver enters Function Setting Mode.
2. Press the [C] key to select the setting you wish to modify.
3. Rotate the selector to select the desired value.
4. Press the [B] key to store the value in memory and advance to the next setting.
5. Press the [C] key to skip any settings you do not wish to modify.
6. Press the [S] key to exit. "SELF" appears on the display.

No.	Function	Choices	Display	Remarks
Function Key				
1	[AUX]	None	AUX _OFF_	←Default
		2-tone	AUX ___ 1 _	
		Autodial	AUX ___ 2 _	
		Autodial Programming	AUX ___ 3 _	
		AUX	AUX ___ 4 _	Optional Board=None
		Call 1	AUX ___ 5 _	
		Call 2	AUX ___ 6 _	
		CH/GID Down	AUX ___ 7 _	
		CH/GID Up	AUX ___ 8 _	
		Channel Entry	AUX ___ 9 _	
		Direct CH1	AUX __ 10 _	
		Direct CH2	AUX __ 11 _	
		Direct CH3	AUX __ 12 _	
		Direct CH4	AUX __ 13 _	
		Display Character	AUX __ 14 _	
		Emergency	AUX __ 15 _	
		Home/CH/GID	AUX __ 16 _	
		Key Lock	AUX __ 17 _	
		Lamp	AUX __ 18 _	
		Low Transmit Power	AUX __ 19 _	
		Monitor	AUX __ 20 _	
		Monitor Momentary	AUX __ 21 _	
		OST	AUX __ 22 _	
		Transceiver Password	AUX __ 23 _	
		Scan	AUX __ 24 _	
		Scan Delete/Add	AUX __ 25 _	
		Scrambler	AUX __ 26 _	
		SelCall	AUX __ 27 _	
		SelCall+Status	AUX __ 28 _	
		Squelch Level	AUX __ 29 _	
		Squelch Off	AUX __ 30 _	
		Squelch Off Momentary	AUX __ 31 _	
		Status	AUX __ 32 _	

REALIGNMENT

No.	Function	Choices	Display	Remarks
		Talk Around	AUX __ 3 3 _	
		VOX	AUX __ 3 4 _	
		Zone Up	AUX __ 3 5 _	
		Zone Down	AUX __ 3 6 _	
2	[S1]	No Function	S 1 __ _ O F F _	
		2-tone	S 1 _ _ _ _ 1 _	
		Autodial	S 1 _ _ _ _ 2 _	
		Autodial Programming	S 1 _ _ _ _ 3 _	
		AUX	S 1 _ _ _ _ 4 _	Optional Board=None
		Call 1	S 1 _ _ _ _ 5 _	
		Call 2	S 1 _ _ _ _ 6 _	
		CH/GID Down	S 1 _ _ _ _ 7 _	
		CH/GID Up	S 1 _ _ _ _ 8 _	
		Channel Entry	S 1 _ _ _ _ 9 _	
		Direct CH1	S 1 _ _ _ 1 0 _	
		Direct CH2	S 1 _ _ _ 1 1 _	
		Direct CH3	S 1 _ _ _ 1 2 _	
		Direct CH4	S 1 _ _ _ 1 3 _	
		Display Character	S 1 _ _ _ 1 4 _	
		Home/CH/GID	S 1 _ _ _ 1 6 _	
		Key Lock	S 1 _ _ _ 1 7 _	
		Lamp	S 1 _ _ _ 1 8 _	←Default
		Low Transmit Power	S 1 _ _ _ 1 9 _	
		Monitor	S 1 _ _ _ 2 0 _	
		Monitor Momentary	S 1 _ _ _ 2 1 _	
		OST	S 1 _ _ _ 2 2 _	
		Transceiver Password	S 1 _ _ _ 2 3 _	
		Scan	S 1 _ _ _ 2 4 _	
		Scan Delete/Add	S 1 _ _ _ 2 5 _	
		Scrambler	S 1 _ _ _ 2 6 _	
		SelCall	S 1 _ _ _ 2 7 _	
		SelCall+Status	S 1 _ _ _ 2 8 _	
		Squelch Level	S 1 _ _ _ 2 9 _	
		Squelch Off	S 1 _ _ _ 3 0 _	
		Squelch Off Momentary	S 1 _ _ _ 3 1 _	
		Status	S 1 _ _ _ 3 2 _	
		Talk Around	S 1 _ _ _ 3 3 _	
		VOX	S 1 _ _ _ 3 4 _	
		Zone Up	S 1 _ _ _ 3 5 _	
		Zone Down	S 1 _ _ _ 3 6 _	

REALIGNMENT

No.	Function	Choices	Display	Remarks
3	[S2]	No Function	S 2 _ _ O F F _	
		2-tone	S 2 _ _ _ _ 1 _	
		Autodial	S 2 _ _ _ _ 2 _	
		AUX	S 2 _ _ _ _ 3 _	Optional Board=None
		Autodial Programming	S 2 _ _ _ _ 4 _	
		Call 1	S 2 _ _ _ _ 5 _	
		Call 2	S 2 _ _ _ _ 6 _	
		CH/GID Down	S 2 _ _ _ _ 7 _	
		CH/GID Up	S 2 _ _ _ _ 8 _	
		Channel Entry	S 2 _ _ _ _ 9 _	
		Direct CH1	S 2 _ _ _ 1 0 _	
		Direct CH2	S 2 _ _ _ 1 1 _	
		Direct CH3	S 2 _ _ _ 1 2 _	
		Direct CH4	S 2 _ _ _ 1 3 _	
		Display Character	S 2 _ _ _ 1 4 _	
		Home/CH/GID	S 2 _ _ _ 1 6 _	
		Key Lock	S 2 _ _ _ 1 7 _	
		Lamp	S 2 _ _ _ 1 8 _	
		Low Transmit Power	S 2 _ _ _ 1 9 _	
		Monitor	S 2 _ _ _ 2 0 _	
		Monitor Momentary	S 2 _ _ _ 2 1 _	
		OST	S 2 _ _ _ 2 2 _	
		Transceiver Password	S 2 _ _ _ 2 3 _	
		Scan	S 2 _ _ _ 2 4 _	
		Scan Delete/Add	S 2 _ _ _ 2 5 _	
		Scrambler	S 2 _ _ _ 2 6 _	
		SelCall	S 2 _ _ _ 2 7 _	
		SelCall+Status	S 2 _ _ _ 2 8 _	
		Squelch Level	S 2 _ _ _ 2 9 _	
		Squelch Off	S 2 _ _ _ 3 0 _	
		Squelch Off Momentary	S 2 _ _ _ 3 1 _	←Default
		Status	S 2 _ _ _ 3 2 _	
		Talk Around	S 2 _ _ _ 3 3 _	
		VOX	S 2 _ _ _ 3 4 _	
		Zone Up	S 2 _ _ _ 3 5 _	
		Zone Down	S 2 _ _ _ 3 6 _	
4	[S]	No Function	S _ _ _ O F F _	
		2-tone	S _ _ _ _ _ 1 _	
		Autodial	S _ _ _ _ _ 2 _	
		AUX	S _ _ _ _ _ 3 _	Optional Board=None

REALIGNMENT

No.	Function	Choices	Display	Remarks
		Autodial Programming	S _ _ _ _ 4 _	
		Call 1	S _ _ _ _ 5 _	
		Call 2	S _ _ _ _ 6 _	
		CH/GID Down	S _ _ _ _ 7 _	
		CH/GID Up	S _ _ _ _ 8 _	
		Channel Entry	S _ _ _ _ 9 _	
		Direct CH1	S _ _ _ 1 0 _	
		Direct CH2	S _ _ _ 1 1 _	
		Direct CH3	S _ _ _ 1 2 _	
		Direct CH4	S _ _ _ 1 3 _	
		Display Character	S _ _ _ 1 4 _	
		Home/CH/GID	S _ _ _ 1 6 _	
		Key Lock	S _ _ _ 1 7 _	
		Lamp	S _ _ _ 1 8 _	
		Low Transmit Power	S _ _ _ 1 9 _	
		Monitor	S _ _ _ 2 0 _	
		Monitor Momentary	S _ _ _ 2 1 _	
		OST	S _ _ _ 2 2 _	
		Transceiver Password	S _ _ _ 2 3 _	
		Scan	S _ _ _ 2 4 _	←Default
		Scan Delete/Add	S _ _ _ 2 5 _	
		Scrambler	S _ _ _ 2 6 _	
		SelCall	S _ _ _ 2 7 _	
		SelCall+Status	S _ _ _ 2 8 _	
		Squelch Level	S _ _ _ 2 9 _	
		Squelch Off	S _ _ _ 3 0 _	
		Squelch Off Momentary	S _ _ _ 3 1 _	
		Status	S _ _ _ 3 2 _	
		Talk Around	S _ _ _ 3 3 _	
		VOX	S _ _ _ 3 4 _	
		Zone Up	S _ _ _ 3 5 _	
		Zone Down	S _ _ _ 3 6 _	
5	[A]	No Function	A _ _ _ O F F _	
		2-tone	A _ _ _ _ 1 _	
		Autodial	A _ _ _ _ 2 _	
		Autodial Programming	A _ _ _ _ 3 _	
		AUX	A _ _ _ _ 4 _	Optional Board=None
		Call 1	A _ _ _ _ 5 _	
		Call 2	A _ _ _ _ 6 _	
		CH/GID Down	A _ _ _ _ 7 _	

REALIGNMENT

No.	Function	Choices	Display	Remarks
		CH/GID Up	A _ _ _ _ 8 _	
		Channel Entry	A _ _ _ _ 9 _	
		Direct CH1	A _ _ _ _ 1 0 _	
		Direct CH2	A _ _ _ _ 1 1 _	
		Direct CH3	A _ _ _ _ 1 2 _	
		Direct CH4	A _ _ _ _ 1 3 _	
		Display Character	A _ _ _ _ 1 4 _	
		Home/CH/GID	A _ _ _ _ 1 6 _	
		Key Lock	A _ _ _ _ 1 7 _	
		Lamp	A _ _ _ _ 1 8 _	
		Low Transmit Power	A _ _ _ _ 1 9 _	
		Monitor	A _ _ _ _ 2 0 _	
		Monitor Momentary	A _ _ _ _ 2 1 _	
		OST	A _ _ _ _ 2 2 _	
		Transceiver Password	A _ _ _ _ 2 3 _	
		Scan	A _ _ _ _ 2 4 _	
		Scan Delete/Add	A _ _ _ _ 2 5 _	←Default
		Scrambler	A _ _ _ _ 2 6 _	
		SelCall	A _ _ _ _ 2 7 _	
		SelCall+Status	A _ _ _ _ 2 8 _	
		Squelch Level	A _ _ _ _ 2 9 _	
		Squelch Off	A _ _ _ _ 3 0 _	
		Squelch Off Momentary	A _ _ _ _ 3 1 _	
		Status	A _ _ _ _ 3 2 _	
		Talk Around	A _ _ _ _ 3 3 _	
		VOX	A _ _ _ _ 3 4 _	
		Zone Up	A _ _ _ _ 3 5 _	
		Zone Down	A _ _ _ _ 3 6 _	
6	[B]	No Function	B _ _ _ _ O F F _	
		2-tone	B _ _ _ _ _ 1 _	
		Autodial	B _ _ _ _ _ 2 _	
		Autodial Programming	B _ _ _ _ _ 3 _	
		AUX	B _ _ _ _ _ 4 _	Optional Board=None
		Call 1	B _ _ _ _ _ 5 _	
		Call 2	B _ _ _ _ _ 6 _	
		CH/GID Down	B _ _ _ _ _ 7 _	
		CH/GID Up	B _ _ _ _ _ 8 _	
		Channel Entry	B _ _ _ _ _ 9 _	
		Direct CH1	B _ _ _ _ 1 0 _	
		Direct CH2	B _ _ _ _ 1 1 _	

REALIGNMENT

No.	Function	Choices	Display	Remarks
		Direct CH3	B _ _ _ _ 1 2 _	
		Direct CH4	B _ _ _ _ 1 3 _	
		Display Character	B _ _ _ _ 1 4 _	
		Home/CH/GID	B _ _ _ _ 1 6 _	
		Key Lock	B _ _ _ _ 1 7 _	
		Lamp	B _ _ _ _ 1 8 _	
		Low Transmit Power	B _ _ _ _ 1 9 _	
		Monitor	B _ _ _ _ 2 0 _	
		Monitor Momentary	B _ _ _ _ 2 1 _	
		OST	B _ _ _ _ 2 2 _	
		Transceiver Password	B _ _ _ _ 2 3 _	
		Scan	B _ _ _ _ 2 4 _	
		Scan Delete/Add	B _ _ _ _ 2 5 _	
		Scrambler	B _ _ _ _ 2 6 _	
		SelCall	B _ _ _ _ 2 7 _	
		SelCall+Status	B _ _ _ _ 2 8 _	
		Squelch Level	B _ _ _ _ 2 9 _	
		Squelch Off	B _ _ _ _ 3 0 _	
		Squelch Off Momentary	B _ _ _ _ 3 1 _	
		Status	B _ _ _ _ 3 2 _	
		Talk Around	B _ _ _ _ 3 3 _	←Default
		VOX	B _ _ _ _ 3 4 _	
		Zone Up	B _ _ _ _ 3 5 _	
		Zone Down	B _ _ _ _ 3 6 _	
7	[C]	No Function	C _ _ _ _ O F F _	
		2-tone	C _ _ _ _ _ 1 _	
		Autodial	C _ _ _ _ _ 2 _	
		Autodial Programming	C _ _ _ _ _ 3 _	
		AUX	C _ _ _ _ _ 4 _	Optional Board=None
		Call 1	C _ _ _ _ _ 5 _	
		Call 2	C _ _ _ _ _ 6 _	
		CH/GID Down	C _ _ _ _ _ 7 _	
		CH/GID Up	C _ _ _ _ _ 8 _	
		Channel Entry	C _ _ _ _ _ 9 _	
		Direct CH1	C _ _ _ _ 1 0 _	
		Direct CH2	C _ _ _ _ 1 1 _	
		Direct CH3	C _ _ _ _ 1 2 _	
		Direct CH4	C _ _ _ _ 1 3 _	
		Display Character	C _ _ _ _ 1 4 _	
		Home/CH/GID	C _ _ _ _ 1 6 _	

REALIGNMENT

No.	Function	Choices	Display	Remarks
		Key Lock	C _ _ _ _ 1 7 _	
		Lamp	C _ _ _ _ 1 8 _	
		Low Transmit Power	C _ _ _ _ 1 9 _	←Default
		Monitor	C _ _ _ _ 2 0 _	
		Monitor Momentary	C _ _ _ _ 2 1 _	
		OST	C _ _ _ _ 2 2 _	
		Transceiver Password	C _ _ _ _ 2 3 _	
		Scan	C _ _ _ _ 2 4 _	
		Scan Delete/Add	C _ _ _ _ 2 5 _	
		Scrambler	C _ _ _ _ 2 6 _	
		SelCall	C _ _ _ _ 2 7 _	
		SelCall+Status	C _ _ _ _ 2 8 _	
		Squelch Level	C _ _ _ _ 2 9 _	
		Squelch Off	C _ _ _ _ 3 0 _	
		Squelch Off Momentary	C _ _ _ _ 3 1 _	
		Status	C _ _ _ _ 3 2 _	
		Talk Around	C _ _ _ _ 3 3 _	
		VOX	C _ _ _ _ 3 4 _	
		Zone Up	C _ _ _ _ 3 5 _	
		Zone Down	C _ _ _ _ 3 6 _	
8	[Selector]	CH/GID Up/Down	CH _ UP / DN	←Default
		Zone Up/Down	ZN _ UP / DN	
		None	KNOB _ OFF	
9	Call 1 (Signaling setting)	DTMF	C A L L 1 _ D T	Only when Call 1 is set.
		2-tone	C A L L 1 _ 2 T	Default=FleetSync (Status)
		FleetSync (Status)	C A L L 1 _ F S	
	Call 1 (List setting)	List None, 1~16	L I S T _ _ _ 1	DTMF
		List None, 1~10	L I S T _ _ _ 1	2-tone
		List None, 1~50	L I S T _ _ _ 1	FleetSync, Default=None
10	Call 2 (Signaling setting)	DTMF	C A L L 2 _ D T	Only when Call 2 is set.
		2-tone	C A L L 2 _ 2 T	Default=FleetSync (Status)
		FleetSync (Status)	C A L L 2 _ F S	
	Call 2 (List setting)	List None, 1~16	L I S T _ _ _ 1	DTMF
		List None, 1~10	L I S T _ _ _ 1	2-tone
		List None, 1~50	L I S T _ _ _ 1	FleetSync, Default=None
11	Operator Selectable (Direct CH)	No	D C O S _ _ N O	←Default
		Yes	D C O S _ Y E S	
12	Keypad Operation	None	K E Y O _ N O N	←Default, Key=16key only
		Channel Entry	K E Y O _ C H E	
		OST	K E Y O _ O S T	

REALIGNMENT

No.	Function	Choices	Display	Remarks
		DTMF (Autodial)	KEYO_ATD	
		DTMF (Keypad Auto PTT)	KEYO_KAP	
		FleetSync (SelCall)	KEYO_SEL	
		FleetSync (Status)	KEYO_STA	
		FleetSync (SelCall+Status)	KEYO_S / S	
Optional Features				
13	Auto Backlight	YES/NO	ATLT_NO_	Default=No
14	Power-on Tone	Current/Off, 1~31	PONT_CUR	Default=Current
15	Control Tone	Current/Off, 1~31	CNTT_CUR	During Self-Programming, it is constant Default=Current
16	Warning Tone	Current/Off, 1~31	WART_CUR	Default=Current
17	Alert Tone	Current/Off, 1~31	ALTT_CUR	Default=Current
18	Sidetone	Current/Off, 1~31	SIDT_CUR	Default=Current
19	Locator Tone	Current/Off, 1~31	LOCT_CUR	Default=Current
20	Minimum Volume	0~31	MINI___0	Default=0
21	Battery Saver	ON/OFF	BATT___ON	Default=ON
22	Battery Warning	Off	BTW_OFF_	
		While Transmitting	BTW_WTX_	←Default
		Always	BTW_ALWY	
		Always w/Beep	BTW_ALWB	
23	Squelch Level	0~9/1STEP	SQL___5_	Default=5
Scan				
24	Priority	None	PRI_NONE	←Default
		Fixed	PRI_FIX_	
		Selected	PRI_SEL_	
		Operator Selectable	PRI_OSEL	
25	Lookback Time A	500~5000ms/50ms Step	LBA___500	Default=500
26	Lookback Time B	500~5000ms/50ms Step	LBB_2000	Default=2000
27	Revert Channel	Last Called	REV_L / C_	←Default
		Last Used	REV_L / U_	
		Selected	REV_SEL_	
		Selected+TalkBack	REV_S / T_	
		Priority	REV_PRI_	Cannot be set when priority=None or selected
		Priority+TalkBack	REV_P / T_	Cannot be set when priority=None or selected
28	Dropout Delay Time	0~300/1s	DODT___3	Default=3
29	Dwell Time	0~300/1s	DWL___3	Default=3
DTMF				
30	DTMF Speed	6, 8, 10, 15	DTSP___6_	Default=6
31	First Digit Delay Time	0~1000ms/50ms	FDDT_200	Default=200
32	First Digit Delay Time w/QT	0~1000ms/50ms	FDWQ_200	Default=200

REALIGNMENT

No.	Function	Choices	Display	Remarks
33	First Digit Time	0, 100, 500, 1000	F D T _ _ _ _ 0	Default=0
34	* and # Digit	0, 100, 500, 1000	* # _ _ _ _ _ 0	Default=0
35	Dial ID	ON/OFF	D I D _ O F F _	Default=OFF, Key=16key only
36	D Code Assignment	D Code	D C A _ D _ C D	Default=D Code
		1~16/1s	D C A _ 1 6 _ _	
37	DTMF Signaling	OFF	D T M S _ O F F	
		Code SQ	D T M S _ C S Q	←Default
		SelCall	D T M S _ S E L	
38	Inter Mediate Code	0~9, A~D, *, #	I M C _ _ _ _ #	DTMF Signaling=SelCall, Default=#
39	Group Code	Off, A~D, *, #	G P C D _ O F F	Default=Off
40	Auto Reset Timer	Off, 1~300/1s	A R T _ _ 1 0 _	Default=10
41	Alert Tone (Individual)	Off, 1~8/ 1	C A T I _ _ _ 1	Default=1
42	Alert Tone (Group)	Off, 1~8/ 1	C A T G _ _ _ 2	Default=2
43	Transpond	Off	T R P _ _ O F F	←Default
		Alert	T R P _ _ A L T	
		ID Code	T R P _ _ I D C	
		Transpond Code	T R P _ _ T R C	
		Ringing Tone	T R P _ _ R I N	
Others				
44	Panel Test/	Enable	P T M _ E N A _	
	Panel Tuning Mode	Disable	P T M _ D I S _	←Default

Refer to the function setting mode flow chart on page 20.

8-5. Memory Reset Mode

- This mode is used to clear data for functions that can be set in Self-Programming Mode or to return to reset values (default).
- Pressing [S] key when "SELF" is shown, sets the display to "CANCEL".
- Turning the selector alternately switches the display between "CANCEL" ↔ "READY".
- Pressing [B] key when "READY" is shown, clears the data and sets the display to "CLEAR".
- Pressing [S] key again, returns the display to "SELF".
- Pressing [S] key when "CANCEL" is shown, returns the display to "SELF" without resetting the data.

9. Firmware Version Information Mode

Turn the transceiver ON with the [Side1] key held down. Then, the version is displayed during holding the [Side1] key.

REALIGNMENT

■ Function setting mode flow chart

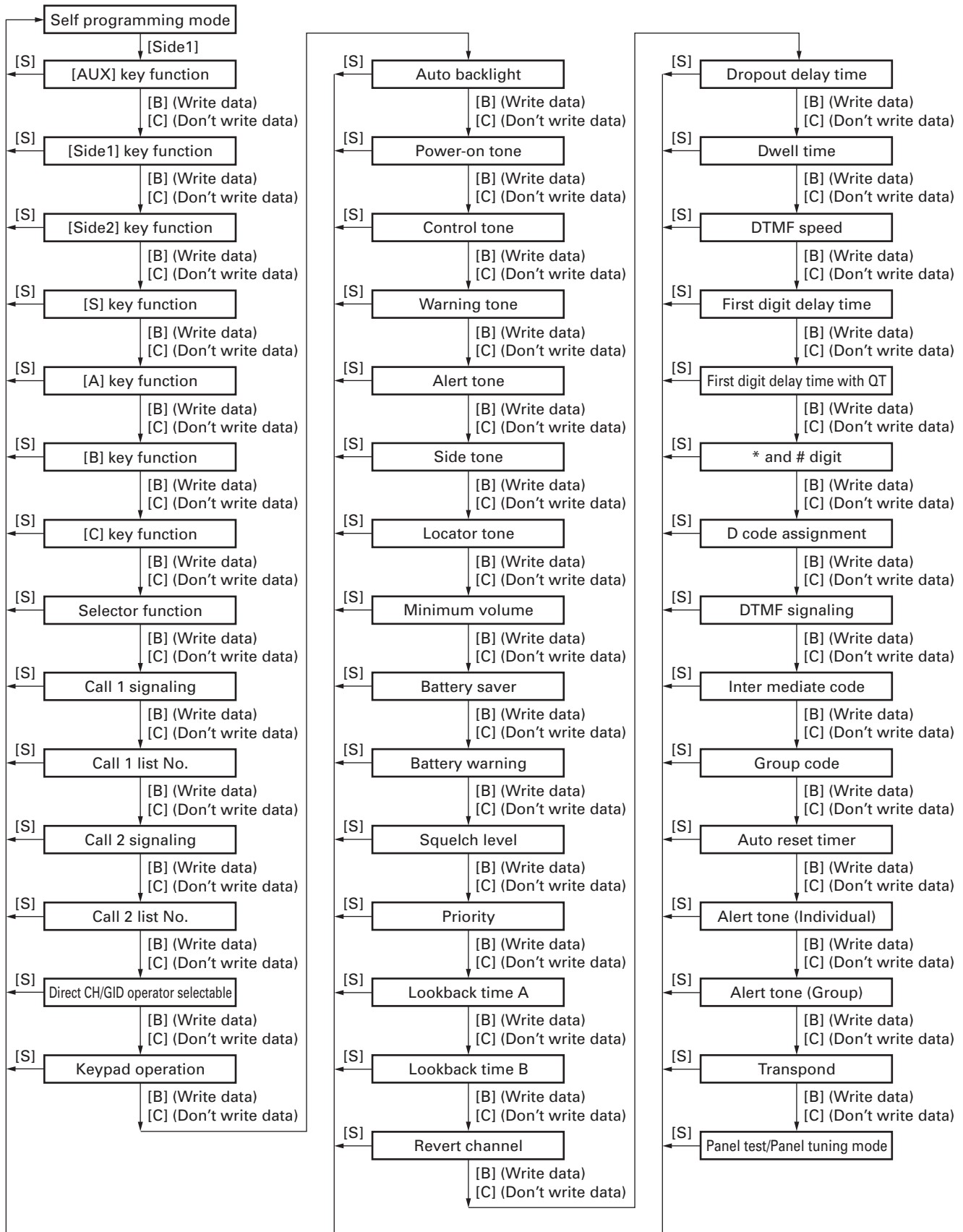

DISASSEMBLY FOR REPAIR

1. Removing the FPC

- 1) Remove the solder from the TX-RX unit using a solder iron (①).
- 2) Peel the double-sided tape (②).
- 3) Remove the solder from the battery terminal block using the solder iron (③).

Note : You must replace the FPC and the double-sided tape (4 x 7 mm) when replacing the volume or the selector.

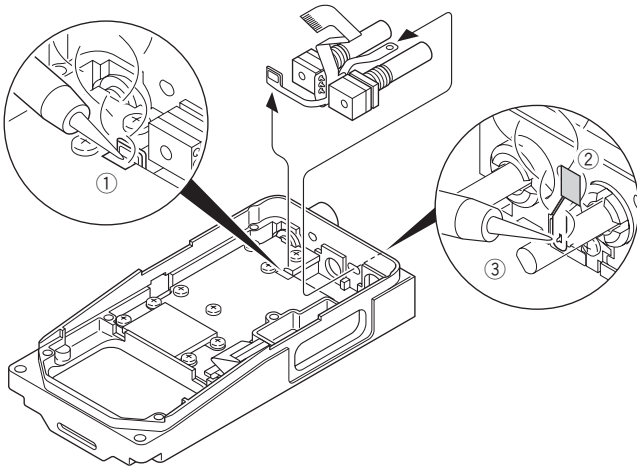

2. Separating the Speaker Holder from the Control Unit

- 1) As in shown in the figure below, the speaker holder is attached to the LCD cover with tab (①). Use a pair of tweezers or similar instrument to lift the speaker holder away from the control unit (②).

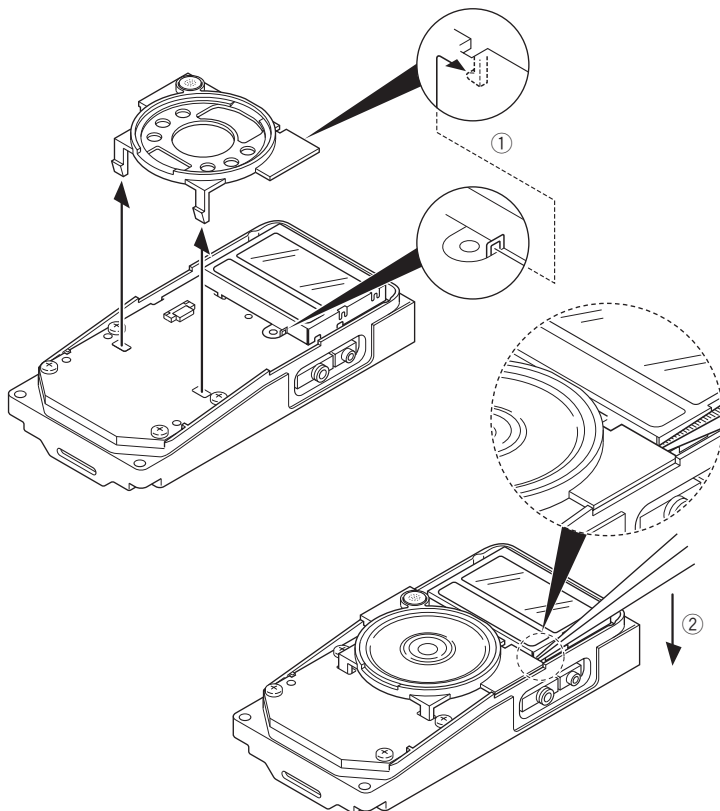

3. How to Assemble the Antenna Connector and its Terminal

The antenna connector and its terminal are supplied as separate parts.

When replacing the antenna connector and/ or terminal, assemble the parts prior to the replacement.

- 1) Mount the antenna connector onto the chassis (①). Double-sided tape is attached to the terminal; peel off the tape cover (②). Attach the terminal to the antenna connector as shown below. Slide the antenna terminal along the adhesive cushion on the chassis so that the adhesive part on the terminal is firmly attached to the antenna connector (③).
- 2) Remove the antenna connector from the chassis with its terminal attached, then solder the center part of antenna connector to its terminal (④). Do not use excessive solder on terminal.

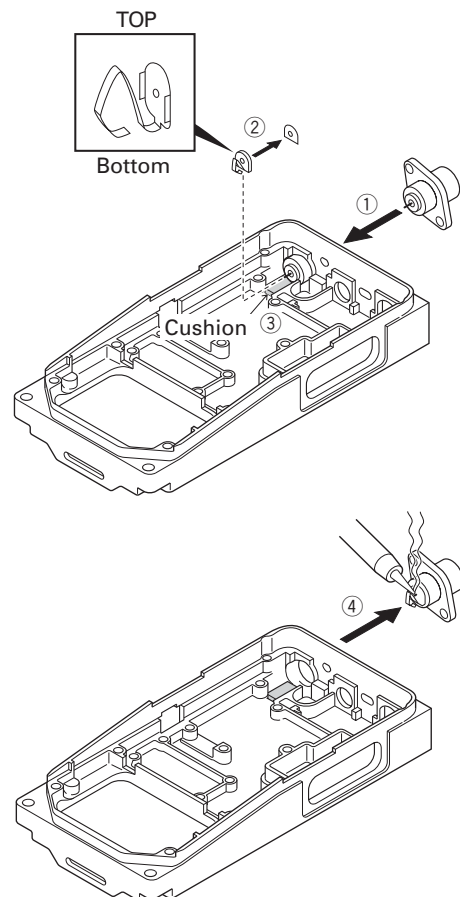

DISASSEMBLY FOR REPAIR

4. Replacing the Speaker and Microphone

- 1) After affixing the double-sided tape (5.4 x 2.7 mm) to the speaker, attach the speaker to the speaker holder (①).
- 2) Insert the microphone into the hold of the holder, as shown by the diagram (②).

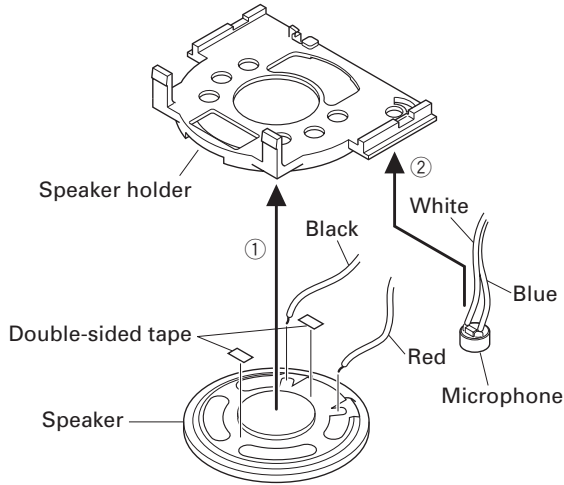

- 3) Match the speaker and microphone lead wires with the color-code of silkscreen of the printed circuit board (③), then solder them in place.

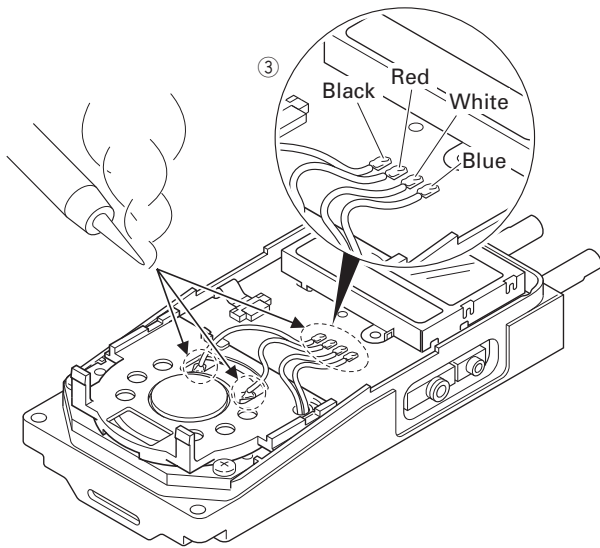

- 4) Lift the speaker holder (④), then flip it over to the left (⑤).
- 5) Insert the tabs of the speaker holder into the slots of the transceiver.
First insert the bottom tabs into the control unit (⑥), then insert the top tabs into the LCD cover (⑦).

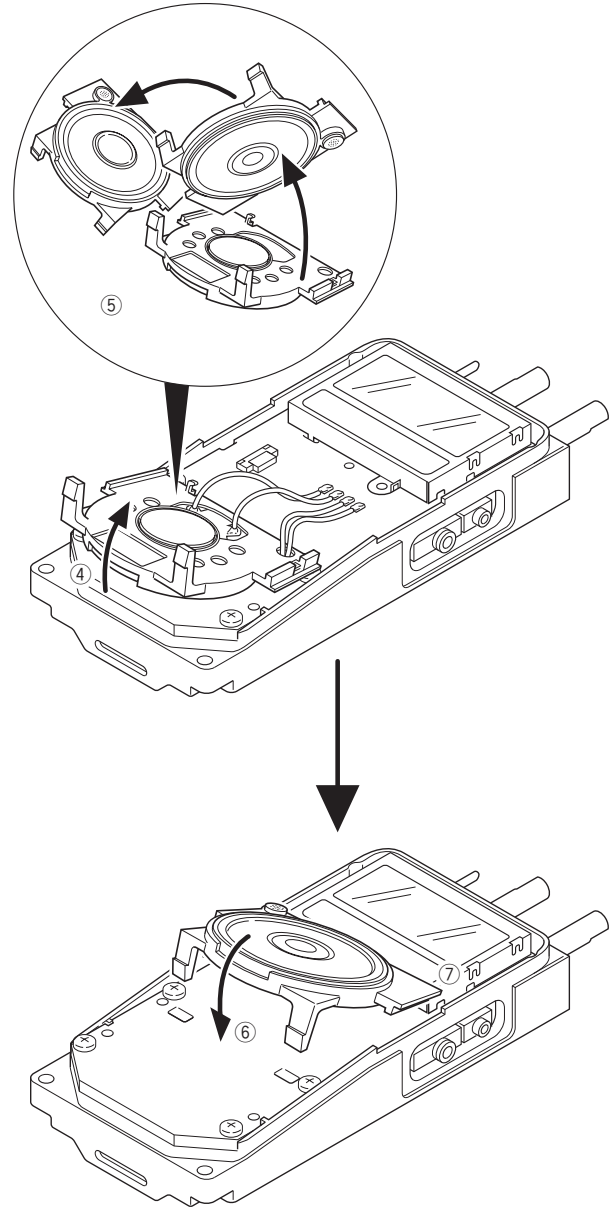

CIRCUIT DESCRIPTION

1. Frequency Configuration

The receiver utilizes double conversion. The first IF is 49.95MHz and the second IF is 450kHz. The first local oscillator signal is supplied from the PLL circuit.

The PLL circuit in the transmitter generates the necessary frequencies. Figure 1 shows the frequencies.

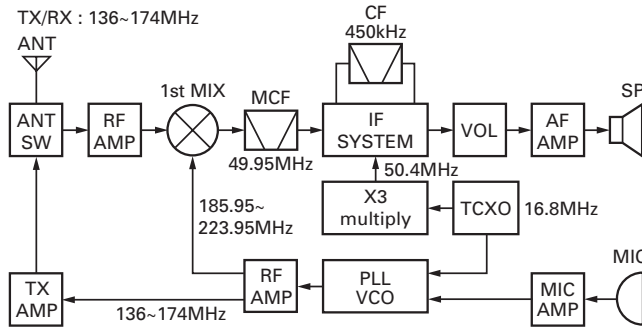

Fig. 1 Frequency configuration

2. Receiver System

The receiver system is shown in Figure 2.

2-1. Front End (RF AMP)

The signal coming from the antenna passes through the transmit/receive switching diode circuit (D604, D605, D606 and D608), passes through a BPF (L715 and L716), and is amplified by the RF amplifier (Q705).

The resulting signal passes through a BPF (L711 and L713) and goes to the mixer. These BPFs are adjusted by variable capacitors (D703, D704, D705 and D706). The input voltage to the variable capacitor is regulated by voltage output from the DC amplifier (IC19).

2-2. First Mixer

The signal from the front end is mixed with the first local oscillator signal generated in the PLL circuit by Q704 to produce a first IF frequency of 49.95 MHz.

The resulting signal passes through the XF701 MCF to cut the adjacent spurious and provide the platinum characteristics, such as adjacent frequency selectivity.

2-3. IF Amplifier Circuit

The first IF signal is passed through a four-pole monolithic crystal filter (XF701) to remove the adjacent channel signal.

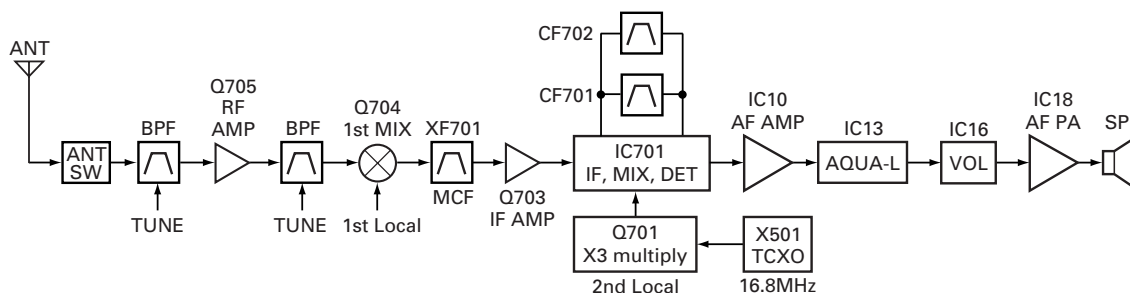

Fig. 2 Receiver system

The filtered first IF signal is amplified by the first IF amplifier (Q703) and then applied to the IF system IC (IC701). The IF system IC provides a second mixer, second local oscillator, limiting amplifier, quadrature detector and RSSI (Received Signal Strength Indicator). The second mixer mixes the first IF signal with the 50.4MHz of the second local oscillator output (TCXO X501) and produces the second IF signal of 450kHz.

The second IF signal is passed through the ceramic filter (Wide : CF701, Narrow : CF702) to remove the adjacent channel signal. The filtered second IF signal is amplified by the limiting amplifier and demodulated by the quadrature detector with the ceramic discriminator (CD701). The demodulated signal is routed to the audio circuit.

2-4. Wide/Narrow Switching Circuit

Wide and Narrow settings can be made for each channel by switching the ceramic filters CF701 (Wide), CF702 (Narrow). The Wide and Narrow is output from IC4.

D701 and D702 are switched to ceramic filters when a Wide/Narrow level is selected.

Q702 turns on/off with the Narrow and the IC701 detector output level is changed to maintain a constant output level during wide or narrow signals.

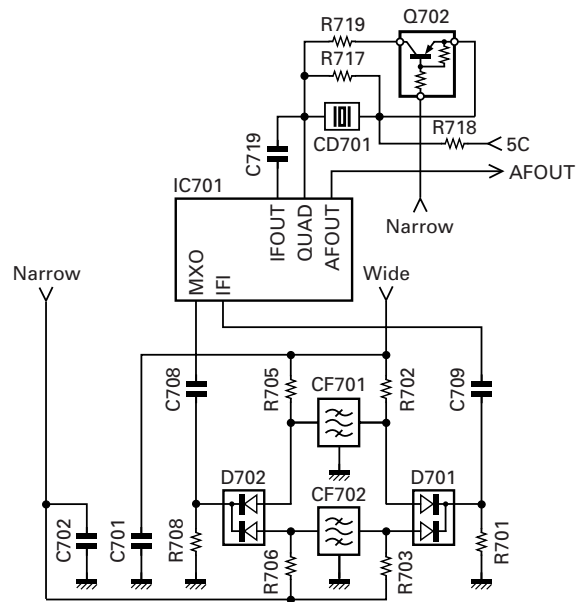

Fig. 3 Wide/Narrow switching circuit

CIRCUIT DESCRIPTION

2-5. Audio Amplifier Circuit

The demodulated signal from IC701 is amplified by IC10, and goes to AF amplifier through IC13.

The signal then goes through an volume control (IC16), and is routed to an audio power amplifier (IC18) where it is amplified and output to the speaker.

2-6. Squelch Circuit

Part of the AF signal from the IC enters the FM IC (IC701) again, and the noise component is amplified and rectified by a filter and an amplifier to produce a DC voltage corresponding to the noise level.

The DC signal from the FM IC goes to the analog port of the microprocessor (IC7). IC7 determines whether to output sounds from the speaker by checking whether the input voltage is higher or lower than the preset value.

To output sounds from the speaker, IC7 sends a high signal to the AM2 line and IC5 sends a high signal to the AM1 line, and turns IC18 on through Q23, Q24, Q27, Q28 and Q35. (See Figure 4)

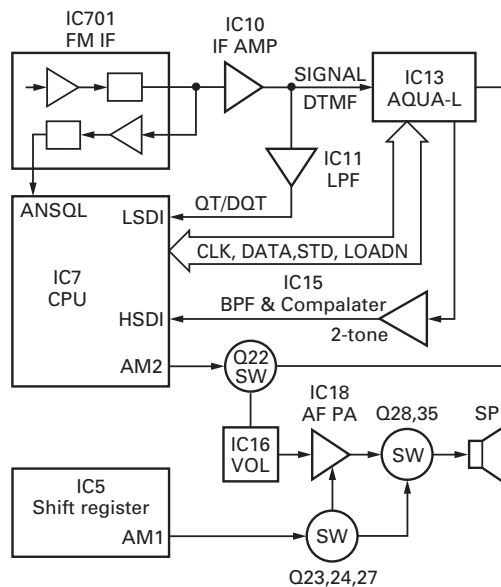

Fig. 4 Audio amplifier and squelch circuit

3. Transmitter System

3-1. Microphone Amplifier

The signal from microphone amplified by IC13 (1/2) and limited by AGC circuit composed of D30, D31, Q25 and Q26, and goes through mute switch (Q30). IC13 is composed of high-pass filter, low-pass filter and pre-emphasis/IDC circuit.

The signal enters the summing amplifier consisting of IC12 (2/2), and passes through the D/A converter (IC16) for the maximum deviation adjustment, and is mixed with the low speed data from the CPU (IC7).

The output signal from the D/A converter goes to the VCO modulation input. The other output signal from the D/A converter passes through the D/A converter (IC16) again for the BAL adjustment, and the buffer amplifier (IC17), and goes to the TCXO modulation input.

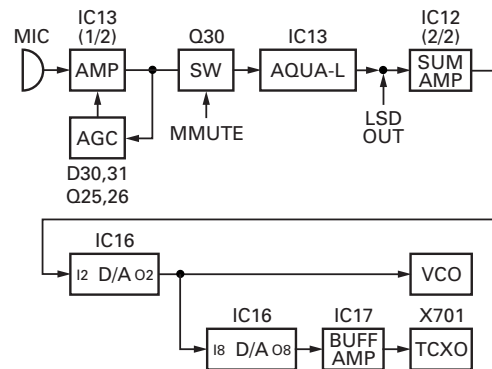

Fig. 5 Microphone amplifier

3-2. Drive and Final Amplifier

The signal from the T/R switch (D518 is on) is amplified by the drive amplifier (Q603) to 50mW.

The output of the drive amplifier is amplified by the RF final amplifier (Q604) to 5.0W (1W when the power is low). The RF final amplifier consists of two MOS FET stages.

The output of the RF final amplifier is then passed through the harmonic filter (LPF) and antenna switch (D604 and D605) and applied to the antenna terminal.

3-3. APC Circuit

The APC circuit always monitors the current flowing through the RF power amplifier (Q604) and keeps a constant current. The voltage drop at R621, R623 and R629 is caused by the current flowing through the RF final amplifier and this voltage is applied to the differential amplifier IC601(1/2).

IC601(2/2) compares the output voltage of IC601(1/2) with the reference voltage from IC7. The output of IC601(2/2) controls the VG of the RF power amplifier, drive amplifier and pre-drive amplifier to make both voltages the same.

The change of power high/low is carried out by the change of the reference voltage.

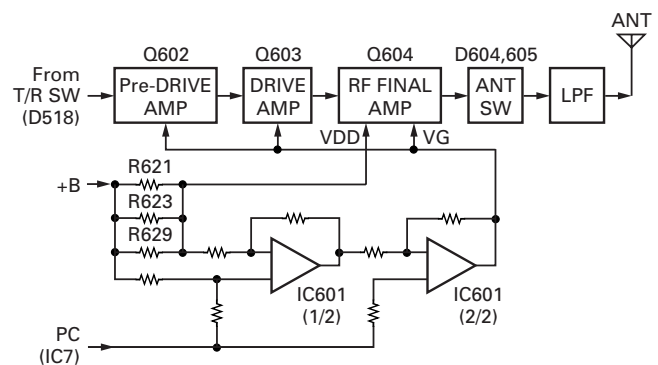

Fig. 6 Drive and final amplifier and APC circuit

CIRCUIT DESCRIPTION

4. Frequency Synthesizer Unit

4-1. Frequency Synthesizer

The frequency synthesizer consists of the TCXO (X501), VCO, PLL IC (IC501) and buffer amplifiers.

The TCXO generates 16.8MHz. The frequency stability is 2.5ppm within the temperature range of -30 to +60°C. The frequency tuning and modulation of the TCXO are done to apply a voltage to pin 1 of the TCXO. The output of the TCXO is applied to pin 8 of the PLL IC.

The VCO consists of 2VCO and covers a dual range of the 185.95~223.95MHz and the 136~174MHz. The VCO generates 185.95~223.95MHz for providing to the first local signal in receive. The operating frequency is generated by Q502 in transmit mode and Q503 in receive mode. The oscillator frequency is controlled by applying the VCO control voltage, obtained from the phase comparator (IC501) to the variable capacitor diodes (D504, D505, D506 and D507 in transmit mode and D508, D509, D510 and D511 in receive mode).

The RX pin of IC4 goes "low" in receive mode causing Q503 and Q504 (2/2) turn on. The TX pin goes "low" in transmit mode causing Q502 and Q504 (1/2) turn on.

The outputs from Q502 and Q503 are amplified by buffer amplifier (Q506) and doubled by Q501 and then sent to PLL IC.

The PLL IC consists of a prescaler, reference divider, phase comparator, charge pump (The frequency step of the PLL circuit is 5 or 6.25kHz). The input signal from the pins 8 and 5 of the PLL IC is divided down to the 5 or 6.25kHz and compared at phase comparator. The pulsed output signal of the phase comparator is applied to the charge pump and transformed into DC signal in the loop filter (LPF). The DC signal is applied to the CV of the VCO and locked to keep the VCO frequency constant.

PLL data is output from PLLDAT (pin 93), PCK (pin 79) and PLE (pin 78) of the microprocessor (IC7). The data are input to the PLL IC when the channel is changed or when transmission is changed to reception and vice versa. A PLL lock condition is always monitored by the pin 77 (UL) of the microprocessor. When the PLL is unlocked, the UL goes low.

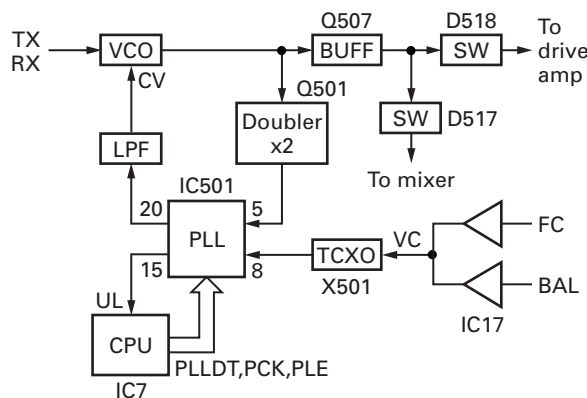

Fig. 7 PLL block diagram

5. Control Circuit

The control circuit consists of microprocessor (IC7) and its peripheral circuits. It controls the TX-RX unit. IC7 mainly performs the following;

- 1) Switching between transmission and reception by PTT signal input.
- 2) Reading system, zone, frequency, and program data from the memory circuit.
- 3) Sending frequency program data to the PLL.
- 4) Controlling squelch on/off by the DC voltage from the squelch circuit.
- 5) Controlling the audio mute circuit by decode data input.
- 6) Transmitting tone and encode data.

5-1. Frequency Shift Circuit

The microprocessor (IC7) operates at a clock of 11.0592 MHz. This oscillator has a circuit that shifts the frequency by Beat shift switch (Q17).

A beat sound may be able to be evaded from generation if "Beat Shift" is set to ON when it is generated in the internal spurious transmission modulated sound of a transceiver.

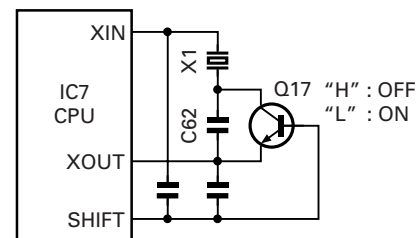

Fig. 8 Frequency shift circuit

5-2. Memory Circuit

Memory circuit consists of the CPU (IC7) and a flash memory (IC8). A flash memory has a capacity of 4M bits and contains the transceiver control program for the CPU. It also stores the data for transceiver channels and operating parameter that are written by the FPU. This program can be easily written from an external devices.

The EEPROM (IC9) stores the last channel data, the scan on status, and other parameters.

Flash memory

Note : The flash memory stores the data that is written by the FPU (KPG-101D), and firmware program (User mode, Test mode, Tuning mode, etc.). This data must be rewritten when replacing the flash memory.

EEPROM

Note : The EEPROM stores tuning data (Deviation, Squelch, etc.).

Realign the transceiver after replacing the EEPROM.

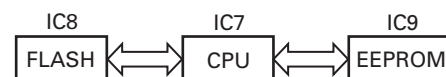

Fig. 9 Memory circuit

CIRCUIT DESCRIPTION

5-3. Low Battery Warning

The battery voltage is monitored by the microprocessor (IC7 pin 123 : BATTLVL). When the battery voltage falls below the voltage set by the Low Battery Warning adjustment during the transmission, the red LED blinks to notify the operator that it is time to replace the battery (When the "On TX" option (default setting) under the Battery Warning / status function in the FPU is selected.). If the battery voltage falls below 5.9V, the transceiver does not transmit and the warning tone beeps while the PTT switch is pressed.

Low battery warning	Battery status
The red LED blinks during the transmission.	The battery voltage is low but the transceiver is still usable.
The red LED blinks and the warning tone beeps while the PTT switch is pressed.	The battery voltage is low and the transceiver is not usable to make calls.

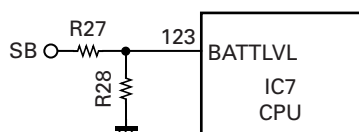

Fig. 10 Low battery warning

5-4. Battery Type Detection

The transceiver automatically detects the battery type, measuring the resistance between the S-terminal and + terminal on the battery pack and changes the supplied voltage to the S-terminal as below. The microprocessor then detects the battery type.

Resistor value	Battery type	Input voltage of S-terminal
1.8MΩ	Li-ion	0.3~1.3V
560kΩ	Ni-Cd	1.3~2.6V
220kΩ	Ni-MH	2.6~5.0V
OPEN	Battery case	0~0.3V

5-5. Key Input

Keys and channel selector circuit.

The signal from the keys and channel selector are directly input to the microprocessor, as shown in Figure 11.

6. Signaling Circuit

6-1. Encode

■ Low-speed data (QT, DQT)

Low-speed data is output from pin 30 of the CPU. The signal passes through MOD amplifier (IC12 1/2), and goes to the buffer amplifier (IC17 2/2). The signal is mixed with the audio signal and goes to the VCO and TCXO (X501) modulation input after passing through the D/A converter (IC16) for BAL adjustment.

■ High-speed data (2-tone, DTMF)

High-speed data (HSD) is output from pin 4 of the CPU. The signal passes through a low-pass CR filter and provides a TX HSD tone and a RX HSD tone. TX HSD deviation making an adjustment by microprocessor is passed through the switch (IC14) and then applied to the audio processor (IC13).

The signal is mixed with the audio signal and goes to the VCO and TCXO. The RX HSD tone is passed a summing amplifier (IC18). The D/A converter (IC16) for audio control, audio power amplifier and then to the speaker.

■ MSK

MSK signal is output from pin 6 of IC13. The signal passes through the D/A converter (IC16) and is routed to the VCO. When encoding MSK, the microphone input signal is muted.

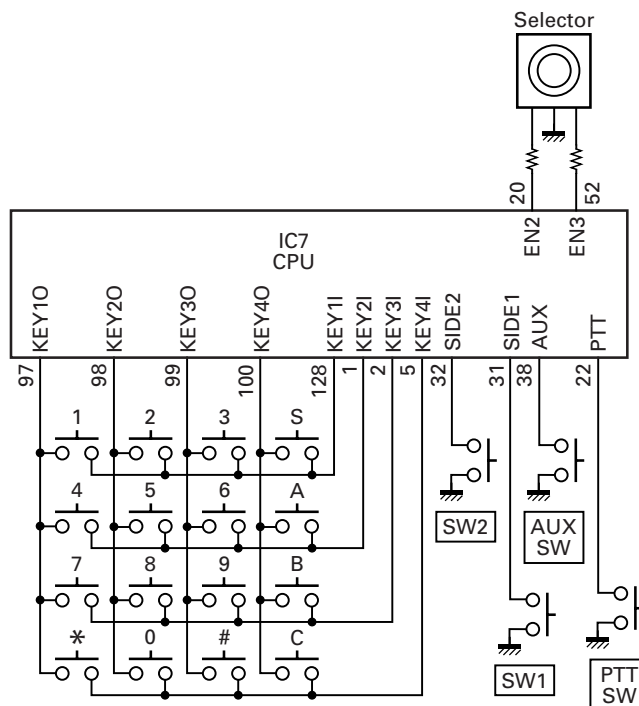

Fig. 11 Key input

CIRCUIT DESCRIPTION

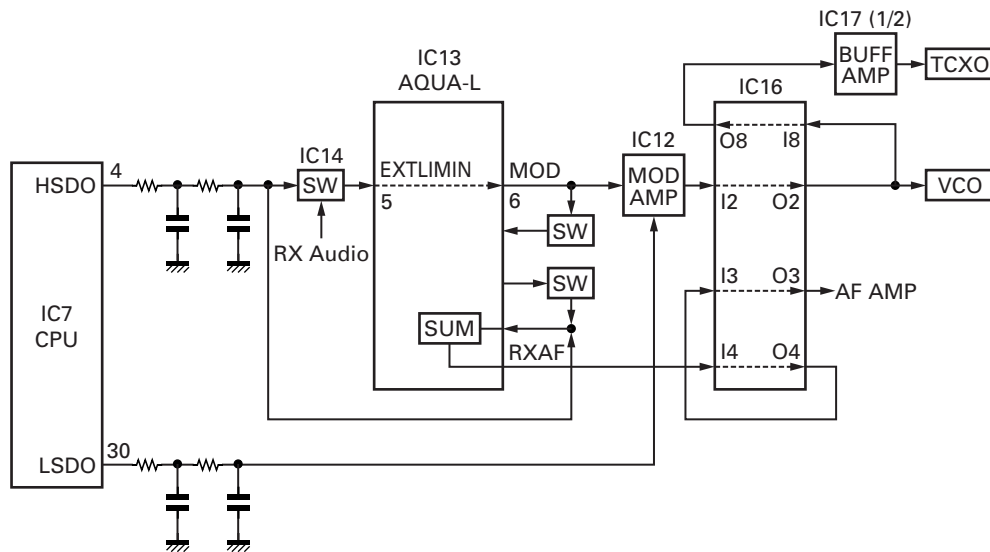

Fig. 12 Encode

6-2. Decode

■ QT/DQT

The output signal from IF IC (IC701) enters the microprocessor (IC7) through IC11. IC7 determines whether the QT or DQT matches the preset value, and controls the AM1 using IC5 and the speaker output sounds according to the squelch results.

■ 2-tone

Part of the received AF signal output from the AF amplifier IC10, and then passes through an audio processor (IC13), goes to the other AF amplifier IC15, is compared, and then goes to IC7. IC7 checks whether 2-tone data is necessary. If it matches, IC7 carries out a specified operation, such as turning the speaker on. (See Figure 4)

■ MSK (Fleet Sync)

Fleet Sync utilizes 1200bps and 2400bps MSK signal is output from pin 6 of IC13. And is routed to the VCO. When encoding MSK, the microphone input signal is muted.

■ DTMF

The DTMF input signal from the IF IC (IC701) is amplified by IC10 and goes to IC13. The decoded information is then processed by the CPU.

7. Power Supply

There are five 5V power supplies for the microprocessor: 5M, 5MS, 5C, 5R and 5T.

5M is always output while the power is on. 5M is always output, but turns off when the power is turned off to prevent malfunction of the microprocessor.

5C is a common 5V and is output when SAVE is not set to OFF.

5R is 5V for reception and output during reception.

5T is 5V for transmission and output during transmission.

SEMICONDUCTOR DATA

Microprocessor : 30625MGP234HU (TX-RX unit IC7)

Pin No.	Port Name	I/O	Function
1	VREF	-	+5V
1	KEY2	I	Key matrix 2 input
2	KEY3	I	Key matrix 3 input
3	PC	O	TX APC adjust
4	HSDO	O	High speed data output
5	KEY4	I	Key matrix 4 input
6	EEPCL	O	EEPROM clock
7	HSDIN	I	High speed data input
8	MDSW	I	Man down switch input
9	DACDAT	O	DAC data
10	BYTE	-	5V
11	CNVSS	-	5V
12	EEPDAT	O	EEPROM data
13	AM2	O	Audio mute 2
14	RESET	I	BATT reset
15	XOUT	O	11.0592MHz clock output
16	DGND	-	DGND (Vss)
17	XIN	I	11.0592MHz clock input
18	VCC	-	5V
19	NMI	-	5V
20	EN2	I	Selector input 2
21	INT	I	BATT voltage INT
22	PTT	I	PTT
23	SHIFT	O	Beat shift
24	BEEP	O	Beep output
25	SFTOE	O	BU4094BCFV output enable
26	DACL	O	M62364FP LD
27	LEDR	O	LED red
28	LEDG	O	LED green
29	OPTDET	I	Option DET
30	LSDOUT	O	Low speed data output
31	SIDE1	I	Side 1 key
32	SIDE2	I	Side 2 key
33	TXD	I/O	TXD (COM0)
34	VCC1	-	5V (Vcc1)
35	RXD	I	RXD (COM0)
36	DGND	-	DGND (Vss)
37	DACCLK	O	DAC CLK
38	AUX	I	AUX KEY

Pin No.	Port Name	I/O	Function
39	TXD2	O	TXD2 (COM1)
40	RXD2/AINH	I	RXD2 (COM1)
41	AFDAT	O	BB TDATA and DTRCLK
42	AFDIO	I/O	BB DI/O
43	AFDIR	O	BB DIR
44	DTRLOAD	O	BB DTMF enable
45	AFSTD	I	BB STD
46	SCLK	O	BB SCLK
47	RDY	-	5V
48	ALE	-	NC
49	HOLD	-	5V
50	HLDA	-	NC
51	EN4	I	Selector input 4
52	EN3	I	Selector input 3
53	5TC	O	5T control
54	EN1	I	Selector input 1
55	BCLK	O	NC
56	RD	O	Read (RD)
57	BHE	O	NC
58	WR	O	Write (WR)
59	APCSW	O	APC SW
60	DSW	O	APC voltage discharge SW
61	LCDINH	O	LCD INH
62	LCDDAT	O	LCD DATA
63	LCDCLK	O	LCD CLK
64	SIM/LCDCE	O	LCD chip select
65	CS0	O	Chip select 0
66	A19	-	NC
67~76	A18~A9	O	Address bus 18~9
77	UL	I	PLL unlock
78	PLE	O	PLL enable
79	PCK	O	PLL clock
80	SFTSTB	-	SFTSTB
81	SELF	I/O	Self programming
82	VCC2	-	5V
83	A8	O	Address bus 8
84	DGND	-	DGND (Vss)
85~92	A7~A0	O	Address bus 7~0
93	PLLDAT	O	PLL data

SEMICONDUCTOR DATA / COMPONENTS DESCRIPTION

Pin No.	Port Name	I/O	Function
94	BB RDF/FD	I	BB RDF/FD
95	TCLK/DTRDO	I	BB TCLK and DTRDO
96	5RC	O	5R control
97	KEY1O	O	Key matrix output
98	KEY2O	O	Key matrix output
99	KEY3O	O	Key matrix output
100	KEY4O	O	Key matrix output
101~108	D7~D0	I/O	Data bus 7~0
109	DT	O	Serial data
110	CK	O	Serial clock
111	AUX3	I/O	Auxiliary 3
112	AUX1	I/O	Auxiliary 1
113	AUX6	I/O	Auxiliary 6
114	AUX2	O	Auxiliary 2
115	AUX5	O	Auxiliary 5
116	AUX4	I/O	Auxiliary 4
117	BATTSEL	I	BATT select
118	THP	I	TX thermal input
119	VOLIN	I	VOL input
120	VOXIN	I	VOX input
121	ASQ	I	RX analog SQ. input
122	RSSI	I	RX RSSI input
123	BATTLVL	I	BATT level
124	AGND	-	DGND (Vss)
125	LSDIN	I	Low speed data input
126	VREF	-	5V (Vref)
127	AVCC	-	5V (AVcc)
128	KEY1	O	Key matrix 1 input

TX-RX unit (X57-7000-XX)

Ref. No.	Use / Function	Operation / Condition
IC1	IC	Voltage detector / INT
IC2	IC	Voltage regulator / 5V
IC3	IC	Voltage detector / RESET
IC4	IC	Shift register
IC5	IC	Shift register
IC6	IC	LCD driver
IC7	Microprocessor	Microprocessor
IC8	IC	Flash memory
IC9	IC	EEPROM
IC10	IC	DET amplifier / VREF
IC11	IC	LSD filter
IC12	IC	TX SUM amplifier
IC13	IC	Audio processor
IC14	IC	AF switch
IC15	IC	RX HSD filter
IC16	IC	D/A converter
IC17	IC	TCXO buffer amplifier
IC18	IC	AF amplifier
IC19	IC	RX BPF tune voltage amplifier
IC501	IC	PLL system
IC601	IC	Comparator (APC)
IC701	IC	FM IF system
Q1	Transistor	5T voltage control
Q4 (1/2)	Transistor	AVR / 5C
Q4 (2/2)	Transistor	AVR / 5T
Q5 (1/2)	FET	5TC switch
Q5 (2/2)	FET	Save switch
Q6	Transistor	5C voltage control
Q7	FET	TX/RX indicator control
Q8	Transistor	5R control switch
Q9	Transistor	5MS control switch
Q12	Transistor	Back light control
Q13	Transistor	Back light DC supply
Q14	FET	RX AF mute
Q15	FET	SSB DC supply control switch
Q16	Transistor	SSB DC supply switch
Q17	Transistor	CPU clock shift switch
Q19	FET	VOX level detector control switch
Q21	Transistor	AF switch

COMPONENTS DESCRIPTION

Ref. No.	Use / Function	Operation / Condition
Q22	FET	AF mute switch
Q23	Transistor	AF amplifier DC supply control switch
Q24	FET	AF amplifier DC supply switch
Q25,26	FET	MIC ALC
Q27	Transistor	AF mute control switch
Q28	FET	AF mute switch
Q29	FET	Logic inverter
Q30	FET	MIC mute switch
Q31,32	Transistor	Audio processor clock shift switch
Q33	FET	TX HSD side tone mute
Q34	FET	Ext. alert input ATT switch
Q35	FET	AF mute switch
Q501	Transistor	F-IN doubler
Q502	FET	TX VCO oscillator
Q503	FET	RX VCO oscillator
Q504	FET	TX/RX VCO DC switch
Q505	Transistor	Ripple filter
Q506	Transistor	RF buffer amplifier
Q507	Transistor	Local amplifier
Q602	FET	Pre-drive amplifier
Q603	FET	TX drive amplifier
Q604	FET	RF final amplifier
Q605	Transistor	APC voltage switch
Q607	Transistor	APC DC switch
Q608	Transistor	APC mute switch
Q609	FET	APC mute switch
Q701	Transistor	2nd local tripler
Q702	Transistor	W/N switch / RX
Q703	Transistor	IF amplifier
Q704	FET	Mixer
Q705	FET	RF amplifier
D1	Diode	5M protect
D2	LED	TX/RX indicator
D4	Diode	Back light current control
D5	LED	LCD back light
D7	LED	LCD back light

Ref. No.	Use / Function	Operation / Condition
D8,9	LED	10 key back light
D12,13	LED	10 key back light
D14,16	Diode	Radio state detector
D17	Diode	RX DET mute control voltage discharge
D24~27	Diode	Key input detect
D28	Diode	AF reference voltage bias supply
D29	Diode	VOX level detector
D30,31	Diode	MIC input level detector
D32	Diode	VOX amplifier gain limiter
D501	Diode	Fast lock up diode
D502,503	Diode	F-IN filter shift switch
D504~507	Variable capacitance diode	Frequency control / TX VCO
D508~511	Variable capacitance diode	Frequency control / RX VCO
D512	Diode	F-IN filter shift switch
D513	Variable capacitance diode	TX VCO modulator
D514	Diode	Ripple filter stabilization diode
D517	Diode	RX local switch
D518	Diode	TX RF switch
D601	Zener diode	APC voltage limiter
D604~606	Diode	ANT switch
D608	Diode	ANT switch
D609	Zener diode	Surge absorber
D610	Varistor	Surge absorber
D701,702	Diode	Ceramic filter W/N switch
D703~706	Variable capacitance diode	RX BPF tuning
D901	Diode	Voltage limiter
TH501	Thermistor	TX temperature protect
TH701,702	Thermistor	Temperature compensation for ASQL
F901	Fuse	Fuse : 2.5A/32V/1608 size (F53-0324-05)

PARTS LIST

* New Parts. Δ indicates safety critical components.

Parts without **Parts No.** are not supplied.

Les articles non mentionnés dans le **Parts No.** ne sont pas fournis.

Teile ohne **Parts No.** werden nicht geliefert.

L : Scandinavia

Y : PX (Far East, Hawaii)

Y : AAFES (Europe)

K : USA

T : England

X : Australia

P : Canada

E : Europe

M : Other Areas

TK-2170 (Y50-5850-XX)

TX-RX UNIT (X57-7000-XX)

Ref. No.	Address	New parts	Parts No.	Description	Desti-nation
TK-2170					
1	1A	*	A02-3890-03	PLASTIC CABINET ASSY	K
2	1B	*	A02-3891-13	PLASTIC CABINET ASSY	K2
3	3A	*	A10-4088-01	CHASSIS	
5	3A	*	B01-0694-03	ESCUTCHEON	
6	2D	*	B09-0686-03	CAP ACCESSORY	
7	2B	*	B11-1826-03	ILLUMINATION GUIDE	
8	2A	*	B11-1827-04	ILLUMINATION GUIDE	
9	2B	*	B11-1828-04	FILTER	
10	2B	*	B38-0901-05	LCD	
13	1A,1B	*	B43-1178-04	BADGE	
17	1C	*	B62-1809-00	INSTRUCTION MANUAL	
20	2A	*	E04-0436-05	RF COAXIAL RECEPTACLE (SMA)	
21	2A	*	E23-1188-04	TERMINAL	
22	3A	*	E23-1189-04	TERMINAL	
23	2B	*	E29-1204-04	INTER CONNECTOR (LCD)	
24	2B	*	E29-1211-04	INTER CONNECTOR (4-KEY)	
25	2A	*	E37-1142-05	FLAT CABLE	
26	3A	*	E72-0421-03	TERMINAL BLOCK	
28	3A	*	F07-1890-04	COVER	
-	-	*	G10-1333-04	FIBROUS SHEET (CABINET ASSY)	
31	3A	*	G11-4315-04	SHEET	
32	2A	*	G11-4316-04	SHEET	
33	2B	*	G11-4335-04	SHEET	
34	1A,1B	*	G11-4351-04	SHEET	
35	2A	*	G13-1885-04	CUSHION	
36	3A	*	G13-2001-04	CUSHION	
38	2A	*	G53-1603-04	PACKING	
39	2B	*	G53-1650-12	PACKING	
40	1A	*	G53-1651-01	PACKING	K
41	1B	*	G53-1652-11	PACKING	K2
42	2B	*	G53-1653-03	PACKING	
43	3A	*	G53-1654-04	PACKING	
44	3A	*	G53-1655-04	PACKING	
46	3C	*	H12-3150-02	PACKING FIXTURE	
47	2D	*	H25-0029-04	PROTECTION BAG (60/110/0.07)	
48	1D	*	H52-2066-02	ITEM CARTON CASE	
50	2B	*	J19-5481-03	HOLDER	
51	2D	*	J19-5483-13	HOLDER ACCESSORY	
52	1B	*	J21-8488-03	MOUNTING HARDWARE	
53	2C	*	J29-0701-05	HOOK ACCESSORY	
54	3A	*	J82-0106-05	FPC	
55	2A	*	J99-0399-04	DOUBLE-SIDED TAPE (4 x 7mm)	
56	1B	*	K29-9278-13	KNOB (VOLUME)	
57	1B	*	K29-9339-03	KNOB (PTT)	
58	1B	*	K29-9340-03	KNOB (SELECTOR)	
59	1B	*	K29-9341-03	KEY TOP (SIDE)	
A	2A,3A	*	N09-2438-05	BINDING HEAD SCREW	
B	2A	*	N14-0583-04	CIRCULAR NUT	
C	3B	*	N14-0805-04	CIRCULAR NUT	
D	3A	*	N30-2610-48	PAN HEAD MACHINE SCREW	
E	3A	*	N30-3006-45	PAN HEAD MACHINE SCREW	
TX-RX UNIT (X57-7000-XX) -10 : K -11 : K2					
F	3A	*	N79-2030-48	PAN HEAD TAPTITE SCREW	
G	2A,2B	*	N83-2005-48	PAN HEAD TAPTITE SCREW	
61	3A	*	R31-0655-05	VARIABLE RESISTOR	
63	1B	*	T07-0369-05	SPEAKER	
64	2B	*	T91-0650-05	MIC ELEMENT	
66	2A	*	W02-3684-05	SELECTOR	
D2			B30-2278-05	LED (RED/YELLOW)	
D5			B30-2210-05	LED (TLY)	
D7			B30-2210-05	LED (TLY)	
D8,9			B30-2050-05	LED	K2
D12,13			B30-2050-05	LED	K2
C2			CK73HB1H102K	CHIP C 1000PF	K
C3			CK73FB1A475K	CHIP C 4.7UF	K
C4			CK73GB1E105K	CHIP C 1.0UF	K
C5,6			CK73HB1H102K	CHIP C 1000PF	K
C7			CK73HB1A104K	CHIP C 0.10UF	K
C9			CK73GB1E105K	CHIP C 1.0UF	K
C11			CK73FB1A225K	CHIP C 2.2UF	K
C13			CK73HB1H102K	CHIP C 1000PF	K
C14,15			CK73HB1E472K	CHIP C 4700PF	K
C16,17			CK73HB1H102K	CHIP C 1000PF	K
C18			CK73HB1A104K	CHIP C 0.10UF	K
C19			CK73HB1H102K	CHIP C 1000PF	K
C20			CK73HB1E472K	CHIP C 4700PF	K
C21			CK73HB1H102K	CHIP C 1000PF	K
C22			CK73HB1E472K	CHIP C 4700PF	K
C23,24			CK73GB1E105K	CHIP C 1.0UF	K
C25			CK73HB1E472K	CHIP C 4700PF	K
C26			CK73HB1H102K	CHIP C 1000PF	K
C27			C92-0712-05	CHIP-TAN 22UF	6.3WV
C28-31			CK73HB1H102K	CHIP C 1000PF	K
C32			CK73HB1A104K	CHIP C 0.10UF	K
C33,34			CK73HB1H102K	CHIP C 1000PF	K
C35			CK73HB1A104K	CHIP C 0.10UF	K
C37			CK73FB1A475K	CHIP C 4.7UF	K
C38,39			CK73HB1A473K	CHIP C 0.047UF	K
C40			CK73HB1H102K	CHIP C 1000PF	K
C42			CK73HB1H681K	CHIP C 680PF	K
C43,44			CK73HB1C103K	CHIP C 0.010UF	K
C45			C92-0712-05	CHIP-TAN 22UF	6.3WV
C46			CK73HB1H102K	CHIP C 1000PF	K
C47			CK73GB1E105K	CHIP C 1.0UF	K
C48-51			CK73HB1H102K	CHIP C 1000PF	K
C52			CK73HB1A104K	CHIP C 0.10UF	K
C53			CK73HB1C103K	CHIP C 0.010UF	K

PARTS LIST

TX-RX UNIT (X57-7000-XX)

Ref. No.	Address	New parts	Parts No.	Description	Destination	Ref. No.	Address	New parts	Parts No.	Description	Destination
C54			CK73HB1H471K	CHIP C 470PF K		C128			CK73HB1H102K	CHIP C 1000PF K	
C55			CK73GB1E105K	CHIP C 1.0UF K		C129			CK73GB1E105K	CHIP C 1.0UF K	
C56			CK73HB1A104K	CHIP C 0.10UF K		C130			CK73HB1A104K	CHIP C 0.10UF K	
C57			C92-0662-05	CHIP-TAN 15UF 6.3WV		C131			CK73HB1H821K	CHIP C 820PF K	
C58			CK73HB1H102K	CHIP C 1000PF K		C132			CK73HB1A104K	CHIP C 0.10UF K	
C59			CC73HCH1H220J	CHIP C 22PF J		C133			CK73GB1E105K	CHIP C 1.0UF K	
C60			CC73HCH1H120J	CHIP C 12PF J		C134			CK73HB1A104K	CHIP C 0.10UF K	
C61			CK73HB1A104K	CHIP C 0.10UF K		C135			CK73GB1E105K	CHIP C 1.0UF K	
C62			CC73HCH1H010C	CHIP C 1.0PF C		C136			CK73HB1H561K	CHIP C 560PF K	
C63			CC73HCH1H120J	CHIP C 12PF J		C137			CK73HB1H102K	CHIP C 1000PF K	
C65			CK73HB1A104K	CHIP C 0.10UF K		C138			CK73HB1A104K	CHIP C 0.10UF K	
C66			CK73HB1C103K	CHIP C 0.010UF K		C139			CK73GB1E105K	CHIP C 1.0UF K	
C67			C92-0514-05	CHIP-TAN 2.2UF 10WV		C140			CK73HB1A104K	CHIP C 0.10UF K	
C68			CK73HB1H102K	CHIP C 1000PF K		C142,143			CK73GB1E105K	CHIP C 1.0UF K	
C69			C92-0560-05	CHIP-TAN 10UF 6.3WV		C145-148			CK73HB1H102K	CHIP C 1000PF K	
C70			CK73HB1E682K	CHIP C 6800PF K		C149			CK73HB1H221K	CHIP C 220PF K	
C71			CK73HB1H392K	CHIP C 3900PF K		C150,151			CK73FB1A225K	CHIP C 2.2UF K	
C72			CK73HB1H122K	CHIP C 1200PF K		C153			CK73GB1E105K	CHIP C 1.0UF K	
C73			CC73HCH1H470J	CHIP C 47PF J		C154,155			CK73HB1H102K	CHIP C 1000PF K	
C74			CK73HB1H122K	CHIP C 1200PF K		C157			CK73GB1A224K	CHIP C 0.22UF K	
C75			CK73HB1C153K	CHIP C 0.015UF K		C158			CK73HB1A104K	CHIP C 0.10UF K	
C76			CK73HB1H332K	CHIP C 3300PF K		C159			CC73HCH1H101J	CHIP C 100PF J	
C77			CK73HB1C153K	CHIP C 0.015UF K		C161			CC73HCH1H101J	CHIP C 100PF J	
C78			CK73HB1A104K	CHIP C 0.10UF K		C162			C92-0560-05	CHIP-TAN 10UF 6.3WV	
C79			CK73HB1H222K	CHIP C 2200PF K		C166			CK73HB1H102K	CHIP C 1000PF K	
C81			CK73HB1A104K	CHIP C 0.10UF K		C168			CK73HB1A473K	CHIP C 0.047UF K	
C82			CC73HCH1H101J	CHIP C 100PF J		C169			CK73HB1A393K	CHIP C 0.039UF K	
C84			CK73HB1H102K	CHIP C 1000PF K		C170			CK73HB1H102K	CHIP C 1000PF K	
C85			CK73HB1C123K	CHIP C 0.012UF K		C171			C92-0560-05	CHIP-TAN 10UF 6.3WV	
C87			CK73HB1A104K	CHIP C 0.10UF K		C172			C92-0665-05	TANTAL 100UF 6.3WV	
C88,89			CC73HCH1H010B	CHIP C 1.0PF B		C173			CK73HB1H221K	CHIP C 220PF K	
C90,91			CK73GB1E104K	CHIP C 0.10UF K		C174			CK73HB1H102K	CHIP C 1000PF K	
C93			CK73GB1E105K	CHIP C 1.0UF K		C175			CK73HB1C103K	CHIP C 0.010UF K	
C95		*	CK73HB1A224K	CHIP C 0.22UF K		C176		*	CK73HB1A224K	CHIP C 0.22UF K	
C96			CK73GB1E105K	CHIP C 1.0UF K		C177			CK73HB1A104K	CHIP C 0.10UF K	
C97			CC73HCH1H101J	CHIP C 100PF J		C178			CK73GB1E105K	CHIP C 1.0UF K	
C98			CK73HB1A683K	CHIP C 0.068UF K		C180			CC73HCH1H101J	CHIP C 100PF J	
C99,100			CK73FB1A475K	CHIP C 4.7UF K		C181			CK73GB0J475K	CHIP C 4.7UF K	
C102			CK73HB1C103K	CHIP C 0.010UF K		C182			CK73HB1H681K	CHIP C 680PF K	
C103			CK73FB1A475K	CHIP C 4.7UF K		C183			CK73HB1H102K	CHIP C 1000PF K	
C104			CK73GB1E104K	CHIP C 0.10UF K		C184			CK73HB1H222K	CHIP C 2200PF K	
C106			CK73HB1H102K	CHIP C 1000PF K		C185			CK73HB1C103K	CHIP C 0.010UF K	
C107			CK73HB1A104K	CHIP C 0.10UF K		C186			CC73HCH1H270J	CHIP C 27PF J	
C108			CK73GB1E105K	CHIP C 1.0UF K		C187			CK73HB1C103K	CHIP C 0.010UF K	
C109			CC73HCH1H100D	CHIP C 10PF D		C188			CC73HCH1H270J	CHIP C 27PF J	
C110			CK73HB1H102K	CHIP C 1000PF K		C189			CK73GB1E104K	CHIP C 0.10UF K	
C111			CK73HB1C103K	CHIP C 0.010UF K		C190-192			CK73HB1H102K	CHIP C 1000PF K	
C112			CC73HCH1H680J	CHIP C 68PF J		C197,198			CK73HB1H102K	CHIP C 1000PF K	
C113-115			CK73HB1A104K	CHIP C 0.10UF K		C199,200			CK73HB1A104K	CHIP C 0.10UF K	
C116			CC73HCH1H120J	CHIP C 12PF J		C201		*	CK73HB1A224K	CHIP C 0.22UF K	
C117			CK73GB1E105K	CHIP C 1.0UF K		C423			CK73FB1A475K	CHIP C 4.7UF K	
C118			CK73HB1A104K	CHIP C 0.10UF K		C501			CK73HB1C103K	CHIP C 0.010UF K	
C119			CK73HB1C103K	CHIP C 0.010UF K		C502			CC73HCH1H470J	CHIP C 47PF J	
C120			CK73FB1A225K	CHIP C 2.2UF K		C503			CC73HCH1H101J	CHIP C 100PF J	
C121			CK73HB1A393K	CHIP C 0.039UF K		C504			CC73HCH1H100D	CHIP C 10PF D	
C122			CK73HB1H102K	CHIP C 1000PF K		C505			CC73HCH1H101J	CHIP C 100PF J	
C123			CC73HCH1H680J	CHIP C 68PF J		C506			CK73HB1C103K	CHIP C 0.010UF K	
C125			CK73HB1A104K	CHIP C 0.10UF K		C507			CC73HCH1H101J	CHIP C 100PF J	
C126			CC73HCH1H470J	CHIP C 47PF J		C508			CK73HB1H471K	CHIP C 470PF K	
C127			CC73HCH1H181J	CHIP C 180PF J		C509			CC73HCH1H100D	CHIP C 10PF D	

PARTS LIST

TX-RX UNIT (X57-7000-XX)

Ref. No.	Address	New parts	Parts No.	Description	Desti-nation	Ref. No.	Address	New parts	Parts No.	Description	Desti-nation
C510			CK73HB1C223K	CHIP C 0.022UF K		C611			CC73HCH1H470J	CHIP C 47PF J	
C511			CK73GB1E105K	CHIP C 1.0UF K		C612			CK73HB1H102K	CHIP C 1000PF K	
C512			CK73HB1C103K	CHIP C 0.010UF K		C613			CK73GB1E105K	CHIP C 1.0UF K	
C513			CK73HB1H102K	CHIP C 1000PF K		C615,616			CK73HB1H102K	CHIP C 1000PF K	
C514			CK73HB1H471K	CHIP C 470PF K		C617			CC73HCH1H390J	CHIP C 39PF J	
C515			CK73HB1H102K	CHIP C 1000PF K		C618			CK73HB1H102K	CHIP C 1000PF K	
C516			CK73GB1E105K	CHIP C 1.0UF K		C619			CC73HCH1H150J	CHIP C 15PF J	
C517			CK73HB1C103K	CHIP C 0.010UF K		C622			CK73HB1H102K	CHIP C 1000PF K	
C518			CK73HB1H102K	CHIP C 1000PF K		C624			CC73HCH1H050B	CHIP C 5.0PF B	
C519-521			CK73GB1E105K	CHIP C 1.0UF K		C625			CK73HB1H102K	CHIP C 1000PF K	
C522			CK73HB1H471K	CHIP C 470PF K		C626			CC73HCH1H101J	CHIP C 100PF J	
C523			C92-0001-05	CHIP-TAN 0.1UF 35WV		C629			CC73HCH1H270J	CHIP C 27PF J	
C524			CK73HB1H471K	CHIP C 470PF K		C632			C92-0514-05	CHIP-TAN 2.2UF 10WV	
C525			C92-0543-05	CHIP-TAN 3.3UF 10WV		C633			CK73HB1H102K	CHIP C 1000PF K	
C526			C92-0001-05	CHIP-TAN 0.1UF 35WV		C635			CK73HB1H102K	CHIP C 1000PF K	
C527			CC73HCH1H120J	CHIP C 12PF J		C636			CC73HCH1H560J	CHIP C 56PF J	
C528			C92-0002-05	CHIP-TAN 0.22UF 35WV		C639			CK73HB1H102K	CHIP C 1000PF K	
C529			CC73HCH1H020C	CHIP C 2.0PF C		C641			CC73HCH1H101J	CHIP C 100PF J	
C530			CC73HCH1H080B	CHIP C 8.0PF B		C643			CK73HB1C103K	CHIP C 0.010UF K	
C531			CC73HCH1H120J	CHIP C 12PF J		C644			CK73FB1A225K	CHIP C 2.2UF K	
C532			CK73HB1H471K	CHIP C 470PF K		C646-648			CK73HB1H102K	CHIP C 1000PF K	
C533			CC73HCH1H050C	CHIP C 5.0PF C		C651			CK73HB1A104K	CHIP C 0.10UF K	
C534,535			CK73HB1H102K	CHIP C 1000PF K		C652			CC73GCH1H270G	CHIP C 27PF G	
C536			CC73HCH1H330J	CHIP C 33PF J		C655			CC73GCH1H680G	CHIP C 68PF G	
C537			CC73HCH1H180J	CHIP C 18PF J		C657			CC73GCH1H070D	CHIP C 7.0PF D	
C538			CC73HCH1H050C	CHIP C 5.0PF C		C658			CK73HB1H102K	CHIP C 1000PF K	
C541			CC73HCH1H560J	CHIP C 56PF J		C669			CC73GCH1H180J	CHIP C 18PF J	
C542			CK73GB1E105K	CHIP C 1.0UF K		C670			CC73GCH1H680J	CHIP C 68PF J	
C543			CC73HCH1H090D	CHIP C 9.0PF D		C671			CC73GCH1H020B	CHIP C 2.0PF B	
C544			CC73HCH1H050C	CHIP C 5.0PF C		C673			CK73HB1H102K	CHIP C 1000PF K	
C545			CC73HCH1H220J	CHIP C 22PF J		C675			CC73GCH1H270J	CHIP C 27PF J	
C548			CC73HCH1H300J	CHIP C 30PF J		C676			CK73GB1H102K	CHIP C 1000PF K	
C549			CC73HCH1H150J	CHIP C 15PF J		C677			CC73GCH1H270J	CHIP C 27PF J	
C550			CK73HB1H471K	CHIP C 470PF K		C678			CC73GCH1H080D	CHIP C 8.0PF D	
C551			CC73HCH1HR75B	CHIP C 0.75PF B		C679			CC73GCH1H100D	CHIP C 10PF D	
C552			CK73HB1H471K	CHIP C 470PF K		C680			CC73GCH1H180J	CHIP C 18PF J	
C555,556			CC73HCH1H080B	CHIP C 8.0PF B		C681			CC73GCH1H110J	CHIP C 11PF J	
C558			CC73HCH1H100D	CHIP C 10PF D		C682			CC73GCH1H130J	CHIP C 13PF J	
C559			CC73HCH1H100B	CHIP C 10PF B		C683			CC73GCH1H100D	CHIP C 10PF D	
C560			CK73HB1H471K	CHIP C 470PF K		C701,702			CK73HB1A104K	CHIP C 0.10UF K	
C562,563			CK73HB1H102K	CHIP C 1000PF K		C703			CC73HCH1H560J	CHIP C 56PF J	
C564,565			CK73HB1A104K	CHIP C 0.10UF K		C704			CK73HB1C103K	CHIP C 0.010UF K	
C566,567			CC73HCH1H0R5B	CHIP C 0.5PF B		C705			CC73HCH1H220J	CHIP C 22PF J	
C568			CK73HB1C103K	CHIP C 0.010UF K		C706			CC73HCH1H560J	CHIP C 56PF J	
C569			CK73HB1H102K	CHIP C 1000PF K		C707			CK73HB1H331K	CHIP C 330PF K	
C570			CK73HB1C103K	CHIP C 0.010UF K		C708,709			CK73HB1A104K	CHIP C 0.10UF K	
C571			CK73HB1H102K	CHIP C 1000PF K		C710			CC73HCH1H470J	CHIP C 47PF J	
C572			C92-0628-05	CHIP-TAN 10UF 10WV		C711			CC73HCH1H680J	CHIP C 68PF J	
C573			CK73HB1H102K	CHIP C 1000PF K		C712			CK73HB1H331K	CHIP C 330PF K	
C574			CC73HCH1H330J	CHIP C 33PF J		C713			CK73HB1A104K	CHIP C 0.10UF K	
C575			CC73HCH1H040C	CHIP C 4.0PF C		C714			CC73HCH1H390J	CHIP C 39PF J	
C576			CC73HCH1H150J	CHIP C 15PF J		C715			CK73HB1H471K	CHIP C 470PF K	
C577,578			CK73HB1H102K	CHIP C 1000PF K		C716			CK73HB1H182K	CHIP C 1800PF K	
C579			CC73HCH1H100D	CHIP C 10PF D		C717			CK73GB1E105K	CHIP C 1.0UF K	
C580,581			CK73HB1H102K	CHIP C 1000PF K		C718			C92-0712-05	CHIP-TAN 22UF 6.3WV	
C601			CK73HB1H102K	CHIP C 1000PF K		C719			CC73HCH1H820J	CHIP C 82PF J	
C602			CC73HCH1H060D	CHIP C 6.0PF D		C720			CK73HB1C103K	CHIP C 0.010UF K	
C603			CK73HB1H102K	CHIP C 1000PF K		C721			CK73HB1H102K	CHIP C 1000PF K	
C604			CC73HCH1H060D	CHIP C 6.0PF D		C722			CK73HB1A104K	CHIP C 0.10UF K	
C610			CK73HB1H102K	CHIP C 1000PF K		C723			CK73HB1A333K	CHIP C 0.033UF K	

PARTS LIST

TX-RX UNIT (X57-7000-XX)

Ref. No.	Address	New parts	Parts No.	Description	Destination	Ref. No.	Address	New parts	Parts No.	Description	Destination
C724			CC73HCH1H330J	CHIP C 33PF J		J1			E11-0457-05	PHONE JACK (2.5/3.5)	
C725			CK73HB1A104K	CHIP C 0.10UF K		F901			F53-0324-05	FUSE	
C726			CK73HB1C103K	CHIP C 0.010UF K		CD701			L79-1474-05	TUNING COIL	
C727			CK73HB1H102K	CHIP C 1000PF K		CF701		*	L72-1010-05	CERAMIC FILTER	
C728			CK73HB1C103K	CHIP C 0.010UF K		CF702		*	L72-1012-05	CERAMIC FILTER	
C729			CC73HCH1H010B	CHIP C 1.0PF B		L1			L92-0140-05	CHIP FERRITE	
C730			CC73HCH1H080B	CHIP C 8.0PF B		L2-9			L92-0138-05	CHIP FERRITE	
C732,733			CK73HB1C103K	CHIP C 0.010UF K		L10			L92-0140-05	CHIP FERRITE	
C734,735			CK73HB1H102K	CHIP C 1000PF K		L11			L92-0149-05	CHIP FERRITE	
C736			CC73HCH1H120G	CHIP C 12PF G		L12,13			L92-0419-15	CHIP FERRITE	
C737			CK73HB1C103K	CHIP C 0.010UF K		L14,15			L92-0138-05	CHIP FERRITE	
C738			CC73HCH1H020B	CHIP C 2.0PF B		L501			L41-4795-39	SMALL FIXED INDUCTOR (4.7UH)	
C739,740			CC73HCH1H120J	CHIP C 12PF J		L502		*	L40-1075-57	SMALL FIXED INDUCTOR (10.0NH)	
C741			CC73HCH1H030B	CHIP C 3.0PF B		L503			L92-0138-05	CHIP FERRITE	
C742			CC73HCH1H050B	CHIP C 5.0PF B		L504			L40-3375-57	SMALL FIXED INDUCTOR (33.0NH)	
C743			CK73HB1C103K	CHIP C 0.010UF K		L505			L40-1001-86	SMALL FIXED INDUCTOR (10UH)	
C744			CC73HCH1H010B	CHIP C 1.0PF B		L506			L40-1802-86	SMALL FIXED INDUCTOR (18UH)	
C745,746			CK73HB1H102K	CHIP C 1000PF K		L507			L40-2775-57	SMALL FIXED INDUCTOR (27.0NH)	
C747			CC73HCH1H050B	CHIP C 5.0PF B		L508,509			L40-1502-86	SMALL FIXED INDUCTOR (15UH)	
C748,749			CK73HB1H102K	CHIP C 1000PF K		L511			L40-1085-57	SMALL FIXED INDUCTOR (100NH)	
C750			CC73HCH1H080B	CHIP C 8.0PF B		L512			L41-3378-14	SMALL FIXED INDUCTOR (33NH)	
C751			CC73HCH1H020B	CHIP C 2.0PF B		L513			L41-2278-14	SMALL FIXED INDUCTOR (22NH)	
C752			CC73HCH1H390J	CHIP C 39PF J		L517,518			L40-1001-86	SMALL FIXED INDUCTOR (10UH)	
C753			CK73HB1H102K	CHIP C 1000PF K		L519			L92-0138-05	CHIP FERRITE	
C755			CC73HCH1H030B	CHIP C 3.0PF B		L520,521			L40-1085-57	SMALL FIXED INDUCTOR (100NH)	
C756			CK73HB1H102K	CHIP C 1000PF K		L601			L40-4775-57	SMALL FIXED INDUCTOR (47.0NH)	
C757			CC73HCH1H040B	CHIP C 4.0PF B		L602			L40-1085-57	SMALL FIXED INDUCTOR (100NH)	
C758			CC73HCH1H270J	CHIP C 27PF J		L603			L92-0138-05	CHIP FERRITE	
C759			CC73HCH1H1R5B	CHIP C 1.5PF B		L604			L40-4775-57	SMALL FIXED INDUCTOR (47.0NH)	
C760			CK73HB1H102K	CHIP C 1000PF K		L605		*	L41-1585-45	SMALL FIXED INDUCTOR (150NH)	
C764,765			CK73HB1H102K	CHIP C 1000PF K		L606			L92-0149-05	CHIP FERRITE	
C767			CK73HB1H102K	CHIP C 1000PF K		L607		*	L41-1275-45	SMALL FIXED INDUCTOR (12NH)	
C768			CC73HCH1H080B	CHIP C 8.0PF B		L609			L92-0149-05	CHIP FERRITE	
C769			CC73HCH1H1R5B	CHIP C 1.5PF B		L610			L34-4563-05	AIR-CORE COIL	
C770			CC73HCH1H220J	CHIP C 22PF J		L611			L34-4577-05	AIR-CORE COIL	
C771			CC73HCH1H470J	CHIP C 47PF J		L612			L34-4574-05	AIR-CORE COIL	
C772			CC73HCH1H040B	CHIP C 4.0PF B		L613			L34-4563-05	AIR-CORE COIL	
C773			CC73HCH1H030B	CHIP C 3.0PF B		L614			L41-2295-39	SMALL FIXED INDUCTOR (2.2UH)	
C774			CK73HB1H102K	CHIP C 1000PF K		L615			L34-4576-05	AIR-CORE COIL	
C775			CC73HCH1H150J	CHIP C 15PF J		L616			L34-4575-05	AIR-CORE COIL	
C776			CC73HCH1H010B	CHIP C 1.0PF B		L617			L34-4567-05	AIR-CORE COIL	
C777			CC73HCH1H100B	CHIP C 10PF B		L618			L34-4566-05	AIR-CORE COIL	
C778			CC73HCH1H030B	CHIP C 3.0PF B		L701			L40-1585-92	SMALL FIXED INDUCTOR (150NH)	
C779			CC73HCH1H330J	CHIP C 33PF J		L702			L40-1085-57	SMALL FIXED INDUCTOR (100NH)	
C901			CK73HB1H102K	CHIP C 1000PF K		L703			L40-1591-86	SMALL FIXED INDUCTOR (1.5UH)	
C904			CK73HB1H102K	CHIP C 1000PF K		L704			L92-0138-05	CHIP FERRITE	
C906			CK73HB1H102K	CHIP C 1000PF K		L705			L41-5685-39	SMALL FIXED INDUCTOR (0.56UH)	
C916			CK73HB1H102K	CHIP C 1000PF K		L706			L40-5675-57	SMALL FIXED INDUCTOR (56.0NH)	
C924-926			CK73HB1H102K	CHIP C 1000PF K		L707			L40-2785-92	SMALL FIXED INDUCTOR (270NH)	
C928			CK73HB1H102K	CHIP C 1000PF K		L708			L40-5675-57	SMALL FIXED INDUCTOR (56.0NH)	
C929			CC73HCH1H470J	CHIP C 47PF J		L709			L40-1285-92	SMALL FIXED INDUCTOR (120NH)	
TC501,502			C05-0384-05	CERAMIC TRIMMER (10PF)		L710			L40-2785-92	SMALL FIXED INDUCTOR (270NH)	
101	2A	*	E37-1141-15	FLAT CABLE		L711			L41-6878-14	SMALL FIXED INDUCTOR (68NH)	
CN1		*	E41-2440-05	FLAT CABLE CONNECTOR		L712			L92-0138-05	CHIP FERRITE	
CN8			E40-5915-05	FLAT CABLE CONNECTOR		L713			L41-6878-14	SMALL FIXED INDUCTOR (68NH)	
CN18			E40-6420-05	FLAT CABLE CONNECTOR		L715			L41-6878-14	SMALL FIXED INDUCTOR (68NH)	
CN60			E40-5932-05	SOCKET FOR PIN ASSY		L716			L41-5678-14	SMALL FIXED INDUCTOR (56NH)	
CN71			E40-5915-05	FLAT CABLE CONNECTOR		L717			L40-5675-57	SMALL FIXED INDUCTOR (56.0NH)	
CN901		*	E40-6420-05	FLAT CABLE CONNECTOR							

PARTS LIST

TX-RX UNIT (X57-7000-XX)

Ref. No.	Address	New parts	Parts No.	Description	Desti-nation	Ref. No.	Address	New parts	Parts No.	Description	Desti-nation
L901			L92-0149-05	CHIP FERRITE		R58,59		*	RK73HB1J473J	CHIP R 47K J 1/16W	
X1			L77-1950-05	CRYSTAL RESONATOR (11.0592MHZ)		R61			RK73HB1J331J	CHIP R 330 J 1/16W	
X2			L77-1976-05	CRYSTAL RESONATOR (3.6864MHZ)		R62			RK73HB1J103J	CHIP R 10K J 1/16W	
X501		*	L77-1969-05	TCXO (16.8MHZ)		R63			RK73HB1J332J	CHIP R 3.3K J 1/16W	
XF701			L71-0617-25	MCF (49.95MHZ)		R64		*	RK73HB1J102J	CHIP R 1.0K J 1/16W	
CP1			RK74HB1J473J	CHIP-COM 47K J 1/16W		R65,66		*	RK73HB1J473J	CHIP R 47K J 1/16W	
CP3,4			RK75HA1J102J	CHIP-COM 1.0K J 1/16W		R67			RK73HB1J472J	CHIP R 4.7K J 1/16W	
CP5			RK74HB1J102J	CHIP-COM 1.0K J 1/16W		R68			RK73GB1J181J	CHIP R 180 J 1/16W	
CP7,8			RK75HA1J102J	CHIP-COM 1.0K J 1/16W		R69		*	RK73HB1J102J	CHIP R 1.0K J 1/16W	
CP10			RK74HB1J102J	CHIP-COM 1.0K J 1/16W		R71		*	RK73HB1J102J	CHIP R 1.0K J 1/16W	
CP11			RK75HA1J102J	CHIP-COM 1.0K J 1/16W		R72			RK73GB1J181J	CHIP R 180 J 1/16W	
CP12,13			RK74HB1J102J	CHIP-COM 1.0K J 1/16W		R73,74		*	RK73HB1J474J	CHIP R 470K J 1/16W	
CP16			RK74HB1J102J	CHIP-COM 1.0K J 1/16W		R75			RK73GB1J391J	CHIP R 390 J 1/16W	K2
CP18			RK74HB1J102J	CHIP-COM 1.0K J 1/16W		R76-80		*	RK73HB1J102J	CHIP R 1.0K J 1/16W	
CP19			RK75HA1J473J	CHIP-COM 47K J 1/16W		R82			RK73GB1J391J	CHIP R 390 J 1/16W	K2
CP22-24			RK74HB1J102J	CHIP-COM 1.0K J 1/16W		R83			R92-1252-05	CHIP R 0 OHM J 1/16W	
CP28			RK74HB1J102J	CHIP-COM 1.0K J 1/16W		R84			RK73HB1J184J	CHIP R 180K J 1/16W	
CP30			RK74HB1J102J	CHIP-COM 1.0K J 1/16W		R89		*	RK73HB1J102J	CHIP R 1.0K J 1/16W	
CP32			RK74HB1J102J	CHIP-COM 1.0K J 1/16W		R90			RK73HB1J394J	CHIP R 390K J 1/16W	
CP34			RK74HB1J102J	CHIP-COM 1.0K J 1/16W		R91			RK73HB1J332J	CHIP R 3.3K J 1/16W	
CP36			RK74HB1J102J	CHIP-COM 1.0K J 1/16W		R92		*	RK73HB1J473J	CHIP R 47K J 1/16W	
CP38			RK74HB1J102J	CHIP-COM 1.0K J 1/16W		R93			RK73HB1J393J	CHIP R 39K J 1/16W	
CP40			RK74HB1J102J	CHIP-COM 1.0K J 1/16W		R94			RK73HB1J684J	CHIP R 680K J 1/16W	
CP42,43			RK75HA1J102J	CHIP-COM 1.0K J 1/16W		R95,96		*	RK73HB1J102J	CHIP R 1.0K J 1/16W	
CP44			RK75HA1J474J	CHIP-COM 470K J 1/16W		R97		*	RK73HB1J474J	CHIP R 470K J 1/16W	
CP45-47			RK75HA1J102J	CHIP-COM 1.0K J 1/16W		R98,99		*	RK73HB1J473J	CHIP R 47K J 1/16W	
CP48,49			RK74HB1J102J	CHIP-COM 1.0K J 1/16W		R100			RK73HB1J223J	CHIP R 22K J 1/16W	
CP50			RK75HA1J102J	CHIP-COM 1.0K J 1/16W		R101			RK73HB1J103J	CHIP R 10K J 1/16W	
CP54			RK75HA1J473J	CHIP-COM 47K J 1/16W		R102		*	RK73HB1J473J	CHIP R 47K J 1/16W	
R1			R92-1252-05	CHIP R 0 OHM J 1/16W		R103			RK73HB1J105J	CHIP R 1.0M J 1/16W	
R2			RK73HB1J153J	CHIP R 15K J 1/16W		R104			RK73HB1J103J	CHIP R 10K J 1/16W	
R7		*	RK73HB1J102J	CHIP R 1.0K J 1/16W		R105			RK73HB1J472J	CHIP R 4.7K J 1/16W	
R8			RK73HB1J272J	CHIP R 2.7K J 1/16W		R106		*	RK73HB1J473J	CHIP R 47K J 1/16W	
R9			RK73HB1J332J	CHIP R 3.3K J 1/16W		R107			RK73HB1J564J	CHIP R 560K J 1/16W	
R11		*	RK73HB1J473J	CHIP R 47K J 1/16W		R108			RK73HB1J334J	CHIP R 330K J 1/16W	
R12			RK73HB1J334J	CHIP R 330K J 1/16W		R109			RK73HB1J824J	CHIP R 820K J 1/16W	
R13			RK73HB1J332J	CHIP R 3.3K J 1/16W		R111			RK73HB1J824J	CHIP R 820K J 1/16W	
R14		*	RK73HB1J102J	CHIP R 1.0K J 1/16W		R112			RK73HB1J334J	CHIP R 330K J 1/16W	
R15			RK73HB1J272J	CHIP R 2.7K J 1/16W		R113			R92-1368-05	CHIP R 0 OHM	
R16			RK73HB1J331J	CHIP R 330 J 1/16W		R114			RK73HB1J184J	CHIP R 180K J 1/16W	
R17			RK73HB1J821J	CHIP R 820 J 1/16W		R115			RK73GB1J103J	CHIP R 10K J 1/16W	
R18			RK73GB1J100J	CHIP R 10 J 1/16W		R116			RK73HB1J393J	CHIP R 39K J 1/16W	
R20			RK73HB1J103J	CHIP R 10K J 1/16W		R117			RK73HB1J683J	CHIP R 68K J 1/16W	
R21			RK73HB1J821J	CHIP R 820 J 1/16W		R119			RK73HB1J101J	CHIP R 100 J 1/16W	
R22,23			R92-1368-05	CHIP R 0 OHM		R121			RK73HB1J184J	CHIP R 180K J 1/16W	
R24			RK73HB1J224J	CHIP R 220K J 1/16W		R122			RK73HB1J104J	CHIP R 100K J 1/16W	
R25			RK73HB1J153J	CHIP R 15K J 1/16W		R125			RK73GB1J152J	CHIP R 1.5K J 1/16W	
R26			R92-1368-05	CHIP R 0 OHM		R129			RK73HB1J105J	CHIP R 1.0M J 1/16W	
R27,28			RK73HH1J474D	CHIP R 470K D 1/16W		R130		*	RK73HB1J474J	CHIP R 470K J 1/16W	
R31			RK73HB1J103J	CHIP R 10K J 1/16W		R131,132			R92-1368-05	CHIP R 0 OHM	
R36			RK73GB1J433J	CHIP R 43K J 1/16W		R134			RK73HB1J154J	CHIP R 150K J 1/16W	
R37			RK73HB1J103J	CHIP R 10K J 1/16W		R135			R92-1368-05	CHIP R 0 OHM	
R39,40		*	RK73HB1J473J	CHIP R 47K J 1/16W		R137			RK73HB1J223J	CHIP R 22K J 1/16W	
R42-44			RK73HB1J103J	CHIP R 10K J 1/16W		R139			RK73HB1J103J	CHIP R 10K J 1/16W	
R45,46		*	RK73HB1J102J	CHIP R 1.0K J 1/16W		R140		*	RK73HB1J102J	CHIP R 1.0K J 1/16W	
R48-52		*	RK73HB1J473J	CHIP R 47K J 1/16W		R141			RK73HB1J105J	CHIP R 1.0M J 1/16W	
R53		*	RK73HB1J474J	CHIP R 470K J 1/16W		R142			RK73HB1J223J	CHIP R 22K J 1/16W	
R54		*	RK73HB1J102J	CHIP R 1.0K J 1/16W		R143		*	RK73HB1J473J	CHIP R 47K J 1/16W	
R55,56		*	RK73HB1J474J	CHIP R 470K J 1/16W		R144			RK73HB1J472J	CHIP R 4.7K J 1/16W	
R57			RK73HB1J103J	CHIP R 10K J 1/16W		R145			RK73HB1J154J	CHIP R 150K J 1/16W	

PARTS LIST

TX-RX UNIT (X57-7000-XX)

Ref. No.	Address	New parts	Parts No.	Description	Destination	Ref. No.	Address	New parts	Parts No.	Description	Destination
R146			RK73HB1J105J	CHIP R 1.0M J 1/16W		R232			RK73HB1J153J	CHIP R 15K J 1/16W	
R147			RK73HB1J103J	CHIP R 10K J 1/16W		R236			RK73HB1J124J	CHIP R 120K J 1/16W	
R149			RK73HB1J105J	CHIP R 1.0M J 1/16W		R239			RK73HB1J104J	CHIP R 100K J 1/16W	
R150			RK73HB1J153J	CHIP R 15K J 1/16W		R240		*	RK73HB1J474J	CHIP R 470K J 1/16W	
R151			RK73HB1J183J	CHIP R 18K J 1/16W		R241		*	RK73HB1J473J	CHIP R 47K J 1/16W	
R152			RK73HB1J105J	CHIP R 1.0M J 1/16W		R242			RK73HB1J104J	CHIP R 100K J 1/16W	
R153			RK73HB1J332J	CHIP R 3.3K J 1/16W		R243		*	RK73HB1J474J	CHIP R 470K J 1/16W	
R154			RK73HB1J683J	CHIP R 68K J 1/16W		R244		*	RK73HB1J473J	CHIP R 47K J 1/16W	
R155			RK73HB1J223J	CHIP R 22K J 1/16W		R245			RK73HB1J103J	CHIP R 10K J 1/16W	
R156-158			RK73HB1J334J	CHIP R 330K J 1/16W		R246			RK73HB1J223J	CHIP R 22K J 1/16W	
R159		*	RK73HB1J474J	CHIP R 470K J 1/16W		R247			RK73HB1J184J	CHIP R 180K J 1/16W	
R160			RK73HB1J224J	CHIP R 220K J 1/16W		R248			R92-1252-05	CHIP R 0 OHM J 1/16W	
R161,162			RK73HB1J124J	CHIP R 120K J 1/16W		R250			R92-1252-05	CHIP R 0 OHM J 1/16W	
R163			RK73HB1J393J	CHIP R 39K J 1/16W		R251		*	RK73HB1J474J	CHIP R 470K J 1/16W	
R164			RK73HB1J184J	CHIP R 180K J 1/16W		R254,255		*	RK73HB1J474J	CHIP R 470K J 1/16W	
R165			RK73HB1J154J	CHIP R 150K J 1/16W		R259			RK73HB1J103J	CHIP R 10K J 1/16W	
R166			RK73HB1J103J	CHIP R 10K J 1/16W		R261			RK73HB1J103J	CHIP R 10K J 1/16W	
R167			RK73GB1J104J	CHIP R 100K J 1/16W		R262		*	RK73HB1J473J	CHIP R 47K J 1/16W	
R168		*	RK73HB1J474J	CHIP R 470K J 1/16W		R501			R92-1368-05	CHIP R 0 OHM	
R169			RK73HB1J223J	CHIP R 22K J 1/16W		R502		*	RK73HB1J102J	CHIP R 1.0K J 1/16W	
R170			R92-1252-05	CHIP R 0 OHM J 1/16W		R503			RK73HB1J100J	CHIP R 10 J 1/16W	
R171			R92-1368-05	CHIP R 0 OHM		R504			RK73HB1J103J	CHIP R 10K J 1/16W	
R172			RK73HB1J684J	CHIP R 680K J 1/16W		R505		*	RK73HB1J102J	CHIP R 1.0K J 1/16W	
R173			RK73HB1J184J	CHIP R 180K J 1/16W		R506			RK73HB1J154J	CHIP R 150K J 1/16W	
R174			RK73HB1J123J	CHIP R 12K J 1/16W		R507			RK73HB1J470J	CHIP R 47 J 1/16W	
R175			RK73HB1J103J	CHIP R 10K J 1/16W		R508			RK73HB1J100J	CHIP R 10 J 1/16W	
R176			RK73HB1J683J	CHIP R 68K J 1/16W		R509			RK73HB1J332J	CHIP R 3.3K J 1/16W	
R177			R92-1368-05	CHIP R 0 OHM		R510			RK73HB1J100J	CHIP R 10 J 1/16W	
R178		*	RK73HB1J102J	CHIP R 1.0K J 1/16W		R511,512			R92-1368-05	CHIP R 0 OHM	
R180			RK73HB1J103J	CHIP R 10K J 1/16W		R513			RK73HB1J470J	CHIP R 47 J 1/16W	
R181			R92-1368-05	CHIP R 0 OHM		R514,515		*	RK73HB1J102J	CHIP R 1.0K J 1/16W	
R183			RK73HB1J103J	CHIP R 10K J 1/16W		R516			RK73HB1J471J	CHIP R 470 J 1/16W	
R187		*	RK73HB1J473J	CHIP R 47K J 1/16W		R517			RK73HB1J472J	CHIP R 4.7K J 1/16W	
R189,190			R92-1368-05	CHIP R 0 OHM		R518			RK73HB1J103J	CHIP R 10K J 1/16W	
R192,193			RK73HB1J104J	CHIP R 100K J 1/16W		R519			RK73HB1J472J	CHIP R 4.7K J 1/16W	
R194,195		*	RK73HB1J102J	CHIP R 1.0K J 1/16W		R520,521			RK73HB1J103J	CHIP R 10K J 1/16W	
R196			RK73HB1J151J	CHIP R 150 J 1/16W		R522			RK73HB1J184J	CHIP R 180K J 1/16W	
R198			R92-1252-05	CHIP R 0 OHM J 1/16W		R523			RK73HB1J220J	CHIP R 22 J 1/16W	
R199		*	RK73HB1J102J	CHIP R 1.0K J 1/16W		R525			RK73HB1J274J	CHIP R 270K J 1/16W	
R200		*	RK73HB1J473J	CHIP R 47K J 1/16W		R527			RK73HB1J683J	CHIP R 68K J 1/16W	
R202		*	RK73HB1J102J	CHIP R 1.0K J 1/16W		R528			RK73HB1J331J	CHIP R 330 J 1/16W	
R203			RK73HB1J222J	CHIP R 2.2K J 1/16W		R529			RK73HB1J181J	CHIP R 180 J 1/16W	
R204			RK73HB1J104J	CHIP R 100K J 1/16W		R530			RK73HB1J271J	CHIP R 270 J 1/16W	
R206			R92-1368-05	CHIP R 0 OHM		R531,532			RK73HB1J220J	CHIP R 22 J 1/16W	
R207			RK73HB1J154J	CHIP R 150K J 1/16W		R533			RK73HB1J472J	CHIP R 4.7K J 1/16W	
R210			RK73HB1J471J	CHIP R 470 J 1/16W		R534			RK73HB1J154J	CHIP R 150K J 1/16W	
R211		*	RK73HB1J474J	CHIP R 470K J 1/16W		R535			RK73HB1J101J	CHIP R 100 J 1/16W	
R212			RK73GB1J101J	CHIP R 100 J 1/16W		R536			RK73HB1J472J	CHIP R 4.7K J 1/16W	
R213			RK73HB1J101J	CHIP R 100 J 1/16W		R540			RK73HB1J332J	CHIP R 3.3K J 1/16W	
R214			RK73HB1J182J	CHIP R 1.8K J 1/16W		R541			RK73HB1J103J	CHIP R 10K J 1/16W	
R215			RK73HB1J334J	CHIP R 330K J 1/16W		R542			RK73HB1J331J	CHIP R 330 J 1/16W	
R216			RK73HB1J274J	CHIP R 270K J 1/16W		R543			RK73HB1J222J	CHIP R 2.2K J 1/16W	
R217,218			R92-1252-05	CHIP R 0 OHM J 1/16W		R545			RK73HB1J333D	CHIP R 33K D 1/16W	
R220			RK73GB1J222J	CHIP R 2.2K J 1/16W		R546			RK73HB1J104D	CHIP R 100K D 1/16W	
R221		*	RK73HB1J473J	CHIP R 47K J 1/16W		R548			RK73HB1J472J	CHIP R 4.7K J 1/16W	
R222,223		*	RK73HB1J102J	CHIP R 1.0K J 1/16W		R549			RK73HB1J470J	CHIP R 47 J 1/16W	
R224,225			RK73HB1J104J	CHIP R 100K J 1/16W		R550			R92-1368-05	CHIP R 0 OHM	
R226			RK73HB1J184J	CHIP R 180K J 1/16W		R601			RK73HB1J472J	CHIP R 4.7K J 1/16W	
R229,230			RK73HB1J123J	CHIP R 12K J 1/16W		R602			R92-1252-05	CHIP R 0 OHM J 1/16W	
R231			RK73HB1J103J	CHIP R 10K J 1/16W		R611			RK73HB1J823J	CHIP R 82K J 1/16W	

PARTS LIST

TX-RX UNIT (X57-7000-XX)

Ref. No.	Address	New parts	Parts No.	Description	Destination	Ref. No.	Address	New parts	Parts No.	Description	Destination
R612			RK73HB1J101J	CHIP R 100 J 1/16W		R749			RK73HB1J184J	CHIP R 180K J 1/16W	
R613		*	RK73HB1J473J	CHIP R 47K J 1/16W		R750			RK73HB1J150J	CHIP R 15 J 1/16W	
R614			RK73HB1J331J	CHIP R 330 J 1/16W		R751			R92-1368-05	CHIP R 0 OHM	
R616			R92-1368-05	CHIP R 0 OHM		R752,753			RK73HB1J105J	CHIP R 1.0M J 1/16W	
R618			RK73HB1J101J	CHIP R 100 J 1/16W		R754,755			R92-0670-05	CHIP R 0 OHM	
R619			RK73HB1J103J	CHIP R 10K J 1/16W		R759			R92-1252-05	CHIP R 0 OHM J 1/16W	
R621			RK73EB2ER39K	CHIP R 0.39 K 1/4W		R760,761			R92-1368-05	CHIP R 0 OHM	
R622			RK73HB1J270J	CHIP R 27 J 1/16W		R901-903			RK73HB1J471J	CHIP R 470 J 1/16W	
R623			RK73EB2ER39K	CHIP R 0.39 K 1/4W		R912			RK73HB1J101J	CHIP R 100 J 1/16W	
R624		*	RK73HB1J473J	CHIP R 47K J 1/16W		R913			RK73HB1J471J	CHIP R 470 J 1/16W	
R625			RK73HB1J151J	CHIP R 150 J 1/16W		R918			RK73HB1J470J	CHIP R 47 J 1/16W	
R626			R92-1252-05	CHIP R 0 OHM J 1/16W		R921,922			RK73HB1J101J	CHIP R 100 J 1/16W	
R627			RK73HB1J123J	CHIP R 12K J 1/16W		R923			R92-1252-05	CHIP R 0 OHM J 1/16W	
R628			RK73HB1J392J	CHIP R 3.9K J 1/16W		S1			S70-0424-05	TACT SWITCH	
R629			RK73EB2ER39K	CHIP R 0.39 K 1/4W		S2			S70-0457-05	TACT SWITCH	
R630,631			RK73HH1J104D	CHIP R 100K D 1/16W		S3,4			S70-0424-05	TACT SWITCH	
R632,633			RK73HH1J334D	CHIP R 330K D 1/16W		D1			RB521S-30	DIODE	
R634			RK73HB1J103J	CHIP R 10K J 1/16W		D4			MA2S111	DIODE	
R635		*	RK73HB1J473J	CHIP R 47K J 1/16W		D14			MA2S111	DIODE	
R636			R92-1368-05	CHIP R 0 OHM		D16,17			MA2S111	DIODE	
R637			RK73HB1J103J	CHIP R 10K J 1/16W		D24-27			MA2S111	DIODE	
R638		*	RK73HB1J474J	CHIP R 470K J 1/16W		D28-31			RB706F-40	DIODE	
R639			RK73HB1J154J	CHIP R 150K J 1/16W		D32			DA221	DIODE	
R640		*	RK73HB1J474J	CHIP R 470K J 1/16W		D501-503			HSC277	DIODE	
R642			RK73HB1J820J	CHIP R 82 J 1/16W		D504-511		*	1SV325F	VARIABLE CAPACITANCE DIODE	
R643		*	RK73HB1J473J	CHIP R 47K J 1/16W		D512			HSC277	DIODE	
R645,646			RK73GB1J271J	CHIP R 270 J 1/16W		D513		*	1SV278F	VARIABLE CAPACITANCE DIODE	
R647			R92-1252-05	CHIP R 0 OHM J 1/16W		D514			HSC277	DIODE	
R648			R92-1368-05	CHIP R 0 OHM		D517,518			HSC277	DIODE	
R701			RK73HB1J103J	CHIP R 10K J 1/16W		D601			UDZS4.7B	ZENER DIODE	
R702,703			RK73HB1J472J	CHIP R 4.7K J 1/16W		D604-606			HVC131	DIODE	
R704			RK73HB1J334J	CHIP R 330K J 1/16W		D608			HVC131	DIODE	
R705,706			RK73HB1J472J	CHIP R 4.7K J 1/16W		D609		*	Q2DZ15F-(X,Y)	ZENER DIODE	
R707			RK73HB1J101J	CHIP R 100 J 1/16W		D610		*	AVRM1608270MAB	VARIATOR	
R708			RK73HB1J103J	CHIP R 10K J 1/16W		D701,702			DAN235E	DIODE	
R710		*	RK73HB1J102J	CHIP R 1.0K J 1/16W		D703-706		*	1SV323F	VARIABLE CAPACITANCE DIODE	
R711		*	RK73HB1J474J	CHIP R 470K J 1/16W		D901			1SR154-400	DIODE	
R713			RK73HB1J334J	CHIP R 330K J 1/16W		IC1		*	XC61CC5002NR	MOS-IC	
R715,716			RK73HB1J332J	CHIP R 3.3K J 1/16W		IC2			XC6204B502PR	MOS-IC	
R717			RK73HB1J272J	CHIP R 2.7K J 1/16W		IC3		*	XC61CN3402NR	MOS-IC	
R718			RK73HB1J100J	CHIP R 10 J 1/16W		IC4,5			BU4094BCFV	MOS-IC	
R719			RK73HB1J332J	CHIP R 3.3K J 1/16W		IC6			LC75834W	MOS-IC	
R721			RK73HB1J124J	CHIP R 120K J 1/16W		IC7		*	30625MGP234HU	MICROPROCESSOR IC	
R722			RK73HB1J101J	CHIP R 100 J 1/16W		IC8			AT29C040A-90TU	ROM IC	
R726			RK73HB1J224J	CHIP R 220K J 1/16W		IC9			CAT24WC64JI	ROM IC	
R727			RK73HB1J681J	CHIP R 680 J 1/16W		IC10-12		*	TK62012F	MOS-IC	
R728			RK73HB1J471J	CHIP R 470 J 1/16W		IC13			AQUA-L	MOS-IC	
R729			RK73HB1J101J	CHIP R 100 J 1/16W		IC14		*	TC7W53FK(F)	MOS-IC	
R731			RK73HB1J222J	CHIP R 2.2K J 1/16W		IC15		*	TK62012F	MOS-IC	
R732			RK73HB1J391J	CHIP R 390 J 1/16W		IC16		*	M62364FP-F	MOS-IC	
R733			RK73HB1J563J	CHIP R 56K J 1/16W		IC17		*	TK62012F	MOS-IC	
R734			RK73HB1J104J	CHIP R 100K J 1/16W		IC18			TA7368F	MOS-IC	
R735			RK73HB1J563J	CHIP R 56K J 1/16W		IC19		*	TC75S51FE(F)	MOS-IC	
R736			RK73HB1J104J	CHIP R 100K J 1/16W		IC501			ADF4111BCP7	MOS-IC	
R738,739			RK73HB1J105J	CHIP R 1.0M J 1/16W		IC601		*	TA75W01FUF	MOS-IC	
R740			RK73HB1J471J	CHIP R 470 J 1/16W		IC701		*	TA31136FNG	MOS-IC	
R741			RK73HB1J470J	CHIP R 47 J 1/16W		Q1			UMG3N	TRANSISTOR	
R742			RK73HB1J471J	CHIP R 470 J 1/16W		Q4			FP210	TRANSISTOR	
R745			RK73HB1J104J	CHIP R 100K J 1/16W		Q5			UPA672T	FET	
R748			RK73HB1J104J	CHIP R 100K J 1/16W							

PARTS LIST

TX-RX UNIT (X57-7000-XX)

Ref. No.	Address	New parts	Parts No.	Description	Destination	Ref. No.	Address	New parts	Parts No.	Description	Destination
Q6			UMG3N	TRANSISTOR							
Q7			UPA672T	FET							
Q8			DTA114EE	DIGITAL TRANSISTOR							
Q9		*	SSM6J08FU(F)	FET							
Q12			2SC4617(S)	TRANSISTOR							
Q13			2SB1132(Q,R)	TRANSISTOR							
Q14,15		*	SSM3K15TE(F)	FET							
Q16			2SA1774(S)	TRANSISTOR							
Q17			2SC4649(N,P)	TRANSISTOR							
Q19		*	SSM3K15TE(F)	FET							
Q21		*	RN4910(F)	TRANSISTOR							
Q22		*	SSM3K15TE(F)	FET							
Q23			DTC144EE	DIGITAL TRANSISTOR							
Q24		*	SSM6J08FU(F)	FET							
Q25		*	2SK1830F	FET							
Q26		*	2SJ347F	FET							
Q27			DTC144EE	DIGITAL TRANSISTOR							
Q28		*	SSM3K01T(F)	FET							
Q29		*	SSM3K15TE(F)	FET							
Q30			2SJ243	FET							
Q31,32			2SC4649(N,P)	TRANSISTOR							
Q33		*	2SJ347F	FET							
Q34		*	SSM3K15TE(F)	FET							
Q35		*	SSM3K01T(F)	FET							
Q501			2SC5488	TRANSISTOR							
Q502,503			2SK508NV(K52)	FET							
Q504		*	SSM6P05FU(F)	FET							
Q505			2SC4617(S)	TRANSISTOR							
Q506,507			2SC5488	TRANSISTOR							
Q602		*	2SK3077F	FET							
Q603			RD01MUS1	FET							
Q604			RD07MVS1	FET							
Q605			DTC114EE	DIGITAL TRANSISTOR							
Q607			DTC114EE	DIGITAL TRANSISTOR							
Q608			DTA144EE	DIGITAL TRANSISTOR							
Q609		*	SSM3K15TE(F)	FET							
Q701			2SC4649(N,P)	TRANSISTOR							
Q702			DTA144EE	DIGITAL TRANSISTOR							
Q703			2SC4649(N,P)	TRANSISTOR							
Q704			3SK318	FET							
Q705		*	3SK294(F)	FET							
TH501			B57331V2104J	THERMISTOR							
TH701,702			B57331V2104J	THERMISTOR							

EXPLODED VIEW

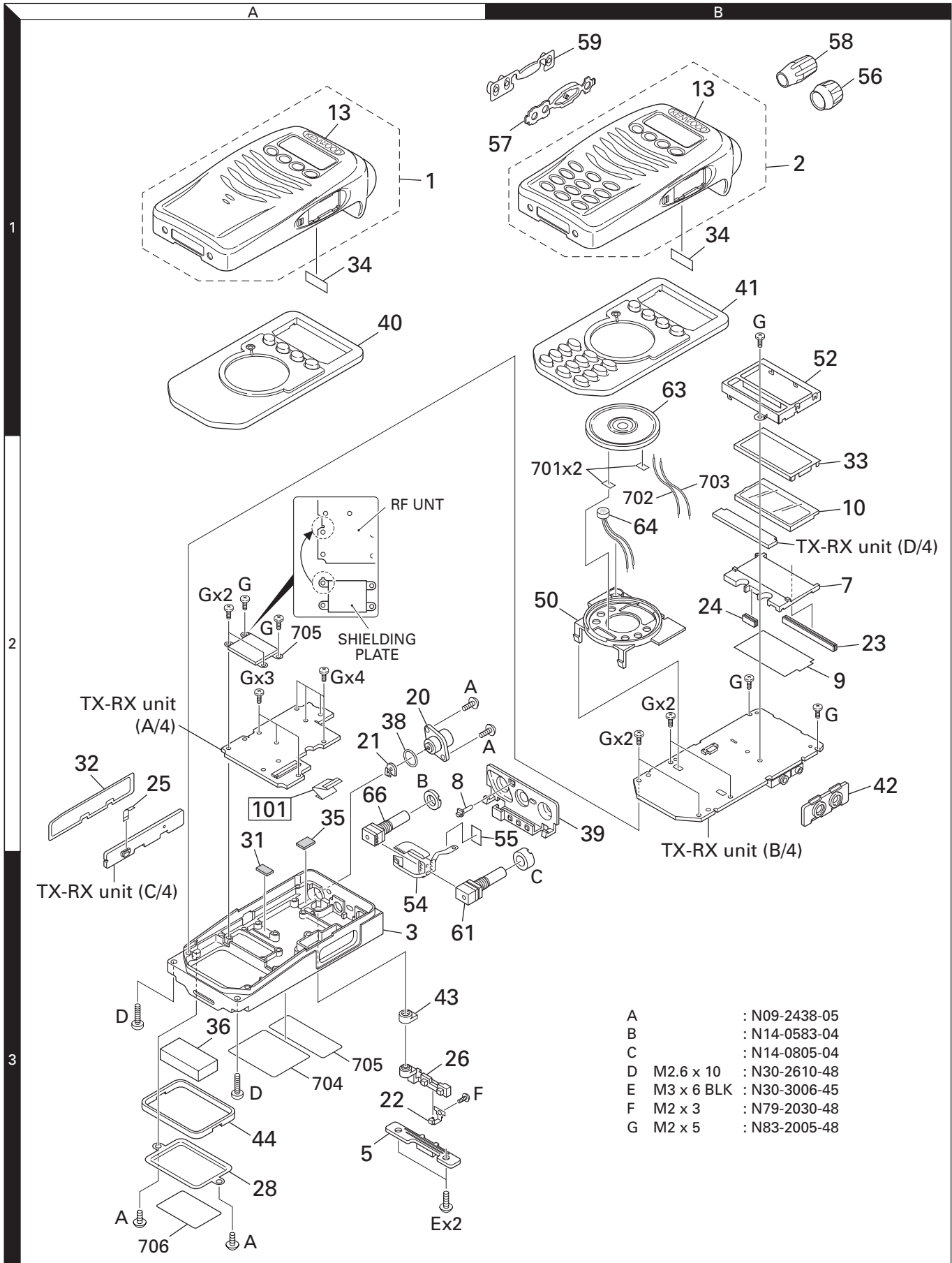

Parts with the exploded numbers larger than 700 are not supplied.

PACKING

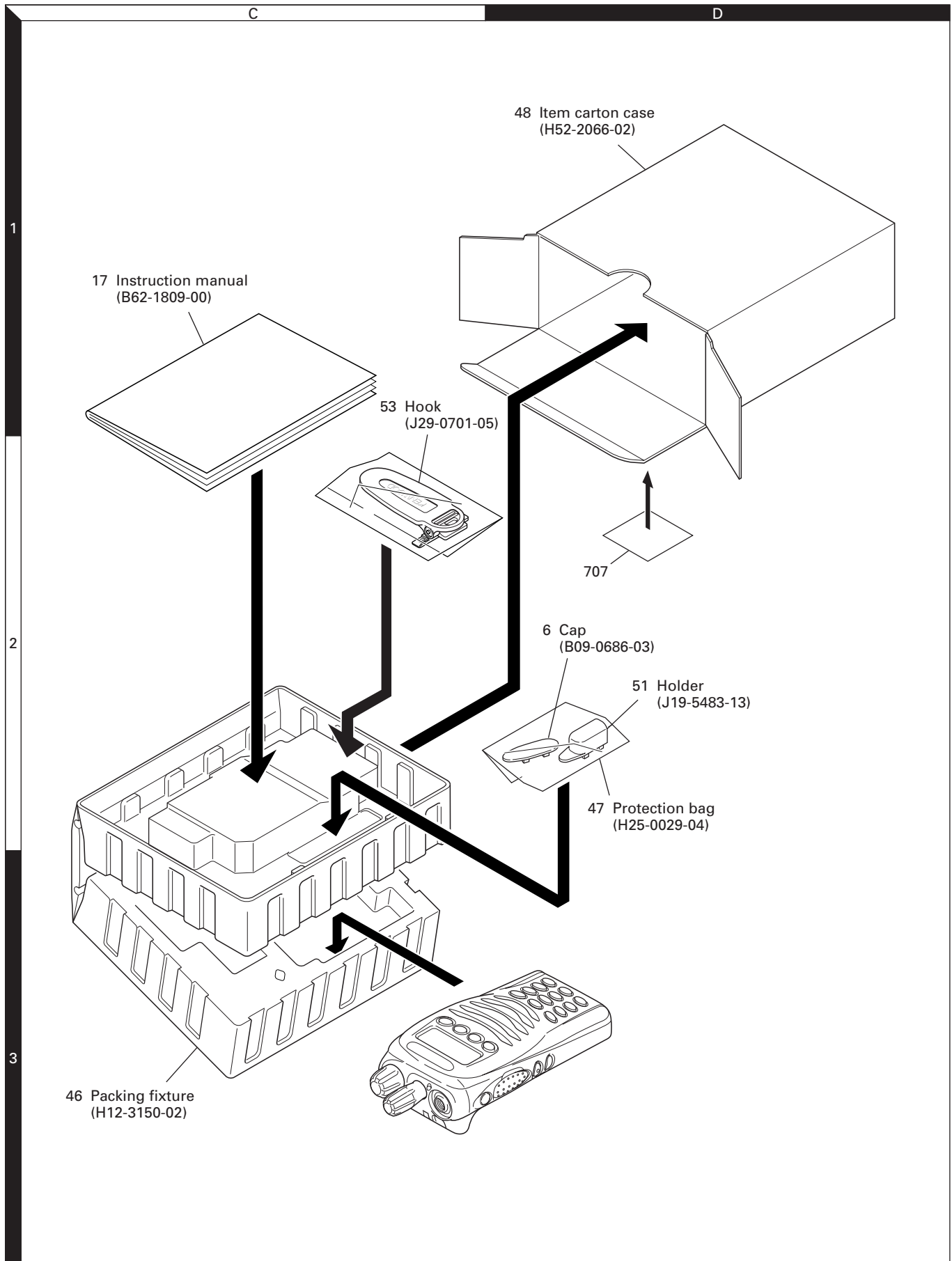

ADJUSTMENT

Controls

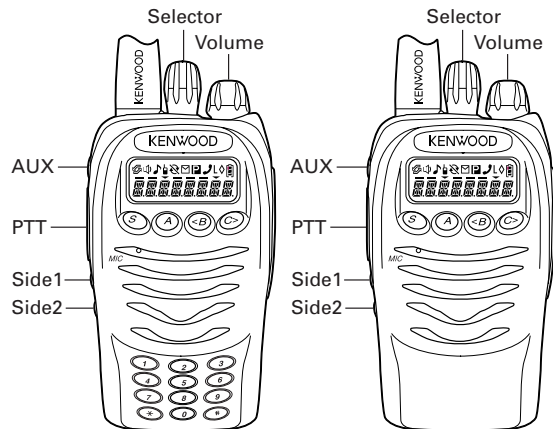

Panel Test Mode

■ Test mode operation features

This transceiver has a test mode. **To enter test mode, press [A] key and turn power on. Hold [A] key until frequency version appears on LCD.** Test mode can be inhibited by programming. To exit test mode, switch the power on again. The following functions are available in test mode.

■ Key operation

Key	Function	Display
[S]	Shifts to Panel tuning mode	-
[A]	Low transmit power	"L" appears
[B]	MSK 1200bps and 2400bps	2400bps : <input checked="" type="checkbox"/> icon appears
[C]	Test signaling CH up	Signaling No.
[Selector]	Test frequency CH up/down	Channel No.
[Side1]	Squelch on/off	🔊
[Side2]	Narrow/Wide	Narrow : "N", Wide : "W"
[PTT]	Transmit	-
[0] to [9] and [#],[*]	Use as the DTMF keypad. If a key is pressed during transmission, the DTMF corresponding to the key that was presses is sent.	-
[AUX]	Segment check	All segment appears

Note :

- If a [S], [A], [B], [C] key is pressed during transmission, the DTMF corresponding to the key that was pressed is sent.

• LED indicator

- Red LED Lights during transmission. Blinks at the low battery voltage warning.
- Green LED Lights when there is carrier.

• LCD display in panel test mode

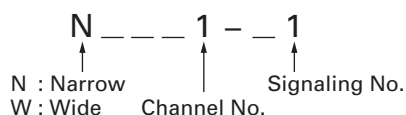

■ Frequency and Signaling

The set has been adjusted for the frequencies shown in the following table. When required, readjust them following the adjustment procedure to obtain the frequencies you want in actual operation.

• Test frequency

CH	RX (MHz)	TX (MHz)
1	155.05000	155.10000
2	136.05000	136.10000
3	173.95000	173.90000
4	144.55000	145.60000
5	164.55000	164.60000
6	155.00000	155.00000
7	155.20000	155.20000
8	155.40000	155.40000
9~16	-	-

• Test signaling

No.	RX	TX
1	None	None
2	None	100Hz Square Wave
4	QT : 67.0Hz	QT : 67.0Hz
5	QT : 151.4Hz	QT : 151.4Hz
6	QT : 210.7Hz	QT : 210.7Hz
7	QT : 254.1Hz	QT : 254.1Hz
8	DQT : 023N	DQT : 023N
9	DQT : 754I	DQT : 754I
10	DTMF : 159D	DTMF : 159D
11	None	DTMF Code 9
12	2-tone : A : 304.7Hz B : 3106.0Hz	2-tone : A : 304.7Hz B : 3106.0Hz
13	Single Tone : 979.9Hz	Single Tone : 979.9Hz
14	None	Single Tone : 1000Hz
15	Skip	Skip
16	None	MSK
17	MSK : Preamble : 0xAAAA Sync : 0x23EB Data : 0x230960C6AAAA CRC : 0xC4D7	MSK : Preamble : 0xAAAA Sync : 0x23EB Data : 0x230960C6AAAA CRC : 0xC4D7

ADJUSTMENT

Panel Tuning Mode

■ Preparations for tuning the transceiver

Before attempting to tune the transceiver, connect the unit to a suitable power supply.

Whenever the transmitter is turned, the unit must be connected to a suitable dummy load (i.e. power meter).

The speaker output connector must be terminated with a 8Ω dummy load and connected to an AC voltmeter and an audio distortion meter or a SINAD measurement meter at all times during tuning.

■ Transceiver tuning

(To place transceiver in tuning mode)

Press [S] key, now in tuning mode. Use [B] key to write tuning data through tuning modes, and [Selector] to adjust tuning requirements (1 to 256 appears on LCD).

Use [C] key to select the adjustment item through tuning modes. Use [A] key to adjust 3 or 5 reference level adjustments, and use [Side2] key to switch between Wide/Narrow.

Channel appears on LCD. Set channel according to tuning requirements.

• LCD display in panel tuning mode

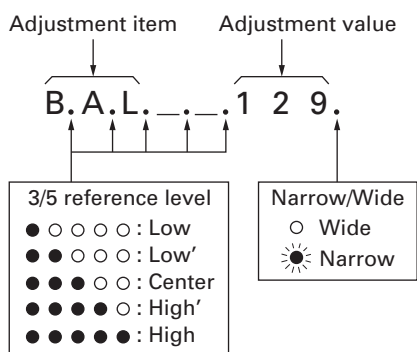

■ 3 or 5 reference level adjustments frequency

Tuning point	RX (MHz)	TX (MHz)
Low	136.05000	136.10000
Low'	145.55000	145.60000
Center	155.05000	155.10000
High'	164.55000	164.60000
High	173.95000	173.90000

■ Adjustment item and Display

(*** : 1~256, MSK only : 1~64)

Order	Adjustment item	Display
1	Frequency	F R E Q _ * * *
2	High power	H P W R _ * * *
3	Low power	L P W R _ * * *
4	Balance	B A L _ _ * * *
5	Max deviation	D E V _ _ * * *
6	VOX 1	V X 1 _ _ * * *
7	VOX 10	V X 1 0 _ * * *
8	QT	Q T _ _ _ * * *
9	DQT	D Q T _ _ * * *
10	DTMF	D T M F _ * * *
11	MSK	M S K _ _ * * *
12	Tone	T O N E _ * * *
13	Sensitivity	S E N S _ * * *
14	Squelch	S Q L _ _ * * *
15	Low RSSI	L R S S I _ * * *
16	Squelch tight	S Q L T _ * * *
17	High RSSI	H R S S I _ * * *
18	Battery	B A T T _ * * *

■ Key operation

Key	Function	
	Push	Hold (1 second)
[S]	End of panel tuning mode	-
[A]	To enter 3 or 5 reference level adjustments	-
[B]	Writes the adjustment value	-
[C]	Go to next adjustment item	Back to last adjustment item
[Selector]	Adjustment value up/down	
[Volume]	Volume level up/down	
[Side1]	Squelch on/off	-
[Side2]	Selects Narrow, Wide	-
[AUX]	All segment appears	-

ADJUSTMENT

Flow chart

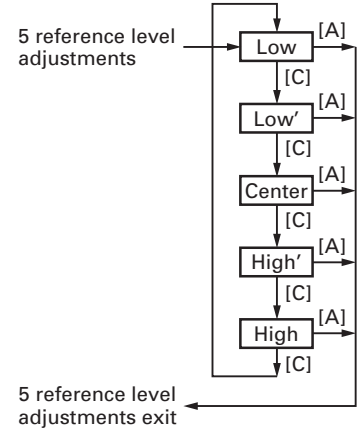
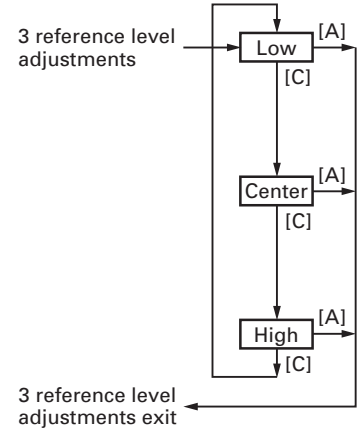
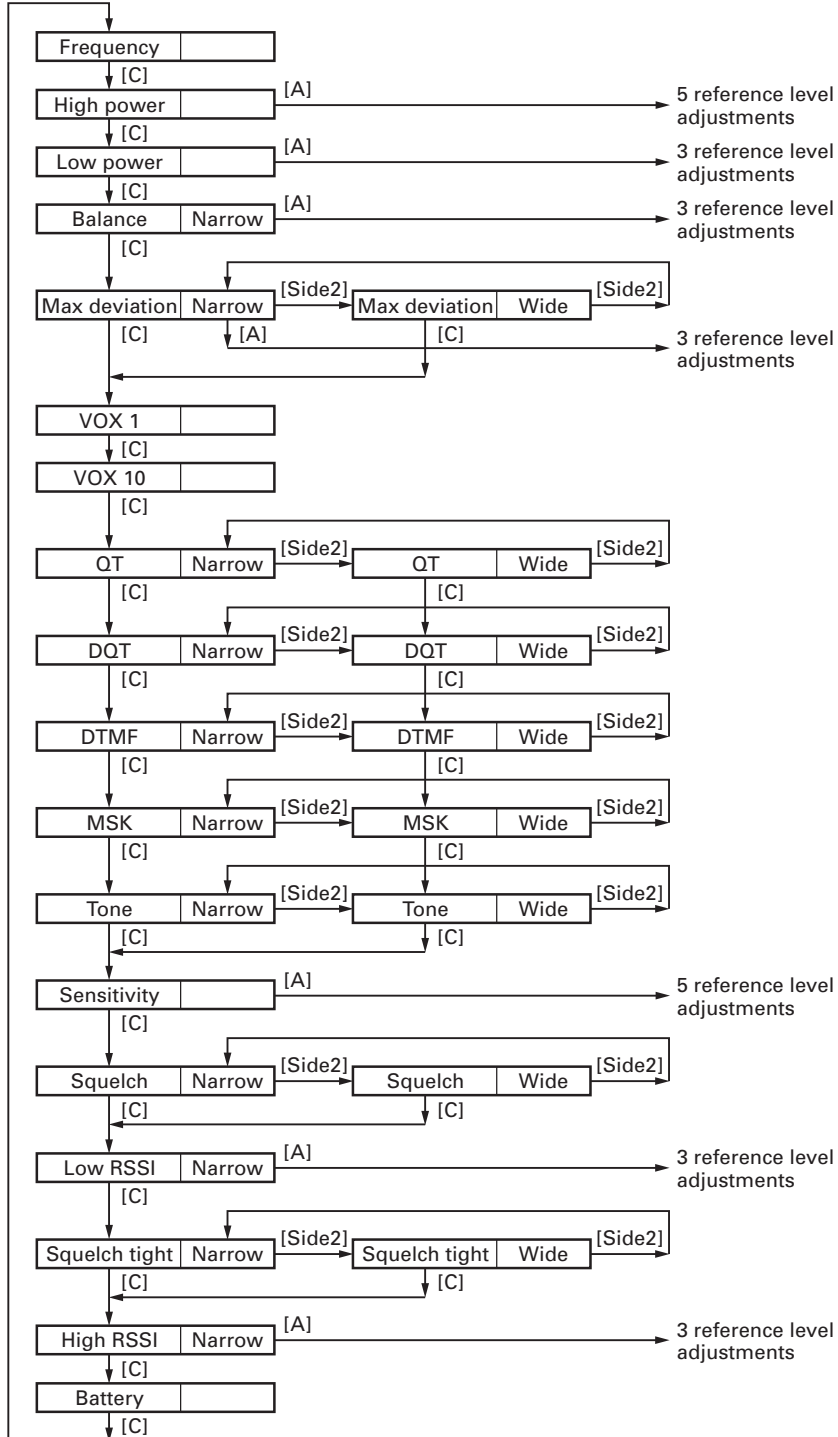

Adjustment Points

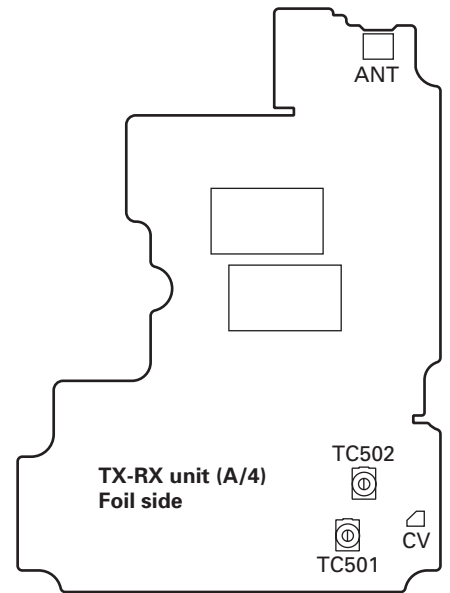

ADJUSTMENT

Test Equipment Required for Alignment

Test Equipment	Major Specifications	
1. Standard Signal Generator (SSG)	Frequency Range	136 to 174MHz
	Modulation	Frequency modulation and external modulation
	Output	-127dBm/0.1μV to greater than -47dBm/1mV
2. Power Meter	Input Impedance	50Ω
	Operation Frequency	136 to 174MHz or more
	Measurement Capability	Vicinity of 10W
3. Deviation Meter	Frequency Range	136 to 174MHz
4. Digital Volt Meter (DVM)	Measuring Range	10mV to 10V DC
	Input Impedance	High input impedance for minimum circuit loading
5. Oscilloscope		DC through 30MHz
6. High Sensitivity Frequency Counter	Frequency Range	10Hz to 1000MHz
	Frequency Stability	0.2ppm or less
7. Ammeter		5A
8. AF Volt Meter (AF VTVM)	Frequency Range	50Hz to 10kHz
	Voltage Range	1mV to 10V
9. Audio Generator (AG)	Frequency Range	50Hz to 5kHz or more
	Output	0 to 1V
10. Distortion Meter	Capability	3% or less at 1kHz
	Input Level	50mV to 10Vrms
11. 8Ω Dummy Load		Approx. 8Ω, 3W
12. Regulated Power Supply		5V to 10V, approx. 5A Useful if ammeter equipped

■ Antenna Connector Adapter

The antenna connector of this radio uses an SMA terminal. Use an antenna connector adapter [SMA(f) – BNC(f) or SMA(f) – N(f)] for adjustment. (The adapter is not provided as an option, so buy a commercially-available one.)

■ Battery Jig (W05-0909-00)

Connect the power cable properly between the battery jig installed in the transceiver and the power supply, and be sure output voltage and the power supply polarity prior to switching the power supply ON, otherwise over voltage and reverse connection may damage the transceiver, or the power supply or both.

When using the battery jig in user mode, the transceiver assumes that a lithium-ion battery pack is attached to the transceiver. In adjustment mode, battery type detection is not performed. Refer to page 26 for details.

Note : When using the battery jig, you must measure the voltage at the terminals of the battery jig. Otherwise, a slight voltage drop may occur within the power cable, between the power supply and the battery jig, especially while the transceiver transmits.

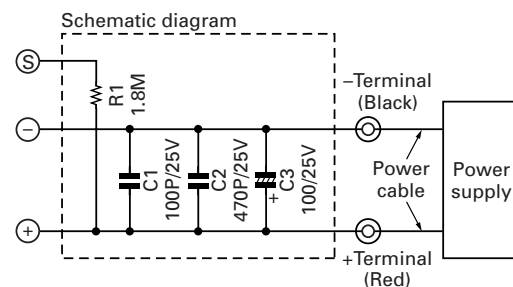
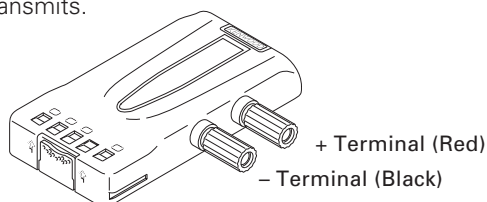

■ Nut wrench

In order to turn the volume nut and the channel selector nut, use a recommendation tool.
KENWOOD part No. : W05-1123-00

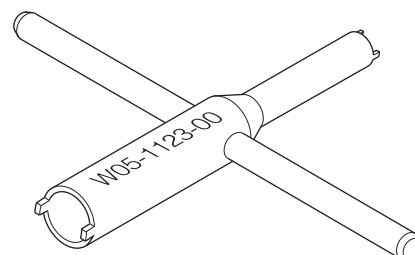

ADJUSTMENT

Common Section

Item	Condition	Measurement			Adjustment			Specifications/Remarks
		Test-equipment	Unit	Terminal	Unit	Parts	Method	
1. Setting	1) BATT terminal voltage : 7.5V 2) SSG standard modulation [Wide] MOD : 1kHz, DEV : 3kHz [Narrow] MOD : 1kHz, DEV : 1.5kHz							
2. VCO lock voltage • RX	[Panel test mode] 1) CH-Sig : 3-1	Power meter	Panel	ANT	TX-RX (A/4)	TC502	3.8V	±0.1V
	2) CH-Sig : 2-1	DVM	TX-RX (A/4)	CV			Check	0.6V or more
	[Panel tuning mode] LPWR* • TX 3) CH-Sig : 3-1 PTT : ON				TX-RX (A/4)	TC501	3.8V	±0.1V
	4) CH-Sig : 2-1 PTT : ON						Check	0.6V or more

* TX can be continued on unlock condition in panel tuning mode.

Transmitter Section

Item	Condition	Measurement			Adjustment			Specifications/Remarks
		Test-equipment	Unit	Terminal	Unit	Parts	Method	
1. Frequency adjust	1) Adj item : [FREQ_] Adjust : [***] CH-Sig : 3-1 PTT : ON	f. counter	Panel	ANT	Panel	Selector knob	High frequency ±50Hz	Note : After replacing the TCXO (X501) align frequency.
2. High power adjust	1) Adj item : [HPWR_] Adjust : [***] 2) Adj item : [H.PWR_] → [H.P.WR_] → [H.P.W.R_] → [H.P.W.R._] → [H.P.W.R.__] Adjust : [***] PTT : ON	Power meter Ammeter					5.0W	±0.1W 2.0A or less
3. High power check	[Panel test mode] 1) CH-Sig : 1-1 PTT : ON						Check	4.5~5.5W 2.1A or less
	2) CH-Sig : 2-1 PTT : ON							
	3) CH-Sig : 3-1 PTT : ON							
4. Low power adjust	1) Adj item : [LPWR_] Adjust : [***] 2) Adj item : [L.PWR_] → [L.P.W.R_] → [L.P.W.R._] → [L.P.W.R.__] Adjust : [***] PTT : ON				Panel	Selector knob	1.0W	±0.1W 1.0A or less

ADJUSTMENT

Item	Condition	Measurement			Adjustment			Specifications/Remarks
		Test-equipment	Unit	Terminal	Unit	Parts	Method	
5. Low power check	[Panel test mode] 1) CH-Sig : 1-1 Set low power (Push [S]) PTT : ON 2) CH-Sig : 2-1 PTT : ON 3) CH-Sig : 3-1 PTT : ON	Power meter Ammeter	Panel	ANT			Check	0.7~1.4W 1.2A or less
6. DQT balance adjust	1) Adj item : [BAL_ _] Adjust : [***.] Deviation meter filter LPF : 3kHz HPF : OFF • Narrow 2) Adj item : [B.AL_ _] → [B.A.L._ _] → [B.A.L._ _] Adjust : [***.] PTT : ON	Deviation meter Oscilloscope AG AF VTVM	Panel	ANT SP/MIC	Panel	Selector knob	Make the demodulation waves into square waves.	
7. Max DEV adjust	1) Adj item : [DEV_ _] Adjust : [***.] AG : 1kHz/75mV at MIC terminal Deviation meter filter LPF : 15kHz HPF : OFF • Narrow 2) Adj item : [D.EV_ _] → [D.E.V._ _] → [D.E.V._ _] Adjust : [***.] PTT : ON							
• Wide	3) Adj item : [DEV_ _] Adjust : [***.] PTT : ON						4.40kHz (According to the larger +, -)	±50Hz
8. MIC sensitivity check	[Panel test mode] 1) CH-Sig : 1-1 AG : 1kHz/15.0mV at MIC terminal PTT : ON						Check	1.3~1.8kHz (Narrow) 2.5~3.5kHz (Wide)
9. VOX1 adjust	1) Adj item : [VOX1_] Adjust : [***] AG : 1kHz/150mV at MIC terminal	AG	Panel	SP/MIC	Panel		After apply signal from AG, press [B] key that numeric will be stored in memory.	
10. VOX10 adjust	1) Adj item : [VOX10] Adjust : [***] AG : 1kHz/2mV at MIC terminal							
11. QT deviation adjust	1) Remove the panel tuning cable assembly from the universal connector. Adj item : [QT_ _ _] Adjust : [***.] Deviation meter filter LPF : 3kHz HPF : OFF PTT : ON • Narrow	Power meter Deviation meter Oscilloscope AG AF VTVM	Panel	ANT SP/MIC	Panel	Selector knob	0.37kHz	±40Hz
• Wide	2) Adj item : [QT_ _ _] Adjust : [***] PTT : ON						0.75kHz	±40Hz

ADJUSTMENT

Item	Condition	Measurement			Adjustment			Specifications/Remarks
		Test-equipment	Unit	Terminal	Unit	Parts	Method	
12. DQT deviation adjust • Narrow	1) Adj item : [DQT_] Adjust : [***.] Deviation meter filter LPF : 3kHz HPF : OFF PTT : ON	Power meter Deviation meter Oscilloscope AG AF VTVM	Panel	ANT SP/MIC	Panel	Selector knob	0.37kHz	±40Hz
	• Wide						2) Adj item : [DQT_] Adjust : [***.] PTT : ON	0.75kHz
13. DTMF deviation adjust • Narrow	1) Adj item : [DTMF_] Adjust : [***.] Deviation meter filter LPF : 15kHz HPF : OFF PTT : ON						1.5kHz	±0.1kHz
	• Wide						2) Adj item : [DTMF_] Adjust : [***.] PTT : ON	3.0kHz
14. MSK deviation adjust • Narrow	1) Adj item : [MSK_] Adjust : [***.] Deviation meter filter LPF : 15kHz HPF : OFF PTT : ON						1.5kHz	±0.1kHz
	• Wide						2) Adj item : [MSK_] Adjust : [***.] PTT : ON	3.0kHz
15. TONE deviation adjust • Narrow	1) Adj item : [TONE_] Adjust : [***.] Deviation meter filter LPF : 15kHz HPF : OFF PTT : ON						1.5kHz	±0.1kHz
	• Wide						2) Adj item : [TONE_] Adjust : [***.] PTT : ON	3.0kHz
16. BATT detection writing	1) Adj item : [BATT_] Adjust : [***.] PTT : ON	Power meter DVM	Panel	ANT BATT terminal	Panel		After pressing the PTT switch, confirm that one predetermined numeric in the range 1 to 256 appears and then press [B] key. That numeric will be stored in memory.	BATT terminal voltage : 5.9V
17. BATT detection check	[Panel test mode] 1) CH-Sig : 1-1 BATT terminal voltage : 6.4V PTT : ON						Check	The transceiver can transmit without causing the LED to blink.
	2) BATT terminal voltage : 5.5V PTT : ON							The transceiver should not transmit and LED blinking.

ADJUSTMENT

Receiver Section

Item	Condition	Measurement			Adjustment			Specifications/Remarks
		Test-equipment	Unit	Terminal	Unit	Parts	Method	
1. Sensitivity adjust	1) Adj item : [SENS_] Adjust : [***] 2) Adj item : [S.ENS_] → [S.E.N.S_] → [S.E.N.S.] → [S.E.N.S.] → [S.E.N.S.] Adjust : [***] SSG output : -103dBm (1.58μV) (MOD : 1kHz±1.5kHz)	SSG AF VTVM Oscilloscope	Panel	ANT SP/MIC	Panel	Selector knob	Adjust for RSSI MAX	Rotate the selector knob and increase the adjustment value starting from "1" to obtain RSSI MAX.
2. Sensitivity check	[Panel test mode] 1) CH-Sig : 1-1 SSG output Wide : -117dBm (0.32μV) (MOD : 1kHz±3kHz) Narrow : -116dBm (0.35μV) (MOD : 1kHz±1.5kHz)						Check	13dB SINAD or more
3. Squelch (Preset) adjust • Narrow	1) Adj item : [SQL_] Adjust : [***] SSG output : -119dBm (0.25μV) (MOD : 1kHz±1.5kHz)				Panel	Selector knob	After input signal from SSG, press [B] key. That numeric will be stored in memory.	After adjusting SQL, check SQL open/close. SSG -118dBm : Open SSG OFF : Close
• Wide	2) Adj item : [SQL_] Adjust : [***] SSG output : -120dBm (0.22μV) (MOD : 1kHz±3.0kHz)							
4. Low RSSI adjust • Narrow	1) Adj item : [LRSSI] Adjust : [***] SSG output : -118dBm (0.28μV) (MOD : 1kHz±1.5kHz)						After input signal from SSG, press [B] key. That numeric will be stored in memory.	
	2) Adj item : [L.RSSI] → [L.R.S.SI] → [L.R.S.S.I.] Adjust : [***]							
5. Squelch (Tight) adjust • Narrow	1) Adj item : [SQLT_] Adjust : [***] SSG output : -115dBm (0.4μV) (MOD : 1kHz±1.5kHz)						After input signal from SSG, press [B] key. That numeric will be stored in memory.	After adjusting SQL, check SQL open/close. SSG -113dBm : Open SSG OFF : Close
• Wide	2) Adj item : [SQLT_] Adjust : [***] SSG output : -116dBm (0.35μV) (MOD : 1kHz±3.0kHz)							
6. High RSSI adjust • Narrow	1) Adj item : [HRSSI] Adjust : [***] SSG output : -70dBm (70.8μV) (MOD : 1kHz±1.5kHz)						After input signal from SSG, press [B] key. That numeric will be stored in memory.	
	2) Adj item : [H.RSSI] → [H.R.S.SI] → [H.R.S.S.I.] Adjust : [***]							

TERMINAL FUNCTION

■ CN60

Pin No.	Pin Name	I/O	Function
1	GND	-	GND
2	SSB	O	Switched B output DC (Battery terminal) $\pm 0.5V$, 150mA max
3	AUX1	I/O	Auxiliary 1 Input: $L \leq 0.45V$, $H \geq 4.7V/25k\Omega$ load Output: $L \leq 0.4V$, $H \geq 4.2V/100k\Omega$ load
4	AUX2	O	Auxiliary 2 Output: $L \leq 0.4V$, $H \geq 4.2V/100k\Omega$ load
5	RXD2	I	RXD Input: $L \leq 0.4V$, $H \geq 4.2V/100k\Omega$ load
6	AUX3	I/O	Auxiliary 3 Input: Active "L", $L \leq 1.0V$, $H \geq 4.0V$ Output: $L \leq 0.4V$, $H \geq 4.2V/100k\Omega$ load
7	AUX4	O	Auxiliary 4 Output: $L \leq 0.4V$, $H \geq 4.2V/100k\Omega$ load
8	AUX5	O	Auxiliary 5 Output: $L \leq 0.4V$, $H \geq 4.2V/100k\Omega$ load
9	TXD2	O	TXD Output: $L \leq 0.4V$, $H \geq 4.2V/100k\Omega$ load
10	TA1	I	Transmit audio 1 Input: $Z_{in} > 22k\Omega$, $350 \pm 50mV_{p-p}$ (Standard modulation)
11	5C	-	5V power supply (50mA max)
12	MIC O	O	TX input Input: $Z_L \geq 2.2k\Omega$, $130 \pm 50mV_{p-p}$ (Standard modulation)
13	TA2	I	Transmit audio 2 Input: $Z_{in} > 22k\Omega$, $350 \pm 50mV_{p-p}$ (Standard modulation)
14	DEO	O	Discriminator audio, 1Vp-p
15	ALT2	I	Alert tone audio 2, 0.5Vp-p
16	ALT1	I	Alert tone audio 1, 0.5Vp-p
17	MIC I	I	MIC signal input (AC coupled) Before pre-emphasis $Z_{in} \geq 22k\Omega$, $130 \pm 50mV_{p-p}$ (Standard modulation)
18	RA O	O	Audio signal output (DC coupled) After de-emphasis $Z_L \geq 30k\Omega$, $1 \pm 0.3V_{p-p}$ (Standard modulation)
19	RA I	I	Audio signal input (DC coupled) After de-emphasis $Z_{in} \geq 15k\Omega$, $1 \pm 0.3V_{p-p}$ (Standard modulation)
20	AUX6	I/O	Auxiliary 6 Input: $L \leq 0.8V$, $H \geq 4.2V$ Output: $L \leq 0.4V$, $H \geq 4.2V/100k\Omega$ load

■ Solder Point Connection

Designation	Function	Condition / Value
MIC I	MIC input	Input sensitivity / impedance (1kHz std. dev.) $500mV_{rms} \pm 100mV$, @ $22k\Omega$ load
MIC O	MIC output	Output voltage / impedance (1kHz, $15mV_{rms}$ MIC input) $60mV_{rms} \pm 20mV$, @ $2.2k\Omega$ load
RA I	Receiver AF input	Input sensitivity / impedance (1kHz rated AF power / Vol. max) $150mV \pm 50mV$, @ $22k\Omega$ load
RA O	Receiver AF output	Output voltage / impedance (1kHz std. mod.) $200mV \pm 50mV$, @ $2.2k\Omega$ load
SP M	Speaker mute	Load $> 100k\Omega$ (Low) $V_{ss} \sim 0.4V$, (High) $V_{dd} - 0.8V \sim V_{dd}$
RXD	RXD	Load $> 100k\Omega$ (Low) $V_{ss} \sim 0.4V$, (High) $V_{dd} - 0.8V \sim V_{dd}$
TXD	TXD	Load $> 100k\Omega$ (Low) $V_{ss} \sim 0.4V$, (High) $V_{dd} - 0.8V \sim V_{dd}$
RSSI	RSSI output	Load $> 100k\Omega$ (Low) $V_{ss} \sim 0.4V$, (High) $V_{dd} - 0.8V \sim V_{dd}$
LSDFO	LSDIN output	Load $> 100k\Omega$ (Low) $V_{ss} \sim 0.4V$, (High) $V_{dd} - 0.8V \sim V_{dd}$
MDSW	Mandown SW input	Load $> 100k\Omega$ (Low) $V_{ss} \sim 0.4V$, (High) $V_{dd} - 0.8V \sim V_{dd}$
5C	DC 5V	Output voltage / 10mA load $5.0V \pm 0.5V$ / 50mA max
DEO	Discriminator signal output	Output voltage / impedance (1kHz std. mod.) $400mV_{rms} \pm 100mV$, @ $2.2k\Omega$ load
ALT	Sidetone input	Input sensitivity / impedance (1kHz rated AF power / Vol. max) $140mV_{rms} \pm 50mV$, @ $22k\Omega$ load
DATA O	Transmit AF input	Input sensitivity / impedance (1kHz std. dev.) $310V_{rms} \pm 50mV$, @ $22k\Omega$ load
A1	AUX1	Load $> 100k\Omega$ (Low) $V_{ss} \sim 0.4V$, (High) $V_{dd} - 0.8V \sim V_{dd}$
A2	AUX2	Load $> 100k\Omega$ (Low) $V_{ss} \sim 0.4V$, (High) $V_{dd} - 0.8V \sim V_{dd}$
A3	AUX3	Load $> 100k\Omega$ (Low) $V_{ss} \sim 0.4V$, (High) $V_{dd} - 0.8V \sim V_{dd}$
A4	AUX4	Load $> 100k\Omega$ (Low) $V_{ss} \sim 0.4V$, (High) $V_{dd} - 0.8V \sim V_{dd}$
A5	AUX5	Load $> 100k\Omega$ (Low) $V_{ss} \sim 0.4V$, (High) $V_{dd} - 0.8V \sim V_{dd}$
A6	AUX6	Load $> 100k\Omega$ (Low) $V_{ss} \sim 0.4V$, (High) $V_{dd} - 0.8V \sim V_{dd}$
SB	Switched B	Output voltage / 7mA load DC (Battery terminal) $\pm 0.5V$ / 150mA max
GND	GND	V_{ss}
TA1	Transmit AF input	Input sensitivity / impedance (1kHz std. dev.) $310V_{rms} \pm 50mV$, @ $22k\Omega$ load

TK-2170 PC BOARD

TX-RX UNIT (X57-7000-XX) (A/4) -10 : K -11 : K2
Component side view (J72-0963-09 A/4)

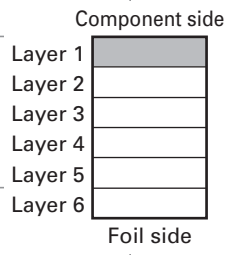
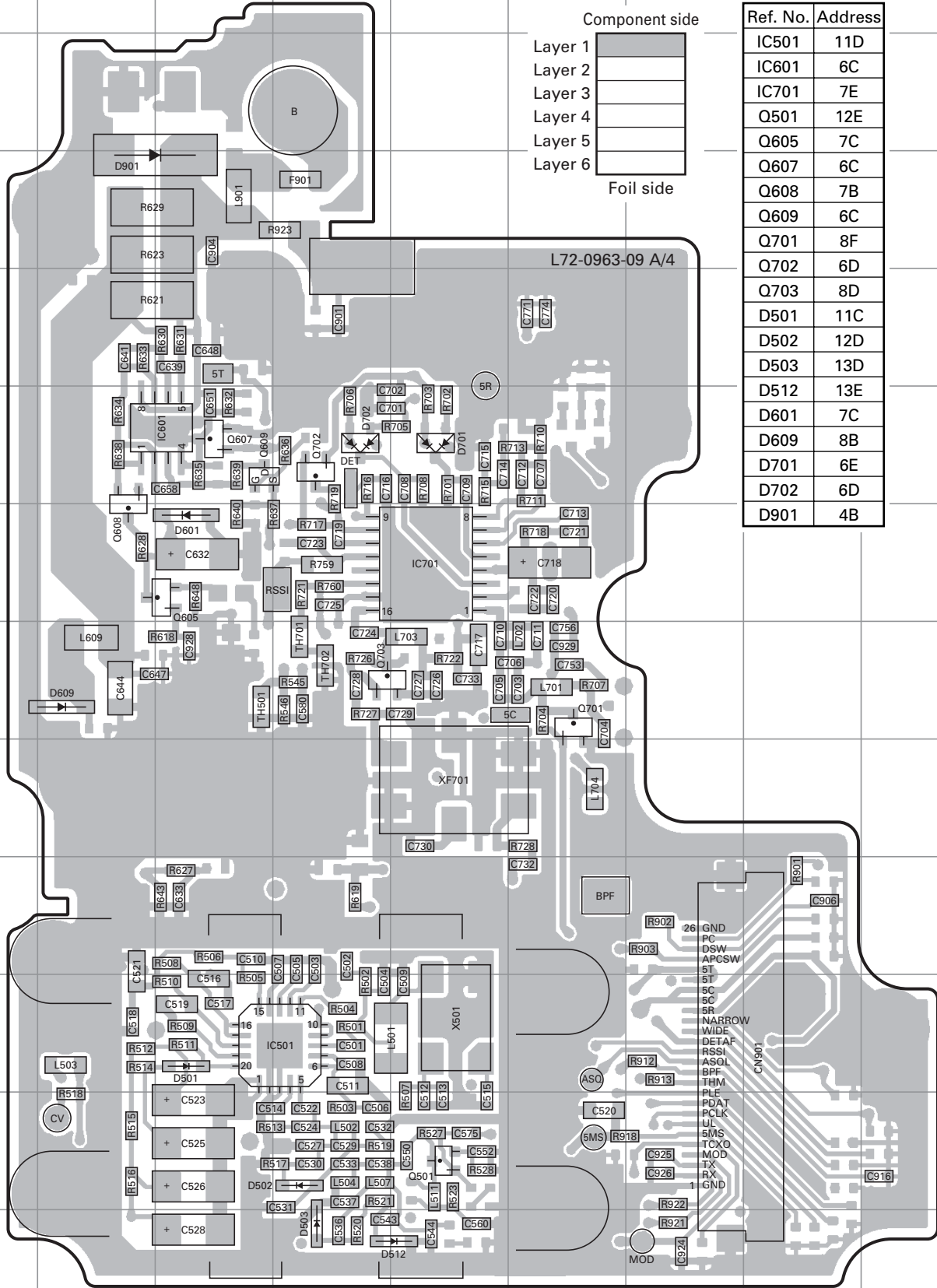

Ref. No.	Address
IC501	11D
IC601	6C
IC701	7E
Q501	12E
Q605	7C
Q607	6C
Q608	7B
Q609	6C
Q701	8F
Q702	6D
Q703	8D
D501	11C
D502	12D
D503	13D
D512	13E
D601	7C
D609	8B
D701	6E
D702	6D
D901	4B

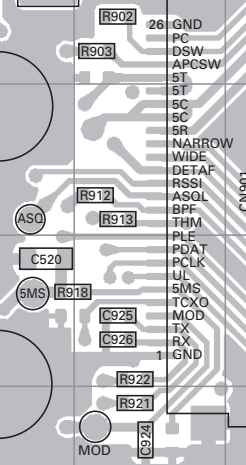

PC BOARD TK-2170

TX-RX UNIT (X57-7000-XX) (A/4) -10 : K -11 : K2 Foil side view (J72-0963-09 A/4)

Ref. No.	Address	Ref. No.	Address
Q502	12G	D509	11I
Q503	11G	D510	11I
Q504	11F	D511	11I
Q505	11E	D513	12G
Q506	12F	D514	11F
Q507	12D	D517	12D
Q602	11D	D518	12C
Q603	10G	D604	6I
Q604	9H	D605	6I
Q704	10D	D606	5H
Q705	6E	D608	5G
D504	12I	D610	7H
D505	12I	D703	8E
D506	13I	D704	7E
D507	13I	D705	5E
D508	11I	D706	5F

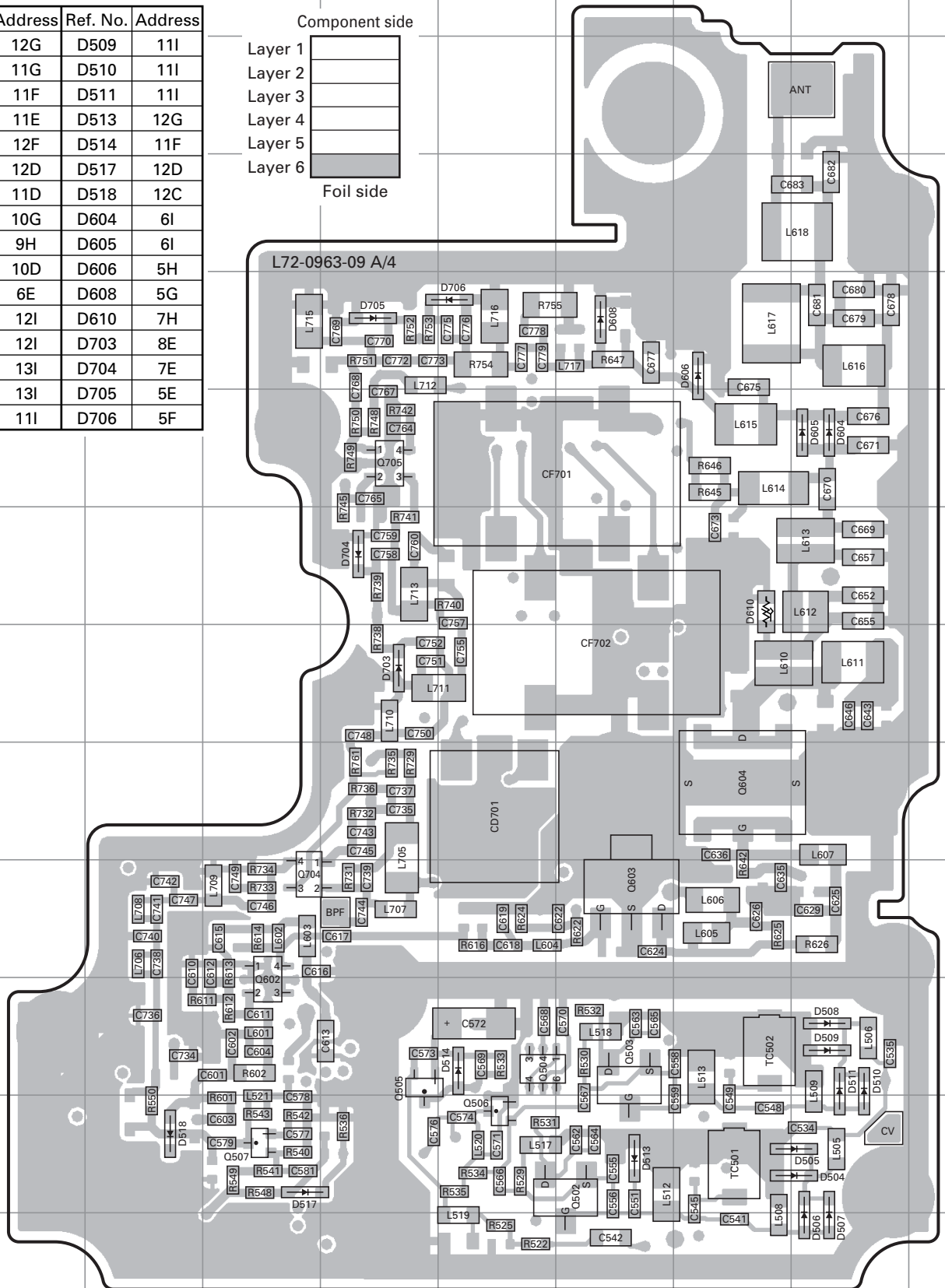
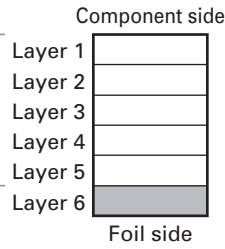

TK-2170 PC BOARD

Ref. No.	Address	Ref. No.	Address	Ref. No.	Address	Ref. No.	Address	Ref. No.	Address
IC4	6M	IC17	12K	Q23	8N	Q32	10G	D12	8D
IC5	6J	IC18	8M	Q24	7M	Q33	7J	D13	10D
IC11	8K	IC19	12G	Q25	12K	Q35	9M	D29	11H
IC12	7J	Q12	7I	Q26	12K	D4	7I	D30	10K
IC13	9J	Q13	6I	Q27	9M	D5	8N	D31	10J
IC14	9K	Q19	10H	Q28	9N	D7	10N	D32	10I
IC15	7H	Q21	10K	Q30	11J	D8	8F		
IC16	12I	Q22	11I	Q31	8G	D9	10F		

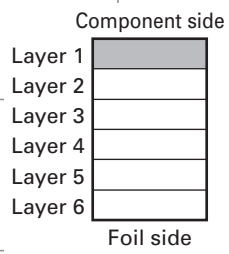

TX-RX UNIT (X57-7000-XX) (B/4) -10 : K -11 : K2 Component side view (J72-0963-09 B/4)

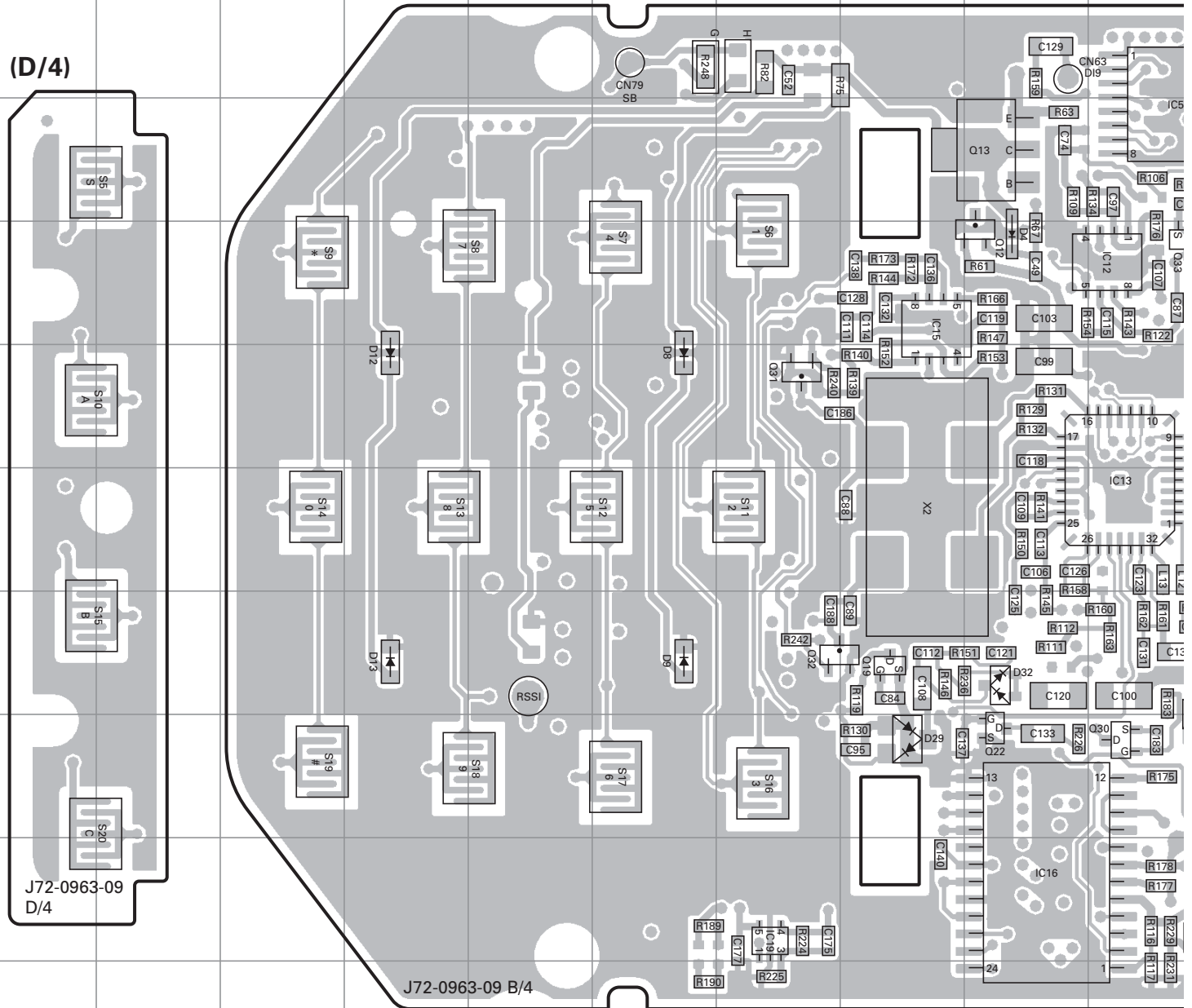

PC BOARD TK-2170

TX-RX UNIT (X57-7000-XX) (C/4) -10 : K -11 : K2
Component side view (J72-0963-09 C/4)

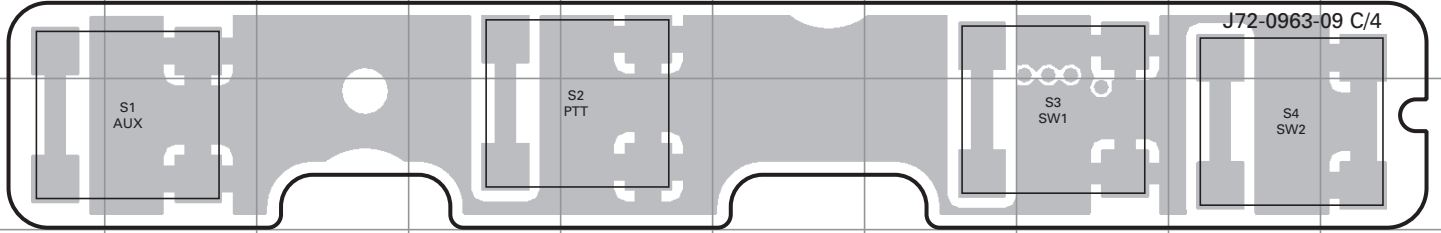

TX-RX UNIT (X57-7000-XX) (B/4) -10 : K -11 : K2
Component side view (J72-0963-09 B/4)

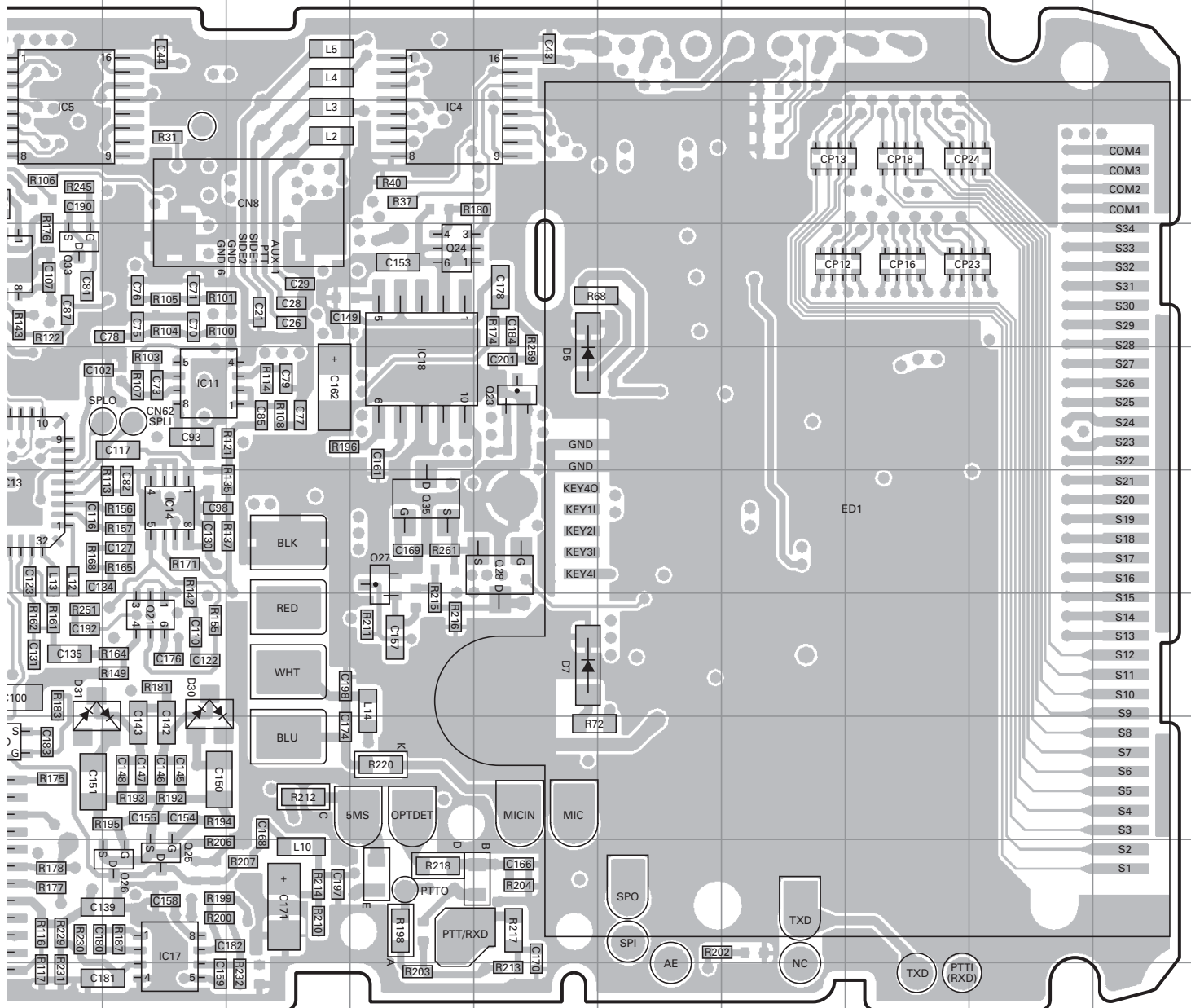

TK-2170 PC BOARD

PC BOARD TK-2170

Ref. No.	Address	Ref. No.	Address	Ref. No.	Address	Ref. No.	Address	Ref. No.	Address
IC4	6M	IC17	12K	Q23	8N	Q32	10G	D12	8D
IC5	6J	IC18	8M	Q24	7M	Q33	7J	D13	10D
IC11	8K	IC19	12G	Q25	12K	Q35	9M	D29	11H
IC12	7J	Q12	7I	Q26	12K	D4	7I	D30	10K
IC13	9J	Q13	6I	Q27	9M	D5	8N	D31	10J
IC14	9K	Q19	10H	Q28	9N	D7	10N	D32	10I
IC15	7H	Q21	10K	Q30	11J	D8	8F		
IC16	12I	Q22	11I	Q31	8G	D9	10F		

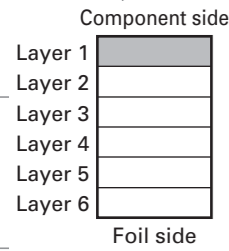

TX-RX UNIT (X57-7000-XX) (C/4) -10 : K -11 : K2
Component side view (J72-0963-09 C/4)

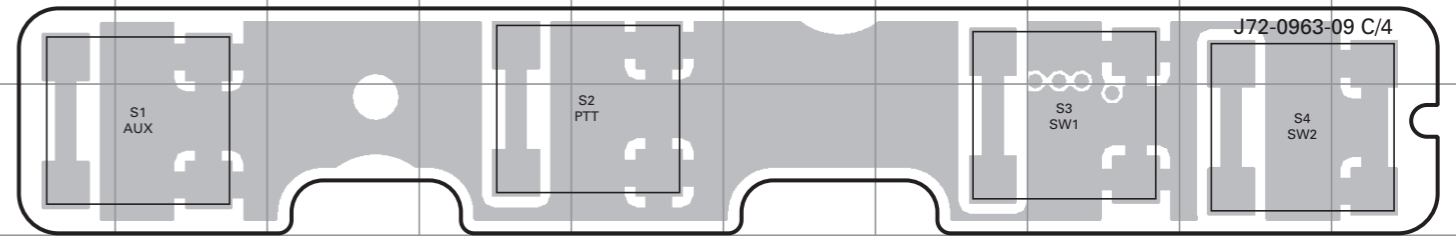

TX-RX UNIT (X57-7000-XX) (B/4) -10 : K -11 : K2
Component side view (J72-0963-09 B/4)

TX-RX UNIT (X57-7000-XX) (B/4) -10 : K -11 : K2
Component side view (J72-0963-09 B/4)

(D/4)

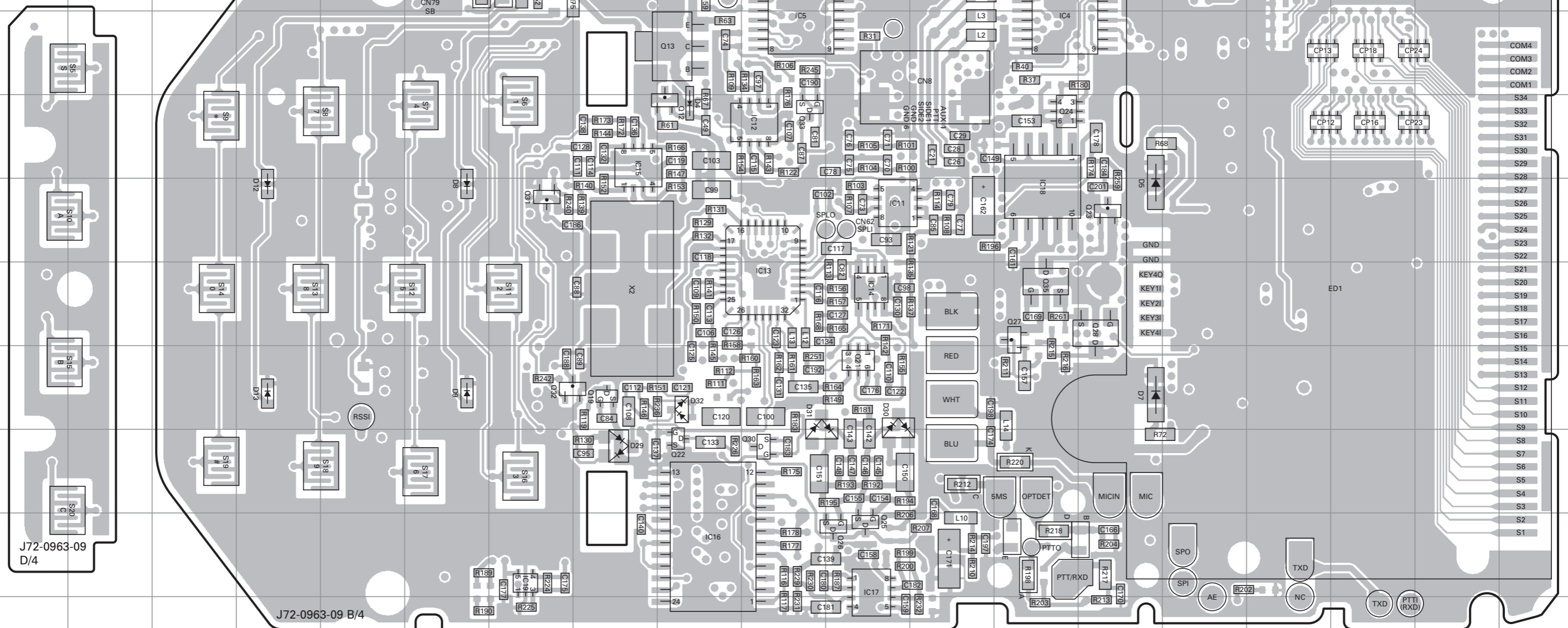

- COM4
- COM3
- COM2
- COM1
- S34
- S33
- S32
- S31
- S30
- S29
- S28
- S27
- S26
- S25
- S24
- S23
- S22
- S21
- S20
- S19
- S18
- S17
- S16
- S15
- S14
- S13
- S12
- S11
- S10
- S9
- S8
- S7
- S6
- S5
- S4
- S3
- S2
- S1

TK-2170 PC BOARD

TX-RX UNIT (X57-7000-XX) (C/4) -10 : K -11 : K2

Foil side view (J72-0963-09 C/4)

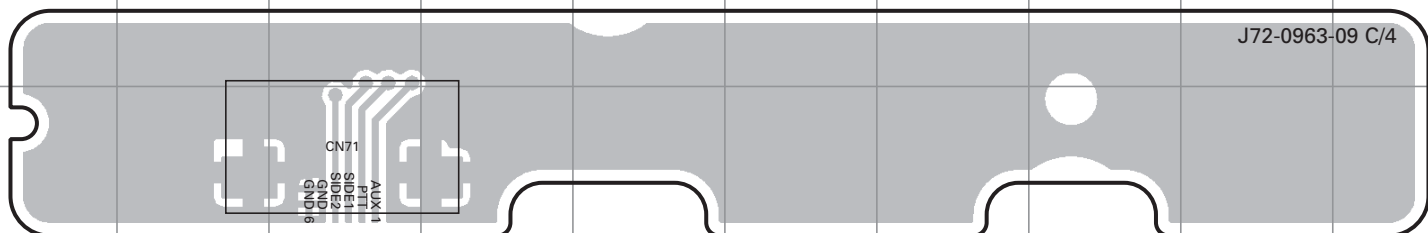

TX-RX UNIT (X57-7000-XX) (B/4) -10 : K -11 : K2

Foil side view (J72-0963-09 B/4)

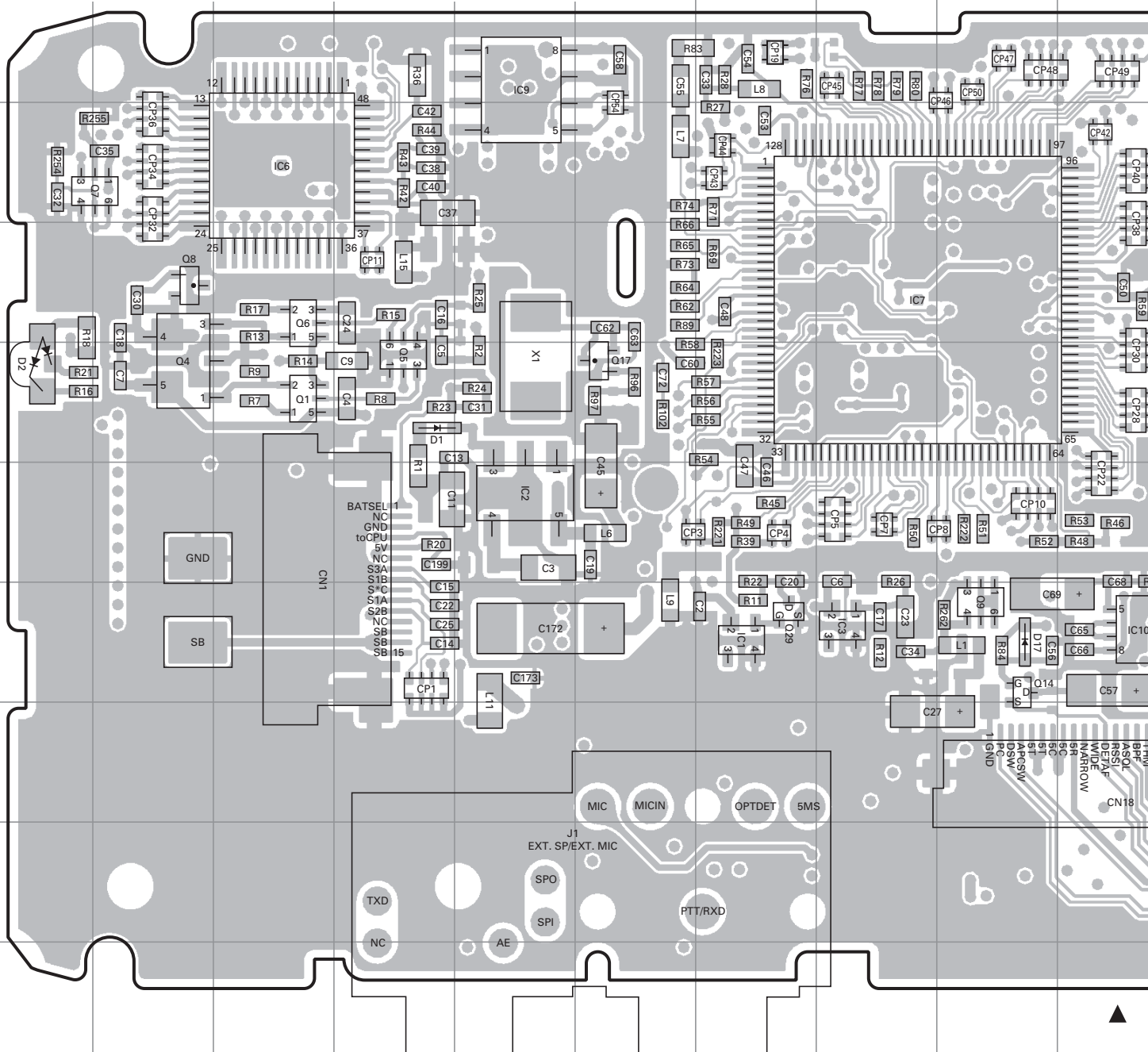

PC BOARD TK-2170

Ref. No.	Address	Ref. No.	Address	Ref. No.	Address	Ref. No.	Address
IC1	10G	Q1	8C	Q15	5M	D16	5K
IC2	9E	Q4	8B	Q16	5N	D17	10I
IC3	10H	Q5	8D	Q17	8F	D24	5L
IC6	6C	Q6	7C	Q29	10G	D25	5M
IC7	7H	Q7	6B	Q34	9O	D26	5M
IC8	7K	Q8	7B	D1	8D	D27	5M
IC9	5E	Q9	10I	D2	8A	D28	10K
IC10	10J	Q14	10I	D14	8M		

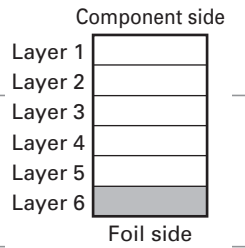

TX-RX UNIT (X57-7000-XX) (B/4) -10 : K -11 : K2 Foil side view (J72-0963-09 B/4)

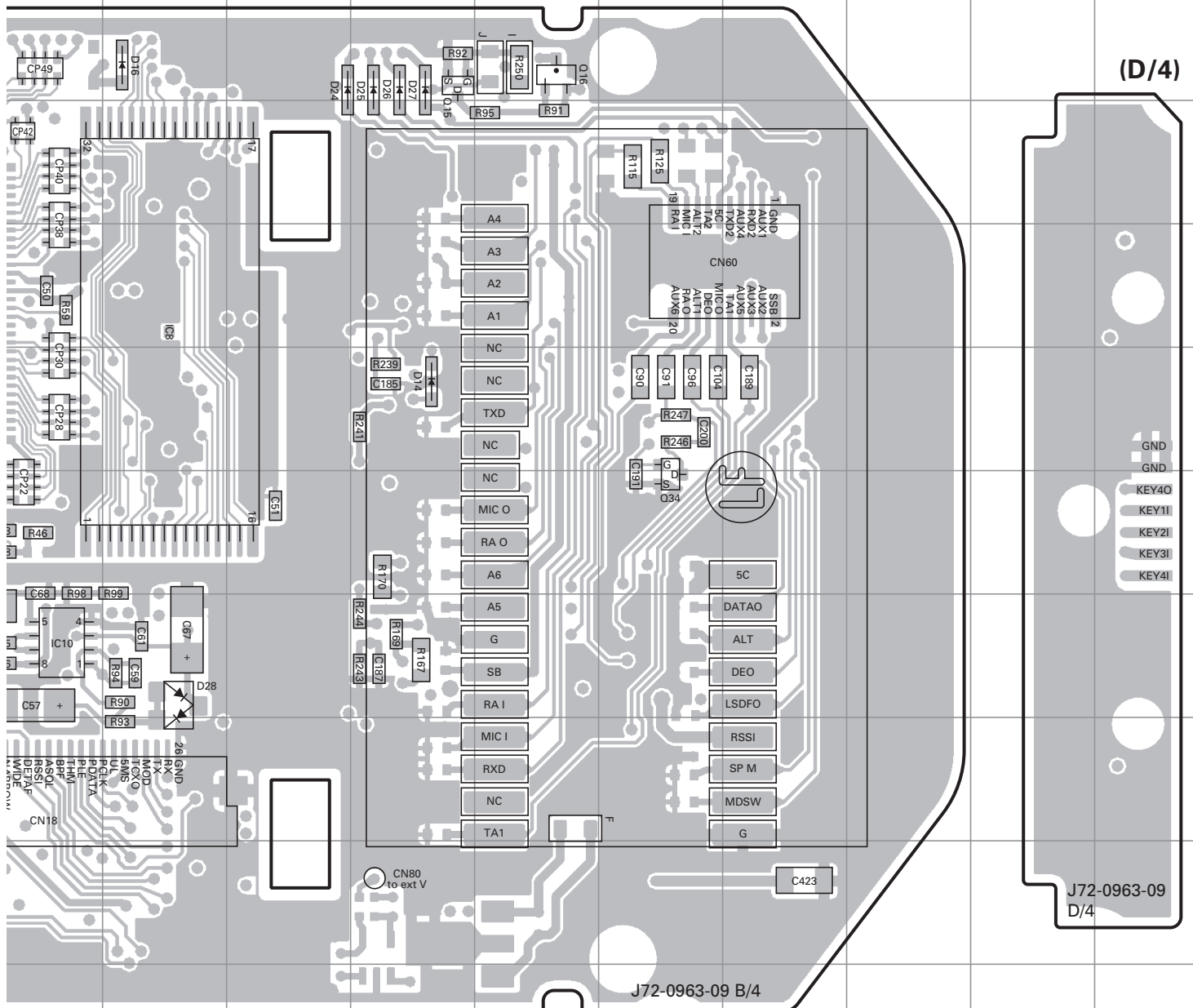

TK-2170 PC BOARD

PC BOARD TK-2170

TX-RX UNIT (X57-7000-XX) (C/4) -10 : K -11 : K2

Foil side view (J72-0963-09 C/4)

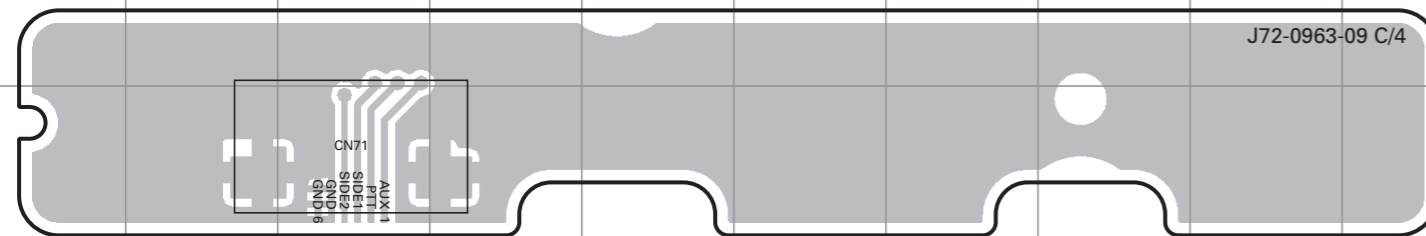

Ref. No.	Address	Ref. No.	Address	Ref. No.	Address	Ref. No.	Address
IC1	10G	Q1	8C	Q15	5M	D16	5K
IC2	9E	Q4	8B	Q16	5N	D17	10I
IC3	10H	Q5	8D	Q17	8F	D24	5L
IC6	6C	Q6	7C	Q29	10G	D25	5M
IC7	7H	Q7	6B	Q34	9O	D26	5M
IC8	7K	Q8	7B	D1	8D	D27	5M
IC9	5E	Q9	10I	D2	8A	D28	10K
IC10	10J	Q14	10I	D14	8M		

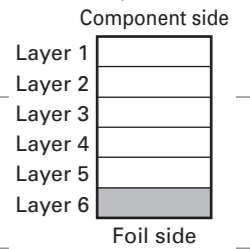

TX-RX UNIT (X57-7000-XX) (B/4) -10 : K -11 : K2

Foil side view (J72-0963-09 B/4)

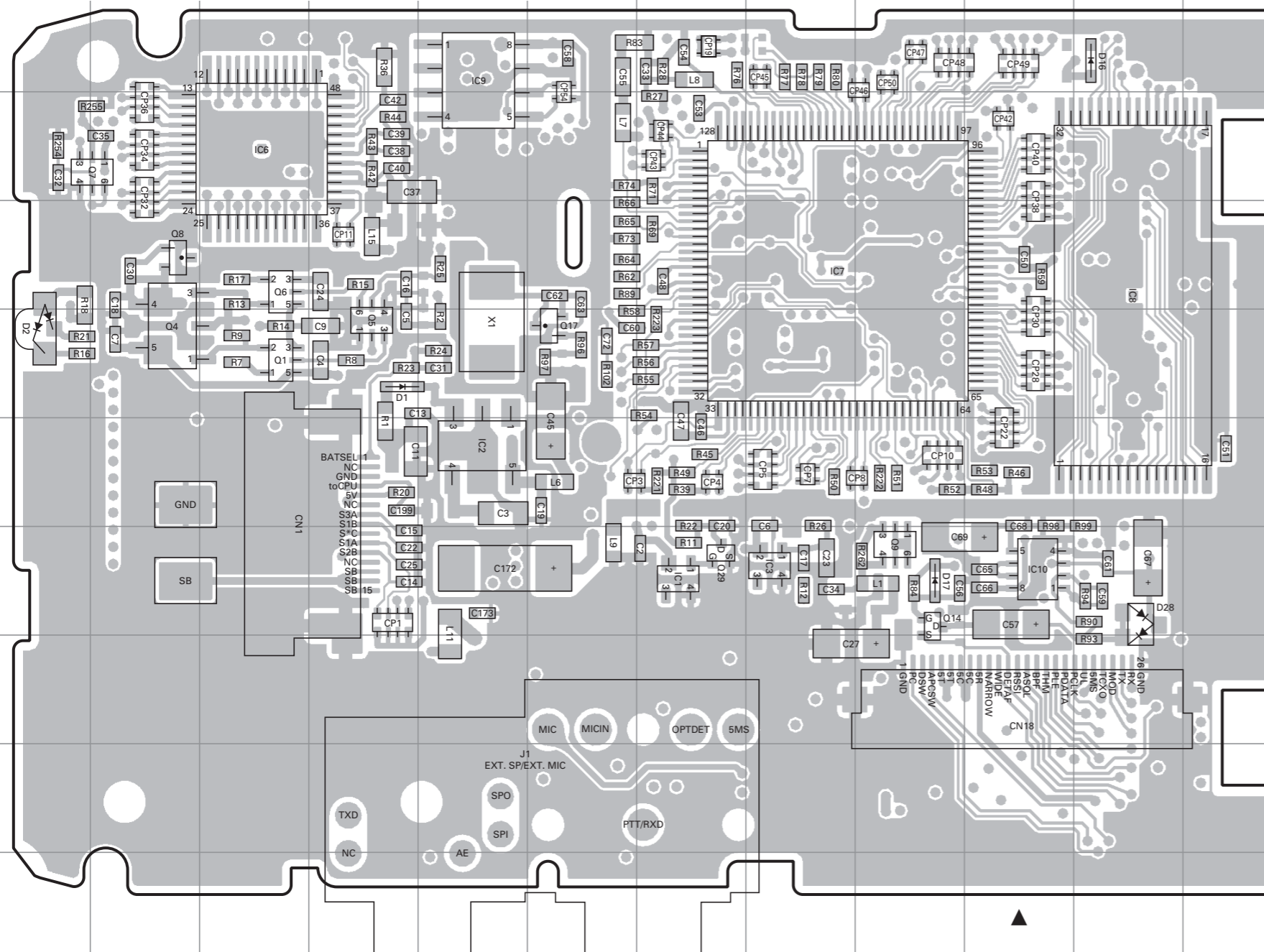

TX-RX UNIT (X57-7000-XX) (B/4) -10 : K -11 : K2

Foil side view (J72-0963-09 B/4)

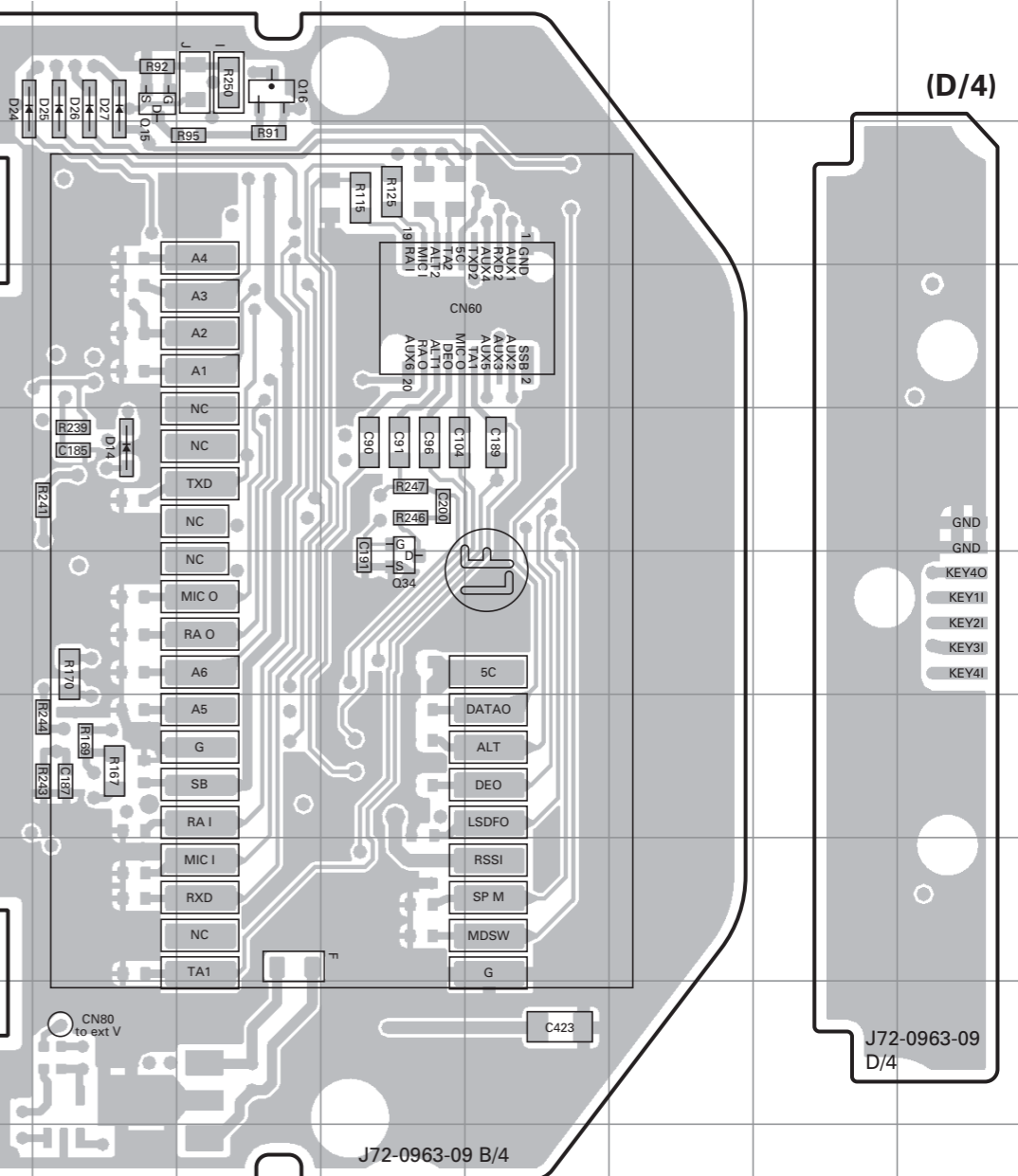

(D/4)

- GND
- GND
- KEY40
- KEY11
- KEY21
- KEY31
- KEY41

J72-0963-09
D/4

TK-2170 SCHEMATIC DIAGRAM

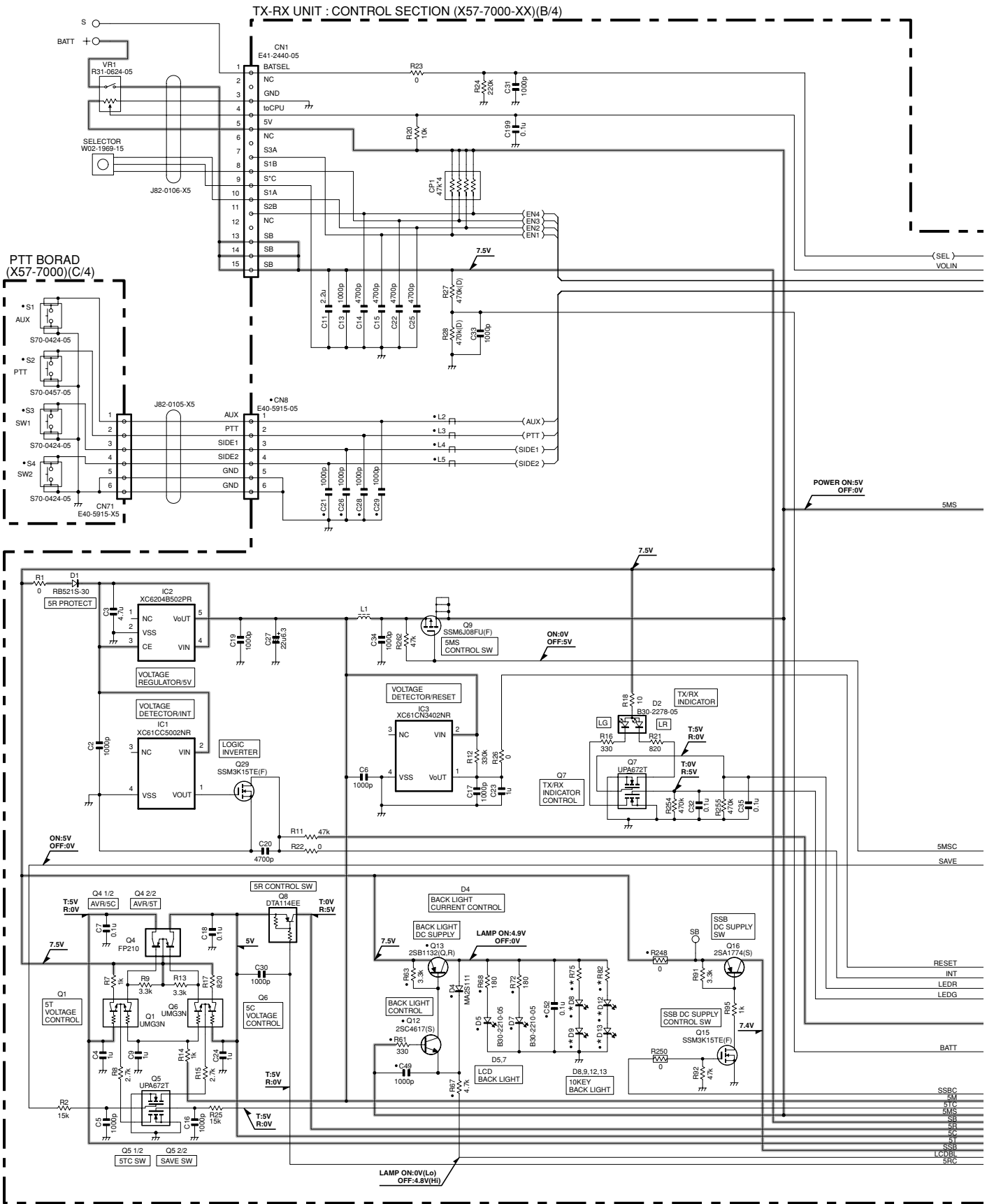

X57-7000-XX	D8	D9	D12	D13	R75	R82
-10	K	4KEY	NO	NO	NO	NO
-11	K2	16KEY	B30-2050-05	B30-2050-05	B30-2050-05	B30-2050-05

SCHEMATIC DIAGRAM TK-2170

TX-RX UNIT (X57-7000-XX) (B/4)

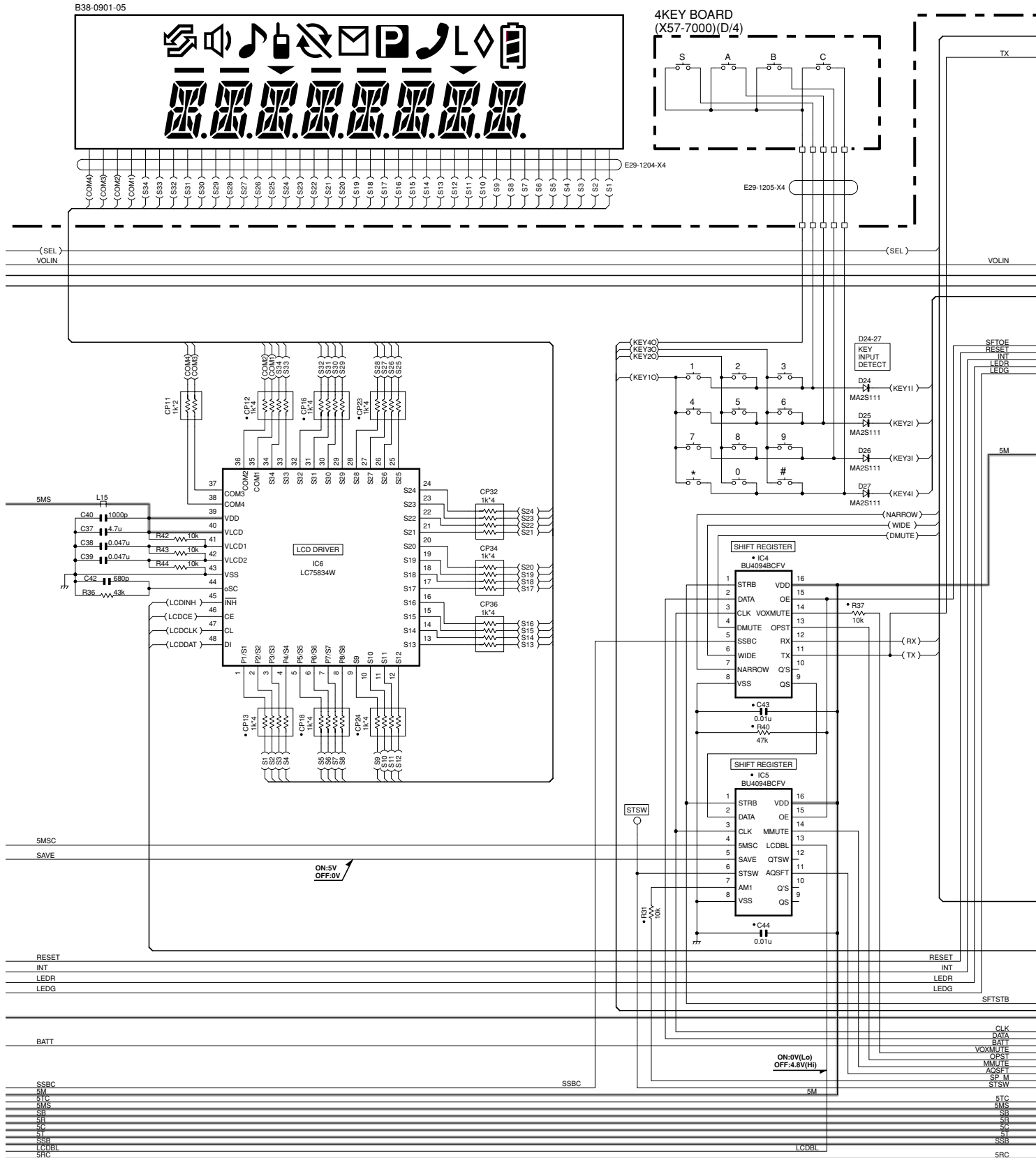

TK-2170 SCHEMATIC DIAGRAM

TX-RX UNIT (X57-7000-XX) (B/4)

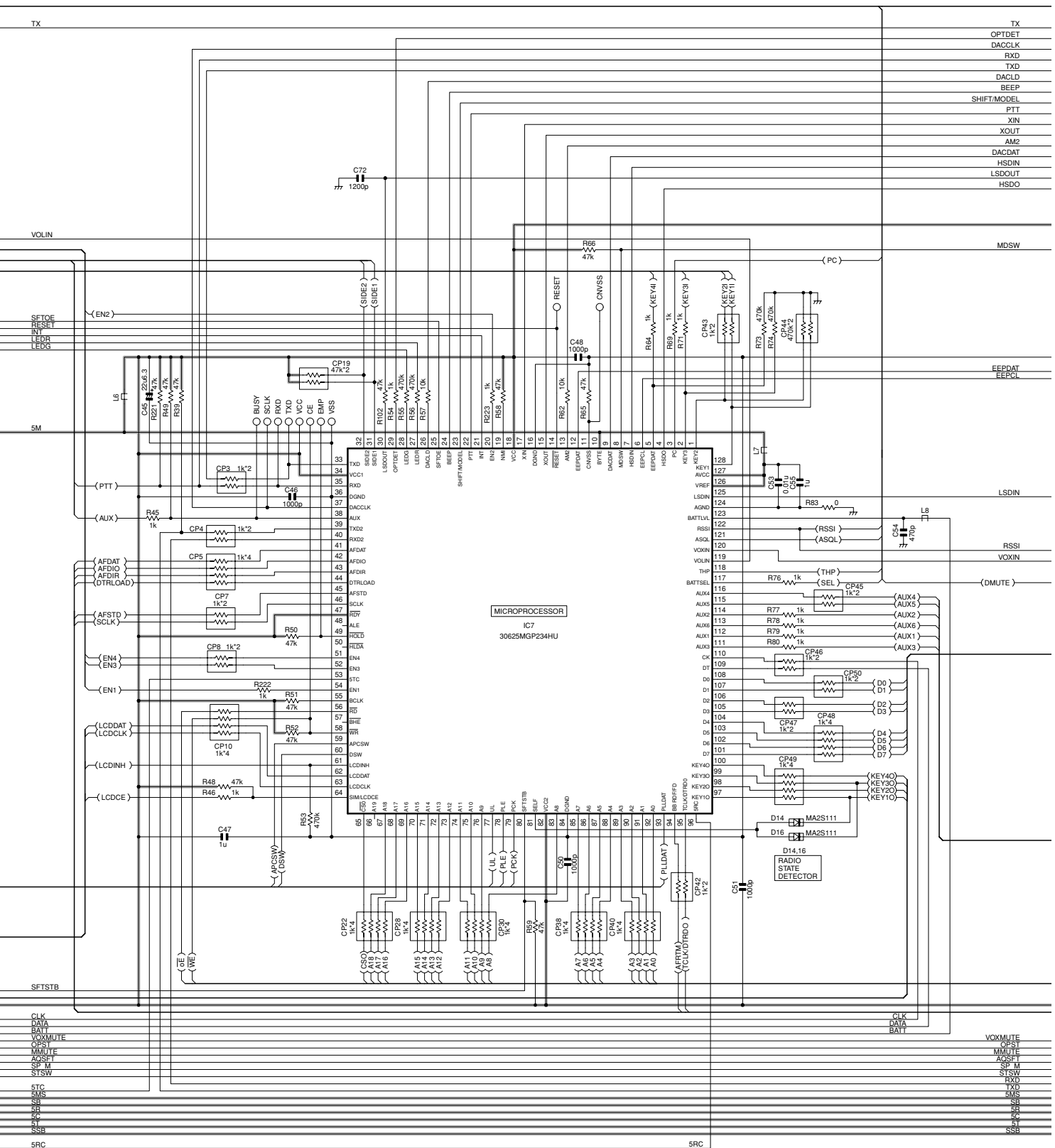

SCHEMATIC DIAGRAM TK-2170

TX-RX UNIT (X57-7000-XX) (B/4)

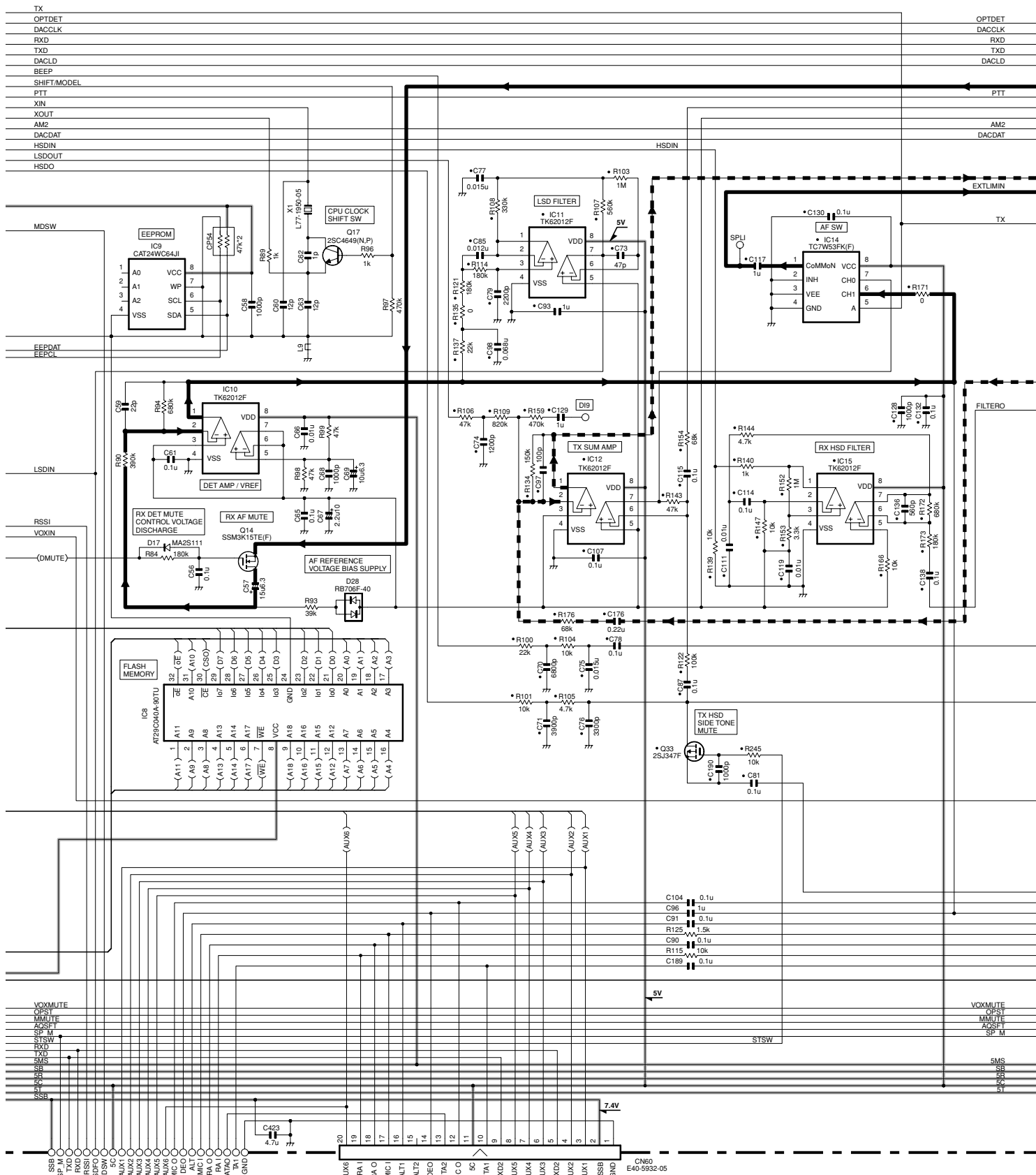

TK-2170 SCHEMATIC DIAGRAM

TX-RX UNIT (X57-7000-XX) (B/4)

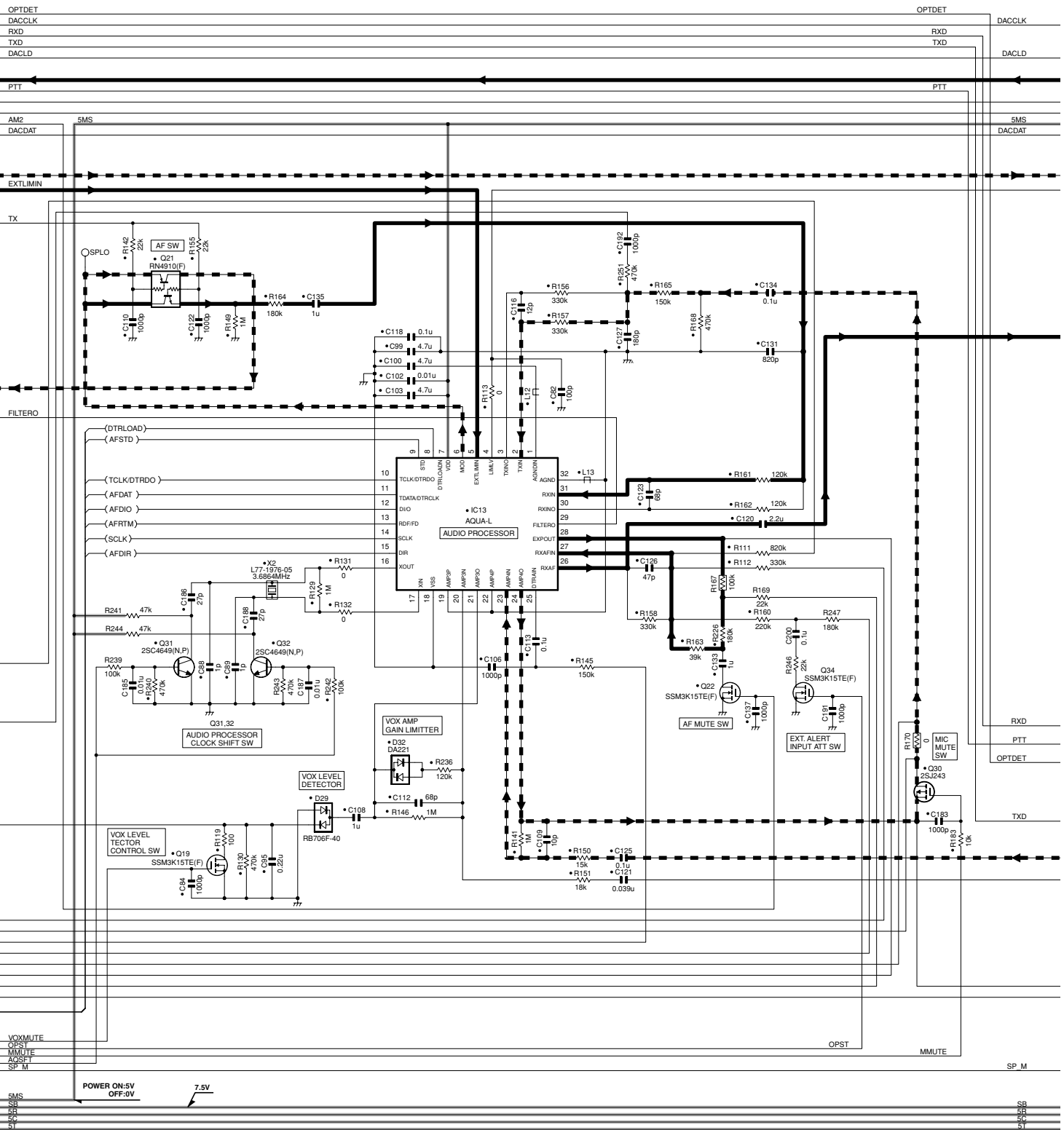

SCHEMATIC DIAGRAM TK-2170

TX-RX UNIT (X57-7000-XX) (B/4)

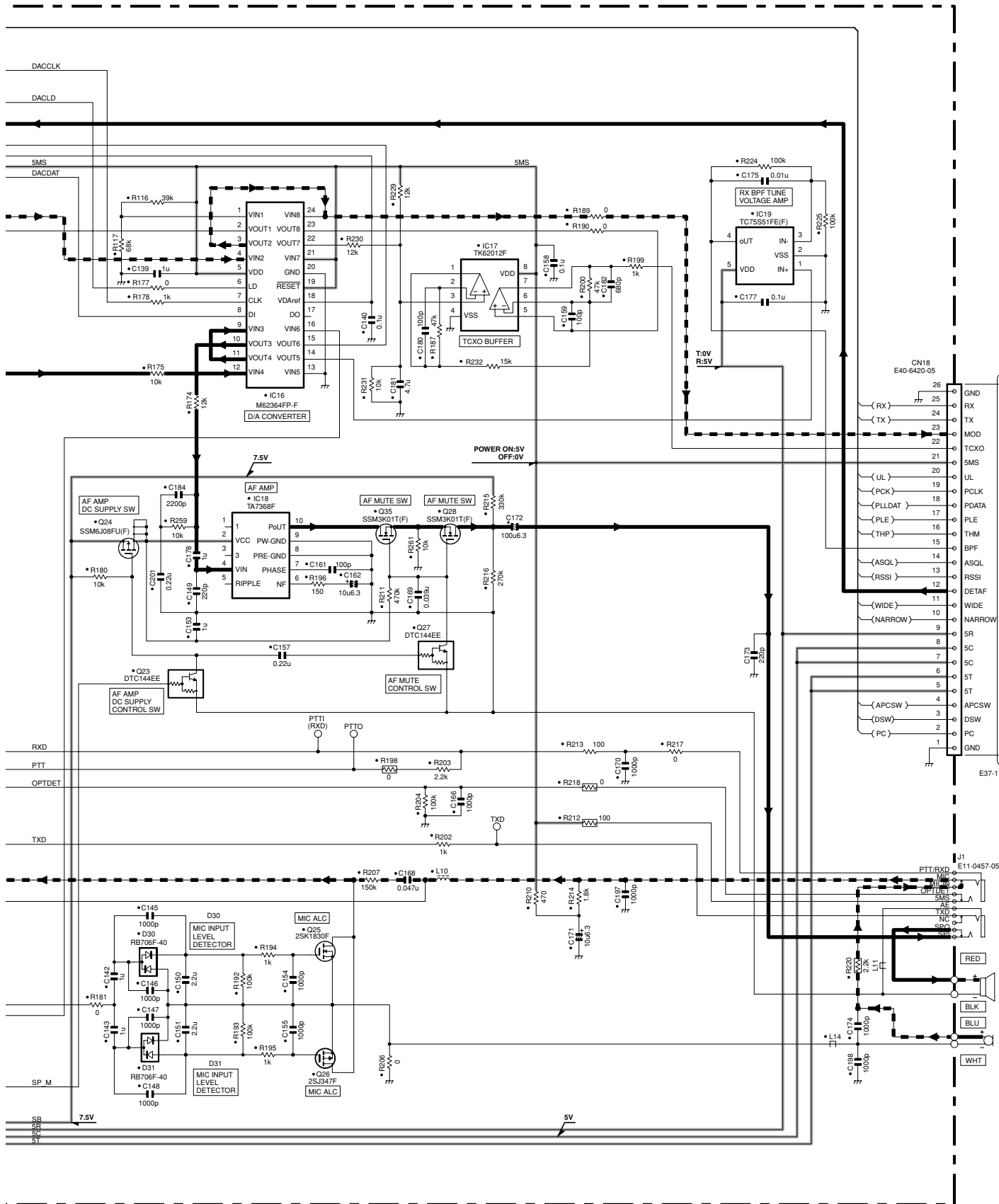

TK-2170 SCHEMATIC DIAGRAM

TX-RX UNIT (X57-7000-XX)(A/4)

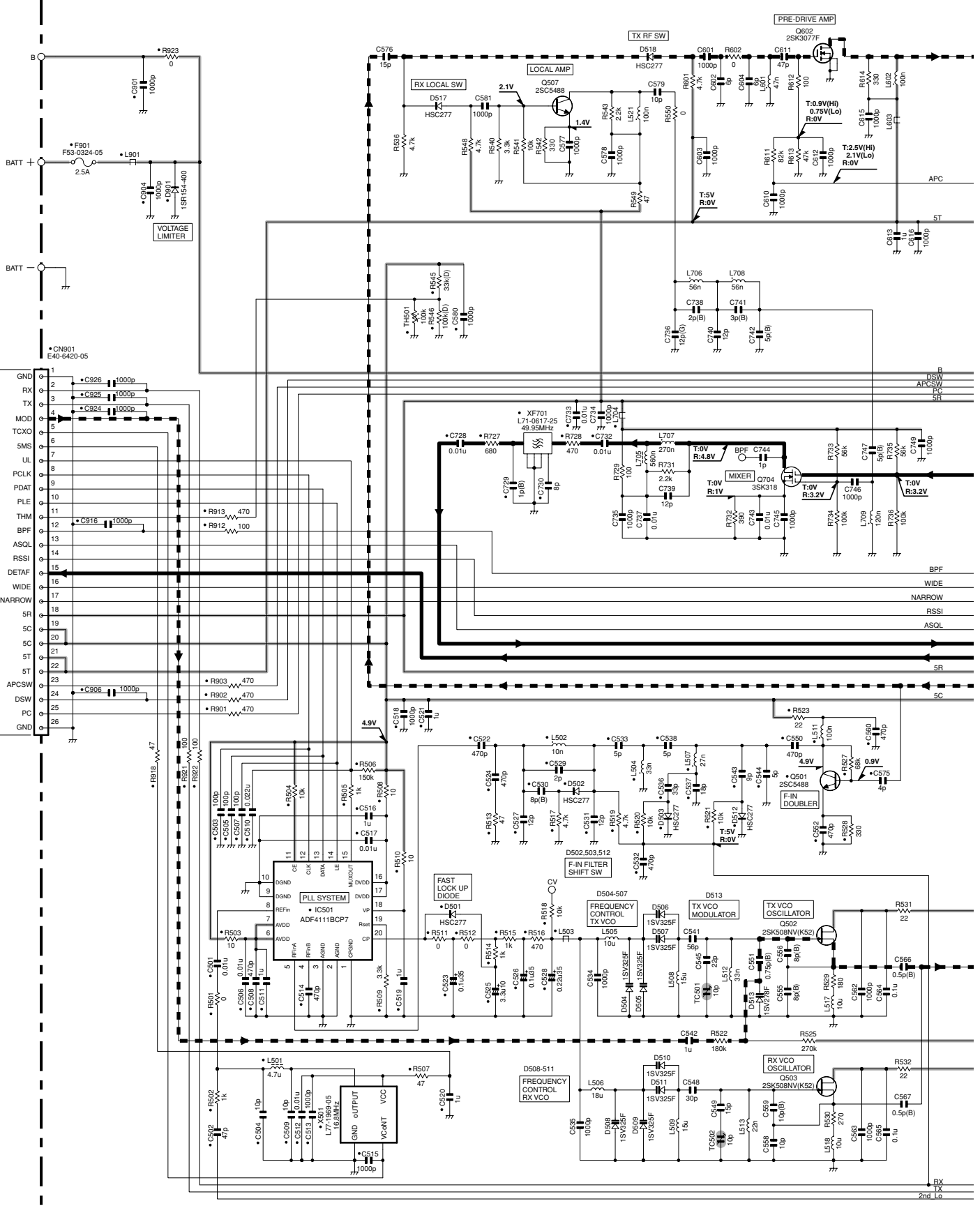

SCHEMATIC DIAGRAM TK-2170

TX-RX UNIT (X57-7000-XX) (A/4)

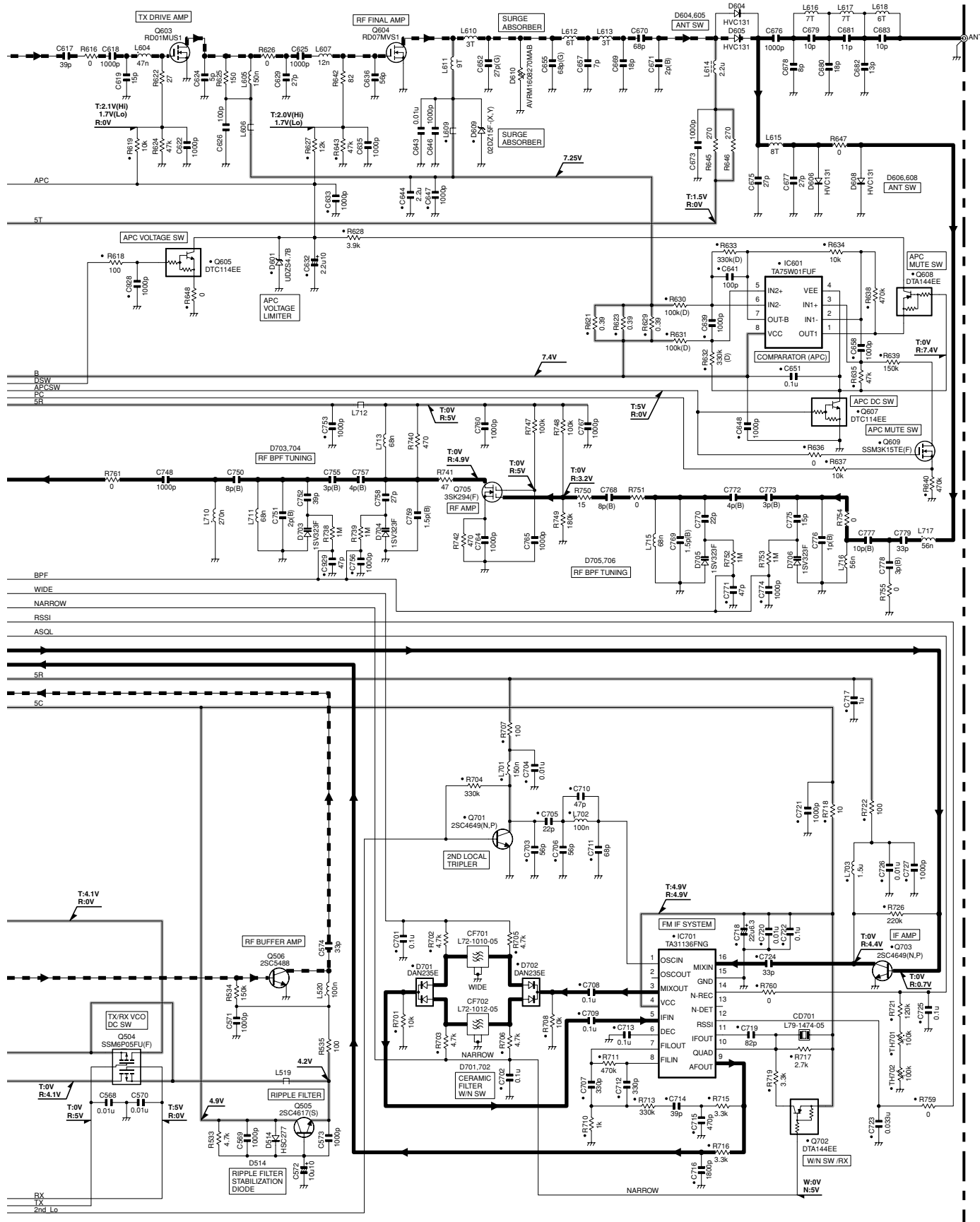

Note : The components marked with a dot (•) are parts of layer 1.



REV	DATE	BY	CHK	APP
1	11/12/54	W.E.	W.E.	W.E.
2	11/12/54	W.E.	W.E.	W.E.
3	11/12/54	W.E.	W.E.	W.E.
4	11/12/54	W.E.	W.E.	W.E.
5	11/12/54	W.E.	W.E.	W.E.
6	11/12/54	W.E.	W.E.	W.E.
7	11/12/54	W.E.	W.E.	W.E.
8	11/12/54	W.E.	W.E.	W.E.
9	11/12/54	W.E.	W.E.	W.E.
10	11/12/54	W.E.	W.E.	W.E.
11	11/12/54	W.E.	W.E.	W.E.
12	11/12/54	W.E.	W.E.	W.E.
13	11/12/54	W.E.	W.E.	W.E.
14	11/12/54	W.E.	W.E.	W.E.
15	11/12/54	W.E.	W.E.	W.E.
16	11/12/54	W.E.	W.E.	W.E.
17	11/12/54	W.E.	W.E.	W.E.
18	11/12/54	W.E.	W.E.	W.E.
19	11/12/54	W.E.	W.E.	W.E.
20	11/12/54	W.E.	W.E.	W.E.
21	11/12/54	W.E.	W.E.	W.E.
22	11/12/54	W.E.	W.E.	W.E.
23	11/12/54	W.E.	W.E.	W.E.
24	11/12/54	W.E.	W.E.	W.E.
25	11/12/54	W.E.	W.E.	W.E.
26	11/12/54	W.E.	W.E.	W.E.
27	11/12/54	W.E.	W.E.	W.E.
28	11/12/54	W.E.	W.E.	W.E.
29	11/12/54	W.E.	W.E.	W.E.
30	11/12/54	W.E.	W.E.	W.E.

TK-2170 BLOCK DIAGRAM

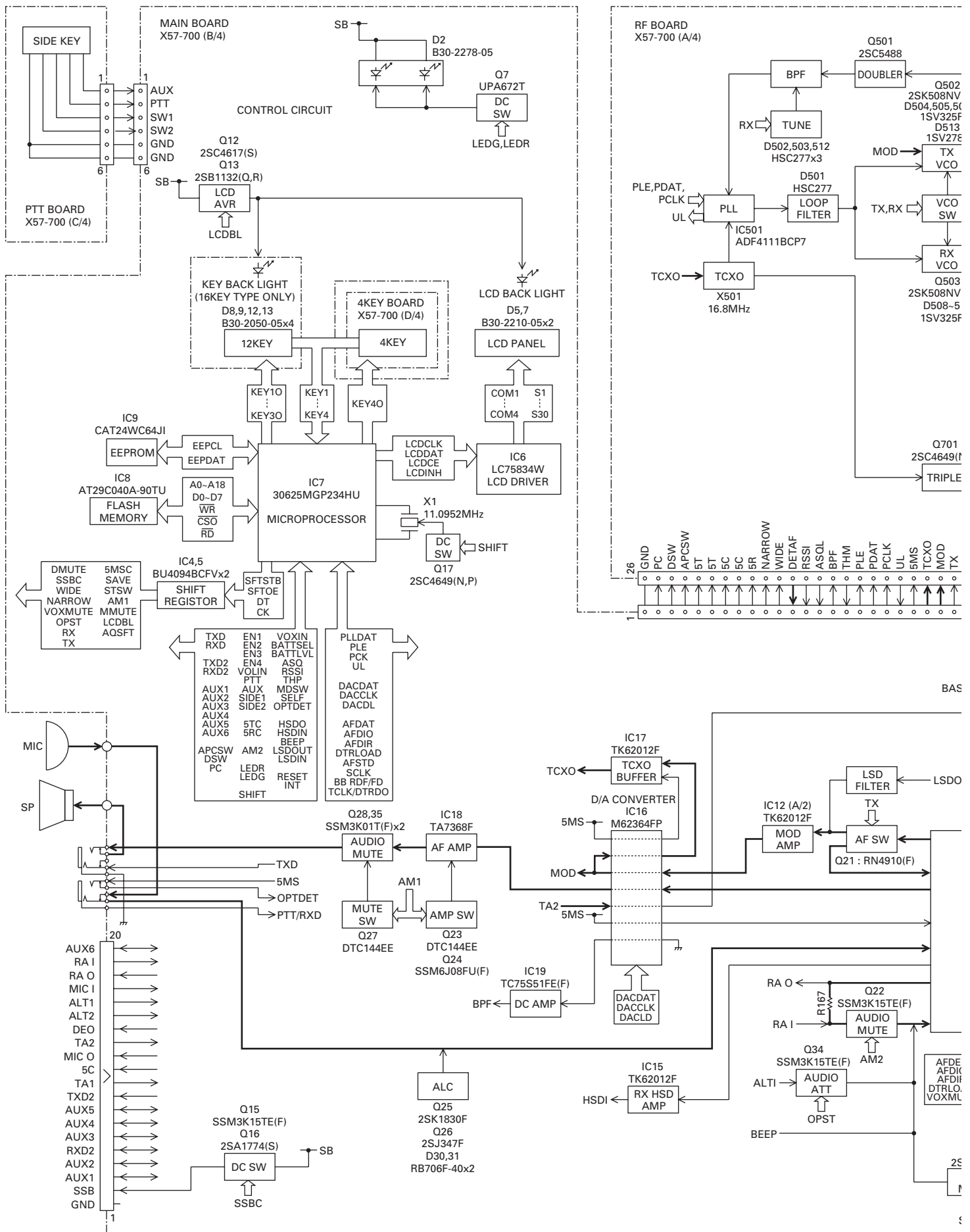

BLOCK DIAGRAM TK-2170

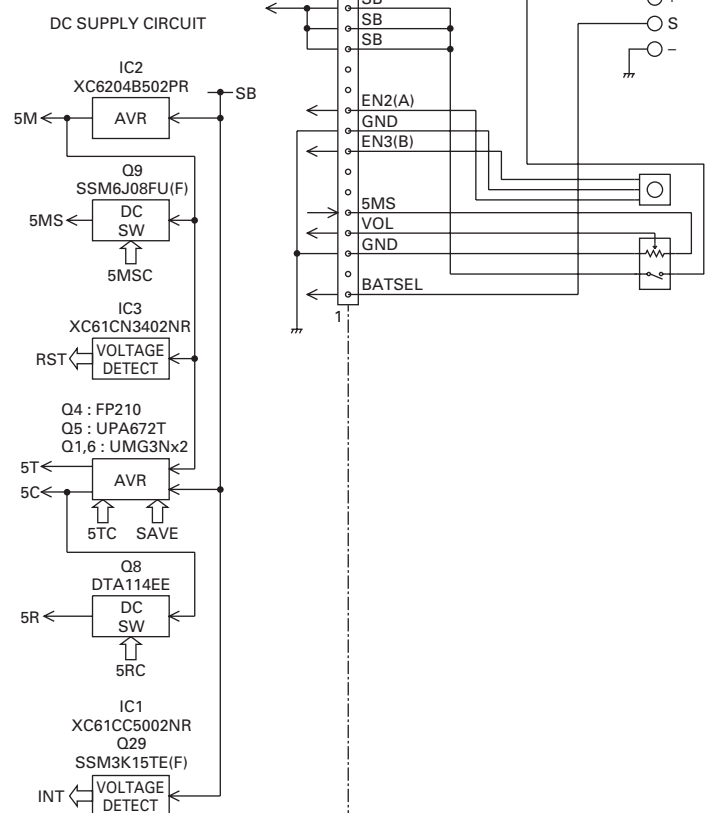
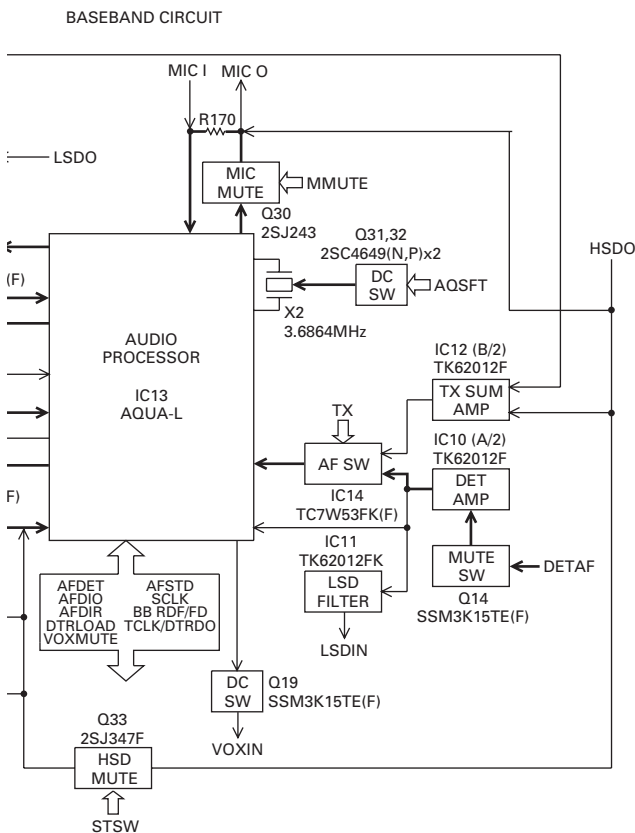
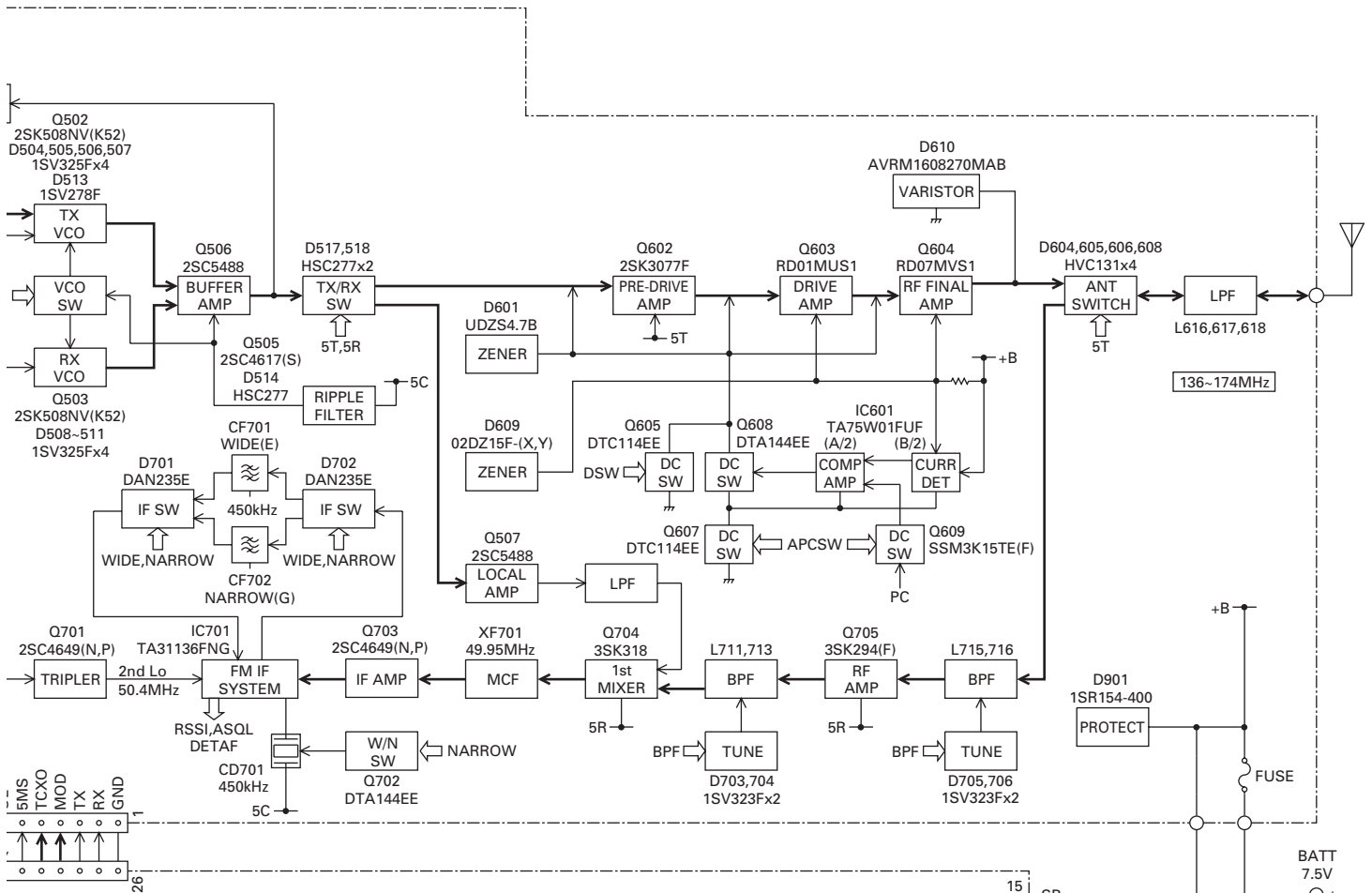

LEVEL DIAGRAM

Receiver Section

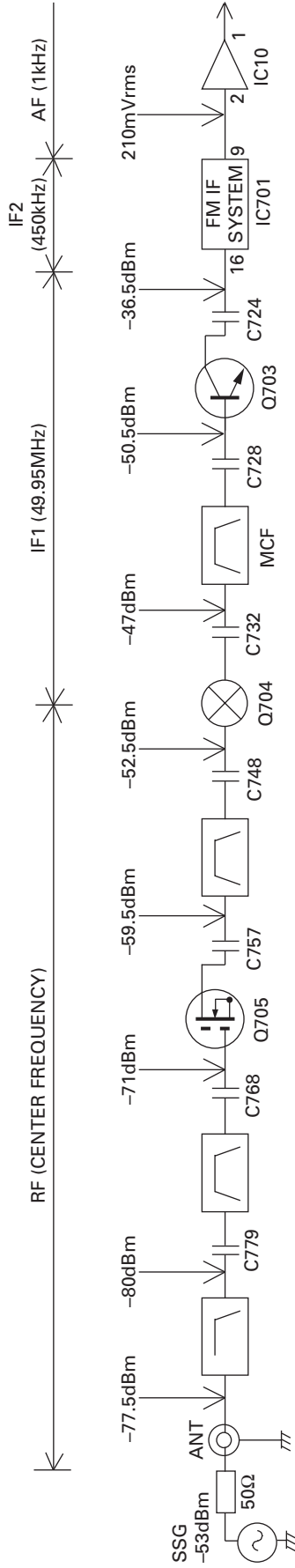

To make measurements in the AF section, connect the AC level meter. (ANT input : -53dBm, 1kHz FM, 3kHz DEV (WIDE).) In the RF section, use a high impedance probe. (ANT input : -53dBm, MOD off.)

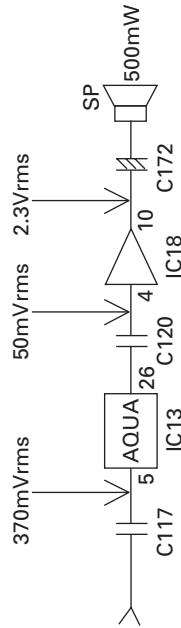

Transmitter Section

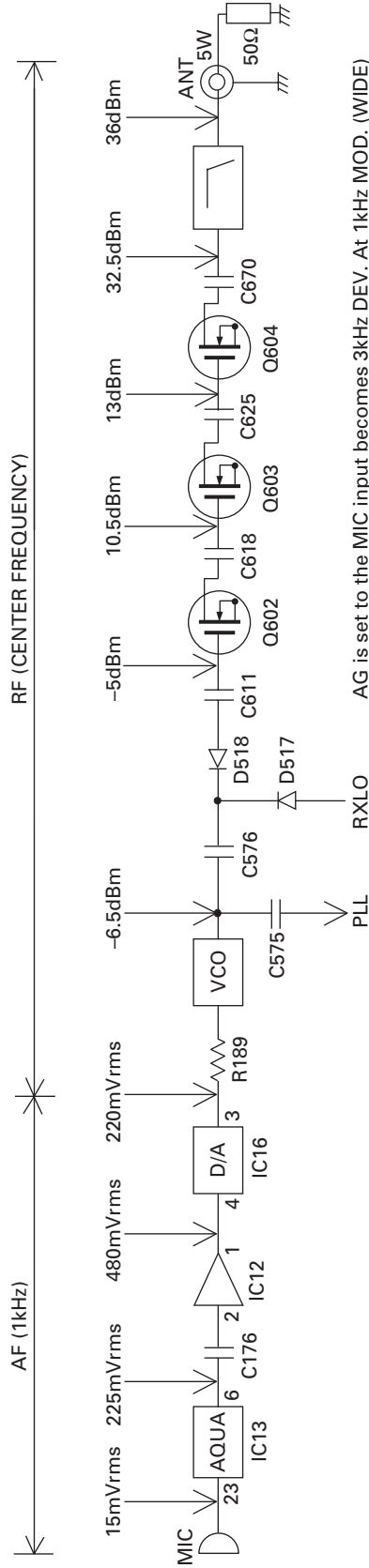

AG is set to the MIC input becomes 3kHz DEV. At 1kHz MOD. (WIDE) To make measurements in the AF section, connect the AC level meter. In the RF section, use a 1000pF coupling capacitor.

KSC-30 (RAPID CHARGER)

External View



Operating Flow Chart

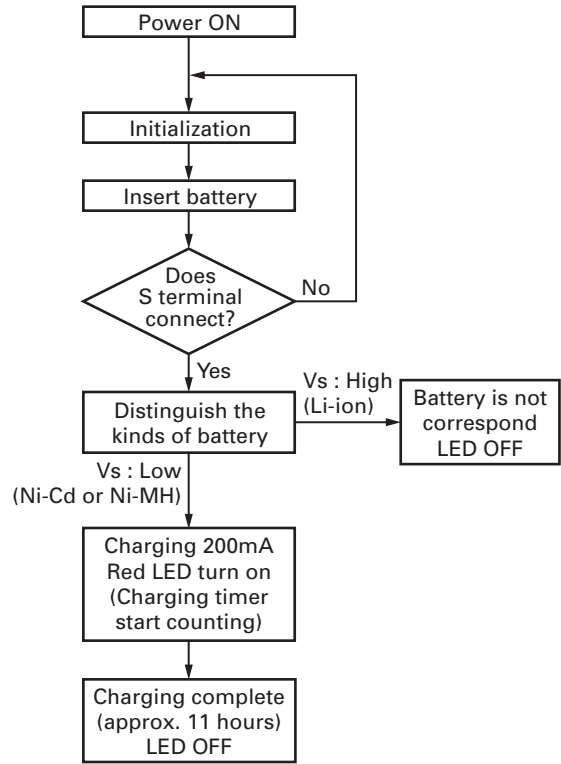

Parts List

Ref. No.	New parts	Parts No.	Description	Destination
		A02-3656-08	Cabinet Bottom	
		A02-3841-08	Cabinet Upper	
		B43-1151-08	Badge	
		B62-1754-08	Instruction manual	K, T
		B62-1755-08	Instruction manual	E
		B72-2209-08	Model name plate	
		E03-0453-08	DC jack	
		E23-1190-08	Relay terminal	
		G13-1547-08	Cushion	
		N83-2610-45	Pan head taprite screw	
		W02-3671-08	Electric circuit module	
		W08-0479-05	AC adapter 120V AC 60Hz	K
		W08-0513-05	AC adapter 230V AC 50Hz	T
		W08-0558-15	AC adapter 230V AC 50Hz	E

Schematic Diagram

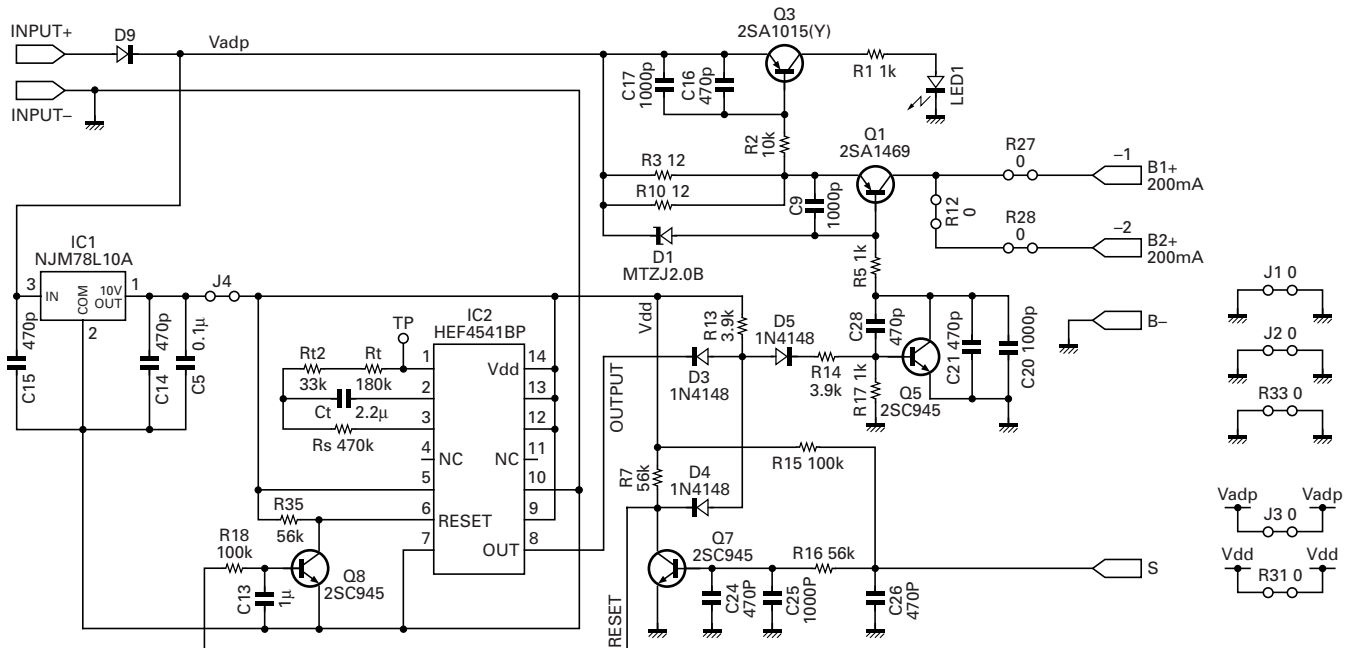

SPECIFICATIONS

GENERAL

Frequency range	136~174MHz
Number of channels	Zone : Max. 128 per radio Conv. Ch : Max. 128 per zone
Channel spacing	Wide : 25, 30kHz Narrow : 12.5, 15kHz
Battery voltage	7.5V DC \pm 20%
Battery life (5-5-90 duty cycle)/Approx. hours	
KNB-24L (1400mAh)	9
KNB-25A (1200mAh)	8
KNB-26N (2000mAh)	12
KNB-35L (1950mAh)	11
Operating temperature range	-22°F~+140°F (-30°C~+60°C)
Frequency stability	\pm 0.00025% (-22°F~+140°F)
Antenna impedance	50 Ω
Channel frequency spread	38MHz
Dimensions (W x H x D)	2-7/32 x 4-9/32 x 1-1/4 in. (56 x 109 x 31.7 mm) with KNB-24L or 35L battery
(Projections not included)	2-7/32 x 4-9/32 x 1-1/2 in. (56 x 109 x 37.9 mm) with KNB-25A or 26N battery
Weight (net)	12.0 oz. (340 g) with battery (KNB-35L), antenna (KRA-22) and beltclip (KBH-12)

RECEIVER (Measurements made per EIA/TIA-603)

Sensitivity (12dB SINAD)	Wide : 0.25 μ V Narrow : 0.28 μ V
Selectivity	Wide : 70dB Narrow : 65dB
Intermodulation distortion	Wide : 65dB Narrow : 60dB
Spurious response	65dB
Audio output (8 Ω impedance)	500mW with less than 5% distortion

TRANSMITTER (Measurements made per EIA/TIA-603)

RF power output	HI : 5W LO : 1W
Spurious response	70dB
Modulation	Wide : 16K0F3E Narrow : 11K0F3E
FM hum & noise	Wide : 45dB Narrow : 43dB
Audio distortion	W/N : Less than 5%

Kenwood Corporation

2967-3, Ishikawa-machi, Hachioji-shi, Tokyo, 192-8525 Japan

Kenwood U.S.A. Corporation

P.O. BOX 22745, 2201 East Dominguez Street, Long Beach, CA 90801-5745, U.S.A.

Kenwood Electronics Canada Inc.

6070 Kestrel Road, Mississauga, Ontario, Canada L5T 1S8

Kenwood Electronics Deutschland GmbH.

Rembrücker Str. 15, 63150 Heusenstamm, Germany

Kenwood Electronics Belgium N.V.

Leuvensesteenweg 248 J, 1800 Vilvoorde, Belgium

Kenwood Electronics France S.A.

13, Boulevard Ney, 75018 Paris, France

Kenwood Electronics U.K. Ltd.

KENWOOD House, Dwight Road, Watford, Herts., WD18 9EB United Kingdom

Kenwood Electronics Europe B.V.

Amsterdamseweg 37, 1422 AC Uithoorn, The Netherlands

Kenwood Electronics Italia S.p.A.

Via G. Sirtori, 7/9 20129 Milano, Italy

Kenwood Electronics Iberica S.A.

Bolivia, 239-08020 Barcelona, Spain

Kenwood Electronics Australia Pty. Ltd.

(A.C.N. 001 499 074)

16 Giffnock Avenue, Centrecourt Estate, North Ryde, N.S.W. 2113 Australia

Kenwood Electronics (Hong Kong) Ltd.

Unit 3712-3724, Level 37, Tower one Metroplaza, 223 Hing Fong Road, Kwai Fong, N.T., Hong Kong

Kenwood Electronics Singapore Pte. Ltd.

1 Ang Mo Kio Street 63, Singapore 569110

