

KENWOOD

Document Copyrights

Copyright 2006 by Kenwood Corporation. All rights reserved.

No part of this manual may be reproduced, translated, distributed, or transmitted in any form or by any means, electronic, mechanical, photocopying, recording, or otherwise, for any purpose without the prior written permission of Kenwood.

Disclaimer

While every precaution has been taken in the preparation of this manual, Kenwood assumes no responsibility for errors or omissions. Neither is any liability assumed for damages resulting from the use of the information contained herein. Kenwood reserves the right to make changes to any products herein at any time for improvement purposes.



Photo is TK-2200 (K2 type).
Does not come with antenna.
Antenna is available as an option.

CONTENTS

GENERAL	2
REALIGNMENT	3
DISASSEMBLY FOR REPAIR	5
CIRCUIT DESCRIPTION	8
TERMINAL FUNCTION	12
SEMICONDUCTOR DATA	12
COMPONENTS DESCRIPTION	13
PARTS LIST	14
EXPLODED VIEW	21
PACKING	22
ADJUSTMENT	23
PC BOARD	
TX-RX UNIT (X57-6880-XX)	28
SCHEMATIC DIAGRAM	32
BLOCK DIAGRAM	36
LEVEL DIAGRAM	38
KSC-31 / KNB-29N / KBH-10	39
SPECIFICATIONS	BACK COVER

TK-2200

GENERAL

INTRODUCTION

SCOPE OF THIS MANUAL

This manual is intended for use by experienced technicians familiar with similar types of commercial grade communications equipment. It contains all required service information for the equipment and is current as of the publication date. Changes which may occur after publication are covered by either Service Bulletins or Manual Revisions. These are issued as required.

ORDERING REPLACEMENT PARTS

When ordering replacement parts or equipment information, the full part identification number should be included. This applies to all parts, components, kits, or chassis. If the part number is not known, include the chassis or kit number of which it is a part, and a sufficient description of the required component for proper identification.

PERSONAL SAFETY

The following precautions are recommended for personal safety:

- DO NOT transmit until all RF connectors are verified secure and any open connectors are properly terminated.
- SHUT OFF and DO NOT operate this equipment near electrical blasting caps or in an explosive atmosphere.
- This equipment should be serviced by a qualified technician only.

SERVICE

This radio is designed for easy servicing. Refer to the schematic diagrams, printed circuit board views, and alignment procedures contained within.

TK-2200

Destination	Number of CH	Frequency No. / Frequency				Factory default CH setting	RF power output
K	2 channel	CH1	151.6250MHz	CH15	151.7750MHz	CH1: 154.5700MHz / QT 67.0Hz CH2: 154.6000MHz / QT 67.0Hz	2W
		CH2	151.9550MHz	CH16	151.8650MHz		
		CH3	154.5700MHz	CH17	151.8950MHz		
		CH4	154.6000MHz	CH18	151.9250MHz		
K2	8 channel	CH5	151.7000MHz	CH19	152.7000MHz	CH1: 154.5700MHz / QT 67.0Hz CH2: 154.6000MHz / QT 67.0Hz CH3: 151.7000MHz / QT 67.0Hz CH4: 151.7600MHz / QT 67.0Hz CH5: 151.8200MHz / QT 67.0Hz CH6: 151.8800MHz / QT 67.0Hz CH7: 151.9400MHz / QT 67.0Hz CH8: 151.5125MHz / QT 67.0Hz	
		CH6	151.7600MHz	CH20	154.4900MHz		
		*CH7	151.8200MHz	CH21	154.5150MHz		
		*CH8	151.8800MHz	CH22	154.5275MHz		
		*CH9	151.9400MHz	CH23	154.5400MHz		
		CH10	151.5125MHz	CH24	154.6000MHz		
		CH11	151.6550MHz	CH25	154.6550MHz		
		CH12	151.6850MHz	CH26	158.4000MHz		
		CH13	151.7150MHz	CH27	158.4075MHz		
		CH14	151.7450MHz				

*Note : Due to FCC regulations, these frequencies transmit at only 1 watt

REALIGNMENT

1. Modes

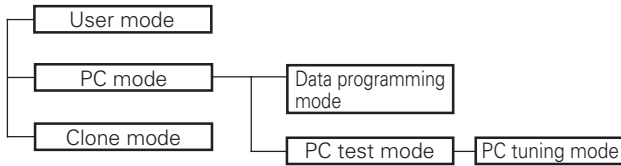

Mode	Function
User mode	For normal use.
PC mode	Used for communication between the radio and PC (IBM compatible).
Data programming mode	Used to read and write frequency data and other features to and from the radio.
PC test mode	Used to check the radio using the PC. This feature is included in the KPG-88D.
Clone mode	Used to transfer programming data from one radio to another.

2. How to Enter Each Mode

Mode	Operation
User mode	Power ON
PC mode	Received commands from PC
Clone mode	[PTT]+[Scan]+Power ON (Two seconds)

3. Getting Acquainted

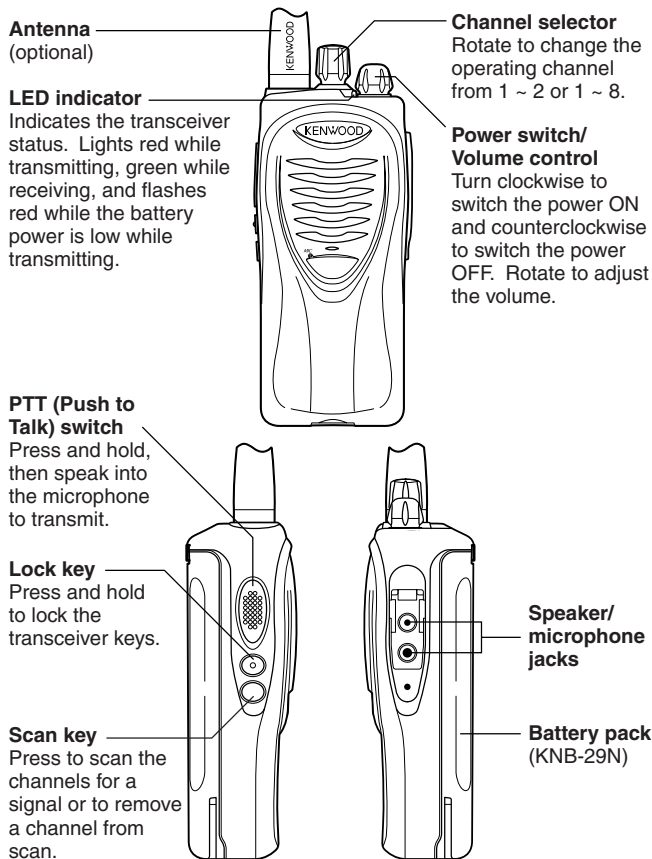

4. PC Mode

4-1. Preface

The TK-2200 transceiver is programmed using a personal computer, a programming interface (KPG-22) and programming software (KPG-88D).

The programming software can be used with an IBM PC or compatible. Figure 1 shows the setup of an IBM PC for programming.

4-2. Connection procedure

1. Connect the TK-2200 to the personal computer with the interface cable.
2. When the POWER is switched on, user mode can be entered immediately. When the PC sends a command, the radio enters PC mode. When data is transmitting from the transceiver, the red LED lights. When data is received by the transceiver, the green LED lights.

Notes:

- The data stored in the personal computer must match the model type when it is written into the EEPROM.
- Change the TK-2200 to PC mode, then attach the interface cable.

4-3. KPG-22 description

(PC programming interface cable: Option)

The KPG-22 is required to interface the TK-2200 with the computer. It has a circuit in its D-subconnector (25-pin) case that converts the RS-232C logic level to the TTL level.

The KPG-22 connects the SP/MIC connector of the TK-2200 to the computer's RS-232C serial port.

4-4. Programming software description

KPG-88D is the programming software for TK-2200 supplied on a CD-ROM. This software runs under Windows 98, ME, Windows 2000 or XP on an IBM-PC or compatible machine.

The data can be input to or read from TK-2200 and edited on the screen. The programmed or edited data can be printed out. It is also possible to tune the transceiver.

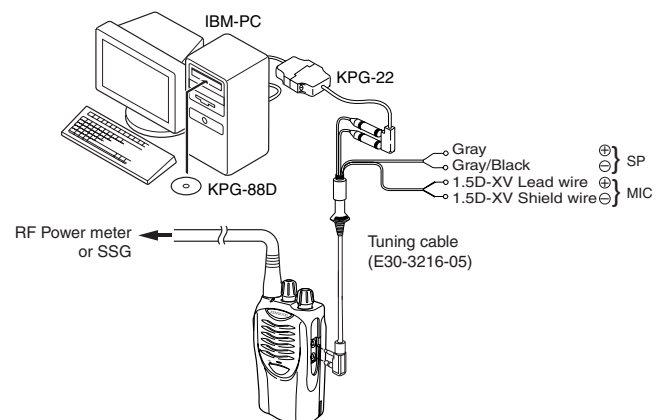

Fig. 1

REALIGNMENT

5. Clone Mode

5-1. Outline

"Clone Mode" copies the transceiver data to another transceiver.

The dealer can copy the transceiver data to another transceiver even without the use of a personal computer.

5-2. Example

The transceiver can copy the programming data to one or more transceivers via RF communication.

The clone master and clone slave/s must be in Clone mode.

5-3. Operation

1. To switch the clone slave/s to Clone mode, press and hold the [PTT] and [Scan] keys while turning the transceiver power ON.
2. Wait for 2 seconds. The LED will light orange and the transceiver will announce "Clone".
3. Select a channel table number using Lock(increment channel table) and Scan(decrement channel table) keys.
4. To switch the clone master to Clone mode, press and hold the [PTT] and [Scan] keys while turning the transceiver power ON.
5. Wait for 2 seconds. The LED will light orange and the transceiver will announce "Clone".
6. Select the same channel table number as the clone slave/s.
7. Press [PTT] on the clone master to begin data transmission. When the clone slave starts to receive data, the LED will light green.
When the clone master finishes sending data, a "confirmation" tone will sound.
If data transmission fails while cloning, an "error" tone will sound from the Slave unit.
8. If the cloning fails, no data will be available in the Slave unit when it is returned to User mode.
9. When the cloning is successful, the Slave unit's "Scan" function will return to their default values (Scan = OFF).

Notes:

- The dealer can clone data to two or more transceivers by repeating the above procedures.
- If the transceivers Clone Mode is configured as "Disabled", the transceiver cannot enter Clone mode.
- The table shown below will cover the frequency tables used for wireless cloning.
- Clone mode cannot be entered in battery low state.
- A unit cannot be a "Master Unit" if it is unprogrammed. If [PTT] is pressed, an "error" tone will sound.
- Once a unit is set to be the Master, it cannot be a slave after the data has been transmitted. This protects the data in the Master unit.
- If the Slave unit is cloned successfully, it will return to User Mode.
- If the Slave unit is not cloned successfully, the led will remain Orange.

- The Master Unit and Slave Unit must be of the same model type and destination in order for Clone to operate.
- Clone mode cannot be accessed if "Super Lock" is activated.
- Electronic interface may cause a failure in data transfer during Wireless Clone, such as when waveforms or electromagnetics are being performed at the workbench.
- Clone mode can be used ONLY by the authorized service personnel.
- The Clone mode setting must be configured as "Disable" before being delivered to the end-user.
- To clone, replace the antenna from both the master transceiver and the slave transceiver with a dummy load.
- The transmit output power is automatically set to Low in Clone mode.

Clone Frequency Table

Table Number	Frequency (MHz)	Table Number	Frequency (MHz)
1	151.6250	15	151.7750
2	151.9550	16	151.8650
3	154.5700	17	151.8950
4	154.6000	18	151.9250
5	151.7000	19	152.7000
6	151.7600	20	154.4900
7	151.8200	21	154.5150
8	151.8800	22	154.5275
9	151.9400	23	154.5400
10	151.5125	24	154.6000
11	151.6550	25	154.6550
12	151.6850	26	158.4000
13	151.7150	27	158.4075
14	151.7450		

DISASSEMBLY FOR REPAIR

■ Removing the case assembly from the chassis.

1. Remove the volume knob ① and channel knob ②.
(The stopper is contained in the channel knob only the K-type transceiver.)
2. Remove the two screws ③.
3. Lift and remove the chassis from the case assembly ④.
(Use a flat-blade screwdriver to easily lift the chassis.)

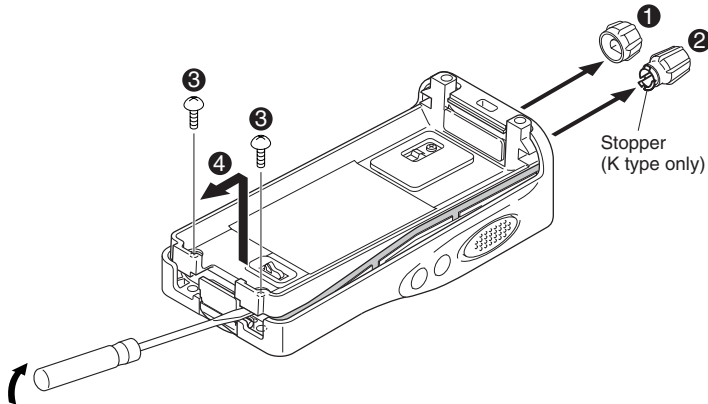

■ Removing the TX-RX unit from the chassis.

1. Remove the packing ⑤ from the SP / MIC jack of the TX-RX unit.
2. Remove the eleven screws ⑥ fixing the TX-RX unit.
3. Remove the fixing bracket ⑦ of the SP / MIC.
4. Remove the solder of the antenna terminal with a soldering iron ⑧.
5. Remove the solder of the positive terminal with a soldering iron ⑨.

Note: You can remove the TX-RX unit from the chassis without removing the solder at the positive terminal. However, in this case, you can not attach the packing (G53-1605-03) that is on the positive terminal to the chassis in assembling. So, it is advisable to remove the solder on the positive terminal first.

6. Remove the FPC from the flat cable connector ⑩.
7. Lift and remove the TX-RX unit from the chassis ⑪.

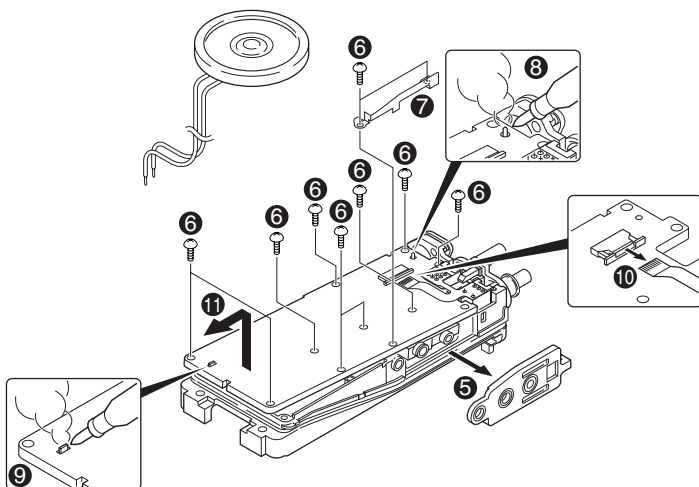

■ Removing the battery release lever from the case assembly.

1. Press the upper part of the lever toward the inside of the case assembly. One side of the shaft will be removed ①.
2. Lift and remove the battery release lever from the case assembly ②.

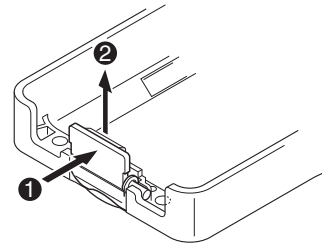

■ Attaching the battery release lever to the case assembly.

1. Insert one side of the shaft into the hole at the lever fitting section on the case assembly ①.

Caution : The thin spring (G01-4543-04) should be positioned above the two tabs of the lever.

2. Tilt the battery release lever slightly forward ②, so that the thick spring (G01-4542-04) is positioned below the case surface.
3. With the thick spring positioned below the case surface, attach the other side of the shaft to the case assembly by pressing the battery release lever ③ until it snaps into place ④.

Caution : Be careful not to tilt the battery release lever too forward.

If the battery release lever is pushed in this state where the two tabs come below the case surface, there is a possibility of damaging the two tabs.

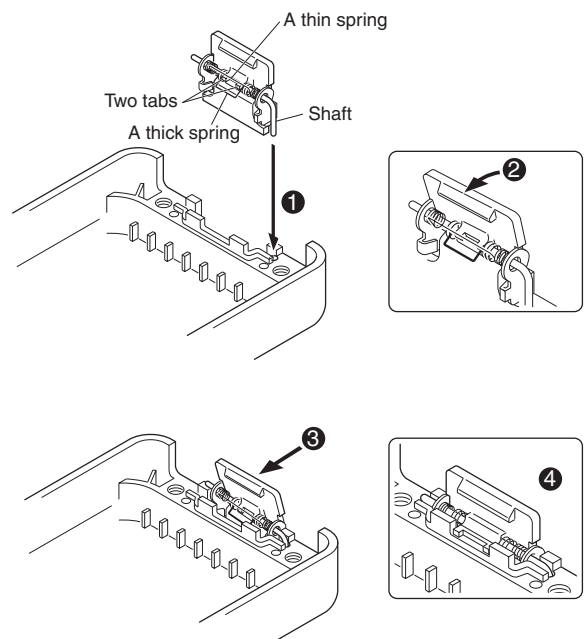

DISASSEMBLY FOR REPAIR

■ Assembling the battery release lever

1. Place the lever **2** onto the stopper **1**.
2. Place the thick spring **3** onto the lever.
3. Hook the right and left ends of the thin spring **4** onto the tabs of the stopper, then place the thin spring onto the lever **5**.
4. Slide the shaft through the hole of the stopper and lever **6**.

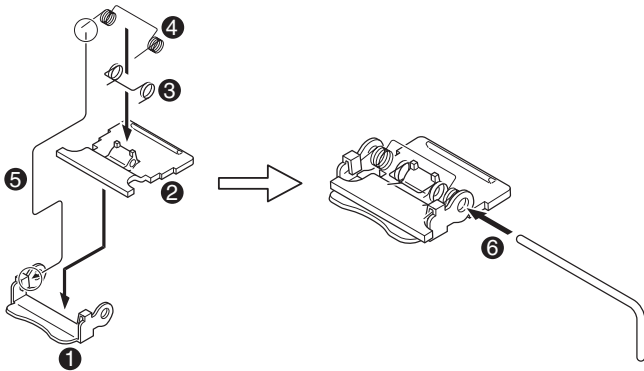

■ Cautions for assembly

1. Attaching the positive terminal to the chassis.

Always attach the positive terminal to the chassis, using the following procedures, before mounting the TX-RX unit onto the chassis.

1. Remove the holder assembly **2** from the packing **1** of the positive terminal.
2. Mount the packing of the positive terminal into the chassis hole **3**.
3. Mount the holder assembly into the packing of the positive terminal **4**.

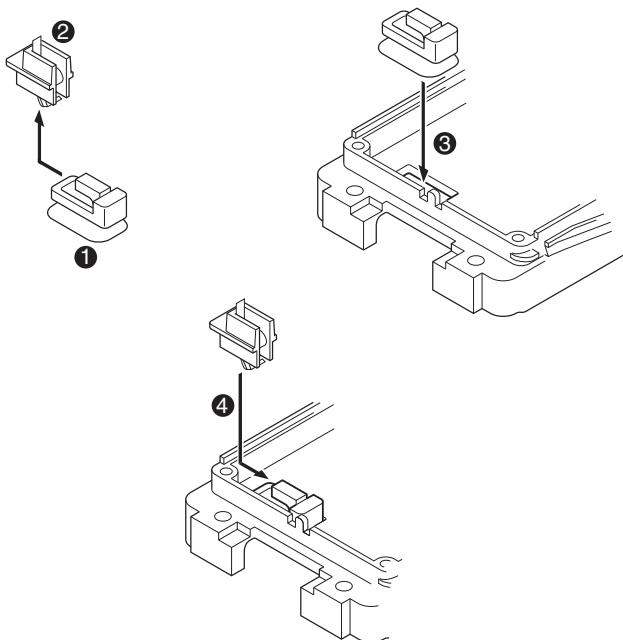

2. Mounting the chassis to the case assembly.

1. Confirm that the waterproof packing attached to the circumference of the chassis is securely inserted in the groove of the chassis **1**.
2. Attach the speaker to the speaker recess of the case assembly **2**. Make sure the speaker is securely inserted.

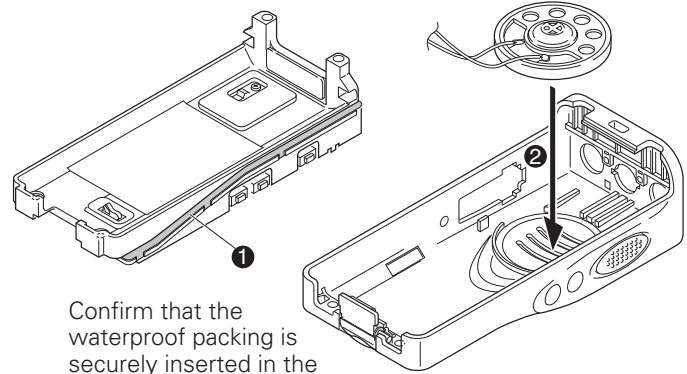

Confirm that the waterproof packing is securely inserted in the groove of the chassis.

3. Insert the upper part of the chassis into the case assembly **3**.

Caution: Take care that the speaker lead wire is not caught by the microphone element.

4. Press the chassis **4** and the case assembly together to attach them.

Caution: If the packing of the SP / MIC does not come to the correct position after attaching the chassis to the case assembly, reposition the packing with your fingers.

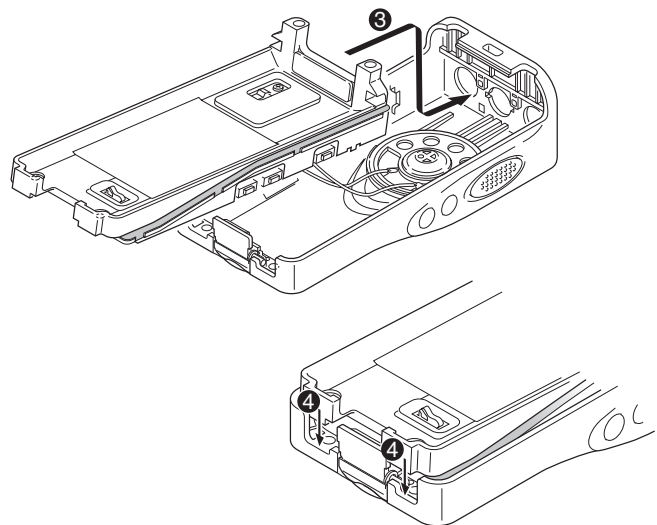

DISASSEMBLY FOR REPAIR

3. Attaching the antenna receptacle to the chassis.

Screw the antenna receptacle to the chassis in the order shown in the drawing so that the antenna receptacle comes to the center of the case hole.

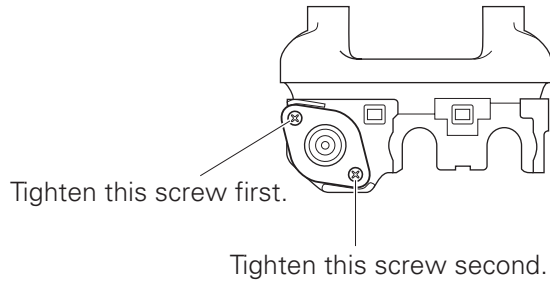

5. Connecting the speaker wires to the TX-RX unit

Note: To connect the speaker wires, you must solder it to the location of the TX-RX unit as illustrated below.

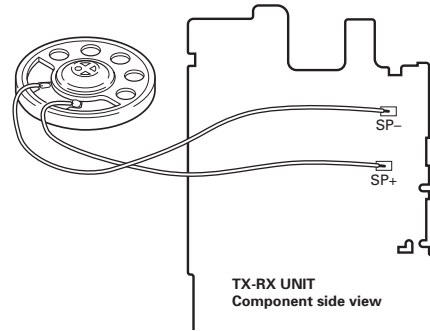

4. The nuts of the volume knob and channel knob

Note that the shapes, colors and heights of nuts of the volume knob and channel knob are different from one another. (The nut of volume knob is silver, and the nut of channel knob is gold)

Use the following jig when removing the nuts of the volume knob and channel knob.

- Jig (Part No. : W05-1012-00)

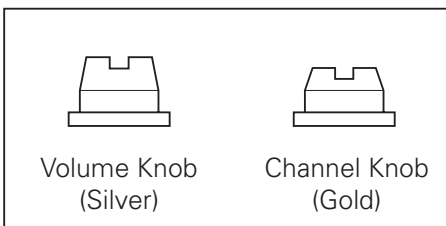

CIRCUIT DESCRIPTION

1. Frequency Configuration

The receiver utilizes double conversion. The first IF is 38.85 MHz and the second IF is 450 kHz. The first local oscillator signal is supplied from the PLL circuit.

The PLL circuit in the transmitter generates the necessary frequencies. Fig. 1 shows the frequencies.

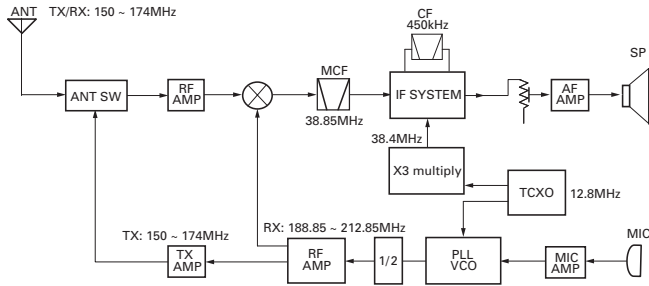

Fig. 1 Frequency configuration

2. Receiver

The frequency configuration of the receiver is shown in Fig. 2.

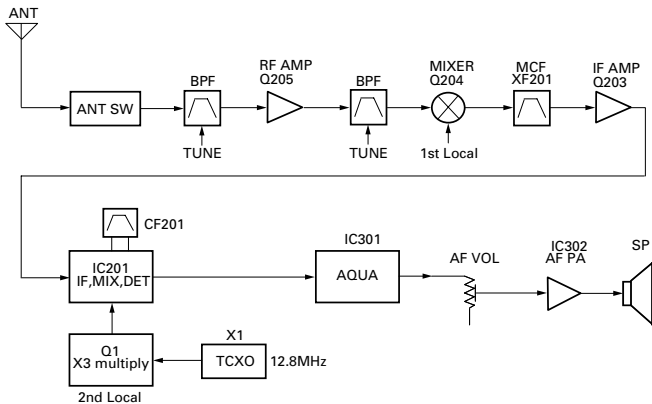

Fig. 2 Receiver section

1) Front End (RF AMP)

The signal coming from the antenna passes through the transmit/receive switching diode circuit, (D103, D104, D105 and D106) passes through a BPF (L214 and L213), and is amplified by the RF amplifier (Q205).

The resulting signal passes through a BPF (L209 and L211) and goes to the mixer. These BPFs are adjusted by variable capacitors (D203, D204, D205 and D206). The input voltage to the variable capacitor is regulated by voltage output from the microprocessor (IC405).

2) First Mixer

The signal from the front end is mixed with the first local oscillator signal generated in the PLL circuit by Q1 to produce a first IF frequency of 38.85 MHz.

The resulting signal passes through the XF201 MCF to cut the adjacent spurious and provide the optimum characteristics, such as adjacent frequency selectivity.

3) IF Amplifier Circuit

The first IF signal is passed through a four-pole monolithic crystal filter (XF201) to remove the adjacent channel signal. The filtered first IF signal is amplified by the first IF amplifier (Q203) and then applied to the IF system IC (IC201). The IF system IC provides a second mixer, second local oscillator, limiting amplifier, quadrature detector and RSSI (Received Signal Strength Indicator). The second mixer mixes the first IF signal with the 38.4MHz of the second local oscillator output (TCXO X1) and produces the second IF signal of 450kHz.

The second IF signal is passed through the ceramic filter (CF201) to remove the adjacent channel signal. The filtered second IF signal is amplified by the limiting amplifier and demodulated by the quadrature detector with the ceramic discriminator (CD201). The demodulated signal is routed to the audio circuit.

4) Wide/Narrow Switching Circuit

Narrow and Wide settings can be made for each channel by switching the demodulation level.

The WIDE (low level) and NARROW (high level) data is output from IC405, pin 45.

When a WIDE (low level) data is received, Q202 turn on. When a NARROW (high level) data is received, Q202 turn off. Q202 turns on/off with the Wide/Narrow data and the IC201 detector output level is switched to maintain a constant output level during wide or narrow signals.

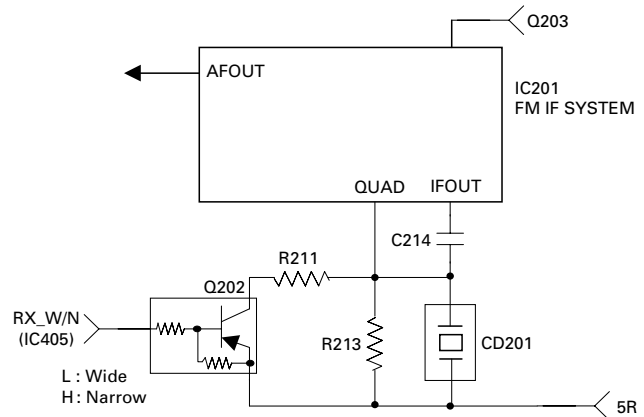

Fig. 3 Wide/Narrow switching circuit

5) Audio Amplifier Circuit

The demodulated signal from IC201 goes to AF amplifier through IC301.

The signal then goes through an AF volume control, and is routed to an audio power amplifier (IC302) where it is amplified and output to the speaker.

CIRCUIT DESCRIPTION

6) Squelch

Part of the AF signal from the IC enters the FM IC (IC201) again, and the noise component is amplified and rectified by a filter and an amplifier to produce a DC voltage corresponding to the noise level.

The DC signal from the FM IC goes to the analog port of the microprocessor (IC405). IC405 determines whether to output sounds from the speaker by checking whether the input voltage is higher or lower than the preset value. To output sounds from the speaker, IC405 sends a high signal to the SP MUTE line and turns IC302 on through Q303, Q304, Q305, Q306 and Q316. (See Fig. 4)

7) Receive Signalling

(1) QT/DQT

The output signal from FM IC (IC201) enters the microprocessor (IC405) through IC301. IC405 determines whether the QT or DQT matches the preset value, and controls the SP MUTE and the speaker output sounds according to the squelch results.

(2) MSK (Fleet Sync)

The MSK input signal from the FM IC goes to pin 31 of IC 301. The signal is demodulated by MSK demodulator in IC 301. The demodulated data goes to the CPU for processing.

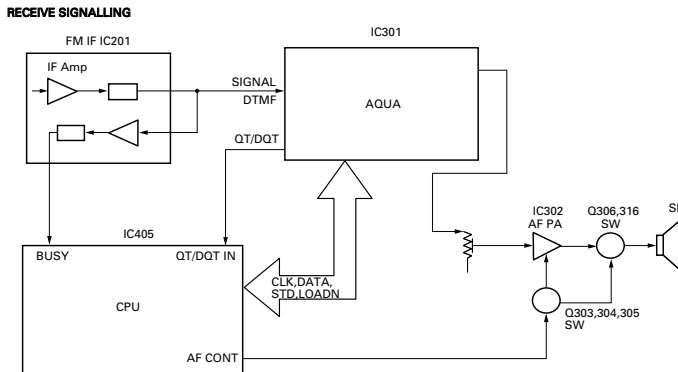

Fig. 4 AF amplifier and squelch

(3) DTMF

The DTMF input signal from the FM IC (IC201) goes to IC301. The decoded information is then processed by the CPU.

3. PLL Frequency Synthesizer

The PLL circuit generates the first local oscillator signal for reception and the RF signal for transmission.

1) PLL

The frequency step of the PLL circuit is 2.5, 5, 6.25 or 7.5kHz. A 12.8MHz reference oscillator signal is divided at IC1 by a fixed counter to produce an oscillator (VCO) output signal which is buffer amplified by Q2 then divided in IC1 by a programmable counter. The divided signal is compared in phase with the 5 or 6.25kHz reference signal from the phase comparator in IC1. The output signal from the phase comparator is filtered through a low-pass filter and passed to the VCO to control the oscillator frequency. (See Fig. 5)

2) VCO

The operating frequency is generated by Q4 in transmit mode and Q3 in receive mode. The oscillator frequency is controlled by applying the VCO control voltage, obtained from the phase comparator, to the varactor diodes (D4 and D7 in transmit mode and D5 and D9 in receive mode). The RX pin is set high in receive mode causing Q5 turn on. The TX pin is set high in transmit mode. The outputs from Q3 and Q4 are amplified by Q6 and sent to the RF amplifiers.

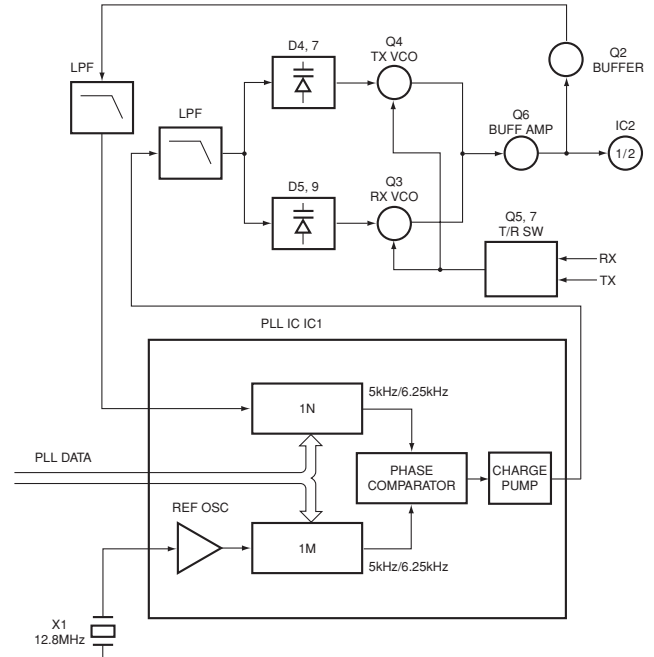

Fig. 5 PLL circuit

3) Unlock Detector

If a pulse signal appears at the LD pin of IC1, an unlock condition occurs, and the DC voltage obtained from C4, R5 and D1 causes the voltage applied to the microprocessor to go low. When the microprocessor detects this condition, the transmitter is disabled, ignoring the push-to-talk switch input signal.

4. Transmitter System

1) Microphone Amplifier

The signal from the microphone passes through the IC301. When encoding DTMF, it is turned OFF for muting the microphone input signal by IC301.

The signal passes through the Audio processor (IC301) for the maximum deviation adjustment, and goes to the VCO modulation input.

CIRCUIT DESCRIPTION

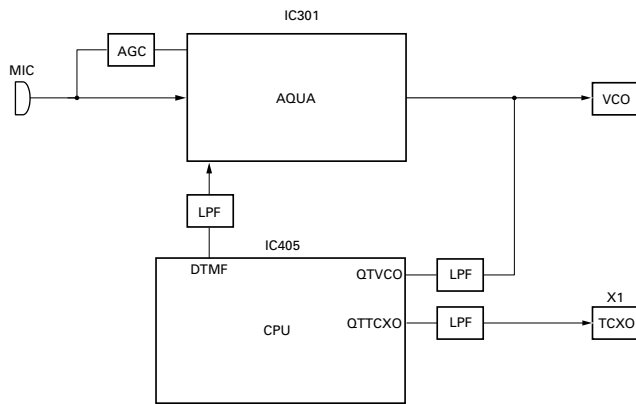

Fig. 6 Microphone amplifier

2) Drive and Final Amplifier

The signal from the T/R switch (D101 is on) is amplified by the pre-drive (Q102) and the drive amplifier (Q103) to 50mW. The output of the drive amplifier is amplified by the RF power amplifier (Q106) to 2W (1W when the power is low). The RF power amplifier consists of two MOS FET stages. The output of the RF power amplifier is then passed through the harmonic filter (LPF) and antenna switch (D103 and D104) and applied to the antenna terminal.

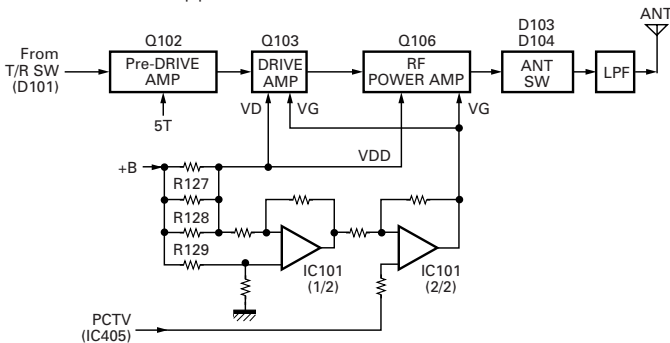

Fig. 7 Drive and final amplifier and APC circuit

3) APC Circuit

The APC circuit always monitors the current flowing through the RF power amplifier (Q106) and keeps a constant current. The voltage drop at R127, R128 and R129 is caused by the current flowing through the RF power amplifier and this voltage is applied to the differential amplifier IC101(1/2). IC101(2/2) compares the output voltage of IC101(1/2) with the reference voltage from IC405. The output of IC101(2/2) controls the VG of the RF power amplifier, drive amplifier and pre-drive amplifier to make both voltages the same. The change of power high/low is carried out by the change of the reference voltage.

4) Encode Signalling

(1) QT/DQT

QT,DQT data of the QTTCXO Line is output from pin 28 of the CPU. The signal passes through a low-pass CR filter and goes to the TCXO(X1).

The QT,DQT data of the QTVCO Line is output from pin 24 of the CPU. The signal passes through a low pass CR filter, mixes with the audio signal, and goes to the VCO modulation input. TX deviation is adjusted by the CPU.

(2) DTMF

High-speed data is output from pin 2 of the CPU. The signal passes through a low-pass CR filter, and provides a TX and SP out tone, and is then applied to the audio processor (IC301). The signal is mixed with the audio signal and goes to the VCO.

TX deviation is adjusted by the CPU.

(3) MSK (Fleet Sync)

Fleet Sync utilizes 1200bps and 2400bps MSK signal is output from pin 6 of IC301. And is routed to the VCO. When encoding MSK, the microphone input signal is muted.

5. Power Supply

There are four 5V power supplies 5M,5C,5R, and 5T. 5M for microprocessor is always output while the power is on. 5M is always output, but turns off when the power is turned off to prevent malfunction of the microprocessor.

5C is a common 5V and is output when SAVE is not set to OFF.

5R is 5V for reception and output during reception.

5T is 5V for transmission and output during transmission.

6. Control Circuit

The control circuit consists of a microprocessor (IC405) and its peripheral circuits. It controls the TX-RX unit. IC405 mainly performs the following:

- (1) Switching between transmission and reception by the PTT signal input.
- (2) Reading system, group, frequency, and program data from the memory circuit.
- (3) Sending frequency program data to the PLL.
- (4) Controlling squelch on/off by the DC voltage from the squelch circuit.
- (5) Controlling the audio mute circuit by the decode data input.
- (6) Transmitting tone and encode data.

1) Frequency Shift Circuit

The microprocessor (IC405) operates at a clock of 7.3728MHz. This oscillator has a circuit that shifts the frequency by BEAT SHIFT SW (Q407,Q408).

A beat sound may be able to be evaded from generation if "Beat Shift" is set to ON when it is generated in the internal spurious transmission modulated sound of a transceiver.

CIRCUIT DESCRIPTION

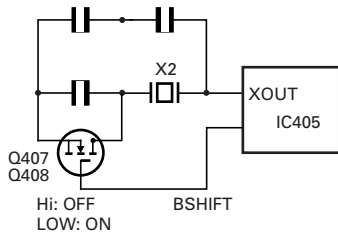

Fig. 8 Frequency shift circuit

2) Memory Circuit

Memory circuit consists of the CPU (IC405) and an EEPROM (IC406). An EEPROM has a capacity of 64k bits that contains the transceiver control program for the CPU and data such as transceiver channels and operating features.

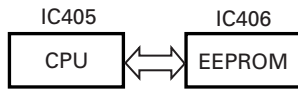

Fig. 9 Memory circuit

3) Low Battery Warning

The battery voltage is checked using by the microprocessor. The transceiver generates a warning tone when it falls below the warning voltage shown in the table.

(1) The red LED blinks when the battery voltage falls below the voltage (1) shown in the table during transmission.

Note:

The transceiver checks the battery voltage during reception even when, in the FPU, the Battery Warning status function is set to "On TX" (default setting).

However, the LED does not blink during reception. During transmission, the LED blinks to generate the warning tone of a low battery voltage.

(2) The transceiver immediately stops transmission when the battery voltage falls below the voltage (2) shown in the table. A message tone beeps while the PTT switch is released.

	Ni-MH Battery
(1)	6.2 [V]
(2)	5.9 [V]

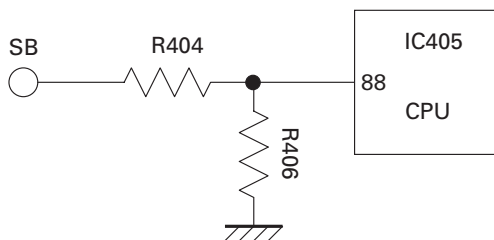

Fig. 10 Low battery warning

7. Control System

Keys and channel selector circuit.

The signal from the keys and channel selector are directly input to the microprocessor, as shown in fig. 11.

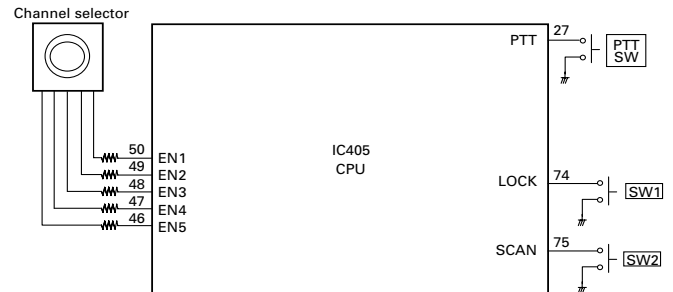

Fig. 11 Control system

TK-2200

TERMINAL FUNCTION / SEMICONDUCTOR DATA

TERMINAL FUNCTION

■ CN401

Pin No.	Name	I/O	Function
1	B	I	B (Battery Voltage)
2	SB	O	Switched B
3	SP1	I	Audio input
4	SP2	O	Audio output
5	GND	-	GND
6	EN1	I	Encoder pulse input

Pin No.	Name	I/O	Function
7	EN2	I	Encoder pulse input
8	GND	-	GND
9	EN3	I	Encoder pulse input
10	EN4	I	Encoder pulse input
11	EN5	I	Encoder pulse input

SEMICONDUCTOR DATA

Microprocessor : 30622MAA-B91GP (TX-RX UNIT : IC405)

■ Pin function

Pin No.	Port Name	I/O	Function
1	PCTV	O	APC/BPF control data output
2	DTMF	O	DTMF/BEEP Output
3	NC	-	NC
4	EEPDAT	I/O	EEPROM data input/output
5	EEPCLK	O	EEPROM clock output
6	BYTE	-	GND
7	GND	-	GND
8	BSHIFT	O	Beat shift switch
9	NC	-	NC
10	RESET	I	CPU reset
11	XOUT	O	CPU clock (7.3728MHz)
12	VSS	-	GND
13	XIN	I	CPU clock (7.3728MHz)
14-15	VCC	-	+5V
16	INT	I	Battery voltage monitor input
17	TCLK/DTRDO	I	Base band IC data input
18	RDF/FD	I	Base band IC data input
19	SCLK	O	Base band IC clock output
20	D I/O	I/O	Base band IC data input/output
21	TDATA/DTRCLK	O	Base band IC data output
22	DIR	O	Base band IC data output
23	STD	I	Base band IC data input
24	QT VCO	O	QT/DQT output
25	DTRLOADN	O	Base band IC data output
26	1/2 OSC	O	3.6864 MHz (7.3728 MHz/2)
27	PTT	I	PTT switch input
28	QT TCXO	O	QT/DQT output
29	TXD	O	Serial data (FPU/FLASH)
30	RXD	I	Serial data (FPU/FLASH)
31	GND	-	GND
32	APCSW	O	APC switch
33-34	NC	-	NC
35	DCSW	O	APC voltage discharge switch
36	TX_W/N	O	TX Wide/Narrow switch
37	RX_SW	O	RX VCO switch
38	TX_SW	O	TX VCO switch
39	GND	-	GND
40	PLL_UL	I	PLL unlock detect input
41	PLL_STB	O	PLL strobe output
42	PLL_DAT	O	PLL data output
43	PLL_CLK	O	PLL clock output
44	VCC	-	+5V

Pin No.	Port Name	I/O	Function
45	RX_W/N	O	RX Wide/Narrow switch
46	EN5	I	Channel selectable input
47	EN4	I	Channel selectable input
48	EN3	I	Channel selectable input
49	EN2	I	Channel selectable input
50	EN1	I	Channel selectable input
51	OPTDET	I	Headset input detect
52	AF_CONT	O	Speaker mute
53	Calling Alert SW	O	Calling alert switch
54	DTMF SW	O	DTMF switch
55-59	NC	-	NC
60	VCC	-	+5V
61	NC	-	NC
62	VSS	-	GND
63-64	GND	-	GND
65-71	NC	-	NC
72	LEDTX	O	Red LED lights control output
73	LEDRX	O	Green LED lights control output
74	PF1	I	Lock key input
75	PF2	I	Scan key input
76	SIM1	-	GND
77	SIM2	-	GND
78-79	NC	-	NC
80	5T_C	O	5T control output
81	5R_C	O	5R control output
82	5C_C	O	5C control output
83-87	NC	-	NC
88	BATT	I	Battery voltage input
89	RSSI	I	Received Signal Strength Indicator input
90	BUSY	I	Busy level input
91	VOX	I	VOX level input
92	QT/DQT_IN	I	QT/DQT input
93	TH_DET	I	Thermistor input
94	AVSS	-	GND
95	NC	-	NC
96	VREF	-	+5V
97	AVCC	-	+5V
98	NC	-	NC
99	MIC_Mute	O	MIC mute
100	NC	-	NC

COMPONENTS DESCRIPTION

TX-RX UNIT (X57-6880-XX)

Ref. No.	Use/Function	Operation/Condition
IC1	IC	PLL system
IC2	IC	VCO 1/2 Divider
IC101	IC	Comparator (APC)
IC201	IC	FM IF system
IC301	IC	Audio processor
IC302	IC	AF AMP
IC401	IC	Voltage Regulator/ 5V
IC402	IC	Voltage Regulator/ 5V
IC403	IC	Voltage detector / Reset
IC404	IC	Voltage detector / Int
IC405	IC	Microprocessor
IC406	IC	EEPROM
Q1	Transistor	Tripler
Q2	Transistor	PLL IC f _{in} AMP
Q3	FET	VCO / RX
Q4	FET	VCO / TX
Q5	Transistor	DC switch / TX VCO
Q6	Transistor	RF Buffer AMP
Q7	Transistor	DC switch / RX VCO
Q8	Transistor	Ripple filter
Q9	Transistor	RF AMP
Q102	Transistor	RF AMP
Q103	FET	TX Drive AMP
Q104	Transistor	APC switch
Q105	FET	APC switch
Q106	FET	TX Final AMP
Q107	Transistor	APC switch
Q108	FET	APC switch
Q109	Transistor	APC switch
Q202	Transistor	W/N switch / RX
Q203	Transistor	IF AMP
Q204	FET	Mixer
Q205	FET	RF AMP
Q301	Transistor	W/N switch / TX
Q302	Transistor	MIC AGC
Q303	Transistor	DC switch / SP Mute
Q304	Transistor	DC switch
Q305	Transistor	DC switch / SP Mute
Q306	FET	SP Mute switch
Q316	FET	SP Mute switch
Q317,318	FET	Audio switch
Q401	Transistor	LED switch / Red
Q402	Transistor	LED switch / Green
Q403	FET	5T switch
Q404	FET	5R switch
Q405	Transistor	5C switch
Q407	FET	Beat Shift switch
Q408	FET	Beat Shift switch
Q901	FET	W/N switch / TX

Ref. No.	Use/Function	Operation/Condition
D1	Diode	Ripple Filter
D4	Variable Capcitanse Diode	Frequency control / TX VCO
D5	Variable Capcitanse Diode	Frequency control / RX VCO
D7	Variable Capcitanse Diode	Frequency control / TX VCO
D9	Variable Capcitanse Diode	Frequency control / RX VCO
D10	Variable Capcitanse Diode	Modulator
D11	Diode	Current steering
D101	Diode	TX/RX RF switch
D102	Zener Diode	APC protect
D103	Diode	ANT switch
D104	Diode	ANT switch
D105	Diode	ANT switch
D106	Diode	ANT switch
D202	Diode	TX/RX RF switch
D203	Variable Capcitanse Diode	RF BPF tuning
D204	Variable Capcitanse Diode	RF BPF tuning
D205	Variable Capcitanse Diode	RF BPF tuning
D206	Variable Capcitanse Diode	RF BPF tuning
D301	Diode	Detector
D302	Diode	Detector
D303	Diode	Isolation
D401	Diode	5V Protection
D402	Diode	Reverse Protection
D403	LED	LED/ Red
D404	LED	LED/ Green
D405	Zener Diode	Limiter

PARTS LIST

CAPACITORS

CC 45 TH 1H 220 J
 1 2 3 4 5 6

- 1 = Type ... ceramic, electrolytic, etc.
- 2 = Shape ... round, square, ect.
- 3 = Temp. coefficient
- 4 = Voltage rating
- 5 = Value
- 6 = Tolerance

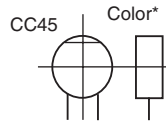

Capacitor value

- 010 = 1pF
- 100 = 10pF
- 101 = 100pF
- 102 = 1000pF = 0.001μF
- 103 = 0.01μF

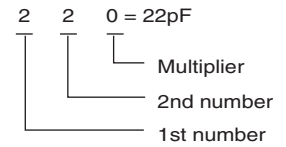

Temperature coefficient

1st Word	C	L	P	R	S	T	U
Color*	Black	Red	Orange	Yellow	Green	Blue	Violet
ppm/°C	0	-80	-150	-220	-330	-470	-750

2nd Word	G	H	J	K	L
ppm/°C	±30	±60	±120	±250	±500

Example : CC45TH = -470 ± 60ppm/°C

Tolerance (More than 10pF)

Code	C	D	G	J	K	M	X	Z	P	No code
(%)	±0.25	±0.5	±2	±5	±10	±20	+40 -40	+80 -20	+100 -0	More than 10μF -10 ~ +50 Less than 4.7μF -10 ~ +75

(Less than 10pF)

Gode	B	C	D	F	G
(pF)	±0.1	±0.25	±0.5	±1	±2

Voltage rating

2nd word \ 1st word	A	B	C	D	E	F	G	H	J	K	V
0	1.0	1.25	1.6	2.0	2.5	3.15	4.0	5.0	6.3	8.0	-
1	10	12.5	16	20	25	31.5	40	50	63	80	35
2	100	125	160	200	250	315	400	500	630	800	-
3	1000	1250	1600	2000	2500	3150	4000	5000	6300	8000	-

Chip capacitors

(EX) C C 7 3 F S L 1 H 0 0 0 J
 1 2 3 4 5 6 7

(Chip)(CH,RH<UJ,SL)

(EX) C K 7 3 F F 1 H 0 0 0 Z
 1 2 3 4 5 6 7

(Chip)(B,F)

Refer to the table above.

- 1 = Type
- 2 = Shape
- 3 = Dimension
- 4 = Temp. coefficient
- 5 = Voltage rating
- 6 = Value
- 7 = Tolerance

Dimension (Chip capacitors)

Dimension code	L	W	T
Empty	5.6 ± 0.5	5.0 ± 0.5	Less than 2.0
A	4.5 ± 0.5	3.2 ± 0.4	Less than 2.0
B	4.5 ± 0.5	2.0 ± 0.3	Less than 2.0
C	4.5 ± 0.5	1.25 ± 0.2	Less than 1.25
D	3.2 ± 0.4	2.5 ± 0.3	Less than 1.5
E	3.0 ± 0.2	1.6 ± 0.2	Less than 1.25
F	2.0 ± 0.3	1.25 ± 0.2	Less than 1.25
G	1.6 ± 0.2	0.8 ± 0.2	Less than 1.0
H	1.0 ± 0.05	0.5 ± 0.05	0.5 ± 0.05

RESISTORS

Chip resistor (Carbon)

(EX) R K 7 3 E B 2 B 0 0 0 J
 1 2 3 4 5 6 7

(Chip)(B,F)

Carbon resistor (Nomal type)

(EX) R D 1 4 B B 2 C 0 0 0 J
 1 2 3 4 5 6 7

- 1 = Type
- 2 = Shape
- 3 = Dimension
- 4 = Temp. coefficient
- 5 = Rating wattage
- 6 = Value
- 7 = Tolerance

Dimension

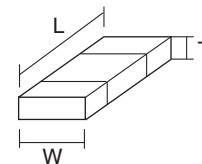

Dimension (Chip resistor)

Dimension code	L	W	T
E	3.2 ± 0.2	1.6 ± 0.2	1.0
F	2.0 ± 0.3	1.25 ± 0.2	1.0
G	1.6 ± 0.2	0.8 ± 0.2	0.5 ± 0.1
H	1.0 ± 0.05	0.5 ± 0.05	0.35 ± 0.05

Rating wattage

Code	Wattage	Code	Wattage	Code	Wattage
1J	1/16W	2C	1/6W	3A	1W
2A	1/10W	2E	1/4W	3D	2W
2B	1/8W	2H	1/2W		

PARTS LIST

* New Parts. Δ indicates safety critical components.
 Parts without **Parts No.** are not supplied.
 Les articles non mentionnés dans le **Parts No.** ne sont pas fournis.
 Teile ohne **Parts No.** werden nicht geliefert.

L: Scandinavia K: USA P: Canada
 Y: PX (Far East, Hawaii) T: England E: Europe
 Y: AAFES (Europe) X: Australia M: Other Areas

TK-2200 (Y50-5910-XX) TX-RX UNIT (X57-6880-XX)

Ref. No.	Address	New parts	Parts No.	Description	Destination	Ref. No.	Address	New parts	Parts No.	Description	Destination
TK-2200						TX-RX UNIT (X57-6880-XX) -10 :K -11 :K2					
1	1A	*	A02-3881-13	CABINET ASSY(2CH)	K	52	1B		K29-9309-03	KNOB(VOL)	
	1A	*	A02-3882-03	CABINET ASSY(8CH)	K2	53	1B		K29-9318-03	KNOB(CH)	
2	3A	*	A10-4094-13	CHASSIS		A	2B		N14-0819-04	CIRCULAR NUT(VOL KNOB)	
3	1B	*	A21-1645-13	DRESSING PANEL(8CH)	K2	B	2B	*	N14-0820-04	CIRCULAR NUT(CH KNOB)	
3	1B	*	A21-1646-13	DRESSING PANEL(2CH)	K	C	2A,2B		N30-2604-46	PAN HEAD MACHINE SCREW(SMA)	
4	2C		B09-0680-03	CAP(SP/MIC) ACCESSORY		D	3A		N30-2606-46	PAN HEAD MACHINE SCREW(CHASSIS)	
5	2B		B11-1817-04	ILLUMINATION GUIDE		E	2A,2B,3B		N83-2005-46	PAN HEAD TAPTITE SCREW(PCB)	
6	1B		B43-1156-04	BADGE(KENWOOD)		54	1C		N99-2043-05	SCREW SET ACCESSORY	
7	1A	*	B43-1173-04	BADGE		55	2B		R31-0653-05	VARIABLE RESISTOR(POWER SW/VOL)	
8	1C	*	B62-1791-10	INSTRUCTION MANUAL		56	2B		S60-0428-15	ROTARY SWITCH(8CH)	
9	1A		D10-0649-03	LEVER		57	1B		T07-0369-05	SPEAKER	
10	1A		D21-0863-04	SHAFT		58	2D		W08-0969-05	CHARGER ACCESSORY	
11	1A		D32-0441-03	STOPPER		59	1D		W08-0970-05	AC ADAPTER(AC120V) ACCESSORY	
12	1B	*	D32-0443-04	STOPPER(2CH)	K	TX-RX UNIT (X57-6880-XX) -10 :K -11 :K2					
14	2A		E04-0451-05	RF COAXIAL RECEPTACLE(SMA)		D403			B30-2156-05	LED(REDF)	
15	3B		E23-1253-04	TERMINAL(BATT-)		D404			B30-2157-05	LED(YELLOW)	
16	2B		E37-0794-05	PROCESSED LEAD WIRE(SP+)		C1			CK73HB1H332K	CHIP C 3300PF K	
17	2B		E37-0803-05	PROCESSED LEAD WIRE(SP-)		C2			CK73HB1C682K	CHIP C 6800PF K	
18	3A		F20-3353-14	INSULATING SHEET(CHASSIS BATT+)		C3			CK73GB1A105K	CHIP C 1.0UF K	
19	2A		G01-4542-04	COIL SPRING(LEVER)		C4			CK73HB1C103K	CHIP C 0.010UF K	
20	1A		G01-4543-04	COIL SPRING(STOPPER)		C5			CK73HB1H102K	CHIP C 1000PF K	
21	2B		G10-1330-04	FIBROUS SHEET(IC302:AUDIO IC)		C6			CK73HB1A104K	CHIP C 0.10UF K	
22	3A		G11-4283-04	RUBBER SHEET(Q103:FINAL FET)		C7 , 8			CC73HCH1H101J	CHIP C 100PF J	
23	2A		G11-4313-04	SHEET(MIC ELEMENT)		C9			CC73HCH1H100C	CHIP C 10PF C	
24	1A		G11-4319-04	SHEET(PTT)		C10			C92-0713-05	CHIP-TAN 10UF 6.3WV	
25	3A		G13-2033-04	CUSHION(TERMINAL BATT-)		C11			CC73HCH1H101J	CHIP C 100PF J	
26	3B		G13-2034-14	CUSHION(TERMINAL BATT-)		C12			CK73HB1H102K	CHIP C 1000PF K	
27	2B		G13-2037-04	CUSHION(CHASSIS VOL/CH)		C13			CK73HB1A104K	CHIP C 0.10UF K	
28	3A		G13-2038-14	CUSHION(CHASSIS-CERAMIC FILTER)		C14			CK73HB1C103K	CHIP C 0.010UF K	
29	2A		G13-2039-04	CUSHION(PCB-CERAMIC FILTER)		C15			CC73HCH1H100C	CHIP C 10PF C	
30	3B		G13-2045-04	CUSHION(CHASSIS)		C16			CK73HB1H102K	CHIP C 1000PF K	
31	2B	*	G13-2076-04	CUSHION(SP)		C17			CC73HCH1H470J	CHIP C 47PF J	
32	3A		G53-1604-03	PACKING(CHASSIS)		C18			CC73HCH1H180J	CHIP C 18PF J	
33	3A		G53-1605-03	PACKING(TERMINAL BATT+)		C19			CK73HB1A104K	CHIP C 0.10UF K	
34	2B		G53-1606-03	PACKING(VOL/CH/LED)		C21			C92-0713-05	CHIP-TAN 10UF 6.3WV	
35	1B		G53-1607-03	PACKING(SP/MIC)		C22			C92-0502-05	CHIP-TAN 0.33UF 35WV	
36	2B		G53-1608-03	PACKING(SP)		C24			CK73HB1H102K	CHIP C 1000PF K	
37	2A		G53-1609-14	PACKING(MIC ELEMENT)		C25			CC73HCH1H020B	CHIP C 2.0PF B	
38	2B		G53-1610-04	PACKING(SMA)		C26			CC73HCH1H300J	CHIP C 30PF J	
40	2C		H12-3158-05	PACKING FIXTURE		C27			C92-0697-05	CHIP-TAN 3.3UF 16WV	
41	1D		H13-2109-03	CARTON BOARD		C29 , 30			CK73HB1H471K	CHIP C 470PF K	
42	1C		H25-0085-04	PROTECTION BAG (100/200/0.07)		C32			C92-0001-05	CHIP C 0.1UF 35WV	
43	3D	*	H52-2035-02	ITEM CARTON CASE		C33 , 34			CK73HB1H102K	CHIP C 1000PF K	
44	2C		J19-5472-03	HOLDER(SP/MIC) ACCESSORY		C35			CC73HCH1H270J	CHIP C 27PF J	
45	2A		J19-5473-03	HOLDER ASSY(TERMINAL BATT+)		C38			CC73HCH1H060B	CHIP C 6.0PF B	
46	2B		J21-8477-04	HARDWARE FIXTURE(VOL/CH)		C39			CK73GB1H332K	CHIP C 3300PF K	
47	2B		J21-8478-04	HARDWARE FIXTURE(SP/MIC)		C40			CC73HCH1H040B	CHIP C 4.0PF B	
48	2C		J29-0713-05	BELT CLIP ACCESSORY		C41			CK73GB1H682K	CHIP C 6800PF K	
49	2B		J82-0092-05	FPC		C42			CC73HCH1H060B	CHIP C 6.0PF B	
50	1A	*	K29-9307-13	BUTTON KNOB(LOCK/SCAN)		C43			CC73HCH1H150J	CHIP C 15PF J	
51	1A		K29-9308-03	BUTTON KNOB(PTT)		C44			CK73HB1H471K	CHIP C 470PF K	

PARTS LIST

TX-RX UNIT (X57-6880-XX)

Ref. No.	Address	New parts	Parts No.	Description	Destination	Ref. No.	Address	New parts	Parts No.	Description	Destination
C45			CK73GB1A105K	CHIP C 1.0UF K		C141			CC73GCH1H120J	CHIP C 12PF J	
C47			CC73HCH1H101J	CHIP C 100PF J		C142			CC73GCH1H300J	CHIP C 30PF J	
C48			CK73HB1H471K	CHIP C 470PF K		C143			CC73GCH1H100C	CHIP C 10PF C	
C49			CC73HCH1H101J	CHIP C 100PF J		C144			CC73GCH1H820J	CHIP C 82PF J	
C50			CC73HCH1H100C	CHIP C 10PF C		C146			CK73GB1H102K	CHIP C 1000PF K	
C51			CK73HB1H102K	CHIP C 1000PF K		C147			CK73HB1H102K	CHIP C 1000PF K	
C52			CC73HCH1H181J	CHIP C 180PF J		C148			CK73GB1H102K	CHIP C 1000PF K	
C53			CC73HCH1H0R5B	CHIP C 0.5PF B		C149			CC73GCH1H240J	CHIP C 24PF J	
C54			CC73HCH1H040B	CHIP C 4.0PF B		C150			CC73GCH1H220J	CHIP C 22PF J	
C55			CC73HCH1H121J	CHIP C 120PF J		C151			CK73GB1H102K	CHIP C 1000PF K	
C57			CC73HCH1H1R5B	CHIP C 1.5PF B		C153,154			CC73GCH1H100C	CHIP C 10PF C	
C58			CC73HCH1H090B	CHIP C 9.0PF B		C155			CC73GCH1H180J	CHIP C 18PF J	
C59			CC73HCH1H1R5B	CHIP C 1.5PF B		C156			CC73GCH1H120J	CHIP C 12PF J	
C60			CC73HCH1H010B	CHIP C 1.0PF B		C157			CC73GCH1H150J	CHIP C 15PF J	
C61			CC73HCH1H040B	CHIP C 4.0PF B		C158			CC73GCH1H220J	CHIP C 22PF J	
C62			CC73HCH1H050B	CHIP C 5.0PF B		C159			CC73GCH1H070D	CHIP C 7.0PF D	
C63			CC73HCH1H101J	CHIP C 100PF J		C160			CC73GCH1H330J	CHIP C 33PF J	
C64			CC73HCH1H040B	CHIP C 4.0PF B		C162			CC73GCH1H390J	CHIP C 39PF J	
C65-67			CC73HCH1H050B	CHIP C 5.0PF B		C201			CK73GB1A224K	CHIP C 0.22UF K	
C68-70			CK73HB1H471K	CHIP C 470PF K		C205			CK73HB1H102K	CHIP C 1000PF K	
C71,72			CK73HB1A104K	CHIP C 0.10UF K		C207			CK73HB1H182K	CHIP C 1800PF K	
C73,74			CC73HCH1H0R5B	CHIP C 0.5PF B		C208			CK73HB1H471K	CHIP C 470PF K	
C75,76			CK73HB1H102K	CHIP C 1000PF K		C209			C92-0713-05	CHIP-TAN 10UF 6.3WV	
C77			CK73HB1H471K	CHIP C 470PF K		C210			CK73HB1H471K	CHIP C 470PF K	
C78			CC73HCH1H330J	CHIP C 33PF J		C211			CK73HB1C103K	CHIP C 0.010UF K	
C79			C92-0713-05	CHIP-TAN 10UF 6.3WV		C213			CK73HB1A104K	CHIP C 0.10UF K	
C80			CK73HB1H471K	CHIP C 470PF K		C214			CC73HCH1H680J	CHIP C 68PF J	
C81			CC73HCH1H150J	CHIP C 15PF J		C215			CK73HB1H102K	CHIP C 1000PF K	
C82-86			CK73HB1H102K	CHIP C 1000PF K		C216			CK73GB1C104K	CHIP C 0.10UF K	
C87			CC73HCH1H100C	CHIP C 10PF C		C217			CK73HB1A104K	CHIP C 0.10UF K	
C90			CK73HB1H102K	CHIP C 1000PF K		C218			CK73GB1C104K	CHIP C 0.10UF K	
C101			CK73HB1H102K	CHIP C 1000PF K		C219			CC73HCH1H330J	CHIP C 33PF J	
C104			CC73GCH1H390J	CHIP C 39PF J		C220			CK73HB1H102K	CHIP C 1000PF K	
C105			CK73HB1H102K	CHIP C 1000PF K		C221			CK73GB1C104K	CHIP C 0.10UF K	
C107			CK73HB1H102K	CHIP C 1000PF K		C222			CK73HB1H102K	CHIP C 1000PF K	
C108			CC73GCH1H150J	CHIP C 15PF J		C224,225			CK73HB1C103K	CHIP C 0.010UF K	
C109			CK73GB1C104K	CHIP C 0.10UF K		C227			CK73HB1H102K	CHIP C 1000PF K	
C110,111			CK73HB1H102K	CHIP C 1000PF K		C228			CC73GCH1H100C	CHIP C 10PF C	
C112			CC73HCH1H100C	CHIP C 10PF C		C230			CC73HCH1H080B	CHIP C 8.0PF B	
C115			CK73HB1H102K	CHIP C 1000PF K		C231,232			CK73GB1H103K	CHIP C 0.010UF K	
C116			CC73GCH1H220J	CHIP C 22PF J		C233			CC73HCH1H020B	CHIP C 2.0PF B	
C117			CC73GCH1H100C	CHIP C 10PF C		C234			CK73HB1C103K	CHIP C 0.010UF K	
C118			CC73GCH1H101J	CHIP C 100PF J		C235			CC73HCH1H090B	CHIP C 9.0PF B	
C119			CC73GCH1H270J	CHIP C 27PF J		C236			CK73GB1H102K	CHIP C 1000PF K	
C120			CK73GB1H102K	CHIP C 1000PF K		C237			CC73HCH1H050B	CHIP C 5.0PF B	
C121			CC73GCH1H100C	CHIP C 10PF C		C238			CC73GCH1H120J	CHIP C 12PF J	
C123			CK73GB1A105K	CHIP C 1.0UF K		C239			CC73HCH1H060B	CHIP C 6.0PF B	
C124,125			CK73HB1H102K	CHIP C 1000PF K		C241			CK73HB1H102K	CHIP C 1000PF K	
C126			C92-0519-05	CHIP-TAN 1.0UF 25WV		C242			CK73GB1C104K	CHIP C 0.10UF K	
C128			CK73HB1H102K	CHIP C 1000PF K		C243			CK73HB1H102K	CHIP C 1000PF K	
C130			CC73GCH1H100C	CHIP C 10PF C		C244			CC73HCH1H040B	CHIP C 4.0PF B	
C132			CK73HB1H102K	CHIP C 1000PF K		C245			CK73HB1H471K	CHIP C 470PF K	
C133			CK73GB1H103K	CHIP C 0.010UF K		C247			CC73GCH1H040B	CHIP C 4.0PF B	
C134			CK73GB1C104K	CHIP C 0.10UF K		C248			CC73GCH1H270J	CHIP C 27PF J	
C135			CK73GB1A105K	CHIP C 1.0UF K		C249			CK73HB1H102K	CHIP C 1000PF K	
C136			CC73GCH1H300J	CHIP C 30PF J		C250			CC73GCH1H040B	CHIP C 4.0PF B	
C137			CK73GB1H103K	CHIP C 0.010UF K		C251			C92-0714-05	CHIP-TAN 4.7UF 6.3WV	
C138			CK73GB1H102K	CHIP C 1000PF K		C252			CK73HB1H102K	CHIP C 1000PF K	
C139			CC73GCH1H680J	CHIP C 68PF J		C253			CC73GCH1H4R5B	CHIP C 4.5PF B	
C140			CC73GCH1H101J	CHIP C 100PF J		C254			CC73GCH1H270J	CHIP C 27PF J	

PARTS LIST

TX-RX UNIT (X57-6880-XX)

Ref. No.	Address	New parts	Parts No.	Description	Destination	Ref. No.	Address	New parts	Parts No.	Description	Destination
C255			CC73GCH1H4R5B	CHIP C 4.5PF B		C405			CC73GCH1H101J	CHIP C 100PF J	
C256			CK73HB1H102K	CHIP C 1000PF K		C407			CK73HB1H102K	CHIP C 1000PF K	
C258			CK73HB1H102K	CHIP C 1000PF K		C409,410			CK73GB1A105K	CHIP C 1.0UF K	
C260			CK73HB1H102K	CHIP C 1000PF K		C411			CK73HB1H102K	CHIP C 1000PF K	
C262			CK73HB1H102K	CHIP C 1000PF K		C415			CK73HB1H471K	CHIP C 470PF K	
C263			CC73GCH1H100C	CHIP C 10PF C		C417			CK73GB1A105K	CHIP C 1.0UF K	
C264			CC73GCH1H040B	CHIP C 4.0PF B		C418,419			CK73HB1H102K	CHIP C 1000PF K	
C265			CC73GCH1H330J	CHIP C 33PF J		C421			CK73GB1A105K	CHIP C 1.0UF K	
C266			CK73HB1H102K	CHIP C 1000PF K		C426,427			CK73GB1A105K	CHIP C 1.0UF K	
C267,268			CC73GCH1H030B	CHIP C 3.0PF B		C428,429			CK73HB1H102K	CHIP C 1000PF K	
C269			CC73GCH1H330J	CHIP C 33PF J		C430			CK73GB1H103K	CHIP C 0.010UF K	
C270			CC73GCH1H040B	CHIP C 4.0PF B		C431			CK73HB1C103K	CHIP C 0.010UF K	
C271			CC73GCH1H110J	CHIP C 11PF J		C432			CC73HCH1H050B	CHIP C 5.0PF B	
C280			CK73HB1H102K	CHIP C 1000PF K		C433,434			CC73HCH1H030B	CHIP C 3.0PF B	
C302			CK73HB1C103K	CHIP C 0.010UF K		C435			CC73HCH1H050B	CHIP C 5.0PF B	
C304			CK73GB1A224K	CHIP C 0.22UF K		C440			CC73GCH1H1R5B	CHIP C 1.5PF B	
C306			C92-0714-05	CHIP-TAN 4.7UF 6.3WV		C443			CK73GB1A474K	CHIP C 0.47UF K	
C307,308			CK73HB1A104K	CHIP C 0.10UF K		C901,902			CK73GB1A105K	CHIP C 1.0UF K	
C309			CC73GCH1H820J	CHIP C 82PF J							
C310			CK73HB1A683K	CHIP C 0.068UF K		TC1,2			C05-0384-05	CERAMIC TRIMMER CAP(10PF)	
C311			CK73GB1A105K	CHIP C 1.0UF K		CN201			E23-1081-05	TERMINAL	
C312			CC73GCH1H120J	CHIP C 12PF J		CN401			E40-6362-05	FLAT CABLE CONNECTOR	
C313			CC73GCH1H121J	CHIP C 120PF J		J301			E11-0457-05	PHONE JACK(2.5/3.5)	
C314			CK73HB1A104K	CHIP C 0.10UF K							
C315			CK73GB1A105K	CHIP C 1.0UF K		F401			F53-0190-05	FUSE(2.5A)	
C316			CK73GB1C473K	CHIP C 0.047UF K		60	2A		J30-1282-04	SPACER(MIC ELEMENT)	
C317			CK73HB1A104K	CHIP C 0.10UF K							
C318			C92-0714-05	CHIP-TAN 4.7UF 6.3WV		CD201			L79-1582-05	TUNING COIL	
C319			CC73GCH1H271J	CHIP C 270PF J		CF201	2A		L72-0973-05	CERAMIC FILTER	
C320			CK73HB1C103K	CHIP C 0.010UF K		L1			L40-4791-37	SMALL FIXED INDUCTOR(4.700UH)	
C321			CK73GB1A105K	CHIP C 1.0UF K		L3			L40-5681-86	SMALL FIXED INDUCTOR(0.56UH)	
C322			CK73HB1C153K	CHIP C 0.015UF K		L5			L40-5681-86	SMALL FIXED INDUCTOR(0.56UH)	
C323			CC73GCH1H820J	CHIP C 82PF J		L6,7			L92-0138-05	FERRITE CHIP	
C324			CC73HCH1H820J	CHIP C 82PF J		L8		*	L41-1875-38	SMALL FIXED INDUCTOR	
C325			CK73HB1A104K	CHIP C 0.10UF K		L9		*	L41-3375-38	SMALL FIXED INDUCTOR	
C326			CK73HB1H102K	CHIP C 1000PF K		L10		*	L41-1885-38	SMALL FIXED INDUCTOR	
C327			CC73HCH1H101J	CHIP C 100PF J		L11		*	L41-1085-38	SMALL FIXED INDUCTOR	
C328			CK73HB1H391K	CHIP C 390PF K		L12			L92-0138-05	FERRITE CHIP	
C329,330			CK73GB1A105K	CHIP C 1.0UF K		L13,14		*	L41-2285-38	SMALL FIXED INDUCTOR	
C331			CK73HB1A104K	CHIP C 0.10UF K		L16			L40-3978-67	SMALL FIXED INDUCTOR(39NH)	
C332			CK73HB1H471K	CHIP C 470PF K		L17			L40-2778-67	SMALL FIXED INDUCTOR(27NH)	
C333,334			CK73GB1C104K	CHIP C 0.10UF K		L18,19			L41-2285-03	SMALL FIXED INDUCTOR	
C335			CC73GCH1H221J	CHIP C 220PF J		L20,21			L40-3391-86	SMALL FIXED INDUCTOR(3.3UH)	
C336			CK73FB1C474K	CHIP C 0.47UF K		L22			L92-0138-05	FERRITE CHIP	
C338			CC73GCH1H101J	CHIP C 100PF J		L23		*	L41-3975-38	SMALL FIXED INDUCTOR	
C339			C92-0560-05	CHIP-TAN 10UF 6.3WV		L24			L92-0141-05	FERRITE CHIP	
C340			CK73GB1C104K	CHIP C 0.10UF K		L25		*	L41-8275-38	SMALL FIXED INDUCTOR	
C341			CK73GB1C473K	CHIP C 0.047UF K		L50			L92-0138-05	FERRITE CHIP	
C342			C92-0560-05	CHIP-TAN 10UF 6.3WV		L102		*	L41-1085-38	SMALL FIXED INDUCTOR	
C343			CK73GB1C473K	CHIP C 0.047UF K		L103			L92-0138-05	FERRITE CHIP	
C344			CC73GCH1H221J	CHIP C 220PF J		L104		*	L41-3375-38	SMALL FIXED INDUCTOR	
C345			C92-0665-05	TANTAL 100UF 6.3WV		L105			L40-1585-54	SMALL FIXED INDUCTOR(150NH)	
C346			CK73GB1H102K	CHIP C 1000PF K		L106			L92-0149-05	FERRITE CHIP	
C348			CK73HB1H471K	CHIP C 470PF K		L107			L40-5675-54	SMALL FIXED INDUCTOR(56NH)	
C351,352			CK73HB1C103K	CHIP C 0.010UF K		L108			L92-0149-05	FERRITE CHIP	
C354			CK73HB1A104K	CHIP C 0.10UF K		L109			L40-2295-85	SMALL FIXED INDUCTOR(2.2UH)	
C355			CK73GB1C104K	CHIP C 0.10UF K		L110		*	L41-5675-38	SMALL FIXED INDUCTOR	
C401			CC73GCH1H471J	CHIP C 470PF J		L111			L40-1092-81	SMALL FIXED INDUCTOR	
C402			CK73HB1H102K	CHIP C 1000PF K		L112			L34-4577-05	AIR-CORE COIL	
C403			CK73GB1C104K	CHIP C 0.10UF K		L113,114			L34-4572-05	AIR-CORE COIL	

PARTS LIST

TX-RX UNIT (X57-6880-XX)

Ref. No.	Address	New parts	Parts No.	Description	Destination	Ref. No.	Address	New parts	Parts No.	Description	Destination
L115			L34-4563-05	AIR-CORE COIL		R42			RK73HB1J472J	CHIP R	4.7K J 1/16W
L116			L34-4576-05	AIR-CORE COIL		R43			RK73HB1J101J	CHIP R	100 J 1/16W
L117			L34-4575-05	AIR-CORE COIL		R44			RK73HB1J102J	CHIP R	1.0K J 1/16W
L118			L34-4567-05	AIR-CORE COIL		R45,46			RK73HB1J332J	CHIP R	3.3K J 1/16W
L119			L34-4566-05	AIR-CORE COIL		R47			RK73HB1J470J	CHIP R	47 J 1/16W
L201			L40-1091-37	SMALL FIXED INDUCTOR(1.000UH)		R48			RK73HB1J331J	CHIP R	330 J 1/16W
L202		*	L41-3975-38	SMALL FIXED INDUCTOR		R49			RK73HB1J222J	CHIP R	2.2K J 1/16W
L203			L92-0138-05	FERRITE CHIP		R50			RK73HB1J472J	CHIP R	4.7K J 1/16W
L204			L40-5685-85	SMALL FIXED INDUCTOR(0.56UH)		R51			RK73HB1J100J	CHIP R	10 J 1/16W
L205		*	L41-6875-38	SMALL FIXED INDUCTOR		R101			RK73HB1J123J	CHIP R	12K J 1/16W
L206		*	L41-1885-38	SMALL FIXED INDUCTOR		R103			R92-1252-05	CHIP R	0 OHM J 1/16W
L207		*	L41-1585-38	SMALL FIXED INDUCTOR		R107			RK73GB1J561J	CHIP R	560 J 1/16W
L209			L41-5678-14	SMALL FIXED INDUCTOR		R108			RK73GB1J152J	CHIP R	1.5K J 1/16W
L210			L92-0138-05	FERRITE CHIP		R109			RK73GB1J150J	CHIP R	15 J 1/16W
L211			L41-5678-14	SMALL FIXED INDUCTOR		R110,111			RK73GB1J331J	CHIP R	330 J 1/16W
L213			L41-5678-14	SMALL FIXED INDUCTOR		R112			RK73GB1J180J	CHIP R	18 J 1/16W
L214			L41-4778-14	SMALL FIXED INDUCTOR		R113			RK73GB1J331J	CHIP R	330 J 1/16W
L301			L92-0140-05	FERRITE CHIP		R114			RK73GB1J473J	CHIP R	47K J 1/16W
L302			L92-0149-05	FERRITE CHIP		R115			RK73GB1J103J	CHIP R	10K J 1/16W
L401			L92-0149-05	FERRITE CHIP		R116			RK73GB1J150J	CHIP R	15 J 1/16W
L402-404			L92-0138-05	FERRITE CHIP		R117			RK73GB1J273J	CHIP R	27K J 1/16W
X1			L77-1931-05	TCXO(12.8MHZ)		R119			RK73GB1J331J	CHIP R	330 J 1/16W
X2			L78-1411-05	RESONATOR(7.37MHZ)		R121			RK73GB1J561J	CHIP R	560 J 1/16W
XF201			L71-0619-05	MCF(38.85MHZ)		R122			RK73GB1J473J	CHIP R	47K J 1/16W
						R123			RK73GB1J820J	CHIP R	82 J 1/16W
CP404			RK75HA1J473J	CHIP-COM 47K J 1/16W		R124			RK73GB1J273J	CHIP R	27K J 1/16W
CP405			RK75HA1J102J	CHIP-COM 1.0K J 1/16W		R126			RK73GB1J222J	CHIP R	2.2K J 1/16W
R1			RK73HB1J223J	CHIP R 22K J 1/16W		R127-129			RK73EB2ER39K	CHIP R	0.39 K 1/4W
R2			RK73HB1J103J	CHIP R 10K J 1/16W		R130-135			RK73GH1J154D	CHIP R	150K D 1/16W
R3			RK73HB1J333J	CHIP R 33K J 1/16W		R136,137			RK73GB1J271J	CHIP R	270 J 1/16W
R4			RK73HB1J563J	CHIP R 56K J 1/16W		R138			RK73GB1J105J	CHIP R	1.0M J 1/16W
R5,6			RK73HB1J104J	CHIP R 100K J 1/16W		R139			RK73GB1J473J	CHIP R	47K J 1/16W
R7			RK73HB1J101J	CHIP R 100 J 1/16W		R140			RK73GB1J563J	CHIP R	56K J 1/16W
R8-11			R92-1368-05	CHIP R 0 OHM		R141			RK73GB1J104J	CHIP R	100K J 1/16W
R12			RK73HB1J222J	CHIP R 2.2K J 1/16W		R142			R92-1252-05	CHIP R	0 OHM J 1/16W
R13			R92-1252-05	CHIP R 0 OHM J 1/16W		R143			RK73GB1J104J	CHIP R	100K J 1/16W
R14			RK73HB1J334J	CHIP R 330K J 1/16W		R144			R92-1252-05	CHIP R	0 OHM J 1/16W
R15			RK73GB1J221J	CHIP R 220 J 1/16W		R203			RK73HB1J184J	CHIP R	180K J 1/16W
R16			RK73GB1J561J	CHIP R 560 J 1/16W		R206			RK73GB1J100J	CHIP R	10 J 1/16W
R17			RK73HB1J101J	CHIP R 100 J 1/16W		R207			RK73HB1J472J	CHIP R	4.7K J 1/16W
R18			R92-1252-05	CHIP R 0 OHM J 1/16W		R208			RK73HB1J823J	CHIP R	82K J 1/16W
R19			RK73GB1J152J	CHIP R 1.5K J 1/16W		R209			RK73HB1J272J	CHIP R	2.7K J 1/16W
R20			RK73HB1J100J	CHIP R 10 J 1/16W		R210,211			RK73HB1J332J	CHIP R	3.3K J 1/16W
R21			RK73GB1J681J	CHIP R 680 J 1/16W		R212			RK73HB1J823J	CHIP R	82K J 1/16W
R22			R92-1252-05	CHIP R 0 OHM J 1/16W		R213			RK73HB1J392J	CHIP R	3.9K J 1/16W
R23			RK73GB1J103J	CHIP R 10K J 1/16W		R215			RK73HB1J101J	CHIP R	100 J 1/16W
R25			RK73HB1J223J	CHIP R 22K J 1/16W		R216			RK73HB1J124J	CHIP R	120K J 1/16W
R26			RK73HB1J103J	CHIP R 10K J 1/16W		R217			RK73HB1J472J	CHIP R	4.7K J 1/16W
R27			RK73HB1J220J	CHIP R 22 J 1/16W		R218			RK73HB1J561J	CHIP R	560 J 1/16W
R30			RK73HB1J123J	CHIP R 12K J 1/16W		R219,220			RK73GB1J561J	CHIP R	560 J 1/16W
R31			RK73HB1J564J	CHIP R 560K J 1/16W		R221			RK73GB1J102J	CHIP R	1.0K J 1/16W
R32			RK73HB1J102J	CHIP R 1.0K J 1/16W		R222			RK73GB1J221J	CHIP R	220 J 1/16W
R33			RK73HB1J154J	CHIP R 150K J 1/16W		R223-226			RK73HB1J823J	CHIP R	82K J 1/16W
R34			RK73HB1J472J	CHIP R 4.7K J 1/16W		R227			R92-1252-05	CHIP R	0 OHM J 1/16W
R35,36			RK73HB1J274J	CHIP R 270K J 1/16W		R228,229			RK73HB1J105J	CHIP R	1.0M J 1/16W
R37			RK73HB1J101J	CHIP R 100 J 1/16W		R230			RK73GB1J222J	CHIP R	2.2K J 1/16W
R38			RK73HB1J181J	CHIP R 180 J 1/16W		R231			RK73GB1J470J	CHIP R	47 J 1/16W
R39			RK73HB1J151J	CHIP R 150 J 1/16W		R233			RK73GB1J221J	CHIP R	220 J 1/16W
R40			RK73HB1J101J	CHIP R 100 J 1/16W		R234			RK73GB1J104J	CHIP R	100K J 1/16W
R41			RK73HB1J154J	CHIP R 150K J 1/16W		R237			RK73GB1J184J	CHIP R	180K J 1/16W

PARTS LIST

TX-RX UNIT (X57-6880-XX)

Ref. No.	Address	New parts	Parts No.	Description	Destination	Ref. No.	Address	New parts	Parts No.	Description	Destination
R238			RK73GB1J104J	CHIP R 100K J 1/16W		R408-412			RK73HB1J473J	CHIP R 47K J 1/16W	
R239			RK73GB1J470J	CHIP R 47 J 1/16W		R413,414			RK73GB1J331J	CHIP R 330 J 1/16W	
R240			R92-1252-05	CHIP R 0 OHM J 1/16W		R416-420			RK73HB1J473J	CHIP R 47K J 1/16W	K
R241,242			RK73HB1J105J	CHIP R 1.0M J 1/16W		R417-420			RK73HB1J473J	CHIP R 47K J 1/16W	K2
R243			R92-0670-05	CHIP R 0 OHM		R421,422			RK73HB1J102J	CHIP R 1.0K J 1/16W	
R291			R92-1252-05	CHIP R 0 OHM J 1/16W		R423			R92-1368-05	CHIP R 0 OHM	
R299			R92-1368-05	CHIP R 0 OHM		R424,425			RK73HB1J473J	CHIP R 47K J 1/16W	
R301			RK73HB1J473J	CHIP R 47K J 1/16W		R426			R92-1368-05	CHIP R 0 OHM	
R304			RK73HB1J564J	CHIP R 560K J 1/16W		R435			RK73HB1J473J	CHIP R 47K J 1/16W	
R305			RK73HB1J104J	CHIP R 100K J 1/16W		R436			R92-1252-05	CHIP R 0 OHM J 1/16W	
R306			RK73HB1J102J	CHIP R 1.0K J 1/16W		R437,438			RK73HB1J473J	CHIP R 47K J 1/16W	
R307,308			R92-1368-05	CHIP R 0 OHM		R445,446			R92-1252-05	CHIP R 0 OHM J 1/16W	
R310			RK73GB1J394J	CHIP R 390K J 1/16W		R447			RK73HB1J472J	CHIP R 4.7K J 1/16W	
R311			RK73HB1J123J	CHIP R 12K J 1/16W		R450			RK73GB1J4R7J	CHIP R 4.7 J 1/16W	
R312			RK73GB1J334J	CHIP R 330K J 1/16W		R451,452			RK73GB1J821J	CHIP R 820 J 1/16W	
R313			RK73GB1J104J	CHIP R 100K J 1/16W		R453,454			RK73HB1J473J	CHIP R 47K J 1/16W	K2
R314			RK73GB1J103J	CHIP R 10K J 1/16W		R454			RK73HB1J473J	CHIP R 47K J 1/16W	K
R315			RK73GB1J334J	CHIP R 330K J 1/16W		R901,902			RK73GB1J472J	CHIP R 4.7K J 1/16W	
R316			RK73GB1J124J	CHIP R 120K J 1/16W		VR1			R12-7491-05	TRIMMING POT.(68K)	
R317			RK73GB1J474J	CHIP R 470K J 1/16W		\$401-403			S70-0414-05	TACT SWITCH	
R318			RK73GB1J122J	CHIP R 1.2K J 1/16W		MIC301	2A	*	T91-0649-05	MIC ELEMENT	
R319			RK73HB1J563J	CHIP R 56K J 1/16W		D1			MA2S111	DIODE	
R320			RK73HB1J332J	CHIP R 3.3K J 1/16W		D4_5			1SV325	VARIABLE CAPACITANCE DIODE	
R321			RK73HB1J224J	CHIP R 220K J 1/16W		D7			1SV325	VARIABLE CAPACITANCE DIODE	
R322			RK73HB1J184J	CHIP R 180K J 1/16W		D9			1SV325	VARIABLE CAPACITANCE DIODE	
R323			RK73HB1J563J	CHIP R 56K J 1/16W		D10			1SV278	VARIABLE CAPACITANCE DIODE	
R324,325			RK73GB1J104J	CHIP R 100K J 1/16W		D11			MA2S111	DIODE	
R326			R92-1252-05	CHIP R 0 OHM J 1/16W		D101			HSC277	DIODE	
R327			RK73GB1J184J	CHIP R 180K J 1/16W		D102			HZU5CLL	ZENER DIODE	
R328			RK73GB1J103J	CHIP R 10K J 1/16W		D103-106			HVC131	DIODE	
R329			RK73GB1J823J	CHIP R 82K J 1/16W		D202			HSC277	DIODE	
R330			RK73HB1J332J	CHIP R 3.3K J 1/16W		D203-206			1SV305	VARIABLE CAPACITANCE DIODE	
R331			RK73GB1J393J	CHIP R 39K J 1/16W		D301,302			RB706F-40	DIODE	
R332			RK73GB1J153J	CHIP R 15K J 1/16W		D303			DAN222	DIODE	
R334			RK73GB1J473J	CHIP R 47K J 1/16W		D401			RB521S-30	DIODE	
R335			RK73GB1J222J	CHIP R 2.2K J 1/16W		D402			1SR154-400	DIODE	
R336			RK73GB1J102J	CHIP R 1.0K J 1/16W		D405			KDZ3.3V	ZENER DIODE	
R337			RK73GB1J151J	CHIP R 150 J 1/16W		IC1			MB15A02	MOS IC	
R338			RK73HB1J222J	CHIP R 2.2K J 1/16W		IC2			UPB1509GV	BI-POLAR IC	
R339			RK73GB1J471J	CHIP R 470 J 1/16W		IC101			TA75W01FU	MOS IC	
R340			RK73GB1J182J	CHIP R 1.8K J 1/16W		IC201			TA31136FN	MOS IC	
R341			RK73GB1J103J	CHIP R 10K J 1/16W		IC301		*	AQUA-L	MOS IC	
R342			RK73GB1J100J	CHIP R 10 J 1/16W		IC302			TA7368F	MOS IC	
R343			RK73GB1J474J	CHIP R 470K J 1/16W		IC401,402			XC6204B502MR	MOS IC	
R344			RK73GB1J102J	CHIP R 1.0K J 1/16W		IC403			BD4840FVE	MOS IC	
R345,346			RK73GB1J101J	CHIP R 100 J 1/16W		IC404			BD4845FVE	MOS IC	
R347			RK73GB1J104J	CHIP R 100K J 1/16W		IC405		*	30622MAA-B91GP	MPU	
R348			RK73GB1J563J	CHIP R 56K J 1/16W		IC406			BR24L08F-W	ROM IC	
R349			RK73GB1J333J	CHIP R 33K J 1/16W		Q1			KTC4082	TRANSISTOR	
R350			R92-1368-05	CHIP R 0 OHM		Q2			2SC5108(Y)	TRANSISTOR	
R354,355			RK73HB1J103J	CHIP R 10K J 1/16W		Q3_4			2SK508NV(K52)	FET	
R357			R92-1368-05	CHIP R 0 OHM		Q5		*	RT1P430U	TRANSISTOR	
R360			R92-1368-05	CHIP R 0 OHM		Q6			2SC5108(Y)	TRANSISTOR	
R365			RK73HB1J473J	CHIP R 47K J 1/16W		Q7		*	RT1P430U	TRANSISTOR	
R388			R92-1368-05	CHIP R 0 OHM		Q8		*	2SC5383	TRANSISTOR	
R403			RK73GB1J101J	CHIP R 100 J 1/16W		Q9			2SC5108(Y)	TRANSISTOR	
R404			RK73HB1J474D	CHIP R 470K D 1/16W		Q102			2SC4926YD	TRANSISTOR	
R405			RK73GB1J334J	CHIP R 330K J 1/16W							
R406			RK73HB1J474D	CHIP R 470K D 1/16W							
R407			RK73HB1J334J	CHIP R 330K J 1/16W							

TK-2200

PARTS LIST

TX-RX UNIT (X57-6880-XX)

Ref. No.	Address	New parts	Parts No.	Description	Destination	Ref. No.	Address	New parts	Parts No.	Description	Destination
Q103		*	RD00HVS1	FET							
Q104		*	RT1N141U	TRANSISTOR							
Q105			2SK879(Y)	FET							
Q106			RD02MUS1	FET							
Q106		*	RD02MUS1-T22	FET							
Q107		*	RT1N141U	TRANSISTOR							
Q108			2SK1824	FET							
Q109			RT1P441U	TRANSISTOR							
Q202			RT1P441U	TRANSISTOR							
Q203			2SC4649(N,P)	TRANSISTOR							
Q204,205			3SK318	FET							
Q301		*	RT1P141U	TRANSISTOR							
Q302			2SC4919	TRANSISTOR							
Q303			RT1N441U	TRANSISTOR							
Q304			2SA1362(GR)	TRANSISTOR							
Q305			RT1N441U	TRANSISTOR							
Q306			CPH3413	FET							
Q316			CPH3413	FET							
Q317,318			2SK1824	FET							
Q401,402		*	RT1N141U	TRANSISTOR							
Q403,404			CPH3317	FET							
Q405		*	RT1P237U	TRANSISTOR							
Q407,408			2SK1830	FET							
Q901			2SK1824	FET							
TH101			157-104-65001	THERMISTOR							
TH203			157-104-65001	THERMISTOR							

EXPLODED VIEW

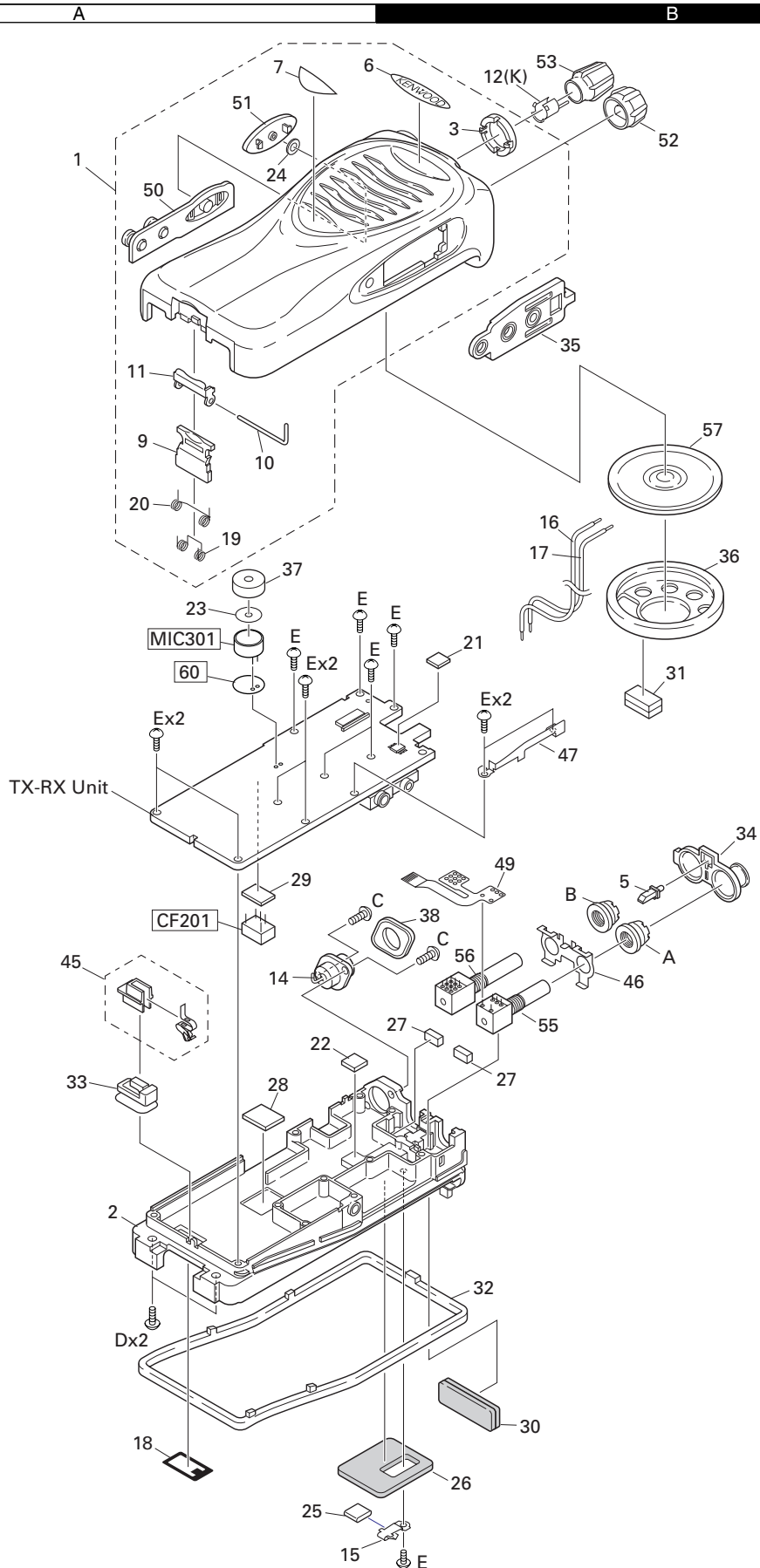

PACKING

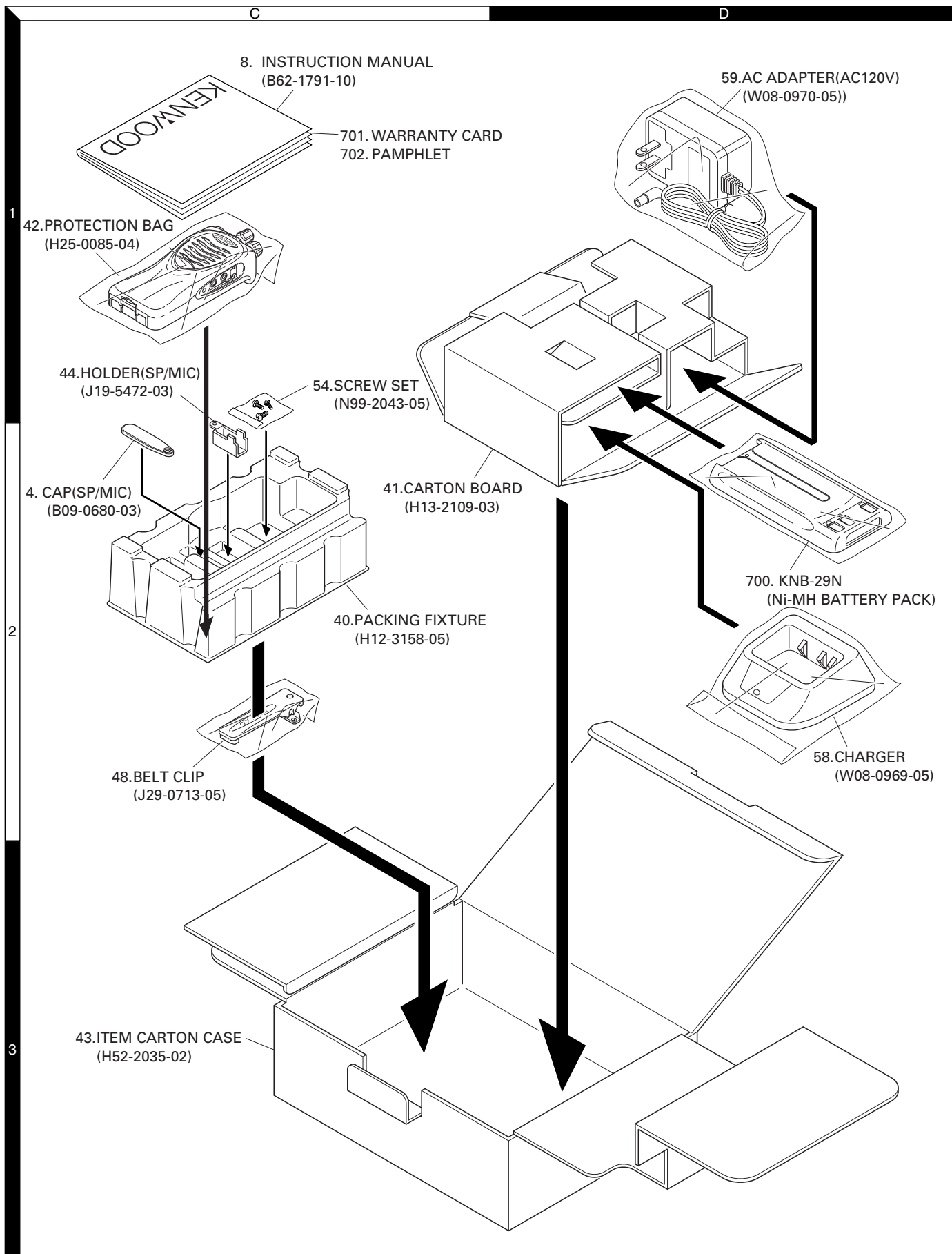

ADJUSTMENT

Test Equipment Required for Alignment

Test Equipment	Major Specifications	
1. Standard Signal Generator (SSG)	Frequency Range Modulation Output	150 to 174MHz. Frequency modulation and external modulation. -127dBm/0.1 μ V to greater than -47dBm/1mV
2. Power Meter	Input Impedance Operation Frequency Measurement Range	50 Ω . 150 to 174MHz. Vicinity of 10W
3. Deviation Meter	Frequency Range	150 to 174MHz.
4. Digital Volt Meter (DVM)	Measuring Range Input Impedance	10mV to 10V DC High input impedance for minimum circuit loading.
5. Oscilloscope		DC through 30MHz.
6. High Sensitivity Frequency Counter	Frequency Range Frequency Stability	10Hz to 1000MHz. 0.2ppm or less.
7. Ammeter		5A.
8. AF Volt Meter (AF VTVM)	Frequency Range Voltage Range	50Hz to 10kHz. 1mV to 10V.
9. Audio Generator (AG)	Frequency Range Output	50Hz to 5kHz or more. 0 to 1V.
10. Distortion Meter	Capability Input Level	3% or less at 1kHz. 50mV to 10Vrms.
11. Spectrum Analyzer	Measuring Range	DC to 1GHz or more
12. Tracking Generator	Center frequency Output Voltage	50kHz to 600MHz 100mV or more
13. 8 Ω Dummy Load		Approx. 8 Ω , 3W.
14. Regulated Power Supply		5V to 10V, approx. 3A Useful if ammeter equipped.

■ The following parts are required for adjustment

1. Antenna connector adapter

The antenna connector of this radio uses an SMA terminal.

Use an antenna connector adapter [SMA(f) – BNC(f) or SMA(f) – N(f)] for adjustment. (The adapter is not provided as an option, so buy a commercially-available one.)

2. Repair Jig (Chassis)

Use jig (part No.: A10-4086-03) for repairing the TK-2200.

Place the TX-RX unit on the jig and fit it with screws.

The jig facilitates the voltage check and protects the final amplifier FET when the voltage on the flow side of the TX-RX unit is checked during repairs.

3. Battery Jig (W05-1011-00)

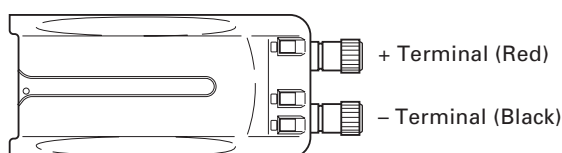

Connect the power cable properly between the battery jig installed in the transceiver and the power supply, and be sure output voltage and the power supply polarity prior to switching the power supply ON, otherwise over voltage and reverse connection may damage the transceiver, or the power supply or both.

Note: When using the battery jig, you must measure the voltage at the terminals of the battery jig. Otherwise, a slight voltage drop may occur within the power cable, between the power supply and the battery jig, especially while the transceiver transmits.

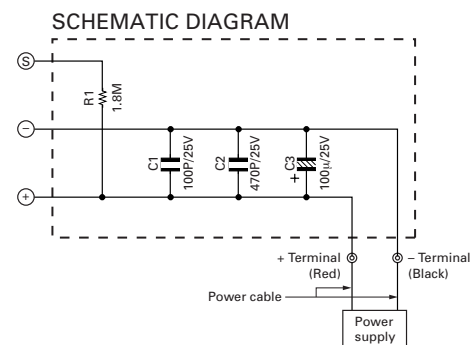

ADJUSTMENT

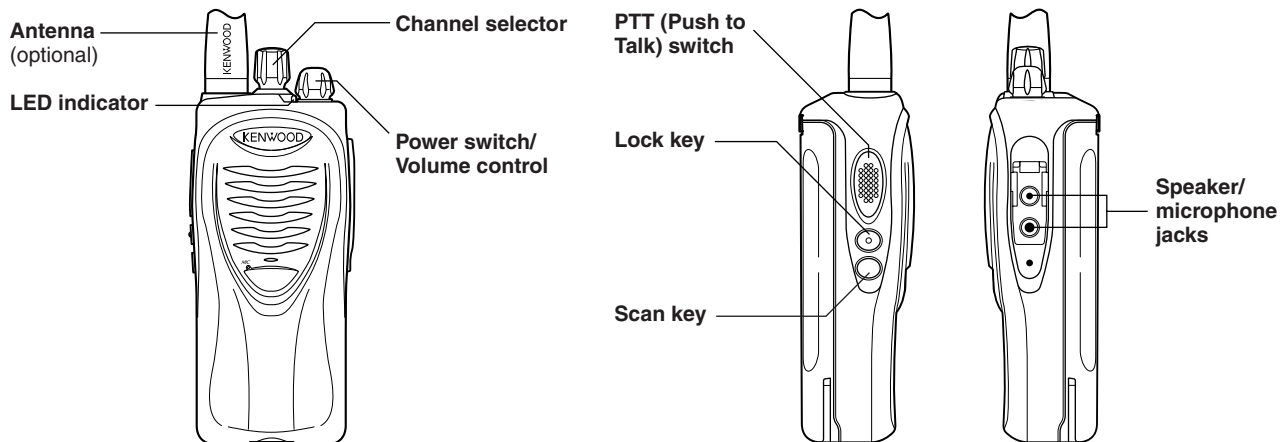

Adjustment points TX-RX unit (X57-688) Component side view

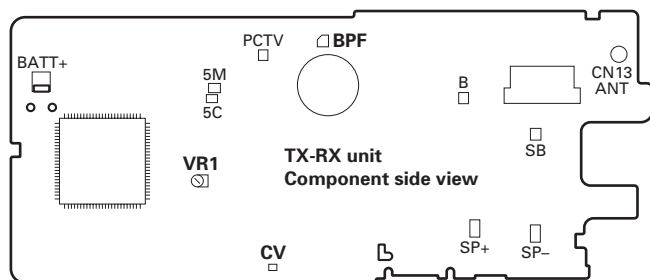

VR1 : Frequency adjustment
 BPF : Band-pass wave form test point
 CV : VCO lock voltage adjustment terminal

Foil Side View

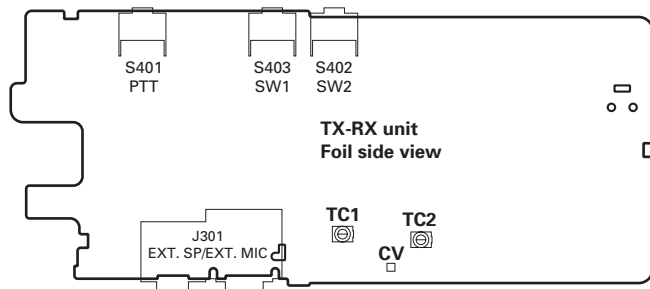

TC1 : Transmit VCO lock voltage adjustment
 TC2 : Receive VCO lock voltage adjustment
 CV : VCO lock voltage adjustment terminal

Fig. 1 Adjustment points

■ Frequency and signalling

The set has been adjusted for the frequencies shown in the following table. When required, re-adjust them following the adjustment procedure to obtain the frequencies you want in actual operation.

Frequency (MHz)

Channel No.	RX Frequency	TX Frequency
1	162.050	162.100
2	150.050	150.100
3	173.950	173.900
4	162.000	162.000
5	162.200	162.200
6	162.400	162.400
7	156.550	156.600
8	168.550	168.600

Signalling

Signalling No.	RX	TX
1	None	None
2	None	100Hz Square Wave
3	QT 67.0Hz	QT 67.0Hz
4	QT 151.4Hz	QT 151.4Hz
5	QT 250.3Hz	QT 250.3Hz
6	DQT D023N	DQT D023N
7	DQT D754I	DQT D754I
8	DTMF 159D	DTMF 159D
9	None	DTMF tone 9

• Preparations for tuning the transceiver

Before attempting to tune the transceiver, connect the unit to a suitable power supply.

Whenever the transmitter is tuned, the unit must be connected to a suitable dummy load (i.e. power meter).

The speaker output connector must be terminated with a 8Ω dummy load and connected to an AC voltmeter and an audio distortion meter or a SINAD measurement meter at all times during tuning.

Adjustment Frequency

TEST CH	RX	TX
Center	162.050MHz	162.100MHz
Low	150.050MHz	150.100MHz
High	173.950MHz	173.900MHz
Low'	156.550MHz	156.600MHz
High'	168.550MHz	168.600MHz

ADJUSTMENT

Common Section

Item	Condition	Measurement		Adjustment		Specifications/ Remark
		Test equipment	Terminal	Parts	Method	
1.Setting	1) BATT terminal vorage:7.5V 2) SSG standard modulation [Wide] MOD:1kHz,DEV:3kHz [Narrow] MOD:1kHz,DEV:1.5kHz					
2.VCO lock voltage RX	1) CH:High	Power meter DVM	ANT CV	TC2	2.3V	±0.1V
	2) CH:Low				Check	0.6V or more
3.VCO lock voltage TX	3) CH:High PTT:ON			TC1	2.3V	±0.1V
	4) CH:Low PTT:ON				Check	0.6V or more

Transmitter Section

Item	Condition	Measurement		Adjustment		Specifications/ Remark
		Test equipment	Terminal	Parts	Method	
1.Frequency Adjust	1) CH:High 2) PTT:ON	Frequency counter	ANT	VR1		High frequency ±50Hz
2.High power Adjust	TEST CH:Low Low' Center High' High (5 points) BATT terminal voltage:7.5V PTT:ON	Power meter Ammeter		Programming Software:KPG-88D		2.0W ±0.1W 1.1 A or less
						1.0W ±0.1W 0.8 A or less
3.Low power Adjust	TEST CH:Low Low' Center High' High (5 points) BATT terminal voltage:7.5V PTT:ON					
4.Max deviation Adjust [Wide]	TEST CH:Center Low High (3 points) AG:1kHz/150mV Deviation meter filter LPF:15kHz HPF:OFF PTT:ON	Power meter Deviation meter Oscilloscope	ANT SP/MIC connector		4.2kHz (According to the larger +,-)	±50Hz
	[Narrow] TEST CH:Center PTT:ON	AG AF VTVM			2.2kHz (According to the larger +,-)	±50Hz
5.VOX 1 Writing	TEST CH:Center AG:1KHz/45mV					
6.VOX 10 Writing	TEST CH:Center AG:1KHz/3.0mV					

ADJUSTMENT

Item	Condition	Measurement		Adjustment		Specifications/ Remark
		Test equipment	Terminal	Parts	Method	
7.DQT Balance Adjust [Wide]	TEST CH: Center Low High (3 points) LPF:3kHz HPF:OFF PTT:ON	Power meter Deviation meter Oscilloscope AG AF VTVM	ANT	Programming Software:KPG-88D	Make the demodulation wave into square waves	
	[Narrow]					
8.QT Deviation Adjust [Wide]	TEST CH: Center Low High (3 points) LPF:3kHz HPF:OFF PTT:ON				0.75kHz	±40Hz
	[Narrow]				TEST CH: Center PTT:ON	0.40kHz
9.DQT Deviation Adjust [Wide]	TEST CH: Center Low High (3 points) LPF:3kHz HPF:OFF PTT:ON				0.75kHz	±40Hz
	[Narrow]				TEST CH:Center PTT:ON	0.40kHz
10.DTMF Deviation Adjust [Wide]	TEST CH:Center LPF:15kHz HPF:OFF PTT:ON				3.0kHz	±100Hz
	[Narrow]				TEST CH:Center PTT:ON	1.5kHz
11.MSK Deviation Adjust [Wide]	TEST CH: Center Low High (3 points) LPF:15kHz HPF:OFF PTT:ON				3.0kHz	±100Hz
	[Narrow]				TEST CH:Center PTT:ON	1.5kHz

ADJUSTMENT

Receiver Section

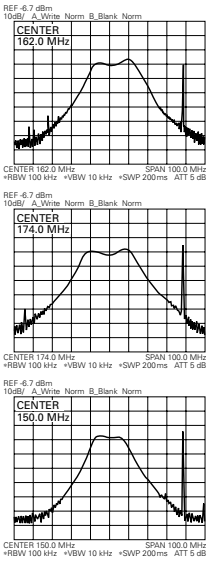
Item	Condition	Measurement		Adjustment		Specifications/ Remark
		Test equipment	Terminal	Parts	Method	
1. BPF Wave Adjust	(1)Center frequency Spectrum analyzer setting Center-f : 162MHz Span : 100MHz RBW : 100kHz VBW : 10kHz ATT : 5dB (2)High-edge frequency Spectrum analyzer setting Center-f : 174MHz (3)Low-edge frequency Spectrum analyzer setting Center-f : 150MHz	Spectrum analyzer	ANT BPF	Programming Software: KPG-88D	Adjust the waveform as shown to the right.	 <p>REF: -6.7 dBm 10dB/ A, White Norm B, Blank Norm CENTER 162.0 MHz SPAN 100.0 MHz RBW 100 kHz +VBW 10 kHz +SWP 200ms ATT 5 dB</p> <p>REF: -6.7 dBm 10dB/ A, White Norm B, Blank Norm CENTER 174.0 MHz SPAN 100.0 MHz RBW 100 kHz +VBW 10 kHz +SWP 200ms ATT 5 dB</p> <p>REF: -6.7 dBm 10dB/ A, White Norm B, Blank Norm CENTER 150.0 MHz SPAN 100.0 MHz RBW 100 kHz +VBW 10 kHz +SWP 200ms ATT 5 dB</p>
2. Sensitivity check [Wide] [Narrow]	TEST CH: Low Center High SSG output: -117 dBm(0.3μV) SSG MOD: 3.0kHz TEST CH: Center SSG output: -115 dBm(0.4μV) SSG MOD: 1.5kHz	SSG DVM Oscilloscope AF VTVM	ANT		Check	12dB SINAD or more
3. SQL1 (Threshold) writing [Wide] [Narrow]	TEST CH: Center Low High SSG output: -123 dBm(0.16μV) SSG MOD: 3.0kHz TEST CH: Center SSG output: -122 dBm(0.18μV) SSG MOD: 1.5kHz			Programming Software: KPG-88D	Write	Squelch open
4. SQL9 (Tight) writing [Wide] [Narrow]	TEST CH: Center Low High SSG output: -117 dBm(0.3μV) SSG MOD: 3.0kHz TEST CH: Center SSG output: -116 dBm(0.35μV) SSG MOD: 1.5kHz					
5. BATT Detection Writing	BATT terminal voltage: 5.9V	DVM	ANT BATT terminal		Write	BATT terminal voltage: 5.9V

TK-2200 PC BOARD

TX-RX UNIT (X57-6880-XX) -10 : K -11 : K2 Component side view (J72-0948-09)

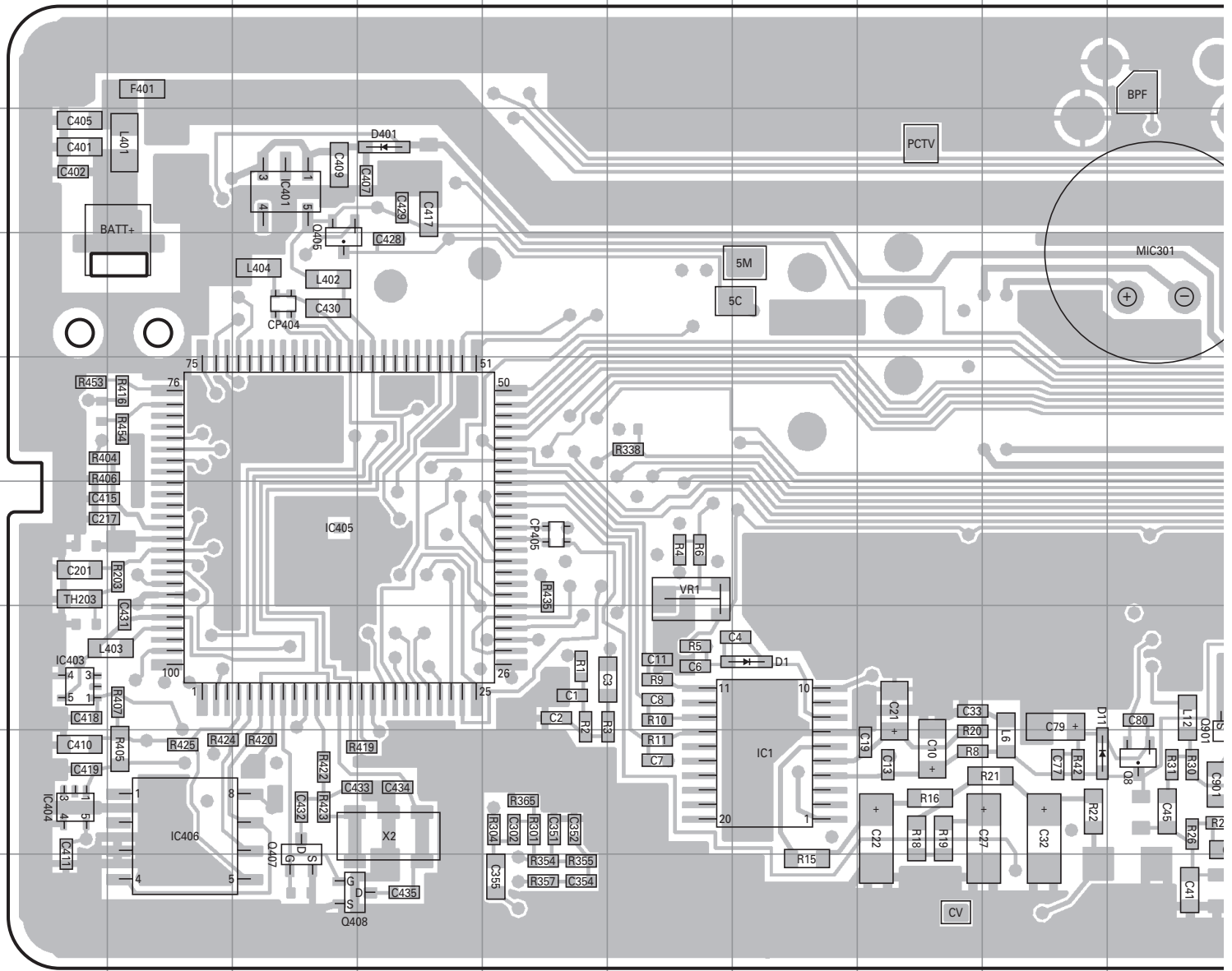

Ref. No.	Address	Ref. No.	Address	Ref. No.	Address	Ref. No.	Address
IC1	9G	Q8	9J	Q305	8O	Q901	8J
IC101	4M	Q104	5L	Q306	9P	D1	8G
IC302	8P	Q105	4K	Q316	9O	D11	9I
IC401	4C	Q107	4L	Q401	8R	D102	4M
IC403	8A	Q108	4L	Q402	8R	D401	4D
IC404	9A	Q109	5L	Q405	5C	D403	8R
IC405	7C	Q303	7P	Q407	9C	D404	8R
IC406	9B	Q304	7P	Q408	10C		

PC BOARD TK-2200

TX-RX UNIT (X57-6880-XX) -10 : K -11 : K2 Component side view (J72-0948-09)

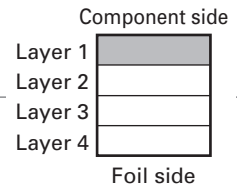
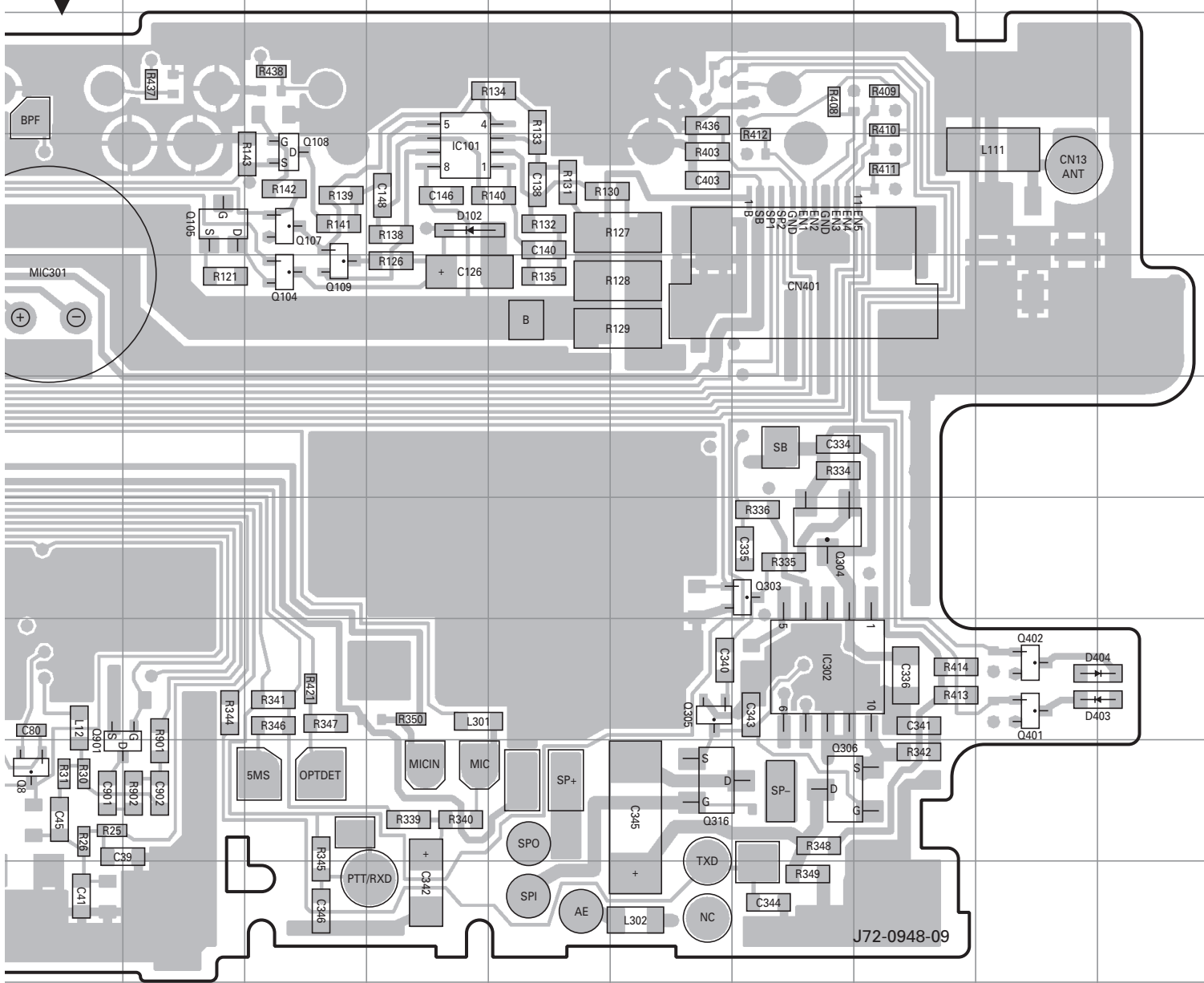

TK-2200 PC BOARD

PC BOARD TK-2200

TX-RX UNIT (X57-6880-XX) -10 : K -11 : K2 Component side view (J72-0948-09)

TX-RX UNIT (X57-6880-XX) -10 : K -11 : K2 Component side view (J72-0948-09)

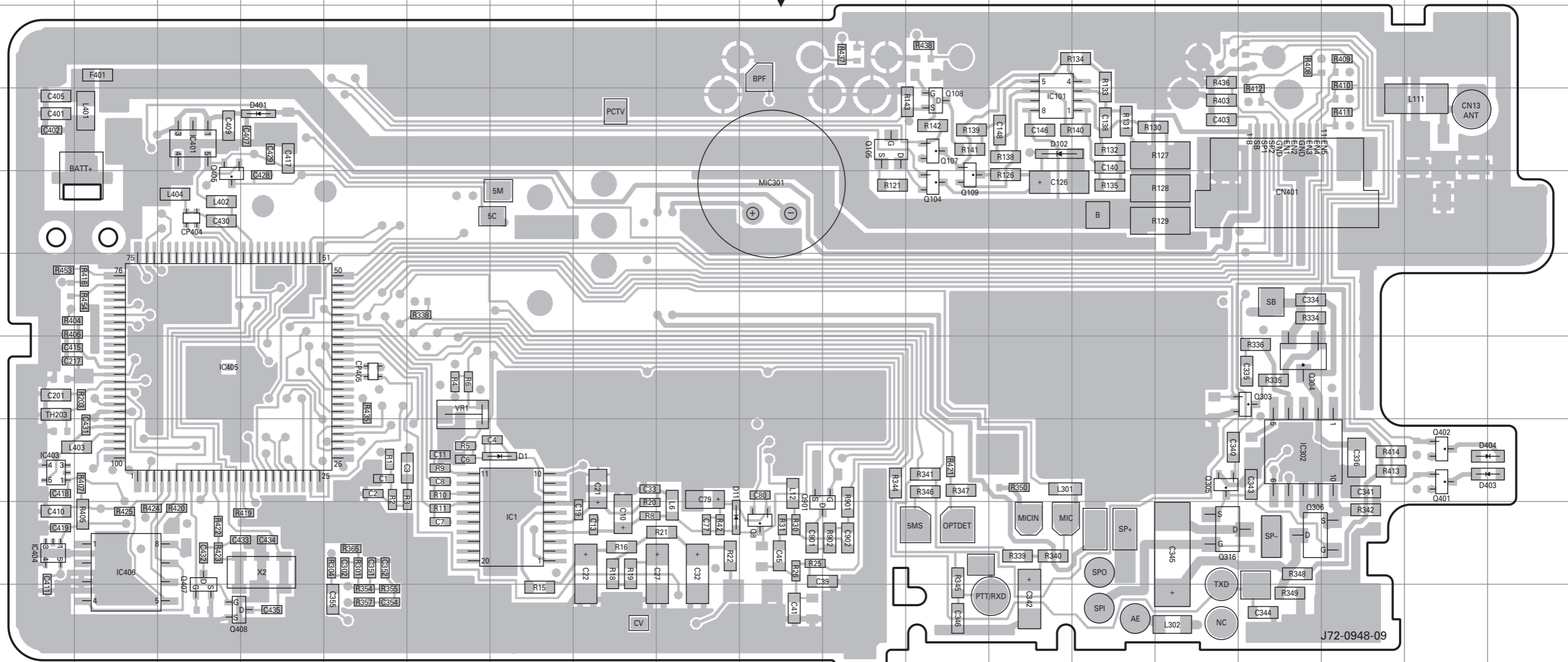

Ref. No.	Address	Ref. No.	Address	Ref. No.	Address	Ref. No.	Address
IC1	9G	Q8	9J	Q305	8O	Q901	8J
IC101	4M	Q104	5L	Q306	9P	D1	8G
IC302	8P	Q105	4K	Q316	9O	D11	9I
IC401	4C	Q107	4L	Q401	8R	D102	4M
IC403	8A	Q108	4L	Q402	8R	D401	4D
IC404	9A	Q109	5L	Q405	5C	D403	8R
IC405	7C	Q303	7P	Q407	9C	D404	8R
IC406	9B	Q304	7P	Q408	10C		

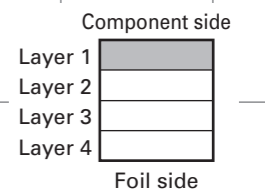

TK-2200 PC BOARD

TX-RX UNIT (X57-6880-XX) -10 : K -11 : K2 Foil side view (J72-0948-09)

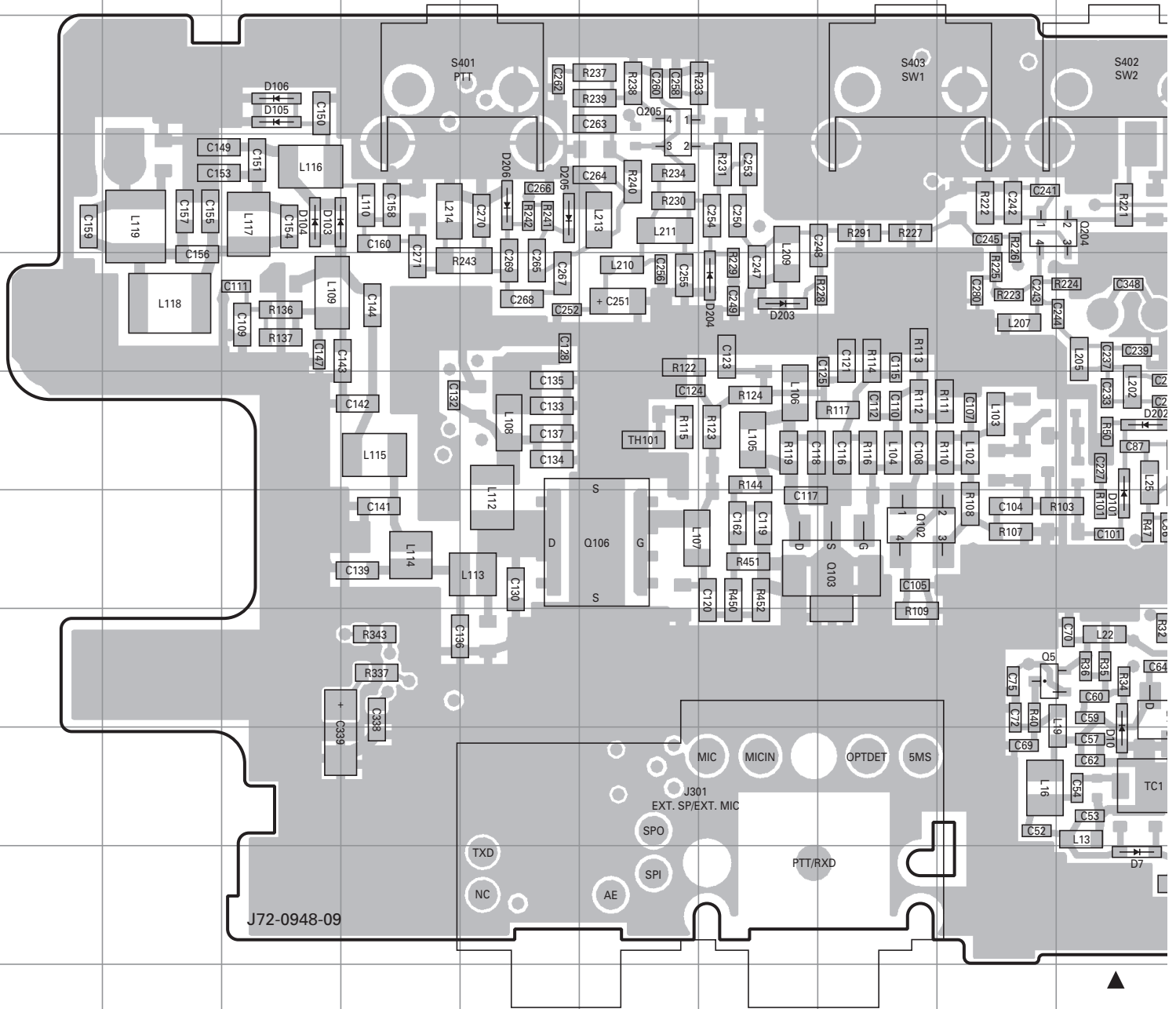

Ref. No.	Address	Ref. No.	Address	Ref. No.	Address	Ref. No.	Address	Ref. No.	Address
IC2	7L	Q6	8K	Q205	3F	D7	10J	D203	5G
IC201	5N	Q7	10L	Q301	6P	D9	10L	D204	5G
IC301	8P	Q9	6K	Q302	9R	D10	9J	D205	4E
IC402	4Q	Q102	7H	Q317	7P	D101	7J	D206	4E
Q1	7O	Q103	7H	Q318	7P	D103	4C	D301	10P
Q2	8L	Q106	7F	Q403	4Q	D104	4C	D302	10Q
Q3	9M	Q202	6O	Q404	3Q	D105	3C	D303	9R
Q4	8J	Q203	4N	D4	9K	D106	3C	D402	4R
Q5	8I	Q204	4J	D5	10L	D202	6J	D405	9R

PC BOARD TK-2200

TX-RX UNIT (X57-6880-XX) -10 : K -11 : K2 Foil side view (J72-0948-09)

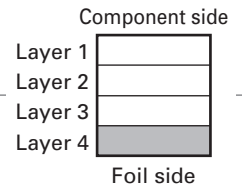
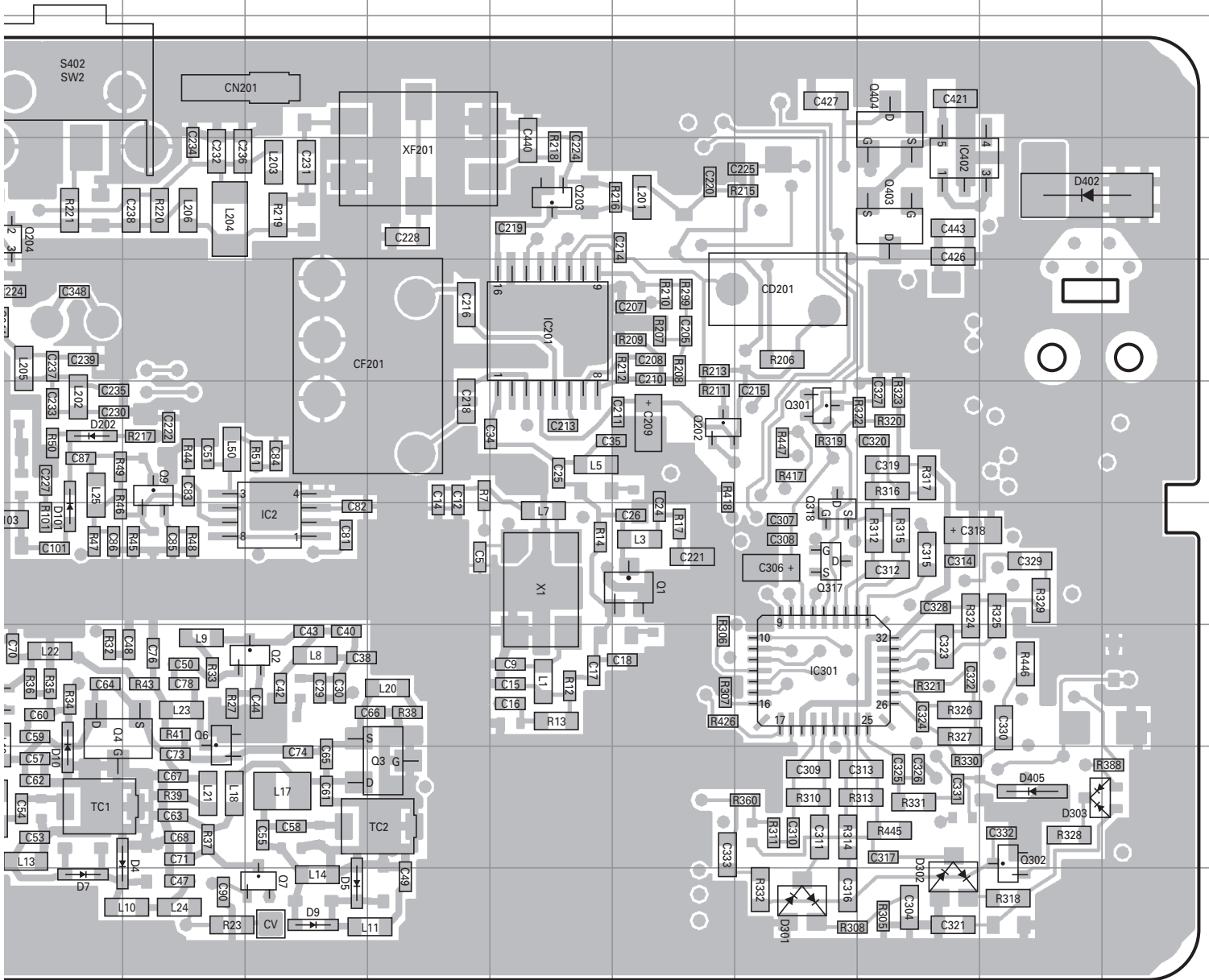

TX-RX UNIT (X57-6880-XX) -10 : K -11 : K2 Foil side view (J72-0948-09)

TX-RX UNIT (X57-6880-XX) -10 : K -11 : K2 Foil side view (J72-0948-09)

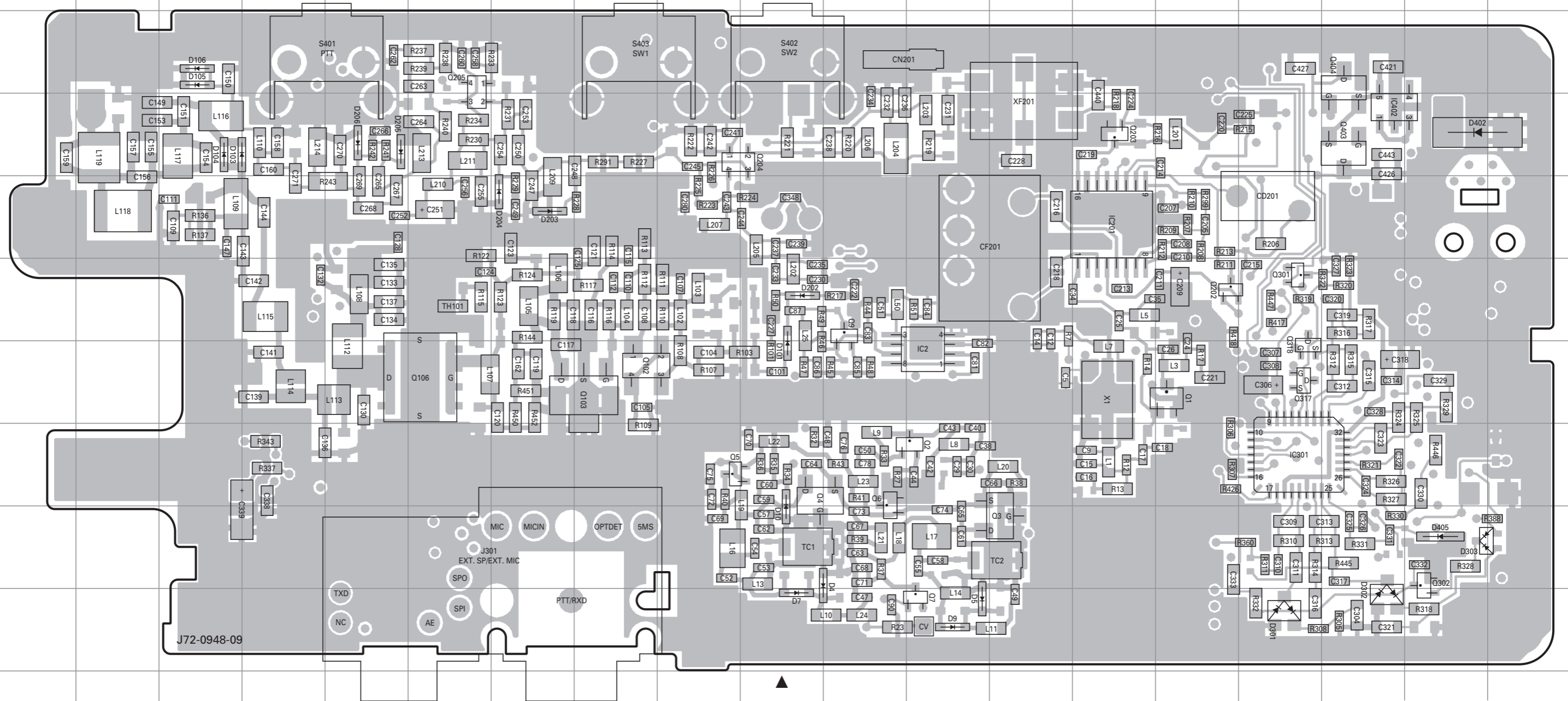

Ref. No.	Address	Ref. No.	Address	Ref. No.	Address	Ref. No.	Address	Ref. No.	Address
IC2	7L	Q6	8K	Q205	3F	D7	10J	D203	5G
IC201	5N	Q7	10L	Q301	6P	D9	10L	D204	5G
IC301	8P	Q9	6K	Q302	9R	D10	9J	D205	4E
IC402	4Q	Q102	7H	Q317	7P	D101	7J	D206	4E
Q1	7O	Q103	7H	Q318	7P	D103	4C	D301	10P
Q2	8L	Q106	7F	Q403	4Q	D104	4C	D302	10Q
Q3	9M	Q202	6O	Q404	3Q	D105	3C	D303	9R
Q4	8J	Q203	4N	D4	9K	D106	3C	D402	4R
Q5	8I	Q204	4J	D5	10L	D202	6J	D405	9R

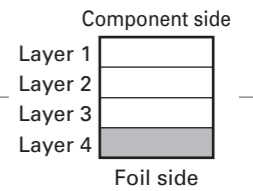

TK-2200

SCHEMATIC DIAGRAM

TX-RX UNIT (X57-6880-XX) -10:K -11:K2

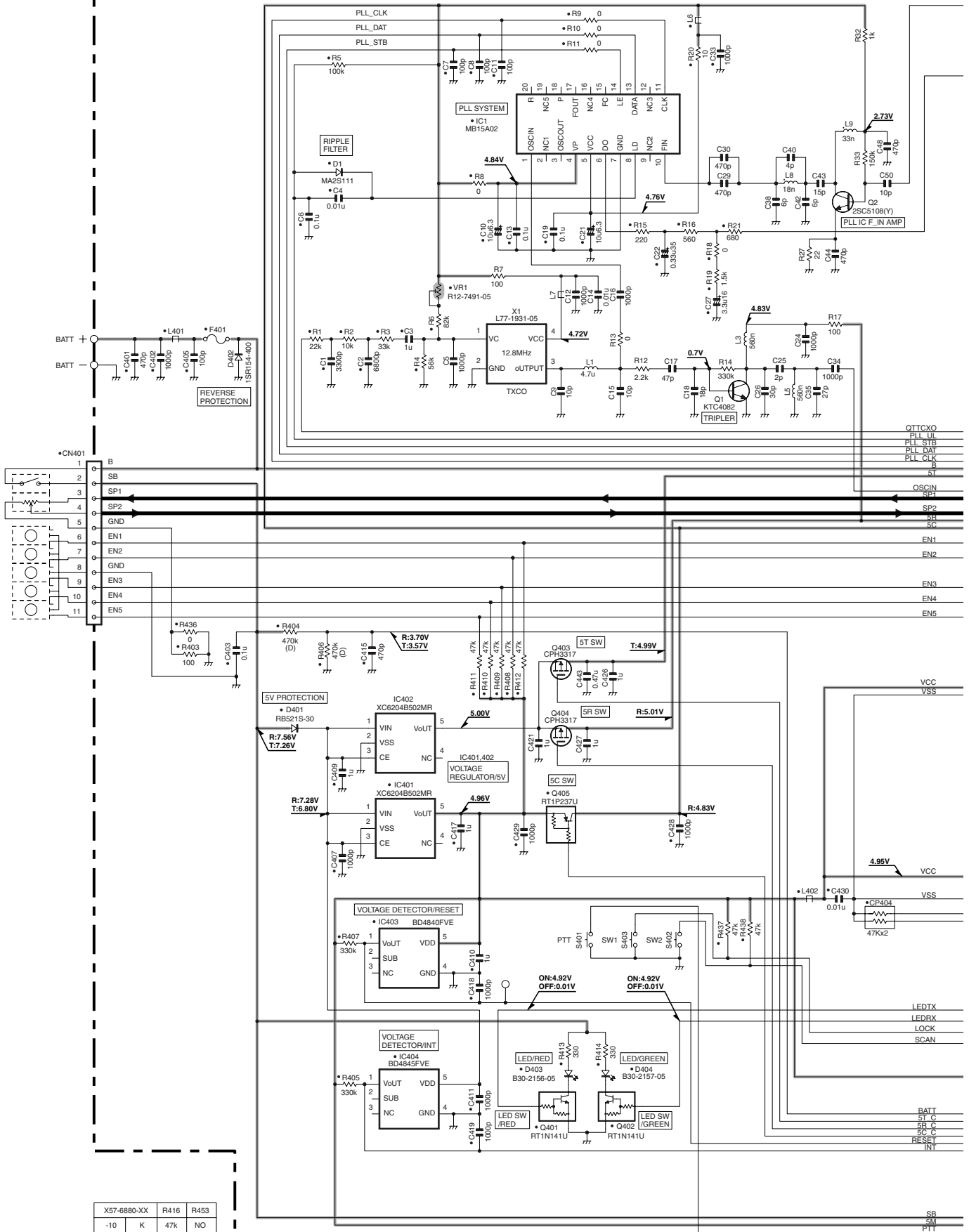

X57-6880-XX	R416	R453
-10	K	47k
-11	K2	NO
		47k

SCHEMATIC DIAGRAM

TK-2200

TX-RX UNIT (X57-6880-XX) -10:K -11:K2

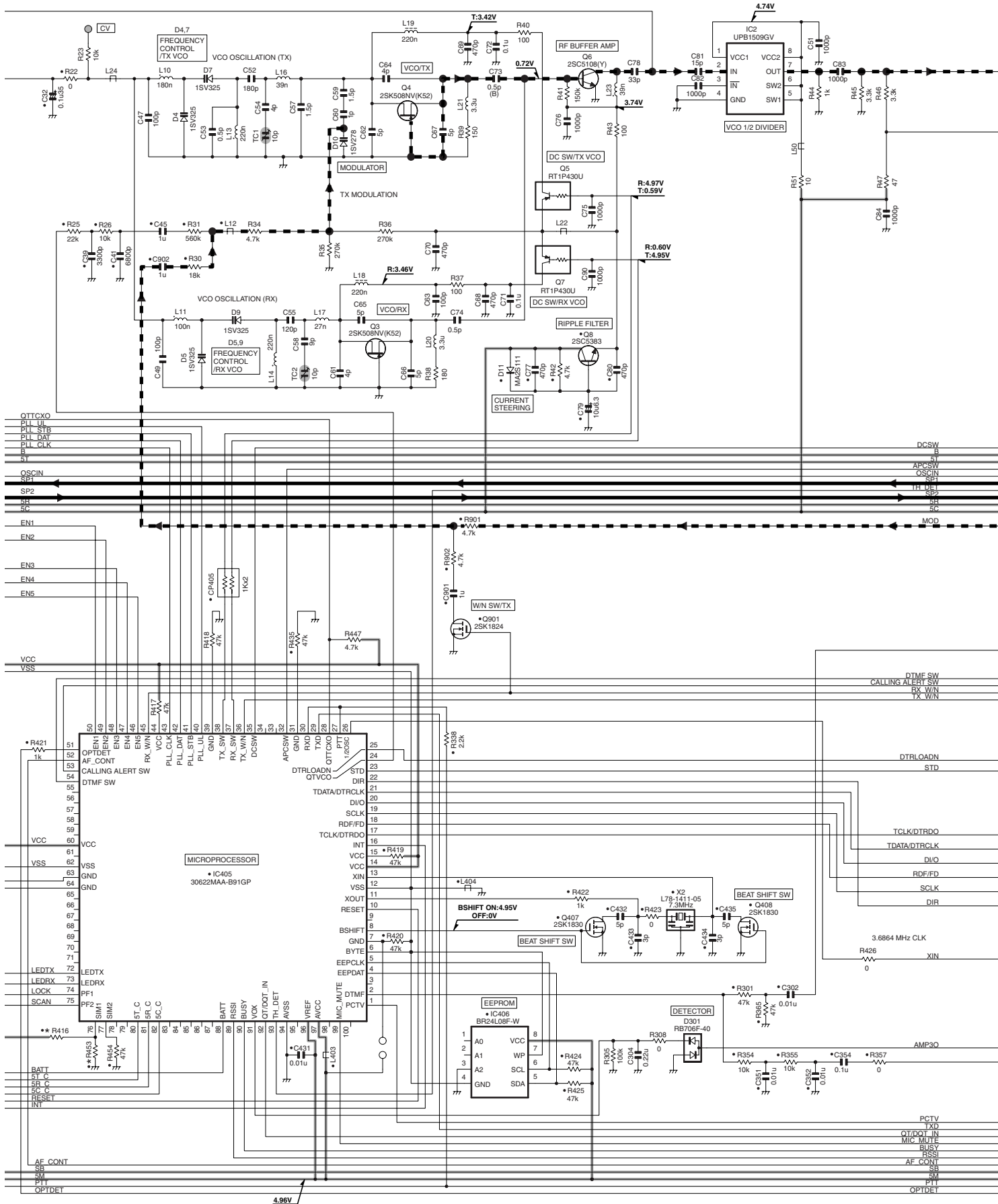

TK-2200

SCHEMATIC DIAGRAM

TX-RX UNIT (X57-6880-XX) -10:K -11:K2

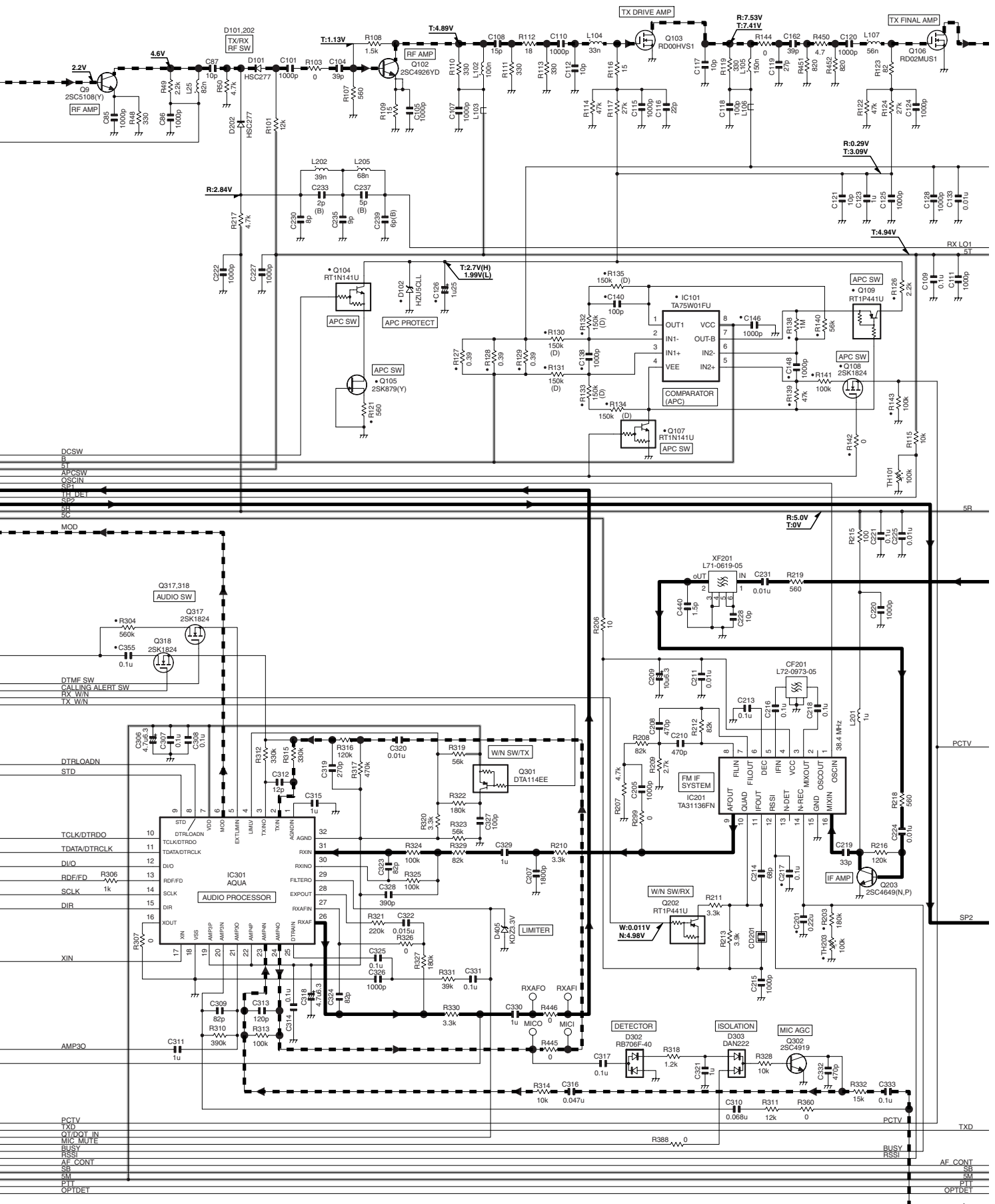

SCHEMATIC DIAGRAM

TK-2200

TX-RX UNIT (X57-6880-XX) -10:K -11:K2

Note : The components marked with a dot (●) are parts of layer1.

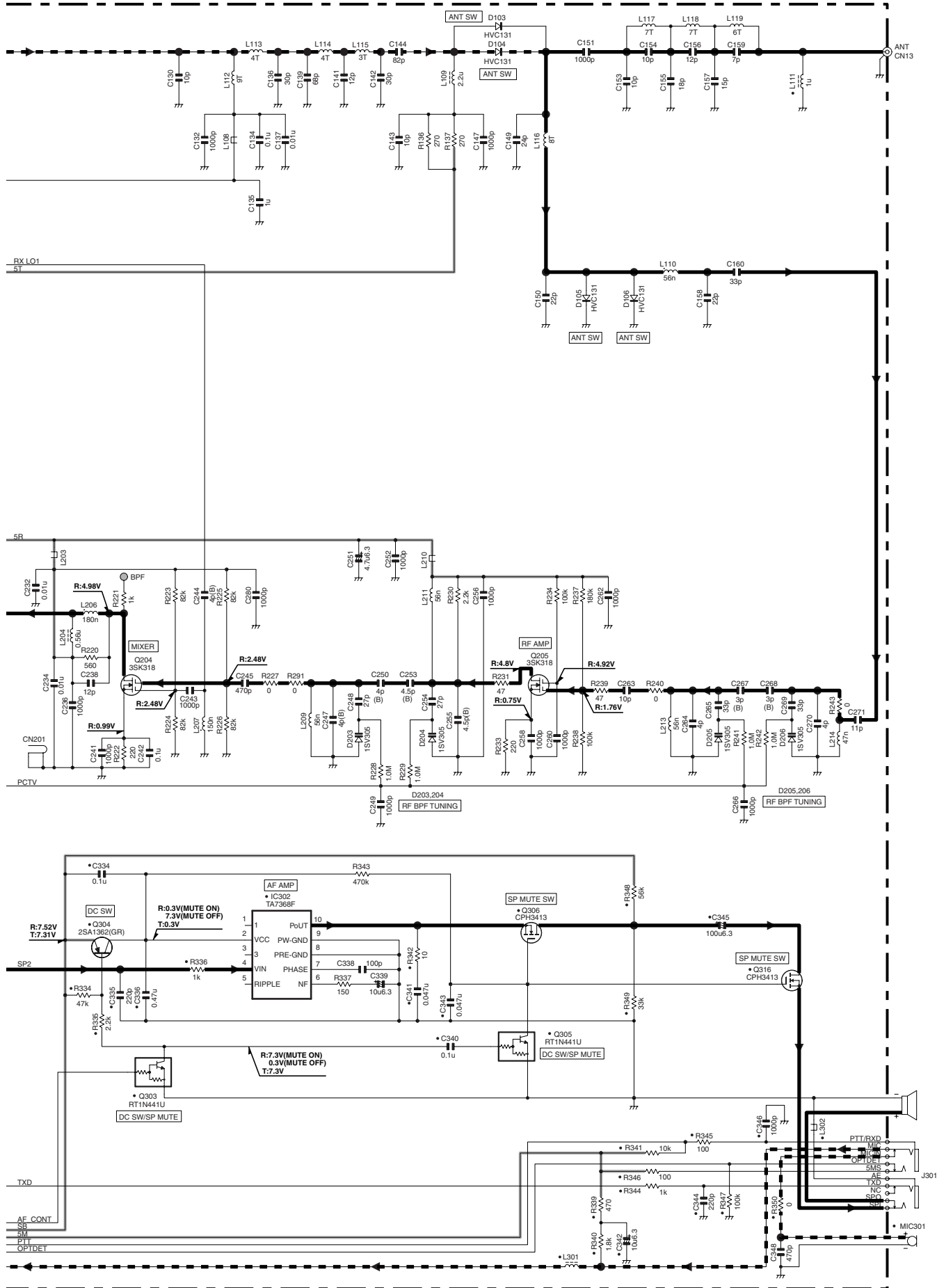

1
2
3
4
5
6
7

TK-2200 SCHEMATIC DIAGRAM

Note : The components marked with a dot (●) are parts of layer1.

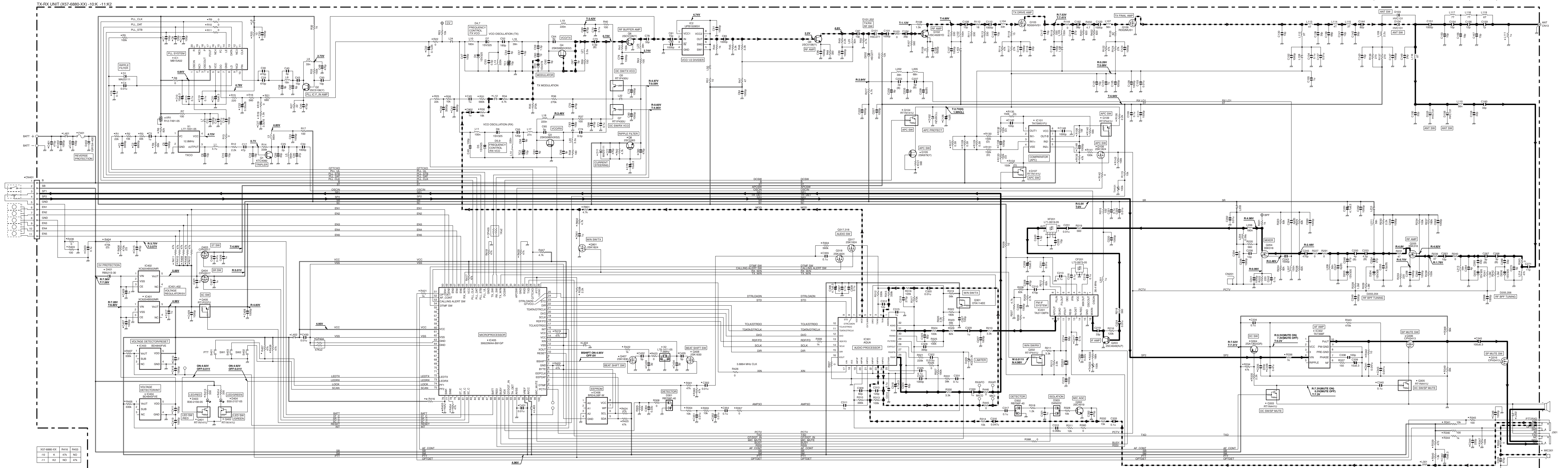

X57-6880-XX	R416	R453
-10	K	47k
-11	K2	47k

BLOCK DIAGRAM

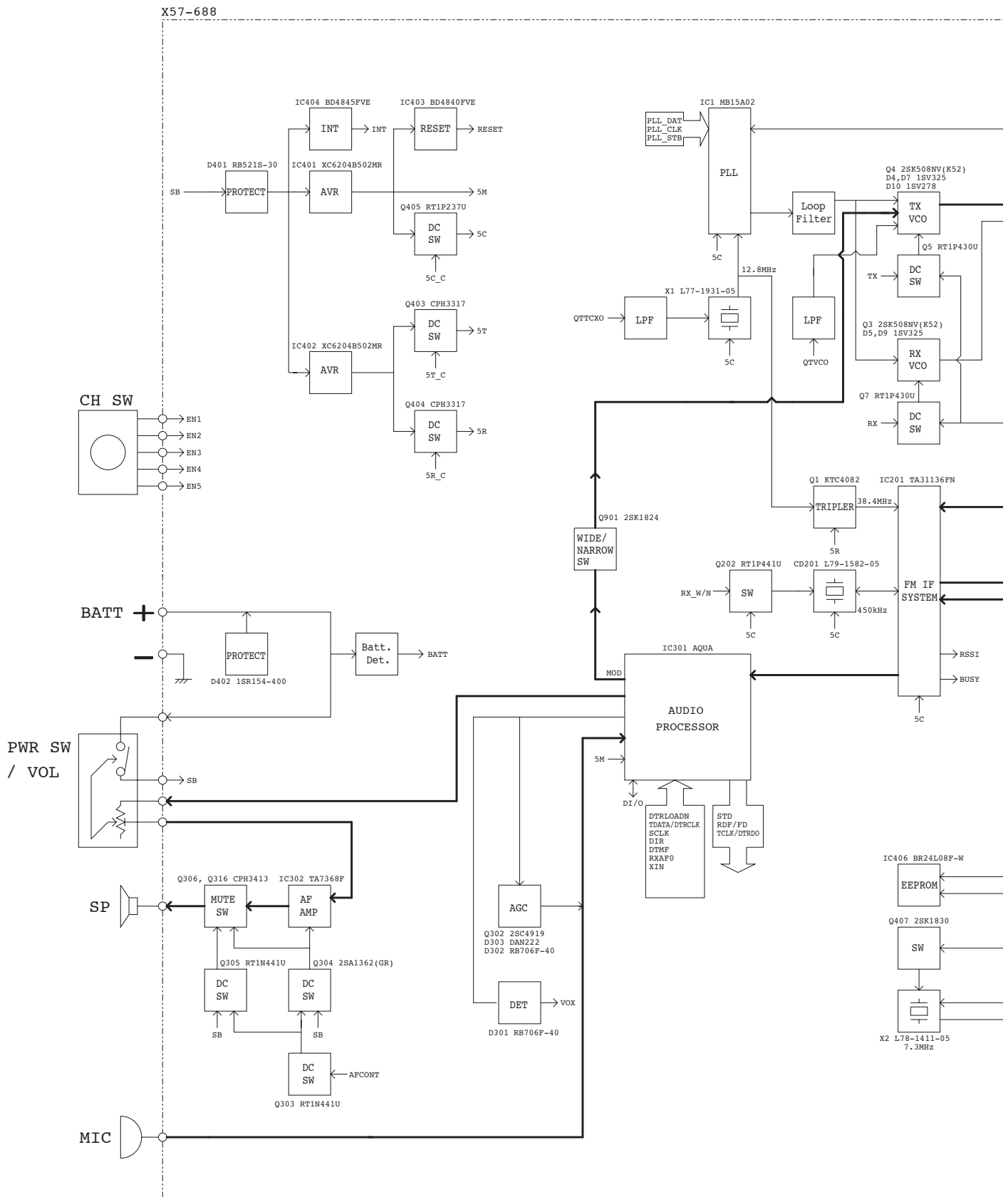

BLOCK DIAGRAM

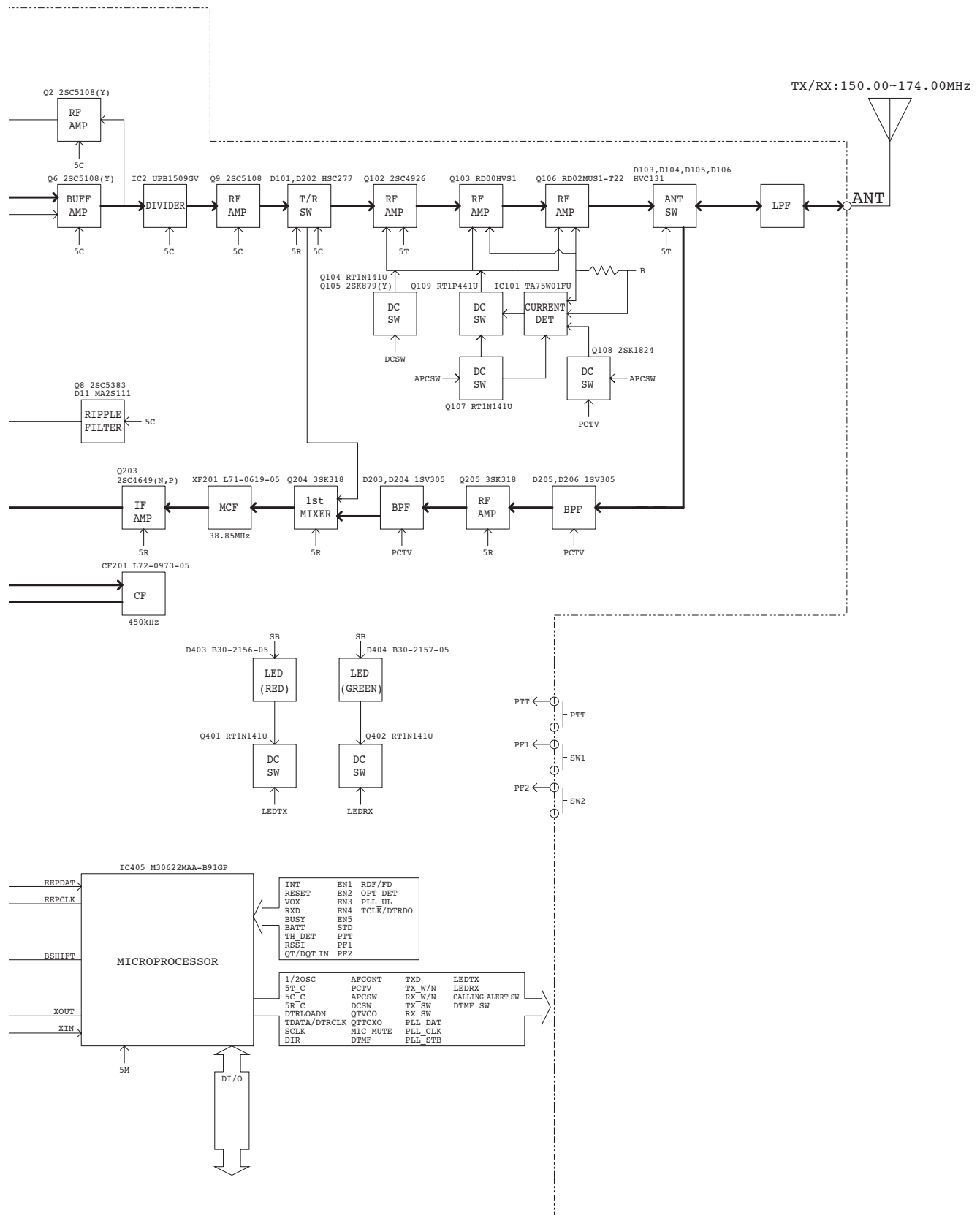

LEVEL DIAGRAM

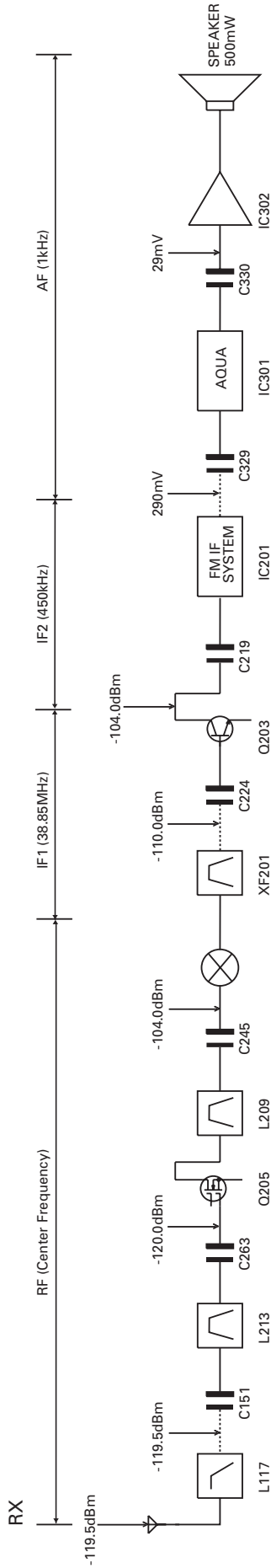

To make measurements in the AF section, connect the AC level meter. (ANT input: -53dBm, 1kHz FM, 3kHz DEV (WIDE))

In the RF section, use 1000pF coupling capacitor. (The display shows the SSG input value required to obtain 12dB SINAD without Local Level.)

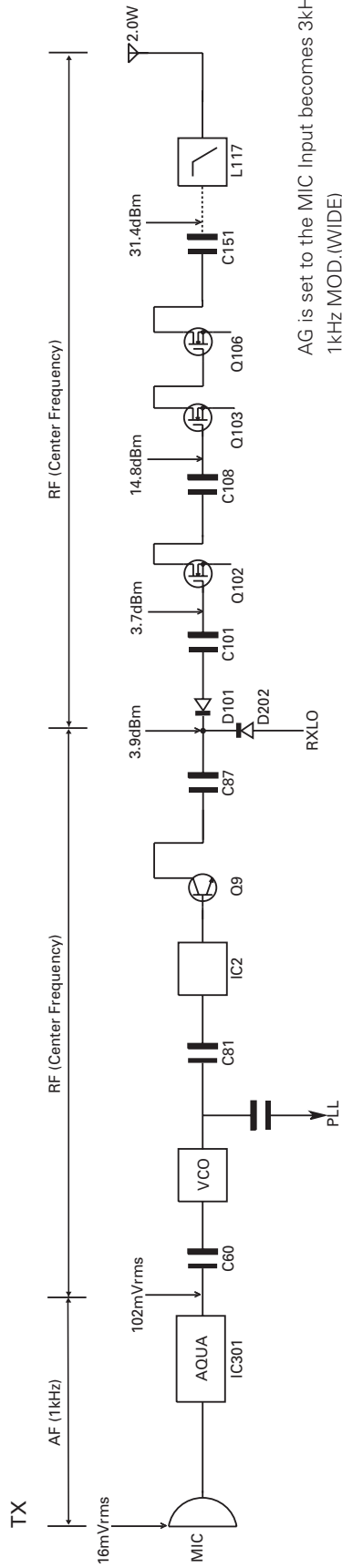

AG is set to the MIC Input becomes 3kHz DEV at 1kHz MOD.(WIDE)

To make measurements in the AF section, connect the AC level meter.

In the RF section, use 1000pF coupling capacitor.

KSC-31 / KNB-29N / KBH-10

KSC-31 (RAPID CHARGER)

External View



Specifications

- Charging current..... 850mA \pm 5%
- Charging time KNB-29N : Approx.180 minutes
KNB-30A : Approx.120 minutes
- Dimensions (Charger only) 86.3W x 46.2H x 100.0D (mm)
3-3/8W x 1-7/8H x 4D (inches)
- Weight (Charger only) Approx.100g / 0.22 lbs

KBH-10 (BELT CLIP)

External View



KNB-29N (Ni-MH BATTERY PACK)

External View



Specifications

- Voltage 7.2V (1.2V x 6)
- Battery capacity... 1500mAh

Schematic Diagram

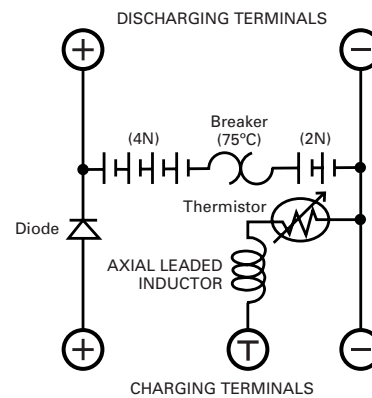

TK-2200

SPECIFICATIONS

General

Frequency Range	150~174MHz
Number of Channels	2 (K) 8 (K2)
Channel Spacing	25kHz, 30kHz (Wide) 12.5kHz, 15kHz (Narrow)
PLL Channel Stepping	2.5kHz, 5kHz, 6.25kHz, 7.5kHz
Operating Voltage	7.5 V DC±20%
Battery Life (5-5-90 duty cycle with KNB-29N battery)	Battery Saver off : Approx. 14 hours Battery Saver on and QT on : Approx. 18 hours Battery Saver on and QT off : Approx. 20 hours
Operating Temperature range	-30°C to +60°C (-22 °F to +140 °F)
Frequency Stability	±2.5ppm (-30°C to +60°C)
Channel Frequency Spread	24MHz
Dimensions and Weight	
Radio Only	54 (2-1/8) W x 122 (4-13/16) H x 21.1 (13/16) D mm (inches) 160g (0.35lbs)
With KNB-29N (1500mAh battery)	54 (2-1/8) W x 122 (4-13/16) H x 33 (1-5/16) D mm (inches)
(Dimensions not including protrusions)	360g (0.79lbs)

Receiver (Measurements made per TIA/EIA-603)

Sensitivity	
EIA 12dB SINAD	0.25µV (Wide)/0.28µV (Narrow)
Selectivity	70dB (Wide)/60dB (Narrow)
Intermodulation	65dB (Wide)/60dB (Narrow)
Spurious Response	65dB
Audio Power Output	500mW at 8Ω less than 10% distortion

Transmitter (Measurements made per TIA/EIA-603)

RF Power Output	2W/1W
Spurious and Harmonics	65dB
Modulation	16KφF3E (Wide)/11KφF3E (Narrow)
FM Noise	45dB (Wide)/40dB (Narrow)
Audio Distortion	Less than 5%

KENWOOD CORPORATION

2967-3, Ishikawa-machi, Hachioji-shi, Tokyo 192-8525, Japan

KENWOOD U.S.A. CORPORATION

P.O. BOX 22745, 2201 East Dominguez Street, Long Beach, CA 90801-5745, U.S.A.

KENWOOD ELECTRONICS CANADA INC.

6070 Kestrel Road, Mississauga, Ontario, Canada L5T 1S8

KENWOOD ELECTRONICS DEUTSCHLAND GMBH

Rembrücker Str. 15, 63150 Heusenstamm, Germany

KENWOOD ELECTRONICS BELGIUM N.V.

Leuvensesteenweg 248 J, 1800 Vilvoorde, Belgium

KENWOOD ELECTRONICS FRANCE S.A.

13, Boulevard Ney, 75018 Paris, France

KENWOOD ELECTRONICS U.K. LIMITED

KENWOOD House, Dwight Road, Watford, Herts., WD18 9EB, United Kingdom

KENWOOD ELECTRONICS EUROPE B.V.

Amsterdamseweg 37, 1422 AC Uithoorn, The Netherlands

KENWOOD ELECTRONICS ITALIA S.p.A.

Via G. Sirtori, 7/9 20129 Milano, Italy

KENWOOD IBERICA S.A.

Bolivia, 239-08020 Barcelona, Spain

KENWOOD ELECTRONICS AUSTRALIA PTY. LTD.

(A.C.N. 001 499 074)

16 Giffnock Avenue, Centrecourt Estate, North Ryde, N.S.W. 2113, Australia

KENWOOD ELECTRONICS (HONG KONG) LTD.

Unit 3712-3724, Level 37, Tower one Metroplaza, 223 Hing Fong Road, Kwai Fong, N.T., Hong Kong

KENWOOD ELECTRONICS SINGAPORE PTE LTD.

1 Genting Lane #07-00 Kenwood Building, Singapore 349544

