

## CONTENTS

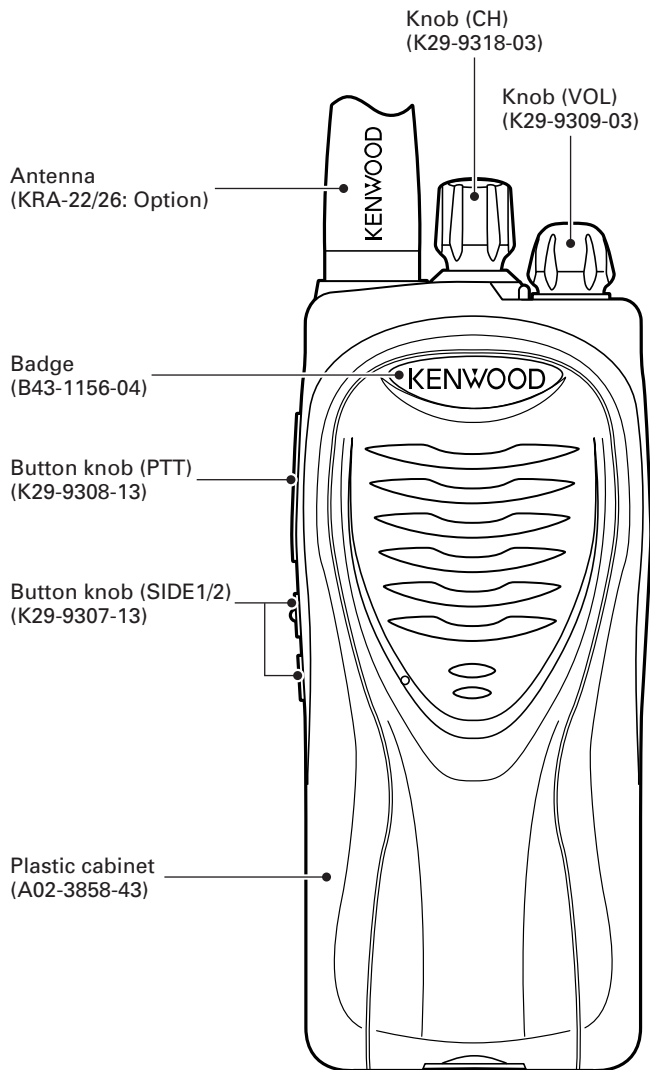

<b>GENERAL</b> .....	<b>2</b>
<b>SYSTEM SET-UP</b> .....	<b>2</b>
<b>REALIGNMENT</b> .....	<b>3</b>
<b>DISASSEMBLY FOOR REPAIR</b> .....	<b>4</b>
<b>CIRCUIT DESCRIPTION</b> .....	<b>6</b>
<b>TERMINAL FUNCTION</b> .....	<b>10</b>
<b>SEMICONDUCTOR DATA</b> .....	<b>11</b>
<b>COMPONENTS DESCRIPTION</b> .....	<b>12</b>
<b>PARTS LIST</b> .....	<b>13</b>
<b>EXPLODED VIEW</b> .....	<b>19</b>
<b>PACKING</b> .....	<b>20</b>
<b>ADJUSTMENT</b> .....	<b>21</b>
<b>PC BOARD</b>	
<b>TX-RX UNIT (X57-6872-71)</b> .....	<b>26</b>
<b>SCHEMATIC DIAGRAM</b> .....	<b>30</b>
<b>BLOCK DIAGRAM</b> .....	<b>34</b>
<b>LEVEL DIAGRAM</b> .....	<b>36</b>
<b>KBH-10 (BELT CLIP)</b> .....	<b>37</b>
<b>KSC-31 (RAPID CHARGER)</b> .....	<b>37</b>
<b>KNB-29N (Ni-MH BATTERY PACK)</b> .....	<b>37</b>
<b>SPECIFICATIONS</b> .....	<b>BACK COVER</b>

Does not come with antenna.  
Antenna is available as an option.



This product uses Lead Free solder.

## GENERAL / SYSTEM SET-UP

### INTRODUCTION

#### SCOPE OF THIS MANUAL

This manual is intended for use by experienced technicians familiar with similar types of commercial grade communications equipment. It contains all required service information for the equipment and is current as of the publication date. Changes which may occur after publication are covered by either Service Bulletins or Manual Revisions. These are issued as required.

#### ORDERING REPLACEMENT PARTS

When ordering replacement parts or equipment information, the full part identification number should be included. This applies to all parts, components, kits, or chassis. If the part number is not known, include the chassis or kit number of which it is a part, and a sufficient description of the required component for proper identification.

### PERSONAL SAFETY

The following precautions are recommended for personal safety:

- DO NOT transmit until all RF connectors are verified secure and any open connectors are properly terminated.
- SHUT OFF and DO NOT operate this equipment near electrical blasting caps or in an explosive atmosphere.
- This equipment should be serviced by a qualified technician only.

### SERVICE

This radio is designed for easy servicing. Refer to the schematic diagrams, printed circuit board views, and alignment procedures contained within.

Model & Destination		Unit		Remarks
		TX-RX unit	Frequency range	
TK-2202	E	X57-6872-71	136~174MHz	IF1 : 38.85MHz LOC : 38.4MHz

### SYSTEM SET-UP

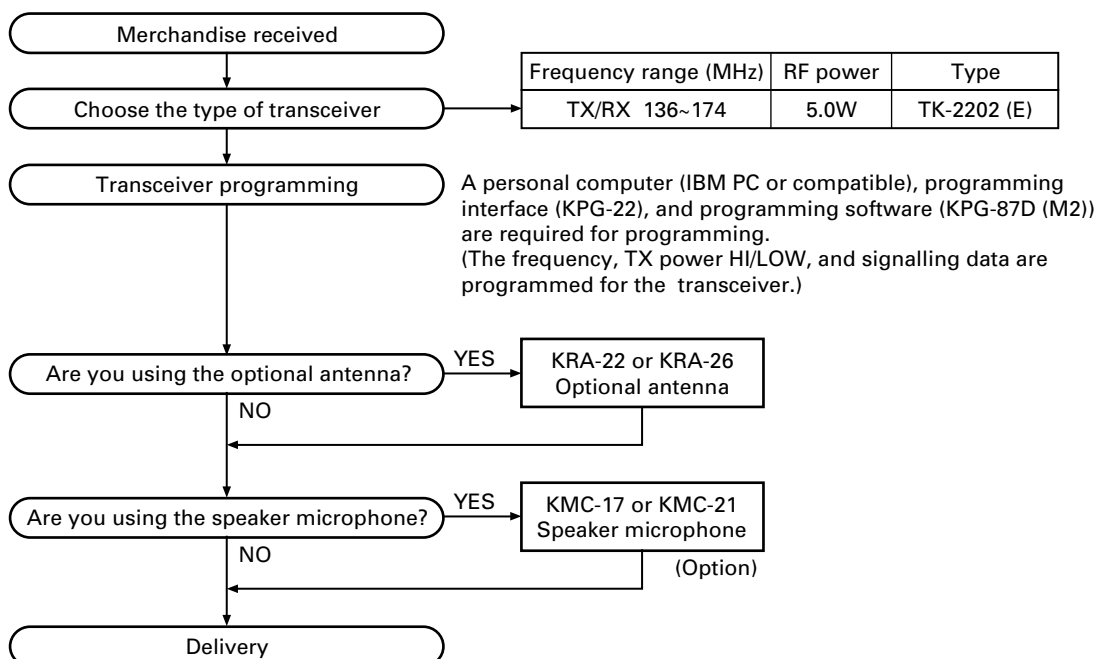

## REALIGNMENT

### 1. Modes

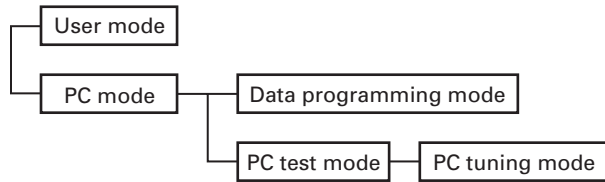

Mode	Function
User mode	For normal use.
PC mode	Used for communication between the transceiver and PC (IBM compatible).
Data programming mode	Used to read and write frequency data and other features to and from the transceiver.
PC test mode	Used to check the transceiver using the PC. This feature is included in the KPG-87D (M2).

### 2. How to Enter Each Mode

Mode	Operation
User mode	Power ON
PC mode	Received commands from PC.

### 3. PC Mode

#### 3-1. Preface

The transceiver are programmed using a personal computer, a programming interface (KPG-22) and programming software (KPG-87D (M2)).

The programming software can be used with an IBM PC or compatible. Figure 1 shows the setup of an IBM PC for programming.

#### 3-2. Connection procedure

1. Connect the transceiver to the personal computer with the interface cable.
2. When the POWER is switched on, user mode can be entered immediately. When the PC sends a command, the radio enters PC mode.

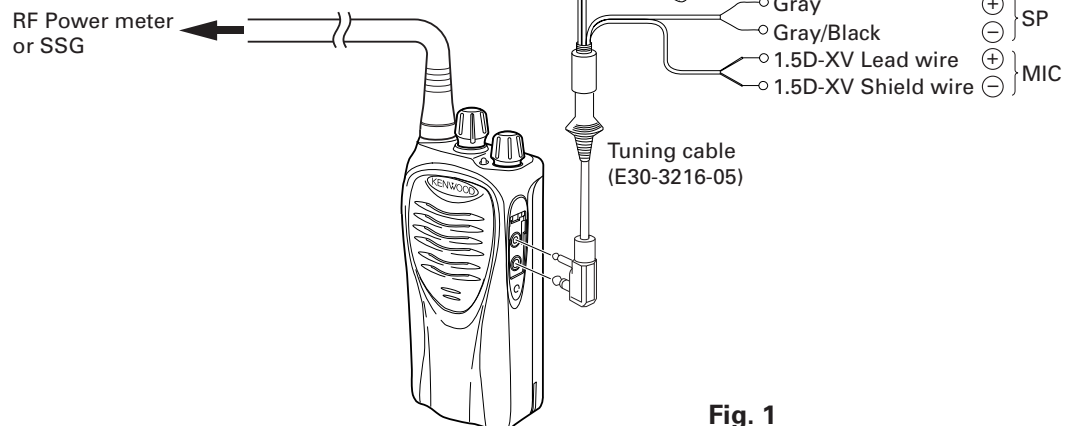

Fig. 1

When data is transmitting from the transceiver, the red LED lights.

When data is received by the transceiver, the green LED lights.

#### Notes:

- The data stored in the personal computer must match the model type when it is written into the EEPROM.
- Change the transceiver to PC mode, then attach the interface cable.

#### 3-3. KPG-22 description

##### (PC programming interface cable: Option)

The KPG-22 is required to interface the transceiver with the computer. It has a circuit in its D-sub connector (25-pin) case that converts the RS-232C logic level to the TTL level.

The KPG-22 connects the SP/MIC connector of the transceiver to the computer's RS-232C serial port.

#### 3-4. Programming software description

KPG-87D (M2) is the programming software for the transceiver supplied on a CD-ROM. This software runs under Windows 98, ME, Windows 2000 or XP on an IBM-PC or compatible machine.

The data can be input to or read from the transceiver and edited on the screen. The programmed or edited data can be printed out. It is also possible to tune the transceiver.

## DISASSEMBLY FOR REPAIR

### Removing the Case Assembly from the Chassis

1. Remove the volume knob (1) and channel knob (2).
2. Remove the two screws (3).
3. Lift and remove the chassis from the case assembly (4).  
(Use a flat-blade screwdriver to easily lift the chassis.)

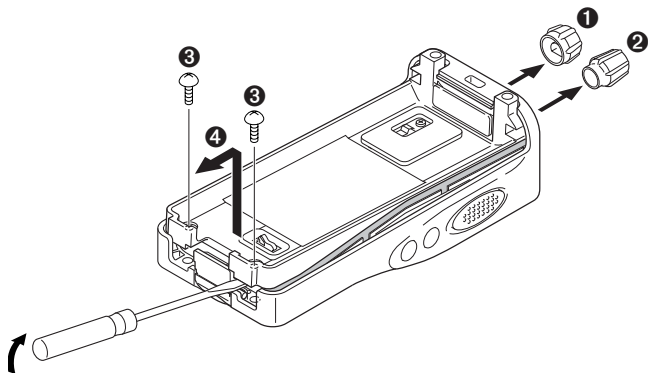

### Removing the TX-RX Unit from the Chassis

1. Remove the packing (5) from the SP / MIC jack of the TX-RX unit.
  2. Remove the eleven screws (6) fixing the TX-RX unit.
  3. Remove the fixing bracket (7) of the SP/MIC.
  4. Remove the solder of the antenna terminal with a soldering iron (8).
  5. Remove the solder of the positive terminal with a soldering iron (9).
- Note:** You can remove the TX-RX unit from the chassis without removing the solder at the positive terminal. However, in this case, you can not attach the packing (G53-1605-03) that is on the positive terminal to the chassis in assembling. So, it is advisable to remove the solder on the positive terminal first.
6. Remove the FPC from the flat cable connector (10).
  7. Lift and remove the TX-RX unit from the chassis (11).

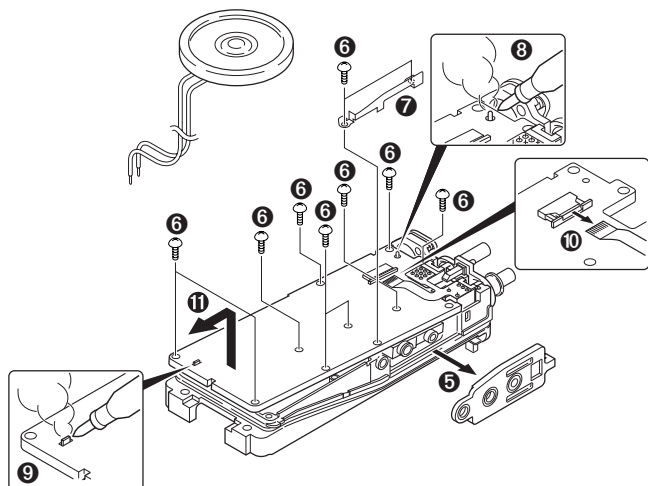

### Removing the Battery Release Lever from the Case Assembly

1. Press the upper part of the lever toward the inside of the case assembly. One side of the shaft will be removed (1).
2. Lift and remove the battery release lever from the case assembly (2).

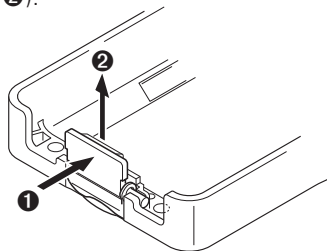

### Attaching the Battery Release Lever to the Case Assembly

1. Insert one side of the shaft into the hole at the lever fitting section on the case assembly (1).
- Caution:** The thin spring (G01-4543-04) should be positioned above the two tabs of the lever.
2. Tilt the battery release lever slightly forward (2), so that the thick spring (G01-4542-04) is positioned below the case surface.
  3. With the thick spring positioned below the case surface, attach the other side of the shaft to the case assembly by pressing the battery release lever (3) until it snaps into place (4).

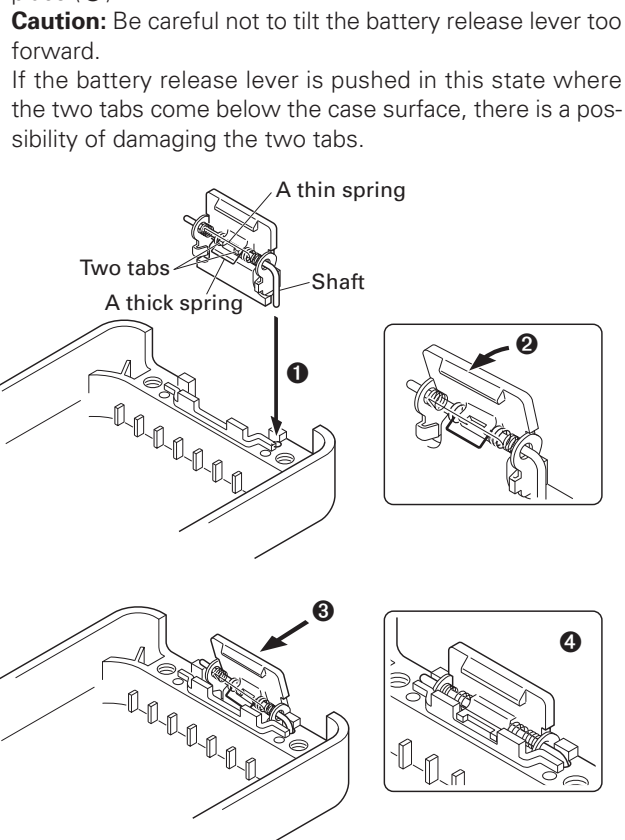

## DISASSEMBLY FOR REPAIR

### Assembling the Battery Release Lever

1. Place the lever (2) onto the stopper (1).
2. Place the thick spring (3) onto the lever.
3. Hook the right and left ends of the thin spring (4) onto the tabs of the stopper, then place the thin spring (5) onto the lever (6).
4. Slide the shaft through the hole of the stopper and lever (6).

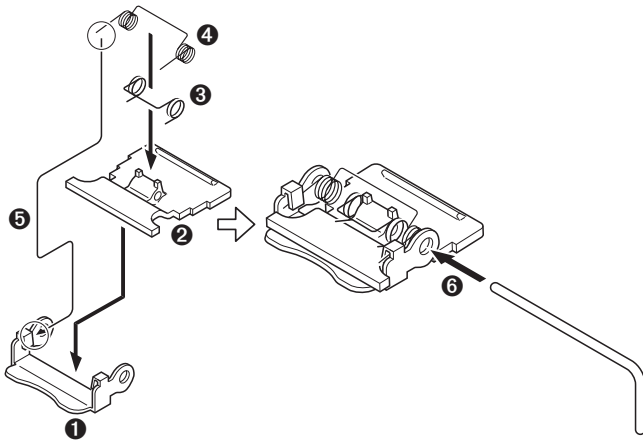

### Cautions for Assembly

#### ■ Attaching the positive terminal to the chassis

Always attach the positive terminal to the chassis, using the following procedures, before mounting the TX-RX unit onto the chassis.

1. Remove the holder assembly (2) from the packing (1) of the positive terminal.
2. Mount the packing of the positive terminal into the chassis hole (3).
3. Mount the holder assembly into the packing of the positive terminal (4).

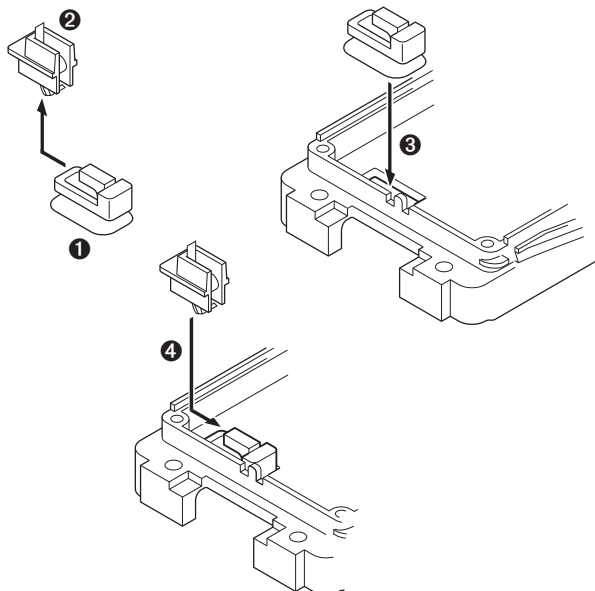

#### ■ Mounting the chassis to the case assembly

1. Confirm that the waterproof packing attached to the circumference of the chassis is securely inserted in the groove of the chassis (1).
2. Attach the speaker to the speaker recess of the case assembly (2). Make sure the speaker is securely inserted.

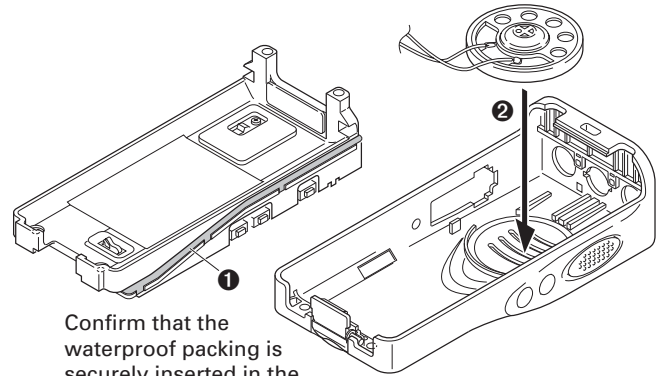

Confirm that the waterproof packing is securely inserted in the groove of the chassis.

3. Insert the upper part of the chassis into the case assembly (3).
- Caution:** Take care that the speaker lead wire is not caught by the microphone element.
4. Press the chassis (4) and the case assembly together to attach them.

**Caution:** If the packing of the SP/MIC does not come to the correct position after attaching the chassis to the case assembly, reposition the packing with your fingers.

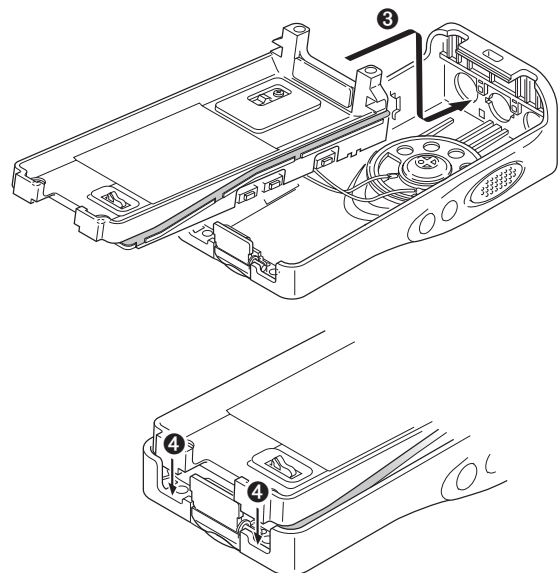

# TK-2202

## DISASSEMBLY FOR REPAIR / CIRCUIT DESCRIPTION

### ■ Attaching the antenna receptacle to the chassis

Screw the antenna receptacle to the chassis in the order shown in the drawing so that the antenna receptacle comes to the center of the case hole.

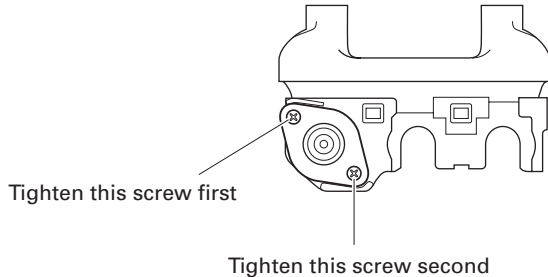

### ■ The nuts of the volume knob and channel knob

Note that the shapes, materials and heights of nuts of the volume knob and channel knob are different from one another. (The nut of volume knob is stainless steel, and the nut of channel knob is brass.)

Use the following jig when removing the nuts of the volume knob and channel knob. Jig (Part No.: W05-1012-00)

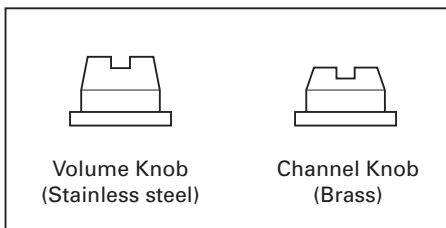

### 1. Frequency Configuration

The receiver utilizes double conversion. The first IF is 38.85MHz and the second IF is 450kHz. The first local oscillator signal is supplied from the PLL circuit.

The PLL circuit in the transmitter generates the necessary frequencies. Fig. 1 shows the frequencies.

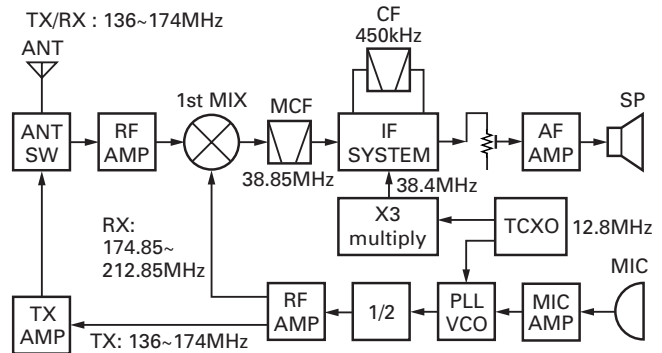

Fig. 1 Frequency configuration

### 2. Receiver

The frequency configuration of the receiver is shown in Fig. 2.

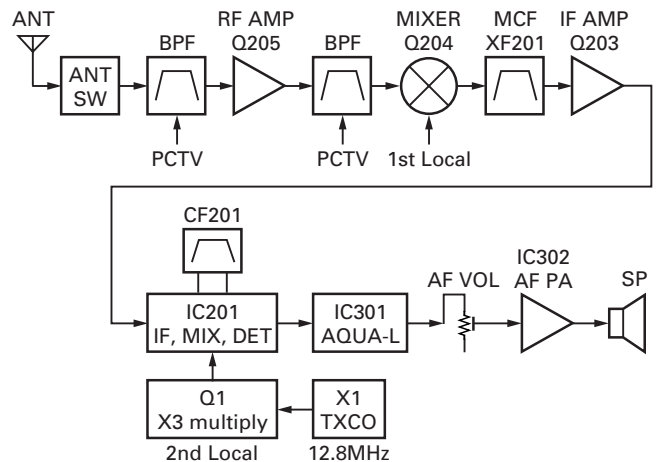

Fig. 2 Receiver section

### ■ Front End (RF AMP)

The signal coming from the antenna passes through the transmit/receive switching diode circuit (D103, D104, D105 and D106), passes through a BPF (L214 and L213), and is amplified by the RF amplifier (Q205).

The resulting signal passes through a BPF (L209 and L211) and goes to the mixer. These BPFs are adjusted by variable capacitors (D203, D204, D205 and D206). The input voltage to the variable capacitor is regulated by voltage output from the microprocessor (IC405).

## CIRCUIT DESCRIPTION

### ■ First Mixer

The signal from the front end is mixed with the first local oscillator signal generated in the PLL circuit by Q1 to produce a first IF frequency of 38.85MHz.

The resulting signal passes through the XF201 MCF to cut the adjacent spurious and provide the optimum characteristics, such as adjacent frequency selectivity.

### ■ IF Amplifier Circuit

The first IF signal is passed through a four-pole monolithic crystal filter (XF201) to remove the adjacent channel signal. The filtered first IF signal is amplified by the first IF amplifier (Q203) and then applied to the IF system IC (IC201). The IF system IC provides a second mixer, second local oscillator, limiting amplifier, quadrature detector and RSSI (Received Signal Strength Indicator). The second mixer mixes the first IF signal with the 38.4MHz of the second local oscillator output (TCXO X1) and produces the second IF signal of 450kHz.

The second IF signal is passed through the ceramic filter (CF201) to remove the adjacent channel signal. The filtered second IF signal is amplified by the limiting amplifier and demodulated by the quadrature detector with the ceramic discriminator (CD201). The demodulated signal is routed to the audio circuit.

### ■ Wide 5k/Wide 4k, Narrow Switching Circuit

Narrow and Wide 5k, Wide 4k settings can be made for each channel by switching the demodulation level.

The WIDE (low level) and NARROW (high level) data is output from IC405, pin 45.

When a WIDE (low level) data is received, Q202 turn on. When a NARROW (high level) data is received, Q202 turn off.

Q202 turns on/off with the Wide/Narrow data and the IC201 detector output level is switched to maintain a constant output level during wide or narrow signals.

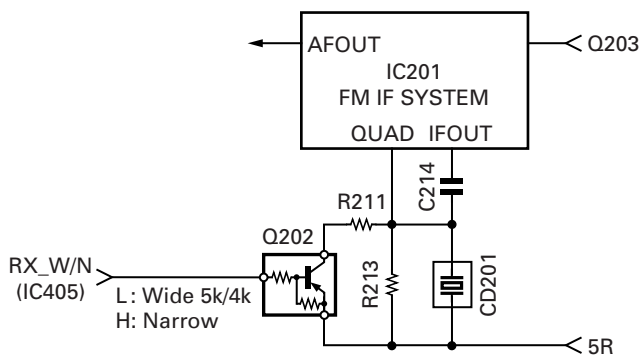

**Fig. 3 Wide 5k/Wide 4k, Narrow switching circuit**

### ■ Audio Amplifier Circuit

The demodulated signal from IC201 goes to AF amplifier through IC301.

The signal then goes through an AF volume control, and is routed to an audio power amplifier (IC302) where it is amplified and output to the speaker.

### ■ Squelch

Part of the AF signal from the IC enters the FM IC (IC201) again, and the noise component is amplified and rectified by a filter and an amplifier to produce a DC voltage corresponding to the noise level.

The DC signal from the FM IC goes to the analog port of the microprocessor (IC405). IC405 determines whether to output sounds from the speaker by checking whether the input voltage is higher or lower than the preset value.

To output sounds from the speaker, IC405 sends a high signal to the SP MUTE line and turns IC302 on through Q303, Q304, Q305, Q306 and Q316. (See Fig. 4.)

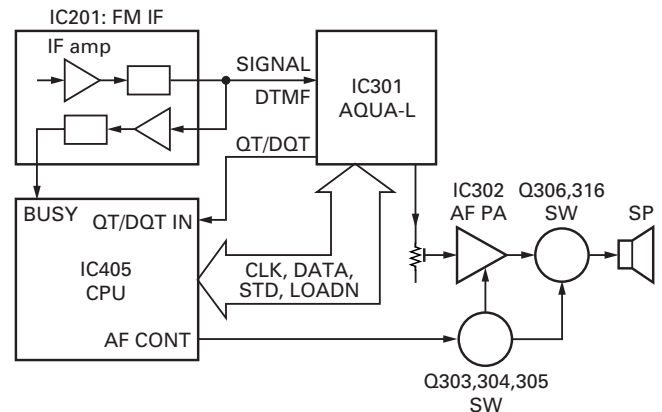

**Fig. 4 AF amplifier and Squelch**

### ■ Receive Signaling

#### • QT/DQT

The output signal from FM IC (IC201) enters the microprocessor (IC405) through IC301. IC405 determines whether the QT or DQT matches the preset value, and controls the SP MUTE and the speaker output sounds according to the squelch results.

## CIRCUIT DESCRIPTION

### 3. PLL Frequency Synthesizer

The PLL circuit generates the first local oscillator signal for reception and the RF signal for transmission.

#### ■ PLL

The frequency step of the PLL circuit is 2.5, 5, 6.25 or 7.5kHz.

A 12.8MHz reference oscillator signal is divided at IC1 by a fixed counter to produce an oscillator (VCO) output signal which is buffer amplified by Q2 then divided in IC1 by a programmable counter. The divided signal is compared in phase with the 5 or 6.25kHz reference signal from the phase comparator in IC1. The output signal from the phase comparator is filtered through a low-pass filter and passed to the VCO to control the oscillator frequency. (See Fig. 5)

#### ■ VCO

The operating frequency is generated by Q4 in transmit mode and Q3 in receive mode. The oscillator frequency is controlled by applying the VCO control voltage, obtained from the phase comparator, to the varactor diodes (D4 and D7 in transmit mode and D5 and D9 in receive mode). The RX pin is set high in receive mode causing Q5 turn on.

The TX pin is set high in transmit mode. The outputs from Q3 and Q4 are amplified by Q6 and sent to the RF amplifiers.

#### ■ Unlock Detector

If a pulse signal appears at the LD pin of IC1, an unlock condition occurs, and the DC voltage obtained from C4, R5 and D1 causes the voltage applied to the microprocessor to go low. When the microprocessor detects this condition, the transmitter is disabled, ignoring the push-to-talk switch input signal.

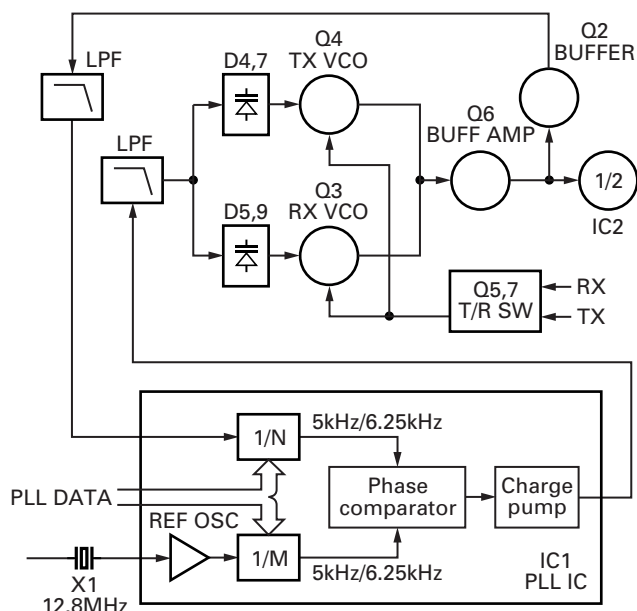

Fig. 5 PLL circuit

### 4. Transmitter System

#### ■ Microphone Amplifier

The signal from the microphone passes through the IC301. When encoding DTMF, it is turned OFF for muting the microphone input signal by IC301.

The signal passes through the Audio processor (IC301) for the maximum deviation adjustment, and goes to the VCO modulation input.

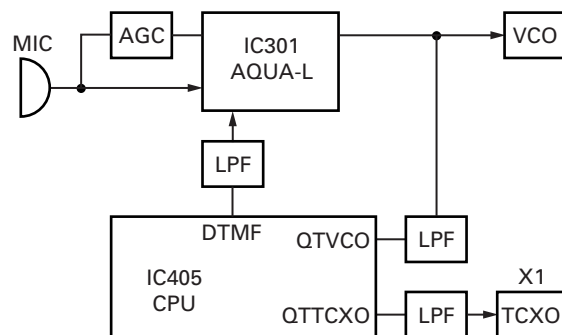

Fig. 6 Microphone amplifier

#### ■ Drive and Final Amplifier

The signal from the T/R switch (D101 is on) is amplified by the pre-drive (Q102) and the drive amplifier (Q103) to 50mW.

The output of the drive amplifier is amplified by the TX final amplifier (Q106) to 5.0W (1W when the power is low). The RF power amplifier consists of two MOS FET stages. The output of the RF power amplifier is then passed through the harmonic filter (LPF) and antenna switch (D103 and D104) and applied to the antenna terminal.

#### ■ APC Circuit

The APC circuit always monitors the current flowing through the TX final amplifier (Q106) and keeps a constant current. The voltage drop at R127, R128 and R129 is caused by the current flowing through the TX final amplifier and this voltage is applied to the differential amplifier IC101 (1/2).

IC101 (2/2) compares the output voltage of IC101 (1/2) with the reference voltage from IC405. The output of IC101 (2/2) controls the VG of the TX final and drive amplifier to make both voltages the same.

The change of power high/low is carried out by the change of the reference voltage.

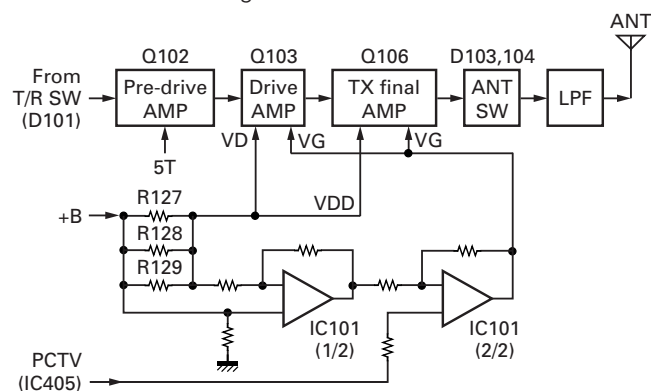

Fig. 7 Drive and Final amplifier and APC circuit



## CIRCUIT DESCRIPTION

### ■ Encode Signaling

#### • QT/DQT

QT, DQT data of the QTTCXO Line is output from pin 28 of the CPU. The signal passes through a low-pass CR filter and goes to the TCXO (X1).

The QT, DQT data of the QTVCO Line is output from pin 24 of the CPU. The signal passes through a low pass CR filter, mixes with the audio signal, and goes to the VCO modulation input. TX deviation is adjusted by the CPU.

### 5. Power Supply

There are four 5V power supplies for the microprocessor: 5M, 5C, 5R, and 5T.

5M for microprocessor is always output while the power is on. 5M is always output, but turns off when the power is turned off to prevent malfunction of the microprocessor.

5C is a common 5V and is output when SAVE is not set to OFF.

5R is 5V for reception and output during reception.

5T is 5V for transmission and output during transmission.

### 6. Control Circuit

The control circuit consists of a microprocessor (IC405) and its peripheral circuits. It controls the TX-RX unit. IC405 mainly performs the following:

- (1) Switching between transmission and reception by the PTT signal input.
- (2) Reading system, group, frequency, and program data from the memory circuit.
- (3) Sending frequency program data to the PLL.
- (4) Controlling squelch on/off by the DC voltage from the squelch circuit.
- (5) Controlling the audio mute circuit by the decode data input.
- (6) Transmitting tone and encode data.

### ■ Frequency Shift Circuit

The microprocessor (IC405) operates at a clock of 7.3728 MHz. This oscillator has a circuit that shifts the frequency by BEAT SHIFT SW (Q407, Q408).

A beat sound may be able to be evaded from generation if "Beat Shift" is set to ON when it is generated in the internal spurious transmission modulated sound of a transceiver.

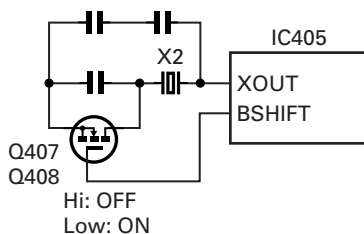

Fig. 8 Frequency shift circuit

### ■ Memory Circuit

Memory circuit consists of the CPU (IC405) and an EEPROM (IC406). An EEPROM has a capacity of 64k bits that contains the transceiver control program for the CPU and data such as transceiver channels and operating features.

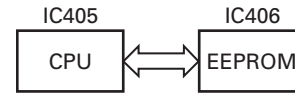

Fig. 9 Memory circuit

### ■ Low Battery Warning

The battery voltage is checked using by the microprocessor.

The transceiver generates a warning tone when it falls below the warning voltage shown in the table.

- (1) The red LED blinks when the battery voltage falls below the voltage (1) shown in the table during transmission.

#### Note:

The transceiver checks the battery voltage during reception even when, in the FPU, the Battery Warning status function is set to "On TX" (default setting).

However, the LED does not blink during reception. During transmission, the LED blinks to generate the warning tone of a low battery voltage.

- (2) The transceiver immediately stops transmission when the battery voltage falls below the voltage (2) shown in the table. A message tone beeps while the PTT switch is released.

	Ni-Cd Battery	Ni-MH Battery
(1)	6.2V	6.2V
(2)	5.9V	5.9V

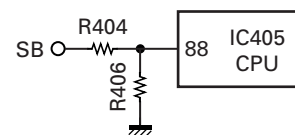

Fig. 10 Low battery warning

## CIRCUIT DESCRIPTION / TERMINAL FUNCTION

### 7. Control System

Keys and channel selector circuit.

The signal from the keys and channel selector are directly input to the microprocessor, as shown in Fig. 11.

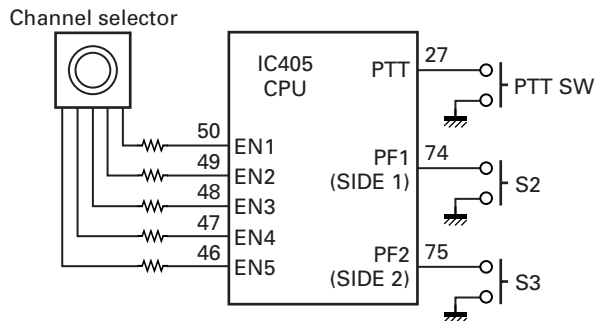

**Fig. 11 Control system**

### CN401

Pin No.	Name	I/O	Function
1	B	I	B (Battery Voltage)
2	SB	O	Switched B
3	SP1	I	Audio input
4	SP2	O	Audio output
5	GND	-	GND
6	EN1	I	Encoder pulse input
7	EN2	I	Encoder pulse input
8	GND	-	GND
9	EN3	I	Encoder pulse input
10	EN4	I	Encoder pulse input
11	EN5	I	Encoder pulse input

## SEMICONDUCTOR DATA

## Microprocessor: 30622MAA-B97GU (TX-RX unit IC405)

Pin No.	Name	I/O	Function
1	PCTV	O	APC/BPF control data output
2	DTMF	O	DTMF/ Beep output
3	NC	-	NC
4	EEPDAT	I/O	EEPROM data input/output
5	EEPCLK	O	EEPROM clock output
6	BYTE	-	GND
7	GND	-	GND
8	BSHIFT	O	Beat shift switch
9	NC	-	NC
10	RESET	I	CPU reset
11	XOUT	O	CPU clock (7.3728MHz)
12	VSS	-	GND
13	XIN	I	CPU clock (7.3728MHz)
14~15	VCC	-	+5V
16	INT	I	Battery voltage monitor input
17	TCLK/DTRDO	I	Base band IC data input
18	RDF/FD	I	Base band IC data input
19	SCLK	O	Base band IC clock output
20	D I/O	I/O	Base band IC data input/output
21	TDATA/DTRCLK	O	Base band IC data output
22	DIR	O	Base band IC data output
23	STD	I	Base band IC data input
24	QT VCO	O	QT/DQT output
25	DTRLOADN	O	Base band IC data output
26	1/2 OSC	O	3.6864MHz (7.3728MHz/2)
27	PTT	I	PTT switch input
28	QT TCXO	O	QT/DQT output
29	TXD	O	Serial data (FPU/FLASH)
30	RXD	I	Serial data (FPU/FLASH)
31	GND	-	GND
32	APCSW	O	APC switch
33,34	NC	-	NC
35	DCSW	O	APC voltage discharge switch
36	TX_W/N	O	TX Wide/Narrow switch
37	RX_SW	O	RX VCO switch
38	TX_SW	O	TX VCO switch
39	GND	-	GND
40	PLL_UL	I	PLL unlock detect input
41	PLL_STB	O	PLL strobe output

Pin No.	Name	I/O	Function
42	PLL_DAT	O	PLL data output
43	PLL_CLK	O	PLL clock output
44	VCC	-	+5V
45	RX_W/N	O	RX Wide/Narrow switch
46~50	EN5~EN1	I	Channel selector input
51	OPTDET	I	Headset input detect
52	AF_CONT	O	Speaker mute
53~59	NC	-	NC
60	VCC	-	+5V
61	NC	-	NC
62	VSS	-	GND
63,64	GND	-	GND
65~71	NC	-	NC
72	LEDTX	O	Red LED lights control output
73	LEDRX	O	Green LED lights control output
74	PF1	I	SIDE 1 key input
75	PF2	I	SIDE 2 key input
76	SIM1	-	GND
77	SIM2	-	GND
78,79	NC	-	NC
80	5T_C	O	5T control output
81	5R_C	O	5R control output
82	5C_C	O	5C control output
83~87	NC	-	NC
88	BATT	I	Battery voltage input
89	RSSI	I	Received Signal Strength Indicator input
90	BUSY	I	Busy level input
91	VOX	I	VOX level input
92	QT/DQT_IN	I	QT/DQT input
93	TH_DET	I	Thermistor input
94	AVSS	-	GND
95	NC	-	NC
96	VREF	-	+5V
97	AVCC	-	+5V
98	NC	-	NC
99	MIC_MUTE	O	MIC mute
100	NC	-	NC

## COMPONENTS DESCRIPTION

## TX-RX UNIT (X57-6872-71)

Ref. No.	Use / Function	Operation / Condition
IC1	IC	PLL system
IC2	IC	VCO 1/2 divider
IC101	IC	Comparator (APC)
IC201	IC	FM IF system
IC301	IC	Audio processor
IC302	IC	AF amplifier
IC401,402	IC	Voltage regulator/ 5V
IC403	IC	Voltage detector/ Reset
IC404	IC	Voltage detector/ INT
IC405	IC	Microprocessor
IC406	IC	EEPROM
IC407	IC	Frequency divider
Q1	Transistor	Tripler
Q2	Transistor	PLL IC f_in amplifier
Q3	FET	VCO/ RX
Q4	FET	VCO/ TX
Q5	Transistor	DC switch/ TX VCO
Q6	FET	RF Buffer amplifier
Q7	Transistor	DC switch/ RX VCO
Q8	FET	Ripple filter
Q9	Transistor	RF amplifier
Q102	Transistor	Pre-drive amplifier
Q103	FET	TX drive amplifier
Q104	Transistor	APC switch
Q105	FET	APC switch
Q106	FET	TX final amplifier
Q107	Transistor	APC switch
Q108	FET	APC switch
Q109	Transistor	APC switch
Q202	Transistor	W/N switch/ RX
Q203	Transistor	IF amplifier
Q204	FET	Mixer
Q205	FET	RF amplifier
Q301	Transistor	W/N switch/ TX
Q302	Transistor	MIC AGC

Ref. No.	Use / Function	Operation / Condition
Q303	Transistor	DC switch/ SP mute
Q304	Transistor	DC switch
Q305	Transistor	DC switch/ SP mute
Q306	FET	SP mute switch
Q316	FET	SP mute switch
Q401	Transistor	LED switch/ Red
Q402	Transistor	LED switch/ Green
Q403	FET	5T switch
Q404	FET	5R switch
Q405	Transistor	5C switch
Q407,408	FET	Beat shift switch
Q901	FET	W/N switch/ TX
D1	Diode	Ripple filter
D4	Variable capacitance diode	Frequency control/ TX VCO
D5	Variable capacitance diode	Frequency control/ RX VCO
D7	Variable capacitance diode	Frequency control/ TX VCO
D9	Variable capacitance diode	Frequency control/ RX VCO
D10	Variable capacitance diode	Modulator
D11	Diode	Current steering
D101	Diode	TX/RX RF switch
D102	Zener diode	APC protect
D103~106	Diode	ANT switch
D202	Diode	TX/RX RF switch
D203~206	Variable	RF BPF tuning
D301,302	Diode	Detector
D303	Diode	Isolation
D401	Diode	5V protection
D402	Diode	Reverse protection
D403	LED	LED/ Red
D404	LED	LED/ Green

## PARTS LIST

\* New Parts.  $\Delta$  indicates safety critical components.

Parts without **Parts No.** are not supplied.

Les articles non mentionnés dans le **Parts No.** ne sont pas fournis.

Teile ohne **Parts No.** werden nicht geliefert.

L : Scandinavia

Y : PX (Far East, Hawaii)

Y : AAFES (Europe)

K : USA

T : England

X : Australia

P : Canada

E : Europe

M : Other Areas

TK-2202 (Y50-5892-71)  
TX-RX UNIT (X57-6872-71)

Ref. No.	Address	New parts	Parts No.	Description	Destination
<b>TK-2202</b>					
1	1A	*	A02-3852-83	PLASTIC CABINET ASSY	
2	1A		A02-3858-43	PLASTIC CABINET	
3	3A	*	A10-4078-31	CHASSIS	
4	1B	*	A21-1645-23	DRESSING PANEL	
6	2C		B09-0680-03	CAP (SP/MIC) ACCESSORY	
7	2B		B11-1817-04	ILLUMINATION GUIDE	
8	1A		B43-1156-04	BADGE	
9	1D	*	B62-1893-00	INSTRUCTION MANUAL	
11	1A		D10-0649-03	LEVER	
12	1A		D21-0863-04	SHAFT	
13	1A		D32-0441-03	STOPPER	
15	2A		E04-0451-05	RF COAXIAL RECEPTACLE (SMA)	
16	3A		E23-1253-04	TERMINAL (BATT-)	
17	2B	*	E37-1175-05	SPEAKER WIRE (BROWN)	
18	2B	*	E37-1176-05	SPEAKER WIRE (GREEN)	
20	3A	*	F20-3353-14	INSULATING SHEET (BATT+)	
22	1A		G01-4542-04	COIL SPRING (LEVER)	
23	1A		G01-4543-04	COIL SPRING (STOPPER)	
24	2B	*	G10-1330-04	FIBROUS SHEET (IC302: AUDIO IC)	
25	3A		G11-4283-04	RUBBER SHEET (Q106: FINAL FET)	
26	2A	*	G11-4313-04	SHEET (MIC ELEMENT)	
28	3A		G13-2033-04	CUSHION (BATT-)	
29	3A	*	G13-2034-14	CUSHION (BATT-)	
30	3A		G13-2038-24	CUSHION (CHASSIS-CF201)	
31	2A		G13-2039-14	CUSHION (CF201)	
32	3B	*	G13-2045-04	CUSHION (CHASSIS)	
34	2B	*	G13-2088-04	CUSHION (CHASSIS-VOL/CH)	
35	3A		G53-1604-03	PACKING	
36	3A		G53-1605-03	PACKING (BATT+)	
37	2B		G53-1606-13	PACKING	
38	1B		G53-1607-03	PACKING	
39	3B		G53-1608-03	PACKING	
40	2A	*	G53-1609-14	PACKING	
41	2A		G53-1610-04	PACKING	
43	2D		H12-3179-05	PACKING FIXTURE	
44	1D		H25-0085-04	PROTECTION BAG (100/200/0.07)	
45	3D	*	H52-2127-02	ITEM CARTON CASE	
47	1D		J19-5472-03	HOLDER (SP/MIC) ACCESSORY	
48	2A		J19-5473-03	HOLDER ASSY	
49	2B		J21-8478-04	MOUNTING HARDWARE	
50	2B	*	J21-8525-03	MOUNTING HARDWARE	
51	2D		J29-0713-05	BELT CLIP ACCESSORY	
52	2B		J82-0092-05	FPC	
54	1A		K29-9307-13	BUTTON KNOB (SIDE1/SIDE2)	
55	1A		K29-9308-13	BUTTON KNOB (PTT)	
56	1B		K29-9309-03	KNOB (VOLUME)	
57	1B		K29-9318-03	KNOB (CH)	
A	2B		N14-0819-04	CIRCULAR NUT (VOLUME)	
B	2B		N14-0820-04	CIRCULAR NUT (CH)	
C	2A,2B		N30-2604-48	PAN HEAD MACHINE SCREW	
D	3A		N30-2606-48	PAN HEAD MACHINE SCREW	
<b>TX-RX UNIT (X57-6872-71)</b>					
E	2A,2B		N83-2005-48	PAN HEAD TAPTITE SCREW	
59	1D	*	N99-2046-05	SCREW SET ACCESSORY	
61	2B		R31-0653-05	VARIABLE RESISTOR	
63	2B	*	S60-0428-15	ROTARY SWITCH	
65	1B	*	T07-0369-15	SPEAKER	
D403			B30-2156-05	LED (RED)	
D404			B30-2157-05	LED (YELLOW)	
C1			CK73HB1H332K	CHIP C 3300PF	K
C2			CK73HB1C682K	CHIP C 6800PF	K
C3			CK73GB1A105K	CHIP C 1.0UF	K
C4			CK73HB1C103K	CHIP C 0.010UF	K
C5			CK73HB1H102K	CHIP C 1000PF	K
C6			CK73HB1A104K	CHIP C 0.10UF	K
C7,8			CC73HCH1H101J	CHIP C 100PF	J
C9			CC73HCH1H100D	CHIP C 10PF	D
C10			C92-0713-05	CHIP-TAN 10UF	6.3WV
C11			CC73HCH1H101J	CHIP C 100PF	J
C12			CK73HB1H102K	CHIP C 1000PF	K
C13			CK73HB1A104K	CHIP C 0.10UF	K
C14			CK73HB1C103K	CHIP C 0.010UF	K
C15			CC73HCH1H100D	CHIP C 10PF	D
C16			CK73HB1H102K	CHIP C 1000PF	K
C17			CC73HCH1H470J	CHIP C 47PF	J
C18			CC73HCH1H180J	CHIP C 18PF	J
C19			CK73HB1A104K	CHIP C 0.10UF	K
C21			C92-0713-05	CHIP-TAN 10UF	6.3WV
C22			CS77AA1VR33M	CHIP-TAN 0.33UF	35WV
C24			CK73HB1H102K	CHIP C 1000PF	K
C25			CC73HCH1H020B	CHIP C 2.0PF	B
C26			CC73HCH1H300J	CHIP C 30PF	J
C27			C92-0697-05	CHIP-TAN 3.3UF	16WV
C29,30			CK73HB1H471K	CHIP C 470PF	K
C32			C92-0001-05	CHIP-TAN 0.1UF	35WV
C33,34			CK73HB1H102K	CHIP C 1000PF	K
C35			CC73HCH1H270J	CHIP C 27PF	J
C38			CC73HCH1H060B	CHIP C 6.0PF	B
C39			CK73GB1H332K	CHIP C 3300PF	K
C40			CC73HCH1H040B	CHIP C 4.0PF	B
C41			CK73GB1H682K	CHIP C 6800PF	K
C42			CC73HCH1H060B	CHIP C 6.0PF	B
C43			CC73HCH1H150J	CHIP C 15PF	J
C44			CK73HB1H471K	CHIP C 470PF	K
C45			CK73GB1A105K	CHIP C 1.0UF	K
C47			CC73HCH1H101J	CHIP C 100PF	J
C48			CK73HB1H471K	CHIP C 470PF	K
C49			CC73HCH1H101J	CHIP C 100PF	J
C50			CC73HCH1H100D	CHIP C 10PF	D

## PARTS LIST

### TX-RX UNIT (X57-6872-71)

Ref. No.	Address	New parts	Parts No.	Description	Destination	Ref. No.	Address	New parts	Parts No.	Description	Destination
C51			CK73HB1H102K	CHIP C 1000PF K		C146			CK73GB1H102K	CHIP C 1000PF K	
C52			CC73HCH1H181J	CHIP C 180PF J		C147			CK73HB1H102K	CHIP C 1000PF K	
C53			CC73HCH1H0R5B	CHIP C 0.5PF B		C148			CK73GB1H102K	CHIP C 1000PF K	
C54			CC73HCH1H040B	CHIP C 4.0PF B		C149			CC73GCH1H220G	CHIP C 22PF G	
C55			CC73HCH1H121J	CHIP C 120PF J		C150			CC73GCH1H560J	CHIP C 56PF J	
C57			CC73HCH1H1R5B	CHIP C 1.5PF B		C151			CK73GB1H102K	CHIP C 1000PF K	
C58			CC73HCH1H060B	CHIP C 6.0PF B		C153			CC73GCH1H100C	CHIP C 10PF C	
C59			CC73HCH1H1R5B	CHIP C 1.5PF B		C154			CC73GCH1H120J	CHIP C 12PF J	
C60			CC73HCH1H010B	CHIP C 1.0PF B		C155			CC73GCH1H160J	CHIP C 16PF J	
C61			CC73HCH1H040B	CHIP C 4.0PF B		C156			CC73GCH1H130J	CHIP C 13PF J	
C62			CC73HCH1H050B	CHIP C 5.0PF B		C157			CC73GCH1H150J	CHIP C 15PF J	
C63			CC73HCH1H101J	CHIP C 100PF J		C158			CC73GCH1H220J	CHIP C 22PF J	
C64			CC73HCH1H040B	CHIP C 4.0PF B		C159			CC73GCH1H050B	CHIP C 5.0PF B	
C65-67			CC73HCH1H050B	CHIP C 5.0PF B		C160			CC73GCH1H330J	CHIP C 33PF J	
C68-70			CK73HB1H471K	CHIP C 470PF K		C201			CK73GB1A224K	CHIP C 0.22UF K	
C71,72			CK73HB1A104K	CHIP C 0.10UF K		C206			CK73HB1H102K	CHIP C 1000PF K	
C73,74			CC73HCH1H0R5B	CHIP C 0.5PF B		C207			CK73HB1H182K	CHIP C 1800PF K	
C75,76			CK73HB1H102K	CHIP C 1000PF K		C208			CK73HB1H471K	CHIP C 470PF K	
C77			CK73HB1H471K	CHIP C 470PF K		C209			C92-0713-05	CHIP-TAN 10UF 6.3WV	
C78			CC73HCH1H330J	CHIP C 33PF J		C210			CK73HB1H471K	CHIP C 470PF K	
C79			C92-0713-05	CHIP-TAN 10UF 6.3WV		C211			CK73HB1C103K	CHIP C 0.010UF K	
C80			CK73HB1H471K	CHIP C 470PF K		C213			CK73HB1A104K	CHIP C 0.10UF K	
C81			CC73HCH1H150J	CHIP C 15PF J		C214			CC73HCH1H680J	CHIP C 68PF J	
C82-86			CK73HB1H102K	CHIP C 1000PF K		C215			CK73HB1H102K	CHIP C 1000PF K	
C87			CC73HCH1H100D	CHIP C 10PF D		C216			CK73GB1C104K	CHIP C 0.10UF K	
C90			CK73HB1H102K	CHIP C 1000PF K		C217			CK73HB1A104K	CHIP C 0.10UF K	
C101			CK73HB1H102K	CHIP C 1000PF K		C218			CK73GB1C104K	CHIP C 0.10UF K	
C104			CC73GCH1H390J	CHIP C 39PF J		C219			CC73HCH1H330J	CHIP C 33PF J	
C105			CK73HB1H102K	CHIP C 1000PF K		C220			CK73HB1H102K	CHIP C 1000PF K	
C107			CK73HB1H102K	CHIP C 1000PF K		C221			CK73GB1C104K	CHIP C 0.10UF K	
C108			CC73GCH1H390J	CHIP C 39PF J		C222			CK73HB1H102K	CHIP C 1000PF K	
C109			CK73GB1C104K	CHIP C 0.10UF K		C224,225			CK73HB1C103K	CHIP C 0.010UF K	
C110,111			CK73HB1H102K	CHIP C 1000PF K		C227			CK73HB1H102K	CHIP C 1000PF K	
C115			CK73HB1H102K	CHIP C 1000PF K		C228			CC73GCH1H100C	CHIP C 10PF C	
C116			CC73GCH1H220J	CHIP C 22PF J		C230			CC73HCH1H080B	CHIP C 8.0PF B	
C117			CC73GCH1H100D	CHIP C 10PF D		C231,232			CK73GB1H103K	CHIP C 0.010UF K	
C118			CC73GCH1H101J	CHIP C 100PF J		C233			CC73HCH1H020B	CHIP C 2.0PF B	
C119			CC73GCH1H270J	CHIP C 27PF J		C234			CK73HB1C103K	CHIP C 0.010UF K	
C120			CK73GB1H102K	CHIP C 1000PF K		C235			CC73HCH1H090B	CHIP C 9.0PF B	
C121			CC73GCH1H100D	CHIP C 10PF D		C236			CK73GB1H102K	CHIP C 1000PF K	
C123			CK73GB1A105K	CHIP C 1.0UF K		C237			CC73HCH1H050B	CHIP C 5.0PF B	
C124,125			CK73HB1H102K	CHIP C 1000PF K		C238			CC73GCH1H120J	CHIP C 12PF J	
C126		*	CS77AA1A6R8M	CHIP-TAN 6.8UF 10WV		C239			CC73HCH1H060B	CHIP C 6.0PF B	
C128			CK73HB1H102K	CHIP C 1000PF K		C241			CK73HB1H102K	CHIP C 1000PF K	
C130			CC73GCH1H100D	CHIP C 10PF D		C242			CK73GB1C104K	CHIP C 0.10UF K	
C131			CC73GCH1H100D	CHIP C 10PF D		C243			CK73HB1H102K	CHIP C 1000PF K	
C132			CK73HB1H102K	CHIP C 1000PF K		C244			CC73HCH1H040B	CHIP C 4.0PF B	
C133			CK73GB1H103K	CHIP C 0.010UF K		C245			CK73HB1H471K	CHIP C 470PF K	
C134			CK73GB1C104K	CHIP C 0.10UF K		C247			CC73GCH1H2R5B	CHIP C 2.5PF B	
C135			CK73GB1A105K	CHIP C 1.0UF K		C248			CC73GCH1H270J	CHIP C 27PF J	
C136			CC73GCH1H390J	CHIP C 39PF J		C249			CK73HB1H102K	CHIP C 1000PF K	
C137			CK73GB1H103K	CHIP C 0.010UF K		C250			CC73GCH1H040B	CHIP C 4.0PF B	
C138			CK73GB1H102K	CHIP C 1000PF K		C251			C92-0714-05	CHIP-TAN 4.7UF 6.3WV	
C139			CC73GCH1H560J	CHIP C 56PF J		C252			CK73HB1H102K	CHIP C 1000PF K	
C140			CC73GCH1H101J	CHIP C 100PF J		C253			CC73GCH1H060B	CHIP C 6.0PF B	
C141			CC73GCH1H120J	CHIP C 12PF J		C254			CC73GCH1H270J	CHIP C 27PF J	
C142			CC73GCH1H130J	CHIP C 13PF J		C255			CC73GCH1H050B	CHIP C 5.0PF B	
C143			CC73GCH1H100D	CHIP C 10PF D		C256			CK73HB1H102K	CHIP C 1000PF K	
C144			CC73GCH1H820J	CHIP C 82PF J		C258			CK73HB1H102K	CHIP C 1000PF K	
C145			CC73GCH1H030B	CHIP C 3.0PF B		C260			CK73HB1H102K	CHIP C 1000PF K	

## PARTS LIST

TX-RX UNIT (X57-6872-71)

Ref. No.	Address	New parts	Parts No.	Description	Desti-nation	Ref. No.	Address	New parts	Parts No.	Description	Desti-nation
C262			CK73HB1H102K	CHIP C 1000PF K		C415			CK73HB1H471K	CHIP C 470PF K	
C263			CC73GCH1H100C	CHIP C 10PF C		C417			CK73GB1A105K	CHIP C 1.0UF K	
C264			CC73GCH1H030B	CHIP C 3.0PF B		C418			CK73HB1E562K	CHIP C 5600PF K	
C265			CC73GCH1H330J	CHIP C 33PF J		C419			CK73HB1H102K	CHIP C 1000PF K	
C266			CK73HB1H102K	CHIP C 1000PF K		C421			CK73GB1A105K	CHIP C 1.0UF K	
C267,268			CC73GCH1H030B	CHIP C 3.0PF B		C426,427			CK73GB1A105K	CHIP C 1.0UF K	
C269			CC73GCH1H330J	CHIP C 33PF J		C428,429			CK73HB1H102K	CHIP C 1000PF K	
C270			CC73GCH1H040B	CHIP C 4.0PF B		C430			CK73GB1H103K	CHIP C 0.010UF K	
C271			CC73GCH1H050B	CHIP C 5.0PF B		C431			CK73HB1C103K	CHIP C 0.010UF K	
C272			CC73GCH1H040B	CHIP C 4.0PF B		C432			CC73HCH1H050B	CHIP C 5.0PF B	
C280			CK73HB1H102K	CHIP C 1000PF K		C433,434			CC73HCH1H030B	CHIP C 3.0PF B	
C302			CK73HB1C103K	CHIP C 0.010UF K		C435			CC73HCH1H050B	CHIP C 5.0PF B	
C304			CK73GB1A224K	CHIP C 0.22UF K		C440			CC73GCH1H1R5B	CHIP C 1.5PF B	
C306			C92-0714-05	CHIP-TAN 4.7UF 6.3WV		C443			CK73GB1A474K	CHIP C 0.47UF K	
C307,308			CK73HB1A104K	CHIP C 0.10UF K		C450,451			CK73HB1C103K	CHIP C 0.010UF K	
C309			CC73GCH1H820J	CHIP C 82PF J		C452			CK73HB1H102K	CHIP C 1000PF K	
C310			CK73HB1A683K	CHIP C 0.068UF K		C901,902			CK73GB1A105K	CHIP C 1.0UF K	
C311			CK73GB1A105K	CHIP C 1.0UF K		TC1,2			C05-0384-05	CERAMIC TRIMMER CAP (10PF)	
C312			CC73GCH1H120J	CHIP C 12PF J		CN201			E23-1278-05	TERMINAL	
C313			CC73GCH1H121J	CHIP C 120PF J		CN401			E40-6362-05	FLAT CABLE CONNECTOR	
C314			CK73HB1A104K	CHIP C 0.10UF K		J301			E11-0457-05	PHONE JACK (2.5/3.5)	
C315			CK73GB1A105K	CHIP C 1.0UF K		F401			F53-0324-05	FUSE	
C316			CK73GB1C104K	CHIP C 0.10UF K		101	2A		J30-1282-14	SPACER	
C317			CK73HB1A104K	CHIP C 0.10UF K		CD201			L79-1582-05	TUNING COIL	
C318			C92-0714-05	CHIP-TAN 4.7UF 6.3WV		CF201	2A	*	L72-1025-05	CERAMIC FILTER	
C319			CC73GCH1H271J	CHIP C 270PF J		L1			L40-4791-37	SMALL FIXED INDUCTOR (4.700UH)	
C320			CK73HB1E562K	CHIP C 5600PF K		L3			L40-5681-86	SMALL FIXED INDUCTOR (0.56UH)	
C321			CK73GB1A105K	CHIP C 1.0UF K		L5			L40-5681-86	SMALL FIXED INDUCTOR (0.56UH)	
C322			CK73HB1C153K	CHIP C 0.015UF K		L6,7			L92-0138-05	CHIP FERRITE	
C323			CC73GCH1H820J	CHIP C 82PF J		L8			L40-1875-92	SMALL FIXED INDUCTOR (18NH)	
C324			CC73HCH1H820J	CHIP C 82PF J		L9			L40-3375-92	SMALL FIXED INDUCTOR (33NH)	
C325			CK73HB1A104K	CHIP C 0.10UF K		L10			L40-1885-92	SMALL FIXED INDUCTOR (180NH)	
C326			CK73HB1H102K	CHIP C 1000PF K		L11			L40-1085-92	SMALL FIXED INDUCTOR (100NH)	
C327			CC73HCH1H101J	CHIP C 100PF J		L12			L92-0138-05	CHIP FERRITE	
C328			CK73HB1H391K	CHIP C 390PF K		L13,14			L40-2285-92	SMALL FIXED INDUCTOR (220NH)	
C329,330			CK73GB1A105K	CHIP C 1.0UF K		L16			L40-3978-67	SMALL FIXED INDUCTOR (39NH)	
C331			CK73HB1A104K	CHIP C 0.10UF K		L17			L40-2778-67	SMALL FIXED INDUCTOR (27NH)	
C332			CK73HB1H471K	CHIP C 470PF K		L18,19			L41-2285-03	SMALL FIXED INDUCTOR (220NH)	
C333,334			CK73GB1C104K	CHIP C 0.10UF K		L20,21			L40-3391-86	SMALL FIXED INDUCTOR (3.3UH)	
C335			CC73GCH1H221J	CHIP C 220PF J		L22			L92-0138-05	CHIP FERRITE	
C336			CK73FB1C474K	CHIP C 0.47UF K		L23			L40-3975-92	SMALL FIXED INDUCTOR (39NH)	
C338			CC73GCH1H101J	CHIP C 100PF J		L24		*	L92-0470-05	CHIP FERRITE	
C339		*	CS77AA0J100M	CHIP-TAN 10UF 6.3WV		L25			L40-8275-92	SMALL FIXED INDUCTOR (82NH)	
C340			CK73GB1C104K	CHIP C 0.10UF K		L50			L92-0138-05	CHIP FERRITE	
C341			CK73GB1C473K	CHIP C 0.047UF K		L102			L40-1085-92	SMALL FIXED INDUCTOR (100NH)	
C342		*	CS77AA0J100M	CHIP-TAN 10UF 6.3WV		L103			L92-0138-05	CHIP FERRITE	
C343			CK73GB1C473K	CHIP C 0.047UF K		L104			L40-2775-92	SMALL FIXED INDUCTOR (27NH)	
C344			CC73GCH1H221J	CHIP C 220PF J		L105			L41-1585-43	SMALL FIXED INDUCTOR (150NH)	
C345			C92-0665-05	TANTAL 100UF 6.3WV		L106			L92-0149-05	CHIP FERRITE	
C346			CK73GB1H102K	CHIP C 1000PF K		L107		*	L41-2775-43	SMALL FIXED INDUCTOR (27NH)	
C348			CK73HB1H471K	CHIP C 470PF K		L108			L92-0149-05	CHIP FERRITE	
C351,352			CK73HB1C103K	CHIP C 0.010UF K		L109			L41-2295-39	SMALL FIXED INDUCTOR (2.2UH)	
C354			CK73HB1A104K	CHIP C 0.10UF K		L110			L40-5675-92	SMALL FIXED INDUCTOR (56NH)	
C401			CC73GCH1H471J	CHIP C 470PF J		L111			L41-1092-44	SMALL FIXED INDUCTOR (1UH)	
C402			CK73HB1H102K	CHIP C 1000PF K		L112			L34-4577-05	AIR-CORE COIL	
C403			CK73GB1C104K	CHIP C 0.10UF K		L113			L34-4563-05	AIR-CORE COIL	
C405			CC73GCH1H101J	CHIP C 100PF J		L114,115			L34-4573-05	AIR-CORE COIL	
C407			CK73HB1H102K	CHIP C 1000PF K		L116			L34-4576-05	AIR-CORE COIL	
C409,410			CK73GB1A105K	CHIP C 1.0UF K							
C411			CK73HB1H102K	CHIP C 1000PF K							

If a part reference number is listed in a shaded box, that part does not come with the PCB.

## PARTS LIST

## TX-RX UNIT (X57-6872-71)

Ref. No.	Address	New parts	Parts No.	Description	Destination	Ref. No.	Address	New parts	Parts No.	Description	Destination
L117			L34-4575-05	AIR-CORE COIL		R43			RK73HB1J101J	CHIP R 100 J 1/16W	
L118			L34-4567-05	AIR-CORE COIL		R44			RK73HB1J102J	CHIP R 1.0K J 1/16W	
L119			L34-4566-05	AIR-CORE COIL		R45,46			RK73HB1J332J	CHIP R 3.3K J 1/16W	
L201			L40-1091-37	SMALL FIXED INDUCTOR (1.000UH)		R47			RK73HB1J470J	CHIP R 47 J 1/16W	
L202			L40-3975-92	SMALL FIXED INDUCTOR (39NH)		R48			RK73HB1J331J	CHIP R 330 J 1/16W	
L203			L92-0138-05	CHIP FERRITE		R49			RK73HB1J222J	CHIP R 2.2K J 1/16W	
L204			L41-5685-39	SMALL FIXED INDUCTOR (0.56UH)		R50			RK73HB1J472J	CHIP R 4.7K J 1/16W	
L205			L40-6875-92	SMALL FIXED INDUCTOR (68NH)		R51			RK73HB1J100J	CHIP R 10 J 1/16W	
L206			L40-1885-92	SMALL FIXED INDUCTOR (180NH)		R101			RK73HB1J123J	CHIP R 12K J 1/16W	
L207			L40-1585-92	SMALL FIXED INDUCTOR (150NH)		R103			RK73GB2A000JX	CHIP R 0.0 J 1/10W	
L209			L41-5678-14	SMALL FIXED INDUCTOR (56NH)		R107			RK73GB2A561J	CHIP R 560 J 1/10W	
L210			L92-0138-05	CHIP FERRITE		R108			RK73GB2A152J	CHIP R 1.5K J 1/10W	
L211			L41-5678-14	SMALL FIXED INDUCTOR (56NH)		R109			RK73GB2A150J	CHIP R 15 J 1/10W	
L213			L41-5678-14	SMALL FIXED INDUCTOR (56NH)		R110,111			RK73GB2A331J	CHIP R 330 J 1/10W	
L214			L41-4778-14	SMALL FIXED INDUCTOR (47NH)		R112			RK73GB2A180J	CHIP R 18 J 1/10W	
L301			L92-0140-05	CHIP FERRITE		R113			RK73GB2A331J	CHIP R 330 J 1/10W	
L302			L92-0149-05	CHIP FERRITE		R114			RK73GB2A472J	CHIP R 4.7K J 1/10W	
L401			L92-0149-05	CHIP FERRITE		R115			RK73GB2A103J	CHIP R 10K J 1/10W	
L402-404			L92-0138-05	CHIP FERRITE		R116			RK73GB2A150J	CHIP R 15 J 1/10W	
X1			L77-1931-05	TCXO (12.8MHZ)		R117			RK73GB2A822J	CHIP R 8.2K J 1/10W	
X3			L77-1633-05	CRYSTAL RESONATOR (7.3728MHZ)		R119			RK73GB2A331J	CHIP R 330 J 1/10W	
XF201		*	L71-0637-05	MCF		R120			RK73GB2A000JX	CHIP R 0.0 J 1/10W	
CP404			RK75HA1J473J	CHIP-COM 47K J 1/16W		R121			RK73GB2A561J	CHIP R 560 J 1/10W	
CP405			RK75HA1J102J	CHIP-COM 1.0K J 1/16W		R122			RK73GB2A474J	CHIP R 470K J 1/10W	
R1			RK73HB1J223J	CHIP R 22K J 1/16W		R123			RK73GB2A820J	CHIP R 82 J 1/10W	
R2			RK73HB1J103J	CHIP R 10K J 1/16W		R124			RK73GB2A124J	CHIP R 120K J 1/10W	
R3			RK73HB1J333J	CHIP R 33K J 1/16W		R126			RK73GB2A222J	CHIP R 2.2K J 1/10W	
R4			RK73HB1J563J	CHIP R 56K J 1/16W		R127-129			RK73EB2ER39K	CHIP R 0.39 K 1/4W	
R5			RK73HB1J104J	CHIP R 100K J 1/16W		R130-135			RK73GH2A154D	CHIP R 150K D 1/10W	
R6			RK73HB1J823J	CHIP R 82K J 1/16W		R136,137			RK73GB2A271J	CHIP R 270 J 1/10W	
R7			RK73HB1J101J	CHIP R 100 J 1/16W		R138			RK73GB2A105J	CHIP R 1.0M J 1/10W	
R8-11			RK73HB1J000JX	CHIP R 0.0 J 1/16W		R139			RK73GB2A473J	CHIP R 47K J 1/10W	
R12			RK73HB1J222J	CHIP R 2.2K J 1/16W		R140			RK73GB2A563J	CHIP R 56K J 1/10W	
R13			RK73GB2A000JX	CHIP R 0.0 J 1/10W		R141			RK73GB2A104J	CHIP R 100K J 1/10W	
R14			RK73HB1J334J	CHIP R 330K J 1/16W		R142			RK73GB2A000JX	CHIP R 0.0 J 1/10W	
R15			RK73GB2A221J	CHIP R 220 J 1/10W		R143			RK73GB2A104J	CHIP R 100K J 1/10W	
R16			RK73GB2A561J	CHIP R 560 J 1/10W		R203			RK73HB1J184J	CHIP R 180K J 1/16W	
R17			RK73HB1J101J	CHIP R 100 J 1/16W		R206			RK73GB2A100J	CHIP R 10 J 1/10W	
R18			RK73GB2A000JX	CHIP R 0.0 J 1/10W		R207			RK73HB1J472J	CHIP R 4.7K J 1/16W	
R19			RK73GB2A152J	CHIP R 1.5K J 1/10W		R208			RK73HB1J823J	CHIP R 82K J 1/16W	
R20			RK73HB1J100J	CHIP R 10 J 1/16W		R209			RK73HB1J272J	CHIP R 2.7K J 1/16W	
R21			RK73GB2A681J	CHIP R 680 J 1/10W		R210,211			RK73HB1J332J	CHIP R 3.3K J 1/16W	
R22			RK73GB2A000JX	CHIP R 0.0 J 1/10W		R212			RK73HB1J823J	CHIP R 82K J 1/16W	
R23			RK73GB2A103J	CHIP R 10K J 1/10W		R213			RK73HB1J392J	CHIP R 3.9K J 1/16W	
R25			RK73HB1J223J	CHIP R 22K J 1/16W		R215			RK73HB1J101J	CHIP R 100 J 1/16W	
R26			RK73HB1J103J	CHIP R 10K J 1/16W		R216			RK73HB1J124J	CHIP R 120K J 1/16W	
R27			RK73HB1J220J	CHIP R 22 J 1/16W		R217			RK73HB1J472J	CHIP R 4.7K J 1/16W	
R30			RK73HB1J123J	CHIP R 12K J 1/16W		R218			RK73HB1J271J	CHIP R 270 J 1/16W	
R31			RK73HB1J564J	CHIP R 560K J 1/16W		R219,220			RK73GB2A471J	CHIP R 470 J 1/10W	
R32			RK73HB1J102J	CHIP R 1.0K J 1/16W		R221			RK73GB2A102J	CHIP R 1.0K J 1/10W	
R33			RK73HB1J154J	CHIP R 150K J 1/16W		R222			RK73GB2A151J	CHIP R 150 J 1/10W	
R34			RK73HB1J472J	CHIP R 4.7K J 1/16W		R223-226			RK73HB1J823J	CHIP R 82K J 1/16W	
R35,36			RK73HB1J274J	CHIP R 270K J 1/16W		R227			RK73GB2A000JX	CHIP R 0.0 J 1/10W	
R37			RK73HB1J101J	CHIP R 100 J 1/16W		R228,229			RK73HB1J105J	CHIP R 1.0M J 1/16W	
R38			RK73HB1J181J	CHIP R 180 J 1/16W		R230			RK73GB2A821J	CHIP R 820 J 1/10W	
R39			RK73HB1J151J	CHIP R 150 J 1/16W		R231			RK73GB2A470J	CHIP R 47 J 1/10W	
R40			RK73HB1J101J	CHIP R 100 J 1/16W		R233			RK73GB2A181J	CHIP R 180 J 1/10W	
R41			RK73HB1J154J	CHIP R 150K J 1/16W		R234			RK73GB2A104J	CHIP R 100K J 1/10W	
R42			RK73HB1J472J	CHIP R 4.7K J 1/16W		R237			RK73GB2A184J	CHIP R 180K J 1/10W	
						R238			RK73GB2A124J	CHIP R 120K J 1/10W	



## PARTS LIST

TX-RX UNIT (X57-6872-71)

Ref. No.	Address	New parts	Parts No.	Description	Desti-nation	Ref. No.	Address	New parts	Parts No.	Description	Desti-nation
R239			RK73GB2A101J	CHIP R 100 J 1/10W		R415,416			RK73GB2A473J	CHIP R 47K J 1/10W	
R240			RK73GB2A000JX	CHIP R 0.0 J 1/10W		R417-420			RK73HB1J473J	CHIP R 47K J 1/16W	
R241,242			RK73HB1J105J	CHIP R 1.0M J 1/16W		R421,422			RK73HB1J102J	CHIP R 1.0K J 1/16W	
R243			RK73FB2B000JX	CHIP R 0.0 J 1/8W		R423			RK73HB1J000JX	CHIP R 0.0 J 1/16W	
R245			RK73GB2A000JX	CHIP R 0.0 J 1/10W		R424,425			RK73HB1J473J	CHIP R 47K J 1/16W	
R291			RK73GB2A000JX	CHIP R 0.0 J 1/10W		R429,430			RK73HB1J000JX	CHIP R 0.0 J 1/16W	
R301			RK73HB1J473J	CHIP R 47K J 1/16W		R435			RK73HB1J473J	CHIP R 47K J 1/16W	
R304			RK73HB1J564J	CHIP R 560K J 1/16W		R436			RK73GB2A000JX	CHIP R 0.0 J 1/10W	
R305			RK73HB1J104J	CHIP R 100K J 1/16W		R437,438			RK73HB1J473J	CHIP R 47K J 1/16W	
R306			RK73HB1J102J	CHIP R 1.0K J 1/16W		R445,446			RK73GB2A000JX	CHIP R 0.0 J 1/10W	
R307,308			RK73HB1J000JX	CHIP R 0.0 J 1/16W		R447			RK73HB1J472J	CHIP R 4.7K J 1/16W	
R310			RK73GB2A394J	CHIP R 390K J 1/10W		R450			RK73HB1J680J	CHIP R 68 J 1/16W	
R311			RK73HB1J123J	CHIP R 12K J 1/16W		R901,902			RK73GB2A472J	CHIP R 4.7K J 1/10W	
R312			RK73GB2A334J	CHIP R 330K J 1/10W		VR1			R12-7491-05	TRIMMING POT. (68K/8)	
R313			RK73GB2A104J	CHIP R 100K J 1/10W		S1-3			S70-0414-05	TACT SWITCH	
R314			RK73GB2A103J	CHIP R 10K J 1/10W		MIC301	2A	*	T91-0649-15	MIC ELEMENT	
R315			RK73GB2A334J	CHIP R 330K J 1/10W		D1			MA2S111-F	DIODE	
R316			RK73GB2A124J	CHIP R 120K J 1/10W		D4,5			1SV325F	VARIABLE CAPACITANCE DIODE	
R317			RK73GB2A474J	CHIP R 470K J 1/10W		D7			1SV325F	VARIABLE CAPACITANCE DIODE	
R318			RK73GB2A122J	CHIP R 1.2K J 1/10W		D9			1SV325F	VARIABLE CAPACITANCE DIODE	
R319			RK73HB1J563J	CHIP R 56K J 1/16W		D10			1SV278F	VARIABLE CAPACITANCE DIODE	
R320			RK73HB1J332J	CHIP R 3.3K J 1/16W		D11			MA2S111-F	DIODE	
R321			RK73HB1J224J	CHIP R 220K J 1/16W		D101			HSC277	DIODE	
R322			RK73HB1J184J	CHIP R 180K J 1/16W		D102			HZU5CLL	ZENER DIODE	
R323			RK73HB1J563J	CHIP R 56K J 1/16W		D103-106			HVC131	DIODE	
R324,325			RK73GB2A104J	CHIP R 100K J 1/10W		D202			HSC277	DIODE	
R326			RK73GB2A000JX	CHIP R 0.0 J 1/10W		D203-206		*	1SV305F	VARIABLE CAPACITANCE DIODE	
R327			RK73GB2A184J	CHIP R 180K J 1/10W		D301,302			RB706F-40	DIODE	
R328			RK73GB2A103J	CHIP R 10K J 1/10W		D303			DAN222	DIODE	
R329			RK73GB2A823J	CHIP R 82K J 1/10W		D401			RB521S-30	DIODE	
R330			RK73HB1J332J	CHIP R 3.3K J 1/16W		D402			1SR154-400	DIODE	
R331			RK73GB2A393J	CHIP R 39K J 1/10W		IC1			MB15A02PFV2E1	MOS-IC	
R332			RK73GB2A153J	CHIP R 15K J 1/10W		IC2			UPB1509GV	BI-POLAR IC	
R334			RK73GB2A473J	CHIP R 47K J 1/10W		IC101			TA75W01FUF	MOS-IC	
R335			RK73GB2A222J	CHIP R 2.2K J 1/10W		IC201			TA31136FNG	MOS-IC	
R336			RK73GB2A102J	CHIP R 1.0K J 1/10W		IC301			AQUA-L	MOS-IC	
R337			RK73GB2A101J	CHIP R 100 J 1/10W		IC302			TA7368F	MOS-IC	
R338			RK73GB2A222J	CHIP R 2.2K J 1/10W		IC401,402			XC6204B502MR	MOS-IC	
R339			RK73GB2A471J	CHIP R 470 J 1/10W		IC403			BD4840FVE	MOS-IC	
R340			RK73GB2A182J	CHIP R 1.8K J 1/10W		IC404			BD4845FVE	MOS-IC	
R341			RK73GB2A103J	CHIP R 10K J 1/10W		IC405		*	30622MAA-B97GU	MICROCONTROLLER IC	
R342			RK73GB2A100J	CHIP R 10 J 1/10W		IC406			BR24L08F-W	ROM IC	
R343			RK73GB2A474J	CHIP R 470K J 1/10W		IC407		*	TC7W74FU-F	MOS-IC	
R344			RK73GB2A102J	CHIP R 1.0K J 1/10W		Q1			KTC4082	TRANSISTOR	
R345,346			RK73GB2A101J	CHIP R 100 J 1/10W		Q2			2SC5108(Y)F	TRANSISTOR	
R347			RK73GB2A104J	CHIP R 100K J 1/10W		Q3,4			2SK508NV(K52)	FET	
R348			RK73GB2A563J	CHIP R 56K J 1/10W		Q5			DTA143TE	DIGITAL TRANSISTOR	
R349			RK73GB2A333J	CHIP R 33K J 1/10W		Q6			2SC5108(Y)F	TRANSISTOR	
R350			RK73HB1J000JX	CHIP R 0.0 J 1/16W		Q7			DTA143TE	DIGITAL TRANSISTOR	
R354,355			RK73HB1J103J	CHIP R 10K J 1/16W		Q8			2SC4617(S)	TRANSISTOR	
R357			RK73HB1J000JX	CHIP R 0.0 J 1/16W		Q9			2SC5108(Y)F	TRANSISTOR	
R360			RK73HB1J000JX	CHIP R 0.0 J 1/16W		Q102			2SC4926YD	TRANSISTOR	
R365			RK73HB1J473J	CHIP R 47K J 1/16W		Q103			2SK2596	FET	
R403			RK73GB2A101J	CHIP R 100 J 1/10W		Q104			DTC114EE	DIGITAL TRANSISTOR	
R404			RK73HH1J474D	CHIP R 470K D 1/16W		Q105		*	2SK879(Y)F	FET	
R405			RK73GB2A334J	CHIP R 330K J 1/10W		Q106			2SK2595-E	FET	
R406			RK73HH1J474D	CHIP R 470K D 1/16W		Q107			DTC114EE	DIGITAL TRANSISTOR	
R407			RK73HB1J334J	CHIP R 330K J 1/16W		Q108			2SK1824	FET	
R408-412			RK73HB1J473J	CHIP R 47K J 1/16W							
R413,414			RK73GB2A331J	CHIP R 330 J 1/10W							

# TK-2202

## PARTS LIST

### TX-RX UNIT (X57-6872-71)

Ref. No.	Address	New parts	Parts No.	Description	Destination	Ref. No.	Address	New parts	Parts No.	Description	Destination
Q109			DTA144EE	DIGITAL TRANSISTOR							
Q202			DTA144EE	DIGITAL TRANSISTOR							
Q203			2SC4649(N,P)	TRANSISTOR							
Q204			3SK318	FET							
Q205			3SK294(F)	FET							
Q301			DTA114EE	DIGITAL TRANSISTOR							
Q302			2SC4919	TRANSISTOR							
Q303			DTC144EE	DIGITAL TRANSISTOR							
Q304			2SA1362(GR)	TRANSISTOR							
Q305			DTC144EE	DIGITAL TRANSISTOR							
Q306		*	2SK3577-A	FET							
Q316		*	2SK3577-A	FET							
Q401,402			DTC114EE	DIGITAL TRANSISTOR							
Q403,404			CPH3317	FET							
Q405			DTA123JE	DIGITAL TRANSISTOR							
Q407,408			2SK1830F	FET							
Q901			2SK1824	FET							
TH101			157-104-65001	THERMISTOR							
TH203			157-104-65001	THERMISTOR							

## EXPLODED VIEW

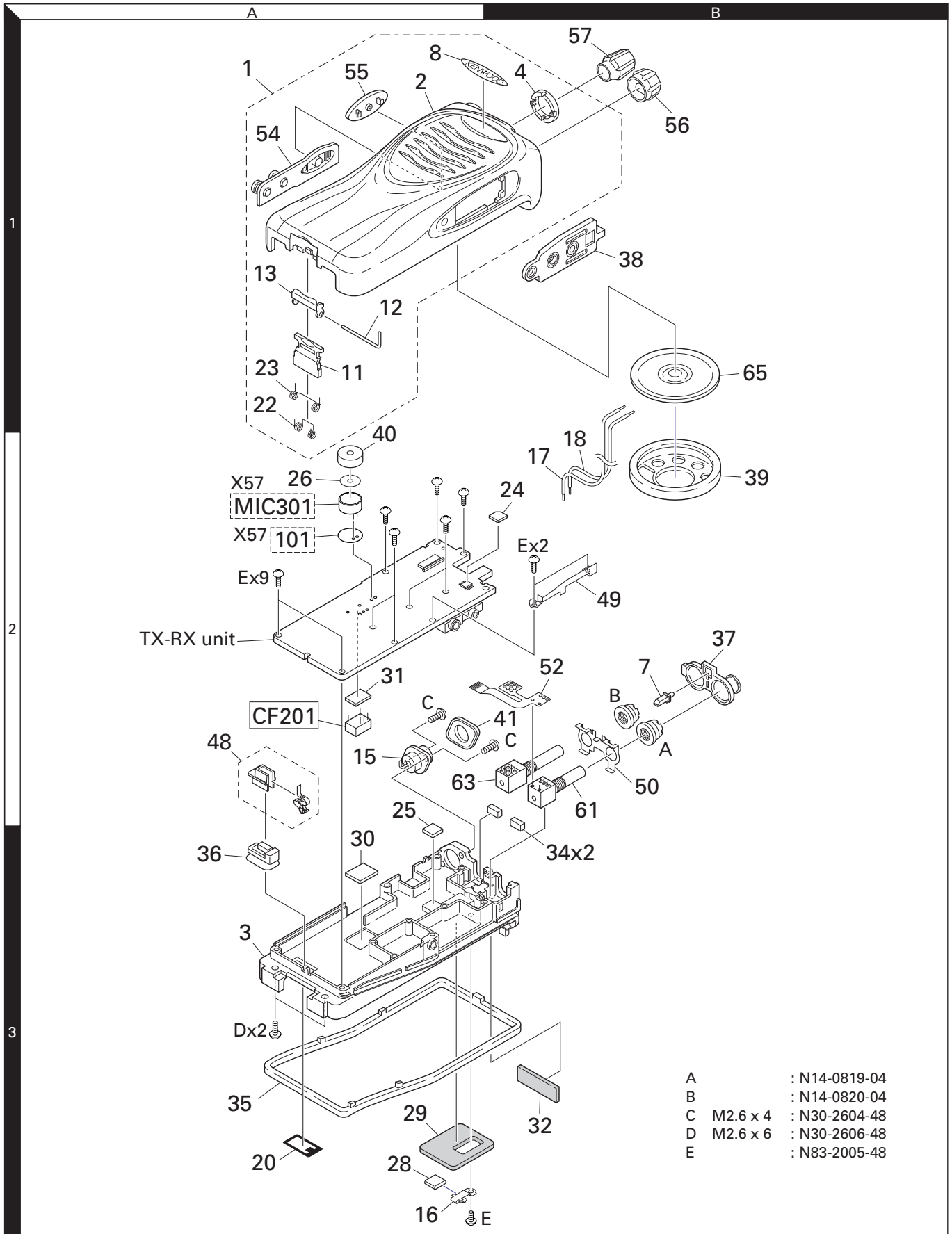

Parts with the exploded numbers larger than 700 are not supplied.

If a part reference number is listed in a box on the exploded view of the PCB, that part does not come with the PCB.

These parts must be ordered separately.

## PACKING

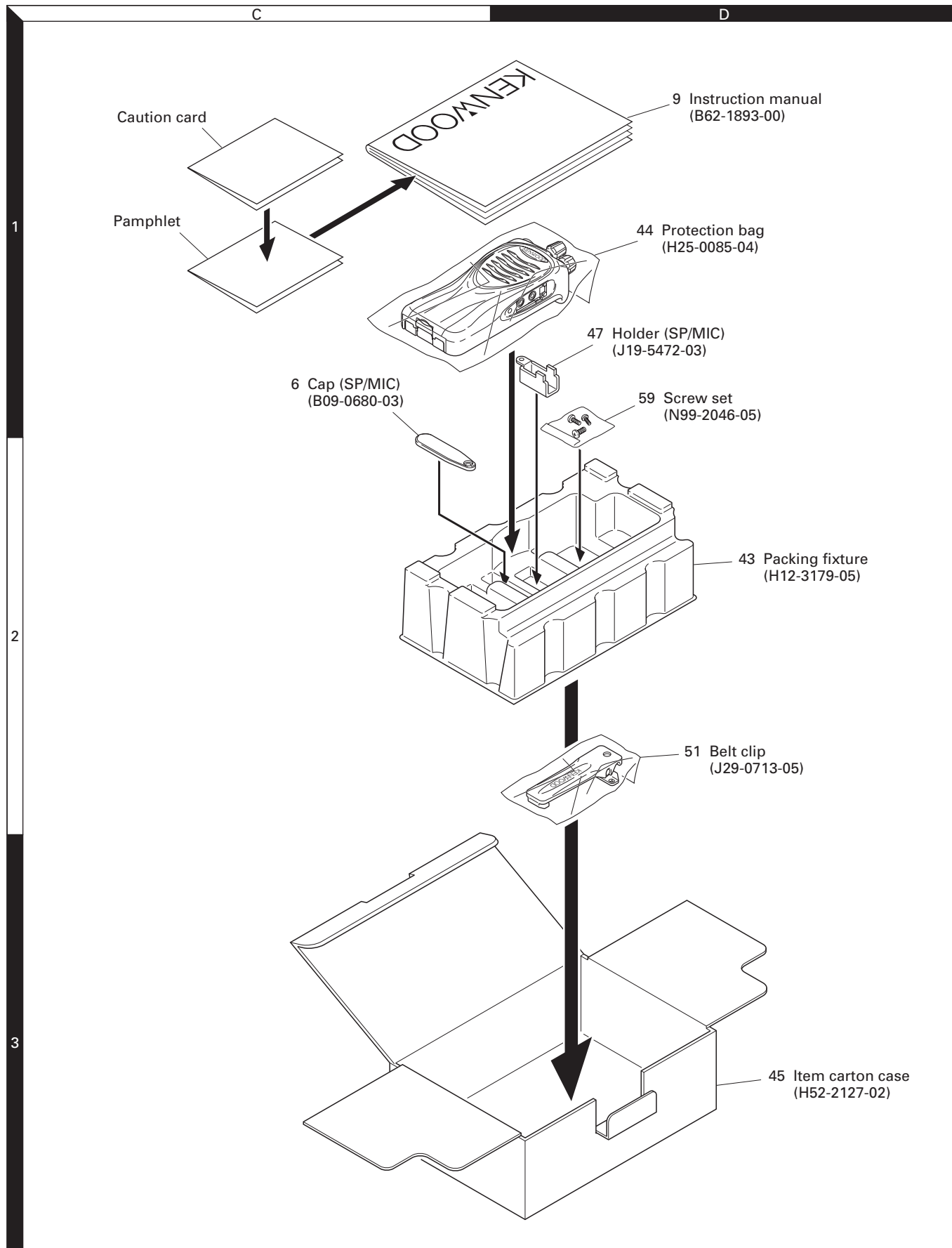

Parts with the exploded numbers larger than 700 are not supplied.

# ADJUSTMENT

## Test Equipment Required for Alignment

Test Equipment	Major Specifications	
1. Standard Signal Generator (SSG)	Frequency Range	136 to 174MHz
	Modulation	Frequency modulation and external modulation
	Output	-127dBm/0.1 $\mu$ V to greater than -47dBm/1mV
2. Power Meter	Input Impedance	50 $\Omega$
	Operation Frequency	136 to 174MHz or more
	Measurement Capability	Vicinity of 10W
3. Deviation Meter	Frequency Range	136 to 174MHz
4. Digital Volt Meter (DVM)	Measuring Range	10mV to 10V DC
	Input Impedance	High input impedance for minimum circuit loading
5. Oscilloscope		DC through 30MHz
6. High Sensitivity Frequency Counter	Frequency Range	10Hz to 1000MHz
	Frequency Stability	0.2ppm or less
7. Ammeter		5A
8. AF Volt Meter (AF VTVM)	Frequency Range	50Hz to 10kHz
	Voltage Range	1mV to 10V
9. Audio Generator (AG)	Frequency Range	50Hz to 5kHz or more
	Output	0 to 1V
10. Distortion Meter	Capability	3% or less at 1kHz
	Input Level	50mV to 10Vrms
11. Spectrum Analyzer	Measuring Range	DC to 1GHz or more
12. Tracking Generator	Center Frequency	50kHz to 600MHz
	Output Voltage	100mV or more
13. 8 $\Omega$ Dummy Load		Approx. 8 $\Omega$ , 3W
14. Regulated Power Supply		5V to 10V, approx. 3A Useful if ammeter equipped

### ■ Antenna Connector Adapter

The antenna connector of this transceiver uses an SMA terminal.

Use an antenna connector adapter [SMA(f) – BNC(f) or SMA(f) – N(f)] for adjustment. (The adapter is not provided as an option, so buy a commercially-available one.)

### ■ Repair Jig (Chassis)

Use jig (part No.: A10-4086-03) for repairing the transceiver. Place the TX-RX unit on the jig and fit it with screws.

The jig facilitates the voltage check and protects the final amplifier FET when the voltage on the flow side of the TX-RX unit is checked during repairs.

### ■ Battery Jig (W05-1011-00)

Connect the power cable properly between the battery jig installed in the transceiver and the power supply, and be sure output voltage and the power supply polarity prior to switching the power supply ON, otherwise over voltage and reverse connection may damage the transceiver, or the power supply or both.

### Note:

When using the battery jig, you must measure the voltage at the terminals of the battery jig. Otherwise, a slight voltage drop may occur within the power cable, between the power supply and the battery jig, especially while the transceiver transmits.

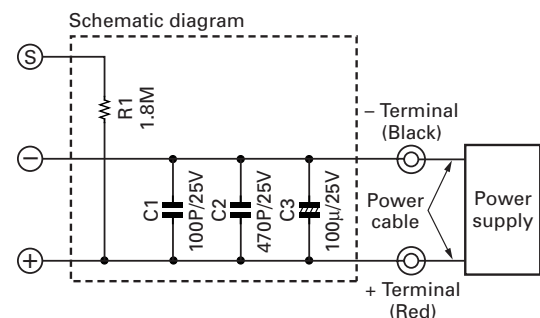
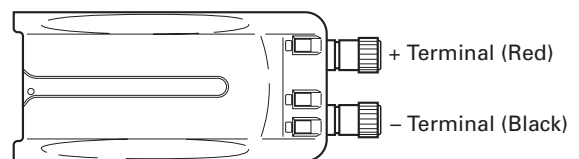

## ADJUSTMENT

### ■ Frequency and Signaling

The transceiver has been adjusted for the frequencies shown in the following table. When required, readjust them following the adjustment procedure to obtain the frequencies you want in actual operation.

#### • Frequency (MHz)

Channel No.	RX Frequency	TX Frequency
1	155.050	155.100
2	136.050	136.100
3	173.950	173.900
4	155.000	155.000
5	155.200	155.200
6	155.400	155.400
7~16	-	-

#### • Signaling

Signaling No.	RX	TX
1	None	None
2	None	100Hz Square Wave
3	QT 67.0Hz	QT 67.0Hz
4	QT 151.4Hz	QT 151.4Hz
5	QT 250.3Hz	QT 250.3Hz
6	DQT D023N	DQT D023N
7	DQT D754I	DQT D754I

### ■ Preparations for Tuning the Transceiver

Before attempting to tune the transceiver, connect the unit to a suitable power supply.

Whenever the transmitter is tuned, the unit must be connected to a suitable dummy load (i.e. power meter).

The speaker output connector must be terminated with a 8W dummy load and connected to an AC voltmeter and an audio distortion meter or a SINAD measurement meter at all times during tuning.

### Adjustment Frequency

Test CH	RX	TX
Low	136.050MHz	136.000MHz
Low'	145.550MHz	145.600MHz
Center	155.050MHz	155.000MHz
High'	164.550MHz	164.600MHz
High	173.950MHz	174.000MHz

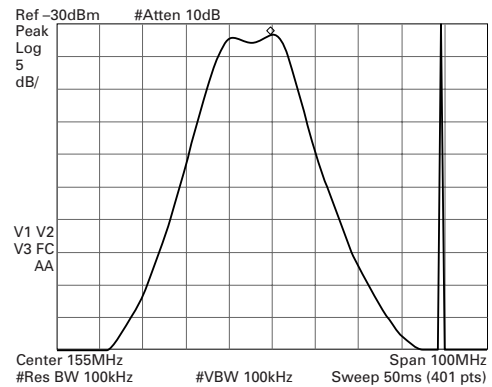

[Center]

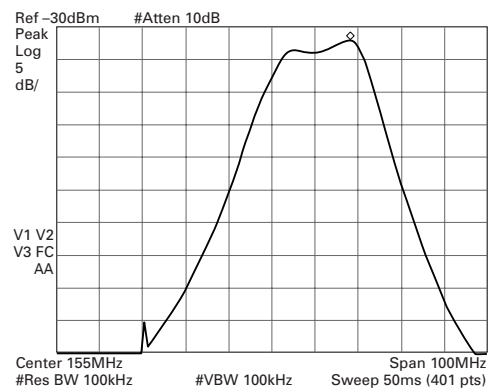

[High-edge]

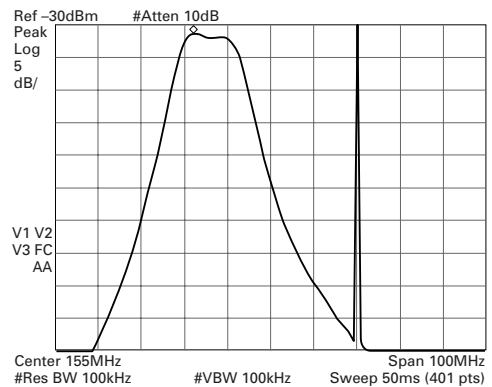

[Low-edge]

Fig. 1

## ADJUSTMENT

## Common Section

Item	Condition	Measurement			Adjustment			Specifications/Remarks
		Test-equipment	Unit	Terminal	Unit	Parts	Method	
1. Setting	1) BATT terminal voltage: 7.5V 2) SSG standard modulation Wide 5k MOD: 1kHz, DEV: 3kHz Wide 4k MOD: 1kHz, DEV: 2.4kHz Narrow MOD: 1kHz, DEV: 1.5kHz							
2. VCO lock voltage	1) CH: High	Power meter	Panel	ANT	TX-RX	TC2	4.0V	±0.1V
	• RX 2) CH: Low	DVM	TX-RX	CV			Check	0.6V or more
	• TX 3) CH: High PTT: ON				TX-RX	TC1	4.2V	±0.1V
	4) CH: Low PTT: ON					Check	0.6V or more	

## Transmitter Section

Item	Condition	Measurement			Adjustment			Specifications/Remarks		
		Test-equipment	Unit	Terminal	Unit	Parts	Method			
1. Frequency adjustment	1) CH: High PTT: ON	F. counter	Panel	ANT	TX-RX	VR1	173.900MHz	±50Hz		
2. High power adjustment	1) Test CH: Low, Low', Center, High', High (5 points) BATT terminal voltage: 7.5V PTT: ON	Power meter Ammeter			PC	KPG-87D (M2)	Low: 5.0W Others: 4.8W	Low: ±0.1W Others: -0W +0.2W 2.0A or less		
3. Low power adjustment	1) Test CH: Low, Low', Center, High', High (5 points) BATT terminal voltage: 7.5V PTT: ON						1.0W	±0.1W 1.0A or less		
4. Maximum deviation adjustment	1) Test CH: Center, Low, High (3 points) AG: 1kHz/150mV Deviation meter filter LPF: 15kHz HPF: OFF PTT: ON	Power meter	Panel	ANT					4.2kHz (According to the larger +, -)	±80Hz
	• Wide 4k 2) Test CH: Center PTT: ON	Deviation meter Oscilloscope AG AF VTVM		SP/MIC connector					3.4kHz (According to the larger +, -)	±80Hz
	• Narrow 2) Test CH: Center PTT: ON								2.2kHz (According to the larger +, -)	±80Hz
5. VOX 1 writing	1) Test CH: Center AG: 1kHz/45mV									
6. VOX 10 writing	1) Test CH: Center AG: 1kHz/4.0mV									

## ADJUSTMENT

Item	Condition	Measurement			Adjustment			Specifications/Remarks
		Test-equipment	Unit	Terminal	Unit	Parts	Method	
7. DQT balance adjustment • Wide 5k  • Wide 4k  • Narrow	1) Test CH: Center, Low, High (3 points) Deviation meter filter LPF: 3kHz HPF: OFF PTT: ON	Power meter  Deviation meter Oscilloscope AG AF VTVM	Panel	ANT	PC	KPG-87D (M2)	Make the demodulation wave into square waves	
	2) Test CH: Center PTT: ON			SP/MIC connector				
	3) Test CH: Center PTT: ON							
8. QT deviation adjustment • Wide 5k  • Wide 4k  • Narrow	1) Test CH: Center, Low, High (3 points) Deviation meter filter LPF: 3kHz HPF: OFF PTT: ON						0.75kHz	±40Hz
	2) Test CH: Center PTT: ON						0.60kHz	±40Hz
	3) Test CH: Center PTT: ON						0.4kHz	±40Hz
9. DQT deviation adjustment • Wide 5k  • Wide 4k  • Narrow	1) Test CH: Center, Low, High (3 points) Deviation meter filter LPF: 3kHz HPF: OFF PTT: ON						0.75kHz	±40Hz
	2) Test CH: Center PTT: ON						0.60kHz	±40Hz
	3) Test CH: Center PTT: ON						0.4kHz	±40Hz

## Receiver Section

Item	Condition	Measurement			Adjustment			Specifications/Remarks
		Test-equipment	Unit	Terminal	Unit	Parts	Method	
1. BPF wave adjustment	1) Center frequency Spectrum analyzer setting Center f.: 155MHz Span: 100MHz RBW: 100kHz VBW: 100kHz ATT: 10dB	SSG  Spectrum analyzer	Panel	ANT	PC	KPG-87D (M2)	Adjust the waveform as shown to the Fig. 1 (page 22)	
	TX-RX		BPF					
	2) High-edge frequency Marker f.: 174MHz							
3) Low-edge frequency Marker f.: 136MHz								



## ADJUSTMENT

Item	Condition	Measurement			Adjustment			Specifications/Remarks
		Test-equipment	Unit	Terminal	Unit	Parts	Method	
2. Sensitivity check • Wide 5k  • Wide 4k  • Narrow	1) Test CH: Low, Center, High SSG output: -114dBm (0.45μV) SSG MOD: 3.0kHz	SSG  DVM Oscilloscope AF VTVM	Panel	ANT  SP/MIC connector			Check	20dB SINAD or more
	2) Test CH: Low, Center, High SSG output: -114dBm (0.45μV) SSG MOD: 2.4kHz							
	3) Test CH: Center SSG output: -112dBm (0.56μV) SSG MOD: 1.5kHz							
3. SQL1 (Threshold) writing • Wide 5k  • Wide 4k  • Narrow	1) Test CH: Low, Center, High SSG output: -120dBm (0.22μV) SSG MOD: 3.0kHz				PC	KPG-87D (M2)	Write	Squelch open
	2) Test CH: Center SSG output: -120dBm (0.22μV) SSG MOD: 2.4kHz							
	2) Test CH: Center SSG output: -119dBm (0.25μV) SSG MOD: 1.5kHz							
4. SQL9 (Tight) writing • Wide 5k  • Wide 4k  • Narrow	1) Test CH: Low, Center, High SSG output: -114dBm (0.45μV) SSG MOD: 3.0kHz						Write	BATT terminal voltage: 5.9V
	2) Test CH: Center SSG output: -114dBm (0.45μV) SSG MOD: 2.4kHz							
	2) Test CH: Center SSG output: -113dBm (0.5μV) SSG MOD: 1.5kHz							
5. BATT detection writing	1) BATT terminal voltage: 5.9V	SSG  DVM	Panel  TX-RX	ANT  BATT terminal				

### Adjustment Points

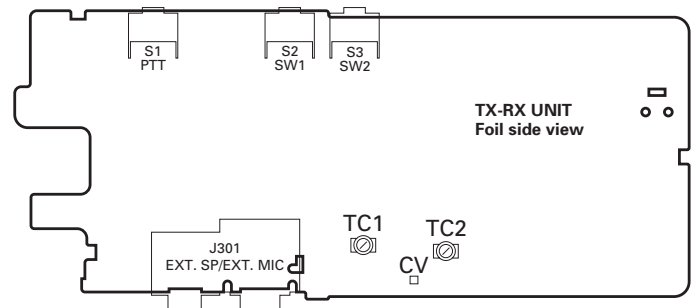
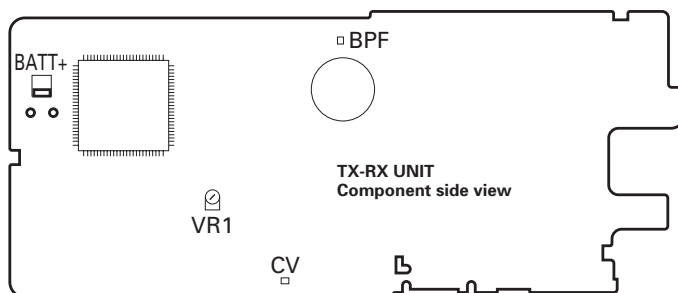

VR1 : Frequency adjustment  
 BPF : Band-pass wave form test point  
 CV : Lock voltage adjustment terminal

TC1 : Transmit lock voltage adjustment  
 TC2 : Receive lock voltage adjustment  
 CV : Lock voltage adjustment terminal

# TK-2202 PC BOARD

## TX-RX UNIT (X57-6872-71) Component side view (J79-0043-09)

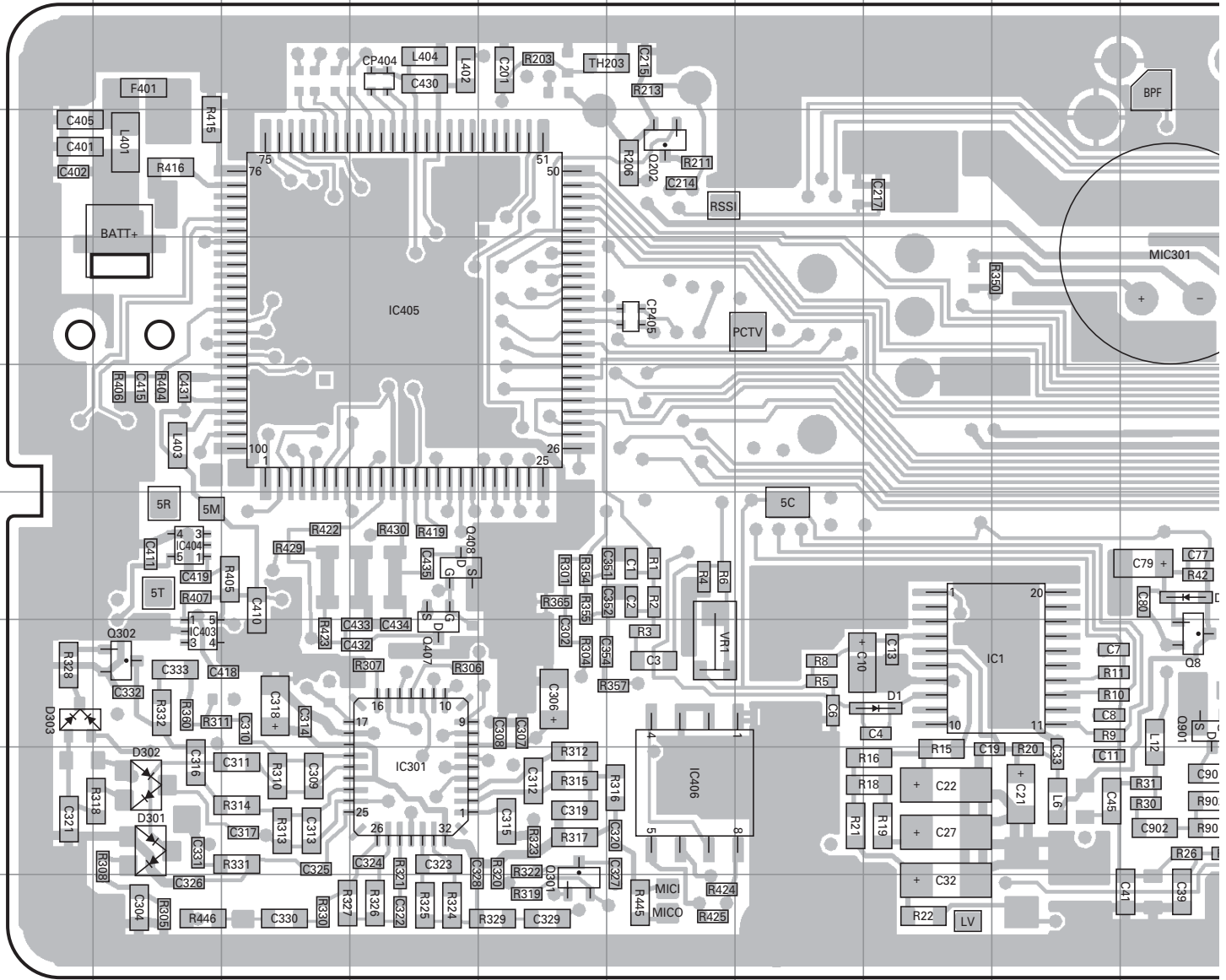

Ref. No.	Address	Ref. No.	Address	Ref. No.	Address	Ref. No.	Address
IC1	8I	Q104	5L	Q304	7P	D1	8H
IC101	4M	Q105	4K	Q305	8O	D11	7J
IC301	9D	Q107	4L	Q306	9P	D102	4M
IC302	8P	Q108	4L	Q316	9O	D301	9B
IC403	8B	Q109	5L	Q401	8R	D302	9B
IC404	7B	Q202	4F	Q402	8R	D303	8A
IC405	5D	Q301	10E	Q407	8D	D403	8R
IC406	9F	Q302	8B	Q408	7D	D404	8R
Q8	8J	Q303	7P	Q901	8J		

# PC BOARD TK-2202

## TX-RX UNIT (X57-6872-71) Component side view (J79-0043-09)

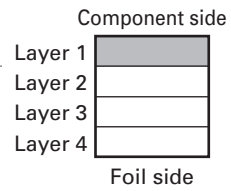
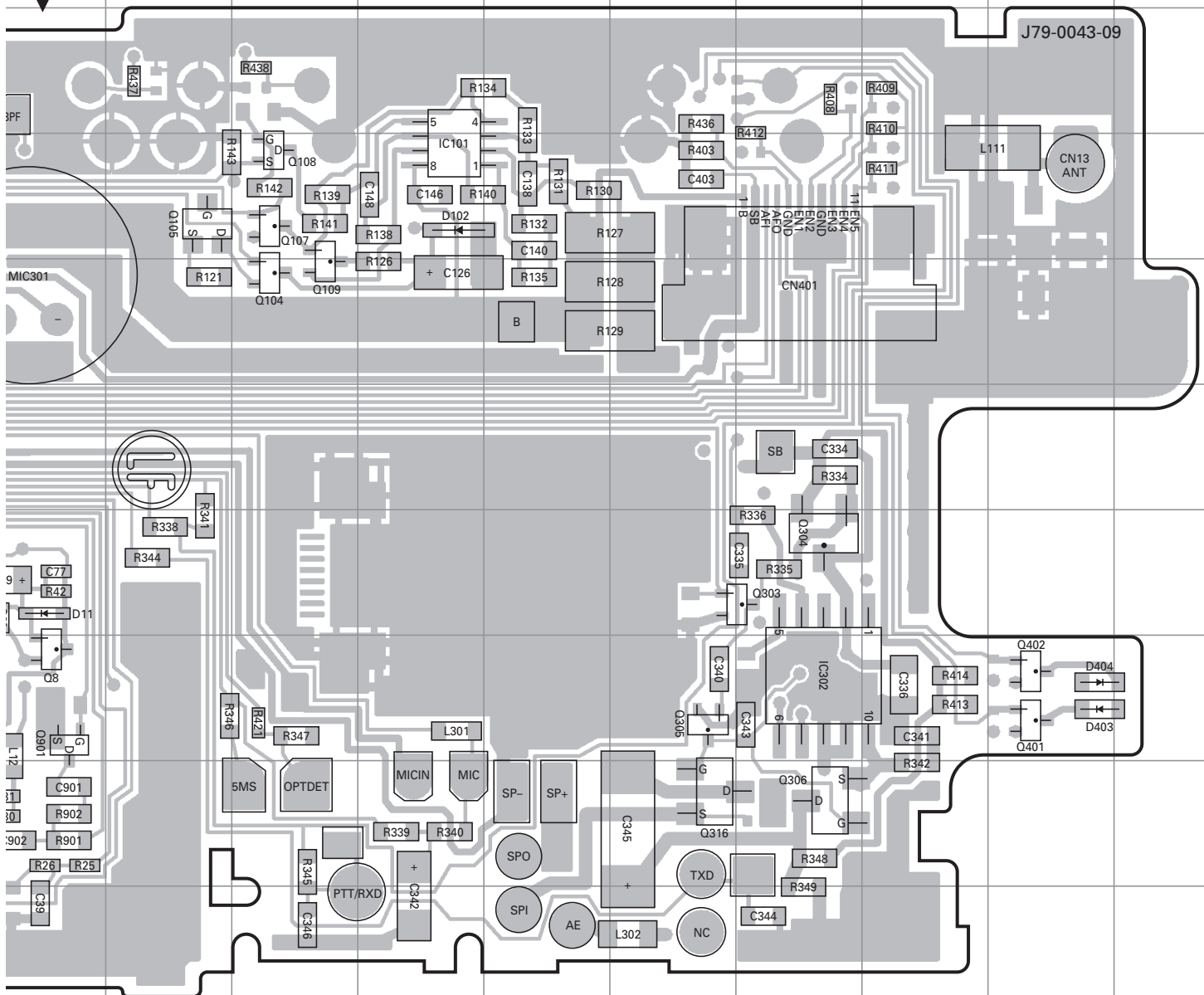

# TK-2202 PC BOARD

# PC BOARD TK-2202

TX-RX UNIT (X57-6872-71) Component side view (J79-0043-09)

TX-RX UNIT (X57-6872-71) Component side view (J79-0043-09)

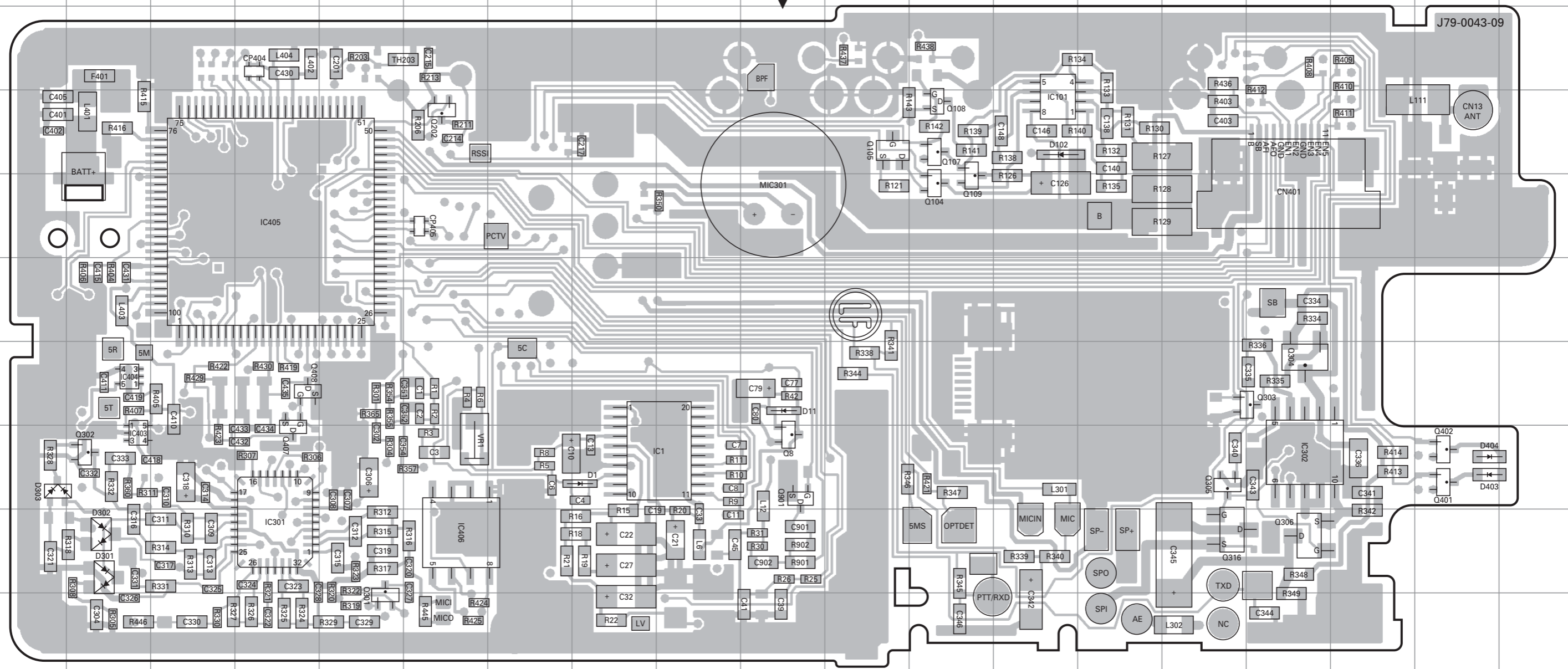

Ref. No.	Address	Ref. No.	Address	Ref. No.	Address	Ref. No.	Address
IC1	8I	Q104	5L	Q304	7P	D1	8H
IC101	4M	Q105	4K	Q305	8O	D11	7J
IC301	9D	Q107	4L	Q306	9P	D102	4M
IC302	8P	Q108	4L	Q316	9O	D301	9B
IC403	8B	Q109	5L	Q401	8R	D302	9B
IC404	7B	Q202	4F	Q402	8R	D303	8A
IC405	5D	Q301	10E	Q407	8D	D403	8R
IC406	9F	Q302	8B	Q408	7D	D404	8R
Q8	8J	Q303	7P	Q901	8J		

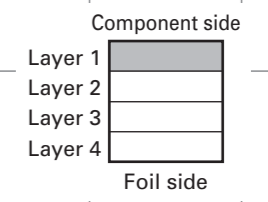

# TK-2202 PC BOARD

## TX-RX UNIT (X57-6872-71) Foil side view (J79-0043-09)

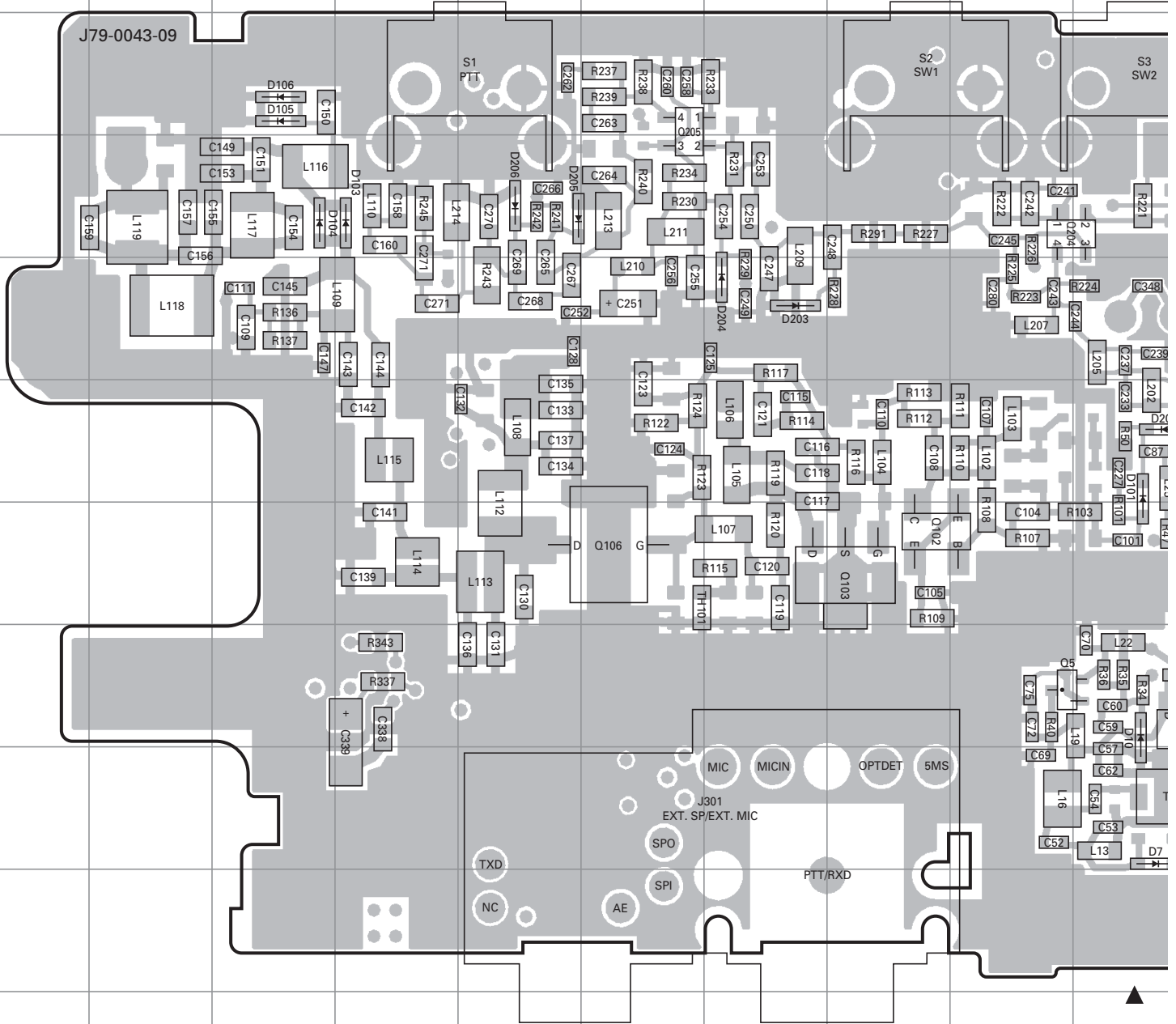

Ref. No.	Address	Ref. No.	Address	Ref. No.	Address	Ref. No.	Address	Ref. No.	Address
IC2	6L	Q4	8J	Q203	4N	D7	9J	D202	6J
IC201	5N	Q5	8I	Q204	4I	D9	10L	D203	5G
IC401	9R	Q6	8K	Q205	3F	D10	8J	D204	5G
IC402	8R	Q7	9L	Q403	8R	D101	6J	D205	4E
IC407	8P	Q9	6K	Q404	9R	D103	4D	D206	4E
Q1	7O	Q102	7H	Q405	9R	D104	4C	D401	8R
Q2	8L	Q103	7H	D4	9J	D105	3C	D402	4R
Q3	9M	Q106	7F	D5	10L	D106	3C		

# PC BOARD TK-2202

## TX-RX UNIT (X57-6872-71) Foil side view (J79-0043-09)

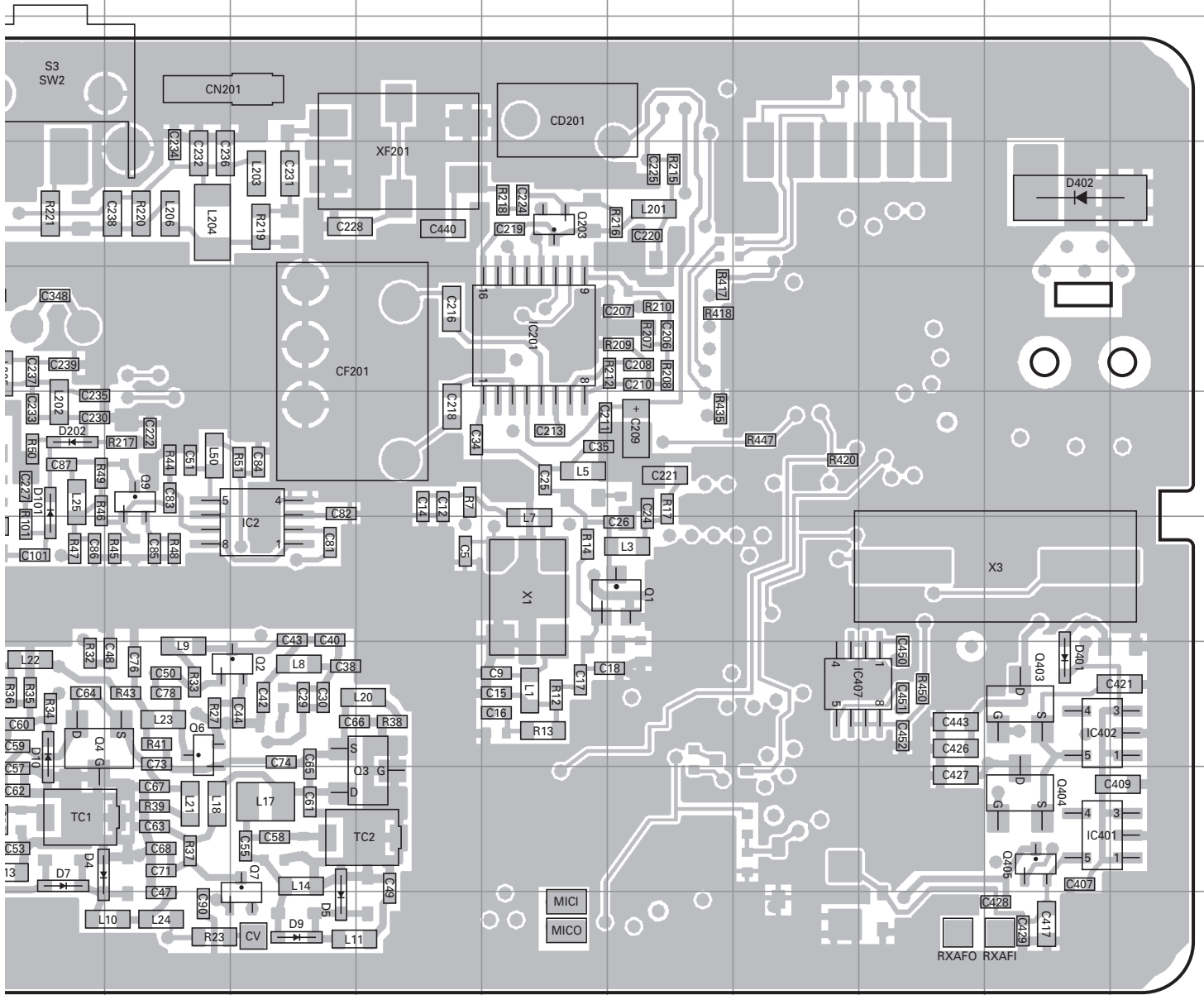

Component side

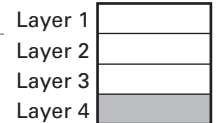

Foil side

TX-RX UNIT (X57-6872-71) Foil side view (J79-0043-09)

TX-RX UNIT (X57-6872-71) Foil side view (J79-0043-09)

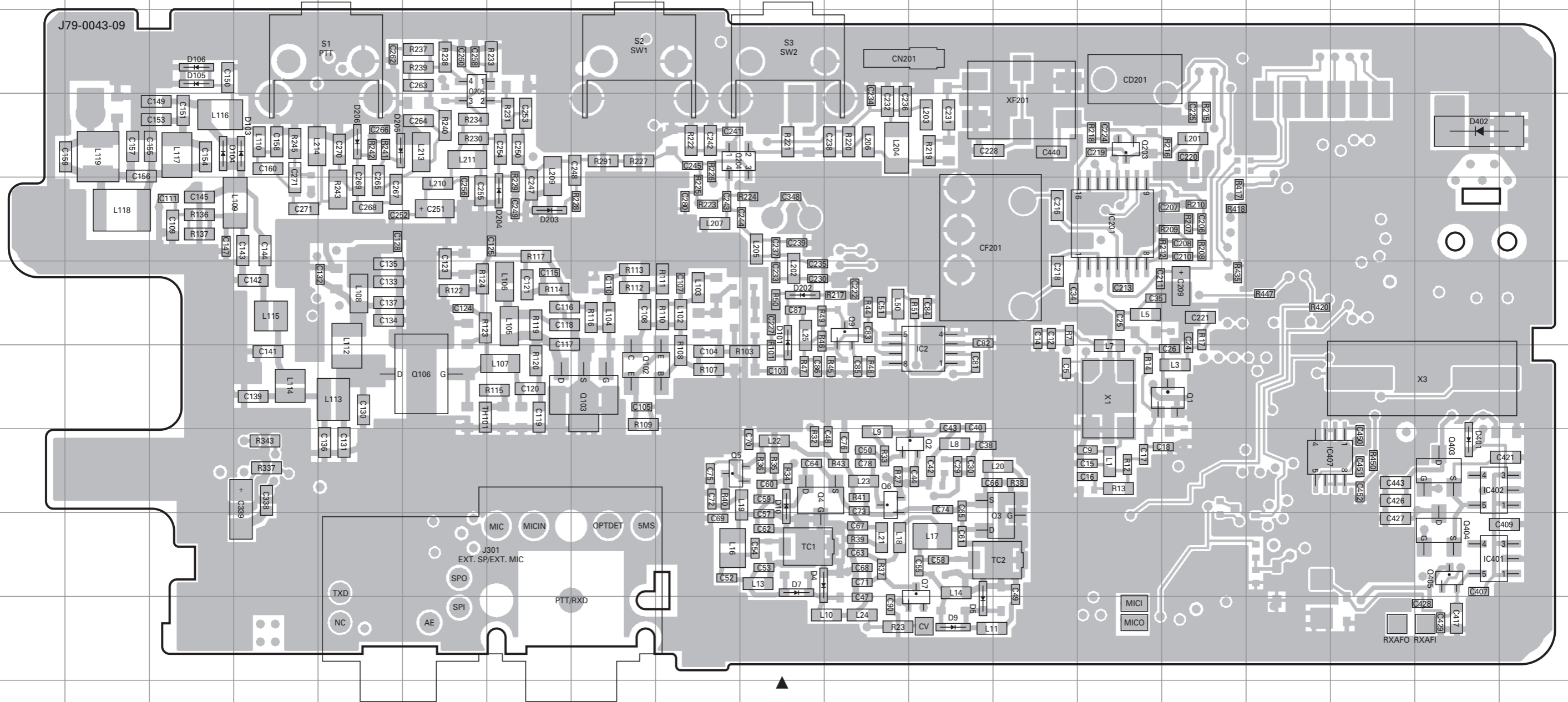

Ref. No.	Address	Ref. No.	Address	Ref. No.	Address	Ref. No.	Address	Ref. No.	Address
IC2	6L	Q4	8J	Q203	4N	D7	9J	D202	6J
IC201	5N	Q5	8I	Q204	4I	D9	10L	D203	5G
IC401	9R	Q6	8K	Q205	3F	D10	8J	D204	5G
IC402	8R	Q7	9L	Q403	8R	D101	6J	D205	4E
IC407	8P	Q9	6K	Q404	9R	D103	4D	D206	4E
Q1	7O	Q102	7H	Q405	9R	D104	4C	D401	8R
Q2	8L	Q103	7H	D4	9J	D105	3C	D402	4R
Q3	9M	Q106	7F	D5	10L	D106	3C		

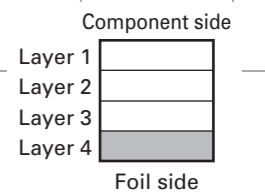

# TK-2202 SCHEMATIC DIAGRAM

TX-RX UNIT (X57-6872-71)

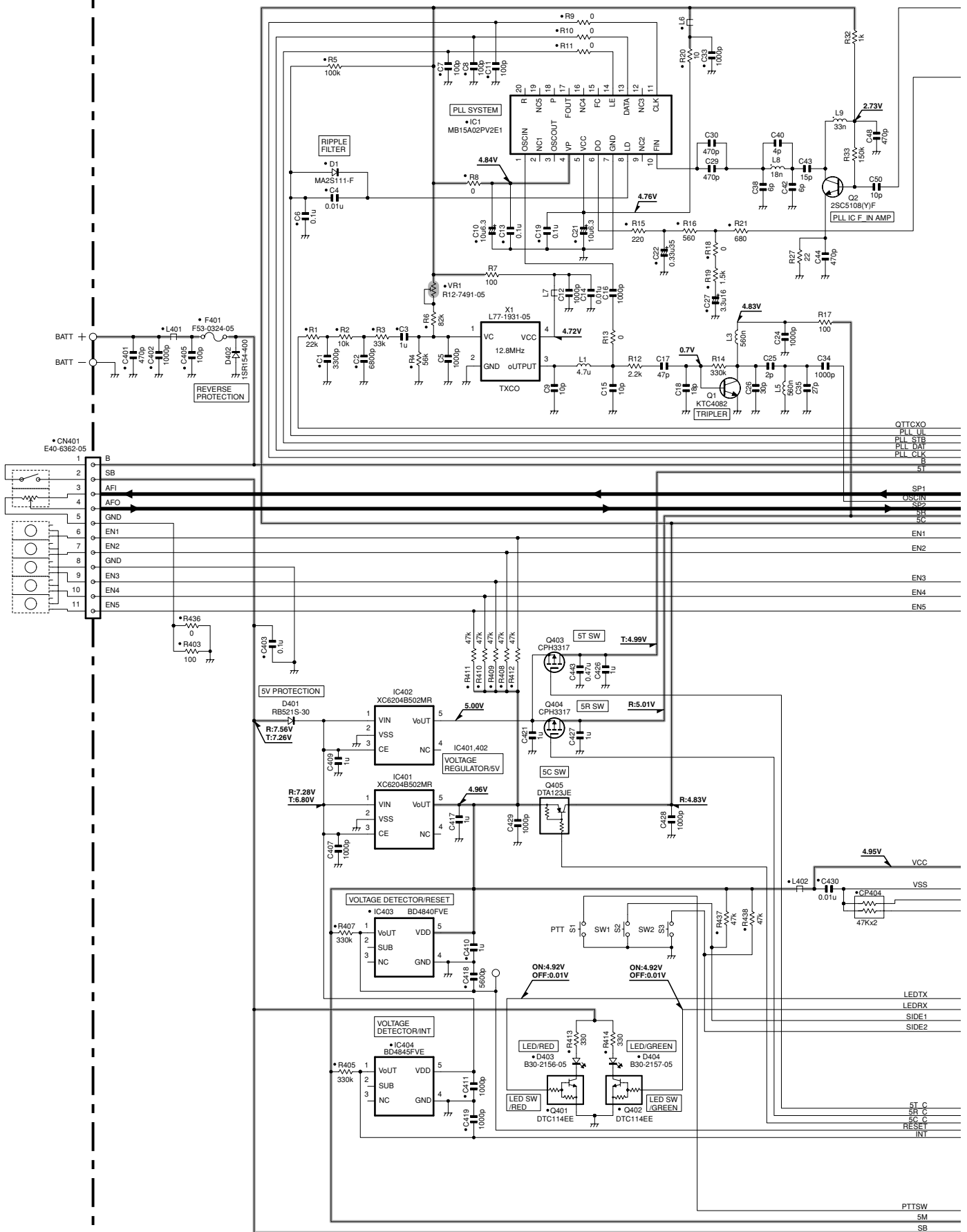



# SCHEMATIC DIAGRAM TK-2202

TX-RX UNIT (X57-6872-71)

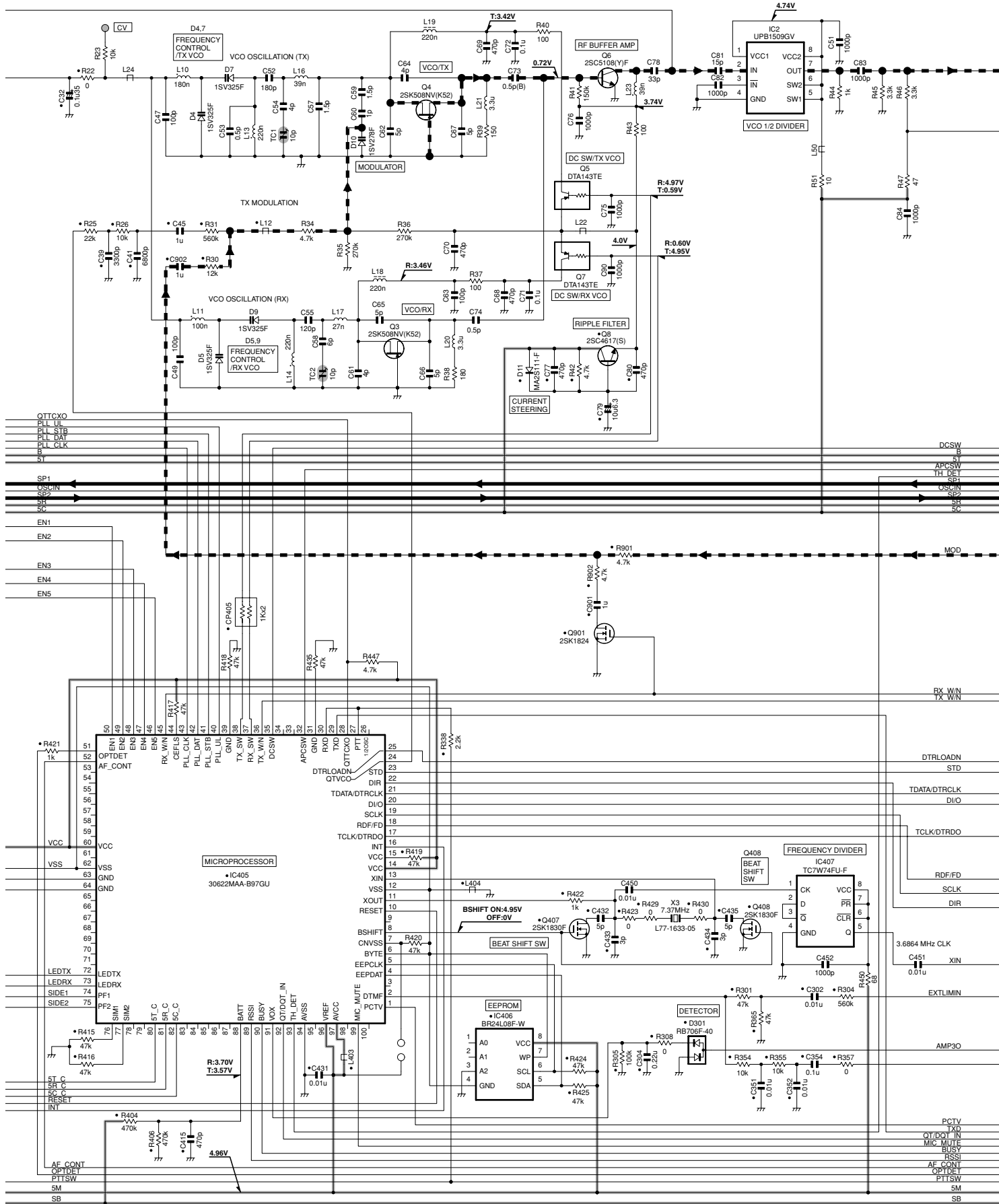

# TK-2202 SCHEMATIC DIAGRAM

TX-RX UNIT (X57-6872-71)

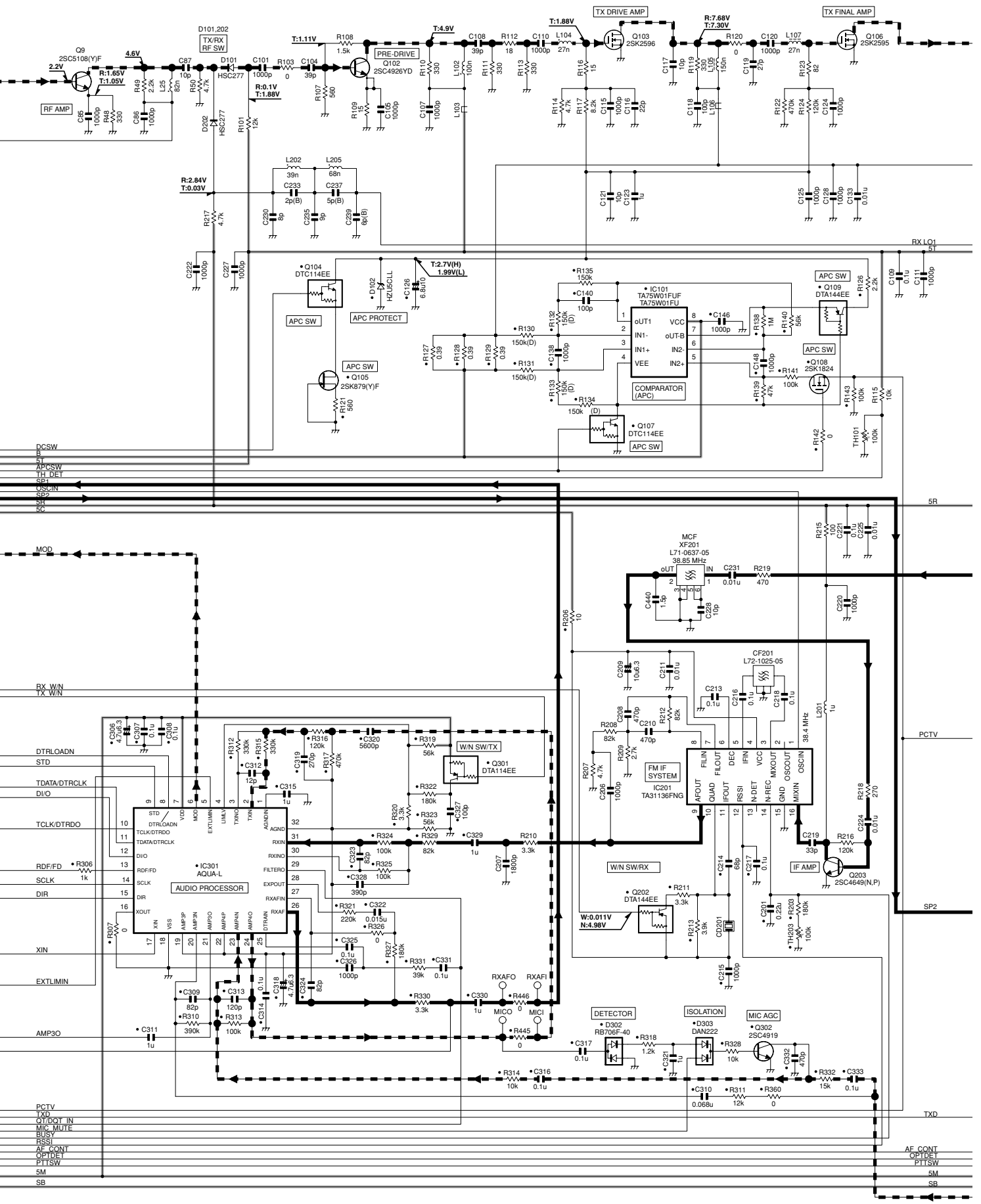

# SCHEMATIC DIAGRAM TK-2202

TX-RX UNIT (X57-6872-71)

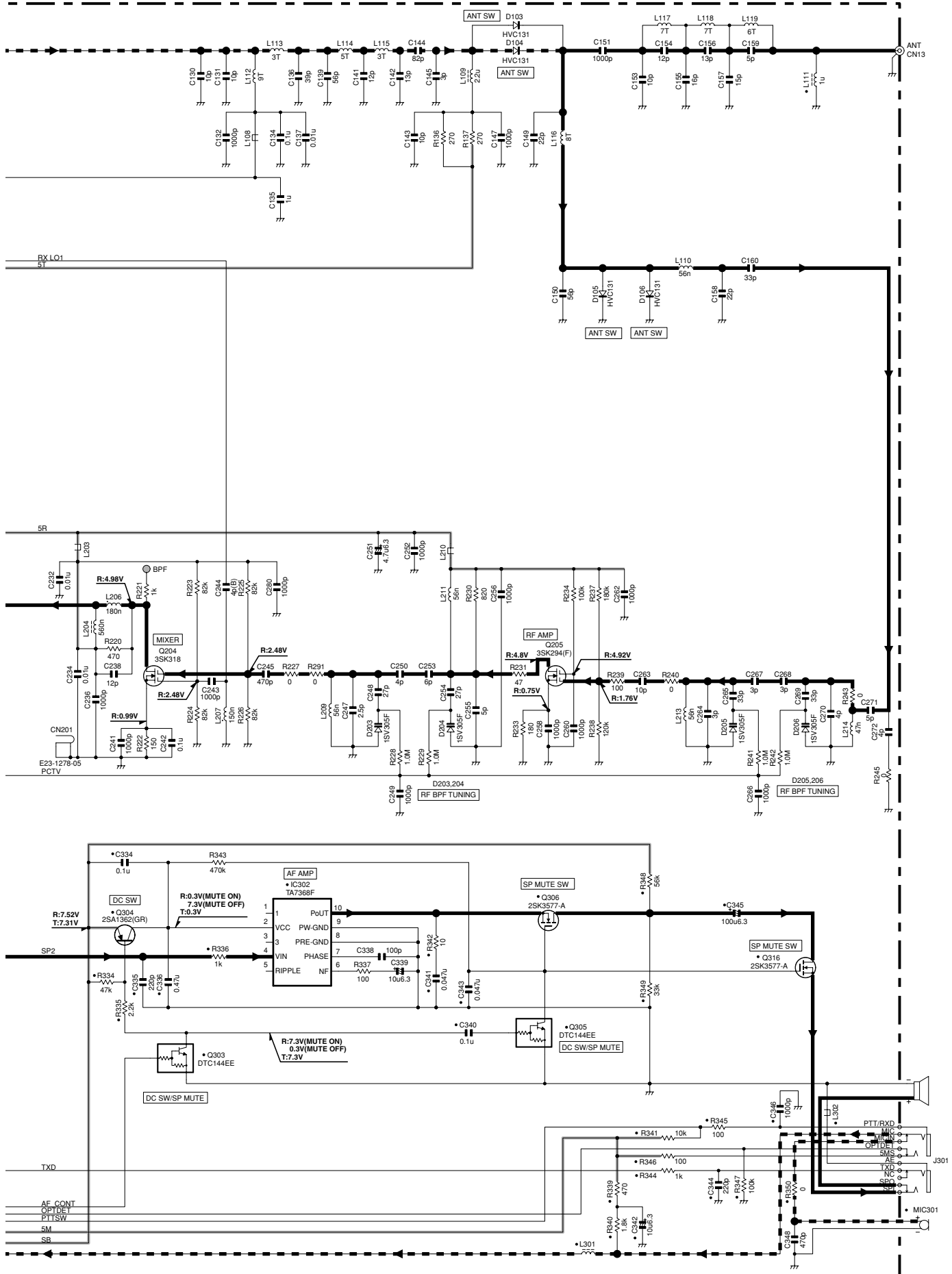

Note : The components marked with a dot (•) are parts of layer 1.

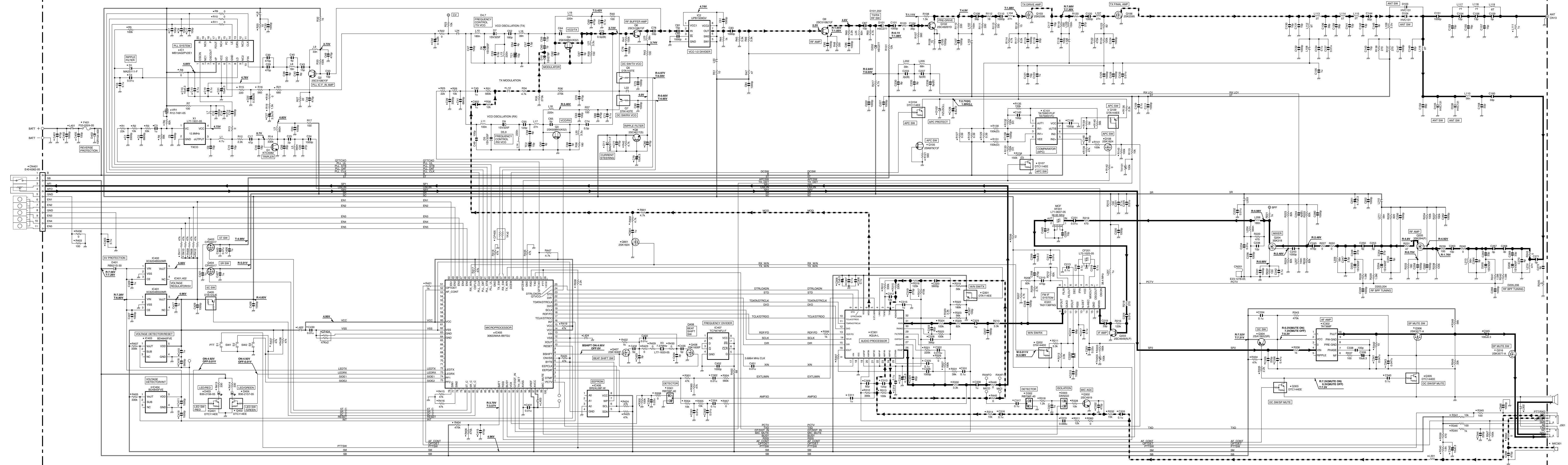

## BLOCK DIAGRAM

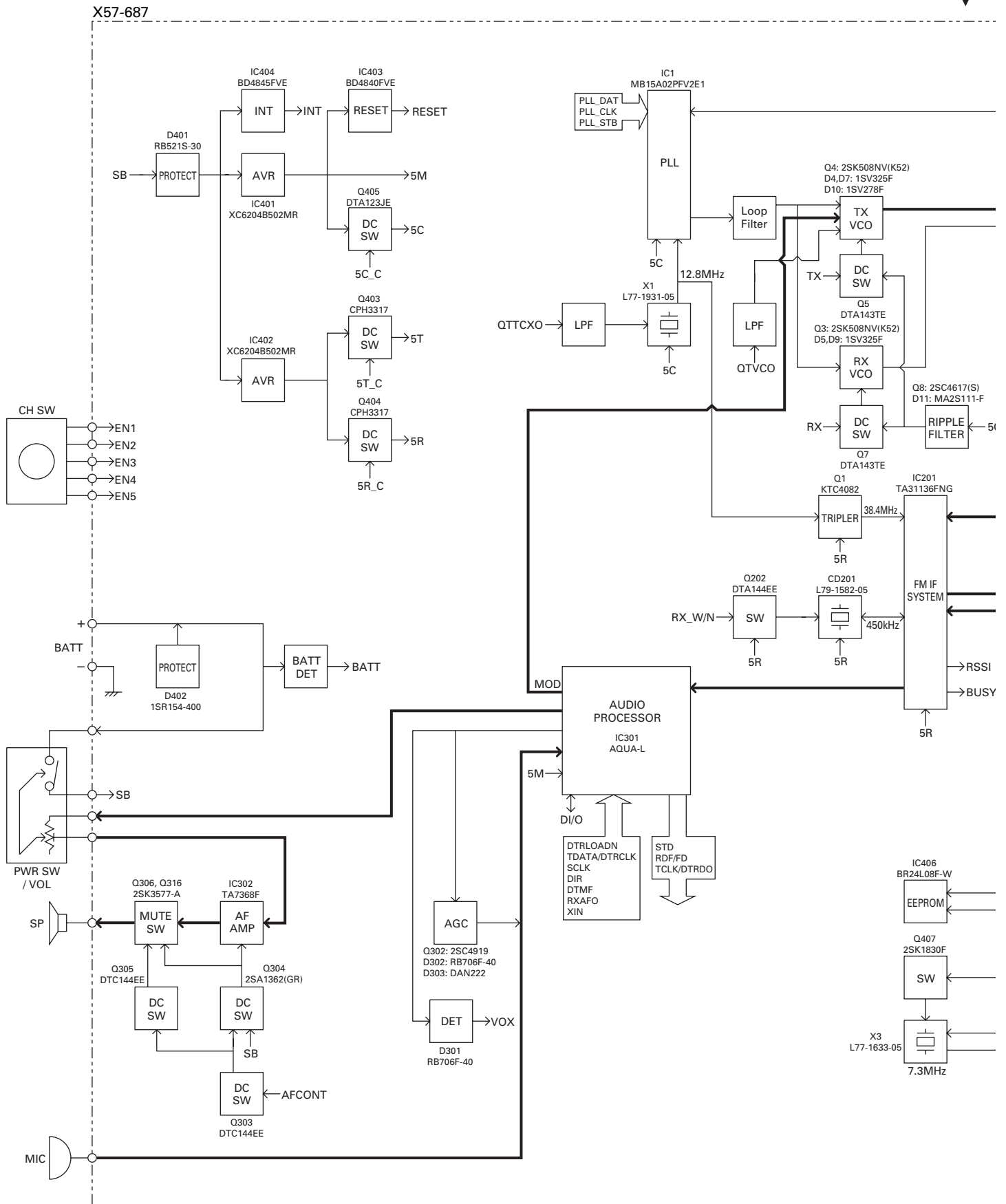

## BLOCK DIAGRAM

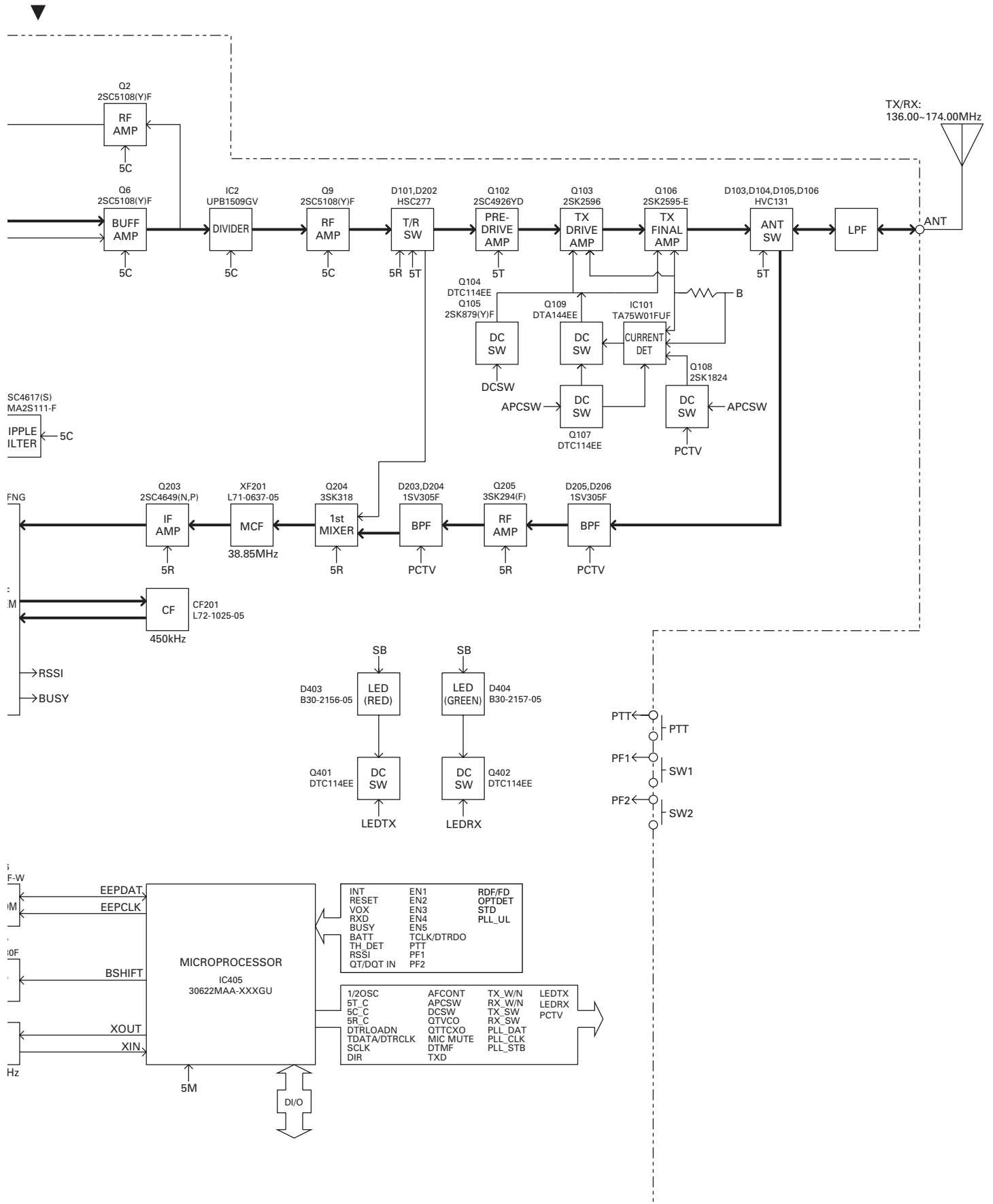

## LEVEL DIAGRAM

### Receiver Section

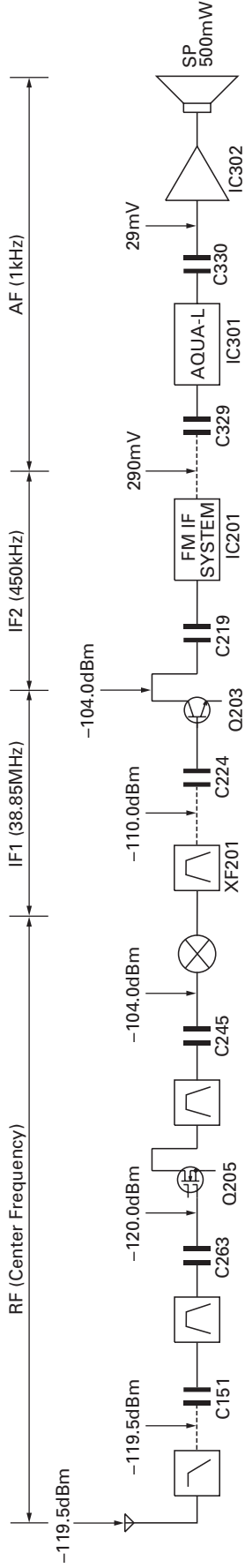

To make measurements in the AF section, connect the AC level meter.  
 (ANT input: -53dBm, 1kHz FM, 3kHz DEV (WIDE 5k).)  
 In the RF section, use 1000pF coupling capacitor.  
 (The display shows the SSG input value required to obtain 12dB SINAD without Local level.)

### Transmitter Section

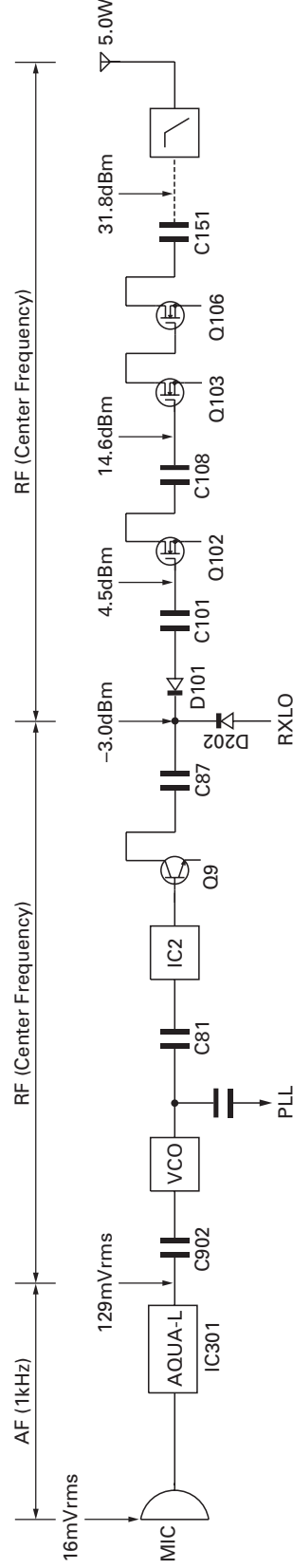

AG is set to the MIC input becomes 3kHz DEV. at 1kHz MOD. (WIDE 5k)  
 To make measurements in the AF section, connect the AC level meter.  
 In the RF section, use 1000pF coupling capacitor.

## KBH-10 / KSC-31 / KNB-29N

### KBH-10 (Belt Clip)

#### ■ External View



### KSC-31 (Rapid Charger)

#### ■ External View



#### ■ Specifications

Charging current.....	850mA ±5%
Charging time.....	KNB-29N : Approx.180 minutes KNB-30A : Approx.120 minutes
Dimensions (Charger only) ...	86.3W x 46.2H x 100.0D (mm) 3-3/8W x 1-7/8H x 4D (inches)
Weight (Charger only) .....	Approx.100g / 0.22 lbs

### KNB-29N (Ni-MH Battery Pack)

#### ■ External View



#### ■ Specifications

Voltage .....	7.2V (1.2V x 6)
Battery capacity.....	1500mAh

#### ■ Schematic Diagram

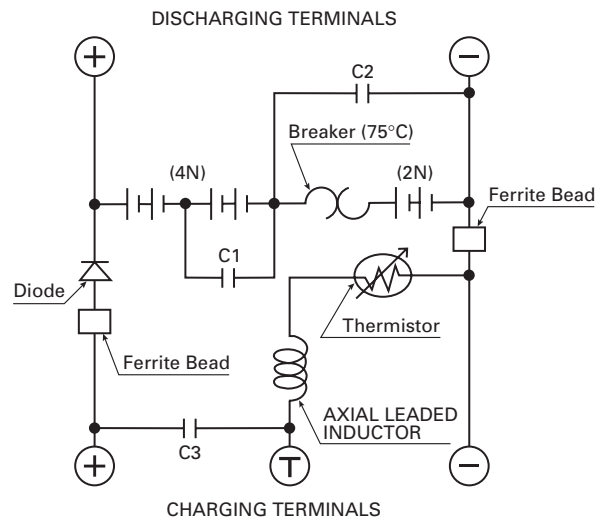



## SPECIFICATIONS

### General (Applicable Standards: EN Standards)

Frequency Range .....	136~174MHz
Number of Channels .....	Max. 8
Channel Spacing .....	25kHz (Wide 5k)    20kHz (Wide 4k)    12.5kHz (Narrow)
Operating Voltage .....	7.5 V DC±20%
Battery Life .....	More than 14 hours at 5 watts (5-5-90 duty cycle with KNB-29N battery)
Operating Temperature Range .....	-30°C to +60°C
Frequency Stability .....	±2.5ppm (-30°C to +60°C)
Channel Frequency Spread .....	38MHz
Dimensions and Weight (Dimensions not including protrusions)	
Radio Only .....	54 W x 122 H x 21.1 D mm 160g
With KNB-29N (1500mAh battery) .....	54 W x 122 H x 33 D mm 360g

### Receiver (Measurements made per EN Standards)

Sensitivity		
EIA 12dB SINAD .....	0.28µV (Wide 5k/4k)	0.35µV (Narrow)
EN 20dB SINAD .....	0.63µV (Wide 5k/4k)	0.70µV (Narrow)
Adjacent Channel Selectivity .....	70dB (Wide 5k/4k)	62dB (Narrow)
Intermodulation .....	65dB	
Spurious Response .....	70dB	
Audio Power Output (4Ω) .....	500mW with less than 10% distortion	

### Transmitter (Measurements made per EN Standards)

RF Power Output .....	5W/1W
Modulation Limiting .....	±5.0kHz at 25kHz, ±4.0kHz at 20kHz, ±2.5kHz at 12.5kHz
Spurious Emission .....	-36dBm ≤ 1GHz, -30dBm > 1GHz
FM Noise (EIA) .....	45dB (Wide 5k)    43dB (Wide 4k)    40dB (Narrow)
Audio Distortion .....	Less than 5%

## Kenwood Corporation

2967-3, Ishikawa-machi, Hachioji-shi, Tokyo, 192-8525 Japan

### Kenwood U.S.A. Corporation

P.O. BOX 22745, 2201 East Dominguez Street, Long Beach, CA 90801-5745, U.S.A.

### Kenwood Electronics Canada Inc.

6070 Kestrel Road, Mississauga, Ontario, Canada L5T 1S8

### Kenwood Electronics Deutschland GmbH

Rembrücker Str. 15, 63150 Heusenstamm, Germany

### Kenwood Electronics Belgium N.V.

Leuvensesteenweg 248 J, 1800 Vilvoorde, Belgium

### Kenwood Electronics France S.A.

13, Boulevard Ney, 75018 Paris, France

### Kenwood Electronics UK Limited

KENWOOD House, Dwight Road, Watford, Herts., WD18 9EB United Kingdom

### Kenwood Electronics Europe B.V.

Amsterdamseweg 37, 1422 AC Uithoorn, The Netherlands

### Kenwood Electronics Italia S.p.A.

Via G. Sirtori, 7/9 20129 Milano, Italy

### Kenwood Ibérica, S.A.

Bolivia, 239-08020 Barcelona, Spain

### Kenwood Electronics Australia Pty. Ltd.

(A.C.N. 001 499 074)

16 Giffnock Avenue, Centrecourt Estate, North Ryde, N.S.W. 2113 Australia

### Kenwood Electronics (Hong Kong) Ltd.

Unit 3712-3724, Level 37, Tower one Metroplaza, 223 Hing Fong Road, Kwai Fong, N.T., Hong Kong

### Kenwood Electronics Singapore Pte Ltd

1 Ang Mo Kio Street 63, Singapore 569110

