

KENWOOD

Document Copyrights

Copyright 2006 by Kenwood Corporation. All rights reserved.

No part of this manual may be reproduced, translated, distributed, or transmitted in any form or by any means, electronic, mechanical, photocopying, recording, or otherwise, for any purpose without the prior written permission of Kenwood.

Disclaimer

While every precaution has been taken in the preparation of this manual, Kenwood assumes no responsibility for errors or omissions. Neither is any liability assumed for damages resulting from the use of the information contained herein. Kenwood reserves the right to make changes to any products herein at any time for improvement purposes.

文档版权信息

Kenwood Corporation 拥有版权 2006。保留所有权利。

未经 Kenwood 公司预先书面同意，无论出于何种目的，均不得以任何形式或任何方式包括电子、机械、影印、录音或其他方式复制、翻译、分发或传播本手册的任何部分。

免责声明

Kenwood 公司在准备本文档时已采取所有必要的预防措施，恕不对错误或疏漏承担任何责任，也不对因使用本文中所含的信息而导致的损害负责。Kenwood 公司保留出于改进的需要而随时对文中的产品信息做出更改的权利。

VHF FM TRANSCEIVER / VHF 调频对讲机

TK-2207G



SERVICE MANUAL / 维修手册

KENWOOD

Kenwood Corporation

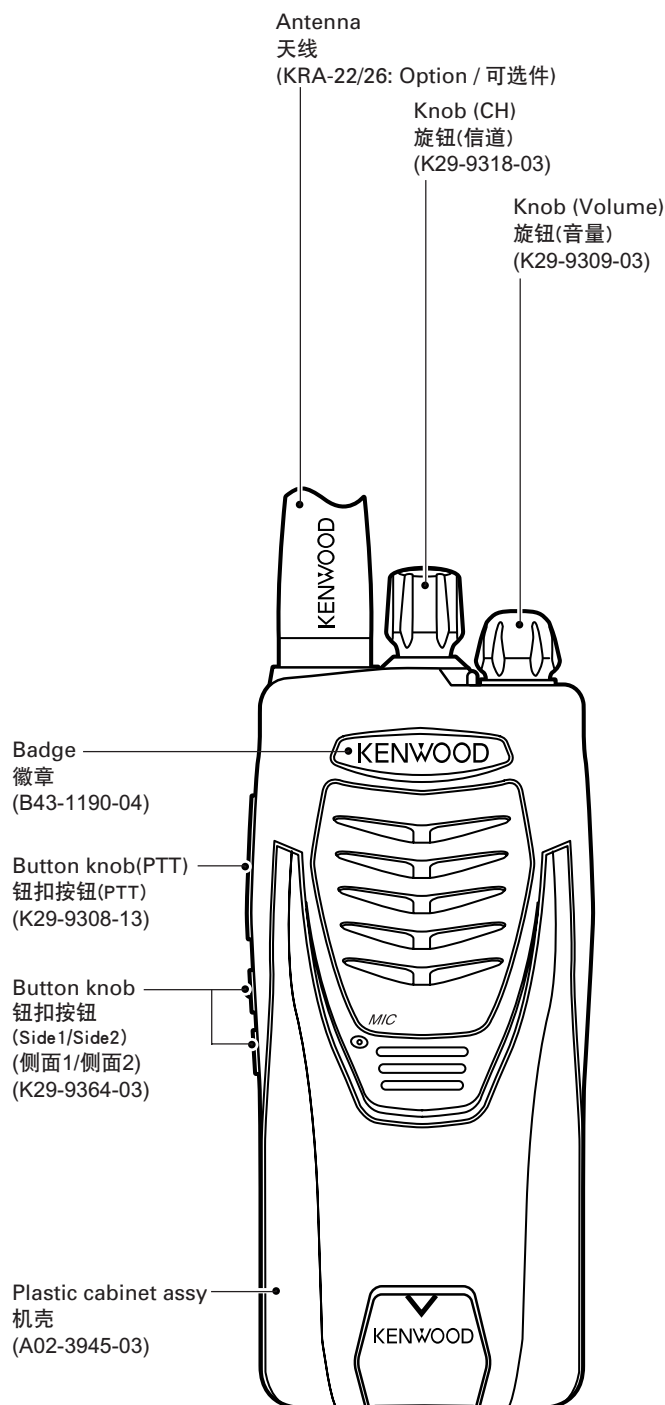
© 2006-4 PRINTED IN JAPAN
B51-8755-00 (S) 576



无铅焊接通信产品  
保护环境建伍领先

⚠ 注意：本产品是无铅化焊接产品
在维修时请使用无铅焊锡
和相应的焊接工具
详细事项请访问如下网址了解：
<http://www.kenwoodhk.com.hk/>

**Does not come with antenna.
Antenna is available as an option.**
不包括天线。天线为选项。



This product uses Lead Free solder.

GENERAL	2	概述	2
SYSTEM SET-UP	3	系统体系	3
REALIGNMENT	4	模式组合	4
DISASSEMBLY FOR REPAIR	7	维修拆卸	7
CIRCUIT DESCRIPTION	12	电路说明	12
TERMINAL FUNCTION	20	端子功能	20
SEMICONDUCTOR DATA	20	半导体数据	20
COMPONENTS DESCRIPTION	22	元件说明	22
PARTS LIST	24	零件表	24
EXPLODED VIEW	30	部件分解图	30
PACKING	31	包装	31
ADJUSTMENT	32	调整	32
PC BOARD		PC 板	
TX-RX UNIT (X57-6870-20)	42	TX-RX 单元 (X57-6870-20)	42
SCHEMATIC DIAGRAM	46	原理图	46
BLOCK DIAGRAM	50	方块图	50
LEVEL DIAGRAM	52	电平图	52
OPTIONAL ACCESSORIES		可选附件	
KSC-31 (RAPID CHARGER)	53	KSC-31 (快速充电器)	53
KNB-29N (Ni-MH BATTERY PACK)	53	KNB-29N (Ni-MH 电池组)	53
KNB-30A (Ni-Cd BATTERY PACK)	54	KNB-30A (Ni-Cd 电池组)	54
KBH-10 (BELT CLIP)	54	KBH-10 (皮带夹)	54
SPECIFICATIONS	55	规格	封底

GENERAL / 概述

INTRODUCTION

SCOPE OF THIS MANUAL

This manual is intended for use by experienced technicians familiar with similar types of commercial grade communications equipment. It contains all required service information for the equipment and is current as of the publication date. Changes which may occur after publication are covered by either Service Bulletins or Manual Revisions. These are issued as required.

ORDERING REPLACEMENT PARTS

When ordering replacement parts or equipment information, the full part identification number should be included. This applies to all parts : components, kits, or chassis. If the part number is not known, include the chassis or kit number of which it is a part, and a sufficient description of the required component for proper identification.

PERSONAL SAFETY

The following precautions are recommended for personal safety:

- DO NOT transmit until all RF connectors are verified secure and any open connectors are properly terminated.
- SHUT OFF and DO NOT operate this equipment near electrical blasting caps or in an explosive atmosphere.
- This equipment should be serviced by a qualified technician only.

引言

本手册的范围

本手册是提供给熟悉通信专业并且具有维修经验的技术人员使用的。它包括了维修该设备所需要的全部资料和现行出版日期。在出版后如果发生变动，则根据需要使用《维修通报》或《手册修订本》进行补充。

替换零件的订购

当订购替换零件或设备资料时,应注明完整的零件识别号码。所有的零件均有识别号码:元件,组件或机壳。如果不知道零件的号码,为了正确地识别,必须注明此元件所属的机壳或组件的号码,并对元件进行充分的说明。

个人安全

为了个人的安全,请注意下列事项:

- 在没有认真核实所有射频插头之前或有任何一个打开的插头没有连接到相应端子上的情况下,均不要发射。
- 在电爆管附近或在易燃性气体环境中,必须关掉电源,不要操作本设备。
- 本设备只应该由有资格的技术人员来维修。

GENERAL / 概述

SERVICE

This transceiver is designed for easy servicing. Refer to the schematic diagrams, printed circuit board views, and alignment procedures contained within.

Unit		TX-RX Unit	Frequency range	Remarks
Model & destination				
TK-2207G	C	X57-6870-20	136~174MHz	IF1 : 38.85MHz LOC : 38.4MHz

维修服务

为了便于维修本设备，建立了完整的维修服务体系，提供了包括原理图，印刷线路板图和调整步骤在内的资料供参考。

单元		TX-RX 单元	频率范围	备注
型号和类型				
TK-2207G	C	X57-6870-20	136~174MHz	IF1 : 38.85MHz LOC : 38.4MHz

SYSTEM SET-UP / 系统体系

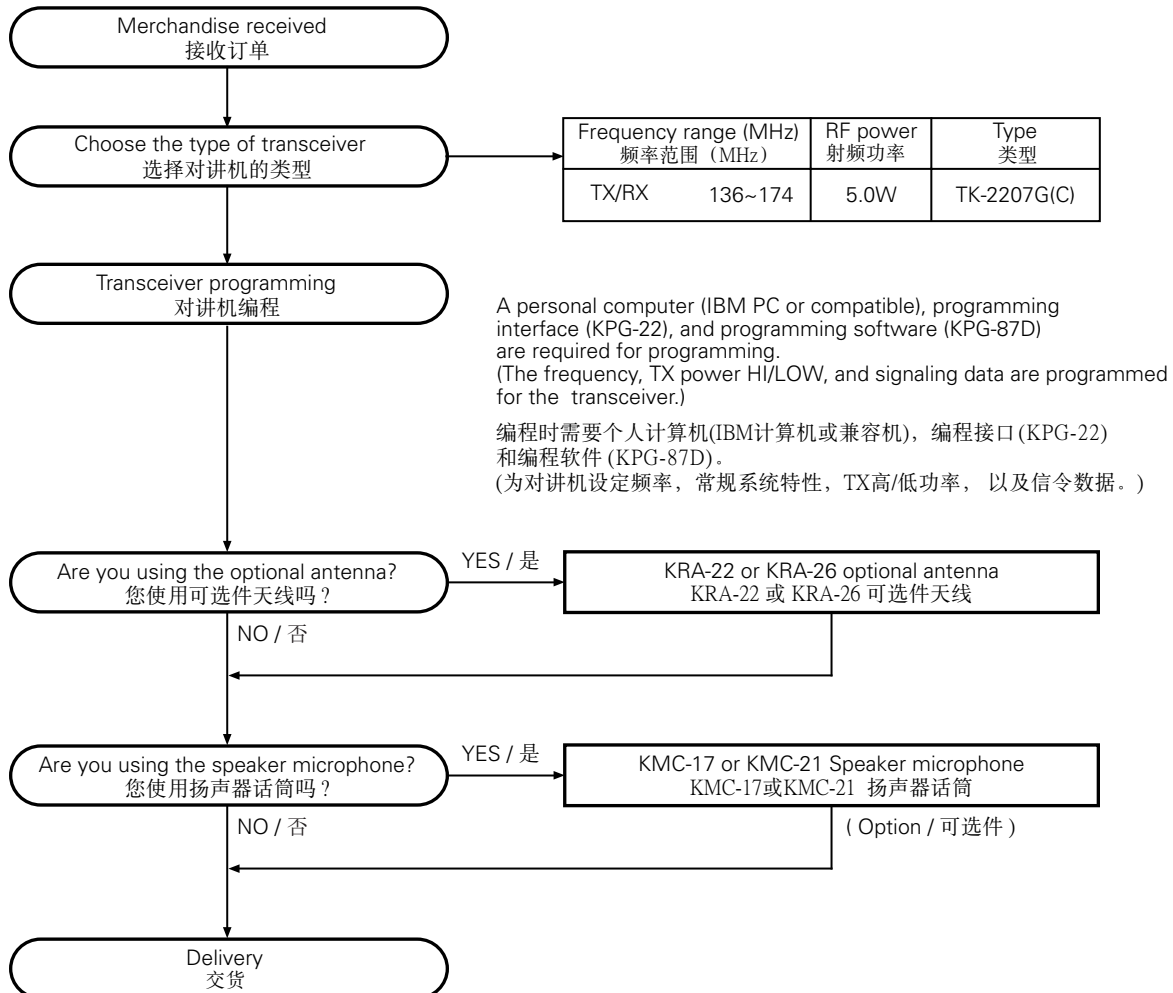

REALIGNMENT / 模式组合

1. Modes

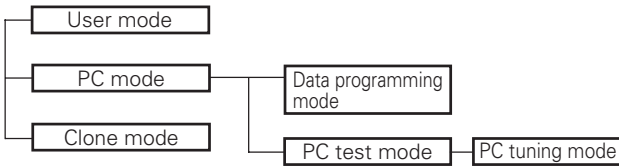

Mode	Function
User mode	For normal use.
PC mode	Used for communication between the transceiver and PC (IBM compatible).
Data programming mode	Used to read and write frequency data and other features to and from the transceiver.
PC test mode	Used to check the transceiver using the PC. This feature is included in the KPG-87D.
Clone mode	Used to transfer programming data from one transceiver to another.

2. How to Enter Each Mode

Mode	Operation
User mode	Power ON
PC mode	Received commands from PC
Clone mode	[PTT]+[Side2]+Power ON (Two seconds)

3. PC Mode

3-1. Preface

The transceiver is programmed using a personal computer, a programming interface cable (KPG-22) and programming software (KPG-87D).

The programming software can be used with an IBM PC or compatible. Figure 1 shows the setup of an IBM PC for programming.

3-2. Connection procedure

1. Connect the transceiver to the personal computer with the interface cable.
2. When the POWER is switched on, user mode can be entered immediately. When the PC sends a command, the transceiver enters PC mode.
When data is transmitting from the transceiver, the red LED lights.
When data is received by the transceiver, the green LED lights.

Notes:

- The data stored in the personal computer must match the model type when it is written into the EEPROM.
- Change the transceiver to PC mode, then attach the interface cable.

3-3. KPG-22 description

(PC programming interface cable: Option)

The KPG-22 is required to interface the transceiver with the computer. It has a circuit in its D-sub connector (25-pin) case that converts the RS-232C logic level to the TTL level.

1. 模式

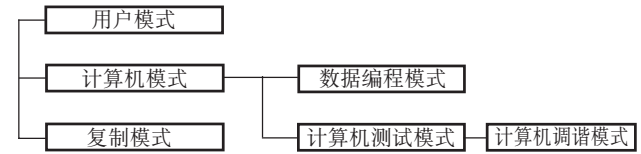

模式	功能
用户模式	一般使用
计算机模式	用于对讲机与计算机(IBM 兼容机)之间的通信。
数据编程模式	用于读出和写入频率数据以及其他功能。
计算机测试模式	用于使用计算机来检测对讲机。此功能包括在 KPG-87D 内。
复制模式	用于从一个对讲机编程数据复制到另一个对讲机。

2. 如何进入每一种模式

模式	操作
用户模式	接通电源
计算机模式	从计算机接收指令
复制模式	[PTT]+[侧面 2]+ 接通电源 (2 秒钟)

3. 计算机模式

3-1. 前言

对讲机使用计算机, 编程接口电缆 (KPG-22) 和编程软件 (KPG-87D) 进行编程。

IBM 计算机或兼容机可以使用编程软件。图 1 显示 IBM 计算机编程的设置。

3-2. 连接步骤

1. 使用接口电缆将对讲机连接到计算机上。
2. 当电源接通时, 立即进入用户模式。当计算机发出指令时, 对讲机进入计算机模式。
当对讲机传送数据时, 红色 LED 亮灯。
当对讲机接收数据时, 绿色 LED 亮灯。

注意:

- 当把储存在计算机中的数据写入到 EEPROM 中时, 机型型号必须相匹配。
- 将对讲机改变为计算机模式, 然后连接接口电缆。

3-3. KPG-22 说明(计算机编程接口电缆: 可选件)

对讲机需要通过接口电缆 KPG-22 与电脑连接。此接口电缆的 D-sub 连接器 (25 芯) 中有一个将 RS-232C 逻辑电平转换为 TTL 电平的电路。

REALIGNMENT / 模式组合

The KPG-22 connects the SP/MIC connector of the transceiver to the computer's RS-232C serial port.

3-4. Programming software KPG-87D description

KPG-87D is the programming software for the transceiver supplied on a CD-ROM. This software runs under Windows 98, ME, Windows 2000 or XP on an IBM-PC or compatible machine.

The data can be input to or read from the transceiver and edited on the screen. The programmed or edited data can be printed out. It is also possible to tune the transceiver.

KPG-22 连接对讲机的 SP/MIC 连接器和电脑的 RS-232C 串行接口。

3-4. 编程软件 KPG-87D 说明

KPG-87D 是以 CD-ROM 形式提供的对讲机用编程软件。此软件的运行环境为 IBM-PC 机或兼容机的 Windows 98,ME,Windows 2000 或 XP。

数据可以被输入到对讲机或从对讲机中读取数据，并且在屏幕上进行编辑。已被编程或编辑的数据可以打印出来。也可以调整对讲机的指标。

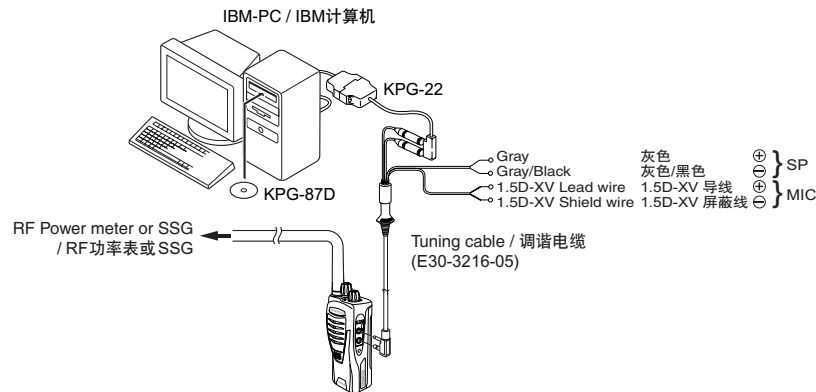

Fig. 1 / 图 1

4. Clone Mode

4-1. Outline

"Clone Mode" copies the transceiver data to another transceiver.

The dealer can copy the transceiver data to another transceiver even without the use of a personal computer.

4-2. Example

The transceiver can copy the programming data to one or more transceivers via RF communication.

The clone source and clone target/s must be in Clone mode.

4-3. Operation

- To switch the clone target/s to Clone mode, press and hold the [PTT] and [Side2] keys while turning the transceiver power ON.
- Wait for 2 seconds. The LED will light orange and the transceiver will announce "Clone".
- Select a channel table number using Side1 (increment channel table) and Side2 (decrement channel table) keys.
- To switch the clone source to Clone mode, press and hold the [PTT] and [Side2] keys while turning the transceiver power ON.
- Wait for 2 seconds. The LED will light orange and the transceiver will announce "Clone".
- Select the same channel table number as the clone target/s.
- Press [PTT] on the clone source to begin data transmission. When the clone target starts to receive data, the LED will light green.

When the clone source finishes sending data, a "confirmation" tone will sound.

If data transmission fails while cloning, an "error" tone will sound from the Target unit.

4. 复制模式

4-1. 概要

"复制模式"可以将一台对讲机的数据复制到其它的对讲机。经销商甚至不使用个人电脑也可以将一台对讲机的数据复制到其它的对讲机。

4-2. 例:

对讲机可以通过 RF 通信复制编程数据到一台或更多的对讲机。

复制主机和复制子机必须处于复制模式。

4-3. 操作方法

- 将子机切换到复制模式，旋转对讲机电源的同时，持续按 [PTT] 键和 [侧面 2] 键。
- 等待 2 秒。LED 将呈橘黄色并且对讲机将发出"复制"的声音。
- 用侧面 1 (频道表递增) 键和侧面 2 (频道表递减) 键选择频率表号码。
- 将主机切换到复制模式，旋转对讲机电源的同时，持续按 [PTT] 键和 [侧面 2] 键。
- 等待 2 秒。LED 将呈橘黄色并且对讲机将发出"复制"的声音。
- 选择与复制子机相同的频率表号码。
- 按复制主机上的 [PTT]，开始数据传输。当复制子机开始接收数据时，LED 将呈绿色。当复制主机完成传送数据时，将发出一个"确认"音。如果在复制过程中数据传输失败，子机将发出一个"错误"音。

REALIGNMENT / 模式组合

8. If the cloning fails, no data will be available in the Target unit when it is returned to User mode.
9. When the cloning is successful, the Target unit's "Scan" and "Key lock" functions will return to their default values (Scan = OFF, Key lock = OFF).

Notes:

- The dealer can clone data to two or more transceivers by repeating the above procedures.
- If the transceivers Clone Mode is configured as "Disabled", the transceiver cannot enter Clone mode.
- The table shown below will cover the frequency tables used for wireless cloning.
- Clone mode cannot be entered in battery low state.
- A unit cannot be a "Source Unit" if it is unprogrammed. If [PTT] is pressed, an "error" tone will sound.
- The language used in cloning depends on the "Model type" setting, not the FPU setting. C type TK-2207G transceiver and C, C2, C5 and C6 type TK-3207/3207G transceivers will use Chinese. Other types English.
- Once a unit is set to be the Source, it cannot be a target after the data has been transmitted. This protects the data in the Source unit.
- Electronic interface may cause a failure in data transfer during Wireless Clone, such as when waveforms or electromagnetics are being performed at the workbench.
- Clone mode can be used ONLY by the authorized service personal.
- The Clone mode setting must be configured as "Disable" before being delivered to the end-user.
- To clone, replace the antenna from both the source transceiver and the target transceiver with a dummy load.
- The transmit output power is automatically set to Low in Clone mode.

Clone Frequency Table

Operating Frequency Clone Frequency Table (MHz)	136~174
1	136.000
2	138.000
3	140.000
4	142.000
5	144.000
6	146.000
7	148.000
8	150.000
9	152.000
10	154.000
11	156.000
12	158.000
13	160.000
14	162.000
15	164.000
16	166.000
17	168.000
18	170.000
19	172.000
20	174.000

8. 如果复制失败，子机回到用户模式时数据随即消失。
9. 当复制成功时，子机的 "扫描" 和 "键锁定" 功能将回到它们的初始值 (扫描 =OFF, 键锁定 =OFF)

注意:

- 经销商可以反复上述过程复制数据到 2 个或更多的对讲机。
- 如果对讲机复制模式被设置为“无效”，则对讲机不能进入复制模式。
- 下表包含了无线复制用的频率表。
- 当电池处于低电压状态时不能进入复制模式。
- 如果对讲机是非编程的它将不能成为主机。如果按[PTT]，将发出一个 "错误" 音。
- 复制时所用的语言是根据 "样机类别" 设置，而不是 FPU 设置，TK-2207G 的 C 类型的对讲机和 TK-3207/3207G 的 C, C2, C5 和 C6 类型的对讲机用中文，其它类别用英文。
- 对讲机一旦被设置为主机，数据传送以后，它就不能成为子机。这是为了保护主机里的数据。
- 在无线复制的数据传输过程中，例如在工作台产生的电波或电磁干扰有可能引起传输失败。
- 复制模式可以仅被批准的服务人员使用。
- 在交付给最终用户之前，复制模式设置必须被设置为“无效”。
- 为了复制，将模拟负载代替主对讲机和子对讲机的天线。
- 在复制模式，发射功率自动设定为低。

复制频率表

操作频率 复制频率表 (MHz)	136~174
1	136.000
2	138.000
3	140.000
4	142.000
5	144.000
6	146.000
7	148.000
8	150.000
9	152.000
10	154.000
11	156.000
12	158.000
13	160.000
14	162.000
15	164.000
16	166.000
17	168.000
18	170.000
19	172.000
20	174.000

DISASSEMBLY FOR REPAIR / 维修拆卸

Disassembly Procedure

■ Removing the case assembly from the chassis

1. Remove the volume knob ① and channel knob ②.
2. Remove two screws ③.
3. Lift and remove the chassis from the case assembly ④.
(Use a flat-head screwdriver to easily lift the chassis.)

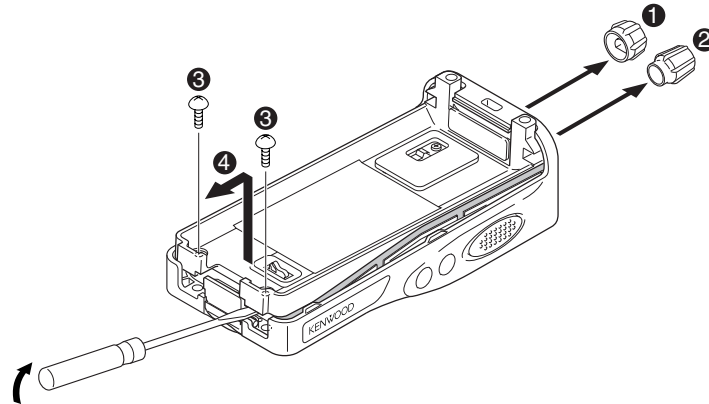

拆卸程序

■ 拆卸机壳

1. 卸下音量旋钮 ① 和信道旋钮 ②。
2. 卸下 2 个螺丝 ③。
3. 抬起机架 ④，将其与机壳分离取出。(使用一字形螺丝刀会比较容易抬起机架。)

■ Removing the TX-RX unit from the chassis

1. Remove the packing ⑤ from the SP / MIC jack of the TX-RX unit.
2. Remove eleven screws ⑥ fixing the TX-RX unit.
3. Remove the fixing bracket ⑦ of the SP / MIC.
4. Remove the solder of the antenna terminal with a soldering iron ⑧.
5. Remove the solder of the positive terminal with a soldering iron ⑨.

Note: You can remove the TX-RX unit from the chassis without removing the solder at the positive terminal. However, in this case, you can not attach the packing (G53-1605-03) that is on the positive terminal to the chassis in assembling. So, it is advisable to remove the solder on the positive terminal first.

6. Remove the FPC from the flat cable connector ⑩.
7. Lift and remove the TX-RX unit from the chassis ⑪.

■ 拆卸 TX-RX 单元

1. 从 TX-RX 单元的 SP / MIC 插孔卸下橡胶垫 ⑤。
2. 卸下固定 TX-RX 单元的 11 个螺丝 ⑥。
3. 卸下 SP / MIC 部的固定支架 ⑦。
4. 用电烙铁烫开天线端子的焊锡 ⑧。
5. 用电烙铁烫开电池正极端子的焊锡 ⑨。

注意：虽然不烫开电池正极端子的焊锡也可以从机架拆卸 TX-RX 单元，但是组装时，电池正极端子连接的垫片 (G53-1605-03) 不能安装到机架。因此，请先烫开电池正极端子的焊锡。

6. 从扁平电缆连接器卸下 FPC ⑩。
7. 拿起 TX-RX 单元 ⑪，从机架拆卸下来。

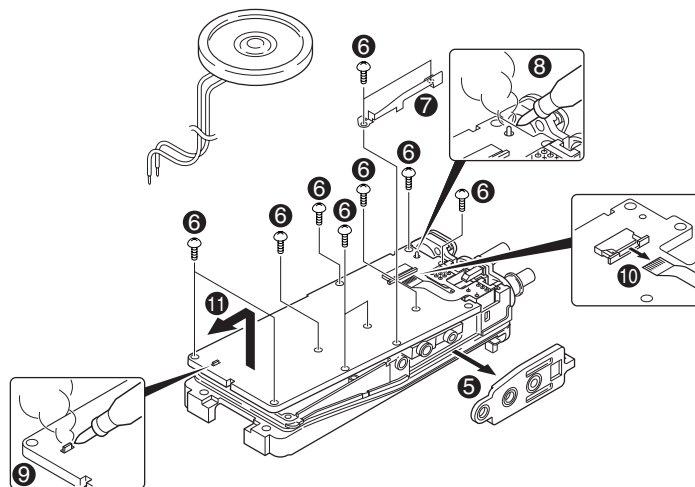

DISASSEMBLY FOR REPAIR / 维修拆卸

■ Removing the battery release lever from the case assembly

1. Press the upper part of the lever toward the inside of the case assembly. One side of the shaft will be removed ①.
2. Lift and remove the battery release lever from the case assembly ②.

Note: Scratch and widen the glue hole if there is difficulty in removing the other end of the shaft.

No glue is required when you reassemble the battery release lever.

■ 从机壳拆卸电池分离拨杆

1. 向机壳的内侧按压拨杆上部之后，就可以卸下轴的一侧 ①。
2. 拿起电池分离拨杆 ②，就可以从机壳上拆卸下来。

注意：如果很难拆卸轴的其他端部时，请刮掉和扩展粘合孔。当你重新组装电池分离杆时，则不需要粘合。

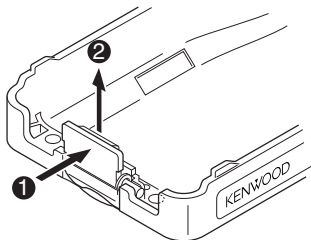

Precautions for Reassembly

■ Attaching the battery release lever to the case assembly

1. Insert one side of the shaft into the hole at the lever fitting section on the case assembly ①.

Note: The thin spring (G01-4543-04) should be positioned above two tabs of the lever.

2. Tilt the battery release lever slightly forward ②, so that the thick spring (G01-4542-04) is positioned below the case surface.

3. With the thick spring positioned below the case surface, attach the other side of the shaft to the case assembly by pressing the battery release lever ③ until it snaps into place ④.

Note: Be careful not to tilt the battery release lever too forward. If the battery release lever is pushed in this state where two tabs come below the case surface, there is a possibility of damaging two tabs.

重新组装注意事项

■ 把电池分离拨杆安装到机壳

1. 把轴的一侧插入到机壳的拨杆安装部的孔里 ①。

注意：细弹簧(G01-4543-04)的横杆部分应安装到拨杆的2个突起的上侧。

2. 轻轻地前推电池分离杆倾斜到 ②，这样粗弹簧(G01-4542-04)被定位在机壳下面。

3. 随着粗弹簧定位到机壳下面，通过按电池分离杆 ③ 直到它嵌到位置 ④ 轴的另一侧接触机壳组件。

注意：注意不要把电池分离杆倾斜得太靠前。

如果电池分离杆被推到机壳下面的2个卡头的位置，就有可能损坏此2个卡头。

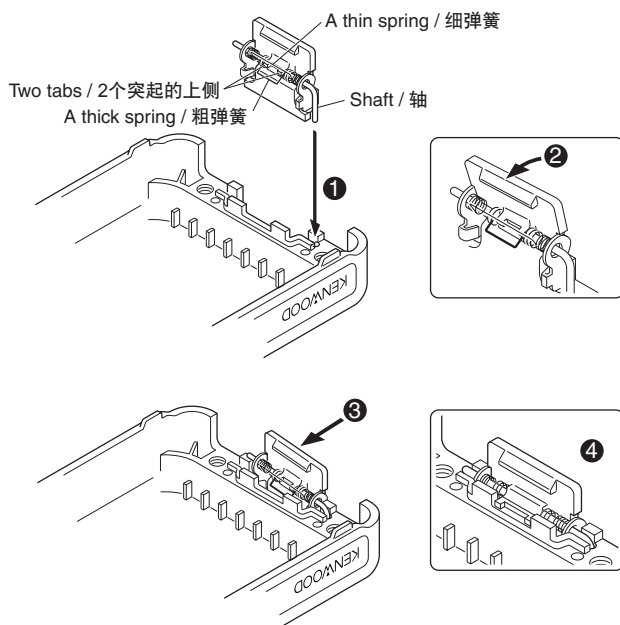

DISASSEMBLY FOR REPAIR / 维修拆卸

■ Assembling the battery release lever

1. Place the lever ② onto the stopper ①.
2. Place the thick spring ③ onto the lever.
3. Hook the right and left ends of the thin spring ④ onto the tabs of the stopper, then place the thin spring onto the lever ⑤.
4. Slide the shaft through the hole of the stopper and lever ⑥.

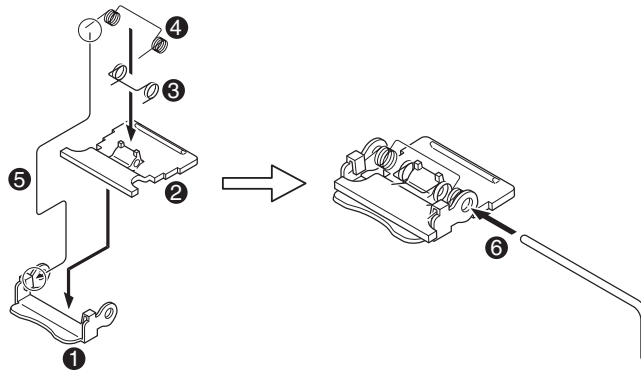

■ 电池分离拨杆的组装方法

1. 把拨杆 ② 置于止动器 ① 的上面。
2. 把粗弹簧 ③ 置于拨杆的上面。
3. 把细弹簧置于拨杆的上面，并让细弹簧 ④ 的左右端置于止动器的两个勾内 ⑤。
4. 把轴穿过止动器和拨杆的孔 ⑥。

■ Attaching the positive terminal to the chassis

Always attach the positive terminal to the chassis, using the following procedures, before mounting the TX-RX unit onto the chassis.

1. Remove the holder assembly ② from the packing ① of the positive terminal.
2. Mount the packing of the positive terminal into the chassis hole ③.
3. Mount the holder assembly into the packing of the positive terminal ④.

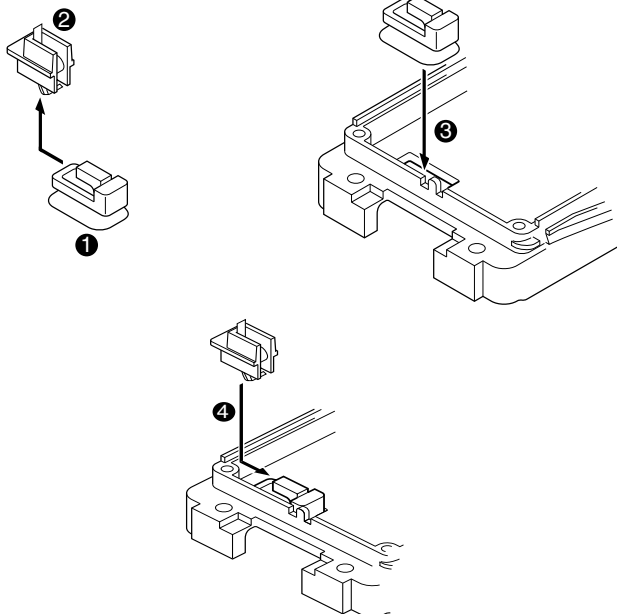

■ 把电池正极端子安装机架

把TX-RX单元组装到机架之前，必须按照以下的顺序把电池正极端子安装到机架。

1. 从电池正极端子的垫片 ① 取下支架总成 ②。
2. 把电池正极端子的垫片装到机架孔 ③。
3. 把支架总成组装到电池正极端子的垫片上 ④。

TK-2207G

DISASSEMBLY FOR REPAIR / 维修拆卸

■ Mounting the chassis to the case assembly

1. Confirm that the waterproof packing attached to the circumference of the chassis is securely inserted in the groove of the chassis ①.
2. Attach the speaker to the speaker recess of the case assembly ②. Make sure the speaker is securely inserted.

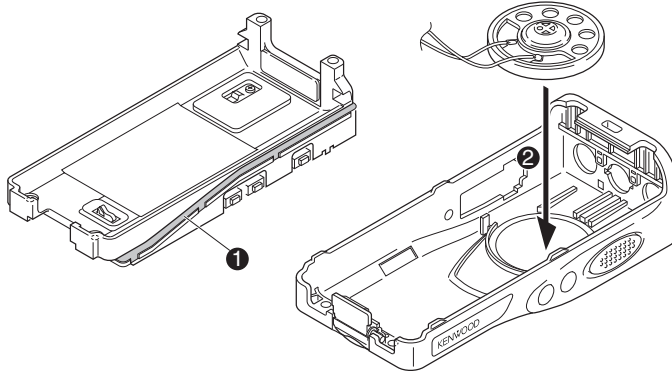

Confirm that the waterproof packing is securely inserted in the groove of the chassis.

确认防水垫是否确实地进入机架的槽里。

3. Insert the upper part of the chassis into the case assembly ③.

Note: Take care that the speaker lead wire is not caught by the microphone element.

4. Press the chassis ④ and the case assembly together to attach them.

Note: If the packing of the SP / MIC does not come to the correct position after attaching the chassis to the case assembly, reposition the packing with your fingers.

■ 安装机壳和机架

1. 确认机架四周的防水垫是否确实地进入机架的槽里 ①。
2. 把扬声器安装到机壳的扬声器安装部 ②。确保扬声器完全被插入。

3. 把机架上侧插到机壳内 ③。

注意：请不要使扬声器引线勾住麦克风。

4. 下压机架 ④，使机架和机壳合为一体并安装好。

注意：把机架安装到机壳后，如果 SP / MIC 的橡胶垫不在正常的位置时，请用手指将其调整到正常的位置。

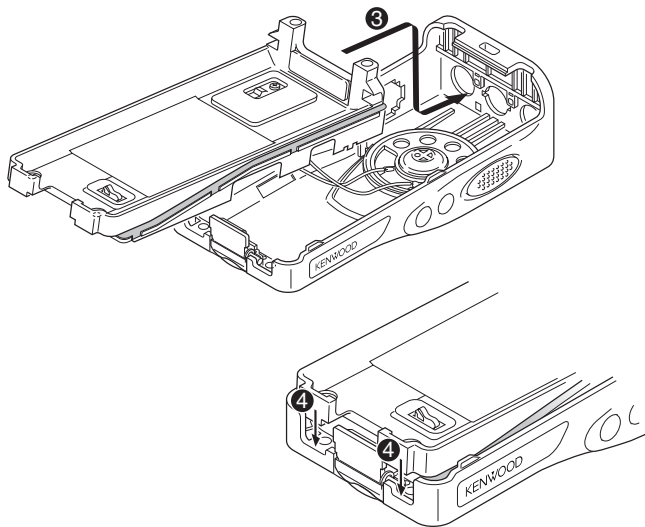

DISASSEMBLY FOR REPAIR / 维修拆卸

■ Attaching the antenna receptacle to the chassis

Screw the antenna receptacle to the chassis in the order shown in the drawing so that the antenna receptacle comes to the center of the case hole.

■ 把天线插座 (Antenna receptacle) 安装到机架

为了能把天线插座安装到机芯孔的中心, 在将天线插座安装到机架时, 请按照图示的顺序固定螺丝。

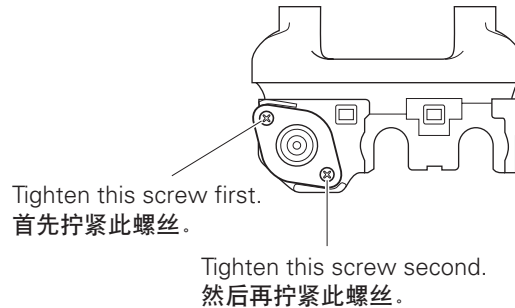

■ The nuts of the volume knob and channel knob

Note that the shapes, colors and heights of nuts of the volume knob and channel knob are different from one another. (The nut of volume knob is silver, and the nut of channel knob is gold)

Use the following jig when removing the nuts of the volume knob and channel knob.

- Jig (Part No. : W05-1012-00)

■ 关于音量旋钮和信道旋钮的螺母

音量旋钮和信道旋钮的螺母形状不同, 颜色高度也不同, 因此请注意。(音量旋钮螺母为银色, 信道旋钮的螺母为金色) 另外, 拆卸音量旋钮和信道旋钮的螺母时, 请使用下列夹具。

- 夹具 (零件号 : W05-1012-00)

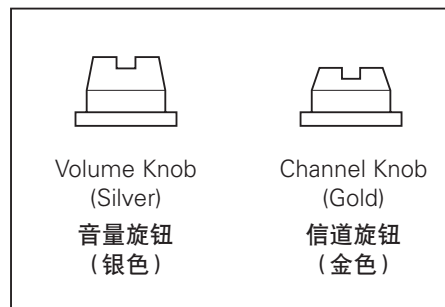

CIRCUIT DESCRIPTION / 电路说明

1. Frequency Configuration

The receiver utilizes double conversion. The first IF is 38.85 MHz and the second IF is 450 kHz. The first local oscillator signal is supplied from the PLL circuit.

The PLL circuit in the transmitter generates the necessary frequencies. Fig. 1 shows the frequencies.

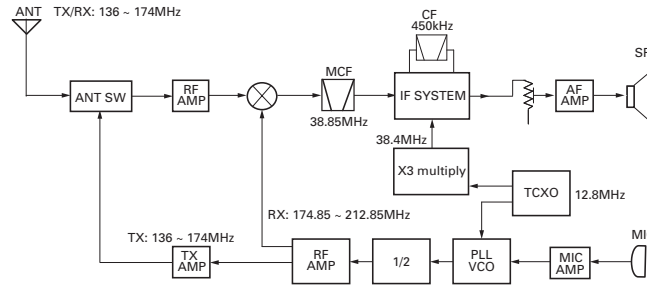

Fig. 1 Frequency configuration / 图 1 频率构成

2. Receiver

The frequency configuration of the receiver is shown in Fig. 2.

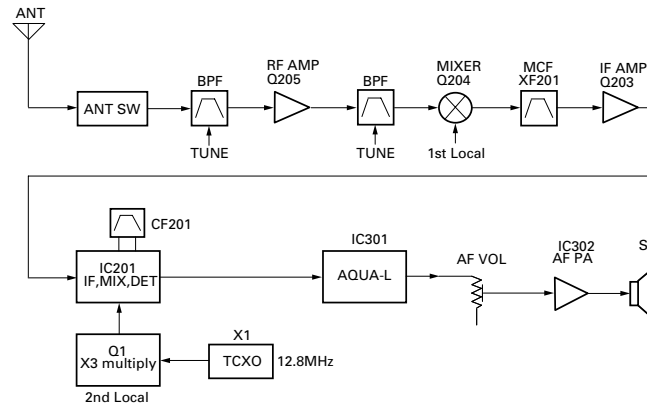

Fig. 2 Receiver section / 图 2 接收部

1) Front End (RF AMP)

The signal coming from the antenna passes through the transmit/receive switching diode circuit, (D103, D104, D105 and D106) passes through a BPF (L214 and L213), and is amplified by the RF amplifier (Q205).

The resulting signal passes through a BPF (L209 and L211) and goes to the mixer. These BPFs are adjusted by variable capacitors (D203, D204, D205 and D206). The input voltage to the variable capacitor is regulated by voltage output from the microprocessor (IC405).

2) First Mixer

The signal from the front end is mixed with the first local oscillator signal generated in the PLL circuit by Q1 to produce a first IF frequency of 38.85 MHz.

The resulting signal passes through the XF201 MCF to cut the adjacent spurious and provide the optimum characteristics, such as adjacent frequency selectivity.

1. 频率构成

本接收机使用二次变频。第一 IF 是 38.85 MHz，第二 IF 是 450 kHz。第一本地振荡信号由 PLL 电路提供。

PLL 电路产生需要的发射频率。

2. 接收部

接收部的频率构成如图 2 所示。

1) 前端 (RF 放大器)

从天线接收的信号进入发送 / 接收转换开关二极管电路 (D103, D104, D105 和 D106)，然后通过 BPF (L214 和 L213)，并且被 RF 放大器 (Q205) 放大。

此信号通过 BPF (L209 和 L211) 然后进入混频。这些 BPF 被可变电容器 (D203, D204, D205 和 D206) 调整。输入可变电容器的电压被经微处理器 (IC405) 的电压输出调整。

2) 第一混频器

前端的信号与 PLL 电路产生的第一本振信号在 Q1 混频，生成 38.85 MHz 频率的第一中频信号。

生成的信号通过 XF201 MCF。

CIRCUIT DESCRIPTION / 电路说明

3) IF Amplifier Circuit

The first IF signal is passed through a four-pole monolithic crystal filter (XF201) to remove the adjacent channel signal. The filtered first IF signal is amplified by the first IF amplifier (Q203) and then applied to the IF system IC (IC201). The IF system IC provides a second mixer, second local oscillator, limiting amplifier, quadrature detector and RSSI (Received Signal Strength Indicator). The second mixer mixes the first IF signal with the 38.4MHz of the second local oscillator output (TCXO X1) and produces the second IF signal of 450kHz.

The second IF signal is passed through the ceramic filter (CF201) to remove the adjacent channel signal. The filtered second IF signal is amplified by the limiting amplifier and demodulated by the quadrature detector with the ceramic discriminator (CD201). The demodulated signal is routed to the audio circuit.

4) Wide/Narrow Switching Circuit

Narrow and Wide settings can be made for each channel by switching the demodulation level.

The WIDE (low level) and NARROW (high level) data is output from IC405, pin 45.

When a WIDE (low level) data is received, Q202 turn on. When a NARROW (high level) data is received, Q202 turn off. Q202 turns on/off with the Wide/Narrow data and the IC201 detector output level is switched to maintain a constant output level during wide or narrow signals.

3) 中频放大电路

第一中频信号通过晶体滤波器 (XF201) 消除相邻信道的信号。经滤波的第一中频信号被第一中频放大器 (Q203) 放大并进入中频系统芯片 (IC201)。中频系统芯片提供第二混频器, 第二本振信号, 限幅放大器, 正交检测器和 RSSI (接收信号强度指示器)。第二混频器将第一中频信号与 38.4MHz 的第二本振信号输出 (TCXO X1) 进行混频, 并生成 450kHz 的第二中频信号。

第二中频信号通过陶瓷滤波器 (CF201) 继续消除相邻信道的信号。经滤波的第二中频信号被限幅放大器放大并被带有陶瓷鉴频器 (CD201) 的正交检测器解调。经解调的信号进入音频电路。

4) 宽 / 窄开关电路

可以通过开启宽窄开关对各信道进行宽窄设定。

WIDE (低电平) 和 NARROW (高电平) 数据被 IC405、45 管脚输出。

当接收到 WIDE (低电平) 数据时, Q202 接通。

当接收到 NARROW (高电平) 数据时, Q202 断开。

Q202 伴随着宽 / 窄数据而接通 / 断开, IC201 检测器输出电平经常变化用来维持宽或窄信号过程中的恒定输出电平。

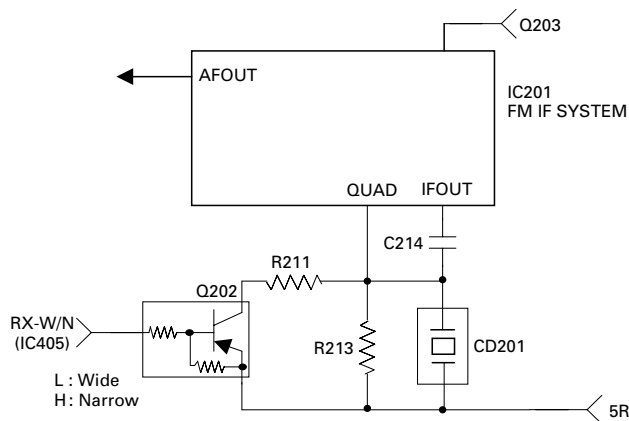

Fig. 3 Wide/Narrow switching circuit / 图 3 宽 / 窄开关电路

5) Audio Amplifier Circuit

The demodulated signal from IC201 goes to AF amplifier through IC301.

The signal then goes through an AF volume control, and is routed to an audio power amplifier (IC302) where it is amplified and output to the speaker.

5) 音频放大器电路

来自于 IC201 的解调信号通过 IC301 送到音频放大器。

信号通过 AF 音量控制, 在音频功率放大器 (IC302) 进行放大后输出到扬声器。

CIRCUIT DESCRIPTION / 电路说明

6) Squelch

Part of the AF signal from the IC enters the FM IC (IC201) again, and the noise component is amplified and rectified by a filter and an amplifier to produce a DC voltage corresponding to the noise level.

The DC signal from the FM IC goes to the analog port of the microprocessor (IC405). IC405 determines whether to output sounds from the speaker by checking whether the input voltage is higher or lower than the preset value. To output sounds from the speaker, IC405 sends a high signal to the SP MUTE line and turns IC302 on through Q303, Q304, Q305, Q306 and Q316. (See Fig. 4)

7) Receive Signaling

(1) QT/DQT

The output signal from FM IC (IC201) enters the microprocessor (IC405) through IC301. IC405 determines whether the QT or DQT matches the preset value, and controls the SP MUTE and the speaker output sounds according to the squelch results.

(2) MSK (Fleet Sync)

The MSK input signal from the FM IC goes to pin 31 of IC 301. The signal is demodulated by MSK demodulator in IC 301. The demodulated data goes to the CPU for processing.

6) 静噪

FM IC (IC201) 输出的 AF 信号的一部分再进入 IC，噪声成份通过滤波器和放大器进行放大和修正，生成与噪声电平相应的 DC 电压。

DC 信号通过 FM IC 被送到微处理器的模拟端口 (IC405)。IC405 通过检测输入的电压是高于还是低于预设值来决定是否从扬声器输出声音。由扬声器输出声音时，IC405 发送高电平信号给 SP MUTE 线，通过 Q303, Q304, Q305, Q306 和 Q316 打开 IC302。(见图 4)。

7) 接收信令

(1) QT/DQT

FM IC (IC201) 输出的信号通过 IC301 进入微处理器 (IC405)。IC405 测定 QT 或 DQT 是否与设置的值匹配，并根据此结果来控制 SP MUTE 和扬声器输出声音。

(2) MSK (Fleet Sync)

来自 FM IC 的 MSK 输入信号送到 IC301 的 31 脚。信号在 IC301 上的 MSK 调制器中进行调制。被解调的数据送到 CPU 进行处理。

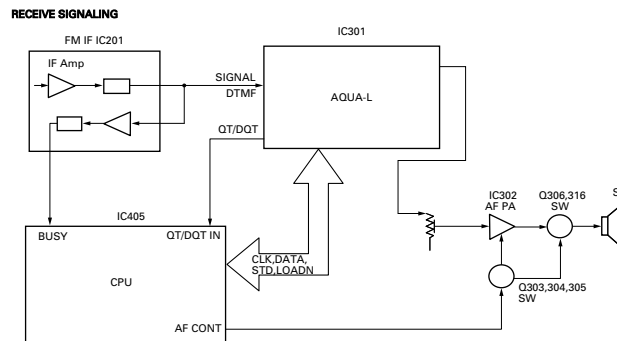

Fig. 4 AF amplifier and squelch / 图 4 AF 放大器和静噪

(3) DTMF

The DTMF input signal from the FM IC (IC201) goes to IC301. The decoded information is then processed by the CPU.

(3) DTMF

FM IC (IC201) 的 DTMF 输出信号送到 IC301。解码数据由 CPU 处理。

3. PLL Frequency Synthesizer

The PLL circuit generates the first local oscillator signal for reception and the RF signal for transmission.

1) PLL

The frequency step of the PLL circuit is 2.5, 5, 6.25 or 7.5kHz.

A 12.8MHz reference oscillator signal is divided at IC1 by a fixed counter to produce an oscillator (VCO) output signal which is buffer amplified by Q2 then divided in IC1 by a programmable counter. The divided signal is compared in phase with the 5 or 6.25kHz reference signal from the phase comparator in IC1. The output signal from the phase comparator is filtered through a low-pass filter and passed to the VCO to control the oscillator frequency. (See Fig. 5)

3. PLL 频率合成

PLL 电路产生用于接收的第一本地振荡信号和发射用的 RF 信号。

1) PLL

PLL 电路的频率步进是 2.5, 5, 6.25 或 7.5kHz。

12.8MHz 的参考振荡信号在 IC1 中被一个固定计数器分频。振荡器 (VCO) 的输出信号由 Q2 缓冲放大, 然后在 IC1 中被一个可编程双模块计数器分频。分频的信号在 IC1 的相位比较器中进行比较。生成的信号通过一个低通滤波器滤波后传送到 VCO 控制振荡器频率。(见图 5)

CIRCUIT DESCRIPTION / 电路说明

2) VCO

The operating frequency is generated by Q4 in transmit mode and Q3 in receive mode. The oscillator frequency is controlled by applying the VCO control voltage, obtained from the phase comparator, to the varactor diodes (D4 and D7 in transmit mode and D5 and D9 in receive mode). The RX pin is set high in receive mode causing Q5 turn on. The TX pin is set high in transmit mode. The outputs from Q3 and Q4 are amplified by Q6 and sent to the RF amplifiers.

2) VCO

所使用的频率在发射模式时由 Q4 生成，在接收模式时由 Q3 生成。通过将相位比较器所获得的 VCO 控制电压输送给可变二极管 (在发射模式时为 D4 和 D7，在接收模式时为 D5 和 D9) 来控制振荡频率。在接收时 RX 脚被设定为高，使 Q5 接通。发射时 TX 脚被设定为高。Q3 和 Q4 的输出被 Q6 放大并且传送给 RF 放大器。

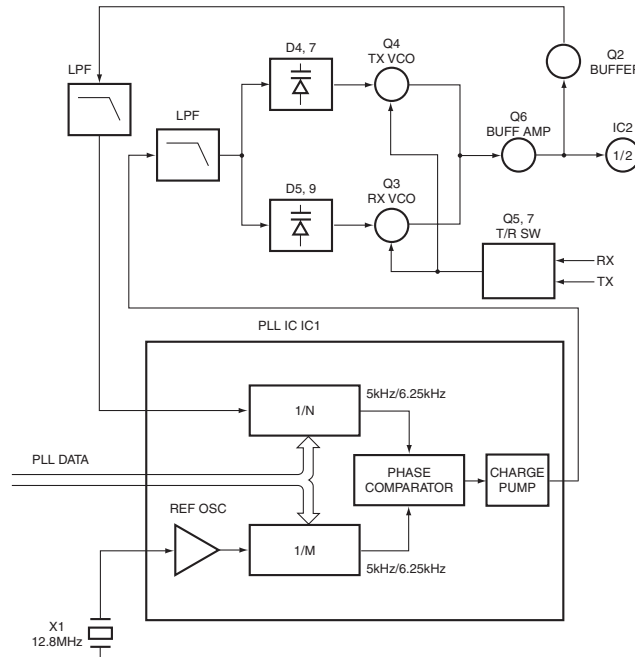

Fig. 5 PLL circuit / 图5 PLL 电路

3) Unlock Detector

If a pulse signal appears at the LD pin of IC1, an unlock condition occurs, and the DC voltage obtained from C4,R5 and D1 causes the voltage applied to the microprocessor to go low. When the microprocessor detects this condition, the transmitter is disabled, ignoring the push-to-talk switch input signal.

3) 失锁检测器

如果脉冲信号出现在IC1的LD管脚上，则发生了失锁的情况，从C4、R5和D1获得的DC电压使微处理器的输入电压变低。微处理器检测到这个情况后发射被禁止，忽略PTT开关的输入信号。

4. Transmitter System

1) Microphone Amplifier

The signal from the microphone passes through the IC301. When encoding DTMF, it is turned OFF for muting the microphone input signal by IC301. The signal passes through the Audio processor (IC301) for the maximum deviation adjustment, and goes to the VCO modulation input.

4. 发射部系统

1) 话筒放大器

来自于话筒的信号通过IC301。当编码DTMF时，话筒输入信号被IC301关闭。信号通过音频处理器 (IC301) 进行最大频偏调整，然后送到VCO调制输入。

CIRCUIT DESCRIPTION / 电路说明

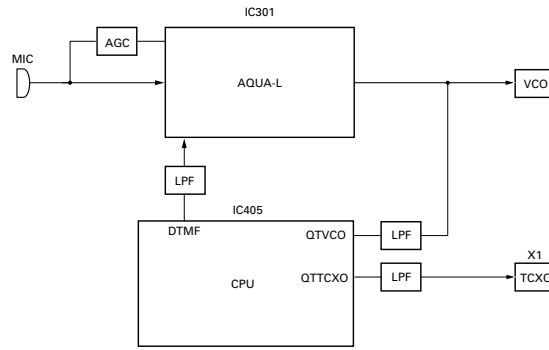

Fig. 6 Microphone amplifier / 图6 话筒放大器

2) Drive and Final Amplifier

The signal from the T/R switch (D101 is on) is amplified by the pre-drive (Q102) and the drive amplifier (Q103) to 50mW. The output of the drive amplifier is amplified by the RF power amplifier (Q106) to 5.0W (1W when the power is low). The RF power amplifier consists of two MOS FET stages. The output of the RF power amplifier is then passed through the harmonic filter (LPF) and antenna switch (D103 and D104) and applied to the antenna terminal.

2) 驱动器 and 终端放大器

来自于 T/R 开关 (D101 ON) 的信号被前置驱动放大器 (Q102) 和驱动放大器 (Q103) 放大到 50mW。

驱动放大器的输出被 RF 功率放大器 (Q106) 放大到 5.0W (当低功率时为 1W)。RF 功率放大器由 2 个 MOS FET 构成。RF 功率放大器的输出通过谐波滤波器 (LPF) 和天线开关 (D103 和 D104) 并且送到天线终端。

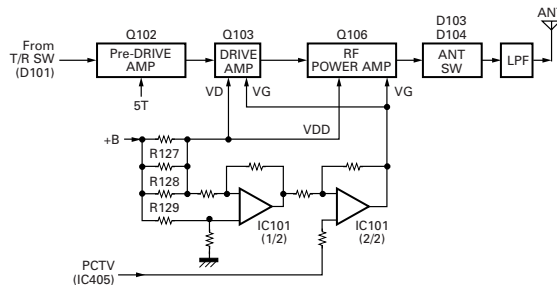

Fig. 7 Drive and final amplifier and APC circuit / 图7 驱动、终端放大器以及 APC 电路

3) APC Circuit

The APC circuit always monitors the current flowing through the RF power amplifier (Q106) and keeps a constant current. The voltage drop at R127, R128 and R129 is caused by the current flowing through the RF power amplifier and this voltage is applied to the differential amplifier IC101(1/2). IC101(2/2) compares the output voltage of IC101(1/2) with the reference voltage from IC405. The output of IC101(2/2) controls the VG of the RF power amplifier, drive amplifier and pre-drive amplifier to make both voltages the same. The change of power high/low is carried out by the change of the reference voltage.

3) 自动功率控制 (APC) 电路

APC 电路一直监视通过射频频率放大器 (Q106) 的电流并保持电流稳定。经过射频频率放大器的电流的变化会引起 R127, R128 和 R129 的电压降低, 此电压送到差分放大器 IC101 (1/2)。

IC101 (2/2) 将 IC101 (1/2) 的输出电压与来自 IC405 的参考电压进行比较。

IC101 (2/2) 的输出电压控制射频频率放大器, 驱动放大器, 预驱动放大器的 VG, 使电压保持一致。

功率高 / 低的变化是通过变更参考电压来实现的。

4) Encode Signaling

(1) QT/DQT

QT, DQT data of the QTTCXO Line is output from pin 28 of the CPU. The signal passes through a low-pass CR filter and goes to the TCXO (X1).

The QT, DQT data of the QTVCO Line is output from pin 24 of the CPU. The signal passes through a low pass CR filter, mixes with the audio signal, and goes to the VCO modulation input. TX deviation is adjusted by the CPU.

4) 编码信号

(1) QT/DQT

QTTCXO 线的 QT, DQT 数据从 CPU 的 28 管脚输出。信号通过低通 CR 滤波器, 并且送到 TCXO (X1)。

QTVCO 线的 QT, DQT 数据从 CPU 的 24 管脚输出。信号通过低通 CR 滤波器, 与音频信号混合, 然后输入到 VCO。TX 频偏被 CPU 调整。

CIRCUIT DESCRIPTION / 电路说明

(2) DTMF

High-speed data is output from pin 2 of the CPU. The signal passes through a low-pass CR filter, and provides a TX and SP out tone, and is then applied to the audio processor (IC301). The signal is mixed with the audio signal and goes to the VCO.

TX deviation is adjusted by the CPU.

(3) MSK (Fleet Sync)

Fleet Sync utilizes 1200bps and 2400bps MSK signal is output from pin 6 of IC301. And is routed to the VCO. When encoding MSK, the microphone input signal is muted.

5. Power Supply

There are four 5V power supplies: 5M, 5C, 5R, and 5T. 5M for microprocessor is always output while the power is on. 5M is always output, but turns off when the power is turned off to prevent malfunction of the microprocessor.

5C is a common 5V and is output when SAVE is not set to OFF.

5R is 5V for reception and output during reception.

5T is 5V for transmission and output during transmission.

6. Control Circuit

The control circuit consists of a microprocessor (IC405) and its peripheral circuits. It controls the TX-RX unit. IC405 mainly performs the following:

- (1) Switching between transmission and reception by the PTT signal input.
- (2) Reading system, group, frequency, and program data from the memory circuit.
- (3) Sending frequency program data to the PLL.
- (4) Controlling squelch on/off by the DC voltage from the squelch circuit.
- (5) Controlling the audio mute circuit by the decode data input.
- (6) Transmitting tone and encode data.

1) Frequency Shift Circuit

The microprocessor (IC405) operates at a clock of 7.3728MHz. This oscillator has a circuit that shifts the frequency by beat shift switch (Q407, Q408).

A beat sound may be able to be evaded from generation if "Beat Shift" is set to ON when it is generated in the internal spurious transmission modulated sound of a transceiver.

(2) DTMF

高速数据从CPU的2脚输出。信号通过低通CR滤波器，提供TX和SP输出音频，并输入到音频处理器 (IC301)。信号与音频信号混合，然后送到VCO。

TX频偏被CPU调整。

(3) MSK (Fleet Sync)

FleetSync使用1200bps和2400bps的MSK信号，这些信号从IC301的6脚输出。并且被发送到VCO。当编码MSK时，话筒输入信号被静音。

5. 电源

有4个5V电源: 5M, 5C, 5R和5T。当电源接通时，微处理器用的5M一直保持输出。5M虽然为经常输出，但在关闭电源时也被关掉，防止微处理器出现故障状态。

5C为公共的5V，在非省电状态时保持输出。

5R为接收用的5V，在接收期间保持输出。

5T为发射用的5V，在发射期间保持输出。

6. 控制电路

控制电路是由微处理器(IC405)和外部电路构成。它控制TX-RX单元。IC405的主要功能如下：

- (1) 根据PTT的输入信号来转换发射和接收状态。
- (2) 从存储电路读出系统，组，频率以及编程数据。
- (3) 发送频率数据给PLL。
- (4) 根据静噪电路输出的DC电压来控制静噪的开启和关闭。
- (5) 根据解码数据控制音频静音。
- (6) 发射 Tone 及编码数据。

1) 频率偏移电路

微处理器 (IC405) 在 7.3728MHz 时钟下工作。此振荡器有可以被拍频偏移开关 (Q407, Q408) 变换频率的电路。

如果“Beat Shift (拍频偏移)”被设定为ON，可以避免产生拍频声音。

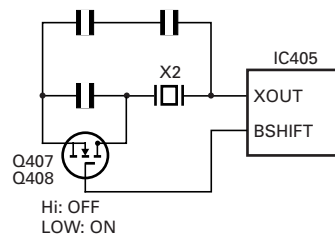

Fig. 8 Frequency shift circuit / 图8 频率偏移电路

CIRCUIT DESCRIPTION / 电路说明

2) Memory Circuit

Memory circuit consists of the CPU (IC405) and an EEPROM (IC406). An EEPROM has a capacity of 64k bits that contains the transceiver control program for the CPU and data such as transceiver channels and operating features.

2) 存储器电路

存储器电路由 CPU (IC405) 和 EEPROM (IC406) 组成。有 64k bits 的容量，包含 CPU 用的对讲机控制程序以及信道和操作功能这样的数据。

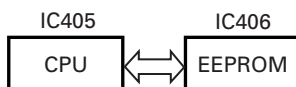

Fig. 9 Memory circuit / 图 9 存储器电路

3) Low Battery Warning

The battery voltage is checked using by the microprocessor. The transceiver generates a warning tone when the battery voltage falls below the warning voltage (2) shown in the table.

(1) The red LED blinks when the battery voltage falls below the voltage (1) shown in the table during transmission.

Note:

During reception, transceiver constantly checks the battery level. When the battery level drops near to 5.9V, the red LED blinks and low battery warning tone is generated.

(2) The transceiver immediately stops transmission when the battery voltage falls below the voltage (2) shown in the table. The warning tone sounds while the PTT switch is pressed.

3) 电池低压警告

通过微处理器监视电池电压。当低于表中所示警告电压(2)时将发出警告音。

(1) 发射中，当电池电压低于电压 (1) 时红色 LED 闪烁。

注意：

对讲机在接收时不断地检测电池电压。当电池电压降到接近 5.9V 时，红色 LED 会闪烁并产生低电池电压警告音。

(2) 当电池电压降到电压 (2) 以下，对讲机将立刻停止发射。按下 PTT 开关时响起警告音。

	Ni-Cd Battery	Ni-MH Battery
(1)	6.2[V]	6.2[V]
(2)	5.9[V]	5.9[V]

	Ni-Cd 电池	Ni-MH 电池
(1)	6.2 [V]	6.2 [V]
(2)	5.9 [V]	5.9 [V]

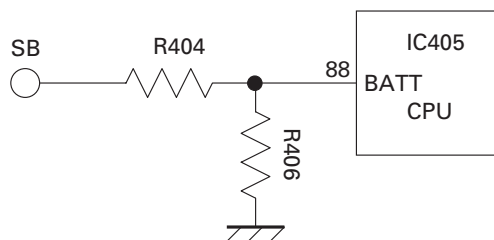

Fig. 10 Low battery warning / 图 10 电池低压警告

CIRCUIT DESCRIPTION / 电路说明

7. Control System

Keys and channel selector circuit.

The signal from the keys and channel selector are directly input to the microprocessor, as shown in Fig. 11.

7. 控制系统

按键和频道选择器电路。

如图11所示，来自按键和频道选择器的信号直接输入到微处理器。

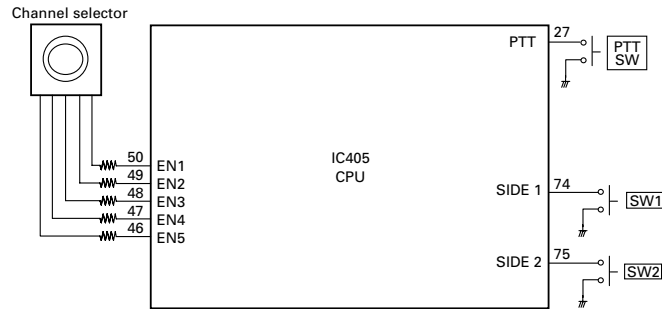

Fig. 11 Control system / 图 11 控制系统

TK-2207G

TERMINAL FUNCTION / 端子功能

■ CN401

Pin No.	Name	I/O	Function
1	B	I	B (Battery Voltage)
2	SB	O	Switched B
3	SP1	I	Audio input
4	SP2	O	Audio output
5	GND	-	GND
6	EN1	I	Encoder pulse input
7	EN2	I	Encoder pulse input
8	GND	-	GND
9	EN3	I	Encoder pulse input
10	EN4	I	Encoder pulse input
11	EN5	I	Encoder pulse input

■ CN401

管脚号码	名称	输入/输出	功能
1	B	输入	B (电池电压)
2	SB	输出	可关闭的 B
3	SP1	输入	音频输入
4	SP2	输出	音频输出
5	GND	-	GND
6	EN1	输入	编码器脉冲输入
7	EN2	输入	编码器脉冲输入
8	GND	-	GND
9	EN3	输入	编码器脉冲输入
10	EN4	输入	编码器脉冲输入
11	EN5	输入	编码器脉冲输入

SEMICONDUCTOR DATA / 半导体数据

Microprocessor : 30622MAA-B95GU (TX-RX UNIT : IC405)

■ Pin function

Pin No.	Port Name	I/O	Function
1	PCTV	O	APC/BPF control data output
2	DTMF	-	DTMF/ Beep output
3	NC	-	NC
4	EEPDAT	I/O	EEPROM data input/output
5	EEPCLK	O	EEPROM clock output
6	BYTE	-	GND
7	GND	-	GND
8	BSHIFT	O	Beat shift switch
9	NC	-	NC
10	RESET	I	CPU reset
11	XOUT	O	CPU clock (7.3728MHz)
12	VSS	-	GND
13	XIN	I	CPU clock (7.3728MHz)
14-15	VCC	-	+5V
16	INT	I	Battery voltage monitor input
17	TCLK/DTRDO	I	Base band IC data input
18	RDF/FD	I	Base band IC data input
19	SCLK	O	Base band IC clock output
20	D I/O	I/O	Base band IC data input / output
21	TDATA/DTRCLK	O	Base band IC data output
22	DIR	O	Base band IC data output
23	STD	I	Base band IC data input
24	QT VCO	O	QT/DQT output
25	DTRLOADN	O	Base band IC data output
26	1/2 OSC	O	3.6864 MHz (7.3728 MHz/2)
27	PTT	I	PTT switch input
28	QT TCXO	O	QT/DQT output
29	TXD	O	Serial data (FPU/FLASH)
30	RXD	I	Serial data (FPU/FLASH)

微处理器 : 30622MAA-B95GU (TX-RX 单元 : IC405)

■ 管脚功能

管脚号码	接口名称	输入/输出	功能
1	PCTV	输出	APC/BPF 控制数据输出
2	DTMF	输出	DTMF/ 哔哔声开关
3	NC	-	NC
4	EEPDAT	输入/输出	EEPROM 数据输入 / 输出
5	EEPCLK	输出	EEPROM 时钟输出
6	BYTE	-	GND
7	GND	-	GND
8	BSHIFT	输出	拍频偏移开关
9	NC	-	NC
10	RESET	输入	CPU 复位
11	XOUT	输出	CPU 时钟 (7.3728MHz)
12	VSS	-	GND
13	XIN	输入	CPU 时钟 (7.3728MHz)
14-15	VCC	-	+5V
16	INT	输入	电池电压监视器输入
17	TCLK/DTRDO	输入	基带 IC 数据输入
18	RDF/FD	输入	基带 IC 数据输入
19	SCLK	输出	基带 IC 时钟输出
20	D I/O	输入/输出	基带 IC 数据输入 / 输出
21	TDATA/DTRCLK	输出	基带 IC 数据输出
22	DIR	输出	基带 IC 数据输出
23	STD	输入	基带 IC 数据输入
24	QT VCO	输出	QT/DQT 输出
25	DTRLOADN	输出	基带 IC 数据输出
26	1/2 OSC	输出	3.6864 MHz (7.3728 MHz/2)
27	PTT	输入	PTT 开关输入
28	QT TCXO	输出	QT/DQT 输出
29	TXD	输出	串行数据 (FPU/FLASH)
30	RXD	输入	串行数据 (FPU/FLASH)

SEMICONDUCTOR DATA / 半导体数据

Pin No.	Port Name	I/O	Function
31	GND	-	GND
32	APCSW	O	APC switch
33	NC	-	NC
34	NC	-	NC
35	DCSW	O	APC voltage discharge switch
36	TX_W/N	O	TX Wide/Narrow switch
37	RX_SW	O	RX VCO switch
38	TX_SW	O	TX VCO switch
39	GND	-	GND
40	PLL_UL	I	PLL unlock detect input
41	PLL_STB	O	PLL strobe output
42	PLL_DAT	O	PLL data output
43	PLL_CLK	O	PLL clock output
44	VCC	-	+5V
45	RX_W/N	O	RX Wide/Narrow switch
46	EN5	I	Channel selector input
47	EN4	I	Channel selector input
48	EN3	I	Channel selector input
49	EN2	I	Channel selector input
50	EN1	I	Channel selector input
51	OPTDET	I	Headset input detect
52	AF_CONT	O	Speaker mute
53-59	NC	-	NC
60	VCC	-	+5V
61	NC	-	NC
62	VSS	-	GND
63-64	GND	-	GND
65-71	NC	-	NC
72	LEDTX	O	Red LED lights control output
73	LEDRX	O	Green LED lights control output
74	PF1	I	SIDE1 key input
75	PF2	I	SIDE2 key input
76	SIM1	-	GND
77	SIM2	-	GND
78-79	NC	-	NC
80	5T_C	O	5T control output
81	5R_C	O	5R control output
82	5C_C	O	5C control output
83-87	NC	-	NC
88	BATT	I	Battery voltage input
89	RSSI	I	Received Signal Strength Indicator input
90	BUSY	I	Busy level input
91	VOX	I	VOX level input
92	QT/DQT_IN	I	QT/DQT input
93	TH_DET	I	Thermistor input
94	AVSS	-	GND
95	NC	-	NC
96	VREF	-	+5V
97	AVCC	-	+5V
98	NC	-	NC
99	MIC_MUTE	O	MIC mute
100	NC	-	NC

管脚号码	接口名称	输入/输出	功能
31	GND	-	GND
32	APCSW	输出	APC 开关
33	NC	-	NC
34	NC	-	NC
35	DCSW	输出	APC 电压放电开关
36	TX_W/N	输出	TX 宽 / 窄带开关
37	RX_SW	输出	RX VCO 开关
38	TX_SW	输出	TX VCO 开关
39	GND	-	GND
40	PLL_UL	输入	PLL 失锁检测输入
41	PLL_STB	输出	PLL 选通输出
42	PLL_DAT	输出	PLL 数据输出
43	PLL_CLK	输出	PLL 时钟输出
44	VCC	-	+5V
45	RX_W/N	输出	RX 宽 / 窄带开关
46	EN5	输入	CH 选择器输入
47	EN4	输入	CH 选择器输入
48	EN3	输入	CH 选择器输入
49	EN2	输入	CH 选择器输入
50	EN1	输入	CH 选择器输入
51	OPTDET	输入	耳机输入检测
52	AF_CONT	输出	扬声器静音
53-59	NC	-	NC
60	VCC	-	+5V
61	NC	-	NC
62	VSS	-	GND
63-64	GND	-	GND
65-71	NC	-	NC
72	LEDTX	输出	红 LED 指示灯控制输出
73	LEDRX	输出	绿 LED 指示灯控制输出
74	PF1	输入	SIDE1 键输入
75	PF2	输入	SIDE2 键输入
76	SIM1	-	GND
77	SIM2	-	GND
78-79	NC	-	NC
80	5T_C	输出	5T 控制输出
81	5R_C	输出	5R 控制输出
82	5C_C	输出	5C 控制输出
83-87	NC	-	NC
88	BATT	输入	电池电压输入
89	RSSI	输入	接收信号强度指示器输入
90	BUSY	输入	忙水平输入
91	VOX	输入	VOX 水平输入
92	QT/DQT_IN	输入	QT/DQT 输入
93	TH_DET	输入	热敏电阻输入
94	AVSS	-	GND
95	NC	-	NC
96	VREF	-	+5V
97	AVCC	-	+5V
98	NC	-	NC
99	MIC_MUTE	输出	MIC 静音
100	NC	-	NC

TK-2207G

COMPONENTS DESCRIPTION / 元件说明

TX-RX UNIT (X57-6870-20)

Ref. No.	Use/Function	Operation/Condition
IC1	IC	PLL system
IC2	IC	VCO 1/2 Divider
IC101	IC	Comparator (APC)
IC201	IC	FM IF system
IC301	IC	Audio processor
IC302	IC	AF AMP
IC401	IC	Voltage regulator/ 5V
IC402	IC	Voltage regulator/ 5V
IC403	IC	Voltage detector / Reset
IC404	IC	Voltage detector / INT
IC405	IC	Microprocessor
IC406	IC	EEPROM
Q1	Transistor	Tripler
Q2	Transistor	PLL IC f _{in} AMP
Q3	FET	VCO / RX
Q4	FET	VCO / TX
Q5	Transistor	DC switch / TX VCO
Q6	Transistor	RF Buffer AMP
Q7	Transistor	DC switch / RX VCO
Q8	Transistor	Ripple filter
Q9	Transistor	RF AMP
Q102	Transistor	RF AMP
Q103	FET	TX Drive AMP
Q104	Transistor	APC switch
Q105	FET	APC switch
Q106	FET	TX Final AMP
Q107	Transistor	APC switch
Q108	FET	APC switch
Q109	Transistor	APC switch
Q202	Transistor	W/N switch / RX
Q203	Transistor	IF AMP
Q204	FET	Mixer
Q205	FET	RF AMP
Q301	Transistor	W/N switch / TX
Q302	Transistor	MIC AGC
Q303	Transistor	DC switch / SP Mute
Q304	Transistor	DC switch
Q305	Transistor	DC switch / SP Mute
Q306	FET	SP Mute switch
Q316	FET	SP Mute switch
Q401	Transistor	LED switch / Red
Q402	Transistor	LED switch / Green
Q403	FET	5T switch
Q404	FET	5R switch
Q405	Transistor	5C switch
Q407	FET	Beat Shift switch
Q408	FET	Beat Shift switch
Q901	FET	W/N Switch/ TX
D1	Diode	Ripple Filter
D4	Variable capacitance diode	Frequency control / TX VCO
D5	Variable capacitance diode	Frequency control / RX VCO

TX-RX 单元 (X57-6870-20)

编号	使用 / 功能	操作 / 状态
IC1	IC	PLL 系统
IC2	IC	VCO 1/2 分频器
IC101	IC	比较器 (APC)
IC201	IC	FM IF 系统
IC301	IC	音频处理器
IC302	IC	AF 放大器
IC401	IC	电压管理器 / 5V
IC402	IC	电压管理器 / 5V
IC403	IC	电压检测器 / 复位
IC404	IC	电压检测器 / INT
IC405	IC	微处理器
IC406	IC	EEPROM
Q1	晶体管	三倍频器
Q2	晶体管	PLL IC f _{in} 放大器
Q3	场效应管	VCO / RX
Q4	场效应管	VCO / TX
Q5	晶体管	DC 开关 / TX VCO
Q6	晶体管	RF 缓冲放大器
Q7	晶体管	DC 开关 / RX VCO
Q8	晶体管	触发滤波器
Q9	晶体管	RF 放大器
Q102	晶体管	RF 放大器
Q103	场效应管	TX 驱动放大器
Q104	晶体管	APC 开关
Q105	场效应管	APC 开关
Q106	场效应管	TX 终端放大器
Q107	晶体管	APC 开关
Q108	场效应管	APC 开关
Q109	晶体管	APC 开关
Q202	晶体管	W/N 开关 / RX
Q203	晶体管	IF 放大器
Q204	场效应管	混频器
Q205	场效应管	RF 放大器
Q301	晶体管	W/N 开关 / TX
Q302	晶体管	MIC AGC
Q303	晶体管	DC 开关 / SP 静音
Q304	晶体管	DC 开关
Q305	晶体管	DC 开关 / SP 静音
Q306	场效应管	SP 静音开关
Q316	场效应管	SP 静音开关
Q401	晶体管	LED 开关 / 红
Q402	晶体管	LED 开关 / 绿
Q403	场效应管	5T 开关
Q404	场效应管	5R 开关
Q405	晶体管	5C 开关
Q407	场效应管	拍频偏移开关
Q408	场效应管	拍频偏移开关
Q901	场效应管	W/N 开关 / TX
D1	二极管	触发滤波器
D4	可变电容二极管	频率控制 / TX VCO
D5	可变电容二极管	频率控制 / RX VCO

COMPONENTS DESCRIPTION / 元件说明

Ref. No.	Use/Function	Operation/Condition
D7	Variable capacitance diode	Frequency control / TX VCO
D9	Variable capacitance diode	Frequency control / RX VCO
D10	Variable capacitance diode	Modulator
D11	Diode	Current steering
D101	Diode	TX/RX RF switch
D102	Zener diode	APC protect
D103	Diode	ANT switch
D104	Diode	ANT switch
D105	Diode	ANT switch
D106	Diode	ANT switch
D202	Diode	TX/RX RF switch
D203	Variable capacitance diode	RF BPF tuning
D204	Variable capacitance diode	RF BPF tuning
D205	Variable capacitance diode	RF BPF tuning
D206	Variable capacitance diode	RF BPF tuning
D301	Diode	Detector
D302	Diode	Detector
D303	Diode	Isolation
D401	Diode	5V Protection
D402	Diode	Reverse Protection
D403	LED	LED/ Red
D404	LED	LED/ Green

编号	使用 / 功能	操作 / 状态
D7	可变电容二极管	频率控制 / TX VCO
D9	可变电容二极管	频率控制 / RX VCO
D10	可变电容二极管	调制器
D11	二极管	电流开关
D101	二极管	TX/RX RF 开关
D102	齐纳二极管	APC 保护
D103	二极管	ANT 开关
D104	二极管	ANT 开关
D105	二极管	ANT 开关
D106	二极管	ANT 开关
D202	二极管	TX/RX RF 开关
D203	可变电容二极管	RF BPF 调谐
D204	可变电容二极管	RF BPF 调谐
D205	可变电容二极管	RF BPF 调谐
D206	可变电容二极管	RF BPF 调谐
D301	二极管	检测器
D302	二极管	检测器
D303	二极管	隔离
D401	二极管	5V 保护器
D402	二极管	反转保护器
D403	LED	LED / 红
D404	LED	LED / 绿

TK-2207G

PARTS LIST / 零件表

* New Parts. △ indicates safety critical components.
 Parts without **Parts No.** are not supplied.
 Les articles non mentionnés dans le **Parts No.** ne sont pas fournis.
 Teile ohne **Parts No.** werden nicht geliefert.

L: Scandinavia K: USA P: Canada
 Y: PX (Far East, Hawaii) T: England E: Europe
 Y: AAFES (Europe) X: Australia M: Other Areas

TK-2207G (Y50-6093-00) TX-RX UNIT (X57-6870-20)

Ref. No.	Address	New parts	Parts No.	Description	Destination
TK-2207G					
1	1A	*	A02-3944-03	PLASTIC CABINET	
2	1A	*	A02-3945-03	PLASTIC CABINET ASSY(16CH)	
3	3A		A10-4078-31	CHASSIS	
4	1B		A21-1644-23	DRESSING PANEL(16CH)	
6	2C		B09-0680-03	CAP(SP/MIC) ACCESSORY	
7	2B		B11-1817-04	ILLUMINATION GUIDE	
8	1B	*	B43-1190-04	BADGE	
10	1C	*	B62-1937-10	INSTRUCTION MANUAL	
11	1A		D10-0649-03	LEVER	
12	1A		D21-0863-04	SHAFT	
13	1A		D32-0441-03	STOPPER	
14	2A		E04-0465-05	RF COAXIAL RECEPTACLE(SMA)	
15	3B		E23-1253-04	TERMINAL(BATT-)	
16	2B		E37-1175-05	PROCESSED LEAD WIRE(BROWN:SP+)	
17	2B		E37-1176-05	PROCESSED LEAD WIRE(GREEN:SP-)	
18	3A		F20-3353-14	INSULATING SHEET(CHASSIS BATT+)	
19	2A		G01-4542-04	COIL SPRING(LEVER)	
20	1A		G01-4543-04	COIL SPRING(STOPPER)	
21	2B		G10-1330-04	FIBROUS SHEET(IC302:AUDIO IC)	
22	2A		G11-4283-04	RUBBER SHEET(Q103:FINAL FET)	
23	2A		G11-4313-04	SHEET(MIC ELEMENT)	
29	3A		G13-2033-04	CUSHION(TERMINAL BATT-)	
30	3B		G13-2034-14	CUSHION(TERMINAL BATT-)	
31	3A		G13-2038-24	CUSHION(CHASSIS-CERAMIC FILTER)	
32	2A		G13-2039-14	CUSHION(PCB-CERAMIC FILTER)	
33	3B		G13-2045-04	CUSHION(CHASSIS)	
34	2B		G13-2088-04	CUSHION(CHASSIS VOL/CH)	
35	3A		G53-1604-03	PACKING(CHASSIS)	
36	3A		G53-1605-03	PACKING(TERMINAL BATT+)	
37	2B		G53-1606-13	PACKING(VOL/CH/LED)	
38	1B		G53-1607-03	PACKING(SP/MIC)	
39	2B		G53-1608-03	PACKING(SP)	
40	2A		G53-1609-14	PACKING(MIC ELEMENT)	
41	2B		G53-1610-04	PACKING(SMA)	
43	2D		H12-3179-05	PACKING FIXTURE	
45	1C		H25-0085-04	PROTECTION BAG (100/200/0.07)	
47	3D	*	H52-2142-02	ITEM CARTON CASE	
48	2D		J19-5472-03	HOLDER(SP/MIC) ACCESSORY	
49	2A		J19-5473-03	HOLDER ASSY(TERMINAL BATT+)	
50	2B		J21-8478-04	MOUNTING HARDWARE(SP/MIC)	
51	2B		J21-8525-03	MOUNTING HARDWARE(VOL/CH)	
52	2D		J29-0713-05	BELT CLIP ACCESSORY	
53	1D		J69-0352-05	HANDSTRAP ACCESSORY	
54	2B		J82-0092-05	FPC	
55	1A		K29-9308-13	BUTTON KNOB(PTT)	
56	1B		K29-9309-03	KNOB(VOL)	
57	1B		K29-9318-03	KNOB(CH)	
58	1A		K29-9364-03	BUTTON KNOB(SIDE1/SIDE2)	
A	2B		N14-0819-04	CIRCULAR NUT(VOL KNOB)	
B	2B		N14-0832-04	CIRCULAR NUT(CH KNOB)	
C	2A,2B		N30-2604-48	PAN HEAD MACHINE SCREW(SMA)	
D	3A		N30-2606-48	PAN HEAD MACHINE SCREW(CHASSIS)	
E	2A,2B,3B		N83-2005-48	PAN HEAD TAPTITE SCREW(PCB)	

Ref. No.	Address	New parts	Parts No.	Description	Destination
60	2D		N99-2046-05	SCREW SET ACCESSORY	
61	2B		R31-0661-05	VARIABLE RESISTOR(POWER SW/VOL)	
62	2B		S60-0434-05	ROTARY SWITCH(16CH)	
63	1B		T07-0369-15	SPEAKER	
TX-RX UNIT (X57-6870-20)					
D403			B30-2156-05	LED(RED)	
D404			B30-2157-05	LED(YELLOW)	
C1			CK73HB1H332K	CHIP C 3300PF K	
C2			CK73HB1C682K	CHIP C 6800PF K	
C3			CK73GB1A105K	CHIP C 1.0UF K	
C4			CK73HB1C103K	CHIP C 0.010UF K	
C5			CK73HB1H102K	CHIP C 1000PF K	
C6			CK73HB1A104K	CHIP C 0.10UF K	
C7 ,8			CC73HCH1H101J	CHIP C 100PF J	
C9			CC73HCH1H100D	CHIP C 10PF D	
C10			CS77CPOJ100M	CHIP-TAN 10UF 6.3WV	
C11			CC73HCH1H101J	CHIP C 100PF J	
C12			CK73HB1H102K	CHIP C 1000PF K	
C13			CK73HB1A104K	CHIP C 0.10UF K	
C14			CK73HB1C103K	CHIP C 0.010UF K	
C15			CC73HCH1H100D	CHIP C 10PF D	
C16			CK73HB1H102K	CHIP C 1000PF K	
C17			CC73HCH1H470J	CHIP C 47PF J	
C18			CC73HCH1H180J	CHIP C 18PF J	
C19			CK73HB1A104K	CHIP C 0.10UF K	
C21			CS77CPOJ100M	CHIP-TAN 10UF 6.3WV	
C22			CS77AA1VR33M	CHIP-TAN 0.33UF 35WV	
C24			CK73HB1H102K	CHIP C 1000PF K	
C25			CC73HCH1H020B	CHIP C 2.0PF B	
C26			CC73HCH1H300J	CHIP C 30PF J	
C27		*	CS77CA1C3R3M	CHIP-TAN 3.3UF 16WV	
C29 ,30			CK73HB1H471K	CHIP C 470PF K	
C32		*	CS77CA1V0R1M	CHIP-TAN 0.1UF 35WV	
C33 ,34			CK73HB1H102K	CHIP C 1000PF K	
C35			CC73HCH1H270J	CHIP C 27PF J	
C38			CC73HCH1H060B	CHIP C 6.0PF B	
C39			CK73GB1H332K	CHIP C 3300PF K	
C40			CC73HCH1H040B	CHIP C 4.0PF B	
C41			CK73GB1H682K	CHIP C 6800PF K	
C42			CC73HCH1H060B	CHIP C 6.0PF B	
C43			CC73HCH1H150J	CHIP C 15PF J	
C44			CK73HB1H471K	CHIP C 470PF K	
C45			CK73GB1A105K	CHIP C 1.0UF K	
C47			CC73HCH1H101J	CHIP C 100PF J	
C48			CK73HB1H471K	CHIP C 470PF K	
C49			CC73HCH1H101J	CHIP C 100PF J	
C50			CC73HCH1H100D	CHIP C 10PF D	
C51			CK73HB1H102K	CHIP C 1000PF K	
C52			CC73HCH1H181J	CHIP C 180PF J	
C53			CC73HCH1H0R5B	CHIP C 0.5PF B	
C54			CC73HCH1H040B	CHIP C 4.0PF B	
C55			CC73HCH1H121J	CHIP C 120PF J	
C57			CC73HCH1H1R5B	CHIP C 1.5PF B	

PARTS LIST / 零件表

TX-RX UNIT (X57-6870-20)

Ref. No.	Address	New parts	Parts No.	Description	Destination	Ref. No.	Address	New parts	Parts No.	Description	Destination
C58			CC73HCH1H060B	CHIP C 6.0PF B		C154			CC73GCH1H100D	CHIP C 10PF D	
C59			CC73HCH1H1R5B	CHIP C 1.5PF B		C155			CC73GCH1H180J	CHIP C 18PF J	
C60			CC73HCH1H010B	CHIP C 1.0PF B		C156			CC73GCH1H120J	CHIP C 12PF J	
C61			CC73HCH1H040B	CHIP C 4.0PF B		C157			CC73GCH1H150J	CHIP C 15PF J	
						C158			CC73GCH1H220J	CHIP C 22PF J	
C62			CC73HCH1H050B	CHIP C 5.0PF B		C159			CC73GCH1H070D	CHIP C 7.0PF D	
C63			CC73HCH1H101J	CHIP C 100PF J		C160			CC73GCH1H330J	CHIP C 33PF J	
C64			CC73HCH1H040B	CHIP C 4.0PF B		C201			CK73GB1A224K	CHIP C 0.22UF K	
C65-67			CC73HCH1H050B	CHIP C 5.0PF B		C206			CK73HB1H102K	CHIP C 1000PF K	
C68-70			CK73HB1H471K	CHIP C 470PF K		C207			CK73HB1H182K	CHIP C 1800PF K	
C71,72			CK73HB1A104K	CHIP C 0.10UF K		C208			CK73HB1H471K	CHIP C 470PF K	
C73,74			CC73HCH1H0R5B	CHIP C 0.5PF B		C209			CS77CP0J100M	CHIP-TAN 10UF 6.3WV	
C75,76			CK73HB1H102K	CHIP C 1000PF K		C210			CK73HB1H471K	CHIP C 470PF K	
C77			CK73HB1H471K	CHIP C 470PF K		C211			CK73HB1C103K	CHIP C 0.010UF K	
C78			CC73HCH1H330J	CHIP C 33PF J		C213			CK73HB1A104K	CHIP C 0.10UF K	
C79			CS77CP0J100M	CHIP-TAN 10UF 6.3WV		C214			CC73HCH1H680J	CHIP C 68PF J	
C80			CK73HB1H471K	CHIP C 470PF K		C215			CK73HB1H102K	CHIP C 1000PF K	
C81			CC73HCH1H150J	CHIP C 15PF J		C216			CK73GB1C104K	CHIP C 0.10UF K	
C82-86			CK73HB1H102K	CHIP C 1000PF K		C217			CK73HB1A104K	CHIP C 0.10UF K	
C87			CC73HCH1H100D	CHIP C 10PF D		C218			CK73GB1C104K	CHIP C 0.10UF K	
C90			CK73HB1H102K	CHIP C 1000PF K		C219			CC73HCH1H330J	CHIP C 33PF J	
C101			CK73HB1H102K	CHIP C 1000PF K		C220			CK73HB1H102K	CHIP C 1000PF K	
C104			CC73GCH1H390J	CHIP C 39PF J		C221			CK73GB1C104K	CHIP C 0.10UF K	
C105			CK73HB1H102K	CHIP C 1000PF K		C222			CK73HB1H102K	CHIP C 1000PF K	
C107			CK73HB1H102K	CHIP C 1000PF K		C224,225			CK73HB1C103K	CHIP C 0.010UF K	
C108			CC73GCH1H390J	CHIP C 39PF J		C227			CK73HB1H102K	CHIP C 1000PF K	
C109			CK73GB1C104K	CHIP C 0.10UF K		C228			CC73GCH1H100C	CHIP C 10PF C	
C110,111			CK73HB1H102K	CHIP C 1000PF K		C230			CC73HCH1H080B	CHIP C 8.0PF B	
C115			CK73HB1H102K	CHIP C 1000PF K		C231,232			CK73GB1H103K	CHIP C 0.010UF K	
C116			CC73GCH1H220J	CHIP C 22PF J		C233			CC73HCH1H020B	CHIP C 2.0PF B	
C117			CC73GCH1H100D	CHIP C 10PF D		C234			CK73HB1C103K	CHIP C 0.010UF K	
C118			CC73GCH1H101J	CHIP C 100PF J		C235			CC73HCH1H090B	CHIP C 9.0PF B	
C119			CC73GCH1H270J	CHIP C 27PF J		C236			CK73GB1H102K	CHIP C 1000PF K	
C120			CK73GB1H102K	CHIP C 1000PF K		C237			CC73HCH1H050B	CHIP C 5.0PF B	
C121			CC73GCH1H100D	CHIP C 10PF D		C238			CC73GCH1H120J	CHIP C 12PF J	
C123			CK73GB1A105K	CHIP C 1.0UF K		C239			CC73HCH1H060B	CHIP C 6.0PF B	
C124,125			CK73HB1H102K	CHIP C 1000PF K		C241			CK73HB1H102K	CHIP C 1000PF K	
C126		*	CS77A1A6R8M	CHIP-TAN 6.8UF 10WV		C242			CK73GB1C104K	CHIP C 0.10UF K	
C128			CK73HB1H102K	CHIP C 1000PF K		C243			CK73HB1H102K	CHIP C 1000PF K	
C130			CC73GCH1H100D	CHIP C 10PF D		C244			CC73HCH1H040B	CHIP C 4.0PF B	
C132			CK73HB1H102K	CHIP C 1000PF K		C245			CK73HB1H471K	CHIP C 470PF K	
C133			CK73GB1H103K	CHIP C 0.010UF K		C247			CC73GCH1H040B	CHIP C 4.0PF B	
C134			CK73GB1C104K	CHIP C 0.10UF K		C248			CC73GCH1H270J	CHIP C 27PF J	
C135			CK73GB1A105K	CHIP C 1.0UF K		C249			CK73HB1H102K	CHIP C 1000PF K	
C136			CC73GCH1H270J	CHIP C 27PF J		C250			CC73GCH1H040B	CHIP C 4.0PF B	
C137			CK73GB1H103K	CHIP C 0.010UF K		C251		*	CS77CP0J4R7M	CHIP-TAN 4.7UF 6.3WV	
C138			CK73GB1H102K	CHIP C 1000PF K		C252			CK73HB1H102K	CHIP C 1000PF K	
C139			CC73GCH1H680J	CHIP C 68PF J		C253			CC73GCH1H4R5B	CHIP C 4.5PF B	
C140			CC73GCH1H101J	CHIP C 100PF J		C254			CC73GCH1H270J	CHIP C 27PF J	
C141			CC73GCH1H220J	CHIP C 22PF J		C255			CC73GCH1H4R5B	CHIP C 4.5PF B	
C142			CC73GCH1H150J	CHIP C 15PF J		C256			CK73HB1H102K	CHIP C 1000PF K	
C143			CC73GCH1H100D	CHIP C 10PF D		C258			CK73HB1H102K	CHIP C 1000PF K	
C144			CC73GCH1H820J	CHIP C 82PF J		C260			CK73HB1H102K	CHIP C 1000PF K	
C146			CK73GB1H102K	CHIP C 1000PF K		C262			CK73HB1H102K	CHIP C 1000PF K	
C147			CK73HB1H102K	CHIP C 1000PF K		C263			CC73GCH1H100C	CHIP C 10PF C	
C148			CK73GB1H102K	CHIP C 1000PF K		C264			CC73GCH1H040B	CHIP C 4.0PF B	
C149			CC73GCH1H220G	CHIP C 22PF G		C265			CC73GCH1H330J	CHIP C 33PF J	
C150			CC73GCH1H220J	CHIP C 22PF J		C266			CK73HB1H102K	CHIP C 1000PF K	
C151			CK73GB1H102K	CHIP C 1000PF K		C267,268			CC73GCH1H030B	CHIP C 3.0PF B	
C153			CC73GCH1H100C	CHIP C 10PF C		C269			CC73GCH1H330J	CHIP C 33PF J	

PARTS LIST / 零件表

TX-RX UNIT (X57-6870-20)

Ref. No.	Address	New parts	Parts No.	Description	Destination	Ref. No.	Address	New parts	Parts No.	Description	Destination
C270			CC73GCH1H040B	CHIP C 4.0PF B		C431			CK73HB1C103K	CHIP C 0.010UF K	
C271			CC73GCH1H110J	CHIP C 11PF J		C432			CC73HCH1H050B	CHIP C 5.0PF B	
C280			CK73HB1H102K	CHIP C 1000PF K		C433,434			CC73HCH1H030B	CHIP C 3.0PF B	
C302			CK73HB1C103K	CHIP C 0.010UF K		C435			CC73HCH1H050B	CHIP C 5.0PF B	
C304			CK73GB1A224K	CHIP C 0.22UF K		C440			CC73GCH1H1R5B	CHIP C 1.5PF B	
C306		*	CS77CP0J4R7M	CHIP-TAN 4.7UF 6.3WV		C443			CK73GB1A474K	CHIP C 0.47UF K	
C307,308			CK73HB1A104K	CHIP C 0.10UF K		C452			CK73HB1H102K	CHIP C 1000PF K	
C309			CC73GCH1H820J	CHIP C 82PF J		C901,902			CK73GB1A105K	CHIP C 1.0UF K	
C310			CK73HB1A683K	CHIP C 0.068UF K		TC1,2			C05-0384-05	CERAMIC TRIMMER CAPACITOR(10PF)	
C311			CK73GB1A105K	CHIP C 1.0UF K		CN201			E23-1278-05	TERMINAL	
C312			CC73GCH1H120J	CHIP C 12PF J		CN401			E40-6573-05	FLAT CABLE CONNECTOR	
C313			CC73GCH1H121J	CHIP C 120PF J		J301		*	E11-0707-05	PHONE JACK(2.5/3.5)	
C314			CK73HB1A104K	CHIP C 0.10UF K		F401			F53-0324-05	FUSE(2.5A)	
C315			CK73GB1A105K	CHIP C 1.0UF K		101	2A	*	J30-1282-14	SPACER(MIC ELEMENT)	
C316			CK73GB1C104K	CHIP C 0.10UF K		CD201			L79-1582-05	TUNING COIL	
C317			CK73HB1A104K	CHIP C 0.10UF K		CF201	2A		L72-0973-05	CERAMIC FILTER	
C318		*	CS77CP0J4R7M	CHIP-TAN 4.7UF 6.3WV		L1			L40-4791-37	SMALL FIXED INDUCTOR(4.700UH)	
C319			CC73GCH1H271J	CHIP C 270PF J		L3			L40-5681-86	SMALL FIXED INDUCTOR(0.56UH)	
C320			CK73HB1C103K	CHIP C 0.010UF K		L5			L40-5681-86	SMALL FIXED INDUCTOR(0.56UH)	
C321			CK73GB1A105K	CHIP C 1.0UF K		L6,7			L92-0138-05	CHIP FERRITE	
C322			CK73HB1C153K	CHIP C 0.015UF K		L8			L40-1875-92	SMALL FIXED INDUCTOR(18NH)	
C323			CC73GCH1H820J	CHIP C 82PF J		L9			L40-3375-92	SMALL FIXED INDUCTOR(33NH)	
C324			CC73HCH1H820J	CHIP C 82PF J		L10			L40-1885-92	SMALL FIXED INDUCTOR(180NH)	
C325			CK73HB1A104K	CHIP C 0.10UF K		L11			L40-1085-92	SMALL FIXED INDUCTOR(100NH)	
C326			CK73HB1H102K	CHIP C 1000PF K		L12			L92-0138-05	CHIP FERRITE	
C327			CC73HCH1H101J	CHIP C 100PF J		L13,14			L40-2285-92	SMALL FIXED INDUCTOR(220NH)	
C328			CK73HB1H391K	CHIP C 390PF K		L16			L40-3978-67	SMALL FIXED INDUCTOR(39NH)	
C329,330			CK73GB1A105K	CHIP C 1.0UF K		L17			L40-2778-67	SMALL FIXED INDUCTOR(27NH)	
C331			CK73HB1A104K	CHIP C 0.10UF K		L18,19			L41-2285-03	SMALL FIXED INDUCTOR(220NH)	
C332			CK73HB1H471K	CHIP C 470PF K		L20,21			L40-3391-86	SMALL FIXED INDUCTOR(3.3UH)	
C333,334			CK73GB1C104K	CHIP C 0.10UF K		L22			L92-0138-05	CHIP FERRITE	
C335			CC73GCH1H221J	CHIP C 220PF J		L23			L40-3975-92	SMALL FIXED INDUCTOR(39NH)	
C336			CK73FB1C474K	CHIP C 0.47UF K		L24		*	L92-0470-05	CHIP FERRITE	
C338			CC73GCH1H101J	CHIP C 100PF J		L25			L40-8275-05	SMALL FIXED INDUCTOR(82NH)	
C339			CS77AA0J100M	CHIP-TAN 10UF 6.3WV		L50			L92-0138-05	CHIP FERRITE	
C340			CK73GB1C104K	CHIP C 0.10UF K		L102			L40-1085-92	SMALL FIXED INDUCTOR(100NH)	
C341			CK73GB1C473K	CHIP C 0.047UF K		L103			L92-0138-05	CHIP FERRITE	
C342			CS77AA0J100M	CHIP-TAN 10UF 6.3WV		L104			L40-2775-92	SMALL FIXED INDUCTOR(27NH)	
C343			CK73GB1C473K	CHIP C 0.047UF K		L105			L40-1585-54	SMALL FIXED INDUCTOR(150NH)	
C344			CC73GCH1H221J	CHIP C 220PF J		L106			L92-0149-05	CHIP FERRITE	
C345		*	CS77CC0J101M	CHIP-TAN 100UF 6.3WV		L107			L40-2775-54	SMALL FIXED INDUCTOR(27NH)	
C346			CK73GB1H102K	CHIP C 1000PF K		L108			L92-0149-05	CHIP FERRITE	
C348			CK73HB1H471K	CHIP C 470PF K		L109			L40-2295-85	SMALL FIXED INDUCTOR(2.2UH)	
C351,352			CK73HB1C103K	CHIP C 0.010UF K		L110			L40-5675-92	SMALL FIXED INDUCTOR(56NH)	
C354			CK73HB1A104K	CHIP C 0.10UF K		L111			L41-1092-44	SMALL FIXED INDUCTOR(1UH)	
C401			CC73GCH1H471J	CHIP C 470PF J		L112			L34-4577-05	AIR-CORE COIL	
C402			CK73HB1H102K	CHIP C 1000PF K		L113			L34-4563-05	AIR-CORE COIL	
C403			CK73GB1C104K	CHIP C 0.10UF K		L114,115			L34-4573-05	AIR-CORE COIL	
C405			CC73GCH1H101J	CHIP C 100PF J		L116			L34-4576-05	AIR-CORE COIL	
C407			CK73HB1H102K	CHIP C 1000PF K		L117			L34-4575-05	AIR-CORE COIL	
C409,410			CK73GB1A105K	CHIP C 1.0UF K		L118			L34-4567-05	AIR-CORE COIL	
C411			CK73HB1H102K	CHIP C 1000PF K		L119			L34-4566-05	AIR-CORE COIL	
C415			CK73HB1H471K	CHIP C 470PF K		L201			L40-1091-37	SMALL FIXED INDUCTOR(1.000UH)	
C417			CK73GB1A105K	CHIP C 1.0UF K		L202			L40-3975-92	SMALL FIXED INDUCTOR(39NH)	
C418			CK73HB1E562K	CHIP C 5600PF K		L203			L92-0138-05	CHIP FERRITE	
C419			CK73HB1H102K	CHIP C 1000PF K		L204			L40-5685-85	SMALL FIXED INDUCTOR(0.56UH)	
C421			CK73GB1A105K	CHIP C 1.0UF K							
C426,427			CK73GB1A105K	CHIP C 1.0UF K							
C428,429			CK73HB1H102K	CHIP C 1000PF K							
C430			CK73GB1H103K	CHIP C 0.010UF K							

PARTS LIST / 零件表

TX-RX UNIT (X57-6870-20)

Ref. No.	Address	New parts	Parts No.	Description	Destination	Ref. No.	Address	New parts	Parts No.	Description	Destination
L205			L40-6875-92	SMALL FIXED INDUCTOR(68NH)		R49			RK73HB1J222J	CHIP R 2.2K J 1/16W	
L206			L40-1885-92	SMALL FIXED INDUCTOR(180NH)		R50			RK73HB1J472J	CHIP R 4.7K J 1/16W	
L207			L40-1585-92	SMALL FIXED INDUCTOR(150NH)		R51			RK73HB1J100J	CHIP R 10 J 1/16W	
L209			L41-5678-14	SMALL FIXED INDUCTOR(56NH)		R101			RK73HB1J123J	CHIP R 12K J 1/16W	
L210			L92-0138-05	CHIP FERRITE		R103			RK73GB2A000JX	CHIP R 0.0 J 1/10W	
L211			L41-5678-14	SMALL FIXED INDUCTOR(56NH)		R107			RK73GB2A561J	CHIP R 560 J 1/10W	
L213			L41-5678-14	SMALL FIXED INDUCTOR(56NH)		R108			RK73GB2A152J	CHIP R 1.5K J 1/10W	
L214			L41-4778-14	SMALL FIXED INDUCTOR(47NH)		R109			RK73GB2A150J	CHIP R 15 J 1/10W	
L301			L92-0140-05	CHIP FERRITE		R110,111			RK73GB2A331J	CHIP R 330 J 1/10W	
L302			L92-0149-05	CHIP FERRITE		R112			RK73GB2A180J	CHIP R 18 J 1/10W	
L401			L92-0149-05	CHIP FERRITE		R113			RK73GB2A331J	CHIP R 330 J 1/10W	
L402-404			L92-0138-05	CHIP FERRITE		R114			RK73GB2A473J	CHIP R 47K J 1/10W	
X1			L77-1931-05	TCXO(12.8MHZ)		R115			RK73GB2A103J	CHIP R 10K J 1/10W	
X2		*	L78-1414-05	RESONATOR(7.37MHZ)		R116			RK73GB2A150J	CHIP R 15 J 1/10W	
XF201			L71-0619-05	MCF(38.85MHZ)		R117			RK73GB2A683J	CHIP R 68K J 1/10W	
CP404			RK75HA1J473J	CHIP-COM 47K J 1/16W		R119			RK73GB2A331J	CHIP R 330 J 1/10W	
CP405			RK75HA1J102J	CHIP-COM 1.0K J 1/16W		R120			RK73GB2A000JX	CHIP R 0.0 J 1/10W	
R1			RK73HB1J223J	CHIP R 22K J 1/16W		R121			RK73GB2A561J	CHIP R 560 J 1/10W	
R2			RK73HB1J103J	CHIP R 10K J 1/16W		R122			RK73GB2A473J	CHIP R 47K J 1/10W	
R3			RK73HB1J333J	CHIP R 33K J 1/16W		R123			RK73GB2A820J	CHIP R 82 J 1/10W	
R4			RK73HB1J563J	CHIP R 56K J 1/16W		R124			RK73GB2A123J	CHIP R 12K J 1/10W	
R5			RK73HB1J104J	CHIP R 100K J 1/16W		R126			RK73GB2A222J	CHIP R 2.2K J 1/10W	
R6			RK73HB1J823J	CHIP R 82K J 1/16W		R127-129			RK73EB2ER39K	CHIP R 0.39 K 1/4W	
R7			RK73HB1J101J	CHIP R 100 J 1/16W		R130-135			RK73GH2A154D	CHIP R 150K D 1/10W	
R8 -11			RK73HB1J000JX	CHIP R 0.0 J 1/16W		R136,137			RK73GB2A271J	CHIP R 270 J 1/10W	
R12			RK73HB1J222J	CHIP R 2.2K J 1/16W		R138			RK73GB2A105J	CHIP R 1.0M J 1/10W	
R13			RK73GB2A000JX	CHIP R 0.0 J 1/10W		R139			RK73GB2A473J	CHIP R 47K J 1/10W	
R14			RK73HB1J334J	CHIP R 330K J 1/16W		R140			RK73GB2A563J	CHIP R 56K J 1/10W	
R15			RK73GB2A221J	CHIP R 220 J 1/10W		R141			RK73GB2A104J	CHIP R 100K J 1/10W	
R16			RK73GB2A561J	CHIP R 560 J 1/10W		R142			RK73GB2A000JX	CHIP R 0.0 J 1/10W	
R17			RK73HB1J101J	CHIP R 100 J 1/16W		R143			RK73GB2A104J	CHIP R 100K J 1/10W	
R18			RK73GB2A000JX	CHIP R 0.0 J 1/10W		R203			RK73HB1J184J	CHIP R 180K J 1/16W	
R19			RK73GB2A152J	CHIP R 1.5K J 1/10W		R206			RK73GB2A100J	CHIP R 10 J 1/10W	
R20			RK73HB1J100J	CHIP R 10 J 1/16W		R207			RK73HB1J472J	CHIP R 4.7K J 1/16W	
R21			RK73GB2A681J	CHIP R 680 J 1/10W		R208			RK73HB1J823J	CHIP R 82K J 1/16W	
R22			RK73GB2A000JX	CHIP R 0.0 J 1/10W		R209			RK73HB1J272J	CHIP R 2.7K J 1/16W	
R23			RK73GB2A103J	CHIP R 10K J 1/10W		R210,211			RK73HB1J332J	CHIP R 3.3K J 1/16W	
R25			RK73HB1J223J	CHIP R 22K J 1/16W		R212			RK73HB1J823J	CHIP R 82K J 1/16W	
R26			RK73HB1J103J	CHIP R 10K J 1/16W		R213			RK73HB1J392J	CHIP R 3.9K J 1/16W	
R27			RK73HB1J220J	CHIP R 22 J 1/16W		R215			RK73HB1J101J	CHIP R 100 J 1/16W	
R30			RK73HB1J123J	CHIP R 12K J 1/16W		R216			RK73HB1J124J	CHIP R 120K J 1/16W	
R31			RK73HB1J564J	CHIP R 560K J 1/16W		R217			RK73HB1J472J	CHIP R 4.7K J 1/16W	
R32			RK73HB1J102J	CHIP R 1.0K J 1/16W		R218			RK73HB1J561J	CHIP R 560 J 1/16W	
R33			RK73HB1J154J	CHIP R 150K J 1/16W		R219,220			RK73GB2A561J	CHIP R 560 J 1/10W	
R34			RK73HB1J472J	CHIP R 4.7K J 1/16W		R221			RK73GB2A102J	CHIP R 1.0K J 1/10W	
R35 ,36			RK73HB1J274J	CHIP R 270K J 1/16W		R222			RK73GB2A221J	CHIP R 220 J 1/10W	
R37			RK73HB1J101J	CHIP R 100 J 1/16W		R223-226			RK73HB1J823J	CHIP R 82K J 1/16W	
R38			RK73HB1J181J	CHIP R 180 J 1/16W		R227			RK73GB2A000JX	CHIP R 0.0 J 1/10W	
R39			RK73HB1J151J	CHIP R 150 J 1/16W		R228,229			RK73HB1J105J	CHIP R 1.0M J 1/16W	
R40			RK73HB1J101J	CHIP R 100 J 1/16W		R230			RK73GB2A222J	CHIP R 2.2K J 1/10W	
R41			RK73HB1J154J	CHIP R 150K J 1/16W		R231			RK73GB2A470J	CHIP R 47 J 1/10W	
R42			RK73HB1J472J	CHIP R 4.7K J 1/16W		R233			RK73GB2A221J	CHIP R 220 J 1/10W	
R43			RK73HB1J101J	CHIP R 100 J 1/16W		R234			RK73GB2A104J	CHIP R 100K J 1/10W	
R44			RK73HB1J102J	CHIP R 1.0K J 1/16W		R237			RK73GB2A184J	CHIP R 180K J 1/10W	
R45 ,46			RK73HB1J332J	CHIP R 3.3K J 1/16W		R238			RK73GB2A104J	CHIP R 100K J 1/10W	
R47			RK73HB1J470J	CHIP R 47 J 1/16W		R239			RK73GB2A470J	CHIP R 47 J 1/10W	
R48			RK73HB1J331J	CHIP R 330 J 1/16W		R240			RK73GB2A000JX	CHIP R 0.0 J 1/10W	
						R241,242			RK73HB1J105J	CHIP R 1.0M J 1/16W	
						R243			RK73FB2B000JX	CHIP R 0.0 J 1/8W	
						R291			RK73GB2A000JX	CHIP R 0.0 J 1/10W	

PARTS LIST / 零件表

TX-RX UNIT (X57-6870-20)

Ref. No.	Address	New parts	Parts No.	Description	Destination	Ref. No.	Address	New parts	Parts No.	Description	Destination
R301			RK73HB1J473J	CHIP R 47K J 1/16W		R435			RK73HB1J473J	CHIP R 47K J 1/16W	
R304			RK73HB1J564J	CHIP R 560K J 1/16W		R436			RK73GB2A000JX	CHIP R 0.0 J 1/10W	
R305			RK73HB1J104J	CHIP R 100K J 1/16W		R437,438			RK73HB1J473J	CHIP R 47K J 1/16W	
R306			RK73HB1J102J	CHIP R 1.0K J 1/16W		R445,446			RK73GB2A000JX	CHIP R 0.0 J 1/10W	
R307,308			RK73HB1J000JX	CHIP R 0.0 J 1/16W		R447			RK73HB1J472J	CHIP R 4.7K J 1/16W	
R310			RK73GB2A394J	CHIP R 390K J 1/10W		R901,902			RK73GB2A472J	CHIP R 4.7K J 1/10W	
R311			RK73HB1J123J	CHIP R 12K J 1/16W		VR1	*		R32-0736-05	SEMI FIXED VARIABLE RESISTOR(68K)	
R312			RK73GB2A334J	CHIP R 330K J 1/10W		S1 -3			S70-0414-05	TACT SWITCH	
R313			RK73GB2A104J	CHIP R 100K J 1/10W		MIC301	2A	*	T91-0649-15	MIC ELEMENT	
R314			RK73GB2A103J	CHIP R 10K J 1/10W		D1			MA2S111	DIODE	
R315			RK73GB2A334J	CHIP R 330K J 1/10W		D4 ,5			1SV325F	VARIABLE CAPACITANCE DIODE	
R316			RK73GB2A124J	CHIP R 120K J 1/10W		D7			1SV325F	VARIABLE CAPACITANCE DIODE	
R317			RK73GB2A474J	CHIP R 470K J 1/10W		D9			1SV325F	VARIABLE CAPACITANCE DIODE	
R318			RK73GB2A122J	CHIP R 1.2K J 1/10W		D10			1SV278F	VARIABLE CAPACITANCE DIODE	
R319			RK73HB1J563J	CHIP R 56K J 1/16W		D11			MA2S111	DIODE	
R320			RK73HB1J332J	CHIP R 3.3K J 1/16W		D101			HSC277	DIODE	
R321			RK73HB1J224J	CHIP R 220K J 1/16W		D102			HZU5CLL	ZENER DIODE	
R322			RK73HB1J184J	CHIP R 180K J 1/16W		D103-106			HVC131	DIODE	
R323			RK73HB1J563J	CHIP R 56K J 1/16W		D202			HSC277	DIODE	
R324,325			RK73GB2A104J	CHIP R 100K J 1/10W		D203-206			1SV305F	VARIABLE CAPACITANCE DIODE	
R326			RK73GB2A000JX	CHIP R 0.0 J 1/10W		D301,302			RB706F-40	DIODE	
R327			RK73GB2A184J	CHIP R 180K J 1/10W		D303			DAN222	DIODE	
R328			RK73GB2A103J	CHIP R 10K J 1/10W		D401			RB521S-30	DIODE	
R329			RK73GB2A823J	CHIP R 82K J 1/10W		D402			1SR154-400	DIODE	
R330			RK73HB1J332J	CHIP R 3.3K J 1/16W		IC1		*	MB15A02PFV2E1	MOS-IC	
R331			RK73GB2A393J	CHIP R 39K J 1/10W		IC2			UPB1509GV	BI-POLAR IC	
R332			RK73GB2A153J	CHIP R 15K J 1/10W		IC101			TA75W01FUF	MOS-IC	
R334			RK73GB2A473J	CHIP R 47K J 1/10W		IC201			TA31136FNG	MOS-IC	
R335			RK73GB2A222J	CHIP R 2.2K J 1/10W		IC301			AQUA-L	MOS-IC	
R336			RK73GB2A102J	CHIP R 1.0K J 1/10W		IC302			TA7368FG	MOS-IC	
R337			RK73GB2A101J	CHIP R 100 J 1/10W		IC401,402			XC6204B502MR	MOS-IC	
R338			RK73GB2A222J	CHIP R 2.2K J 1/10W		IC403			BD4840FVE	MOS-IC	
R339			RK73GB2A471J	CHIP R 470 J 1/10W		IC404			BD4845FVE	MOS-IC	
R340			RK73GB2A182J	CHIP R 1.8K J 1/10W		IC405		*	30622MAA-B95GU	MICROPROCESSOR IC	
R341			RK73GB2A103J	CHIP R 10K J 1/10W		IC406			BR24L08F-W	ROM IC	
R342			RK73GB2A100J	CHIP R 10 J 1/10W		Q1			KTC4082	TRANSISTOR	
R343			RK73GB2A474J	CHIP R 470K J 1/10W		Q2			2SC5108(Y)F	TRANSISTOR	
R344			RK73GB2A102J	CHIP R 1.0K J 1/10W		Q3 ,4			2SK508NV(K52)	FET	
R345,346			RK73GB2A101J	CHIP R 100 J 1/10W		Q5			DTA143TE	DIGITAL TRANSISTOR	
R347			RK73GB2A104J	CHIP R 100K J 1/10W		Q6			2SC5108(Y)F	TRANSISTOR	
R348			RK73GB2A563J	CHIP R 56K J 1/10W		Q7			DTA143TE	DIGITAL TRANSISTOR	
R349			RK73GB2A333J	CHIP R 33K J 1/10W		Q8			2SC4617(S)	TRANSISTOR	
R350			RK73HB1J000JX	CHIP R 0.0 J 1/16W		Q9			2SC5108(Y)F	TRANSISTOR	
R354,355			RK73HB1J103J	CHIP R 10K J 1/16W		Q102			2SC4926YD	TRANSISTOR	
R357			RK73HB1J000JX	CHIP R 0.0 J 1/16W		Q103			2SK2596	FET	
R360			RK73HB1J000JX	CHIP R 0.0 J 1/16W		Q104			DTC114EE	DIGITAL TRANSISTOR	
R365			RK73HB1J473J	CHIP R 47K J 1/16W		Q105			2SK879(Y)F	FET	
R403			RK73GB2A101J	CHIP R 100 J 1/10W		Q106			2SK2595-E	FET	
R404			RK73HH1J474D	CHIP R 470K D 1/16W		Q107			DTC114EE	DIGITAL TRANSISTOR	
R405			RK73GB2A334J	CHIP R 330K J 1/10W		Q108			2SK1824-A	FET	
R406			RK73HH1J474D	CHIP R 470K D 1/16W		Q109			DTA144EE	DIGITAL TRANSISTOR	
R407			RK73HB1J334J	CHIP R 330K J 1/16W		Q202			DTA144EE	DIGITAL TRANSISTOR	
R408-412			RK73HB1J473J	CHIP R 47K J 1/16W		Q203			2SC4649(N,P)	TRANSISTOR	
R413,414			RK73GB2A331J	CHIP R 330 J 1/10W		Q204,205			3SK318	FET	
R415,416			RK73GB2A473J	CHIP R 47K J 1/10W		Q301			DTA114EE	DIGITAL TRANSISTOR	
R417-420			RK73HB1J473J	CHIP R 47K J 1/16W		Q302			2SC4919	TRANSISTOR	
R421,422			RK73HB1J102J	CHIP R 1.0K J 1/16W							
R423			RK73HB1J000JX	CHIP R 0.0 J 1/16W							
R424,425			RK73HB1J473J	CHIP R 47K J 1/16W							
R426			RK73HB1J000JX	CHIP R 0.0 J 1/16W							

PARTS LIST / 零件表

TX-RX UNIT (X57-6870-20)

Ref. No.	Address	New parts	Parts No.	Description	Destination	Ref. No.	Address	New parts	Parts No.	Description	Destination
Q303			DTC144EE	DIGITAL TRANSISTOR							
Q304		*	2SA1362(GR)-F	TRANSISTOR							
Q305			DTC144EE	DIGITAL TRANSISTOR							
Q306		*	2SK3577-A	FET							
Q316		*	2SK3577-A	FET							
Q401,402			DTC114EE	DIGITAL TRANSISTOR							
Q403,404			CPH3317	FET							
Q405			DTA123JE	DIGITAL TRANSISTOR							
Q407,408			2SK1830F	FET							
Q901			2SK1824-A	FET							
TH101			157-104-65001	THERMISTOR							
TH203			157-104-65001	THERMISTOR							

TK-2207G

EXPLODED VIEW / 部件分解图

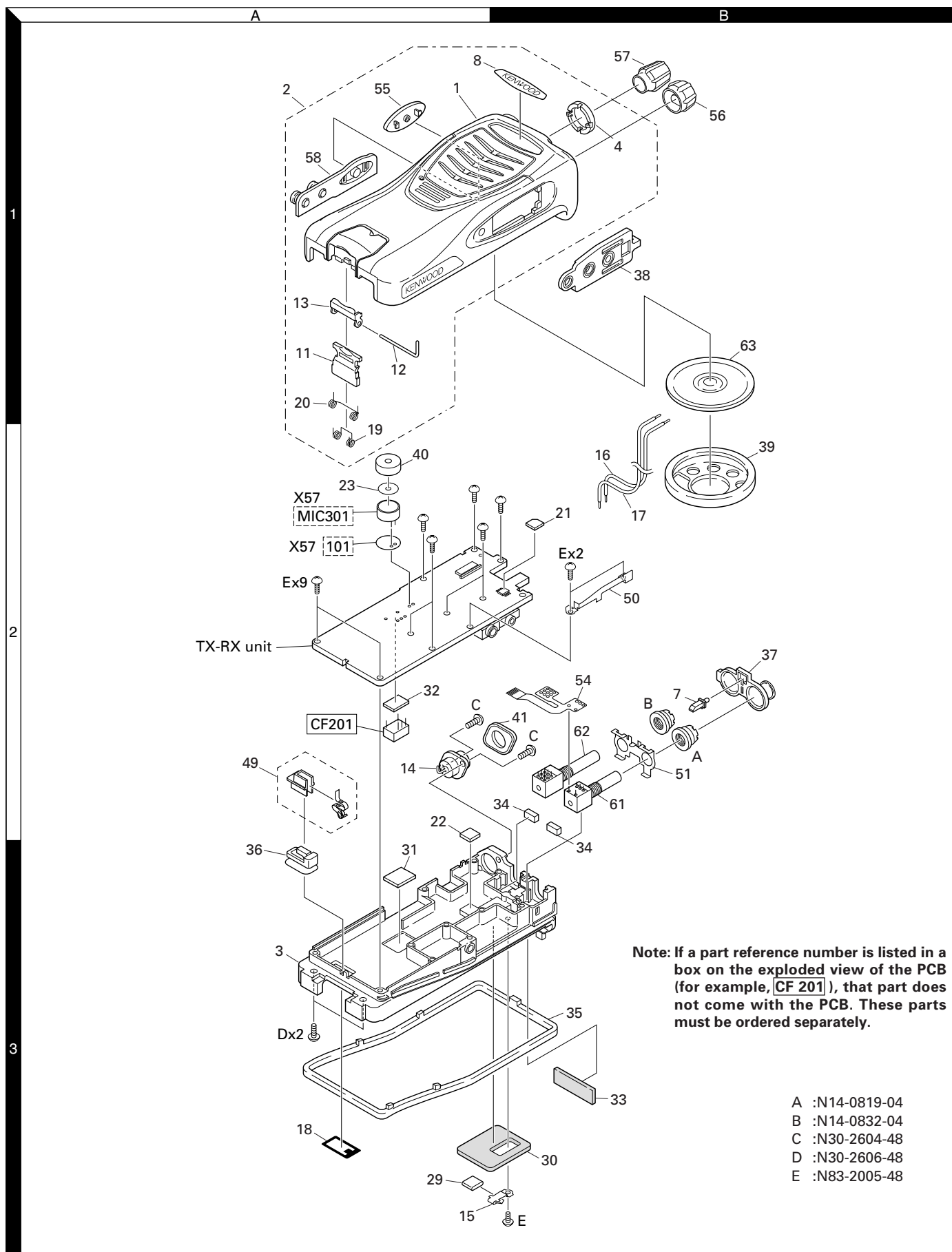

PACKING / 包装

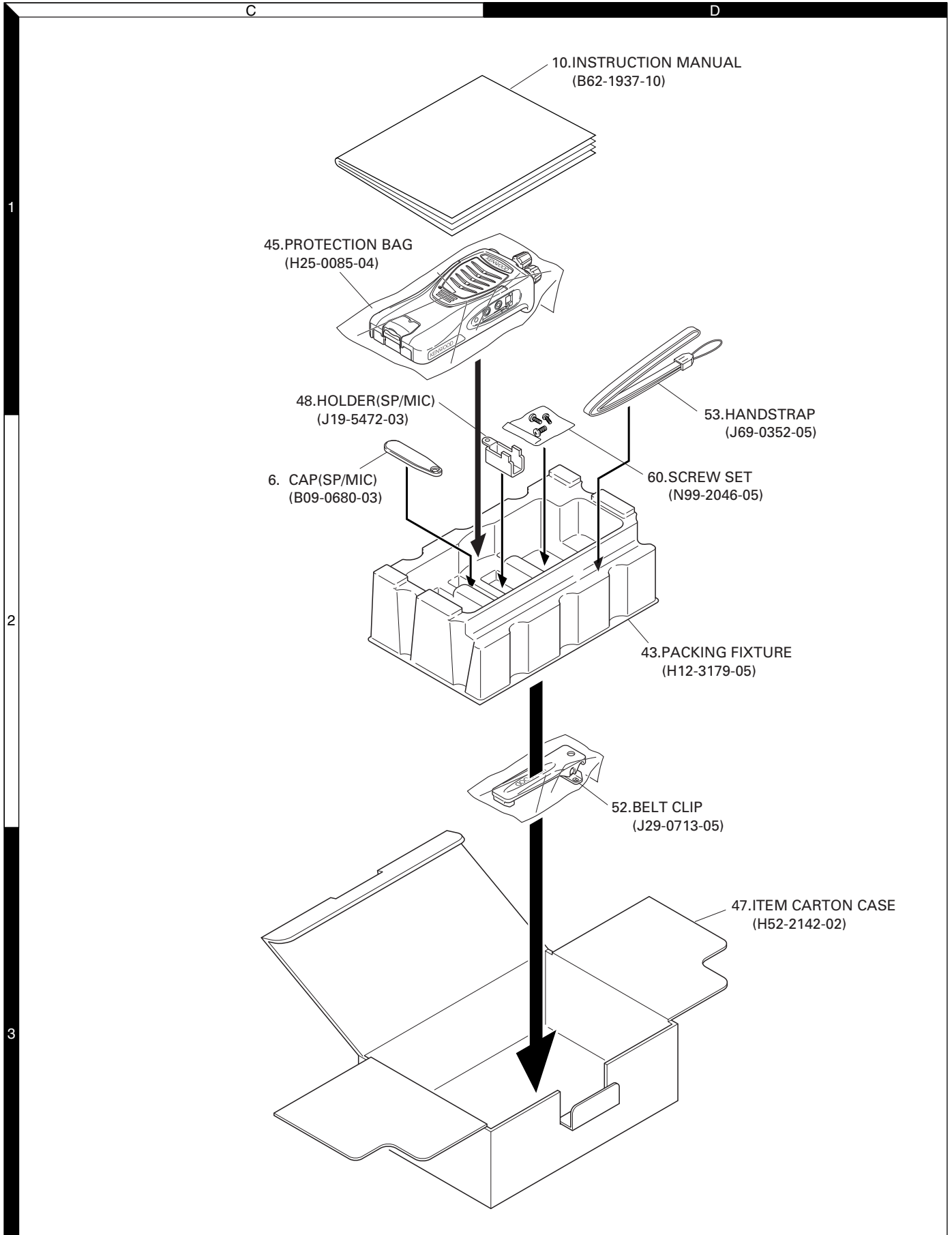

ADJUSTMENT / 调整

Test Equipment Required for Alignment

Test Equipment	Major Specifications	
1. Standard Signal Generator (SSG)	Frequency Range Modulation Output	136 to 174MHz Frequency modulation and external modulation -127dBm/0.1 μ V to greater than -47dBm/1mV
2. Power Meter	Input Impedance Operation Frequency Measurement Range	50 Ω 136 to 174MHz Vicinity of 10W
3. Deviation Meter	Frequency Range	136 to 174MHz
4. Digital Volt Meter (DVM)	Measuring Range Input Impedance	10mV to 10V DC High input impedance for minimum circuit loading
5. Oscilloscope		DC through 30MHz
6. High Sensitivity Frequency Counter	Frequency Range Frequency Stability	10Hz to 1000MHz 0.2ppm or less
7. Ammeter		5A
8. AF Volt Meter (AF VTVM)	Frequency Range Voltage Range	50Hz to 10kHz 1mV to 10V
9. Audio Generator (AG)	Frequency Range Output	50Hz to 5kHz or more 0 to 1V
10. Distortion Meter	Capability Input Level	3% or less at 1kHz 50mV to 10Vrms
11. Spectrum Analyzer	Measuring Range	DC to 1GHz or more
12. Tracking Generator	Center frequency Output Voltage	50kHz to 600MHz 100mV or more
13. 8 Ω Dummy Load		Approx. 8 Ω , 3W
14. Regulated Power Supply		5V to 10V, approx. 3A Useful if ammeter equipped

所需的用于调整的测试设备

测试设备	主要特性	
1. 标准信号发生器 (SSG)	频率范围 调制 输出	136 到 174MHz 调频和外部调制 -127dBm/0.1 μ V 到 大于 -47dBm/1mV
2. 功率计	输入阻抗 操作频率 测量范围	50 Ω 136 到 174MHz 10W 左右
3. 频偏仪	频率范围	136 到 174MHz
4. 数字电压表 (DVM)	测量范围 输入阻抗	直流 10mV 到 10V 为最小电路负载高输入阻抗
5. 示波器		直流到 30MHz
6. 高灵敏度频率计数器	频率范围 频率稳定性	10Hz 到 1000MHz 0.2ppm 或更低
7. 电流表		5A
8. 音频电压表 (AF VTVM)	频率范围 电压范围	50Hz 到 10kHz 1mV 到 10V
9. 音频发生器 (AG)	频率范围 输出	50Hz 到 5kHz 或更高 0 到 1V
10. 失真测试仪	容量 输入电平	1kHz 时 3% 或更低 50mV 到 10Vrms
11. 频谱分析仪	测量范围	直流到 1GHz 或更高
12. 轨迹发生器	中心频率 输出电压	50kHz 到 600MHz 100mV 或更高
13. 8 Ω 假负载		大约 8 Ω , 3W
14. 可调电源		5V 到 10V, 大约 3A 配备了电流表时有用

ADJUSTMENT / 调整

■ The following parts are required for adjustment

1. Antenna connector adapter

The antenna connector of this transceiver uses an SMA terminal.

Use an antenna connector adapter [SMA(f) – BNC(f) or SMA(f) – N(f)] for adjustment. (The adapter is not provided as an option, so buy a commercially-available one.)

2. Repair Jig (Chassis)

Use jig (part No.: A10-4086-03) for repairing the transceiver. Place the TX-RX unit on the jig and fit it with screws.

The jig facilitates the voltage check and protects the final amplifier FET when the voltage on the flow side of the TX-RX unit is checked during repairs.

3. Battery Jig (W05-1011-00)

Connect the power cable properly between the battery jig installed in the transceiver and the power supply, and be sure output voltage and the power supply polarity prior to switching the power supply ON, otherwise over voltage and reverse connection may damage the transceiver, or the power supply or both.

Note: When using the battery jig, you must measure the voltage at the terminals of the battery jig. Otherwise, a slight voltage drop may occur within the power cable, between the power supply and the battery jig, especially while the transceiver transmits.

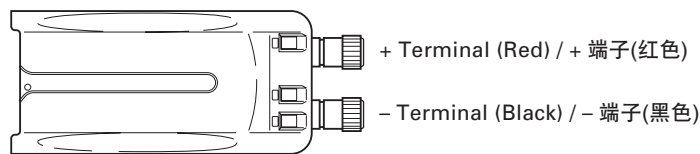

■ 下面是调整时所需的部件

1. 天线接口转换头

此对讲机的天线接口使用 SMA 终端。

使用天线接口转换头 [SMA(f)-BNC(f) 或 SMA(f)-N(f)] 进行调整。(转换头不作为可选件提供, 因此请购买商用转换头。)

2. 维修机架 (机壳)

使用机壳 (A10-4086-03) 维修对讲机。将 TX-RX 单元放置在机壳上, 并且拧上螺钉。

在维修过程中, 需要在 TX-RX 单元的电路板上检测电压时, 机壳可以方便地进行电压检测, 并且保护模块。

3. 电池夹具 (W05-1011-00)

在对讲机的电池夹具和电源之间连接适当的电源电缆, 确认了输出电压之后接通电源开关, 电压超过或极性颠倒都有可能损坏对讲机。

注意: 当使用电池夹具时, 你必须测定电池夹具的终端电压。因为, 电源和电池夹具之间会有一些的电压下降, 尤其在对讲机发射的时候。

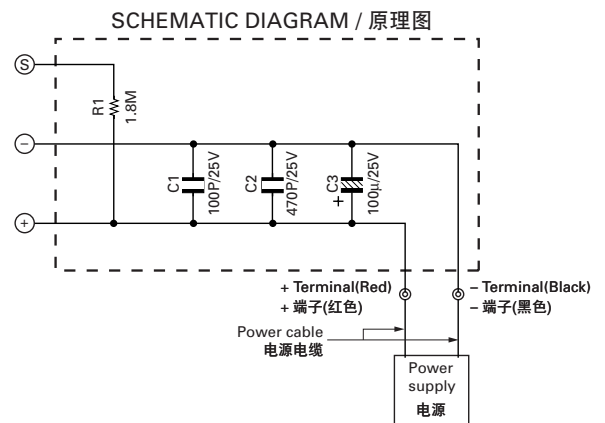

ADJUSTMENT / 调整

Adjustment points

调整点

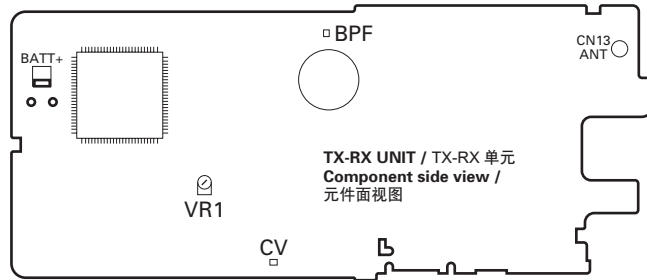

VR1 : Frequency adjustment
BPF : Band-pass wave form test point
CV : Lock voltage adjustment terminal

VR1 : 频率调整
BPF : 带通波形测试点
CV : 锁定电压调整端子

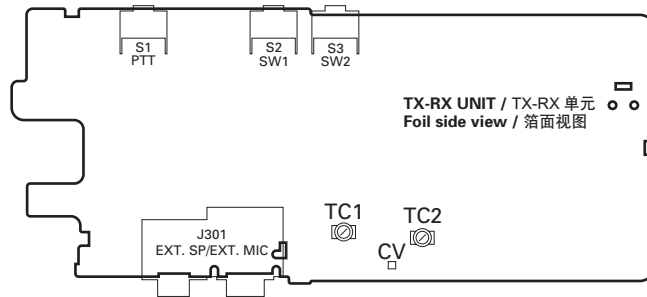

TC1 : Transmit lock voltage adjustment
TC2 : Receive lock voltage adjustment
CV : Lock voltage adjustment terminal

TC1 : 发射锁定电压调整
TC2 : 接收锁定电压调整
CV : 锁定电压调整端子

ADJUSTMENT / 调整

■ Frequency and signaling

The transceiver has been adjusted for the frequencies shown in the following table. When required, readjust them following the adjustment procedure to obtain the frequencies you want in actual operation.

Frequency (MHz)

Channel No.	RX	TX
1	155.050	155.100
2	136.050	136.100
3	173.950	173.900
4	155.000	155.000
5	155.200	155.200
6	155.400	155.400
7~16	—	—

Signaling

Signaling No.	RX	TX
1	None	None
2	None	100Hz Square Wave
3	QT 67.0Hz	QT 67.0Hz
4	QT 151.4Hz	QT 151.4Hz
5	QT 250.3Hz	QT 250.3Hz
6	DQT D023N	DQT D023N
7	DQT D754I	DQT D754I
8	DTMF 159D	DTMF 159D
9	None	DTMF tone 9

• Preparations for tuning the transceiver

Before attempting to tune the transceiver, connect the unit to a suitable power supply.

Whenever the transmitter is tuned, the unit must be connected to a suitable dummy load (i.e. power meter).

The speaker output connector must be terminated with a 8Ω dummy load and connected to an AC voltmeter and an audio distortion meter or a SINAD measurement meter at all times during tuning.

Adjustment Frequency

TEST CH	RX	TX
Low	136.050MHz	136.100MHz
Low'	145.550MHz	145.600MHz
Center	155.050MHz	155.100MHz
High'	164.550MHz	164.600MHz
High	173.950MHz	173.900MHz

■ 频率和信令

频率设定调整如下表所示。当需要时，按照如下调整程序重新调整，以便获得您在实际操作时希望的频率。

频率 (MHz)

信道号码	接收	发射
1	155.050	155.100
2	136.050	136.100
3	173.950	173.900
4	155.000	155.000
5	155.200	155.200
6	155.400	155.400
7~16	—	—

信令

信令号码	接收	发射
1	无	无
2	无	100Hz 方形波
3	QT 67.0Hz	QT 67.0Hz
4	QT 151.4Hz	QT 151.4Hz
5	QT 250.3Hz	QT 250.3Hz
6	DQT D023N	DQT D023N
7	DQT D754I	DQT D754I
8	DTMF 159D	DTMF 159D
9	无	DTMF 音频 9

• 调谐对讲机的准备

在调谐对讲机之前，把装置连接到规定的电源。

任何时候调整发射，装置必须连接到合适的假负载（即功率表）。

在全部调谐过程中，扬声器输出端子必须连接8Ω假负载连接到AC伏特计和音频失真仪或SINAD测试表。

调整频率

测试 CH	接收	发射
低	136.050MHz	136.100MHz
低'	145.550MHz	145.600MHz
中心	155.050MHz	155.100MHz
高'	164.550MHz	164.600MHz
高	173.950MHz	173.900MHz

ADJUSTMENT / 调整

Common Section

Item	Condition	Measurement		Adjustment		Specifications/ Remark
		Test equipment	Terminal	Parts	Method	
1. Setting	1) BATT terminal voltage:7.5V 2) SSG standard modulation [Wide] MOD:1kHz,DEV:3kHz [Narrow] MOD:1kHz,DEV:1.5kHz					
2. VCO lock voltage RX	1) CH:High	Power meter DVM	ANT CV	TC2	4.0V	±0.1V
	2) CH:Low				Check	0.6V or more
3. VCO lock voltage TX	3) CH:High PTT:ON			TC1	4.2V	±0.1V
	4) CH:Low PTT:ON				Check	0.6V or more

Transmitter Section

Item	Condition	Measurement		Adjustment		Specifications/ Remark
		Test equipment	Terminal	Parts	Method	
1. Frequency Adjust	1) CH:High 2) PTT:ON	Frequency counter	ANT	VR1	High frequency ±50Hz	Note: After replacing the TCXO(X1) align frequency.
2. High power Adjust	TEST CH: Low Low' Center High' High (5 points) BATT terminal voltage:7.5V PTT:ON	Power meter Ammeter		Programming Software:KPG-87D	5.0W	±0.1W 2.0 A or less
					1.05W	±0.1W 1.0 A or less
4. Max deviation Adjust [Wide]	TEST CH: Center Low High (3 points) AG:1kHz/150mV Deviation meter filter LPF:15kHz HPF:OFF PTT:ON	Power meter Deviation meter Oscilloscope AG AF VTVM	ANT SP/MIC connector		4.2kHz (According to the larger +,-)	±80Hz
	[Narrow]				TEST CH:High PTT:ON	2.2kHz (According to the larger +,-)
5. VOX 1 Writing	TEST CH:Center AG:1KHz/45mV					

ADJUSTMENT / 调整

公用部分

项目	条件	测量		调整		规格 / 备注
		测试设备	端子	部件	方法	
1. 设置	1) BATT端子电压 : 7.5V 2) SSG 标准调制 [宽] MOD:1kHz,DEV:3kHz [窄] MOD:1kHz,DEV:1.5kHz					
2. VCO 锁定电压 RX	1) CH : 高	功率表 DVM	ANT CV	TC2	4.0 V	±0.1V
	2) CH : 低				检查	0.6V 或以上
3. VCO 锁定电压 TX	3) CH : 高 PTT : ON			TC1	4.2 V	±0.1V
	4) CH : 低 PTT : ON				检查	0.6V 或以上

发射部分

项目	条件	测量		调整		规格 / 备注
		测试设备	端子	部件	方法	
1. 频率调整	1) CH : 高 2) PTT : ON	频率计	ANT	VR1	高频率 ± 50Hz	注意: 更换 TCXO(X1)后, 请调整频率。
2. 高功率调整	测试 CH : 低 低 / 中心 高 / 高 (5 点) BATT 端子电压 : 7.5V PTT : ON	功率表 电流表		编程软件 : KPG-87D	5.0W	±0.1W 2.0 A 或以下
3. 低功率调整	测试 CH : 低 低 / 中心 高 / 高 (5 点) BATT 端子电压 : 7.5V PTT : ON				1.05W	±0.1W 1.0 A 或以下
4. 最大频偏调整 [宽]	测试 CH : 中心 低 高 (3 点) AG : 1kHz / 150mV 频偏仪滤波器 LPF : 15kHz HPF : OFF PTT : ON	功率表 频偏仪 示波器 AG AF VTVM	ANT SP / MIC 连接器		4.2kHz (按照最大+,-)	± 80Hz
	[窄]	测试 CH : 高 PTT : ON			2.2kHz (按照最大+,-)	± 80Hz
5. VOX 1 写入	测试 CH : 中心 AG : 1kHz / 45mV					

ADJUSTMENT / 调整

Item	Condition	Measurement		Adjustment		Specifications/ Remark
		Test equipment	Terminal	Parts	Method	
6.VOX 10 Writing	TEST CH:Center AG:1kHz/3.0mV	Power meter Deviation meter	ANT SP/MIC connector	Programming Software:KPG-87D		
7.DQT balance Adjust [Wide]	TEST CH: Center Low High (3 points) LPF:3kHz HPF:OFF PTT:ON	Oscilloscope AG AF VTVM	ANT	Programming Software:KPG-87D	Make the demodulation wave into square waves	
[Narrow]	TEST CH:Center PTT:ON					
8.QT deviation Adjust [Wide]	TEST CH: Center Low High (3 points) LPF:3kHz HPF:OFF PTT:ON				0.75kHz	±40Hz
[Narrow]	TEST CH: Center PTT:ON				0.38kHz	±40Hz
9.DQT deviation Adjust [Wide]	TEST CH: Center Low High (3 points) LPF:3kHz HPF:OFF PTT:ON				0.75kHz	±40Hz
[Narrow]	TEST CH:Center PTT:ON				0.38kHz	±40Hz
10.DTMF deviation Adjust [Wide]	TEST CH:Center LPF:15kHz HPF:OFF PTT:ON				3.0kHz	±100Hz
[Narrow]	TEST CH:Center PTT:ON				1.5kHz	±100Hz
11.MSK deviation Adjust [Wide]	TEST CH: Center LPF:15kHz HPF:OFF PTT:ON				3.1kHz	±100Hz
[Narrow]	TEST CH:Center PTT:ON				1.5kHz	±100Hz

ADJUSTMENT / 调整

项目	条件	测量		调整		规格 / 备注		
		测试设备	端子	部件	方法			
6. VOX 10 写入	测试 CH : 中心 AG : 1KHz / 3.0mV	功率表 频偏仪 示波器 AG AF VTVM	ANT SP/MIC 连接器 ANT	编程软件 : KPG-87D				
7. DQT 平衡调整 [宽]	测试 CH : 中心 低 高 (3点) LPF : 3kHz HPF : OFF PTT : ON						编程软件 : KPG-87D	把解调波调整 为方波
[窄]	测试 CH : 中心 PTT : ON							
8. QT 频偏调整 [宽]	测试 CH : 中心 低 高 (3点) LPF : 3kHz HPF : OFF PTT : ON						0.75kHz	±40Hz
[窄]	测试 CH : 中心 PTT : ON						0.38kHz	±40Hz
9. DQT 频偏调整 [宽]	测试 CH : 中心 低 高 (3点) LPF : 3kHz HPF : OFF PTT : ON						0.75kHz	±40Hz
[窄]	测试 CH : 中心 PTT : ON						0.38kHz	±40Hz
10. DTMF 频偏调整 [宽]	测试 CH : 中心 LPF : 15kHz HPF : OFF PTT : ON						3.0kHz	±100Hz
[窄]	测试 CH : 中心 PTT : ON						1.5kHz	±100Hz
11. MSK 频偏调整 [宽]	测试 CH : 中心 LPF : 15kHz HPF : OFF PTT : ON						3.1kHz	±100Hz
[窄]	测试 CH : 中心 PTT : ON						1.5kHz	±100Hz

ADJUSTMENT / 调整

Receiver Section

Item	Condition	Measurement		Adjustment		Specifications/ Remark
		Test equipment	Terminal	Parts	Method	
1. BPF Wave Adjust	(1)Center frequency Spectrum analyzer setting Center-f : 155MHz Span : 50MHz RBW : 300kHz VBW : 10kHz ATT : 5dB (2)High-edge frequency Spectrum analyzer setting Center-f : 174MHz (3)Low-edge frequency Spectrum analyzer setting Center-f : 136MHz	Spectrum analyzer	ANT BPF	Programming Software: KPG-87D	Adjust the waveform as shown to the right.	
2. Sensitivity Check [Wide]	TEST CH: Low Center High SSG output:-117 dBm(0.3μV) SSG MOD:3.0kHz	SSG DVM Oscilloscope AF VTVM	ANT		Check	12dB SINAD or more
[Narrow]	TEST CH: Center SSG output:-115 dBm(0.4μV) SSG MOD:1.5kHz					
3. SQL1 (Threshold) Writing [Wide]	TEST CH: Center Low High SSG output:-123 dBm(0.16μV) SSG MOD:3.0kHz			Programming Software: KPG-87D	Write	Squelch open
[Narrow]	TEST CH: Center SSG output:-122 dBm(0.18μV) SSG MOD:1.5kHz					
4. SQL9 (Tight) Writing [Wide]	TEST CH: Center Low High SSG output:-117 dBm(0.3μV) SSG MOD:3.0kHz					
[Narrow]	TEST CH:Center SSG output:-116 dBm(0.35μV) SSG MOD:1.5kHz					
5. BATT detection Writing	BATT terminal voltage:5.9V	DVM	ANT BATT terminal		Write	BATT terminal voltage:5.9V

ADJUSTMENT / 调整

接收部分

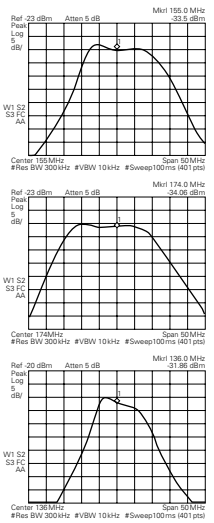
项目	条件	测量		调整		规格 / 备注
		测试设备	端子	部件	方法	
1. BPF 波形调整	(1)中心频率 频谱分析仪设定 Center-f : 155MHz Span : 50MHz RBW : 300kHz VBW : 10kHz ATT : 5dB (2)高边频率 频谱分析仪设定 Center-f : 174MHz (3)低边频率 频谱分析仪设定 Center-f : 136MHz	频谱分析仪	ANT BPF	编程软件 : KPG-87D	调整波形如 右图所示	
2. 灵敏度检查 [宽]	测试 CH : 低 中心 高 SSG 输出 : -117 dBm (0.3 μ V) SSG MOD : 3.0kHz	SSG DVM 示波器 AF VTVM	ANT		检查	12dB SINAD 或 以上
[窄]	测试 CH : 中心 SSG 输出 : -115 dBm (0.4 μ V) SSG MOD : 1.5kHz					
3. SQL1 (静噪阈值) 写入 [宽]	测试 CH : 中心 低 高 SSG 输出 : -123 dBm (0.16 μ V) SSG MOD : 3.0kHz			编程软件 : KPG-87D	写入	静噪开放
[窄]	测试 CH : 中心 SSG 输出 : -122 dBm (0.18 μ V) SSG MOD : 1.5kHz					
4. SQL9 (深静噪) 写入 [宽]	测试 CH : 中心 低 高 SSG 输出 : -117 dBm (0.3 μ V) SSG MOD : 3.0kHz					
[窄]	测试 CH : 中心 SSG 输出 : -116 dBm (0.35 μ V) SSG MOD : 1.5kHz					
5. 电池检测写入	BATT 端子电压 : 5.9V	DVM	ANT BATT 端子		写入	BATT 端子电压 : 5.9V

TK-2207G PC BOARD / PC 板

TX-RX UNIT (X57-6870-20) Component side view (J79-0043-09)

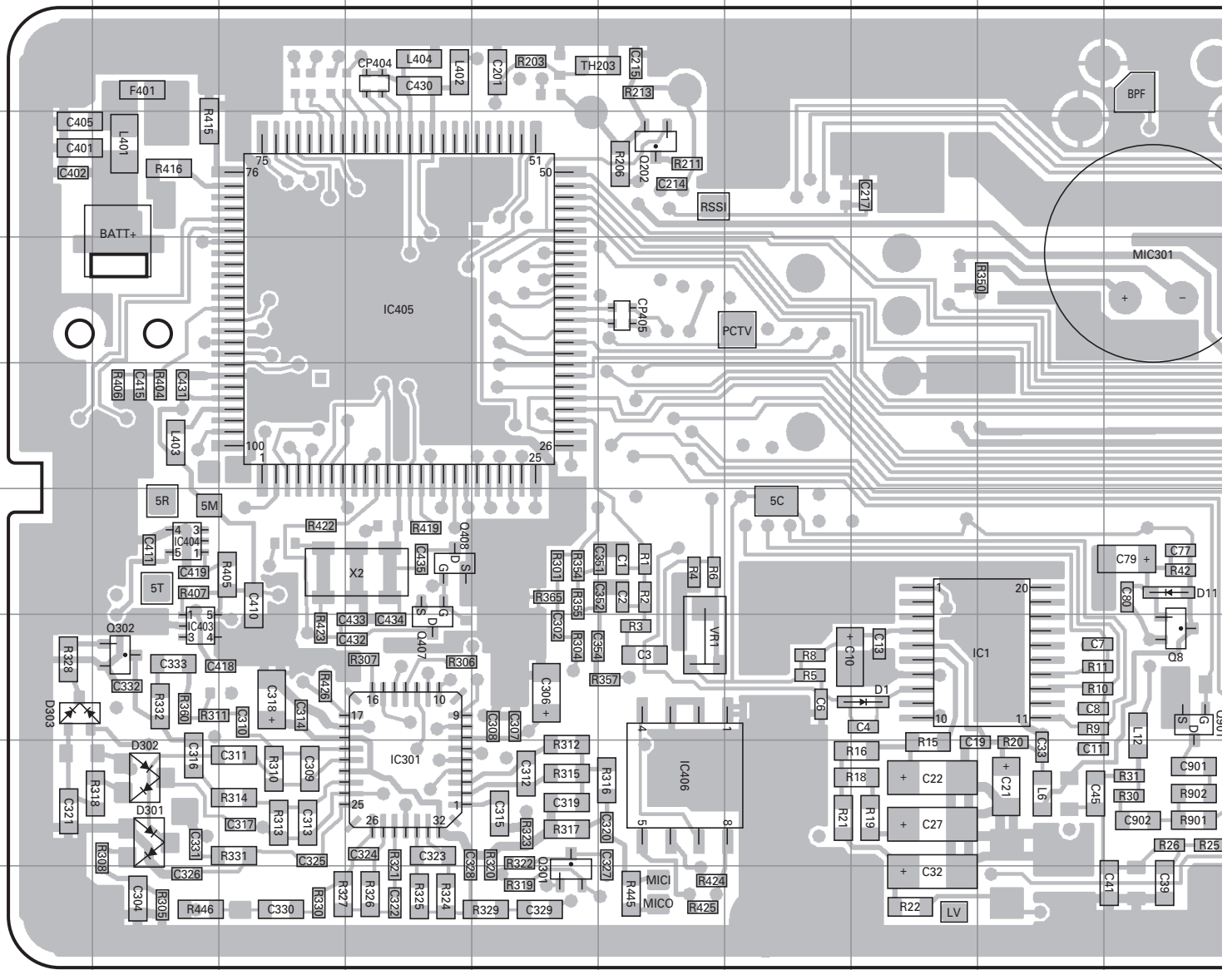

Ref. No.	Address	Ref. No.	Address	Ref. No.	Address	Ref. No.	Address
IC1	8I	Q104	5L	Q304	7P	D1	8H
IC101	4M	Q105	4K	Q305	8O	D11	7J
IC301	9D	Q107	4L	Q306	9P	D102	4M
IC302	8P	Q108	4L	Q316	9O	D301	9B
IC403	8B	Q109	5L	Q401	8R	D302	9B
IC404	7B	Q202	4F	Q402	8R	D303	8A
IC405	5D	Q301	10E	Q407	8D	D403	8R
IC406	9F	Q302	8B	Q408	7D	D404	8R
Q8	8J	Q303	7P	Q901	8J		

PC BOARD / PC 板 TK-2207G

TX-RX UNIT (X57-6870-20) Component side view (J79-0043-09)

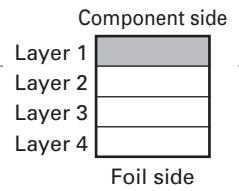
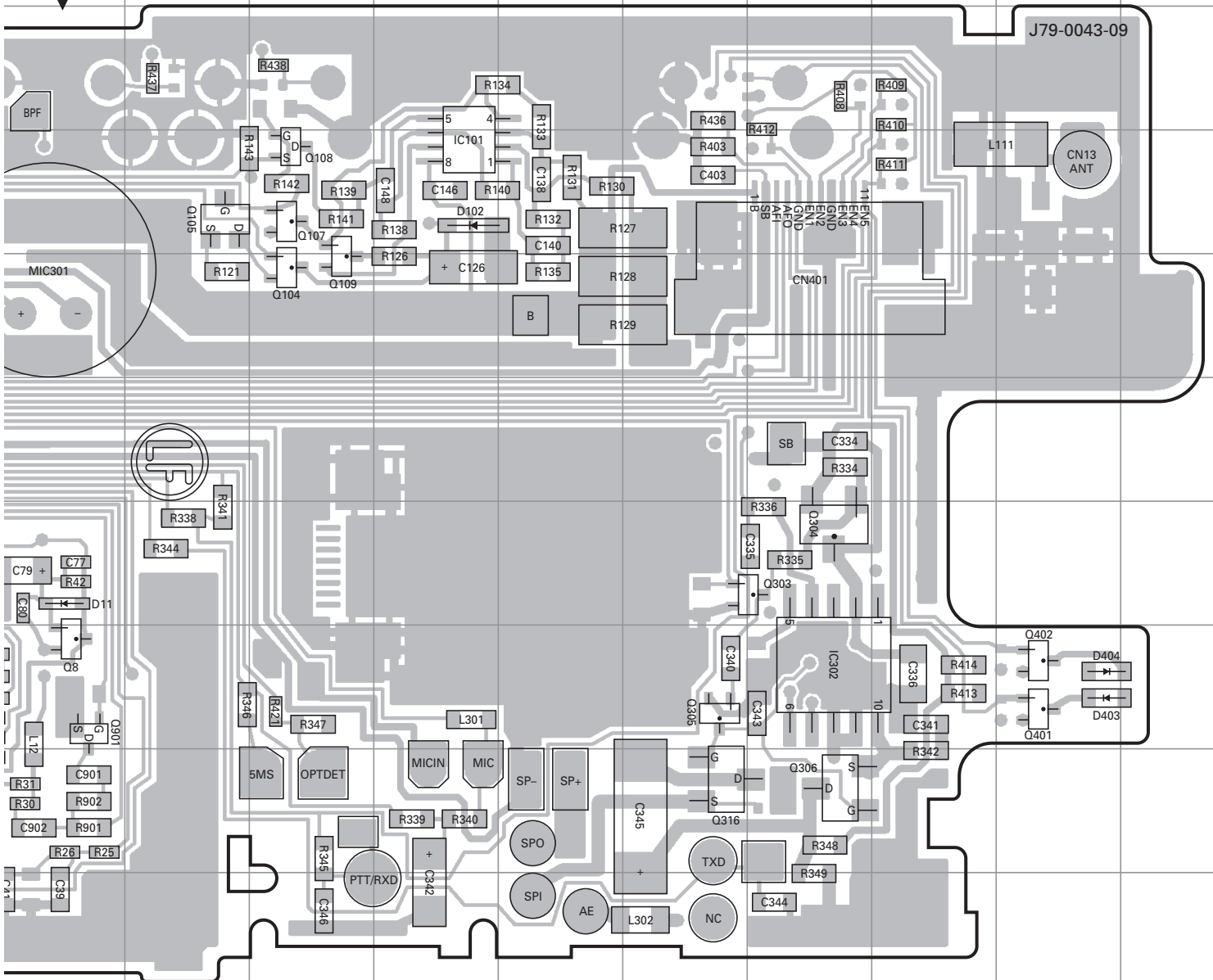

TK-2207G PC BOARD / PC 板

PC BOARD / PC 板 TK-2207G

TX-RX UNIT (X57-6870-20) Component side view (J79-0043-09)

TX-RX UNIT (X57-6870-20) Component side view (J79-0043-09)

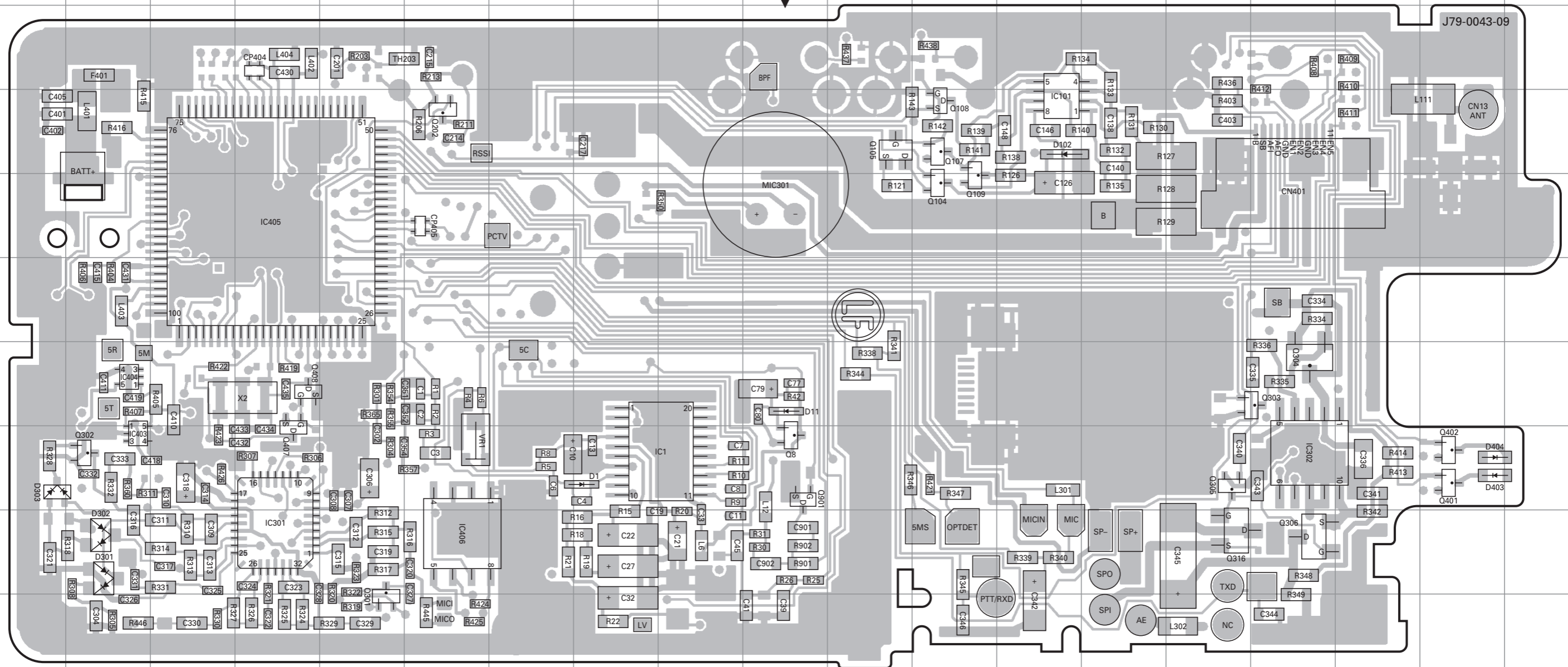

Ref. No.	Address	Ref. No.	Address	Ref. No.	Address	Ref. No.	Address
IC1	8I	Q104	5L	Q304	7P	D1	8H
IC101	4M	Q105	4K	Q305	8O	D11	7J
IC301	9D	Q107	4L	Q306	9P	D102	4M
IC302	8P	Q108	4L	Q316	9O	D301	9B
IC403	8B	Q109	5L	Q401	8R	D302	9B
IC404	7B	Q202	4F	Q402	8R	D303	8A
IC405	5D	Q301	10E	Q407	8D	D403	8R
IC406	9F	Q302	8B	Q408	7D	D404	8R
Q8	8J	Q303	7P	Q901	8J		

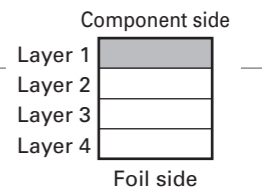

TK-2207G PC BOARD / PC 板

TX-RX UNIT (X57-6870-20) Foil side view (J79-0043-09)

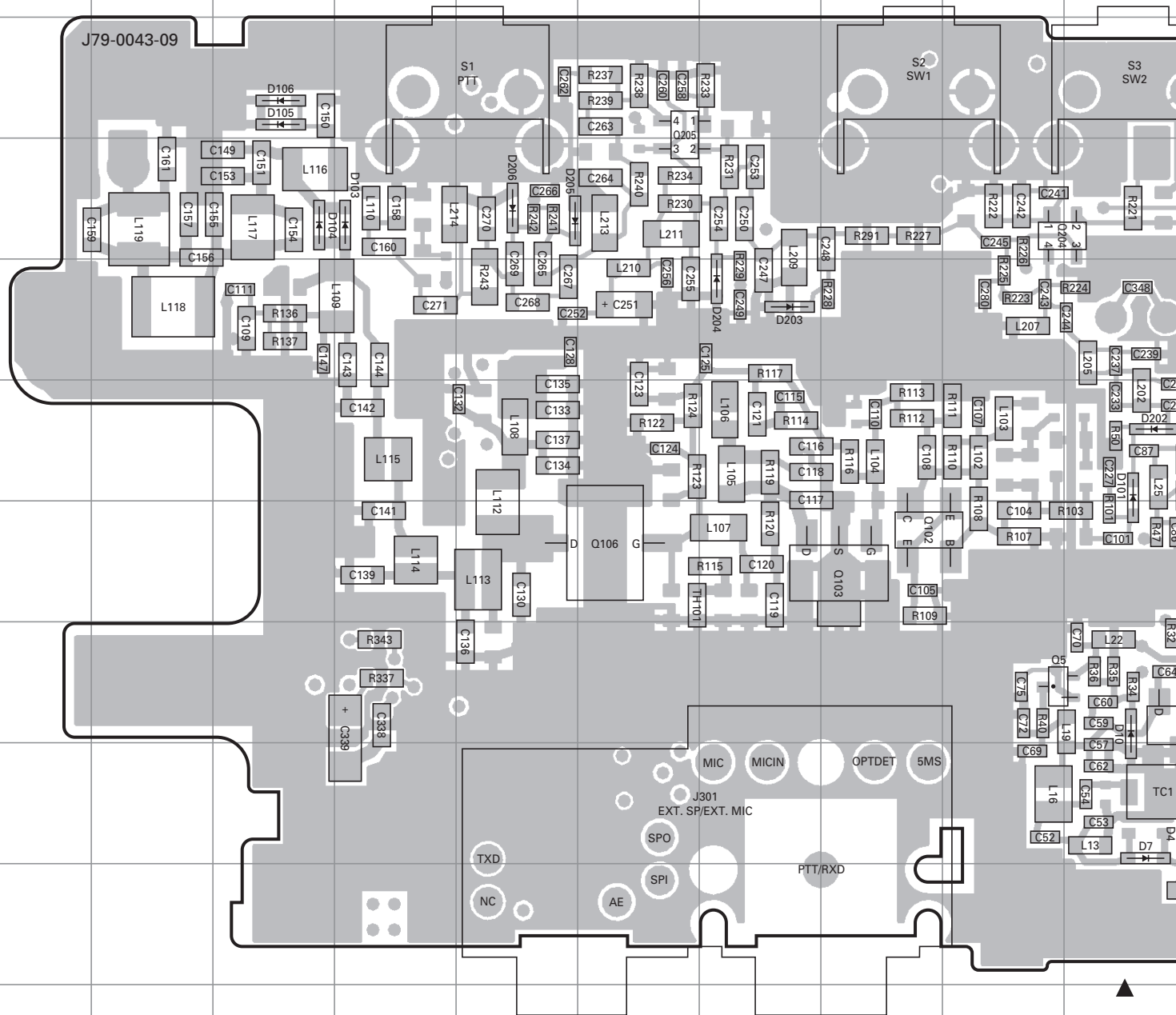

Ref. No.	Address	Ref. No.	Address	Ref. No.	Address	Ref. No.	Address	Ref. No.	Address
IC2	7L	Q5	8I	Q204	4I	D9	10L	D203	5G
IC201	5N	Q6	8K	Q205	3F	D10	8J	D204	5G
IC401	9R	Q7	9L	Q403	8R	D101	6J	D205	4E
IC402	8R	Q9	6K	Q404	9R	D103	4D	D206	4E
Q1	7O	Q102	7H	Q405	9R	D104	4C	D401	8R
Q2	8L	Q103	7H	D4	9J	D105	3C	D402	4R
Q3	9M	Q106	7F	D5	10L	D106	3C		
Q4	8J	Q203	4N	D7	9J	D202	6J		

PC BOARD / PC 板 TK-2207G

TX-RX UNIT (X57-6870-20) Foil side view (J79-0043-09)

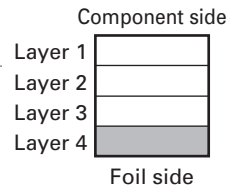
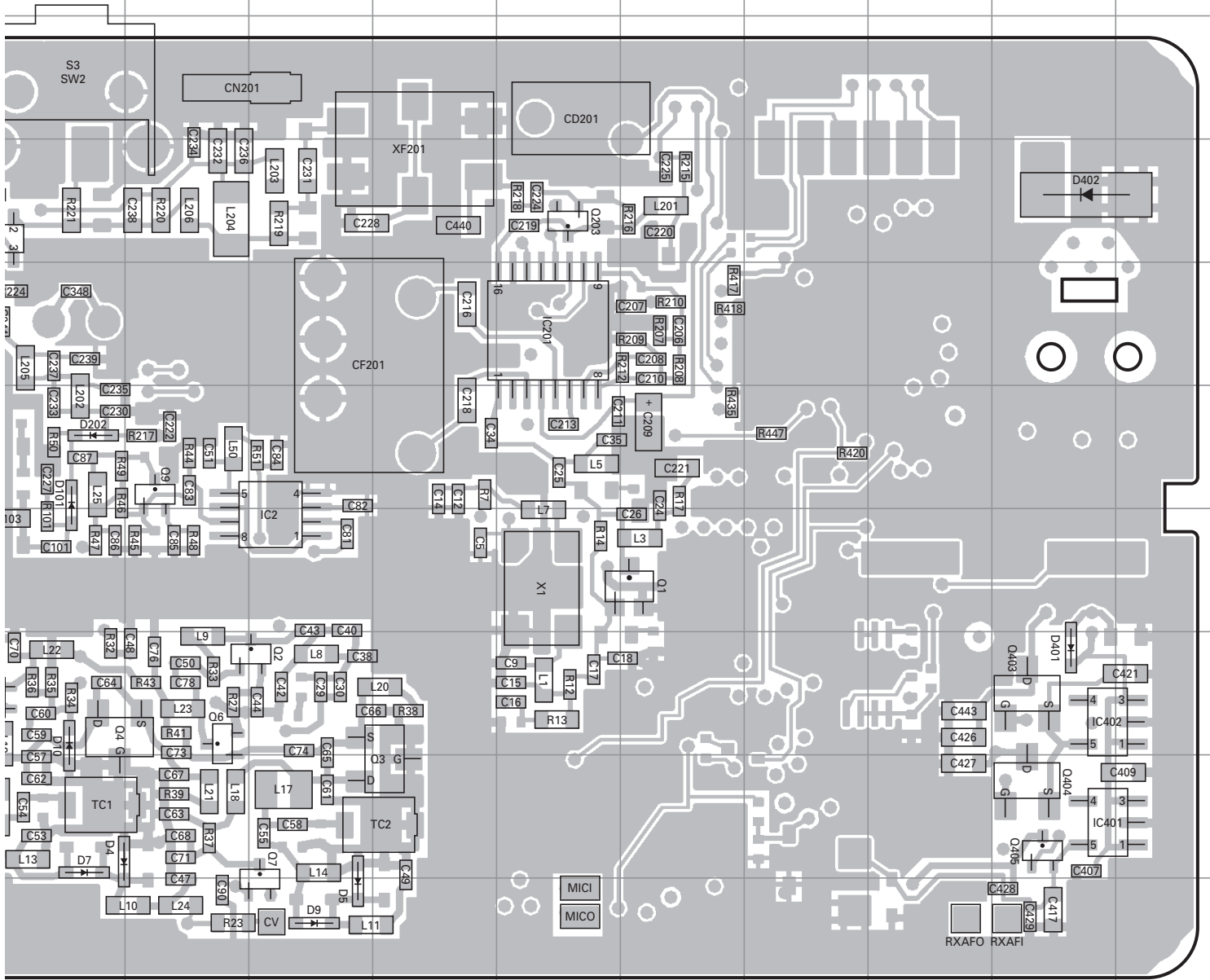

TX-RX UNIT (X57-6870-20) Foil side view (J79-0043-09)

TX-RX UNIT (X57-6870-20) Foil side view (J79-0043-09)

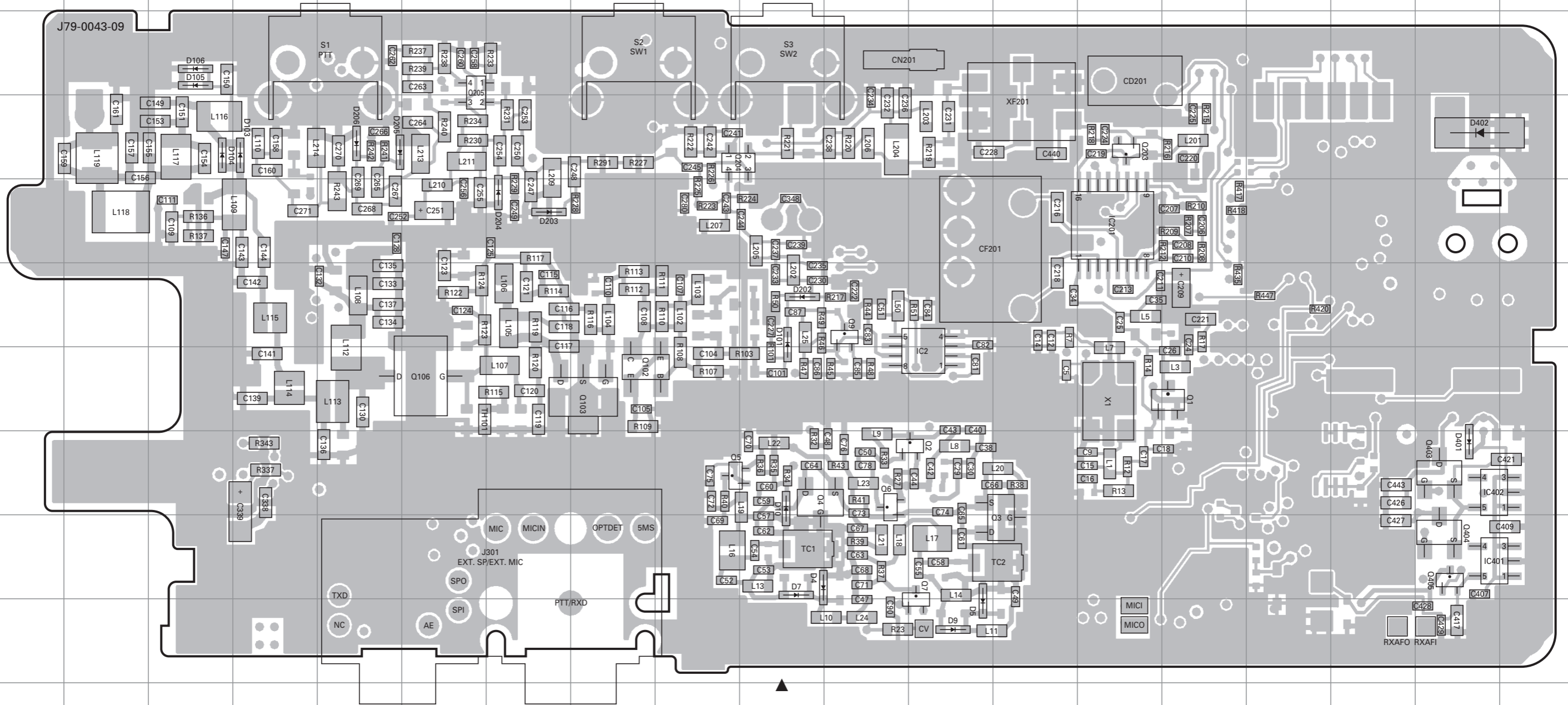

Ref. No.	Address	Ref. No.	Address	Ref. No.	Address	Ref. No.	Address	Ref. No.	Address
IC2	7L	Q5	8I	Q204	4I	D9	10L	D203	5G
IC201	5N	Q6	8K	Q205	3F	D10	8J	D204	5G
IC401	9R	Q7	9L	Q403	8R	D101	6J	D205	4E
IC402	8R	Q9	6K	Q404	9R	D103	4D	D206	4E
Q1	7O	Q102	7H	Q405	9R	D104	4C	D401	8R
Q2	8L	Q103	7H	D4	9J	D105	3C	D402	4R
Q3	9M	Q106	7F	D5	10L	D106	3C		
Q4	8J	Q203	4N	D7	9J	D202	6J		

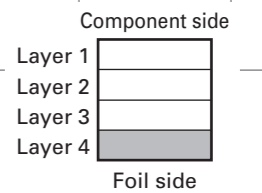

TK-2207G SCHEMATIC DIAGRAM / 原理图

TX-RX UNIT (X57-6870-20)

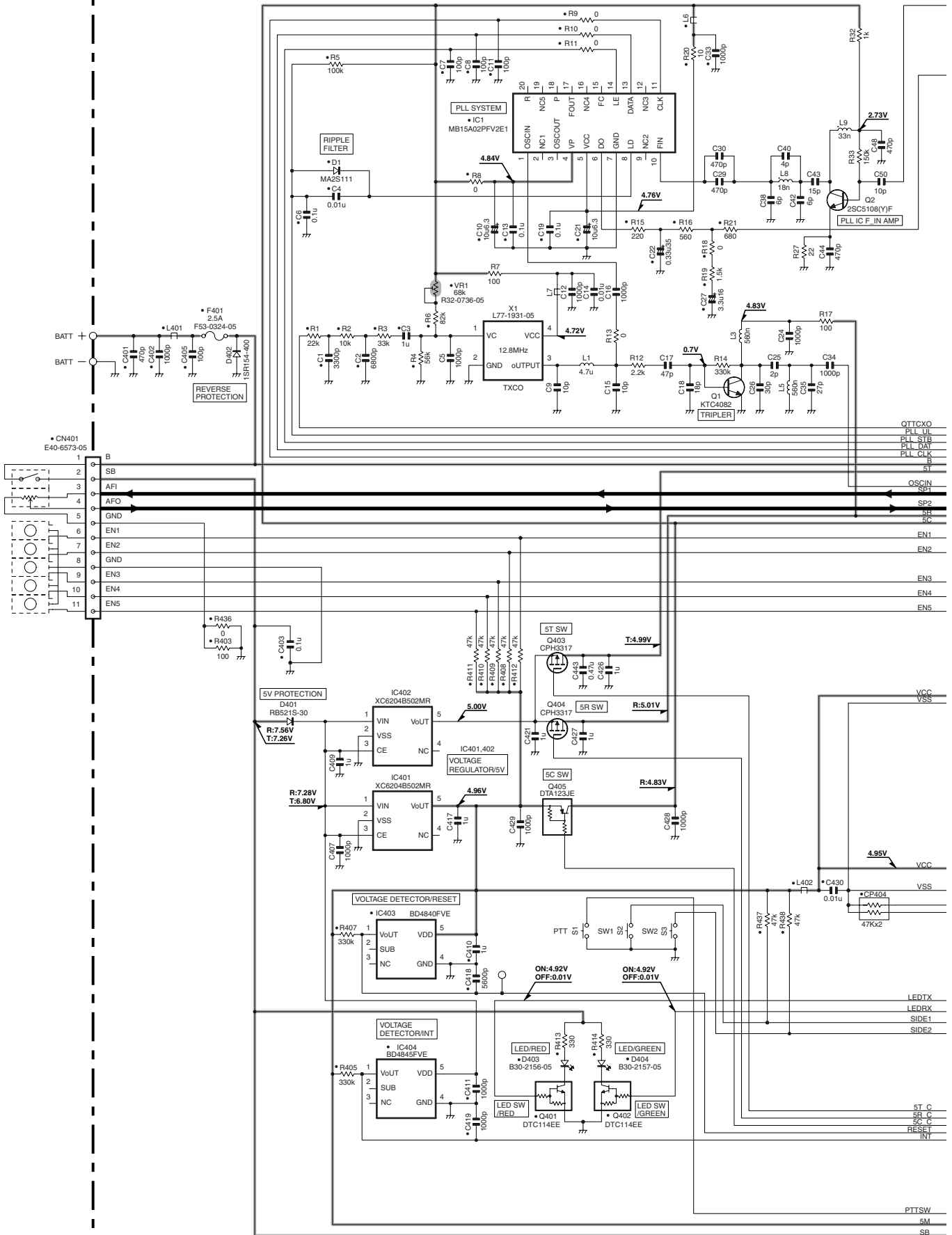

SCHEMATIC DIAGRAM / 原理图 TK-2207G

TX-RX UNIT (X57-6870-20)

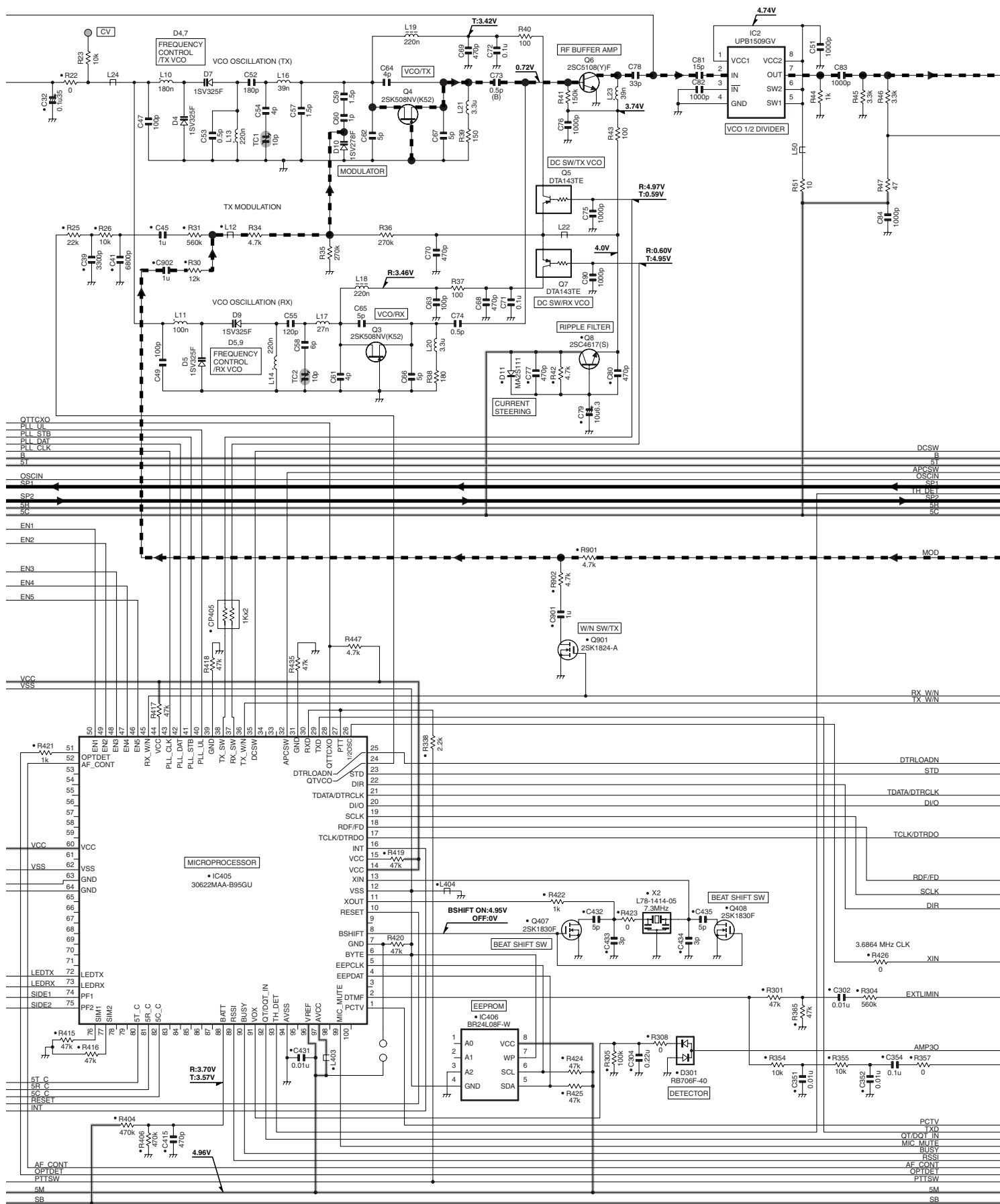

TK-2207G SCHEMATIC DIAGRAM / 原理图

TX-RX UNIT (X57-6870-20)

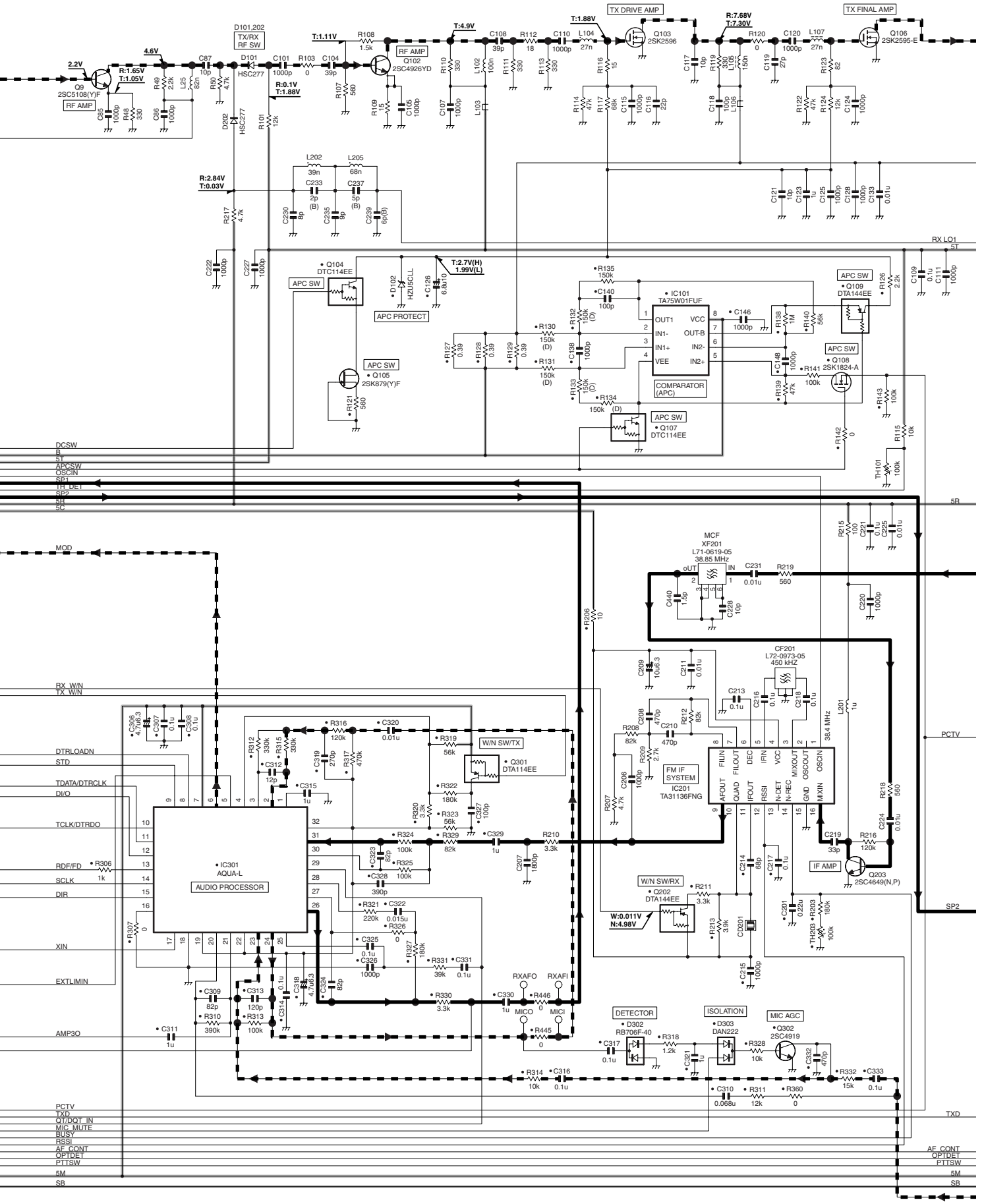

SCHEMATIC DIAGRAM / 原理图 TK-2207G

TX-RX UNIT (X57-6870-20)

Note : The components marked with a dot (●) are parts of layer 1.

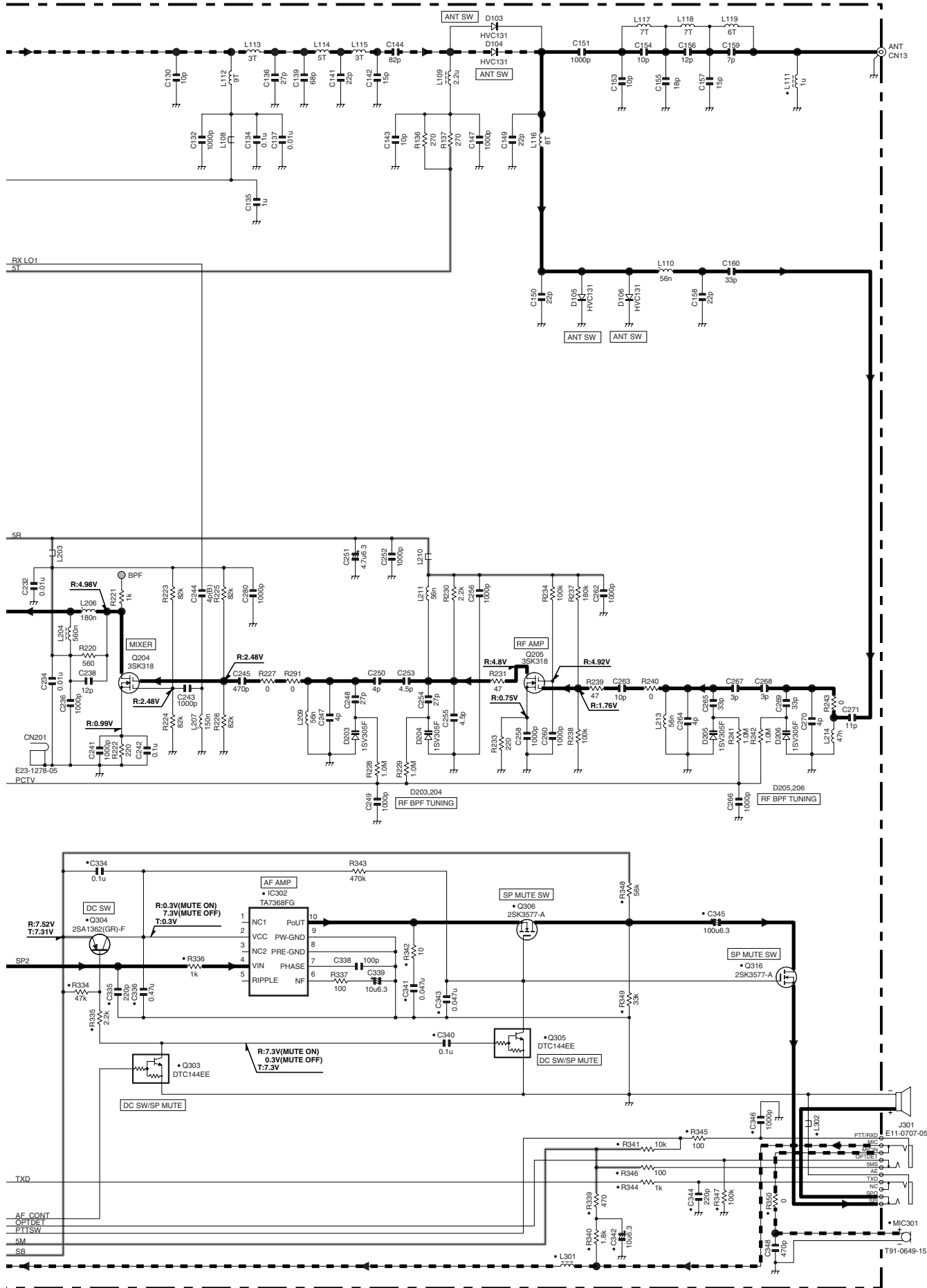

TK-2207G SCHEMATIC DIAGRAM / 原理图

TX-RX UNIT (X57-6870-20)

Note : The components marked with a dot (●) are parts of layer 1.

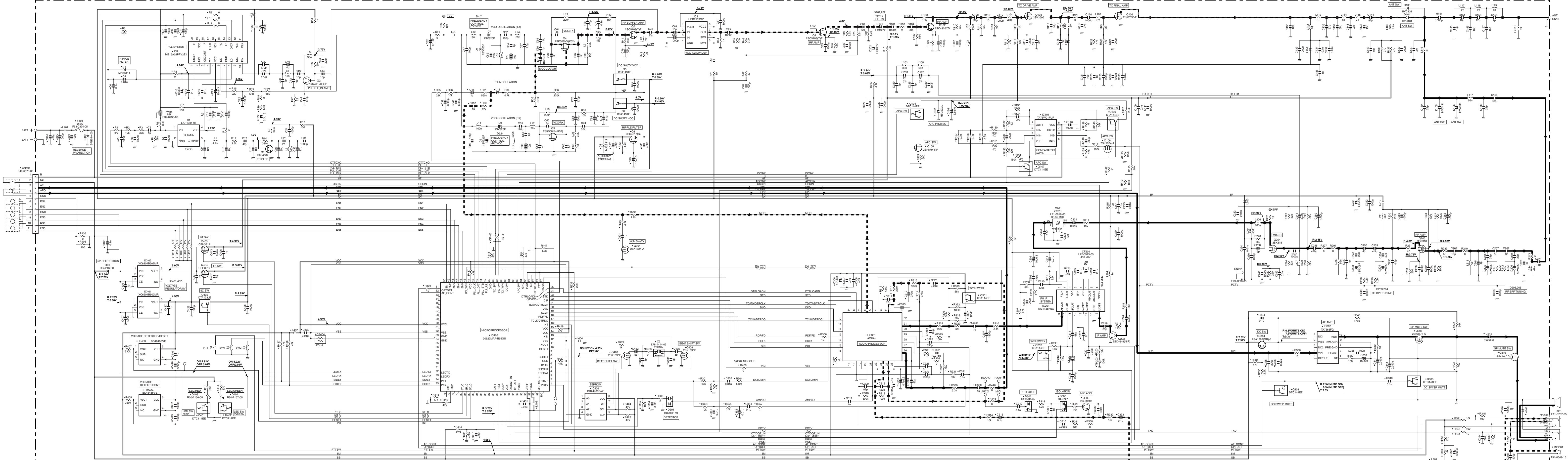

BLOCK DIAGRAM / 方块图

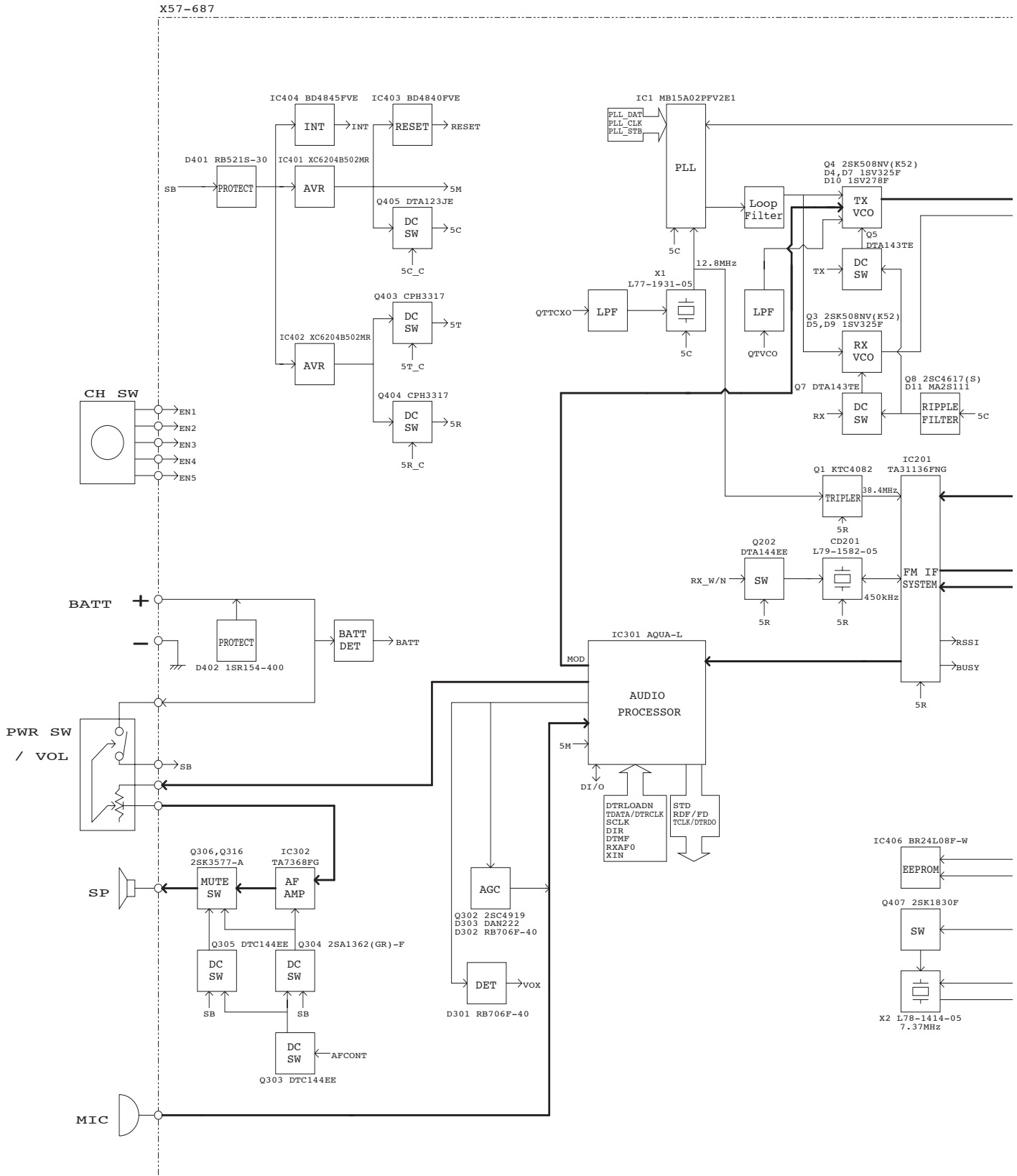

BLOCK DIAGRAM / 方块图

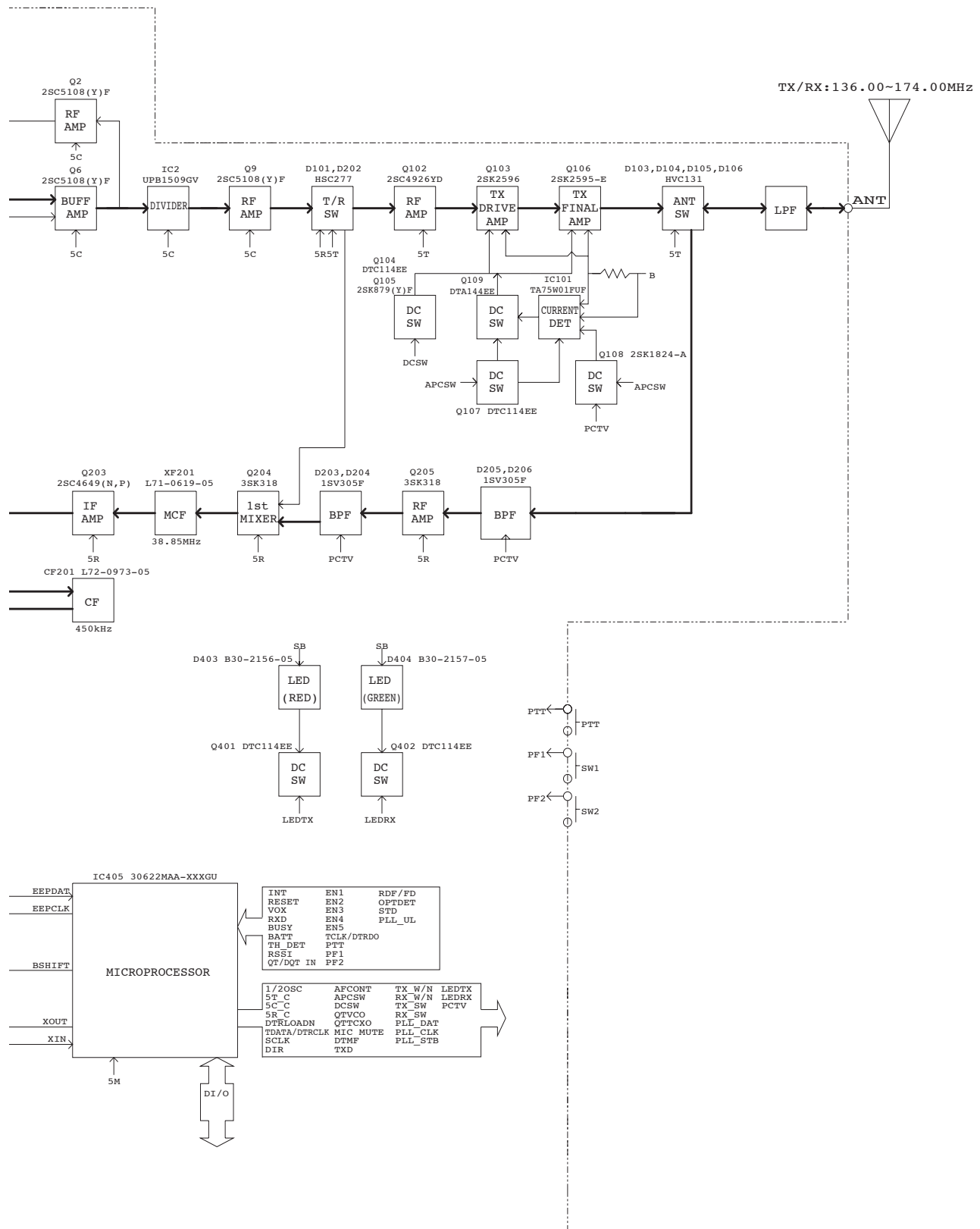

LEVEL DIAGRAM / 电平图

Receiver Section / 接收部

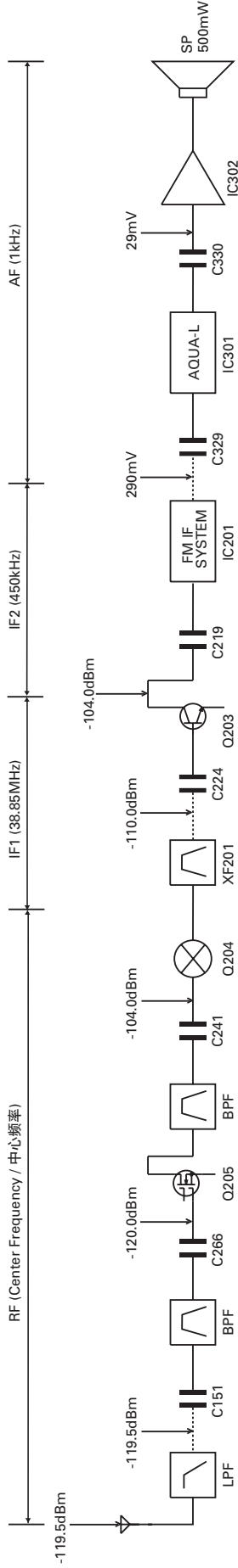

如要在 AF 部测量, 则连接 AC 电平表。(天线输入:
-53dBm, 1kHz FM, 3kHz DEV(宽))
如要在 RF 部测量, 请使用 1000pF 耦合电容器。
(图中显示了获得 12dB SINAD 所需的 SSG 输入值,
没有本地电平。)

To make measurements in the AF section, connect
the AC level meter. (ANT input: -53dBm, 1kHz FM,
3kHz DEV (WIDE).)
In the RF section, use 1000pF coupling capacitor.
(The display shows the SSG input value required to
obtain 12dB SINAD without local level.)

Transmitter Section / 发射部

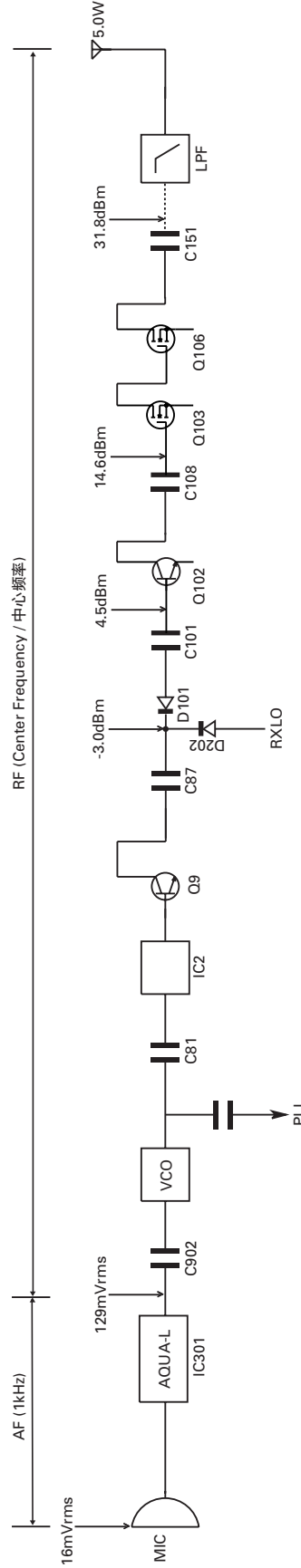

AG 被设置成话筒输入得到 3kHz DEV 在 1kHz MOD
(宽)。

如要在 AF 部测量, 则连接 AC 电平表。
如要在 RF 部测量, 请使用 1000pF 耦合电容器。

AG is set to the MIC input becomes 3kHz DEV at
1kHz MOD. (WIDE)
To make measurements in the AF section, connect
the AC level meter.
In the RF section, use 1000pF coupling capacitor.

OPTIONAL ACCESSORIES / 可选附件

KSC-31 (RAPID CHARGER / 快速充电器)

External View / 外视图



Specifications / 规格

Charging current.....	850mA ±5%
Charging time	KNB-29N : Approx.180 minutes KNB-30A : Approx.120 minutes
Dimensions (Charger only)	86.3W x 46.2H x 100.0D (mm) 3-3/8W x 1-7/8H x 4D (inches)
Weight (Charger only)	Approx.100g / 0.22 lbs

KNB-29N (Ni-MH BATTERY PACK / Ni-MH 电池组)

External View / 外视图



Specifications / 规格

Voltage	7.2V (1.2V x 6)
Battery capacity...	1500mAh

Schematic Diagram / 原理图

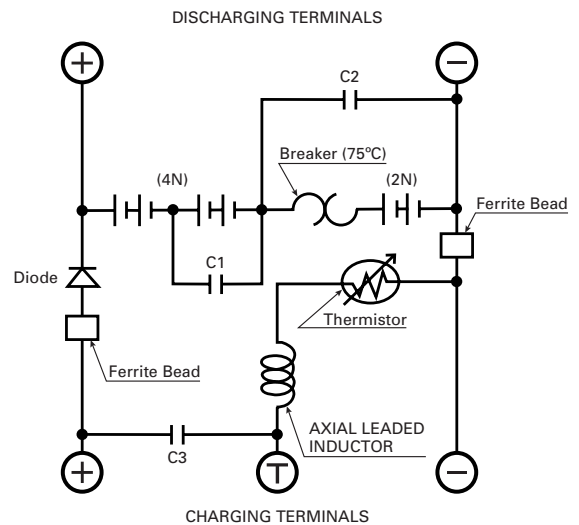

TK-2207G

OPTIONAL ACCESSORIES / 可选附件

KNB-30A (Ni-Cd BATTERY PACK / Ni-Cd 电池组)

■ External View / 外视图

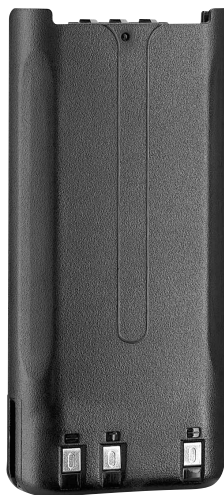

KBH-10 (BELT CLIP / 皮带夹)

■ External View / 外视图



■ Specifications / 规格

Voltage 7.2V (1.2V x 6)

Battery capacity ... 1100mAh

■ Schematic Diagram / 原理图

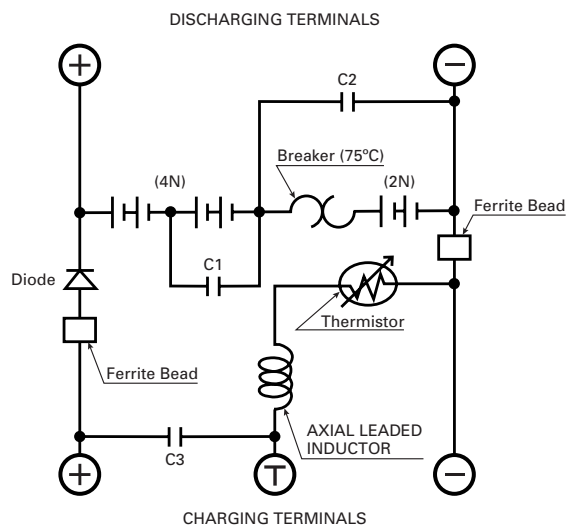

SPECIFICATIONS

General

Frequency Range	136~174MHz (C)
Number of Channels	Max. 16
Channel Spacing	25kHz, 30kHz (Wide) 12.5kHz, 15kHz (Narrow)
PLL Channel Stepping	2.5kHz, 5kHz, 6.25kHz, 7.5kHz
Operating Voltage	7.5 V DC \pm 20%
Battery Life	More than 14 hours at 5 watts (5-5-90 duty cycle with KNB-29N battery) More than 9 hours at 5 watts (5-5-90 duty cycle with KNB-30A battery)
Operating Temperature Range	-30°C to +60°C (-22 °F to +140 °F)
Frequency Stability	\pm 2.5ppm (-30°C to +60°C)
Channel Frequency Spread	38MHz
Dimensions and Weight (Dimensions not including protrusions)	
Radio Only	54 (2-1/8) W x 122 (4-13/16) H x 21.1 (13/16) D mm (inches) 160g (0.35 lbs)
With KNB-29N (1500mAh battery)	54 (2-1/8) W x 122 (4-13/16) H x 33 (1-5/16) D mm (inches) 360g (0.79 lbs)
With KNB-30A (1100mAh battery)	54 (2-1/8) W x 122 (4-13/16) H x 33 (1-5/16) D mm (inches) 340g (0.75 lbs)

Receiver (Measurements made per TIA/EIA-603)

Sensitivity	
EIA 12dB SINAD	0.25 μ V (Wide)/0.28 μ V (Narrow)
Selectivity	70dB (Wide)/60dB (Narrow)
Intermodulation	65dB (Wide)/60dB (Narrow)
Spurious Response	65dB
Audio Power Output	500mW at 8 Ω less than 10% distortion

Transmitter (Measurements made per TIA/EIA-603)

RF Power Output	5W/1W
Spurious and Harmonics	65dB
Modulation	16K0F3E (Wide)/11K0F3E (Narrow)
FM Noise	45dB (Wide)/40dB (Narrow)
Audio Distortion	Less than 5%

概述

频率范围	136 ~174MHz (C)
频道数	最大 16
信道间距	25kHz, 30kHz (宽) 12.5kHz, 15kHz (窄)
PLL 频道步进	2.5kHz, 5kHz, 6.25kHz, 7.5kHz
电池电压	7.5 V 直流 ±20%
电池寿命	5W 时长于 14 个小时 (使用 KNB-29N 电池 5-5-90 工作周期) 5W 时长于 9 个小时 (使用 KNB-30A 电池 5-5-90 工作周期)
温度范围	-30°C 到 +60°C (-22° F 到 + 140° F)
频率稳定性	± 2.5ppm (-30°C 到 +60°C)
信道频率扩展	38MHz
尺寸和重量	
(尺寸大小不包括突出部分)	
仅对讲机时	54 (2-1/8) 宽 x 122 (4-13/16) 高 x 21.1 (13/16) 长 mm (英寸) 160g (0.35 lbs)
带有 KNB-29N (1500mAh 电池)	54 (2-1/8) 宽 x 122 (4-13/16) 高 x 33 (1-5/16) 长 mm (英寸) 360g (0.79 lbs)
带有 KNB-30A (1100mAh 电池)	54 (2-1/8) 宽 x 122 (4-13/16) 高 x 33 (1-5/16) 长 mm (英寸) 340g (0.75 lbs)

接收部 (根据标准 TIA / EIA-603 测定)

灵敏度	
EIA 12dB SINAD	0.25µV (宽) / 0.28µV (窄)
选择性	70dB (宽) / 60dB (窄)
互调	65dB (宽) / 60dB (窄)
杂散响应抗扰性	65dB
音频功率输出	8 Ω 时为 500mW, 失真小于 10%

发射部 (根据标准 TIA / EIA-603 测定)

射频功率输出	5W / 1W
杂散射频分量	65dB
调制	16K0F3E (宽) / 11K0F3E (窄)
FM 噪音	45dB (宽) / 40dB (窄)
音频失真	低于 5%

Kenwood Corporation

2967-3, Ishikawa-machi, Hachioji-shi, Tokyo, 192-8525 Japan

Kenwood U.S.A. Corporation

P.O. BOX 22745, 2201 East Dominguez Street, Long Beach, CA 90801-5745, U.S.A.

Kenwood Electronics Canada Inc.

6070 Kestrel Road, Mississauga, Ontario, Canada L5T 1S8

Kenwood Electronics Deutschland GmbH

Rembrücker Str. 15, 63150 Heusenstamm, Germany

Kenwood Electronics Belgium N.V.

Leuvensesteenweg 248 J, 1800 Vilvoorde, Belgium

Kenwood Electronics France S.A.

L'Etoile Paris Nord 2, 50 Allée des Impressionnistes, Bp 58416 Villepinte, 95944 Roissy Ch De Gaulle Cedex

Kenwood Electronics UK Limited

KENWOOD House, Dwight Road, Watford, Herts., WD18 9EB United Kingdom

Kenwood Electronics Europe B.V.

Amsterdamseweg 37, 1422 AC Uithoorn, The Netherlands

Kenwood Electronics Italia S.p.A.

Via G. Sirtori, 7/9 20129 Milano, Italy

Kenwood Ibérica, S.A.

Bolivia, 239-08020 Barcelona, Spain

Kenwood Electronics Australia Pty. Ltd.

(A.C.N. 001 499 074)

16 Giffnock Avenue, Centrecourt Estate, North Ryde, N.S.W. 2113 Australia

Kenwood Electronics (Hong Kong) Ltd.

Unit 3712-3724, Level 37, Tower one Metroplaza, 223 Hing Fong Road, Kwai Fong, N.T., Hong Kong

Kenwood Electronics Singapore Pte Ltd

1 Ang Mo Kio Street 63, Singapore 569110

