



CONTENTS

GENERAL	2
SYSTEM SET-UP	3
REALIGNMENT	3
DISASSEMBLY FOR REPAIR	5
CIRCUIT DESCRIPTION	8
SEMICONDUCTOR DATA	12
TERMINAL FUNCTION	12
COMPONENTS DESCRIPTION	13
PARTS LIST	14
EXPLODED VIEW	20
PACKING	21
ADJUSTMENT	23
PC BOARD	
TX-RX UNIT (X57-7572-71)	28
SCHEMATIC DIAGRAM	32
BLOCK DIAGRAM	36
LEVEL DIAGRAM	38
SPECIFICATIONS	39

E type does not come with the antenna.

TK-2302

Document Copyrights

Copyright 2009 by Kenwood Corporation. All rights reserved.

No part of this manual may be reproduced, translated, distributed, or transmitted in any form or by any means, electronic, mechanical, photocopying, recording, or otherwise, for any purpose without the prior written permission of Kenwood.

Disclaimer

While every precaution has been taken in the preparation of this manual, Kenwood assumes no responsibility for errors or omissions. Neither is any liability assumed for damages resulting from the use of the information contained herein. Kenwood reserves the right to make changes to any products herein at any time for improvement purposes.

GENERAL

INTRODUCTION

SCOPE OF THIS MANUAL

This manual is intended for use by experienced technicians familiar with similar types of commercial grade communications equipment. It contains all required service information for the equipment and is current as of the publication date. Changes which may occur after publication are covered by either Service Bulletins or Manual Revisions. These are issued as required.

ORDERING REPLACEMENT PARTS

When ordering replacement parts or equipment information, the full part identification number should be included. This applies to all parts : components, kits, or chassis. If the part number is not known, include the chassis or kit number of which it is a part, and a sufficient description of the required component for proper identification.

PERSONAL SAFETY

The following precautions are recommended for personal safety:

- DO NOT transmit until all RF connectors are verified secure and any open connectors are properly terminated.
- SHUT OFF and DO NOT operate this equipment near electrical blasting caps or in an explosive atmosphere.
- This equipment should be serviced by a qualified technician only.

SERVICE

This transceiver is designed for easy servicing. Refer to the schematic diagrams, printed circuit board views, and alignment procedures contained within.

Model	Type	TX-RX unit	Frequency range	Remarks
TK-2302	E,T	X57-7572-71	136~174MHz	IF1: 38.85MHz LOC: 38.4MHz

SYSTEM SET-UP

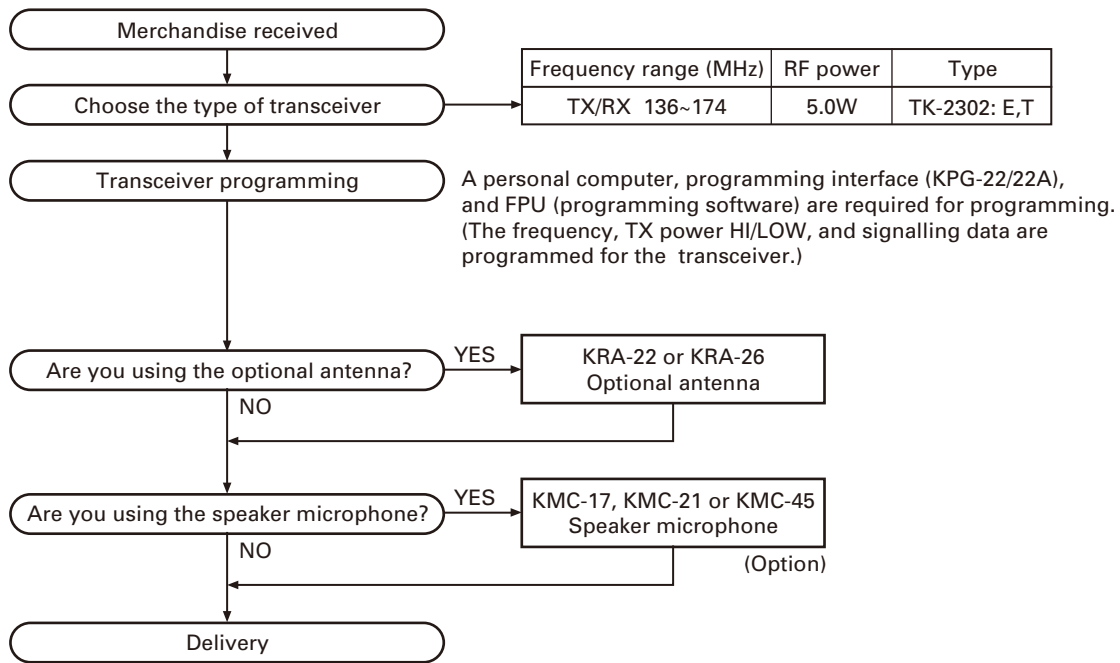

REALIGNMENT

1. Modes

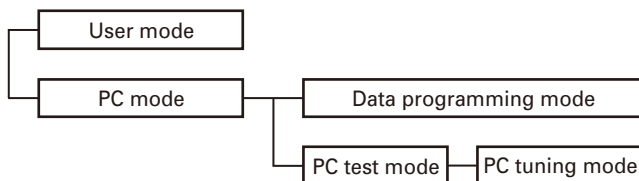

Mode	Function
User mode	For normal use.
PC mode	Used for communication between the transceiver and PC.
Data programming mode	Used to read and write frequency data and other features to and from the transceiver.
PC test mode	Used to check the transceiver using the PC. This feature is included in the FPU.

2. How to Enter Each Mode

Mode	Operation
User mode	Power ON
PC mode	Received commands from PC

3. PC Mode

3-1. Preface

The transceiver is programmed by using a personal computer, a programming interface (KPG-22/22A, USB adapter (KCT-53U)) and FPU (programming software).

The programming software can be used with a PC. Figure 1 shows the setup of a PC for programming.

3-2. Connection Procedure

1. Connect the transceiver to the personal computer with the interface cable and USB adapter (when the interface cable is KPG-22A, the KCT-53U can be used).

REALIGNMENT

Note:

- You must install the KCT-53U driver in the computer to use the USB adapter (KCT-53U).
- When using the USB adapter (KCT-53U) for the first time, plug the KCT-53U into a USB port on the computer with the computer power ON.

2. When the POWER is switched on, user mode can be entered immediately. When the PC sends a command, the transceiver enters PC mode.
 When data is read from the transceiver, the red LED lights.
 When data is written to the transceiver, the green LED lights.

Note:

- The data stored in the personal computer must match Model Name and Model Type when it is written into EEPROM.
- Do not press the [PTT] key during data transmission or reception.

**3-3. KPG-22/KPG-22A Description
 (PC programming interface cable: Option)**

The KPG-22/22A is required to interface the transceiver with the computer. It has a circuit in its D-sub connector (KPG-22: 25-pin, KPG-22A: 9-pin) case that converts the RS-232C logic level to the TTL level.

The KPG-22/22A connects the SP/MIC connector of the transceiver to the RS-232C serial port of the computer.

3-4. KCT-53U Description (USB adapter: Option)

The KCT-53U is a cable which connects the KPG-22A to a USB port on a computer.

When using the KCT-53U, install the supplied CD-ROM (with driver software) in the computer. The KCT-53U driver runs under Windows 2000 or XP.

3-5. FPU (Programming Software) Description

The FPU is the programming software for the transceiver supplied on a CD-ROM. The software on this disk allows a user to program the transceiver via Programming interface cable (KPG-22/22A).

3-6. Programming with PC

If data is transferred to the transceiver from a PC with the FPU, the data for each set can be modified.

Data can be programmed into the EEPROM in RS-232C format via the SP/MIC jack.

In this mode the PTT line operate as TXD and RXD data lines respectively.

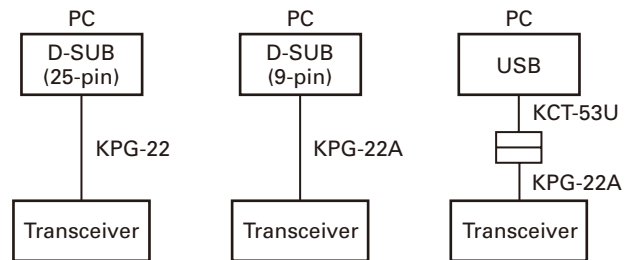
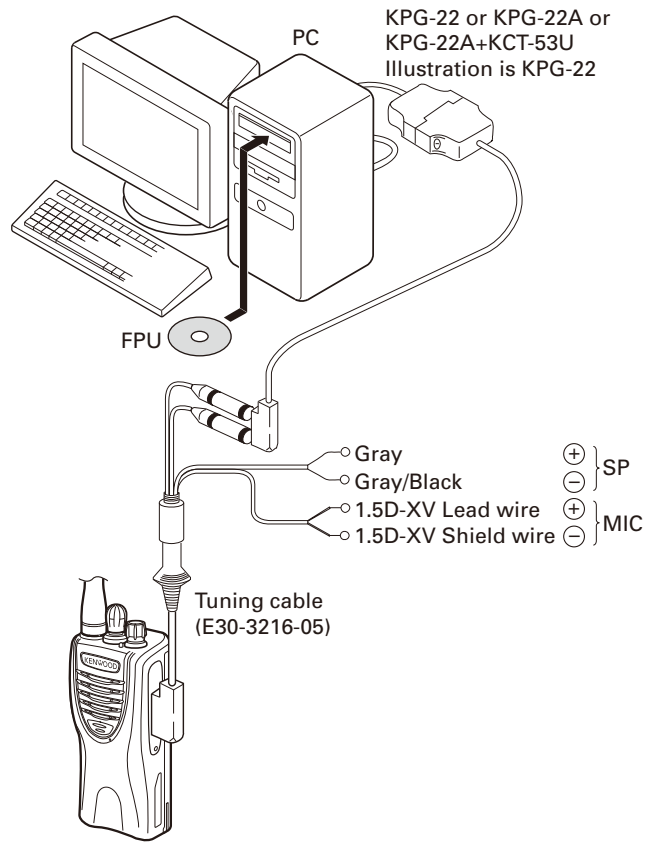

Fig. 1

List of FPU for transceiver

Model	Type	FPU
TK-2302	E,T	KPG-119D(M2)

DISASSEMBLY FOR REPAIR

1. Removing the Case Assembly from the Chassis

1. Remove the volume knob ① and channel knob ②.
2. Remove the two screws ③.
3. Lift and remove the chassis from the case assembly ④.
(Use a flat-blade screwdriver to easily lift the chassis.)

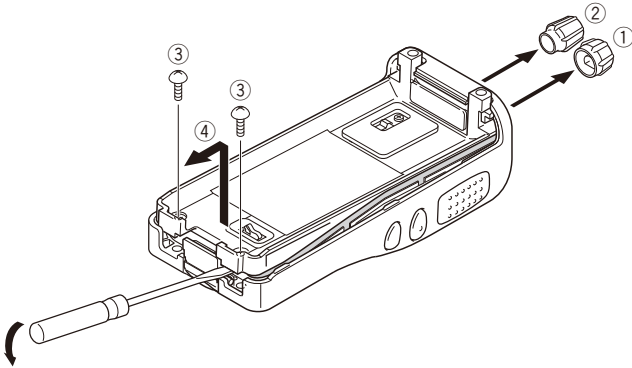

2. Removing the TX-RX unit from the Chassis

1. Detach the solder of speaker wire from the PCB beforehand.
 2. Remove the packing ⑤ from the SP/MIC jack of the TX-RX unit.
 3. Remove the ten screws ⑥ fixing the TX-RX unit.
 4. Remove the solder of the antenna terminal with a soldering iron ⑦.
 5. Remove the solder of the positive terminal with a soldering iron ⑧.
- Note:** You can remove the TX-RX unit from the chassis without removing the solder at the positive terminal. However, in this case, you can not attach the packing (G53-1605-03) that is on the positive terminal to the chassis in assembling. So, it is advisable to remove the solder on the positive terminal first.
6. Remove the FPC from the flat cable connector ⑨.
 7. Lift and remove the TX-RX unit from the chassis ⑩.

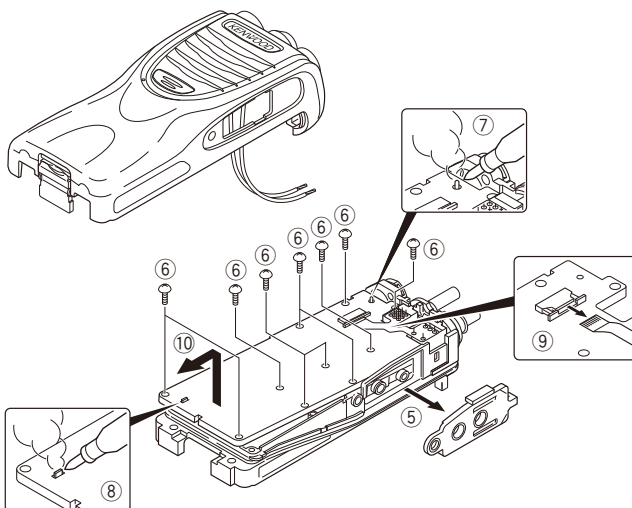

3. Removing the Battery Release Lever from the Case Assembly

1. Press the upper part of the lever toward the inside of the case assembly. One side of the shaft will be removed ①.
2. Lift and remove the battery release lever from the case assembly ②.

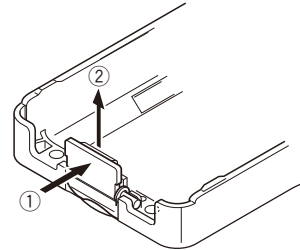

4. Attaching the Battery Release Lever to the Case Assembly

1. Insert one side of the shaft into the hole at the lever fitting section on the case assembly ①.
Caution: The thin spring (G01-4543-14) should be positioned above the two tabs of the lever.
2. Tilt the battery release lever slightly forward ②, so that the thick spring (G01-4542-04) is positioned below the case surface.
3. With the thick spring positioned below the case surface, attach the other side of the shaft to the case assembly by pressing the battery release lever ③ until it snaps into place ④.

Caution: Be careful not to tilt the battery release lever too forward.
If the battery release lever is pushed in this state where the two tabs come below the case surface, there is a possibility of damaging the two tabs.

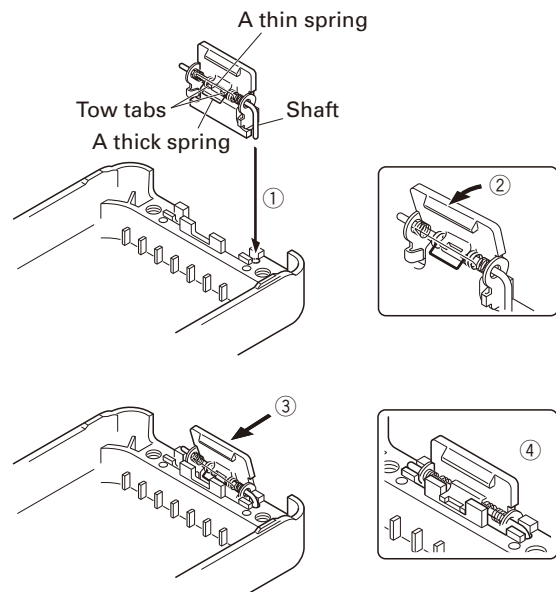

DISASSEMBLY FOR REPAIR

5. Assembling the Battery Release Lever

1. Place the lever ② onto the stopper ①.
2. Place the thick spring ③ onto the lever.
3. Hook the right and left ends of the thin spring ④ onto the tabs of the stopper, then place the thin spring ④ onto the lever ⑤.
4. Slide the shaft through the hole of the stopper and lever ⑥.

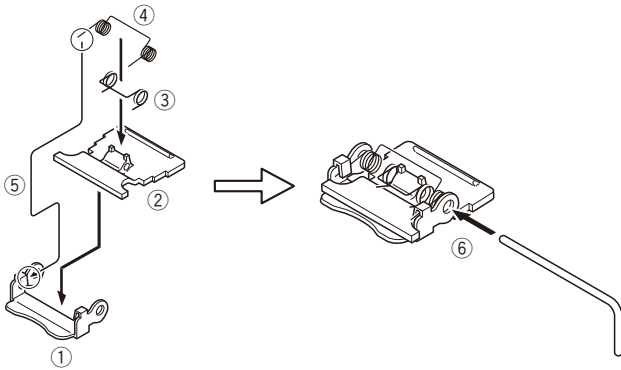

6. Attaching the Positive Terminal to the Chassis

Always attach the positive terminal to the chassis, using the following procedures, before mounting the TX-RX unit onto the chassis.

1. Remove the holder assembly ② from the packing ① of the positive terminal.
2. Mount the packing of the positive terminal into the chassis hole ③.
3. Mount the holder assembly into the packing of the positive terminal ④.

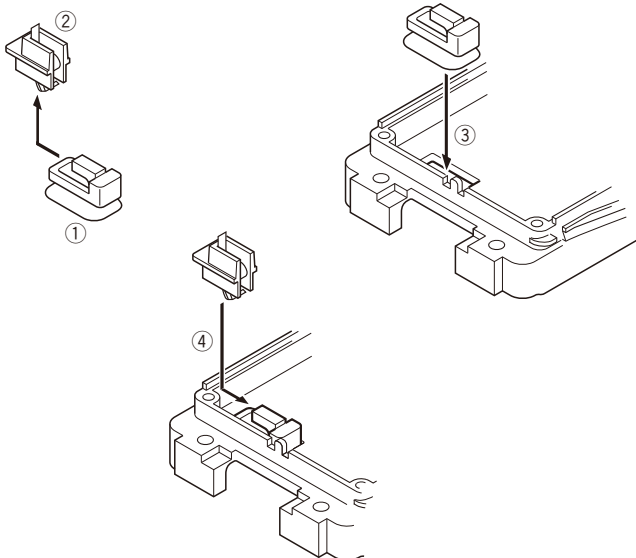

7. Mounting the Chassis to the Case Assembly

1. Confirm that the waterproof packing attached to the circumference of the chassis is securely inserted in the groove of the chassis ①.
2. Attach the speaker with waterproof packing to the speaker recess of the case assembly ②. Make sure the speaker clasp is securely inserted.
3. Tighten the speaker clasp into the case assembly with the screw.
4. Insert the upper part of the chassis into the case assembly ③.
5. Press the chassis ④ and the case assembly together to attach them.

Caution: Take care that the speaker lead wire is not caught by the microphone element.

Caution: If the packing of the SP/MIC does not come to the correct position after attaching the chassis to the case assembly, reposition the packing with your fingers.

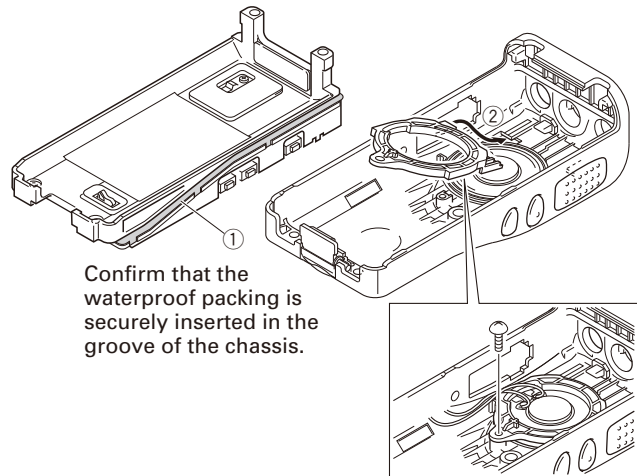

Confirm that the waterproof packing is securely inserted in the groove of the chassis.

DISASSEMBLY FOR REPAIR

8. Attaching the Antenna Receptacle to the Chassis

Screw the antenna receptacle to the chassis in the order shown in the drawing so that the antenna receptacle comes to the center of the case hole.

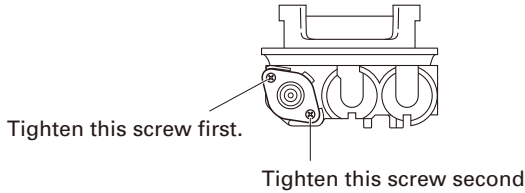

9. The Nuts of the Volume Knob and Channel Knob

Note that the shapes, colors and heights of nuts of the volume knob and channel knob are different from one another. (The nut of volume knob is silver, and the nut of channel knob is gold)

Use the following jig when removing the nuts of the volume knob and channel knob.

- Jig (Part No.: W05-1012-00)

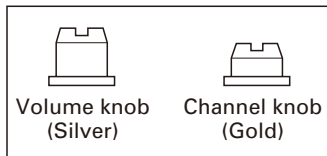

10. Screw sequence for mounting the TX-RX unit to the chassis

Attach the TX-RX unit to the chassis using the screws in the order shown in the drawing below.

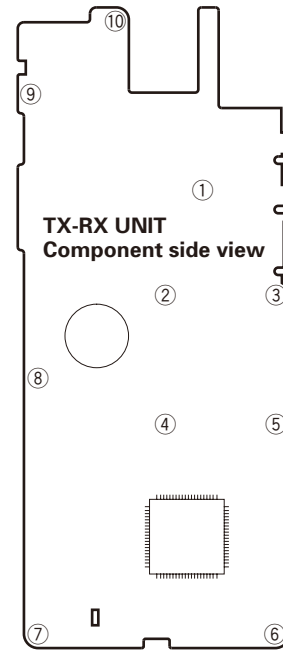

CIRCUIT DESCRIPTION

1. Frequency Configuration

The receiver utilizes double conversion. The first IF is 38.85MHz and the second IF is 450kHz. The first local oscillator signal is supplied from the PLL circuit.

The PLL circuit in the transmitter generates the necessary frequencies. Fig. 1 shows the frequencies.

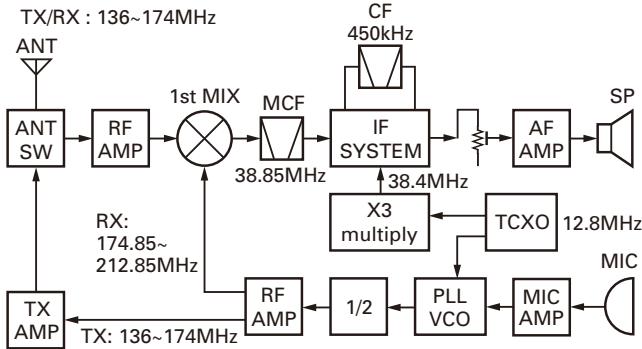

Fig. 1 Frequency configuration

2. Receiver

The frequency configuration of the receiver is shown in Fig. 2.

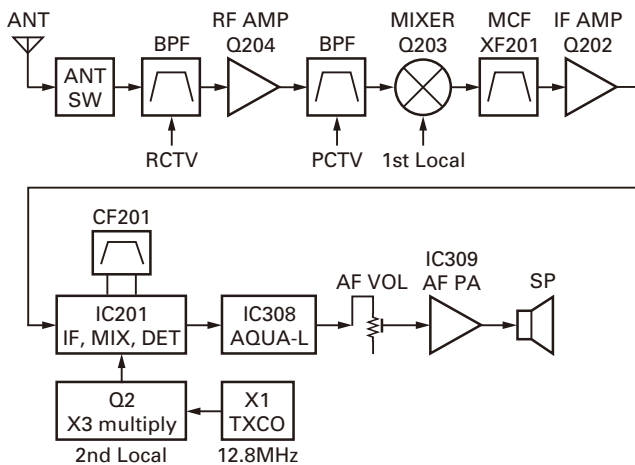

Fig. 2 Receiver section

■ Front End (RF AMP)

The signal coming from the antenna passes through the transmit/receive switching diode circuit, (D103, D104 and D105) passes through a BPF (L214, L216 and L213), and is amplified by the RF amplifier (Q204).

The resulting signal passes through a BPF (L209 and L211) and goes to the mixer. These BPFs are adjusted by variable capacitors (D203, D204, D205 and D202). The input voltage to the variable capacitor is regulated by voltage output from the MCU (IC306).

■ First Mixer

The signal from the front end is mixed with the first local oscillator signal generated in the PLL circuit by Q203 to produce a first IF frequency of 38.85MHz.

The resulting signal passes through the XF201 MCF to cut the adjacent spurious and provide the optimum characteristics, such as adjacent frequency selectivity.

■ IF Amplifier Circuit

The first IF signal is passed through a four-pole monolithic crystal filter (XF201) to remove the adjacent channel signal. The filtered first IF signal is amplified by the first IF amplifier (Q202) and then applied to the IF system IC (IC201). The IF system IC provides a second mixer, limiting amplifier, quadrature detector and RSSI (Received Signal Strength Indicator). The second mixer mixes the first IF signal with the 38.4MHz of the second local oscillator output (TCXO X1 and Q2) and produces the second IF signal of 450kHz.

The second IF signal is passed through the ceramic filter (CF201) to remove the adjacent channel signal. The filtered second IF signal is amplified by the limiting amplifier and demodulated by the quadrature detector with the ceramic discriminator (CD201). The demodulated signal is routed to the audio circuit.

■ Wide/Narrow Switching Circuit

Narrow and Wide settings can be made for each channel by switching the demodulation level.

The WIDE (low level) and NARROW (high level) data is output from IC306, pin 5. When a WIDE (low level) data is received, Q201 turns on. When a NARROW (high level) data is received, Q201 turns off.

Q201 turns on/off with the Wide/Narrow data and the IC201 detector output level is switched to maintain a constant output level during wide or narrow signals.

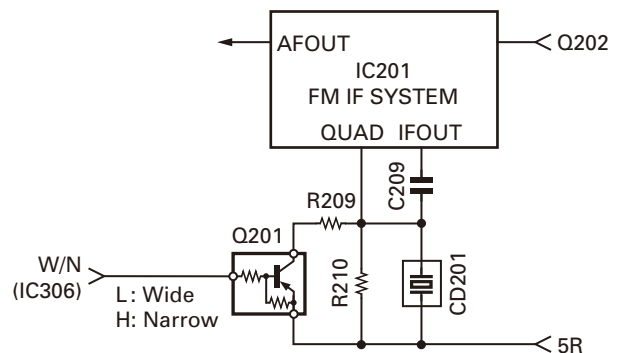

Fig. 3 Wide/Narrow switching circuit

■ Audio Amplifier Circuit

The demodulated signal from IC201 goes to AF amplifier through IC308.

The signal then goes through an AF volume control, and is routed to an audio power amplifier (IC309) where it is amplified and output to the speaker.

CIRCUIT DESCRIPTION

■ Squelch

Part of the AF signal from the IC enters the FM IC (IC201) again, and the noise component is amplified and rectified by a filter and an amplifier to produce a DC voltage corresponding to the noise level.

The DC signal from the FM IC goes to the analog port of the MCU (IC306). IC306 determines whether to output sounds from the speaker by checking whether the input voltage is higher or lower than the preset value.

To output sounds from the speaker, IC306 sends a high signal to the AF_CONT line and turns IC309 on through Q312, Q313, Q314, Q315 and Q316. (See Fig. 4)

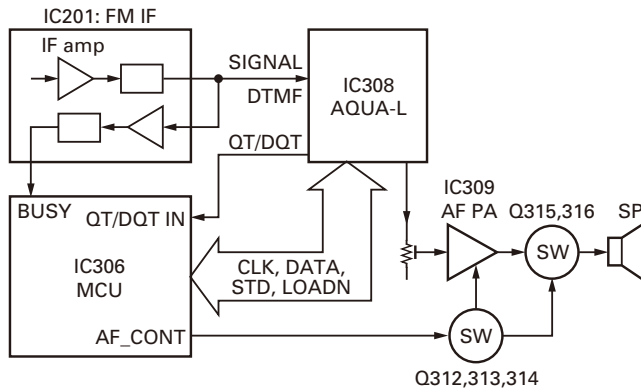

Fig. 4 AF amplifier and squelch

■ Receive Signaling

• QT/DQT

The output signal from FM IC (IC201) enters the MCU (IC306) through IC308. IC306 determines whether the QT or DQT matches the preset value, and controls the SP MUTE and the speaker output sounds according to the squelch results.

3. PLL Frequency Synthesizer

The PLL circuit generates the first local oscillator signal for reception and the RF signal for transmission.

■ PLL

The frequency step of the PLL circuit is 2.5, 5, 6.25 or 7.5kHz.

A 12.8MHz reference oscillator signal is divided at IC1 by a fixed counter to produce an oscillator (VCO) output signal which is buffer amplified by Q3 then divided in IC1 by a programmable counter. The divided signal is compared in phase with the 5, 10, 12.5 or 15kHz reference signal from the phase comparator in IC1. The output signal from the phase comparator is filtered through a low-pass filter and passed to the VCO to control the oscillator frequency. (See Fig. 5)

■ VCO

The twice of operating frequency is generated by Q5 in transmit mode and Q4 in receive mode. The oscillator frequency is controlled by applying the VCO control voltage, obtained from the phase comparator, to the varactor diodes (D4 and D8 in transmit mode and D3 and D6 in receive mode).

The RX_SW pin is set high in receive mode causing Q7 turn on. The TX_SW pin is set high in transmit mode. The outputs from Q4 and Q5 are amplified by Q9 and sent to the prescaler (IC2).

■ Unlock Detector

If a pulse signal appears at the LD pin of IC1, an unlock condition occurs, and the DC voltage obtained from C4 and Q1 causes the voltage applied to the MCU to go low. When the MCU detects this condition, the transmitter is disabled, ignoring the push-to-talk switch input signal.

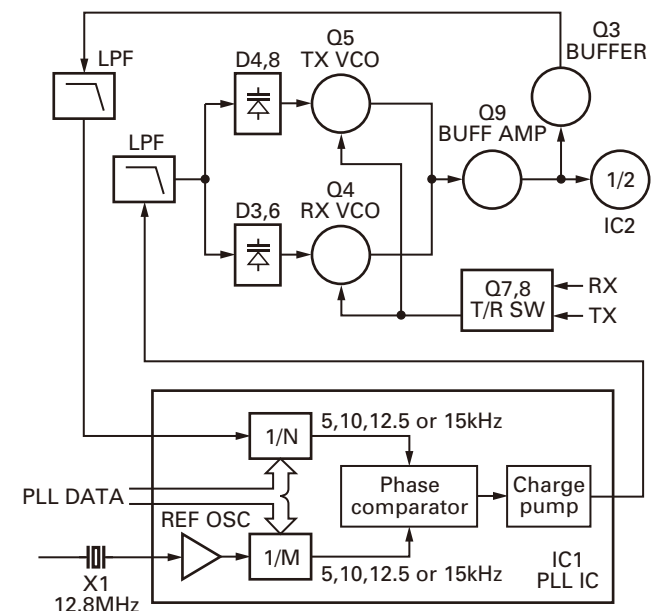

Fig. 5 PLL circuit

CIRCUIT DESCRIPTION

4. Transmitter System

■ Microphone Amplifier

The signal from the microphone passes through the IC308. When encoding DTMF, it is turned OFF for muting the microphone input signal by IC308.

The signal passes through the Audio processor (IC308) for the maximum deviation adjustment, and goes to the VCO modulation input.

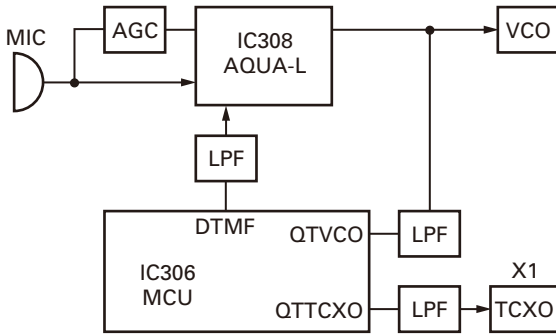

Fig. 6 Microphone amplifier

■ Drive and Final Amplifier

The signal from the T/R switch (D10 is on) is amplified by the pre-drive (Q101) and the drive amplifier (Q102) to 800mW.

The output of the drive amplifier is amplified by the RF power amplifier (Q105) to 5.0W (1W when the power is low). The output of the RF power amplifier is then passed through the harmonic filter (LPF) and antenna switch (D103) and applied to the antenna terminal.

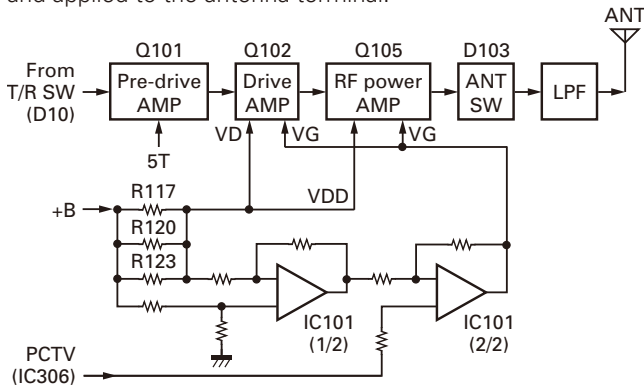

Fig. 7 Drive and final amplifier and APC circuit

■ APC Circuit

The APC circuit always monitors the current flowing through the drive amplifier and RF power amplifier (Q102 and Q105) and keeps a constant current.

The voltage drop at R117, R120 and R123 is caused by the current flowing through the RF power amplifier and drive amplifier, and this voltage is applied to the differential amplifier IC101 (1/2).

IC101 (2/2) compares the output voltage of IC101 (1/2) with the reference voltage from IC306. The output of IC101 (2/2) controls the VG of the RF power amplifier and drive amplifier to make both voltages the same.

The change of power high/low is carried out by the change of the reference voltage.

■ Encode Signaling

• QT/DQT

QT/DQT data of the QTTXCO Line is output from pin 14 of the MCU. The signal passes through a low-pass CR filter and goes to the TCXO (X1).

The QT/DQT data of the QTVCO Line is output from pin 15 of the MCU. The signal passes through a low pass CR filter, mixes with the audio signal, and goes to the VCO modulation input. TX deviation is adjusted by the MCU.

5. Power Supply

There are four 5V power supplies in the transceiver: 5M, 5C, 5R, and 5T. 5M for MCU is always output while the power is on. 5M is always output, but turns off when the power is turned off to prevent malfunction of the MCU.

5C is a common 5V and is output when SAVE is not set to OFF.

5R is 5V for reception and output during reception.

5T is 5V for transmission and output during transmission.

6. Control Circuit

The control circuit consists of a MCU (IC306) and its peripheral circuits. It controls the TX-RX unit. IC306 mainly performs the following:

- 1) Switching between transmission and reception by the PTT signal input.
- 2) Reading system, group, frequency, and program data from the memory circuit.
- 3) Sending frequency program data to the PLL.
- 4) Controlling squelch on/off by the DC voltage from the squelch circuit.
- 5) Controlling the audio mute circuit by the decode data input.
- 6) Transmitting tone and encode data.

CIRCUIT DESCRIPTION

■ Frequency Shift Circuit

The MCU (IC306) operates at a clock of 14.746 MHz. This oscillator has a circuit that shifts the frequency by BEAT SHIFT SW (Q305, Q306).

A beat sound may be able to be evaded from generation if "Beat Shift" is set to ON when it is generated in the internal spurious transmission modulated sound of a transceiver.

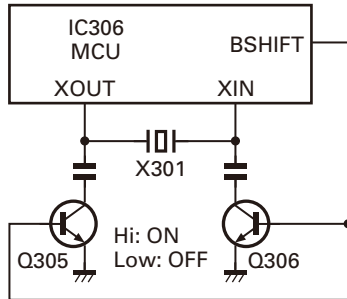

Fig. 8 Frequency shift circuit

■ Memory Circuit

Memory circuit consists of the MCU (IC306) and an EEPROM (IC305). An EEPROM has a capacity of 16k bits that contains the transceiver control program for the MCU and data such as transceiver channels and operating features.



Fig. 9 Memory circuit

■ Low Battery Warning

The battery voltage is checked using by the MCU. The transceiver generates a warning tone when it falls below the warning voltage shown in the table.

1) The red LED blinks when the battery voltage falls below the voltage (1) shown in the table during transmission.

Note: The transceiver checks the battery voltage during reception even when, in the FPU, the Battery Warning status function is set to "On TX" (default setting).

However, the LED does not blink during reception. During transmission, the LED blinks to generate the warning tone of a low battery voltage.

2) The transceiver immediately stops transmission when the battery voltage falls below the voltage (2) shown in the table. A message tone beeps while the PTT switch is released.

	Ni-Cd Battery	Ni-MH Battery	Li-ion Battery
(1)	6.2V	6.2V	6.2V
(2)	5.9V	5.9V	5.9V

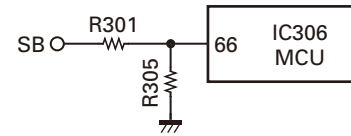

Fig. 10 Low battery warning

7. Control System

Keys and channel selector circuit. The signal from the keys and channel selector are directly input to the MCU, as shown in Fig. 11.

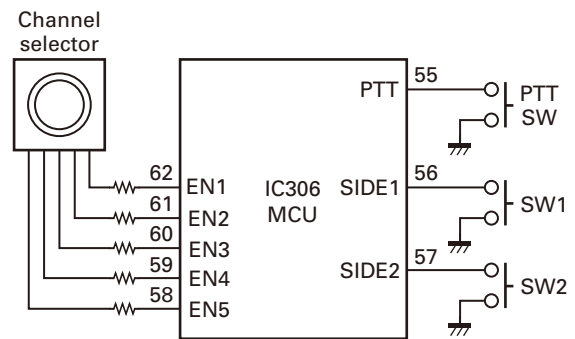

Fig. 11 Control system

SEMICONDUCTOR DATA

MCU: R5F212CCKCMC (TX-RX unit IC306)

Pin No.	Signal Name	I/O	Function
1	5T_C	O	5T control
2	PLL_STB	O	PLL strobe
3	5C_C	O	5C control
4	5R_C	O	5R control
5	W/N	O	Wide/Narrow switch
6	MODE	I	No function
7	AF_CONT	O	Speaker mute
8	BSHIFT	O	Beat shift control
9	RESET	I	MCU reset
10	XOUT	O	MCU clock (14.746MHz)
11	VSS	-	GND
12	XIN	I	MCU clock (14.746MHz)
13	VCC	I	Power supply input
14	QTTCXO	O	QT/DQT output
15	QTVCO	O	QT/DQT output
16~21	AUX6~AUX1	I/O	No function
22	MIC_MUTE	O	MIC mute
23	AF_MUTE	O	No function
24~32	N.C	O	No function
33	RXDATA	I	No function
34	TXDATA	O	No function
35	OPTDET	I	Headset detect
36	TX_SW	O	TX VCO switch
37	RX_SW	O	RX VCO switch
38	LEDRX	O	Green LED control
39	LEDTX	O	Red LED control
40	APC_SW	O	APC switch
41	DC_SW	O	APC discharge switch
42	STD	I	Baseband IC data input
43	1/2 OSC	O	Baseband IC clock (3.6864MHz)
44	INT	I	No function
45	TXD	O	Serial data output

Pin No.	Signal Name	I/O	Function
46	RXD	I	Serial data input
47	DIR	O	Baseband IC data output
48	DI/O	I/O	Baseband IC data input / output
49	DTRLOADN	O	Baseband IC data output
50	TDATA/DTRCLK	O	Baseband IC data output
51	SCLK	O	Serial clock for baseband IC
52	TCLK/DTRDO	I	Baseband IC data input
53	RDF/FD	I	Baseband IC data input
54	MDSW	I	No function
55	PTT	I	PTT switch input
56	SIDE1	I	Side1 key input
57	SIDE2	I	Side2 key input
58~62	EN5~EN1	I	Channel selector input
63	DIST1	I	No function
64	DIST2	I	No function
65	PLL_UL	I	PLL unlock signal input
66	BATT	I	Battery voltage detect
67	RSSI	I	RSSI input
68	BUSY	I	Busy signal input
69	VOX	I	VOX signal detect
70	QT/DQT_IN	I	QT/DQT signal input
71	EEPCLK	O	EEPROM clock
72	EEPDAT	I/O	EEPROM data input / output
73	TH_DET	I	Temperature detect
74	DTMF	I	DTMF/BEEP output
75	AVSS	-	GND
76	PCTV	I	APC/BPF control voltage
77	VREF	I	Reference voltage input
78	AVCC	I	Power supply input
79	PLL_DAT	O	PLL data output
80	PLL_CLK	O	PLL clock output

TERMINAL FUNCTION

TX-RX unit (X57-7572-71)

Pin No.	Name	I/O	Function
CN301			
1	B	I	B (Battery Voltage)
2	SB	O	Switched B
3	AFVOL_IN	I	Audio input
4	AFVOL_OUT	O	Audio output
5	AFVOL_GND	-	GND

Pin No.	Name	I/O	Function
6	EN1	I	Encoder pulse input
7	EN2	I	Encoder pulse input
8	GND	-	GND
9	EN3	I	Encoder pulse input
10	EN4	I	Encoder pulse input
11	EN5	I	Encoder pulse input

COMPONENTS DESCRIPTION

TX-RX unit (X57-7572-71)

Ref. No.	Part Name	Description
IC1	IC	PLL system IC
IC2	IC	Prescaler
IC101	IC	APC
IC201	IC	FM system IC
IC301	IC	Voltage detector/ Reset
IC303,304	IC	Voltage regulator/ 5V
IC305	IC	EEPROM
IC306	IC	MCU
IC308	IC	Audio processor
IC309	IC	Audio amplifier
Q1	Transistor	Rectification
Q2	Transistor	Tripler
Q3	Transistor	RF amplifier
Q4	FET	VCO/ RX
Q5	FET	VCO/ TX
Q6	Transistor	Rectification
Q7	Transistor	DC switch/ RX VCO
Q8	Transistor	DC switch/ TX VCO
Q9	Transistor	RF amplifier
Q10	Transistor	Ripple filter
Q11	Transistor	RF amplifier
Q101	Transistor	RF amplifier
Q102	FET	TX drive amplifier
Q103	Transistor	Discharge switch
Q104	FET	Discharge switch
Q105	FET	TX final amplifier
Q106	Transistor	DC switch
Q107	FET	DC switch
Q108	Transistor	DC switch
Q201	Transistor	Wide/Narrow switch/ RX
Q202	Transistor	IF amplifier
Q203	FET	Mixer

Ref. No.	Part Name	Description
Q204	FET	Low noise amplifier
Q301	Transistor	DC switch/ Red color LED
Q302	Transistor	DC switch/ Green color LED
Q303	Transistor	DC switch/ 5R
Q304	Transistor	DC switch/ 5T
Q305,306	Transistor	Beat shift switch
Q307	Transistor	Wide/Narrow switch/ TX
Q308	Transistor	Rectification
Q310,311	Transistor	MIC mute
Q312,313	Transistor	DC switch
Q314	Transistor	Mute switch
Q315,316	FET	Mute switch
D3	Variable Capacitance Diode	Frequency control/ RX VCO
D4	Variable Capacitance Diode	Frequency control/ TX VCO
D6	Variable Capacitance Diode	Frequency control/ RX VCO
D8	Variable Capacitance Diode	Frequency control/ TX VCO
D9	Variable Capacitance Diode	Modulator
D10	Diode	TX/RX RF switch
D101	Zener diode	Voltage protection
D103~105	Diode	ANT switch
D202~205	Variable Capacitance Diode	RF BPF tuning
D301	Diode	Reverse voltage protection
D302	Diode	Rectification
D303	LED	Red color LED
D304	LED	Green color LED
D306	Diode	Rectification
D307	Diode	Limiter
D308,309	Diode	Rectification

PARTS LIST

CAPACITORS

$\frac{C}{1} \frac{C}{2} \frac{45}{3} \frac{TH}{4} \frac{1H}{5} \frac{220}{6} \frac{J}{6}$

- 1 = Type ... ceramic, electrolytic, etc.
- 2 = Shape ... round, square, etc.
- 3 = Temp. coefficient
- 4 = Voltage rating
- 5 = Value
- 6 = Tolerance

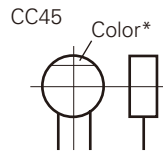

• Capacitor value

- 010 = 1pF
- 100 = 10pF
- 101 = 100pF
- 102 = 1000pF = 0.001μF
- 103 = 0.01μF

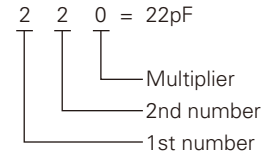

• Temperature coefficient

1st Word	C	L	P	R	S	T	U
Color*	Black	Red	Orange	Yellow	Green	Blue	Violet
ppm/°C	0	-80	-150	-220	-330	-470	-750

2nd Word	G	H	J	K	L
ppm/°C	±30	±60	±120	±250	±500

Example : CC45TH = -470±60ppm/°C

• Tolerance (More than 10pF)

Code	C	D	G	J	K	M	X	Z	P	No code
(%)	±0.25	±0.5	±2	±5	±10	±20	+40 -20	+80 -20	+100 -0	More than 10μF : -10~+50 Less than 4.7μF : -10~+75

(Less than 10pF)

Code	B	C	D	F	G
(pF)	±0.1	±0.25	±0.5	±1	±2

• Voltage rating

2nd word \ 1st word	A	B	C	D	E	F	G	H	J	K	V
0	1.0	1.25	1.6	2.0	2.5	3.15	4.0	5.0	6.3	8.0	-
1	10	12.5	16	20	25	31.5	40	50	63	80	35
2	100	125	160	200	250	315	400	500	630	800	-
3	1000	1250	1600	2000	2500	2150	4000	5000	6300	8000	-

• Chip capacitors

- (EX) $\frac{C}{1} \frac{C}{2} \frac{73}{3} \frac{F}{4} \frac{SL}{5} \frac{1H}{6} \frac{000}{7} \frac{J}{7}$ → Refer to the table above.
- (Chip) (CH, RH, UJ, SL)
- 1 = Type
 - 2 = Shape
 - 3 = Dimension
 - 4 = Temp. coefficient
 - 5 = Voltage rating
 - 6 = Value
 - 7 = Tolerance
- (EX) $\frac{C}{1} \frac{K}{2} \frac{73}{3} \frac{F}{4} \frac{F}{5} \frac{1H}{6} \frac{000}{7} \frac{Z}{7}$
- (Chip) (B, F)

• Dimension

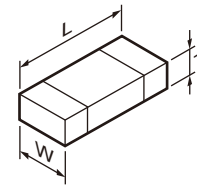

Chip capacitor

Code	L	W	T
Empty	5.6±0.5	5.0±0.5	Less than 2.0
A	4.5±0.5	3.2±0.4	Less than 2.0
B	4.5±0.5	2.0±0.3	Less than 2.0
C	4.5±0.5	1.25±0.2	Less than 1.25
D	3.2±0.4	2.5±0.3	Less than 1.5
E	3.2±0.2	1.6±0.2	Less than 1.25
F	2.0±0.3	1.25±0.2	Less than 1.25
G	1.6±0.2	0.8±0.2	Less than 1.0
H	1.0±0.05	0.5±0.05	0.5±0.05

Chip resistor

Code	L	W	T
E	3.2±0.2	1.6±0.2	1.0
F	2.0±0.3	1.25±0.2	1.0
G	1.6±0.2	0.8±0.2	0.5±0.1
H	1.0±0.05	0.5±0.05	0.35±0.05

• Rating wattage

Code	Wattage	Code	Wattage	Code	Wattage
1J	1/16W	2C	1/6W	3A	1W
2A	1/10W	2E	1/4W	3D	2W
2B	1/8W	2H	1/2W		

RESISTORS

• Chip resistor (Carbon)

- (EX) $\frac{R}{1} \frac{D}{2} \frac{73}{3} \frac{E}{4} \frac{B}{5} \frac{2B}{6} \frac{000}{7} \frac{J}{7}$
- (Chip) (B, F)

• Carbon resistor (Normal type)

- (EX) $\frac{R}{1} \frac{D}{2} \frac{14}{3} \frac{B}{4} \frac{B}{5} \frac{2C}{6} \frac{000}{7} \frac{J}{7}$

- 1 = Type
- 2 = Shape
- 3 = Dimension
- 4 = Temp. coefficient
- 5 = Rating wattage
- 6 = Value
- 7 = Tolerance

PARTS LIST

* New Parts. Δ indicates safety critical components.

Parts without **Parts No.** are not supplied.

Les articles non mentionnés dans le **Parts No.** ne sont pas fournis.

Teile ohne **Parts No.** werden nicht geliefert.

L : Scandinavia

Y : PX (Far East, Hawaii)

Y : AAFES (Europe)

K : USA

T : England

X : Australia

P : Canada

E : Europe

M : Other Areas

TK-2302 (Y50-634X-XX)

TX-RX UNIT (X57-7572-71)

Ref. No.	Address	New parts	Parts No.	Description	Desti-nation
TK-2302					
1	1A		A02-4040-03	PLASTIC CABINET ASSY	
2	3A		A10-4124-11	CHASSIS	
4	2C,2E		B09-0725-03	CAP ACCESSORY	
7	1C,1E	*	B62-2110-00	INSTRUCTION MANUAL	
9	1A		D10-0649-03	LEVER	
10	1A		D21-0863-04	SHAFT	
11	1A		D32-0441-13	STOPPER	
13	2B	*	E04-0477-15	RF COAXIAL RECEPTACLE (SMA)	
14	3A		E23-1253-04	TERMINAL (BATT-)	
15	2A		E23-1254-04	TERMINAL (BATT+)	
16	2B		E37-1175-15	SP WIRE LEAD (BROWN)	
17	2B		E37-1176-15	SP WIRE LEAD (GREEN)	
19	3A		F20-3353-14	INSULATING SHEET (CHASSIS-BATT+)	
21	1A		G01-4542-04	COIL SPRING (LEVER)	
22	1A		G01-4543-14	COIL SPRING (STOPPER)	
23	2A		G10-1330-04	FIBROUS SHEET (AUDIO IC)	
24	2A		G11-4465-04	RUBBER SHEET (FINAL FET)	
25	3B		G13-2009-04	CUSHION (CHASSIS)	
26	3A		G13-2033-04	CUSHION (BATT-)	
27	3A		G13-2034-14	CUSHION (CHASSIS-)	
28	3A		G13-2038-24	CUSHION (CHASSIS-CERAMIC FILTER)	
29	2A		G13-2039-14	CUSHION (PCB-CERAMIC FILTER)	
30	1A	*	G13-2285-04	CUSHION	
31	3A		G53-1604-03	PACKING (CHASSIS)	
32	2A		G53-1605-03	PACKING (BATT+)	
33	2A		G53-1609-14	PACKING (ECM)	
34	2B		G53-1799-03	PACKING (VOLUME/SELECTOR)	
35	1B		G53-1800-03	PACKING (SP/MIC)	
36	1B		G53-1801-03	PACKING (SPEAKER)	
37	2B		G53-1802-04	PACKING (SMA)	
46	2A		J19-5463-03	HOLDER (BATT+)	
47	2A		J19-5473-03	HOLDER ASSY (BATT+)	
48	2C,2E		J19-5521-03	HOLDER (SP/MIC) ACCESSORY	
49	2B		J19-5522-03	SPEAKER CLASP	
50	1D,2E		J29-0734-05	BELT HOOK ACCESSORY	
51	2A		J82-0121-05	FPC	
52	1A		J99-0737-04	ADHESIVE SHEET (PTT)	
54	1B		K29-9309-13	KNOB (VOLUME)	
55	1A		K29-9425-03	BUTTON KNOB (PTT)	
56	1A		K29-9426-03	BUTTON KNOB (MONI/PF)	
57	1B		K29-9427-03	KNOB (SELECTOR)	
A	3B		N14-0848-05	CIRCULAR NUT (SELECTOR)	
B	3B		N14-0849-05	CIRCULAR NUT (VOLUME)	
C	2B		N30-2604-48	PAN HEAD MACHINE SCREW	
D	3A		N30-2606-48	PAN HEAD MACHINE SCREW	
E	2A,3A,2B		N83-2005-48	PAN HEAD TAPTITE SCREW	
61	2C,2E		N99-2046-05	SCREW SET ACCESSORY	
63	2A		R31-0670-15	VARIABLE RESISTOR	
65	2A		S60-0440-05	ROTARY SWITCH	

Ref. No.	Address	New parts	Parts No.	Description	Desti-nation
67	1B		T07-0369-15	SPEAKER	
68	2F	*	T90-1037-05	HELICAL ANTENNA ACCESSORY	T
71	1F		W08-0988-05	CHARGER (KSC-35)	T
72	1F		W08-0993-05	AC ADAPTER (SWITCHING)	T
TX-RX UNIT (X57-7572-71)					
D303			B30-2315-05	LED (RED)	
D304			B30-2314-05	LED (GREEN)	
C1			CK73HB1H392K	CHIP C 3900PF	K
C2			CK73HB1C682K	CHIP C 6800PF	K
C3			CK73GB1A105K	CHIP C 1.0UF	K
C4			CK73HB1A104K	CHIP C 0.10UF	K
C5			CK73HB1H102K	CHIP C 1000PF	K
C6			CK73HB1E103K	CHIP C 0.010UF	K
C7			CC73HCH1H100D	CHIP C 10PF	D
C8-10			CC73HCH1H101J	CHIP C 100PF	J
C11			CK73FB0J106K	CHIP C 10UF	K
C12			CK73HB1H102K	CHIP C 1000PF	K
C13			CC73HCH1H100D	CHIP C 10PF	D
C14,15			CK73HB1E103K	CHIP C 0.010UF	K
C16			CC73HCH1H470J	CHIP C 47PF	J
C17			CK73HB1E103K	CHIP C 0.010UF	K
C18			CC73HCH1H180J	CHIP C 18PF	J
C23			CK73HB1E103K	CHIP C 0.010UF	K
C25			CC73HCH1H300J	CHIP C 30PF	J
C26			CC73HCH1H020B	CHIP C 2.0PF	B
C27			CS77AA1VR33M	CHIP TNTL 0.33UF	35WV
C29			CC73HCH1H270J	CHIP C 27PF	J
C30			CK73HB1H102K	CHIP C 1000PF	K
C31			CK73HB1E103K	CHIP C 0.010UF	K
C32			CS77CA1C3R3M	CHIP TNTL 3.3UF	16WV
C33			CK73HB1H471K	CHIP C 470PF	K
C35			CS77CA1VR22M	CHIP TNTL 0.22UF	35WV
C36			CK73HB1H392K	CHIP C 3900PF	K
C39			CK73HB1C682K	CHIP C 6800PF	K
C40			CC73HCH1H060B	CHIP C 6.0PF	B
C41			CC73HCH1H040B	CHIP C 4.0PF	B
C42			CC73HCH1H060B	CHIP C 6.0PF	B
C44,45			CK73GB1A105K	CHIP C 1.0UF	K
C47			CC73HCH1H150J	CHIP C 15PF	J
C48			CC73HCH1H010B	CHIP C 1.0PF	B
C49			CC73HCH1H0R5B	CHIP C 0.5PF	B
C50			CK73HB1H471K	CHIP C 470PF	K
C51			CC73HCH1H100D	CHIP C 10PF	D
C52			CC73HCH1H470J	CHIP C 47PF	J
C53			CC73HCH1H181J	CHIP C 180PF	J
C56			CC73HCH1H060B	CHIP C 6.0PF	B
C57			CC73HCH1H090B	CHIP C 9.0PF	B
C58			CC73HCH1H020B	CHIP C 2.0PF	B
C59			CC73HCH1H2R5B	CHIP C 2.5PF	B
C60			CC73HCH1H4R5B	CHIP C 4.5PF	B
C61			CC73HCH1H050B	CHIP C 5.0PF	B
C62			CK73HB1H471K	CHIP C 470PF	K

PARTS LIST

TX-RX UNIT (X57-7572-71)

Ref. No.	Address	New parts	Parts No.	Description	Destination	Ref. No.	Address	New parts	Parts No.	Description	Destination
C63-65			CC73HCH1H060B	CHIP C 6.0PF B		C204			CK73HB1H102K	CHIP C 1000PF K	
C66			CK73HB1H471K	CHIP C 470PF K		C205			CK73HB1H182K	CHIP C 1800PF K	
C67			CC73HCH1H060B	CHIP C 6.0PF B		C206			CK73HB1H681K	CHIP C 680PF K	
C68			CK73HB1H471K	CHIP C 470PF K		C207			CK73HB1H821K	CHIP C 820PF K	
C70,71			CC73HCH1H0R5B	CHIP C 0.5PF B		C208			CK73HB1A104K	CHIP C 0.10UF K	
C72,73			CK73HB1A104K	CHIP C 0.10UF K		C209			CC73HCH1H680J	CHIP C 68PF J	
C74			CK73HB1H102K	CHIP C 1000PF K		C210,211			CK73HB1A104K	CHIP C 0.10UF K	
C75			CK73HB1H471K	CHIP C 470PF K		C212			CK73HB1H102K	CHIP C 1000PF K	
C76			CS77CP0J100M	CHIP TNTL 10UF 6.3WV		C213,214			CK73HB1A104K	CHIP C 0.10UF K	
C77			CK73HB1H102K	CHIP C 1000PF K		C215			CC73HCH1H101J	CHIP C 100PF J	
C78			CC73HCH1H330J	CHIP C 33PF J		C216,217			CK73HB1E103K	CHIP C 0.010UF K	
C79,80			CK73HB1H471K	CHIP C 470PF K		C221			CC73HCH1H180J	CHIP C 18PF J	
C81			CC73HCH1H150J	CHIP C 15PF J		C223			CC73HCH1H070B	CHIP C 7.0PF B	
C82,83			CK73HB1H471K	CHIP C 470PF K		C224			CC73HCH1H060B	CHIP C 6.0PF B	
C84			CK73HB1H102K	CHIP C 1000PF K		C225			CK73HB1E103K	CHIP C 0.010UF K	
C86-88			CK73HB1H102K	CHIP C 1000PF K		C226			CC73HCH1H130J	CHIP C 13PF J	
C89			CC73HCH1H101J	CHIP C 100PF J		C227			CC73HCH1H070B	CHIP C 7.0PF B	
C101			CK73HB1H102K	CHIP C 1000PF K		C228			CK73HB1A104K	CHIP C 0.10UF K	
C102			CC73HCH1H680J	CHIP C 68PF J		C229			CC73HCH1H060B	CHIP C 6.0PF B	
C103			CK73GB1A105K	CHIP C 1.0UF K		C230			CK73HB1E103K	CHIP C 0.010UF K	
C106,107			CK73HB1H102K	CHIP C 1000PF K		C231			CK73HB1H102K	CHIP C 1000PF K	
C108			CC73HCH1H101J	CHIP C 100PF J		C232			CC73HCH1H150J	CHIP C 15PF J	
C109			CK73HB1A104K	CHIP C 0.10UF K		C233			CK73HB1H102K	CHIP C 1000PF K	
C110			CK73HB1H102K	CHIP C 1000PF K		C235			CK73HB1E103K	CHIP C 0.010UF K	
C114			CK73HB1H102K	CHIP C 1000PF K		C236			CK73HB1H102K	CHIP C 1000PF K	
C115,116		*	CK73HB1A684K	CHIP C 0.68UF K		C237			CC73HCH1H040B	CHIP C 4.0PF B	
C118			CK73HB1H102K	CHIP C 1000PF K		C238			CK73HB1H102K	CHIP C 1000PF K	
C119			CC73HCH1H270J	CHIP C 27PF J		C243			CK73FB0J106K	CHIP C 10UF K	
C120			CK73HB1H102K	CHIP C 1000PF K		C244			CC73HCH1H030B	CHIP C 3.0PF B	
C122,123			CK73HB1H102K	CHIP C 1000PF K		C245			CK73HB1H102K	CHIP C 1000PF K	
C124			CK73GB1A105K	CHIP C 1.0UF K		C246			CC73HCH1H560J	CHIP C 56PF J	
C125			CK73HB1E103K	CHIP C 0.010UF K		C247			CC73HCH1H030B	CHIP C 3.0PF B	
C127			CK73GB1A105K	CHIP C 1.0UF K		C248			CK73HB1H102K	CHIP C 1000PF K	
C129,130			CK73HB1H102K	CHIP C 1000PF K		C249			CC73HCH1H2R5B	CHIP C 2.5PF B	
C131			CC73HCH1H101J	CHIP C 100PF J		C250			CC73HCH1H560J	CHIP C 56PF J	
C132			CC73GCH1H010B	CHIP C 1.0PF B		C251			CC73GCH1H050B	CHIP C 5.0PF B	
C134			CK73HB1H102K	CHIP C 1000PF K		C252			CK73HB1H102K	CHIP C 1000PF K	
C135			CK73HB1A104K	CHIP C 0.10UF K		C254,255			CK73HB1H102K	CHIP C 1000PF K	
C136			CK73HB1H471K	CHIP C 470PF K		C257			CC73HCH1H390J	CHIP C 39PF J	
C138			CC73GCH1H820J	CHIP C 82PF J		C258			CC73HCH1H040B	CHIP C 4.0PF B	
C139			CC73GCH1H110J	CHIP C 11PF J		C259			CC73HCH1H560J	CHIP C 56PF J	
C140			CK73HB1H102K	CHIP C 1000PF K		C260			CC73HCH1H040B	CHIP C 4.0PF B	
C141			CC73GCH1H270J	CHIP C 27PF J		C261			CK73HB1H102K	CHIP C 1000PF K	
C143			CC73GCH1H130J	CHIP C 13PF J		C262			CC73HCH1H040B	CHIP C 4.0PF B	
C145			CC73GCH1H820J	CHIP C 82PF J		C263			CC73HCH1H560J	CHIP C 56PF J	
C146			CC73GCH1H050B	CHIP C 5.0PF B		C264			CC73HCH1H050B	CHIP C 5.0PF B	
C148			CK73HB1H102K	CHIP C 1000PF K		C265			CC73HCH1H330J	CHIP C 33PF J	
C149			CC73GCH1H220J	CHIP C 22PF J		C303			CK73HB1H102K	CHIP C 1000PF K	
C150			CK73GB1H102K	CHIP C 1000PF K		C304			CK73HB1A104K	CHIP C 0.10UF K	
C151			CC73GCH1H100D	CHIP C 10PF D		C305			CC73HCH1H101J	CHIP C 100PF J	
C152			CC73GCH1H110J	CHIP C 11PF J		C306			CK73GB1A105K	CHIP C 1.0UF K	
C153			CC73GCH1H100D	CHIP C 10PF D		C307			CC73HCH1H101J	CHIP C 100PF J	
C154			CC73GCH1H180J	CHIP C 18PF J		C310			CK73GB1A105K	CHIP C 1.0UF K	
C155			CC73GCH1H130J	CHIP C 13PF J		C311			CC73HCH1H101J	CHIP C 100PF J	
C156			CC73GCH1H150J	CHIP C 15PF J		C312			CK73HB1H102K	CHIP C 1000PF K	
C157			CC73HCH1H330J	CHIP C 33PF J		C313			CC73HCH1H101J	CHIP C 100PF J	
C158			CC73GCH1H070B	CHIP C 7.0PF B		C315			CC73HCH1H101J	CHIP C 100PF J	
C201			CK73GB1C224K	CHIP C 0.22UF K		C316			CK73HB1H102K	CHIP C 1000PF K	
C202			CK73FB0J106K	CHIP C 10UF K		C318			CK73HB1E103K	CHIP C 0.010UF K	
C203			CK73HB1E103K	CHIP C 0.010UF K		C319,320			CK73HB1H102K	CHIP C 1000PF K	

PARTS LIST

TX-RX UNIT (X57-7572-71)

Ref. No.	Address	New parts	Parts No.	Description	Desti-nation	Ref. No.	Address	New parts	Parts No.	Description	Desti-nation
C321			CK73GB1A105K	CHIP C 1.0UF K		101	2A		J30-1282-14	SPACER	
C322			CK73HB1H102K	CHIP C 1000PF K		CD201			L79-1866-05	TUNING COIL	
C323			CK73GB1A105K	CHIP C 1.0UF K		CF201	2A		L72-1025-05	CERAMIC FILTER	
C325			CK73HB1H102K	CHIP C 1000PF K		L1			L92-0138-05	CHIP FERRITE	
C327			CK73HB1H102K	CHIP C 1000PF K		L2			L40-4791-86	SMALL FIXED INDUCTOR (4.7UH)	
C331			CK73HB1A104K	CHIP C 0.10UF K		L4			L40-5681-86	SMALL FIXED INDUCTOR (0.56UH)	
C332			CC73HCH1H050B	CHIP C 5.0PF B		L6			L40-5681-86	SMALL FIXED INDUCTOR (0.56UH)	
C334			CK73HB1E103K	CHIP C 0.010UF K		L7			L92-0138-05	CHIP FERRITE	
C335			CK73FBOJ106K	CHIP C 10UF K		L8			L40-1875-71	SMALL FIXED INDUCTOR (18NH)	
C337			CC73HCH1H050B	CHIP C 5.0PF B		L9			L92-0470-05	CHIP FERRITE	
C339			CK73GB1A105K	CHIP C 1.0UF K		L10,11			L40-1885-92	SMALL FIXED INDUCTOR (180NH)	
C341			CK73HB1H102K	CHIP C 1000PF K		L12			L40-3375-71	SMALL FIXED INDUCTOR (33NH)	
C353,354			CK73HB1E103K	CHIP C 0.010UF K		L13,14			L40-1885-92	SMALL FIXED INDUCTOR (180NH)	
C356			CK73HB1H102K	CHIP C 1000PF K		L15			L40-3378-67	SMALL FIXED INDUCTOR (33NH)	
C358			CK73GB1C224K	CHIP C 0.22UF K		L16			L40-2278-67	SMALL FIXED INDUCTOR (22NH)	
C359			CK73FBOJ106K	CHIP C 10UF K		L17,18			L41-2785-45	SMALL FIXED INDUCTOR (270NH)	
C360			CK73HB1A104K	CHIP C 0.10UF K		L19,20			L40-1885-92	SMALL FIXED INDUCTOR (180NH)	
C361			CK73GB1A105K	CHIP C 1.0UF K		L21			L92-0138-05	CHIP FERRITE	
C362			CK73HB1H102K	CHIP C 1000PF K		L22			L40-3975-71	SMALL FIXED INDUCTOR (39NH)	
C363			CC73HCH1H820J	CHIP C 82PF J		L23			L92-0138-05	CHIP FERRITE	
C364			CC73HCH1H120J	CHIP C 12PF J		L24			L40-8275-71	SMALL FIXED INDUCTOR (82NH)	
C365			CC73HCH1H121J	CHIP C 120PF J		L101			L40-6875-57	SMALL FIXED INDUCTOR (68.0NH)	
C366			CK73HB1A104K	CHIP C 0.10UF K		L102			L40-2275-71	SMALL FIXED INDUCTOR (22NH)	
C367			CK73GB1A105K	CHIP C 1.0UF K		L103			L41-1585-45	SMALL FIXED INDUCTOR (150NH)	
C368			CK73HB1H271K	CHIP C 270PF K		L104			L92-0472-05	CHIP FERRITE	
C369,370			CK73HB1A104K	CHIP C 0.10UF K		L105			L40-2275-92	SMALL FIXED INDUCTOR (22NH)	
C371			CK73FBOJ106K	CHIP C 10UF K		L106			L34-4577-05	AIR-CORE COIL	
C372			CK73HB1H102K	CHIP C 1000PF K		L107			L92-0472-05	CHIP FERRITE	
C373			CC73HCH1H121J	CHIP C 120PF J		L108			L34-4563-05	AIR-CORE COIL	
C374-376			CK73HB1H102K	CHIP C 1000PF K		L109			L34-4573-05	AIR-CORE COIL	
C377			CK73HB1A683K	CHIP C 0.068UF K		L110			L34-4575-05	AIR-CORE COIL	
C378			CC73HCH1H820J	CHIP C 82PF J		L111			L41-6885-39	SMALL FIXED INDUCTOR (0.68UH)	
C379,380			CK73GB1A105K	CHIP C 1.0UF K		L112			L34-4576-05	AIR-CORE COIL	
C381			CK73HB1H391K	CHIP C 390PF K		L113			L34-4575-05	AIR-CORE COIL	
C382			CK73HB1C153K	CHIP C 0.015UF K		L114			L34-4567-05	AIR-CORE COIL	
C383-385			CK73HB1A104K	CHIP C 0.10UF K		L115			L40-1275-92	SMALL FIXED INDUCTOR (12NH)	
C386			CK73HB1E103K	CHIP C 0.010UF K		L116			L34-4566-05	AIR-CORE COIL	
C388,389			CK73HB1H102K	CHIP C 1000PF K		L117			L41-1092-44	SMALL FIXED INDUCTOR (1UH)	
C390,391			CK73GB1A105K	CHIP C 1.0UF K		L201			L40-1091-86	SMALL FIXED INDUCTOR (1.0UH)	
C392			CK73HB1A333K	CHIP C 0.033UF K		L202,203			L40-3975-71	SMALL FIXED INDUCTOR (39NH)	
C393			CK73FBOJ106K	CHIP C 10UF K		L204			L92-0138-05	CHIP FERRITE	
C395			CC73HCH1H221J	CHIP C 220PF J		L205			L41-5685-39	SMALL FIXED INDUCTOR (0.56UH)	
C396			CK73HB1A104K	CHIP C 0.10UF K		L206			L40-1285-92	SMALL FIXED INDUCTOR (120NH)	
C397			CK73GB1C474K	CHIP C 0.47UF K		L207			L40-1585-92	SMALL FIXED INDUCTOR (150NH)	
C399			CC73HCH1H101J	CHIP C 100PF J		L209			L41-5678-14	SMALL FIXED INDUCTOR (56NH)	
C400			CK73FBOJ106K	CHIP C 10UF K		L210			L92-0138-05	CHIP FERRITE	
C402			CK73HB1A104K	CHIP C 0.10UF K		L211			L41-5678-14	SMALL FIXED INDUCTOR (56NH)	
C403			CK73HB1A473J	CHIP C 0.047UF J		L213			L41-5678-14	SMALL FIXED INDUCTOR (56NH)	
C404			CS77CCQJ101M	CHIP TNL 100UF 6.3WV		L214			L41-2778-14	SMALL FIXED INDUCTOR (27NH)	
C405			CC73HCH1H221J	CHIP C 220PF J		L216			L41-2778-14	SMALL FIXED INDUCTOR (27NH)	
C408			CK73HB1H102K	CHIP C 1000PF K		L301			L92-0472-05	CHIP FERRITE	
C413-415			CK73HB1H102K	CHIP C 1000PF K		L302-304			L92-0138-05	CHIP FERRITE	
C418			CC73HCH1H390J	CHIP C 39PF J		L305			L92-0140-05	CHIP FERRITE	
TC1,2			C05-0384-05	CERAMIC TRIMMER CAP (10PF)		L306			L40-2775-71	SMALL FIXED INDUCTOR (27NH)	
CN2			E23-1278-05	TERMINAL		X1			L77-3042-05	TCXO (12.8MHZ)	
CN301			E40-6573-05	FLAT CABLE CONNECTOR		X301			L78-1433-05	RESONATOR (14.746MHZ)	
J301			E11-0703-05	PHONE JACK		XF201			L71-0637-15	MCF	
F301			F53-0324-05	FUSE (2.5A)		CP1			RK75HA1J101J	CHIP-COM 100 J 1/16W	

If a part reference number is listed in a shaded box, that part does not come with the PCB.

PARTS LIST

TX-RX UNIT (X57-7572-71)

Ref. No.	Address	New parts	Parts No.	Description	Destination	Ref. No.	Address	New parts	Parts No.	Description	Destination
CP201			RK75HA1J104J	CHIP-COM 100K J 1/16W		R118			RK73HB1J472J	CHIP R 4.7K J 1/16W	
CP202			RK75HA1J474J	CHIP-COM 470K J 1/16W		R119			RK73HB1J393J	CHIP R 39K J 1/16W	
CP203		*	RK75HA1J823J	CHIP-COM 82K J 1/16W		R120			RK73EB2ER39K	CHIP R 0.39 K 1/4W	
CP204			RK75HA1J474J	CHIP-COM 470K J 1/16W		R121			RK73HB1J270J	CHIP R 27 J 1/16W	
CP301,302			RK75HA1J473J	CHIP-COM 47K J 1/16W		R122			RK73HB1J124J	CHIP R 120K J 1/16W	
CP303,304			RK75HA1J102J	CHIP-COM 1.0K J 1/16W		R123			RK73EB2ER39K	CHIP R 0.39 K 1/4W	
R1			RK73HB1J183J	CHIP R 18K J 1/16W		R124,125			RK73GH2A154D	CHIP R 150K D 1/10W	
R2			RK73HB1J103J	CHIP R 10K J 1/16W		R126,127			RK73GH2A334D	CHIP R 330K D 1/10W	
R3			RK73HB1J683J	CHIP R 68K J 1/16W		R128			RK73HB1J105J	CHIP R 1.0M J 1/16W	
R4			RK73HB1J124J	CHIP R 120K J 1/16W		R129			RK73HB1J473J	CHIP R 47K J 1/16W	
R5			RK73HB1J224J	CHIP R 220K J 1/16W		R130			RK73HB1J000J	CHIP R 0.0 J 1/16W	
R7			RK73HB1J000J	CHIP R 0.0 J 1/16W		R131			RK73HB1J563J	CHIP R 56K J 1/16W	
R8			RK73HB1J101J	CHIP R 100 J 1/16W		R132			RK73HB1J104J	CHIP R 100K J 1/16W	
R9			RK73HB1J222J	CHIP R 2.2K J 1/16W		R133			RK73HB1J474J	CHIP R 470K J 1/16W	
R10			RK73HB1J102J	CHIP R 1.0K J 1/16W		R134			RK73GB2A151J	CHIP R 150 J 1/10W	
R11			RK73HB1J334J	CHIP R 330K J 1/16W		R201			RK73HB1J184J	CHIP R 180K J 1/16W	
R12			RK73HB1J221J	CHIP R 220 J 1/16W		R203			RK73HB1J472J	CHIP R 4.7K J 1/16W	
R13			RK73HB1J101J	CHIP R 100 J 1/16W		R204			RK73HB1J823J	CHIP R 82K J 1/16W	
R14			RK73HB1J100J	CHIP R 10 J 1/16W		R205			RK73HB1J100J	CHIP R 10 J 1/16W	
R15			RK73HB1J561J	CHIP R 560 J 1/16W		R206			RK73HB1J152J	CHIP R 1.5K J 1/16W	
R16			RK73HB1J000J	CHIP R 0.0 J 1/16W		R207			RK73HB1J332J	CHIP R 3.3K J 1/16W	
R17			RK73HB1J152J	CHIP R 1.5K J 1/16W		R208			RK73HB1J823J	CHIP R 82K J 1/16W	
R18			RK73HB1J681J	CHIP R 680 J 1/16W		R209			RK73HB1J332J	CHIP R 3.3K J 1/16W	
R19			RK73HB1J153J	CHIP R 15K J 1/16W		R210,211			RK73HB1J472J	CHIP R 4.7K J 1/16W	
R20			RK73HB1J000J	CHIP R 0.0 J 1/16W		R212			RK73HB1J101J	CHIP R 100 J 1/16W	
R21,22			RK73HB1J103J	CHIP R 10K J 1/16W		R213			RK73HB1J225J	CHIP R 2.2M J 1/16W	
R26			RK73HB1J273J	CHIP R 27K J 1/16W		R214			RK73HB1J471J	CHIP R 470 J 1/16W	
R27			RK73HB1J824J	CHIP R 820K J 1/16W		R215			RK73HB1J391J	CHIP R 390 J 1/16W	
R28			RK73HB1J102J	CHIP R 1.0K J 1/16W		R216			RK73HB1J471J	CHIP R 470 J 1/16W	
R29			RK73HB1J154J	CHIP R 150K J 1/16W		R217			RK73HB1J221J	CHIP R 220 J 1/16W	
R30			RK73HB1J104J	CHIP R 100K J 1/16W		R218,219			RK73HB1J104J	CHIP R 100K J 1/16W	
R31			RK73HB1J274J	CHIP R 270K J 1/16W		R220			RK73HB1J470J	CHIP R 47 J 1/16W	
R32			RK73HB1J684J	CHIP R 680K J 1/16W		R222,223			RK73HB1J000J	CHIP R 0.0 J 1/16W	
R33			RK73HB1J101J	CHIP R 100 J 1/16W		R224			RK73HB1J222J	CHIP R 2.2K J 1/16W	
R34			RK73HB1J181J	CHIP R 180 J 1/16W		R225			RK73HB1J470J	CHIP R 47 J 1/16W	
R35			RK73HB1J680J	CHIP R 68 J 1/16W		R226			RK73HB1J221J	CHIP R 220 J 1/16W	
R36			RK73HB1J101J	CHIP R 100 J 1/16W		R227			RK73HB1J824J	CHIP R 820K J 1/16W	
R37			RK73HB1J472J	CHIP R 4.7K J 1/16W		R228			RK73HB1J474J	CHIP R 470K J 1/16W	
R38			RK73HB1J154J	CHIP R 150K J 1/16W		R229,230			RK73HB1J000J	CHIP R 0.0 J 1/16W	
R39			RK73HB1J101J	CHIP R 100 J 1/16W		R231			RK73HB1J102J	CHIP R 1.0K J 1/16W	
R40			RK73HB1J100J	CHIP R 10 J 1/16W		R301			RK73HH1J474D	CHIP R 470K D 1/16W	
R41			RK73HB1J102J	CHIP R 1.0K J 1/16W		R302			RK73GB2A000J	CHIP R 0.0 J 1/10W	
R42,43			RK73HB1J332J	CHIP R 3.3K J 1/16W		R303			RK73HB1J101J	CHIP R 100 J 1/16W	
R44			RK73HB1J220J	CHIP R 22 J 1/16W		R304			RK73HB1J334J	CHIP R 330K J 1/16W	
R45			RK73HB1J331J	CHIP R 330 J 1/16W		R305			RK73HH1J474D	CHIP R 470K D 1/16W	
R46			RK73HB1J222J	CHIP R 2.2K J 1/16W		R306			RK73HB1J184J	CHIP R 180K J 1/16W	
R47			RK73HB1J472J	CHIP R 4.7K J 1/16W		R307			RK73GB2A271J	CHIP R 270 J 1/10W	
R101			RK73HB1J103J	CHIP R 10K J 1/16W		R308			RK73GB2A221J	CHIP R 220 J 1/10W	
R102			RK73HB1J123J	CHIP R 12K J 1/16W		R309,310			RK73GB2A000J	CHIP R 0.0 J 1/10W	
R103			RK73HB1J331J	CHIP R 330 J 1/16W		R313			RK73HB1J102J	CHIP R 1.0K J 1/16W	
R104			RK73HB1J680J	CHIP R 68 J 1/16W		R314,315			RK73HB1J103J	CHIP R 10K J 1/16W	
R106			RK73HB1J000J	CHIP R 0.0 J 1/16W		R316			RK73HB1J222J	CHIP R 2.2K J 1/16W	
R108			RK73HB1J563J	CHIP R 56K J 1/16W		R317			RK73HB1J472J	CHIP R 4.7K J 1/16W	
R109			RK73HB1J101J	CHIP R 100 J 1/16W		R318			RK73HB1J182J	CHIP R 1.8K J 1/16W	
R110			RK73HB1J473J	CHIP R 47K J 1/16W		R319			RK73HB1J000J	CHIP R 0.0 J 1/16W	
R111			RK73HB1J822J	CHIP R 8.2K J 1/16W		R320			RK73HB1J123J	CHIP R 12K J 1/16W	
R113			RK73HB1J331J	CHIP R 330 J 1/16W		R321			RK73HB1J103J	CHIP R 10K J 1/16W	
R114			RK73GB2A000J	CHIP R 0.0 J 1/10W		R323			RK73HB1J102J	CHIP R 1.0K J 1/16W	
R115			RK73HB1J182J	CHIP R 1.8K J 1/16W		R324,325			RK73HB1J472J	CHIP R 4.7K J 1/16W	
R117			RK73EB2ER39K	CHIP R 0.39 K 1/4W		R340-342			RK73HB1J103J	CHIP R 10K J 1/16W	

PARTS LIST

TX-RX UNIT (X57-7572-71)

Ref. No.	Address	New parts	Parts No.	Description	Destination	Ref. No.	Address	New parts	Parts No.	Description	Destination
R344			RK73HB1J474J	CHIP R 470K J 1/16W		D202-205			1SV305F	VARIABLE CAPACITANCE DIODE	
R345			RK73HB1J273J	CHIP R 27K J 1/16W		D301			GN1G	DIODE	
R347			RK73GB2A000J	CHIP R 0.0 J 1/10W		D302			HRC0203C	DIODE	
R348			RK73HB1J102J	CHIP R 1.0K J 1/16W		D306			KDR731	DIODE	
R349			RK73HB1J105J	CHIP R 1.0M J 1/16W		D307			MC2850	DIODE	
R350			RK73HB1J124J	CHIP R 120K J 1/16W		D308,309			KDR731	DIODE	
R351			RK73HB1J334J	CHIP R 330K J 1/16W		IC1			MB15A02PFV2E1	MOS-IC	
R352			RK73HB1J104J	CHIP R 100K J 1/16W		IC2			UPB1509GV	BI-POLAR IC	
R353			RK73HB1J123J	CHIP R 12K J 1/16W		IC101			BA2904FVM	MOS-IC	
R354			RK73HB1J334J	CHIP R 330K J 1/16W		IC201			TA31136FNG	MOS-IC	
R355			RK73HB1J124J	CHIP R 120K J 1/16W		IC301			BD4840FVE	MOS-IC	
R356			RK73HB1J472J	CHIP R 4.7K J 1/16W		IC303			XC6209B502PR	MOS-IC	
R357			RK73HB1J563J	CHIP R 56K J 1/16W		IC304			XC6209B502MR	MOS-IC	
R358			RK73HB1J474J	CHIP R 470K J 1/16W		IC305			BR24L16F-W	ROM IC	
R359			RK73HB1J473J	CHIP R 47K J 1/16W		IC306			RF5F212CCKCMC	MICRO CONTROL UNIT	
R360			RK73HB1J332J	CHIP R 3.3K J 1/16W		IC308			AQUA-L	MOS-IC	
R361			RK73GB2A000J	CHIP R 0.0 J 1/10W		IC309			TA7368FG	MOS-IC	
R362			RK73HB1J184J	CHIP R 180K J 1/16W		Q1			KTC4075E(Y,GR)	TRANSISTOR	
R363,364			RK73HB1J104J	CHIP R 100K J 1/16W		Q2			2SC4774	TRANSISTOR	
R365			RK73HB1J332J	CHIP R 3.3K J 1/16W		Q3			2SC5636	TRANSISTOR	
R366			RK73HB1J154J	CHIP R 150K J 1/16W		Q4,5			2SK1875-F(V)	FET	
R367			RK73HB1J393J	CHIP R 39K J 1/16W		Q6			KTC4075E(Y,GR)	TRANSISTOR	
R368			RK73GB2A000J	CHIP R 0.0 J 1/10W		Q7,8			RT1P430U	TRANSISTOR	
R369			RK73HB1J823J	CHIP R 82K J 1/16W		Q9			2SC5636	TRANSISTOR	
R370			RK73HB1J102J	CHIP R 1.0K J 1/16W		Q10			KTC4075E(Y,GR)	TRANSISTOR	
R371			RK73HB1J822J	CHIP R 8.2K J 1/16W		Q11			2SC5636	TRANSISTOR	
R372			RK73HB1J000J	CHIP R 0.0 J 1/16W		Q101			2SC4926YD	TRANSISTOR	
R373			RK73HB1J224J	CHIP R 220K J 1/16W		Q102			RD01MUS1-T113	FET	
R374			RK73HB1J822J	CHIP R 8.2K J 1/16W		Q103			RT1N441U	TRANSISTOR	
R375			RK73HB1J182J	CHIP R 1.8K J 1/16W		Q104			2SK879-F(Y)	FET	
R376			RK73HB1J471J	CHIP R 470 J 1/16W		Q105			RD07MVS1BT122	FET	
R377			RK73HB1J473J	CHIP R 47K J 1/16W		Q106			RT1N441U	TRANSISTOR	
R378			RK73HB1J561J	CHIP R 560 J 1/16W		Q107			2SK1824-A	FET	
R379			RK73HB1J102J	CHIP R 1.0K J 1/16W		Q108			RT1P441U	TRANSISTOR	
R380			RK73HB1J474J	CHIP R 470K J 1/16W		Q201			RT1P441U	TRANSISTOR	
R381			RK73HB1J151J	CHIP R 150 J 1/16W		Q202			2SC4774	TRANSISTOR	
R383			RK73HB1J563J	CHIP R 56K J 1/16W		Q203,204			3SK318	FET	
R384			RK73HB1J333J	CHIP R 33K J 1/16W		Q301,302			RT1N441U	TRANSISTOR	
R385			RK73GB2A101J	CHIP R 100 J 1/10W		Q303			RT1P141U	TRANSISTOR	
R387			RK73HB1J104J	CHIP R 100K J 1/16W		Q304			DTB723YE	DIGITAL TRANSISTOR	
R388			RK73HB1J101J	CHIP R 100 J 1/16W		Q305,306			2SC4919	TRANSISTOR	
R389			RK73HB1J000J	CHIP R 0.0 J 1/16W		Q307			RT1N441U	TRANSISTOR	
R390			RK73GB2A000J	CHIP R 0.0 J 1/10W		Q308			KTC4075E(Y,GR)	TRANSISTOR	
R391			RK73HB1J102J	CHIP R 1.0K J 1/16W		Q310			2SC4116(GR)F	TRANSISTOR	
R393			RK73GB2A000J	CHIP R 0.0 J 1/10W		Q311			2SA1586(Y,GR)F	TRANSISTOR	
R394			RK73HB1J473J	CHIP R 47K J 1/16W		Q312			RT1N441U	TRANSISTOR	
R398			RK73HB1J000J	CHIP R 0.0 J 1/16W		Q313			2SB1694	TRANSISTOR	
VR1			R32-0737-05	SEMI FIXED VARIABLE RESISTOR		Q314			RT1N441U	TRANSISTOR	
S1-3			S70-0414-05	TACT SWITCH		Q315,316			2SK3577-A	FET	
MIC301	2A		T91-0651-15	MIC ELEMENT		TH101			B57331V2104J	THERMISTOR	
D3,4			1SV325F	VARIABLE CAPACITANCE DIODE		TH201			B57331V2104J	THERMISTOR	
D6			1SV325F	VARIABLE CAPACITANCE DIODE							
D8			1SV325F	VARIABLE CAPACITANCE DIODE							
D9			1SV278F	VARIABLE CAPACITANCE DIODE							
D10			MC2858	DIODE							
D101			UDZW5.1(B)	ZENER DIODE							
D103			HSC277	DIODE							
D104,105			HVC131	DIODE							

EXPLODED VIEW

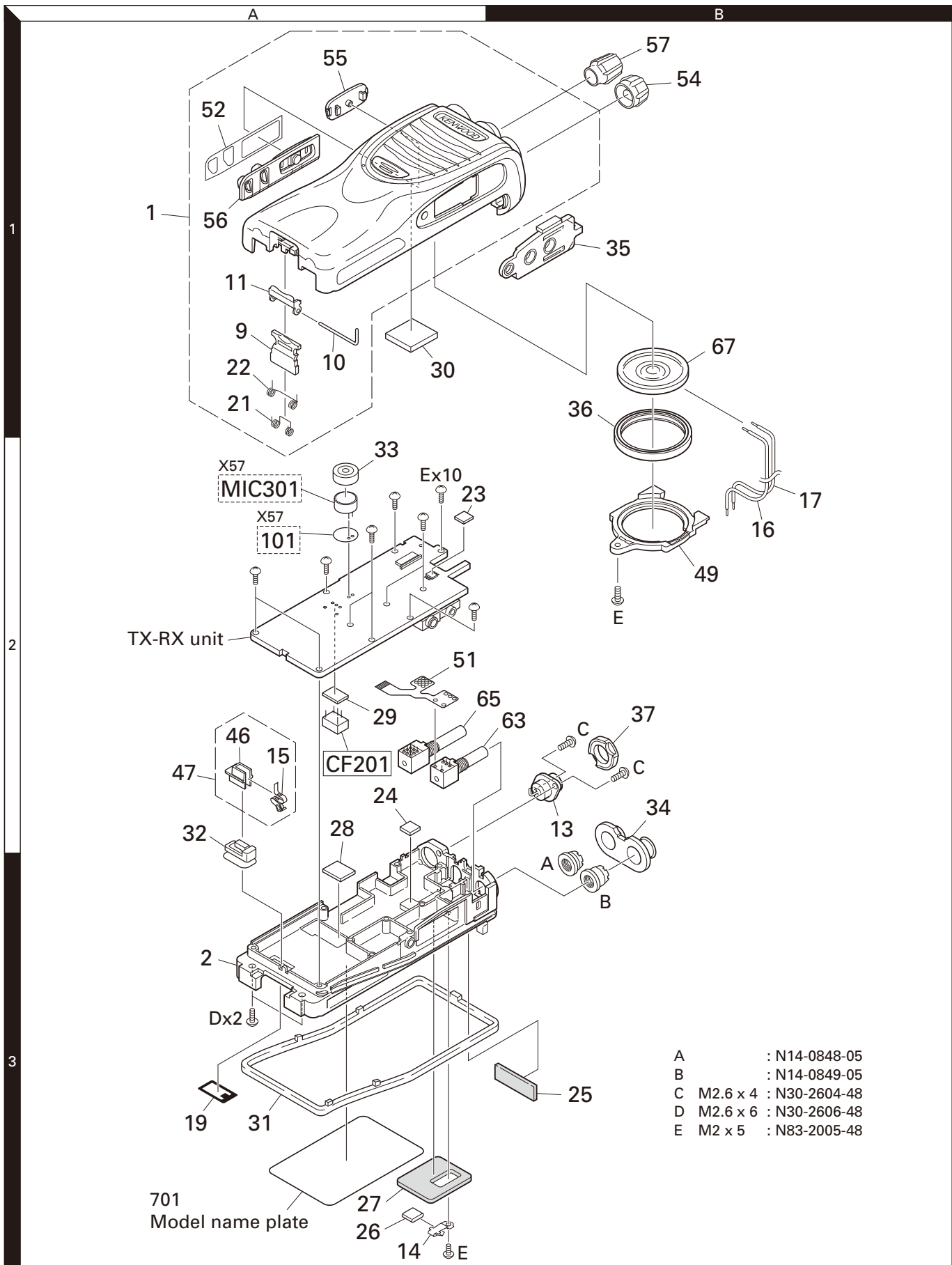

PACKING (E TYPE)

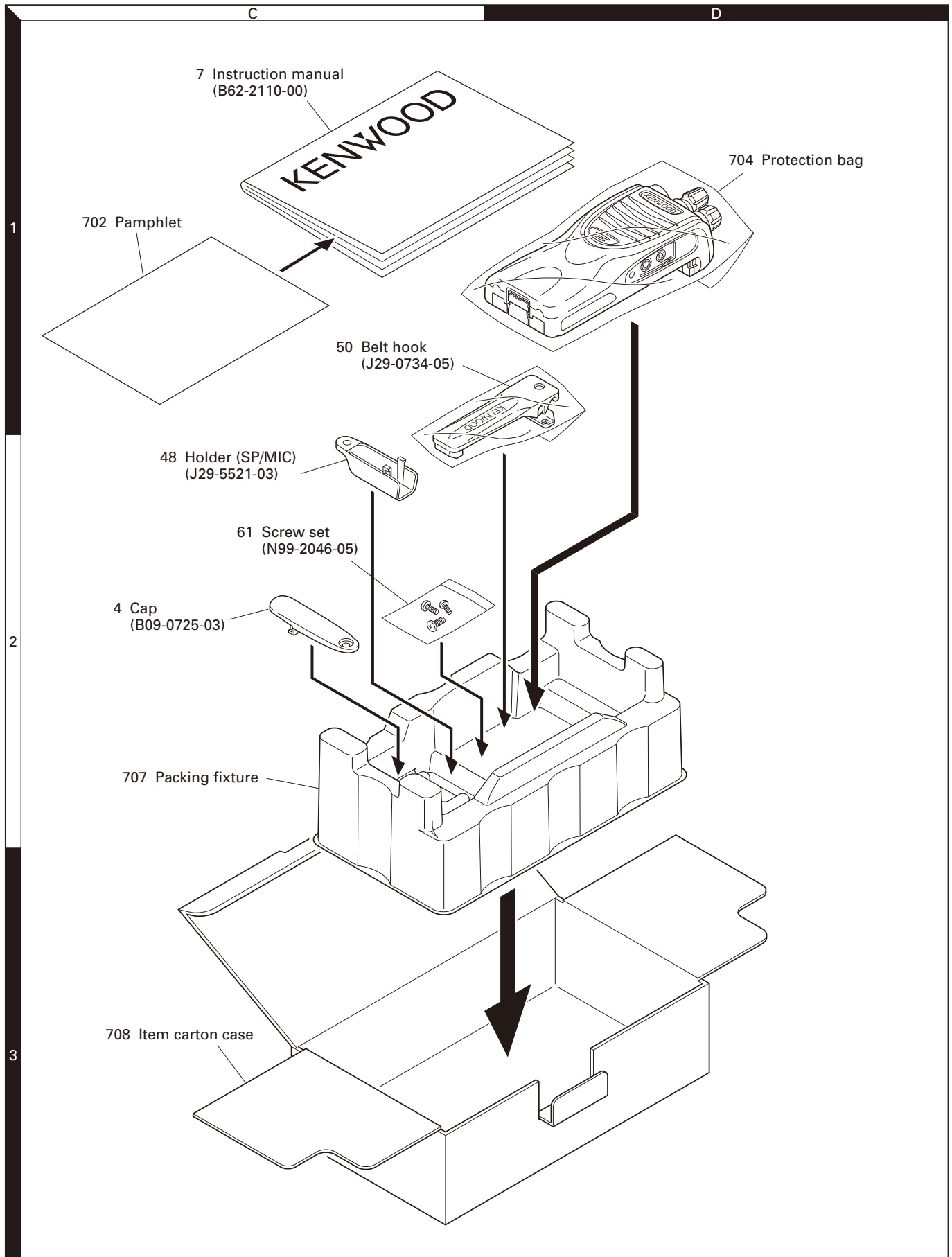

Parts with the exploded numbers larger than 700 are not supplied.

PACKING (T TYPE)

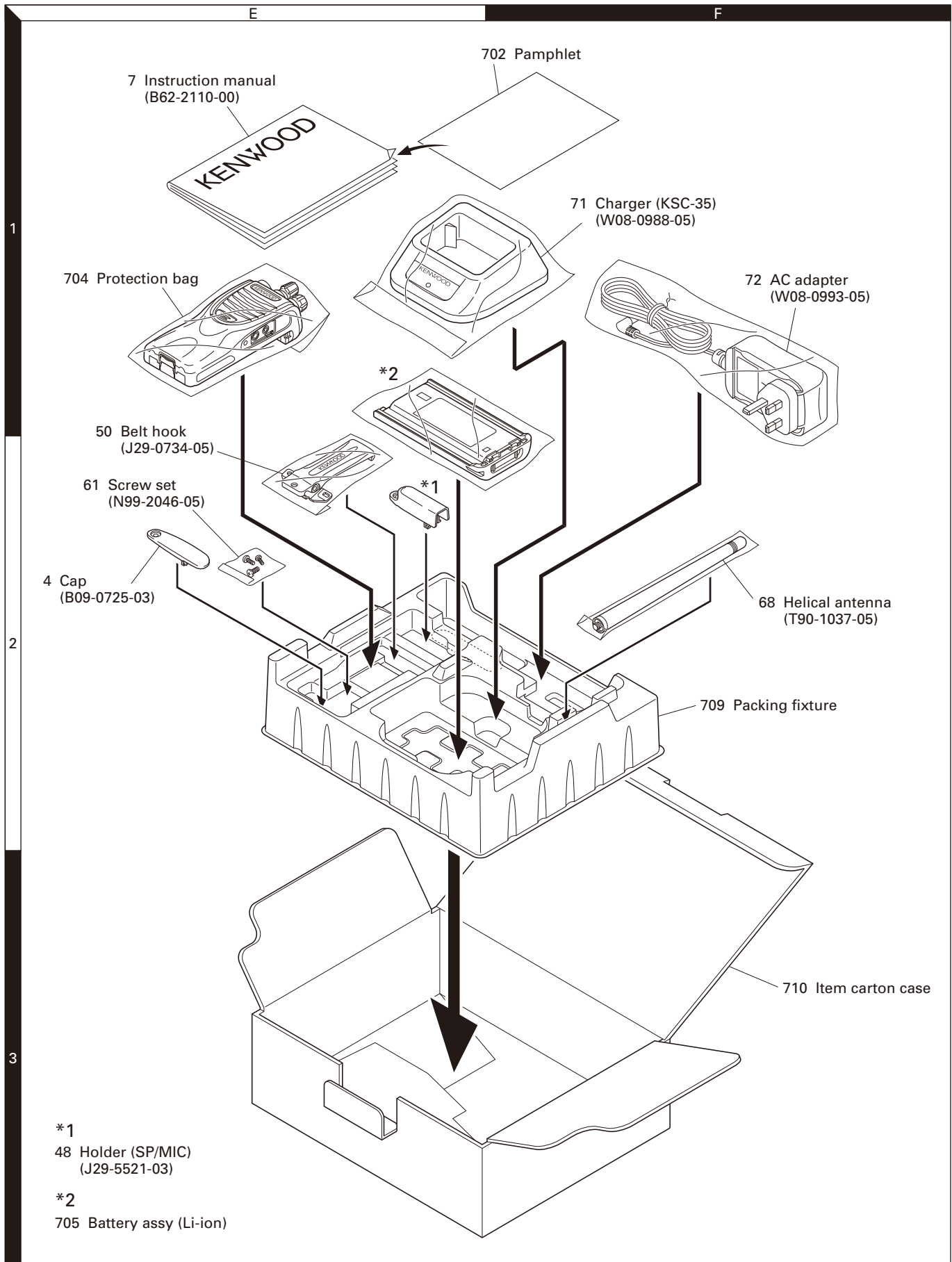

Parts with the exploded numbers larger than 700 are not supplied.

ADJUSTMENT

Test Equipment Required for Alignment

Test Equipment	Major Specifications	
1. Standard Signal Generator (SSG)	Frequency Range Modulation Output	136 to 174MHz Frequency modulation and external modulation -127dBm/0.1 μ V to greater than -47dBm/1mV
2. RF Power Meter	Input Impedance Operation Frequency Measurement Range	50 Ω 136 to 174MHz Vicinity of 10W
3. Deviation Meter	Frequency Range	136 to 174MHz
4. Digital Volt Meter (DVM)	Measuring Range Input Impedance	10mV to 10V DC High input impedance for minimum circuit loading
5. Oscilloscope		DC through 30MHz
6. High Sensitivity Frequency Counter	Frequency Range Frequency Stability	10Hz to 1000MHz 0.2ppm or less
7. DC Ammeter		5A
8. AF Volt Meter (AF VTVM)	Frequency Range Voltage Range	50Hz to 10kHz 1mV to 10V
9. Audio Generator (AG)	Frequency Range Output	50Hz to 5kHz or more 0 to 1V
10. Distortion Meter	Capability Input Level	3% or less at 1kHz 50mV to 10Vrms
11. Spectrum Analyzer	Measuring Range	DC to 1GHz or more
12. Tracking Generator	Center frequency Output Voltage	50kHz to 600MHz 100mV or more
13. 8 Ω Dummy Load		Approx. 8 Ω , 3W
14. Regulated Power Supply		5V to 10V, approx. 3A Useful if ammeter equipped

■ Antenna connector adapter

The antenna connector of this transceiver uses an SMA terminal.

Use an antenna connector adapter [SMA(f) – BNC(f) or SMA(f) – N(f)] for adjustment. (The adapter is not provided as an option, so buy a commercially-available one.)

■ Repair Jig (Chassis)

Use jig (part No.: A10-4215-03) for repairing the transceiver. Place the TX-RX unit on the jig and fit it with screws.

The jig facilitates the voltage check and protects the final amplifier FET when the voltage on the flow side of the TX-RX unit is checked during repairs.

■ Battery Jig (W05-1011-00)

Connect the power cable properly between the battery jig installed in the transceiver and the power supply, and be sure output voltage and the power supply polarity prior to switching the power supply ON, otherwise over voltage and reverse connection may damage the transceiver, or the power supply or both.

Note: When using the battery jig, you must measure the voltage at the terminals of the battery jig. Otherwise, a slight voltage drop may occur within the power cable, between the power supply and the battery jig, especially while the transceiver transmits.

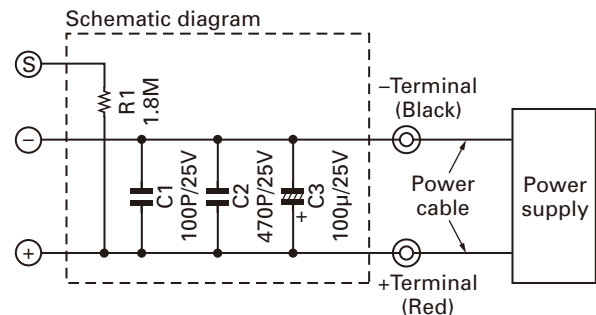
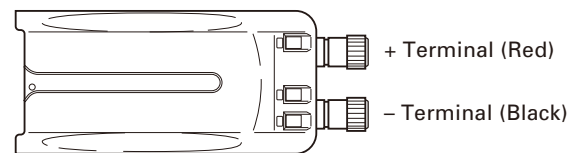

ADJUSTMENT

Frequency and Signaling

The transceiver has been adjusted for the frequencies shown in the following table. When required, re-adjust them following the adjustment procedure to obtain the frequencies you want in actual operation.

■ Frequency (MHz)

Channel No.	RX Frequency	TX Frequency
1	155.050	155.100
2	136.050	136.100
3	173.950	173.900
4	155.000	155.000
5	155.200	155.200
6	155.400	155.400
7~16	-	-

■ Signaling

Signaling No.	RX	TX
1	None	None
2	None	100Hz Square Wave
3	QT 67.0Hz	QT 67.0Hz
4	QT 151.4Hz	QT 151.4Hz
5	QT 250.3Hz	QT 250.3Hz
6	DQT D023N	DQT D023N
7	DQT D754I	DQT D754I

Preparations for Tuning the Transceiver

Before attempting to tune the transceiver, connect the unit to a suitable power supply.

Whenever the transmitter is tuned, the unit must be connected to a suitable dummy load (i.e. power meter).

The speaker output connector must be terminated with a 8Ω dummy load and connected to an AC voltmeter and an audio distortion meter or a SINAD measurement meter at all times during tuning.

■ Adjustment frequency

TEST CH	RX	TX
Center	155.050MHz	155.100MHz
Low	136.050MHz	136.100MHz
High	173.950MHz	173.900MHz
Low'	145.550MHz	145.600MHz
High'	164.550MHz	164.600MHz

■ List of FPU for transceiver

Model	Type	FPU
TK-2302	E,T	KPG-119D(M2)

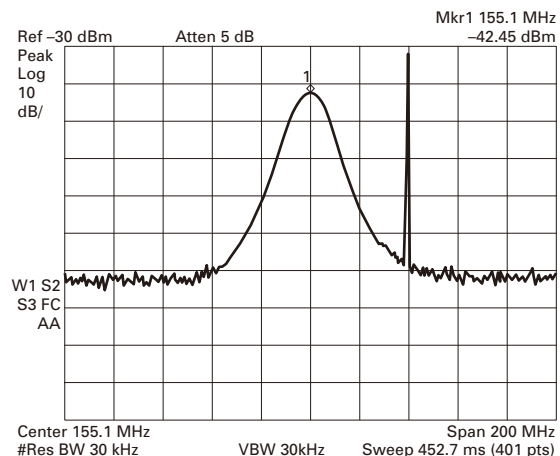

Fig. 1 Center frequency

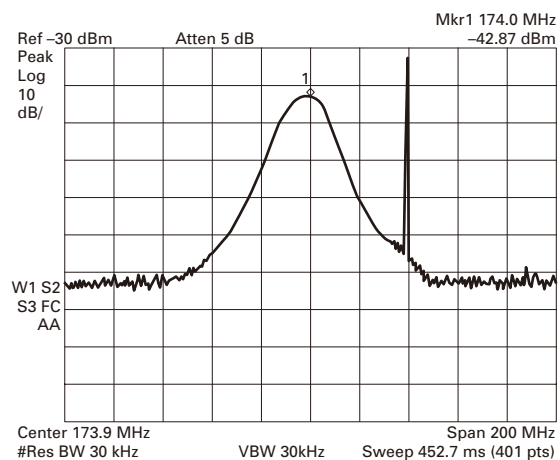

Fig. 2 High-edge frequency

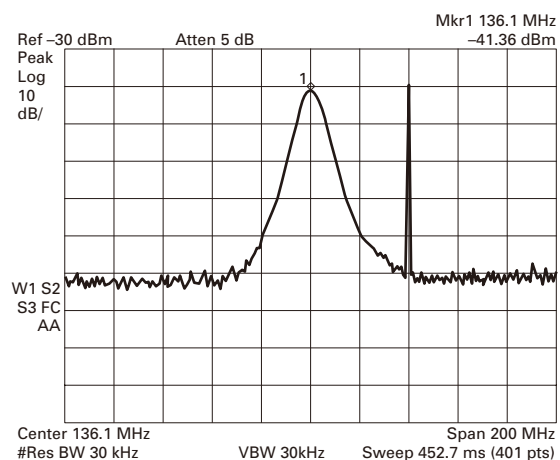



Fig. 3 Low-edge frequency

ADJUSTMENT

Common Section

Item	Condition	Measurement			Adjustment			Specifications / Remarks		
		Test-equipment	Unit	Terminal	Unit	Parts	Method			
1. Setting	1) BATT terminal voltage: 7.5V 2) SSG standard modulation [Wide 5k] MOD: 1kHz, DEV: 3kHz [Wide 4k] MOD: 1kHz, DEV: 2.4kHz [Narrow] MOD: 1kHz, DEV: 1.5kHz									
2. VCO lock voltage RX	1) CH: High	Power meter DVM	TX-RX	ANT	TX-RX	TC1	4.1V	±0.1V		
	2) CH: Low							Check	0.6V or more	
3. VCO lock voltage TX	3) CH: High PTT: ON					LV (CV)	TX-RX	TC2	4.1V	±0.1V
	4) CH: Low PTT: ON								Check	0.6V or more

Transmitter Section

Item	Condition	Measurement			Adjustment			Specifications / Remarks	
		Test-equipment	Unit	Terminal	Unit	Parts	Method		
1. Frequency Adjust	1) CH: High PTT: ON	f. counter		ANT	TX-RX	VR1	173.900MHz	±50Hz	
2. High Transmit Power	1) TEST CH: Low, Low', Center, High', High (5 points) BATT terminal voltage: 7.5V PTT: ON	Power meter Ammeter		ANT		FPU		5.0W±0.1W 2.0A or less	
3. Low Transmit Power	1) TEST CH: Low, Low', Center, High', High (5 points) BATT terminal voltage: 7.5V PTT: ON							1.0W±0.1W 1.0A or less	
4. Maximum Deviation [Wide 5k]	1) TEST CH: Center, Low, High (3 points) AG: 1kHz/150mV Deviation meter filter LPF: 15kHz HPF: OFF PTT: ON						Power meter Deviation meter Oscilloscope AG AF VTVM		ANT
[Wide 4k]	2) TEST CH: Center PTT: ON		3.3kHz (According to the larger +, -)	±80Hz					
[Narrow]	3) TEST CH: Center PTT: ON		2.1kHz (According to the larger +, -)	±80Hz					
5. DQT Balance [Wide 5k]	1) TEST CH: Center, Low, High (3 points) Deviation meter filter LPF: 3kHz HPF: OFF PTT: ON			SP/MIC connector			Make the demodulation wave into square waves.		
[Wide 4k]	2) TEST CH: Center PTT: ON								
[Narrow]	3) TEST CH: Center PTT: ON								

ADJUSTMENT

Item	Condition	Measurement			Adjustment			Specifications / Remarks
		Test-equipment	Unit	Terminal	Unit	Parts	Method	
6. QT Fine Deviation [Wide 5k]	1) TEST CH: Center, Low, High (3 points) Deviation meter filter LPF: 3kHz HPF: OFF PTT: ON	Power meter Deviation meter Oscilloscope		ANT		FPU	0.75kHz	±40Hz
	[Wide 4k]	2) TEST CH: Center PTT: ON	AG AF VTVM	SP/MIC connector			0.60kHz	±40Hz
	[Narrow]	3) TEST CH: Center PTT: ON					0.38kHz	±40Hz
7. DQT Fine Deviation [Wide 5k]	1) TEST CH: Center, Low, High (3 points) Deviation meter filter LPF: 3kHz HPF: OFF PTT: ON						0.75kHz	±40Hz
	[Wide 4k]	2) TEST CH: Center PTT: ON					0.60kHz	±40Hz
	[Narrow]	3) TEST CH: Center PTT: ON					0.38kHz	±40Hz

Receiver Section

Item	Condition	Measurement			Adjustment			Specifications / Remarks
		Test-equipment	Unit	Terminal	Unit	Parts	Method	
1. BPF Wave Adjust	1) Center frequency Spectrum analyzer setting Center-f: 155MHz Span: 200MHz RBW: 30kHz VBW: 30kHz ATT: 5dB 2) High-edge frequency Spectrum analyzer setting Center-f: 174MHz 3) Low-edge frequency Spectrum analyzer setting Center-f: 136MHz	S S G S p e c t r u m a n a l y z e r	TX-RX	ANT BPF		FPU	Adjust the waveform as shown to the Fig. 1~3.	
2. Sensitivity [Wide 5k]	1) TEST CH: Low, Center, High (3 points) SSG output : -110dBm (0.7µV) SSG MOD: 3.0kHz	S S G D V M O s c i l l o s c o p e A F V T V M		ANT SP/MIC connector			Check	20dB SINAD or more
	[Wide 4k]	2) TEST CH: Center SSG output : -110dBm (0.7µV) SSG MOD: 2.4kHz						
	[Narrow]	3) TEST CH: Center SSG output : -110dBm (0.7µV) SSG MOD: 1.5kHz						

ADJUSTMENT

Item	Condition	Measurement			Adjustment			Specifications / Remarks	
		Test-equipment	Unit	Terminal	Unit	Parts	Method		
3. Squelch Open [Wide 5k]	1) TEST CH: Center, Low, High (3 points) SSG output : -121dBm (0.2μV) SSG MOD: 3.0kHz	SSG DVM Oscilloscope AF VTVM		ANT SP/MIC connector		FPU	Write		
	[Wide 4k]								2) TEST CH: Center SSG output : -121dBm (0.2μV) SSG MOD: 2.4kHz
	[Narrow]								3) TEST CH: Center SSG output : -120dBm (0.22μV) SSG MOD: 1.5kHz
4. Squelch Tight [Wide 5k]	1) TEST CH: Center, Low, High (3 points) SSG output : -115dBm (0.44μV) SSG MOD: 3.0kHz								
	[Wide 4k]								2) TEST CH:Center SSG output : -115dBm (0.44μV) SSG MOD: 2.4kHz
	[Narrow]								3) TEST CH:Center SSG output : -114dBm (0.4μV) SSG MOD: 1.5kHz
5. Battery Warning Level	1) BATT terminal voltage: 5.9V	SSG DVM	TX-RX	ANT BATT terminal			Write	BATT terminal voltage: 5.9V	

Adjustment Points

■ Component side view

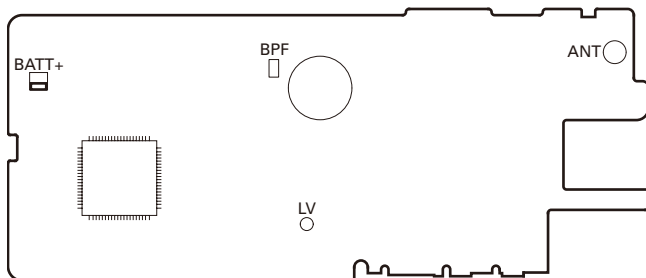

BPF: BPF Wave Adjust
LV (CV): VCO lock voltage
BATT+: Battery Warning Level

■ Foil side view

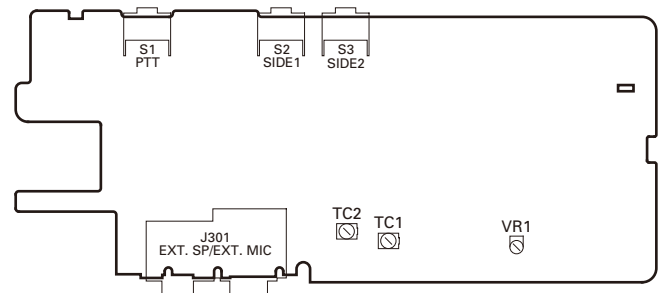

TC1 : VCO lock voltage (RX)
TC2 : VCO lock voltage (TX)
VR1 : Frequency adjustment

TK-2302 PC BOARD

TX-RX UNIT (X57-7572-71) Component side view (J79-0261-09)

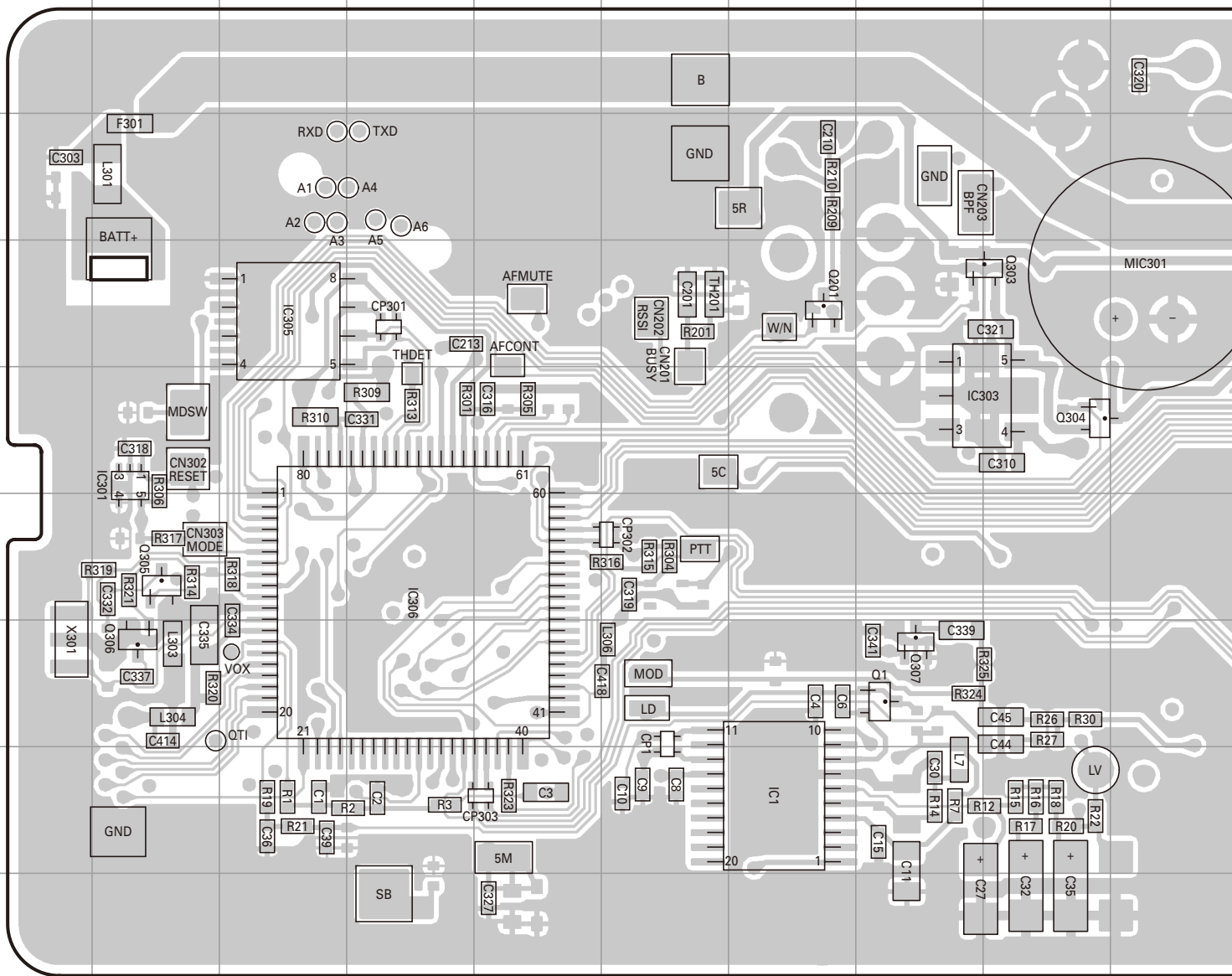

Ref. No.	Address	Ref. No.	Address	Ref. No.	Address	Ref. No.	Address
IC1	9G	Q103	4M	Q303	5I	Q315	8O
IC101	4N	Q104	5M	Q304	6I	Q316	8O
IC301	6B	Q106	3M	Q305	7B	D101	4M
IC303	6H	Q107	3M	Q306	8B	D303	8S
IC305	5C	Q108	4M	Q307	8H	D304	8S
IC306	7D	Q201	5G	Q312	8P		
IC309	7O	Q301	6P	Q313	7P		
Q1	8H	Q302	6P	Q314	8O		

PC BOARD TK-2302

TX-RX UNIT (X57-7572-71) Component side view (J79-0261-09)

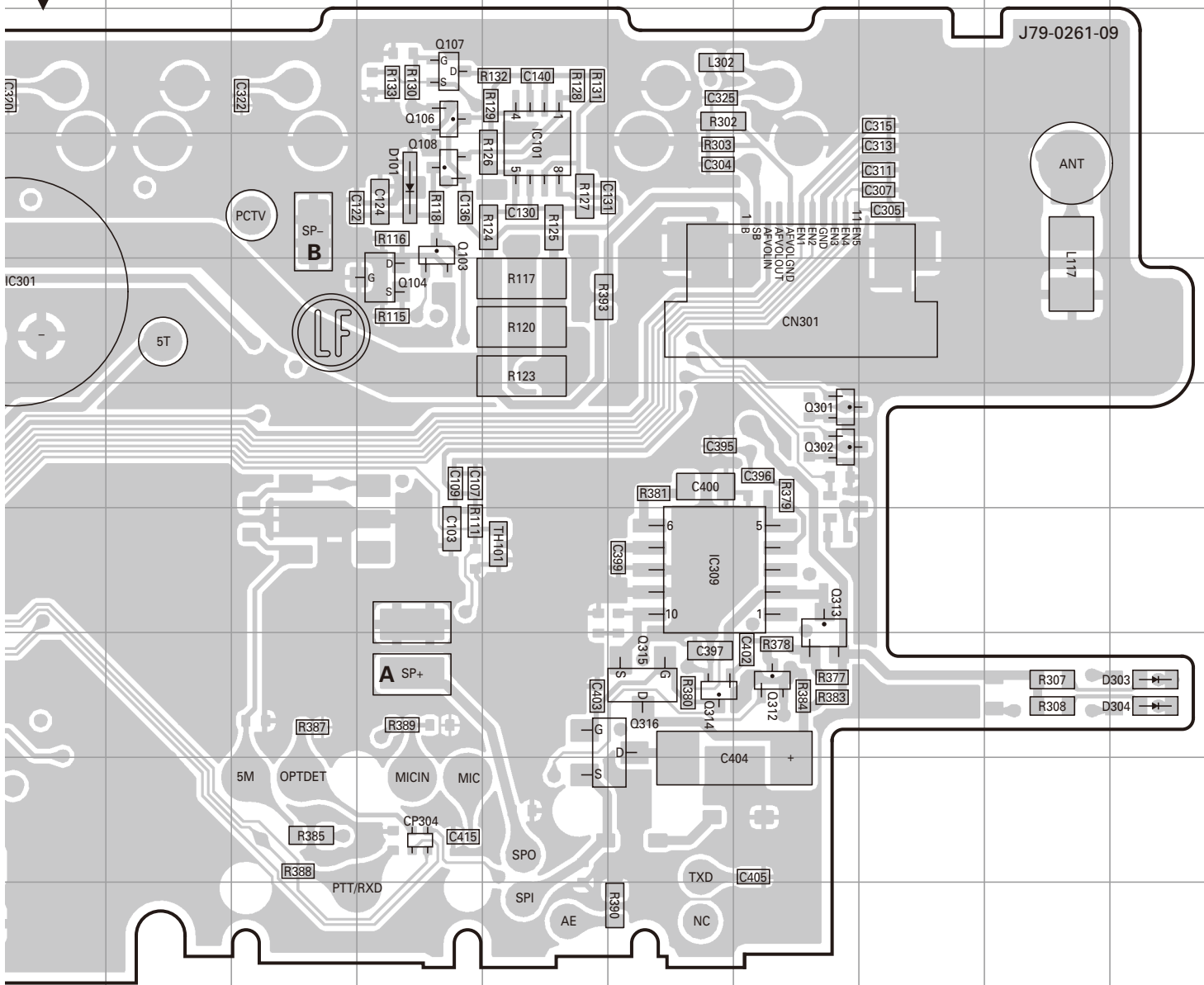

A: Green speaker wire soldering position.
B: Brown speaker wire soldering position.

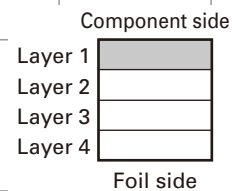

TK-2302 PC BOARD

TX-RX UNIT (X57-7572-71) Foil side view (J79-0261-09)

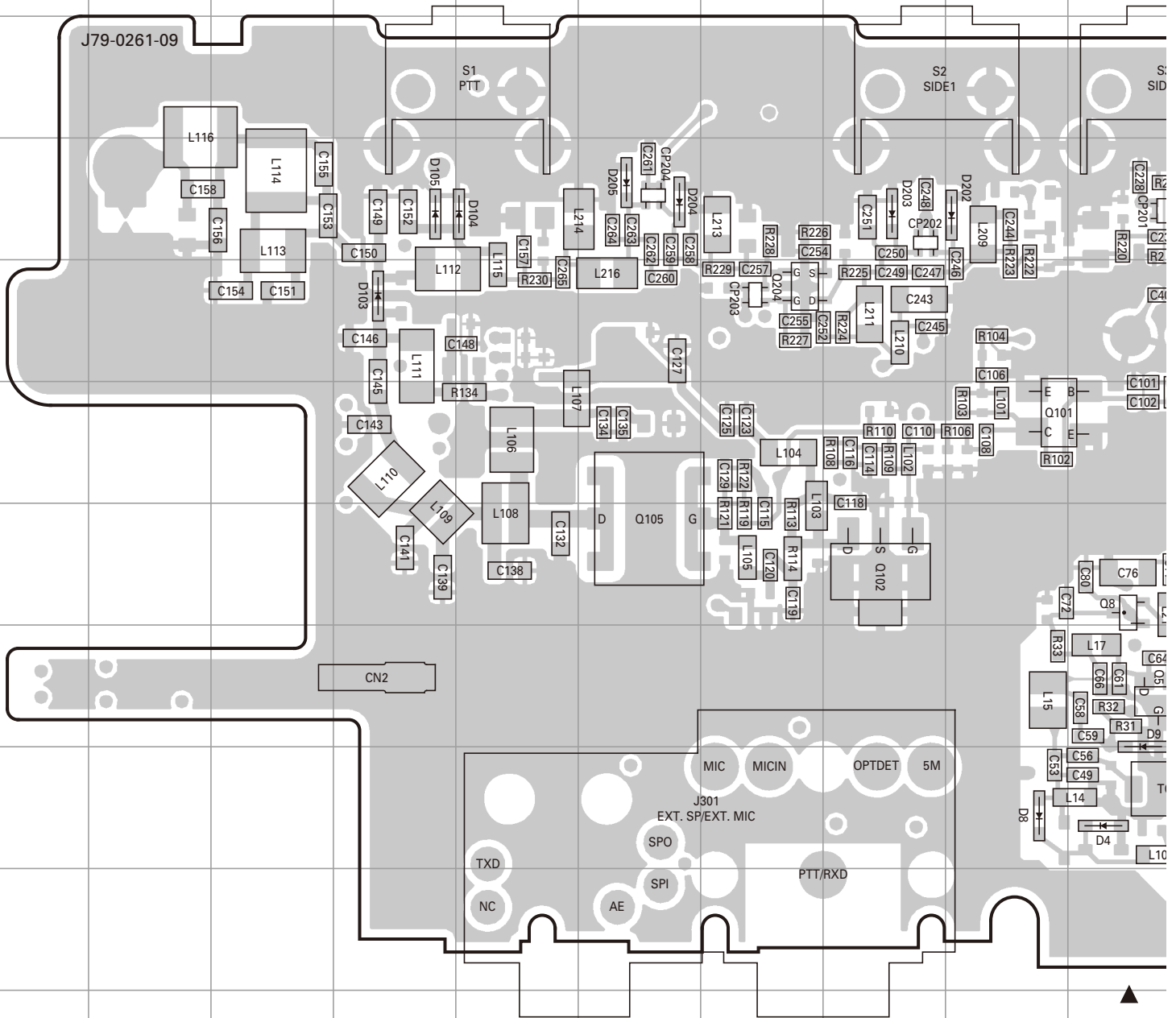

Ref. No.	Address	Ref. No.	Address	Ref. No.	Address	Ref. No.	Address	Ref. No.	Address
IC2	6K	Q7	8K	Q203	4K	D9	8J	D301	4R
IC201	6N	Q8	7J	Q204	5G	D10	5L	D302	10P
IC304	9P	Q9	7K	Q308	7R	D103	5D	D306	8R
IC308	8P	Q10	7K	Q310	7R	D104	4E	D307	8Q
Q2	8N	Q11	5L	Q311	7R	D105	4D	D308	7Q
Q3	7L	Q101	6I	D3	10K	D202	4I	D309	7Q
Q4	9L	Q102	7H	D4	9J	D203	4H		
Q5	8J	Q105	7F	D6	10K	D204	4F		
Q6	7K	Q202	5N	D8	9I	D205	4F		

PC BOARD TK-2302

TX-RX UNIT (X57-7572-71) Foil side view (J79-0261-09)

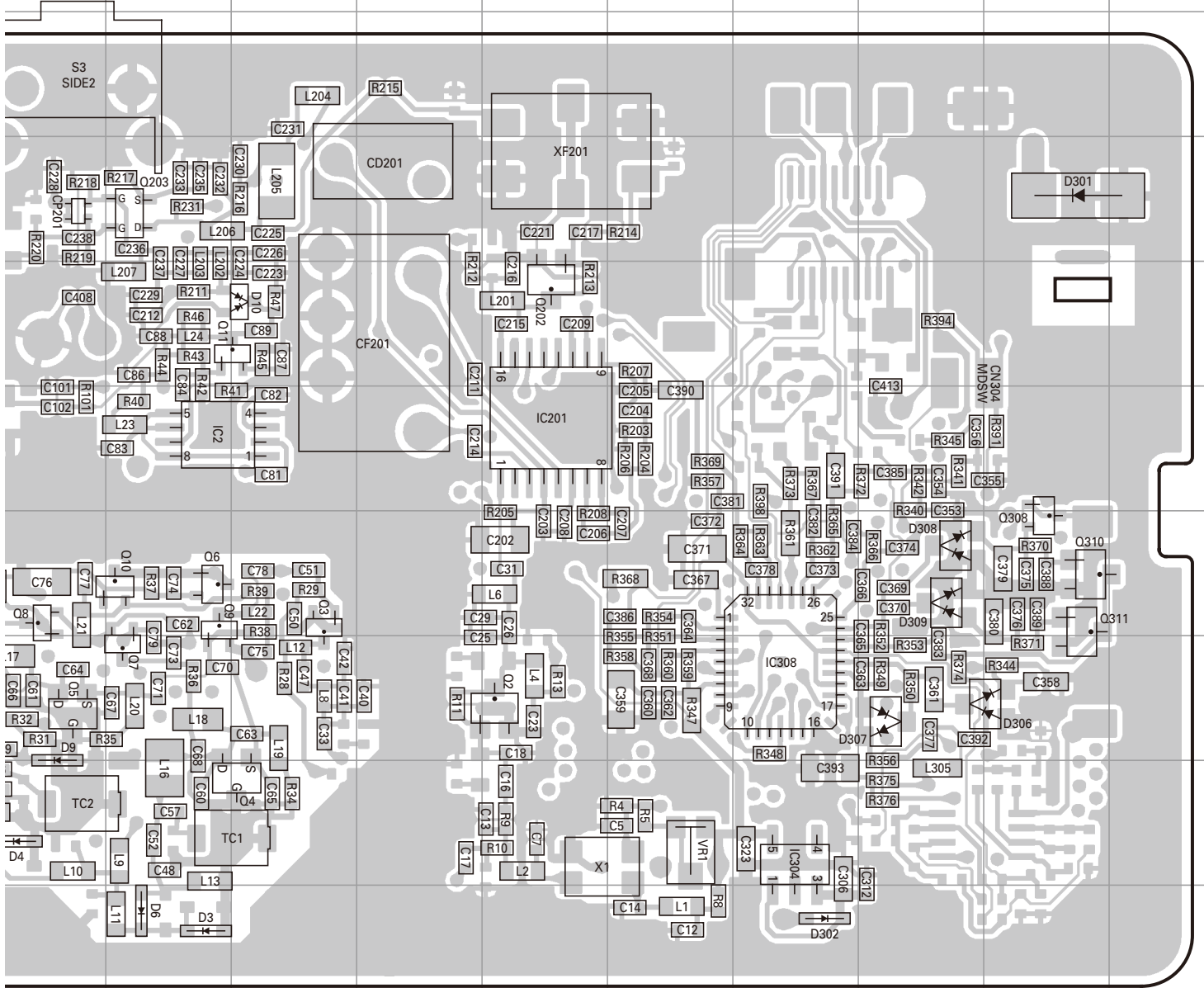

Component side

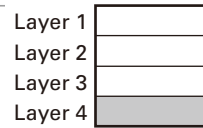

Foil side

TK-2302 SCHEMATIC DIAGRAM

TX-RX UNIT (X57-7572-71)

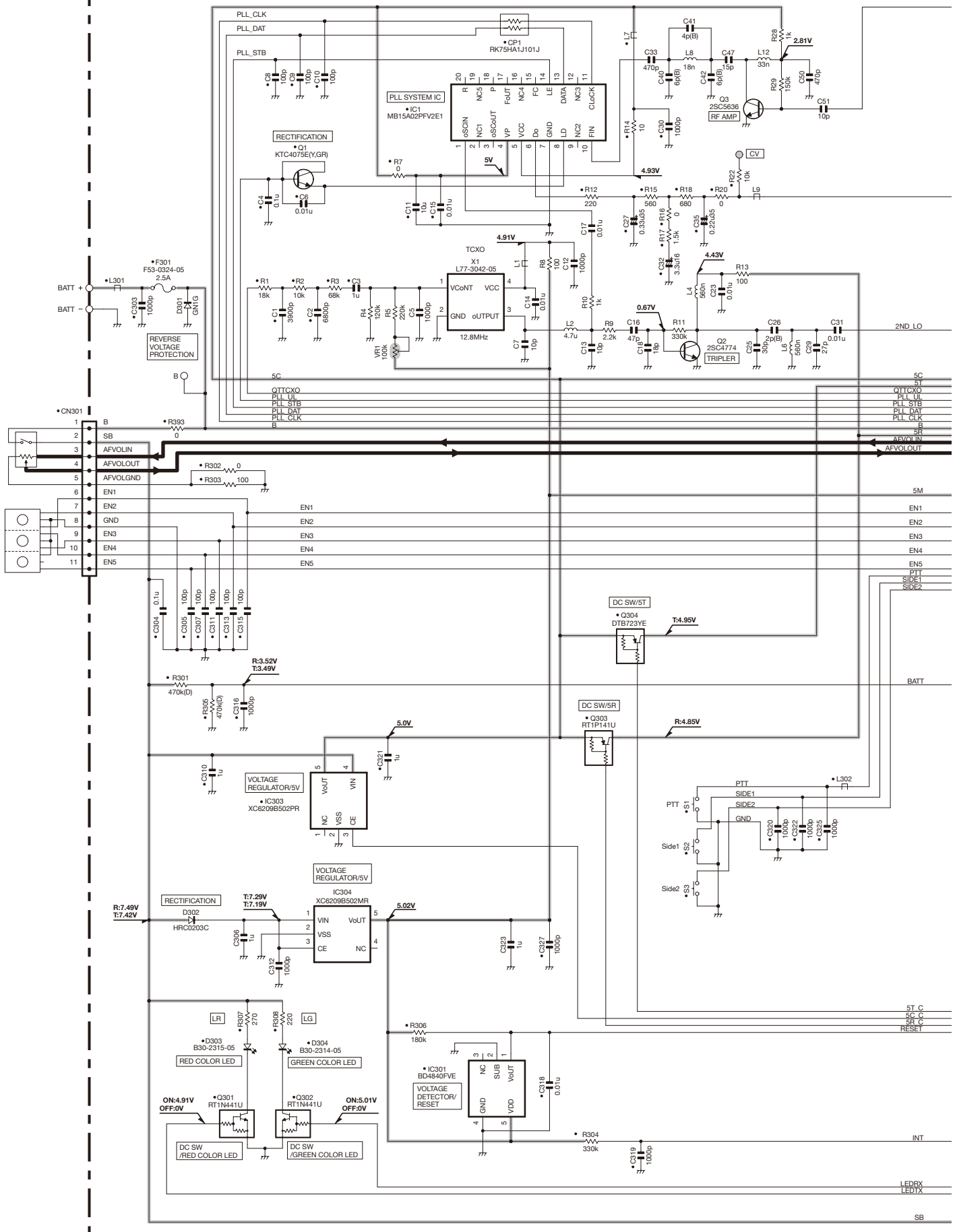

SCHEMATIC DIAGRAM TK-2302

TX-RX UNIT (X57-7572-71)

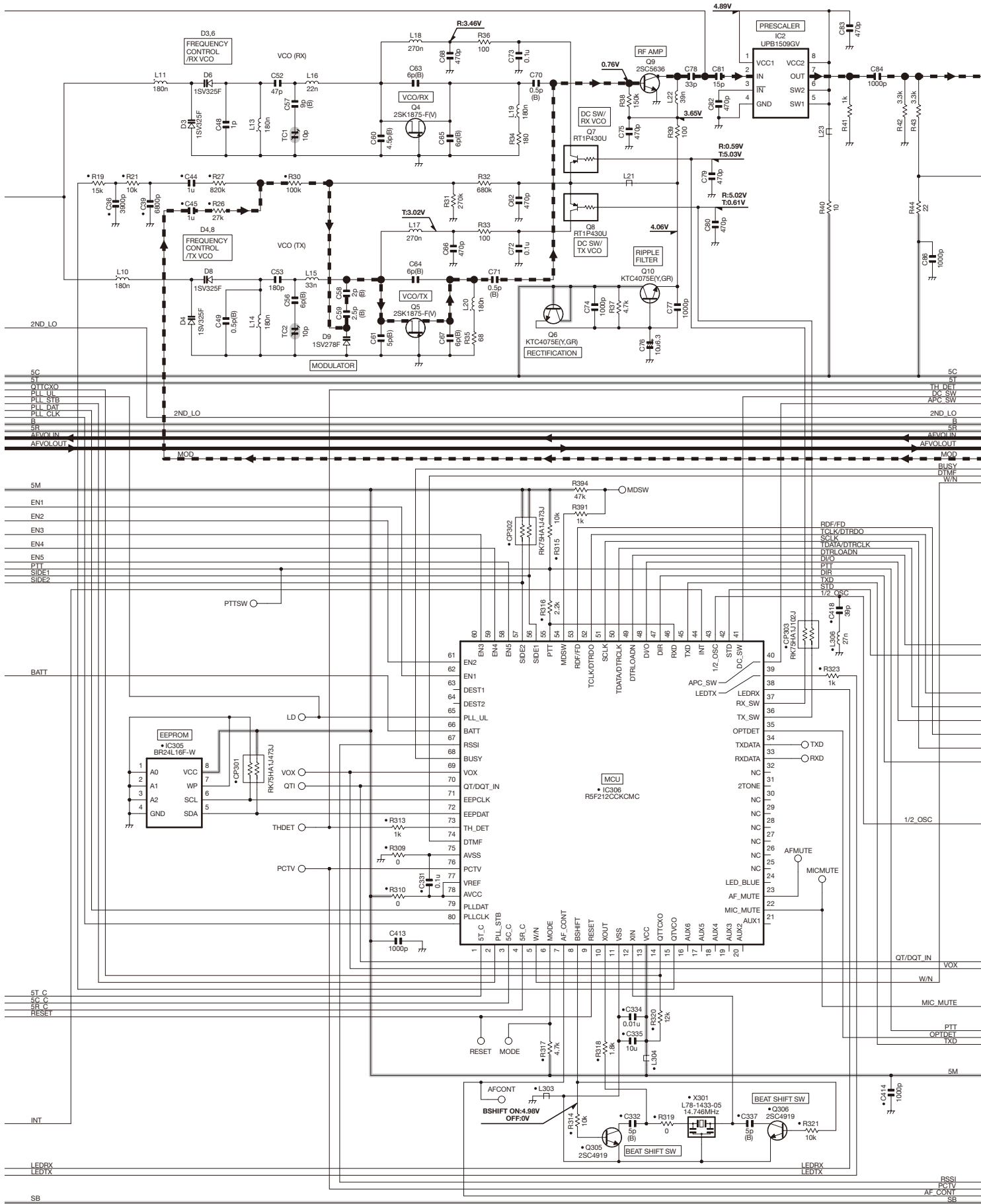

TK-2302 SCHEMATIC DIAGRAM

TX-RX UNIT (X57-7572-71)

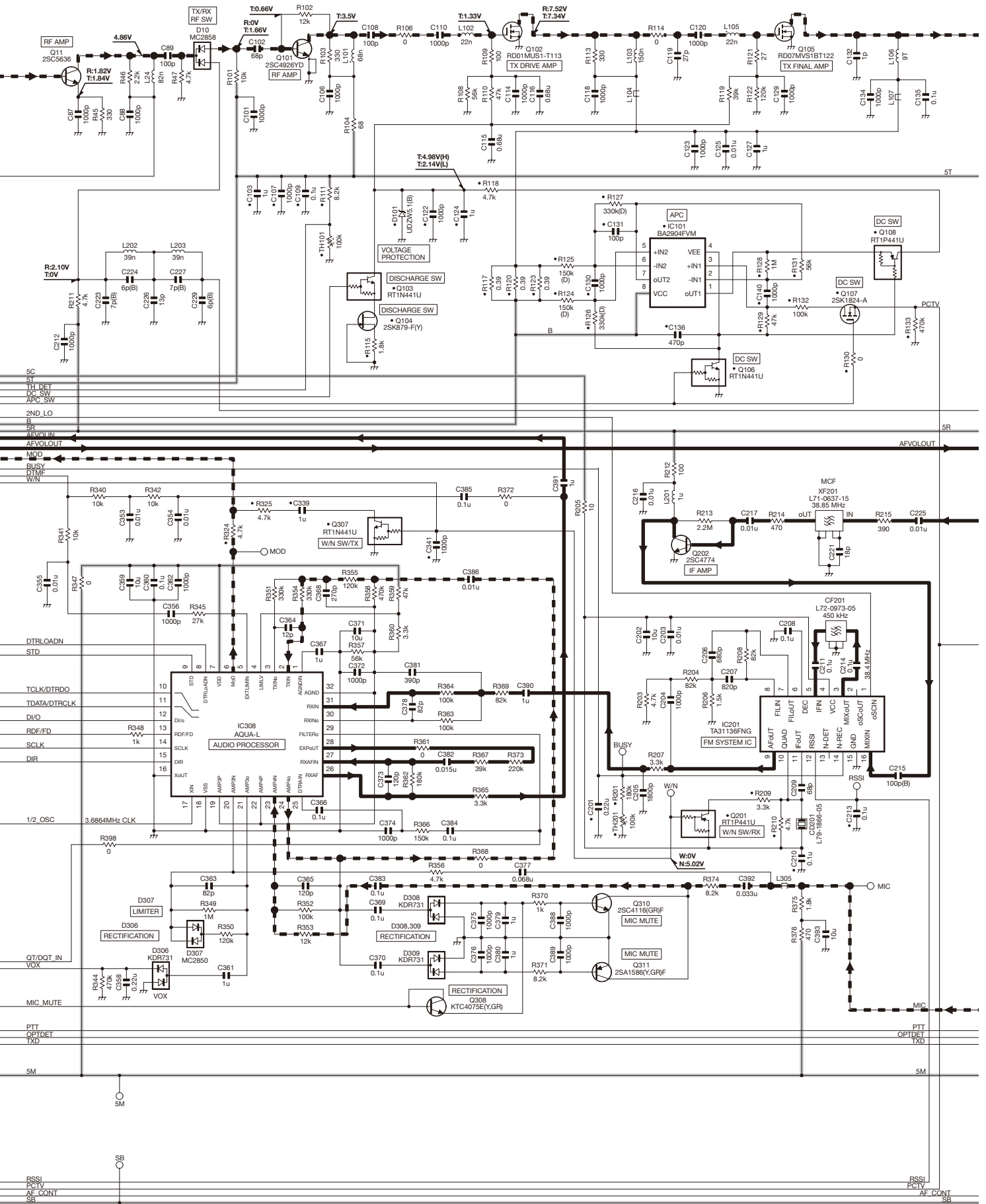

SCHEMATIC DIAGRAM TK-2302

TX-RX UNIT (X57-7572-71)

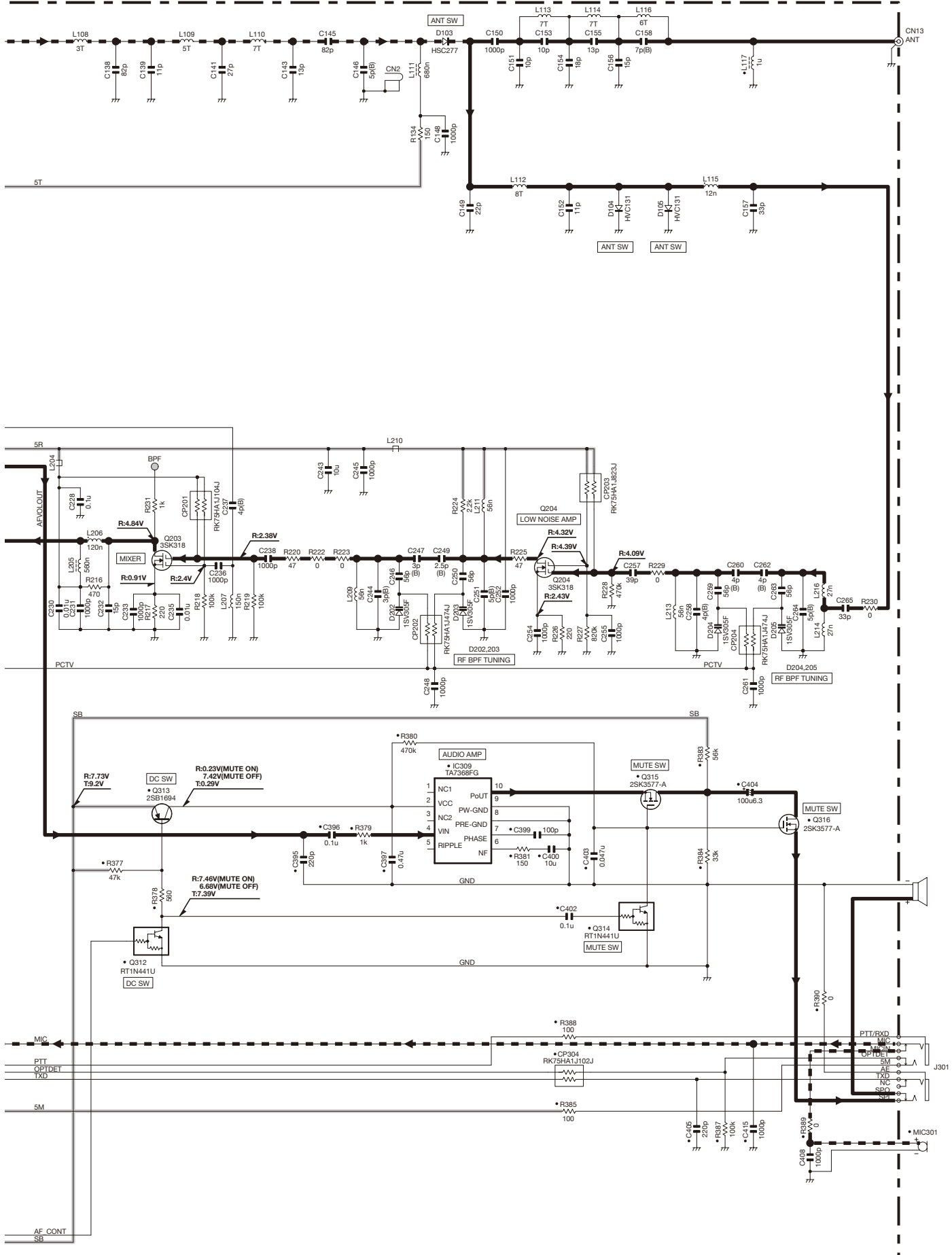

Note : The components marked with a dot (•) are parts of layer 1.

BLOCK DIAGRAM

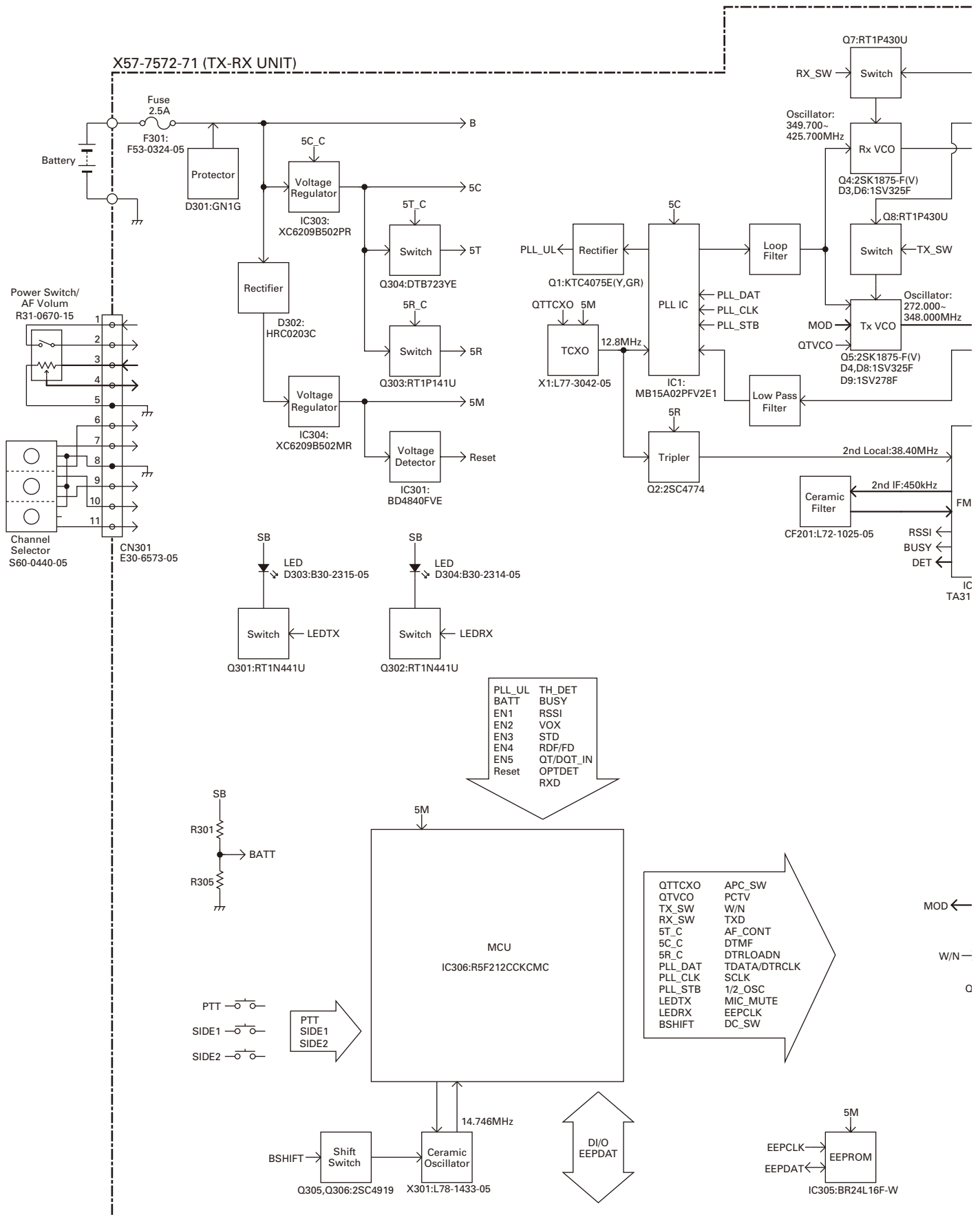

BLOCK DIAGRAM

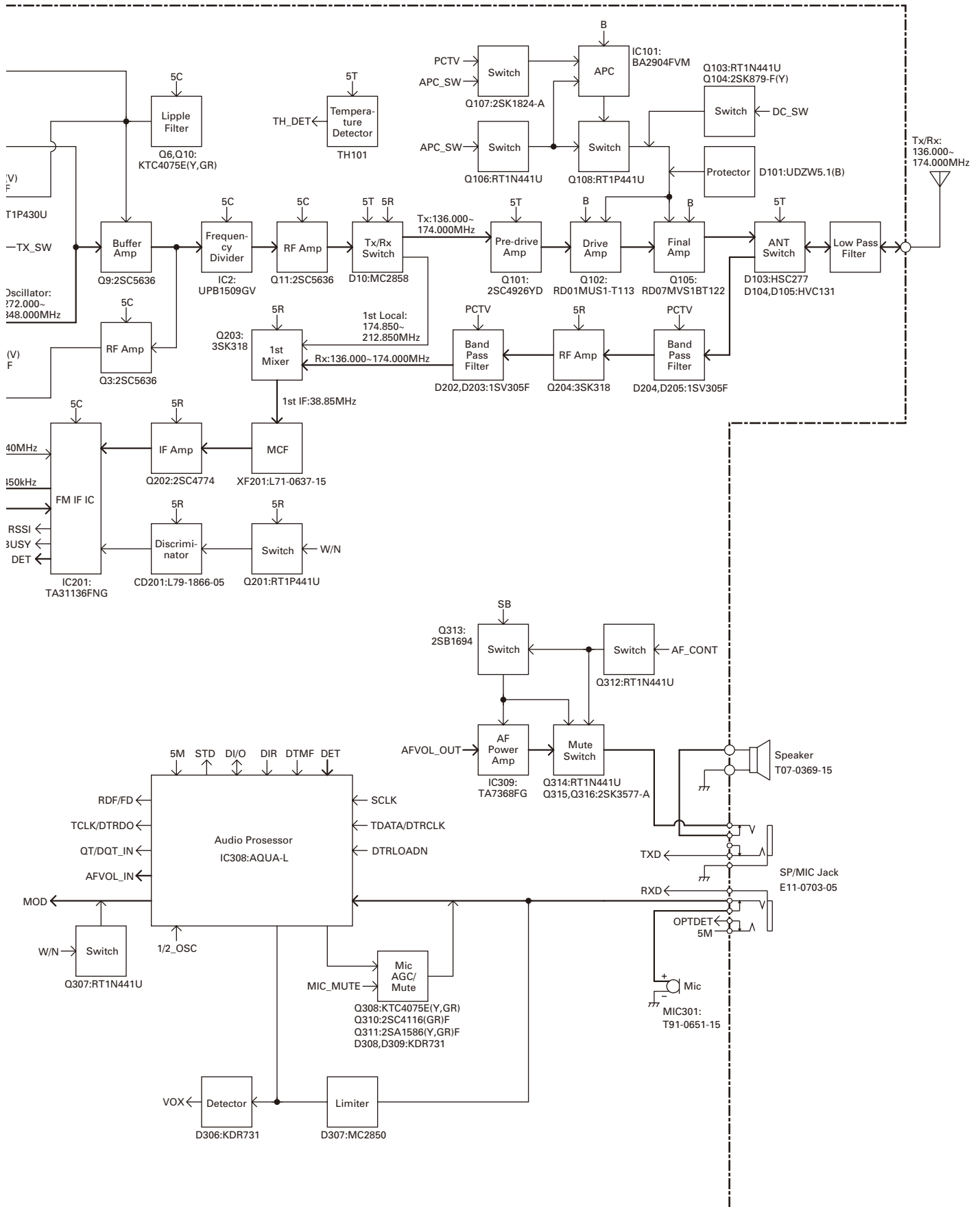

LEVEL DIAGRAM

Receiver Section

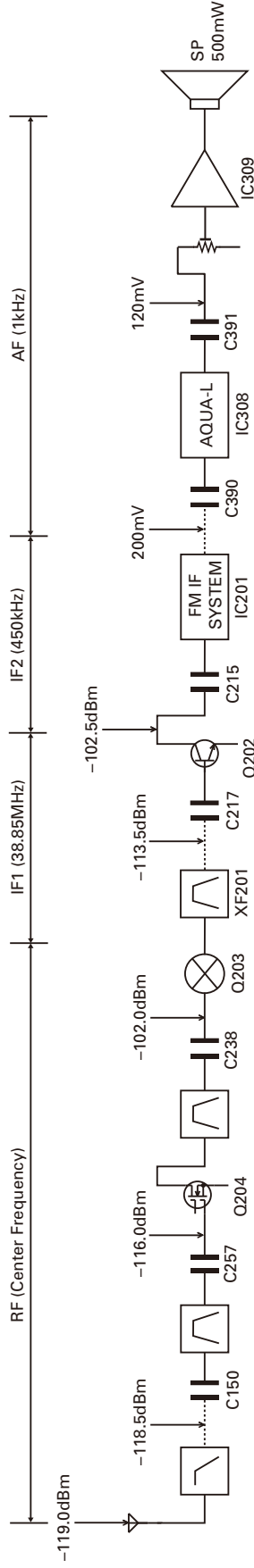

To make measurements in the AF section, connect the AC level meter.
 (ANT input: -53dBm, 1kHz FM, 3kHz DEV (Wide 5k).)
 In the RF section, use 1000pF coupling capacitor.
 (The display shows the SSG input value required to obtain 12dB SINAD without Local Level.)

Transmitter Section

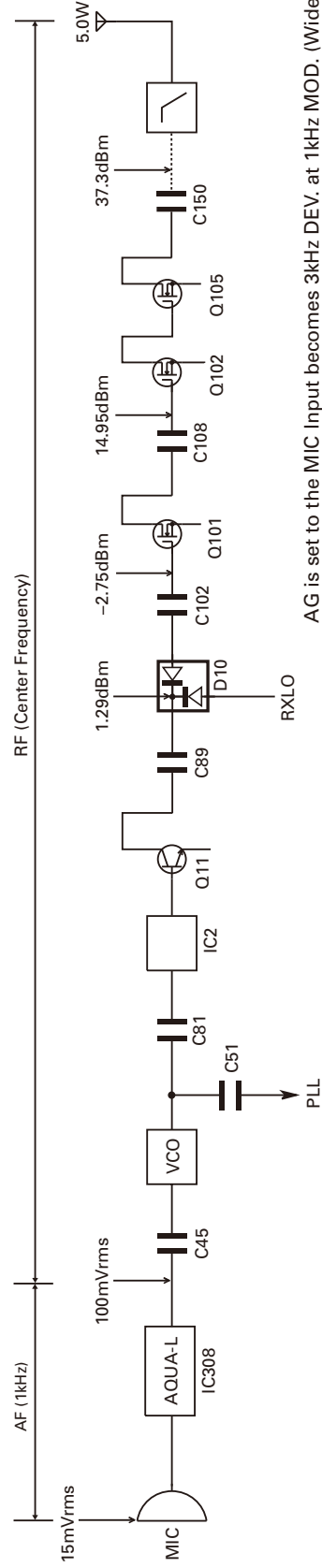

AG is set to the MIC Input becomes 3kHz DEV. at 1kHz MOD. (Wide 5k).
 To make measurements in the AF section, connect the AC level meter.
 In the RF section, use 1000pF coupling capacitor.

SPECIFICATIONS

General

Frequency Range.....	136~174MHz
Number of Channels.....	Max. 16
Channel Spacing	25kHz (Wide 5k) / 20kHz (Wide 4k) / 12.5kHz (Narrow)
PLL Channel Stepping	2.5kHz, 5kHz, 6.25kHz, 7.5kHz
Operating Voltage	7.5 V DC \pm 20%
Battery Life	More than 18 hours at 5 watts (5-5-90 duty cycle with KNB-45L battery)
Operating Temperature Range	-30°C to +60°C (-10°C to +60°C when KNB-45L in use)
Frequency Stability	\pm 2.5ppm (-30°C to +60°C)
Channel Frequency Spread.....	38MHz
Dimensions and Weight (Dimensions not including protrusions)	
Radio Only	160g
With KNB-45L (2000mAh battery)	54 W x 122 H x 33.8 D mm 280g

Receiver (Measurements made per EN standard)

Sensitivity	
EIA 12dB SINAD.....	0.28 μ V (Wide 5k/4k) / 0.35 μ V (Narrow)
EN 20dB SINAD.....	-3dB μ V (0.35 μ V) (Wide 5k/4k) / -2dB μ V (0.4 μ V) (Narrow)
Adjacent Channel Selectivity	70dB (Wide 5k/4k) / 62dB (Narrow)
Intermodulation	65dB
Spurious Response Rejection.....	70dB
Audio Output	500mW/8 Ω
Audio Distortion.....	Less than 10%

Transmitter (Measurements made per EN standard)

RF Power Output.....	5W/1W
Modulation Limiting.....	\pm 5.0kHz at 25kHz, \pm 4.0kHz at 20kHz, \pm 2.5kHz at 12.5kHz
Spurious Emission.....	-36dBm \leq 1GHz, -30dBm $>$ 1GHz
FM Noise (EIA)	45dB (Wide 5k) / 43dB (Wide 4k) / 40dB (Narrow)
Modulation Distortion.....	Less than 5%

TK-2302

Kenwood Corporation

2967-3, Ishikawa-machi, Hachioji-shi, Tokyo, 192-8525 Japan

Kenwood U.S.A. Corporation

P.O. BOX 22745, 2201 East Dominguez Street, Long Beach,
CA 90801-5745, U.S.A.

Kenwood Electronics Canada Inc.

6070 Kestrel Road, Mississauga, Ontario, Canada L5T 1S8

Kenwood Electronics Deutschland GmbH

Rembrücker Str. 15, 63150 Heusenstamm, Germany

Kenwood Electronics Belgium N.V.

Leuvensesteenweg 248 J, 1800 Vilvoorde, Belgium

Kenwood Electronics France S.A.

L'Etoile Paris Nord 2, 50 Allée des Impressionnistes,
Bp 58416 Villepinte, 95944 Roissy Ch De Gaulle Cedex

Kenwood Electronics UK Limited

KENWOOD House, Dwight Road, Watford, Herts.,
WD18 9EB United Kingdom

Kenwood Electronics Europe B.V.

Amsterdamseweg 37, 1422 AC Uithoorn, The Netherlands

Kenwood Electronics Italia S.p.A.

Via G. Sirtori, 7/9 20129 Milano, Italy

Kenwood Ibérica, S.A.

Bolivia, 239-08020 Barcelona, Spain

Kenwood Electronics Australia Pty. Ltd.

(A.C.N. 001 499 074)

16 Giffnock Avenue, Centrecourt Estate, North Ryde, N.S.W. 2113 Australia

Kenwood Electronics (Hong Kong) Ltd.

Unit 3712-3724, Level 37, Tower one Metroplaza, 223 Hing Fong Road,
Kwai Fong, N.T., Hong Kong

Kenwood Electronics Singapore Pte Ltd

1 Ang Mo Kio Street 63, Singapore 569110



TK-2302 PC BOARD

PC BOARD TK-2302

TX-RX UNIT (X57-7572-71) Component side view (J79-0261-09)

TX-RX UNIT (X57-7572-71) Component side view (J79-0261-09)

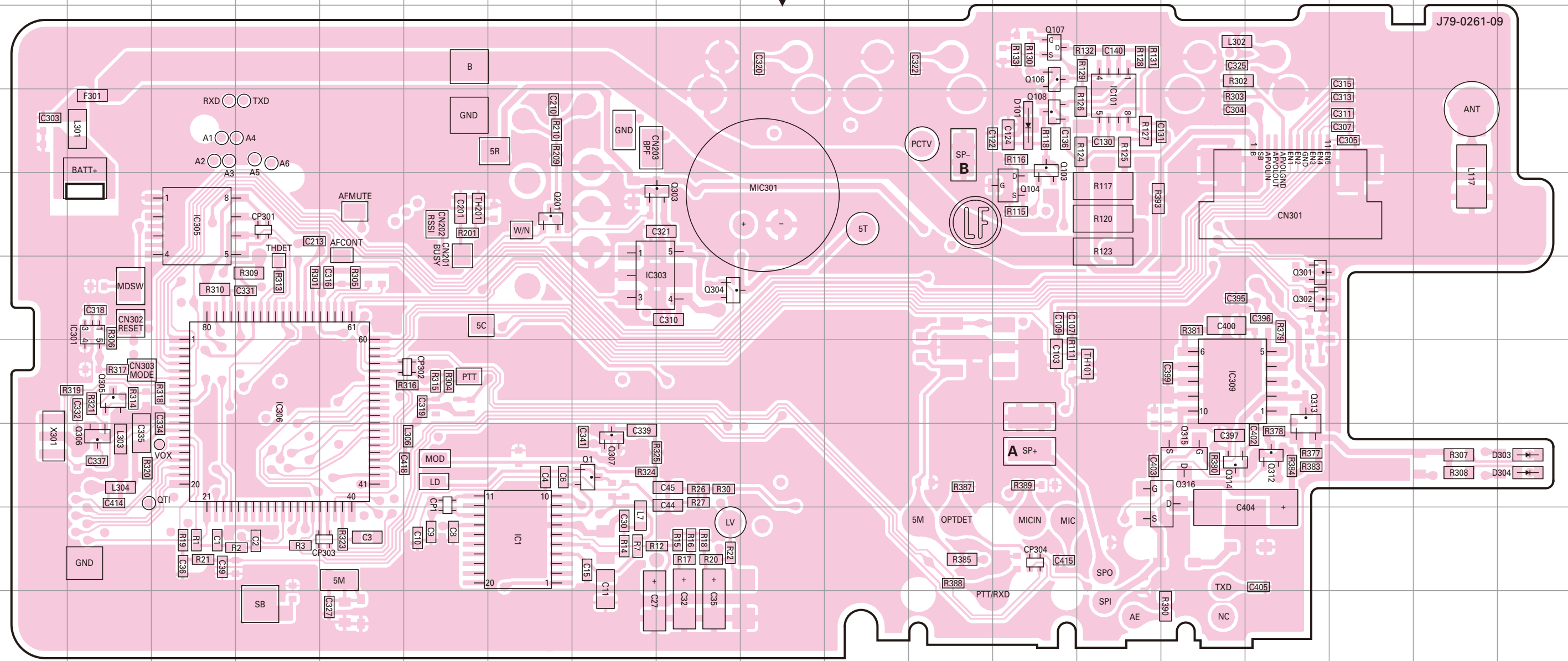

A: Green speaker wire soldering position.
B: Brown speaker wire soldering position.

Ref. No.	Address	Ref. No.	Address	Ref. No.	Address	Ref. No.	Address
IC1	9G	Q103	4M	Q303	5I	Q315	8O
IC101	4N	Q104	5M	Q304	6I	Q316	8O
IC301	6B	Q106	3M	Q305	7B	D101	4M
IC303	6H	Q107	3M	Q306	8B	D303	8S
IC305	5C	Q108	4M	Q307	8H	D304	8S
IC306	7D	Q201	5G	Q312	8P		
IC309	7O	Q301	6P	Q313	7P		
Q1	8H	Q302	6P	Q314	8O		

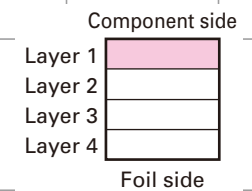

TK-2302 PC BOARD

PC BOARD TK-2302

TX-RX UNIT (X57-7572-71) Foil side view (J79-0261-09)

TX-RX UNIT (X57-7572-71) Foil side view (J79-0261-09)

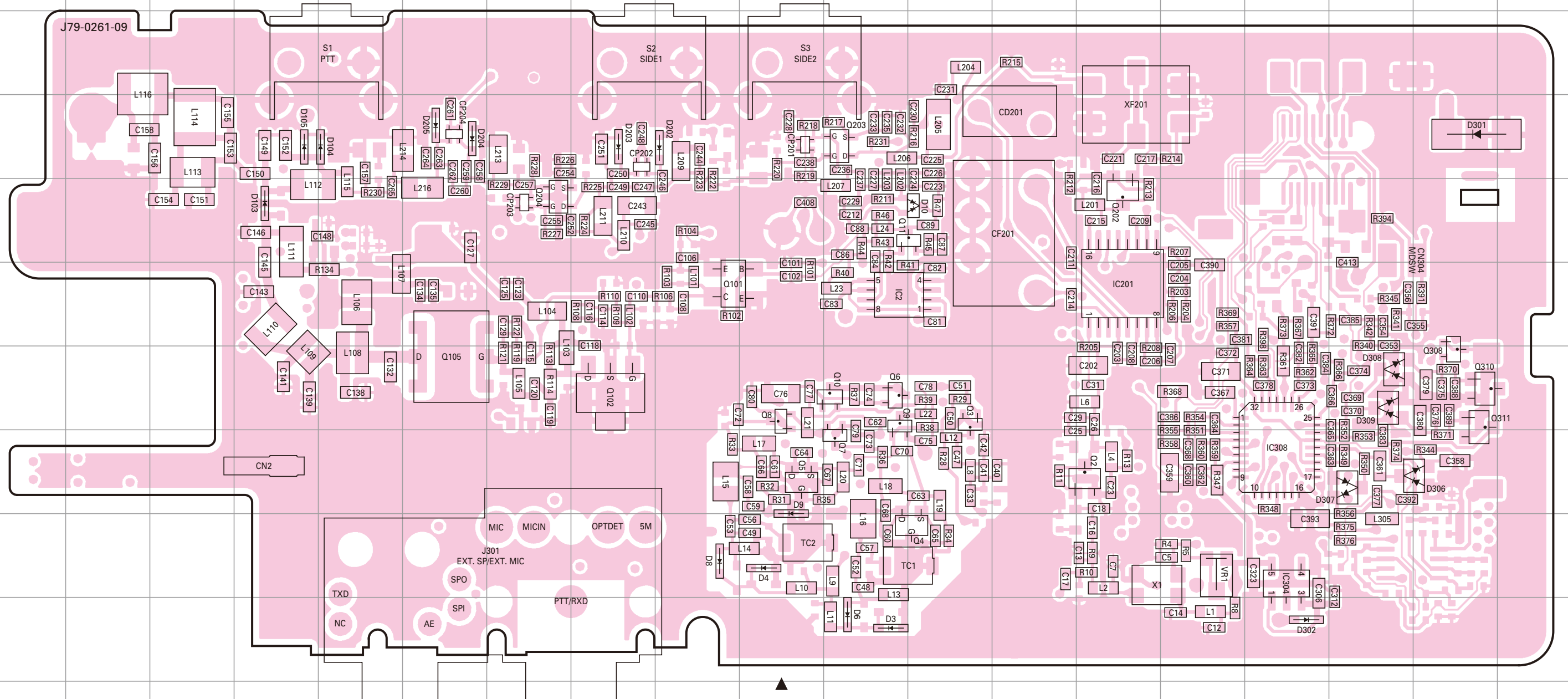

Ref. No.	Address	Ref. No.	Address	Ref. No.	Address	Ref. No.	Address	Ref. No.	Address
IC2	6K	Q7	8K	Q203	4K	D9	8J	D301	4R
IC201	6N	Q8	7J	Q204	5G	D10	5L	D302	10P
IC304	9P	Q9	7K	Q308	7R	D103	5D	D306	8R
IC308	8P	Q10	7K	Q310	7R	D104	4E	D307	8Q
Q2	8N	Q11	5L	Q311	7R	D105	4D	D308	7Q
Q3	7L	Q101	6I	D3	10K	D202	4I	D309	7Q
Q4	9L	Q102	7H	D4	9J	D203	4H		
Q5	8J	Q105	7F	D6	10K	D204	4F		
Q6	7K	Q202	5N	D8	9I	D205	4F		

