

VHF FM TRANSCEIVER / VHF 调频对讲机

TK-2307

SERVICE MANUAL / 维修手册

KENWOOD

Kenwood Corporation

© 2008-9 PRINTED IN JAPAN
B51-8837-00 (N) 435



无铅焊接通信产品  
保护环境建伍领先

⚠ 注意：本产品是无铅化焊接产品
在维修时请使用无铅焊锡
和相应的焊接工具
详细事项请访问如下网址了解：
<http://www.kenwoodhk.com.hk/>

CONTENTS / 目录

GENERAL	3	概 述.....	3
SYSTEM SET-UP	4	系统体系.....	4
REALIGNMENT	4	模式组合.....	4
DISASSEMBLY FOR REPAIR	9	维修拆卸.....	9
CIRCUIT DESCRIPTION	14	电路说明.....	14
SEMICONDUCTOR DATA	22	半导体数据.....	22
TERMINAL FUNCTION	23	端子功能.....	23
COMPONENTS DESCRIPTION	24	元件说明.....	24
PARTS LIST	26	零 件 表.....	26
EXPLODED VIEW	31	部件分解图.....	31
PACKING	32	包 装.....	32
ADJUSTMENT	34	调 整.....	35
PC BOARD		PC 板	
TX-RX UNIT (X57-7570-20)	44	TX-RX 单元 (X57-7570-20).....	44
SCHEMATIC DIAGRAM	48	原 理 图.....	48
BLOCK DIAGRAM	52	方 块 图.....	52
LEVEL DIAGRAM	54	电 平 图.....	54
OPTIONAL ACCESSORIES		可选附件	
KBH-10 (Belt clip)	55	KBH-10 (皮带夹).....	55
KSC-35 (Rapid charger)	55	KSC-35 (快速充电器).....	55
KNB-45L (Li-ion battery pack)	55	KNB-45L (锂离子电池).....	55
KSC-31 (Rapid charger)	56	KSC-31 (快速充电器).....	56
KNB-29N (Ni-MH battery pack)	56	KNB-29N (镍氢电池).....	56
KNB-30A (Ni-Cd battery pack)	56	KNB-30A (镍镉电池).....	56
SPECIFICATIONS	57	规 格.....	58

Document Copyrights

Copyright 2008 by Kenwood Corporation. All rights reserved.

No part of this manual may be reproduced, translated, distributed, or transmitted in any form or by any means, electronic, mechanical, photocopying, recording, or otherwise, for any purpose without the prior written permission of Kenwood.

Disclaimer

While every precaution has been taken in the preparation of this manual, Kenwood assumes no responsibility for errors or omissions. Neither is any liability assumed for damages resulting from the use of the information contained herein. Kenwood reserves the right to make changes to any products herein at any time for improvement purposes.

文档版权信息

Kenwood Corporation 拥有版权 2008。保留所有权利。

未经 Kenwood 公司预先书面同意，无论出于何种目的，均不得以任何形式或任何方式包括电子、机械、影印、录音或其他方式复制、翻译、分发或传播本手册的任何部分。

免责声明

Kenwood 公司在准备本文档时已采取所有必要的预防措施，恕不对错误或疏漏承担任何责任，也不对因使用本文中所含的信息而导致的损害负责。Kenwood 公司保留出于改进的需要而随时对文中的产品信息做出更改的权利。

GENERAL / 概述

INTRODUCTION

SCOPE OF THIS MANUAL

This manual is intended for use by experienced technicians familiar with similar types of commercial grade communications equipment. It contains all required service information for the equipment and is current as of the publication date. Changes which may occur after publication are covered by either Service Bulletins or Manual Revisions. These are issued as required.

ORDERING REPLACEMENT PARTS

When ordering replacement parts or equipment information, the full part identification number should be included. This applies to all parts : components, kits, or chassis. If the part number is not known, include the chassis or kit number of which it is a part, and a sufficient description of the required component for proper identification.

PERSONAL SAFETY

The following precautions are recommended for personal safety:

- DO NOT transmit until all RF connectors are verified secure and any open connectors are properly terminated.
- SHUT OFF and DO NOT operate this equipment near electrical blasting caps or in an explosive atmosphere.
- This equipment should be serviced by a qualified technician only.

SERVICE

This transceiver is designed for easy servicing. Refer to the schematic diagrams, printed circuit board views, and alignment procedures contained within.

Model	Type	TX-RX unit	Frequency range	Remarks
TK-2307	M,C,X	X57-7570-20	136~174MHz	IF1: 38.85MHz LOC: 38.4MHz

引言

本手册的范围

本手册是提供给熟悉通信专业并且具有维修经验的技术人员使用的。它包括了维修该设备所需要的全部资料和现行出版日期。在出版后可能发生变动，如果需要，可以参照《维修通报》或《手册修订本》进行补充。

替换零件的订购

当订购替换零件或设备资料时，应注意完整的零件识别号码。所有的零件均有识别号码：元件，组件或机壳。如果不知道零件的号码，为了正确地识别，必须注明此元件所属的机壳或组件的号码，并对元件进行充分的说明。

个人安全

为了个人的安全，请注意下列事项：

- 在没有认真核实所有射频插头之前或有任何一个脱开的插头没有连接到相应端口上的情况下均不要发射。
- 在电爆管附近或在易燃性气体环境中，必须关闭电源，不要操作本设备。
- 本设备只应该由有资格的技术人员进行维修。

维修服务

为了便于维修本设备，建立了完整的维修服务体系，提供了包括原理图，印刷电路板图和调整步骤在内的资料供参考。

型号	类型	TX-RX 单元	频率范围	备注
TK-2307	M, C, X	X57-7570-20	136~174MHz	IF1:38.85MHz LOC:38.4MHz

SYSTEM SET-UP / 系统体系

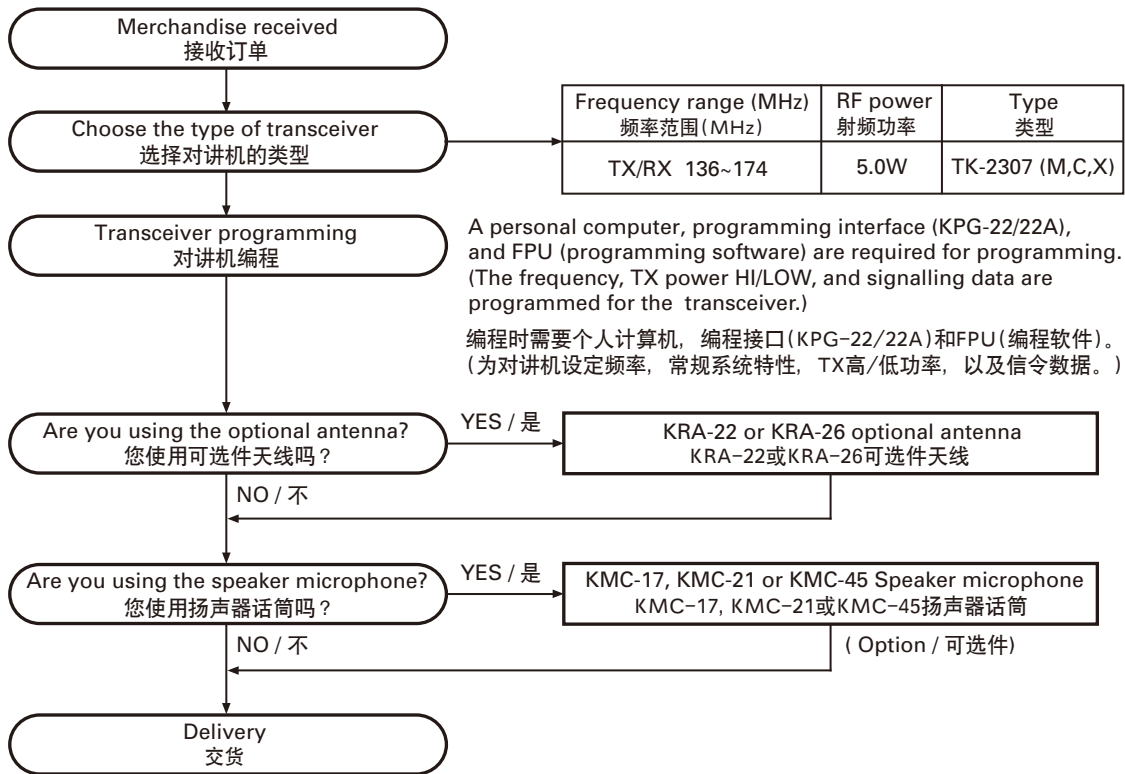

REALIGNMENT / 模式组合

1. Modes

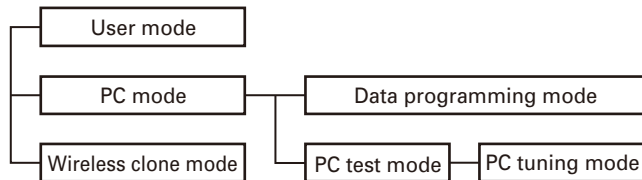

Mode	Function
User mode	For normal use.
PC mode	Used for communication between the transceiver and PC.
Data programming mode	Used to read and write frequency data and other features to and from the transceiver.
PC test mode	Used to check the transceiver using the PC. This feature is included in the FPU.
Wireless clone mode	Used to transfer programming data from one transceiver to another.

1. 模式

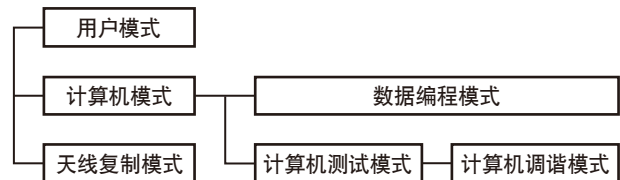

模式	功能
用户模式	一般使用
计算机模式	用户对讲机与计算机之间的通信。
数据编程模式	用于读出和写入频率数据以及其他功能。
计算机测试模式	用于使用计算机来检测对讲机。此功能包括在FPU。
天线复制模式	用于从一个对讲机编程数据复制到另一个对讲机。

REALIGNMENT / 模式组合

2. How to Enter Each Mode

Mode	Operation
User mode	Power ON
PC mode	Received commands from PC
Wireless clone mode	[PTT]+[Side2]+Power ON (Two seconds)

3. PC Mode

3-1. Preface

The transceiver is programmed by using a personal computer, a programming interface (KPG-22/22A, USB adapter (KCT-53U)) and FPU (programming software).

The programming software can be used with a PC or compatible. Figure 1 shows the setup of a PC for programming.

3-2. Connection Procedure

1. Connect the transceiver to the personal computer with the interface cable and USB adapter (when the interface cable is KPG-22A, the KCT-53U can be used).

Notes:

- You must install the KCT-53U driver in the computer to use the USB adapter (KCT-53U).
- When using the USB adapter (KCT-53U) for the first time, plug the KCT-53U into a USB port on the computer with the computer power ON.

2. When the POWER is switched on, user mode can be entered immediately. When the PC sends a command, the transceiver enters PC mode.

When data is read from the transceiver, the red LED lights.

When data is written to by the transceiver, the green LED lights.

Notes :

- The data stored in the personal computer must match Model Name and Model Type when it is written into EEPROM.
- Do not press the [PTT] key during data transmission or reception.

3-3. KPG-22/KPG-22A Description (PC programming interface cable : Option)

The KPG-22/22A is required to interface the transceiver with the computer. It has a circuit in its D-sub connector (KPG-22: 25-pin, KPG-22A: 9-pin) case that converts the RS-232C logic level to the TTL level.

The KPG-22/22A connects the SP/MIC connector of the transceiver to the RS-232C serial port of the computer.

3-4. KCT-53U Description (USB adapter : Option)

The KCT-53U is a cable which connects the KPG-22A to a USB port on a computer.

When using the KCT-53U, install the supplied CD-ROM (with driver software) in the computer. The KCT-53U driver runs under Windows 2000 or XP.

2. 如何进入每一种模式

模式	操作
用户模式	接通电源
计算机模式	从计算机接收指令
天线复制模式	[PTT]+[侧面2]+接通电源(2秒钟)

3. PC 模式

3-1. 前言

对讲机采用个人电脑、编程接口 (KPG-22/22A, USB 适配器 (KCT-53U)) 和 FPU (编程软件) 进行编程。

编程软件可以在 PC 或兼容的 PC 上进行使用。图 1 给出了 PC 进行编程的设置。

3-2. 连接操作

1. 使用接口电缆和 USB 适配器将对讲机连接到个人电脑 (接口电缆为 KPG-22A 时, 可以使用 KCT-53U)。

注意:

- 必须在电脑上安装 KCT-53U 驱动程序才能使用 USB 适配器 (KCT-53U)。
- 首次使用 USB 适配器 (KCT-53U) 时, 请在电脑开机的情况下将 KCT-53U 插入电脑的 USB 端口。

2. 对讲机电源打开时, 可以立即进入用户模式。PC 发送指令时, 对讲机进入 PC 模式。

对讲机发送数据时, 红色的 LED 点亮。

对讲机接收数据时, 绿色的 LED 点亮。

注意:

- 个人电脑保存的数据写入 EEPROM 时, 必须与机型和类型相符。
- 请勿在数据发送或接收期间按 [PTT] 键。

3-3. KPG-22/KPG-22A 说明 (PC 编程接口电缆: 选购件)

将对讲机与电脑相连需要 KPG-22/22A。该电缆的 D-sub 连接器 (KPG-22: 25 针, KPG-22A: 9 针) 盒具有将 RS-232C 逻辑电平转换为 TTL 电平的电路。

KPG-22/22A 将对讲机的 SP/MIC 连接器连接到电脑的 RS-232C 串行端口。

3-4. KCT-53U 说明 (USB 适配器: 选购件)

KCT-53U 是将 KPG-22A 连接到电脑 USB 端口的电缆。

使用 KCT-53U 时, 请在电脑上安装附带的 CD-ROM (带有驱动程序软件)。KCT-53U 驱动程序运行于 Windows 2000 或 XP 下。

REALIGNMENT / 模式组合

3-5. FPU (Programming Software) Description

The FPU is the programming software for the transceiver supplied on a CD-ROM. The software on this disk allows a user to program the transceiver transceivers via Programming interface cable (KPG-22/22A).

3-6. Programming with PC

If data is transferred to the transceiver from a PC with the FPU, the data for each set can be modified.

Data can be programmed into the EEPROM in RS-232C format via the SP/MIC jack.

In this mode the PTT line operate as TXD and RXD data lines respectively.

3-5. FPU (编程软件) 说明

FPU 是 CD-ROM 附带的用于对讲机的编程软件。该光盘上的软件允许用户通过编程接口电缆 (KPG-22/22A) 对对讲机进行编程。

3-6. 使用 PC 编程

如果使用 FPU 将数据从 PC 传输到对讲机，则每套对讲机的数据均可修改。

通过 SP/MIC 插孔可以将数据以 RS-232C 格式写入 EEPROM。在该模式下，PTT 线路分别用作 TXD 和 RXD 数据线路。

List of FPU for transceiver

Model	Type	FPU
TK-2307	M,X	KPG-118D(M)
	C	KPG-118D(C)

对讲机的 FPU 名单

型号	类型	FPU
TK-2307	M, X	KPG-118D(M)
	C	KPG-118D(C)

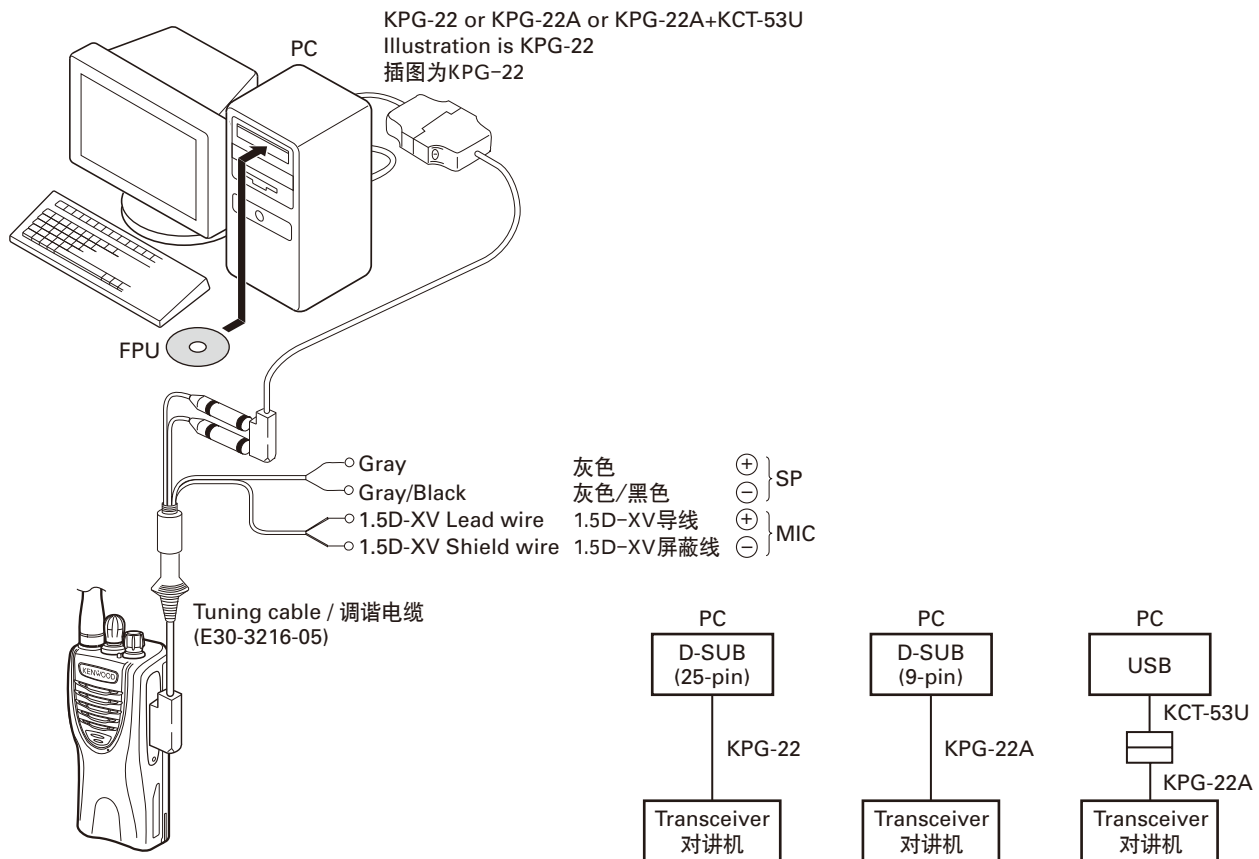

Fig. 1 / 图 1

REALIGNMENT / 模式组合

4. Wireless Clone Mode

4-1. Outline

“Wireless Clone Mode” copies the transceiver data to another transceiver.

The dealer can copy the transceiver data to another transceiver even without the use of a personal computer.

4-2. Example

The transceiver can copy the programming data to one or more transceivers via RF communication.

The clone source and clone target/s must be in wireless clone mode.

4-3. Operation

- To switch the clone target/s to wireless clone mode, press and hold the [PTT] and [side2] keys while turning the transceiver power ON.
- Wait for 2 seconds. The LED will light orange and the transceiver will announce “Clone”.
- Select a channel table number using Side1 (increment channel table) and Side2 (decrement channel table) keys.
- To switch the clone source to wireless clone mode, press and hold the [PTT] and [side2] keys while turning the transceiver power ON.
- Wait for 2 seconds. The LED will light orange and the transceiver will announce “Clone”.
- Select the same channel table number as the clone target/s.
- Press [PTT] on the clone source to begin data transmission.
When the clone target starts to receive data, the LED will light green.
When the clone source finishes sending data, a “confirmation” tone will sound.
If data transmission fails while cloning, an “error” tone will sound from the target unit.
- If the cloning fails, no data will be available in the target unit when it is returned to User mode.
- When the cloning is successful, the target unit’s “Scan” and “Key lock” functions will return to their default values (Scan = OFF, Key lock = OFF).

Notes:

- The dealer can clone data to two or more transceivers by repeating the above procedures.
- If the transceivers wireless clone mode is configured as “Disabled”, the transceiver cannot enter wireless clone mode.
- The table shown below will cover the frequency tables used for wireless cloning.
- Wireless clone mode cannot be entered in battery low state.
- A unit cannot be a “Source Unit” if it is unprogrammed. If [PTT] is pressed, an “error” tone will sound.
- The language used in cloning depends on the “Model type” setting, not the FPU setting.

4. 天线复制模式

4-1. 概要

“天线复制模式”可以将一台对讲机的数据复制到其它的对讲机。

经销商甚至不使用个人电脑也可以将一台对讲机的数据复制到其它的对讲机。

4-2. 例：

对讲机可以通过 RF 通信复制编程数据到一台或更多的对讲机。

复制主机和复制子机必须处于天线复制模式。

4-3. 操作方法

- 将子机切换到天线复制模式，旋转对讲机电源的同时，持续按 [PTT] 键和 [侧 2] 键。
- 等待 2 秒。LED 将呈橘黄色并且对讲机将发出“复制”的声音。
- 用侧 1 (频道表递增) 键和侧 2 (频道表递减) 键选择频道表号码。
- 将主机切换到天线复制模式，旋转对讲机电源的同时，持续按 [PTT] 键和 [侧 2] 键。
- 等待 2 秒。LED 将呈橘黄色并且对讲机将发出“复制”的声音。
- 选择与复制子机相同的频道表号码。
- 按复制主机上的 [PTT]，开始数据传输。
当复制子机开始接收数据时，LED 将呈绿色。
当复制主机完成传送数据时，将发出一个“确认”音。
如果在复制过程中数据传输失败，子机将发出一个“错误”音。
- 如果复制失败，子机回到用户模式时数据随即消失。
- 当复制成功时，子机的“扫描”和“键锁定”功能将回到它们的初始值 (扫描 =OFF, 键锁定 =OFF)

注释：

- 经销商可以反复上述过程复制数据到 2 个或更多的对讲机。
- 如果对讲机天线复制模式被设置为“无效”，则对讲机不能进入天线复制模式。
- 下表包含了无线复制用的频率表。
- 当电池处于低电压状态时不能进入天线复制模式。
- 如果对讲机是非编程的它将不能成为主机。如果按 [PTT]，将发出一个“错误”音。
- 复制时所用的语言是根据“样机类别”设置，而不是 FPU 设置。

REALIGNMENT / 模式组合

- Once a unit is set to be the source, it cannot be a target after the data has been transmitted. This protects the data in the source unit.
- Electronic interface may cause a failure in data transfer during wireless clone, such as when waveforms or electromagnetics are being performed at the workbench.
- **Wireless clone mode can be used ONLY by the authorized service personnel.**
- **The wireless clone mode setting must be configured as "Disable" before being delivered to the end-user.**
- **To clone, replace the antenna from both the source transceiver and the target transceiver with a dummy load.**
- **The transmit output power is automatically set to Low in wireless clone mode.**

• Clone frequency table

No.	Operating frequency 136~174MHz
1	136.150
2	138.150
3	140.150
4	142.150
5	144.150
6	146.150
7	148.150
8	150.150
9	152.150
10	154.150
11	156.150
12	158.150
13	160.150
14	162.150
15	164.150
16	166.150
17	168.150
18	170.150
19	172.150
20	174.150

- 对讲机一旦被设置为主机，数据传送以后，它就不能成为子机。这是为了保护主机里的数据。
- 在无线复制的数据传输过程中，例如在工作台产生的电波或电磁干扰有可能引起传输失败。
- **天线复制模式可以仅被批准的服务人员使用。**
- **在交付给最终用户之前，天线复制模式设置必须被设置为“无效”。**
- 为了复制，将模拟负载代替主对讲机和子对讲机的天线。
- 在天线复制模式，发射功率自动设定为低。

• 复制频率表

号码	操作频率 136~174MHz
1	136.150
2	138.150
3	140.150
4	142.150
5	144.150
6	146.150
7	148.150
8	150.150
9	152.150
10	154.150
11	156.150
12	158.150
13	160.150
14	162.150
15	164.150
16	166.150
17	168.150
18	170.150
19	172.150
20	174.150

DISASSEMBLY FOR REPAIR / 维修拆卸

1. Removing the Case Assembly from the Chassis

1. Remove the volume knob ① and channel knob ②.
2. Remove the two screws ③.
3. Lift and remove the chassis from the case assembly ④.
(Use a flat-blade screwdriver to easily lift the chassis.)

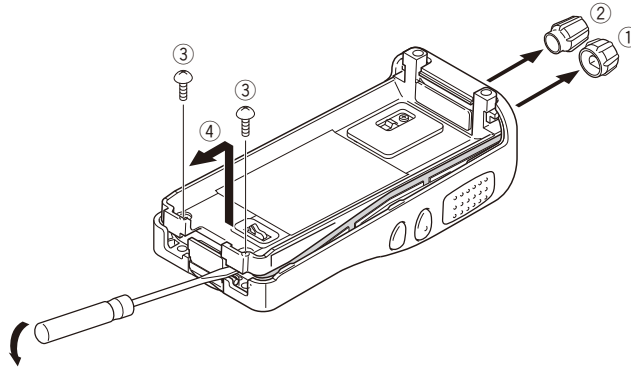

1. 拆卸机壳

1. 卸下音量旋钮 ① 和信道旋钮 ②。
2. 卸下 2 个螺丝 ③。
3. 抬起机架 ④，将其与机壳分离取出。（使用一字形螺丝刀会比较容易抬起机架。）

2. Removing the TX-RX unit from the Chassis

1. Detach the solder of speaker wire from the PCB beforehand.
2. Remove the packing ⑤ from the SP/MIC jack of the TX-RX unit.
3. Remove the ten screws ⑥ fixing the TX-RX unit.
4. Remove the solder of the antenna terminal with a soldering iron ⑦.
5. Remove the solder of the positive terminal with a soldering iron ⑧.
- Note:** You can remove the TX-RX unit from the chassis without removing the solder at the positive terminal. However, in this case, you can not attach the packing (G53-1605-03) that is on the positive terminal to the chassis in assembling. So, it is advisable to remove the solder on the positive terminal first.
6. Remove the FPC from the flat cable connector ⑨.
7. Lift and remove the TX-RX unit from the chassis ⑩.

2. 拆卸 TX-RX 单元

1. 先从 PCB 上取下扬声器引线的焊锡。
2. 从 TX-RX 单元的 SP/MIC 插孔卸下橡胶垫 ⑤。
3. 卸下固定 TX-RX 单元的 10 个螺丝 ⑥。
4. 用电烙铁烫开天线端子的焊锡 ⑦。
5. 用电烙铁烫开电池正极端子的焊锡 ⑧。

补充说明：虽然不烫开电池正极端子的焊锡也可以从机架拆卸 TX-RX 单元，但是组装时，电池正极端子连接的垫片 (G53-1605-03) 不能安装到机架。因此，请先烫开电池正极端子的焊锡。

6. 从扁平电缆连接器卸下 FPC ⑨。
7. 拿起 TX-RX 单元 ⑩，从机架拆卸下来。

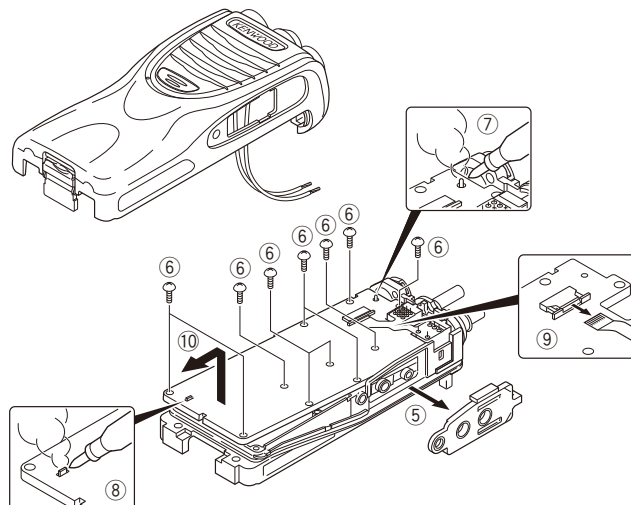

DISASSEMBLY FOR REPAIR / 维修拆卸

3. Removing the Battery Release Lever from the Case Assembly

1. Press the upper part of the lever toward the inside of the case assembly. One side of the shaft will be removed ①.
2. Lift and remove the battery release lever from the case assembly ②.

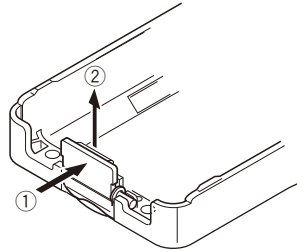

3. 从机壳拆卸电池分离拨杆

1. 向机壳的内侧按压拨杆上部之后，就可以卸下轴的一侧 ①。
2. 拿起电池分离拨杆 ②，就可以从机壳上拆卸下来。

4. Attaching the Battery Release Lever to the Case Assembly

1. Insert one side of the shaft into the hole at the lever fitting section on the case assembly ①.
Caution: The thin spring (G01-4543-04) should be positioned above the two tabs of the lever.
2. Tilt the battery release lever slightly forward ②, so that the thick spring (G01-4542-04) is positioned below the case surface.
3. With the thick spring positioned below the case surface, attach the other side of the shaft to the case assembly by pressing the battery release lever ③ until it snaps into place ④.

Caution: Be careful not to tilt the battery release lever too forward.

If the battery release lever is pushed in this state where the two tabs come below the case surface, there is a possibility of damaging the two tabs.

4. 把电池分离拨杆安装到机壳

1. 把轴的一侧插入到机壳的拨杆安装部的孔里 ①。
注意：细弹簧 (G01-4543-04) 的横杆部分应安装到拨杆的 2 个突起的上侧。
2. 轻轻地前推电池分离杆倾斜到 ②，这样粗弹簧 (G01-4542-04) 被定位在机壳下面。
3. 随着粗弹簧定位到机壳下面，通过按电池分离杆 ③ 直到它嵌到位置 ④ 轴的另一侧接触机壳组件。
注意：注意不要把电池分离杆倾斜得太靠前。如果电池分离杆被推到机壳下面的 2 个卡头的位置，就有可能损坏此 2 个卡头。

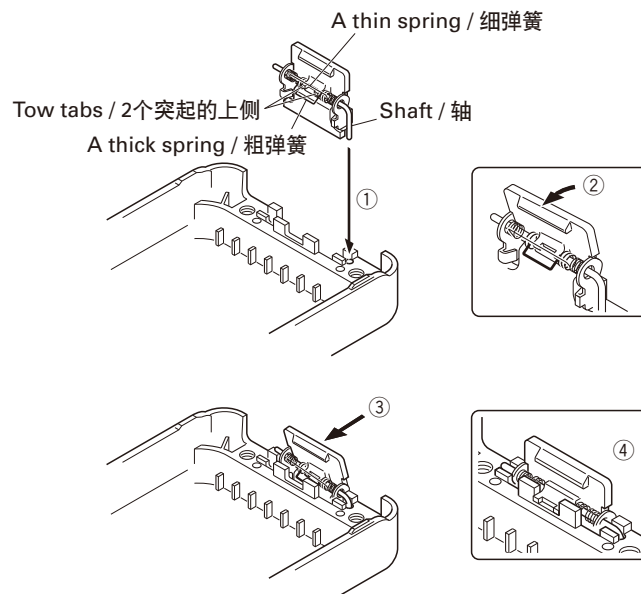

DISASSEMBLY FOR REPAIR / 维修拆卸

5. Assembling the Battery Release Lever

1. Place the lever ② onto the stopper ①.
2. Place the thick spring ③ onto the lever.
3. Hook the right and left ends of the thin spring ④ onto the tabs of the stopper, then place the thin spring onto the lever ⑤.
4. Slide the shaft through the hole of the stopper and lever ⑥.

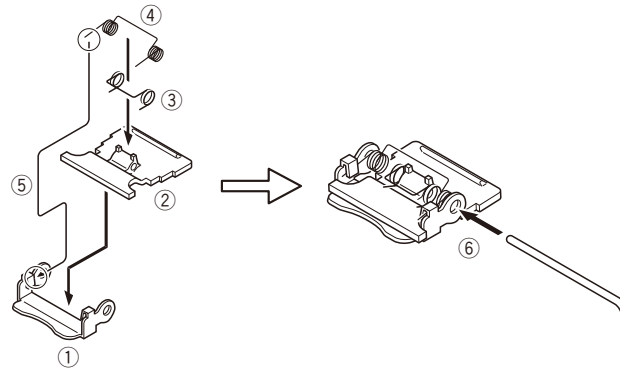

5. 电池分离拨杆的组装方法

1. 把拨杆 ② 置于止动器 ① 的上面。
2. 把粗弹簧 ③ 置于拨杆的上面。
3. 把细弹簧置于拨杆的上面，并让细弹簧 ④ 的左右端置于止动器的两个勾内 ⑤。
4. 把轴穿过止动器和拨杆的孔 ⑥。

6. Attaching the Positive Terminal to the Chassis

Always attach the positive terminal to the chassis, using the following procedures, before mounting the TX-RX unit onto the chassis.

1. Remove the holder assembly ② from the packing ① of the positive terminal.
2. Mount the packing of the positive terminal into the chassis hole ③.
3. Mount the holder assembly into the packing of the positive terminal ④.

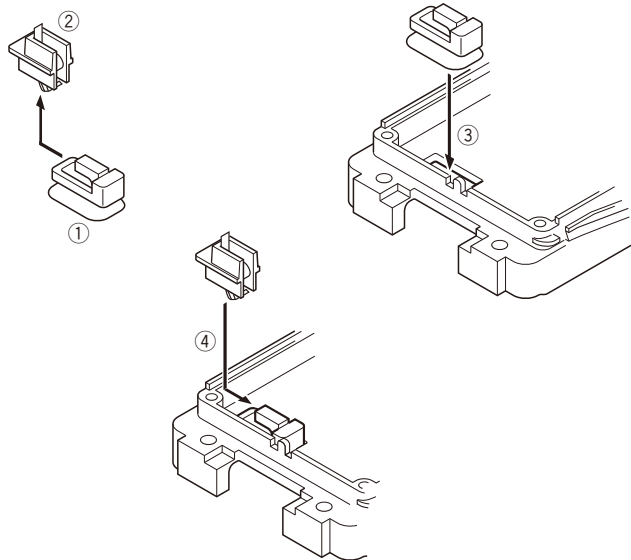

6. 把电池正极端子安装机架

把 TX-RX 单元组装到机架之前，必须按照以下的顺序把电池正极端子安装到机架。

1. 从电池正极端子的垫片 ① 取下支架总成 ②。
2. 把电池正极端子的垫片装到机架孔 ③。
3. 把支架总成组装到电池正极端子的垫片上 ④。

DISASSEMBLY FOR REPAIR / 维修拆卸

7. Mounting the Chassis to the Case Assembly

1. Confirm that the waterproof packing attached to the circumference of the chassis is securely inserted in the groove of the chassis ①.
2. Attach the speaker with waterproof packing to the speaker recess of the case assembly ②. Make sure the speaker clasp is securely inserted.
3. Tighten the speaker clasp into the case assembly with the screw.
4. Insert the upper part of the chassis into the case assembly ③.

Caution: Take care that the speaker lead wire is not caught by the microphone element.

5. Press the chassis ④ and the case assembly together to attach them.

Caution: If the packing of the SP/MIC does not come to the correct position after attaching the chassis to the case assembly, reposition the packing with your fingers.

7. 安装机壳和机架

1. 确认机架四周的防水垫是否确实地进入机架的槽里 ①。
2. 把带有防水垫的扬声器安装到机壳的扬声器安装部 ②。确保扬声器钩子完全被插入。
3. 使用螺丝把扬声器钩子旋入机壳。
4. 把机架上侧插到机壳内 ③。

注意: 请不要使扬声器引线勾住麦克风。

5. 下压机架 ④，使机架和机壳合为一体并安装好。

注意: 把机架安装到机壳后，如果 SP/MIC 的橡胶垫不在正常的位置时，请用手指将其调整到正常的位置。

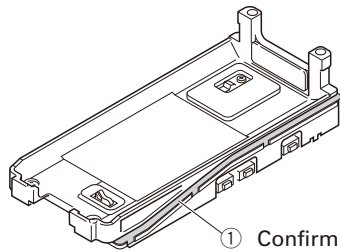

- ① Confirm that the waterproof packing is securely inserted in the groove of the chassis.

确认防水垫是否确实地进入机架的槽里。

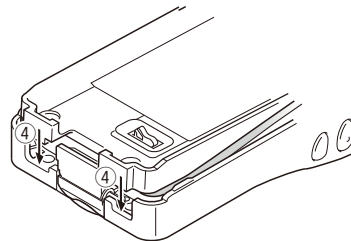
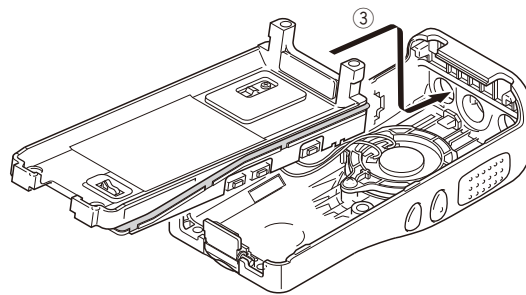
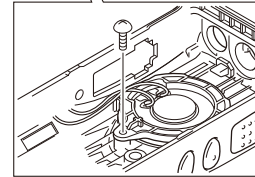
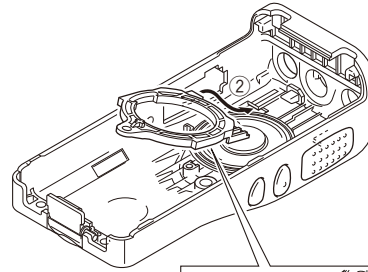

DISASSEMBLY FOR REPAIR / 维修拆卸

8. Attaching the Antenna Receptacle to the Chassis

Screw the antenna receptacle to the chassis in the order shown in the drawing so that the antenna receptacle comes to the center of the case hole.

8. 把天线插座安装到机架

为了能把天线插座安装到机芯孔的中心，在将天线插座安装到机架时，请按照图示的顺序固定螺丝。

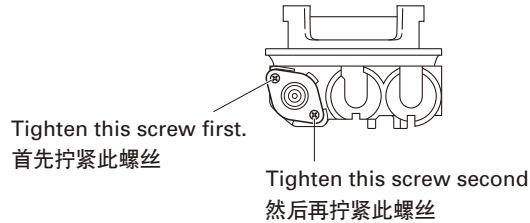

9. The Nuts of the Volume Knob and Channel Knob

Note that the shapes, colors and heights of nuts of the volume knob and channel knob are different from one another. (The nut of volume knob is silver, and the nut of channel knob is gold)

Use the following jig when removing the nuts of the volume knob and channel knob.

- Jig (Part No.: W05-1012-00)

9. 关于音量旋钮和信道旋钮的螺母

音量旋钮和信道旋钮的螺母形状不同，颜色高度也不同，因此请注意。（音量旋钮螺母为银色，信道旋钮的螺母为金色）另外，拆卸音量旋钮和信道旋钮的螺母时，请使用下列夹具。

- 夹具（零件号：W05-1012-00）

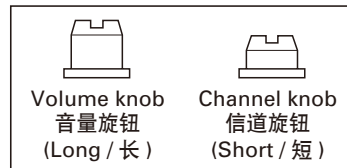

10. Screw sequence for mounting the TX-RX unit to the chassis

Attach the TX-RX unit to the chassis using the screws in the order shown in the drawing below.

Note: From screw ④ onward no sequence is need.

10. 安装 TX-RX 单元到机架上的螺钉顺序

利用下图所示的螺钉顺序安装 TX-RX 单元到机架上。

补充说明：螺丝④的旋紧顺序可以忽略。

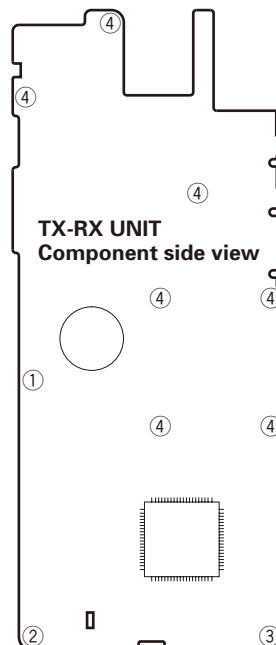

CIRCUIT DESCRIPTION / 电路说明

1. Frequency Configuration

The receiver utilizes double conversion. The first IF is 38.85MHz and the second IF is 450kHz. The first local oscillator signal is supplied from the PLL circuit.

The PLL circuit in the transmitter generates the necessary frequencies. Fig. 1 shows the frequencies.

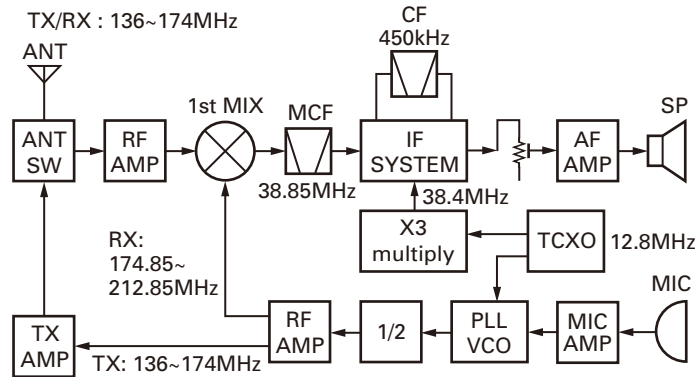

Fig. 1 Frequency configuration / 频率构成

1. 频率构成

本接收机使用二次变频。第一 IF 是 38.85MHz，第二 IF 是 450kHz。第一本地振荡信号由 PLL 电路提供。

PLL 电路产生需要的发射频率。

2. Receiver

The frequency configuration of the receiver is shown in Fig. 2.

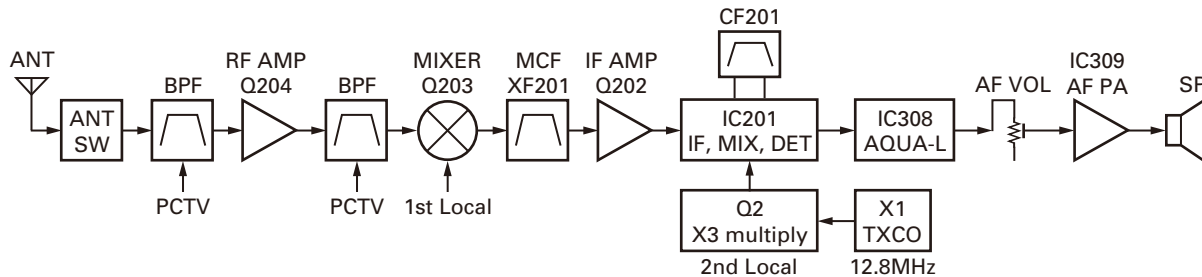

Fig. 2 Receiver section / 图 2 接收部构成

2. 接收部

接收部的频率构成如图 2 所示。

■ Front End (RF AMP)

The signal coming from the antenna passes through the transmit/receive switching diode circuit, (D103, D104 and D105) passes through a BPF (L214, L216 and L213), and is amplified by the RF amplifier (Q204).

The resulting signal passes through a BPF (L209 and L211) and goes to the mixer. These BPFs are adjusted by variable capacitors (D203, D204, D205 and D202). The input voltage to the variable capacitor is regulated by voltage output from the MCU (IC306).

■ 前端 (RF 放大器)

从天线接收的信号进入发送 / 接收转换开关二极管电路 (D103, D104, D105 和 D106)，然后通过 BPF (L214, L216 和 L213)，并且被 RF 放大器 (Q204) 放大。

此信号通过 BPF (L209 和 L211) 然后进入混频。这些 BPF 被可变电容器 (D203, D204, D205 和 D202) 调整。输入可变电容器的电压被经 MCU (IC306) 的电压输出调整。

CIRCUIT DESCRIPTION / 电路说明

■ First Mixer

The signal from the front end is mixed with the first local oscillator signal generated in the PLL circuit by Q203 to produce a first IF frequency of 38.85MHz.

The resulting signal passes through the XF201 MCF to cut the adjacent spurious and provide the optimum characteristics, such as adjacent frequency selectivity.

■ IF Amplifier Circuit

The first IF signal is passed through a four-pole monolithic crystal filter (XF201) to remove the adjacent channel signal. The filtered first IF signal is amplified by the first IF amplifier (Q202) and then applied to the IF system IC (IC201). The IF system IC provides a second mixer, limiting amplifier, quadrature detector and RSSI (Received Signal Strength Indicator). The second mixer mixes the first IF signal with the 38.4MHz of the second local oscillator output (TCXO X1 and Q2) and produces the second IF signal of 450kHz.

The second IF signal is passed through the ceramic filter (CF201) to remove the adjacent channel signal. The filtered second IF signal is amplified by the limiting amplifier and demodulated by the quadrature detector with the ceramic discriminator (CD201). The demodulated signal is routed to the audio circuit.

■ Wide/Narrow Switching Circuit

Narrow and Wide settings can be made for each channel by switching the demodulation level.

The WIDE (low level) and NARROW (high level) data is output from IC306, pin 5. When a WIDE (low level) data is received, Q201 turn on. When a NARROW (high level) data is received, Q201 turn off.

Q201 turns on/off with the Wide/Narrow data and the IC201 detector output level is switched to maintain a constant output level during wide or narrow signals.

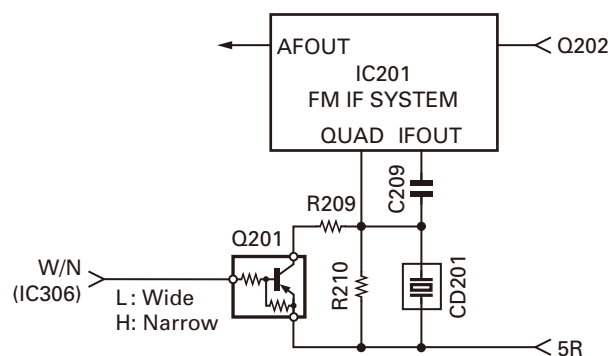

Fig. 3 Wide/Narrow switching circuit / 图 3 宽 / 窄开关电路

■ Audio Amplifier Circuit

The demodulated signal from IC201 goes to AF amplifier through IC308.

The signal then goes through an AF volume control, and is routed to an audio power amplifier (IC309) where it is amplified and output to the speaker.

■ 第一混频器

前端的信号与 PLL 电路产生的第一本振信号在 Q203 混频，生成 38.85MHz 频率的第一中频信号。

生成的信号通过 XF201 MCF。

■ 中频放大电路

第一中频信号通过晶体滤波器 (XF201) 消除相邻信道的信号。经滤波的第一中频信号被第一中频放大器 (Q202) 放大并进入中频系统芯片 (IC201)。中频系统芯片提供第二混频器，限幅放大器，正交检测器和 RSSI (接收信号强度指示器)。第二混频器将第一中频信号与 38.4MHz 的第二本振信号输出 (TCXO X1 和 Q2) 进行混频，并生成 450kHz 的第二中频信号。

第二中频信号通过陶瓷滤波器 (CF201) 继续消除相邻信道的信号。经滤波的第二中频信号被限幅放大器放大并被带有陶瓷鉴频器 (CD201) 的正交检测器解调。经解调的信号进入音频电路。

■ 宽 / 窄开关电路

可以通过开启宽窄开关对各信道进行宽窄设定。

WIDE (低电平) 和 NARROW (高电平) 数据被 IC306、5 管脚输出。当接收到 WIDE (低电平) 数据时，Q201 接通。当接收到 NARROW (高电平) 数据时，Q201 断开。

Q201 伴随着宽 / 窄数据而接通 / 断开，IC201 检测器输出电平经常变化用来维持宽或窄信号过程中的恒定输出电平。

■ 音频放大器电路

来自于 IC201 的解调信号通过 IC308 送到音频放大器。

信号通过 AF 音量控制，在音频功率放大器 (IC309) 进行放大后输出到扬声器。

CIRCUIT DESCRIPTION / 电路说明

■ Squelch

Part of the AF signal from the IC enters the FM IC (IC201) again, and the noise component is amplified and rectified by a filter and an amplifier to produce a DC voltage corresponding to the noise level.

The DC signal from the FM IC goes to the analog port of the MCU (IC306). IC306 determines whether to output sounds from the speaker by checking whether the input voltage is higher or lower than the preset value.

To output sounds from the speaker, IC306 sends a high signal to the AF_CONT line and turns IC309 on through Q312, Q313, Q314, Q315 and Q316. (See Fig. 4)

■ 静噪

FM IC (IC201) 输出的 AF 信号的一部分再进入 IC，噪声成份通过滤波器和放大器进行放大和修正，生成与噪声电平相应的 DC 电压。

DC 信号通过 FM IC 被送到 MCU 的模拟端口 (IC306)。IC306 通过检测输入的电压是高于还是低于预设值来决定是否从扬声器输出声音。

由扬声器输出声音时，IC306 发送高电平信号给 AF_CONT 线，通过 Q312, Q313, Q314, Q315 和 Q316 打开 IC309。(见图 4)。

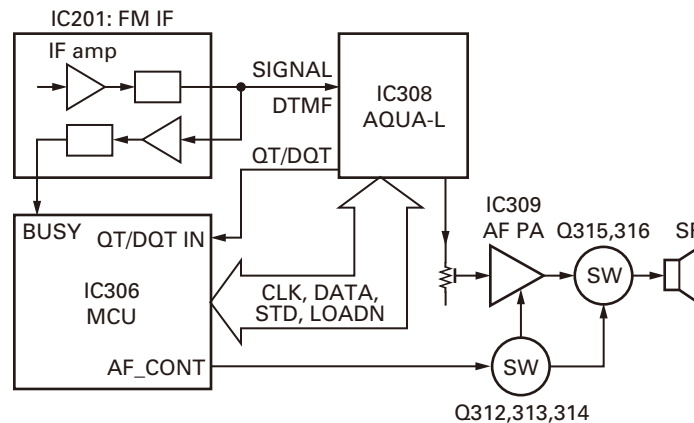

Fig. 4 AF amplifier and squelch / 图 4 音频放大器以及静噪

■ Receive Signaling

• QT/DQT

The output signal from FM IC (IC201) enters the MCU (IC306) through IC308. IC306 determines whether the QT or DQT matches the preset value, and controls the SP MUTE and the speaker output sounds according to the squelch results.

• MSK (Fleet Sync)

The MSK input signal from the FM IC goes to pin 31 of IC 308. The signal is demodulated by MSK demodulator in IC 308. The demodulated data goes to the MCU for processing.

• DTMF

The DTMF input signal from the FM IC (IC201) goes to IC308. The decoded information is then processed by the MCU.

■ 接收信令

• QT/DQT

FM IC (IC201) 输出的信号通过 IC308 进入 MCU (IC306)。IC306 测定 QT 或 DQT 是否与设置的值匹配，并根据此结果来控制 SP MUTE 和扬声器输出声音。

• MSK (Fleet Sync)

来自 FM IC 的 MSK 输入信号送到 IC308 的 31 脚。信号在 IC308 上的 MSK 调解器中进行调解。被解调的数据送到 MCU 进行处理。

• DTMF

FM IC (IC201) 的 DTMF 输出信号送到 IC308。解码数据由 MCU 处理。

CIRCUIT DESCRIPTION / 电路说明

3. PLL Frequency Synthesizer

The PLL circuit generates the first local oscillator signal for reception and the RF signal for transmission.

■ PLL

The frequency step of the PLL circuit is 2.5, 5, 6.25 or 7.5kHz.

A 12.8MHz reference oscillator signal is divided at IC1 by a fixed counter to produce an oscillator (VCO) output signal which is buffer amplified by Q3 then divided in IC1 by a programmable counter. The divided signal is compared in phase with the 5, 10, 12.5 or 15kHz reference signal from the phase comparator in IC1. The output signal from the phase comparator is filtered through a low-pass filter and passed to the VCO to control the oscillator frequency. (See Fig. 5)

■ VCO

The twice of operating frequency is generated by Q5 in transmit mode and Q4 in receive mode. The oscillator frequency is controlled by applying the VCO control voltage, obtained from the phase comparator, to the varactor diodes (D4 and D8 in transmit mode and D3 and D6 in receive mode).

The RX_SW pin is set high in receive mode causing Q7 turn on. The TX_SW pin is set high in transmit mode. The outputs from Q4 and Q5 are amplified by Q9 and sent to the prescaler (IC2).

■ Unlock Detector

If a pulse signal appears at the LD pin of IC1, an unlock condition occurs, and the DC voltage obtained from C4 and Q1 causes the voltage applied to the MCU to go low. When the MCU detects this condition, the transmitter is disabled, ignoring the push-to-talk switch input signal.

3. PLL 频率合成

PLL 电路产生用于接收的第一本地振荡信号和发射用的 RF 信号。

■ PLL

PLL 电路的频率步进是 2.5, 5, 6.25 或 7.5kHz。

12.8MHz 的参考振荡信号在 IC1 中被一个固定计数器分频。振荡器 (VCO) 的输出信号由 Q3 缓冲放大, 然后在 IC1 中被一个可编程双模块计数器分频。分频的信号在 IC1 的相位比较器中进行比较。生成的信号通过一个低通滤波器滤波后传送到 VCO 控制振荡器频率。(见图 5)

■ VCO

所使用的两倍频率在发射模式时由 Q5 生成, 在接收模式时由 Q4 生成。通过将相位比较器所获得的 VCO 控制电压输送给可变二极管 (在发射模式时为 D4 和 D8, 在接收模式时为 D3 和 D6) 来控制振荡频率。

在接收时 RX_SW 脚被设定为高, 使 Q7 接通。发射时 TX_SW 脚被设定为高。Q4 和 Q5 的输出被 Q9 放大并且传送给预计数器 (IC2)。

■ 失锁检测器

如果脉冲信号出现在 IC1 的 LD 管脚上, 则发生了失锁的情况, 从 C4 和 Q1 获得的 DC 电压使 MCU 的输入电压变低。MCU 检测到这个情况后发射被禁止, 忽略 PTT 开关的输入信号。

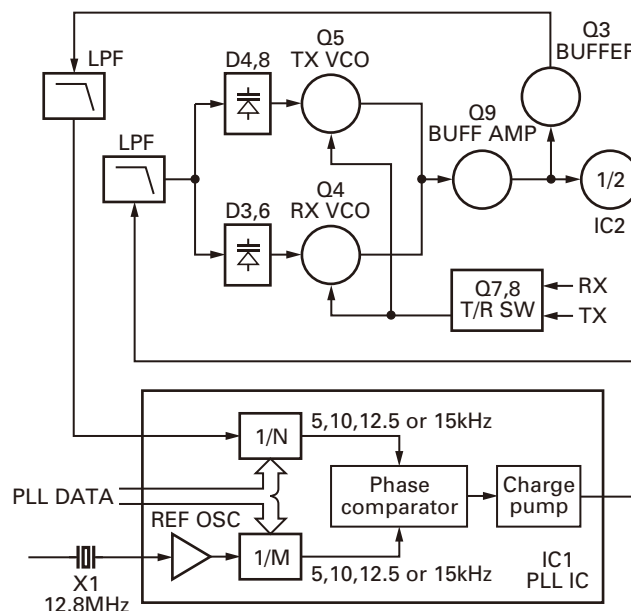

Fig. 5 PLL circuit / 图 5 PLL 电路

CIRCUIT DESCRIPTION / 电路说明

4. Transmitter System

■ Microphone Amplifier

The signal from the microphone passes through the IC308. When encoding DTMF, it is turned OFF for muting the microphone input signal by IC308.

The signal passes through the Audio processor (IC308) for the maximum deviation adjustment, and goes to the VCO modulation input.

4. 发射部系统

■ 话筒放大器

来自于话筒的信号通过 IC308。当编码 DTMF 时，话筒输入信号被 IC308 关闭。

信号通过音频处理器 (IC308) 进行最大频偏调整，然后送到 VCO 调制输入。

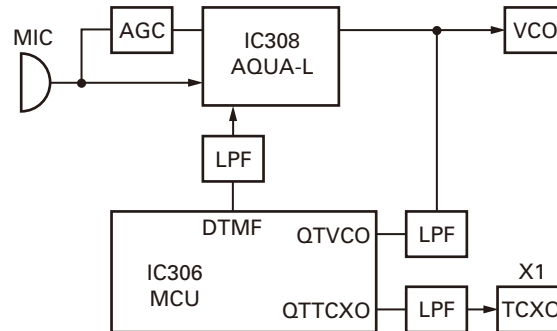

Fig. 6 Microphone amplifier / 图 6 话筒放大器

■ Drive and Final Amplifier

The signal from the T/R switch (D10 is on) is amplified by the pre-drive (Q101) and the drive amplifier (Q102) to 800mW.

The output of the drive amplifier is amplified by the RF power amplifier (Q105) to 5.0W (1W when the power is low). The output of the RF power amplifier is then passed through the harmonic filter (LPF) and antenna switch (D103) and applied to the antenna terminal.

■ APC Circuit

The APC circuit always monitors the current flowing through the drive amplifier and RF power amplifier (Q102 and Q105) and keeps a constant current.

The voltage drop at R117, R120 and R123 is caused by the current flowing through the RF power amplifier and drive amplifier, and this voltage is applied to the differential amplifier IC101 (1/2).

IC101 (2/2) compares the output voltage of IC101 (1/2) with the reference voltage from IC306. The output of IC101 (2/2) controls the VG of the RF power amplifier and drive amplifier to make both voltages the same.

The change of power high/low is carried out by the change of the reference voltage.

■ 驱动器 and 终端放大器

来自于 T/R 开关 (D10 ON) 的信号被前置驱动放大器 (Q101) 和驱动放大器 (Q102) 放大到 800mW。

驱动放大器的输出被 RF 功率放大器 (Q105) 放大到 5.0W (当低功率时为 1W)。RF 功率放大器的输出通过谐波滤波器 (LPF) 和天线开关 (D103) 并且送到天线终端。

■ 自动功率控制 (APC) 电路

APC 电路一直监视通过驱动放大器，射频功率放大器 (Q102 和 Q105) 的电流并保持电流稳定。经过射频功率放大器和驱动放大器的电流的变化会引起 R117, R120 和 R123 的电压降低，此电压送到差分放大器 IC101 (1/2)。

IC101 (2/2) 将 IC101 (1/2) 的输出电压与来自 IC306 的参考电压进行比较。IC101 (2/2) 的输出电压控制射频功率放大器，驱动放大器的 VG，使电压保持一致。

功率高 / 低的变化是通过变更参考电压来实现的。

CIRCUIT DESCRIPTION / 电路说明

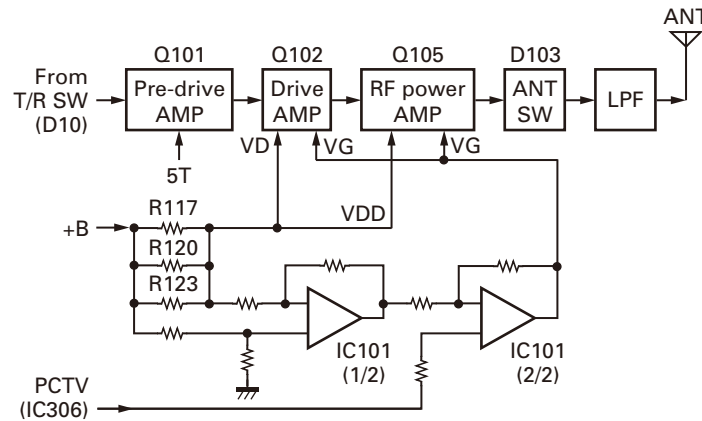

Fig. 7 Drive and final amplifier and APC circuit / 图 7 驱动、终端放大器以及 APC 电路

■ Encode Signaling

• QT/DQT

QT/DQT data of the QTTCXO Line is output from pin 14 of the MCU. The signal passes through a low-pass CR filter and goes to the TCXO (X1).

The QT/DQT data of the QTVCO Line is output from pin 15 of the MCU. The signal passes through a low pass CR filter, mixes with the audio signal, and goes to the VCO modulation input. TX deviation is adjusted by the MCU.

• DTMF

High-speed data is output from pin 74 of the MCU. The signal passes through a low-pass CR filter, and provides a TX and SP out tone, and is then applied to the audio processor (IC308). The signal is mixed with the audio signal and goes to the VCO.

TX deviation is adjusted by the MCU.

• MSK (Fleet Sync)

Fleet Sync utilizes 1200bps and 2400bps MSK signal is output from pin 6 of IC308. And is routed to the VCO. When encoding MSK, the microphone input signal is muted.

5. Power Supply

There are four 5V power supplies in the transceiver: 5M, 5C, 5R, and 5T. 5M for MCU is always output while the power is on. 5M is always output, but turns off when the power is turned off to prevent malfunction of the MCU.

5C is a common 5V and is output when SAVE is not set to OFF.

5R is 5V for reception and output during reception.

5T is 5V for transmission and output during transmission.

■ 编码信令

• QT/DQT

QTTCXO 线的 QT/DQT 数据从 MCU 的 14 管脚输出。信号通过低通 CR 滤波器，并且送到 TCXO (X1)。

QTVCO 线的 QT/DQT 数据从 MCU 的 15 管脚输出。信号通过低通 CR 滤波器，与音频信号混合，然后输入到 VCO。TX 频偏被 MCU 调整。

• DTMF

高速数据从 MCU 的 74 脚输出。信号通过低通 CR 滤波器，提供 TX 和 SP 输出音频，并输入到音频处理器 (IC308)。信号与音频信号混合，然后送到 VCO。

TX 频偏被 MCU 调整。

• MSK (Fleet Sync)

FleetSync 使用 1200bps 和 2400bps 的 MSK 信号，这些信号从 IC308 的 6 脚输出。并且被发送到 VCO。当编码 MSK 时，话筒输入信号被静音。

5. 电源

本机用 4 个 5V 电源提供给：5M, 5C, 5R 和 5T。当电源接通时，MCU 用的 5M 一直保持输出。5M 虽然为经常输出，但在关闭电源时也被关掉，防止 MCU 出现故障状态。

5C 为公共的 5V，在非省电状态时保持输出。

5R 为接收用的 5V，在接收期间保持输出。

5T 为发射用的 5V，在发射期间保持输出。

CIRCUIT DESCRIPTION / 电路说明

6. Control Circuit

The control circuit consists of a MCU (IC306) and its peripheral circuits. It controls the TX-RX unit. IC306 mainly performs the following:

- 1) Switching between transmission and reception by the PTT signal input.
- 2) Reading system, group, frequency, and program data from the memory circuit.
- 3) Sending frequency program data to the PLL.
- 4) Controlling squelch on/off by the DC voltage from the squelch circuit.
- 5) Controlling the audio mute circuit by the decode data input.
- 6) Transmitting tone and encode data.

■ Frequency Shift Circuit

The MCU (IC306) operates at a clock of 14.746 MHz. This oscillator has a circuit that shifts the frequency by BEAT SHIFT SW (Q305, Q306).

A beat sound may be able to be evaded from generation if "Beat Shift" is set to ON when it is generated in the internal spurious transmission modulated sound of a transceiver.

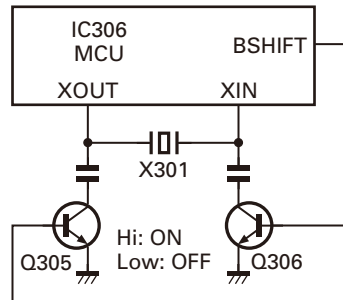

Fig. 8 Frequency shift circuit / 图 8 频率偏移电路

■ Memory Circuit

Memory circuit consists of the MCU (IC306) and an EEPROM (IC305). An EEPROM has a capacity of 16k bits that contains the transceiver control program for the MCU and data such as transceiver channels and operating features.



Fig. 9 Memory circuit / 图 9 存储器电路

■ Low Battery Warning

The battery voltage is checked using by the MCU. The transceiver generates a warning tone when it falls below the warning voltage shown in the table.

- 1) The red LED blinks when the battery voltage falls below the voltage (1) shown in the table during transmission.

6. 控制电路

控制电路是由 MCU (IC306) 和外部电路构成。它控制 TX-RX 单元。IC306 的主要功能如下：

- 1) 根据 PTT 的输入信号来转换发射和接收状态。
- 2) 从存储电路读出系统，组，频率以及编程数据。
- 3) 发送频率数据给 PLL。
- 4) 根据静噪电路输出的 DC 电压来控制静噪的开启和关闭。
- 5) 根据解码数据控制音频静音。
- 6) 发射 Tone 及编码数据。

■ 频率偏移电路

MCU (IC306) 在 14.746MHz 时钟下工作。此振荡器有可以被 BEAT SHIFT SW (Q305, Q306) 变换频率的电路。

如果 "Beat Shift" 被设定为 ON, 可以避免产生拍频声音。

■ 存储器电路

存储器电路由 MCU (IC306) 和 EEPROM (IC305) 组成。有 16k bits 的容量，包含 MCU 用的对讲机控制程序以及信道和操作功能这样的数据。

■ 电池低压警告

通过 MCU 监视电池电压。当低于警告电压时将发出警告音。

- 1) 发射中，当电池电压低于电压 (1) 时红色 LED 闪烁。

CIRCUIT DESCRIPTION / 电路说明

Note: The transceiver checks the battery voltage during reception even when, in the FPU, the Battery Warning status function is set to "On TX" (default setting). However, the LED does not blink during reception. During transmission, the LED blinks to generate the warning tone of a low battery voltage.

2) The transceiver immediately stops transmission when the battery voltage falls below the voltage (2) shown in the table. A message tone beeps while the PTT switch is released.

注：即使电池电压警告功能在FPU中被设置为“On TX”（默认设定），对讲机在接收时也检测电池电压。但是在接收期间LED指示灯并不闪烁。发射时电池电压过低LED会闪烁并产生警告音。

2) 当电池电压降到电压(2)以下，对讲机将立刻停止发射。PTT开关放开时会有一声提示音。

	Ni-Cd Battery	Ni-MH Battery	Li-ion Battery
(1)	6.2V	6.2V	6.2V
(2)	5.9V	5.9V	5.9V

	镍镉电池	镍氢电池	锂离子电池
(1)	6.2V	6.2V	6.2V
(2)	5.9V	5.9V	5.9V

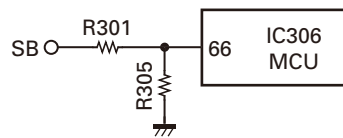

Fig. 10 Low battery warning / 图 10 电池低压警告

7. Control System

Keys and channel selector circuit. The signal from the keys and channel selector are directly input to the MCU, as shown in Fig. 11.

7. 控制系统

按键和频道选择器电路。如图 11 所示，来自按键和频道选择器的信号直接输入到 MCU。

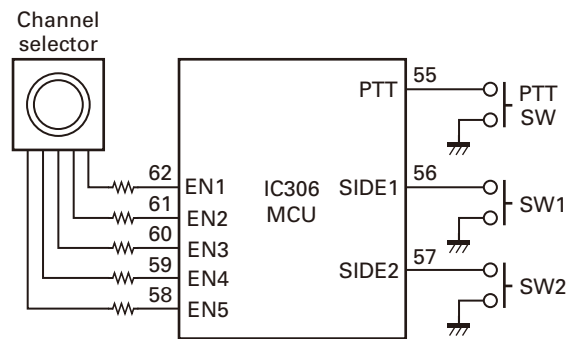

Fig. 11 Control system / 图 11 控制系统

MCU: R5F212CCKCMB (TX-RX unit IC306)

Pin No.	Signal Name	I/O	Function
1	5T_C	O	5T control
2	PLL_STB	O	PLL strobe
3	5C_C	O	5C control
4	5R_C	O	5R control
5	W/N	O	Wide/Narrow switch
6	MODE	I	No function
7	AF_CONT	O	Speaker mute
8	BSHIFT	O	Beat shift control
9	RESET	I	MCU reset
10	XOUT	O	MCU clock (14.746MHz)
11	VSS	-	GND
12	XIN	I	MCU clock (14.746MHz)
13	VCC	I	Power supply input
14	QTTCXO	O	QT/DQT output
15	QTVCO	O	QT/DQT output
16~21	AUX6~AUX1	I/O	No function
22	MIC_MUTE	O	MIC mute
23	AF_MUTE	O	No function
24~32	N.C	O	No function
33	RXDATA	I	No function
34	TXDATA	O	No function
35	OPTDET	I	Headset detect
36	TX_SW	O	TX VCO switch
37	RX_SW	O	RX VCO switch
38	LEDRX	O	Green LED control
39	LEDTX	O	Red LED control
40	APC_SW	O	APC switch
41	DC_SW	O	APC discharge switch
42	STD	I	Baseband IC data input
43	1/2 OSC	O	Baseband IC clock (3.6864MHz)
44	INT	I	No function
45	TXD	O	Serial data output
46	RXD	I	Serial data input
47	DIR	O	Baseband IC data output
48	DI/O	I/O	Baseband IC data input / output
49	DTRLOADN	O	Baseband IC data output
50	TDATA/DTRCLK	O	Baseband IC data output
51	SCLK	O	Serial clock for baseband IC
52	TCLK/DTRDO	I	Baseband IC data input
53	RDF/FD	I	Baseband IC data input
54	MDSW	I	No function
55	PTT	I	PTT switch input
56	SIDE1	I	Side1 key input
57	SIDE2	I	Side2 key input

MCU: R5F212CCKCMB(TX-RX 单元 IC306)

管脚号码	信号名称	输入/输出	功 能
1	5T_C	输出	5T 控制
2	PLL_STB	输出	PLL 选通
3	5C_C	输出	5C 控制
4	5R_C	输出	5R 控制
5	W/N	输出	宽 / 窄开关
6	MODE	输入	无功能
7	AF_CONT	输出	扬声器静音
8	BSHIFT	输出	拍频偏移开关
9	RESET	输入	MCU 复位
10	XOUT	输出	MCU 时钟 (14.746MHz)
11	VSS	-	GND
12	XIN	输入	MCU 时钟 (14.746MHz)
13	VCC	输入	电源输入
14	QTTCXO	输出	QT/DQT 输出
15	QTVCO	输出	QT/DQT 输出
16~21	AUX6~AUX1	输入/输出	无功能
22	MIC_MUTE	输出	麦克风静音
23	AF_MUTE	输出	无功能
24~32	N.C	输出	无功能
33	RXDATA	输入	无功能
34	TXDATA	输出	无功能
35	OPTDET	输入	耳机检测
36	TX_SW	输出	TX VCO 开关
37	RX_SW	输出	RX VCO 开关
38	LEDRX	输出	绿色 LED 控制
39	LEDTX	输出	红色 LED 控制
40	APC_SW	输出	APC 开关
41	DC_SW	输出	APC 放电开关
42	STD	输入	基带 IC 数据输入
43	1/2 OSC	输出	基带 IC 时钟 (3.6864MHz)
44	INT	输入	无功能
45	TXD	输出	串行数据输出
46	RXD	输入	串行数据输入
47	DIR	输出	基带 IC 数据输出
48	DI/O	输入/输出	基带 IC 数据输入 / 输出
49	DTRLOADN	输出	基带 IC 数据输出
50	TDATA/DTRCLK	输出	基带 IC 数据输出
51	SCLK	输出	基带 IC 串行时钟
52	TCLK/DTRDO	输入	基带 IC 数据输入
53	RDF/FD	输入	基带 IC 数据输入
54	MDSW	输入	无功能
55	PTT	输入	PTT 开关输入
56	SIDE1	输入	Side1 键输入
57	SIDE2	输入	Side2 键输入

SEMICONDUCTOR DATA / 半导体数据

Pin No.	Signal Name	I/O	Function
58~62	EN5~EN1	I	Channel selector input
63	DIST1	I	No function
64	DIST2	I	No function
65	PLL_UL	I	PLL unlock signal input
66	BATT	I	Battery voltage detect
67	RSSI	I	RSSI input
68	BUSY	I	Busy signal input
69	VOX	I	VOX signal detect
70	QT/DQT_IN	I	QT/DQT signal input
71	EEPCLK	O	EEPROM clock
72	EEPDAT	I/O	EEPROM data input / output
73	TH_DET	I	Temperature detect
74	DTMF	I	DTMF/BEEP output
75	AVSS	-	GND
76	PCTV	I	APC/BPF control voltage
77	VREF	I	Reference voltage input
78	AVCC	I	Power supply input
79	PLL_DAT	O	PLL data output
80	PLL_CLK	O	PLL clock output

管脚号码	信号名称	输入/输出	功能
58~62	EN5~EN1	输入	频道选择器输入
63	DIST1	输入	无功能
64	DIST2	输入	无功能
65	PLL_UL	输入	PLL 失锁信号输入
66	BATT	输入	电池电压检测
67	RSSI	输入	RSSI 输入
68	BUSY	输入	繁忙信号输入
69	VOX	输入	VOX 信号检测
70	QT/DQT_IN	输入	QT/DQT 信号输入
71	EEPCLK	输出	EEPROM 时钟
72	EEPDAT	输入/输出	EEPROM 数据输入/输出
73	TH_DET	输入	温度检测
74	DTMF	输入	DTMF/BEEP 输出
75	AVSS	-	GND
76	PCTV	输入	APC/BPF 控制电压
77	VREF	输入	参考电压输入
78	AVCC	输入	电源输入
79	PLL_DAT	输出	PLL 数据输出
80	PLL_CLK	输出	PLL 时钟输出

TERMINAL FUNCTION / 端子功能

TX-RX unit (X57-7570-20)

Pin No.	Name	I/O	Function
CN301			
1	B	I	B (Battery Voltage)
2	SB	O	Switched B
3	AFVOL_IN	I	Audio input
4	AFVOL_OUT	O	Audio output
5	AFVOL_GND	-	GND
6	EN1	I	Encoder pulse input
7	EN2	I	Encoder pulse input
8	GND	-	GND
9	EN3	I	Encoder pulse input
10	EN4	I	Encoder pulse input
11	EN5	I	Encoder pulse input

TX-RX 单元 (X57-7570-20)

管脚号码	名称	输入/输出	功能
CN301			
1	B	输入	B (电池电压)
2	SB	输出	可关闭的 B
3	AFVOL_IN	输入	音频输入
4	AFVOL_OUT	输出	音频输出
5	AFVOL_GND	-	GND
6	EN1	输入	编码器脉冲输入
7	EN2	输入	编码器脉冲输入
8	GND	-	GND
9	EN3	输入	编码器脉冲输入
10	EN4	输入	编码器脉冲输入
11	EN5	输入	编码器脉冲输入

COMPONENTS DESCRIPTION / 元件说明

TX-RX unit (X57-7570-20)

Ref. No.	Part Name	Description
IC1	IC	PLL system IC
IC2	IC	Prescaler
IC101	IC	APC
IC201	IC	FM system IC
IC301	IC	Voltage detector/ Reset
IC303,304	IC	Voltage regulator/ 5V
IC305	IC	EEPROM
IC306	IC	MCU
IC308	IC	Audio processor
IC309	IC	Audio amplifier
Q1	Transistor	Rectification
Q2	Transistor	Tripler
Q3	Transistor	RF amplifier
Q4	FET	VCO/ RX
Q5	FET	VCO/ TX
Q6	Transistor	Rectification
Q7	Transistor	DC switch/ RX VCO
Q8	Transistor	DC switch/ TX VCO
Q9	Transistor	RF amplifier
Q10	Transistor	Ripple filter
Q11	Transistor	RF amplifier
Q101	Transistor	RF amplifier
Q102	FET	TX drive amplifier
Q103	Transistor	Discharge switch
Q105	FET	TX final amplifier
Q106	Transistor	DC switch
Q107	FET	DC switch
Q108	Transistor	DC switch
Q201	Transistor	Wide/Narrow switch/ RX
Q202	Transistor	IF amplifier
Q203	FET	Mixer
Q204	FET	Low noise amplifier
Q301	Transistor	DC switch/ Red color LED
Q302	Transistor	DC switch/ Green color LED
Q303	Transistor	DC switch/ 5R
Q304	Transistor	DC switch/ 5T
Q305,306	Transistor	Beat shift switch
Q307	Transistor	Wide/Narrow switch/ TX
Q308	Transistor	Rectification
Q310,311	Transistor	MIC mute
Q312,313	Transistor	DC switch
Q314	Transistor	Mute switch
Q315,316	FET	Mute switch

TX-RX 单元 (X57-7570-20)

有关号码	名称	说明
IC1	IC	PLL 系统 IC
IC2	IC	预计计数器
IC101	IC	APC
IC201	IC	FM 系统 IC
IC301	IC	电压检测器 / 复位
IC303, 304	IC	稳压器 / 5V
IC305	IC	EEPROM
IC306	IC	MCU
IC308	IC	音频处理器
IC309	IC	音频放大器
Q1	晶体管	整流
Q2	晶体管	三倍频器
Q3	晶体管	RF 放大器
Q4	场效应管	VCO/ RX
Q5	场效应管	VCO/ TX
Q6	晶体管	整流
Q7	晶体管	DC 开关 / RX VCO
Q8	晶体管	DC 开关 / TX VCO
Q9	晶体管	RF 放大器
Q10	晶体管	纹波滤波器
Q11	晶体管	RF 放大器
Q101	晶体管	RF 放大器
Q102	场效应管	TX 驱动放大器
Q103	晶体管	放电开关
Q105	场效应管	TX 末级放大器
Q106	晶体管	DC 开关
Q107	场效应管	DC 开关
Q108	晶体管	DC 开关
Q201	晶体管	宽 / 窄开关 / RX
Q202	晶体管	中频放大器
Q203	场效应管	混频器
Q204	场效应管	低噪音放大器
Q301	晶体管	DC 开关 / 红色 LED
Q302	晶体管	DC 开关 / 绿色 LED
Q303	晶体管	DC 开关 / 5R
Q304	晶体管	DC 开关 / 5T
Q305, 306	晶体管	拍频偏移开关
Q307	晶体管	宽 / 窄开关 / TX
Q308	晶体管	整流
Q310, 311	晶体管	麦克风静音
Q312, 313	晶体管	DC 开关
Q314	晶体管	静音开关
Q315, 316	场效应管	静音开关

COMPONENTS DESCRIPTION / 元件说明

Ref. No.	Part Name	Description
D3	Variable Capacitance Diode	Frequency control/ RX VCO
D4	Variable Capacitance Diode	Frequency control/ TX VCO
D6	Variable Capacitance Diode	Frequency control/ RX VCO
D8	Variable Capacitance Diode	Frequency control/ TX VCO
D9	Variable Capacitance Diode	Modulator
D10	Diode	TX/RX RF switch
D101	Zener diode	Voltage protection
D103~105	Diode	ANT switch
D202~205	Variable Capacitance Diode	RF BPF tuning
D301	Diode	Reverse voltage protection
D302	Diode	Rectification
D303	LED	Red color LED
D304	LED	Green color LED
D306	Diode	Rectification
D307	Diode	Limiter
D308,309	Diode	Rectification

有关号码	名称	说明
D3	可变电容二极管	频率控制 / RX VCO
D4	可变电容二极管	频率控制 / TX VCO
D6	可变电容二极管	频率控制 / RX VCO
D8	可变电容二极管	频率控制 / TX VCO
D9	可变电容二极管	调制器
D10	二极管	TX/RX RF 开关
D101	稳压二极管	电压保护
D103~105	二极管	天线开关
D202~205	可变电容二极管	RF BPF 调谐
D301	二极管	逆向电压保护
D302	二极管	整流
D303	LED	红色 LED
D304	LED	绿色 LED
D306	二极管	整流
D307	二极管	限幅器
D308, 309	二极管	整流

TK-2307

PARTS LIST / 零件表

* New Parts. Δ indicates safety critical components.

Parts without **Parts No.** are not supplied.

Les articles non mentionnés dans le **Parts No.** ne sont pas fournis.

Teile ohne **Parts No.** werden nicht geliefert.

L : Scandinavia

Y : PX (Far East, Hawaii)

Y : AAFES (Europe)

K : USA

T : England

X : Australia

P : Canada

E : Europe

M : Other Areas

TK-2307 (Y50-634X-XX)

TX-RX UNIT (X57-7570-20)

Ref. No.	Address	New parts	Parts No.	Description	Destination
TK-2307					
1	1A	*	A02-4040-03	PLASTIC CABINET ASSY	
2	3A	*	A10-4124-01	CHASSIS	
4	2C,2E	*	B09-0725-03	CAP ACCESSORY	
7	1C	*	B62-2090-00	INSTRUCTION MANUAL	C
7	1C	*	B62-2108-00	INSTRUCTION MANUAL	X
8	1E	*	B62-2113-00	INSTRUCTION MANUAL	M
9	1A		D10-0649-03	LEVER	
10	1A		D21-0863-04	SHAFT	
11	1A		D32-0441-13	STOPPER	
13	2B		E04-0477-05	ANTENNA CONNECTOR (SMA)	
14	3A		E23-1253-04	TERMINAL (BATT-)	
15	2A		E23-1254-04	TERMINAL (BATT+)	
16	2B	*	E37-1175-15	SP WIRE LEAD (BROWN)	
17	2B	*	E37-1176-15	SP WIRE LEAD (GREEN)	
19	3A		F20-3353-14	INSULATING SHEET (CHASSIS BATT+)	
21	1A		G01-4542-04	COIL SPRING (LEVER)	
22	1A		G01-4543-14	COIL SPRING (STOPPER)	
23	2A		G10-1330-04	FIBROUS SHEET (AUDIO IC)	
24	2A	*	G11-4465-04	RUBBER SHEET (FINAL FET)	
25	3B		G13-2009-04	CUSHION (CHASSIS)	
26	3A		G13-2033-04	CUSHION (BATT-)	
27	3A		G13-2034-14	CUSHION (CHASSIS-)	
28	3A		G13-2038-24	CUSHION (CHASSIS-CERAMIC FILTER)	
29	2A		G13-2039-14	CUSHION (PCB-CERAMIC FILTER)	
30	3A		G53-1604-03	PACKING (CHASSIS)	
31	2A		G53-1605-03	PACKING (BATT+)	
32	2A		G53-1609-14	PACKING (ECM)	
33	2B	*	G53-1799-03	PACKING (VOLUME/SELECTOR)	
34	1B	*	G53-1800-03	PACKING (SP/MIC)	
35	1B	*	G53-1801-03	PACKING (SPEAKER)	
36	2B	*	G53-1802-04	PACKING (SMA)	
38	2E	*	H12-4250-05	PACKING FIXTURE	M
39	2D	*	H12-4251-05	PACKING FIXTURE	C,X
42	3E	*	H52-2299-03	ITEM CARTON CASE	M
43	3D	*	H52-2300-13	ITEM CARTON CASE	C,X
46	2A		J19-5463-03	HOLDER (BATT+)	
47	2A		J19-5473-03	HOLDER ASSY (BATT+)	
48	2C,2E	*	J19-5521-03	HOLDER (SP/MIC) ACCESSORY	
49	2B	*	J19-5522-03	SPEAKER CLASP	
50	2C,1E		J29-0734-05	BELT HOOK ACCESSORY	
51	2A	*	J82-0121-05	FPC	
52	1A	*	J99-0737-04	ADHESIVE SHEET (PTT)	
54	1B	*	K29-9309-13	KNOB (VOLUME)	
55	1A	*	K29-9425-03	BUTTON KNOB (PTT)	
56	1A	*	K29-9426-03	BUTTON KNOB (MON/PF)	
57	1B	*	K29-9427-03	KNOB (SELECTOR)	
A	3B	*	N14-0848-05	CIRCULAR NUT (SELECTOR)	
B	3B	*	N14-0849-05	CIRCULAR NUT (VOLUME)	
C	2B		N30-2604-48	PAN HEAD MACHINE SCREW (SMA)	
D	3A		N30-2606-48	PAN HEAD MACHINE SCREW	
E	2A,3A,2B		N63-2005-48	PAN HEAD TAPTITE SCREW	

Ref. No.	Address	New parts	Parts No.	Description	Destination
61	2C,2E		N99-2046-05	SCREW SET ACCESSORY	
63	2A	*	R31-0670-15	VARIABLE RESISTOR	
65	2A	*	S60-0440-05	ROTARY SWITCH	
67	1B		T07-0369-15	SPEAKER	
68	2D,2F		T90-1036-15	HELICAL ANTENNA	
71	1C		W08-0988-05	CHARGER	X
72	1D	*	W08-1069-05	AC ADAPTER (SWITCHING)	C
74	1C	*	W08-1074-05	CHARGER	C
TX-RX UNIT (X57-7570-20)					
D303		*	B30-2315-05	LED (RED)	
D304		*	B30-2314-05	LED (GREEN)	
C1			CK73HB1H332K	CHIP C 3300PF	K
C2			CK73HB1C682K	CHIP C 6800PF	K
C3			CK73GB1A105K	CHIP C 1.0UF	K
C4			CK73HB1A104K	CHIP C 0.10UF	K
C5			CK73HB1H102K	CHIP C 1000PF	K
C6			CK73HB1E103K	CHIP C 0.010UF	K
C7			CC73HCH1H100D	CHIP C 10PF	D
C8-10			CC73HCH1H101J	CHIP C 100PF	J
C11			CK73FBJ106K	CHIP C 10UF	K
C12			CK73HB1H102K	CHIP C 1000PF	K
C13			CC73HCH1H100D	CHIP C 10PF	D
C14,15			CK73HB1E103K	CHIP C 0.010UF	K
C16			CC73HCH1H470J	CHIP C 47PF	J
C17			CK73HB1E103K	CHIP C 0.010UF	K
C18			CC73HCH1H180J	CHIP C 18PF	J
C23			CK73HB1E103K	CHIP C 0.010UF	K
C25			CC73HCH1H300J	CHIP C 30PF	J
C26			CC73HCH1H020B	CHIP C 2.0PF	B
C27			CS77AA1VR33M	CHIP TNTL 0.33UF	35WV
C29			CC73HCH1H270J	CHIP C 27PF	J
C30			CK73HB1H102K	CHIP C 1000PF	K
C31			CK73HB1E103K	CHIP C 0.010UF	K
C32			CS77CA1C3R3M	CHIP TNTL 3.3UF	16WV
C33			CK73HB1H471K	CHIP C 470PF	K
C35			CS77CA1V0R1M	CHIP TNTL 0.1UF	35WV
C36			CK73HB1H332K	CHIP C 3300PF	K
C39			CK73HB1C682K	CHIP C 6800PF	K
C40			CC73HCH1H060B	CHIP C 6.0PF	B
C41			CC73HCH1H040B	CHIP C 4.0PF	B
C42			CC73HCH1H060B	CHIP C 6.0PF	B
C44,45			CK73GB1A105K	CHIP C 1.0UF	K
C47			CC73HCH1H150J	CHIP C 15PF	J
C49			CC73HCH1H0R5B	CHIP C 0.5PF	B
C50			CK73HB1H471K	CHIP C 470PF	K

PARTS LIST / 零件表

TX-RX UNIT (X57-7570-20)

Ref. No.	Address	New parts	Parts No.	Description	Desti-nation	Ref. No.	Address	New parts	Parts No.	Description	Desti-nation
C51			CC73HCH1H100D	CHIP C 10PF D		C151			CC73GCH1H100D	CHIP C 10PF D	
C52			CC73HCH1H121J	CHIP C 120PF J		C152			CC73GCH1H110J	CHIP C 11PF J	
C53			CC73HCH1H181J	CHIP C 180PF J		C153			CC73GCH1H100D	CHIP C 10PF D	
C56			CC73HCH1H060B	CHIP C 6.0PF B		C154			CC73GCH1H180J	CHIP C 18PF J	
C57			CC73HCH1H090B	CHIP C 9.0PF B		C155			CC73GCH1H120J	CHIP C 12PF J	
C58			CC73HCH1H020B	CHIP C 2.0PF B		C156			CC73GCH1H150J	CHIP C 15PF J	
C59			CC73HCH1H2R5B	CHIP C 2.5PF B		C157			CC73HCH1H330J	CHIP C 33PF J	
C60		*	CC73HCH1H4R5B	CHIP C 4.5PF B		C158			CC73GCH1H070B	CHIP C 7.0PF B	
C61			CC73HCH1H050B	CHIP C 5.0PF B		C201			CK73GB1C224K	CHIP C 0.22UF K	
C62			CK73HB1H471K	CHIP C 470PF K		C202			CK73FB0J106K	CHIP C 10UF K	
C63			CC73HCH1H050B	CHIP C 5.0PF B		C203			CK73HB1E103K	CHIP C 0.010UF K	
C64			CC73HCH1H060B	CHIP C 6.0PF B		C204			CK73HB1H102K	CHIP C 1000PF K	
C65			CC73HCH1H050B	CHIP C 5.0PF B		C205			CK73HB1H182K	CHIP C 1800PF K	
C66			CK73HB1H471K	CHIP C 470PF K		C206,207			CK73HB1H561K	CHIP C 560PF K	
C67			CC73HCH1H060B	CHIP C 6.0PF B		C208			CK73HB1A104K	CHIP C 0.10UF K	
C68			CK73HB1H471K	CHIP C 470PF K		C209			CC73HCH1H680J	CHIP C 68PF J	
C70,71			CC73HCH1H0R5B	CHIP C 0.5PF B		C210,211			CK73HB1A104K	CHIP C 0.10UF K	
C72,73			CK73HB1A104K	CHIP C 0.10UF K		C212			CK73HB1H102K	CHIP C 1000PF K	
C74			CK73HB1H102K	CHIP C 1000PF K		C213,214			CK73HB1A104K	CHIP C 0.10UF K	
C75			CK73HB1H471K	CHIP C 470PF K		C215			CC73HCH1H020B	CHIP C 2.0PF B	
C76			CS77CP0J100M	CHIP TNL 10UF 6.3WV		C216,217			CK73HB1E103K	CHIP C 0.010UF K	
C77			CK73HB1H102K	CHIP C 1000PF K		C220			CC73HCH1H010B	CHIP C 1.0PF B	
C78			CC73HCH1H330J	CHIP C 33PF J		C221			CC73HCH1H120J	CHIP C 12PF J	
C79,80			CK73HB1H471K	CHIP C 470PF K		C223			CC73HCH1H070B	CHIP C 7.0PF B	
C81			CC73HCH1H150J	CHIP C 15PF J		C224			CC73HCH1H060B	CHIP C 6.0PF B	
C82,83			CK73HB1H471K	CHIP C 470PF K		C225			CK73HB1E103K	CHIP C 0.010UF K	
C84			CK73HB1H102K	CHIP C 1000PF K		C226			CC73HCH1H130J	CHIP C 13PF J	
C86-88			CK73HB1H102K	CHIP C 1000PF K		C227			CC73HCH1H070B	CHIP C 7.0PF B	
C89			CC73HCH1H101J	CHIP C 100PF J		C228			CK73HB1A104K	CHIP C 0.10UF K	
C101			CK73HB1H102K	CHIP C 1000PF K		C229			CC73HCH1H060B	CHIP C 6.0PF B	
C102			CC73HCH1H390J	CHIP C 39PF J		C230			CK73HB1E103K	CHIP C 0.010UF K	
C103			CK73GB1A105K	CHIP C 1.0UF K		C231			CK73HB1H102K	CHIP C 1000PF K	
C106,107			CK73HB1H102K	CHIP C 1000PF K		C232			CC73HCH1H120J	CHIP C 12PF J	
C108			CC73HCH1H390J	CHIP C 39PF J		C233			CK73HB1H102K	CHIP C 1000PF K	
C109			CK73HB1A104K	CHIP C 0.10UF K		C235			CK73HB1E103K	CHIP C 0.010UF K	
C110			CK73HB1H102K	CHIP C 1000PF K		C236			CK73HB1H102K	CHIP C 1000PF K	
C114			CK73HB1H102K	CHIP C 1000PF K		C237			CC73HCH1H060B	CHIP C 6.0PF B	
C118			CK73HB1H102K	CHIP C 1000PF K		C238			CK73HB1H102K	CHIP C 1000PF K	
C119			CC73HCH1H270J	CHIP C 27PF J		C243			CK73FB0J106K	CHIP C 10UF K	
C120			CK73HB1H102K	CHIP C 1000PF K		C244			CC73HCH1H030B	CHIP C 3.0PF B	
C122,123			CK73HB1H102K	CHIP C 1000PF K		C245			CK73HB1H102K	CHIP C 1000PF K	
C124			CK73GB1A105K	CHIP C 1.0UF K		C246			CC73HCH1H560J	CHIP C 56PF J	
C125			CK73HB1E103K	CHIP C 0.010UF K		C247			CC73HCH1H030B	CHIP C 3.0PF B	
C127			CK73GB1A105K	CHIP C 1.0UF K		C248			CK73HB1H102K	CHIP C 1000PF K	
C129,130			CK73HB1H102K	CHIP C 1000PF K		C249			CC73HCH1H2R5B	CHIP C 2.5PF B	
C131			CC73HCH1H101J	CHIP C 100PF J		C250			CC73HCH1H560J	CHIP C 56PF J	
C132			CC73GCH1H100D	CHIP C 10PF D		C251			CC73GCH1H050B	CHIP C 5.0PF B	
C134			CK73HB1H102K	CHIP C 1000PF K		C252			CK73HB1H102K	CHIP C 1000PF K	
C135			CK73HB1A104K	CHIP C 0.10UF K		C254,255			CK73HB1H102K	CHIP C 1000PF K	
C136			CK73HB1H471K	CHIP C 470PF K		C257			CC73HCH1H390J	CHIP C 39PF J	
C138			CC73GCH1H270J	CHIP C 27PF J		C258			CC73HCH1H040B	CHIP C 4.0PF B	
C139			CC73GCH1H680J	CHIP C 68PF J		C259			CC73HCH1H560J	CHIP C 56PF J	
C140			CK73HB1H102K	CHIP C 1000PF K		C260			CC73HCH1H040B	CHIP C 4.0PF B	
C141			CC73GCH1H270J	CHIP C 27PF J		C261			CK73HB1H102K	CHIP C 1000PF K	
C143			CC73GCH1H130J	CHIP C 13PF J		C262			CC73HCH1H040B	CHIP C 4.0PF B	
C145			CC73GCH1H820J	CHIP C 82PF J		C263			CC73HCH1H560J	CHIP C 56PF J	
C146			CC73GCH1H070B	CHIP C 7.0PF B		C264			CC73HCH1H050B	CHIP C 5.0PF B	
C148			CK73HB1H102K	CHIP C 1000PF K		C265			CC73HCH1H300J	CHIP C 30PF J	
C149			CC73GCH1H220J	CHIP C 22PF J		C303			CK73HB1H102K	CHIP C 1000PF K	
C150			CK73GB1H102K	CHIP C 1000PF K		C304			CK73HB1A104K	CHIP C 0.10UF K	

PARTS LIST / 零件表

TX-RX UNIT (X57-7570-20)

Ref. No.	Address	New parts	Parts No.	Description	Destination	Ref. No.	Address	New parts	Parts No.	Description	Destination
C305			CC73HCH1H101J	CHIP C 100PF J		C405			CC73HCH1H221J	CHIP C 220PF J	
C306			CK73GB1A105K	CHIP C 1.0UF K		C408			CK73HB1H102K	CHIP C 1000PF K	
C307			CC73HCH1H101J	CHIP C 100PF J		C413-415			CK73HB1H102K	CHIP C 1000PF K	
C310			CK73GB1A105K	CHIP C 1.0UF K		C418			CC73HCH1H390J	CHIP C 39PF J	
C311			CC73HCH1H101J	CHIP C 100PF J		TC1,2			C05-0384-05	CERAMIC TRIMMER CAP (10PF)	
C312			CK73HB1H102K	CHIP C 1000PF K		CN301			E40-6573-05	FLAT CABLE CONNECTOR	
C313			CC73HCH1H101J	CHIP C 100PF J		J301			E11-0703-05	PHONE JACK (2.5/3.5)	
C315			CC73HCH1H101J	CHIP C 100PF J		F301			F53-0324-05	FUSE (2.5A)	
C316			CK73HB1H102K	CHIP C 1000PF K		101	2A		J30-1282-14	SPACER	
C318			CK73HB1E103K	CHIP C 0.010UF K		CD201			L79-1866-05	TUNING COIL	
C319,320			CK73HB1H102K	CHIP C 1000PF K		CF201	2A		L72-0973-05	CERAMIC FILTER	
C321			CK73GB1A105K	CHIP C 1.0UF K		L1			L92-0138-05	CHIP FERRITE	
C322			CK73HB1H102K	CHIP C 1000PF K		L2			L40-4791-86	SMALL FIXED INDUCTOR (4.7UH)	
C323			CK73GB1A105K	CHIP C 1.0UF K		L4			L40-5681-86	SMALL FIXED INDUCTOR (0.56UH)	
C325			CK73HB1H102K	CHIP C 1000PF K		L6			L40-5681-86	SMALL FIXED INDUCTOR (0.56UH)	
C327			CK73HB1H102K	CHIP C 1000PF K		L7			L92-0138-05	CHIP FERRITE	
C331			CK73HB1A104K	CHIP C 0.10UF K		L8			L40-1875-71	SMALL FIXED INDUCTOR (18NH)	
C332			CC73HCH1H050B	CHIP C 5.0PF B		L9			L92-0470-05	CHIP FERRITE	
C334			CK73HB1E103K	CHIP C 0.010UF K		L10,11			L40-1885-92	SMALL FIXED INDUCTOR (180NH)	
C335			CK73FB0J106K	CHIP C 10UF K		L12			L40-3375-71	SMALL FIXED INDUCTOR (33NH)	
C337			CC73HCH1H050B	CHIP C 5.0PF B		L13,14			L40-1885-92	SMALL FIXED INDUCTOR (180NH)	
C339			CK73GB1A105K	CHIP C 1.0UF K		L15			L40-3378-67	SMALL FIXED INDUCTOR (33NH)	
C341			CK73HB1H102K	CHIP C 1000PF K		L16			L40-2278-67	SMALL FIXED INDUCTOR (22NH)	
C353,354			CK73HB1E103K	CHIP C 0.010UF K		L17,18			L41-2785-45	SMALL FIXED INDUCTOR (270NH)	
C356			CK73HB1H102K	CHIP C 1000PF K		L19,20			L40-1885-92	SMALL FIXED INDUCTOR (180NH)	
C358			CK73GB1C224K	CHIP C 0.22UF K		L21			L92-0138-05	CHIP FERRITE	
C359			CK73FB0J106K	CHIP C 10UF K		L22			L40-3975-71	SMALL FIXED INDUCTOR (39NH)	
C360			CK73HB1A104K	CHIP C 0.10UF K		L23			L92-0138-05	CHIP FERRITE	
C361			CK73GB1A105K	CHIP C 1.0UF K		L24			L40-8275-71	SMALL FIXED INDUCTOR (82NH)	
C362			CK73HB1H102K	CHIP C 1000PF K		L102			L40-4775-71	SMALL FIXED INDUCTOR (47NH)	
C363			CC73HCH1H820J	CHIP C 82PF J		L103			L41-1585-45	SMALL FIXED INDUCTOR (150NH)	
C364			CC73HCH1H120J	CHIP C 12PF J		L104	*		L92-0472-05	CHIP FERRITE	
C365			CC73HCH1H121J	CHIP C 120PF J		L105			L40-2275-92	SMALL FIXED INDUCTOR (22NH)	
C366			CK73HB1A104K	CHIP C 0.10UF K		L106			L34-4577-05	AIR-CORE COIL	
C367			CK73GB1A105K	CHIP C 1.0UF K		L107	*		L92-0472-05	CHIP FERRITE	
C368			CK73HB1H271K	CHIP C 270PF K		L108			L34-4563-05	AIR-CORE COIL	
C369,370			CK73HB1A104K	CHIP C 0.10UF K		L109			L34-4573-05	AIR-CORE COIL	
C371			CK73FB0J106K	CHIP C 10UF K		L110			L34-4575-05	AIR-CORE COIL	
C372			CK73HB1H102K	CHIP C 1000PF K		L111	*		L41-6885-39	SMALL FIXED INDUCTOR (0.68UH)	
C373			CC73HCH1H121J	CHIP C 120PF J		L112			L34-4576-05	AIR-CORE COIL	
C374-376			CK73HB1H102K	CHIP C 1000PF K		L113			L34-4575-05	AIR-CORE COIL	
C377			CK73HB1A683K	CHIP C 0.068UF K		L114			L34-4567-05	AIR-CORE COIL	
C378			CC73HCH1H820J	CHIP C 82PF J		L115			L40-1275-92	SMALL FIXED INDUCTOR (12NH)	
C379,380			CK73GB1A105K	CHIP C 1.0UF K		L116			L34-4566-05	AIR-CORE COIL	
C381			CK73HB1H391K	CHIP C 390PF K		L117			L41-1092-44	SMALL FIXED INDUCTOR (1UH)	
C382			CK73HB1C153K	CHIP C 0.015UF K		L201			L40-1091-86	SMALL FIXED INDUCTOR (1.0UH)	
C383-385			CK73HB1A104K	CHIP C 0.10UF K		L202,203			L40-3975-71	SMALL FIXED INDUCTOR (39NH)	
C386			CK73HB1E103K	CHIP C 0.010UF K		L204			L92-0138-05	CHIP FERRITE	
C388,389			CK73HB1H102K	CHIP C 1000PF K		L205			L41-5685-39	SMALL FIXED INDUCTOR (0.56UH)	
C390,391			CK73GB1A105K	CHIP C 1.0UF K		L206			L40-1885-92	SMALL FIXED INDUCTOR (180NH)	
C392			CK73HB1A333K	CHIP C 0.033UF K		L207			L40-1085-92	SMALL FIXED INDUCTOR (100NH)	
C393			CK73FB0J106K	CHIP C 10UF K		L209			L41-5678-14	SMALL FIXED INDUCTOR (56NH)	
C395			CC73HCH1H221J	CHIP C 220PF J		L210			L92-0138-05	CHIP FERRITE	
C396			CK73HB1A104K	CHIP C 0.10UF K		L211			L41-5678-14	SMALL FIXED INDUCTOR (56NH)	
C397			CK73GB1C474K	CHIP C 0.47UF K		L213			L41-5678-14	SMALL FIXED INDUCTOR (56NH)	
C399			CC73HCH1H101J	CHIP C 100PF J		L214			L41-2778-14	SMALL FIXED INDUCTOR (27NH)	
C400			CK73FB0J106K	CHIP C 10UF K		L216			L41-2778-14	SMALL FIXED INDUCTOR (27NH)	
C402			CK73HB1A104K	CHIP C 0.10UF K		L216			L41-2778-14	SMALL FIXED INDUCTOR (27NH)	
C403			CK73HB1A473J	CHIP C 0.047UF J		L301	*		L92-0472-05	CHIP FERRITE	
C404			CS77CC0J101M	CHIP TNL 100UF 6.3WV							

PARTS LIST / 零件表

TX-RX UNIT (X57-7570-20)

Ref. No.	Address	New parts	Parts No.	Description	Desti-nation	Ref. No.	Address	New parts	Parts No.	Description	Desti-nation
L302-304			L92-0138-05	CHIP FERRITE		R107			RK73HB1J331J	CHIP R 330 J 1/16W	
L305			L92-0140-05	CHIP FERRITE		R108			RK73HB1J473J	CHIP R 47K J 1/16W	
L306			L40-2775-71	SMALL FIXED INDUCTOR (27NH)		R109			RK73HB1J271J	CHIP R 270 J 1/16W	
X1		*	L77-3042-05	TCXO (12.8MHZ)		R110			RK73HB1J104J	CHIP R 100K J 1/16W	
X301		*	L78-1433-05	RESONATOR (14.746MHZ)		R111			RK73HB1J822J	CHIP R 8.2K J 1/16W	
XF201			L71-0619-05	MCF (38.85MHZ/6.5KH)		R113			RK73HB1J331J	CHIP R 330 J 1/16W	
CP1			RK75HA1J101J	CHIP-COM 100 J 1/16W		R114			RK73GB2A000J	CHIP R 0.0 J 1/10W	
CP201			RK75HA1J104J	CHIP-COM 100K J 1/16W		R116			RK73HB1J000J	CHIP R 0.0 J 1/16W	
CP202			RK75HA1J474J	CHIP-COM 470K J 1/16W		R117			RK73EB2ER39K	CHIP R 0.39 K 1/4W	
CP203			RK75HA1J104J	CHIP-COM 100K J 1/16W		R118			RK73HB1J222J	CHIP R 2.2K J 1/16W	
CP204			RK75HA1J474J	CHIP-COM 470K J 1/16W		R119			RK73HB1J473J	CHIP R 47K J 1/16W	
CP301,302			RK75HA1J473J	CHIP-COM 47K J 1/16W		R120			RK73EB2ER39K	CHIP R 0.39 K 1/4W	
CP303,304			RK75HA1J102J	CHIP-COM 1.0K J 1/16W		R121			RK73HB1J470J	CHIP R 47 J 1/16W	
R1			RK73HB1J223J	CHIP R 22K J 1/16W		R122			RK73HB1J104J	CHIP R 100K J 1/16W	
R2			RK73HB1J103J	CHIP R 10K J 1/16W		R123			RK73EB2ER39K	CHIP R 0.39 K 1/4W	
R3			RK73HB1J473J	CHIP R 47K J 1/16W		R124,125			RK73GH2A154D	CHIP R 150K D 1/10W	
R4			RK73HB1J104J	CHIP R 100K J 1/16W		R126,127			RK73GH2A334D	CHIP R 330K D 1/10W	
R5			RK73HB1J154J	CHIP R 150K J 1/16W		R128			RK73HB1J105J	CHIP R 1.0M J 1/16W	
R7			RK73HB1J000J	CHIP R 0.0 J 1/16W		R129			RK73HB1J473J	CHIP R 47K J 1/16W	
R8			RK73HB1J101J	CHIP R 100 J 1/16W		R130			RK73HB1J000J	CHIP R 0.0 J 1/16W	
R9			RK73HB1J222J	CHIP R 2.2K J 1/16W		R131			RK73HB1J563J	CHIP R 56K J 1/16W	
R10			RK73HB1J102J	CHIP R 1.0K J 1/16W		R132			RK73HB1J104J	CHIP R 100K J 1/16W	
R11			RK73HB1J334J	CHIP R 330K J 1/16W		R133			RK73HB1J474J	CHIP R 470K J 1/16W	
R12			RK73HB1J221J	CHIP R 220 J 1/16W		R134			RK73GB2A151J	CHIP R 150 J 1/10W	
R13			RK73HB1J101J	CHIP R 100 J 1/16W		R201			RK73HB1J184J	CHIP R 180K J 1/16W	
R14			RK73HB1J100J	CHIP R 10 J 1/16W		R203			RK73HB1J472J	CHIP R 4.7K J 1/16W	
R15			RK73HB1J561J	CHIP R 560 J 1/16W		R204			RK73HB1J823J	CHIP R 82K J 1/16W	
R16			RK73HB1J000J	CHIP R 0.0 J 1/16W		R205			RK73HB1J100J	CHIP R 10 J 1/16W	
R17			RK73HB1J152J	CHIP R 1.5K J 1/16W		R206			RK73HB1J272J	CHIP R 2.7K J 1/16W	
R18			RK73HB1J681J	CHIP R 680 J 1/16W		R207			RK73HB1J332J	CHIP R 3.3K J 1/16W	
R19			RK73HB1J223J	CHIP R 22K J 1/16W		R208			RK73HB1J823J	CHIP R 82K J 1/16W	
R20			RK73HB1J000J	CHIP R 0.0 J 1/16W		R209			RK73HB1J332J	CHIP R 3.3K J 1/16W	
R21,22			RK73HB1J103J	CHIP R 10K J 1/16W		R210,211			RK73HB1J472J	CHIP R 4.7K J 1/16W	
R26			RK73HB1J273J	CHIP R 27K J 1/16W		R212			RK73HB1J101J	CHIP R 100 J 1/16W	
R27			RK73HB1J824J	CHIP R 820K J 1/16W		R213			RK73HB1J184J	CHIP R 180K J 1/16W	
R28			RK73HB1J102J	CHIP R 1.0K J 1/16W		R214			RK73HB1J471J	CHIP R 470 J 1/16W	
R29			RK73HB1J154J	CHIP R 150K J 1/16W		R215			RK73HB1J391J	CHIP R 390 J 1/16W	
R30			RK73HB1J104J	CHIP R 100K J 1/16W		R216			RK73HB1J561J	CHIP R 560 J 1/16W	
R31			RK73HB1J274J	CHIP R 270K J 1/16W		R217			RK73HB1J221J	CHIP R 220 J 1/16W	
R32			RK73HB1J684J	CHIP R 680K J 1/16W		R218,219			RK73HB1J104J	CHIP R 100K J 1/16W	
R33			RK73HB1J101J	CHIP R 100 J 1/16W		R220			RK73HB1J560J	CHIP R 56 J 1/16W	
R34			RK73HB1J181J	CHIP R 180 J 1/16W		R222,223			RK73HB1J000J	CHIP R 0.0 J 1/16W	
R35			RK73HB1J680J	CHIP R 68 J 1/16W		R224			RK73HB1J222J	CHIP R 2.2K J 1/16W	
R36			RK73HB1J101J	CHIP R 100 J 1/16W		R225			RK73HB1J470J	CHIP R 47 J 1/16W	
R37			RK73HB1J472J	CHIP R 4.7K J 1/16W		R226			RK73HB1J221J	CHIP R 220 J 1/16W	
R38			RK73HB1J154J	CHIP R 150K J 1/16W		R228			RK73HB1J563J	CHIP R 56K J 1/16W	
R39			RK73HB1J101J	CHIP R 100 J 1/16W		R229			RK73HB1J100J	CHIP R 10 J 1/16W	
R40			RK73HB1J100J	CHIP R 10 J 1/16W		R230			RK73HB1J000J	CHIP R 0.0 J 1/16W	
R41			RK73HB1J102J	CHIP R 1.0K J 1/16W		R231			RK73HB1J102J	CHIP R 1.0K J 1/16W	
R42,43			RK73HB1J332J	CHIP R 3.3K J 1/16W		R301			RK73HH1J474D	CHIP R 470K D 1/16W	
R44			RK73HB1J220J	CHIP R 22 J 1/16W		R302			RK73GB2A000J	CHIP R 0.0 J 1/10W	
R45			RK73HB1J331J	CHIP R 330 J 1/16W		R303			RK73HB1J101J	CHIP R 100 J 1/16W	
R46			RK73HB1J222J	CHIP R 2.2K J 1/16W		R304			RK73HB1J334J	CHIP R 330K J 1/16W	
R47			RK73HB1J472J	CHIP R 4.7K J 1/16W		R305			RK73HH1J474D	CHIP R 470K D 1/16W	
R101,102			RK73HB1J103J	CHIP R 10K J 1/16W		R306			RK73HB1J184J	CHIP R 180K J 1/16W	
R103			RK73HB1J331J	CHIP R 330 J 1/16W		R307			RK73GB2A271J	CHIP R 270 J 1/10W	
R104			RK73HB1J220J	CHIP R 22 J 1/16W		R308			RK73GB2A221J	CHIP R 220 J 1/10W	
R105			RK73HB1J331J	CHIP R 330 J 1/16W		R309,310			RK73GB2A000J	CHIP R 0.0 J 1/10W	
R106			RK73HB1J180J	CHIP R 18 J 1/16W		R313			RK73HB1J102J	CHIP R 1.0K J 1/16W	
						R314,315			RK73HB1J103J	CHIP R 10K J 1/16W	

PARTS LIST / 零件表

TX-RX UNIT (X57-7570-20)

Ref. No.	Address	New parts	Parts No.	Description	Destination	Ref. No.	Address	New parts	Parts No.	Description	Destination
R316			RK73HB1J222J	CHIP R 2.2K J 1/16W		MIC301	2A		T91-0651-15	MIC ELEMENT (ECM)	
R317			RK73HB1J472J	CHIP R 4.7K J 1/16W		D3,4			1SV325F	VARIABLE CAPACITANCE DIODE	
R318			RK73HB1J182J	CHIP R 1.8K J 1/16W		D6			1SV325F	VARIABLE CAPACITANCE DIODE	
R319			RK73HB1J000J	CHIP R 0.0 J 1/16W		D8			1SV325F	VARIABLE CAPACITANCE DIODE	
R320			RK73HB1J123J	CHIP R 12K J 1/16W		D9			1SV278F	VARIABLE CAPACITANCE DIODE	
						D10			MC2858	DIODE	
R321			RK73HB1J103J	CHIP R 10K J 1/16W		D101			UDZW5.1(B)	ZENER DIODE	
R323			RK73HB1J102J	CHIP R 1.0K J 1/16W		D103			HSC277	DIODE	
R324,325			RK73HB1J472J	CHIP R 4.7K J 1/16W		D104,105			HVC131	DIODE	
R340-342			RK73HB1J103J	CHIP R 10K J 1/16W		D202-205			1SV305F	VARIABLE CAPACITANCE DIODE	
R344			RK73HB1J474J	CHIP R 470K J 1/16W		D301			GN1G	DIODE	
R345			RK73HB1J273J	CHIP R 27K J 1/16W		D302	*		HRC0203C	DIODE	
R347			RK73GB2A000J	CHIP R 0.0 J 1/10W		D306	*		KDR731	DIODE	
R348			RK73HB1J102J	CHIP R 1.0K J 1/16W		D307			MC2850	DIODE	
R349			RK73HB1J105J	CHIP R 1.0M J 1/16W		D308,309	*		KDR731	DIODE	
R350			RK73HB1J124J	CHIP R 120K J 1/16W		IC1			MB15A02PFV2E1	MOS-IC	
R351			RK73HB1J334J	CHIP R 330K J 1/16W		IC2			UPB1509GV	BI-POLAR IC	
R352			RK73HB1J104J	CHIP R 100K J 1/16W		IC101	*		BA2904FVM	MOS-IC	
R353			RK73HB1J123J	CHIP R 12K J 1/16W		IC201			TA31136FNG	MOS-IC	
R354			RK73HB1J334J	CHIP R 330K J 1/16W		IC301			BD4840FVE	MOS-IC	
R355			RK73HB1J124J	CHIP R 120K J 1/16W		IC303			XC6209B502PPR	MOS-IC	
R356			RK73HB1J472J	CHIP R 4.7K J 1/16W		IC304	*		XC6209B502MR	MOS-IC	
R357			RK73HB1J563J	CHIP R 56K J 1/16W		IC305			BR24L16F-W	ROM IC	
R358			RK73HB1J474J	CHIP R 470K J 1/16W		IC306	*		R5F212CCKCMB	MICRO CONTROL UNIT	
R359			RK73HB1J473J	CHIP R 47K J 1/16W		IC308			AQUA-L	MOS-IC	
R360			RK73HB1J332J	CHIP R 3.3K J 1/16W		IC309			TA7368FG	MOS-IC	
R361			RK73GB2A000J	CHIP R 0.0 J 1/10W		Q1	*		KTC4075E(Y,GR)	TRANSISTOR	
R362			RK73HB1J184J	CHIP R 180K J 1/16W		Q2	*		2SC4774	TRANSISTOR	
R363,364			RK73HB1J104J	CHIP R 100K J 1/16W		Q3			2SC5636	TRANSISTOR	
R365			RK73HB1J332J	CHIP R 3.3K J 1/16W		Q4,5			2SK1875-F(V)	FET	
R366			RK73HB1J154J	CHIP R 150K J 1/16W		Q6	*		KTC4075E(Y,GR)	TRANSISTOR	
R367			RK73HB1J393J	CHIP R 39K J 1/16W		Q7,8			RT1P430U	TRANSISTOR	
R368			RK73GB2A000J	CHIP R 0.0 J 1/10W		Q9			2SC5636	TRANSISTOR	
R369			RK73HB1J823J	CHIP R 82K J 1/16W		Q10	*		KTC4075E(Y,GR)	TRANSISTOR	
R370			RK73HB1J102J	CHIP R 1.0K J 1/16W		Q11			2SC5636	TRANSISTOR	
R371			RK73HB1J272J	CHIP R 2.7K J 1/16W		Q101			2SC4926YD	TRANSISTOR	
R372			RK73HB1J000J	CHIP R 0.0 J 1/16W		Q102			ROA0004PXDOQ	FET	
R373			RK73HB1J224J	CHIP R 220K J 1/16W		Q103			RT1N441U	TRANSISTOR	
R374			RK73HB1J123J	CHIP R 12K J 1/16W		Q105			RD07MVS1BT122	FET	
R375			RK73HB1J182J	CHIP R 1.8K J 1/16W		Q106			RT1N441U	TRANSISTOR	
R376			RK73HB1J471J	CHIP R 470 J 1/16W		Q107			2SK1824-A	FET	
R377			RK73HB1J473J	CHIP R 47K J 1/16W		Q108			RT1P441U	TRANSISTOR	
R378			RK73HB1J561J	CHIP R 560 J 1/16W		Q201			RT1P441U	TRANSISTOR	
R379			RK73HB1J102J	CHIP R 1.0K J 1/16W		Q202	*		2SC4774	TRANSISTOR	
R380			RK73HB1J474J	CHIP R 470K J 1/16W		Q203,204			3SK318	FET	
R381			RK73HB1J151J	CHIP R 150 J 1/16W		Q301,302			RT1N441U	TRANSISTOR	
R383			RK73HB1J563J	CHIP R 56K J 1/16W		Q303			RT1P141U	TRANSISTOR	
R384			RK73HB1J333J	CHIP R 33K J 1/16W		Q304	*		DTB723YE	DIGITAL TRANSISTOR	
R385			RK73GB2A101J	CHIP R 100 J 1/10W		Q305,306			2SC4919	TRANSISTOR	
R387			RK73HB1J104J	CHIP R 100K J 1/16W		Q307			RT1N441U	TRANSISTOR	
R388			RK73HB1J101J	CHIP R 100 J 1/16W		Q308	*		KTC4075E(Y,GR)	TRANSISTOR	
R389			RK73HB1J000J	CHIP R 0.0 J 1/16W		Q310			2SC4116(GR)F	TRANSISTOR	
R390			RK73GB2A000J	CHIP R 0.0 J 1/10W		Q311			2SA1586(Y,GR)F	TRANSISTOR	
R391			RK73HB1J102J	CHIP R 1.0K J 1/16W		Q312			RT1N441U	TRANSISTOR	
R393			RK73GB2A000J	CHIP R 0.0 J 1/10W		Q313	*		2SB1694	TRANSISTOR	
R394			RK73HB1J473J	CHIP R 47K J 1/16W		Q314			RT1N441U	TRANSISTOR	
R398			RK73HB1J000J	CHIP R 0.0 J 1/16W		Q315,316			2SK3577-A	FET	
VR1		*	R32-0737-05	SEMI FIXED VARIABLE RESISTOR		TH101			B57331V2104J	THERMISTOR	
S1-3			S70-0414-05	TACT SWITCH		TH201			B57331V2104J	THERMISTOR	

EXPLODED VIEW / 部件分解图

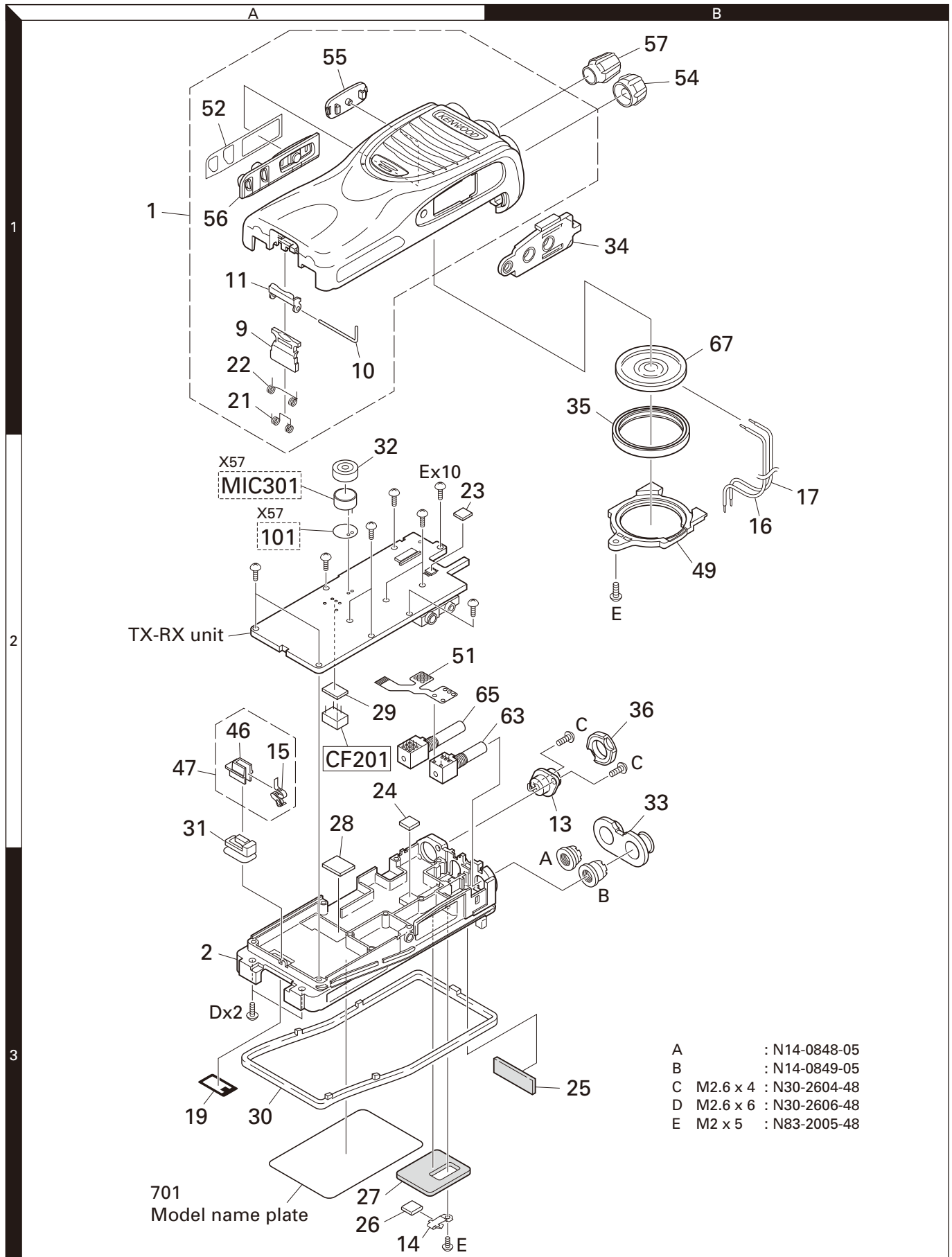

Parts with the exploded numbers larger than 700 are not supplied.

If a part reference number is listed in a box on the exploded view of the PCB, that part does not come with the PCB. These parts must be ordered separately.

PACKING (C,X TYPE) / 包装 (C,X 类型)

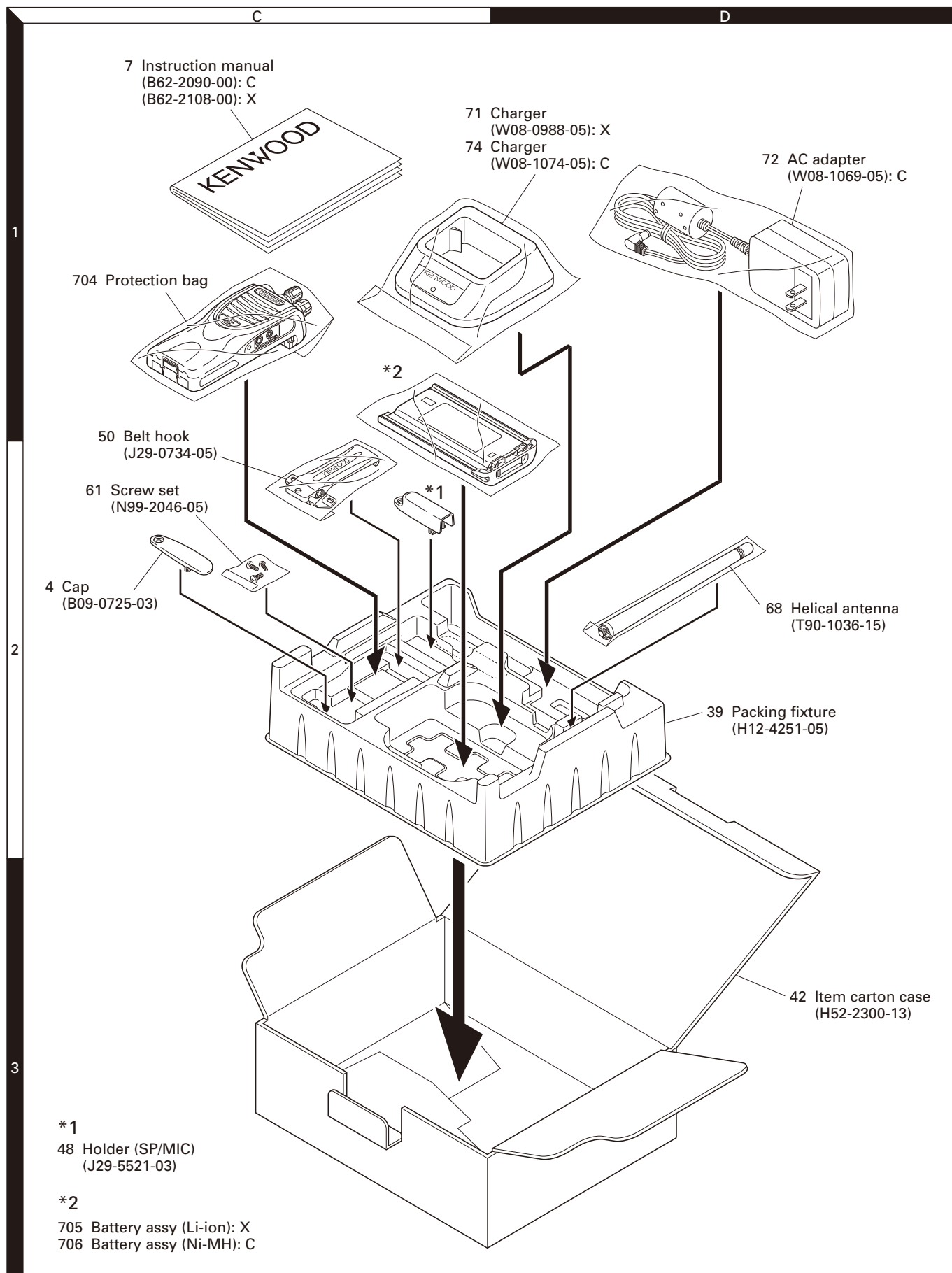

Parts with the exploded numbers larger than 700 are not supplied.

PACKING (M TYPE) / 包装 (M 类型)

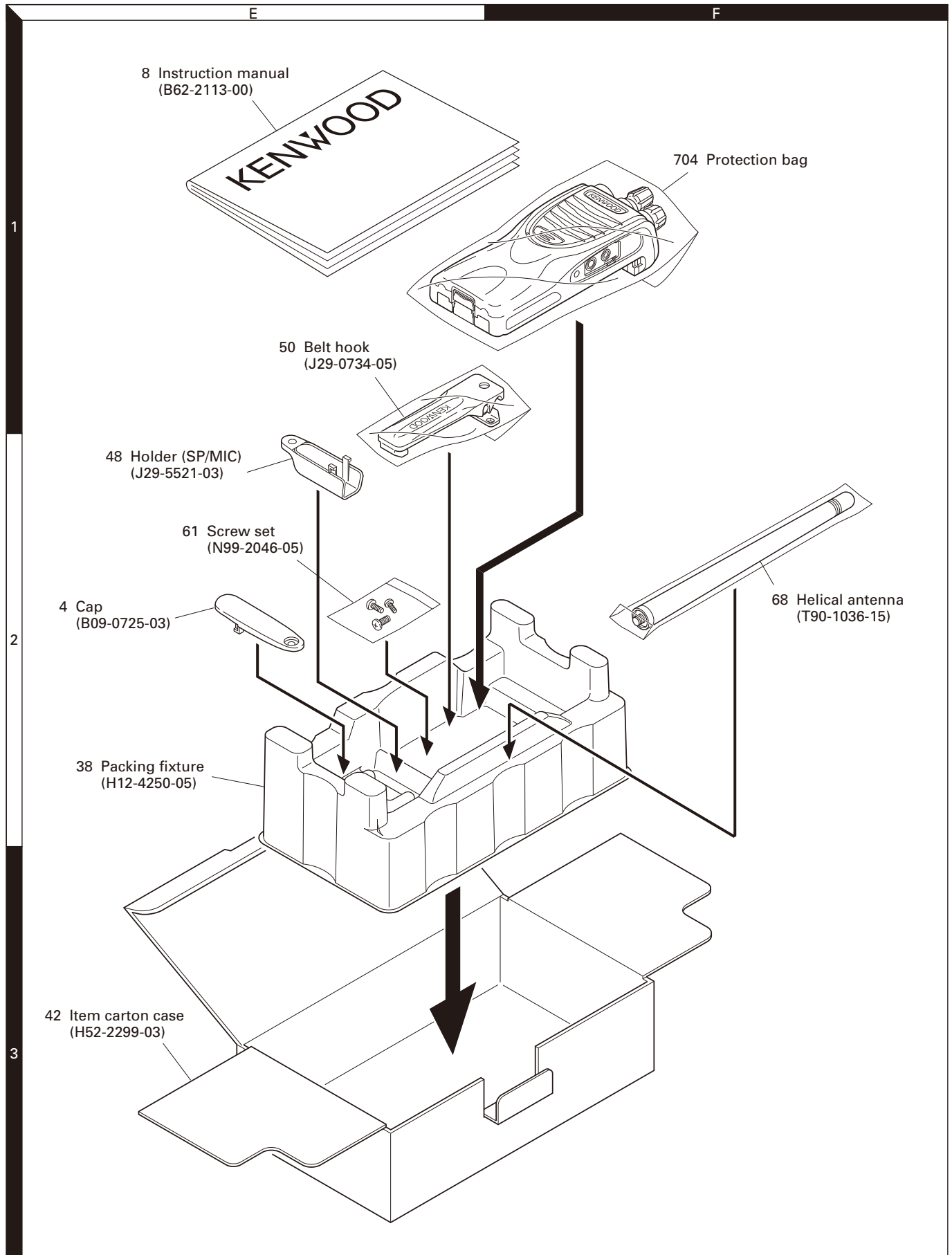

Parts with the exploded numbers larger than 700 are not supplied.

ADJUSTMENT

Test Equipment Required for Alignment

Test Equipment	Major Specifications	
1. Standard Signal Generator (SSG)	Frequency Range Modulation Output	136 to 174MHz Frequency modulation and external modulation -127dBm/0.1μV to greater than -47dBm/1mV
2. RF Power Meter	Input Impedance Operation Frequency Measurement Range	50Ω 136 to 174MHz Vicinity of 10W
3. Deviation Meter	Frequency Range	136 to 174MHz
4. Digital Volt Meter (DVM)	Measuring Range Input Impedance	10mV to 10V DC High input impedance for minimum circuit loading
5. Oscilloscope		DC through 30MHz
6. High Sensitivity Frequency Counter	Frequency Range Frequency Stability	10Hz to 1000MHz 0.2ppm or less
7. DC Ammeter		5A
8. AF Volt Meter (AF VTVM)	Frequency Range Voltage Range	50Hz to 10kHz 1mV to 10V
9. Audio Generator (AG)	Frequency Range Output	50Hz to 5kHz or more 0 to 1V
10. Distortion Meter	Capability Input Level	3% or less at 1kHz 50mV to 10Vrms
11. Spectrum Analyzer	Measuring Range	DC to 1GHz or more
12. Tracking Generator	Center frequency Output Voltage	50kHz to 600MHz 100mV or more
13. 4Ω Dummy Load		Approx. 4Ω, 3W
14. Regulated Power Supply		5V to 10V, approx. 3A Useful if ammeter equipped

■ Antenna connector adapter

The antenna connector of this transceiver uses an SMA terminal.

Use an antenna connector adapter [SMA(f) – BNC(f) or SMA(f) – N(f)] for adjustment. (The adapter is not provided as an option, so buy a commercially-available one.)

■ Repair Jig (Chassis)

Use jig (part No.: A10-4215-03) for repairing the transceiver. Place the TX-RX unit on the jig and fit it with screws.

The jig facilitates the voltage check and protects the final amplifier FET when the voltage on the flow side of the TX-RX unit is checked during repairs.

■ Battery Jig (W05-1011-00)

Connect the power cable properly between the battery jig installed in the transceiver and the power supply, and be sure output voltage and the power supply polarity prior to switching the power supply ON, otherwise over voltage and reverse connection may damage the transceiver, or the power supply or both.

Note: When using the battery jig, you must measure the voltage at the terminals of the battery jig. Otherwise, a slight voltage drop may occur within the power cable, between the power supply and the battery jig, especially while the transceiver transmits.

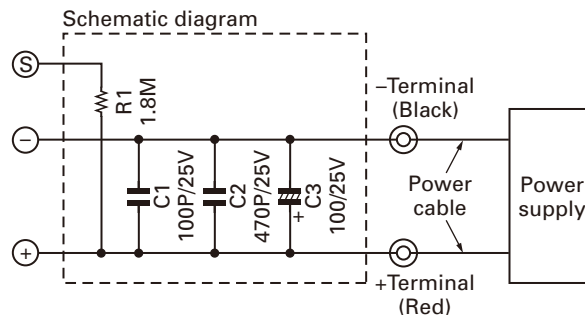
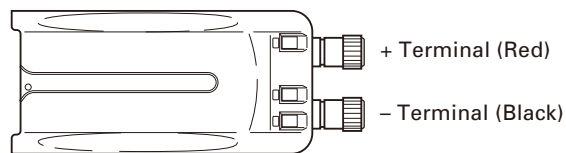

调 整

所需的用于调整的测试设备

测试设备	主要规格	
1. 标准信号发生器 (SSG)	频率范围 调制 输出	136 到 174MHz 调频和外部调制 -127dBm/0.1 μ V 到大于 -47dBm/1mV
2. RF 功率计	输入阻抗 操作频率 测量范围	50 Ω 136 到 174MHz 10W 左右
3. 频偏仪	频率范围	136 到 174MHz
4. 数字电压表 (DVM)	测量范围 输入阻抗	直流 10mV 到 10V 为最小电路负载高输入阻抗
5. 示波器		直流到 30MHz
6. 高灵敏度频率计数器	频率范围 频率稳定性	10Hz 到 1000MHz 0.2ppm 或更低
7. 直流电流表		5A
8. 音频电压表 (AF VTVM)	频率范围 电压范围	50Hz 到 10kHz 1mV 到 10V
9. 音频发生器 (AG)	频率范围 输出	50Hz 到 5kHz 或更高 0 到 1V
10. 失真测试仪	能力 输入电平	在 1kHz 时 3% 或更低 50mV 到 10Vrms
11. 频谱分析仪	测量范围	直流到 1GHz 或更高
12. 轨迹发生器	中心频率 输出电压	50kHz 到 600MHz 100mV 或更高
13. 4 Ω 假负载		大约 4 Ω , 3W
14. 可调电源		5V 到 10V, 大约 3A 配备了电流表时更好

■ 天线接口转换头

此对讲机的天线接口使用 SMA 终端。

使用天线接口转换头 [SMA(f)-BNC(f) 或 SMA(f)-N(f)] 进行调整。(转换头不作为可选件提供,因此请购买商用转换头。)

■ 维修机架 (机壳)

使用机壳 (A10-4215-03) 维修对讲机。将 TX-RX 单元放置在机壳上, 并且拧上螺钉。

在维修过程中, 需要在 TX-RX 单元的电路板上检测电压时, 机壳可以方便地进行电压检测, 并且保护模块。

■ 电池夹具 (W05-1011-00)

在对讲机的电池夹具和电源之间连接适当的电源电缆, 确认了输出电压之后接通电源开关, 电压超过或极性颠倒都有可能损坏对讲机。

注: 当使用电池夹具时, 你必须测定电池夹具的终端电压。因为, 电源和电池夹具之间会有一些的电压下降, 尤其在对讲机发射的时候。

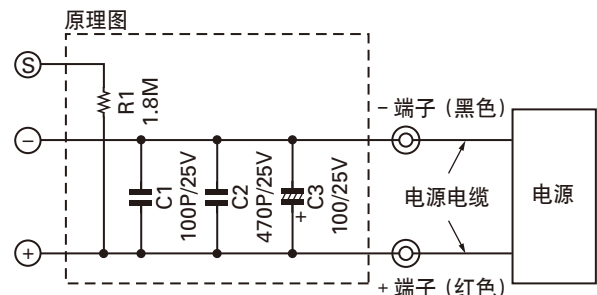
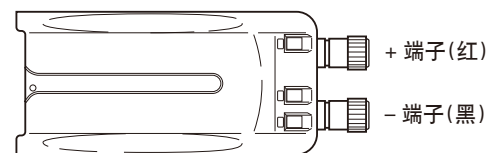

ADJUSTMENT / 调整

Frequency and Signaling

The transceiver has been adjusted for the frequencies shown in the following table. When required, re-adjust them following the adjustment procedure to obtain the frequencies you want in actual operation.

■ Frequency (MHz)

Channel No.	RX Frequency	TX Frequency
1	155.050	155.100
2	136.050	136.100
3	173.950	173.900
4	155.000	155.000
5	155.200	155.200
6	155.400	155.400
7~16	-	-

■ Signaling

Signaling No.	RX	TX
1	None	None
2	None	100Hz Square Wave
3	QT 67.0Hz	QT 67.0Hz
4	QT 151.4Hz	QT 151.4Hz
5	QT 250.3Hz	QT 250.3Hz
6	DQT D023N	DQT D023N
7	DQT D754I	DQT D754I
8	DTMF Decode [159D]	DTMF Encode [159D]
9	None	DTMF Tone 9

Preparations for Tuning the Transceiver

Before attempting to tune the transceiver, connect the unit to a suitable power supply.

Whenever the transmitter is tuned, the unit must be connected to a suitable dummy load (i.e. power meter).

The speaker output connector must be terminated with a 8Ω dummy load and connected to an AC voltmeter and an audio distortion meter or a SINAD measurement meter at all times during tuning.

■ Adjustment frequency

TEST CH	RX	TX
Center	155.050MHz	155.100MHz
Low	136.050MHz	136.100MHz
High	173.950MHz	173.900MHz
Low'	145.550MHz	145.600MHz
High'	164.550MHz	164.600MHz

■ List of FPU for transceiver

Model	Type	FPU
TK-2307	M	KPG-118D(M)
	C	KPG-118D(C)
	X	KPG-118D(M)

频率和信令

频率设定调整如下表所示。当需要时，按照如下调整程序重新调整，以便获得您在实际操作时希望的频率。

■ 频率 (MHz)

信道号码	RX 频率	TX 频率
1	155.050	155.100
2	136.050	136.100
3	173.950	173.900
4	155.000	155.000
5	155.200	155.200
6	155.400	155.400
7~16	-	-

■ 信令

信令号码	RX	TX
1	无	无
2	无	100Hz 方形波
3	QT 67.0Hz	QT 67.0Hz
4	QT 151.4Hz	QT 151.4Hz
5	QT 250.3Hz	QT 250.3Hz
6	DQT D023N	DQT D023N
7	DQT D754I	DQT D754I
8	DTMF 解码 [159D]	DTMF 编码 [159D]
9	无	DTMF 音频 9

调谐对讲机的准备

在调谐对讲机之前，把装置连接到规定的电源。

任何时候调整发射，装置必须连接到合适的假负载（即功率表）。

在全部调谐过程中，扬声器输出端子必须连接 8Ω 假负载连接到 AC 伏特计和音频失真仪或 SINAD 测试表。

■ 调整频率

测试 CH	RX	TX
中心	155.050MHz	155.100MHz
低	136.050MHz	136.100MHz
高	173.950MHz	173.900MHz
低'	145.550MHz	145.600MHz
高'	164.550MHz	164.600MHz

■ 对讲机的 FPU 名单

型号	类型	FPU
TK-2307	M	KPG-118D(M)
	C	KPG-118D(C)
	X	KPG-118D(M)

ADJUSTMENT / 调整

Adjustment Points / 调整点

■ Component side view / 元件面视图

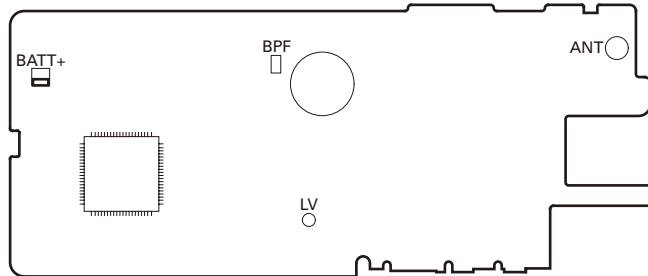

BPF: BPF Wave Adjust / BPF 波形调整
 LV (CV): VCO lock voltage / VCO 锁定电压
 BATT+: Battery Warning Level / 电池警告电平

■ Foil side view / 箔面视图

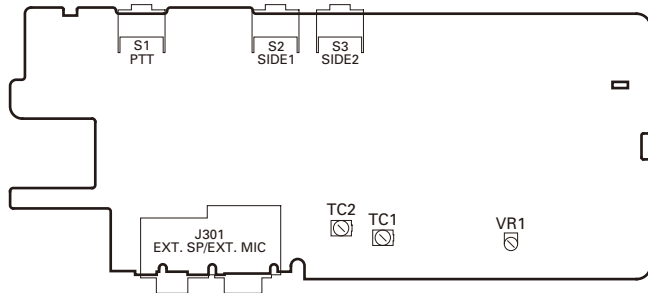

TC1 : VCO lock voltage (RX) / VCO 锁定电压 (RX)
 TC2 : VCO lock voltage (TX) / VCO 锁定电压 (TX)
 VR1 : Frequency adjustment / 频率调整

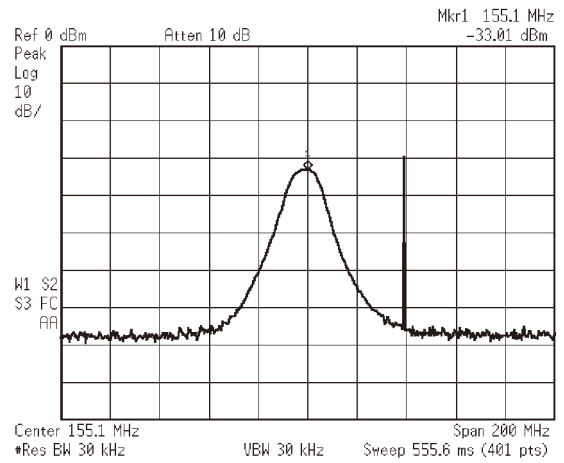

Fig. 1 Center frequency / 图 1 中心频率

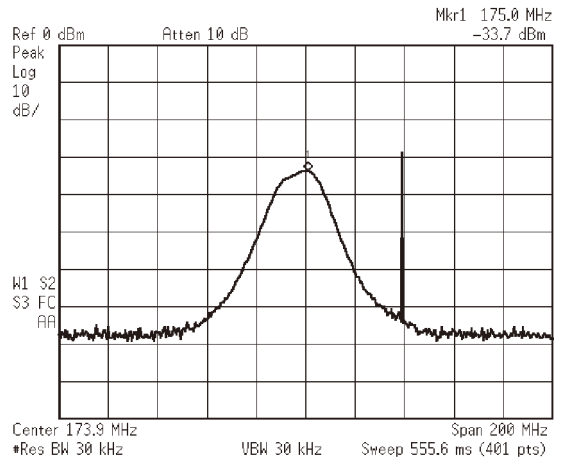

Fig. 2 High-edge frequency / 图 2 高边频率

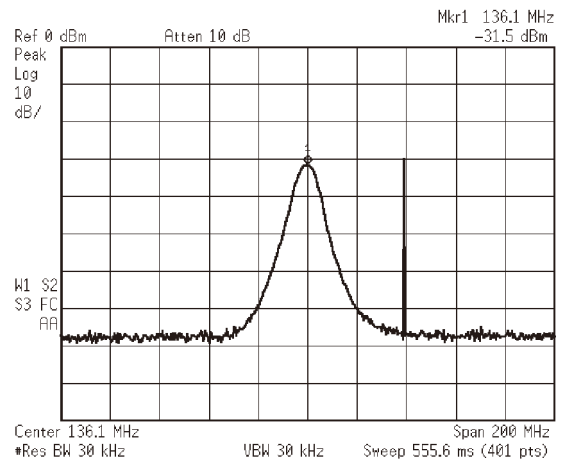



Fig. 3 Low-edge frequency / 图 3 低边频率

ADJUSTMENT

Common Section

Item	Condition	Measurement			Adjustment			Specifications / Remarks
		Test-equipment	Unit	Terminal	Unit	Parts	Method	
1. Setting	1) BATT terminal vorage: 7.5V 2) SSG standard modulation [Wide] MOD: 1kHz, DEV: 3kHz [Narrow] MOD: 1kHz, DEV: 1.5kHz							
2. VCO lock voltage RX	1) CH: High	Power meter DVM	TX-RX	ANT LV (CV)	TX-RX	TC1	4.0V	±0.1V
	2) CH: Low						Check	0.6V or more
3. VCO lock voltage TX	3) CH: High PTT: ON				TX-RX	TC2	4.1V	±0.1V
	4) CH: Low PTT: ON						Check	0.6V or more

Transmitter Section

Item	Condition	Measurement			Adjustment			Specifications / Remarks
		Test-equipment	Unit	Terminal	Unit	Parts	Method	
1. Frequency Adjust	1) CH: High PTT: ON	f. counter		ANT	TX-RX	VR1	173.900MHz	±50Hz
2. High Transmit Power	1) TEST CH: Low, Low', Center, High', High (5 points) BATT terminal voltage: 7.5V PTT: ON	Power meter Ammeter				FPU		5.0W±0.1W 2.0A or less
3. Low Transmit Power	1) TEST CH: Low, Low', Center, High', High (5 points) BATT terminal voltage: 7.5V PTT: ON							1.0W±0.1W 1.0A or less
4. Maximum Deviation [Wide]	1) TEST CH: Center, Low, High (3 points) AG: 1kHz/150mV Deviation meter filter LPF: 15kHz HPF: OFF PTT: ON	Power meter Deviation meter Oscilloscope AG AF VTVM		ANT			4.4kHz (According to the lager +, -)	±80Hz
	[Narrow]			2) TEST CH: Center PTT: ON			SP/MIC connector	2.2kHz (According to the lager +, -)
5. DQT Balance [Wide]	1) TEST CH: Center, Low, High (3 points) Deviation meter filter LPF: 3kHz HPF: OFF PTT: ON						Make the demodulation wave into square waves.	
	[Narrow]	2) TEST CH: Center PTT: ON						

调 整

公用部分

项 目	条 件	测 量			调 整			规 格 / 备 注
		测量装置	单元	端子	单元	部件	方 法	
1. 设置	1) BATT 终端电压 : 7.5V 2) SSG 标准调制 [宽] MOD: 1kHz, DEV: 3kHz [窄] MOD: 1kHz, DEV: 1.5kHz							
2. VCO 锁定电压 RX	1) CH: 高	功率计	TX-RX	ANT	TX-RX	TC1	4.0V	±0.1V
	2) CH: 低	DVM		LV (CV)			检查	0.6V 或更高
3. VCO 锁定电压 TX	3) CH: 高 PTT: 开启					TX-RX	TC2	4.1V
	4) CH: 低 PTT: 开启						检查	0.6V 或更高

发 射 部

项 目	条 件	测 量			调 整			规 格 / 备 注
		测量装置	单元	端子	单元	部件	方 法	
1. 频率调整	1) CH: 高 PTT: 开启	频率计数器		ANT	TX-RX	VR1	173.900MHz	±50Hz
2. 高发射功率	1) 测试 CH: 低, 低', 中心, 高', 高 (5 点) BATT 终端电压 : 7.5V PTT: 开启	功率计 电流表				FPU		5.0W ± 0.1W 2.0A 或更低
3. 低发射功率	1) 测试 CH: 低, 低', 中心, 高', 高 (5 点) BATT 终端电压 : 7.5V PTT: 开启							1.0W ± 0.1W 1.0A 或更低
4. 最大频偏 [宽]	1) 测试 CH: 中心, 低, 高 (3 点) AG: 1kHz/150mV 频偏仪滤波器 LPF: 15kHz HPF: 关闭 PTT: 开启	功率计 频偏仪 示波器		ANT			4.2kHz (按照最大 +, -)	±80Hz
	[窄]	2) 测试 CH: 中心 PTT: 开启	AG AF VTVM	SP/MIC 连接器			2.2kHz (按照最大 +, -)	±80Hz
5. DQT 平衡 [宽]	1) 测试 CH: 中心, 低, 高 (3 点) 频偏仪滤波器 LPF: 3kHz HPF: 关闭 PTT: 开启						把解调波调整为方波	
	[窄]	2) 测试 CH: 中心 PTT: 开启						

ADJUSTMENT

Item	Condition	Measurement			Adjustment			Specifications / Remarks
		Test-equipment	Unit	Terminal	Unit	Parts	Method	
6. QT Fine Deviation [Wide]	1) TEST CH: Center, Low, High (3 points) Deviation meter filter LPF: 3kHz HPF: OFF PTT: ON	Power meter Deviation meter Oscilloscope AG AF VTVM		ANT SP/MIC connector		FPU	0.75kHz	±40Hz
	[Narrow]						2) TEST CH: Center PTT: ON	
7. DQT Fine Deviation [Wide]	1) TEST CH: Center, Low, High (3 points) Deviation meter filter LPF: 3kHz HPF: OFF PTT: ON					FPU	0.75kHz	±40Hz
	[Narrow]						2) TEST CH: Center PTT: ON	
8. DTMF Fine Deviation [Wide]	1) TEST CH: Center Deviation meter filter LPF: 15kHz HPF: OFF PTT: ON					FPU	3.0kHz	±100Hz
	[Narrow]						2) TEST CH: Center PTT: ON	
9. MSK Fine Deviation [Wide]	1) TEST CH: Center Deviation meter filter LPF: 15kHz HPF: OFF PTT: ON					FPU	3.0kHz	±100Hz
	[Narrow]						2) TEST CH: Center PTT: ON	

Receiver Section

Item	Condition	Measurement			Adjustment			Specifications / Remarks
		Test-equipment	Unit	Terminal	Unit	Parts	Method	
1. BPF Wave Adjust	1) Center frequency Spectrum analyzer setting Center-f: 155MHz Span: 200MHz RBW: 30kHz VBW: 30kHz ATT: 10dB 2) High-edge frequency Spectrum analyzer setting Center-f: 174MHz 3) Low-edge frequency Spectrum analyzer setting Center-f: 136MHz	S5G Spectrum analyzer	TX-RX	ANT BPF		FPU	Adjust the waveform as shown to the Fig. 1~3.	

调 整

项 目	条 件	测 量			调 整			规 格 / 备 注
		测量装置	单元	端子	单元	部件	方 法	
6. QT 细频偏 [宽]	1) 测试 CH: 中心, 低, 高 (3 点) 频偏仪滤波器 LPF: 3kHz HPF: 关闭 PTT: 开启	功率计 频偏仪 示波器 AG AF VTVM		ANT SP/MIC 连接器		FPU	0. 75kHz	± 40Hz
[窄]	2) 测试 CH: 中心 PTT: 开启						0. 38kHz	± 40Hz
7. DQT 细频偏 [宽]	1) 测试 CH: 中心, 低, 高 (3 点) 频偏仪滤波器 LPF: 3kHz HPF: 关闭 PTT: 开启						0. 75kHz	± 40Hz
[窄]	2) 测试 CH: 中心 PTT: 开启						0. 38kHz	± 40Hz
8. DTMF 细频偏 [宽]	1) 测试 CH: 中心 频偏仪滤波器 LPF: 15kHz HPF: 关闭 PTT: 开启						3. 0kHz	± 100Hz
[窄]	2) 测试 CH: 中心 PTT: 开启						1. 5kHz	± 100Hz
9. MSK 细频偏 [宽]	1) 测试 CH: 中心 频偏仪滤波器 LPF: 15kHz HPF: 关闭 PTT: 开启						3. 0kHz	± 100Hz
[窄]	2) 测试 CH: 中心 PTT: 开启						1. 5kHz	± 100Hz

接 收 部

项 目	条 件	测 量			调 整			规 格 / 备 注
		测量装置	单元	端子	单元	部件	方 法	
1. BPF 波形 调整	1) 中心频率 频谱分析仪设定 Center-f: 155MHz Span: 200MHz RBW: 30kHz VBW: 30kHz ATT: 10dB 2) 高边频率 频谱分析仪设定 Center-f: 174MHz 3) 低边频率 频谱分析仪设定 Center-f: 136MHz	SSG 频谱分析 仪		ANT BPF		FPU	调整波形如图 1~3 所示	

ADJUSTMENT

Item	Condition	Measurement			Adjustment			Specifications / Remarks
		Test-equipment	Unit	Terminal	Unit	Parts	Method	
2. Sensitivity [Wide]	1) TEST CH: Low, Center, High (3 points) SSG otuput : -117dBm (0.3 μ V) SSG MOD: 3.0kHz	SSG DVM Oscilloscope AF VTVM		ANT SP/MIC connector			Check	12dB SINAD or more
[Narrow]	2) TEST CH: Center SSG otuput : -115dBm (0.4 μ V) SSG MOD: 1.5kHz							
3. Squelch Open [Wide]	1) TEST CH: Center, Low, High (3 points) SSG otuput : -123dBm (0.16 μ V) SSG MOD: 3.0kHz					FPU	Write	
[Narrow]	2) TEST CH: Center SSG otuput : -122dBm (0.18 μ V) SSG MOD: 1.5kHz							
4. Squelch Tight [Wide]	1) TEST CH: Center, Low, High (3 points) SSG otuput : -117dBm (0.3 μ V) SSG MOD: 3.0kHz							
[Narrow]	2) TEST CH:Center SSG otuput : -116dBm (0.35 μ V) SSG MOD: 1.5kHz							
5. Battery Warning Level	1) BATT terminal voltage: 5.9V	SSG DVM	TX-RX	ANT BATT terminal			Write	BATT terminal voltage: 5.9V

调 整

项 目	条 件	测 量			调 整			规 格 / 备 注
		测量装置	单元	端子	单元	部件	方 法	
2. 灵敏度 [宽]	1) 测试CH: 中心, 低, 高 (3点) SSG 输出 : - 117dBm(0. 3μV) SSG 调制 :3. 0kHz	SSG DVM 示波器 AF VTVM		ANT SP/MIC 连接器			检查	12dB SINAD 或更高
[窄]	2) 测试CH: 中心 SSG 输出 : - 115dBm(0. 4μV) SSG 调制 :1. 5kHz							
3. 打开静噪 [宽]	1) 测试CH: 中心, 低, 高 (3点) SSG 输出 : - 123dBm(0. 16μV) SSG 调制 :3. 0kHz					FPU	写入	
[窄]	2) 测试CH: 中心 SSG 输出 : - 122dBm(0. 18μV) SSG 调制 :1. 5kHz							
4. 深静噪 [宽]	1) 测试CH: 中心, 低, 高 (3点) SSG 输出 : - 117dBm(0. 3μV) SSG 调制 :3. 0kHz							
[窄]	2) 测试CH: 中心 SSG 输出 : - 116dBm(0. 35μV) SSG 调制 :1. 5kHz							
5. 电池警告 电平	1) BATT 终端电压 :5. 9V	SSG DVM	TX-RX	ANT BATT 终端			写入	BATT 终端电压 :5. 9V

TK-2307 PC BOARD / PC板

TX-RX UNIT (X57-7570-20) Component side view (J79-0186-09)

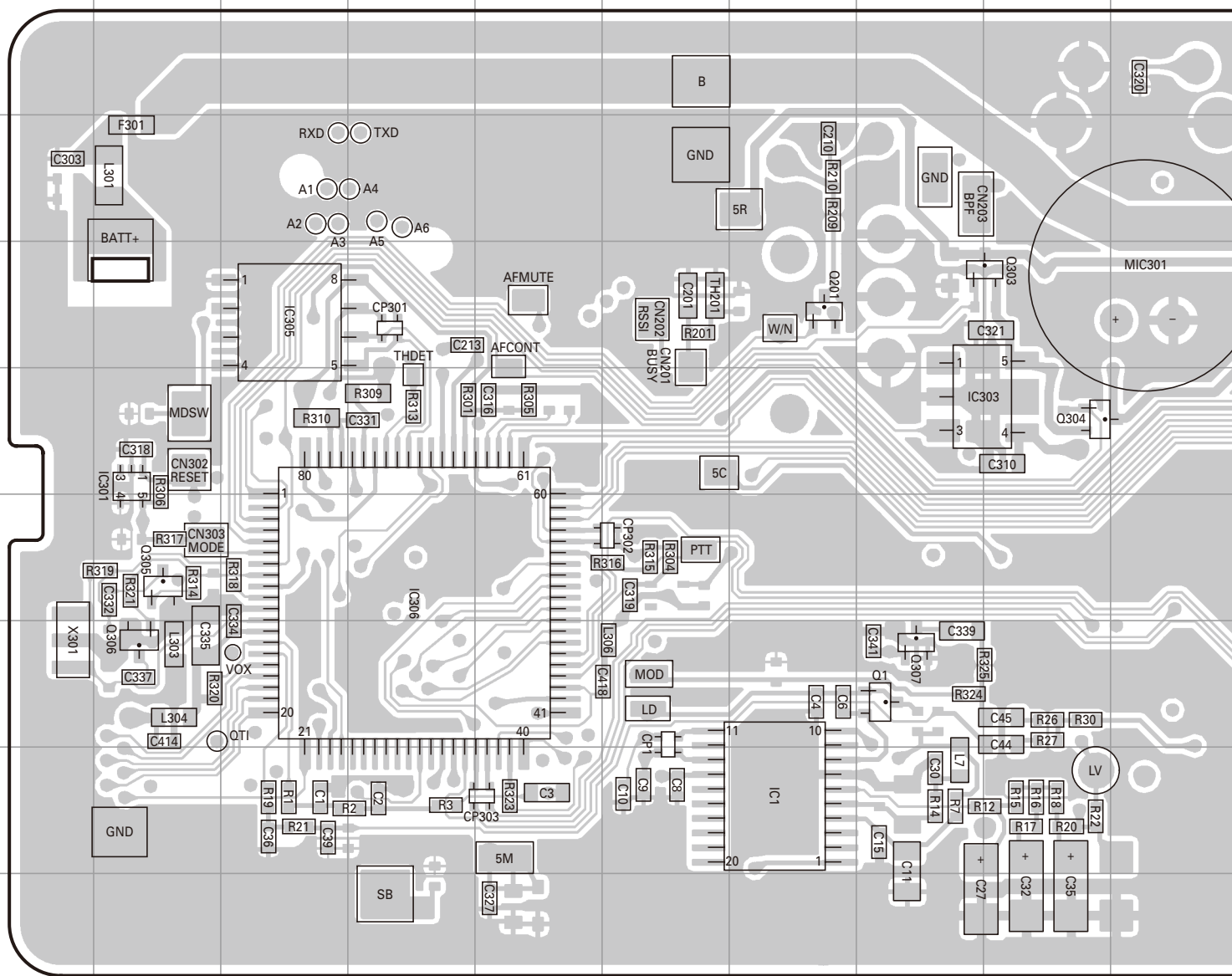

Ref. No.	Address	Ref. No.	Address	Ref. No.	Address	Ref. No.	Address
IC1	9G	Q103	4M	Q304	6I	Q316	8O
IC101	4N	Q106	3M	Q305	7B	D101	4M
IC301	6B	Q107	3M	Q306	8B	D303	8S
IC303	6H	Q108	4M	Q307	8H	D304	8S
IC305	5C	Q201	5G	Q312	8P		
IC306	7D	Q301	6P	Q313	7P		
IC309	7O	Q302	6P	Q314	8O		
Q1	8H	Q303	5I	Q315	8O		

TK-2307 PC BOARD / PC板

TX-RX UNIT (X57-7570-20) Foil side view (J79-0186-09)

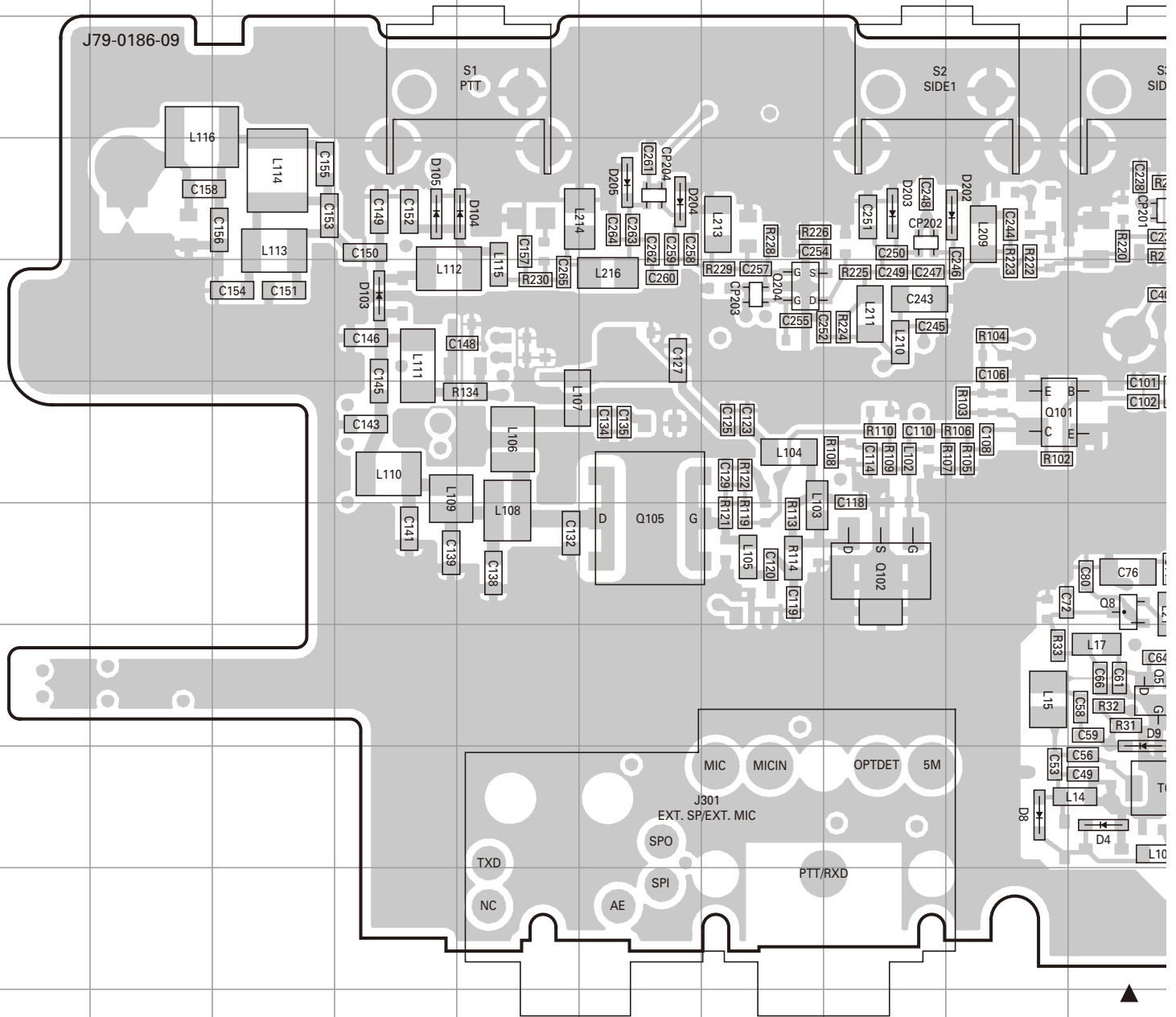

Ref. No.	Address	Ref. No.	Address	Ref. No.	Address	Ref. No.	Address	Ref. No.	Address
IC2	6K	Q7	8K	Q203	4K	D9	8J	D301	4R
IC201	6N	Q8	7J	Q204	5G	D10	5L	D302	10P
IC304	9P	Q9	7K	Q308	7R	D103	5D	D306	8R
IC308	8P	Q10	7K	Q310	7R	D104	4E	D307	8Q
Q2	8N	Q11	5L	Q311	7R	D105	4D	D308	7Q
Q3	7L	Q101	6I	D3	10K	D202	4I	D309	7Q
Q4	9L	Q102	7H	D4	9J	D203	4H		
Q5	8J	Q105	7F	D6	10K	D204	4F		
Q6	7K	Q202	5N	D8	9I	D205	4F		

PC BOARD / PC板 TK-2307

TX-RX UNIT (X57-7570-20) Foil side view (J79-0186-09)

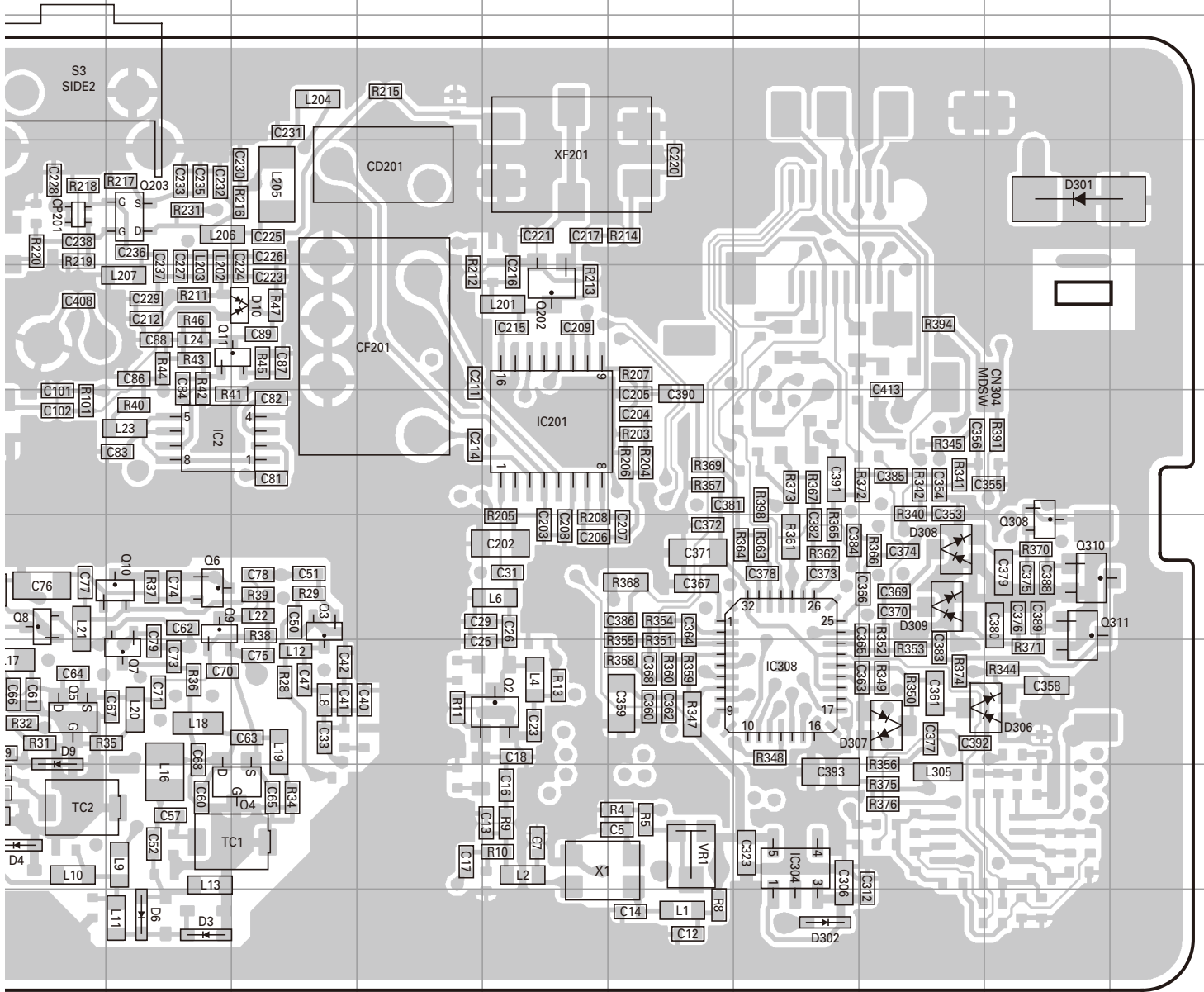

Component side

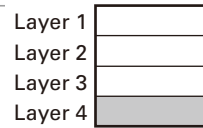

Foil side

TK-2307 SCHEMATIC DIAGRAM / 原理图

TX-RX UNIT (X57-7570-20)

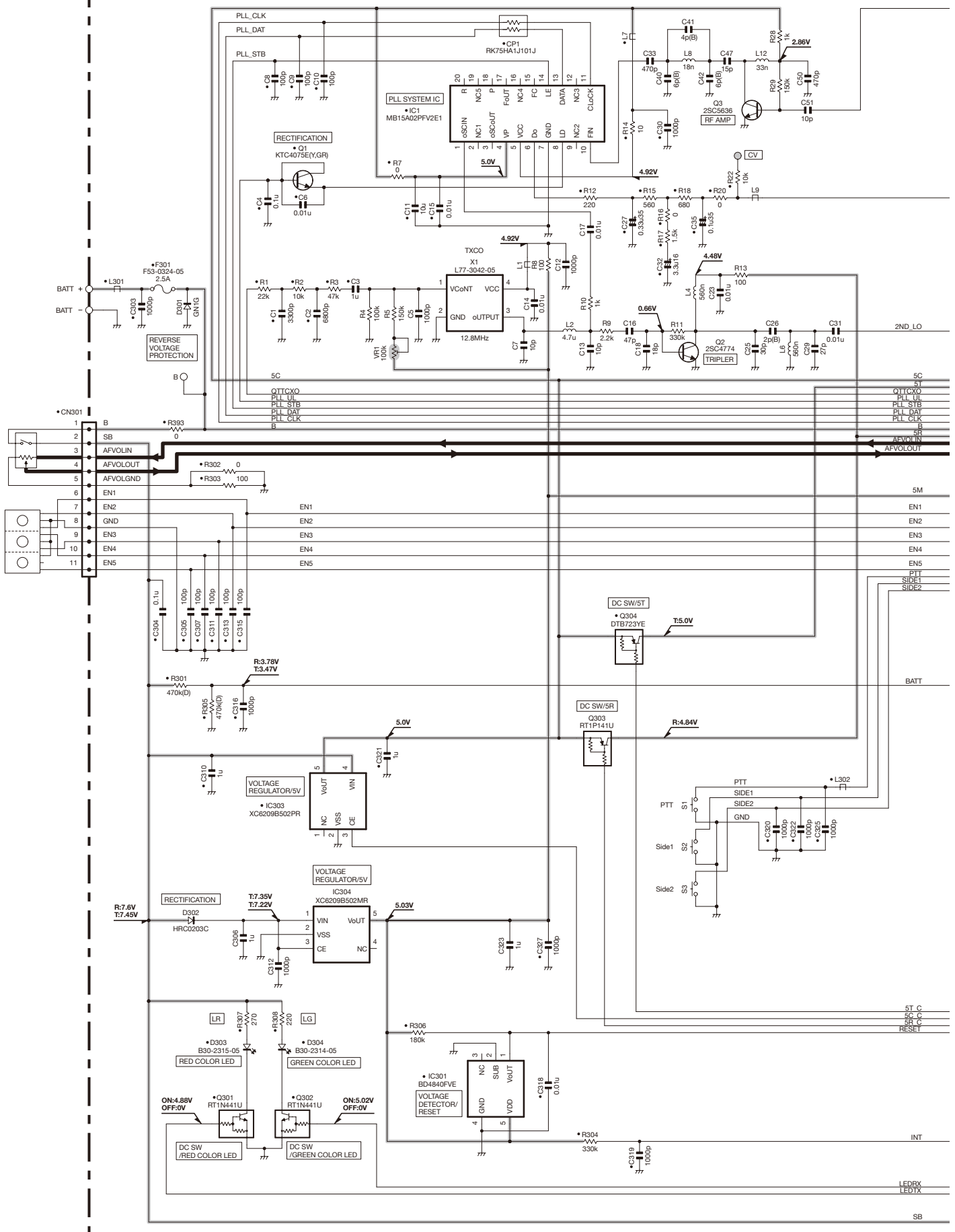

SCHEMATIC DIAGRAM / 原理图 TK-2307

TX-RX UNIT (X57-7570-20)

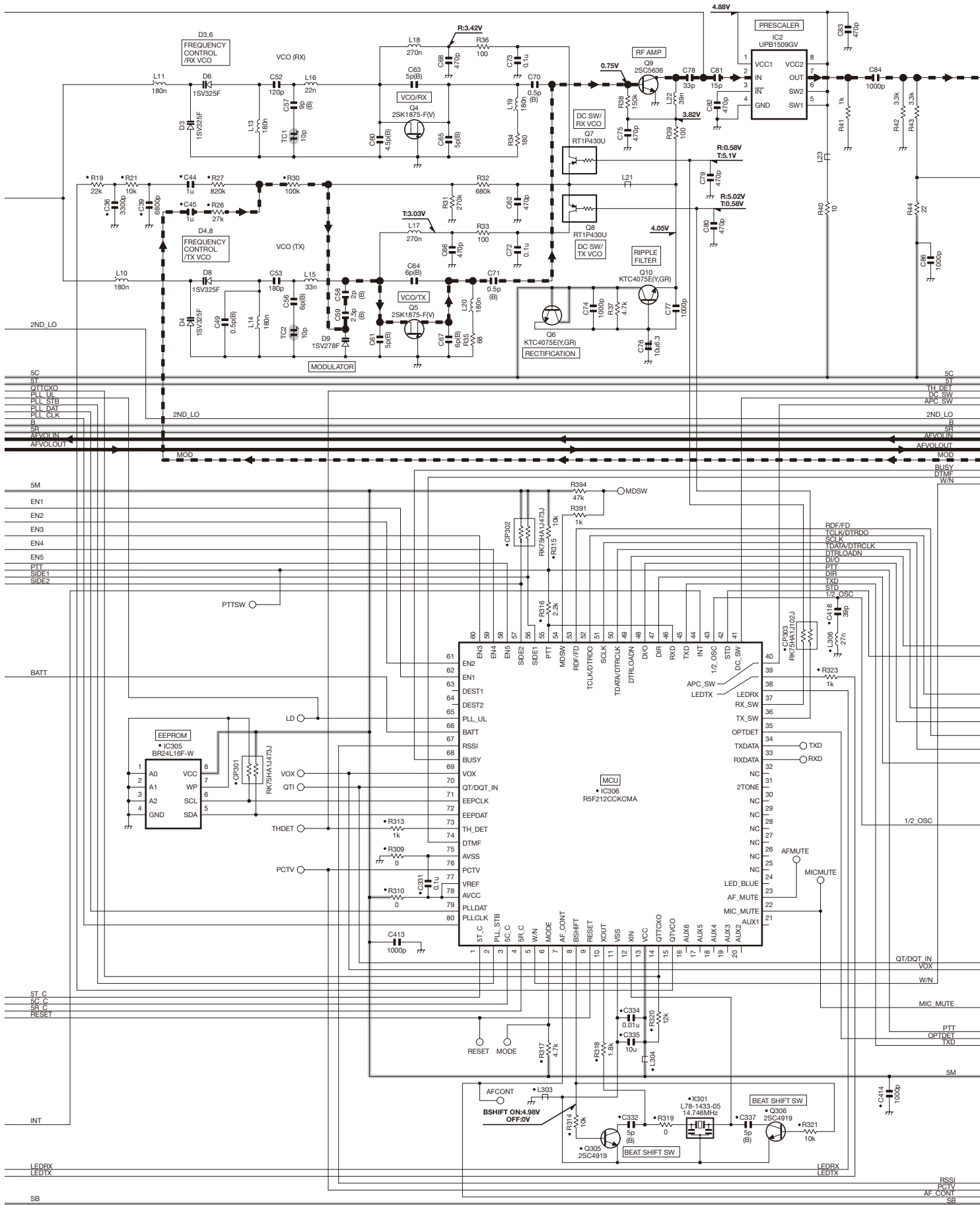

TK-2307 SCHEMATIC DIAGRAM / 原理图

TX-RX UNIT (X57-750-20)

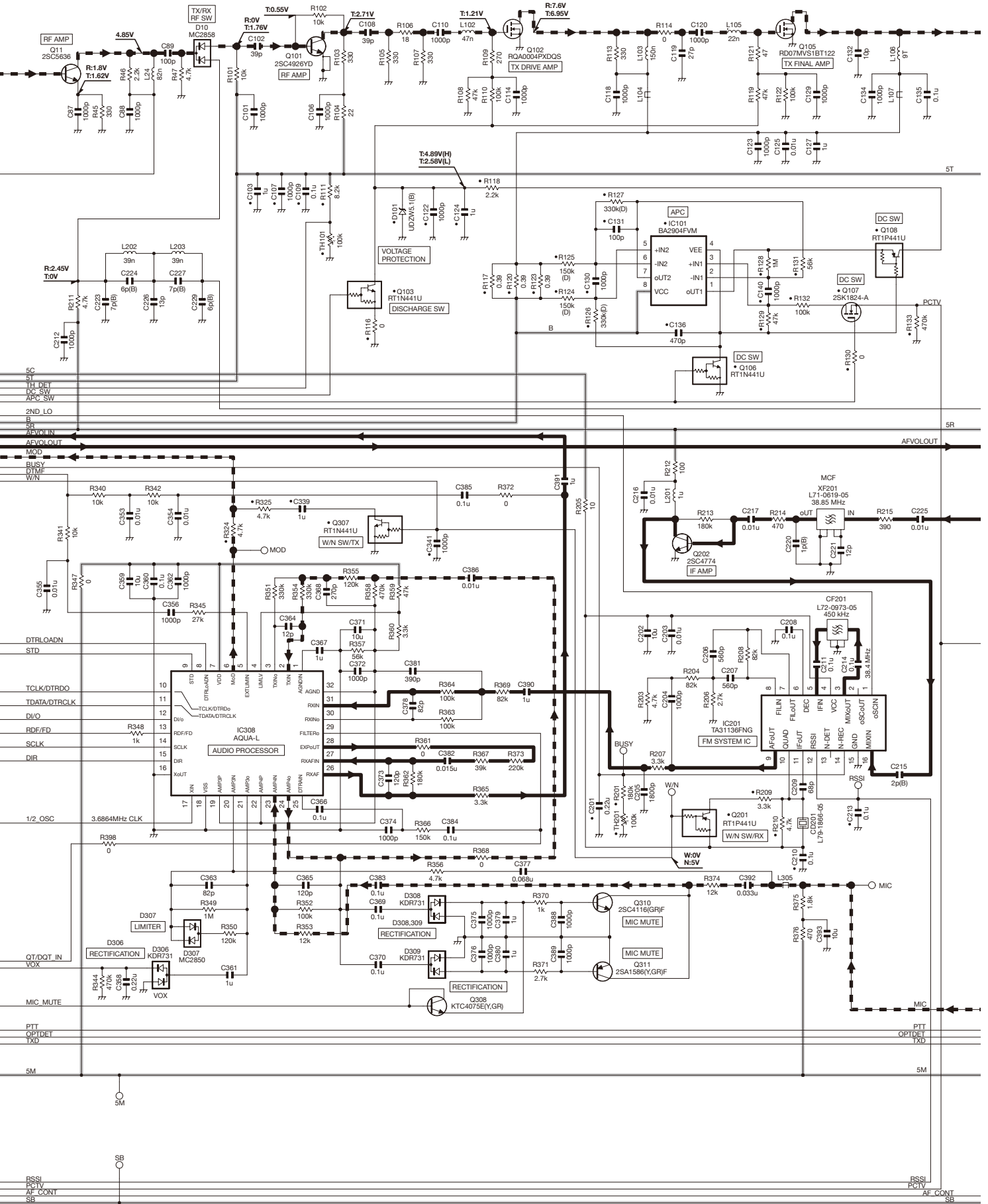

SCHEMATIC DIAGRAM / 原理图 TK-2307

TX-RX UNIT (X57-7570-20)

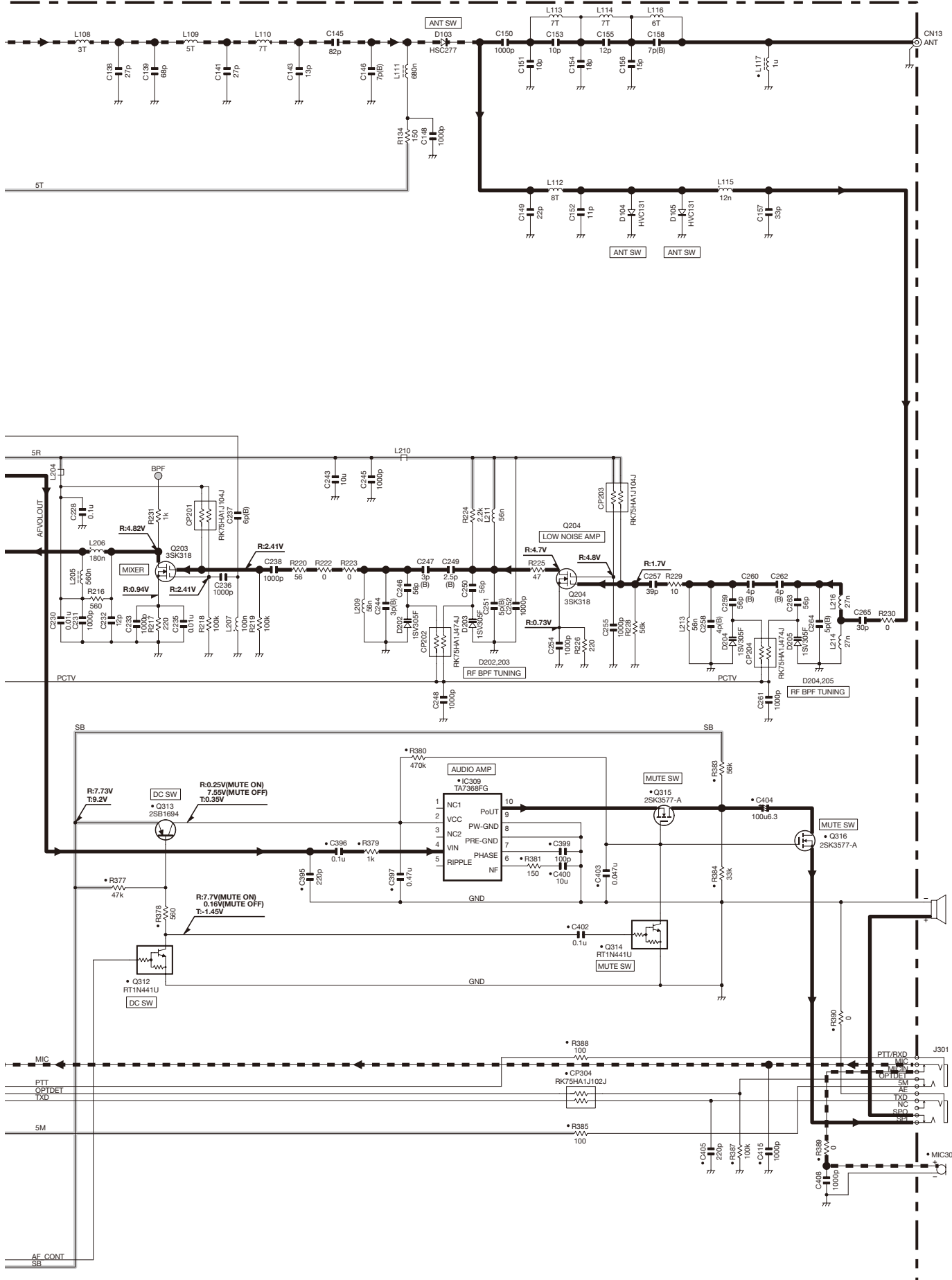

Note : The components marked with a dot (•) are parts of layer 1.

BLOCK DIAGRAM / 方块图

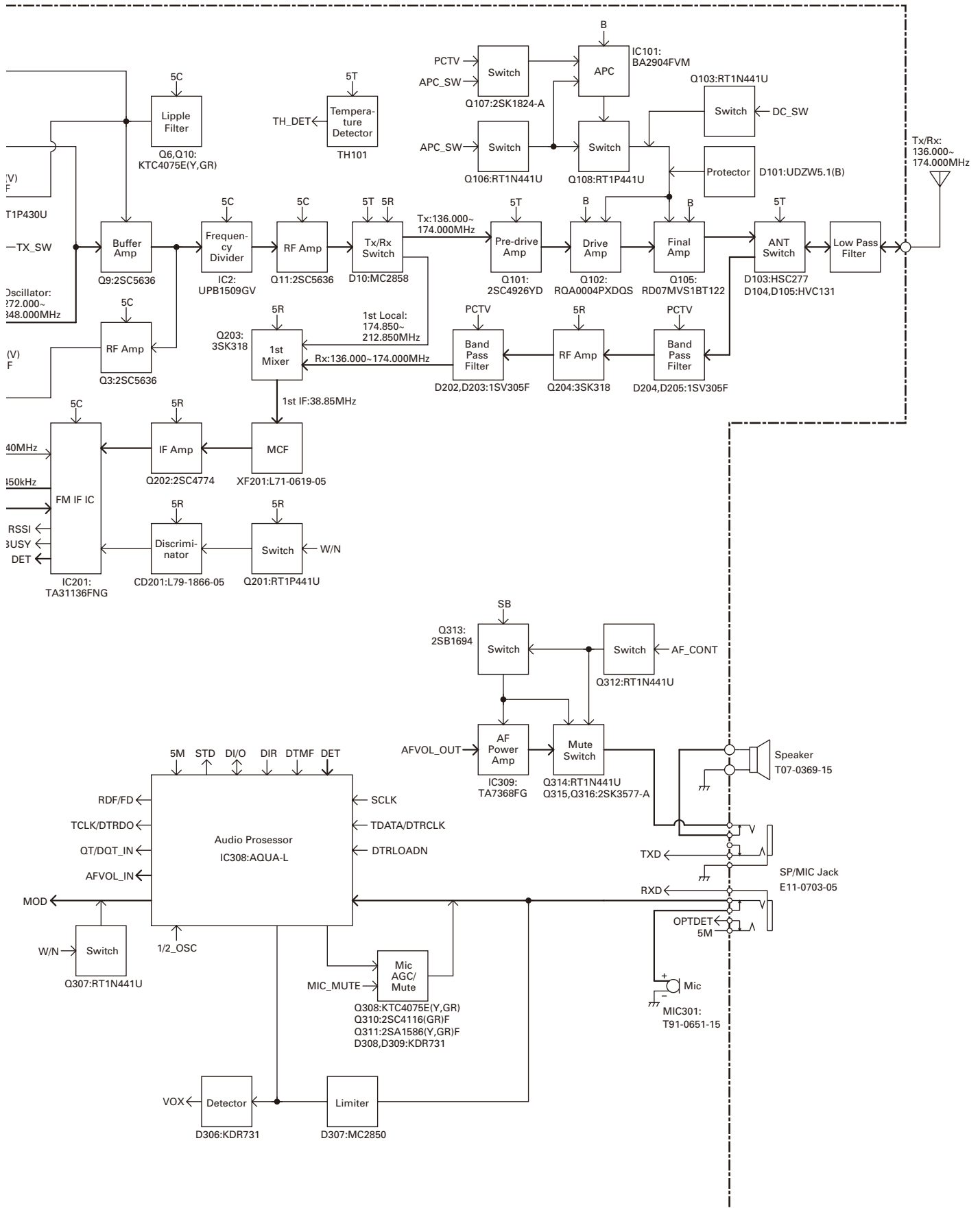

LEVEL DIAGRAM / 电平图

Receiver Section / 接收部分

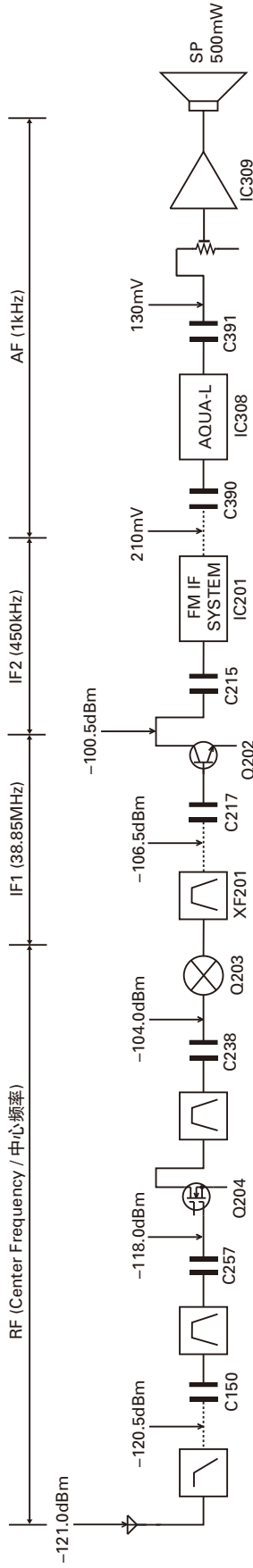

To make measurements in the AF section, connect the AC level meter.
 (ANT input: -53dBm, 1kHz FM, 3kHz DEV (WIDE).)
 In the RF section, use 1000pF coupling capacitor.
 (The display shows the SSG input value required to obtain 12dB SINAD without Local Level.)

如要在AF 部测量, 则连接AC电平表。
 (天线输入: -53dBm, 1kHz FM, 3kHz DEV (宽))
 如要在RF 部测量, 请使用1000pF耦合电容器。
 (图中显示了获得12dB SINAD 所需的SSG输入值, 没有本地电平。)

Transmitter Section / 发射部分

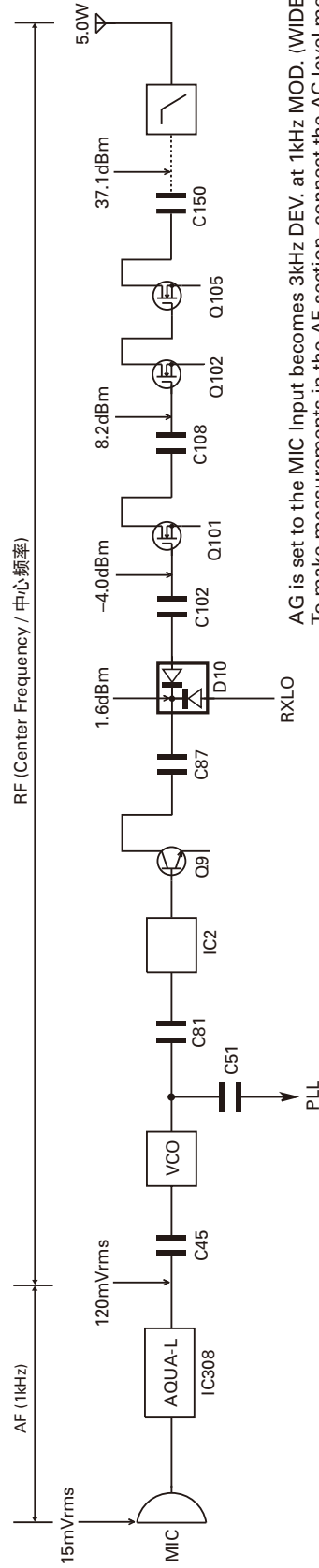

AG is set to the MIC Input becomes 3kHz DEV. at 1kHz MOD. (WIDE).
 To make measurements in the AF section, connect the AC level meter.
 In the RF section, use 1000pF coupling capacitor.

AG 被设置成话筒输入得到3kHz DEV 在1kHz MOD (宽)。
 如要在AF部测量, 则连接AC电平表。
 如要在RF部测量, 请使用1000pF耦合电容器。

OPTIONAL ACCESSORIES / 可选附件

KBH-10 (Belt clip / 皮带夹)

■ External View / 外视图



KNB-45L (Li-ion battery pack / 锂离子电池)

■ External View / 外视图



KSC-35 (Rapid charger / 快速充电器)

■ External View / 外视图



■ Specifications / 规格

Voltage / 电压.....7.4V (3.7V x 2)
 Charging current / 充电电流..... 2000mAh

■ Circuit Diagram / 电路图

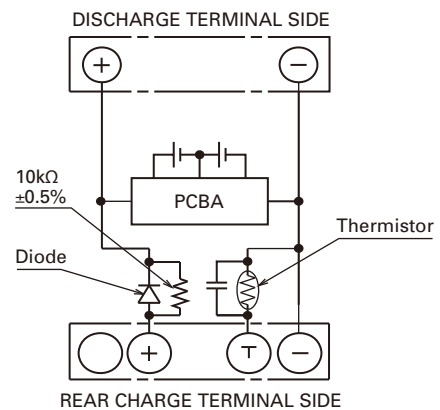

■ Specifications

Charging time KNB-45L: Approx. 180 minutes
 Dimensions (Charger only)
 86.3 W x 43.2 H x 100.0 D (mm)
 3-3/8 W x 1-45/64 H x 4 D (inches)
 Weight (Charger only).....Approx. 90g / 0.2 lbs

■ 规格

充电时间.....KNB-45L: 约 180 分
 尺寸 (仅充电器时)..... 86.3 宽 × 43.2 高 × 100.0 长 (mm)
 3-3/8 宽 × 1-45/64 高 × 4 长 (英寸)
 重量 (仅充电器时)..... 约 90g

SPECIFICATIONS

General

Frequency Range.....	136~174MHz
Number of channels	Max. 16
Channel Spacing	25kHz, 30kHz (Wide) / 12.5kHz, 15kHz (Narrow)
PLL Channel Stepping	2.5kHz, 5kHz, 6.25kHz, 7.5kHz
Operating Voltage	7.5 V DC±20%
Battery Life	More than 14 hours at 5 watts (5-5-90 duty cycle with KNB-45L battery)
Operating Temperature range	-30°C to +60°C (-22°F to +140°F)
Frequency Stability	±2.5ppm (-30°C to +60°C)
Channel Frequency Spread.....	38MHz
Dimensions and Weight (Dimensions not including protrusions)	
Radio Only	160g (5.6oz)
With KNB-45L (2000mAh battery)	54 (2.13) W x 122 (4.8) H x 33.8 (1.33) D mm (inches)
	280g (9.9oz)

Receiver (Measurements made per TIA/EIA-603)

Sensitivity	
EIA 12dB SINAD.....	0.25µV (Wide) / 0.28µV (Narrow)
Selectivity	70dB (Wide) / 60dB (Narrow)
Intermodulation	65dB (Wide) / 60dB (Narrow)
Spurious response.....	65dB
Audio Power Output.....	500mW at 4Ω less than 10% distortion

Transmitter (Measurements made per TIA/EIA-603)

RF Power Output.....	5W/1W
Spurious and Harmonics.....	65dB
Modulation.....	16K0F3E (Wide) / 11K0F3E (Narrow)
FM Noise	45dB (Wide) / 40dB (Narrow)
Audio Distortion.....	Less than 5%

规 格

概 述

频率范围.....	136~174MHz
频道数.....	最大 16
信道间距.....	25kHz, 30kHz (宽)/ 12.5kHz, 15kHz (窄)
PLL 频道步进.....	2.5kHz, 5kHz, 6.25kHz, 7.5kHz
电池电压.....	7.5V 直流 ±20%
电池寿命.....	5W 时长于 18 个小时 (使用 KNB-45L 电池 5-5-90 工作周期)
温度范围.....	-30°C 到 +60°C (-22 °F 到 +140 °F)
频率稳定性.....	±2.5ppm (-30°C 到 +60°C)
信道频率扩展.....	38MHz
尺寸和重量 (尺寸大小不包括突出部分)	
仅对讲机时.....	160g (5.6oz)
带有 KNB-45L (2000mAh 电池).....	54 (2.13) 宽 × 122 (4.8) 高 × 33.8 (1.33) 长 mm (英寸) 280g (9.9oz)

接收部 (根据 TIA/EIA-603 进行测量)

灵敏度	
EIA 12dB SINAD.....	0.25μV (宽)/ 0.28μV (窄)
选择性.....	70dB (宽)/ 60dB (窄)
互调.....	65dB (宽)/ 60dB (窄)
假信号响应.....	65dB
音频功率输出.....	4Ω 时为 500mW, 失真小于 10%

发射部 (根据 TIA/EIA-603 进行测量)

射频功率输出.....	5W/1W
假信号和谐波.....	65dB
调制.....	16K0F3E (宽)/ 11K0F3E (窄)
FM 噪音.....	45dB (宽)/ 40dB (窄)
音频失真.....	低于 5%

Kenwood Corporation

2967-3, Ishikawa-machi, Hachioji-shi, Tokyo, 192-8525 Japan

Kenwood U.S.A. Corporation

P.O. BOX 22745, 2201 East Dominguez Street, Long Beach,
CA 90801-5745, U.S.A.

Kenwood Electronics Canada Inc.

6070 Kestrel Road, Mississauga, Ontario, Canada L5T 1S8

Kenwood Electronics Deutschland GmbH

Rembrücker Str. 15, 63150 Heusenstamm, Germany

Kenwood Electronics Belgium N.V.

Leuvensesteenweg 248 J, 1800 Vilvoorde, Belgium

Kenwood Electronics France S.A.

L'Etoile Paris Nord 2, 50 Allée des Impressionnistes,
Bp 58416 Villepinte, 95944 Roissy Ch De Gaulle Cedex

Kenwood Electronics UK Limited

KENWOOD House, Dwight Road, Watford, Herts.,
WD18 9EB United Kingdom

Kenwood Electronics Europe B.V.

Amsterdamseweg 37, 1422 AC Uithoorn, The Netherlands

Kenwood Electronics Italia S.p.A.

Via G. Sirtori, 7/9 20129 Milano, Italy

Kenwood Ibérica, S.A.

Bolivia, 239-08020 Barcelona, Spain

Kenwood Electronics Australia Pty. Ltd.

(A.C.N. 001 499 074)

16 Giffnock Avenue, Centrecourt Estate, North Ryde, N.S.W. 2113 Australia

Kenwood Electronics (Hong Kong) Ltd.

Unit 3712-3724, Level 37, Tower one Metroplaza, 223 Hing Fong Road,
Kwai Fong, N.T., Hong Kong

Kenwood Electronics Singapore Pte Ltd

1 Ang Mo Kio Street 63, Singapore 569110



TX-RX UNIT (X57-7570-20) Foil side view (J79-0186-09)

TX-RX UNIT (X57-7570-20) Foil side view (J79-0186-09)

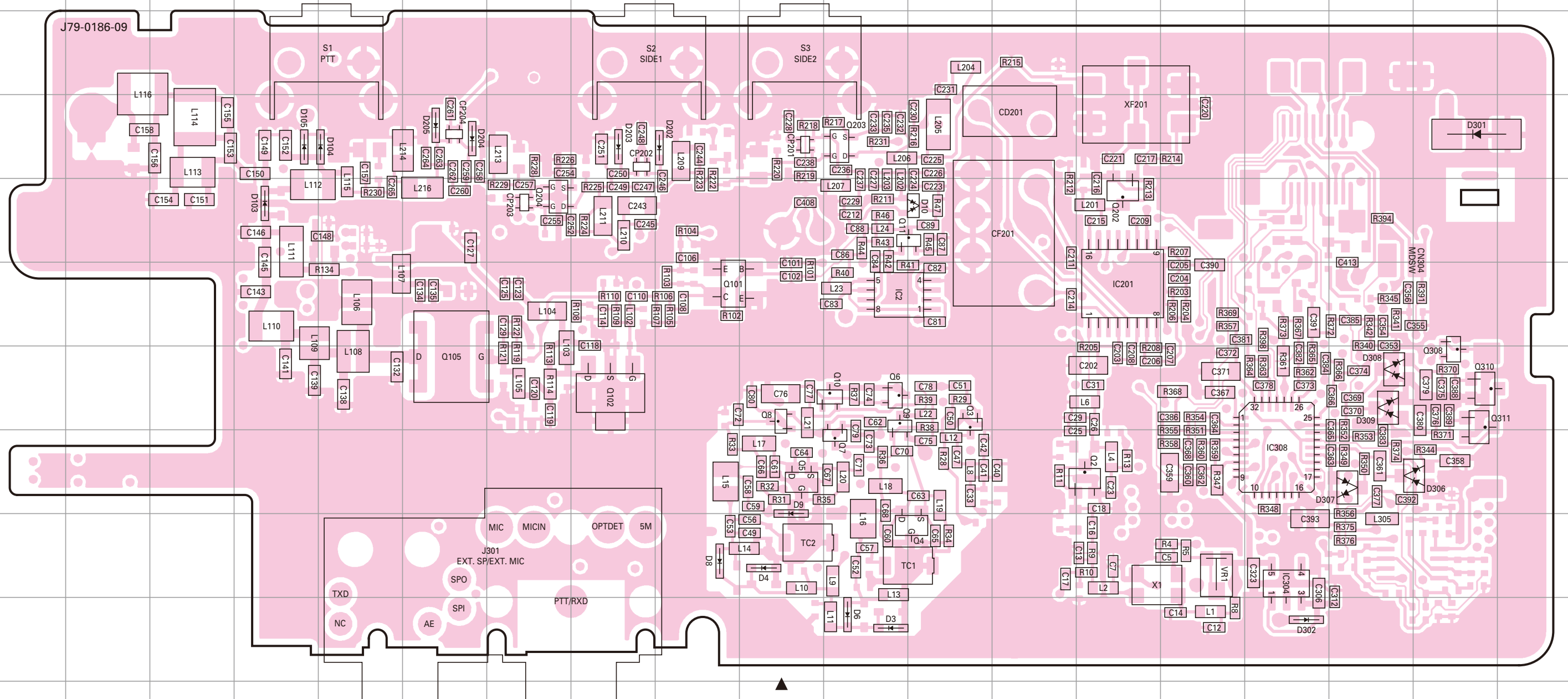

Ref. No.	Address	Ref. No.	Address	Ref. No.	Address	Ref. No.	Address	Ref. No.	Address
IC2	6K	Q7	8K	Q203	4K	D9	8J	D301	4R
IC201	6N	Q8	7J	Q204	5G	D10	5L	D302	10P
IC304	9P	Q9	7K	Q308	7R	D103	5D	D306	8R
IC308	8P	Q10	7K	Q310	7R	D104	4E	D307	8Q
Q2	8N	Q11	5L	Q311	7R	D105	4D	D308	7Q
Q3	7L	Q101	6I	D3	10K	D202	4I	D309	7Q
Q4	9L	Q102	7H	D4	9J	D203	4H		
Q5	8J	Q105	7F	D6	10K	D204	4F		
Q6	7K	Q202	5N	D8	9I	D205	4F		

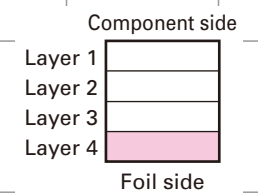

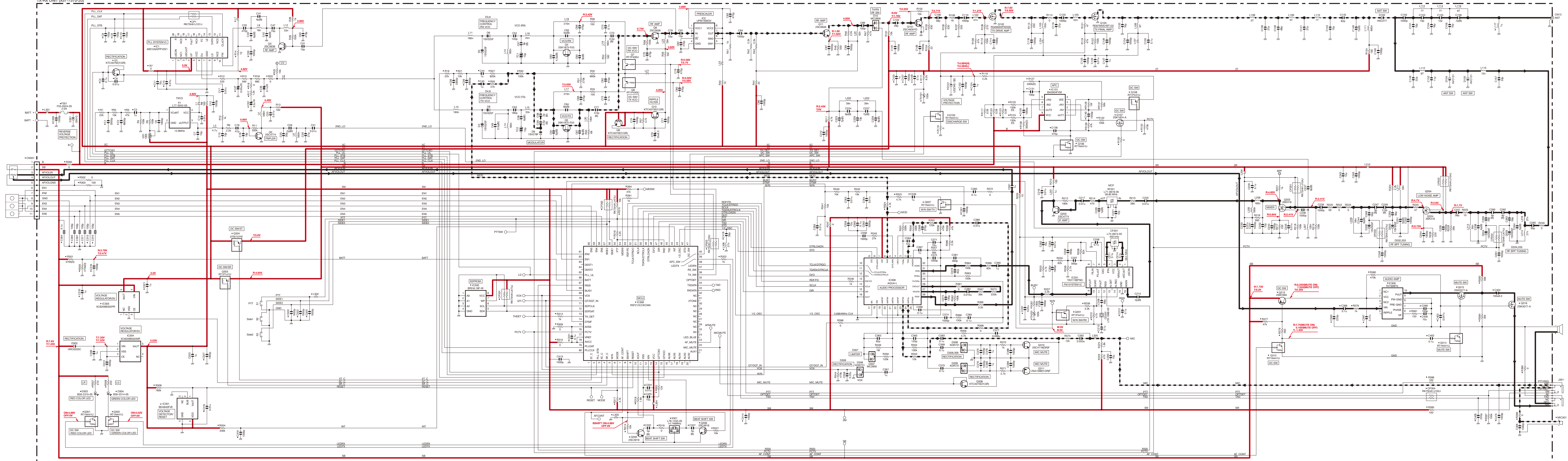

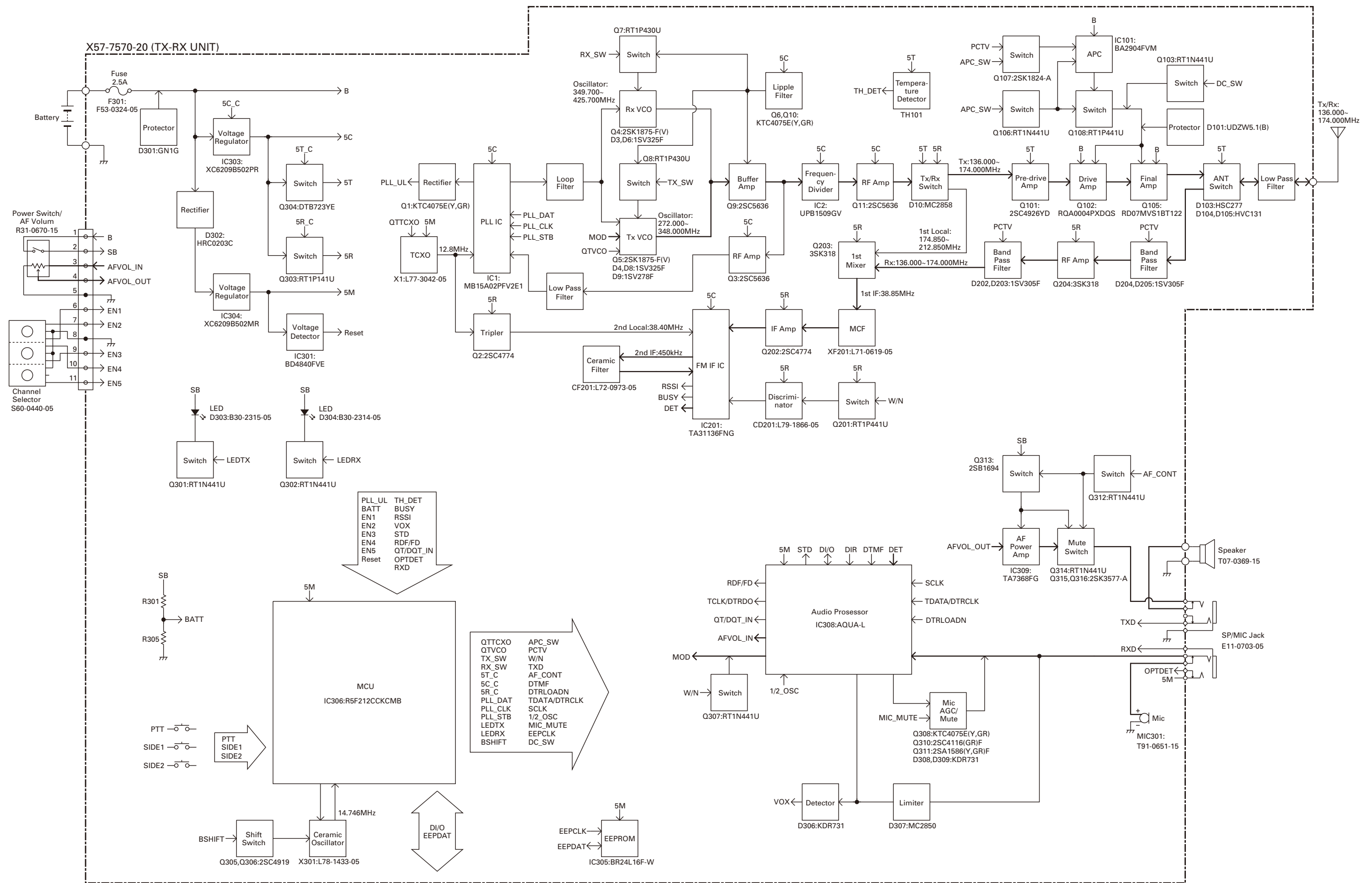

PLL_UL
 BATT
 EN1
 EN2
 EN3
 EN4
 EN5
 Reset

QTTCXO
 QTVCO
 TX_SW
 RX_SW
 5T_C
 5C_C
 5R_C
 PLL_DAT
 PLL_CLK
 PLL_STB
 LEDTX
 LEDRX
 BSHIFT

APC_SW
 PCTV
 W/N
 TXD
 TXD
 AF_CONT
 DTMF
 DTRLOADN
 TDATA/DTRCLK
 SCLK
 1/2_OSC
 MIC_MUTE
 MIC_AGC/Mute
 DC_SW

PTT
 SIDE1
 SIDE2

BSHIFT
 Q305,Q306:2SC4919

EEPROM
 IC305:BR24L16F-W

Q308:KTC4075E(Y,GR)
 Q310:2SC4116(GR)F
 Q311:2SA1586(Y,GR)F
 D308,D309:KDR731

MIC
 MIC301:
 T91-0651-15