

VHF FM TRANSCEIVER / VHF 调频手持对讲机

# TK-2317

SERVICE MANUAL / 维修手册

C version / C 版本

# KENWOOD

Kenwood Corporation

© 2011-2 PRINTED IN JAPAN  
B51-8957-00 (Y)

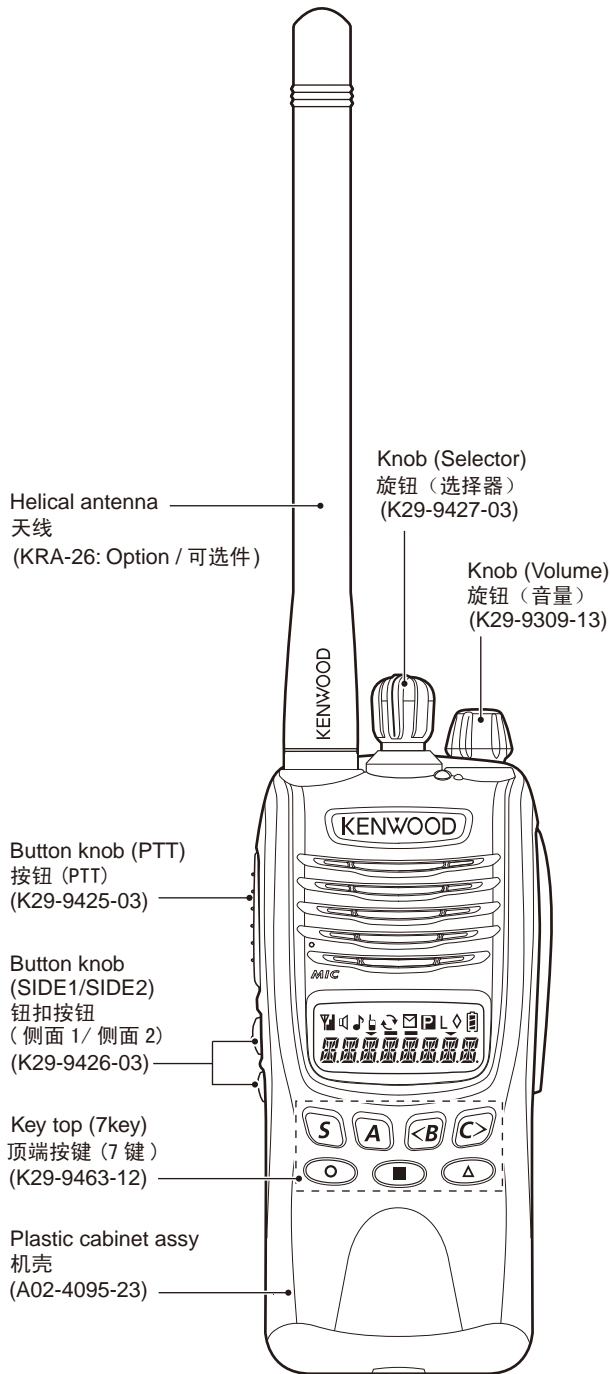

无铅焊接通信产品    
保护环境建伍领先

**⚠ 注意：**本产品是无铅化焊接产品  
在维修时请使用无铅焊锡  
和相应的焊接工具  
详细事项请访问如下网址了解：  
<http://www.kenwoodhk.com.hk/>



## CONTENTS / 目录

<b>GENERAL</b> .....	<b>3</b>	概 述.....	3
<b>SYSTEM SET-UP</b> .....	<b>4</b>	系统体系.....	4
<b>REALIGNMENT</b> .....	<b>5</b>	模式组合.....	5
<b>DISASSEMBLY FOR REPAIR</b> .....	<b>15</b>	维修拆卸.....	15
<b>CIRCUIT DESCRIPTION</b> .....	<b>21</b>	电路说明.....	21
<b>SEMICONDUCTOR DATA</b> .....	<b>29</b>	半导体数据.....	29
<b>COMPONENTS DESCRIPTION</b> .....	<b>31</b>	元件说明.....	31
<b>PARTS LIST</b> .....	<b>33</b>	零 件 表.....	33
<b>EXPLODED VIEW</b> .....	<b>40</b>	部件分解图.....	40
<b>PACKING</b> .....	<b>41</b>	包 装.....	41
<b>ADJUSTMENT</b> .....	<b>42</b>	调 整.....	42
<b>PC BOARD</b>		印刷电路板	
<b>TX-RX UNIT (X57-7880-20)</b> .....	<b>52</b>	收发单元 (X57-7880-20).....	52
<b>SCHEMATIC DIAGRAM</b> .....	<b>56</b>	原 理 图.....	56
<b>BLOCK DIAGRAM</b> .....	<b>62</b>	方 块 图.....	62
<b>LEVEL DIAGRAM</b> .....	<b>64</b>	电 平 图.....	64
<b>OPTIONAL ACCESSORIES</b>		可选附件	
<b>KNB-29N (Ni-MH Battery Pack)</b> .....	<b>65</b>	KNB-29N (镍氢电池).....	65
<b>KNB-45L (Li-ion Battery Pack)</b> .....	<b>65</b>	KNB-45L (锂离子电池).....	65
<b>KNB-53N (Ni-MH Battery Pack)</b> .....	<b>65</b>	KNB-53N (镍氢电池).....	65
<b>KMC-48GPS (GPS Speaker Microphone) ..</b>	<b>65</b>	KMC-48GPS (GPS 扬声器麦克风) ..	65
<b>SPECIFICATIONS</b> .....	<b>BACK COVER</b>	规 格.....	封底

## Document Copyrights

Copyright 2011 by Kenwood Corporation. All rights reserved.

No part of this manual may be reproduced, translated, distributed, or transmitted in any form or by any means, electronic, mechanical, photocopying, recording, or otherwise, for any purpose without the prior written permission of Kenwood.

## Disclaimer

While every precaution has been taken in the preparation of this manual, Kenwood assumes no responsibility for errors or omissions. Neither is any liability assumed for damages resulting from the use of the information contained herein. Kenwood reserves the right to make changes to any products herein at any time for improvement purposes.

## 文档版权信息

Kenwood Corporation 拥有版权 2011。保留所有权利。

未经 Kenwood 公司预先书面同意，无论出于何种目的，均不得以任何形式或任何方式包括电子、机械、影印、录音或其他方式复制、翻译、分发或传播本手册的任何部分。

## 免责声明

Kenwood 公司在准备本文档时已采取所有必要的预防措施，恕不对错误或疏漏承担任何责任，也不对因使用本文中所含的信息而导致的损害负责。Kenwood 公司保留出于改进的需要而随时对文中的产品信息做出更改的权利。

# GENERAL / 概述

## INTRODUCTION

### SCOPE OF THIS MANUAL

This manual is intended for use by experienced technicians familiar with similar types of commercial grade communications equipment. It contains all required service information for the equipment and is current as of the publication date. Changes which may occur after publication are covered by either Service Bulletins or Manual Revisions. These are issued as required.

## ORDERING REPLACEMENT PARTS

When ordering replacement parts or equipment information, the full part identification number should be included. This applies to all parts : components, kits, or chassis. If the part number is not known, include the chassis or kit number of which it is a part, and a sufficient description of the required component for proper identification.

## 引言

### 本手册的范围

本手册是提供给熟悉通信专业并且具有维修经验的技术人员使用的。它包括了维修该设备所需要的全部资料和现行出版日期。在出版后可能发生变动，如果需要，可以参照《维修通报》或《手册修订本》进行补充。

## 替换零件的订购

当订购替换零件或设备资料时，应注意完整的零件识别号码。所有的零件均有识别号码：元件，组件或机壳。如果不知道零件的号码，为了正确地识别，必须注明此元件所属的机壳或组件的号码，并对元件进行充分的说明。

# TK-2317

## PERSONAL SAFETY

The following precautions are recommended for personal safety:

- DO NOT transmit until all RF connectors are verified secure and any open connectors are properly terminated.
- SHUT OFF and DO NOT operate this equipment near electrical blasting caps or in an explosive atmosphere.
- This equipment should be serviced by a qualified technician only.

## SERVICE

This transceiver is designed for easy servicing. Refer to the schematic diagrams, printed circuit board views, and alignment procedures contained within.

Model	Type	TX-RX unit	Frequency range	Remarks
TK-2317	C	X57-7880-20	136~174MHz	IF1: 49.95MHz LOC: 50.4MHz

## 个人安全

个人安全为了个人的安全，请注意下列事项：

- 在没有认真核实所有射频插头之前或有任何一个脱开的插头没有连接到相应端口上的情况下均不要发射。
- 在电爆管附近或在易燃性气体环境中，必须关闭电源，不要操作本设备。
- 本设备只应该由有资格的技术人员进行维修。

## 维修服务

为了便于维修本设备，建立了完整的维修服务体系，提供了包括原理图，印刷电路板图和调整步骤在内的资料供参考。

型号	类型	收发单元	频率范围	备注
TK-2317	C	X57-7880-20	136 ~ 174MHz	IF1: 49.95MHz LOC: 50.4MHz

## SYSTEM SET-UP / 系统体系

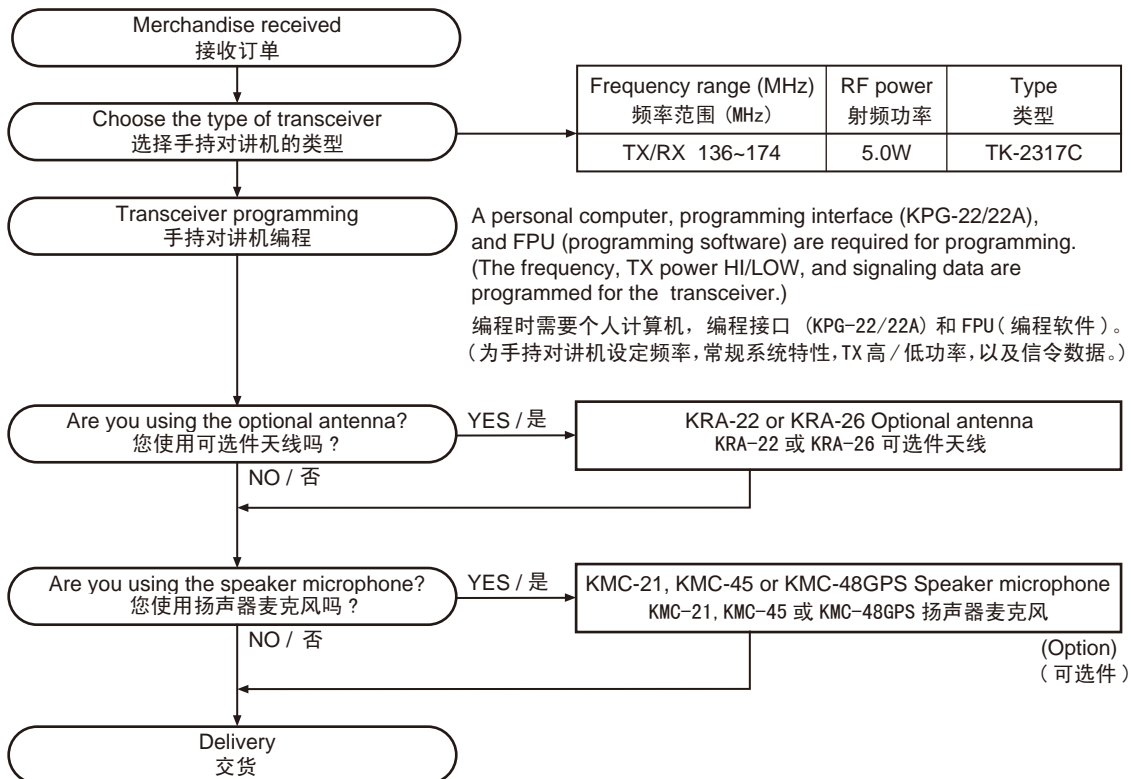

## REALIGNMENT / 模式组合

## 1. Modes

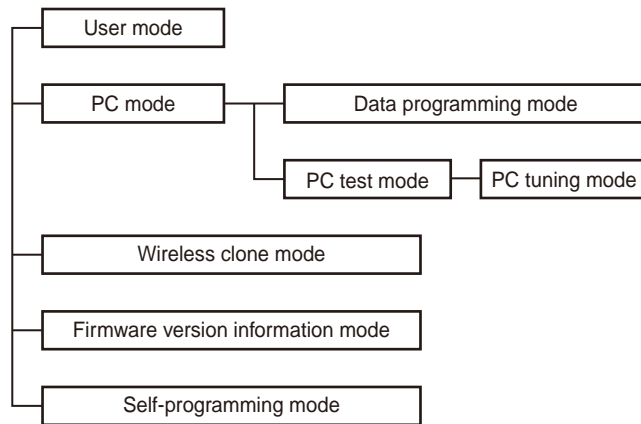

Mode	Function
User mode	For normal use.
PC mode	Used for communication between the transceiver and PC.
Data programming mode	Used to read and write frequency data and other features to and from the transceiver.
PC test mode	Used to check the transceiver using the PC. This feature is included in the FPU.
Wireless clone mode	Used to transfer programming data from one transceiver to another.
Firmware version information mode	Used to confirm the internal firmware version.
Self-programming mode	You can program the frequency signaling and other function using only the transceiver.

## 2. How to Enter Each Mode

Mode	Operation
User mode	Power ON
PC mode	Received commands from PC
Wireless clone mode	[<B] + Power ON (Two seconds)
Firmware version information mode	[Side1] + [Side2] + Power ON (Two seconds)
Self-programming mode	[S] + Power ON (Two seconds)

## 3. PC Mode

## 3-1. Preface

The transceiver is programmed by using a personal computer, a programming interface (KPG-22/22A, USB adapter (KCT-53U)) and FPU (programming software).

The programming software can be used with a PC. Figure 1 shows the setup of a PC for programming.

## 1. 模式

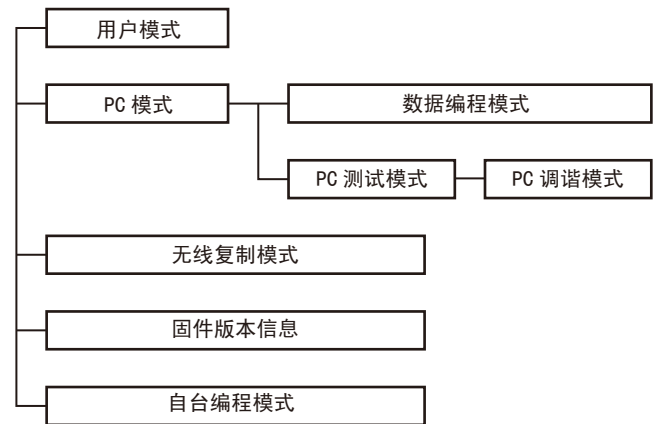

模式	功能
用户模式	一般使用。
PC 模式	用于手持对讲机与计算机之间的通信。
数据编程模式	用于阅读和写入频率数据以及其他功能。
PC 测试模式	用于使用计算机检测手持对讲机。此特性包括在 FPU 内。
无线复制模式	用于从一个手持对讲机编程数据复制到另一个手持对讲机。
固件版本信息	用于确认内部固件版本。
自台编程模式	您可以只使用手持对讲机自身来进行编程频率、信令和其他功能。

## 2. 如何进入每一种模式

模式	功能
用户模式	接通电源
PC 模式	从计算机接收指令
无线复制模式	[<B]+ 接通电源 (2 秒钟)
固件版本信息	[侧面 1]+[侧面 2]+ 接通电源(2 秒钟)
自台编程模式	[S]+ 接通电源 (2 秒钟)

## 3. PC 模式

## 3-1. 前言

手持对讲机采用个人电脑、编程接口 (KPG-22/22A, USB 适配器 (KCT-53U)) 和 FPU (编程软件) 进行编程。

编程软件可以在 PC 上进行使用。图 1 给出了 PC 进行编程的设置。

## REALIGNMENT / 模式组合

**3-2. Connection Procedure**

1. Connect the transceiver to the personal computer with the interface cable and USB adapter (when the interface cable is KPG-22A, the KCT-53U can be used).

**Note:**

- You must install the KCT-53U driver in the computer to use the USB adapter (KCT-53U).
  - When using the USB adapter (KCT-53U) for the first time, plug the KCT-53U into a USB port on the computer with the computer power ON.
2. When the POWER is switched on, user mode can be entered immediately. When the PC sends a command, the transceiver enters PC mode.  
When data is read from the transceiver, the red LED lights.  
When data is written to by the transceiver, the green LED lights.

**Note:**

- The data stored in the personal computer must match Model Name and Model Type when it is written into EEPROM.
- Do not press the [PTT] key during data transmission or reception.

**3-3. KPG-22/KPG-22A Description  
(PC programming interface cable: Option)**

The KPG-22/22A is required to interface the transceiver with the computer. It has a circuit in its D-sub connector (KPG-22: 25-pin, KPG-22A: 9-pin) case that converts the RS-232C logic level to the TTL level.

The KPG-22/22A connects the SP/MIC connector of the transceiver to the RS-232C serial port of the computer.

**3-4. KCT-53U Description (USB adapter: Option)**

The KCT-53U is a cable which connects the KPG-22A to a USB port on a computer.

When using the KCT-53U, install the supplied CD-ROM (with driver software) in the computer. The KCT-53U driver runs under Windows 2000, XP or Vista (32-bit).

**3-5. FPU (Programming Software) Description**

The FPU is the programming software for the transceiver supplied on a CD-ROM. This software runs under windows XP, Vista or 7 on a PC. The software on this disk allows a user to program the transceiver transceivers via Programming interface cable (KPG-22/22A).

**Note:**

- Use the FPU that matches the market when you first set the market code and model name/frequency data to the service unit. The unit set by mistake cannot be restored.

**3-2. 连接操作**

1. 使用接口电缆和 USB 适配器将手持对讲机连接到个人电脑（接口电缆为 KPG-22A 时，可以使用 KCT-53U）。

**注意：**

- 必须在电脑上安装 KCT-53U 驱动程序才能使用 USB 适配器 (KCT-53U)。
  - 首次使用 USB 适配器 (KCT-53U) 时，请在电脑开机的情况下将 KCT-53U 插入电脑的 USB 端口。
2. 手持对讲机电源打开时，可以立即进入用户模式 PC 发送指令时，手持对讲机进入 PC 模式。  
手持对讲机发送数据时，红色的 LED 点亮。  
手持对讲机接收数据时，绿色的 LED 点亮。

**注意：**

- 个人电脑保存的数据写入 EEPROM 时，必须与机型和类型相符。
- 请勿在数据发送或接收期间按 [PTT] 键。

**3-3. KPG-22/KPG-22A 说明  
(PC 编程接口电缆：选配件)**

将手持对讲机与电脑相连需要 KPG-22/22A。该电缆的 D-sub 连接器 (KPG-22: 25 针, KPG-22A: 9 针) 盒具有将 RS-232C 逻辑电平转换为 TTL 电平的电路。

KPG-22/22A 将手持对讲机的 SP/MIC 连接器连接到电脑的 RS-232C 串行端口。

**3-4. KCT-53U 说明 (USB 适配器：选配件)**

KCT-53U 是将 KPG-22A 连接到电脑 USB 端口的电缆。

使用 KCT-53U 时，请在电脑上安装附带的 CD-ROM (带有驱动程序软件)。KCT-53U 驱动程序在 Windows2000, XP 或 Vista (32 位) 下运行。

**3-5. FPU (编程软件) 说明**

FPU 是 CD-ROM 附带的用于手持对讲机的编程软件。该软件在 PC 的 WindowsXP、Vista 或 7 下运行。该光盘上的软件允许用户通过编程接口电缆 (KPG-22/22A) 对手持对讲机进行编程。

**注意：**

- 初次设置服务单元的市场代码和机型 / 频率数据时，请使用与市场相符的 FPU。若单元设置有误，将无法予以恢复。

## REALIGNMENT / 模式组合

### 3-6. Programming with PC

If data is transferred to the transceiver from a PC with the FPU, the data for each set can be modified.

Data can be programmed into the EEPROM in RS-232C format via the SP/MIC jack.

In this mode the PTT line operate as TXD and RXD data lines respectively.

### 3-6. 使用 PC 编程

如果使用 FPU 将数据从 PC 传输到手持对讲机，则每套手持对讲机的数据均可修改。

通过 SP/MIC 插孔可以将数据以 RS-232C 格式写入 EEPROM。在该模式下，PTT 线路分别用作 TXD 和 RXD 数据线路。

#### List of FPU for transceiver

Model	Type	FPU
TK-2317	C	KPG-134D (C)

#### 手持对讲机的 FPU 名单

型号	类型	FPU
TK-2317	C	KPG-134D (C)

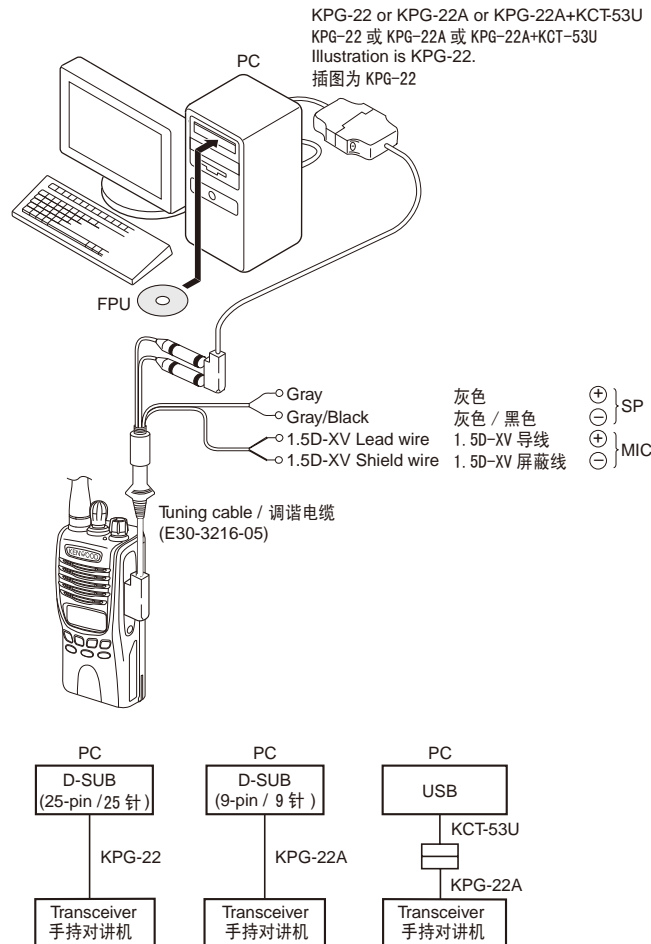

Fig. 1 / 图 1



## REALIGNMENT / 模式组合

## 4. Wireless Clone Mode

## 4-1. Outline

“Wireless Clone Mode” copies the transceiver data to another transceiver.

The dealer can copy the transceiver data to another transceiver even without the use of a personal computer.

## 4-2. Example

The transceiver can copy the programming data to one or more transceivers via RF communication.

The clone source and clone target/s must be in wireless clone mode.

## 4-3. Operation

1. To switch the clone target/s to Wireless Clone mode, press and hold the [ <B ] key while turning the transceiver power ON.
2. Wait for 2 seconds. “CLONE” appears on the LCD, followed by “FRQTBL 1”.
3. Select a channel table number using the [ Selector ] knob.
4. To switch the clone source to Wireless Clone mode, press and hold the [ <B ] key while turning the transceiver power ON.
5. Wait for 2 seconds. “CLONE” appears on the LCD, followed by “FRQTBL 1”.
6. Select the same channel table number as the clone target/s.
7. Press the [ S ] key on the clone master to begin data transmission. When the clone target starts to receive data, the green LED will light and “CLONING” will appear on the LCD. The source unit will display “MASTER”.
8. When the clone source finishes sending data, a “confirmation” tone will sound and “COMPLETE” will appear on the LCD. If data transmission failed while cloning, the target unit will produced an error tone and “CLONE NG” will appear on the LCD.
9. If the cloning fails, no data will be available in the target unit when it is returned to User mode.
10. When the cloning is successful, the target unit's “Scan” and “Key lock” functions will return to their default values (Scan = OFF, Key lock = OFF).
11. The source will remain in clone mode after cloning. The target unit will return to user mode after a successful cloning.

## Note:

- The dealer can clone data to two or more transceivers by repeating the above procedures.
- If the transceivers wireless clone Mode is configured as “Disabled”, the transceiver cannot enter Clone mode.
- The table shown below will cover the frequency tables used for wireless cloning.
- Wireless clone mode cannot be entered in battery low state.
- A unit cannot be a “Source Unit” if it is unprogrammed. If the [ S ] key is pressed, an “error” tone will sound.
- Once a unit is set to be the source, it cannot be a target after the data has been transmitted. This protects the data in the source unit.
- MSK signaling is used in cloning.

## 4. 无线复制模式

## 4-1. 概要

“无线复制模式”可以将一台手持对讲机的数据复制到其它的手持对讲机。

经销商甚至不使用个人电脑也可以将一台手持对讲机的数据复制到其它的手持对讲机。

## 4-2. 例

手持对讲机可以通过 RF 通信复制编程数据到一台或更多的手持对讲机。

复制主机和复制子机必须处于无线复制模式。

## 4-3. 操作方法

1. 将子机切换到无线复制模式，接通 (ON) 手持对讲机电源开关的同时，持续按 [ <B ] 键。
2. 等待 2 秒。LCD 上显示 “CLONE”，然后显示 “FRQTBL 1”。
3. 用 [ 选择器 ] 旋钮选择频率表号码。
4. 将主机切换到无线复制模式，打开手持对讲机电源 (ON) 的同时，持续按 [ <B ] 键。
5. 等待 2 秒。在 LCD 上显示 “CLONE”，然后显示 “FRQTBL 1”。
6. 选择与复制子机相同的频率表号码。
7. 按复制主机上的 [ S ] 键，开始传输数据。当复制子机开接收数据时，绿色 LED 将亮灯，并且 “CLONING” 显示在 LCD 上。主机将显示 “MASTER”。
8. 当复制主机完成数据传送，将发出一个 “确认” 音，并且在 LCD 上显示出 “COMPLETE”。如果复制中数据通讯失败，子机将发出错语音，而且在 LCD 上显示出 “CLONE NG”。
9. 如果复制失败，子机回到用户模式时会无可用数据。
10. 当复制成功时，子机的 “扫描” 和 “键锁定” 功能将返回到它们的初始值 (扫描 = OFF, 键锁定 = OFF)。
11. 主机在复制后将停留在复制模式。复制成功后，子机将返回到用户模式。

## 注：

- 经销上可以把同样的数据反复地复制到两台或更多的手持对讲机。
- 如果手持对讲机的无复制模式被设定为 “禁用”，则手持对讲机不能进入复制模式。
- 此表是使用于无线复制的频率表。
- 在电池低电压状态时，不能进入无复制模式。
- 如果没有被编程，就不能成为 “主机”。如果 [ S ] 键被按，将会发出 “错误” 音。
- 手持对讲机一旦被设定为主机，而且数据被传送之后，它就不能成为子机。此功能是为了保护主机内的数据。
- MSK 信号用于复制。
- 电子干扰有可能导致无线复制时数据传送失败，如在工作台上受到电波或电磁的干扰。



## REALIGNMENT / 模式组合

- Electronic interface may cause a failure in data transfer during Wireless Clone, such as when waveforms or electromagnetics are being performed at the workbench.
- Wireless clone mode can be used ONLY by the authorized service personnel.
- The wireless clone mode setting must be configured as “Disable” before being delivered to the end-user.
- To wireless clone, replace the antenna from both the source transceiver and the target transceiver with a dummy load.
- The transmit output power is automatically set to Low in Clone mode.

### 4-4. Adding the Data Password

If the Data password is set to the transceiver, you must enter the password to activate a clone mode. The maximum length of the password is 6 digits.

The following describes how to enter the password.

1. Press and hold the [ <B ] key for 2 seconds while turning the transceiver power on.
2. “CLN.LOCK.R”(When the Read authorization password is set to the transceiver.) / “CLN.LOCK.W” (When the Overwrite password is set to the transceiver.) is displayed on the LCD.
3. If the [selector] knob is rotated while “CLN.LOCK.R”/ “CLN.LOCK.W” is displayed, the number (0 to 9) flashes on the LCD.

When you press the [C>] key, the currently selected number is determined.

If you press the [A] key, the least digit of the password is deleted.

If you press the [S] key after entering the password in this procedure, “FRQTBL 1” is displayed if the entered password is correct.

If the password is incorrect, “CLN.LOCK.R”/ “CLN.LOCK.W” is redisplayed. (with error tone)

#### • Clone frequency table

No.	Operating frequency 136~174 (MHz)
1	136.000
2	138.000
3	140.000
4	142.000
5	144.000
6	146.000
7	148.000
8	150.000
9	152.000
10	154.000
11	156.000
12	158.000
13	160.000
14	162.000
15	164.000
16	166.000
17	168.000
18	170.000
19	172.000
20	174.000

- 无复制模式只可以由授权的服务人员使用。
- 在向最终用户交货之前，无复制模式必须设置为“禁用”。
- 无复制时，取下主手持对讲机和子手持对讲机的天线并装上假负载。
- 在复制模式，手持对讲机输出功率自动地被设定为低功率。

### 4-4. 增加数据密码

如果数据密码被设定于手持对讲机，则您必须先输入密码才能启动复制模式。密码的最大长度为 6 位数字。

输入密码的方法说明如下。

1. 打开手持对讲机电源的同时，持续按 [ <B ] 键 2 秒。
2. “CLN. LOCK. R”（当读取授权密码被设定到手持对讲机时） / “CLN. LOCK. W”（重写密码被设定到手持对讲机时）被显示在 LCD。
3. 在 “CLN. LOCK. R” / “CLN. LOCK. W” 被显示时，如果 [ 选择器 ] 旋钮被转动，在 LCD 上会闪烁出数字 (0 ~ 9)。当您按了 [C>] 键，通常被选择的数字将被确定。如果您按了 [A] 键，密码的最小位数字将被删除。在此程序中输入了密码，并且被输入的密码正确，如果您按了 [S] 键，则显示出 “FRQTBL 1”。如果密码错误，则继续显示 “CLN. LOCK. R” / “CLN. LOCK. W”。（发出错误音）

#### • 复制频率表

号码	操作频率 136 ~ 174 (MHz)
1	136.000
2	138.000
3	140.000
4	142.000
5	144.000
6	146.000
7	148.000
8	150.000
9	152.000
10	154.000
11	156.000
12	158.000
13	160.000
14	162.000
15	164.000
16	166.000
17	168.000
18	170.000
19	172.000
20	174.000

## REALIGNMENT / 模式组合

## 5. Firmware Version Information Mode

Turn the transceiver ON with the [Side1] and [Side2] keys held down. Then, the version is displayed during holding the [Side1] and [Side2] keys.

## 6. Self Programming Mode

Write mode for frequency data and signaling, etc. To be used ONLY by the authorized service person maintaining the user's equipment. After programming, reset the FPU to the "Self- Programming" disabled mode. Transceivers CANNOT be delivered to the end-user in the self-programming mode.

## 6-1. Enter to the Self Programming Mode

Press and hold the [S] key for 2 seconds while turning the transceiver power on.

When the transceiver enters in the self programming mode, "1- 1" is displayed 2 seconds after "SELF" is displayed.

**Note:**

This mode (self programming mode) cannot be set when it has been disabled with the FPU.

## 6-2. Adding the Data Password

If the Data password is set to the transceiver, you must enter the password to activate a self programming mode. The maximum length of the password is 6 digits.

The following describes how to enter the password.

1. Press and hold the [S] key for 2 seconds while turning the transceiver power on.
2. "SLF.LOCK.R" (When the Read authorization password is set to the transceiver.) / "SLF.LOCK.W" (When the Overwrite password is set to the transceiver.) is displayed on the LCD.
3. If the [selector] knob is rotated while "SLF.LOCK.R"/"SLF.LOCK.W" is displayed, the number (0 to 9) flashes on the LCD.

When you press the [C>] key, the currently selected number is determined.

If you press the [A] key, the least digit of the password is deleted.

If you press the [S] key after entering the password in this procedure, "SELF" is displayed if the entered password is correct.

If the password is incorrect, "SLF.LOCK.R"/"SLF.LOCK.W" is redisplayed.

## 6-3. Channel Selection Mode

In this mode, the Zone or Channel can be selected.

Press and hold the [S] key for 2 seconds while turning the transceiver power on to enter self programming mode. When the transceiver enters in the self programming mode, the transceiver automatically enters the Channel Selection mode.

2 seconds after displaying "SELF", "1- 1" appears on the LCD.

## 5. 固件版本信息

按下 [侧面 1] 和 [侧面 2] 键打开手持对讲机的电源。然后按 [侧面 1] 和 [侧面 2] 键显示版本。

## 6. 自台编程模式

频率数据和信令等的写入模式。只可以由负责维护用户设备的授权服务人员使用。编程之后，复位自台编程模式为禁用状态。手持对讲机不能以自台编程模式开启的状态交付给最终用户。

## 6-1. 进入自台编程模式

打开手持对讲机电源的同时，持续按 [S] 键 2 秒。

当手持对讲机进入了自台编程模式，显示 "SELF" 2 秒钟，然后显示 "1-1"。

**注：**

当自台编程模式被 FPU 禁用时，此模式不能被设定。

## 6-2. 增加数据密码

如果数据密码被设定到手持对讲机，则您必须输入密码来激活自台编程模式。密码的最大长度为 6 位数字。

输入密码的方法说明如下。

1. 打开手持对讲机电源的同时，持续按 [S] 键 2 秒。
2. "SLF.LOCK.R" (当读取授权密码被设定到手持对讲机时) / "SLF.LOCK.W" (重写密码被设定到手持对讲机时) 被显示在 LCD。
3. 在 "SLF.LOCK.R" / "SLF.LOCK.W" 被显示时，如果 [选择器] 旋钮被转动，在 LCD 上会闪烁出数字 (0 ~ 9)。当您按了 [C>] 键，通常被选择的数字将被确定。如果您按了 [A] 键，密码的最小位数字将被删除。在此程序中输入了密码，并且被输入的密码正确，如果您按了 [S] 键，则显示出 "SELF"。如果密码错误，则继续显示 "SLF.LOCK.R" / "SLF.LOCK.W"。

## 6-3. 信道选择模式

在此模式，可以选择区域或信道。

打开手持对讲机电源的同时，持续按 [S] 键 2 秒，则进入自台编程模式。当手持对讲机进入自台编程模式，则手持对讲机将自动进入信道选择模式。

显示 "SELF" 2 秒钟之后，在 LCD 上出现 "1-1"。

## REALIGNMENT / 模式组合

The setup item for channel selection mode is as follows.

Setup item	Display	Remarks
Select Zone/Channel	>***< - *** *** - >***<	Zone: 1~128 Channel: 1~128

## Key operation

Key	Key Function
[Selector]	Toggle between Zone selection and Channel selection
[Side1]	No action
[Side2]	No action
[S]	Enter the Item Setting mode
[A]	Return to the Channel Selection mode
[<B]	Decrement the blinking Zone/Channel number by 1. Press and hold to decrement in steps of 10.
[C>]	Increment the blinking Zone/Channel number by 1. Press and hold to decrement in steps of 10.

## Note:

If a non-existing Zone-Channel is selected and the memory for all 128 channels is already filled, an error tone will sound and "MEM.FULL" will appear on the LCD for 2 seconds.

## 6-4. Item Selection Mode

In this mode, the following items can be selected.

- RX frequency
- RX signaling
- TX frequency
- TX signaling
- RF power Hi/Low
- Scan Del/Add
- Beat shift on/off
- Comander on/off
- Band W/N

When the [S] key is pressed in the Channel Selection mode, the transceiver enters the Item Selection mode.

## Key operation

Key	Key Function
[Selector]	The selected item changes
[Side1]	No action
[Side2]	No action
[S]	Enter the Item Setting mode
[A]	Return to the Channel Selection mode
[<B]	Error tone sounds
[C>]	Error tone sounds

信道选择模式的设定项目如下所示。

设定项目	显示	备注
选择 区域 / 信道	>***< - *** *** - >***<	区域：1 ~ 128 信道：1 ~ 128

## 键操作方法

键	键功能
[选择器]	在区域选择和信道选择之间切换
[侧面1]	无作用
[侧面2]	无作用
[S]	进入项目设定模式
[A]	返回到信道选择模式
[<B]	以步进值 1 减小闪动的区域 / 信道。按住时则以步进值 10 减小。
[C>]	以步进值 1 增大闪动的区域 / 信道。按住时则以步进值 10 增大。

## 注：

如果选择了不存在的区域 - 频道和所有的 128 个信道的存储器已经被占满，则将发出错误音，同时在 LCD 上显示 "MEM.FULL" 2 秒钟。

## 6-4. 项目选择模式

在此模式，可以选择如下项目。

- RX 频率
- RX 信令
- TX 频率
- TX 信令
- RF 功率高 / 低
- 扫描删除 / 添加
- 拍频偏移 ON/OFF
- 压扩器 ON/OFF
- 宽带 / 窄带

在信道选择模式，当按了 [S] 键，手持对讲机将进入项目选择模式。

## 键操作方法

键	键功能
[选择器]	变更选择项目
[侧面1]	无作用
[侧面2]	无作用
[S]	进入项目设定模式
[A]	返回到信道选择模式
[<B]	错误音
[C>]	错误音

## REALIGNMENT / 模式组合

## 6-5. Item Setting Mode

In this mode, the selected item in the Item Selection mode can be programmed.

When the [S] key is pressed in the Item Selection mode, the transceiver enters the Item Setting mode.

The setup items for item setting mode are as follows.

Setup item	Display	Remarks
1. RX frequency	1. RX FREQ → ***.*****	Receive frequency 136.00000~174.00000MHz
2. RX signaling	2. RX SIG TONE OFF/ QT ***.*/ DQT ***N/ DQT ***I	Receive QT/DQT
3. TX frequency	3. TX FREQ → ***.*****	Transmit frequency 136.00000~174.00000MHz
4. TX signaling	4. TX SIG → TONE OFF/ QT ***.*/ DQT***N/ DQT***I	Transmit QT/DQT
5. RF power Hi/Low	5. PWR ***	HI/LOW
6. Scan Del/Add	6. SCN ***	DEL/ADD
7. Beat shift on/off	7. SFT ***	ON/OFF
8. Comander on/off	8. CMP ***	ON/OFF
9. Band W/N	9. BAND ***	W/N

## Key operation

Key	Key Function
[Selector]	Changing the selection item (RX/TX frequency and RX/TX signaling only)
[Side1]	No action
[Side2]	No action
[S]	<ul style="list-style-type: none"> <li>• Store the current settings and return to the Item Selection mode.</li> <li>• A MHz digit of the frequency blinks. (RX/TX frequency only)</li> <li>• The icon of the current signaling configuration blinks. (RX/TX signaling only)</li> </ul>
[A]	Abort the current settings and return to the Item Selection mode without backup
[<B]	Toggle/Decrease the blinking value.
[>C]	Toggle/Increase the blinking value.

## 6-5. 项目设定模式

在此模式，项目选择模式中被选择的项目可以进行编程。

在项目选择模式，当按了 [S] 键，手持对讲机将进入项目设定模式。

项目设定模式的设定项目如下所示。

设定项目	显示	备注
1. RX 频率	1. RX FREQ → ***.*****	接收频率 136.00000 ~ 174.00000MHz
2. RX 信令	2. RX SIG → TONE OFF/ QT***.*/ DQT***N/ DQT***I	接收 QT/DQT
3. TX 频率	3. TX FREQ → ***.*****	发射频率 136.00000 ~ 174.00000MHz
4. TX 信令	4. TX SIG → TONE OFF/ QT***.*/ DQT***N/ DQT***I	发射 QT/DQT
5. RF 功率高 / 低	5. PWR***	HI/LOW
6. 扫描删除 / 添加	6. SCN***	DEL/ADD
7. 拍频偏移 ON/OFF	7. SFT***	ON/OFF
8. 压扩器 ON/OFF	8. CMP***	ON/OFF
9. 宽带 / 窄带	8. BAND***	W/N

## 键操作方法

键	键功能
[选择器]	变更选择项目（仅 RX/TX 频率和 RX/TX 信令）
[侧面 1]	无作用
[侧面 2]	无作用
[S]	<ul style="list-style-type: none"> <li>• 保存当前的设定和返回到项目选择模式。</li> <li>• 频率的 MHz 数字闪动。（仅 RX/TX 频率）</li> <li>• 当前的信令配置闪动。（仅 RX/TX 信令）</li> </ul>
[A]	放弃当前的设定并返回到项目选择模式。
[<B]	切换 / 减小闪动的数值
[>C]	切换 / 增大闪动的数值

## REALIGNMENT / 模式组合

### 6-6. Self Programming Mode flow chart

#### ■ Channel selection mode flow chart

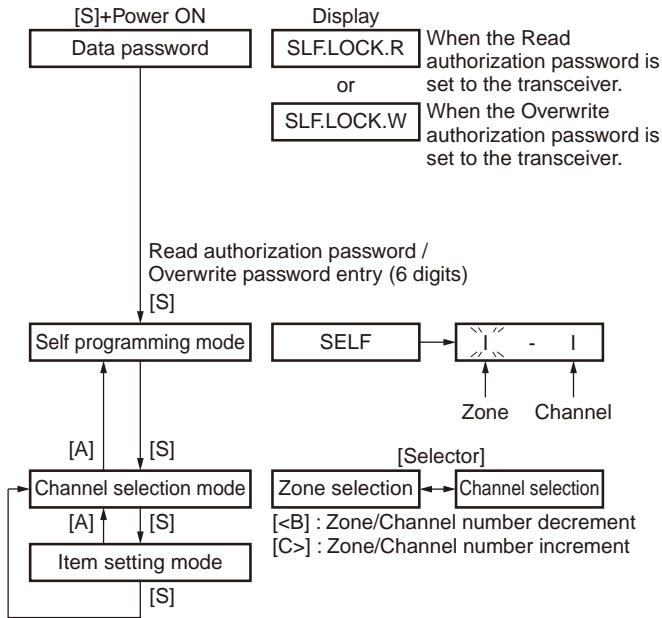

### 6-6. 自台编程模式流程图

#### ■ 信道选择模式流程图

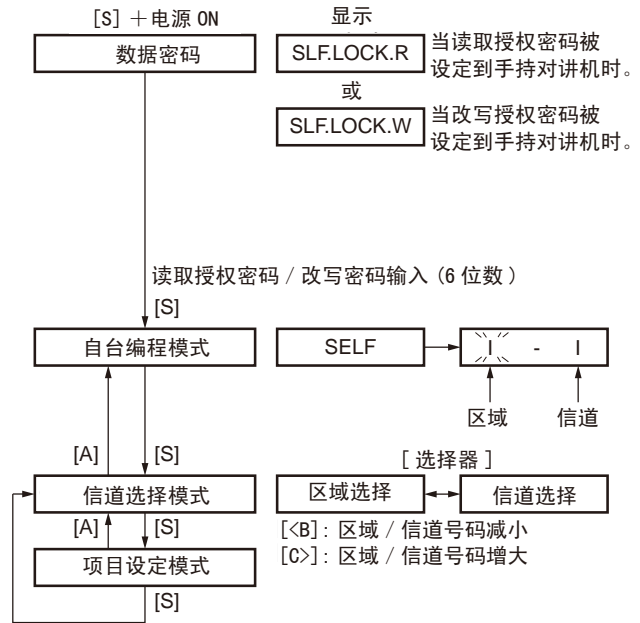

#### ■ Item selection mode flow chart

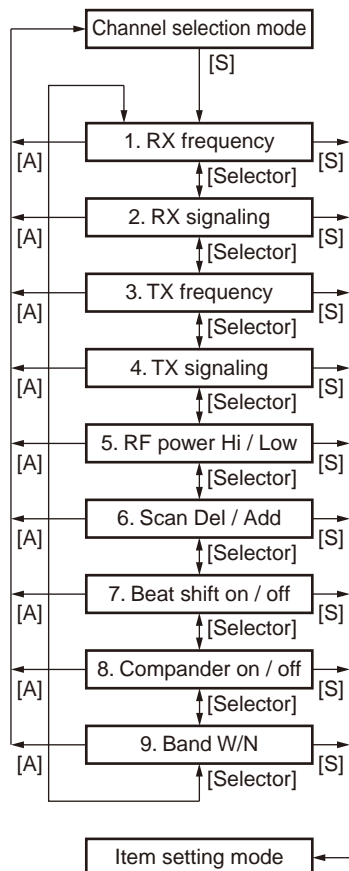

#### ■ 项目选择模式流程图

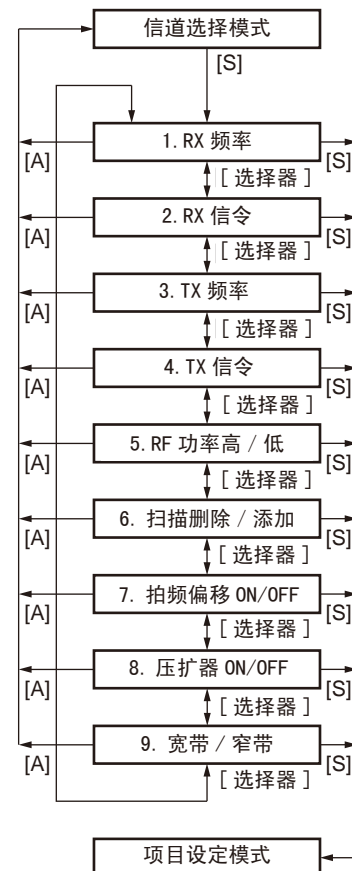

## REALIGNMENT / 模式组合

Item setting mode flow chart

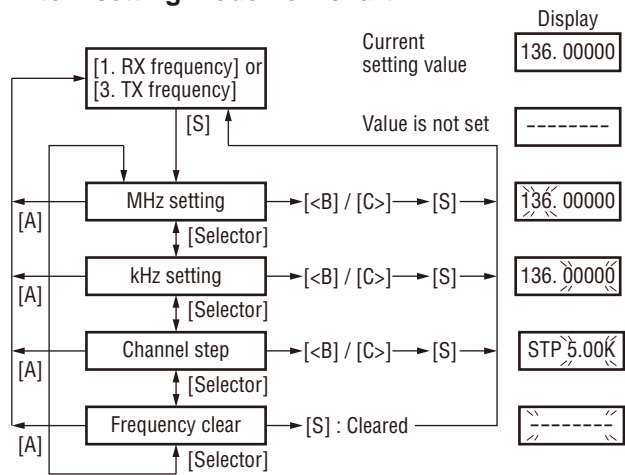

项目设定模式流程图

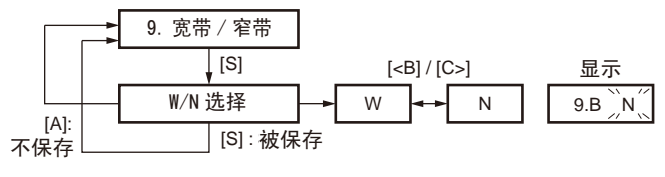
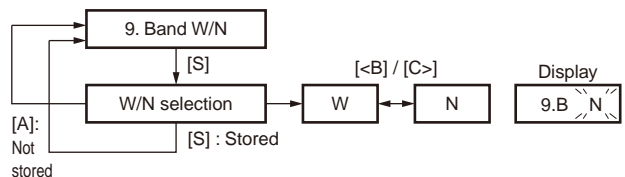
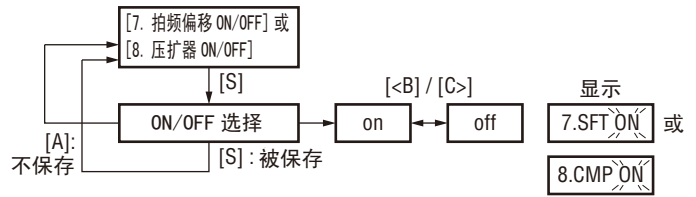
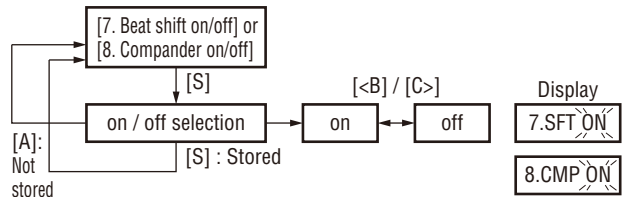
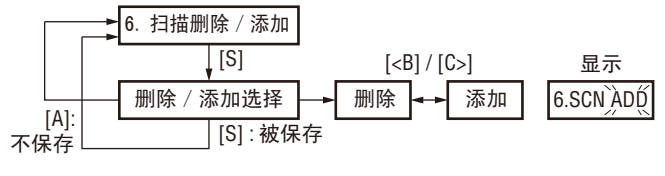
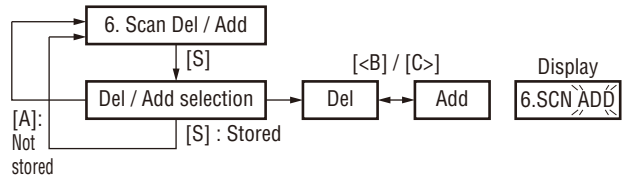
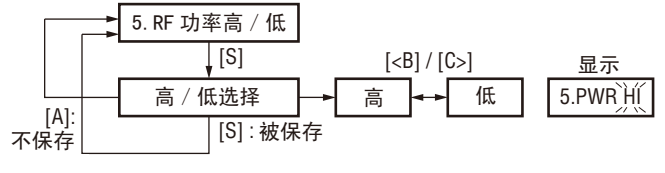
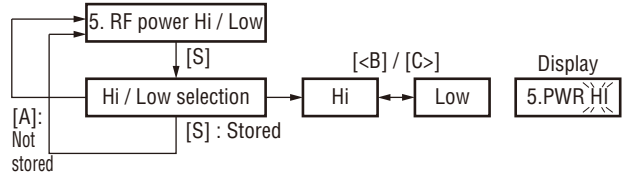
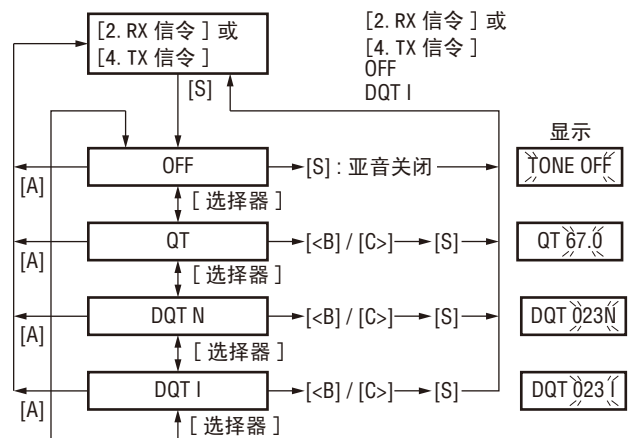
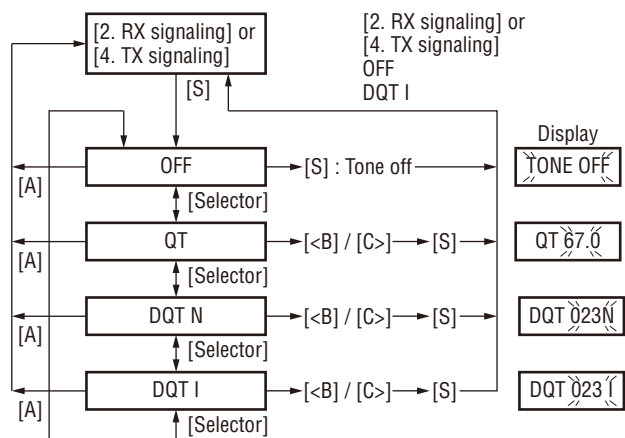
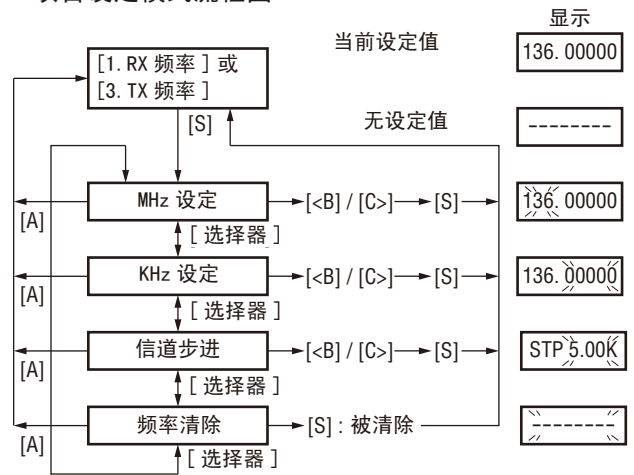



# DISASSEMBLY FOR REPAIR / 维修拆卸

## 1. Removing the Case Assembly from the Chassis

1. Remove the selector knob ① and volume knob ②.
2. Remove the two screws ③.
3. Lift and remove the chassis from the case assembly ④.  
(Use a flat-blade screwdriver to easily lift the chassis.)

## 1. 从机架上拆卸机壳

1. 拆卸选择器旋钮 ① 和音量旋钮 ②。
2. 拧下 2 个螺丝 ③。
3. 从机体拉出并卸下机壳 ④。  
(使用一字螺丝刀容易拉出机壳。)

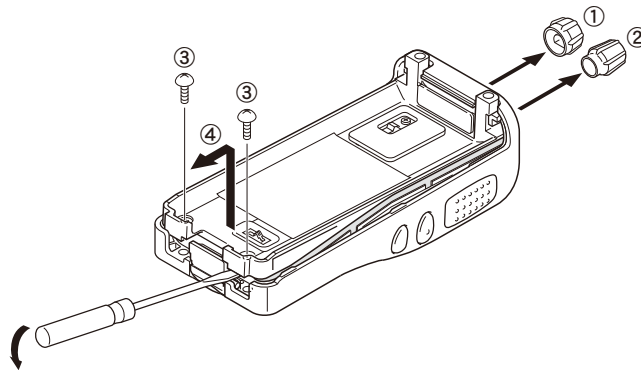

## 2. Removing the Holder Assembly from the Chassis

1. Remove the holder from the chassis.  
**Note:** Taking care not to cut the speaker and microphone lead.
2. Detach the solder of speaker and microphone lead from the PCB beforehand.
3. Remove the packing ⑤ from the SP/MIC jack of the TX-RX unit.

## 2. 从机架卸下支架

1. 从机架卸下支架。  
注意：小心不要折断扬声器引线和麦克风引线。
2. 卸下 PC 板上的扬声器引线和麦克风引线上的焊锡。
3. 卸下 SP/MIC 连接器的橡胶垫 ⑤。

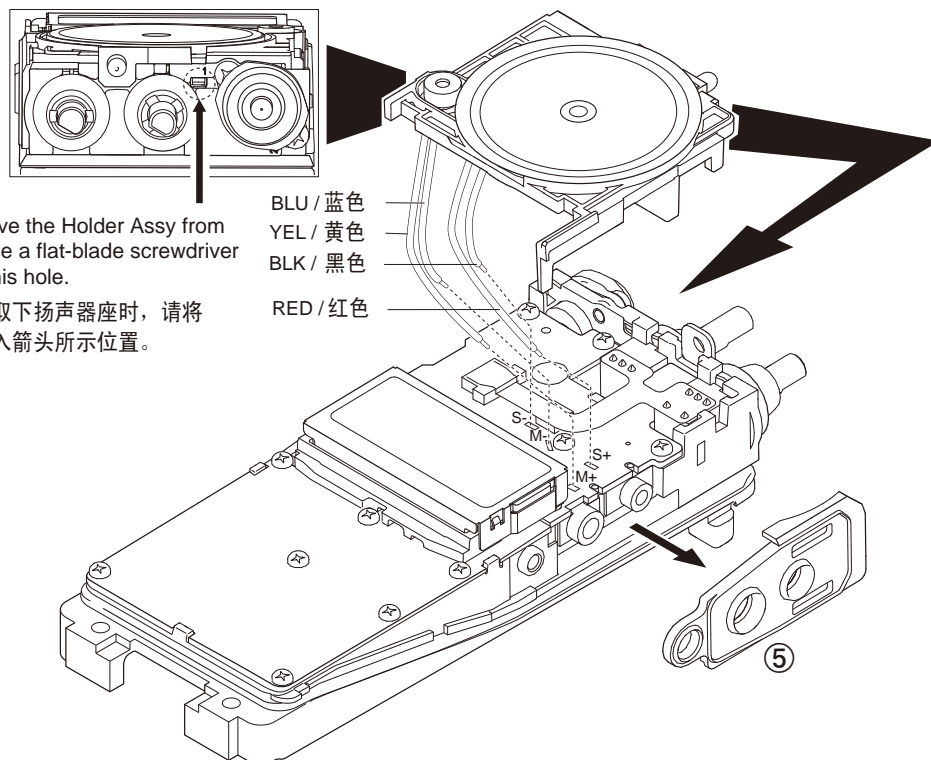

## DISASSEMBLY FOR REPAIR / 维修拆卸

## 3. Removing the TX-RX unit from the Chassis

1. Remove the eleven screws ⑥ fixing the TX-RX unit.
  2. Remove the solder of the antenna terminal with a soldering iron ⑦.
  3. Remove the solder of the positive terminal with a soldering iron ⑧.
- Note:** You can remove the TX-RX unit from the chassis without removing the solder at the positive terminal. However, in this case, you can not attach the packing (G53-1605-03) that is on the positive terminal to the chassis in assembling. So, it is advisable to remove the solder on the positive terminal first.
4. Remove the FPC from the flat cable connector ⑨.
  5. Lift and remove the TX-RX unit from the chassis ⑩.

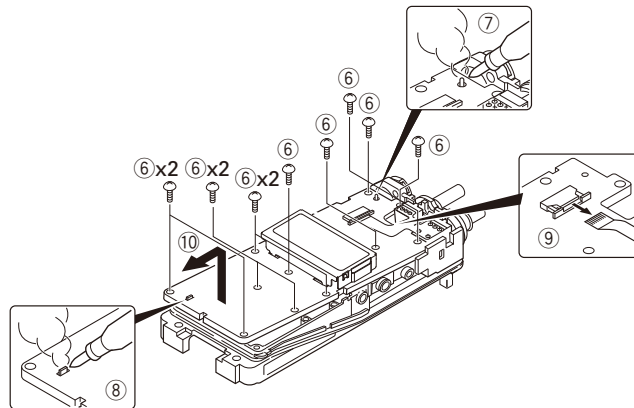

## 3. 从机架拆卸收发单元

1. 卸下固定收发单元的 11 个螺丝 ⑥。
2. 用电烙铁烫开天线端子的焊锡。⑦
3. 用电烙铁烫开电池正极端子的焊锡。⑧

注：不用烫下焊锡拆卸正极的端子，你也可以拆卸收发单元。

但是组装时，正极端子连接的垫片（G53-1605-03）不能安装到机架。因此，请先烫开正极端子的焊锡。

4. 从扁平电缆连接器拆卸 FPC。⑨
5. 从机架抬起收发单元。⑩

## 4. Removing the Battery Release Lever from the Case Assembly

1. Press the upper part of the lever toward the inside of the case assembly. One side of the shaft will be removed ①.
2. Lift and remove the battery release lever from the case assembly ②.

**Note:** Scratch and widen the glue hole if there is difficulty in removing the other end of the shaft.

No glue is required when you reassemble the battery release lever.

## 4. 从机壳拆卸电池分离拨杆

1. 向机壳的内侧按压拨杆上部之后，就可以卸下轴的一侧。①
2. 拿起电池分离杆，就可以从机壳上拆卸下来。②

注：如果很难拆卸轴的其他端部时，请刮掉和扩展粘合孔。当你重新组装电池分离杆时，则不需要粘合。

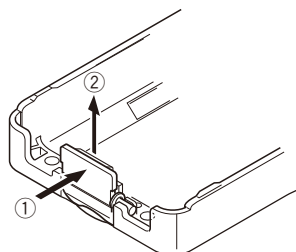

## DISASSEMBLY FOR REPAIR / 维修拆卸

### 5. Attaching the Battery Release Lever to the Case Assembly

1. Insert one side of the shaft into the hole at the lever fitting section on the case assembly ①.  
Caution: The thin spring (G01-4543-04) should be positioned above the two tabs of the lever.
2. Tilt the battery release lever slightly forward ②, so that the thick spring (G01-4542-04) is positioned below the case surface.
3. With the thick spring positioned below the case surface, attach the other side of the shaft to the case assembly by pressing the battery release lever ③ until it snaps into place ④.

**Caution:** Be careful not to tilt the battery release lever too forward.

If the battery release lever is pushed in this state where the two tabs come below the case surface, there is a possibility of damaging the two tabs.

### 5. 安装电池分离拨杆到机壳

1. 把轴的一侧插入到机壳的拨杆安装部的孔里。①

注：细弹簧（G01-4543-04）必须安装到拨杆的2个突起上面。

2. 轻轻地前推电池分离拨杆倾斜倒②，这样粗弹簧（G01-4542-04）就被定位在机壳下面。

3. 粗弹簧被定位到机壳下面之后，通过按电池分离拨杆③直到它嵌入位置④，轴的另一侧接触机壳组件。

注：注意不要把电池分离拨杆倾斜得太靠前。

如果电池分离拨杆被推到分离拨杆下面的2个卡头的位置，就有可能损坏这2个卡头。

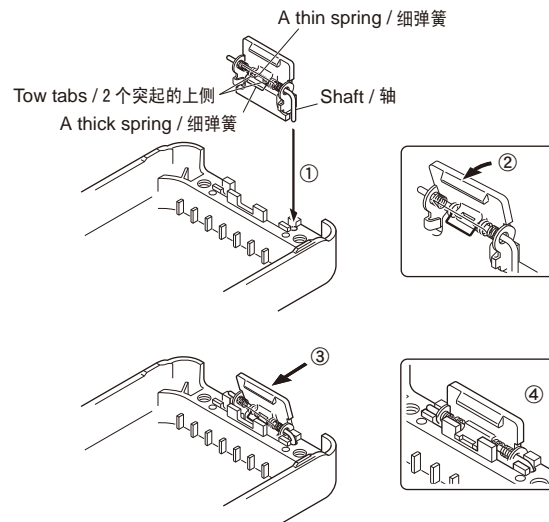

## DISASSEMBLY FOR REPAIR / 维修拆卸

### 6. Assembling the Battery Release Lever

1. Place the lever ② onto the stopper ①.
2. Place the thick spring ③ onto the lever.
3. Hook the right and left ends of the thin spring ④ onto the tabs of the stopper, then place the thin spring ④ onto the lever ⑤.
4. Slide the shaft through the hole of the stopper and lever ⑥.

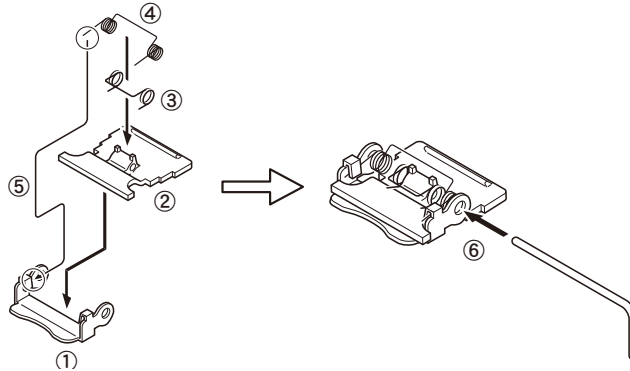

### 6. 电池分离拨杆的组装方法

1. 请把拨杆 ② 置于止动器 ① 的上面。
2. 请把粗弹簧 ③ 置于拨杆的上面。
3. 请把细弹簧置于拨杆上面，并让细弹簧 ④ 的左右端置于止动器的两个卡头内。⑤
4. 滑动轴穿过止动器和拨杆的孔。⑥

### 7. Attaching the Positive Terminal to the Chassis

Always attach the positive terminal to the chassis, using the following procedures, before mounting the TX-RX unit onto the chassis.

1. Remove the holder assembly ② from the packing ① of the positive terminal.
2. Mount the packing of the positive terminal into the chassis hole ③.
3. Mount the holder assembly into the packing of the positive terminal ④.

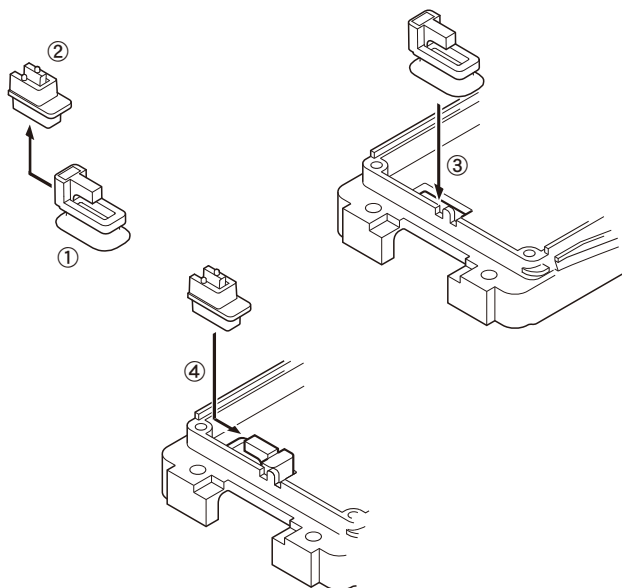

### 7. 把正极端子安装到机架

把收发单元组装到机架之前，必须按照以下的顺序把电池正极端子安装到机架。

1. 从正极端子的垫片 ① 上取下机架 ②。
2. 把正极端子的垫片安装到机架孔上。③
3. 把支架安装到正极端子的垫片上。④

## DISASSEMBLY FOR REPAIR / 维修拆卸

### 8. Mounting the Chassis to the Case

#### Assembly

1. Confirm that the waterproof packing attached to the circumference of the chassis is securely inserted in the groove of the chassis ①.
2. Insert the upper part of the chassis into the case assembly ②.
3. Press the chassis ③ and the case assembly together to attach them.

**Caution:** If the packing of the SP/MIC does not come to the correct position after attaching the chassis to the case assembly, reposition the packing with your fingers.

### 8. 安装机壳机架

1. 确认机架四周的防水垫是否确实进入机壳的槽里。①
2. 把机架上部插到机壳里。②
3. 按压机架 ③，使机架和机壳成为一个整体。

注：把机架安装到机壳上后，如果 SP/MIC 不在正确的位置的话，请用手指调整到正确的位置。

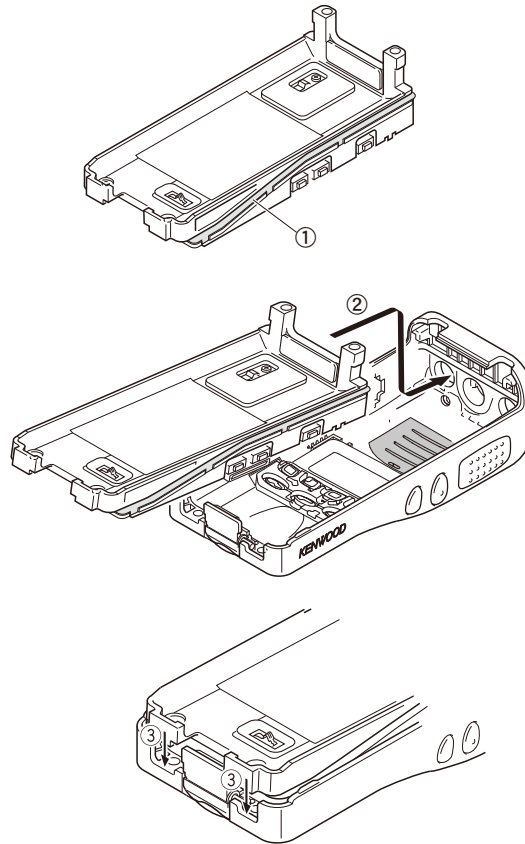

### 9. Attaching the Antenna Receptacle to the Chassis

Screw the antenna receptacle to the chassis in the order shown in the drawing so that the antenna receptacle comes to the center of the case hole.

### 9. 把天线座安装到机架

为了能把天线座安装到机芯孔的中心，在将天线座安装到机架时，请按照图示的顺序固定螺丝。

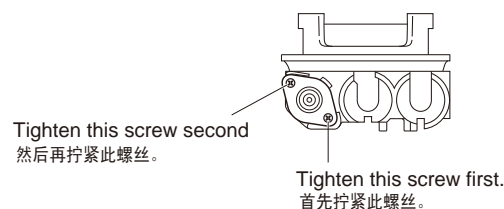

## DISASSEMBLY FOR REPAIR / 维修拆卸

### 10. The Nuts of the Volume Knob and Channel Knob

Note that the shapes, colors and heights of nuts of the volume knob and selector knob are different from one another. (The nut of volume knob is silver, and the nut of selector knob is gold)

Use the following jig when removing the nuts of the volume knob and selector knob.

- Jig (Part No.: W05-1012-00)

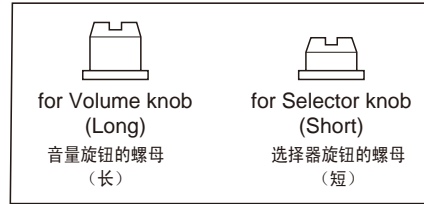

### 10. 关于音量旋钮和选择器旋钮的螺母

音量旋钮和选择器旋钮的螺母形状不同，颜色高度也不同，因此请注意。（音量旋钮螺母为银色，选择器旋钮的螺母为金色）另外，拆卸音量旋钮和选择器旋钮的螺母时，请使用下列夹具。

- 夹具（零件号：W05-1012-00）

### 11. Screw sequence for mounting the TX-RX unit to the chassis

Attach the TX-RX unit to the chassis using the screws in the order shown in the drawing below.

### 11. 安装收发单元到机架上的螺钉顺序

利用下图所示的螺钉顺序安装收发单元到机架上。

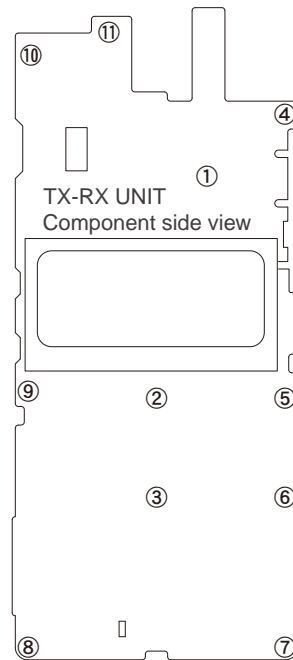



# CIRCUIT DESCRIPTION / 电路说明

## 1. Frequency Configuration

The receiver utilizes double conversion. The first IF is 49.95MHz and the second IF is 450kHz. The first Local oscillator is supplied from the PLL circuit.

The PLL circuit in the transmitter generates the necessary frequencies.

## 1. 频率构成

接收部采用二次变频超外差方式。第一中频为 49.95MHz，第二中频为 450kHz。第一本振频率信号由锁相环电路提供。

发射部由锁相环电路直接产生所需的频率。图 1 显示各种频率。

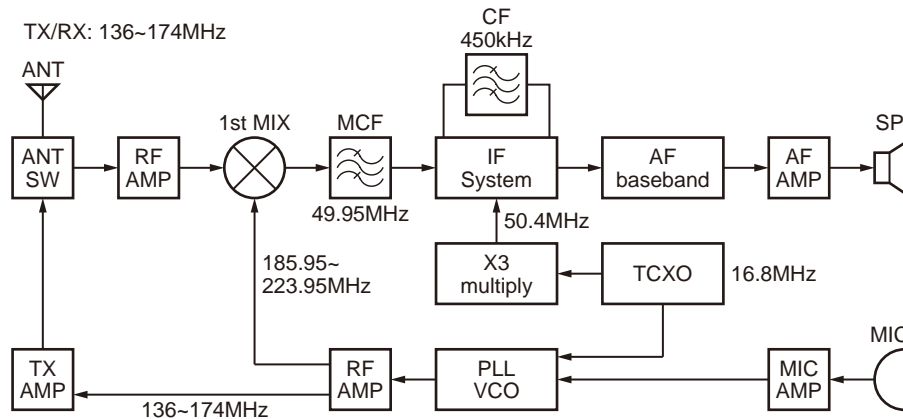

Fig. 1 Frequency configuration / 图 1 频率构成

## 2. Receiver System

The receiver system is shown in Figure 2.

## 2. 接收部系统

接收部系统的如图 2 所示。

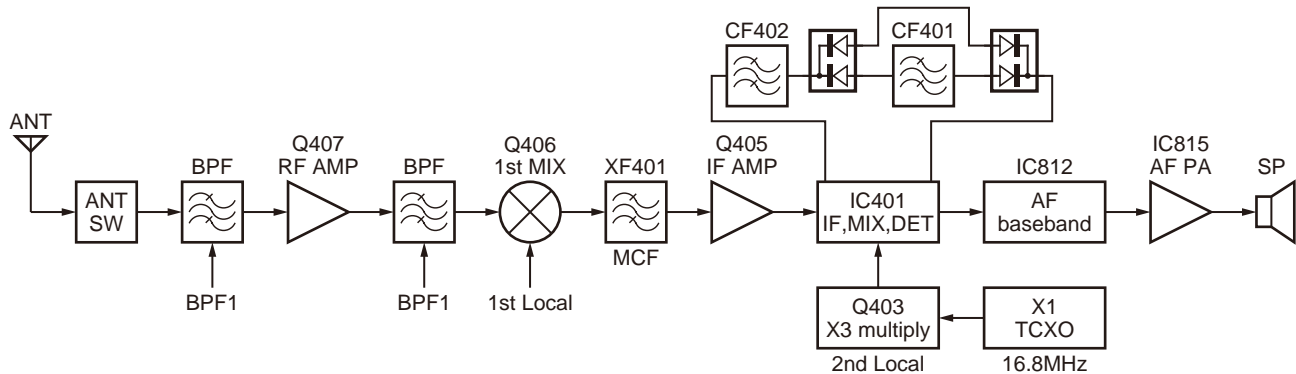

Fig. 2 Receiver system / 图 2 接收部系统

### 2-1. Front End (RF Amplifier) Circuit

The signal coming from the antenna passes through the transmit / receive switching diode circuit (D201, D202, D203 and D204) and a BPF (L418 and L419), and is then amplified by the RF amplifier (Q407).

The resulting signal passes through a BPF (L419, L418, L416 and L414) and goes to the mixer. These BPFs are adjusted by variable capacitance diodes (D408, D407, D405 and D404). The input voltage to the variable capacitance diodes is a regulated voltage output from the DC amplifier (IC811).

### 2-1. 前级（射频放大器）电路

从天线接收的信号进入发送 / 接收转换开关二极管电路 (D201、D202、D203 和 D204)，然后通过 BPF (L418 和 L419)，并且被射频放大器 (Q407) 放大。

此信号通过 BPF (L419, L418, L416 和 L414) 然后进入混频。这些 BPF 被可变电容器 (D408, D407, D405 和 D404) 调整。输入可变电容器的电压被经直流放大器 (IC811) 的电压输出调整。

## CIRCUIT DESCRIPTION / 电路说明

## 2-2. First Mixer

The signal from the front end is mixed with the first local oscillator signal generated in the PLL circuit by Q406 to produce a first IF frequency of 49.95MHz.

The resulting signal passes through the XF401 MCF to cut the adjacent spurious and provide the optimum characteristics, such as adjacent frequency selectivity.

## 2-3. IF Amplifier Circuit

The first IF signal is passed through a four-pole monolithic crystal filter (XF401) to remove the adjacent channel signal. The filtered first IF signal is amplified by the first IF amplifier (Q405) and is then applied to the IF system IC (IC401).

The IF system IC provides a second mixer, limiting amplifier, quadrature detector and RSSI (Received Signal Strength Indicator). The second mixer mixes the first IF signal with the 50.4MHz signal of the second local oscillator output (Q403) and produces the second IF signal of 450kHz.

The second IF signal is passed through the ceramic filter (Wide: CF402, Narrow: CF401) to remove the adjacent channel signal. The filtered second IF signal is amplified by the limiting amplifier and demodulated by the quadrature detector with the ceramic discriminator (CD401). The demodulated signal is routed to the audio circuit.

## 2-4. Wide/Narrow Switching Circuit

Wide and narrow settings can be made for each channel by switching the ceramic filters CF401 (narrow).

The second IF signal always passes the ceramic filters CF402 (Wide).

The wide and narrow switching data is output from the MCU (IC820).

D401 and D402 are switched to ceramic filters when a narrow mode is selected.

Q404 turns on/off with the Narrow and the IC401 detector output level is changed to maintain a constant output level during wide or narrow signals.

## 2-2. 第一混频器

前端的信号与 PLL 电路产生的第一本振信号在 Q406 混频，生成 49.95MHz 频率的第一中频信号。

生成的信号通过晶体滤波器 (XF401)。

## 2-3. 中频放大电路

第一中频信号通过晶体滤波器 (XF401) 消除相邻信道的信号。经滤波的第一中频信号被第一中频放大器 (Q405) 放大并进入中频系统芯片 (IC401)。中频系统芯片提供第二混频器、限幅放大器、正交检测器和 RSSI (接收信号强度指示器)。

第二混频器将第一中频信号与 50.4MHz 的第二本振信号输出 (Q403) 进行混频，并生成 450kHz 的第二中频信号。

第二中频信号通过陶瓷滤波器 (宽:CF402、窄:CF401) 继续消除相邻信道的信号。经滤波的第二中频信号被限幅放大器放大并被带有陶瓷鉴频器 (CD401) 的正交检测器解调。经解调的信号进入音频电路。

## 2-4. 宽 / 窄切换电路

通过切换陶瓷滤波器 CF402 (宽)、CF401 (窄) 可以对每一信道进行宽、窄  $\rightarrow$  设置。

第二中频信号通过陶瓷滤波器 CF402 (宽)。

宽、窄控制信号从 IC820 输出。

选择宽 / 窄电平时，将 D401 和 D402 切换到陶瓷滤波器。

Q404 伴随着宽 / 窄数据而接通 / 断开，IC401 检测器输出电平经常变化用来维持宽或窄信号过程中的恒定输出电平。

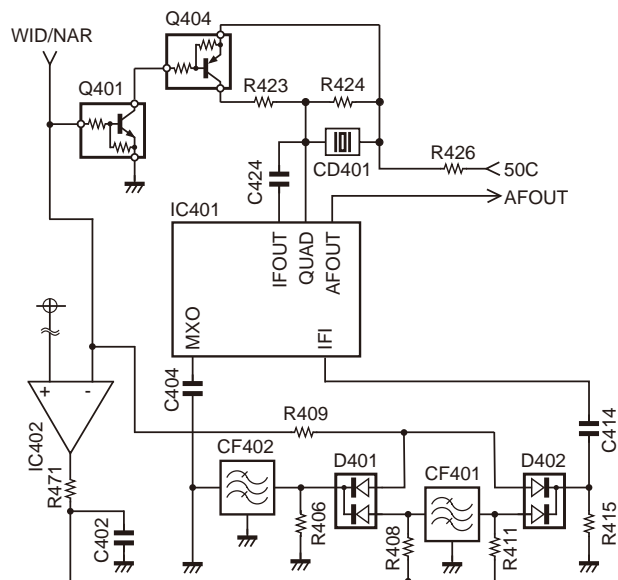

Fig. 3 Wide/Narrow switching circuit / 图 3 宽 / 窄切换电路

## CIRCUIT DESCRIPTION / 电路说明

### 2-5. Audio Amplifier Circuit

The demodulated signal from IC401 is sent to an audio power amplifier (IC815) through baseband IC (IC812), where it is amplified and output to the speaker.

### 2-6. Squelch Circuit

Part of the AF signal from the IC401 enters the FM system IC (IC401) again, and the noise component is amplified and rectified by a filter and an amplifier to produce a DC voltage corresponding to the noise level.

The DC signal from the FM IC goes to the analog port of the MCU (IC820). IC820 determines whether or not to output sounds from the speaker by checking if the input voltage is higher or lower than the preset value.

To output sounds from the speaker, IC820 sends a high signal to the AF\_CONT line and turns IC815 on through Q813, Q814, Q818 and Q819.

### 2-5. 音频放大器电路

来自于 IC401 的解调信号，并通过 IC815 送到 AF 放大器，在音频功率放大器 (IC815) 进行放大后输出到扬声器。

### 2-6. 静噪电路

FM IC (IC401) 输出的 AF 信号的一部分再进入 IC，噪声成份通过滤波器和放大器进行放大和修正，生成与噪声电平相应的 DC 电压。

DC 信号通过 FM IC 被送到微处理器的模拟端口微处理器 (IC820)。IC820 通过检测输入的电压是高于还是低于预设值来决定是否从扬声器输出声音。

由扬声器输出声音时，IC820 发送高电平信号给 AF\_CONT，通过 Q813、Q814、Q818 和 Q819 打开 IC815。

## 3. Transmitter System

### 3-1. Microphone Amplifier Circuit

The signal from the microphone is limited by the AGC circuit, which is composed of D807, D808, Q810, Q811 and the mute switch (Q809). IC812 is composed of a high-pass filter, low-pass filter and pre-emphasis/IDC circuit.

The signal from the microphone and the low speed data from the MCU (IC820) enter the baseband IC (IC812) and pass through each path and are mixed inside the IC.

The output signal from the baseband IC goes to the VCO modulation input. The other output signal passes through the amplifier (IC3) and goes to the TCXO modulation input.

## 3. 发射机系统

### 3-1. 麦克风放大器电路

麦克风的信号被并受由 D807, D808, Q810 和 Q811 组成的 AGC 电路的限幅，然后通过静音开关 (Q809)。IC812 由高通滤波器、低通滤波器和预加重 / IDC 电路组成。

麦克风的信号和从微处理器来的低速数据进入基带 IC 后这些信号在 IC 内部被混合。

基带 IC 的输出信号送入 VCO 调制输入。基带 IC 的其他输出信号送入 TCXO 调制输入。

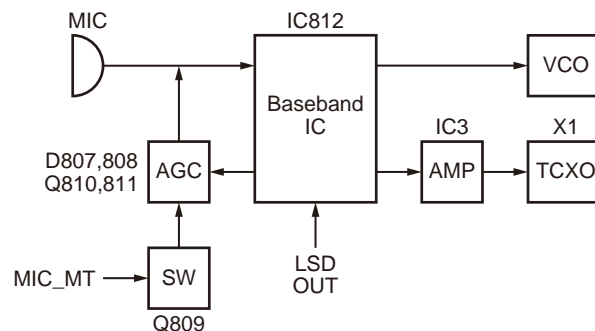

Fig. 4 Microphone amplifier circuit / 图 4 麦克风放大器电路

### 3-2. Driver and Final Amplifier Circuit

The signal from the T/R switch (D18 is on) is amplified by the RF AMP (Q201) and pre-drive amplifier (Q203) to 50mW.

The output of the pre-drive amplifier is amplified by the drive amplifier (Q204) and the RF final amplifier (Q205) to 5.0W (1W when the power is low).

The drive amplifier and the RF final amplifier consist of two MOS FET stages.

The output of the RF final amplifier is then passed through the antenna switch (D201 and D202) and the harmonic filter (LPF), and is applied to the antenna terminal.

### 3-2. 驱动器和终端放大器电路

来自于 T/R 开关 (D18 ON) 的信号被预驱动放大器 (Q203) 和驱动放大器 (Q204) 放大到 50mW。

驱动放大器的输出被 RF 功率放大器 (Q205) 放大到 5.0W (当低功率时为 1W)。RF 功率放大器由 2 个 MOS FET 构成。

RF 功率放大器的输出通过谐波滤波器 (LPF) 和天线开关 (D201 和 D202) 并且送到天线终端。

## CIRCUIT DESCRIPTION / 电路说明

## 3-3. APC Circuit

The APC circuit always monitors the current flowing through the drive amplifier (Q204) and the RF power amplifier (Q205) and keeps a constant current. The voltage drop at R307, R309 and R310 is caused by the current flowing through the RF final amplifier. This voltage is applied to the differential amplifier IC301 (1/2).

IC301 (2/2) compares the output voltage of IC301 (1/2) with the reference voltage from IC811. The output of IC301 (2/2) controls the VG of the RF power amplifier and the drive amplifier to make both voltages the same.

The change of power high/low is carried out by the change of the reference voltage.

## 3-3. 自动功率控制 (APC) 电路

APC 电路一直监视通过驱动放大器 (Q204) 和射频功率放大器 (Q205) 的电流并保持电流稳定。经过射频功率放大器的电流的变化会引起 R307、R309 和 R310 的电压降低, 此电压送到差分放大器 IC301 (1/2)。

IC301 (2/2) 将 IC301 (1/2) 的输出电压与来自 IC811 的参考电压进行比较。IC301 (2/2) 的输出电压控制射频功率放大器、驱动放大器、预驱动放大器的 VG, 使电压保持一致。

功率高/低的变化是通过变更参考电压来实现的。

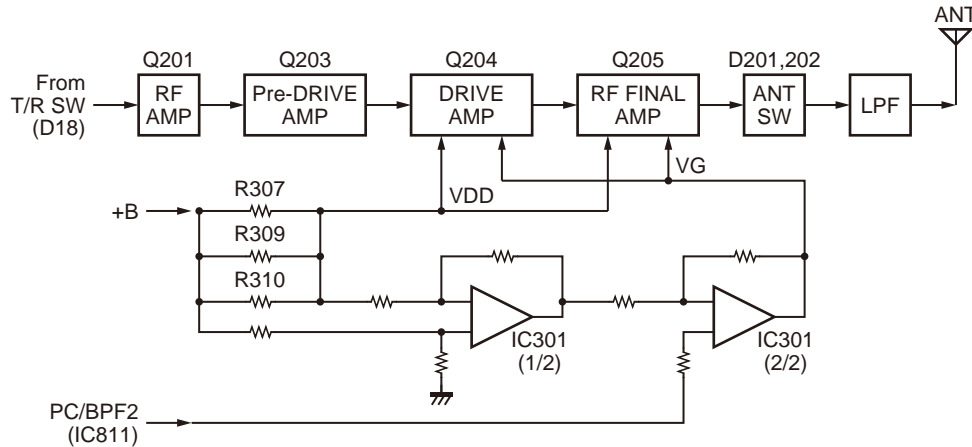

Fig. 5 Driver and final amplifier and APC circuit

图 5 驱动器和终端放大器电路和自动功率控制 (APC) 电路

## 4. Frequency Synthesizer Unit

## 4-1. Frequency synthesizer

The frequency synthesizer consists of the TCXO (X1), VCO, PLL-IC (IC1), and buffer amplifiers.

The TCXO generates 16.8MHz. The frequency stability is 1.5ppm within the temperature range of  $-30^{\circ}\text{C}$  to  $+60^{\circ}\text{C}$ . The frequency tuning and modulation of the TCXO are done to apply voltage to pin 1 of the TCXO. The output of the TCXO is applied to pin 10 of PLL-IC.

The VCO consists of 2 VCO and covers a dual range of 136.00~174.00MHz and 185.95~223.95MHz. The VCO generates 185.95~223.95MHz for providing the first local signal for reception. The operating frequency is generated by Q5 in transmitting mode and Q4 in receiving mode. The oscillation frequency is controlled by applying the VCO control voltage, obtained from the phase comparator (IC1) to the variable capacitance diodes (D4, D6, D8 and D9 in transmitting mode and D10 and D12 in receiving mode)

The TX/RX pin of IC820 goes "high" in transmitting mode, causing Q7 and Q4 to turn off, and Q5 turn on. The TX/RX pin goes "low" in receiving mode.

The output from Q4 and Q5 are amplified by a buffer amplifier (Q8) and Q2, and then sent to the PLL-IC.

The PLL-IC consists of a prescaler, reference divider,

## 4. 频率合成器电路

## 4-1. 频率合成器

频率合成器由 TCXO (X1)、VCO、PLL IC (IC1) 和缓冲放大器组成。

TCXO 产生 16.8MHz 的频率。在温度为  $-30^{\circ}\text{C}$  ~  $+60^{\circ}\text{C}$  的范围内, 频率的稳定性为 1.5ppm。进行频率调谐和 TCXO 调制, 以便给 TCXO 的引脚 1 提供电压。TCXO 的输出加在 PLL IC 的引脚 10 上。

VCO 由 2VCO 组成, 并且覆盖了 136.00 ~ 174.00MHz 和 185.95 ~ 223.95MHz 双波段。VCO 产生 185.95 ~ 223.95MHz 的频率, 以提供接收的第一个本振信号。发射模式时, 操作频率由 Q5 产生, 而接收模式时, 操作频率由 Q4 产生。振荡频率由加在 VCO 上的控制电压控制, 控制电压从可变电容二极管 (在发射模式是 D6 和 D9, 在接收模式是 D10 和 D12) 的相位比较器 (IC1) 处获得。

IC820 的 TX/RX 引脚在接收模式时为 "低" 电位, 使 Q7 和 Q4 打开。TX/RX 引脚在发射模式时为 "高" 电位, 使 Q5 导通。Q4 和 Q5 的输出由缓冲放大器 (Q8) 和 Q2 放大, 然后发送到 PLL IC。

PLL IC 由预计计数器、基准除法器、相位比较器、电荷泵组成 (PLL IC 的频率步长为 5kHz 或 6.25kHz)。PLL IC 的引脚 10 和 17 的输入信号下分成 5kHz 或 6.25kHz, 并在相位比较器处进行比较。相位比较器的脉冲输出信号加在电荷泵上, 并转换成环路滤波器 (LPF) 的 DC 信号。DC 信号加在 VCO 的 CV 上并锁定, 使 VCO 的频率恒定。

## CIRCUIT DESCRIPTION / 电路说明

phase comparator, and charge pump. The input signal from pin 10 and 17 of the PLL-IC is divided down and compared at the phase comparator. The pulsed output signal of the phase comparator is applied to the charge pump and transformed into a DC signal in the loop filter (LPF). The DC signal is applied to the CV of the VCO and locked to keep the VCO frequency constant.

PLL data is output from PL\_STB (pin 20), PL\_CLK (pin 8), and PL\_DAT (pin 21) of the MCU (IC820). The data is input to the PLL-IC when the channel is changed or transmission is changed to reception and vice versa. PLL lock condition is always monitored by pin 18 (PL\_UL) of the MCU. When the PLL is unlocked, PL\_UL goes low.

PLL 数据从微处理器 (IC820) 的 PL\_DAT (针脚 21), PL\_CLK (针脚 8) 和 PL\_STB (针脚 20) 输出。当信道改变时, 或由发射变为接收或由接收变为发射时, 数据输入 PLL IC。PLL 的锁定条件总是由微处理器的针脚 18 (PL\_UL) 监控。当 PLL 失锁时, UL 为低电位。

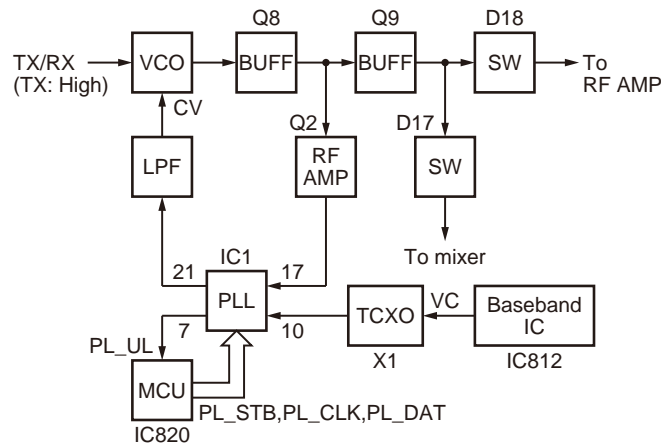

Fig. 6 PLL block diagram / 图 6 PLL 方块图

### 5. Control Circuit

The control consists of the MCU (IC820) and its peripheral circuits. It controls the TX-RX unit. IC820 mainly performs the following:

- 1) Switching between transmission and reception by PTT signal input.
- 2) Reading channel information, frequency, and program data from the memory circuit.
- 3) Sending frequency program data to the PLL.
- 4) Controlling squelch on/off via the DC voltage from the squelch circuit.
- 5) Controlling the audio mute circuit via the decode data input.
- 6) Transmitting tone and encode data.

#### 5-1. Frequency Shift Circuit

The MCU (IC820) and baseband IC (IC812) operates at a clock frequency of 19.2MHz. The oscillator circuit has the baseband IC. This oscillator has a circuit that shifts the frequency via Beat shift switch (Q806).

A beat sound may be able to be evaded form generation if "Beat Shift" is set to ON when it is generated in the internal spurious transmission modulated sound of the transceiver.

### 5. 控制电路

控制电路是由微处理器 (IC820) 和外部电路构成。它控制收发单元。IC820 的主要功能如下：

- 1) 根据 PTT 的输入信号来转换发射和接收状态。
- 2) 从存储电路读出信道信息、频率以及编程数据。
- 3) 发送频率数据给 PLL。
- 4) 根据静噪电路输出的 DC 电压来控制静噪的开启和关闭。
- 5) 根据解码数据控制音频静音。
- 6) 发射 Tone 及编码数据。

#### 5-1. 频率偏移电路

微处理器 (IC820) 和基带 IC (IC812) 在 19.2MHz 时钟下工作。此振荡器有可以被拍频偏移开关 (Q806) 变换频率的电路。如果“拍频偏移”被设定为 ON, 可以避免产生拍频声音。



## CIRCUIT DESCRIPTION / 电路说明

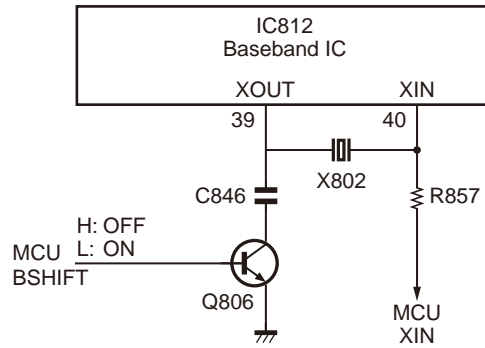

Fig. 7 Frequency shift circuit / 图 7 频率偏移电路

### 5-2. Memory Circuit

The Memory circuit consists of the MCU (IC820) and EEPROM (IC810). The EEPROM has a capacity of 512k bits and stores the channel information, the last channel data, the scan on status, and other parameters.

#### ■ EEPROM

##### Note:

The EEPROM stores tuning data (Deviation, Squelch, etc.).  
Realign the transceiver after replacing the EEPROM.

### 5-2. 存储电路

存储电路由微处理器 (IC820) 和 EEPROM (IC810) 组成。有 512k 位的容量，包含微处理器用的对讲机控制程序以及信道和操作功能这样的数据。

#### ■ EEPROM

##### 注意：

EEPROM 保存调谐数据 (频偏、静噪等)。  
更换 EEPROM 后，请重新校正手持对讲机。

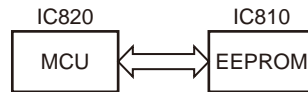

Fig. 8 Memory circuit / 图 8 存储电路

### 5-3. Low Battery Warning

The battery voltage is monitored by the MCU (IC820 pin 63: BATT). When the battery voltage falls below the voltage set by the Low Battery Warning adjustment, the red LED blinks, notifying the operator that it is time to replace the battery (when the always option (default setting) under the Battery Warning function in the FPU is selected). If the battery voltage falls below 5.6V, the transceiver does not transmit and the warning tone beeps while the PTT switch is pressed.

### 5-3. 低电池电量警告

电池电压由微处理器 (IC820 引脚 63: BATT) 监控。发射期间，当电池电压低于低电池电量警告调节设置的电压时，红色 LED 闪烁，通知操作者应该更换电池了 (当选择了 FPU 电池警告功能下的选项 (默认) 时)。如果电池电压低于 5.9V，按下 PTT 开关时手持对讲机不发射并响起警告音。

Low battery warning	Battery status
The red LED blinks during transmission.	The battery voltage is low but the transceiver is still usable.
The red LED blinks and the warning tone beeps while the PTT switch is pressed.	The battery voltage is low and the transceiver cannot be used to make calls.

低电池电量警告	电池状态
发射期间红色 LED 闪烁。	电池电压低，但手持对讲机仍可使用。
按下 PTT 开关时，红色 LED 闪烁并响起警告音。	电池电压低，不能使用手持对讲机进行呼叫。

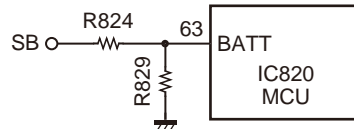

Fig. 9 Low battery warning / 图 9 低电池电量警告



## CIRCUIT DESCRIPTION / 电路说明

### 5-4. Key Input

Keys and channel selector circuit.

The signal from the keys and channel selector are directly input to the MCU, as shown in Figure 10.

### 5-4. 键输入

键和信道选择电路。

如图 10 所示，键和信道选择器的信号被直接输入微处理器。

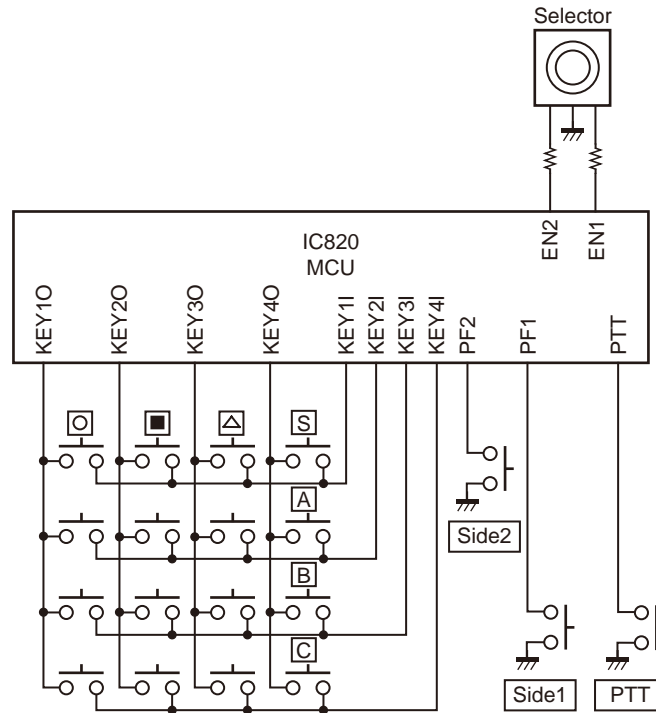

Fig. 10 Key input / 图 10 键输入

## 6. Signaling Circuit

### 6-1. Encode

#### ■ Low-speed data (QT, DQT)

Low-speed data is output from pin 2 of the MCU. The signal passes through the low pass CR filter, and goes to the baseband IC (IC812). The signal is mixed with the audio signal and goes to the VCO and TCXO (X1) modulation input after passing through the D/A converter inside the baseband IC (IC812) for BAL adjustment.

## 6. 信令电路

### 6-1. 编码

#### ■ 低速数据 (QT, DQT)

低速数据从微处理器的引脚 2 (LSD0) 输出。信号通过低通 CR 滤波器，并且送到基带 IC (IC812)。此信号与音频信号混合，在基带 IC (IC812) 中进行信号处理之后，进入 VCO 和 TCXO (X1) 调制输入。

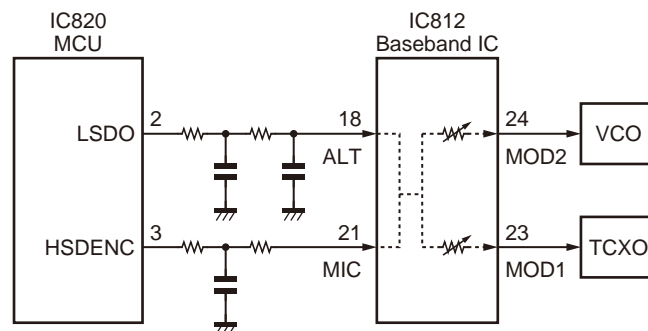

Fig. 11 Encode / 图 11 编码

## CIRCUIT DESCRIPTION / 电路说明

### ■ High-speed data (2-tone)

High-speed data (HSD) is output from pin 3 of the MCU. HSD deviation made by an adjustment in the MCU is passed through the low pass CR filter and then applied to the baseband (IC812).

The signal is mixed with the audio signal and goes to the VCO and TCXO.

### ■ MSK/DTMF

The MSK/DTMF signal is generated in the baseband IC (IC812). The signal passes through the D/A converter (inside the baseband IC812) and is routed to the VCO. When encoding the MSK/DTMF, the microphone input signal is muted.

## 6-2. Dceode

### ■ QT/DQT

The output signal from the IF IC (IC401) enters the MCU (IC820) through IC812. IC820 determines whether or not the QT or DQT matches the preset value, and controls the AFSW and speaker output sounds according to the squelch results.

### ■ 2-tone

Part of the received AF signal output from the IF IC (IC401) passes through the baseband IC (IC812) goes to the other AF amplifier IC808, is compared, and then goes to IC820. IC820 checks whether or not the 2-tone data is necessary. If it matches, IC820 carries out a specified operation, such as turning the speaker on.

### ■ DTMF / MSK

The DTMF and MSK input signal from the IF IC (IC401) goes to IC812. The decoded information is then processed by the MCU.

## 7. Power Supply

There are five 5V power supplies and three 3.3V power supplies: 50M, 50V, 50C, 50R, 50T, 33M, 33MS and 33B.

50M and 33M are always output while the power is on.

33MS is always output, but turns off when the power is turned off, to prevent malfunction of the MCU.

50C is a common 5V and is output when SAVE is not set to ON.

50R is 5V for reception and output during reception.

50T is 5V for transmission and output during transmission.

50V is 5V for the SP/MIC connector.

33B is 3.3V for the baseband IC (IC812).

### ■ 高速数据 (2-音)

高速数据 (HSD) 从微处理器的引脚 3 (HSDENC) 输出。信号通过低通 CR 滤波器。由微处理器进行调整的 TX 频偏被施加到基带 IC (IC812)。

此信号与音频信号混合，然后送入 VCO 和 TCXO。

### ■ MSK/DTMF

MSK 和 DTMF 信号由基带 IC (IC812) 生成。

MSK 信号从 IC812 的引脚 24 输出。此信号通过数模转换器，然后发送给 VCO。编码 MSK 和 DTMF 信号时，麦克风输入信号被静音。

## 6-2. 解码

### ■ QT/DQT

IF IC (IC401) 的输出信号通过 IC812 送入微处理器 (IC820)。IC820 确认 QT 或 DQT 是否与预设值匹配，控制 AFSW，然后扬声器根据静噪结果输出声音。

### ■ 2-音

部分接收的 AF 信号从 IF IC (IC401) 输出，然后通过基带 IC (IC812) 送入另一个 AF 放大器 IC808 进行比较，然后送入 IC820。IC820 检查是否需要 2-音数据。如果匹配，IC820 就执行特定的操作，如打开扬声器。

### ■ DTMF/MSK

IF IC (IC401) 的 DTMF 和 MSK 输入信号送入 IC812。然后由微处理器处理解码信息。

## 7. 电源

微处理器有 5 个 5V 电源和 2 个 3.3V 电源。

电源打开时，50M 和 33M 总是输出。50M 总是输出，但电源关闭时 33MS 关闭，以防止微处理器出现故障。

50C 是普通的 5V 电源，它在 SAVE 没有设为 ON 时输出。

50R 是接收用 5V 电源，它在接收期间输出。

50V 是 SP/MIC 用 5V 电源。

33B 是基带 IC (IC812) 用 3.3V 电源。

## SEMICONDUCTOR DATA / 半导体数据

## MCU: F363BEDFEKDLB (TX-RX unit IC820)

Pin No.	Signal Name	I/O	Function
1	BSHIFT	O	CPU clock frequency shift
2	LSDO	O	QT/DQT output
3	HSDENC	O	BEEP output
4	EN1	I	Encoder detect for direction
5	EN2	I	Pull up for P8_4 (EN2)
6	MODE	I	(Using E8a emulator)
7	NC	-	NC
8	PL_CLK	O	PLL IC clock output
9	RESET	-	Hardware reset input
10	XOUT	-	NC
11	VSS	-	GND
12	XIN	-	Main clock input (19.2MHz)
13	VCC	-	3.3V
14	EMPTT	O	Emergency PTT
15	EN2	I	Encoder Interrupt
16	CM_IRQ	I	Baseband IC IRQ
17	INT0	I	Battery low interrupt (4.5V)
18	PL_UL	I	PLL IC unlock input
19	PTT	I	PTT input
20	PL_STB	O	PLL IC STB output
21	PL_DAT	O	PLL IC data output
22	NC	-	NC
23	33MSC	O	33MS control for switched 33M
24	TXD	O	Serial data (FPU) to PC
25	RXD	I	Serial data (FPU) from PC
26	EM_CLK	O	For E8a emulator
27	APCSW	O	APC enable/disable
28	TX/RX	O	TX/RX switch H: TX, L: RX
29	50VC	O	5V AVR control for GPS SP MIC (option/OPT DET)
30	5TC	O	5T control output
31	EP_DTO	O	EEPROM IC data output
32	EP_CLK	O	EEPROM IC clock output
33	CM_DTO	O	Baseband IC data output
34	EPM	O	For FDT tool
35	5RC	O	5R control output
36	EP_WP	O	EEPROM IC write protect output
37	EP_DTI	I	EEPROM IC data input
38	EP_CS	O	EEPROM IC chip select output
39	CE	O	For FDT tool
40	CM_CLK	O	Baseband IC clock output

## 微处理器：F363BEDFEKDLB (收发单元 IC820)

管脚号	端口名称	输入/输出	功能
1	BSHIFT	输出	拍频偏移
2	LSDO	输出	低速数据输出
3	HSDENC	输出	高速数据输出
4	EN1	输入	编码器输入 1
5	EN2	输入	编码器输入 2
6	MODE	输入	微处理器模式选定
7	NC	-	未连接
8	PL_CLK	输出	PLL 时钟
9	RESET	-	微处理器复位
10	XOUT	-	未连接
11	VSS	-	接地
12	XIN	-	19.2MHz 时钟输入
13	VCC	-	3.3V
14	EMPTT	输出	EMG 键
15	EN2	输入	编码器输入 2
16	CM_IRQ	输入	基带 IC 的中断请求
17	INT0	输入	电池低电平检测
18	PL_UL	输入	PLL 失锁检测
19	PTT	输入	PTT 键输入
20	PL_STB	输出	PLL 启用
21	PL_DAT	输出	PLL 数据
22	NC	-	未连接
23	33MSC	输出	33MS 控制
24	TXD	输出	串行数据输出 (FPU)
25	RXD	输入	串行数据输入 (FPU)
26	EM_CLK	输出	仿真器的 CLK
27	APCSW	输出	APC 开关
28	TX/RX	输出	收发控制
29	50VC	输出	5V 稳压器控制 GPS 扬声器麦克风 (Option/OPT DET)
30	5TC	输出	5T 控制
31	EP_DTO	输出	EEPROM 数据输出
32	EP_CLK	输出	EEPROM 时钟
33	CM_DTO	输出	基带 IC 的命令数据
34	EPM	输出	仿真器的 EPM
35	5RC	输出	5R 控制
36	EP_WP	输出	EEPROM 选择
37	EP_DTI	输入	EEPROM 数据输入
38	EP_CS	输出	EEPROM 选择
39	CE	输出	仿真器的 CE
40	CM_CLK	输出	基带 IC 的串行时钟

Pin No.	Signal Name	I/O	Function
41	CM_DTI	I	Baseband IC data input
42	CM_CNS	O	Baseband IC chip select output
43	DC_SW	O	APC voltage discharge switch
44	KEY1O	O	Key Matrix output 1
45	KEY2O	O	Key Matrix output 2
46	KEY3O	O	Key Matrix output 3
47	KEY4O	O	Key Matrix output 4
48	KEY1I	I	Key Matrix input 1
49	KEY2I	I	Key Matrix input 2
50	KEY3I	I	Key Matrix input 3
51	KEY4I	I	Key Matrix input 4
52	PF1	I	Side key 1 input
53	PF2	I	Side key 2 input
54	LCDBL	O	LCD backlight switch L: ON, H: OFF
55	LC_INH	O	LCD diver IC INH output
56	LC_CLK	O	LCD diver IC clock output
57	LC_DAT	O	LCD diver IC data output
58	LC_CE	O	LCD diver IC chip enable output
59	LC_MOD	O	LCD diver IC mode output
60	HSDDEC	I	HSD decode input
61	QT/DQT	I	QT/DQT decode input
62	CVIN	I	VCO lock voltage reading for auto alignment
63	BATT	I	Battery level input
64	VOX	I	VOX Level Input
65	BUSY	I	RX busy input
66	TH_DET	I	Temperature level input
67	RSSI	I	RSSI input
68	WID/NAR	O	Wide Narrow switch H: WID, L: NAR
69	ASSIST	O	Assist switch
70	AF_MUT	O	Speaker mute output
71	MIC_MT	O	Mic mute output
72	MAN_DN	I	MAN down
73	5CC	O	5C control output
74	LEDBLU	O	Blue LED light control
75	AVSS	-	GND
76	LEDGRN	O	Green LED light control
77	VREF	-	3.3V for A/D reference
78	AVCC	-	3.3V
79	LEDRED	O	Red LED light control
80	OPTDET	I	Option detection input

管脚号	端口名称	输入 / 输出	功 能
41	CM_DTI	输入	基带 IC 的串行数据
42	CM_CNS	输出	基带 IC 的回复数据
43	DC_SW	输出	APC 加速开关
44	KEY1O	输出	键矩阵输出 1
45	KEY2O	输出	键矩阵输出 2
46	KEY3O	输出	键矩阵输出 3
47	KEY4O	输出	键矩阵输出 4
48	KEY1I	输入	键矩阵输入 1
49	KEY2I	输入	键矩阵输入 2
50	KEY3I	输入	键矩阵输入 3
51	KEY4I	输入	键矩阵输入 4
52	PF1	输入	侧面 1 键输入
53	PF2	输入	侧面 2 键输入
54	LCDBL	输出	LCD 背光开关控制
55	LC_INH	输出	LCD IC 中断请求
56	LC_CLK	输出	LCD IC 时钟
57	LC_DAT	输出	LCD IC 数据
58	LC_CE	输出	LCD IC 启用
59	LC_MOD	输出	LCD IC
60	HSDDET	输入	高速数据输入
61	QT/DQT	输入	QT/DQT 数据输入
62	CVIN	输入	CV 电压检测
63	BATT	输入	电池电压检测
64	VOX	输入	VOX 电平
65	BUSY	输入	静噪电平
66	TH_DET	输入	温度检测
67	RSSI	输入	RSSI 电平
68	WID/NAR	输出	宽 / 窄切换
69	ASSIST	输出	辅助开关
70	AF_MUT	输出	AF-IC 静噪开关
71	MIC_MT	输出	MIC 静噪开关
72	MAN_DN	输入	跌倒检测
73	5CC	输出	5C 控制
74	LEDBLU	输出	蓝色 LED
75	AVSS	-	接地
76	LEDGRN	输出	绿色 LED
77	VREF	-	参考电压
78	AVCC	-	3.3V
79	LEDRED	输出	红色 LED
80	OPTDET	输入	可选件检测

## COMPONENTS DESCRIPTION / 元件说明

## TX-RX unit (X57-7880-20)

Ref. No.	Part Name	Description
IC1	IC	PLL system
IC2	IC	DC amplifier (CV IN/ADJ)
IC3	IC	DC amplifier (FADJ/MOD)
IC301	IC	DC amplifier (APC)
IC401	IC	FM IF system
IC402	IC	Comparator (NAR switch)
IC801	IC	Voltage regulator (50M)
IC802	IC	Voltage regulator (50C)
IC803	IC	Voltage regulator (50V)
IC804	IC	Voltage regulator (33M)
IC805	IC	Low battery level detector
IC806	IC	Voltage regulator (33B)
IC807	IC	Reset (MCU)
IC808	IC	HSD amplifier
IC810	IC	EEPROM
IC811	IC	RX BPF DC amplifier
IC812	IC	Baseband IC
IC815	IC	AF power amplifier
IC817	IC	VOX amplifier
IC820	IC	MCU
IC821	IC	LCD driver
Q2	Transistor	Buffer amplifier
Q3	Transistor	Ripple filter
Q4	FET	RX VCO
Q5	FET	TX VCO
Q6	FET	T/R VCO switching
Q7	Transistor	T/R VCO SW control
Q8	Transistor	Buffer amplifier
Q9	Transistor	RF amplifier
Q11,12	FET	Assist switch
Q201	Transistor	RF amplifier (TX)
Q203	Transistor	Pri-drive amplifier
Q204	FET	Drive amplifier
Q205	FET	Final power amplifier
Q301	Transistor	APC switch
Q303	FET	APC switch control
Q304	Transistor	APC switch
Q305	FET	APC switch
Q306	Transistor	APC switch
Q401	Transistor	W/N switch control
Q403	Transistor	Tripler
Q404	Transistor	W/N switch
Q405	Transistor	IF amplifier
Q406	FET	Mixer
Q407	FET	RF amplifier (RX)
Q801	FET	LED switch (RED/GRN)

## 收发单元 (X57-7880-20)

有关号码	零件名称	说明
IC1	IC	PLL 系统
IC2	IC	直流放大器 (CV IN/ADJ)
IC3	IC	直流放大器 (FADJ/MOD)
IC301	IC	直流放大器 (APC)
IC401	IC	FM 系统
IC402	IC	窄滤波器开关
IC801	IC	稳压器 /50M
IC802	IC	稳压器 /50C
IC803	IC	稳压器 /50V
IC804	IC	稳压器 /33M
IC805	IC	稳压器 / 电池电压
IC806	IC	稳压器 /33B
IC807	IC	稳压器 / 复位
IC808	IC	高速数据放大器
IC810	IC	EEPROM
IC811	IC	直流放大器
IC812	IC	基带 IC
IC815	IC	AF 功率放大器
IC817	IC	VOX 放大器
IC820	IC	微处理器
IC821	IC	LCD 驱动
Q2	晶体管	射频缓冲放大器
Q3	晶体管	纹波滤波器
Q4	场效应管	RX VCO 振荡器
Q5	场效应管	TX VCO 振荡器
Q6	场效应管	T/R VCO 开关
Q7	晶体管	T/R VCO 开关控制
Q8	晶体管	射频缓冲放大器
Q9	晶体管	射频放大器
Q11, 12	场效应管	辅助开关
Q201	晶体管	射频放大器
Q203	晶体管	预驱动放大器
Q204	场效应管	驱动放大器
Q205	场效应管	末级放大器
Q301	晶体管	直流开关 /APC
Q303	场效应管	直流开关控制 /APC
Q304	晶体管	直流开关 /APC
Q305	场效应管	直流开关 /APC
Q306	晶体管	直流开关 /APC
Q401	晶体管	宽 / 窄开关控制
Q403	晶体管	倍频器
Q404	晶体管	宽 / 窄开关
Q405	晶体管	IF 放大器
Q406	场效应管	混频器
Q407	场效应管	射频放大器
Q801	场效应管	LED 开关 / 红色, 绿色

## COMPONENTS DESCRIPTION / 元件说明

Ref. No.	Part Name	Description
Q802	FET	DC switch (50T)
Q803	FET	DC switch (50R)
Q804	FET	DC switch (33MS)
Q805	FET	LED switch (bule)
Q806	Transistor	Beet shift switch
Q809	Transistor	MIC mute
Q810,811	Transistor	MIC AGC control
Q813	Transistor	AF mute switch control
Q814	Transistor	AF power mute
Q815,816	FET	Level converter
Q817	Transistor	AF mute switch control
Q818,819	FET	AF power mute
Q820	Transistor	Back light switch
Q821	Transistor	Back light switch control
Q822	Transistor	EMG PTT switch
D4	Variable capacitance diode	TX VCO tune
D6	Variable capacitance diode	TX VCO tune
D8,9	Variable capacitance diode	TX VCO tune
D10	Variable capacitance diode	RX VCO tune
D12	Variable capacitance diode	RX VCO tune
D13	Diode	Speed up (VCO)
D14	Variable capacitance diode	TX assist tune
D15	Variable capacitance diode	RX assist tune
D16	Variable capacitance diode	TX modulation
D17,18	Diode	T/R switch
D201-204	Diode	T/R ANT switch
D301	Zenor diode	Over voltage prevention
D401,402	Diode	NAR filter switch
D404,405	Variable capacitance diode	RX BPT tune
D407,408	Variable capacitance diode	RX BPT tune
D801	LED	Busy LED (green)
D803	Diode	Protection
D804	LED	Signal LED (blue)
D805	LED	TX LED (red)
D806	Zenor diode	Over voltage prevention
D807,808	Diode	Mic level Detection
D809,810	Diode	VOX level Detection
D817	Diode	Speed up (back light)
D818-821	LED	LCD back light
D824	LED	LCD back light
D829-832	Diode	Key input detect

有关号码	零件名称	说 明
Q802	场效应管	直流开关 /50T
Q803	场效应管	直流开关 /50R
Q804	场效应管	直流开关 /33MS
Q805	场效应管	LED 开关 / 蓝色
Q806	晶体管	拍频偏移开关
Q809	晶体管	麦克风静音
Q810, 811	晶体管	麦克风 AGC 控制
Q813	晶体管	AF 静音开关控制
Q814	晶体管	AF 放大器静音开关
Q815, 816	场效应管	电平位移
Q817	晶体管	AF 静音开关控制
Q818, 819	场效应管	AF 放大器静音开关
Q820	晶体管	背光开关
Q821	晶体管	背光开关控制
Q822	晶体管	直流开关 /EMG PTT
D4	可变电容二极管	频率控制 /TX VCO
D6	可变电容二极管	频率控制 /TX VCO
D8, 9	可变电容二极管	频率控制 /TX VCO
D10	可变电容二极管	频率控制 /RX VCO
D12	可变电容二极管	频率控制 /RX VCO
D13	二极管	加速 /VCO
D14	可变电容二极管	辅助调谐 / 发射
D15	可变电容二极管	辅助调谐 / 接收
D16	可变电容二极管	调制器
D17, 18	二极管	收发开关
D201-204	二极管	天线开关
D301	稳压二极管	过电压保护
D401, 402	二极管	窄滤波器开关
D404, 405	可变电容二极管	RX BPF 调谐
D407, 408	可变电容二极管	RX BPF 调谐
D801	LED	LED/ 绿色
D803	二极管	保护
D804	LED	LED/ 蓝色
D805	LED	LED/ 红色
D806	稳压二极管	过电压保护
D807, 808	二极管	麦克风电平检测
D809, 810	二极管	VOX 电平检测
D817	二极管	加速
D818-821	LED	LCD 背光
D824	LED	LCD 背光
D829-832	二极管	键矩阵



## PARTS LIST / 零件表

\* New Parts.  $\Delta$  indicates safety critical components.  
 Parts without **Parts No.** are not supplied.  
 \* 新零件。  $\Delta$  代表对安全至关重要的零件。  
 我们不会提供没有零件号的零件。

L : Scandinavia      K : USA      P : Canada  
 Y : PX (Far East, Hawaii)      T : England      E : Europe  
 C : China      X : Australia      M : Other Areas

TK-2317  
 TX-RX UNIT (X57-7880-20)

Ref. No.	Address	New parts	Parts No.	Description	Desti-nation	Ref. No.	Address	New parts	Parts No.	Description	Desti-nation
<b>TK-2317</b>						<b>TX-RX UNIT (X57-7880-20)</b>					
1	1A		A02-4095-23	PLASTIC CABINET ASSY		62	1B		T07-0787-05	SPEAKER	
3	2C		B09-0725-03	CAP(SP/MIC)      ACCESSORY		64	1B		T91-0672-05	MIC ELEMENT	
4	1B		B43-1622-04	BADGE(FRONT)		W1	2A		W02-3748-05	ENCODER(SELECTOR)	
5	1B		B43-1623-04	BADGE(REAR)							
6	1C	*	B62-2261-00	INSTRUCTION MANUAL      ACCESSORY							
9	1A		D10-0649-03	LEVER							
10	1A		D21-0863-04	SHAFT(LEVER)							
11	1A		D32-0441-13	STOPPER(LEVER)							
13	2A		E04-0477-15	RF COAXIAL RECEPTACLE(SMA)							
14	3A		E23-1253-04	TERMINAL(GND)							
15	2A		E23-1254-04	TERMINAL(+VE)							
16	1B		E37-1165-15	PROCESSED LEAD WIRE(SP/RED)							
17	1B		E37-1514-05	PROCESSED LEAD WIRE(SP/BL)							
19	3A		F20-3353-14	INSULATING SHEET(+VE)							
21	2A		G01-4542-04	COIL SPRING							
22	2A		G01-4543-14	COIL SPRING							
23	2B		G10-1330-04	FIBROUS SHEET(IC)							
24	2A		G11-4465-04	RUBBER SHEET(FET)							
25	3A		G13-2009-04	CUSHION(CHASSIS)							
27	3A		G13-2033-04	CUSHION(-VE)							
28	3A		G13-2034-14	CUSHION(CHASSIS-)							
29	2B		G13-2038-34	CUSHION(X57)							
30	2B		G13-2088-04	CUSHION(IC820)							
31	3B	*	G13-2340-14	CUSHION(CF401,CF402)		101	2B		B11-1876-03	ILLUMINATION GUIDE(LCD)	
34	2B	*	G13-2346-04	CUSHION(X57)		102	2B	*	B11-1877-14	FILTER(LCD)	
35	3A		G53-1604-03	PACKING(CHASSIS)		103	2B		B38-0935-05	LCD	
36	2A		G53-1605-03	PACKING(+VE)		D801			B30-1790-05	LED( BLUE)	
37	2A		G53-1802-04	PACKING(SMA)		D804			B30-2314-05	LED(GREEN)	
39	2B		G53-1845-03	PACKING(VOL/SEL)		D805			B30-2315-05	LED(RED)	
40	1B		G53-1846-03	PACKING(SPK)		D818-821	*		B30-2337-05	LED(YELLOW)	
41	1B		G53-1847-03	PACKING(SP/MIC)		D824	*		B30-2337-05	LED(YELLOW)	
46	2A		J19-5463-03	HOLDER(+VE)		C1			CC73HCH1H101J	CHIP C      100PF      J	
47	2A		J19-5473-03	HOLDER ASSY(+VE)		C3			CC73HCH1H100B	CHIP C      10PF      B	
49	1B	*	J19-5545-14	HOLDER ASSY(SPK)		C4			CK73HB1H102K	CHIP C      1000PF      K	
48	2C		J19-5549-03	HOLDER(SP/MIC)      ACCESSORY		C5			CC73HCH1H101J	CHIP C      100PF      J	
50	1C		J29-0734-05	BELT CLIP      ACCESSORY		C7			CC73HCH1H100B	CHIP C      10PF      B	
52	2A		J82-0127-05	FPC		C8			CC73HCH1H101J	CHIP C      100PF      J	
54	1B		K29-9309-13	KNOB(VOL)		C9			CK73HB1E103K	CHIP C      0.010UF      K	
55	1A		K29-9425-03	BUTTON KNOB(PTT)		C10			CC73HCH1H101J	CHIP C      100PF      J	
56	1A		K29-9426-03	BUTTON KNOB(SIDE1,2)		C11			CK73HB1E103K	CHIP C      0.010UF      K	
57	1B		K29-9427-03	KNOB(SELECTOR)		C12			CC73HCH1H101J	CHIP C      100PF      J	
58	1A		K29-9463-12	KEY TOP(7KEY)		C14			CK73HB1A473K	CHIP C      0.047UF      K	
A	2A		N14-0848-05	CIRCULAR NUT(SELECTOR)		C15			CK73HB1A224K	CHIP C      0.22UF      K	
B	2B		N14-0849-05	CIRCULAR NUT(VOL)		C16 ,17			CC73HCH1H101J	CHIP C      100PF      J	
C	2A		N30-2604-48	PAN HEAD MACHINE SCREW(SMA)		C18			CK73HB1E103K	CHIP C      0.010UF      K	
D	3A		N30-2606-48	PAN HEAD MACHINE SCREW		C19			CC73HCH1H101J	CHIP C      100PF      J	
E	2B,3A		N83-2005-48	PAN HEAD TAPTITE SCREW		C20			CK73HB1H471K	CHIP C      470PF      K	
60	2C		N99-2046-05	SCREW SET      ACCESSORY		C21			CK73HB1E103K	CHIP C      0.010UF      K	
VR1	2A		R31-0676-05	VARIABLE RESISTOR		C23			CS77CA1VR15M	CHIP TNTL      0.15UF      35WV	
						C24			C92-0588-05	CHIP TNTL      1.5UF      16WV	
						C25			C92-0872-05	CHIP TNTL      0.068UF      35WV	
						C27			CK73HB1A224K	CHIP C      0.22UF      K	
						C28			CK73HB1H471K	CHIP C      470PF      K	
						C29 ,30			CC73HCH1H150J	CHIP C      15PF      J	
						C33			CC73HCH1H470J	CHIP C      47PF      J	
						C34			CK73HB1H471K	CHIP C      470PF      K	
						C35			CK73HB1E103K	CHIP C      0.010UF      K	
						C37 ,38			CK73HB1A104K	CHIP C      0.10UF      K	

## PARTS LIST / 零件表

TX-RX UNIT (X57-7880-20)

Ref. No.	Address	New parts	Parts No.	Description	Destination	Ref. No.	Address	New parts	Parts No.	Description	Destination
C39			CK73HB1H471K	CHIP C 470PF K		C243			CK73GB1H102K	CHIP C 1000PF K	
C41			CC73HCH1H101J	CHIP C 100PF J		C244			CK73HB1H471K	CHIP C 470PF K	
C43			CC73HCH1H101J	CHIP C 100PF J		C245			CC73HCH1H180J	CHIP C 18PF J	
C44			CK73HB1H102K	CHIP C 1000PF K		C246			CC73GCH1H110J	CHIP C 11PF J	
C45			CK73HB1H471K	CHIP C 470PF K		C247			CK73GB1H102K	CHIP C 1000PF K	
C47			CC73HCH1H820J	CHIP C 82PF J		C248			CC73GCH1H100C	CHIP C 10PF C	
C48			CC73HCH1H070B	CHIP C 7.0PF B		C249			CC73GCH1H150J	CHIP C 15PF J	
C49			CK73HB1H102K	CHIP C 1000PF K		C250			CC73GCH1H200J	CHIP C 20PF J	
C50			CK73HB1A104K	CHIP C 0.10UF K		C253			CC73GCH1H060B	CHIP C 6.0PF B	
C51			CC73HCH1H470J	CHIP C 47PF J		C255			CC73GCH1H220J	CHIP C 22PF J	
C52			CC73HCH1H030B	CHIP C 3.0PF B		C256			CC73GCH1H070B	CHIP C 7.0PF B	
C53			CC73HCH1H070B	CHIP C 7.0PF B		C257			CC73GCH1H080B	CHIP C 8.0PF B	
C55			CK73FB0J106K	CHIP C 10UF K		C264			CC73HCH1H470J	CHIP C 47PF J	
C57			CC73HCH1H0R3B	CHIP C 0.3PF B		C265			CC73HCH1H330J	CHIP C 33PF J	
C58			CC73HCH1H130G	CHIP C 13PF G		C271			CC73GCH1H030B	CHIP C 3.0PF B	
C59			CC73HCH1H150G	CHIP C 15PF G		C301			CK73HB1A104K	CHIP C 0.10UF K	
C60 ,61			CC73HCH1H060B	CHIP C 6.0PF B		C302			CK73HB1H471K	CHIP C 470PF K	
C62 ,63			CK73HB1E103K	CHIP C 0.010UF K		C303			CK73FB1E225K	CHIP C 2.2UF K	
C66 ,67			CC73HCH1H0R5B	CHIP C 0.5PF B		C304			CK73HB1H471K	CHIP C 470PF K	
C70			CK73HB1H102K	CHIP C 1000PF K		C305			CC73HCH1H101J	CHIP C 100PF J	
C71			CC73HCH1H330J	CHIP C 33PF J		C307			CC73HCH1H470J	CHIP C 47PF J	
C72			CC73HCH1H050B	CHIP C 5.0PF B		C308			CC73HCH1H100B	CHIP C 10PF B	
C73			CC73HCH1H150J	CHIP C 15PF J		C309			CK73HB1H471K	CHIP C 470PF K	
C74 ,75			CK73HB1H102K	CHIP C 1000PF K		C311			CK73HB1H471K	CHIP C 470PF K	
C76			CK73HB1A104K	CHIP C 0.10UF K		C314			CK73HB1H471K	CHIP C 470PF K	
C77			CC73HCH1H180J	CHIP C 18PF J		C315			CK73HB1H102K	CHIP C 1000PF K	
C78			CK73HB1A105K	CHIP C 1.0UF K		C402-407			CK73HB1A104K	CHIP C 0.10UF K	
C85 ,86			CC73HCH1H220J	CHIP C 22PF J		C408			CC73HCH1H330J	CHIP C 33PF J	
C87			CK73HB1H102K	CHIP C 1000PF K		C409			CK73HB1E103K	CHIP C 0.010UF K	
C88			CC73HCH1H220J	CHIP C 22PF J		C410			CC73HCH1H220J	CHIP C 22PF J	
C89			CK73HB1H471K	CHIP C 470PF K		C411			CC73HCH1H820J	CHIP C 82PF J	
C98			CK73HB1H102K	CHIP C 1000PF K		C412			CK73HB1H471K	CHIP C 470PF K	
C201			CK73HB1H102K	CHIP C 1000PF K		C414			CK73HB1A104K	CHIP C 0.10UF K	
C203			CK73HB1H102K	CHIP C 1000PF K		C415			CC73HCH1H390J	CHIP C 39PF J	
C204			CK73HB1A104K	CHIP C 0.10UF K		C416			CC73HCH1H820J	CHIP C 82PF J	
C205			CK73HB1H102K	CHIP C 1000PF K		C417			CK73HB1H471K	CHIP C 470PF K	
C209			CC73HCH1H300J	CHIP C 30PF J		C418			CK73HB1A104K	CHIP C 0.10UF K	
C210			CK73GB1A224K	CHIP C 0.22UF K		C419			CC73HCH1H390J	CHIP C 39PF J	
C211-213			CK73HB1H102K	CHIP C 1000PF K		C420			CK73HB1H182K	CHIP C 1800PF K	
C214			CK73HB1A104K	CHIP C 0.10UF K		C421			CK73HB1H471K	CHIP C 470PF K	
C215			CC73HCH1H220J	CHIP C 22PF J		C422,423			CK73GB0J106K	CHIP C 10UF K	
C216			CK73HB1H102K	CHIP C 1000PF K		C424			CC73HCH1H560J	CHIP C 56PF J	
C217			CC73HCH1H300J	CHIP C 30PF J		C425			CK73HB1E103K	CHIP C 0.010UF K	
C218			CC73HCH1H180J	CHIP C 18PF J		C426			CK73HB1H102K	CHIP C 1000PF K	
C219			CK73HB1H102K	CHIP C 1000PF K		C427			CK73HB1A104K	CHIP C 0.10UF K	
C221			CK73HB1H102K	CHIP C 1000PF K		C428			CK73HB1A333K	CHIP C 0.033UF K	
C222			CC73HCH1H820J	CHIP C 82PF J		C429			CC73HCH1H330J	CHIP C 33PF J	
C223-225			CK73HB1H102K	CHIP C 1000PF K		C431			CK73HB1A224K	CHIP C 0.22UF K	
C227			CC73GCH1H270J	CHIP C 27PF J		C433			CK73HB1E103K	CHIP C 0.010UF K	
C228			CC73GCH1H130J	CHIP C 13PF J		C435			CK73HB1E103K	CHIP C 0.010UF K	
C229,230			CC73HCH1H151J	CHIP C 150PF J		C436			CC73HCH1H020B	CHIP C 2.0PF B	
C233			CK73GB1C104K	CHIP C 0.10UF K		C437			CC73HCH1H160J	CHIP C 16PF J	
C234			CK73GB1A105K	CHIP C 1.0UF K		C438			CC73HCH1H020B	CHIP C 2.0PF B	
C235			CK73HB1H102K	CHIP C 1000PF K		C439			CK73HB1E103K	CHIP C 0.010UF K	
C236			CC73GCH1H390J	CHIP C 39PF J		C440,441			CK73HB1H102K	CHIP C 1000PF K	
C237			CC73GCH1H470J	CHIP C 47PF J		C442			CC73HCH1H100B	CHIP C 10PF B	
C238			CC73GCH1H120J	CHIP C 12PF J		C443			CK73HB1E103K	CHIP C 0.010UF K	
C239			CC73GCH1H220J	CHIP C 22PF J		C444			CC73HCH1H020B	CHIP C 2.0PF B	
C240			CK73GB1H102K	CHIP C 1000PF K		C445,446			CC73HCH1H130J	CHIP C 13PF J	
C241			CC73GCH1H1R5B	CHIP C 1.5PF B		C447,448			CC73HCH1H030B	CHIP C 3.0PF B	

## PARTS LIST / 零件表

TX-RX UNIT (X57-7880-20)

Ref. No.	Address	New parts	Parts No.	Description	Desti-nation	Ref. No.	Address	New parts	Parts No.	Description	Desti-nation
C449			CK73HB1E103K	CHIP C 0.010UF K		C863			CK73HB1E103K	CHIP C 0.010UF K	
C450			CC73HCH1H010B	CHIP C 1.0PF B		C865			CK73HB1H471K	CHIP C 470PF K	
C451,452			CK73HB1H102K	CHIP C 1000PF K		C866			CK73GB0J106K	CHIP C 10UF K	
C453			CC73HCH1H2R5B	CHIP C 2.5PF B		C869			CK73GB0J106K	CHIP C 10UF K	
C454,455			CK73HB1H102K	CHIP C 1000PF K		C872			CK73HB1H102K	CHIP C 1000PF K	
C456			CC73HCH1H080B	CHIP C 8.0PF B		C873			CK73HB1E103K	CHIP C 0.010UF K	
C459			CK73HB1H102K	CHIP C 1000PF K		C874			CK73HB1A104K	CHIP C 0.10UF K	
C461,462			CK73HB1H102K	CHIP C 1000PF K		C876			CK73GB0J106K	CHIP C 10UF K	
C463			CC73HCH1H2R5B	CHIP C 2.5PF B		C877			CK73HB1H102K	CHIP C 1000PF K	
C464			CC73HCH1H390J	CHIP C 39PF J		C878			CK73HB1E103K	CHIP C 0.010UF K	
C465			CK73HB1H102K	CHIP C 1000PF K		C879			CK73GB0J106K	CHIP C 10UF K	
C466,467			CC73HCH1H060B	CHIP C 6.0PF B		C881			CK73HB1A104K	CHIP C 0.10UF K	
C468			CC73HCH1H270J	CHIP C 27PF J		C882			CK73HB1H102K	CHIP C 1000PF K	
C469			CC73HCH1H050B	CHIP C 5.0PF B		C883			CK73HB1H152K	CHIP C 1500PF K	
C470			CK73HB1H102K	CHIP C 1000PF K		C884			CK73HB1A105K	CHIP C 1.0UF K	
C474,475			CK73HB1H102K	CHIP C 1000PF K		C885			CC73HCH1H181J	CHIP C 180PF J	
C477,478			CK73HB1H102K	CHIP C 1000PF K		C886			CC73HCH1H221J	CHIP C 220PF J	
C479			CC73HCH1H2R5B	CHIP C 2.5PF B		C887			CC73HCH1H121J	CHIP C 120PF J	
C480			CC73HCH1H240J	CHIP C 24PF J		C890,891			CK73HB1H391K	CHIP C 390PF K	
C481			CC73HCH1H470J	CHIP C 47PF J		C892			CK73HB1A105K	CHIP C 1.0UF K	
C482			CC73HCH1H060B	CHIP C 6.0PF B		C893		*	CK73HB0J475M	CHIP C 4.7UF M	
C484			CC73HCH1H060B	CHIP C 6.0PF B		C894			CK73HB1A105K	CHIP C 1.0UF K	
C485			CC73HCH1H200J	CHIP C 20PF J		C896			CK73HB1A104K	CHIP C 0.10UF K	
C486			CC73HCH1H020B	CHIP C 2.0PF B		C897,898			CK73HB1A474K	CHIP C 0.47UF K	
C487			CC73HCH1H100B	CHIP C 10PF B		C899,900			CK73HB1H471K	CHIP C 470PF K	
C488			CC73HCH1H030B	CHIP C 3.0PF B		C901			CK73HB1A474K	CHIP C 0.47UF K	
C489			CC73HCH1H330J	CHIP C 33PF J		C902,903			CK73GB0J225K	CHIP C 2.2UF K	
C490			CC73HCH1H240J	CHIP C 24PF J		C904			CK73HB1A474K	CHIP C 0.47UF K	
C491			CC73HCH1H390J	CHIP C 39PF J		C905,906			CK73HB1H471K	CHIP C 470PF K	
C495			CK73HB1H471K	CHIP C 470PF K		C907			CC73HCH1H470J	CHIP C 47PF J	
C496			CK73HB1A104K	CHIP C 0.10UF K		C909			CK73HB1A104K	CHIP C 0.10UF K	
C803,804			CK73HB1H102K	CHIP C 1000PF K		C910			CK73HB1A683K	CHIP C 0.068UF K	
C806,807			CK73HB1H102K	CHIP C 1000PF K		C911			CK73GB0J106K	CHIP C 10UF K	
C808,809			CK73GB1A105K	CHIP C 1.0UF K		C912			CK73HB1H102K	CHIP C 1000PF K	
C810,811			CK73HB1H102K	CHIP C 1000PF K		C913			CK73HB1H332K	CHIP C 3300PF K	
C812-816			CK73GB1A105K	CHIP C 1.0UF K		C914,915			CK73HB1A105K	CHIP C 1.0UF K	
C818,819			CK73HB1H102K	CHIP C 1000PF K		C916-919			CK73HB1H102K	CHIP C 1000PF K	
C821			CK73HB1H102K	CHIP C 1000PF K		C920			CK73GB1A105K	CHIP C 1.0UF K	
C823			CK73GB1A105K	CHIP C 1.0UF K		C921			CC73HCH1H101J	CHIP C 100PF J	
C825			CK73HB1A105K	CHIP C 1.0UF K		C922			CK73HB1A104K	CHIP C 0.10UF K	
C826			CK73HB1A104K	CHIP C 0.10UF K		C923			CK73FB0J106K	CHIP C 10UF K	
C828			CK73GB1A105K	CHIP C 1.0UF K		C924			CC73HCH1H101J	CHIP C 100PF J	
C829			CK73HB1E103K	CHIP C 0.010UF K		C925			CK73HB1A473J	CHIP C 0.047UF J	
C831			CK73GB0J106K	CHIP C 10UF K		C926			CS77CC0J101M	CHIP TNL 100UF 6.3WV	
C832,833			CK73HB1A104K	CHIP C 0.10UF K		C930			CK73HB1H102K	CHIP C 1000PF K	
C834			CK73HB1H102K	CHIP C 1000PF K		C936			CK73HB1H102K	CHIP C 1000PF K	
C837			CK73HB1H102K	CHIP C 1000PF K		C945			CK73HB1A104K	CHIP C 0.10UF K	
C840			CK73HB1H332K	CHIP C 3300PF K		C946			CK73HB1A105K	CHIP C 1.0UF K	
C842			CK73HB1H392K	CHIP C 3900PF K		C947			CK73HB1H471K	CHIP C 470PF K	
C843			CK73HB1H102K	CHIP C 1000PF K		C948,949			CK73HB1H102K	CHIP C 1000PF K	
C844			CK73HB1A104K	CHIP C 0.10UF K		C950			CK73HB0J105K	CHIP C 1.0UF K	
C846			CC73HCH1H050B	CHIP C 5.0PF B		C951			CK73HB1H102K	CHIP C 1000PF K	
C848			CK73HB1H271K	CHIP C 270PF K		C964,965			CK73GB1C225K	CHIP C 2.2UF K	
C849			CK73HB1A104K	CHIP C 0.10UF K		105	2B	*	E29-1229-15	INTER CONNECTOR(LCD)	
C850			CK73HB1H102K	CHIP C 1000PF K		CN801			E40-6827-05	FLAT CABLE CONNECTOR	
C852			CK73HB1A104K	CHIP C 0.10UF K		J802			E11-0703-05	PHONE JACK(EXT SP/MIC)	
C857			CK73HB1H332K	CHIP C 3300PF K		F801			F53-0324-15	FUSE(2.5A)	
C858			CK73HB1E682K	CHIP C 6800PF K		F802			F53-0319-15	FUSE(1.0A)	
C859			CK73HB1A105K	CHIP C 1.0UF K							
C861			CK73HB1H102K	CHIP C 1000PF K							

## PARTS LIST / 零件表

## TX-RX UNIT (X57-7880-20)

Ref. No.	Address	New parts	Parts No.	Description	Destination	Ref. No.	Address	New parts	Parts No.	Description	Destination
107	2B	*	G11-4525-14	SHEET(LCD)		L802,803			L92-0161-05	BEADS CORE	
109	1B		J21-8619-03	MOUNTING HARDWARE(LCD)		X1			L77-3050-05	TCXO(16.8MHZ)	
CD401			L79-1866-05	TUNING COIL		X802			L78-1434-05	RESONATOR(19.2MHZ)	
CF401			L72-1045-05	CERAMIC FILTER(450KHZ/NAR)		XF401	*		L71-0671-05	MCF(49.95MHZ)	
CF402			L72-1010-05	CERAMIC FILTER(450KHZ/WID)		CP1			RK74HB1J101J	CHIP-COM 100 J	1/16W
L1			L41-4795-39	SMALL FIXED INDUCTOR(4.7UH)		CP802			RK75HA1J102J	CHIP-COM 1.0K J	1/16W
L2			L40-1575-57	SMALL FIXED INDUCTOR(15NH)		CP812			RK75HA1J102J	CHIP-COM 1.0K J	1/16W
L4			L92-0163-05	BEADS CORE		CP814			RK75HA1J474J	CHIP-COM 470K J	1/16W
L5			L40-1001-86	SMALL FIXED INDUCTOR(10UH)		CP817			RK75HA1J473J	CHIP-COM 47K J	1/16W
L7			L40-1001-86	SMALL FIXED INDUCTOR(10UH)		CP818-821			RK74HB1J103J	CHIP-COM 10K J	1/16W
L8			L40-2702-86	SMALL FIXED INDUCTOR(27UH)		CP823			RK74HB1J103J	CHIP-COM 10K J	1/16W
L10			L40-3391-86	SMALL FIXED INDUCTOR(3.3UH)		CP826			RK74HB1J103J	CHIP-COM 10K J	1/16W
L11			L40-1502-86	SMALL FIXED INDUCTOR(15UH)		CP827,828			RK75HA1J473J	CHIP-COM 47K J	1/16W
L14			L40-3391-86	SMALL FIXED INDUCTOR(3.3UH)		CP836,837			RK75HA1J102J	CHIP-COM 1.0K J	1/16W
L15			L41-3978-14	SMALL FIXED INDUCTOR(39NH)		CP840-844			RK75HA1J103J	CHIP-COM 10K J	1/16W
L16			L92-0163-05	BEADS CORE		CP845,846			RK75HA1J472J	CHIP-COM 4.7K J	1/16W
L17			L41-2278-14	SMALL FIXED INDUCTOR(22NH)		CP847			RK75HA1J473J	CHIP-COM 47K J	1/16W
L18 ,19			L40-1001-86	SMALL FIXED INDUCTOR(10UH)		R1 ,2			RK73HB1J000J	CHIP R 0 J	1/16W
L20			L40-1085-71	SMALL FIXED INDUCTOR(100NH)		R5			RK73HB1J103J	CHIP R 10K J	1/16W
L21			L40-1085-57	SMALL FIXED INDUCTOR(100NH)		R6			RK73HB1J000J	CHIP R 0 J	1/16W
L25			L40-1575-71	SMALL FIXED INDUCTOR(15NH)		R7			RK73HB1J103J	CHIP R 10K J	1/16W
L27			L40-1085-57	SMALL FIXED INDUCTOR(100NH)		R8			RK73HB1J331J	CHIP R 330 J	1/16W
L202			L40-1085-71	SMALL FIXED INDUCTOR(100NH)		R9			RK73HB1J101J	CHIP R 100 J	1/16W
L203			L40-4775-71	SMALL FIXED INDUCTOR(47NH)		R10			RK73HB1J122J	CHIP R 1.2K J	1/16W
L204			L40-1085-71	SMALL FIXED INDUCTOR(100NH)		R11			RK73HB1J103J	CHIP R 10K J	1/16W
L205			L92-0162-05	BEADS CORE		R13			RK73HB1J102J	CHIP R 1.0K J	1/16W
L206			L40-3975-71	SMALL FIXED INDUCTOR(39NH)		R14			RK73HB1J223J	CHIP R 22K J	1/16W
L207			L34-4577-05	AIR-CORE COIL		R15 ,16			RK73HB1J100J	CHIP R 10 J	1/16W
L208			L92-0149-05	CHIP FERRITE		R17			RK73HB1J000J	CHIP R 0 J	1/16W
L210			L92-0149-05	CHIP FERRITE		R18			RK73HB1J391J	CHIP R 390 J	1/16W
L211			L34-4569-05	AIR-CORE COIL		R19			RK73HB1J471J	CHIP R 470 J	1/16W
L212			L34-4563-05	AIR-CORE COIL		R20			RK73HB1J000J	CHIP R 0 J	1/16W
L213			L34-4565-05	AIR-CORE COIL		R21			RK73HB1J471J	CHIP R 470 J	1/16W
L214			L34-4566-05	AIR-CORE COIL		R22			RK73HB1J000J	CHIP R 0 J	1/16W
L216			L41-2295-39	SMALL FIXED INDUCTOR(2.2UH)		R26			RK73HB1J105J	CHIP R 1.0M J	1/16W
L217			L34-4577-05	AIR-CORE COIL		R27			RK73HB1J103J	CHIP R 10K J	1/16W
L219			L34-4566-05	AIR-CORE COIL		R28			RK73HB1J000J	CHIP R 0 J	1/16W
L220			L34-4569-05	AIR-CORE COIL		R29			RK73HB1J474J	CHIP R 470K J	1/16W
L221			L34-4568-05	AIR-CORE COIL		R30			RK73HB1J821J	CHIP R 820 J	1/16W
L222			L40-4775-57	SMALL FIXED INDUCTOR(47NH)		R31			RK73HB1J106J	CHIP R 10M J	1/16W
L302			L92-0138-05	CHIP FERRITE		R33			RK73HB1J470J	CHIP R 47 J	1/16W
L401			L41-1885-53	SMALL FIXED INDUCTOR(0.18UH)		R37			RK73HB1J152J	CHIP R 1.5K J	1/16W
L402			L40-1085-57	SMALL FIXED INDUCTOR(100NH)		R39			RK73GB2A563J	CHIP R 56K J	1/10W
L403			L40-1591-86	SMALL FIXED INDUCTOR(1.5UH)		R40			RK73HB1J104J	CHIP R 100K J	1/16W
L406			L92-0138-05	CHIP FERRITE		R41 ,42			RK73HB1J271J	CHIP R 270 J	1/16W
L407			L41-5685-39	SMALL FIXED INDUCTOR(0.56UH)		R43			RK73HB1J104J	CHIP R 100K J	1/16W
L408			L40-5675-57	SMALL FIXED INDUCTOR(56NH)		R44			RK73GB2A220J	CHIP R 22 J	1/10W
L409			L41-2285-53	SMALL FIXED INDUCTOR(0.22UH)		R45			RK73HB1J220J	CHIP R 22 J	1/16W
L410			L40-5675-57	SMALL FIXED INDUCTOR(56NH)		R46			RK73HB1J154J	CHIP R 150K J	1/16W
L411			L41-1585-53	SMALL FIXED INDUCTOR(0.15UH)		R47			RK73HB1J101J	CHIP R 100 J	1/16W
L412			L41-2785-53	SMALL FIXED INDUCTOR(0.27UH)		R49			RK73HB1J103J	CHIP R 10K J	1/16W
L414			L41-6878-14	SMALL FIXED INDUCTOR(68NH)		R50			RK73HB1J470J	CHIP R 47 J	1/16W
L415			L92-0138-05	CHIP FERRITE		R51			RK73HB1J471J	CHIP R 470 J	1/16W
L416			L41-6878-14	SMALL FIXED INDUCTOR(68NH)		R52			RK73HB1J103J	CHIP R 10K J	1/16W
L418			L41-6878-14	SMALL FIXED INDUCTOR(68NH)		R53			RK73HB1J472J	CHIP R 4.7K J	1/16W
L419			L41-5678-14	SMALL FIXED INDUCTOR(56NH)		R56 ,57			RK73HB1J000J	CHIP R 0 J	1/16W
L420			L40-4775-57	SMALL FIXED INDUCTOR(47NH)		R58			RK73GB2A224J	CHIP R 220K J	1/10W
L801			L92-0472-05	CHIP FERRITE		R60			RK73HB1J471J	CHIP R 470 J	1/16W
						R62			RK73HB1J683J	CHIP R 68K J	1/16W

## PARTS LIST / 零件表

TX-RX UNIT (X57-7880-20)

Ref. No.	Address	New parts	Parts No.	Description	Desti-nation	Ref. No.	Address	New parts	Parts No.	Description	Desti-nation
R63			RK73HB1J102J	CHIP R 1.0K J 1/16W		R417			RK73HB1J154J	CHIP R 150K J 1/16W	
R67			RK73HB1J103J	CHIP R 10K J 1/16W		R419			RK73HB1J823J	CHIP R 82K J 1/16W	
R68			RK73HB1J000J	CHIP R 0 J 1/16W		R421,422			RK73HB1J332J	CHIP R 3.3K J 1/16W	
R98 ,99			RK73HB1J183J	CHIP R 18K J 1/16W		R423			RK73HB1J222J	CHIP R 2.2K J 1/16W	
R104,105			RK73HB1J103J	CHIP R 10K J 1/16W		R424			RK73HB1J182J	CHIP R 1.8K J 1/16W	
R201			RK73HB1J472J	CHIP R 4.7K J 1/16W		R425			RK73HB1J000J	CHIP R 0 J 1/16W	
R202			RK73HB1J182J	CHIP R 1.8K J 1/16W		R426			RK73HB1J100J	CHIP R 10 J 1/16W	
R203			RK73HB1J100J	CHIP R 10 J 1/16W		R427			RK73HB1J683J	CHIP R 68K J 1/16W	
R205			RK73HB1J101J	CHIP R 100 J 1/16W		R428			RK73HB1J000J	CHIP R 0 J 1/16W	
R206			RK73HB1J222J	CHIP R 2.2K J 1/16W		R429			RK73HB1J101J	CHIP R 100 J 1/16W	
R207			RK73HB1J101J	CHIP R 100 J 1/16W		R433			RK73HB1J684J	CHIP R 680K J 1/16W	
R209			RK73HB1J181J	CHIP R 180 J 1/16W		R434			RK73HB1J221J	CHIP R 220 J 1/16W	
R211			RK73HB1J100J	CHIP R 10 J 1/16W		R435			RK73HB1J000J	CHIP R 0 J 1/16W	
R212			RK73HB1J681J	CHIP R 680 J 1/16W		R436			RK73HB1J101J	CHIP R 100 J 1/16W	
R213			RK73HB1J122J	CHIP R 1.2K J 1/16W		R437			RK73HB1J472J	CHIP R 4.7K J 1/16W	
R214			RK73HB1J270J	CHIP R 27 J 1/16W		R438			RK73HB1J102J	CHIP R 1.0K J 1/16W	
R215			RK73HB1J331J	CHIP R 330 J 1/16W		R439			RK73HB1J391J	CHIP R 390 J 1/16W	
R216			RK73HB1J471J	CHIP R 470 J 1/16W		R440			RK73HB1J563J	CHIP R 56K J 1/16W	
R217			RK73HB1J120J	CHIP R 12 J 1/16W		R441			RK73HB1J104J	CHIP R 100K J 1/16W	
R218			RK73HB1J471J	CHIP R 470 J 1/16W		R442			RK73HB1J000J	CHIP R 0 J 1/16W	
R219			RK73HB1J823J	CHIP R 82K J 1/16W		R443			RK73HB1J563J	CHIP R 56K J 1/16W	
R220			RK73HB1J470J	CHIP R 47 J 1/16W		R444			RK73HB1J104J	CHIP R 100K J 1/16W	
R221			RK73HB1J563J	CHIP R 56K J 1/16W		R445			RK73HB1J000J	CHIP R 0 J 1/16W	
R222			RK73HB1J000J	CHIP R 0 J 1/16W		R447			RK73HB1J471J	CHIP R 470 J 1/16W	
R223			RK73HB1J151J	CHIP R 150 J 1/16W		R448			RK73HB1J000J	CHIP R 0 J 1/16W	
R224			RK73HB1J683J	CHIP R 68K J 1/16W		R449			RK73HB1J391J	CHIP R 390 J 1/16W	
R225			RK73HB1J000J	CHIP R 0 J 1/16W		R450,451			RK73HB1J474J	CHIP R 470K J 1/16W	
R226			RK73HB1J120J	CHIP R 12 J 1/16W		R452			RK73HB1J104J	CHIP R 100K J 1/16W	
R227			RK73GB2A000J	CHIP R 0 J 1/10W		R453			RK73HB1J564J	CHIP R 560K J 1/16W	
R228			RK73HB1J333J	CHIP R 33K J 1/16W		R455			RK73HB1J104J	CHIP R 100K J 1/16W	
R229,230			RK73GB2A4R7J	CHIP R 4.7 J 1/10W		R456			RK73HB1J154J	CHIP R 150K J 1/16W	
R231			RK73FB2B000J	CHIP R 0 J 1/8W		R457,458			RK73HB1J000J	CHIP R 0 J 1/16W	
R232,233			RK73HB1J271J	CHIP R 270 J 1/16W		R461,462			RK73HB1J474J	CHIP R 470K J 1/16W	
R235			RK73GB2A823J	CHIP R 82K J 1/10W		R463,464			RK73HB1J000J	CHIP R 0 J 1/16W	
R237			RK73HB1J120J	CHIP R 12 J 1/16W		R468			RK73HB1J000J	CHIP R 0 J 1/16W	
R240			RK73GB2A000J	CHIP R 0 J 1/10W		R469,470			RK73HB1J333J	CHIP R 33K J 1/16W	
R301			RK73HB1J000J	CHIP R 0 J 1/16W		R471			RK73HB1J472J	CHIP R 4.7K J 1/16W	
R303			RK73HB1J561J	CHIP R 560 J 1/16W		R701-704			RK73HB1J473J	CHIP R 47K J 1/16W	
R304			RK73HB1J000J	CHIP R 0 J 1/16W		R705-712			RK73HB1J102J	CHIP R 1.0K J 1/16W	
R305			RK73HB1J333J	CHIP R 33K J 1/16W		R713,714			RK73HB1J472J	CHIP R 4.7K J 1/16W	
R306			RK73HB1J472J	CHIP R 4.7K J 1/16W		R802			RK73GB2A221J	CHIP R 220 J 1/10W	
R307			RK73EB2ER39K	CHIP R 0.39 K 1/4W		R803			RK73HB1J473J	CHIP R 47K J 1/16W	
R308			RK73HB1J182J	CHIP R 1.8K J 1/16W		R804,805			RK73HB1J104J	CHIP R 100K J 1/16W	
R309,310			RK73EB2ER39K	CHIP R 0.39 K 1/4W		R806,807			RK73HB1J000J	CHIP R 0 J 1/16W	
R311,312			RK73HH1J154D	CHIP R 150K D 1/16W		R810			RK73HB1J104J	CHIP R 100K J 1/16W	
R313,314			RK73HH1J474D	CHIP R 470K D 1/16W		R811			RK73GB2A271J	CHIP R 270 J 1/10W	
R315			RK73HB1J103J	CHIP R 10K J 1/16W		R813			RK73HB1J473J	CHIP R 47K J 1/16W	
R316			RK73HB1J563J	CHIP R 56K J 1/16W		R814-816			RK73HB1J104J	CHIP R 100K J 1/16W	
R317			RK73HB1J000J	CHIP R 0 J 1/16W		R817			RK73HB1J223J	CHIP R 22K J 1/16W	
R318			RK73HB1J474J	CHIP R 470K J 1/16W		R818			RK73GB2A331J	CHIP R 330 J 1/10W	
R319			RK73HB1J224J	CHIP R 220K J 1/16W		R819,820			RK73HB1J104J	CHIP R 100K J 1/16W	
R320			RK73HB1J105J	CHIP R 1.0M J 1/16W		R821			RK73HB1J473J	CHIP R 47K J 1/16W	
R406			RK73HB1J182J	CHIP R 1.8K J 1/16W		R822			RK73HB1J102J	CHIP R 1.0K J 1/16W	
R408			RK73HB1J103J	CHIP R 10K J 1/16W		R824			RK73HH1J824D	CHIP R 820K D 1/16W	
R409			RK73HB1J153J	CHIP R 15K J 1/16W		R829			RK73HH1J394D	CHIP R 390K D 1/16W	
R410			RK73HB1J334J	CHIP R 330K J 1/16W		R830			RK73HH1J103D	CHIP R 10K D 1/16W	
R411			RK73HB1J103J	CHIP R 10K J 1/16W		R831,832			RK73HB1J000J	CHIP R 0 J 1/16W	
R414			RK73HB1J101J	CHIP R 100 J 1/16W		R835,836			RK73HB1J102J	CHIP R 1.0K J 1/16W	
R415			RK73HB1J182J	CHIP R 1.8K J 1/16W		R839			RK73HB1J000J	CHIP R 0 J 1/16W	
R416			RK73HB1J122J	CHIP R 1.2K J 1/16W		R842			RK73HB1J223J	CHIP R 22K J 1/16W	



## PARTS LIST / 零件表

TX-RX UNIT (X57-7880-20)

Ref. No.	Address	New parts	Parts No.	Description	Destination	Ref. No.	Address	New parts	Parts No.	Description	Destination
R844			RK73HB1J000J	CHIP R 0 J 1/16W		R926			RK73HB1J274J	CHIP R 270K J 1/16W	
R845			RK73HB1J103J	CHIP R 10K J 1/16W		R927			RK73HB1J473J	CHIP R 47K J 1/16W	
R847			RK73HB1J105J	CHIP R 1.0M J 1/16W		R928			RK73HB1J273J	CHIP R 27K J 1/16W	
R848			RK73HB1J332J	CHIP R 3.3K J 1/16W		R929			RK73HB1J102J	CHIP R 1.0K J 1/16W	
R849			RK73HB1J000J	CHIP R 0 J 1/16W		R930			RK73HB1J101J	CHIP R 100 J 1/16W	
R850			RK73HB1J102J	CHIP R 1.0K J 1/16W		R931			RK73HB1J000J	CHIP R 0 J 1/16W	
R851			RK73HB1J223J	CHIP R 22K J 1/16W		R932			RK73HB1J103J	CHIP R 10K J 1/16W	
R852			RK73HB1J104J	CHIP R 100K J 1/16W		R933			RK73HB1J102J	CHIP R 1.0K J 1/16W	
R853			RK73HB1J103J	CHIP R 10K J 1/16W		R934			RK73HB1J472J	CHIP R 4.7K J 1/16W	
R854-856			RK73HB1J000J	CHIP R 0 J 1/16W		R935-937			RK73HB1J103J	CHIP R 10K J 1/16W	
R857			RK73HB1J680J	CHIP R 68 J 1/16W		R952			RK73HB1J331J	CHIP R 330 J 1/16W	
R858			RK73HB1J000J	CHIP R 0 J 1/16W		R953			RK73HB1J472J	CHIP R 4.7K J 1/16W	
R860			RK73HB1J104J	CHIP R 100K J 1/16W		R954,955			RK73HB1J121J	CHIP R 120 J 1/16W	
R861			RK73HB1J823J	CHIP R 82K J 1/16W		R956			RK73HB1J471J	CHIP R 470 J 1/16W	
R865			RK73HB1J223J	CHIP R 22K J 1/16W		R960,961			RK73HB1J000J	CHIP R 0 J 1/16W	
R867,868			RK73HB1J103J	CHIP R 10K J 1/16W		R962			RK73HB1J103J	CHIP R 10K J 1/16W	
R869			RK73HB1J472J	CHIP R 4.7K J 1/16W		R963			RK73HB1J184J	CHIP R 180K J 1/16W	
R871			RK73HB1J104J	CHIP R 100K J 1/16W		R964			RK73HB1J332J	CHIP R 3.3K J 1/16W	
R872			RK73HB1J121J	CHIP R 120 J 1/16W		R965			RK73HB1J000J	CHIP R 0 J 1/16W	
R874			RK73HB1J150J	CHIP R 15 J 1/16W		R967			RK73HB1J000J	CHIP R 0 J 1/16W	
R875			RK73HB1J000J	CHIP R 0 J 1/16W		R968			RK73HB1J102J	CHIP R 1.0K J 1/16W	
R876			RK73HB1J564J	CHIP R 560K J 1/16W		R978			RK73HB1J000J	CHIP R 0 J 1/16W	
R877			RK73HB1J105J	CHIP R 1.0M J 1/16W		R980			RK73HB1J472D	CHIP R 4.7K D 1/16W	
R878			RK73HB1J103J	CHIP R 10K J 1/16W		R981			RK73HB1J000J	CHIP R 0 J 1/16W	
R879-883			RK73HB1J000J	CHIP R 0 J 1/16W		R982			RK73HB1J121J	CHIP R 120 J 1/16W	
R884			RK73HB1J564J	CHIP R 560K J 1/16W		R986			RK73HB1J471J	CHIP R 470 J 1/16W	
R885			RK73HB1J105J	CHIP R 1.0M J 1/16W		R989			RK73HB1J102J	CHIP R 1.0K J 1/16W	
R887			RK73HB1J100J	CHIP R 10 J 1/16W		R991			RK73HB1J472J	CHIP R 4.7K J 1/16W	
R888			RK73HB1J473J	CHIP R 47K J 1/16W		R992			RK73HB1J824J	CHIP R 820K J 1/16W	
R890			RK73HB1J153J	CHIP R 15K J 1/16W		R993			RK73HB1J472D	CHIP R 4.7K D 1/16W	
R891			RK73HB1J473J	CHIP R 47K J 1/16W		S1			S70-0414-05	TACT SWITCH	
R892,893			RK73HB1J000J	CHIP R 0 J 1/16W		S2 ,3			S70-0483-05	TACT SWITCH	
R894			RK73HB1J104J	CHIP R 100K J 1/16W		D4			1SV323F	VARIABLE CAPACITANCE DIODE	
R895			RK73HB1J394J	CHIP R 390K J 1/16W		D6			1SV323F	VARIABLE CAPACITANCE DIODE	
R896			RK73HB1J104J	CHIP R 100K J 1/16W		D8 ,9			1SV323F	VARIABLE CAPACITANCE DIODE	
R897			RK73HB1J222J	CHIP R 2.2K J 1/16W		D10			1SV325F	VARIABLE CAPACITANCE DIODE	
R898			RK73HB1J273J	CHIP R 27K J 1/16W		D12			1SV325F	VARIABLE CAPACITANCE DIODE	
R899			RK73HB1J184J	CHIP R 180K J 1/16W		D13			HSC119	DIODE	
R900			RK73HB1J104J	CHIP R 100K J 1/16W		D14 ,15			HVC375B-E	VARIABLE CAPACITANCE DIODE	
R902			RK73HB1J103J	CHIP R 10K J 1/16W		D16			HVC350B	VARIABLE CAPACITANCE DIODE	
R903			RK73HB1J101J	CHIP R 100 J 1/16W		D17 ,18			HSC277	DIODE	
R904			RK73HB1J474J	CHIP R 470K J 1/16W		D201,202			HVC131	DIODE	
R905			RK73HB1J272J	CHIP R 2.7K J 1/16W		D203,204			RN142S	DIODE	
R906			RK73HB1J102J	CHIP R 1.0K J 1/16W		D301			UDZW5.1(B)	ZENER DIODE	
R907			RK73HB1J272J	CHIP R 2.7K J 1/16W		D401,402			KDS121E-P	DIODE	
R908			RK73HB1J104J	CHIP R 100K J 1/16W		D404,405			1SV323F	VARIABLE CAPACITANCE DIODE	
R909			RK73HB1J105J	CHIP R 1.0M J 1/16W		D407,408			1SV323F	VARIABLE CAPACITANCE DIODE	
R910,911			RK73HB1J103J	CHIP R 10K J 1/16W		D803			GN1G	DIODE	
R912			RK73HB1J000J	CHIP R 0 J 1/16W		D806			RKZ5.1B2KG	ZENER DIODE	
R913			RK73HB1J182J	CHIP R 1.8K J 1/16W		D807-809			KDR731	DIODE	
R914			RK73HB1J471J	CHIP R 470 J 1/16W		D810			MC2850	DIODE	
R915			RK73HB1J152J	CHIP R 1.5K J 1/16W		D817			MA2S111-F	DIODE	
R916			RK73HB1J123J	CHIP R 12K J 1/16W		D829-832			1SS388F	DIODE	
R918			RK73HB1J473J	CHIP R 47K J 1/16W		IC1			AK1541	MOS-IC	
R919			RK73HB1J682J	CHIP R 6.8K J 1/16W		IC2			BD7542FVM	MOS-IC	
R920			RK73HB1J561J	CHIP R 560 J 1/16W		IC3			TC75S51FE(F)	MOS-IC	
R921,922			RK73HB1J473J	CHIP R 47K J 1/16W		IC301			NJM2904RB1-ZB	BI-POLAR IC	
R923			RK73HB1J151J	CHIP R 150 J 1/16W		IC401			NJM2591V	BI-POLAR IC	
R924			RK73HB1J474J	CHIP R 470K J 1/16W							
R925			RK73HB1J334J	CHIP R 330K J 1/16W							



## PARTS LIST / 零件表

TX-RX UNIT (X57-7880-20)

Ref. No.	Address	New parts	Parts No.	Description	Destination	Ref. No.	Address	New parts	Parts No.	Description	Destination
IC402		*	NJU7108	MOS-IC							
IC801			XC6209B502P-G	MOS-IC							
IC802			XC6209B502M-G	MOS-IC							
IC803			XC6209B502P-G	MOS-IC							
IC804		*	XC6209B332M-G	MOS-IC							
IC805		*	XC61CN4502M-G	MOS-IC							
IC806		*	XC6209B332M-G	MOS-IC							
IC807			XC6120N302N-G	MOS-IC							
IC808			NJM2904RB1-ZB	BI-POLAR IC							
IC810			EX25512ATA00A	ROM IC							
IC811			HA1630D03MM	MOS-IC							
IC812		*	CD686AQ3	MOS-IC							
IC815			TA7368FG	MOS-IC							
IC817			TC75S51FE(F)	MOS-IC							
IC820			F363BEDFEKDLB	MCU							
IC821			NJU6434	MOS-IC							
Q2			2SC5636	TRANSISTOR							
Q3			KTC4075E(Y,GR)	TRANSISTOR							
Q4 ,5			MCH3914(7)-H	FET							
Q6			SSM6L05FU-F	FET							
Q7			SSM3J05FU-F	FET							
Q8 ,9			2SC5636	TRANSISTOR							
Q11			SSM3J05FU-F	FET							
Q12			2SK1830F	FET							
Q201			2SC5636	TRANSISTOR							
Q203			2SC5455-A	TRANSISTOR							
Q204			RD01MUS1-T113	FET							
Q205			RD07MUS2BT112	FET							
Q301			RT1N140U-T111	TRANSISTOR							
Q303			2SK1830F	FET							
Q304			RT1N141U-T111	TRANSISTOR							
Q305			2SK1824-A	FET							
Q306			RT1P441U-T111	TRANSISTOR							
Q401			RT1N441U-T111	TRANSISTOR							
Q403			KTC4080E-P	TRANSISTOR							
Q404			RT1P441U-T111	TRANSISTOR							
Q405			KTC4080E-P	TRANSISTOR							
Q406			3SK318	FET							
Q407			3SK294-FP	FET							
Q801			UPA672T-A	FET							
Q802,803			SSM6L05FU-F	FET							
Q804			SSM3J05FU-F	FET							
Q805			2SK1830F	FET							
Q806			2SC4919-S	TRANSISTOR							
Q809			KTC4075E(Y,GR)	TRANSISTOR							
Q810			2SC4116(GR)F	TRANSISTOR							
Q811			2SA1586(Y,GR)F	TRANSISTOR							
Q813			RT1N141U-T111	TRANSISTOR							
Q814			2SB1694	TRANSISTOR							
Q815,816			UPA672T-A	FET							
Q817			RT1N441U-T111	TRANSISTOR							
Q818,819			2SK3577-A	FET							
Q820			2SC4617(S)	TRANSISTOR							
Q821			2SB1694	TRANSISTOR							
Q822			RT1N141U-T111	TRANSISTOR							
TH201			ERTJ0EV104J	THERMISTOR							
TH401			NCP18WM224J0S	THERMISTOR							

## EXPLODED VIEW / 部件分解图

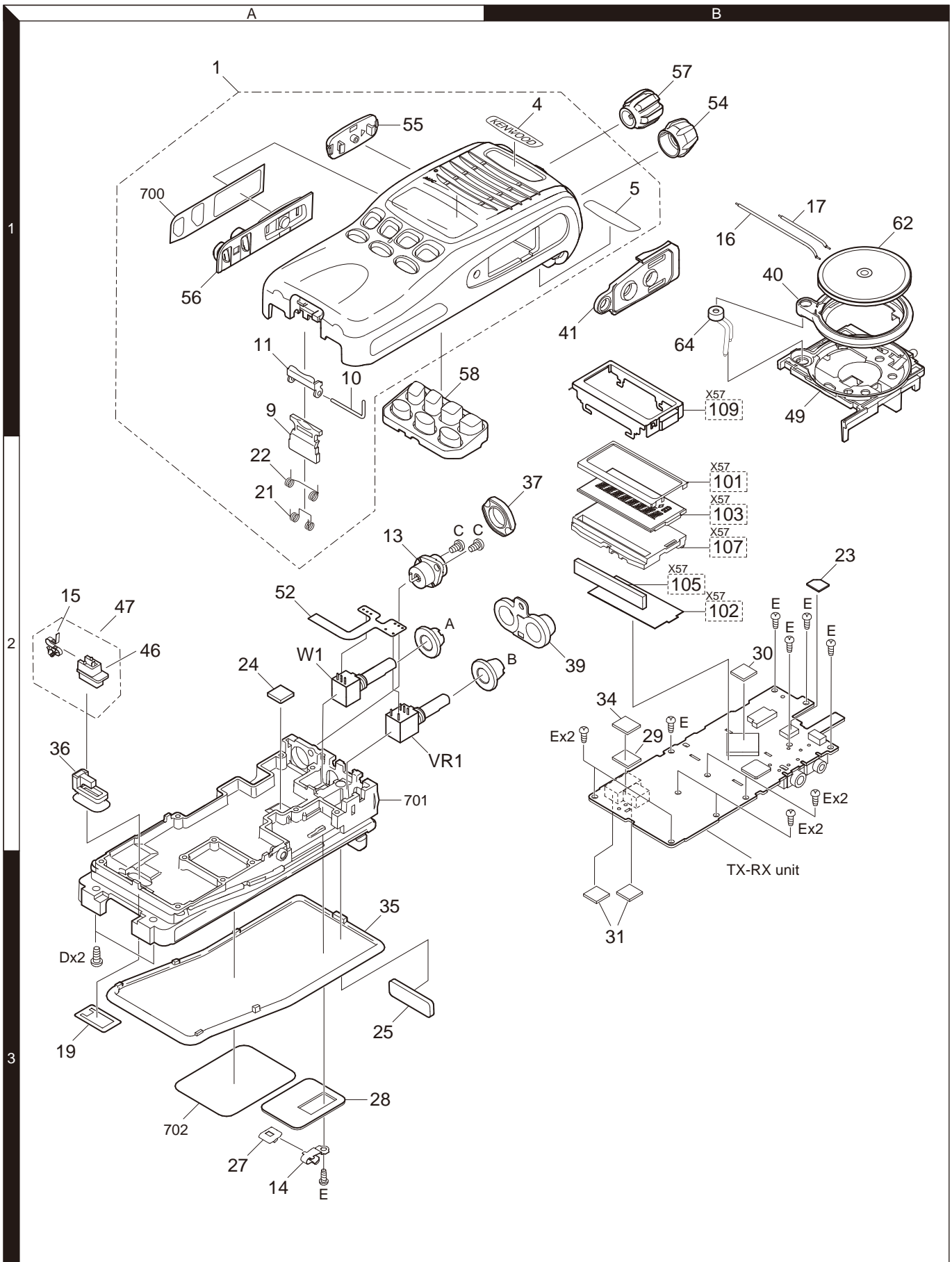

## PACKING / 包装

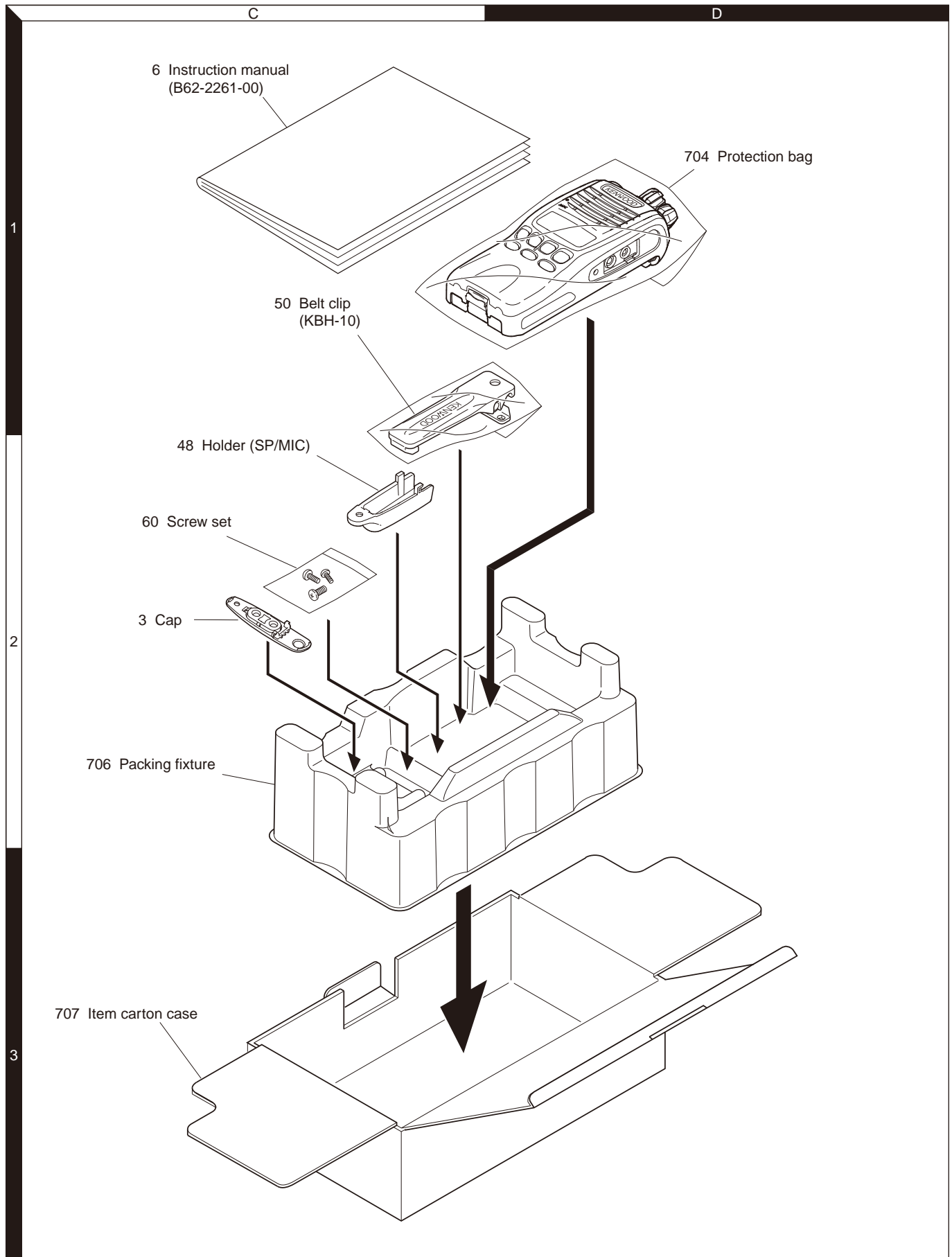

Parts with the exploded numbers larger than 700 are not supplied. / 编号大于 700 的零件未提供分解图。

## ADJUSTMENT

### Test Equipment Required for Alignment

Test Equipment	Major Specifications	
1. Standard Signal Generator (SSG)	Frequency Range Modulation Output	136 to 174MHz Frequency modulation and external modulation -127dBm/0.1μV to greater than -47dBm/1mV
2. RF Power Meter	Input Impedance Operation Frequency Measurement Range	50Ω 136 to 174MHz Vicinity of 10W
3. Deviation Meter	Frequency Range	136 to 174MHz
4. Digital Volt Meter (DVM)	Measuring Range Input Impedance	10mV to 10V DC High input impedance for minimum circuit loading
5. Oscilloscope		DC through 30MHz
6. High Sensitivity Frequency Counter	Frequency Range Frequency Stability	10Hz to 1000MHz 0.2ppm or less
7. DC Ammeter		5A
8. AF Volt Meter (AF VTVM)	Frequency Range Voltage Range	50Hz to 10kHz 1mV to 10V
9. Audio Generator (AG)	Frequency Range Output	50Hz to 5kHz or more 0 to 1V
10. Distortion Meter	Capability Input Level	3% or less at 1kHz 50mV to 10Vrms
11. Spectrum Analyzer	Measuring Range	DC to 1GHz or more
12. Tracking Generator	Center frequency Output Voltage	50kHz to 600MHz 100mV or more
13. 8Ω Dummy Load		Approx. 8Ω, 3W
14. Regulated Power Supply		5V to 10V, approx. 3A Useful if ammeter equipped

#### ■ Antenna connector adapter

The antenna connector of this transceiver uses an SMA terminal.

Use an antenna connector adapter [SMA(f) – BNC(f) or SMA(f) – N(f)] for adjustment. (The adapter is not provided as an option, so buy a commercially-available one.)

#### ■ Repair Jig (Chassis)

Use jig (part No.: A10-4215-03) for repairing the transceiver. Place the TX-RX unit on the jig and fit it with screws.

The jig facilitates the voltage check and protects the final amplifier FET when the voltage on the flow side of the TX-RX unit is checked during repairs.

#### ■ Battery Jig (W05-1011-00)

Connect the power cable properly between the battery jig installed in the transceiver and the power supply, and be sure output voltage and the power supply polarity prior to switching the power supply ON, otherwise over voltage and reverse connection may damage the transceiver, or the power supply or both.

**Note:** When using the battery jig, you must measure the voltage at the terminals of the battery jig. Otherwise, a slight voltage drop may occur within the power cable, between the power supply and the battery jig, especially while the transceiver transmits.

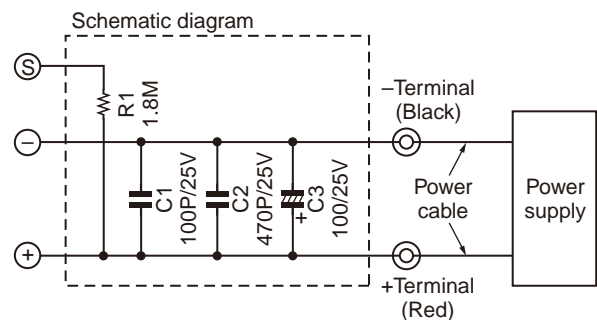
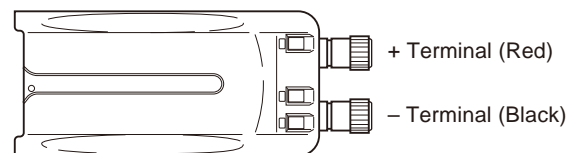

## 调整

## 调整所需的测试设备

测试设备	主要规格	
1. 标准信号发生器 (SSG)	频率范围 调制 输出	136 到 174MHz 调频和外部调制 -127dBm/0.1 $\mu$ V 到大于 -47dBm/1mV
2. 功率计	输入阻抗 操作频率 测量范围	50 $\Omega$ 136 到 174MHz 10W 左右
3. 频偏仪	频率范围	136 到 174MHz
4. 数字电压表 (DVM)	测量范围 输入阻抗	直流 10mV 到 10V 为最小电路负载高输入阻抗
5. 示波器		直流到 30MHz
6. 高灵敏度频率计数器	频率范围 频率稳定性	10Hz 到 1000MHz 0.2ppm 或更低
7. 直流电流表		5A
8. 音频电压表 (AF VTVM)	频率范围 电压范围	50Hz 到 10kHz 1mV 到 10V
9. 音频发生器 (AG)	频率范围 输出	50Hz 到 5kHz 或更高 0V 到 1V
10. 失真测试仪	能力 输入电平	在 1kHz 时 3%或更低 50mV 到 10Vrms
11. 频谱分析仪	测量范围	直流到 1GHz 或更高
12. 轨迹发生器	中心频率 输出电压	50kHz 到 600MHz 100mV 或更高
13. 8 $\Omega$ 假负载		大约 8 $\Omega$ , 3W
14. 可调电源		5V 到 10V, 大约 3A 配备了电流表时更好

## ■ 天线接口转换头

此手持对讲机的天线接口使用 SMA 终端。

使用天线接口转换头 [SMA (f)-BNC (f) 或 SMA (f)-N (f)] 进行调整。(转换头不作为可选件提供,因此请购买商用转换头。)

## ■ 维修机架 (机壳)

使用机壳 (part No.: A10-4215-03) 维修 TK-2317。将收发单元放置在机壳上,并且拧上螺钉。

在维修过程中,当需要在收发单元的电路板上检测到电压时,机壳可以方便地进行电压检测,并且保护模块。

## ■ 电池夹具 (W05-1011-00)

在通手持对讲机电池夹具和电源之间连接适当的电源电缆,确认了输出电压之后接通电源开关,电压超过或极性颠倒都有可能损坏手持对讲机。

注意:当使用电池夹具时,你必须测定电池夹具的终端电压。因为,电源和电池夹具之间会有一些的电压下降,尤其在手持对讲机发射的时候。

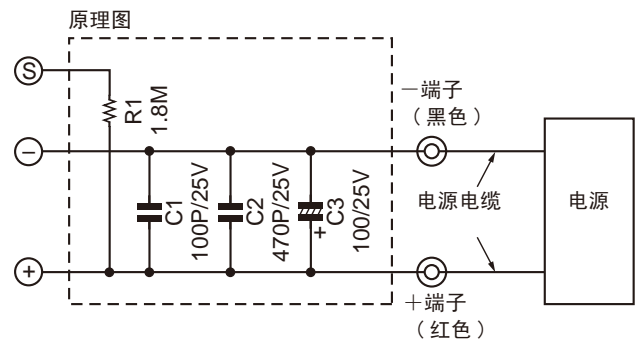
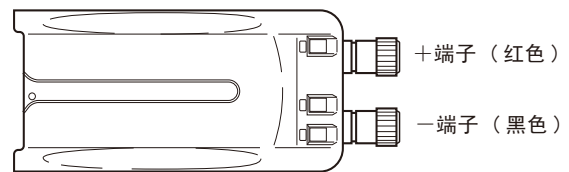

## ADJUSTMENT

### Frequency and Signaling

The transceiver has been adjusted for the frequencies shown in the following table. When required, re-adjust them following the adjustment procedure to obtain the frequencies you want in actual operation.

#### ■ Frequency (MHz)

Channel No.	RX Frequency	TX Frequency
1	155.05000	155.10000
2	136.05000	136.10000
3	173.85000	173.90000
4	155.00000	155.00000
5	155.20000	155.20000
6	155.40000	155.40000
7-16	-	-

#### ■ Signaling

Signaling No.	RX (Decode)	TX (Encode)
1	None	None
2	None	100Hz Square Wave
3	QT 67.0Hz	QT 67.0Hz
4	QT 151.4Hz	QT 151.4Hz
5	QT 210.7Hz	QT 210.7Hz
6	QT 254.1Hz	QT 254.1Hz
7	DQT D023N	DQT D023N
8	DQT D754I	DQT D754I
9	DTMF (Code: 159D)	DTMF (Code: 159D)
10	None	DTMF (Code: 9)
11	None	MSK (1010)
12	FleetSync (100~1000)	FleetSync (100~1000)
13	None	Single Tone (1000Hz)
14	2-tone (A: 304.7Hz, B: 3106.0Hz)	2-tone (A: 304.7Hz, B: 3106.0Hz)
15	None	DTMF Tone (1477Hz)
16	Single Tone (979.9Hz)	Single Tone (979.7Hz)
17	None	MSK PN9
18	None	DTMF (Code: 3)

### Preparations for Tuning the Transceiver

Before attempting to tune the transceiver, connect the unit to a suitable power supply.

Whenever the transmitter is tuned, the unit must be connected to a suitable dummy load (i.e. power meter).

The speaker output connector must be terminated with a  $8\Omega$  dummy load and connected to an AC voltmeter and an audio distortion meter or a SINAD measurement meter at all times during tuning.

#### ■ Adjustment frequency (MHz)

TEST CH	RX	TX
Low	136.05000	136.10000
Low'	145.55000	145.50000
Center	155.05000	155.10000
High'	164.55000	164.50000
High	173.85000	173.90000

### Adjustment Points

TX-RX UNIT  
Component side view

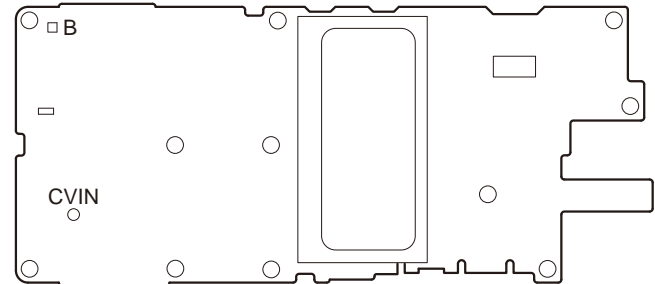

**Note:** "CVIN" VCO Lock voltage.



## 调整

## 频率和信令

已经根据下表所示的频率调整了设置。需要时，按调整步骤重新调整，以获得实际操作时想要的频率。

## ■测试频率 (MHz)

信道	接收频率	发射频率
1	155.05000	155.10000
2	136.05000	136.10000
3	173.85000	173.90000
4	155.00000	155.00000
5	155.20000	155.20000
6	155.40000	155.40000
7 ~ 16	-	-

## ■测试信令

编号	接收 (解码)	发射 (编码)
1	无	无
2	无	100Hz 方波
3	QT 67.0Hz	QT 67.0Hz
4	QT 151.4Hz	QT 151.4Hz
5	QT 210.7Hz	QT 210.7Hz
6	QT 254.1Hz	QT 254.1Hz
7	DQT D023N	DQT D023N
8	DQT D754I	DQT D754I
9	DTMF (码: 159D)	DTMF (码: 159D)
10	无	DTMF (码: 9)
11	无	MSK (1010)
12	FleetSync (100 ~ 1000)	FleetSync (100 ~ 1000)
13	无	单音 (1000Hz)
14	2-音 (A: 304.7Hz, B: 3106.0Hz)	2-音 (A: 304.7Hz, B: 3106.0Hz)
15	无	DTMF Tone (1477Hz)
16	单音 (979.9Hz)	单音 (979.9Hz)
17	无	MSK PN9
18	无	DTMF (码: 3)

## 调谐手持对讲机的准备

在尝试调谐手持对讲机前，请将手持对讲机连接到合适的电源上。

发射打开时，手持对讲机必须连接到合适的等效负载上（如功率表）。

扬声器输出连接器必须端接  $8\Omega$  的等效负载，调谐期间，必须始终连接到交流电压表和音频失真仪或 SINAD 测量仪表上。

## ■调整频率 (MHz)

调谐点	接收	发射
低	136.05000	136.10000
低'	145.55000	145.50000
中	155.05000	155.10000
高'	164.55000	164.50000
高	173.85000	173.90000

## 调整点

收发单元  
元件面视图

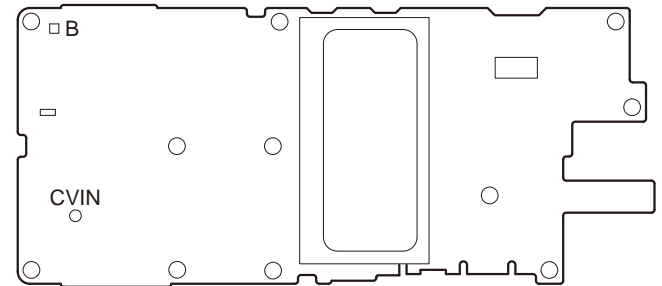

注意：“CVIN” VCO 锁定电压

## ADJUSTMENT

## Common Section

Item	Condition	Measurement			Adjustment			Specifications / Remarks
		Test-equipment	Unit	Terminal	Unit	Parts	Method	
1. Setting	1) BATT terminal voltage: 7.5V 2) SSG standard modulation [Wide] MOD: 1kHz, DEV: 3kHz [Narrow] MOD: 1kHz, DEV: 1.5kHz							
2. Receive Assist Voltage	1) (Auto tuning) <b>*Note</b>	Power meter		ANT	TX-RX	FPU		(4.0V±0.1V)
	2) CH: Low	DVM	TX-RX	CVIN			Check	0.6V or more
3. Transmit Assist Voltage	1) (Auto tuning) <b>*Note</b>				TX-RX	FPU		(4.0V±0.1V)
	2) CH: Low PTT: ON						Check	0.6V or more

**Note:** At test mode, click [Tune Assist Voltage] button in test mode dialog box, then start automatic adjustment of Recive/Transmit assist voltage.

## Transmitter Section

Item	Condition	Measurement			Adjustment			Specifications / Remarks
		Test-equipment	Unit	Terminal	Unit	Parts	Method	
1. Frequency	1) TEST CH: Center PTT: ON	f. counter		ANT	TX-RX	FPU	155.100MHz	±50Hz
2. High Transmit Power	1) TEST CH: Low, Low', Center, High', High (5 points) BATT terminal voltage: 7.5V PTT: ON	Power meter Ammeter				FPU	5.0W	±0.1W 2.0A or less
3. Low Transmit Power	1) TEST CH: Low, Low', Center, High', High (5 points) BATT terminal voltage: 7.5V PTT: ON						1.0W	±0.1W 1.0A or less
4. DQT Balance [Wide] 1	1) TEST CH: Low, Low', Center, High', High (5 points) Deviation meter filter LPF: 3kHz HPF: OFF PTT: ON	Power meter Deviation meter Oscilloscope		ANT			Make the demodulation wave into square waves.	
5. Maximum Deviation [Wide]	1) TEST CH: Center, Low, Low', High, High' (5 points) Deviation meter filter LPF: 15kHz HPF: OFF PTT: ON						4.4kHz (According to the larger +, -)	±80Hz <b>Note:</b> FPU AUTO INPUT 1kHz/150mV

## 调整

## 公用部分

项目	条件	测量			调整			规格 / 备注
		测量装置	单元	端子	单元	部件	方法	
1. 设定	1) BATT 端子电压 : 7.5V 2) 标准信号发生器调制 [宽] 调制 : 1kHz, 频偏 : 3kHz [窄] 调制 : 1kHz, 频偏 : 1.5kHz							
2. 接收辅助电压	1) (自动调整) * 注意	功率计	收发	天线	收发	FPU		(4.0V ± 0.1V)
	2) 信道 : 低	DVM		CVIN			检查	0.6V 或更高
3. 发射辅助电压	1) (自动调整) * 注意				收发	FPU		(4.0V ± 0.1V)
	2) 信道 : 低 PTT: ON						检查	0.6V 或更高

注意：在测试模式时，按下对活框里的 [ 调整辅助电压 ] 按钮后，就会自动开始调整接收 / 发射辅助电压。

## 发射部分

项目	条件	测量			调整			规格 / 备注
		测量装置	单元	端子	单元	部件	方法	
1. 频率	1) 测试信道 : 中 PTT: ON	频率计数器		天线	收发	FPU	155.100MHz	± 50Hz
2. 高发射功率	1) 测试信道 : 低, 低', 中, 高', 高 (5点) BATT 端子电压 : 7.5V PTT: ON	功率计 电流表				FPU	5.0W	± 0.1W 2.0A 或更低
3. 低发射功率	1) 测试信道 : 低, 低', 中, 高', 高 (5点) 端子电压 : 7.5V PTT: ON						1.0W	± 0.1W 1.0A 或更低
4. DQT 平衡 [ 宽带 ] 1	1) 测试信道 : 低, 低', 中, 高', 高 (5点) 频偏仪滤波器 LPF: 3kHz HPF: OFF PTT: ON	功率计 频偏仪 示波器		天线			把解调波调整为方波	
5. 最大频偏 [ 宽带 ]	1) 测试信道 : 中, 低, 低', 高, 高' (5点) 频偏仪滤波器 LPF: 15kHz HPF: OFF PTT: ON						4.4kHz (按照较大+, -)	± 80Hz 注意: FPU 自动输入 1kHz/150mV

## ADJUSTMENT

Item	Condition	Measurement			Adjustment			Specifications / Remarks
		Test-equipment	Unit	Terminal	Unit	Parts	Method	
6. DQT Deviation [Wide]	1) TEST CH: 1 Deviation meter filter LPF: 3kHz HPF: OFF PTT: ON	Power meter Deviation meter Oscilloscope		ANT		FPU	0.75kHz	±40Hz
7. QT Deviation [Wide]	1) TEST CH: 1 Deviation meter filter LPF: 3kHz HPF: OFF PTT: ON						0.75kHz	±40Hz
8. DTMF Deviation [Wide]	1) TEST CH: 1 Deviation meter filter LPF: 15kHz HPF: OFF PTT: ON						3.0kHz	±100Hz
9. MSK Deviation [Wide]	1) TEST CH: 1 Deviation meter filter LPF: 15kHz HPF: OFF PTT: ON						3.0kHz	±100Hz

**Note:** Regarding deviation alignment item, narrow value is calculated from wide alignment value.

## Receiver Section

Item	Condition	Measurement			Adjustment			Specifications / Remarks
		Test-equipment	Unit	Terminal	Unit	Parts	Method	
1. Sensitivity (Semiauto-matic)	1) TEST CH: Low, Center, High (3 points) SSG otuput : -90dBm (7.08μV) SSG MOD: 3.0kHz	SSG DVM Oscilloscope		ANT		FPU	Press [Start] (Auto tuning)	

## 调整

项目	条件	测量			调整			规格 / 备注
		测量装置	单元	端子	单元	部件	方法	
6. DQT 频偏 [宽带]	1) 测试信道：1 频偏仪滤波器 LPF: 3kHz HPF: OFF PTT: ON	功率计 频偏仪 示波器		天线		FPU	0. 75kHz	±40Hz
7. QT 频偏 [宽带]	1) 测试信道：1 频偏仪滤波器 LPF: 3kHz HPF: OFF PTT: ON						0. 75kHz	±40Hz
8. DTMF 频偏 [宽带]	1) 测试信道：1 频偏仪滤波器 LPF: 15kHz HPF: OFF PTT: ON						3. 0kHz	±100Hz
9. MSK 频偏 [宽带]	1) 测试信道：1 频偏仪滤波器 LPF: 15kHz HPF: OFF PTT: ON						3. 0kHz	±100Hz

注意：窄带的 TX 频偏是被自动调整的。

## 接收部分

项目	条件	测量			调整			规格 / 备注
		测量装置	单元	端子	单元	部件	方法	
1. 灵敏度 (半自动)	1) 测试信道：低，中，高(3点) SSG 输出：-90dBm (7.08 μV) SSG 调制：3.0kHz	SSG DVM 示波器		天线		FPU	按[开始] (自动调谐)	

## ADJUSTMENT

Item	Condition	Measurement			Adjustment			Specifications / Remarks
		Test-equipment	Unit	Terminal	Unit	Parts	Method	
2. Open Squelch (5) [Wide]	1) TEST CH: Center, High (2 points) SSG output: -121dBm (0.20μV) SSG MOD: 3.0kHz	SSG DVM Oscilloscope		ANT		FPU	Press [Start] (Auto tuning)	
	2) TEST CH: Low (1 point) SSG output: -121dBm (0.20μV) SSG MOD: 3.0kHz							
(5) [Narrow]	3) TEST CH: Center, High (2 points) SSG output: -120dBm (0.22μV) SSG MOD: 1.5kHz 4) TEST CH: Low (1 point) SSG output: -120dBm (0.22μV) SSG MOD: 1.5kHz							
3. Tight Squelch [Wide]	1) TEST CH: Center, High (2 points) SSG output: -116dBm (0.35μV) SSG MOD: 3.0kHz							
	2) TEST CH: Low (1 point) SSG output: -116dBm (0.35μV) SSG MOD: 3.0kHz							
[Narrow]	3) TEST CH: Center, High (2 points) SSG output: -115dBm (0.40μV) SSG MOD: 1.5kHz 2) TEST CH: Low (1 point) SSG output: -115dBm (0.40μV) SSG MOD: 1.5kHz							
4. Low RSSI [Wide]	1) TEST CH: Center, Low, High (3 points) SSG output: -120dBm (0.22μV) SSG MOD: 3.0kHz							
	[Narrow]							
5. High RSSI [Wide]	1) TEST CH: Center, Low, High (3 points) SSG output: -80dBm (22.4μV) SSG MOD: 3.0kHz							
	[Narrow]							



## 调整

项目	条件	测量			调整			规格 / 备注
		测量装置	单元	端子	单元	部件	方法	
2. 静噪 (浅) (5) [宽带]	1) 测试信道: 中, 高 (2点) SSG 输出: -121dBm (0.20 μV) SSG 调制: 3.0kHz	SSG DVM 示波器		天线		FPU	按 [开始] (自动调谐)	
	2) 测试信道: 低 (1点) SSG 输出: -121dBm (0.20 μV) SSG 调制: 3.0kHz							
(5) [窄带]	3) 测试信道: 中, 高 (2点) SSG 输出: -120dBm (0.22 μV) SSG 调制: 1.5kHz 2) 测试信道: 低 (1点) SSG 输出: -120dBm (0.22 μV) SSG 调制: 3.0kHz							
3. 静噪 (深) [宽带]	1) 测试信道: 中, 高 (点) SSG 输出: -116dBm (0.35 μV) SSG 调制: 3.0kHz							
	2) 测试信道: 低 (1点) SSG 输出: -116dBm (0.35 μV) SSG 调制: 3.0kHz							
[窄带]	3) 测试信道: 中, 高 (2点) SSG 输出: -115dBm (0.40 μV) SSG 调制: 1.5kHz 4) 测试信道: 低 (1点) SSG 输出: -115dBm (0.40 μV) SSG 调制: 1.5kHz							
4. 低 RSSI [宽带]	1) 测试信道: 中, 低, 高 (3点) SSG 输出: -120dBm (0.22 μV) SSG 调制: 3.0kHz							
	[窄带]							
5. 高 RSSI [宽带]	1) 测试信道: 中, 低, 高 (3点) SSG 输出: -80dBm (22.4 μV) SSG 调制: 3.0kHz							
	[窄带]							

# TK-2317 PC BOARD / 印刷电路板

## TX-RX UNIT (X57-7880-20) Component side view (J79-0287-19)

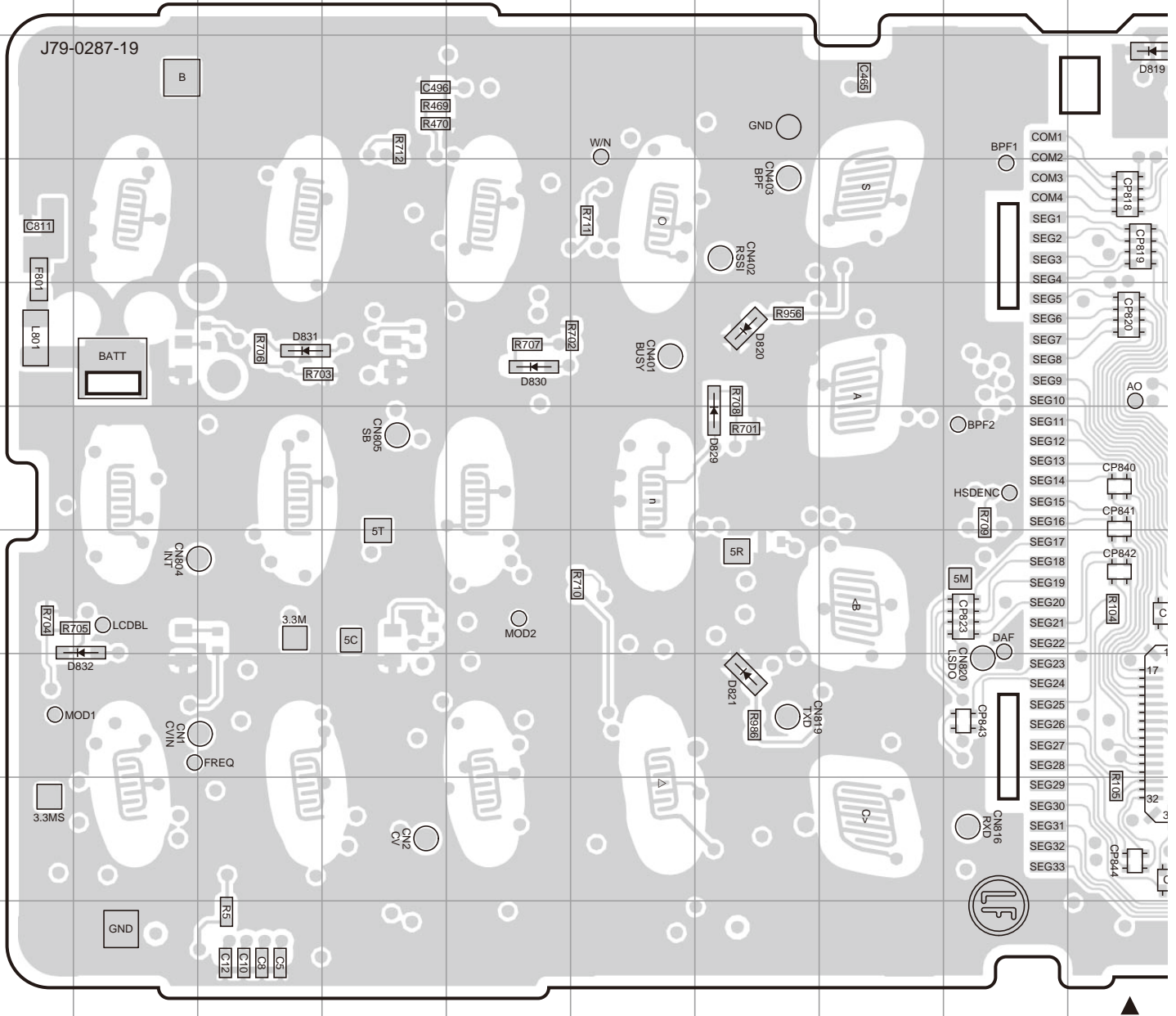

Ref. No.	Address	Ref. No.	Address	Ref. No.	Address	Ref. No.	Address
IC301	3N	Q306	4N	Q818	7P	D820	5G
IC810	4K	Q801	8Q	Q819	8O	D821	8G
IC815	7O	Q805	5P	Q822	4N	D824	3K
IC820	6L	Q813	5P	D801	8R	D829	6G
IC821	8K	Q814	6O	D804	8S	D830	5E
Q303	3M	Q815	9K	D805	8S	D831	5C
Q304	3M	Q816	8M	D818	3L	D832	8B
Q305	3M	Q817	6P	D819	3J		



# TK-2317 PC BOARD / 印刷电路板

## TX-RX UNIT (X57-7880-20) Foil side view (J79-0287-19)

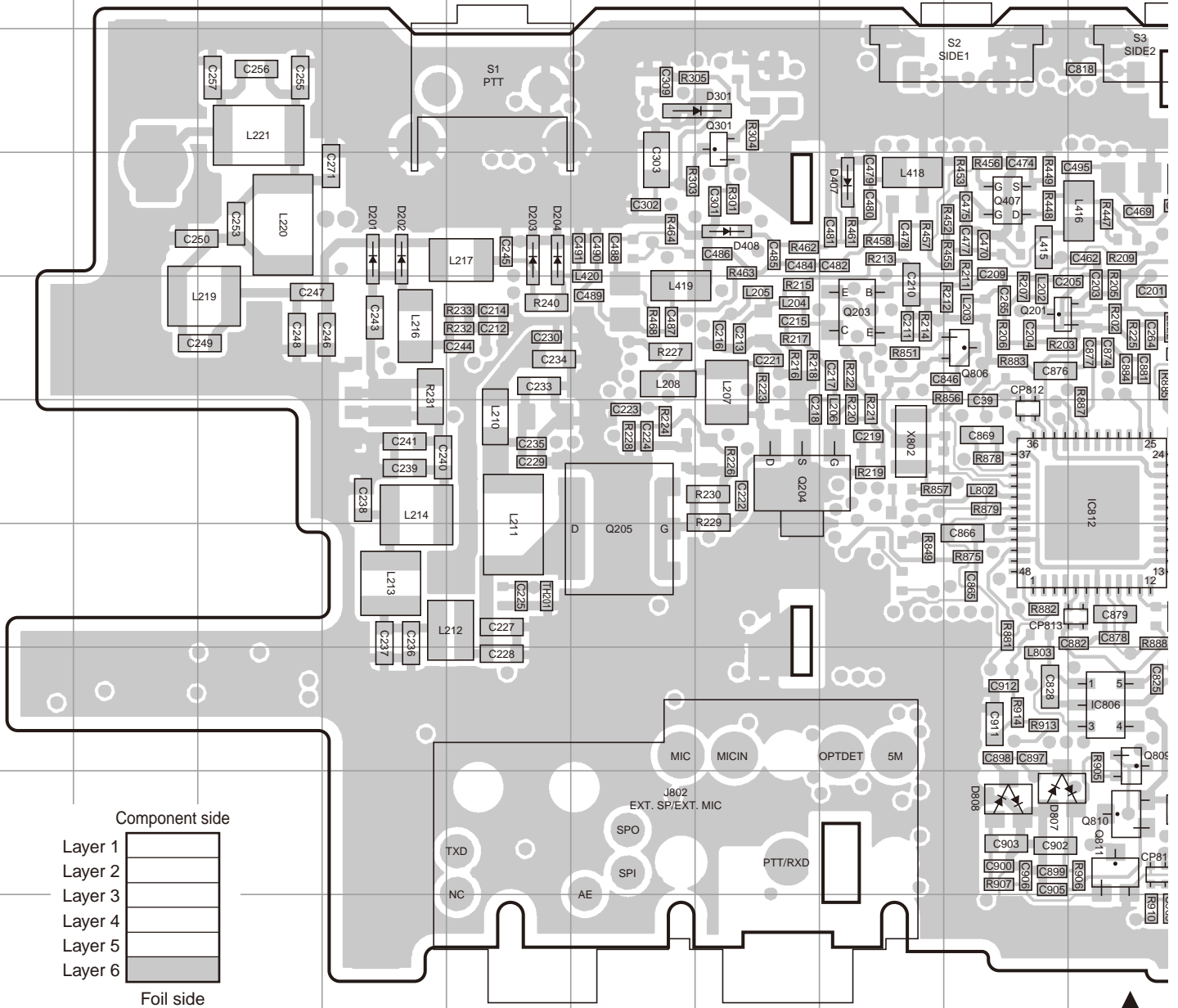

Ref. No.	Address	Ref. No.	Address	Ref. No.	Address	Ref. No.	Address	Ref. No.	Address	Ref. No.	Address	Ref. No.	Address	Ref. No.	Address
IC1	9Q	IC806	8J	Q6	7L	Q301	3G	Q806	5I	D10	9L	D203	4E	D806	
IC2	8O	IC807	7P	Q7	8L	Q401	4N	Q809	8J	D12	10L	D204	4E	D807	
IC3	9R	IC808	4L	Q8	7M	Q403	5O	Q810	9J	D13	7L	D301	3G	D808	
IC401	5N	IC811	5K	Q9	7N	Q404	4N	Q811	9J	D14	9M	D401	3O	D809	
IC402	4O	IC812	6J	Q11	8P	Q405	6N	Q820	8R	D15	9M	D402	3O	D810	
IC801	6P	IC817	9K	Q12	9P	Q406	4M	Q821	8Q	D16	9N	D404	3L	D817	
IC802	7R	Q2	8P	Q201	5I	Q407	4I	D4	8M	D17	7M	D405	4K		
IC803	6Q	Q3	7M	Q203	5H	Q802	7P	D6	8M	D18	7M	D407	4H		
IC804	7Q	Q4	8L	Q204	6G	Q803	7O	D8	8M	D201	4D	D408	4G		
IC805	7R	Q5	8N	Q205	7F	Q804	7Q	D9	8M	D202	4D	D803	3R		

# PC BOARD / 印刷电路板 TK-2317

## TX-RX UNIT (X57-7880-20) Foil side view (J79-0287-19)

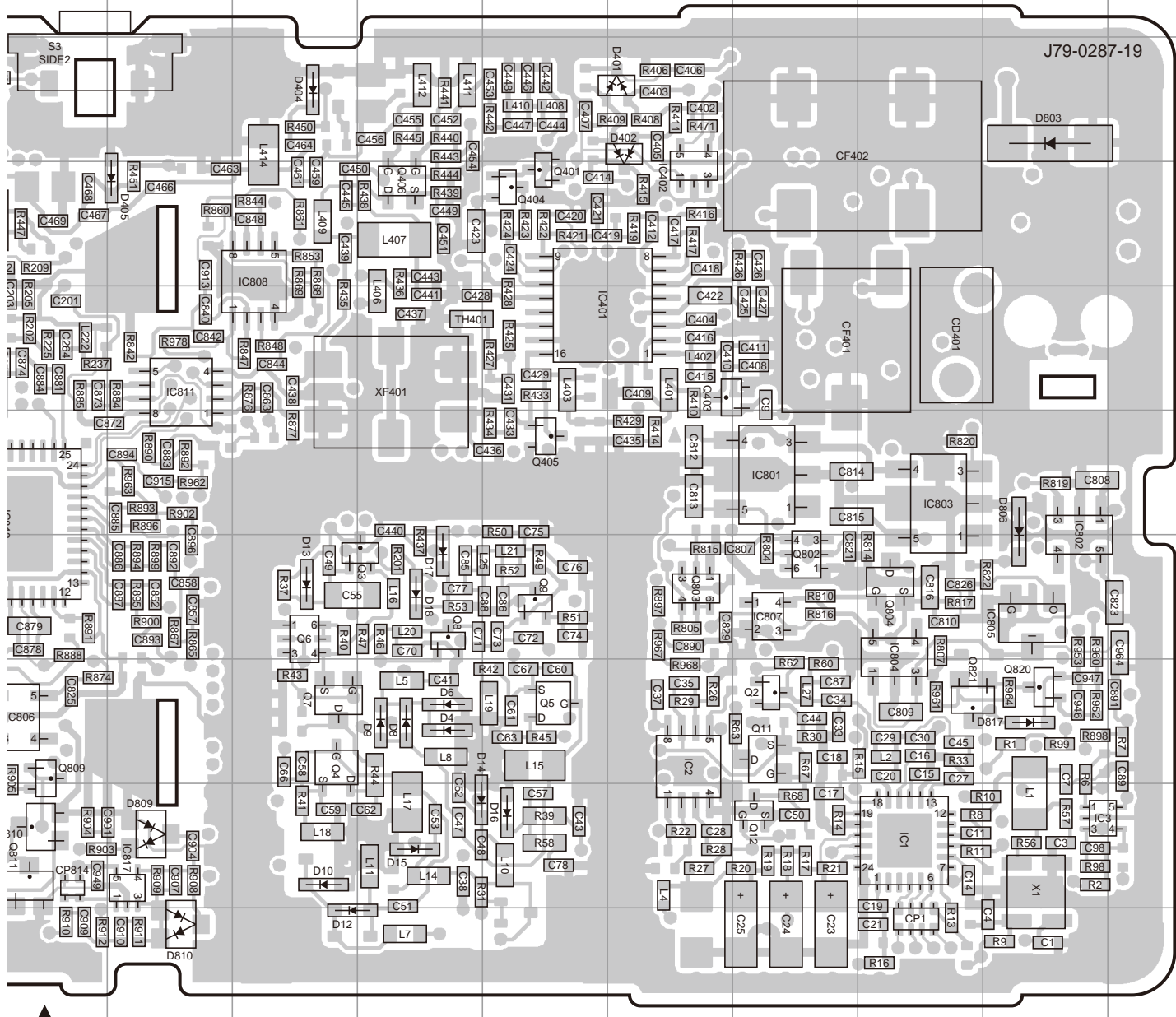

ss	Ref. No.	Address
	D806	6R
	D807	9I
	D808	9I
	D809	9K
	D810	10K
	D817	8R



# TK-2317 SCHEMATIC DIAGRAM / 原理图

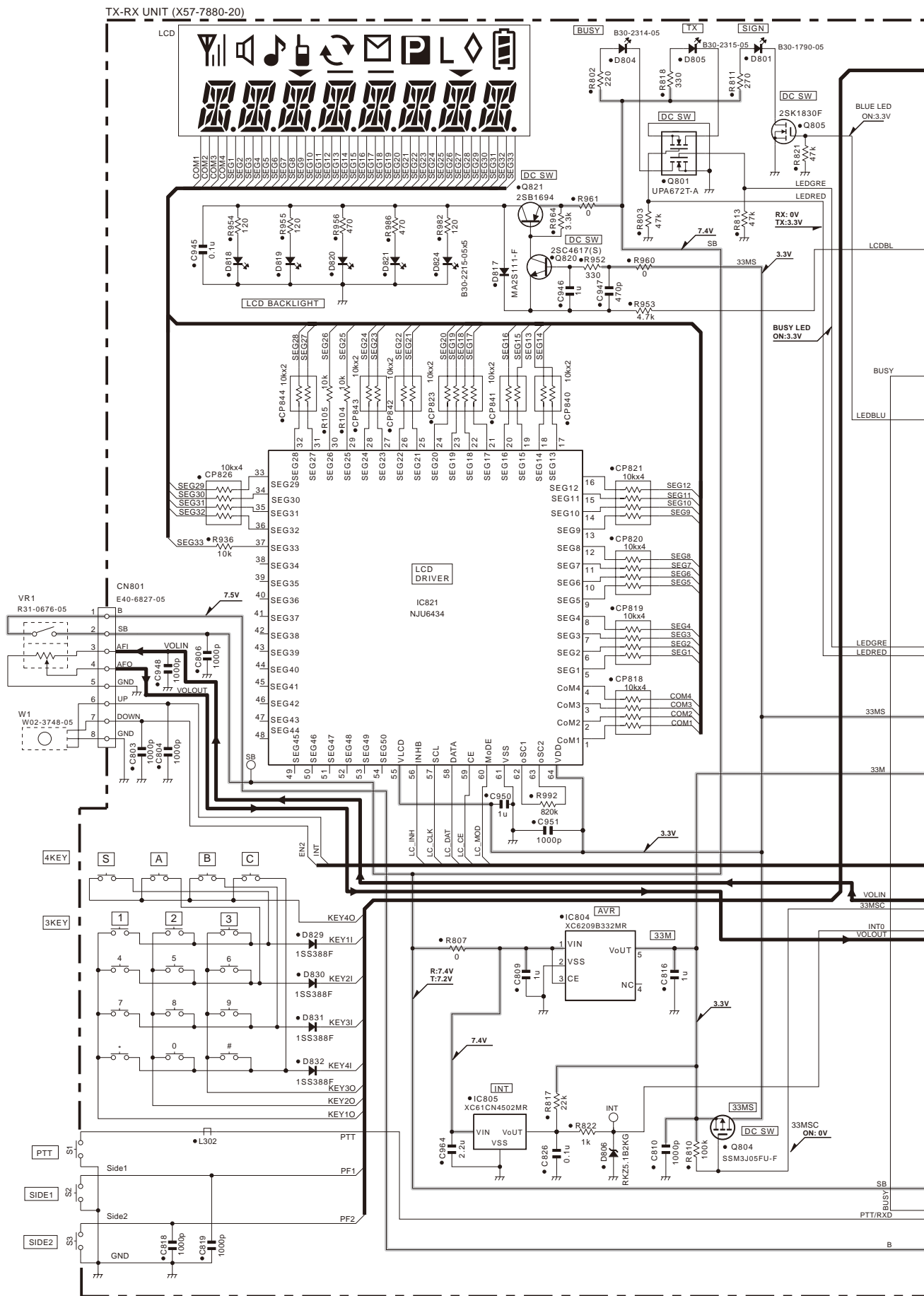

# SCHEMATIC DIAGRAM / 原理图 TK-2317

TX-RX UNIT (X57-7880-20)

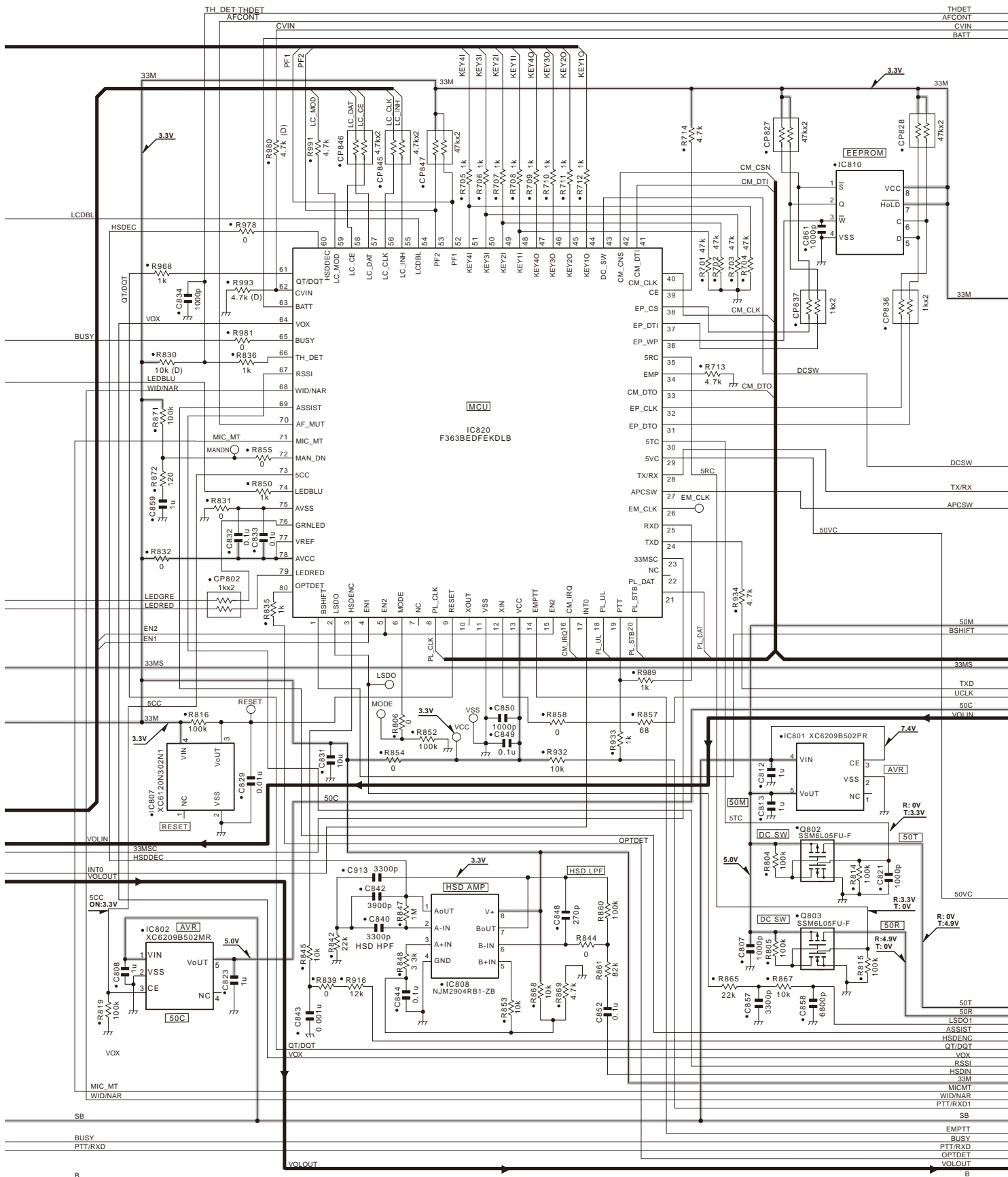



# TK-2317 SCHEMATIC DIAGRAM / 原理图

TX-RX UNIT (X57-7880-20)

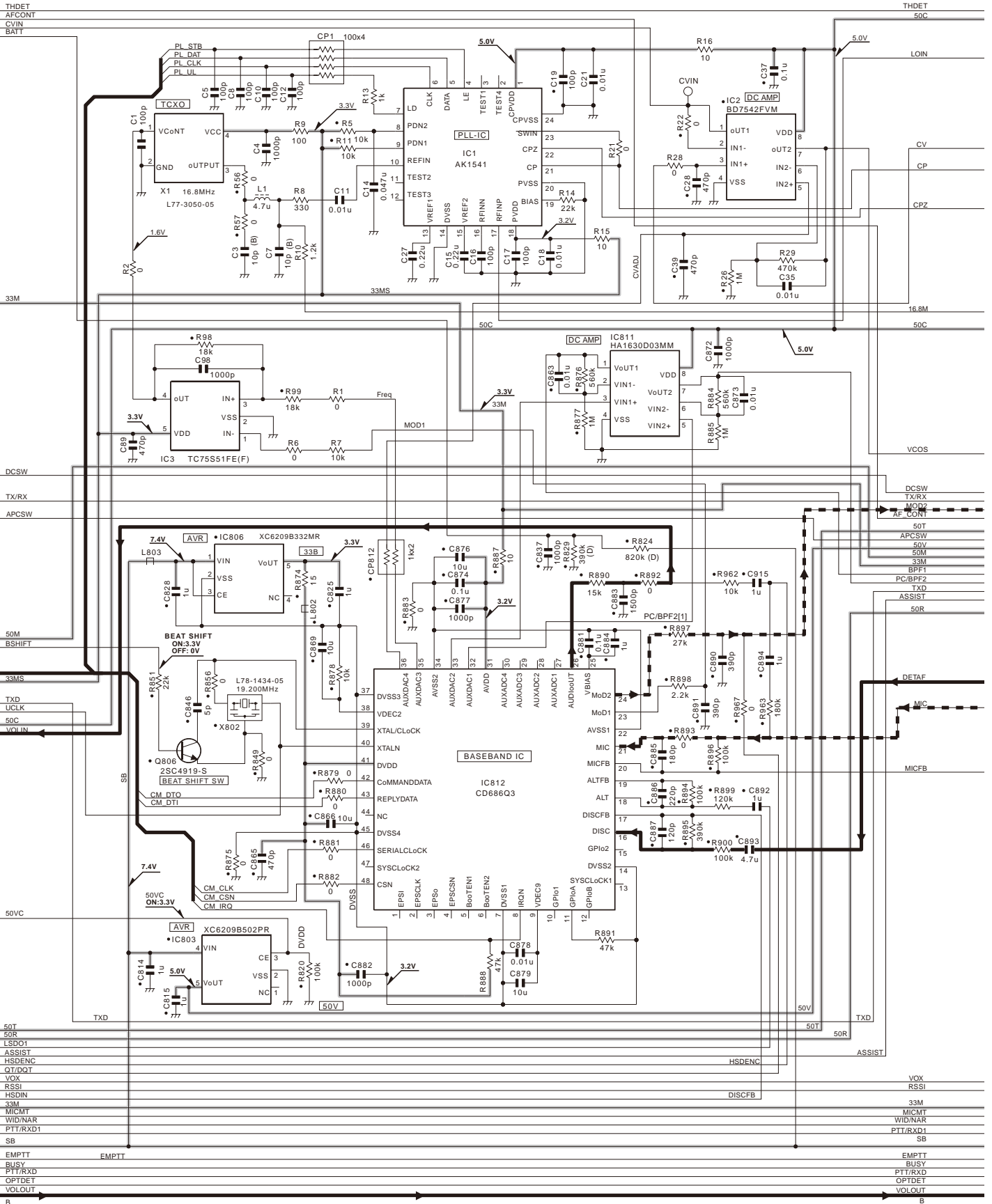

# SCHEMATIC DIAGRAM / 原理图 TK-2317

TX-RX UNIT (X57-7880-20)

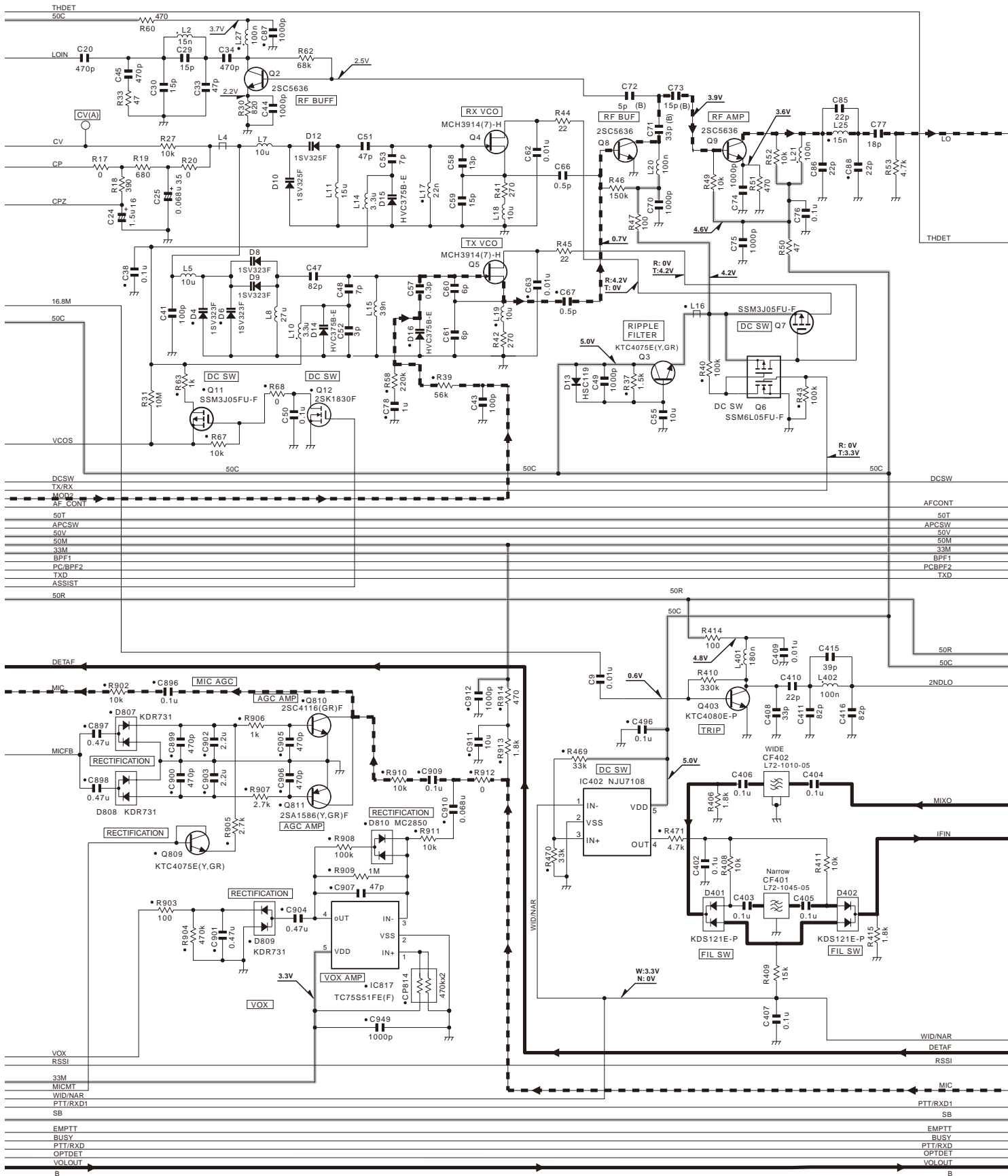

# TK-2317 SCHEMATIC DIAGRAM / 原理图

TX-RX UNIT (X57-7880-20)

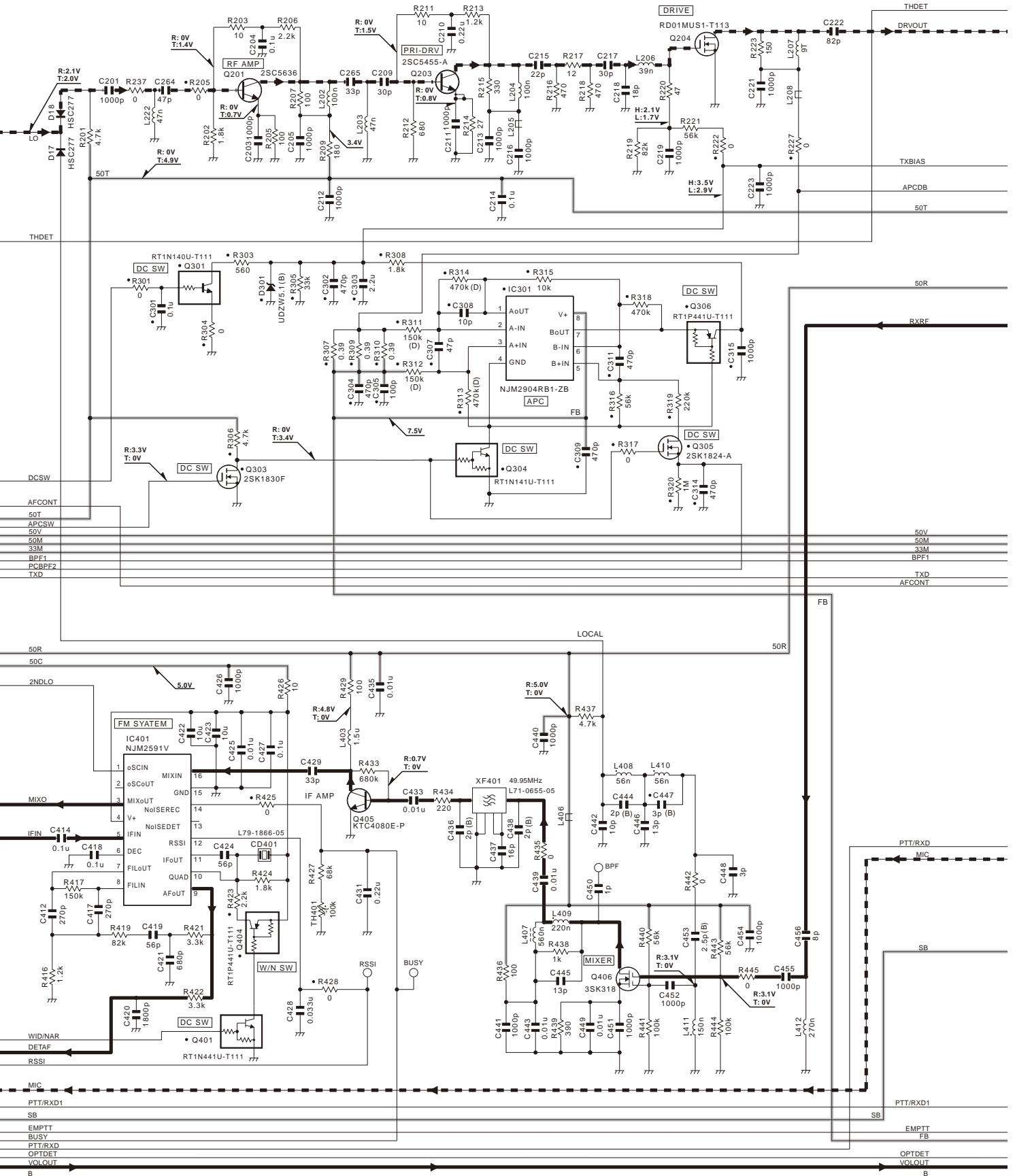

# SCHEMATIC DIAGRAM / 原理图 TK-2317

TX-RX UNIT (X57-7880-20)

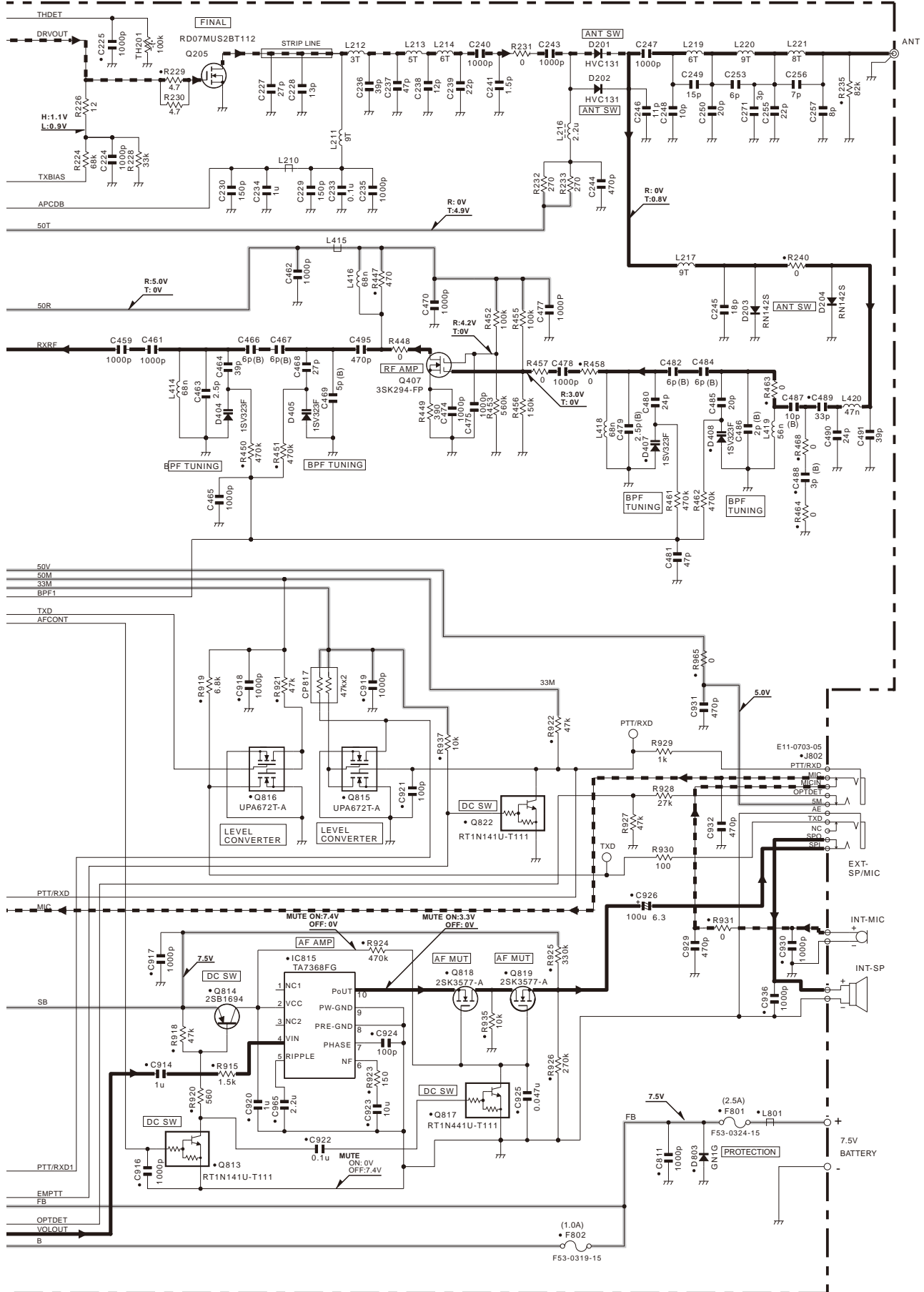

Note : The components marked with a dot (•) are parts of layer 1. / 注意：标有点号 (•) 的零件为第一层的零件。 61

X57-788

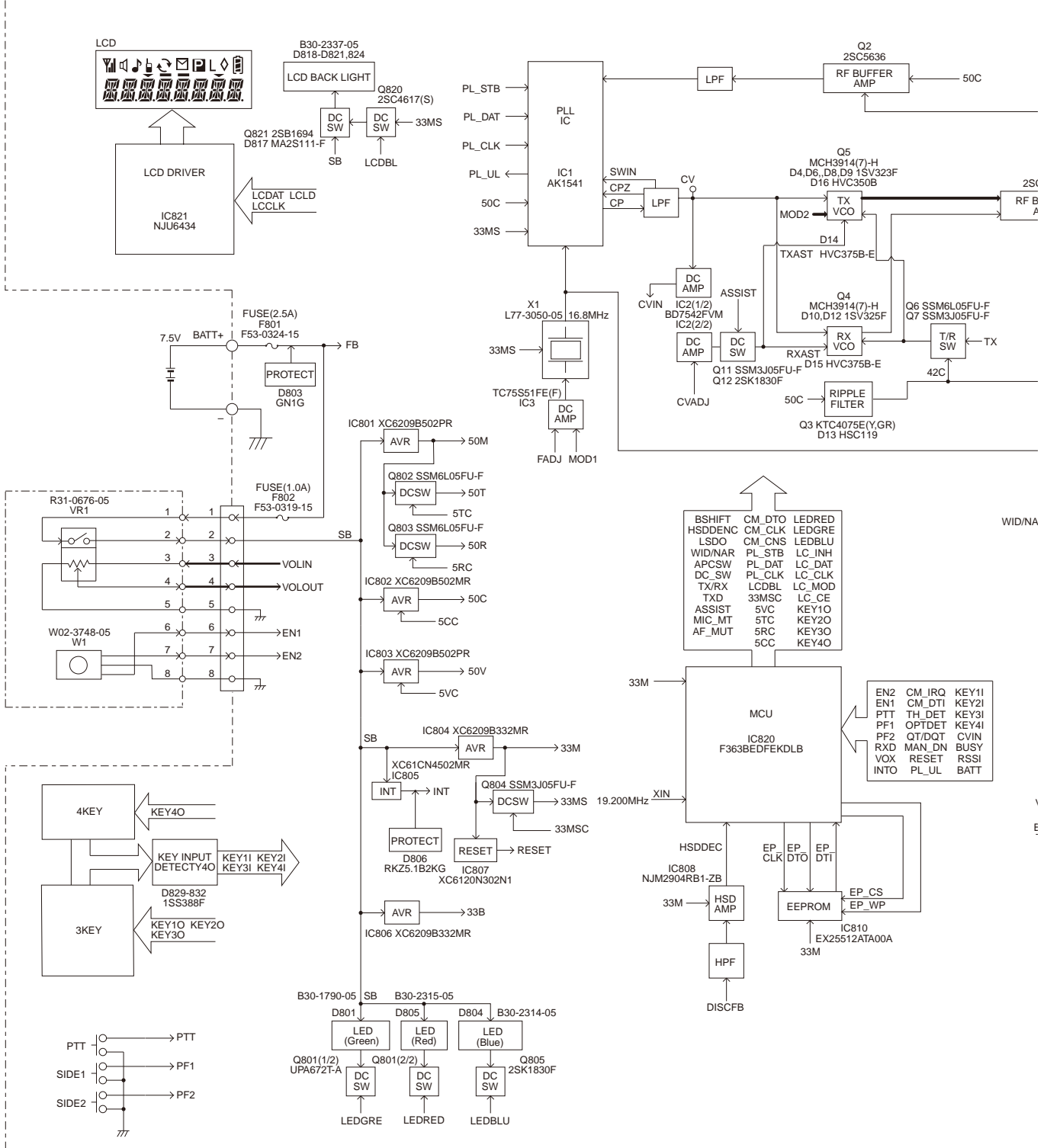



## LEVEL DIAGRAM / 电平图

### Receiver Section / 接收部分

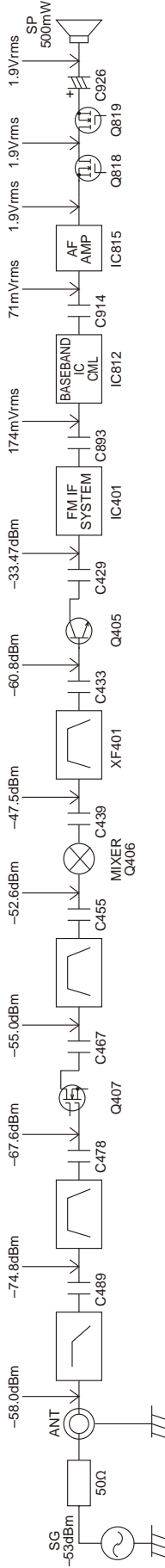

To make measurements in the AF section, connect the AC level meter.  
 (ANT input: -53dBm, 1kHz FM, 1.5kHz Dev (Narrow)).  
 In the RF section, use a high impedance probe. (ANT input: -53dBm, MOD off).

要在 AF 段进行测量, 请连接交流电平表。  
 (ANT 输入: -53dBm, 1kHz FM, 1.5kHz 频偏 (窄带))。  
 在 RF 段, 请使用高阻抗探针。(ANT 输入: -53dBm, MOD 关。)

### Transmitter Section / 发射部分

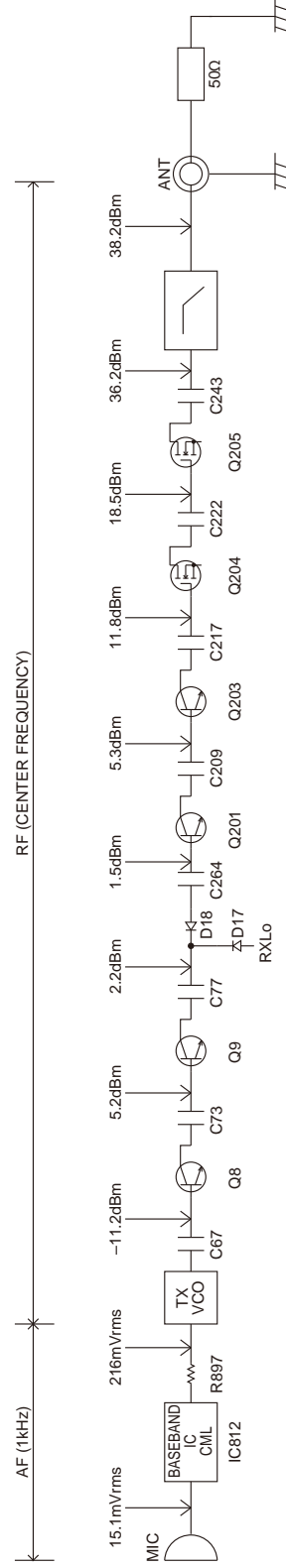

AG is set to the MIC input becomes 1.5kHz Dev. At 1kHz MOD. (Narrow)  
 To make measurements in the AF section, connect the AC level meter.  
 In the RF section, use a 1000pF coupling capacitor.

AG 被设为麦克风输入, 为 1.5kHz 频偏在 1kHz 调制。(窄带)  
 要在 AF 段进行测量, 请连接交流电平表。  
 在 RF 段, 请使用 1000pF 耦合电容。



## OPTIONAL ACCESSORIES / 可选附件

### KNB-29N (Ni-MH Battery Pack / 镍氢电池)

#### ■ External View / 外视图



#### ■ Specifications / 规格

Voltage / 电压 ..... 7.2V (1.2V x 6)  
 Battery capacity / 电池容量 ..... typ. 1500mAh

### KNB-53N (Ni-MH Battery Pack / 镍氢电池)

#### ■ External View / 外视图



#### ■ Specifications / 规格

Voltage / 电压 ..... 7.2V (1.2V x 6)  
 Battery capacity / 电池容量 ..... typ. 1400mAh

### KNB-45L (Li-ion Battery Pack / 锂离子电池)

#### ■ External View / 外视图



#### ■ Specifications / 规格

Voltage / 电压 ..... 7.4V (3.7V x 2)  
 Battery capacity / 电池容量 ..... typ. 2000mAh

### KMC-48GPS (GPS Speaker Microphone / GPS 扬声器麦克风)

#### ■ External View / 外视图



#### ■ Specifications / 规格

Operating temperature range / 工作温度范围 ..... -30°C ~ +60°C  
 Microphone impedance / 麦克风阻抗 ..... 2.2 kΩ (max / 最大)  
 Speaker impedance / 扬声器阻抗 ... 1.2 kHz下为 16 Ω ± 15 %

## SPECIFICATIONS / 规格

**General**

Frequency Range .....	136~174MHz
Channel Spacing .....	25kHz (Wide) / 12.5kHz (Narrow)
PLL Channel Stepping.....	2.5kHz, 5kHz, 6.25kHz, 7.5kHz
Operating Voltage .....	7.5 V DC±20%
Battery Life .....	More than 12 hours at 5 watts (5-5-90 duty cycle with KNB-45L battery)
Operating Temperature range.....	-30°C to +60°C
Frequency Stability .....	±2.5ppm (-30°C to +60°C)
Channel Frequency Spread.....	38MHz
Dimensions and Weight (Dimensions not including protrusions)	
Radio Only.....	180g
With KNB-45L .....	54 W x 122.0 H x 33.7 D mm 300g

**Receiver (Measurements made per China GB standard)**

Sensitivity	
EIA 12dB SINAD .....	0.25µV (Wide) / 0.28µV (Narrow)
Selectivity .....	70dB (Wide) / 60dB (Narrow)
Intermodulation Distortion .....	70dB (Wide) / 60dB (Narrow)
Spurious response .....	70dB
Audio Output.....	500mW at 8Ω

**Transmitter (Measurements made per China GB standard)**

RF Output Power .....	5W/1W
Spurious Response .....	70dB
Modulation.....	16K0F3E (Wide) / 11K0F3E (Narrow)
FM Hum and Noise.....	45dB (Wide) / 40dB (Narrow)
Modulation Distortion.....	Less than 5%

Measurements made per China GB standard and specifications shown are typical.

Kenwood reserves the right to change specifications without prior notice or obligation.

**概述**

频率范围.....	136 ~ 174MHz
信道间隔.....	25kHz (宽带) / 12.5kHz (窄带)
PLL 频道步进 .....	2.5kHz, 5kHz, 6.25kHz, 7.5kHz
工作电源电压.....	7.5 V DC±20%
电池寿命.....	在5W时高于12时间 (使用KNB-45L电池5-5-90工作周期)
工作温度范围.....	-30°C ~ +60°C
频率稳定度.....	±2.5ppm (-30°C ~ +60°C)
信道频率扩展.....	38MHz
尺寸及重量 (未包括凸起部分)	
仅对讲机时.....	180g
带有KNB-45L .....	54宽 x 122.0高 x 33.7长 mm, 300g

**接收部 (根据中国 GB 标准测定)**

灵敏度	
EIA 12dB SINAD.....	0.25 µV (宽带) / 0.28 µV (窄带)
选择性.....	70dB (宽带) / 60dB (窄带)
互调.....	70dB (宽带) / 60dB (窄带)
杂散响应抗扰性.....	70dB
音频输出功率.....	500mW (8Ω时)

**发射部 (根据中国 GB 标准测定)**

射频功率输出.....	5W/1W
杂散射频分量.....	70dB
调制.....	16K0F3E (宽带) / 11K0F3E (窄带)
FM 噪音.....	45dB (宽带) / 40dB (窄带)
调制失真.....	低于5%

依据中国 GB 标准获得的测量值和所示规格均为典型值。  
建伍公司有权变更技术规格，恕不预先通知。

**Kenwood Corporation**

2967-3, Ishikawa-machi, Hachioji-shi, Tokyo, 192-8525 Japan

**Kenwood U.S.A. Corporation**

P.O. BOX 22745, 2201 East Dominguez Street, Long Beach, CA 90801-5745, U.S.A.

**Kenwood Electronics Canada Inc.**

6070 Kestrel Road, Mississauga, Ontario, Canada L5T 1S8

**Kenwood Electronics Deutschland GmbH**

Rembrücker Str. 15, 63150 Heusenstamm, Germany

**Kenwood Electronics Belgium N.V.**

Leuvensesteenweg 248 J, 1800 Vilvoorde, Belgium

**Kenwood Electronics France S.A.**

L' Etoile Paris Nord 2, 50 Allée des Impressionnistes, Bp 58416 Villepinte, 95944 Roissy Ch De Gaulle Cedex

**Kenwood Electronics UK Limited**

KENWOOD House, Dwight Road, Watford, Herts., WD18 9EB United Kingdom

**Kenwood Electronics Europe B.V.**

Amsterdamseweg 37, 1422 AC Uithoorn, The Netherlands

**Kenwood Electronics Italia S.p.A.**

Via G. Sirtori, 7/9 20129 Milano, Italy

**Kenwood Ibérica, S.A.**

Bolivia, 239-08020 Barcelona, Spain

**Kenwood Electronics Australia Pty. Ltd.**

Talavera Business Park Building A, 4 Talavera Road, North Ryde NSW 2113 Australia

**Kenwood Electronics (Hong Kong) Ltd.**

Suite 2504, 25/F, Tower 2, Nina Tower, No. 8 Yeung Uk Road, Tsuen Wan, New Territories, Hong Kong

**Kenwood Electronics Singapore Pte Ltd**

1 Ang Mo Kio Street 63, Singapore 569110

TX-RX UNIT (X57-7880-20) Component side view (J79-0287-19)

TX-RX UNIT (X57-7880-20) Component side view (J79-0287-19)

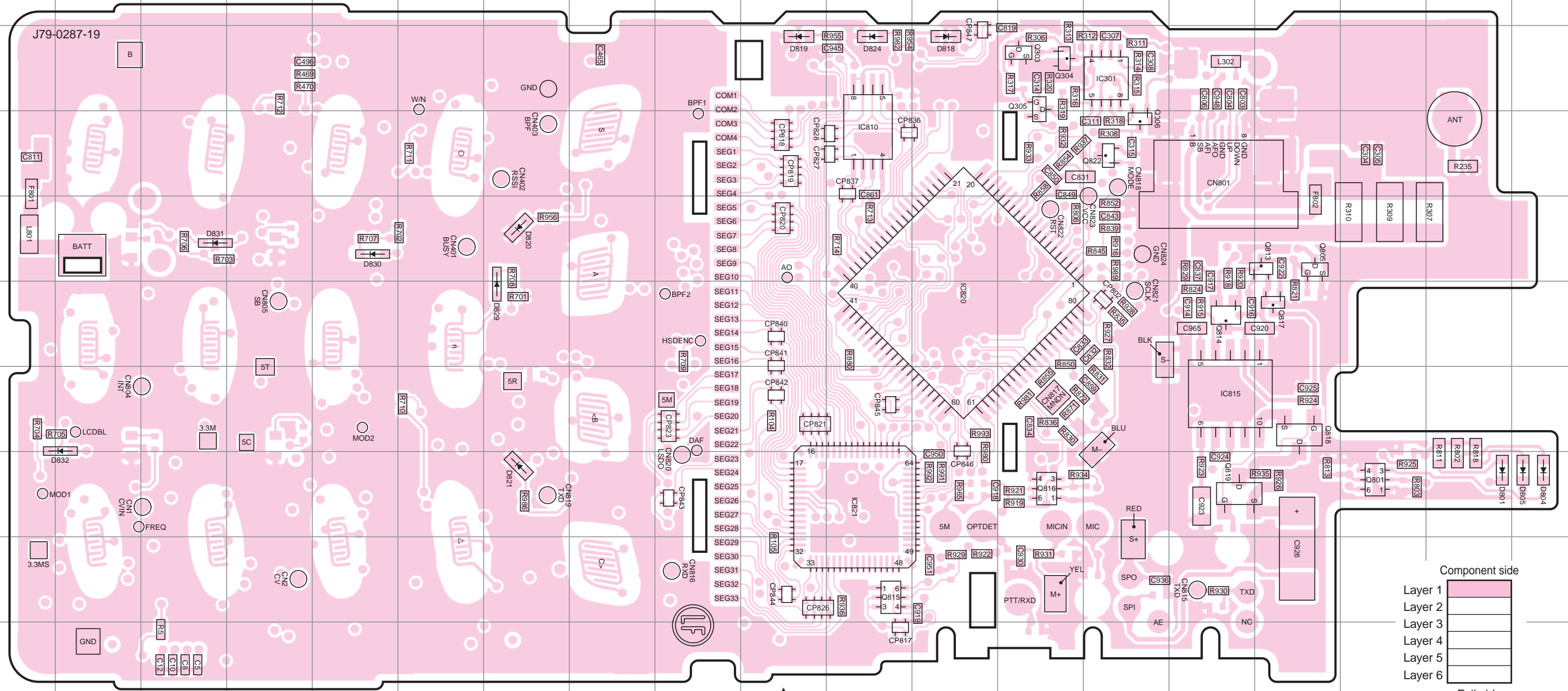

Ref. No.	Address	Ref. No.	Address	Ref. No.	Address	Ref. No.	Address
IC301	3N	Q306	4N	Q818	7P	D820	5G
IC810	4K	Q801	8Q	Q819	8O	D821	8G
IC815	7O	Q805	5P	Q822	4N	D824	3K
IC820	6L	Q813	5P	D801	8R	D829	6G
IC821	8K	Q814	6O	D804	8S	D830	5E
Q303	3M	Q815	9K	D805	8S	D831	5C
Q304	3M	Q816	8M	D818	3L	D832	8B
Q305	3M	Q817	6P	D819	3J		



TX-RX UNIT (X57-7880-20) Foil side view (J79-0287-19)

TX-RX UNIT (X57-7880-20) Foil side view (J79-0287-19)

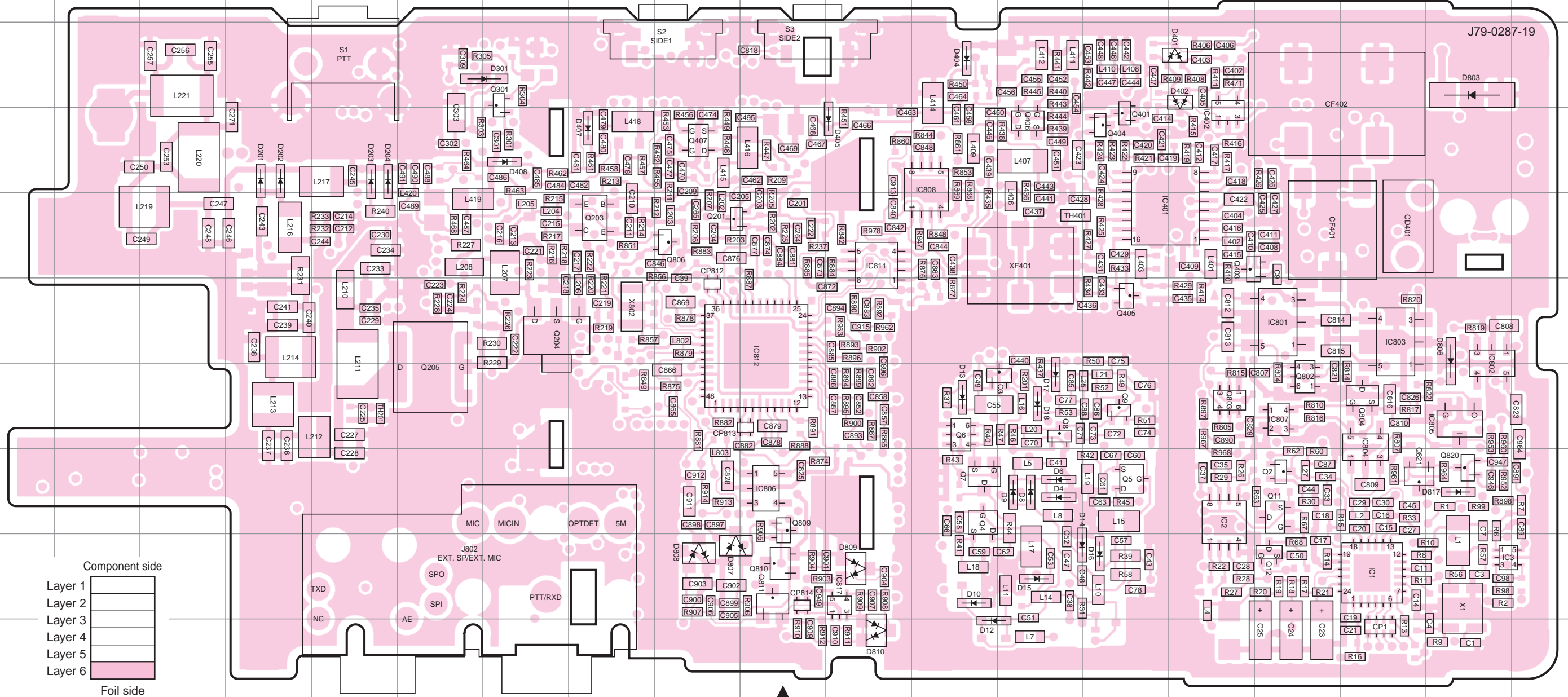

Ref. No.	Address	Ref. No.	Address	Ref. No.	Address	Ref. No.	Address	Ref. No.	Address	Ref. No.	Address	Ref. No.	Address	Ref. No.	Address
IC1	9Q	IC806	8J	Q6	7L	Q301	3G	Q806	5I	D10	9L	D203	4E	D806	6R
IC2	8O	IC807	7P	Q7	8L	Q401	4N	Q809	8J	D12	10L	D204	4E	D807	9I
IC3	9R	IC808	4L	Q8	7M	Q403	5O	Q810	9J	D13	7L	D301	3G	D808	9I
IC401	5N	IC811	5K	Q9	7N	Q404	4N	Q811	9J	D14	9M	D401	3O	D809	9K
IC402	4O	IC812	6J	Q11	8P	Q405	6N	Q820	8R	D15	9M	D402	3O	D810	10K
IC801	6P	IC817	9K	Q12	9P	Q406	4M	Q821	8Q	D16	9N	D404	3L	D817	8R
IC802	7R	Q2	8P	Q201	5I	Q407	4I	D4	8M	D17	7M	D405	4K		
IC803	6Q	Q3	7M	Q203	5H	Q802	7P	D6	8M	D18	7M	D407	4H		
IC804	7Q	Q4	8L	Q204	6G	Q803	7O	D8	8M	D201	4D	D408	4G		
IC805	7R	Q5	8N	Q205	7F	Q804	7Q	D9	8M	D202	4D	D803	3R		



