

## CONTENTS

<b>GENERAL</b> .....	<b>2</b>
<b>SYSTEM SET-UP</b> .....	<b>3</b>
<b>REALIGNMENT</b> .....	<b>3</b>
<b>DISASSEMBLY FOR REPAIR</b> .....	<b>5</b>
<b>CIRCUIT DESCRIPTION</b> .....	<b>7</b>
<b>SEMICONDUCTOR DATA</b> .....	<b>12</b>
<b>TERMINAL FUNCTION</b> .....	<b>13</b>
<b>COMPONENTS DESCRIPTION</b> .....	<b>14</b>
<b>PARTS LIST</b> .....	<b>15</b>
<b>EXPLODED VIEW</b> .....	<b>22</b>
<b>PACKING</b> .....	<b>23</b>
<b>ADJUSTMENT</b> .....	<b>24</b>
<b>PC BOARD</b>	
<b>TX-RX UNIT (X57-7782-71)</b> .....	<b>30</b>
<b>SCHEMATIC DIAGRAM</b> .....	<b>34</b>
<b>BLOCK DIAGRAM</b> .....	<b>40</b>
<b>LEVEL DIAGRAM</b> .....	<b>42</b>
<b>OPTIONAL ACCESSORIES</b>	
<b>KNB-55L (Li-ion Battery Pack)</b> .....	<b>43</b>
<b>KNB-56N (Ni-MH Battery Pack)</b> .....	<b>43</b>
<b>KNB-57L (Li-ion Battery Pack)</b> .....	<b>43</b>
<b>SPECIFICATIONS</b> .....	<b>BACK COVER</b>

# TK-2360

## Document Copyrights

Copyright 2010 by Kenwood Corporation. All rights reserved.

No part of this manual may be reproduced, translated, distributed, or transmitted in any form or by any means, electronic, mechanical, photocopying, recording, or otherwise, for any purpose without the prior written permission of Kenwood.

## Disclaimer

While every precaution has been taken in the preparation of this manual, Kenwood assumes no responsibility for errors or omissions. Neither is any liability assumed for damages resulting from the use of the information contained herein. Kenwood reserves the right to make changes to any products herein at any time for improvement purposes.

## Firmware Copyrights

The title to and ownership of copyrights for firmware embedded in Kenwood product memories are reserved for Kenwood Corporation. Any modifying, reverse engineering, copy, reproducing or disclosing on an Internet website of the firmware is strictly prohibited without prior written consent of Kenwood Corporation. Furthermore, any reselling, assigning or transferring of the firmware is also strictly prohibited without embedding the firmware in Kenwood product memories.

# GENERAL

## INTRODUCTION

### SCOPE OF THIS MANUAL

This manual is intended for use by experienced technicians familiar with similar types of commercial grade communications equipment. It contains all required service information for the equipment and is current as of the publication date. Changes which may occur after publication are covered by either Service Bulletins or Manual Revisions. These are issued as required.

## ORDERING REPLACEMENT PARTS

When ordering replacement parts or equipment information, the full part identification number should be included. This applies to all parts : components, kits, or chassis. If the part number is not known, include the chassis or kit number of which it is a part, and a sufficient description of the required component for proper identification.

## PERSONAL SAFETY

The following precautions are recommended for personal safety:

- DO NOT transmit until all RF connectors are verified secure and any open connectors are properly terminated.
- SHUT OFF and DO NOT operate this equipment near electrical blasting caps or in an explosive atmosphere.
- This equipment should be serviced by a qualified technician only.

## SERVICE

This transceiver is designed for easy servicing. Refer to the schematic diagrams, printed circuit board views, and alignment procedures contained within.

Model	Type	TX-RX unit	Frequency range	Remarks
TK-2360	E	X57-7782-71	136~174MHz	IF1: 49.95MHz LOC: 50.4MHz

## SYSTEM SET-UP

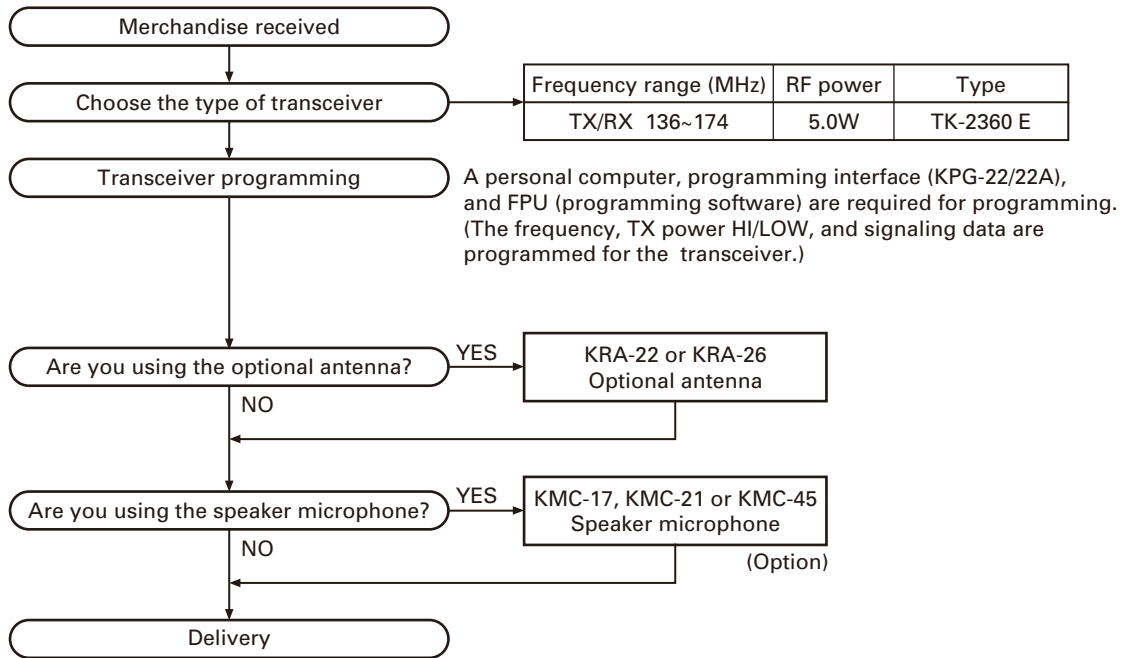

## REALIGNMENT

### 1. Modes

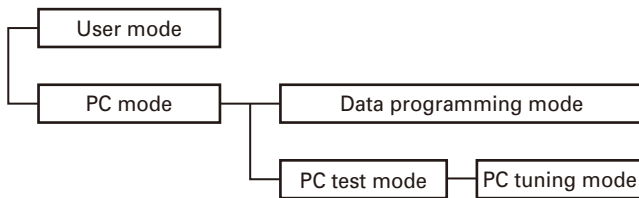

Mode	Function
User mode	For normal use.
PC mode	Used for communication between the transceiver and PC.
Data programming mode	Used to read and write frequency data and other features to and from the transceiver.
PC test mode	Used to check the transceiver using the PC. This feature is included in the FPU.

### 2. How to Enter Each Mode

Mode	Operation
User mode	Power ON
PC mode	Received commands from PC

### 3. PC Mode

#### 3-1. Preface

The transceiver is programmed by using a personal computer, a programming interface (KPG-22/22A, USB adapter (KCT-53U)) and FPU (programming software).

The programming software can be used with a PC or compatible. Figure 1 shows the setup of a PC for programming.

#### 3-2. Connection Procedure

1. Connect the transceiver to the personal computer with the interface cable and USB adapter (when the interface cable is KPG-22A, the KCT-53U can be used).

## REALIGNMENT

**Note:**

- You must install the KCT-53U driver in the computer to use the USB adapter (KCT-53U).
  - When using the USB adapter (KCT-53U) for the first time, plug the KCT-53U into a USB port on the computer with the computer power ON.
2. When the POWER is switched on, user mode can be entered immediately. When the PC sends a command, the transceiver enters PC mode. When data is read from the transceiver, the red LED lights. When data is written to by the transceiver, the green LED lights.

**Note:**

- The data stored in the personal computer must match Model Name and Model Type when it is written into EEPROM.
- Do not press the [PTT] key during data transmission or reception.

### 3-3. KPG-22/KPG-22A Description

**(PC programming interface cable: Option)**

The KPG-22/22A is required to interface the transceiver with the computer. It has a circuit in its D-sub connector (KPG-22: 25-pin, KPG-22A: 9-pin) case that converts the RS-232C logic level to the TTL level.

The KPG-22/22A connects the SP/MIC connector of the transceiver to the RS-232C serial port of the computer.

### 3-4. KCT-53U Description (USB adapter: Option)

The KCT-53U is a cable which connects the KPG-22A to a USB port on a computer.

When using the KCT-53U, install the supplied CD-ROM (with driver software) in the computer. The KCT-53U driver runs under Windows 2000, XP or Vista (32-bit).

### 3-5. FPU (Programming Software) Description

The FPU is the programming software for the transceiver supplied on a CD-ROM. This software runs under windows XP, Vista or 7 on a PC. The software on this disk allows a user to program the transceiver transceivers via Programming interface cable (KPG-22/22A).

### 3-6. Programming with PC

If data is transferred to the transceiver from a PC with the FPU, the data for each set can be modified.

Data can be programmed into the EEPROM in RS-232C format via the SP/MIC jack.

In this mode the PTT line operate as TXD and RXD data lines respectively.

**List of FPU for transceiver**

Model	Type	FPU
TK-2360	E	KPG-128D (ver. 1.10 or later)

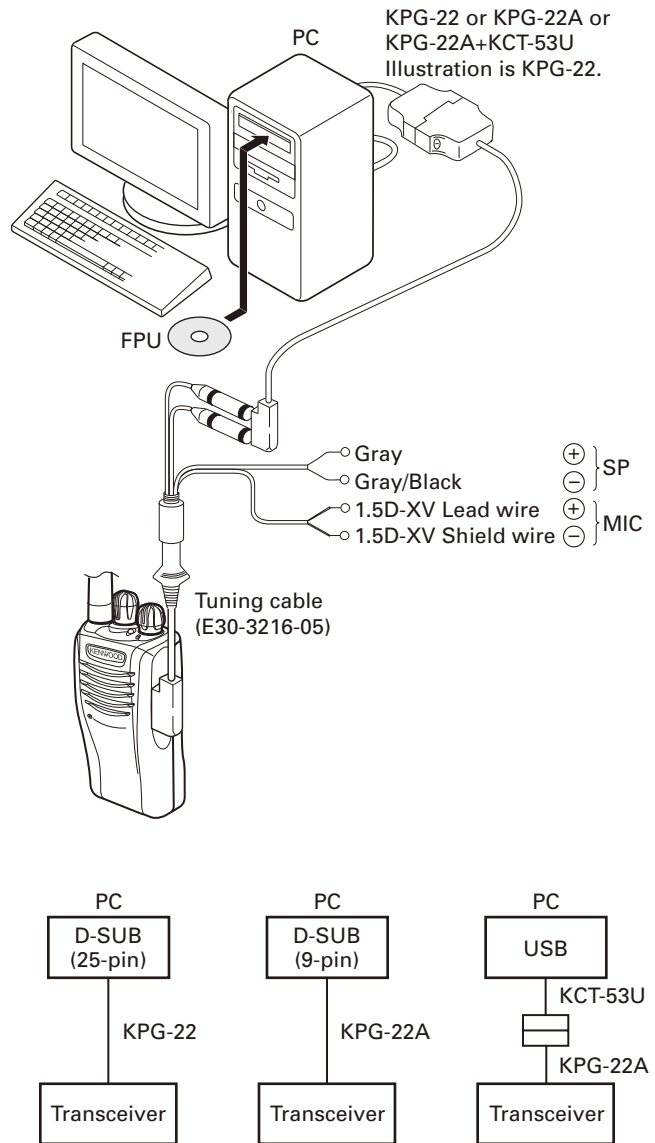
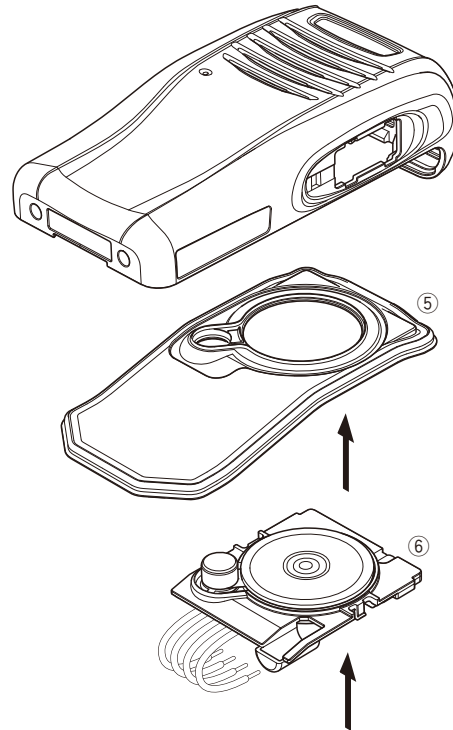
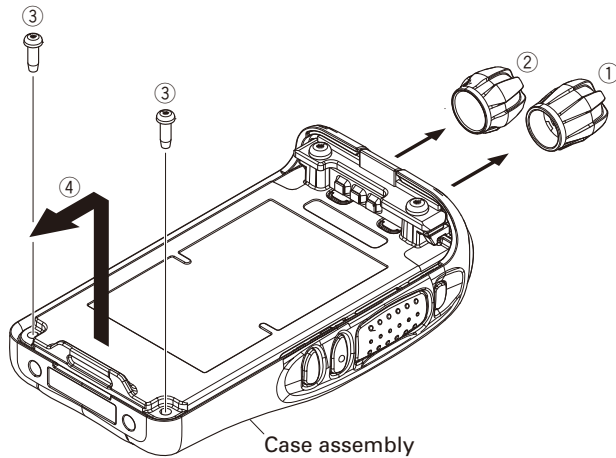

**Fig. 1**

## DISASSEMBLY FOR REPAIR

### 1. Removing the Case Assembly from the Chassis

1. Remove the selector knob ① and volume knob ②.
2. Remove the two screws ③.
3. Lift and remove the chassis from the case assembly ④.



### 2. Removing the TX-RX unit from the Chassis

1. Remove the packing ⑤ from the chassis.
2. Remove the holder ⑥ from the chassis.
3. Detach the solder of speaker wire and mic wire from the PCB beforehand.
4. Remove the packing ⑦ from the SP/MIC jack of the TX-RX unit.
5. Remove the FPC from the flat cable connectors ⑧ ⑨.
6. Remove the 13 screws ⑩ fixing the TX-RX unit.
- Note:** Take care not to put stress onto the FPC when removing the screw, as the FPC is sitting on the screw.
7. Lift and remove the TX-RX unit from the chassis ⑪.

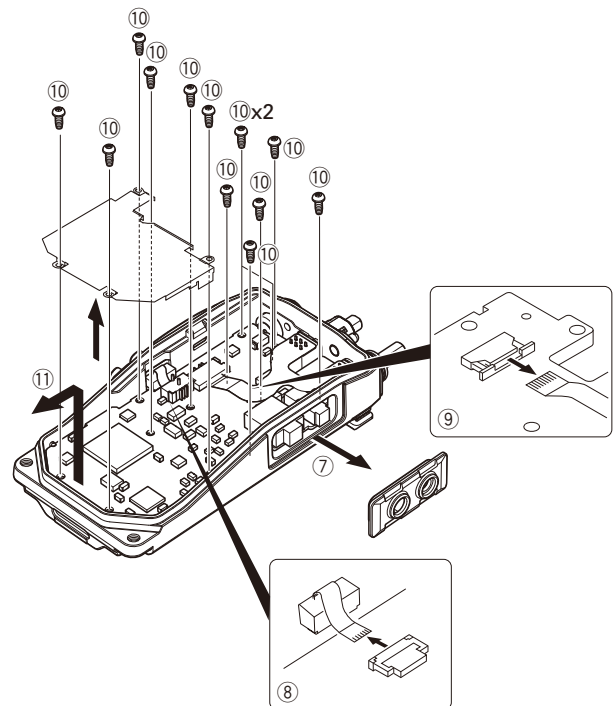

## DISASSEMBLY FOR REPAIR

### 3. Mounting the Chassis to the Case

#### Assembly

1. Mount the holder ① to the chassis ②.  
Confirm that the holder is securely locked to the chassis.
2. Insert the packing ③ to the phone jack side of the chassis.  
Confirm the mounting direction of packing.  
Confirm that the packing is securely inserted to the chassis and SP/MIC jack.
3. Insert the packing ④ to the chassis.  
Confirm that the packing is securely inserted to the chassis and that it does not protrude out.
4. Insert the upper part of the chassis into the case assembly ⑤.
5. Press the chassis and the case assembly together to attach them.

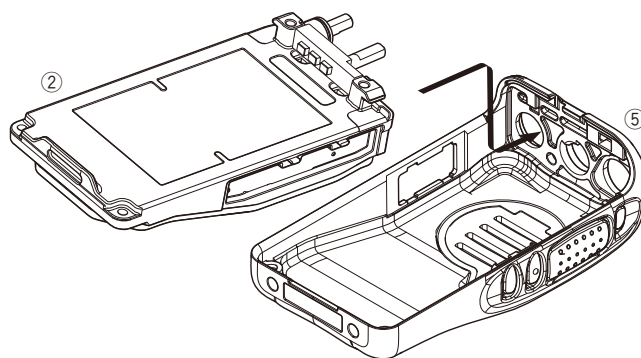
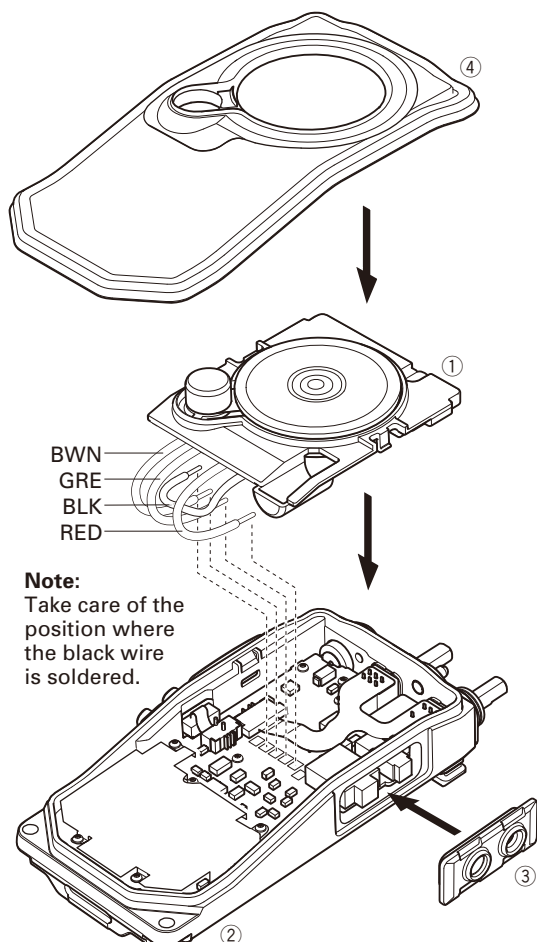

### 4. Attaching the Antenna Receptacle to the Chassis

Screw the antenna receptacle to the chassis in the order shown in the drawing so that the antenna receptacle comes to the center of the case hole.

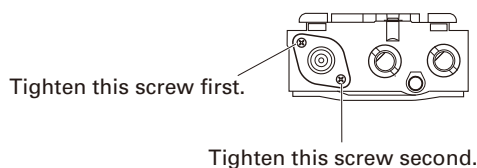

### 5. The Nuts of the Volume Knob and Selector Knob

Note that the shapes and heights of nuts of the volume knob and selector knob are different from one another. Use the following jig when removing the nuts of the volume knob and selector knob.

- Jig (Part No.: W05-1012-00)

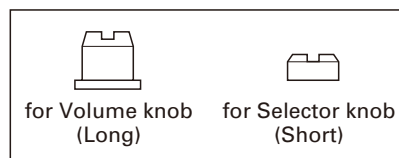

# CIRCUIT DESCRIPTION

## 1. Overview

The TK-2360 is a VHF portable transceiver designed to operate in the frequency range of 136~174MHz. The unit consists of a receiver, transmitter, phase-locked loop (PLL) frequency synthesizer, base band parts, power supply and control circuits.

## 2. Frequency Configuration

The receiver utilizes double conversion. The first IF is 49.95MHz and the second IF is 450kHz. The first Local oscillator is supplied from the PLL circuit.

The PLL circuit in the transmitter generates the necessary frequencies.

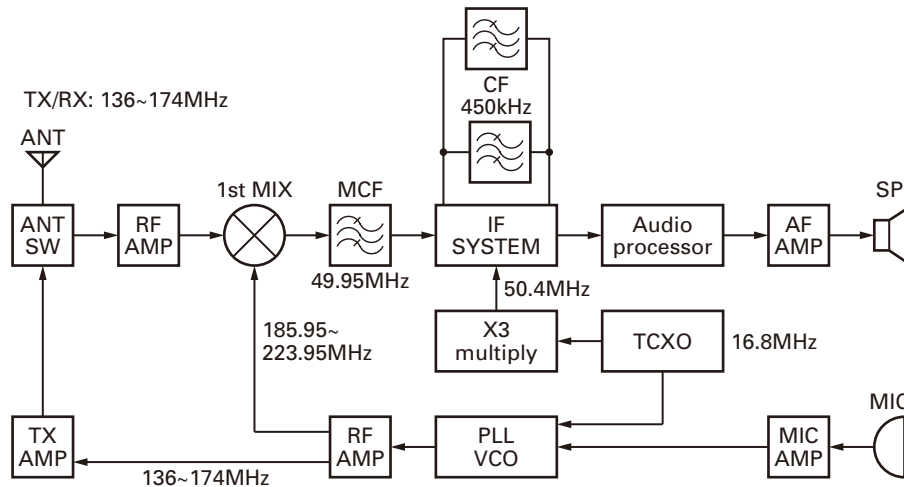

Fig. 1 Frequency configuration

## 3. Receiver System

The receiver system is shown in Figure 2.

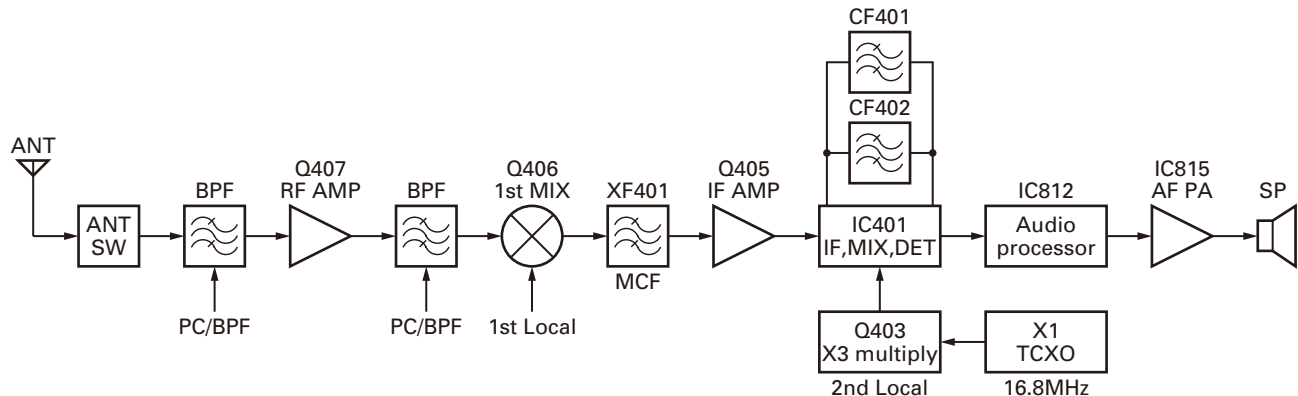

Fig. 2 Receiver system

### 3-1. Front End (RF Amplifier) Circuit

The signal coming from the antenna passes through the transmit/receive switching diode circuit (D201, D202, D203 and D204) and a BPF (L418 and L419), and is then amplified by the RF amplifier (Q407).

The resulting signal passes through a BPF (L414 and L416) and goes to the mixer. These BPFs are adjusted by variable capacitors (D404, D405, D407 and D408). The input voltage to the variable capacitor is a regulated voltage output from the DC amplifier (IC811).

### 3-2. First Mixer

The signal from the front end is mixed with the first local oscillator signal generated in the PLL circuit by Q406 to produce a first IF frequency of 49.95 MHz.

The resulting signal passes through the XF401 MCF to cut the adjacent spurious and provide the optimum characteristics, such as adjacent frequency selectivity.

## CIRCUIT DESCRIPTION

### 3-3. IF Amplifier Circuit

The first IF signal is passed through a four-pole monolithic crystal filter (XF401) to remove the adjacent channel signal. The filtered first IF signal is amplified by the first IF amplifier (Q405) and is then applied to the IF system IC (IC401).

The IF system IC provides a second mixer, limiting amplifier, quadrature detector and RSSI (Received Signal Strength Indicator). The second mixer mixes the first IF signal with the 50.4MHz signal of the second local oscillator output (Q403) and produces the second IF signal of 450kHz.

The second IF signal is passed through the ceramic filter (Wide: CF402, Narrow: CF401) to remove the adjacent channel signal. The filtered second IF signal is amplified by the limiting amplifier and demodulated by the quadrature detector with the ceramic discriminator (CD401). The demodulated signal is routed to the audio circuit.

### 3-4. Wide/Narrow Switching Circuit

Wide and Narrow settings can be made for each channel by switching the ceramic filters CF402 (Wide), CF401 (Narrow). The Wide and Narrow switching data is output from IC809.

D401 and D402 are switched to ceramic filters when a Wide/Narrow level is selected.

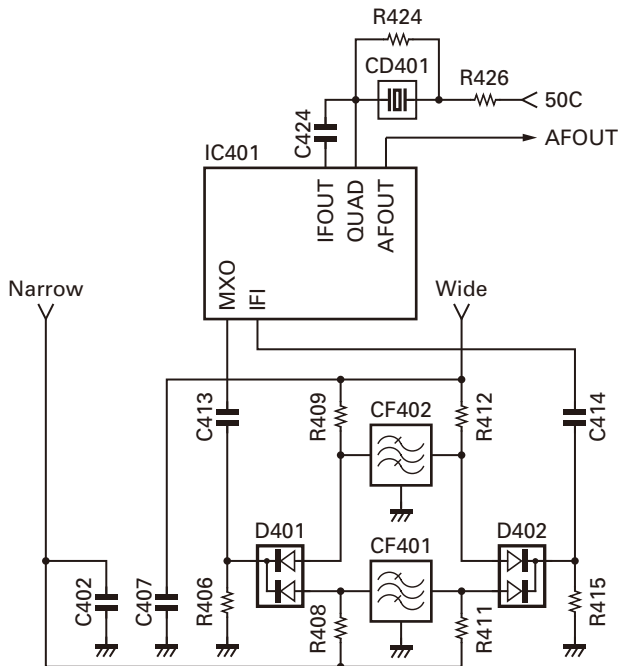

Fig. 3 Wide/Narrow switching circuit

### 3-5. Audio Amplifier Circuit

The demodulated signal from IC401 is sent to an AF amplifier through IC812, and is routed to an audio power amplifier (IC815) where it is amplified and output to the speaker.

### 3-6. Squelch Circuit

Part of the AF signal from the IC401 enters the FM IC (IC401) again, and the noise component is amplified and rectified by a filter and an amplifier to produce a DC voltage corresponding to the noise level.

The DC signal from the FM IC goes to the analog port of the MCU (IC809). IC809 determines whether or not to output sounds from the speaker by checking if the input voltage is higher or lower than the preset value.

To output sounds from the speaker, IC809 sends a high signal to the AFSW line and turns IC815 on through Q813, Q814, Q818 and Q819.

## 4. Transmitter System

### 4-1. Microphone Amplifier Circuit

The signal from the microphone is limited by the AGC circuit, which is composed of D807, 808, Q810, Q811 and the mute switch (Q809). IC812 is composed of a high-pass filter, low-pass filter and pre-emphasis/IDC circuit.

The signal from the microphone and the low speed data from the MCU (IC809) enter the Audio processor IC (IC812) and pass through each path and are mixed inside the IC.

The output signal from the audio processor goes to the VCO modulation input. The other output signal passes through the amplifier (IC3) and goes to the TCXO modulation input.

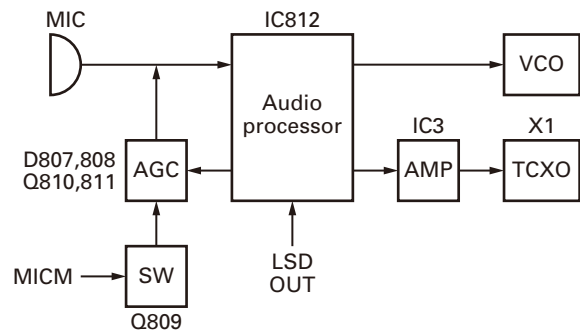

Fig. 4 Microphone amplifier circuit



## CIRCUIT DESCRIPTION

### 4-2. Driver and Final Amplifier Circuit

The signal from the T/R switch (D18 is on) is amplified by the RF AMP (Q201) and pre-drive amplifier (Q203) to 50mW.

The output of the pre-drive amplifier is amplified by the drive amplifier (Q204) and the RF final amplifier (Q205) to 5.0W (1W when the power is low).

The drive amplifier and the RF final amplifier consist of two MOS FET stages.

The output of the RF final amplifier is then passed through the harmonic filter (LPF) and antenna switch (D201 and D202) and is applied to the antenna terminal.

### 4-3. APC Circuit

The APC circuit always monitors the current flowing through the drive amplifier (Q204) and the RF power amplifier (Q205) and keeps a constant current. The voltage drop at R307, R309 and R310 is caused by the current flowing through the RF final amplifier. This voltage is applied to the differential amplifier IC301 (1/2).

IC301 (2/2) compares the output voltage of IC301 (1/2) with the reference voltage from IC811. The output of IC301 (2/2) controls the VG of the RF power amplifier and the drive amplifier to make both voltages the same.

The change of power high/low is carried out by the change of the reference voltage.

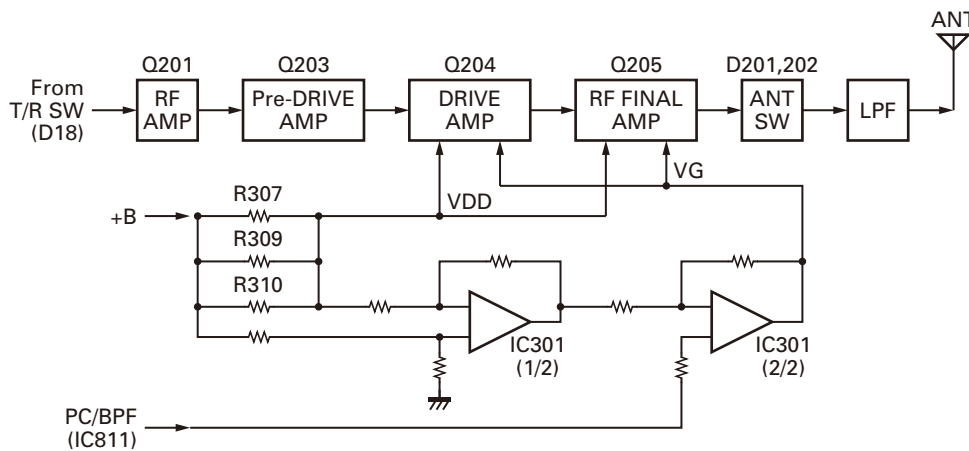

Fig. 5 Driver and final amplifier and APC circuit

## 5. Frequency Synthesizer Unit

### 5-1. Frequency synthesizer

The frequency synthesizer consists of the TCXO (X1), VCO, PLL-IC (IC1), and buffer amplifiers.

The TCXO generates 16.8MHz. The frequency stability is 1.5ppm within the temperature range of  $-30^{\circ}\text{C}$  to  $+60^{\circ}\text{C}$ . The frequency tuning and modulation of the TCXO are done to apply voltage to pin 1 of the TCXO. The output of the TCXO is applied to pin 10 of PLL-IC.

The VCO consists of 2 VCOs and covers a dual range of 185.95~223.95MHz and 136~174MHz. The VCO generates 185.95~223.95MHz for providing the first local signal for reception. The operating frequency is generated by Q5 in transmitting mode and Q4 in receiving mode. The oscillation frequency is controlled by applying the VCO control voltage, obtained from the phase comparator (IC1) to the variable capacitance diodes (D6, D7, D8, and D9 in transmitting mode and D3 and D5 in receiving mode)

The TX pin of IC809 goes "high" in transmitting mode, causing Q7 and Q4 to turn off, and Q5 turn on. The TX pin goes "low" in receiving mode.

The output from Q4 and Q5 are amplified by a buffer amplifier (Q8) and Q2, and then sent to the PLL-IC.

The PLL-IC consists of a prescaler, reference divider, phase comparator, and charge pump. The input signal from pin 10 and 17 of the PLL-IC is divided down and compared at the phase comparator. The pulsed output signal of the phase comparator is applied to the charge pump and transformed into a DC signal in the loop filter (LPF). The DC signal is applied to the CV of the VCO and locked to keep the VCO frequency constant.

PLL data is output from PLLLE (pin 46), PLLCLK (pin 47), and PLLDAT (pin 45) of the MCU (IC809). The data is input to the PLL-IC when the channel is changed or transmission is changed to reception and vice versa. The PLL lock condition is always monitored by pin 48 (PLLLD) of the MCU. When the PLL is unlocked, PLLLD goes low.

## CIRCUIT DESCRIPTION

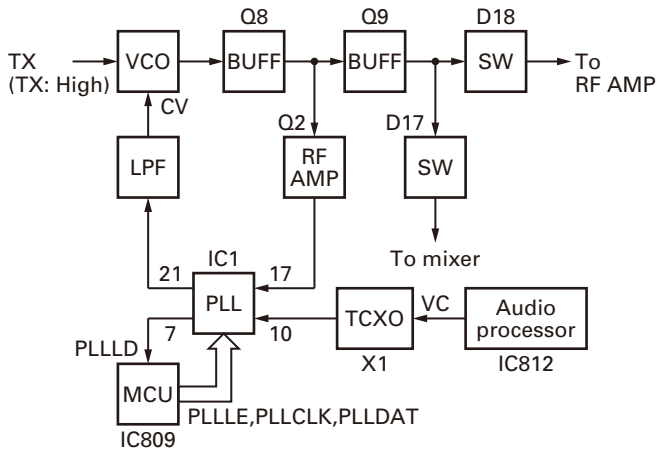

Fig. 6 PLL block diagram

### 6. Control Circuit

The control consists of the MCU (IC809) and its peripheral circuits. It controls the TX-RX unit. IC809 mainly performs the following;

- 1) Switching between transmission and reception by PTT signal input.
- 2) Reading channel information, frequency, and program data from the memory circuit.
- 3) Sending frequency program data to the PLL.
- 4) Controlling squelch on/off via the DC voltage from the squelch circuit.
- 5) Controlling the audio mute circuit via the decode data input.
- 6) Transmitting tone and encode data.

#### 6-1. Frequency Shift Circuit

The MCU (IC809) operates at a clock frequency of 12.0MHz. This oscillator has a circuit that shifts the frequency via Beat shift switch (Q806, Q807).

A beat sound may be able to be evaded form generation if "Beat Shift" is set to ON when it is generated in the internal spurious transmission modulated sound of the transceiver.

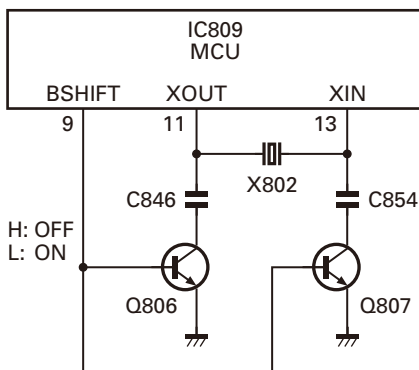

Fig. 7 Frequency shift circuit

#### 6-2. Memory Circuit

The Memory circuit consists of the MCU (IC809) and EEPROM (IC810). The EEPROM has a capacity of 64k bits and stores the channel information, the last channel data, the scan on status, and other parameters.

#### ■ EEPROM

##### Note:

The EEPROM stores tuning data (Deviation, Squelch, etc.).

Realign the transceiver after replacing the EEPROM.

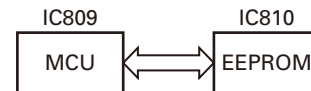

Fig. 8 Memory circuit

#### 6-3. Low Battery Warning

The battery voltage is monitored by the MCU (IC809 pin 86: BATT). When the battery voltage falls below the voltage set by the Low Battery Warning adjustment, the red LED blinks, notifying the operator that it is time to replace the battery (when the always option (default setting) under the Battery Warning function in the FPU is selected). If the battery voltage falls below 5.9V, the transceiver does not transmit and the warning tone beeps while the PTT switch is pressed.

Low battery warning	Battery status
The red LED blinks during transmission.	The battery voltage is low but the transceiver is still usable.
The red LED blinks and the warning tone beeps while the PTT switch is pressed.	The battery voltage is low and the transceiver cannot be used to make calls.

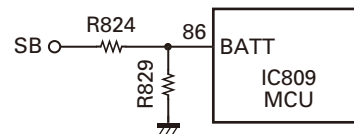

Fig. 9 Low battery warning

#### 6-4. Battery Type Detection

The transceiver automatically detects the battery type, measuring the resistance between the S-terminal and +terminal on the battery pack and changes the supplied voltage to the S-terminal as below. The MCU then detects the battery type.

Resistor value	Battery type	Input voltage of S-terminal
1.8MΩ	Li-ion	0.3~1.5V
220kΩ	Ni-MH	2.9~5.5V
OPEN	Battery case	0~0.3V

## CIRCUIT DESCRIPTION

### 6-5. Key Input

Keys and channel selector circuit.

The signal from the keys and channel selector are directly input to the MCU, as shown in Figure 10.

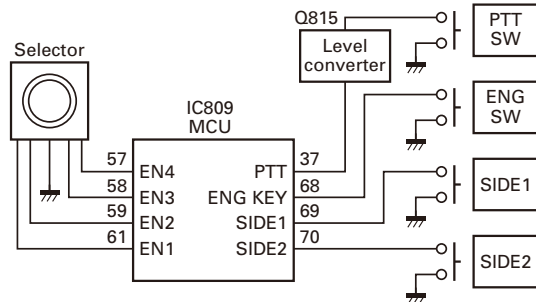

Fig. 10 Key input

## 7. Signaling Circuit

### 7-1. Encode

#### ■ Low-speed data (QT, DQT)

Low-speed data is output from pin 24 of the MCU. The signal passes through the low pass CR filter, and goes to the audio processor (IC812). The signal is mixed with the audio signal and goes to the VCO and TCXO (X1) modulation input after passing through the D/A converter inside the audio processor (IC812) for BAL adjustment.

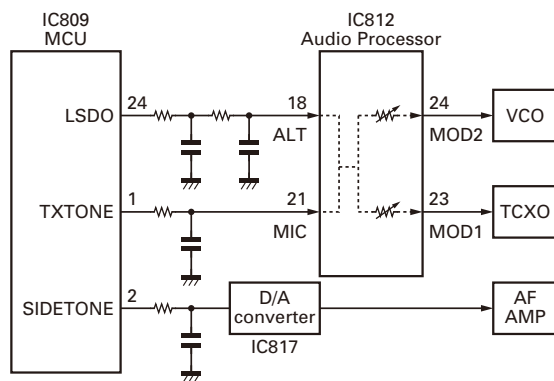

Fig. 11 Encode

#### ■ High-speed data (5-tone, DTMF)

High-speed data (HSD) is output from pin 1 of the MCU. HSD deviation made by an adjustment in the MCU is passed through the low pass CR filter and then applied to the audio processor (IC812).

The signal is mixed with the audio signal and goes to the VCO and TCXO. The side tone is output from Pin 2 of the MCU. The signal passes through low pass CR filter and D/A converter, and goes to the audio power amplifier. The level is controlled by the MCU.

#### ■ MSK

The MSK signal is generated in the audio processor (IC812). The signal passes through the D/A converter (inside

the audio processor: IC812) and is routed to the VCO. When encoding the MSK, the microphone input signal is muted.

### 7-2. Dcode

#### ■ QT/DQT

The output signal from the IF IC (IC401) enters the MCU (IC809) through IC812. IC809 determines whether or not the QT or DQT matches the preset value, and controls the AFSW and speaker output sounds according to the squelch results.

#### ■ 5-tone

Part of the received AF signal output from the IF IC (IC401) passes through an audio processor (IC812) goes to the other AF amplifier IC808 and 816, is compared, and then goes to IC809. IC809 checks whether or not the 2-tone data is necessary. If it matches, IC809 carries out a specified operation, such as turning the speaker on.

#### ■ MSK (Fleet Sync)

The MSK input signal from the IF IC (IC401) goes to IC812. The decoded information is then processed by the MCU.

#### ■ DTMF

The DTMF input signal from the IF IC (IC401) goes to IC812. The decoded information is then processed by the MCU.

## 8. Power Supply

There are five 5V power supplies and three 3.3V power supplies: 50M, 50V, 50C, 50R, 50T, 33M, 33MSC and 33BC.

50M and 33M are always output while the power is on. 33MS is always output, but turns off when the power is turned off, to prevent malfunction of the MCU.

50C is a common 5V and is output when SAVE is not set to ON.

50R is 5V for reception and output during reception.

50T is 5V for transmission and output during transmission.

50V is 5V for the SP/MIC connector.

33B is 3.3V for the audio processor (IC812).

## 9. Motion Detector

The emergency function uses a triaxial acceleration sensor (IC813).

MCU determines the Man-down, Stationary and Motion status via the acceleration sensor and the SPI method of data communication.

Using the FPU settings, you can activate Emergency status from amongst the three operations.



Fig. 12 Motion detector circuit

## SEMICONDUCTOR DATA

## MCU: F3640MDFBKDKA (TX-RX unit: IC809)

Pin No.	Signal Name	I/O	Function
1	TXTONE	O	N tone/DTMF/emergency tone output
2	SIDETONE	O	N tone/DTMF/voice/beep output
3	WIDE	O	Wide switch
4	NARROW	O	Narrow switch
5	HSDI	I	HSD input
6	BYTE	I	Single chip mode
7	CNVSS	I	Single chip mode
8	NC	-	NC
9	BSFT	O	Beat shift for CPU clock
10	RESET	I	Reset signal input
11	XOUT	O	Oscillation circuit
12	VSS	-	GND
13	XIN	I	Oscillation circuit
14	VCC1	-	Power supply
15	NMI/SD	O	NC
16	INT	I	INT signal input
17	VOXM	O	VOX mute
18	BBIRQ	I	IRQ from base band IC
19	BBCS	O	Chip select for base band IC
20	BBRXD	I	RXD from base band IC
21	BBCLK	O	Clock for base band IC
22	BBTXD	O	TXD for base band IC
23	VOXSW	O	VOX switch
24	LSDO	O	Low speed data output
25	EEPRXD	I	Data input from EEPROM
26	EEPCS	O	Chip select for EEPROM
27	NC	-	NC
28	NC	-	NC
29	TXD1	O	For onboard writing/TXD for 2pin jack
30	RXD1	I	For onboard writing/RXD for 2pin jack
31	CLK1	O	For onboard writing
32	BUSY	O	For onboard writing
33	NC	-	NC
34	NC	-	NC
35	EEPTXD	O	Data output for EEPROM
36	EEPCLK	O	Clock for EEPROM
37	PTT	I	PTT key input
38	OPTDET	I	2pin option detection
39	EPM	I	For onboard writing
40	MDSW	I	External connection terminal of man down switch
41	EXTMICSW	O	External MIC compulsion ON switch

Pin No.	Signal Name	I/O	Function
42	TX	O	Tx VCO switch/fin filter
43	DACCE	O	Chip enable for DAC IC
44	CE	I	For onboard writing
45	PLLDAT	O	Data for PLL IC & DAC IC
46	PLLE	O	Load enable for PLL IC
47	PLLCLK	O	Clock for PLL IC & DAC IC
48	PLLLD	I	Lock detect signal from PLL IC
49	33BC	O	33B control
50	33MSC	O	33MS control
51	50VC	O	50V control
52	50TC	O	50T control
53	50RC	O	50R control (SAVE)
54	50CC	O	50C control (SAVE)
55	AFSW	O	Power switch for AF amp
56	PDSW	-	NC
57	EN4	I	Encoder input 4
58	EN3	I	Encoder input 3
59	EN2	I	Encoder input 2
60	VCC2	-	Power supply
61	EN1	I	Encoder input 1
62	VSS	-	GND
63	LEDR	O	Red LED
64	LEDG	O	Green LED
65	LEDB	O	Blue LED
66	APCSW	O	APC switch
67	DCSW	O	Discharge switch
68	EMGKEY	I	Emergency key input
69	SIDE1	I	Side 1 key input
70	SIDE2	I	Side 2 key input
71	MICM	O	MIC mute
72	MDINT	I	INT from Motion sensor IC
73	NC	-	NC
74	MDCS	O	Chip select for Motion sensor IC
75	MDRXD	I	RXD from Motion sensor IC
76	MDTXD	O	TXD for Motion sensor IC
77	MDCLK	O	CLK for Motion sensor IC
78	NC	-	NC
79	CVIN	I	NC
80	TMP	I	Temperature detection
81	VOLIN	I	AF volume level
82	VOX	I	VOX signal input
83	ASQL	I	Analog squelch input
84	RSSI	I	RSSI input
85	LSDI	I	LSD input
86	BATT	I	Battery voltage check

## SEMICONDUCTOR DATA

Pin No.	Signal Name	I/O	Function
87	NC	-	NC
88	NC	-	NC
89	NC	-	NC
90	NC	-	NC
91	BSEL	I	Battery detection
92	NC	-	NC
93	NC	-	NC

Pin No.	Signal Name	I/O	Function
94	AVSS	-	GND
95	HSDI2	I	DTMF detect
96	VREF	I	Reference voltage input
97	AVCC	-	Power supply
98	NC	-	NC
99	SIM1	I	Destination selection 1
100	SIM2	I	Destination selection 2

## TERMINAL FUNCTION

## TX-RX unit (X57-7782-71)

Pin No.	Name	I/O	Function
<b>CN801</b>			
1	VOL IN	I	Audio input
2	33MS	-	33MS
3	SB	-	Switched B
4	SB	-	Switched B
5	+B	-	B (Battery Voltage)
6	+B	-	B (Battery Voltage)
7	EN2	I	Encoder pulse input
8	EN4	I	Encoder pulse input
9	GND	-	GND
10	EN3	I	Encoder pulse input
11	EN1	I	Encoder pulse input

Pin No.	Name	I/O	Function
<b>CN802</b>			
1	GND	O	GND
2	EMGKEY	O	EMG key output
3	PTT/RXD	O	PTT/RXD key output
4	SIDE1	O	SIDE1 key output
5	SIDE2	O	SIDE2 key output
6	GND	O	GND
<b>CN803</b>			
1	GND	I	GND
2	EMGKEY	I	EMG key input
3	PTT/RXD	I	PTT/RXD key input
4	SIDE1	I	SIDE1 key input
5	SIDE2	I	SIDE2 key input
6	GND	I	GND

## COMPONENTS DESCRIPTION

## TX-RX unit (X57-7782-71)

Ref. No.	Part Name	Description
IC1	IC	PLL system
IC3	IC	AF AMP
IC301	IC	Comparator (APC)
IC401	IC	FM IF system
IC801~803	IC	Voltage regulator/5V
IC804	IC	Voltage regulator/3.3V
IC805	IC	Voltage detector/INT
IC806	IC	Voltage rerulator/3.3V
IC807	IC	Voltage detector/RESET
IC808	IC	AF AMP
IC809	IC	MCU
IC810	IC	EEPROM
IC811	IC	DC AMP
IC812	IC	Base band IC
IC813	IC	Motion sensor
IC814	IC	VOX AMP
IC815	IC	AF AMP
IC816	IC	HPF
IC817	IC	Electrical volume
Q2	Transistor	Doubler
Q3	Transistor	Ripple filter
Q4	FET	VCO/RX
Q5	FET	VCO/TX
Q6,7	FET	TX/RX switch
Q8	Transistor	RF buffer AMP
Q9,201	Transistor	RF AMP
Q203	Transistor	Pre drive AMP
Q204	FET	Drive AMP
Q205	FET	FINAL AMP
Q301	Transistor	DC switch
Q303	FET	DC switch
Q304	Transistor	DC switch
Q305	FET	DC switch
Q306	Transistor	DC switch
Q403	Transistor	Tripler
Q405	Transistor	IF AMP
Q406	FET	Mixer
Q407	FET	RF AMP
Q801~805	FET	DC switch
Q806,807	Transistor	Switch
Q808	FET	VOX AMP
Q809~811	Transistor	AGC
Q812	FET	VOX switch
Q813,814	Transistor	DC switch

Ref. No.	Part Name	Description
Q815,816	FET	Level converter
Q817	Transistor	DC switch
Q818,819	FET	MUTE switch
Q820	Transistor	DC switch
D3,5	Variable capaci- tance diode	Frequency control/RX VCO
D6~9	Variable capaci- tance diode	Frequency control/TX VCO
D10	Variable capaci- tance diode	Frequency control/RX VCO
D11	Variable capaci- tance diode	Frequency control/TX VCO
D12	Variable capaci- tance diode	Modulator /TX VCO
D13	Diode	Ripple filter
D14,15	Diode	VCO Speed up
D17,18	Diode	TX/RX RF switch
D201~204	Diode	ANT switch
D301	Zenor Diode	Protect
D401,402	Diode	W/N switch
D404,405 D407,408	Variable capaci- tance diode	BPF tuning
D801	LED	LED/blue
D802,803	Diode	Protect
D804	LED	LED/green
D805	LED	LED/red
D806	Zenor Diode	Protect
D807~810	Diode	Current steering

## PARTS LIST

\* New Parts. Δ indicates safety critical components.

Parts without **Parts No.** are not supplied.

Les articles non mentionnés dans le **Parts No.** ne sont pas fournis.

Teile ohne **Parts No.** werden nicht geliefert.

L : Scandinavia

Y : PX (Far East, Hawaii)

C : China

K : USA

T : England

X : Australia

P : Canada

E : Europe

M : Other Areas

TK-2360

TX-RX UNIT (X57-7782-71)

Ref. No.	Address	New parts	Parts No.	Description	Desti-nation
<b>TK-2360</b>					
1	1A		A02-4087-03	PLASTIC CABINET ASSY	
2	3A		A10-4133-01	CHASSIS	
4	3B		B01-0694-13	ESCUTCHEON	
5	1D		B09-0686-03	CAP	
6	1B		B11-1869-04	ILLUMINATION GUIDE	
			B43-1633-04	BADGE	
8	2C		B62-2210-00	INSTRUCTION MANUAL	
12	1D		D32-0449-04	STOPPER (4CH.WHITE) ACCESSORY	
13	2D		D32-0450-04	STOPPER (8CH.GRAY) ACCESSORY	
14	2D		D32-0451-04	STOPPER (12CH.BLACK) ACCESSORY	
16	3B		E04-0467-15	RF COAXIAL RECEPTACLE (SMA)	
17	3B		E23-1345-04	TERMINAL ASSY (ANT)	
18	2B		E37-1165-15	PROCESSED LEAD WIRE (SP.RED)	
19	2B		E37-1166-15	PROCESSED LEAD WIRE (SP.BLACK)	
20	2B		E37-1511-05	PROCESSED LEAD WIRE (ECM.GR)	
22	2B		E37-1512-05	PROCESSED LEAD WIRE (ECM.BR)	
23	3B		E72-0433-03	TERMINAL BLOCK	
24	2A		F10-3128-03	SHIELDING COVER	
25	1A		G10-1324-04	FIBROUS SHEET (CABINET)	
27	2B		G11-4272-14	RUBBER CUSHION	
28	3A		G11-4315-14	SHEET (SP)	
29	1B		G11-4351-04	SHEET (COOLING)	
30	3A		G11-4488-04	SHEET (CABI-TOPG)	
31	1B		G11-4527-04	SHEET (PTT)	
33	3A		G13-2038-24	CUSHION (CERAFIL)	
34	3A		G13-2287-04	CUSHION (CHASS,ANT)	
35	3B		G53-1603-04	PACKING (ANT)	
36	2A		G53-1830-02	PACKING (CHASSIS)	
37	1B		G53-1831-02	PACKING (TOP)	
39	3B		G53-1832-03	PACKING (JACK)	
40	3B		G53-1833-04	PACKING (TERMINAL)	
45	1D		J19-5483-23	HOLDER ACCESSORY	
46	2B		J19-5533-02	HOLDER (SP)	
47	1D		J29-0701-15	BELT CLIP ACCESSORY	
48	3A		J87-0027-05	FPC (LEAD FREE) (PTT)	
49	2B		J87-0038-05	FPC (LEAD FREE) (VOL/SELECT)	
51	1B		K29-9450-03	KNOB (VOL)	
52	1B		K29-9451-03	KNOB (SELECTOR)	
53	1A		K29-9452-03	KNOB (PTT)	
54	1A		K29-9453-03	BUTTON KNOB (SIDE1/SIDE2/AUX)	
A	3B		N09-2438-05	BINDING HEAD SCREW (ANT)	
B	3A		N09-6565-05	PAN HEAD SCREW (CASE)	
C	2B		N14-0851-04	CIRCULAR NUT (SELECTOR)	
D	2B		N14-0858-04	CIRCULAR NUT (VOL)	
E	3A,3B		N30-3006-43	PAN HEAD MACHINE SCREW (ESCUTCHE)	
F	3B		N78-2030-48	PAN HEAD TAPTITE SCREW (TERM-BL)	
G	2A,2B		N83-2005-48	PAN HEAD TAPTITE SCREW (UNIT)	
56	2B		R31-0665-05	VARIABLE RESISTOR (VOL)	
58	2B		S60-0443-05	ROTARY SWITCH (SELECTOR)	

Ref. No.	Address	New parts	Parts No.	Description	Desti-nation
60	2B		T07-0787-05	SPEAKER	
<b>TX-RX UNIT (X57-7782-71)</b>					
D801			B30-1790-05	LED (BLUE)	
D804			B30-2314-05	LED (GREEN)	
D805			B30-2315-05	LED (RED)	
C1			CK73HB1H471K	CHIP C 470PF	K
C3			CC73HCH1H100B	CHIP C 10PF	B
C4			CK73HB1H102K	CHIP C 1000PF	K
C5			CC73HCH1H100B	CHIP C 10PF	B
C7,8			CK73HB1E103K	CHIP C 0.010UF	K
C9-12			CC73HCH1H101J	CHIP C 100PF	J
C14			CK73HB1A473K	CHIP C 0.047UF	K
C15			CK73HB1A224K	CHIP C 0.22UF	K
C16,17			CC73HCH1H101J	CHIP C 100PF	J
C18			CK73HB1E103K	CHIP C 0.010UF	K
C20			CC73HCH1H101J	CHIP C 100PF	J
C21			CK73HB1E103K	CHIP C 0.010UF	K
C23			CS77CA1VR15M	CHIP TNTL 0.15UF	35WV
C24			C92-0588-05	CHIP TNTL 1.5UF	16WV
C25			C92-0872-05	CHIP TNTL 0.068UF	35WV
C27			CK73HB1A224K	CHIP C 0.22UF	K
C29,30			CK73HB1A104K	CHIP C 0.10UF	K
C31			CK73HB1H102K	CHIP C 1000PF	K
C32			CS77CA1A220M	CHIP TNTL 22UF	10WV
C35			CC73HCH1H101J	CHIP C 100PF	J
C36			CK73HB0J105K	CHIP C 1.0UF	K
C41			CC73HCH1H101J	CHIP C 100PF	J
C42			CC73HCH1H470J	CHIP C 47PF	J
C43			CC73HCH1H820J	CHIP C 82PF	J
C44			CC73HCH1H070B	CHIP C 7.0PF	B
C45			CC73HCH1H110J	CHIP C 11PF	J
C46			CC73HCH1H010B	CHIP C 1.0PF	B
C47			CC73HCH1H030B	CHIP C 3.0PF	B
C48			CC73HCH1H130G	CHIP C 13PF	G
C49			CC73HCH1H150G	CHIP C 15PF	G
C50			CC73HCH1H0R5B	CHIP C 0.5PF	B
C51,52			CC73HCH1H060B	CHIP C 6.0PF	B
C53,54			CK73HB1E103K	CHIP C 0.010UF	K
C55			CC73GCH1H0R5B	CHIP C 0.5PF	B
C56			CC73HCH1H0R5B	CHIP C 0.5PF	B
C70			CK73HB1H102K	CHIP C 1000PF	K
C71			CC73HCH1H330J	CHIP C 33PF	J
C72			CC73HCH1H100D	CHIP C 10PF	D
C73			CC73HCH1H150J	CHIP C 15PF	J
C74,75			CK73HB1H102K	CHIP C 1000PF	K
C76			CK73HB1A104K	CHIP C 0.10UF	K
C77			CC73HCH1H180G	CHIP C 18PF	G

## PARTS LIST

## TX-RX UNIT (X57-7782-71)

Ref. No.	Address	New parts	Parts No.	Description	Destination	Ref. No.	Address	New parts	Parts No.	Description	Destination
C80,81			CK73HB1H102K	CHIP C 1000PF K		C308			CC73HCH1H100C	CHIP C 10PF C	
C82			CC73HCH1H100D	CHIP C 10PF D		C309			CK73HB1H471K	CHIP C 470PF K	
C85			CC73HCH1H180J	CHIP C 18PF J		C311			CK73HB1H471K	CHIP C 470PF K	
C87			CC73HCH1H470J	CHIP C 47PF J		C313			CC73HCH1H101J	CHIP C 100PF J	
C91			CC73HCH1H150J	CHIP C 15PF J		C314			CK73HB1H471K	CHIP C 470PF K	
C93			CC73HCH1H150J	CHIP C 15PF J		C315			CK73HB1H102K	CHIP C 1000PF K	
C94			CK73HB1H471K	CHIP C 470PF K		C402-407			CK73HB1A104K	CHIP C 0.10UF K	
C98			CK73HB1H471K	CHIP C 470PF K		C408			CC73HCH1H560J	CHIP C 56PF J	
C99			CK73FB0J106K	CHIP C 10UF K		C409			CK73HB1E103K	CHIP C 0.010UF K	
C201			CC73HCH1H180J	CHIP C 18PF J		C410			CC73HCH1H220J	CHIP C 22PF J	
C203			CK73HB1H102K	CHIP C 1000PF K		C411			CC73HCH1H560J	CHIP C 56PF J	
C204			CK73HB1A104K	CHIP C 0.10UF K		C412			CK73HB1H331K	CHIP C 330PF K	
C205-207			CK73HB1H102K	CHIP C 1000PF K		C413,414			CK73HB1A104K	CHIP C 0.10UF K	
C208			CK73HB1H471K	CHIP C 470PF K		C415			CC73HCH1H470J	CHIP C 47PF J	
C209			CC73HCH1H390J	CHIP C 39PF J		C416			CC73HCH1H680J	CHIP C 68PF J	
C210			CK73HB1A224K	CHIP C 0.22UF K		C417			CK73HB1H331K	CHIP C 330PF K	
C211-213			CK73HB1H102K	CHIP C 1000PF K		C418			CK73HB1A104K	CHIP C 0.10UF K	
C214			CK73HB1A104K	CHIP C 0.10UF K		C419			CC73HCH1H390J	CHIP C 39PF J	
C215			CC73HCH1H220J	CHIP C 22PF J		C420			CK73HB1H182K	CHIP C 1800PF K	
C216,217			CK73HB1H102K	CHIP C 1000PF K		C421			CK73HB1H471K	CHIP C 470PF K	
C218			CC73HCH1H180J	CHIP C 18PF J		C422,423			CK73FB0J106K	CHIP C 10UF K	
C219			CK73HB1H102K	CHIP C 1000PF K		C424			CC73HCH1H820J	CHIP C 82PF J	
C221			CK73HB1H102K	CHIP C 1000PF K		C425			CK73HB1E103K	CHIP C 0.010UF K	
C222			CC73HCH1H101J	CHIP C 100PF J		C426			CK73HB1H102K	CHIP C 1000PF K	
C223-225			CK73HB1H102K	CHIP C 1000PF K		C427			CK73HB1A104K	CHIP C 0.10UF K	
C229,230			CC73HCH1H151J	CHIP C 150PF J		C428			CK73HB1A333K	CHIP C 0.033UF K	
C231,232			CC73GCH1H270J	CHIP C 27PF J		C429			CK73HB1E103K	CHIP C 0.010UF K	
C233			CK73GB1C104K	CHIP C 0.10UF K		C431			CK73HB1A104K	CHIP C 0.10UF K	
C234			CK73GB1E105K	CHIP C 1.0UF K		C432,433			CK73HB1E103K	CHIP C 0.010UF K	
C235			CK73HB1H102K	CHIP C 1000PF K		C434			CK73HB1H102K	CHIP C 1000PF K	
C236			CC73GCH1H330J	CHIP C 33PF J		C435			CK73HB1E103K	CHIP C 0.010UF K	
C237			CC73GCH1H470J	CHIP C 47PF J		C436			CC73HCH1H020B	CHIP C 2.0PF B	
C238			CC73GCH1H040B	CHIP C 4.0PF B		C437			CC73HCH1H220J	CHIP C 22PF J	
C239			CC73GCH1H180J	CHIP C 18PF J		C438			CC73HCH1H010B	CHIP C 1.0PF B	
C240			CK73GB1H102K	CHIP C 1000PF K		C439			CK73HB1E103K	CHIP C 0.010UF K	
C241			CC73GCH1H040B	CHIP C 4.0PF B		C440,441			CK73HB1H102K	CHIP C 1000PF K	
C242			CC73GCH1H050B	CHIP C 5.0PF B		C442			CC73HCH1H120G	CHIP C 12PF G	
C243			CK73GB1H102K	CHIP C 1000PF K		C443			CK73HB1E103K	CHIP C 0.010UF K	
C244			CK73HB1H471K	CHIP C 470PF K		C444			CC73HCH1H020B	CHIP C 2.0PF B	
C245			CC73HCH1H220J	CHIP C 22PF J		C445,446			CC73HCH1H120J	CHIP C 12PF J	
C246			CC73GCH1H180J	CHIP C 18PF J		C447			CC73HCH1H030B	CHIP C 3.0PF B	
C247			CK73GB1H102K	CHIP C 1000PF K		C448			CC73HCH1H050B	CHIP C 5.0PF B	
C248			CC73GCH1H100C	CHIP C 10PF C		C449			CK73HB1E103K	CHIP C 0.010UF K	
C249			CC73GCH1H130G	CHIP C 13PF G		C450			CC73HCH1H010B	CHIP C 1.0PF B	
C250			CC73GCH1H220G	CHIP C 22PF G		C451,452			CK73HB1H102K	CHIP C 1000PF K	
C251			CC73HCH1H150J	CHIP C 15PF J		C453			CC73HCH1H020B	CHIP C 2.0PF B	
C253			CC73GCH1H040B	CHIP C 4.0PF B		C454,455			CK73HB1H102K	CHIP C 1000PF K	
C254			CC73HCH1H120J	CHIP C 12PF J		C456			CC73HCH1H080B	CHIP C 8.0PF B	
C255			CC73GCH1H240G	CHIP C 24PF G		C459			CK73HB1H102K	CHIP C 1000PF K	
C256			CC73GCH1H050B	CHIP C 5.0PF B		C461,462			CK73HB1H102K	CHIP C 1000PF K	
C257			CC73GCH1H130G	CHIP C 13PF G		C463			CC73HCH1H020B	CHIP C 2.0PF B	
C258			CC73HCH1H120J	CHIP C 12PF J		C464			CC73HCH1H390J	CHIP C 39PF J	
C260			CC73HCH1H050B	CHIP C 5.0PF B		C465			CK73HB1H102K	CHIP C 1000PF K	
C263			CC73FCH1H050B	CHIP C 5.0PF B		C466			CC73HCH1H030B	CHIP C 3.0PF B	
C301			CK73HB1A104K	CHIP C 0.10UF K		C467			CC73HCH1H040B	CHIP C 4.0PF B	
C302			CK73HB1H471K	CHIP C 470PF K		C468			CC73HCH1H270J	CHIP C 27PF J	
C303			CK73FB1E475K	CHIP C 4.7UF K		C469			CC73HCH1H1R5B	CHIP C 1.5PF B	
C304			CK73HB1H471K	CHIP C 470PF K		C470			CK73HB1H102K	CHIP C 1000PF K	
C305,306			CC73HCH1H101J	CHIP C 100PF J		C474,475			CK73HB1H102K	CHIP C 1000PF K	
C307			CC73HCH1H470J	CHIP C 47PF J		C477			CK73HB1H102K	CHIP C 1000PF K	



## PARTS LIST

TX-RX UNIT (X57-7782-71)

Ref. No.	Address	New parts	Parts No.	Description	Desti-nation	Ref. No.	Address	New parts	Parts No.	Description	Desti-nation
C478			CC73HCH1H180J	CHIP C 18PF J		C882,883			CK73HB1H102K	CHIP C 1000PF K	
C479			CC73HCH1H1R5B	CHIP C 1.5PF B		C884			CK73GB1A105K	CHIP C 1.0UF K	
C480			CC73HCH1H220J	CHIP C 22PF J		C885			CC73HCH1H121J	CHIP C 120PF J	
C481			CC73HCH1H470J	CHIP C 47PF J		C886			CC73HCH1H221J	CHIP C 220PF J	
C482			CC73HCH1H040B	CHIP C 4.0PF B		C887,888			CC73HCH1H101J	CHIP C 100PF J	
C483			CK73HB1H102K	CHIP C 1000PF K		C890			CK73HB1H821K	CHIP C 820PF K	
C484			CC73HCH1H030B	CHIP C 3.0PF B		C892			CK73GB1A105K	CHIP C 1.0UF K	
C485			CC73HCH1H150J	CHIP C 15PF J		C893			CK73HB0J105K	CHIP C 1.0UF K	
C486			CC73HCH1H010B	CHIP C 1.0PF B		C895			CK73HB1A104K	CHIP C 0.10UF K	
C487			CC73HCH1H100B	CHIP C 10PF B		C896			CK73HB0J105K	CHIP C 1.0UF K	
C488			CC73HCH1H030B	CHIP C 3.0PF B		C897,898			CK73HB1A474K	CHIP C 0.47UF K	
C489			CC73HCH1H330J	CHIP C 33PF J		C899,900			CK73HB1H471K	CHIP C 470PF K	
C491			CC73HCH1H180J	CHIP C 18PF J		C901			CK73HB1A474K	CHIP C 0.47UF K	
C801-804			CK73HB1H102K	CHIP C 1000PF K		C902,903			CK73GB0J225K	CHIP C 2.2UF K	
C806,807			CK73HB1H102K	CHIP C 1000PF K		C904			CK73HB1A474K	CHIP C 0.47UF K	
C808,809			CK73GB1A105K	CHIP C 1.0UF K		C905,906			CK73HB1H471K	CHIP C 470PF K	
C810,811			CK73HB1H102K	CHIP C 1000PF K		C907			CC73HCH1H470J	CHIP C 47PF J	
C812-816			CK73GB1A105K	CHIP C 1.0UF K		C908			CK73HB1H102K	CHIP C 1000PF K	
C818,819			CK73HB1H102K	CHIP C 1000PF K		C909			CK73HB0J105K	CHIP C 1.0UF K	
C821			CK73HB1H102K	CHIP C 1000PF K		C910			CK73HB1A683K	CHIP C 0.068UF K	
C823			CK73GB1A105K	CHIP C 1.0UF K		C911			CK73FB0J106K	CHIP C 10UF K	
C824			CK73HB1H102K	CHIP C 1000PF K		C912			CK73HB1H102K	CHIP C 1000PF K	
C825			CK73GB1A105K	CHIP C 1.0UF K		C913,914			CK73HB1E103K	CHIP C 0.010UF K	
C826			CK73HB1H102K	CHIP C 1000PF K		C916-919			CK73HB1H102K	CHIP C 1000PF K	
C829			CK73HB1H102K	CHIP C 1000PF K		C920			CK73GB1A105K	CHIP C 1.0UF K	
C831			CK73FB0J106K	CHIP C 10UF K		C922			CK73HB1A104K	CHIP C 0.10UF K	
C834			CK73HB1A104K	CHIP C 0.10UF K		C923			CK73FB0J106K	CHIP C 10UF K	
C835			CK73FB0J106K	CHIP C 10UF K		C924			CC73HCH1H101J	CHIP C 100PF J	
C837-839			CK73HB1H102K	CHIP C 1000PF K		C925			CK73HB1A473K	CHIP C 0.047UF K	
C840			CK73HB1E103K	CHIP C 0.010UF K		C926			CS77CC0J101M	CHIP TNL 100UF 6.3VW	
C841			CK73HB1H471K	CHIP C 470PF K		C928,929			CC73HCH1H101J	CHIP C 100PF J	
C842			CK73HB1A104K	CHIP C 0.10UF K		C930			CK73HB1H102K	CHIP C 1000PF K	
C843			CK73HB1A473J	CHIP C 0.047UF J		C931			CC73HCH1H101J	CHIP C 100PF J	
C844			CK73HB1A104K	CHIP C 0.10UF K		C932			CK73HB1H102K	CHIP C 1000PF K	
C846			CC73HCH1H110J	CHIP C 11PF J		C935			CC73HCH1H101J	CHIP C 100PF J	
C848			CK73HB1H681K	CHIP C 680PF K		C936			CK73HB1H102K	CHIP C 1000PF K	
C849			CK73HB1A104K	CHIP C 0.10UF K		C940			CK73HB1H471K	CHIP C 470PF K	
C850			CK73HB1H102K	CHIP C 1000PF K		C942			CC73HCH1H101J	CHIP C 100PF J	
C851,852			CK73HB1E103K	CHIP C 0.010UF K		C943-946			CK73HB1H102K	CHIP C 1000PF K	
C854			CC73HCH1H110J	CHIP C 11PF J		C947,948			CK73HB1H182K	CHIP C 1800PF K	
C855			CK73HB1A104K	CHIP C 0.10UF K		C949			CK73HB1H102K	CHIP C 1000PF K	
C856			CK73HB1H102K	CHIP C 1000PF K		C950,951			CK73HB1H272K	CHIP C 2700PF K	
C857			CK73HB1H332K	CHIP C 3300PF K		C952-954			CK73HB1A104K	CHIP C 0.10UF K	
C858			CK73HB1E682K	CHIP C 6800PF K		C956			CK73HB1A104K	CHIP C 0.10UF K	
C859			CK73GB1A105K	CHIP C 1.0UF K		C957			CK73GB0J225K	CHIP C 2.2UF K	
C860,861			CK73HB1H102K	CHIP C 1000PF K		C958			CK73GB1A105K	CHIP C 1.0UF K	
C863			CK73HB1H471K	CHIP C 470PF K		C961,962			CK73HB1H682K	CHIP C 6800PF K	
C865			CK73HB1A104K	CHIP C 0.10UF K		C964			CK73FB1E475K	CHIP C 4.7UF K	
C866			CS77CA1A220M	CHIP TNL 22UF 10VW		C965			CK73HB1H272K	CHIP C 2700PF K	
C868			CK73HB1H102K	CHIP C 1000PF K		CN801			E40-6573-05	FLAT CABLE CONNECTOR	
C869			CK73FB0J106K	CHIP C 10UF K		CN802,803			E40-6568-05	FLAT CABLE CONNECTOR	
C871			CK73HB1E103K	CHIP C 0.010UF K		CN829			E23-1326-05	TERMINAL	
C872,873			CK73HB1H102K	CHIP C 1000PF K		J801			E11-0484-05	3.5D PHONE JACK (3.5D/3P)	
C874			CK73HB1A104K	CHIP C 0.10UF K		J802			E11-0715-05	2.5D PHONE JACK	
C875			CK73HB1H102K	CHIP C 1000PF K		F801			F53-0372-05	FUSE (3.15A)	
C876			CK73FB0J106K	CHIP C 10UF K		F802			F53-0319-15	FUSE (1A)	
C877			CK73HB1H102K	CHIP C 1000PF K		CD401			L79-1848-05	TUNING COIL (450KHZ)	
C878			CK73HB1E103K	CHIP C 0.010UF K		CF401			L72-1012-05	CERAMIC FILTER (450KHZ/NAR)	
C879			CK73FB0J106K	CHIP C 10UF K		CF402			L72-1010-05	CERAMIC FILTER (450KHZ/WID)	
C880,881			CK73HB1A104K	CHIP C 0.10UF K							

## PARTS LIST

## TX-RX UNIT (X57-7782-71)

Ref. No.	Address	New parts	Parts No.	Description	Destination	Ref. No.	Address	New parts	Parts No.	Description	Destination
L1			L41-4795-39	SMALL FIXED INDUCTOR (4.7UH)		CP803			RK75HA1J102J	CHIP-COM 1.0K J 1/16W	
L2			L92-0163-05	BEADS CORE		CP804			RK75HA1J472J	CHIP-COM 4.7K J 1/16W	
L3,4			L40-1001-86	SMALL FIXED INDUCTOR (10UH)		CP805			RK75HA1J473J	CHIP-COM 47K J 1/16W	
L5			L40-1502-86	SMALL FIXED INDUCTOR (15UH)		CP806			RK74HB1J102J	CHIP-COM 1.0K J 1/16W	
L6			L40-2702-86	SMALL FIXED INDUCTOR (27UH)		CP807			RK75HA1J102J	CHIP-COM 1.0K J 1/16W	
L7,8			L40-3391-86	SMALL FIXED INDUCTOR (3.3UH)		CP808-811			RK75HA1J473J	CHIP-COM 47K J 1/16W	
L9			L41-2278-14	SMALL FIXED INDUCTOR (22NH)		CP814,815			RK75HA1J473J	CHIP-COM 47K J 1/16W	
L10			L41-3978-14	SMALL FIXED INDUCTOR (39NH)		CP816			RK75HA1J474J	CHIP-COM 470K J 1/16W	
L11,12			L40-1001-86	SMALL FIXED INDUCTOR (10UH)		CP817			RK75HA1J473J	CHIP-COM 47K J 1/16W	
L13			L92-0163-05	BEADS CORE		CP818			RK75HA1J474J	CHIP-COM 470K J 1/16W	
L20,21			L40-1085-57	SMALL FIXED INDUCTOR (100NH)		CP819			RK75HA1J473J	CHIP-COM 47K J 1/16W	
L30			L40-1085-57	SMALL FIXED INDUCTOR (100NH)		CP820			RK75HA1J102J	CHIP-COM 1.0K J 1/16W	
L31			L40-1875-57	SMALL FIXED INDUCTOR (18.0NH)		R1			RK73GB2A000J	CHIP R 0.0 J 1/10W	
L33			L40-1575-57	SMALL FIXED INDUCTOR (15.0NH)		R2			RK73HB1J474J	CHIP R 470K J 1/16W	
L34			L40-1875-57	SMALL FIXED INDUCTOR (18.0NH)		R6			RK73HB1J473J	CHIP R 47K J 1/16W	
L201			L41-1085-53	SMALL FIXED INDUCTOR (0.1UH)		R7			RK73HB1J103J	CHIP R 10K J 1/16W	
L202			L40-1085-71	SMALL FIXED INDUCTOR (100NH)		R8			RK73HB1J000J	CHIP R 0.0 J 1/16W	
L204			L40-1085-71	SMALL FIXED INDUCTOR (100NH)		R9			RK73HB1J101J	CHIP R 100 J 1/16W	
L205			L92-0162-05	BEADS CORE		R10			RK73HB1J122J	CHIP R 1.2K J 1/16W	
L206			L40-3975-71	SMALL FIXED INDUCTOR (39NH)		R13			RK73HB1J102J	CHIP R 1.0K J 1/16W	
L207			L34-4577-05	AIR-CORE COIL		R14			RK73HB1J223J	CHIP R 22K J 1/16W	
L208			L92-0149-05	CHIP FERRITE		R15,16			RK73HB1J100J	CHIP R 10 J 1/16W	
L210			L92-0149-05	CHIP FERRITE		R17			RK73HB1J471J	CHIP R 470 J 1/16W	
L211			L34-4569-05	AIR-CORE COIL (9T)		R18			RK73HB1J391J	CHIP R 390 J 1/16W	
L212			L34-4563-05	AIR-CORE COIL (3T)		R19			RK73HB1J122J	CHIP R 1.2K J 1/16W	
L213,214			L34-4565-05	AIR-CORE COIL (5T)		R20			RK73HB1J000J	CHIP R 0.0 J 1/16W	
L215			L34-4574-05	AIR-CORE COIL (6T)		R21			RK73HB1J103J	CHIP R 10K J 1/16W	
L216			L41-2295-39	SMALL FIXED INDUCTOR (2.2UH)		R27,28			RK73HB1J106J	CHIP R 10M J 1/16W	
L217			L34-4577-05	AIR-CORE COIL (9T)		R29			RK73HB1J123J	CHIP R 12K J 1/16W	
L219			L34-4566-05	AIR-CORE COIL (6T)		R30			RK73HB1J473J	CHIP R 47K J 1/16W	
L220			L34-4569-05	AIR-CORE COIL (9T)		R31			RK73HB1J152J	CHIP R 1.5K J 1/16W	
L221			L34-4568-05	AIR-CORE COIL (8T)		R32,33			RK73HB1J104J	CHIP R 100K J 1/16W	
L222			L40-3375-71	SMALL FIXED INDUCTOR (33NH)		R41,42			RN73HH1J271D	CHIP R 270 D 1/16W	
L230		*	L41-5675-53	SMALL FIXED INDUCTOR (56NH)		R44,45		*	RN73GH1J220D	CHIP R 22 D 1/16W	
L401			L41-1585-53	SMALL FIXED INDUCTOR (0.15UH)		R46			RK73HB1J154J	CHIP R 150K J 1/16W	
L402			L40-1085-71	SMALL FIXED INDUCTOR (100NH)		R47			RK73HB1J101J	CHIP R 100 J 1/16W	
L403			L40-1591-86	SMALL FIXED INDUCTOR (1.5UH)		R48			RK73HB1J332J	CHIP R 3.3K J 1/16W	
L406			L92-0138-05	CHIP FERRITE		R49			RK73HB1J103J	CHIP R 10K J 1/16W	
L407			L41-6885-39	SMALL FIXED INDUCTOR (0.68UH)		R50			RK73HB1J470J	CHIP R 47 J 1/16W	
L408			L40-5675-71	SMALL FIXED INDUCTOR (56NH)		R51			RK73HB1J471J	CHIP R 470 J 1/16W	
L409			L41-2785-53	SMALL FIXED INDUCTOR (0.27UH)		R52			RK73HB1J103J	CHIP R 10K J 1/16W	
L410			L40-5675-71	SMALL FIXED INDUCTOR (56NH)		R53			RK73HB1J472J	CHIP R 4.7K J 1/16W	
L411			L41-1285-53	SMALL FIXED INDUCTOR (0.12UH)		R60			RK73HB1J471J	CHIP R 470 J 1/16W	
L412			L41-2785-53	SMALL FIXED INDUCTOR (0.27UH)		R61			RK73HB1J683J	CHIP R 68K J 1/16W	
L414			L41-6878-14	SMALL FIXED INDUCTOR (68NH)		R62			RK73HB1J821J	CHIP R 820 J 1/16W	
L415			L92-0138-05	CHIP FERRITE		R70			RK73HB1J470J	CHIP R 47 J 1/16W	
L416			L41-6878-14	SMALL FIXED INDUCTOR (68NH)		R98			RK73HB1J224J	CHIP R 220K J 1/16W	
L418			L41-6878-14	SMALL FIXED INDUCTOR (68NH)		R99			RK73HB1J104J	CHIP R 100K J 1/16W	
L419			L41-5678-14	SMALL FIXED INDUCTOR (56NH)		R201			RK73HB1J472J	CHIP R 4.7K J 1/16W	
L420			L40-5675-71	SMALL FIXED INDUCTOR (56NH)		R202			RK73HB1J182J	CHIP R 1.8K J 1/16W	
L801			L92-0472-05	CHIP FERRITE		R203			RK73HB1J331J	CHIP R 330 J 1/16W	
X1			L77-3050-05	TCXO (16.8MHZ)		R205			RK73HB1J101J	CHIP R 100 J 1/16W	
X802			L77-3049-05	CRYSTAL RESONATOR (12MHZ)		R206			RK73HB1J222J	CHIP R 2.2K J 1/16W	
XF401			L71-0655-05	MCF (49.95MHZ)		R207			RK73HB1J101J	CHIP R 100 J 1/16W	
CP1			RK74HB1J101J	CHIP-COM 100 J 1/16W		R209			RK73HB1J181J	CHIP R 180 J 1/16W	
CP2			RK75HA1J103J	CHIP-COM 10K J 1/16W		R210			RK73HB1J000J	CHIP R 0.0 J 1/16W	
CP401			RK75HA1J474J	CHIP-COM 470K J 1/16W		R211,212			RK73HB1J681J	CHIP R 680 J 1/16W	
CP801			RK74HB1J102J	CHIP-COM 1.0K J 1/16W		R213			RK73HB1J122J	CHIP R 1.2K J 1/16W	
CP802			RK75HA1J473J	CHIP-COM 47K J 1/16W		R214			RK73HB1J220J	CHIP R 22 J 1/16W	
						R215			RK73HB1J331J	CHIP R 330 J 1/16W	

## PARTS LIST

TX-RX UNIT (X57-7782-71)

Ref. No.	Address	New parts	Parts No.	Description	Destination	Ref. No.	Address	New parts	Parts No.	Description	Destination
R216			RK73HB1J471J	CHIP R 470 J 1/16W		R449			RK73HB1J561J	CHIP R 560 J 1/16W	
R217			RK73HB1J120J	CHIP R 12 J 1/16W		R452			RK73HB1J104J	CHIP R 100K J 1/16W	
R218			RK73HB1J471J	CHIP R 470 J 1/16W		R453			RK73HB1J564J	CHIP R 560K J 1/16W	
R219			RK73HB1J823J	CHIP R 82K J 1/16W		R455			RK73HB1J104J	CHIP R 100K J 1/16W	
R220			RK73HB1J390J	CHIP R 39 J 1/16W		R456			RK73HB1J154J	CHIP R 150K J 1/16W	
R221			RK73HB1J393J	CHIP R 39K J 1/16W		R457			RK73HB1J470J	CHIP R 47 J 1/16W	
R223			RK73HB1J470J	CHIP R 47 J 1/16W		R458			RK73HB1J000J	CHIP R 0.0 J 1/16W	
R224			RK73HB1J683J	CHIP R 68K J 1/16W		R461,462			RK73HB1J474J	CHIP R 470K J 1/16W	
R226			RK73HB1J180J	CHIP R 18 J 1/16W		R463,464			RK73FB2B000J	CHIP R 0.0 J 1/8W	
R227			RK73GB2A000J	CHIP R 0.0 J 1/10W		R801			RK73HB1J000J	CHIP R 0.0 J 1/16W	
R228			RK73HB1J563J	CHIP R 56K J 1/16W		R802			RK73GB2A331J	CHIP R 330 J 1/10W	
R229,230			RK73GB2A4R7J	CHIP R 4.7 J 1/10W		R803			RK73HB1J473J	CHIP R 47K J 1/16W	
R232,233			RK73HB1J271J	CHIP R 270 J 1/16W		R804,805			RK73HB1J104J	CHIP R 100K J 1/16W	
R235			RK73GB2A823J	CHIP R 82K J 1/10W		R806-809			RK73HB1J101J	CHIP R 100 J 1/16W	
R237			RK73HB1J271J	CHIP R 270 J 1/16W		R810			RK73HB1J104J	CHIP R 100K J 1/16W	
R238			RK73HB1J180J	CHIP R 18 J 1/16W		R811			RK73GB2A271J	CHIP R 270 J 1/10W	
R239			RK73HB1J271J	CHIP R 270 J 1/16W		R812			RK73HB1J104J	CHIP R 100K J 1/16W	
R240			RK73GB2A000J	CHIP R 0.0 J 1/10W		R813			RK73HB1J473J	CHIP R 47K J 1/16W	
R301			RK73HB1J000J	CHIP R 0.0 J 1/16W		R814-816			RK73HB1J104J	CHIP R 100K J 1/16W	
R303			RK73HB1J561J	CHIP R 560 J 1/16W		R817			RK73HB1J223J	CHIP R 22K J 1/16W	
R304			RK73HB1J000J	CHIP R 0.0 J 1/16W		R818			RK73GB2A331J	CHIP R 330 J 1/10W	
R305			RK73HB1J333J	CHIP R 33K J 1/16W		R819,820			RK73HB1J104J	CHIP R 100K J 1/16W	
R306			RK73HB1J472J	CHIP R 4.7K J 1/16W		R821			RK73HB1J473J	CHIP R 47K J 1/16W	
R307			RK73EB2ER39K	CHIP R 0.39 K 1/4W		R822			RK73HB1J102J	CHIP R 1.0K J 1/16W	
R308			RK73HB1J182J	CHIP R 1.8K J 1/16W		R823			RK73HB1J473J	CHIP R 47K J 1/16W	
R309,310			RK73EB2ER39K	CHIP R 0.39 K 1/4W		R824			RK73HH1J914D	CHIP R 910K D 1/16W	
R311,312			RK73HH1J154D	CHIP R 150K D 1/16W		R825			RK73HB1J124J	CHIP R 120K J 1/16W	
R313,314			RK73HH1J474D	CHIP R 470K D 1/16W		R826,827			RK73GB2A000J	CHIP R 0.0 J 1/10W	
R315			RK73HB1J103J	CHIP R 10K J 1/16W		R828			RK73HH1J103D	CHIP R 10K D 1/16W	
R316			RK73HB1J333J	CHIP R 33K J 1/16W		R829			RK73HH1J474D	CHIP R 470K D 1/16W	
R317			RK73HB1J000J	CHIP R 0.0 J 1/16W		R830			RK73HB1J184J	CHIP R 180K J 1/16W	
R318			RK73HB1J474J	CHIP R 470K J 1/16W		R833			RK73HB1J473J	CHIP R 47K J 1/16W	
R319			RK73HB1J104J	CHIP R 100K J 1/16W		R835-838			RK73HB1J000J	CHIP R 0.0 J 1/16W	
R320			RK73HB1J105J	CHIP R 1.0M J 1/16W		R839			RK73HB1J223J	CHIP R 22K J 1/16W	
R406			RK73HB1J103J	CHIP R 10K J 1/16W		R841			RK73HB1J473J	CHIP R 47K J 1/16W	
R408,409			RK73HB1J472J	CHIP R 4.7K J 1/16W		R842			RK73HB1J102J	CHIP R 1.0K J 1/16W	
R410			RK73HB1J334J	CHIP R 330K J 1/16W		R843			RK73HB1J104J	CHIP R 100K J 1/16W	
R411,412			RK73HB1J472J	CHIP R 4.7K J 1/16W		R844-846			RK73HB1J103J	CHIP R 10K J 1/16W	
R414			RK73HB1J101J	CHIP R 100 J 1/16W		R847			RK73HB1J105J	CHIP R 1.0M J 1/16W	
R415			RK73HB1J103J	CHIP R 10K J 1/16W		R848			RK73HB1J332J	CHIP R 3.3K J 1/16W	
R416			RK73HB1J152J	CHIP R 1.5K J 1/16W		R849			RK73GB2A000J	CHIP R 0.0 J 1/10W	
R417			RK73HB1J334J	CHIP R 330K J 1/16W		R850			RK73HB1J473J	CHIP R 47K J 1/16W	
R419			RK73HB1J334J	CHIP R 330K J 1/16W		R851			RK73HB1J223J	CHIP R 22K J 1/16W	
R421,422			RK73HB1J332J	CHIP R 3.3K J 1/16W		R852			RK73HB1J473J	CHIP R 47K J 1/16W	
R424			RK73HB1J272J	CHIP R 2.7K J 1/16W		R853			RK73HB1J103J	CHIP R 10K J 1/16W	
R426			RK73HB1J100J	CHIP R 10 J 1/16W		R854			RK73GB2A000J	CHIP R 0.0 J 1/10W	
R427			RK73HB1J124J	CHIP R 120K J 1/16W		R855			RK73HB1J152J	CHIP R 1.5K J 1/16W	
R429			RK73HB1J101J	CHIP R 100 J 1/16W		R856			RK73HB1J000J	CHIP R 0.0 J 1/16W	
R433			RK73HB1J474J	CHIP R 470K J 1/16W		R857			RK73HB1J181J	CHIP R 180 J 1/16W	
R434			RK73HB1J271J	CHIP R 270 J 1/16W		R858			RK73HB1J102J	CHIP R 1.0K J 1/16W	
R435,436			RK73HB1J101J	CHIP R 100 J 1/16W		R859			RK73GB2A000J	CHIP R 0.0 J 1/10W	
R437			RK73HB1J472J	CHIP R 4.7K J 1/16W		R860			RK73HB1J684J	CHIP R 680K J 1/16W	
R438			RK73HB1J102J	CHIP R 1.0K J 1/16W		R861			RK73HB1J104J	CHIP R 100K J 1/16W	
R439			RK73HB1J151J	CHIP R 150 J 1/16W		R862			RK73GB2A000J	CHIP R 0.0 J 1/10W	
R440,441			RK73HB1J823J	CHIP R 82K J 1/16W		R863			RK73HB1J223J	CHIP R 22K J 1/16W	
R442			RK73HB1J000J	CHIP R 0.0 J 1/16W		R864			RK73HB1J102J	CHIP R 1.0K J 1/16W	
R443,444			RK73HB1J823J	CHIP R 82K J 1/16W		R865			RK73HB1J223J	CHIP R 22K J 1/16W	
R445			RK73GB2A221J	CHIP R 220 J 1/10W		R866			RK73HB1J102J	CHIP R 1.0K J 1/16W	
R447			RK73HB1J471J	CHIP R 470 J 1/16W		R867			RK73HB1J103J	CHIP R 10K J 1/16W	
R448			RK73GB2A470J	CHIP R 47 J 1/10W		R868			RK73HB1J222J	CHIP R 2.2K J 1/16W	

## PARTS LIST

## TX-RX UNIT (X57-7782-71)

Ref. No.	Address	New parts	Parts No.	Description	Destination	Ref. No.	Address	New parts	Parts No.	Description	Destination
R869,870			RK73HB1J473J	CHIP R 47K J 1/16W		D5			1SV325F	VARIABLE CAPACITANCE DIODE	
R871			RK73HB1J104J	CHIP R 100K J 1/16W		D6-9			1SV323F	VARIABLE CAPACITANCE DIODE	
R872			RK73HB1J121J	CHIP R 120 J 1/16W		D10,11			HVC375B-E	VARIABLE CAPACITANCE DIODE	
R874			RK73GB2A100J	CHIP R 10 J 1/10W		D12			1SV281-F	VARIABLE CAPACITANCE DIODE	
R875			RK73GB2A000J	CHIP R 0.0 J 1/10W		D13-15			HSC119	DIODE	
R876			RK73HB1J102J	CHIP R 1.0K J 1/16W		D17,18			HSC277	DIODE	
R883			RK73GB2A000J	CHIP R 0.0 J 1/10W		D201,202			HVC131	DIODE	
R884			RK73HB1J564J	CHIP R 560K J 1/16W		D203,204			RN142S	DIODE	
R885			RK73HB1J105J	CHIP R 1.0M J 1/16W		D301			UDZW5.1(B)	ZENER DIODE	
R886			RK73GB2A000J	CHIP R 0.0 J 1/10W		D401,402			KDS121E-P	DIODE	
R887			RK73HB1J100J	CHIP R 10 J 1/16W		D404,405			1SV323F	VARIABLE CAPACITANCE DIODE	
R888,889			RK73HB1J473J	CHIP R 47K J 1/16W		D407,408			1SV323F	VARIABLE CAPACITANCE DIODE	
R890			RK73HB1J273J	CHIP R 27K J 1/16W		D802			HSC119	DIODE	
R892,893			RK73HB1J000J	CHIP R 0.0 J 1/16W		D803			GN1G	DIODE	
R894			RK73HB1J104J	CHIP R 100K J 1/16W		D806			RKZ5.1B2KG	ZENER DIODE	
R895			RK73HB1J224J	CHIP R 220K J 1/16W		D807-809			KDR731	DIODE	
R896			RK73HB1J823J	CHIP R 82K J 1/16W		D810			MC2850	DIODE	
R897			RK73HB1J103J	CHIP R 10K J 1/16W		IC1			AK1541	MOS-IC	
R898			RK73HB1J000J	CHIP R 0.0 J 1/16W		IC3			TC75S51FE(F)	MOS-IC	
R899,900			RK73HB1J474J	CHIP R 470K J 1/16W		IC301			NJM2904RB1-ZB	BI-POLAR IC	
R901			RK73HB1J564J	CHIP R 560K J 1/16W		IC401			TA31136FNG	MOS-IC	
R902			RK73HB1J103J	CHIP R 10K J 1/16W		IC801			XC6209B502PR	MOS-IC	
R903			RK73HB1J101J	CHIP R 100 J 1/16W		IC802			XC6209B502MR	MOS-IC	
R904			RK73HB1J474J	CHIP R 470K J 1/16W		IC803			XC6209B502PR	MOS-IC	
R905			RK73HB1J272J	CHIP R 2.7K J 1/16W		IC804			XC6209B332MR	MOS-IC	
R906			RK73HB1J102J	CHIP R 1.0K J 1/16W		IC805			XC61CN4502MR	MOS-IC	
R907			RK73HB1J272J	CHIP R 2.7K J 1/16W		IC806			XC6209B332MR	MOS-IC	
R908			RK73HB1J104J	CHIP R 100K J 1/16W		IC807			XC6120N302N1	MOS-IC	
R909			RK73HB1J105J	CHIP R 1.0M J 1/16W		IC808			HA1630D03MM	MOS-IC	
R910,911			RK73HB1J103J	CHIP R 10K J 1/16W		IC809			F3640MDFBKDKA	MCU	
R912			RK73HB1J000J	CHIP R 0.0 J 1/16W		IC810			EX25064ASA00A	ROM IC	
R913			RK73HB1J182J	CHIP R 1.8K J 1/16W		IC811			TC75S51FE(F)	MOS-IC	
R914			RK73HB1J471J	CHIP R 470 J 1/16W		IC812			CD686Q3	MOS-IC	
R918			RK73HB1J473J	CHIP R 47K J 1/16W		IC813			BMA150	MOS-IC	
R919			RK73HB1J682J	CHIP R 6.8K J 1/16W		IC814			TC75S51FE(F)	MOS-IC	
R920			RK73HB1J222J	CHIP R 2.2K J 1/16W		IC815			TA7368FG	MOS-IC	
R921,922			RK73HB1J473J	CHIP R 47K J 1/16W		IC816			HA1630D03MM	MOS-IC	
R923			RK73HB1J151J	CHIP R 150 J 1/16W		IC817			AK2331	MOS-IC	
R924			RK73HB1J474J	CHIP R 470K J 1/16W		Q2			2SC5636	TRANSISTOR	
R925			RK73HB1J334J	CHIP R 330K J 1/16W		Q3			KTC4075E(Y,GR)	TRANSISTOR	
R926			RK73HB1J274J	CHIP R 270K J 1/16W		Q4,5			MCH3914(7)-H	FET	
R927			RK73HB1J473J	CHIP R 47K J 1/16W		Q6			SSM6L05FU-F	FET	
R928			RK73HB1J273J	CHIP R 27K J 1/16W		Q7			SSM3J05FU-F	FET	
R929			RK73HB1J102J	CHIP R 1.0K J 1/16W		Q8,9			2SC5636	TRANSISTOR	
R930			RK73HB1J101J	CHIP R 100 J 1/16W		Q201			2SC5636	TRANSISTOR	
R931			RK73HB1J562J	CHIP R 5.6K J 1/16W		Q203			2SC4926YD	TRANSISTOR	
R936			RK73GB2A000J	CHIP R 0.0 J 1/10W		Q204			RD01MUS1-T113	FET	
R937			RK73HB1J103J	CHIP R 10K J 1/16W		Q205			RD07MUS2BT112	FET	
R938			RK73HB1J105J	CHIP R 1.0M J 1/16W		Q301			RT1N140U-T111	TRANSISTOR	
R939			RK73HB1J823J	CHIP R 82K J 1/16W		Q303			2SK1830F	FET	
R940			RK73HB1J105J	CHIP R 1.0M J 1/16W		Q304			RT1N141U-T111	TRANSISTOR	
R941			RK73HB1J563J	CHIP R 56K J 1/16W		Q305			2SK1824-A	FET	
R942			RK73HB1J221J	CHIP R 220 J 1/16W		Q306			RT1P441U-T111	TRANSISTOR	
R945,946			RK73HB1J104J	CHIP R 100K J 1/16W		Q403			KTC4080E-P	TRANSISTOR	
R947			RK73HB1J103J	CHIP R 10K J 1/16W		Q405			KTC4080E-P	TRANSISTOR	
S801-804			S70-0516-05	TACT SWITCH		Q406			3SK318	FET	
MIC801			T91-0651-15	MIC ELEMENT		Q407			3SK294-FP	FET	
D3			1SV325F	VARIABLE CAPACITANCE DIODE		Q801			SSM6N17FU	FET	
						Q802,803			SSM6L05FU-F	FET	
						Q804			SSM3J05FU-F	FET	

## PARTS LIST

TX-RX UNIT (X57-7782-71)

Ref. No.	Address	New parts	Parts No.	Description	Destination	Ref. No.	Address	New parts	Parts No.	Description	Destination
Q805			2SK1830F	FET							
Q806,807			2SC4919-S	TRANSISTOR							
Q808			2SK1830F	FET							
Q809			KTC4075E(Y,GR)	TRANSISTOR							
Q810			2SC4116(GR)F	TRANSISTOR							
Q811			2SA1586(Y,GR)F	TRANSISTOR							
Q812			2SK1830F	FET							
Q813			RT1N141U-T111	TRANSISTOR							
Q814			2SA1362-F(GR)	TRANSISTOR							
Q815,816			UPA672T-A	FET							
Q817			RT1N441U-T111	TRANSISTOR							
Q818,819			2SK3577-A	FET							
Q820			RT1N141U-T111	TRANSISTOR							
TH201			ERTJ0EV104J	THERMISTOR							
TH401			B57331V2104J	THERMISTOR							

## EXPLODED VIEW

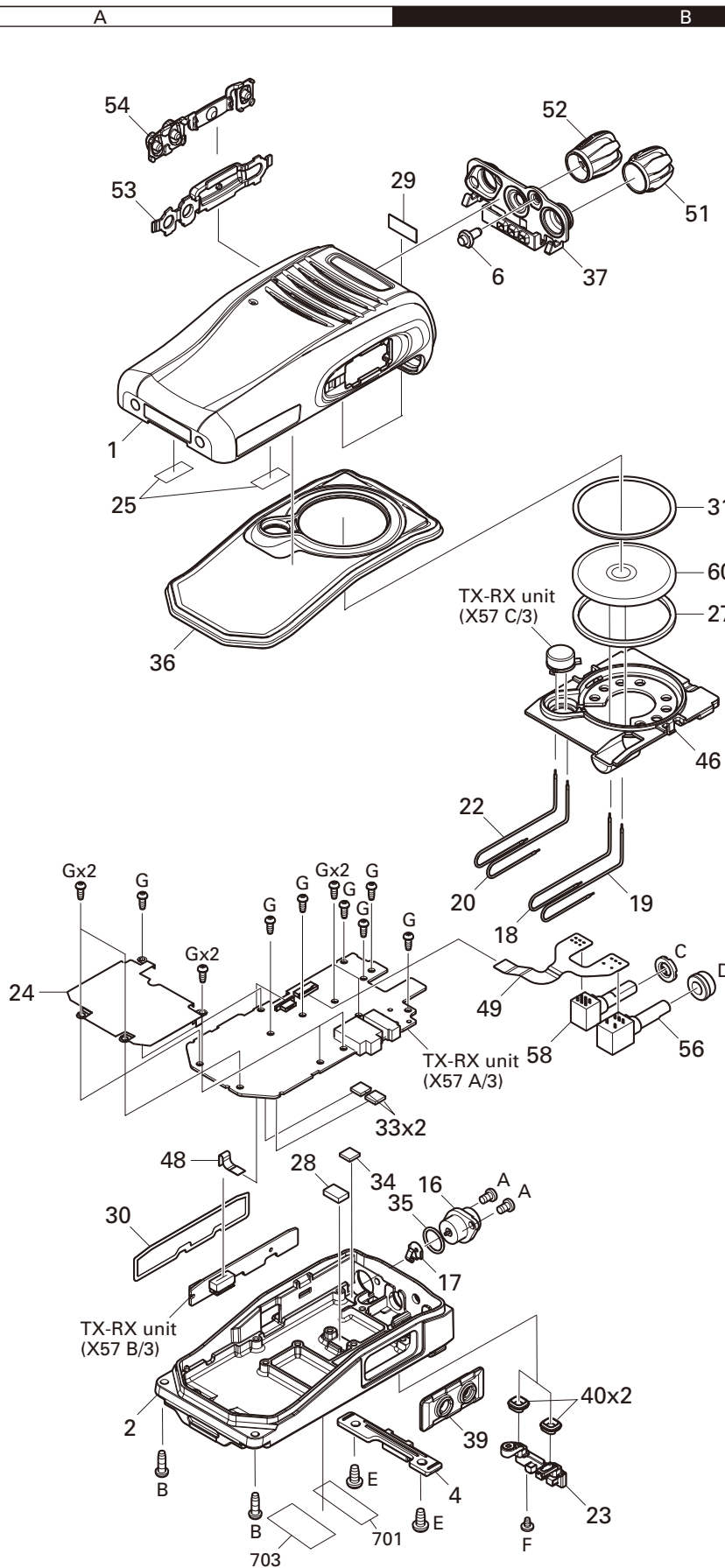

- A: N09-2438-05
- B: N09-6565-05
- C: N14-0851-04
- D: N14-0858-04
- E: N30-3006-43
- F: N78-2030-48
- G: N83-2005-48

## PACKING

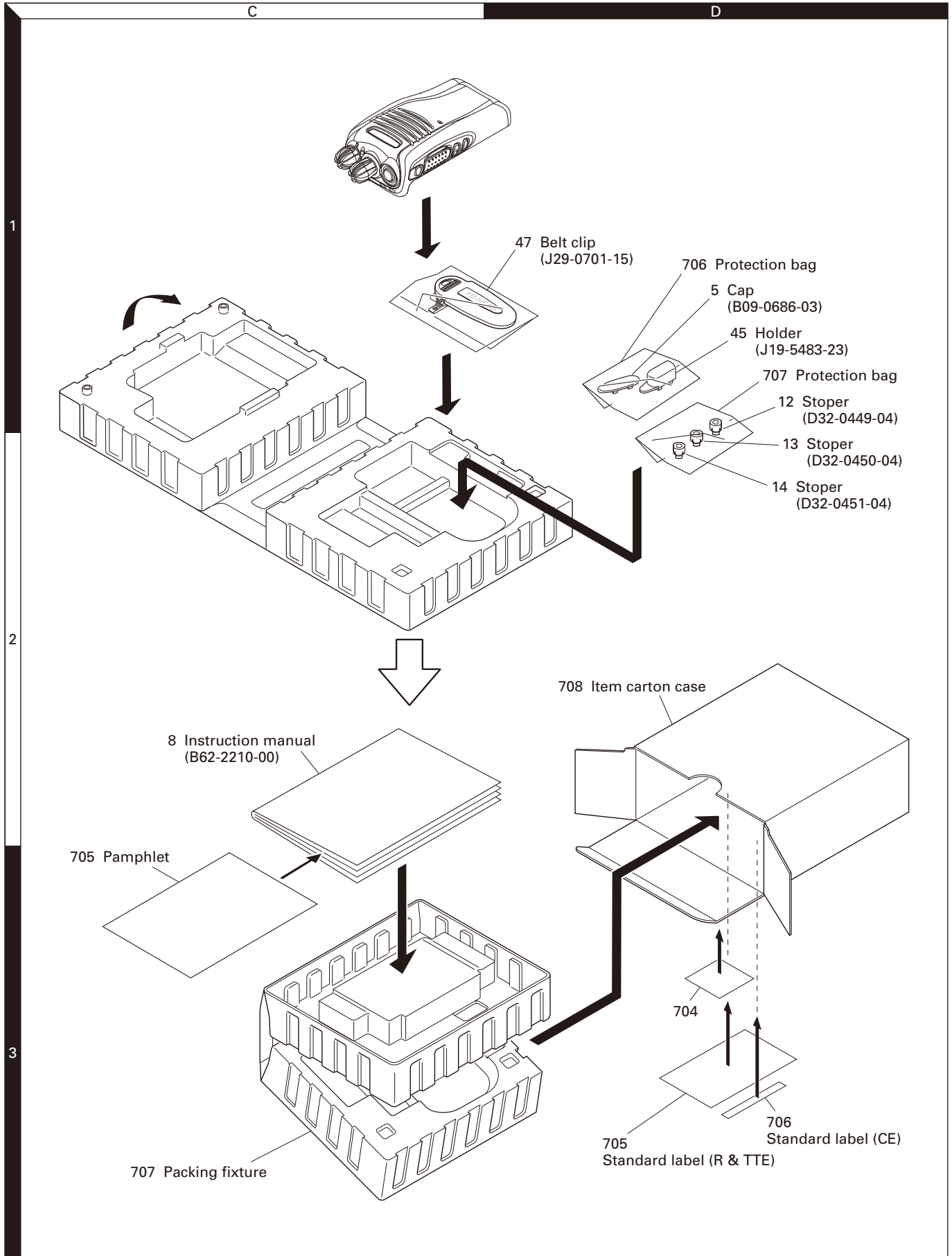

Parts with the exploded numbers larger than 700 are not supplied.

## ADJUSTMENT

### Test Equipment Required for Alignment

Test Equipment	Major Specifications	
1. Standard Signal Generator (SSG)	Frequency Range Modulation Output	136 to 174MHz Frequency modulation and external modulation -127dBm/0.1μV to greater than -47dBm/1mV
2. RF Power Meter	Input Impedance Operation Frequency Measurement Range	50Ω 136 to 174MHz Vicinity of 10W
3. Deviation Meter	Frequency Range	136 to 174MHz
4. Digital Volt Meter (DVM)	Measuring Range Input Impedance	10mV to 10V DC High input impedance for minimum circuit loading
5. Oscilloscope		DC through 30MHz
6. High Sensitivity Frequency Counter	Frequency Range Frequency Stability	10Hz to 1000MHz 0.2ppm or less
7. DC Ammeter		5A
8. AF Volt Meter (AF VTVM)	Frequency Range Voltage Range	50Hz to 10kHz 1mV to 10V
9. Audio Generator (AG)	Frequency Range Output	50Hz to 5kHz or more 0 to 1V
10. Distortion Meter	Capability Input Level	3% or less at 1kHz 50mV to 10Vrms
11. Spectrum Analyzer	Measuring Range	DC to 1GHz or more
12. Tracking Generator	Center frequency Output Voltage	50kHz to 600MHz 100mV or more
13. 8Ω Dummy Load		Approx. 8Ω, 3W
14. Regulated Power Supply		5V to 10V, approx. 3A Useful if ammeter equipped

#### ■ Antenna connector adapter

The antenna connector of this transceiver uses an SMA terminal.

Use an antenna connector adapter [SMA(f) – BNC(f) or SMA(f) – N(f)] for adjustment. (The adapter is not provided as an option, so buy a commercially-available one.)

#### ■ Repair Jig (Chassis)

Use jig (part No.: A10-4134-03) for repairing the transceiver. Place the TX-RX unit on the jig and fit it with screws.

The jig facilitates the voltage check and protects the final amplifier FET when the voltage on the flow side of the TX-RX unit is checked during repairs.

#### ■ Battery Jig (W05-0909-00)

Connect the power cable properly between the battery jig installed in the transceiver and the power supply, and be sure output voltage and the power supply polarity prior to switching the power supply ON, otherwise over voltage and reverse connection may damage the transceiver, or the power supply or both.

**Note:** When using the battery jig, you must measure the voltage at the terminals of the battery jig. Otherwise, a slight voltage drop may occur within the power cable, between the power supply and the battery jig, especially while the transceiver transmits.

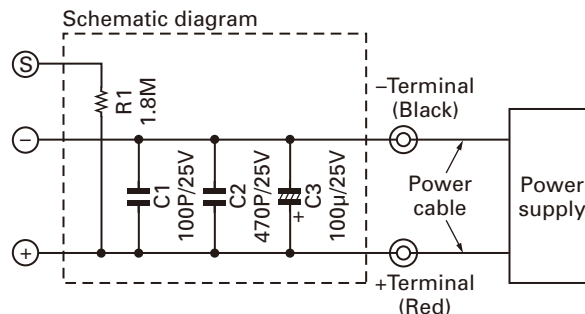
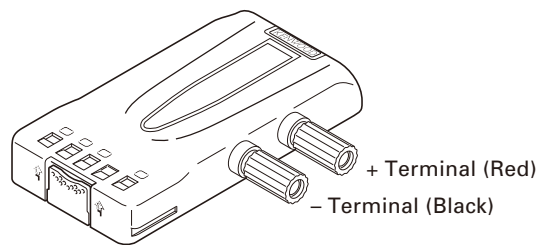



## ADJUSTMENT

### Frequency and Signaling

The transceiver has been adjusted for the frequencies shown in the following table. When required, re-adjust them following the adjustment procedure to obtain the frequencies you want in actual operation.

#### ■ Test Frequency (MHz)

CH	RX Frequency	TX Frequency
1	155.05000	155.10000
2	136.05000	136.10000
3	173.95000	173.90000
4	155.00000	155.00000
5	155.20000	155.20000
6	155.40000	155.40000
7~16	-	-

#### ■ Signaling

No.	Decode	Encode
1	None	None
2	None	100Hz Square Wave
3	-	-
4	QT 67.0Hz	QT 67.0Hz
5	QT 151.4Hz	QT 151.4Hz
6	QT 210.7Hz	QT 210.7Hz
7	QT 254.1Hz	QT 254.1Hz
8	DQT D023N	DQT D023N
9	DQT D754I	DQT D754I
10	DTMF Decode (Code: 159D)	DTMF Encode (Code: 159D)
11	None	DTMF Encode (Code: 9)
12	-	-
13	Single Tone Decode (979.9Hz)	Single Tone Encode (979.9Hz)
14	None	Single Tone Encode (1000Hz)
15	5-tone 12345 (CCIR)	5-tone 12345 (CCIR)
16	None	MSK
17	MSK Decode	MSK Encode

### Preparations for Tuning the Transceiver

Before attempting to tune the transceiver, connect the unit to a suitable power supply.

Whenever the transmitter is tuned, the unit must be connected to a suitable dummy load (i.e. power meter).

The speaker output connector must be terminated with a 8Ω dummy load and connected to an AC voltmeter and an audio distortion meter or a SINAD measurement meter at all times during tuning.

#### ■ Adjustment frequency (MHz)

Tuning point	RX	TX
Low	136.05000	136.10000
Low'	145.55000	145.60000
Center	155.05000	155.10000
High'	164.55000	164.60000
High	173.95000	173.90000

### Adjustment Points

TX-RX UNIT  
Component side view

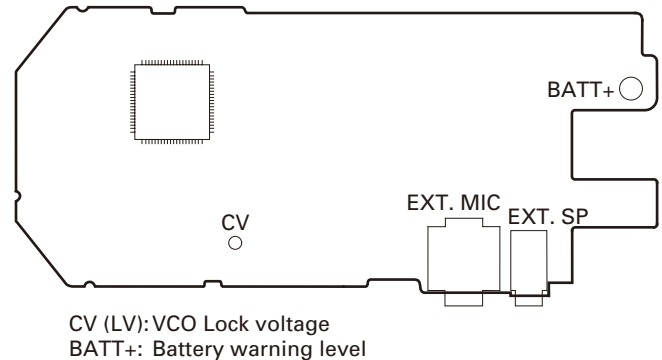

Foil side view

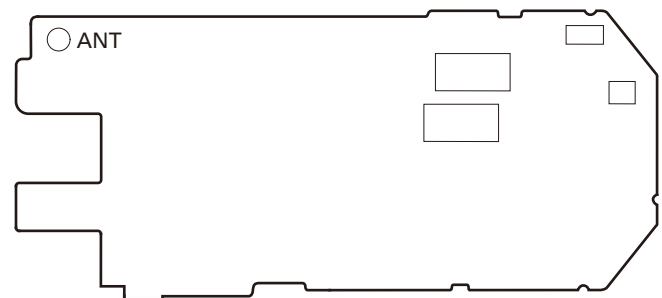

## ADJUSTMENT

## Common Section

Item	Condition	Measurement			Adjustment			Specifications / Remarks
		Test-equipment	Unit	Terminal	Unit	Parts	Method	
1. Setting	1) BATT terminal voltage: 7.5V 2) SSG standard modulation [Wide] MOD: 1kHz, DEV: 3kHz [Narrow] MOD: 1kHz, DEV: 1.5kHz							
2. Receive VCO Lock Voltage	1) TEST CH: 3	Power meter DVM	TX-RX	ANT CV		FPU	4.2V	±0.1V
	2) TEST CH: 2						Check	0.6V or more
3. Transmit VCO Lock Voltage	3) TEST CH: 3 Transmit: ON						4.2V	±0.1V
	3) TEST CH: 2 Transmit: ON						Check	0.6V or more

## Transmitter Section

Item	Condition	Measurement			Adjustment			Specifications / Remarks
		Test-equipment	Unit	Terminal	Unit	Parts	Method	
1. Frequency	1) TEST CH: 3 Transmit: ON	f. counter		ANT		FPU	173.900MHz	±50Hz
2. High Transmit Power	1) Adj item: Low, Low', Center, High', High (5 points) BATT terminal voltage: 7.5V Transmit: ON	Power meter Ammeter				FPU		4.8W±0.1W 1.9A or less
3. Low Transmit Power	1) Adj item: Low, Low', Center, High', High (5 points) BATT terminal voltage: 7.5V Transmit: ON							1.0W±0.1W 0.9A or less
4. DQT Balance [Narrow]	1) Adj item: Low, Center, High (3 points) Deviation meter filter LPF: 3kHz HPF: OFF Transmit: ON	Power meter Deviation meter Oscilloscope AG AF VTVM		ANT SP/MIC connector		FPU	Adjust 2kHz deviation to be the same as 20Hz.	±0.5dB
5. Maximum Deviation [Narrow]	1) Adj item: Center, Low, High (3 points) AG: 1kHz/150mV Deviation meter filter LPF: 15kHz HPF: OFF Transmit: ON						2.1kHz (According to the lager +, -)	±100Hz
[Wide 4k]	2) TEST CH: 1 Transmit: ON						3.3kHz (According to the lager +, -)	±100Hz
[Wide 5k]		4.2kHz (According to the lager +, -)	±100Hz					

## ADJUSTMENT

Item	Condition	Measurement			Adjustment			Specifications / Remarks					
		Test-equipment	Unit	Terminal	Unit	Parts	Method						
6. DTMF Deviation [Narrow]	1) TEST CH: 1 Deviation meter filter LPF: 15kHz HPF: OFF Transmit: ON	Power meter Deviation meter Oscilloscope AG AF VTVM		ANT SP/MIC connector		FPU	1.5kHz	±100Hz					
	[Wide 4K]						2) TEST CH: 1 Transmit: ON	2.4kHz	±100Hz				
	[Wide 5K]							3.0kHz	±100Hz				
7. MSK Deviation [Narrow]	1) TEST CH: 1 Deviation meter filter LPF: 15kHz HPF: OFF Transmit: ON											1.5kHz	±100Hz
	[Wide 4K]						2) TEST CH: 1 Transmit: ON					2.4kHz	±100Hz
	[Wide 5K]											3.0kHz	±100Hz
8. Single Tone Deviation [Narrow]	1) TEST CH: 1 Deviation meter filter LPF: 15kHz HPF: OFF Transmit: ON											1.5kHz	±100Hz
	[Wide 4K]						2) TEST CH: 1 Transmit: ON					2.4kHz	±100Hz
	[Wide 5K]											3.0kHz	±100Hz
9. QT Deviation [Narrow]	1) TEST CH: Center, Low, High (3 points) Deviation meter filter LPF: 3kHz HPF: OFF Transmit: ON						0.37kHz	±40Hz					
	[Wide 4K]	2) TEST CH: 1 Transmit: ON					0.60kHz	±40Hz					
	[Wide 5K]						0.75kHz	±40Hz					
10. DQT Deviation [Narrow]	1) TEST CH: 1 Deviation meter filter LPF: 3kHz HPF: OFF Transmit: ON						0.37kHz	±40Hz					
	[Wide 4K]	2) TEST CH: 1 Transmit: ON					0.60kHz	±40Hz					
	[Wide 5K]						0.75kHz	±40Hz					

## ADJUSTMENT

Item	Condition	Measurement			Adjustment			Specifications / Remarks
		Test-equipment	Unit	Terminal	Unit	Parts	Method	
11. Battery Warning Level	1) BATT terminal voltage: 5.9V	DVM	TX-RX	BATT terminal		FPU	Write	BATT terminal voltage: 5.9V
12. Battery Detection Check	1) BATT terminal voltage: 5.5V PTT: ON	Power meter DVM		ANT BATT terminal			Check	LED blinks No transmit power
	2) BATT terminal voltage: 7.5V PTT: ON							LED does not blink

## Receiver Section

Item	Condition	Measurement			Adjustment			Specifications / Remarks
		Test-equipment	Unit	Terminal	Unit	Parts	Method	
1. Sensitivity	1) Adj item: Low, Low', Center, High', High (5 points) SSG output : -70dBm (70.8μV) SSG MOD: 1.5kHz	SSG DVM Oscilloscope AF VTVM		ANT SP/MIC connector		FPU	Write	
2. Sensitivity Check [Narrow]	1) Adj item: Low, High (2 points) SSG output: -115dBm (0.4μV) SSG MOD: 1.5kHz						Check	13dB SINAD or more
[Wide 5k]	2) TEST CH: 1 SSG output: -116dBm (0.35μV) SSG MOD: 3.0kHz							
3. High RSSI [Narrow]	1) Adj item: Center, Low, High (3 points) SSG output: -70dBm (70.8μV) SSG MOD: 1.5kHz					FPU	Write	
[Wide 4k]	2) TEST CH: 1 SSG output: -70dBm (70.8μV) SSG MOD: 2.4kHz							
[Wide 5k]	3) TEST CH: 1 SSG output: -70dBm (70.8μV) SSG MOD: 3.0kHz							

## ADJUSTMENT

Item	Condition	Measurement			Adjustment			Specifications / Remarks
		Test-equipment	Unit	Terminal	Unit	Parts	Method	
4. Low RSSI [Narrow]	1) Adj item: Center, Low, High (3 points) SSG output: -118dBm (0.28 $\mu$ V) SSG MOD: 1.5kHz	SSG DVM Oscilloscope AF VTVM		ANT SP/MIC connector		FPU	Write	
[Wide 4k]	2) TEST CH: 1 SSG output: -118dBm (0.28 $\mu$ V) SSG MOD: 2.4kHz							
[Wide 5k]	3) TEST CH: 1 SSG output: -118dBm (0.28 $\mu$ V) SSG MOD: 3.0kHz							
5. Open Squelch [Narrow]	1) Adj item: Center, Low, High (3 points) SSG output: -117dBm (0.32 $\mu$ V) SSG MOD: 1.5kHz							
[Wide 4k]	2) TEST CH: 1 SSG output: -118dBm (0.28 $\mu$ V) SSG MOD: 2.4kHz							
[Wide 5k]	3) TEST CH: 1 SSG output: -118dBm (0.28 $\mu$ V) SSG MOD: 3.0kHz							
6. Tight Squelch [Narrow]	1) Adj item: Center, Low, High (3 points) SSG output: -113dBm (0.50 $\mu$ V) SSG MOD: 1.5kHz							
[Wide 4k]	2) TEST CH: 1 SSG output: -114dBm (0.45 $\mu$ V) SSG MOD: 2.4kHz							
[Wide 5k]	3) TEST CH: 1 SSG output: -114dBm (0.45 $\mu$ V) SSG MOD: 3.0kHz							

# TK-2360 PC BOARD

## TX-RX UNIT (X57-7782-71) Component side view (J79-0259-19)

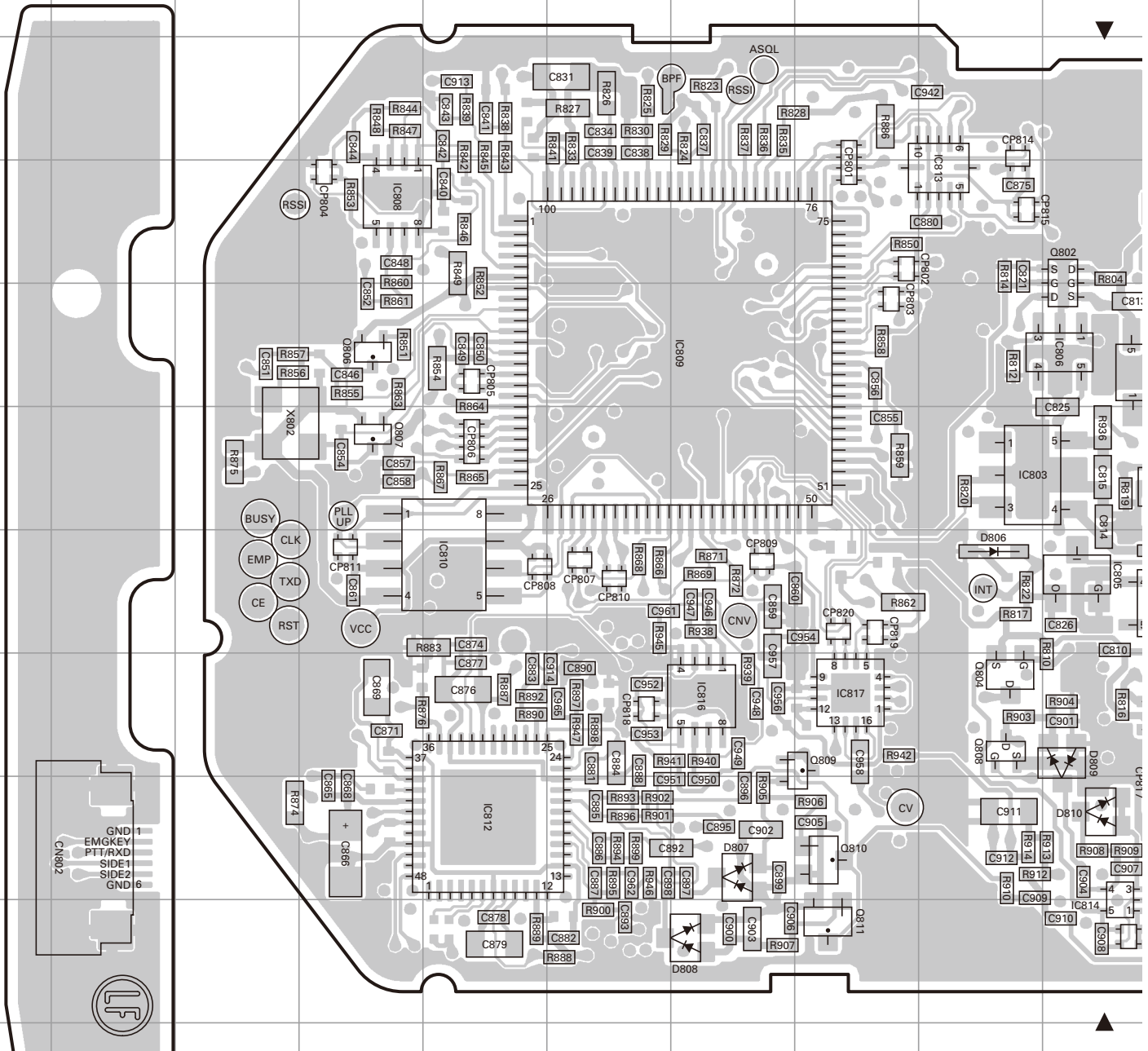

J79-0259-19 B/3

Ref. No.	Address	Ref. No.	Address	Ref. No.	Address	Ref. No.	Address	Ref. No.	Address
IC301	4P	IC812	9E	Q801	8Q	Q812	10K	D803	4Q
IC801	5J	IC813	4I	Q802	4J	Q813	6P	D804	8S
IC802	6K	IC814	10J	Q803	4K	Q814	6O	D805	8R
IC803	6I	IC815	7O	Q804	8I	Q815	9K	D806	7I
IC804	7J	IC816	8G	Q805	8P	Q816	8K	D807	9G
IC805	7J	IC817	8H	Q806	5D	Q817	6P	D808	10G
IC806	5J	Q301	8L	Q807	6D	Q818	7P	D809	8J
IC807	8J	Q303	3Q	Q808	8I	Q819	8O	D810	9J
IC808	4D	Q304	4P	Q809	8H	D301	7L		
IC809	5G	Q305	4O	Q810	9H	D801	8R		
IC810	7E	Q306	3O	Q811	10H	D802	7J		

# PC BOARD TK-2360

## TX-RX UNIT (X57-7782-71) Component side view (J79-0259-19)

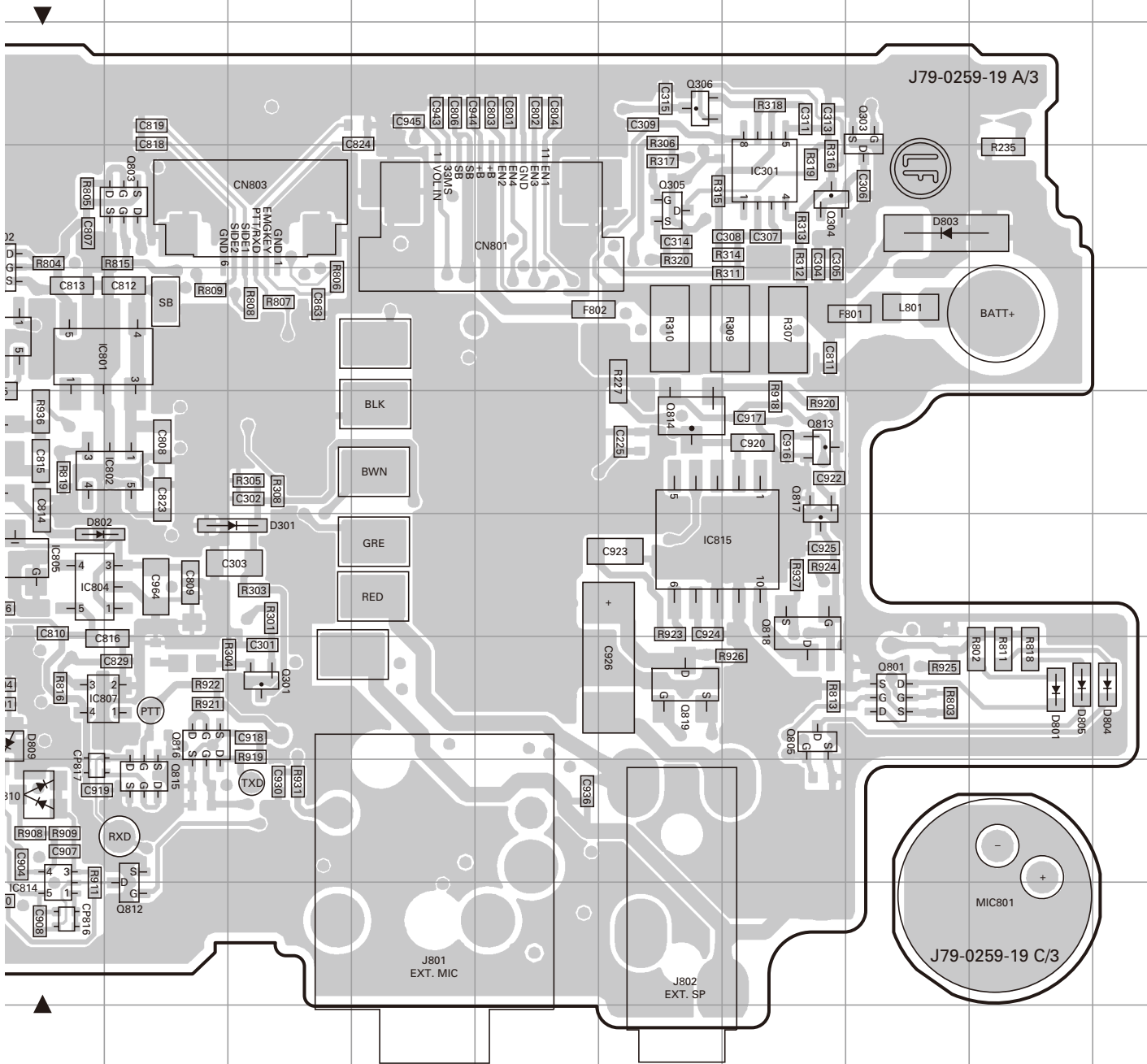

Component side

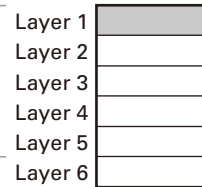

Foil side

# TK-2360 PC BOARD

## TX-RX UNIT (X57-7782-71) Foil side view (J79-0259-19)

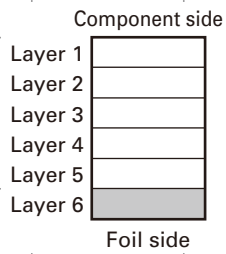
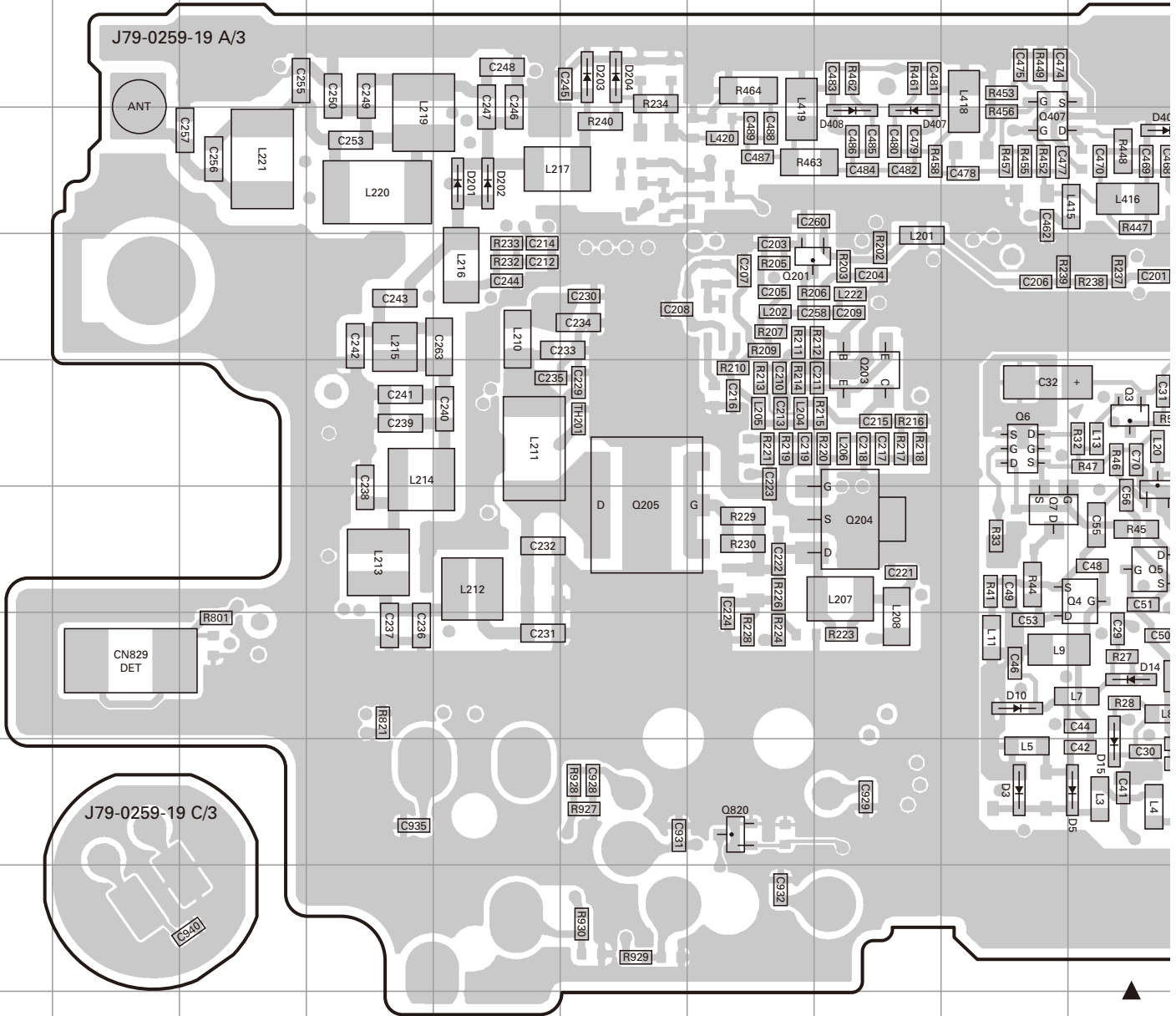



# PC BOARD TK-2360

## TX-RX UNIT (X57-7782-71) Foil side view (J79-0259-19)

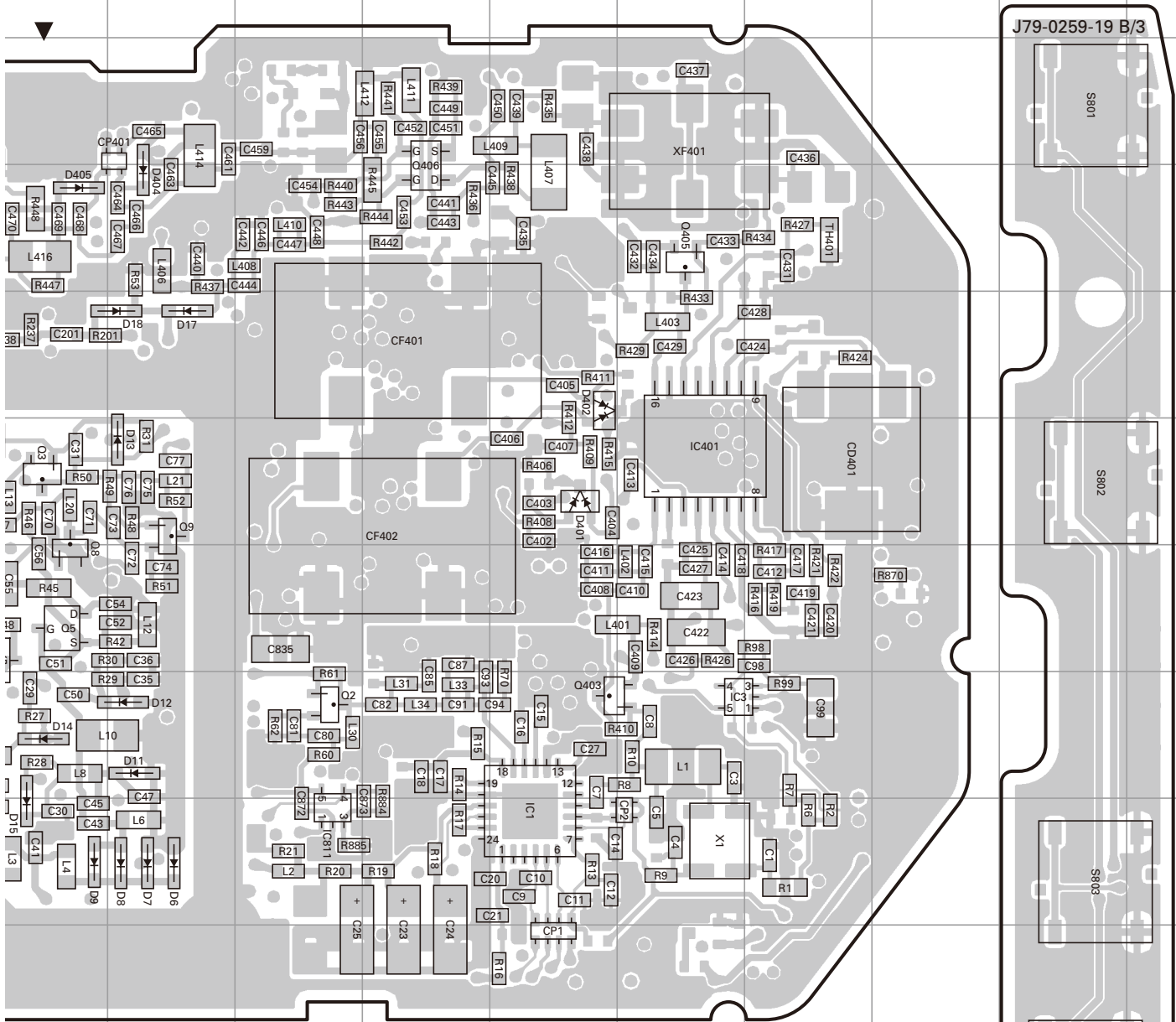

Ref. No.	Address	Ref. No.	Address	Ref. No.	Address	Ref. No.	Address	Ref. No.	Address
IC1	9N	Q8	7J	Q820	9G	D13	6K	D402	5N
IC3	8O	Q9	6K	D3	9I	D14	8J	D404	4K
IC401	6O	Q201	5G	D5	9J	D15	9J	D405	4J
IC811	9L	Q203	6H	D6	9K	D17	5K	D407	4H
Q2	8L	Q204	7H	D7	9K	D18	5K	D408	4H
Q3	6J	Q205	7F	D8	9K	D201	4E		
Q4	7J	Q403	8N	D9	9J	D202	4E		
Q5	7J	Q405	4O	D10	8I	D203	3F		
Q6	6I	Q406	4M	D11	8K	D204	3F		
Q7	7I	Q407	4I	D12	8K	D401	6N		

# TK-2360 SCHEMATIC DIAGRAM

TX-RX UNIT(X57-7782-71)(A/3)

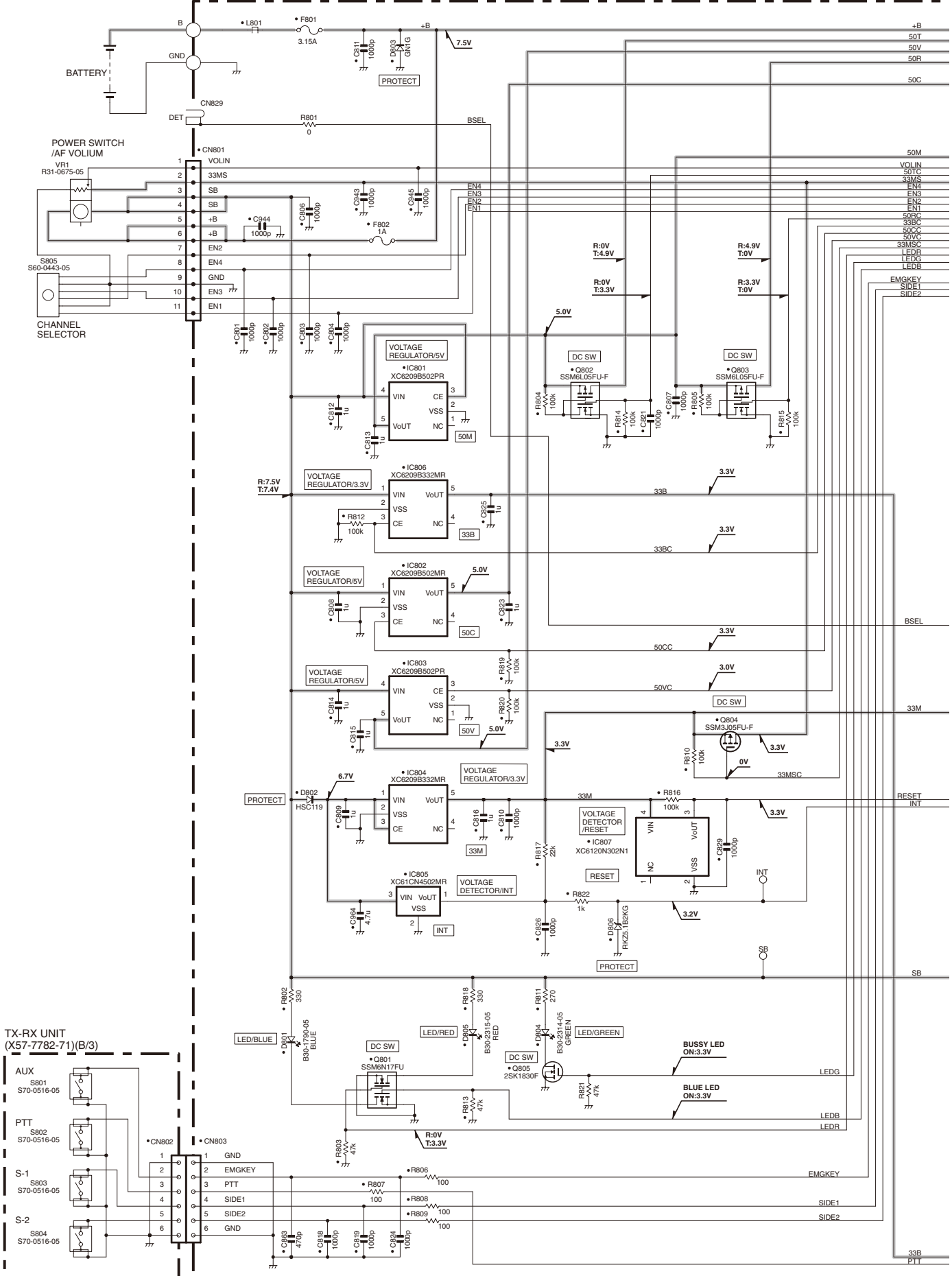

# SCHEMATIC DIAGRAM TK-2360

TX-RX UNIT (X57-7782-71) (A/3)

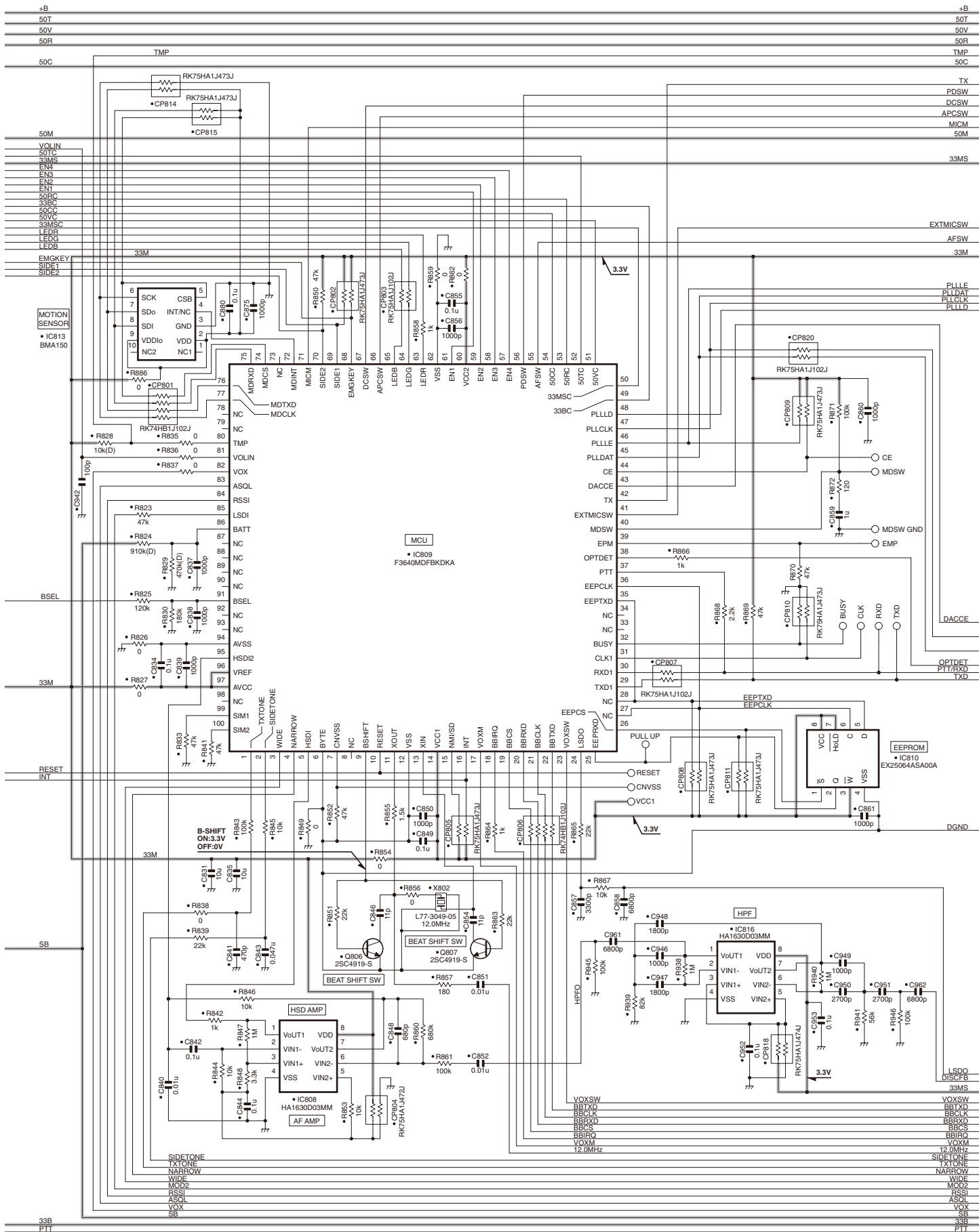

# TK-2360 SCHEMATIC DIAGRAM

TX-RX UNIT (X57-7782-71) (A/3)

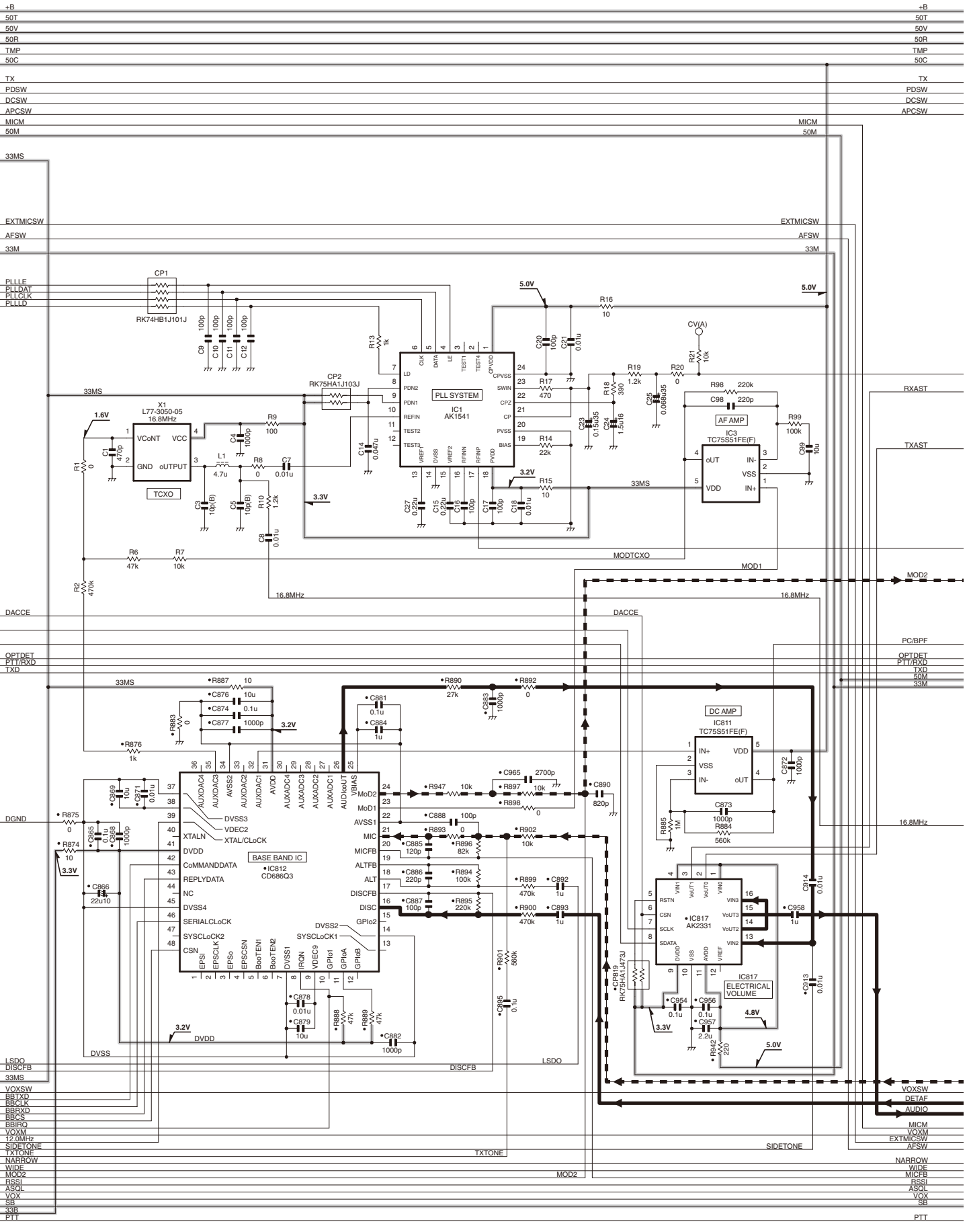

# SCHEMATIC DIAGRAM TK-2360

TX-RX UNIT (X57-7782-71) (A/3)

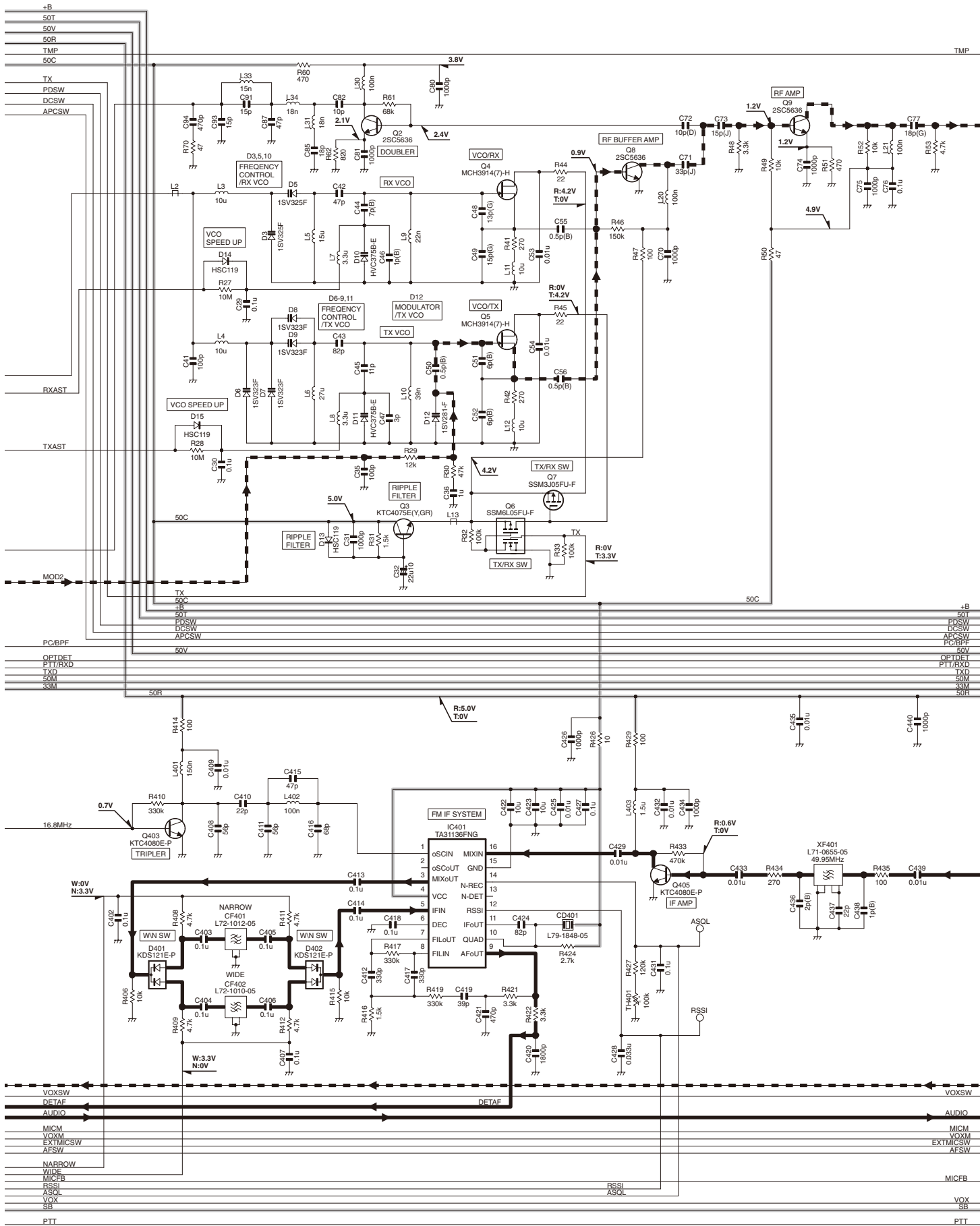

# TK-2360 SCHEMATIC DIAGRAM

TX-RX UNIT (X57-7782-71) (A/3)

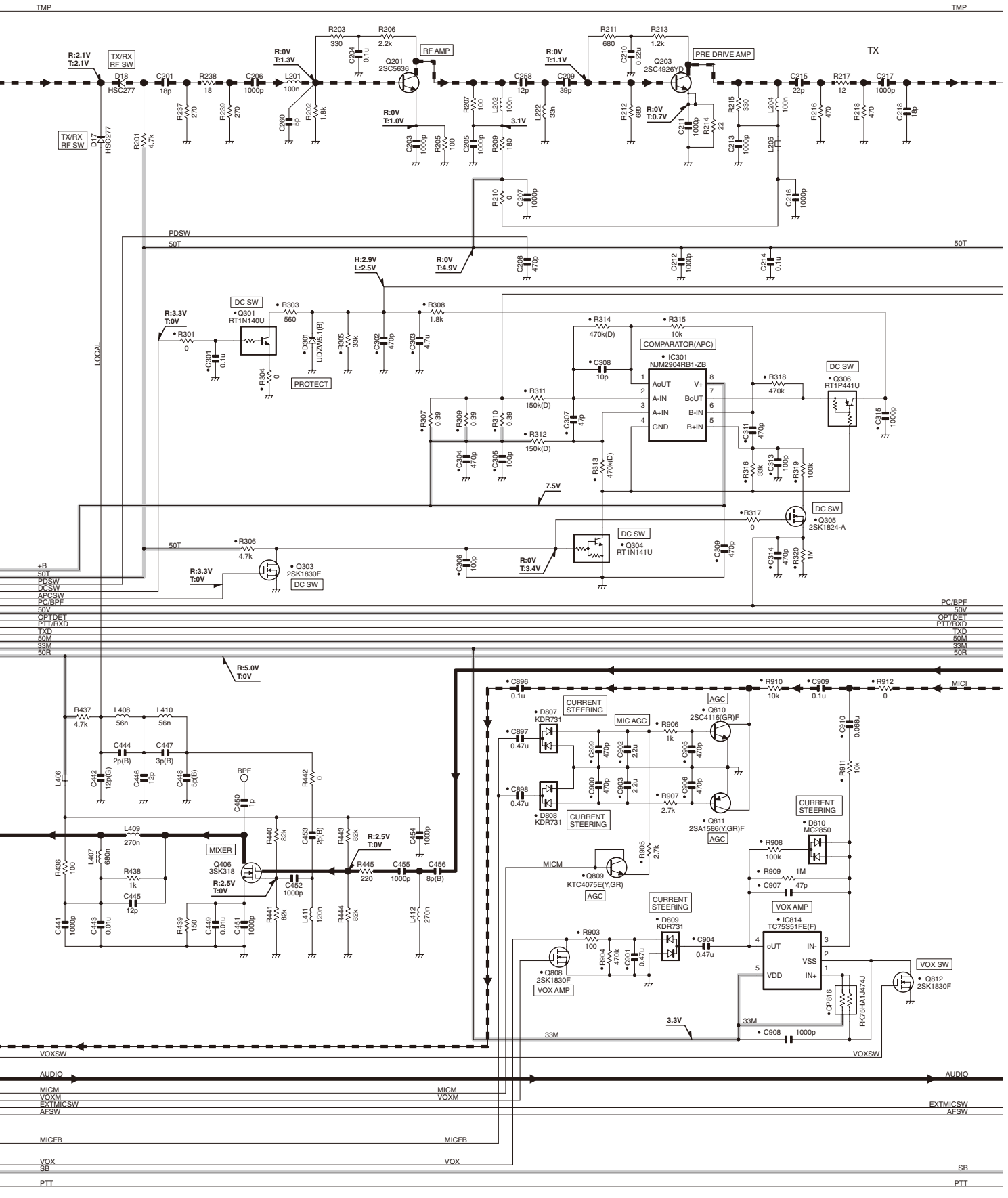

# SCHEMATIC DIAGRAM TK-2360

TX-RX UNIT (X57-7782-71) (A/3)

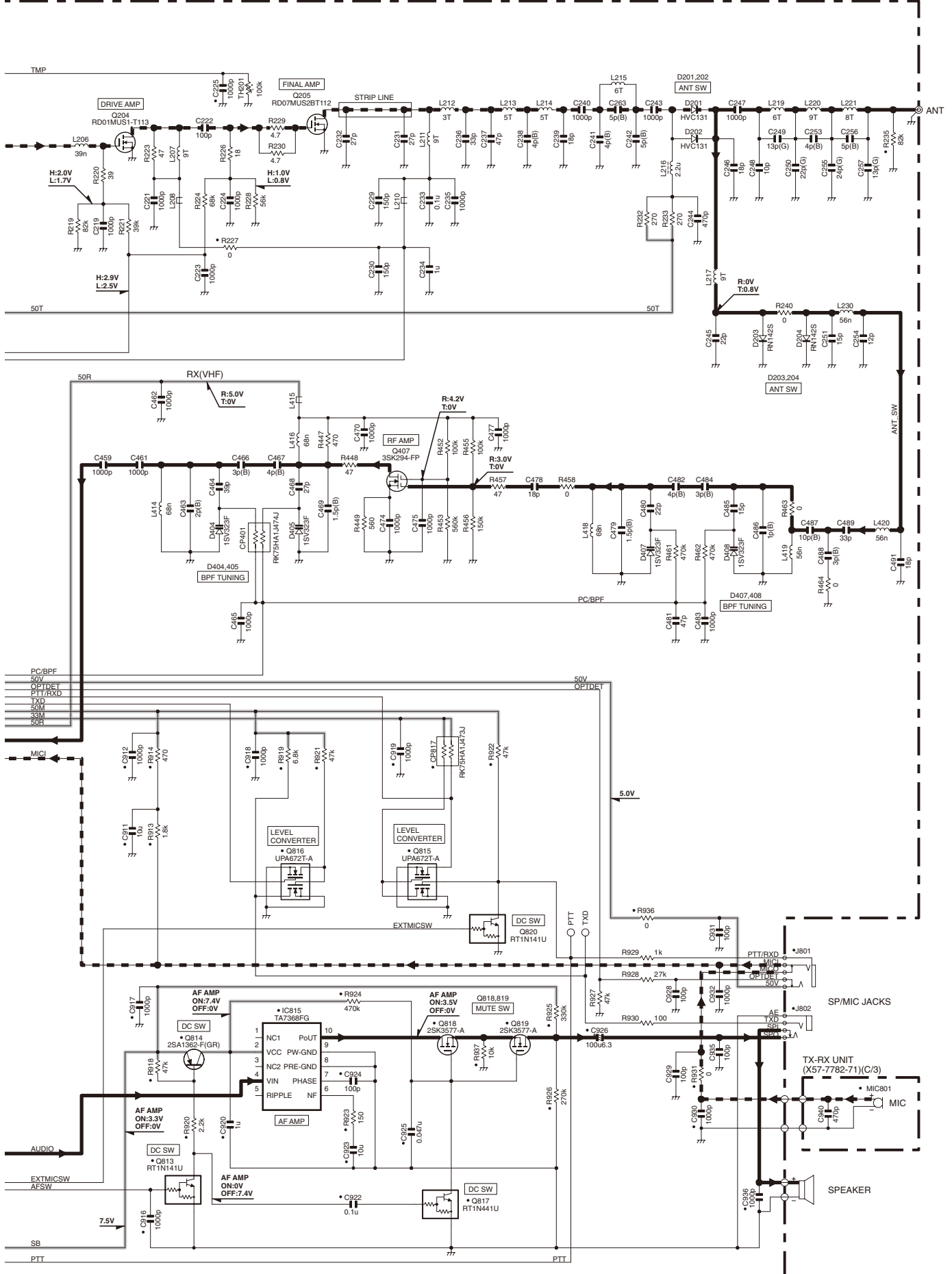

Note : The components marked with a dot (•) are parts of layer 1.

## BLOCK DIAGRAM

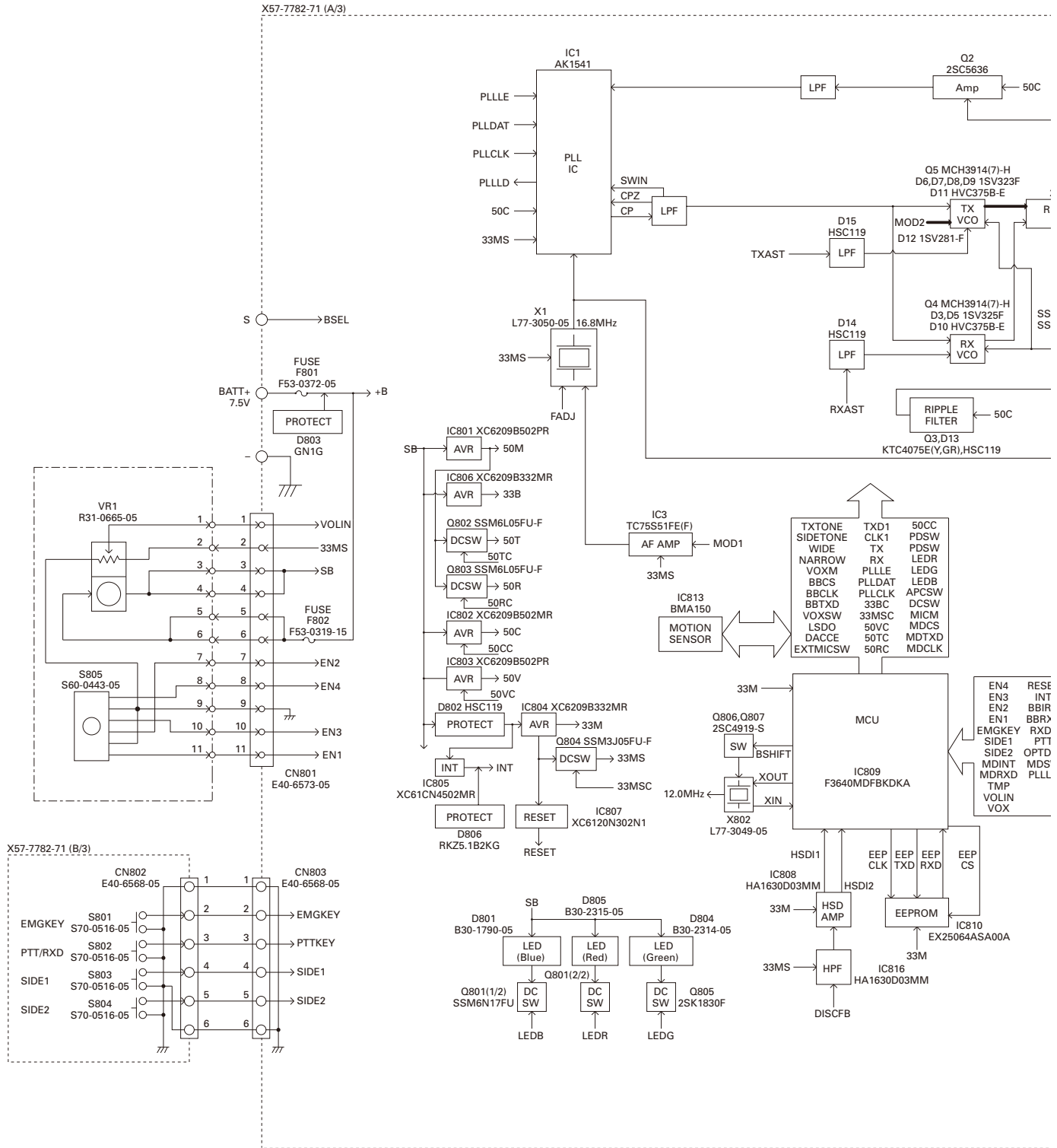



## BLOCK DIAGRAM

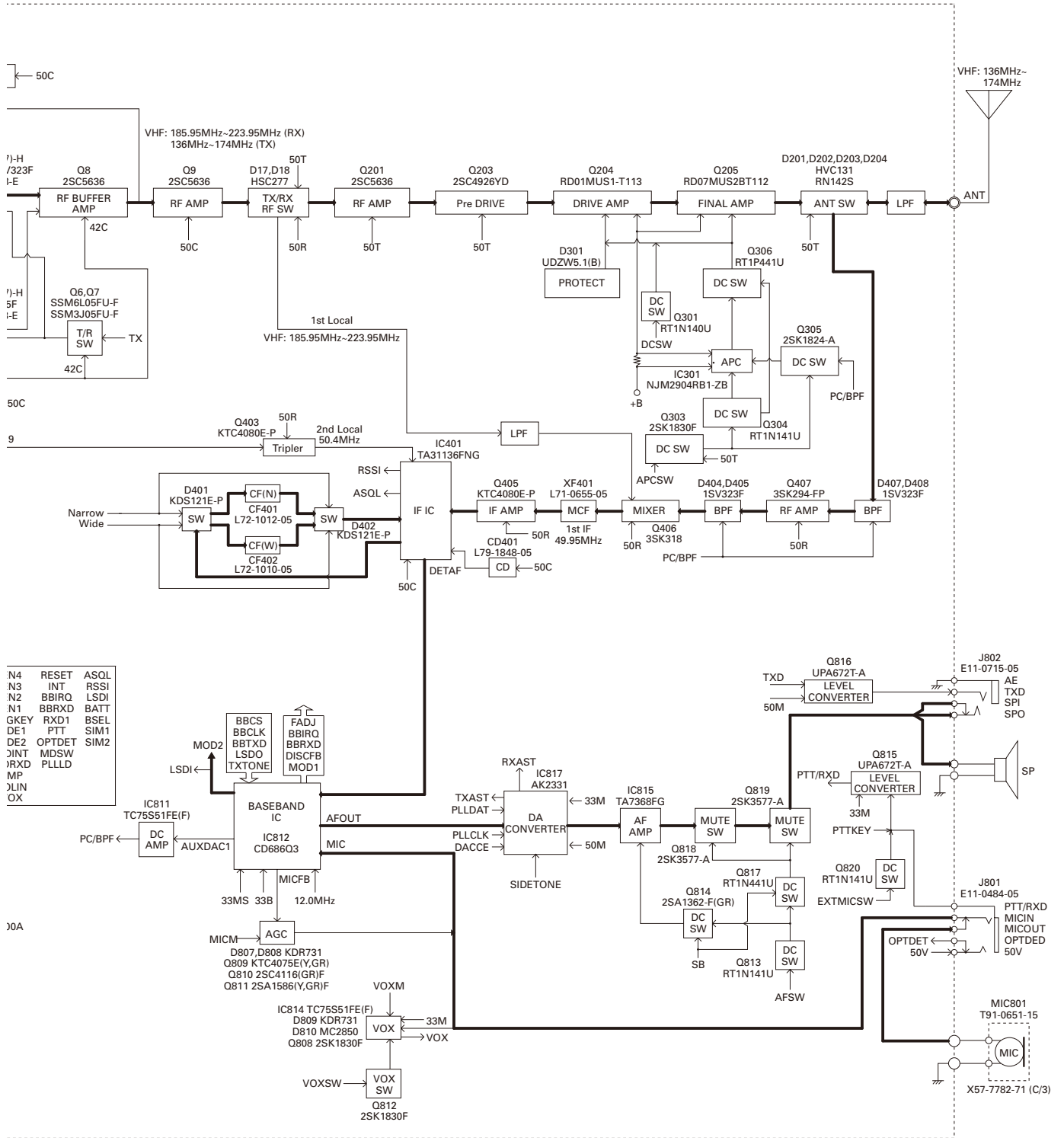

## LEVEL DIAGRAM

### Receiver Section

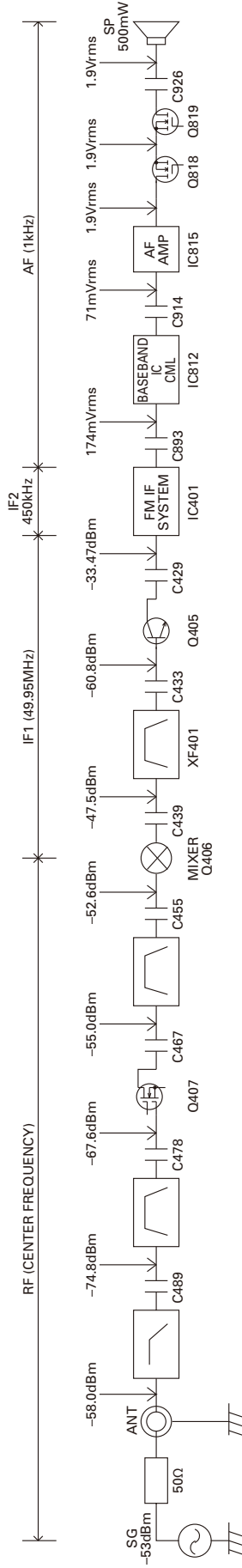

### Transmitter Section

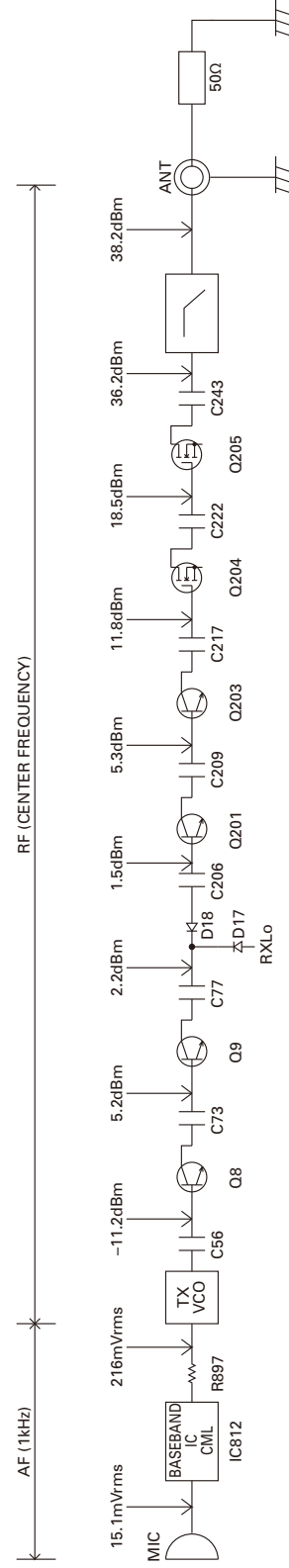

To make measurements in the AF section, connect the AC level meter.  
 (ANT input: -53dBm, 1kHz FM, 1.5kHz Dev (Narrow)).  
 In the RF section, use a high impedance probe. (ANT input: -53dBm, MOD off).

AG is set to the MIC input becomes 1.5kHz Dev, At 1kHz MOD. (Narrow)  
 To make measurements in the AF section, connect the AC level meter.  
 In the RF section, use a 1000pF coupling capacitor.

## OPTIONAL ACCESSORIES

### KNB-55L (Li-ion Battery Pack)

#### ■ External View



#### ■ Schematic Diagram

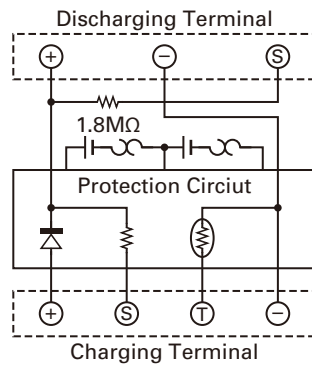

#### ■ Specifications

Voltage : 7.4V (3.7V x 2)  
Capacity : 1480mAh

### KNB-56N (Ni-MH Battery Pack)

#### ■ External View



#### ■ Schematic Diagram

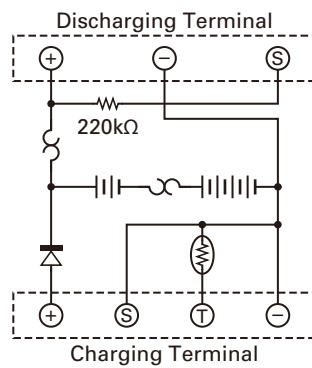

#### ■ Specifications

Voltage : 7.2V (1.2V x 6)  
Capacity : 1400mAh

### KNB-57L (Li-ion Battery Pack)

#### ■ External View



#### ■ Schematic Diagram

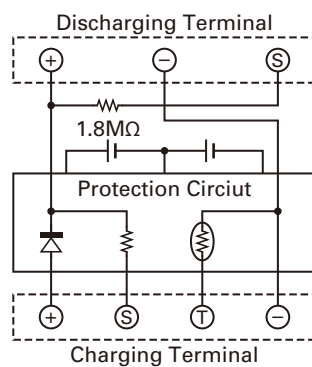

#### ■ Specifications

Voltage : 7.4V (3.7V x 2)  
Capacity : 2000mAh

## SPECIFICATIONS

### GENERAL

Frequency Range .....	136~174 MHz		
Number of Channels .....	MAX. 16		
Channel Spacing .....	25kHz (Wide 5k)	20kHz (Wide 4k)	12.5kHz (Narrow)
Operating Voltage .....	7.5V DC±20%		
Battery Life .....	More than 9 hours at 5 Watts (5-5-90 duty cycle, save off) With KNB-55L (1480mAh)		
Operating Temperature Range .....	-30°C to +60°C		
Frequency Stability .....	±2.5ppm (-30°C to +60°C)		
Channel Frequency Spread .....	38MHz		
Dimensions and Weight (Dimensions not included)			
Radio only .....	56 W x 103.7 H x 14.0 D mm	163g	
With KNB-55L .....	56 W x 103.7 H x 29.1 D mm	260g	

### RECEIVER (Measurements mode per EN Standards)

Sensitivity			
EIA 12dB SINAD .....	0.25µV (Wide 5k/4k)	0.28µV (Narrow)	
EN 20dB SINAD.....	-3dBµV (0.35µV) (Wide 5k/4k)	-2dBµV (0.40µV) (Narrow)	
Adjacent Channel Selectivity .....	70dB (Wide 5k/4k)	63dB (Narrow)	
Intermodulation .....	68dB		
Spurious Response Rejection .....	70dB		
Audio Distortion.....	Less than 5%		
Audio Output .....	500mW/8Ω		

### TRANSMITTER (Measurements mode per EN Standards)

RF Output Power.....	5W/1W		
Spurious Emission .....	-36dBm ≤ 1GHz	-30dBm > 1GHz	
FM Noise (EIA) .....	45dB (Wide 5k/4k)	43dB (Narrow)	
Microphone Impedance.....	1.8kΩ		
Modulation Distortion .....	Less than 5%		
Modulation .....	16K0F3E, 14K0F3E, 14K0F2D, 12K0F2D, 8K50F3E, 7K50F2D		

## Kenwood Corporation

2967-3, Ishikawa-machi, Hachioji-shi, Tokyo, 192-8525 Japan

### Kenwood U.S.A. Corporation

P.O. BOX 22745, 2201 East Dominguez Street, Long Beach,  
CA 90801-5745, U.S.A.

### Kenwood Electronics Canada Inc.

6070 Kestrel Road, Mississauga, Ontario, Canada L5T 1S8

### Kenwood Electronics Deutschland GmbH

Rembrücker Str. 15, 63150 Heusenstamm, Germany

### Kenwood Electronics Belgium N.V.

Leuvensesteenweg 248 J, 1800 Vilvoorde, Belgium

### Kenwood Electronics France S.A.

L'Etoile Paris Nord 2, 50 Allée des Impressionnistes,  
Bp 58416 Villepinte, 95944 Roissy Ch De Gaulle Cedex

### Kenwood Electronics UK Limited

KENWOOD House, Dwight Road, Watford, Herts.,  
WD18 9EB United Kingdom

### Kenwood Electronics Europe B.V.

Amsterdamseweg 37, 1422 AC Uithoorn, The Netherlands

### Kenwood Electronics Italia S.p.A.

Via G. Sirtori, 7/9 20129 Milano, Italy

### Kenwood Ibérica, S.A.

Bolivia, 239-08020 Barcelona, Spain

### Kenwood Electronics Australia Pty. Ltd.

Talavera Business Park Building A, 4 Talavera Road,  
North Ryde NSW 2113 Australia

### Kenwood Electronics (Hong Kong) Ltd.

Unit 3712-3724, Level 37, Tower one Metroplaza, 223 Hing Fong Road,  
Kwai Fong, N.T., Hong Kong

### Kenwood Electronics Singapore Pte Ltd

1 Ang Mo Kio Street 63, Singapore 569110



TX-RX UNIT (X57-7782-71) Component side view (J79-0259-19)

TX-RX UNIT (X57-7782-71) Component side view (J79-0259-19)

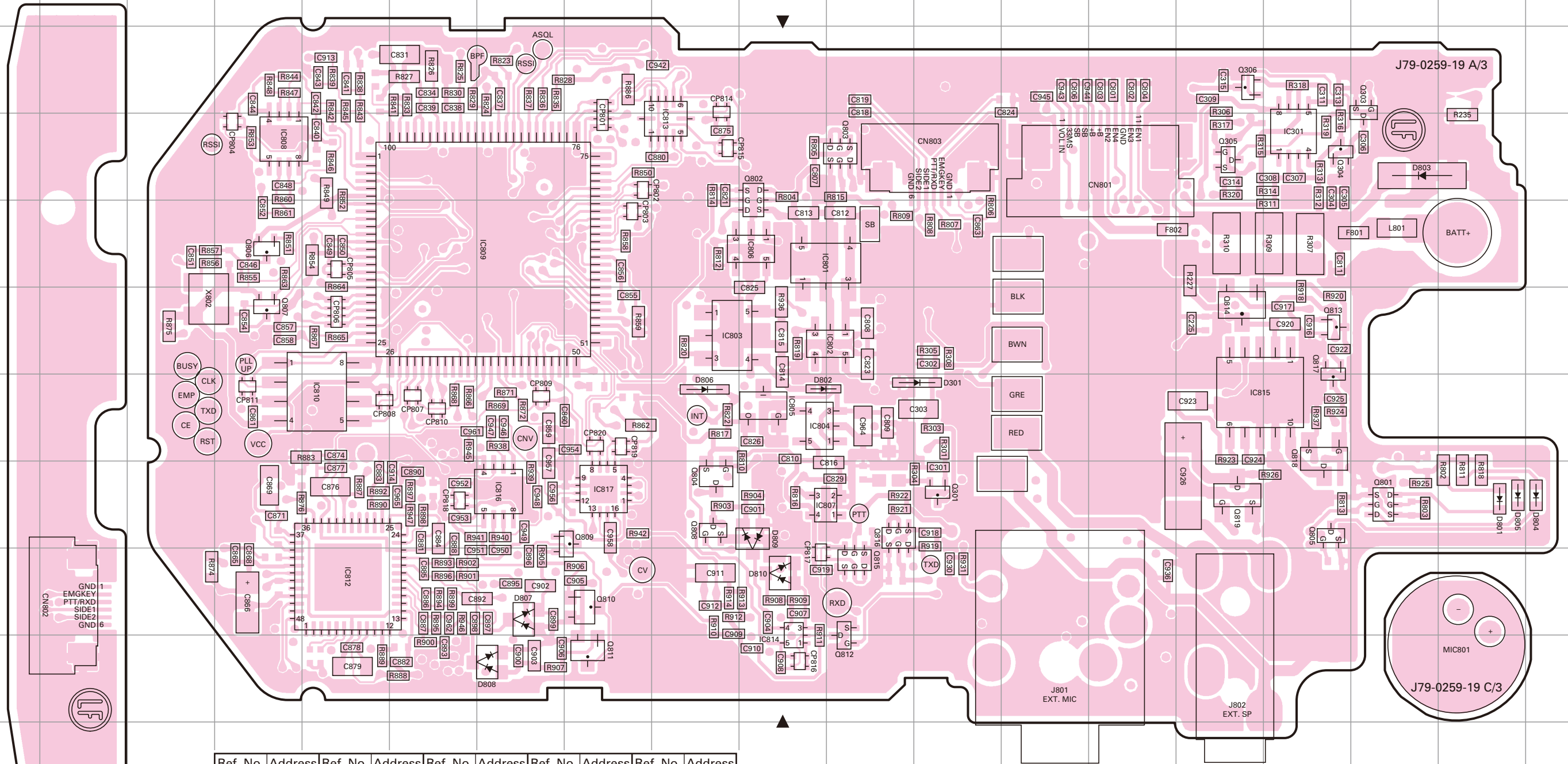

Ref. No.	Address	Ref. No.	Address	Ref. No.	Address	Ref. No.	Address	Ref. No.	Address
IC301	4P	IC812	9E	Q801	8Q	Q812	10K	D803	4Q
IC801	5J	IC813	4I	Q802	4J	Q813	6P	D804	8S
IC802	6K	IC814	10J	Q803	4K	Q814	6O	D805	8R
IC803	6I	IC815	7O	Q804	8I	Q815	9K	D806	7I
IC804	7J	IC816	8G	Q805	8P	Q816	8K	D807	9G
IC805	7J	IC817	8H	Q806	5D	Q817	6P	D808	10G
IC806	5J	Q301	8L	Q807	6D	Q818	7P	D809	8J
IC807	8J	Q303	3Q	Q808	8I	Q819	8O	D810	9J
IC808	4D	Q304	4P	Q809	8H	D301	7L		
IC809	5G	Q305	4O	Q810	9H	D801	8R		
IC810	7E	Q306	3O	Q811	10H	D802	7J		

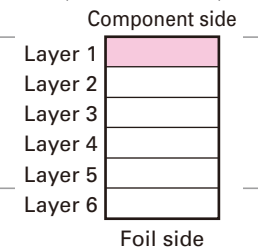

# TK-2360 PC BOARD

# PC BOARD TK-2360

TX-RX UNIT (X57-7782-71) Foil side view (J79-0259-19)

TX-RX UNIT (X57-7782-71) Foil side view (J79-0259-19)

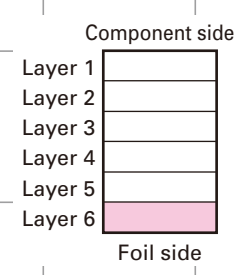
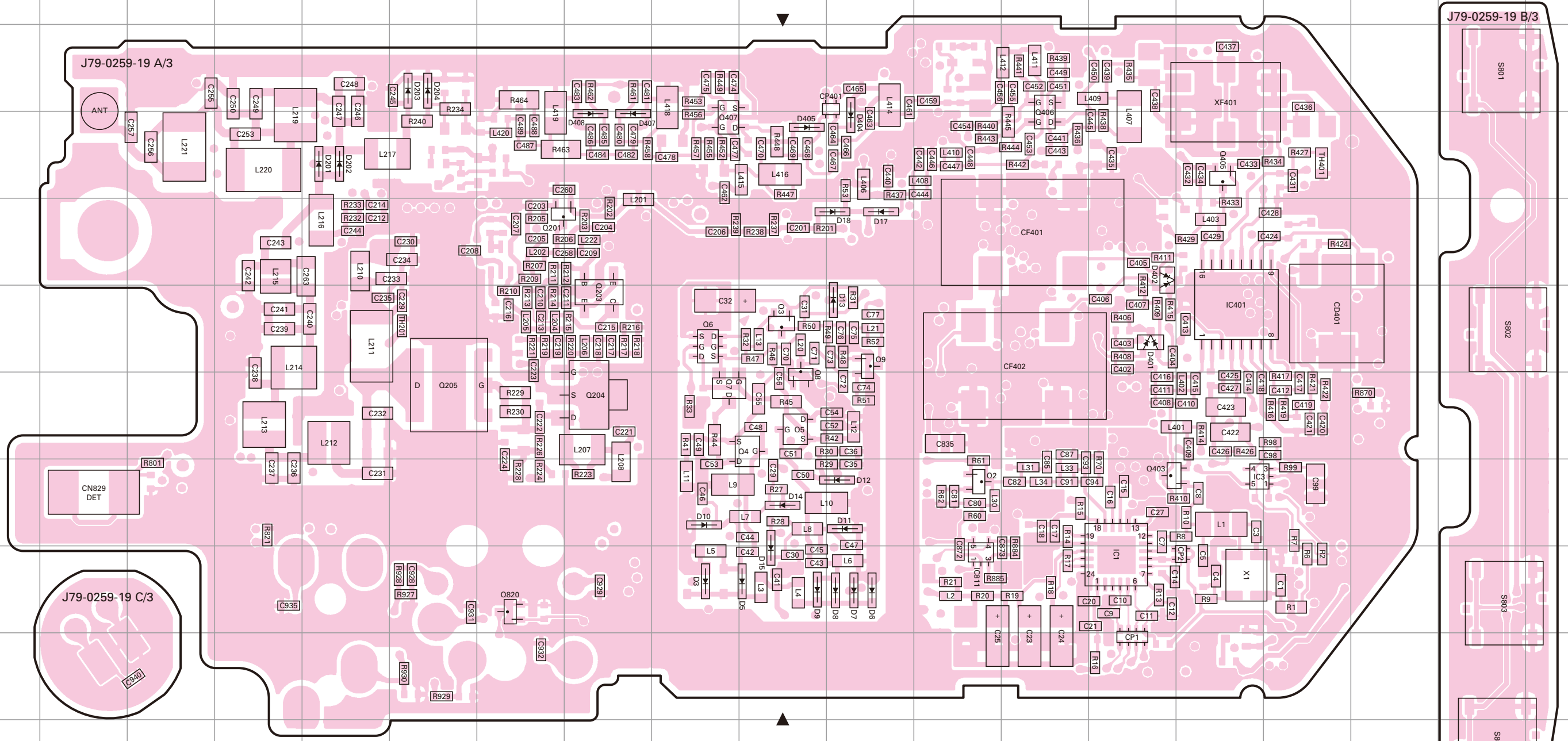

Ref. No.	Address	Ref. No.	Address	Ref. No.	Address	Ref. No.	Address	Ref. No.	Address
IC1	9N	Q8	7J	Q820	9G	D13	6K	D402	5N
IC3	8O	Q9	6K	D3	9I	D14	8J	D404	4K
IC401	6O	Q201	5G	D5	9J	D15	9J	D405	4J
IC811	9L	Q203	6H	D6	9K	D17	5K	D407	4H
Q2	8L	Q204	7H	D7	9K	D18	5K	D408	4H
Q3	6J	Q205	7F	D8	9K	D201	4E		
Q4	7J	Q403	8N	D9	9J	D202	4E		
Q5	7J	Q405	4O	D10	8I	D203	3F		
Q6	6I	Q406	4M	D11	8K	D204	3F		
Q7	7I	Q407	4I	D12	8K	D401	6N		

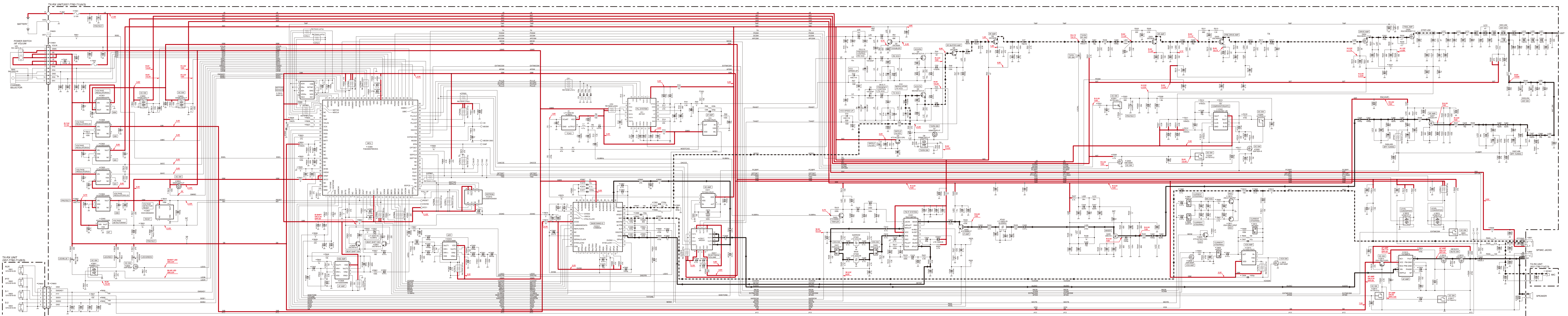

TX-RX UNIT (X57-7782-71(A)3)

TX-RX UNIT (X57-7782-71(B)3)

