

TK-280

SERVICE MANUAL

E VERSIONS



Photo is E type with KRA-14

CONTENTS

GENERAL	2
SYSTEM SET-UP	2
OPERATING FEATURES	3
REALIGNMENT	16
CIRCUIT DESCRIPTION	20
SEMICONDUCTOR DATA	26
DESCRIPTION OF COMPONENTS	32
PARTS LIST	33
EXPLODED VIEW	40
PACKING	41
ADJUSTMENT	42
TERMINAL FUNCTION	52
PC BOARD VIEWS	
DISPLAY UNIT (X54-3210-12)	53
TX-RX UNIT (X57-6192-70)	59
SCHMATIC DIAGRAM	65
BLOCK DIAGRAM	69
LEVEL DIAGRAM	71
OPTIONS	72
SPECIFICATIONS	BACK COVER

CAUTION

When using an external power connector, please use with maximum final module protection of 9V.

GENERAL / SYSTEM SET-UP

INTRODUCTION

SCOPE OF THIS MANUAL

This manual is intended for use by experienced technicians familiar with similar types of commercial grade communications equipment. It contains all required service information for the equipment and is current as of the publication data. Changes which may occur after publication are covered by either Service Bulletins or Manual Revisions. These are issued as required.

ORDERING REPLACEMENT PARTS

When ordering replacement parts or equipment information, the full part identification number should be included. This applies to all parts : components, kits, or chassis. If the part number is not known, include the chassis or kit number of which it is a part, and a sufficient description of the required component for proper identification.

PERSONNEL SAFETY

The following precautions are recommended for personnel safety:

- DO NOT transmit until all RF connectors are verified secure and any open connectors are properly terminated.

- SHUT OFF and DO NOT operate this equipment near electrical blasting caps or in an explosive atmosphere.
- This equipment should be serviced by a qualified technician only.

SERVICE

This radio is designed for easy servicing. Refer to the schematic diagrams, printed circuit board views, and alignment procedures contained within.

NOTE

The terms "Wide" and "Semi wide" used in this service manual correspond to "Wide 5K" and "Wide 4K" respectively that appear in the menu and help texts of the KPG-60D (Field Programming Unit).

Model & destination	Unit		Frequency range	Remarks	QT/DQT	5TONE/DTMF/DMS or 2TONE(Decode only)	Charger	Battery	
	X57-619X-XX	X54-321X-XX							
TK-280	E, T	✓	✓	146~174MHz	IF1 : 44.85MHz LOC : 44.395MHz	✓	✓	OP	OP

SYSTEM SET-UP

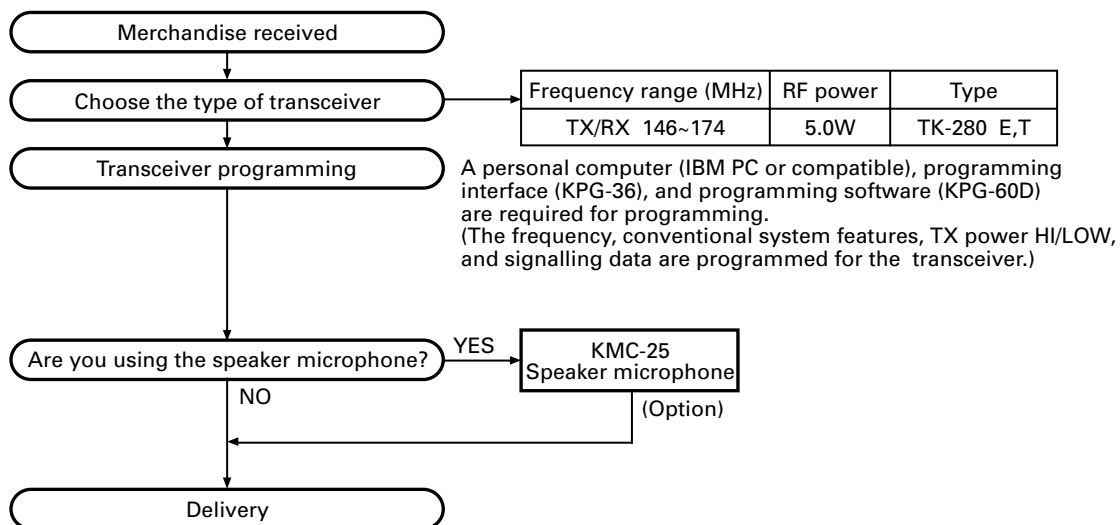

OPERATING FEATURES

1. Operation Features

The TK-280 is a VHF FM Radio designed in both 5tone Model and DTMF/2tone/DMS Model. The programmable features are summarized.

This transceiver can handle up to 250 groups with 250 channels in each group.



1-1. 5tone Model

In this model, you can program Basic or Full level features. When you select Basic level, only 1frame 5tone can be programmed, and various functions are limited.

When you select "Special setting" in the Full Level, you can use Encode/Decode format. Using Encode/Decode format, you can further program the transceiver to run the script.

1-2. DTMF/2tone/DMS Model

You can use Option signalling which is DTMF or 2tone(only for Decode) or DMS(Digital Message System -FFSK signalling) for every channel.

2. Transceiver Controls and Indicators

2-1. Physical Layout

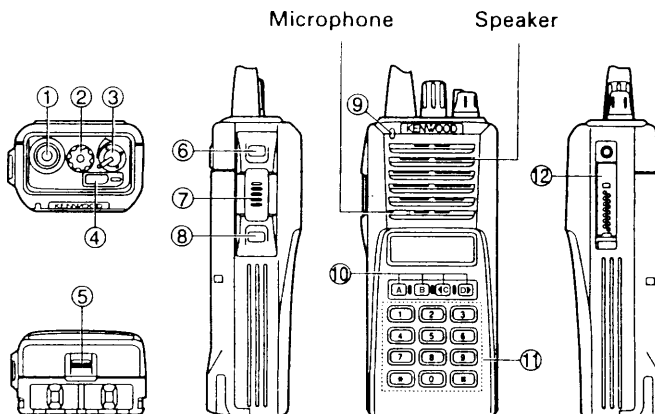

Note: The transceiver is also available without the DTMF keypad (11).

2-2. Panel controls

The key on the top and front panel is momentary-type push buttons. The functions of these keys and knob are explained below.

① Antenna connector

Connect the supplied antenna here.

② Group or Channel selector knob (Programmable)

Turning the group (or channel) selector knob clockwise increases the group (or channel) number by one. Turning the knob in the counterclockwise direction decreases the group (or channel) number by one.

After the group number (or channel number) reaches the highest group number (or channel number), it goes back to lowest group number (or channel number).

Group numbers (or channel numbers) not set are skipped.

Caution : The FPU (KPG-60D) allows selecting between group selector and channel selector.

③ Volume/Power switch

Transceiver Power and Volume switch. Turn clockwise to switch On the transceiver. Turn counterclockwise fully to switch OFF the transceiver. Also adjusts the volume level.

When the power is switched off, all the parameters, such as the group and channel, are stored in memory. When the power is switched on again, the group returns to the previous conditions.

④ Auxiliary (orange) key (Programmable)

⑤ Battery pack release catch

Push down to release the battery pack. See Installing the Ni-Cd Battery Pack.

⑥ MONITOR key* (Programmable)

⑦ PTT (Push-To-Talk) key

Press this key, then speak into the microphone to call a station.

⑧ CALL key* (Programmable)

⑨ TX/BATT indicator

This red LED lights during transmission (it does not light during busy or when transmit is prohibited). If the battery voltage falls below the programmed voltage during transmission, the brightness of this indicator decreases at intervals of about one second, so it can be used as the battery voltage alert function.

⑩ A, B, ◀ C, and D ▶ key (Programmable)

⑪ DTMF keypad (keypad model only)

Press the keys on the telephone keypad to send DTMF tones.

⑫ Universal connector

Connect the external KMC-25 speaker/ microphone (optional) here. Otherwise, keep the supplied cover in place.

* : MONITOR and CALL are arbitrary names chosen for these buttons. They can be used for any of the auxiliary functions.

OPERATING FEATURES

2-3. Programmable keys

The FPU (KPG-60D) enables programmable keys to select the following functions.

Function	DTMF/2tone/DMS Model	5tone Model	note
None	Yes	Yes	
Auto Dial	Yes	Yes	
Auto Dial Programming	Yes	Yes	
AUX B	Yes	Yes	Only when voice scrambler is not selected
Call 1	No	Yes	
Call 2	No	Yes	
Call 3	No	Yes	
Call 4	No	Yes	
Call 5	No	Yes	
Call 6	No	Yes	
Channel Down	Yes	Yes	
Channel Entry	Yes	Yes	
Channel Name	Yes	Yes	
Channel Up	Yes	Yes	
Emergency Call	Yes	Yes	
Fixed Volume	Yes	Yes	
Group Down	Yes	Yes	
Group Up	Yes	Yes	
Home Channel	Yes	Yes	
Key Lock	Yes	Yes	
Lamp	Yes	Yes	
Low Power	Yes	Yes	
Monitor	Yes	Yes	
Monitor Momentary	Yes	Yes	
Operator Selectable Tone	Yes	Yes	
Queue	Yes	Yes	
Radio Password	Yes	Yes	
Receive Entry	No	Yes	
Scan	Yes	Yes	
Scan Delete/Add	Yes	Yes	
Scrambler	Yes	Yes	
Selcall Entry	Yes	Yes	
Selcall List	Yes	Yes	
Selcall+Status Entry	Yes	Yes	
Selcall+Status List	Yes	Yes	
Shift	Yes	Yes	
Squelch Level	Yes	Yes	
Squelch Momentary	Yes	Yes	
Squelch Off	Yes	Yes	
Status Entry	No	Yes	
Status List	No	Yes	
Talk Around	Yes	Yes	
Channel Up/Down	Yes	Yes	
Group Up/Down	Yes	Yes	

OPERATING FEATURES

■ Auto Dial

To transmit the stored DTMF code automatically.

When you select DTMF Encode in the “Auto Dial Mode” menu, Auto Dial, Re-Dial, Dial ID and Store & Send modes are available.

Press the [Auto Dial] key to enter the “Auto Dial Mode”.

Select the desired number to send. It is used the Selector or the [2] and [8] keys to select.

Press the [*] key to transmit the numbers.

■ Auto Dial Programming

You can store the DTMF code and Name, or erase it at the transceiver.

● To store a DTMF code:

Press the [Autodial Programming] key to enter “Autodial Programming Mode”. Select the desired memory number you wish to store.

Press the [*] key to select the desired memory number(Enter Autodial Memory Name).

Press the [*] key to store the Memory Name. Now, enter the DTMF codes you want to store.

Press the [*] key to store the numbers.

A beep sound confirms that the numbers are stored in the memory.

● To erase the stored DTMF Code:

Press the [Autodial Programming] key to enter Autodial Programming mode.

Press the [#] key to enter Auto Dial Clear mode. Select the Memory Number you want to erase.

Press the [*] key to erase the stored numbers and exit Auto Dial Clear mode.

■ AUX B

This function can be programmed when the voice scrambler board is not installed.

If this key is pressed, an underscore (“_”) appears at the extreme right of the LCD and OPT port which is inside of the transceiver turns to the active level(Low). If pressed again, the underscore disappears and the OPT ports turns to the deactive level(High).

■ Channel Name

Press this key to switch between the “Channel Name” and “Grp#/Ch#” for the display. If no channel name is programmed, the transceiver automatically displays the group#/channel#.

■ Channel Up/Down

When this key is pressed each time, the channel number to be selected is increased/decreased and repeats if held for one second or longer.

■ Call 1 to 6 (5tone)

Press the [CALL #] key to transmit the 5tone code that is programmed to “Call #” in the System Parameters.

■ Channel Entry

You can directly recall the channel using the numeric keypad without using the [Channel Up/ Down].

To access the channel directly, enter 1 to 3 digit numbers, depending on the number of the programmed channels.

For example, if the radio has 199 programmed channels (the maximum channel number is a 3-digit number) and you would like to recall channel 5, you must enter [0], [0], [5]. If the radio has 99 channels (2-digit number), you must enter [0], [5] to access channel 5.

■ Emergency Call

Pressing this key causes the transceiver to enter the emergency mode. The transceiver jumps to the programmed “Emergency group/channel” and transmits for programmed “Duration of Transmission time”.

The transceiver disables mic mute while transmitting. After finishing transmission, the transceiver receivers for programmed “Duration of Receiving”. The transceiver mutes the speaker while receiving. Following the above sequence, the transceiver continues to transmit and receive.

You can select whether or not the emergency ID is transmitted in the emergency mode.

■ Fixed Volume

This function is used for changing the volume level, it is Power on Tone, Control Tone, Warning Tone, Alert Tone, AF Volume Type.

If these Tone is set up in “Fixed”, the Tone level can be changed when [Fixed Volume] key is pressed.

When [Fixed Volume] key is pressed, Tone level changes in turn to Low(Tone Volume Low), High(Tone Volume High) and Off.

■ Group Up/Down

When this key is pressed each time, the group number to be selected is increased/decreased and repeats if held for one second or longer.

■ Home Channel

Press this key once, the channel switches to the pre-programmed home channel.

■ Key Lock

Key Lock prevents accidental operation of the transceiver. When Key Lock is activated, all keys other that PTT, Emergency, Monitor, Monitor Momentary, Shift, Squelch, Squelch Momentary, Lamp, Volume are locked.

“LOCKED” appears momentarily when the Key Lock key is pressed.

OPERATING FEATURES

■ Lamp

Press the [Lamp] key to toggle the display backlight ON or OFF. The backlight automatically turns OFF approximately 5 seconds after it is switched ON.

Press any key other than [Lamp] while the backlight is ON to reset the 5-second timer. The timer will reset and the backlight will remain on for 5 seconds.

■ Low Power

When you press this key, "LO" appears and the transceiver switches to RF Low Power.

If you press this key while "LO" is displayed, the Power status reverts to the preset default setting. If "TX Power" is set to 'Low Power', no change occurs.

■ Monitor

● Model = DTMF/2tone/DMS:

When this key pressed once, "MON" icon lights and squelch unmutes if a carrier is present, regardless of the specified Signalling (including Option Signalling).

If pressed again, "MON" icon goes off and squelch mutes.

● Model = 5tone:

Depend on Monitor Function and Monitor Key Action in the System Parameters.

You can select either QT/DQT or 5tone decoding to be canceled when Monitor key is pressed.

When Monitor function is activated, "MON" icon appears.

■ Monitor Momentary

● Model = DTMF/2tone/DMS:

While pressing this key, "MON" appears and the squelch unmutes if a carrier is present, regardless of the specified Signalling (including Option Signalling).

If released, "MON" disappears, and the squelch mutes.

● Model = 5tone:

Depend on Monitor Function in the System Parameters.

You can select either QT/DQT or 5tone decoding to be canceled while pressing Monitor key.

When Monitor function is activated, "MON" icon appears.

■ Operator Selectable Tone

When this key is pressed, the "OST" appears and Encode/Decode QT/DQT is switched to the OST Tone pair. If pressed again, the "OST" display goes off and Encode/Decode QT/DQT returns to transceivers pre-set.

When this key is held down for 1 sec, the transceiver enters "OST Select Mode". In this mode, the display shows OST No. or OST Name which is set to the channel and operator can select one of OST Tone pair using, [Selector] or [2], [8] key of Key Pad.

If pressed this key again, the displayed OST code is memorized to the channel, the transceiver exits from the OST Select Mode, returns to normal channel display and "OST" display.

16 kinds of OST Tone pairs can be programmed in the Operator Selectable Tone window.

While in the OST Select mode, the transceiver does not look back at the priority channel in the scan resume mode.

■ Queue

Press [Queue] key to toggle Queue mode ON or OFF.

When it is ON, you will see the contents of the Queue buffer. You can scroll the Queue buffer using the selector, keys [2]/[8].

When you are in Queue mode, [D] or [6] key to toggle the Selcall and Status displays.

When you are in Queue mode, press the [C] or [4] key to toggle the Code and Selcall/Status displays.

Hold down the [D] or [6] key to delete the top stack of the Queue buffer.

Hold down the [C] or [4] key to cancel Queue mode and return to normal operation.

■ Radio Password

Back up is done even if the power supply is cut off.

A lock isn't canceled unless a proper password is inputted. The character which can be inputted is to 6 digits with the number of 0 - 9. A lock is canceled if it is the same as Code set up at "Optional Feature - Radio Password".

If the entered Radio Password is incorrect, the "Key Input Error Tone" sounds and the transceiver remains in "LOCK 1" screen.

■ Receive Entry (5tone)

Press [Receive Entry] key to enter the desired Selcall code you want to receive.

This function can be activated only when "RX Address" is set to the channel and "Selectable Receive Digit" has been entered.

When you enter Receive Entry mode, the "RX Address" number appears on the LCD.

To enter Selcall number, use the keypad . You can also use the channel selector to select the number . Then press [C] key to enter the selected number. The selected digit will shift left to enter the next digit.

Press [D] key to move the cursor 1 position right.

Hold down [D] key ([6] key on a keypad) to clear the entered number.

■ Scan

Press the [Scan] key to toggle scanning the channels ON and OFF. When the transceiver is scanning, "Revert CH Display" is temporary disabled and the SCN icon and "-SCAN-" appear.

■ Scan Delete/Add

Press the [Scan Del/Add] key to temporarily delete or add each channel from/to the SCAN list.

When a channel is added to the SCAN list, (∞) appears on LCD.

When the transceiver exits SCAN mode, the added or deleted channels are erased from the SCAN list.

The original SCAN list is restored.

OPERATING FEATURES

■ Scrambler

Press the [Scrambler] key to toggle the Scrambler ON or OFF. When it is activated, “_” (underscore) appears on LCD.

If you hold down the Scrambler key for more than 2 seconds, the transceiver enters “Scrambler Code Select Mode”.

You can select the Scrambler Code [1 to 4] using the [2], [8] keys or the Channel selector.

(Voice Scrambler unit must be installed)

■ Selcall Entry

Press [Selcall Entry] key to enter the desired Selcall code you want to call.

● Model = 5tone:

This function can be activated only when “TX Address” is set to the channel and “Selectable Selcall Digit” has been entered. When you enter Selcall Entry mode, the “TX Address” number appears on the LCD.

● Model = DTMF/2tone/DMS:

A transceivers unit ID is defined by a combination of 3-digit Fleet and 4-digit ID numbers.

To enter Selcall number, use the keypad . You can also use the channel selector to select the number.

Then press [C] key to enter the selected number.

The selected digit will shift left to enter the next digit.

Press [D] key to move the cursor 1 position right.

Hold down [D] key ([6] key on a keypad) to clear the entered number.

■ Selcall List

Press [Selcall List] key to enter Selcall List mode.

● Model = 5tone:

Select the check box of “Selectable Selcall Digit”. The number of digit you selected in “Selcall List” will be displayed on LCD. If “Selcall List” has not been programmed, same digits of Selcall List code that you checked as “Selectable Selcall” digits will appear on LCD.

● Model = DTMF/2tone/DMS:

The ID List code of DMS will appear on LCD.

To select the Selcall List, use the selector knob or [2]/[8] key.

■ Selcall+Status Entry

Select the selcall number you wish to call.

Press [Selcall + Status Entry] key to enter “Selcall Entry Mode”.

It works as “Selcall Entry Mode” mode.

If you press [CALL] or [*] key again, it works as “Status Entry Mode”.

■ Selcall+Status List

Select the selcall number you wish to call.

Press [Selcall + Status List] key to enter “Selcall List Select Mode”.

It works as “Status List” mode.

If you press [Selcall + Status List] key again, it works as “Status List Select Mode”.

■ Shift

It allows you to enable [Shift + Function] key access. When [Shift] key is pressed, SFT appears on LCD.

■ Squelch Level

Press [Squelch Level] key to enter “Squelch Level Adjustment Mode”.

The squelch level can be adjusted by the selector knob or [2]/[8] key.

Press [Squelch Level] key again to store the adjusted squelch level.

■ Squelch Momentary

Press [Squelch Momentary] key to force the squelch unmute. “MON” icon appears on LCD and BUSY LED (Green) lights.

If released, the squelch unmutes and “MON” disappears. Also, BUSY LED (Green) goes off.

■ Squelch Off

Press [Squelch Off] key to force the squelch unmute . “MON” icon appears on LCD and BUSY LED (Green) lights. If the key is pressed again, the squelch unmutes and “MON” disappears. Also, BUSY LED (Green) goes off.

■ Status Entry (5tone)

It allows the operator to input the status and transmit it to the base station.

Both TX Address and “Selectable Status Digit” must be programmed to perform the operation.

Press [Status Entry] key to access Status Entry mode.

“TX Address” of the channel appears on LCD.

Enter the desired code using a numeric keypad.

If the transceiver does not have the numeric keypad, or Selector knob to select the desired number and press [C] key to enter. The cursor moves to next position.

■ Status List (5tone)

Press [Status List] key to enter Status List mode.

Select the check box of “5tone - System Parameters - Selectable Status Digit”. The number of digit you selected in “5tone - Status List” will be displayed on LCD. If “Status List” has not been programmed, same digits of Status List code that you checked as “Selectable Status” digits will appear on LCD.

To select the Status List, use the selector knob or [2]/[8] key.

■ Talk Around

When Talk Around function is activated, “TA” appears and the transceiver transmits on the receive frequency, using receiver’s QT/DQT code.

The operator can call the other party directly (without repeater).

■ None

When you press this key, the transceiver emits the “Key Input Error Tone” (no function is performed).

OPERATING FEATURES

2-4. Display

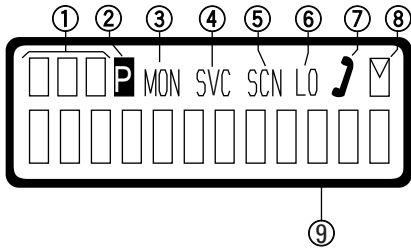

- ① **Sub display**
Displays the system, channel and group numbers. Also displays various functions, such as TA.
- ② **P (Priority) indicator**
The P indicator (**P**) appears when a selected channel is programmed as priority.
- ③ **MON (Monitor) indicator**
The MON indicator appears when the button programmed as MONITOR is pressed.
- ④ **SVC (Service) indicator**
This icon is not used on this transceiver.
- ⑤ **SCN (Scan) indicator**
The SCN indicator appears when using Scan mode.
- ⑥ **LO indicator**
Appears when low power is selected.
- ⑦ **Handset indicator**
This icon is not used on this transceiver.
- ⑧ **MAIL indicator**
Flashes when a status message (5tone or DMS) is received. Lights when a status message is stored in the stack memory.
- ⑨ **Alphanumeric display**
The twelve-character dot matrix alphanumeric display shows the group and channel numbers. You can program group and channel names with up to ten characters in place of these numbers. The left display is used as an add indicator (∞) and the right is used for the selective call ($\#$) or scrambler (_) function. The add indicator shows the channels unlocked out of the scanning sequence. Selective call and scrambler are optional functions that can be programmed.

3. Scan Operating

1) Scan types

- **Single Group Scan**

You can scan all valid (ADD) channels in the displayed group that can be selected with the group selector.

- **Multiple Group Scan**

You can scan all valid (ADD) channels in the all valid (ADD) group.

2) Scan Start Condition

One or more non-priority channels must be added to all channels that can be scanned. The transceiver must be in normal receive mode (PTT off).

When you activate the key programmed to the scan function, the scan starts. The scan icon "SCN" lights and "-SCAN-" or revert channel (programmable) is indicated on alphanumeric display.

3) Scan Stop Condition

The scan stops temporarily if the following conditions are satisfied.

- ① A carrier is detected, then signalling matches on channels for which receive the signalling is set by the programming software.
- ② A carrier is detected on the channel for which receiving signalling is not set by the programming software or when the monitor (signalling cancel) function is activated.

4) Scan Channel Types

- ① Priority channel is the most important channel for the scan, and always detects a signal during scan and when the scan stops temporarily.
- ② Non-priority channels detects a signal during scan. For the channels that can be selected with the group or channel selector when the scan does not occur, adds an indicator (∞) lights.

5) Priority Channel Setting

A priority channel can be set as follows with the programming software (KPG-60D).

- ① Specify a priority channel as a fixed priority channel.
- ② Make a selected channel a priority channel.

6) Scan Type According to the Priority Channel

- ① When no priority channel is set : Only the non-priority channels are scanned.
If a non-priority channel stops temporarily, it stops until there is no signal on the channel.
- ② When priority channel is set : Either priority channel is scanned.
If a non-priority channel stops temporarily, a priority channel signal is detected at certain intervals.
If a priority channel stops temporarily, it stops until there is no signal on the priority channel.

OPERATING FEATURES

7) Revert Channel

The revert channel is used to transmit during scanning and set by the programming software (KPG-60D).

- ① Priority
The transceiver reverts to the priority channel
- ② Priority with talkback
The transceiver reverts to the priority channel.
If you press PTT during a resume timer (dropout delay time, TX dwell time) or calling, you can transmit on current channel to answer to the call however revert channel is set to priority channel.
After resume time, scan re-starts and transmission channel is return to priority channel.
- ③ Selected channel
The transceiver reverts to the channel before scanning or the channel that you changed during scan.
- ④ Last called channel
The transceiver reverts to the last called channel during the scan.
- ⑤ Last used channel
The transceiver reverts to the last used (transmitted) channel during scan. "Last used" revert channel includes talkback function.
- ⑥ Selected with talkback
The transceiver reverts to the channel before scanning or the channel that you changed during scan.

8) Scan End

When you reactivate the key programmed to the scan function during scan mode, the scan ends.

The scan icon "SCN" and "-SCAN-" or revert channel (programmable) display goes off.

9) Temporarily Delete/Add

It is possible to delete or add channel temporarily during scan. When scan stops on unnecessary channel for example by interference of the other party, activate the delete/add function (for example press the key), then that channel is deleted temporarily and scan re-start immediately.

When you would like to add the deleted channel temporarily to scan sequence, select the desired (deleted) channel during scan, activate the delete/add function (for example press the key) before scan re-start.

That channel is added temporarily to scan sequence. The temporary deleted or added channels are returns to pre-set delete/add, when the transceiver exits from scan mode.

4. Details of Features

1) Time-out timer

The time-out timer can be programmed off or in 30 seconds increments from 30 seconds to five minutes. If the transmitter is keyed continuously for longer than the programmed time, the transmitter is disabled and a warning tone sounds while the PTT button is held down. The alert tone stops when the PTT button is released.

2) Sub LCD display

You can use 3-digit the display to display the channel number or group number. It is useful when the main (12-digit) display indicates, group or channel name or other functions.

3) Selective Call Alert LED

You can select whether or not the LED on the transceiver flashes in an orange color when selective call was occurred.

4) PTT ID

PTT ID provides a DTMF or FFSK (DMS : Fleet-ID) ANI to be sent with every time PTT (beginning of transmission, end of transmission, or both).

You can program PTT ID "on" or "off" for each channel. The contents of ID are programmed for each transceiver.

The timing that the transceiver sends ID is programmable.
BOT : DTMF ID (BOT)/FFSK ID is sent on beginning of transmission.

EOT : DTMF ID (EOT)/FFSK ID is sent on end of transmission.

Both : DTMF ID (BOT)/FFSK ID is sent on beginning of transmission and DTMF ID (EOT)/FFSK ID is sent on end of transmission.

5) Radio password

When the password is set in the transceiver, user can not use the transceiver unless enter the correct password.

This code can be up to 6 digits from 0 to 9 and input with the keypad or selector, and "CALL" key.

6) Minimum Volume

The minimum volume is programmable (off (0) to 31). The transceiver remains the minimum volume level however the mechanical volume position is set to zero.

7) "TOT" Pre-Alert

The transceiver has "TOT" pre-alert timer. This parameter selects the time at which the transceiver generates "TOT" pre-alert tone before "TOT" is expired.

"TOT" will be expired when the selected time passes from a TOT pre-alert tone.

8) "TOT" Re-Key Time

The transceiver has "TOT" re-key timer. This timer is the time you can not transmit after "TOT" exceeded. After "TOT" re-key time expired you can transmit again.

OPERATING FEATURES

9) "TOT" Reset Time

The transceiver has "TOT" reset timer. This timer is the minimum wait time allowed during a transmission that will reset the "TOT" count.

"TOT" reset time causes the "TOT" to continue even after PTT is released unless the "TOT" reset timer has expired.

10) OST (Operator Selectable Tone)

The transceiver is capable to have "OST" function and 16 tone pair (QT/DQT) with max 10-digit name for each tone pair.

- "OST" Back Up

The transceiver is programmable the selected "OST" code is memorized or not. If you set to Disable (no memorized), the "OST" function always starts at "off".

11) Clear to Transpond

The transceiver waits the transpond of 5tone/2tone/DTMF if channel is busy until channel open. This feature prevents the interference to other party.

12) Keypad Operation

This parameter selects the default use of the numerical field of the keypad.

You can select from "DTMF", "Selcall Entry", "Status Entry" and "OST"

In the case of "OST":

Enter to use the keypad to recall OST directly. To recall OST memory 1 - 9, press the OST number directly for 1 second. To recall OST memory 10 - 16, press "*" for 1 second, then press 0 - 6.

Example; Recall OST memory 15 : "*" "5"

When OST memory is recalled by Keypad 1 - 9, the "OST" display lights and OST is turned ON. If the keypad # is pressed, OST is turned OFF, and the "OST" display goes off.

13) Battery Warning

This transceiver has battery warning feature. If the low voltage is detected without limiting it during the transmission, the transceiver warns it by flashing red LED or beeps or LO icon.

Then more low voltage is detected during transmission, the transceiver stops transmission and warns.

Measurements given by this function should be used just as a reference.

14) Battery Save

Battery Saver becomes active when the squelch is closed. The receiver circuit power is toggled ON and OFF to prolong battery life, except in Scan mode.

The "ON" time is automatically selected by the signal conditions.

The "OFF" time is selectable as [OFF], [Short](200ms), [Med](400ms) and [Long](800ms).

15) Auto Light on

You can use the transceiver to turn on the backlight automatically when a key is pressed.

You can turn off the back light by pressing the [Lamp] key while the backlight is ON. You can manually turn on the light at any time by pressing the [Lamp] key.

16) Squelch Logic Signal

This signal is useful for external radio control units which require a signal at the time of Carrier Operate Relay or Tone Operate Relay.

17) TX Sense

Select one of the following three output functions for data communication:

Mic PTT:

Indicates the state of the Microphone PTT.

Mic PTT on = Low; Mic PTT off = High.

TX line:

Indicates the actual transmitter activity.

TX on = Low; TX off = High.

18) Com Port

Com0:

This function selects the external serial port function at the universal connector (TXD/RXD). PC programming is accepted, regardless of this setting.

Com1:

This function selects the external COM1 pin serial port function. if you select External Switch, you can use the External Switch as the input terminal (TXD1/RXD1).

5. Option Signalling (DTMF/2 tone)

Built-in DTMF decoder is available for option signalling.

Built-in 2-Tone decoder is available for option signalling.

It is possible to use individual call, group call, stun, kill. Stun and kill are used with DTMF only.

Preset operation is triggered when matches with Option Signaling

When Option Signaling matches on a Group Channel where set to Yes, the Option Signaling display flashes and Option Signaling is canceled. Settings after this will cause "Transpond" or "Alert" to sound.

Setting the Selective Call Alert LED will make an orange LED start flashing.

Mute or Unmute is triggered by the ID/QT/DQT/Carrier when option signaling is a match (when Option Signal is deactivated by a transmission).

OPERATING FEATURES

AND/OR

Option Signaling match conditions can be selected with AND/OR logic.

	Alert/Transpond	AF Mute Open
AND	Triggers at match with QT/DQT/ID+DTMF(2tone);Both	Triggers at match with QT/DQT/ID+DTMF(2tone);Both
OR	Triggers only for match with DTMF (2tone) : Opt	Triggers only for match with QT/DQT/ID;Signaling

Even if set for OR, AF mute cannot be canceled just by a match with DTMF.

In channels not set with QT/DQT, signaling is a match just by receiving the carrier.

Auto Reset

When Option Signaling matches on a Group channel where set to Yes, Option Signaling is canceled when it matches a group channel set to Yes.

After Option Signaling is a match, Option Signaling can automatically set to Reset after a specified time.

Stun/Kill

If the Stun code matches, a predetermined action will occur. Whether option signalling is activated or not, when stun code matches on any channel, the transceiver will become stun or kill.

While stun is active("LOCK 2" appears), if the stun code + "#" code is received, stun will disactive.

While kill is active("ERROR" appears), the transceiver will be disable all functions. The transceiver must be reprogrammed by the FPU(KPG-60D) to operation again.

6. Alphanumeric Two-way Paging Function (Digital Message System)

■ General

The Alphanumeric Two-way Paging Function (DMS) is a Kenwood proprietary protocol. It enables a variety of paging functions.

■ ID Construction

A radio unit ID is defined by a combination of 3-digit Fleet and 4-digit ID numbers. Each radio unit must be assigned its own Fleet and ID numbers.

■ Digital Message System[DMS]

• Inter-fleet Call

Inter-Fleet Calls allow a radio of one Fleet number to call a radio with a different Fleet number (radio users can manually dial a Unit ID with a different Fleet number).

■ PTT ID

A pre-programmed unique ID can be sent at the beginning of transmission and/or the end of transmission to identify which radio unit is on air.

■ Selective Call (SELCALL)

This is a voice call to a particular individual or group of stations.

• Example of call types;

[100][ALL] : <Group Call>

All the units whose fleet number is "100" are called.

[100][1000] : <Individual Call>

The unit, whose the fleet number is "100" and ID number is "1000", is called.

[ALL][ALL] : <Broadcast Call>

All the units are called.

[ALL][1000] : <Supervisor Call>

All ID "1000" are called regardless of their fleet number.

• Unit ID Encode Block

Encode ID Block can be set to limit manual dial ID. The radio unit will not accept an ID other than these IDs which are entered from the keypad. If Inter-fleet Call is enabled, block ID setting affects each fleet group.

■ Status Message

Using a 2-digit number, you can send and receive a Status message which may be decided in your talk group. Each Status may be displayed with 16 alphanumeric characters if programmed in the radio. A maximum of 15 received messages can be stored in the stack memory, and it can be reviewed after reception. If the message memory becomes full, the oldest one will be erased. The stack memory will be cleared by turning radio power off.

• Status 80~99 (Special)

Status numbers from 80 to 99 are reserved for special purposes. Entering these statuses from the DTMF keypad can be inhibited.

Please notice that the following status numbers are used for special purposes;

80~89 : Reserved for future use.

90 : Remote kill on. Disable all transceiver functions.

91 : Remote stun on. The transceiver cannot operate.

92 : Turns stun off.

93 : Spare.

94 : Acknowledgement status sent when the radio unit is in stun mode.

95~98 : Reserved for future use.

99 : Emergency Status.

Note : Remote stun works with DTMF stun function also.

• Automatic Status Response

If you pre-select a status number and leave the radio in the Status Mode, it can automatically respond with the selected status number upon request from the base station. (The request function is initiated by serial control on the base station (Optional).)

OPERATING FEATURES

■ Short Message (Optional)

A maximum of 48 characters can be sent (External equipment is required). Received Short Messages will be displayed in the same manner as a Status Message. A maximum of 15 received messages can be stored in the stack memory. In the Stack Mode, 3-digit LCD indicates the received Short Message as "Q1"~"Q15".

■ Long Message

A maximum of 4096 characters can be sent (External equipment is required). Received Long Message will not be displayed or stacked in the radio memory but is output through the COM (Data) port.

■ Emergency Function

Emergency status 99 will be sent at the beginning of each emergency transmission.

• Emergency Status response

"Alert" can be selected for the called radio unit's response to reception of status 99 which is used as an emergency status.

■ Other Functions

• Manual Dial

Fleet, ID and Status numbers can be entered from DTMF keypad. (DTMF microphone is required.)

• Data TX with QT/DQT

Whether programmed QT/DQT is modulated or not with a data transmission except for Selcall. A radio unit can receive a data message regardless of QT/DQT if the receiving unit is not scanning.

• DMS Baud Rate

FFSK data baud rate setting. The same rate must be set as a communication partner.

1200bps :

Data communication is made in 1200bps. The communication area is much wider than 2400bps. Recommended for repeater operation.

2400bps :

Data communication is made in 2400bps. The communication area is narrower than 1200bps, but it will decrease the data traffic. Data rate 2400bps may not work properly depending on the repeater's characteristic.

• Inter-fleet call

• Status/Short/Long Message on Data Group/Channel

Status/Short/Long Message transmission is made whether on the Data Group/Channel.

• Status/Short/Unit ID Message Serial Output

Whether a received Status/Short message or PTT ID is outputted or not to serial port.

■ Parameters

• GTC Count

Number of "Go To data Channel" messages to be sent before transmitting a data message if it is being made on Data Group/Channel. If a radio unit receives a GTC message, it will move to the Data Group/Channel of the current Group. Increase this item to make sure the called radio unit moves to the Data Group/Channel.

• Random Access (Contention)

When a channel is busy, radio unit will not transmit (depending on its Busy Channel Lockout setting). As soon as a channel is cleared, some transmissions may crash. Random access is used to avoid this by employing a random transmission sequence.

• Number of Retries

Number of Retries is the maximum number of retry transmission when no acknowledgement is received in the Maximum ACK Wait Time. Increase this item to improve data communication reliability.

• TX Busy Wait Time

TX Busy Wait Time is the maximum amount of time before giving up the data transmission when the channel is busy. Also, this timer affects if it expires during Random Access period.

• Maximum ACK Wait Time

Maximum ACK Wait Time is the maximum amount of time to wait for an acknowledgement from the called radio unit. It is used as an interval time of retries. It must be set greater than the ACK Delay Time of the called radio unit.

• ACK Delay Time

ACK Delay Time is the amount of time from the end of receiving a data to the beginning of sending an acknowledgement. It should be adjusted as the repeater's hang-up delay time. Also, it must be set less than the Maximum ACK Wait Time of the calling radio unit.

• TX Delay Time (RX Capture)

TX Delay Time is the amount of unmodulated transmission to let the called unit stop scanning or exit its battery save mode. It is used only when starting a data communication sequence.

• Data TX Modulation Delay Time

Data TX Modulation Delay Time is the amount of time from the beginning of transmission to the beginning of a data modulation. It is used every time data is transmitted.

OPERATING FEATURES

7. 5tone

When you select 5tone Model, you can set the following options.

When you select Basic level features, only 1 frame 5tone format can be programmed.

When you select Full level features, up to 3 frame 5tone format can be programmed.

Enabling "Setting Level" on each menu, you can also use "Encode/decode format".

Using "Encode/decode format", you can further program the transceiver to run the script.

■ 5tone Standard

The selected 5tone Standard is used for 5tone encoding and decoding.

Range:

ZVEI, CCIR, EEA, PZVEI, DZVEI, PCCIR, PDZVEI, ZVEI-2, EIA, Natel, AP-369, Kenwood

■ Monitor Function

You can select either QT/DQT or 5tone decoding to be canceled when [Monitor] or [Monitor Momentary] key is pressed.

When Monitor function is activated, "MON" icon appears.

When the transceiver is set up in "QT/DQT", cancels the decoding in QT/DQT Decode.

The squelch is controlled by the signal carrier only.

When the transceiver is set up in "5tone", cancels the decoding in 5tone Decode.

The squelch is controlled by QT/DQT Decode only.

If QT/DQT code is programmed in QT/DQT Decode, incoming signal must match the QT/DQT code to open the squelch.

■ Digit Entry Method

Receive, Selcall or Status Digit appears when you enter their entry mode, pressing [Receive Entry], [Selcall Entry] or [Status Entry] key, or "Keypad Operation" is programmed to "Selcall Entry" or "Status Entry" and press [0] - [9] key.

You can select the operation of the function. Or the digit number when entering their entry mode appears.

When the transceiver is set up in "Overwrite", new their digit number will overwrite the previous their digit when entering their entry mode.

When the transceiver is set up in "Replace", new their digit number will overwrite the their digit that is programmed in RX Address or TX Address menu when entering their entry mode.

■ Busy Channel Lockout

You can inhibit the transmission while the channel is busy. You can program the following different conditions.

When the transceiver is set up in "Lockout 1":

Do not transmit when the transceiver is receiving the carrier.

Transmit when the transceiver is not receiving the carrier.

When the transceiver is set up in "Lockout 2":

Do not transmit when the transceiver is receiving the carrier and QT/DQT code does not match.

Transmit when the transceiver is not receiving the carrier or receiving the QT/DQT code matches.

■ Selectable Receive Digit

Select the check box to change Receive Code (maximum 8 digits) manually when receiving Decode Code. You cannot select Selectable Receive Digit, Store Selcall Digit and Store Status Digit at the same time.

For example, the transceiver receives 5tone code, #59401 when you have 4th and 5th digit checked in Selectable Receive Digit menu. In this case, #01 is stored as Receive Code.

Press [Receive Entry] key to enter Receive Entry mode.

When you enter Receive Entry Mode, you can change the Receive Code, #01.

You can receive the Receive Code after the modification.

■ Selectable Selcall Digit

Select the check box to change Selcall Code (maximum 8 digits) manually when transmitting Encode Code. You cannot select Selectable Selcall Digit and Selectable Status Digit at the same time.

For example, the transceiver receives 5tone code, #59401 when you have 4th and 5th digit checked in Selectable Selcall Digit menu. In this case, #01 is stored as Selcall.

Press [Selcall Entry] key or "Keypad Operation" to enter Selcall Entry mode.

When you enter Selcall Entry Mode, you can change the Selcall Code, #01.

You can transmit the Selcall after the modification.

■ Selectable Status Digit

Select the check box to change Status Code (maximum 8 digits) manually when transmitting Encode Code. You cannot select Selectable Selcall Digit and Selectable Status Digit at the same time.

For example, the transceiver receives 5tone code, #5940167 when you have 6th and 7th digit checked in Selectable Status Digit menu.

Press [Selcall Entry] key or "Keypad Operation" to enter Status Entry mode.

When you enter Status Entry Mode, you can change the Status Code, #67.

You can transmit the Status code after the modification.

■ Automatic Close

It compares the selected digits of RX Address code in Channel menu when the transceiver receives 5tone signalling. If the selected digits matches to the received 5tone code, the transceiver closes Monitor. You can select maximum 8 digits of RX Address.

OPERATING FEATURES

■ Copy from TX/RX Address

You can select to copy the digit to the memory when you change the channel, using [Selector] key.

The memory represents the code that is displayed by the keypad.

Or Key Buffer, “^K1 ... ^K8” used by Encode Format.

Receive Digit in “RX Address” is copied when the channel is changed. Selcall/Status Digit in “TX Address” is copied when the channel is changed.

■ Encode Code

When “Special Setting” is disabled, you can select the Encode Code to transmit when [Call 1-6] key is pressed.

You can select up to 3 codes to transmit 3-frame 5tone code. The Encode Code is transmitted from left to right digit. 24 different Encode Codes are available.

When “Special Setting” is enabled, you can select the Encode Format setting from #1 to #32.

You can select the Encode Format name, configured in Encode Format menu.

■ Decode Code

When “Special Setting” is disabled, you can select the Decode Code setting from #1 to #8.

The transceiver tries to decode the selected Decode Code setting (maximum 8 different settings) at the same time. When the code matches in “5tone Code” menu, the transceiver operates as programmed in “Decode Code” menu.

When “Special Setting” is enabled, you can select the Decode Format setting from #1 to #32.

You can select the Decode Format name, configured in Decode Format menu.

You can program the 5-tone code you want to receive for each channel. At the same time, you can be on stand-by for a Single tone.

If the 5-tone code set in your transceiver matches a received code, Monitor is activated and a beep sounds. You can display the received 5-tone code on the LCD screen and transmit an acknowledgement to the Base station. Furthermore, you can activate the Horn Alert, Transfer, stun, and kill features.

■ Selcall/Status List

You can program Selcall or Status Message when you select the party from the List to make a 5tone selective call. Or you want to display Selcall(Status) Code or Message when you receive the call.

Maximum 8-digit can be programmed for the Code and 100 different Selcalls or Status are available for Selcall/Status List.

You can assign 16 alphanumeric characters to each message.

■ Programmable Alert Tone

You can program the alert type from type 1 to type 8, when the expected 5-tone is received.

You can program the number of times to repeat outputting and frequency and duration for the Alert Tone.

When you select “Special Setting”, you can further configure the beep tone type from No. 1 to No. 47, using the Encode/Decode format.

■ Encode/Decode Format

You can use Encode/Decode Format script function when you select “Feature Level”=FULL and “Special Setting”=Enabled.

In order to write the Encode/Decode Format script, you need the technical knowledge of 5tone signalling functions. Of course, you can write the script to perform all the functions that you can do with “Feature Level”=BASIC and FULL and “Special Setting”=Disabled. (Menu driven method)

In addition, you can write the original script to control various functions and signalling timing.

Refer to each function of Encode/Decode Format Code for details. Sample scripts are also available in the KPG-60D.

You can create 32 different types of Encode/Decode Formats. You can assign a name up to 12 characters for each Encode/Decode Format.

8. Audible User Feedback Tones

The transceiver outputs various combinations of tones to notify the user of the transceiver operating state. The main tones are listed below.

■ Power on tone

This tone is output when the transceiver is turned on. (The high tone is output for 500ms.)

■ Alert tone

This tone is output when the transceiver is TX inhibition for TOT, battery warning and PLL unlocked. It is output until the PTT button is released.

■ Group call tone

Sounds when a group call with the correct DTMF/2-tone option signalling is received.

■ DMS signalling alert tone

Sounds when an individual call with the correct DMS signalling is received.

■ Individual call tone

Sounds when an individual call with the correct DTMF/2-tone option signalling is received.

OPERATING FEATURES

■ Key press tone [A]

Sounds when a key is pressed. For toggle keys, sounds when toggle function is turned on (key press tone [B] sounds when it is turned off).

■ Key press tone [B]

Sounds when a key is pressed. For toggle keys, sounds when the toggle function is turned off (key press tone [A] sounds when it is turned on).

■ Key press tone [C]

Sounds when a key is pressed. Also sounds when storing data, adding a DTMF code to memory, and when changing test mode settings.

■ Key input error tone

Sounds when a key is pressed but that key cannot be used.

■ Roll over tone

Sounds at the smallest group/channel.

■ Transpond tone

Sounds when an individual call with the correct DTMF/2-tone option signalling is received. For group calls, only the group tone will sound, not the transpond tone.

■ Pre alert tone

Sounds prior to the TOT TX inhibit activation. If TOT pre alert is set, the tone sounds at the amount of time programmed, before the TOT expires (TOT time–TOT pre alert time = Pre alert tone sounding time).

REALIGNMENT

1. Modes

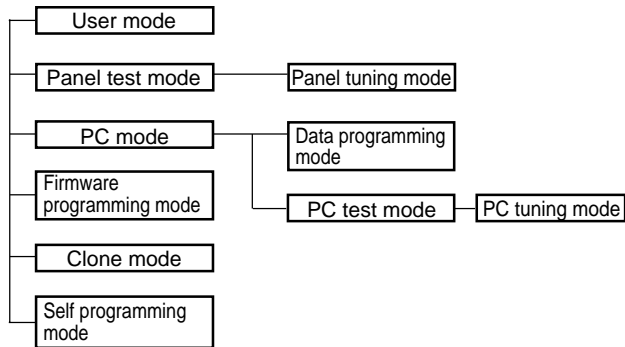

Mode	Function
User mode	For normal use.
Panel test mode	Used by the dealer to check the fundamental characteristics.
Panel tuning mode	Used by the dealer to tune the radio.
PC mode	Used for communication between the radio and PC (IBM compatible).
Data programming mode	Used to read and write frequency data and other features to and from the radio.
PC test mode	Used to check the radio using the PC. This feature is included in the FPU. See panel tuning.
Firmware programming mode	Used when changing the main program of the flash memory.
Clone mode	Used to transfer programming data from one radio to another.
Self programming mode	Frequency, signalling and features write to the radio.

2. How to Enter Each Mode

Mode	Operation
User mode	Power ON
Panel test mode	[B]+Power ON
PC mode	Received commands from PC
Panel tuning mode	[Panel test mode]+[A]
Firmware programming mode	[A]+Power ON
Clone mode	[D]+Power ON
Self programming mode	[CALL]+Power ON

3. Panel Test Mode

Setting method refer to ADJUSTMENT.

4. Panel Tuning Mode

Setting method refer to ADJUSTMENT.

5. PC Mode

5-1. Preface

The TK-280 transceiver is programmed by using a personal computer, programming interface (KPG-36) and programming software (KPG-60D).

The programming software can be used with an IBM PC or compatible. Figure 1 shows the setup of an IBM PC for programming.

5-2. Connection procedure

1. Connect the TK-280 to the personal computer with the interface cable.
2. When the POWER switch on, user mode can be entered immediately. When PC sends command the radio enter PC mode, and "PROGRAM" is displayed on the LCD. When data transmitting from transceiver, the red LED is blinking. When data receiving to transceiver, the green LED is blinking.

Notes:

- The data stored in the personal computer must match model type, when it is written into the flash memory.
- Change the TK-280 to PC mode, then attach the interface cable.

5-3. KPG-36 description

(PC programming interface cable: Option)

The KPG-36 is required to interface the TK-280 to the computer. It has a circuit in its D-subconnector (25-pin) case that converts the RS-232C logic level to the TTL level.

The KPG-36 connects the universal connector of the TK-280 to the computers RS-232C serial port.

5-4. Programming software KPG-60D Description

The KPG-60D is the programming software for the transceiver supplied on two 3.5" floppy disks. This software runs under MS-Windows 95/98 on an IBM-PC or compatible machine.

The data can be input to or read from the transceiver and edited on the screen. The programmed or edited data can be printed out. It is also possible to tune the transceiver.

We recommend that install the KPG-60D for example to hard disk first then use it.

5-5. Programming with IBM PC

If data is transferred to the transceiver from an IBM PC with the KPG-60D, the destination data (basic radio information) for each set can be modified. Normally, it is not necessary to modify the destination data because their values are determined automatically when the frequency range (frequency type) is set.

The values should be modified only if necessary. Data can be programmed into the flash memory in RS-232C format via the universal connector.

REALIGNMENT

KPG-60D instruction manual parts No. : B62-1315-XX

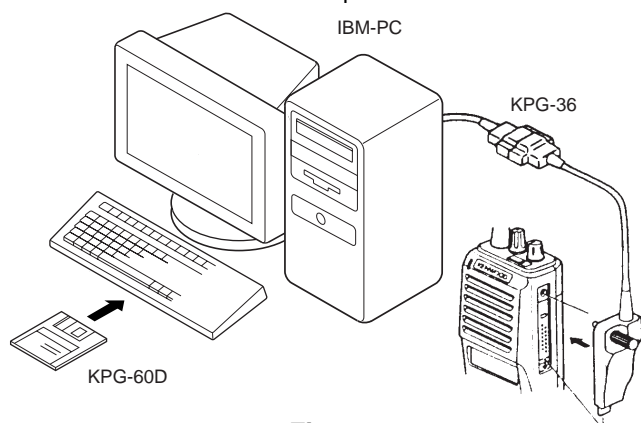

Fig. 1

6. Firmware Programming Mode

6-1. Preface

Flash memory is mounted on the TK-280. This allows the TK-280 to be upgraded when new features are released in the future. (For details on how to obtain the firmware, contact Customer Service.)

6-2. Connection procedure

Connect the TK-280 to the personal computer (IBM PC or compatible) with the interface cable (KPG-36). (Connection is the same as in the PC Mode.)

6-3. Programming

1. Start up the firmware programming software (Fpro.exe).
2. Set the communications speed (normally, 57600 bps) and communications port in the configuration item.
3. Set the firmware to be updated by File name item.
4. Turn the TK-280 power ON with the [A] switch held down. Hold the switch down until the display changes to "PROG 57600". When "PROG 57600" appears, release your finger from the switch.
5. Check the connection between the TK-280 and the personal computer, and make sure that the TK-280 is in the Program mode.
6. Press write button in the window. A window opens on the display to indicate progress of writing. When the TK-280 starts to receive data, the [P] icon is blinking.
7. If writing ends successfully, the LED on the TK-280 lights and the checksum is displayed.
8. If you want to continue programming other TK-280 s, repeat steps 4 to 7.

Notes:

- This mode cannot be entered if the Firmware Programming mode is set to Disable in the Programming software (KPG-60D).
- When programming the firmware, it is recommend to copy the data from the floppy disk to your hard disk before update the radio firmware.
Directry copying from the floppy disk to the radio may not work because the access speed is too slow.

6-4. Function

1. If you press the [MON] switch (top of left side) while "PROG 57600" is displayed, the version is displayed. If you press the [MON] switch again while the version is displayed, "PROG 57600" is redisplayed.
2. If you press the [CALL] switch (bottom of left side) while "PROG 57600" is displayed, the display changes to "PROG 19200" to indicate that the write speed is low speed (19200 bps). If you press the [CALL] switch again while "PROG 19200" is displayed, the display changes to "PROG 38400", and the write speed becomes the middle-speed mode (38400 bps). If you press the [CALL] switch again while "PROG 38400" is displayed, the display returns to "PROG 57600".
3. If you press the [CALL] switch while the version is displayed, the checksum is displayed. If you press the [CALL] switch again while the checksum is displayed, the version is redisplayed.

Note:

Normally, write in the high-speed mode.

7. Clone Mode

Programming data can be transferred from one radio to another by connecting them via their external universal connectors. The operation is as follows (the transmit radio is the master and the receive radio is a slave).

1. Turn the master TK-280 power ON with the [D] key held down. If the Data password is set to the TK-280, the TK-280 displays "CLONE LOCK". If the password is not set, the TK-280 displays "CLONE MODE".
2. When you enter the correct password, and "CLONE MODE" is displayed, the TK-280 can be used as the cloning master. The following describes how to enter the password.
3. How to enter the password with the keypad;
If you press a key while "CLONE LOCK" is displayed, the number that was pressed is displayed on the TK-280. Each press of the key shifts the display in order to the left. When you enter the password and press the [*] key, "CLONE MODE" is displayed if the entered password is correct. If the password is incorrect, "CLONE LOCK" is redisplayed.
How to enter the password with the encoder;
If the encoder is rotated while "CLONE LOCK" is displayed, numbers (0 to 9) are displayed flashing. When you press the [D] key, the currently selected number is determined. If you press the [CALL] key after entering the password in this procedure, "CLONE MODE" is displayed if the entered password is correct. If the password is incorrect, "CLONE LOCK" is redisplayed.
4. Power on the slave TK-280.
5. Connect the cloning cable (No. E30-3325-05) to the universal connectors on the master and slave.

REALIGNMENT

6. Press the [D] key on the master while the master displays "CLONE MODE". The data of the master is sent to the slave. While the slave is receiving the data, "PROGRAM" is displayed. When cloning of data is completed, the master displays "END", and the slave automatically operates in the User mode. The slave can then be operated by the same program as the master.
7. The other slave can be continuously cloned. When the [D] key on the master is pressed while the master displays "END", the master displays "CLONE MODE". Carry out the operation in step 4 to 6.

Note:

Only the same models can be cloned together.

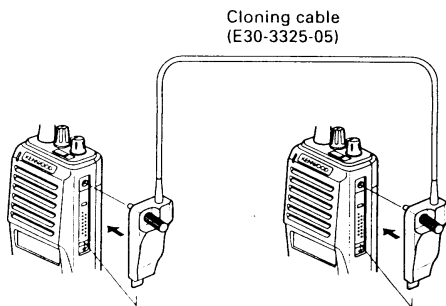

Fig. 2

8. Self Programming Mode

Write mode for frequency data and signalling etc. Mainly used by the person maintaining the user equipment.

8-1. Enter to the self programming mode

Delete R134 (SELF, Figure 3) in the TX-RX unit and turn the power switch on while pressing the [CALL] key. When enter the self programming mode, "SELF PROG" is displayed.

Note :

This mode (self programming mode) cannot be set when it has been disabled with the KPG-60D.

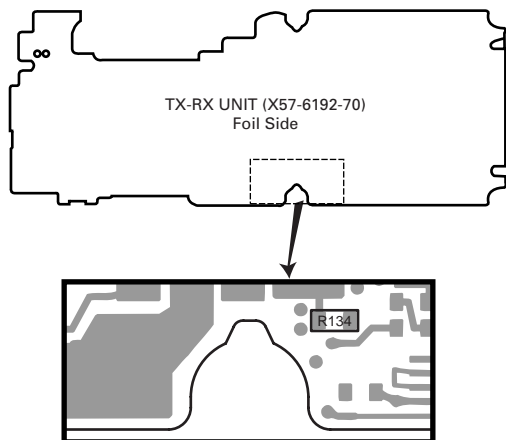

Fig. 3

8-2. Channel Setting Mode

This is a mode for making channel settings with the panel keys without using the FPU.

Pressing [MON] when [SELF PROG] is displayed, sets Channel Setting Mode.

Select an item set with [D] and change the selection with the encoder.

The data displayed with [C] is stored in the memory and then proceeds to the next item. Pressing [D] proceeds to the next item without storing it in the memory.

Press [MON] to set the display to [SELF PROG] and return to reset (default) status.

Items set in Channel Setting Mode are as follows.

Function settings	Display	Remarks
Channel select	Channel or Group	
RX Frequency	RXF	[CALL] : Freq. On/Off switching [B] : 5kHz/6.25kHz/1MHz step switching
RX Signalling	RXS	[CALL] : OFF/QT/DQT switching [B] : 1 step/Standard switching [A] : DQT Normal/Invert switching
TX Frequency	TXF	Key operation same as RX Frequencies
TX Signalling	TXS	Key operation same as RX Signalling
Scan Delete/Add	SCN	DEL/ADD
RF Power	PWR	HIGH/LOW
Beat Shift	SFT	YES/NO
Wide/Semi wide /Narrow	W/N	Wide/Semi wide/Narrow
Compander	CMP	ON/OFF

REALIGNMENT

• Flow Chart

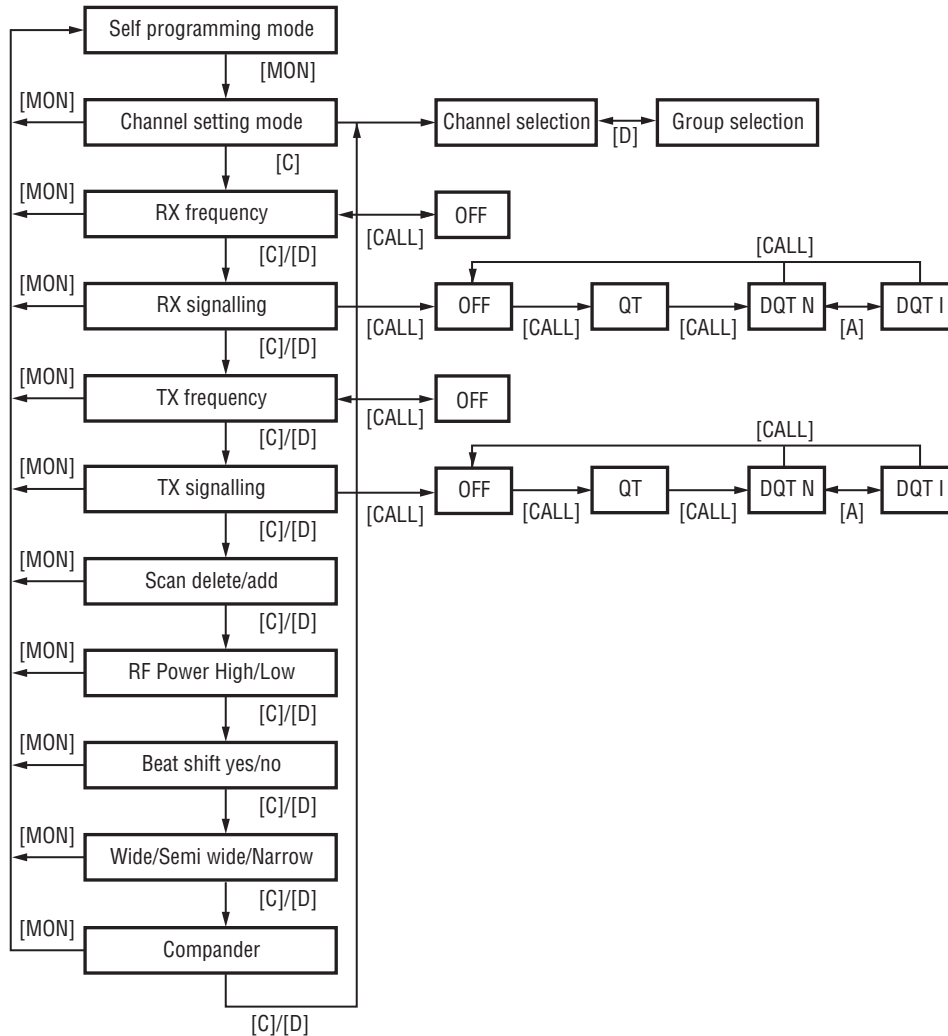

8-3. Memory Reset Mode

This mode is used to clear data for functions that can be set in Self Programming Mode or to return to reset values (default).

Pressing [A] when [SELF PROG] is shown, sets the display to [CLEAR NO?].

Turning the encoder alternately switches the display between [CLEAR NO?] ↔ [CLEAR YES?].

Pressing [A] when [CLEAR YES?] is shown, clears the data and sets the display to [ALL CLEAR].

Pressing [A] again, returns the display to [SELF PROG].

Pressing [A] when [CLEAR NO?] is shown, returns the display to [SELF PROG] without resetting the data.

CIRCUIT DESCRIPTION

1. Overview

This transceiver is VHF/FM portable transceiver designed to operate in the frequency range of 146 to 174MHz (E, T).

2. Circuit Configuration by Frequency

The receiver is a double-conversion superheterodyne with a first intermediate frequency (IF) of 44.85MHz and a second IF of 455kHz. Incoming signals from the antenna are mixed with the local signal from the PLL to produce the first IF of 44.85MHz.

This is then mixed with the 44.395MHz second local oscillator output to produce the 455kHz second IF. This is detected to give the demodulated signal.

The transmit signal frequency is generated by the PLL VCO, and modulated by the signal from the microphone. It is then amplified and sent to the antenna.

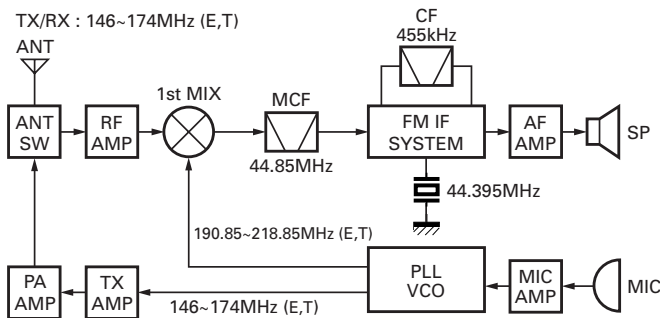

Fig. 1 Frequency configuration

3. Receiver System

3-1. RF unit

An incoming RF signal from the antenna terminal is passed through the antenna switch (D12, D14, D22 and D401 are off) and then the bandpass filter (L403,404,405,406). The bandpass filter is adjusted by a variable capacitor. The input voltage to the variable capacitor is regulated by the voltage output from

the D/A converter (IC8). The signal is amplified by RF amplifier (Q24), and passed through the bandpass filter (L31,33) and band-eliminate filter (L27,29) to remove the spurious signal again. The resulting signal is applied to the first mixer (IC18), where it is mixed with the first local oscillator signal output from the frequency synthesizer to produce the first IF (44.85MHz). The 1st mixer uses the GaAs IC.

3-2. IF unit

The first IF signal is passed through a crystal filter (XF1) to remove a adjacent channel signal. The filtered first IF signal is amplified by the first IF amplifier (Q12) and then applied to the IF system IC (IC12). The IF system IC provides a second mixer, second local oscillator, limiting amplifier, quadrature detector and RSSI (Received Signal Strength Indicator). The second mixer mixes the first IF signal with the 44.395MHz of second local oscillator output (crystal unit X2) and produces the second IF signal of 455kHz.

The second IF signal is passed through the ceramic filter (CF1; Wide, Semi wide, CF2 ; Narrow) to more remove the adjacent channel signal. The filtered second IF signal is amplified by the limiting amplifier and demodulated by the quadrature detector with ceramic discriminator (CD1). The demodulated signal is routed to the audio circuit.

3-3. Wide, Semi wide/Narrow changeover circuit

Narrow and Wide, Semi wide settings can be made for each channel by switching the ceramic filters CF1 (Wide, Semi wide), CF2 (Narrow).

The WIDE, SEMI WIDE (high level) and NARROW (low level) data is output from IC19 (microcomputer) pin 99.

When a WIDE, SEMI WIDE (high level) data is received, Q6 turn off and Q7 turn on. When a NARROW (low level) data is received, Q6 turn on and Q7 turn off. D5, D7 are switched to ceramic filters when a high/low level data is received.

Q9 turns on/off with the Wide, Semi wide/Narrow data and the IC12 detector output level is changed to maintain a constant output level during wide or narrow signals.

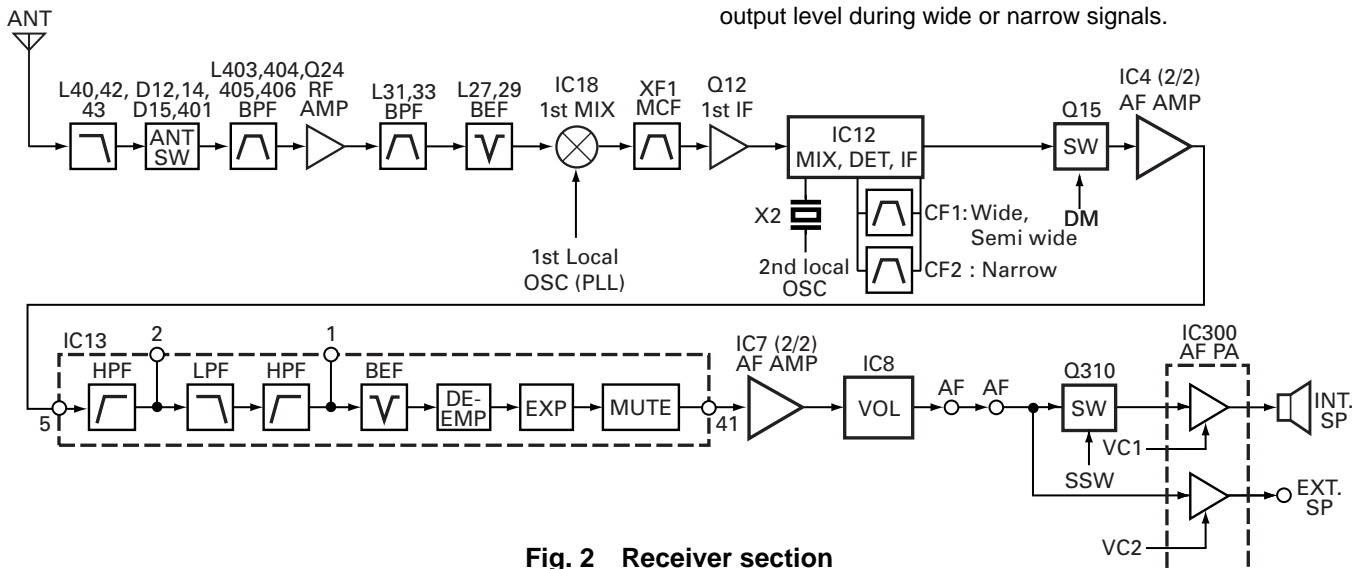

Fig. 2 Receiver section

CIRCUIT DESCRIPTION

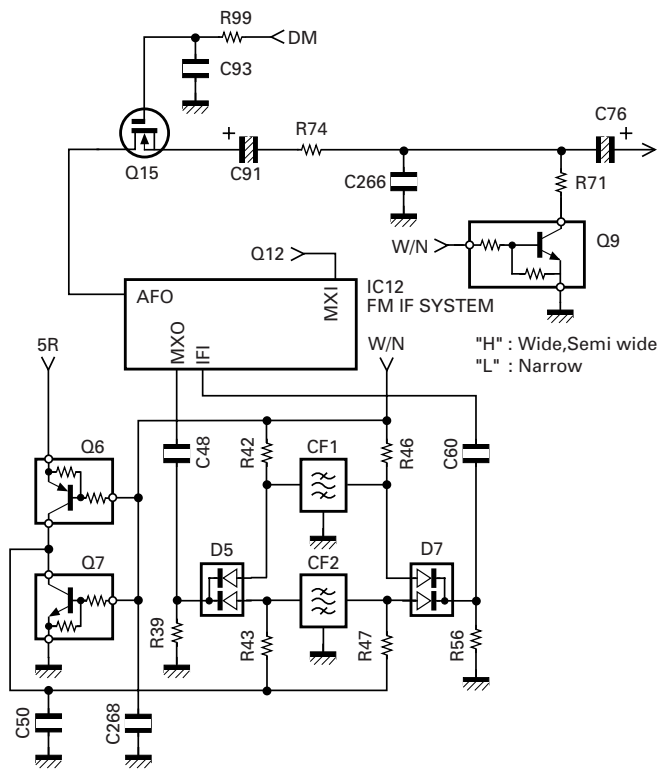

Fig. 3 Wide, Semi wide/Narrow changeover circuit

3-4. Audio amplifier circuit

The demodulated signal from IC4 goes through the mute switch (Q15) and is amplified by IC4 (2/2), high-pass filtered, low-pass filtered, high-pass filtered, band-eliminate filtered, and de-emphasized by IC13.

The signal then goes through an AF amplifier IC7 (2/2), an electronic volume control (IC8), and an AF switch (Q310 is on), and is routed to audio power amplifier (IC300), where it is amplified and output to the internal speaker.

The audio mute signal (AM) from the shift register becomes Low in the standby and Q304, Q305 which are power supply circuit for IC300 turn off. Also, IC13 is set to the power down mode according to data from microprocessor, and the AF signal is muted. When the audio is output, AM becomes High to turn Q304, Q305 ON, and voltage is supplied to power terminal VP of IC300. Also, IC13 is canceled out of the power down mode.

The speaker is switched by the logic of speaker switching terminal SSW on the universal connector. When SP-MIC is not attached, the logic of SSW becomes High and SW (Q310) is turned ON, and the AF signal is input to both amplifiers of IC300.

When SP-MIC is attached, SSW is connected to GND at inside of SP-MIC. For this reason, Q310 is turned OFF, and the AF signal is input only to amplifier for EXT SP of IC300.

Change of INT/EXT SP refer to Fig. 4.

AM	SSW	VC1	VC2	SP
H	H	H	L	INT
H	L	L	H	EXT
L	H	L	L	MUTE
L	L	L	L	MUTE

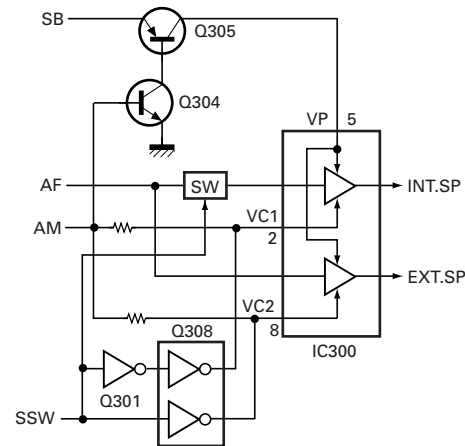

Fig. 4 Audio amplifier circuit

3-5. Squelch circuit

The output from IC12 enters FM IC again, then passed through a band-pass filter. The noise component output from IC12 is amplified by Q4 and rectified by D4 to produce a DC voltage corresponding to the noise level. The DC voltage is sent to the analog port of the CPU (IC19). And IC12 outputs a DC voltage (RSSI) corresponding to the input of the IF amplifier. The CPU reads the RSSI signal via pin 93.

IC19 determines whether to output sounds from the speaker by comparing the input voltage of pin 91 and pin 93 with the preset value.

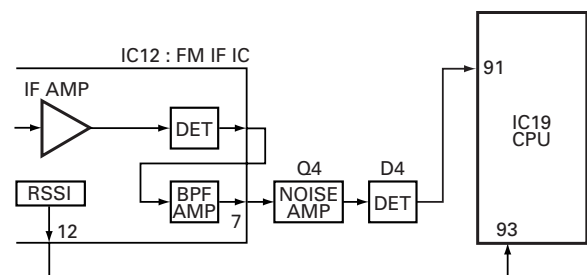

Fig. 5 Squelch circuit

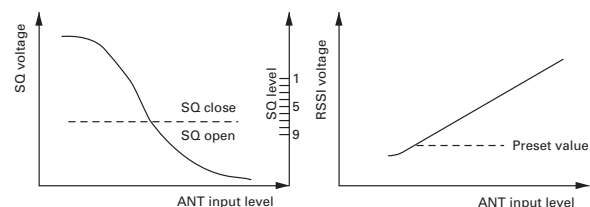

Fig. 6 Squelch and RSSI voltage vs ANT input level

4. Transmitter System

4-1. Microphone amplifier

The signal from the internal microphone goes through the mute switch (Q300).

When the SP-MIC is not attached, the microphone switching terminal (MSW) on the universal connector becomes High, and mute switch (Q300) is turned ON. When the SP-MIC is

CIRCUIT DESCRIPTION

attached, MSW is connected to GND at inside of SP-MIC. For this reason, Q300 is turned OFF, the internal microphone is muted, and only the input of the external microphone is supplied to the microphone amplifier of the TX-RX unit.

The signal from microphone passes through the limiter circuit in D8, and Mic mute switch (Q17 is off in TX) and through the low-pass filter (IC25:1/2), the high-pass filter, the ALC circuit, the low-pass filter, the high-pass filter, and pre-emphasis/IDC circuit in IC13. When encoding DTMF, mute switch (Q13) is turned OFF for muting the microphone input signal.

The signal passes through the D/A converter (IC8) for the maximum deviation adjustment, and enters the summing amplifier consisting of IC7 (1/2), and is mixed with the low speed data from the CPU (IC19) and 9600bps DATA from Optional Board Terminal.

The output signal from the summing amplifier passes through the D/A converter (IC8) again and goes to the VCO modulation input.

The other output signal from the summing amplifier passes through the D/A converter (IC8) again for the BAL adjustment, and the buffer amplifier (IC1 : 2/2), and goes to the VCXO modulation input.

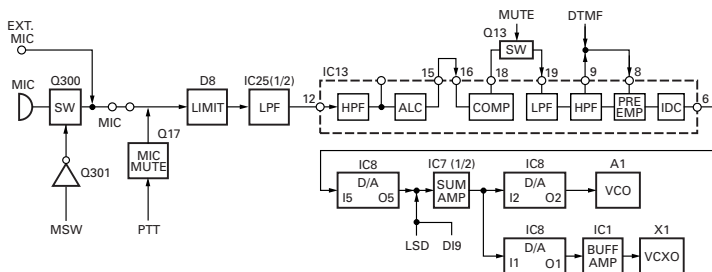

Fig. 7 Microphone amplifier

4-2. Drive and Final amplifier

The signal from the T/R switch (D9 is on) is amplified by drive amplifier (Q20) to 30mW.

The output of the drive amplifier is amplified by the RF power amplifier (IC100) to 5.0W (1W when the power is low). The RF power amplifier consists of two stages MOS FET transistor. The output of the RF power amplifier is then passed through the harmonic filter (LPF) and antenna switch (D12 and D401 is on) and applied to the antenna terminal.

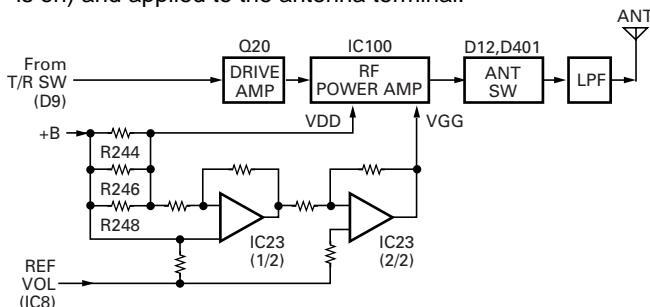

Fig. 8 Drive and final amplifier and APC circuit

4-3. APC circuit

The APC circuit always monitors the current flowing through the RF power amplifier (IC100) and keeps a constant current. The voltage drop at R244, R246 and R248 is caused by the current flowing through the RF power amplifier and this voltage is applied to the differential amplifier (IC23 1/2).

IC23(2/2) compares the output voltage of IC23(1/2) with the reference voltage from IC8, and the output of IC23(2/2) controls the VGG of the RF power amplifier to make the both voltages to same voltage.

The change of power high/low is carried out by the change of the reference voltage. Q22,23 and 25 are turned on in transmit and the APC circuit is active.

5. Frequency Synthesizer Unit

5-1. Frequency synthesizer

The frequency synthesizer consists of the VCXO (X1), VCO (A1), PLL IC(IC14) and buffer amplifiers.

The VCXO generates 16.8MHz. The frequency stability is 1.5ppm within the temperature range of -30 to +60°C. The frequency tuning and modulation of the VCXO are done to apply a voltage to pin 1 of the VCXO. The output of the VCXO is applied to pin 8 of the PLL IC.

The TK-280's VCO consists of 2VCO and covers a dual range of the 190.85~218.85MHz (E,T) and the 146~174MHz (E,T). The VCO generates 190.85~218.85MHz (E,T) for providing to the first local signal in receive. In TX, the pin 3 of the VCO goes low and the VCO generates 146~174MHz (E,T).

The output of the VCO is amplified by the buffer amplifier (Q16) and routed to the pin 5 of the PLL IC. Also the output of the VCO is amplified by the buffer amplifier (Q18) and routed to the next stage according to T/R switch (D9, D23).

The PLL IC consists of a prescaler, fractional divider, reference divider, phase comparator, charge pump. This PLL IC is fractional-N type synthesizer and performs in the 40, 50 or 60kHz reference signal which is eighth of the channel step (5, 6.25 or 7.5kHz). The input signal from the pins 5 and 8 of the PLL IC is divided down to the 40, 50 or 60kHz and compared at phase comparator. The pulsed output signal of the phase comparator is applied to the charge pump and transformed into DC signal in the loop filter (LPF). The DC signal is applied to the pin 1 of the VCO and locked to keep the VCO frequency constant.

PLL data is output from DT (pin 75). CP (pin 19) and EP (pin 47) of the microprocessor (IC19). The data are input to the PLL IC when the channel is changed or when transmission is changed to reception and vice versa. A PLL lock condition is always monitored by the pin 31 (UL) of the microprocessor. When the PLL is unlocked, the UL goes low.

CIRCUIT DESCRIPTION

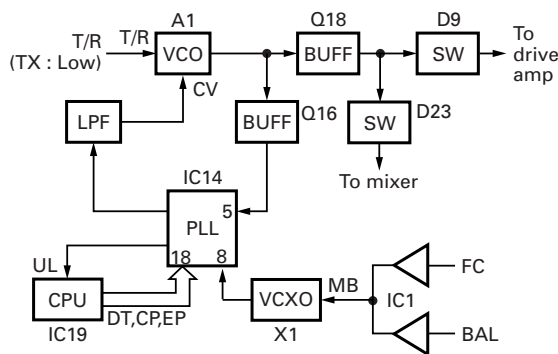

Fig. 9 PLL block diagram

6. Control Circuit

The control circuit consists of microprocessor (IC19) and its peripheral circuits. It controls the TX-RX unit and transfers data to and from the display unit. IC19 mainly performs the following;

- 1) Switching between transmission and reception by PTT signal input.
- 2) Reading system, group, frequency, and program data from the memory circuit.
- 3) Sending frequency program data to the PLL.
- 4) Controlling squelch on/off by the DC voltage from the squelch circuit.
- 5) Controlling the audio mute circuit by decode data input.
- 6) Transmitting tone and encode data.

6-1. Memory circuit

Memory circuit consists of the CPU (IC19) and a flash memory (IC17), a flash memory has a capacity of 2M bits that contains the transceiver control program for the CPU and data such as transceiver channels and operating features.

This program can be easily written from an external devices. Data. such as operating status, are programmed into the EEPROM (IC20).

• Flash Memory

Note : The flash memory holds data such as written with the FPU (KPG-60D), firmware program (User mode, Test mode, Tuning mode, etc.) This data must be rewritten when replacing the flash memory.

• EEPROM

Note : The EEPROM stores tuning data (Deviation, Squelch, etc.).

Realign the transceiver after replacing the EEPROM.

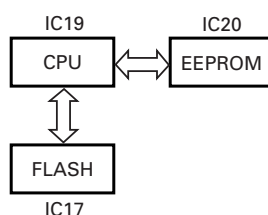

6-2. Low battery warning

The battery voltage is monitored by the microprocessor (IC19). When the battery voltage falls below the voltage set by the Low Battery Warning adjustment, the red LED flashes to notify the operator that it is time to replace the battery. If the battery voltage falls even more (approx. 5.8V), a beep sounds and transmission is stopped.

Low battery warning	Battery condition
The red LED flashes during transmission	The battery voltage is low but the transceiver is still usable.
The red LED flashes and continuous beep sounds while PTT pressed	The battery voltage is low and the transceiver is not usable to make calls.

6-3. Key input

If the clock is supplied to CLK terminal when the RES terminal (CPU pin 78) of the decade counter (IC301) is set to Low, Q0 to Q7 become High sequentially. Normally, K11 and K12 are Low (pulled down). When any key is pressed. K11 or K12 become High. The CPU detects which key is pressed, according to the voltage of K11 and K12 and clock timing.

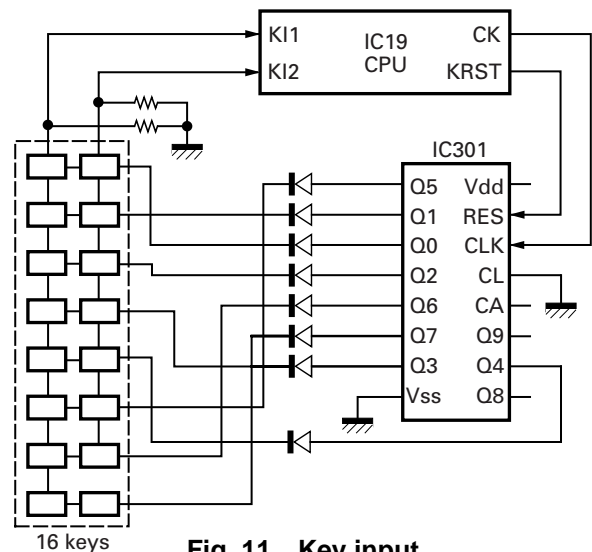

Fig. 11 Key input

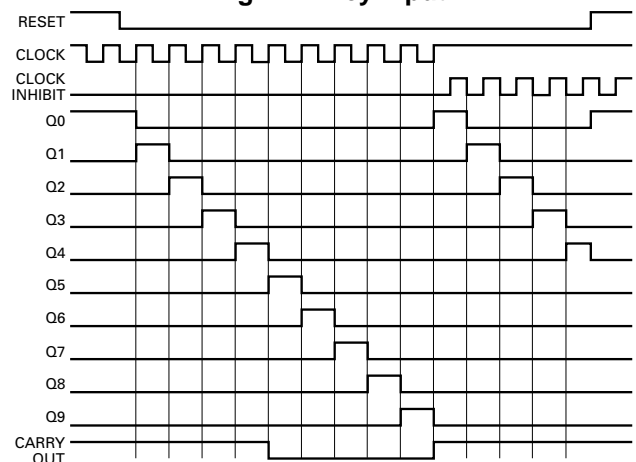

Fig. 12 Decade counter timing chart

CIRCUIT DESCRIPTION

7. Signalling Circuit

7-1. Encode

- **Low-speed data (QT,DQT)**

Low-speed data is output from pin 1 of the CPU. The signal passes through a low-pass CR filter, and goes to the summing amplifier (IC7 1/2). The signal is mixed with the audio signal and goes to the VCO (A1) and VCXO (X1) modulation input after passing through the D/A converter (IC8) for BAL adjustment.

- **High-speed data (5 tone, DTMF)**

High-speed data (HSD) is output from pin 2 of the CPU. The signal passes through a low-pass filter consisting of IC10, and provides a TX HSD tone and a RX HSD tone. TX HSD deviation making an adjustment by microprocessor is passed through the D/A converter (IC8) and then applied to the audio processor (IC13).

The signal is mixed with the audio signal and goes to the VCO and VCXO. The RX HSD tone is passed a summing amplifier (IC7 2/2). The D/A converter (IC8) for audio control, audio power amplifier and then to the speaker.

- **FFSK**

ESN utilizes 1200bps FFSK signal. FFSK signal is output from pin 6 of IC13. The signal passes through the D/A converter (IC8) for the FFSK deviation adjustment. and is routed to the VCO. When encoding FFSK, the microphone input signal is muted.

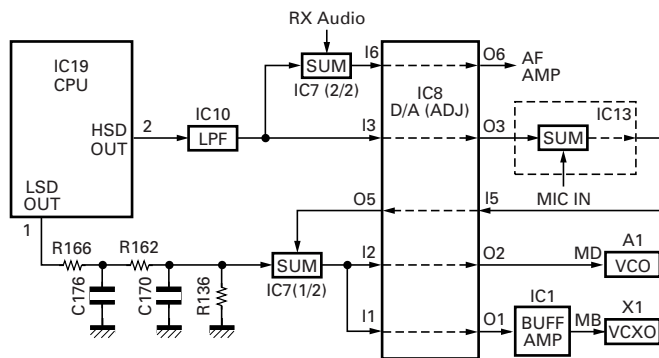

Fig. 13 Encode

7-2. Decode

- **Low-speed data (QT,DQT)**

The demodulated signal from the IF IC (IC12) is amplified by IC4 (2/2) and passes through a low-pass filter (IC11) to remove audio components. The signal is input to pin 95 of the CPU.

The CPU digitizes this signal, performs processing such as DC restoration, and decodes the signal.

- **High-speed data (DTMF)**

The DTMF input signal from the IF IC (IC12) is amplified by IC4 (2/2) and goes to IC16, the DTMF decoder. The decoded information is then processed by the CPU. During transmission and standby, the DTMF IC is set to the power down mode when the PD terminal is High. When the line is busy, the PD terminal becomes Low, the power down mode is canceled and decoding is carried out.

- **High-speed data (2 tone, 5 tone)**

The demodulated signal from the IF IC (IC12) is amplified by IC4 (2/2) and passes through an audio processor (IC13) and band-pass filter (IC2) to remove a low-speed data. The CPU digitizes this signal, performs processing such as DC restoration, and decodes the signal.

- **FFSK**

The FFSK input signal from the IF IC is amplified by IC4 (1/2) and goes to pin 5 of IC13. The signal is demodulated by FFSK demodulator in IC13. The demodulated data goes to the CPU for processing.

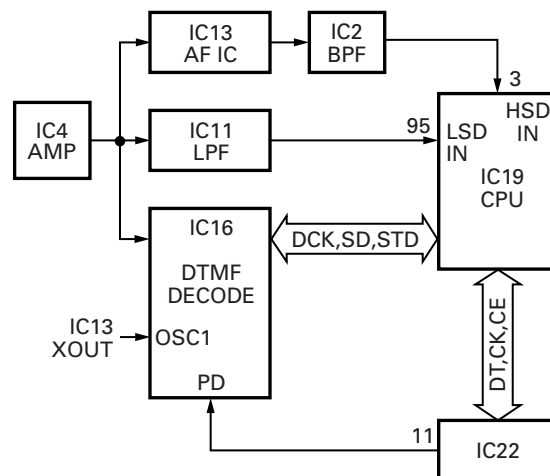

Fig. 14 Decode

CIRCUIT DESCRIPTION

8. Power Supply Circuit

Battery +B is supplied via a 3A fuse from the battery terminal connected to the TX-RX unit. After passing through the power switch, power supply (SB) is applied to the three AVRs. IC5 supplies 5V (5M) to the control circuit, and IC9 supplies 5V (5C) to common circuits. IC6 supplies to the TX circuit, the RX circuit and common circuits of needless save mode. During transmission, 5TC becomes Low and Q3 is turned ON to supply 5V (5T) to the TX circuit. During reception, 5RC becomes Low and Q2 is turned ON to supply 5V (5R) to the RX Circuit.

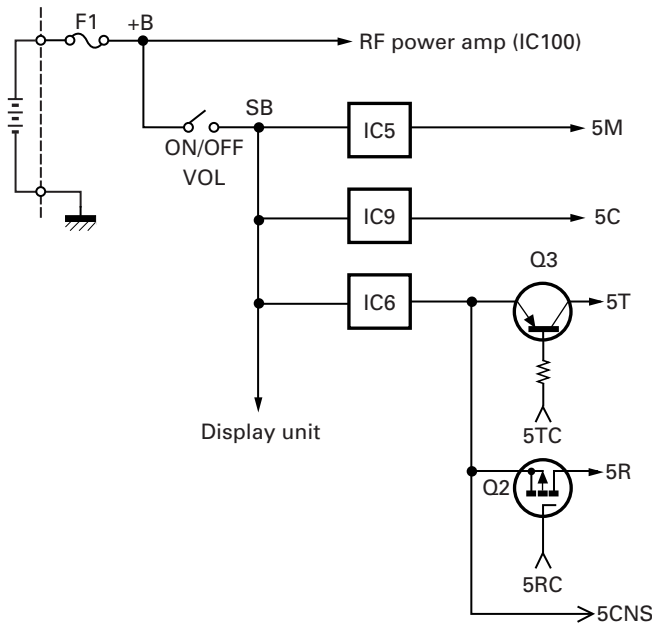

Fig. 15 Power supply circuit

9. Optional Board Terminal

Terminals for mounting the option board are provided at the bottom edge of the TX-RX unit. The table below shows the correspondence between the board and terminals. R37, R69, R249, R258, R259, R304, R305 may have to be removed depending on the type of option board being used.

Name	Function
SB	Battery (7.5V)
GND	Ground
TXD	Serial data
RXD	Serial data
SQ	Busy: high
LOK	Link acquired : low (TX mode)
DI/ANI	Modulation (ANI) input
DEO	Detect output
TXAI/MUTE	Modulation output from board or mic mute: low
TXAO	Modulation input to board
RXAI	Received signal input to board
RXAO	Received signal output from board
D1	Binary 1
D2	Binary 2
OPT	Scramble, Emergency:low
PTTIN	PTT switch signal input to board (TX:low)
5CNS	Battery (5V)
DI9	9600 bps data output
RXEMAO	Received signal output from board (after de-emphasis)
RXEMAI	Received signal input to board (after de-emphasis)
PTTOUT	PTT switch signal output from board (TX:low)
MONI	Busy:low
LAMP	Busy:low
AAC	Audio Amp Control signal output from board (Busy:high)
Audio Beep	Beep signal output from board.
AUX TXD	Serial data
AUX RXD	Serial data/Option switch port.
/EXT SW	

Table 1 Terminal name and function

SEMICONDUCTOR DATA

Microprocessor : 30620M8-394GP (TX-RX UNIT : IC19)

■ Pin function

Pin No.	Port Name	I/O	Function
1	LSDOUT	O	Low speed data output.
2	HSDOUT	O	High speed data output.
3	HSDIN	I	High speed data input.
4	DTMSTD	I	DTMF decode IC data detect input.
5	SELF	I	Self programming mode input.
6	BYTE	I	+5V.
7	CNVSS	I	GND.
8	SFTOE	O	Shift register output enable.
9	LCDCS	O	LCD driver chip select output.
10	RESET	I	Microcomputer reset input.
11	XOUT	-	9.8304MHz (System clock).
12	VSS	-	GND.
13	XIN	-	9.8304MHz (System clock).
14	VCC	-	+5V
15	AUX	I	AUX switch input.
16	AFTRD	I	FFSK modulation data output timing pulse input.
17	AFRTM	I	FFSK demodulation data input timing pulse input.
18	EN2	I	Encoder pulse input 2.
19	PLLCLK	O	PLL IC clock output.
20	BEEP	O	Beep data output.
21	AFRDT	I	FFSK demodulation data input.
22	AFREG1	O	AF IC register switching data output 1.
23	AFREG2	O	AF IC register switching data output 2.
24	EEPDAT	O	EEPROM data output.
25	DACSTB	O	D/A converter IC data strobe output.
26	AFCLR	O	FFSK flame reset output.
27	SAVE	O	Battery save output.
28	LAMP	I	LAMP switch input.
29	AUXTXD	O	External Serial interface output.
30	AUXRXD	I	External Serial interface input.
31	PLLUL	I	PLL unlock detect input.
32	AFFFSKE	O	FFSK modulation enable (Enable active "H").
33	TXD	O	Serial interface output (ex. PC).
34	RXD	I	Serial interface input (ex. PC).
35	AFDAT	O	FFSK data output.
36	PTT	I	PTT switch input.
37	RDY	-	Not used.
38	ALE	-	Not used.
39	HOLD	-	Not used.
40	HLDA	-	Not used.
41	BLCK	-	Not used.
42	RD	-	Flash memory RD bus.
43	BHE	-	Not used.
44	WR	-	Flash memory WR bus.
45	DTMCLK	O	DTMF decode IC clock output.
46	CNTCLK	O	Common clock output.
47	PLLSTB	O	PLL IC data strobe output.
48	CS0	O	Flash memory chip enable.
49	A19	-	Not used.
50-59	A9-A18	-	Flash memory address bus.
60	VCC	-	+5V
61	A8	-	Flash memory address bus.

Pin No.	Port Name	I/O	Function
62	VSS	-	GND.
63-70	A0~A7	-	Flash memory address bus.
71	MONI	I	Monitor switch input.
72	EN4	I	Encoder pulse input 4.
73	EN3	I	Encoder pulse input 3.
74	EN1	I	Encoder pulse input 1.
75	MINDAT	O	Common data output.
76	KEY2	I	Key scan input 2.
77	KEY1	I	Key scan input 1.
78	RESET	O	Key scan IC reset output..
79-86	D0~D7	-	Flash memory data bus.
87	DTMDAT	I	DTMF decode IC data input.
88	PF	I	PF switch input.
89	VOL	I	Volume level input.
90	BATT	I	Battery voltage input.
91	ANLSQL	I	Squelch level input.
92	TEMP	I	Thermistor input.
93	RSSI	I	Received signal strength indicator input (RSSI).
94	AVSS	-	GND.
95	LSDIN	I	Low speed data input.
96	VREF	-	+5V
97	AVCC	-	+5V
98	SFTSTB1	O	Shift register data strobe output.
99	W/N	O	Wide/Narrow switching output.
100	AFSTB	O	AF IC data strobe output.

Shift register 1 : BU4094BCFV (TX-RX UNIT : IC21)

■ Pin function

Pin No.	Port	Port Name	Function
1	ES	ES	Strobe
2	DT	DAT	Data
3	CK		Clock
4	Q1	LEDR	Red LED. H : ON, L : OFF
5	Q2	LEDG	Green LED. H : ON, L : OFF
6	Q3	KEYBLT	Key back light. H : ON, L : OFF
7	Q4	MMUTE	Mic mute. H : Unmute, L : Mute
8	VSS		GND
9	QS		IC 21 data output
10			NC
11	Q8	DTMPD	DTMF decode IC power down. H : Power down, L : Busy
12	Q7	BSHIFT	Beat shift. H : ON, L : OFF
13	Q6	5TC	TX power control. H : RX, L : TX
14	Q5	5RC	RX power control. H : TX, L : RX
15	OE		Output enable
16	VDC		+5V

SEMICONDUCTOR DATA

Shift register 2 : BU4094BCFV (TX-RX UNIT : IC22)

■ Pin function

Pin No.	Port	Port Name	Function
1	ES	ES	Strobe
2	DT	DAT	Data
3	CK		Clock
4	Q1	AM1	Audio mute 1. H : Unmute, L : Mute
5	Q2	LOK	TX Logic Signal output. Active logic level is Low. Logic type can select "TX Line" or "Mic PTT" in the KPG-60D.
6	Q3	T/R	TX/RX switching. H : RX, L : TX
7	Q4	DM	Dead mute. H : RX, L : TX
8	VSS	GND	
9			NC
10			NC
11	Q8	SQ	Squelch signal output. Signal logic type can select "Carrier Operate Relay" or "Tone Operate Relay" in the KPG-60D. Active logic level is Low.
12	Q7	CODE2	Option board data 2. H : ON, L : OFF
13	Q6	CODE1	Option board data 1. H : ON, L : OFF
14	Q5	OPT	- Option board control. Please set option board type in the KPG-60D. H : ON, L : OFF - Auxiliary signal output. Please set key function in the KPG-60D.
15	OE		Output enable
16	VDC		+5V

Audio Processor : TC35453F (TX-RX Unit : IC13)

■ Block diagram

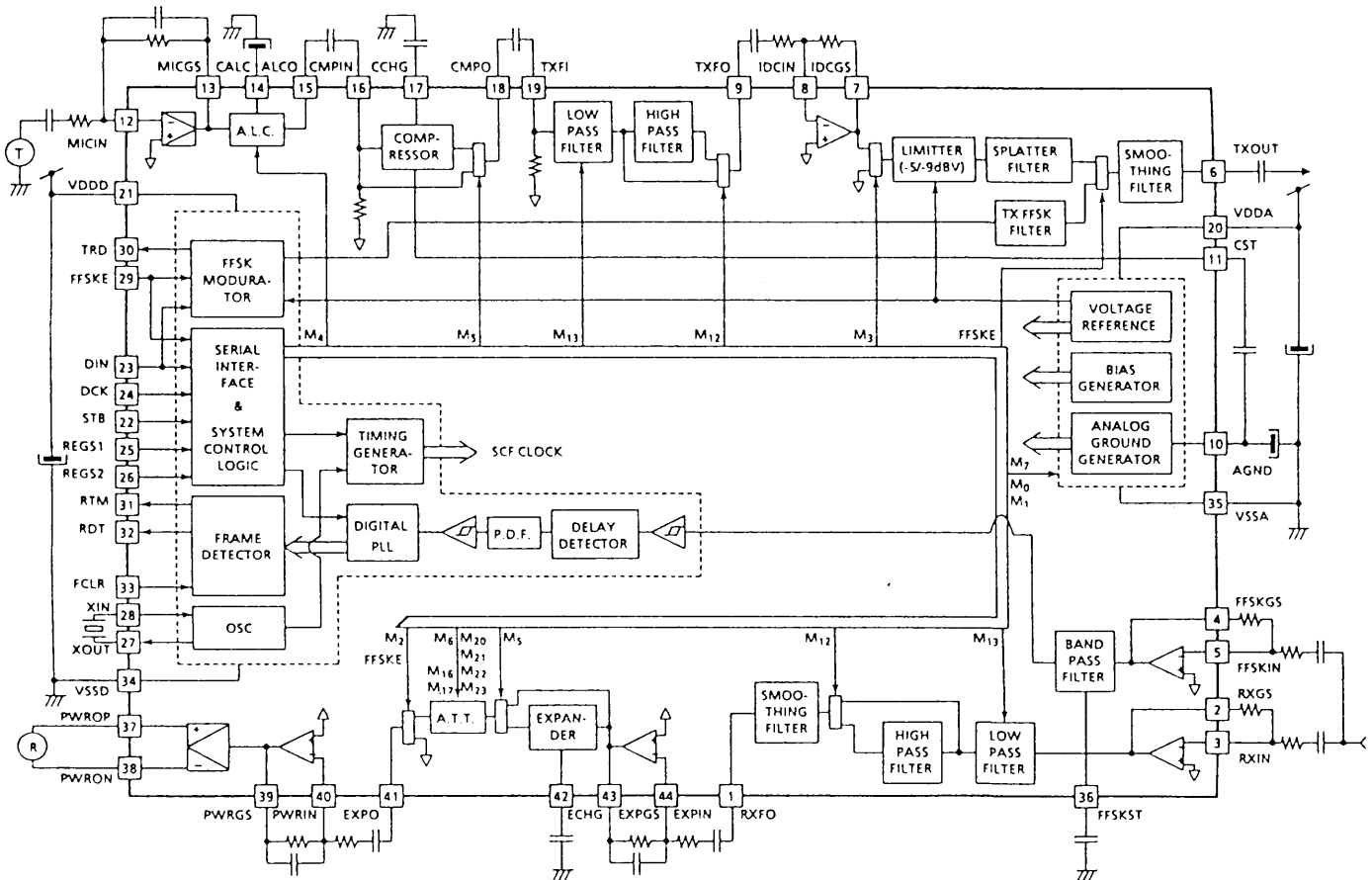

■ Pin function

Pin No.	Port Name	I/O	Function
1	RXFO	O	RX audio filter output.
2	RXGS	O	RX audio signal level setting amplifier output.
3	RXIN	I	RX audio signal level setting amplifier input.
4	FFSKGS	O	FFSK RX level setting amplifier output.
5	FFSKIN	I	FFSK RX level setting amplifier input.
6	TXOUT	O	TX signal output.
7	IDCGS	O	IDC input level setting amplifier output.
8	IDCIN	I	IDC input level setting amplifier input.
9	TXFO	O	TX audio filter circuit output.
10	AGND	-	Analog reference voltage stabilization.
11	CST	I/O	Compressor stabilization.
12	MICIN	I	Microphone amplifier input.
13	MICGS	O	Microphone amplifier output.
14	CALC	I/O	ALC Circuit response time setting.
15	ALCO	O	ALC circuit output.
16	CMPIN	I	Compressor input.
17	CCHG	I/O	Compressor response time setting.
18	CMPO	O	Compressor output.
19	TXFI	I	TX audio filter input.
20	VDDA	-	Analog power supply.
21	VDDD	-	Digital power supply.
22	STB	I	Data strobe pulse input / system reset input 1.
23	DIN	I	Data input.

Pin No.	Port Name	I/O	Function
24	DCK	I	Data synchronized clock input.
25	REGS1	I	Internal register select input 1
26	REGS2	I	Internal register select input 2.
27	XOUT	O	Oscillation circuit output.
28	XIN	I	Oscillation circuit input.
29	FFSKE	I	FFSK modulation enable input.
30	TRD	O	FFSK modulation data latch timing output.
31	RTM	O	FFSK RX synchronized clock output.
32	RDT	O	FFSK RX data output.
33	FCLR	I	Flame detect circuit reset input 1 System reset input 2.
34	VSSD	-	Digital ground.
35	VSSA	-	Analog ground.
36	FFSKST	I/O	FFSK modem demodulation circuit stabilization.
37	PWRGP	O	Speaker operation positive output.
38	PWRGN	O	Speaker operation negative output.
39	PWRGS	O	RX output level setting amplifier output.
40	PWRIN	I	RX output level setting amplifier input.
41	EXPO	O	Expander output.
42	ECHG	I/O	Expander response time setting.
43	EXPGS	O	Expander input level setting amplifier output.
44	EXPIN	I	Expander input level setting amplifier input.

SEMICONDUCTOR DATA

D/A Converter : M62364FP (TX-RX Unit : IC8)

■ Block diagram

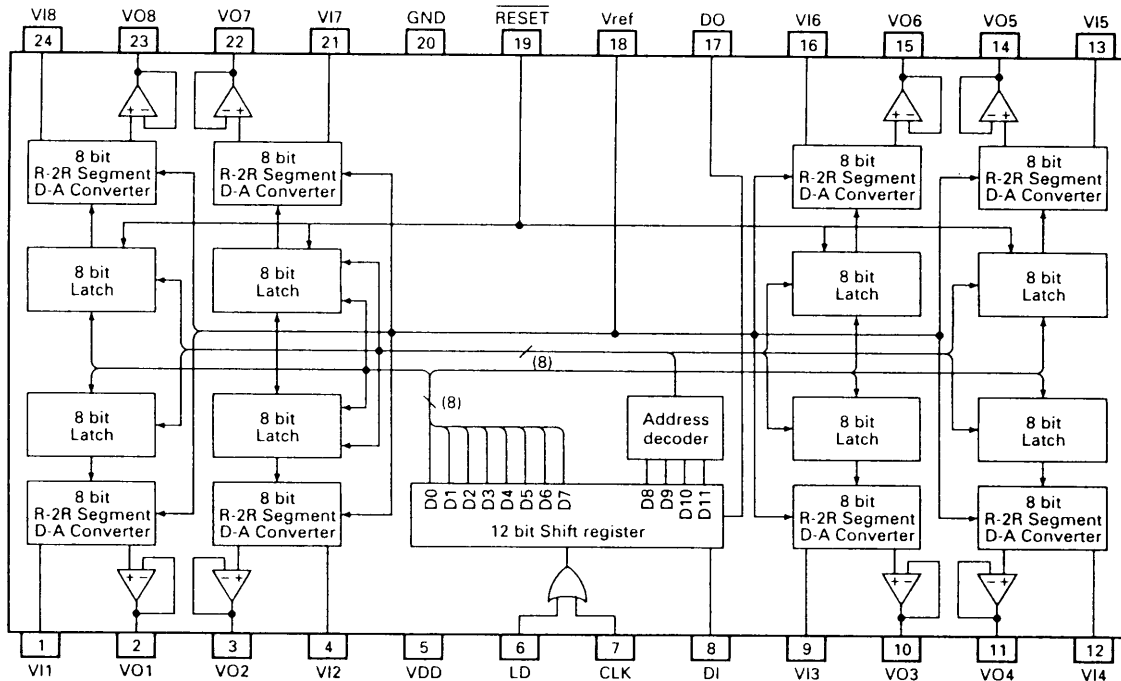

■ Pin function

Pin No.	Pin code	I/O	Function
1	VI1	I	D/A converter input.
2,3	VO1,VO2	O	8-bit resolution D/A.
4	VI2	I	D/A Converter input.
5	VDD	-	Power supply.
6	LD	I	When the LD is at the low level, the clock input reception mode is entered. and data can be uptaken by the 12-bit shift register. Then at the threshold rising from low to high, the 12-bit shift register value is loaded to the D/A output register.
7	CLK	I	Shift clock input. With the rise of the shift clock, the input signal from the DI is input to the 12-bit shift register.
8	DI	I	Serial data input. Input serial data 12 bits long.
9	VI3	I	D/A converter input.

Pin No.	Pin code	I/O	Function
10,11	VO3,VO4	O	8-bit resolution D/A.
12,13	VI4,VI5	I	D/A converter input.
14,15	VO5,VO6	O	8-bit resolution D/A.
16	VI6	I	D/A converter input.
17	DO	O	12-bit shift register MSB bit data is output.
18	Vref	-	Terminal for determining the D/A Conversion reference point level. $V_o = (V_{IN} - V_{DAref}) \times n/256 + V_{DAref}$
19	RESET	-	When a low level signal is input to the RESET terminal, all the D/A output register value become low.
20	GND	-	GND.
21	VI7	I	D/A converter input.
22,23	VO7,VO8	O	8-bit resolution D/A.
24	VI8	I	D/A converter input.

PLL System : SA7025DK (TX-RX Unit : IC14)

■ Block diagram

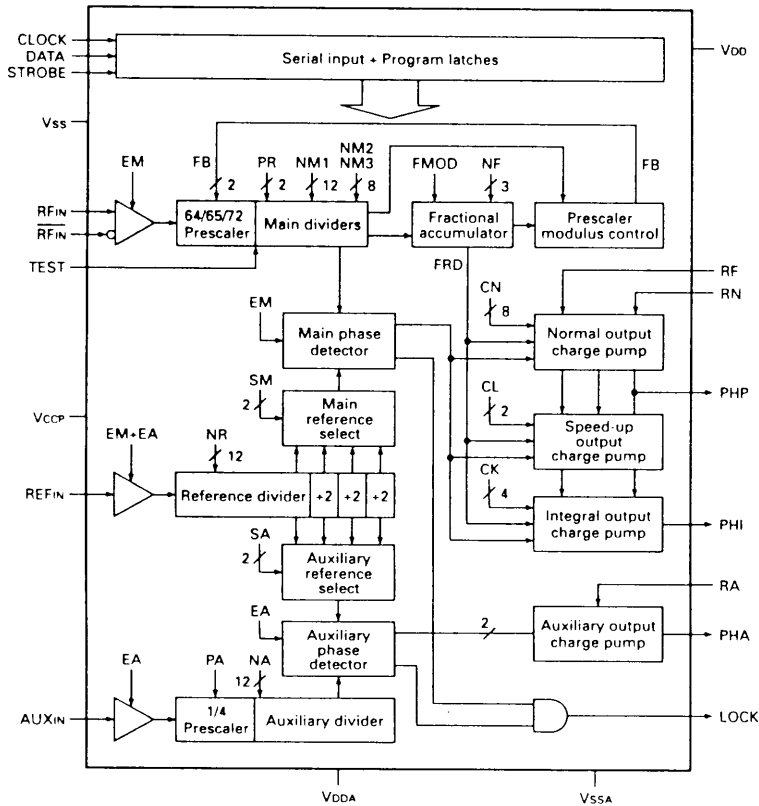

Audio Power Amplifier : TDA7053AT

(Display Unit : IC300)

■ Block diagram

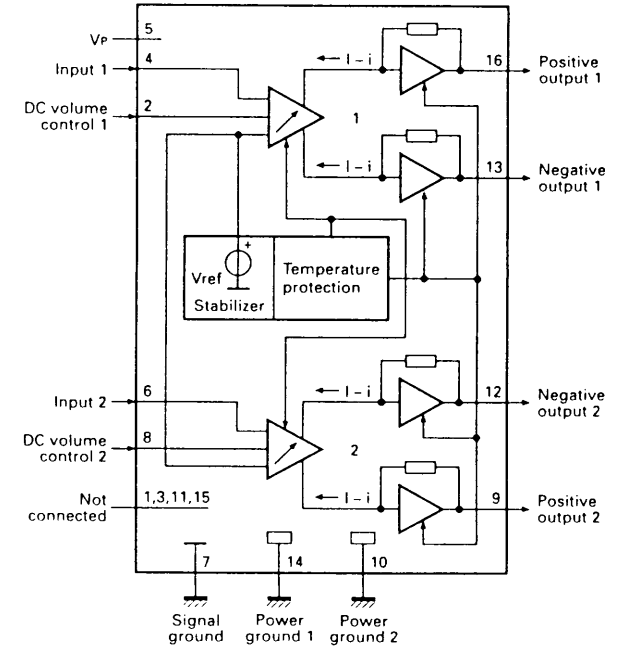

■ Pin description

Pin No.	Symbol	Description
1	CLOCK	Serial clock input.
2	DATA	Serial data input.
3	STROBE	Serial strobe input.
4	VSS	Digital ground.
5	RFIN	Prescaler positive input.
6	RFIN	Prescaler negative input.
7	VCCP	Prescaler positive Supply voltage. This pin supplies power to the prescaler and RF input buffer.
8	REFIN	Reference divider input.
9	RA	Auxiliary current setting; resistor to VSSA.
10	AUXIN	Auxiliary divider input.
11	PHA	Auxiliary phase detector output.
12	VSSA	analog ground.
13	PHI	Integral phase detector output.
14	PHP	Proportional phase detector output.
15	VDDA	Analog supply voltage. This pin supplies power to the charge pumps, Auxiliary prescaler, Auxiliary and Reference buffers.
16	RN	Main current setting; resistor to VSSA.
17	RF	Fractional compensation current setting; resistor to VSSA.
18	LOCK	Lock detector output.
19	TEST	Test pin; connect to VDD.
20	VDD	Digital supply voltage. This pin supplies power to the CMOS digital part of the device.

■ Pin description

Pin No.	Symbol	Description
1	NC	Not connected.
2	VC1	DC volume control 1.
3	NC	Not connected.
4	V _{I(1)}	Voltage input 1.
5	VP	Positive Supply voltage.
6	V _{I(2)}	Voltage input 2.
7	SGND	Signal ground.
8	VC2	DC volume control 2.
9	OUT2+	Positive output 2.
10	PGND2	Power ground 2.
11	NC	Not connected.
12	OUT2-	Negative output 2.
13	OUT1-	Negative output 1.
14	PGND1	Power ground 1.
15	NC	Not connected.
16	OUT1+	Positive output 1.

SEMICONDUCTOR DATA

Voltage Detector : RN5VL42C (TX-RX Unit : IC3)

■ Block diagram (CMOS output)

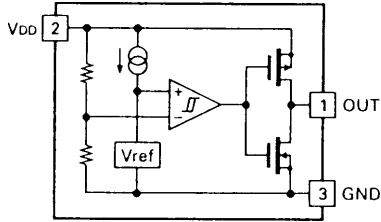

■ Pin function

Pin No.	Pin code	Function
1	OUT	Output.
2	VDD	Power supply.
3	GND	Ground.

VCO System : X58-4580-10 (SUB Unit : A1)

■ Circuit diagram

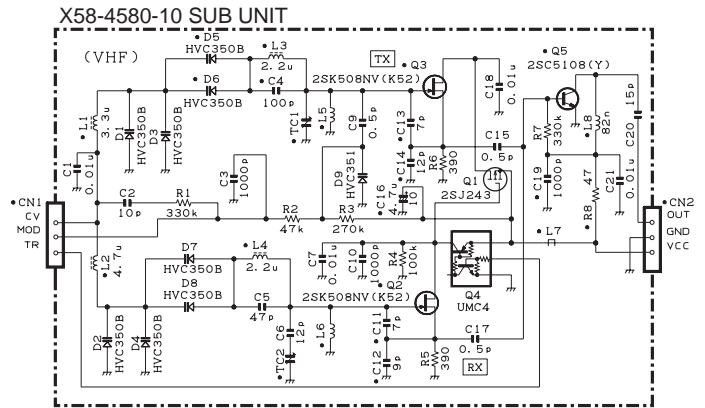

Counter : MC74HC4017F (Display Unit : IC301)

■ Logic circuit

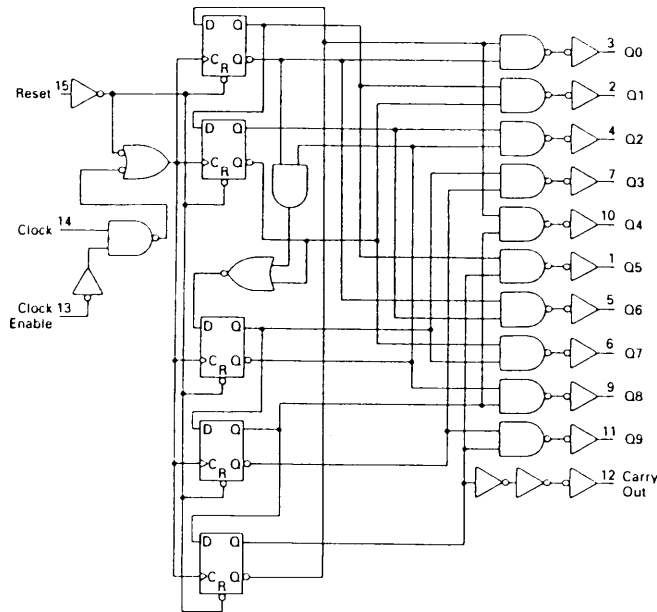

• Input

CLOCK (pin No.14) - Clock Input

The rising edge of this clock advances the count.

• Controller Input

RESET (pin No.15) - Asynchronous Reset Input

When this pin is High, the counter is initialized. and Q0 and CARRY OUT output become High. At this time, Q1 to Q9 become Low.

CLOCK ENABLE (Pin No.13) - Clock Enable Input (Low active)

The count operation is forbidden when this pin is High. When it is Low, the normal count is carried out. When the clock input (pin No.14) is used as enable (High active), this input can be used for the count as the rising clock.

• Output

Q0 to Q9 (pins 3,2,4,7,10,1,5,6,9,11) - Decoded Decade Counter Output

These outputs become High only during a single clock cycle.

CARRY OUT (pin No.12) - Cascade Output Pin

This output is used as the cascade output, or as the ÷10 output during the 50% duty cycle. When the count reaches "5", this output becomes Low. When the count reaches "0" or is reset, this output becomes High. When counters are cascade-connected, this output sends the rise signal to clock input of the next counter.

DESCRIPTION OF COMPONENTS

DISPLAY UNIT (X54-3210-12)

Ref. No.	Use/Function	Operation/Condition
IC300	IC	Audio power amplifier
IC301	IC	Counter /Key scan
Q300	FET	DC switch / INT MIC on/off
Q301	FET	DC switch
Q302	Transistor	DC switch / LED (Red) driver
Q303	Transistor	DC switch / LED (Green) driver
Q304	Transistor	DC switch
Q305	Transistor	Current driver / Audio amp AVR
Q306	Transistor	DC switch
Q307	Transistor	Current driver / LCD back light LED AVR
Q308	FET	DC switch / SP INT/EXT
Q309	Transistor	Temperature compensation
Q310	FET	Mute switch
D300	Zener diode	Surge absorption
D301	LED	LED / Red, Green
D302	Diode	Quick discharge /AF mute
D303	Zener diode	Voltage reference
D304	Diode	Voltage reference
D305-310	LED	LCD back light
D315-318	Diode	Reverse current prevention
D319-321	Zener diode	Surge absorption

TX-RX UNIT (X57-6192-70)

Ref. No.	Use/Function	Operation/Condition
IC1,2	IC	Buffer amplifier
IC3	IC	Voltage detector / Reset
IC4	IC	Buffer amplifier
IC5	IC	Voltage regulator / 5M
IC6	IC	Voltage regulator / 5V
IC7	IC	Buffer amplifier
IC8	IC	D/A converter (Adjustment)
IC9	IC	Voltage regulator / 5C
IC10	IC	Active filter / For HSDout
IC11	IC	Active filter / For LSDin
IC12	IC	FM IF system
IC13	IC	Audio processor
IC14	IC	PLL system
IC16	IC	DTMF decoder
IC17	IC	Flash memory
IC18	IC	Active DBM
IC19	IC	Microprocessor
IC20	IC	EEPROM
IC21,22	IC	Shift register / Output expander
IC23	IC	Comparator (APC)
IC24	IC	Analog switch
IC25	IC	Active filter
Q1	Transistor	Switch
Q2	FET	DC switch / 5R
Q3	Transistor	DC switch / 5T
Q4	Transistor	Noise amplifier / Squelch
Q5	FET	DC switch / Save
Q6	Transistor	2 nd IF W/N switch sets to on when Narrow

Ref. No.	Use/Function	Operation/Condition
Q7	Transistor	2 nd IF W/N switch sets to on when Wide
Q8	Transistor	Ripple filter
Q9	Transistor	DC switch / W/N audio amplitude adjust
Q10	Transistor	AF mute switch
Q11	FET	Mute switch
Q12	Transistor	IF amplifier
Q13	FET	Mute switch / MIC line mute
Q14	FET	DC switch
Q15	FET	DET mute
Q16	Transistor	PLL IC fin amplifier
Q17	FET	Mute switch / MIC line mute
Q18	Transistor	Buffer amplifier
Q19	Transistor	Clock frequency shift
Q20	Transistor	RF amplifier / TX driver
Q21	FET	DC switch
Q22	Transistor	DC switch
Q23	FET	DC switch
Q24	FET	RF amplifier
Q25	Transistor	DC switch
D1	Diode	Reverse protection
D2	Diode	Overload protection
D3	Diode	Reverse current protection
D4	Diode	Noise detection
D5	Diode	RF switch (2 nd IF wide/narrow)
D6	Diode	Current steering
D7	Diode	RF switch (2 nd IF wide/narrow)
D8	Diode	Voltage clamp
D9	Diode	TX/RX switch
D10	Diode	Overload protection
D11	Diode	Speed up
D12,14	Diode	ANT switch
D16,17	Diode	Varactor tuning
D18,19	Diode	Surge absorption
D20,21	Diode	Varactor tuning
D22	Diode	ANT switch
D23	Diode	TX/RX switch
D24	Diode	Voltage drop
D401	Diode	ANT switch
D402	Diode	Discharge

SUB UNIT (X58-4580-10)

Ref. No.	Use/Function	Operation/Condition
Q1	FET	DC switch
Q2,3	FET	VCO oscillation
Q4	Transistor	DC switch
Q5	Transistor	RF Buffer amplifier
D1-D8	Diode	Frequency control
D9	Diode	TX modulation

PARTS LIST

* New Parts. Δ indicates safety critical components.
 Parts without **Parts No.** are not supplied.
 Les articles non mentionnés dans le **Parts No.** ne sont pas fournis.
 Teile ohne **Parts No.** werden nicht geliefert.

L: Scandinavia K: USA P: Canada
 Y: PX (Far East, Hawaii) T: England E: Europe
 Y: AAFES (Europe) X: Australia M: Other Areas

TK-280

DISPLAY UNIT (X54-3210-12)

Ref. No.	Address	New parts	Parts No.	Description	Destination	Ref. No.	Address	New parts	Parts No.	Description	Destination
TK-280						50	1B		K29-5231-03	KNOB (VOL)	
1	1A		A02-2055-53	CABINET ASSY(16KEYS)		51	1B		K29-5232-03	KNOB (ENC)	
2	3B		A62-0535-04	PANEL ASSY		A	3B		N14-0569-04	CIRCULAR NUT(VOL,ENC)	
3	2C		B09-0363-03	CAP (SP/MIC) ACSY		B	3B		N30-2604-46	PAN HEAD MACHINE SCREW(ANT)	
4	2A		B38-0834-05	LCD ASSY		C	3A		N30-2610-46	PAN HEAD MACHINE SCREW(CASE)	
5	1B		B43-1106-14	BADGE (KENWOOD)		D	2B		N67-2606-46	PAN HEAD SEMS SCREW W(P-MODULE)	
6	1C	*	B62-1266-00	INSTRUCTION MANUAL ACSY		E	3A,3B		N79-2025-46	PAN HEAD TAPTITE SCREW(TERMINAL)	
7	3B	*	B72-1713-04	MODEL NAME PLATE		F	2A,2B		N83-2005-46	PAN HEAD TAPTITE SCREW(UNIT)	
8	3B		E04-0416-05	RF COAXIAL RECEPTACLE(SMA)		52	2C		N99-2004-05	SCREW SET ACSY	
9	2B		E23-1104-04	TERMINAL(ANT)		53	3B		R31-0617-05	VARIABLE RESISTOR(POWER SW/VOL)	
10	3A,3B		E23-1166-04	RELAY TERMINAL		54	2B		S70-0414-05	TACT SWITCH	
11	2B		E37-0672-05	FLAT CABLE		SP	1B		T07-0714-05	SPEAKER	
12	3A		E37-0673-05	LEAD WIRE WITH CONNECTOR(PTT)		ANT	2C		T90-0680-05	HELICAL ANTENNA ACSY	T
13	1B		E37-0674-15	LEAD WIRE WITH CONNECTOR(SP)		ANT	2C		T90-0695-15	HELICAL ANTENNA ACSY	E
14	3B		E58-0440-05	SQUARE SOCKET (SP/MIC)		MIC	2B		T91-0579-05	MIC ELEMENT	
15	3B	*	E72-0412-13	TERMINAL BLOCK		IC100	2B		M68731HM	IC(POWER MODULE)	
16	2B		F10-2272-03	SHIELDING CASE (DBM)		55	3B		W02-1814-05	ENCODER	
17	3A		F10-2305-04	SHIELDING PLATE(PLL)		56	3B		G13-1794-04	CUSHION(MCF)	
18	2A		F10-2310-03	SHIELDING PLATE(LCD)		DISPLAY UNIT (X54-3210-12)					
19	2A		F10-2340-03	SHIELDING CASE (VCO-OUT)		D301			B30-2019-05	LED(RE/GR)	
20	2B	*	F10-2341-13	SHIELDING CASE (DBM/VCO)		D305-310			B30-2171-05	LED	
21	3B	*	F10-2353-14	SHIELDING PLATE(P-MODULE)		C301			CC73GCH1H470J	CHIP C 47PF J	
22	2B		F10-2360-03	SHIELDING CASE (FRONT END)		C302			C92-0560-05	CHIP-TAN 10UF 6.3WV	
23	3B		F20-1181-04	INSULATING SHEET		C304			CK73FB1C474K	CHIP C 0.47UF K	
24	2B		F20-3303-04	INSULATING SHEET(MIC/GND)		C305			CC73GCH1H101J	CHIP C 100PF J	
25	1A		G01-0881-04	COIL SPRING		C307			CK73GB1C104K	CHIP C 0.10UF K	
26	1B		G09-0418-05	KNOB SPRING (VOL,ENC)		C308			CC73GCH1H101J	CHIP C 100PF J	
27	1B		G10-0799-04	FIBROUS SHEET (SP)		C309			CK73FB1C474K	CHIP C 0.47UF K	
28	3A		G11-2544-04	SHEET (CHASSIS)		C310			CK73GB1C104K	CHIP C 0.10UF K	
29	3A		G11-2590-04	SHEET (PTT)		C311			CC73GCH1H470J	CHIP C 47PF J	
30	2A		G13-1731-04	CUSHION (LCD)		C312			CK73GB1C104K	CHIP C 0.10UF K	
31	3B		G13-1762-04	CUSHION (VOL/CHASSIS)		C313			C92-0628-05	CHIP-TAN 10UF 10WV	
32	3B		G13-1791-14	CUSHION (TERMINAL)		C314			C92-0647-05	TAN C 3.3UF 4WV	
33	3B		G53-0811-03	PACKING (TOP)		C315			CC73GCH1H101J	CHIP C 100PF J	
34	1B		G53-0896-02	PACKING (16KEYS)		C316,317			CC73GCH1H470J	CHIP C 47PF J	
35	3A		G53-1510-04	PACKING (BATT+)		C318			CC73GCH1H101J	CHIP C 100PF J	
36	3B		G53-1520-24	PACKING (TERMINAL)		C321-333			CC73GCH1H470J	CHIP C 47PF J	
37	2D		H12-3014-02	PACKING FIXTURE		C335-339			CK73GB1E153K	CHIP C 0.015UF K	
38	1D		H13-1072-04	CARTON BOARD		C340			CC73GCH1H470J	CHIP C 47PF J	
39	3D		H52-1225-12	ITEM CARTON CASE		C341-344			CC73GCH1H470J	CHIP C 47PF J	
40	1A		J19-1572-04	HOLDER		CN300			E40-5891-05	FLAT CABLE CONNECTOR(24P)	
41	2B		J21-8398-03	HARDWARE FIXTURE(P-MODULE)		CN301			E40-5892-05	FLAT CABLE CONNECTOR(14P)	
42	2C		J29-0658-05	HOOK ACSY		CN302			E40-5662-05	PIN ASSY SOCKET(2P-SP)	
43	3B		J30-1263-04	SPACER (TERMINAL-)		CN303			E40-5887-05	PIN ASSY(4P-PTT)	
44	2A		J30-1264-04	SPACER (TERMINAL+)		CN304			E40-5823-05	FLAT CABLE CONNECTOR(LCD)	
45	3B		J82-0045-05	FPC (VOL,ENC)		L300,301			L92-0141-05	FERRITE CHIP	
46	3B		J82-0066-05	FPC (SQUARE SOCKET)		L302,303			L92-0138-05	FERRITE CHIP	
47	1A		K29-5157-03	KNOB (PTT)		L304,305			L92-0141-05	FERRITE CHIP	
48	1A		K29-5158-03	KEY TOP (PTT)		L306,307			L92-0138-05	FERRITE CHIP	
49	1A		K29-5165-03	LEVER KNOB							

PARTS LIST

DISPLAY UNIT (X54-3210-12)

TX-RX UNIT (X57-6192-70)

Ref. No.	Address	New parts	Parts No.	Description	Destination	Ref. No.	Address	New parts	Parts No.	Description	Destination	
L308,309			L92-0141-05	FERRITE CHIP		TX-RX UNIT (X57-6192-70)						
CP300,301			R90-0723-05	MULTI-COMP 47K X2		C1			CK73GB1H102K	CHIP C 1000PF K		
CP302,303			R90-0724-05	MULTI-COMP 1K X4		C2 ,3			CK73GB1E103K	CHIP C 0.010UF K		
R300			RK73GB1J103J	CHIP R 10K J 1/16W		C4 -6			CK73GB1H102K	CHIP C 1000PF K		
R301			RK73FB2A101J	CHIP R 100 J 1/10W		C7			CK73GB1C104K	CHIP C 0.10UF K		
R302			RK73GB1J470J	CHIP R 47 J 1/16W		C9			CK73GB1E103K	CHIP C 0.010UF K		
R303			RK73GB1J471J	CHIP R 470 J 1/16W		C10			CK73GB1H102K	CHIP C 1000PF K		
R304			RK73GB1J182J	CHIP R 1.8K J 1/16W		C11			CK73GB1E103K	CHIP C 0.010UF K		
R305			RK73GB1J104J	CHIP R 100K J 1/16W		C12			CC73GCH1H101J	CHIP C 100PF J		
R306			R92-1252-05	CHIP R 0 OHM		C13			C92-0628-05	CHIP-TAN 10UF 10WV		
R307			RK73GB1J821J	CHIP R 820 J 1/16W		C14			C92-0592-05	CHIP-TAN 4.7UF 6.3WV		
R308			RK73GB1J153J	CHIP R 15K J 1/16W		C15			CK73GB1H102K	CHIP C 1000PF K		
R309			R92-1252-05	CHIP R 0 OHM		C16			C92-0650-05	TANTAL 10UF 6.3WV		
R310			RK73GB1J331J	CHIP R 330 J 1/16W		C17			CK73FB1C334K	CHIP C 0.33UF K		
R311			RK73GB1J102J	CHIP R 1.0K J 1/16W		C18			C92-0628-05	CHIP-TAN 10UF 10WV		
R312			RK73GB1J104J	CHIP R 100K J 1/16W		C19			C92-0592-05	CHIP-TAN 4.7UF 6.3WV		
R313,314			RK73GB1J102J	CHIP R 1.0K J 1/16W		C20			CK73GB1C104K	CHIP C 0.10UF K		
R315			RK73GB1J104J	CHIP R 100K J 1/16W		C21			CK73GB1H331K	CHIP C 330PF K		
R316			RK73GB1J473J	CHIP R 47K J 1/16W		C22			C92-0592-05	CHIP-TAN 4.7UF 6.3WV		
R317			RK73GB1J472J	CHIP R 4.7K J 1/16W		C23 -25			CK73GB1H102K	CHIP C 1000PF K		
R318			RK73GB1J104J	CHIP R 100K J 1/16W		C26			CK73GB1E223K	CHIP C 0.022UF K		
R319-321			RK73GB1J820J	CHIP R 82 J 1/16W		C27 -29			CK73GB1H102K	CHIP C 1000PF K		
R324,325			RK73GB1J102J	CHIP R 1.0K J 1/16W		C30			CK73GB1C104K	CHIP C 0.10UF K		
R326			RK73GB1J124J	CHIP R 120K J 1/16W		C31			CK73FB1A105K	CHIP C 1.0UF K		
R327			RK73GB1J563J	CHIP R 56K J 1/16W		C32 ,33			CK73GB1H102K	CHIP C 1000PF K		
R328			RK73GB1J124J	CHIP R 120K J 1/16W		C34			CK73GB1E103K	CHIP C 0.010UF K		
R331			RK73GB1J103J	CHIP R 10K J 1/16W		C35			CK73GB1C104K	CHIP C 0.10UF K		
R332			RK73GB1J272J	CHIP R 2.7K J 1/16W		C36 ,37			CK73GB1H102K	CHIP C 1000PF K		
R333			RK73GB1J103J	CHIP R 10K J 1/16W		C38 ,39			CK73GB1C104K	CHIP C 0.10UF K		
R336			R92-1252-05	CHIP R 0 OHM		C40			C92-0713-05	TAN C 10UF 6.3WV		
R337			RK73GB1J472J	CHIP R 4.7K J 1/16W		C41			CK73GB1H102K	CHIP C 1000PF K		
R338-341			RK73GB1J101J	CHIP R 100 J 1/16W		C42			CK73GB1C333K	CHIP C 0.033UF K		
S301-303			S70-0457-05	TACT SWITCH(PTT)		C43			CK73GB1H102K	CHIP C 1000PF K		
D300			NNCD6.8G	ZENER DIODE		C45			CC73GCH1H121J	CHIP C 120PF J		
D302			1SS373	DIODE		C46			CK73GB1C104K	CHIP C 0.10UF K		
D303			015A22.4-X	ZENER DIODE		C47			CK73GB1H102K	CHIP C 1000PF K		
D304			MA2S111	DIODE		C48			CK73GB1C104K	CHIP C 0.10UF K		
D315			IMN10	DIODE		C49			CC73GCH1H100D	CHIP C 10PF D		
D316,317			MA2S111	DIODE		C50			CK73GB1E103K	CHIP C 0.010UF K		
D318			IMN10	DIODE		C51			CC73GCH1H271J	CHIP C 270PF J		
D319-321			015AZ6.8	ZENER DIODE		C52			CK73GB1H102K	CHIP C 1000PF K		
IC300			TDA7053AT	IC(AUDIO AMP)		C53			CK73GB1E103K	CHIP C 0.010UF K		
IC301			MC74HC4017F	IC(COUNTER)		C54			CK73GB1C104K	CHIP C 0.10UF K		
Q300			2SJ243	FET		C55			C92-0662-05	CHIP-TAN 15UF 6.3WV		
Q301			UPA672T	FET		C56			CK73GB1H472K	CHIP C 4700PF K		
Q302-304			2SC4617(S)	TRANSISTOR		C57			CK73GB1H102K	CHIP C 1000PF K		
Q305			2SB798(DL,DK)	TRANSISTOR		C58			CK73GB1H222K	CHIP C 2200PF K		
Q306			2SC4617(S)	TRANSISTOR		C59			CK73GB1C273K	CHIP C 0.027UF K		
Q307			2SB1132(Q,R)	TRANSISTOR		C60			CK73GB1C104K	CHIP C 0.10UF K		
Q308			UPA672T	FET		C61			CK73GB1E123K	CHIP C 0.012UF K		
Q309			2SC4617(S)	TRANSISTOR		C62			CK73GB1H122J	CHIP C 1200PF J		
Q310			2SK1824	FET		C63			CK73GB1H102K	CHIP C 1000PF K		
TH300			TN10-3S154JT	THERMISTOR		C64 ,65			CC73GCH1H820J	CHIP C 82PF J		
						C66			CK73GB1C104K	CHIP C 0.10UF K		
						C67 ,68			CK73GB1E103K	CHIP C 0.010UF K		
						C69			CK73GB1C104K	CHIP C 0.10UF K		

PARTS LIST

TX-RX UNIT (X57-6192-70)

Ref. No.	Address	New parts	Parts No.	Description	Destination	Ref. No.	Address	New parts	Parts No.	Description	Destination
C70			CC73GCH1H220J	CHIP C 22PF J		C137			CC73GCH1H100D	CHIP C 10PF D	
C71			CK73GB1C683K	CHIP C 0.068UF K		C138			CK73GB1H102K	CHIP C 1000PF K	
C72			CC73GCH1H100D	CHIP C 10PF D		C139			CC73GCH1H220J	CHIP C 22PF J	
C73			CK73GB1C104K	CHIP C 0.10UF K		C140			C92-0592-05	CHIP-TAN 4.7UF 6.3WV	
C74			CK73GB1E103K	CHIP C 0.010UF K		C141			CK73GB1H102K	CHIP C 1000PF K	
C75			CK73GB1C104K	CHIP C 0.10UF K		C142			CC73GCH1H150J	CHIP C 15PF J	
C76			C92-0773-05	TAN C 15UF 6.3WV		C143			C92-0714-05	TAN C 4.7UF 6.3WV	
C77			CK73GB1H562J	CHIP C 5600PF J		C144			CK73FB1H563K	CHIP C 0.056UF K	
C78			C92-0713-05	TAN C 10UF 6.3WV		C146			CK73HB1H102K	CHIP C 1000PF K	
*1 C79			C92-0656-05	TAN C 2.2UF 6.3WV		C148			CK73GB1H102K	CHIP C 1000PF K	
C80			CK73GB1H102K	CHIP C 1000PF K		C149			CC73GCH1H060D	CHIP C 6.0PF D	
C81			CK73GB1C333K	CHIP C 0.033UF K		C154			CK73GB1H102K	CHIP C 1000PF K	
C82			CC73GCH1H101J	CHIP C 100PF J		C157			CK73GB1H102K	CHIP C 1000PF K	
C83			CK73GB1H562J	CHIP C 5600PF J		C158			CK73HB1C103K	CHIP C 0.010UF K	
C84			CK73GB1H102K	CHIP C 1000PF K		C159			CK73GB1C104K	CHIP C 0.10UF K	
C85			CK73GB1H562J	CHIP C 5600PF J		C160			CC73GCH1H100D	CHIP C 10PF D	
C86			CK73GB1C333K	CHIP C 0.033UF K		C164			CK73GB1E103K	CHIP C 0.010UF K	
C87			CK73GB1C104K	CHIP C 0.10UF K		C165			CC73GCH1H050C	CHIP C 5.0PF C	
C88			CC73GCH1H820J	CHIP C 82PF J		C166			CK73HB1C103K	CHIP C 0.010UF K	
C90			CK73GB1H102K	CHIP C 1000PF K		C167			CC73GCH1H150J	CHIP C 15PF J	
C91			C92-0773-05	TAN C 15UF 6.3WV		C168			CC73GCH1H220J	CHIP C 22PF J	
C92			CK73GB1H272J	CHIP C 2700PF J		C169			CC73GCH1H1R5B	CHIP C 1.5PF B	
C93			CK73GB1C104K	CHIP C 0.10UF K		C170			CK73GB1E103K	CHIP C 0.010UF K	
C94			CK73GB1H102K	CHIP C 1000PF K		C171			CK73HB1C103K	CHIP C 0.010UF K	
C95			CC73GCH1H330J	CHIP C 33PF J		C172			CC73GCH1H120J	CHIP C 12PF J	
C96			CC73GCH1H030C	CHIP C 3.0PF C		C175			CK73GB1C104K	CHIP C 0.10UF K	
C97_98			CK73GB1H272J	CHIP C 2700PF J		C176			CK73GB1H472K	CHIP C 4700PF K	
C101			CK73GB1C104K	CHIP C 0.10UF K		C177,178			CK73GB1H102K	CHIP C 1000PF K	
C102			CC73GCH1H151J	CHIP C 150PF J		C179			CK73GB1H471K	CHIP C 470PF K	
C103			CK73GB1H152J	CHIP C 1500PF J		C180,181			CK73GB1H102K	CHIP C 1000PF K	
C104			CK73GB1H102K	CHIP C 1000PF K		C182			CK73GB1E103K	CHIP C 0.010UF K	
C105			CK73GB1E103K	CHIP C 0.010UF K		C183			CC73GCH1H100D	CHIP C 10PF D	
C106			CC73GCH1H030C	CHIP C 3.0PF C		C184			CC73GCH1H270J	CHIP C 27PF J	
C107			C92-0650-05	TAN C 10UF 6.3WV		C186			CK73GB1H102K	CHIP C 1000PF K	
C108			C92-0714-05	TAN C 4.7UF 6.3WV		C187			CC73GCH1H270J	CHIP C 27PF J	
C109			CK73GB1C104K	CHIP C 0.10UF K		C189,190			CK73GB1H102K	CHIP C 1000PF K	
C110			CK73GB1H102K	CHIP C 1000PF K		C191			CK73HB1C103K	CHIP C 0.010UF K	
C111			C92-0713-05	TAN C 10UF 6.3WV		C192,193			CK73GB1H102K	CHIP C 1000PF K	
C112			CK73GB1H102K	CHIP C 1000PF K		C194			CC73GCH1H390J	CHIP C 39PF J	
C113			CK73GB1C104K	CHIP C 0.10UF K		C195			CC73GCH1H220J	CHIP C 22PF J	
C116,117			CK73GB1C104K	CHIP C 0.10UF K		C196			CK73HB1H102K	CHIP C 1000PF K	
C119			CK73GB1C473K	CHIP C 0.047UF K		C197			CC73GCH1H150J	CHIP C 15PF J	
C120,121			CK73GB1C104K	CHIP C 0.10UF K		C198			CK73FB1C474K	CHIP C 0.47UF K	
C122			CK73GB1E103K	CHIP C 0.010UF K		C199			CK73GB1H102K	CHIP C 1000PF K	
C123,124			CK73GB1C104K	CHIP C 0.10UF K		C200			C92-0565-05	CHIP-TAN 6.8UF 10WV	
C125			C92-0519-05	CHIP-TAN 1.0UF 25WV		C201			CC73GCH1H270J	CHIP C 27PF J	
C126			C92-0714-05	TAN C 4.7UF 6.3WV		C202			CC73GCH1H180J	CHIP C 18PF J	
C127			CK73GB1C104K	CHIP C 0.10UF K		C203			CK73GB1H102K	CHIP C 1000PF K	
C128			CK73GB1H562J	CHIP C 5600PF J		C204			CC73GCH1H330J	CHIP C 33PF J	
C129			CK73GB1H102K	CHIP C 1000PF K		C205			CK73GB1H102K	CHIP C 1000PF K	
C130			CK73GB1H562J	CHIP C 5600PF J		C206			CC73GCH1H270J	CHIP C 27PF J	
C132			CC73GCH1H220J	CHIP C 22PF J		C207			CC73GCH1H090B	CHIP C 9.0PF B	
C133			CK73GB1E153K	CHIP C 0.015UF K		C208			CK73GB1E103K	CHIP C 0.010UF K	
C134			CK73GB1E103K	CHIP C 0.010UF K		C209			CC73GCH1H0R5B	CHIP C 0.5PF B	
C135			CK73GB1C333K	CHIP C 0.033UF K		C210,211			CK73GB1H102K	CHIP C 1000PF K	
C136			CK73GB1E103K	CHIP C 0.010UF K		C212			CC73GCH1H270J	CHIP C 27PF J	

Note

*1 C79:0.10UF capacitor is applied in the product having serial No. of 201XXXXX.
C79 CK73GB1C104K CHIP C 0.10UF K

PARTS LIST

TX-RX UNIT (X57-6192-70)

Ref. No.	Address	New parts	Parts No.	Description	Destination	Ref. No.	Address	New parts	Parts No.	Description	Destination
C213			CK73FB1C474K	CHIP C 0.47UF K		CN5 -12			E23-1081-05	TERMINAL	
C214			CC73GCH1H330J	CHIP C 33PF J		F1			F53-0130-05	FUSE(3A)	
C215			CC73GCH1H101J	CHIP C 100PF J		CD1			L79-1072-05	TUNING COIL	
C216			CC73GCH1H330J	CHIP C 33PF J		CF1			L72-0962-05	CERAMIC FILTER(455KHz)	
C217			CC73GCH1H101J	CHIP C 100PF J		CF2			L72-0963-05	CERAMIC FILTER(455KHz)	
C218			CK73GB1H102K	CHIP C 1000PF K		L1			L92-0149-05	FERRITE CHIP	
C219			CC73GCH1H120J	CHIP C 12PF J		L2			L92-0138-05	FERRITE CHIP	
C220			CC73GCH1H101J	CHIP C 100PF J		L3			L40-4791-37	SMALL FIXED INDUCTOR(4.7UH)	
C221			CC73GCH1H220J	CHIP C 22PF J		L4			L40-1091-37	SMALL FIXED INDUCTOR(1.0UH)	
C222			CK73GB1H102K	CHIP C 1000PF K		L5 .6			L92-0138-05	FERRITE CHIP	
C223			CC73GCH1H100C	CHIP C 10PF C		L8			L92-0138-05	FERRITE CHIP	
C224-226			CK73GB1H102K	CHIP C 1000PF K		L9			L40-2771-36	SMALL FIXED INDUCTOR(27NH)	
C227			CC73GCH1H150J	CHIP C 15PF J		L10			L40-6871-36	SMALL FIXED INDUCTOR(68NH)	
C228			CK73GB1H102K	CHIP C 1000PF K		L11, 12			L92-0138-05	FERRITE CHIP	
C229			CC73GCH1H470J	CHIP C 47PF J		L14			L40-1081-36	SMALL FIXED INDUCTOR(100NH)	
C230			CK73GB1H102K	CHIP C 1000PF K		L15			L40-3371-36	SMALL FIXED INDUCTOR(33NH)	
C231			CC73GCH1H080B	CHIP C 8.0PF B		L17			L40-4771-36	SMALL FIXED INDUCTOR(47NH)	
C233			CC73GCH1H080B	CHIP C 8.0PF B		L18			L39-1272-05	TOROIDAL COIL	
C234			CC73GCH1H470J	CHIP C 47PF J		L19			L92-0138-05	FERRITE CHIP	
C235			CK73GB1E103K	CHIP C 0.010UF K		L20			L40-1081-36	SMALL FIXED INDUCTOR(100NH)	
C236			CK73GB1H102K	CHIP C 1000PF K		L21, 22			L39-1272-05	TOROIDAL COIL	
C237			CC73GCH1H270J	CHIP C 27PF J		L24			L92-0138-05	FERRITE CHIP	
C238,239			CK73GB1H102K	CHIP C 1000PF K		L25			L40-1081-36	SMALL FIXED INDUCTOR(100NH)	
C241			CK73GB1H102K	CHIP C 1000PF K		L26			L92-0138-05	FERRITE CHIP	
C242			CC73GCH1H270J	CHIP C 27PF J		L27			L40-8278-67	SMALL FIXED INDUCTOR(82NH)	
C243			CK73GB1H102K	CHIP C 1000PF K		L28			L92-0138-05	FERRITE CHIP	
C244			CC73GCH1H100C	CHIP C 10PF C		L29			L40-6875-54	SMALL FIXED INDUCTOR(68NH)	
C245			CK73GB1H102K	CHIP C 1000PF K		L30			L92-0149-05	FERRITE CHIP	
C246			CC73GCH1H130J	CHIP C 13PF J		L31			L40-1878-67	SMALL FIXED INDUCTOR(18NH)	
C247			CC73GCH1H040B	CHIP C 4.0PF B		L32			L34-4565-05	AIR-CORE COIL(5T)	
C248			CC73GCH1H330J	CHIP C 33PF J		L33			L40-1878-67	SMALL FIXED INDUCTOR(18NH)	
C249			CK73GB1H102K	CHIP C 1000PF K		L34			L40-1095-34	SMALL FIXED INDUCTOR(1UH)	
C251			CC73GCH1H150J	CHIP C 15PF J		L35			L40-1088-67	SMALL FIXED INDUCTOR(100NH)	
C252,253			CK73GB1H102K	CHIP C 1000PF K		L36			L40-3978-67	SMALL FIXED INDUCTOR(39NH)	
C255			CK73GB1H102K	CHIP C 1000PF K		L37			L34-4568-05	AIR-CORE COIL(8T)	
C256,257			CK73HB1C103K	CHIP C 0.010UF K		L38			L40-3971-36	SMALL FIXED INDUCTOR(39NH)	
C259			CK73GB1E103K	CHIP C 0.010UF K		L39			L34-4568-05	AIR-CORE COIL(8T)	
C260			CC73GCH1H150J	CHIP C 15PF J		L40			L40-1588-67	SMALL FIXED INDUCTOR(150NH)	
C261			CK73GB1E103K	CHIP C 0.010UF K		L41			L34-4568-05	AIR-CORE COIL(8T)	
C263			CC73GCH1H1R5B	CHIP C 1.5PF B		L45			L40-1092-81	SMALL FIXED INDUCTOR	
C265			CK73GB1C104K	CHIP C 0.10UF K		L49			L92-0138-05	FERRITE CHIP	
C266			CC73GCH1H181J	CHIP C 180PF J		L51			L40-2288-67	SMALL FIXED INDUCTOR(220NH)	
C267			CC73GCH1H680J	CHIP C 68PF J		L402			L40-3363-77	SMALL FIXED INDUCTOR(3.3NH)	
C268			CK73GB1C104K	CHIP C 0.10UF K		L403-406			L34-4568-05	AIR-CORE COIL(8T)	
C401			CK73GB1C104K	CHIP C 0.10UF K		L407,408			L34-4567-05	AIR-CORE COIL(7T)	
C402			CC73GCH1H391J	CHIP C 390PF J		X1			L77-1789-05	TCXO(16.8MHZ)	
C403			CC73GCH1H390J	CHIP C 39PF J		X2			L77-1760-15	CRYSTAL RESONATOR(44.395MHZ)	
C404			CK73GB1H102K	CHIP C 1000PF K		X3			L77-1708-05	CRYSTAL RESONATOR(3.579545MHZ)	
C408			C92-0602-05	CHIP-TAN 1.0UF 10WV		X4			L78-0462-05	RESONATOR (9.8304M)	
C410			C92-0714-05	TAN C 4.7UF 6.3WV		XF1			L71-0572-05	MCF (44.85MHZ)	
C412			CK73HB1A104K	CHIP C 0.10UF K		CP1			R90-0724-05	MULTI-COMP 1K X4	
*2 C421			CC73GCH1H471J	CHIP C 470PF J		CP2			R90-0718-05	MULTI-COMP 4.7K X4	
CN1			E40-5823-05	FLAT CABLE CONNECTOR(10P)		CP4, .5			R90-0743-05	MULTIPLE RESISTOR 47K X2	
CN2			E40-9517-05	PIN ASSY SOCKET(4P)							
CN3			E40-5890-05	FLAT CABLE CONNECTOR(24P)							
CN4			E23-0342-05	TEST TERMINAL							

PARTS LIST

TX-RX UNIT (X57-6192-70)

Ref. No.	Address	New parts	Parts No.	Description	Destination	Ref. No.	Address	New parts	Parts No.	Description	Destination
CP6 -21			R90-0741-05	MULTIPLE RESISTOR 1K X2		R61			RK73GB1J103J	CHIP R	10K J 1/16W
CP22-24			R90-0743-05	MULTIPLE RESISTOR 47K X2		R62			RN73GH1J913D	CHIP R	91K D 1/16W
R1			RK73GB1J103J	CHIP R 10K J 1/16W		R63			RK73GB1J474J	CHIP R	470K J 1/16W
R2			RK73GB1J473J	CHIP R 47K J 1/16W		R64			RK73GB1J153J	CHIP R	15K J 1/16W
R3			RK73GB1J154J	CHIP R 150K J 1/16W		R65			RK73GB1J103J	CHIP R	10K J 1/16W
R4			RK73GB1J104J	CHIP R 100K J 1/16W		R66			R92-1252-05	CHIP R	0 OHM
R5			RK73HB1J103J	CHIP R 10K J 1/16W		R67			RN73GH1J274D	CHIP R	270K D 1/16W
R6 ,7			RK73GB1J104J	CHIP R 100K J 1/16W		R68			RK73GB1J223J	CHIP R	22K J 1/16W
R8			R92-1368-05	CHIP R 0 OHM		R69			R92-1252-05	CHIP R	0 OHM
R9			RK73HB1J474J	CHIP R 470K J 1/16W		R70			RN73GH1J682D	CHIP R	6.8K D 1/16W
R10			RK73HB1J103J	CHIP R 10K J 1/16W		R71			RK73GB1J183J	CHIP R	18K J 1/16W
R11			RK73GB1J104J	CHIP R 100K J 1/16W		R72			RK73GB1J155J	CHIP R	1.5M J 1/16W
R12			RK73GB1J184J	CHIP R 180K J 1/16W		R73			RK73GB1J471J	CHIP R	470 J 1/16W
R13			RK73GB1J333J	CHIP R 33K J 1/16W		R74			RK73GB1J183J	CHIP R	18K J 1/16W
R14			RK73GB1J223J	CHIP R 22K J 1/16W		R75			RN73GH1J683D	CHIP R	68K D 1/16W
R15			RK73GB1J104J	CHIP R 100K J 1/16W		R76			RK73GB1J474J	CHIP R	470K J 1/16W
R16 ,17			RK73GB1J473J	CHIP R 47K J 1/16W		R77			RK73GB1J393J	CHIP R	39K J 1/16W
R18			RK73GB1J154J	CHIP R 150K J 1/16W		R78			RN73GH1J682D	CHIP R	6.8K D 1/16W
R19			RK73GB1J104J	CHIP R 100K J 1/16W		R79			RK73GB1J101J	CHIP R	100 J 1/16W
R20			RK73HB1J104J	CHIP R 100K J 1/16W		R80			RK73GB1J152J	CHIP R	1.5K J 1/16W
R21			RK73GB1J473J	CHIP R 47K J 1/16W		R81			RK73GB1J220J	CHIP R	22 J 1/16W
R22 ,23			RK73GB1J823J	CHIP R 82K J 1/16W		R83			RK73GB1J184J	CHIP R	180K J 1/16W
R24			RK73GB1J473J	CHIP R 47K J 1/16W		R84			R92-1252-05	CHIP R	0 OHM
R25			RK73GB1J472J	CHIP R 4.7K J 1/16W		R85			RK73GB1J103J	CHIP R	10K J 1/16W
R26			RK73GB1J473J	CHIP R 47K J 1/16W		R86			RK73GB1J183J	CHIP R	18K J 1/16W
R27			RK73GB1J332J	CHIP R 3.3K J 1/16W		R89			RK73GB1J102J	CHIP R	1.0K J 1/16W
R28			RK73GB1J474J	CHIP R 470K J 1/16W		R90			RK73GB1J153J	CHIP R	15K J 1/16W
R29			RK73GB1J184J	CHIP R 180K J 1/16W		R91			RK73GB1J473J	CHIP R	47K J 1/16W
R30			RK73GB1J334J	CHIP R 330K J 1/16W		R93			RK73HB1J682J	CHIP R	6.8K J 1/16W
R31			RK73GB1J102J	CHIP R 1.0K J 1/16W		R94			RK73HB1J683J	CHIP R	68K J 1/16W
R32			RK73GB1J104J	CHIP R 100K J 1/16W		R95			RK73GB1J394J	CHIP R	390K J 1/16W
R33			RK73GB1J184J	CHIP R 180K J 1/16W		R96			RK73GB1J152J	CHIP R	1.5K J 1/16W
R34			RK73GB1J683J	CHIP R 68K J 1/16W		R97			RK73GB1J151J	CHIP R	150 J 1/16W
R35			RK73GB1J220J	CHIP R 22 J 1/16W		R99			RK73GB1J104J	CHIP R	100K J 1/16W
R36			RK73GB1J154J	CHIP R 150K J 1/16W		R100			R92-1252-05	CHIP R	0 OHM
R37			R92-1252-05	CHIP R 0 OHM		R101			RK73GB1J560J	CHIP R	56 J 1/16W
R38			RK73GB1J101J	CHIP R 100 J 1/16W		R102			RK73GB1J333J	CHIP R	33K J 1/16W
R39			RK73GB1J472J	CHIP R 4.7K J 1/16W		R104			RK73GB1J102J	CHIP R	1.0K J 1/16W
R40 ,41			RK73GB1J334J	CHIP R 330K J 1/16W		R106			RK73GB1J470J	CHIP R	47 J 1/16W
R42 ,43			RK73GB1J223J	CHIP R 22K J 1/16W		R107			RK73GB1J473J	CHIP R	47K J 1/16W
R44			RK73GB1J473J	CHIP R 47K J 1/16W		R109			R92-1252-05	CHIP R	0 OHM
R45			RK73GB1J472J	CHIP R 4.7K J 1/16W		R110			RK73GB1J220J	CHIP R	22 J 1/16W
R46 ,47			RK73GB1J223J	CHIP R 22K J 1/16W		R114			RK73GB1J223J	CHIP R	22K J 1/16W
R48			R92-1252-05	CHIP R 0 OHM		R115			RK73GB1J184J	CHIP R	180K J 1/16W
R49			RK73GB1J223J	CHIP R 22K J 1/16W		R116			RK73GB1J103J	CHIP R	10K J 1/16W
R50			RN73GH1J913D	CHIP R 91K D 1/16W		R118			RK73GB1J331J	CHIP R	330 J 1/16W
R51			RN73GH1J683D	CHIP R 68K D 1/16W		R119			RK73GB1J101J	CHIP R	100 J 1/16W
R52			RN73GH1J913D	CHIP R 91K D 1/16W		R120			RK73GB1J224J	CHIP R	220K J 1/16W
R53			RK73GB1J473J	CHIP R 47K J 1/16W		R121			RK73GB1J222J	CHIP R	2.2K J 1/16W
R54			RK73GB1J123J	CHIP R 12K J 1/16W		R122			RK73GB1J331J	CHIP R	330 J 1/16W
R55			RN73GH1J333D	CHIP R 33K D 1/16W		R123			RK73GB1J183J	CHIP R	18K J 1/16W
R56			RK73GB1J472J	CHIP R 4.7K J 1/16W		R127			RK73GB1J103J	CHIP R	10K J 1/16W
R57			RK73GB1J183J	CHIP R 18K J 1/16W		R129			RK73HB1J104J	CHIP R	100K J 1/16W
R58			RK73GB1J184J	CHIP R 180K J 1/16W		R132,133			R92-1368-05	CHIP R	0 OHM
R59			RK73GB1J564J	CHIP R 560K J 1/16W		R134			R92-1252-05	CHIP R	0 OHM
R60			RK73GB1J123J	CHIP R 12K J 1/16W		R136			RK73GB1J103J	CHIP R	10K J 1/16W

PARTS LIST

TX-RX UNIT (X57-6192-70)

Ref. No.	Address	New parts	Parts No.	Description	Destination	Ref. No.	Address	New parts	Parts No.	Description	Destination
R137			RK73HB1J103J	CHIP R 10K J 1/16W		R298			R92-1252-05	CHIP R 0 OHM	
R139,140			RK73HB1J473J	CHIP R 47K J 1/16W		R300			R92-1252-05	CHIP R 0 OHM	
R143-151			RK73HB1J102J	CHIP R 1.0K J 1/16W		R303-305			R92-1252-05	CHIP R 0 OHM	
R155			RK73GB1J102J	CHIP R 1.0K J 1/16W		*3 R306			RK73HB1J102J	CHIP R 1.0K J 1/16W	
R159			RK73GB1J154J	CHIP R 150K J 1/16W		R307			RK73GB1J272J	CHIP R 2.7K J 1/16W	
R162			RK73GB1J103J	CHIP R 10K J 1/16W		R308			RK73GB1J684J	CHIP R 680K J 1/16W	
R163			RK73HB1J103J	CHIP R 10K J 1/16W		R309			RK73GB1J221J	CHIP R 220 J 1/16W	
R166			RK73GB1J223J	CHIP R 22K J 1/16W		R401			RK73GB1J224J	CHIP R 220K J 1/16W	
R167,168			R92-1252-05	CHIP R 0 OHM		R402,403			RK73GB1J394J	CHIP R 390K J 1/16W	
R177			RK73GB1J101J	CHIP R 100 J 1/16W		R404,405			RK73GB1J104J	CHIP R 100K J 1/16W	
R180			RK73GB1J473J	CHIP R 47K J 1/16W		R406			RK73HB1J473J	CHIP R 47K J 1/16W	
R184			RK73GB1J102J	CHIP R 1.0K J 1/16W		R408			RK73GB1J153J	CHIP R 15K J 1/16W	
R185			RK73GB1J470J	CHIP R 47 J 1/16W		R409			RK73GB1J394J	CHIP R 390K J 1/16W	
R189			RK73HB1J473J	CHIP R 47K J 1/16W		R410			RK73GB1J472J	CHIP R 4.7K J 1/16W	
R190			RK73GB1J472J	CHIP R 4.7K J 1/16W		R411			RK73HB1J102J	CHIP R 1.0K J 1/16W	
R192			RK73GB1J223J	CHIP R 22K J 1/16W		R412			RK73HB1J471J	CHIP R 470 J 1/16W	
R195			RK73GB1J222J	CHIP R 2.2K J 1/16W		R413			RK73GB1J681J	CHIP R 680 J 1/16W	
R199			RK73HB1J102J	CHIP R 1.0K J 1/16W		R414			RK73HB1J184J	CHIP R 180K J 1/16W	
R202			RK73GB1J181J	CHIP R 180 J 1/16W		R415			RK73GB1J474J	CHIP R 470K J 1/16W	
R217			RK73HB1J473J	CHIP R 47K J 1/16W		*4 R416			RK73GB1J474J	CHIP R 470K J 1/16W	
R218			RK73GB1J220J	CHIP R 22 J 1/16W		D1			1SR154-400	DIODE	
R220			RK73HB1J102J	CHIP R 1.0K J 1/16W		D2 ,3			MA2S111	DIODE	
R221			RK73GB1J221J	CHIP R 220 J 1/16W		D4			RB706F-40	DIODE	
R239			R92-1252-05	CHIP R 0 OHM		D5			DAN222	DIODE	
R240			RK73GB1J331J	CHIP R 330 J 1/16W		D6			MA2S111	DIODE	
R243			RK73GB1J220J	CHIP R 22 J 1/16W		D7			DAN222	DIODE	
R244			RK73EB2ER39K	CHIP R 0.39 K 1/4W		D8			RB706F-40	DIODE	
R246			RK73EB2ER39K	CHIP R 0.39 K 1/4W		D9			MA2S077	DIODE	
R247			R92-1252-05	CHIP R 0 OHM		D10			HZU5ALL	DIODE	
R248			RK73EB2ER39K	CHIP R 0.39 K 1/4W		D11			MA742	DIODE	
R249			R92-1252-05	CHIP R 0 OHM		D12, 14			HVC131	DIODE	
R250-252			RN73GH1J154D	CHIP R 150K D 1/16W		D16, 17			HVC350B	VARIABLE CAPACITANCE DIODE	
R253			RK73GB1J221J	CHIP R 220 J 1/16W		D18, 19			DA221	DIODE	
R254-256			RN73GH1J154D	CHIP R 150K D 1/16W		D20, 21			HVC350B	VARIABLE CAPACITANCE DIODE	
R257			RK73GB1J221J	CHIP R 220 J 1/16W		D22			HVC131	DIODE	
R258,259			R92-1252-05	CHIP R 0 OHM		D23			MA2S077	DIODE	
R260			RK73GB1J103J	CHIP R 10K J 1/16W		D24			1SS373	DIODE	
R261			RK73GB1J470J	CHIP R 47 J 1/16W		D401			HVC131	DIODE	
R262,263			RK73GB1J104J	CHIP R 100K J 1/16W		D402			MA2S111	DIODE	
R264			RK73GB1J680J	CHIP R 68 J 1/16W		IC1, 2			TC75W51FU	IC(BUFFER AMP)	
R265			RK73GB1J473J	CHIP R 47K J 1/16W		IC3			RN5VL42C	IC(VOLTAGE DETECTOR)	
R266			RK73GB1J683J	CHIP R 68K J 1/16W		IC4			TC75W51FU	IC(BUFFER AMP)	
R267			R92-1252-05	CHIP R 0 OHM		IC5			S-81350HG-KD	IC(VOLTAGE REGULATOR/5M)	
R268			RK73GB1J105J	CHIP R 1.0M J 1/16W		IC6			NJU7201U50	IC(VOLTAGE REGULATOR/5V)	
R269,270			RK73GB1J473J	CHIP R 47K J 1/16W		IC7			TC75W51FU	IC(BUFFER AMP)	
R271			R92-1252-05	CHIP R 0 OHM		IC8			M62364FP	IC(D/A CONVERTER)	
R272			RK73GB1J222J	CHIP R 2.2K J 1/16W		IC9			TK11250BM	IC(VOLTAGE REGULATOR/5C)	
R273			RK73GB1J103J	CHIP R 10K J 1/16W		IC10			TC75SS1F	IC(ACTIVE FILTER)	
R274			RK73GB1J470J	CHIP R 47 J 1/16W		IC11			TC75W51FU	IC(ACTIVE FILTER)	
R276			RK73GB1J103J	CHIP R 10K J 1/16W		IC12			TA31136FN	IC(FM IF)	
R281			RK73GB1J331J	CHIP R 330 J 1/16W		IC13			TC35453F	IC(AUDIO PROCESSOR)	
R282,283			RK73GB1J472J	CHIP R 4.7K J 1/16W		IC14			SA7025DK	IC(PLL SYSTEM)	
R284			R92-1252-05	CHIP R 0 OHM		IC16			LC73872M	IC(DTMF DECODER)	
R294			RK73GB1J221J	CHIP R 220 J 1/16W		IC17			AT29C020-90TI	IC(FLASH MEMORY)	
R295			R92-1252-05	CHIP R 0 OHM		IC18			GN2011(Q)	IC(ACTIVE DBM)	
R296,297			RK73HB1J473J	CHIP R 47K J 1/16W		IC19			30620M8-394GP	IC(CPU)	

38

Note

*3 R306:470K resistor is applied in the product having serial No. of 201XXXXX.
R306 RK73HB1J474J CHIP R 470K J 1/16W

*4 R416:This resistor is not used in the product having serial No. of 201XXXXX.

PARTS LIST

TX-RX UNIT (X57-6192-70)
SUB UNIT (X58-4580-10)

Ref. No.	Address	New parts	Parts No.	Description	Destination	Ref. No.	Address	New parts	Parts No.	Description	Destination
IC20			AT2416N10SI2.5	IC(EEPROM)							
IC21,22			BU4094BCFV	IC(SHIFT REGISTER)							
IC23			NJM2904V	IC(APC)		L1			L40-3391-37	SMALL FIXED INDUCTOR(3.3UH)	
IC24			TC7S66FU	IC(ANALOG SWITCH)		L2			L40-4791-37	SMALL FIXED INDUCTOR(4.7UH)	
IC25			TC75W51FU	IC(ACTIVE FILTER)		L3 ,4			L40-2291-37	SMALL FIXED INDUCTOR(2.2UH)	
Q1			DTC144EE	DIGITAL TRANSISTOR		L5			L34-4577-05	AIR-CORE COIL(9T)	
Q2			2SJ243	FET		L6			L34-4575-05	AIR-CORE COIL(7T)	
Q3			2SA1745(6,7)	TRANSISTOR		L7			L92-0138-05	FERRITE CHIP	
Q4			2SC4617(S)	TRANSISTOR		L8			L40-8275-44	SMALL FIXED INDUCTOR(82.0NH)	
Q5			2SJ243	FET		R1			RK73HB1J334J	CHIP R 330K J 1/16W	
Q6			DTA144EE	DIGITAL TRANSISTOR		R2			RK73HB1J473J	CHIP R 47K J 1/16W	
Q7			DTC144EE	DIGITAL TRANSISTOR		R3			RK73HB1J274J	CHIP R 270K J 1/16W	
Q8			2SC4617(S)	TRANSISTOR		R4			RK73HB1J104J	CHIP R 100K J 1/16W	
Q9 ,10			DTC144EE	DIGITAL TRANSISTOR		R5 ,6			RK73HB1J391J	CHIP R 390 J 1/16W	
Q11			2SK1824	FET		R7			RK73HB1J334J	CHIP R 330K J 1/16W	
Q12			2SC5108(Y)	TRANSISTOR		R8			RK73HB1J470J	CHIP R 47 J 1/16W	
Q13 -15			2SK1824	FET		D1 -8			HVC350B	VARIABLE CAPACITANCE DIODE	
Q16			2SC5108(Y)	TRANSISTOR		D9			HVC351	VARIABLE CAPACITANCE DIODE	
Q17			2SK1824	FET		Q1			2SJ243	FET	
Q18			2SC5108(Y)	TRANSISTOR		Q2 ,3			2SK508NV(K52)	FET	
Q19			2SC4619	TRANSISTOR		Q4			UMC4	TRANSISTOR	
Q20			2SC4988	TRANSISTOR		Q5			2SC5108(Y)	TRANSISTOR	
Q21 ,22			DTC114EE	DIGITAL TRANSISTOR							
Q23			2SK1824	FET							
Q24			3SK239A	FET							
Q25			DTA144EE	DIGITAL TRANSISTOR							
TH1			157-302-65801	THERMISTOR							
TH401			157-104-65001	THERMISTOR							
A1			X58-4580-10	SUB UNIT							
A1:SUB UNIT (VCO) X58-4580-10											
The A1 is replaceable as a unit assembly so individual parts are not kept in stock.											
C1			CK73HB1C103K	CHIP C 0.010UF K							
C2			CC73HCH1H100B	CHIP C 10PF B							
C3			CK73HB1H102K	CHIP C 1000PF K							
C4			CC73HCH1H101J	CHIP C 100PF J							
C5			CC73HCH1H470J	CHIP C 47PF J							
C6			CC73HCH1H120J	CHIP C 12PF J							
C7			CK73HB1C103K	CHIP C 0.010UF K							
C9			CC73HCH1H0R5B	CHIP C 0.5PF B							
C10			CK73HB1H102K	CHIP C 1000PF K							
C11			CC73HCH1H070B	CHIP C 7.0PF B							
C12			CC73HCH1H090B	CHIP C 9.0PF B							
C13			CC73HCH1H070B	CHIP C 7.0PF B							
C14			CC73HCH1H120J	CHIP C 12PF J							
C15			CC73HCH1H0R5B	CHIP C 0.5PF B							
C16			C92-0606-05	CHIP-TAN 4.7UF 10WV							
C17			CC73HCH1H0R5B	CHIP C 0.5PF B							
C18			CK73HB1C103K	CHIP C 0.010UF K							
C19			CK73HB1H102K	CHIP C 1000PF K							
C20			CC73HCH1H150J	CHIP C 15PF J							
C21			CK73HB1C103K	CHIP C 0.010UF K							
TC1 ,2			C05-0384-05	CERAMIC TRIMMER CAP(10P/8)							
CN1 ,2			E40-5622-05	PIN ASSY(3P)							

EXPLODED VIEW

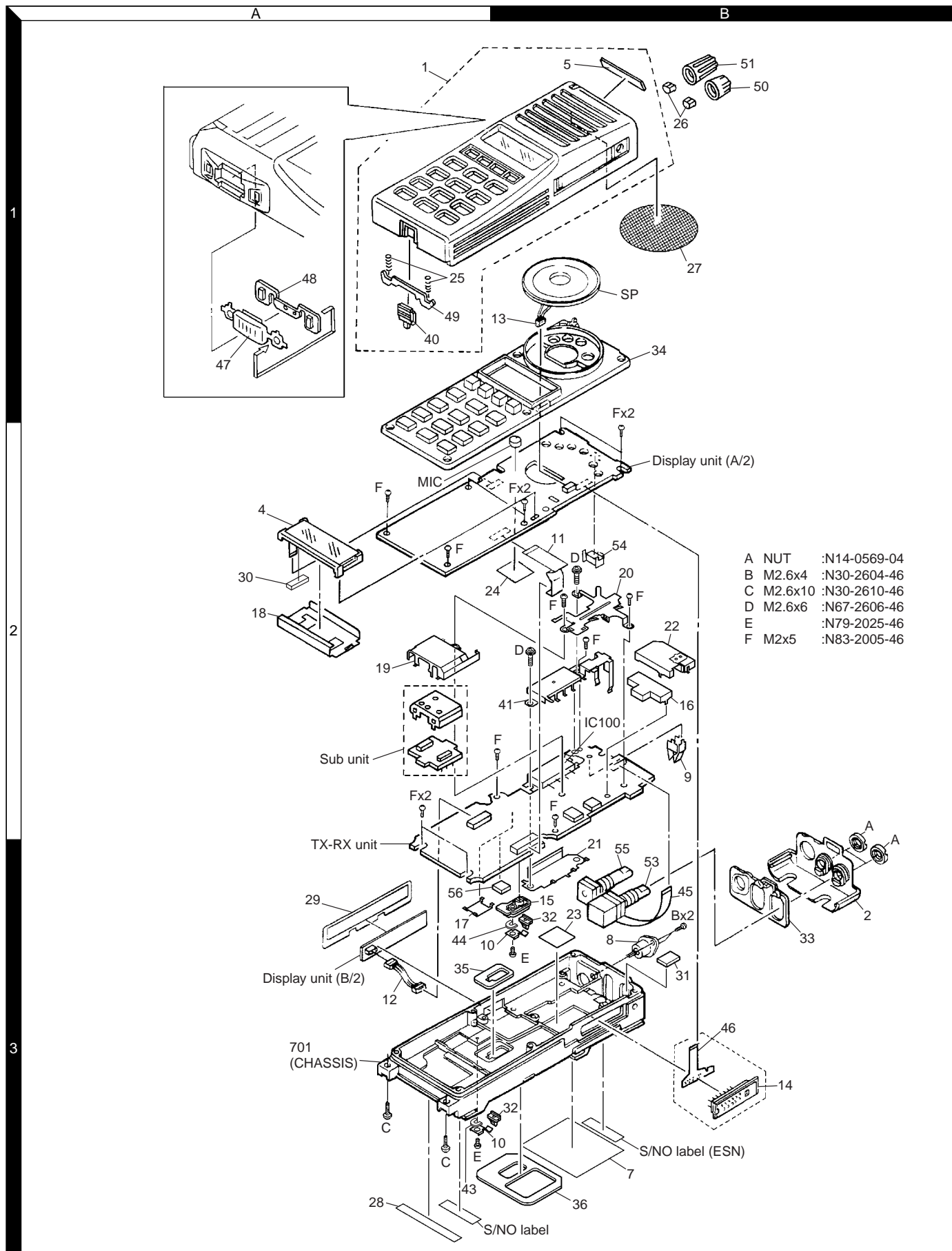

PACKING

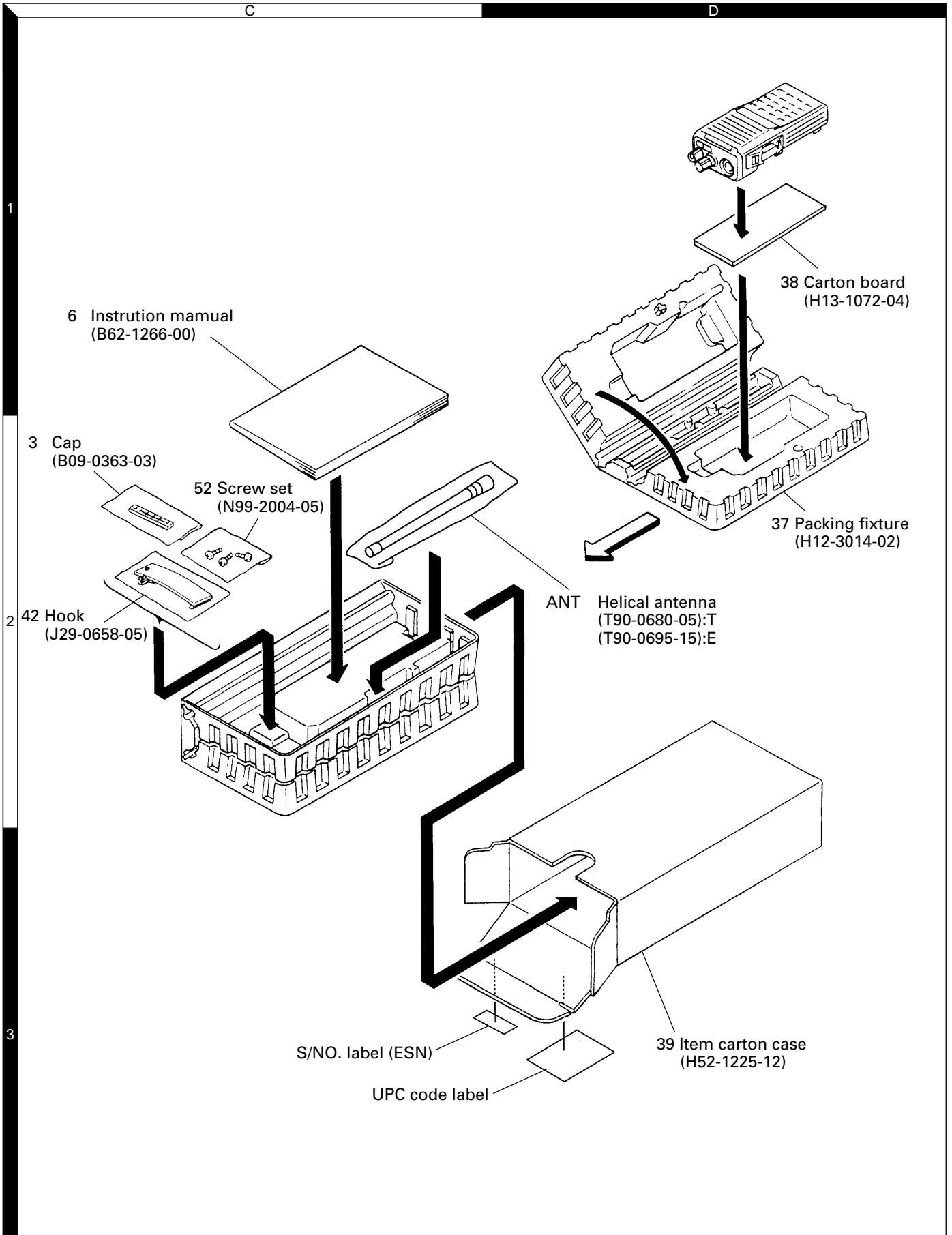

ADJUSTMENT

Test Equipment Required for Alignment

Test Equipment	Major Specifications	
1. Standard Signal Generator (SSG)	Frequency Range Modulation Output	146 to 174MHz Frequency modulation and external modulation. -127dBm/0.1μV to greater than -47dBm/1mV
2. Power Meter	Input Impedance Operation Frequency Measurement Range	50Ω. 146 to 174MHz or more. Vicinity of 10W
3. Deviation Meter	Frequency Range	146 to 174MHz.
4. Digital Volt Meter (DVM)	Measuring Range Input Impedance	10mV to 10V DC High input impedance for minimum circuit loading.
5. Oscilloscope		DC through 30MHz.
6. High Sensitivity Frequency Counter	Frequency Range Frequency Stability	10Hz to 1000MHz. 0.2ppm or less.
7. Ammeter		5A.
8. AF Volt Meter (AF VTVM)	Frequency Range Voltage Range	50Hz to 10kHz. 1mV to 10V.
9. Audio Generator (AG)	Frequency Range Output	50Hz to 5kHz or more. 0 to 1V.
10. Distortion Meter	Capability Input Level	3% or less at 1kHz. 50mV to 10Vrms.
11. 16Ω Dummy Load		Approx. 16Ω, 3W.
12. Regulated Power Supply		5V to 10V, approx. 5A Useful if ammeter equipped.

■ The following parts are required for adjustment

1. Antenna connector adapter

The antenna connector of this radio uses an SMA terminal. Use an antenna connector adapter [SMA(f) – BNC(f) or SMA(f) – N(f)] for adjustment. (The adapter is not provided as an option, so buy a commercially-available one.)

Note

When the antenna connector adapter touches the knob, draw out the knob to mount the connector.

2. Universal connector

Use the interface cable (KPG-36) for PC tuning or the lead wire with plug (E30-3287-18) and screw (N08-0535-08) for panel tuning. Connect the plug to the universal connector of the radio and tighten the screw.

The lead wire with plug (E30-3287-18) and screw (N08-0535-08) terminals are as follows. Numbers are universal connector terminal numbers.

Caution

1. When connecting the plug to the universal connector of the radio, a short circuit may occur. To prevent this, be sure to turn the radio POWER switch off.
2. Since the RX AF output is a BTL output, there is a DC component. Isolate this with a capacitor or transformer as shown in the figure.
3. Do not connect an instrument between red or black and GND.

• Universal connector

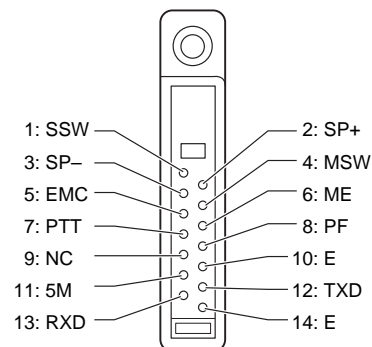

ADJUSTMENT

• Panel tuning

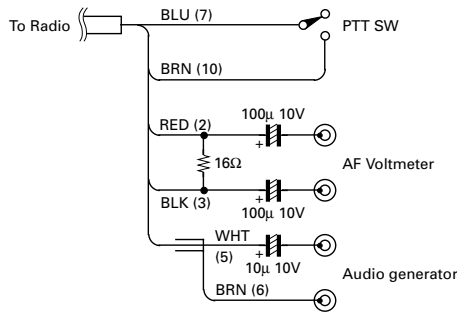
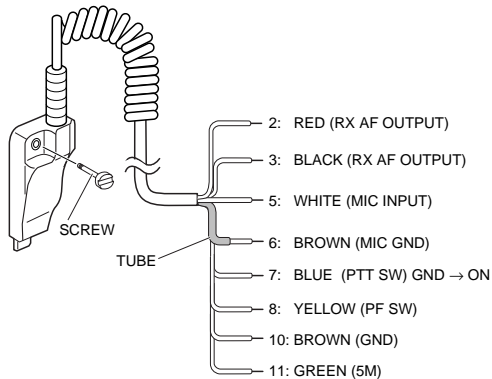

• PC tuning

Connect the wires to the PCB in the connector case of interface cable.

For output the wires out of the connector case, need to process the connector case.

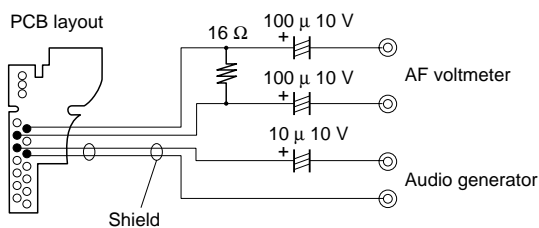
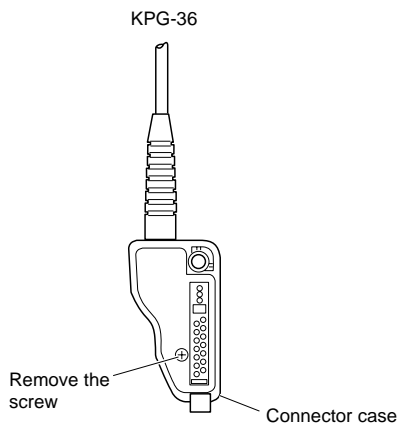

Repair Jig (Chassis)

Use jig (part No.: W05-0825-00) for repairing the TK-280.

The jig facilitates the voltage check and protects the module when the voltage on the flow side of the TX-RX unit is checked during repairs.

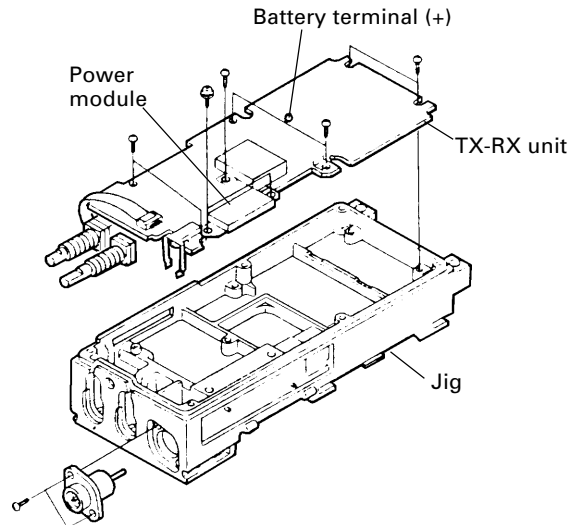

How to Remove the Flat Cable

1. Gently draw out both sides of the connector lever uniformly in the direction of the arrow with tweezers. (CN300, CN301)

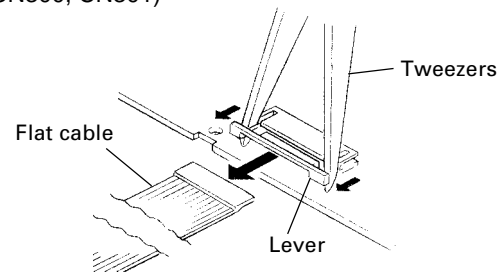

2. Gently rise up the connector lever in the direction of the arrow with a fine regular screwdriver or tweezers. (CN1, CN3, CN304)

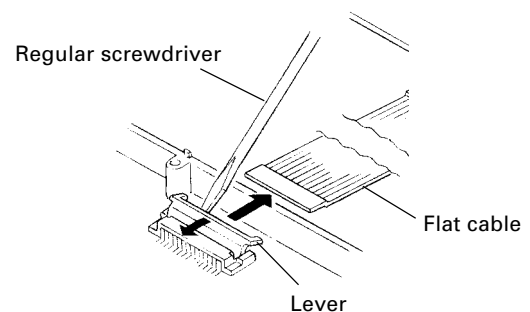

ADJUSTMENT

Test Mode

■ Test mode operating features



This transceiver has a test mode. **To enter test mode, press [B] key and turn power on. Hold [B] key until test channel No. and test signalling No. appears on LCD.** Test mode can be inhibited by programming. To exit test mode, switch the power on again. The following functions are available in test mode.

• Controls

Controls	"SFT" appears	"SFT" not appears
[PTT]	Used when making a transmission.	Used when making a transmission.
[AUX]	Unused	Unused
[MON]	Shift OFF.	Monitor ON and OFF.
[CALL]	Lights the lamp for five seconds. Lighting is extended for a further five seconds by pressing any key while the lamp is lit.	Changes wide, semi-wide and narrow.
[A]	FFSK 1200bps and 2400bps.	Sets to the Tuning mode.
[B]	Shift OFF	Shift ON.
[C]	Companer function ON and OFF.	RF power HIGH and LOW.
[D]	Best shift ON and OFF.	Changes signalling.
[O] to [9], and [#],[*]	Shift OFF	Used as the DTMF keypad. If a key is pressed during transmission, the DTMF corresponding to the key that was pressed is sent.
[ENCODER]	Changes channel.	Changes channel.

Note: If a [A],[B],[C],[D] key is pressed during transmission, the DTMF corresponding to the key that was pressed is sent.

• LCD indicator

"SCN"	Unused
" 	Lights at Companer ON.
"LO"	Lights at RF Power Low.
"P"	Unused
"MON"	Lights at monitor ON.
"SVC"	Unused
" 	Lights at FFSK 2400bps.

• LED indicator

Red LED Lights during transmission. Blinks at the low battery voltage warning.

Green LED Lights when there is a carrier.

• Sub LCD indicator

"SFT" appears at Shift ON.

■ Frequency and signalling

The set has been adjusted for the frequencies shown in the following table. When required, re-adjust them following the adjustment procedure to obtain the frequencies you want in actual operation.

Frequency (MHz)

Channel No.	E, T	
	RX (MHz)	TX (MHz)
1	160.05000	160.10000
2	146.05000	146.10000
3	173.95000	173.90000
4	160.00000	160.00000
5	160.20000	160.20000
6	160.40000	160.40000
7 ~ 16	—	—

Signalling

Signalling No.	RX	TX
1	None	None
2	None	100Hz Square
3	QT 67.0Hz	QT 67.0Hz
4	QT 151.4Hz	QT 151.4Hz
5	QT 210.7Hz	QT 210.7Hz
6	QT 250.3Hz	QT 250.3Hz
7	DQT 023N	DQT 023N
8	DQT 754I	DQT 754I
9	DTMF DEC.(159D)	DTMF ENC.(159D)
10	None	DTMF tone 9
11	2Tone (321.7/928.1Hz)	None
12	Single Tone 1200Hz	Single Tone 1200Hz
13	5Tone DEC.(EIA #12345)	5Tone ENC.(EIA #12345)
14	—	FFSK(1:1 Pattern)
15	FFSK Code	FFSK Code

• Preparations for tuning the transceiver

Before attempting to tune the transceiver, connect the unit to a suitable power supply.

When ever the transmitter is turned, the unit must be connected to a suitable dummy load (i.e. power meter).

The speaker output connector must be terminated with a 16Ω dummy load and connected to an AC voltmeter and an audio distortion meter or a SINAD measurement meter at all times during tuning.

• Transceiver tuning

(To place transceiver in tuning mode)

Channel appears on LCD. Set channel according to tuning requirements.

ADJUSTMENT

LCD display (Test mode)

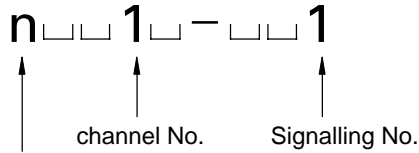

Wide/Semi wide/Narrow

Press [A], now in tuning mode. Use [◀ C] button to write tuning data through tuning modes, and channel selector knob to adjust tuning requirements (1 to 256 appears on LCD).

Use [D ▶] button to select the adjustment item through tuning modes. Use [B] button to adjust 3 or 5 point tuning, and use [CALL] button to switch between Wide/Semi wide/Narrow.

LCD display (Tuning mode)



Panel Tuning Mode

TEST Ch	E, T	
	RX frequency (MHz)	TX frequency (MHz)
L	146.05000	146.10000
L2	153.05000	153.10000
C	160.05000	160.10000
H2	167.05000	167.10000
H	173.95000	173.90000

■ Tuning mode

5-point tuning ex. RF Power High

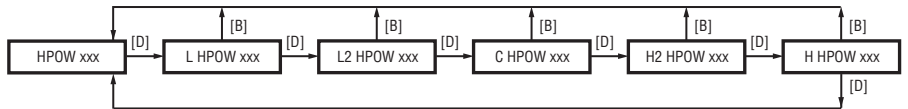

3-point tuning ex. Max Deviation (Narrow)

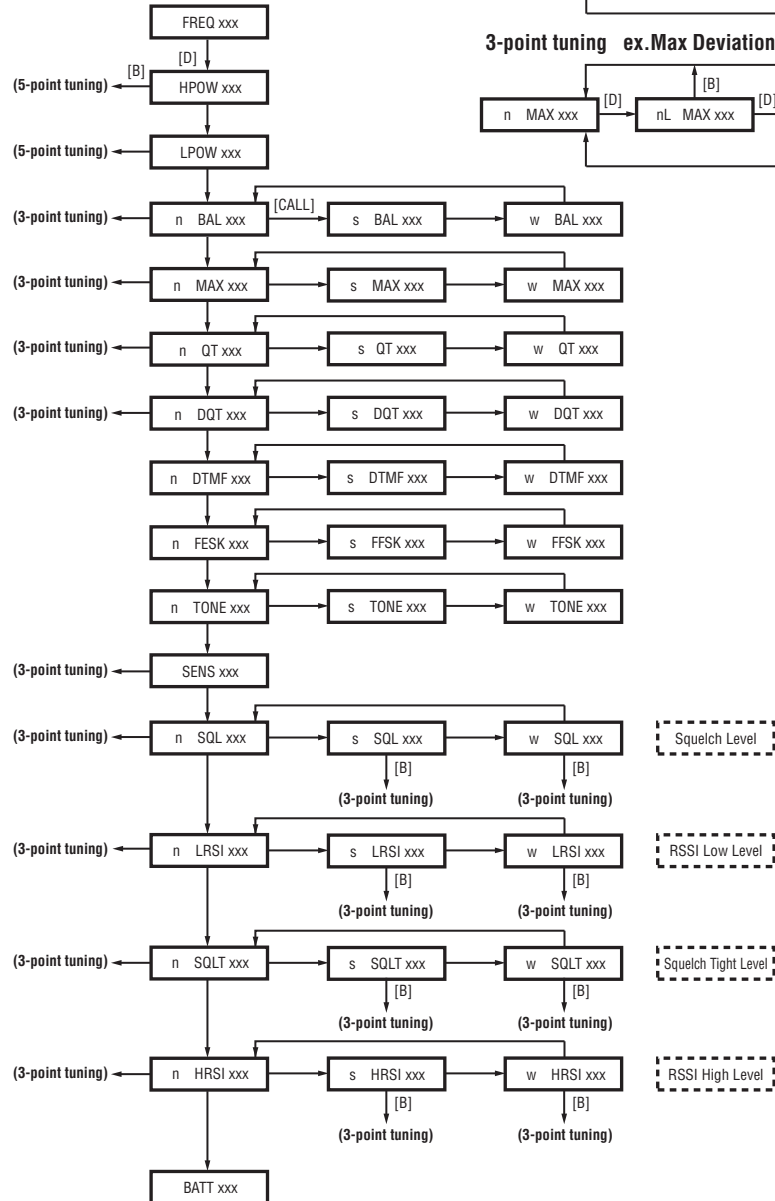
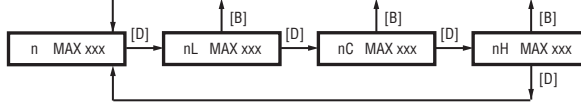

ADJUSTMENT

Common Section

Item	Condition	Measurement			Adjustment			Specifications/ Remark
		Test equipment	Unit	Terminal	Unit	Parts	Method	
1. Setting	1) BATT terminal voltage:7.5V 2) SSG Standard modulation [Wide] MOD:1kHz, DEV:3kHz [Semi Wide] MOD:1kHz, DEV:2.4kHz [Narrow] MOD:1kHz, DEV:1.5kHz							
2. VCO lock voltage	[Panel Test Mode] 1) CH-Sig:2-1	Power meter DVM	Panel TX-RX	ANT CV (CN14)			Check	0.8V or more
RX	2) CH-Sig:3-1							4.4V or less
TX	3) CH-Sig:2-1 PTT:ON							0.8V or more
	4) CH-Sig:3-1 PTT:ON							4.4V or less

Transmitter Section [Panel Tuning Mode except when Panel TEST Mode is specified.]

Item	Condition	Measurement			Adjustment			Specifications/ Remark
		Test equipment	Unit	Terminal	Unit	Parts	Method	
1. Frequency Adjust	1) Adj item [FREQ] Adjust [***] PTT:ON	Power meter Am meter	Panel	ANT	Panel	Encoder knob	Center frequency ± 100Hz (Note:) After replacing the TCXO (X1), align using KPG-60D.	
2. Max Power Check	1) Adj item [HPOW] Adjust [256] 2) Adj item [L HPOW] → [L2 HPOW] → [C HPOW] → [H2 HPOW] → [H HPOW] Adjust [256] PTT:ON						Check	5.2W or more (L, H CH 4.9W)
3. Hight Power Adjust	1) Adj item [HPOW] Adjust [***] 2) Adj item [L HPOW] → [L2 HPOW] → [C HPOW] → [H2 HPOW] → [H HPOW] Adjust [***] PTT:ON					Encoder knob	5.0W (L, H CH 4.7W)	±0.1W 2.2A or less
4. Hight Power Check	[Panel Test Mode] 1) CH-Sig:1-1 PTT:ON 2) CH-Sig:2-1 PTT:ON 3) CH-Sig:3-1 PTT:ON						Check	4.8~5.2W 2.3A or less (L, H CH 4.5~5.0W)
5. Low Power Adjust	1) Adj item [LPOW] Adjust [***] 2) Adj item [L LPOW] → [L2 LPOW] → [C LPOW] → [H2 LPOW] → [H LPOW] Adjust [***] PTT:ON						0.8W	±0.1W 1.0A or less
6. Low Power Check	[Panel Test Mode] 1) CH-Sig:1-1 Set low power (Push [C]) PTT:ON 2) CH-Sig:2-1 PTT:ON 3) CH-Sig:3-1 PTT:ON						Check	0.5~1.5W 1.2A or less

ADJUSTMENT

Transmitter Section [Panel Tuning Mode except when Panel TEST Mode is specified.]

Item	Condition	Measurement			Adjustment			Specifications/ Remark
		Test equipment	Unit	Terminal	Unit	Parts	Method	
7. DQT Balance Adjust [Narrow]	1) Adj item [n BAL] Adjust [***] LPF:3kHz HPF:OFF	Power meter Dev meter Oscilloscope AG AF VTVM	Panel	ANT universal connector	Panel	Encoder knob	Make the demodulation waves into square waves.	
	2) Adj item [nL BAL] → [nC BAL] → [nH BAL] Adjust [***] PTT:ON							
	[Semi wide] 3) Adj item [s BAL] Adjust [***] PTT:ON							
[Wide]	4) Adj item [w BAL] Adjust [***] PTT:ON							
8. Max DEV Adjust [Narrow]	1) Adj item [n MAX] Adjust [***] AG:1kHz / 150mV Dev meter filter LPF:15kHz HPF:OFF						1.85kHz (According to the larger +,-)	±50Hz
	2) Adj item [nL MAX] → [nC MAX] → [nH MAX] Adjust [***] PTT:ON							
	[Semi wide] 3) Adj item [s MAX] Adjust [***] PTT:ON						3.4kHz (According to the larger +,-)	±50Hz
[Wide]	4) Adj item [w MAX] Adjust [***] PTT:ON						4.20kHz (According to the larger+,-)	±50Hz
9. MIC Sensitivity Check	[Panel Test Mode] 1) CH-Sig:1-1 AG:1kHz / 8mV LPF:15kHz PTT:ON						Check	1.2~2.0kHz
10.QT Deviation Adjust [Narrow]	1) Adj item [n QT] Adjust [***] LPF:3kHz HPF:OFF		Panel	ANT universal connector	Panel	Encoder knob	0.35kHz	±50Hz
	2) Adj item [nL QT] → [nC QT] → [nH QT] Adjust [***] PTT:ON							
	[Semi wide] 3) Adj item [s QT] Adjust [***] PTT:ON						0.60kHz	±50Hz
[Wide]	4) Adj item [w QT] Adjust [***] PTT:ON						0.75kHz	±50Hz

ADJUSTMENT

Transmitter Section [Panel Tuning Mode except when Panel TEST Mode is specified.]

Item	Condition	Measurement			Adjustment			Specifications/ Remark
		Test equipment	Unit	Terminal	Unit	Parts	Method	
11.DQT Deviation Adjust [Narrow]	1) Adj item [n DQT] Adjust [***] LPF:3kHz HPF:OFF	Power meter Dev meter Oscilloscope AG AF VTVM	Panel	ANT universal connector	Panel	Encoder knob	0.35kHz	±50kHz
	2) Adj item [nL DQT] → [nC DQT] → [nH DQT] Adjust [***] PTT:ON							
	[Semi wide]							
[Wide]	4) Adj item [DQT] Adjust [***] PTT:ON						0.75kHz	±50kHz
12.DTMF Deviation Adjust [Narrow]	1) Adj item [n DTMF] Adjust [***] LPF:15kHz HPF:OFF PTT:ON						1.4kHz	±0.1kHz
	[Semi wide]	2) Adj item [s DTMF] Adjust [***] PTT:ON					2.4kHz	±0.1kHz
	[Wide]	3) Adj item [w DTMF] Adjust [***] PTT:ON					3.0kHz	±0.1kHz
13.MSK Deviation Adjust [Narrow]	1) Adj item [n FFSK] Adjust [***] LPF:15kHz HPF:OFF PTT:ON						1.4kHz	±0.1kHz
	[Semi wide]	2) Adj item [s FFSK] Adjust [***] PTT:ON					2.4kHz	±0.1kHz
	[Wide]	3) Adj item [FFSK] Adjust [***] PTT:ON					3.0kHz	±0.1kHz
14.TONE Deviation Adjust [Narrow]	1) Adj item [n TONE] Adjust [***] LPF:15kHz HPF:OFF PTT:ON						1.4kHz	±0.1kHz
	[Semi wide]	2) Adj item [s TONE] Adjust [***] PTT:ON					2.4kHz	±0.1kHz
	[Wide]	3) Adj item [w TONE] Adjust [***] PTT:ON					3.0kHz	±0.1kHz

ADJUSTMENT

Transmitter Section [Panel Tuning Mode except when Panel TEST Mode is specified.]

Item	Condition	Measurement			Adjustment			Specifications/ Remark
		Test equipment	Unit	Terminal	Unit	Parts	Method	
15.BATT Detection Writing	1) Adj item [BATT] Adjust [***] PTT:ON	Power meter DVM	Panel	ANT BATT terminal	Panel	Encoder knob	After pressing the PTT switch, confirm that one predeter- mined numeric in the range 1 to 256 appears and then press [C] key. That numeric will be stored in memory.	BATT terminal voltage:6.2V
16.BATT Detection Check	[Panel Test Mode] 1) CH-Sig:1-1 BATT terminal voltage:6.5V PTT:ON						Check	No blinking of LED
	2) BATT terminal voltage:5.7V PTT:ON							Blinking of LED

Receiver Section [Panel Tuning Mode except when Panel TEST Mode is specified.]

Item	Condition	Measurement			Adjustment			Specifications/ Remark
		Test equipment	Unit	Terminal	Unit	Parts	Method	
1. Sensitivity Adjust	1) Adj item [SENS] Adjust [***] 2) Adj item [L SENS] → [C SENS] → [H SENS] Adjust [***] SSG OUT:-118dBm (0.28μV) MOD:1kHz / ±3kHz	SSG AF VTVM Oscilloscope	Panel	ANT Universal Connector	Panel	Encoder knob	Adjust for maximam SINAD.	14dB SINAD or more.
2. Sensitivity Check	[Panel Test Mode] 1) CH-Sig:1-1 SSG OUT Wide:-118dBm (0.28μV) (MOD:1kHz / ±3kHz) Narrow:-117dBm (0.316μV) (MOD:1kHz / ±1.5kHz)						Check	12dB SINAD or more

ADJUSTMENT

Receiver Section [Panel Tuning Mode except when Panel TEST Mode is specified.]

Item	Condition	Measurement			Adjustment			Specifications/ Remark
		Test equipment	Unit	Terminal	Unit	Parts	Method	
3. Squelch (Preset) Adjust [Narrow] [Semi wide] [Wide]	1) Adj item [n SQL] Adjust [***] SSG OUT: 12dB SINAD level	SSG AF VTVM Oscilloscope	Panel	ANT Universal Connector	Panel	Encoder knob	Adjust to point of opening squelch.	
	2) Adj item [nL SQL] → [nC SQL] → [nH SQL] Adjust [***]							
	3) Adj item [s SQL] Adjust [***] 12dB SINAD level							
	4) Adj item [sL SQL] → [sC SQL] → [sH SQL] Adjust [***]							
	5) Adj item [w SQL] Adjust [***] 12dB SINAD level							
	6) Adj item [wL SQL] → [wC SQL] → [wH SQL] Adjust [***]							
4. RSSI (Low) Adjust [Narrow] [Semi wide] [Wide]	1) Adj item [n LRSI] Adjust [***] SSG OUT: 12dB SINAD level						After input signal from SSG,press [D] key. That numeric will be stored in memory.	
	2) Adj item [nL LRSI] → [nC LRSI] → [nH LRSI] Adjust [***]							
	3) Adj item [s LRSI] Adjust [***] 12dB SINAD level							
	4) Adj item [sL LRSI] → [sC LRSI] → [sH LRSI] Adjust [***]							
	5) Adj item [w LRSI] Adjust [***] 12dB SINAD level							
	6) Adj item [wL LRSI] → [wC LRSI] → [wH LRSI] Adjust [***]							
5. Squelch (Preset) Check	[Panel Test Mode] 1) CH-Sig:1-1 SSG OUT: 12dB SINAD level						Check	Squelch must be opened.
	2) SSG OUT:OFF							Squelch must be closed.

ADJUSTMENT

Receiver Section [Panel Tuning Mode except when Panel TEST Mode is specified.]

Item	Condition	Measurement			Adjustment			Specifications/ Remark
		Test equipment	Unit	Terminal	Unit	Parts	Method	
6. Squelch (Tight) Adjust [Narrow] [Semi wide] [Wide]	1) Adj item [n SQLT] Adjust [***] SSG OUT: 12dB SINAD LEVEL +4dB	SSG AF VTVM Oscilloscope	Panel	ANT Universal Connector	Panel	Encoder knob	Adjust to point of opening squelch.	
	2) Adj item [nL SQLT] → [nC SQLT] → [nH SQLT] Adjust [***]							
	3) Adj item [sL SQLT] → [sC SQLT] → [sH SQLT] Adjust [***]							
	4) Adj item [wL SQLT] → [wC SQLT] → [wH SQLT] Adjust [***]							
7. RSSI (High) Adjust [Narrow] [Semi wide] [Wide]	1) Adj item [n HRSI] Adjust [***] SSG OUT: -70dBm (70.7μV)						After input signal from SSG,press [D] key. That numeric will be stored in memory.	
	2) Adj item [nL HRSI] → [nC HRSI] → [nH HRSI] Adjust [***]							
	3) Adj item [sL HRSI] → [sC HRSI] → [sH HRSI] Adjust [***]							
	4) Adj item [wL HRSI] → [wC HRSI] → [wH HRSI] Adjust [***]							
8. Squelch (Tight) Check	[Panel Test Mode] 1) CH-Sig:1-1 SSG OUT: 12dB SINAD LEVEL +4dB						Check	Squelch must be opened.

Adjustment points
TX-RX unit (X57-6192-70)
component side view

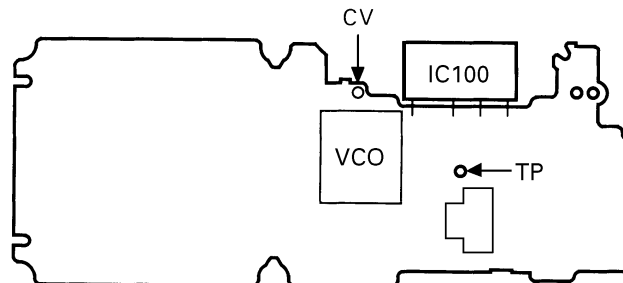

TERMINAL FUNCTION

CN No.	Pin No.	Name	I/O	Function
TX-RX UNIT (X57-6192-70): TX-RX section				
CN1	1	B	O	Power input after passing through the fuse.
	2	B	O	Power input after passing through the fuse.
	3	SB	I	Power output after power switch.
	4	SB	I	Power output after power switch.
	5	5M	O	5V.
	6	VOL	I	Volume level input for audio control.
	7	E	-	GND
	8	EN2	I	Encoder pulse input.
	9	E	-	GND
	10	EN1	I	Encoder pulse input.
CN2 for X54-SW section	1	MON	I	Normally; 5V. MON when connected GND.
	2	LAMP	I	Normally; 5V. LAMP when connected GND.
	3	PTT	I	Normally; 5V. transmit when connected GND.
	4	GND	-	GND
CN3 for X54-Display unit	1	AF	O	Audio output.
	2	AFE	-	Audio GND.
	3	NC	-	Not use.
	4	PF	I	External PF signal input.
	5	CK	O	Clock data output.
	6	RXD	I	Serial control signal input.
	7	TXD	O	Serial control signal output.
	8	DT	O	Data output for LCD driver/decade counter.
	9	KRS	O	Key scan IC reset output.
	10	KI1	I	KEY input
	11	KI2	I	KEY input
	12	GND	-	GND
	13	5M	O	5V.
	14	AM	O	Audio mute signal output. Mute: "L". Unmute: "H"
	15	CS	O	LCD driver chip select output.
	16	NC	-	Not use.
	17	PTT	I	PTT signal input.
	18	AUX	I	AUX key input.
	19	LR	O	TX LED control. Normally: 0V, lighting: 5V.
	20	LG	O	RX LED control. Normally: 0V, lighting: 5V.
	21	LBL	O	Backlight LED control. Normally: 0V, lighting: 5V.
	22	ME	-	MIC GND.
	23	MIC	I	MIC signal input.
	24	SB	O	Power output after power switch.
DISPLAY UNIT (X54-3210-12 A/2) : DISPLAY section				
CN300 for X57-TX-RX unit	1	SB	I	Power input after power switch.
	2	MIC	O	MIC signal output.
	3	ME	-	MIC GND.
	4	LBL	I	Backlight LED control. Normally: 0V, lighting: 5V.
	5	LG	I	RX LED control. Normally: 0V, lighting: 5V.
	6	LR	I	TX LED control. Normally: 0V, lighting: 5V.
	7	AUX	O	AUX key output.

CN No.	Pin No.	Name	I/O	Function	
	8	PTT	O	PTT signal output.	
	9	NC	-	Not use.	
	10	CS	I	LCD driver chip select input.	
	11	AM	I	Audio mute signal input. Mute: "L", Unmute: "H"	
	12	5M	I	5V.	
	13	GND	-	GND	
	14	KI2	O	KEY output	
	15	KI1	O	KEY output	
	16	KRS	I	Key scan IC reset input	
	17	DT	I	Data input for LCD driver/decade counter.	
	18	TXD	I	Serial control signal input.	
	19	RXD	O	Serial control signal output.	
	20	CK	I	Clock data input.	
	21	PF	O	External PF signal output.	
	22	NC	-	Not use.	
	23	AFE	-	Audio GND.	
	24	AF	I	Audio input.	
	CN301	1	SSW	I	EXT/INT speaker switch input.
		2	SP+	O	BTL output + for external speaker.
		3	SP-	O	BTL output - for external speaker.
		4	MSW	I	EXT/INT MIC switch input.
		5	EMC	I	External microphone input.
		6	ME	-	External microphone ground.
		7	PTT	I	External PTT input.
8		PF	I	Programmable function key input.	
9		NC	-	Not use.	
10		E	-	GND	
11		5M	O	5V output	
12		TXD	O	Serial data output.	
13		RXD	I	Serial data input.	
14		NC (E)	-	Not use (GND)	
CN302	1	SP	O	Output for internal speaker.	
	2	E	-	GND	
CN304	1	NC	-	Not use.	
	2	LEDK	I	Backlight LED control.	
	3	LEDA	O	Backlight LED control.	
	4	VCI	O	LCD power supply.	
	5	SOD	O	Serial data output for LCD driver.	
	6	SID	I	Serial data input for LCD driver.	
	7	SCLK	O	Clock data output for LCD driver.	
	8	CS	O	LCD driver chip select output.	
	9	Vcc	O	5V	
	10	GND	-	GND	
DISPLAY UNIT (X54-3210-12 B/2) : SW section					
CN303 For X57-TX-RX unit	1	MON	O	Normally; 5V.,MON when connected GND.	
	2	LAMP	O	Normally; 5V, LAMP when connected GND.	
	3	PTT	O	Normally; 5V, transmit when connected GND.	
	4	GND	-	GND	

DISPLAY UNIT (X54-3210-12) Component Side View

DISPLAY UNIT (X54-3210-12)

Ref. No.	Address
D301	9C
D305	8L
D306	6L
D307	8N
D308	6N
D309	8Q
D310	6Q

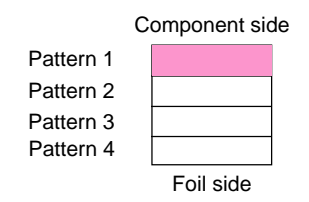
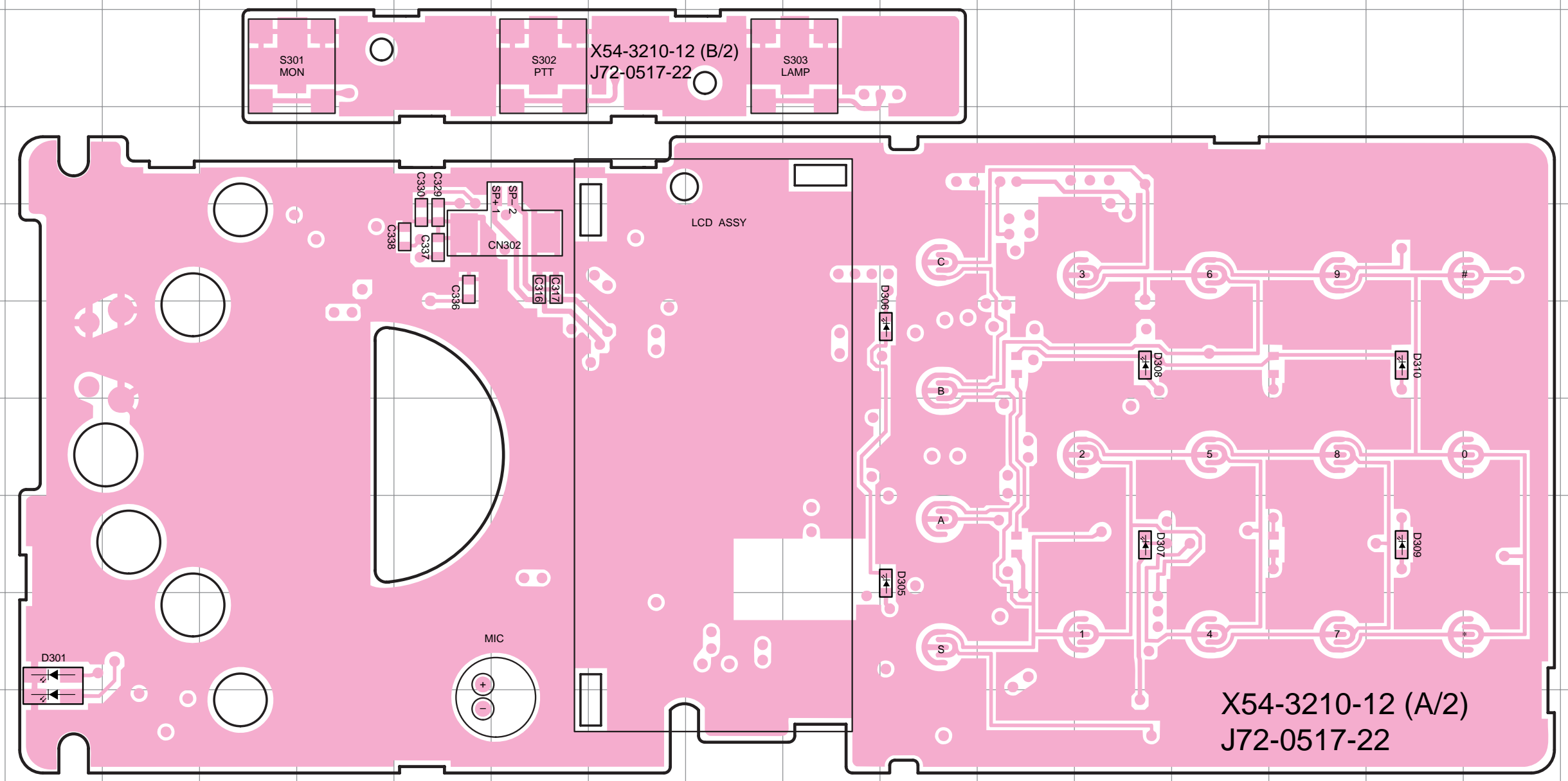

TK-280 PC BOARD VIEW

DISPLAY UNIT (X54-3210-12) Foil Side View

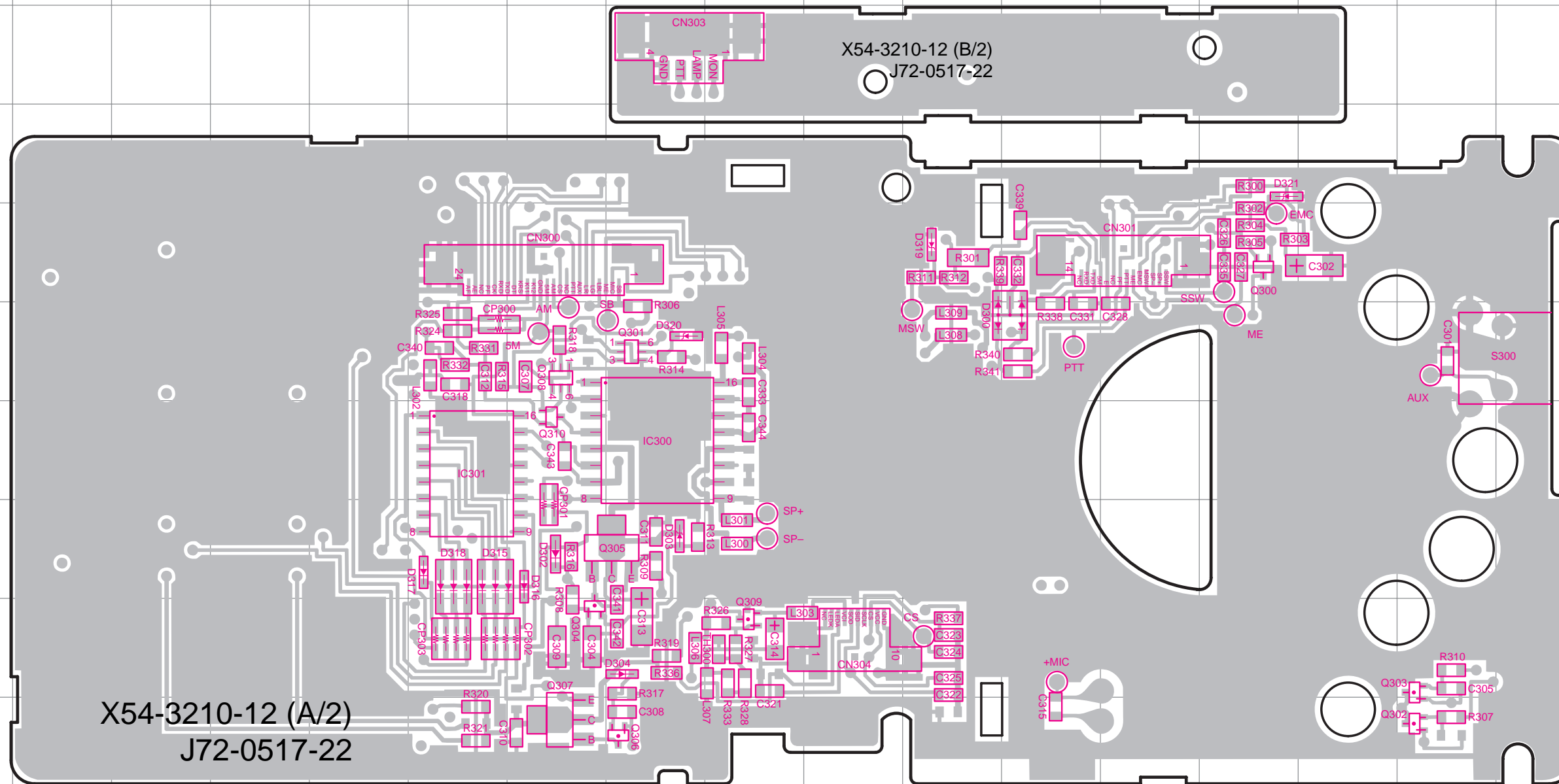

DISPLAY UNIT (X54-3210-12)

Ref. No.	Address
D300	6L
D302	8G
D303	8H
D304	9H
D315	8F
D316	8G
D317	8F
D318	8F
D319	5K
D320	6H
D321	4N
IC300	7H
IC301	7F
Q300	5N
Q301	6H
Q302	10P
Q303	9P
Q304	9G
Q305	8H
Q306	10H
Q307	10G
Q308	6G
Q309	9I
Q310	7G

2SC4617

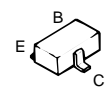

2SB798

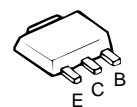

2SJ243
2SK1824



MC74HC4017F

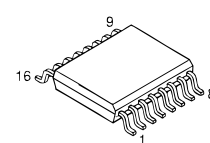

2SB1132

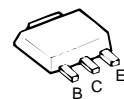

UPA672T

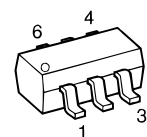

TDA7053AT

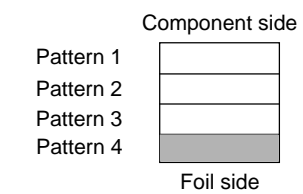
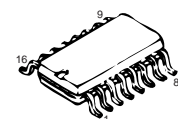

DISPLAY UNIT (X54-3210-12) Component Side + Foil Side View

DISPLAY UNIT (X54-3210-12)

Ref. No.	Address
D300	6H
D301	9C
D302	8M
D303	8L
D304	9L
D305	8L
D306	6L
D307	8N
D308	6N
D309	8Q
D310	6Q
D315	8N
D316	8M
D317	8N
D318	8N
D319	5I
D320	6L
D321	4F
IC300	7L
IC301	7N
Q300	5F
Q301	6L
Q302	10D
Q303	9D
Q304	9M
Q305	8L
Q306	10L
Q307	10M
Q308	6M
Q309	9K
Q310	7M

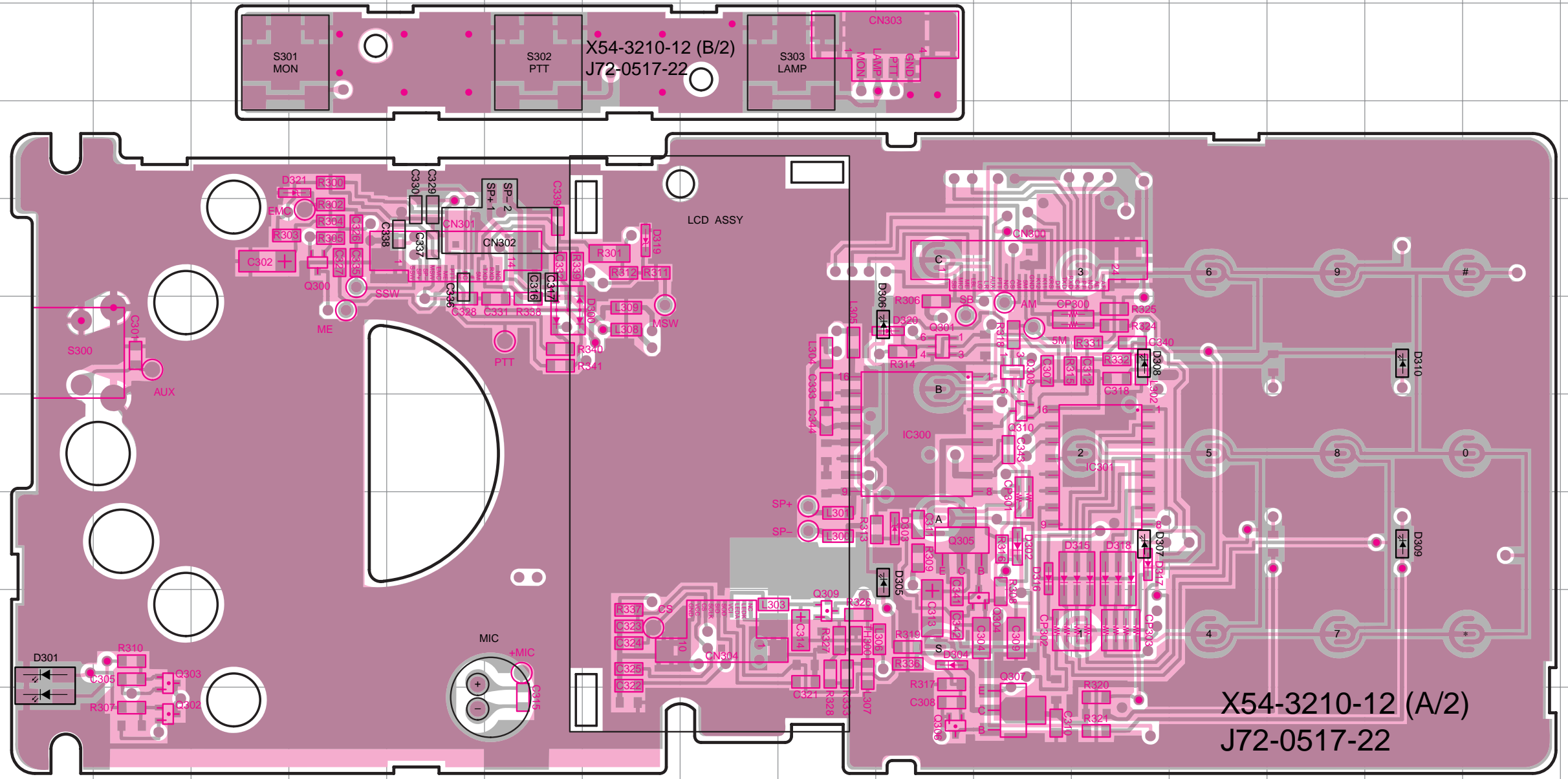

X54-3210-12 (A/2)
J72-0517-22

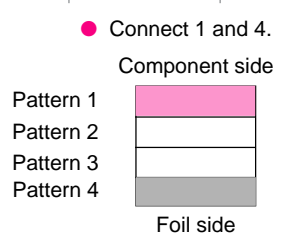

2SC4617

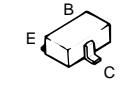

2SB798

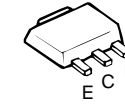

2SJ243
2SK1824

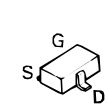

MC74HC4017F

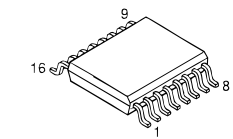

2SB1132

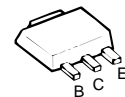

UPA672T

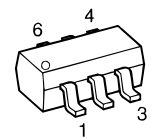

TDA7053AT

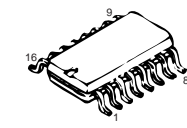

TK-280 PC BOARD VIEW

TX-RX UNIT (X57-6192-70) Component Side View

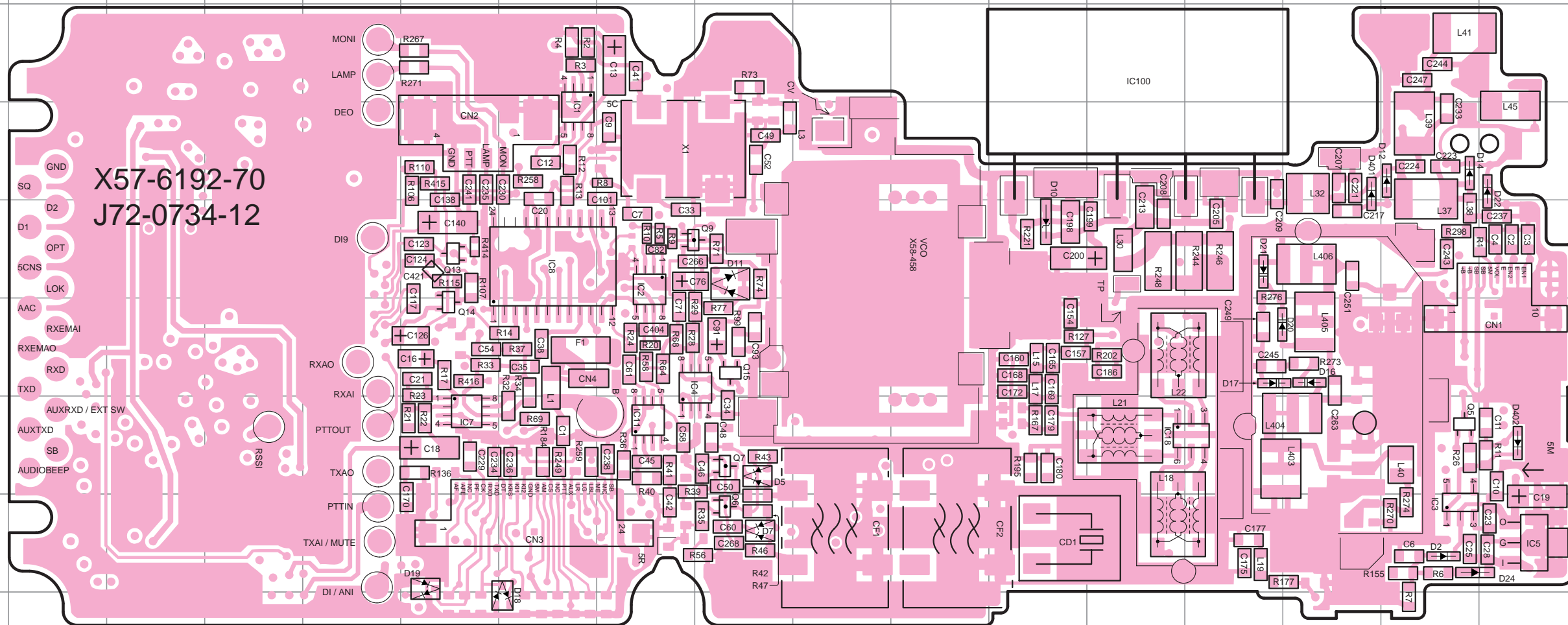

TX-RX UNIT (X57-6192-70)

Ref. No.	Address
D2	8P
D5	7I
D7	8I
D10	5L
D12	4P
D14	4P
D16	6O
D17	6N
D18	9G
D19	8F
D20	6N
D21	5N
D22	4Q
D24	8Q
D401	4O
D402	7Q
IC1	4G
IC2	5H
IC3	8P
IC4	6I
IC5	8Q
IC7	7F
IC8	5G
IC11	7H
IC18	7N
Q5	7P
Q6	8I
Q7	7I
Q9	5I
Q13	5F
Q14	6F
Q15	6I

X57-6192-70
J72-0734-12

Serial No. 201XXXXX

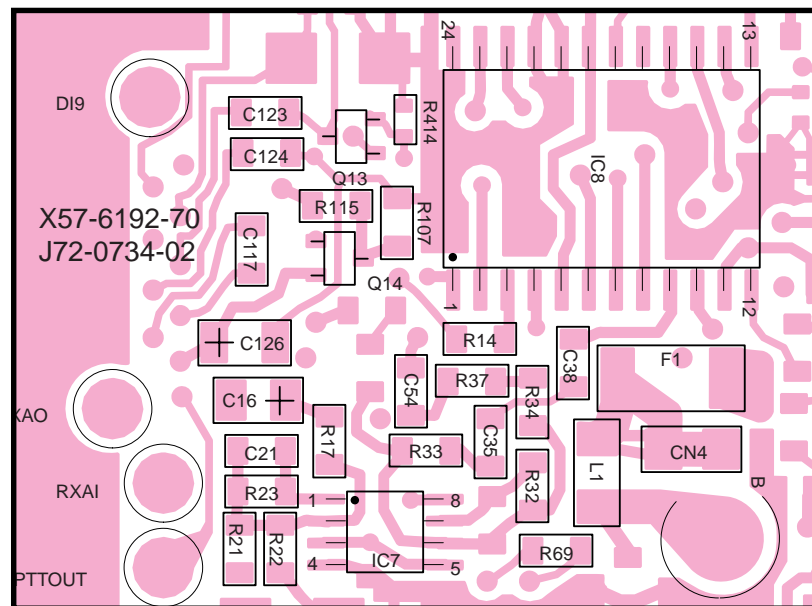

TX-RX UNIT	PC BOARD	C421	R416
Serial No. 201XXXXX	J72-0734-02	NO	NO
Serial No. 202X1671~	J72-0734-12	YES	YES

DTA144EE
DTC144EE

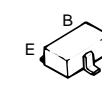

2SJ243
2SK1824

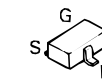

S-81350HG-KD

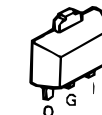

M62364FP

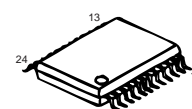

TA75W01FU
TC75W51FU

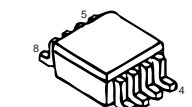

RN5VL42C

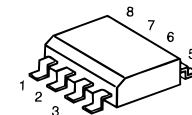

GN2011

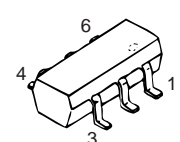

Component side

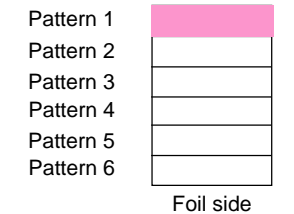

TX-RX UNIT (X57-6192-70) Foil Side View

TX-RX UNIT (X57-6192-70)

Ref. No.	Address
D1	6L
D3	7M
D4	7L
D6	6J
D8	8O
D9	6H
D23	6H
IC6	6D
IC9	7D
IC10	8N
IC12	8J
IC13	6N
IC14	5K
IC16	3M
IC17	4Q
IC19	7Q
IC20	3Q
IC21	3P
IC22	3Q
IC23	5F
IC24	4M
IC25	9M
Q1	5E
Q2	5D
Q3	6D
Q4	7K
Q8	6J
Q10	7N
Q11	7I
Q12	9I
Q16	6J
Q17	9N
Q18	6I
Q19	8Q
Q20	5G
Q21	5G
Q22	5F
Q23	5G
Q24	8E
Q25	5G

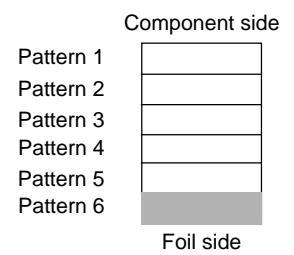
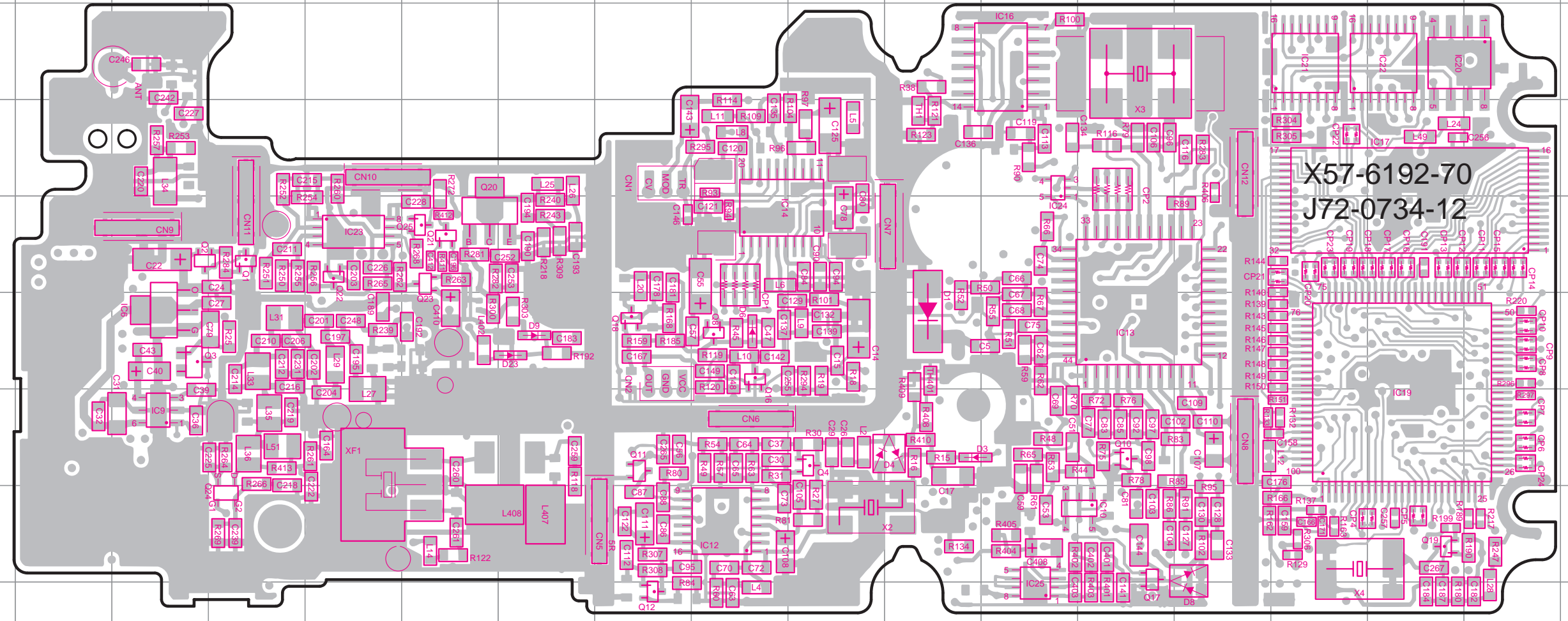

- DTA144EE
- DTC114EE
- DTC144EE
- 2SA1745
- 2SC4617
- 2SC4619
- 2SC5108

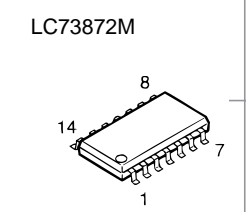
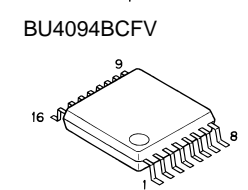
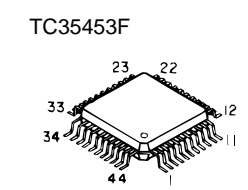
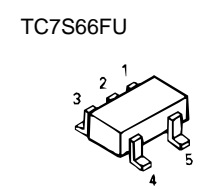
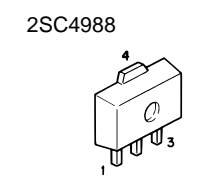
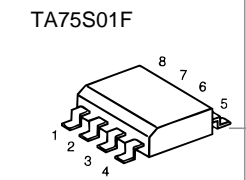
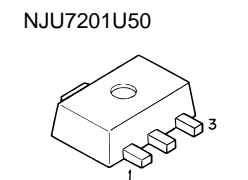
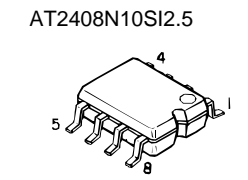
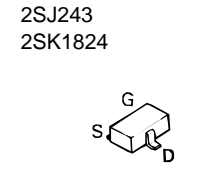
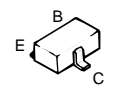
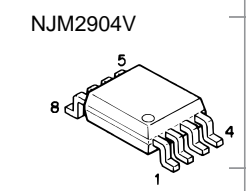
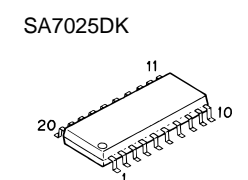
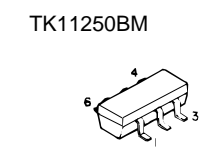
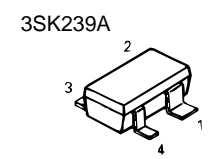

TK-280 PC BOARD VIEW

TX-RX UNIT (X57-6192-70) Component Side + Foil Side View

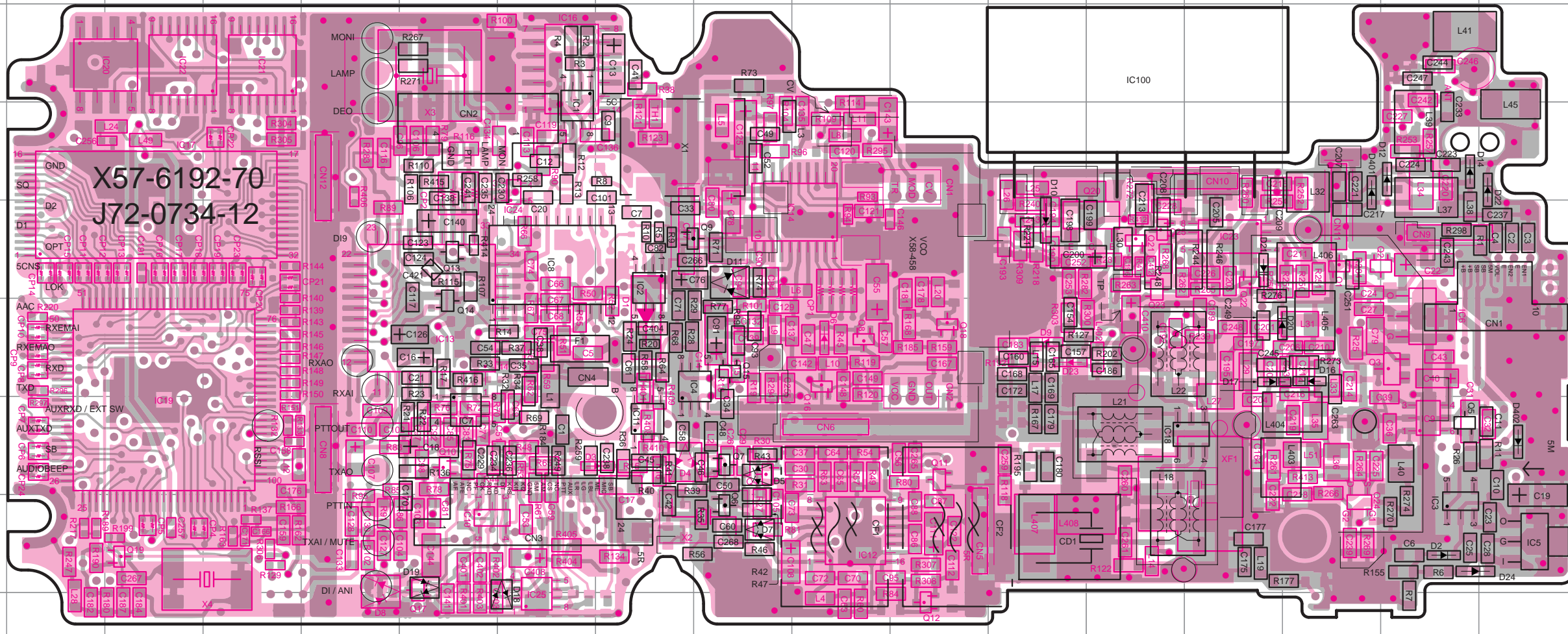

TX-RX UNIT (X57-6192-70)

Ref. No.	Address
D1	6H
D2	8P
D3	7G
D4	7I
D5	7I
D6	6J
D7	8I
D8	8F
D9	6L
D10	5L
D11	5I
D12	4P
D14	4P
D16	6O
D17	6N
D18	9G
D19	8F
D20	6N
D21	5N
D22	4Q
D23	6L
D24	8Q
D401	4O
D402	7Q
IC1	4G
IC2	5H
IC3	8P
IC4	6I
IC5	8Q
IC6	6P
IC7	7F
IC8	5G
IC9	6P
IC10	6F
IC11	7H
IC12	8J
IC13	6F
IC14	6I
IC16	6G
IC17	4C
IC18	7N
IC19	7C
IC20	3C
IC21	6D
IC22	3C
IC23	5N
IC24	4G
IC25	9G
Q1	5O
Q2	5O
Q3	6P
Q4	7I
Q5	7P
Q6	8I
Q7	7I
Q8	5J
Q9	5I
Q10	7F
Q11	7K
Q12	9K
Q13	5F
Q14	5F
Q15	6I
Q16	6J
Q17	6F
Q18	6K
Q19	6C
Q20	5M
Q21	5M
Q22	5N
Q23	5M
Q24	8O
Q25	5N

DTA144EE
DTC114EE
DTC144EE
2SA1745
2SC4617
2SC4619
2SC5108

2SJ243
2SK1824

TK11250BM

TC35453F

BU4094BCFV

TA75W01FU
TC75W51FU

GN2011

● Connect 1 and 6.

Component side

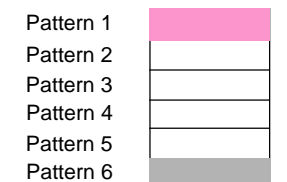

Foil side

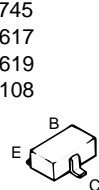

TC7S66FU

AT29C020-90T1

SA7025DK

NJM2904V

RN5VL42C
TA75S01F

S-81350HG-KD

AT2408N10SI2.5

NJU7201U50

M62364FP

LC73872M

2SC4988

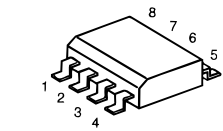
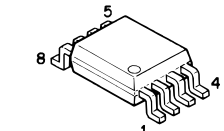
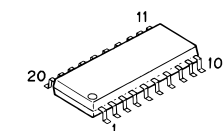
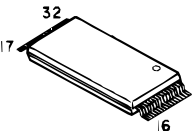
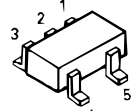

3SK239A

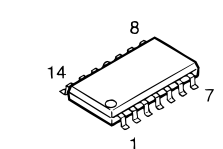
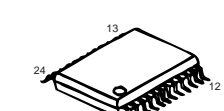
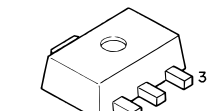
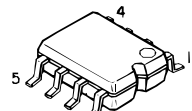
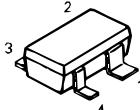

SCHEMATIC DIAGRAM TK-280

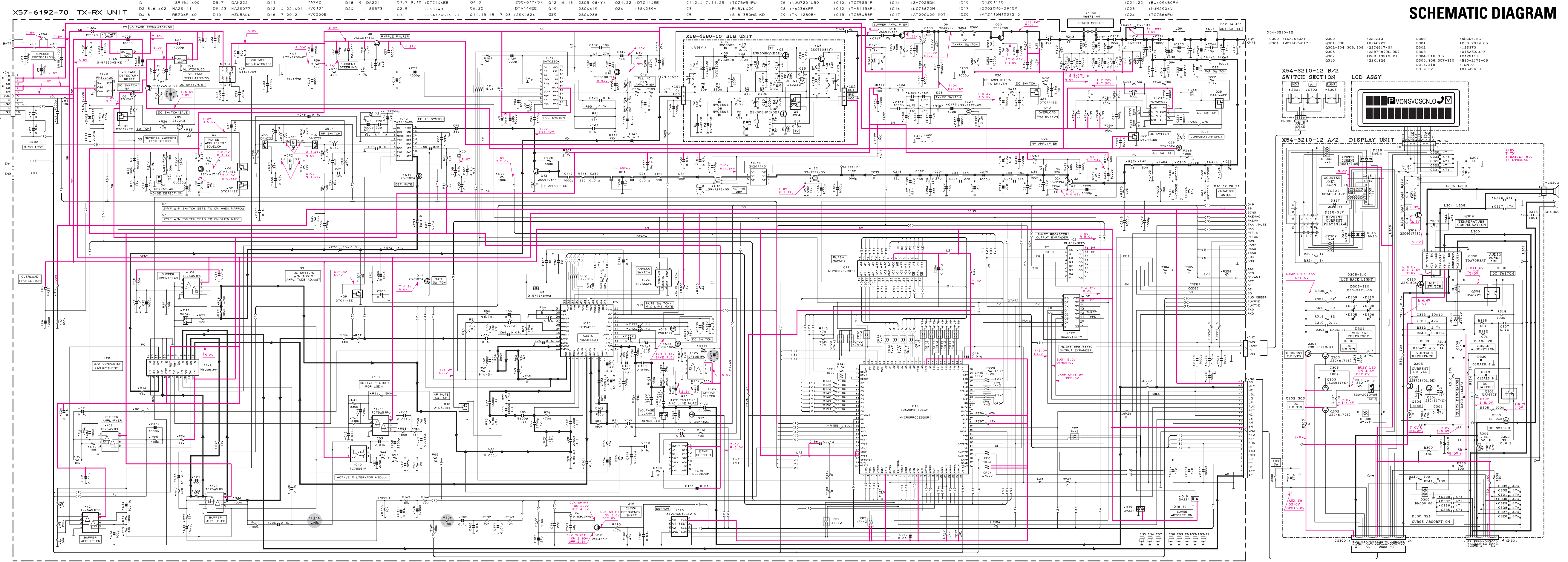

TX-RX UNIT	C79	C21	R306	R416
Rev. 1.1 No. 201XXXXX	0.10u	NO	4.70k	NO
Rev. 1.1 No. 202XXXXX	2.2u, 6.3	4.70p	1.0k	4.70k

Table on the left indicates the parts used among different serial numbers.

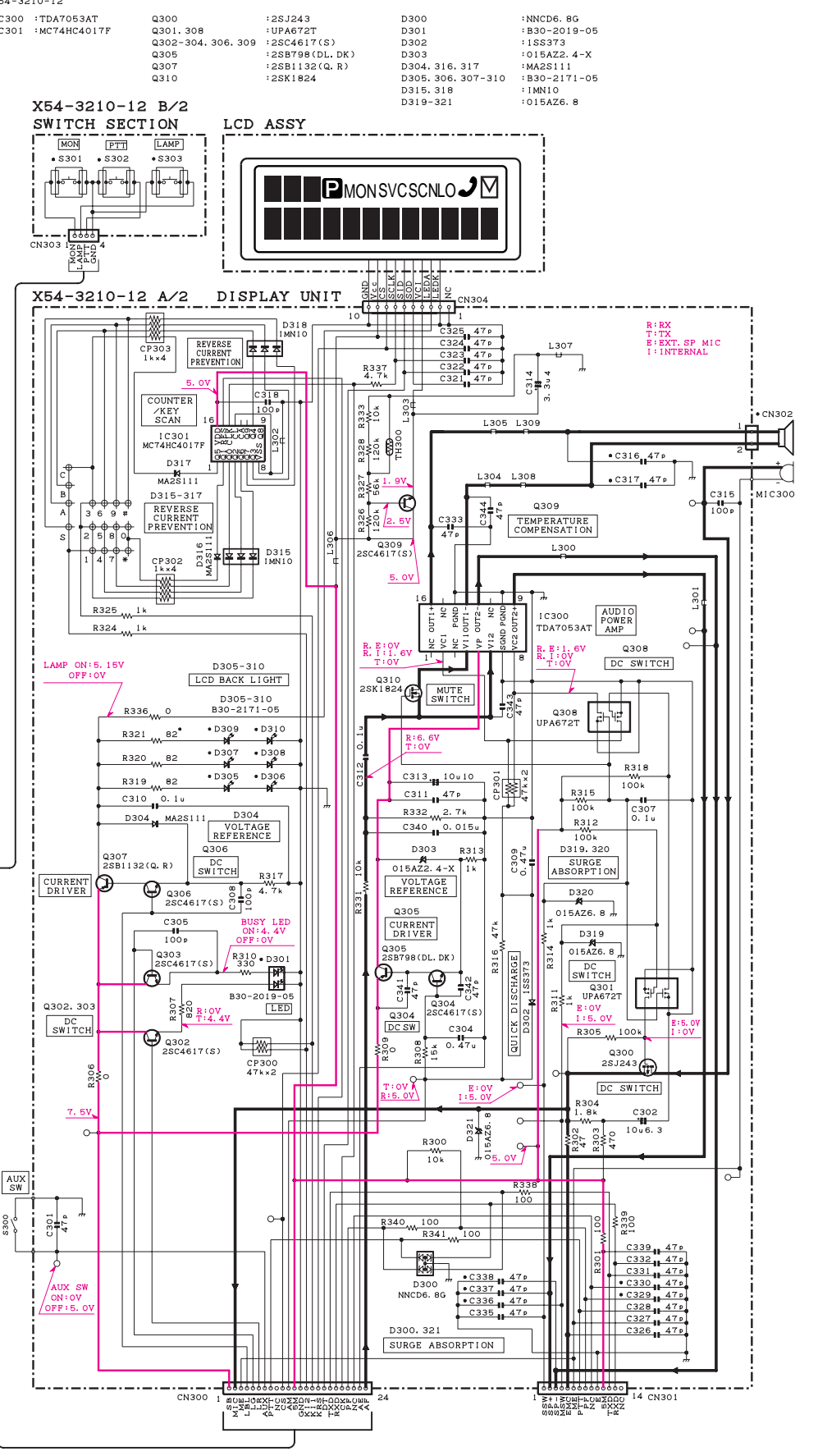

Note: Component marked with a dot (●) are parts of pattern 1.

TK-280 TK-280

BLOCK DIAGRAM

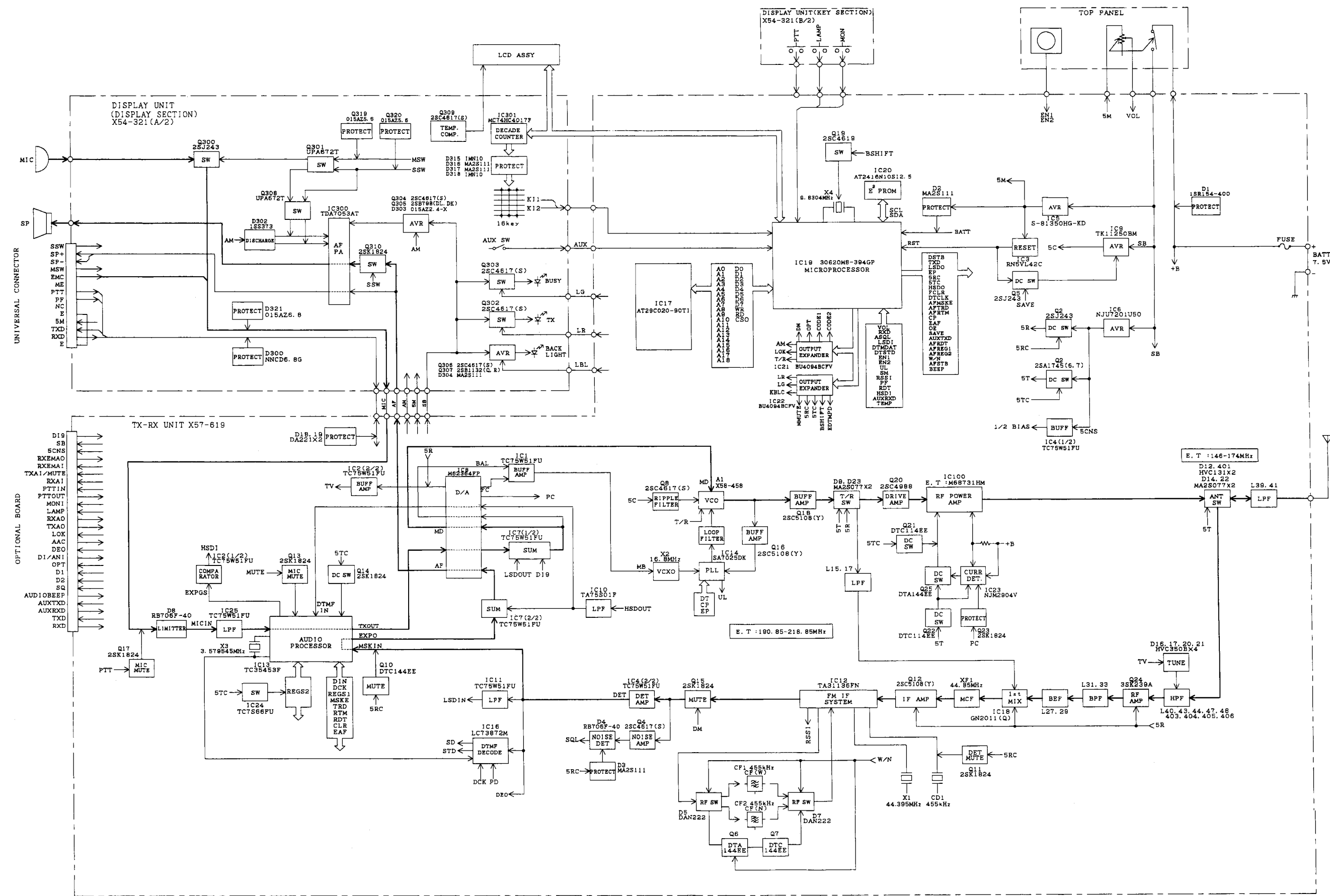

LEVEL DIAGRAM

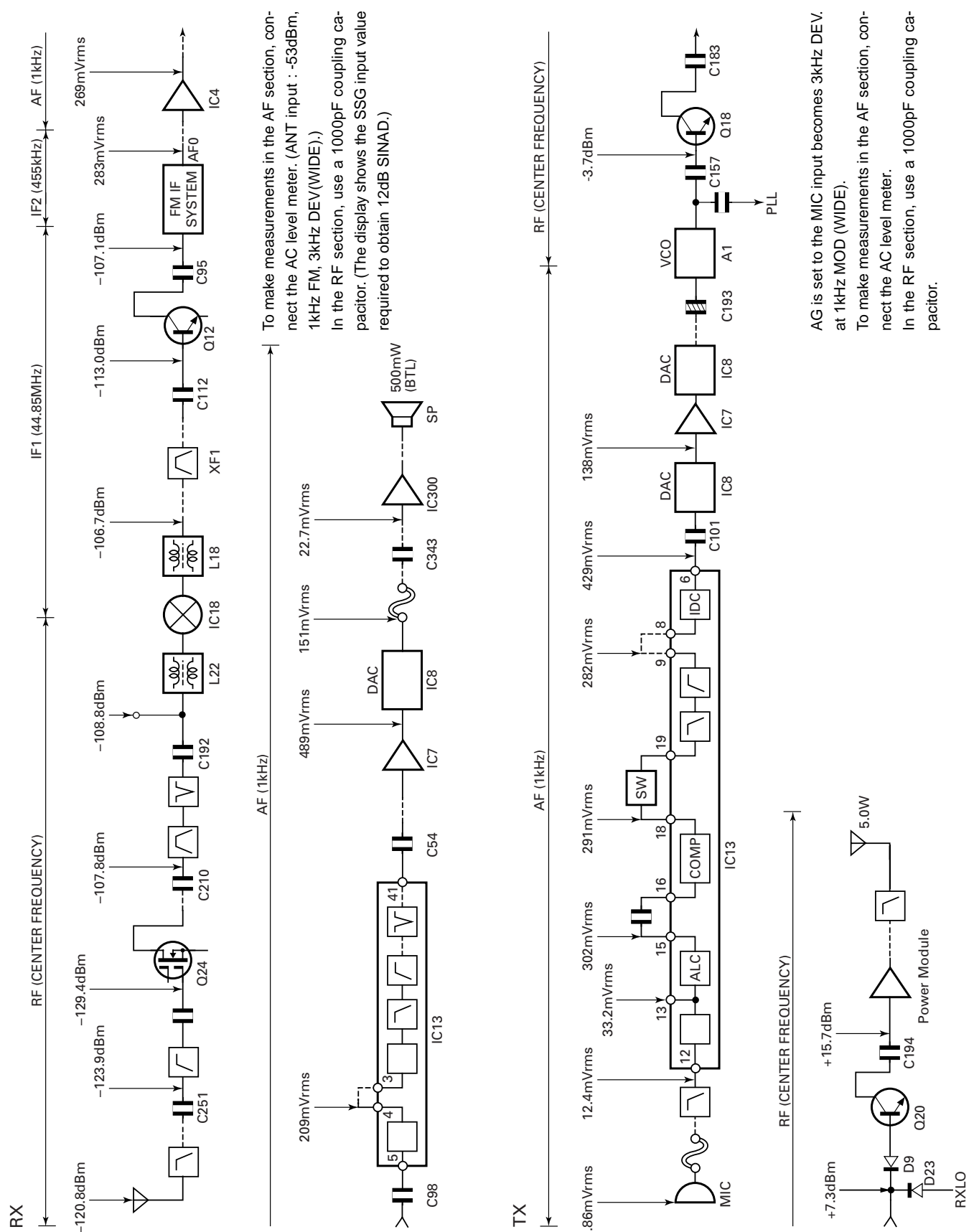

TK-280

TK-280

KNB-16A/17A (Ni-Cd BATTERY) / KPG-36 (PROGRAMMING INTERFACE CABLE) / KSC-19 (CHARGER) / KRA-14 (HELICAL ANTENNA)

KNB-16A External View



KNB-16A Circuit Diagram

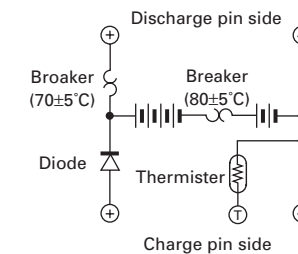

KNB-16A Specifications

Voltage	7.2V (1.2V x 6)
Charging current	1100mAh
Dimensions (mm)	58 W x 110.8 H x 17.2 D (Projections included)
Charger and charging time	
KSC-19 (Normal Charger)	Approx. 8 hours
KSC-20 (Rapid Charger)	Approx. 1 hour
Weight	180g

KNB-17A Specifications

Voltage	7.2V (1.2V x 6)
Charging current	1500mAh
Dimensions (mm)	58.0 W x 110.8 H x 20.0 D (Projections included)
Charger and charging time	
KSC-19 (Normal Charger)	Approx. 8 hours
KSC-20 (Rapid Charger)	Approx. 1.3 hour
Weight	220g

KNB-17A External View



KNB-17A Circuit Diagram

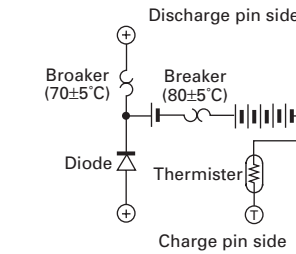

KPG-36 External View

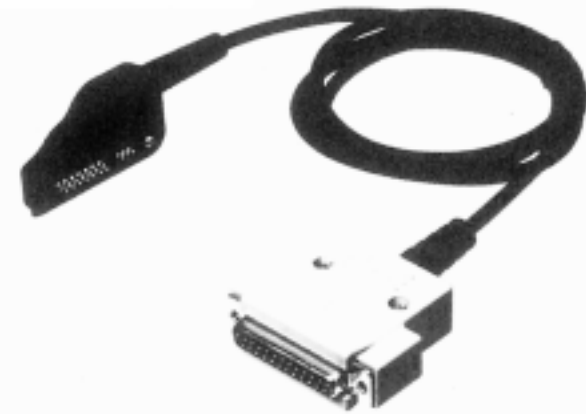

KSC-19 External View



KSC-19 Charging

KNB-16A	
Voltage	7.2V
Battery capacity	1100mAh
Charging time	Approx. 8 hours
KNB-17A	
Voltage	7.2V
Battery capacity	1500mAh
Charging time	Approx. 8 hours

KRA-14 External View



KMC-25 (SPEAKER MICROPHONE)

External View



Circuit Diagram

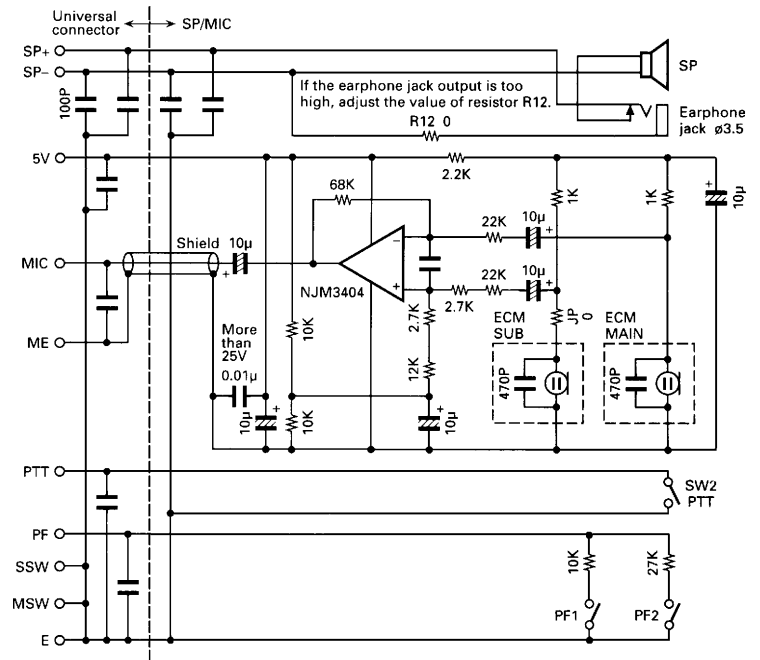

Specifications

Microphone	
Impedance	2kΩ
Sensitivity	-65dB±4.0dB at 1kHz
Speaker	
Impedance	16Ω
Input	0.5W
Maximum input	1.5W
Dimensions	62W x 81 H x 29 D (mm)
Weight (With plug cord)	Approx. 0.17kg

SPECIFICATIONS

General

Frequency Range	
RX, TX	E, T : 146 to 174MHz
Groups	Maximum 250
Channels	Maximum 250 (Case of 1 Group)
Channel Spacing (Wide/Semi wide/Narrow)	25kHz/20kHz/12.5kHz (PLL channel stepping 5kHz, 6.25kHz)
Battery Voltage	DC 7.5V \pm 20%
Battery Life	More than 8 hours at 5-5-90 duty cycle with KNB-16A battery More than 10 hours at 5-5-90 duty cycle with KNB-17A battery
Temperature Range	-30°C to +60°C (-22°F to + 140°F)
Dimension and Weight	
With KNB-16A (1100mAh battery)	5.33" (135mm) H x 2.29" (58mm) W x 1.34" (34mm) D 1.01lbs (460g)
(Dimensions not including Protrusions, Weight includes antenna and belt hook)	

Receiver (Measurements made per EIA-RS 316B, ETS)

RF Input Impedance	50 Ω
Sensitivity	
12dB SINAD (Wide/Narrow)	0.25 μ V/0.28 μ V
Selectivity (Wide/Narrow)	70dB/65dB (EIA), 73dB/63dB (ETS)
Intermodulation (Wide/Narrow)	70dB/65dB (EIA), 65dB (ETS)
Spurious (Except for IF 1/2)	70dB
Frequency Stability	\pm 0.00025% (-30°C to +60°C)
Channel Spread	28MHz : E, T
Audio Power Output	500mW at 16 Ω less than 5% distortion

Transmitter (Measurements made per EIA-RS 316B)

RF Power Output	
Hi	5W
Low	1W
RF Output Impedance	50 Ω
Spurious	-70dB
Modulation (Wide/Semi wide/Narrow)	16K0F3E, 14K0F2D/14K0F3E, 12K0F2D/8K50F3E, 7K50F2D
FM Noise (Wide/Narrow)	-45dB/-40dB
Audio Distortion (Wide/Narrow)	Less than 3% / 3%
Frequency Stability	\pm 0.00025% (-30°C to +60°C)
Channel Spread	28MHz : E, T

NOTE

The terms "Wide" and "Semi wide" used in this service manual correspond to "Wide 5K" and "Wide 4K" respectively that appear in the menu and help texts of the KPG-60D (Field Programming Unit).

KENWOOD CORPORATION

14-6, Dogenzaka 1-chome, Shibuya-ku, Tokyo 150-8501, Japan

KENWOOD SERVICE CORPORATION

P.O. BOX 22745, 2201 East Dominguez Street, Long Beach, CA 90801-5745, U.S.A.

KENWOOD ELECTRONICS CANADA INC.

6070 Kestrel Road, Mississauga, Ontario, Canada L5T 1S8

KENWOOD ELECTRONICS DEUTSCHLAND GMBH

Rembrücker Str. 15, 63150 Heusenstamm, Germany

KENWOOD ELECTRONICS BELGIUM N.V.

Mechelsesteenweg 418 B-1930 Zaventem, Belgium

KENWOOD ELECTRONICS FRANCE S.A.

13, Boulevard Ney, 75018 Paris, France

KENWOOD ELECTRONICS U.K. LIMITED

KENWOOD House, Dwight Road, Watford, Herts., WD1 8EB United Kingdom

KENWOOD ELECTRONICS EUROPE B.V.

Amsterdamseweg 37, 1422 AC Uithoorn, The Netherlands

KENWOOD ELECTRONICS ITALIA S.p.A.

Via G. Sirtori, 7/9 20129 Milano, Italy

KENWOOD IBERICA S.A.

Bolivia, 239-08020 Barcelona, Spain

KENWOOD ELECTRONICS AUSTRALIA PTY. LTD.

(A.C.N. 001 499 074)

16 Giffnock Avenue, North Ryde, N.S.W. 2113, Australia

KENWOOD ELECTRONICS (HONG KONG) LTD.

Unit 3712-3724, Level 37, Tower one Metroplaza, 223 Hing Fong Road, Kwai Fong, N.T., Hong Kong

KENWOOD ELECTRONICS TECHNOLOGIES(S) PTE LTD.

Sales Marketing Division

1 Ang Mo Kio Street 63, Singapore 569110