

UHF FM TRANSCEIVER / UHF 调频手持对讲机

# TK-3000

SERVICE MANUAL / 维修手册



C6 version / C6 版本

# KENWOOD

Kenwood Corporation

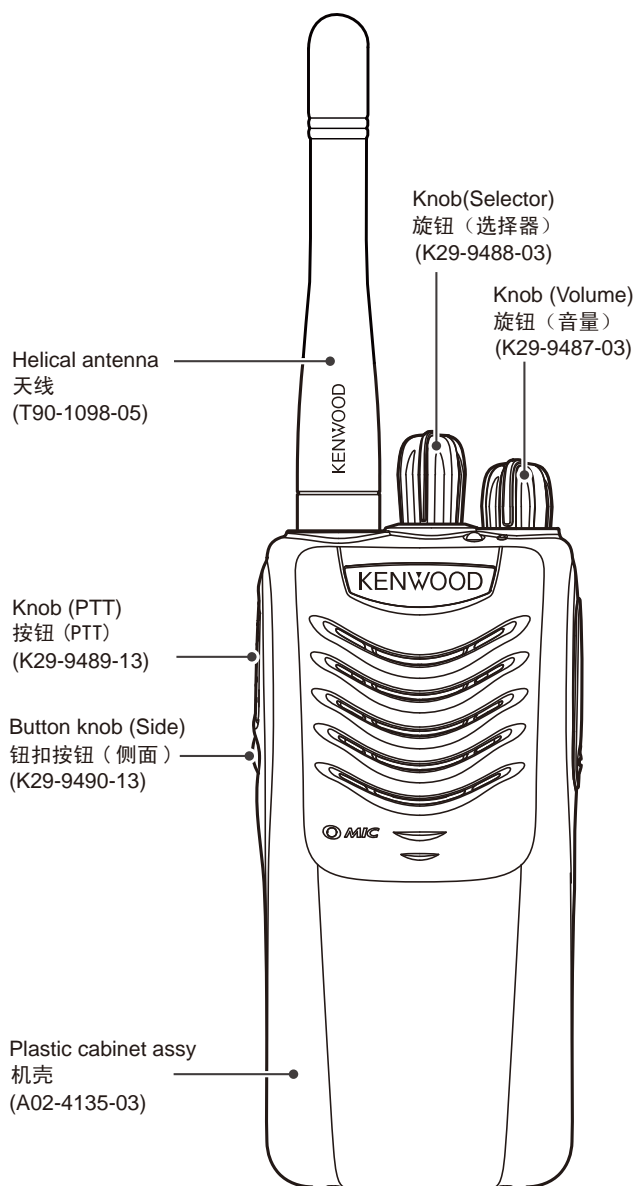
© 2011-5 PRINTED IN JAPAN  
B51-8978-00 (Y)



无铅焊接通信产品    
保护环境建伍领先

⚠ 注意：本产品是无铅化焊接产品  
在维修时请使用无铅焊锡  
和相应的焊接工具  
详细事项请访问如下网址了解：  
<http://www.kenwoodhk.com.hk/>

<b>GENERAL</b> .....	<b>3</b>	概 述.....	3
<b>SYSTEM SET-UP</b> .....	<b>4</b>	系统体系.....	4
<b>REALIGNMENT</b> .....	<b>5</b>	模式组合.....	5
<b>DISASSEMBLY FOR REPAIR</b> .....	<b>9</b>	维修拆卸.....	9
<b>CIRCUIT DESCRIPTION</b> .....	<b>11</b>	电路说明.....	11
<b>SEMICONDUCTOR DATA</b> .....	<b>16</b>	半导体数据.....	16
<b>COMPONENTS DESCRIPTION</b> .....	<b>17</b>	元件说明.....	17
<b>PARTS LIST</b> .....	<b>19</b>	零 件 表.....	19
<b>EXPLODED VIEW</b> .....	<b>24</b>	部件分解图.....	24
<b>ADJUSTMENT</b> .....	<b>25</b>	调 整.....	26
<b>PC BOARD</b>		印刷电路板	
<b>TX-RX UNIT (X57-8100-23)</b> .....	<b>32</b>	收发单元 (X57-8100-23).....	32
<b>LEVEL DIAGRAM</b> .....	<b>36</b>	电 平 图.....	36
<b>SCHEMATIC DIAGRAM</b> .....	<b>37</b>	原 理 图.....	37
<b>BLOCK DIAGRAM</b> .....	<b>39</b>	方 块 图.....	39
<b>SPECIFICATIONS</b> .....	<b>BACK COVER</b>	规 格.....	封底

### Document Copyrights

Copyright 2011 by Kenwood Corporation. All rights reserved.

No part of this manual may be reproduced, translated, distributed, or transmitted in any form or by any means, electronic, mechanical, photocopying, recording, or otherwise, for any purpose without the prior written permission of Kenwood.

### Disclaimer

While every precaution has been taken in the preparation of this manual, Kenwood assumes no responsibility for errors or omissions. Neither is any liability assumed for damages resulting from the use of the information contained herein. Kenwood reserves the right to make changes to any products herein at any time for improvement purposes.

### 文档版权信息

Kenwood Corporation 拥有版权 2011。保留所有权利。

未经 Kenwood 公司预先书面同意，无论出于何种目的，均不得以任何形式或任何方式包括电子、机械、影印、录音或其他方式复制、翻译、分发或传播本手册的任何部分。

### 免责声明

Kenwood 公司在准备本文档时已采取所有必要的预防措施，恕不对错误或疏漏承担任何责任，也不对因使用本文中所含的信息而导致的损害负责。Kenwood 公司保留出于改进的需要而随时对文中的产品信息做出更改的权利。

# GENERAL / 概述

## INTRODUCTION

### SCOPE OF THIS MANUAL

This manual is intended for use by experienced technicians familiar with similar types of commercial grade communications equipment. It contains all required service information for the equipment and is current as of the publication date. Changes which may occur after publication are covered by either Service Bulletins or Manual Revisions. These are issued as required.

## ORDERING REPLACEMENT PARTS

When ordering replacement parts or equipment information, the full part identification number should be included. This applies to all parts : components, kits, or chassis. If the part number is not known, include the chassis or kit number of which it is a part, and a sufficient description of the required component for proper identification.

## PERSONAL SAFETY

The following precautions are recommended for personal safety:

- DO NOT transmit until all RF connectors are verified secure and any open connectors are properly terminated.
- SHUT OFF and DO NOT operate this equipment near electrical blasting caps or in an explosive atmosphere.
- This equipment should be serviced by a qualified technician only.

## SERVICE

This transceiver is designed for easy servicing. Refer to the schematic diagrams, printed circuit board views, and alignment procedures contained within.

Model	Type	TX-RX unit	Frequency range	Remarks
TK-3000	C6	X57-8100-23	350~390MHz	IF1: 38.85MHz LOC: 38.4MHz

## 引言

### 本手册的范围

本手册是提供给熟悉通信专业并且具有维修经验的技术人员使用的。它包括了维修该设备所需要的全部资料和现行出版日期。在出版后可能发生变动，如果需要，可以参照《维修通报》或《手册修订本》进行补充。

## 替换零件的订购

当订购替换零件或设备资料时，应注意完整的零件识别号码。所有的零件均有识别号码：元件，组件或机壳。如果不知道零件的号码，为了正确地识别，必须注明此元件所属的机壳或组件的号码，并对元件进行充分的说明。

## 个人安全

为了个人的安全，请注意下列事项：

- 在没有认真核实所有射频插头之前或有任何一个脱开的插头没有连接到相应端口上的情况下均不要发射。
- 在电爆管附近或在易燃性气体环境中，必须关闭电源，不要操作本设备。
- 本设备只应该由有资格的技术人员进行维修。

## 维修服务

为了便于维修本设备，建立了完整的维修服务体系，提供了包括原理图，印刷电路板图和调整步骤在内的资料供参考。

型号	类型	收发单元	频率范围	备注
TK-3000	C6	X57-8100-23	350 ~ 390MHz	IF1: 38.85MHz LOC: 38.4MHz

## SYSTEM SET-UP / 系统体系

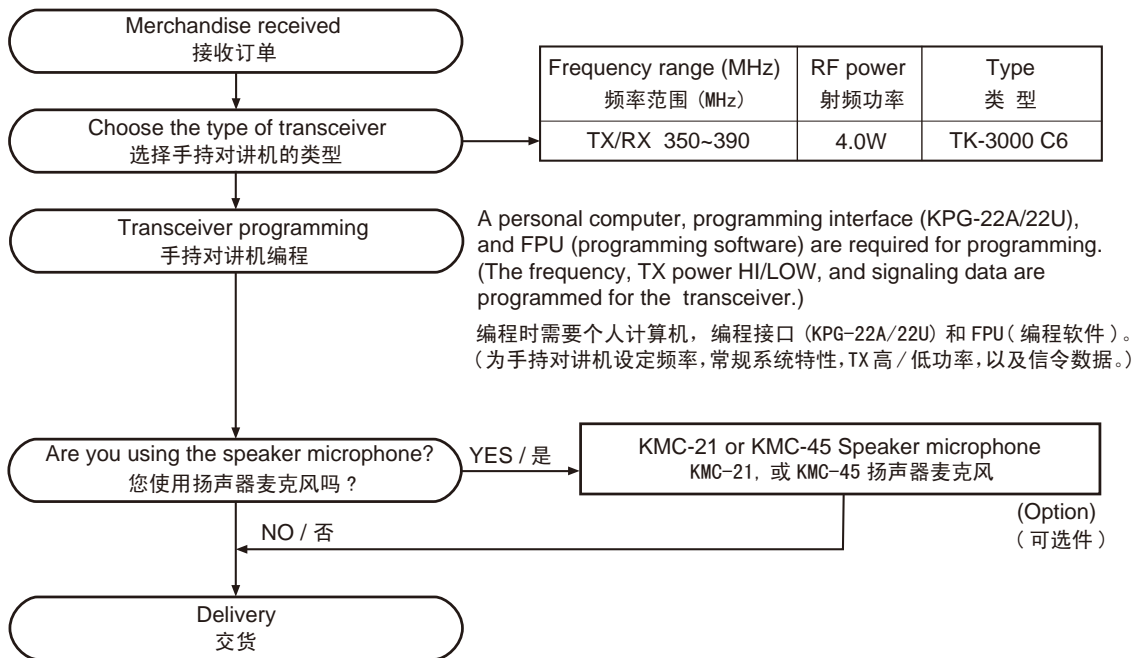

## REALIGNMENT / 模式组合

### 1. Modes

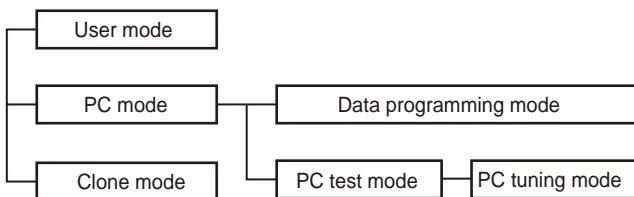

Mode	Function
User mode	For normal use.
PC mode	Used for communication between the transceiver and PC.
Data programming mode	Used to read and write frequency data and other features to and from the transceiver.
PC test mode	Used to check the transceiver using the PC. This feature is included in the FPU.
Clone mode	Used to transfer programming data from one transceiver to another.

### 1. 模式

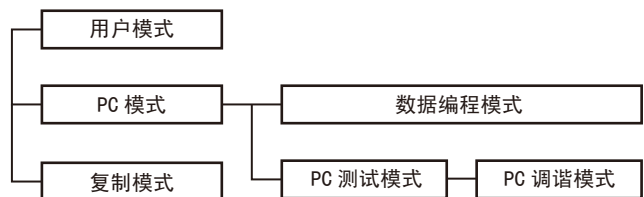

模式	功能
用户模式	一般使用。
PC 模式	用于手持对讲机与计算机之间的通信。
数据编程模式	用于阅读和写入频率数据以及其他功能。
PC 测试模式	用于使用计算机检测手持对讲机。此特性包括在 FPU 内。
复制模式	用于从一个手持对讲机编程数据复制到另一个手持对讲机。

## REALIGNMENT / 模式组合

## 2. How to Enter Each Mode

Mode	Operation
User mode	Power ON
PC mode	Received commands from PC
Clone mode	[PTT]+[Side]+Power ON (Two seconds)

## 3. PC Mode

## 3-1. Preface

The transceiver is programmed by using a personal computer, a programming interface (KPG-22A/22U, USB adapter (KCT-53U)) and programming software (KPG-137D: ver.1.10 or later).

The programming software can be used with a PC. Figure 1 shows the setup of a PC for programming.

## 3-2. Connection Procedure

1. Connect the transceiver to the personal computer with the interface cable and USB adapter (when the interface cable is KPG-22A, the KCT-53U can be used).

**Note:**

- You must install the KPG-22U driver in the computer to use the USB programming interface cable (KPG-22U).
  - You must install the KCT-53U driver in the computer to use the USB adapter (KCT-53U).
  - When using the USB adapter (KCT-53U) for the first time, plug the KCT-53U into a USB port on the computer with the computer power ON.
2. When the POWER is switched on, user mode can be entered immediately. When the PC sends a command, the transceiver enters PC mode.  
When data is read from the transceiver, the red LED lights.  
When data is written to by the transceiver, the green LED lights.

**Note:**

- The data stored in the personal computer must match Model Name and Model Type when it is written into EEPROM.
- Do not press the [PTT] key during data transmission or reception.

## 3-3. KPG-22A Description

**(PC programming interface cable: Option)**

The KPG-22A is required to interface the transceiver with the computer. It has a circuit in its D-sub connector case that converts the RS-232C logic level to the TTL level.

The KPG-22A connects the SP/MIC connector of the transceiver to the RS-232C serial port of the computer.

## 3-4. KPG-22U Description

**(USB programming interface cable: Option)**

The KPG-22U is a cable which connects to a USB port on a computer.

## 2. 如何进入每一种模式

模式	功能
用户模式	接通电源
PC 模式	从计算机接收指令
复制模式	[PTT]+[侧面]+接通电源(2秒钟)

## 3. PC 模式

## 3-1. 前言

手持对讲机采用个人电脑、编程接口 (KPG-22A/22U, USB 适配器 (KCT-53U)) 和编程软件 (KPG-137D: ver. 1.10 或更高版本) 进行编程。

编程软件可以在 PC 上进行使用。图 1 给出了 PC 进行编程的设置。

## 3-2. 连接操作

1. 使用接口电缆和 USB 适配器将手持对讲机连接到个人电脑 (接口电缆为 KPG-22A 时, 可以使用 KCT-53U)。

**注意:**

- 必须在电脑上安装 KPG-22U 驱动程序才能使用 USB 编程接口电缆 (KPG-22U)。
  - 必须在电脑上安装 KCT-53U 驱动程序才能使用 USB 适配器 (KCT-53U)。
  - 首次使用 USB 适配器 (KCT-53U) 时, 请在电脑开机的情况下将 KCT-53U 插入电脑的 USB 端口。
2. 手持对讲机电源打开时, 可以立即进入用户模式 PC 发送指令时, 手持对讲机进入 PC 模式。  
手持对讲机发送数据时, 红色的 LED 点亮。  
手持对讲机接收数据时, 绿色的 LED 点亮。

**注意:**

- 个人电脑保存的数据写入 EEPROM 时, 必须与机型和类型相符。
- 请勿在数据发送或接收期间按 [PTT] 键。

## 3-3. KPG-22A 说明

**(PC 编程接口电缆: 选购件)**

将手持对讲机与电脑相连需要 KPG-22A。该电缆的 D-sub 连接器盒具有将 RS-232C 逻辑电平转换为 TTL 电平的电路。

KPG-22A 将手持对讲机的 SP/MIC 连接器连接到电脑的 RS-232C 串行端口。

## 3-4. KPG-22U 说明

**(PC 编程接口电缆: 选购件)**

KPG-22U 是连接到电脑 USB 端口的电缆。

## REALIGNMENT / 模式组合

When using the KPG-22U, install the supplied CD-ROM (with driver software) in the computer. The KPG-22U driver runs under Windows XP, Vista or 7.

### 3-5. KCT-53U Description (USB adapter: Option)

The KCT-53U is a cable which connects the KPG-22A to a USB port on a computer.

When using the KCT-53U, install the supplied CD-ROM (with driver software) in the computer. The KCT-53U driver runs under Windows 2000, XP or Vista (32-bit).

### 3-6. Programming Software KPG-137D Description

The KPG-137D is the programming software for the transceiver supplied on a CD-ROM. This software runs under windows XP, Vista or 7 on a PC. The software on this disk allows a user to program the transceiver via Programming interface cable (KPG-22A/22U).

#### Note:

- Use the FPU that matches the market when you first set the market code and model name/frequency data to the service unit. The unit set by mistake cannot be restored.
- Receive frequencies listed below may result in the interference of reception due to the harmonics of internal oscillators. Enter a frequency not listed in the table.

No.	FREQUENCY (MHz)
1	364.79375
2	364.79500
3	364.80000
4	364.80500
5	364.80625
6	383.99375
7	383.99500
8	384.00000
9	384.00500
10	384.00625

### 3-7. Programming with PC

If data is transferred to the transceiver from a PC with the FPU, the data for each set can be modified.

Data can be programmed into the EEPROM in RS-232C format via the SP/MIC jack.

In this mode the PTT line operate as TXD and RXD data lines respectively.

使用 KPG-22U 时，请在电脑上安装附带的 CD-ROM (带有驱动程序)。KPG-22U 驱动程序可以在 Windows XP、Vista 或 7 下运行。

### 3-5. KCT-53U 说明 (USB 适配器：选配件)

KCT-53U 是将 KPG-22A 连接到电脑 USB 端口的电缆。

使用 KCT-53U 时，请在电脑上安装附带的 CD-ROM (带有驱动程序)。KCT-53U 驱动程序在 Windows2000, XP 或 Vista (32 位) 下运行。

### 3-6. 编程软件 KPG-137D 说明

KPG-137D 是 CD-ROM 附带的用于手持对讲机的编程软件。该软件在 PC 的 WindowsXP、Vista 或 7 下运行。该光盘上的软件允许用户通过编程接口电缆 (KPG-22A/22U) 对手持对讲机进行编程。

#### 注意：

- 初次设置服务单元的市场代码和机型 / 频率数据时，请使用与市场相符的 FPU。若单元设置有误，将无法予以恢复。
- 下面列出的接收频率由于内部振荡器的谐波可能对信号接收造成干扰。输入在表格中没有列出的频率。

编号	频率 (MHz)
1	364.79375
2	364.79500
3	364.80000
4	364.80500
5	364.80625
6	383.99375
7	383.99500
8	384.00000
9	384.00500
10	384.00625

### 3-7. 使用 PC 编程

如果使用 FPU 将数据从 PC 传输到手持对讲机，则每套手持对讲机的数据均可修改。

通过 SP/MIC 插孔可以将数据以 RS-232C 格式写入 EEPROM。在该模式下，PTT 线路分别用作 TXD 和 RXD 数据线路。

## REALIGNMENT / 模式组合

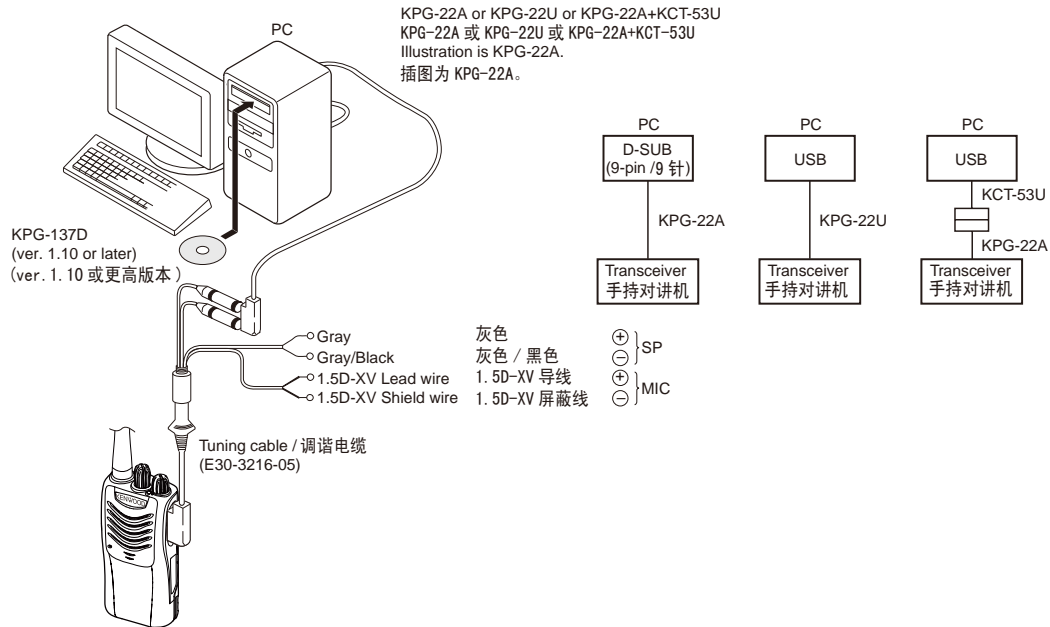

Fig. 1 / 图 1

## 4. Clone Mode

Programming data can be transferred from one transceiver to another by connecting them via their SP/MIC connectors.

Cloning can be performed as described below (the transmit transceiver is the source and the receive transceiver is the target).

The following data cannot be cloned.

- Tuning data
- Model name data
- ESN data

1. Turn the source transceiver and target transceiver power OFF.
2. Turn the source transceiver power ON while pressing the [PTT] and [Side] keys, to enter clone mode.
3. Connect the cloning cable (part No. E30-3410-05) to the SP/MIC connectors on the source and target transceivers.
4. Turn the target transceiver power ON.
5. Press the [Side] key on the source transceiver. The data of the source is sent to the target. While the source is sending data, red LED will light. While the target is receiving the data, green LED will light. When cloning of data is completed, the source red LED turned off, and the target automatically operates in the User mode.
6. Additional targets can be continuously cloned. When the [Side] key on the source is pressed, the data of the source is sent to the target again. Repeat steps 3 to 5 to clone additional transceivers.

## 4. 复制模式

用 SP/MIC 连接器连接手持对讲机，可以将编程数据从一台手持对讲机传输到另一台手持对讲机。

如下所述可进行复制（发射手持对讲机为主机，接收手持对讲机为子机）。

以下数据不能复制。

- 调谐数据
- 机型数据
- ESN 数据

1. 关闭主机和子机的电源。
2. 按 [PTT] 和 [侧面] 键的同时打开主机的电源，使其进入复制模式。
3. 将复制电缆（零件号 E30-3410-05）连接到主、子机的 SP/MIC 连接器上。
4. 打开子机的电源。
5. 按主机上的 [侧面] 键。  
主机的数据便被发送到子机。主机发送数据时，红色 LED 将呈。子机接收数据时，绿色 LED 呈。数据复制完成后，主机的红色 LED 熄灭，子机自动以用户模式运行。
6. 可以继续复制其他子机。按主机上的 [侧面] 键，主机的数据再次被发送到子机。重复步骤 3 ~ 5 复制其他手持对讲机。

## REALIGNMENT

### Note:

- The Model name and Market codes must be the same in order to clone the transceiver.
- If the transceivers clone mode is configured as "Disabled", the transceiver cannot enter clone mode.
- If the Read authorization password is set to the transceiver, the transceiver cannot enter to the clone mode.
- Cannot be cloned if the password (overwrite password) is programmed to the target.

### 注意：

- 机型和市场代码必须相同才能复制手持对讲机。
- 如果手持对讲机复制模式被设置为“无效”，则手持对讲机不能进入复制模式。
- 如果手持对讲机设置了读取授权密码，则手持对讲机无法进入复制模式。
- 如果子机编程设有密码（改写密码），则无法复制。

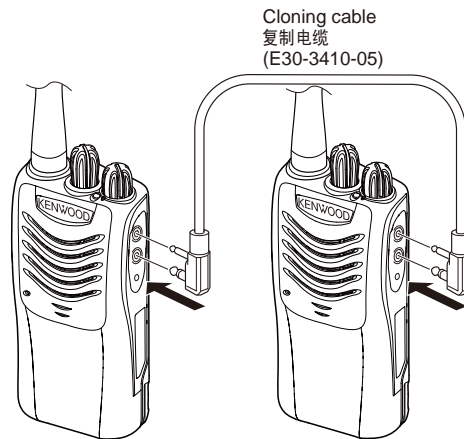

Fig. 2 / 图 2



## DISASSEMBLY FOR REPAIR / 维修拆卸

## 1. Separating the Case Assembly from the Chassis

1. Remove the two knobs (①).
2. Remove the two screws (②).
3. Expand the right and left sides of the bottom of the case assembly, lift the chassis, and remove it from the case assembly (③).
4. Taking care not to cut the speaker lead (④), open the chassis and case assembly.

**Note:**

Solder the speaker wire back in its original position if you have removed it.

## 1. 从机架上分离外壳

1. 取下两旋钮 (①)。
2. 取下两颗螺钉 (②)。
3. 掀开外壳底部的左右两侧，取下机架，并外壳中取出 (③)。
4. 小心不要折断扬声器引线 (④)。拆下机架和外壳。

**注意：**

如果取下了扬声器的导线，请将其焊接到原位置上。

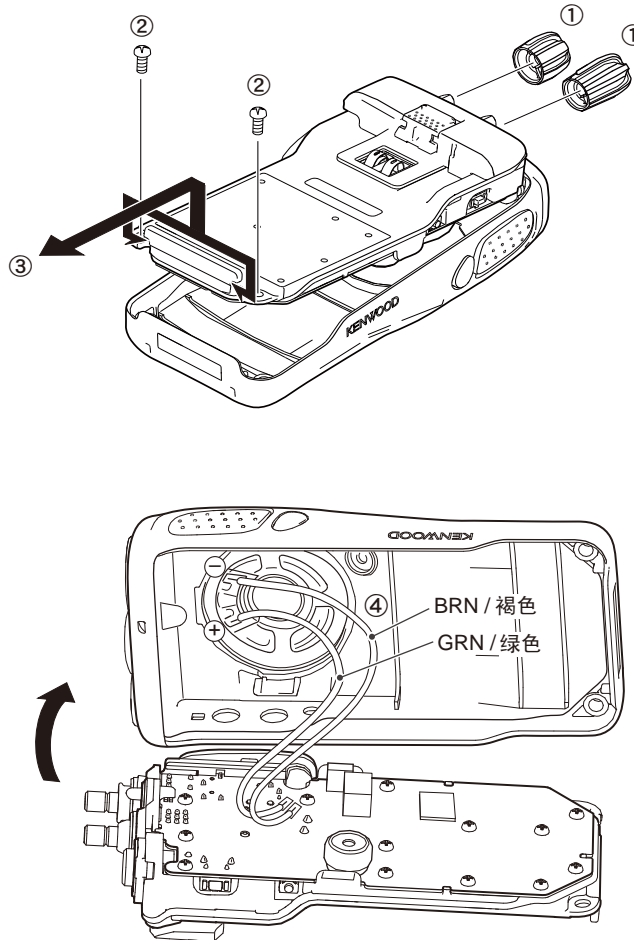

# TK-3000

## DISASSEMBLY FOR REPAIR / 维修拆卸

### 2. Removing the TX-RX unit from the Chassis

1. Remove the packing (⑤).
2. Remove the 13 screws (⑥).
3. Remove the packing (⑦) and two hexagon nuts (⑧).
4. Remove the solder from the antenna terminal using a soldering iron then lift the unit off (⑨).

#### Note:

When reassembling the unit in the chassis, be sure to solder the antenna terminal.

### 2. 拆卸收发单元

1. 取下橡胶垫 (⑤)。
2. 取下 13 颗螺钉 (⑥)。
3. 取下橡胶垫 (⑦) 和两个六角形螺母 (⑧)。
4. 用电烙铁烫开天线端点处的焊锡，并拆卸主板 (⑨)。

#### 注意：

当重新将主板安装到机架上时，确保将天线端点处焊接好。

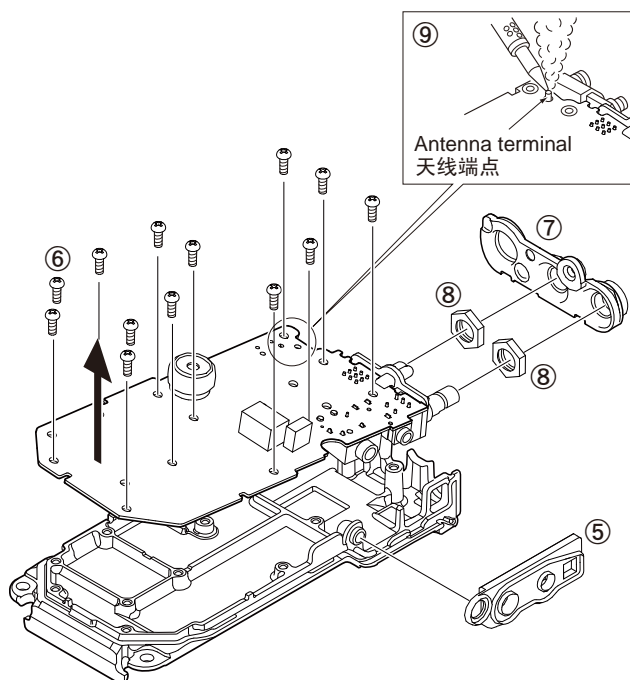

### 3. Removing the Rear Panel

1. Raise the rear panel on the chassis (⑩).

### 3. 取下后面板

1. 从机架上提起后面板 (⑩)。

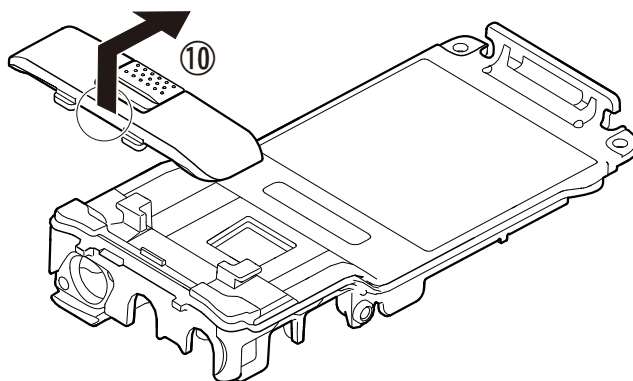

# CIRCUIT DESCRIPTION / 电路说明

## 1. Frequency Configuration

The receiver utilizes double conversion. The first IF is 38.85MHz and the second IF is 450kHz. The first Local oscillator is supplied from the PLL circuit.

The PLL circuit in the transmitter generates the necessary frequencies.

## 1. 频率构成

接收部采用二次变频超外差方式。第一中频为 38.85MHz，第二中频为 450kHz。第一本振频率信号由锁相环电路提供。发射部由锁相环电路直接产生所需的频率。

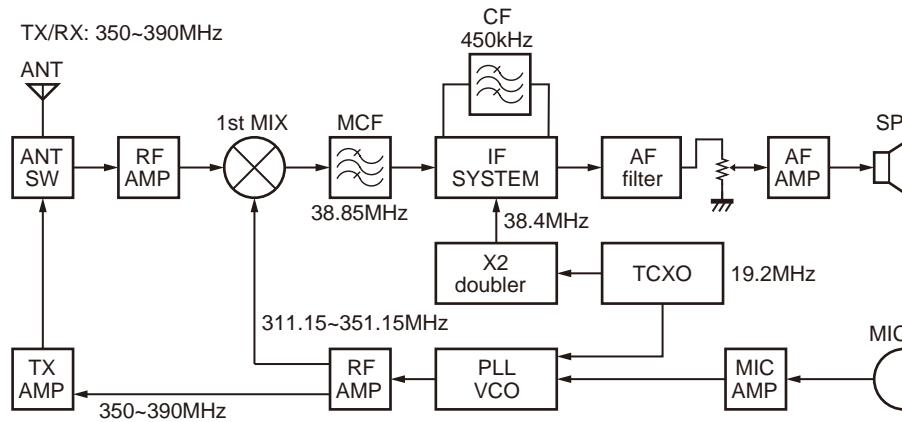

Fig. 1 Frequency configuration / 图 1 频率构成

## 2. Receiver System

The receiver system is shown in Figure 2.

## 2. 接收部系统

接收部系统的如图 2 所示。

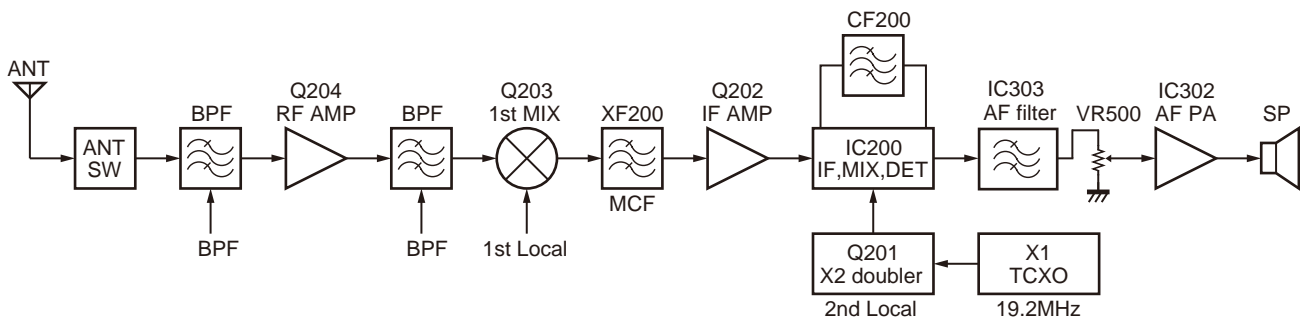

Fig. 2 Receiver system / 图 2 接收部系统

### 2-1. Front End (RF Amplifier) Circuit

The signal coming from the antenna passes through the transmit/receive switching diode circuit (D101, D102, D103 and D105) and a BPF (L208 and L210), and is then amplified by the RF amplifier (Q204).

The resulting signal passes through a BPF (L215, L218 and L219) and goes to the mixer. These BPFs are adjusted by variable capacitors (D201, D202, and D204). The input voltage to the variable capacitor is a regulated voltage output from the DAC (IC300)

### 2-1. 前端（高频放大器）电路

从天线接收的信号进入发送/接收转换开关二极管电路 (D101、D102、D103 和 D105)，然后通过 BPF (L208, L210)，并且被射频放大器 (Q204) 放大。

此信号通过 BPF (L215, L218 和 L219) 然后进入混频。这些 BPF 被可变电容器 (D201, D202 和 D204) 调整。输入可变电容器的电压被经 DAC (IC300) 的电压输出调整。

## 2-2. First Mixer

The signal from the front end is mixed with the first local oscillator signal generated in the PLL circuit by Q203 to produce a first IF frequency of 38.85 MHz.

The resulting signal passes through the XF200 MCF to cut the adjacent spurious and provide the optimum characteristics, such as adjacent frequency selectivity.

## 2-3. IF Amplifier Circuit

The first IF signal is passed through a four-pole monolithic crystal filter (XF200) to remove the adjacent channel signal.

The filtered first IF signal is amplified by the first IF amplifier (Q202) and then applied to the IF system IC (IC200).

The IF system IC provides a second mixer, second local oscillator, limiting amplifier, quadrature detector and RSSI (Received Signal Strength Indicator). The second mixer mixes the first IF signal with the 38.4MHz of the second local oscillator output (TCXO X1) and produces the second IF signal of 450kHz.

The second IF signal is passed through the ceramic filter (CF200) to remove the adjacent channel signal. The filtered second IF signal is amplified by the limiting amplifier and demodulated by the quadrature detector with the ceramic discriminator (CD200). The demodulated signal is routed to the audio circuit.

## 2-4. Audio Amplifier Circuit

The demodulated signal from IC200 is amplified by IC305, IC303 and goes to AF amplifier through IC302.

The signal then goes through an volume control (VR500), and is routed to an audio power amplifier (IC302) where it is amplified and output to the speaker.

To output sounds from the speaker, IC400 sends a high signal to the SPMUT line and turns IC400 on through Q300, Q301, Q302 and Q306.

## 3. Transmitter System

### 3-1. Microphone Amplifier Circuit

The signal from microphone amplified by IC301 and goes through mute switch (IC300).

IC304 is composed of high-pass filter, low-pass filter and pre-emphasis/IDC circuit.

The output signal from the DAC IC (IC300) goes to the VCO modulation input.

## 2-2. 第一混频器

前端的信号与 PLL 电路产生的第一本振信号在 Q203 混频, 生成 38.85MHz 频率的第一中频信号。

生成的信号通过 XF200 MCF。

## 2-3. 中频放大电路

第一中频信号通过晶体滤波器 (XF200) 消除相邻信道的信号。经滤波的第一中频信号被第一中频放大器 (Q202) 放大并进入中频系统芯片 (IC200)。

中频系统芯片提供第二混频器、第二本振信号、限幅放大器、正交检测器和 RSSI (接收信号强度指示器)。第二混频器将第一中频信号与 38.4MHz 的第二本振信号输出 (TCXO X1) 进行混频, 并生成 450kHz 的第二中频信号。

第二中频信号通过陶瓷滤波器 (CF200) 继续消除相邻信道的信号。经滤波的第二中频信号被限幅放大器放大并被带有陶瓷鉴频器 (CD200) 的正交检测器解调。经解调的信号进入音频电路。

## 2-4. 音频放大器电路

来自于 IC200 的解调信号被 IC305 放大, 并通过 IC302, IC303 送到 AF 放大器。

信号通过 AF 音量控制 (VR500), 在音频功率放大器 (IC302) 进行放大后输出到扬声器。

由扬声器输出声音时, IC400 发送高电平信号给 SPMUT, 通过 Q300、Q301、Q302 和 Q306 打开 IC400。

## 3. 发射机系统

### 3-1. 麦克风放大器电路

麦克风的信号被 IC301 放大, 然后通过静音开关 (IC300)。

IC304 由高通滤波器、低通滤波器和预加重 / IDC 电路组成。DAC IC (IC300) 的输出信号送入 VCO 调制输入。

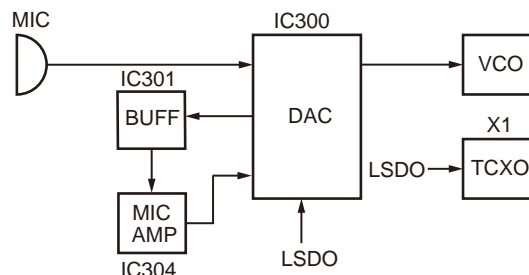

Fig. 3 Microphone amplifier circuit / 图3 麦克风放大器电路

## CIRCUIT DESCRIPTION / 电路说明

### 3-2. Drive and Final Amplifier Circuit

The signal from the T/R switch (D100 is on) is amplified by the pre-drive amplifier (Q100) to 30mW.

The output of the pre-drive amplifier is amplified by the drive amplifier (Q101) and the RF final amplifier (Q102) to 4.0W (1W when the power is low).

The drive amplifier and the RF final amplifier consist of two MOS FET stages.

The output of the RF final amplifier is then passed through the harmonic filter (LPF) and antenna switch (D101 and D102) and is applied to the antenna terminal.

### 3-2. 驱动器和末级放大器电路

来自于 T/R 开关 (D100 ON) 的信号被预驱动放大器 (Q100) 放大到 30mW。

预驱动放大器的输出被驱动放大器 (Q101) 和射频末级放大器 (Q102) 放大到 4.0W (当低功率时为 1W)。

驱动放大器和 RF 末级放大器由 2 个 MOS FET 构成。

射频末级放大器的输出通过谐波滤波器 (LPF) 和天线开关 (D101 和 D102) 并且送到天线终端。

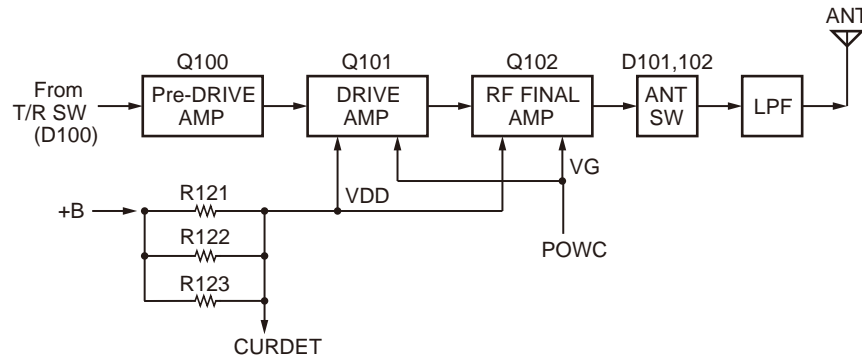

Fig. 4 Drive and final amplifier circuit / 图 4 驱动及末级放大器电路

## 4. Frequency Synthesizer Circuit

### 4-1. Frequency Synthesizer

The frequency synthesizer consists of the TCXO (X1), VCO, PLL IC (IC1) and buffer amplifiers.

The TCXO generates 19.2MHz. The frequency stability is 2.5 ppm within the temperature range of  $-30$  to  $+60^{\circ}\text{C}$ .

The frequency tuning and modulation of the TCXO are done to apply a voltage to pin 1 of the TCXO. The output of the TCXO is applied to pin 1 of the PLL IC.

The VCO consists of 1VCO and covers a dual range of the 350.00~390.00MHz and the 311.15~351.15MHz. The VCO generates 311.15~351.15MHz for providing to the first local signal in receive.

The PLL IC consists of a prescaler, reference divider, phase comparator, charge pump (The frequency step of the PLL circuit is 5 or 6.25 kHz).

PLL data is output from DATA (pin 19), CLOCK (pin 18) and PLDL (pin 20) of the MCU (IC400). The data are input to the PLL IC when the channel is changed or when transmission is changed to reception and vice versa. A PLL lock condition is always monitored by the pin 22 (PLUL) of the MCU. When the PLL is unlocked, the PLUL goes low.

## 4. 频率合成器电路

### 4-1. 频率合成器

频率合成器由 TCXO (X1)、VCO、PLL IC (IC1) 和缓冲放大器组成。

TCXO 产生 19.2MHz 的频率。在温度为  $-30 \sim +60^{\circ}\text{C}$  的范围内，频率的稳定性为 2.5ppm。

进行频率调谐和 TCXO 调制，以便给 TCXO 的引脚 1 提供电压。TCXO 的输出加在 PLL IC 的引脚 1 上。

VCO 由 1VCO 组成，并且覆盖了 350.00 ~ 390.00MHz 和 311.15 ~ 351.15MHz 双波段。VCO 产生 311.15 ~ 351.15MHz 的频率，以提供接收的第一个本振信号。

PLL IC 由预计数器、基准除法器、相位比较器、电荷泵组成 (PLL 电路的频率步长为 5kHz 或 6.25kHz)。

PLL 数据从 MCU (IC400) 的 DATA (引脚 19)，CLOCK (引脚 18) 和 PLDL (引脚 20) 输出。当信道改变时，或当由发射变为接收或由接收变为发射时，数据输入 PLL IC。PLL 的锁定条件总是由 MCU 的引脚 22 (PLUL) 监控。当 PLL 失锁时，PLUL 为低电位。

## CIRCUIT DESCRIPTION / 电路说明

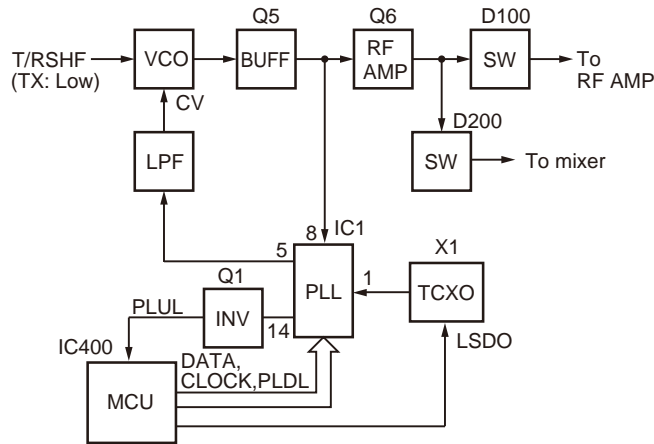

Fig. 5 PLL block diagram / 图 5 PLL 方块图

## 5. Control Circuit

The control consists of the MCU (IC400) and its peripheral circuits. It controls the TX-RX unit. IC400 mainly performs the following;

- 1) Switching between transmission and reception by PTT signal input.
- 2) Reading channel information, frequency, and program data from the memory circuit.
- 3) Sending frequency program data to the PLL.
- 4) Controlling squelch on/off via the DC voltage from the squelch circuit.
- 5) Controlling the audio mute circuit via the decode data input.
- 6) Transmitting tone and encode data.

### Note:

The EEPROM stores tuning data (Deviation, Squelch, etc.).

Realign the transceiver after replacing the EEPROM.

## 6. Signaling Circuit

### 6-1. Encode

#### ■ Low-speed data (QT, DQT)

Low-speed data is output from pin 49 (LSDO) of the MCU (IC400). The signal passes through a low-pass CR filter. The signal is mixed with the audio signal and goes to the VCO and TCXO (X1) modulation input after signal processing in the DAC IC (IC300).

#### ■ High-speed data (DTMF)

High-speed data (HSD) is output from pin 50 (HSDO) of the MCU.

The signal passes through a low-pass CR filter. TX deviation making an adjustment by MCU is applied to the DAC IC (IC300). The signal is mixed with the audio signal and goes to the VCO and TCXO.

## 5. 控制电路

控制电路是由微处理器 (IC400) 和外部电路构成。它控制收发单元。IC400 的主要功能如下：

- 1) 根据 PTT 的输入信号来转换发射和接收状态。
- 2) 从存储电路读出信道信息、频率以及编程数据。
- 3) 发送频率数据给 PLL。
- 4) 根据静噪电路输出的 DC 电压来控制静噪的开启和关闭。
- 5) 根据解码数据控制音频静音。
- 6) 发射 Tone 及编码数据。

### 注意：

EEPROM 保存调谐数据 (频偏、静噪等)。

更换 EEPROM 后，请重新校正手持对讲机。

## 6. 信令电路

### 6-1. 编码

#### ■ 低速数据 (QT, DQT)

低速数据从微处理器 (IC400) 的引脚 49 (LSDO) 输出。信号通过低通 CR 滤波器。此信号与音频信号混合，在 DAC IC (IC300) 中进行信号处理之后，进入 VCO 和 TCXO (X1) 调制输入。

#### ■ 高速数据 (DTMF)

高速数据 (HSD) 从微处理器的引脚 50 (HSDO) 输出。

信号通过低通 CR 滤波器。由微处理器进行调整的 TX 频偏被施加到 DAC IC (IC300)。此信号与音频信号混合，然后送入 VCO 和 TCXO。

## CIRCUIT DESCRIPTION / 电路说明

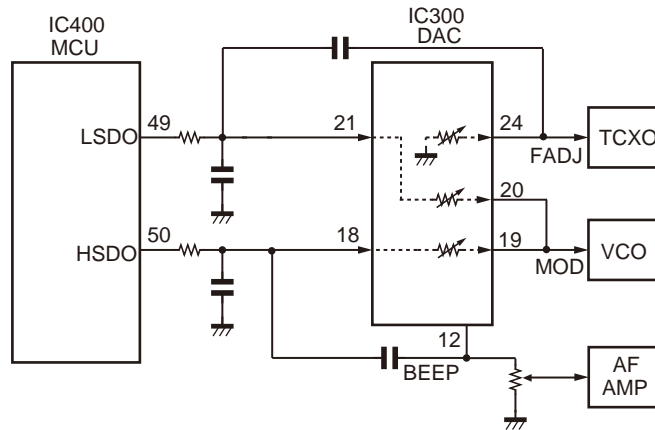

Fig. 6 Encode / 图 6 编码

## 6-2. Decode

## ■ QT/DQT

The output signal from IF IC (IC200) enters the MCU (IC400) through IC300. IC400 determines whether the QT or DQT matches the preset value, and controls the SPMUT and the speaker output sounds according to the squelch results.

## 7. Power Supply

There are five 5V power supplies for the MCU:

5M is always output while the power is on.

5C is a common 5V and is output when SAVE is not set to ON.

5R is 5V for reception and output during reception.

5T is 5V for transmission and output during transmission.

5MS is 5V for the SP/MIC connector and the DAC IC (IC300).

## 6-2. 解码

## ■ QT/DQT

IF IC (IC200) 的输出信号通过 IC300 送入微处理器 (IC400)。IC400 确认 QT 或 DQT 是否与预设值匹配，控制 SPMUT，然后扬声器根据静噪结果输出声音。

## 7. 电源

微处理器有 5 个 5V 电源。

电源打开时，5M 总是输出。

5C 是普通的 5V 电源，它在 SAVE 没有设为 ON 时输出。

5R 是接收用 5V 电源，它在接收期间输出。

5T 是为发射用的 5V 电源，它在发射期间保持输出。

5MS 是 SP/MIC 和 DAC IC (IC300) 的 5V 电源。

## MCU: F2136ACNKDRB (TX-RX unit IC400)

Pin No.	Signal Name	I/O	Function
1	NC	O	NC
2	VREF	-	Reference voltage input
3	MODE	I	Mode select for MCU
4, 5	NC	O	NC
6	RESET	I	Reset signal input
7	XOUT	O	Oscillation circuit
8	Vss	-	GND
9	XIN	I	Oscillation circuit
10	Vcc	-	Power supply
11	BSFT	O	Beat shift for MCU clock
12~14	NC	O	NC
15	E2WP	O	Write protect for EEPROM
16	E2DAT	I/O	Data input/output from EEPROM
17	E2CLK	O	Clock for EEPROM
18	CLOCK	O	Clock for PLL/DAC IC
19	DATA	O	Data for PLL/DAC IC
20	PLDL	O	Load enable for PLL IC
21	PLPS	O	Power saving for PLL IC
22	PLUL	I	Lock detect signal from PLL IC
23	NC	O	NC
24	EN4	I	Encoder input 4
25	EN3	I	Encoder input 3
26	EN2	I	Encoder input 2
27	EN1	I	Encoder input 1
28	NC	O	NC
29	OPTDET	I	2pin option detection
30	LEDR	O	LED (red) control
31	LEDG	O	LED (green) control
32	SPMUT	O	Power switch for AF amp
33	NC	O	NC
34	5TC	O	5T control
35	5CC	O	5C control (SAVE)
36	5MSC	O	5MS control
37	DACLD	O	Load enable for DAC IC
38	PTT	I	PTT key input
39	PFKEY	I	PF key input
40	INT	I	INT signal input
41	VDCSW	O	Voltage discharge switch
42	WID/NAR	O	Wide/Narrow control
43	RXD	I	Serial data input (FPU)
44	TXD	O	Serial data output (FPU)
45, 46	NC	O	NC
47	VOXIN	I	VOX level input
48	CVDET	I	VCO voltage detection

## 微处理器：F2136ACNKDRB（收发单元 IC400）

管脚号	端口名称	输入/输出	功能
1	NC	输出	未连接
2	VREF	-	基准电压
3	MODE	输入	选择模式 (MCU)
4, 5	NC	输出	未连接
6	RESET	输入	MCU 复位
7	XOUT	输出	MCU 时钟输出
8	Vss	-	接地
9	XIN	输入	11.0592MHz 时钟输入
10	Vcc	-	5.0V
11	BSFT	输出	拍频偏移
12 ~ 14	NC	输出	未连接
15	E2WP	输出	EEPROM 写入控制
16	E2DAT	输入/输出	EEPROM 数据输入 / 输出
17	E2CLK	输出	EEPROM 时钟
18	CLOCK	输出	PLL/DAC 时钟
19	DATA	输出	PLL/DAC 数据
20	PLDL	输出	PLL 启用
21	PLPS	输出	PLL 省电状态控制
22	PLUL	输入	PLL 失锁检测
23	NC	输出	未连接
24	EN4	输入	编码器输入 4
25	EN3	输入	编码器输入 3
26	EN2	输入	编码器输入 2
27	EN1	输入	编码器输入 1
28	NC	输出	未连接
29	OPTDET	输入	耳机检测
30	LEDR	输出	红色 LED 控制
31	LEDG	输出	绿色 LED 控制
32	SPMUT	输出	AF IC 开关
33	NC	输出	未连接
34	5TC	输出	5T 控制
35	5CC	输出	5C 控制
36	5MSC	输出	5MS 控制
37	DACLD	输出	DAC 启用
38	PTT	输入	PTT 键输入
39	PFKEY	输入	侧面键输入
40	INT	输入	MCU 停止
41	VDCSW	输出	电压放电开关
42	WID/NAR	输出	宽 / 窄切换
43	RXD	输入	串行数据输出 (FPU)
44	TXD	输出	串行数据输入 (FPU)
45, 46	NC	输出	未连接
47	VOXIN	输入	VOX 水平输入
48	CVDET	输入	VCO 电压电平



## SEMICONDUCTOR DATA / 半导体数据

Pin No.	Signal Name	I/O	Function
49	LSDO	O	Low speed data output
50	HSDO	O	DTMF/beep output
51	BATT	I	Battery voltage input
52	RSSI	I	RSSI input
53	SQL	I	Squelch input
54	LSDIN	I	LSD input
55	THDET	I	Thermistor input
56	CURDET	I	Current detection
57	T/RSHF	O	VCO Shift control
58	5VC	O	5V control
59~61	NC	O	NC
62	TYPE2	I	Destination selection 2
63	TYPE1	I	Destination selection 1
64	5RC	O	5R control

管脚号	端口名称	输入 / 输出	功 能
49	LSDO	输出	低速数据
50	HSDO	输出	侧音 AF 输出
51	BATT	输入	电池电压输入
52	RSSI	输入	RSSI 电平
53	SQL	输入	静噪电平
54	LSDIN	输入	低速数据
55	THDET	输入	热敏电阻输入
56	CURDET	输入	电流检测
57	T/RSHF	输出	VCO 偏移控制
58	5VC	输出	5V 控制
59 ~ 61	NC	输出	未连接
62	TYPE2	输入	类型选择 2
63	TYPE1	输入	类型选择 1
64	5RC	输出	5R 控制

## COMPONENTS DESCRIPTION / 元件说明

## TX-RX unit (X57-8100-23)

Ref. No.	Part Name	Description
IC1	IC	PLL system
IC200	IC	FM IF system
IC300	IC	DAC
IC301	IC	LSD buffer
IC302	IC	AF power AMP
IC303	IC	AF filter
IC304	IC	MIC AMP
IC305	IC	QT/DQT filter
IC400	IC	MCU
IC401	IC	EEPROM
IC500	IC	Voltage detector/RESET
IC501	IC	Voltage regulator/5V
IC503	IC	Voltage regulator/5V
Q1	Transistor	DC switch
Q2	Transistor	TX/RX RF switch
Q3	Transistor	Ripple filter
Q4	FET	VCO
Q5	Transistor	RF buffer AMP
Q6	Transistor	RF AMP
Q7	Transistor	Voltage regulator/3V

## 收发单元 (X57-8100-23)

有关号码	零件名称	说 明
IC1	IC	PLL 系统
IC200	IC	FM IF 系统
IC300	IC	DAC
IC301	IC	LSD 缓冲器
IC302	IC	AF 放大器
IC303	IC	AF 滤波器
IC304	IC	麦克风放大器
IC305	IC	QT/DQT 滤波器
IC400	IC	微处理器
IC401	IC	EEPROM
IC500	IC	电压检测器 / 复位
IC501	IC	电压调节器 / 5V
IC503	IC	电压调节器 / 5V
Q1	晶体管	直流开关
Q2	晶体管	收发开关
Q3	晶体管	纹波滤波器
Q4	场效应管	VCO 振荡器
Q5	晶体管	射频缓冲放大器
Q6	晶体管	射频放大器
Q7	晶体管	电压调节器 / 3V

## COMPONENTS DESCRIPTION / 元件说明

Ref. No.	Part Name	Description
Q100	Transistor	Pre drive AMP
Q101	FET	Drive AMP
Q102	FET	Final AMP
Q103	Transistor	Voltage discharge switch
Q200	Transistor	W/N switch
Q201	Transistor	Doubler
Q202	Transistor	IF AMP
Q203	FET	Mixer
Q204	FET	RF AMP
Q300, 301	Transistor	DC switch
Q302	FET	Mute switch
Q303	FET	DC switch
Q304	Transistor	DC switch
Q305	Transistor	W/N switch
Q306	FET	Mute switch
Q400	Transistor	Switch
Q401,402	Transistor	DC switch
Q500,501	FET	DC switch
Q502	Transistor	DC switch
D1	Diode	Current steering
D2, 3	Variable capacitance diode	Frequency control/ VCO
D4	Diode	TX/RX RF switch
D5	Variable capacitance diode	Frequency control/ VCO
D6	Variable capacitance diode	Modulator /TX VCO
D7	Diode	Ripple filter
D8	Diode	Current steering
D100	Diode	TX/RX RF switch
D101~103	Diode	ANT switch
D105	Diode	ANT switch
D200	Diode	TX/RX RF switch
D201, 202	Variable capacitance diode	RX BPF tuning
D204	Variable capacitance diode	RX BPF tuning
D260, 261	Variable capacitance diode	RX BPF tuning
D301	Diode	Current steering
D400	LED	LED/green
D401	LED	LED/red
D402	Diode	VCO speed up
D500	Diode	Protect
D501	Diode	Current steering

有关号码	零件名称	说 明
Q100	晶体管	预驱动放大器
Q101	场效应管	驱动放大器
Q102	场效应管	末级放大器
Q103	晶体管	电压放电开关
Q200	晶体管	宽 / 窄开关
Q201	晶体管	倍频器
Q202	晶体管	IF 放大器
Q203	场效应管	混频器
Q204	场效应管	高频放大器
Q300, 301	晶体管	直流开关
Q302	场效应管	静音开关
Q303	场效应管	直流开关
Q304	晶体管	直流开关
Q305	晶体管	宽 / 窄开关
Q306	场效应管	静音开关
Q400	晶体管	开关
Q401, 402	晶体管	直流开关
Q500, 501	场效应管	直流开关
Q502	晶体管	直流开关
D1	二极管	整流
D2, 3	可变电容二极管	频率控制 /VCO
D4	二极管	收发开关
D5	可变电容二极管	频率控制 /VCO
D6	可变电容二极管	调制器 /TX VCO
D7	二极管	纹波滤波器
D8	二极管	整流
D100	二极管	收发开关
D101 ~ 103	二极管	天线开关
D105	二极管	天线开关
D200	二极管	收发开关
D201, 202	可变电容二极管	RX BPF 调谐
D204	可变电容二极管	RX BPF 调谐
D260, 261	可变电容二极管	RX BPF 调谐
D301	二极管	整流
D400	LED	LED/ 绿色
D401	LED	LED/ 红色
D402	二极管	VCO 加速
D500	二极管	保护
D501	二极管	整流

## PARTS LIST / 零件表

\* New Parts.  $\Delta$  indicates safety critical components.  
 Parts without **Parts No.** are not supplied.  
 \* 新零件。  $\Delta$  代表对安全至关重要的零件。  
 我们不会提供没有零件号的零件。

L : Scandinavia      K : USA      P : Canada  
 Y : PX (Far East, Hawaii)      T : England      E : Europe  
 C : China      X : Australia      M : Other Areas

TK-3000  
 TX-RX UNIT (X57-8100-23)

Ref. No.	Address	New parts	Parts No.	Description	Desti-nation	Ref. No.	Address	New parts	Parts No.	Description	Desti-nation
<b>TK-3000</b>						<b>TX-RX UNIT (X57-8100-23)</b>					
1	1A		A02-4135-03	PLASTIC CABINET ASSY		D400			B30-1782-05	LED(GREEN)	
2	3A		A10-4150-21	CHASSIS		D401			B30-1779-05	LED(RED)	
3	3B		A82-0081-02	REAR PANEL		C1			CS77CA1ER47M	CHIP TNTL 0.47UF 25WV	
4	2B		B11-1892-03	ILLUMINATION GUIDE		C2			CK73HB1H102K	CHIP C 1000PF K	
6	3B		E04-0486-05	RF COAXIAL RECEPTACLE(SMA)		C3			CK73HB1A104K	CHIP C 0.10UF K	
7	2A		E23-1364-04	TERMINAL		C4			CS77CA1C100M	CHIP TNTL 10UF 16WV	
8	1B		E37-1539-05	PROCESSED LEAD WIRE(SP- BRN)		C5			CS77CA1E010M	CHIP TNTL 1.0UF 25WV	
9	1B		E37-1540-05	PROCESSED LEAD WIRE(SP+ GRN)		C7			CC73HCH1H220G	CHIP C 22PF G	
10	2A		E72-0436-03	TERMINAL BLOCK		C8			CK73HB1A104K	CHIP C 0.10UF K	
11	3B		G01-4571-04	COIL SPRING		C9			CC73HCH1H030B	CHIP C 3.0PF B	
			G10-1828-04	FIBROUS SHEET(SP)		C10,11			CK73HB1A105K	CHIP C 1.0UF K	
13	2A		G11-4437-04	SHEET(Q102-CHASSIS)		C12			CC73HCH1H680G	CHIP C 68PF G	
14	3A		G13-2364-14	CUSHION(CHASSIS)		C13			CS77CP0J010M	CHIP TNTL 1.0UF 6.3WV	
15	3B		G13-2348-14	CUSHION(BATT-TERMINAL)		C14,15			CK73HB1C103K	CHIP C 0.010UF K	
16	2A	*	G53-1867-13	PACKING(CHASSIS)		C16			CK73HB1H102K	CHIP C 1000PF K	
18	1B	*	G53-1868-12	PACKING(TOP)		C17			CC73HCH1H040B	CHIP C 4.0PF B	
19	3B	*	G53-1869-13	PACKING(JACK)		C19			CK73HB1H102K	CHIP C 1000PF K	
20	1A	*	G53-1871-14	PACKING(MIC)		C20			CS77CA1A220M	CHIP TNTL 22UF 10WV	
22	1B		K29-9487-03	KNOB(VOL)		C21,22			CC73GCH1HR75B	CHIP C 0.75PF B	
23	1B		K29-9488-03	KNOB(SELECTOR)		C23,24			CK73HB1H102K	CHIP C 1000PF K	
24	1A	*	K29-9489-13	KNOB(PTT)		C25			CC73HCH1H050B	CHIP C 5.0PF B	
25	1A	*	K29-9490-13	BUTTON KNOB(SIDE)		C26			CK73HB1H102K	CHIP C 1000PF K	
26	3B		K29-9491-03	LEVER KNOB(BATTERY)		C27			CC73HCH1H220J	CHIP C 22PF J	
A	2B		N09-2438-05	BINDING HEAD SCREW		C28			CK73HB1H102K	CHIP C 1000PF K	
B	3A		N30-2606-48	PAN HEAD MACHINE SCREW		C29			CC73GCH1H0R5B	CHIP C 0.5PF B	
C	1A,2A		N83-2005-48	PAN HEAD TAPTITE SCREW		C30			CK73HB1H102K	CHIP C 1000PF K	
28	1B		T07-0787-05	SPEAKER		C31			CK73HB1C103K	CHIP C 0.010UF K	
				<b>ACCESSORIES / 随机附件</b>		C32			CK73HB1H102K	CHIP C 1000PF K	
			B09-0744-03	CAP(SP/MIC) ACCESSORY		C33			CC73HCH1H330J	CHIP C 33PF J	
			B62-2309-00	INSTRUCTION MANUAL ACCESSORY		C34			CK73HB1H102K	CHIP C 1000PF K	
			J29-0751-05	BELT CLIP ACCESSORY		C35			CC73HCH1H060B	CHIP C 6.0PF B	
			N35-3005-43	BINDING HEAD SCREW ACCESSORY		C36			CC73HCH1H040B	CHIP C 4.0PF B	
			T90-1098-05	HELICAL ANTENNA ACCESSORY		C37			CC73HCH1H060B	CHIP C 6.0PF B	
			W08-1245-05	AC ADAPTER ACCESSORY		C38			CC73GCH1H220J	CHIP C 22PF J	
			W08-1248-15	CHARGER ACCESSORY		C39			CC73HCH1H150G	CHIP C 15PF G	
			W09-1071-15	BATTERY ASSY ACCESSORY		C40,41			CK73HB1H102K	CHIP C 1000PF K	
						C42			CC73HCH1H040B	CHIP C 4.0PF B	
		*	X57-8100-24	TX-RX UNIT (FOR SERVICE)		C43			CK73HB1H102K	CHIP C 1000PF K	
						C54			CC73HCH1H040B	CHIP C 4.0PF B	
						C100			CC73HCH1H100B	CHIP C 10PF B	
						C101			CC73HCH1H271J	CHIP C 270PF J	
						C102			CC73HCH1H220J	CHIP C 22PF J	
						C103,104			CC73HCH1H271J	CHIP C 270PF J	
						C105			CK73HB1A104K	CHIP C 0.10UF K	
						C107			CC73HCH1H271J	CHIP C 270PF J	
						C108			CC73HCH1H120J	CHIP C 12PF J	
						C109			CC73HCH1H090B	CHIP C 9.0PF B	
						C110,111			CC73HCH1H271J	CHIP C 270PF J	
						C112			CC73HCH1H221J	CHIP C 220PF J	
						C113,114			CC73HCH1H271J	CHIP C 270PF J	
						C116			CK73HB1C103K	CHIP C 0.010UF K	
						C117			CK73FB1A225K	CHIP C 2.2UF K	
						C119,120			CC73HCH1H271J	CHIP C 270PF J	

## PARTS LIST / 零件表

TX-RX UNIT (X57-8100-23)

Ref. No.	Address	New parts	Parts No.	Description	Destination	Ref. No.	Address	New parts	Parts No.	Description	Destination
C124			CC73HCH1H271J	CHIP C 270PF J		C240-242			CK73HB1H471K	CHIP C 470PF K	
C127			CC73GCH1H181J	CHIP C 180PF J		C243			CK73HB1A104K	CHIP C 0.10UF K	
C128			CC73GCH1H0R5B	CHIP C 0.5PF B		C244			CK73HB1H471K	CHIP C 470PF K	
C129			CC73HCH1H271J	CHIP C 270PF J		C245			CC73HCH1H020B	CHIP C 2.0PF B	
C130			CC73GCH1H090B	CHIP C 9.0PF B		C247			CC73HCH1HR75B	CHIP C 0.75PF B	
C131			CC73GCH1H820J	CHIP C 82PF J		C248			CK73HB1A104K	CHIP C 0.10UF K	
C132			CC73GCH1H060B	CHIP C 6.0PF B		C250			CK73HB1H471K	CHIP C 470PF K	
C133			CC73HCH1H070B	CHIP C 7.0PF B		C252			CC73HCH1H010B	CHIP C 1.0PF B	
C134			CC73HCH1H271J	CHIP C 270PF J		C253			CC73HCH1H100B	CHIP C 10PF B	
C135			CC73GCH1H030B	CHIP C 3.0PF B		C254			CC73HCH1H1R5B	CHIP C 1.5PF B	
C136			CC73GCH1H150J	CHIP C 15PF J		C255			CK73HB1A104K	CHIP C 0.10UF K	
C137			CC73GCH1H3R5B	CHIP C 3.5PF B		C256			CK73HB1H471K	CHIP C 470PF K	
C138			CC73GCH1H090B	CHIP C 9.0PF B		C257			CC73HCH1H030B	CHIP C 3.0PF B	
C139			CK73FB1A475K	CHIP C 4.7UF K		C258			CK73HB1H102K	CHIP C 1000PF K	
C145			CC73HCH1H271J	CHIP C 270PF J		C259			CK73HB1C103K	CHIP C 0.010UF K	
C146			CC73HCH1H1R5B	CHIP C 1.5PF B		C262			CK73HB1H471K	CHIP C 470PF K	
C150			CC73HCH1H020C	CHIP C 2.0PF C		C263			CC73HCH1H180J	CHIP C 18PF J	
C153			CC73HCH1H390J	CHIP C 39PF J		C268,269			CC73HCH1H100B	CHIP C 10PF B	
C158,159			CC73HCH1H271J	CHIP C 270PF J		C270			CC73HCH1H1R5B	CHIP C 1.5PF B	
C173			CC73GCH1H560J	CHIP C 56PF J		C271			CC73HCH1H020B	CHIP C 2.0PF B	
C174			CC73GCH1H120J	CHIP C 12PF J		C274			CK73HB1H471K	CHIP C 470PF K	
C175			CC73GCH1H330J	CHIP C 33PF J		C275			CK73HB1C103K	CHIP C 0.010UF K	
C179			CC73GCH1H220J	CHIP C 22PF J		C276			CK73HB1H471K	CHIP C 470PF K	
C182			CC73GCH1H220J	CHIP C 22PF J		C277			CK73HB1A104K	CHIP C 0.10UF K	
C183			CC73GCH1H150J	CHIP C 15PF J		C300,301			CK73HB1H102K	CHIP C 1000PF K	
C185			CC73GCH1H120J	CHIP C 12PF J		C302			C92-0953-05	ELECTRO 100UF 6.3WV	
C187			CC73GCH1H090B	CHIP C 9.0PF B		C303			CK73HB1C473K	CHIP C 0.047UF K	
C200			CK73FB1A106K	CHIP C 10UF K		C304			CK73FB1A106K	CHIP C 10UF K	
C201			CK73HB1H102K	CHIP C 1000PF K		C305			CK73HB1C103K	CHIP C 0.010UF K	
C202			CK73HB1C103K	CHIP C 0.010UF K		C306			CK73HB1A224K	CHIP C 0.22UF K	
C203			CC73HCH1H101J	CHIP C 100PF J		C308			CK73GB1E105K	CHIP C 1.0UF K	
C204			CK73HB1E223K	CHIP C 0.022UF K		C309			CK73HB1A104K	CHIP C 0.10UF K	
C205			CK73HB1A104K	CHIP C 0.10UF K		C310			CK73HB1C473K	CHIP C 0.047UF K	
C206,207			CC73HCH1H221J	CHIP C 220PF J		C311			CK73HB1A105K	CHIP C 1.0UF K	
C208			CK73HB1A104K	CHIP C 0.10UF K		C312			CK73HB1C473K	CHIP C 0.047UF K	
C209			CC73HCH1H220J	CHIP C 22PF J		C313			CK73HB1A104K	CHIP C 0.10UF K	
C210			CK73HB1A104K	CHIP C 0.10UF K		C314			CC73HCH1H101J	CHIP C 100PF J	
C211			CK73HB1C333K	CHIP C 0.033UF K		C315			CK73FB1A106K	CHIP C 10UF K	
C212,213			CK73HB1A104K	CHIP C 0.10UF K		C316			CK73HB1A104K	CHIP C 0.10UF K	
C214			CK73HB1C103K	CHIP C 0.010UF K		C317			CK73HB1C103K	CHIP C 0.010UF K	
C215			CC73HCH1H220J	CHIP C 22PF J		C318			CC73HCH1H221J	CHIP C 220PF J	
C216			CK73HB1C103K	CHIP C 0.010UF K		C319			CK73HB1C103K	CHIP C 0.010UF K	
C217			CC73HCH1H050C	CHIP C 5.0PF C		C320			CK73GB1E104K	CHIP C 0.10UF K	
C218			CK73HB1C103K	CHIP C 0.010UF K		C321			CK73HB1C103K	CHIP C 0.010UF K	
C219			CC73HCH1H220J	CHIP C 22PF J		C322			CC73HCH1H271J	CHIP C 270PF J	
C220			CK73HB1H102K	CHIP C 1000PF K		C323			CK73HB1A104K	CHIP C 0.10UF K	
C221			CK73HB1C103K	CHIP C 0.010UF K		C324			CK73HB1A184K	CHIP C 0.18UF K	
C222			CC73HCH1H080D	CHIP C 8.0PF D		C326			CK73HB1H822K	CHIP C 8200PF K	
C223			CC73HCH1H080B	CHIP C 8.0PF B		C328			CK73HB1A394K	CHIP C 0.39UF K	
C224			CK73HB1C103K	CHIP C 0.010UF K		C329			CK73HB1C333K	CHIP C 0.033UF K	
C225			CC73HCH1H050B	CHIP C 5.0PF B		C330			CK73HB1H561K	CHIP C 560PF K	
C226			CK73HB1H471K	CHIP C 470PF K		C332			CK73HB1C103K	CHIP C 0.010UF K	
C227			CK73HB1C103K	CHIP C 0.010UF K		C333			CK73HB1H102K	CHIP C 1000PF K	
C228			CC73HCH1H030B	CHIP C 3.0PF B		C334,335			CK73HB1A184K	CHIP C 0.18UF K	
C230			CC73HCH1H050B	CHIP C 5.0PF B		C336			CK73HB1C103K	CHIP C 0.010UF K	
C233			CC73HCH1H040B	CHIP C 4.0PF B		C337			CK73HB1A184K	CHIP C 0.18UF K	
C236			CC73HCH1H100B	CHIP C 10PF B		C338			CC73HCH1H331J	CHIP C 330PF J	
C237			CC73HCH1H120J	CHIP C 12PF J		C339			CK73HB1A104K	CHIP C 0.10UF K	
C238			CC73HCH1H040B	CHIP C 4.0PF B		C340			CC73HCH1H100B	CHIP C 10PF B	
C239			CC73HCH1HR75B	CHIP C 0.75PF B		C341			CK73HB1H222K	CHIP C 2200PF K	

## PARTS LIST / 零件表

TX-RX UNIT (X57-8100-23)

Ref. No.	Address	New parts	Parts No.	Description	Desti-nation	Ref. No.	Address	New parts	Parts No.	Description	Desti-nation
C342			CK73HB1C103K	CHIP C 0.010UF K		L101			L40-3375-71	SMALL FIXED INDUCTOR(33NH)	
C343			CK73HB1A184K	CHIP C 0.18UF K		L102			L40-1275-71	SMALL FIXED INDUCTOR(12NH)	
C344			CK73HB1C273K	CHIP C 0.027UF K		L103			L41-3375-53	SMALL FIXED INDUCTOR(33NH)	
C345			CK73HB1H102K	CHIP C 1000PF K		L104			L34-4572-05	AIR-CORE COIL	
C346			CK73HB1A184K	CHIP C 0.18UF K		L108			L34-4571-05	AIR-CORE COIL	
C347			CK73GB1A105K	CHIP C 1.0UF K		L109			L41-2285-43	SMALL FIXED INDUCTOR(220NH)	
C349			CK73HB1C333K	CHIP C 0.033UF K		L110			L34-4573-05	AIR-CORE COIL	
C350			CK73HB1H102K	CHIP C 1000PF K		L111,112			L34-4572-05	AIR-CORE COIL	
C352			CK73HB1H102K	CHIP C 1000PF K		L113			L41-1575-53	SMALL FIXED INDUCTOR(15NH)	
C353			CK73GB1E105K	CHIP C 1.0UF K		L204			L41-5685-39	SMALL FIXED INDUCTOR(0.56UH)	
C354			CK73HB1A224K	CHIP C 0.22UF K		L205			L40-1875-71	SMALL FIXED INDUCTOR(18NH)	
C355			CK73HB1A105K	CHIP C 1.0UF K		L208			L41-1578-14	SMALL FIXED INDUCTOR(15NH)	
C357,358			CK73HB1A104K	CHIP C 0.10UF K		L210			L41-1578-14	SMALL FIXED INDUCTOR(15NH)	
C360			CK73HB1A104K	CHIP C 0.10UF K		L211			L40-5681-86	SMALL FIXED INDUCTOR(0.56UH)	
C397			CC73HCH1H271J	CHIP C 270PF J		L212			L40-8281-86	SMALL FIXED INDUCTOR(0.82UH)	
C400			CK73HB1A104K	CHIP C 0.10UF K		L213			L40-5681-86	SMALL FIXED INDUCTOR(0.56UH)	
C401			CK73HB1H102K	CHIP C 1000PF K		L214			L40-3975-71	SMALL FIXED INDUCTOR(39NH)	
C402			CC73HCH1H120J	CHIP C 12PF J		L215			L41-1578-14	SMALL FIXED INDUCTOR(15NH)	
C403			CC73HCH1H010B	CHIP C 1.0PF B		L216			L40-1885-92	SMALL FIXED INDUCTOR(180NH)	
C404			CK73HB1A104K	CHIP C 0.10UF K		L217			L41-2785-45	SMALL FIXED INDUCTOR(270NH)	
C405			CK73HB1H102K	CHIP C 1000PF K		L218,219			L41-1578-14	SMALL FIXED INDUCTOR(15NH)	
C406			CC73HCH1H120J	CHIP C 12PF J		X1			L77-3074-05	TCXO(19.2MHZ)	
C407			CK73HB1H102K	CHIP C 1000PF K		X400			L77-2974-05	CRYSTAL RESONATOR(11.0592MHZ)	
C408			CK73HB1C103K	CHIP C 0.010UF K		XF200			L71-0669-05	MCF(38.85MHZ)	
C409			CK73HB1H102K	CHIP C 1000PF K		R1			RK73HB1J105J	CHIP R 1.0M J 1/16W	
C411-415			CK73HB1H102K	CHIP C 1000PF K		R2			RK73HB1J103J	CHIP R 10K J 1/16W	
C500			CC73HCH1H101J	CHIP C 100PF J		R3			RK73HB1J222J	CHIP R 2.2K J 1/16W	
C501,502			CK73HB1H102K	CHIP C 1000PF K		R5			RK73HB1J821J	CHIP R 820 J 1/16W	
C503			CK73FB1A475K	CHIP C 4.7UF K		R7			RK73HB1J272J	CHIP R 2.7K J 1/16W	
C504			CK73HB1H102K	CHIP C 1000PF K		R9			RK73HB1J103J	CHIP R 10K J 1/16W	
C505			CK73GB1E105K	CHIP C 1.0UF K		R11			RK73HB1J104J	CHIP R 100K J 1/16W	
C506			CK73HB1H102K	CHIP C 1000PF K		R12			RK73HB1J272J	CHIP R 2.7K J 1/16W	
C507			CK73FB1A106K	CHIP C 10UF K		R13			RK73HB1J104J	CHIP R 100K J 1/16W	
C511			CK73HB1H102K	CHIP C 1000PF K		R14			RK73HB1J103J	CHIP R 10K J 1/16W	
C513,514			CK73GB1E105K	CHIP C 1.0UF K		R15			RK73HB1J104J	CHIP R 100K J 1/16W	
C515,516			CC73HCH1H271J	CHIP C 270PF J		R16, 17			RK73HB1J103J	CHIP R 10K J 1/16W	
C517			CK73FB1A475K	CHIP C 4.7UF K		R18			RK73HB1J223J	CHIP R 22K J 1/16W	
C522-524			CC73HCH1H271J	CHIP C 270PF J		R19-22			RK73HB1J103J	CHIP R 10K J 1/16W	
C525			CK73HB1H102K	CHIP C 1000PF K		R25			RK73HB1J100J	CHIP R 10 J 1/16W	
CN103			E23-1167-05	TERMINAL		R26			RK73HB1J392J	CHIP R 3.9K J 1/16W	
J300	2B		E11-0484-05	3.5D PHONE JACK(MIC)		R27			RK73HB1J221J	CHIP R 220 J 1/16W	
J301	2B		E11-0717-05	2.5D PHONE JACK(SP)		R28			RK73HB1J680J	CHIP R 68 J 1/16W	
F101			F53-0287-05	FUSE(0.5A)		R29			RK73HB1J472J	CHIP R 4.7K J 1/16W	
F300			F53-0467-05	FUSE(0.315A)		R30			RK73HB1J470J	CHIP R 47 J 1/16W	
F500			F53-0372-05	FUSE(3.15A)		R32			RK73HB1J102J	CHIP R 1.0K J 1/16W	
101	2A		J30-1308-04	SPACER(MIC300)		R33			RK73HB1J473J	CHIP R 47K J 1/16W	
CF200	2A		L72-1046-05	CERAMIC FILTER(450KHZ)		R34			RK73HB1J100J	CHIP R 10 J 1/16W	
CD200	2A		L79-1914-05	CERAMIC DISCRIMINATOR		R37			RK73HB1J562J	CHIP R 5.6K J 1/16W	
L1			L40-2785-92	SMALL FIXED INDUCTOR(270NH)		R38			RK73HB1J332J	CHIP R 3.3K J 1/16W	
L2			L41-1078-14	SMALL FIXED INDUCTOR(10NH)		R39			RK73HB1J271J	CHIP R 270 J 1/16W	
L3			L41-2778-14	SMALL FIXED INDUCTOR(27NH)		R40			RK73HB1J102J	CHIP R 1.0K J 1/16W	
L4 -6			L40-2785-92	SMALL FIXED INDUCTOR(270NH)		R41			RK73HB1J100J	CHIP R 10 J 1/16W	
L7			L40-2775-71	SMALL FIXED INDUCTOR(27NH)		R42			RK73HB1J332J	CHIP R 3.3K J 1/16W	
L8			L40-1575-71	SMALL FIXED INDUCTOR(15NH)		R43			RK73HB1J103J	CHIP R 10K J 1/16W	
L9			L40-4775-71	SMALL FIXED INDUCTOR(47NH)		R45			RK73HB1J000J	CHIP R 0 J 1/16W	
L10			L40-2785-92	SMALL FIXED INDUCTOR(270NH)		R50			RK73HB1J104J	CHIP R 100K J 1/16W	
L12			L40-2785-92	SMALL FIXED INDUCTOR(270NH)		R51			RK73HB1J333J	CHIP R 33K J 1/16W	
L100			L40-1575-71	SMALL FIXED INDUCTOR(15NH)		R100			RK73HB1J472J	CHIP R 4.7K J 1/16W	
						R101			RK73HB1J102J	CHIP R 1.0K J 1/16W	

If a part reference number is listed in a shaded box, that part does not come with the PCB.

维修部件的 PCB 板里不含阴影显示文字的零件。

## PARTS LIST / 零件表

## TX-RX UNIT (X57-8100-23)

Ref. No.	Address	New parts	Parts No.	Description	Destination	Ref. No.	Address	New parts	Parts No.	Description	Destination
R102			RK73HB1J222J	CHIP R 2.2K J 1/16W		R305-308			RK73HB1J102J	CHIP R 1.0K J 1/16W	
R103			RK73HB1J150J	CHIP R 15 J 1/16W		R309			RK73HB1J182J	CHIP R 1.8K J 1/16W	
R104			RK73HB1J222J	CHIP R 2.2K J 1/16W		R310,311			RK73HB1J102J	CHIP R 1.0K J 1/16W	
R105			RK73HB1J100J	CHIP R 10 J 1/16W		R312,313			RK73HB1J222J	CHIP R 2.2K J 1/16W	
R106			RK73HB1J473J	CHIP R 47K J 1/16W		R314			RK73HB1J392J	CHIP R 3.9K J 1/16W	
R107			RK73HB1J270J	CHIP R 27 J 1/16W		R315			RK73HB1J103J	CHIP R 10K J 1/16W	
R108			RK73HB1J683J	CHIP R 68K J 1/16W		R316			RK73HB1J000J	CHIP R 0 J 1/16W	
R109			RK73HB1J470J	CHIP R 47 J 1/16W		R317			RK73HB1J334J	CHIP R 330K J 1/16W	
R111			RK73HB1J683J	CHIP R 68K J 1/16W		R318			RK73HB1J274J	CHIP R 270K J 1/16W	
R112			RK73HB1J390J	CHIP R 39 J 1/16W		R321			RK73HB1J474J	CHIP R 470K J 1/16W	
R113			RK73HB1J473J	CHIP R 47K J 1/16W		R322			RK73HB1J105J	CHIP R 1.0M J 1/16W	
R114			RK73GB2A000J	CHIP R 0 J 1/10W		R323			RK73HB1J562J	CHIP R 5.6K J 1/16W	
R115			RK73FB2B000J	CHIP R 0 J 1/8W		R324,325			RK73HH1J473D	CHIP R 47K D 1/16W	
R116			RK73HB1J393J	CHIP R 39K J 1/16W		R326			RK73HB1J000J	CHIP R 0 J 1/16W	
R117			RK73HB1J271J	CHIP R 270 J 1/16W		R327			RK73HB1J824J	CHIP R 820K J 1/16W	
R119			RK73HB1J271J	CHIP R 270 J 1/16W		R328			RK73HB1J684J	CHIP R 680K J 1/16W	
R120			RK73HB1J331J	CHIP R 330 J 1/16W		R329,330			RK73HB1J103J	CHIP R 10K J 1/16W	
R121-123			RK73EB2ER39K	CHIP R 0.39 K 1/4W		R332			RK73HB1J272J	CHIP R 2.7K J 1/16W	
R136			RK73HB1J182J	CHIP R 1.8K J 1/16W		R334			RK73HB1J103J	CHIP R 10K J 1/16W	
R155			RK73HB1J150J	CHIP R 15 J 1/16W		R335			RK73HB1J000J	CHIP R 0 J 1/16W	
R156,157			RK73HB1J000J	CHIP R 0 J 1/16W		R336			RK73HB1J823J	CHIP R 82K J 1/16W	
R200			RK73HB1J103J	CHIP R 10K J 1/16W		R337			RK73HB1J000J	CHIP R 0 J 1/16W	
R201			RK73HB1J470J	CHIP R 47 J 1/16W		R340			RK73HB1J103J	CHIP R 10K J 1/16W	
R202			RK73HB1J272J	CHIP R 2.7K J 1/16W		R342			RK73HB1J153J	CHIP R 15K J 1/16W	
R203			RK73HB1J393J	CHIP R 39K J 1/16W		R344			RK73HB1J103J	CHIP R 10K J 1/16W	
R204			RK73HB1J271J	CHIP R 270 J 1/16W		R345			RK73HB1J000J	CHIP R 0 J 1/16W	
R205			RK73HB1J682J	CHIP R 6.8K J 1/16W		R347			RK73HB1J103J	CHIP R 10K J 1/16W	
R206			RK73HB1J274J	CHIP R 270K J 1/16W		R348			RK73HB1J563J	CHIP R 56K J 1/16W	
R207			RK73HB1J562J	CHIP R 5.6K J 1/16W		R350			RK73HB1J471J	CHIP R 470 J 1/16W	
R208			RK73HB1J101J	CHIP R 100 J 1/16W		R351			RK73HB1J181J	CHIP R 180 J 1/16W	
R209			RK73HB1J470J	CHIP R 47 J 1/16W		R352			RK73HB1J104J	CHIP R 100K J 1/16W	
R210			RK73HB1J334J	CHIP R 330K J 1/16W		R353			RK73HB1J102J	CHIP R 1.0K J 1/16W	
R212			RK73HB1J184J	CHIP R 180K J 1/16W		R354			RK73HB1J334J	CHIP R 330K J 1/16W	
R213			RK73HB1J222J	CHIP R 2.2K J 1/16W		R355			RK73HB1J473J	CHIP R 47K J 1/16W	
R214			RK73HB1J561J	CHIP R 560 J 1/16W		R356			RK73HB1J183J	CHIP R 18K J 1/16W	
R215			RK73HB1J331J	CHIP R 330 J 1/16W		R357			RK73HB1J564J	CHIP R 560K J 1/16W	
R217			RK73HB1J222J	CHIP R 2.2K J 1/16W		R358			RK73HB1J473J	CHIP R 47K J 1/16W	
R218			RK73HB1J102J	CHIP R 1.0K J 1/16W		R360			RK73HB1J184J	CHIP R 180K J 1/16W	
R220			RK73HB1J104J	CHIP R 100K J 1/16W		R361			RK73HB1J821J	CHIP R 820 J 1/16W	
R221			RK73HB1J823J	CHIP R 82K J 1/16W		R363			RK73HB1J562J	CHIP R 5.6K J 1/16W	
R222			RK73HB1J104J	CHIP R 100K J 1/16W		R364			RK73HB1J471J	CHIP R 470 J 1/16W	
R223			RK73HB1J000J	CHIP R 0 J 1/16W		R365			RK73HB1J000J	CHIP R 0 J 1/16W	
R224			RK73HB1J563J	CHIP R 56K J 1/16W		R366			RK73HB1J104J	CHIP R 100K J 1/16W	
R226,227			RK73HB1J474J	CHIP R 470K J 1/16W		R367			RK73HB1J473J	CHIP R 47K J 1/16W	
R229			RK73HB1J474J	CHIP R 470K J 1/16W		R369			RK73HB1J103J	CHIP R 10K J 1/16W	
R230			RK73HB1J820J	CHIP R 82 J 1/16W		R370			RK73HH1J473D	CHIP R 47K D 1/16W	
R231			RK73HB1J271J	CHIP R 270 J 1/16W		R371			RK73HB1J472J	CHIP R 4.7K J 1/16W	
R232,233			RK73HB1J104J	CHIP R 100K J 1/16W		R372			RK73HH1J473D	CHIP R 47K D 1/16W	
R237,238			RK73HB1J474J	CHIP R 470K J 1/16W		R373			RK73HB1J000J	CHIP R 0 J 1/16W	
R239			RK73HB1J151J	CHIP R 150 J 1/16W		R374			RK73HH1J473D	CHIP R 47K D 1/16W	
R240			RK73HB1J683J	CHIP R 68K J 1/16W		R375			RK73HB1J103J	CHIP R 10K J 1/16W	
R241,242			RK73HB1J470J	CHIP R 47 J 1/16W		R376			RK73HH1J473D	CHIP R 47K D 1/16W	
R243,244			RK73HB1J000J	CHIP R 0 J 1/16W		R377			RK73HB1J393J	CHIP R 39K J 1/16W	
R258			RK73HB1J181J	CHIP R 180 J 1/16W		R378			RK73HB1J102J	CHIP R 1.0K J 1/16W	
R267			RK73HB1J000J	CHIP R 0 J 1/16W		R379			RK73HB1J104J	CHIP R 100K J 1/16W	
R300			RK73HB1J152J	CHIP R 1.5K J 1/16W		R386			RK73HB1J392J	CHIP R 3.9K J 1/16W	
R301			RK73HB1J101J	CHIP R 100 J 1/16W		R388			RK73HB1J472J	CHIP R 4.7K J 1/16W	
R302			RK73HB1J102J	CHIP R 1.0K J 1/16W		R389			RK73HB1J102J	CHIP R 1.0K J 1/16W	
R303			RK73HB1J471J	CHIP R 470 J 1/16W		R390			RK73HB1J000J	CHIP R 0 J 1/16W	
R304			RK73HB1J473J	CHIP R 47K J 1/16W		R392,393			RK73HB1J102J	CHIP R 1.0K J 1/16W	

## PARTS LIST / 零件表

TX-RX UNIT (X57-8100-23)

Ref. No.	Address	New parts	Parts No.	Description	Destination	Ref. No.	Address	New parts	Parts No.	Description	Destination
R400			RK73HB1J472J	CHIP R 4.7K J 1/16W		Q102			RD07MUS2BT112	FET	
R401			RK73HB1J102J	CHIP R 1.0K J 1/16W		Q103			RT1N141U-T111	TRANSISTOR	
R406			RK73HB1J101J	CHIP R 100 J 1/16W		Q200			RT1P237U-T111	TRANSISTOR	
R407			RK73HB1J473J	CHIP R 47K J 1/16W		Q201,202			KTC4080E-P	TRANSISTOR	
R408			RK73HB1J101J	CHIP R 100 J 1/16W		Q203,204			3SK318	FET	
R409,410			RK73GB2A221J	CHIP R 220 J 1/10W		Q300,301			RT1N441U-T111	TRANSISTOR	
R411,412			RK73HB1J472J	CHIP R 4.7K J 1/16W		Q302			2SK3577-A	FET	
R413			RK73HB1J102J	CHIP R 1.0K J 1/16W		Q303			SSM6J08FU(F)	FET	
R414			RK73HB1J474J	CHIP R 470K J 1/16W		Q304			RT1P237U-T111	TRANSISTOR	
R438			RK73HB1J473J	CHIP R 47K J 1/16W		Q305			RT1N144U-T111	TRANSISTOR	
R455			RK73HB1J102J	CHIP R 1.0K J 1/16W		Q306			2SK3577-A	FET	
R470			RK73HB1J103J	CHIP R 10K J 1/16W		Q400			2SC4919-S	TRANSISTOR	
R473			RK73HB1J000J	CHIP R 0 J 1/16W		Q401,402			RT1N144U-T111	TRANSISTOR	
R502			RK73HB1J334J	CHIP R 330K J 1/16W		Q500,501			SSM3J05FU-F	FET	
R505			RK73HB1J473J	CHIP R 47K J 1/16W		Q502			RT1P237U-T111	TRANSISTOR	
R508			RK73HB1J473J	CHIP R 47K J 1/16W		Q401,402			RT1N144U-T111	TRANSISTOR	
R509			RK73HB1J104J	CHIP R 100K J 1/16W		Q500,501			SSM3J05FU-F	FET	
R511			RK73HB1J334J	CHIP R 330K J 1/16W		Q502			RT1P237U-T111	TRANSISTOR	
V/R500	2B		R31-0684-05	VARIABLE RESISTOR		TH100			B57331V2104J	THERMISTOR	
S400	2B		S70-0414-05	TACT SWITCH(PTT)							
S401			S70-0514-05	TACT SWITCH							
S402	2B		S60-0447-05	ROTARY SWITCH(SELECTOR)							
MIC300	2A		T91-0674-05	MIC ELEMENT							
D1			DA2S101	DIODE							
D2 ,3			1SV325F	VARIABLE CAPACITANCE DIODE							
D4			HSC277	DIODE							
D5 ,6			HVC350B	VARIABLE CAPACITANCE DIODE							
D7 ,8			DA2S101	DIODE							
D100			HSC277	DIODE							
D101-103			HVC131	DIODE							
D105			HVC131	DIODE							
D200			HSC277	DIODE							
D201,202			HVC350B	VARIABLE CAPACITANCE DIODE							
D204			HVC350B	VARIABLE CAPACITANCE DIODE							
D260,261			HVC350B	VARIABLE CAPACITANCE DIODE							
D301			KDR731	DIODE							
D402			DA2S101	DIODE							
D500			GN1G	DIODE							
D501			RB521S-30	DIODE							
IC1			MB15E03SL-E1	MOS-IC							
IC200			NJM2591V	BI-POLAR IC							
IC300			R2A20178NP	DAC IC							
IC301			NJM12904RB1	MOS-IC							
IC302			TA7368PL	MOS-IC							
IC303-305			NJM12904RB1	MOS-IC							
IC400			F2136ACNKDRB	MCU							
IC401			EX24016ATAS0A	ROM IC							
IC500			XC6120N302N-G	MOS-IC							
IC501			XC6209B502P-G	MOS-IC							
IC503			XC6209B502P-G	MOS-IC							
Q1 ,2			RT1N141U-T111	TRANSISTOR							
Q3			2SC5383-T111	TRANSISTOR							
Q4			MCH3914(7)-H	FET							
Q5			2SC5108(Y)F	TRANSISTOR							
Q6			2SC5636	TRANSISTOR							
Q7			2SC5383-T111	TRANSISTOR							
Q100			2SC4926YD	TRANSISTOR							
Q101			RFM01U7P	FET							

If a part reference number is listed in a shaded box, that part does not come with the PCB.

维修部件的 PCB 板里不含阴影显示文字的零件。

# TK-3000

## EXPLODED VIEW / 部件分解图

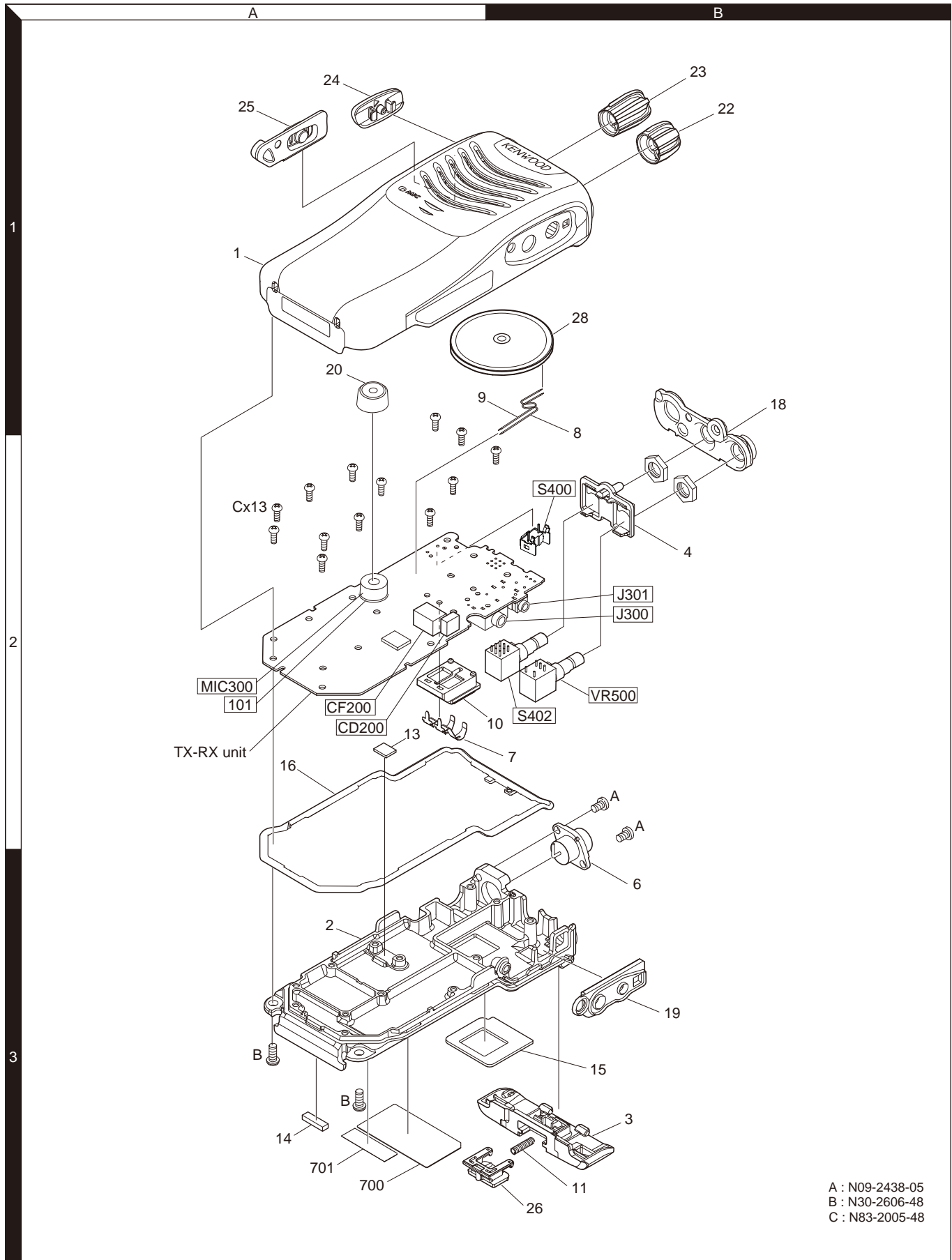

Parts with the exploded numbers larger than 700 are not supplied. / 编号大于 700 的零件未提供分解图。  
 If a part reference number is listed in a box on the exploded view of the PCB, that part does not come with the PCB.  
 These parts must be ordered separately. / 维修部件的 PCB 板里不含方里的文字所表示的零件。这些零件必需另外购买。



## ADJUSTMENT

### Test Equipment Required for Alignment

Test Equipment	Major Specifications	
1. Standard Signal Generator (SSG)	Frequency Range Modulation Output	350 to 390MHz Frequency modulation and external modulation -127dBm/0.1μV to greater than -47dBm/1mV
2. RF Power Meter	Input Impedance Operation Frequency Measurement Range	50Ω 350 to 390MHz Vicinity of 10W
3. Deviation Meter	Frequency Range	350 to 390MHz
4. Digital Volt Meter (DVM)	Measuring Range Input Impedance	10mV to 10V DC High input impedance for minimum circuit loading
5. Oscilloscope		DC through 30MHz
6. High Sensitivity Frequency Counter	Frequency Range Frequency Stability	10Hz to 1000MHz 0.2ppm or less
7. DC Ammeter		5A
8. AF Volt Meter (AF VM)	Frequency Range Voltage Range	50Hz to 10kHz 1mV to 10V
9. Audio Generator (AG)	Frequency Range Output	50Hz to 5kHz or more 0 to 1V
10. Distortion Meter	Capability Input Level	3% or less at 1kHz 50mV to 10Vrms
11. Spectrum Analyzer	Measuring Range	DC to 1GHz or more
12. Tracking Generator	Center Frequency Output Voltage	50kHz to 600MHz 100mV or more
13. 8Ω Dummy Load		Approx. 8Ω, 3W
14. Regulated Power Supply		5V to 10V, approx. 3A Useful if ammeter equipped

#### ■ Antenna connector adapter

The antenna connector of this transceiver uses an SMA terminal.

Use an antenna connector adapter [SMA(f) – BNC(f) or SMA(f) – N(f)] for adjustment. (The adapter is not provided as an option, so buy a commercially-available one.)

#### ■ DC Supply

BATT+, BATT- : External power supply terminal (Fasten it with an alligator clip.)

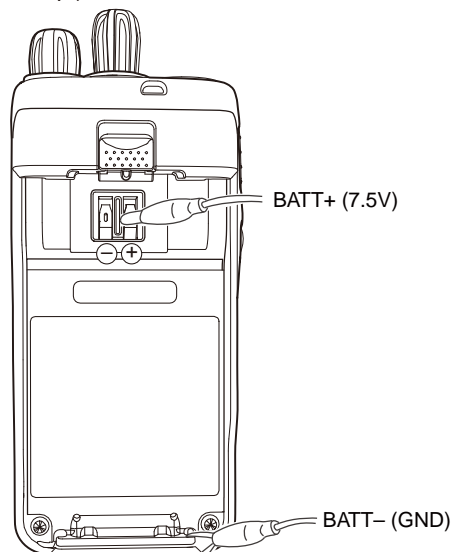

#### Adjustment Points

TX-RX UNIT Component side view

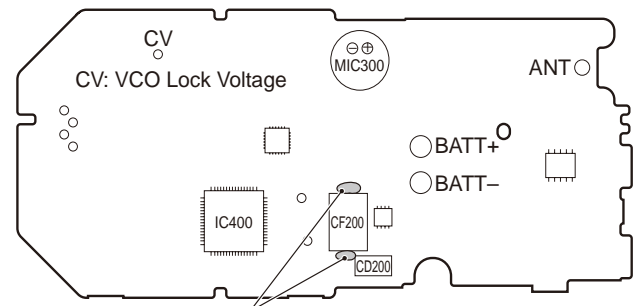

**Note:** When replacing CF200, apply bond to the point shown in the figure.

TX-RX UNIT Foil side view

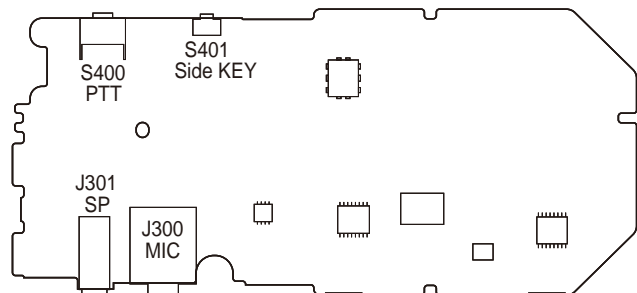

## 调整

### 调整所需的测试设备

测试设备	主要规格	
1. 标准信号发生器 (SSG)	频率范围 调制 输出	350 到 390MHz 调频和外部调制 -127dBm/0.1 $\mu$ V 到大于 -47dBm/1mV
2. 功率计	输入阻抗 操作频率 测量范围	50 $\Omega$ 350 到 390MHz 10W 左右
3. 频偏仪	频率范围	350 到 390MHz
4. 数字电压表 (DVM)	测量范围 输入阻抗	直流 10mV 到 10V 为最小电路负载高输入阻抗
5. 示波器		直流到 30MHz
6. 高灵敏度频率计数器	频率范围 频率稳定性	10Hz 到 1000MHz 0.2ppm 或更低
7. 直流电流表		5A
8. 音频电压表 (AF VM)	频率范围 电压范围	50Hz 到 10kHz 1mV 到 10V
9. 音频发生器 (AG)	频率范围 频率范围	50Hz 到 5kHz 或更高 0V 到 1V
10. 失真测试仪	能力 入电平	在 1kHz 时 3% 或更低 50mV 到 10Vrms
11. 频谱分析仪	测量范围	直流到 1GHz 或更高
12. 轨迹发生器	中心频率 输出电压	50kHz 到 600MHz 100mV 或更高
13. 8 $\Omega$ 假负载		大约 8 $\Omega$ , 3W
14. 可调电源		5V 到 10V, 大约 3A 配备了电流表时更好

#### ■ 天线接口转换头

此手持对讲机的天线接口使用 SMA 终端。

使用天线接口转换头 [SMA (f) -BNC (f) 或 SMA (f) -N (f)] 进行调整。(转换头不作为可选件提供, 因此请购买商用转换头。)

#### ■ DC 电源

BATT+, BATT- : 外部电源插脚 (用鳄鱼嘴夹固定。)

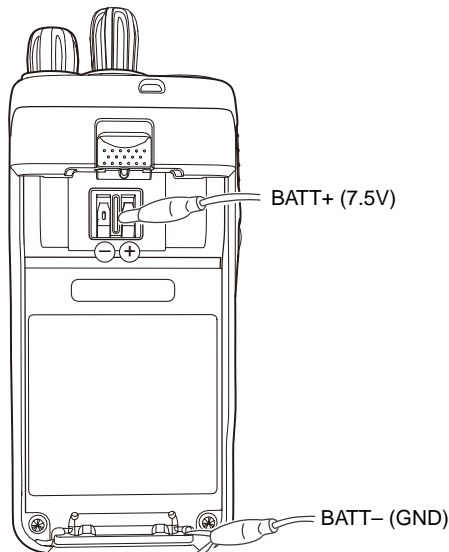

#### 调整点

##### 收发单元 (元件面视图)

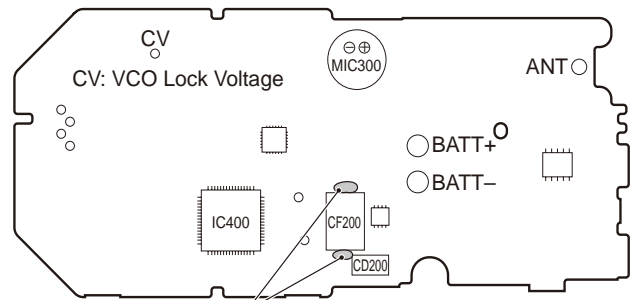

注意: 当交换 CF200 时需要按照图上指示涂上粘合剂。

##### 收发单元 (箱面视图)

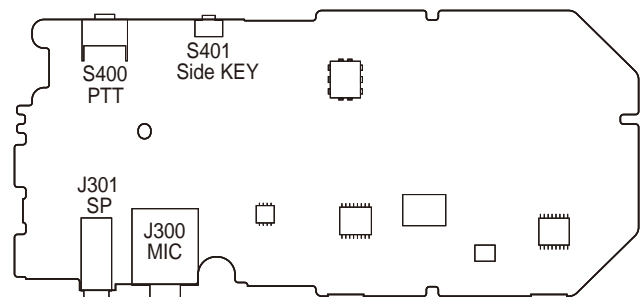

# ADJUSTMENT / 调整

## Frequency and Signaling

The transceiver has been adjusted for the frequencies shown in the following table. When required, re-adjust them following the adjustment procedure to obtain the frequencies you want in actual operation.

### ■ Test Frequency (MHz)

CH	RX Frequency	TX Frequency
1	370.05000	370.10000
2	350.05000	350.10000
3	389.95000	389.90000
4	370.00000	370.00000
5	370.20000	370.20000
6	370.40000	370.40000
7-16	-	-

### ■ Signaling

No.	RX (Decode)	TX (Encode)
1	None	None
2	None	100Hz Square Wave
3	QT 67.0Hz	QT 67.0Hz
4	QT 151.4Hz	QT 151.4Hz
5	QT 210.7Hz	QT 210.7Hz
6	QT 254.1Hz	QT 254.1Hz
7	DQT D023N	DQT D023N
8	DQT D754I	DQT D754I
9	None	DTMF (Code: 159D)
10	None	DTMF (Code: 9)

## Preparations for Tuning the Transceiver

Before attempting to tune the transceiver, connect the unit to a suitable power supply.

Whenever the transmitter is tuned, the unit must be connected to a suitable dummy load (i.e. power meter).

The speaker output connector must be terminated with a 8Ω dummy load and connected to an AC voltmeter and an audio distortion meter or a SINAD measurement meter at all times during tuning.

### ■ Adjustment frequency (MHz)

Tuning point	RX	TX
Low	350.05000	350.10000
Center	370.05000	370.10000
High	389.95000	389.90000

## 频率和信令

已经根据下表所示的频率调整了设置。需要时，按调整步骤重新调整，以获得实际操作时想要的频率。

### ■ 测试频率 (MHz)

信道	接收频率	发射频率
1	370.05000	370.10000
2	350.05000	350.10000
3	389.95000	389.90000
4	370.00000	370.00000
5	370.20000	370.20000
6	370.40000	370.40000
7 ~ 16	-	-

### ■ 信令

编号	接收 (解码)	发射 (编码)
1	无	无
2	无	100Hz 方波
3	QT 67.0Hz	QT 67.0Hz
4	QT 151.4Hz	QT 151.4Hz
5	QT 210.7Hz	QT 210.7Hz
6	QT 254.1Hz	QT 254.1Hz
7	DQT D023N	DQT D023N
8	DQT D754I	DQT D754I
9	无	DTMF (码: 159D)
10	无	DTMF (码: 9)

## 调谐手持对讲机的准备

在尝试调谐手持对讲机前，请将手持对讲机连接到合适的电源上。

发射打开时，手持对讲机必须连接到合适的等效负载上（如功率表）。

扬声器输出连接器必须端接 8Ω 的等效负载，调谐期间，必须始终连接到交流电压表和音频失真仪或 SINAD 测量仪表上。

### ■ 调整频率 (MHz)

调谐点	接收	发射
低	350.05000	350.10000
中	370.05000	370.10000
高	389.95000	389.90000

## ADJUSTMENT

### Common Section

Item	Condition	Measurement			Adjustment			Specifications / Remarks
		Test-equipment	Unit	Terminal	Unit	Parts	Method	
1. Setting	1) BATT terminal voltage: 7.5V 2) SSG standard modulation [Wide] MOD: 1kHz, DEV: 3kHz [Narrow] MOD: 1kHz, DEV: 1.5kHz							
2. VCO Lock Voltage	1) Adj item: High		TX-RX	ANT (CV)		FPU	4.0V	±0.1V

### Transmitter Section

Item	Condition	Measurement			Adjustment			Specifications / Remarks
		Test-equipment	Unit	Terminal	Unit	Parts	Method	
1. Frequency	1) Adj item: High Press [Transmit] button.	f. counter	TX-RX	ANT		FPU	389.900MHz	±50Hz
2. High Transmit Power and Protective Current	1) Adj item: Low, Center, High (3 points) BATT terminal voltage: 7.5V Press [Transmit] button.	Power meter Ammeter	TX-RX	ANT		FPU	3.8W	±0.1W 2.0A or less
3. Low Transmit Power	1) Adj item: Low, Center, High (3 points) BATT terminal voltage: 7.5V Press [Transmit] button.						1.0W	±0.1W 1.0A or less
4. DQT Balance [Wide]	1) Adj item: Low, Center, High (3 points) (Signaling Square Wave) Deviation meter filter LPF: 3kHz HPF: OFF Press [Transmit] button.	Power meter  Deviation meter Oscilloscope AG AF VM	TX-RX	ANT  SP/MIC connector		FPU	Make the modulation wave into square waves.	
5. Maximum Deviation [Wide]	1) Adj item: Center, Low, High (3 points) AG: 1kHz/150mV Deviation meter filter LPF: 15kHz HPF: OFF Press [Transmit] button.						4.0kHz (According to the larger +, -)	
6. Battery Warning Level	1) BATT terminal voltage: 5.9V	DVM	TX-RX	BATT terminal		FPU	Write	BATT terminal voltage: 5.9V
7. Battery Detection Check (User mode)	1) BATT terminal voltage: 5.7V PTT: ON	Power meter		ANT			Check	LED blinks No transmit power
	2) BATT terminal voltage: 7.5V PTT: ON	DVM		BATT terminal				LED does not blink

- This transceiver is designed to make adjustments simple.
- It is not necessary to adjust the fixed values for the DTMF-DEV, DQT-DEV, QT-DEV, and MIC sensitivity.
- The TX-DEV Narrow setting uses the Wide calculated adjustment level value.

## 调整

## 共通部分

项目	条件	测量			调整			规格 / 备注
		测量装置	单元	端子	单元	部件	方法	
1. 设定	1) BATT 端子电压 : 7.5V 2) 标准信号发生器调制 [宽] 调制 : 1kHz, 频偏 : 3kHz [窄] 调制 : 1kHz, 频偏 : 1.5kHz							
2. VCO 锁定电压	1) 调整项目 : 高		收发	天线 (CV)		FPU	4.0V	±0.1V

## 发射部分

项目	条件	测量			调整			规格 / 备注
		测量装置	单元	端子	单元	部件	方法	
1. 频率	1) 调整项目 : 高 按 [发射] 按钮。	频率计数器	收发	天线		FPU	389.900MHz	±50Hz
2. 高发射功率和保护电流	1) 调整项目 : 低, 中, 高 (3点) BATT 端子电压 : 7.5V 按 [发射] 按钮。	功率计 电流表				FPU	3.8W	±0.1W 2.0A 或更低
3. 低发射功率	1) 调整项目 : 低, 中, 高 (3点) BATT 端子电压 : 7.5V 按 [发射] 按钮。						1.0W	±0.1W 1.0A 或更低
4. DQT 平衡 [宽带]	1) 调整项目 : 低, 中, 高 (3点) (信令信道 : 方波) 频偏仪滤波器 LPF : 3kHz HPF : OFF 按 [发射] 按钮。	功率计 频偏仪 示波器 AG AF VM	收发	天线 SP/MIC 连接器		FPU	把解调波调整为方波。	
5. 最大频偏 [宽带]	1) 调整项目 : 中, 低, 高 (3点) AG : 1kHz/150mV 频偏仪滤波器 LPF : 15kHz HPF : OFF 按 [发射] 按钮。						4.0kHz (按照较大+, -)	±100Hz
6. 电池警告电平	1) BATT 端子电压 : 5.9V	DVM	收发	BATT 端子		FPU	写入	BATT 端子电压 : 5.9V
7. 电池指示检查 (用户模式)	1) BATT 端子电压 : 5.7V PTT : 开启	功率计		天线			检查	手持对讲机不能发射, LED 闪烁
	2) BATT 端子电压 : 7.5V PTT : 开启	DVM		BATT 端子				手持对讲机可以发射, 不会引起 LED 闪烁

• 该手持对讲机的设计采用了简化调整。  
• 不需要调整 DTMF 频偏, BPF, MIC 灵敏度。  
• 窄带的 TX 频偏是被自动调整。

## ADJUSTMENT

### Receiver Section

Item	Condition	Measurement			Adjustment			Specifications / Remarks
		Test-equipment	Unit	Terminal	Unit	Parts	Method	
1. Sensitivity Check [Narrow]	1) Adj item: Low, High (2 points) SSG output: -115dBm (0.4μV) SSG DEV: 1.5kHz	SSG DVM Oscilloscope AF VM	TX-RX	ANT SP/MIC connector			Check	12dB SINAD or more
	[Wide]							
2. Squelch Level 5 Write [Wide]	(3 points) 1) Adj item: Low SSG output: -121dBm (0.2μV) SSG DEV: 3.0kHz 2) Adj item: Center SSG output: -122dBm (0.178μV) SSG DEV: 3.0kHz 3) Adj item: High SSG output: -122dBm (0.178μV) SSG DEV: 3.0kHz					FPU	Write	
	[Narrow]	(3 points) 4) Adj item: Low SSG output: -120dBm (0.22μV) SSG DEV: 1.5kHz 5) Adj item: Center SSG output: -120dBm (0.22μV) SSG DEV: 1.5kHz 6) Adj item: High SSG output: -120dBm (0.22μV) SSG DEV: 1.5kHz						
<ul style="list-style-type: none"> <li>• It is not necessary to adjust the fixed value for the BPF.</li> <li>• The Squelch Level 9 setting uses the Squelch Level 5 calculated adjustment level value.</li> </ul>								

## 调整

## 接收部分

项目	条件	测量			调整			规格 / 备注
		测量装置	单元	端子	单元	部件	方法	
1. 灵敏度检查 [窄带]	1) 调整项目: 低, 高 (2点) SSG 输出: -115dBm (0.4 μV) SSG 频偏: 1.5kHz	SSG DVM 示波器 AF VM	收发	天线 SP/MIC 连接器			检查	12dB SINAD 或更高
[宽带]	2) 测试信道: 1 SSG 输出: -117dBm (0.32 μV) SSG 频偏: 3.0kHz							
2. 静噪 (5) [宽带]	(3点) 1) 调整项目: 低 SSG 输出: - 121dBm (0.2 μV) SSG 频偏: 3.0kHz 2) 调整项目: 中 SSG 输出: - 122dBm (0.178 μV) SSG 频偏: 3.0kHz 3) 调整项目: 高 SSG 输出: - 122dBm (0.178 μV) SSG 频偏: 3.0kHz				FPU	写入		
[窄带]	(3点) 4) 调整项目: 低 SSG 输出: - 120dBm (0.22 μV) SSG 频偏: 1.5kHz 5) 调整项目: 中 SSG 输出: - 120dBm (0.22 μV) SSG 频偏: 1.5kHz 6) 调整项目: 高 SSG 输出: - 120dBm (0.22 μV) SSG 频偏: 1.5kHz							
<ul style="list-style-type: none"> <li>• 不需要 BPF 调整。</li> <li>• 静噪 (9) 是被自动调整。</li> </ul>								

# TK-3000 PC BOARD / 印刷电路板

## TX-RX UNIT (X57-8100-23) Component side view (J79-0306-19)

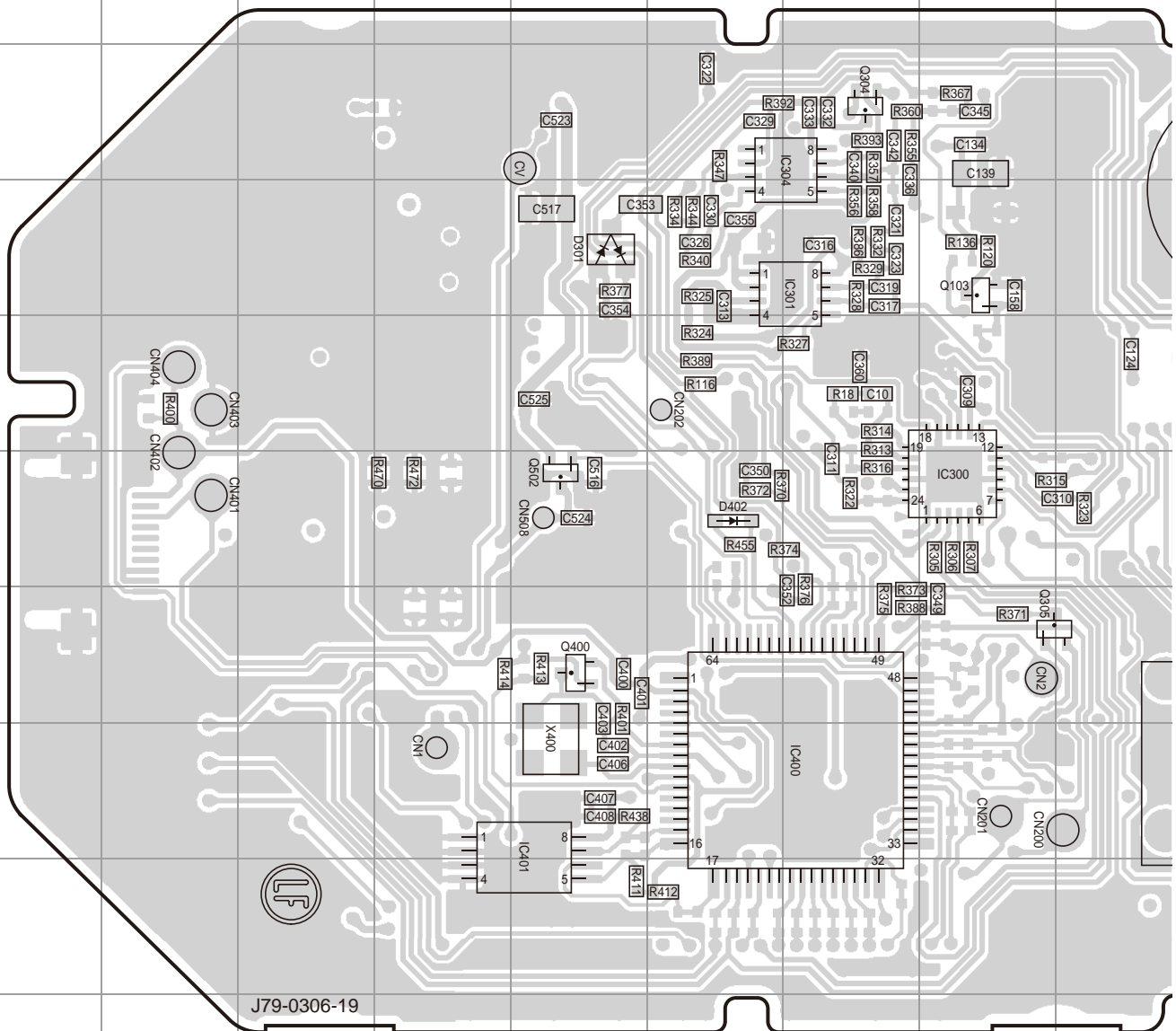

Ref. No.	Address	Ref. No.	Address	Ref. No.	Address
IC300	6I	Q103	4I	Q501	3N
IC301	4H	Q300	4O	Q502	6F
IC302	6P	Q301	4P	D301	4F
IC303	8L	Q302	5P	D400	8R
IC304	3H	Q303	7P	D401	8R
IC400	8H	Q304	3H	D402	6G
IC401	8F	Q305	7I	D500	6K
IC500	4M	Q306	5P	D501	5O
IC501	4M	Q400	7F		
IC503	4O	Q500	5M		



# PC BOARD / 印刷电路板 TK-3000

## TX-RX UNIT (X57-8100-23) Component side view (J79-0306-19)

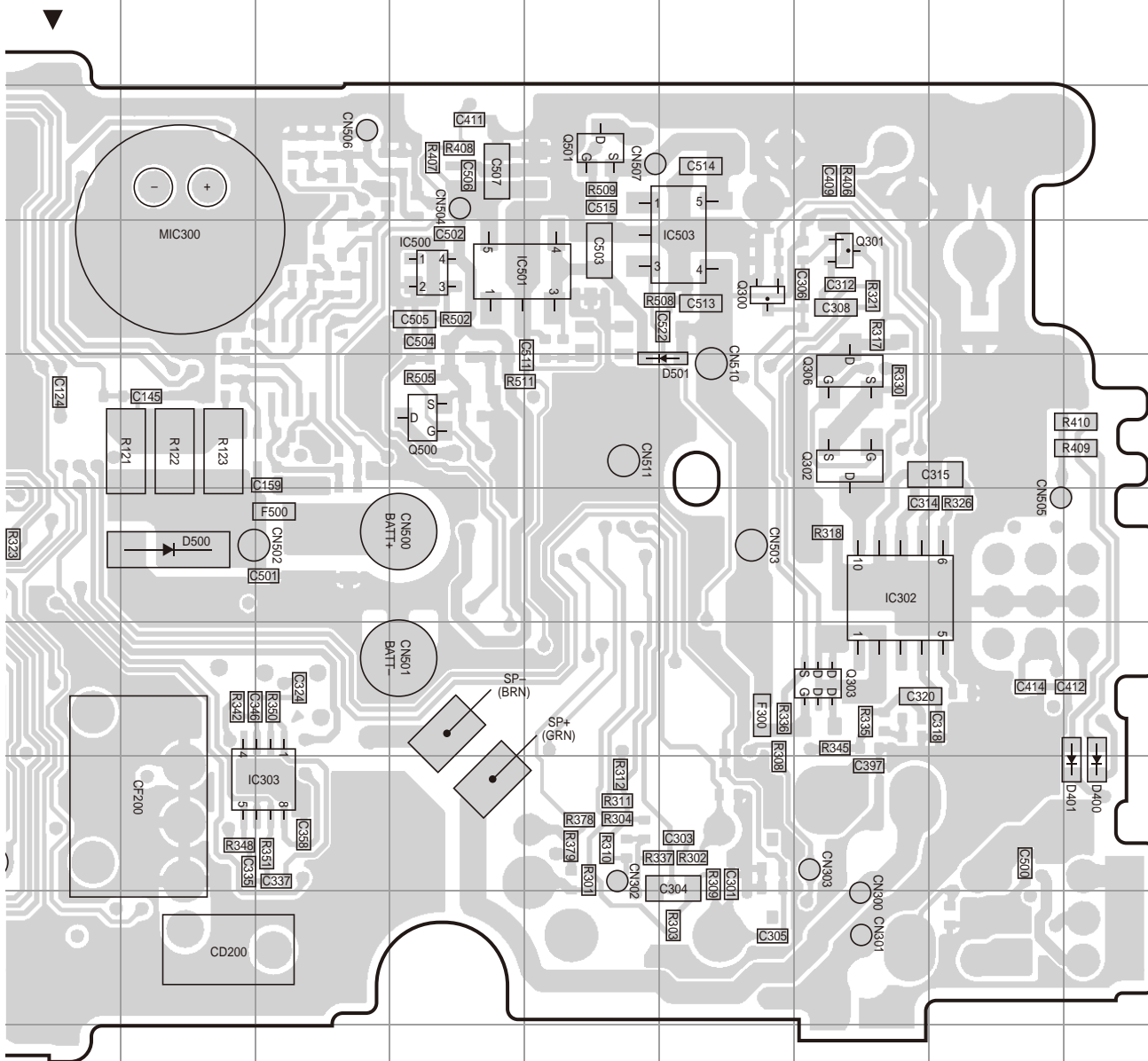

Component side

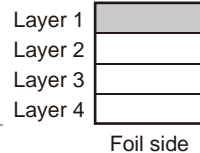

# TK-3000 PC BOARD / 印刷电路板

## TX-RX UNIT (X57-8100-23) Foil side view (J79-0306-19)

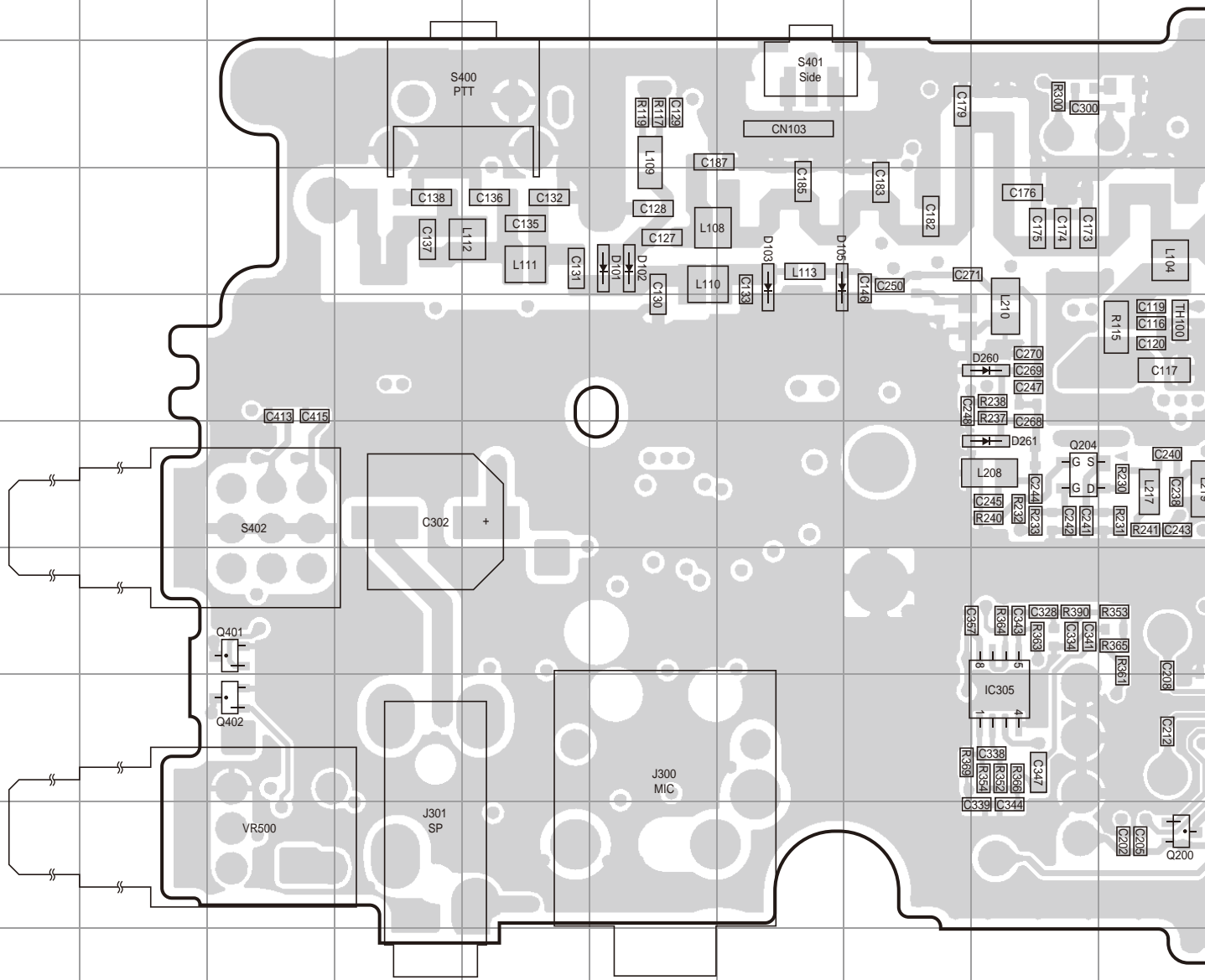

Ref. No.	Address	Ref. No.	Address	Ref. No.	Address	Ref. No.	Address
IC1	8P	Q100	4M	D1	3P	D102	4F
IC200	8K	Q101	5L	D2	3O	D103	4G
IC305	8I	Q102	4K	D3	3O	D105	4G
Q1	7P	Q200	9J	D4	4O	D200	6O
Q2	4O	Q201	9N	D5	4O	D201	6K
Q3	5O	Q202	8L	D6	4O	D202	6K
Q4	5P	Q203	6M	D7	5O	D204	6L
Q5	5P	Q204	6I	D8	3P	D260	5I
Q6	6O	Q401	7C	D100	5N	D261	6I
Q7	9P	Q402	8C	D101	4F		

# PC BOARD / 印刷电路板 TK-3000

## TX-RX UNIT (X57-8100-23) Foil side view (J79-0306-19)



J79-0306-19

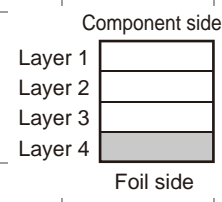

## LEVEL DIAGRAM / 电平图

### Receiver Section / 接收部分

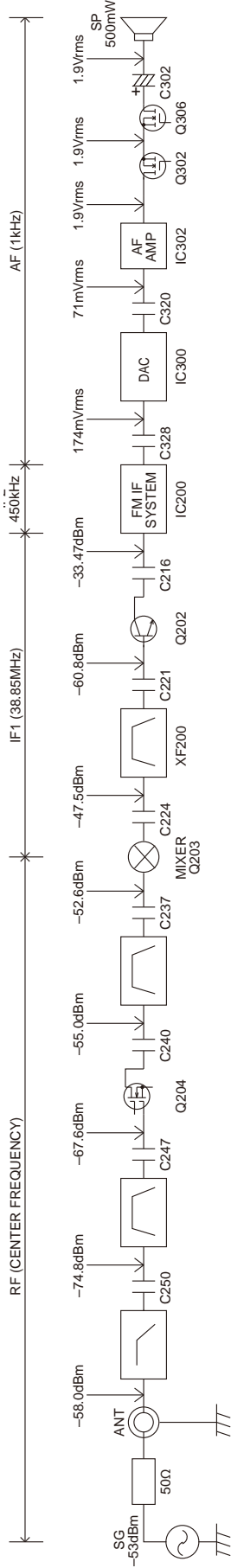

To make measurements in the AF section, connect the AC level meter. (ANT input: -53dBm, 1kHz FM, 1.5kHz Dev (Narrow).)  
 In the RF section, use a high impedance probe. (ANT input: -53dBm, MOD off.)  
 要在 AF 段进行测量, 请连接交流电平表。  
 (ANT 输入: -53dBm, 1kHz FM, 1.5kHz 频偏 (窄带)).  
 在 RF 段, 请使用高阻抗探针。(ANT 输入: -53dBm, MOD 关。)

### Transmitter Section / 发射部分

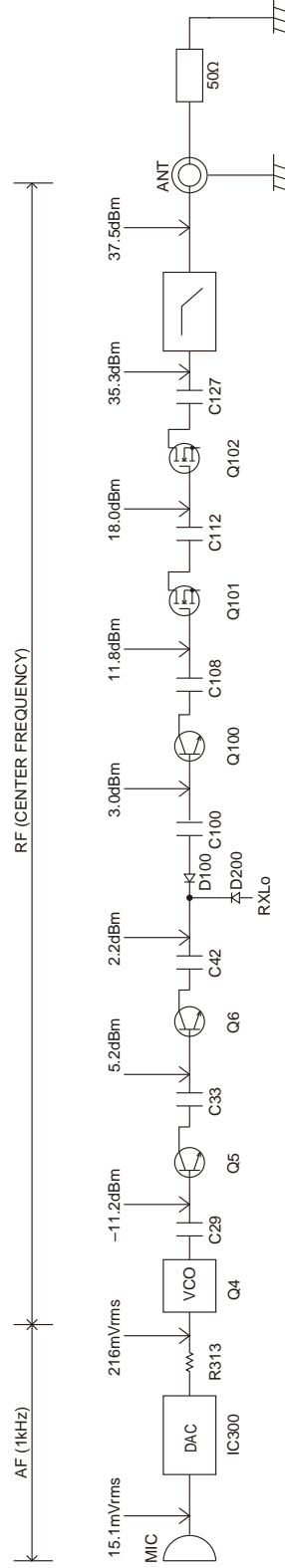

AG is set to the MIC input becomes 1.5kHz Dev, at 1kHz MOD. (Narrow)  
 To make measurements in the AF section, connect the AC level meter.  
 In the RF section, use a 1000pF coupling capacitor.

AG 被设为麦克风输入, 为 1.5kHz 频偏在 1kHz 调制。(窄带)  
 要在 AF 段进行测量, 请连接交流电平表。  
 在 RF 段, 请使用 1000pF 耦合电容。

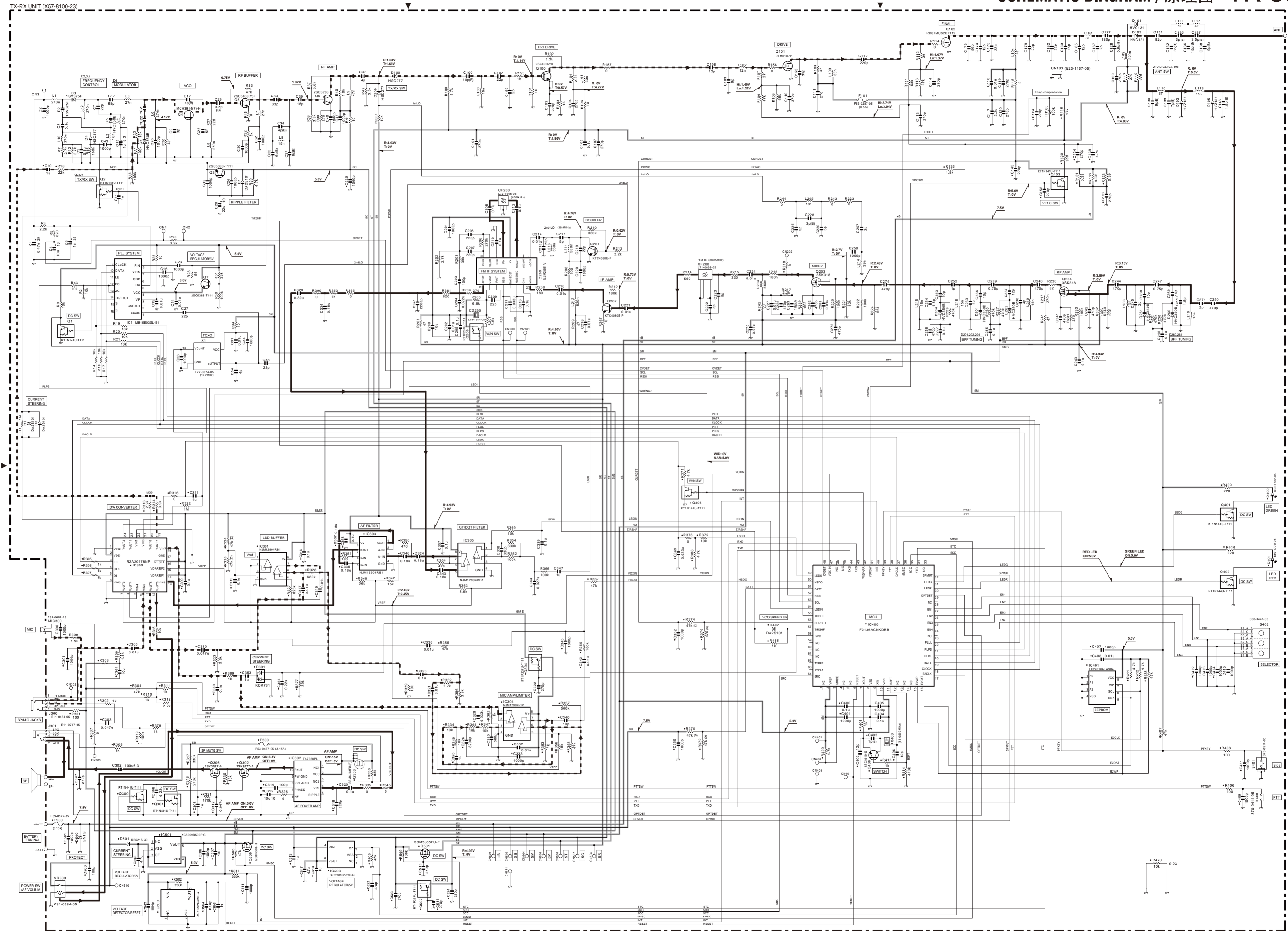

Note: The components marked with a dot (•) are parts of layer 1.  
 注意: 标有点(•)的零件为第一层的零件。

TX-RX UNIT (X57-8100-23)

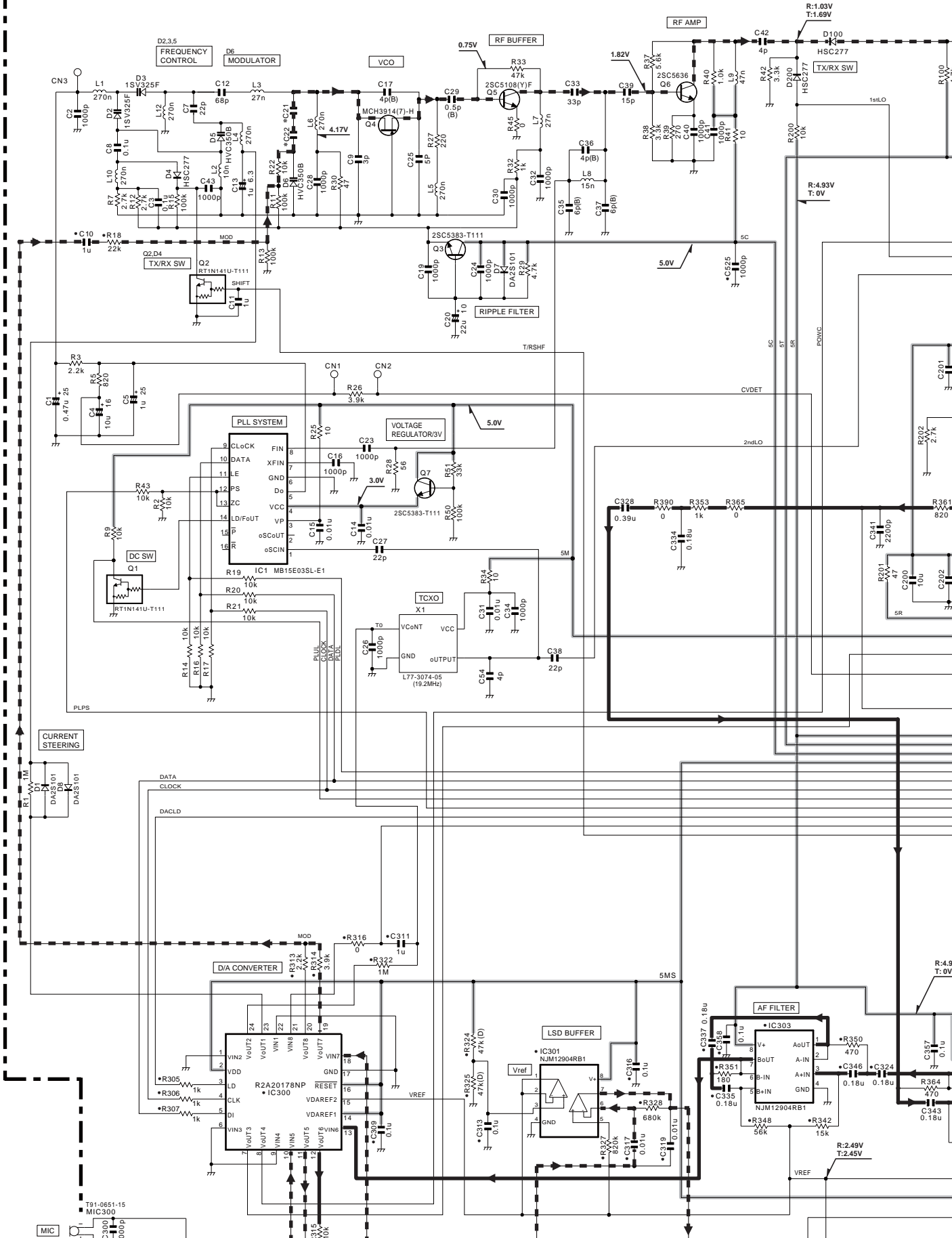

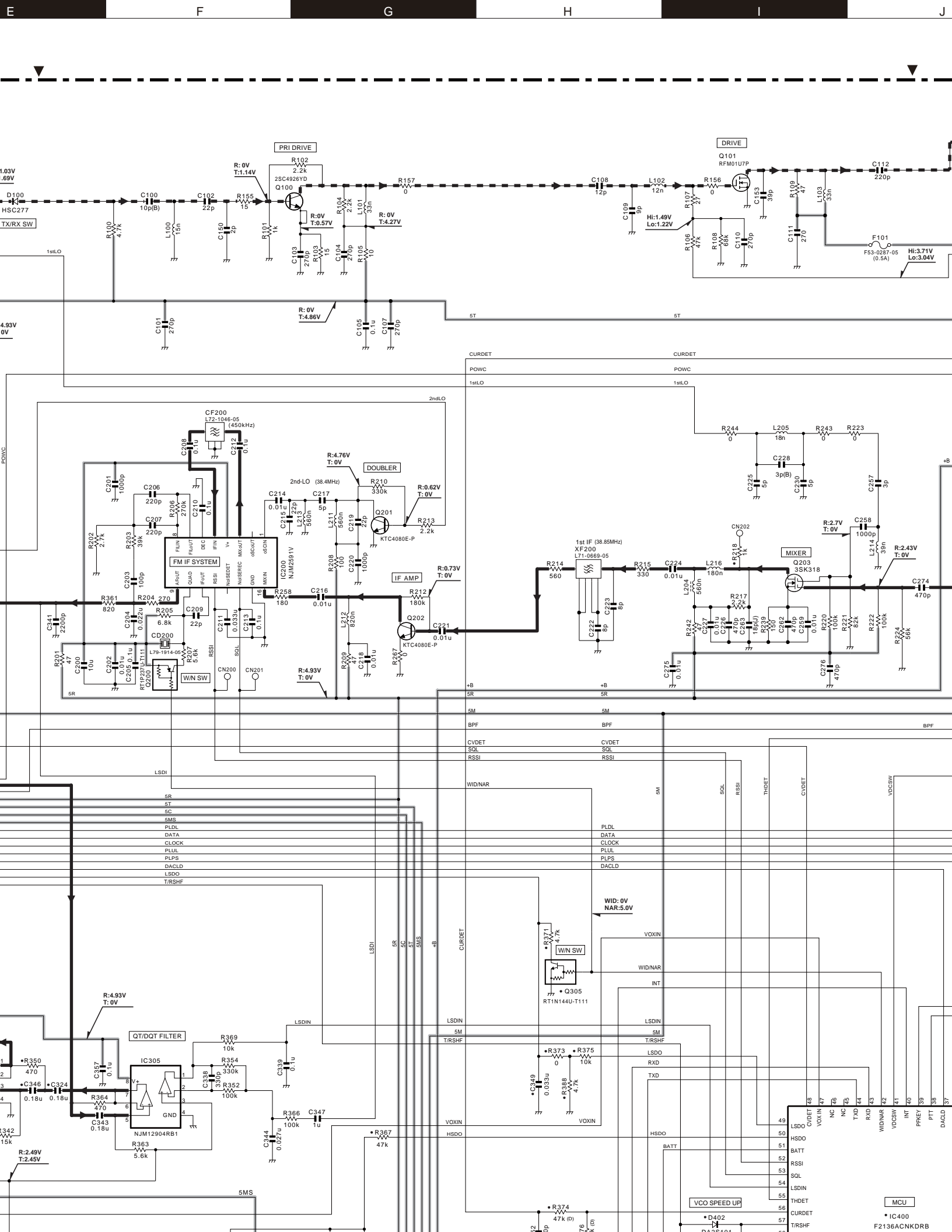

# SCHMATIC DIAGRAM / 原理图 TK-3000

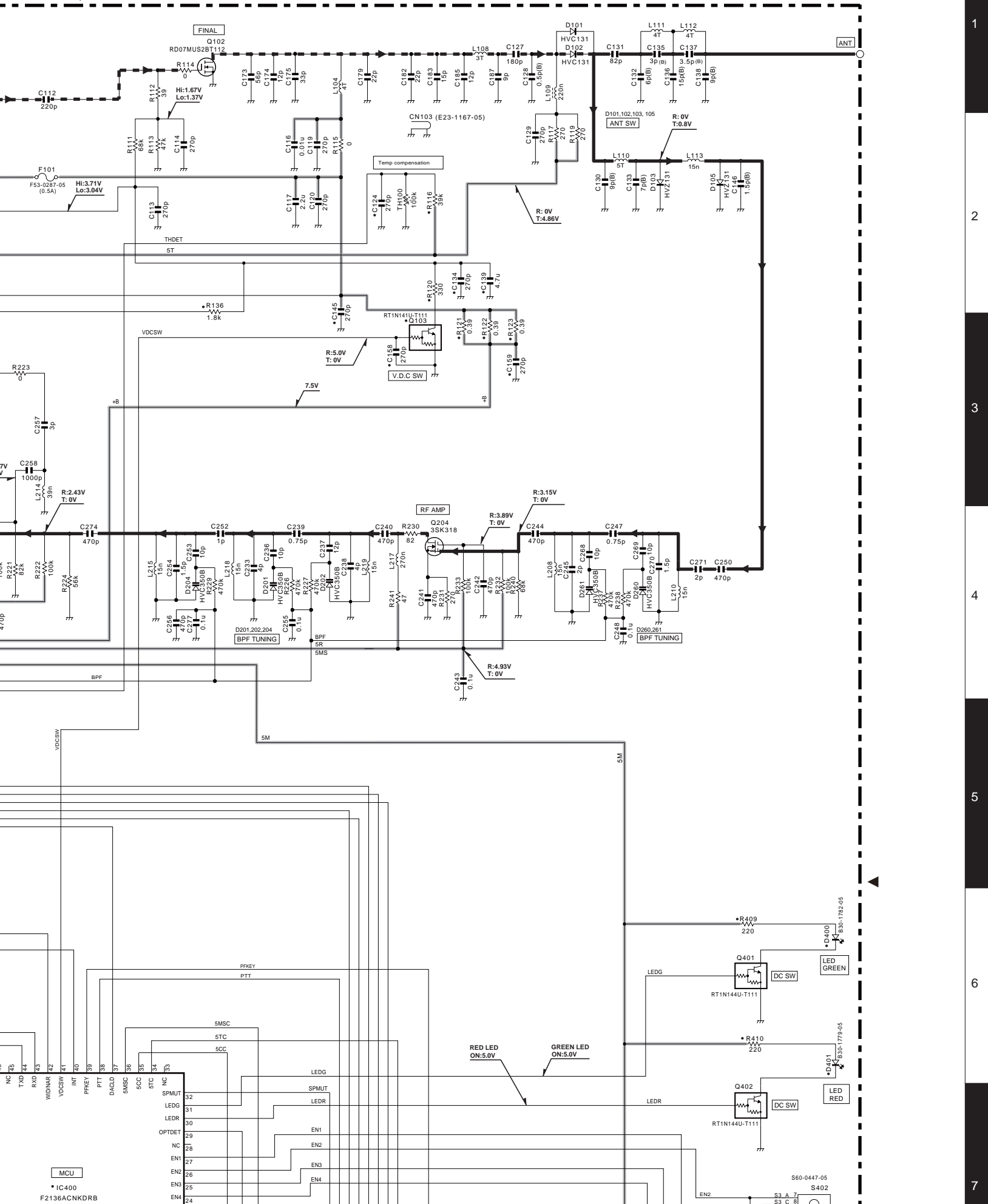



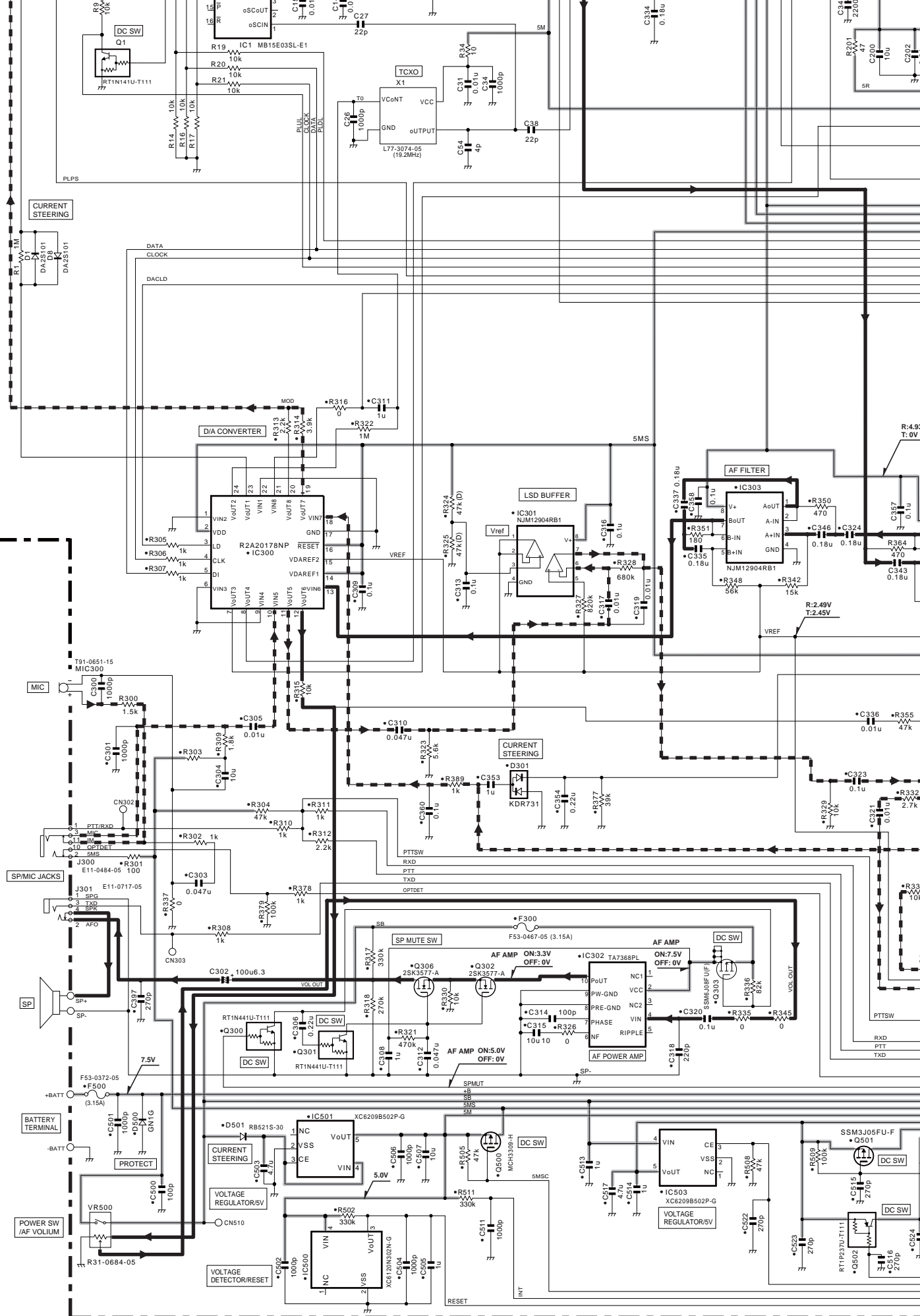

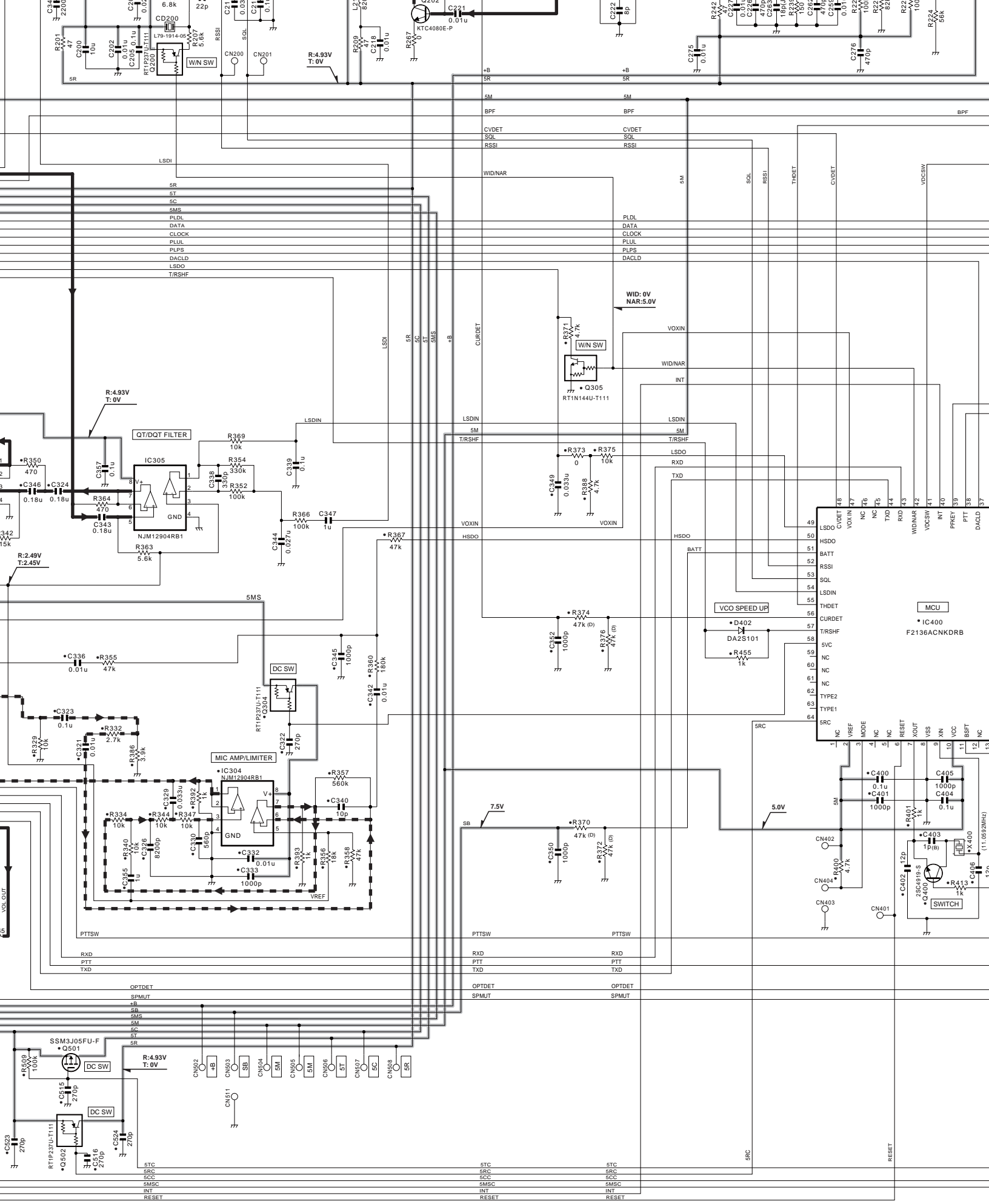

MCU  
IC400  
F2136ACNKDRB

SWITCH  
R413  
C403  
C404  
C405  
R401  
R402  
R403  
R404  
R405  
R406  
C401  
C402  
C406

(11.0528MHz)

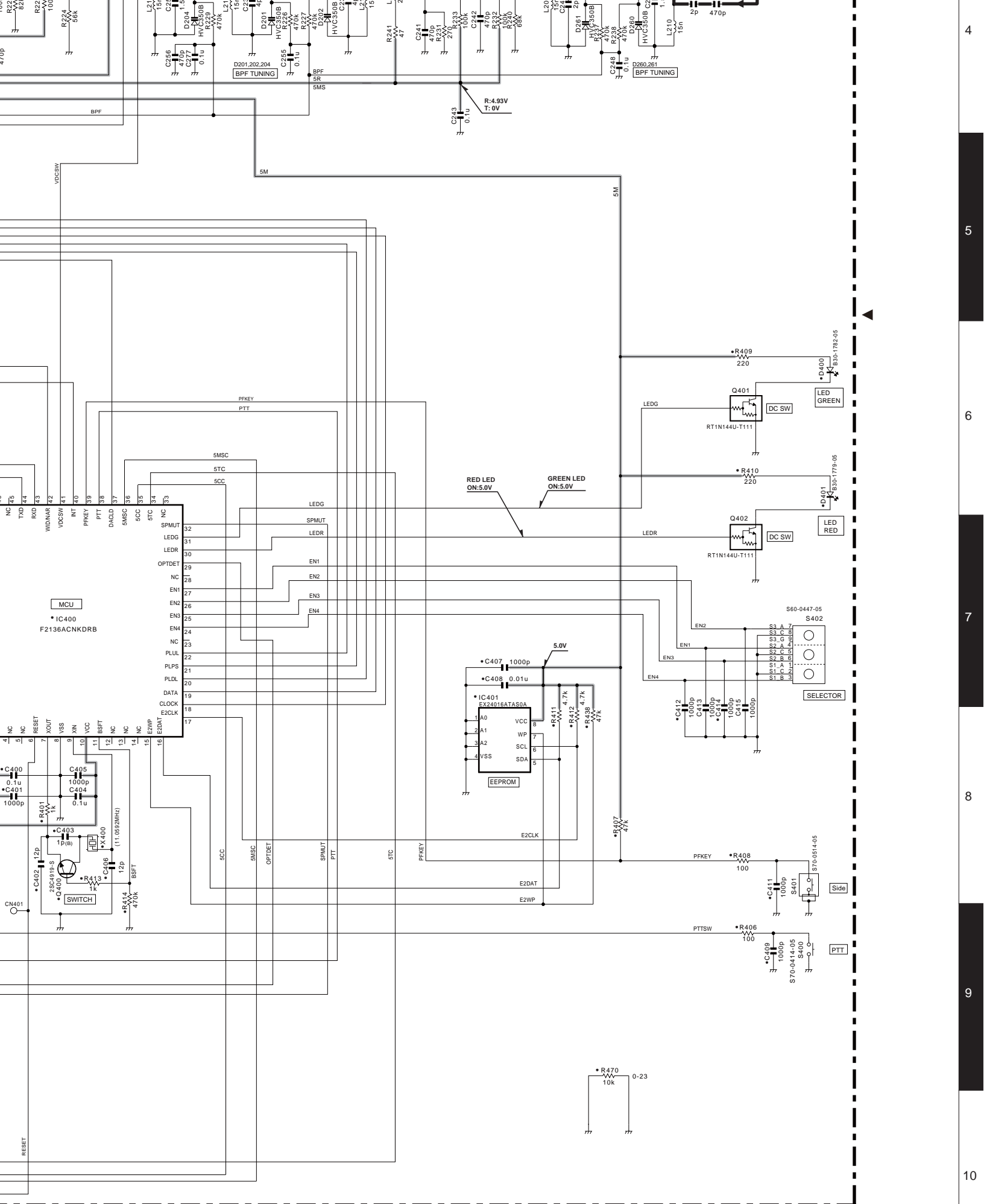

Note : The components marked with a dot (•) are parts of layer 1.  
 注意：标有点号 (•) 的零件为第一层的零件。

MEMO / 笔记

## BLOCK DIAGRAM / 方块图

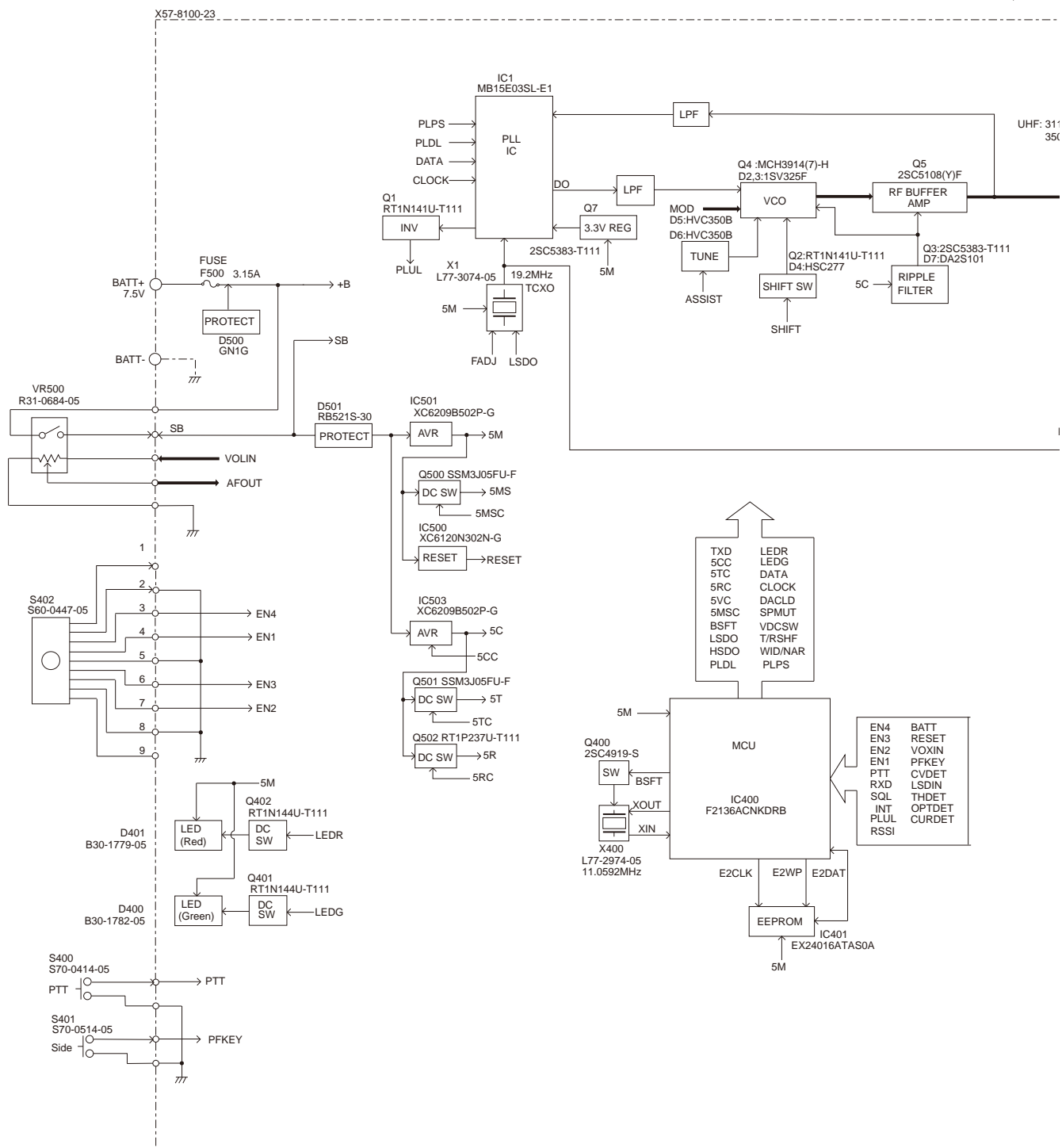

## BLOCK DIAGRAM / 方块图

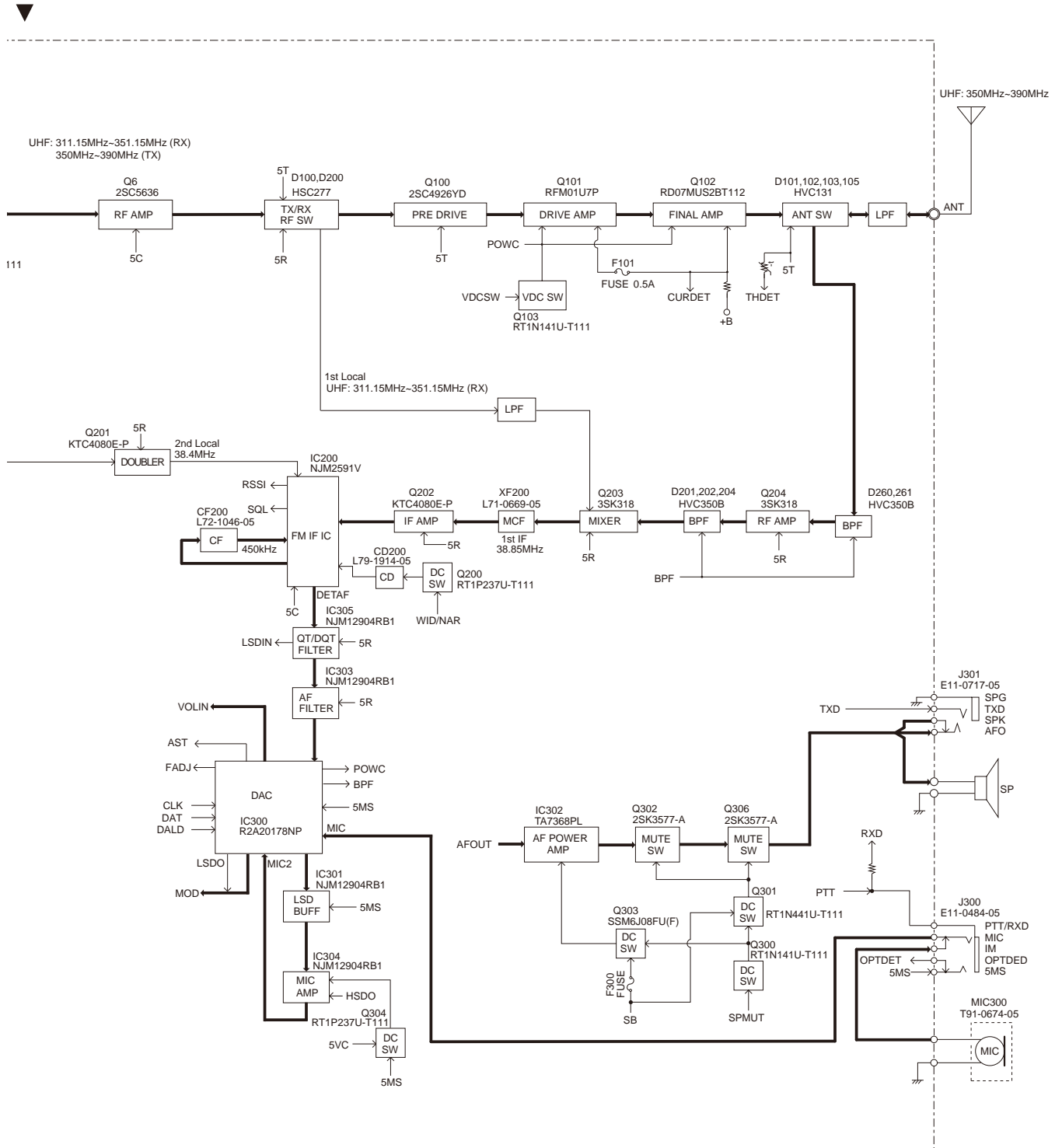

# TK-3000

## SPECIFICATIONS / 规格

### General

Frequency Range	350~390MHz
Number of Channels	Max. 16
Channel Spacing	25kHz (Wide) / 12.5kHz (Narrow)
PLL Channel Stepping	5kHz, 6.25kHz
Operating Voltage	7.5 V DC±20%
Battery Life	More than 10 hours at 4 watts (5-5-90 duty cycle, save off) With KNB-63L battery
Operating Temperature Range	-20°C to +60°C
Frequency Stability	±2.5ppm
Channel Frequency Spread	40MHz
Dimensions and Weight (Dimensions not including protrusions)	
Radio Only	54 W x 113 H x 14 D mm, 130g
With KNB-63L battery (1130mAh battery)	
	54 W x 113 H x 24.9 D mm, 203g

### Receiver (Measurements made per China GB standard)

Sensitivity	
EIA 12dB SINAD	0.25µV (Wide) / 0.28µV (Narrow)
Selectivity	70dB (Wide) / 60dB (Narrow)
Intermodulation Distortion	65dB (Wide) / 60dB (Narrow)
Spurious Response	65dB
Audio Output	500mW at 8Ω

### Transmitter (Measurements made per China GB standard)

RF Output Power	4W/1W
Spurious Response	65dB
Modulation	16K0F3E (Wide) / 11K0F3E (Narrow)
FM Hum & Noise	45dB (Wide) / 40dB (Narrow)
Modulation Distortion	Less than 5%

Measurements made per China GB standard and specifications shown are typical.  
Kenwood reserves the right to change specifications without prior notice or obligation.

### 概述

频率范围	350 ~ 390MHz
信道数量	最大 16
信道间隔	25kHz (宽带), 12.5kHz (窄带)
PLL 频道步进	5kHz, 6.25kHz
工作电源电压	7.5V DC±20%
电池寿命	在 4W 时高于 10 时间 (5-5-90 工作周期, 电池省电 off 状态) 使用 KNB-63L
工作温度范围	-20°C ~ +60°C
频率稳定度	±2.5ppm
信道频率扩展	40MHz
尺寸及重量 (宽 × 高 × 深) (尺寸大小不包括突出部分)	
仅对讲机时	54 × 113 × 14 mm, 130g
带有附件电池	54 × 113 × 24.9 mm, 203g

### 接收部 (根据中国 GB 标准测定)

#### 灵敏度

EIA 12dB SINAD	0.25 µV (宽带), 0.28 µV (窄带)
选择性	70dB (宽带), 60dB (窄带)
互调抑制	65dB (宽带), 60dB (窄带)
杂散响应	65dB
音频输出功率	8 Ω 时 500mW

### 发射部 (根据中国 GB 标准测定)

射频功率输出	4W/1W
杂散射频分量	65dB
调制	16K0F3E (宽带), 11K0F3E (窄带)
调频噪声	45dB (宽带), 40dB (窄带)
调制失真	低于 5%

依据中国 GB 标准获得的测量值和所示规格均为典型值。  
建伍公司有权变更技术规格, 恕不预先通知。

## Kenwood Corporation

2967-3, Ishikawa-machi, Hachioji-shi, Tokyo, 192-8525 Japan

### Kenwood U.S.A. Corporation

P.O. BOX 22745, 2201 East Dominguez Street, Long Beach, CA 90801-5745, U.S.A.

### Kenwood Electronics Canada Inc.

6070 Kestrel Road, Mississauga, Ontario, Canada L5T 1S8

### Kenwood Electronics Deutschland GmbH

Rembrücker Str. 15, 63150 Heusenstamm, Germany

### Kenwood Electronics Belgium N.V.

Leuvensesteenweg 248 J, 1800 Vilvoorde, Belgium

### Kenwood Electronics France S.A.

L'Etoile Paris Nord 2, 50 Allée des Impressionnistes, Bp 58416 Villepinte, 95944 Roissy Ch De Gaulle Cedex

### Kenwood Electronics UK Limited

KENWOOD House, Dwight Road, Watford, Herts., WD18 9EB United Kingdom

### Kenwood Electronics Europe B.V.

Amsterdamseseweg 37, 1422 AC Uithoorn, The Netherlands

### Kenwood Electronics Italia S.p.A.

Via G. Sirtori, 7/9 20129 Milano, Italy

### Kenwood Ibérica, S.A.

Carretera de Rubi, 88 Planta 1 A 08174 Sant Cugat del Vallés Barcelona, Spain

### Kenwood Electronics Australia Pty. Ltd.

Talavera Business Park Building A, 4 Talavera Road, North Ryde NSW 2113 Australia

### Kenwood Electronics (Hong Kong) Ltd.

Suite 2504, 25/F, Tower 2, Nina Tower, No. 8 Yeung Uk Road, Tsuen Wan, New Territories, Hong Kong

### Kenwood Electronics Singapore Pte Ltd

1 Ang Mo Kio Street 63, Singapore 569110

TX-RX UNIT (X57-8100-23) Component side view (J79-0306-19)

TX-RX UNIT (X57-8100-23) Component side view (J79-0306-19)

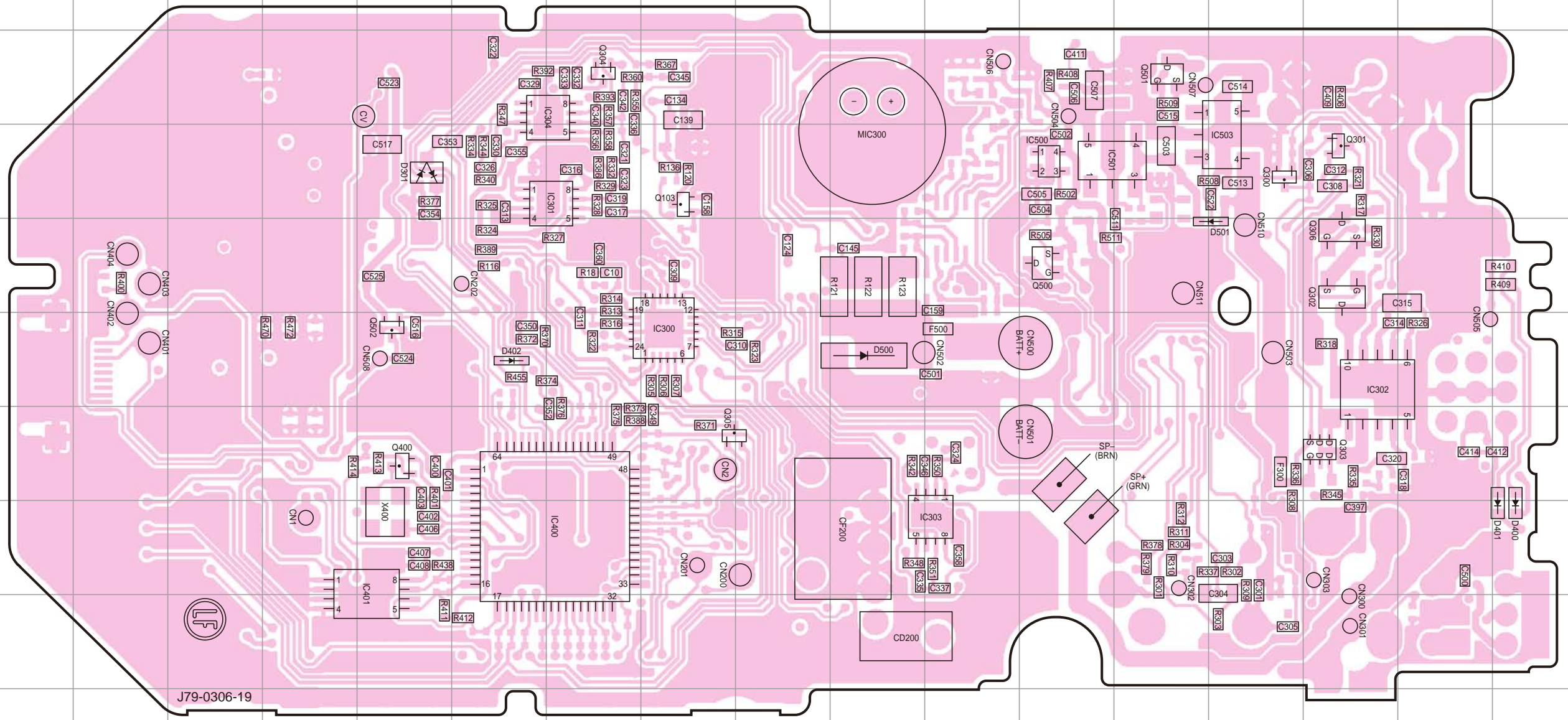

Ref. No.	Address	Ref. No.	Address	Ref. No.	Address
IC300	6I	Q103	4I	Q501	3N
IC301	4H	Q300	4O	Q502	6F
IC302	6P	Q301	4P	D301	4F
IC303	8L	Q302	5P	D400	8R
IC304	3H	Q303	7P	D401	8R
IC400	8H	Q304	3H	D402	6G
IC401	8F	Q305	7I	D500	6K
IC500	4M	Q306	5P	D501	5O
IC501	4M	Q400	7F		
IC503	4O	Q500	5M		

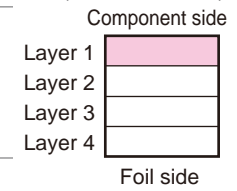



# TK-3000 PC BOARD / 印刷电路板

# PC BOARD / 印刷电路板 TK-3000

TX-RX UNIT (X57-8100-23) Foil side view (J79-0306-19)

TX-RX UNIT (X57-8100-23) Foil side view (J79-0306-19)

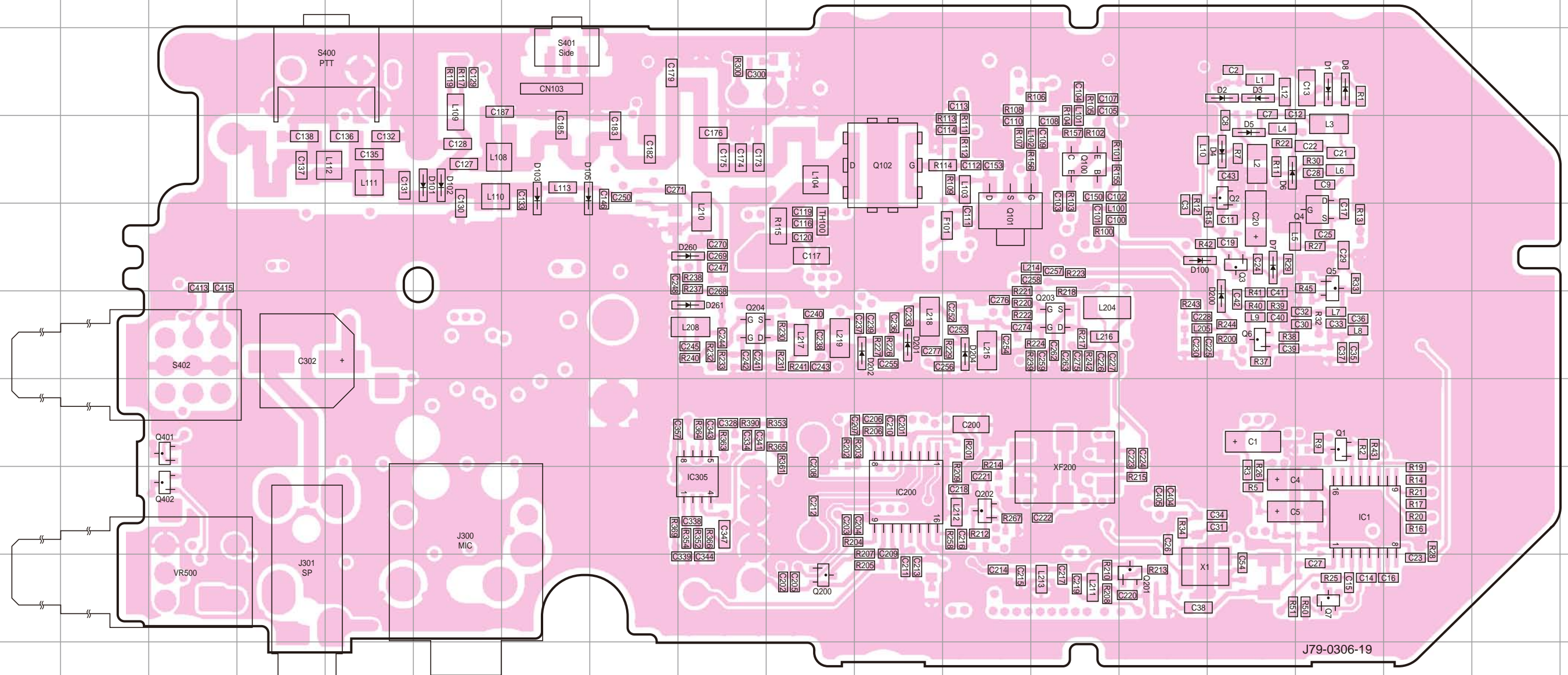

Ref. No.	Address	Ref. No.	Address	Ref. No.	Address	Ref. No.	Address
IC1	8P	Q100	4M	D1	3P	D102	4F
IC200	8K	Q101	5L	D2	3O	D103	4G
IC305	8I	Q102	4K	D3	3O	D105	4G
Q1	7P	Q200	9J	D4	4O	D200	6O
Q2	4O	Q201	9N	D5	4O	D201	6K
Q3	5O	Q202	8L	D6	4O	D202	6K
Q4	5P	Q203	6M	D7	5O	D204	6L
Q5	5P	Q204	6I	D8	3P	D260	5I
Q6	6O	Q401	7C	D100	5N	D261	6I
Q7	9P	Q402	8C	D101	4F		

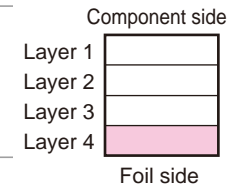

J79-0306-19

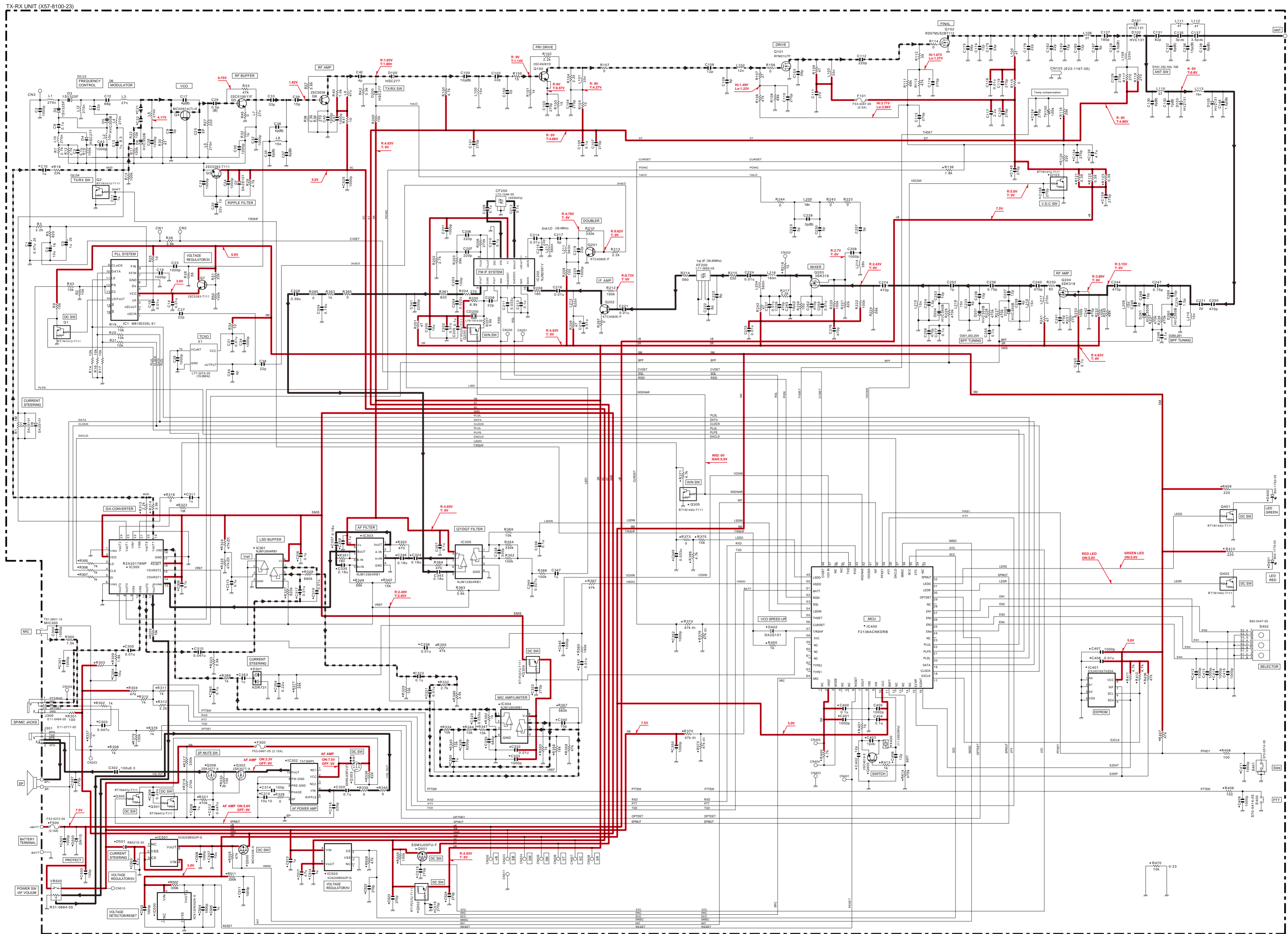

Note: The components marked with a dot (•) are parts of layer 1.  
 注意：标有点号 (•) 的零件为第一层的零件。

