

UHF FM TRANSCEIVER

TK-3000

SERVICE MANUAL

E,T versions

KENWOOD

JVC KENWOOD Corporation

© 2011-12 PRINTED IN JAPAN
B53-7006-00 (Y) PDF

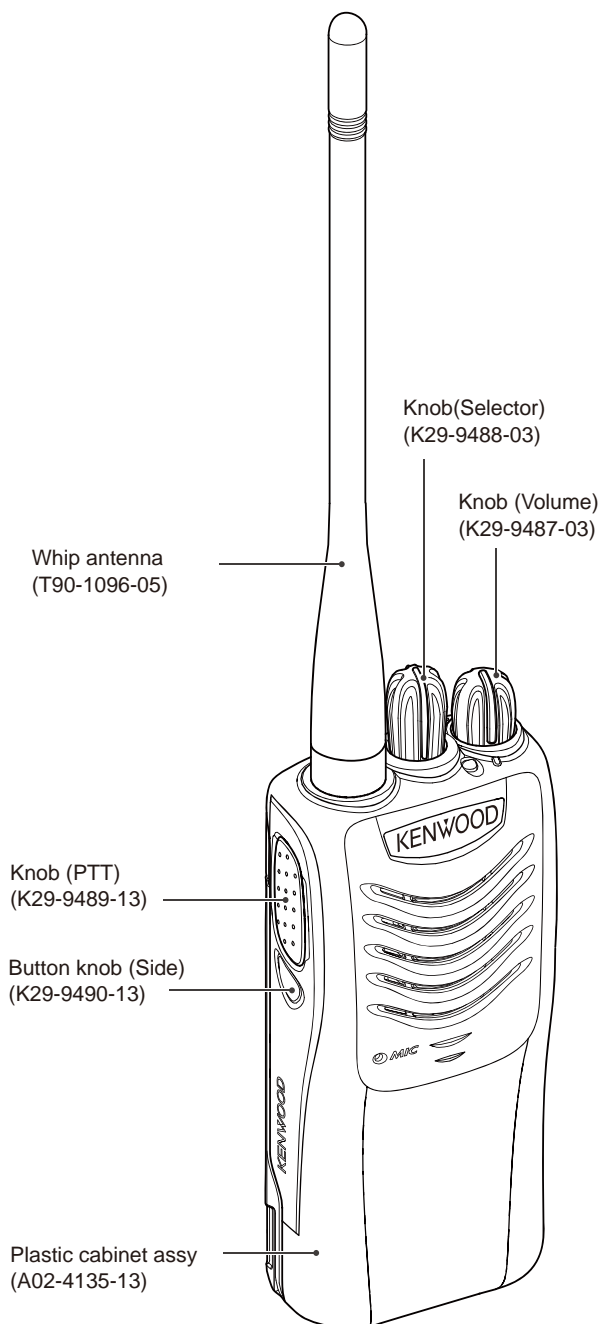

CONTENTS

GENERAL	2
SYSTEM SET-UP	3
REALIGNMENT	3
DISASSEMBLY FOR REPAIR	6
CIRCUIT DESCRIPTION	7
SEMICONDUCTOR DATA	10
COMPONENTS DESCRIPTION	11
PARTS LIST	12
EXPLODED VIEW	17
ADJUSTMENT	18
PC BOARD	
TX-RX UNIT (X57-8102-71)	22
SCHEMATIC DIAGRAM	26
BLOCK DIAGRAM	30
LEVEL DIAGRAM	32
SPECIFICATIONS	33



TK-3000

Document Copyrights

Copyright 2011 by JVC KENWOOD Corporation. All rights reserved.

No part of this manual may be reproduced, translated, distributed, or transmitted in any form or by any means, electronic, mechanical, photocopying, recording, or otherwise, for any purpose without the prior written permission of JVC KENWOOD Corporation.

Disclaimer

While every precaution has been taken in the preparation of this manual, JVC KENWOOD Corporation assumes no responsibility for errors or omissions. Neither is any liability assumed for damages resulting from the use of the information contained herein. JVC KENWOOD Corporation reserves the right to make changes to any products herein at any time for improvement purposes.

GENERAL

INTRODUCTION

SCOPE OF THIS MANUAL

This manual is intended for use by experienced technicians familiar with similar types of commercial grade communications equipment. It contains all required service information for the equipment and is current as of the publication date. Changes which may occur after publication are covered by either Service Bulletins or Manual Revisions. These are issued as required.

ORDERING REPLACEMENT PARTS

When ordering replacement parts or equipment information, the full part identification number should be included. This applies to all parts : components, kits, or chassis. If the part number is not known, include the chassis or kit number of which it is a part, and a sufficient description of the required component for proper identification.

PERSONAL SAFETY

The following precautions are recommended for personal safety:

- DO NOT transmit until all RF connectors are verified secure and any open connectors are properly terminated.
- SHUT OFF and DO NOT operate this equipment near electrical blasting caps or in an explosive atmosphere.
- This equipment should be serviced by a qualified technician only.

SERVICE

This transceiver is designed for easy servicing. Refer to the schematic diagrams, printed circuit board views, and alignment procedures contained within.

Model	Type	TX-RX unit	Frequency range	Remarks
TK-3000	E,T	X57-8102-71	440~470MHz	IF1: 38.85MHz LOC: 38.4MHz

SYSTEM SET-UP

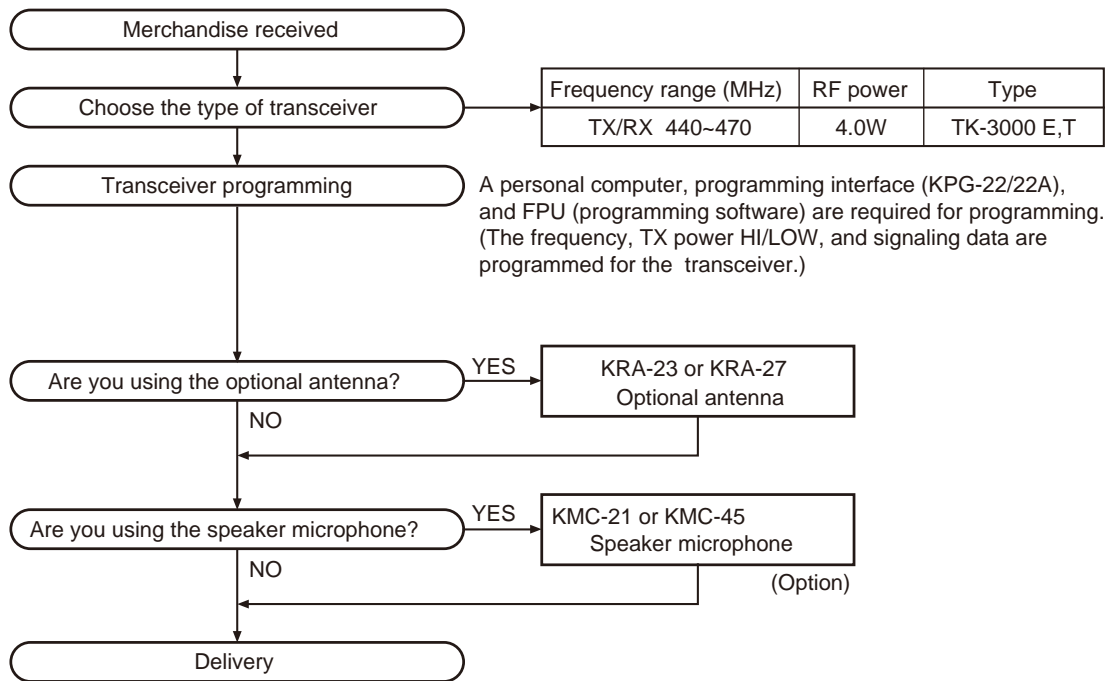

REALIGNMENT

1. Modes

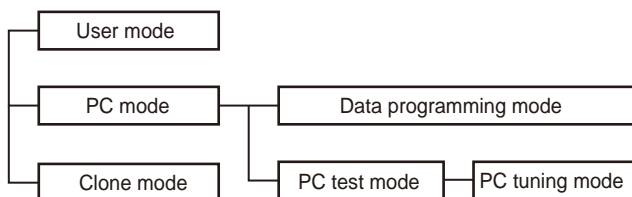

Mode	Function
User mode	For normal use.
PC mode	Used for communication between the transceiver and PC.
Data programming mode	Used to read and write frequency data and other features to and from the transceiver.
PC test mode	Used to check the transceiver using the PC. This feature is included in the FPU.
Clone mode	Used to transfer programming data from one transceiver to another.

2. How to Enter Each Mode

Mode	Operation
User mode	Power ON
PC mode	Received commands from PC
Clone mode	[PTT]+[Side]+Power ON (Two seconds)

3. PC Mode

3-1. Preface

The transceiver is programmed by using a personal computer, a programming interface (KPG-22A/22U) and programming software (KPG-137D: ver.2.00 or later).

The programming software can be used with a PC. Figure 1 shows the setup of a PC for programming.

3-2. Connection Procedure

1. Connect the transceiver to the personal computer with the interface cable .

Note:

- You must install the KPG-22U driver in the computer to use the USB programming interface cable (KPG-22U).

REALIGNMENT

- When the POWER is switched on, user mode can be entered immediately. When the PC sends a command, the transceiver enters PC mode.
When data is read from the transceiver, the red LED lights.
When data is written to by the transceiver, the green LED lights.

Note:

- The data stored in the personal computer must match Model Name and Model Type when it is written into EEPROM.
- Do not press the [PTT] key during data transmission or reception.

3-3. KPG-22A Description

(PC programming interface cable: Option)

The KPG-22A is required to interface the transceiver with the computer. It has a circuit in its D-sub connector (KPG-22A: 9-pin) case that converts the RS-232C logic level to the TTL level.

The KPG-22A connects the SP/MIC connector of the transceiver to the RS-232C serial port of the computer.

3-4. KPG-22U Description

(USB programming interface cable: Option)

The KPG-22U is a cable which connects to a USB port on a computer.

When using the KPG-22U, install the supplied CD-ROM (with driver software) in the computer. The KPG-22U driver runs under Windows XP, Vista or 7.

3-5. Programming Software KPG-137D Description

The KPG-137D is the programming software for the transceiver supplied on a CD-ROM. This software runs under windows XP, Vista or 7 on a PC. The software on this disk allows a user to program the transceiver via Programming interface cable (KPG-22A/22U).

Note:

- Receive frequencies listed below may result in the interference of reception due to the harmonics of internal oscillators. Enter a frequency not listed in the table.

No.	FREQUENCY (MHz)
1	441.59375
2	441.59500
3	441.60000
4	441.60500
5	441.60625
6	460.79375
7	460.79500
8	460.80000
9	460.80500
10	460.80625

No.	FREQUENCY (MHz)
11	479.99375
12	479.99500
13	480.00000

Note: Guaranteed frequency range 440~470MHz

3-6. Programming with PC

If data is transferred to the transceiver from a PC with the FPU, the data for each set can be modified.

Data can be programmed into the EEPROM in RS-232C format via the SP/MIC jack.

In this mode the PTT line operate as TXD and RXD data lines respectively.

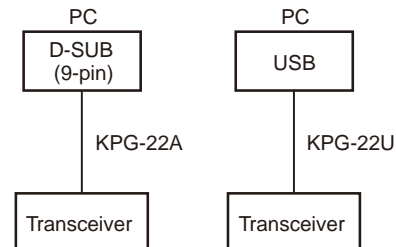
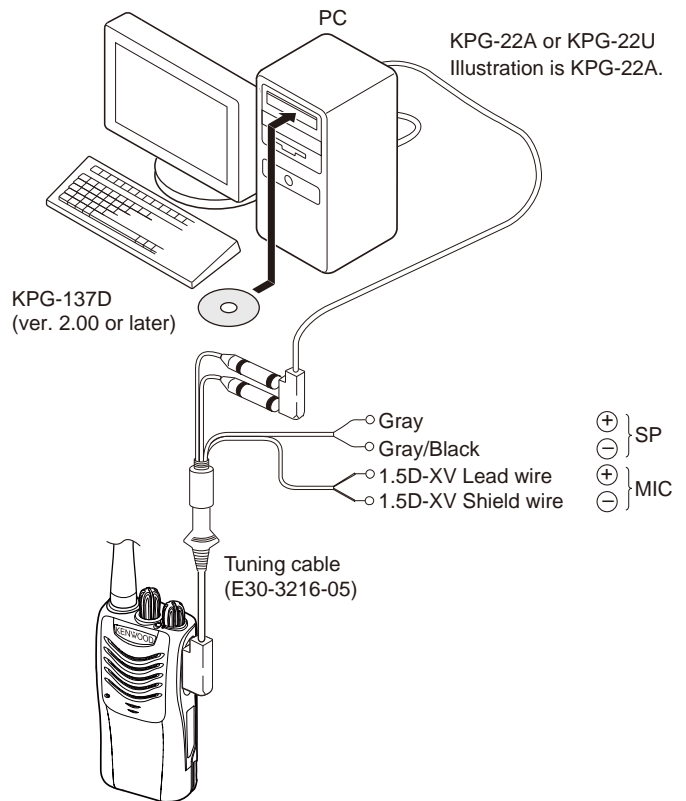

Fig. 1

REALIGNMENT

4. Clone mode

Programming data can be transferred from one transceiver to another by connecting them via their SP/MIC connectors.

Cloning can be performed as described below (the transmit transceiver is the source and the receive transceiver is the target).

The following data cannot be cloned.

- Tuning data
- Model name data
- ESN data

1. Turn the source transceiver and target transceiver power OFF.
2. Turn the source transceiver power ON while pressing the [PTT] and [Side] keys, to enter clone mode.
3. Connect the cloning cable (part No. E30-3410-05) to the SP/MIC connectors on the source and target transceivers.
4. Turn the target transceiver power ON.
5. Press the [Side] key on the source transceiver. The data of the source is sent to the target. While the source is sending data, red LED will light. While the target is receiving the data, green LED will light. When cloning of data is completed, the source red LED turned off, and the target automatically operates in the User mode.
6. Additional targets can be continuously cloned. When the [Side] key on the source is pressed, the data of the source is sent to the target again. Repeat steps 3 to 5 to clone additional transceivers.

Note:

- The Model name and Market codes must be the same in order to clone the transceiver.
- If the transceivers clone mode is configured as "Disabled", the transceiver cannot enter clone mode.
- If the Read authorization password is set to the transceiver, the transceiver cannot enter to the clone mode.
- Cannot be cloned if the password (overwrite password) is programmed to the target.

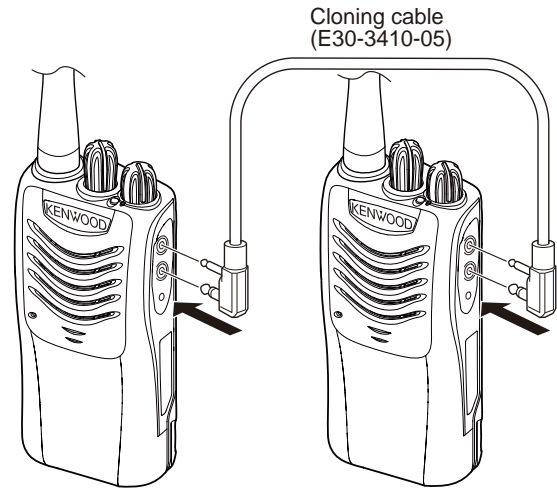
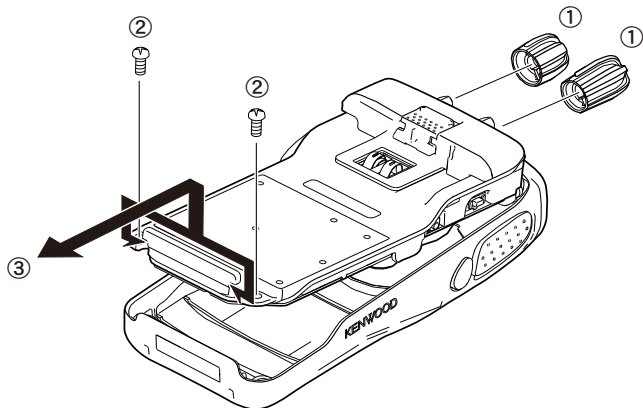

Fig. 2

DISASSEMBLY FOR REPAIR

1. Separating the Case Assembly from the Chassis

1. Remove the two knobs (1).
2. Remove the two screws (2).
3. Expand the right and left sides of the bottom of the case assembly, lift the chassis, and remove it from the case assembly (3).



4. Taking care not to cut the speaker lead (4), open the chassis and case assembly.

Note:

Solder the speaker wire back in its original position if you have removed it.

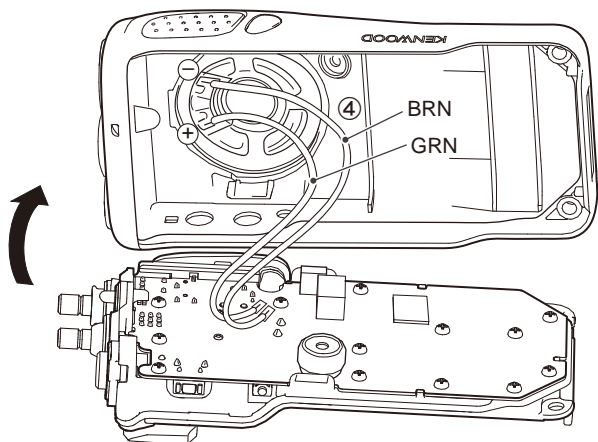

2. Removing the TX-RX unit from the Chassis

1. Remove the packing (5).
2. Remove the 13 screws (6).
3. Remove the packing (7) and two hexagon nuts (8).
4. Remove the solder from the antenna terminal using a soldering iron then lift the unit off (9).

Note:

When reassembling the unit in the chassis, be sure to solder the antenna terminal.

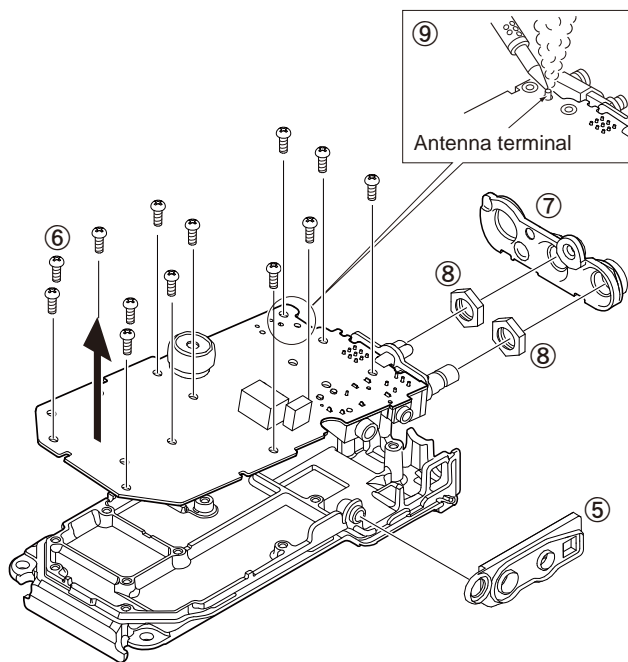

3. Removing the Rear Panel

1. Raise the rear panel on the chassis (10).

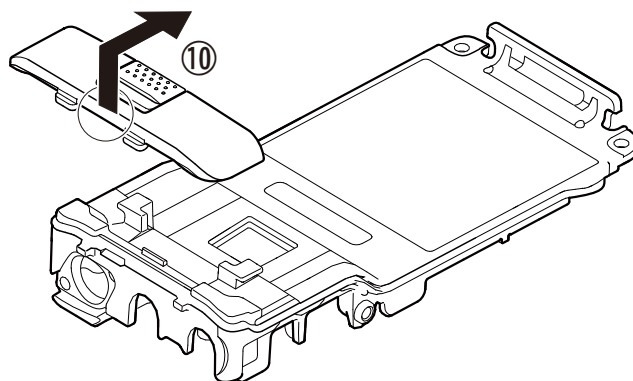

CIRCUIT DESCRIPTION

1. Frequency Configuration

The receiver utilizes double conversion. The first IF is 38.85MHz and the second IF is 450kHz. The first Local oscillator is supplied from the PLL circuit.

The PLL circuit in the transmitter generates the necessary frequencies.

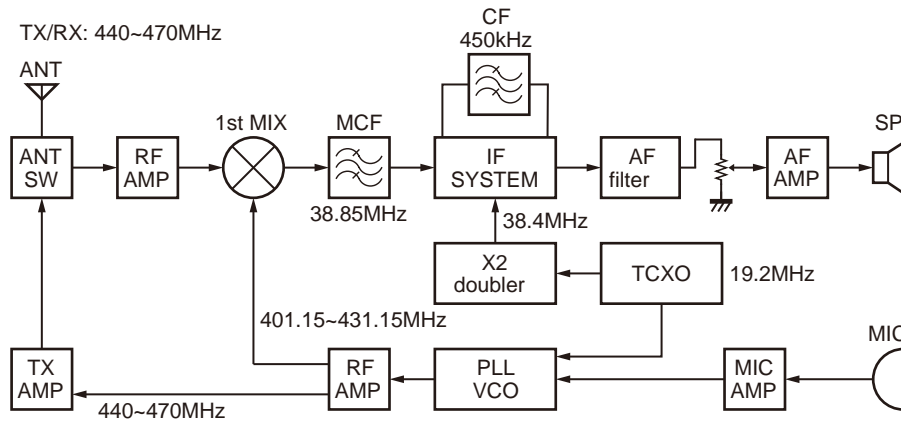

Fig. 1 Frequency configuration

2. Receiver System

The receiver system is shown in Figure 2.

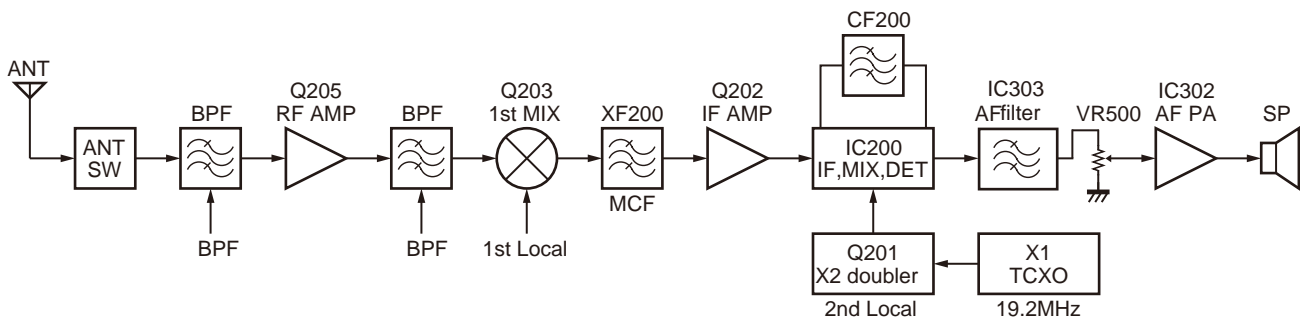

Fig. 2 Receiver system

2-1. Front End (RF Amplifier) Circuit

The signal coming from the antenna passes through the transmit/receive switching diode circuit (D101, D102, D103 and D105) and a BPF (L208 and L210), and is then amplified by the RF amplifier (Q205).

The resulting signal passes through a BPF (L215, L218 and L219) and goes to the mixer. These BPFs are adjusted by variable capacitors (D201, D202, and D204). The input voltage to the variable capacitor is a regulated voltage output from the DAC (IC300).

2-2. First Mixer

The signal from the front end is mixed with the first local oscillator signal generated in the PLL circuit by Q203 to produce a first IF frequency of 38.85 MHz.

The resulting signal passes through the XF200 MCF to cut the adjacent spurious and provide the optimum characteristics, such as adjacent frequency selectivity.

CIRCUIT DESCRIPTION

2-3. IF Amplifier Circuit

The first IF signal is passed through a four-pole monolithic crystal filter (XF200) to remove the adjacent channel signal.

The filtered first IF signal is amplified by the first IF amplifier (Q202) and then applied to the IF system IC (IC200).

The IF system IC provides a second mixer, second local oscillator, limiting amplifier, quadrature detector and RSSI (Received Signal Strength Indicator). The second mixer mixes the first IF signal with the 38.4MHz of the second local oscillator output (TCXO X1) and produces the second IF signal of 450kHz.

The second IF signal is passed through the ceramic filter (CF200) to remove the adjacent channel signal. The filtered second IF signal is amplified by the limiting amplifier and demodulated by the quadrature detector with the ceramic discriminator (CD201). The demodulated signal is routed to the audio circuit.

2-4. Audio Amplifier Circuit

The demodulated signal from IC200 is amplified by IC305, IC303 and goes to AF amplifier through IC302.

The signal then goes through an volume control (VR500), and is routed to an audio power amplifier (IC302) where it is amplified and output to the speaker.

To output sounds from the speaker, IC400 sends a high signal to the SPMUT line and turns IC400 on through Q300, Q301, Q302 and Q306.

3. Transmitter System

3-1. Microphone Amplifier Circuit

The signal from microphone amplified by IC301 and goes through mute switch (IC300).

IC304 is composed of high-pass filter, low-pass filter and pre-emphasis/IDC circuit.

The output signal from the DAC IC (IC300) goes to the VCO modulation input.

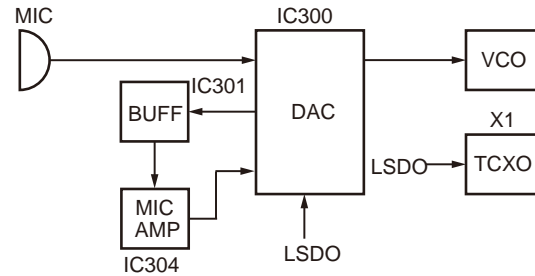

Fig. 3 Microphone amplifier circuit

3-2. Driver and Final Amplifier Circuit

The signal from the T/R switch (D100 is on) is amplified by the pre-drive amplifier (Q100) to 30mW.

The output of the pre-drive amplifier is amplified by the drive amplifier (Q101) and the RF final amplifier (Q102) to 4.0W (1W when the power is low).

The drive amplifier and the RF final amplifier consist of two MOS FET stages.

The output of the RF final amplifier is then passed through the harmonic filter (LPF) and antenna switch (D101 and D102) and is applied to the antenna terminal.

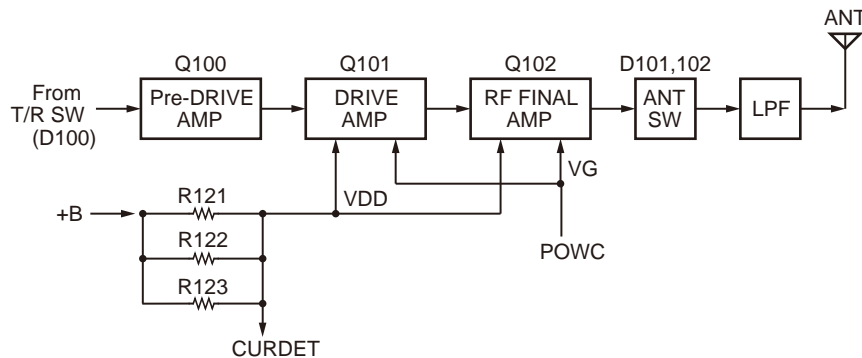

Fig. 4 Drive and final amplifier circuit

SEMICONDUCTOR DATA

MCU: F2136ACNKDRB (TX-RX unit: IC400)

Pin No.	Signal Name	I/O	Function
1	NC	O	NC
2	VREF	-	Reference voltage input
3	MODE	I	Mode select for MCU
4	NC	O	NC
5	NC	O	NC
6	RESET	I	Reset signal input
7	XOUT	O	Oscillation circuit
8	Vss	-	GND
9	XIN	I	Oscillation circuit
10	Vcc	-	Power supply
11	BSFT	O	Beat shift for MCU clock
12	NC	O	NC
13	NC	O	NC
14	NC	O	NC
15	E2WP	O	Write protect for EEPROM
16	E2DAT	I/O	Data input/output from EEPROM
17	E2CLK	O	Clock for EEPROM
18	CLOCK	O	Clock for PLL/DAC IC
19	DATA	O	Data for PLL/DAC IC
20	PLDL	O	Load enable for PLL IC
21	PLPS	O	Power saving for PLL IC
22	PLUL	I	Lock detect signal from PLL IC
23	NC	O	NC
24	EN4	I	Encoder input 4
25	EN3	I	Encoder input 3
26	EN2	I	Encoder input 2
27	EN1	I	Encoder input 1
28	NC	O	NC
29	OPTDET	I	2pin option detection
30	LEDR	O	LED (red) control
31	LEDG	O	LED (green) control
32	SPMUT	O	Power switch for AF amp
33	NC	O	NC
34	5TC	O	5T control
35	5CC	O	5C control (SAVE)
36	5MSC	O	5MS control
37	DACLD	O	Load enable for DAC IC
38	PTT	I	PTT key input
39	PFKEY	I	PF key input
40	INT	I	INT signal input
41	VDCSW	O	Voltage discharge switch
42	WID/NAR	O	Wide/Narrow control
43	RXD	I	Serial data input (FPU)
44	TXD	O	Serial data output (FPU)

Pin No.	Signal Name	I/O	Function
45	NC	O	NC
46	NC	O	NC
47	VOXIN	I	VOX level input
48	CVDET	I	VCO voltage detection
49	LSDO	O	Low speed data output
50	HSDO	O	DTMF/beep output
51	BATT	I	Battery voltage input
52	RSSI	I	RSSI input
53	SQL	I	Squelch input
54	LSDIN	I	LSD input
55	THDET	I	Thermistor input
56	CURDET	I	Current detection
57	T/RSHF	O	VCO shift control
58	5VC	O	5V control
59	NC	O	NC
60	NC	O	NC
61	NC	O	NC
62	TYPE2	I	Destination selection 2
63	TYPE1	I	Destination selection 1
64	5RC	O	5R control

COMPONENTS DESCRIPTION

TX-RX unit (X57-8102-71)

Ref. No.	Part Name	Description
IC1	IC	PLL system
IC200	IC	FM IF system
IC300	IC	DAC
IC301	IC	LSD buffer
IC302	IC	AF power AMP
IC303	IC	AF filter
IC304	IC	MIC AMP
IC305	IC	QT/DQT filter
IC400	IC	MCU
IC401	IC	EEPROM
IC500	IC	Voltage detector/RESET
IC501	IC	Voltage regulator/5V
IC503	IC	Voltage regulator/5V
Q1	Transistor	DC switch
Q2	Transistor	TX/RX RF switch
Q3	Transistor	Ripple filter
Q4	FET	VCO
Q5	Transistor	RF buffer AMP
Q6	Transistor	RF AMP
Q7	Transistor	Voltage regulator/3V
Q100	Transistor	Pre drive AMP
Q101	FET	Drive AMP
Q102	FET	Final AMP
Q103	Transistor	Voltage discharge switch
Q200	Transistor	W/N switch
Q201	Transistor	Doubler
Q202	Transistor	IF AMP
Q203	FET	Mixer
Q205	FET	RF AMP
Q300	Transistor	DC switch
Q301	Transistor	DC switch
Q302	FET	Mute switch
Q303	FET	DC switch
Q304	Transistor	DC switch
Q305	Transistor	W/N switch
Q306	FET	Mute switch
Q400	Transistor	Switch
Q401	Transistor	DC switch
Q402	Transistor	DC switch
Q500	FET	DC switch
Q501	FET	DC switch
Q502	Transistor	DC switch
D1	Diode	Current steering

Ref. No.	Part Name	Description
D2	Variable capacitance diode	Frequency control/ VCO
D3	Variable capacitance diode	Frequency control/ VCO
D4	Diode	TX/RX RF switch
D5	Variable capacitance diode	Frequency control/ VCO
D6	Variable capacitance diode	Modulator /TX VCO
D7	Diode	Ripple filter
D8	Diode	Current steering
D100	Diode	TX/RX RF switch
D101	Diode	ANT switch
D102	Diode	ANT switch
D103	Diode	ANT switch
D105	Diode	ANT switch
D200	Diode	TX/RX RF switch
D201	Variable capacitance diode	RX BPF tuning
D202	Variable capacitance diode	RX BPF tuning
D204	Variable capacitance diode	RX BPF tuning
D260	Variable capacitance diode	RX BPF tuning
D261	Variable capacitance diode	RX BPF tuning
D301	Diode	Current steering
D400	LED	LED/green
D401	LED	LED/red
D402	Diode	VCO speed up
D500	Diode	Protect
D501	Diode	Current steering

TK-3000

PARTS LIST

* New Parts. Δ indicates safety critical components.
 Parts without **Parts No.** are not supplied.
 Les articles non mentionnés dans le **Parts No.** ne sont pas fournis.
 Teile ohne **Parts No.** werden nicht geliefert.

L : Scandinavia K : USA P : Canada
 Y : PX (Far East, Hawaii) T : England E : Europe
 C : China X : Australia M : Other Areas

TK-3000 TX-RX UNIT (X57-8102-71)

Ref. No.	Address	New parts	Parts No.	Description	Desti-nation
TK-3000					
1	1A		A02-4135-13	PLASTIC CABINET ASSY	
2	3A		A10-4150-41	CHASSIS	
3	3B		A82-0081-02	REAR PANEL	
4	2B		B11-1892-03	ILLUMINATION GUIDE	
6	3B		E04-0486-05	RF COAXIAL RECEPTACLE(SMA)	
7	2A		E23-1364-04	TERMINAL	
8	1B		E37-1539-05	PROCESSED LEAD WIRE(SP-BRN)	
9	1B		E37-1540-05	PROCESSED LEAD WIRE(SP+GRN)	
10	2A		E72-0436-03	TERMINAL BLOCK	
11	2B	*	F10-3186-04	SHIELDING CASE	
12	3B		G01-4571-04	COIL SPRING	
13	2A		G11-4437-04	SHEET(Q102-SHASSIS)	
14	3A		G13-2364-14	CUSHION(CHASSIS)	
15	3B		G13-2366-04	CUSHION(BATT-TERMINAL)	
16	2A		G53-1867-13	PACKING(CHASSIS)	
18	1B		G53-1868-12	PACKING(TOP)	
19	3B		G53-1869-13	PACKING(JACK)	
20	1A		G53-1871-14	PACKING(MIC)	
22	1B		K29-9487-03	KNOB(VOL)	
23	1B		K29-9488-03	KNOB(SELECTOR)	
24	1A	*	K29-9489-13	KNOB(PTT)	
25	1A		K29-9490-13	BUTTON KNOB(SIDE)	
26	3B		K29-9491-03	LEVER KNOB(BATTERY)	
A	2B		N09-2438-05	BINDING HEAD SCREW	
B	3A		N30-2606-48	PAN HEAD MACHINE SCREW	
C	1A,2A		N83-2005-48	PAN HEAD TAPTITE SCREW	
28	1B		T07-0787-05	SPEAKER	
ACCESSORY					
			B09-0744-03	CAP(SP/MIC) ACCESSORY	
		*	B62-2418-00	INSTRUCTION MANUAL ACCESSORY	
		*	B62-2425-00	INSTRUCTION MANUAL ACCESSORY	
		*	B62-2426-00	INSTRUCTION MANUAL ACCESSORY	
		*	B62-2427-00	INSTRUCTION MANUAL ACCESSORY	
		*	B62-2428-00	INSTRUCTION MANUAL ACCESSORY	
		*	B62-2429-00	INSTRUCTION MANUAL ACCESSORY	
		*	B62-2430-00	INSTRUCTION MANUAL ACCESSORY	
		*	B62-2431-00	INSTRUCTION MANUAL ACCESSORY	
			J29-0756-05	BELT CLIP ACCESSORY	
			N35-3005-43	BINDING HEAD SCREW ACCESSORY	
			T90-1096-05	WHIP ANTENNA ACCESSORY	
			W08-1246-15	AC ADAPTER ACCESSORY	E
		*	W08-1249-35	CHARGER ACCESSORY	
		*	W08-1251-15	AC ADAPTER ACCESSORY	T
		*	W09-1073-15	BATTERY ASSY ACCESSORY	
		*	X57-8102-72	TX-RX UNIT(FOR SERVICE)	

Ref. No.	Address	New parts	Parts No.	Description	Desti-nation
TX-RX UNIT (X57-8102-71)					
D400			B30-1782-05	LED(GREEN)	
D401			B30-1779-05	LED(RED)	
C1			CS77CA1ER47M	CHIP TNTL 0.47UF 25WV	
C2			CK73HB1H102K	CHIP C 1000PF K	
C3			CK73HB1A104K	CHIP C 0.10UF K	
C4			CS77CA1C100M	CHIP TNTL 10UF 16WV	
C5			CS77CA1E010M	CHIP TNTL 1.0UF 25WV	
C7			CC73HCH1H150J	CHIP C 15PF J	
C8			CK73HB1A104K	CHIP C 0.10UF K	
C9			CC73HCH1H030B	CHIP C 3.0PF B	
C10 , 11			CK73HB1A105K	CHIP C 1.0UF K	
C12			CC73HCH1H220J	CHIP C 22PF J	
C13			CS77CP0J010M	CHIP TNTL 1.0UF 6.3WV	
C14 , 15			CK73HB1C103K	CHIP C 0.010UF K	
C16			CK73HB1H102K	CHIP C 1000PF K	
C17			CC73HCH1H040B	CHIP C 4.0PF B	
C19			CK73HB1H102K	CHIP C 1000PF K	
C20			CS77CA1A220M	CHIP TNTL 22UF 10WV	
C21 , 22			CC73GCH1HR75B	CHIP C 0.75PF B	
C23 , 24			CK73HB1H102K	CHIP C 1000PF K	
C25			CC73HCH1H050B	CHIP C 5.0PF B	
C26			CK73HB1H102K	CHIP C 1000PF K	
C27			CC73HCH1H220J	CHIP C 22PF J	
C28			CK73HB1H102K	CHIP C 1000PF K	
C29			CC73GCH1H0R5B	CHIP C 0.5PF B	
C30			CK73HB1H102K	CHIP C 1000PF K	
C31			CK73HB1C103K	CHIP C 0.010UF K	
C32			CK73HB1H102K	CHIP C 1000PF K	
C33			CC73HCH1H330J	CHIP C 33PF J	
C34			CK73HB1H102K	CHIP C 1000PF K	
C35			CC73HCH1H060B	CHIP C 6.0PF B	
C36			CC73HCH1H020B	CHIP C 2.0PF B	
C37			CC73HCH1H060B	CHIP C 6.0PF B	
C38			CC73GCH1H220J	CHIP C 22PF J	
C39			CC73HCH1H100B	CHIP C 10PF B	
C40 , 41			CK73HB1H102K	CHIP C 1000PF K	
C42			CC73HCH1H040B	CHIP C 4.0PF B	
C43			CK73HB1H102K	CHIP C 1000PF K	
C54 , 55			CC73HCH1H040B	CHIP C 4.0PF B	
C100			CC73HCH1H100B	CHIP C 10PF B	
C101			CC73HCH1H271J	CHIP C 270PF J	
C102			CC73HCH1H220J	CHIP C 22PF J	
C103,104			CC73HCH1H271J	CHIP C 270PF J	
C105			CK73HB1A104K	CHIP C 0.10UF K	
C107			CC73HCH1H271J	CHIP C 270PF J	
C108			CC73HCH1H120J	CHIP C 12PF J	
C109			CC73HCH1H090B	CHIP C 9.0PF B	
C110,111			CC73HCH1H271J	CHIP C 270PF J	
C112			CC73HCH1H221J	CHIP C 220PF J	
C113,114			CC73HCH1H271J	CHIP C 270PF J	
C116			CK73HB1C103K	CHIP C 0.010UF K	
C117			CK73FB1A225K	CHIP C 2.2UF K	
C119,120			CC73HCH1H271J	CHIP C 270PF J	

PARTS LIST

TX-RX UNIT (X57-8102-71)

Ref. No.	Address	New parts	Parts No.	Description	Desti-nation	Ref. No.	Address	New parts	Parts No.	Description	Desti-nation
C124			CC73HCH1H271J	CHIP C 270PF J		C241-244			CK73HB1H471K	CHIP C 470PF K	
C127			CC73GCH1H181J	CHIP C 180PF J		C245			CC73HCH1H050B	CHIP C 5.0PF B	
C129			CC73HCH1H271J	CHIP C 270PF J		C246			CK73HB1H471K	CHIP C 470PF K	
C130			CC73GCH1H060B	CHIP C 6.0PF B		C247			CC73HCH1H0R5B	CHIP C 0.5PF B	
C131			CC73GCH1H181J	CHIP C 180PF J		C248			CK73HB1H471K	CHIP C 470PF K	
C132			CC73GCH1H050B	CHIP C 5.0PF B		C250			CC73HCH1H271J	CHIP C 270PF J	
C133			CC73HCH1H060B	CHIP C 6.0PF B		C252			CC73HCH1H0R5B	CHIP C 0.5PF B	
C134			CC73HCH1H271J	CHIP C 270PF J		C253			CC73HCH1H270J	CHIP C 27PF J	
C135			CC73GCH1H020B	CHIP C 2.0PF B		C254			CC73HCH1H040B	CHIP C 4.0PF B	
C136			CC73GCH1H080B	CHIP C 8.0PF B		C255			CK73HB1A104K	CHIP C 0.10UF K	
C137			CC73GCH1H020B	CHIP C 2.0PF B		C256			CK73HB1H471K	CHIP C 470PF K	
C138			CC73GCH1H030B	CHIP C 3.0PF B		C257			CC73HCH1H020B	CHIP C 2.0PF B	
C139			CK73FB1A475K	CHIP C 4.7UF K		C258			CK73HB1H471K	CHIP C 470PF K	
C145			CC73HCH1H271J	CHIP C 270PF J		C259			CK73HB1C103K	CHIP C 0.010UF K	
C146			CC73HCH1H1R5B	CHIP C 1.5PF B		C262			CK73HB1H471K	CHIP C 470PF K	
C150			CC73HCH1H020C	CHIP C 2.0PF C		C263			CC73HCH1H180J	CHIP C 18PF J	
C153			CC73HCH1H390J	CHIP C 39PF J		C268			CC73HCH1H150J	CHIP C 15PF J	
C158,159			CC73HCH1H271J	CHIP C 270PF J		C269			CC73HCH1H220J	CHIP C 22PF J	
C170			CC73GCH1H390J	CHIP C 39PF J		C270			CC73HCH1H2R5B	CHIP C 2.5PF B	
C172			CC73GCH1H070B	CHIP C 7.0PF B		C271			CC73HCH1H030B	CHIP C 3.0PF B	
C174			CC73GCH1H330J	CHIP C 33PF J		C274			CK73HB1H471K	CHIP C 470PF K	
C175			CC73GCH1H030B	CHIP C 3.0PF B		C275			CK73HB1C103K	CHIP C 0.010UF K	
C181			CC73GCH1H020B	CHIP C 2.0PF B		C276			CK73HB1H471K	CHIP C 470PF K	
C184			CC73GCH1H060B	CHIP C 6.0PF B		C277			CK73HB1A104K	CHIP C 0.10UF K	
C186			CC73GCH1H060B	CHIP C 6.0PF B		C300,301			CK73HB1H102K	CHIP C 1000PF K	
C195			CC73HCH1H101J	CHIP C 100PF J		C302			C92-0953-05	ELECTRO 100UF 6.3WV	
C200			CK73FB1A106K	CHIP C 10UF K		C303			CK73HB1C473K	CHIP C 0.047UF K	
C201			CK73HB1H102K	CHIP C 1000PF K		C304			CK73FB1A106K	CHIP C 10UF K	
C202			CK73HB1C103K	CHIP C 0.010UF K		C305			CK73HB1C103K	CHIP C 0.010UF K	
C203			CC73HCH1H101J	CHIP C 100PF J		C306			CK73HB1A224K	CHIP C 0.22UF K	
C204			CK73HB1E223K	CHIP C 0.022UF K		C308			CK73GB1E105K	CHIP C 1.0UF K	
C205			CK73HB1A104K	CHIP C 0.10UF K		C309			CK73HB1A104K	CHIP C 0.10UF K	
C206,207			CC73HCH1H391J	CHIP C 390PF J		C310			CK73HB1C473K	CHIP C 0.047UF K	
C208			CK73HB1A104K	CHIP C 0.10UF K		C311			CK73HB1A105K	CHIP C 1.0UF K	
C209			CC73HCH1H220J	CHIP C 22PF J		C312			CK73HB1C473K	CHIP C 0.047UF K	
C210			CK73HB1A104K	CHIP C 0.10UF K		C313			CK73HB1A104K	CHIP C 0.10UF K	
C211			CK73HB1C333K	CHIP C 0.033UF K		C314			CC73HCH1H101J	CHIP C 100PF J	
C212,213			CK73HB1A104K	CHIP C 0.10UF K		C315			CK73FB1A106K	CHIP C 10UF K	
C214			CK73HB1C103K	CHIP C 0.010UF K		C316			CK73HB1A104K	CHIP C 0.10UF K	
C215			CC73HCH1H220J	CHIP C 22PF J		C317			CK73HB1C103K	CHIP C 0.010UF K	
C216			CK73HB1C103K	CHIP C 0.010UF K		C318			CC73HCH1H221J	CHIP C 220PF J	
C217			CC73HCH1H050C	CHIP C 5.0PF C		C319			CK73HB1C103K	CHIP C 0.010UF K	
C218			CK73HB1C103K	CHIP C 0.010UF K		C320			CK73GB1E104K	CHIP C 0.10UF K	
C219			CC73HCH1H220J	CHIP C 22PF J		C321			CK73HB1C103K	CHIP C 0.010UF K	
C220			CK73HB1H102K	CHIP C 1000PF K		C322			CC73HCH1H271J	CHIP C 270PF J	
C221			CK73HB1C103K	CHIP C 0.010UF K		C323			CK73HB1A104K	CHIP C 0.10UF K	
C222			CC73HCH1H080D	CHIP C 8.0PF D		C324			CK73HB1A184K	CHIP C 0.18UF K	
C223			CC73HCH1H080B	CHIP C 8.0PF B		C325			CK73HB1E153K	CHIP C 0.015UF K	
C224			CK73HB1C103K	CHIP C 0.010UF K		C326			CK73HB1H822K	CHIP C 8200PF K	
C225			CC73HCH1H060B	CHIP C 6.0PF B		C328			CK73HB1A184K	CHIP C 0.18UF K	
C226			CK73HB1H471K	CHIP C 470PF K		C329			CK73HB1C333K	CHIP C 0.033UF K	
C227			CK73HB1C103K	CHIP C 0.010UF K		C330			CK73HB1H102K	CHIP C 1000PF K	
C228			CC73HCH1H020B	CHIP C 2.0PF B		C332			CK73HB1C103K	CHIP C 0.010UF K	
C230			CC73HCH1H060B	CHIP C 6.0PF B		C333			CK73HB1H102K	CHIP C 1000PF K	
C233			CC73HCH1H040B	CHIP C 4.0PF B		C334,335			CK73HB1A184K	CHIP C 0.18UF K	
C236			CC73HCH1H330J	CHIP C 33PF J		C336			CK73HB1C103K	CHIP C 0.010UF K	
C237			CC73HCH1H220J	CHIP C 22PF J		C337			CK73HB1A184K	CHIP C 0.18UF K	
C238			CC73HCH1H060B	CHIP C 6.0PF B		C338			CC73HCH1H331J	CHIP C 330PF J	
C239			CC73HCH1HR75B	CHIP C 0.75PF B		C339			CK73HB1A563K	CHIP C 0.056UF K	
C240			CC73HCH1H060B	CHIP C 6.0PF B		C340			CC73HCH1H100B	CHIP C 10PF B	

PARTS LIST

TX-RX UNIT (X57-8102-71)

Ref. No.	Address	New parts	Parts No.	Description	Destination	Ref. No.	Address	New parts	Parts No.	Description	Destination
C341			CK73HB1H222K	CHIP C 2200PF K		L10			L40-2785-92	SMALL FIXED INDUCTOR(270NH)	
C342			CK73HB1C103K	CHIP C 0.010UF K		L12			L40-2785-92	SMALL FIXED INDUCTOR(270NH)	
C343			CK73HB1A184K	CHIP C 0.18UF K		L51			L41-4795-39	SMALL FIXED INDUCTOR(4.7UH)	
C344			CK73HB1C273K	CHIP C 0.027UF K		L100			L40-1575-71	SMALL FIXED INDUCTOR(15NH)	
C345			CK73HB1H102K	CHIP C 1000PF K		L101			L40-3375-71	SMALL FIXED INDUCTOR(33NH)	
C346			CK73HB1A184K	CHIP C 0.18UF K		L102			L40-1275-71	SMALL FIXED INDUCTOR(12NH)	
C347			CK73GB1A105K	CHIP C 1.0UF K		L103			L41-3375-53	SMALL FIXED INDUCTOR(33NH)	
C349			CK73HB1A154K	CHIP C 0.15UF K		L104			L34-4572-05	AIR-CORE COIL(4T)	
C350			CK73HB1H102K	CHIP C 1000PF K		L109			L41-2285-14	SMALL FIXED INDUCTOR(220NH)	
C352			CK73HB1H102K	CHIP C 1000PF K		L110-112			L34-4572-05	AIR-CORE COIL(4T)	
C353			CK73GB1E105K	CHIP C 1.0UF K		L204			L41-5685-39	SMALL FIXED INDUCTOR(0.56UH)	
C354			CK73HB1A224K	CHIP C 0.22UF K		L205			L40-1575-71	SMALL FIXED INDUCTOR(15NH)	
C355			CK73HB1A105K	CHIP C 1.0UF K		L208			L41-8268-14	SMALL FIXED INDUCTOR(8.2NH)	
C357,358			CK73HB1A104K	CHIP C 0.10UF K		L210			L41-8268-14	SMALL FIXED INDUCTOR(8.2NH)	
C360			CK73HB1A104K	CHIP C 0.10UF K		L211			L40-5681-86	SMALL FIXED INDUCTOR(0.56UH)	
C361			CC73HCH1H101J	CHIP C 100PF J		L212			L40-8281-86	SMALL FIXED INDUCTOR(0.82UH)	
C385,386			CC73HCH1H101J	CHIP C 100PF J		L213			L40-5681-86	SMALL FIXED INDUCTOR(0.56UH)	
C397			CC73HCH1H271J	CHIP C 270PF J		L214			L40-2775-71	SMALL FIXED INDUCTOR(27NH)	
C400			CK73HB1A104K	CHIP C 0.10UF K		L215			L41-8268-14	SMALL FIXED INDUCTOR(8.2NH)	
C401			CK73HB1H102K	CHIP C 1000PF K		L216			L40-1885-92	SMALL FIXED INDUCTOR(180NH)	
C402			CC73HCH1H120J	CHIP C 12PF J		L217			L41-2785-45	SMALL FIXED INDUCTOR(270NH)	
C403			CC73HCH1H010B	CHIP C 1.0PF B		L218,219			L41-8268-14	SMALL FIXED INDUCTOR(8.2NH)	
C404			CK73HB1A104K	CHIP C 0.10UF K		X1			L77-3074-05	TCXO (19.2 MHZ)	
C405			CK73HB1H102K	CHIP C 1000PF K		X400			L77-2974-05	CRYSTAL RESONATOR(11.0592MHZ)	
C406			CC73HCH1H120J	CHIP C 12PF J		XF200			L71-0669-05	MCF(38.85MHZ)	
C407			CK73HB1H102K	CHIP C 1000PF K		R1			RK73HB1J105J	CHIP R 1.0M J 1/16W	
C408			CK73HB1C103K	CHIP C 0.010UF K		R2			RK73HB1J103J	CHIP R 10K J 1/16W	
C409			CK73HB1H102K	CHIP C 1000PF K		R3			RK73HB1J222J	CHIP R 2.2K J 1/16W	
C411-415			CK73HB1H102K	CHIP C 1000PF K		R5			RK73HB1J821J	CHIP R 820 J 1/16W	
C500			CC73HCH1H101J	CHIP C 100PF J		R7			RK73HB1J272J	CHIP R 2.7K J 1/16W	
C501,502			CK73HB1H102K	CHIP C 1000PF K		R9			RK73HB1J103J	CHIP R 10K J 1/16W	
C503			CK73FB1A475K	CHIP C 4.7UF K		R11			RK73HB1J104J	CHIP R 100K J 1/16W	
C504			CK73HB1H102K	CHIP C 1000PF K		R12			RK73HB1J272J	CHIP R 2.7K J 1/16W	
C505			CK73GB1E105K	CHIP C 1.0UF K		R13			RK73HB1J104J	CHIP R 100K J 1/16W	
C506			CK73HB1H102K	CHIP C 1000PF K		R14			RK73HB1J103J	CHIP R 10K J 1/16W	
C507			CK73FB1A106K	CHIP C 10UF K		R15			RK73HB1J104J	CHIP R 100K J 1/16W	
C511			CK73HB1H102K	CHIP C 1000PF K		R16,17			RK73HB1J103J	CHIP R 10K J 1/16W	
C513,514			CK73GB1E105K	CHIP C 1.0UF K		R18			RK73HB1J223J	CHIP R 22K J 1/16W	
C515,516			CC73HCH1H271J	CHIP C 270PF J		R19 -22			RK73HB1J103J	CHIP R 10K J 1/16W	
C517			CK73FB1A475K	CHIP C 4.7UF K		R25			RK73HB1J100J	CHIP R 10 J 1/16W	
C522-525			CC73HCH1H271J	CHIP C 270PF J		R26			RK73HB1J392J	CHIP R 3.9K J 1/16W	
CN101			E23-1167-05	TERMINAL		R27			RK73HB1J221J	CHIP R 220 J 1/16W	
CN104			E23-1167-05	TERMINAL		R28			RK73HB1J680J	CHIP R 68 J 1/16W	
J300	2B		E11-0484-05	3.5D PHONE JACK(3.5D/MIC)		R29			RK73HB1J472J	CHIP R 4.7K J 1/16W	
J301	2B		E11-0717-05	2.5D PHONE JACK(2.5D/SP)		R30			RK73HB1J470J	CHIP R 47 J 1/16W	
F101			F53-0287-05	FUSE(0.5A)		R32			RK73HB1J102J	CHIP R 1.0K J 1/16W	
F300			F53-0467-05	FUSE(0.315A)		R33			RK73HB1J473J	CHIP R 47K J 1/16W	
F500			F53-0372-05	FUSE(3.15A)		R34			RK73HB1J100J	CHIP R 10 J 1/16W	
101	2A		J30-1308-04	SPACER(MIC300)		R37			RK73HB1J562J	CHIP R 5.6K J 1/16W	
CF200	2A		L72-1046-05	CERAMIC FILTER(450KHZ)		R38			RK73HB1J332J	CHIP R 3.3K J 1/16W	
CD200	2A		L79-1914-05	TUNING COIL		R39			RK73HB1J271J	CHIP R 270 J 1/16W	
L1			L40-2785-92	SMALL FIXED INDUCTOR(270NH)		R40			RK73HB1J222J	CHIP R 2.2K J 1/16W	
L2			L41-5668-14	SMALL FIXED INDUCTOR(5.6NH)		R41			RK73HB1J100J	CHIP R 10 J 1/16W	
L3			L41-1878-14	SMALL FIXED INDUCTOR(18NH)		R42			RK73HB1J332J	CHIP R 3.3K J 1/16W	
L4 -6			L40-2785-92	SMALL FIXED INDUCTOR(270NH)		R43			RK73HB1J103J	CHIP R 10K J 1/16W	
L7			L40-2775-71	SMALL FIXED INDUCTOR(27NH)		R45			RK73HB1J000J	CHIP R 0 J 1/16W	
L8			L40-1575-71	SMALL FIXED INDUCTOR(15NH)		R50			RK73HB1J104J	CHIP R 100K J 1/16W	
L9			L40-2275-71	SMALL FIXED INDUCTOR(22NH)		R51			RK73HB1J333J	CHIP R 33K J 1/16W	
						R100			RK73HB1J472J	CHIP R 4.7K J 1/16W	
						R101			RK73HB1J102J	CHIP R 1.0K J 1/16W	

PARTS LIST

TX-RX UNIT (X57-8102-71)

Ref. No.	Address	New parts	Parts No.	Description	Desti-nation	Ref. No.	Address	New parts	Parts No.	Description	Desti-nation
R102			RK73HB1J222J	CHIP R 2.2K J 1/16W		R303			RK73HB1J471J	CHIP R 470 J 1/16W	
R103			RK73HB1J150J	CHIP R 15 J 1/16W		R304			RK73HB1J473J	CHIP R 47K J 1/16W	
R104			RK73HB1J222J	CHIP R 2.2K J 1/16W		R305-308			RK73HB1J102J	CHIP R 1.0K J 1/16W	
R105			RK73HB1J100J	CHIP R 10 J 1/16W		R309			RK73HB1J182J	CHIP R 1.8K J 1/16W	
R106			RK73HB1J473J	CHIP R 47K J 1/16W		R310,311			RK73HB1J102J	CHIP R 1.0K J 1/16W	
R107			RK73HB1J270J	CHIP R 27 J 1/16W		R312,313			RK73HB1J222J	CHIP R 2.2K J 1/16W	
R108			RK73HB1J683J	CHIP R 68K J 1/16W		R314			RK73HB1J392J	CHIP R 3.9K J 1/16W	
R109			RK73HB1J470J	CHIP R 47 J 1/16W		R315			RK73HB1J103J	CHIP R 10K J 1/16W	
R111			RK73HB1J683J	CHIP R 68K J 1/16W		R316			RK73HB1J000J	CHIP R 0 J 1/16W	
R112			RK73HB1J390J	CHIP R 39 J 1/16W		R317			RK73HB1J334J	CHIP R 330K J 1/16W	
R113			RK73HB1J473J	CHIP R 47K J 1/16W		R318			RK73HB1J274J	CHIP R 270K J 1/16W	
R114			RK73GB2A000J	CHIP R 0 J 1/10W		R321			RK73HB1J474J	CHIP R 470K J 1/16W	
R115			RK73FB2B000J	CHIP R 0 J 1/8W		R322			RK73HB1J105J	CHIP R 1.0M J 1/16W	
R116			RK73HB1J393J	CHIP R 39K J 1/16W		R323			RK73HB1J562J	CHIP R 5.6K J 1/16W	
R117			RK73HB1J271J	CHIP R 270 J 1/16W		R324,325			RK73HH1J473D	CHIP R 47K D 1/16W	
R119			RK73HB1J271J	CHIP R 270 J 1/16W		R326			RK73HB1J101J	CHIP R 100 J 1/16W	
R120			RK73HB1J331J	CHIP R 330 J 1/16W		R327			RK73HB1J824J	CHIP R 820K J 1/16W	
R121-123			RK73EB2ER39K	CHIP R 0.39 K 1/4W		R328			RK73HB1J684J	CHIP R 680K J 1/16W	
R136			RK73HB1J182J	CHIP R 1.8K J 1/16W		R329,330			RK73HB1J103J	CHIP R 10K J 1/16W	
R138,139			RK73GB2A000J	CHIP R 0 J 1/10W		R331			RK73HB1J473J	CHIP R 47K J 1/16W	
R155			RK73HB1J150J	CHIP R 15 J 1/16W		R332			RK73HB1J272J	CHIP R 2.7K J 1/16W	
R156,157			RK73HB1J000J	CHIP R 0 J 1/16W		R334			RK73HB1J103J	CHIP R 10K J 1/16W	
R200			RK73HB1J103J	CHIP R 10K J 1/16W		R335			RK73HB1J000J	CHIP R 0 J 1/16W	
R201			RK73HB1J470J	CHIP R 47 J 1/16W		R336			RK73HB1J473J	CHIP R 47K J 1/16W	
R202			RK73HB1J471J	CHIP R 470 J 1/16W		R337			RK73HB1J000J	CHIP R 0 J 1/16W	
R203			RK73HB1J184J	CHIP R 180K J 1/16W		R340			RK73HB1J103J	CHIP R 10K J 1/16W	
R204			RK73HB1J271J	CHIP R 270 J 1/16W		R342			RK73HB1J153J	CHIP R 15K J 1/16W	
R205			RK73HB1J682J	CHIP R 6.8K J 1/16W		R344			RK73HB1J103J	CHIP R 10K J 1/16W	
R206			RK73HB1J684J	CHIP R 680K J 1/16W		R345			RK73HB1J561J	CHIP R 560 J 1/16W	
R207			RK73HB1J562J	CHIP R 5.6K J 1/16W		R347			RK73HB1J103J	CHIP R 10K J 1/16W	
R208,209			RK73HB1J101J	CHIP R 100 J 1/16W		R348			RK73HB1J183J	CHIP R 18K J 1/16W	
R210			RK73HB1J334J	CHIP R 330K J 1/16W		R350			RK73HB1J471J	CHIP R 470 J 1/16W	
R212			RK73HB1J394J	CHIP R 390K J 1/16W		R351			RK73HB1J561J	CHIP R 560 J 1/16W	
R213			RK73HB1J332J	CHIP R 3.3K J 1/16W		R352			RK73HB1J104J	CHIP R 100K J 1/16W	
R214			RK73HB1J561J	CHIP R 560 J 1/16W		R353			RK73HB1J102J	CHIP R 1.0K J 1/16W	
R215			RK73HB1J331J	CHIP R 330 J 1/16W		R354			RK73HB1J334J	CHIP R 330K J 1/16W	
R217			RK73HB1J152J	CHIP R 1.5K J 1/16W		R355			RK73HB1J473J	CHIP R 47K J 1/16W	
R218			RK73HB1J102J	CHIP R 1.0K J 1/16W		R356			RK73HB1J183J	CHIP R 18K J 1/16W	
R220			RK73HB1J104J	CHIP R 100K J 1/16W		R357			RK73HB1J564J	CHIP R 560K J 1/16W	
R221			RK73HB1J563J	CHIP R 56K J 1/16W		R358			RK73HB1J473J	CHIP R 47K J 1/16W	
R222			RK73HB1J104J	CHIP R 100K J 1/16W		R360			RK73HB1J184J	CHIP R 180K J 1/16W	
R223			RK73HB1J000J	CHIP R 0 J 1/16W		R361			RK73HB1J821J	CHIP R 820 J 1/16W	
R224			RK73HB1J563J	CHIP R 56K J 1/16W		R363			RK73HB1J562J	CHIP R 5.6K J 1/16W	
R225			RK73HB1J000J	CHIP R 0 J 1/16W		R364			RK73HB1J471J	CHIP R 470 J 1/16W	
R226,227			RK73HB1J474J	CHIP R 470K J 1/16W		R365			RK73HB1J000J	CHIP R 0 J 1/16W	
R229			RK73HB1J474J	CHIP R 470K J 1/16W		R366			RK73HB1J104J	CHIP R 100K J 1/16W	
R230			RK73HB1J000J	CHIP R 0 J 1/16W		R367			RK73HB1J473J	CHIP R 47K J 1/16W	
R231			RK73HB1J331J	CHIP R 330 J 1/16W		R369			RK73HB1J103J	CHIP R 10K J 1/16W	
R232,233			RK73HB1J104J	CHIP R 100K J 1/16W		R370			RK73HH1J473D	CHIP R 47K D 1/16W	
R235			RK73HB1J8R2J	CHIP R 8.2 J 1/16W		R371			RK73HB1J182J	CHIP R 1.8K J 1/16W	
R237,238			RK73HB1J474J	CHIP R 470K J 1/16W		R372			RK73HH1J473D	CHIP R 47K D 1/16W	
R239			RK73HB1J101J	CHIP R 100 J 1/16W		R373			RK73HB1J000J	CHIP R 0 J 1/16W	
R240			RK73HB1J683J	CHIP R 68K J 1/16W		R374			RK73HH1J473D	CHIP R 47K D 1/16W	
R241,242			RK73HB1J470J	CHIP R 47 J 1/16W		R375			RK73HB1J103J	CHIP R 10K J 1/16W	
R243,244			RK73HB1J000J	CHIP R 0 J 1/16W		R376			RK73HH1J473D	CHIP R 47K D 1/16W	
R258			RK73HB1J000J	CHIP R 0 J 1/16W		R377			RK73HB1J393J	CHIP R 39K J 1/16W	
R267			RK73HB1J000J	CHIP R 0 J 1/16W		R378			RK73HB1J102J	CHIP R 1.0K J 1/16W	
R300			RK73HB1J152J	CHIP R 1.5K J 1/16W		R379			RK73HB1J104J	CHIP R 100K J 1/16W	
R301			RK73HB1J101J	CHIP R 100 J 1/16W		R386			RK73HB1J392J	CHIP R 3.9K J 1/16W	
R302			RK73HB1J102J	CHIP R 1.0K J 1/16W		R388			RK73HB1J182J	CHIP R 1.8K J 1/16W	

PARTS LIST

TX-RX UNIT (X57-8102-71)

Ref. No.	Address	New parts	Parts No.	Description	Destination	Ref. No.	Address	New parts	Parts No.	Description	Destination
R389			RK73HB1J102J	CHIP R 1.0K J 1/16W		Q5			2SC5108(Y)F	TRANSISTOR	
R390			RK73HB1J000J	CHIP R 0 J 1/16W		Q6			2SC5636	TRANSISTOR	
R392,393			RK73HB1J102J	CHIP R 1.0K J 1/16W		Q7			2SC5383-T111	TRANSISTOR	
R394			RK73HB1J000J	CHIP R 0 J 1/16W		Q100			2SC4926YD	TRANSISTOR	
R396			RK73HB1J000J	CHIP R 0 J 1/16W		Q101			RFM01U7P	FET	
R400			RK73HB1J472J	CHIP R 4.7K J 1/16W		Q102			RD07MUS2BT112	FET	
R401			RK73HB1J102J	CHIP R 1.0K J 1/16W		Q103			RT1N141U-T111	TRANSISTOR	
R406			RK73HB1J101J	CHIP R 100 J 1/16W		Q200			RT1P237U-T111	TRANSISTOR	
R407			RK73HB1J473J	CHIP R 47K J 1/16W		Q201,202			KTC4080E-P	TRANSISTOR	
R408			RK73HB1J101J	CHIP R 100 J 1/16W		Q203			3SK318	FET	
R409,410			RK73GB2A221J	CHIP R 220 J 1/10W		Q205			3SK294-FP	FET	
R411,412			RK73HB1J472J	CHIP R 4.7K J 1/16W		Q300,301			RT1N441U-T111	TRANSISTOR	
R413			RK73HB1J102J	CHIP R 1.0K J 1/16W		Q302			2SK3577-A	FET	
R414			RK73HB1J474J	CHIP R 470K J 1/16W		Q303			SSM6J08FU(F)	FET	
R438			RK73HB1J473J	CHIP R 47K J 1/16W		Q304			RT1P237U-T111	TRANSISTOR	
R455			RK73HB1J102J	CHIP R 1.0K J 1/16W		Q305			RT1N144U-T111	TRANSISTOR	
R475			RK73HB1J000J	CHIP R 0 J 1/16W		Q306			2SK3577-A	FET	
R502			RK73HB1J334J	CHIP R 330K J 1/16W		Q400			2SC4919-S	TRANSISTOR	
R505			RK73HB1J473J	CHIP R 47K J 1/16W		Q401,402			RT1N144U-T111	TRANSISTOR	
R508			RK73HB1J473J	CHIP R 47K J 1/16W		Q500,501			SSM3J05FU-F	FET	
R509			RK73HB1J104J	CHIP R 100K J 1/16W		Q502			RT1P237U-T111	TRANSISTOR	
R511			RK73HB1J334J	CHIP R 330K J 1/16W		TH100			B57331V2104J	THERMISTOR(100K)	
VR500	2B		R31-0684-05	VARIABLE RESISTOR							
S400	2B		S70-0414-05	TACT SWITCH(PTT)							
S401			S70-0514-05	TACT SWITCH(SIDE)							
S402	2B		S60-0447-05	ROTARY SWITCH(SELECTOR)							
MIC300	2A		T91-0674-05	MIC ELEMENT							
D1			DA2S101	DIODE							
D2 ,3			1SV325F	VARIABLE CAPACITANCE DIODE							
D4			HSC277	DIODE							
D5 ,6			HVC350B	VARIABLE CAPACITANCE DIODE							
D7 ,8			DA2S101	DIODE							
D100			HSC277	DIODE							
D101-103			HVC131	DIODE							
D105			HVC131	DIODE							
D200			HSC277	DIODE							
D201,202			HVC355B	VARIABLE CAPACITANCE DIODE							
D204			HVC355B	VARIABLE CAPACITANCE DIODE							
D260,261			HVC355B	VARIABLE CAPACITANCE DIODE							
D301			KDR731	DIODE							
D380		*	DZ2S068(M)	ZENER DIODE							
D402			DA2S101	DIODE							
D500			GN1G	DIODE							
D501			RB521S-30	DIODE							
IC1			MB15E03SL-E1	MOS-IC							
IC200			NJM2591V	BI-POLAR IC							
IC300			R2A20178NP	DAC IC							
IC301			NJM12904RB1	MOS-IC							
IC302			TA7368PL	MOS-IC							
IC303-305			NJM12904RB1	MOS-IC							
IC400			F2136ACNKDRB	MCU							
IC401			EX24016ATAS0A	ROM IC							
IC500			XC6120N302N-G	MOS-IC							
IC501			XC6209B502P-G	MOS-IC							
IC503			XC6209B502P-G	MOS-IC							
Q1 ,2			RT1N141U-T111	TRANSISTOR							
Q3			2SC5383-T111	TRANSISTOR							
Q4			MCH3914(7)-H	FET							

EXPLODED VIEW

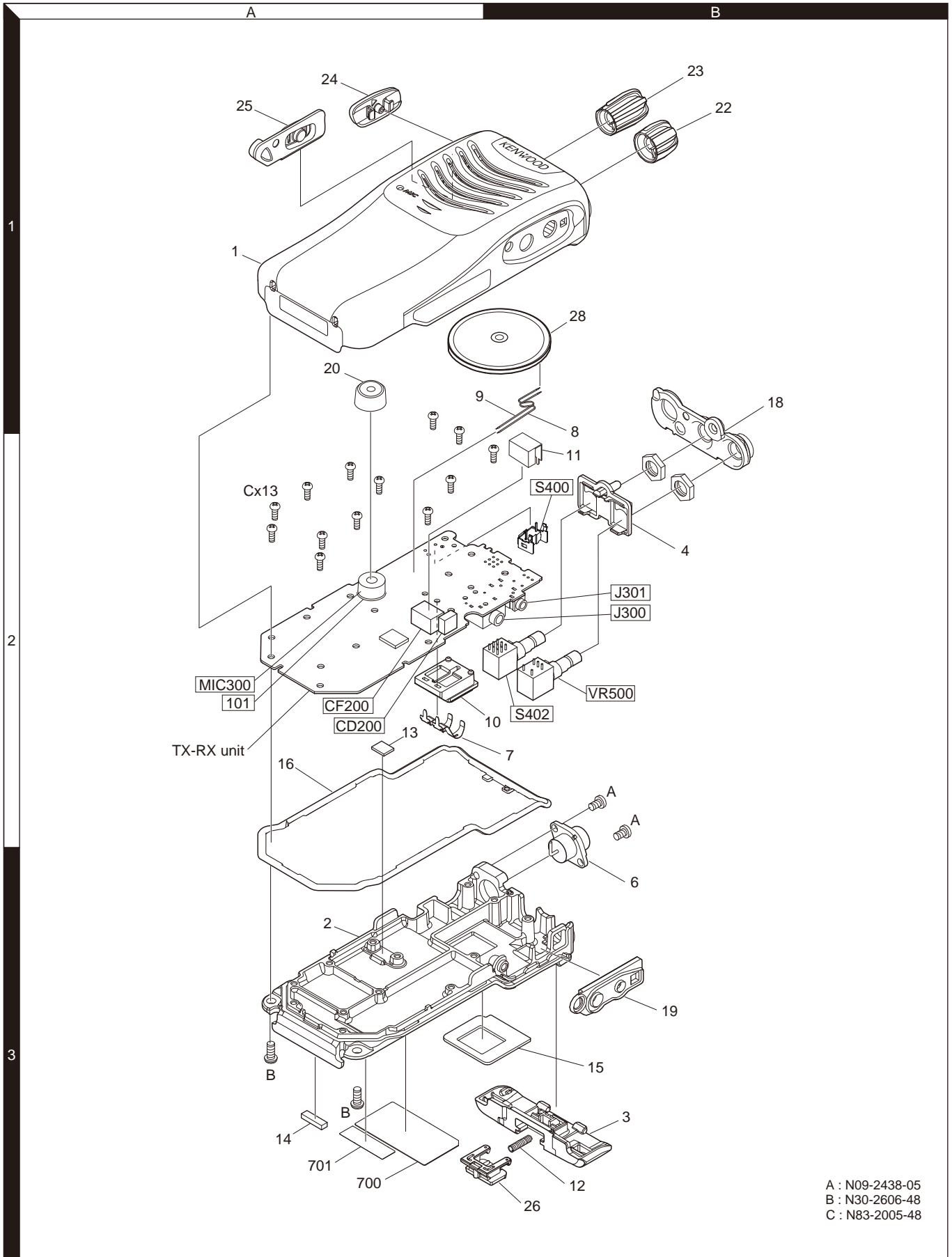

A : N09-2438-05
 B : N30-2606-48
 C : N83-2005-48

Parts with the exploded numbers larger than 700 are not supplied.
 If a part reference number is listed in a box on the exploded view of the PCB, that part does not come with the PCB.
 These parts must be ordered separately.

ADJUSTMENT

Test Equipment Required for Alignment

Test Equipment	Major Specifications	
1. Standard Signal Generator (SSG)	Frequency Range Modulation Output	440 to 470MHz Frequency modulation and external modulation -127dBm/0.1μV to greater than -47dBm/1mV
2. RF Power Meter	Input Impedance Operation Frequency Measurement Range	50Ω 440 to 470MHz Vicinity of 10W
3. Deviation Meter	Frequency Range	440 to 470MHz
4. Digital Volt Meter (DVM)	Measuring Range Input Impedance	10mV to 10V DC High input impedance for minimum circuit loading
5. Oscilloscope		DC through 30MHz
6. High Sensitivity Frequency Counter	Frequency Range Frequency Stability	10Hz to 1000MHz 0.2ppm or less
7. DC Ammeter		5A
8. AF Volt Meter (AF VM)	Frequency Range Voltage Range	50Hz to 10kHz 1mV to 10V
9. Audio Generator (AG)	Frequency Range Output	50Hz to 5kHz or more 0 to 1V
10. Distortion Meter	Capability Input Level	3% or less at 1kHz 50mV to 10Vrms
11. Spectrum Analyzer	Measuring Range	10kHz to 1GHz or more
12. Tracking Generator	Center frequency Output Voltage	50kHz to 600MHz 100mV or more
13. 8Ω Dummy Load		Approx. 8Ω, 3W
14. Regulated Power Supply		5V to 10V, approx. 3A Useful if ammeter equipped

■ Antenna connector adapter

The antenna connector of this transceiver uses an SMA terminal.

Use an antenna connector adapter [SMA(f) – BNC(f) or SMA(f) – N(f)] for adjustment. (The adapter is not provided as an option, so buy a commercially-available one.)

■ DC Supply

BATT+, BATT- : External power supply terminal (Fasten it with an alligator clip.)

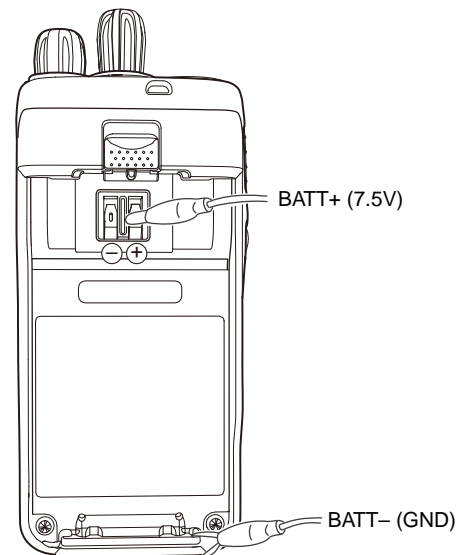

ADJUSTMENT

Frequency and Signaling

The transceiver has been adjusted for the frequencies shown in the following table. When required, re-adjust them following the adjustment procedure to obtain the frequencies you want in actual operation.

■ Test Frequency (MHz)

CH	RX Frequency	TX Frequency
1	460.05000	460.10000
2	440.05000	440.10000
3	479.95000	479.90000
4	460.00000	460.00000
5	460.20000	460.20000
6	460.40000	460.40000
7-16	-	-

■ Signaling

No.	RX (Decode)	TX (Encode)
1	None	None
2	None	100Hz Square Wave
3	QT 67.0Hz	QT 67.0Hz
4	QT 151.4Hz	QT 151.4Hz
5	QT 210.7Hz	QT 210.7Hz
6	QT 254.1Hz	QT 254.1Hz
7	DQT D023N	DQT D023N
8	DQT D754I	DQT D754I
9	None	DTMF (Code: 159D)
10	None	DTMF (Code: 9)

Preparations for Tuning the Transceiver

Before attempting to tune the transceiver, connect the unit to a suitable power supply.

Whenever the transmitter is tuned, the unit must be connected to a suitable dummy load (i.e. power meter).

The speaker output connector must be terminated with a 8Ω dummy load and connected to an AC voltmeter and an audio distortion meter or a SINAD measurement meter at all times during tuning.

■ Adjustment frequency (MHz)

Tuning point	RX	TX
Low	440.05000	440.10000
Center	460.05000	460.10000
High	479.95000	479.90000

Adjustment Points

TX-RX UNIT

Component side view

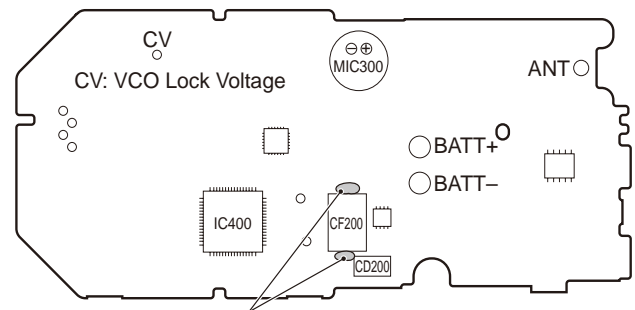

Note: When replacing CF200 with shielding case, apply bond to the point shown in the figure.

Foil side view

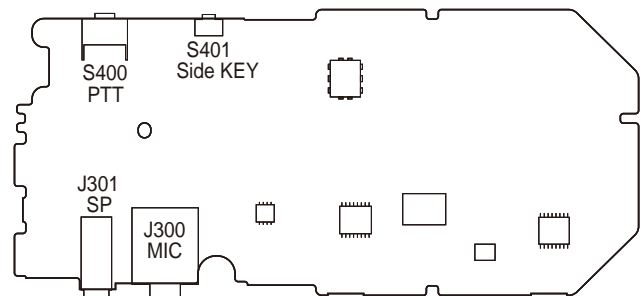

TK-3000

ADJUSTMENT

Common Section

Item	Condition	Measurement			Adjustment			Specifications / Remarks
		Test-equipment	Unit	Terminal	Unit	Parts	Method	
1. Setting	1) BATT terminal voltage: 7.5V 2) SSG standard modulation [Wide] MOD: 1kHz, DEV: 3kHz [Narrow] MOD: 1kHz, DEV: 1.5kHz							
2. VCO Lock Voltage	1) Adj item: High		TX-RX	ANT (CV)		FPU	4.0V	±0.1V

Transmitter Section

Item	Condition	Measurement			Adjustment			Specifications / Remarks
		Test-equipment	Unit	Terminal	Unit	Parts	Method	
1. Frequency	1) Adj item: High Press [Transmit] button.	f. counter	TX-RX	ANT		FPU	479.900MHz	±50Hz
2. High Transmit Power and Protective Current *Note	1) Adj item: Low, Center, High (3 points) BATT terminal voltage: 7.5V Press [Transmit] button.	Power meter Ammeter	TX-RX	ANT		FPU	4.0W	±0.1W 2.0A or less
3. Low Transmit Power	1) Adj item: Low, Center, High (3 points) BATT terminal voltage: 7.5V Press [Transmit] button.						1.0W	±0.1W 1.0A or less
4. DQT Balance [Wide]	1) Adj item: Low, Center, High (3 points) (Signaling Square Wave) Deviation meter filter LPF: 3kHz HPF: OFF Press [Transmit] button.						Power meter Deviation meter Oscilloscope AG AF VTVM	TX-RX
5. Maximum Deviation [Wide]	1) Adj item: Center, Low, High (3 points) AG: 1kHz/150mV Deviation meter filter LPF: 15kHz HPF: OFF Press [Transmit] button.	4.0kHz (According to the lager +, -)	±100Hz					
6. Battery Warning Level	1) BATT terminal voltage: 5.9V	DVM	TX-RX	BATT terminal		FPU	Write	BATT terminal voltage: 5.9V

***Note** : Please do not adjust High Transmit power without connecting TX Power meter or 50 ohm dummy lead to the Ant terminal.

ADJUSTMENT

Item	Condition	Measurement			Adjustment			Specifications / Remarks
		Test-equipment	Unit	Terminal	Unit	Parts	Method	
7. Battery Detection Check (User mode)	1) BATT terminal voltage: 5.7V PTT: ON	Power meter	TX-RX	ANT			Check	LED blinks No transmit power
	2) BATT terminal voltage: 7.5V PTT: ON	DVM		BATT terminal				LED does not blink

• This transceiver is designed to make adjustments simple.
 • It is not necessary to adjust the fixed values for the DTMF-DEV, DQT-DEV, QT-DEV, and MIC sensitivity.
 • The TX-DEV Narrow setting uses the Wide calculated adjustment level value.

Receiver Section

Item	Condition	Measurement			Adjustment			Specifications / Remarks
		Test-equipment	Unit	Terminal	Unit	Parts	Method	
1. Sensitivity Check [Narrow]	1) Adj item: Low, High (2 points) SSG output: -116dBm (0.35 μ V) SSG DEV: 1.5kHz	SSG DVM Oscilloscope AF VM	TX-RX	ANT SP/MIC connector			Check	12dB SINAD or more
	[Wide]							
2. Squelch Level 5 Write [Wide]	1) Adj item: Low, Center, High (3 points) SSG output: -118dBm (0.28 μ V) SSG DEV: 3.0kHz					FPU	Write	
	[Narrow]	2) Adj item: Low, Center, High (3 points) SSG output: -118dBm (0.28 μ V) SSG DEV: 1.5kHz						

• It is not necessary to adjust the fixed value for the BPF.
 • The Squelch Level 9 setting uses the Squelch Level 5 calculated adjustment level value.

TK-3000 PC BOARD

TX-RX UNIT (X57-8102-71) Component side view (J79-0306-29)

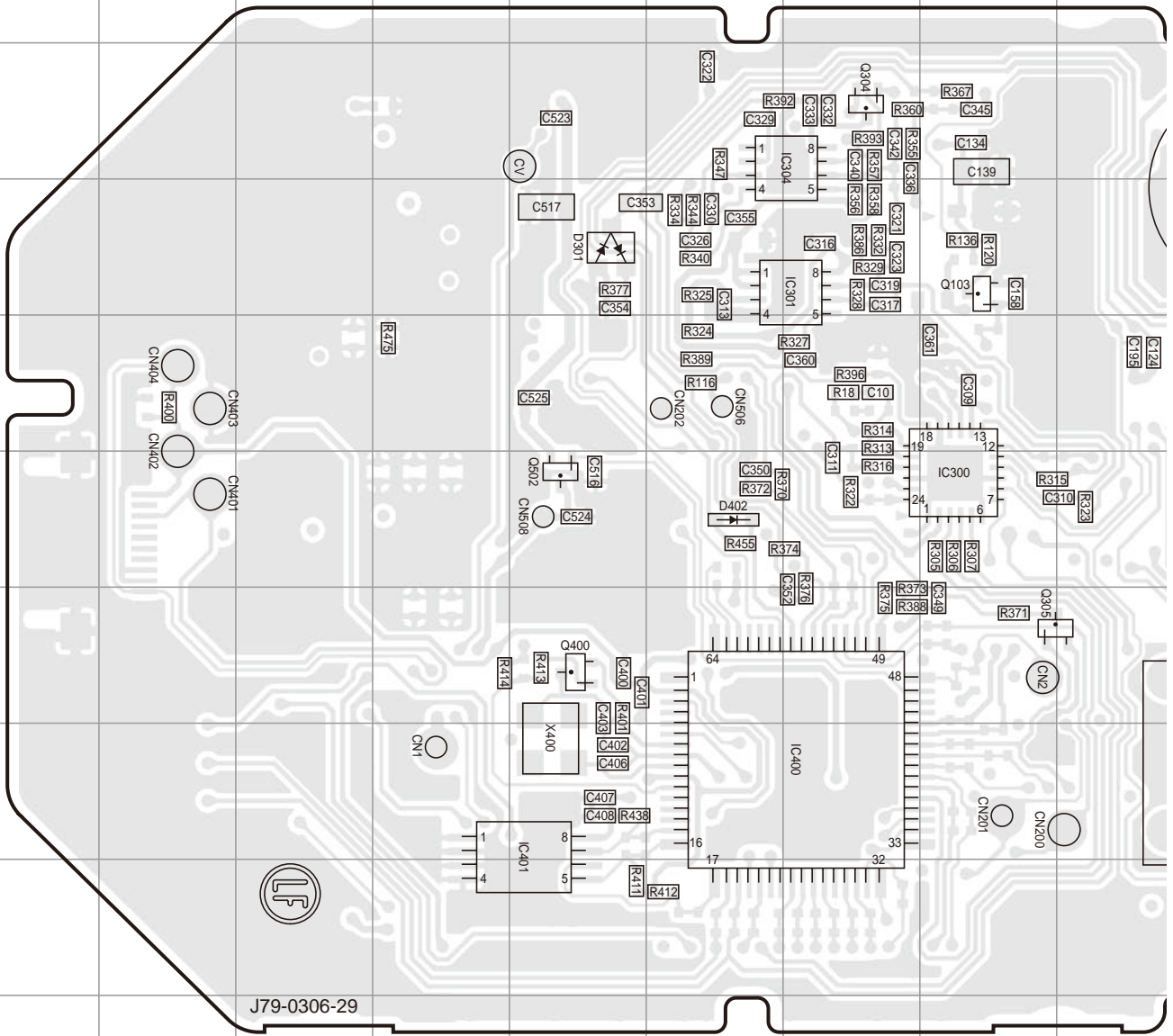

Ref. No.	Address	Ref. No.	Address	Ref. No.	Address
IC300	6I	Q103	4I	Q501	3N
IC301	4H	Q300	4O	Q502	6F
IC302	6P	Q301	4P	D301	4F
IC303	8L	Q302	5P	D380	9O
IC304	3H	Q303	7P	D400	8R
IC400	8H	Q304	3H	D401	8R
IC401	8F	Q305	7I	D402	6G
IC500	4M	Q306	5P	D500	6K
IC501	4M	Q400	7F	D501	5O
IC503	4O	Q500	5M		

The mark (Chip jumper resistor) position for service unit

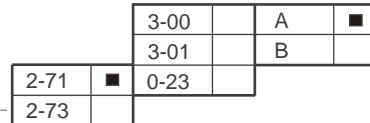

PC BOARD TK-3000

TX-RX UNIT (X57-8102-71) Component side view (J79-0306-29)

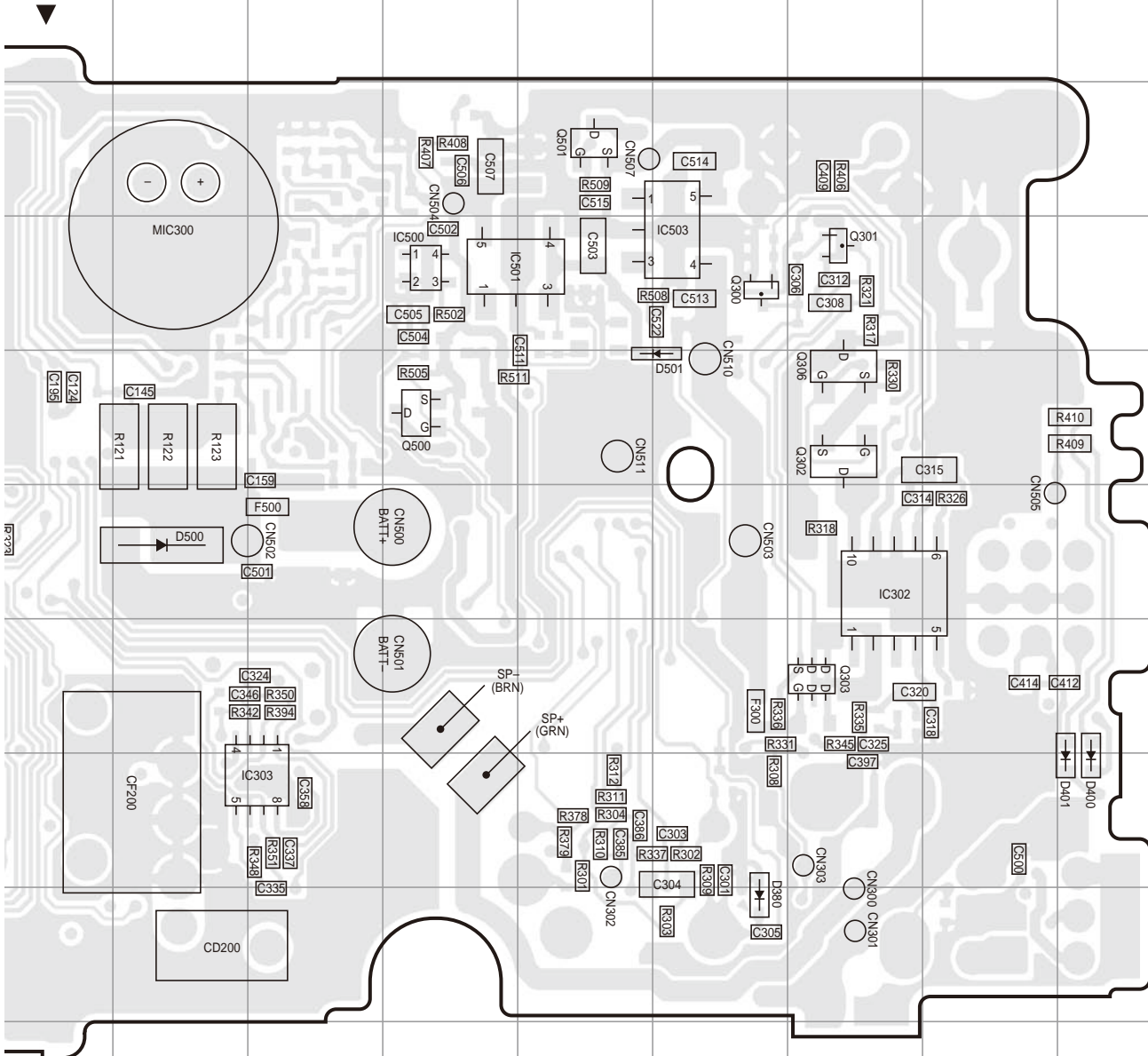

unit

Component side

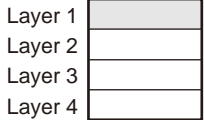

Foil side

TK-3000 PC BOARD

TX-RX UNIT (X57-8102-71) Foil side view (J79-0306-29)

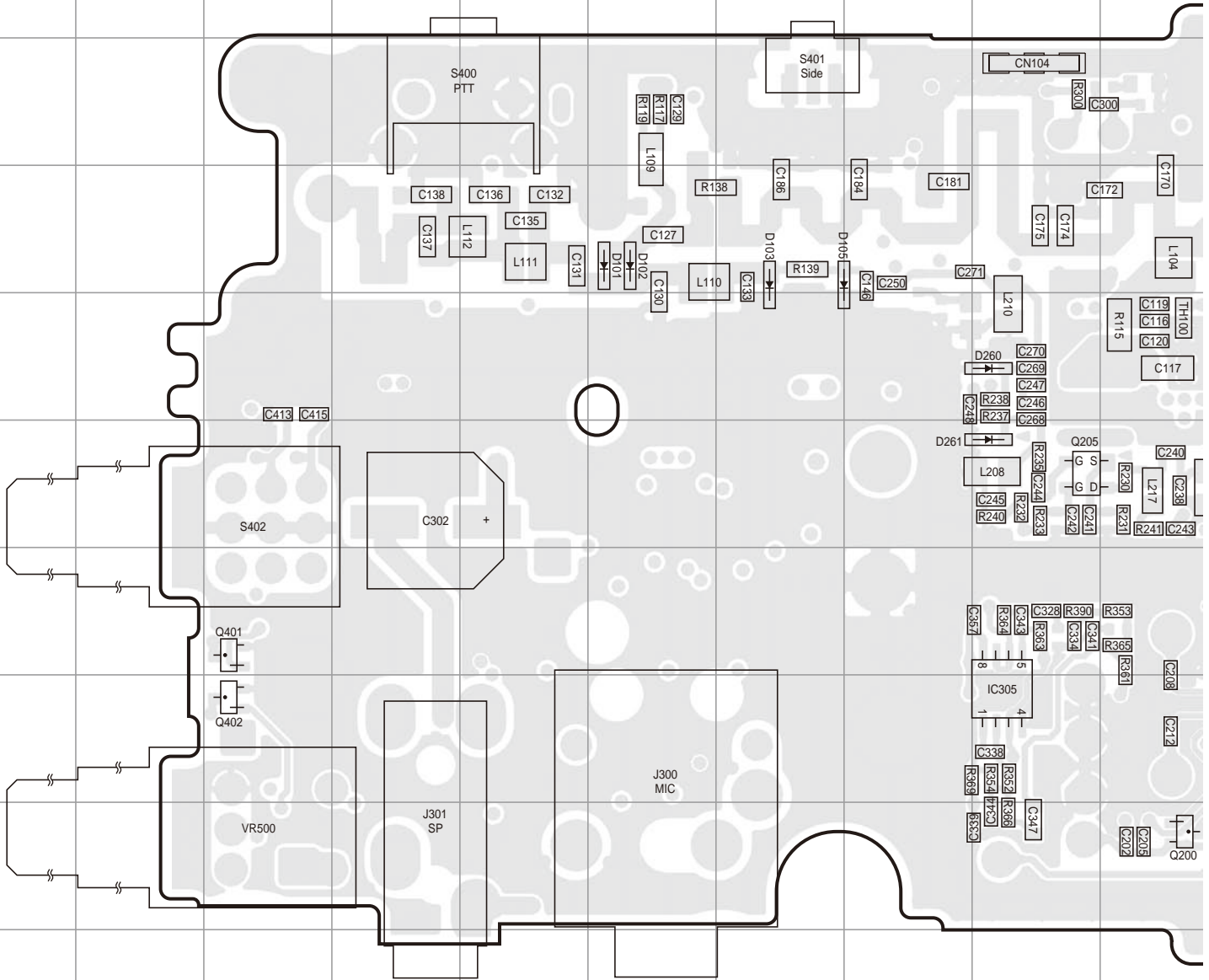

Ref. No.	Address	Ref. No.	Address	Ref. No.	Address	Ref. No.	Address
IC1	8P	Q100	4M	D1	3P	D102	4F
IC200	8K	Q101	5L	D2	3O	D103	4G
IC305	8I	Q102	4K	D3	3O	D105	4G
Q1	7P	Q200	9J	D4	4O	D200	6O
Q2	4O	Q201	9N	D5	4O	D201	6K
Q3	5O	Q202	8L	D6	4O	D202	6K
Q4	5P	Q203	6M	D7	5O	D204	6L
Q5	5P	Q205	6I	D8	3P	D260	5I
Q6	6O	Q401	7C	D100	5N	D261	6I
Q7	9P	Q402	8C	D101	4F		

PC BOARD TK-3000

TX-RX UNIT (X57-8102-71) Foil side view (J79-0306-29)

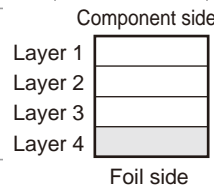
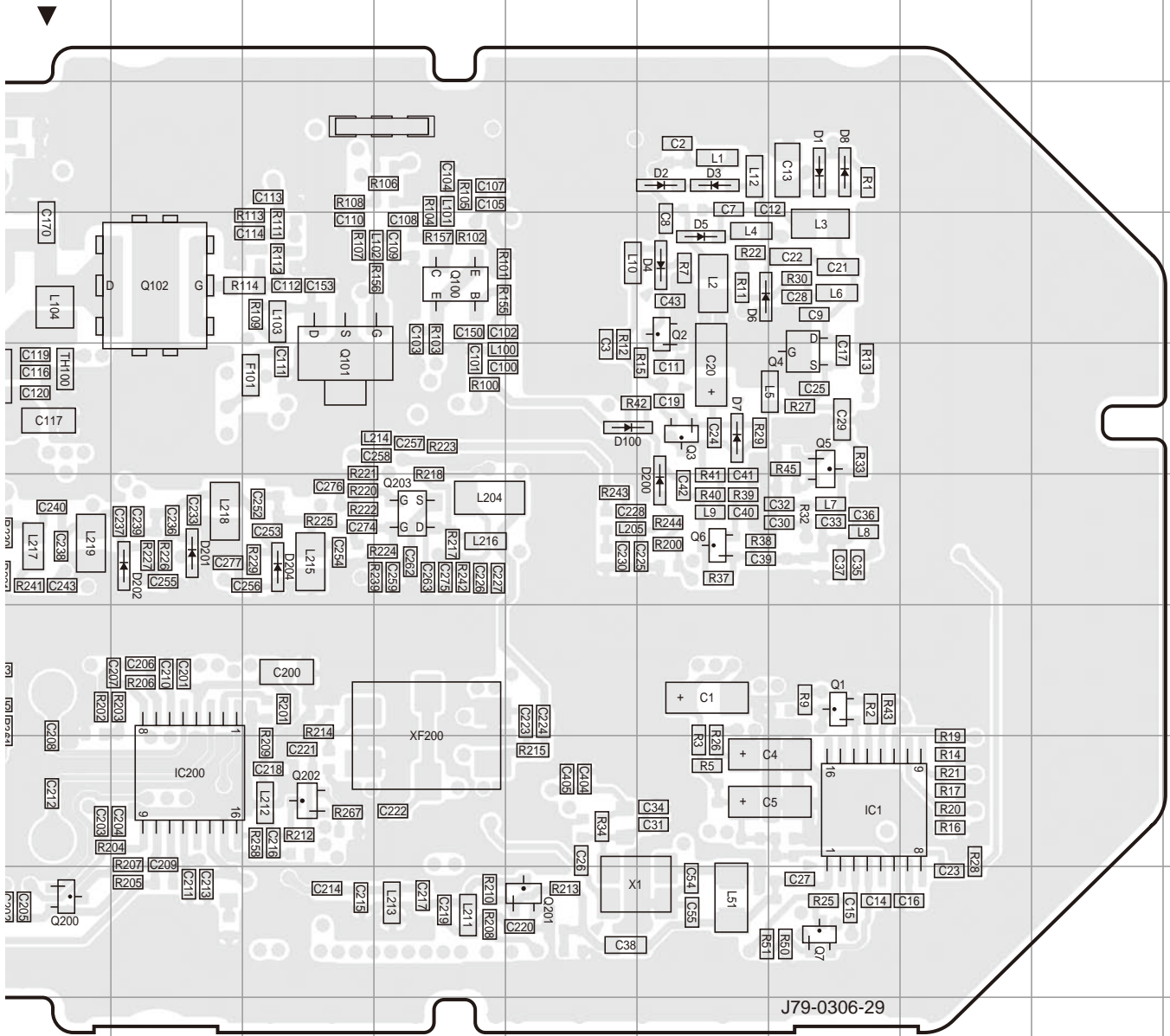

SCHEMATIC DIAGRAM TK-3000

TX-RX UNIT (X57-8102-71)

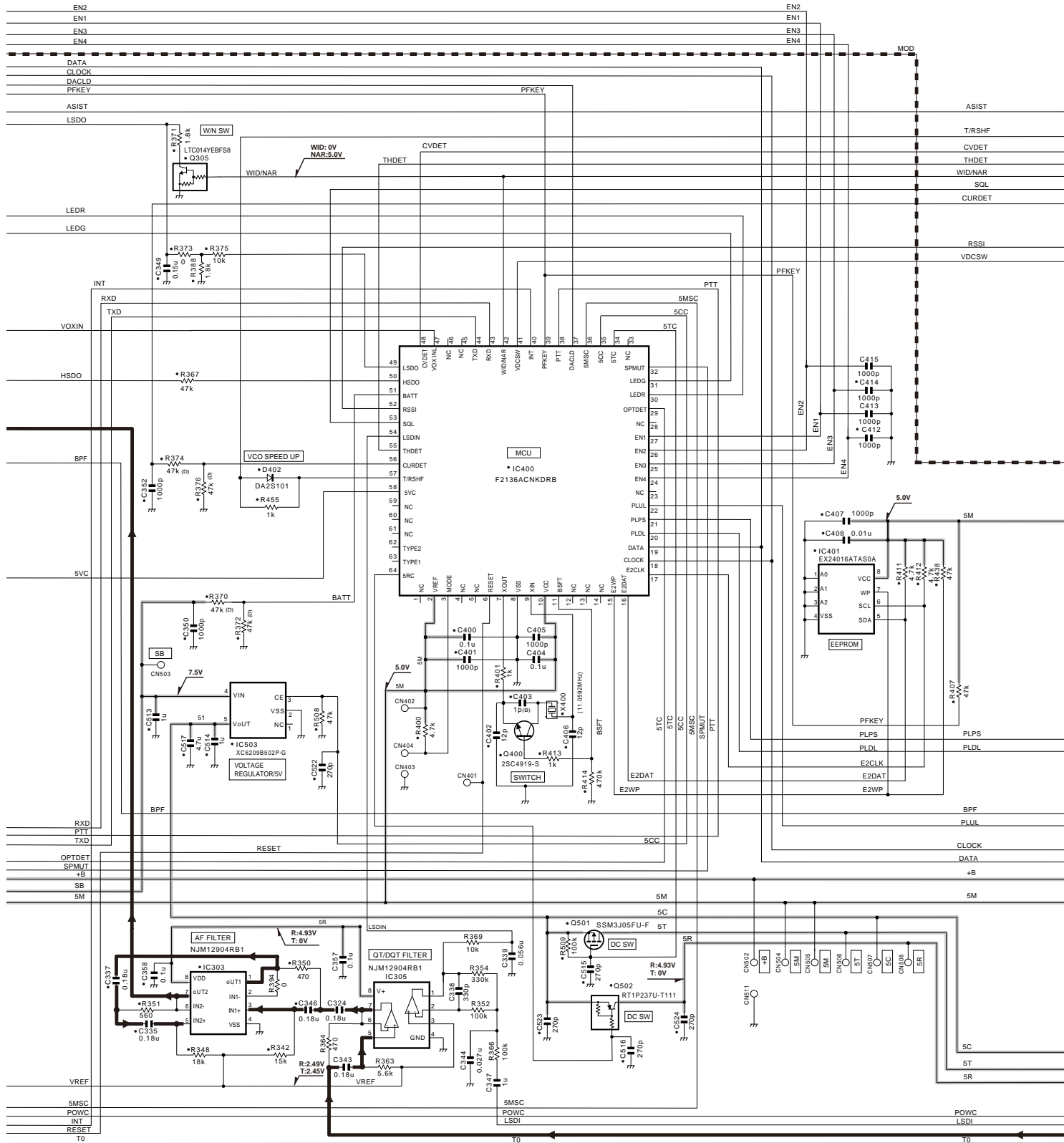

TK-3000 SCHEMATIC DIAGRAM

TX-RX UNIT (X57-8102-71)

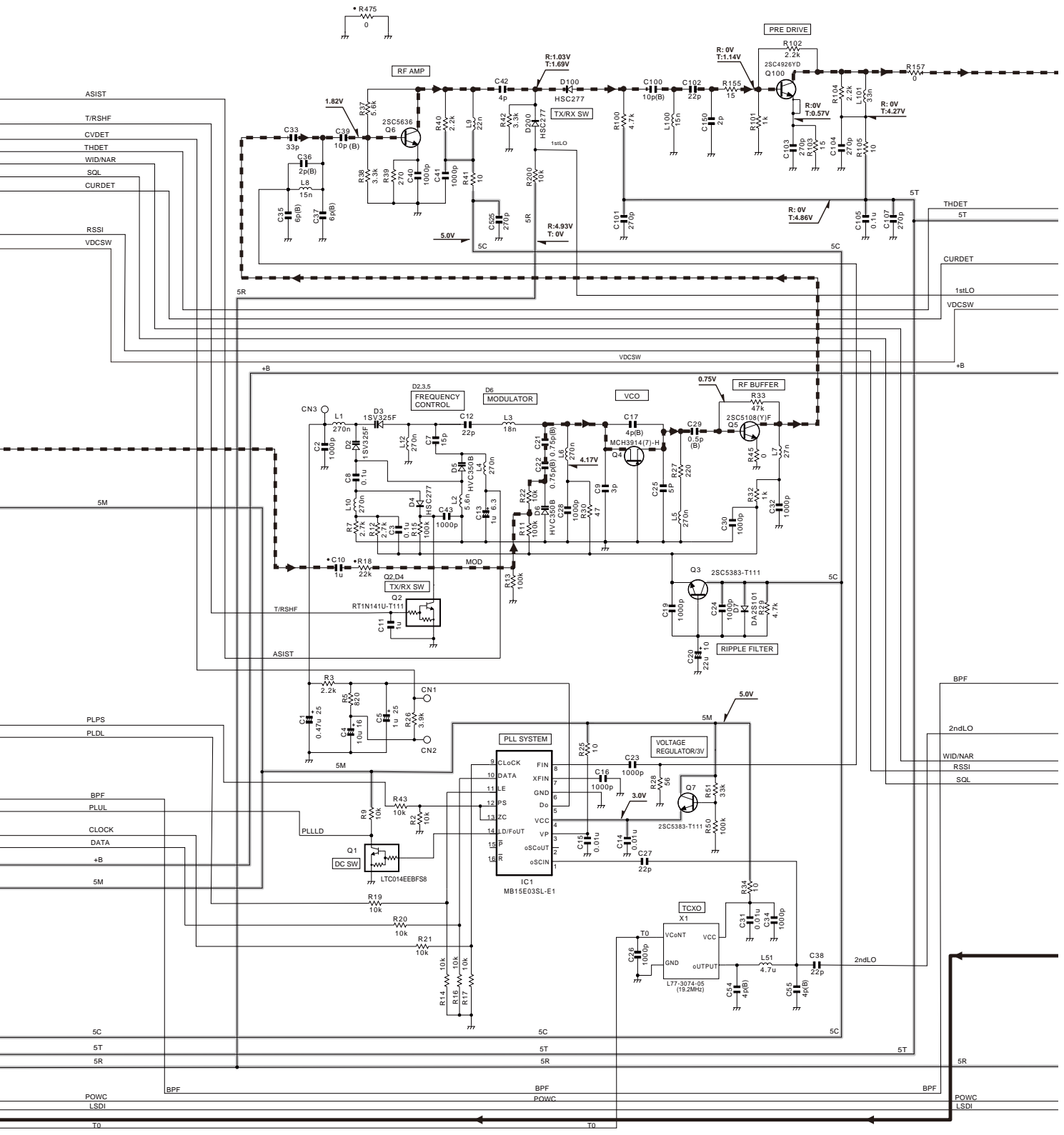

SCHEMATIC DIAGRAM TK-3000

TX-RX UNIT (X57-8102-71)

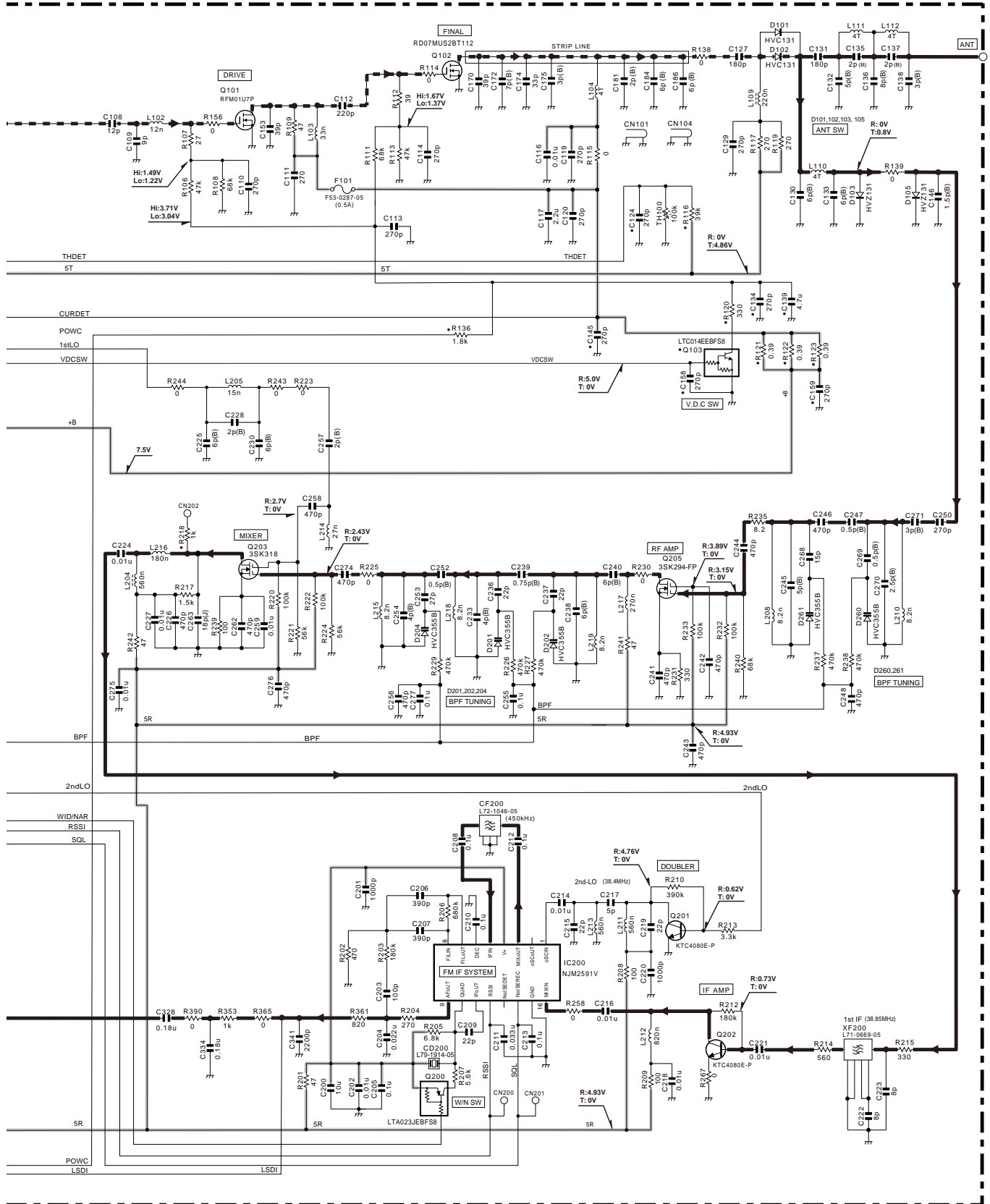

Note : The components marked with a dot (•) are parts of layer 1.

BLOCK DIAGRAM

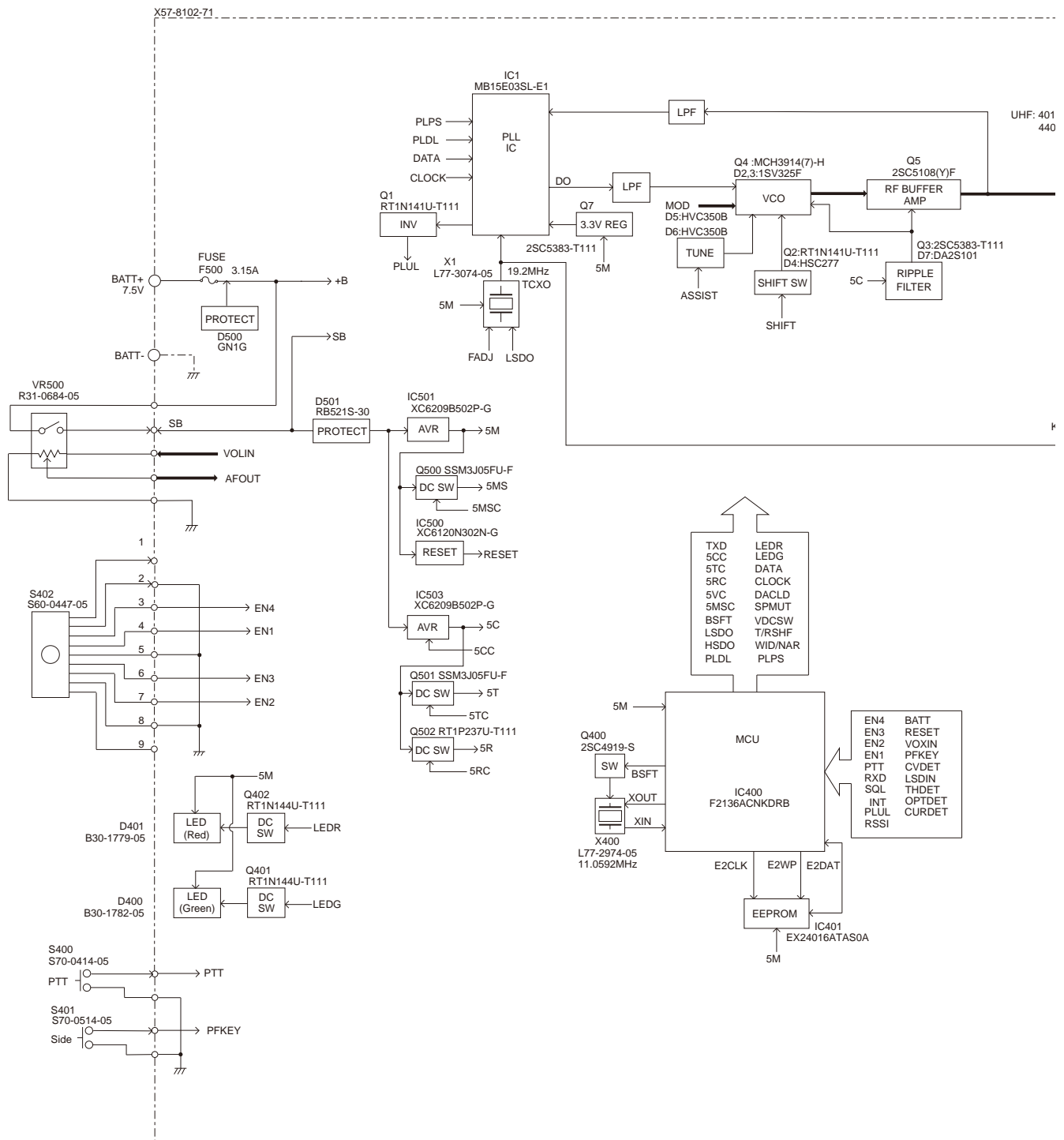

BLOCK DIAGRAM

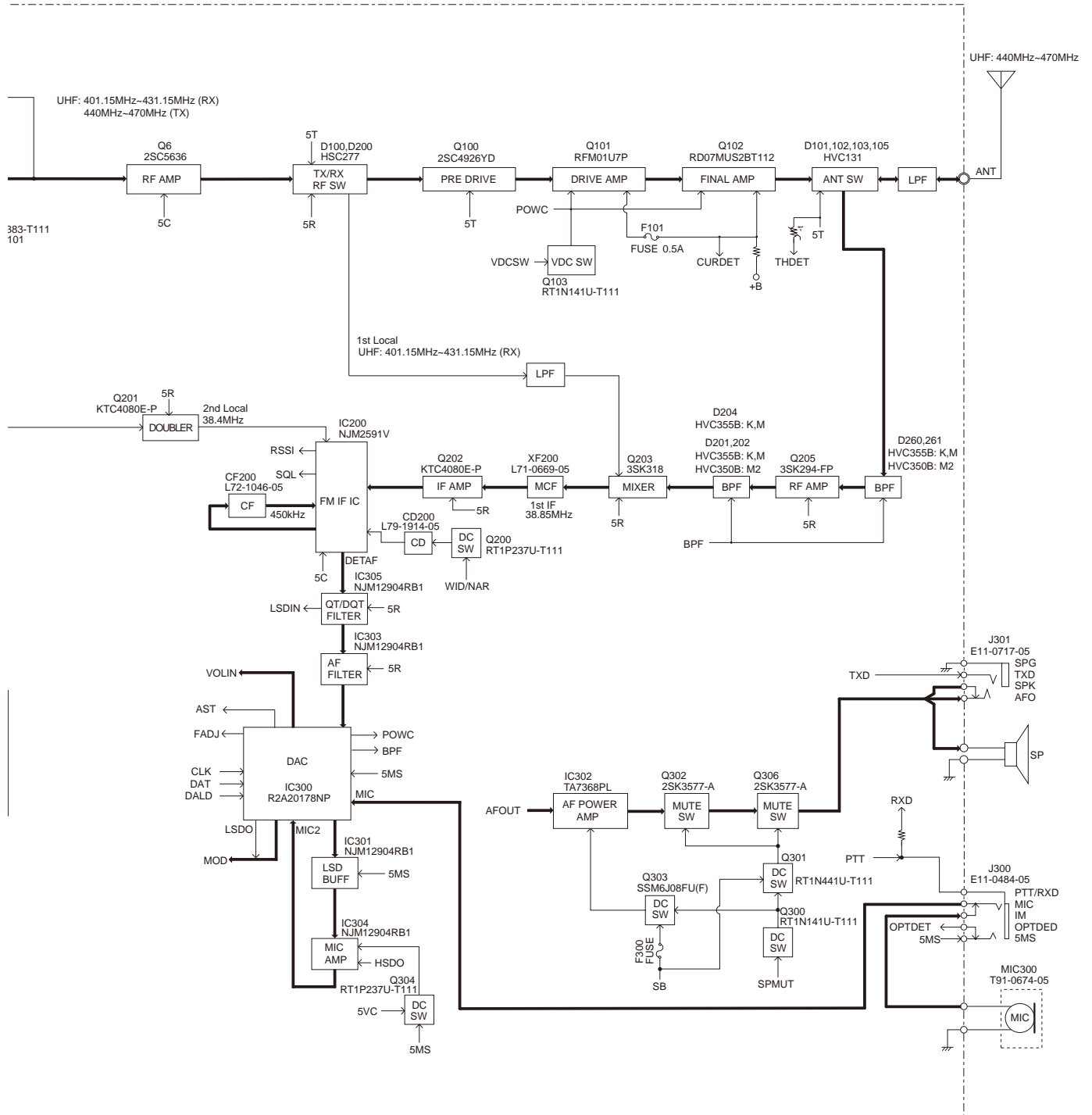

SPECIFICATIONS

GENERAL

Frequency Range	440~470MHz
Number of Channels	Max. 16
Channel Spacing	25kHz (Wide) / 20kHz (Wide 4k) / 12.5kHz (Narrow)
Operating Voltage	7.5 V DC±20%
Battery Life	Applox 10 hours at 4 watts (5-5-90 duty cycle) With KNB-63L battery
Operating Temperature Range	-20°C to +60°C
Frequency Stability	±5.0ppm
Channel Frequency Spread	30MHz
Dimensions and Weight (Dimensions not including protrusions)	
Radio Only	54 W x 113 H x 14 D mm, 130g
With KNB-63L battery (1130mAh battery)	54 W x 113 H x 24.9 D mm, 203g

RECEIVER (Measurements mode per EN Standards)

Sensitivity		
EIA 12dB SINAD	0.28µV (Wide/Wide 4k)	0.35µV (Narrow)
EN 20dB SINAD	-3dBµV (0.35µV) (Wide/Wide 4k)	-1dBµV (0.45µV) (Narrow)
Adjacent Channel Selectivity	70dB (Wide/Wide 4k)	60dB (Narrow)
Intermodulation.....	65dB	
Spurious Response Rejection	70dB	
Audio Distortion	Less than 5%	
Audio Output.....	500mW/8Ω	

TRANSMITTER (Measurements mode per EN Standards)

RF Output Power	4W/1W
Spurious Emission.....	-36dBm ≤ 1GHz -30dBm > 1GHz
FM Noise (EIA)	45dB (Wide) 43dB (Wide 4k) 40dB (Narrow)
Modulation Distortion.....	Less than 5%
Modulation	16K0F3E, 14K0F3E, 8K50F3E

Measurements made per EN standards or TIA/EIA 603 and specifications shown are typical.
JVC KENWOOD Corporation reserves the right to change specifications without prior notice or obligation.

TK-3000

JVC KENWOOD Corporation

3-12, Moriyacho, Kanagawa-ku, Yokohama-shi,
Kanagawa, 221-0022 Japan

Kenwood U.S.A. Corporation

P.O. BOX 22745, 2201 East Dominguez Street, Long Beach,
CA 90801-5745, U.S.A.

Kenwood Electronics Canada Inc.

6070 Kestrel Road, Mississauga, Ontario, Canada L5T 1S8

Kenwood Electronics Deutschland GmbH

Rembrücker Str. 15, 63150 Heusenstamm, Germany

Kenwood Electronics Belgium N.V.

Leuvensesteenweg 248 J, 1800 Vilvoorde, Belgium

Kenwood Electronics France S.A.

L'Etoile Paris Nord 2, 50 Allée des Impressionnistes,
Bp 58416 Villepinte, 95944 Roissy Ch De Gaulle Cedex

Kenwood Electronics UK Limited

Kenwood House, Dwight Road, Watford, Herts.,
WD18 9EB United Kingdom

Kenwood Electronics Europe B.V.

Amsterdamseweg 37, 1422 AC Uithoorn, The Netherlands

Kenwood Electronics Italia S.p.A.

Via G. Sirtori, 7/9 20129 Milano, Italy

Kenwood Ibérica, S.A.

Carretera de Rubi, 88 Planta 1 A 08174 Sant Cugat del Vallès
Barcelona, Spain

Kenwood Electronics Australia Pty. Ltd.

Talavera Business Park Building A, 4 Talavera Road,
North Ryde NSW 2113 Australia

Kenwood Electronics (Hong Kong) Ltd.

Suite 2504, 25/F, Tower 2, Nina Tower, No. 8 Yeung Uk Road,
Tsuen Wan, New Territories, Hong Kong

Kenwood Electronics Singapore Pte Ltd

1 Ang Mo Kio Street 63, Singapore 569110

TK-3000 PC BOARD

PC BOARD TK-3000

TX-RX UNIT (X57-8102-71) Component side view (J79-0306-29)

TX-RX UNIT (X57-8102-71) Component side view (J79-0306-29)

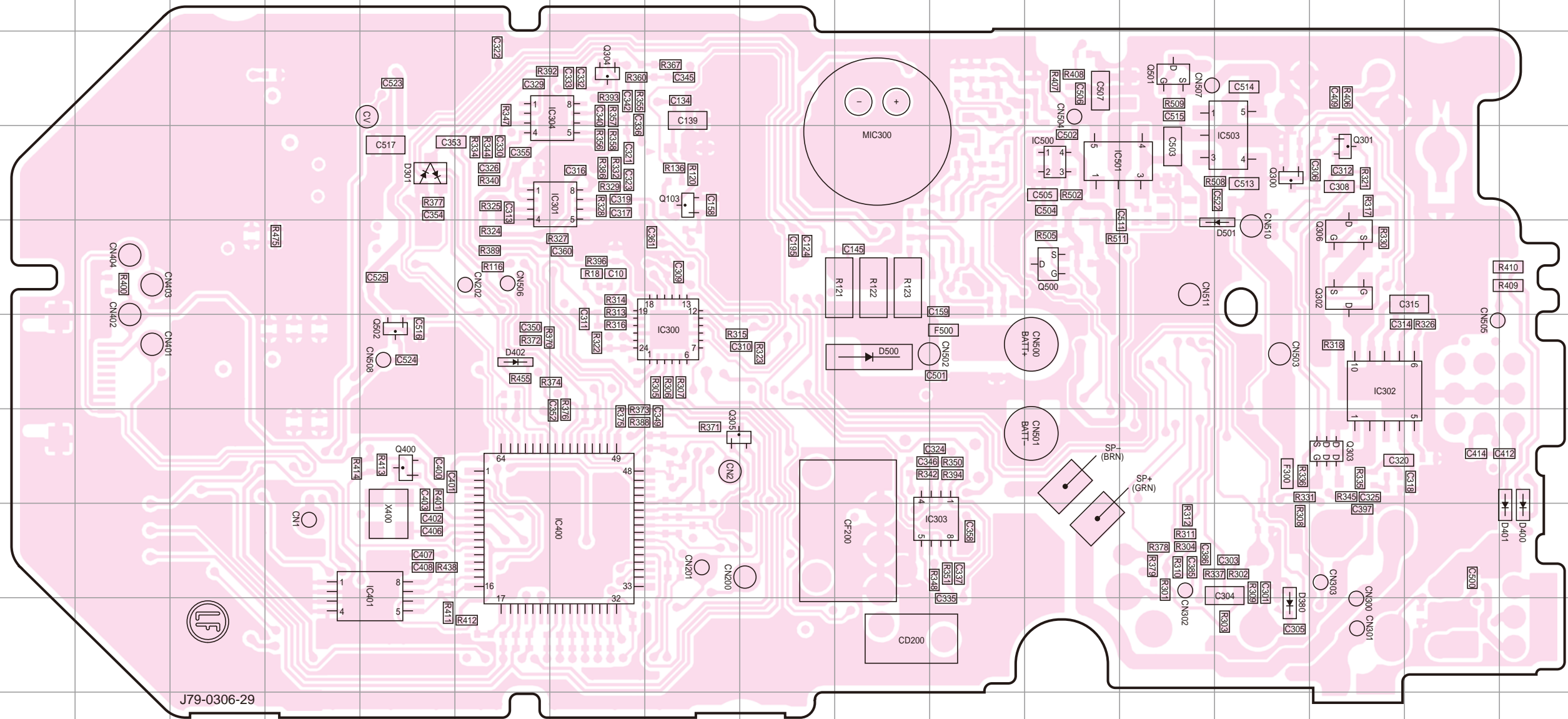

Ref. No.	Address	Ref. No.	Address	Ref. No.	Address
IC300	6I	Q103	4I	Q501	3N
IC301	4H	Q300	4O	Q502	6F
IC302	6P	Q301	4P	D301	4F
IC303	8L	Q302	5P	D380	9O
IC304	3H	Q303	7P	D400	8R
IC400	8H	Q304	3H	D401	8R
IC401	8F	Q305	7I	D402	6G
IC500	4M	Q306	5P	D500	6K
IC501	4M	Q400	7F	D501	5O
IC503	4O	Q500	5M		

The mark (Chip jumper resistor) position for service unit

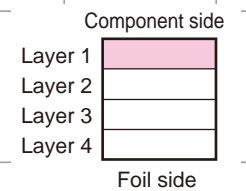
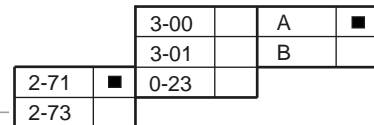

TK-3000 PC BOARD

PC BOARD TK-3000

TX-RX UNIT (X57-8102-71) Foil side view (J79-0306-29)

TX-RX UNIT (X57-8102-71) Foil side view (J79-0306-29)

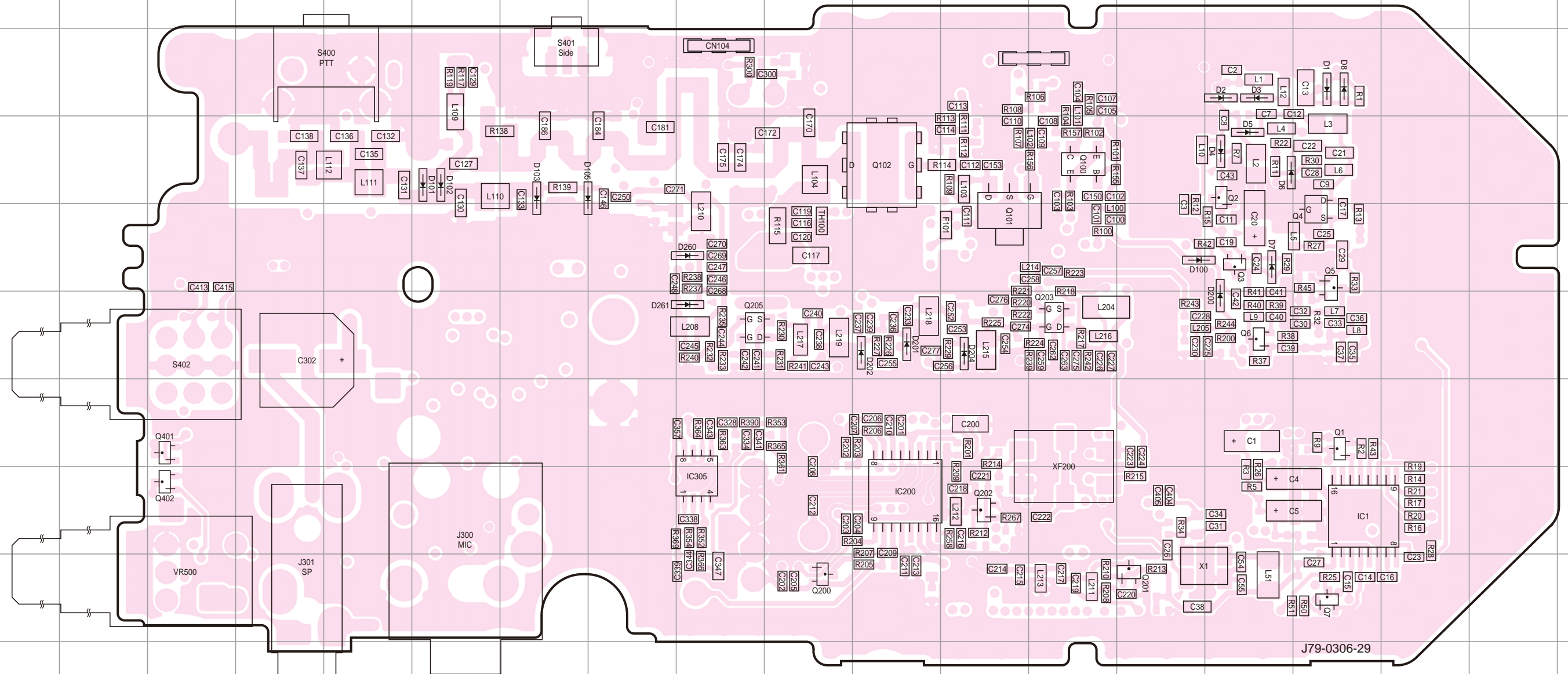

Ref. No.	Address	Ref. No.	Address	Ref. No.	Address	Ref. No.	Address
IC1	8P	Q100	4M	D1	3P	D102	4F
IC200	8K	Q101	5L	D2	3O	D103	4G
IC305	8I	Q102	4K	D3	3O	D105	4G
Q1	7P	Q200	9J	D4	4O	D200	6O
Q2	4O	Q201	9N	D5	4O	D201	6K
Q3	5O	Q202	8L	D6	4O	D202	6K
Q4	5P	Q203	6M	D7	5O	D204	6L
Q5	5P	Q205	6I	D8	3P	D260	5I
Q6	6O	Q401	7C	D100	5N	D261	6I
Q7	9P	Q402	8C	D101	4F		

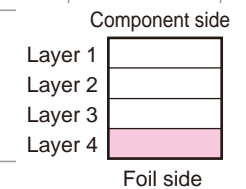

J79-0306-29

TX-RX UNIT(X57-8102-71)

