

TK-3107G

SERVICE MANUAL / 维修手册

C, C2 versions

KENWOOD

Kenwood Corporation

© 2009-9 PRINTED IN JAPAN
B51-8881-00 (N) PDF

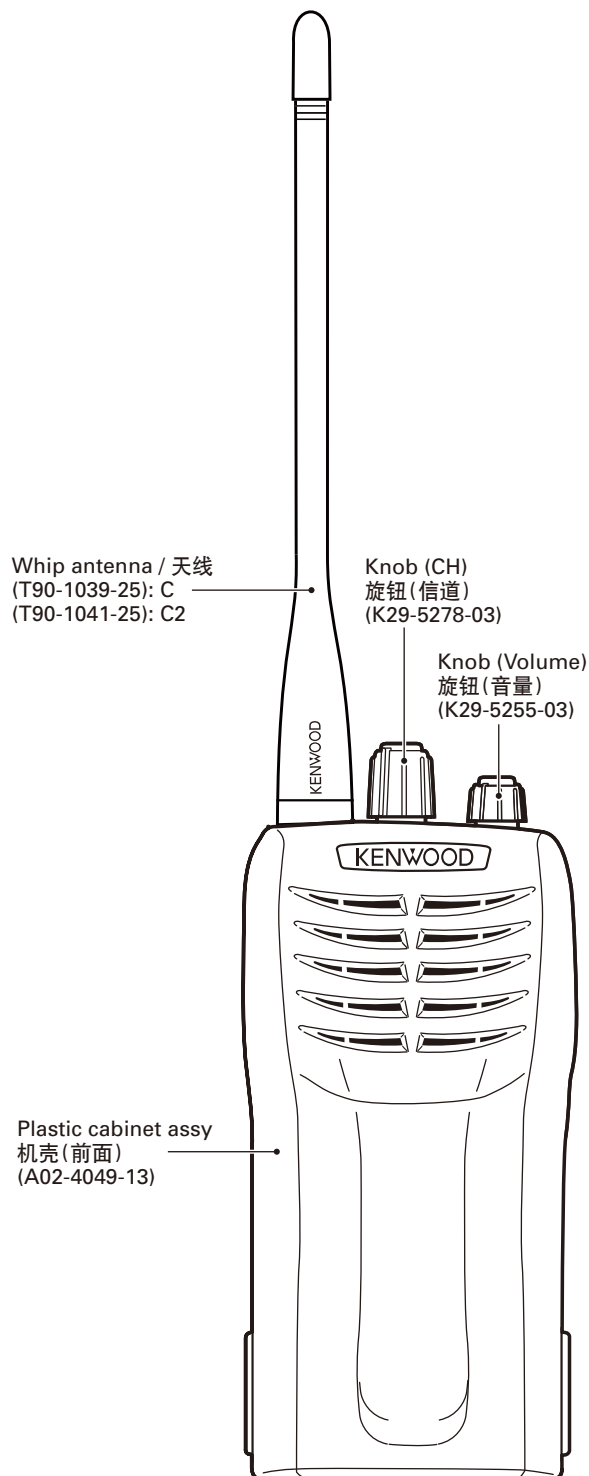

CONTENTS

GENERAL	3
SYSTEM SET-UP	4
REALIGNMENT	4
DISASSEMBLY FOR REPAIR	7
CIRCUIT DESCRIPTION	9
SEMICONDUCTOR DATA	15
COMPONENTS DESCRIPTION	17
PARTS LIST	19
EXPLODED VIEW	25
PACKING	26
ADJUSTMENT	27
PC BOARD	
TX-RX UNIT (X57-6030-XX)	34
SCHEMATIC DIAGRAM	38
BLOCK DIAGRAM	42
LEVEL DIAGRAM	44
OPTIONAL ACCESSORIES	
KNB-14 (Ni-Cd battery pack)	45
KNB-15A (Ni-Cd battery pack)	45
KNB-20N (Ni-MH battery pack)	45
SPECIFICATIONS	BACK COVER

目 录

概 述.....	3	PC 板	
系统体系.....	4	TX-RX 单元 (X57-6030-XX).....	34
模式组合.....	4	原 理 图.....	38
维修拆卸.....	7	方 块 图.....	42
电路说明.....	9	电 平 图.....	44
半导体数据.....	16	可选附件	
元件说明.....	17	KNB-14 (镍镉电池).....	45
零 件 表.....	19	KNB-15A (镍镉电池).....	45
部件分解图.....	25	KNB-20N (镍氢电池).....	45
包 装.....	26	规 格.....	封底
调 整.....	27		

Document Copyrights

Copyright 2009 by Kenwood Corporation. All rights reserved.

No part of this manual may be reproduced, translated, distributed, or transmitted in any form or by any means, electronic, mechanical, photocopying, recording, or otherwise, for any purpose without the prior written permission of Kenwood.

Disclaimer

While every precaution has been taken in the preparation of this manual, Kenwood assumes no responsibility for errors or omissions. Neither is any liability assumed for damages resulting from the use of the information contained herein. Kenwood reserves the right to make changes to any products herein at any time for improvement purposes.

文档版权信息

Kenwood Corporation 拥有版权 2009。保留所有权利。

未经 Kenwood 公司预先书面同意，无论出于何种目的，均不得以任何形式或任何方式包括电子、机械、影印、录音或其他方式复制、翻译、分发或传播本手册的任何部分。

免责声明

Kenwood 公司在准备本文档时已采取所有必要的预防措施，恕不对错误或疏漏承担任何责任，也不对因使用本文中所含的信息而导致的损害负责。Kenwood 公司保留出于改进的需要而随时对文中的产品信息做出更改的权利。

GENERAL / 概述

INTRODUCTION

SCOPE OF THIS MANUAL

This manual is intended for use by experienced technicians familiar with similar types of commercial grade communications equipment. It contains all required service information for the equipment and is current as of the publication date. Changes which may occur after publication are covered by either Service Bulletins or Manual Revisions. These are issued as required.

ORDERING REPLACEMENT PARTS

When ordering replacement parts or equipment information, the full part identification number should be included. This applies to all parts : components, kits, or chassis. If the part number is not known, include the chassis or kit number of which it is a part, and a sufficient description of the required component for proper identification.

PERSONAL SAFETY

The following precautions are recommended for personal safety:

- DO NOT transmit until all RF connectors are verified secure and any open connectors are properly terminated.
- SHUT OFF and DO NOT operate this equipment near electrical blasting caps or in an explosive atmosphere.
- This equipment should be serviced by a qualified technician only.

SERVICE

This transceiver is designed for easy servicing. Refer to the schematic diagrams, printed circuit board views, and alignment procedures contained within.

Model	Type	TX-RX unit	Frequency range	Remarks
TK-3107G	C	X57-6030-10	450~470MHz	IF1: 38.85MHz LOC: 38.4MHz
	C2	X57-6030-25	400~420MHz	

引言

本手册的范围

本手册是提供给熟悉通信专业并且具有维修经验的技术人员使用的。它包括了维修该设备所需要的全部资料和现行出版日期。在出版后可能发生变动，如果需要，可以参照《维修通报》或《手册修订本》进行补充。

替换零件的订购

当订购替换零件或设备资料时，应注意完整的零件识别号码。所有的零件均有识别号码：元件，组件或机壳。如果不知道零件的号码，为了正确地识别，必须注明此元件所属的机壳或组件的号码，并对元件进行充分的说明。

个人安全

为了个人的安全，请注意下列事项：

- 在没有认真核实所有射频插头之前或有任何一个脱开的插头没有连接到相应端口上的情况下均不要发射。
- 在电爆管附近或在易燃性气体环境中，必须关闭电源，不要操作本设备。
- 本设备只应该由有资格的技术人员进行维修。

维修服务

为了便于维修本设备，建立了完整的维修服务体系，提供了包括原理图，印刷电路板图和调整步骤在内的资料供参考。

型号	类型	TX-RX 单元	频率范围	备注
TK-3107G	C	X57-6030-10	450~470MHz	IF1: 38.85MHz LOC: 38.4MHz
	C2	X57-6030-25	400~420MHz	

SYSTEM SET-UP / 系统体系

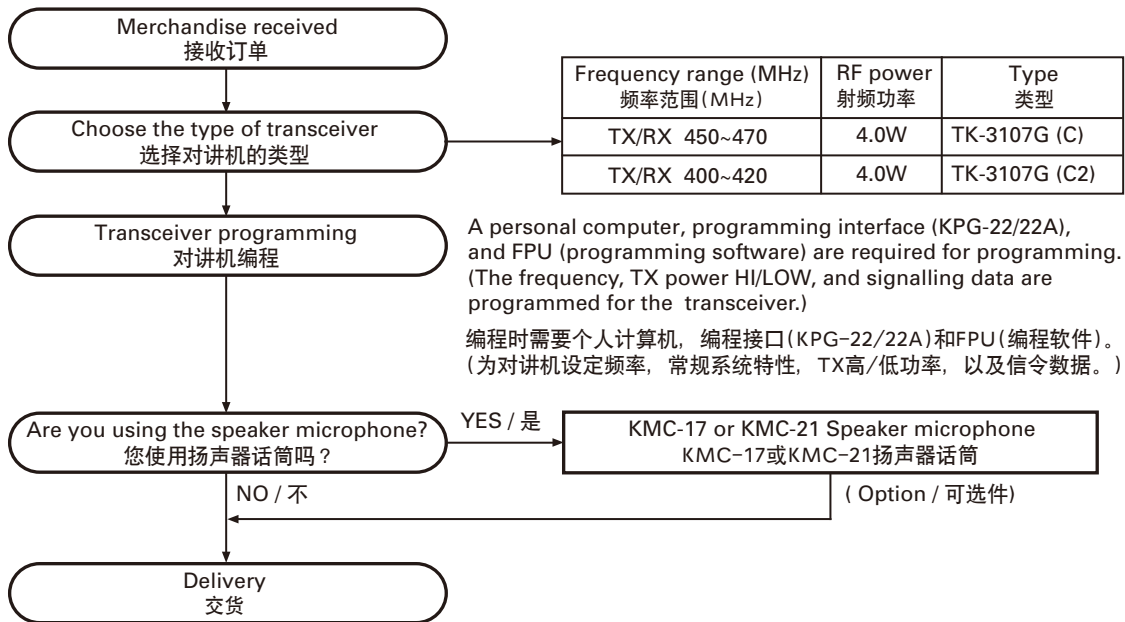

REALIGNMENT / 模式组合

1. Modes

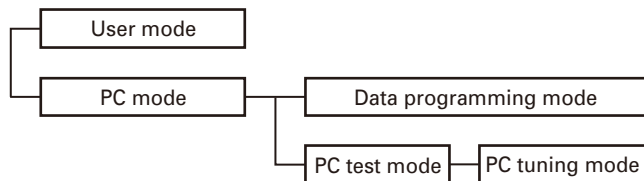

Mode	Function
User mode	For normal use.
PC mode	Used for communication between the transceiver and PC.
Data programming mode	Used to read and write frequency data and other features to and from the transceiver.
PC test mode	Used to check the transceiver using the PC. This feature is included in the FPU.

1. 模式

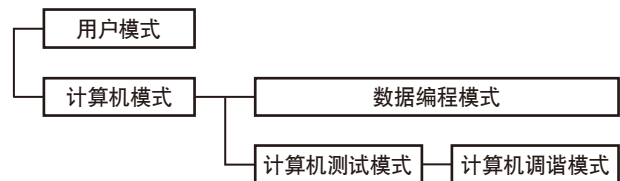

模式	功能
用户模式	一般使用
计算机模式	用户对讲机与计算机之间的通信。
数据编程模式	用于读出和写入频率数据以及其他功能。
计算机测试模式	用于使用计算机来检测对讲机。此功能包括在FPU。

REALIGNMENT / 模式组合

2. How to Enter Each Mode

Mode	Operation
User mode	Power ON
PC mode	Received commands from PC

3. PC Mode

3-1. Preface

The transceiver is programmed by using a personal computer, a programming interface (KPG-22/22A, USB adapter (KCT-53U)) and FPU (programming software).

The programming software can be used with a PC. Figure 1 shows the setup of a PC for programming.

3-2. Connection Procedure

1. Connect the transceiver to the personal computer with the interface cable and USB adapter (when the interface cable is KPG-22A, the KCT-53U can be used).

Note:

- You must install the KCT-53U driver in the computer to use the USB adapter (KCT-53U).
- When using the USB adapter (KCT-53U) for the first time, plug the KCT-53U into a USB port on the computer with the computer power ON.

2. When the POWER is switched on, user mode can be entered immediately. When the PC sends a command, the transceiver enters PC mode.

When data is read from the transceiver, the red LED lights.

When data is written to by the transceiver, the green LED lights.

Note:

- The data stored in the personal computer must match Model Name and Model Type when it is written into EEPROM.
- Do not press the [PTT] key during data transmission or reception.

3-3. KPG-22/KPG-22A Description (PC programming interface cable : Option)

The KPG-22/22A is required to interface the transceiver with the computer. It has a circuit in its D-sub connector (KPG-22: 25-pin, KPG-22A: 9-pin) case that converts the RS-232C logic level to the TTL level.

The KPG-22/22A connects the SP/MIC connector of the transceiver to the RS-232C serial port of the computer.

3-4. KCT-53U Description (USB adapter : Option)

The KCT-53U is a cable which connects the KPG-22A to a USB port on a computer.

When using the KCT-53U, install the supplied CD-ROM (with driver software) in the computer. The KCT-53U driver runs under Windows 2000 or XP.

2. 如何进入每一种模式

模式	操作
用户模式	接通电源
计算机模式	从计算机接收指令

3. PC 模式

3-1. 前言

对讲机采用个人电脑、编程接口 (KPG-22/22A, USB 适配器 (KCT-53U)) 和 FPU (编程软件) 进行编程。

编程软件可以在 PC 上进行使用。图 1 给出了 PC 进行编程的设置。

3-2. 连接操作

1. 使用接口电缆和 USB 适配器将对讲机连接到个人电脑 (接口电缆为 KPG-22A 时, 可以使用 KCT-53U)。

注意:

- 必须在电脑上安装 KCT-53U 驱动程序才能使用 USB 适配器 (KCT-53U)。
- 首次使用 USB 适配器 (KCT-53U) 时, 请在电脑开机的情况下将 KCT-53U 插入电脑的 USB 端口。

2. 对讲机电源打开时, 可以立即进入用户模式。PC 发送指令时, 对讲机进入 PC 模式。

对讲机发送数据时, 红色的 LED 点亮。

对讲机接收数据时, 绿色的 LED 点亮。

注意:

- 个人电脑保存的数据写入 EEPROM 时, 必须与机型和类型相符。
- 请勿在数据发送或接收期间按 [PTT] 键。

3-3. KPG-22/KPG-22A 说明 (PC 编程接口电缆: 选配件)

将对讲机与电脑相连需要 KPG-22/22A。该电缆的 D-sub 连接器 (KPG-22: 25 针, KPG-22A: 9 针) 盒具有将 RS-232C 逻辑电平转换为 TTL 电平的电路。

KPG-22/22A 将对讲机的 SP/MIC 连接器连接到电脑的 RS-232C 串行端口。

3-4. KCT-53U 说明 (USB 适配器: 选配件)

KCT-53U 是将 KPG-22A 连接到电脑 USB 端口的电缆。

使用 KCT-53U 时, 请在电脑上安装附带的 CD-ROM (带有驱动程序软件)。KCT-53U 驱动程序运行于 Windows 2000 或 XP 下。

REALIGNMENT / 模式组合

3-5. FPU (Programming Software) Description

The FPU is the programming software for the transceiver supplied on a CD-ROM. The software on this disk allows a user to program the transceiver transceivers via Programming interface cable (KPG-22/22A).

3-6. Programming with PC

If data is transferred to the transceiver from a PC with the FPU, the data for each set can be modified.

Data can be programmed into the EEPROM in RS-232C format via the SP/MIC jack.

In this mode the PTT line operate as TXD and RXD data lines respectively.

3-5. FPU (编程软件) 说明

FPU 是 CD-ROM 附带的用于对讲机的编程软件。该光盘上的软件允许用户通过编程接口电缆 (KPG-22/22A) 对对讲机进行编程。

3-6. 使用 PC 编程

如果使用 FPU 将数据从 PC 传输到对讲机，则每套对讲机的数据均可修改。

通过 SP/MIC 插孔可以将数据以 RS-232C 格式写入 EEPROM。

在该模式下，PTT 线路分别用作 TXD 和 RXD 数据线路。

List of FPU for transceiver

Model	Type	FPU
TK-3107G	C,C2	KPG-55D

对讲机的 FPU 名单

型号	类型	FPU
TK-3107G	C, C2	KPG-55D

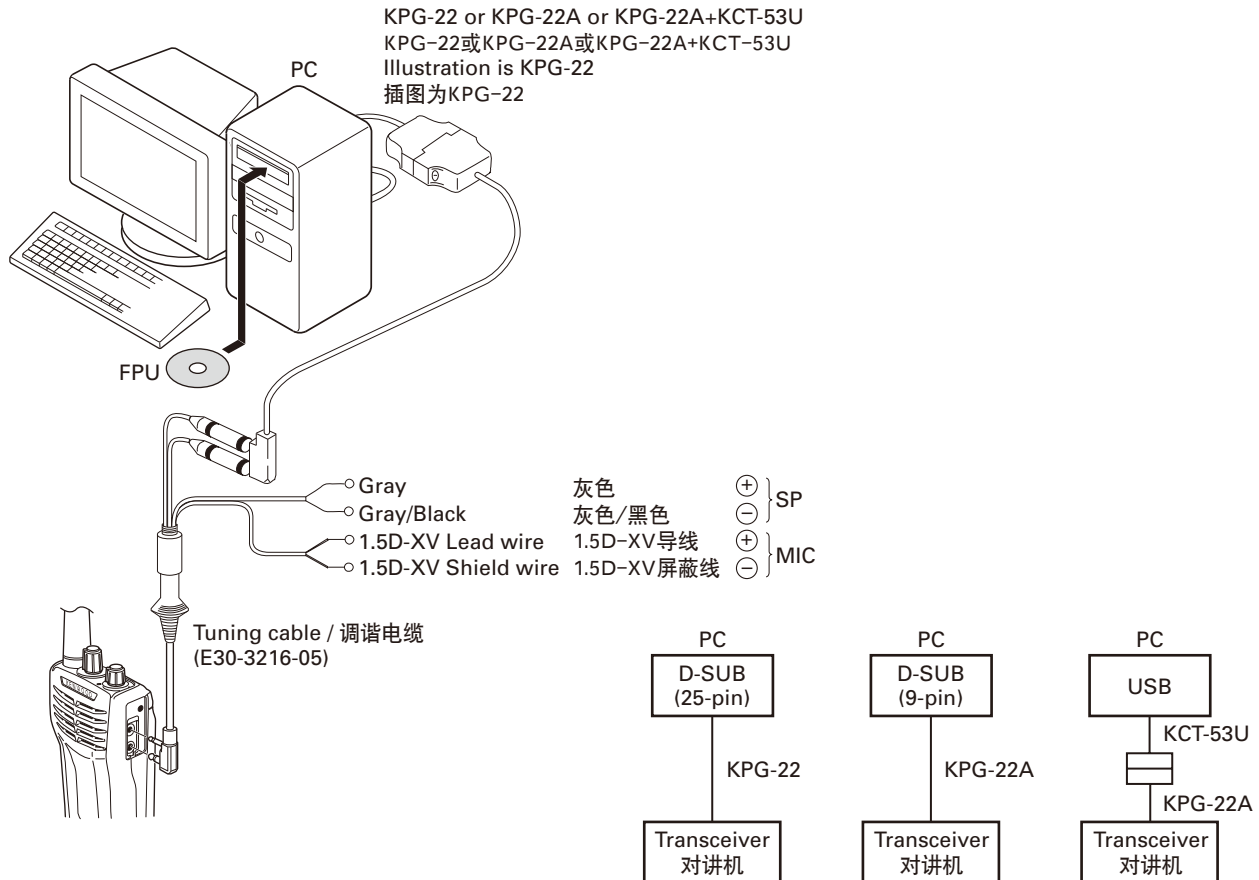

Fig. 1 / 图 1

DISASSEMBLY FOR REPAIR / 维修拆卸

1. Removing the Case Assembly from the Chassis

1. Remove the two knobs (①), cushion (②) and three round nuts (③).
2. Remove the two screws (④).
3. Expand the right and left sides of the bottom of the case assembly, lift the chassis, and remove it from the case assembly (⑤).
4. Taking care not to cut the speaker lead (⑥), open the chassis and case assembly.

Note: Solder the speaker wire back in its original position if you have removed it.

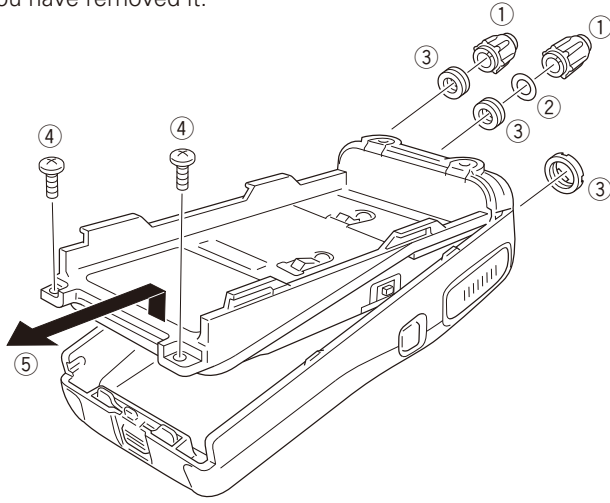

1. 拆卸机壳

1. 取下旋钮 (①)，缓冲垫 (②) 和两个环形螺母 (③)。
 2. 取下两颗螺钉 (④)。
 3. 掀开外壳底部的左右两侧，取下底座，并外壳中取出 (⑤)。
 4. 小心不要折断扬声器引线 (⑥)。拆下底座和外壳。
- 注意：**如果取下了扬声器的导线，请将其焊接到原位上。

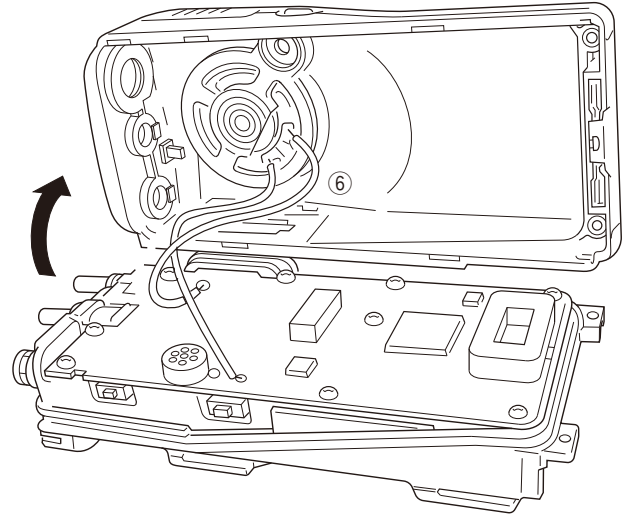

2. Removing the TX-RX unit from the Chassis

1. Remove the eleven screws (⑦).
2. Remove the FPC from connector (CN400) (⑧).
3. Remove the solder from the antenna terminal using a soldering iron then lift the unit off (⑨).
4. Remove the waterproof packing (⑩) and cushion (⑪) from the antenna connector.
5. Remove the two screws (⑫) and remove the antenna connector.

Note: When reassembling the unit in the chassis, be sure to solder the antenna terminal.

2. 拆卸 TX-RX 单元

1. 取下 11 颗螺钉 (⑦)。
 2. 从连接器 (CN400) 取下 FPC (⑧)。
 3. 用电烙铁将天线端点焊开，然后取下主板 (⑨)。
 4. 从天线连接器取下防水橡胶圈 (⑩) 和树脂垫片 (⑪)。
 5. 取下两颗螺钉 (⑫) 并取下天线连接器。
- 注意：**当重新将主板安装到底座上时，确保将天线端点焊好。

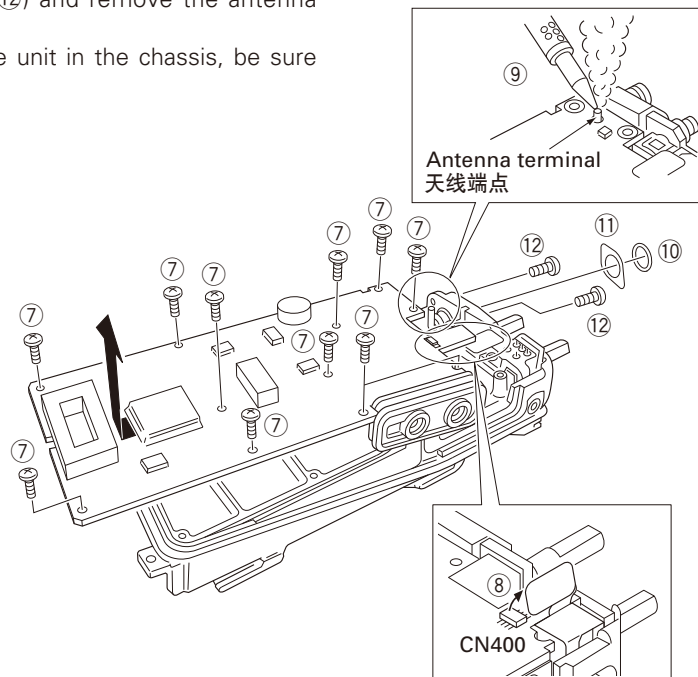

DISASSEMBLY FOR REPAIR / 维修拆卸

3. Removing the lever

1. Raise the lever on the lower case (13), insert a small flat screwdriver into the space between the case and lever, open the case carefully (14) and lift the lever off.

Note: Do not force to separate the case from the lever.

3. 取下夹扭

1. 提起在外壳下部 (13) 上的锁扣, 在外壳和锁扣之间插入一个小型平头改锥, 小心地打开外壳 (14) 并卸下锁扣。
注意: 不要用力拆卸锁扣和外壳。

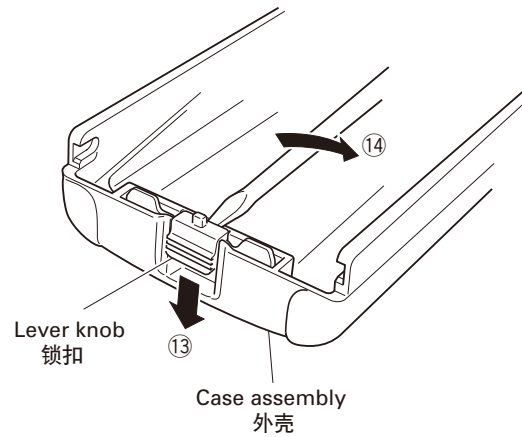

CIRCUIT DESCRIPTION / 电路说明

1. Frequency Configuration

The receiver utilizes double conversion. The first IF is 38.85MHz and the second IF is 450kHz. The first local oscillator signal is supplied from the PLL circuit.

The PLL circuit in the transmitter generates the necessary frequencies. Fig. 1 shows the frequencies.

1. 频率构成

接收部采用二次变频超外差方式。第一中频为 38.85MHz，第二中频为 450kHz。第一本振频率信号由锁相环电路 (PLL) 提供。

发射部由锁相环电路直接产生所需要的频率。图 1 显示各种频率。

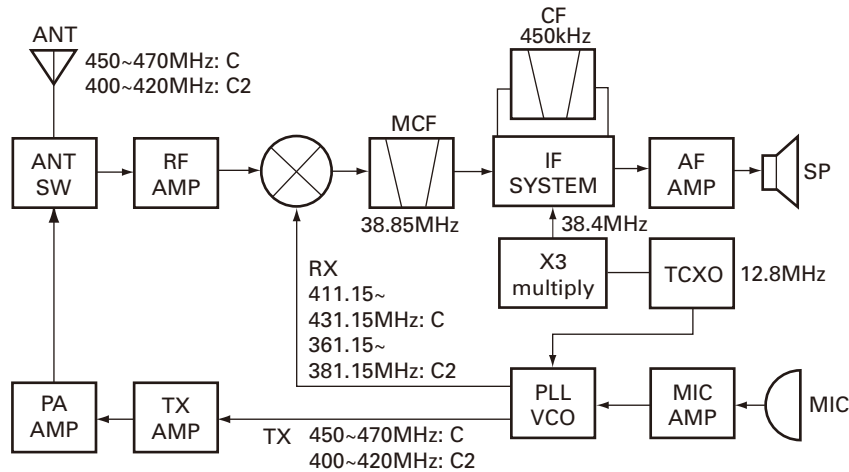

Fig. 1 Frequency configuration / 图 1 电路构成

2. Receiver

The frequency configuration of the receiver is shown in Fig. 2.

2-1. Front-end RF amplifier

An incoming signal from the antenna is applied to an RF amplifier (Q203) after passing through a transmit/receive switch circuit (D102 and D103 are off) and a 3-pole LC filter. After the signal is amplified (Q203), the signal is filtered by a band pass filter (a 3-pole LC filter) to eliminate unwanted signals before it is passed to the first mixer.

The voltage of these diodes are controlled by to track the MCU (IC403) center frequency of the band pass filter. (See Fig. 2)

2. 接收部

接收部的频率构成如图 2 所示。

2-1. 前端射频放大器

从天线输入的信号经过收发转换电路 (D102 和 D103 断开) 和三极管 LC 滤波器后, 在射频放大器 (Q203) 处放大。信号被放大后 (Q203), 在通过第一混频器之前, 经过带通滤波器 (一个三极管 LC 滤波器) 滤波来消除不要的信号。这些变容二极管的电压由带通滤波器的 MCU (IC403) 中心频率控制。(参见图 2)

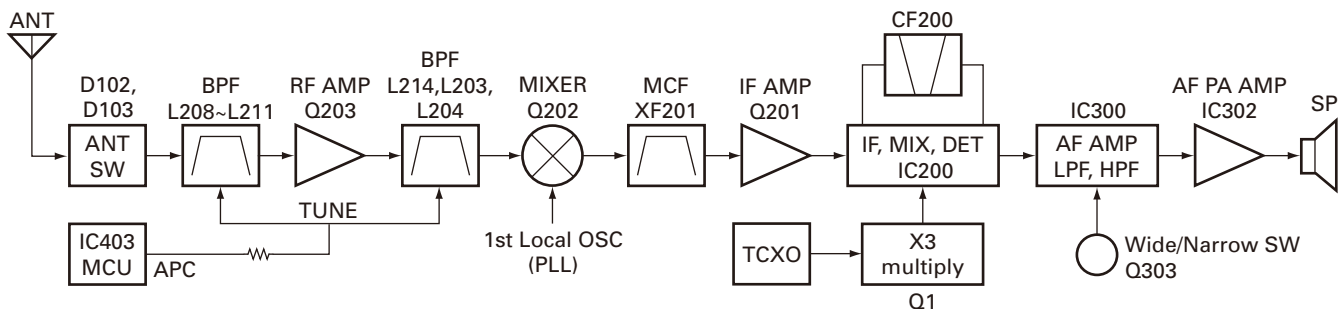

Fig. 2 Receiver section configuration / 图 2 接收部构成

CIRCUIT DESCRIPTION / 电路说明

2-2. First mixer

The signal from the RF amplifier is heterodyned with the first local oscillator signal from the PLL frequency synthesizer circuit at the first mixer (Q202) to create a 38.85MHz first intermediate frequency (1st IF) signal. The first IF signal is then fed through two monolithic crystal filters (MCFs : XF201) to further remove spurious signals.

2-3. IF amplifier

The first IF signal is amplified by Q201, and then enters IC200 (FM processing IC). The signal is heterodyned again with a second local oscillator signal within IC200 to create a 450kHz second IF signal. The second IF signal is then fed through a 450kHz ceramic filter (CF200) to further eliminate unwanted signals before it is amplified and FM detected in IC200.

XF201: L71-0522-05

Item	Rating
Nominal center frequency	38.850MHz
Pass band width	±5.0kHz or more at 3dB
40dB stop band width	±20.0kHz or less
Ripple	1.0dB or less
Insertion loss	4.0dB or less
Guaranteed attenuation	80dB or more at fo-910kHz
Terminal impedance	610Ω / 3pF

CF200: L72-0958-05

Item	Rating
Nominal center frequency	450kHz
6dB band width	±6.0kHz or more
50dB band width	±12.5kHz or less
Ripple	2.0dB or less at fo ±4kHz
Insertion loss	6.0dB or less
Guaranteed attenuation	35.0dB or more at fo ±100kHz
Terminal impedance	2.0kΩ

2-4. AF amplifier

The recovered AF signal obtained from IC200 is amplified by IC300 (1/4), filtered by the IC300 low-pass filter (2/4) and IC300 high-pass filter (3/4) and (4/4), and de-emphasized by R303 and C306. The AF signal is then passed through a WIDE/NARROW switch (Q303). The processed AF signal passes through an AF volume control and is amplified to a sufficient level to drive a loud speaker by an AF power amplifier (IC302).

2-2. 第一混频器

来自射频放大器的信号与来自锁相环频率合成器电路的第一本振信号在第一混频器 (Q202) 处混频并生成 38.85MHz 的第一中频 (1st IF) 信号。第一中频信号通过两个单片晶体滤波器 (MCFs: XF201) 进一步消除邻道的杂波信号。

2-3. 中频放大器

第一中频信号通过 Q201 放大, 然后进入芯片 IC200 (调频处理芯片)。信号在 IC200 中与第二本振信号再次混频生成一个 450kHz 的第二中频信号。在芯片 IC200 中第二本振信号被放大和鉴频之前, 通过一个 450kHz 陶瓷滤波器 (CF200) 滤除无用杂散信号。

XF201: L71-0522-05

项 目	额 定 值
标称中心频率	38.850MHz
通频带宽	±5.0kHz 或更大在 3dB 内
40dB 止频带宽	±20.0kHz 或更小
脉动	1.0dB 或更小
插入损耗	4.0dB 或更小
保证衰减	80dB 或更大
终端阻抗	610Ω / 3pF

CF200: L72-0958-05

项 目	额 定 值
标称中心频率	450kHz
6dB 频带宽度	±6.0kHz 或更大
50dB 频带宽度	±12.5kHz 或更小
脉动	2.0dB 或更小
插入损耗	6.0dB 或更小
保证衰减	35.0dB 或更大
终端阻抗	2.0kΩ

2-4. 音频放大器

在 IC200 中鉴频解调出的音频信号通过 IC300 (1/4) 放大, 通过 IC300 低通滤波器 (2/4) 以及 IC300 高通滤波器 (3/4) 和 (4/4) 滤波, 并且通过 R303 和 C306 去加重。然后音频信号通过一个宽 / 窄转换开关 (Q303)。经过处理的音频信号通过音量控制电路再经过音频功率放大器 (IC302) 放大后、驱动扬声器。

CIRCUIT DESCRIPTION / 电路说明

2-5. Squelch

Part of the AF signal from the IC enters the FM IC again, and the noise component is amplified and rectified by a filter and an amplifier to produce a DC voltage corresponding to the noise level.

The DC signal from the FM IC goes to the analog port of the microprocessor (IC403). IC403 determines whether to output sounds from the speaker by checking whether the input voltage is higher or lower than the preset value.

To output sounds from the speaker, IC403 sends a high signal to the MUTE and AFCO lines and turns IC302 on through Q302, Q304, Q305, Q306 and Q307. (See Fig. 3)

2-5. 噪音抑制电路

从 IC200 输出的音频信号的一部分重新进入 IC200，通过滤波器和放大器将噪音放大和整流并生成一个对应于噪音电平的直流电压。直流信号进入微处理器的模拟端口 (IC403)。IC403 通过检测输入电压是否高于或低于预设值来决定是否通过扬声器输出声音。

要通过扬声器输出声音，IC403 向静音和自动频率控制振荡器连线发送一个高电平信号并开启 IC302 通过 Q302, Q304, Q305, Q306 和 Q307。(参见图 3)

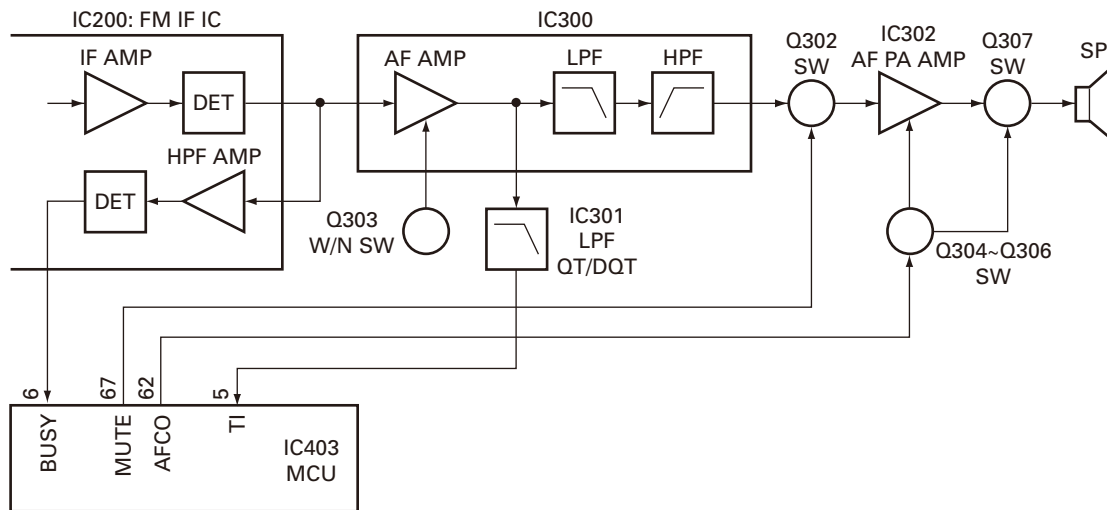

Fig. 3 AF amplifier and Squelch / 图 3 音频放大器和噪音抑制电路

2-6. Receive signaling

• QT/DQT

300Hz and higher audio frequencies of the output signal from IF IC are cut by a low-pass filter (IC301). The resulting signal enters the microprocessor (IC403). IC403 determines whether the QT or DQT matches the preset value, and controls the MUTE and AFCO and the speaker output sounds according to the squelch results.

2-6. 接收信令

• QT/DQT

来自于中频芯片输出信号的 300Hz 和更高的音频被低通滤波器 (Q301) 截断。所得到的信号输入微处理器 (IC403)。IC403 确定 QT 或 DQT 是否匹配预设置，并且根据噪声抑制电路的结果控制 MUTE 和 AFCO 以及扬声器输出声音。

3. PLL Frequency Synthesizer

The PLL circuit generates the first local oscillator signal for reception and the RF signal for transmission.

3-1. PLL

The frequency step of the PLL circuit is 5 or 6.25kHz. A 12.8MHz reference oscillator signal is divided at IC1 by a fixed counter to produce the 5 or 6.25kHz reference frequency. The voltage controlled oscillator (VCO) output signal is buffer amplified by Q6, then divided in IC1 by a dual-module programmable counter. The divided signal is compared in phase with the 5 or 6.25kHz reference signal in the phase comparator in IC1. The output signal from the phase comparator is filtered through a low-pass filter and passed to the VCO to control the oscillator frequency. (See Fig. 4)

3. 锁相环频率合成器

锁相环电路生成用于接收的第一本振信号和用于发送的射频载波信号。

3-1. 锁相环电路

锁相环电路的步进频率为 5 或 6.25kHz。12.8MHz 的参考振荡器信号通过一个混合计数器在 IC1 中被分频并生成 5 或 6.25kHz 的参考频率。压控振荡器 (VCO) 输出的信号通过 Q6 缓冲放大器，然后在 IC1 中被可编程脉冲吞除计数器分频。被分频的信号在带有 5 或 6.25kHz 参考信号的相位比较器的 IC1 中被比较。从相位比较器输出的信号进入一个低通滤波器后，并通过压控振荡器来控制振荡器频率。(参见图 4)

3-2. VCO

The operating frequency is generated by Q4 in transmit mode and Q3 in receive mode. The oscillator frequency is controlled by applying the VCO control voltage, obtained from the phase comparator, to the varactor diodes (D2 and D4 in transmit mode and D1 and D3 in receive mode). The T/R pin is set high in receive mode causing Q5 and Q7 to turn Q4 off, and turn Q3 on. The T/R pin is set low in transmit mode. The outputs from Q3 and Q4 are amplified by Q6 and sent to the buffer amplifiers.

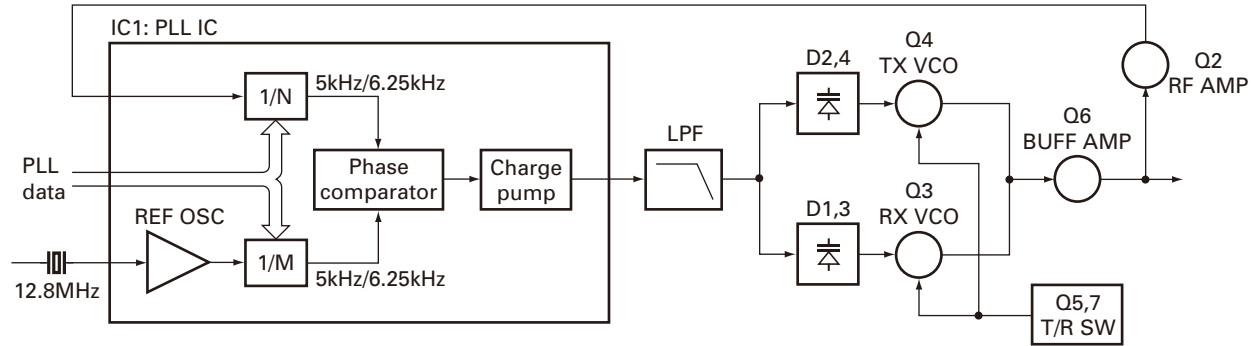

Fig. 4 PLL circuit / 图 4 锁相环电路

3-3. Unlock detector

If a pulse signal appears at the LD pin of IC1, an unlock condition occurs, and the DC voltage obtained from D7, R6, and C1 causes the voltage applied to the UL pin of the microprocessor to go low. When the microprocessor detects this condition, the transmitter is disabled, ignoring the push-to-talk switch input signal. (See Fig. 5)

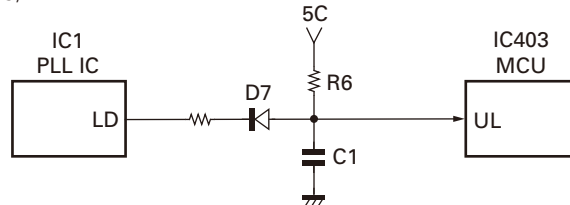

Fig. 5 Unlock detector circuit / 图 4 失锁检测器电路

4. Transmitter

4-1. Transmit audio

The modulation signal from the microphone is amplified by IC500 (1/2), passes through a preemphasis circuit, and amplified by the other IC500 (1/2) to perform IDC operation. The signal then passes through a low-pass filter (splatter filter) (Q501 and Q502) and cuts 3kHz and higher frequencies. The resulting signal goes to the VCO through the VCO modulation terminal for direct FM modulation. (See Fig. 6)

4-2. QT/DQT encoder

A necessary signal for QT/DQT encoding is generated by IC403 and FM-modulated to the PLL reference signal. Since the reference OSC does not modulate the loop characteristic frequency or higher, modulation is performed at the VCO side by adjusting the balance. (See Fig. 6)

3-2. 压控振荡器

在发射模式中通过 Q4 产生操作频率，在接收模式中通过 Q3 产生操作频率。通过相位比较器到变容二极管（在发射模式中为 D2 和 D4，在接收模式中为 D1 和 D3）采用压控振荡器控制电压来控制振荡频率。在接收模式中，由于 Q5 和 Q7 切断 Q4 并且导通 Q3，所以发射 / 接收管脚设置为高电平。在发射模式中，发射 / 接收管脚设置为低电平。Q3 和 Q4 的输出通过 Q6 被放大并被发送到缓冲放大器。

3-3. 失锁检测器

如果 IC1 的 LD 管脚上出现高电平，则产生失锁状态，并从 D7, R6 获得直流电压，且 C1 产生的提供给微处理器 UL 管脚的电压降低。当微处理器检测到此情况时，不能进行发射，无视通话转换开关输入信号。（参见图 5）

4. 发射部

4-1. 发射音频

来自于话筒的调制信号通过 IC500 (1/2) 被放大，经过一个预加重电路，并通过另一个 IC500 (1/2) 放大后进行 IDC 处理。然后信号通过一个低通滤波器（分离滤波器）(Q501 和 Q502) 并滤除比 3kHz 频率更高的部分。得到的信号进入压控振荡器直接进行调频调制。（参见图 6）

4-2. QT/DQT 编码器

QT/DQT 编码所需的信号通过 IC403 产生，被锁相环电路的基准频率调整。由于基准振荡器不能对频率环路特性外的频率进行调制，因此通过分配器在压控振荡器一侧进行调制。（参见图 6）

CIRCUIT DESCRIPTION / 电路说明

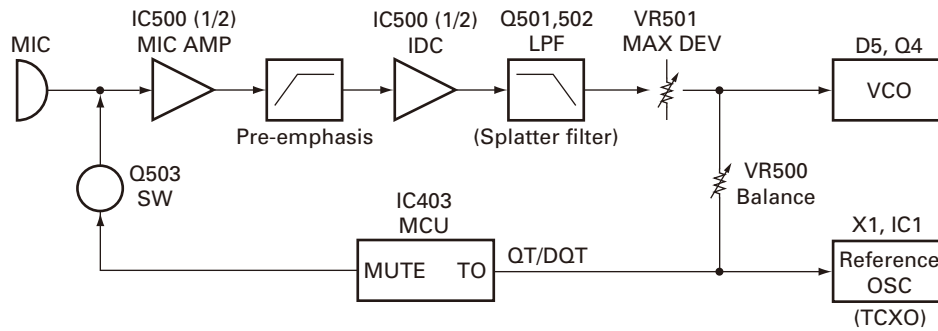

Fig. 6 Transmit audio QT/DQT / 图6 发射音频 QT/DQT

4-3. VCO and RF amplifier

The transmit signal obtained from the VCO buffer amplifier Q100, is amplified by Q101 and Q102. This amplified signal is passed to the power amplifier, Q105 and Q107, which consists of a 2-stage FET amplifier and is capable of producing up to 4W of RF power. (See Fig. 7)

4-4. ANT switch and LPF

The RF amplifier output signal is passed through a low-pass filter network and a transmit/receive switching circuit before it is passed to the antenna terminal. The transmit/receive switching circuit is comprised of D101, D102 and D103. D102 and D103 are turned on (conductive) in transmit mode and off (isolated) in receive mode.

4-3. 压控振荡器和射频放大器

从压控振荡缓冲放大器 (Q100) 接收到的发送信号通过 Q101 和 Q102 被放大。这个放大信号通过功率放大器, Q105 和 Q107 (包括一个二级场效应管放大器), 并能产生 4W 射频功率。(参见图 7)

4-4. 天线转换开关和 LPF

在其到达天线终端之前, 射频放大器输出信号通过一个低通滤波器网络和一个发射/接收转换电路。发射/接收转换电路由 D101, D102 和 D103 构成。D102 和 D103 在发射模式下开启 (通导), 在接收模式下关闭 (隔离)。

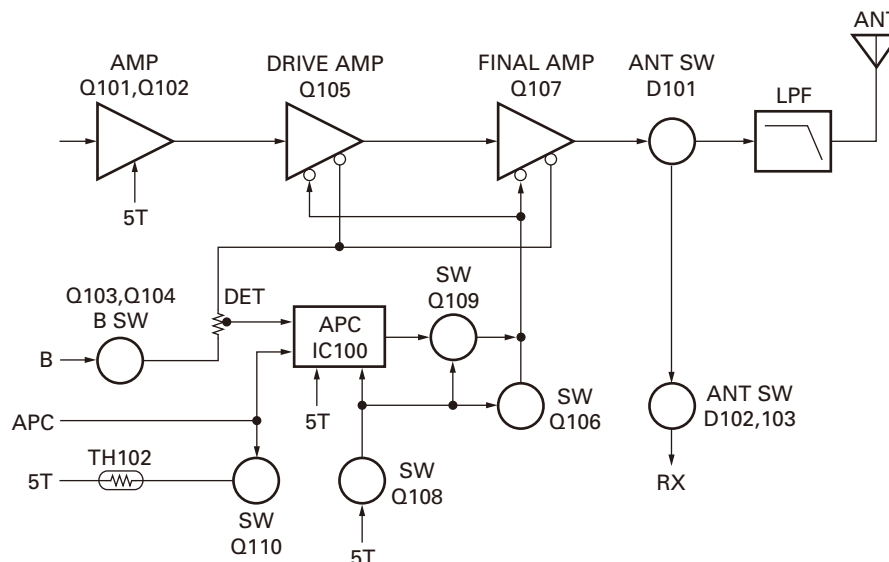

Fig. 7 APC system / 图7 自动功率控制系统

4-5. APC

The automatic power control (APC) circuit stabilizes the transmitter output power at a predetermined level by sensing the drain current of the final amplifier Field Effect Transistor (FET). The voltage comparator, IC100 (2/2), compares the voltage obtained from the above drain current with a reference voltage which is set using the microprocessor. An APC voltage proportional to the difference between the sensed voltage and the reference voltage appears at the output of IC100 (1/2). This output voltage controls the gate of the FET power amplifier, which keeps the transmitter output power constant. The transmitter output power can be varied by the microprocessor which in turn changes the reference voltage and hence, the output power.

4-6. Terminal protection circuit

When the thermistor (TH102) reaches about 80°C, the protection circuit turns on Q110 to protect transmitting final amplifier (Q107) from the over heating.

5. Power supply

A 5V reference power supply [5M] for the control circuit is derived from an internal battery. This reference is used to provide a 5V supply in transmit mode [5T], a 5V supply in receive mode [5R], and a 5V supply common in both modes [5C] based on the control signal sent from the microprocessor.

6. Control system

The IC403 MCU operates at 7.37MHz. This oscillator has a circuit that shifts the frequency according to the EEPROM data.

4-5. 自动功率控制

自动功率控制 (APC) 电路，通过检测末级放大器场效应管的集极电流来稳定发射的输出功率。电压比较电路，IC100 (2/2) 用微处理器设定的参考电压来比较从未级电流所获得的电压。自动功率控制电压与 IC100 (1/2) 输出的自动检测电压和参考电压之间的差值成正比。此输出电压控制场效应管功率放大器，保持发射部输出功率常数。发射部输出功率可以通过微处理器进行改变，在微处理器中改变参考电压来控制输出功率。

4-6. 温度保护电路

当热敏电阻 (TH102) 的温度达到 80°C 时，保护电路开启 Q110 来保护末级放大器 (Q107) 避免过热。

5. 电源

为控制电路提供的 5V 参考电源 [5M] 源于一个内部电池。此参考电源通常在发射模式中 [5T] 提供一个 5V 电源，在接收模式中 [5R] 提供一个 5V 电源，并且在发源于微处理器的控制信号的基础上，在两种模式中 [5C] 提供一个共用的 5V 电源。

6. 控制系统

IC403 微处理器在 7.37MHz 的情况下运行。此振荡器有一个按照 EEPROM 的数据转移频率的电路。

SEMICONDUCTOR DATA

MCU: 38268MCA060GU (IC403)

Pin No.	I/O	Port Name	Function
1	O	VC1	Variable capacity tune control
2	O	VC2	Variable capacity tune control
3	I	NC	NC
4	I	TIBI	QT/DQT external circuit center point input
5	I	TI	QT/DQT signal input
6	I	BUSY	Busy input
7	I	BATT	Battery voltage detection
8	I	NC	NC
9	O	VCCN	Frequency regulation output
10	O	APC	TX: Auto power control D/A output RX: BPF tuning D/A output
11~14	I	NC	NC
15	O	BEEP	Beep output
16	O	TO	QT/DQT output
17	I	NC	NC
18	I	PTT	[PTT] key input Connected to RXD
19	O	TXD	RS-232C output Connected to SP/MIC test (REM)
20	I	RXD	RS-232C input Connected to [PTT] line
21	I	NC	NC
22	I	SELF	Self program L: Disable
23	I	MONI	[MONI] key input
24~27	I	NC	NC
28	I	ENC3	Encode input (channel select)
29	I	ENC2	Encode input (channel select)
30	I	ENC1	Encode input (channel select)
31	I	ENC0	Encode input (channel select)
32	I	INTO	Power detection control
33	I	RST	Reset input
34	I	NC	NC
35	O	NC	NC
36	I	XIN	7.3728MHz oscillator
37	O	XOUT	7.3728MHz oscillator
38	I	VSS	GND
39	O	SHIFT	Beat shift H: Shift on
40	O	PABC	Final supply H: On
41	O	WNRC	Audio reference sensitivity L: Narrow
42	O	WNTC	MAX Dev. Control Narrow: H
43~46	I	NC	NC
47	I/O	SDA	EEPROM data line

Pin No.	I/O	Port Name	Function
48	O	SCL	EEPROM clock line
49	I	UL	PLL unlock detection pin L: Unlock
50~54	I	NC	NC
55	O	DT	Common data output
56	O	CK	Common clock output
57	O	NC	NC
58	O	LE	PLL IC enable H: latches
59,60	O	NC	NC
61	O	5MC	Control of power supply (5M) for everything except the microcomputer and EEPROM L: Power supply on
62	O	AFCO	AF amp power supply H: On
63	O	RX	TX/RX VCO select H: RX
64	O	GLED	Green LED control H: Lit
65	O	RLED	RED LED control H: Lit
66	O	SAVE	Save control H: Save off
67	O	MUTE	Mute control H: Mic mute, L: AF mute
68	O	5RC	Reception power supply control L: On
69	O	5TC	Transmission power supply control H: On
70~88	O	NC	NC
89	I	VCC	Microcomputer power supply, 5V input
90	I	VREF	A/D conversion reference voltage; connected to Vcc
91	I	AVSS	A/D converter power supply; connected to Vss
92~95	O	NC	NC
96~100	I	NC	NC

FET: 2SK2596-E (Q105)

■ Absolute Maximum Ratings (Ta=25°C)

Item	VDSS	VGSS	ID	Pch	Tch	Tstg
Rating	17V	±10V	0.4A	3W Tc=25°C	150°C	-45~+150°C

FET: 2SK2595-E (Q107)

■ Absolute Maximum Ratings (Ta=25°C)

Item	VDS	VGSS	ID	Pch	Tch	Tstg
Rating	17V	±10V	1.1A	20W Tc=25°C	150°C	-45~+150°C

微处理器：38268MCA060GU(IC403)

管脚号	I/O	端口名称	功 能
1	0	VC1	各种电容调谐控制
2	0	VC2	各种电容调谐控制
3	I	NC	NC
4	I	TIBI	QT/DQT 外部电路中心点控制
5	I	TI	QT/DQT 信号输入
6	I	BUSY	繁忙信号输入
7	1	BATT	电池电压检测
8	1	NC	NC
9	0	VCCN	频率稳压输出
10	0	APC	发射：自动功率控制数字 / 模拟输出 接收：BPF 调谐数字 / 模拟输出
11~14	I	NC	NC
15	0	BEEP	Beep 输出
16	0	TO	QT/DQT 输出
17	1	NC	NC
18	I	PTT	[PTT] 键输入与 RXD 连
19	0	TXD	RX-232C 输出与扬声器 / 话筒测试连接 (REM)
20	I	RXD	RX-232C 输入与 [PTT] 线连接
21	1	NC	NC
22	I	SELF	自台编程 L: 禁用
23	I	MON1	[监听] 键输入
24~27	I	NC	NC
28	1	ENC3	编码输入 (信道选择)
29	1	ENC2	编码输入 (信道选择)
30	1	ENC1	编码输入 (信道选择)
31	1	ENC0	编码输入 (信道选择)
32	1	INT0	功率检测控制
33	I	RST	复位输入
34	I	NC	NC
35	0	NC	NC
36	1	XIN	7.3728MHz 振荡器
37	0	XOUT	7.3728MHz 振荡器
38	I	VSS	接地
39	0	SHIFT	拍频偏移 H: 开启转移
40	0	PABC	未级提供 H: 开启
41	0	WNRC	音频参考灵敏度 L: 窄
42	0	WNTC	最大 Dev. 控制 H: 窄
43~46	1	NC	NC
47	I/O	SDA	EEPROM 数据线

管脚号	I/O	端口名称	功 能
48	0	SCL	EEPROM 时钟线
49	I	UL	锁相环电路失锁检测管腿 L: 失锁
50~54	1	NC	NC
55	0	DT	共用数据输出
56	0	CK	共用时钟输出
57	0	NC	NC
58	0	LE	锁相环电路芯片有效 H: 锁存
59, 60	0	NC	NC
61	0	5MC	除了 CPU 和 EEPROM 以外电源控制 L: 电源开启
62	0	AFCO	音频放大电源 H: 开启
63	0	RX	发射 / 接收压控振荡器选择 H: 接收
64	0	GLED	绿色指示灯控制 H: 点亮
65	0	RLED	红色指示灯控制 H: 点亮
66	0	SAVE	电池省电控制 H: 省电 OFF
67	0	MUTE	静音控制 H: 扬声器静音, L: 音频静音
68	0	5RC	接收电源控制 L: 开启
69	0	5TC	发射电源控制 L: 开启
70~88	0	NC	NC
89	1	VCC	CPU 电源 5V 输入
90	1	VREF	模拟 / 数字转换参考电压 ; 与 Vcc 连接
91	1	AVSS	模拟 / 数字转换器电源 ; 与 Vss 连接
92~95	0	NC	NC
96~100	I	NC	NC

FET: 2SK2596-E(Q105)

■绝对最大额定值 (Ta=25℃)

项目	VDSS	VGSS	ID	Pch	Tch	Tstg
额定值	17V	±10V	0.4A	3W Tc=25℃	150℃	-45~+150℃

FET: 2SK2595-E(Q107)

■绝对最大额定值 (Ta=25℃)

项目	VDS	VGSS	ID	Pch	Tch	Tstg
额定值	17V	±10V	1.1A	20W Tc=25℃	150℃	-45~+150℃

COMPONENTS DESCRIPTION / 元件说明

TX-RX UNIT (X57-6030-XX)

Ref No.	Part Name	Description
IC1	IC	Phase locked loop system
IC100	IC	Automatic power control
IC200	IC	IF system
IC300	IC	Audio amplifier active filter
IC301	IC	Active filter
IC302	IC	Audio power amplifier
IC400	IC	Reset switch
IC401	IC	EEPROM
IC402	IC	Voltage detect
IC403	IC	MCU
IC404	IC	Voltage regulator
IC500	IC	MIC amplifier/ Limiter
Q1	Transistor	Tripler
Q2	Transistor	RF amplifier
Q3	FET	VCO RX
Q4	Transistor	VCO TX
Q5	FET	DC switch
Q6	Transistor	RF buffer amplifier
Q7	Transistor	DC switch
Q8	Transistor	Ripple filter
Q100	Transistor	RF amplifier
Q101	Transistor	TX pre-drive
Q102	FET	TX drive
Q103	FET	DC switch
Q104	Transistor	DC switch
Q105	FET	TX drive
Q106	FET	DC switch
Q107	FET	TX final
Q108,109	Transistor	DC switch
Q110	Transistor	Temperature protection switch
Q200	Transistor	DC switch
Q201	Transistor	IF amplifier
Q202	FET	Mixer
Q203	FET	Mixer RF amplifier
Q300	Transistor	Active filter
Q302	FET	Audio mute switch
Q303~306	Transistor	DC switch
Q307	FET	Audio mute switch
Q400~402	Transistor	DC switch
Q403	Transistor	Beat shift switch

TX-RX 单元 (X57-6030-XX)

有关号码	名称	说明
IC1	IC	锁相环路系统
IC100	IC	自动功率控制
IC200	IC	中频系统
IC300	IC	音频放大器有源滤波器
IC301	IC	有源滤波器
IC302	IC	音频功率放大器
IC400	IC	复位开关
IC401	IC	EEPROM
IC402	IC	电压检测
IC403	IC	微处理器
IC404	IC	电压调节器
IC500	IC	音频放大 / 限幅器
Q1	晶体管	三倍频
Q2	晶体管	射频放大器
Q3	场效应管	压控振荡器接收
Q4	晶体管	压控振荡器发射
Q5	场效应管	直流开关
Q6	晶体管	射频缓冲放大器
Q7	晶体管	直流开关
Q8	晶体管	脉动滤波器
Q100	晶体管	射频放大器
Q101	晶体管	预放大器
Q102	场效应管	驱动放大器
Q103	场效应管	直流开关
Q104	晶体管	直流开关
Q105	场效应管	驱动放大器
Q106	场效应管	直流开关
Q107	场效应管	末级射频功率放大器
Q108, 109	晶体管	直流开关
Q110	晶体管	温度保护开关
Q200	晶体管	直流开关
Q201	晶体管	中频放大器
Q202	场效应管	混频器
Q203	场效应管	混频器射频放大器
Q300	晶体管	有源滤波器
Q302	场效应管	音频静音控制开关
Q303~306	晶体管	直流开关
Q307	场效应管	音频静音控制开关
Q400~402	晶体管	直流开关
Q403	晶体管	差拍移动开关

COMPONENTS DESCRIPTION / 元件说明

Ref No.	Part Name	Description
Q404	Transistor	DC switch
Q405	FET	DC switch
Q406~408	Transistor	DC switch
Q500	FET	DC switch
Q501,502	Transistor	Active filter
Q503	Transistor	MIC mute/ AGC
Q504	Transistor	DC switch
D1~4	Variable capacitance diode	Frequency control
D5	Variable capacitance diode	TX modulation
D6	Diode	Current steering
D7	Diode	Unlock detect
D100	Diode	RF switch
D101~103	Diode	Antenna switch
D200	Diode	RF switch
D201~204	Variable capacitance diode	BPF tuning
D300	Diode	Limiter
D400	LED	TX
D401	LED	Busy
D500	Diode	AGC detect
D501	Diode	MIC mute/ AGC switch
D502	Diode	Reverse protection

有关号码	名称	说明
Q404	晶体管	直流开关
Q405	场效应管	直流开关
Q406~408	晶体管	直流开关
Q500	场效应管	直流开关
Q501, 502	晶体管	有源滤波器
Q503	晶体管	扬声器静音 / 自动增益控制
Q504	晶体管	直流开关
D1~4	可变电容二极管	频率控制
D5	可变电容二极管	调制发射
D6	二极管	电流方向
D7	二极管	失锁检测
D100	二极管	射频开关
D101~103	二极管	天线开关
D200	二极管	射频开关
D201~204	可变电容二极管	BPF 调谐
D300	二极管	限幅器
D400	LED	发送
D401	LED	繁忙
D500	二极管	自动增益控制检测
D501	二极管	扬声器静音 / 自动增益控制开关
D502	二极管	反向保护

PARTS LIST / 零件表

* New Parts. Δ indicates safety critical components.

Parts without **Parts No.** are not supplied.

Les articles non mentionnés dans le **Parts No.** ne sont pas fournis.

Teile ohne **Parts No.** werden nicht geliefert.

L : Scandinavia

Y : PX (Far East, Hawaii)

C : China

K : USA

T : England

X : Australia

P : Canada

E : Europe

M : Other Areas

TK-3107G

TX-RX UNIT (X57-6030-XX)

Ref. No.	Address	New parts	Parts No.	Description	Desti-nation
TK-3107G					
1	1A		A02-4049-13	PLASTIC CABINET ASSY	
3	3B		A82-0034-03	REAR PANEL	
5	2D		B09-0351-03	CAP (SP/MIC) ACCESSORY	
9	2B		E04-0449-05	RF COAXIAL RECEPTACLE (SMA)	
10	3B		E23-1183-04	RELAY TERMINAL (BATT-)	
14	1A		G01-0881-04	COIL SPRING (BATT RELEASE)	
-			G11-2583-04	SHEET (HOLDER)	
16	3B		G11-2588-14	RUBBER SHEET (CHASSIS)	
17	1B		G11-4478-04	SHEET (CH)	
18	3B		G13-1709-04	CUSHION (VOL)	
19	3B		G13-1763-04	CUSHION (TERMINAL BATT+)	
20	3B		G13-1867-14	CUSHION (TERMINAL BATT-)	
21	2B		G13-1959-04	CUSHION (RECEPTACLE)	
22	2A		G13-1985-04	CUSHION (X400)	
23	3B		G13-1986-04	CUSHION (VR501)	
24	3B		G13-2069-24	CUSHION (HOLDER)	
25	2B		G53-0791-03	PACKING (SP/MIC)	
26	2A		G53-0842-13	PACKING (SP)	
27	2B		G53-0860-04	PACKING (CHASSIS)	
28	2B		G53-1528-04	PACKING (SMA)	
33	1A		J19-1572-04	HOLDER (BATT RELEASE)	
34	2B		J19-5344-13	HOLDER (VOL/CH)	
35	3D		J21-4493-04	SP/MIC HOLDER ACCESSORY	
36	2D		J29-0734-05	BELT CLIP ACCESSORY	
37	1B		J69-0345-04	RING (VOL, CH)	
38	2B		J82-0059-15	FPC	
40	1B		K29-5255-03	KNOB (VOL)	
41	1A		K29-5274-03	BUTTON KNOB (MONI)	
42	1A		K29-5275-23	BUTTON KNOB (PTT)	
43	1B		K29-5278-03	KNOB (CH)	
44	1A		K29-5337-03	LEVER KNOB (BATT RELEASE)	
A	2B		N09-2438-05	BINDING HEAD SCREW (SMA)	
B	1B		N14-0581-44	CIRCULAR NUT (VOL, CH)	
C	1B		N14-0804-24	CIRCULAR NUT (SMA)	
D	3A		N30-2606-48	PAN HEAD MACHINE SCREW	
E	3B		N79-2030-48	PAN HEAD TAPTITE SCREW	
F	2A,2B		N83-2005-48	PAN HEAD TAPTITE SCREW	
46	3D		N99-0396-15	SCREW SET ACCESSORY	
48	2B		R31-0647-05	VARIABLE RESISTOR	
50	2B	*	S60-0424-35	ROTARY SWITCH	
52	1A		T07-0369-15	SPEAKER	
53	2C		T90-1039-25	WHIP ANTENNA ACCESSORY	C
53	2C		T90-1041-25	WHIP ANTENNA ACCESSORY	C2

Ref. No.	Address	New parts	Parts No.	Description	Desti-nation
TX-RX UNIT (X57-6030-XX) -10: C -25: C2					
D400			B30-2156-05	LED (RED)	
D401			B30-2157-05	LED (YELLOW)	
C1			CK73GB1C104K	CHIP C 0.10UF	K
C2,3			CC73GCH1H101J	CHIP C 100PF	J
C4			CK73GB1C104K	CHIP C 0.10UF	K
C5			CS77AA0J4R7M	CHIP TNTL 4.7UF	6.3WV
C6			CC73GCH1H101J	CHIP C 100PF	J
C7			CK73GB1H471K	CHIP C 470PF	K
C9			CC73GCH1H130J	CHIP C 13PF	J
C10			CC73GCH1H470J	CHIP C 47PF	J
C12			CS77CA1V0R1M	CHIP TNTL 0.1UF	35WV
C14			CC73GCH1H130J	CHIP C 13PF	J
C15			CS77CA1C010M	CHIP TNTL 1.0UF	16WV
C16			CC73GCH1H680J	CHIP C 68PF	J
C17			CK73GB1H331K	CHIP C 330PF	K
C18			CS77CA1V0R1M	CHIP TNTL 0.1UF	35WV
C19,20			CK73GB1H103K	CHIP C 0.010UF	K
C23			CS77AA0J100M	CHIP TNTL 10UF	6.3WV
C24			CK73GB1H103K	CHIP C 0.010UF	K
C25			CK73GB1H471K	CHIP C 470PF	K
C26			CC73GCH1H121J	CHIP C 120PF	J
C27			CK73GB1H471K	CHIP C 470PF	K
C28			CC73GCH1H330J	CHIP C 33PF	J
C29			CC73GCH1H020C	CHIP C 2.0PF	C
C30			CK73GB1H102K	CHIP C 1000PF	K
C31			CC73GCH1H101J	CHIP C 100PF	J
C34			CC73GCH1H180J	CHIP C 18PF	J
C35			CC73GCH1H070B	CHIP C 7.0PF	B
C35			CC73GCH1H150J	CHIP C 15PF	J
C36			CC73GCH1H070B	CHIP C 7.0PF	B
C36			CC73GCH1H080B	CHIP C 8.0PF	B
C37			CC73GCH1H300J	CHIP C 30PF	J
C37			CC73GCH1H330J	CHIP C 33PF	J
C38			CC73GCH1H050C	CHIP C 5.0PF	C
C38			CC73GCH1H060B	CHIP C 6.0PF	B
C39			CC73GCH1H080D	CHIP C 8.0PF	D
C39			CC73GCH1H100C	CHIP C 10PF	C
C40			CC73GCH1H0R5B	CHIP C 0.5PF	B
C41			CC73GCH1H040B	CHIP C 4.0PF	B
C41			CC73GCH1H050B	CHIP C 5.0PF	B
C42			CC73GCH1H100D	CHIP C 10PF	D
C42			CC73GCH1H120G	CHIP C 12PF	G
C43			CK73GB1H102K	CHIP C 1000PF	K
C44			CC73GCH1H060B	CHIP C 6.0PF	B
C44			CC73GCH1H120G	CHIP C 12PF	G
C45			CC73GCH1H090B	CHIP C 9.0PF	B
C45			CC73GCH1H100C	CHIP C 10PF	C
C46			CK73GB1H471K	CHIP C 470PF	K
C47			CC73GCH1H010B	CHIP C 1.0PF	B
C48			CK73GB1H471K	CHIP C 470PF	K
C49			CC73GCH1H0R5B	CHIP C 0.5PF	B
C51			CC73GCH1H680J	CHIP C 68PF	J
C52			CK73GB1H471K	CHIP C 470PF	K

PARTS LIST / 零件表

TX-RX UNIT (X57-6030-XX)

Ref. No.	Address	New parts	Parts No.	Description	Destination	Ref. No.	Address	New parts	Parts No.	Description	Destination
C53			CC73GCH1H060D	CHIP C 6.0PF D		C204			CK73GB1H472K	CHIP C 4700PF K	
C54			CC73GCH1H030B	CHIP C 3.0PF B		C205,206			CC73GCH1H331J	CHIP C 330PF J	
C55			CK73GB1H471K	CHIP C 470PF K		C207			CK73GB1C104K	CHIP C 0.10UF K	
C56			CS77AAQJ4R7M	CHIP TNTL 4.7UF 6.3WV		C208			CC73GCH1H270J	CHIP C 27PF J	
C100			CC73GCH1H220J	CHIP C 22PF J		C209			CK73GB1C104K	CHIP C 0.10UF K	
C101-103			CK73GB1H471K	CHIP C 470PF K		C210			CK73GB1H103K	CHIP C 0.010UF K	
C104			CK73GB1C104K	CHIP C 0.10UF K		C211			CK73GB1C104K	CHIP C 0.10UF K	
C105			CC73GCH1H060D	CHIP C 6.0PF D		C212			CC73GCH1H330J	CHIP C 33PF J	
C106,107			CK73GB1H471K	CHIP C 470PF K		C213			CK73GB1C104K	CHIP C 0.10UF K	
C108			CC73GCH1H070D	CHIP C 7.0PF D		C214			CK73GB1H103K	CHIP C 0.010UF K	
C109,110			CK73GB1H471K	CHIP C 470PF K		C215			CC73GCH1H130J	CHIP C 13PF J	
C111			CC73GCH1H060D	CHIP C 6.0PF D		C217			CK73HB1E103K	CHIP C 0.010UF K	
C112			CK73GB1H471K	CHIP C 470PF K		C218			CK73GB1H471K	CHIP C 470PF K	
C113			CK73GB1C104K	CHIP C 0.10UF K		C219			CC73GCH1H150J	CHIP C 15PF J	
C114,115			CK73GB1H471K	CHIP C 470PF K		C220			CK73HB1E103K	CHIP C 0.010UF K	
C116			CK73GB1H102K	CHIP C 1000PF K		C222			CC73HCH1H010B	CHIP C 1.0PF B	C
C118			CC73GCH1H270J	CHIP C 27PF J		C222			CC73HCH1H050B	CHIP C 5.0PF B	C2
C119			CK73GB1H102K	CHIP C 1000PF K		C223			CC73GCH1H020C	CHIP C 2.0PF C	
C120,121			CK73GB1H471K	CHIP C 470PF K		C224			CK73GB1H471K	CHIP C 470PF K	
C123			CK73GB1H102K	CHIP C 1000PF K		C226			CC73GCH1H0R3B	CHIP C 0.3PF B	C
C125			CK73GB1H471K	CHIP C 470PF K		C226			CC73GCH1H0R5B	CHIP C 0.5PF B	C2
C126			CK73FB1A105K	CHIP C 1.0UF K		C227			CC73GCH1H100C	CHIP C 10PF C	C
C127			CS77AA1A6R8M	CHIP TNTL 6.8UF 10WV		C227			CC73GCH1H150G	CHIP C 15PF G	C2
C128			CK73GB1H103K	CHIP C 0.010UF K		C228			CC73GCH1H080B	CHIP C 8.0PF B	C2
C129			CK73GB1H471K	CHIP C 470PF K		C228			CC73GCH1H270J	CHIP C 27PF J	C
C130			CC73FCH1H220G	CHIP C 22PF G		C229			CK73GB1H471K	CHIP C 470PF K	
C131			CK73GB1C104K	CHIP C 0.10UF K		C231,232			CK73GB1H471K	CHIP C 470PF K	
C132			CK73GB1H471K	CHIP C 470PF K		C233,234			CC73GCH1H0R3B	CHIP C 0.3PF B	
C134			CC73GCH1H101J	CHIP C 100PF J		C235			CC73GCH1H3R5B	CHIP C 3.5PF B	
C135			CC73GCH1H010C	CHIP C 1.0PF C		C236			CC73GCH1H0R3B	CHIP C 0.3PF B	C
C136			CC73GCH1H070B	CHIP C 7.0PF B		C236			CC73GCH1H0R5B	CHIP C 0.5PF B	C2
C138			CC73GCH1H101J	CHIP C 100PF J	C	C237			CK73GB1H471K	CHIP C 470PF K	
C138,139			CK73GB1H471K	CHIP C 470PF K	C2	C238			CC73GCH1H0R3B	CHIP C 0.3PF B	C
C139			CK73GB1H471K	CHIP C 470PF K	C	C238			CC73GCH1H0R5B	CHIP C 0.5PF B	C2
C140			CC73GCH1H040B	CHIP C 4.0PF B	C2	C239			CC73GCH1H040B	CHIP C 4.0PF B	C
C141			CK73GB1H471K	CHIP C 470PF K		C239			CC73GCH1H050B	CHIP C 5.0PF B	C2
C142			CC73GCH1H030B	CHIP C 3.0PF B	C	C241			CC73GCH1H060B	CHIP C 6.0PF B	C
C142			CC73GCH1H050B	CHIP C 5.0PF B	C2	C241			CC73GCH1H2R5B	CHIP C 2.5PF B	C2
C143			CK73GB1H471K	CHIP C 470PF K		C252			CC73GCH1H060B	CHIP C 6.0PF B	C2
C144			CC73GCH1H020B	CHIP C 2.0PF B		C252			CC73GCH1H4R5B	CHIP C 4.5PF B	C
C145			CK73GB1H471K	CHIP C 470PF K		C253,254			CK73GB1H471K	CHIP C 470PF K	
C147			CC73GCH1H1R5B	CHIP C 1.5PF B	C2	C255			CC73GCH1H4R5B	CHIP C 4.5PF B	
C147-149			CC73GCH1H010B	CHIP C 1.0PF B	C	C256			CK73GB1C104K	CHIP C 0.10UF K	
C149			CC73GCH1H010B	CHIP C 1.0PF B	C2	C257			CK73GB1H471K	CHIP C 470PF K	
C150			CC73GCH1H040B	CHIP C 4.0PF B	C2	C258			CK73GB1C104K	CHIP C 0.10UF K	
C150			CC73GCH1H050B	CHIP C 5.0PF B	C	C259			CC73GCH1H030B	CHIP C 3.0PF B	C
C151			CC73GCH1H020B	CHIP C 2.0PF B	C2	C259			CC73GCH1H060B	CHIP C 6.0PF B	C2
C151			CC73GCH1H1R5B	CHIP C 1.5PF B	C	C260			CC73GCH1H2R5B	CHIP C 2.5PF B	C
C153			CC73GCH1H030B	CHIP C 3.0PF B	C	C260			CC73GCH1H3R5B	CHIP C 3.5PF B	C2
C153			CC73GCH1H040B	CHIP C 4.0PF B	C2	C261			CK73HB1A104K	CHIP C 0.10UF K	
C154			CC73GCH1H010B	CHIP C 1.0PF B	C	C262			CK73GB1C104K	CHIP C 0.10UF K	
C154			CC73GCH1H020B	CHIP C 2.0PF B	C2	C263-265			CK73HB1H471K	CHIP C 470PF K	C2
C155			CC73GCH1H1R5B	CHIP C 1.5PF B	C	C263,264			CC73HCH1H220J	CHIP C 22PF J	C
C156			CK73GB1C104K	CHIP C 0.10UF K		C265			CK73HB1H471K	CHIP C 470PF K	C
C157			CK73GB1H471K	CHIP C 470PF K		C267			CC73HCH1H470J	CHIP C 47PF J	
C165			CK73GB1H471K	CHIP C 470PF K		C268			CC73GCH1H010B	CHIP C 1.0PF B	C2
C200			CS77AAQJ100M	CHIP TNTL 10UF 6.3WV		C300			CK73GB1H822K	CHIP C 8200PF K	
C201			CK73GB1H103K	CHIP C 0.010UF K		C301			CK73GB1E183K	CHIP C 0.018UF K	
C202			CC73GCH1H270J	CHIP C 27PF J		C302,303			CK73GB1C104K	CHIP C 0.10UF K	
C203			CK73GB1H471K	CHIP C 470PF K		C304			CS77AAQJ100M	CHIP TNTL 10UF 6.3WV	

PARTS LIST / 零件表

TX-RX UNIT (X57-6030-XX)

Ref. No.	Address	New parts	Parts No.	Description	Destination	Ref. No.	Address	New parts	Parts No.	Description	Destination
C305			CK73GB1H103J	CHIP C 0.010UF J		C516			CC73GCH1H100D	CHIP C 10PF D	
C306			CK73GB1C473K	CHIP C 0.047UF K		C517			CK73GB1H471K	CHIP C 470PF K	
C307			CS77AA0J100M	CHIP TNTL 10UF 6.3WV		C518			CK73GB1E223J	CHIP C 0.022UF J	
C308			CK73GB1H562K	CHIP C 5600PF K		C519			CS77AA0J4R7M	CHIP TNTL 4.7UF 6.3WV	
C309			CK73GB1H103J	CHIP C 0.010UF J		C520			CK73GB1E223J	CHIP C 0.022UF J	
C311			CS77AA0J100M	CHIP TNTL 10UF 6.3WV		C521			CK73GB1H102K	CHIP C 1000PF K	
C312			CK73GB1H103J	CHIP C 0.010UF J		C522			CK73FB1E104K	CHIP C 0.10UF K	
C313			CK73FB1A105K	CHIP C 1.0UF K		C523			CS77CP0G2R2M	CHIP TNTL 2.2UF 4.0WV	
C314			CK73GB1H102K	CHIP C 1000PF K		C524			CK73GB1C273K	CHIP C 0.027UF K	
C316			CK73GB1H103J	CHIP C 0.010UF J		C525			CK73GB1C104K	CHIP C 0.10UF K	
C318			CK73GB1C333J	CHIP C 0.033UF J		C526			CK73GB1H471K	CHIP C 470PF K	
C319			CK73GB1C473J	CHIP C 0.047UF J		C527			CS77AA0J100M	CHIP TNTL 10UF 6.3WV	
C320,321			CK73GB1C333J	CHIP C 0.033UF J		C528			CK73GB1H471K	CHIP C 470PF K	
C322			CK73FB1E104K	CHIP C 0.10UF K		C529			CK73FB1H471K	CHIP C 470PF K	
C327			CK73GB1C104K	CHIP C 0.10UF K		C530			CC73HCH1H221J	CHIP C 220PF J	
C330			CC73GCH1H101J	CHIP C 100PF J		C531			CC73GCH1H221J	CHIP C 220PF J	
C331			CK73FB1C474K	CHIP C 0.47UF K		C532			CK73GB1H471K	CHIP C 470PF K	
C332			CS77AA0J100M	CHIP TNTL 10UF 6.3WV		TC1			C05-0383-05	CERAMIC TRIMMER CAPACITOR (6PF)	C
C333			CK73GB1A474K	CHIP C 0.47UF K		TC1.2			C05-0384-05	CERAMIC TRIMMER CAPACITOR (10PF)	C2
C334			CC73GCH1H221J	CHIP C 220PF J		TC2			C05-0384-05	CERAMIC TRIMMER CAPACITOR (10PF)	C
C335			CK73GB1C473K	CHIP C 0.047UF K		TC201			C05-0383-05	CERAMIC TRIMMER CAPACITOR (6PF)	
C336			CK73GB1H103K	CHIP C 0.010UF K		TC202,203			C05-0369-05	CERAMIC TRIMMER CAPACITOR (6PF)	
C337			CS77CC0J101M	CHIP TNTL 100UF 6.3WV		101	2B		E23-1182-04	RELAY TERMINAL	
C338			CC73GCH1H560J	CHIP C 56PF J		CN400			E40-5998-15	PIN ASSY	
C400			CK73GB1C104K	CHIP C 0.10UF K		J500			E11-0703-05	PHONE JACK (2.5/3.5D)	
C402-404			CK73GB1H471K	CHIP C 470PF K		F500			F53-0392-05	FUSE (32V/3A)	
C406			CK73GB1H471K	CHIP C 470PF K		102	2B		G13-1867-14	CUSHION	
C407			CK73GB1H102K	CHIP C 1000PF K		103	2B		G53-0862-04	PACKING	
C408			CS77AA0J100M	CHIP TNTL 10UF 6.3WV		104	2B		J19-1571-04	HOLDER	
C409			CC73GCH1H030B	CHIP C 3.0PF B		105	2B		J30-1249-04	SPACER	
C410,411			CK73GB1H471K	CHIP C 470PF K		CF200			L72-0958-05	CERAMIC FILTER	
C412			CC73GCH1H100D	CHIP C 10PF D		L1			L92-0140-05	CHIP FERRITE	
C413			CK73GB1H102K	CHIP C 1000PF K		L2			L41-8295-39	SMALL FIXED INDUCTOR (8.2UH)	
C414			CK73GB1H471K	CHIP C 470PF K		L4			L40-4781-86	SMALL FIXED INDUCTOR (0.47UH)	
C415			CC73GCH1H100D	CHIP C 10PF D		L5			L40-5681-86	SMALL FIXED INDUCTOR (0.56UH)	
C416			CK73GB1H471K	CHIP C 470PF K		L6			L40-1875-92	SMALL FIXED INDUCTOR (18NH)	
C417			CK73EF1C105Z	CHIP C 1.0UF Z		L7			L92-0140-05	CHIP FERRITE	
C418			CK73GB1H103K	CHIP C 0.010UF K		L8			L40-1085-92	SMALL FIXED INDUCTOR (100NH)	
C420,421			CK73GB1H103K	CHIP C 0.010UF K		L9			L40-3391-86	SMALL FIXED INDUCTOR (3.3UH)	
C422			CK73HB1E103K	CHIP C 0.010UF K		L10			L92-0140-05	CHIP FERRITE	
C423			CK73GB1C333K	CHIP C 0.033UF K		L11			L40-3391-86	SMALL FIXED INDUCTOR (3.3UH)	
C424			CK73FB1A105K	CHIP C 1.0UF K		L12			L40-1085-92	SMALL FIXED INDUCTOR (100NH)	
C425			CK73HB1E103K	CHIP C 0.010UF K		L13,14			L33-0744-05	SMALL FIXED INDUCTOR (23NH)	
C427			CK73GB1H471K	CHIP C 470PF K		L13,14			L33-1267-05	SMALL FIXED INDUCTOR (27NH)	
C429,430			CK73FB1A105K	CHIP C 1.0UF K		L15			L40-1085-92	SMALL FIXED INDUCTOR (100NH)	
C500,501			CK73GB1C273K	CHIP C 0.027UF K		L16,17			L40-2285-38	SMALL FIXED INDUCTOR (220NH)	
C502			CK73GB1H392K	CHIP C 3900PF K		L18			L40-4775-92	SMALL FIXED INDUCTOR (47NH)	
C503			CK73GB1C333K	CHIP C 0.033UF K		L19			L92-0140-05	CHIP FERRITE	
C504			CS77AA0J4R7M	CHIP TNTL 4.7UF 6.3WV		L20			L40-3391-86	SMALL FIXED INDUCTOR (3.3UH)	
C505			CK73FB1A105K	CHIP C 1.0UF K		L21			L40-2275-92	SMALL FIXED INDUCTOR (22NH)	
C506			CK73GB1H471K	CHIP C 470PF K		L100			L40-2275-92	SMALL FIXED INDUCTOR (22NH)	
C507			CS77CP0G2R2M	CHIP TNTL 2.2UF 4.0WV		L101			L40-1875-92	SMALL FIXED INDUCTOR (18NH)	
C508			CK73GB1H103K	CHIP C 0.010UF K		L102			L40-1575-92	SMALL FIXED INDUCTOR (15NH)	
C509			CK73GB1H332K	CHIP C 3300PF K		L103			L92-0140-05	CHIP FERRITE	
C510			CC73GCH1E681J	CHIP C 680PF J		L104			L41-1098-40	SMALL FIXED INDUCTOR (1000NH)	
C511			CK73GB1C473K	CHIP C 0.047UF K		L105			L92-0149-05	CHIP FERRITE	
C512			CK73GB1H332K	CHIP C 3300PF K		L106			L34-4551-05	AIR-CORE COIL (47NH)	
C513			CC73GCH1E681J	CHIP C 680PF J							
C514			CK73GB1C473K	CHIP C 0.047UF K							
C515			CK73GB1H103K	CHIP C 0.010UF K							

PARTS LIST / 零件表

TX-RX UNIT (X57-6030-XX)

Ref. No.	Address	New parts	Parts No.	Description	Destination	Ref. No.	Address	New parts	Parts No.	Description	Destination
L107			L92-0149-05	CHIP FERRITE		R24			RN73GH1J472D	CHIP R 4.7K D 1/16W	C2
L109			L40-2285-54	SMALL FIXED INDUCTOR (220NH)		R24		*	RN73GH1J822D	CHIP R 8.2K D 1/16W	C
L110			L34-4547-05	AIR-CORE COIL (18NH)		R25			RK73GB2A151J	CHIP R 150 J 1/10W	C2
L112			L34-4547-05	AIR-CORE COIL (18NH)	C2	R25,26			RK73GB2A101J	CHIP R 100 J 1/10W	C
L112,113			L34-4547-05	AIR-CORE COIL (18NH)	C	R26			RK73GB2A101J	CHIP R 100 J 1/10W	C2
L113			L34-4548-05	AIR-CORE COIL (25NH)	C2	R27			RN73GH1J271D	CHIP R 270 D 1/16W	C2
L114			L34-4546-05	AIR-CORE COIL (47NH)	C	R27			RN73GH1J331D	CHIP R 330 D 1/16W	C
L114			L34-4547-05	AIR-CORE COIL (18NH)	C2	R28			RK73GB2A220J	CHIP R 22 J 1/10W	
L118			L41-1092-44	SMALL FIXED INDUCTOR (1UH)		R29			RK73GB2A000J	CHIP R 0.0 J 1/10W	
L119			L40-2263-92	SMALL FIXED INDUCTOR (2.2NH)	C	R30			RK73GB2A124J	CHIP R 120K J 1/10W	
L119			L40-3363-92	SMALL FIXED INDUCTOR (3.3NH)	C2	R31			RK73GB2A101J	CHIP R 100 J 1/10W	
L120		*	L41-2763-47	SMALL FIXED INDUCTOR (2.7NH)	C2	R32			RK73GB2A472J	CHIP R 4.7K J 1/10W	
L200			L41-1095-39	SMALL FIXED INDUCTOR (1.0UH)		R33			RK73GB2A102J	CHIP R 1.0K J 1/10W	
L202			L40-1575-92	SMALL FIXED INDUCTOR (15NH)	C	R34			RK73GB2A104J	CHIP R 100K J 1/10W	
L202			L40-1875-92	SMALL FIXED INDUCTOR (18NH)	C2	R100			RK73GB2A332J	CHIP R 3.3K J 1/10W	
L203,204			L34-4546-05	AIR-CORE COIL (47NH)		R101			RK73GB2A562J	CHIP R 5.6K J 1/10W	
L206			L40-1575-92	SMALL FIXED INDUCTOR (15NH)	C	R102			RK73GB2A271J	CHIP R 270 J 1/10W	
L206			L40-1875-92	SMALL FIXED INDUCTOR (18NH)	C2	R103			RK73GB2A332J	CHIP R 3.3K J 1/10W	
L207			L40-2775-92	SMALL FIXED INDUCTOR (27NH)	C	R104			RK73GB2A100J	CHIP R 10 J 1/10W	
L207			L40-4775-92	SMALL FIXED INDUCTOR (47NH)	C2	R105,106			RK73GB2A332J	CHIP R 3.3K J 1/10W	
L208			L41-1278-14	SMALL FIXED INDUCTOR (12NH)		R107			RK73GB2A473J	CHIP R 47K J 1/10W	
L209			L34-4547-05	AIR-CORE COIL (18NH)	C2	R108			RK73GB2A331J	CHIP R 330 J 1/10W	
L209,210			L34-4546-05	AIR-CORE COIL (47NH)	C	R109			RK73GB2A220J	CHIP R 22 J 1/10W	
L210			L34-4546-05	AIR-CORE COIL (47NH)	C2	R110			RK73GB2A681J	CHIP R 680 J 1/10W	
L211			L41-1278-14	SMALL FIXED INDUCTOR (12NH)		R111			RK73GB2A220J	CHIP R 22 J 1/10W	
L212			L34-4850-15	COIL		R112			RK73GB2A152J	CHIP R 1.5K J 1/10W	
L214			L34-4546-05	AIR-CORE COIL (47NH)		R113			RK73GB2A331J	CHIP R 330 J 1/10W	
L400			L40-2281-86	SMALL FIXED INDUCTOR (0.22U)		R115			RK73GB2A100J	CHIP R 10 J 1/10W	
L401			L92-0140-05	CHIP FERRITE		R117			RK73GB2A124J	CHIP R 120K J 1/10W	C
L402,403			L40-2281-86	SMALL FIXED INDUCTOR (0.22U)		R117,118			RK73GB2A473J	CHIP R 47K J 1/10W	C2
L500			L92-0140-05	CHIP FERRITE		R118			RK73GB2A473J	CHIP R 47K J 1/10W	C
L501,502			L92-0149-05	CHIP FERRITE		R119			RK73GB2A472J	CHIP R 4.7K J 1/10W	
X1			L77-1877-15	TCXO (12.8MHZ)		R120			RK73GB2A000J	CHIP R 0.0 J 1/10W	
X400			L77-1761-15	CRYSTAL RESONATOR (7.3728MHZ)		R121			RK73GB2A470J	CHIP R 47 J 1/10W	
XF201			L71-0522-05	MCF (38.85MHZ)		R122			RK73GB2A681J	CHIP R 680 J 1/10W	
106	2B		N78-2640-48	PAN HEAD TAPTITE SCREW		R123			RK73FB2B000J	CHIP R 0.0 J 1/8W	
CP1			RK75GB1J102J	CHIP-COM 1.0K J 1/16W		R124			RK73GB2A681J	CHIP R 680 J 1/10W	
R1,2			RK73GB2A102J	CHIP R 1.0K J 1/10W		R125			RK73GB2A183J	CHIP R 18K J 1/10W	C2
R3			RK73GB2A100J	CHIP R 10 J 1/10W		R125,126			RK73GB2A473J	CHIP R 47K J 1/10W	C
R4			RK73GB2A102J	CHIP R 1.0K J 1/10W		R126			RK73GB2A473J	CHIP R 47K J 1/10W	C2
R5			RK73GB2A561J	CHIP R 560 J 1/10W		R127			RK73FB2B000J	CHIP R 0.0 J 1/8W	C
R6			RK73GB2A154J	CHIP R 150K J 1/10W		R128			RK73GB2A470J	CHIP R 47 J 1/10W	
R7			RK73GB2A561J	CHIP R 560 J 1/10W		R130-132			RK73EB2ER39K	CHIP R 0.39 K 1/4W	
R8			RK73GB2A334J	CHIP R 330K J 1/10W		R133-138			RK73GH2A154D	CHIP R 150K D 1/10W	
R9			RK73GB2A272J	CHIP R 2.7K J 1/10W		R139			RK73GB2A271J	CHIP R 270 J 1/10W	
R10			RK73GB2A222J	CHIP R 2.2K J 1/10W		R140			RK73GB2A103J	CHIP R 10K J 1/10W	
R11			RK73GB2A473J	CHIP R 47K J 1/10W		R141			RK73GB2A473J	CHIP R 47K J 1/10W	
R12			RK73GB2A274J	CHIP R 270K J 1/10W		R142			RK73GB2A105J	CHIP R 1.0M J 1/10W	
R13			RK73GB2A000J	CHIP R 0.0 J 1/10W		R143			RK73GB2A000J	CHIP R 0.0 J 1/10W	
R14			RK73GB2A101J	CHIP R 100 J 1/10W		R144			RK73GB2A222J	CHIP R 2.2K J 1/10W	
R15			RK73GB2A103J	CHIP R 10K J 1/10W		R145			RK73GB2A184J	CHIP R 180K J 1/10W	
R16			RK73GB2A473J	CHIP R 47K J 1/10W		R146			RK73GB2A104J	CHIP R 100K J 1/10W	
R18			RK73GB2A104J	CHIP R 100K J 1/10W		R147			RK73GB2A000J	CHIP R 0.0 J 1/10W	
R19			RK73GB2A101J	CHIP R 100 J 1/10W		R152			RK73GB2A391J	CHIP R 390 J 1/10W	
R20			RK73GB2A102J	CHIP R 1.0K J 1/10W		R153			RK73GB2A332J	CHIP R 3.3K J 1/10W	
R21			RK73GB2A104J	CHIP R 100K J 1/10W		R154			RK73GB2A271J	CHIP R 270 J 1/10W	
R22			RK73GB2A473J	CHIP R 47K J 1/10W		R200			RK73GB2A100J	CHIP R 10 J 1/10W	
R23		*	RN73GH1J392D	CHIP R 3.9K D 1/16W	C2	R201			RK73GB2A102J	CHIP R 1.0K J 1/10W	
R23			RN73GH1J682D	CHIP R 6.8K D 1/16W	C	R202			RK73GB2A394J	CHIP R 390K J 1/10W	
						R203,204			RK73GB2A332J	CHIP R 3.3K J 1/10W	

PARTS LIST / 零件表

TX-RX UNIT (X57-6030-XX)

Ref. No.	Address	New parts	Parts No.	Description	Destination	Ref. No.	Address	New parts	Parts No.	Description	Destination
R205			RK73GB2A153J	CHIP R 15K J 1/10W		R327			RK73GB2A000J	CHIP R 0.0 J 1/10W	
R206			RK73GB2A474J	CHIP R 470K J 1/10W		R328			RK73GB2A102J	CHIP R 1.0K J 1/10W	
R207			RK73GB2A104J	CHIP R 100K J 1/10W		R329			RK73GB2A000J	CHIP R 0.0 J 1/10W	
R208			RK73GB2A684J	CHIP R 680K J 1/10W		R330			RK73GB2A473J	CHIP R 47K J 1/10W	
R209			RK73GB2A272J	CHIP R 2.7K J 1/10W		R331			RK73GB2A222J	CHIP R 2.2K J 1/10W	
R210			RK73GB2A471J	CHIP R 470 J J 1/10W		R332			RK73GB2A151J	CHIP R 150 J J 1/10W	
R212			RK73HB1J470J	CHIP R 47 J J 1/16W		R333			RK73GB2A474J	CHIP R 470K J 1/10W	
R213			RK73GB2A000J	CHIP R 0.0 J 1/10W		R334			RK73GB2A100J	CHIP R 10 J J 1/10W	
R214			RK73GB2A103J	CHIP R 10K J 1/10W		R335			RK73GB2A563J	CHIP R 56K J 1/10W	
R215			RK73HB1J151J	CHIP R 150 J J 1/16W		R336			RK73GB2A333J	CHIP R 33K J 1/10W	
R216			RK73HB1J103J	CHIP R 10K J 1/16W	C2	R338			RK73GB2A473J	CHIP R 47K J 1/10W	
R216			RK73HB1J563J	CHIP R 56K J 1/16W	C	R339			RK73GB2A822J	CHIP R 8.2K J 1/10W	
R218			RK73GB2A101J	CHIP R 100 J J 1/10W		R340			RK73GH2A124D	CHIP R 120K D 1/10W	
R219			RK73GB2A332J	CHIP R 3.3K J 1/10W		R341			RK73GB2A104J	CHIP R 100K J 1/10W	
R220			RK73GB2A151J	CHIP R 150 J J 1/10W	C2	R342			RK73GB2A472J	CHIP R 4.7K J 1/10W	
R220			RK73GB2A221J	CHIP R 220 J J 1/10W	C	R400			RK73GB2A334J	CHIP R 330K J 1/10W	
R221			RK73GB2A104J	CHIP R 100K J 1/10W		R401			RK73GB2A104J	CHIP R 100K J 1/10W	
R222			RK73GB2A102J	CHIP R 1.0K J 1/10W	C	R402			RK73GB2A221J	CHIP R 220 J 1/10W	
R225			RK73GB2A100J	CHIP R 10 J J 1/10W	C	R403			RK73GB2A181J	CHIP R 180 J 1/10W	
R225			RK73GB2A220J	CHIP R 22 J J 1/10W	C2	R404			RK73GB2A000J	CHIP R 0.0 J 1/10W	
R226			RK73HB1J561J	CHIP R 560 J J 1/16W		R405			RK73GB2A102J	CHIP R 1.0K J 1/10W	
R227			RK73GB2A000J	CHIP R 0.0 J 1/10W		R406			RK73GB2A222J	CHIP R 2.2K J 1/10W	
R228			RK73GB2A104J	CHIP R 100K J 1/10W		R407			RK73GB2A102J	CHIP R 1.0K J 1/10W	
R229			RK73HB1J683J	CHIP R 68K J 1/16W		R408			RK73GB2A104J	CHIP R 100K J 1/10W	
R230			RK73HB1J104J	CHIP R 100K J 1/16W		R409			RK73GB2A102J	CHIP R 1.0K J 1/10W	
R231,232			RK73GB2A104J	CHIP R 100K J 1/10W		R410			RK73GB2A822J	CHIP R 8.2K J 1/10W	
R234			RK73HB1J104J	CHIP R 100K J 1/16W	C2	R411			RK73GB2A224J	CHIP R 220K J 1/10W	
R234,235			RK73HB1J104J	CHIP R 100K J 1/16W	C	R412			RK73GB2A100J	CHIP R 10 J 1/10W	
R235			RK73HB1J183J	CHIP R 18K J 1/16W	C2	R413			RK73GB2A102J	CHIP R 1.0K J 1/10W	
R236			RK73HB1J103J	CHIP R 10K J 1/16W	C2	R414,415			RK73GB2A473J	CHIP R 47K J 1/10W	
R236			RK73HB1J563J	CHIP R 56K J 1/16W	C	R416			RK73GB2A472J	CHIP R 4.7K J 1/10W	
R237			RK73GB2A104J	CHIP R 100K J 1/10W	C	R417			RK73GB2A100J	CHIP R 10 J 1/10W	
R237			RK73GB2A183J	CHIP R 18K J 1/10W	C2	R418			RK73GB2A222J	CHIP R 2.2K J 1/10W	
R238			RK73HB1J222J	CHIP R 2.2K J 1/16W	C	R419			RK73GB2A000J	CHIP R 0.0 J 1/10W	
R239			RK73HB1J271J	CHIP R 270 J J 1/16W		R420			RK73GB2A102J	CHIP R 1.0K J 1/10W	
R240			RK73HB1J000J	CHIP R 0.0 J 1/16W		R421			RK73HB1J473J	CHIP R 47K J 1/16W	
R300			RK73GH2A913D	CHIP R 91K D 1/10W		R422			RK73GB2A272J	CHIP R 2.7K J 1/10W	
R301,302			RK73GB2A562J	CHIP R 5.6K J 1/10W		R423			RK73HB1J473J	CHIP R 47K J 1/16W	
R303			RK73GB2A332J	CHIP R 3.3K J 1/10W		R424,425			RK73GB2A332J	CHIP R 3.3K J 1/10W	
R304			RK73GB2A105J	CHIP R 1.0M J 1/10W		R426			RK73GB2A822J	CHIP R 8.2K J 1/10W	
R305			RK73GB2A183J	CHIP R 18K J 1/10W		R427			RK73GB2A102J	CHIP R 1.0K J 1/10W	
R306			RK73GB2A124J	CHIP R 120K J 1/10W		R428			RK73GB2A272J	CHIP R 2.7K J 1/10W	
R307			RK73GB2A473J	CHIP R 47K J 1/10W		R429			RK73GB2A821J	CHIP R 820 J 1/10W	
R308			RK73GB2A103J	CHIP R 10K J 1/10W		R430			RK73HB1J101J	CHIP R 100 J 1/16W	
R309			RK73GB2A474J	CHIP R 470K J 1/10W		R431			RK73HB1J000J	CHIP R 0.0 J 1/16W	
R311			RK73FB2B000J	CHIP R 0.0 J 1/8W		R432			RK73GB2A103J	CHIP R 10K J 1/10W	
R312			RK73GB2A123J	CHIP R 12K J 1/10W		R433,434			RK73GB2A153J	CHIP R 15K J 1/10W	
R313			RK73GB2A104J	CHIP R 100K J 1/10W		R435			RK73GB2A103J	CHIP R 10K J 1/10W	
R314			RK73GH2A474D	CHIP R 470K D 1/10W		R500,501			RK73GB2A472J	CHIP R 4.7K J 1/10W	
R315			RK73GH2A394D	CHIP R 390K D 1/10W		R502			RK73GB2A823J	CHIP R 82K J 1/10W	
R316			RK73GB2A274J	CHIP R 270K J 1/10W		R503			RK73GB2A123J	CHIP R 12K J 1/10W	C2
R317			RK73GH2A274D	CHIP R 270K D 1/10W		R503			RK73GB2A683J	CHIP R 68K J 1/10W	C
R318			RK73GB2A184J	CHIP R 180K J 1/10W		R504			RK73GB2A333J	CHIP R 33K J 1/10W	C
R320			RK73GB2A473J	CHIP R 47K J 1/10W		R504			RK73GB2A683J	CHIP R 68K J 1/10W	C2
R321			RK73GB2A223J	CHIP R 22K J 1/10W		R505			RK73GB2A124J	CHIP R 120K J 1/10W	C2
R322			RK73GH2A224D	CHIP R 220K D 1/10W		R505			RK73GB2A154J	CHIP R 150K J 1/10W	C
R323			RK73GB2A104J	CHIP R 100K J 1/10W		R506			RK73GB2A103J	CHIP R 10K J 1/10W	C2
R324			RK73GB2A562J	CHIP R 5.6K J 1/10W		R506			RK73GB2A223J	CHIP R 22K J 1/10W	C
R325			RK73GB2A104J	CHIP R 100K J 1/10W		R507			RK73GB2A473J	CHIP R 47K J 1/10W	
R326			RK73GH2A562D	CHIP R 5.6K D 1/10W		R508			RK73GB2A222J	CHIP R 2.2K J 1/10W	C2

PARTS LIST / 零件表

TX-RX UNIT (X57-6030-XX)

Ref. No.	Address	New parts	Parts No.	Description	Destination	Ref. No.	Address	New parts	Parts No.	Description	Destination
R508			RK73GB2A562J	CHIP R 5.6K J 1/10W	C	IC302			TA7368FG	MOS-IC	
R509			RK73GB2A124J	CHIP R 120K J 1/10W		IC400			PST9140NR	MOS-IC	
R510			RK73GB2A332J	CHIP R 3.3K J 1/10W		IC401			AT24C08BN-SH	ROM IC	
R511			RK73GB2A103J	CHIP R 10K J 1/10W		IC402			R3111N451C-F	MOS-IC	
R512			RK73GB2A185J	CHIP R 1.8M J 1/10W		IC403			38268MCA060GU	MCU	
R513			RK73GB2A473J	CHIP R 47K J 1/10W	C2	IC404			XC6201P502PR	MOS-IC	
R513-515			RK73GB2A333J	CHIP R 33K J 1/10W	C	IC500			NJM2100V-ZB	MOS-IC	
R514,515			RK73GB2A333J	CHIP R 33K J 1/10W	C2	Q1			2SC4649(N,P)	TRANSISTOR	
R516			RK73GB2A103J	CHIP R 10K J 1/10W		Q2			2SC5108(Y)F	TRANSISTOR	
R517			RK73GB2A185J	CHIP R 1.8M J 1/10W		Q3			2SK508NV(K52)	FET	
R518			RK73GB2A103J	CHIP R 10K J 1/10W	C2	Q4			2SC4228(R44)	TRANSISTOR	
R518			RK73GB2A682J	CHIP R 6.8K J 1/10W	C	Q5			2SJ243-A	FET	
R519,520			RK73GB2A333J	CHIP R 33K J 1/10W		Q6			2SC5108(Y)F	TRANSISTOR	
R521			RK73GB2A332J	CHIP R 3.3K J 1/10W		Q7			UMC4N	TRANSISTOR	
R522			RK73GB2A182J	CHIP R 1.8K J 1/10W		Q8			2SC4617(S)	TRANSISTOR	
R523			RK73GB2A682J	CHIP R 6.8K J 1/10W		Q100,101			2SC5108(Y)F	TRANSISTOR	
R524			RK73GB2A513J	CHIP R 51K J 1/10W		Q102			2SC4988-E	TRANSISTOR	
R525			RK73GB2A152J	CHIP R 1.5K J 1/10W		Q103			2SK1824-A	FET	
R526,527			RK73GH2A153D	CHIP R 15K D 1/10W		Q104			UFMMT717	TRANSISTOR	
R528			RK73GB2A754J	CHIP R 750K J 1/10W		Q105			2SK2596-E	FET	
R529			RK73GB2A183J	CHIP R 18K J 1/10W		Q106			2SK1824-A	FET	
R530			RK73GB2A101J	CHIP R 100 J 1/10W		Q107			2SK2595-E	FET	
R531			RK73GB2A000J	CHIP R 0.0 J 1/10W		Q108			DTC114EE	DIGITAL TRANSISTOR	
R532			RK73GB2A821J	CHIP R 820 J 1/10W		Q109			DTA144EE	DIGITAL TRANSISTOR	
R533			RK73GB2A104J	CHIP R 100K J 1/10W		Q110			DTC114TE	DIGITAL TRANSISTOR	
R534			RK73GB2A182J	CHIP R 1.8K J 1/10W		Q200			DTA114EE	DIGITAL TRANSISTOR	
R535			RK73GB2A471J	CHIP R 470 J 1/10W		Q201			2SC4649(N,P)	TRANSISTOR	
R536			RK73HB1J102J	CHIP R 1.0K J 1/16W		Q202,203			3SK318	FET	
R537			RK73HB1J101J	CHIP R 100 J 1/16W		Q300			2SC4617(S)	TRANSISTOR	
R538			RK73GB2A101J	CHIP R 100 J 1/10W		Q302			2SK1824-A	FET	
R539			RK73HB1J000J	CHIP R 0.0 J 1/16W		Q303			DTA144EE	DIGITAL TRANSISTOR	
R540			RK73FB2B000J	CHIP R 0.0 J 1/8W		Q304			DTC144EE	DIGITAL TRANSISTOR	
R541			RK73GB2A472J	CHIP R 4.7K J 1/10W		Q305			2SA1362-F(GR)	TRANSISTOR	
R542,543			RK73GB2A000J	CHIP R 0.0 J 1/10W		Q306			DTC144EE	DIGITAL TRANSISTOR	
R548			RK73GB2A332J	CHIP R 3.3K J 1/10W		Q307			2SK1588-AZ	FET	
VR1			R32-0736-05	SEMI FIXED VARIABLE RESISTOR (68K)		Q400,401			DTC114EE	DIGITAL TRANSISTOR	
VR500			R32-0739-05	SEMI FIXED VARIABLE RESISTOR (220K)		Q402		*	DTA114YEB	DIGITAL TRANSISTOR	
VR501			R32-0684-05	SEMI FIXED VARIABLE RESISTOR (47K)		Q403			DTC144EE	DIGITAL TRANSISTOR	
S402,403			S70-0414-05	TACT SWITCH		Q404			UMG3N	TRANSISTOR	
						Q405			UPA672T-A	FET	
MIC500			T91-0651-15	MIC ELEMENT		Q406			FP210	TRANSISTOR	
D1-4			MA2S376	VARIABLE CAPACITANCE DIODE		Q407			UMG3N	TRANSISTOR	
D5			MA360	VARIABLE CAPACITANCE DIODE	C	Q408			DTA123JE	DIGITAL TRANSISTOR	
D5			1SV214-F	VARIABLE CAPACITANCE DIODE	C2	Q500			2SK1824-A	FET	
D6,7			MA2S111-F	DIODE		Q501,502			2SC4617(S)	TRANSISTOR	
D100			HSC277	DIODE		Q503			2SC4919	TRANSISTOR	
D101			HVU131-E	DIODE		Q504		*	DTA143ZEB	DIGITAL TRANSISTOR	
D102,103			HSC277	DIODE		TH102			157-503-65001	THERMISTOR	
D200			HSC277	DIODE		TH500,501			157-302-65801	THERMISTOR	
D201-204			HVC350B	VARIABLE CAPACITANCE DIODE							
D300			DA221	DIODE							
D500			1SS372F	DIODE							
D501			DAN222	DIODE							
D502			GN1G	DIODE							
IC1			MB15A02PFV2E1	MOS-IC							
IC100			NJM2904V-ZB	MOS-IC							
IC200			TA31136FNG	MOS-IC							
IC300			NJM2902V-ZB	MOS-IC							
IC301			NJM2904V-ZB	MOS-IC							

EXPLODED VIEW / 部件分解图

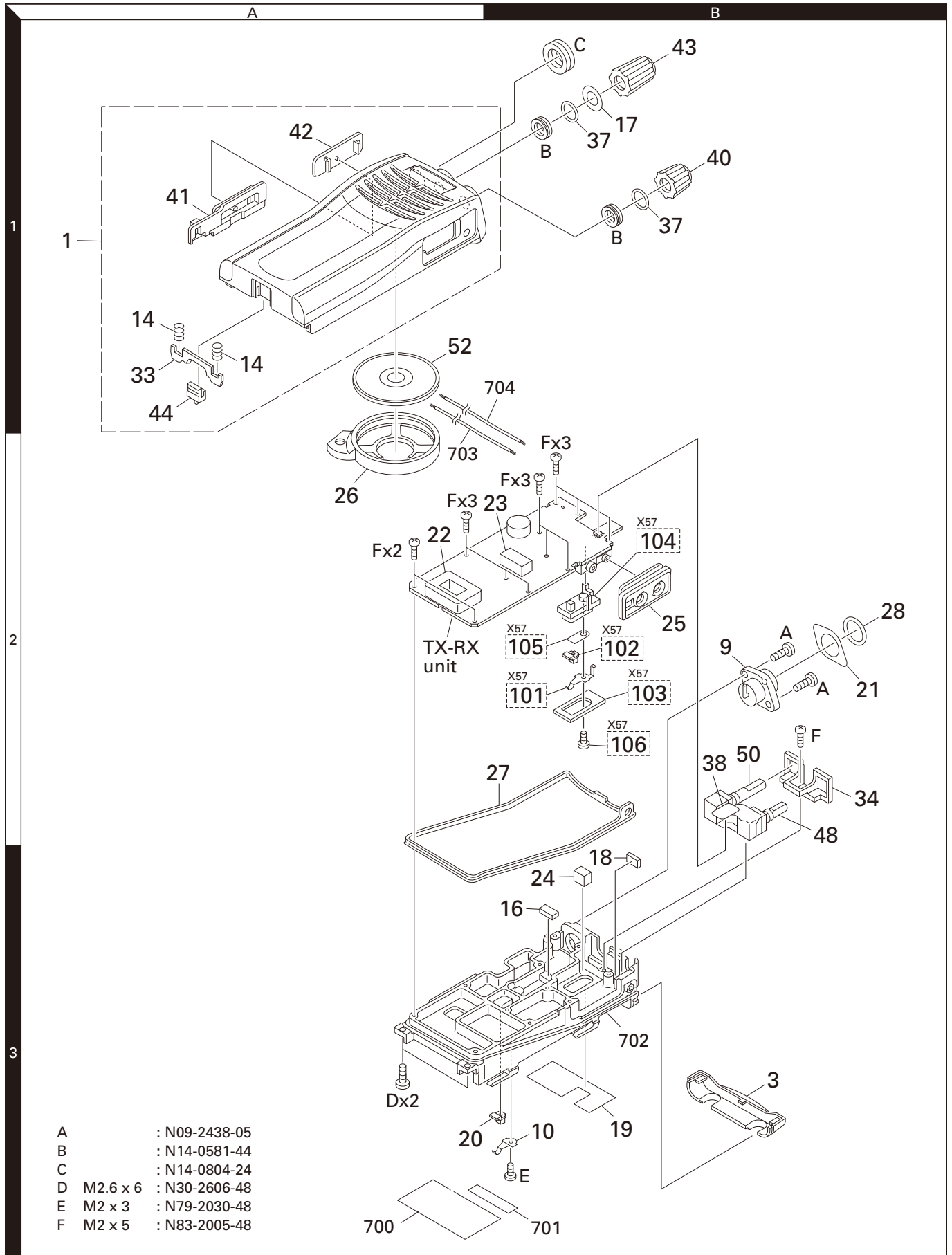

PACKING / 包装

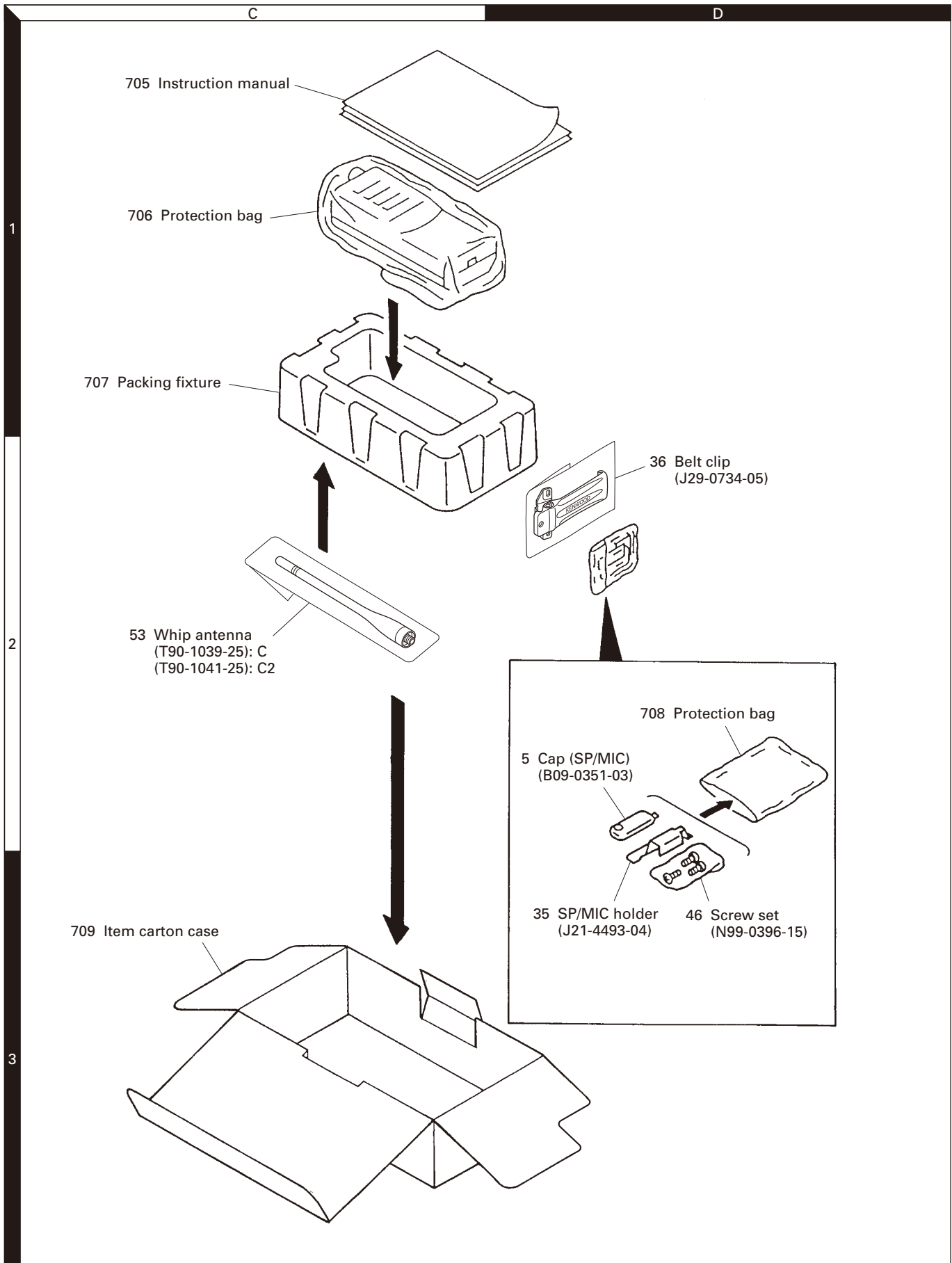

ADJUSTMENT / 调整

Test Equipment Required for Alignment

Test Equipment	Major Specifications	
1. Standard Signal Generator (SSG)	Frequency Range Modulation Output	Operational frequency range of the transceiver Frequency modulation and external modulation -127dBm/0.1 μ V to greater than -47dBm/1mV
2. RF Power Meter	Input Impedance Operation Frequency Measurement Range	50 Ω Operational frequency range of the transceiver Vicinity of 10W
3. Deviation Meter	Frequency Range	Operational frequency range of the transceiver
4. Digital Volt Meter (DVM)	Measuring Range Input Impedance	10mV to 10V DC High input impedance for minimum circuit loading
5. Oscilloscope		DC through 30MHz
6. High Sensitivity Frequency Counter	Frequency Range Frequency Stability	10Hz to 1000MHz 0.2ppm or less
7. DC Ammeter		5A
8. AF Volt Meter (AF VTVM)	Frequency Range Voltage Range	50Hz to 10kHz 1mV to 10V
9. Audio Generator (AG)	Frequency Range Output	50Hz to 5kHz or more 0 to 1V
10. Distortion Meter	Capability Input Level	3% or less at 1kHz 50mV to 10Vrms
11. Spectrum Analyzer	Measuring Range	DC to 1GHz or more
12. Tracking Generator	Center frequency Output Voltage	50kHz to 600MHz 100mV or more
13. 8 Ω Dummy Load		Approx. 8 Ω , 3W
14. Regulated Power Supply		5V to 10V, approx. 3A Useful if ammeter equipped

所需的用于调整的测试设备

测试设备	主要规格	
1. 标准信号发生器 (SSG)	频率范围 调制 输出	对讲机的操作频率范围 调频和外部调制 -127dBm/0.1 μ V 到大于 -47dBm/1mV
2. RF 功率计	输入阻抗 操作频率 测量范围	50 Ω 对讲机的操作频率范围 10W 左右
3. 频偏仪	频率范围	对讲机的操作频率范围
4. 数字电压表 (DVM)	测量范围 输入阻抗	直流 10mV 到 10V 为最小电路负载高输入阻抗
5. 示波器		直流到 30MHz
6. 高灵敏度频率计数器	频率范围 频率稳定性	10Hz 到 1000MHz 0.2ppm 或更低
7. 直流电流表		5A
8. 音频电压表 (AF VTVM)	频率范围 电压范围	50Hz 到 10kHz 1mV 到 10V
9. 音频发生器 (AG)	频率范围 输出	50Hz 到 5kHz 或更高 0 到 1V
10. 失真测试仪	能力 输入电平	在 1kHz 时 3% 或更低 50mV 到 10Vrms
11. 频谱分析仪	测量范围	直流到 1GHz 或更高
12. 轨迹发生器	中心频率 输出电压	50kHz 到 600MHz 100mV 或更高
13. 8 Ω 假负载		大约 8 Ω , 3W
14. 可调电源		5V 到 10V, 大约 3A 配备了电流表时更好

ADJUSTMENT / 调整

Controls

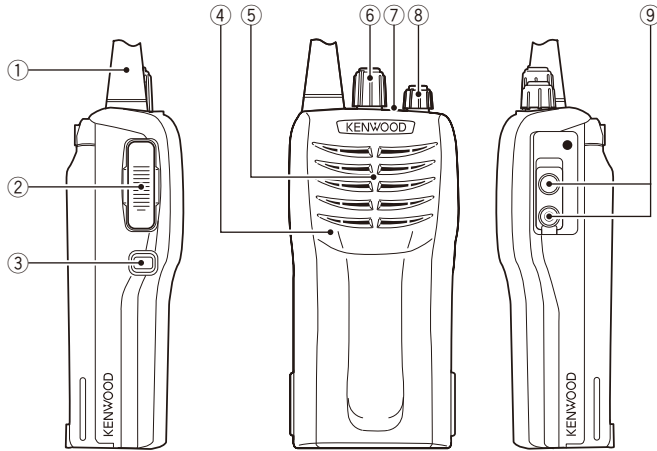

控制

- | | |
|-------------------------------|---------------|
| ① Antenna | ① 天线 |
| ② PTT switch | ② 通话转换开关 |
| ③ Monitor key | ③ 监听键 |
| ④ Microphone | ④ 话筒 |
| ⑤ Speaker | ⑤ 扬声器 |
| ⑥ Chennel selector | ⑥ 信道选择器 |
| ⑦ LED indicator | ⑦ 发光二极管指示灯 |
| ⑧ Power switch/Volume control | ⑧ 电源开关 / 音量控制 |
| ⑨ SP/MIC jack | ⑨ 扬声器 / 话筒插口 |

Caution:

- Use a non-conductive rod such as a Ceramic rod for adjustment (especially of trimmers and coils).
Kenwood order No.: W05-1206-00 (0.4 x 0.9mm)
Kenwood order No.: W05-1207-00 (0.4 x 1.3mm)
- To protect the SSG, do not send out signals while adjusting the receiving unit.
- The indicated SSG output levels are for maximum output.

注意事项:

- 使用一个专用调整棒进行调整（特别是微调电容器和线圈）。
建伍订货单号码：W05-1206-00 (0.4×0.9mm)
建伍订货单号码：W05-1207-00 (0.4×1.3mm)
- 为了保护标准信号发生器，在调整接收部分时对讲机不要发射。
- 显示的标准信号发生器输出电平为最大输出值。

Adjustment Points

■ Component side view

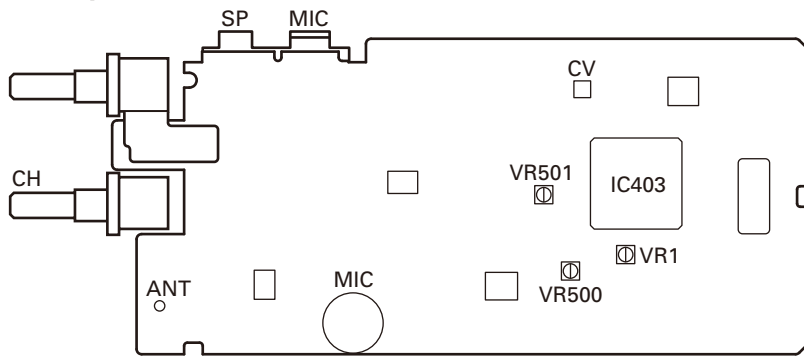

调整点

■ 元件面视图

- ANT : Antenna connector / 天线连接器
 CH : Channel selector / 信道选择器
 SP : Speaker jack / 扬声器插座
 MIC : Microphone jack / 话筒插座
 CV : Lock voltage adjustment terminal
 锁定电压调整终端
 VR500 : DQT waveform adjustment
 DQT 波形调整
 VR501 : DEV adjustment / DEV 调整

Note: To fine tune the frequency when not using a computer, adjust VR1.
注意: 当不使用电脑微调频率时，可调整 VR1。

■ Foil side view

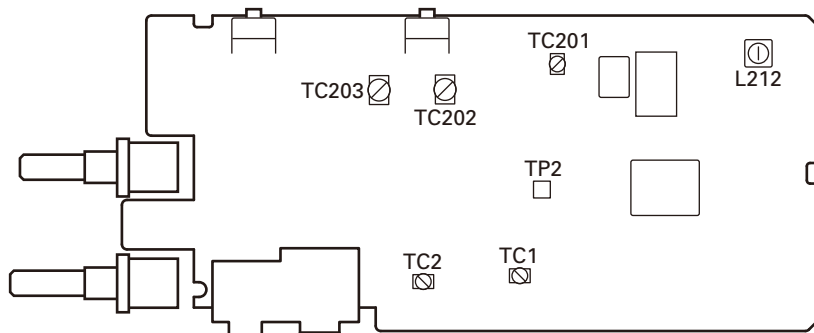

■ 箔面视图

- TC201~203 : Band-pass filter waveform adjustment
 带通滤波器波形调整
 L212 : AF level adjustment
 音频电平调整
 TC1 : Transmit lock voltage adjustment
 发射锁定电压调整
 TC2 : Receive lock voltage adjustment
 接收锁定电压调整
 TP2 : Band-pass filter test point
 带通滤波器测试点

ADJUSTMENT / 调整

Adjustment Frequency List

CH	C		C2	
	TX f (MHz)	RX f (MHz)	TX f (MHz)	RX f (MHz)
Center	460.000	460.100	410.000	410.100
Low	450.000	450.100	400.000	400.100
Hi	469.975	469.900	419.975	419.900

Remarks

- Connect the transceiver to the PC
- Send the channel data to the transceiver, then backup the data.
- Program the adjustment frequencies which are in the list, into the transceiver.

Note: Remember to reload the channel data you backed up after making the adjustments.

Service Jig

■ Jig (chassis) for adjustment

Part number: A10-1392-03

■ Use the jig as follows:

1. Insert the coaxial antenna connector into the jig.
2. Place the unit on the jig and fix it with 12 screws (①).
3. Solder the antenna terminal to the terminal of the unit.

Note: Supply power from an external power supply.

Relay terminal: +, Jig (chassis): -

调整频率清单

信道	C		C2	
	发射频率 (MHz)	接收频率 (MHz)	发射频率 (MHz)	接收频率 (MHz)
中心	460.000	460.100	410.000	410.100
低	450.000	450.100	400.000	400.100
高	469.975	469.900	419.975	419.900

备注

- 将对讲机与计算机连接。
- 向对讲机发送信道数据，然后备份数据。
- 将清单中的调整频率编程，输入对讲机。

注意: 在进行调整后，重新载入备份的信道数据。

维修夹具

■ 用于调整的模板 (机架)

部件号码 :A10-1392-03

■ 按照下述方法使用模板:

1. 将同轴天线连接器插入模板。
2. 将主板放置在模板上，然后用 12 颗螺钉拧紧 (①)。
3. 将天线的端点与主板的焊点焊接。

注意: 供电来自于外部电源。

继电器端点 :+, 模板 (机架): -

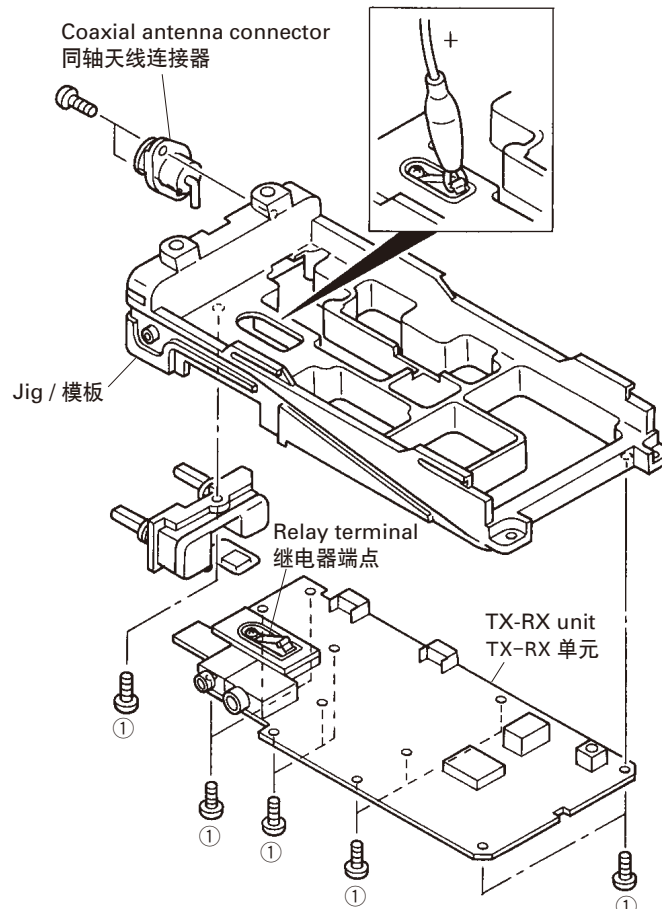

ADJUSTMENT

Use the KPG-55D programming software for adjustment of the next item in PC Mode (see page 5).
 Squelch Level, Transmit frequency, DQT Balance, RF Power, QT Deviation, DQT Deviation, Battery Level

Section Common to the Transmitter and Receiver (VCO)

Item	Condition	Measurement			Adjustment			Specifications / Remarks
		Test-equipment	Unit	Terminal	Unit	Parts	Method	
1. Setting	1) Power supply voltage Battery terminal: 7.5V 2) SSG standard modulation [Wide] MOD: 1kHz, DEV: 3kHz [Narrow] MOD: 1kHz, DEV: 1.5kHz							
2. VCO lock voltage	1) CH: TX high	Digital voltmeter	TX-RX	CV	TX-RX	TC1	3.7V	±0.1V
	2) CH: RX high					TC2	3.7V	±0.1V
	3) CH: TX low						Check	More than 1.0V
	4) CH: RX low							

Receiver Section

Item	Condition	Measurement			Adjustment			Specifications / Remarks
		Test-equipment	Unit	Terminal	Unit	Parts	Method	
1. Band-pass filter	1) CH: RX center 2) Tracking generator output : -40dBm Connect the spectrum analyzer to TP2 terminal.	Tracking generator Spectrum analyzer	TX-RX	ANT TP2	TX-RX	TC201 TC202 TC203	Adjust the frequency so that it becomes the spectrum waveform shown in Fig. 1.	
2. AF level	1) CH: RX center SSG output: -53dBm (501µV) MOD: 1kHz DEV: ±3.0kHz (Wide) : ±1.5kHz (Narrow)	SSG Oscilloscope AF V.M Distortion meter		ANT SP		L212	Adjust to the MAX AF level	
3. Sensitivity (Wide)	1) CH: RX center CH: RX Lo CH: RX Hi SSG output: -116dBm (0.35µV) MOD: 1kHz DEV: ±3.0kHz					Check	SINAD: 12dB or higher	
(Narrow)	2) CH: RX center SSG output: -114dBm (0.45µV) DEV: ±1.5kHz							
4. Squelch level (PC mode)	1) CH: RX center MONI: ON				PC key	Level 9 Adjust to close the squelch.	The squelch must be closed.	
	2) Level 9 SSG output: -117dBm (0.36µV)					Level 3 Adjust to close the squelch.	The squelch must be closed.	
	3) Level 3 SSG output: -125dBm(0.126µV)							

调 整

在计算机模式下使用 KPG-55D 编程软件调整下记项目（参见第 5 页）。
 噪音抑制电路电平，发射频率，DQT 均衡，射频功率，QT 偏差，DQT 偏差，电池电平

发射部和接收部共用部分（压控振荡器）

项 目	条 件	测 量			调 整			规 格 / 备 注
		测量装置	单元	端子	单元	部件	方 法	
1. 设定	1) 电源电压电池终端 : 7.5V 2) SSG 标准调制 [宽] MOD: 1kHz, DEV: 3kHz [窄] MOD: 1kHz, DEV: 1.5kHz							
2. 压控振荡器	1) CH: 发射高端频点	数字电压表	TX-RX	CV	TX-RX	TC1	3. 7V	±0.1V
	2) CH: 接收高端频点						TC2	3. 7V
	3) CH: 发射低端频点						检查	高于 1.0V
	4) CH: 接收低端频点							

接收部分

项 目	条 件	测 量			调 整			规 格 / 备 注
		测量装置	单元	端子	单元	部件	方 法	
1. 带通滤波器	1) CH: 接收中心频点 2) 轨迹发生器输出 : -40dBm 将频谱分析仪连接到 TP2 端点。	轨迹发生器 频谱分析仪	TX-RX	天线 TP2	TX-RX	TC201 TC202 TC203	调整频率使其成为图 1 所示的频谱波形。	
2. 音频电平	1) CH: 接收中心频点 SSG 输出 : -53dBm (501μV) MOD: 1kHz DEV: ±3.0kHz (宽) : ±1.5kHz (窄)	标准信号 发射器 示波器 音频电压表 失真测试仪		天线 扬声器			L212	调整到最大音频电平
3. 灵敏度 (宽)	1) CH: 接收中心频点 CH: 接收低端频点 CH: 接收高端频点 SSG 输出 : -116dBm (0.35μV) MOD: 1kHz DEV: ±3.0kHz (宽)						检查	SINAD: 12dB 或更高
	(窄)						2) CH: 接收中心频点 SSG 输出 : -114dBm (0.45μV) DEV: ±1.5kHz	
4. 噪音抑制电路电平 (计算机模式)	1) CH: 接收中心频点 MONI: 开启					PC 机 键	第 9 级 经调整关闭静噪。	必须关闭静噪。
	2) 第 9 级 SSG 输出 : -117dBm (0.36μV)							
	3) 第 3 级 SSG 输出 : -125dBm (0.126μV)						第 3 级 经调整关闭静噪。	必须关闭静噪。

ADJUSTMENT

Transmitter Section

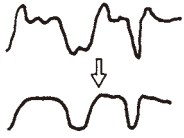
Item	Condition	Measurement			Adjustment			Specifications / Remarks
		Test-equipment	Unit	Terminal	Unit	Parts	Method	
1. Transmit frequency (PC mode)	1) CH: TX center PTT: ON	f.counter	TX-RX	ANT		PC key	Adjust to center frequency	Within $\pm 100\text{Hz}$
2. DQT/QT Balance (PC mode)	1) CH: TX center	Modulation analyzer or Linear detector (LPF: 3kHz) Oscilloscope			TX-RX	VR500	Rectify the waveform to square wave	
3. Power (PC mode)	1) CH:TX center Battery terminal: 7.5V PTT: ON	Power meter Ammeter					Adjust it to 4.1W	$\pm 0.1\text{W}$ 1.8A or less
4. MAX DEV	1) CH: TX center AG: 1kHz/120mV PTT: ON	Modulation analyzer or Linear detector (LPF: 15kHz) Oscilloscope AG		ANT	TX-RX	VR501	Adjust it to $\pm 4.2\text{kHz}$ (Wide) Narrow check (+, - Peak whichever is Maximum)	$\pm 100\text{Hz}$ $\pm 1.8\text{kHz} \sim 2.2\text{kHz}$
5. MIC SENS	1) CH: TX center AG: 1kHz/12mV	AF V.M		MIC			Check (+, - Peak whichever is Maximum)	$\pm 2.2\text{kHz} \sim 3.8\text{kHz}$ (Wide) $\pm 1.1\text{kHz} \sim 1.9\text{kHz}$ (Narrow)
6. QT DEV (PC mode)	1) CH: TX high QT: 67.0Hz	Modulation analyzer or Linear detector (LPF: 3kHz) Oscilloscope AG AF V.M		ANT		PC key	Adjust it to $\pm 0.75\text{kHz}$ (Wide) Adjust it to $\pm 0.35\text{kHz}$ (Narrow)	$\pm 50\text{Hz}$
7. DQT DEV (PC mode)	1) DQT: 023N center	Modulation analyzer or Linear detector (LPF: 3kHz) Oscilloscope					Adjust it to $\pm 0.65\text{kHz}$ (Wide) Adjust it to $\pm 0.30\text{kHz}$ (Narrow)	$\pm 50\text{Hz}$
8. Battery Level (PC mode)	1) Battery terminal: 5.8V	Digital voltmeter		BATT			Adjust so that the LED flashes.	The LED must flash.

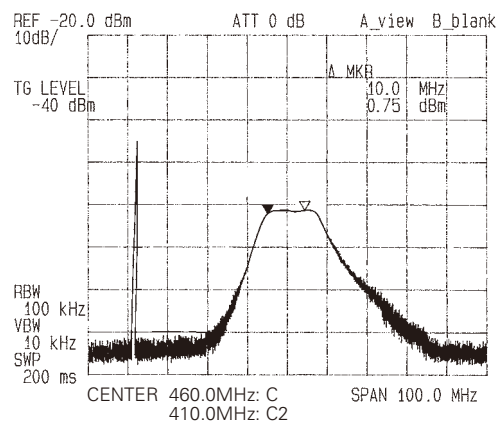
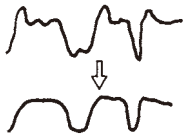

Fig. 1

调 整

发射部分

项 目	条 件	测 量			调 整			规 格 / 备 注
		测量装置	单元	端子	单元	部件	方 法	
1. 发射频率 (计算机模式)	1)CH: 发射中心频点 PTT: 开启	频率计数器	TX-RX	天线		PC 机 按键	调整到中心频率	±100Hz 以内
2. DQT/QT 平衡 (计算机模式)	1)CH: 发射中心频点	频谱分析仪或线性检测器 (LPF:3kHz) 示波器			TX-RX	VR500	将波形整流为方波形	
3. 功率 (计算机模式)	1)CH: 发射中心频点 电池终端 :7.5V PTT: 开启	功率表 电流表					调整到 4.1W	±0.1W 1.8A 或更低
4. 最大 DEV	1)CH: 发射中心频点 AG:1kHz/120mV PTT: 开启	频谱分析仪或线性检测器 (LPF:15kHz) 示波器 音频发生器 音频电压表		天线	TX-RX	VR501	调整到 ±4.2kHz (宽) 窄频带检查 (+, - 极端值)	±100Hz ±1.8kHz ~ 2.2kHz
5. 调制灵敏度	1)CH: 发射中心频点 AG:1kHz/12mV	音频电压表		MIC			检查 (+, - 极端值)	±2.2kHz ~ 3.8kHz (宽) ±1.1kHz ~ 1.9kHz (窄)
6. QT DEV (计算机模式)	1)CH: 发射高端频点 QT:67.0Hz	频谱分析仪或线性检测器 (LPF:3kHz) 示波器 音频发生器 音频电压表		天线		PC 机 按键	调整到 ±0.65kHz (宽) 调整到 ±0.30kHz (窄)	±50Hz
7. DQT DEV (计算机模式)	1)DQT:023N 中心频点	频谱分析仪或线性检测器 (LPF:3kHz) 示波器					调整到 ±0.75kHz (宽) 调整到 ±0.35kHz (窄)	±50Hz
8. 电池电平 (计算机模式)	1) 电池终端 :5.8V	数字电压表		BATT			经调整使指示灯闪烁。	指示灯必须闪烁。



图 1

TK-3107G PC BOARD / PC板

TX-RX UNIT (X57-6030-XX) -10 : C -25 : C2
Component side view (J79-0171-09)

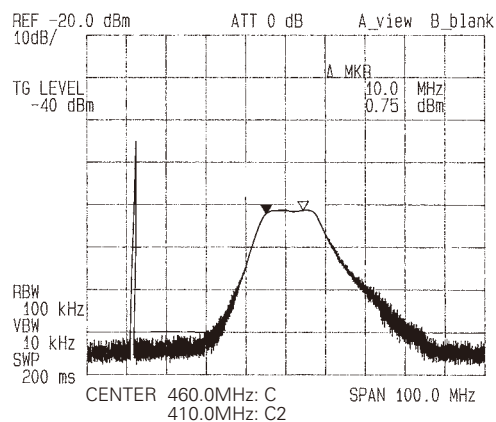
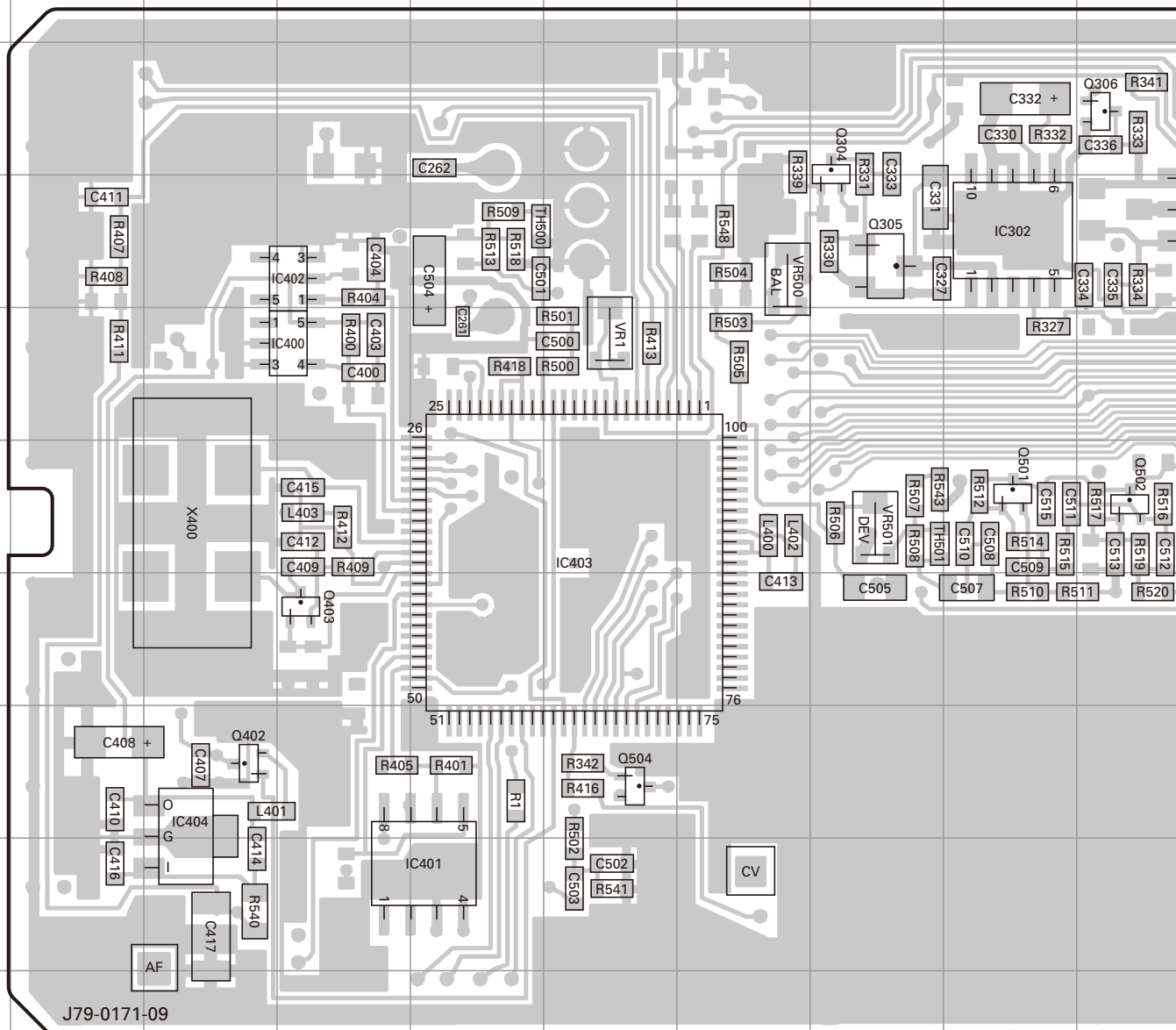

Ref. No.	Address	Ref. No.	Address	Ref. No.	Address
IC100	4O	Q106	4M	Q500	6K
IC302	4I	Q108	4L	Q501	6I
IC400	5D	Q109	4N	Q502	6J
IC401	9E	Q110	4M	Q503	8N
IC402	4D	Q304	3H	Q504	8F
IC403	6F	Q305	4H	D400	7R
IC404	8C	Q306	3J	D401	7R
IC500	6K	Q307	4K	D500	8L
Q103	5P	Q402	8C	D501	8M
Q104	5P	Q403	7D		

PC BOARD / PC板 TK-3107G

TX-RX UNIT (X57-6030-XX) -10 : C -25 : C2
Component side view (J79-0171-09)

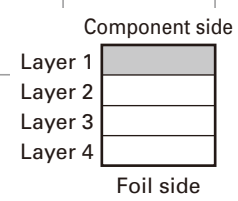
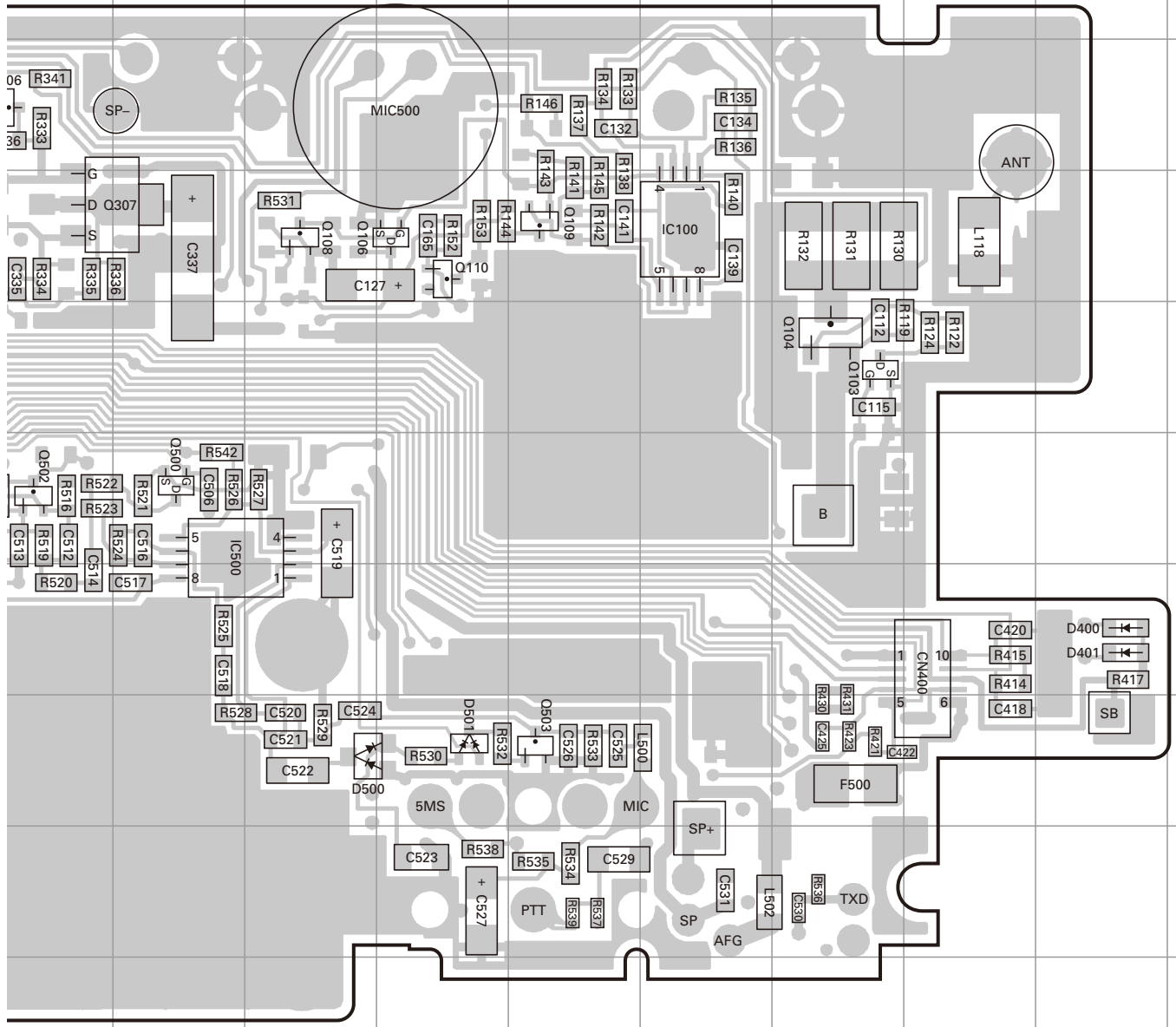

PC BOARD / PC板 TK-3107G

TX-RX UNIT (X57-6030-XX) -10 : C -25 : C2
Foil side view (J79-0171-09)

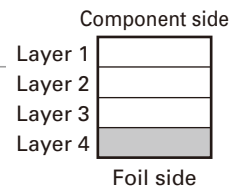
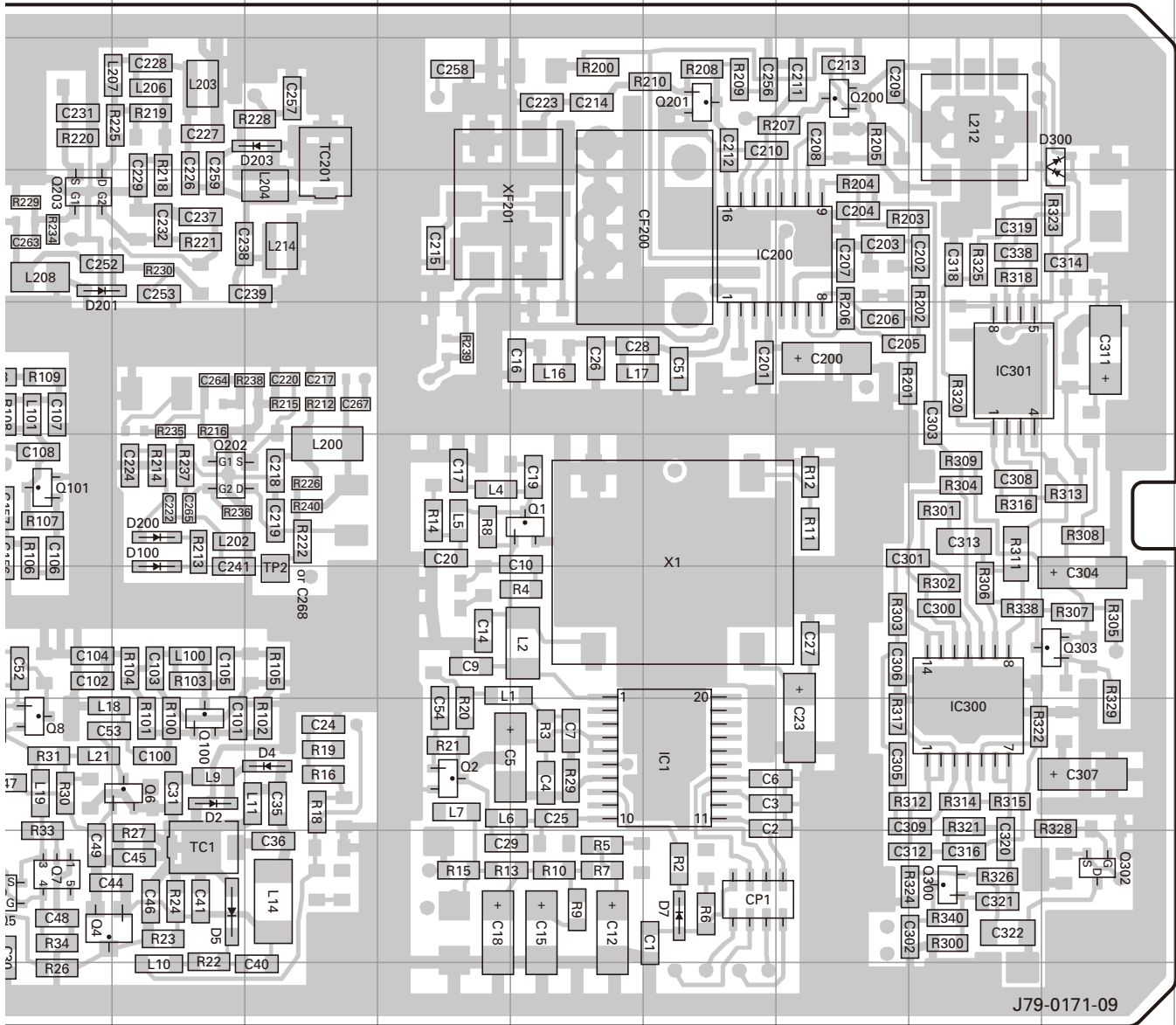

TK-3107G SCHEMATIC DIAGRAM / 原理图

TX-RX UNIT (X57-6030-XX)

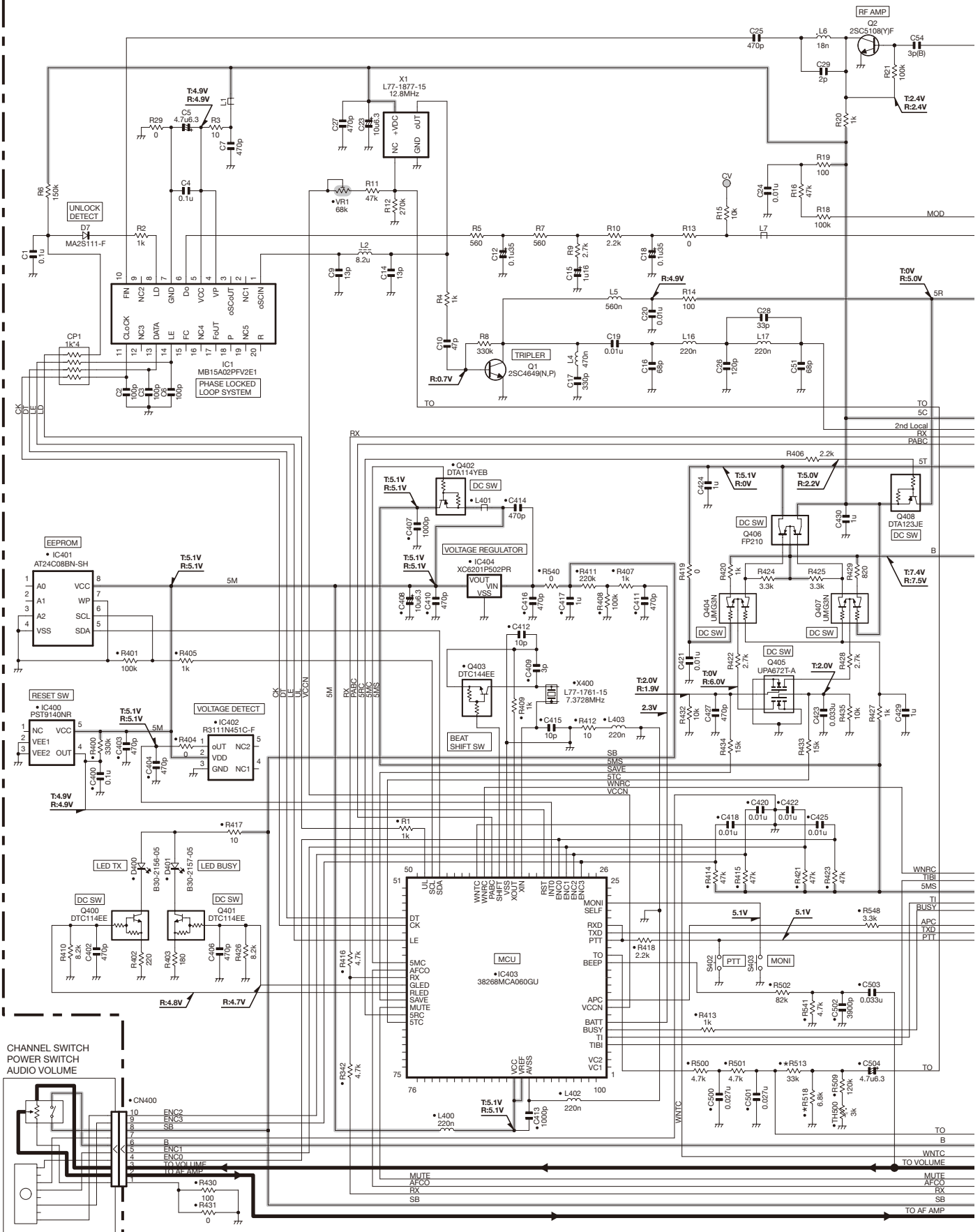

X57-6030-XX	R513	R518
-10	C	33k 6.8k
-25	C2	47k 10k

SCHEMATIC DIAGRAM / 原理图 TK-3107G

TX-RX UNIT (X57-6030-XX)

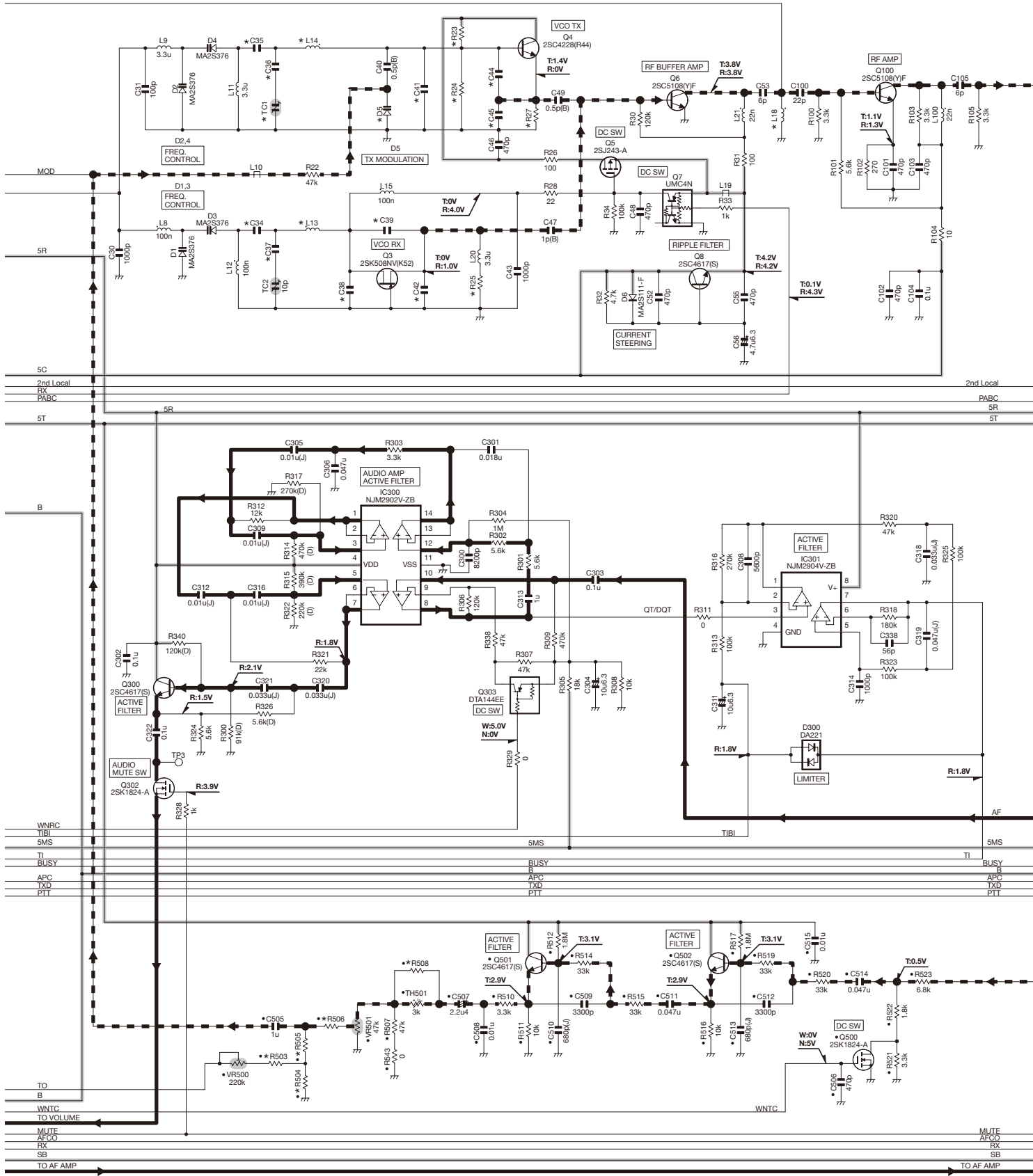

X57-6030-XX	D5	L13	L14	L18	R23	R24	R25	R27	R503	R504	R505	R506	R508	C34	C35	C36	C37	C38	C39	C41	C42	C44	C45	TC1					
-10	C	MA360	23n	23n	47n	6.8k	8.2k	100	330	68k	33k	150k	22k	33k	150k	22k	5.6k	18p(B)	7p	8p(B)	33p	5p	8p(D)	4p	10p(D)	6p	10p(C)	6p	
-25	C2	1SV214-F	27n	27n	NO	3.9k	4.7k	150	270	12k	68k	120k	10k	2.2k	33p(C)	15p(J)	7p(B)	30p(J)	6p(B)	10p(C)	5p(B)	12p	12p	9p(B)	10p				

TK-3107G SCHEMATIC DIAGRAM / 原理图

TX-RX UNIT (X57-6030-XX)

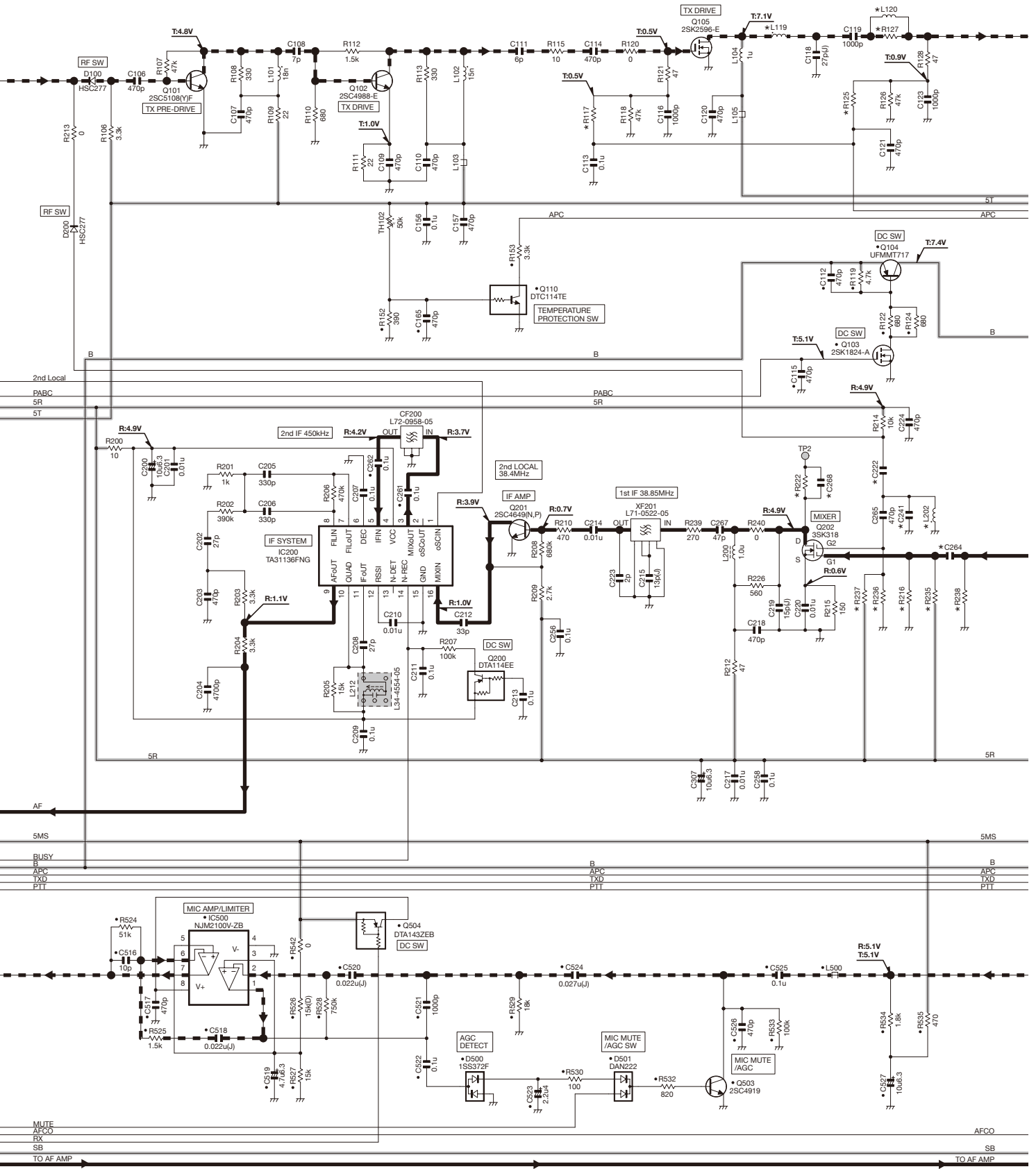

	X57-6030-XX	L119	L120	L202	R117	R125	R127	R216	R222	R235	R236	R237	R238	C222	C241	C264	C268
-10	C	2.2n	NO	15n	120k	47k	0	56k	1k	100k	56k	100k	2.2k	1p	6p	22p	NO
-25	C2	3.3n	2.7n	18n	47k	18k	NO	10k	NO	18k	10k	18k	NO	5p(B)	2.5p(B)	470p	1p(B)

SCHEMATIC DIAGRAM / 原理图 TK-3107G

TX-RX UNIT (X57-6030-XX)

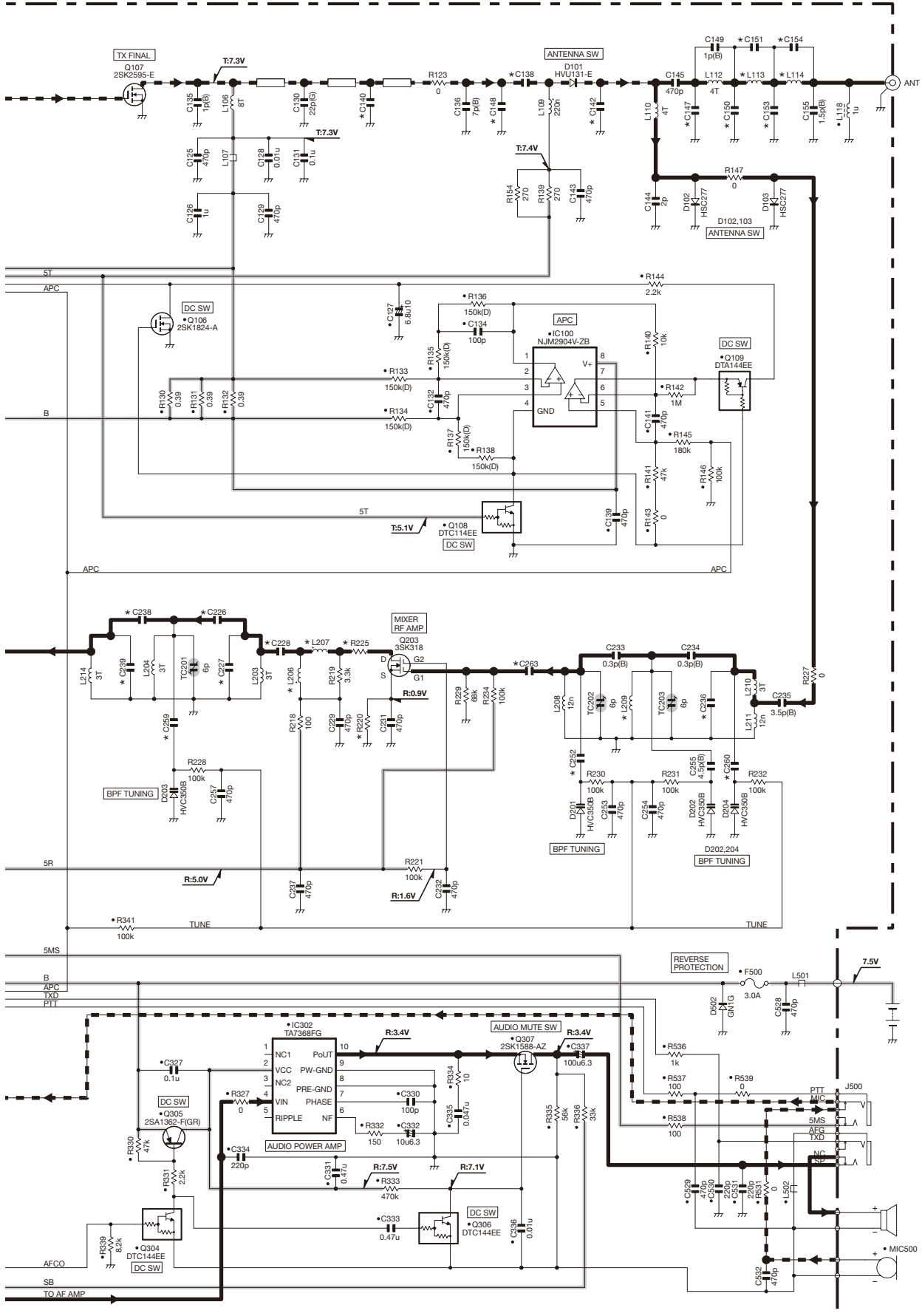

X57-6030-XX	L113	L114	L206	L207	L209	R220	R225	C138	C140	C142	C147	C148	C150	C151	C153	C154	C227	C228	C236	C238	C239	C252	C259	C260	C263
-10	C	18n	47n	15n	27n	47n	220	10	100p	NO	3p(B)	1p	5p	1.5p(B)	3p	1p(B)	0.3p(B)	27p(L)	0.3p(B)	0.3p(B)	4p	4.5p	3p	2.5p(B)	22p
-11	C2	25n	18n	18n	47n	18n	150	22	470p	4p(B)	5p(B)	1.5p(B)	NO	4p(B)	2p(B)	4p(B)	2p(B)	8p(B)	0.5p(B)	0.5p(B)	5p(B)	6p(B)	6p(B)	3.5p(B)	470p

Note : The components marked with a dot (•) are parts of layer 1.

BLOCK DIAGRAM / 方块图

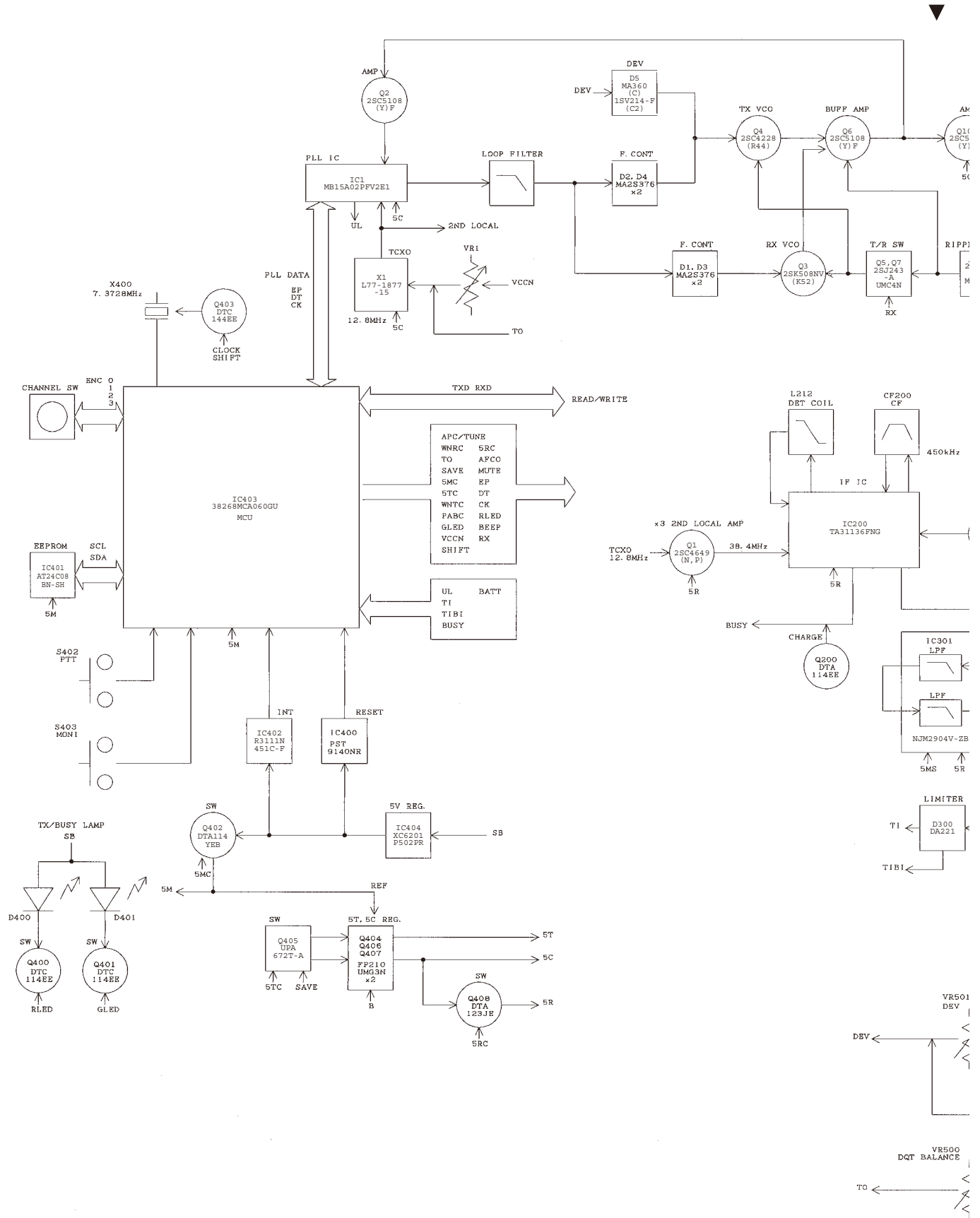

BLOCK DIAGRAM / 方块图

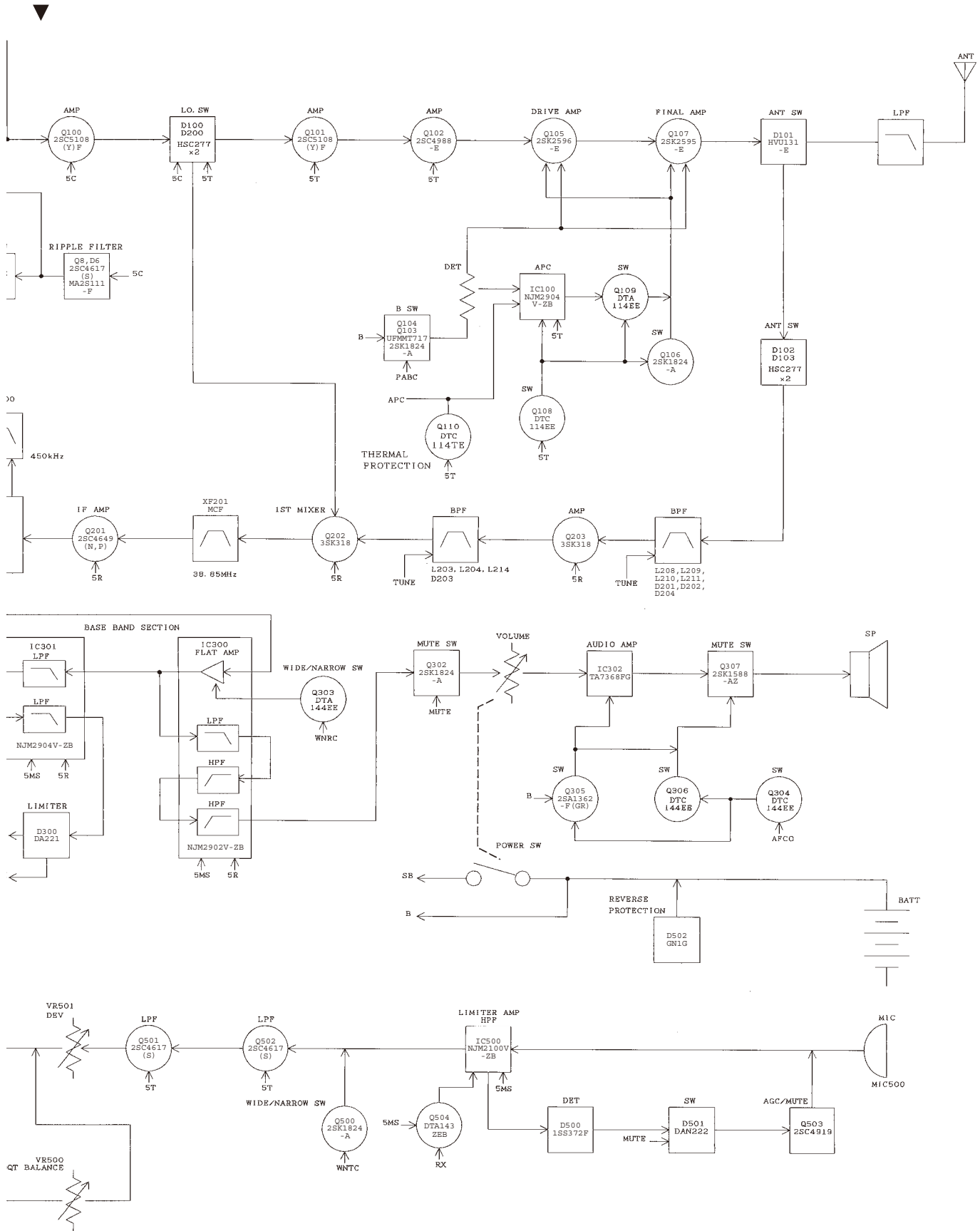

Receiver Section / 接收部分

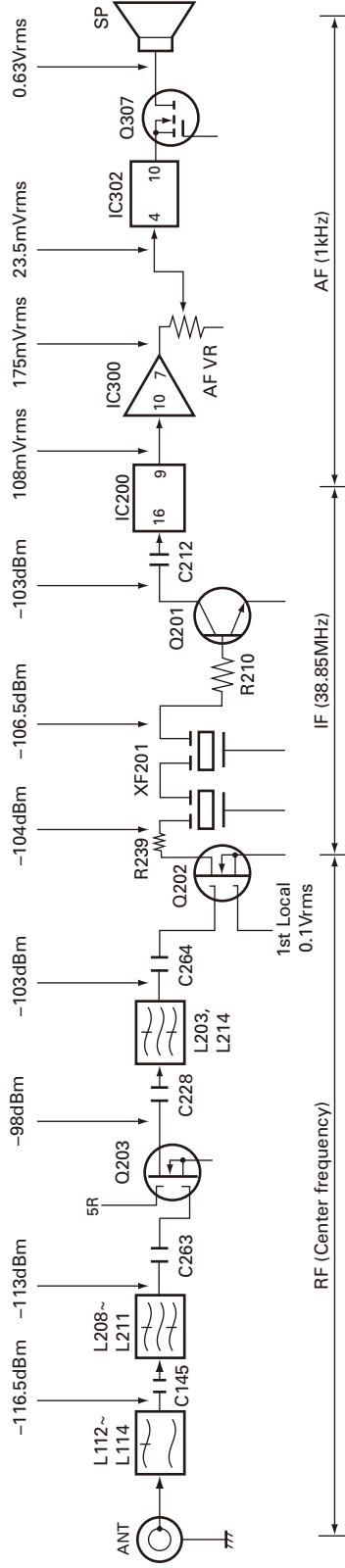

SG output level for obtaining 12dB / SINAD when injected to each point through a 470pF coupling capacitor. Measure the 1st Local level on a RF VTVM.

Modulate the AF level with a frequency of 1kHz and deviation of 1.5kHz (Narrow, 3kHz (Wide)). Then take the signal from the signal generator output when set to -53dBm and obtain the level shown on an AF VTVM when the AF output has been adjusted to 0.63Vrms with the AF vol.

Transmitter Section / 发射部分

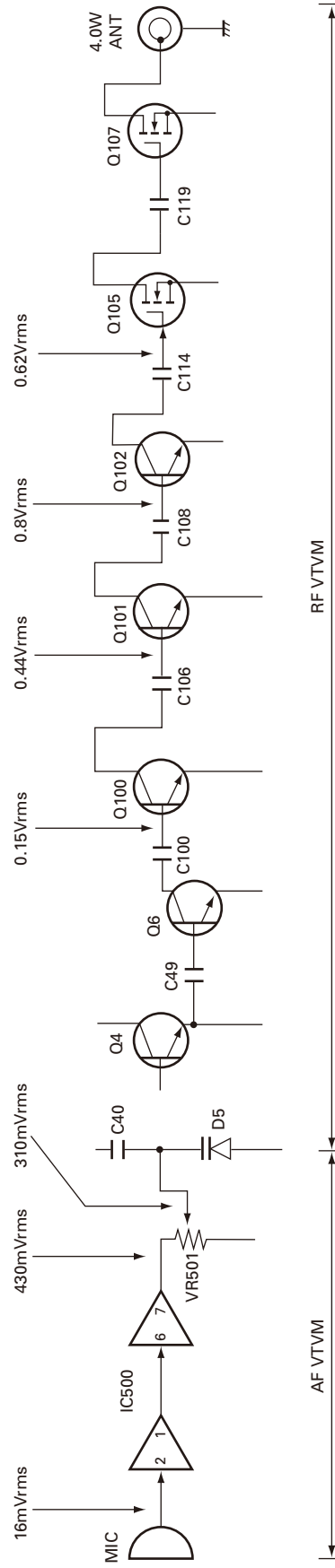

Measure the audio frequency on an AF VTVM and radio frequency on a RF VTVM at high impedance. Set the MIC input to obtain a modulation factor of 60% with the transmit frequency at center and a modulation frequency of 1kHz.

OPTIONAL ACCESSORIES / 可选附件

KNB-14 (Ni-Cd BATTERY / 镍镉电池)

External View / 外视图



Schematic Diagram / 电路图

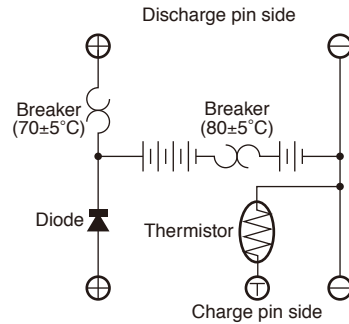

Specifications / 规格

Voltage / 电压.....7.2V (1.2V x 6)
 Capacity / 充电电流..... 600mAh
 Weight / 重量..... 165g

KNB-15A (Ni-Cd BATTERY / 镍镉电池)

External View / 外视图



Schematic Diagram / 电路图

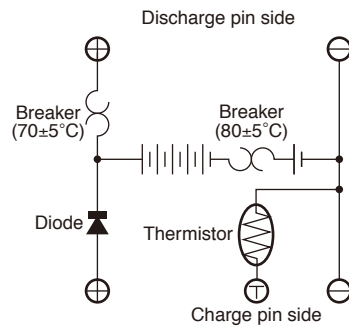

Specifications / 规格

Voltage / 电压.....7.2V (1.2V x 6)
 Capacity / 充电电流..... 1100mAh
 Weight / 重量..... 210g

KNB-20N (Ni-MH BATTERY / 镍氢电池)

External View / 外视图



Schematic Diagram / 电路图

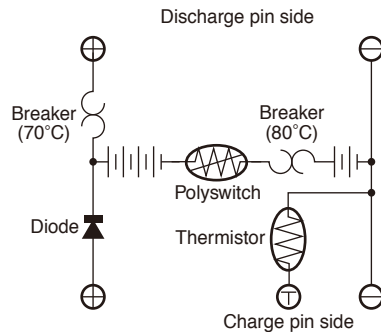

Specifications / 规格

Voltage / 电压.....7.2V (1.2V x 6)
 Capacity / 充电电流..... 1600mAh
 Weight / 重量..... 210g

TK-3107G

SPECIFICATIONS / 规格

GENERAL

Frequency Range.....	450 to 470 MHz : C, 400 to 420MHz: C2
RF power output.....	4W
Number of channels	16CH
Operating Voltage.....	7.5V DC \pm 20%
Temperature Range	-30°C to + 60°C
Frequency stability.....	\pm 2.5ppm
Antenna impedance.....	50 Ω
Channel frequency spread.....	20MHz
Dimensions and Weight	
With KNB-15A (7.2V 1100mAh battery).....	58 W X 125.5 H X 35 D mm 380g

概述

频率范围.....	450-470MHz:C, 400-420MHz:C2
射频功率输出.....	4W
信道数量.....	16 信道
工作电压.....	7.5V 直流 \pm 20%
温度范围.....	-30°C 到 +60°C
频率稳定性.....	\pm 2.5ppm
天线阻抗.....	50 Ω
信道频率扩展.....	20MHz
尺寸和重量	
带有 KNB-15A (7.2V 1100mAh 电池)	58 宽 \times 125.5 高 \times 35 长 mm 380g

Kenwood Corporation

2967-3, Ishikawa-machi, Hachioji-shi, Tokyo, 192-8525 Japan

Kenwood U.S.A. Corporation

P.O. BOX 22745, 2201 East Dominguez Street, Long Beach, CA 90801-5745, U.S.A.

Kenwood Electronics Canada Inc.

6070 Kestrel Road, Mississauga, Ontario, Canada L5T 1S8

Kenwood Electronics Deutschland GmbH

Rembrücker Str. 15, 63150 Heusenstamm, Germany

Kenwood Electronics Belgium N.V.

Leuvensesteenweg 248 J, 1800 Vilvoorde, Belgium

Kenwood Electronics France S.A.

L'Etoile Paris Nord 2, 50 Allée des Impressionnistes, Bp 58416 Villepinte, 95944 Roissy Ch De Gaulle Cedex

Kenwood Electronics UK Limited

KENWOOD House, Dwight Road, Watford, Herts., WD18 9EB United Kingdom

Kenwood Electronics Europe B.V.

Amsterdamseweg 37, 1422 AC Uithoorn, The Netherlands

Kenwood Electronics Italia S.p.A.

Via G. Sirtori, 7/9 20129 Milano, Italy

Kenwood Ibérica, S.A.

Bolivia, 239-08020 Barcelona, Spain

Kenwood Electronics Australia Pty. Ltd.

(A.C.N. 001 499 074)

16 Giffnock Avenue, Centrecourt Estate, North Ryde, N.S.W. 2113 Australia

Kenwood Electronics (Hong Kong) Ltd.

Unit 3712-3724, Level 37, Tower one Metroplaza, 223 Hing Fong Road, Kwai Fong, N.T., Hong Kong

Kenwood Electronics Singapore Pte Ltd

1 Ang Mo Kio Street 63, Singapore 569110

TK-3107G PC BOARD / PC板

TX-RX UNIT (X57-6030-XX) -10 : C -25 : C2
Component side view (J79-0171-09)

PC BOARD / PC板 TK-3107G

TX-RX UNIT (X57-6030-XX) -10 : C -25 : C2
Component side view (J79-0171-09)

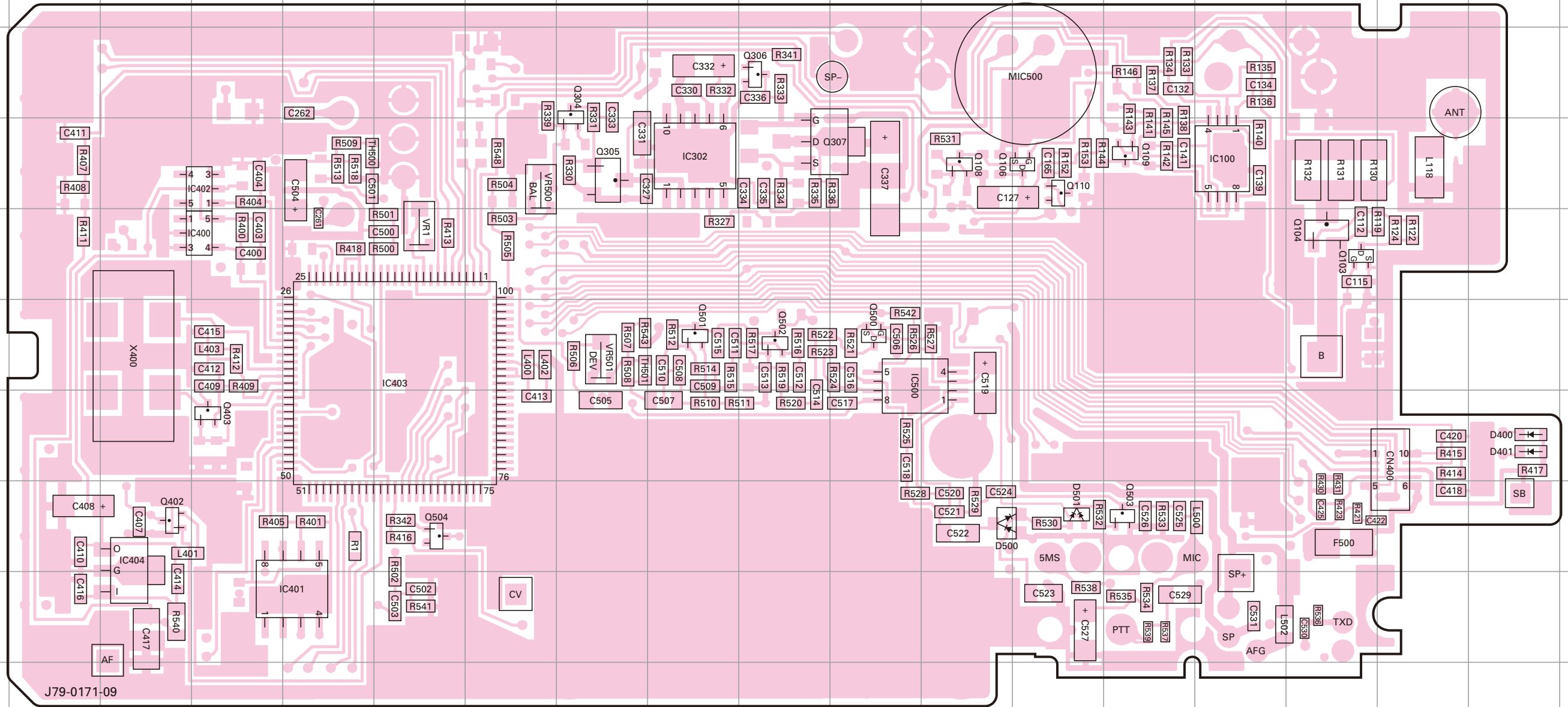

Ref. No.	Address	Ref. No.	Address	Ref. No.	Address
IC100	4O	Q106	4M	Q500	6K
IC302	4I	Q108	4L	Q501	6I
IC400	5D	Q109	4N	Q502	6J
IC401	9E	Q110	4M	Q503	8N
IC402	4D	Q304	3H	Q504	8F
IC403	6F	Q305	4H	D400	7R
IC404	8C	Q306	3J	D401	7R
IC500	6K	Q307	4K	D500	8L
Q103	5P	Q402	8C	D501	8M
Q104	5P	Q403	7D		

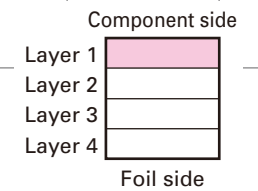

TK-3107G PC BOARD / PC板

PC BOARD / PC板 TK-3107G

TX-RX UNIT (X57-6030-XX) -10 : C -25 : C2
Foil side view (J79-0171-09)

TX-RX UNIT (X57-6030-XX) -10 : C -25 : C2
Foil side view (J79-0171-09)

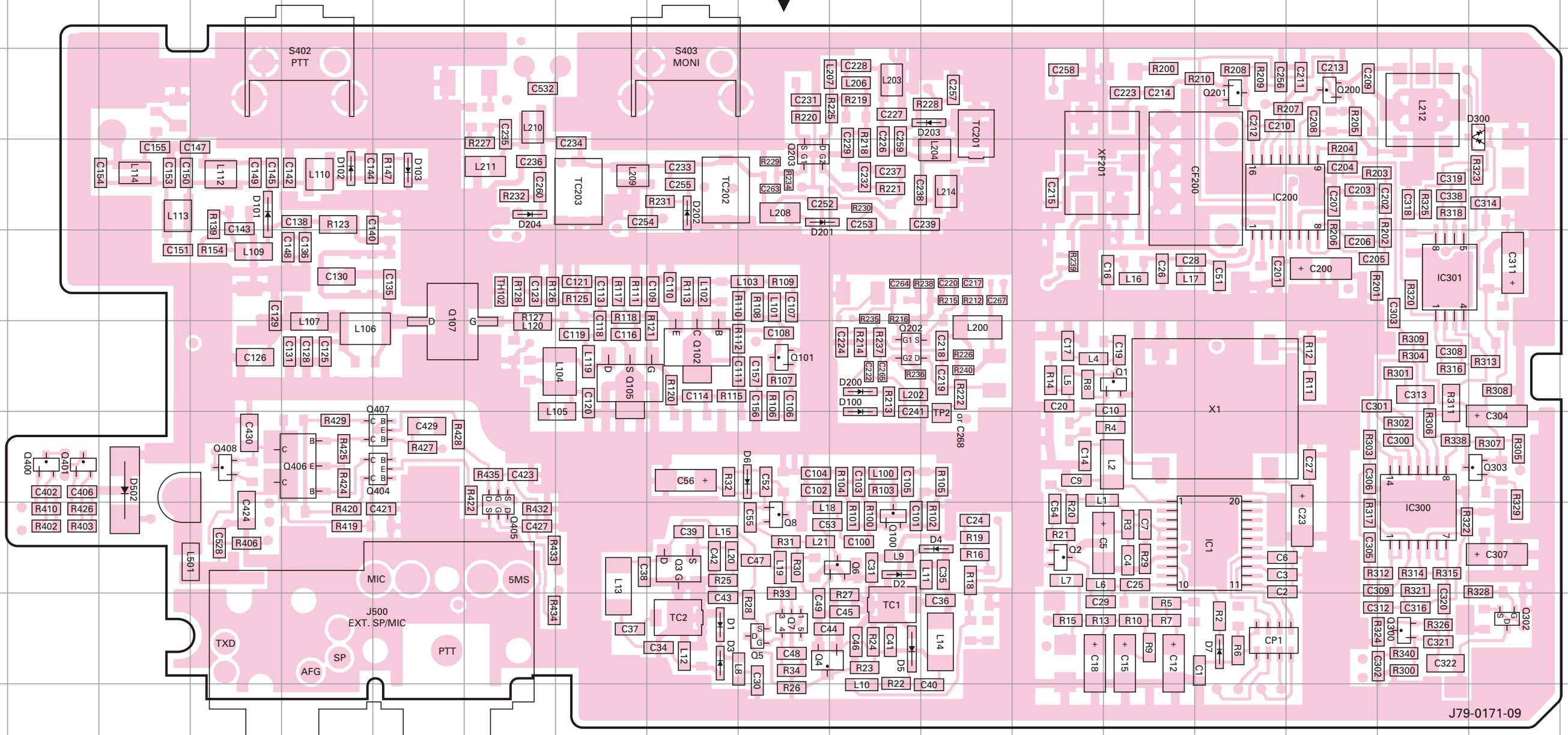

Ref. No.	Address	Ref. No.	Address	Ref. No.	Address	Ref. No.	Address	Ref. No.	Address
IC1	8O	Q7	9J	Q203	4J	Q408	7D	D102	4E
IC200	4O	Q8	8J	Q300	9Q	D1	9I	D103	4F
IC300	8Q	Q100	8K	Q302	9R	D2	8K	D200	6K
IC301	5Q	Q101	6J	Q303	7R	D3	9I	D201	4J
Q1	6N	Q102	6I	Q400	7B	D4	8L	D202	4I
Q2	8M	Q105	6H	Q401	7B	D5	9K	D203	3L
Q3	8I	Q107	6F	Q404	7F	D6	7J	D204	4G
Q4	9J	Q200	3P	Q405	8G	D7	9O	D300	3R
Q5	9J	Q201	3O	Q406	7E	D100	6K	D502	7C
Q6	8K	Q202	6K	Q407	7F	D101	4D		

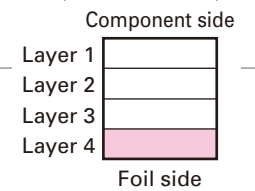

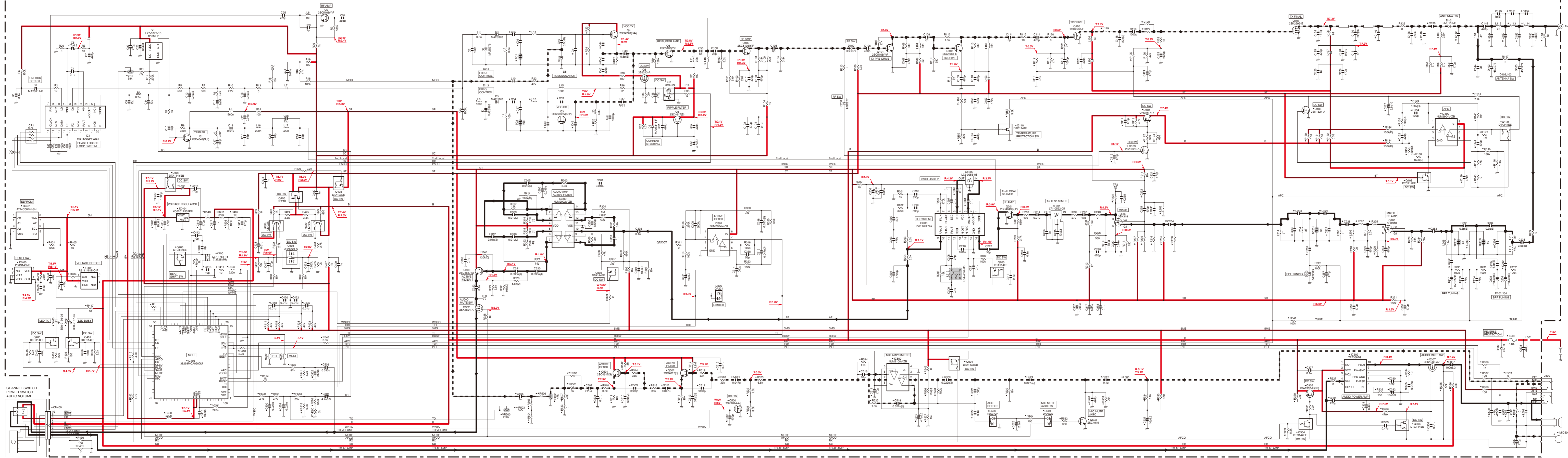

X57-6030-XX	R513	R518	
-10	C	33k	6.8k
-25	C2	47k	10k

X57-6030-XX	D5	L13	L14	L18	R23	R24	R25	R27	R27	R504	R505	R506	R508	R508	C34	C35	C36	C37	C38	C39	C41	C42	C44	C45	C41	
-10	C	MA360	23n	23n	47n	6.8k	8.2k	100	330	68k	33k	150k	22k	5.6k	18k5	7p	8p0	33p	5p	8p0	4p	10p0	6p	10p0	6p	10p0
-25	C2	18V214-F	27n	27n	10k	3.9k	4.7k	150	270	12k	68k	120k	10k	2.2k	33p0	15p0	30p0	6p0	10p0	10p0	15p0	15p0	15p0	15p0	15p0	15p0

X57-6030-XX	L119	L120	L202	R117	R117	R125	R127	R216	R222	R236	R237	R238	C222	C241	C264	C268	
-10	C	2.2n	NO	15n	120k	47k	0	56k	1k	100k	56k	100k	2.2k	1p	6p	22p	NO
-25	C2	3.3n	2.7n	18n	47k	18k	NO	10k	NO	18k	10k	18k	10k	5p0	2.5p0	4700	1p0

X57-6030-XX	L114	L208	L207	L209	R220	R225	C138	C140	C142	C148	C149	C150	C151	C153	C154	C226	C227	C228	C236	C238	C239	C252	C259	C260	C263	
-10	C	18n	47n	15n	27n	47n	220	100n	NO	100n	1p0	1p	5p	1.5p0	3p0	15p0	15p0	10p	27p0	0.3p0	0.3p0	4p	4.5p	3p	2.5p0	22p
-11	C2	25n	18n	18n	47n	18n	150	22	470n	4p0	5p0	NO	4p0	2p0	4p0	0.5p0	15p0	1p0	0.5p0	0.5p0	0.5p0	8p0	8p0	3.5p0	47p0	

