

UHF FM TRANSCEIVER

TK-3140

SERVICE MANUAL

ADDENDUM

KENWOOD

© 2001-11 PRINTED IN JAPAN
B51-8615-00 (S) 1422

This addendum adds important information on the Clone and Self-Programming mode of the TK-3140 transceiver.

CONTENTS

REALIGNMENT

Clone Mode	2
Self Programming Mode	2



**Does not come with antenna.
Antenna is available as an option.**

KENWOOD CORPORATION

14-6, Dogenzaka 1-chome, Shibuya-ku, Tokyo 150-8501, Japan
KENWOOD SERVICE CORPORATION
 P.O. BOX 22745, 2201 East Dominguez Street, Long Beach, CA 90801-5745, U.S.A.
KENWOOD ELECTRONICS CANADA INC.
 6070 Kestrel Road, Mississauga, Ontario, Canada L5T 1S8
KENWOOD ELECTRONICS DEUTSCHLAND GMBH
 Rembrücker Str. 15, 63150 Heusenstamm, Germany
KENWOOD ELECTRONICS BELGIUM N.V.
 Leuvensesteenweg 248 J, 1800 Vilvoorde, Belgium
KENWOOD ELECTRONICS FRANCE S.A.
 13, Boulevard Ney, 75018 Paris, France
KENWOOD ELECTRONICS U.K. LIMITED
 Kenwood House, Dwight Road, Watford, Herts., WD1 8EB United Kingdom
KENWOOD ELECTRONICS EUROPE B.V.
 Amsterdamseweg 37, 1422 AC Uithoorn, The Netherlands

KENWOOD ELECTRONICS ITALIA S.p.A.
 Via G. Sirtori, 7/9 20129 Milano, Italy
KENWOOD IBERICA S.A.
 Bolivia, 239-08020 Barcelona, Spain
KENWOOD ELECTRONICS AUSTRALIA PTY. LTD.
 (A.C.N. 001 499 074)
 16 Giffnock Avenue, Centrecourt Estate, North Ryde, N.S.W. 2113, Australia
KENWOOD ELECTRONICS (HONG KONG) LTD.
 Unit 3712-3724, Level 37, Tower one Metroplaza, 223 Hing Fong Road, Kwai Fong, N.T., Hong Kong
KENWOOD ELECTRONICS TECHNOLOGIES(S) PTE LTD.
 Sales Marketing Division
 1 Ang Mo Kio Street 63, Singapore 569110

REALIGNMENT

1. Clone Mode

Programming data can be transferred from one radio to another by connecting them via their external universal connectors. The operation is as follows (the transmit radio is the master and the receive radio is a slave).

1. Turn the master TK-3140 power ON with the [C] key held down. If the password is set to the TK-3140, the TK-3140 displays "CLONE LOCK". If the "Data Password" is not set, the TK-3140 displays "CLONE MODE".
2. When "CLONE LOCK" is displayed, only the "tuning control knob" and [S] key can be accepted. When you enter the correct password, and "CLONE MODE" is displayed, the TK-3140 can be used as the cloning master. The following describes how to enter the password.
3. How to enter the password with the "tuning control knob"; If the "tuning control knob" is rotated while "CLONE LOCK" is displayed, numbers (0 to 9) are displayed flashing. When you press the [S] key, the currently selected number is determined. If you press the [S] key after entering the password in this procedure, "CLONE MODE" is displayed if the entered password is correct. If the password is incorrect, "CLONE LOCK" is redisplayed.
4. Power on the slave TK-3140.
5. Connect the cloning cable (No. E30-3325-05) to the universal connectors on the master and slave.
6. Press the [S] key on the master while the master displays "CLONE MODE". The data of the master is sent to the slave. While the slave is receiving the data, "PROGRAM" is displayed. When cloning of data is completed, the master displays "END", and the slave automatically operates in the User mode. The slave can then be operated by the same program as the master.
7. The other slave can be continuously cloned. When the [S] key on the master is pressed while the master displays "END", the master displays "CLONE MODE". Carry out the operation in step 4 to 6.

Note:

Only the same models can be cloned together.

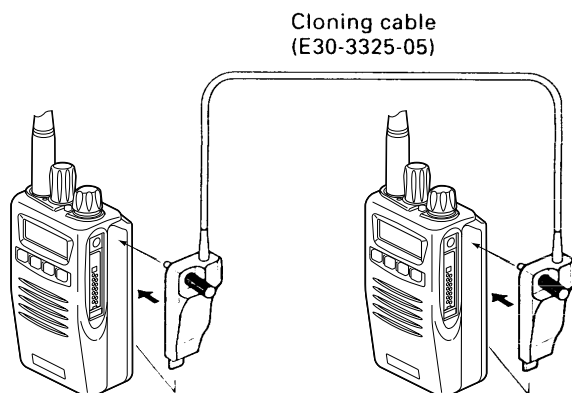

Fig. 1

2. Self Programming Mode

Write mode for frequency data and signalling etc. Mainly used by the person maintaining the user equipment.

2-1. Enter to the self programming mode

Delete R351 (Figure 2) in the TX-RX unit and turn the power switch on while pressing the [Side 2] key. When enter the self programming mode, "SELF PROG" is displayed.

Note :

This mode (self programming mode) cannot be set when it has been disabled with the FPU.

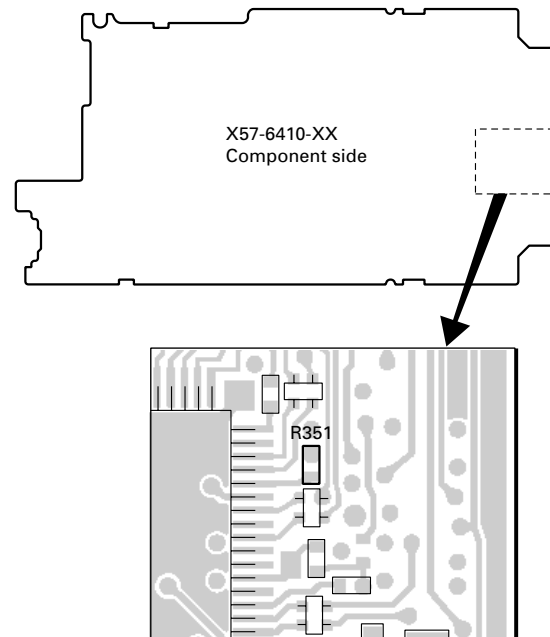

Fig. 2

REALIGNMENT

2-2. Channel Setting Mode

This is a mode for making channel settings with the panel keys without using the FPU.

Pressing [Side 1] key when [SELF PROG] is displayed, sets Channel Setting Mode.

Select an item set with [C] key and change the selection with the "tuning control knob".

The data displayed with [B] key is stored in the memory and then proceeds to the next item. Pressing [C] key proceeds to the next item without storing it in the memory.

Press [Side 1] key to set the display to [SELF PROG] and return to reset (default) status.

Items set in Channel Setting Mode are as follows.

Function settings	Display	Remarks
Channel select	CH or GRP	
RX Frequency	RXF	[Side 2] : Freq. On/Off switching [A] : 5kHz/6.25kHz/7.5kHz/1MHz step switching
RX Signalling	RXS	[Side 2] : OFF/QT/DQT switching [A] : 1 step/Standard switching [S] : DQT Normal/Invert switching
TX Frequency	TXF	Key operation same as RX Frequencies
TX Signalling	TXS	Key operation same as RX Signalling
Scan Del/Add	SCN	Delete/Add
Busy Channel Lockout	BSY	YES/NO
RF Power	PWR	HIGH/LOW
Beat Shift	SFT	YES/NO
Wide/Narrow	W/N	Wide/Narrow

• Flow Chart

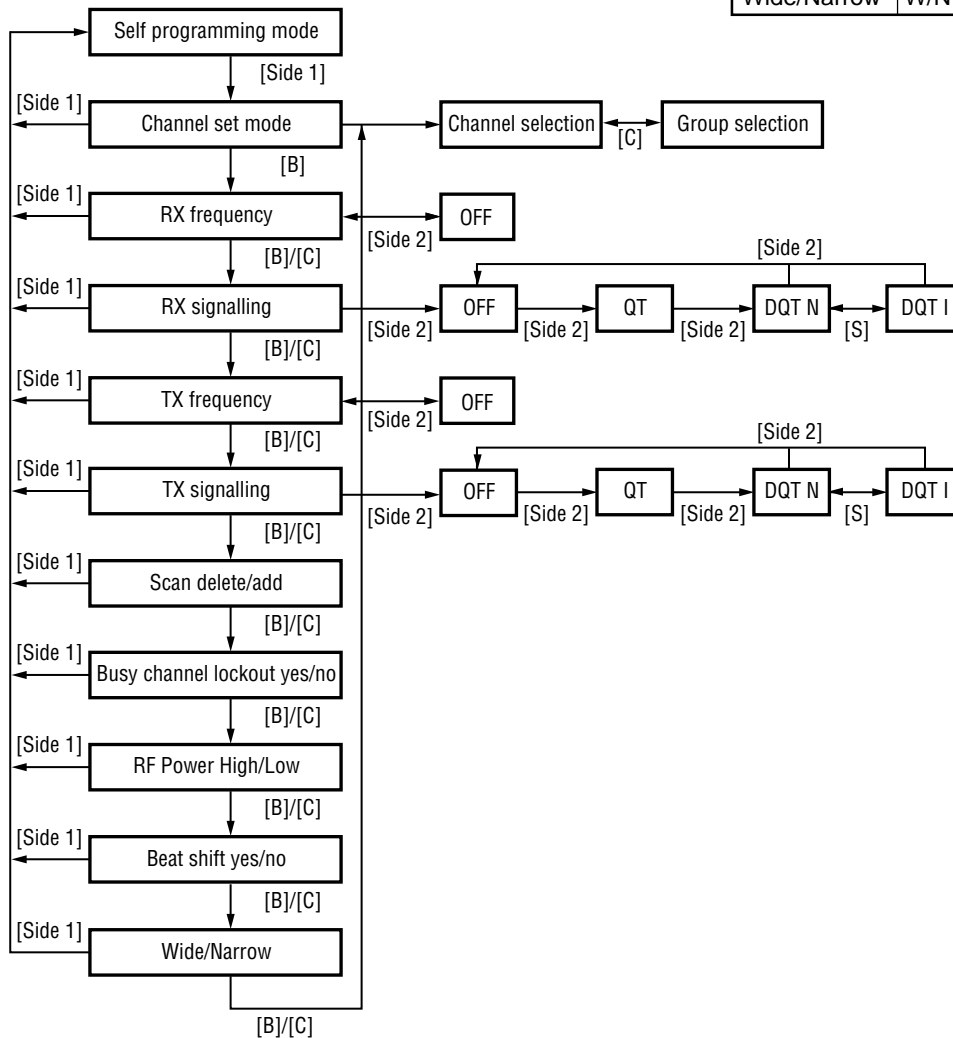

REALIGNMENT

2-3. Function Setting Mode

This is a mode for using the panel keys to make function settings without using the FPU, that operate on all channels.

Pressing the [Side 2] key when [SELF PROG] is displayed, sets the Function Setting Mode.

Select an item set with [C] key and change the selection with the encoder.

Press [Side 2] key to display [SELF PROG] and return to reset (default) status.

Items set in Function Set Mode are as follows.

Function settings	Display	Remarks
[A]	A	Key Function
[B]	B	Key Function
[C]	C	Key Function
[S]	S	Key Function
[Side 1]	SD1	Key Function
[Side 2]	SD2	Key Function
[AUX]	AUX	Key Function
[KNOB]	KNB	Knob Function
T.O.T	TOT	ON/OFF at T.O.T all settings ON:TOT[60s]/Pre-Alert[10s]/ Rekey Time[5s]/Reset Time[5s] OFF:TOT[600s]/Pre-Alert[Off]/ Rekey Time[Off]/Reset Time[Off]
Power ON Tone	Ptn	Continuous, 1-31, OFF
Control Tone	Ctn	Continuous, 1-31, OFF
Warning Tone	Wtn	Continuous, 1-31, OFF
Alert Tone	Atn	Continuous, 1-31, OFF
Other Tone	Otn	Continuous, 1-31, OFF
Battery Save	BAT	OFF/SHORT/MEDIUM/LONG
Battery Status	BST	ON/OFF
Squelch Level	SQL	SQL 0-9

• Flow Chart

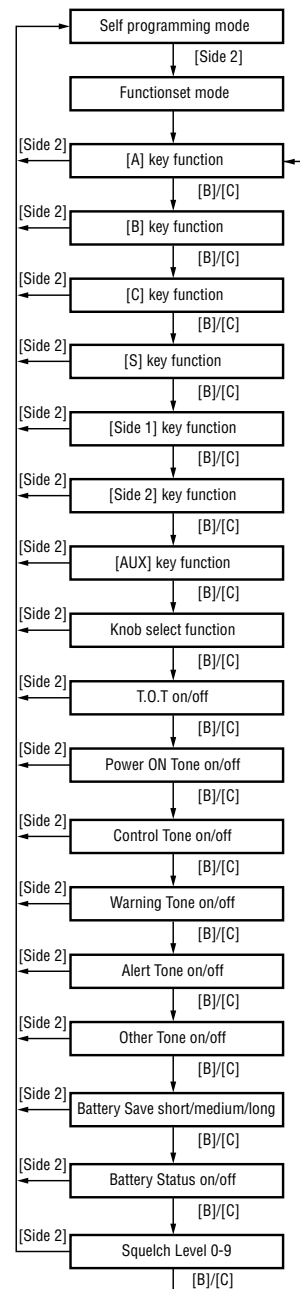

2-4. Memory Reset Mode

This mode is used to clear data for functions that can be set in Self Programming Mode or to return to reset values (default).

Pressing [S] key when [SELF PROG] is shown, sets the display to [CLEAR NO?].

Turning the encoder alternately switches the display between [CLEAR NO?] ↔ [CLEAR YES?].

Pressing [S] key when [CLEAR YES?] is shown, clears the data and sets the display to [ALL CLEAR].

Pressing [S] key again, returns the display to [SELF PROG].

Pressing [S] key when [CLEAR NO?] is shown, returns the display to [SELF PROG] without resetting the data.

