

UHF FM TRANSCEIVER

TK-3140

SERVICE MANUAL

KENWOOD

© 2001-10 PRINTED IN JAPAN
B51-8603-00 (S) 1422



CONTENTS

GENERAL	2
SYSTEM SET-UP	2
OPERATING FEATURES	3
REALIGNMENT	4
CIRCUIT DESCRIPTION	6
SEMICONDUCTOR DATA	12
DESCRIPTION OF COMPONENTS	13
PARTS LIST	14
EXPLODED VIEW	22
PACKING	23
ADJUSTMENT	24
TERMINAL FUNCTION	34
PC BOARD VIEWS	
TX-RX UNIT (X57-6410-10)	35
SCHEMATIC DIAGRAM	45
BLOCK DIAGRAM	49
LEVEL DIAGRAM	51
KSC-25	52
KNB-24L,KNB-25A,KNB-26N,KRA-23	55
SPECIFICATIONS	BACK COVER

**Does not come with antenna.
Antenna is available as an option.**

TK-3140

GENERAL / SYSTEM SET-UP

INTRODUCTION

SCOPE OF THIS MANUAL

This manual is intended for use by experienced technicians familiar with similar types of commercial grade communications equipment. It contains all required service information for the equipment and is current as of the publication date. Changes which may occur after publication are covered by either Service Bulletins or Manual Revisions. These are issued as required.

ORDERING REPLACEMENT PARTS

When ordering replacement parts or equipment information, the full part identification number should be included. This applies to all parts : components, kits, or chassis. If the part number is not known, include the chassis or kit number of which it is a part, and a sufficient description of the required component for proper identification.

PERSONNEL SAFETY

The following precautions are recommended for personnel safety:

- DO NOT transmit until all RF connectors are verified secure and any open connectors are properly terminated.
- SHUT OFF and DO NOT operate this equipment near electrical blasting caps or in an explosive atmosphere.
- This equipment should be serviced by a qualified technician only.

SERVICE

This radio is designed for easy servicing. Refer to the schematic diagrams, printed circuit board views, and alignment procedures contained within.

SYSTEM SET-UP

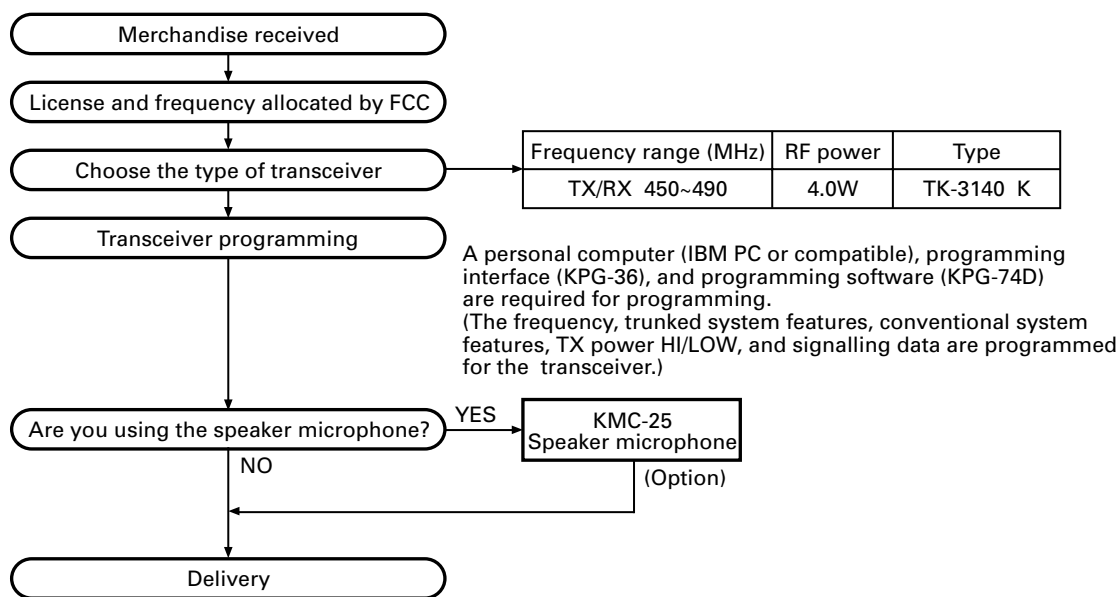

OPERATING FEATURES

1. Operation Features

The TK-3140 is an UHF FM radio designed to operate in both trunking format and conventional format. The programmable features are summarized.

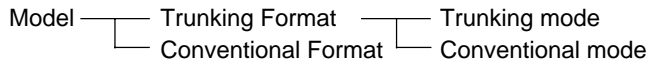

■ Trunking Format

This format can handle up to 32 systems with up to 250 groups in each system. The transceiver can be used in both trunked mode and conventional mode. Systems, groups, and their functions are programmed.

■ Conventional Format

This format can handle up to 250 groups with 250 channels in each group. The transceiver can be used only in conventional mode. Groups, channels, and their functions are programmed.

2. Transceiver Controls and Indicators

2-1. Physical Layout

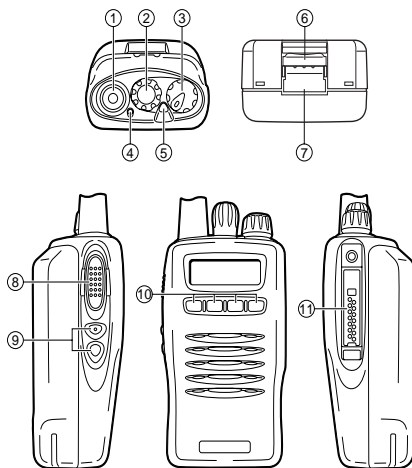

① Antenna connector

Connect an (optional) antenna here.

② Rotary encoder

Rotate this encoder to activate its programmable function. (System or Group Up/ Down in Trunking Format, and Group or Channel Up/ Down in Conventional Format.) For further details, contact your dealer.

③ POWER switch/ VOLUME control

Turn clockwise to switch ON the transceiver. Rotate to adjust the volume. Turn counterclockwise fully to switch OFF the transceiver.

④ Transmit/ Battery low indicator

This red LED lights during transmission. If programmed by your dealer, when the battery pack power is low, the LED flashes during transmission. Replace or recharge the battery pack.

⑤ Auxiliary (orange) key

Press to activate its auxiliary function {page 13}.

⑥ Battery pack safety catch

Flip this catch to prevent accidentally pressing the battery pack release latch.

⑦ Battery pack release latch

Press this latch to release the battery pack.

⑧ PTT (Push-To-Talk) switch

Press this switch, then speak into the microphone to call a station.

⑨ Side 1, Side 2 keys

Press to activate their auxiliary functions.

⑩ S, A, ◀ B, and C ▶ keys

Press to activate their auxiliary functions.

⑪ Universal connector

Connect the (optional KMC-25) speaker/ microphone here. Otherwise, keep the supplied cover in place.

2-2. Programmable keys

Keys ②, ⑤, ⑧ and ⑨ can be programmed with the auxiliary functions listed in the following table. The keys can only be programmed with functions, depending on whether you are using Conventional Format or Trunking Format. Please contact your dealer for further details on these functions.

Function	Conventional Format	Trunking Format
Auto Telephone	No	Yes
Channel Down	Yes	No
Channel Up	Yes	No
Channel Up/Down ¹	Yes	No
Display Character	Yes	Yes
DTMF ID (BOT)	Yes	Yes
DTMF ID (EOT)	Yes	Yes
Emergency ²	Yes	Yes
Group Down	Yes	Yes
Group Up	Yes	Yes
Group Up/Down ¹	Yes	Yes
Home Channel	Yes	No
Home Group	No	Yes
Key Lock	Yes	Yes
Lamp	Yes	Yes
Memory (RCL/STO)	Yes	Yes
Memory (RCL)	Yes	Yes
Memory (STO)	Yes	Yes
Message Mode ³	Yes	Yes

OPERATING FEATURES / REALIGNMENT

Function	Conventional Format	Trunking Format
Monitor Momentary	Yes	Yes
Monitor Toggle	Yes	Yes
None	Yes	Yes
Operator Selectable Tone	Yes	No
Redial	Yes	Yes
RF Power Low	Yes	Yes
Scan	Yes	Yes
Scan Del/Add	Yes	Yes
Scan Temporary Delete	No	Yes
SP Attenuation ⁴	Yes	Yes
Squelch Level	Yes	No
Squelch Off Momentary	Yes	Yes
Squelch Off Toggle	Yes	Yes
System Down	No	Yes
System Up	No	Yes
System Up/Down ¹	No	Yes
Talk Around	Yes	No
Telephone Disconnect	No	Yes

- ¹ These functions can be programmed only on key ②, the encoder.
- ² This function can be programmed only on key ⑤, the Auxiliary (orange) key.
- ³ This function can be programmed only on key ⑨'s A key.
- ⁴ This function can be programmed only on the programmable function key of the optional KMC-25 speaker/ microphone.

2-3. Display

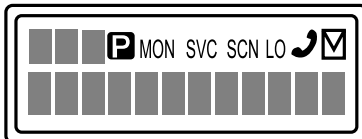

Indicator	Description
■■■	Displays the channel or group number in conventional mode and the system or group number in trunking mode.
P	Appears when performing Priority Scan.
MON	Appears when the key programmed as Monitor is pressed.
SVC	This icon is not used on this transceiver.
SCN	Appears when performing Scan.
LO	Appears when the key programmed as RF Power LO is pressed.
☎	Appears while using the telephone system.
M	Appears when you have a message.
■■■■■■■■■■	Displays the group name or the system/ group number with up to 10 digits. The remaining 2 digits are used for various indicators.

REALIGNMENT

1. Modes

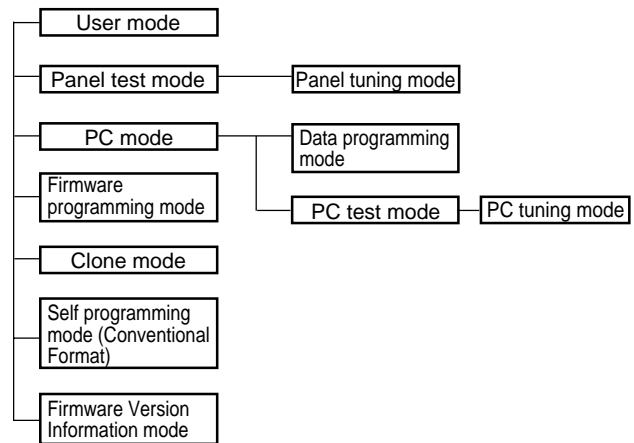

Mode	Function
User mode	For normal use.
Panel test mode	Used by the dealer to check the fundamental characteristics.
Panel tuning mode	Used by the dealer to tune the radio.
PC mode	Used for communication between the radio and PC (IBM compatible).
Data programming mode	Used to read and write frequency data and other features to and from the radio.
PC test mode	Used to check the radio using the PC. This feature is included in the FPU. See panel tuning.
Firmware programming mode	Used when changing the main program of the flash memory.
Clone mode	Used to transfer programming data from one radio to another.
Self programming mode (Conventional Format)	Frequency, signalling and features write to the radio.
Firmware version information mode	Firmware version number is displayed on the LCD.

2. How to Enter Each Mode

Mode	Operation
User mode	Power ON
Panel test mode	[A]+Power ON (Two seconds)
PC mode	Received commands from PC
Panel tuning mode	[Panel test mode]+[S]
Firmware programming mode	[S]+Power ON
Clone mode	[C]+Power ON (Two seconds)
Self programming mode (Conventional Format)	[LAMP]+Power ON (Two seconds)
Firmware version information mode	[side 1] + Power ON (Two seconds)

3. Panel Test Mode

Setting method refer to ADJUSTMENT.

4. Panel Tuning Mode

Setting method refer to ADJUSTMENT.

REALIGNMENT

5. PC Mode

5-1. Preface

The TK-3140 transceiver is programmed by using a personal computer, programming interface (KPG-36) and programming software (KPG-74D).

The programming software can be used with an IBM PC or compatible. Figure 1 shows the setup of an IBM PC for programming.

5-2. Connection procedure

1. Connect the TK-3140 to the personal computer with the interface cable.
2. When the POWER switch on, user mode can be entered immediately. When PC sends command the radio enter PC mode, and "PROGRAM" is displayed on the LCD. When data transmitting from transceiver, the red LED is blinking. When data receiving to transceiver, the green LED is blinking.

Notes:

- The data stored in the personal computer must match model type, when it is written into the flash memory.
- Change the TK-3140 to PC mode, then attach the interface cable.

5-3. KPG-36 description

(PC programming interface cable: Option)

The KPG-36 is required to interface the TK-3140 to the computer. It has a circuit in its D-subconnector (25-pin) case that converts the RS-232C logic level to the TTL level.

The KPG-36 connects the universal connector of the TK-3140 to the computers RS-232C serial port.

5-4. Programming software description

The KPG-74D programming disk is supplied in 3-1/2" disk format. The software on this disk allows a user to program TK-3140 radios via programming interface cable (KPG-36).

5-5. Programming with IBM PC

If data is transferred to the transceiver from an IBM PC with the KPG-74D, the destination data (basic radio information) for each set can be modified. Normally, it is not necessary to modify the destination data because their values are determined automatically when the frequency range (frequency type) is set.

The values should be modified only if necessary. Data can be programmed into the flash memory in RS-232C format via the universal connector.

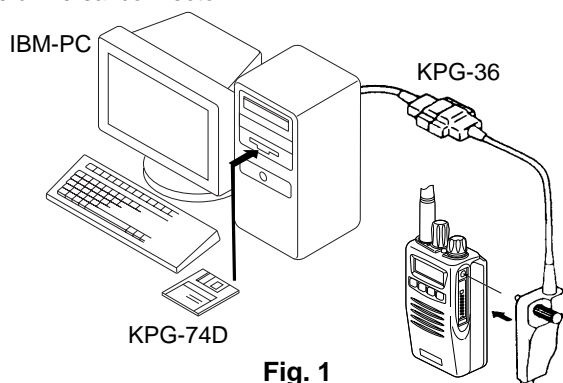

Fig. 1

6. Firmware Programming Mode

6-1. Preface

Flash memory is mounted on the TK-3140. This allows the TK-3140 to be upgraded when new features are released in the future. (For details on how to obtain the firmware, contact Customer Service.)

6-2. Connection procedure

Connect the TK-3140 to the personal computer (IBM PC or compatible) with the interface cable (KPG-36). (Connection is the same as in the PC Mode.)

6-3. Programming

1. Start up the programming software (Fpro.exe).
2. Set the communications speed (normally, 57600 bps) and communications port in the configuration item.
3. Set the firmware to be updated by file name item.
4. Turn the TK-3140 power ON with the [S] switch held down. When "PROG 57600" appears, release your finger from the switch.
5. Check the connection between the TK-3140 and the personal computer, and make sure that the TK-3140 is in the Program mode.
6. Press write button in the window. A window opens on the display to indicate progress of writing. When the TK-3140 starts to receive data, the [P] icon is blinking.
7. If writing ends successfully, the LED on the TK-3140 lights and the checksum is displayed.
9. If you want to continue programming other TK-3140 s, repeat steps 4 to 7.

Notes:

- This mode cannot be entered if the Firmware Programming mode is set to Disable in the Programming software (KPG-74D).
- When programming the firmware, it is recommend to copy the data from the floppy disk to your hard disk before update the radio firmware. Directry copying from the floppy disk to the radio may not work because the access speed is too slow.

6-4. Function

1. If you press the [Side2] switch while "PROG 57600" is displayed, the checksum is displayed. If you press the [Side2] switch again while the checksum is displayed, "PROG 57600" is redisplayed.
2. If you press the [Side1] switch while "PROG 57600" is displayed, the display changes to "PROG 19200" to indicate that the write speed is low speed (19200 bps). If you press the [Side1] switch again while "PROG 19200" is displayed, the display changes to "PROG 38400", and the write speed becomes the middle-speed mode (38400 bps). If you press the [Side1] switch again while "PROG 38400" is displayed, the display returns to "PROG 57600".

Note:

Normally, write in the high-speed mode.

CIRCUIT DESCRIPTION

1. Overview

This transceiver is UHF/FM portable transceiver designed to operate in the frequency range of 450 to 490MHz (K) and an UHF/FM band EFJ LTR™ trunked system compatible FM portable transceiver that can be programmed to operate on both LTR and conventional systems.

2. Circuit Configuration by Frequency

The receiver is a double-conversion superheterodyne with a first intermediate frequency (IF) of 44.85MHz and a second IF of 455kHz. Incoming signals from the antenna are mixed with the local signal from the PLL to produce the first IF of 44.85MHz.

This is then mixed with the 44.395MHz second local oscillator output to produce the 455kHz second IF. This is detected to give the demodulated signal.

The transmit signal frequency is generated by the PLL VCO, and modulated by the signal from the microphone. It is then amplified and sent to the antenna.

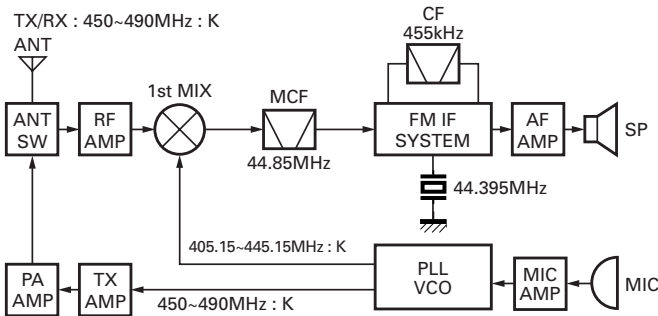

Fig. 1 Frequency configuration

3. Receiver System

3-1. RF unit

An incoming RF signal from the antenna terminal is passed through the antenna switch (D102, D103, D104, and D105 are

off) and then the bandpass filter (L215,217). High pass filter HPF (L219) the 1st image response improve. And the bandpass filter is adjusted by a variable capacitor. The input voltage to the variable capacitor is regulated by the voltage output from the D/A converter (IC307). The signal is amplified by RF amplifier Q207, and passed through the bandpass filter (L209,210,211). The resulting signal is applied to the first mixer (Q206), where it is mixed with the first local oscillator signal output from the frequency synthesizer to produce the first IF (44.85MHz).

3-2. IF unit

The first IF signal is passed through a four-pole monolithic crystal filter (XF200) to remove a adjacent channel signal. The filtered first IF signal is amplified by the first IF amplifier (Q205) and then applied to the IF system IC (IC200). The IF system IC provides a second mixer, second local oscillator, limiting amplifier, quadrature detector and RSSI (Received Signal Strength Indicator). The second mixer mixes the first IF signal with the 44.395MHz of second local oscillator output (crystal unit X200) and produces the second IF signal of 455kHz.

The second IF signal is passed through the ceramic filter (CF200; Wide, CF201 ; Narrow) to more remove the adjacent channel signal. The filtered second IF signal is amplified by the limiting amplifier and demodulated by the quadrature detector with ceramic discriminator (CD200). The demodulated signal is routed to the audio circuit.

Center Frequency		Nominal 455kHz
Band Width	3dB	Min. ±6.5kHz
	50dB	Max. ±15.5kHz
Stop Band Attenuation	±18~±33kHz	Min. 55.0dB
	±100kHz	Min. 50.0dB
Spurious Response	0.1~1.0MHz	Min. 20.0dB
Ripple	Within 455±6.5kHz	Max. 2.0dB
Insertion Loss	at 455 kHz	Max. 4.0dB
Group Delay Time	Within 455±3.0kHz	Max. 25.0µ sec
	Within 455±5.0kHz	Max. 50.0µ sec

Table 1 Ceramic filter (L72-0995-05): CF200

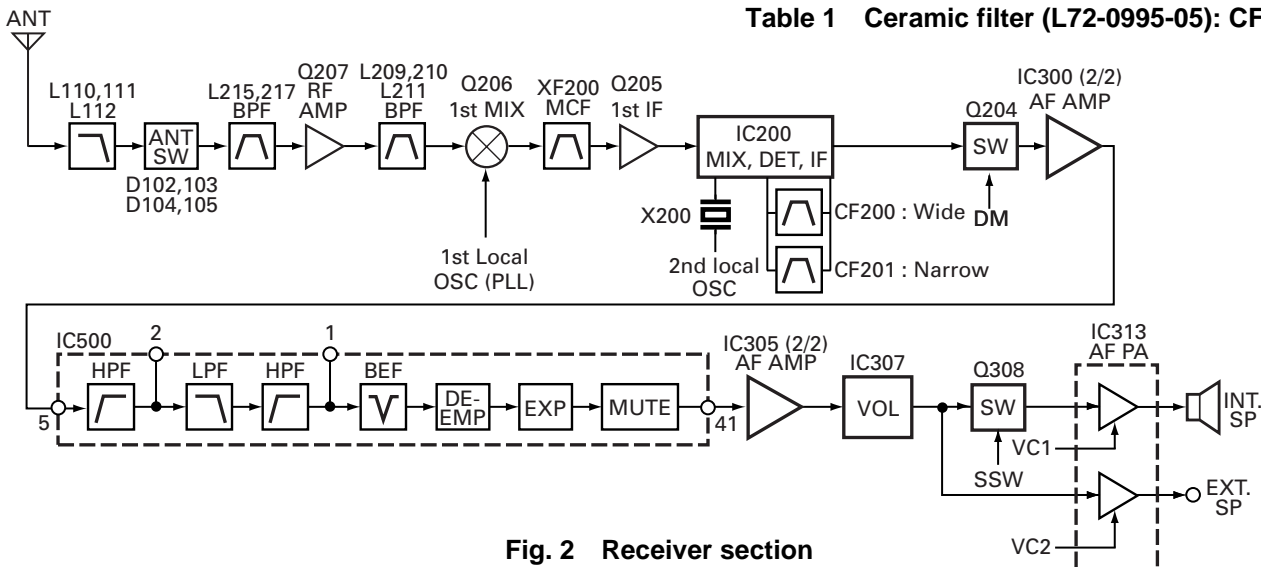

Fig. 2 Receiver section

CIRCUIT DESCRIPTION

Center Frequency	Nominal 455kHz	
Band Width	6dB	Min. ± 4.5 kHz
	40dB	Max. ± 10.0 kHz
Stop Band Attenuation	± 100 kHz	Min. 25.0dB
Ripple	Within 455 ± 3.0 kHz	Max. 1.5dB
Insertion Loss	at 455 kHz	Max. 6.0dB

Table 2 Ceramic filter (L72-0996-05): CF201

3-3. Wide/Narrow changeover circuit

Narrow and Wide settings can be made for each channel by switching the ceramic filters CF200 (Wide), CF201 (Narrow).

The WIDE (high level) and NARROW (low level) data is output from IC311.

Regardless of NARROW or WIDE band selection, signals always pass through the filter, CF200.

When the WIDE band is selected, Q201 is turned ON, then D202 and D203 are turned OFF.

So, the signal does not pass through the filter CF201. When the NARROW band is selected, Q201 is turned OFF, then D202 and D203 are turned ON. So, the signal passes through the filters, CF200 and CF201.

Q202 turns on/off with the Wide/Narrow data and the IC200 detector output level is changed to maintain a constant output level during wide or narrow signals.

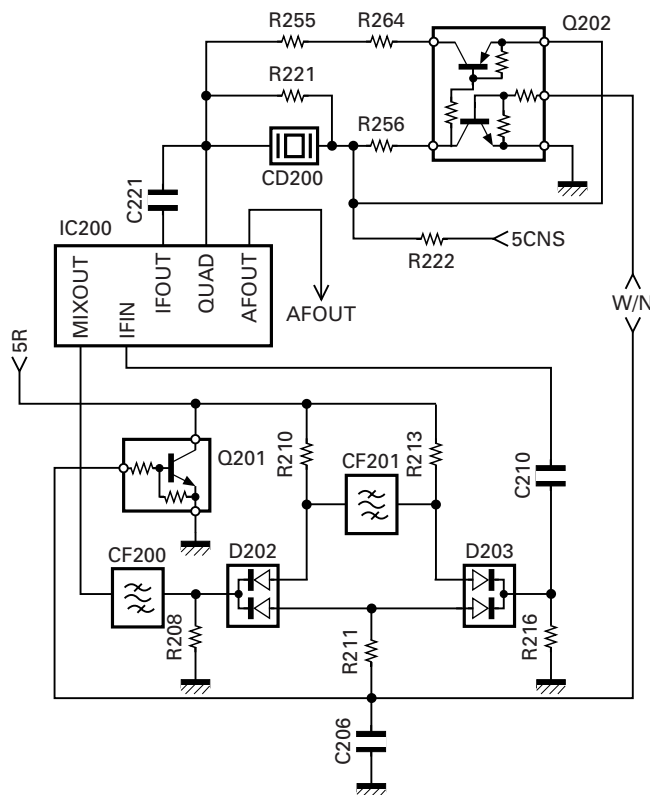

Fig. 3 Wide/Narrow changeover circuit

3-4. Audio amplifier circuit

The demodulated signal from IC200 goes through the mute switch (Q204) and is amplified by IC300 (2/2), high-pass filtered, low-pass filtered, high-pass filtered, band-eliminate filtered, and de-emphasized by IC500.

The signal then goes through an AF amplifier IC305 (2/2), an electronic volume control (IC307), and an AF switch (Q308 is on), and is routed to audio power amplifier (IC313), where it is amplified and output to the internal speaker.

The audio mute signal (AM1) from the shift register becomes Low in the standby and Q302, Q303 which are power supply circuit for IC313 turn off. Also, IC500 is set to the power down mode according to data from microprocessor, and the AF signal is muted. When the audio is output, AM1 becomes High to turn Q302, Q303 ON, and voltage is supplied to power terminal VP of IC313. Also, IC500 is canceled out of the power down mode.

The speaker is switched by the logic of speaker switching terminal SSW on the universal connector. When SP-MIC is not attached, the logic of SSW becomes High and SW (Q308) is turned ON, and the AF signal is input to both amplifiers of IC313.

When SP-MIC is attached, SSW is connected to GND at inside of SP-MIC. For this reason, Q308 is turned OFF, and the AF signal is input only to amplifier for EXT SP of IC313.

Change of INT/EXT SP refer to Fig. 4.

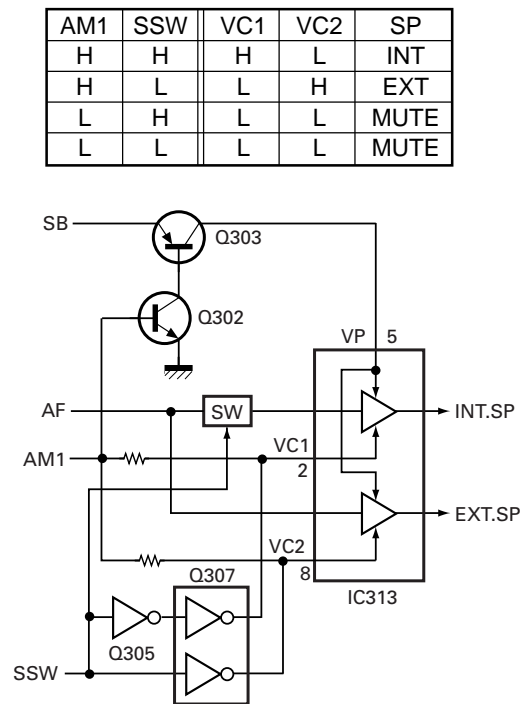

Fig. 4 Audio amplifier circuit

CIRCUIT DESCRIPTION

3-5. Squelch circuit

The output from IC200 enters FM IC again, then passed through a band-pass filter. And passed through a band-pass filter IC202 (2/2). The noise component output from IC202 (2/2) is amplified by Q208 and rectified by D201 to produce a DC voltage corresponding to the noise level. The DC voltage is sent to the analog port of the CPU (IC309). And IC200 outputs a DC voltage (RSSI) corresponding to the input of the IF amplifier. The CPU reads the RSSI signal via pin 93.

IC309 determines whether to output sounds from the speaker by comparing the input voltage of pin 91 and pin 93 with the preset value.

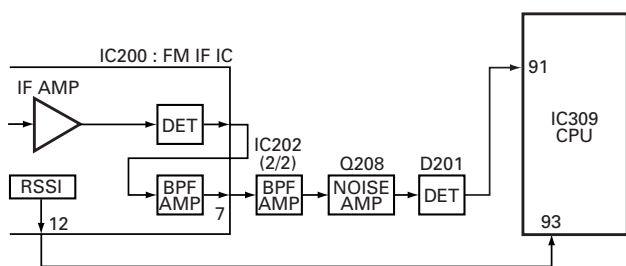

Fig. 5 Squelch circuit

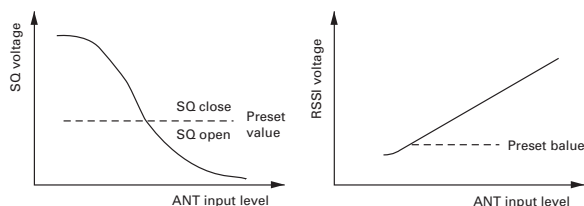

Fig. 6 Squelch and RSSI voltage vs ANT input level

4. Transmitter System

4-1. Microphone amplifier

The signal from the internal microphone goes through the mute switch (Q301).

When the SP-MIC is not attached, the microphone switching terminal (MSW) on the universal connector becomes High, and mute switch (Q301) is turned ON. When the SP-MIC is attached, MSW is connected to GND at inside of SP-MIC. For this reason, Q301 is turned OFF, the internal microphone is muted, and only the input of the external microphone is supplied to the microphone amplifier.

The signal from microphone passes through the limiter circuit in D508 and amplified by IC501 (1/2), Mic mute switch (Q502 is off in TX) and through the high-pass filter, the ALC circuit, the low-pass filter, the high-pass filter, and pre-emphasis/IDC circuit in IC500 on the small board. When encoding DTMF, mute switch (Q500) is turned OFF for muting the microphone input signal.

The signal passes through the D/A converter (IC307) for the maximum deviation adjustment, and enters the summing amplifier consisting of IC305 (1/2), and is mixed with the low speed data from the CPU (IC309).

The output signal from the summing amplifier passes through the D/A converter (IC307) again and goes to the VCO modulation input.

The other output signal from the summing amplifier passes through the D/A converter (IC307) again for the BAL adjustment, and the buffer amplifier (IC302 (2/2)), and goes to the VCXO modulation input.

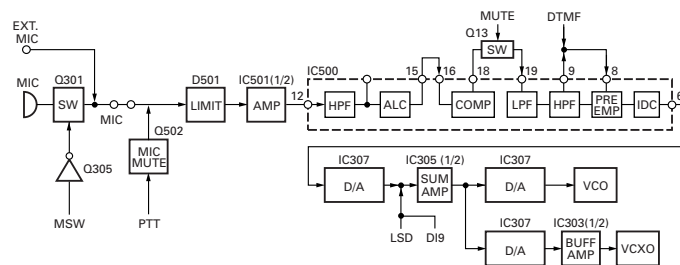

Fig. 7 Microphone amplifier

4-2. Drive and Final amplifier

The signal from the T/R switch (D101 is on) is amplified by the pre-drive (Q100 and 101) drive amplifier (Q103) to +15~17dBm.

The output of the drive amplifier is amplified by the RF power amplifier (Q106) to 4.0W (1W when the power is low). The RF power amplifier is MOS FET transistor. The output of the RF power amplifier is then passed through the harmonic filter (LPF) and antenna switch (D102,103 are on) and applied to the antenna terminal.

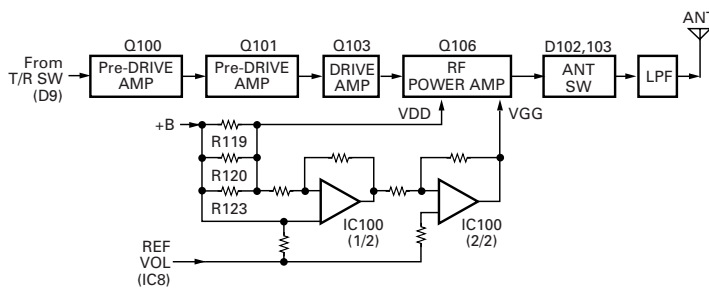

Fig. 8 Drive and final amplifier and APC circuit

4-3. APC circuit

The APC circuit always monitors the current flowing through the drive amplifier (Q103) and the RF power amplifier (Q106) and keeps a constant current. The voltage drop at R119, R120 and R123 is caused by the current flowing through the RF power amplifier and this voltage is applied to the differential amplifier (IC100 1/2).

IC100(2/2) compares the output voltage of IC100(1/2) with the reference voltage from IC307, and the output of IC100(2/2) controls the VGG of the RF power amplifier to make the both voltages to same voltage.

The change of power high/low is carried out by the change of the reference voltage. Q105,107 and 108 are turned on in transmit and the APC circuit is active.

CIRCUIT DESCRIPTION

7. Signalling Circuit

7-1. Encode

- **Low-speed data (QT,DQT,LTR)**

Low-speed data is output from pin 1 of the CPU. The signal passes through a low-pass CR filter, and goes to the summing amplifier (IC305 1/2). The signal is mixed with the audio signal and goes to the VCO and VCXO (X1) modulation input after passing through the D/A converter (IC307) for BAL adjustment.

- **High-speed data (DTMF)**

High-speed data is output from pin 2 of the CPU. The signal passes through a low-pass filter consisting of IC304, and provides a TX DTMF tone and a RX DTMF tone TX DTMF deviation making an adjustment by microprocessor is passed through the D/A converter (IC307), and then applied to the audio processor (IC500).

The signal is mixed with the audio signal and goes to the VCO and VCXO, the RX DTMF tone is passed a summing amplifier (IC305 2/2), the D/A converter (IC307) for audio control, audio power amplifier and then to the speaker.

- **MSK (ESN)**

ESN utilizes 1200bps MSK signal. MSK signal is output from pin 6 of IC500. The signal passes through the D/A converter (IC307) for the MSK deviation adjustment. and is routed to the VCO. When encoding MSK, the microphone input signal is muted.

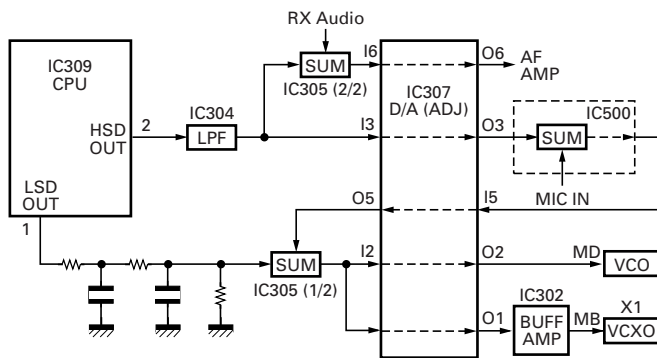

Fig. 13 Encode

7-2. Decode

- **Low-speed data (QT,DQT,LTR)**

The demodulated signal from the IF IC (IC200) is amplified by IC300 (2/2) and passes through a low-pass filter (IC306) to remove audio components. The signal is input to pin 95 of the CPU.

The CPU digitizes this signal, performs processing such as DC restoration, and decodes the signal.

- **High-speed data (DTMF)**

The DTMF input signal from the IF IC (IC200) is amplified by IC300 (2/2) and goes to IC301, the DTMF decoder. The decoded information is then processed by the CPU. During transmission and standby, the DTMF IC is set to the power down mode when the PD terminal is High. When the line is busy, the PD terminal becomes Low, the power down mode is canceled and decoding is carried out.

- **High-speed data (2 tone)**

The demodulated signal from the IF IC (IC200) is amplified by IC300 (2/2) and passes through an audio processor (IC500) and band-pass filter IC303 (1/2) and IC201 (1/2) to remove a low-speed data. The CPU digitizes this signal, performs processing such as DC restoration, and decodes the signal.

- **MSK (ESN)**

The MSK input signal from the IF IC is amplified by IC300 (1/2) and goes to pin 5 of IC500. The signal is demodulated by MSK demodulator in IC500. The demodulated data goes to the CPU for processing.

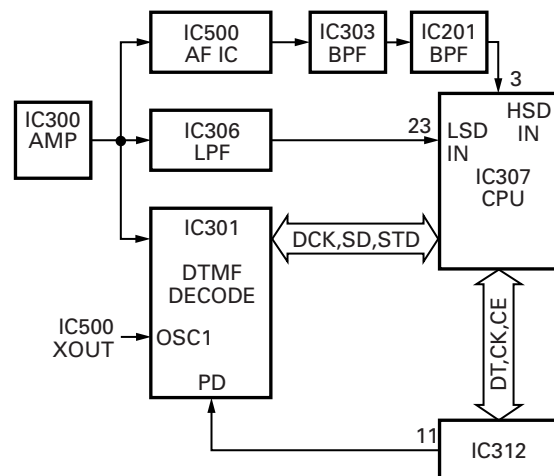

Fig. 14 Decode

CIRCUIT DESCRIPTION

8. Power Supply Circuit

Battery +B is supplied via a 3A fuse from the battery terminal connected to the TX-RX unit. After passing through the power switch, power supply (SB) is applied to the three AVRs. IC5 supplies 5V (5M) to the control circuit, and IC9 supplies 5V (5C) to common circuits. IC6 supplies to the TX circuit, the RX circuit and common circuits of needless save mode. During transmission, 5TC becomes Low and Q3 is turned ON to supply 5V (5T) to the TX circuit. During reception, 5RC becomes Low and Q2 is turned ON to supply 5V (5R) to the RX Circuit.

The power supply voltage monitor IC (IC404) monitors power supply voltage (SB). If the voltage falls (less than 5V), the VOUT port goes "LOW" level, the CPU INT port also goes "LOW" level, and the CPU stops.

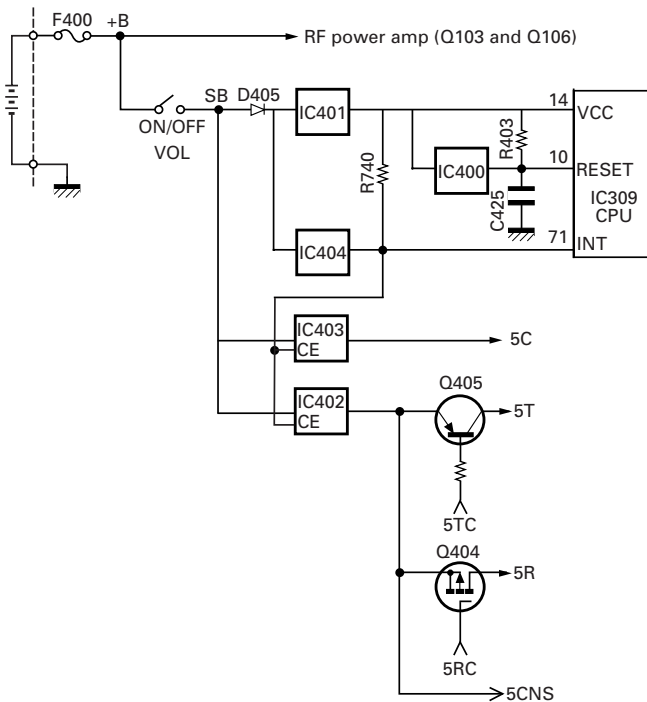

Fig. 15 Power supply circuit

SEMICONDUCTOR DATA

Microprocessor : 30620M8A-XXXGP (TX-RX UNIT : IC309)

■ Pin function

Pin No.	Port Name	I/O	Function
1	LSDO	O	Low speed data output. (QT/DQT/LTR)
2	HSDO	O	High speed data output. (DTMF)
3	HSDI	I	High speed data input. (2Tone)
4	DSTB	O	D/A converter data strobe output.
5	5RC	O	RX power control. H: TX L: RX
6	BYTE	-	+5V.
7	CNV _{SS}	-	GND.
8	AFDAT	O	MODEM MSK encode data output.
9	AFRDT	I	MODEM MSK decode data input.
10	RESET	-	CPU reset.
11	XOUT	-	CPU clock.
12	VSS	-	GND.
13	XIN	-	CPU clock.
14	Vcc	-	+5V
15	-	-	NC
16	DTSTD	I	DTMF decoder data detect input.
17	AFTRD	I	MODEM MSK encode data output timing Pulse input.
18	AFRTM	I	MODEM MSK decode data Input timing pulse input.
19	EEPDAT	I/O	EEPROM data input/output.
20	BEEP	O	Beep output.
21	SKEY	I	[S] Key input.
22	AKEY	I	[A] Key input.
23	BKEY	I	[B] Key input.
24	CKEY	I	[C] Key input.
25	AUX	I	[AUX] Key input.
26	PTT	I	[PTT] Key input.
27	MONI	I	[MON] Key input.
28	LAMP	I	[LAMP] Key input.
29	AUXTXD	O	External serial interface (COM1) TDX1.
30	AUXRXD	I	External serial interface (COM1) RXD1.
31	DTMDAT	I	DTMF decoder data input.
32	DTCLK	O	DTMF decoder clock output.
33	TXD	O	Serial interface (COM0) TXD0 (to MIC connector).
34	RXD	I	Serial interface (COM0) RXD0 (to MIC connector).
35	DAT	O	Common data output.
36	CLK	O	Common clock output.
37	RDY	-	Can not used.
38	ALE	-	Can not used.
39	HOLD	-	Can not used.
40	HLDA	-	Can not used.
41	BLCK	-	Can not used.
42	RD	O	Flash memory RD bus.
43	BHE	-	Can not used.
44	WR	O	Flash memory WR bus.
45	SAVE	O	Battery save output.
46	SELF	I	Self programming mode enable input.
47	CS/MODE	O	LCD driver chip select output.
48	CS0	O	Flash memory chip enable.
49	A19	-	Can not used.
50-59	A18-A9	-	Flash memory address bus.

Pin No.	Port Name	I/O	Function
60	Vcc	-	+5V
61	A8	O	Flash memory address bus.
62	VSS	-	GND.
63-70	A7-A0	O	Flash memory address bus.
71	UL	I	PLL unlock detect input.
72	EP	O	PLL IC Data Strobe output.
73	DP	O	PLL IC Data output.
74	CP	O	PLL IC Clock output.
75-78	EN4-1	I	Rotary SW input 4-1.
79-86	D7-D0	I	Flash memory data bus.
87	PF	I	SP-Mic PF switch input.
88	VOL	I	Volume level input.
89	BATT2	I	Battery distinction input.
90	BATT1	I	Battery voltage
91	ASQL	I	Squelch level input.
92	TEMP	I	Thermistor input.
93	RSSI	I	Received signal strength indicator input (RSSI).
94	AVSS	-	GND.
95	LSDI	I	Low speed data input (QT/DQT/LTR).
96	VREF	-	+5V
97	AVCC	-	+5V
98	SFTSTB1	O	Shift register data strobe output.
99	OE	O	Shift register output enable output.
100	AFSTB	O	MODEM data strobe output.

DESCRIPTION OF COMPONENTS

TX-RX UNIT (X57-6410-10)

Ref. No.	Use/Function	Operation/Condition
IC1	MOS IC	PLL IC
IC100	MOS IC	APC AMP
IC200	MOS IC	IF IC
IC201	MOS IC	AF AMP Filter
IC300	MOS IC	AF AMP Filter
IC301	MOS IC	DTMF Decoder
IC302	MOS IC	AF AMP Filter
IC303	MOS IC	AF AMP Filter
IC304	MOS IC	AF AMP Filter
IC305	MOS IC	AF AMP Filter
IC306	MOS IC	AF AMP Filter
IC307	MOS IC	Potential Meter
IC308	ROM IC	Flash ROM
IC309	MPU	MPU
IC310	ROM IC	EEPROM
IC311,312	MOS IC	Shift Register
IC313	BI-POLAR IC	AF Power AMP
IC400	MOS IC	Detector
IC401	MOS IC	5M AVR
IC402	MOS IC	5CNS AVR
IC403	MOS IC	5C AVR
IC404	MOS IC	Detector
IC500	MOS IC	Base Band IC
IC501	MOS IC	AF AMP Filter
Q1	TRANSISTOR	f in RF AMP
Q2	FET	RX VCO oscilstion
Q3	FET	TX VCO oscilstion
Q4	FET	VCO switch
Q5	TRANSISTOR	Buffer AMP
Q6	TRANSISTOR	VCO switch
Q7	TRANSISTOR	Ripple filter
Q8	TRANSISTOR	TX/RX common RF AMP
Q100	TRANSISTOR	Pre-drive AMP
Q101	TRANSISTOR	Pre-drive AMP
Q103	FET	TX Drive AMP
Q104,105	TRANSISTOR	APC Switch
Q106	FET	TX Final AMP
Q107	FET	APC Switch
Q108	TRANSISTOR	APC Switch
Q201	TRANSISTOR	W/N Switch
Q202	TRANSISTOR	W/N Switch
Q203	FET	AF detect switch
Q204	FET	DM switch
Q205	TRANSISTOR	IF AMP
Q206	FET	Front-end 1st mixer
Q207	FET	Front-end RF AMP
Q208	TRANSISTOR	Noise AMP
Q300	TRANSISTOR	Beet shift Switch
Q301	FET	Mic mutte
Q302	TRANSISTOR	AF AMP AVR switch
Q303	TRANSISTOR	AF AMP AVR
Q304	TRANSISTOR	LCD AVR
Q305	FET	Int/Ext switch

Ref. No.	Use/Function	Operation/Condition
Q306	TRANSISTOR	TX LED switch
Q307	FET	Int/Ext switch
Q308	FET	Int/Ext switch
Q309	TRANSISTOR	BUSY LED switch
Q310	TRANSISTOR	LCD LED AVR switch
Q311	TRANSISTOR	LCD LED AVR
Q400	FET	5MS switch
Q401	FET	5MS switch
Q403	TRANSISTOR	5R Switch
Q404	FET	5R Switch
Q405	TRANSISTOR	5T switch
Q406	FET	SAVE switch
Q500	TRANSISTOR	RX AF mute
Q501	FET	TX AF mute
Q502	FET	Mic mutte
D1	VARIABLE CAPACITANCE DIODE	TX VCO
D2	VARIABLE CAPACITANCE DIODE	RX VCO
D3	VARIABLE CAPACITANCE DIODE	TX VCO
D4	VARIABLE CAPACITANCE DIODE	RX VCO
D5	VARIABLE CAPACITANCE DIODE	TX VCO modulation
D6	DIODE	Ripple filter switch
D7,8	VARIABLE CAPACITANCE DIODE	TX VCO
D9,10	VARIABLE CAPACITANCE DIODE	RX VCO
D100,101	DIODE	TX/RX RF switch
D102-105	DIODE	ANT switch
D106	ZENER DIODE	APC protect
D200	DIODE	SQL voltage charge
D201	DIODE	SQL rectification
D202,203	DIODE	W/N Switch
D204-208	VARIABLE CAPACITANCE DIODE	BPF Tuning
D209	DIODE	DM charge/discharge switch
D300	DIODE	AF AMP bias
D301	DIODE	AF AMP protect
D302	DIODE	Surge absorption
D303,304	ZENER DIODE	Protect
D305	ZENER DIODE	AF AMP AVR
D306	DIODE	Surge absorption
D307	ZENER DIODE	Protect
D308	ZENER DIODE	Mic input protect
D309	LED	TX red LED
D310	LED	RX green LED
D402	DIODE	Surge absorption
D403	DIODE	5MS protect switch
D405	DIODE	5M protect
D501	DIODE	Mis input protect

PARTS LIST

CAPACITORS

CC 45 TH 1H 220 J
 1 2 3 4 5 6

- 1 = Type ... ceramic, electrolytic, etc.
- 2 = Shape ... round, square, ect.
- 3 = Temp. coefficient
- 4 = Voltage rating
- 5 = Value
- 6 = Tolerance

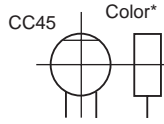

Capacitor value

- 010 = 1pF
- 100 = 10pF
- 101 = 100pF
- 102 = 1000pF = 0.001μF
- 103 = 0.01μF

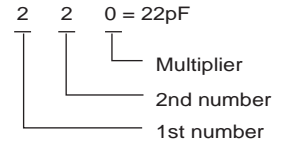

Temperature coefficient

1st Word	C	L	P	R	S	T	U
Color*	Black	Red	Orange	Yellow	Green	Blue	Violet
ppm/°C	0	-80	-150	-220	-330	-470	-750

2nd Word	G	H	J	K	L
ppm/°C	±30	±60	±120	±250	±500

Example : CC45TH = -470 ± 60ppm/°C

Tolerance (More than 10pF)

Code	C	D	G	J	K	M	X	Z	P	No code
(%)	±0.25	±0.5	±2	±5	±10	±20	+40 -40	+80 -20	+100 -0	More than 10μF -10 ~ +50 Less than 4.7μF -10 ~ +75

(Less than 10pF)

Code	B	C	D	F	G
(pF)	±0.1	±0.25	±0.5	±1	±2

Voltage rating

2nd word \ 1st word	A	B	C	D	E	F	G	H	J	K	V
0	1.0	1.25	1.6	2.0	2.5	3.15	4.0	5.0	6.3	8.0	-
1	10	12.5	16	20	25	31.5	40	50	63	80	35
2	100	125	160	200	250	315	400	500	630	800	-
3	1000	1250	1600	2000	2500	3150	4000	5000	6300	8000	-

Chip capacitors

(EX) C C 7 3 F S L 1 H 0 0 0 J
 1 2 3 4 5 6 7

(Chip)(CH,RH<UJ,SL)

(EX) C K 7 3 F F 1 H 0 0 0 Z
 1 2 3 4 5 6 7

(Chip)(B,F)

Refer to the table above.

- 1 = Type
- 2 = Shape
- 3 = Dimension
- 4 = Temp. coefficient
- 5 = Voltage rating
- 6 = Value
- 7 = Tolerance

Dimension (Chip capacitors)

Dimension code	L	W	T
Empty	5.6 ± 0.5	5.0 ± 0.5	Less than 2.0
A	4.5 ± 0.5	3.2 ± 0.4	Less than 2.0
B	4.5 ± 0.5	2.0 ± 0.3	Less than 2.0
C	4.5 ± 0.5	1.25 ± 0.2	Less than 1.25
D	3.2 ± 0.4	2.5 ± 0.3	Less than 1.5
E	3.0 ± 0.2	1.6 ± 0.2	Less than 1.25
F	2.0 ± 0.3	1.25 ± 0.2	Less than 1.25
G	1.6 ± 0.2	0.8 ± 0.2	Less than 1.0
H	1.0 ± 0.05	0.5 ± 0.05	0.5 ± 0.05

RESISTORS

Chip resistor (Carbon)

(EX) R K 7 3 E B 2 B 0 0 0 J
 1 2 3 4 5 6 7

(Chip)(B,F)

Carbon resistor (Nomal type)

(EX) R D 1 4 B B 2 C 0 0 0 J
 1 2 3 4 5 6 7

- 1 = Type
- 2 = Shape
- 3 = Dimension
- 4 = Temp. coefficient
- 5 = Rating wattage
- 6 = Value
- 7 = Tolerance

Dimension

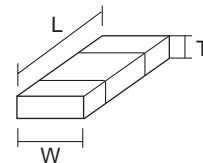

Dimension (Chip resistor)

Dimension code	L	W	T
E	3.2 ± 0.2	1.6 ± 0.2	1.0
F	2.0 ± 0.3	1.25 ± 0.2	1.0
G	1.6 ± 0.2	0.8 ± 0.2	0.5 ± 0.1
H	1.0 ± 0.05	0.5 ± 0.05	0.35 ± 0.05

Rating wattage

Code	Wattage	Code	Wattage	Code	Wattage
1J	1/16W	2C	1/6W	3A	1W
2A	1/10W	2E	1/4W	3D	2W
2B	1/8W	2H	1/2W		

PARTS LIST

* New Parts. Δ indicates safety critical components.
 Parts without **Parts No.** are not supplied.
 Les articles non mentionnés dans le **Parts No.** ne sont pas fournis.
 Teile ohne **Parts No.** werden nicht geliefert.

TK-3140

TX-RX UNIT (X57-6410-10)

Ref. No.	Address	New parts	Parts No.	Description	Destination
TK-3140					
1	1B	*	A02-3653-04	CABINET ASSY	
2	3A	*	A10-4052-11	CHASSIS	
5	3B	*	B01-0688-03	ESCUTCHEON(BELT HOOK)	
6	2C	*	B09-0625-03	CAP ACCESSORY	
7	2B	*	B10-2700-02	FRONT GLASS	
8	1A	*	B38-0859-05	LCD ASSY	
9	1C	*	B62-1476-10	INSTRUCTION MANUAL	
10	3A	*	B72-2064-04	MODEL NAME PLATE	
13	3B	*	E04-0436-05	RF COAXIAL RECEPTACLE(SMA)	
14	3B	*	E23-1188-04	TERMINAL(ANTENNA)	
15	3A	*	E23-1189-04	TERMINAL(BATT -)	
16	3A	*	E37-0978-05	LEAD WIRE WITH CONNECTOR(SW2)	
17	3A	*	E37-1007-05	LEAD WIRE WITH CONNECTOR(PTT)	
18	3B	*	E58-0440-05	SQUARE SOCKET	
19	3A	*	E72-0413-03	TERMINAL BLOCK(BATT TERMINAL)	
20	2A	*	F10-2415-04	SHIELDING PLATE(CPU)	
21	1A	*	F10-2416-03	SHIELDING PLATE(LCD)	
22	2A	*	F10-2444-04	SHIELDING PLATE	
23	3A,3B	*	F15-1006-04	SHADE	
25	1B	*	G10-1280-04	FIBROUS SHEET(SPEAKER)	
26	3A	*	G11-4046-04	SHEET(PTT)	
27	2A	*	G11-4050-04	SHEET(TCXO)	
28	1A	*	G11-4089-04	SHEET(LCD)	
29	3A	*	G11-4090-04	SHEET(FINAL FET)	
30	1A	*	G11-4174-04	SHEET(LCD)	
31	3B	*	G11-4186-04	SHEET	
32	3B	*	G11-4187-04	SHEET(CHASSIS)	
33	1A,2A	*	G11-4188-04	SHEET	
34	1B	*	G11-4189-04	SHEET(CABINET)	
35	1A	*	G11-4190-04	SHEET(CABINET)	
36	3A	*	G13-1885-04	CUSHION(ANT.SUB PCB)	
37	3B	*	G53-1539-02	PACKING(TOP)	
38	2B	*	G53-1540-02	PACKING(4 KEYS)	
39	3A	*	G53-1547-04	PACKING(TERMINAL BLOCK)	
40	1D	*	H52-1816-02	ITEM CARTON CASE	
45	2A	*	J19-5430-03	HOLDER(VOL/ENC)	
46	2A	*	J21-8423-04	HARDWARE FIXTURE(SUB PCB)	
47	2A	*	J21-8424-04	HARDWARE FIXTURE(CHASSIS)	
48	2C	*	J29-0688-05	BELT HOOK ACCESSORY	
49	1B	*	J30-1269-04	SPACER(VOL)	
50	2B	*	J82-0078-05	FPC(VOL/ENC)	
51	3B	*	J82-0079-05	FPC(UNIVERSAL)	
55	1A	*	K29-9131-03	KNOB(PTT)	
56	1B	*	K29-9132-03	KEY TOP(SW1, SW2)	
57	1B	*	K29-9133-03	KNOB(VOL)	
58	1B	*	K29-9134-03	KNOB(ENC)	
A	2C	*	N08-0548-04	DRESSED SCREW ACCESSORY	
B	3B	*	N14-0569-04	CIRCULAR NUT	

Ref. No.	Address	New parts	Parts No.	Description	Destination
TX-RX UNIT (X57-6410-10)					
C	3B		N30-2604-46	PAN HEAD MACHINE SCREW	
D	3A		N30-2608-46	PAN HEAD MACHINE SCREW	
E	3B		N30-3006-45	PAN HEAD MACHINE SCREW	
F	3B		N79-2035-46	PAN HEAD TAPTITE SCREW	
G	1A,2A		N83-2005-46	PAN HEAD TAPTITE SCREW	
60	2B		R31-0617-05	VARIABLE RESISTOR	
61	2B		S60-0415-05	ROTARY SWITCH	
SP	2B	*	T07-0732-05	SPEAKER ASSY	
62	2B	*	T91-0630-05	MIC ELEMENT ASSY	
TX-RX UNIT (X57-6410-10)					
D309			B30-2156-05	LED(RE D)	
D310			B30-2157-05	LED(YELLOW)	
C1			CK73HB1H471K	CHIP C 470PF K	
C2			CK73HB1H102K	CHIP C 1000PF K	
C4			CC73HCH1H100D	CHIP C 10PF D	
C5			CK73HB1H471K	CHIP C 470PF K	
C8			CK73HB1H102K	CHIP C 1000PF K	
C9			CC73HCH1H100D	CHIP C 10PF D	
C10			CK73HB1H471K	CHIP C 470PF K	
C11			C92-0713-05	CHIP-TAN 10UF 6.3WV	
C12-14			CK73HB1H471K	CHIP C 470PF K	
C16			C92-0521-05	CHIP-TAN 0.47UF 20WV	
C17,18			CK73HB1A104K	CHIP C 0.10UF K	
C19			CK73HB1H102K	CHIP C 1000PF K	
C20			CC73HCH1H050C	CHIP C 5.0PF C	
C22			CC73HCH1H030C	CHIP C 3.0PF C	
C23			CC73HCH1H050C	CHIP C 5.0PF C	
C24			C92-0001-05	CHIP-C 0.1UF 35WV	
C25			CC73HCH1H100D	CHIP C 10PF D	
C27			CK73HB1H471K	CHIP C 470PF K	
C28			CC73HCH1H101J	CHIP C 100PF J	
C29			CK73HB1H102K	CHIP C 1000PF K	
C30			CC73HCH1H100D	CHIP C 10PF D	
C31			CC73HCH1H110J	CHIP C 11PF J	
C32			CC73HCH1H060D	CHIP C 6.0PF D	
C33			CC73HCH1H110J	CHIP C 11PF J	
C34			CC73HCH1H060D	CHIP C 6.0PF D	
C36			CC73GCH1H040B	CHIP C 4.0PF B	
C37			CC73GCH1H010B	CHIP C 1.0PF B	
C38			CC73GCH1H050B	CHIP C 5.0PF B	
C39			CK73HB1H471K	CHIP C 470PF K	
C40			CC73GCH1H020B	CHIP C 2.0PF B	
C41			CC73GCH1H060B	CHIP C 6.0PF B	
C42			CC73GCH1H040B	CHIP C 4.0PF B	
C43			CC73GCH1H0R5B	CHIP C 0.5PF B	
C44			CC73GCH1H050B	CHIP C 5.0PF B	
C45			CK73HB1H471K	CHIP C 470PF K	
C46			CC73HCH1H101J	CHIP C 100PF J	
C47			CC73GCH1H0R5B	CHIP C 0.5PF B	
C48,49			CK73HB1H102K	CHIP C 1000PF K	
C50			C92-0712-05	CHIP-TAN 22UF 6.3WV	
C51			CC73HCH1H070D	CHIP C 7.0PF D	

PARTS LIST

TX-RX UNIT (X57-6410-10)

Ref. No.	Address	New parts	Parts No.	Description	Destination	Ref. No.	Address	New parts	Parts No.	Description	Destination
C52			CK73HB1H102K	CHIP C 1000PF K		C203-205			CK73HB1A104K	CHIP C 0.10UF K	
C53			CC73HCH1H330J	CHIP C 33PF J		C206			CK73HB1C103K	CHIP C 0.010UF K	
C54-56			CK73HB1H471K	CHIP C 470PF K		C207			CK73HB1H471K	CHIP C 470PF K	
C57			CC73HCH1H070D	CHIP C 7.0PF D		C208,209			CK73HB1H221K	CHIP C 220PF K	
C58			CC73GCH1H010B	CHIP C 1.0PF B		C210			CK73HB1A104K	CHIP C 0.10UF K	
C60			CK73HB1H102K	CHIP C 1000PF K		C211			CK73HB1H102K	CHIP C 1000PF K	
C64			CK73HB1H471K	CHIP C 470PF K		C212			CC73HCH1H220J	CHIP C 22PF J	
C65,66			CC73HCH1H020C	CHIP C 2.0PF C		C213			CC73HCH1H100D	CHIP C 10PF D	
C67			C92-0001-05	CHIP-C 0.1UF 35WV		C214			CK73HB1A104K	CHIP C 0.10UF K	
C68			C92-0714-05	CHIP-TAN 4.7UF 6.3WV		C215			C92-0773-05	CHIP-TAN 15UF 6.3WV	
C100-102			CK73HB1H471K	CHIP C 470PF K		C216			CK73HB1A104K	CHIP C 0.10UF K	
C103			CC73HCH1H070D	CHIP C 7.0PF D		C217			CK73HB1H221K	CHIP C 220PF K	
C104,105			CK73HB1H471K	CHIP C 470PF K		C218			CK73HB1A104K	CHIP C 0.10UF K	
C106			CC73HCH1H060D	CHIP C 6.0PF D		C219			CK73HB1A333K	CHIP C 0.033UF K	
C108			CK73HB1A104K	CHIP C 0.10UF K		C220			CK73HB1A104K	CHIP C 0.10UF K	
C109			CC73HCH1H050C	CHIP C 5.0PF C		C221			CC73HCH1H680J	CHIP C 68PF J	
C110			CC73HCH1H130J	CHIP C 13PF J		C222			CK73HB1A104K	CHIP C 0.10UF K	
C111			CK73HB1H471K	CHIP C 470PF K		C223			CK73HB1C103K	CHIP C 0.010UF K	
C115			CK73HB1H471K	CHIP C 470PF K		C224			C92-0713-05	CHIP-TAN 10UF 6.3WV	
C116			CC73HCH1H330J	CHIP C 33PF J		C225			CK73HB1C103K	CHIP C 0.010UF K	
C119			CC73GCH1H300G	CHIP C 30PF G		C227			CK73HB1A104K	CHIP C 0.10UF K	
C122			CK73HB1H471K	CHIP C 470PF K		C228,229			CK73HB1C103K	CHIP C 0.010UF K	
C123			C92-0565-05	CHIP-TAN 6.8UF 10WV		C230			CC73HCH1H100D	CHIP C 10PF D	
C124			CK73GB0J105K	CHIP C 1.0UF K		C231			CK73HB1C103K	CHIP C 0.010UF K	
C125			CK73HB1H102K	CHIP C 1000PF K		C232			CK73HB1H471K	CHIP C 470PF K	
C126,127			CK73HB1H471K	CHIP C 470PF K		C233			CK73HB1C103K	CHIP C 0.010UF K	
C128			CC73HCH1H101J	CHIP C 100PF J		C234			CK73HB1H471K	CHIP C 470PF K	
C129,130			CK73HB1H471K	CHIP C 470PF K		C235			CC73HCH1H060D	CHIP C 6.0PF D	
C131			CC73GCH1H270G	CHIP C 27PF G		C236			CC73HCH1H020C	CHIP C 2.0PF C	
C132			CK73HB1C103K	CHIP C 0.010UF K		C237			CC73HCH1H150J	CHIP C 15PF J	
C133		*	CK73GB1A105K	CHIP C 1.0UF K		C238			CC73HCH1H100D	CHIP C 10PF D	
C134			CK73HB1A104K	CHIP C 0.10UF K		C239			CK73HB1H471K	CHIP C 470PF K	
C135			CC73GCH1H200G	CHIP C 20PF G		C240			CC73HCH1H75C	CHIP C 0.75PF C	
C136			CK73HB1H471K	CHIP C 470PF K		C241			CC73HCH1H070D	CHIP C 7.0PF D	
C137			CK73HB1C103K	CHIP C 0.010UF K		C242			CK73HB1A104K	CHIP C 0.10UF K	
C139			CK73HB1H471K	CHIP C 470PF K		C243			CK73HB1H102K	CHIP C 1000PF K	
C143			CC73GCH1H100C	CHIP C 10PF C		C244			CC73GCH1H050B	CHIP C 5.0PF B	
C144			CC73GCH1H070B	CHIP C 7.0PF B		C245			CK73HB1H471K	CHIP C 470PF K	
C146			CC73GCH1H270J	CHIP C 27PF J		C248			CC73HCH1H330J	CHIP C 33PF J	
C147			CK73HB1H471K	CHIP C 470PF K		C249			CC73HCH1H030C	CHIP C 3.0PF C	
C148			CC73HCH1H050C	CHIP C 5.0PF C		C250			CK73HB1H471K	CHIP C 470PF K	
C149			CC73HCH1H101J	CHIP C 100PF J		C251			CC73GCH1H020B	CHIP C 2.0PF B	
C150			CC73HCH1H020C	CHIP C 2.0PF C		C252			CC73HCH1H330J	CHIP C 33PF J	
C151			CC73HCH1H1R5C	CHIP C 1.5PF C		C253			CK73HB1A104K	CHIP C 0.10UF K	
C152			CC73HCH1H040C	CHIP C 4.0PF C		C255			CK73HB1A104K	CHIP C 0.10UF K	
C153			CC73HCH1H020C	CHIP C 2.0PF C		C256			CC73HCH1H330J	CHIP C 33PF J	
C154			CC73HCH1H150J	CHIP C 15PF J		C257-260			CK73HB1H471K	CHIP C 470PF K	
C155			CC73HCH1H050C	CHIP C 5.0PF C		C261			CK73GB1H471K	CHIP C 470PF K	
C156			CC73HCH1H020C	CHIP C 2.0PF C		C263			CC73HCH1H330J	CHIP C 33PF J	
C157			CC73HCH1H010C	CHIP C 1.0PF C		C264			CK73HB1H471K	CHIP C 470PF K	
C158			CC73HCH1H030C	CHIP C 3.0PF C		C266			CK73HB1H471K	CHIP C 470PF K	
C160			CK73HB1H102K	CHIP C 1000PF K		C267			CC73GCH1H030B	CHIP C 3.0PF B	
C164			CC73GCH1H330G	CHIP C 33PF G		C268			CC73HCH1H330J	CHIP C 33PF J	
C200			CK73GB1A474K	CHIP C 0.47UF K		C269			CC73GCH1H030B	CHIP C 3.0PF B	
C201			CK73HB1A104K	CHIP C 0.10UF K		C270			CC73HCH1H030C	CHIP C 3.0PF C	
C202			CK73HB1H221K	CHIP C 220PF K		C274			CC73GCH1H030B	CHIP C 3.0PF B	

PARTS LIST

TX-RX UNIT (X57-6410-10)

Ref. No.	Address	New parts	Parts No.	Description	Destination	Ref. No.	Address	New parts	Parts No.	Description	Destination
C275			CC73HCH1H101J	CHIP C 100PF J		C352-354			CK73HB1A104K	CHIP C 0.10UF K	
C276			CK73HB1H471K	CHIP C 470PF K		C355			C92-0628-05	CHIP-TAN 10UF 10WV	
C277			CC73GCH1H040B	CHIP C 4.0PF B		C356			CC73HCH1H470J	CHIP C 47PF J	
C278-280			CK73HB1A104K	CHIP C 0.10UF K		C357,358			C92-0712-05	CHIP-TAN 22UF 6.3WV	
C281			CK73HB1H471K	CHIP C 470PF K		C359			CC73HCH1H470J	CHIP C 47PF J	
C282			CK73HB1H102K	CHIP C 1000PF K		C362			CC73HCH1H470J	CHIP C 47PF J	
C283,284			CK73HB1A104K	CHIP C 0.10UF K		C364			CC73HCH1H470J	CHIP C 47PF J	
C285			CC73GCH1H0R5B	CHIP C 0.5PF B		C369			CC73HCH1H101J	CHIP C 100PF J	
C286			CC73GCH1H060B	CHIP C 6.0PF B		C371			CC73HCH1H470J	CHIP C 47PF J	
C288			CK73HB1H471K	CHIP C 470PF K		C375			CC73HCH1H470J	CHIP C 47PF J	
C289			CC73GCH1H020B	CHIP C 2.0PF B		C382			CK73HB1A104K	CHIP C 0.10UF K	
C290			CC73GCH1H040B	CHIP C 4.0PF B		C383,384			CC73HCH1H470J	CHIP C 47PF J	
C292			CC73HCH1H030C	CHIP C 3.0PF C		C386			CC73HCH1H470J	CHIP C 47PF J	
C293			CC73GCH1H2R5B	CHIP C 2.5PF B		C388			CK73HB1H102K	CHIP C 1000PF K	
C294			CK73GB1H471K	CHIP C 470PF K		C389			CC73HCH1H470J	CHIP C 47PF J	
C295			CK73HB1H471K	CHIP C 470PF K		C390			CK73HB1A104K	CHIP C 0.10UF K	
C298			CK73HB1H471K	CHIP C 470PF K		C391,392			CK73HB1C103K	CHIP C 0.010UF K	
C300			C92-0713-05	CHIP-TAN 10UF 6.3WV		C394-398			CK73HB1A104K	CHIP C 0.10UF K	
C301			CK73HB1H471K	CHIP C 470PF K		C399			CK73HB1C103K	CHIP C 0.010UF K	
C302			CK73HB1A104K	CHIP C 0.10UF K		C400			CK73HB1H471K	CHIP C 470PF K	
C303			CK73HB1A473K	CHIP C 0.047UF K		C402-405			CK73HB1H102K	CHIP C 1000PF K	
C304			CC73HCH1H330J	CHIP C 33PF J		C408			CK73HB1H102K	CHIP C 1000PF K	
C305			CK73HB1C103K	CHIP C 0.010UF K		C410			CK73FB1A475K	CHIP C 4.7UF K	
C306-308			CK73HB1A104K	CHIP C 0.10UF K		C411	*		CK73GB1A105K	CHIP C 1.0UF K	
C309			CC73HCH1H101J	CHIP C 100PF J		C413			C92-0713-05	CHIP-TAN 10UF 6.3WV	
C310			CK73HB1C103K	CHIP C 0.010UF K		C415			CC73HCH1H101J	CHIP C 100PF J	
C311			CC73HCH1H101J	CHIP C 100PF J		C416			C92-0713-05	CHIP-TAN 10UF 6.3WV	
C312			C92-0713-05	CHIP-TAN 10UF 6.3WV		C417			CK73GB0J105K	CHIP C 1.0UF K	
C313			CC73HCH1H101J	CHIP C 100PF J		C419			CK73HB1H102K	CHIP C 1000PF K	
C314			CK73HB1H471K	CHIP C 470PF K		C420			CC73HCH1H101J	CHIP C 100PF J	
C315			C92-0713-05	CHIP-TAN 10UF 6.3WV		C421	*		CK73GB1A105K	CHIP C 1.0UF K	
C316			CK73HB1A333K	CHIP C 0.033UF K		C422			CK73GB0J105K	CHIP C 1.0UF K	
C318			CK73HB1H221K	CHIP C 220PF K		C423			C92-0713-05	CHIP-TAN 10UF 6.3WV	
C319			CC73HCH1H121J	CHIP C 120PF J		C424			CC73HCH1H101J	CHIP C 100PF J	
C320			CK73HB1A104K	CHIP C 0.10UF K		C425			CK73HB1A104K	CHIP C 0.10UF K	
C321			CK73HB1H271K	CHIP C 270PF K		C426			CC73HCH1H101J	CHIP C 100PF J	
C322			CK73HB1C103K	CHIP C 0.010UF K		C500			CK73GB1H122K	CHIP C 1200PF K	
C323			CK73HB1H222K	CHIP C 2200PF K		C501,502			CK73HB1A104K	CHIP C 0.10UF K	
C324			CK73HB1A104K	CHIP C 0.10UF K		C503,504			CK73HB1C103K	CHIP C 0.010UF K	
C325			CK73HB1C123K	CHIP C 0.012UF K		C506			CK73HB1A104K	CHIP C 0.10UF K	
C327			CK73GB1H103K	CHIP C 0.010UF K		C507			CK73HB1C103K	CHIP C 0.010UF K	
C328			CK73GB1C683K	CHIP C 0.068UF K		C508			CK73HB1A104K	CHIP C 0.10UF K	
C329			CK73GB0J105K	CHIP C 1.0UF K		C509-511			CK73GB1H562J	CHIP C 5600PF J	
C330			CK73HB1A104K	CHIP C 0.10UF K		C512-514			CK73GB1H272J	CHIP C 2700PF J	
C331			CK73HB1C223K	CHIP C 0.022UF K		C515			CC73HCH1H030C	CHIP C 3.0PF C	
C332-335			CK73HB1C103K	CHIP C 0.010UF K		C516			CC73HCH1H151J	CHIP C 150PF J	
C336,337			CC73HCH1H270J	CHIP C 27PF J		C517			CK73HB1A104K	CHIP C 0.10UF K	
C338			CC73HCH1H160J	CHIP C 16PF J		C518			CK73HB1A333K	CHIP C 0.033UF K	
C339-342			CK73HB1C103K	CHIP C 0.010UF K		C519			CC73HCH1H030C	CHIP C 3.0PF C	
C344			C92-0713-05	CHIP-TAN 10UF 6.3WV		C520			CK73GB1H152J	CHIP C 1500PF J	
C345			CK73GB1A474K	CHIP C 0.47UF K		C521			C92-0713-05	CHIP-TAN 10UF 6.3WV	
C346,347			CC73HCH1H470J	CHIP C 47PF J		C522			CK73HB1A104K	CHIP C 0.10UF K	
C348			CK73GB1A474K	CHIP C 0.47UF K		C523,524			CK73HB1H102K	CHIP C 1000PF K	
C349			CK73HB1C153K	CHIP C 0.015UF K		C525			CK73HB1A104K	CHIP C 0.10UF K	
C350			C92-0647-05	CHIP-TAN 3.3UF 4WV		C526			CK73GB1H562J	CHIP C 5600PF J	
C351			CC73HCH1H470J	CHIP C 47PF J		C527,528			CK73HB1A104K	CHIP C 0.10UF K	

PARTS LIST

TX-RX UNIT (X57-6410-10)

Ref. No.	Address	New parts	Parts No.	Description	Destination	Ref. No.	Address	New parts	Parts No.	Description	Destination
C529			CK73GB1H562J	CHIP C 5600PF J		L202			L40-5681-86	SMALL FIXED INDUCTOR(0.56UH)	
C530			CK73FB0J475K	CHIP C 4.7UF K		L203			L92-0163-05	BEADS CORE	
C531			CK73HB1C153K	CHIP C 0.015UF K		L204			L40-1095-85	SMALL FIXED INDUCTOR(1.0UH)	
C532			CK73HB1H561K	CHIP C 560PF K		L205			L40-1875-57	SMALL FIXED INDUCTOR(18.0NH5%)	
C533			CK73HB1H102K	CHIP C 1000PF K		L206			L40-2275-57	SMALL FIXED INDUCTOR(22.0NH5%)	
C534			CC73HCH1H560J	CHIP C 56PF J		L207			L40-2775-92	SMALL FIXED INDUCTOR(27NH)	
C535			CK73HB1A104K	CHIP C 0.10UF K		L209-211			L41-8268-14	SMALL FIXED INDUCTOR	
C536,537			CK73FB0J475K	CHIP C 4.7UF K		L212			L92-0163-05	BEADS CORE	
C538			CK73HB1H471K	CHIP C 470PF K		L213			L41-2285-03	SMALL FIXED INDUCTOR	
C539,540			CK73HB1H102K	CHIP C 1000PF K		L215			L41-8268-14	SMALL FIXED INDUCTOR	
C541			CK73GB1C563K	CHIP C 0.056UF K		L217			L41-8268-14	SMALL FIXED INDUCTOR	
C542,543			CK73HB1H102K	CHIP C 1000PF K		L219			L41-4778-03	SMALL FIXED INDUCTOR	
C554-557			CK73HB1H102K	CHIP C 1000PF K		L300-313			L92-0163-05	BEADS CORE	
C710			CC73GCH1H2R5B	CHIP C 2.5PF B		L314-317			L92-0408-05	FERRITE CHIP	
C720			C92-0714-05	CHIP-TAN 4.7UF 6.3WV		L320			L92-0163-05	BEADS CORE	
C730		*	CS77SJOJ2R2M	CHIP-TAN 2.2UF 6.3WV		L400			L92-0149-05	FERRITE CHIP	
TC1,2			C05-0384-05	CERAMIC TRIMMER CAP(10PF)		L500			L92-0163-05	BEADS CORE	
CN300			E40-6178-05	PIN ASSY SOCKET		X1			L77-1871-05	TCXO (16.8MHZ)	
CN301,302			E40-5856-05	FLAT CABLE CONNECTOR		X200			L77-1760-15	CRYSTAL RESONATOR(44.395MHZ)	
CN303-306			E40-5929-05	PIN ASSY		X300			L77-1810-05	CRYSTAL RESONATOR(9.8304MHZ)	
CN400			E40-5856-05	FLAT CABLE CONNECTOR		X500			L77-1708-05	CRYSTAL RESONATOR(3.579545MHZ)	
CN500			E40-6179-05	PIN ASSY		XF200			L71-0530-05	MCF (44.85MHZ)	
F400			F53-0190-05	FUZE		CP1,2			RK75HA1J102J	CHIP-COM 1.0K J 1/16W	
CD200			L79-1779-05	TUNING COIL		CP300-313			RK75HA1J102J	CHIP-COM 1.0K J 1/16W	
CF200			L72-0995-05	CERAMIC FILTER		CP314			RK75HA1J473J	CHIP-COM 47K J 1/16W	
CF201			L72-0996-05	CERAMIC FILTER		CP315			RK75HA1J102J	CHIP-COM 1.0K J 1/16W	
L1			L40-4795-85	SMALL FIXED INDUCTOR(4.7UH)		CP316			RK75HA1J473J	CHIP-COM 47K J 1/16W	
L3,4			L92-0163-05	BEADS CORE		CP317-320			RK75HA1J102J	CHIP-COM 1.0K J 1/16W	
L5			L40-1275-92	SMALL FIXED INDUCTOR(12NH)		CP322			RK75HA1J102J	CHIP-COM 1.0K J 1/16W	
L6			L40-1875-92	SMALL FIXED INDUCTOR(18NH)		CP323,324			RK75HA1J473J	CHIP-COM 47K J 1/16W	
L7			L92-0163-05	BEADS CORE		CP326,327			RK75HA1J473J	CHIP-COM 47K J 1/16W	
L8			L40-1085-92	SMALL FIXED INDUCTOR(100NH)		CP400,401			RK75HA1J473J	CHIP-COM 47K J 1/16W	
L9			L92-0163-05	BEADS CORE		CP500,501			RK75HA1J472J	CHIP-COM 4.7K J 1/16W	
L10-12			L40-1085-92	SMALL FIXED INDUCTOR(100NH)		R1			RK73HB1J101J	CHIP R 100 J 1/16W	
L15			L40-2278-67	SMALL FIXED INDUCTOR(22NH)		R3			RK73HB1J151J	CHIP R 150 J 1/16W	
L16			L40-2778-67	SMALL FIXED INDUCTOR(27NH)		R4			RK73HB1J183J	CHIP R 18K J 1/16W	
L17,18			L41-2285-03	SMALL FIXED INDUCTOR		R5			RK73HB1J153J	CHIP R 15K J 1/16W	
L19,20			L40-3391-86	SMALL FIXED INDUCTOR(3.3UH)		R6			RK73HB1J560J	CHIP R 56 J 1/16W	
L21			L40-2275-92	SMALL FIXED INDUCTOR(22NH)		R7			RK73HB1J222J	CHIP R 2.2K J 1/16W	
L22			L92-0163-05	BEADS CORE		R8			RK73HB1J102J	CHIP R 1.0K J 1/16W	
L23			L40-2275-92	SMALL FIXED INDUCTOR(22NH)		R9			R92-1368-05	CHIP R 0 OHM	
L100			L40-1875-92	SMALL FIXED INDUCTOR(18NH)		R10			RK73HB1J102J	CHIP R 1.0K J 1/16W	
L101			L40-2275-92	SMALL FIXED INDUCTOR(22NH)		R11			RK73HB1J154J	CHIP R 150K J 1/16W	
L102			L92-0162-05	BEADS CORE		R13-15			RK73HB1J473J	CHIP R 47K J 1/16W	
L103			L40-1575-54	SMALL FIXED INDUCTOR(15NH)		R16			RK73HB1J181J	CHIP R 180 J 1/16W	
L104			L92-0149-05	FERRITE CHIP		R17			RK73HB1J101J	CHIP R 100 J 1/16W	
L106			L34-4602-05	AIR-CORE COIL		R18			RK73HB1J151J	CHIP R 150 J 1/16W	
L107			L92-0149-05	FERRITE CHIP		R19			RK73HB1J101J	CHIP R 100 J 1/16W	
L108			L40-2285-54	SMALL FIXED INDUCTOR(220NH)		R20			RK73HB1J104J	CHIP R 100K J 1/16W	
L109			L34-4572-05	AIR-CORE COIL		R21			RK73HB1J154J	CHIP R 150K J 1/16W	
L110-112			L34-4564-05	AIR-CORE COIL		R22			RK73HB1J472J	CHIP R 4.7K J 1/16W	
L113			L40-1092-81	SMALL FIXED INDUCTOR		R23			RK73HB1J101J	CHIP R 100 J 1/16W	
L114,115			L40-8265-57	SMALL FIXED INDUCTOR(8.2NH5%)		R24			RK73HB1J102J	CHIP R 1.0K J 1/16W	
L116			L40-1263-92	SMALL FIXED INDUCTOR(1.2NH)		R25			RK73HB1J682J	CHIP R 6.8K J 1/16W	
L201			L40-1091-86	SMALL FIXED INDUCTOR(1.0UH)		R26			RK73HB1J103J	CHIP R 10K J 1/16W	
						R27			RK73HB1J331J	CHIP R 330 J 1/16W	

PARTS LIST

TX-RX UNIT (X57-6410-10)

Ref. No.	Address	New parts	Parts No.	Description	Destination	Ref. No.	Address	New parts	Parts No.	Description	Destination
R28			RK73HH1J333D	CHIP R 33K D 1/16W		R219			RK73HB1J224J	CHIP R 220K J 1/16W	
R29			RK73HH1J104D	CHIP R 100K D 1/16W		R220		*	RK73HB1J332J	CHIP R 3.3K J 1/16W	
R31			RK73HB1J470J	CHIP R 47 J 1/16W		R221			RK73HH1J332D	CHIP R 3.3K D 1/16W	
R32-35			R92-1368-05	CHIP R 0 OHM		R222			RK73HB1J220J	CHIP R 22 J 1/16W	
R100,101			RK73HB1J472J	CHIP R 4.7K J 1/16W		R223			RK73HB1J184J	CHIP R 180K J 1/16W	
R102			RK73HB1J473J	CHIP R 47K J 1/16W		R226			RK73HB1J221J	CHIP R 220 J 1/16W	
R103			RK73HB1J331J	CHIP R 330 J 1/16W		R227,228			RK73HB1J331J	CHIP R 330 J 1/16W	
R104			RK73HB1J220J	CHIP R 22 J 1/16W		R229			RK73HB1J472J	CHIP R 4.7K J 1/16W	
R105			RK73HB1J681J	CHIP R 680 J 1/16W		R230			R92-1368-05	CHIP R 0 OHM	
R106			RK73HB1J152J	CHIP R 1.5K J 1/16W		R231			R92-1252-05	CHIP R 0 OHM J 1/16W	
R107			RK73HB1J100J	CHIP R 10 J 1/16W		R232			RK73HB1J102J	CHIP R 1.0K J 1/16W	
R108,109			RK73HB1J331J	CHIP R 330 J 1/16W		R233			RK73HB1J151J	CHIP R 150 J 1/16W	
R111			RK73HB1J180J	CHIP R 18 J 1/16W		R234			RK73HB1J104J	CHIP R 100K J 1/16W	
R112			RK73HB1J331J	CHIP R 330 J 1/16W		R235			RK73HB1J563J	CHIP R 56K J 1/16W	
R114			RK73HB1J124J	CHIP R 120K J 1/16W		R236			RK73HB1J104J	CHIP R 100K J 1/16W	
R115			RK73HB1J473J	CHIP R 47K J 1/16W		R237			RK73HB1J563J	CHIP R 56K J 1/16W	
R116			RK73HB1J222J	CHIP R 22 J 1/16W		R238			R92-1368-05	CHIP R 0 OHM	
R119,120			RK73EB2ER39K	CHIP R 0.39 K 1/4W		R239-241			RK73HB1J105J	CHIP R 1.0M J 1/16W	
R121			RK73HB1J473J	CHIP R 47K J 1/16W		R243			RK73HB1J221J	CHIP R 220 J 1/16W	
R122			R92-0670-05	CHIP R 0 OHM		R244			RK73HB1J104J	CHIP R 100K J 1/16W	
R123			RK73EB2ER39K	CHIP R 0.39 K 1/4W		R246			RK73HB1J104J	CHIP R 100K J 1/16W	
R124			R92-1368-05	CHIP R 0 OHM		R247			RK73HB1J683J	CHIP R 68K J 1/16W	
R125			RK73GB1J101J	CHIP R 100 J 1/16W		R248,249			RK73HB1J105J	CHIP R 1.0M J 1/16W	
R126			RK73HB1J473J	CHIP R 47K J 1/16W		R250			RK73HB1J102J	CHIP R 1.0K J 1/16W	
R127-129			RK73HH1J154D	CHIP R 150K D 1/16W		R252			RK73HB1J470J	CHIP R 47 J 1/16W	
R131-133			RK73HH1J154D	CHIP R 150K D 1/16W		R253			R92-1252-05	CHIP R 0 OHM J 1/16W	
R134			RK73HB1J103J	CHIP R 10K J 1/16W		R254			RK73HB1J470J	CHIP R 47 J 1/16W	
R136			RK73HB1J473J	CHIP R 47K J 1/16W		R255			RK73HH1J272D	CHIP R 2.7K D 1/16W	
R138			R92-1368-05	CHIP R 0 OHM		R256			RK73HB1J473J	CHIP R 47K J 1/16W	
R139			RK73HH1J105D	CHIP R 1M D 1/16W		R259			RK73HB1J473J	CHIP R 47K J 1/16W	
R140			RK73HB1J222J	CHIP R 2.2K J 1/16W		R260			RK73HB1J223J	CHIP R 22K J 1/16W	
R142,143			RK73HB1J104J	CHIP R 100K J 1/16W		R264			RK73HB1J181J	CHIP R 180 J 1/16W	
R144			R92-0670-05	CHIP R 0 OHM		R265			RK73HB1J334J	CHIP R 330K J 1/16W	
R145,146			RK73HB1J271J	CHIP R 270 J 1/16W		R266			RK73HB1J272J	CHIP R 2.7K J 1/16W	
R147			R92-1252-05	CHIP R 0 OHM J 1/16W		R267			RK73HB1J334J	CHIP R 330K J 1/16W	
R149			R92-1368-05	CHIP R 0 OHM		R268			RK73HB1J221J	CHIP R 220 J 1/16W	
R151,152			R92-1368-05	CHIP R 0 OHM		R270			R92-0670-05	CHIP R 0 OHM	
R200			RK73HB1J224J	CHIP R 220K J 1/16W		R273			R92-1368-05	CHIP R 0 OHM	
R201			RK73HB1J104J	CHIP R 100K J 1/16W		R276			R92-1368-05	CHIP R 0 OHM	
R202			RK73HB1J153J	CHIP R 15K J 1/16W		R300			RK73HB1J154J	CHIP R 150K J 1/16W	
R203			RK73HH1J224D	CHIP R 220K D 1/16W		R301			RK73HB1J104J	CHIP R 100K J 1/16W	
R204			RK73HH1J824D	CHIP R 8.2K D 1/16W		R302			RK73HB1J393J	CHIP R 39K J 1/16W	
R205			RK73HB1J334J	CHIP R 330K J 1/16W		R303			RK73HB1J474J	CHIP R 470K J 1/16W	
R206			RK73HB1J333J	CHIP R 33K J 1/16W		R304			RK73HB1J394J	CHIP R 390K J 1/16W	
R207			RK73HB1J154J	CHIP R 150K J 1/16W		R305			RK73HB1J153J	CHIP R 15K J 1/16W	
R208			RK73HB1J472J	CHIP R 4.7K J 1/16W		R307			RK73HB1J103J	CHIP R 10K J 1/16W	
R209			RK73HB1J103J	CHIP R 10K J 1/16W		R308			RK73HB1J472J	CHIP R 4.7K J 1/16W	
R210			RK73HB1J123J	CHIP R 12K J 1/16W		R309			R92-1368-05	CHIP R 0 OHM	
R211			RK73HB1J223J	CHIP R 22K J 1/16W		R310			RK73HB1J473J	CHIP R 47K J 1/16W	
R212			RK73HB1J472J	CHIP R 4.7K J 1/16W		R311			RK73HB1J154J	CHIP R 150K J 1/16W	
R213			RK73HB1J123J	CHIP R 12K J 1/16W		R312			RK73HB1J104J	CHIP R 100K J 1/16W	
R214			RK73HB1J334J	CHIP R 330K J 1/16W		R313			RK73HB1J103J	CHIP R 10K J 1/16W	
R215			RK73HB1J332J	CHIP R 3.3K J 1/16W		R314			RK73HB1J474J	CHIP R 470K J 1/16W	
R216			RK73HB1J472J	CHIP R 4.7K J 1/16W		R315			RK73HB1J472J	CHIP R 4.7K J 1/16W	
R217			RK73HB1J334J	CHIP R 330K J 1/16W		R316			RK73HB1J104J	CHIP R 100K J 1/16W	
R218			RK73HB1J123J	CHIP R 12K J 1/16W		R317			RK73HB1J184J	CHIP R 180K J 1/16W	

PARTS LIST

TX-RX UNIT (X57-6410-10)

Ref. No.	Address	New parts	Parts No.	Description	Destination	Ref. No.	Address	New parts	Parts No.	Description	Destination
R318			RK73HB1J104J	CHIP R 100K J 1/16W		R388			RK73HB1J474J	CHIP R 470K J 1/16W	
R319			RK73HB1J473J	CHIP R 47K J 1/16W		R389			RK73HB1J472J	CHIP R 4.7K J 1/16W	
R320			RK73HB1J563J	CHIP R 56K J 1/16W		R390			RK73HB1J821J	CHIP R 820 J 1/16W	
R321			RK73HB1J823J	CHIP R 82K J 1/16W		R391,392			RK73HB1J331J	CHIP R 330 J 1/16W	
R322			RK73HB1J154J	CHIP R 150K J 1/16W		R393			R92-1368-05	CHIP R 0 OHM	
R323			RK73HB1J823J	CHIP R 82K J 1/16W		R397,398			R92-1368-05	CHIP R 0 OHM	
R324,325			RK73HB1J334J	CHIP R 330K J 1/16W		R400			RK73HB1J103J	CHIP R 10K J 1/16W	
R326			R92-1368-05	CHIP R 0 OHM		R401,402			RK73HH1J474D	CHIP R 470K D 1/16W	
R327			RK73HB1J473J	CHIP R 47K J 1/16W		R403			RK73HB1J334J	CHIP R 330K J 1/16W	
R328			RK73HB1J104J	CHIP R 100K J 1/16W		R404			RK73HB1J105J	CHIP R 1.0M J 1/16W	
R329,330			RK73HB1J184J	CHIP R 180K J 1/16W		R405			R92-1252-05	CHIP R 0 OHM J 1/16W	
R331			RK73HB1J124J	CHIP R 120K J 1/16W		R406			RK73HB1J103J	CHIP R 10K J 1/16W	
R332			RK73HB1J474J	CHIP R 470K J 1/16W		R407			RK73HB1J224J	CHIP R 220K J 1/16W	
R333			RK73HB1J473J	CHIP R 47K J 1/16W		R408			RK73HB1J472J	CHIP R 4.7K J 1/16W	
R334			RK73HB1J184J	CHIP R 180K J 1/16W		R409			RK73HB1J473J	CHIP R 47K J 1/16W	
R336-338			RK73HB1J223J	CHIP R 22K J 1/16W		R410,411			R92-1368-05	CHIP R 0 OHM	
R339-341			RK73HB1J103J	CHIP R 10K J 1/16W		R413			RK73HB1J105J	CHIP R 1.0M J 1/16W	
R342			RK73HB1J223J	CHIP R 22K J 1/16W		R414			RK73HB1J103J	CHIP R 10K J 1/16W	
R343			RK73HB1J103J	CHIP R 10K J 1/16W		R500			R92-1368-05	CHIP R 0 OHM	
R344,345			R92-1368-05	CHIP R 0 OHM		R501			RK73HH1J913D	CHIP R 91K D 1/16W	
R346			RK73HB1J473J	CHIP R 47K J 1/16W		R502			RK73HH1J683D	CHIP R 68K D 1/16W	
R347			RK73HB1J102J	CHIP R 1.0K J 1/16W		R503			RK73HH1J333D	CHIP R 33K D 1/16W	
R348			RK73HB1J472J	CHIP R 4.7K J 1/16W		R504			RK73HH1J913D	CHIP R 91K D 1/16W	
R349,350			RK73HB1J473J	CHIP R 47K J 1/16W		R505			RK73HB1J564J	CHIP R 560K J 1/16W	
R351			R92-1368-05	CHIP R 0 OHM		R506			R92-1368-05	CHIP R 0 OHM	
R352,353			RK73HB1J102J	CHIP R 1.0K J 1/16W		R507			RK73HH1J274D	CHIP R 270K D 1/16W	
R354,355			R92-1368-05	CHIP R 0 OHM		R508			RK73HH1J913D	CHIP R 91K D 1/16W	
R356			RK73HB1J473J	CHIP R 47K J 1/16W		R509			R92-1368-05	CHIP R 0 OHM	
R357			RK73HB1J471J	CHIP R 470 J 1/16W		R510			RK73HH1J682D	CHIP R 6.8K D 1/16W	
R358			R92-1368-05	CHIP R 0 OHM		R511			RK73GB1J155J	CHIP R 1.5M J 1/16W	
R359			RK73HB1J153J	CHIP R 15K J 1/16W		R512			RK73HH1J683D	CHIP R 68K D 1/16W	
R360			RK73HB1J182J	CHIP R 1.8K J 1/16W		R513			RK73HB1J474J	CHIP R 470K J 1/16W	
R361			RK73GB1J102J	CHIP R 1.0K J 1/16W		R514			RK73HH1J682D	CHIP R 6.8K D 1/16W	
R362			RK73HB1J473J	CHIP R 47K J 1/16W		R515			RK73HB1J101J	CHIP R 100 J 1/16W	
R363			RK73HB1J124J	CHIP R 120K J 1/16W		R516			RK73HB1J184J	CHIP R 180K J 1/16W	
R364			RK73HB1J104J	CHIP R 100K J 1/16W		R517			RK73HB1J103J	CHIP R 10K J 1/16W	
R365			RK73HB1J473J	CHIP R 47K J 1/16W		R518			RK73HB1J223J	CHIP R 22K J 1/16W	
R366			RK73HB1J102J	CHIP R 1.0K J 1/16W		R519			RK73HB1J102J	CHIP R 1.0K J 1/16W	
R367			RK73HB1J103J	CHIP R 10K J 1/16W		R520			RK73HB1J472J	CHIP R 4.7K J 1/16W	
R368			RK73HB1J102J	CHIP R 1.0K J 1/16W		R521			RK73HB1J394J	CHIP R 390K J 1/16W	
R369			RK73HB1J563J	CHIP R 56K J 1/16W		R522			RK73HB1J333J	CHIP R 33K J 1/16W	
R370			RK73HB1J104J	CHIP R 100K J 1/16W		R523			RK73HB1J470J	CHIP R 47 J 1/16W	
R371			RK73HB1J272J	CHIP R 2.7K J 1/16W		R524			RK73HB1J224J	CHIP R 220K J 1/16W	
R372			R92-1368-05	CHIP R 0 OHM		R525			RK73HB1J184J	CHIP R 180K J 1/16W	
R373			RK73HB1J124J	CHIP R 120K J 1/16W		R526			RK73HB1J394J	CHIP R 390K J 1/16W	
R374			RK73HB1J104J	CHIP R 100K J 1/16W		R527			RK73HB1J224J	CHIP R 220K J 1/16W	
R376			RK73HB1J103J	CHIP R 10K J 1/16W		R528			RK73HB1J220J	CHIP R 22 J 1/16W	
R377			RK73HB1J104J	CHIP R 100K J 1/16W		R529			RK73HB1J473J	CHIP R 47K J 1/16W	
R378			RK73HB1J101J	CHIP R 100 J 1/16W		R530			RK73HB1J474J	CHIP R 470K J 1/16W	
R379			RK73HB1J821J	CHIP R 820 J 1/16W		R531			RK73HB1J184J	CHIP R 180K J 1/16W	
R380,381			RK73HB1J101J	CHIP R 100 J 1/16W		R532,533			RK73HB1J104J	CHIP R 100K J 1/16W	
R382			RK73HB1J103J	CHIP R 10K J 1/16W		R537			R92-1368-05	CHIP R 0 OHM	
R383			RK73HB1J101J	CHIP R 100 J 1/16W		R603-611			RK73HB1J471J	CHIP R 470 J 1/16W	
R384			RK73HB1J331J	CHIP R 330 J 1/16W		R612,613			R92-1368-05	CHIP R 0 OHM	
R385			RK73HB1J470J	CHIP R 47 J 1/16W		R614,615			RK73HB1J473J	CHIP R 47K J 1/16W	
R386			RK73HB1J331J	CHIP R 330 J 1/16W		R617,618			RK73HB1J473J	CHIP R 47K J 1/16W	

PARTS LIST

TX-RX UNIT (X57-6410-10)

Ref. No.	Address	New parts	Parts No.	Description	Destination	Ref. No.	Address	New parts	Parts No.	Description	Destination
R619			R92-1368-05	CHIP R 0 OHM		Q4			2SJ347	FET	
R620			RK73HB1J473J	CHIP R 47K J 1/16W		Q5			2SC5108(Y)	TRANSISTOR	
R621			R92-1368-05	CHIP R 0 OHM		Q6			RN47A4	TRANSISTOR	
R623			R92-1368-05	CHIP R 0 OHM		Q7			2SC4617(S)	TRANSISTOR	
R740			RK73HB1J473J	CHIP R 47K J 1/16W		Q8			2SC5108(Y)	TRANSISTOR	
S600-602			S70-0457-05	TACT SWITCH		Q100			2SC5108(Y)	TRANSISTOR	
D1-4			HVC376B	VARIABLE CAPACITANCE DIODE		Q101			2SC5192	TRANSISTOR	
D5			1SV278	VARIABLE CAPACITANCE DIODE		Q103			2SK2596	FET	
D6			MA2S111	DIODE		Q104,105			DTC114EE	DIGITAL TRANSISTOR	
D7-10			HVC376B	VARIABLE CAPACITANCE DIODE		Q106			2SK3476	FET	
D100,101			HSC277	DIODE		Q107			2SK1824	FET	
D102-105			HVC131	DIODE		Q108			DTA144EE	DIGITAL TRANSISTOR	
D106			HZU5CLL	ZENER DIODE		Q201			DTC144EE	DIGITAL TRANSISTOR	
D200			HVC131	DIODE		Q202			RN47A4	TRANSISTOR	
D201			RB706F-40	DIODE		Q203			2SK1824	FET	
D202,203			DAN235E	DIODE		Q204			2SK1830	FET	
D204-208			HVC369B	VARIABLE CAPACITANCE DIODE		Q205			2SC4649(N,P)	TRANSISTOR	
D209			MA2S111	DIODE		Q206,207			3SK318	FET	
D300			RB706F-40	DIODE		Q208			2SC4617(S)	TRANSISTOR	
D301			1SS373	DIODE		Q300			2SC4649(N,P)	TRANSISTOR	
D302			DA221	DIODE		Q301			2SJ347	FET	
D303,304			015AZ6.8	ZENER DIODE		Q302			2SC4617(S)	TRANSISTOR	
D305			015AZ2.4-X	ZENER DIODE		Q303			2SB1132(Q,R)	TRANSISTOR	
D306			DA221	DIODE		Q304			2SC4617(S)	TRANSISTOR	
D307			015AZ6.8	ZENER DIODE		Q305			UPA672T	FET	
D308			NNCD6.8G	ZENER DIODE		Q306			2SC4617(S)	TRANSISTOR	
D402			1SR154-400	DIODE		Q307			UPA672T	FET	
D403			MA2S111	DIODE		Q308			2SK1824	FET	
D405			RB521S-30	DIODE		Q309,310			2SC4617(S)	TRANSISTOR	
D501			RB706F-40	DIODE		Q311			2SA1362(Y)	TRANSISTOR	
IC1			SA7025DK	MOS IC		Q400			2SJ347	FET	
IC100			TA75W01FU	MOS IC		Q401			2SK1830	FET	
IC200			TA31136FN	MOS IC		Q403			DTC144EE	DIGITAL TRANSISTOR	
IC201			TC75W51FU	MOS IC		Q404			2SJ347	FET	
IC300			TC75W51FU	MOS IC		Q405			KTA2015(Y)	TRANSISTOR	
IC301			LC73872M	MOS IC		Q406			2SJ347	FET	
IC302,303			TC75W51FU	MOS IC		Q500			DTC144EE	DIGITAL TRANSISTOR	
IC304			TC75S51F	MOS IC		Q501			UPA672T	FET	
IC305,306			TC75W51FU	MOS IC		Q502			2SK1830	FET	
IC307			M62364FP	MOS IC		TH1			ERTJ0EV104H	THERMISTOR	
IC308			AT29C020-90T1	ROM IC		TH200			ERTJ0EV104H	THERMISTOR	
IC308			W29C020C90	SRAM IC		TH300			TN10-3S154JT	THERMISTOR	
IC309			30620M8A-2N3GP	MPU							
IC310			AT2416N10SI2.5	ROM IC							
IC311,312			BU4094BCFV	MOS IC							
IC313			TDA7053AT	BI-POLAR IC							
IC400			XC61CN4202NR	MOS IC							
IC401		*	XC6204B502MR	MOS IC							
IC402			XC62GR5012PR	MOS IC							
IC403		*	XC6204B502MR	MOS IC							
IC404			XC61CN5002NR	MOS IC							
IC500			TC35453F	MOS IC							
IC501			TC75W51FU	MOS IC							
Q1			2SC5108(Y)	TRANSISTOR							
Q2,3			2SK508NV(K52)	FET							

PACKING

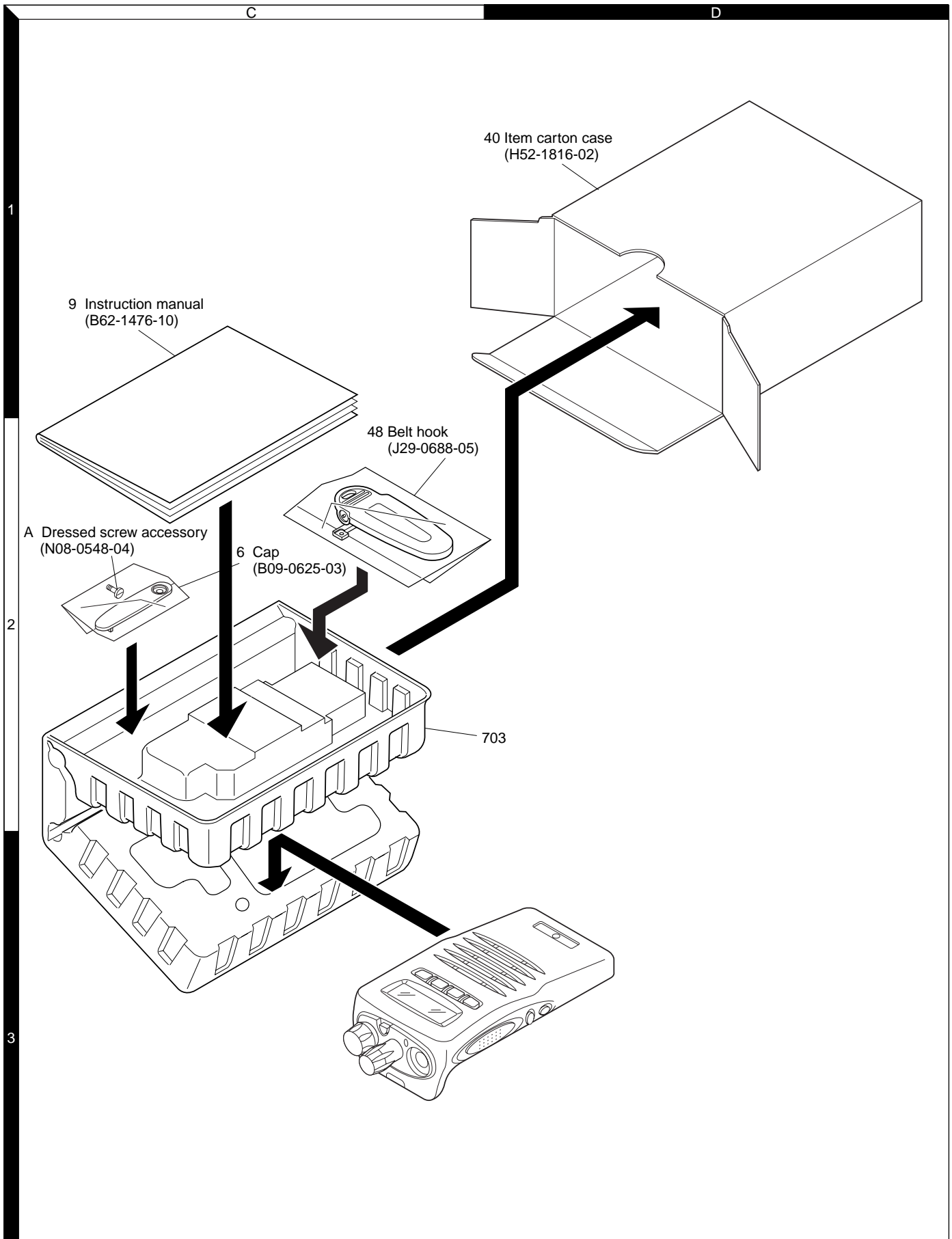

ADJUSTMENT

Test Equipment Required for Alignment

Test Equipment	Major Specifications	
1. Standard Signal Generator (SSG)	Frequency Range Modulation Output	400 to 512MHz Frequency modulation and external modulation. -127dBm/0.1μV to greater than -47dBm/1mV
2. Power Meter	Input Impedance Operation Frequency Measurement Range	50Ω. 400 to 512MHz or more. Vicinity of 10W
3. Deviation Meter	Frequency Range	400 to 512MHz.
4. Digital Volt Meter (DVM)	Measuring Range Input Impedance	10mV to 10V DC High input impedance for minimum circuit loading.
5. Oscilloscope		DC through 30MHz.
6. High Sensitivity Frequency Counter	Frequency Range Frequency Stability	10Hz to 1000MHz. 0.2ppm or less.
7. Ammeter		5A.
8. AF Volt Meter (AF VTVM)	Frequency Range Voltage Range	50Hz to 10kHz. 1mV to 10V.
9. Audio Generator (AG)	Frequency Range Output	50Hz to 5kHz or more. 0 to 1V.
10. Distortion Meter	Capability Input Level	3% or less at 1kHz. 50mV to 10Vrms.
11. Spectrum Analyzer	Measuring Range	DC to 1GHz or more
12. Tracking Generator	Center frequency Output Voltage	50kHz to 600MHz 100mV or more
13. 16Ω Dummy Load		Approx. 16Ω, 3W.
14. Regulated Power Supply		5V to 10V, approx. 5A Useful if ammeter equipped.

■ The following parts are required for adjustment

1. Antenna connector adapter

The antenna connector of this radio uses an SMA terminal. Use an antenna connector adapter [SMA(f) – BNC(f)] for adjustment. (The adapter is not provided as an option, so buy a commercially-available one.)

Note

When the antenna connector adapter touches the knob, draw out the knob to mount the connector.

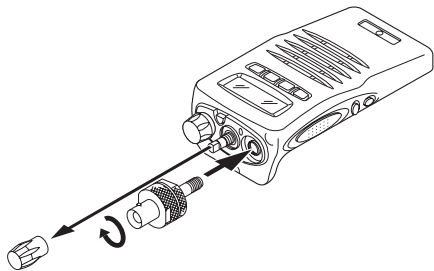

2. Universal connector

Use the interface cable (KPG-36) for PC tuning or the lead wire with plug (E30-3287-18) and screw (N08-0535-08) for panel tuning. Connect the plug to the universal connector of the radio and tighten the screw.

The lead wire with plug (E30-3287-18) and screw (N08-0535-08) terminals are as follows. Numbers are universal connector terminal numbers.

Caution

1. When connecting the plug to the universal connector of the radio, a short circuit may occur. To prevent this, be sure to turn the radio POWER switch off.
2. Since the RX AF output is a BTL output, there is a DC component. Isolate this with a capacitor or transformer as shown in the figure.
3. Do not connect an instrument between red or black and GND.

• Universal connector

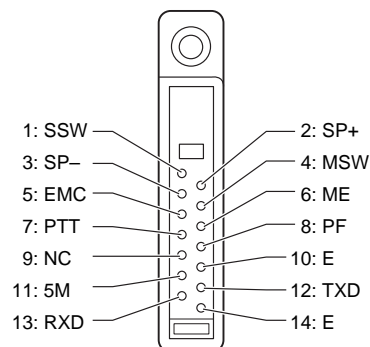

ADJUSTMENT

• Panel tuning

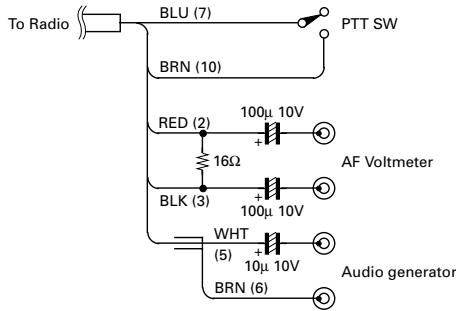
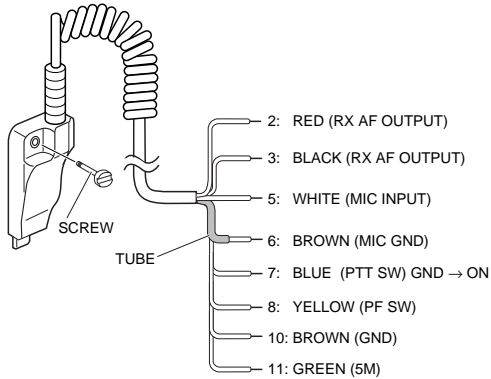

• PC tuning

Connect the wires to the PCB in the connector case of interface cable.

For output the wires out of the connector case, need to process the connector case.

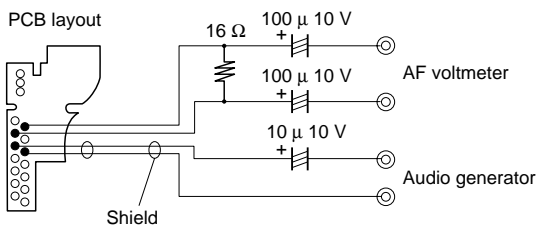
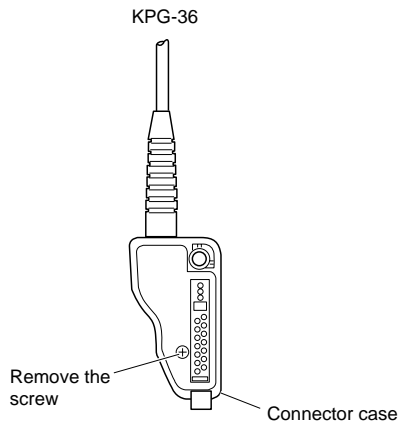

■ Removing the front panel

After removing the battery pack, knobs, and antenna, remove the 2 screws from the back of the transceiver.

Lift the chassis away from the bottom part gently, then pull out the chassis as shown below.

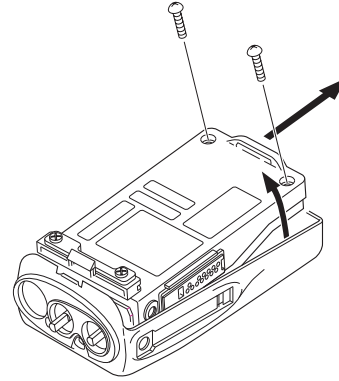

■ Connecting the PTT, MIC, SP, and SW2 cables

When connecting the PTT, MIC, SP and SW2 2-wire cables, ensure that the color of each cable mates as shown in the following diagram.

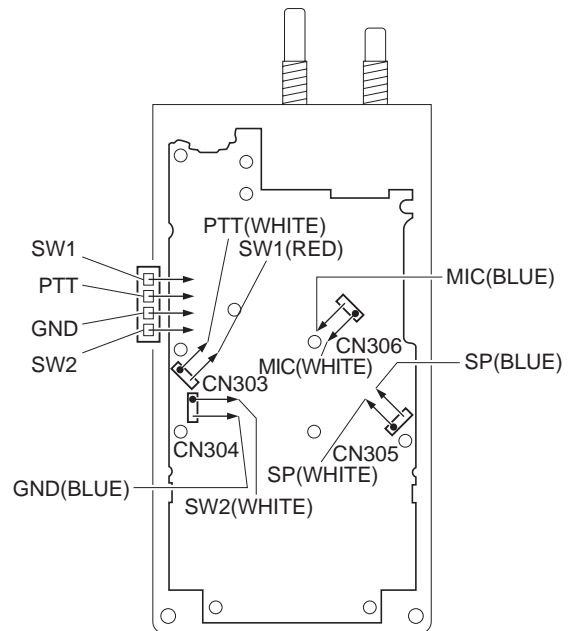

ADJUSTMENT

■ How to assemble the antenna connector and its terminal.

The antenna connector and its terminal are supplied as separate parts.

When replacing the antenna connector and/ or terminal, assemble the parts prior to the replacement.

1. Mount the antenna connector onto the chassis ①.
 - Double-sided adhesive tape is attached to the terminal; peel off the tape cover ②.
 - Attach the terminal to the antenna connector as shown below.
 - Slide the antenna terminal along the adhesive cushion on the chassis so that the adhesive part on the terminal is firmly attached to the antenna connector ③.
2. Remove the antenna connector from the chassis with its terminal attached, then solder the center part of antenna connector to its terminal √.

Do not use excessive solder on terminal.

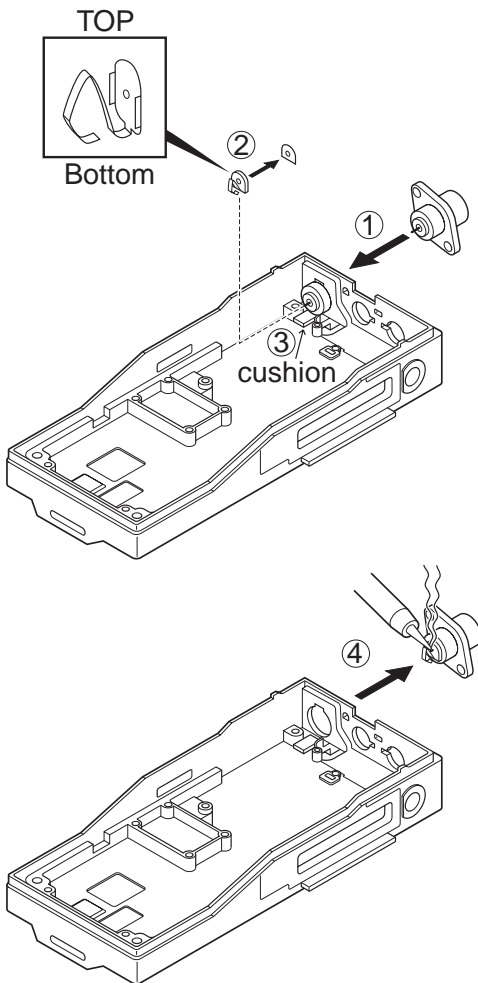

Repair Jig (Chassis)

Use jig (part No.: A10-4060-04) for repairing the TK-3140. Place the TX-RX unit on the jig and fit it with screws.

The jig facilitates the voltage check and protects the final amplifier FET when the voltage on the flow side of the TX-RX unit is checked during repairs.

How to Remove the Cable

1. Gently draw out both sides of the connector lever uniformly in the direction of the arrow with tweezers. (CN303, CN304, CN305, CN306)

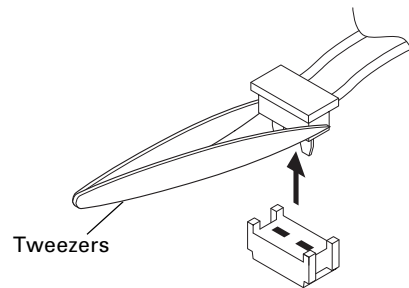

2. Gently rise up the connector lever in the direction of the arrow with a fine regular screwdriver or tweezers. (CN301, CN302, CN400)

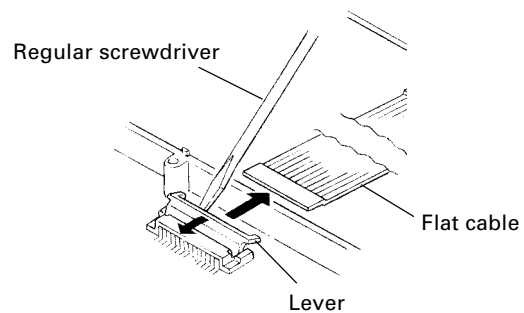

ADJUSTMENT

Test Mode

■ Test mode operating features



This transceiver has a test mode. **To enter test mode, press [A] key and turn power on. Hold [A] key until test channel No. and test signalling No. appears on LCD.** Test mode can be inhibited by programming. To exit test mode, switch the power on again. The following functions are available in test mode.

• Controls

Controls	"FCN" appears	"FCN" not appears
[PTT]	Used when making a transmission.	Used when making a transmission.
[AUX]	Unused	Unused
[MON]	Monitor ON and OFF.	Monitor ON and OFF.
[LAMP]	Lights the lamp for five seconds. Lighting is extended for a further five seconds by pressing any key while the lamp is lit.	Changes wide and narrow.
[S]	Sets to the Tuning mode.	Sets to the Tuning mode.
[A]	Function OFF	Function ON.
[B]	Compander function ON and OFF.	RF power HIGH and LOW.
[C]	Beat shift ON and OFF	Changes signalling.
[O] to [9], and [#],[*]	Used as the DTMF keypad. If a key is pressed during transmission, the DTMF corresponding to the key that was pressed is sent. (keypad model)	Used as the DTMF keypad. If a key is pressed during transmission, the DTMF corresponding to the key that was pressed is sent. (keypad model)
[ENCODER]	Changes channel.	Changes channel.

Note: If a [S],[A],[B],[C] key is pressed during transmission, the DTMF corresponding to the key that was pressed is sent.

• LCD indicator

"SCN"	Unused
" 	Lights at Compander ON.
"LO"	Lights at RF Power Low.
"P"	Unused
"MON"	Lights at monitor ON.
"SVC"	Unused
" 	Unused

• LED indicator

Red LED	Lights during transmission. Blinks at the low battery voltage warning.
Green LED	Lights when there is a carrier.

• Sub LCD indicator

"FCN"	appears at Function ON.
"n"	appears at Narrow ON.

■ Frequency and signalling

The set has been adjusted for the frequencies shown in the following table. When required, re-adjust them following the adjustment procedure to obtain the frequencies you want in actual operation.

Frequency (MHz)

Channel No.	K	
	RX	TX
1	470. 05000	470. 10000
2	450. 05000	450. 10000
3	489. 95000	489. 90000
4	470. 00000	470. 00000
5	470. 20000	470. 20000
6	470. 40000	470. 40000
7~16	—	—

Signalling

Signalling No.	RX	TX
1	None	None
2	None	100Hz square
3	LTR data	LTR data
4	QT 67.0Hz	QT 67.0Hz
5	QT 151.4Hz	QT 151.4Hz
6	QT 210.7Hz	QT 210.7Hz
7	QT 250.3Hz	QT 250.3Hz
8	DQT D023N	DQT D023N
9	DQT D754I	DQT D754I
10	DTMF DEC, (159D)	DTMF ENC, (159D)
11	None	DTMF tone 9
12	2 tone 321.7/928.1Hz	None
13	Single tone 1200Hz	Single tone 1200Hz
14	None	MSK
15	MSK code	MSK code

• Preparations for tuning the transceiver

Before attempting to tune the transceiver, connect the unit to a suitable power supply.

Whenever the transmitter is turned, the unit must be connected to a suitable dummy load (i.e. power meter).

The speaker output connector must be terminated with a 16Ω dummy load and connected to an AC voltmeter and an audio distortion meter or a SINAD measurement meter at all times during tuning.

• Transceiver tuning

(To place transceiver in tuning mode)

Channel appears on LCD. Set channel according to tuning requirements.

ADJUSTMENT

LCD display (Test mode)

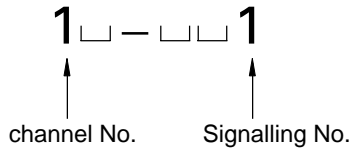

Press [S], now in tuning mode. Use [◀ B] button to write tuning data through tuning modes, and channel selector knob to adjust tuning requirements (1 to 256 appears on LCD).

Use [C ▶] button to select the adjustment item through tuning modes. Use [A] button to adjust 3 or 5 point tuning, and use [LAMP] button to switch between Wide/Narrow.

LCD display (Tuning mode)



Panel Tuning Mode frequency table

TEST Ch	K	
	RX frequency (MHz)	TX frequency (MHz)
L	440.05000	440.10000
L2	450.05000	450.10000
C	470.05000	470.10000
H2	480.05000	480.10000
H	489.95000	489.90000

Panel Tuning Mode flow chart

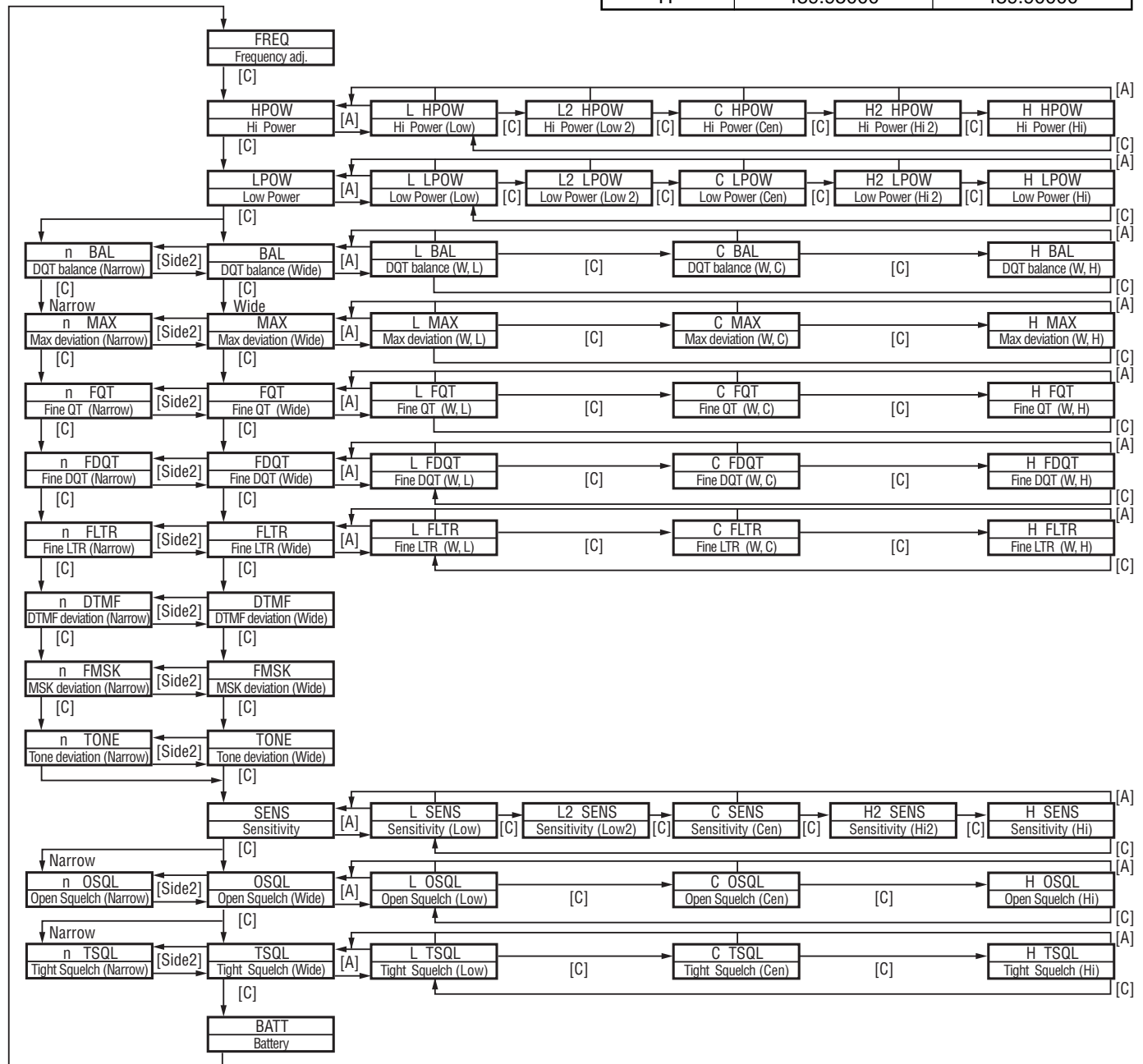

ADJUSTMENT

Common Section

Item	Condition	Measurement			Adjustment			Specifications/ Remark
		Test equipment	Unit	Terminal	Unit	Parts	Method	
1. Setting	1) BATT terminal voltage:7.5V 2) SSG Standard modulation [Wide] MOD:1kHz, DEV:3kHz [Narrow] MOD:1kHz, DEV:1.5kHz							
2. VCO lock voltage	[Panel Test Mode] 1) CH-Sig:2-1	Power meter DVM	Panel TX-RX	ANT CV	TX-RX	TC2	4.1V	±0.1V
RX	2) CH-Sig:3-1						Check	0.6V or more
TX	3) CH-Sig:2-1 PTT:ON					TC1	4.1V	±0.1V
	4) CH-Sig:3-1 PTT:ON						Check	0.6V or more

Transmitter Section

Item	Condition	Measurement			Adjustment			Specifications/ Remark
		Test equipment	Unit	Terminal	Unit	Parts	Method	
1. Frequency Adjust	1) Adj item [FREQ] Adjust [***] PTT:ON	Power meter Am meter	Panel	ANT	Panel	Encoder knob	Center frequency ± 100Hz	
2. Hight Power Adjust	1) Adj item [HPOW] Adjust [***] 2) Adj item [L HPOW] → [L2 HPOW] → [C HPOW] → [H2 HPOW] → [H HPOW] Adjust [***] PTT:ON					Encoder knob	4.0W	±0.1W 2.0A or less
3. Hight Power Check	[Panel Test Mode] 1) CH-Sig:1-1 PTT:ON 2) CH-Sig:2-1 PTT:ON 3) CH-Sig:3-1 PTT:ON						Check	3.7~4.3W 2.0A or less
4. Low Power Adjust	1) Adj item [LPOW] Adjust [***] 2) Adj item [L LPOW] → [L2 LPOW] → [C LPOW] → [H2 LPOW] → [H LPOW] Adjust [***] PTT:ON				Panel	Encoder knob	1.0W	±0.05W 1.0A or less
5. Low Power Check	[Panel Test Mode] 1) CH-Sig:1-1 Set low power (Push [B]) PTT:ON 2) CH-Sig:2-1 PTT:ON 3) CH-Sig:3-1 PTT:ON						Check	0.5~1.5W 1.2A or less

ADJUSTMENT

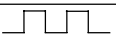
Item	Condition	Measurement			Adjustment			Specifications/ Remark
		Test equipment	Unit	Terminal	Unit	Parts	Method	
6. DQT Balance Adjust [Wide]	1) Adj item [BAL] Adjust [***] LPF:3kHz HPF:OFF	Power meter Dev meter Oscilloscope AG AF VTVM	Panel	ANT Universal connector	Panel	Encoder knob	Make the demodulation waves into square waves.	
	2) Adj item [L BAL] → [C BAL] → [H BAL] Adjust [***] PTT:ON							
[Narrow]	3) Adj item [n BAL] Adjust [***] PTT:ON							
7. Max DEV Adjust [Wide]	1) Adj item [MAX] Adjust [***] AG:1kHz / 150mV Dev meter filter LPF:15kHz HPF:OFF						3.8kHz (According to the larger +,-)	±50Hz
	2) Adj item [L MAX] → [C MAX] → [H MAX] Adjust [***] PTT:ON							
[Narrow]	1) Adj item [n MAX] Adjust [***] PTT:ON						1.75kHz (According to the larger+,-)	
8. MIC Sensitivity Check	[Panel Test Mode] 1) CH-Sig:1-1 AG:1kHz / Wide:15mV Narrow:16mV LPF:15kHz PTT:ON						Check	Wide:2.4~3.6kHz Narrow:1.0~2.2kHz
9. QT Deviation Adjust [Wide]	1) Adj item [FQT] Adjust [***] LPF:3kHz HPF:OFF	Power meter Dev meter Oscilloscope AG AF VTVM	Panel	ANT Universal connector	Panel	Encoder knob	Wide:0.75kHz Narrow:0.35kHz	±50Hz
	2) Adj item [L FQT] → [C FQT] → [H FQT] Adjust [***] PTT:ON							
[Narrow]	3) Adj item [n FQT] Adjust [***] PTT:ON							
10.DQT Devition Adjust [Wide]	1) Adj item [FDQT] Adjust [***] LPF:3kHz HPF:OFF							
	2) Adj item [L FDQT] → [C FDQT] → [H FDQT] Adjust [***] PTT:ON							
[Narrow]	3) Adj item [n FDQT] Adjust [***] PTT:ON							

ADJUSTMENT

Item	Condition	Measurement			Adjustment			Specifications/ Remark
		Test equipment	Unit	Terminal	Unit	Parts	Method	
11.LTR Deviation Adjust [Wide]	1) Adj item [FLTR] Adjust [***] LPF:3kHz HPF:OFF	Power meter Dev meter Oscilloscope AG AF VTVM	Panel	ANT Universal connector	Panel	Encoder knob	1.0kHz	±0.1kHz
	2) Adj item [L FLTR] → [C FLTR] → [H FLTR] Adjust [***] PTT:ON							
[Narrow]	3) Adj item [n FLTR] Adjust [***] PTT:ON						0.75kHz	±50Hz
12.DTMF Deviation Adjust [Wide]	1) Adj item [DTMF] Adjust [***] LPF:15kHz HPF:OFF PTT:ON						Wide:2.5kHz Narrow:1.25kHz	±0.1kHz
	[Narrow]	2) Adj item [n DTMF] Adjust [***] PTT:ON						
13.MSK Deviation Adjust [Wide]	1) Adj item [FMSK] Adjust [***] LPF:15kHz HPF:OFF PTT:ON						Wide:1.0kHz Narrow:0.75kHz	±0.1kHz
	[Narrow]	2) Adj item [n FMSK] Adjust [***] PTT:ON						
14.TONE Deviation Adjust [Wide]	1) Adj item [TONE] Adjust [***] LPF:15kHz HPF:OFF PTT:ON						Wide:3.0kHz Narrow:1.5kHz	±0.1kHz
	[Narrow]	2) Adj item [n TONE] Adjust [***] PTT:ON						
15.BATT Detection Writing	1) Adj item [BATT] Adjust [***] PTT:ON	Power meter DVM	Panel	ANT BATT terminal	Panel	Encoder knob	After pressing the PTT switch, confirm that one predeter- mined numeric in the range 1 to 256 appears and then press [B] key. That numeric will be stored in memory.	BATT terminal voltage:6.2V
16.BATT Detection Check	[Panel Test Mode] 1) CH-Sig:1-1 BATT terminal voltage: NiCd, NiMH:6.5V Li-ion:6.8V PTT:ON						Check	No blinking of LED
	2) BATT terminal voltage: NiCd, NiMH:5.7V Li-ion:6.0V PTT:ON							Blinking of LED

ADJUSTMENT

Receiver Section

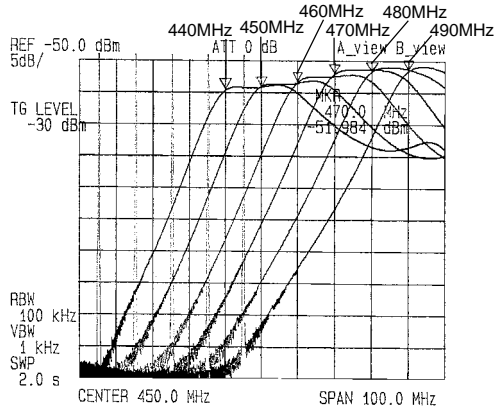
Item	Condition	Measurement			Adjustment			Specifications/ Remark
		Test equipment	Unit	Terminal	Unit	Parts	Method	
1. Sensitivity Adjust (BPF characteristic)	1) Adj item [SENS] Adjust [***] 2) Low-edge frequency Adj item [L SENS]→[L2 SENS]→ [C SENS]→[H2 SENS]→ [H SENS] Spe-Ana setting Center-f : 450MHz(K) Span : 100MHz RBW : 100kHz VBW : 1kHz REF level : -50dBm ATT : 0dB Tra-G setting Input level:-30dBm	Tracking generator Spectrum analyzer	Panel TX-RX	ANT BPF Need couple capacitor (1000PF)	Panel	Encoder knob	Adjustment Turn a knob and make “fo” level 1dB above from peak level. Caution Adjustment “SENS” value ≥60	 <p style="text-align: center;">Band Pass Filter Characteristic (K)</p>
2. Sensitivity Check	[Panel Test Mode] 1) CH-Sig:1-1 SSG OUT Wide:-117dBm (MOD:1kHz / ±3kHz) Narrow:-116dBm (MOD:1kHz / ±1.5kHz)	SSG AF VTVM Oscilloscope	Panel	ANT Universal connector			Check	12dB SINAD or more
3. Squelch Adjust (Open)	1) Adj item [O SQL] Adjust [***] 2) Adj item [L OSQL] → [C OSQL] → [H OSQL] Adjust [***] SSG OUT: 12dB SINAD level 3) Adj item [n OSQL] Adjust [***] SSG OUT: 12dB SINAD level					Encoder knob squelch.	Adjust to point of opening	
4. Squelch Check (Open)	[Panel Test Mode] 1) CH-Sig:1-1 SSG OUT: 12dB SINAD level 2) SSG OUT:OFF						Check	Squelch must be opened. Squelch must be closed.

ADJUSTMENT

Item	Condition	Measurement			Adjustment			Specifications/ Remark
		Test equipment	Unit	Terminal	Unit	Parts	Method	
5. Squelch Adjust	1) Adj item [T SQL] Adjust [***]	SSG AF VTVM Oscilloscope	Panel	ANT Universal connector		Encoder knob	Adjust to point of opening squelch.	
	2) Adj item [L TSQL] → [C TSQL] → [H TSQL] Adjust [***] SSG OUT: 12dB SINAD level+5dB							
	3) Adj item [n TSQL] Adjust [***] SSG OUT: 12dB SINAD level+5dB							
6. Squelch Check (Tight)	[Panel Test Mode] 1) CH-Sig:1-1 SSG OUT: 12dB SINAD level+8dB						Check	Squelch must be opened.
	2) SSG OUT:OFF							Squelch must be closed.

**Adjustment points
TX-RX unit (X57-6410-10)
component side view**

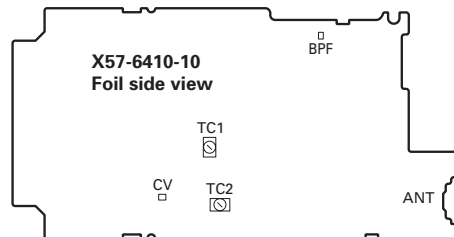

TERMINAL FUNCTION

CN No.	Pin No.	Name	I/O	Function
TX-RX UNIT (X57-6410-10): TX-RX section				
CN301	1	NC	-	Not used
	2	RXD	I	Serial data input
	3	TXD	O	Serial data output
	4	5M	O	5V output
	5	E	-	GND
	6	NC	-	Not used
	7	PF	I	Programmable function key input
	8	PTT	I	External PTT input
	9	ME	-	External microphone ground
	10	ENC	I	External microphone input
	11	MSW	I	EXT/INT MIC switch input
	12	SP-	O	BTL output + for external
	13	SP+	O	BTL output - for external
	14	SSW	I	EXT/INT speaker switch input
CN302	1	NC	-	Not used
	2	LEDK	I	Backlight LED control
	3	LEDA	O	Backlight LED control
	4	CKEY	I	C key input
	5	BKEY	I	B key input
	6	AKEY	I	A key input
	7	SKEY	I	S key input
	8	VEE	-	GND
	9	SDO	O	Serial data output for LCD
	10	SID	I	Serial data input for LCD
	11	SCLK	O	Clock data output for LCD
	12	CS	O	LCD chip select output
	13	VCC	-	5V
	14	GND	-	GND
CN303		PTT	I	PTT key input
		LAMP	I	SIDE1 key input
CN304		MON	I	SIDE2 key input
		GND	-	GND
CN305		SP+	O	BTL output + for internal
		SP-	O	BTL output - for internal
CN306		EMC+	O	Internal microphone input
		EMC-	-	Internal microphone ground

CN No.	Pin No.	Name	I/O	Function
CN400	1	S_DET	I	Battery detect input
	2	AUXKEY	I	AUX key input
	3	GND	-	GND
	4	5M	-	5V
	5	VOL	I	Volume level input for audio control
	6	CH1	I	Encoder pulse input
	7	CH2	I	Encoder pulse input
	8	GND	-	GND
	9	CH3	I	Encoder pulse input
	10	CH4	I	Encoder pulse input
	11	SB	I	Power input after passing through the fuse
	12	SB	I	Power input after passing through the fuse
	13	+B	O	Power output after power switch
	14	+B	O	Power output after power switch
CN300, 500	1	XOUT	O	3.589545MHz output
	2	GND	-	GND
	3	AFCLR	O	MSK flame reset output
	4	AFRDT	O	MSK modulation data output timing pulse input
	5	AFRTM	O	MSK demodulation data output timing pulse input
	6	AFTRD	O	MSK demodulation data input
	7	AFMSKE	O	MSK modulation enable
	8	CLK		Clock data input
	9	AFDAT	O	MSK data output
	10	AFREG2	O	AF IC register switching data output 2
	11	AFREG1	O	AF IC register switching data output 1
	12	AFSTB	O	AF IC data strobe output
	13	5CNS		5V
	14	MMUTE	O	MIC mute
	15	5TC	-	5T control
	16	5C	-	5V
	17	GND	-	GND
	18	MICI		MIC input
	19	PTT	I	PTT key input
	20	ME	-	MIC ground
	21	ME	-	MIC ground
	22	TXHSD	O	HSD output (TX)
	23	GND	-	GND
	24	TXAF	O	Audio output (TX)
	25	RXAF1	I	Audio input (TX)
	26	5RC	-	5R control
	27	HSDIN	O	HSD output (RX)
	28	RXAFO	O	Audio output (RX)
	29	GND	-	GND
	30	GND	-	GND

PC BOARD VIEW

TK-3140

TX-RX UNIT (X57-6410-10) Component Side View

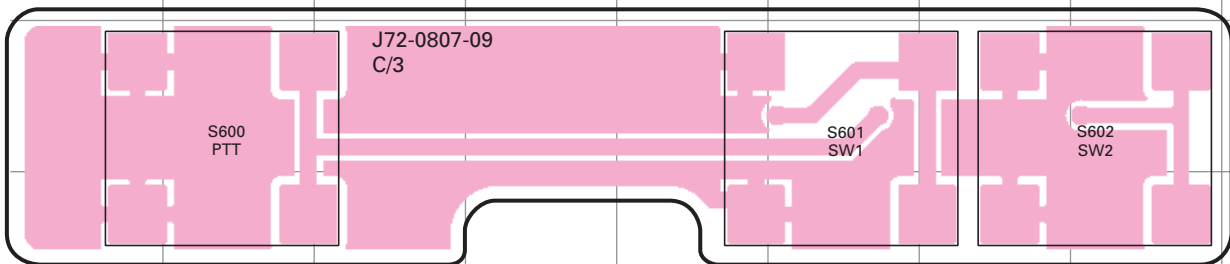
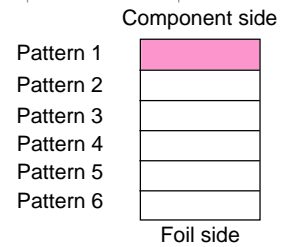
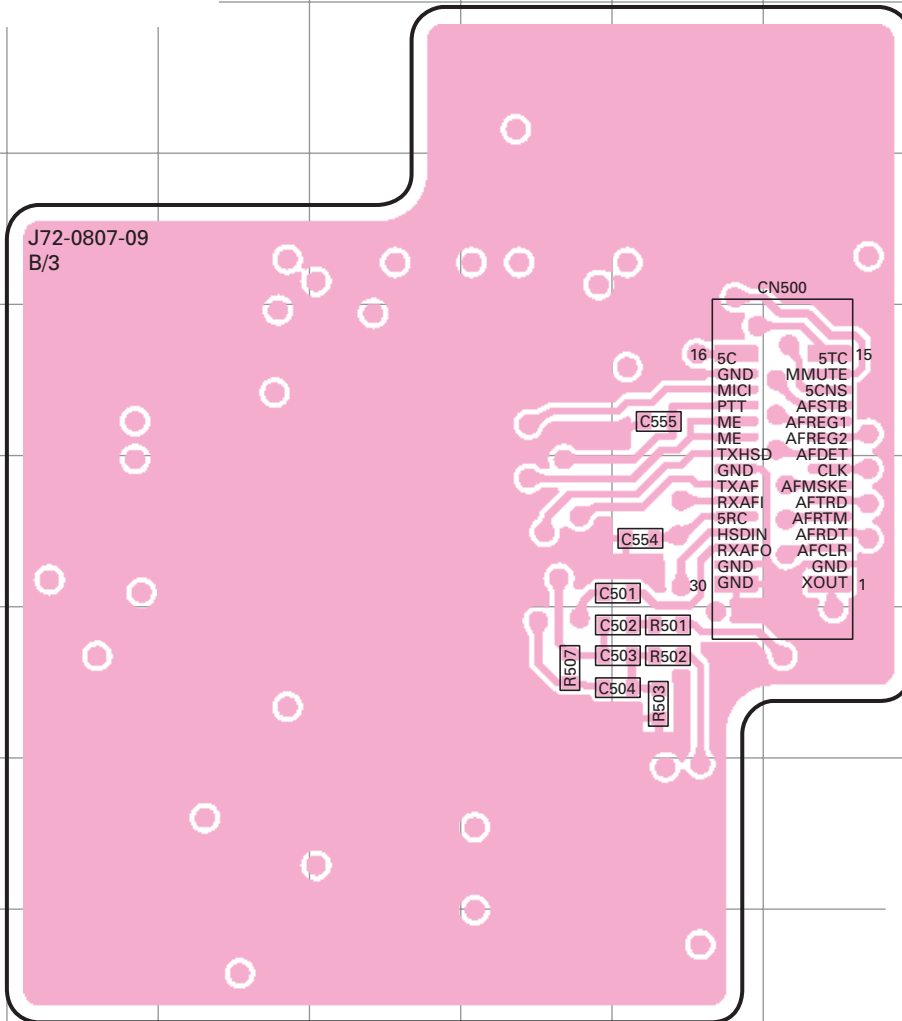

TK-3140

PC BOARD VIEW

TX-RX UNIT (X57-6410-10) Foil Side View

TX-RX UNIT
(X57-6410-10)

Ref. No.	Address
IC500	6F
IC501	9G
Q500	8D
Q501	6H
Q502	8H
D501	8H

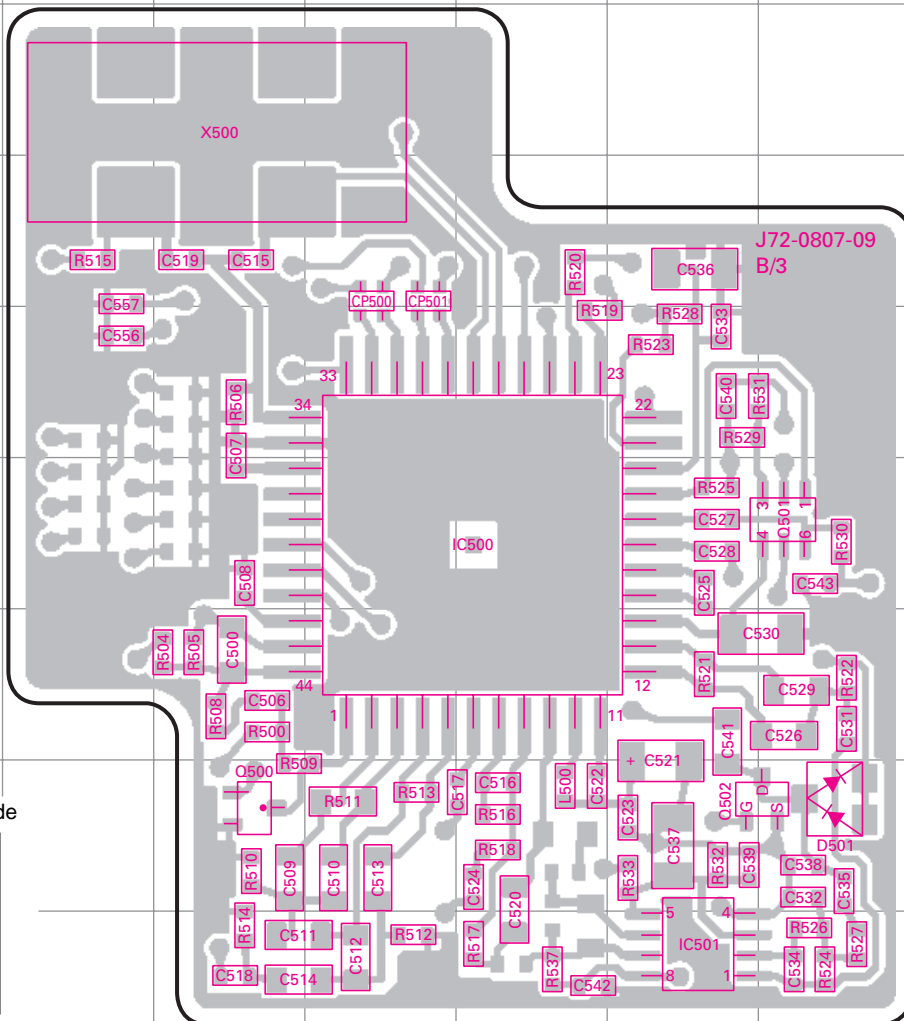

Component side

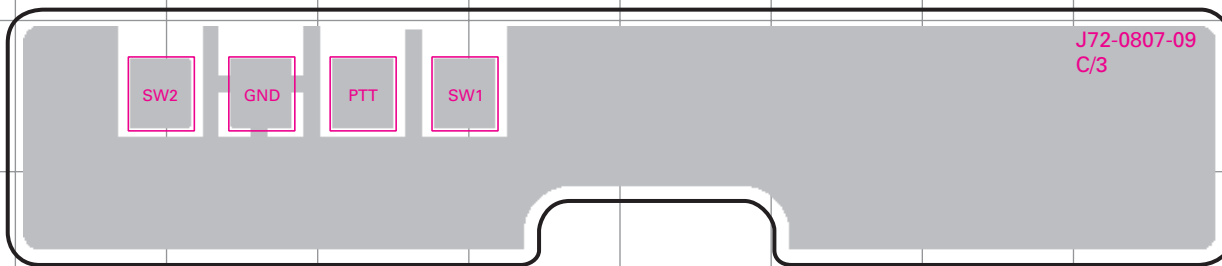
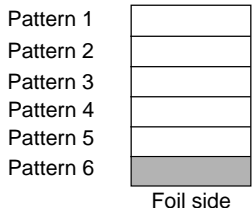

TC35453F

TC75W51FU

DTC144EE

UPA672T

2SK1830

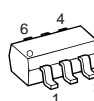
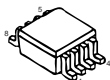
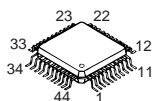

PC BOARD VIEW

TK-3140

TX-RX UNIT (X57-6410-10) Component Side View + Foil Side View

TX-RX UNIT (X57-6410-10)

Ref. No.	Address
IC500	5I
IC501	8H
Q500	7K
Q501	5G
Q502	7H
D501	7G

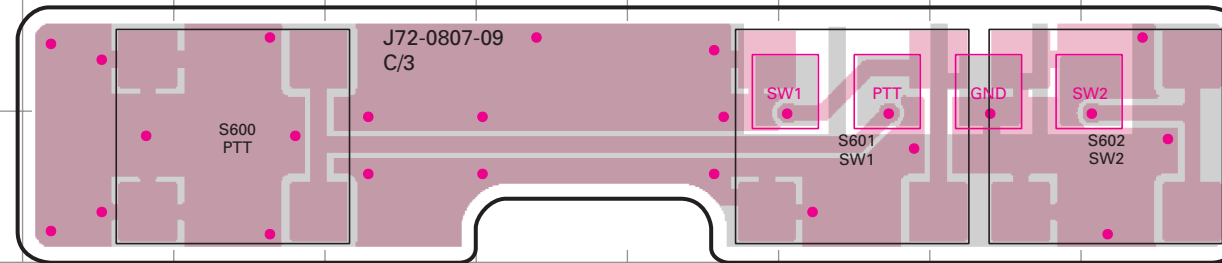
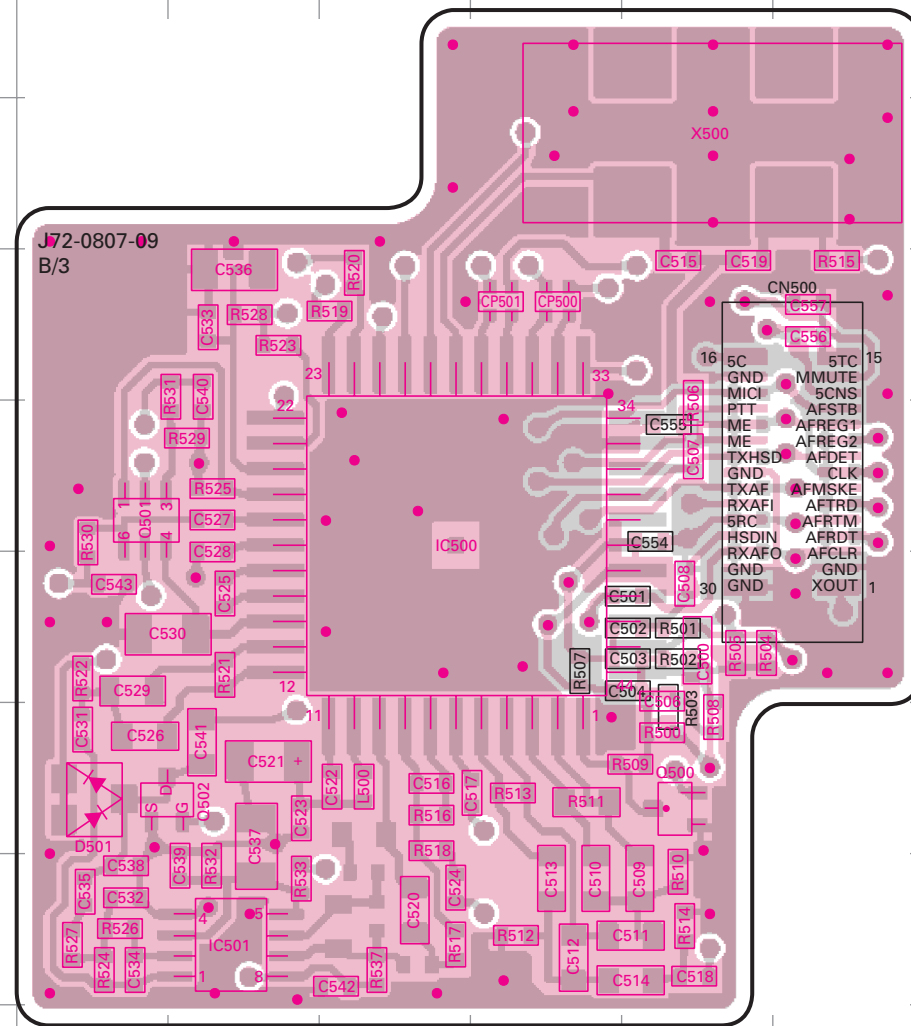

TC35453F

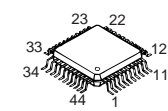

TC75W51FU

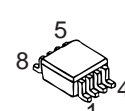

DTC144EE

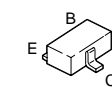

UPA672T

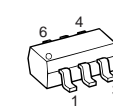

2SK1830

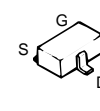

● Connect 1 and 6.

Component side

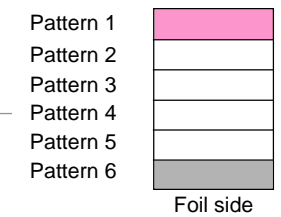

TK-3140

PC BOARD VIEW

TX-RX UNIT (X57-6410-10) (A/3) Component Side View

TX-RX UNIT (X57-6410-10)

Ref. No.	Address
IC100	7H
IC302	8M
IC303	4M
IC308	5O
IC309	7O
IC310	10P
IC311	3N
IC312	3P
IC313	4F
IC400	5I
IC401	6E
IC403	6H
Q100	6H
Q104	8I
Q105	7I
Q107	7I
Q108	6H
Q300	10N
Q301	5I
Q302	6G
Q304	10K
Q305	4I
Q306	10E
Q307	4H
Q308	4E
Q309	9E
Q310	9L
Q311	9L
Q400	6E
Q401	5I
Q403	10F
Q404	10F
Q405	10G
D106	7I
D301	7F
D302	3J
D303	4I
D304	5L
D305	6G
D306	4J
D307	5H
D308	4I
D309	8C
D310	8C
D402	10D
D405	7E

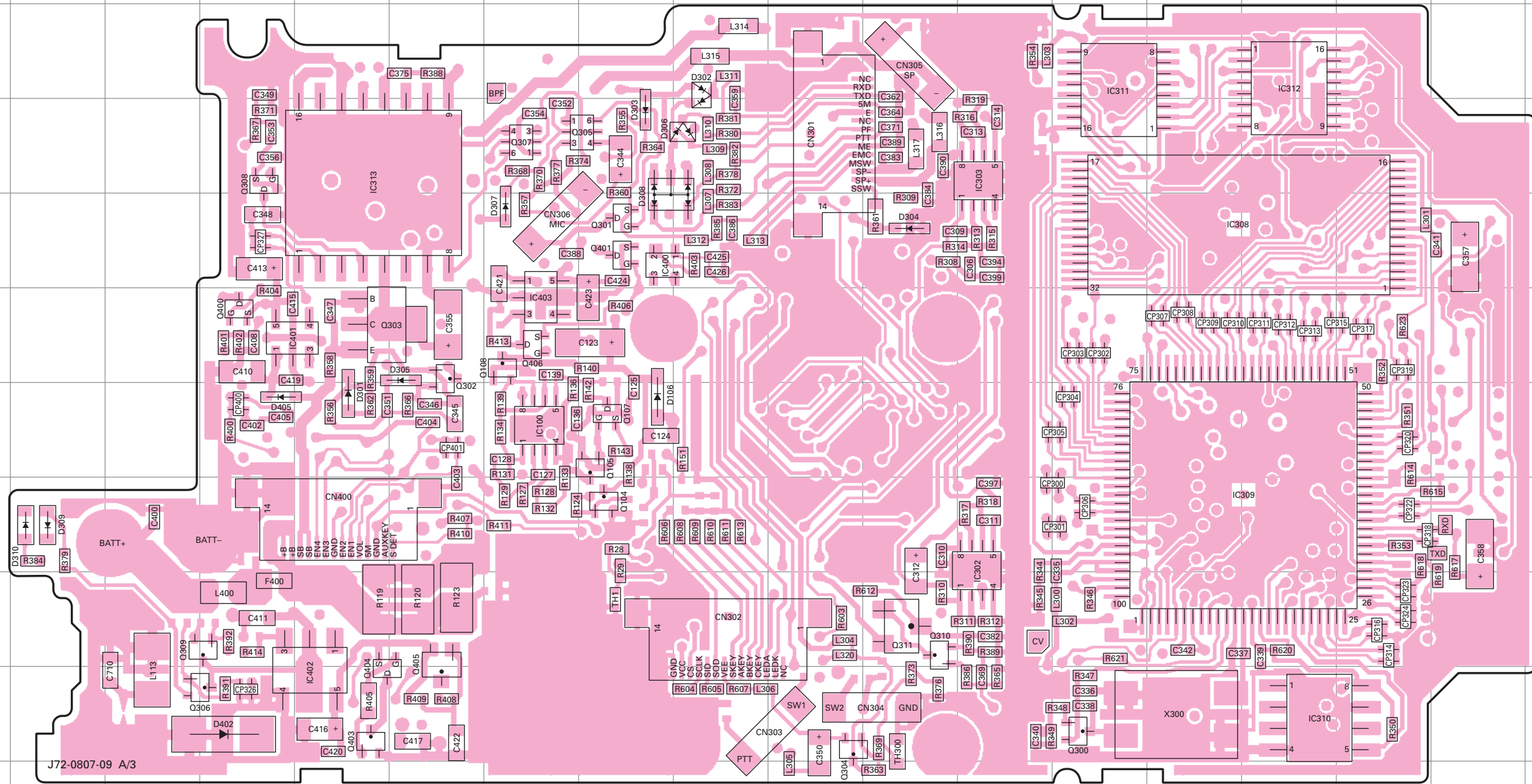

DTA144EE
DTC144EE
2SA1362
2SC4617
2SC5108



2SC4649

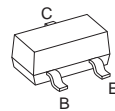

DA221



2SJ347
2SK1830



UPA672T

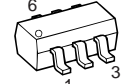

2SK1824

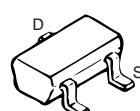

AT2416N10SI2.5

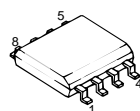

AT29C020-90TI

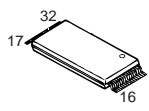

BU4094BCFV

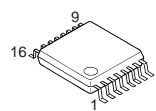

TA75W01FU
TC75W51FU

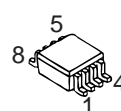

TDA7053AT

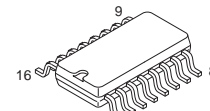

30620M8A-2N3GP

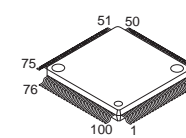

Component side

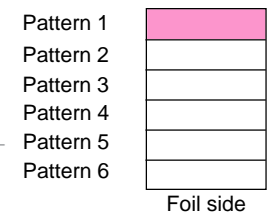

TX-RX UNIT (X57-6410-10) (A/3) Foil Side View

TX-RX UNIT (X57-6410-10)

Ref. No.	Address
IC1	8F
IC200	4H
IC201	6E
IC300	7D
IC301	9C
IC304	8E
IC305	5C
IC306	10E
IC307	4D
IC402	7O
Q1	7G
Q2	9I
Q3	8I
Q4	9J
Q5	8J
Q6	9J
Q7	10J
Q8	7J
Q100	6L
Q101	6L
Q103	7K
Q106	10L
Q201	5D
Q202	5I
Q203	5G
Q204	5H
Q205	4I
Q206	4L
Q207	6N
Q208	6D
D1	7H
D2	10I
D3	7H
D4	10H
D5	7I
D6	9J
D7	8H
D8	7H
D9	10I
D10	10H
D100	5J
D101	5K
D102	9N
D103	9O
D104	9O
D105	8O
D200	8D
D201	7E
D202	5E
D203	5E
D204	4N
D205	5N
D206	5M
D207	7M
D208	8M
D300	7D
D403	6O

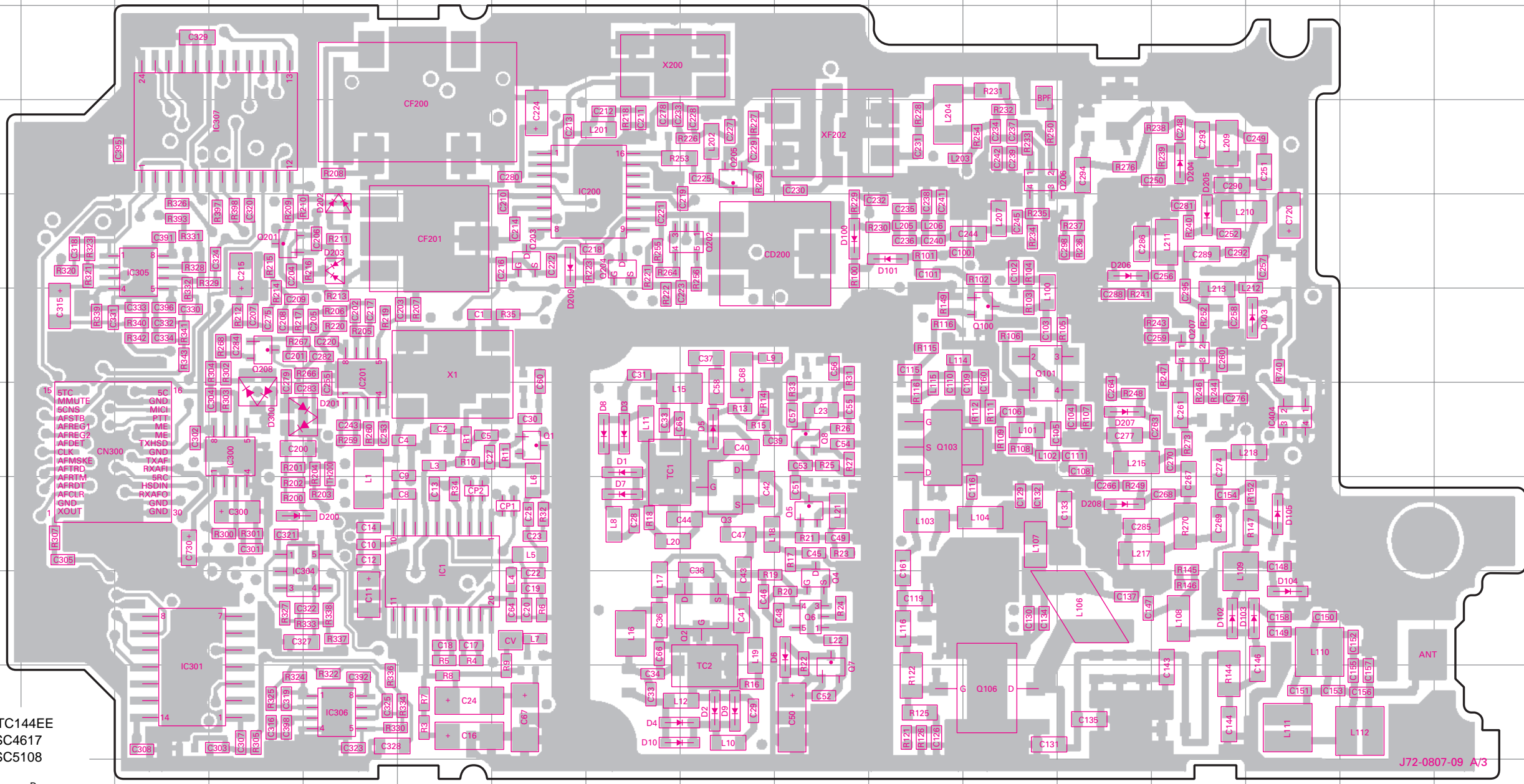

DTC144EE
2SC4617
2SC5108

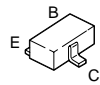

2SC5192

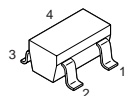

2SC4649

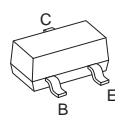

RN47A4



2SJ347
2SK1830



2SK3476

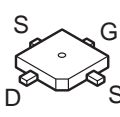

2SK1824

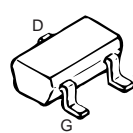

TC75S51F

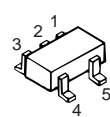

XC62GR5012PR

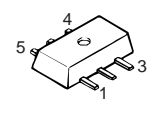

SA7025DK

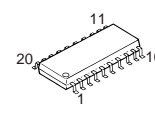

TC75W51FU

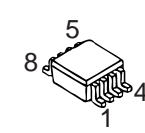

TA31136FN

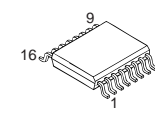

LC73872M

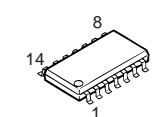

Pattern 1
Pattern 2
Pattern 3
Pattern 4
Pattern 5
Pattern 6



TK-3140

PC BOARD VIEW

TX-RX UNIT (X57-6410-10) (A/3) Component Side View + Foil Side View

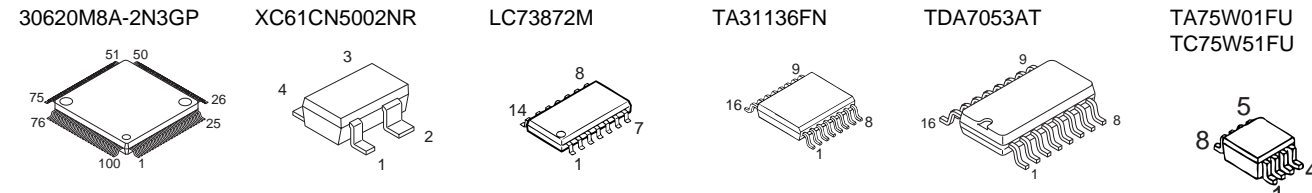

TX-RX UNIT (X57-6410-10)

Ref. No.	Address	Ref. No.	Address
IC1	8N	D8	6L
IC100	7H	D9	10K
IC200	4L	D10	10L
IC201	6O	D100	5J
IC300	7P	D101	5I
IC301	9Q	D102	9F
IC302	8M	D103	9F
IC303	4M	D104	9E
IC304	8O	D105	8E
IC305	5Q	D200	8P
IC306	10O	D201	7O
IC307	4P	D202	5O
IC308	5O	D203	5O
IC309	7O	D204	4F
IC310	10P	D205	5F
IC311	3N	D206	5G
IC312	3P	D207	7G
IC313	4F	D208	8G
IC400	5I	D300	7P
IC401	6E	D301	7F
IC402	7E	D302	3J
IC403	6H	D303	4I
Q1	7M	D304	5L
Q2	9K	D305	6G
Q3	8K	D306	4J
Q4	9J	D307	5H
Q5	8J	D308	4I
Q6	9J	D309	8C
Q7	10J	D310	8C
Q8	7J	D402	10D
Q100	6H	D403	6E
Q101	6H	D405	7E
Q103	7I		
Q104	8I		
Q105	7I		
Q106	10H		
Q107	7I		
Q108	6H		
Q201	5P		
Q202	5K		
Q203	5M		
Q204	5L		
Q205	4K		
Q206	4H		
Q207	6F		
Q208	6P		
Q300	10N		
Q301	5I		
Q302	6G		
Q304	10K		
Q305	4I		
Q306	10E		
Q307	4H		
Q308	4E		
Q309	9E		
Q310	9L		
Q311	9L		
Q400	6E		
Q401	5I		
Q403	10F		
Q404	10F		
Q405	10G		
D106	7I		
D1	7L		
D2	10K		
D3	7L		
D4	10L		
D5	7K		
D6	9J		
D7	8L		

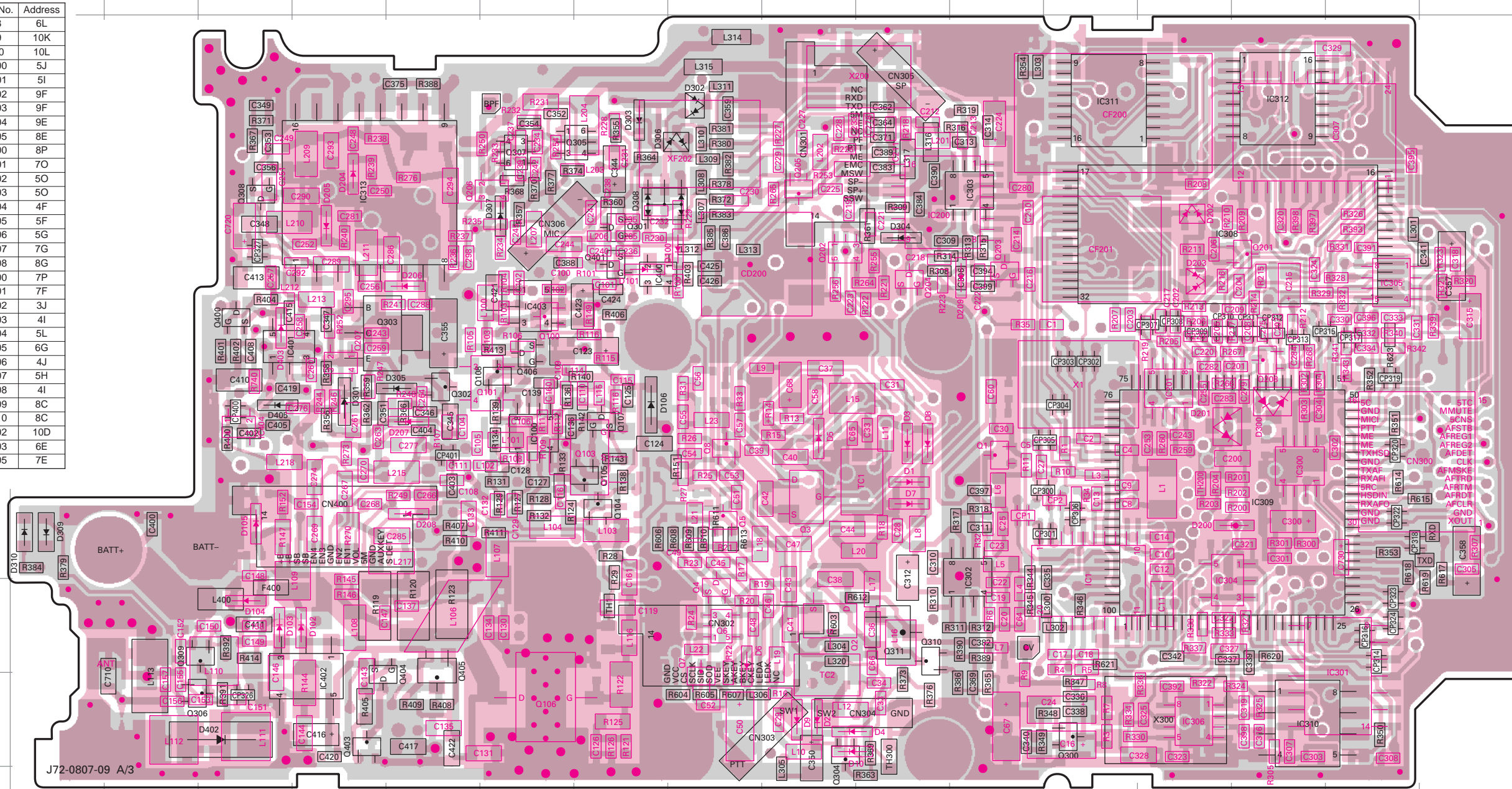

DTA144EE DTC114EE DTC144EE 2SA1362 2SC4617 2SC5108	2SB1132	2SC5192	2SC4649	RN47A4	DA221	2SK508NV	2SJ347 2SK1830	2SK2596	UPA672T	2SK3476
2SK1824	TC75S51F	W29C020C90	AT2416N10SI2.5	XC62GR5012PR	AT29C020-90TI	TC35453F	SA7025DK	BU4094BCFV	M62364FP	

● Connect 1 and 6.
Component side

Pattern 1
Pattern 2
Pattern 3
Pattern 4
Pattern 5
Pattern 6

Foil side

TK-3140 TK-3140

BLOCK DIAGRAM

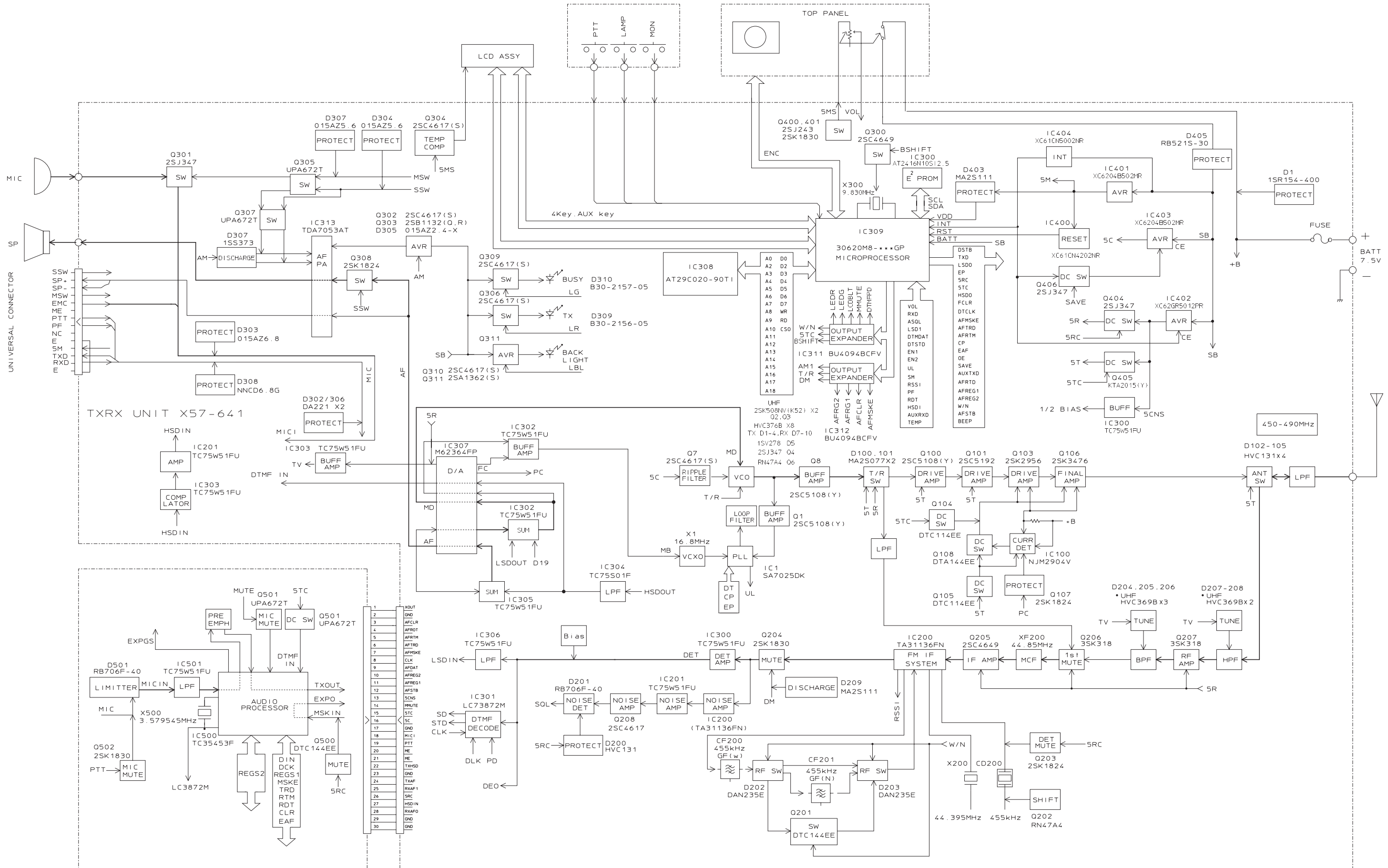

LEVEL DIAGRAM

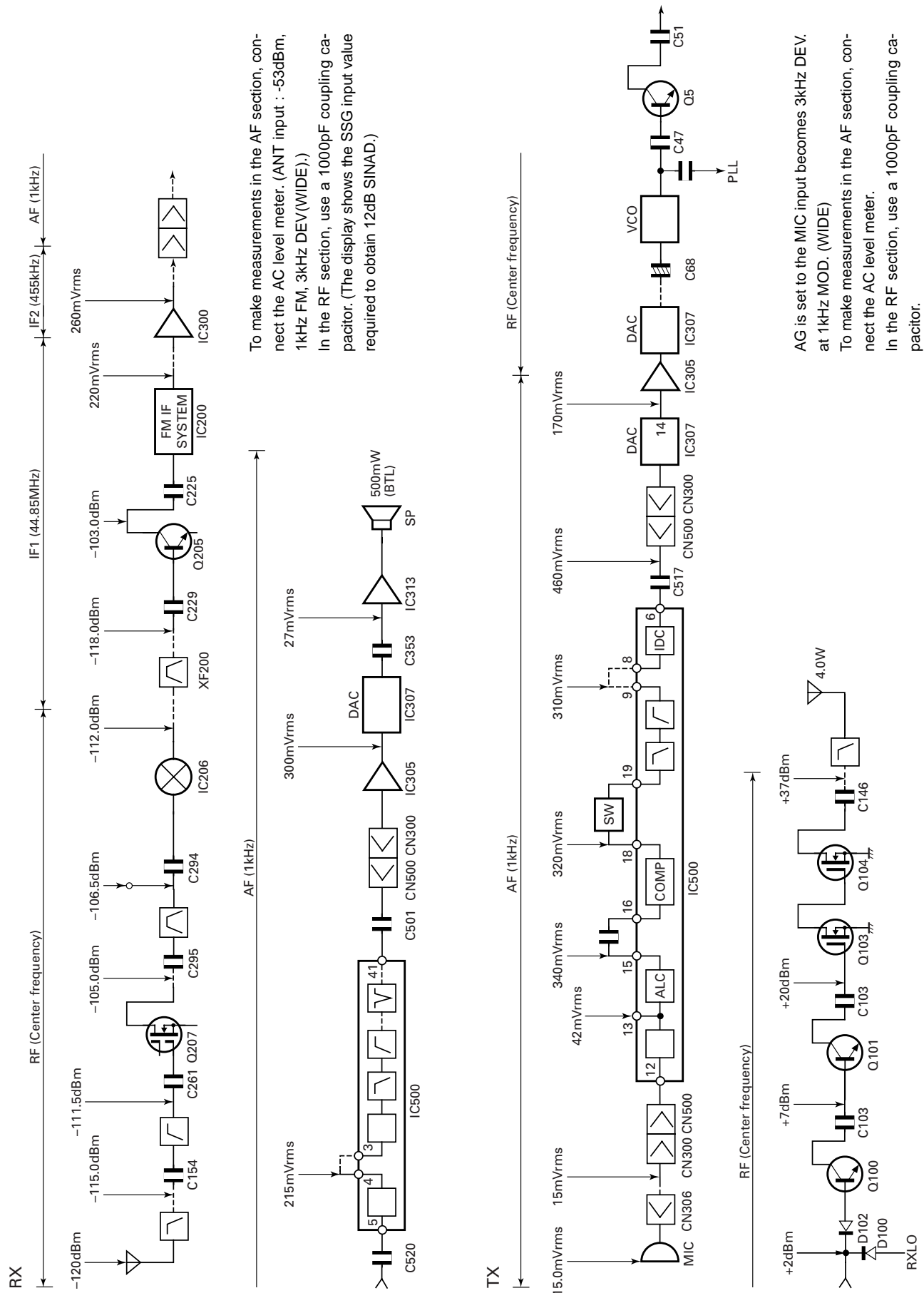

KSC-25

KSC-25 Circuit Description ■ Charger Flow chart

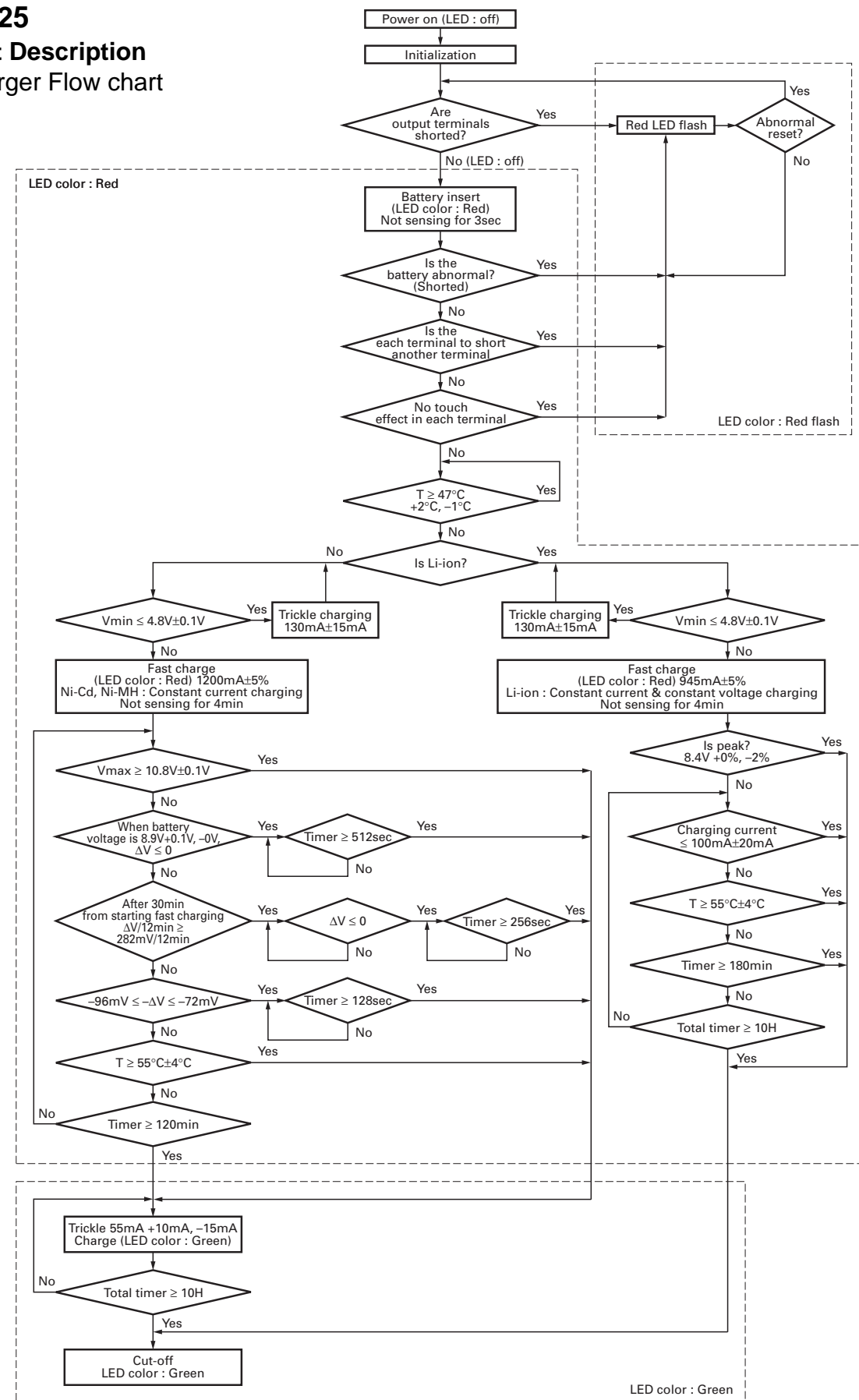

KSC-25

KSC-25 PC BOARD VIEWS

CHARGER UNIT (W02-3641-08) Component side view

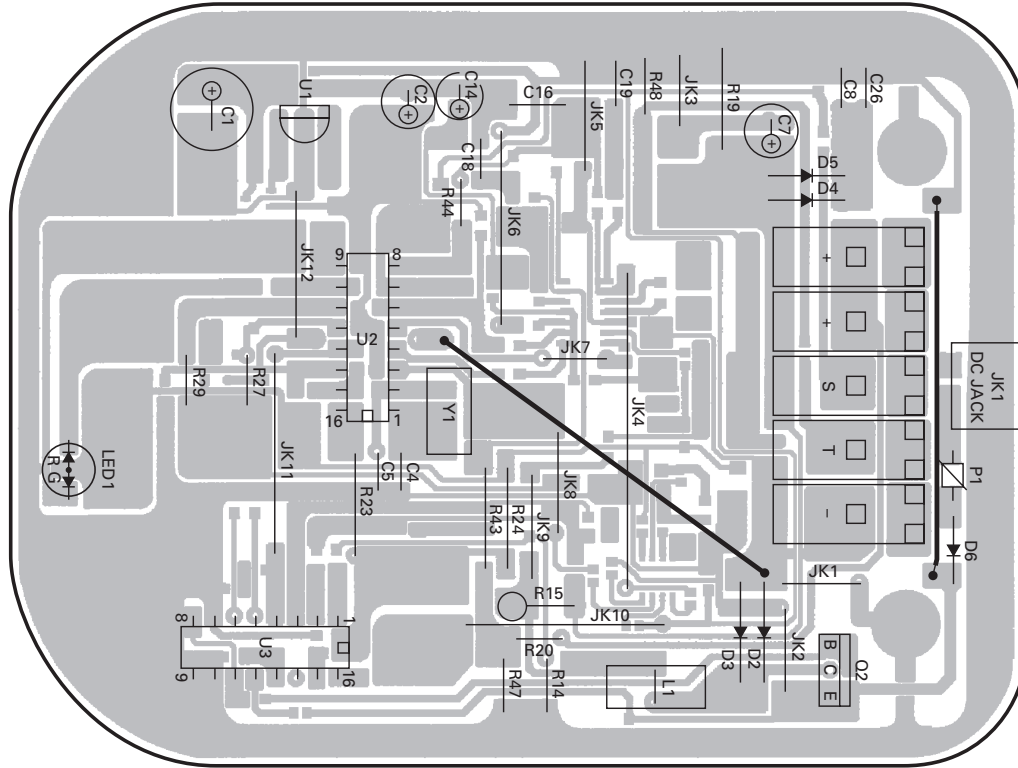

CHARGER UNIT (W02-3641-08) Foil side view

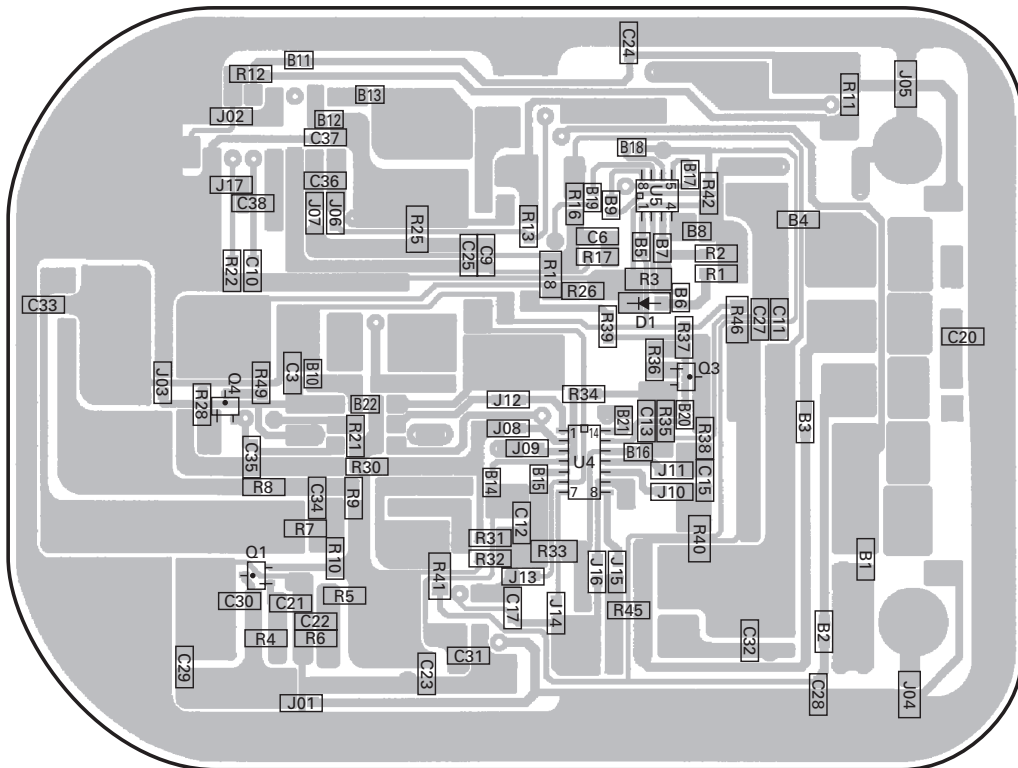

KSC-25 Schematic Diagram

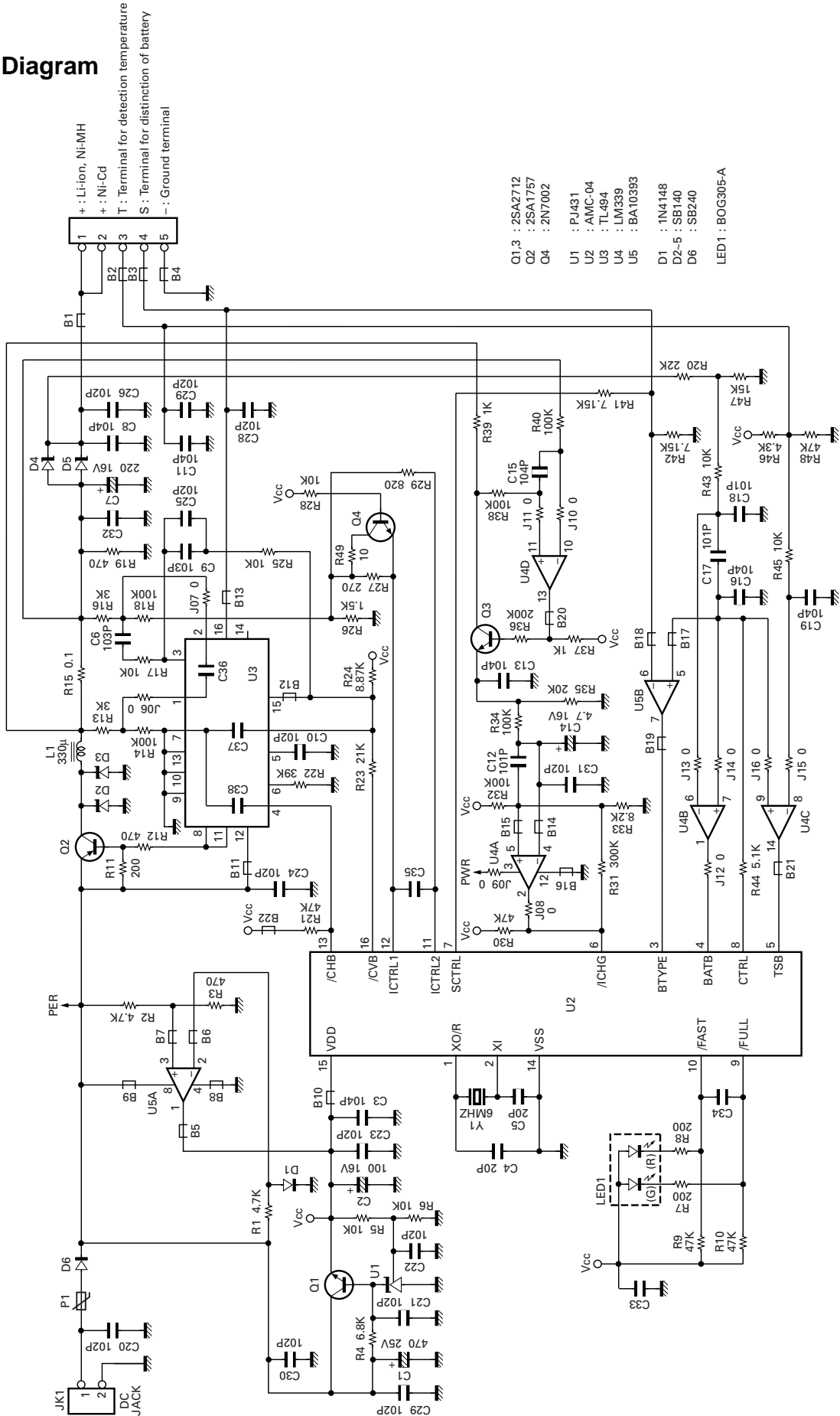

- Q1,3 : 2SA2712
- Q2 : 2SA1757
- O4 : 2N7002
- U1 : PU431
- U2 : AMC-04
- U3 : TL494
- U4 : LM339
- U5 : BA10393
- D1 : 1N4148
- D2-5 : SB140
- D6 : SB240
- LED1 : BOG305-A

KSC-25 / KNB-24L / KNB-25A / KNB-26N / KRA-23

KSC-25

PARTS LIST

* New Parts. ⚠ indicates safety critical components.
 Parts without **Parts No.** are not supplied.
 Les articles non mentionnés dans le **Parts No.** ne sont pas fournis.
 Teile ohne **Parts No.** werden nicht geliefert.

KSC-25

Ref. No.	Address	New parts	Parts No.	Description	Destination
KSC-25					
		*	A02-3655-08	Cabinet UPPER	
		*	A02-3656-08	Cabinet BOTTOM	
		*	B43-1141-08	Badge	
		*	B62-1607-00	Instruction manual	
		*	E03-0200-08	DC jack	
		*	E23-1190-08	Relay terminal	
		*	G13-1547-08	Cushion	
		*	N80-2610-45	Screw	
		*	W02-3641-08	Charger unit	
		*	W08-0942-05	AC adapter 120VAC 60HZ	



KNB-24L

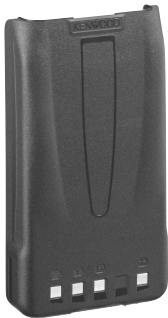

Li-ion Battery Pack
1400mAh

DISCHARGING TERMINALS

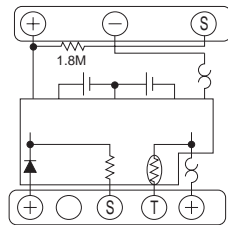

CHARGING TERMINALS

KNB-25A



Ni-Cd Battery pack
1200mAh

DISCHARGING TERMINALS

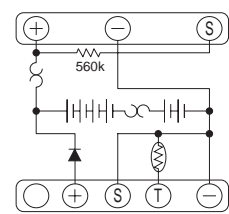

CHARGING TERMINALS

KNB-26N



Ni-MH Battery pack
2000mAh

DISCHARGING TERMINALS

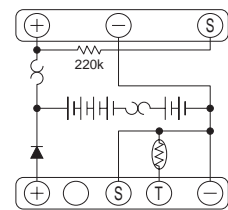

CHARGING TERMINALS

KRA-23 UHF Helical Antenna



M: 440-490MHz

SPECIFICATION

General

Frequency Range	
RX, TX.....	K : 450 to 490MHz
Systems	Trunked Mode : Maximum 32
Groups	Maximum 250
Channels	Trunked Mode : Maximum 600
	Conventional Mode : Maximum 250
Channel Spacing (Wide/Narrow).....	25/12.5kHz
PLL Channel Stepping	5.0, 6.25kHz
Operating Voltage	DC 7.5V \pm 20%
Battery Life	About 9 hours at 5-5-90 duty cycle with KNB-24L battery
	About 8 hours at 5-5-90 duty cycle with KNB-25A battery
	About 12 hours at 5-5-90 duty cycle with KNB-26N battery
Temperature Range	-30°C to +60°C (-22°F to + 140°F)
Dimension and Weight	
With KNB-24L (1400mAh battery)	4.13" (105mm) H x 2.21" (56mm) W x 1.16" (29.5mm) D x 0.66lbs (300g)

Receiver (Measurements made per TIA/EIA-603)

RF Input Impedance	50 Ω
Sensitivity	
12dB SINAD (Wide/Narrow)	0.25 μ V/0.28 μ V
Selectivity (Wide/Narrow)	70dB/65dB
Intermodulation (Wide/Narrow)	70dB/62dB
Spurious	70dB
Frequency Stability	\pm 0.00025% (-30°C to +60°C)
Channel Spread	40MHz : K
Audio Power Output	500mW at 16 Ω less than 5% distortion

Transmitter (Measurements made per TIA/EIA-603)

RF Power Output	
Hi	4W
Low	1W
RF Output Impedance	50 Ω
Spurious	70dB
Modulation (Wide/Narrow)	16K0F3E/11K0F3E
FM Noise (Wide/Narrow)	45dB/40dB
Audio Distortion	Less than 3%
Frequency Stability	\pm 0.00025% (-30°C to +60°C)
Channel Spread	40MHz : K

KENWOOD CORPORATION

14-6, Dogenzaka 1-chome, Shibuya-ku, Tokyo 150-8501, Japan

KENWOOD SERVICE CORPORATION

P.O. BOX 22745, 2201 East Dominguez Street, Long Beach, CA 90801-5745, U.S.A.

KENWOOD ELECTRONICS CANADA INC.

6070 Kestrel Road, Mississauga, Ontario, Canada L5T 1S8

KENWOOD ELECTRONICS DEUTSCHLAND GMBH

Rembrücker Str. 15, 63150 Heusenstamm, Germany

KENWOOD ELECTRONICS BELGIUM N.V.

Leuvensesteenweg 248 J, 1800 Vilvoorde, Belgium

KENWOOD ELECTRONICS FRANCE S.A.

13, Boulevard Ney, 75018 Paris, France

KENWOOD ELECTRONICS U.K. LIMITED

KENWOOD House, Dwight Road, Watford, Herts., WD1 8EB United Kingdom

KENWOOD ELECTRONICS EUROPE B.V.

Amsterdamseweg 37, 1422 AC Uithoorn, The Netherlands

KENWOOD ELECTRONICS ITALIA S.p.A.

Via G. Sirtori, 7/9 20129 Milano, Italy

KENWOOD IBERICA S.A.

Bolivia, 239-08020 Barcelona, Spain

KENWOOD ELECTRONICS AUSTRALIA PTY. LTD.

(A.C.N. 001 499 074)

16 Giffnock Avenue, Centrecourt Estate, North Ryde, N.S.W. 2113, Australia

KENWOOD ELECTRONICS (HONG KONG) LTD.

Unit 3712-3724, Level 37, Tower one Metroplaza, 223 Hing Fong Road, Kwai Fong, N.T., Hong Kong

KENWOOD ELECTRONICS TECHNOLOGIES(S) PTE LTD.

Sales Marketing Division

1 Ang Mo Kio Street 63, Singapore 569110

