

TK-3168

SERVICE MANUAL



Does not come with antenna.
Antenna is available as an option.

CONTENTS

GENERAL	2
SYSTEM SET-UP	2
REALIGNMENT	3
DISASSEMBLY FOR REPAIR	4
CIRCUIT DESCRIPTION	6
INSTALLATION	10
TERMINAL FUNCTION	11
SEMICONDUCTOR DATA	12
COMPONENTS DESCRIPTION	13
PARTS LIST	14
EXPLODED VIEW	21
PACKING	22
ADJUSTMENT	23
PC BOARD	
TX-RX UNIT (X57-6730-XX)	28
SCHEMATIC DIAGRAM	32
BLOCK DIAGRAM	36
LEVEL DIAGRAM	38
KSC-30	39
SPECIFICATIONS	BACK COVER

GENERAL / SYSTEM SET-UP

INTRODUCTION

SCOPE OF THIS MANUAL

This manual is intended for use by experienced technicians familiar with similar types of commercial grade communications equipment. It contains all required service information for the equipment and is current as of the publication date. Changes which may occur after publication are covered by either Service Bulletins or Manual Revisions. These are issued as required.

ORDERING REPLACEMENT PARTS

When ordering replacement parts or equipment information, the full part identification number should be included. This applies to all parts, components, kits, or chassis. If the part number is not known, include the chassis or kit number of which it is a part, and a sufficient description of the required component for proper identification.

Unit		TX-RX Unit	Frequency range	Remarks
Model & destination				
TK-3168	A	X57-6730-31	440~480MHz	IF1 : 49.95MHz LOC : 50.4MHz
TK-3168	A3	X57-6730-32	400~430MHz	IF1 : 49.95MHz LOC : 50.4MHz

PERSONAL SAFETY

The following precautions are recommended for personal safety:

- DO NOT transmit until all RF connectors are verified secure and any open connectors are properly terminated.
- SHUT OFF and DO NOT operate this equipment near electrical blasting caps or in an explosive atmosphere.
- This equipment should be serviced by a qualified technician only.

SERVICE

This radio is designed for easy servicing. Refer to the schematic diagrams, printed circuit board views, and alignment procedures contained within.

SYSTEM SET-UP

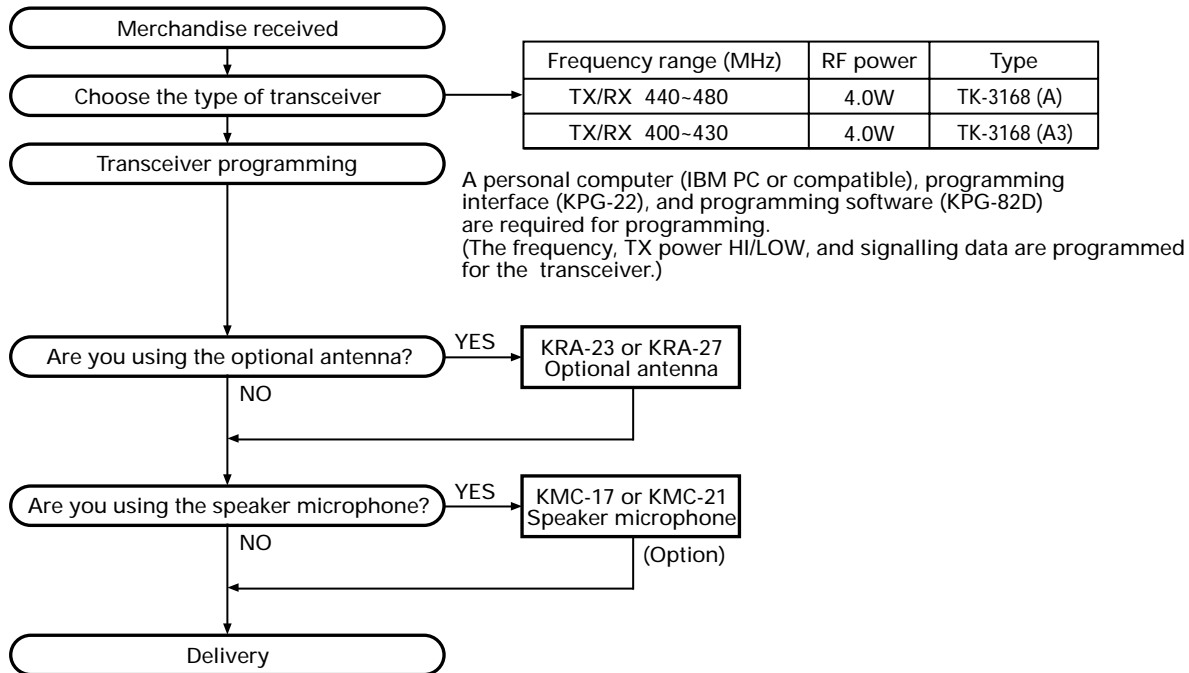

REALIGNMENT

REALIGNMENT

1. Modes

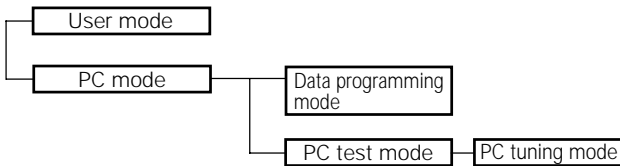

Mode	Function
User mode	For normal use.
PC mode	Used for communication between the radio and PC (IBM compatible).
Data programming mode	Used to read and write frequency data and other features to and from the radio.
PC test mode	Used to check the radio using the PC. This feature is included in the KPG-82D.

2. How to Enter Each Mode

Mode	Operation
User mode	Power ON
PC mode	Received commands from PC

3. PC Mode

3-1. Preface

The TK-3168 transceiver is programmed using a personal computer, a programming interface (KPG-22) and programming software (KPG-82D).

The programming software can be used with an IBM PC or compatible. Figure 1 shows the setup of an IBM PC for programming.

3-2. Connection procedure

1. Connect the TK-3168 to the personal computer with the interface cable.
2. When the POWER is switched on, user mode can be entered immediately. When the PC sends a command, the radio enters PC mode.
When data is transmitting from the transceiver, the red LED lights.
When data is received by the transceiver, the green LED lights.

Notes:

- The data stored in the personal computer must match the model type when it is written into the EEPROM.
- Change the TK-3168 to PC mode, then attach the interface cable.

3-3. KPG-22 description

(PC programming interface cable: Option)

The KPG-22 is required to interface the TK-3168 with the computer. It has a circuit in its D-subconnector (25-pin) case

that converts the RS-232C logic level to the TTL level.

The KPG-22 connects the SP/MIC connector of the TK-3168 to the computer's RS-232C serial port.

3-4. Programming software description

KPG-82D is the programming software for TK-3168 supplied on a CD-ROM. This software runs under Windows 98, ME, Windows 2000 or XP on an IBM-PC or compatible machine.

The data can be input to or read from TK-3168 and edited on the screen. The programmed or edited data can be printed out. It is also possible to tune the transceiver.

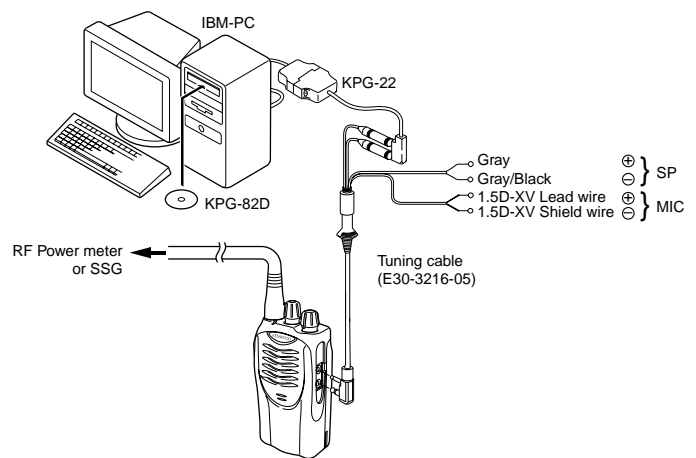

Fig. 1

TK-3168

DISASSEMBLY FOR REPAIR

1. Separating the case assembly from the chassis.

1. Remove the volume knob ①.
2. Remove the two screws ②.
3. Lift the chassis ③, and remove it from the case assembly.

Note: After separating the case assembly from the chassis, remove the channel knob.

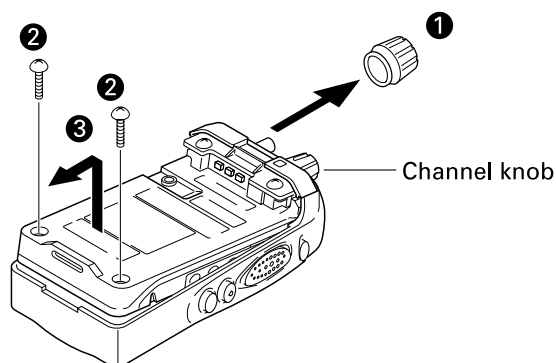

3. How to remove the battery terminal block.

1. Remove the two screws ⑩, then pull out the back cover ⑪.
2. Remove the screw ⑫.

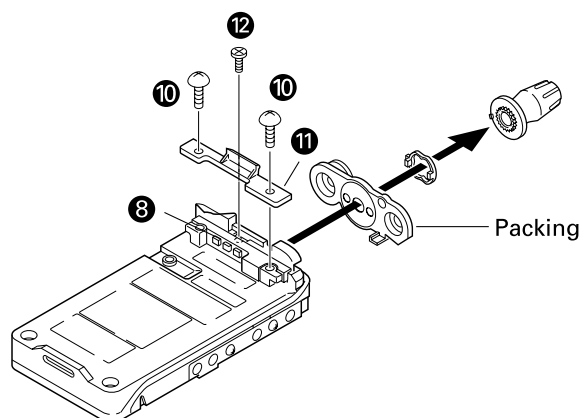

2. Separating the chassis from the TX/RX unit.

1. Remove the two screws ④ fixing the TX/RX unit B/2.
2. Remove the twelve screws ⑤ and two screws ⑥ fixing the TX/RX unit A/2.
3. Remove the solder from the antenna terminal using a soldering iron ⑦, then lift the unit off.

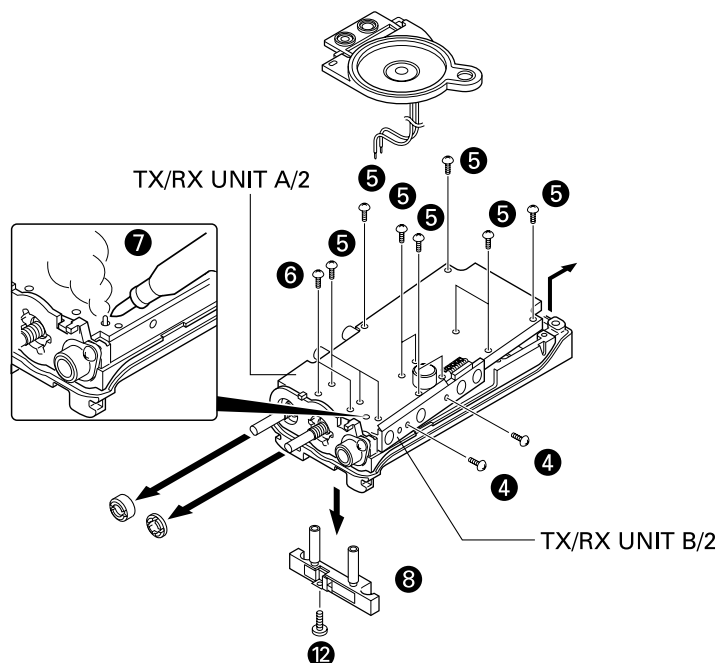

Note: The two screws ⑥ of TX/RX unit A/2 are fixing the battery terminal block ⑧.

DISASSEMBLY FOR REPAIR

Assembling

- Installation of battery terminal block and packing

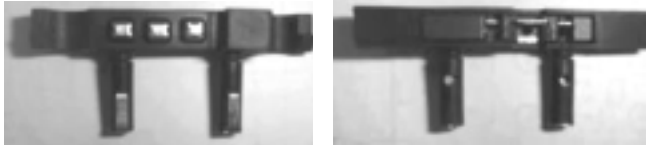

Install them so that no distortion or deformation occurs.

- Installation of speakers and cushion, and wire styling of speakers

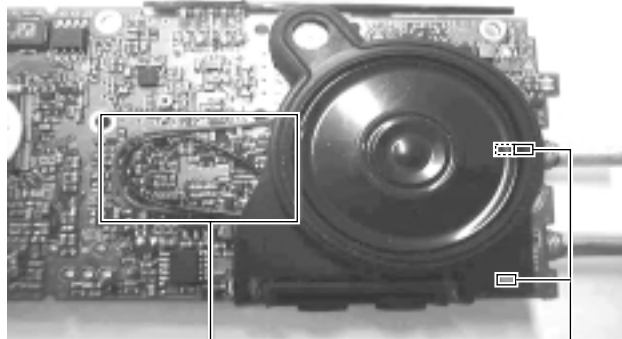

Wire Styling

Install the cushion according to the guide.

Install the speakers so that they do not protrude from the cushion. Perform the wire styling of speakers as shown in a photograph.

- Attaching the cushion

Attach the cushion as shown in Fig. 1.

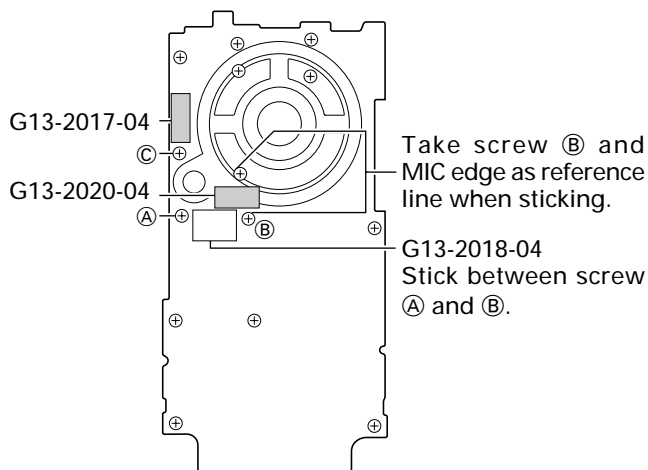

Fig. 1

Note: Cushion must not cover the screws (A), (B) and (C).

- Installation of chassis and cabinet assy

Do not press this area, top packing easily deform.



First, mount the set to the cabinet assy.



Second, press down the Chassis to the cabinet assy as shown in the diagram.

Good Condition

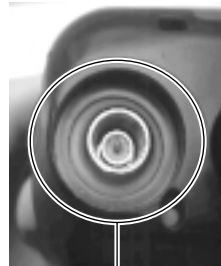

After mount, packing should be in this condition.

NG Condition



Packing deform.

Packing protruded out.



Note:

- Take care that the packing does not protrude from the chassis or case.
- Replace the protruded or deformed packing with a new one.

CIRCUIT DESCRIPTION

6) Tone Volume Fixed Circuit

This function generates a TONE signal sound even if the AF volume of the transceiver is the minimum. A TONE signal is sent through Q602 to the AF amplifier when, in the FPU, "TONE Volume Fixed" is set to ON.

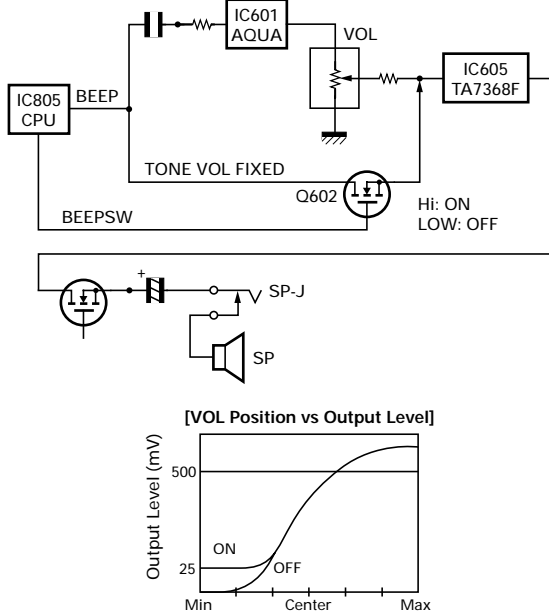

Fig. 4 Tone volume fixed circuit

7) Squelch

Part of the AF signal from the IC enters the FM IC (IC401) again, and the noise component is amplified and rectified by a filter and an amplifier to produce a DC voltage corresponding to the noise level.

The DC signal from the FM IC goes to the analog port of the microprocessor (IC805). IC805 determines whether to output sounds from the speaker by checking whether the input voltage is higher or lower than the preset value.

To output sounds from the speaker, IC805 sends a high signal to the SP MUTE line and turns IC605 on through Q603, Q604, Q607 and Q608. (See Fig. 5)

8) Receive Signalling

(1) QT/DQT

The output signal from IF IC (IC401) enters the microprocessor (IC805) through IC601. IC805 determines whether the QT or DQT matches the preset value, and controls the SP MUTE and the speaker output sounds according to the squelch results.

(2) DTMF

The DTMF input signal from the IF IC (IC401) is amplified by IC602 and goes to IC601, the DTMF decoder. The decoded information is then processed by the CPU.

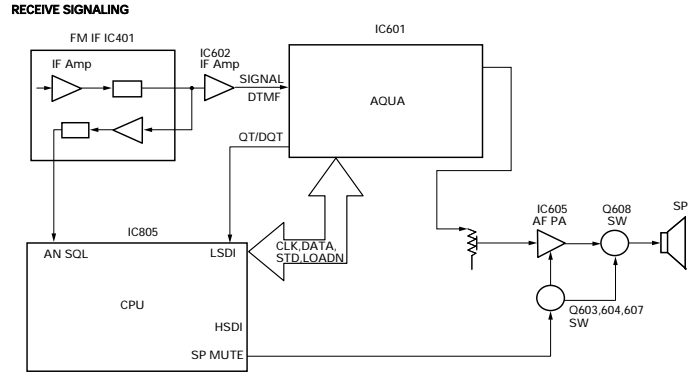

Fig. 5 AF amplifier and squelch

3. PLL Frequency Synthesizer

The PLL circuit generates the first local oscillator signal for reception and the RF signal for transmission.

1) PLL

The frequency step of the PLL circuit is 5 or 6.25kHz.

A 16.8MHz reference oscillator signal is divided at IC1 by a fixed counter to produce oscillator (VCO) output signal which is buffer amplified by Q9 then divided in IC1 by a dual-module programmable counter. The divided signal is compared in phase with the 5 or 6.25kHz reference signal from the phase comparator in IC1. The output signal from the phase comparator is filtered through a low-pass filter and passed to the VCO to control the oscillator frequency. (See Fig. 6)

2) VCO

The operating frequency is generated by Q6 in transmit mode and Q5 in receive mode. The oscillator frequency is controlled by applying the VCO control voltage, obtained from the phase comparator, to the varactor diodes (D4 and D7 in transmit mode and D3 and D9 in receive mode). The RX pin is set high in receive mode causing Q8 and Q12 to turn Q6 off and turn Q5 on.

The TX pin is set high in transmit mode. The outputs from Q5 and Q6 are amplified by Q9 and sent to the RF amplifiers.

CIRCUIT DESCRIPTION

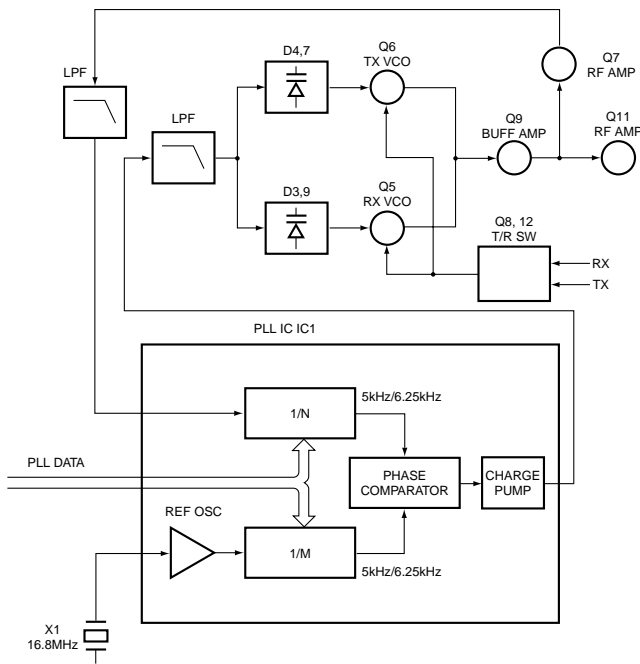

Fig. 6 PLL circuit

3) Unlock Detector

If a pulse signal appears at the LD pin of IC1, an unlock condition occurs, and the DC voltage obtained from C19, R6, and Q1 causes the voltage applied to the microprocessor to go high. When the microprocessor detects this condition, the transmitter is disabled, ignoring the push-to-talk switch input signal. (See Fig. 7)

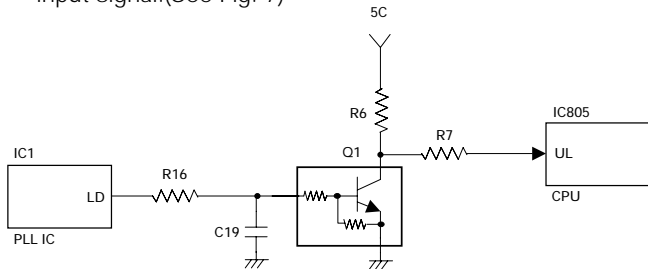

Fig. 7 Unlock detector circuit

4. Transmitter System

1) Microphone Amplifier

The signal from the microphone passes through IC601. When encoding DTMF, it is turned OFF for muting the microphone input signal by IC601. The signal passes through the Audio processor (IC601) for the maximum deviation adjustment, and goes to the VCXO modulation input.

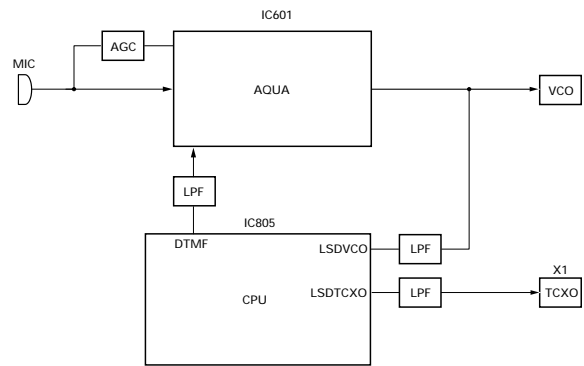

Fig. 8 Microphone amplifier

2) Drive and Final Amplifier

The signal from the T/R switch (D201 is on) is amplified by the pre-drive (Q206) and drive amplifier (Q207) to 50mW. The output of the drive amplifier is amplified by the RF power amplifier (Q211) to 4.0W (1W when the power is low). The RF power amplifier consists of two MOS FET stages. The output of the RF power amplifier is then passed through the harmonic filter (LPF) and antenna switch (D204 and D206) and applied to the antenna terminal.

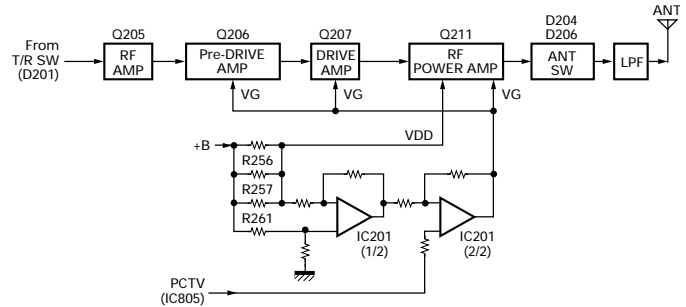

Fig. 9 Drive and final amplifier and APC circuit

3) APC Circuit

The APC circuit always monitors the current flowing through the RF power amplifier (Q211) and keeps a constant current. The voltage drop at R256, R257 and R261 is caused by the current flowing through the RF power amplifier and this voltage is applied to the differential amplifier IC201(1/2). IC201(2/2) compares the output voltage of IC201(1/2) with the reference voltage from IC805. The output of IC201(2/2) controls the VG of the RF power amplifier, Drive amplifier and Pre-Drive amplifier to make both voltages the same. The change of power high/low is carried out by the change of the reference voltage.

4) Encode Signalling

(1) QT/DQT

QT, DQT data of the LSDTCXO Line is output from pin 22 of the CPU. The signal passes through a low-pass CR filter and goes to the TCXO(X1).

The QT, DQT data of the LSDVCO Line is output from pin

CIRCUIT DESCRIPTION

20 of the CPU. The signal passes through a low pass CR filter, mixes with the audio signal, and goes to the VCO modulation input. TX deviation is adjusted by the CPU.

(2) DTMF

High-speed data is output from pin 2 of the CPU. The signal passes through a low-pass CR filter, and provides a TX and SP out tone, and is then applied to the audio processor (IC601). The signal is mixed with the audio signal and goes to the VCO.

TX deviation is adjusted by the CPU.

5. Power Supply

There are 3.5V power supply for PLL circuit and five 5V power supplies for the microprocessor: 5M,5MS,5C,5R, and 5T. 5M for microprocessor is always output while the power is on. 5M is always output, but turns off when the power is turned off to prevent malfunction of the microprocessor.

5C is a common 5V and is output when SAVE is not set to OFF.

5R is 5V for reception and output during reception.

5T is 5V for transmission and output during transmission.

6. Control Circuit

The control circuit consists of a microprocessor (IC805) and its peripheral circuits. It controls the TX-RX unit. IC805 mainly performs the following:

- (1) Switching between transmission and reception by the PTT signal input.
- (2) Reading system, group, frequency, and program data from the memory circuit.
- (3) Sending frequency program data to the PLL.
- (4) Controlling squelch on/off by the DC voltage from the squelch circuit.
- (5) Controlling the audio mute circuit by the decode data input.
- (6) Transmitting tone and encode data.

1) Frequency Shift Circuit

The microprocessor (IC805) operates at a clock of 7.3728MHz. This oscillator has a circuit that shifts the frequency by BEAT SHIFT SW (Q810).

A beat sound may be able to be evaded from generation if "Beat Shift" is set to ON when it is generated in the internal spurious transmission modulated sound of a transceiver.

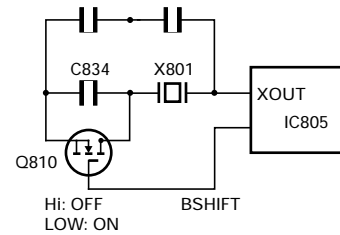

Fig. 10 Frequency shift circuit

2) Memory Circuit

Memory circuit consists of the CPU (IC805) and an EEPROM (IC804). An EEPROM has a capacity of 64k bits that contains the transceiver control program for the CPU and data such as transceiver channels and operating features.

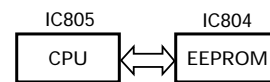

Fig. 11 Memory circuit

3) Low Battery Warning

The battery voltage is checked using by the microprocessor. The transceiver generates a warning tone when it falls below the warning voltage shown in the table.

- (1) The red LED blinks when the battery voltage falls below the voltage (1) shown in the table during transmission.
- (2) The red LED blinks when the battery voltage falls below the voltage (2) shown in the table during transmission.

Note:

The transceiver checks the battery voltage during reception even when, in the FPU, the Battery Warning status function is set to "On TX" (default setting).

However, the LED does not blink during reception. During transmission, the LED blinks to generate the warning tone of a low battery voltage.

- (3) The transceiver immediately stops transmission when the battery voltage falls below the voltage (3) shown in the table. A message tone beeps while the PTT switch is released.

	Battery Case	Li-ion Battery	Ni-Cd Battery	Ni-MH Battery
(1)	6.2[V]	6.5[V]	6.2[V]	6.2[V]
(2)	7.5[V]	7.1[V]	6.8[V]	7.0[V]
(3)	5.9[V]	6.2[V]	5.9[V]	5.9[V]

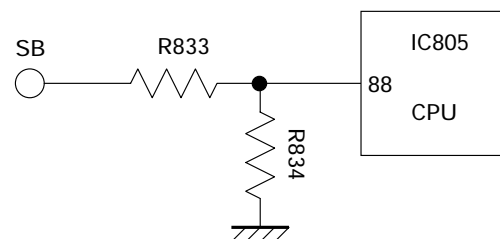

Fig. 12 Low battery warning

CIRCUIT DESCRIPTION / INSTALLATION

4) Battery Type Detection

The transceiver automatically detects the battery type, measuring the resistance between the S-terminal and + terminal on the battery pack and changes the supplied voltage to the S-terminal as below. The microprocessor then detects the battery type.

Resistor value	Battery type	Input voltage of S-terminal
1.8MΩ	Li-ion	0.3~1.3V
560kΩ	Ni-Cd	1.3~2.6V
220kΩ	Ni-MH	2.6~5.0V
OPEN	Battery case	0~0.3V

7. Control System

Keys and channel selector circuit.

The signal from keys and channel selector input to microprocessor directly as shown in fig. 13.

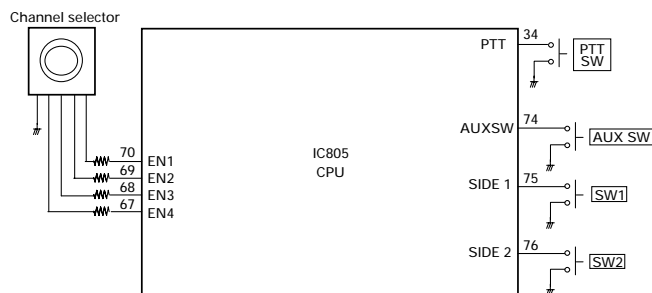

Fig. 13 Control system

INSTALLATION

1. Optional Board

Remove the TX/RX unit from the radio before installing the optional board in the radio.

The procedure for removing the TX/RX unit is described in the DISASSEMBLY FOR REPAIR section in the Service Manual.

Install the optional board on the back of the TX/RX unit.

For details on installation of the optional board, refer to Installation Information supplied with the optional board.

When installing the optional board, also refer to the chart in TERMINAL FUNCTION section (page 11) given in the Service Manual.

Note: To install and use the Scrambler Board, remove "R601" and "R647" from the front of the TX/RX unit.

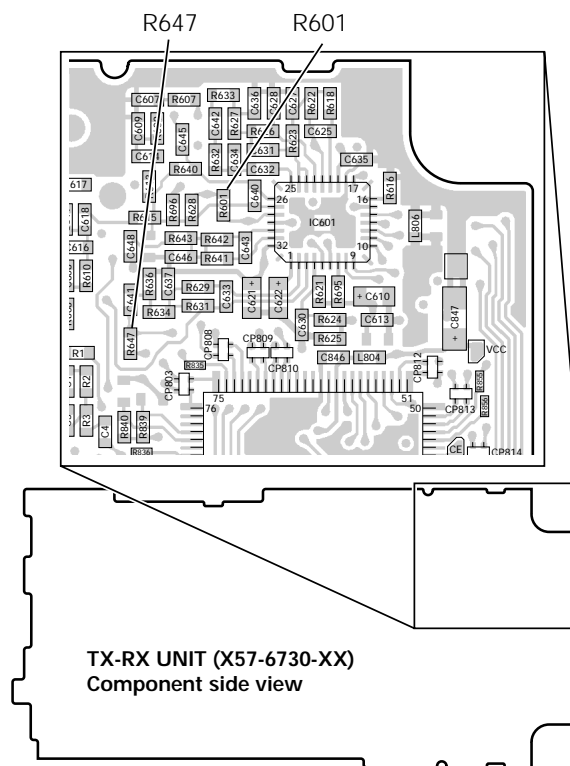

TERMINAL FUNCTION

■ CN801

Pin No.	Designation	Function	Condition	Value
1	GND	GND		Vss
2	SB	Switched B	Output Voltage/7mA load	DC (Battery terminal) $\pm 0.5V$
3	A3	AUX3	Load >100k Ω	(Low) Vss - 0.4V (High) Vdd-0.8V - Vdd
4	TXAFI	Transmit AF input	Input sensitivity/Impedance (1kHz std. dev.)	280 \pm 50mVrms @22k Ω Load
5	A2	AUX2	Load >100k Ω	(Low) Vss - 0.4V (High) Vdd-0.8V - Vdd
6	A6	AUX6	Load >100k Ω	(Low) Vss - 0.4V (High) Vdd-0.8V - Vdd
7	A1	AUX1	Load >100k Ω	(Low) Vss - 0.4V (High) Vdd-0.8V - Vdd
8	A5	AUX5	Load >100k Ω	(Low) Vss - 0.4V (High) Vdd-0.8V - Vdd
9	A4	AUX4	Load >100k Ω	(Low) Vss - 0.4V (High) Vdd-0.8V - Vdd
10	NC	Non connection		Non connection
11	5C	DC 5V	Output Voltage/10mA load	5.0 \pm 0.5V
12	DEO	Discriminator signal output	Output voltage/Impedance (1kHz std. mod.)	280 \pm 50mVrms @2.2k Ω Load
13	TXAFI	Transmit AF input	Input sensitivity/Impedance (1kHz std. dev.)	280 \pm 50mVrms @22k Ω Load
14	DEO	Discriminator signal output	Output voltage/Impedance (1kHz std. mod.)	280 \pm 50mVrms @2.2k Ω Load
15	NC	Non connection		Non connection
16	ALT	Sidetone input	Input sensitivity/Impedance (1kHz rated AF power/Vol. MAX)	7 \pm 3mVrms @22k Ω Load
17	NC	Non connection		Non connection
18	NC	Non connection		Non connection
19	NC	Non connection		Non connection
20	GND	GND		Vss

■ Solder point connection

Designation	Function	Condition	Value
MIC_I	Mic input	Input sensitivity/Impedance (1kHz std. dev.)	7 \pm 3mVrms @22k Ω Load
MIC_O	Mic o utput	Output voltage/Impedance (1kHz 15mVrms mic input)	2.6 \pm 1.0mVrms @2.2k Ω Load
		Output voltage/Impedance (1kHz 100mVrms mic input)	90 \pm 20mVrms @100k Ω Load
RA_I	Receiver AF input	Input sensitivity/Impedance (1kHz rated AF power/Vol. MAX)	75 \pm 20mVrms @22k Ω Load
RA_O	Receiver AF output	Output voltage/Impedance (1kHz std. mod.)	150 \pm 50mVrms @2.2k Ω Load
		Output voltage/Impedance (1kHz system mod.)	290 \pm 50mVrms @100k Ω Load
A1	AUX1	Load >100k Ω	(Low) Vss - 0.4V (High) Vdd-0.8V - Vdd
A2	AUX2	Load >100k Ω	(Low) Vss - 0.4V (High) Vdd-0.8V - Vdd
A3	AUX3	Load >100k Ω	(Low) Vss - 0.4V (High) Vdd-0.8V - Vdd
A4	AUX4	Load >100k Ω	(Low) Vss - 0.4V (High) Vdd-0.8V - Vdd
A5	AUX5	Load >100k Ω	(Low) Vss - 0.4V (High) Vdd-0.8V - Vdd
A6	AUX6	Load >100k Ω	(Low) Vss - 0.4V (High) Vdd-0.8V - Vdd
SB	Switched B	Output Voltage/7mA load	DC (Battery terminal) $\pm 0.5V$
GND	GND		Vss
5C	DC 5V	Output Voltage/10mA load	5.0 \pm 0.5V
TXAFI	Transmit AF input	Input sensitivity/Impedance (1kHz std. dev.)	280 \pm 50mVrms @22k Ω Load
DEO	Discriminator signal output	Output voltage/Impedance (1kHz std. mod.)	280 \pm 50mVrms @2.2k Ω Load
LSDFO	Received sub-tone output	Output voltage/Impedance (150Hz 15% mod.)	180 \pm 50mVrms @2.2k Ω Load
ALT	Sidetone input	Input sensitivity/Impedance (1kHz rated AF power/Vol. MAX)	7 \pm 3mVrms @22k Ω Load

SEMICONDUCTOR DATA

Microprocessor : M30622MCA7G7GP (TX-RX UNIT : IC805)

■ Pin function

Pin No.	Port Name	I/O	Function
1	PCTV	O	APC/BPF control data output.
2	DTMF	O	DTMF
3	NC	-	NC
4	EEPDAT	I/O	EEPROM data input/output.
5	EEPCLK	O	EEPROM Clock
6	BYTE	I	GND.
7	CNVSS	I	GND.
8	AUX5	O	Option Board 5
9	AUX6	O	Option Board 6
10	RESET	I	CPU reset.
11	XOUT	O	CPU clock.
12	VSS	-	GND.
13	XIN	I	CPU clock.
14	VCC	-	+5V.
15	NC	I	NC
16	INT	I	Battery voltage monitor input Low battery : L
17	RDF/FD	I	Base Band IC Data input
18	TCLK/ DTRDI	I	Base Band IC Data input
19	NC	-	NC
20	LSDVCO	O	Low speed data output. (VCO)
21	NC	I	NC
22	LSDTCXO	O	Low speed data output. (TCXO)
23	NC	I	NC
24	BEEP	O	Beep output.
25	OPTDET	I	Option detect input
26	NC	-	NC
27	NC	-	NC
28	NC	-	NC
29	AUX4	O	Option board port 4
30	AUX2	I/O	Option board port 2
31	NC	-	NC
32	NC	-	NC
33	TXD	I/O	Serial data.
34	PTT/RXD	I	PTT on : L/Serial data.
35	STD	I	Base Band IC Data input
36	BBDIR	O	Base Band IC Data output
37	BBCLK	O	Base Band IC clock output
38	BBDI/O	I/O	Base Band IC Data input/output
39	NC	-	NC
40	TDATA/ DTRCLK	O	Base Band IC Data output
41	DTRLOADN	O	Base Band IC Data output
42	AUX3	O	Option board port 3
43	AUX1	O	Option board port 1
44	NC	-	NC
45	NC	-	NC
46	DSW	O	APC voltage discharge Switch
47	BEEPSW	O	Beep switch.
48	AFCOUT	O	AF amp power supply control
49	AFMUTE	O	RX audio mute
50	NC	-	NC
51	TX	O	TX VCO power supply switch TX:L
52	RX	O	RX VCO power supply switch RX:L

Pin No.	Port Name	I/O	Function
53	BSHIFT	O	Beet shift switch.
54	W/N	O	W/N switch Wide:L
55	NC	-	NC
56	APCSW	O	APC switch output.
57	SAVE	O	Battery save output.
58	5TC	O	5T control output.
59	5RC	O	5R control output.
60	VCC	-	+5V.
61	5MSC	O	5M control output.
62	VSS	-	GND.
63	NC	-	NC
64	NC	-	NC
65	NC	-	NC
66	NC	-	NC
67	EN4	I	CH selector input 4.
68	EN3	I	CH selector input 3.
69	EN2	I	CH selector input 2.
70	EN1	I	CH selector input 1.
71	NC	-	NC
72	LEDTX	O	RED LED lights control output
73	LEDRX	O	GREEN LED lights control output
74	AUXSW	I	Key input.(Emergency)
75	SIDE1	I	Side key 1 input.
76	SIDE2	I	Side key 2 input.
77	NC	-	NC
78	NC	-	NC
79	SIM1	I	Destination select 1.
80	SIM2	I	Destination select 2.
81	NC	-	NC
82	PLLUL	I	PLL unlock detect input. unlock : L
83	RFCLK	O	PLL clock output. Latch : L
84	RFDAT	O	PLL data output.
85	PS	O	PLL power save output.
86	PLLSTB	O	PLL strobe output.
87	BATTSEL	I	Battery distinction input.
88	BATT	I	Battery voltage input.
89	VOX	I	VOX input.
90	RSSQL	I	Received signal strength indicator input.
91	ANSQL	I	Squelch level input.
92	LSDI	I	Low speed data input (QT/DOT).
93	THM	I	Thermistor input.
94	AVSS	-	GND.
95	NC	-	NC
96	VREF	-	+5V.
97	AVCC	-	+5V.
98	NC	-	NC
99	NC	-	NC
100	NC	-	NC

COMPONENTS DESCRIPTION

TX-RX UNIT (X57-673X-XX)

Ref. No.	Use/Function	Operation/Condition
IC1	IC	PLL system
IC201	IC	Comparator (APC)
IC401	IC	FM IF system
IC601	IC	Audio processor
IC602	IC	AF AMP
IC604	IC	VOX AMP
IC605	IC	AF power AMP
IC801	IC	Voltage regulator / 5V
IC802	IC	Voltage detector / Reset
IC803	IC	Voltage detector / INT
IC804	IC	EEPROM
IC805	IC	Microprocessor
IC806	IC	Flip Flop
Q1	Transistor	Level shift
Q2	Transistor	Level shift
Q3	Transistor	Level shift
Q4	Transistor	Tripler
Q5	FET	VCO / RX
Q6	FET	VCO / TX
Q7	Transistor	PLL IC f_in AMP
Q8	FET	DC switch / TX VCO
Q9	Transistor	RF Buffer AMP
Q10	Transistor	Ripple filter
Q11	Transistor	RF AMP
Q12	FET	DC switch / RX VCO
Q205	Transistor	Pre-drive AMP
Q206	FET	Pre-drive AMP
Q207	FET	TX Drive AMP
Q208	Transistor	APC switch
Q209	FET	APC switch
Q210	Transistor	APC switch
Q211	FET	TX Final AMP
Q212	FET	APC switch
Q213	Transistor	APC switch
Q401	Transistor	W/N switch
Q402	Transistor	IF AMP
Q403	FET	Mixer
Q404	FET	RF AMP
Q407	FET	DC switch
Q601	FET	AF Mute
Q602	FET	Beep switch
Q603	Transistor	DC switch / SP Mute
Q604	Transistor	DC switch
Q605	Transistor	MIC AGC
Q606	Transistor	MIC AGC
Q607	Transistor	DC switch / SP Mute
Q608	FET	SP Mute switch
Q801	Transistor	5T switch
Q802(1/2)	FET	5TC switch
Q802(2/2)	FET	SAVE switch
Q803(1/2)	Transistor	AVR / 5C
Q803(2/2)	Transistor	AVR / 5T
Q804	Transistor	5C switch

Ref. No.	Use/Function	Operation/Condition
Q805(1/2)	Transistor	LED switch / Green
Q805(2/2)	Transistor	LED switch / Red
Q806	Transistor	AVR / PLLB
Q807	Transistor	PLLB switch
Q808	Transistor	5MS switch
Q809	Transistor	5R switch
Q810	FET	Beet shift switch
D3	Variable capacitance diode	Frequency control / RX VCO
D4	Variable capacitance diode	Frequency control / TX VCO
D7	Variable capacitance diode	Frequency control / TX VCO
D9	Variable capacitance diode	Frequency control / RX VCO
D10	Variable capacitance diode	Modulation
D11	Diode	Current steering
D201	Diode	TX/RX RF switch
D203	Zener diode	APC protect
D204	Diode	ANT switch
D206	Diode	ANT switch
D208	Diode	ANT switch
D212	Diode	ANT switch
D401	Diode	TX/RX RF switch
D402	Variable capacitance diode	RF BPF tuning
D403	Variable capacitance diode	RF BPF tuning
D404	Variable capacitance diode	RF BPF tuning
D405	Variable capacitance diode	RF BPF tuning
D406	Variable capacitance diode	RF BPF tuning
D407	Diode	Rectifier
D603	Diode	Limiter
D604	Diode	Detector
D605	Diode	Detector
D606	Diode	Detector
D801	Diode	5M protect
D802	LED	LED / Red
D803	LED	LED / Green
D805	Diode	Reverse protection

TK-3168

PARTS LIST

* New Parts. △ indicates safety critical components.
 Parts without **Parts No.** are not supplied.
 Les articles non mentionnés dans le **Parts No.** ne sont pas fournis.
 Teile ohne **Parts No.** werden nicht geliefert.

L: Scandinavia K: USA P: Canada
 Y: PX (Far East, Hawaii) T: England E: Europe
 Y: AAFES (Europe) X: Australia M: Other Areas

TK-3168 (Y50-5790-XX) TX-RX UNIT (X57-6730-XX)

Ref. No.	Address	New parts	Parts No.	Description	Destination
TK-3168					
1	1B		A02-3835-43	CABINET ASSY	
2	2B		A10-4068-31	CHASSIS	
3	3A		A82-0054-02	REAR PANEL	
4	3A		B01-0694-03	ESCUTCHEON	
5	2D		B09-0676-13	CAP ACCESSORY	
6	1C		B62-1786-00	INSTRUCTION MANUAL	
7	3B	*	B72-2257-04	MODEL NAME PLATE	A
7	3B	*	B72-2258-04	MODEL NAME PLATE	A3
8	3A		E04-0446-05	RF COAXIAL RECEPTACLE(SMA)	
10	2A		E37-1101-05	SPEAKER WIRE(RED)	
11	2A		E37-1102-05	SPEAKER WIRE(BLACK)	
12	3A		E72-0416-23	BATT TERMINAL BLOCK	
13	2B		G11-4090-04	SHEET(FINAL FET)	
14	3B		G11-4254-04	SHEET(PTT)	
15	3A		G11-4287-04	SHEET(BATT TERMINAL BLOCK)	
16	3A		G11-4289-04	SHEET(CHASSIS)	
17	3B	*	G11-4293-04	SHEET	
18	2A	*	G11-4294-04	SHEET	
19	3B	*	G11-4295-04	SHEET	
20	1A	*	G11-4306-04	SHEET	
21	2A	*	G11-4312-04	SHEET	
22	2B		G13-2001-04	CUSHION(CHASSIS)	
23	2B	*	G13-2014-04	CUSHION(CHASSIS BOTTOM)	
24	2B		G13-2017-04	CUSHION	
25	2B		G13-2018-04	CUSHION	
26	3A		G13-2019-04	CUSHION	
27	2B		G13-2020-04	CUSHION	
28	3A	*	G13-2026-04	CUSHION	
29		*	G13-2027-04	CUSHION	
30	2B		G53-1580-03	PACKING(CHASSIS)	
31	1B		G53-1581-12	PACKING(SPEAKER)	
32	3B		G53-1582-03	PACKING(BATT TERMINAL BLOCK)	
33	3A	*	G53-1641-02	PACKING	
34	3C		H12-3150-02	PACKING FIXTURE	
35			H25-2345-04	PROTECTION BAG	
36	1D	*	H52-2062-02	ITEM CARTON CASE	
37	2A		J19-5454-03	HOLDER	
38	2D		J21-8464-04	HARDWARE FIXTURE ACCESSORY	
39	2C		J29-0701-05	HOOK ACCESSORY	
40	3A		J30-1275-04	SPACER(CH KNOB)	
41	1A		K29-9278-13	KNOB(VOLUME)	
42	3A		K29-9280-13	KNOB(CH SELECTOR)	
43	1B	*	K29-9332-03	KNOB(PTT)	
A	3A		N14-0583-04	CIRCULAR NUT(CH)	
B	3A		N14-0805-04	CIRCULAR NUT(VOLUME)	
C	3A		N30-2604-46	PAN HEAD MACHINE SCREW	
D	3B		N30-2612-46	PAN HEAD MACHINE SCREW	
E	3A,3B		N30-3006-45	PAN HEAD MACHINE SCREW	
F	2D		N35-3004-45	BINDING HEAD MACHINE SCREW	
G	3A,3B		N78-2040-46	PAN HEAD TAPTITE SCREW	
H	2A,2B		N83-2005-46	PAN HEAD TAPTITE SCREW	

Ref. No.	Address	New parts	Parts No.	Description	Destination
43	2A		R31-0650-05	VARIABLE RESISTOR	
44	2A		S60-0420-05	ROTARY SWITCH	
45	1B		T07-0369-05	SPEAKER	
TX-RX UNIT (X57-6730-XX) 0-31 : A 0-32 : A3					
D802			B30-2156-05	LED(RED)	
D803			B30-2157-05	LED(YELLOW)	
C1			CK73GB1H392K	CHIP C 3900PF K	
C2			CK73GB1H471K	CHIP C 470PF K	
C3			CK73GB1H103K	CHIP C 0.010UF K	
C5			CK73GB1H471K	CHIP C 470PF K	
C6			CK73GB1H103K	CHIP C 0.010UF K	
C7			CK73GB1H471K	CHIP C 470PF K	
C8			CC73GCH1H100	D CHIP C 10PF D	
C9			CK73GB1H103K	CHIP C 0.010UF K	
C10			CC73GCH1H100	D CHIP C 10PF D	
C11-13			CC73GCH1H101	J CHIP C 100PF J	
C14			C92-0713-05	CHIP-TAN 10UF 6.3WV	
C15			CK73GB1H102K	CHIP C 1000PF K	
C16			CC73GCH1H470	J CHIP C 47PF J	
C18,19			CK73GB1C104K	CHIP C 0.10UF K	
C22			CK73GB1C104K	CHIP C 0.10UF K	
C24			C92-0713-05	CHIP-TAN 10UF 6.3WV	
C25			CK73GB1H471K	CHIP C 470PF K	
C27			CK73GB1H103K	CHIP C 0.010UF K	
C28			CC73GCH1H560	J CHIP C 56PF J	
C29			CK73GB1H471K	CHIP C 470PF K	
C30			CC73GCH1H220	J CHIP C 22PF J	
C31			CC73GCH1H560	J CHIP C 56PF J	
C32			C92-0002-05	CHIP-TAN 0.22UF 35WV	
C33			CC73GCH1H470	J CHIP C 47PF J	
C34			CK73GB1H471K	CHIP C 470PF K	
C35			CC73GCH1H680	J CHIP C 68PF J	
C36			C92-0585-05	CHIP-TAN 4.7UF 16WV	
C37			CK73GB1H103K	CHIP C 0.010UF K	A
C37			CK73GB1H822K	CHIP C 8200PF K	A3
C38,39			C92-0002-05	CHIP-TAN 0.22UF 35WV	
C40			CK73GB1H183K	CHIP C 0.018UF K	
C41,42			CK73GB1A105K	CHIP C 1.0UF K	
C43,44			CC73HCH1H101	J CHIP C 100PF J	
C45			CC73HCH1H020	B CHIP C 2.0PF B	A
C45			CC73HCH1H050	B CHIP C 5.0PF B	A3
C46			CC73HCH1H220	J CHIP C 22PF J	A3
C46			CC73HCH1H270	J CHIP C 27PF J	A
C47			CK73GB1H471K	CHIP C 470PF K	
C48			CC73HCH1H120	J CHIP C 12PF J	
C49			CC73HCH1H390	J CHIP C 39PF J	
C50			CC73HCH1H020	C CHIP C 2.0PF C	A3
C50			CC73HCH1H040	C CHIP C 4.0PF C	A
C51			CC73HCH1H120	J CHIP C 12PF J	A
C51			CC73HCH1H220	J CHIP C 22PF J	A3
C52			CC73GCH1H050	C CHIP C 5.0PF C	A

PARTS LIST

TX-RX UNIT (X57-6730-XX)

Ref. No.	Address	New parts	Parts No.	Description	Destination	Ref. No.	Address	New parts	Parts No.	Description	Destination
C52			CC73GCH1H070	D CHIP C 7.0PF D	A3	C290-293			CK73GB1H471K	CHIP C 470PF K	
C53			CC73HCH1H030	B CHIP C 3.0PF B	A	C294			CC73GCH1H101	J CHIP C 100PF J	
C53			CC73HCH1H050	B CHIP C 5.0PF B	A3	C295			CC73GCH1H270	J CHIP C 27PF J	A3
C54			CC73HCH1H020	C CHIP C 2.0PF C	A3	C295			CC73GCH1H330	J CHIP C 33PF J	A
C54			CC73HCH1H030	C CHIP C 3.0PF C	A	C296			CK73GB1H471K	CHIP C 470PF K	
C55,56			CC73HCH1H010	B CHIP C 1.0PF B		C297			CK73GB1H103K	CHIP C 0.010UF K	
C57			CC73GCH1H030	C CHIP C 3.0PF C	A	C298			CK73GB1C104K	CHIP C 0.10UF K	
C57			CC73GCH1H040	C CHIP C 4.0PF C	A3	C299			CK73GB1A105K	CHIP C 1.0UF K	
C58			CC73HCH1H050	B CHIP C 5.0PF B		C300			CC73GCH1H180	J CHIP C 18PF J	A3
C59			CC73GCH1H050	C CHIP C 5.0PF C	A	C300			CC73GCH1H220	J CHIP C 22PF J	A
C59			CC73GCH1H070	D CHIP C 7.0PF D	A3	C301			CK73GB1H103K	CHIP C 0.010UF K	
C60			CC73HCH1H040	B CHIP C 4.0PF B	A	C308			CC73GCH1H150	J CHIP C 15PF J	A3
C60			CC73HCH1H050	B CHIP C 5.0PF B	A3	C308			CC73GCH1H270	J CHIP C 27PF J	A
C61			CK73HB1H471K	CHIP C 470PF K		C309			CK73GB1H471K	CHIP C 470PF K	
C62			CC73HCH1H070	B CHIP C 7.0PF B	A	C326			CK73GB1H471K	CHIP C 470PF K	
C62			CC73HCH1H090	B CHIP C 9.0PF B	A3	C333			CC73GCH1H040	B CHIP C 4.0PF B	A3
C63			CC73GCH1H100	D CHIP C 10PF D		C341			CC73GCH1H150	J CHIP C 15PF J	A3
C64			CC73HCH1H050	B CHIP C 5.0PF B	A	C341			CC73GCH1H3R5	B CHIP C 3.5PF B	A
C64			CC73HCH1H060	B CHIP C 6.0PF B	A3	C349			CC73GCH1H070	B CHIP C 7.0PF B	
C65			CC73HCH1H101	J CHIP C 100PF J		C351			CC73GCH1H270	J CHIP C 27PF J	
C66			CC73HCH1H120	J CHIP C 12PF J		C352			CK73GB1H471K	CHIP C 470PF K	
C67			CK73HB1H471K	CHIP C 470PF K		C353			CC73GCH1H040	B CHIP C 4.0PF B	
C68			CK73GB1H471K	CHIP C 470PF K		C355			CC73GCH1H050	B CHIP C 5.0PF B	
C69			CC73HCH1H070	B CHIP C 7.0PF B		C356			CC73GCH1H101	J CHIP C 100PF J	
C70			CK73HB1H471K	CHIP C 470PF K		C358			CC73GCH1H030	B CHIP C 3.0PF B	A
C71			CC73GCH1H0R5	B CHIP C 0.5PF B		C358			CC73GCH1H040	B CHIP C 4.0PF B	A3
C72			CC73HCH1H0R5	B CHIP C 0.5PF B		C359			CC73GCH1H010	B CHIP C 1.0PF B	A3
C73			CK73GB1H471K	CHIP C 470PF K		C359			CC73GCH1H1R5	B CHIP C 1.5PF B	A
C74			CC73HCH1H100	D CHIP C 10PF D		C360			CC73GCH1H080	B CHIP C 8.0PF B	A3
C75,76			CK73HB1H471K	CHIP C 470PF K		C360			CC73GCH1H3R5	B CHIP C 3.5PF B	A
C77			C92-0713-05	CHIP-TAN 10UF 6.3WV		C361			CC73GCH1H2R5	B CHIP C 2.5PF B	
C78			CK73HB1H471K	CHIP C 470PF K		C363			CC73GCH1H070	B CHIP C 7.0PF B	A3
C80			CC73HCH1H070	D CHIP C 7.0PF D		C363			CC73GCH1H4R5	B CHIP C 4.5PF B	A
C82			CC73HCH1H330	J CHIP C 33PF J		C364			CC73GCH1H020	B CHIP C 2.0PF B	A
C83-85			CK73HB1H471K	CHIP C 470PF K		C364			CC73GCH1H1R5	B CHIP C 1.5PF B	A3
C86			CC73HCH1H070	D CHIP C 7.0PF D		C368			CC73GCH1H100	D CHIP C 10PF D	A
C92			CK73GB1H471K	CHIP C 470PF K		C368			CC73GCH1H150	J CHIP C 15PF J	A3
C94,95			CK73HB1A104K	CHIP C 0.10UF K		C371			CC73GCH1H010	B CHIP C 1.0PF B	A
C201,202			CK73GB1H471K	CHIP C 470PF K		C371			CC73GCH1H020	B CHIP C 2.0PF B	A3
C205			CK73GB1A224K	CHIP C 0.22UF K		C372			CK73GB1H471K	CHIP C 470PF K	
C223			CK73GB1H471K	CHIP C 470PF K	A3	C401			CK73GB1H182K	CHIP C 1800PF K	
C223,224			CK73GB1H471K	CHIP C 470PF K	A	C402,403			CC73GCH1H331	J CHIP C 330PF J	
C224			CC73GCH1H090	D CHIP C 9.0PF D	A3	C405			CC73GCH1H390	J CHIP C 39PF J	
C226			CK73GB1H471K	CHIP C 470PF K		C406			C92-0713-05	CHIP-TAN 10UF 6.3WV	
C233			CK73GB1H471K	CHIP C 470PF K		C407			CK73GB1H103K	CHIP C 0.010UF K	
C241			CK73GB1H471K	CHIP C 470PF K		C408			CK73GB1C104K	CHIP C 0.10UF K	
C242			CC73GCH1H060	D CHIP C 6.0PF D		C409			CC73GCH1H680	J CHIP C 68PF J	
C243			CK73GB1C104K	CHIP C 0.10UF K		C410			CK73GB1H471K	CHIP C 470PF K	
C248			CC73GCH1H050	C CHIP C 5.0PF C	A3	C411-413			CK73GB1C104K	CHIP C 0.10UF K	
C249			CC73GCH1H130	J CHIP C 13PF J		C414			CC73GCH1H100	D CHIP C 10PF D	
C255			CK73GB1H471K	CHIP C 470PF K		C415			CK73GB1H471K	CHIP C 470PF K	
C258			CK73GB1C104K	CHIP C 0.10UF K		C416,417			CK73GB1H103K	CHIP C 0.010UF K	
C280			CC73GCH1H330	J CHIP C 33PF J	A3	C418			CK73GB1H471K	CHIP C 470PF K	
C280			CK73GB1H471K	CHIP C 470PF K	A	C419			CC73GCH1H010	B CHIP C 1.0PF B	
C282			CC73GCH1H101	J CHIP C 100PF J	A3	C420			CK73GB1C104K	CHIP C 0.10UF K	
C282			CC73GCH1H220	J CHIP C 22PF J	A	C421			CC73GCH1H080	B CHIP C 8.0PF B	
C283			CC73GCH1H100	D CHIP C 10PF D		C422			CK73GB1H103K	CHIP C 0.010UF K	
C284			CC73GCH1H200	J CHIP C 20PF J		C424			CK73GB1H103K	CHIP C 0.010UF K	
C286			C92-0565-05	CHIP-TAN 6.8UF 10WV		C425			CC73GCH1H060	D CHIP C 6.0PF D	
C288			CK73GB1A105K	CHIP C 1.0UF K		C426			CC73GCH1H020	B CHIP C 2.0PF B	A

PARTS LIST

TX-RX UNIT (X57-6730-XX)

Ref. No.	Address	New parts	Parts No.	Description	Destination	Ref. No.	Address	New parts	Parts No.	Description	Destination
C426			CC73GCH1H2R5	B CHIP C 2.5PF B	A3	C609			CK73GB1H103K	CHIP C 0.010UF K	
C427			CC73GCH1H100	D CHIP C 10PF D		C610			C92-0714-05	CHIP-TAN 4.7UF 6.3WV	
C428			CK73GB1H471K	CHIP C 470PF K		C611			CK73GB1A105K	CHIP C 1.0UF K	
C429			CC73GCH1H120	J CHIP C 12PF J		C613-615			CK73GB1C104K	CHIP C 0.10UF K	
C430			CK73GB1H471K	CHIP C 470PF K		C616			CK73GB1H332K	CHIP C 3300PF K	
C431			CK73GB1H103K	CHIP C 0.010UF K		C618			CK73GB1C104K	CHIP C 0.10UF K	
C432			CK73GB1H471K	CHIP C 470PF K		C619			CK73GB1H392K	CHIP C 3900PF K	
C434			CC73GCH1H050	B CHIP C 5.0PF B	A	C621,622			C92-0714-05	CHIP-TAN 4.7UF 6.3WV	
C434			CC73GCH1H090	B CHIP C 9.0PF B	A3	C624			CK73GB1C104K	CHIP C 0.10UF K	
C435			CK73GB1H471K	CHIP C 470PF K		C625			CC73GCH1H680	J CHIP C 68PF J	
C439			CC73GCH1H180	J CHIP C 18PF J	A3	C627			CK73GB1E123K	CHIP C 0.012UF K	
C439			CK73GB1H471K	CHIP C 470PF K	A	C628			CK73GB1H222K	CHIP C 2200PF K	
C445			CC73GCH1H050	B CHIP C 5.0PF B	A	C629			CK73GB1C104K	CHIP C 0.10UF K	
C445			CC73GCH1H3R5	B CHIP C 3.5PF B	A3	C630			CC73GCH1H101	J CHIP C 100PF J	
C447			CC73GCH1H470	J CHIP C 47PF J		C631			CK73GB1E123K	CHIP C 0.012UF K	
C448			CC73GCH1H030	B CHIP C 3.0PF B	A	C632			CK73GB1C104K	CHIP C 0.10UF K	
C448			CC73GCH1H4R5	B CHIP C 4.5PF B	A3	C633			CC73GCH1H020	B CHIP C 2.0PF B	
C456			CK73HB1H471K	CHIP C 470PF K		C634			CK73GB1H102K	CHIP C 1000PF K	
C464			CC73GCH1H020	B CHIP C 2.0PF B	A	C635			CK73GB1C104K	CHIP C 0.10UF K	
C464			CC73GCH1H4R5	B CHIP C 4.5PF B	A3	C636			CK73GB1C683K	CHIP C 0.068UF K	
C465			CC73GCH1H1R5	B CHIP C 1.5PF B	A3	C637			CC73GCH1H101	J CHIP C 100PF J	
C465			CC73GCH1H2R5	B CHIP C 2.5PF B	A	C638			CK73GB1H471K	CHIP C 470PF K	
C466			CC73GCH1H470	J CHIP C 47PF J		C639			CC73GCH1H470	J CHIP C 47PF J	
C467			CK73HB1H471K	CHIP C 470PF K		C640			CC73GCH1H101	J CHIP C 100PF J	
C468,469			CC73GCH1H030	B CHIP C 3.0PF B	A	C641,642			CK73GB1C104K	CHIP C 0.10UF K	
C468,469			CC73GCH1H3R5	B CHIP C 3.5PF B	A3	C643			CC73GCH1H680	J CHIP C 68PF J	
C470			CK73HB1H471K	CHIP C 470PF K		C645			CK73GB0J225K	CHIP C 2.2UF K	
C471			CC73GCH1H470	J CHIP C 47PF J		C646			CK73GB1H821K	CHIP C 820PF K	
C472			C92-0714-05	CHIP-TAN 4.7UF 6.3WV		C647			CK73GB1H471K	CHIP C 470PF K	
C473			CC73HCH1H070	B CHIP C 7.0PF B		C648,649			CK73GB1C104K	CHIP C 0.10UF K	
C474,475			CK73GB1H471K	CHIP C 470PF K		C650			C92-0713-05	CHIP-TAN 10UF 6.3WV	
C478,479			CK73HB1H471K	CHIP C 470PF K		C652			CK73GB1H471K	CHIP C 470PF K	
C481,482			CK73GB1H471K	CHIP C 470PF K		C653			CK73GB1A224K	CHIP C 0.22UF K	
C483			CC73GCH1H050	B CHIP C 5.0PF B	A	C655			CK73GB1C223K	CHIP C 0.022UF K	
C483			CC73GCH1H060	B CHIP C 6.0PF B	A3	C657			CC73GCH1H470	J CHIP C 47PF J	
C484			CC73GCH1H470	J CHIP C 47PF J		C658			CK73GB1C104K	CHIP C 0.10UF K	
C485			CC73GCH1H030	B CHIP C 3.0PF B	A	C660			CK73GB1A105K	CHIP C 1.0UF K	
C485			CC73GCH1H2R5	B CHIP C 2.5PF B	A3	C662			CK73GB1C104K	CHIP C 0.10UF K	
C487			CK73GB1H471K	CHIP C 470PF K		C664			CK73GB1H102K	CHIP C 1000PF K	
C488			CC73GCH1H030	B CHIP C 3.0PF B		C667			CK73GB1H471K	CHIP C 470PF K	
C489			CC73GCH1H470	J CHIP C 47PF J		C668			CK73GB1H103K	CHIP C 0.010UF K	
C490			CC73GCH1H0R5	B CHIP C 0.5PF B	A	C669			CK73GB1H471K	CHIP C 470PF K	
C490			CC73GCH1H010	B CHIP C 1.0PF B	A3	C671			CK73GB1C104K	CHIP C 0.10UF K	
C491			CC73GCH1H050	B CHIP C 5.0PF B	A3	C672,673			CK73GB1H392K	CHIP C 3900PF K	
C491			CC73GCH1H060	B CHIP C 6.0PF B	A	C674			CC73GCH1H221	J CHIP C 220PF J	
C492			CC73GCH1H030	B CHIP C 3.0PF B	A	C675,676			C92-0804-05	CHIP-TAN 1.5UF 15WV	
C492			CC73GCH1H4R5	B CHIP C 4.5PF B	A3	C677			CK73GB1H332K	CHIP C 3300PF K	
C493			CK73GB1H471K	CHIP C 470PF K		C678			CK73FB1C474K	CHIP C 0.47UF K	
C494			CK73GB1H103K	CHIP C 0.010UF K		C679			CC73GCH1H101	J CHIP C 100PF J	
C495			CC73GCH1H010	C CHIP C 1.0PF C		C680			C92-0560-05	CHIP-TAN 10UF 6.3WV	
C501			CK73GB1H471K	CHIP C 470PF K		C681			CK73GB1C223K	CHIP C 0.022UF K	
C503			CC73HCH1H0R5	B CHIP C 0.5PF B	A	C684			CK73GB1C104K	CHIP C 0.10UF K	
C504			CK73HB1H471K	CHIP C 470PF K		C686			CK73GB1C473K	CHIP C 0.047UF K	
C506			CK73GB1A105K	CHIP C 1.0UF K		C687			C92-0560-05	CHIP-TAN 10UF 6.3WV	
C507			CK73GB0J225K	CHIP C 2.2UF K		C688			CC73GCH1H221	J CHIP C 220PF J	
C508			CK73GB1H471K	CHIP C 470PF K		C689			CK73GB1C223K	CHIP C 0.022UF K	
C601			CK73GB1A224K	CHIP C 0.22UF K		C690			CK73GB1H102K	CHIP C 1000PF K	
C605			C92-0632-05	CHIP-TAN 6.8UF 6.3WV		C691			C92-0665-05	TANTAL 100UF 6.3WV	
C607			CK73GB1H103K	CHIP C 0.010UF K		C692			CC73GCH1H221	J CHIP C 220PF J	
C608			CK73GB1H392K	CHIP C 3900PF K		C693			CK73GB1H471K	CHIP C 470PF K	

PARTS LIST

TX-RX UNIT (X57-6730-XX)

Ref. No.	Address	New parts	Parts No.	Description	Destination	Ref. No.	Address	New parts	Parts No.	Description	Destination
C695			CK73GB1H471K	CHIP C 470PF K		L14			L41-1578-14	SMALL FIXED INDUCTOR	A
C696			CK73GB1A224K	CHIP C 0.22UF K		L14			L41-1878-14	SMALL FIXED INDUCTOR	A3
C801			CK73GB1A105K	CHIP C 1.0UF K		L15			L41-1878-14	SMALL FIXED INDUCTOR	A
C802			CK73GB1H103K	CHIP C 0.010UF K		L15			L41-2278-14	SMALL FIXED INDUCTOR	A3
C803,804			CK73GB1A105K	CHIP C 1.0UF K		L16			L40-1275-92	SMALL FIXED INDUCTOR(12NH)	
C805			CK73GB1H471K	CHIP C 470PF K		L17,18			L41-2285-03	SMALL FIXED INDUCTOR	
C807			CK73GB1H471K	CHIP C 470PF K		L19			L40-1875-92	SMALL FIXED INDUCTOR(18NH)	
C809			CK73GB1A105K	CHIP C 1.0UF K		L20,21			L40-3391-86	SMALL FIXED INDUCTOR(3.3UH)	
C811			CK73GB1C104K	CHIP C 0.10UF K		L22			L92-0163-05	BEADS CORE	
C812			CK73GB1H103K	CHIP C 0.010UF K		L23			L40-2275-92	SMALL FIXED INDUCTOR(22NH)	A
C814			CK73GB1H103K	CHIP C 0.010UF K		L23			L40-2775-92	SMALL FIXED INDUCTOR(27NH)	A3
C816,817			CK73GB1H471K	CHIP C 470PF K		L25			L40-2275-92	SMALL FIXED INDUCTOR(22NH)	
C818			CK73GB1H103K	CHIP C 0.010UF K		L205			L40-1875-92	SMALL FIXED INDUCTOR(18NH)	
C819			CK73GB1H471K	CHIP C 470PF K		L207			L40-1875-92	SMALL FIXED INDUCTOR(18NH)	
C820,821			CK73GB1A105K	CHIP C 1.0UF K		L208			L92-0138-05	FERRITE CHIP	
C822			CK73GB1H471K	CHIP C 470PF K		L209			L40-8265-92	SMALL FIXED INDUCTOR(8.2NH)	
C823			CK73GB1H103K	CHIP C 0.010UF K		L213			L40-8265-92	SMALL FIXED INDUCTOR(8.2NH)	
C825			C92-0713-05	CHIP-TAN 10UF 6.3WV		L216			L40-1575-54	SMALL FIXED INDUCTOR(15NH)	
C828			CK73GB1H471K	CHIP C 470PF K		L217			L92-0149-05	FERRITE CHIP	
C830			CK73GB1C104K	CHIP C 0.10UF K		L218			L40-1263-92	SMALL FIXED INDUCTOR(1.2NH)	A
C833			CK73GB1A105K	CHIP C 1.0UF K		L218			L40-1563-92	SMALL FIXED INDUCTOR(1.5NH)	A3
C834			CK73GB1C104K	CHIP C 0.10UF K		L220			L34-4602-05	AIR-CORE COIL	
C835,836			CK73GB1A105K	CHIP C 1.0UF K		L221			L92-0149-05	FERRITE CHIP	
C837			CK73GB1H471K	CHIP C 470PF K		L222			L40-2285-54	SMALL FIXED INDUCTOR(220NH)	
C840			CK73GB1H471K	CHIP C 470PF K		L223			L34-4572-05	AIR-CORE COIL	
C841			CK73GB1H103K	CHIP C 0.010UF K		L224-226			L34-4564-05	AIR-CORE COIL	
C842			CC73GCH1H150	J CHIP C 15PF J		L227			L40-1092-81	SMALL FIXED INDUCTOR	
C843			CC73GCH1H030	C CHIP C 3.0PF C		L228			L41-3369-16	SMALL FIXED INDUCTOR	A3
C845			CC73GCH1H150	J CHIP C 15PF J		L401			L92-0138-05	FERRITE CHIP	
C846			CK73GB1H103K	CHIP C 0.010UF K		L402			L40-1875-92	SMALL FIXED INDUCTOR(18NH)	
C847			C92-0712-05	CHIP-TAN 22UF 6.3WV		L403			L40-5685-85	SMALL FIXED INDUCTOR(0.56UH)	
C849			CK73GB1H471K	CHIP C 470PF K		L404			L40-2785-92	SMALL FIXED INDUCTOR(270NH)	
C850			CK73GB1H103K	CHIP C 0.010UF K		L405			L40-2775-92	SMALL FIXED INDUCTOR(27NH)	A
C852,853			CK73GB1H471K	CHIP C 470PF K		L405			L40-3375-92	SMALL FIXED INDUCTOR(33NH)	A3
C854			CK73GB1H103K	CHIP C 0.010UF K		L407-409			L41-6868-14	SMALL FIXED INDUCTOR	A
C861			CK73FB1A475K	CHIP C 4.7UF K		L407-409			L41-8268-14	SMALL FIXED INDUCTOR	A3
CTC1,2			C05-0384-05	CERAMIC TRIMMER CAP(10PF)		L410			L92-0138-05	FERRITE CHIP	
3B			E37-1085-05	FLAT CABLE		L411			L41-2285-03	SMALL FIXED INDUCTOR	
CN801			E40-5932-05	PIN ASSY SOCKET		L413,414			L41-6868-14	SMALL FIXED INDUCTOR	A
J601			E11-0457-05	PHONE JACK (2.5/3.5)		L413,414			L41-8268-14	SMALL FIXED INDUCTOR	A3
F801		*	F20-3352-04	INSULATING SHEET		L415			L41-4778-03	SMALL FIXED INDUCTOR	
			F53-0190-05	FUSE		L416			L40-5681-86	SMALL FIXED INDUCTOR(0.56UH)	
			G11-4300-04	RUBBER CUSHION		L601			L92-0140-05	FERRITE CHIP	
		*	J99-0374-04	ADHESIVE TAPE		L602			L92-0149-05	FERRITE CHIP	
CD401			L79-1582-05	TUNING COIL		L801			L92-0149-05	FERRITE CHIP	
CF401		*	L72-1015-05	CERAMIC FILTER		L802			L92-0140-05	FERRITE CHIP	
L1			L40-4795-85	SMALL FIXED INDUCTOR(4.7UH)		L803-807			L92-0138-05	FERRITE CHIP	
L3			L40-1581-86	SMALL FIXED INDUCTOR(0.15UH)		X1			L77-1932-05	TCXO (16.8MHZ)	
L5			L92-0138-05	FERRITE CHIP		X801			L77-1933-05	CRYSTAL RESONATOR(7.3728MHZ)	
L6			L40-1085-92	SMALL FIXED INDUCTOR(100NH)		XF401			L71-0617-15	MCF (49.95MHZ)	
L7			L92-0138-05	FERRITE CHIP		RCP1,2			RK75HA1J473J	CHIP-COM 47K J 1/16W	
L8			L40-1885-92	SMALL FIXED INDUCTOR(180NH)		RCP3,4			RK75HA1J102J	CHIP-COM 1.0K J 1/16W	
L9			L40-2785-92	SMALL FIXED INDUCTOR(270NH)		RCP801,802			RK75HA1J473J	CHIP-COM 47K J 1/16W	
L10			L92-0163-05	BEADS CORE		RCP803-805			RK75HA1J102J	CHIP-COM 1.0K J 1/16W	
L11			L40-1885-92	SMALL FIXED INDUCTOR(180NH)		RCP806			RK75HA1J102J	CHIP-COM 47K J 1/16W	
L12			L40-2785-92	SMALL FIXED INDUCTOR(270NH)		RCP807			RK75HA1J102J	CHIP-COM 1.0K J 1/16W	
						RCP808			RK75HA1J472J	CHIP-COM 4.7K J 1/16W	
						RCP809-818			RK75HA1J102J	CHIP-COM 1.0K J 1/16W	

PARTS LIST

TX-RX UNIT (X57-6730-XX)

Ref. No.	Address	New parts	Parts No.	Description	Destination	Ref. No.	Address	New parts	Parts No.	Description	Destination
R1			RK73GB1J223J	CHIP R 22K J 1/16W		R230			RK73GB1J180J	CHIP R 18 J 1/16W	
R2			RK73GB1J103J	CHIP R 10K J 1/16W		R231,232			RK73GB1J331J	CHIP R 330 J 1/16W	
R3			RK73GB1J474J	CHIP R 470K J 1/16W		R234			RK73GB1J103J	CHIP R 10K J 1/16W	
R4			R92-1252-05	CHIP R 0 OHM J 1/16W		R235			RK73GB1J101J	CHIP R 100 J 1/16W	
R5			RK73GB1J224J	CHIP R 220K J 1/16W		R237			RK73GB1J123J	CHIP R 12K J 1/16W	A3
R6			RK73GB1J473J	CHIP R 47K J 1/16W		R237			RK73GB1J223J	CHIP R 22K J 1/16W	A
R7,8			R92-1252-05	CHIP R 0 OHM J 1/16W		R242			RK73GB1J124J	CHIP R 120K J 1/16W	A
R9			RK73GB1J393J	CHIP R 39K J 1/16W		R242			RK73GB1J563J	CHIP R 56K J 1/16W	A3
R12			RK73GB1J101J	CHIP R 100 J 1/16W		R247			RK73GB1J473J	CHIP R 47K J 1/16W	
R13			R92-1252-05	CHIP R 0 OHM J 1/16W		R251			R92-1252-05	CHIP R 0 OHM J 1/16W	
R14			RK73GB1J222J	CHIP R 2.2K J 1/16W		R252			RK73GB1J220J	CHIP R 22 J 1/16W	
R15			R92-1252-05	CHIP R 0 OHM J 1/16W		R253			R92-1252-05	CHIP R 0 OHM J 1/16W	
R16			RK73GB1J102J	CHIP R 1.0K J 1/16W		R255			R92-1252-05	CHIP R 0 OHM J 1/16W	
R17			RK73GB1J101J	CHIP R 100 J 1/16W		R256,257			RK73EB2ER39K	CHIP R 0.39 K 1/4W	
R18			RK73GB1J474J	CHIP R 470K J 1/16W		R259,260			RK73GB1J473J	CHIP R 47K J 1/16W	A
R19			RK73GB1J100J	CHIP R 10 J 1/16W		R259,260			RK73GB1J683J	CHIP R 68K J 1/16W	A3
R20,21			R92-1252-05	CHIP R 0 OHM J 1/16W		R261			RK73EB2ER39K	CHIP R 0.39 K 1/4W	
R22			RK73GB1J122J	CHIP R 1.2K J 1/16W		R262			R92-0670-05	CHIP R 0 OHM	
R23			RK73GB1J471J	CHIP R 470 J 1/16W	A3	R263			RK73GB1J101J	CHIP R 100 J 1/16W	
R23,24			RK73GB1J681J	CHIP R 680 J 1/16W	A	R264,265			RK73GH1J154D	CHIP R 150K D 1/16W	
R24			RK73GB1J102J	CHIP R 1.0K J 1/16W	A3	R267-270			RK73GH1J154D	CHIP R 150K D 1/16W	
R25			RK73GB1J103J	CHIP R 10K J 1/16W		R271			RK73GB1J103J	CHIP R 10K J 1/16W	
R26			RK73GB1J223J	CHIP R 22K J 1/16W		R272			RK73GB1J473J	CHIP R 47K J 1/16W	
R27			RK73GB1J103J	CHIP R 10K J 1/16W		R273			R92-1252-05	CHIP R 0 OHM J 1/16W	
R28			RK73GB1J393J	CHIP R 39K J 1/16W		R274			RK73GB1J105J	CHIP R 1.0M J 1/16W	
R29			RK73GB1J104J	CHIP R 100K J 1/16W	A	R275			RK73GB1J222J	CHIP R 2.2K J 1/16W	
R29			RK73GB1J823J	CHIP R 82K J 1/16W	A3	R276,277			RK73GB1J104J	CHIP R 100K J 1/16W	
R30			RK73HB1J123J	CHIP R 12K J 1/16W	A3	R278			R92-0670-05	CHIP R 0 OHM A	
R30			RK73HB1J333J	CHIP R 33K J 1/16W	A	R279,280			RK73GB1J271J	CHIP R 270 J 1/16W	
R31			RK73GB1J560J	CHIP R 56 J 1/16W		R281,282			R92-1252-05	CHIP R 0 OHM J 1/16W	
R32			RK73HB1J153J	CHIP R 15K J 1/16W		R401			RK73GB1J100J	CHIP R 10 J 1/16W	
R33			RK73HB1J473J	CHIP R 47K J 1/16W		R403			RK73GB1J102J	CHIP R 1.0K J 1/16W	
R34			RK73GB1J473J	CHIP R 47K J 1/16W		R404			RK73GB1J334J	CHIP R 330K J 1/16W	
R35			RK73GB1J220J	CHIP R 22 J 1/16W		R406			RK73GB1J332J	CHIP R 3.3K J 1/16W	
R36			RK73HB1J100J	CHIP R 10 J 1/16W		R407			RK73GB1J474J	CHIP R 470K J 1/16W	
R37			RK73HB1J181J	CHIP R 180 J 1/16W		R408			RK73GB1J332J	CHIP R 3.3K J 1/16W	
R38			RK73HB1J100J	CHIP R 10 J 1/16W		R409			RK73GB1J392J	CHIP R 3.9K J 1/16W	
R39			RK73HB1J151J	CHIP R 150 J 1/16W		R412			RK73GB1J122J	CHIP R 1.2K J 1/16W	A
R40			RK73GB1J102J	CHIP R 1.0K J 1/16W		R412			RK73GB1J331J	CHIP R 330 J 1/16W	A3
R41			RK73GB1J154J	CHIP R 150K J 1/16W		R413			RK73GB1J124J	CHIP R 120K J 1/16W	
R43			RK73HB1J154J	CHIP R 150K J 1/16W		R414			RK73GB1J681J	CHIP R 680 J 1/16W	
R44			RK73HB1J472J	CHIP R 4.7K J 1/16W		R415			RK73GB1J472J	CHIP R 4.7K J 1/16W	
R46			RK73HB1J101J	CHIP R 100 J 1/16W		R416			RK73GB1J101J	CHIP R 100 J 1/16W	
R47			RK73HB1J682J	CHIP R 6.8K J 1/16W		R417			RK73GB1J470J	CHIP R 47 J 1/16W	
R48			RK73HB1J103J	CHIP R 10K J 1/16W		R419			RK73GB1J222J	CHIP R 2.2K J 1/16W	
R49			RK73GJ1J333D	CHIP R 33K D 1/16W		R420			RK73GB1J151J	CHIP R 150 J 1/16W	
R50			RK73HB1J331J	CHIP R 330 J 1/16W		R422			RK73GB1J104J	CHIP R 100K J 1/16W	
R51			RK73GJ1J104D	CHIP R 100K D 1/16W		R423			RK73GB1J563J	CHIP R 56K J 1/16W	
R55			RK73HB1J222J	CHIP R 2.2K J 1/16W		R424			RK73HB1J104J	CHIP R 100K J 1/16W	
R56			RK73HB1J470J	CHIP R 47 J 1/16W		R425			RK73GB1J563J	CHIP R 56K J 1/16W	
R57			R92-1368-05	CHIP R 0 OHM		R427			R92-1252-05	CHIP R 0 OHM J 1/16W	
R58			RK73GB1J472J	CHIP R 4.7K J 1/16W		R430,431			RK73HB1J105J	CHIP R 1.0M J 1/16W	
R202			RK73GB1J472J	CHIP R 4.7K J 1/16W		R438			RK73HB1J105J	CHIP R 1.0M J 1/16W	
R203			R92-1252-05	CHIP R 0 OHM J 1/16W		R440			RK73HB1J221J	CHIP R 220 J 1/16W	
R204			RK73GB1J153J	CHIP R 15K J 1/16W		R441			RK73HB1J101J	CHIP R 100 J 1/16W	
R207			RK73GB1J333J	CHIP R 33K J 1/16W		R457			RK73HB1J104J	CHIP R 100K J 1/16W	
R215			R92-1252-05	CHIP R 0 OHM J 1/16W		R459			RK73GB1J104J	CHIP R 100K J 1/16W	
R222			RK73GB1J331J	CHIP R 330 J 1/16W		R460			RK73GB1J683J	CHIP R 68K J 1/16W	
R224			RK73GB1J220J	CHIP R 22 J 1/16W		R461			R92-1252-05	CHIP R 0 OHM J 1/16W	
R229			RK73GB1J331J	CHIP R 330 J 1/16W		R462,463			RK73GB1J105J	CHIP R 1.0M J 1/16W	

PARTS LIST

TX-RX UNIT (X57-6730-XX)

Ref. No.	Address	New parts	Parts No.	Description	Destination	Ref. No.	Address	New parts	Parts No.	Description	Destination
R464			R92-0670-05	CHIP R 0 OHM		R681			RK73GB1J222J	CHIP R 2.2K J 1/16W	
R465			RK73GB1J332J	CHIP R 3.3K J 1/16W		R682			RK73GB1J100J	CHIP R 10 J 1/16W	
R469			RK73GB1J221J	CHIP R 220 J 1/16W		R683			RK73GB1J474J	CHIP R 470K J 1/16W	
R471			RK73GB1J104J	CHIP R 100K J 1/16W		R684			RK73GB1J182J	CHIP R 1.8K J 1/16W	
R474			RK73GB1J103J	CHIP R 10K J 1/16W		R686			RK73GB1J471J	CHIP R 470 J 1/16W	
R475			RK73GB1J683J	CHIP R 68K J 1/16W		R687			RK73GB1J102J	CHIP R 1.0K J 1/16W	
R476			RK73GB1J103J	CHIP R 10K J 1/16W		R688,689			RK73GB1J101J	CHIP R 100 J 1/16W	
R601			R92-1252-05	CHIP R 0 OHM J 1/16W		R691			RK73GB1J333J	CHIP R 33K J 1/16W	
R602			RK73GB1J124J	CHIP R 120K J 1/16W	A3	R692			R92-1252-05	CHIP R 0 OHM J 1/16W	
R602			RK73GB1J184J	CHIP R 180K J 1/16W	A	R693			RK73GB1J273J	CHIP R 27K J 1/16W	
R603			R92-1252-05	CHIP R 0 OHM J 1/16W		R694,695			R92-1252-05	CHIP R 0 OHM J 1/16W	
R604			RK73GB1J184J	CHIP R 180K J 1/16W		R696			RK73GB1J103J	CHIP R 10K J 1/16W	
R607-609			RK73GB1J103J	CHIP R 10K J 1/16W		R697			R92-1252-05	CHIP R 0 OHM J 1/16W	
R610			RK73GB1J472J	CHIP R 4.7K J 1/16W		R698			RK73GB1J152J	CHIP R 1.5K J 1/16W	
R612			RK73GB1J273J	CHIP R 27K J 1/16W		R802			RK73GB1J101J	CHIP R 100 J 1/16W	
R613			RK73GB1J824J	CHIP R 820K J 1/16W		R803,804			R92-1252-05	CHIP R 0 OHM J 1/16W	
R615			RK73GB1J334J	CHIP R 330K J 1/16W		R805			RK73GB1J153J	CHIP R 15K J 1/16W	
R616			R92-1252-05	CHIP R 0 OHM J 1/16W		R807			RK73GB1J103J	CHIP R 10K J 1/16W	
R617			RK73GB1J473J	CHIP R 47K J 1/16W		R808			RK73GB1J102J	CHIP R 1.0K J 1/16W	
R618			RK73G1J364D	CHIP R 360K D 1/16W		R809			RK73GB1J272J	CHIP R 2.7K J 1/16W	
R621			RK73GB1J473J	CHIP R 47K J 1/16W		R810			RK73GB1J334J	CHIP R 330K J 1/16W	
R622			RK73GB1J684J	CHIP R 680K J 1/16W		R811			RK73GB1J332J	CHIP R 3.3K J 1/16W	
R623			RK73GB1J274G	CHIP R 270K G 1/16W		R812			RK73GB1J334J	CHIP R 330K J 1/16W	
R624			RK73GB1J562J	CHIP R 5.6K J 1/16W		R813			RK73GB1J332J	CHIP R 3.3K J 1/16W	
R625			RK73GB1J563J	CHIP R 56K J 1/16W		R814			RK73GB1J153J	CHIP R 15K J 1/16W	
R626,627			RK73GB1J184J	CHIP R 180K J 1/16W		R815			R92-1252-05	CHIP R 0 OHM J 1/16W	
R628			RK73GB1J224J	CHIP R 220K J 1/16W		R816			RK73GB1J224J	CHIP R 220K J 1/16W	
R629			RK73GB1J394J	CHIP R 390K J 1/16W		R817			RK73GB1J272J	CHIP R 2.7K J 1/16W	
R630			RK73GB1J684J	CHIP R 680K J 1/16W		R818			RK73GB1J821J	CHIP R 820 J 1/16W	
R631			RK73GB1J394J	CHIP R 390K J 1/16W		R819			RK73GB1J103J	CHIP R 10K J 1/16W	
R632			RK73GB1J823J	CHIP R 82K J 1/16W		R820			RK73GB1J561J	CHIP R 560 J 1/16W	
R633			RK73GB1J223J	CHIP R 22K J 1/16W		R821			RK73GB1J331J	CHIP R 330 J 1/16W	
R634			RK73GB1J153J	CHIP R 15K J 1/16W		R823			RK73GB1J102J	CHIP R 1.0K J 1/16W	
R636			RK73GB1J474J	CHIP R 470K J 1/16W		R824			RK73GB1J183J	CHIP R 18K J 1/16W	
R637			RK73GB1J394J	CHIP R 390K J 1/16W		R825			RK73GB1J473J	CHIP R 47K J 1/16W	
R639			RK73GB1J393J	CHIP R 39K J 1/16W		R827			RK73GB1J102J	CHIP R 1.0K J 1/16W	
R640			RK73GB1J184J	CHIP R 180K J 1/16W		R828			RK73GB1J332J	CHIP R 3.3K J 1/16W	
R641,642			RK73GB1J124J	CHIP R 120K J 1/16W		R829			RK73GB1J272J	CHIP R 2.7K J 1/16W	
R643			RK73GB1J184J	CHIP R 180K J 1/16W		R830			RK73GB1J821J	CHIP R 820 J 1/16W	
R644,645			RK73GB1J472J	CHIP R 4.7K J 1/16W		R833,834			RK73GB1J474D	CHIP R 470K D 1/16W	
R646			RK73GB1J223J	CHIP R 22K J 1/16W		R835,836			RK73HB1J102J	CHIP R 1.0K J 1/16W	
R647			R92-1252-05	CHIP R 0 OHM J 1/16W		R839,840			RK73GB1J473J	CHIP R 47K J 1/16W	
R648			RK73GB1J103J	CHIP R 10K J 1/16W		R841			R92-1252-05	CHIP R 0 OHM J 1/16W	
R649			RK73GB1J104J	CHIP R 100K J 1/16W		R842			R92-1368-05	CHIP R 0 OHM	
R651			R92-1252-05	CHIP R 0 OHM J 1/16W		R844			RK73GB1J473J	CHIP R 47K J 1/16W	
R652			RK73GB1J273J	CHIP R 27K J 1/16W		R845			R92-1368-05	CHIP R 0 OHM	
R655			RK73GB1J105J	CHIP R 1.0M J 1/16W		R847,848			RK73GB1J102J	CHIP R 1.0K J 1/16W	
R665			R92-1252-05	CHIP R 0 OHM J 1/16W		R849			R92-1252-05	CHIP R 0 OHM J 1/16W	
R666			RK73GB1J822J	CHIP R 8.2K J 1/16W		R851			R92-1368-05	CHIP R 0 OHM	
R667			RK73GB1J104J	CHIP R 100K J 1/16W		R852			RK73HB1J473J	CHIP R 47K J 1/16W	
R668			RK73GB1J473J	CHIP R 47K J 1/16W		R854			RK73GB1J680J	CHIP R 68 J 1/16W	
R669			RK73GB1J222J	CHIP R 2.2K J 1/16W		R855-857			RK73HB1J102J	CHIP R 1.0K J 1/16W	
R670			RK73GB1J102J	CHIP R 1.0K J 1/16W		R858			R92-1368-05	CHIP R 0 OHM	
R671			RK73GB1J683J	CHIP R 68K J 1/16W		R859			RK73GB1J104J	CHIP R 100K J 1/16W	
R672			RK73GB1J102J	CHIP R 1.0K J 1/16W		VR1			R12-7491-05	TRIMMING POT.(68K)	
R673			RK73GB1J272J	CHIP R 2.7K J 1/16W		S802-805			S70-0457-05	TACT SWITCH	
R674			R92-1252-05	CHIP R 0 OHM J 1/16W		MIC60			T91-0543-05	MIC ELEMENT	
R675			RK73GB1J822J	CHIP R 8.2K J 1/16W							
R676			RK73GB1J151J	CHIP R 150 J 1/16W							
R677-679			R92-1252-05	CHIP R 0 OHM J 1/16W							

PARTS LIST

TX-RX UNIT (X57-6730-XX)

Ref. No.	Address	New parts	Parts No.	Description	Destination	Ref. No.	Address	New parts	Parts No.	Description	Destination
D3,4			1SV325	VARIABLE CAPACITANCE DIODE		Q801			UMG3N	TRANSISTOR	
D7			1SV325	VARIABLE CAPACITANCE DIODE		Q802			UPA672T	FET	
D9			1SV325	VARIABLE CAPACITANCE DIODE		Q803			FP210	TRANSISTOR	
D10			1SV278	VARIABLE CAPACITANCE DIODE		Q804			UMG3N	TRANSISTOR	
D11			HSC277	DIODE		Q805			UMG9N	TRANSISTOR	
D201			HSC277	DIODE		Q806			KTA1298(Y)	TRANSISTOR	
D203			HZU5CLL	ZENER DIODE		Q807			UMG3N	TRANSISTOR	
D204			HVC131	DIODE		Q808,809			DTA123JE	DIGITAL TRANSISTOR	
D206			HVC131	DIODE		Q810			2SK1824	FET	
D208			HVC131	DIODE		TH1			B57331V2104J	THERMISTOR	
D212			HVC131	DIODE		TH600			B57331V2104J	THERMISTOR	
D401			HSC277	DIODE							
D402-406			HVC369B	VARIABLE CAPACITANCE DIODE							
D407			RB521S-30	DIODE							
D603-606			RB706F-40	DIODE							
D801			RB521S-30	DIODE							
D805			1SR154-400	DIODE							
IC1			MB15E03SL	MOS IC							
IC201			TA75W01FU	MOS IC							
IC401			TA31136FN	MOS IC							
IC601			AQUA	MOS IC							
IC602			TC75S51FE	MOS IC							
IC604			TC75S51FE	MOS IC							
IC605			TA7368F	MOS IC							
IC801			XC6204B502MR	MOS IC							
IC802			PST9134NR	MOS IC							
IC803			XC61CN5002NR	MOS IC							
IC804			CAT24WC64JI	ROM IC							
IC805			30622MCA-7G7	GP MPU							
IC806			TC7W74FU	MOS IC							
Q1			DTC144EE	DIGITAL TRANSISTOR							
Q2,3			UMG9N	TRANSISTOR							
Q4			KTC4082	TRANSISTOR							
Q5,6			2SK508NV(K52)) FET							
Q7			2SC5108(Y)	TRANSISTOR							
Q8			2SJ347	FET							
Q9			2SC5108(Y)	TRANSISTOR							
Q10			2SC4617(S)	TRANSISTOR							
Q11			2SC5108(Y)	TRANSISTOR							
Q12			2SJ347	FET							
Q205			2SC5108(Y)	TRANSISTOR							
Q206			2SK3077	FET							
Q207			2SK2596	FET							
Q208			DTC114EE	DIGITAL TRANSISTOR							
Q209			2SK879(GR)	FET							
Q210			DTC114EE	DIGITAL TRANSISTOR							
Q211			2SK3476	FET							
Q212			2SK1824	FET							
Q213			DTA144EE	DIGITAL TRANSISTOR							
Q401			DTA144EE	DIGITAL TRANSISTOR							
Q402			2SC4649(N,P)	TRANSISTOR							
Q403,404			3SK318	FET							
Q407,408			2SK1824	FET							
Q601,602			2SK1824	FET							
Q603			DTC144EE	DIGITAL TRANSISTOR							
Q604			2SA1362(GR)	TRANSISTOR							
Q605			2SC4116(Y)	TRANSISTOR							
Q606			2SA1586(Y,GR)	TRANSISTOR							
Q607			DTC144EE	DIGITAL TRANSISTOR							
Q608			2SK1588	FET							

EXPLODED VIEW

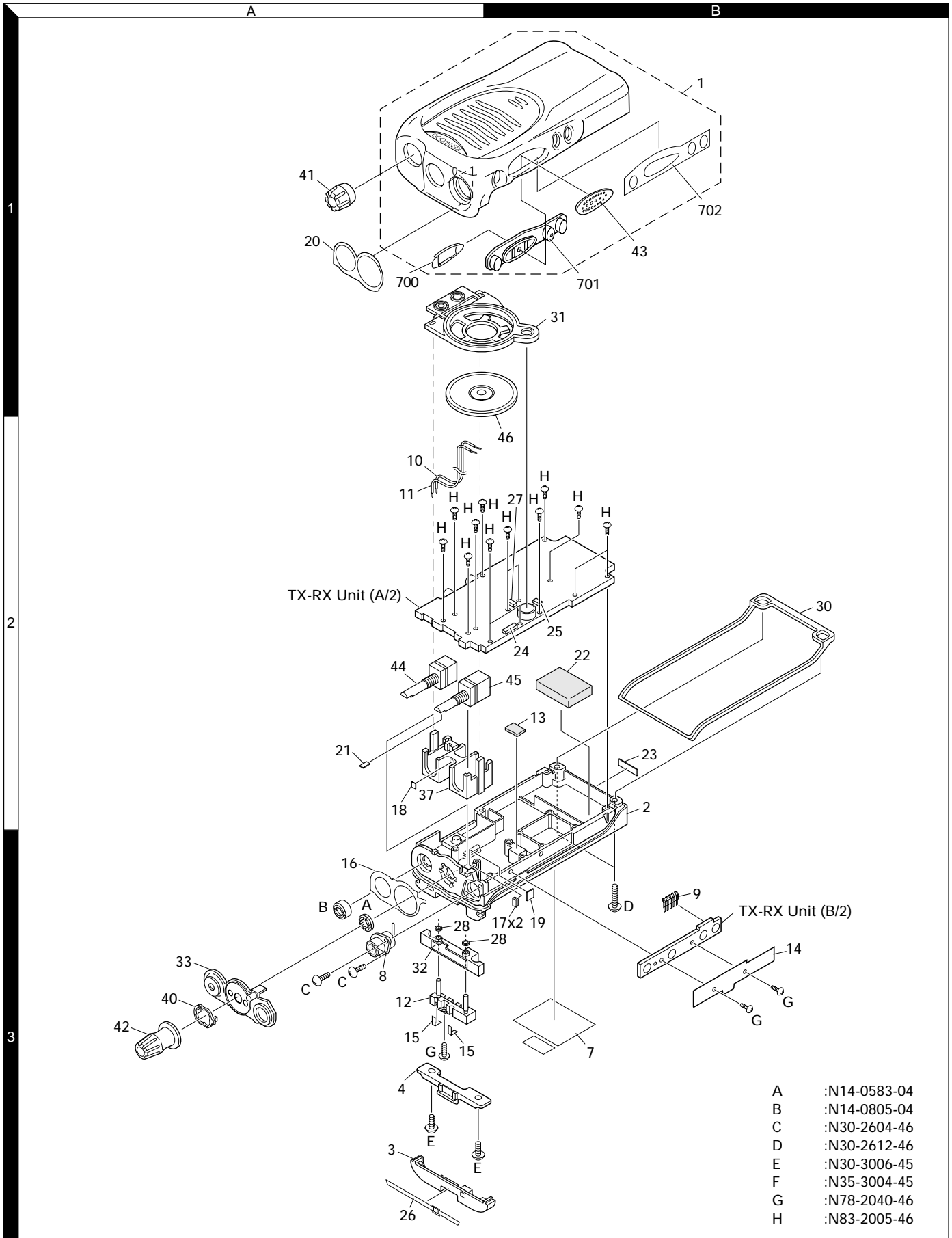

- A :N14-0583-04
- B :N14-0805-04
- C :N30-2604-46
- D :N30-2612-46
- E :N30-3006-45
- F :N35-3004-45
- G :N78-2040-46
- H :N83-2005-46

PACKING

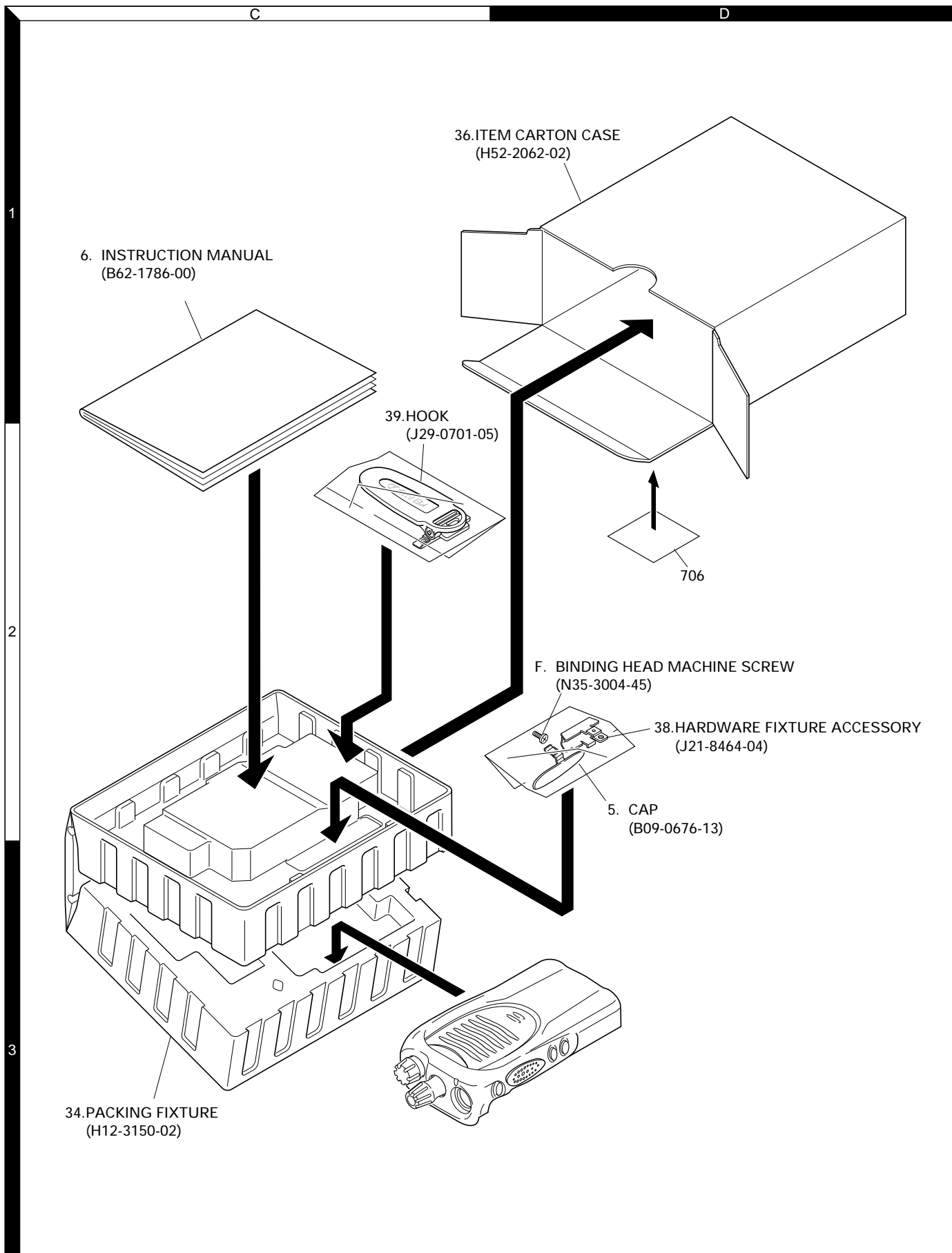

ADJUSTMENT

Test Equipment Required for Alignment

Test Equipment	Major Specifications	
1. Standard Signal Generator (SSG)	Frequency Range Modulation Output	400 ~ 512MHz Frequency modulation and external modulation. -127dBm/0.1μV to greater than -47dBm/1mV
2. Power Meter	Input Impedance Operation Frequency Measurement Range	50Ω. 400 ~ 512MHz Vicinity of 10W
3. Deviation Meter	Frequency Range	400 ~ 512MHz
4. Digital Volt Meter (DVM)	Measuring Range Input Impedance	10mV to 10V DC High input impedance for minimum circuit loading.
5. Oscilloscope		DC through 30MHz.
6. High Sensitivity Frequency Counter	Frequency Range Frequency Stability	10Hz to 1000MHz. 0.2ppm or less.
7. Ammeter		5A.
8. AF Volt Meter (AF VTVM)	Frequency Range Voltage Range	50Hz to 10kHz. 1mV to 10V.
9. Audio Generator (AG)	Frequency Range Output	50Hz to 5kHz or more. 0 to 1V.
10. Distortion Meter	Capability Input Level	3% or less at 1kHz. 50mV to 10Vrms.
11. 8Ω Dummy Load		Approx. 8Ω, 3W.
12. Regulated Power Supply		5V to 10V, approx. 3A Useful if ammeter equipped.

■ The following parts are required for adjustment

1. Antenna connector adapter

The antenna connector of this radio uses an SMA terminal. Use an antenna connector adapter [SMA(f) – BNC(f) or SMA(f) – N(f)] for adjustment. (The adapter is not provided as an option, so buy a commercially-available one.)

2. Repair Jig (Chassis)

Use jig (part No.: A10-4082-02) for repairing the TK-3168. Place the TX-RX unit on the jig and fit it with screws.

The jig facilitates the voltage check and protects the final amplifier FET when the voltage on the flow side of the TX-RX unit is checked during repairs.

3. Battery Jig (W05-0909-00)

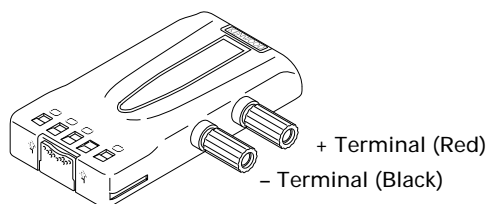

Connect the power cable properly between the battery jig installed in the transceiver and the power supply, and be sure output voltage and the power supply polarity prior to switching the power supply ON, otherwise over voltage and reverse connection may damage the transceiver, or the power supply or both.

When using the battery jig in user mode, the transceiver assumes that a lithium-ion battery pack is attached to the transceiver. In adjustment mode, battery type detection is not performed. Refer to page 10 for details.

Note: When using the battery jig, you must measure the voltage at the terminals of the battery jig. Otherwise, a slight voltage drop may occur within the power cable, between the power supply and the battery jig, especially while the transceiver transmits.

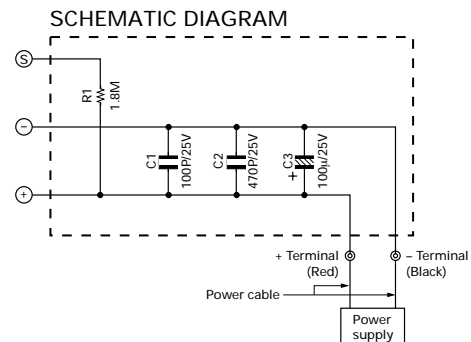

ADJUSTMENT

Adjustment points TX-RX unit (X57-673) Component side view

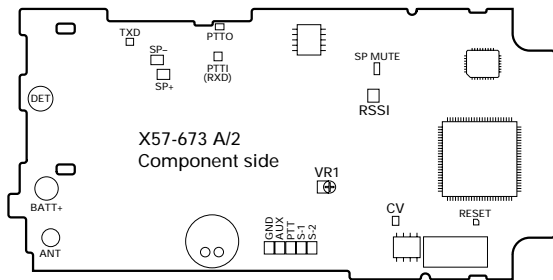

VR1 : Frequency adjustment
RSSI : Band-pass wave form test point

Foil Side View

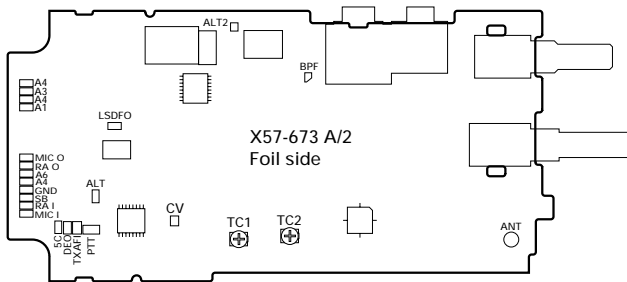

TC1 : Transmit lock voltage adjustment
TC2 : Receive lock voltage adjustment
CV : Lock voltage adjustment terminal.

Fig. 1 Adjustment points

■ Frequency and signalling

The set has been adjusted for the frequencies shown in the following table. When required, re-adjust them following the adjustment procedure to obtain the frequencies you want in actual operation.

Frequency (MHz) A type

Channel No.	RX Frequency	TX Frequency
1	460.050	460.100
2	440.050	440.100
3	479.950	479.900
4	460.000	460.000
5	460.200	460.200
6	460.400	460.400
7~16	—	—

Frequency (MHz) A3 type

Channel No.	RX Frequency	TX Frequency
1	415.050	415.100
2	400.050	400.100
3	429.950	429.900
4	415.000	415.000
5	415.200	415.200
6	415.400	415.400
7~16	—	—

Signalling

Signalling No.	RX	TX
1	None	None
2	None	100Hz Square Wave
3	QT 67.0Hz	QT 67.0Hz
4	QT 151.4Hz	QT 151.4Hz
5	QT 210.7Hz	QT 210.7Hz
6	QT 254.1Hz	QT 254.1Hz
7	DOT D023N	DOT D023N
8	DOT D754I	DOT D754I
9	DTMF 159D	DTMF 159D
10	None	DTMF tone 9

• Preparations for tuning the transceiver

Before attempting to tune the transceiver, connect the unit to a suitable power supply.

Whenever the transmitter is tuned, the unit must be connected to a suitable dummy load (i.e. power meter).

The speaker output connector must be terminated with a 8Ω dummy load and connected to an AC voltmeter and an audio distortion meter or a SINAD measurement meter at all times during tuning.

Adjustment Frequency (A type)

TEST CH	A	
	RX	TX
Center	460.050MHz	460.100MHz
Low	440.050MHz	440.100MHz
High	479.950MHz	479.900MHz
Low'	450.050MHz	450.100MHz
High'	470.050MHz	470.100MHz
	460.000MHz	460.000MHz
	460.200MHz	460.200MHz
	460.400MHz	460.400MHz

Adjustment Frequency (A3 type)

TEST CH	A3	
	RX	TX
Center	415.050MHz	415.100MHz
Low	400.050MHz	400.100MHz
High	429.950MHz	429.900MHz
Low'	407.550MHz	407.600MHz
High'	422.550MHz	422.600MHz
	415.000MHz	415.000MHz
	415.200MHz	415.200MHz
	415.400MHz	415.400MHz

ADJUSTMENT

Common Section

Item	Condition	Measurement		Adjustment		Specifications/ Remark
		Test equipment	Terminal	Parts	Method	
1.Setting	1) BATT terminal vorage:7.5V 2) SSG standard modulation [Wide] MOD:1kHz,DEV:3kHz [Narrow] MOD:1kHz,DEV:1.5kHz					
2.VCO lock voltage RX	1) CH:High	Power meter DVM	ANT CV	TC2	ADJ	3.5V \pm 0.2V
	2) CH:Low				Check	0.6V or more
3.VCO lock voltage TX	3) CH:High PTT:ON			TC1	ADJ	3.5V \pm 0.2V
	4) CH:Low PTT:ON				Check	0.6V or more

Transmitter Section

Item	Condition	Measurement		Adjustment		Specifications/ Remark
		Test equipment	Terminal	Parts	Method	
1.Frequency Adjust [Wide]	1) CH:Center 2) PTT:ON	Frequency counter	ANT	VR1		Center frequency \pm 50Hz
2.High power Adjust [Wide]	TEST CH: Low Low' Center High' High (5 points) BATT terminal voltage:7.5V PTT:ON	Power meter Ampere meter		Programming Software:KPG-82D		4.0W \pm 0.1W 2.0 A or less
3.Low power Adjust [Wide]	TEST CH: Low Low' Center High' High (5 points) BATT terminal voltage:7.5V PTT:ON					1.0W \pm 0.1W 1.0 A or less
4.Max deviation Adjust [Wide]	TEST CH: Low Center High (3 points) AG:1kHz/150mV Dev meter filter LPF:15kHz HPF:OFF PTT:ON	Power meter Dev meter Oscilloscope AG AF VTVM	ANT SP/MIC connector		4.2kHz (According to the lager +,-)	\pm 50Hz
	[Narrow]				TEST CH: Center PTT:ON	2.1kHz (According to the lager +,-)
5.VOX 1 Writing [Wide]	TEST CH: Center AG:1KHz/60mV	Power meter Dev meter Oscilloscope				
6.VOX 10 Writing [Wide]	TEST CH: Center AG:1KHz/4.0mV	AG AF VTVM				

ADJUSTMENT

Item	Condition	Measurement		Adjustment		Specifications/ Remark
		Test equipment	Terminal	Parts	Method	
7.DQT TCXO Balance Writing [Wide] [Narrow]	TEST CH: Center	Power mete Dev meter Oscilloscope AG AF VTVM	ANT	Programming Software:KPG-82D	Write	200 hex
						120 hex
8.DQT VCO Balance Adjust [Wide] [Narrow]	TEST CH: Low Center High (3 points) LPF:3kHz HPF:OFF PTT:ON				Make the demodulation wave into square waves	
	TEST CH: Center PTT:ON					
9. QT Deviation Adjust [Wide] [Narrow]	TEST CH: Low Center High (3 points) LPF:3kHz HPF:OFF					±40Hz
	TEST CH:Center PTT:ON					±40Hz
10.DQT Deviation Adjust [Wide] [Narrow]	TEST CH: Low Center High (3 points) LPF:3kHz HPF:OFF PTT:ON					±40Hz
	TEST CH: Center PTT:ON					±40Hz
11.DTMF Deviation Adjust [Wide 5k] [Narrow]	TEST CH: Center LPF:15kHz HPF:OFF PTT:ON					±100Hz
	TEST CH: Center PTT:ON					±100Hz
12.BATT Detection Writing [Wide 5k]	BATT terminal voltage:5.9V PTT:ON	Power meter DVM	ANT BATT terminal		Write	BATT terminal voltage:5.9V
13.BATT Detection Check	1) BATT terminal voltage:5.5V PTT:ON			ANT	Check	LED blinks
	2) BATT terminal voltage:7.5V PTT:ON					LED does not blink

ADJUSTMENT

Receiver Section

Item	Condition	Measurement		Adjustment		Specifications/ Remark
		Test equipment	Terminal	Parts	Method	
1. BPF Wave form ADJ [Wide]	TEST CH: Low Low' Center High' High (5 points) SSG otuput: -103 dBm(1.58μV)	SSG DVM Oscilloscope AF VTVM	ANT RSSI	Programming Software: KPG-82D	RSSI MAX	
2. Sesitivity check [Wide]	TEST CH: Low Low' Center High' High (5 points) SSG otuput: -117 dBm(0.3μV) SSG MOD: 3kHz		ANT		Check	12dB SINAD or more
[Narrow]	TEST CH: Center SSG otuput: -115 dBm(0.4μV) SSG MOD: 1.5kHz			12dB SINAD or more		
3. Squelch tight writing [Wide]	TEST CH: Center SSG otuput: -117 dBm(0.3μV) SSG MOD: 3.0kHz			Programming Software: KPG-82D	Squelch open	
[Narrow]	TEST CH: Center SSG otuput: -116 dBm(0.35μV) SSG MOD: 1.5kHz				Squelch open	
4. Squelch threshold writing [Wide]	TEST CH: Center SSG otuput: -122 dBm(0.18μV) SSG MOD: 3.0kHz				Squelch open	
[Narrow]	TEST CH: Center SSG otuput: -121 dBm(0.2μV) SSG MOD: 1.5kHz				Squelch open	
5. RSSI writing [Wide]	TEST CH: Center SSG otuput: -123 dBm(0.16μV) SSG MOD: off					
[Narrow]	TEST CH: Center SSG otuput: -122 dBm(0.18μV) SSG MOD: off					

PC BOARD TK-3168

TX-RX UNIT (X57-6730-XX) -31 : A -32 : A3
Foil side view (J72-0896-09)

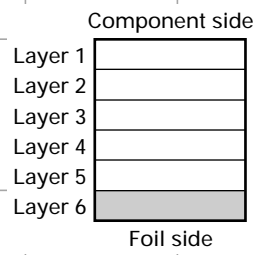
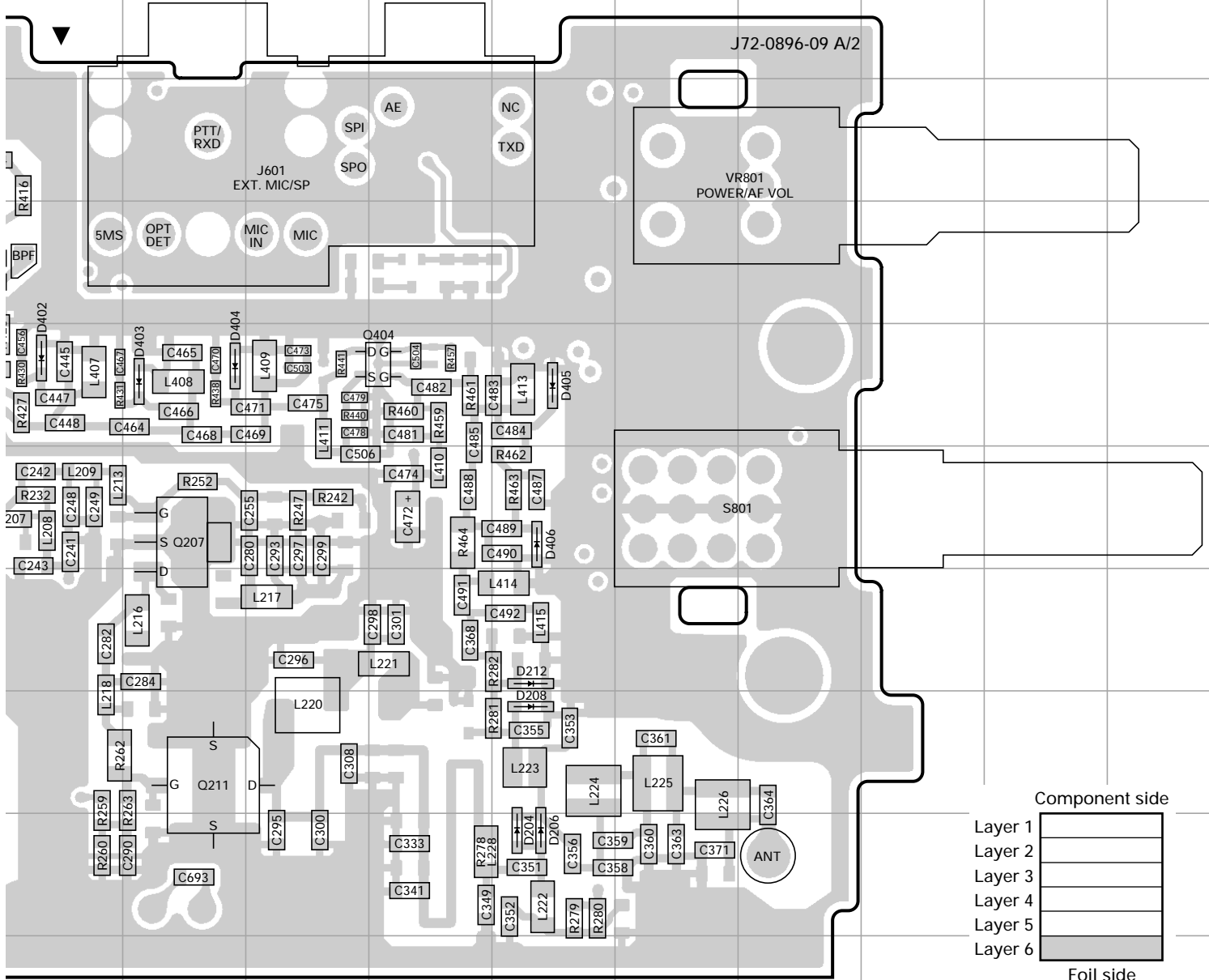

TX-RX UNIT (X57-6730-XX)

Ref. NO.	Address
IC1	8D
IC401	4F
IC801	3D
Q4	5E
Q5	8I
Q6	8H
Q7	7E
Q8	8G
Q9	8H
Q10	7G
Q11	7H
Q12	7G
Q205	5H
Q206	6I

Ref. NO.	Address
Q207	6K
Q211	8K
Q401	3G
Q402	4G
Q403	4I
Q404	5M
Q808	3C
D3	9I
D4	9G
D7	9G
D9	9I
D10	8G
D11	7G
D201	7H

Ref. NO.	Address
D204	9N
D206	9N
D208	8N
D212	7N
D401	6G
D402	5J
D403	5K
D404	5K
D405	5N
D406	6N
D801	3D

TK-3168 PC BOARD

PC BOARD TK-3168

TX-RX UNIT (X57-6730-XX) -31 : A -32 : A3
Component side view (J72-0896-09)

TX-RX UNIT (X57-6730-XX) -31 : A -32 : A3
Component side view (J72-0896-09)

TX-RX UNIT
(X57-6730-XX)

Ref. NO.	Address
IC201	9G
IC601	4Q
IC602	6M
IC604	6L
IC605	3L
IC802	8K
IC803	8K
IC804	9O
IC805	7Q
IC806	8R
Q1	7O
Q3	8O
Q208	8H
Q209	7H
Q210	9G
Q212	9F
Q213	9H
Q407	6M
Q408	9N
Q601	5M
Q602	2N
Q603	4M
Q604	3M
Q605	5J
Q606	4J
Q607	4M
Q608	4L
Q801	4G
Q802	6I
Q803	4F
Q804	3G
Q805	7D
Q806	6K
Q807	6J
Q809	3E
Q810	9R
D203	8H
D407	6M
D603	5M
D604	7K
D605	5K
D802	8C
D803	8C
D805	9E

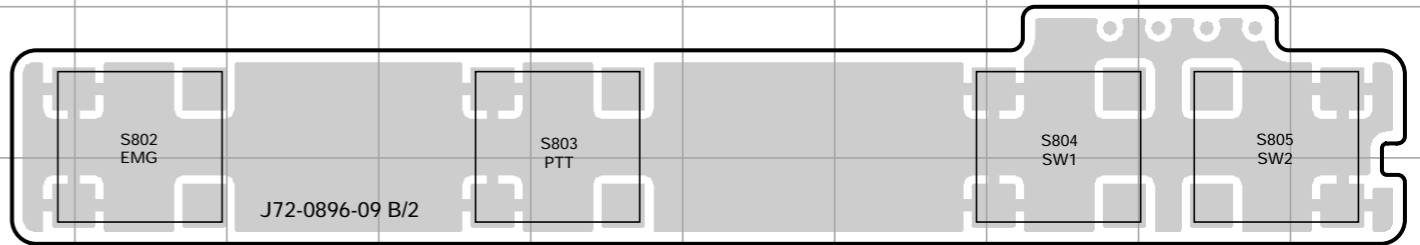
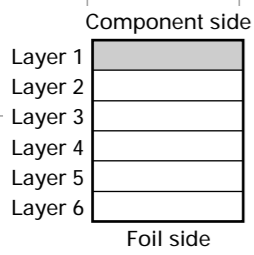
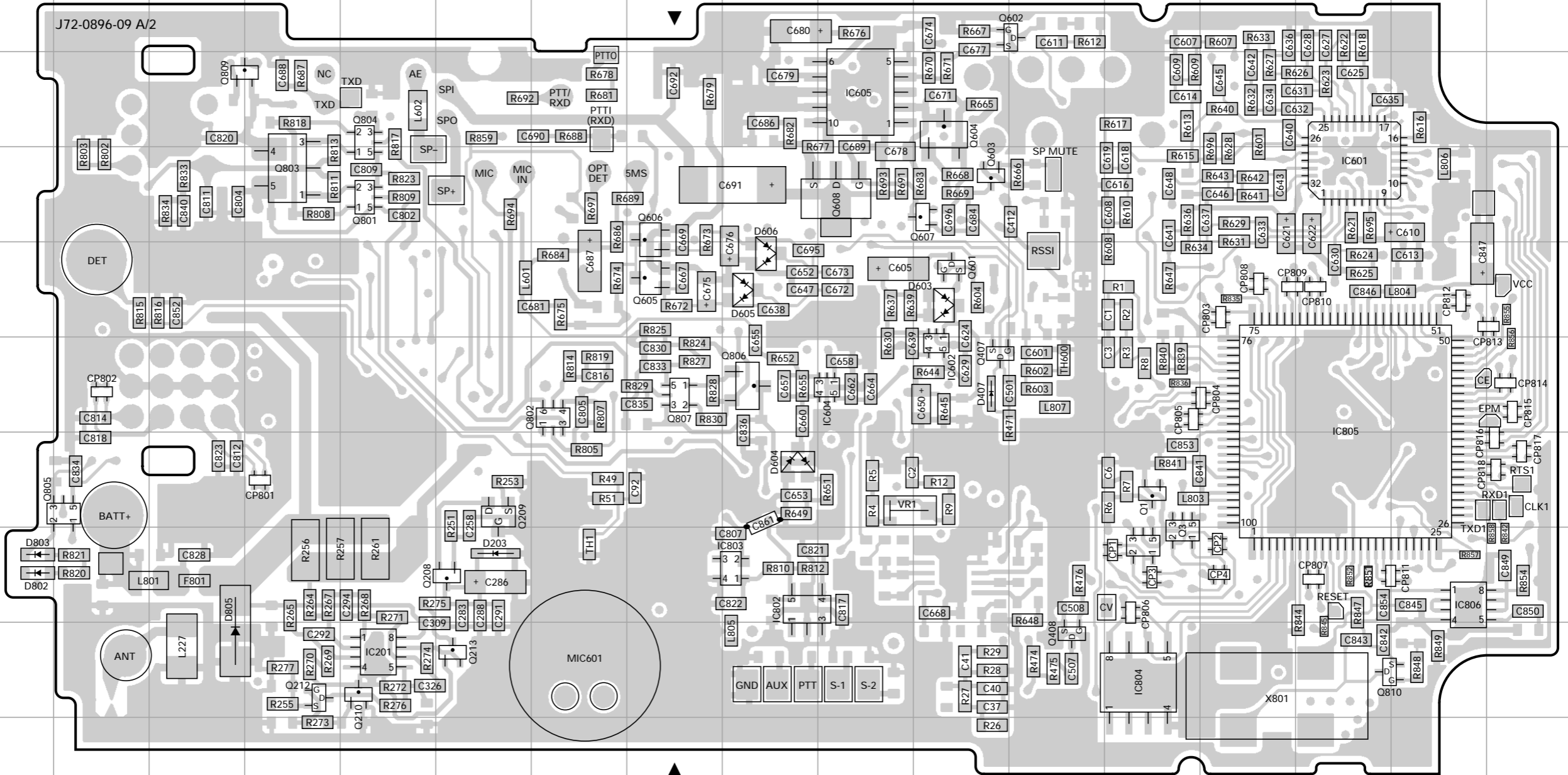

TK-3168 PC BOARD

PC BOARD TK-3168

TX-RX UNIT (X57-6730-XX) -31 : A -32 : A3
Foil side view (J72-0896-09)

TX-RX UNIT (X57-6730-XX) -31 : A -32 : A3
Foil side view (J72-0896-09)

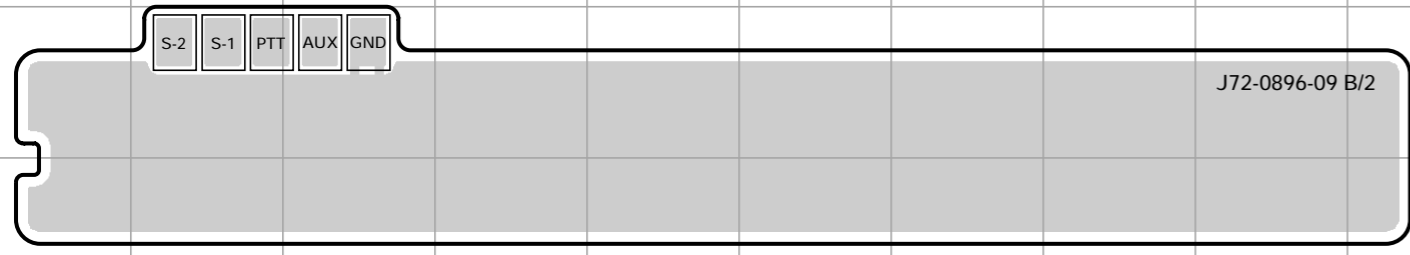
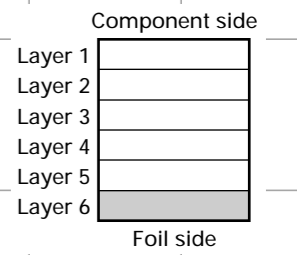
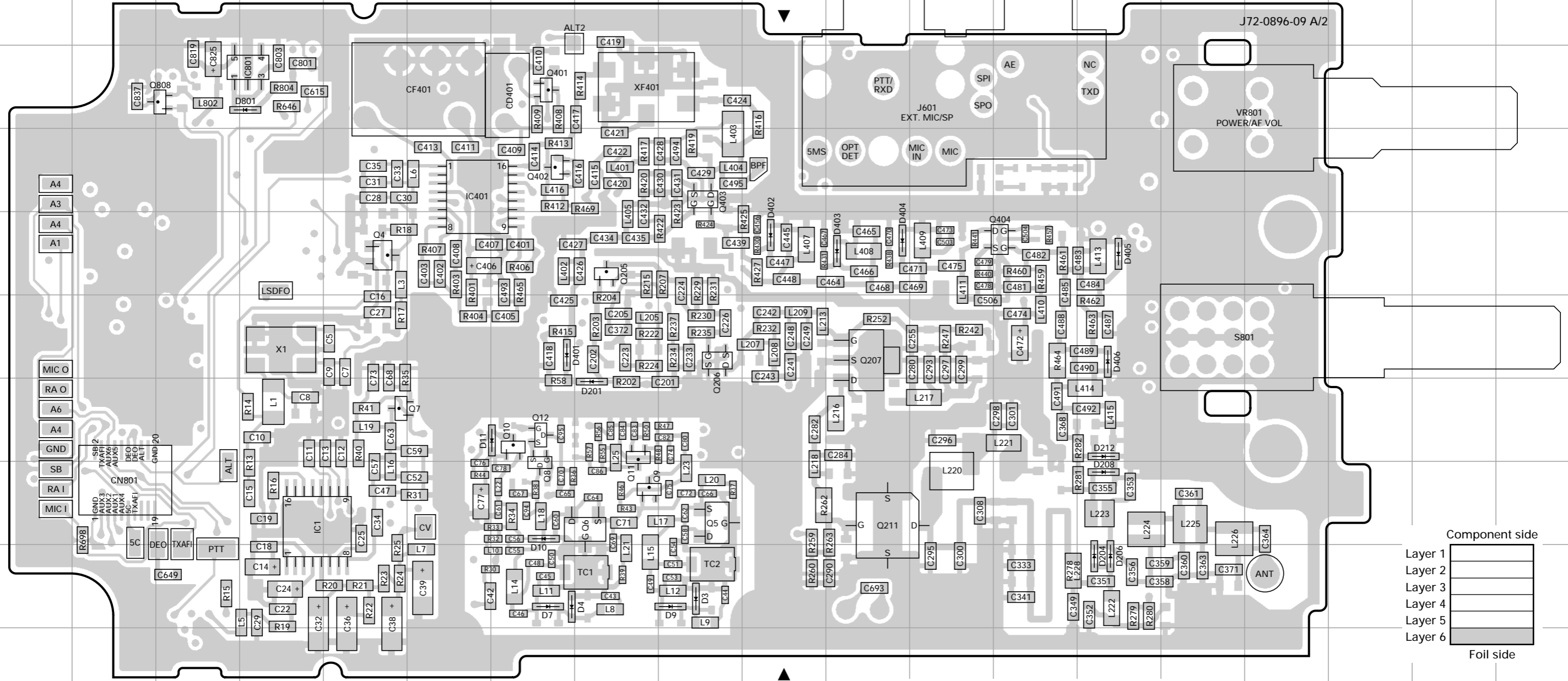

TX-RX UNIT (X57-6730-XX)

Ref. NO.	Address	Ref. NO.	Address	Ref. NO.	Address
IC1	8D	Q207	6K	D204	9N
IC401	4F	Q211	8K	D206	9N
IC801	3D	Q401	3G	D208	8N
Q4	5E	Q402	4G	D212	7N
Q5	8I	Q403	4I	D401	6G
Q6	8H	Q404	5M	D402	5J
Q7	7E	Q808	3C	D403	5K
Q8	8G	D3	9I	D404	5K
Q9	8H	D4	9G	D405	5N
Q10	7G	D7	9G	D406	6N
Q11	7H	D9	9I	D801	3D
Q12	7G	D10	8G		
Q205	5H	D11	7G		
Q206	6I	D201	7H		

TK-3168 SCHEMATIC DIAGRAM

TX-RX UNIT (X57-6730-XX)

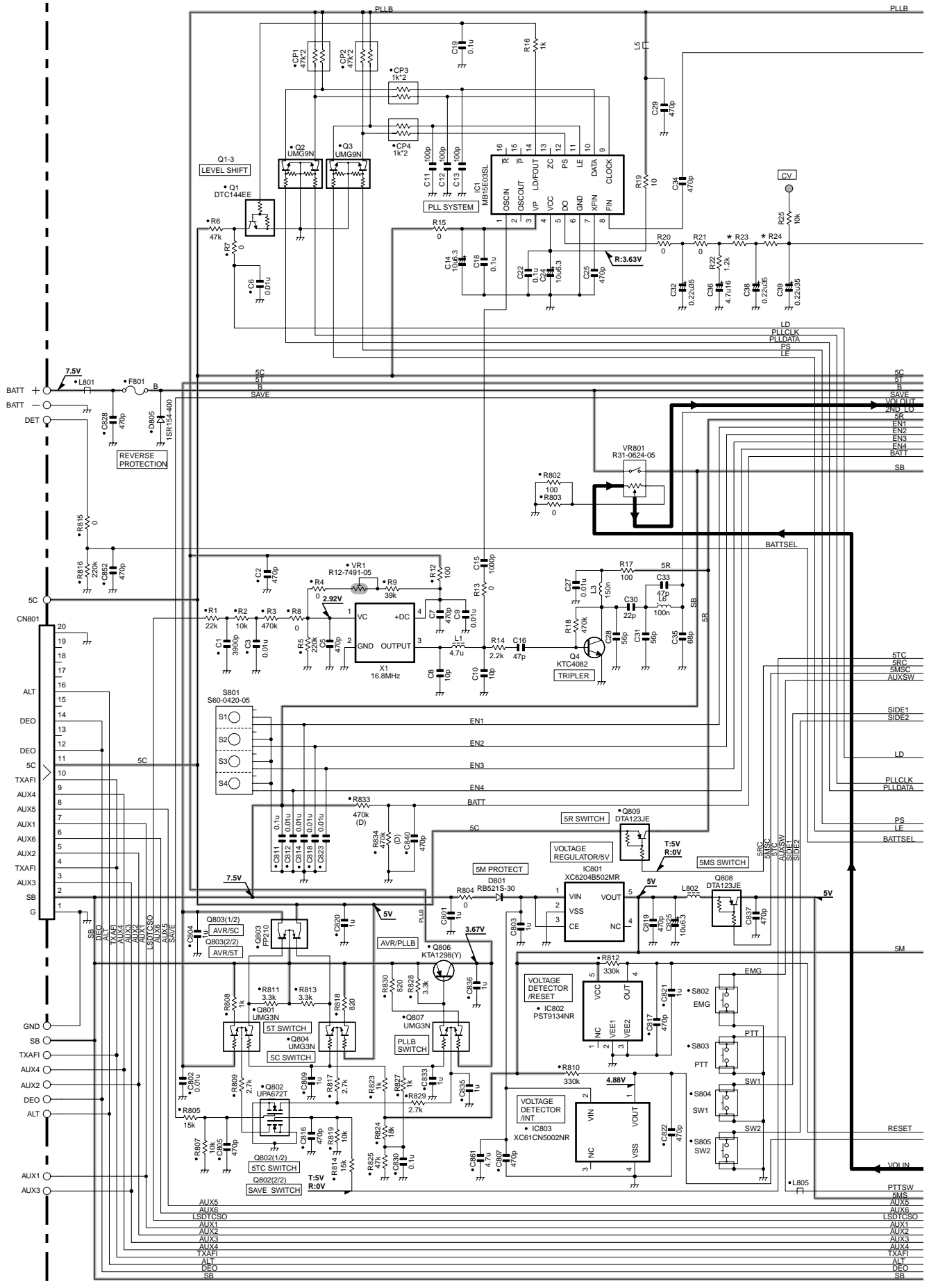

TK-3168 SCHEMATIC DIAGRAM

TX-RX UNIT (X57-6730-XX)

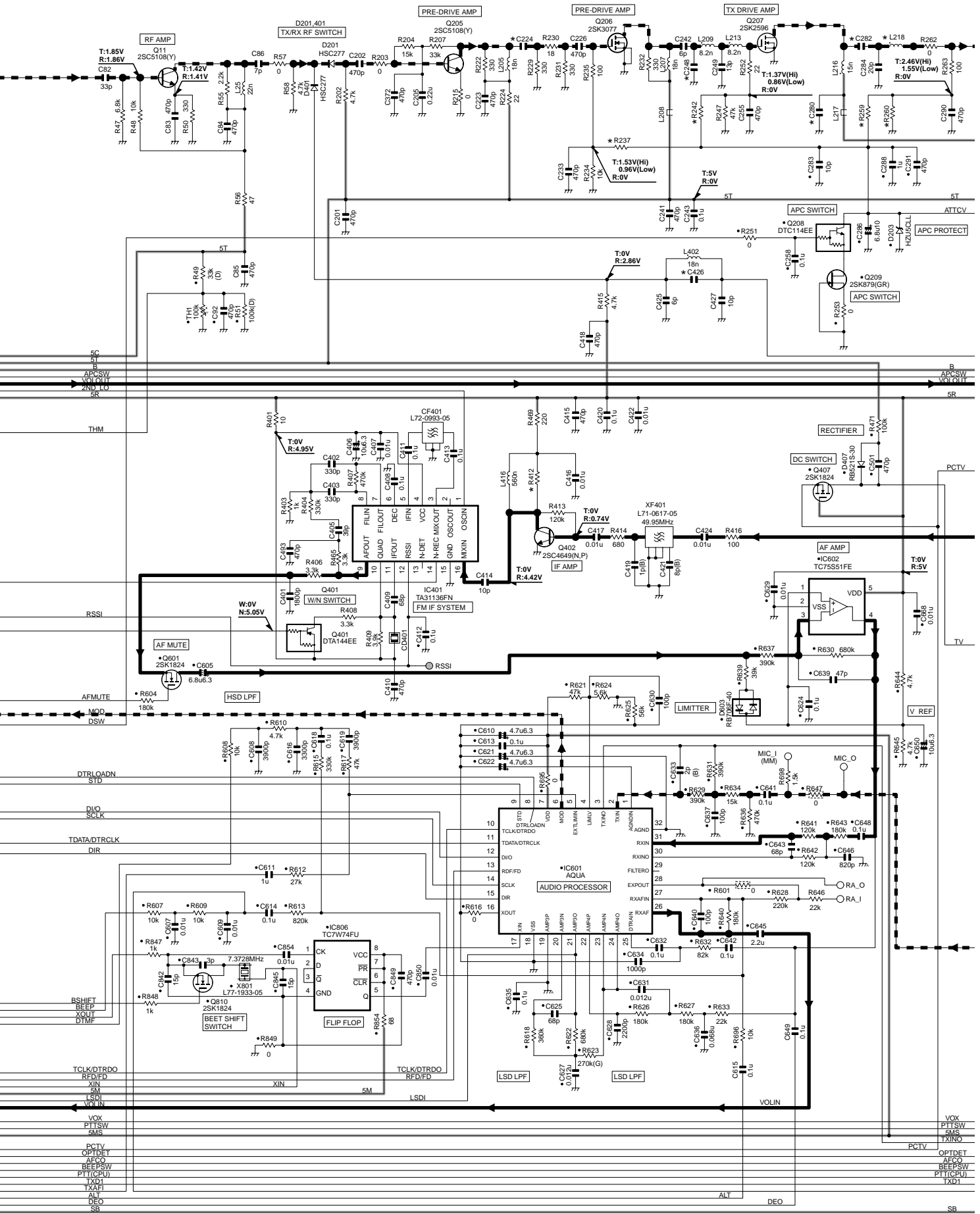

SCHEMATIC DIAGRAM TK-3168

TX-RX UNIT (X57-6730-XX)

Note : The components marked with a dot (●) are parts of layer1.

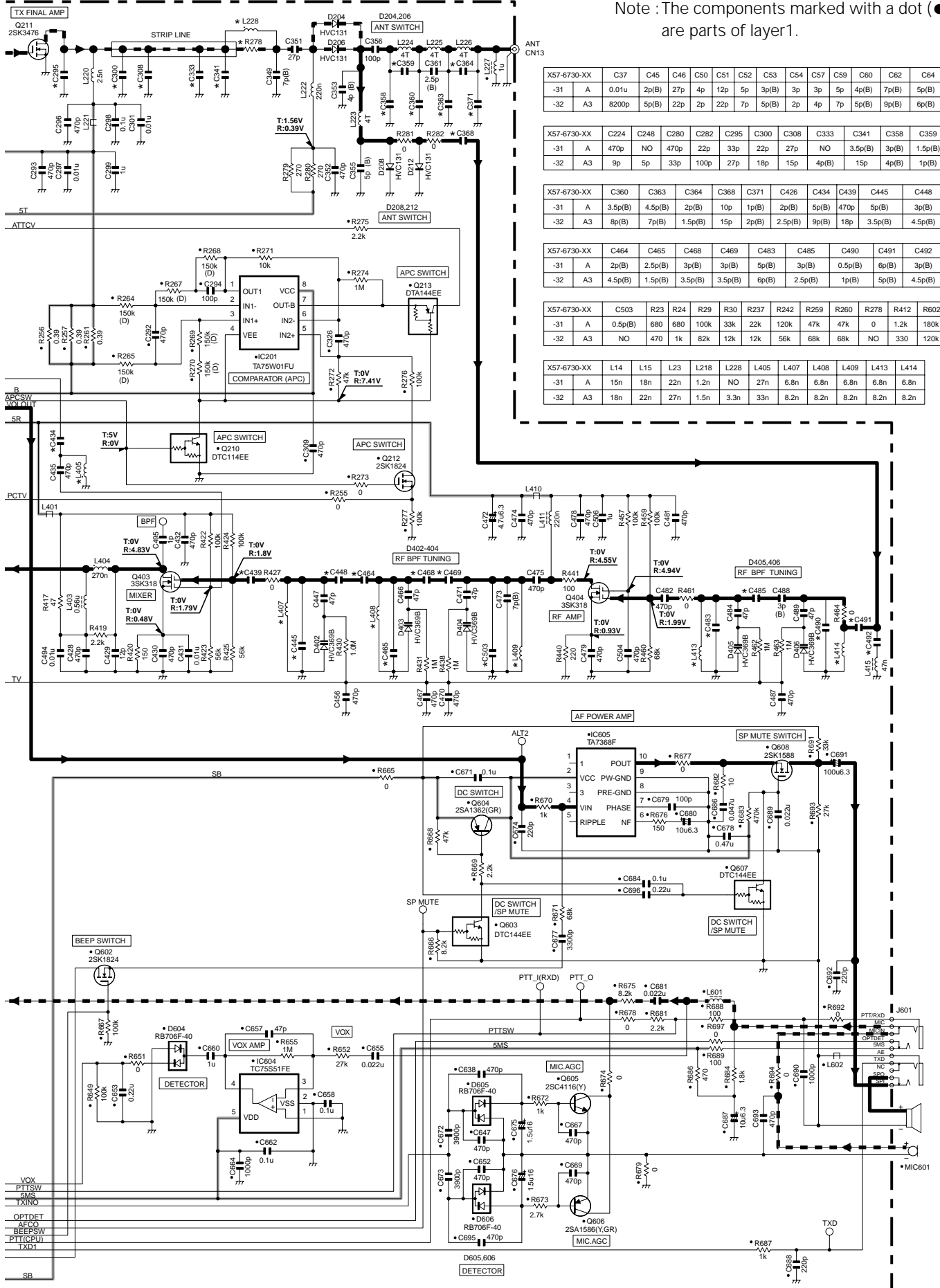

X57-6730-XX	C37	C45	C46	C50	C51	C52	C53	C54	C57	C59	C60	C62	C64	
-31	A	0.01u	2p(B)	27p	4p	12p	5p	3p(B)	3p	3p	5p	4p(B)	7p(B)	5p(B)
-32	A3	8200p	5p(B)	22p	2p	22p	7p	5p(B)	2p	4p	7p	5p(B)	9p(B)	6p(B)

X57-6730-XX	C224	C248	C280	C282	C295	C300	C308	C333	C341	C358	C359	
-31	A	470p	NO	470p	22p	33p	27p	NO	3.5p(B)	3p(B)	1.5p(B)	
-32	A3	9p	5p	33p	100p	27p	18p	15p	4p(B)	15p	4p(B)	1p(B)

X57-6730-XX	C360	C363	C364	C368	C371	C426	C434	C439	C445	C448	
-31	A	3.5p(B)	4.5p(B)	2p(B)	10p	1p(B)	2p(B)	5p(B)	470p	3p(B)	
-32	A3	8p(B)	7p(B)	1.5p(B)	15p	2p(B)	2.5p(B)	9p(B)	18p	3.5p(B)	4.5p(B)

X57-6730-XX	C464	C465	C468	C469	C483	C485	C490	C491	C492	
-31	A	2p(B)	2.5p(B)	3p(B)	3p(B)	5p(B)	3p(B)	0.5p(B)	6p(B)	3p(B)
-32	A3	4.5p(B)	1.5p(B)	3.5p(B)	3.5p(B)	6p(B)	2.5p(B)	1p(B)	5p(B)	4.5p(B)

X57-6730-XX	C503	R23	R24	R29	R30	R237	R242	R259	R260	R278	R412	R602	
-31	A	0.5p(B)	680	680	100k	33k	22k	120k	47k	47k	0	1.2k	180k
-32	A3	NO	470	1k	82k	12k	12k	56k	68k	68k	NO	330	120k

X57-6730-XX	L14	L15	L23	L218	L228	L405	L407	L408	L409	L413	L414
-31	A	15n	18n	22n	1.2n	NO	27n	6.8n	6.8n	6.8n	6.8n
-32	A3	18n	22n	27n	1.5n	3.3n	33n	8.2n	8.2n	8.2n	8.2n

1
2
3
4
5
6
7

TK-3168 SCHEMATIC DIAGRAM

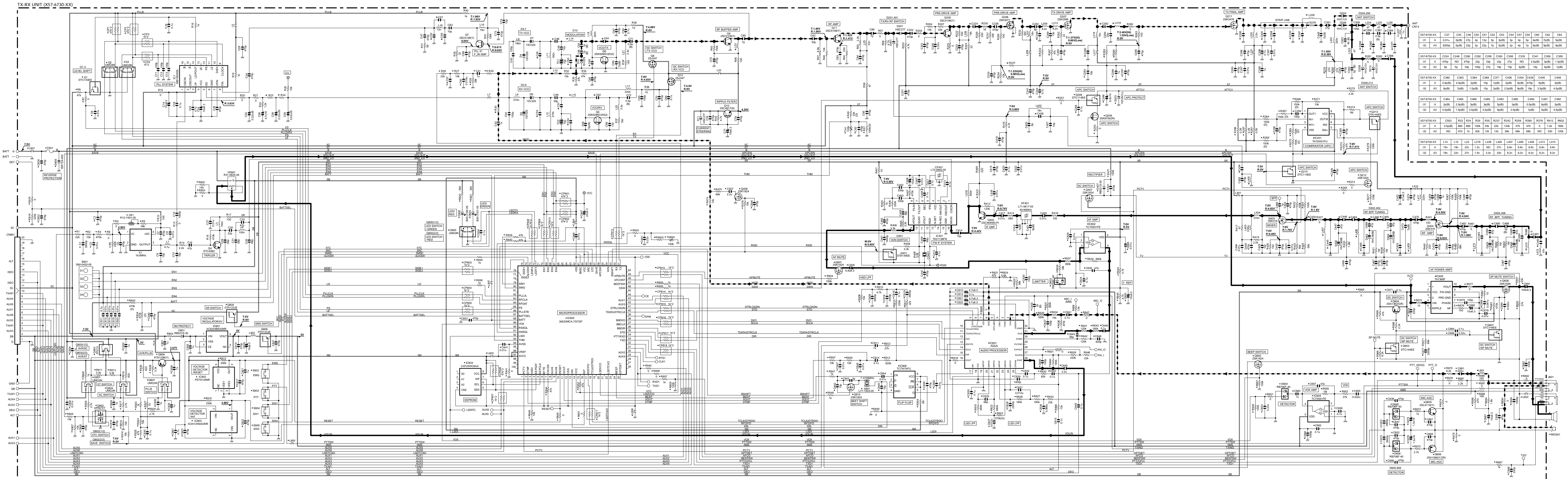

Part No.	Quantity	Value	Notes											
X57-6730-XX	C37	C45	C46	C50	C51	C52	C53	C54	C57	C59	C60	C62	C64	
-31	A	0.01u	20p(B)	27p	4p	15p	5p	30p(B)	7p	5p(B)	2p	4p	7p	5p(B)
-32	A3	800p	5p(B)	22p	2p	22p	7p	5p(B)	2p	4p	7p	5p(B)	6p(B)	
X57-6730-XX	C224	C248	C280	C282	C285	C300	C308	C333	C341	C358	C359			
-31	A	470p	NO	470p	22p	33p	22p	NO	3.5p(B)	3p(B)	1.5p(B)			
-32	A3	9p	5p	33p	100p	27p	15p	15p	4p(B)	15p	4p(B)			
X57-6730-XX	C360	C363	C364	C368	C371	C408	C434	C439	C445	C448				
-31	A	2p(B)	4.5p(B)	2p(B)	15p	25p(B)	5p(B)	5p(B)	47p	3p(B)				
-32	A3	8p(B)	7p(B)	1.5p(B)	15p	2p(B)	2.5p(B)	6p(B)	18p	15p				
X57-6730-XX	C464	C465	C468	C469	C483	C485	C490	C491	C492					
-31	A	2p(B)	2.5p(B)	3p(B)	30p(B)	5p(B)	3p(B)	0.5p(B)	6p(B)	30p(B)				
-32	A3	4.5p(B)	1.5p(B)	3.5p(B)	3.5p(B)	6p(B)	2.5p(B)	1p(B)	2.5p(B)	4.5p(B)				
X57-6730-XX	C503	R23	R24	R29	R30	R33	R237	R242	R259	R260	R278	R412	R602	
-31	A	0.5p(B)	680	680	100k	33k	22k	120k	47k	47k	0	1.2k	180k	
-32	A3	18p	22p	27p	1.5p	3.3p	33p	8.2p	56k	68k	68k	NO	330	
X57-6730-XX	L14	L15	L23	L28	L28	L405	L407	L408	L409	L413	L414			
-31	A	15p	18p	22p	1.2p	NO	27p	6.8n	6.8n	6.8n	6.8n			
-32	A3	18p	22p	27p	1.5p	3.3n	33n	8.2n	8.2n	8.2n	8.2n			

BLOCK DIAGRAM

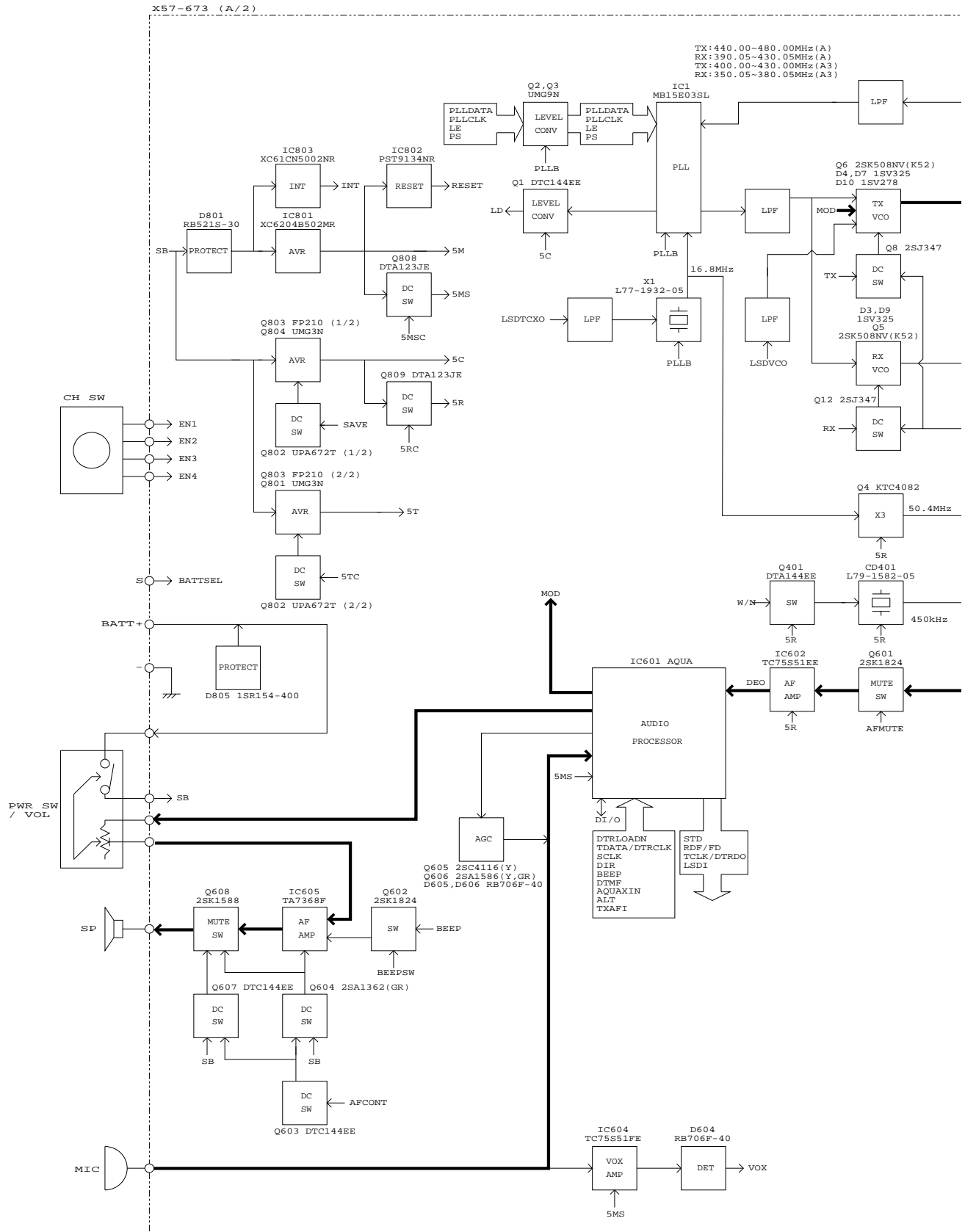

BLOCK DIAGRAM

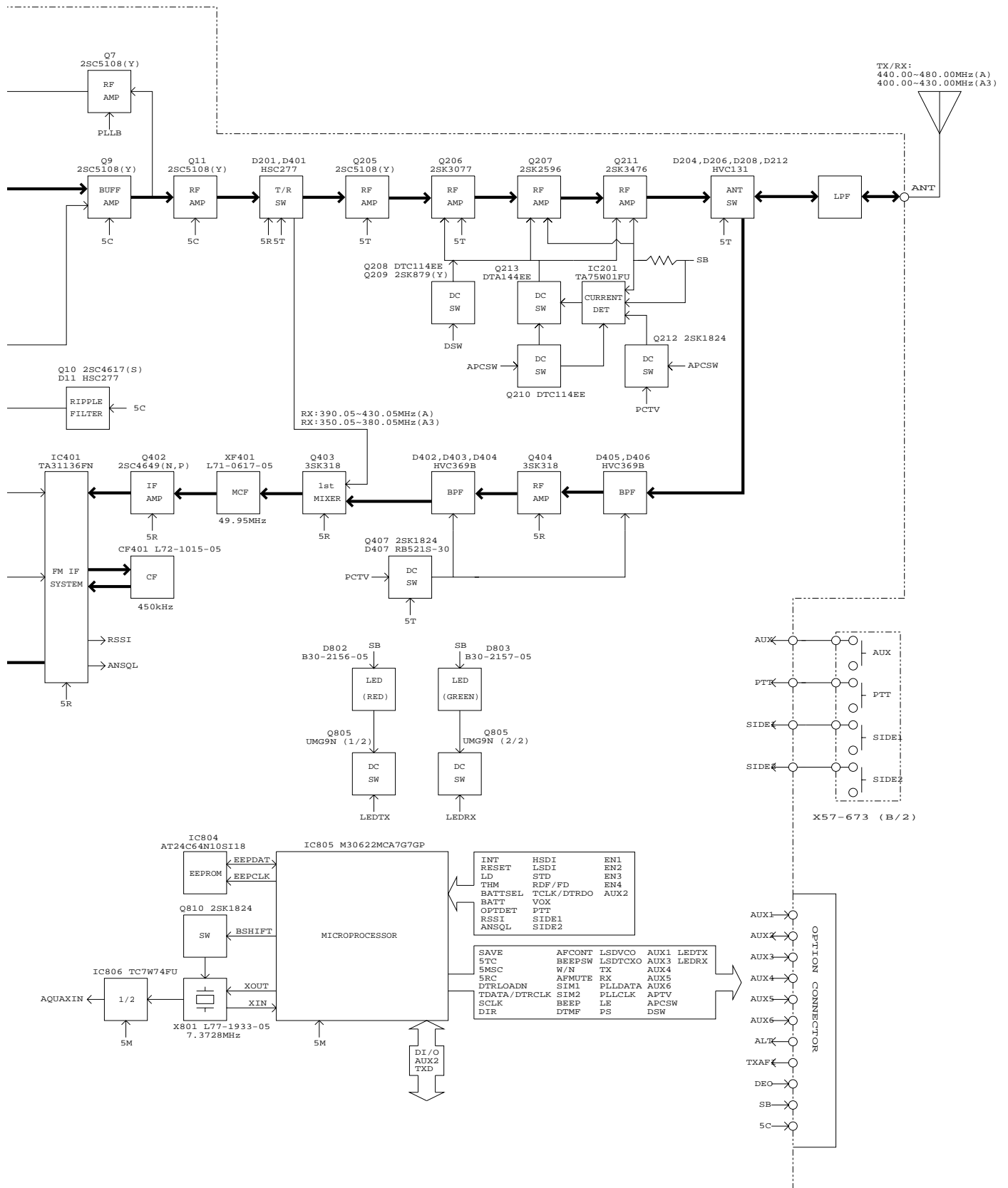

KSC-30



Operating flow chart

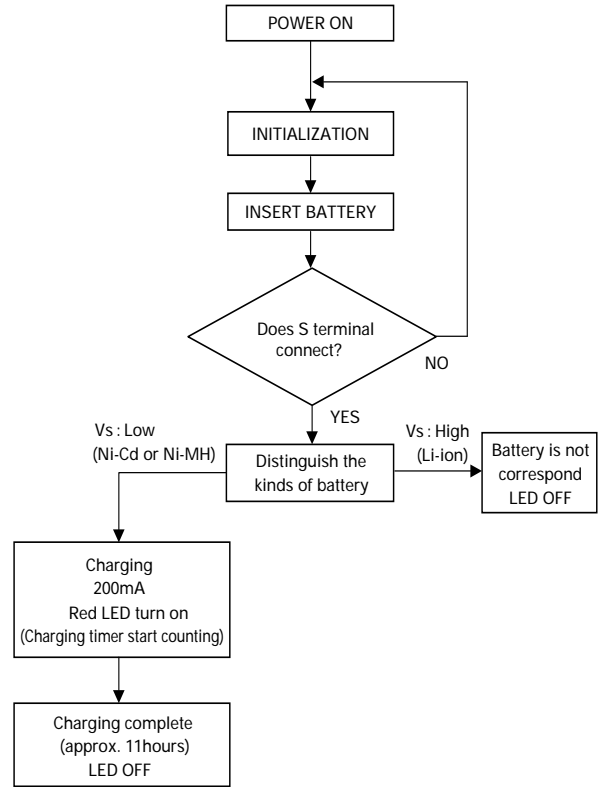

Ref. No.	Address	New parts	Parts No.	Description	Destination
KSC-30					
		*	A02-3656-08	CABINET BOTTOM	
		*	A02-3841-08	CABINET UPPER	
		*	B43-1151-08	BADGE	
		*	B62-1754-08	INSTRUCTION MANUAL	K,T
		*	B62-1755-08	INSTRUCTION MANUAL	E
		*	B72-2209-08	MODEL NAME PLATE	
		*	E03-0453-08	DC JACK	
			E23-1190-08	RELAY TERMINAL	
			G13-1547-08	CUSHION	
			N83-2610-45	PAN HEAD TAPTITE SCREW	
		*	W02-3671-08	ELECTRIC CIRCUIT MODULE	
			W08-0479-05	AC ADAPTER 120V AC 60HZ	K
			W08-0513-05	AC ADAPTER 230V AC 50HZ	T
			W08-0558-15	AC ADAPTER 230V AC 50HZ	E

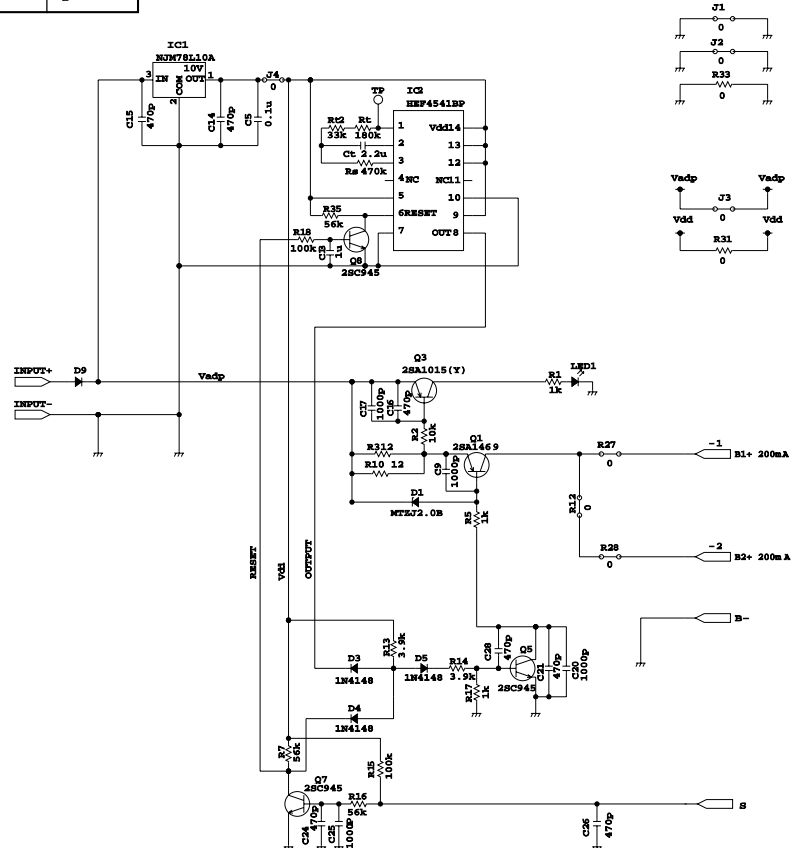

SPECIFICATIONS

General

Frequency Range	440~480MHz (A), 400~430MHz (A3)
Number of channels	Max. 16
Number of groups	Max. 16
Channel Spacing	25kHz (Wide) 12.5kHz (Narrow)
PLL Channel Stepping	5kHz, 6.25kHz
Operating Voltage	7.5 VDC \pm 20%
Battery Life	More than 9 hours at 4 watts (5-5-90 duty cycle with KNB-24L battery)
Operating Temperature range	-30°C to +60°C (-22 °F to +140 °F)
Dimensions and Weight	
With KNB-24L (1400mAh battery)	56 (2-3/16) W x 109.3 (4-5/16) H x 34.5 (1-3/8) D mm (in) 290g (0.64lbs)
With KNB-25A (1200mAh battery)	56 (2-3/16) W x 109.3 (4-5/16) H x 40.7 (1-5/8) D mm (in) 355g (0.78lbs)
With KNB-26N (2000mAh battery)	56 (2-3/16) W x 109.3 (4-5/16) H x 40.7 (1-5/8) D mm (in) 400g (0.88lbs)

Receiver (Measurements made per EIA standard EIA-603)

Sensitivity	
EIA 12dB SINAD	0.25 μ V (Wide)/0.28 μ V (Narrow)
Selectivity	70dB (Wide)/62dB (Narrow)
Intermodulation	65dB (Wide)/62dB (Narrow)
Spurious response	65dB
Audio Power Output	500mW/8 Ω
Frequency Stability	\pm 2.5ppm
Channel Frequency Spread	40MHz (A), 30MHz (A3)

Transmitter (Measurements made per EIA standard EIA-603)

RF Power output	4W/1W
Spurious and Harmonics	70dB
Modulation	16K ϕ F3E (Wide)/11K ϕ F3E (Narrow)
FM Noise	45dB (Wide)/40dB (Narrow)
Audio Distortion	Less than 5%
Frequency Stability	\pm 2.5ppm
Channel Frequency Spread	40MHz (A), 30MHz (A3)

KENWOOD CORPORATION

2967-3, Ishikawa-machi, Hachioji-shi, Tokyo 192-8525, Japan

KENWOOD U.S.A. CORPORATION

P.O. BOX 22745, 2201 East Dominguez Street, Long Beach, CA 90801-5745, U.S.A.

KENWOOD ELECTRONICS CANADA INC.

6070 Kestrel Road, Mississauga, Ontario, Canada L5T 1S8

KENWOOD ELECTRONICS DEUTSCHLAND GMBH

Rembrücker Str. 15, 63150 Heusenstamm, Germany

KENWOOD ELECTRONICS BELGIUM N.V.

Leuvensesteenweg 248 J, 1800 Vilvoorde, Belgium

KENWOOD ELECTRONICS FRANCE S.A.

13, Boulevard Ney, 75018 Paris, France

KENWOOD ELECTRONICS U.K. LIMITED

KENWOOD House, Dwight Road, Watford, Herts., WD18 9EB, United Kingdom

KENWOOD ELECTRONICS EUROPE B.V.

Amsterdamseweg 37, 1422 AC Uithoorn, The Netherlands

KENWOOD ELECTRONICS ITALIA S.p.A.

Via G. Sirtori, 7/9 20129 Milano, Italy

KENWOOD IBERICA S.A.

Bolivia, 239-08020 Barcelona, Spain

KENWOOD ELECTRONICS AUSTRALIA PTY. LTD.

(A.C.N. 001 499 074)

16 Giffnock Avenue, Centrecourt Estate, North Ryde, N.S.W. 2113, Australia

KENWOOD ELECTRONICS (HONG KONG) LTD.

Unit 3712-3724, Level 37, Tower one Metroplaza, 223 Hing Fong Road, Kwai Fong, N.T., Hong Kong

KENWOOD ELECTRONICS SINGAPORE PTE LTD.

1 Genting Lane #07-00 Kenwood Building, Singapore 349544

