



CONTENTS

GENERAL	2
SYSTEM SET-UP	2
REALIGNMENT	3
DISASSEMBLY FOR REPAIR	6
CIRCUIT DESCRIPTION	7
SEMICONDUCTOR DATA	13
COMPONENTS DESCRIPTION	14
PARTS LIST	16
EXPLODED VIEW	25
PACKING	26
ADJUSTMENT	27
TERMINAL FUNCTION	39
PC BOARD	
DISPLAY UNIT (X54-3470-11)	42
TX-RX UNIT (X57-6942-71)	46
SCHEMATIC DIAGRAM	
DISPLAY UNIT (X54-3470-11)	50
TX-RX UNIT (X57-6942-71)	52
BLOCK DIAGRAM	60
LEVEL DIAGRAM	62
OPTIONAL ACCESSORIES	
KNB-31A/32N/33L	63
KSC-32	63
SPECIFICATIONS	BACK COVER

**Does not come with antenna.
Antenna is available as an option.**

TK-3180

GENERAL / SYSTEM SET-UP

INTRODUCTION

SCOPE OF THIS MANUAL

This manual is intended for use by experienced technicians familiar with similar types of commercial grade communications equipment. It contains all required service information for the equipment and is current as of the publication date. Changes which may occur after publication are covered by either Service Bulletins or Manual Revisions. These are issued as required.

ORDERING REPLACEMENT PARTS

When ordering replacement parts or equipment information, the full part identification number should be included. This applies to all parts : components, kits, or chassis. If the part number is not known, include the chassis or kit number of which it is a part, and a sufficient description of the required component for proper identification.

PERSONAL SAFETY

The following precautions are recommended for personal safety:

- DO NOT transmit until all RF connectors are verified secure and any open connectors are properly terminated.
- SHUT OFF and DO NOT operate this equipment near electrical blasting caps or in an explosive atmosphere.
- This equipment should be serviced by a qualified technician only.

SERVICE

This transceiver is designed for easy servicing. Refer to the schematic diagrams, printed circuit board views, and alignment procedures contained within.

SYSTEM SET-UP

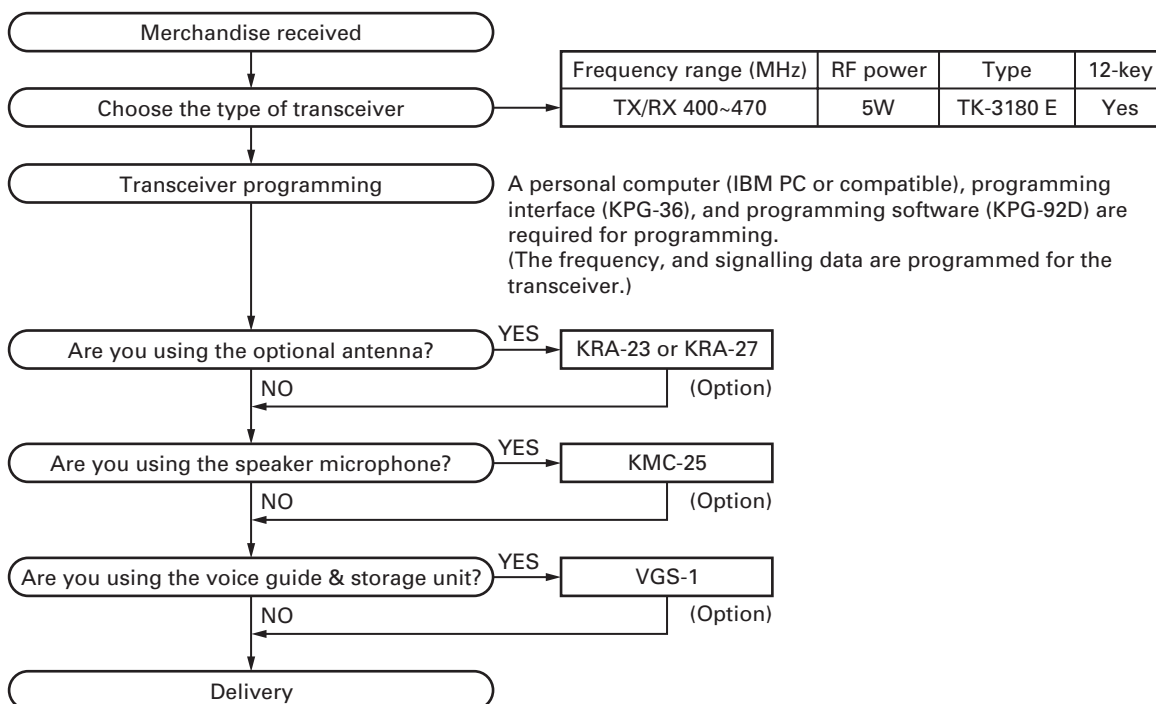

REALIGNMENT

1. Modes

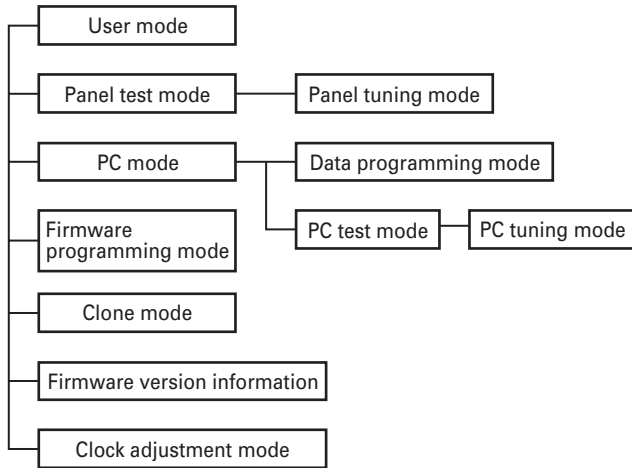

Mode	Function
User mode	For customer uses.
Panel test mode	Used by the dealer to check the fundamental characteristics.
Panel tuning mode	Used by the dealer to tune the radio.
PC mode	Uses for communication between the radio and PC (IBM compatible).
Data programming mode	Uses to read and write frequency data and other features to and from the radio.
PC test mode	Uses to check the radio using the PC. This feature is included in the FPU. See panel tuning.
Firmware programming mode	Uses to changing the main program of the flash memory.
Clone mode	Uses to transfer programming data from one radio to another.
Firmware version information	Uses to confirm the internal firmware version.
Clock adjustment mode	Used by dealer to adjust date and time.

2. How to Enter Each Mode

Mode	Operation
User mode	Power ON
Panel test mode	[A] + Power ON
PC mode	Received commands from PC
Panel tuning mode	[Panel test mode] + [S]
Firmware programming mode	[S] + Power ON
Clone mode	[B] + Power ON
Firmware version information	[Side1] + Power ON
Clock adjustment mode	[C] + Power ON

3. Panel Test Mode

Setting method refer to ADJUSTMENT.

4. Panel Tuning Mode

Setting method refer to ADJUSTMENT.

5. PC Mode

5-1. Preface

The transceiver is programmed by using a personal computer, programming interface (KPG-36) and programming software (KPG-92D).

The programming software can be used with an IBM PC or compatible. Figure 1 shows the setup of an IBM PC for programming.

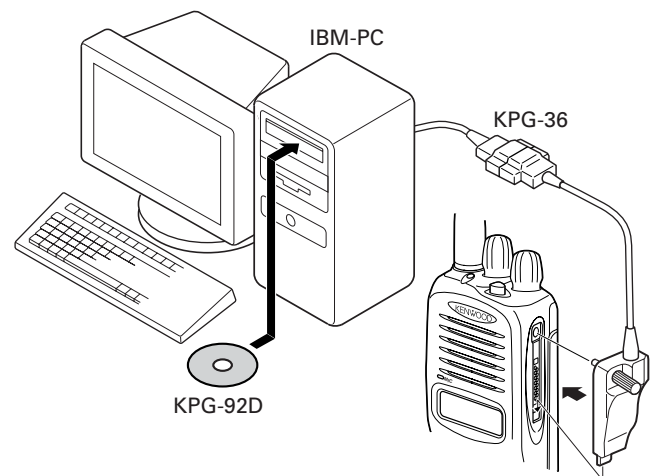

Fig. 1

REALIGNMENT

5-2. Connection procedure

1. Connect the transceiver to the personal computer with the interface cable.
2. When the POWER switch on, user mode can be entered immediately. When PC sends command the radio enter PC mode, and "PROGRAM" is displayed on the LCD. When data transmitting from transceiver, the red LED is lights. When data receiving to transceiver, the green LED is lights.

Note:

- The data stored in the personal computer must match model type, when it is written into the flash memory.

5-3. KPG-36 description

(PC programming interface cable: Option)

The KPG-36 is required to interface the transceiver to the computer. It has a circuit in its D-subconnector (25-pin) case that converts the RS-232C logic level to the TTL level.

The KPG-36 connects the universal connector of the transceiver to the computers RS-232C serial port.

5-4. Programming software KPG-92D description

The KPG-92D is the programming software for the transceiver supplied on a CD-ROM. This software runs under MS-Windows 98, ME, Windows 2000 or XP on an IBM-PC or compatible machine.

The data can be input to or read from the transceiver and edited on the screen. The programmed or edited data can be printed out. It is also possible to tune the transceiver.

6. Firmware Programming Mode

6-1. Preface

Flash memory is mounted on the transceiver. This allows the transceiver to be upgraded when new features are released in the future. (For details on how to obtain the firmware, contact Customer Service.)

6-2. Connection procedure

Connect the transceiver to the personal computer (IBM PC or compatible) with the interface cable (KPG-36). (Connection is the same as in the PC Mode.)

6-3. Programming

1. Start up the firmware programming software (Fpro.exe).
2. Set the communications speed (normally, 115200 bps) and communications port in the configuration item.
3. Set the firmware to be updated by File name item.
4. Turn the transceiver power ON with the [S] switch held down. Then, the orange LED on the transceiver lights and "PROG 115200" is displayed.

5. Check the connection between the transceiver and the personal computer, and make sure that the transceiver is in the Program mode.
6. Press write button in the window. When the transceiver starts to receive data, the [PG] display is blinking.
7. If writing ends successfully, the checksum is calculated and a result is displayed.
8. If you want to continue programming other transceivers, repeat steps 4 to 7.

Note:

- This mode cannot be entered if the Firmware Programming mode is set to Disable in the Programming software.

6-4. Function

1. If you press the [Side2] switch (under of left side) while "PROG 115200" is displayed, the display changes to "PROG 19200" to indicate that the write speed is low speed (19200 bps). If you press the [Side2] switch again while "PROG 19200" is displayed, the display changes to "PROG 38400". If you press the [Side2] switch again while "PROG 38400" is displayed, the display changes to "PROG 57600". If you press the [Side2] switch again while "PROG 57600" is displayed, the display returns to "PROG 115200".
2. If you press the [Side1] switch (top of left side) while "PROG 115200" is displayed, the checksum is calculated, and a result is displayed. If you press the [Side1] switch again while the checksum is displayed, "PROG 115200" is redisplayed.

Note:

Normally, write in the high-speed mode.

7. Clone Mode

Programming data can be transferred from one radio to another by connecting them via their external universal connectors. The operation is as follows (the transmit radio is the master and the receive radio is a slave).

The "password" of description by explanation of 1. to 7. are "Read Authorization Password".

1. Turn the master transceiver power ON with the [B] key held down. If the Data password is set to the transceiver, the transceiver displays "CLONE LOCK". If the password is not set, the transceiver displays "CLONE MODE".
2. When you enter the correct password, and "CLONE MODE" is displayed, the transceiver can be used as the cloning master. The following describes how to enter the password.

REALIGNMENT

3.
 - How to enter the password with the keypad;
If you press a key while "CLONE LOCK" is displayed, the number that was pressed is displayed on the transceiver. Each press of the key shifts the display in order to the left. When you enter the password and press the [*] or [S] key, "CLONE MODE" is displayed if the entered password is correct. If the password is incorrect, "CLONE LOCK" is redisplayed.
 - How to enter the password with the encoder;
If the encoder is rotated while "CLONE LOCK" is displayed, numbers (0 to 9) are displayed flashing. When you press the [C] key, the currently selected number is determined. If you press the [S] key after entering the password in this procedure, "CLONE MODE" is displayed if the entered password is correct. If the password is incorrect, "CLONE LOCK" is redisplayed.
4. Power on the slave transceiver.
5. Connect the cloning cable (part No. E30-3325-05) to the universal connectors on the master and slave.
6. Press the [S] key on the master while the master displays "CLONE MODE". The data of the master is sent to the slave. While the slave is receiving the data, "PROGRAM" is displayed. When cloning of data is completed, the master displays "END", and the slave automatically operates in the User mode. The slave can then be operated by the same program as the master.
7. The other slave can be continuously cloned. When the [S] key on the master is pressed while the master displays "END", the master displays "CLONE MODE". Carry out the operation in step 4 to 6.

Notes:

- Can not be cloned if the password (over write password) is programmed to the slave.
- Only the same models can be cloned together.

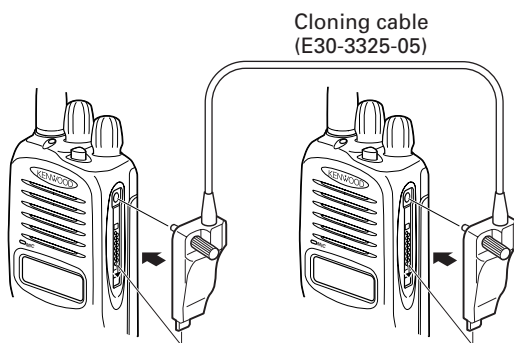

Fig. 2

8. Firmware Version Information Mode

Turn the transceiver ON with the [Side1] switch held down. Then, the version is displayed during holding the [Side1] switch.

9. Clock Adjustment Mode

9-1. Flow chart of operation

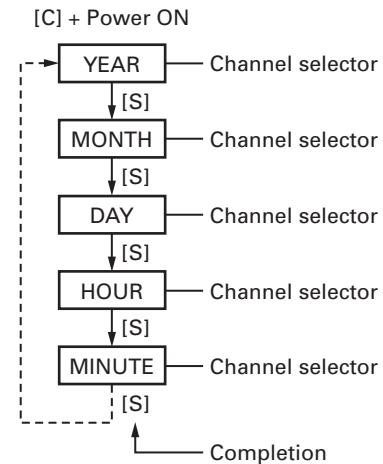

DISASSEMBLY FOR REPAIR

1. How to Attach the Rubber Spacer

- 1) Press the rubber spacer with fingers and insert it between the rubber spacer and the rear panel without crevice.

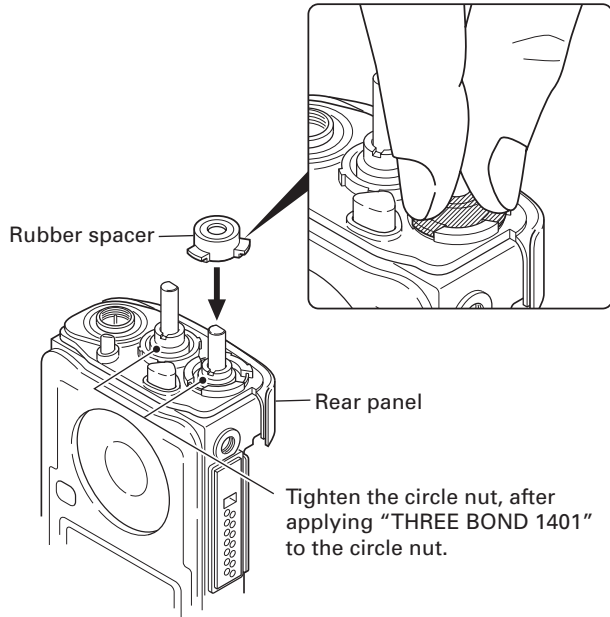

2. How to Attach the TX-RX Unit

- 1) In order to attach the TX-RX unit in chassis, don't put in the TX-RX unit aslant. Please level the chassis and the TX-RX unit and attach them.

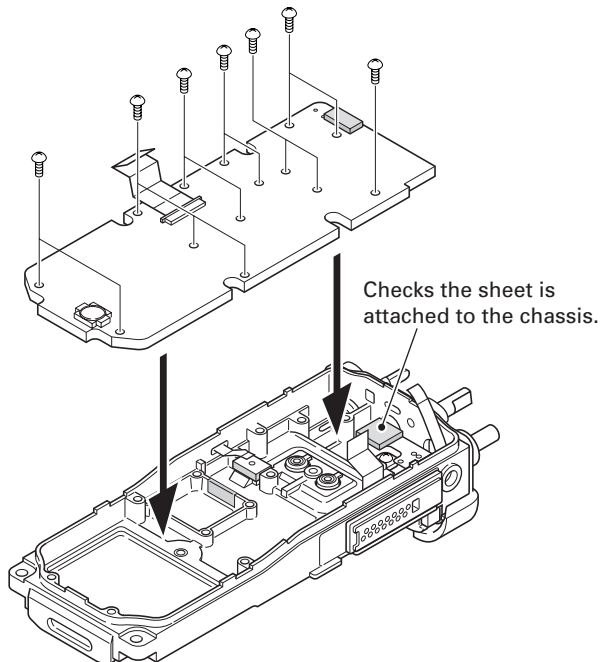

3. How to Attach the VGS-1

- 1) Remove the 2 screws.
- 2) The tip of tweezers is put into the screw hole of the cover and is pried, the cover will remove.
- 3) Use the 2 rubber cushions and attach them to the VGS-1.
- 4) Plug the VGS-1 into the VGS-1 connector of the PC board, pressing down on the top of the VGS-1 until secure.
- 5) The spacer turns the adhesive surface down. Next, push between the chassis and VGS-1.
- 6) Replace the cover and tighten the 2 screws.

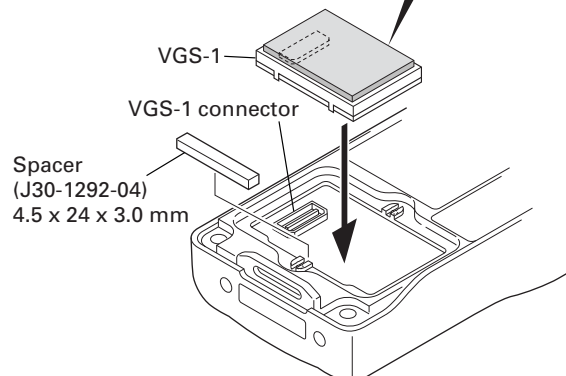
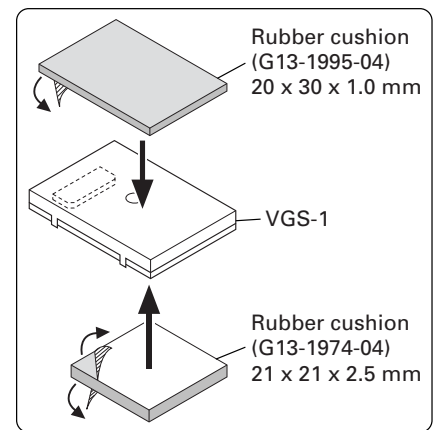
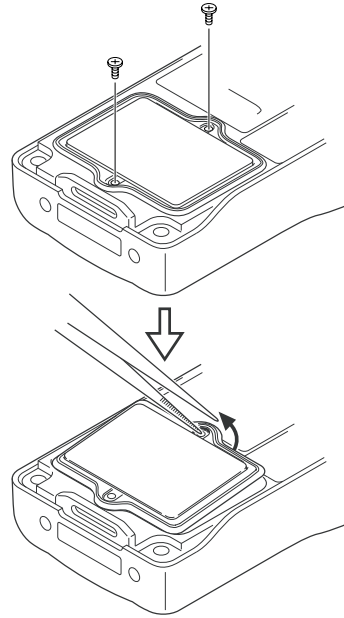

CIRCUIT DESCRIPTION

1. Overview

This transceiver is UHF/FM portable transceiver designed to operate in the frequency range of 400 to 470MHz.

2. Circuit Configuration by Frequency

The receiver is a double-conversion superheterodyne with a first intermediate frequency (IF) of 59.85MHz and a second IF of 455kHz. Incoming signals from the antenna are mixed with the local signal from the PLL to produce the first IF of 59.85MHz.

This is then mixed with the 59.395MHz second local oscillator output to produce the 455kHz second IF. This is detected to give the demodulated signal.

The transmit signal frequency is generated by the PLL VCO, and modulated by the signal from the microphone. It is then amplified and sent to the antenna.

3. Receiver System

3-1. RF unit

An incoming RF signal from the antenna terminal is passed through the antenna switch (D106, D107, D213 and D214 are off) and then the bandpass filter (L215, L216). The bandpass filter is adjusted by a variable capacitor. The input voltage to the variable capacitor is regulated by the voltage output from the D/A converter (IC605). The signal is amplified by RF amplifier (Q207), and passed through the bandpass filter (L210, L211, L212).

The resulting signal is applied to the first mixer (Q206), where it is mixed with the first local oscillator signal output from the frequency synthesizer to produce the first IF (59.85MHz).

3-2. IF unit

The first IF signal is passed through a four-pole monolithic crystal filter (XF200) to remove a adjacent channel signal. The filtered first IF signal is amplified by the first IF amplifier (Q205) and then applied to the IF system IC (IC200). The IF system IC provides a second mixer, second local oscillator, limiting amplifier, quadrature detector and RSSI (Received Signal Strength Indicator). The second mixer mixes the first IF signal with the 59.395MHz of second local oscillator output (crystal unit X200) and produces the second IF signal of 455kHz.

The second IF signal is passed through the ceramic filter (CF201 : Wide, CF200 : Narrow) to more remove the adjacent channel signal. The filtered second IF signal is amplified by the limiting amplifier and demodulated by the quadrature detector with ceramic discriminator (CD200). The demodulated signal is routed to the audio circuit.

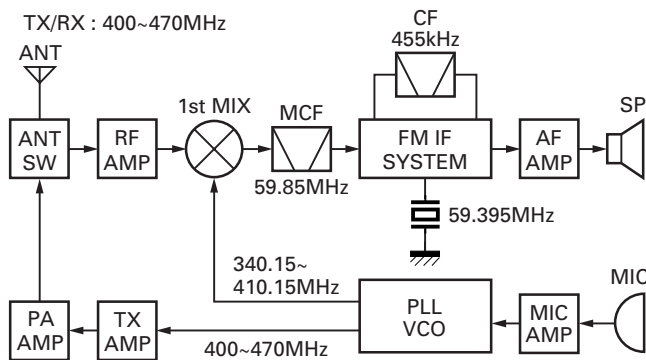

Fig. 1 Frequency configuration

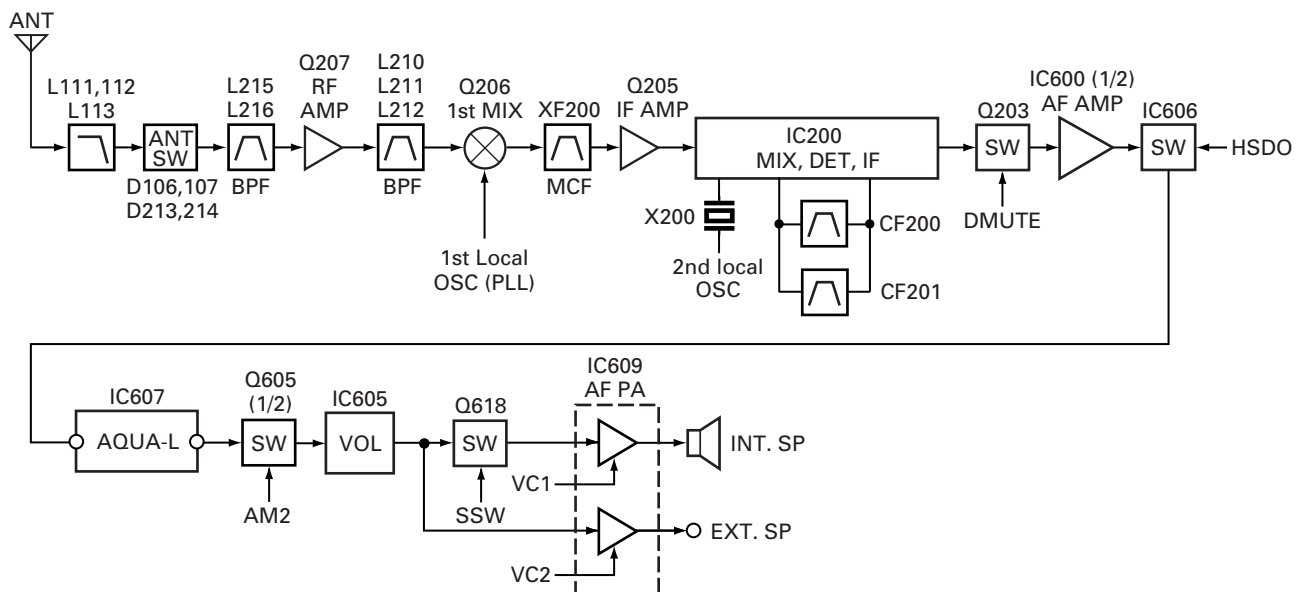

Fig. 2 Receiver section

CIRCUIT DESCRIPTION

3-3. Wide/Narrow switching circuit

Wide and Narrow settings can be made for each channel by switching the ceramic filters CF201 (Wide), CF200 (Narrow). The Wide (low level) and Narrow (high level) is output from IC502.

When a Wide (low level) is selected, Q200 (N-ch) turn off and Q200 (P-ch) turn on. When a Narrow (high level) is selected, Q200 (N-ch) turn on and Q200 (P-ch) turn off. D201 and D203 are switched to ceramic filters when a high/low level is selected.

Q204 turns on/off with the Wide/Narrow and the IC200 detector output level is changed to maintain a constant output level during wide or narrow signals.

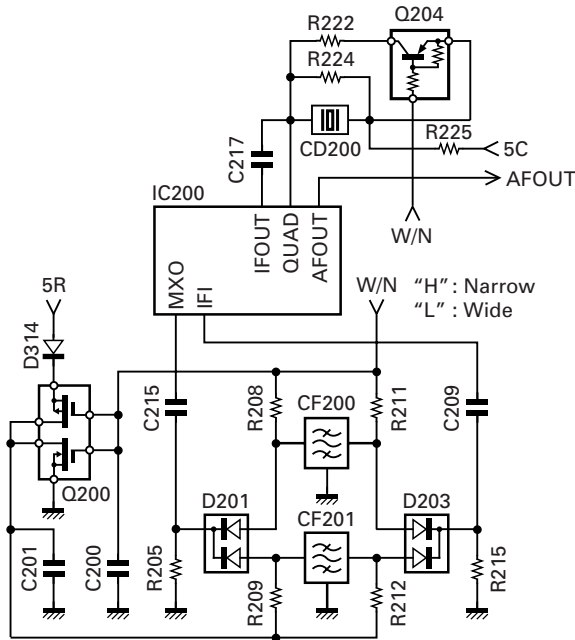

Fig. 3 Wide/Narrow switching circuit

3-4. Audio amplifier circuit

The demodulated signal from IC200 goes through the mute switch (Q203), IC600 (1/2) and IC606, high-pass filtered, low-pass filtered, high-pass filtered and de-emphasized by IC607.

The signal then goes through mute switch (Q605 1/2), and an electronic volume control (IC605), and an AF switch (Q618 is on), and is routed to audio power amplifier (IC609), where it is amplified and output to the internal speaker.

The audio mute signal (AM1) from the IC502 becomes Low in the standby and Q612, Q613 which are power supply circuit for IC609 turn off. Also, the audio mute signal (AM2) becomes High to turn Q605 (1/2) off. When the audio is output, AM1 becomes High to turn Q612, Q613 on, and voltage is supplied to power terminal VP of IC609. Also, AM2 becomes Low to turn Q605 (1/2) on.

The speaker is switched by the logic of speaker switching terminal SSW on the universal connector. When SP-MIC is not attached, the logic of SSW becomes High and SW (Q618) is turned on, and the AF signal is input to both amplifiers of IC609.

When SP-MIC is attached, SSW is connected to GND at inside of SP-MIC. For this reason, Q618 is turned off, and the AF signal is input only to amplifier for EXT SP of IC609.

Change of INT/EXT SP refer to Fig. 4.

AM1	AM2	SSW	VC1	VC2	SP
H	L	H	H	L	INT
H	L	L	L	H	EXT
L	H	H	L	L	MUTE
L	H	L	L	L	MUTE

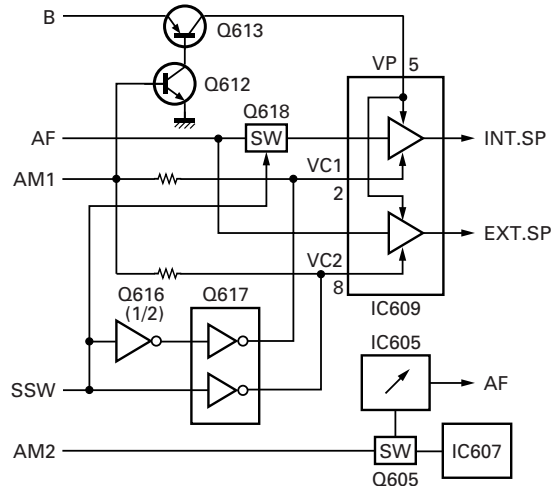

Fig. 4 Audio amplifier circuit

3-5. Squelch circuit

The output from IC200 enters FM IC again, then passed through a bandpass filter. The noise component output from IC200 is amplified by Q201 and rectified by D202 to produce a DC voltage corresponding to the noise level. The DC voltage is sent to the analog port of the CPU (IC502). And IC200 outputs a DC voltage (RSSI) corresponding to the input of the IF amplifier. The CPU reads the RSSI signal via pin 125.

IC502 determines whether to output sounds from the speaker by comparing the input voltage of pin 124 and pin 125 with the preset value.

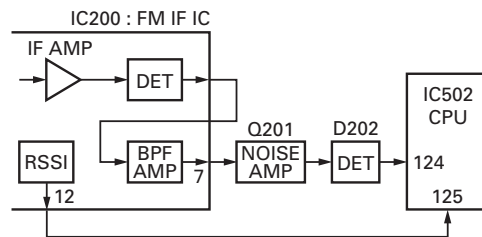

Fig. 5 Squelch circuit

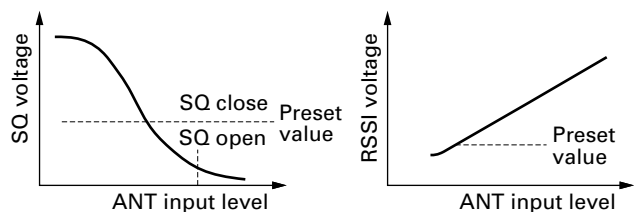

Fig. 6 Squelch and RSSI voltage vs ANT input level

CIRCUIT DESCRIPTION

4. Transmitter System

4-1. Microphone amplifier

The signal from the internal microphone goes through the mute switch (Q614).

When the SP-MIC is not attached, the microphone switching terminal (MSW) on the universal connector becomes High, and mute switch (Q614) is turned on. When the SP-MIC is attached, MSW is connected to GND at inside of SP-MIC. For this reason, Q614 is turned off, the internal microphone is muted, and only the input of the external microphone is supplied to the microphone amplifier.

The signal from microphone goes through D/A converter (IC605), mute switch (Q610), and amplified by IC608 (1/2) and limited by AGC circuit composed of D601, D602, Q606 and Q607. IC607 is composed of high-pass filter, low-pass filter and pre-emphasis/IDC circuit.

The signal passes through the D/A converter (IC605) for the maximum deviation adjustment, and enters the summing amplifier consisting of IC600 (2/2), and is mixed with the low speed data from the CPU (IC502).

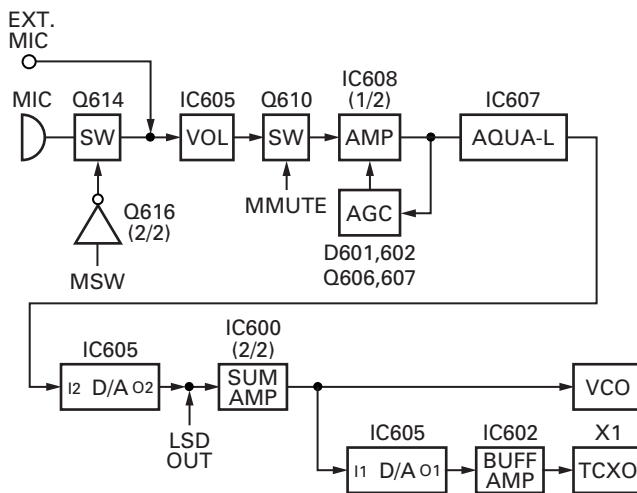

Fig. 7 Microphone amplifier

The output signal from the summing amplifier goes to the VCO modulation input. The other output signal from the summing amplifier passes through the D/A converter (IC605) again for the BAL adjustment, and the buffer amplifier (IC602), and goes to the TCXO modulation input.

4-2. VOX

The IC608 (2/2) amplify the audio signal captured in the microphone, and then the signal is converted into the DC voltage D603 rectifies.

The DC voltage activates the CPU (IC502), and the VOX starts.

4-3. Drive and Final amplifier

The signal from the T/R switch (D100 is on) is amplified by drive amplifier (Q100, Q101 and Q102) to +15~17dBm.

The output of the drive amplifier is amplified by the RF power amplifier (Q105) to 5.0W (1W when the power is low). The RF power amplifier is MOS FET. The output of the RF power amplifier is then passed through the harmonic filter (LPF) and antenna switch (D106, D107 are on) and applied to the antenna terminal.

4-4. APC circuit

The APC circuit always monitors the current flowing through the RF power amplifier (Q105) and keeps a constant current. The voltage drop at R125, R127 and R130 is caused by the current flowing through the RF power amplifier and this voltage is applied to the differential amplifier (IC100 1/2).

IC100 (2/2) compares the output voltage of IC100 (1/2) with the reference voltage from IC502, and the output of IC100 (2/2) controls the VGG of Q101, Q102 and Q105 to make the both voltages to same voltage.

The change of power high/low is carried out by the change of the reference voltage. Q106, Q107 and Q108 are turned on and Q104 is turned off in transmit and the APC circuit is active.

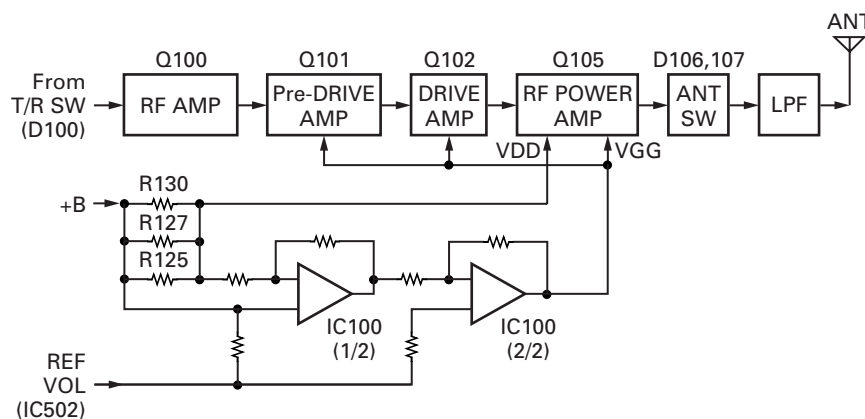

Fig. 8 Drive and final amplifier and APC circuit

CIRCUIT DESCRIPTION

5. Frequency Synthesizer Unit

5-1. Frequency synthesizer

The frequency synthesizer consists of the TCXO (X1), VCO, PLL IC (IC1) and buffer amplifiers.

The TCXO generates 16.8MHz. The frequency stability is 2.5ppm within the temperature range of -30 to +60°C. The frequency tuning and modulation of the TCXO are done to apply a voltage to pin 1 of the TCXO. The output of the TCXO is applied to pin 8 of the PLL IC.

The VCO consists of 2VCO and covers a dual range of the 340.15~410.15MHz and the 400~470 MHz. The VCO generates 340.15~410.15MHz for providing to the first local signal in receive. The operating frequency is generated by Q7 in transmit mode and Q6 in receive mode. The oscillator frequency is controlled by applying the VCO control voltage, obtained from the phase comparator (IC1) to the variable capacitor diodes (D9 and D12 in transmit mode and D6 and D11 in receive mode).

The T/R pin of IC502 goes "high" in receive mode causing Q8 and Q7 to turn off, and Q6 turn on. The T/R pin goes "low" in transmit mode.

The outputs from Q6 and Q7 are amplified by buffer amplifier (Q10) and doubled by Q14 and Q15, and then sent to PLL IC.

The PLL IC consists of a prescaler, reference divider, phase comparator, charge pump (The frequency step of the PLL circuit is 20 or 25kHz). The input signal from the pins 8 and 5 of the PLL IC is divided down to the 20 or 25kHz and compared at phase comparator. The pulsed output signal of the phase comparator is applied to the charge pump and transformed into DC signal in the loop filter (LPF). The DC signal is applied to the CV of the VCO and locked to keep the VCO frequency constant.

PLL data is output from DT (pin 112), PCK (pin 82) and PLE (pin 81) of the microprocessor (IC502). The data are input to the PLL IC when the channel is changed or when transmission is changed to reception and vice versa. A PLL lock condition is always monitored by the pin 80 (UL) of the microprocessor. When the PLL is unlocked, the UL goes low.

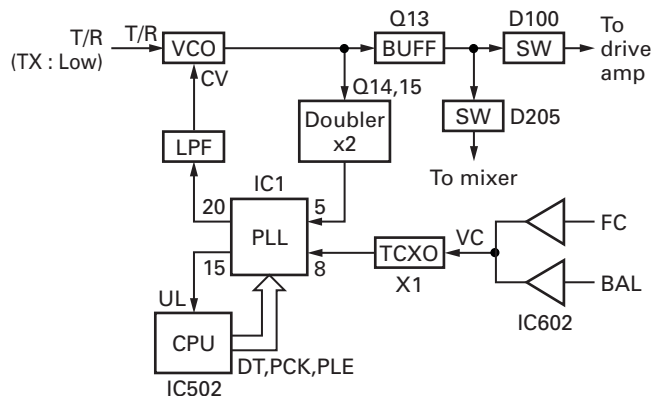

Fig. 9 PLL block diagram

6. Control Circuit

The control circuit consists of microprocessor (IC502) and its peripheral circuits. It controls the TX-RX unit and transfers data to the Display unit. IC502 mainly performs the following;

- 1) Switching between transmission and reception by PTT signal input.
- 2) Reading system, zone, frequency, and program data from the memory circuit.
- 3) Sending frequency program data to the PLL.
- 4) Controlling squelch on/off by the DC voltage from the squelch circuit.
- 5) Controlling the audio mute circuit by decode data input.
- 6) Transmitting tone and encode data.

6-1. Memory circuit

Memory circuit consists of the CPU (IC502) and a flash memory (IC500). A flash memory has a capacity of 4M bits and contains the transceiver control program for the CPU. It also stores the data for transceiver channels and operating parameter that are written by the FPU. This program can be easily written from an external devices.

The EEPROM (IC504) stores the last channel data, the scan on status, and other parameters.

Flash memory

Note : The flash memory stores the data that is written by the FPU (KPG-92D), and firmware program (User mode, Test mode, Tuning mode, etc.). This data must be rewritten when replacing the flash memory.

EEPROM

Note : The EEPROM stores tuning data (Deviation, Squelch, etc.).

Realign the transceiver after replacing the EEPROM.

Real-time clock

The clock function is based on real-time clock IC (IC503). When the power supply is off, it is backed up by an internal secondary lithium battery

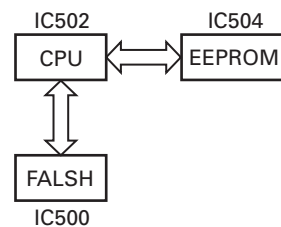

Fig. 10 Memory circuit

CIRCUIT DESCRIPTION

6-2. Low battery warning

The battery voltage is monitored by the microprocessor (IC502 pin 126 : BATTLVL). When the battery voltage falls below the voltage set by the Low Battery Warning adjustment during the transmission, the red LED blinks to notify the operator that it is time to replace the battery (When the "On TX" option (default setting) under the Battery Warning / status function in the FPU is selected.). If the battery voltage falls below 5.8V, the transceiver does not transmit and the warning tone beeps while the PTT switch is pressed.

Low battery warning	Battery condition
The red LED blinks during the transmission.	The battery voltage is low but the transceiver is still usable.
The red LED blinks and the warning tone beeps while the PTT switch is pressed.	The battery voltage is low and the transceiver is not usable to make calls.

6-3. Battery type detection

The transceiver automatically detects the battery type, measuring the resistance between the S-terminal and GND terminal on the battery pack and changes the supplied voltage to the S-terminal as below. The microprocessor then detects the battery type.

Resistor value	Battery type	Input voltage of S-terminal
Open	Ni-Cd	4.5~5.0V
150kΩ	Ni-MH	2.0~3.34V
47kΩ	Li-ion	0.8~2.0V
Short	Battery case	0~0.8V

6-4. Key input

When any key is pressed, K11 or K12 become Low. And CPU (IC502) set Q1 to Q9 "Low" sequentially. The CPU detects which key is pressed, according to the voltage of K11 and K12 and Q1 to Q9 timing.

7. Signaling Circuit

7-1. Encode

■ Low-speed data (QT, DQT)

Low-speed data is output from pin 33 of the CPU. The signal passes through a low-pass filter (IC601 1/2), and goes to the summing amplifier (IC600 2/2). The signal is mixed with the audio signal and goes to the VCO and TCXO (X1) modulation input after passing through the D/A converter (IC605) for BAL adjustment.

■ High-speed data (5-tone, DTMF)

High-speed data (HSD) is output from pin 7 of the CPU. The signal passes through a low-pass CR filter and provides a TX HSD tone and a RX HSD tone. TX HSD deviation making an adjustment by microprocessor is passed through the switch (IC606) and then applied to the audio processor (IC607).

The signal is mixed with the audio signal and goes to the VCO and TCXO. The RX HSD tone is passed a summing amplifier (IC607). The D/A converter (IC605) for audio control, audio power amplifier and then to the speaker.

■ MSK

MSK signal is output from pin 6 of IC607. The signal passes through the D/A converter (IC605) for the MSK deviation adjustment, and is routed to the VCO. When encoding MSK, the microphone input signal is muted.

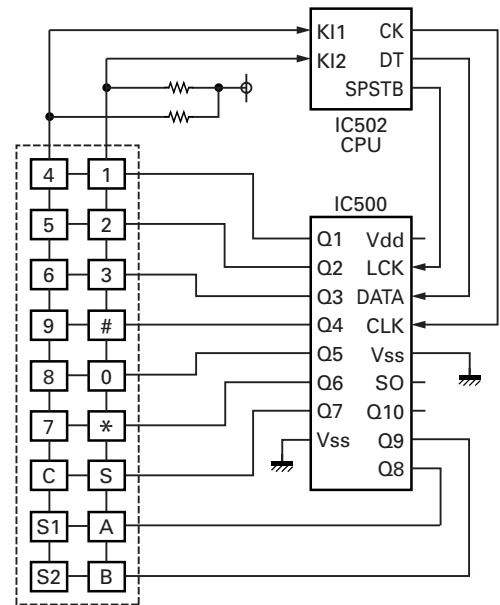

Fig. 11 Key input

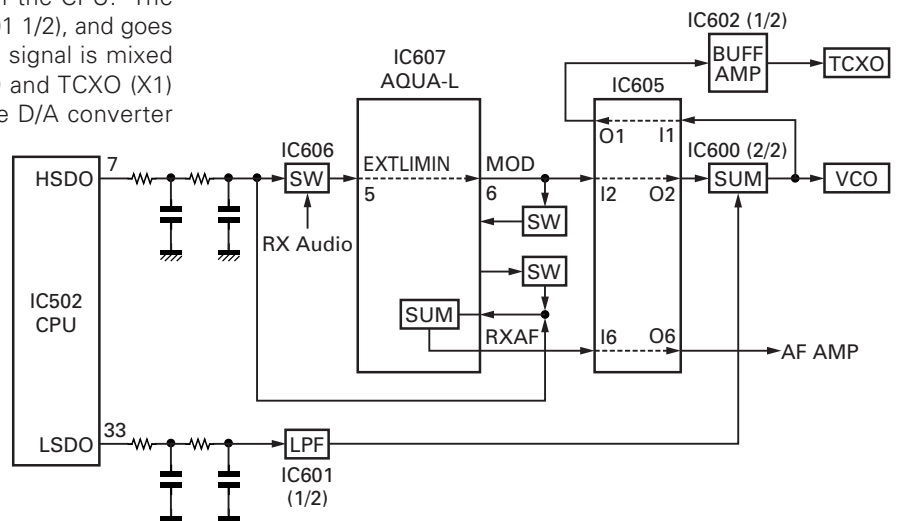

Fig. 12 Encode

CIRCUIT DESCRIPTION

7-2. Decode

■ Low-speed data (QT, DQT)

The demodulated signal from the IF IC (IC200) is amplified by IC600 (1/2) and passes through a low-pass filter (IC607) to remove audio components. The signal is input to pin 128 of the CPU.

The CPU digitizes this signal, performs processing such as DC restoration, and decodes the signal.

■ High-speed data (DTMF)

The DTMF input signal from the IF IC (IC200) is amplified by IC600 (1/2) and goes to IC607, the DTMF decoder. The decoded information is then processed by the CPU. During transmission and standby, the DTMF IC is set to the power down mode.

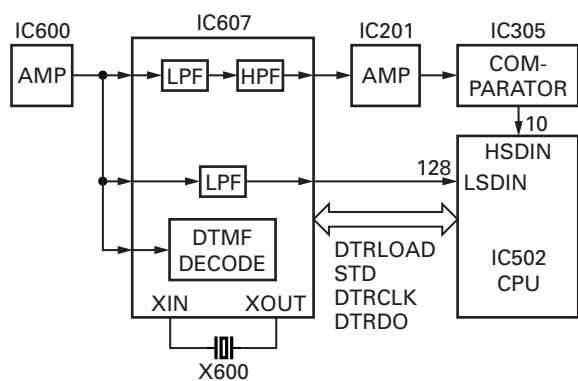

Fig. 13 Decode

■ High-speed data (5-tone)

The demodulated signal from the IF IC (IC200) is amplified by IC600 (1/2) and passes through an audio processor (IC607) and amplifier IC604 (1/2) and comparator IC604 (2/2) to remove a low-speed data. The CPU digitizes this signal and decodes the signal.

■ MSK

The MSK input signal from the IF IC is amplified by IC600 (1/2) and goes to pin 5 of IC607. The signal is demodulated by MSK demodulator in IC607. The demodulated data goes to the CPU for processing.

8. Power Supply Circuit

Battery +B is supplied via a 2.5A fuse from the battery terminal connected to the TX-RX unit. Power supply (+B) is applied to the four AVRs. IC402 supplies 5V (5M) to the control circuit. IC401 and IC403 supplies 5V to common circuits. IC406 supplies to the TX circuit, the RX circuit and common circuits. During transmission, 5TC becomes Low and Q406 is turned on to supply 5V (5T) to the TX circuit. During reception, 5RC becomes Low and Q405 is turned on to supply 5V (5R) to the RX circuit.

The power supply voltage monitor IC (IC400) monitors power supply voltage (+B). If the voltage falls (less than 5.6V), the VOUT port goes "LOW" level, the CPU INT port also goes "HIGH" level, and the CPU stops.

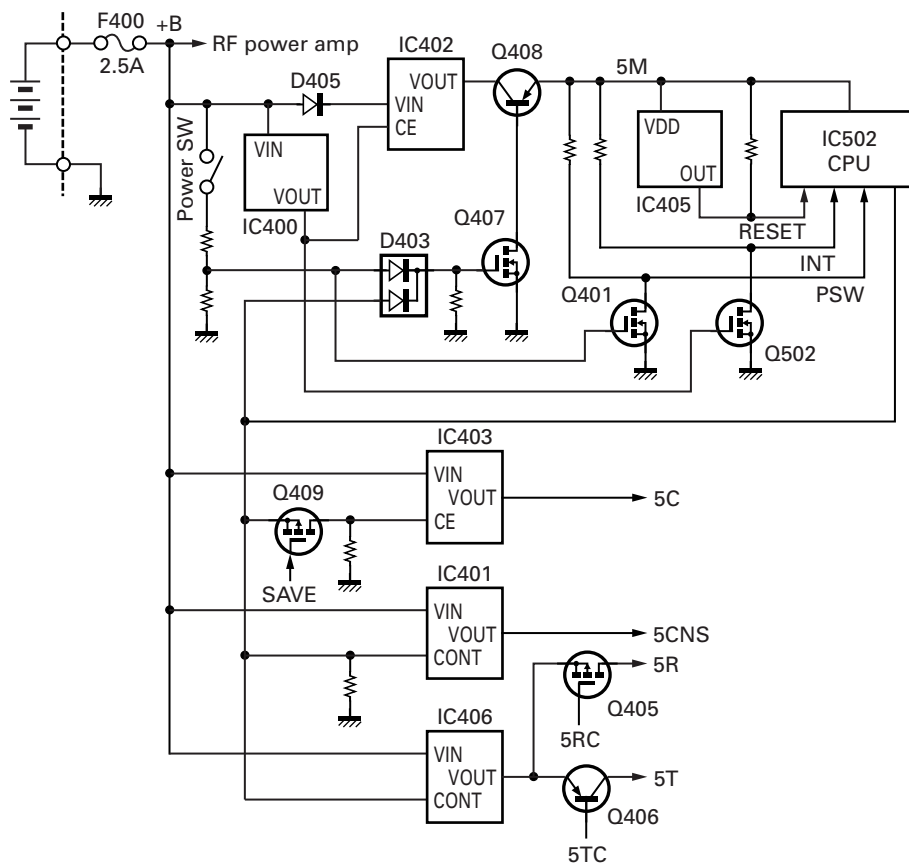

Fig. 14 Power supply circuit

SEMICONDUCTOR DATA

Microprocessor : 30625MGP169GU (TX-RX unit IC502)

Pin No.	Port Name	I/O	Function
1	VREF	-	+5V
2	AVCC	-	+5V
3	SBC	O	Switched B control
4	5RC	O	RX control
5	5TC	O	TX control
6	APC/TV2	O	TX APC adjust / TV adjust 2
7	HSDO	O	High speed data output
8	STSW	O	Side tone switch
9	RTCL/EEPCL	O	RTC/EEPROM clock
10	HSDIN	I	High speed data input
11	MAN-DN IN	I	Man down switch input
12	RTDT/EEPDAT	I/O	RTC/EEPROM data
13	BYTE	-	+5V
14	CNVSS	-	DGND (Vss)
15	DMUTE	O	Det mute
16	AM2	O	Audio mute 2
17	RST	I	Reset
18	Xout	O	11.0592MHz clock output
19	DGND	-	DGND (Vss)
20	Xin	I	11.0592MHz clock input
21	VCC1	-	+5V
22	NMI	-	+5V
23	PSW	I	Power switch input
24	INT	I	BATT voltage INT
25	INTRA	I	RTC INT
26	SHIFT/MODEL	I/O	Beat shift (CPU) / Model select
27	BEEP	O	Beep out
28	SPSTB	O	BU2099 storage enable
29	VCO ADJ	O	VCO adjust switch
30	LEDR	O	LED red
31	LEDG	O	LED green
32	DSTB	O	STB for DAC
33	LSDO	O	Low speed data output
34	KEY1	I	Key matrix 1 input
35	KEY2	I	Key matrix 2 input
36	TXD1	I/O	TXD1 and PTT (SC20-460)
37	Vcc1	-	+5V
38	RXD1	I	RXD1
39	DGND	-	DGND (Vss)

Pin No.	Port Name	I/O	Function
40	MMUTE	O	Mic mute
41	AUX	I	AUX key
42	TXD	O	TXD (COM0)
43	RXD	I	RXD (COM0)
44	AFDAT	O	BB TDATA and DTRCLK
45	AFDIO	I/O	BB DI/O
46	AFDIR	O	BB DIR
47	DTRLOAD	O	BB DTMF enable
48	AFSTD	I	BB STD
49	LSW	O	BB LIM switch
50	RDY	-	+5V
51	NC	-	Non connection
52	HOLD	-	+5V
53	NC	-	Non connection
54~57	EN4~EN1	I	Encoder in 4~1
58	NC	O	Non connection
59	RD	O	Read (RD)
60	NC	O	Non connection
61	WR	O	Write (WR)
62	APCSW	O	APC switch output
63	DSW	O	APC voltage discharge switch
64	5UC	O	5U control
65	BTSE/VOX	O	BATT select / VOX input switch
66	LCDRST	O	LCD reset
67	LCDCS	O	LCD chip select
68	CS0	O	Chip select 0
69	NC	-	-
70~79	A18~A9	O	Address bus 18~9
80	UL	I	PLL unlock
81	PLE	O	PLL enable
82	PCK	O	PLL clock
83	BB. SFT	O	Beat shift (AQUA-L)
84	OPT6	O	Option board I/F 6
85	VCC2	-	+5V
86	A8	O	Address bus 8
87	DGND	-	DGND (Vss)
88~95	A7~A0	O	Address bus 7~0
96	PTT	I	PTT input
97	AFRTM	I	BB RDF/FD

TK-3180

SEMICONDUCTOR DATA / COMPONENTS DESCRIPTION

Pin No.	Port Name	I/O	Function
98	TCLK/DTRDO	I	BB TCLK and DTRDO
99	SAVE	O	Save
100	T/R	O	TX/RX switch
101	AM1	O	AF PA switch
102	LCDRS	O	LCDRS
103	SSW	I	EXT/INT SP switch input
104~111	D7~D0	I/O	Data bus 7~0
112	DT	O	Serial data
113	CK	O	Serial clock
114	W/N	O	Wide/Narrow switch
115~119	OPT 1~OPT 5	I/O	Option board I/F 1~5
120	BATTSEL/VOX	I	BATT select and VOX input
121	THP/VCO ADJ	I	Thermal detect and VCO adjust
122	VOL	I	Volume level input
123	PF	I	PF key in
124	ASQ	I	RX Analog SQ. input
125	RSSI	I	RX RSSI input
126	BATT LVL	I	BATT level
127	AGND	-	DGND (Vss)
128	LSDIN	I	Low speed data input

Key Processor

: BU2099FV (Display unit IC500)

Pin No.	Port Name	I/O	Function
1	Vss	-	GND
2	NC	-	
3	DATA	I	Serial data input
4	CLK	I	Serial clock input
5	LCK	I	Storage enable input
6	Q0	O	LCD back light control
7~15	Q1~Q9	O	Key matrix output
16	Q10	O	NC
17	Q11	O	NC
18	SO	O	NC
19	OE	I	/LCDRST
20	VDD	I	5V

Display unit (X54-3470-11)

Ref. No.	Part name	Description
IC500	IC	Key processor
IC501	IC	Voltage regulator / LCD
IC502,503	IC	LCD control
Q501,502	Transistor	Back light control
Q504	FET	LCD reset
Q505	FET	Contrast control
D500	Diode	Contrast control
D501,502	LED	Key back light
D511~520	LED	Key back light
D522	Diode	Key control

TX-RX unit (X57-6942-71)

Ref. No.	Part name	Description
IC1	IC	PLL system
IC100	IC	Comparator (APC)
IC200	IC	FM IF system
IC400	IC	Voltage detector / INT
IC401~403	IC	Voltage regulator / 5V
IC404	IC	5T control
IC405	IC	Voltage detector / Reset
IC406	IC	Voltage regulator / 5V
IC500	IC	Flash memory
IC502	IC	Microprocessor
IC503	IC	RTC processor
IC504	IC	EEPROM
IC505	IC	Selector
IC600	IC	AF buffer
IC601	IC	LSD LPF / V REF
IC602	IC	LSD buffer to TCXO
IC603	IC	Tune
IC604	IC	HSD BPF / HSD COMP
IC605	IC	D/A converter
IC606	IC	AF switch
IC607	IC	AQUA-L
IC608	IC	MIC AMP / VOX
IC609	IC	AF power AMP
Q1,2	Transistor	Fin filter shift switch
Q6	FET	VCO / RX
Q7	FET	VCO / TX
Q8	FET	DC switch / TX VCO
Q9	FET	DC switch / RX VCO
Q10	Transistor	RF buffer AMP
Q11	Transistor	DC switch / RX VCO
Q12	FET	Ripple filter

COMPONENTS DESCRIPTION

Ref. No.	Part name	Description
Q13	Transistor	RF AMP
Q14,15	Transistor	PLL IC f_in AMP
Q100	Transistor	RF AMP
Q101	FET	Pre-drive AMP
Q102	FET	TX drive AMP
Q104	Transistor	APC switch
Q105	FET	TX final AMP
Q106	Transistor	APC switch
Q107,108	FET	APC switch
Q200	FET	W/N filter shift switch
Q201	Transistor	SQL noise AMP
Q202	FET	W/N noise switch
Q203	FET	AF mute
Q204	Transistor	W/N switch / RX
Q205	Transistor	IF AMP
Q206	FET	Mixer
Q207	FET	RF AMP
Q400	Transistor	LED switch / Green or Red
Q401	FET	Power switch
Q402	FET	SBC switch
Q403	Transistor	SB2 switch
Q404	Transistor	5R switch
Q405	FET	5R switch
Q406	Transistor	5T switch
Q407	FET	5M switch
Q408	Transistor	5M switch
Q409	FET	SAVE switch
Q502	FET	INT switch
Q602	Transistor	LIMIT switch
Q605	Transistor	AF switch
Q606,607	Transistor	MIC AGC
Q608	FET	AF switch
Q609	FET	OP switch
Q610	FET	MMUTE switch
Q611	FET	OP switch
Q612,613	Transistor	SP control
Q614	FET	MIC shift switch
Q615	Transistor	SP control
Q616,617	FET	AF mute
Q618	FET	SP control
Q619	FET	Side tone switch
Q620	Transistor	Side tone switch
Q621	Transistor	Beat shift switch (CPU)
Q622	Transistor	5UC switch
Q623,624	FET	5UC switch

Ref. No.	Part name	Description
Q625,626	Transistor	Beat shift switch (AQUA-L)
D1~4	Diode	T / R switch
D6,11	Variable capacitance diode	Frequency control / RX VCO
D9,12	Variable capacitance diode	Frequency control / TX VCO
D17	Variable capacitance diode	Modulaor
D18	Diode	Current steering
D100	Diode	TX/RX RF switch
D103	Zener diode	APC protect
D106,107	Diode	ANT switch
D108	Zener diode	APC switch
D200	Diode	SQL control
D201	Diode	Filter switch
D202	Diode	SQL rectifier
D203	Diode	Filter switch
D204	Diode	DMUTE control
D205	Diode	TX/RX RF switch
D206~210	Variable capacitance diode	RF BPF tuning
D212	Diode	ANT switch
D213,214	Diode	ANT switch
D314	Diode	5R protector
D400	LED	LED Red & Green
D402	Diode	Reverse protection
D403	Diode	Power switch control
D404	Diode	Batt level control
D405	Diode	5M protector
D406	Diode	5M control
D408	Diode	5T control
D500~502	Diode	RTC BATT control
D600	Diode	AF BUFFER control
D601~603	Diode	Detector
D604	Zener diode	MIC shift control
D605	Diode	SP control
D606	Zener diode	MIC shift control
D607	Zener diode	SP control
D608	Zener diode	MIC shift control
D609	Diode	RXD control
D610	Diode	TXD control
D611	Zener diode	PTT PF TXD RXD control
D612	Zener diode	OPT control
D613	Diode	SSW control
D614	Diode	SP control

TK-3180

PARTS LIST

* New Parts. Δ indicates safety critical components.

Parts without **Parts No.** are not supplied.

Les articles non mentionnés dans le **Parts No.** ne sont pas fournis.

Teile ohne **Parts No.** werden nicht geliefert.

L : Scandinavia

K : USA

P : Canada

Y : PX (Far East, Hawaii)

T : England

E : Europe

Y : AAFES (Europe)

X : Australia

M : Other Areas

TK-3180 (Y50-5882-71)

DISPLAY UNIT (X54-3470-11)

Ref. No.	Address	New parts	Parts No.	Description	Destination
TK-3180					
2	1A		A02-3848-03	PLASTIC CABINET ASSY	
3	3A		A10-4076-21	CHASSIS	
4	3B		A62-1093-02	PANEL	
6	2D		B09-0625-03	CAP ACCESSORY	
7	1A		B10-2764-02	FRONT GLASS	
8	2A		B11-1815-04	FILTER (LCD)	
9	2A		B11-1816-12	ILLUMINATION GUIDE (LCD)	
10	3B		B11-1820-04	ILLUMINATION GUIDE (BUSY/TX)	
11	2A		B38-0900-05	LCD ASSY	
12	2C	*	B62-1760-00	INSTRUCTION MANUAL	
13	3A	*	B72-2264-04	MODEL NAME-PLATE	
15	2B		E04-0416-05	RF COAXIAL RECEPTACLE (SMA)	
16	3B		E23-1104-04	ANTENNA TERMINAL	
17	2A		E37-1101-05	SPEAKER WIRE (RED)	
18	2A		E37-1102-05	SPEAKER WIRE (BLACK)	
19	2A		E37-1107-05	FLAT CABLE	
20	3B		E58-0511-05	RECTANGULAR RECEPTACLE	
21	3B		E72-0419-03	TERMINAL BLOCK	
23	3A		F07-1880-04	COVER	
24	2B	*	F12-0476-04	SHIELDING SHEET	
25	2B	*	F12-0477-14	SHIELDING SHEET	
26	2A	*	F15-1012-04	SHADE	
27	3B		F20-3350-04	INSULATING SHEET	
29	2A	*	G10-1340-04	FIBROUS SHEET	
30	2A	*	G10-1341-04	FIBROUS SHEET	
28	3A		G11-2622-04	SHEET	
31	2A		G11-4272-04	RUBBER CUSHION	
32	3A		G11-4273-14	SHEET	
33	3A	*	G11-4308-14	RUBBER SHEET (FINAL FET)	
34	1A	*	G11-4326-04	SHEET	
35	3A		G11-4332-04	SHEET	
36	2B		G13-1934-04	CUSHION	
37	2A		G13-2055-04	CUSHION	
38	2A	*	G13-2068-04	CUSHION	
40	1A		G53-1686-01	PACKING	
41	3B	*	G53-1600-12	PACKING	
42	3B		G53-1601-04	PACKING	
43	3A		G53-1602-14	PACKING	
44	2B,3B		G53-1603-04	PACKING	
46	2C,1D		H12-3180-12	PACKING FIXTURE	
47	3D		H52-2060-02	ITEM CARTON CASE	
49	2A		J19-5460-02	HOLDER	
50	2B		J19-5478-03	HOLDER	
51	2C		J29-0710-15	HOOK ACCESSORY	
52	3B		J30-1279-04	SPACER	
53	2B		J82-0089-05	FPC (VOL./SELECTOR)	
54	3B	*	J82-0090-25	FPC (UNIVERSAL CONNECTOR)	
55	3A		J82-0091-15	FPC (PTT)	
57	1A		K29-9302-23	KNOB (PTT)	
58	1A		K29-9303-03	BUTTON KNOB (SIDE)	
59	1B		K29-9304-03	KNOB (VOLUME)	

Ref. No.	Address	New parts	Parts No.	Description	Destination
60	1A		K29-9305-03	KNOB (CH SELECTOR)	
A	2D		N08-0548-14	DRESSED SCREW ACCESSORY	
B	3B		N09-2426-04	HEXAGON HEAD SCREW	
C	3B		N14-0806-04	CIRCULAR NUT	
D	3B		N14-0810-04	CIRCULAR NUT	
E	2A,3A	*	N30-2004-43	PAN HEAD MACHINE SCREW	
F	2B		N30-2604-48	PAN HEAD MACHINE SCREW	
G	3A		N30-2608-43	PAN HEAD MACHINE SCREW	
H	2C		N30-3008-60	PAN HEAD MACHINE SCREW	
J	2A,2B		N83-2005-48	PAN HEAD TAPTITE SCREW	
62	3B		R31-0652-05	VARIABLE RESISTOR	
64	2B		S60-0430-05	ROTARY SWITCH	
66	1A		T07-0749-15	SPEAKER	
68	3A		W09-0971-05	LITHIUM CELL	
DISPLAY UNIT (X54-3470-11)					
D501,502			B30-2215-05	LED	
D511-516			B30-2215-05	LED	
D517-520			B30-2210-05	LED (TLY)	
C500-503			CK73HB1H471K	CHIP C 470PF K	
C508			CK73HB1H471K	CHIP C 470PF K	
C513			CK73GB1C104K	CHIP C 0.10UF K	
C518			CK73HB1H471K	CHIP C 470PF K	
C522			CK73HB1H102K	CHIP C 1000PF K	
C523,524			C92-0827-05	CHIP-TAN 4.7UF 10WV	
C525			CK73HB1H471K	CHIP C 470PF K	
C527,528		*	C92-0826-05	CHIP-TAN 1.0UF 16WV	
C537,538			CK73GB0J475K	CHIP C 4.7UF K	
C539-546			CC73HCH1H470J	CHIP C 47PF J	
C548-551			CC73HCH1H470J	CHIP C 47PF J	
C553,554			CK73HB1H102K	CHIP C 1000PF K	
C555			CK73HBOJ105K	CHIP C 1.0UF K	
C556			CK73HB1H102K	CHIP C 1000PF K	
C557			CK73HB1H471K	CHIP C 470PF K	
C562			CK73HBOJ105K	CHIP C 1.0UF K	
C563,564			CK73HB1H102K	CHIP C 1000PF K	
C565			CK73HBOJ105K	CHIP C 1.0UF K	
CN507			E40-6410-05	FLAT CABLE CONNECTOR	
CN508,509			E40-6413-05	FLAT CABLE CONNECTOR	
L550			L92-0163-05	BEADS CORE	
L553-556			L92-0163-05	BEADS CORE	
CP501			RK75HA1J102J	CHIP-COM 1.0K J 1/16W	
CP503,504			RK75HA1J102J	CHIP-COM 1.0K J 1/16W	
CP506,507			RK75HA1J102J	CHIP-COM 1.0K J 1/16W	
CP509			RK75HA1J102J	CHIP-COM 1.0K J 1/16W	
R500,501			RK73HB1J102J	CHIP R 1.0K J 1/16W	
R517			R92-1368-05	CHIP R 0 OHM	
R518			RK73HB1J331J	CHIP R 330 J 1/16W	
R520			RK73HB1J472J	CHIP R 4.7K J 1/16W	

PARTS LIST

DISPLAY UNIT (X54-3470-11)
TX-RX UNIT (X57-6942-71)

Ref. No.	Address	New parts	Parts No.	Description	Desti-nation	Ref. No.	Address	New parts	Parts No.	Description	Desti-nation
R522			RK73HB1J391J	CHIP R 390 J 1/16W		C29			CC73HCH1H470J	CHIP C 47PF J	
R524-526			RK73HB1J391J	CHIP R 390 J 1/16W		C30			C92-0001-05	CHIP-TAN 0.1UF 35WV	
R527			R92-1368-05	CHIP R 0 OHM		C31			CC73HCH1H470J	CHIP C 47PF J	
R531			R92-1368-05	CHIP R 0 OHM		C32,33			CC73HCH1H101J	CHIP C 100PF J	
R533			R92-1368-05	CHIP R 0 OHM		C35			CC73HCH1H470J	CHIP C 47PF J	
R534			RK73HB1J101J	CHIP R 100 J 1/16W		C37			CC73HCH1H470J	CHIP C 47PF J	
R535			R92-1368-05	CHIP R 0 OHM		C38			CC73GCH1H820J	CHIP C 82PF J	
R537			RK73HB1J101J	CHIP R 100 J 1/16W		C41			CC73GCH1H121J	CHIP C 120PF J	
R540-543			RK73HB1J471J	CHIP R 470 J 1/16W		C43			CK73HB0J105K	CHIP C 1.0UF K	
R544			RK73HH1J184D	CHIP R 180K D 1/16W		C44			CC73HCH1H150J	CHIP C 15PF J	
R545			RK73HH1J474D	CHIP R 470K D 1/16W		C45			CC73HCH1H090B	CHIP C 9.0PF B	
R546			RK73HH1J273D	CHIP R 27K D 1/16W		C46			CC73HCH1H030B	CHIP C 3.0PF B	
R547			RK73HH1J223D	CHIP R 22K D 1/16W		C47			CC73HCH1H010B	CHIP C 1.0PF B	
R552			RK73HB1J471J	CHIP R 470 J 1/16W		C48			CC73HCH1HR75B	CHIP C 0.75PF B	
R559			R92-1368-05	CHIP R 0 OHM		C49			CC73HCH1H2R5B	CHIP C 2.5PF B	
R560			RK73HB1J474J	CHIP R 470K J 1/16W		C50			CC73HCH1H030B	CHIP C 3.0PF B	
R561			RK73HB1J103J	CHIP R 10K J 1/16W		C51			CC73HCH1H070B	CHIP C 7.0PF B	
R562-568			RK73HB1J102J	CHIP R 1.0K J 1/16W		C52			CC73HCH1H040B	CHIP C 4.0PF B	
R570			R92-1252-05	CHIP R 0 OHM J 1/16W		C53			CC73HCH1H330J	CHIP C 33PF J	
R571			R92-1368-05	CHIP R 0 OHM		C54			CC73HCH1H070B	CHIP C 7.0PF B	
R573			RK73HB1J474J	CHIP R 470K J 1/16W		C55			CC73HCH1H040B	CHIP C 4.0PF B	
R574			R92-1368-05	CHIP R 0 OHM		C56			CC73HCH1H101J	CHIP C 100PF J	
R576-580			RK73HB1J331J	CHIP R 330 J 1/16W		C57,58			CC73GCH1H0R5B	CHIP C 0.5PF B	
R581			R92-1368-05	CHIP R 0 OHM		C59-62			CC73HCH1H101J	CHIP C 100PF J	
MIC500	2A		T91-0579-05	MIC ELEMENT		C63	*		C92-0838-05	CHIP-TAN 10UF 10WV	
D500			MA2S111	DIODE		C64			CC73HCH1H101J	CHIP C 100PF J	
D522			DA221	DIODE		C65			CC73HCH1H070D	CHIP C 7.0PF D	
IC500			BU2099FV	MOS-IC		C66,67			CC73HCH1H100C	CHIP C 10PF C	
IC501			XC6201P352MR	MOS-IC		C68-70			CK73HB1H471K	CHIP C 470PF K	
IC502,503			HD74LV2G34AUS	MOS-IC		C71			CC73HCH1H070D	CHIP C 7.0PF D	
Q501			2SC4617(S)	TRANSISTOR		C72-74			CC73HCH1H470J	CHIP C 47PF J	
Q502			2SB1132(Q,R)	TRANSISTOR		C75			CC73HCH1H040B	CHIP C 4.0PF B	
Q504			2SK1830	FET		C78			CC73HCH1H101J	CHIP C 100PF J	
Q505		*	2SJ144(Y)	FET		C79			CK73HB1H222K	CHIP C 2200PF K	
TX-RX UNIT (X57-6942-71)						C100,101			CK73HB1H471K	CHIP C 470PF K	
D400			B30-2278-05	LED (RED/YELLOW)		C103,104			CK73HB1H471K	CHIP C 470PF K	
C1,2			CC73HCH1H101J	CHIP C 100PF J		C105			CC73HCH1H060D	CHIP C 6.0PF D	
C3			CC73HCH1H100C	CHIP C 10PF C		C106,107			CK73HB1H471K	CHIP C 470PF K	
C4			CK73HB1C103K	CHIP C 0.010UF K		C109			CK73HB1H471K	CHIP C 470PF K	
C5			CC73HCH1H100C	CHIP C 10PF C		C111			CK73HB1A104K	CHIP C 0.10UF K	
C6			CK73HB1H102K	CHIP C 1000PF K		C113			CK73HB1H471K	CHIP C 470PF K	
C7,8			CC73HCH1H470J	CHIP C 47PF J		C114			CC73HCH1H090D	CHIP C 9.0PF D	
C9-13			CC73HCH1H101J	CHIP C 100PF J		C116			CK73HB1H471K	CHIP C 470PF K	
C14-16			CC73HCH1H470J	CHIP C 47PF J		C117			CK73HB1A104K	CHIP C 0.10UF K	
C17			CC73HCH1H120G	CHIP C 12PF G		C118			CC73HCH1H220J	CHIP C 22PF J	
C18			CC73HCH1H101J	CHIP C 100PF J		C119,120			CC73HCH1H100C	CHIP C 10PF C	
C19			CC73HCH1H100B	CHIP C 10PF B		C121			CK73GB1E105K	CHIP C 1.0UF K	
C20			CC73HCH1H101J	CHIP C 100PF J		C122			CK73HB1H471K	CHIP C 470PF K	
C21			CK73HB1C223K	CHIP C 0.022UF K		C123	*		C92-0852-05	CHIP-TAN 10UF 16WV	
C22			CC73HCH1H1R5B	CHIP C 1.5PF B		C125-128			CK73HB1H471K	CHIP C 470PF K	
C23			CC73HCH1H020B	CHIP C 2.0PF B		C129			CC73HCH1H270J	CHIP C 27PF J	
C24			C92-0001-05	CHIP-TAN 0.1UF 35WV		C131			CK73HB1H471K	CHIP C 470PF K	
C25			C92-0588-05	CHIP-TAN 1.5UF 16WV		C132			CC73HCH1H101J	CHIP C 100PF J	
C26			CC73HCH1H060B	CHIP C 6.0PF B		C133			CK73HB1H471K	CHIP C 470PF K	
C27			CC73HCH1H2R5B	CHIP C 2.5PF B		C134			C93-0765-05	CHIP C 51PF 50WV	
C28			CC73HCH1H090B	CHIP C 9.0PF B		C135			CK73HB1H471K	CHIP C 470PF K	
						C136			CK73HB1C103K	CHIP C 0.010UF K	
						C138			CK73HB1H471K	CHIP C 470PF K	
						C139			CK73GB1C104K	CHIP C 0.10UF K	
						C140			CK73GB1E105K	CHIP C 1.0UF K	

PARTS LIST

TX-RX UNIT (X57-6942-71)

Ref. No.	Address	New parts	Parts No.	Description	Destination	Ref. No.	Address	New parts	Parts No.	Description	Destination
C142			C93-0764-05	CHIP C 47PF 50WV		C253			CK73HB1H471K	CHIP C 470PF K	
C143			CK73HB1C103K	CHIP C 0.010UF K		C255			CC73GCH1H010B	CHIP C 1.0PF B	
C144			CK73HB1H471K	CHIP C 470PF K		C256			CC73GCH1H040B	CHIP C 4.0PF B	
C145			C93-0753-05	CHIP C 16PF 50WV		C257			CC73HCH1H330J	CHIP C 33PF J	
C149			CC73GCH1H101J	CHIP C 100PF J		C258			CK73HB1H471K	CHIP C 470PF K	
C150			CK73HB1H471K	CHIP C 470PF K		C260			CC73GCH1H010B	CHIP C 1.0PF B	
C151			CC73GCH1H030B	CHIP C 3.0PF B		C261			CK73HB1H471K	CHIP C 470PF K	
C152			CC73GCH1H470J	CHIP C 47PF J		C262			CC73HCH1H330J	CHIP C 33PF J	
C153			CC73HCH1H070B	CHIP C 7.0PF B		C263			CC73HCH1H040B	CHIP C 4.0PF B	
C154			CC73HCH1H2R5B	CHIP C 2.5PF B		C264			C92-0784-05	CHIP-TAN 4.7UF 10WV	
C155			CC73HCH1H100B	CHIP C 10PF B		C265,266			CK73HB1H471K	CHIP C 470PF K	
C156			CC73GCH1H020B	CHIP C 2.0PF B		C269,270			CK73HB1H471K	CHIP C 470PF K	
C157			CC73HCH1H110J	CHIP C 11PF J		C271			CK73HB0J105K	CHIP C 1.0UF K	
C159			CC73HCH1H050B	CHIP C 5.0PF B		C273-275			CK73HB1H471K	CHIP C 470PF K	
C161			C93-0744-05	CHIP C 6.0PF 50WV		C276			CC73GCH1H3R5B	CHIP C 3.5PF B	
C163		*	C93-0757-05	CHIP C 24PF 50WV		C277			CC73HCH1H330J	CHIP C 33PF J	
C200			CK73HB1A104K	CHIP C 0.10UF K		C279			CC73GCH1H1R5B	CHIP C 1.5PF B	
C201			CK73HB1C103K	CHIP C 0.010UF K		C280			CK73HB1H471K	CHIP C 470PF K	
C202			CK73HB1C223K	CHIP C 0.022UF K		C281			CC73HCH1H330J	CHIP C 33PF J	
C203			CK73HB1H102K	CHIP C 1000PF K		C282			CC73HCH1H1R5B	CHIP C 1.5PF B	
C204			CK73HB1A104K	CHIP C 0.10UF K		C283			CC73HCH1H050B	CHIP C 5.0PF B	
C205			CK73HB1C103K	CHIP C 0.010UF K		C284			CC73GCH1H030B	CHIP C 3.0PF B	
C206			CK73HB1H102K	CHIP C 1000PF K		C285			CK73HB1H471K	CHIP C 470PF K	
C207			CK73HB1A104K	CHIP C 0.10UF K		C286			CC73GCH1H101J	CHIP C 100PF J	
C208			CK73HB1H182K	CHIP C 1800PF K		C287			CC73GCH1H090B	CHIP C 9.0PF B	
C209,210			CK73HB1A104K	CHIP C 0.10UF K		C288			CC73HCH1H050B	CHIP C 5.0PF B	
C211,212			CK73HB1H221K	CHIP C 220PF K		C290			CK73HB0J224K	CHIP C 0.22UF K	
C213			CC73HCH1H101J	CHIP C 100PF J		C292			CK73HB1C103K	CHIP C 0.010UF K	
C214		*	C92-0851-05	CHIP-TAN 15UF 10WV		C401,402			CK73HB1H471K	CHIP C 470PF K	
C215,216			CK73HB1A104K	CHIP C 0.10UF K		C404-414			CK73HB1H471K	CHIP C 470PF K	
C217			CC73HCH1H680J	CHIP C 68PF J		C415			CK73FB1A475K	CHIP C 4.7UF K	
C218			CC73HCH1H470J	CHIP C 47PF J		C416			CK73HB1H102K	CHIP C 1000PF K	
C219			CK73HB1A333K	CHIP C 0.033UF K		C418			CK73HB1H102K	CHIP C 1000PF K	
C220			CK73HB1C103K	CHIP C 0.010UF K		C419			CK73GB1E105K	CHIP C 1.0UF K	
C221		*	C92-0838-05	CHIP-TAN 10UF 10WV		C420			CK73GB1C104K	CHIP C 0.10UF K	
C222			CK73HB1A104K	CHIP C 0.10UF K		C421			CK73GB1A224K	CHIP C 0.22UF K	
C226			CK73HB1H471K	CHIP C 470PF K		C422			CK73GB1E105K	CHIP C 1.0UF K	
C227,228			CK73HB1C103K	CHIP C 0.010UF K		C423		*	C92-0852-05	CHIP-TAN 10UF 16WV	
C229			CC73HCH1H040B	CHIP C 4.0PF B		C425			CK73GB1E105K	CHIP C 1.0UF K	
C230			CC73HCH1H270J	CHIP C 27PF J		C426			CC73HCH1H101J	CHIP C 100PF J	
C231			CC73HCH1H040B	CHIP C 4.0PF B		C427			CK73GB1E105K	CHIP C 1.0UF K	
C232			CK73HB1C103K	CHIP C 0.010UF K		C428			CK73HB1H471K	CHIP C 470PF K	
C233			CK73HB1H471K	CHIP C 470PF K		C429			CK73GB1E105K	CHIP C 1.0UF K	
C234			CK73HB1A104K	CHIP C 0.10UF K		C431			CK73HB1H471K	CHIP C 470PF K	
C235,236			CK73HB1C103K	CHIP C 0.010UF K		C432		*	C92-0852-05	CHIP-TAN 10UF 16WV	
C237			CK73HB1H471K	CHIP C 470PF K		C433			CK73HB1H471K	CHIP C 470PF K	
C238			CC73HCH1H100D	CHIP C 10PF D		C434			CC73HCH1H101J	CHIP C 100PF J	
C239			CC73HCH1H090B	CHIP C 9.0PF B		C435			CK73GB1A224K	CHIP C 0.22UF K	
C240			CC73HCH1H040B	CHIP C 4.0PF B		C436			CK73GB1H103K	CHIP C 0.010UF K	
C241			CC73HCH1H120G	CHIP C 12PF G		C437			CC73HCH1H101J	CHIP C 100PF J	
C242			CK73HB1H471K	CHIP C 470PF K		C441			CK73GB1E105K	CHIP C 1.0UF K	
C243			CK73HB1C103K	CHIP C 0.010UF K		C442			CK73GB1A224K	CHIP C 0.22UF K	
C244			CC73HCH1H040B	CHIP C 4.0PF B		C443			CK73GB1E105K	CHIP C 1.0UF K	
C245			CK73HB1H471K	CHIP C 470PF K		C445			CC73HCH1H470J	CHIP C 47PF J	
C246			CC73HCH1H120G	CHIP C 12PF G		C446			CK73HB1H471K	CHIP C 470PF K	
C247			CC73HCH1H050B	CHIP C 5.0PF B		C447			CK73HB1E472K	CHIP C 4700PF K	
C248			CK73HB1H471K	CHIP C 470PF K		C450,451			CK73GB0J475K	CHIP C 4.7UF K	
C250			CK73HB1H471K	CHIP C 470PF K		C453			CK73HB1H102K	CHIP C 1000PF K	
C251			CC73HCH1H040B	CHIP C 4.0PF B		C500		*	C92-0852-05	CHIP-TAN 10UF 16WV	
C252			CC73HCH1H330J	CHIP C 33PF J		C502		*	C92-0852-05	CHIP-TAN 10UF 16WV	

PARTS LIST

TX-RX UNIT (X57-6942-71)

Ref. No.	Address	New parts	Parts No.	Description	Desti- nation	Ref. No.	Address	New parts	Parts No.	Description	Desti- nation
C503			CK73GB1E105K	CHIP C 1.0UF K		C669			CK73HB1H102K	CHIP C 1000PF K	
C505-508			CK73GB1E105K	CHIP C 1.0UF K		C670			CK73HB1A104K	CHIP C 0.10UF K	
C509			CC73HCH1H270J	CHIP C 27PF J		C672			CK73HB1H102K	CHIP C 1000PF K	
C510			CC73HCH1H040C	CHIP C 4.0PF C		C673-675			CK73HB1A104K	CHIP C 0.10UF K	
C511			CC73HCH1H270J	CHIP C 27PF J		C676			CC73HCH1H470J	CHIP C 47PF J	
C512			CK73HB1C103K	CHIP C 0.010UF K		C677			CK73HB1H222K	CHIP C 2200PF K	
C514			CK73HB1C103K	CHIP C 0.010UF K		C678			CK73GB1C104K	CHIP C 0.10UF K	
C515			CC73HCH1H150G	CHIP C 15PF G		C679,680			CK73HB1A104K	CHIP C 0.10UF K	
C516			CK73HB1C103K	CHIP C 0.010UF K		C681			CK73HB1H102K	CHIP C 1000PF K	
C517			CK73HB1A104K	CHIP C 0.10UF K		C682			CK73HB1C153K	CHIP C 0.015UF K	
C518			CK73HB0J105K	CHIP C 1.0UF K		C683			CK73HB1C123K	CHIP C 0.012UF K	
C600			CK73HB1A104K	CHIP C 0.10UF K		C684			CK73HB1H102K	CHIP C 1000PF K	
C601			CC73HCH1H220J	CHIP C 22PF J		C685			CK73HB1A104K	CHIP C 0.10UF K	
C602			CK73HB1A104K	CHIP C 0.10UF K		C686			CK73HB1A683K	CHIP C 0.068UF K	
C603			CK73HB1E472K	CHIP C 4700PF K		C687	*		C92-0838-05	CHIP-TAN 10UF 10WV	
C604,605			CC73HCH1H680J	CHIP C 68PF J		C688			CK73GB1A474K	CHIP C 0.47UF K	
C608			CK73HB1A104K	CHIP C 0.10UF K		C689			CK73HB1C103K	CHIP C 0.010UF K	
C609,610			CK73HB1C103K	CHIP C 0.010UF K		C690			CC73HCH1H470J	CHIP C 47PF J	
C611			CC73HCH1H101J	CHIP C 100PF J		C691			CK73GB1A474K	CHIP C 0.47UF K	
C612,613			CK73HB1A104K	CHIP C 0.10UF K		C692			CC73HCH1H470J	CHIP C 47PF J	
C614			CK73HB1H471K	CHIP C 470PF K		C693			CK73GB1A474K	CHIP C 0.47UF K	
C615			CC73HCH1H101J	CHIP C 100PF J		C694			CK73HB1H152K	CHIP C 1500PF K	
C616			CK73HB1H471K	CHIP C 470PF K		C695			CK73HB1A104K	CHIP C 0.10UF K	
C617	*		C92-0848-05	CHIP-TAN 2.2UF 16WV		C696			CK73HB1C103K	CHIP C 0.010UF K	
C618	*		C92-0838-05	CHIP-TAN 10UF 10WV		C697,698			CK73HB1A104K	CHIP C 0.10UF K	
C619			CK73HB1H561K	CHIP C 560PF K		C699			C92-0816-05	CHIP-TAN 10UF 16WV	
C620			CK73HB1A104K	CHIP C 0.10UF K		C700			CC73HCH1H470J	CHIP C 47PF J	
C621			CK73HB1C103K	CHIP C 0.010UF K		C702-710			CC73HCH1H470J	CHIP C 47PF J	
C622			CK73HB1E562K	CHIP C 5600PF K		C711-714			CK73HB1H102K	CHIP C 1000PF K	
C625			CK73HB1A104K	CHIP C 0.10UF K		C715-717			CK73HB1A104K	CHIP C 0.10UF K	
C627			CK73HB1C103K	CHIP C 0.010UF K		C718			CC73HCH1H180J	CHIP C 18PF J	
C628			CK73HB1A104K	CHIP C 0.10UF K		C719			CC73HCH1H220J	CHIP C 22PF J	
C630			CK73HB1H271K	CHIP C 270PF K		C720			CK73HB1H471K	CHIP C 470PF K	
C631			CK73HB1A104K	CHIP C 0.10UF K		C721			CK73HB1H102K	CHIP C 1000PF K	
C632			CK73GB1E105K	CHIP C 1.0UF K		C725			CK73HB1H392K	CHIP C 3900PF K	
C633			CK73HB1C103K	CHIP C 0.010UF K		C727			CK73HB1A104K	CHIP C 0.10UF K	
C635			CC73HCH1H101J	CHIP C 100PF J		C728			CK73HB0J105K	CHIP C 1.0UF K	
C636			CK73HB1A104K	CHIP C 0.10UF K		C729			CK73HB1H271K	CHIP C 270PF K	
C638			CK73HB1H102K	CHIP C 1000PF K		C730			CK73HB1H332K	CHIP C 3300PF K	
C640,641			CK73GB0J475K	CHIP C 4.7UF K		C732			CK73HB1H471K	CHIP C 470PF K	
C642		*	CK73HB1A473J	CHIP C 0.047UF J		C734			CC73HCH1H220J	CHIP C 22PF J	
C644		*	CK73HB1C123J	CHIP C 0.012UF J		C736			CC73HCH1H470J	CHIP C 47PF J	
C645			CK73HB1A104K	CHIP C 0.10UF K		C737			CK73GB0J475K	CHIP C 4.7UF K	
C646			CK73GB0J475K	CHIP C 4.7UF K		C738			CK73HB1H221K	CHIP C 220PF K	
C647		*	CK73HB1C123J	CHIP C 0.012UF J		C739-751			CC73HCH1H470J	CHIP C 47PF J	
C648			CK73HB1H102K	CHIP C 1000PF K		C752,753			CC73HCH1H010B	CHIP C 1.0PF B	
C650,651			CK73HB1A104K	CHIP C 0.10UF K		C754			CK73HB1A104K	CHIP C 0.10UF K	
C652			CC73HCH1H680J	CHIP C 68PF J		C755			CK73HB1E472K	CHIP C 4700PF K	
C653-655			CK73HB1A104K	CHIP C 0.10UF K		C756			CK73HB1A104K	CHIP C 0.10UF K	
C656			CK73HB0J224K	CHIP C 0.22UF K		C757			CK73HB1E472K	CHIP C 4700PF K	
C657			CC73HCH1H330J	CHIP C 33PF J		C759	*		CK73HB1C123J	CHIP C 0.012UF J	
C658			CK73HB1A104K	CHIP C 0.10UF K		C763			CK73HB1H471K	CHIP C 470PF K	
C659,660			CK73GB1C104K	CHIP C 0.10UF K		C765			CC73HCH1H270G	CHIP C 27PF G	
C661			CK73HB1A104K	CHIP C 0.10UF K		C766,767			CK73HB1H102K	CHIP C 1000PF K	
C662			CK73HB1H102K	CHIP C 1000PF K		C770			CK73HB1H102K	CHIP C 1000PF K	
C663			CK73HB0J105K	CHIP C 1.0UF K		C771			CC73HCH1H270G	CHIP C 27PF G	
C665			CK73GB1E223K	CHIP C 0.022UF K		C772			CK73HB0J105K	CHIP C 1.0UF K	
C666			CK73HB1A104K	CHIP C 0.10UF K		TC1,2			C05-0384-05	CERAMIC TRIMMER (10PF)	
C667			CC73HCH1H470J	CHIP C 47PF J		CN400	*		E40-6452-05	FLAT CABLE CONNECTOR	
C668			CC73HCH1H390J	CHIP C 39PF J							

PARTS LIST

TX-RX UNIT (X57-6942-71)

Ref. No.	Address	New parts	Parts No.	Description	Destination	Ref. No.	Address	New parts	Parts No.	Description	Destination
CN500			E40-6413-05	FLAT CABLE CONNECTOR		L400			L92-0149-05	CHIP FERRITE	
CN502,503			E23-0342-05	TEST TERMINAL		L500-503			L92-0163-05	BEADS CORE	
CN600			E40-6389-05	PIN ASSY		L600			L92-0163-05	BEADS CORE	
CN602		*	E40-6453-05	FLAT CABLE CONNECTOR		L601			L92-0419-15	CHIP FERRITE	
CN603			E23-1263-05	TERMINAL		L602-607			L92-0163-05	BEADS CORE	
F400			F53-0324-05	FUSE		L608,609			L92-0467-05	CHIP FERRITE	
F601,602			F53-0315-05	FUSE		L610,611			L92-0408-05	CHIP FERRITE	
CN501			J19-5386-05	HOLDER		L612			L92-0163-05	BEADS CORE	
CD200			L79-1072-05	TUNING COIL		L615			L92-0163-05	BEADS CORE	
CF200			L72-1013-05	CERAMIC FILTER		X1			L77-1952-05	TCXO (16.8MHZ)	
CF201			L72-1014-05	CERAMIC FILTER		X200			L77-1957-05	CRYSTAL RESONATOR (59.395MHZ)	
L1			L41-4795-39	SMALL FIXED INDUCTOR (4.7UH)		X500			L77-1958-05	CRYSTAL RESONATOR (11.0592MHZ)	
L2		*	L40-1867-92	SMALL FIXED INDUCTOR (1.8NH)		X501			L77-1802-05	CRYSTAL RESONATOR (32768HZ)	
L3		*	L40-3367-92	SMALL FIXED INDUCTOR (3.3NH)		X600			L77-1976-05	CRYSTAL RESONATOR (3.6864MHZ)	
L4		*	L40-1878-92	SMALL FIXED INDUCTOR (18NH)		XF200			L71-0622-05	MCF (59.85MHZ)	
L6			L40-2275-92	SMALL FIXED INDUCTOR (22NH)		CP400,401			RK75HA1J473J	CHIP-COM 47K J 1/16W	
L8			L40-1075-92	SMALL FIXED INDUCTOR (10NH)		CP500-510			RK75HA1J102J	CHIP-COM 1.0K J 1/16W	
L9			L92-0138-05	CHIP FERRITE		CP511			RK75HA1J331J	CHIP-COM 330 J 1/16W	
L10			L40-2702-86	SMALL FIXED INDUCTOR (27UH)		CP512-515			RK75HA1J102J	CHIP-COM 1.0K J 1/16W	
L11			L40-3391-86	SMALL FIXED INDUCTOR (3.3UH)		CP516			RK75HA1J103J	CHIP-COM 10K J 1/16W	
L12			L92-0163-05	BEADS CORE		CP517			RK75HA1J102J	CHIP-COM 1.0K J 1/16W	
L13			L40-2702-86	SMALL FIXED INDUCTOR (27UH)		CP518			RK75HA1J473J	CHIP-COM 47K J 1/16W	
L14			L40-3391-86	SMALL FIXED INDUCTOR (3.3UH)		CP519			RK75HA1J103J	CHIP-COM 10K J 1/16W	
L17			L40-1878-67	SMALL FIXED INDUCTOR (18NH)		CP521			RK75HA1J102J	CHIP-COM 1.0K J 1/16W	
L18			L40-2778-67	SMALL FIXED INDUCTOR (27NH)		CP522			RK75HA1J101J	CHIP-COM 100 J 1/16W	
L20			L40-2785-92	SMALL FIXED INDUCTOR (270NH)		CP600			RK75HA1J473J	CHIP-COM 47K J 1/16W	
L21,22			L40-3391-86	SMALL FIXED INDUCTOR (3.3UH)		CP601-603			RK75HA1J102J	CHIP-COM 1.0K J 1/16W	
L23			L92-0163-05	BEADS CORE		CP604,605			RK75HA1J331J	CHIP-COM 330 J 1/16W	
L24,25			L40-2275-92	SMALL FIXED INDUCTOR (22NH)		CP606			RK75HA1J102J	CHIP-COM 1.0K J 1/16W	
L27			L40-1075-92	SMALL FIXED INDUCTOR (10NH)		CP607,608			RK75HA1J101J	CHIP-COM 100 J 1/16W	
L30			L40-2285-92	SMALL FIXED INDUCTOR (220NH)		R2			RK73HB1J101J	CHIP R 100 J 1/16W	
L100			L40-3375-92	SMALL FIXED INDUCTOR (33NH)		R3			R92-1368-05	CHIP R 0 OHM	
L101			L40-2275-92	SMALL FIXED INDUCTOR (22NH)		R4			RK73HB1J100J	CHIP R 10 J 1/16W	
L102			L92-0138-05	CHIP FERRITE		R5			RK73HB1J103J	CHIP R 10K J 1/16W	
L103			L40-1575-92	SMALL FIXED INDUCTOR (15NH)		R6,7			RK73HB1J223J	CHIP R 22K J 1/16W	
L104			L40-1875-54	SMALL FIXED INDUCTOR (18NH)		R8-10			RK73HB1J100J	CHIP R 10 J 1/16W	
L105			L92-0149-05	CHIP FERRITE		R11			RK73HB1J102J	CHIP R 1.0K J 1/16W	
L106			L40-2275-92	SMALL FIXED INDUCTOR (22NH)		R12			RK73HB1J272J	CHIP R 2.7K J 1/16W	
L107			L34-4566-05	AIR-CORE COIL		R13			RK73HB1J154J	CHIP R 150K J 1/16W	
L108			L92-0149-05	CHIP FERRITE		R14,15			RK73HB1J100J	CHIP R 10 J 1/16W	
L109			L40-2285-54	SMALL FIXED INDUCTOR (220NH)		R16			RK73HB1J821J	CHIP R 820 J 1/16W	
L110			L34-4572-05	AIR-CORE COIL		R17,18			RK73HB1J271J	CHIP R 270 J 1/16W	
L111-113			L34-4564-05	AIR-CORE COIL		R19,20			RK73HB1J223J	CHIP R 22K J 1/16W	
L115			L41-8669-16	SMALL FIXED INDUCTOR (8.6NH)		R21			RK73HB1J821J	CHIP R 820 J 1/16W	
L200			L92-0141-05	CHIP FERRITE		R22			RK73HB1J103J	CHIP R 10K J 1/16W	
L201			L40-1091-86	SMALL FIXED INDUCTOR (1.0UH)		R23,24			RK73HB1J472J	CHIP R 4.7K J 1/16W	
L202			L40-1591-86	SMALL FIXED INDUCTOR (1.5UH)		R29			RK73HB1J184J	CHIP R 180K J 1/16W	
L203			L92-0138-05	CHIP FERRITE		R30,31			RK73HB1J473J	CHIP R 47K J 1/16W	
L204			L41-2785-39	SMALL FIXED INDUCTOR (0.27UH)		R32			RK73HB1J100J	CHIP R 10 J 1/16W	
L206,207			L40-1575-92	SMALL FIXED INDUCTOR (15NH)		R33			RK73HB1J181J	CHIP R 180 J 1/16W	
L208			L40-3375-92	SMALL FIXED INDUCTOR (33NH)		R34			RK73HB1J151J	CHIP R 150 J 1/16W	
L210-212			L41-1078-14	SMALL FIXED INDUCTOR (10NH)		R35			RK73HB1J100J	CHIP R 10 J 1/16W	
L213			L92-0138-05	CHIP FERRITE		R36			RK73HB1J154J	CHIP R 150K J 1/16W	
L214			L41-2285-03	SMALL FIXED INDUCTOR (220NH)		R37			RK73HB1J472J	CHIP R 4.7K J 1/16W	
L215,216			L41-1078-14	SMALL FIXED INDUCTOR (10NH)		R38			RK73HB1J101J	CHIP R 100 J 1/16W	
L217			L41-3978-03	SMALL FIXED INDUCTOR (39NH)		R39			RK73HB1J472J	CHIP R 4.7K J 1/16W	
L218			L40-8265-92	SMALL FIXED INDUCTOR (8.2NH)		R40			RK73HB1J682J	CHIP R 6.8K J 1/16W	
L220			L41-5685-39	SMALL FIXED INDUCTOR (0.56UH)		R41			RK73HB1J103J	CHIP R 10K J 1/16W	
						R42			RK73HB1J331J	CHIP R 330 J 1/16W	
						R43			RK73HB1J222J	CHIP R 2.2K J 1/16W	

PARTS LIST

TX-RX UNIT (X57-6942-71)

Ref. No.	Address	New parts	Parts No.	Description	Desti-nation	Ref. No.	Address	New parts	Parts No.	Description	Desti-nation
R44			RK73HB1J470J	CHIP R 47 J 1/16W		R214			RK73HB1J334J	CHIP R 330K J 1/16W	
R45			R92-1368-05	CHIP R 0 OHM		R215			RK73HB1J472J	CHIP R 4.7K J 1/16W	
R46			RK73HB1J472J	CHIP R 4.7K J 1/16W		R216			RK73HB1J392J	CHIP R 3.9K J 1/16W	
R47			RK73HB1J474J	CHIP R 470K J 1/16W		R217			RK73HB1J184J	CHIP R 180K J 1/16W	
R51			R92-1368-05	CHIP R 0 OHM		R218			RK73HB1J822J	CHIP R 8.2K J 1/16W	
R53			R92-1368-05	CHIP R 0 OHM		R219			RK73GB1J153J	CHIP R 15K J 1/16W	
R100			RK73HH1J333D	CHIP R 33K D 1/16W		R220			RK73HB1J334J	CHIP R 330K J 1/16W	
R101			RK73HB1J472J	CHIP R 4.7K J 1/16W		R221			RK73GB1J332J	CHIP R 3.3K J 1/16W	
R102			RK73HB1J223J	CHIP R 22K J 1/16W		R222			RK73HB1J272J	CHIP R 2.7K J 1/16W	
R103			RK73HB1J822J	CHIP R 8.2K J 1/16W		R223			RK73HB1J474J	CHIP R 470K J 1/16W	
R104			RK73HB1J473J	CHIP R 47K J 1/16W		R224			RK73HB1J392J	CHIP R 3.9K J 1/16W	
R105			RK73HB1J100J	CHIP R 10 J 1/16W		R225			RK73HB1J100J	CHIP R 10 J 1/16W	
R106			RK73HB1J331J	CHIP R 330 J 1/16W		R226			RK73HB1J562J	CHIP R 5.6K J 1/16W	
R107			RK73HB1J220J	CHIP R 22 J 1/16W		R227			R92-1368-05	CHIP R 0 OHM	
R108			RK73HB1J331J	CHIP R 330 J 1/16W		R228			RK73HB1J221J	CHIP R 220 J 1/16W	
R109			RK73HB1J180J	CHIP R 18 J 1/16W		R230			RK73HB1J564J	CHIP R 560K J 1/16W	
R110			RK73HB1J331J	CHIP R 330 J 1/16W		R231			RK73HB1J121J	CHIP R 120 J 1/16W	
R111			RK73HB1J101J	CHIP R 100 J 1/16W		R232			RK73HB1J221J	CHIP R 220 J 1/16W	
R112			RK73HB1J103J	CHIP R 10K J 1/16W		R233			RK73HB1J472J	CHIP R 4.7K J 1/16W	
R113			RK73HB1J822J	CHIP R 8.2K J 1/16W		R234			RK73HB1J470J	CHIP R 47 J 1/16W	
R115			RK73HB1J331J	CHIP R 330 J 1/16W		R236			RK73HB1J681J	CHIP R 680 J 1/16W	
R116			RK73HB1J103J	CHIP R 10K J 1/16W		R237			RK73HB1J151J	CHIP R 150 J 1/16W	
R117			RK73HB1J473J	CHIP R 47K J 1/16W		R239			RK73HB1J104J	CHIP R 100K J 1/16W	
R119			RK73HB1J470J	CHIP R 47 J 1/16W		R240			RK73HB1J154J	CHIP R 150K J 1/16W	
R120			R92-1368-05	CHIP R 0 OHM		R241			RK73HB1J104J	CHIP R 100K J 1/16W	
R122			RK73HB1J271J	CHIP R 270 J 1/16W		R242			RK73HB1J184J	CHIP R 180K J 1/16W	
R123			RK73HB1J561J	CHIP R 560 J 1/16W		R243			R92-1252-05	CHIP R 0 OHM J 1/16W	
R124			R92-1368-05	CHIP R 0 OHM		R244-246			RK73HB1J105J	CHIP R 1.0M J 1/16W	
R125			RK73EB2ER39K	CHIP R 0.39 K 1/4W		R248			RK73HB1J680J	CHIP R 68 J 1/16W	
R126			RK73HB1J470J	CHIP R 47 J 1/16W		R249			RK73HB1J221J	CHIP R 220 J 1/16W	
R127			RK73EB2ER39K	CHIP R 0.39 K 1/4W		R251			RK73HB1J104J	CHIP R 100K J 1/16W	
R128			RK73HH1J104D	CHIP R 100K D 1/16W		R253			RK73HB1J104J	CHIP R 100K J 1/16W	
R130			RK73EB2ER39K	CHIP R 0.39 K 1/4W		R254			RK73HB1J683J	CHIP R 68K J 1/16W	
R132,133			RK73HH1J154D	CHIP R 150K D 1/16W		R255			RK73HB1J104J	CHIP R 100K J 1/16W	
R134			R92-1368-05	CHIP R 0 OHM		R256-258			RK73HB1J105J	CHIP R 1.0M J 1/16W	
R135			RK73HB1J102J	CHIP R 1.0K J 1/16W		R259			R92-1252-05	CHIP R 0 OHM J 1/16W	
R137-140			RK73HH1J154D	CHIP R 150K D 1/16W		R400			R92-1368-05	CHIP R 0 OHM	
R141			RK73HB1J103J	CHIP R 10K J 1/16W		R402			RK73HB1J821J	CHIP R 820 J 1/16W	
R142			RK73HB1J473J	CHIP R 47K J 1/16W		R403			RK73HB1J561J	CHIP R 560 J 1/16W	
R143			R92-1368-05	CHIP R 0 OHM		R404			RK73HB1J103J	CHIP R 10K J 1/16W	
R144			RK73HB1J105J	CHIP R 1.0M J 1/16W		R405			RK73HB1J104J	CHIP R 100K J 1/16W	
R145			RK73HB1J222J	CHIP R 2.2K J 1/16W		R406			RK73HB1J224J	CHIP R 220K J 1/16W	
R146,147			RK73HB1J104J	CHIP R 100K J 1/16W		R407			RK73HB1J684J	CHIP R 680K J 1/16W	
R148,149			RK73HB1J271J	CHIP R 270 J 1/16W		R408,409			RK73HB1J474J	CHIP R 470K J 1/16W	
R152			R92-1368-05	CHIP R 0 OHM		R410			RK73HB1J103J	CHIP R 10K J 1/16W	
R153			RK73HB1J393J	CHIP R 39K J 1/16W		R411,412			RK73HH1J474D	CHIP R 470K D 1/16W	
R154			R92-1368-05	CHIP R 0 OHM		R414			RK73HB1J103J	CHIP R 10K J 1/16W	
R155			RK73EB2E823J	CHIP R 82K J 1/4W		R415			RK73HB1J153J	CHIP R 15K J 1/16W	
R157,158			R92-1368-05	CHIP R 0 OHM		R416			R92-1368-05	CHIP R 0 OHM	
R200			RK73HB1J824J	CHIP R 820K J 1/16W		R417			RK73HB1J684J	CHIP R 680K J 1/16W	
R202			RK73HB1J224J	CHIP R 220K J 1/16W		R418			RK73HB1J474J	CHIP R 470K J 1/16W	
R203			RK73HB1J683J	CHIP R 68K J 1/16W		R419			RK73HB1J105J	CHIP R 1.0M J 1/16W	
R204			RK73HB1J104J	CHIP R 100K J 1/16W		R421			RK73HB1J102J	CHIP R 1.0K J 1/16W	
R205			RK73HB1J472J	CHIP R 4.7K J 1/16W		R422			RK73HB1J472J	CHIP R 4.7K J 1/16W	
R206			RK73HB1J152J	CHIP R 1.5K J 1/16W		R423,424			RK73HB1J103J	CHIP R 10K J 1/16W	
R207			R92-1368-05	CHIP R 0 OHM		R425-427			RK73HB1J473J	CHIP R 47K J 1/16W	
R208,209			RK73HB1J223J	CHIP R 22K J 1/16W		R428			RK73HB1J124J	CHIP R 120K J 1/16W	
R210			RK73HB1J332J	CHIP R 3.3K J 1/16W		R430			RK73HB1J103J	CHIP R 10K J 1/16W	
R211,212			RK73HB1J223J	CHIP R 22K J 1/16W		R500			R92-1368-05	CHIP R 0 OHM	
R213			RK73HB1J471J	CHIP R 470 J 1/16W		R504			R92-1368-05	CHIP R 0 OHM	

PARTS LIST

TX-RX UNIT (X57-6942-71)

Ref. No.	Address	New parts	Parts No.	Description	Destination	Ref. No.	Address	New parts	Parts No.	Description	Destination
R505			RK73HB1J473J	CHIP R 47K J 1/16W		R660			R92-1368-05	CHIP R 0 OHM	
R506			R92-1368-05	CHIP R 0 OHM		R661			RK73HB1J334J	CHIP R 330K J 1/16W	
R507			RK73HB1J474J	CHIP R 470K J 1/16W		R663			RK73HB1J103J	CHIP R 10K J 1/16W	
R508-510			RK73HB1J473J	CHIP R 47K J 1/16W		R664			RK73HB1J124J	CHIP R 120K J 1/16W	
R511			R92-1368-05	CHIP R 0 OHM		R666			RK73HB1J105J	CHIP R 1.0M J 1/16W	
R512			RK73HB1J473J	CHIP R 47K J 1/16W		R667			RK73HB1J394J	CHIP R 390K J 1/16W	
R513			RK73HB1J102J	CHIP R 1.0K J 1/16W		R668			RK73HB1J154J	CHIP R 150K J 1/16W	
R514			RK73HB1J472J	CHIP R 4.7K J 1/16W		R669			RK73HB1J124J	CHIP R 120K J 1/16W	
R515			RK73HB1J473J	CHIP R 47K J 1/16W		R670			R92-1252-05	CHIP R 0 OHM J 1/16W	
R516,517			RK73HB1J102J	CHIP R 1.0K J 1/16W		R671			RK73HB1J104J	CHIP R 100K J 1/16W	
R518			RK73HB1J153J	CHIP R 15K J 1/16W		R672			RK73HB1J224J	CHIP R 220K J 1/16W	
R519			RK73HB1J474J	CHIP R 470K J 1/16W		R673,674			R92-1368-05	CHIP R 0 OHM	
R520			RK73HB1J103J	CHIP R 10K J 1/16W		R675			RK73HB1J105J	CHIP R 1.0M J 1/16W	
R521			RK73HB1J272D	CHIP R 2.7K D 1/16W		R676			RK73HB1J274J	CHIP R 270K J 1/16W	
R522			RK73HB1J512D	CHIP R 5.1K D 1/16W		R677			RK73HB1J223J	CHIP R 22K J 1/16W	
R523,524			R92-1368-05	CHIP R 0 OHM		R679			R92-1368-05	CHIP R 0 OHM	
R525			RK73HB1J102J	CHIP R 1.0K J 1/16W		R680			RK73HB1J274J	CHIP R 270K J 1/16W	
R526			R92-1252-05	CHIP R 0 OHM J 1/16W		R681			RK73HB1J102J	CHIP R 1.0K J 1/16W	
R527			RK73HB1J473J	CHIP R 47K J 1/16W		R682			RK73HB1J272J	CHIP R 2.7K J 1/16W	
R528			RK73HB1J474J	CHIP R 470K J 1/16W		R683			RK73HB1J154J	CHIP R 150K J 1/16W	
R600			RK73HB1J684J	CHIP R 680K J 1/16W		R684			R92-1252-05	CHIP R 0 OHM J 1/16W	
R601			RK73HB1J394J	CHIP R 390K J 1/16W		R685			RK73HB1J472J	CHIP R 4.7K J 1/16W	
R603			R92-1368-05	CHIP R 0 OHM		R686			RK73HB1J474D	CHIP R 470K D 1/16W	
R604			RK73HB1J184J	CHIP R 180K J 1/16W		R687			RK73HB1J105J	CHIP R 1.0M J 1/16W	
R605			RK73HB1J393J	CHIP R 39K J 1/16W		R688			RK73HB1J273J	CHIP R 27K J 1/16W	
R606			RK73HB1J184J	CHIP R 180K J 1/16W		R689,690			R92-1368-05	CHIP R 0 OHM	
R607			RK73HB1J223J	CHIP R 22K J 1/16W		R691			RK73HB1J103J	CHIP R 10K J 1/16W	
R609			RK73HB1J104J	CHIP R 100K J 1/16W		R692			RK73HB1J823J	CHIP R 82K J 1/16W	
R612			RK73HB1J103J	CHIP R 10K J 1/16W		R693			RK73HB1J472J	CHIP R 4.7K J 1/16W	
R613			RK73HB1J104J	CHIP R 100K J 1/16W		R694			RK73HB1J104D	CHIP R 100K D 1/16W	
R614			RK73HB1J683J	CHIP R 68K J 1/16W		R695			RK73HB1J103J	CHIP R 10K J 1/16W	
R615			RK73HB1J473J	CHIP R 47K J 1/16W		R696			RK73HB1J184J	CHIP R 180K J 1/16W	
R616			RK73HB1J104J	CHIP R 100K J 1/16W		R697			RK73HB1J474J	CHIP R 470K J 1/16W	
R617			RK73HB1J683J	CHIP R 68K J 1/16W		R698			RK73HB1J105J	CHIP R 1.0M J 1/16W	
R618			R92-1368-05	CHIP R 0 OHM		R699			RK73HB1J334J	CHIP R 330K J 1/16W	
R619			RK73HB1J184J	CHIP R 180K J 1/16W		R700			RK73HB1J184J	CHIP R 180K J 1/16W	
R623			RK73HB1J104J	CHIP R 100K J 1/16W		R701			RK73HB1J223J	CHIP R 22K J 1/16W	
R624			R92-1368-05	CHIP R 0 OHM		R702,703			RK73HB1J473J	CHIP R 47K J 1/16W	
R625			RK73HB1J472J	CHIP R 4.7K J 1/16W		R704			RK73HB1J471J	CHIP R 470 J 1/16W	
R626			RK73HB1J184J	CHIP R 180K J 1/16W		R705,706			RK73HB1J153J	CHIP R 15K J 1/16W	
R627			RK73HB1J684J	CHIP R 680K J 1/16W		R707			RK73HB1J182J	CHIP R 1.8K J 1/16W	
R628,629			R92-1368-05	CHIP R 0 OHM		R708			RK73HB1J102J	CHIP R 1.0K J 1/16W	
R631			RK73HB1J474J	CHIP R 470K J 1/16W		R709			RK73HB1J104J	CHIP R 100K J 1/16W	
R635,636			RK73HB1J472J	CHIP R 4.7K J 1/16W		R710			RK73HB1J102J	CHIP R 1.0K J 1/16W	
R637			RK73HB1J332J	CHIP R 3.3K J 1/16W		R711			RK73HB1J473J	CHIP R 47K J 1/16W	
R638			RK73HB1J103J	CHIP R 10K J 1/16W		R712			RK73HB1J104J	CHIP R 100K J 1/16W	
R641			RK73HB1J273J	CHIP R 27K J 1/16W		R713			RK73HB1J102J	CHIP R 1.0K J 1/16W	
R642			RK73HB1J472J	CHIP R 4.7K J 1/16W		R714			RK73HB1J104J	CHIP R 100K J 1/16W	
R643			RK73HB1J104J	CHIP R 100K J 1/16W		R715			RK73HB1J272J	CHIP R 2.7K J 1/16W	
R644			RK73HB1J103J	CHIP R 10K J 1/16W		R716			RK73HB1J104J	CHIP R 100K J 1/16W	
R645			RK73HB1J472J	CHIP R 4.7K J 1/16W		R717-720			RK73HB1J101J	CHIP R 100 J 1/16W	
R648			RK73HB1J104J	CHIP R 100K J 1/16W		R721			RK73HB1J103J	CHIP R 10K J 1/16W	
R650			RK73HB1J472J	CHIP R 4.7K J 1/16W		R722			RK73HB1J474J	CHIP R 470K J 1/16W	
R652			RK73HB1J103J	CHIP R 10K J 1/16W		R723			RK73HB1J470J	CHIP R 47 J 1/16W	
R654			RK73HB1J683J	CHIP R 68K J 1/16W		R724			RK73HB1J102J	CHIP R 1.0K J 1/16W	
R655			RK73HB1J682J	CHIP R 6.8K J 1/16W		R725,726			RK73HB1J331J	CHIP R 330 J 1/16W	
R656			RK73HB1J563J	CHIP R 56K J 1/16W		R728-734			RK73HB1J102J	CHIP R 1.0K J 1/16W	
R657			RK73HB1J564J	CHIP R 560K J 1/16W		R735			RK73HB1J473J	CHIP R 47K J 1/16W	
R658			RK73HB1J473J	CHIP R 47K J 1/16W		R736,737			RK73HB1J472J	CHIP R 4.7K J 1/16W	
R659			R92-1252-05	CHIP R 0 OHM J 1/16W		R738			RK73HB1J124J	CHIP R 120K J 1/16W	

PARTS LIST

TX-RX UNIT (X57-6942-71)

Ref. No.	Address	New parts	Parts No.	Description	Desti-nation	Ref. No.	Address	New parts	Parts No.	Description	Desti-nation
R739			RK73HB1J184J	CHIP R 180K J 1/16W		D200			MA2S111	DIODE	
R740,741			RK73HB1J123J	CHIP R 12K J 1/16W		D201			DAN222	DIODE	
R742			RK73HB1J822J	CHIP R 8.2K J 1/16W		D202			RB706F-40	DIODE	
R744			RK73HB1J472J	CHIP R 4.7K J 1/16W		D203			DAN222	DIODE	
R745			RK73HB1J823J	CHIP R 82K J 1/16W		D204			MA2S111	DIODE	
R747			R92-1368-05	CHIP R 0 OHM		D205			HSC277	DIODE	
R748			RK73HB1J104J	CHIP R 100K J 1/16W		D206-210			HVC369B	VARIABLE CAPACITANCE DIODE	
R750			RK73HB1J823J	CHIP R 82K J 1/16W		D212			HVC369B	VARIABLE CAPACITANCE DIODE	
R752			R92-1368-05	CHIP R 0 OHM		D213,214			HVC131	DIODE	
R753			RK73HB1J103J	CHIP R 10K J 1/16W		D314			MA2S111	DIODE	
R754			RK73HB1J472J	CHIP R 4.7K J 1/16W		D402			1SR154-400	DIODE	
R755			R92-1252-05	CHIP R 0 OHM J 1/16W		D403			1SS301	DIODE	
R758			RK73HB1J473J	CHIP R 47K J 1/16W		D404			MA2S111	DIODE	
R760			RK73HB1J104J	CHIP R 100K J 1/16W		D405			RB521S-30	DIODE	
R761			RK73HB1J222J	CHIP R 2.2K J 1/16W		D406			MA2S111	DIODE	
R762			RK73HB1J472J	CHIP R 4.7K J 1/16W		D408			MA2S111	DIODE	
R764,765			R92-1252-05	CHIP R 0 OHM J 1/16W		D500			MA2S111	DIODE	
R766			RK73HB1J222J	CHIP R 2.2K J 1/16W		D501,502			1SS388	DIODE	
R767			RK73HB1J474J	CHIP R 470K J 1/16W		D600-603			RB706F-40	DIODE	
R768			RK73HB1J101J	CHIP R 100 J 1/16W		D604			015AZ6.8	ZENER DIODE	
R769-771			RK73HB1J102J	CHIP R 1.0K J 1/16W		D605			1SS373	DIODE	
R772			R92-1368-05	CHIP R 0 OHM		D606			015AZ6.8	ZENER DIODE	
R773			RK73HB1J823J	CHIP R 82K J 1/16W		D607			015AZ2.4-X	ZENER DIODE	
R775			RK73HB1J563J	CHIP R 56K J 1/16W		D608			015AZ6.8	ZENER DIODE	
R776			RK73HB1J473J	CHIP R 47K J 1/16W		D609,610			DA221	DIODE	
R777			RK73HB1J100J	CHIP R 10 J 1/16W		D611			NNCD6.8G	ZENER DIODE	
R780			RK73HB1J103J	CHIP R 10K J 1/16W		D612			015AZ6.8	ZENER DIODE	
R781,782			R92-1368-05	CHIP R 0 OHM		D613			DA221	DIODE	
R783			RK73HB1J683J	CHIP R 68K J 1/16W		D614			DAN222	DIODE	
R784			RK73HB1J473J	CHIP R 47K J 1/16W		IC1			ADF4111BCP7	MOS-IC	
R785			RK73HH1J123D	CHIP R 12K D 1/16W		IC100			TA75W01FU	MOS-IC	
R786		*	RK73HH1J562D	CHIP R 5.6K D 1/16W		IC200			TA31136FN	MOS-IC	
R787			RK73HH1J103D	CHIP R 10K D 1/16W		IC400			XC61CC5602NR	MOS-IC	
R788			RK73HB1J473J	CHIP R 47K J 1/16W		IC401			TK11250CUCB	MOS-IC	
R790			R92-1368-05	CHIP R 0 OHM		IC402,403			XC6204B502MR	MOS-IC	
R792			RK73HB1J223J	CHIP R 22K J 1/16W		IC404			TC75S51FE	MOS-IC	
R794			R92-1368-05	CHIP R 0 OHM		IC405			S-80942CNNBG9C	MOS-IC	
R796			R92-1252-05	CHIP R 0 OHM J 1/16W		IC406			TK11250CUCB	MOS-IC	
R800			R92-1252-05	CHIP R 0 OHM J 1/16W		IC500			AT29C040A-90TU	ROM IC	
R801-804			R92-1368-05	CHIP R 0 OHM		IC502			30625MGP169GU	MICROPROCESSOR IC	
R805			RK73HB1J473J	CHIP R 47K J 1/16W		IC503			RV5C386A	MOS-IC	
R806			RK73HB1J474J	CHIP R 470K J 1/16W		IC504			AT24256N10SI27	ROM IC	
R807,808			RK73HB1J473J	CHIP R 47K J 1/16W		IC505			TC7W53FK	HYBRID IC	
R809			RK73HB1J474J	CHIP R 470K J 1/16W		IC600-604			TC75W51FK	MOS-IC	
R810			RK73HB1J473J	CHIP R 47K J 1/16W		IC605			M62364FP	MOS-IC	
R811-813			R92-1368-05	CHIP R 0 OHM		IC606			TC7W53FK	HYBRID IC	
R814			RK73HB1J474J	CHIP R 470K J 1/16W		IC607			AQUA-L	MOS-IC	
R816			RK73HH1J474D	CHIP R 470K D 1/16W		IC608			TC75W51FK	MOS-IC	
S400			S70-0483-05	TACT SWITCH		IC609			TDA7053AT	BI-POLAR IC	
D1-4			HVC131	DIODE		Q1			DTA144EE	DIGITAL TRANSISTOR	
D6			1SV325	VARIABLE CAPACITANCE DIODE		Q2			DTC144EE	DIGITAL TRANSISTOR	
D9			1SV325	VARIABLE CAPACITANCE DIODE		Q6,7			2SK508NV(K52)	FET	
D11,12			1SV325	VARIABLE CAPACITANCE DIODE		Q8,9			2SJ347	FET	
D17			1SV278	VARIABLE CAPACITANCE DIODE		Q10			2SC5108(Y)	TRANSISTOR	
D18			MA2S111	DIODE		Q11			2SK1830	FET	
D100			HSC277	DIODE		Q12			2SC4617(S)	TRANSISTOR	
D103		*	HZU3CLL	ZENER DIODE		Q13-15			2SC5108(Y)	TRANSISTOR	
D106,107			HVC131	DIODE		Q100			2SC5108(Y)	TRANSISTOR	
D108			HZU2ALL	ZENER DIODE		Q101			2SK3077	FET	
						Q102			2SK3391	FET	

PARTS LIST

TX-RX UNIT (X57-6942-71)

Ref. No.	Address	New parts	Parts No.	Description	Destination	Ref. No.	Address	New parts	Parts No.	Description	Destination
Q104			2SC4738(GR)	TRANSISTOR							
Q105			RD07MVS1	FET							
Q106			DTC114EE	DIGITAL TRANSISTOR							
Q107,108			2SK1824	FET							
Q200			HN1L02FU	FET							
Q201			2SC4617(S)	TRANSISTOR							
Q202			2SJ243	FET							
Q203			2SK1824	FET							
Q204			DTA144EE	DIGITAL TRANSISTOR							
Q205			2SC5108(Y)	TRANSISTOR							
Q206,207			3SK318	FET							
Q400			UMG9N	TRANSISTOR							
Q401			SSM3K15TE	FET							
Q402			2SK1830	FET							
Q403			2SA1955(A)	TRANSISTOR							
Q404			DTC144EE	DIGITAL TRANSISTOR							
Q405			2SJ347	FET							
Q406			2SA1955(A)	TRANSISTOR							
Q407			2SK1830	FET							
Q408			2SA1955(A)	TRANSISTOR							
Q409			2SJ347	FET							
Q502			SSM3K15TE	FET							
Q602			DTA114EE	DIGITAL TRANSISTOR							
Q605			RN4910	TRANSISTOR							
Q606			2SC4738(GR)	TRANSISTOR							
Q607			2SA1832(GR)	TRANSISTOR							
Q608-610			2SJ243	FET							
Q611			HN1L02FU	FET							
Q612			2SC4617(S)	TRANSISTOR							
Q613			2SB1132(Q,R)	TRANSISTOR							
Q614			2SJ347	FET							
Q615			2SC4617(S)	TRANSISTOR							
Q616,617			UPA672T	FET							
Q618			2SK1824	FET							
Q619			2SJ243	FET							
Q620			DTA144TE	DIGITAL TRANSISTOR							
Q621			2SC4649(N,P)	TRANSISTOR							
Q622			FMMT717	TRANSISTOR							
Q623,624			2SK1830	FET							
Q625,626			2SC4649(N,P)	TRANSISTOR							
TH100			ERTJ0EV104H	THERMISTOR							
TH200			ERTJ0EV104H	THERMISTOR							

EXPLODED VIEW

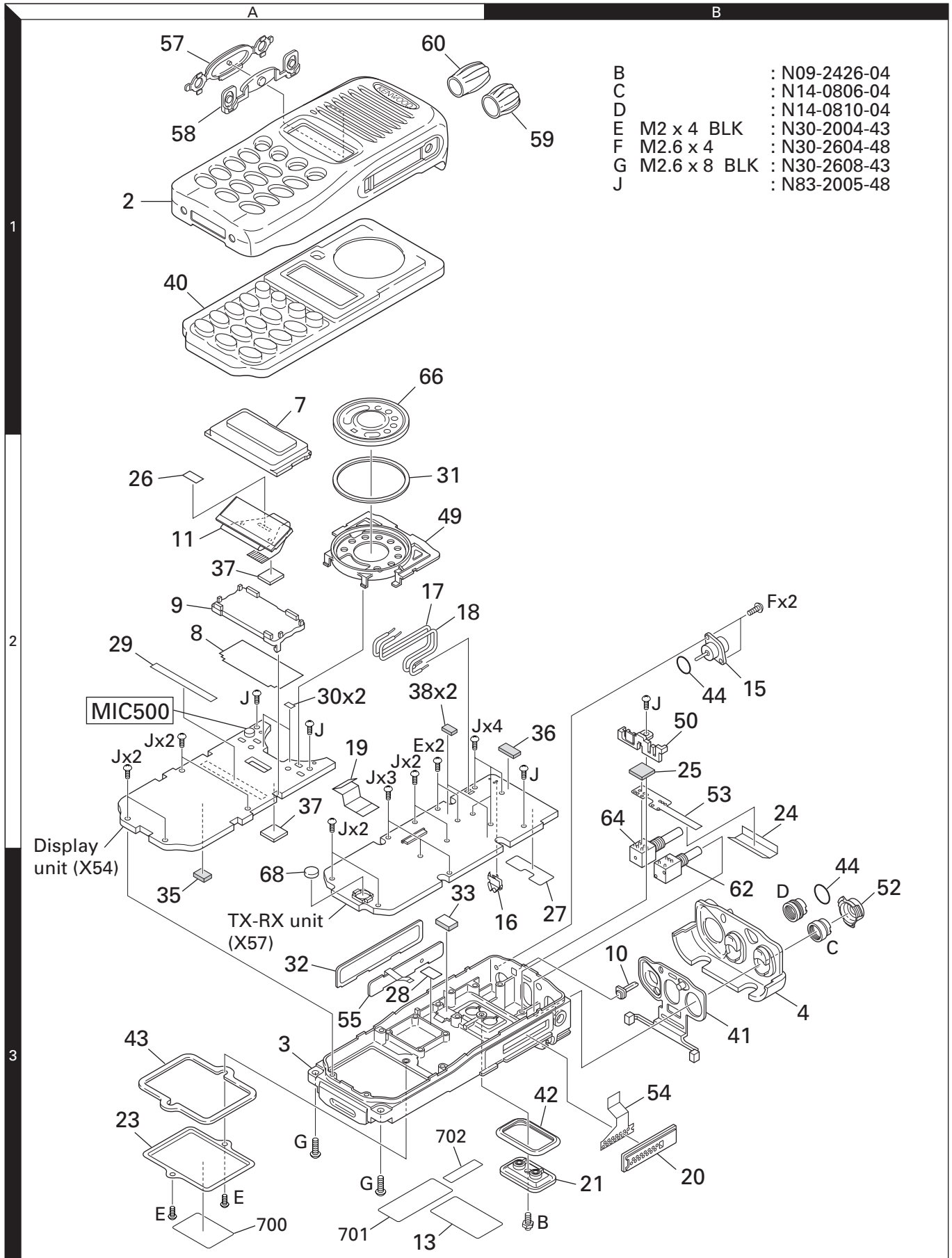

Parts with the exploded numbers larger than 700 are not supplied.

PACKING

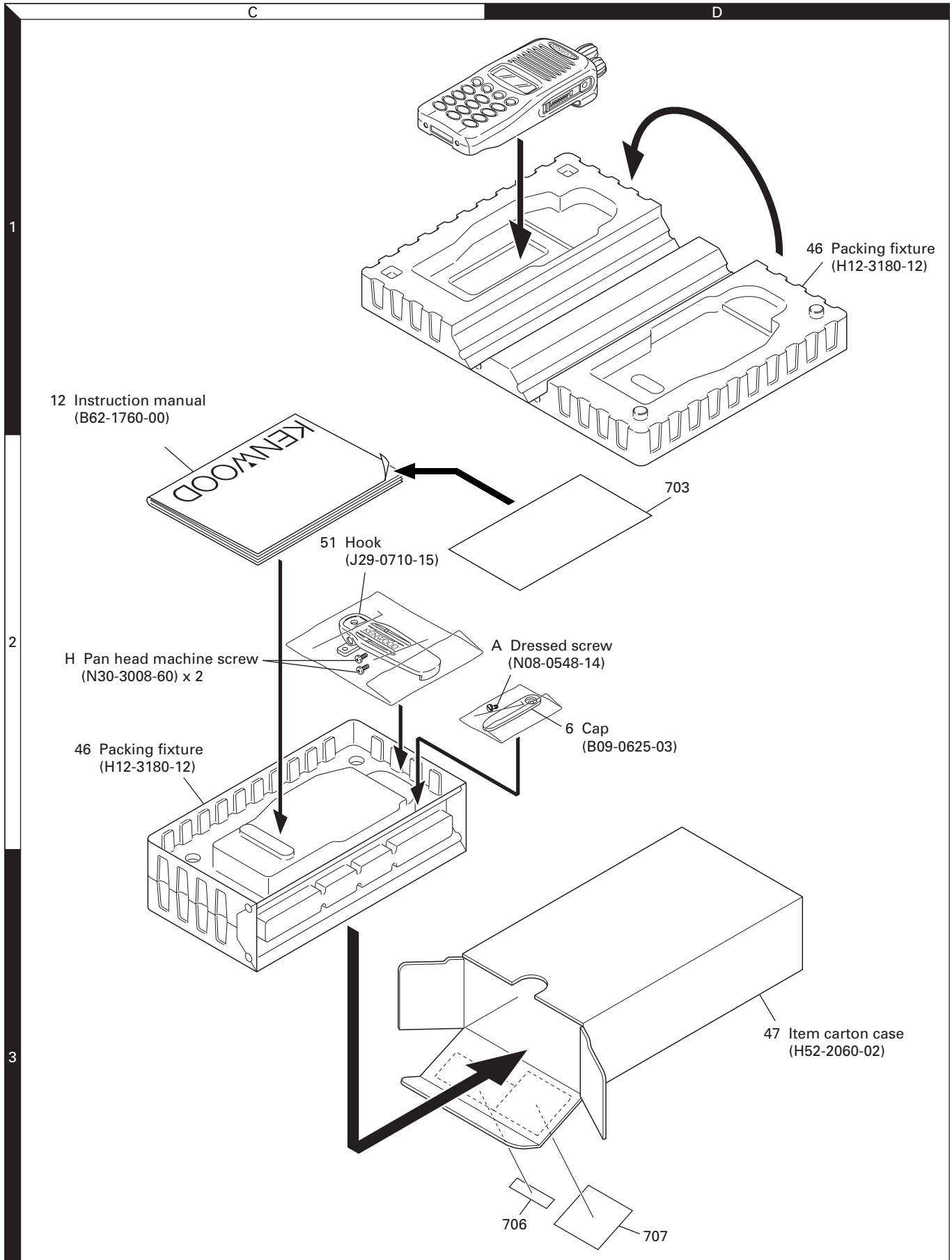

ADJUSTMENT

Controls

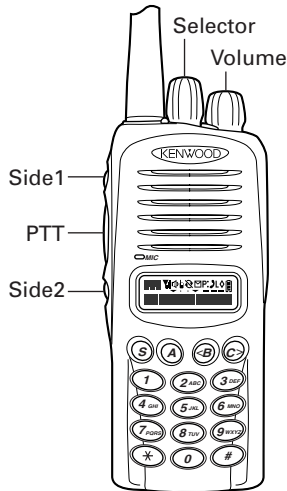

Key	"FNC" appears	
	Function	Display
[S]	High power / Low power	Low : L icon appears
[A]	Function off	-
[B]	Compander on/off	On : M icon appears
[C]	Beat shift on/off	On : D icon appears
[Selector]	Test frequency CH up/down	-
[Side1]	Squelch level 0	On : P icon appears
[Side2]	LCD all lights	LCD all point appears
[PTT]	Transmit	-
[0] to [9] and [#],[*]	Function off	-

Note :

- If a [S], [A], [B], [C] key is pressed during transmission, the DTMF corresponding to the key that was pressed is sent.

• LED indicator

- Red LED Lights during transmission. Blinks at the low battery voltage warning.
- Green LED Lights when there is carrier.

• Sub LCD indicator

- "FNC" Appears at function on.

• LCD display in panel test mode

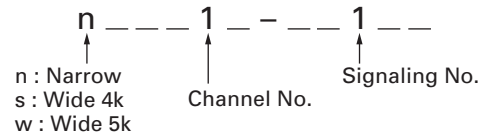

Panel Test Mode

■ Test mode operation features

This transceiver has a test mode. **To enter test mode, press [A] key and turn power on. Hold [A] key until frequency version appears on LCD.** Test mode can be inhibited by programming. To exit test mode, switch the power on again. The following functions are available in test mode.

■ Key operation

Key	"FNC" not appears	
	Function	Display
[S]	Shifts to Panel tuning mode	-
[A]	Function on	"FNC" appears
[B]	MSK 1200bps and 2400bps	2400bps : <input checked="" type="checkbox"/> icon appears
[C]	Test signaling CH up	Signaling No.
[Selector]	Test frequency CH up/down	Channel No.
[Side1]	Squelch on/off	M
[Side2]	Narrow/Wide 4k/Wide 5k	Narrow : "n" Wide 4k : "s" Wide 5k : "w"
[PTT]	Transmit	-
[0] to [9] and [#],[*]	Use as the DTMF keypad. If a key is pressed during transmission, the DTMF corresponding to the key that was presses is sent.	-

■ Frequency and Signaling

The set has been adjusted for the frequencies shown in the following table. When required, readjust them following the adjustment procedure to obtain the frequencies you want in actual operation.

• Test frequency

CH	RX (MHz)	TX (MHz)
1	435.05000	435.10000
2	400.05000	400.10000
3	469.95000	469.90000
4	435.00000	435.00000
5	435.20000	435.20000
6	435.40000	435.40000
7~16	-	-

ADJUSTMENT

• Test signaling

No.	RX	TX
1	None	None
2	None	100Hz Square Wave
3	LTR Data : AREA=0, GOTO=12 HOME=12 ID=47, FREE=25	LTR Data : AREA=0, GOTO=12 HOME=12 ID=47, FREE=25
4	QT : 67.0Hz	QT : 67.0Hz
5	QT : 151.4Hz	QT : 151.4Hz
6	QT : 210.7Hz	QT : 210.7Hz
7	QT : 254.1Hz	QT : 254.1Hz
8	DQT : D023N	DQT : D023N
9	DQT : D754I	DQT : D754I
10	DTMF : 159D	DTMF : 159D
11	None	DTMF Code 9
12	2-tone : A : 304.7Hz B : 3106.0Hz	2-tone : A : 304.7Hz B : 3106.0Hz
13	Single Tone : 979.9Hz	Single Tone : 979.9Hz
14	None	Single Tone : 1000Hz
15	5-tone (CCIR 12345)	5-tone (CCIR 12345)
16	None	MSK
17	MSK : Preamble : 0xAAAA Sync : 0x23EB Data : 0x230960C6AAAA CRC : 0xC4D7	MSK : Preamble : 0xAAAA Sync : 0x23EB Data : 0x230960C6AAAA CRC : 0xC4D7

Note : The "LTR" and "2-tone signaling" are not used.

Panel Tuning Mode

■ Preparations for tuning the transceiver

Before attempting to tune the transceiver, connect the unit to a suitable power supply.

Whenever the transmitter is turned, the unit must be connected to a suitable dummy load (i.e. power meter).

The speaker output connector must be terminated with a 8Ω dummy load and connected to an AC voltmeter and an audio distortion meter or a SINAD measurement meter at all times during tuning.

■ Transceiver tuning

(To place transceiver in tuning mode)

Press [S] key, now in tuning mode. Use [B] key to write tuning data through tuning modes, and [Selector] to adjust tuning requirements (1 to 256 appears on LCD).

Use [C] key to select the adjustment item through tuning modes. Use [A] key to adjust 3 or 5 reference level adjustments, and use [Side2] key to switch between Wide 5k/Wide 4k/Narrow.

Channel appears on LCD. Set channel according to tuning requirements.

• LCD display in panel tuning mode

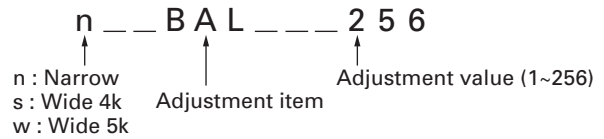

■ Key operation

Key	Function	
	Push	Hold (1 second)
[S]	End of panel tuning mode	-
[A]	To enter 3 or 5 reference level adjustments	-
[B]	Writes the adjustment value	-
[C]	Go to next adjustment item	Back to last adjustment item
[Selector]	Adjustment value up/down	
[Volume]	Volume level up/down	
[Side1]	Squelch on/off	-
[Side2]	Selects Narrow, Wide 4k, Wide 5k	-

■ 3 or 5 reference level adjustments frequency

Tuning point	RX (MHz)	TX (MHz)
Low	400.05000	400.10000
Low'	427.05000	417.60000
Center	435.05000	435.10000
High'	452.55000	452.60000
High	469.95000	469.90000

■ Adjustment item and Display (*** : 1~256)

Order	Adjustment item	Display
1	Frequency	FREQ ***
2	Shift 1	SHFT1 ***
3	Shift 2	SHFT2 ***
4	High power	HPWR ***
5	Low power	LPWR ***
6	Balance	BAL ***
7	Max deviation	DEV ***
8	VOX 1	VOX1 ***
9	VOX 10	VOX10 ***
10	QT	QT ***
11	DQT	DQT ***
12	LTR	LTR ***
13	DTMF	DTMF ***
14	MSK	MSK ***
15	Tone	TONE ***
16	Sensitivity 1	SENS1 ***
17	Sensitivity 2	SENS2 ***
18	Squelch	SQL ***
19	Low RSSI	LRSSI ***
20	Squelch tight	SQLT ***
21	High RSSI	HRSSI ***
22	Battery	BATT ***

ADJUSTMENT

Flow chart

Note : Adjustment of the LTR performs only K markets.

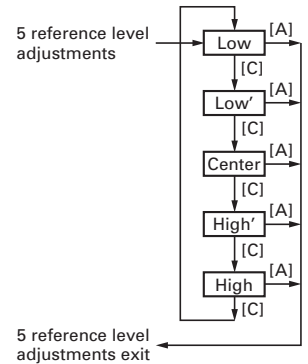
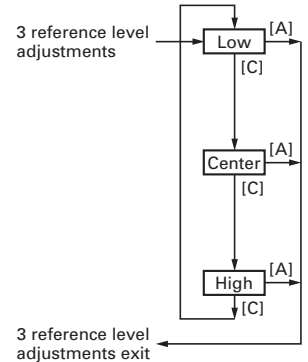
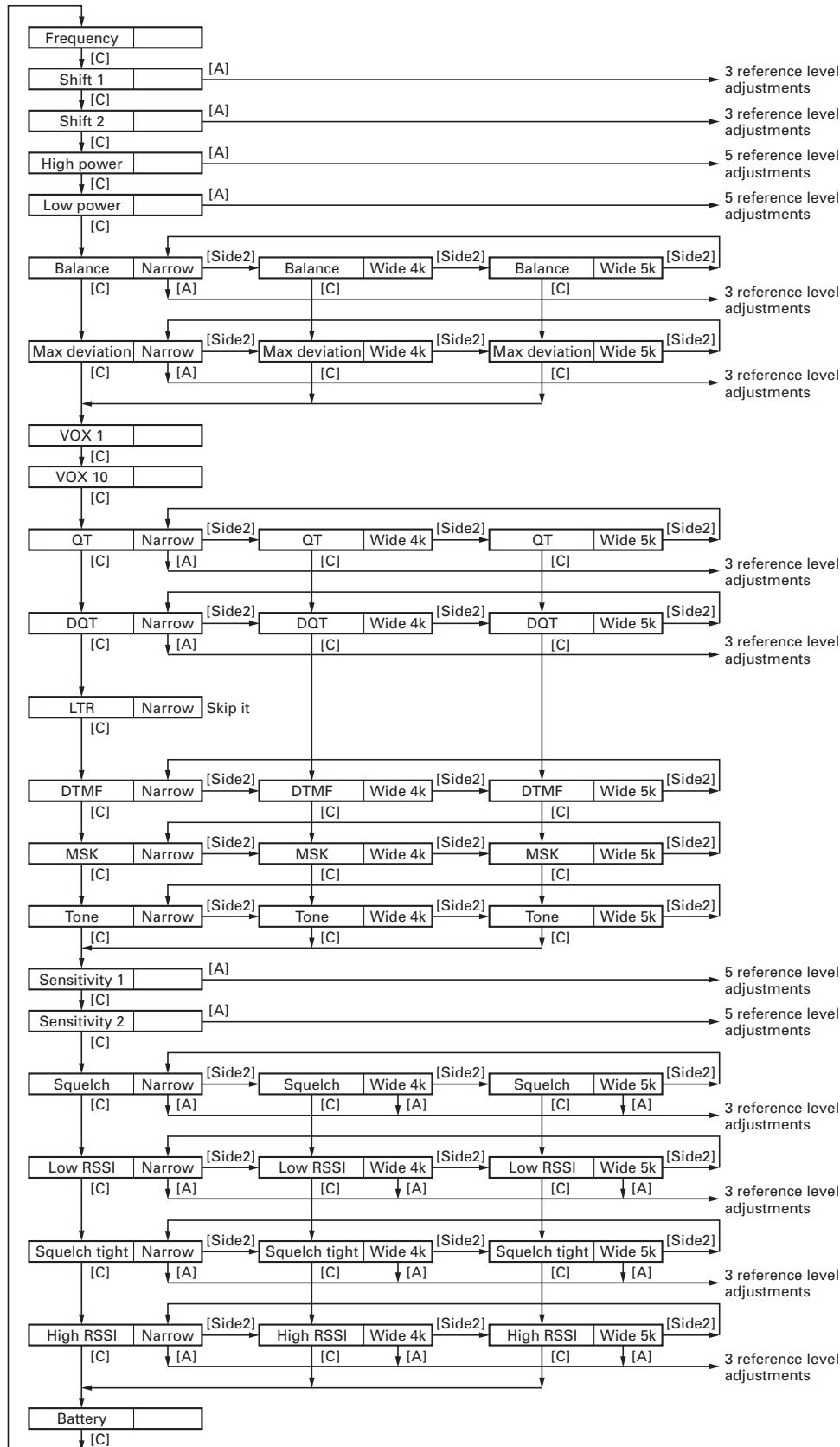

ADJUSTMENT

Test Equipment Required for Alignment

Test Equipment	Major Specifications	
1. Standard Signal Generator (SSG)	Frequency Range	400 to 520MHz
	Modulation	Frequency modulation and external modulation
	Output	-127dBm/0.1μV to greater than -47dBm/1mV
2. Power Meter	Input Impedance	50Ω
	Operation Frequency	400 to 520MHz or more
	Measurement Capability	Vicinity of 10W
3. Deviation Meter	Frequency Range	400 to 520MHz
4. Digital Volt Meter (DVM)	Measuring Range	10mV to 10V DC
	Input Impedance	High input impedance for minimum circuit loading
5. Oscilloscope		DC through 30MHz
6. High Sensitivity Frequency Counter	Frequency Range	10Hz to 1000MHz
	Frequency Stability	0.2ppm or less
7. Ammeter		5A
8. AF Volt Meter (AF VTVM)	Frequency Range	50Hz to 10kHz
	Voltage Range	1mV to 10V
9. Audio Generator (AG)	Frequency Range	50Hz to 5kHz or more
	Output	0 to 1V
10. Distortion Meter	Capability	3% or less at 1kHz
	Input Level	50mV to 10Vrms
11. 8Ω Dummy Load		Approx. 8Ω, 3W
12. Regulated Power Supply		5V to 10V, approx. 5A Useful if ammeter equipped

■ Universal connector

Use the interface cable (KPG-36) for PC tuning or the lead wire with plug (E30-3287-18) and screw (N08-0535-08) for panel tuning. Connect the plug to the universal connector of the radio and tighten the screw.

The lead wire with plug (E30-3287-18) and screw (N08-0535-08) terminals are as follows. Numbers are universal connector terminal numbers.

Caution

- When connecting the plug to the universal connector of the radio, a short circuit may occur. To prevent this, be sure to turn the radio POWER switch off.
- Since the RX AF output is a BTL output, there is a DC component. Isolate this with a capacitor or transformer as shown in the figure.
- Do not connect an instrument between red or black and GND.

• Universal connector

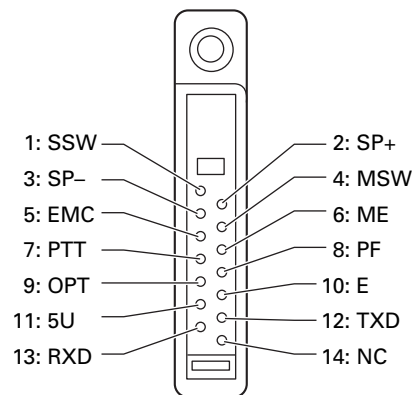

ADJUSTMENT

• Panel tuning

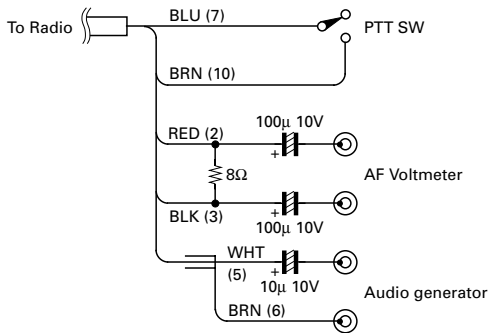
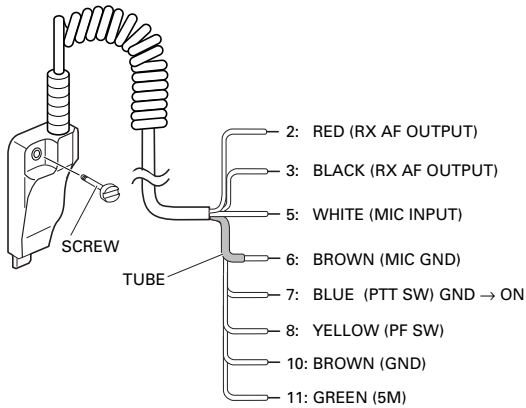

• PC tuning

Connect the wires to the PCB in the connector case of interface cable.

For output the wires out of the connector case, need to process the connector case.

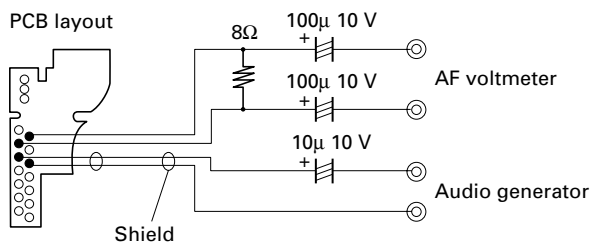
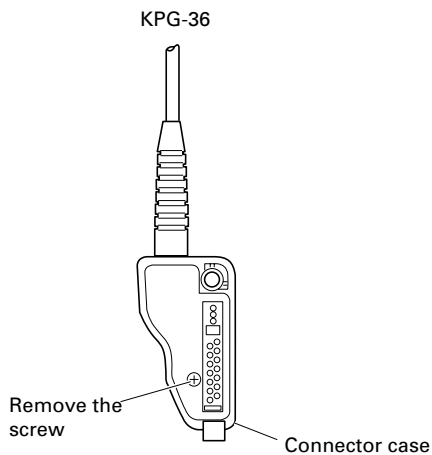

■ Check Jig for the VGS-1

KENWOOD part No. : W05-1127-00

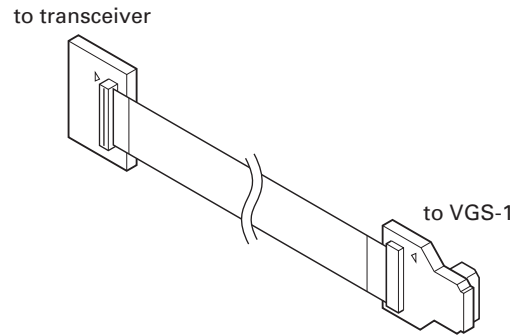

■ Nut wrench

In order to turn the volume nut and the channel selector nut, use a recommendation tool.

KENWOOD part No. : W05-1123-00

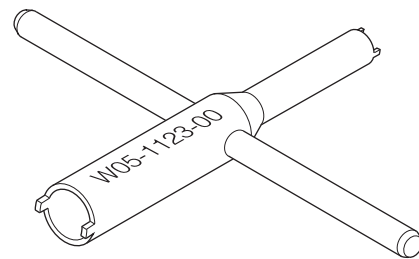

ADJUSTMENT

Common Section

Item	Condition	Measurement			Adjustment			Specifications/Remarks
		Test-equipment	Unit	Terminal	Unit	Parts	Method	
1. Setting	1) BATT terminal voltage : 7.5V 2) SSG standard modulation [Wide 5k] MOD : 1kHz, DEV : 3kHz [Wide 4k] MOD : 1kHz, DEV : 2.4kHz [Narrow] MOD : 1kHz, DEV : 1.5kHz							
2. VCO lock voltage • RX	[Panel test mode] 1) CH-Sig : 3-1	Power meter	Panel	ANT	TX-RX	TC2	4.30V	±0.05V
	2) CH-Sig : 2-1	DVM	TX-RX	CV			Check	0.6V or more
	[Panel tuning mode] LPWR* 3) CH-Sig : 3-1 PTT : ON				TX-RX	TC1	4.30V	±0.05V
		4) CH-Sig : 2-1 PTT : ON						Check

* TX can be continued on unlock condition in panel tuning mode.

Transmitter Section (E market model skips adjustment of LTR.)

Item	Condition	Measurement			Adjustment			Specifications/Remarks
		Test-equipment	Unit	Terminal	Unit	Parts	Method	
1. Frequency adjust	1) Adj item : [FREQ] Adjust : [***] PTT : ON	f. counter	Panel	ANT	Panel	Selector knob	Center frequency ±80Hz	Note : After replacing the TCXO (X1) align frequency.
2. Frequency shift 1 adjust	1) Adj item : [SHFT1] Adjust : [***] 2) Adj item : [L SHFT1] → [C SHFT1] → [H SHFT1] Adjust : [***] PTT : ON						[L SHFT1] Low frequency+5.00kHz [C SHFT1] Center frequency+5.00kHz [H SHFT1] High frequency+5.00kHz	±80Hz
3. Frequency shift 2 adjust	1) Adj item : [SHFT2] Adjust : [***] 2) Adj item : [L SHFT2] → [C SHFT2] → [H SHFT2] Adjust : [***] PTT : ON						[L SHFT2] Low frequency+6.25kHz [C SHFT2] Center frequency+6.25kHz [H SHFT2] High frequency+6.25kHz	±80Hz
4. High power adjust	1) Adj item : [HPWR] Adjust : [***] 2) Adj item : [L HPWR] → [L' HPWR] → [C HPWR] → [H' HPWR] → [H HPWR] Adjust : [***] PTT : ON	Power meter Ammeter					5.0W	±0.1W 2.3A or less
5. High power check	[Panel test mode] 1) CH-Sig : 1-1 PTT : ON						Check	4.5~5.5W 2.4A or less
	2) CH-Sig : 2-1 PTT : ON							
	3) CH-Sig : 3-1 PTT : ON							

ADJUSTMENT

Item	Condition	Measurement			Adjustment			Specifications/Remarks
		Test-equipment	Unit	Terminal	Unit	Parts	Method	
6. Low power adjust	1) Adj item : [LPWR] Adjust : [***] 2) Adj item : [L LPWR] → [L' LPWR] → [C LPWR] → [H' LPWR] → [H LPWR] Adjust : [***] PTT : ON	Power meter Ammeter	Panel	ANT	Panel	Selector knob	1.0W	±0.1W 1.2A or less
7. Low power check	[Panel test mode] 1) CH-Sig : 1-1 Set low power (Push [S]) PTT : ON 2) CH-Sig : 2-1 PTT : ON 3) CH-Sig : 3-1 PTT : ON						Check	0.7~1.4W 1.2A or less
8. DQT balance adjust	1) Adj item : [n BAL] Adjust : [***] Deviation meter filter LPF : 3kHz HPF : OFF • Narrow 2) Adj item : [nL BAL] → [nC BAL] → [nH BAL] Adjust : [***] PTT : ON • Wide 4k 3) Adj item : [s BAL] Adjust : [***] PTT : ON • Wide 5k 4) Adj item : [w BAL] Adjust : [***] PTT : ON	Deviation meter Oscilloscope AG AF VTVM	Panel	ANT Universal connector	Panel	Selector knob	Make the demodulation waves into square waves.	
9. Max DEV adjust	1) Adj item : [n DEV] Adjust : [***] AG : 1kHz/125mV at MIC terminal Deviation meter filter LPF : 15kHz HPF : OFF • Narrow 2) Adj item : [nL DEV] → [nC DEV] → [nH DEV] Adjust : [***] PTT : ON • Wide 4k 3) Adj item : [s DEV] Adjust : [***] PTT : ON • Wide 5k 4) Adj item : [w DEV] Adjust : [***] PTT : ON						2.10kHz (According to the larger +, -)	±50Hz
							3.5kHz (According to the larger +, -)	±50Hz
							4.4kHz (According to the larger +, -)	±50Hz
10. MIC sensitivity check	[Panel test mode] 1) CH-Sig : 1-1 DEV : 1.5kHz (Narrow) 2.4kHz (Wide 4k) 3.0kHz (Wide 5k) Deviation meter filter LPF : 15kHz HPF : OFF PTT : ON						Check	AG : 1kHz/6.7mV~18.3mV at MIC terminal

ADJUSTMENT

Item	Condition	Measurement			Adjustment			Specifications/Remarks
		Test-equipment	Unit	Terminal	Unit	Parts	Method	
11. VOX1 adjust	1) Adj item : [VOX1] Adjust : [***] AG : 1kHz/45mV at MIC terminal	AG	Panel	Universal connector	Panel		After apply signal from AG, press [B] key that numeric will be stored in memory.	
12. VOX10 adjust	1) Adj item : [VOX10] Adjust : [***] AG : 1kHz/3mV at MIC terminal							
13. QT deviation adjust	1) Remove the panel tuning cable assembly from the universal connector. Adj item : [n QT] Adjust : [***] Deviation meter filter LPF : 3kHz HPF : OFF • Narrow 2) Adj item : [nL QT] → [nC QT] → [nH QT] Adjust : [***] PTT : ON	Power meter Deviation meter Oscilloscope AG AF VTVM	Panel	ANT Universal connector	Panel	Selector knob	0.35kHz	±50Hz
• Wide 4k	3) Adj item : [s QT] Adjust : [***] PTT : ON						0.60kHz	±50Hz
• Wide 5k	4) Adj item : [w QT] Adjust : [***] PTT : ON						0.75kHz	±50Hz
14. DQT deviation adjust	1) Adj item : [n DQT] Adjust : [***] Deviation meter filter LPF : 3kHz HPF : OFF • Narrow 2) Adj item : [nL DQT] → [nC DQT] → [nH DQT] Adjust : [***] PTT : ON							
• Wide 4k	3) Adj item : [s DQT] Adjust : [***] PTT : ON						0.60kHz	±50Hz
• Wide 5k	4) Adj item : [w DQT] Adjust : [***] PTT : ON						0.75kHz	±50Hz
15. LTR deviation adjust	1) Adj item : [n LTR] Skip it							
• Narrow	2) Adj item : [nL LTR] → [nC LTR] → [nH LTR] Skip it							
• Wide	3) Adj item : [w LTR] Skip it							

ADJUSTMENT

Item	Condition	Measurement			Adjustment			Specifications/Remarks	
		Test-equipment	Unit	Terminal	Unit	Parts	Method		
16. DTMF deviation adjust • Narrow	1) Adj item : [n DTMF] Adjust : [***] Deviation meter filter LPF : 15kHz HPF : OFF PTT : ON	Power meter Deviation meter Oscilloscope AG AF VTVM	Panel	ANT Universal connector	Panel	Selector knob	1.25kHz	±0.1kHz	
	• Wide 4k						2) Adj item : [s DTMF] Adjust : [***] PTT : ON	2.0kHz	±0.1kHz
	• Wide 5k						3) Adj item : [w DTMF] Adjust : [***] PTT : ON	2.5kHz	±0.1kHz
17. MSK deviation adjust • Narrow	1) Adj item : [n MSK] Adjust : [***] Deviation meter filter LPF : 15kHz HPF : OFF PTT : ON						1.5kHz	±0.1kHz	
	• Wide 4k						2) Adj item : [s MSK] Adjust : [***] PTT : ON	2.4kHz	±0.1kHz
	• Wide 5k						3) Adj item : [w MSK] Adjust : [***] PTT : ON	3.0kHz	±0.1kHz
18. TONE deviation adjust • Narrow	1) Adj item : [n TONE] Adjust : [***] Deviation meter filter LPF : 15kHz HPF : OFF PTT : ON						1.5kHz	±0.1kHz	
	• Wide 4k						2) Adj item : [s TONE] Adjust : [***] PTT : ON	2.4kHz	±0.1kHz
	• Wide 5k						3) Adj item : [w TONE] Adjust : [***] PTT : ON	3.0kHz	±0.1kHz
19. BATT detection writing	1) Adj item : [BATT] Adjust : [***] PTT : ON	Power meter DVM	Panel	ANT BATT terminal	Panel		After pressing the PTT switch, confirm that one predetermined numeric in the range 1 to 256 appears and then press [B] key. That numeric will be stored in memory.	BATT terminal voltage : 5.8V	
20. BATT detection check	[Panel test mode] 1) CH-Sig : 1-1 BATT terminal voltage : 6.6V Connect "S" terminal to GND. PTT : ON						Check	The transceiver can transmit without causing the LED to blink.	
	2) BATT terminal voltage : 5.8V Connect "S" terminal to GND. PTT : ON							The transceiver should not transmit and LED blinking.	

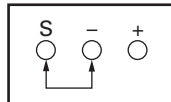

ADJUSTMENT

Receiver Section

Item	Condition	Measurement			Adjustment			Specifications/Remarks	
		Test-equipment	Unit	Terminal	Unit	Parts	Method		
1. Sensitivity fixed value write	1) Adj item : [H' SENS1]→ [H SENS1]	SSG AF VTVM Oscilloscope	Panel	ANT	Panel	Selector knob		Write the value as followings [H' SENS1] : "100" [H SENS1] : "256"	
	2) Adj item : [L SENS2] → [L' SENS2] → [C SENS2]			Universal connector				Write the value as followings [L SENS2] : "1" [L' SENS2] : "20" [C SENS2] : "40"	
2. Sensitivity 2 adjust	1) Adj item : [H SENS2] [H' SENS2] Adjust : [***] SSG output : -118dBm (0.28μV) (MOD : 1kHz±1.5kHz)					Adjust for 12dB SINAD	Rotate the selector knob and increase the adjustment value starting from "1" to obtain SINAD 12dB.		
3. Sensitivity 1 adjust	1) Adj item : [SENS1] Adjust : [***] 2) Adj item : [L SENS1] → [L' SENS1] → [C SENS1] SSG output : -118dBm (0.28μV) (MOD : 1kHz±1.5kHz)						Rotate the selector knob and decrease the adjustment value starting from "256" to obtain SINAD 12dB.		
4. Sensitivity check	[Panel test mode] 1) CH-Sig : 1-1 SSG output Wide 5k : -117dBm (0.32μV) (MOD : 1kHz±3kHz) Narrow : -117dBm (0.32μV) (MOD : 1kHz±1.5kHz)					Check	12dB SINAD or more		
5. Squelch (Preset) adjust • Narrow	1) Adj item : [n SQL] Adjust : [***] SSG output : -118dBm (0.28μV) (MOD : 1kHz±1.5kHz)				Panel	Selector knob	After input signal from SSG, press [B] key. That numeric will be stored in memory.	After adjusting SQL, check SQL open/close. SSG -118dBm : Open SSG OFF : Close [nC SQL] MOD 1kHz±1.5kHz [sC SQL] MOD 1kHz±2.4kHz [wC SQL] MOD 1kHz±3.0kHz	
	2) Adj item : [nL SQL] → [nC SQL] → [nH SQL] Adjust : [***]								
	• Wide 4k	3) Adj item : [s SQL] Adjust : [***] SSG output : -118dBm (0.28μV) (MOD : 1kHz±2.4kHz)							
		4) Adj item : [sL SQL] → [sC SQL] → [sH SQL] Adjust : [***]							
	• Wide 5k	5) Adj item : [w SQL] Adjust : [***] SSG output : -118dBm (0.28μV) (MOD : 1kHz±3.0kHz)							
		6) Adj item : [wL SQL] → [wC SQL] → [wH SQL] Adjust : [***]							

ADJUSTMENT

Item	Condition	Measurement			Adjustment			Specifications/Remarks	
		Test-equipment	Unit	Terminal	Unit	Parts	Method		
6. Low RSSI adjust • Narrow	1) Adj item : [n LRSSI] Adjust : [***] SSG output : -118dBm (0.28μV) (MOD : 1kHz/±1.5kHz)	SSG AF VTVM Oscilloscope	Panel	ANT Universal connector	Panel	Selector knob	After input signal from SSG, press [B] key. That numeric will be stored in memory.		
	2) Adj item : [nL LRSSI] → [nC LRSSI] → [nH LRSSI] Adjust : [***]								
	• Wide 4k								3) Adj item : [s LRSSI] Adjust : [***] SSG output : -118dBm (0.28μV) (MOD : 1kHz/±2.4kHz)
	4) Adj item : [sL LRSSI] → [sC LRSSI] → [sH LRSSI] Adjust : [***]								
	• Wide 5k								5) Adj item : [w LRSSI] Adjust : [***] SSG output : -118dBm (0.28μV) (MOD : 1kHz/±3.0kHz)
	6) Adj item : [wL LRSSI] → [wC LRSSI] → [wH LRSSI] Adjust : [***]								
7. Squelch (Tight) adjust • Narrow	1) Adj item : [n SQLT] Adjust : [***] SSG output : -113dBm (0.5μV) (MOD : 1kHz/±1.5kHz)						After input signal from SSG, press [B] key. That numeric will be stored in memory.	After adjusting SQL, check SQL open/close. SSG -113dBm : Open SSG OFF : Close [nC SQLT] MOD 1kHz/±1.5kHz [sC SQLT] MOD 1kHz/±2.4kHz [wC SQLT] MOD 1kHz/±3.0kHz	
	2) Adj item : [nL SQLT] → [nC SQLT] → [nH SQLT] Adjust : [***]								
	• Wide 4k								3) Adj item : [s SQLT] Adjust : [***] SSG output : -113dBm (0.5μV) (MOD : 1kHz/±2.4kHz)
	4) Adj item : [sL SQLT] → [sC SQLT] → [sH SQLT] Adjust : [***]								
	• Wide 5k								5) Adj item : [w SQLT] Adjust : [***] SSG output : -113dBm (0.5μV) (MOD : 1kHz/±3.0kHz)
	6) Adj item : [wL SQLT] → [wC SQLT] → [wH SQLT] Adjust : [***]								

ADJUSTMENT

Item	Condition	Measurement			Adjustment			Specifications/Remarks
		Test-equipment	Unit	Terminal	Unit	Parts	Method	
8. High RSSI adjust • Narrow	1) Adj item : [n HRSSI] Adjust : [***] SSG output : -70dBm (MOD : 1kHz±1.5kHz)	SSG AF VTVM Oscilloscope	Panel	ANT	Panel	Selector knob	After input signal from SSG, press [B] key. That numeric will be stored in memory.	
	2) Adj item : [nL HRSSI] → [nC HRSSI] → [nH HRSSI] Adjust : [***]			Universal Connector				
	• Wide 4k			3) Adj item : [s HRSSI] Adjust : [***] SSG output : -70dBm (MOD : 1kHz±2.4kHz)				
	4) Adj item : [sL HRSSI] → [sC HRSSI] → [sH HRSSI] Adjust : [***]							
	• Wide 5k			5) Adj item : [w HRSSI] Adjust : [***] SSG output : -70dBm (MOD : 1kHz±3.0kHz)				
	6) Adj item : [wL HRSSI] → [wC HRSSI] → [wH HRSSI] Adjust : [***]							

Adjustment Points

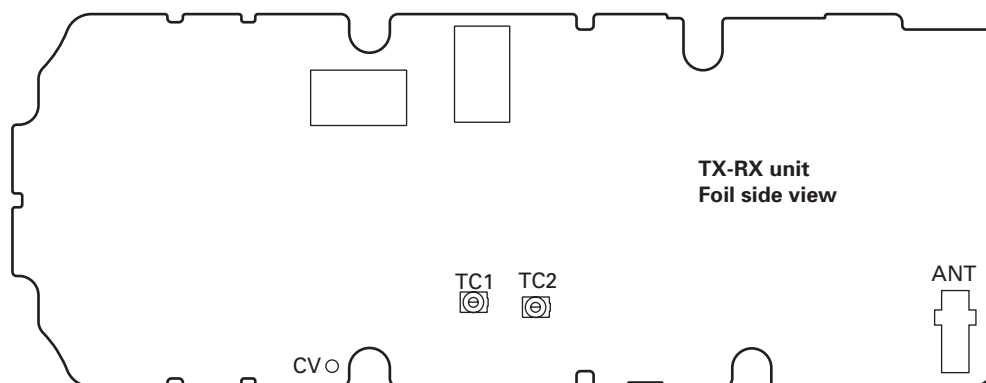

TERMINAL FUNCTION

Display unit (X54-3470-11)

Pin No.	Name	I/O	Function
CN507			
1	SW2	O	Key matrix output (Side2 key)
2	K1	I	Key matrix input (Side key)
3	GND	-	GND
4	PTT	I	PTT input
5	SW1	O	Key matrix output (Side1 key)
CN508			
1	NC	-	Non connection
2	V5	O	LCD driving voltage output
3	Vss	-	GND
4	V5OUT	I	Step up voltage input
5	C2-	-	Step up capacitor connecting terminal
6	C2+	-	Step up capacitor connecting terminal
7	C1-	-	Step up capacitor connecting terminal
8	C1+	-	Step up capacitor connecting terminal
9	Vci	O	Voltage converter power supply output
10	VDD	O	LCD power supply output
11	OSC1	-	Non connection
12	OSC2	-	Non connection
13	RESET	O	LCD reset output
14	P/S	O	GND
15	RS	O	Register select output
16	R/W	O	GND
17	SCL	O	Serial clock output
18	SIO	O	Serial data output
19	CS	O	Chip select output
20	Vss	-	
CN509			
1	NC	-	Non connection
2	NC	-	Non connection
3	NC	-	Non connection
4	LCDRS	I	LCD RS input
5	AGND	-	GND
6	ME	-	Internal microphone ground
7	MIC	O	Internal microphone output
8	PTT	O	PTT output
9	SPSTB	I	Shift register storage enable input
10	CLK	I	Serial clock input
11	DATA	I	Serial data input
12	KI1	O	Key matrix 1 output
13	KI2	O	Key matrix 2 output

Pin No.	Name	I/O	Function
14	NC	-	Non connection
15	SB2	I	Power input after power switch
16	NC	-	Non connection
17	DGND	-	GND
18	LCDCS	I	LCD chip select input
19	LCDRST	I	LCD reset input
20	5M	I	5V

TX-RX unit (X57-6942-71)

Pin No.	Name	I/O	Function
CN400			
1	SB1	I	Power input after power switch
2	+B	O	Power output after passing through the fuse
3	EN3	I	Encoder pulse input
4	EN4	I	Encoder pulse input
5	DGND	-	GND
6	EN2	I	Encoder pulse input
7	EN1	I	Encoder pulse input
8	DGND	-	GND
9	VOL	I	Volume level input for audio control
10	5M	O	5V
CN500			
1	5M	O	5V
2	LCDRST	O	LCD reset output
3	LCDCS	O	LCD chip select output
4	DGND	-	GND
5	NC	-	Non connection
6	SB2	O	Power output after power switch
7	NC	-	Non connection
8	KI2	I	Key matrix 2 input
9	KI1	I	Key matrix 1 input
10	DATA	O	Serial data output
11	CLK	O	Serial clock output
12	SPSTB	O	Shift register storage enable output
13	PTT	I	PTT input
14	MIC	I	Internal microphone input
15	ME	-	Internal microphone ground
16	AGND	-	GND
17	LCDRS	O	LCD RS output
18	NC	-	Non connection
19	NC	-	Non connection
20	NC	-	Non connection

TERMINAL FUNCTION

Pin No.	Name	I/O	Function
CN600			
1	OPT1	I/O	Option board I/F 1 Output : $L \leq 0.45V$, $H \geq 4.7V/25k\Omega$ load Input : $L \leq 1.0V$, $H \geq 4.0V$, Input voltage : $0V \sim 5.0V$
2	OPT3	I/O	Option board I/F 3 Output : $L \leq 0.45V$, $H \geq 4.7V/25k\Omega$ load Input : $L \leq 1.0V$, $H \geq 4.0V$, Input voltage : $0V \sim 5.0V$
3	RXD1	I	Serial data input Input : $L \leq 1.0V$, $H \geq 4.0V$, Input voltage : $0V \sim 5.0V$
4	TXD1	O	Serial data output / PTT signal output (SC20-460) Output : $L \leq 0.45V$, $H \geq 4.7V/25k\Omega$ load
5	NC	-	
6	OPT4	O	Option board I/F 4 Output : $L \leq 0.45V$, $H \geq 4.7V/25k\Omega$ load
7	USEL	O	UART speed select output L : 19200bps fixed
8	OPT5	O	Option board I/F 5 Output : $L \leq 0.45V$, $H \geq 4.7V/25k\Omega$ load
9	DGND	-	GND
10	AGND	-	GND
11	AI	I	VGS audio input $Z_{in} \geq 10k\Omega$, 1Vp-p max, Input voltage : $0V \sim 5.0V$
12	AO	O	VGS audio output $Z_o \geq 10k\Omega$
13	AGND	-	GND
14	5A	O	5V power supply output 78mA max
15	STON	I	Side tone input 1kHz, 5Vp-p
16	DI/ANI	I	Data signal input $Z_{in} \geq 22k\Omega$, $600 \pm 200mVp-p$
17	TCONT	I	Speaker mute signal input Input : $L \leq 1.0V$, $H \geq 4.0V$, Input voltage : $0V \sim 5.0V$
18	MAN DOWN	O	Man down output Output : $L \leq 0.45V$, $H \geq 4.7V/25k\Omega$ load
19	INH	O	MIC mute signal input
20	OPT2	I/O	Option board I/F 2 Output : $L \leq 0.45V$, $H \geq 4.7V/25k\Omega$ load Input : $L \leq 1.0V$, $H \geq 4.0V$, Input voltage : $0V \sim 5.0V$
21	TXO	O	MIC signal output (AC coupled) before pre-emphasis $Z_L \geq 22k\Omega$, $130 \pm 50mVp-p$
22	RXEO	O	Audio signal output (DC coupled) after de-emphasis $Z_L \geq 30k\Omega$, $1 \pm 0.3Vp-p$
23	RXEI	I	Audio signal input (DC coupled) after de-emphasis $Z_{in} \geq 15k\Omega$, $1 \pm 0.3Vp-p$

Pin No.	Name	I/O	Function
24	TXI	I	MIC signal input (AC coupled) before pre-emphasis $Z_{in} \geq 22k\Omega$, $130 \pm 50mVp-p$
25	OPT6	O	Option board I/F 6 Output : $L \leq 0.45V$, $H \geq 4.7V/25k\Omega$ load
26	SB2	I	Power input after power switch 7.5V typ, 100mA max
CN602			
1	NC	-	Non connection
2	RXD	I	Serial data input
3	TXD	O	Serial data output
4	5U	O	5V output
5	E	-	GND
6	OPT	I/O	Option interface I/O
7	PF	I	Programmable function key input
8	PTT	I	External PTT input
9	ME	-	External microphone ground
10	EMC	I	External microphone input
11	MSW	I	EXT/INT MIC switch input
12	SP-	O	BTL output + for external speaker
13	SP+	O	BTL output - for external speaker
14	SSW	I	EXT/INT SP switch input

Universal connector

Pin No.	Name	I/O	Function
1	SSW	I	Ext/Int speaker switch input L : External speaker ON, H : Internal speaker ON, Input voltage : $0V \sim 5.0V$
2	SP+	O	BTL output + for external speaker Audio output power at volume max (1kHz, Batt = 7.5V) 1.3±0.5W typ (at $R_L=8\Omega$) 0.9±0.5W typ (at $R_L=16\Omega$)
3	SP-	O	BTL output - for external speaker Audio output power at volume max (1kHz, Batt = 7.5V) 1.3±0.5W typ (at $R_L=8\Omega$) 0.9±0.5W typ (at $R_L=16\Omega$)
4	MSW	I	Ext/Int MIC switch Input L : External Mic ON, H : Internal Mic ON Input voltage : $0V \sim 5.0V$

TERMINAL FUNCTION

Pin No.	Name	I/O	Function
5	EMC	I	External MIC input Impedance : 1.8k Ω typ (at 1kHz) Audio level : 7.5 \pm 2.5mVrms for 60% of system deviation Nominal DC voltage : 5.0 \pm 1V DC
6	ME	-	External MIC GND
7	PTT	I	External PTT input L : PTT ON
8	PF	I	Programmable function key input Input voltage : 0V~5.0V Input level : 4.4V~5.0V (None), 3.1V~4.4V (PF2 key ON), 2.3V~3.1V (PF1 key ON), 0V~2.3V (PF1,PF2 key ON) (Pull up to 5V 10k Ω)
9	OPT	-	Non connection
10	E	-	GND
11	5U	O	5V power supply output Max output current : 140mA
12	TXD	O	Serial data output L \leq 0.45V, H \geq 4.7V/25k Ω load Baud rate : 115200bps max
13	RXD	I	Serial data input Input : L \leq 1.0V, H \geq 4.0V, Input voltage : 0V~5.0V Baud rate : 57600bps max
14	NC (E)	-	Not use (GND)

Solder pad

Name	I/O	Function
OPT5	O	Option board I/F 5 Output : L \leq 0.45V, H \geq 4.7V/25k Ω load
OPT6	O	Option board I/F 6 Output : L \leq 0.45V, H \geq 4.7V/25k Ω load
OPT3	I/O	Option board I/F 3 Output : L \leq 0.45V, H \geq 4.7V/25k Ω load Input : L \leq 1.0V, H \geq 4.0V, Input voltage : 0V~5.0V
OPT1	O	Option board I/F 1 Output : L \leq 0.45V, H \geq 4.7V/25k Ω load

Name	I/O	Function
RXD	I	Serial data input Input : L \leq 1.0V, H \geq 4.0V, Input voltage : 0V~5.0V
TXD	O	Serial data output Output : L \leq 0.45V, H \geq 4.7V/25k Ω load
RXI	I	Audio signal input (DC coupled) before de-emphasis
STON	I	Side tone input 1kHz, 5Vp-p
TCONT	I	Speaker mute signal input Input : L \leq 1.0V, H \geq 4.0V, Input voltage : 0V~5.0V
TXO	O	MIC signal output (AC coupled) before pre-emphasis ZL \geq 22k Ω , 130 \pm 50mVp-p
RXEO	O	Audio signal output (DC coupled) after de-emphasis ZL \geq 30k Ω , 1 \pm 0.3Vp-p
OPT2	I/O	Option board I/F 2 Output : L \leq 0.45V, H \geq 4.7V/25k Ω load Input : L \leq 1.0V, H \geq 4.0V, Input voltage : 0V~5.0V
OPT4	O	Option board I/F 4 Output : L \leq 0.45V, H \geq 4.7V/25k Ω load
GND	-	GND
SB2	I	Power input after power switch 7.5V typ, 100mA max
RXEI	I	Audio signal input (DC coupled) after de-emphasis Zin \geq 15k Ω , 1 \pm 0.3Vp-p
TXI	I	MIC signal input (AC coupled) before pre-emphasis Zin \geq 22k Ω , 130 \pm 50mVp-p
RXO	O	Audio signal output (DC coupled) before de-emphasis
5A	O	5V power supply output 78mA max
DI/ANI	I	Data signal input Zin \geq 22k Ω , 600 \pm 200mVp-p
INH	O	MIC mute signal input
RSSI	O	RSSI output Zo=56k Ω
MDSW	I	Man down switch input Input : L \leq 1.0V, H \geq 4.0V, Input voltage : 0V~5.0V
GND	-	GND for man down switch
RXD1	I	Serial data input Input : L \leq 1.0V, H \geq 4.0V, Input voltage : 0V~5.0V
TXD1	O	Serial data output / PTT signal output (SC20-460) Output : L \leq 0.45V, H \geq 4.7V/25k Ω load

TK-3180 PC BOARD

DISPLAY UNIT (X54-3470-11) Component side view (J72-0921-39)

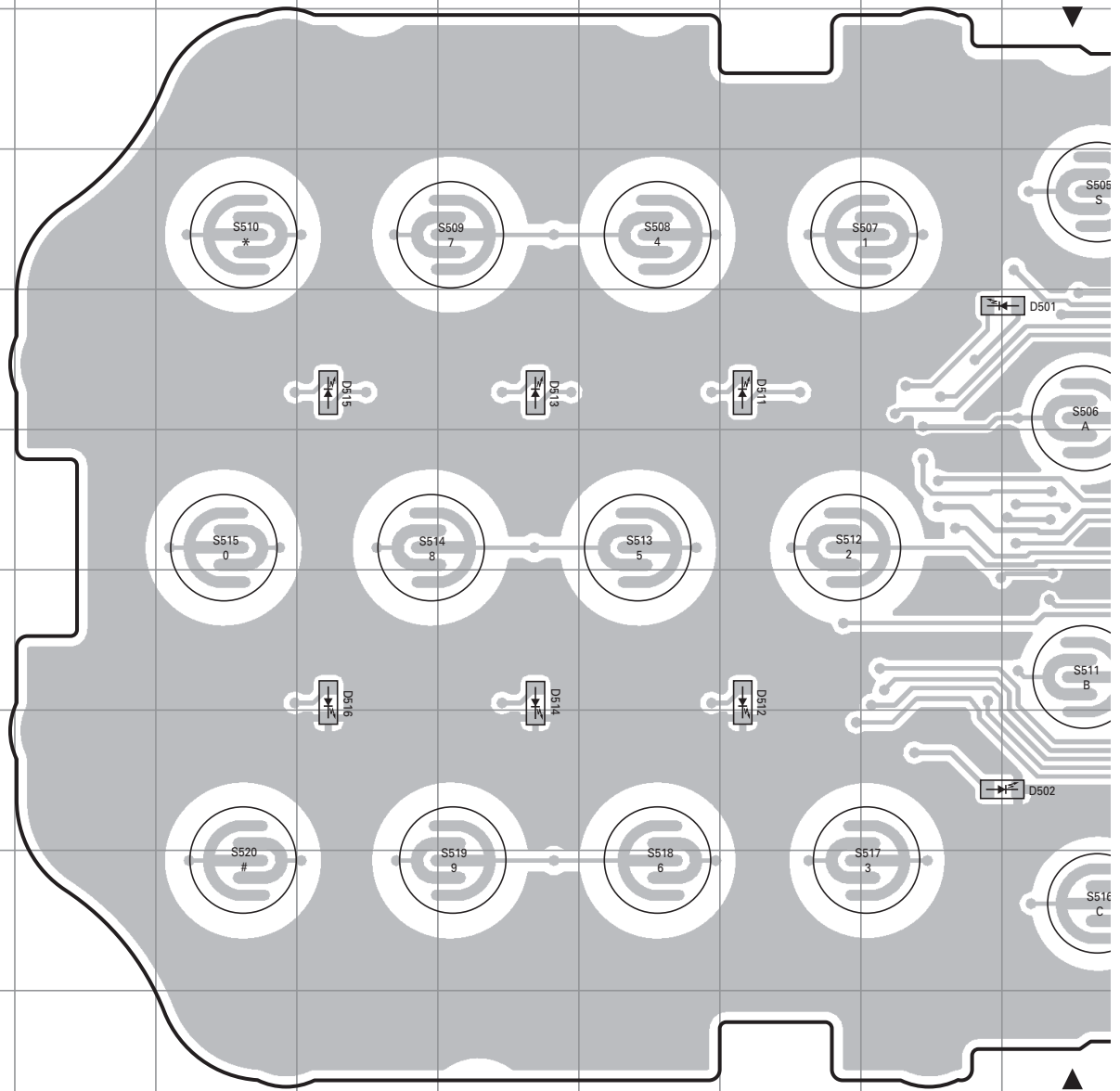

Ref. No.	Address	Ref. No.	Address
D501	5J	D515	5E
D502	8J	D516	7E
D511	5H	D517	3M
D512	7H	D518	3N
D513	5F	D519	10N
D514	7F	D520	10M

DISPLAY UNIT (X54-3470-11) Component side view (J72-0921-39)

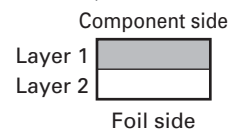
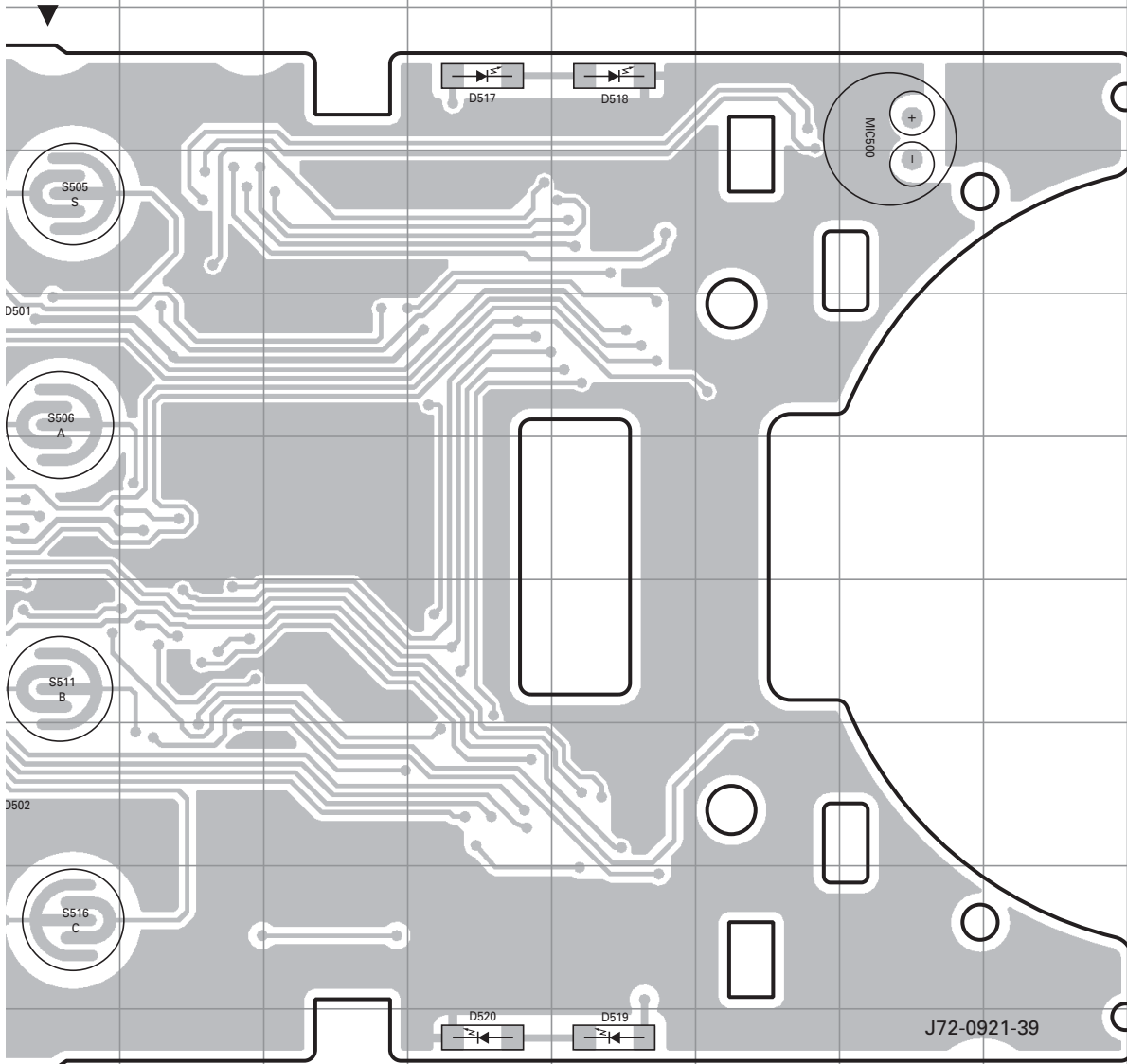

DISPLAY UNIT (X54-3470-11) Component side view (J72-0921-39)

DISPLAY UNIT (X54-3470-11) Component side view (J72-0921-39)

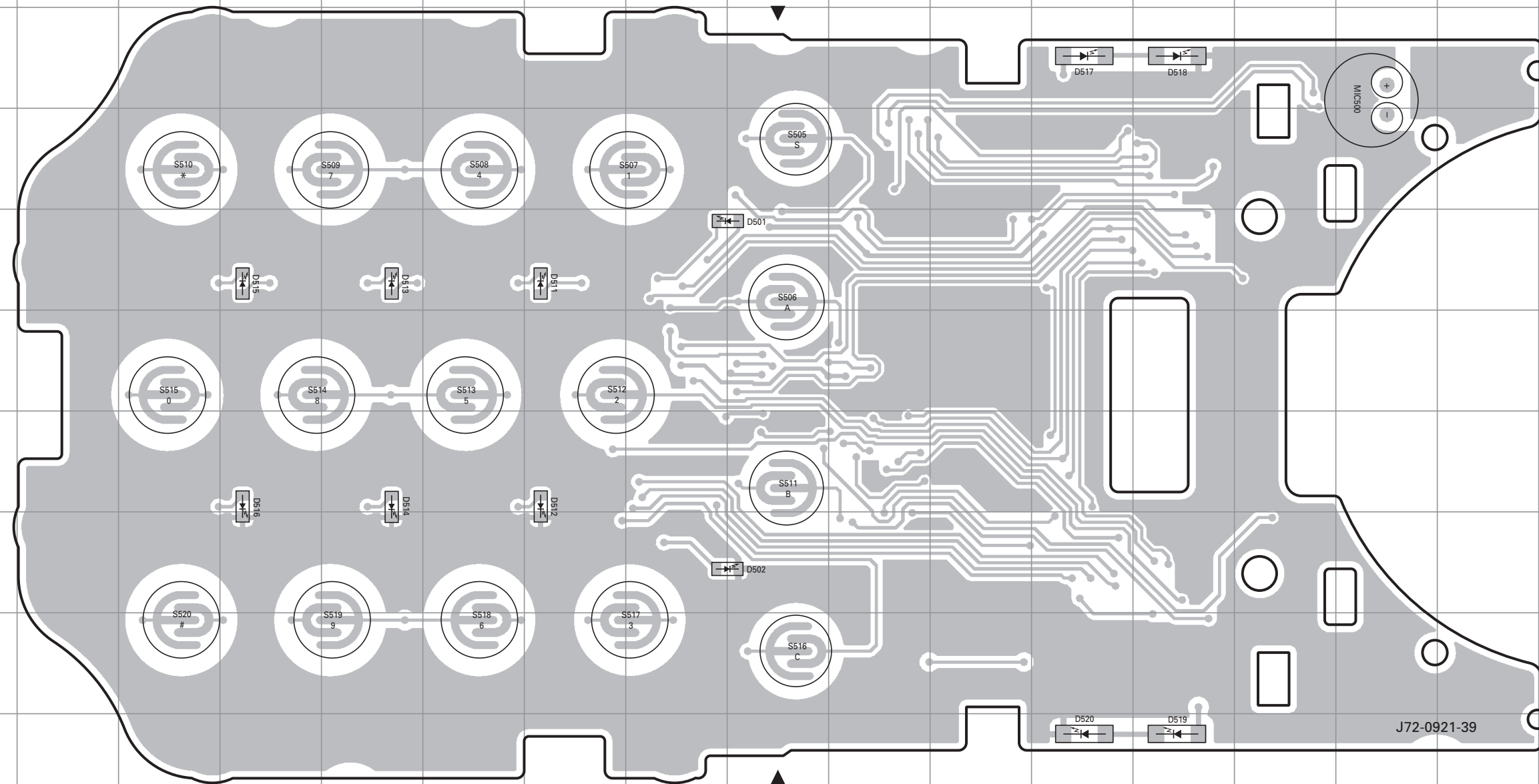

Ref. No.	Address	Ref. No.	Address
D501	5J	D515	5E
D502	8J	D516	7E
D511	5H	D517	3M
D512	7H	D518	3N
D513	5F	D519	10N
D514	7F	D520	10M

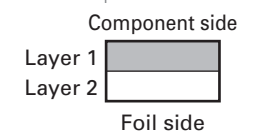

J72-0921-39

TK-3180 PC BOARD

DISPLAY UNIT (X54-3470-11) Foil side view (J72-0921-39)

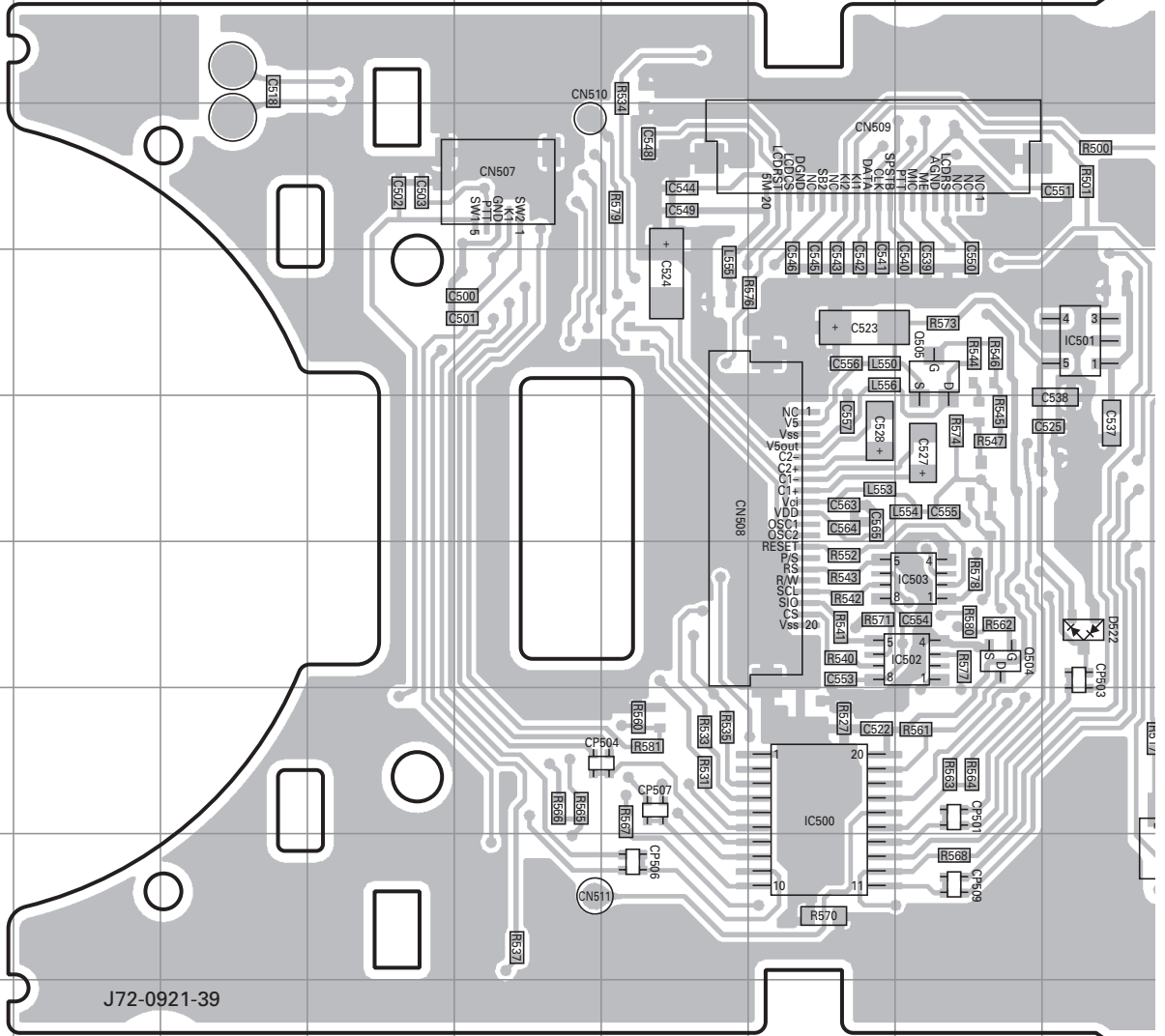

J72-0921-39

Ref. No.	Address	Ref. No.	Address
IC500	8H	Q502	9K
IC501	5J	Q504	7I
IC502	7I	Q505	5I
IC503	7I	D500	8K
Q501	8K	D522	7J

DISPLAY UNIT (X54-3470-11) Foil side view (J72-0921-39)

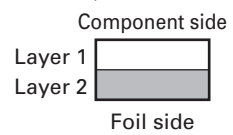
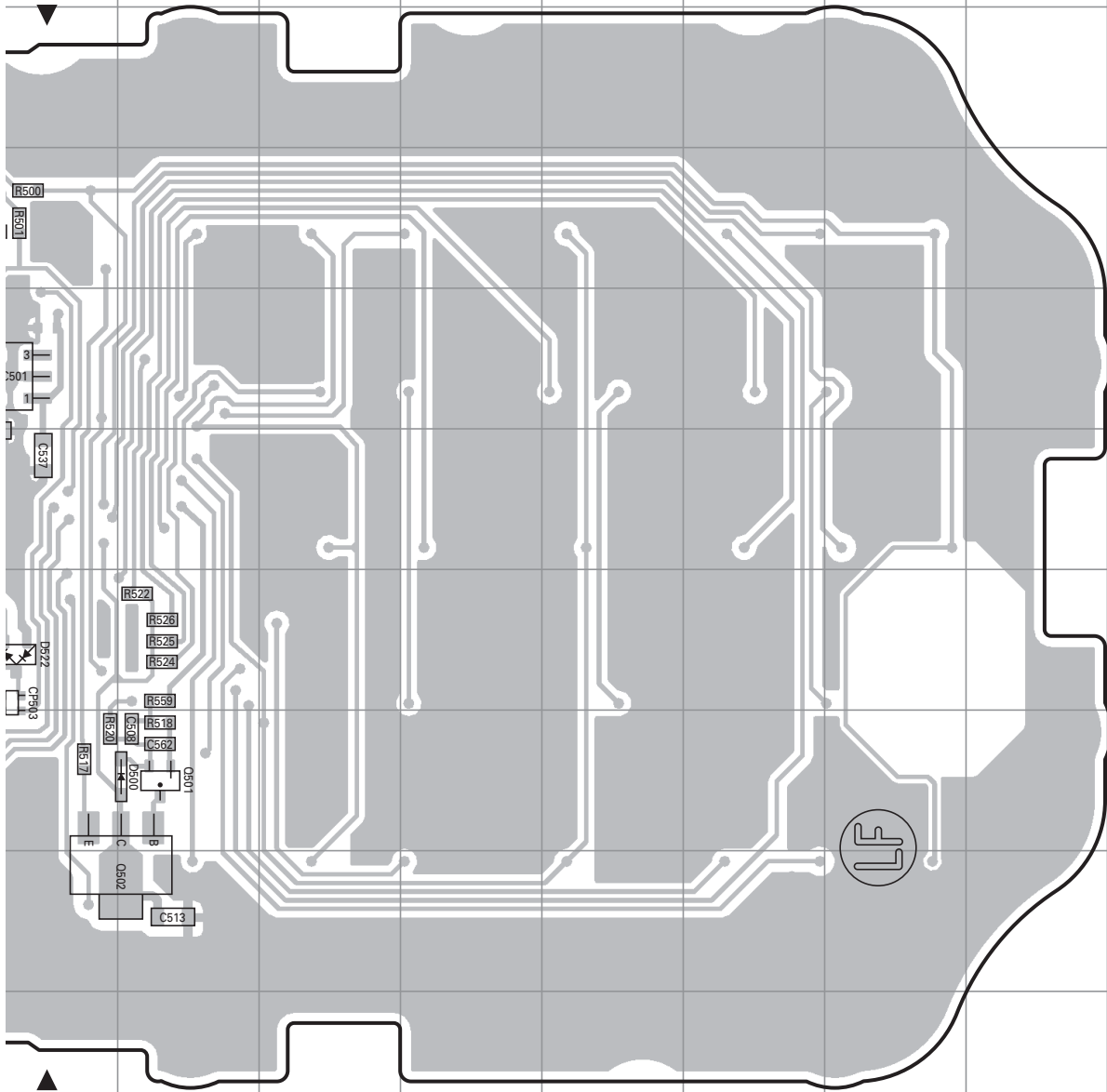

DISPLAY UNIT (X54-3470-11) Foil side view (J72-0921-39)

DISPLAY UNIT (X54-3470-11) Foil side view (J72-0921-39)

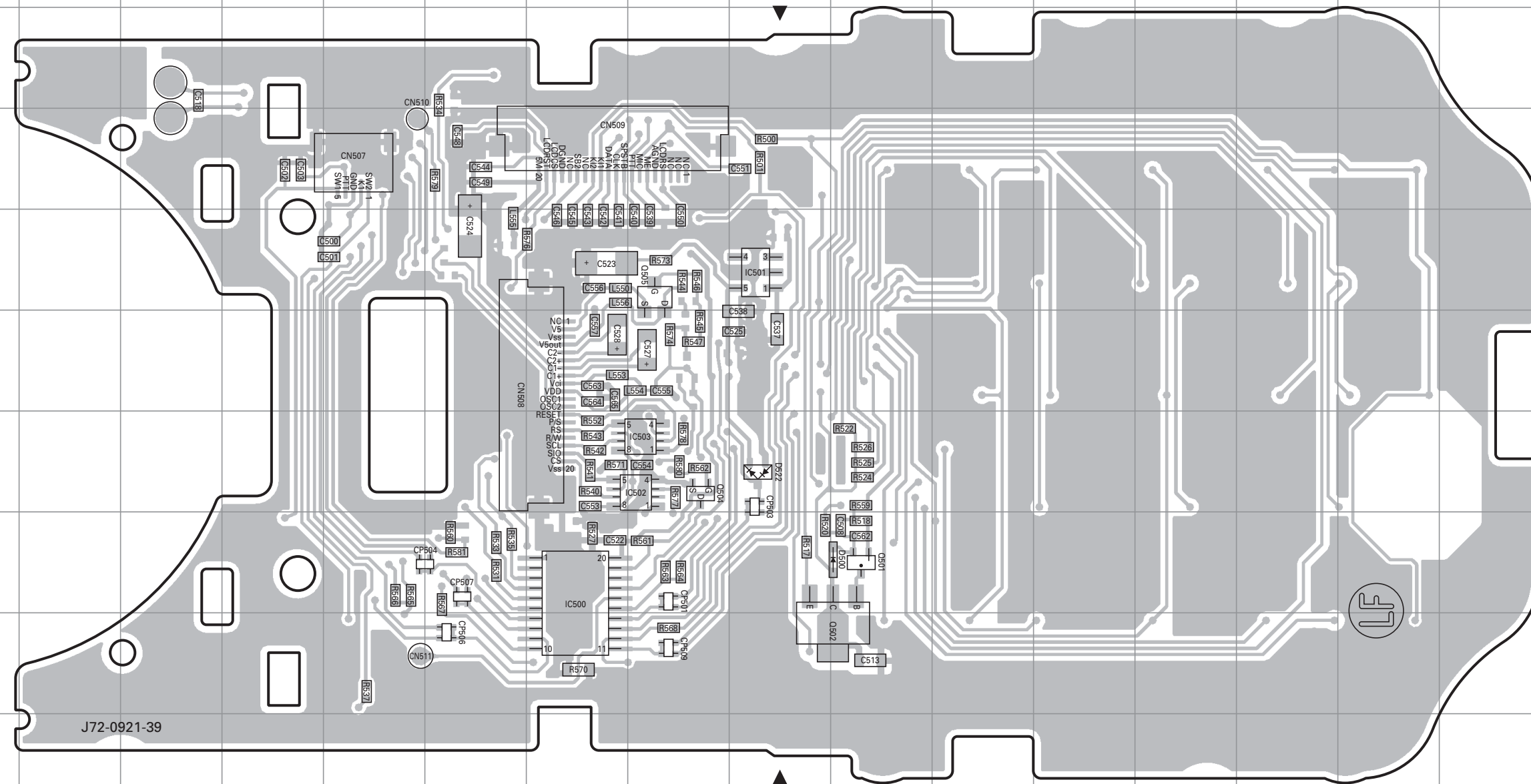

J72-0921-39

Ref. No.	Address	Ref. No.	Address
IC500	8H	Q502	9K
IC501	5J	Q504	7I
IC502	7I	Q505	5I
IC503	7I	D500	8K
Q501	8K	D522	7J

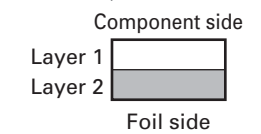

TK-3180 PC BOARD

TX-RX UNIT (X57-6942-71) Component side view (J72-0920-29)

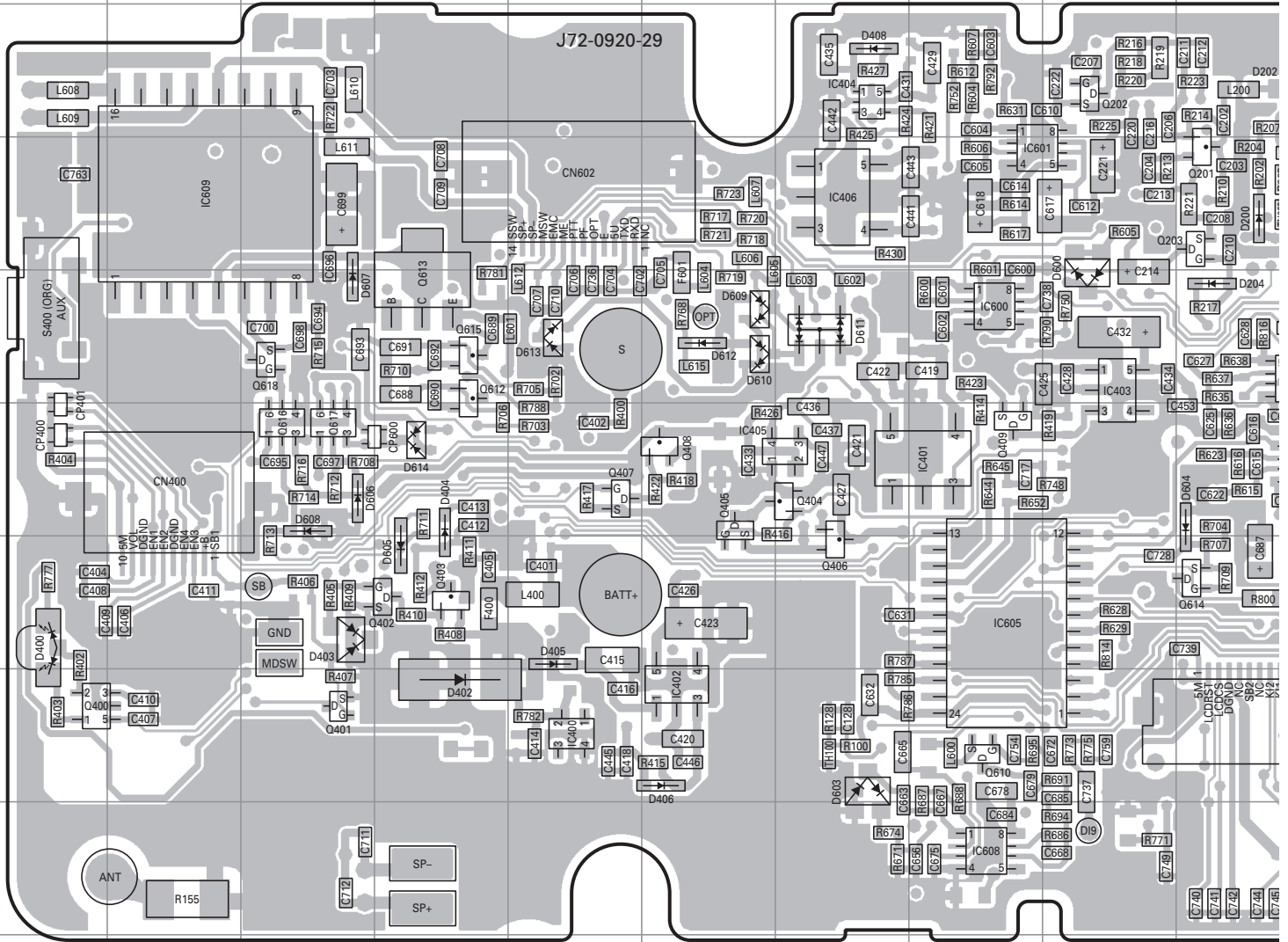

Ref. No.	Address	Ref. No.	Address	Ref. No.	Address	Ref. No.	Address	Ref. No.	Address	Ref. No.	Address
IC400	8E	IC602	7K	Q403	7D	Q610	8H	D200	4J	D601	8L
IC401	6H	IC603	6J	Q404	6G	Q611	3K	D202	3J	D602	8L
IC402	8F	IC604	5J	Q405	6F	Q612	5D	D204	5J	D603	8G
IC403	5I	IC605	7H	Q406	7G	Q613	5D	D400	7A	D604	6J
IC404	3G	IC606	6L	Q407	6E	Q614	7J	D402	8D	D605	7D
IC405	6G	IC607	5L	Q408	6F	Q615	5D	D403	7C	D606	6C
IC406	4G	IC608	9H	Q409	6H	Q616	6C	D404	6D	D607	5C
IC500	9P	IC609	4B	Q502	5N	Q617	6C	D405	7E	D608	6C
IC502	6P	Q201	4J	Q602	6L	Q618	5C	D406	8F	D609	5F
IC503	4Q	Q202	3I	Q605	4K	Q619	7L	D408	3G	D610	5F
IC504	3Q	Q203	4J	Q606	8M	Q620	4K	D500	4R	D611	5G
IC505	8N	Q400	8A	Q607	8M	Q621	4P	D501	3R	D612	5F
IC600	5H	Q401	8C	Q608	5K	Q625	3O	D502	4R	D613	5E
IC601	4H	Q402	7D	Q609	3K	Q626	3N	D600	5I	D614	6D

TX-RX UNIT (X57-6942-71) Component side view (J72-0920-29)

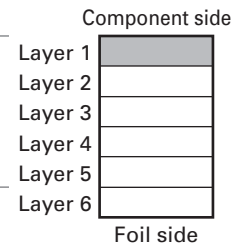
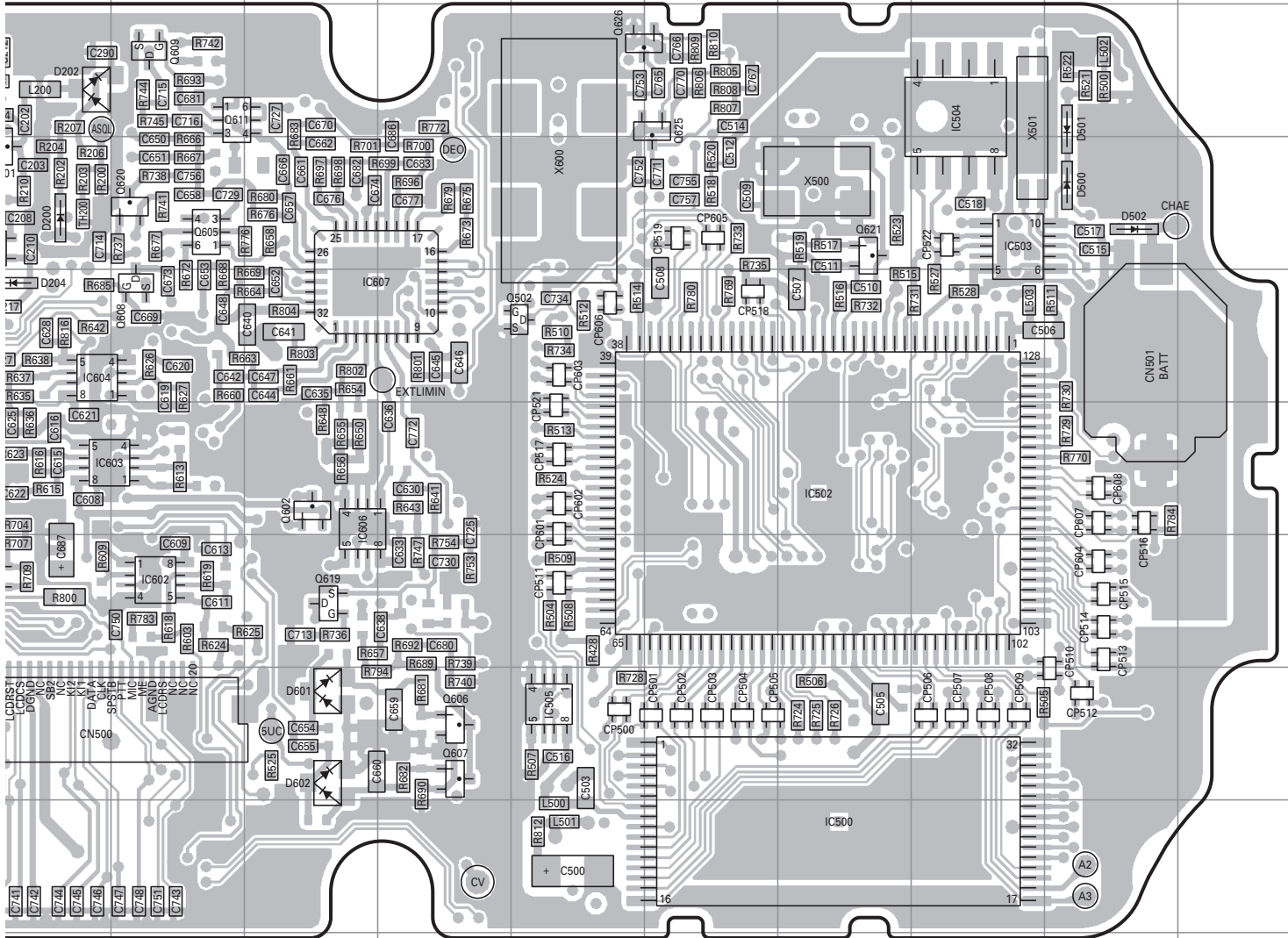

TX-RX UNIT (X57-6942-71) Component side view (J72-0920-29)

TX-RX UNIT (X57-6942-71) Component side view (J72-0920-29)

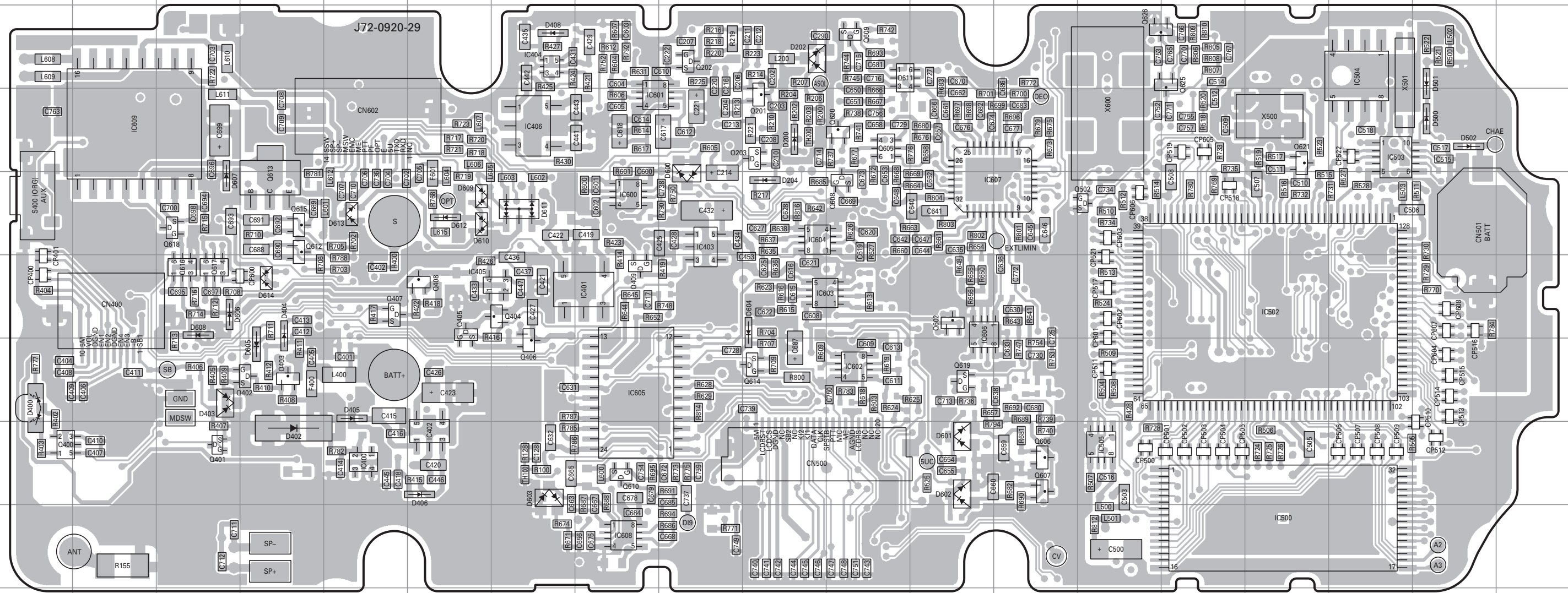

Ref. No.	Address	Ref. No.	Address	Ref. No.	Address	Ref. No.	Address	Ref. No.	Address	Ref. No.	Address
IC400	8E	IC602	7K	Q403	7D	Q610	8H	D200	4J	D601	8L
IC401	6H	IC603	6J	Q404	6G	Q611	3K	D202	3J	D602	8L
IC402	8F	IC604	5J	Q405	6F	Q612	5D	D204	5J	D603	8G
IC403	5I	IC605	7H	Q406	7G	Q613	5D	D400	7A	D604	6J
IC404	3G	IC606	6L	Q407	6E	Q614	7J	D402	8D	D605	7D
IC405	6G	IC607	5L	Q408	6F	Q615	5D	D403	7C	D606	6C
IC406	4G	IC608	9H	Q409	6H	Q616	6C	D404	6D	D607	5C
IC500	9P	IC609	4B	Q502	5N	Q617	6C	D405	7E	D608	6C
IC502	6P	Q201	4J	Q602	6L	Q618	5C	D406	8F	D609	5F
IC503	4Q	Q202	3I	Q605	4K	Q619	7L	D408	3G	D610	5F
IC504	3Q	Q203	4J	Q606	8M	Q620	4K	D500	4R	D611	5G
IC505	8N	Q400	8A	Q607	8M	Q621	4P	D501	3R	D612	5F
IC600	5H	Q401	8C	Q608	5K	Q625	3O	D502	4R	D613	5E
IC601	4H	Q402	7D	Q609	3K	Q626	3N	D600	5I	D614	6D

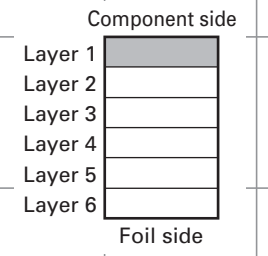

TK-3180 PC BOARD

TX-RX UNIT (X57-6942-71) Foil side view (J72-0920-29)

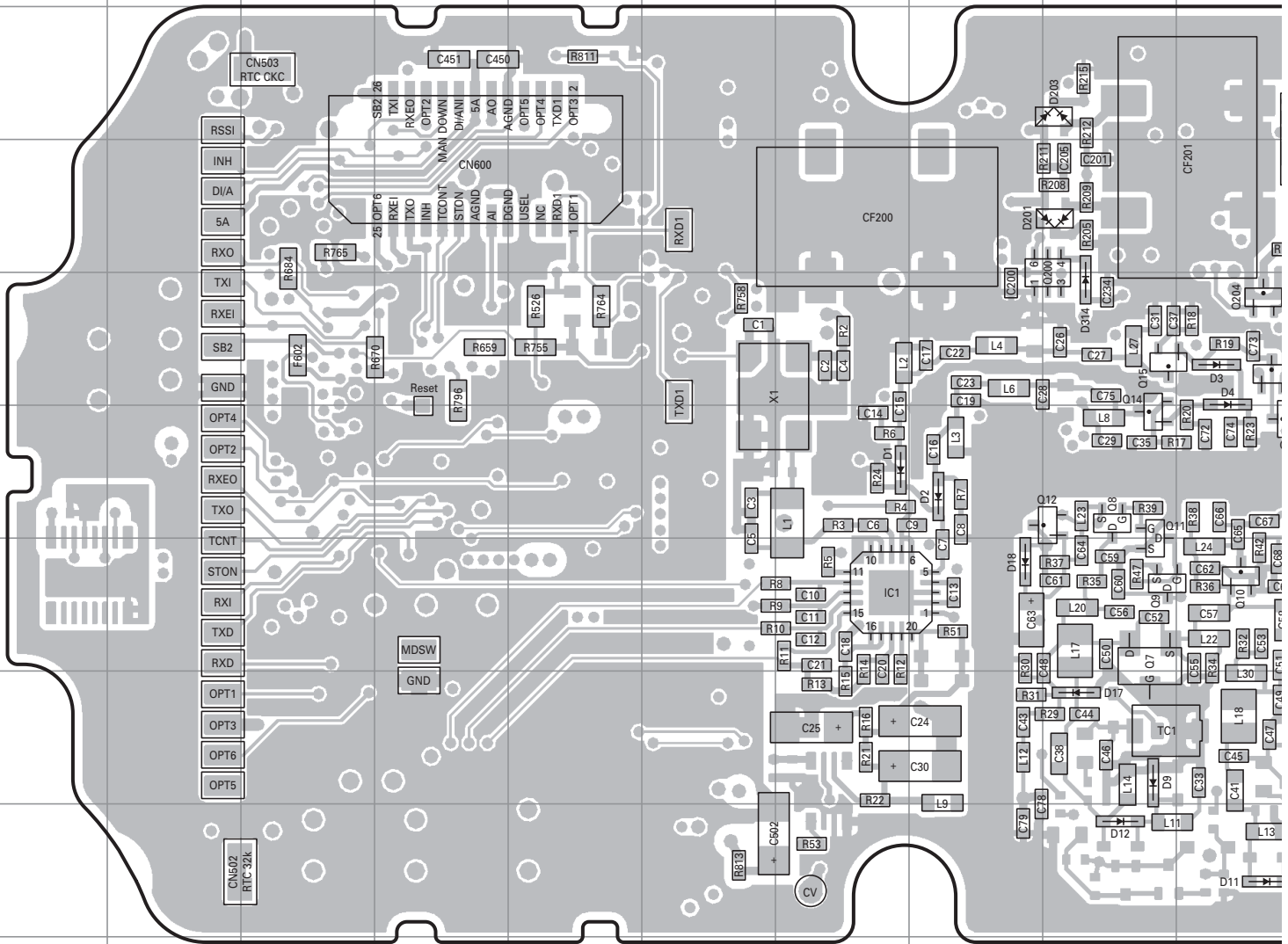

Ref. No.	Address	Ref. No.	Address	Ref. No.	Address	Ref. No.	Address	Ref. No.	Address	Ref. No.	Address
IC1	7G	Q11	6I	Q106	5O	Q624	3Q	D18	7H	D207	3O
IC100	6P	Q12	6I	Q107	6P	D1	6G	D100	6L	D208	3O
IC200	3K	Q13	6J	Q108	5O	D2	6H	D103	5P	D209	5Q
Q1	6J	Q14	6I	Q200	5I	D3	5J	D106	8P	D210	6Q
Q2	5J	Q15	5I	Q204	5J	D4	5J	D107	8P	D212	6Q
Q6	8K	Q100	7L	Q205	4L	D6	9K	D108	4O	D213	7Q
Q7	7I	Q101	8K	Q206	5N	D9	8I	D201	4I	D214	7Q
Q8	6I	Q102	7M	Q207	4P	D11	9J	D203	3I	D314	5I
Q9	7I	Q104	4P	Q622	3Q	D12	9I	D205	6L		
Q10	7J	Q105	8M	Q623	3M	D17	8I	D206	4N		

PC BOARD TK-3180

TX-RX UNIT (X57-6942-71) Foil side view (J72-0920-29)

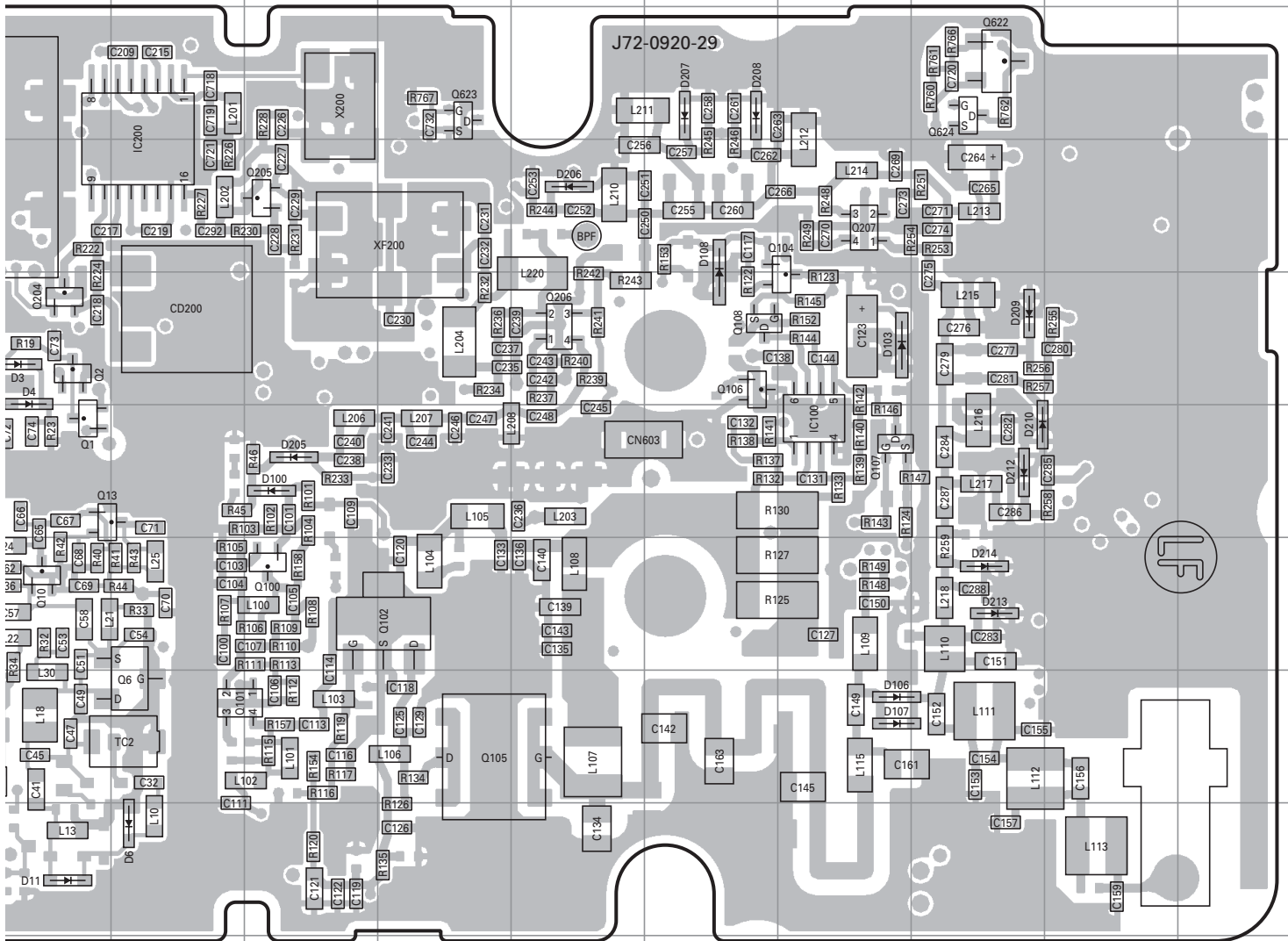

Component side

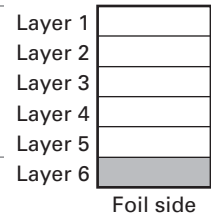

TK-3180 PC BOARD

PC BOARD TK-3180

TX-RX UNIT (X57-6942-71) Foil side view (J72-0920-29)

TX-RX UNIT (X57-6942-71) Foil side view (J72-0920-29)

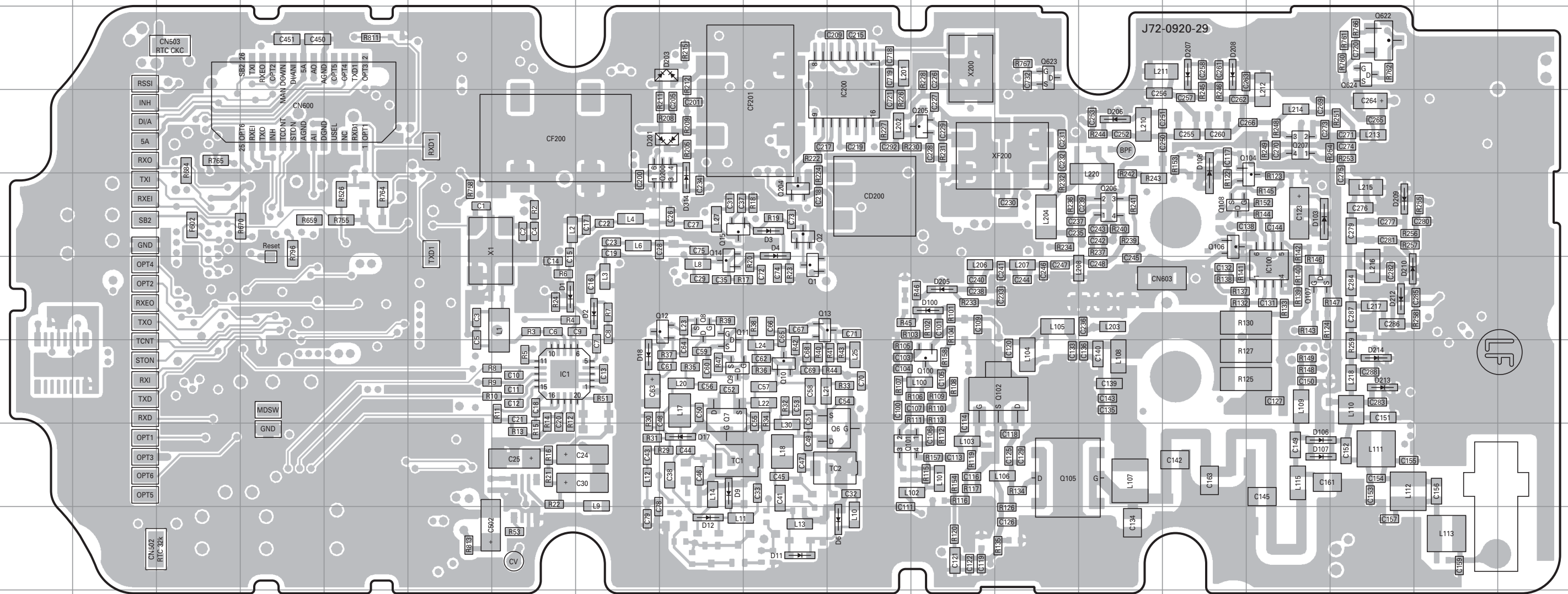

Ref. No.	Address	Ref. No.	Address	Ref. No.	Address	Ref. No.	Address	Ref. No.	Address	Ref. No.	Address
IC1	7G	Q11	6I	Q106	5O	Q624	3Q	D18	7H	D207	3O
IC100	6P	Q12	6I	Q107	6P	D1	6G	D100	6L	D208	3O
IC200	3K	Q13	6J	Q108	5O	D2	6H	D103	5P	D209	5Q
Q1	6J	Q14	6I	Q200	5I	D3	5J	D106	8P	D210	6Q
Q2	5J	Q15	5I	Q204	5J	D4	5J	D107	8P	D212	6Q
Q6	8K	Q100	7L	Q205	4L	D6	9K	D108	4O	D213	7Q
Q7	7I	Q101	8K	Q206	5N	D9	8I	D201	4I	D214	7Q
Q8	6I	Q102	7M	Q207	4P	D11	9J	D203	3I	D314	5I
Q9	7I	Q104	4P	Q622	3Q	D12	9I	D205	6L		
Q10	7J	Q105	8M	Q623	3M	D17	8I	D206	4N		

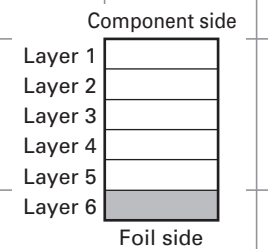

TK-3180 SCHEMATIC DIAGRAM

LCD ASSY
(B38-0900-05)

DISPLAY UNIT
(X54-3470-11)

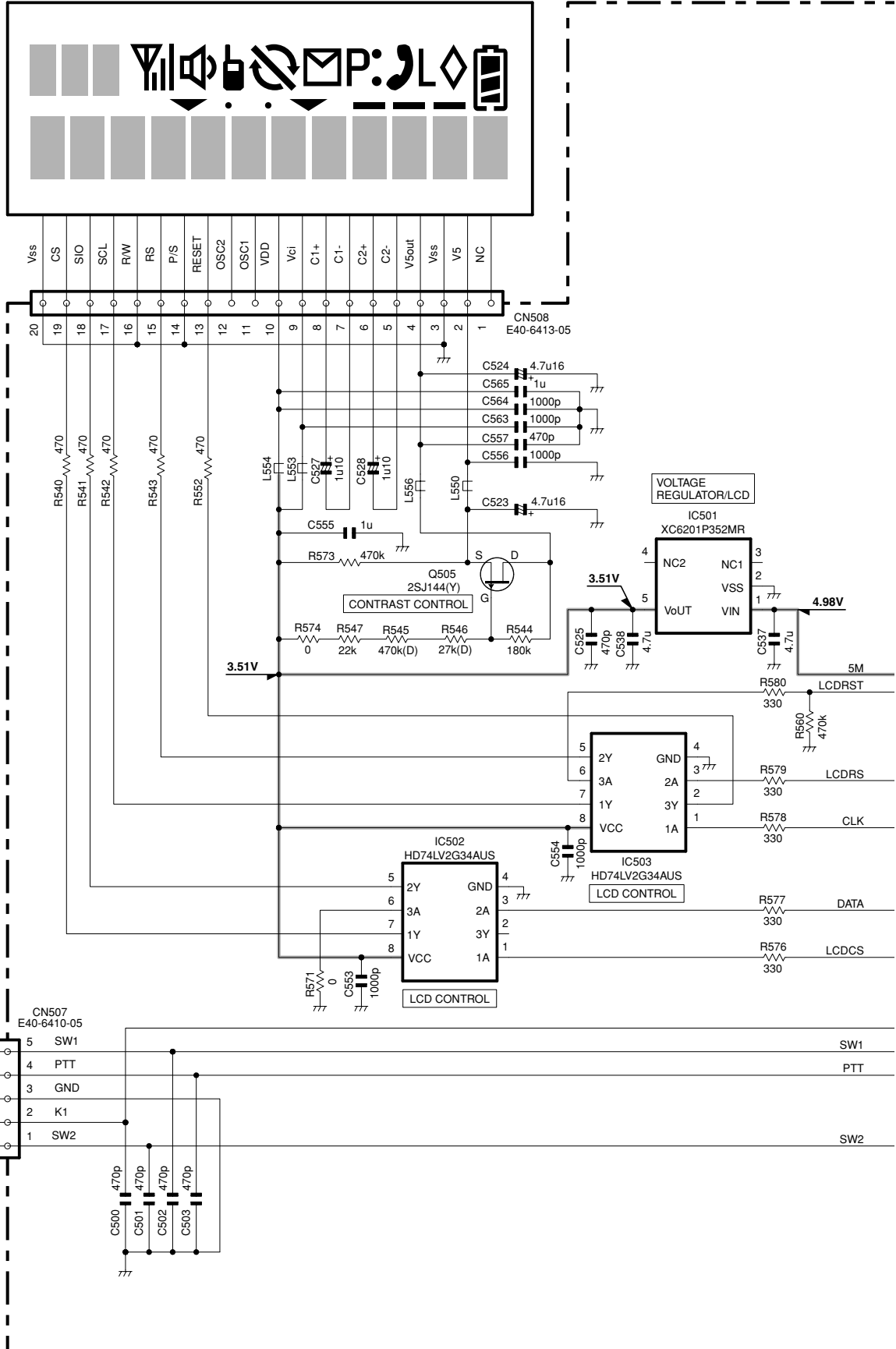

SIDE KEY SECTION

SCHEMATIC DIAGRAM TK-3180

DISPLAY UNIT (X54-3470-11)

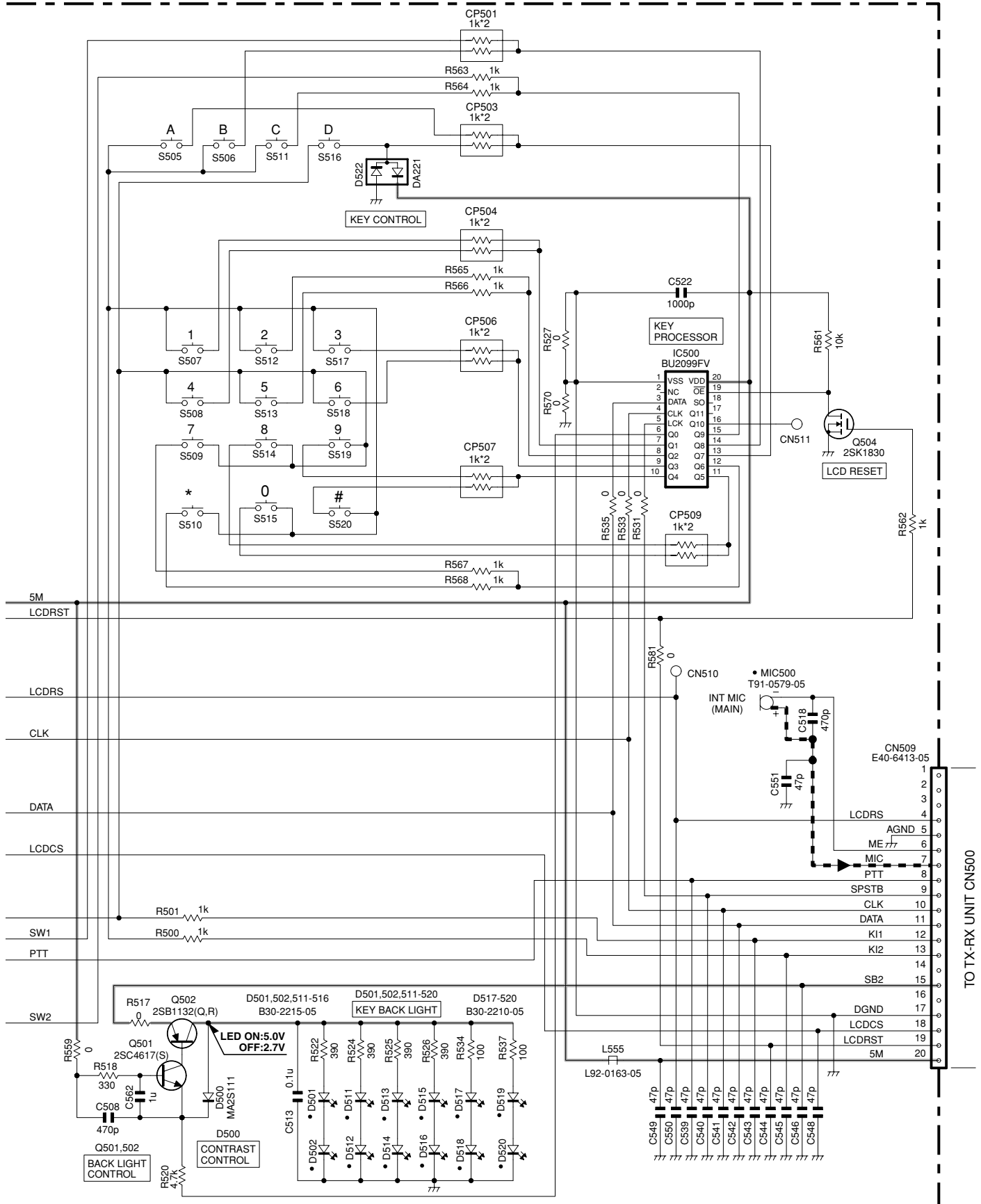

Note : The components marked with a dot (•) are parts of layer 1.

LCD ASSY
(B38-0900-05)

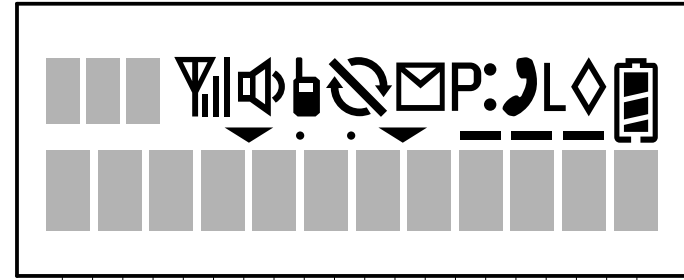

DISPLAY UNIT
(X54-3470-11)

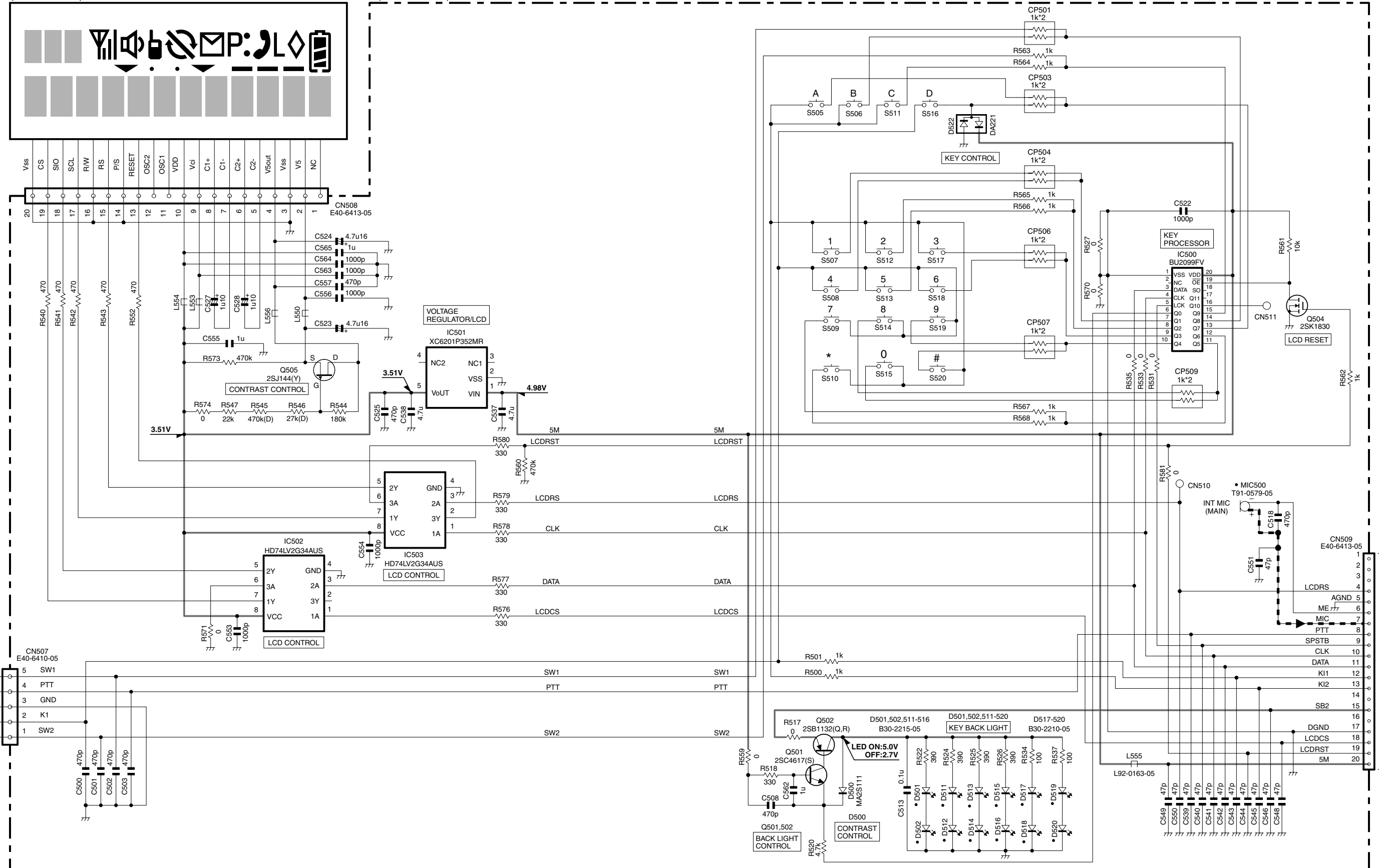

SIDE KEY SECTION

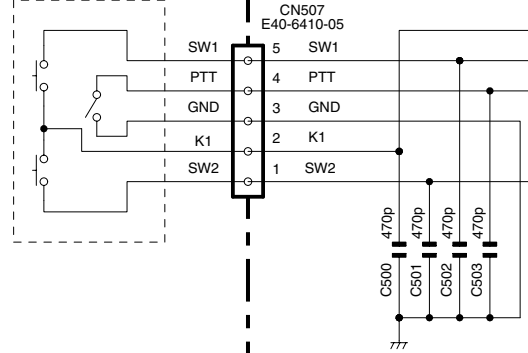

TO TX-RX UNIT CN500

TK-3180 SCHEMATIC DIAGRAM

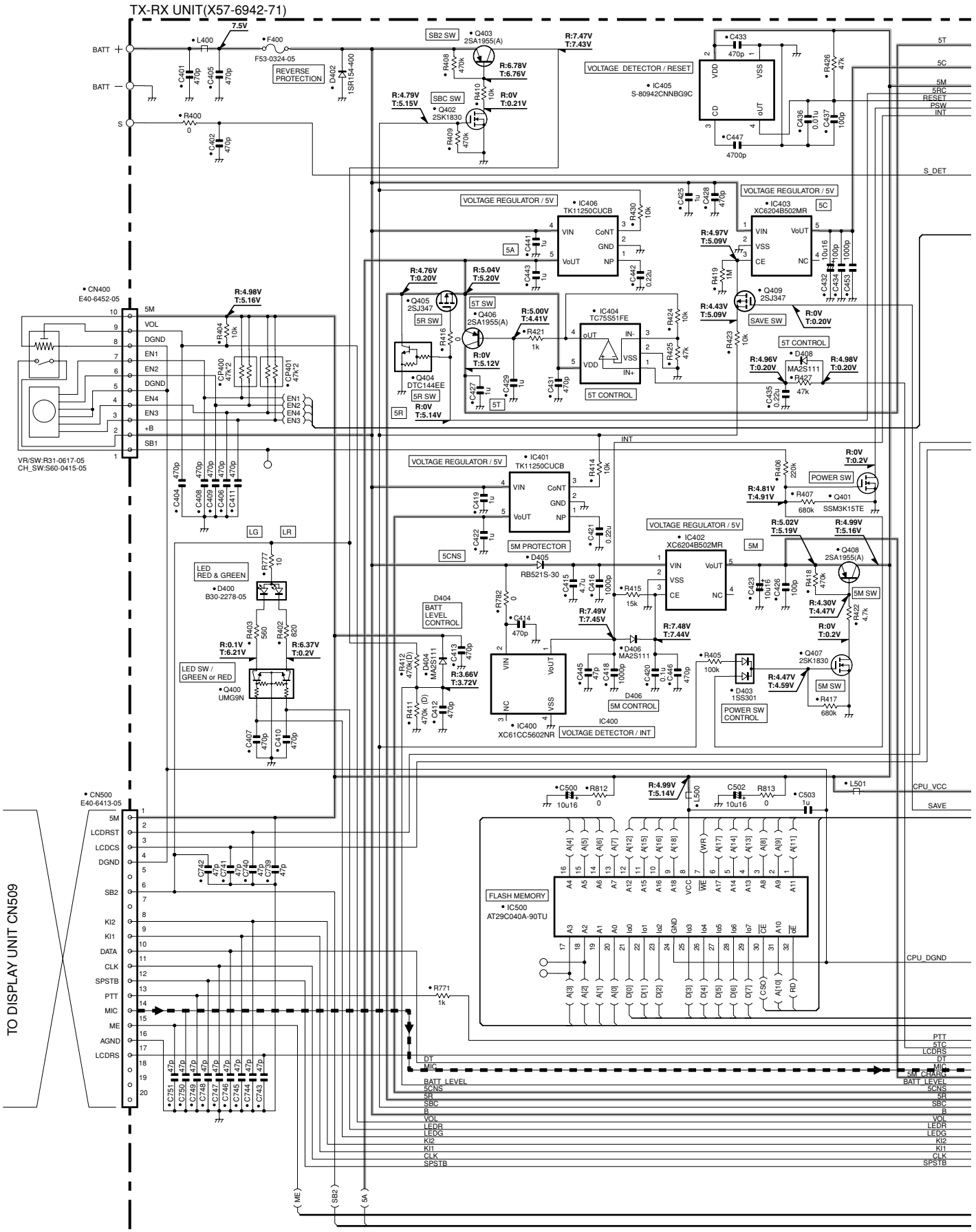

SCHEMATIC DIAGRAM TK-3180

TX-RX UNIT (X57-6942-71)

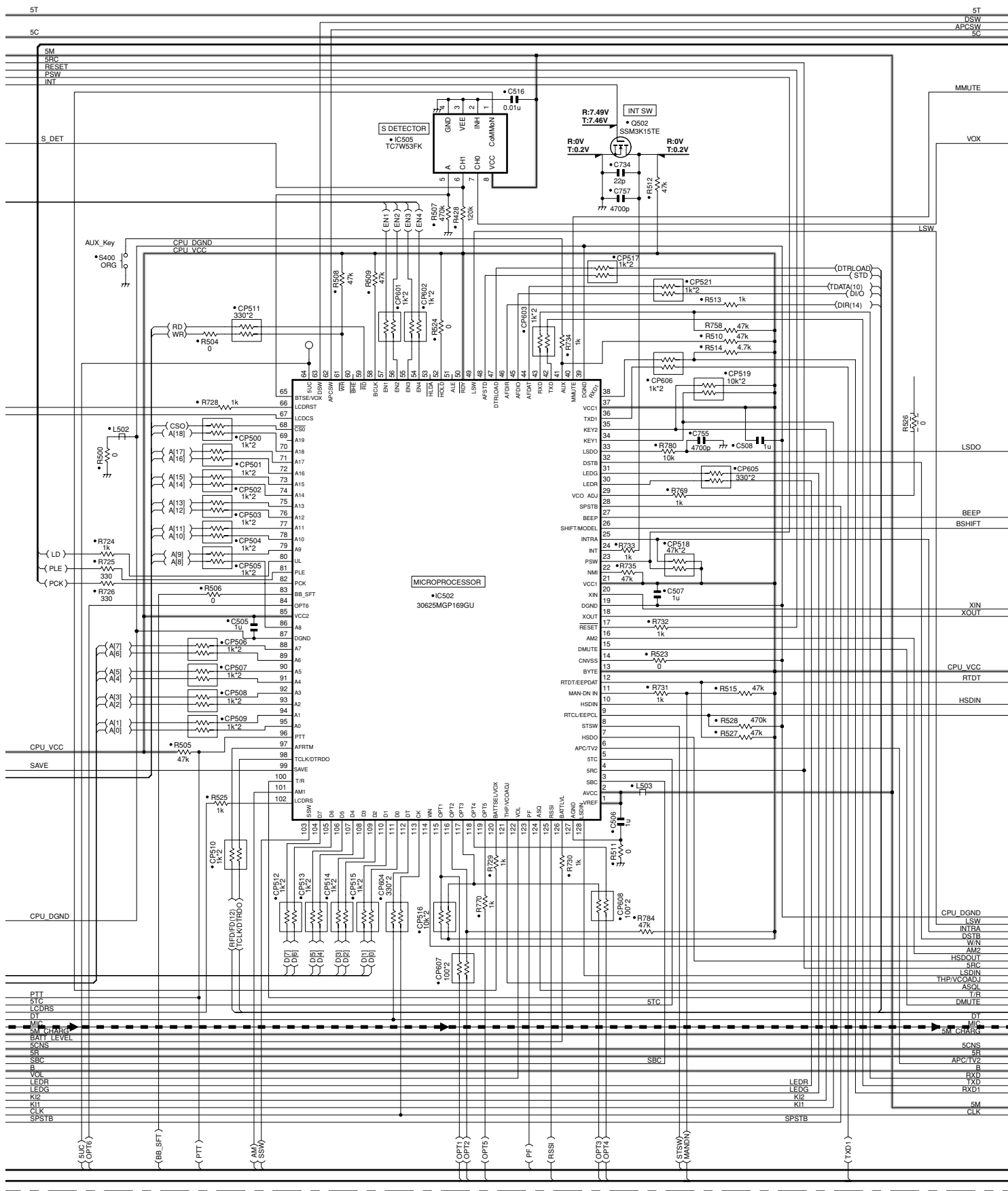

TK-3180 SCHEMATIC DIAGRAM

TX-RX UNIT (X57-6942-71)

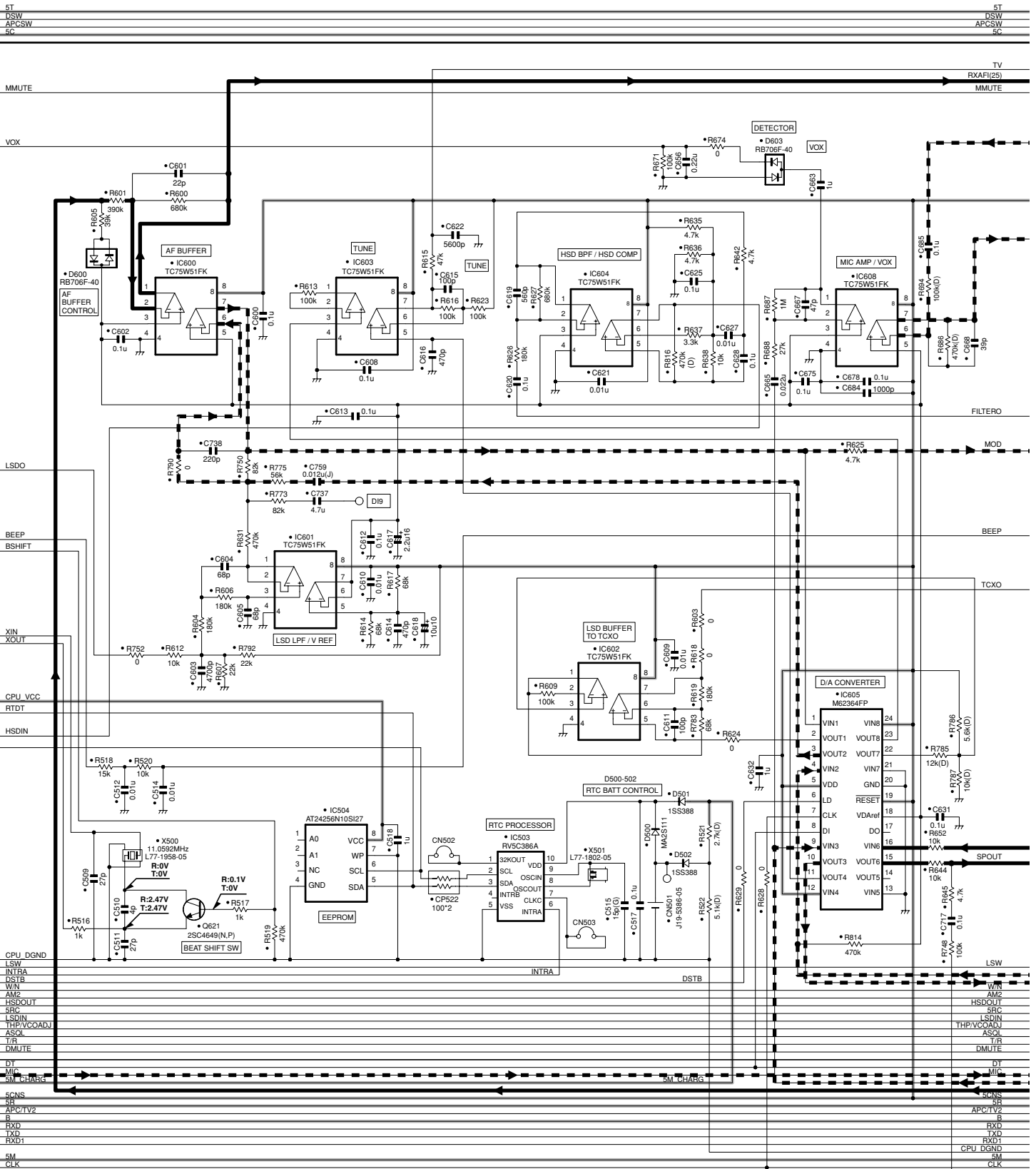

SCHEMATIC DIAGRAM TK-3180

TX-RX UNIT (X57-6942-71)

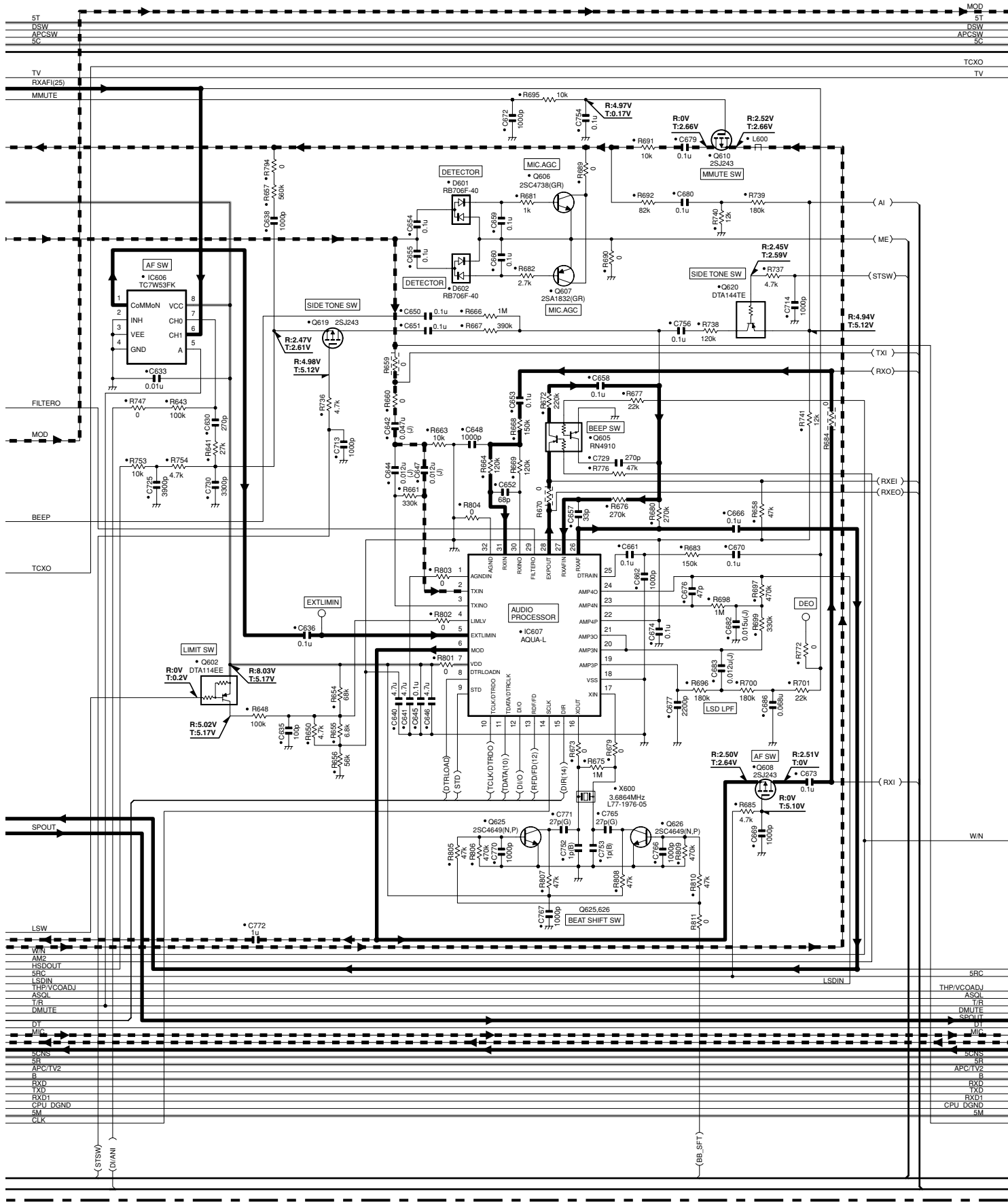

SCHEMATIC DIAGRAM TK-3180

TX-RX UNIT (X57-6942-71)

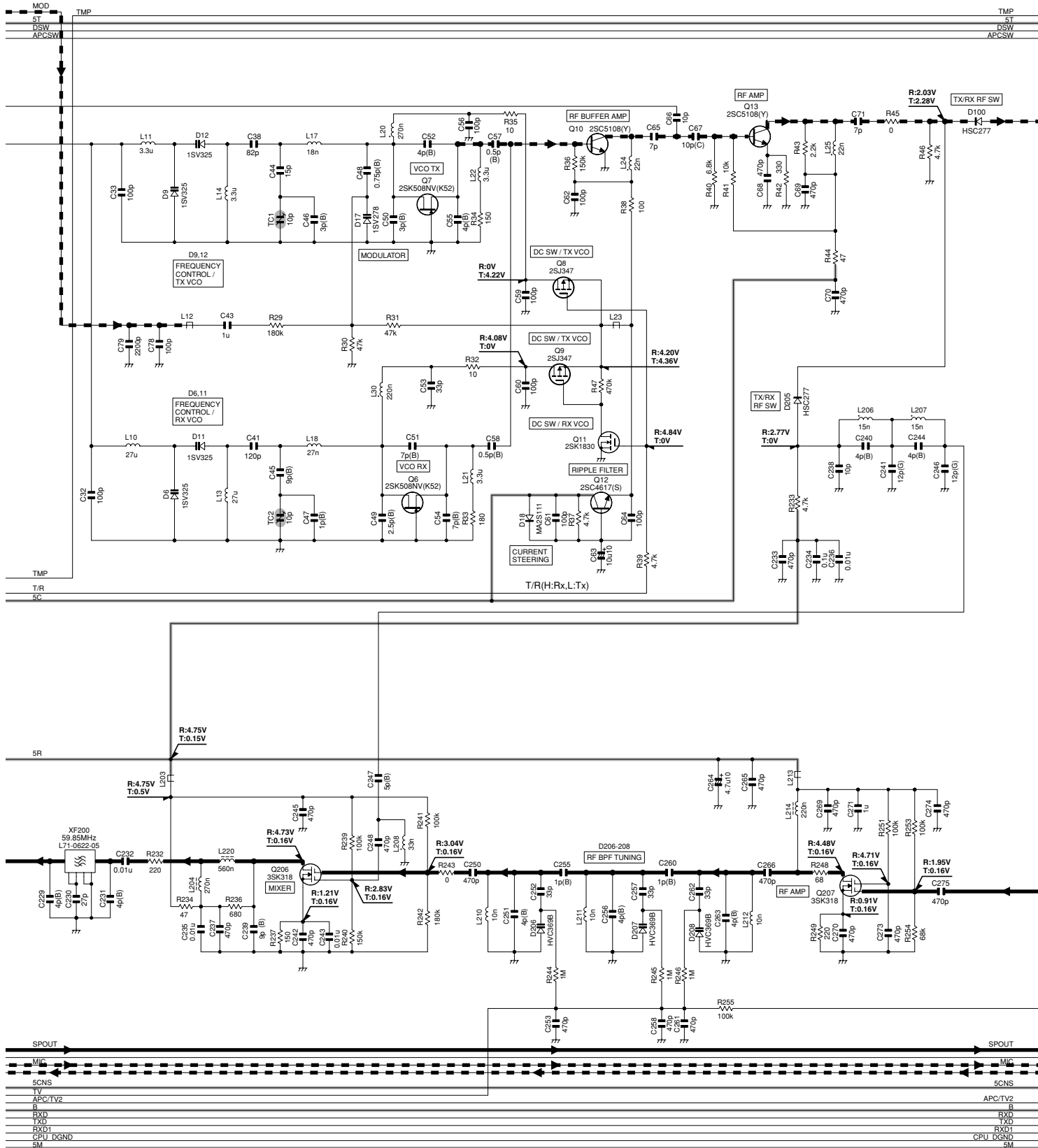

AE AF AG AH AI

TK-3180 SCHEMATIC DIAGRAM

TX-RX UNIT (X57-6942-71)

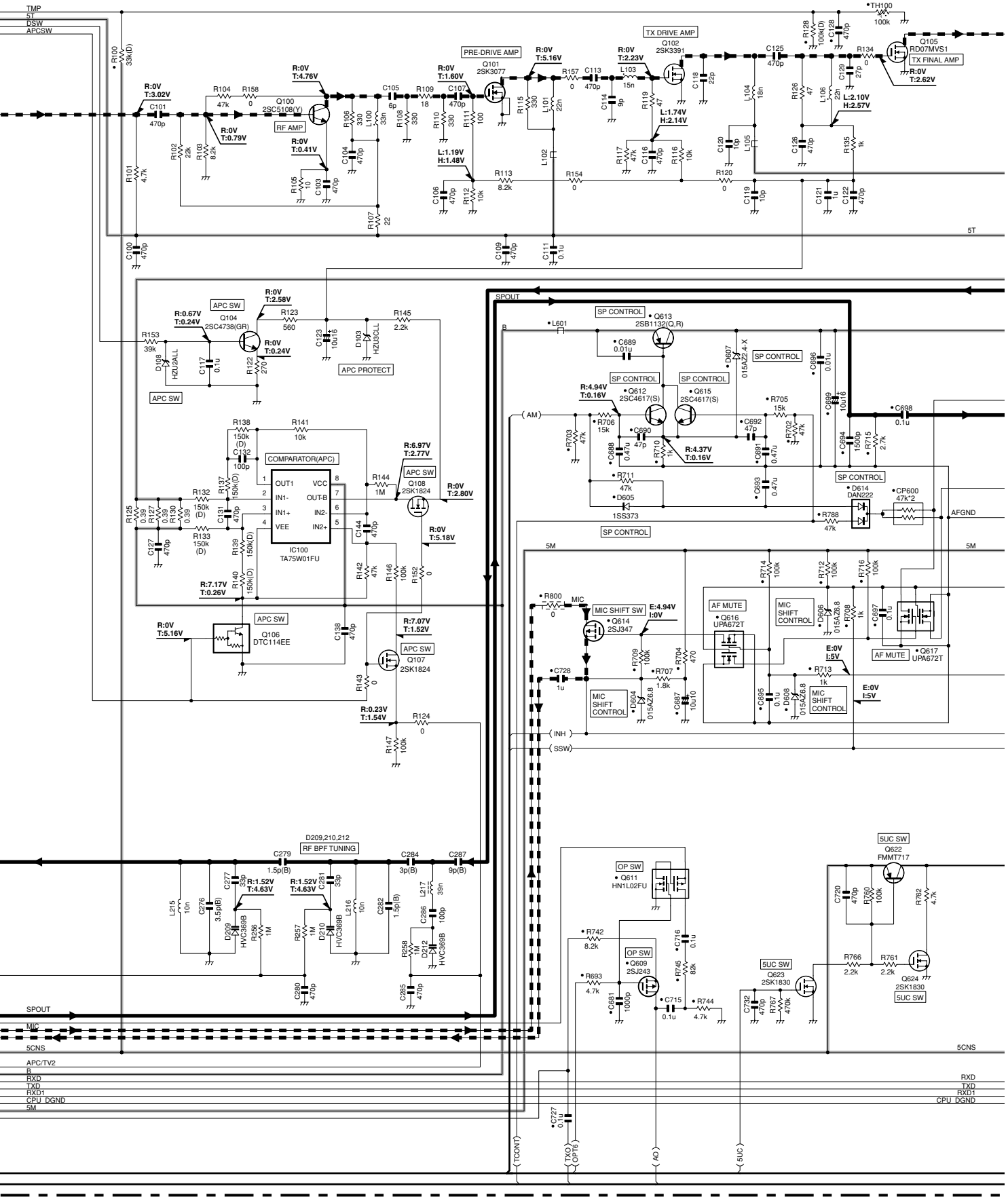

SCHEMATIC DIAGRAM TK-3180

TX-RX UNIT (X57-6942-71)

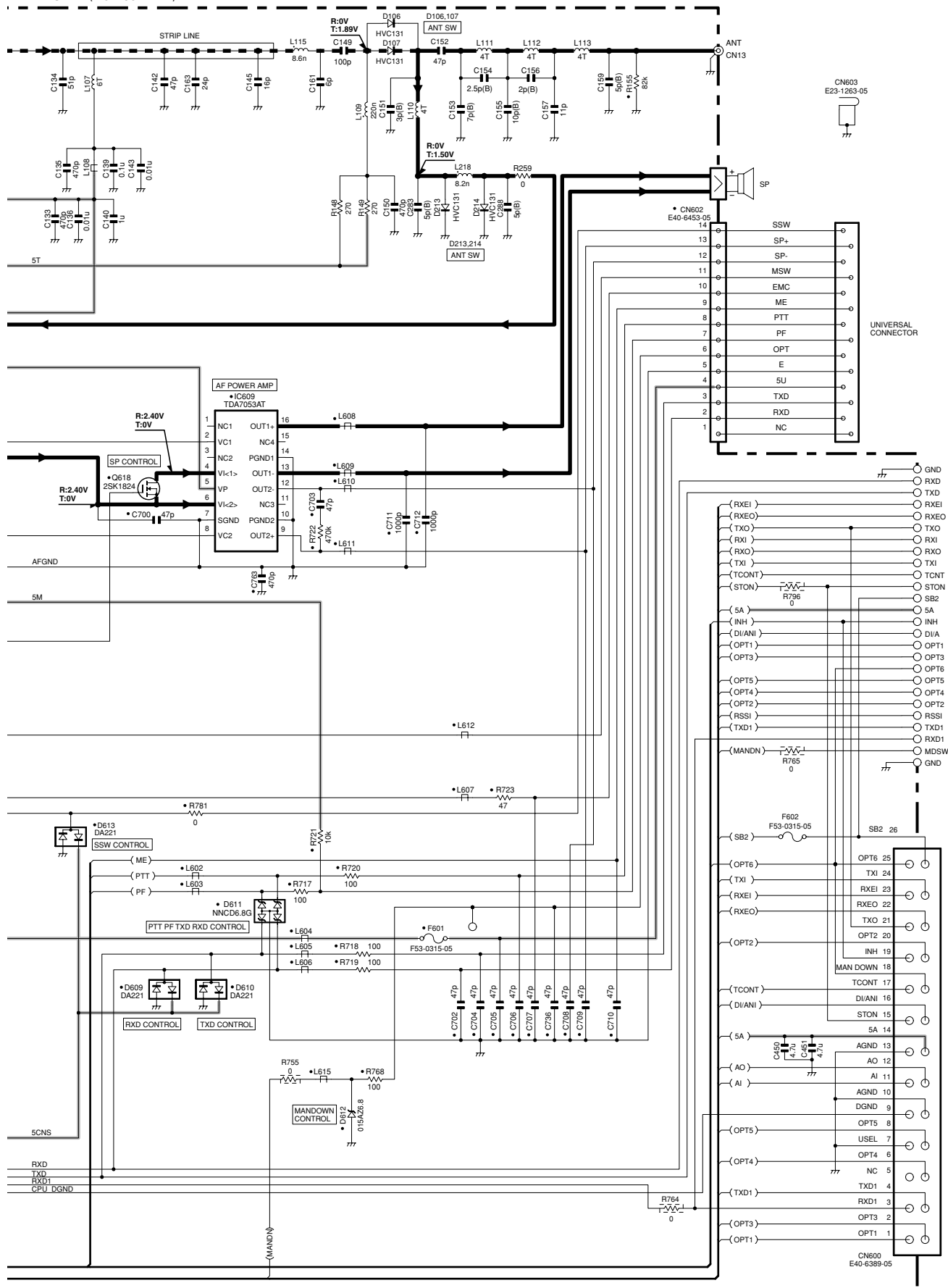

Note : The components marked with a dot (•) are parts of layer 1.

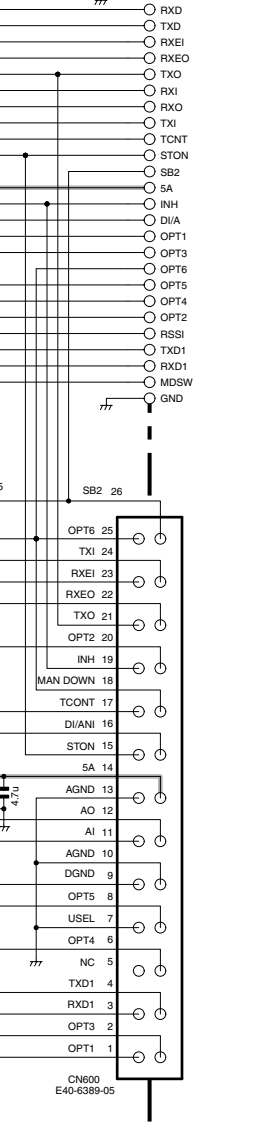


BLOCK DIAGRAM

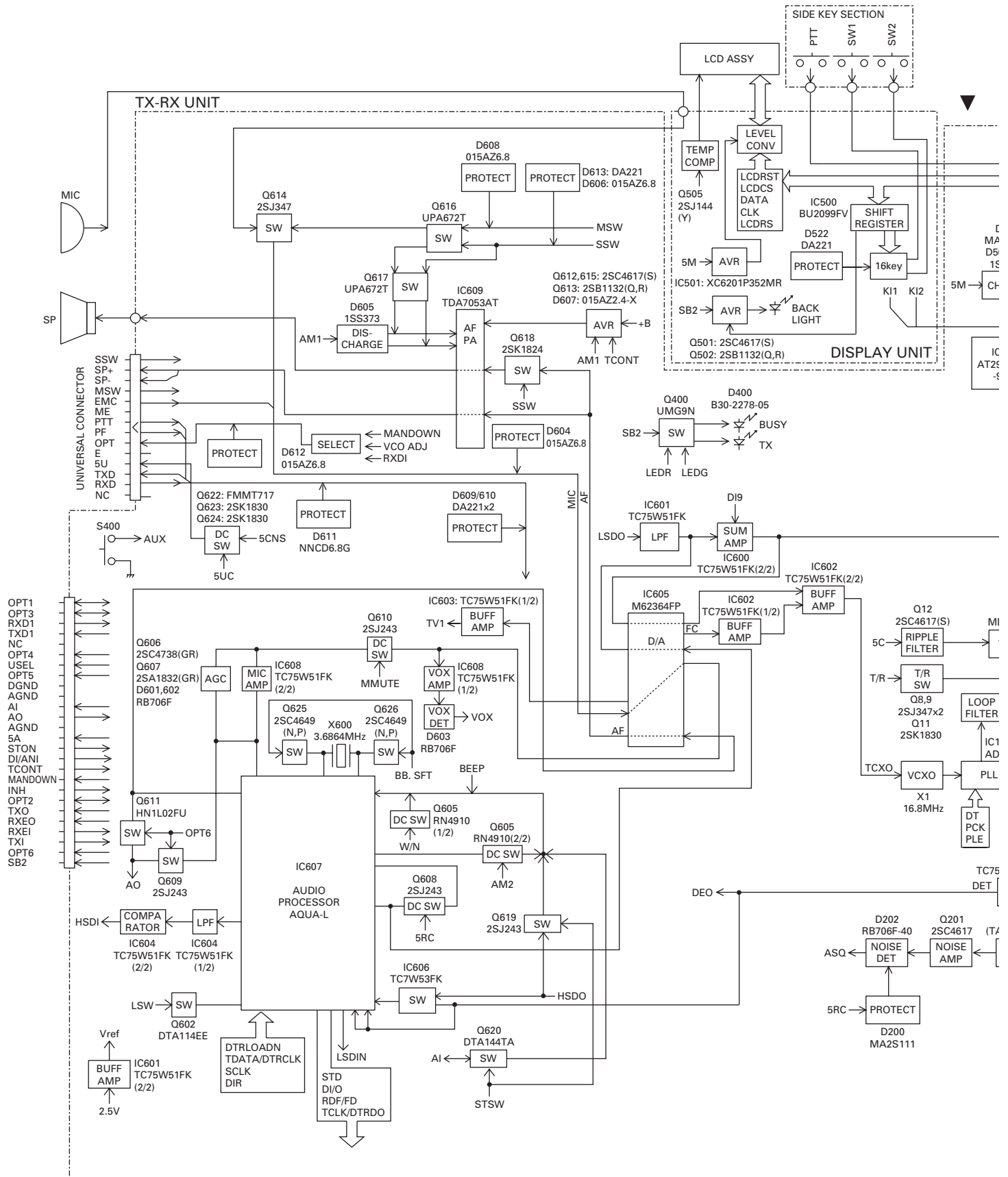

BLOCK DIAGRAM

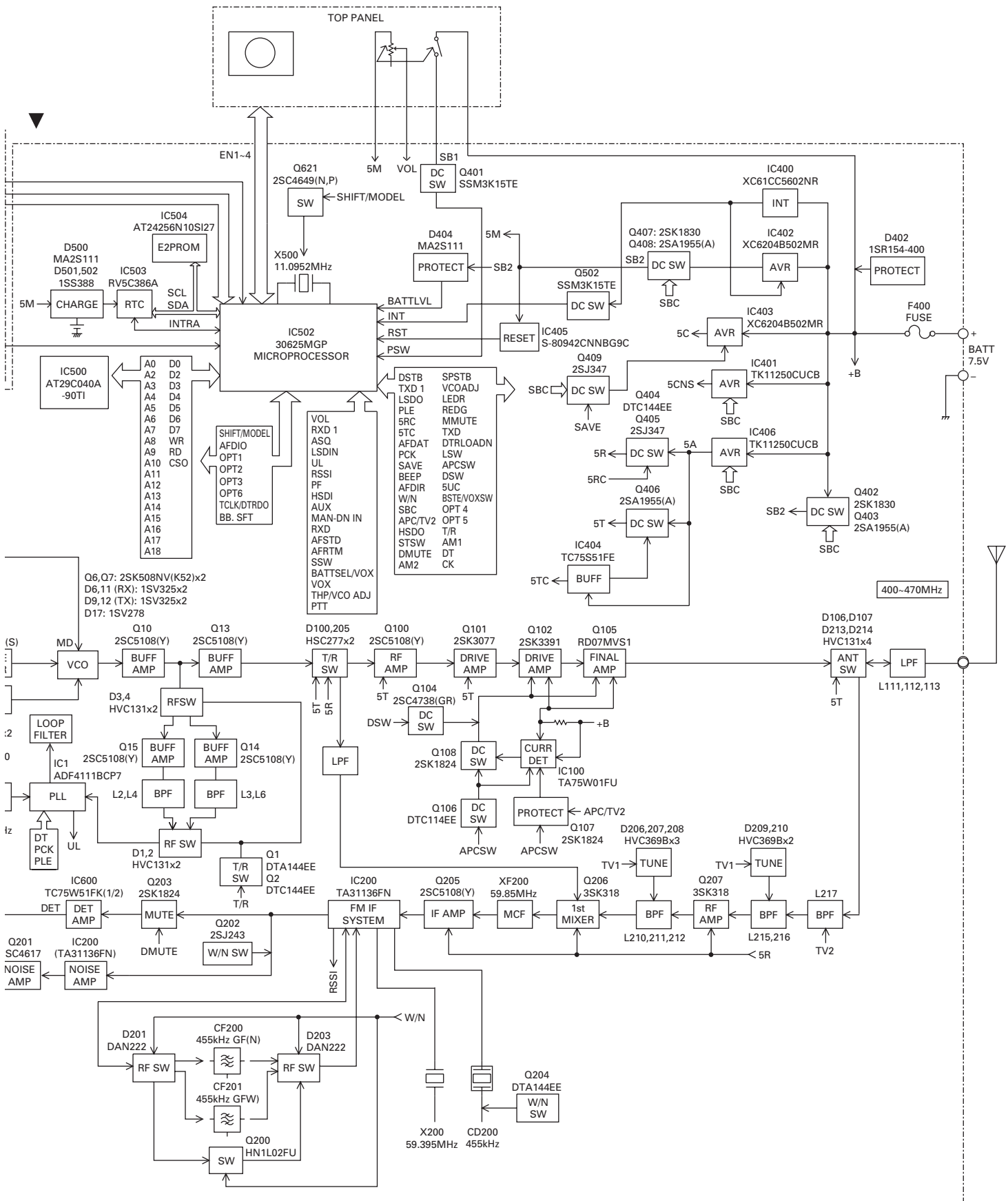

LEVEL DIAGRAM

Receiver Section

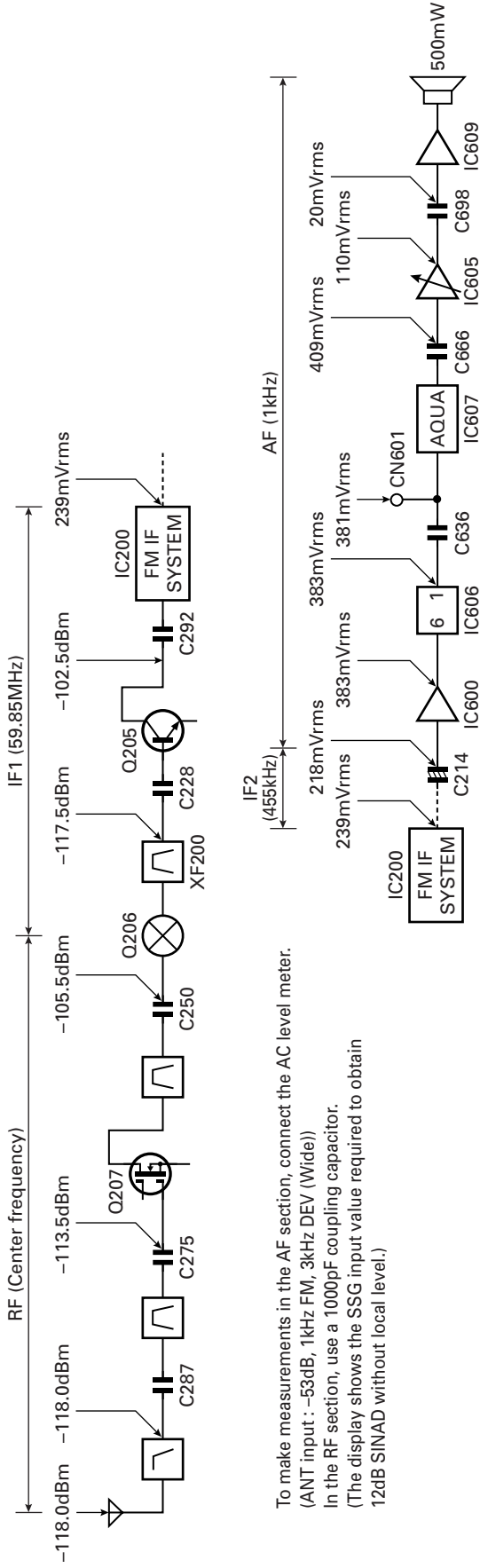

To make measurements in the AF section, connect the AC level meter. (ANT input : -53dB, 1kHz FM, 3kHz DEV (Wide))
 In the RF section, use a 1000pF coupling capacitor.
 (The display shows the SSG input value required to obtain 12dB SINAD without local level.)

Transmitter Section

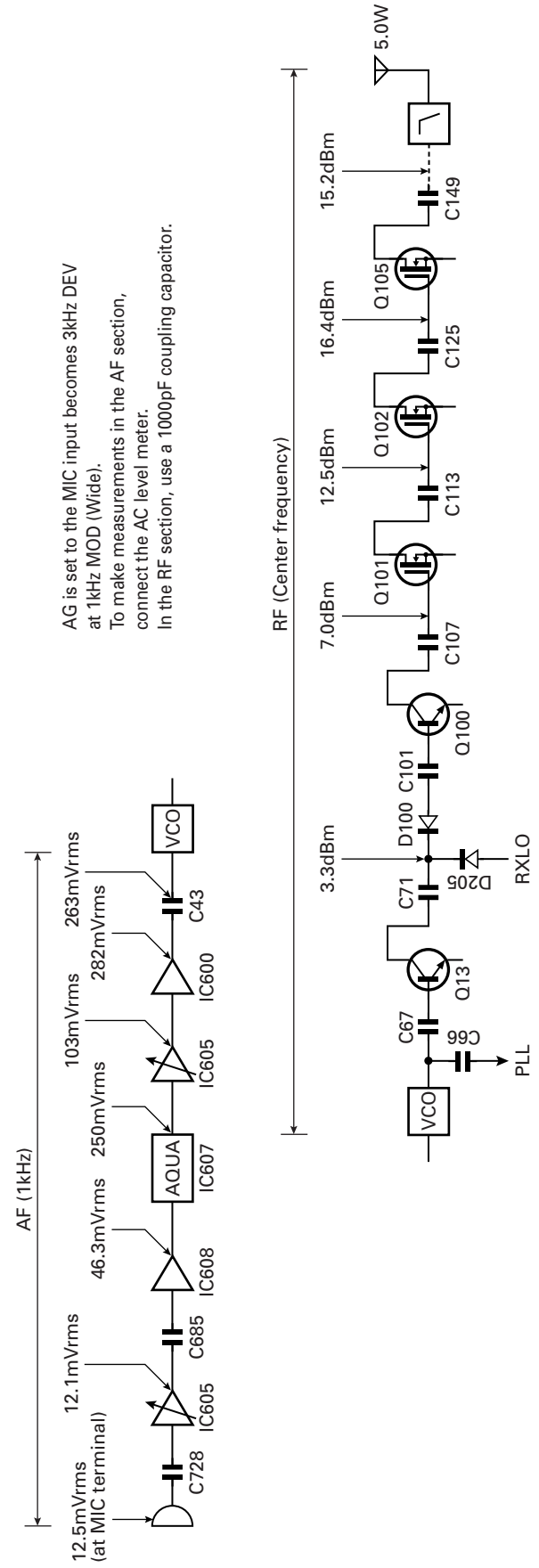

AG is set to the MIC input becomes 3kHz DEV at 1kHz MOD (Wide).
 To make measurements in the AF section, connect the AC level meter.
 In the RF section, use a 1000pF coupling capacitor.

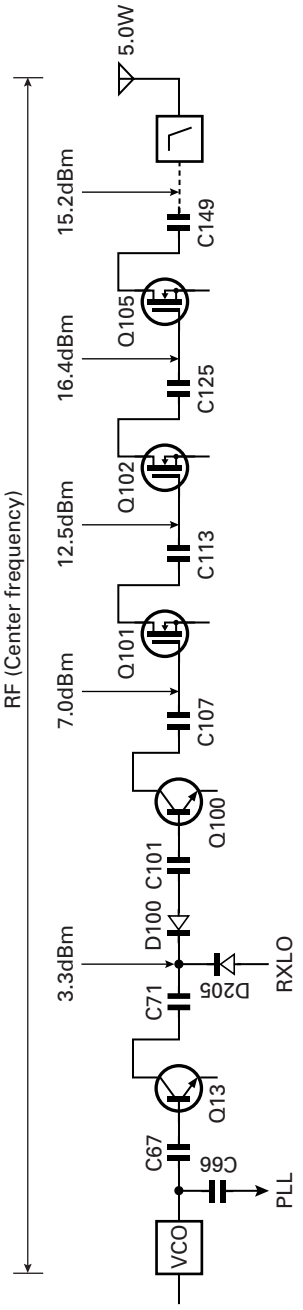

OPTIONAL ACCESSORIES

KNB-31A (Ni-Cd 7.2V 1700mAh)

KNB-32N (Ni-MH 7.2V 2500mAh)

■ External view



KNB-33L (Li-ion 7.4V 1700mAh)

■ External view



■ **KNB-31A Internal wiring**

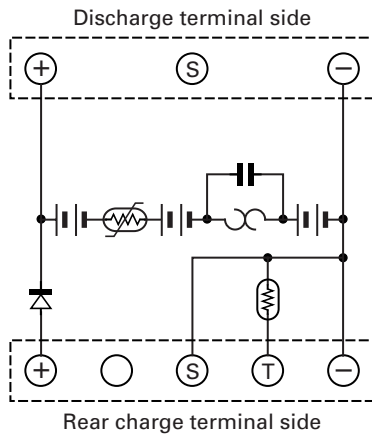

■ **Internal wiring**

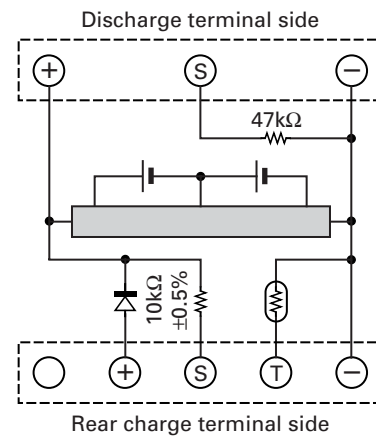

■ **KNB-32N Internal wiring**

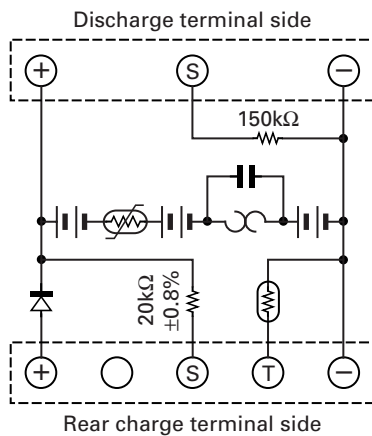

KSC-32 (Rapid charger)

■ External view



SPECIFICATIONS

GENERAL

Frequency range	400~470MHz
Number of channels	Max. 512 channels total per radio
	Zone : Max. 128 per radio Ch : Max. 250 per zone
Channel spacing	Wide 5k : 25kHz Wide 4k : 20kHz Narrow : 12.5kHz
Battery voltage	7.5V DC \pm 20%
Battery life (5-5-90 duty cycle, during hi-power)	
KNB-31A (1700mAh)	Approx. 9 hours
KNB-32N (2500mAh)	Approx. 14 hours
KNB-33L (1700mAh)	Approx. 10 hours
Operating temperature range	-30°C~+60° (-10°C~+60°C when KNB-32N or KNB-33L in use.)
Frequency stability	\pm 2.5ppm (-30°C~+60°C)
Antenna impedance	50 Ω
Channel frequency spread	70MHz
Dimensions (W x H x D Projections not included)	58 x 136 x 33 mm with KNB-33L battery
	58 x 136 x 39.5 mm with KNB-31A or 32N battery
Weight (net)	400 g with battery (KNB-33L), antenna (KRA-23) and belt-clip (KBH-11)

RECEIVER (Measurements made per EN standard)

Sensitivity			
EIA 12dB SINAD	Wide 5k : 0.28 μ V	Wide 4k : 0.28 μ V	Narrow : 0.32 μ V
EN 20dB SINAD	Wide 5k : -3dB μ V	Wide 4k : -3dB μ V	Narrow : -2dB μ V
Adjust channel selectivity	Wide 5k : 73dB	Wide 4k : 73dB	Narrow : 63dB
Intermodulation	65dB		
Spurious response rejection	70dB		
Audio output (8 Ω impedance)	500mW with less than 3% distortion		

TRANSMITTER (Measurements made per EN standard)

RF power output	HI : 5W LO : 1W
Modulation limiting	Wide 5k : \pm 5.0kHz at 25kHz Wide 4k : \pm 4.0kHz at 20kHz
	Narrow : \pm 2.5kHz at 12.5kHz
Spurious emission	-36dBm \leq 1GHz, -30dBm $>$ 1GHz
FM noise (EIA)	Wide 5k : 45dB Wide 4k : 45dB Narrow : 40dB
Modulation distortion	Less than 3%

KENWOOD CORPORATION

2967-3, Ishikawa-machi, Hachioji-shi, Tokyo, 192-8525 Japan

KENWOOD U.S.A. CORPORATION

P.O. BOX 22745, 2201 East Dominguez Street, Long Beach, CA 90801-5745, U.S.A.

KENWOOD ELECTRONICS CANADA INC.

6070 Kestrel Road, Mississauga, Ontario, Canada L5T 1S8

KENWOOD ELECTRONICS DEUTSCHLAND GMBH

Rembrücker Str. 15, 63150 Heusenstamm, Germany

KENWOOD ELECTRONICS BELGIUM N.V.

Leuvensesteenweg 248 J, 1800 Vilvoorde, Belgium

KENWOOD ELECTRONICS FRANCE S.A.

13, Boulevard Ney, 75018 Paris, France

KENWOOD ELECTRONICS U.K. LIMITED

KENWOOD House, Dwight Road, Watford, Herts., WD18 9EB United Kingdom

KENWOOD ELECTRONICS EUROPE B.V.

Amsterdamseweg 37, 1422 AC Uithoorn, The Netherlands

KENWOOD ELECTRONICS ITALIA S.p.A.

Via G. Sirtori, 7/9 20129 Milano, Italy

KENWOOD IBERICA S.A.

Bolivia, 239-08020 Barcelona, Spain

KENWOOD ELECTRONICS AUSTRALIA PTY. LTD.

(A.C.N. 001 499 074)

16 Giffnock Avenue, Centrecourt Estate, North Ryde, N.S.W. 2113 Australia

KENWOOD ELECTRONICS (HONG KONG) LTD.

Unit 3712-3724, Level 37, Tower one Metroplaza, 223 Hing Fong Road, Kwai Fong, N.T., Hong Kong

KENWOOD ELECTRONICS SINGAPORE PTE LTD.

1 Ang Mo Kio Street 63, Singapore 569110

