

KENWOOD

Document Copyrights

Copyright 2006 by Kenwood Corporation. All rights reserved.

No part of this manual may be reproduced, translated, distributed, or transmitted in any form or by any means, electronic, mechanical, photocopying, recording, or otherwise, for any purpose without the prior written permission of Kenwood.

Disclaimer

While every precaution has been taken in the preparation of this manual, Kenwood assumes no responsibility for errors or omissions. Neither is any liability assumed for damages resulting from the use of the information contained herein. Kenwood reserves the right to make changes to any products herein at any time for improvement purposes.

Refer to the TK-3200 service manual (B51-8695-00) for any information which has not been covered in this TK-3200L service manual.

CONTENTS

GENERAL	2
REALIGNMENT	3
CIRCUIT DESCRIPTION	6
PARTS LIST	7
EXPLODED VIEW	13
PACKING	14
ADJUSTMENT	15
PC BOARD	
TX-RX UNIT (X57-6900-XX)	20
SCHEMATIC DIAGRAM	24
BLOCK DIAGRAM	28
LEVEL DIAGRAM	30
OPTIONAL ACCESSORIES	
KSC-35 (RAPID CHARGER)	31
KNB-45L (Li-ion BATTERY PACK)	31
SPECIFICATIONS	BACK COVER



Photo is TK-3200L (K3 type).



This product uses Lead Free solder.

GENERAL

INTRODUCTION

SCOPE OF THIS MANUAL

This manual is intended for use by experienced technicians familiar with similar types of commercial grade communications equipment. It contains all required service information for the equipment and is current as of the publication date. Changes which may occur after publication are covered by either Service Bulletins or Manual Revisions. These are issued as required.

ORDERING REPLACEMENT PARTS

When ordering replacement parts or equipment information, the full part identification number should be included. This applies to all parts, components, kits, or chassis. If the part number is not known, include the chassis or kit number of which it is a part, and a sufficient description of the required component for proper identification.

PERSONAL SAFETY

The following precautions are recommended for personal safety:

- DO NOT transmit until all RF connectors are verified secure and any open connectors are properly terminated.
- SHUT OFF and DO NOT operate this equipment near electrical blasting caps or in an explosive atmosphere.
- This equipment should be serviced by a qualified technician only.

SERVICE

This transceiver is designed for easy servicing. Refer to the schematic diagrams, printed circuit board views, and alignment procedures contained within.

TK-3200L (ProTalk)

Destination	Number of CH	Frequency No. / Frequency		Default CH setting	RF power output		
K	2-channel	CH1	464.5000MHz	CH29	462.9125MHz	2W	
		CH2	464.5500MHz	CH30	464.4875MHz		
		CH3	467.7625MHz	CH31	464.5125MHz		
K2	8-channel	CH4	467.8125MHz	CH32	464.5375MHz		CH1: 464.5500MHz / QT 67.0Hz
		CH5	467.8500MHz	CH33	464.5625MHz		CH2: 467.9250MHz / QT 67.0Hz
		CH6	467.8750MHz	CH34	466.0375MHz		CH3: 461.0375MHz / QT 67.0Hz
		CH7	467.9000MHz	CH35	466.0625MHz		CH4: 461.0625MHz / QT 67.0Hz
		CH8	467.9250MHz	CH36	466.0875MHz		CH5: 461.0875MHz / QT 67.0Hz
		CH9	461.0375MHz	CH37	466.1125MHz		CH6: 461.1125MHz / QT 67.0Hz
		CH10	461.0625MHz	CH38	466.1375MHz		CH7: 461.1375MHz / QT 67.0Hz
		CH11	461.0875MHz	CH39	466.1625MHz		CH8: 461.1625MHz / QT 67.0Hz
		CH12	461.1125MHz	CH40	466.1875MHz		
		K3	15-channel	CH13	461.1375MHz		CH41
CH14	461.1625MHz			CH42	466.2375MHz		CH2: 467.9250MHz/QT 67.0Hz
CH15	461.1875MHz			CH43	466.2625MHz		CH3: 461.0375MHz/QT 67.0Hz
CH16	461.2125MHz			CH44	466.2875MHz	CH4: 461.0625MHz/QT 67.0Hz	
CH17	461.2375MHz			CH45	466.3125MHz	CH5: 461.0875MHz/QT 67.0Hz	
CH18	461.2625MHz			CH46	466.3375MHz	CH6: 461.1125MHz/QT 67.0Hz	
CH19	461.2875MHz			CH47	466.3625MHz	CH7: 461.1375MHz/QT 67.0Hz	
CH20	461.3125MHz			CH48	467.7875MHz	CH8: 461.1625MHz/QT 67.0Hz	
CH21	461.3375MHz			CH49	467.8375MHz	CH9: 464.5000MHz/QT 67.0Hz	
CH22	461.3625MHz			CH50	467.8625MHz	CH10: 467.7625MHz/QT 67.0Hz	
CH23	462.7625MHz			CH51	467.8875MHz	CH11: 467.8125MHz/QT 67.0Hz	
CH24	462.7875MHz			CH52	467.9125MHz	CH12: 467.8500MHz/QT 67.0Hz	
CH25	462.8125MHz			CH53	469.4875MHz	CH13: 467.8750MHz/QT 67.0Hz	
CH26	462.8375MHz			CH54	469.5125MHz	CH14: 467.9000MHz/QT 67.0Hz	
CH27	462.8625MHz			CH55	469.5375MHz	CH15: 461.1875MHz/QT 67.0Hz	
CH28	462.8875MHz	CH56	469.5625MHz				

REALIGNMENT

1. Modes

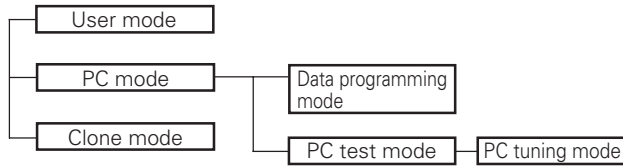

Mode	Function
User mode	For normal use.
PC mode	Used for communication between the transceiver and PC (IBM compatible).
Data programming mode	Used to read and write frequency data and other features to and from the transceiver.
PC test mode	Used to check the transceiver using the PC. This feature is included in the FPU.
Clone mode	Used to transfer programming data from one transceiver to another.

2. How to Enter Each Mode

Mode	Operation
User mode	Power ON
PC mode	Received commands from PC
Clone mode	[PTT]+[Side2]+Power ON (Two seconds)

3. Getting Acquainted

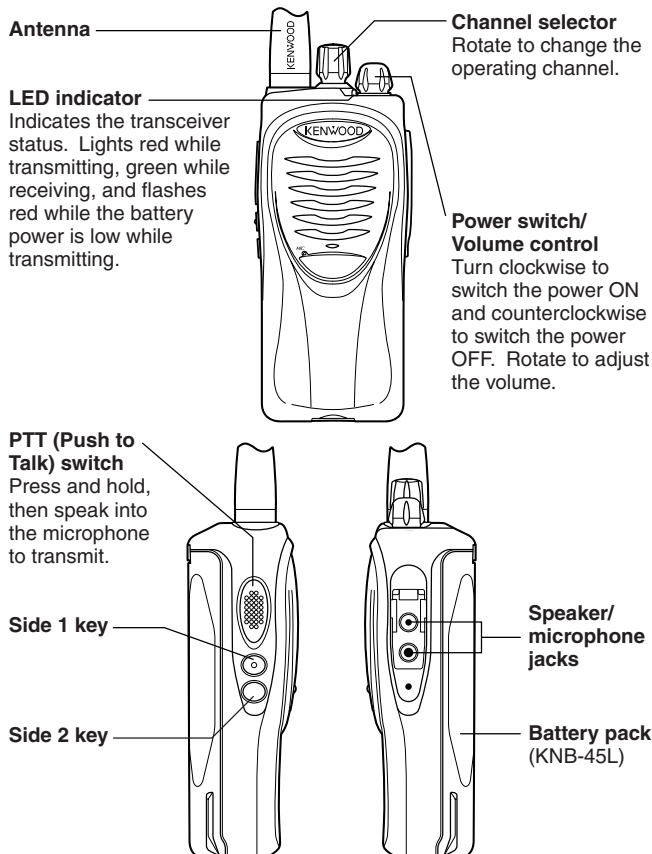

4. PC Mode

4-1. Preface

The transceiver is programmed using a personal computer, a programming interface (KPG-22/22A), USB adapter (KCT-53U) and programming software (KPG-88D).

The programming software can be used with an IBM PC or compatible. Figure 1 shows the setup of an IBM PC for programming.

4-2. Connection procedure

1. Connect the transceiver to the personal computer with the interface cable and USB adapter (When the interface cable is KPG-22A, the KCT-53U can be used.).

Notes:

- You must install the KCT-53U driver in the computer to use the USB adapter (KCT-53U).
- When using the USB adapter (KCT-53U) for the first time, plug the KCT-53U into a USB port on the computer with the computer power ON.

2. When the POWER is switched on, user mode can be entered immediately. When the PC sends a command, the transceiver enters PC mode.
When data is transmitting from the transceiver, the red LED lights.
When data is received by the transceiver, the green LED lights.

Notes:

- The data stored in the computer must match the model type when it is written into the EEPROM.
- Change the transceiver to PC mode, then attach the interface cable.

4-3. KPG-22/KPG-22A description (PC programming interface cable: Option)

The KPG-22/22A is required to interface the transceiver with the computer. It has a circuit in its D-sub connector (KPG-22 : 25-pin, KPG-22A : 9-pin) case that converts the RS-232C logic level to the TTL level.

The KPG-22/22A connects the SP/MIC connector of the transceiver to the RS-232C serial port of the computer.

4-4. KCT-53U description (USB adapter : Option)

The KCT-53U is a cable which connects the KPG-22A to a USB port on a computer.

When using the KCT-53U, install the supplied CD-ROM (with driver software) in the computer. The KCT-53U driver runs under Windows 2000 or XP.

REALIGNMENT

4-5. Programming software KPG-88D description

KPG-88D is the programming software for the transceiver supplied on a CD-ROM. This software runs under Windows 98, ME, Windows 2000 or XP on an IBM-PC or compatible machine.

The data can be input to or read from the transceiver and edited on the screen. The programmed or edited data can be printed out. It is also possible to tune the transceiver.

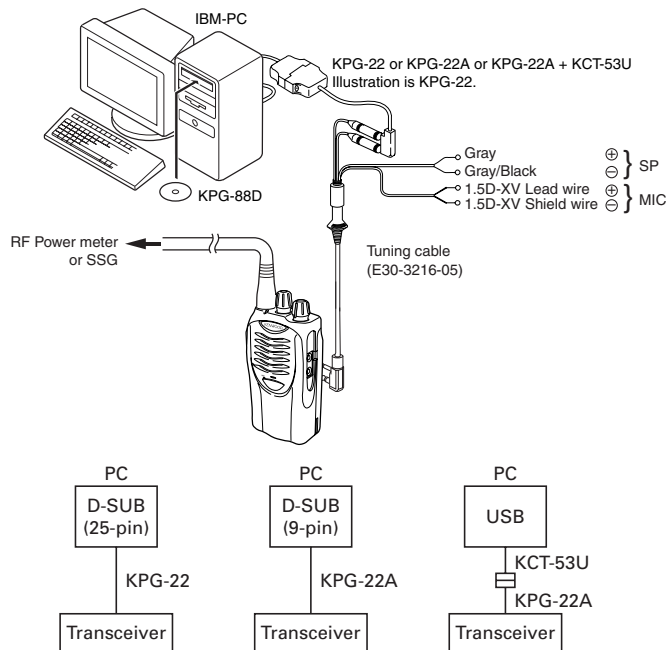

Fig. 1

5. Clone Mode

5-1. Outline

"Clone Mode" copies the transceiver data to another transceiver.

The dealer can copy the transceiver data to another transceiver even without the use of a personal computer.

5-2. Example

The transceiver can copy the programming data to one or more transceivers via RF communication.

The clone source and clone target/s must be in Clone mode.

5-3. Operation

1. To switch the clone target/s to Clone mode, press and hold the [PTT] and [Side2] keys while turning the transceiver power ON.
2. Wait for 2 seconds. The LED will light orange and the transceiver will announce "Clone".
3. Select a channel table number using Side1 (increment channel table) and Side2 (decrement channel table) keys.
4. To switch the clone source to Clone mode, press and hold the [PTT] and [Side2] keys while turning the transceiver power ON.
5. Wait for 2 seconds. The LED will light orange and the transceiver will announce "Clone".
6. Select the same channel table number as the clone target/s.
7. Press [PTT] on the clone source to begin data transmission. When the clone target starts to receive data, the LED will light green.

When the clone source finishes sending data, a "confirmation" tone will sound.

If data transmission fails while cloning, an "error" tone will sound from the Target unit.

8. If the cloning fails, no data will be available in the Target unit when it is returned to User mode.
9. When the cloning is successful, the Target unit's "Scan" function will return to its default value (Scan = OFF).

Notes:

- The dealer can clone data to two or more transceivers by repeating the above procedures.
- If the transceivers Clone Mode is configured as "Disabled", the transceiver cannot enter Clone mode.
- The table shown below will cover the frequency tables used for wireless cloning.
- A unit cannot be a "Source Unit" if it is unprogrammed. If [PTT] is pressed, an "error" tone will sound.
- Once a unit is set to be the Source, it cannot be a target after the data has been transmitted. This protects the data in the Source unit.
- If the Target unit is cloned successfully, it will return to User Mode.
- If the Target unit is not cloned successfully, the led will remain Orange.
- The Source Unit and Target Unit must be of the same model type and destination in order for Clone to operate.
- Clone mode cannot be accessed if "Super Lock" is activated.
- Electronic interface may cause a failure in data transfer during Wireless Clone, such as when waveforms or electromagnetics are being performed at the workbench.
- Clone mode can be used ONLY by the authorized service personnel.
- The Clone mode setting must be configured as "Disable" before being delivered to the end-user.
- To clone, replace the antenna from both the source transceiver and the target transceiver with a dummy load.
- The transmit output power is automatically set to Low in Clone mode.

REALIGNMENT**Clone Frequency Table**

Table Number	Frequency (MHz)	Table Number	Frequency (MHz)
1	464.5000	29	462.9125
2	464.5500	30	464.4875
3	467.7625	31	464.5125
4	467.8125	32	464.5375
5	467.8500	33	464.5625
6	467.8750	34	466.0375
7	467.9000	35	466.0625
8	467.9250	36	466.0875
9	461.0375	37	466.1125
10	461.0625	38	466.1375
11	461.0875	39	466.1625
12	461.1125	40	466.1875
13	461.1375	41	466.2125
14	461.1625	42	466.2375
15	461.1875	43	466.2625
16	461.2125	44	466.2875
17	461.2375	45	466.3125
18	461.2625	46	466.3375
19	461.2875	47	466.3625
20	461.3125	48	467.7875
21	461.3375	49	467.8375
22	461.3625	50	467.8625
23	462.7625	51	467.8875
24	462.7875	52	467.9125
25	462.8125	53	469.4875
26	462.8375	54	469.5125
27	462.8625	55	469.5375
28	462.8875	56	469.5625

CIRCUIT DESCRIPTION

1. Control Circuit

The control circuit consists of a microprocessor (IC405) and its peripheral circuits. It controls the TX-RX unit. IC405 mainly performs the following:

- (1) Switching between transmission and reception by the PTT signal input.
- (2) Reading system, group, frequency, and program data from the memory circuit.
- (3) Sending frequency program data to the PLL.
- (4) Controlling squelch on/off by the DC voltage from the squelch circuit.
- (5) Controlling the audio mute circuit by the decode data input.
- (6) Transmitting tone and encode data.

1) Frequency Shift Circuit

The microprocessor (IC405) operates at a clock of 7.3728MHz. This oscillator has a circuit that shifts the frequency by BEAT SHIFT SW (Q407, Q408).

A beat sound may be able to be evaded from generation if "Beat Shift" is set to ON when it is generated in the internal spurious transmission modulated sound of a transceiver.

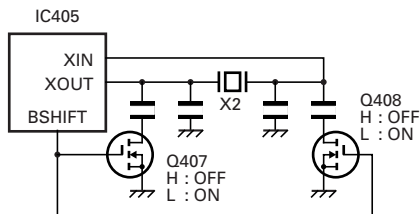

Fig. 1 Frequency shift circuit

2) Memory Circuit

Memory circuit consists of the CPU (IC405) and an EEPROM (IC406). An EEPROM has a capacity of 8k bits that contains the transceiver control program for the CPU and data such as transceiver channels and operating features.

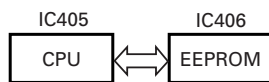

Fig. 2 Memory circuit

3) Low Battery Warning

The battery voltage is checked using by the microprocessor. The transceiver generates a warning tone when the battery voltage falls below the warning voltage (2) shown in the table.

- (1) The red LED blinks when the battery voltage falls below the voltage (1) shown in the table during transmission.

Note:

During reception, transceiver constantly checks the battery level. When the battery level drops near to 5.9V, the red LED blinks and low battery warning tone is generated.

- (2) The transceiver immediately stops transmission when the battery voltage falls below the voltage (2) shown in the table. The warning tone sounds while the PTT switch is pressed.

	Ni-MH Battery	Li-ion Battery
(1)	6.2V	6.2V
(2)	5.9V	5.9V

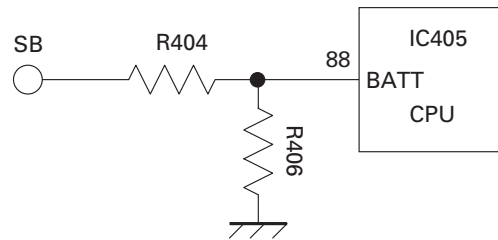

Fig. 3 Low battery warning

PARTS LIST

* New Parts. Δ indicates safety critical components.
 Parts without **Parts No.** are not supplied.
 Les articles non mentionnés dans le **Parts No.** ne sont pas fournis.
 Teile ohne **Parts No.** werden nicht geliefert.

L: Scandinavia K: USA P: Canada
 Y: PX (Far East, Hawaii) T: England E: Europe
 Y: AAFES (Europe) X: Australia M: Other Areas

TK-3200L (Y50-6200-XX) TX-RX UNIT (X57-6900-XX)

Ref. No.	Address	New parts	Parts No.	Description	Destination	Ref. No.	Address	New parts	Parts No.	Description	Destination
TK-3200L											
1	1A	*	A02-3985-03	PLASTIC CABINET ASSY(15CH+SCAN)	K3	A	2B		N14-0819-04	CIRCULAR NUT(VOL KNOB)	
	1A	*	A02-3986-03	PLASTIC CABINET ASSY(2CH)	K	B	2B		N14-0832-04	CIRCULAR NUT(CH KNOB)	
1	1A	*	A02-3987-03	PLASTIC CABINET ASSY(8CH)	K2	C	2A,2B		N30-2604-48	PAN HEAD MACHINE SCREW(SMA)	
2	3A	*	A10-4094-43	CHASSIS		D	3A		N30-2606-48	PAN HEAD MACHINE SCREW(CHASSIS)	
3	1B	*	A21-1645-23	DRESSING PANEL(8CH)	K2	E	2A,2B,3B		N83-2005-48	PAN HEAD TAPTITE SCREW(PCB)	
3	1B		A21-1646-13	DRESSING PANEL(2CH)	K	54	2C		N99-2046-05	SCREW SET ACCESSORY	
3	1B	*	A21-1655-03	DRESSING PANEL(15CH+SCAN)	K3	55	2B		R31-0661-05	VARIABLE RESISTOR(POWER SW/VOL)	
4	2C		B09-0680-03	CAP(SP/MIC) ACCESSORY		56	2B		S60-0434-05	ROTARY SWITCH(16CH)	K3
5	2B		B11-1817-04	ILLUMINATION GUIDE		56	2B		S60-0435-05	ROTARY SWITCH(8CH)	K,K2
6	1B		B43-1156-04	BADGE(KENWOOD)		57	1B	*	T07-0760-25	SPEAKER	
7	1A	*	B43-1604-04	BADGE(TK-3200L)		58	3D		T90-1039-15	WHIP ANTENNA ACCESSORY	
8	1C	*	B62-1978-00	INSTRUCTION MANUAL		59	1C		W08-0988-05	CHARGER ACCESSORY	
9	1A		D10-0649-03	LEVER		60	1D		W08-0989-05	AC ADAPTER(AC120V) ACCESSORY	
10	1A		D21-0863-04	SHAFT		TX-RX UNIT (X57-6900-XX) -12 :K -13 :K2 -14 :K3					
11	1A		D32-0441-03	STOPPER		D403			B30-2156-05	LED(RED)	
12	1B		D32-0443-04	STOPPER(2CH)	K	D404			B30-2157-05	LED(YELLOW)	
14	2A		E04-0465-05	RF COAXIAL RECEPTACLE(SMA)		C1			CK73HB1H332K	CHIP C 3300PF	K
15	3B		E23-1253-04	TERMINAL(BATT-)		C2			CK73HB1C682K	CHIP C 6800PF	K
16	2B		E37-1175-05	PROCESSED LEAD WIRE(BROWN:SP+)		C3			CK73GB1A105K	CHIP C 1.0UF	K
17	2B		E37-1176-05	PROCESSED LEAD WIRE(GREEN:SP-)		C4			CK73HB1C103K	CHIP C 0.010UF	K
18	3A		F20-3353-14	INSULATING SHEET(CHASSIS BATT+)		C5			CK73HB1H102K	CHIP C 1000PF	K
19	2A		G01-4542-04	COIL SPRING(LEVER)		C6			CK73HB1A104K	CHIP C 0.10UF	K
20	1A		G01-4543-04	COIL SPRING(STOPPER)		C7 ,8			CC73HCH1H101J	CHIP C 100PF	J
21	2B		G10-1330-04	FIBROUS SHEET(IC302:AUDIO IC)		C9			CC73HCH1H100C	CHIP C 10PF	C
22	3A		G11-4283-04	RUBBER SHEET(Q103:FINAL FET)		C10			CS77CPOJ100M	CHIP TINTL 10UF 6.3WV	
23	2A		G11-4313-04	SHEET(MIC ELEMENT)		C11			CC73HCH1H101J	CHIP C 100PF	J
24	3B		G13-2009-04	CUSHION(CHASSIS)		C12			CK73HB1H102K	CHIP C 1000PF	K
25	3A		G13-2033-04	CUSHION(TERMINAL BATT-)		C13			CK73HB1A104K	CHIP C 0.10UF	K
26	3B		G13-2034-14	CUSHION(TERMINAL BATT-)		C14			CK73HB1C103K	CHIP C 0.010UF	K
28	3A		G13-2038-24	CUSHION(CHASSIS-CERAMIC FILTER)		C15			CC73HCH1H100C	CHIP C 10PF	C
29	2A		G13-2039-14	CUSHION(PCB-CERAMIC FILTER)		C16			CK73HB1H102K	CHIP C 1000PF	K
30	2B		G13-2076-04	CUSHION(SP)		C17			CC73HCH1H470J	CHIP C 47PF	J
31	2B		G13-2088-04	CUSHION(CHASSIS VOL/CH)		C18			CC73HCH1H180J	CHIP C 18PF	J
32	3A		G53-1604-03	PACKING(CHASSIS)		C19			CK73HB1A104K	CHIP C 0.10UF	K
33	3A		G53-1605-03	PACKING(TERMINAL BATT+)		C21			CS77CPOJ100M	CHIP TINTL 10UF 6.3WV	
34	2B		G53-1606-13	PACKING(VOL/CH/LED)		C22			CS77AA1VR33M	CHIP TINTL 0.33UF 35WV	
35	1B		G53-1607-03	PACKING(SP/MIC)		C24			CK73HB1H102K	CHIP C 1000PF	K
36	2B		G53-1608-03	PACKING(SP)		C25			CC73HCH1H020B	CHIP C 2.0PF	B
37	2A		G53-1609-14	PACKING(MIC ELEMENT)		C26			CC73HCH1H300J	CHIP C 30PF	J
38	2B		G53-1610-04	PACKING(SMA)		C27			CS77CA1C3R3M	CHIP TINTL 3.3UF 16WV	
40	2C	*	H12-4221-05	PACKING FIXTURE		C29 ,30			CK73HB1H471K	CHIP C 470PF	K
42	1C	*	H25-0085-04	PROTECTION BAG (100/200/0.07)		C32			CS77CA1V0R1M	CHIP TINTL 0.1UF 35WV	
43	3D	*	H52-2181-02	ITEM CARTON CASE		C33 ,34			CK73HB1H102K	CHIP C 1000PF	K
44	2C		J19-5472-03	HOLDER(SP/MIC) ACCESSORY		C35			CC73HCH1H270J	CHIP C 27PF	J
45	2A		J19-5473-03	HOLDER ASSY(TERMINAL BATT+)		C38			CC73HCH1H050B	CHIP C 5.0PF	B
46	2B		J21-8478-04	HARDWARE FIXTURE(SP/MIC)		C39			CK73GB1H332K	CHIP C 3300PF	K
47	2B		J21-8525-03	MOUNTING HARDWARE(VOL/CH)		C40			CC73HCH1H030B	CHIP C 3.0PF	B
48	2D		J29-0734-05	BELT CLIP ACCESSORY		C41			CK73GB1H682K	CHIP C 6800PF	K
49	2B		J82-0092-05	FPC		C42			CC73HCH1H050B	CHIP C 5.0PF	B
50	1A		K29-9308-23	BUTTON KNOB(PTT)		C43			CC73HCH1H100C	CHIP C 10PF	C
51	1B		K29-9309-03	KNOB(VOL)		C44			CK73HB1H471K	CHIP C 470PF	K
52	1B		K29-9318-03	KNOB(CH)		C45			CK73GB1A105K	CHIP C 1.0UF	K
53	1A		K29-9364-03	BUTTON KNOB(SIDE1/SIDE2)		C47			CC73HCH1H101J	CHIP C 100PF	J

TK-3200L

PARTS LIST

TX-RX UNIT (X57-6900-XX)

Ref. No.	Address	New parts	Parts No.	Description	Destination	Ref. No.	Address	New parts	Parts No.	Description	Destination
C48			CK73HB1H471K	CHIP C 470PF K		C157			CC73GCH1H2R5B	CHIP C 2.5PF B	
C49			CC73HCH1H101J	CHIP C 100PF J		C158			CC73GCH1H101J	CHIP C 100PF J	
C50			CC73HCH1H100C	CHIP C 10PF C		C159			CC73GCH1H020C	CHIP C 2.0PF C	
						C160			CC73GCH1H020B	CHIP C 2.0PF B	
C52			CC73HCH1H070B	CHIP C 7.0PF B							
C54			CC73HCH1H060B	CHIP C 6.0PF B		C161			CC73GCH1H050B	CHIP C 5.0PF B	
C55			CC73HCH1H120J	CHIP C 12PF J		C163			CC73GCH1H030B	CHIP C 3.0PF B	
C58			CC73HCH1H060B	CHIP C 6.0PF B		C164			CC73GCH1H050B	CHIP C 5.0PF B	
C59			CC73HCH1H1R5B	CHIP C 1.5PF B		C166			CC73GCH1HR75B	CHIP C 0.75PF B	
						C168			CC73GCH1H010B	CHIP C 1.0PF B	
C60			CC73HCH1H010B	CHIP C 1.0PF B							
C61			CC73HCH1H030B	CHIP C 3.0PF B		C169			CC73GCH1H060B	CHIP C 6.0PF B	
C62			CC73HCH1H020B	CHIP C 2.0PF B		C190			CK73GB1A105K	CHIP C 1.0UF K	
C63			CC73HCH1H101J	CHIP C 100PF J		C191			CK73GB1H103K	CHIP C 0.010UF K	
C64			CC73HCH1H050B	CHIP C 5.0PF B		C201			CK73GB1A224K	CHIP C 0.22UF K	
						C205			CK73HB1H102K	CHIP C 1000PF K	
C65 ,66			CC73HCH1H070B	CHIP C 7.0PF B							
C67			CC73HCH1H050B	CHIP C 5.0PF B		C207			CK73HB1H182K	CHIP C 1800PF K	
C68 -70			CK73HB1H471K	CHIP C 470PF K		C208			CK73HB1H471K	CHIP C 470PF K	
C71 ,72			CK73HB1A104K	CHIP C 0.10UF K		C209			CS77CPOJ100M	CHIP TNL 10UF 6.3WV	
C73 ,74			CC73HCH1HOR5B	CHIP C 0.5PF B		C210			CK73HB1H471K	CHIP C 470PF K	
						C211			CK73HB1C103K	CHIP C 0.010UF K	
C75 ,76			CK73HB1H102K	CHIP C 1000PF K							
C77			CK73HB1H471K	CHIP C 470PF K		C213			CK73HB1A104K	CHIP C 0.10UF K	
C78			CC73HCH1H330J	CHIP C 33PF J		C214			CC73HCH1H680J	CHIP C 68PF J	
C79			CS77CPOJ100M	CHIP TNL 10UF 6.3WV		C215			CK73HB1H102K	CHIP C 1000PF K	
C80			CK73HB1H471K	CHIP C 470PF K		C216			CK73GB1C104K	CHIP C 0.10UF K	
						C217			CK73HB1A104K	CHIP C 0.10UF K	
C83			CC73HCH1H150J	CHIP C 15PF J							
C84 -86			CK73HB1H102K	CHIP C 1000PF K		C218			CK73GB1C104K	CHIP C 0.10UF K	
C87			CC73HCH1H100C	CHIP C 10PF C		C219			CC73HCH1H330J	CHIP C 33PF J	
C90			CK73HB1H102K	CHIP C 1000PF K		C220			CK73HB1H102K	CHIP C 1000PF K	
C100			CK73HB1H471K	CHIP C 470PF K		C221			CK73GB1C104K	CHIP C 0.10UF K	
						C222			CK73HB1H102K	CHIP C 1000PF K	
C101			CK73GB1H471K	CHIP C 470PF K							
C102			CC73GCH1H120J	CHIP C 12PF J		C224,225			CK73HB1C103K	CHIP C 0.010UF K	
C106			CK73HB1H471K	CHIP C 470PF K		C228			CC73GCH1H100C	CHIP C 10PF C	
C107			CC73GCH1H060B	CHIP C 6.0PF B		C230			CK73HB1C103K	CHIP C 0.010UF K	
C108			CK73HB1H471K	CHIP C 470PF K		C231			CK73GB1H103K	CHIP C 0.010UF K	
						C232			CK73HB1C103K	CHIP C 0.010UF K	
C110,111			CK73GB1H471K	CHIP C 470PF K							
C112			CC73GCH1H070D	CHIP C 7.0PF D		C233			CC73GCH1H060B	CHIP C 6.0PF B	
C113			CK73GB1C104K	CHIP C 0.10UF K		C234			CK73HB1H102K	CHIP C 1000PF K	
C116			CC73GCH1H120J	CHIP C 12PF J		C236			CC73GCH1H180J	CHIP C 18PF J	
C119			CK73GB1H471K	CHIP C 470PF K		C237			CK73HB1H102K	CHIP C 1000PF K	
						C238			CK73GB1C104K	CHIP C 0.10UF K	
C122,123			CC73GCH1H330J	CHIP C 33PF J							
C124			CC73HCH1H100C	CHIP C 10PF C		C239			CK73GB1H102K	CHIP C 1000PF K	
C126			CS77CA1C010M	CHIP TNL 1.0UF 16WV		C240			CC73GCH1H3R5B	CHIP C 3.5PF B	
C128			CK73HB1H471K	CHIP C 470PF K		C241			CK73GB1H471K	CHIP C 470PF K	
C129			CK73GB1H471K	CHIP C 470PF K		C244			CC73GCH1H2R5B	CHIP C 2.5PF B	
						C245			CC73GCH1H220J	CHIP C 22PF J	
C130			CK73HB1H471K	CHIP C 470PF K							
C132			CC73GCH1H200J	CHIP C 20PF J		C246			CC73GCH1H020B	CHIP C 2.0PF B	
C133			CK73GB1H471K	CHIP C 470PF K		C247			CK73HB1H471K	CHIP C 470PF K	
C134			CK73GB1H103K	CHIP C 0.010UF K		C248			CC73GCH1H020B	CHIP C 2.0PF B	
C135			CK73GB1C104K	CHIP C 0.10UF K		C249			CC73GCH1H4R5B	CHIP C 4.5PF B	
						C250			CC73GCH1H220J	CHIP C 22PF J	
C136			CK73GB1A105K	CHIP C 1.0UF K							
C138			CK73GB1H102K	CHIP C 1000PF K		C251			CK73HB1H471K	CHIP C 470PF K	
C140			CC73GCH1H101J	CHIP C 100PF J		C252			CC73GCH1H010B	CHIP C 1.0PF B	
C145			CC73GCH1H180J	CHIP C 18PF J		C253			CC73GCH1H1R5B	CHIP C 1.5PF B	
C146			CK73GB1H102K	CHIP C 1000PF K		C254			CK73HB1H471K	CHIP C 470PF K	
						C255			CC73GCH1H220J	CHIP C 22PF J	
C148			CK73GB1H102K	CHIP C 1000PF K							
C149			CC73GCH1H070B	CHIP C 7.0PF B		C256			CS77CPOJ4R7M	CHIP TNL 4.7UF 6.3WV	
C151			CC73GCH1H030B	CHIP C 3.0PF B		C257			CC73GCH1H040B	CHIP C 4.0PF B	
C152			CC73GCH1H200J	CHIP C 20PF J		C258			CK73HB1H471K	CHIP C 470PF K	
C154			CK73GB1H471K	CHIP C 470PF K		C259			CK73GB1H471K	CHIP C 470PF K	
						C262,263			CK73HB1H471K	CHIP C 470PF K	
C156			CC73GCH1H040B	CHIP C 4.0PF B							

PARTS LIST

TX-RX UNIT (X57-6900-XX)

Ref. No.	Address	New parts	Parts No.	Description	Destination	Ref. No.	Address	New parts	Parts No.	Description	Destination
C265			CK73HB1H471K	CHIP C 470PF K		C405			CC73GCH1H101J	CHIP C 100PF J	
C266			CK73GB1H471K	CHIP C 470PF K		C407			CK73HB1H102K	CHIP C 1000PF K	
C267			CC73GCH1H2R5B	CHIP C 2.5PF B		C409,410			CK73GB1A105K	CHIP C 1.0UF K	
C268			CC73GCH1H220J	CHIP C 22PF J		C411			CK73HB1H102K	CHIP C 1000PF K	
C269			CC73GCH1H020B	CHIP C 2.0PF B		C415			CK73HB1H471K	CHIP C 470PF K	
C270,271			CK73HB1H471K	CHIP C 470PF K		C417			CK73GB1A105K	CHIP C 1.0UF K	
C272			CC73GCH1H020B	CHIP C 2.0PF B		C418,419			CK73HB1H102K	CHIP C 1000PF K	
C273			CC73GCH1H220J	CHIP C 22PF J		C421			CK73GB1A105K	CHIP C 1.0UF K	
C275			CC73GCH1H2R5B	CHIP C 2.5PF B		C426,427			CK73GB1A105K	CHIP C 1.0UF K	
C276			CC73GCH1H040B	CHIP C 4.0PF B		C428,429			CK73HB1H102K	CHIP C 1000PF K	
C290			CC73GCH1H020B	CHIP C 2.0PF B		C430			CK73GB1H103K	CHIP C 0.010UF K	
C291			CC73GCH1H060B	CHIP C 6.0PF B		C431			CK73HB1C103K	CHIP C 0.010UF K	
C292			CK73HB1H102K	CHIP C 1000PF K		C432			CC73HCH1H050B	CHIP C 5.0PF B	
C301			CK73HB1H392K	CHIP C 3900PF K		C433,434			CC73HCH1H030B	CHIP C 3.0PF B	
C302			CK73HB1H271K	CHIP C 270PF K		C435			CC73HCH1H050B	CHIP C 5.0PF B	
C304			CK73GB1A224K	CHIP C 0.22UF K		C440			CC73GCH1H1R5B	CHIP C 1.5PF B	
C306			CS77CP0J4R7M	CHIP TNL 4.7UF 6.3WV		C443			CK73GB1A474K	CHIP C 0.47UF K	
C307,308			CK73HB1A104K	CHIP C 0.10UF K		C901,902			CK73GB1A105K	CHIP C 1.0UF K	
C309			CC73GCH1H820J	CHIP C 82PF J		C904			CC73GCH1H200J	CHIP C 20PF J	
C310			CK73HB1A683K	CHIP C 0.068UF K		C905			CC73GCH1H060B	CHIP C 6.0PF B	
C311			CK73GB1A105K	CHIP C 1.0UF K		TC1 ,2			C05-0384-05	CERAMIC TRIMMER CAPACITOR(10PF)	
C312			CC73GCH1H120J	CHIP C 12PF J		CN201			E23-1278-05	TERMINAL	
C313			CC73GCH1H121J	CHIP C 120PF J		CN401			E40-6573-05	FLAT CABLE CONNECTOR	
C314			CK73HB1A104K	CHIP C 0.10UF K		J301			E11-0707-05	PHONE JACK(2.5/3.5)	
C315			CK73GB1A105K	CHIP C 1.0UF K		F401			F53-0324-05	FUSE(2.5A)	
C316			CK73GB1C104K	CHIP C 0.10UF K		101	2A		J30-1282-14	SPACER(MIC ELEMENT)	
C317			CK73HB1A104K	CHIP C 0.10UF K		CD201			L79-1582-05	TUNING COIL	
C318			CS77CP0J4R7M	CHIP TNL 4.7UF 6.3WV		CF201	2A		L72-0973-05	CERAMIC FILTER	
C319			CC73GCH1H271J	CHIP C 270PF J		L1			L40-4791-37	SMALL FIXED INDUCTOR(4.700UH)	
C320			CK73HB1C103K	CHIP C 0.010UF K		L3			L40-5681-86	SMALL FIXED INDUCTOR(0.56UH)	
C321			CK73GB1A105K	CHIP C 1.0UF K		L5			L40-5681-86	SMALL FIXED INDUCTOR(0.56UH)	
C322			CK73HB1C153K	CHIP C 0.015UF K		L6 ,7			L92-0138-05	CHIP FERRITE	
C323			CC73GCH1H820J	CHIP C 82PF J		L8 ,9			L41-1875-06	SMALL FIXED INDUCTOR(18NH)	
C324			CC73HCH1H820J	CHIP C 82PF J		L10 ,11			L41-1085-06	SMALL FIXED INDUCTOR(100NH)	
C325			CK73HB1A104K	CHIP C 0.10UF K		L12			L92-0138-05	CHIP FERRITE	
C326			CK73HB1H102K	CHIP C 1000PF K		L13 ,14			L41-1085-06	SMALL FIXED INDUCTOR(100NH)	
C327			CC73HCH1H101J	CHIP C 100PF J		L16 ,17			L40-2778-67	SMALL FIXED INDUCTOR(27NH)	
C328			CK73HB1H391K	CHIP C 390PF K		L18 ,19			L41-2285-03	SMALL FIXED INDUCTOR(220NH)	
C329,330			CK73GB1A105K	CHIP C 1.0UF K		L20 ,21			L40-3391-86	SMALL FIXED INDUCTOR(3.3UH)	
C331			CK73HB1A104K	CHIP C 0.10UF K		L22			L92-0138-05	CHIP FERRITE	
C332			CK73HB1H471K	CHIP C 470PF K		L23			L41-2275-06	SMALL FIXED INDUCTOR(22NH)	
C333,334			CK73GB1C104K	CHIP C 0.10UF K		L24			L92-0470-05	CHIP FERRITE	
C335			CC73GCH1H221J	CHIP C 220PF J		L25			L41-2275-06	SMALL FIXED INDUCTOR(22NH)	
C336			CK73FB1C474K	CHIP C 0.47UF K		L100,101			L41-1575-06	SMALL FIXED INDUCTOR(15NH)	
C338			CC73GCH1H101J	CHIP C 100PF J		L102			L92-0138-05	CHIP FERRITE	
C339			CS77AA0J100M	CHIP TNL 10UF 6.3WV		L103			L40-8265-92	SMALL FIXED INDUCTOR(8.2NH)	
C340			CK73GB1C104K	CHIP C 0.10UF K		L105			L40-1575-54	SMALL FIXED INDUCTOR(15NH)	
C341			CK73GB1C473K	CHIP C 0.047UF K		L106			L92-0149-05	CHIP FERRITE	
C342			CS77AA0J100M	CHIP TNL 10UF 6.3WV		L107			L40-1263-92	SMALL FIXED INDUCTOR(1.2NH)	
C343			CK73GB1C473J	CHIP C 0.047UF J		L109			L92-0149-05	CHIP FERRITE	
C344			CC73GCH1H221J	CHIP C 220PF J		L110			L40-2285-54	SMALL FIXED INDUCTOR(220NH)	
C345			CS77CC0J101M	CHIP TNL 100UF 6.3WV		L111			L41-1092-44	SMALL FIXED INDUCTOR(1UH)	
C346			CK73GB1H102K	CHIP C 1000PF K		L201			L40-1091-37	SMALL FIXED INDUCTOR(1.000UH)	
C348			CK73HB1H471K	CHIP C 470PF K		L202			L92-0138-05	CHIP FERRITE	
C351,352			CK73HB1C103K	CHIP C 0.010UF K		L203			L41-5685-39	SMALL FIXED INDUCTOR(0.56UH)	
C354			CK73HB1A104K	CHIP C 0.10UF K							
C355			CK73GB1C104K	CHIP C 0.10UF K							
C401			CC73GCH1H471J	CHIP C 470PF J							
C402			CK73HB1H102K	CHIP C 1000PF K							
C403			CK73GB1C104K	CHIP C 0.10UF K							

If a part reference number is listed in a shaded box, that part does not come with the PCB.

TK-3200L

PARTS LIST

TX-RX UNIT (X57-6900-XX)

Ref. No.	Address	New parts	Parts No.	Description	Destination	Ref. No.	Address	New parts	Parts No.	Description	Destination
L204			L40-2785-92	SMALL FIXED INDUCTOR(270NH)		R46			RK73HB1J103J	CHIP R 10K J 1/16W	
L211,212			L41-8268-14	SMALL FIXED INDUCTOR(8.2NH)		R47			RK73HB1J220J	CHIP R 22 J 1/16W	
L214			L41-8268-14	SMALL FIXED INDUCTOR(8.2NH)		R48			RK73HB1J331J	CHIP R 330 J 1/16W	
L215			L41-2285-03	SMALL FIXED INDUCTOR(220NH)		R49			RK73HB1J222J	CHIP R 2.2K J 1/16W	
L220			L34-4602-05	AIR-CORE COIL		R50			RK73HB1J472J	CHIP R 4.7K J 1/16W	
L223			L34-4572-05	AIR-CORE COIL		R100			RK73HB1J472J	CHIP R 4.7K J 1/16W	
L224-226			L34-4564-05	AIR-CORE COIL		R103			RK73GB2A473J	CHIP R 47K J 1/10W	
L228,229			L41-8268-14	SMALL FIXED INDUCTOR(8.2NH)		R105			RK73GB2A331J	CHIP R 330 J 1/10W	
L230			L41-3978-03	SMALL FIXED INDUCTOR(39NH)		R106			RK73GB2A220J	CHIP R 22 J 1/10W	
L250			L41-1875-06	SMALL FIXED INDUCTOR(18NH)		R107			RK73HB1J101J	CHIP R 100 J 1/16W	
L290			L41-3078-17	SMALL FIXED INDUCTOR(30NH)		R109			RK73HB1J103J	CHIP R 10K J 1/16W	
L301			L92-0140-05	CHIP FERRITE		R110			RK73GB2A331J	CHIP R 330 J 1/10W	
L302			L92-0149-05	CHIP FERRITE		R112			RK73GB2A000J	CHIP R 0.0 J 1/10W	
L401			L92-0149-05	CHIP FERRITE		R114			RK73GB2A473J	CHIP R 47K J 1/10W	
L402-404			L92-0138-05	CHIP FERRITE		R115			RK73GB2A822J	CHIP R 8.2K J 1/10W	
L410			L92-0138-05	CHIP FERRITE		R116			RK73GB2A220J	CHIP R 22 J 1/10W	
L411			L41-1875-06	SMALL FIXED INDUCTOR(18NH)		R121			RK73GB2A220J	CHIP R 22 J 1/10W	
L412			L40-8265-92	SMALL FIXED INDUCTOR(8.2NH)		R124			RK73GB2A333J	CHIP R 33K J 1/10W	
X1			L77-1931-05	TCXO(12.8MHZ)		R126			RK73GB2A222J	CHIP R 2.2K J 1/10W	
X2			L78-1414-05	RESONATOR(7.37MHZ)		R127-129			RK73EB2ER39K	CHIP R 0.39 K 1/4W	
XF201			L71-0619-05	MCF(38.85MHZ)		R130-135			RK73GH2A154D	CHIP R 150K D 1/10W	
CP404			RK75HA1J473J	CHIP-COM 47K J 1/16W		R137			RK73FB2B000J	CHIP R 0.0 J 1/8W	
CP405			RK75HA1J102J	CHIP-COM 1.0K J 1/16W		R138			RK73GB2A105J	CHIP R 1.0M J 1/10W	
R1			RK73HB1J104J	CHIP R 100K J 1/16W		R139			RK73GB2A473J	CHIP R 47K J 1/10W	
R2			RK73HB1J103J	CHIP R 10K J 1/16W		R140			RK73GB2A563J	CHIP R 56K J 1/10W	
R3			RK73HB1J333J	CHIP R 33K J 1/16W		R141			RK73GB2A104J	CHIP R 100K J 1/10W	
R4			RK73HB1J563J	CHIP R 56K J 1/16W		R142			RK73GB2A000J	CHIP R 0.0 J 1/10W	
R5 ,6			RK73HB1J104J	CHIP R 100K J 1/16W		R143			RK73GB2A104J	CHIP R 100K J 1/10W	
R7			RK73HB1J101J	CHIP R 100 J 1/16W		R145			RK73GB2A000J	CHIP R 0.0 J 1/10W	
R8 -11			RK73HB1J000J	CHIP R 0.0 J 1/16W		R147			RK73GB2A000J	CHIP R 0.0 J 1/10W	
R12			RK73HB1J222J	CHIP R 2.2K J 1/16W		R150-152			RK73GB2A000J	CHIP R 0.0 J 1/10W	
R13			RK73GB2A000J	CHIP R 0.0 J 1/10W		R190			RK73GB2A101J	CHIP R 100 J 1/10W	
R14			RK73HB1J334J	CHIP R 330K J 1/16W		R191,192			RK73GB2A271J	CHIP R 270 J 1/10W	
R15			RK73GB2A221J	CHIP R 220 J 1/10W		R193,194			RK73GB2A473J	CHIP R 47K J 1/10W	
R16			RK73GB2A561J	CHIP R 560 J 1/10W		R203			RK73HB1J184J	CHIP R 180K J 1/16W	
R17			RK73HB1J101J	CHIP R 100 J 1/16W		R206			RK73GB2A100J	CHIP R 10 J 1/10W	
R18			RK73GB2A181J	CHIP R 180 J 1/10W		R207			RK73HB1J472J	CHIP R 4.7K J 1/16W	
R19			RK73GB2A122J	CHIP R 1.2K J 1/10W		R208			RK73HB1J823J	CHIP R 82K J 1/16W	
R20			RK73HB1J100J	CHIP R 10 J 1/16W		R209			RK73HB1J272J	CHIP R 2.7K J 1/16W	
R21			RK73GB2A681J	CHIP R 680 J 1/10W		R210,211			RK73HB1J332J	CHIP R 3.3K J 1/16W	
R22			RK73GB2A000J	CHIP R 0.0 J 1/10W		R212			RK73HB1J823J	CHIP R 82K J 1/16W	
R23			RK73GB2A103J	CHIP R 10K J 1/10W		R213			RK73HB1J392J	CHIP R 3.9K J 1/16W	
R25			RK73HB1J223J	CHIP R 22K J 1/16W		R215			RK73HB1J101J	CHIP R 100 J 1/16W	
R26			RK73HB1J103J	CHIP R 10K J 1/16W		R216			RK73HB1J124J	CHIP R 120K J 1/16W	
R27			RK73HB1J220J	CHIP R 22 J 1/16W		R217			RK73HB1J472J	CHIP R 4.7K J 1/16W	
R30			RK73HB1J333J	CHIP R 33K J 1/16W		R218			RK73HB1J561J	CHIP R 560 J 1/16W	
R31			RK73HB1J474J	CHIP R 470K J 1/16W		R219			RK73GB2A561J	CHIP R 560 J 1/10W	
R32			RK73HB1J102J	CHIP R 1.0K J 1/16W		R226,227			RK73GB2A102J	CHIP R 1.0K J 1/10W	
R33			RK73HB1J154J	CHIP R 150K J 1/16W		R228			RK73GB2A151J	CHIP R 150 J 1/10W	
R34			RK73HB1J474J	CHIP R 470K J 1/16W		R233			RK73HB1J104J	CHIP R 100K J 1/16W	
R35 ,36			RK73HB1J274J	CHIP R 270K J 1/16W		R236			RK73HB1J563J	CHIP R 56K J 1/16W	
R37			RK73HB1J101J	CHIP R 100 J 1/16W		R238			RK73HB1J104J	CHIP R 100K J 1/16W	
R38			RK73HB1J181J	CHIP R 180 J 1/16W		R239			RK73HB1J563J	CHIP R 56K J 1/16W	
R39			RK73HB1J151J	CHIP R 150 J 1/16W		R240			RK73GB2A000J	CHIP R 0.0 J 1/10W	
R40			RK73HB1J101J	CHIP R 100 J 1/16W		R241			RK73HB1J105J	CHIP R 1.0M J 1/16W	
R41			RK73HB1J154J	CHIP R 150K J 1/16W		R243,244			RK73HB1J105J	CHIP R 1.0M J 1/16W	
R42			RK73HB1J472J	CHIP R 4.7K J 1/16W		R248			RK73GB2A221J	CHIP R 220 J 1/10W	
R43			RK73HB1J101J	CHIP R 100 J 1/16W		R249			RK73GB2A220J	CHIP R 22 J 1/10W	
						R251			RK73HB1J104J	CHIP R 100K J 1/16W	
						R253			RK73HB1J104J	CHIP R 100K J 1/16W	

PARTS LIST

TX-RX UNIT (X57-6900-XX)

Ref. No.	Address	New parts	Parts No.	Description	Destination	Ref. No.	Address	New parts	Parts No.	Description	Destination
R254			RK73HB1J683J	CHIP R 68K J 1/16W		R416-420			RK73HB1J473J	CHIP R 47K J 1/16W	K
R255			RK73GB2A000J	CHIP R 0.0 J 1/10W		R417-420			RK73HB1J473J	CHIP R 47K J 1/16W	K2,K3
R256,257			RK73HB1J105J	CHIP R 1.0M J 1/16W		R421,422			RK73HB1J102J	CHIP R 1.0K J 1/16W	
R258			RK73FB2B000J	CHIP R 0.0 J 1/8W		R423			RK73HB1J000J	CHIP R 0.0 J 1/16W	
R299			RK73HB1J000J	CHIP R 0.0 J 1/16W		R424,425			RK73HB1J473J	CHIP R 47K J 1/16W	
R301			RK73HB1J103J	CHIP R 10K J 1/16W		R426			RK73HB1J000J	CHIP R 0.0 J 1/16W	
R304			RK73HB1J273J	CHIP R 27K J 1/16W		R435			RK73HB1J473J	CHIP R 47K J 1/16W	
R305			RK73HB1J104J	CHIP R 100K J 1/16W		R436			RK73GB2A000J	CHIP R 0.0 J 1/10W	
R306			RK73HB1J102J	CHIP R 1.0K J 1/16W		R437,438			RK73HB1J473J	CHIP R 47K J 1/16W	
R307,308			RK73HB1J000J	CHIP R 0.0 J 1/16W		R445,446			RK73GB2A000J	CHIP R 0.0 J 1/10W	
R310			RK73GB2A394J	CHIP R 390K J 1/10W		R447			RK73HB1J123J	CHIP R 12K J 1/16W	
R311			RK73HB1J123J	CHIP R 12K J 1/16W		R453			RK73HB1J223J	CHIP R 22K J 1/16W	
R312			RK73GB2A334J	CHIP R 330K J 1/10W		R456			RK73HB1J473J	CHIP R 47K J 1/16W	K3
R313			RK73GB2A104J	CHIP R 100K J 1/10W		R456,457			RK73HB1J473J	CHIP R 47K J 1/16W	K2
R314			RK73GB2A103J	CHIP R 10K J 1/10W		R457			RK73HB1J473J	CHIP R 47K J 1/16W	K
R315			RK73GB2A334J	CHIP R 330K J 1/10W		R901,902			RK73GB2A472J	CHIP R 4.7K J 1/10W	
R316			RK73GB2A124J	CHIP R 120K J 1/10W		R903			RK73GB2A000J	CHIP R 0.0 J 1/10W	
R317			RK73GB2A474J	CHIP R 470K J 1/10W		VR1		R32-0736-05		SEMI FIXED VARIABLE RESISTOR(68K)	
R318			RK73GB2A122J	CHIP R 1.2K J 1/10W		\$401-403		S70-0414-05		TACT SWITCH	
R319			RK73HB1J563J	CHIP R 56K J 1/16W		MIC301	2A	T91-0651-15		MIC ELEMENT	
R320			RK73HB1J332J	CHIP R 3.3K J 1/16W		D1		MA2S111-F		DIODE	
R321			RK73HB1J224J	CHIP R 220K J 1/16W		D2 -9		HVC376B		VARIABLE CAPACITANCE DIODE	
R322			RK73HB1J184J	CHIP R 180K J 1/16W		D10		1SV278F		VARIABLE CAPACITANCE DIODE	
R323			RK73HB1J563J	CHIP R 56K J 1/16W		D11		MA2S111-F		DIODE	
R324,325			RK73GB2A104J	CHIP R 100K J 1/10W		D101		HSC277		DIODE	
R326			RK73GB2A000J	CHIP R 0.0 J 1/10W		D102		HZU5CLL		ZENER DIODE	
R327			RK73GB2A184J	CHIP R 180K J 1/10W		D103,104		HVC131		DIODE	
R328			RK73GB2A103J	CHIP R 10K J 1/10W		D106		HVC131		DIODE	
R329			RK73GB2A823J	CHIP R 82K J 1/10W		D122		HVC131		DIODE	
R330			RK73HB1J332J	CHIP R 3.3K J 1/16W		D202		HSC277		DIODE	
R331			RK73GB2A154J	CHIP R 150K J 1/10W		D203-206		HVC355B		VARIABLE CAPACITANCE DIODE	
R332			RK73GB2A153J	CHIP R 15K J 1/10W		D210		HVC355B		VARIABLE CAPACITANCE DIODE	
R334			RK73GB2A473J	CHIP R 47K J 1/10W		D301,302		RB706F-40		DIODE	
R335			RK73GB2A222J	CHIP R 2.2K J 1/10W		D303		DAN222		DIODE	
R336			RK73GB2A102J	CHIP R 1.0K J 1/10W		D401		RB521S-30		DIODE	
R337			RK73GB2A151J	CHIP R 150 J 1/10W		D402		1SR154-400		DIODE	
R338			RK73HB1J222J	CHIP R 2.2K J 1/16W		D405		KDZ3.3V		ZENER DIODE	
R339			RK73GB2A471J	CHIP R 470 J 1/10W		IC1		MB15A02PFV2E1		MOS-IC	
R340			RK73GB2A182J	CHIP R 1.8K J 1/10W		IC101		TA75W01FUF		MOS-IC	
R341			RK73GB2A103J	CHIP R 10K J 1/10W		IC201		TA31136FNG		MOS-IC	
R342			RK73GB2A100J	CHIP R 10 J 1/10W		IC301		AQUA-L		MOS-IC	
R343			RK73GB2A474J	CHIP R 470K J 1/10W		IC302		TA7368FG		MOS-IC	
R344			RK73GB2A102J	CHIP R 1.0K J 1/10W		IC401,402		XC6204B502MR		MOS-IC	
R345,346			RK73GB2A101J	CHIP R 100 J 1/10W		IC403		BD4840FVE		MOS-IC	
R347			RK73GB2A104J	CHIP R 100K J 1/10W		IC404		BD4845FVE		MOS-IC	
R348			RK73GB2A563J	CHIP R 56K J 1/10W		IC405	*	30622MAPA49GU		MICROCONTROLLER IC	
R349			RK73GB2A333J	CHIP R 33K J 1/10W		IC406		BR24L08F-W		ROM IC	
R350			RK73HB1J000J	CHIP R 0.0 J 1/16W		Q1		KTC4082		TRANSISTOR	
R354,355			RK73HB1J103J	CHIP R 10K J 1/16W		Q2		2SC5108(Y)F		TRANSISTOR	
R357			RK73HB1J000J	CHIP R 0.0 J 1/16W		Q3 ,4		2SK508NV(K52)		FET	
R360			RK73HB1J000J	CHIP R 0.0 J 1/16W		Q5		RT1P430U		TRANSISTOR	
R388			RK73HB1J000J	CHIP R 0.0 J 1/16W		Q6		2SC5108(Y)F		TRANSISTOR	
R403			RK73GB2A101J	CHIP R 100 J 1/10W		Q7		RT1P430U		TRANSISTOR	
R404			RK73HB1J474D	CHIP R 470K D 1/16W		Q8		2SC5383-T111		TRANSISTOR	
R405			RK73GB2A334J	CHIP R 330K J 1/10W		Q9		2SC4619(P,Q)		TRANSISTOR	
R406			RK73HB1J474D	CHIP R 470K D 1/16W		Q100		2SC4619(P,Q)		TRANSISTOR	
R407			RK73HB1J334J	CHIP R 330K J 1/16W		Q101		2SK3077F		FET	
R408-412			RK73HB1J473J	CHIP R 47K J 1/16W							
R413,414			RK73GB2A331J	CHIP R 330 J 1/10W							
R415			RK73HB1J473J	CHIP R 47K J 1/16W	K3						

TK-3200L

PARTS LIST

TX-RX UNIT (X57-6900-XX)

Ref. No.	Address	New parts	Parts No.	Description	Destination	Ref. No.	Address	New parts	Parts No.	Description	Destination
Q102			2SK2596	FET							
Q103			2SK3476-F	FET							
Q104			RT1N141U	TRANSISTOR							
Q105			2SK679(Y)F	FET							
Q107			RT1N141U	TRANSISTOR							
Q108			2SK1824-A	FET							
Q109			RT1P441U	TRANSISTOR							
Q202			RT1P441U	TRANSISTOR							
Q203			2SC4649(N,P)	TRANSISTOR							
Q204,205			3SK318	FET							
Q301			RT1P141U	TRANSISTOR							
Q302			2SC4919	TRANSISTOR							
Q303			RT1N441U	TRANSISTOR							
Q304			2SA1362-F(GR)	TRANSISTOR							
Q305			RT1N441U	TRANSISTOR							
Q306			2SK3577-A	FET							
Q316			2SK3577-A	FET							
Q317,318			2SK1824-A	FET							
Q401,402			RT1N141U	TRANSISTOR							
Q403,404			CPH3317	FET							
Q405			RT1P237U-T111	TRANSISTOR							
Q407,408			2SK1830F	FET							
Q901			2SK1824-A	FET							
TH101			B57331V2104J	THERMISTOR							
TH203			B57331V2104J	THERMISTOR							

EXPLODED VIEW

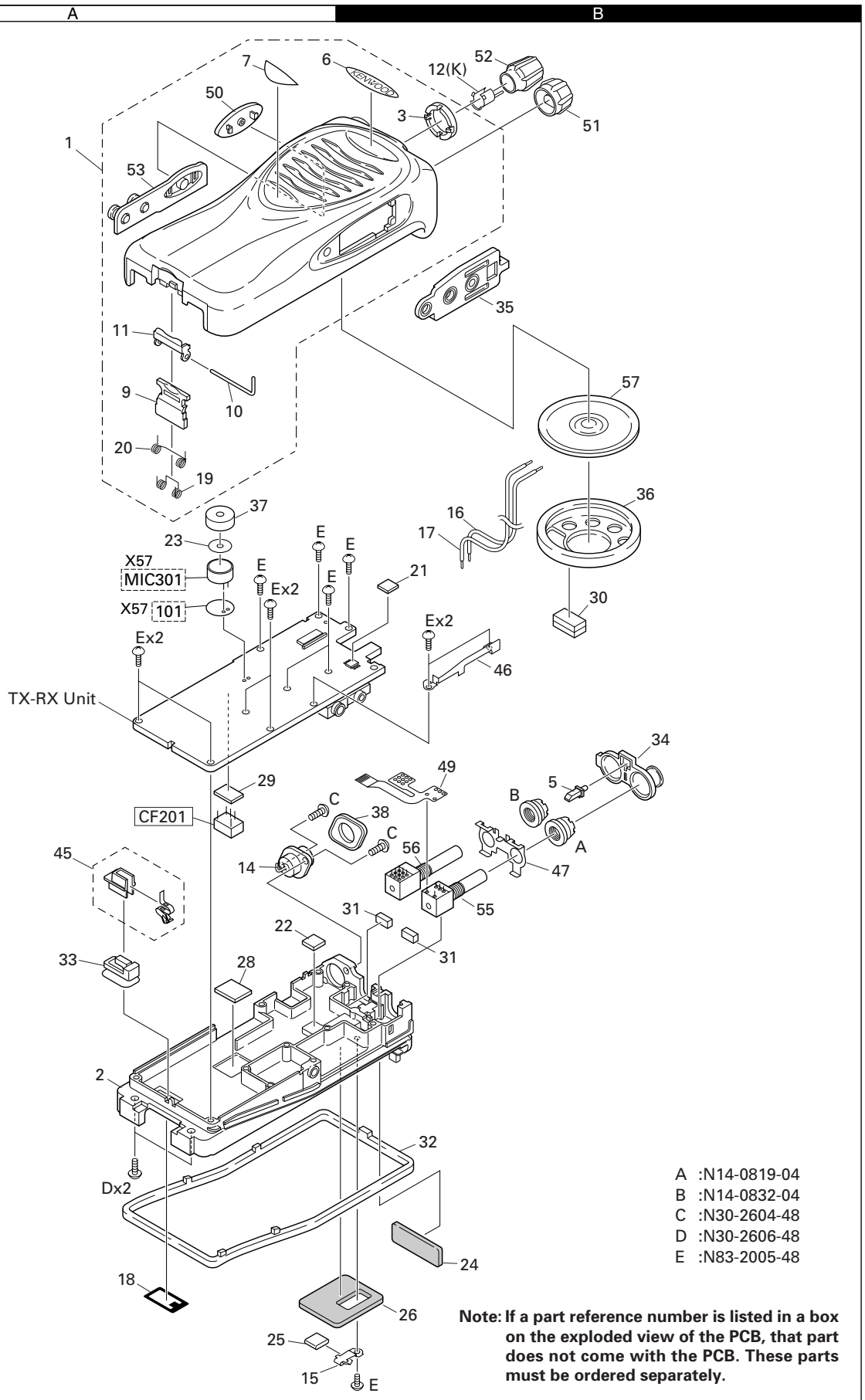

- A :N14-0819-04
- B :N14-0832-04
- C :N30-2604-48
- D :N30-2606-48
- E :N83-2005-48

PACKING

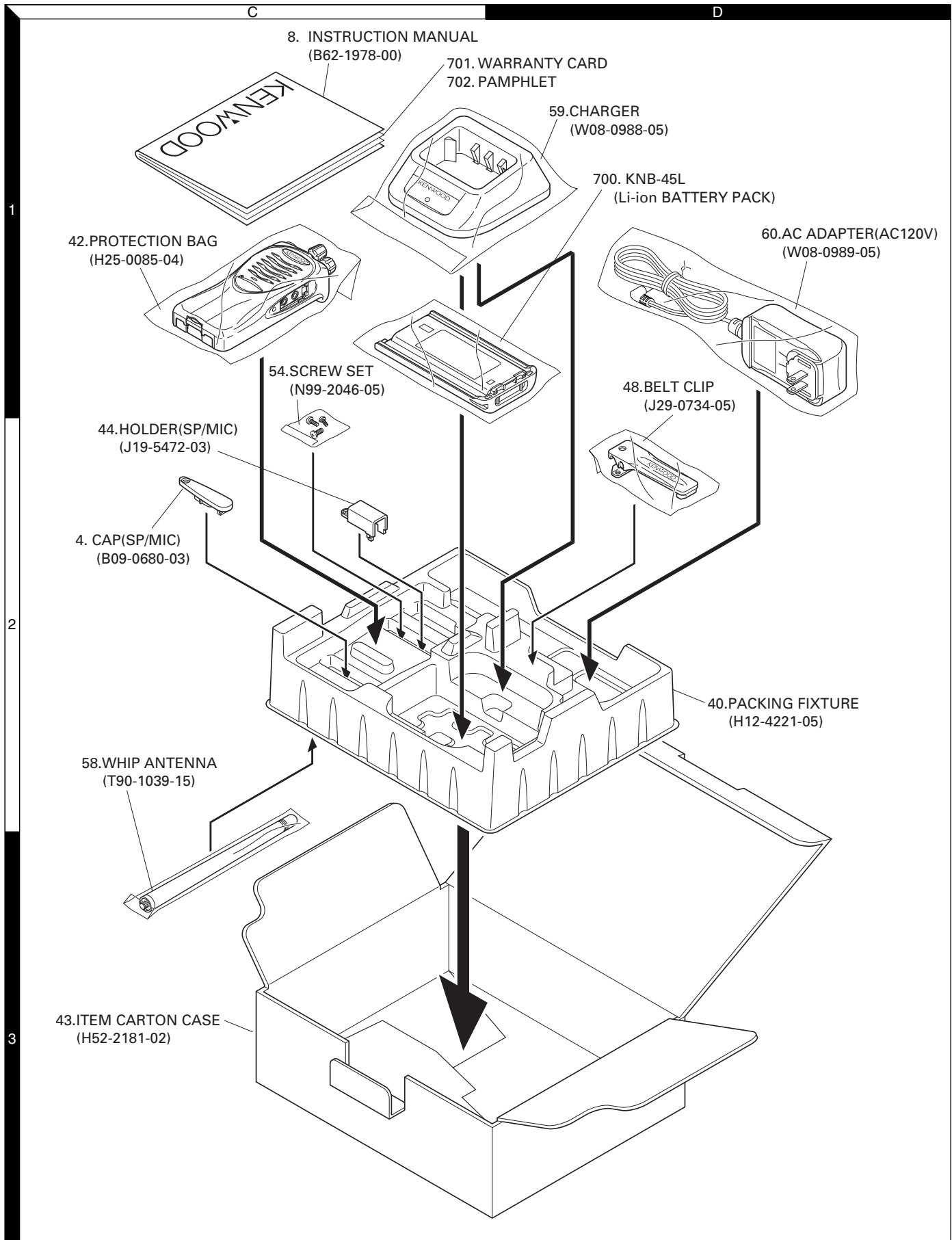

ADJUSTMENT

Test Equipment Required for Alignment

Test Equipment	Major Specifications	
1. Standard Signal Generator (SSG)	Frequency Range	450 to 470MHz
	Modulation	Frequency modulation and external modulation
	Output	-127dBm/0.1μV to greater than -47dBm/1mV
2. Power Meter	Input Impedance	50Ω
	Operation Frequency	450 to 470MHz
	Measurement Range	Vicinity of 10W
3. Deviation Meter	Frequency Range	450 to 470MHz
4. Digital Volt Meter (DVM)	Measuring Range	10mV to 10V DC
	Input Impedance	High input impedance for minimum circuit loading
5. Oscilloscope		DC through 30MHz
6. High Sensitivity Frequency Counter	Frequency Range	10Hz to 1000MHz
	Frequency Stability	0.2ppm or less
7. Ammeter		5A
8. AF Volt Meter (AF VTVM)	Frequency Range	50Hz to 10kHz
	Voltage Range	1mV to 10V
9. Audio Generator (AG)	Frequency Range	50Hz to 5kHz or more
	Output	0 to 1V
10. Distortion Meter	Capability	3% or less at 1kHz
	Input Level	50mV to 10Vrms
11. Spectrum Analyzer	Measuring Range	DC to 1GHz or more
12. Tracking Generator	Center frequency	50kHz to 600MHz
	Output Voltage	100mV or more
13. 8Ω Dummy Load		Approx. 8Ω, 3W
14. Regulated Power Supply		5V to 10V, approx. 3A Useful if ammeter equipped

■ The following parts are required for adjustment

1. Antenna connector adapter

The antenna connector of this transceiver uses an SMA terminal.

Use an antenna connector adapter [SMA(f) – BNC(f) or SMA(f) – N(f)] for adjustment. (The adapter is not provided as an option, so buy a commercially-available one.)

2. Repair Jig (Chassis)

Use jig (part No.: A10-4086-03) for repairing the transceiver. Place the TX-RX unit on the jig and fit it with screws.

The jig facilitates the voltage check and protects the final amplifier FET when the voltage on the flow side of the TX-RX unit is checked during repairs.

3. Battery Jig (W05-1011-00)

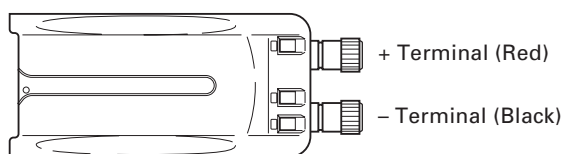

Connect the power cable properly between the battery jig installed in the transceiver and the power supply, and be sure output voltage and the power supply polarity prior to switching the power supply ON, otherwise over voltage and reverse connection may damage the transceiver, or the power supply or both.

Note: When using the battery jig, you must measure the voltage at the terminals of the battery jig. Otherwise, a slight voltage drop may occur within the power cable, between the power supply and the battery jig, especially while the transceiver transmits.

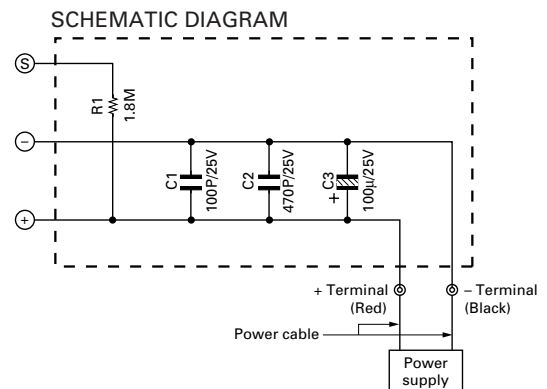

TK-3200L

ADJUSTMENT

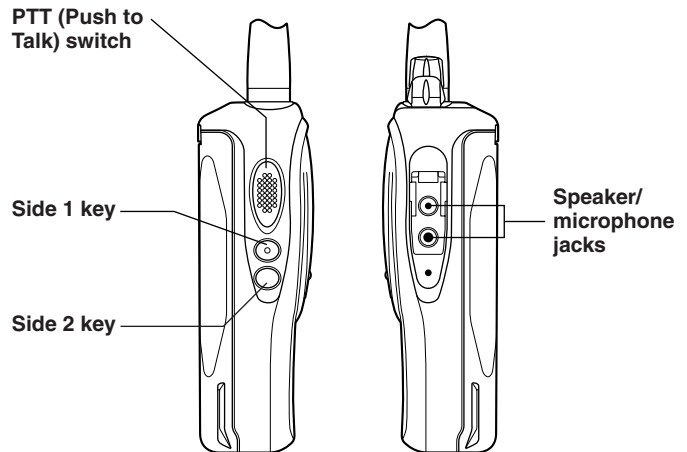
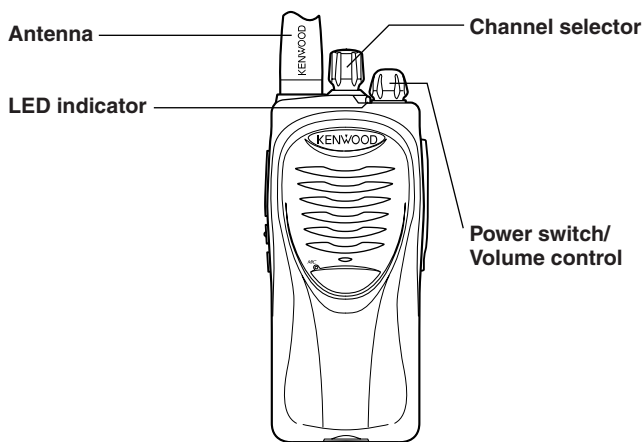

Adjustment points

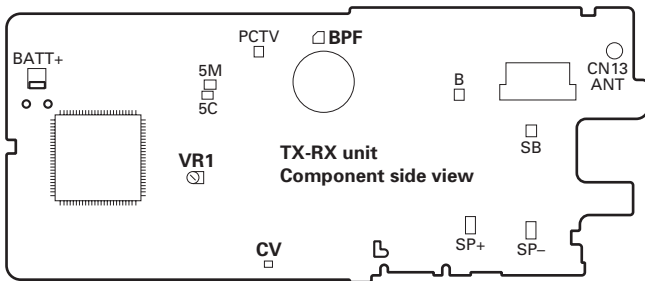

VR1 : Frequency adjustment
 BPF : Band-pass wave form test point
 CV : VCO lock voltage adjustment terminal

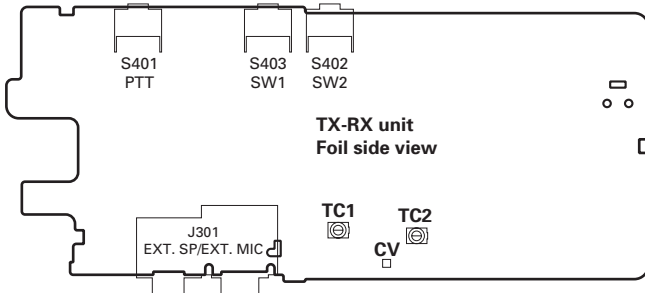

TC1 : Transmit VCO lock voltage adjustment
 TC2 : Receive VCO lock voltage adjustment
 CV : VCO lock voltage adjustment terminal

■ Frequency and signaling

The transceiver has been adjusted for the frequencies shown in the following table. When required, readjust them following the adjustment procedure to obtain the frequencies you want in actual operation.

Frequency (MHz)

Channel No.	RX Frequency	TX Frequency
1	460.050	460.100
2	450.050	450.100
3	469.950	469.900
4	460.000	460.000
5	460.200	460.200
6	460.400	460.400
7	455.050	455.100
8	465.050	465.100

Signaling

Signaling No.	RX	TX
1	None	None
2	None	100Hz Square Wave
3	QT 67.0Hz	QT 67.0Hz
4	QT 151.4Hz	QT 151.4Hz
5	QT 250.3Hz	QT 250.3Hz
6	DQT D023N	DQT D023N
7	DQT D754I	DQT D754I
8	DTMF 159D	DTMF 159D
9	None	DTMF tone 9

• Preparations for tuning the transceiver

Before attempting to tune the transceiver, connect the unit to a suitable power supply.

Whenever the transmitter is tuned, the unit must be connected to a suitable dummy load (i.e. power meter).

The speaker output connector must be terminated with a 8Ω dummy load and connected to an AC voltmeter and an audio distortion meter or a SINAD measurement meter at all times during tuning.

Adjustment Frequency

TEST CH	RX Frequency	TX Frequency
Low	450.050MHz	450.100MHz
Low'	455.050MHz	455.100MHz
Center	460.050MHz	460.100MHz
High'	465.050MHz	465.100MHz
High	469.950MHz	469.900MHz

ADJUSTMENT

Common Section

Item	Condition	Measurement		Adjustment		Specifications/ Remark
		Test equipment	Terminal	Parts	Method	
1.Setting	1) BATT terminal voltage:7.5V 2) SSG standard modulation [Wide] MOD:1kHz,DEV:3kHz [Narrow] MOD:1kHz,DEV:1.5kHz					
2.VCO lock voltage RX	1) CH:High	Power meter	ANT CV	TC2	2.5V	±0.1V
	2) CH:Low	DVM			Check	0.6V or more
3.VCO lock voltage TX	3) CH:High PTT:ON			TC1	3.0V	±0.1V
	4) CH:Low PTT:ON				Check	0.6V or more

Transmitter Section

Item	Condition	Measurement		Adjustment		Specifications/ Remark
		Test equipment	Terminal	Parts	Method	
1.Frequency Adjust	1) CH:High 2) PTT:ON	Frequency counter	ANT	VR1	High frequency ±50Hz	Note: After replacing the TCXO (X1) align frequency.
2.High power Adjust	TEST CH: Low Low' Center High' High (5 points) BATT terminal voltage:7.5V PTT:ON	Power meter Ammeter		Programming Software:KPG-88D	2.0W	±0.1W 1.3 A or less
3.Low power Adjust	TEST CH: Low Low' Center High' High (5 points) BATT terminal voltage:7.5V PTT:ON				1.0W	±0.1W 1.0 A or less
4.DQT balance Adjust [Wide]	TEST CH: Center Low High (3 points) LPF:3kHz HPF:OFF PTT:ON	Power meter Deviation meter Oscilloscope AG AF VTVM				Make the demodulation wave into square waves.
[Narrow]	TEST CH:Center PTT:ON					

ADJUSTMENT

Item	Condition	Measurement		Adjustment		Specifications/ Remark		
		Test equipment	Terminal	Parts	Method			
5. Max deviation Adjust [Wide]	TEST CH: Center Low High (3 points) AG:1kHz/150mV Deviation meter filter LPF:15kHz HPF:OFF PTT:ON	Power meter Deviation meter Oscilloscope AG AF VTVM	ANT SP/MIC connector	Programming Software:KPG-88D	4.2kHz (According to the larger +,-)	±80Hz		
	[Narrow]				TEST CH: Center PTT:ON		2.2kHz (According to the larger +,-)	±80Hz
6. VOX 1 Writing	TEST CH: Center AG:1kHz/45mV							
7. QT deviation Adjust [Wide]	TEST CH: Center Low High (3 points) LPF:3kHz HPF:OFF PTT:ON				ANT	Programming Software:KPG-88D	0.80kHz	±40Hz
	[Narrow]			TEST CH: Center PTT:ON			0.40kHz	
8. DQT deviation Adjust [Wide]	TEST CH: Center Low High (3 points) LPF:3kHz HPF:OFF PTT:ON						0.75kHz	±40Hz
	[Narrow]			TEST CH:Center PTT:ON			0.40kHz	
9. DTMF deviation Adjust [Wide]	TEST CH:Center LPF:15kHz HPF:OFF PTT:ON						3.0kHz	±100Hz
	[Narrow]			TEST CH:Center PTT:ON			1.5kHz	
10. MSK deviation Adjust [Wide]	TEST CH: Center Low High (3 points) LPF:15kHz HPF:OFF PTT:ON						3.0kHz	±100Hz
	[Narrow]	TEST CH:Center PTT:ON			1.5kHz	±100Hz		

ADJUSTMENT

Receiver Section

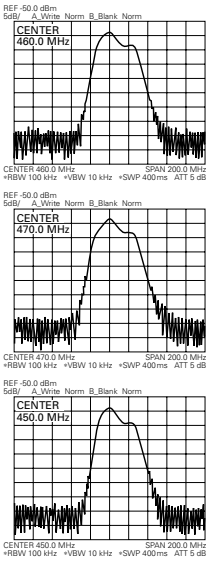
Item	Condition	Measurement		Adjustment		Specifications/ Remark
		Test equipment	Terminal	Parts	Method	
1. BPF Wave Adjust	(1)Center frequency Spectrum analyzer setting Center-f : 460MHz Span : 200MHz RBW : 100kHz VBW : 10kHz ATT : 5dB (2)High-edge frequency Spectrum analyzer setting Center-f : 470MHz (3)Low-edge frequency Spectrum analyzer setting Center-f : 450MHz	Spectrum analyzer	ANT BPF	Programming Software: KPG-88D	Adjust the waveform as shown to the right.	 <p>REF: -50.0 dBm 5dB/ - A:White Norm B:Blank Norm CENTER 460.0 MHz SPAN 200.0 MHz *RBW 100 kHz *VBW 10 kHz *SWP 400ms ATT 5 dB</p> <p>REF: -50.0 dBm 5dB/ - A:White Norm B:Blank Norm CENTER 470.0 MHz SPAN 200.0 MHz *RBW 100 kHz *VBW 10 kHz *SWP 400ms ATT 5 dB</p> <p>REF: -50.0 dBm 5dB/ - A:White Norm B:Blank Norm CENTER 450.0 MHz SPAN 200.0 MHz *RBW 100 kHz *VBW 10 kHz *SWP 400ms ATT 5 dB</p>
2. Sensitivity Check [Wide]	TEST CH: Low Center High SSG output: -117 dBm(0.3μV) SSG MOD: 3.0kHz	SSG DVM Oscilloscope AF VTVM	ANT		Check	12dB SINAD or more
[Narrow]	TEST CH: Center SSG output: -115 dBm(0.4μV) SSG MOD: 1.5kHz					
3. SQL1 (Threshold) Writing [Wide]	TEST CH: Center Low High SSG output: -123 dBm(0.16μV) SSG MOD: 3.0kHz			Programming Software: KPG-88D	Write	Squelch open
[Narrow]	TEST CH: Center SSG output: -122 dBm(0.18μV) SSG MOD: 1.5kHz					
4. SQL9 (Tight) Writing [Wide]	TEST CH: Center Low High SSG output: -117 dBm(0.3μV) SSG MOD: 3.0kHz					
[Narrow]	TEST CH: Center SSG output: -116 dBm(0.35μV) SSG MOD: 1.5kHz					
5. BATT detection Writing	BATT terminal voltage: 5.9V	DVM	ANT BATT terminal		Write	BATT terminal voltage: 5.9V

TK-3200L PC BOARD

TX-RX UNIT (X57-6900-XX) -12 : K -13 : K2 -14 : K3
Component side view (J79-0048-09)

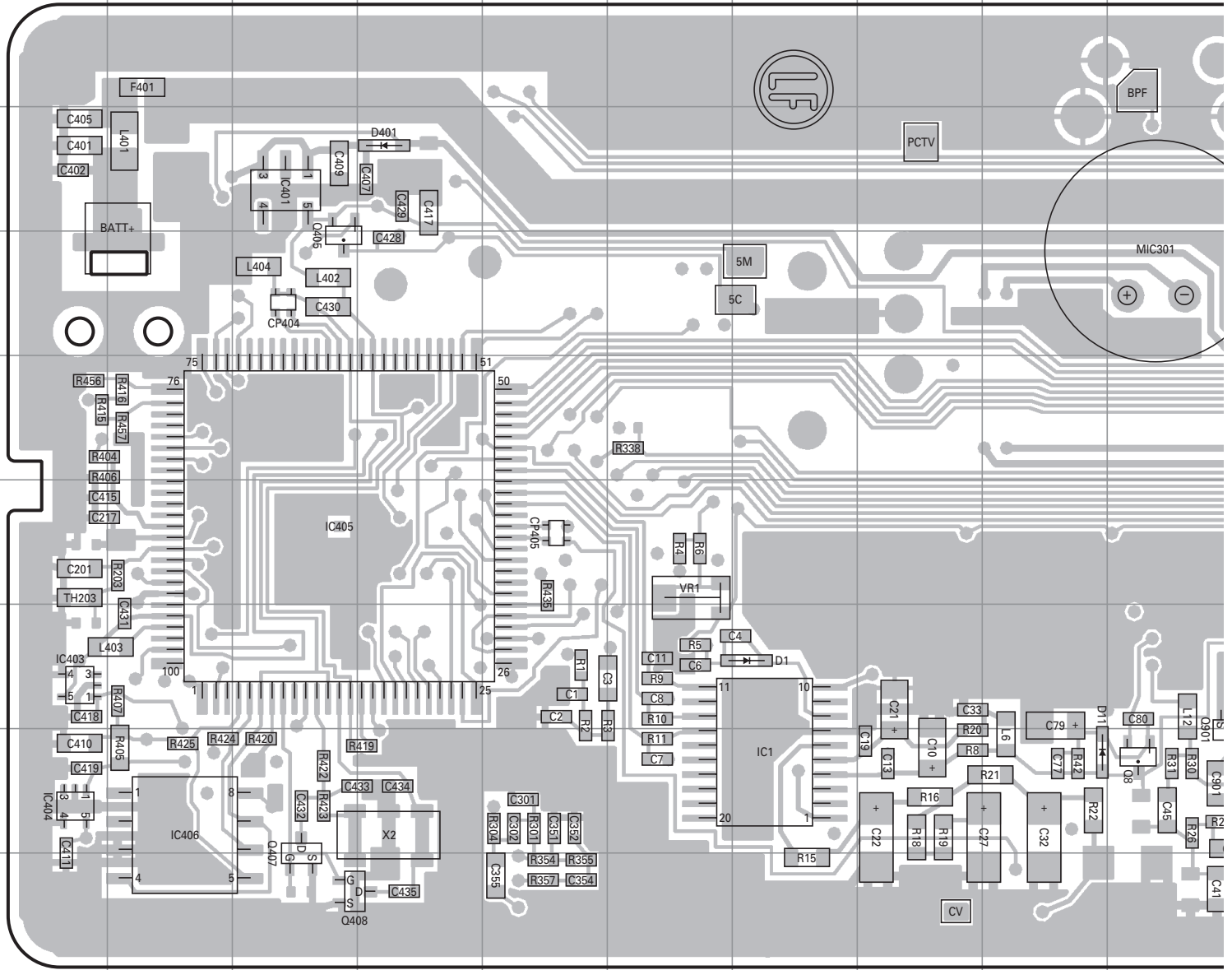

Ref. No.	Address	Ref. No.	Address	Ref. No.	Address	Ref. No.	Address
IC1	9G	Q8	9J	Q305	8O	Q901	9J
IC101	4M	Q104	5L	Q306	9P	D1	8G
IC302	8P	Q105	4K	Q316	9O	D11	9I
IC401	4C	Q107	4L	Q401	8R	D102	4M
IC403	8A	Q108	4L	Q402	8R	D401	4D
IC404	9A	Q109	5L	Q405	5C	D403	8R
IC405	7C	Q303	7P	Q407	9C	D404	8R
IC406	9B	Q304	7P	Q408	10C		

PC BOARD TK-3200L

TX-RX UNIT (X57-6900-XX) -12 : K -13 : K2 -14 : K3
Component side view (J79-0048-09)

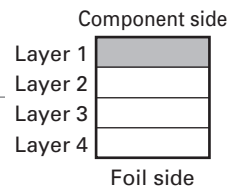
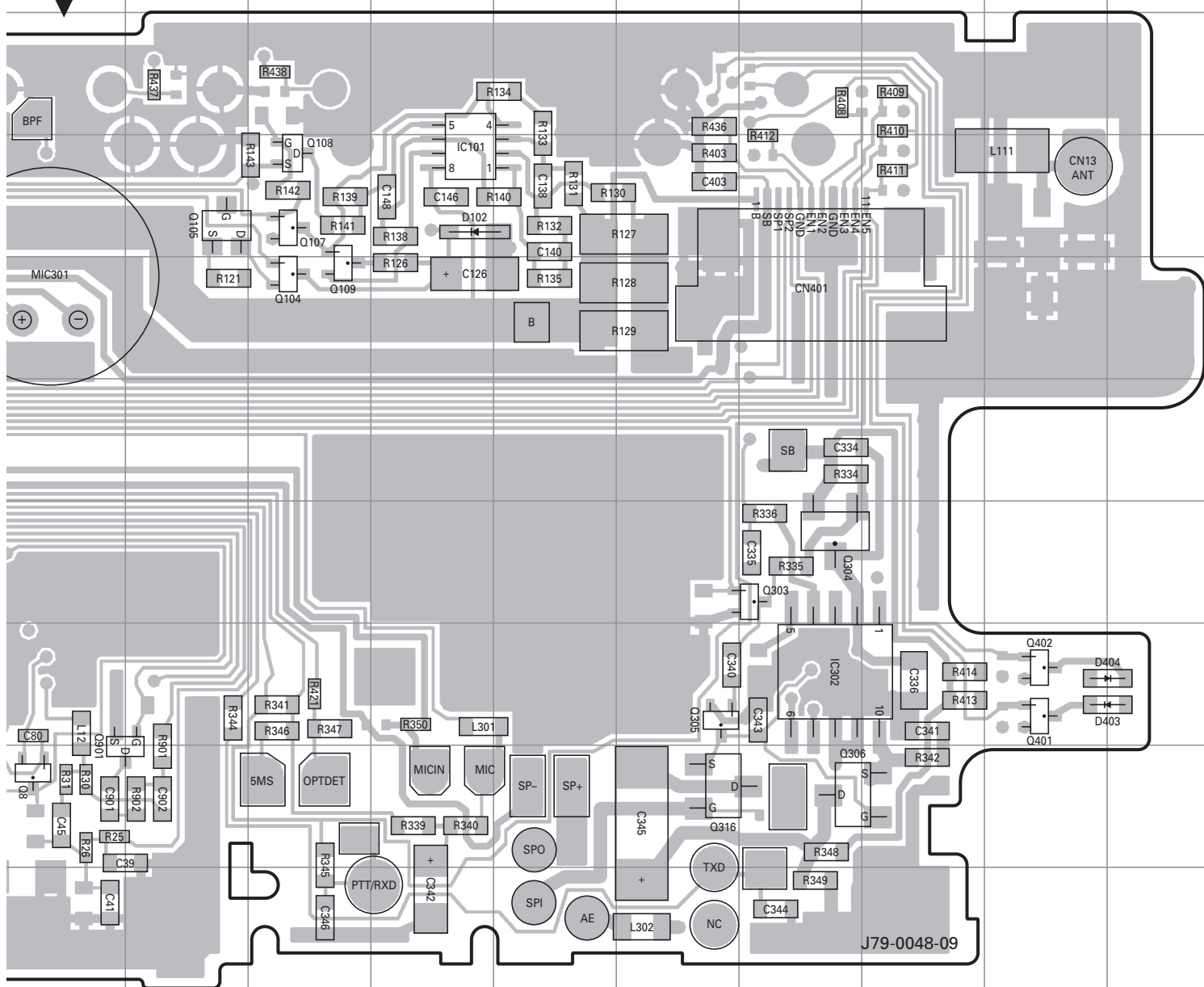

TK-3200L PC BOARD

PC BOARD TK-3200L

TX-RX UNIT (X57-6900-XX) -12 : K -13 : K2 -14 : K3
Component side view (J79-0048-09)

TX-RX UNIT (X57-6900-XX) -12 : K -13 : K2 -14 : K3
Component side view (J79-0048-09)

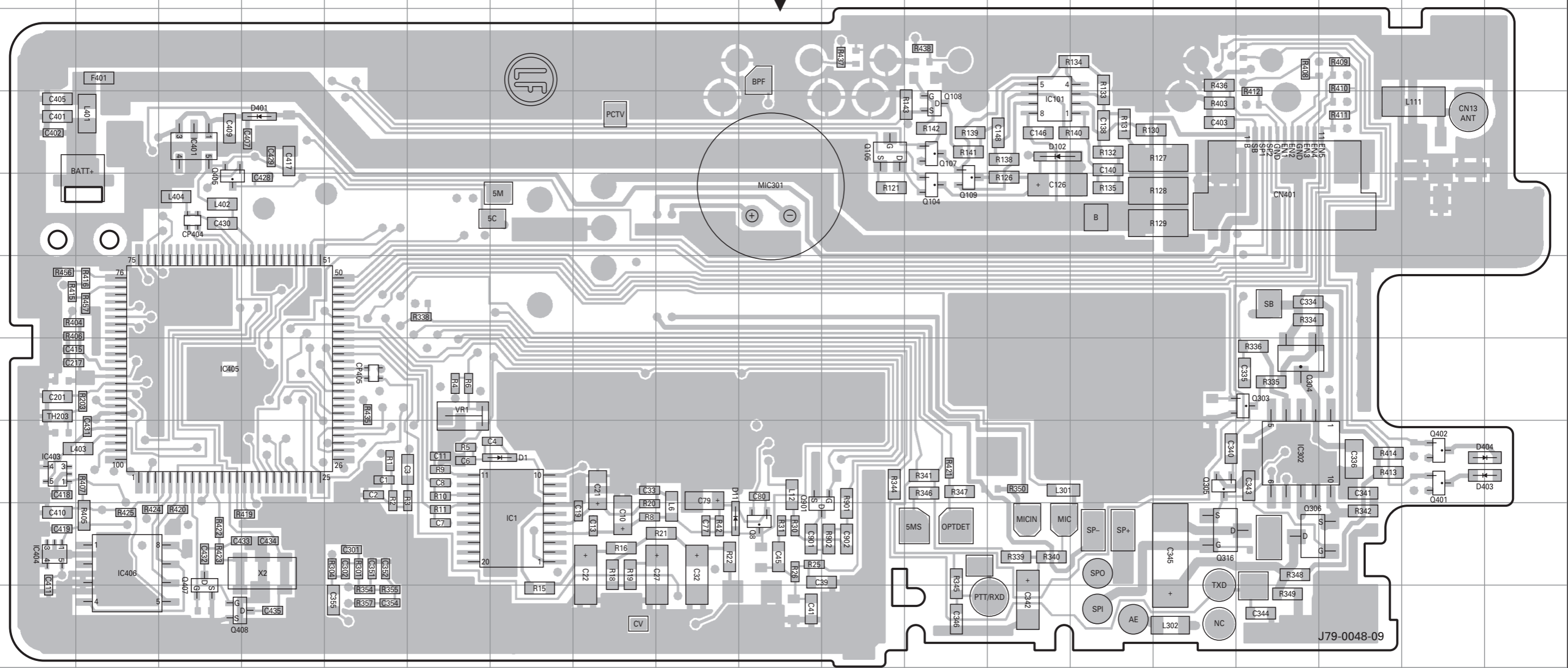

Ref. No.	Address	Ref. No.	Address	Ref. No.	Address	Ref. No.	Address
IC1	9G	Q8	9J	Q305	8O	Q901	9J
IC101	4M	Q104	5L	Q306	9P	D1	8G
IC302	8P	Q105	4K	Q316	9O	D11	9I
IC401	4C	Q107	4L	Q401	8R	D102	4M
IC403	8A	Q108	4L	Q402	8R	D401	4D
IC404	9A	Q109	5L	Q405	5C	D403	8R
IC405	7C	Q303	7P	Q407	9C	D404	8R
IC406	9B	Q304	7P	Q408	10C		

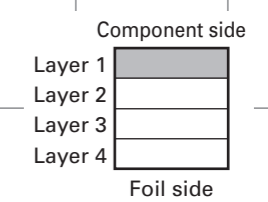

J79-0048-09

PC BOARD TK-3200L

TX-RX UNIT (X57-6900-XX) -12 : K -13 : K2 -14 : K3
Foil side view (J79-0048-09)

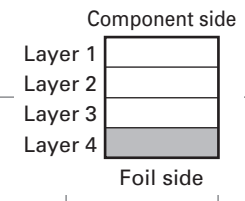
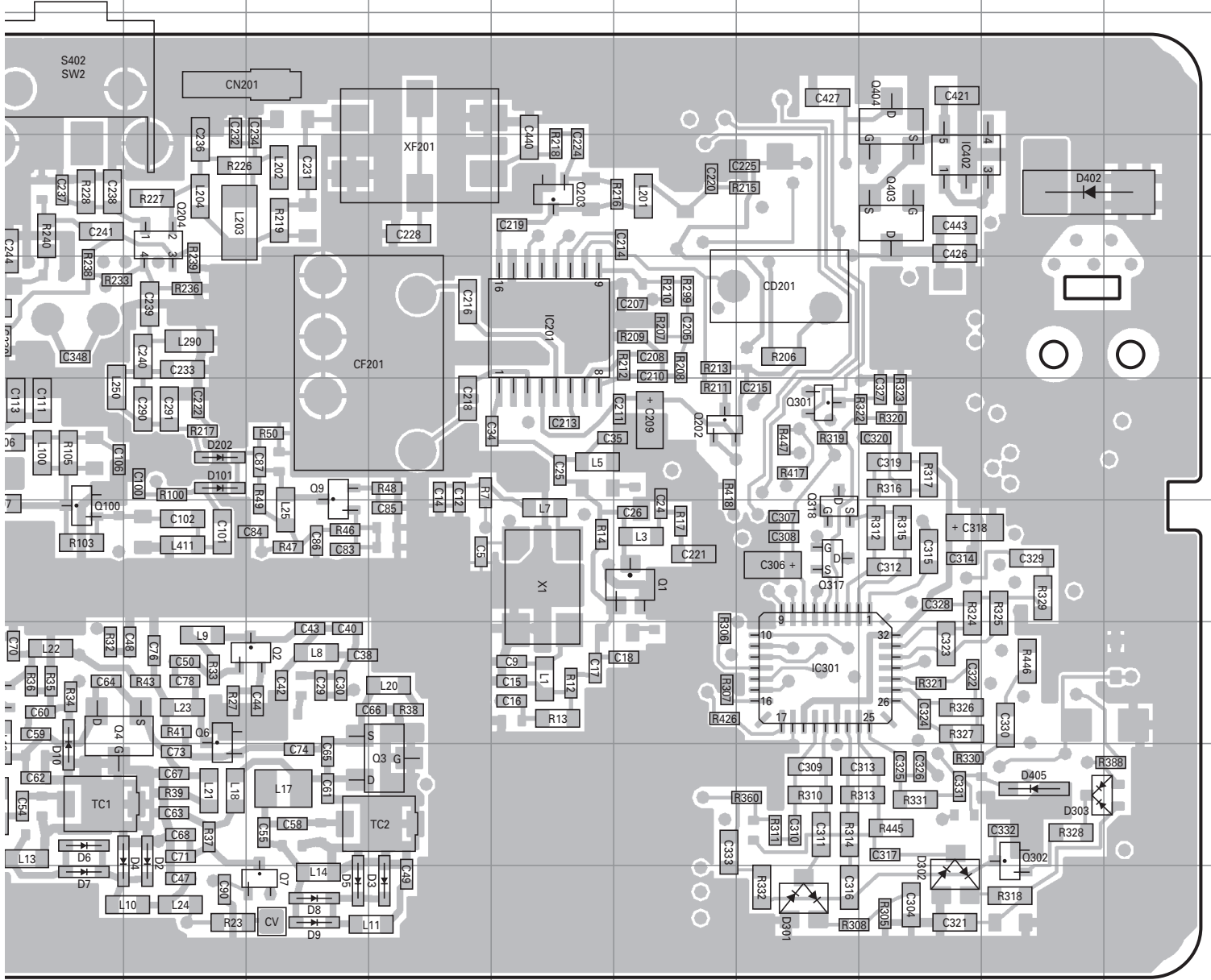

TK-3200L PC BOARD

PC BOARD TK-3200L

TX-RX UNIT (X57-6900-XX) -12 : K -13 : K2 -14 : K3
Foil side view (J79-0048-09)

TX-RX UNIT (X57-6900-XX) -12 : K -13 : K2 -14 : K3
Foil side view (J79-0048-09)

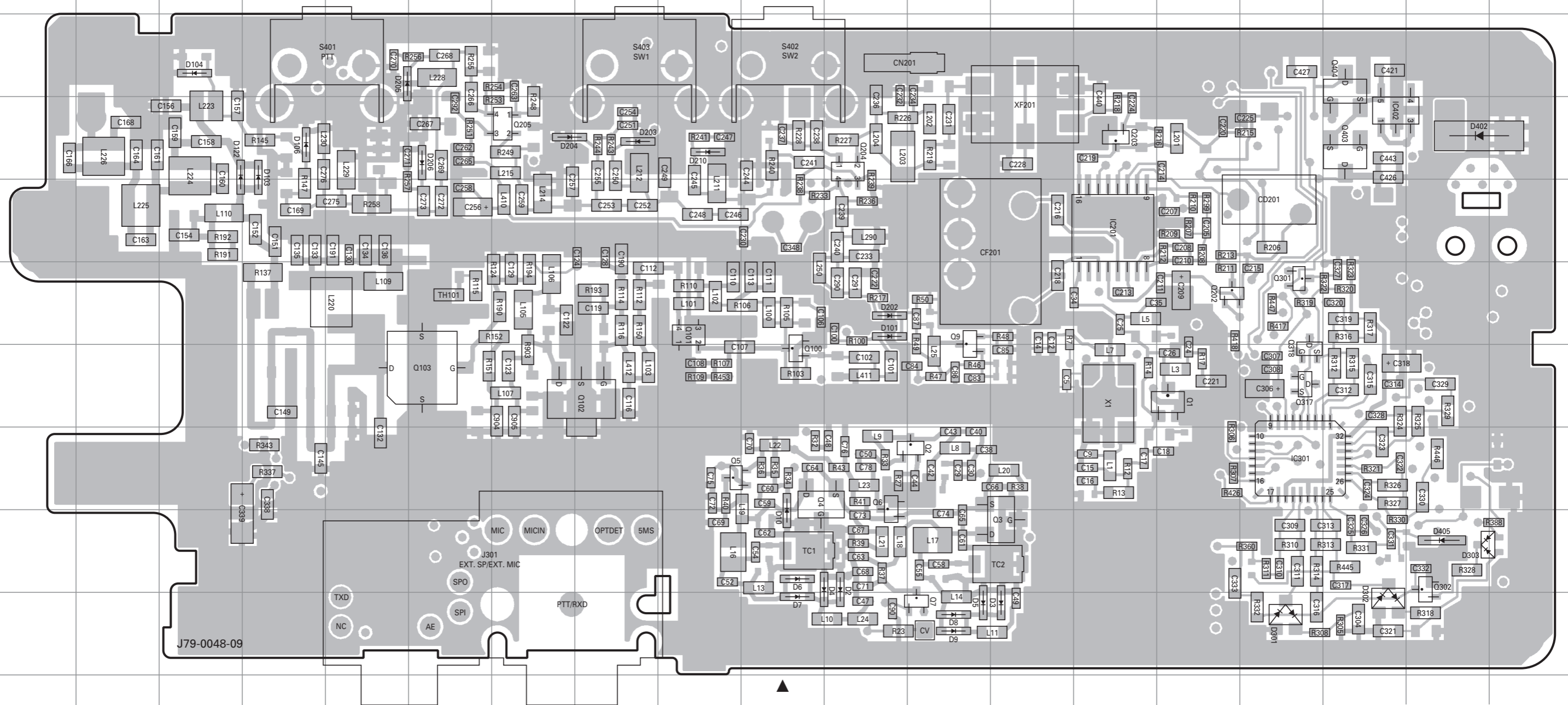

Ref. No.	Address	Ref. No.	Address	Ref. No.	Address	Ref. No.	Address	Ref. No.	Address	Ref. No.	Address
IC201	5N	Q7	10L	Q205	4G	D4	9K	D104	3C	D301	10P
IC301	8P	Q9	6L	Q301	6P	D5	10L	D106	4D	D302	10Q
IC402	4Q	Q100	7J	Q302	9R	D6	9J	D122	4C	D303	9R
Q1	7O	Q101	6I	Q317	7P	D7	10J	D202	6K	D402	4R
Q2	8L	Q102	7H	Q318	7P	D8	10L	D203	4H	D405	9R
Q3	9M	Q103	7F	Q403	4Q	D9	10L	D204	4G		
Q4	8J	Q202	6O	Q404	3Q	D10	9J	D205	3E		
Q5	8I	Q203	4N	D2	9K	D101	6K	D206	4F		
Q6	8K	Q204	4K	D3	10M	D103	4D	D210	4I		

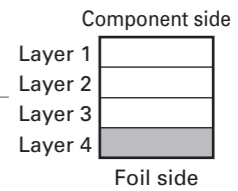

TK-3200L SCHEMATIC DIAGRAM

TX-RX UNIT (X57-6900-XX) -12:K -13:K2 -14:K3

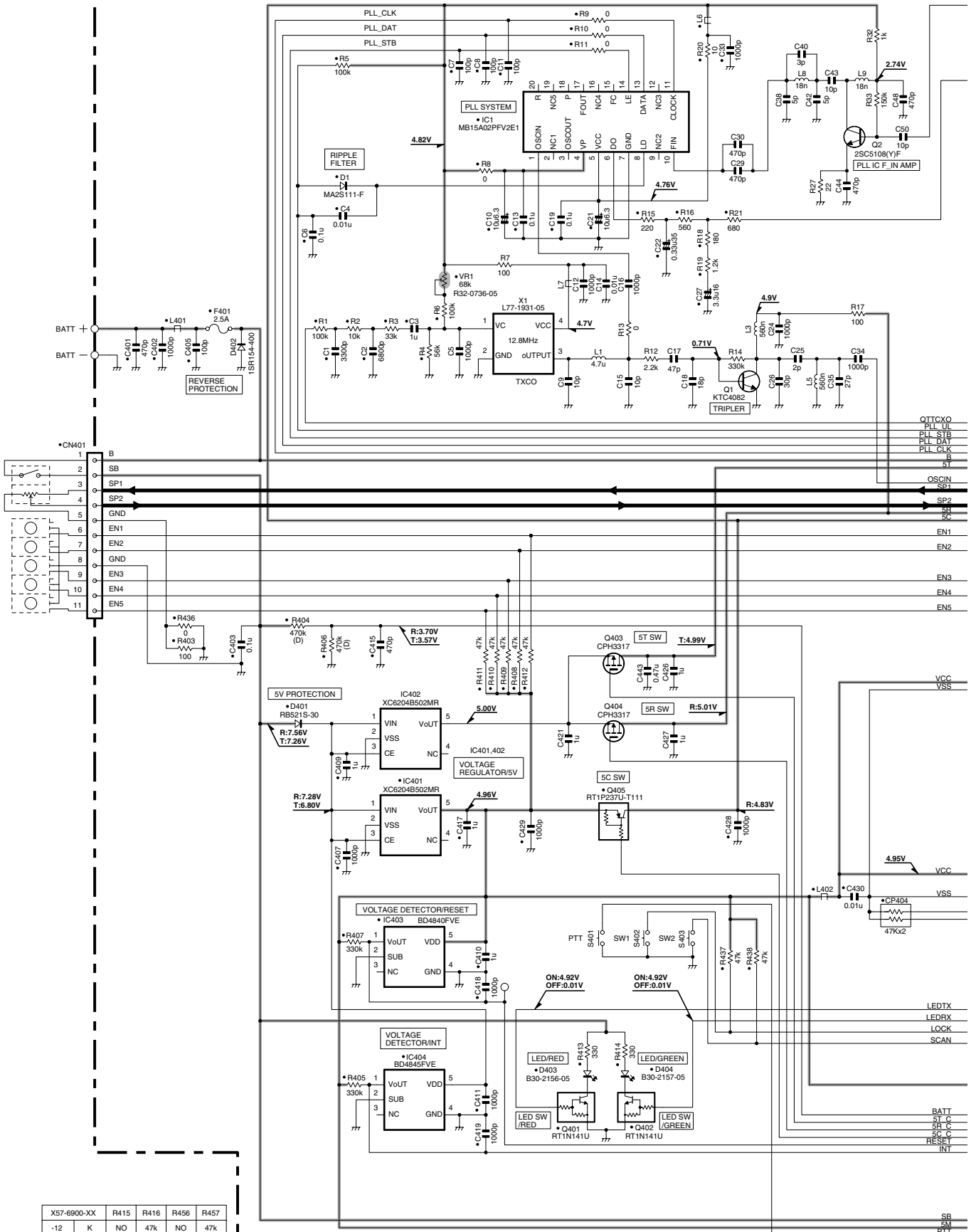

X57-6900-XX	R415	R416	R456	R457
-12	K	NO	47k	NO
-13	K2	NO	NO	47k
-14	K3	47k	NO	47k

SCHEMATIC DIAGRAM TK-3200L

TX-RX UNIT (X57-6900-XX) -12:K -13:K2 -14:K3

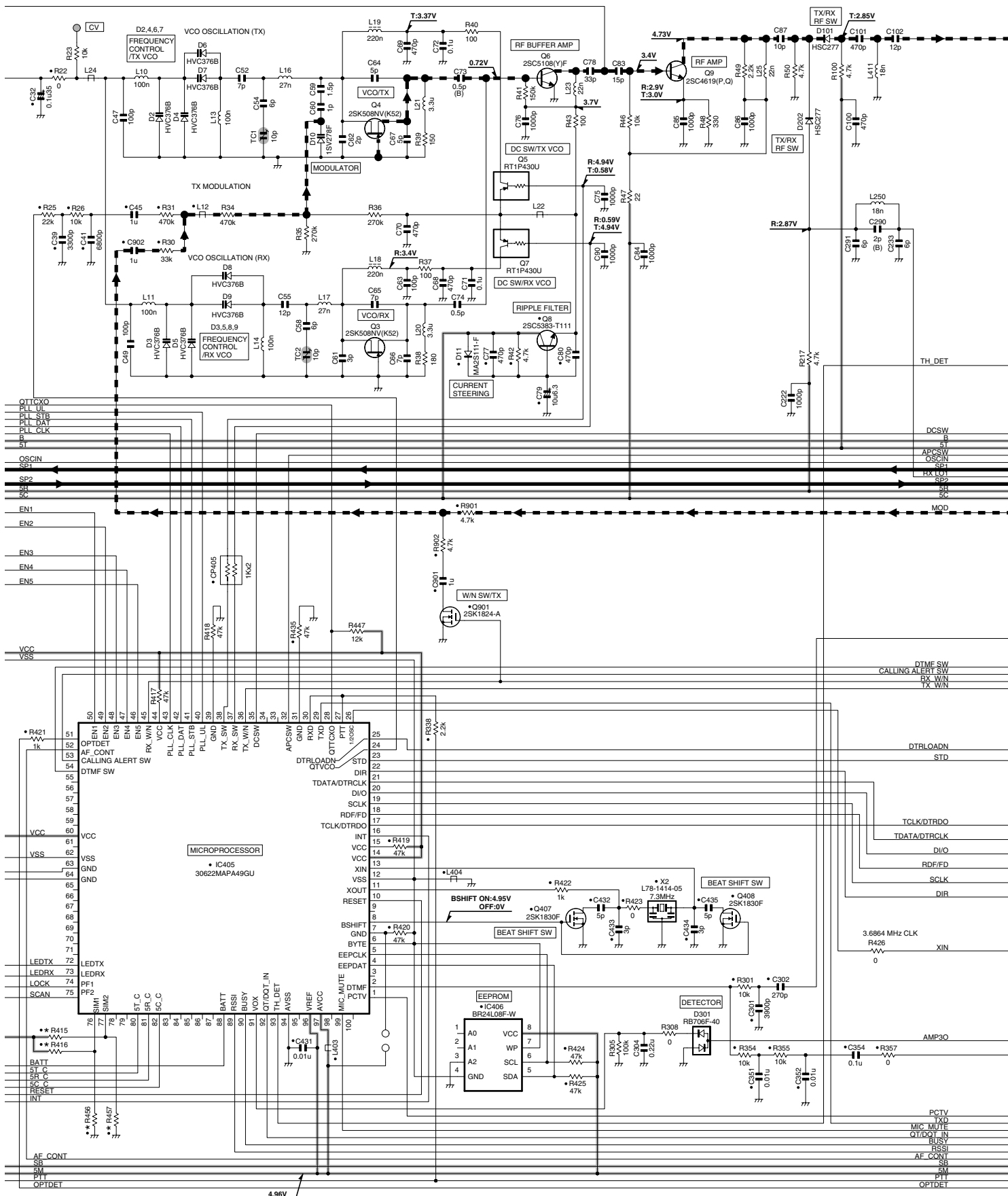

TK-3200L SCHEMATIC DIAGRAM

TX-RX UNIT (X57-6900-XX) -12.K -13.K2 -14.K3

Note : The components marked with a dot (●) are parts of layer 1.

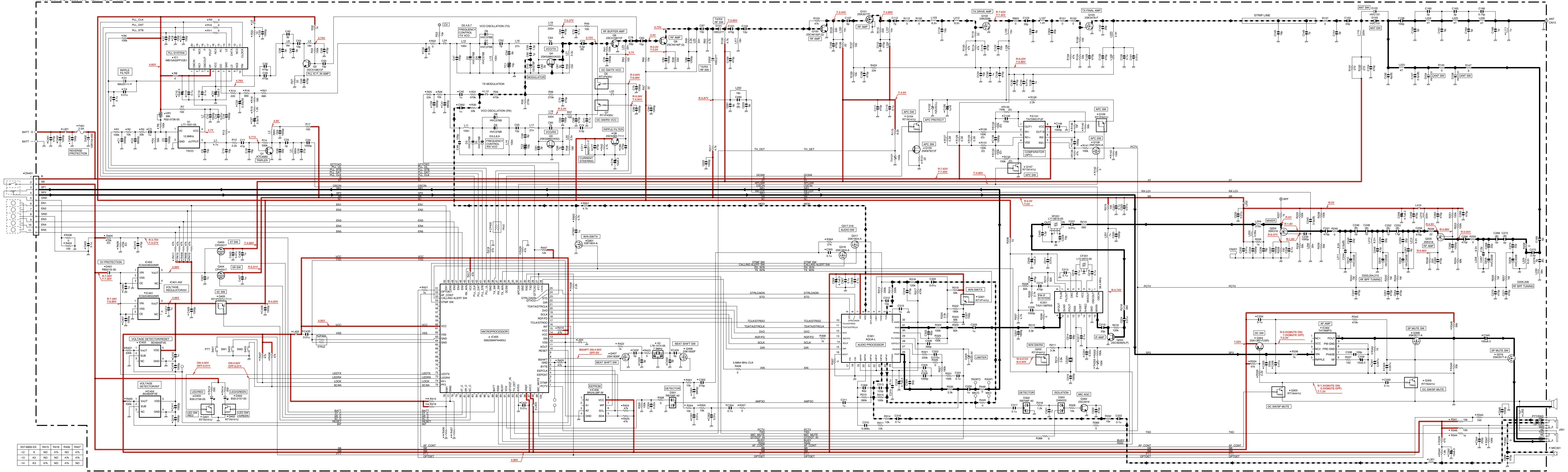

X57-6900-XX	R415	R416	R456	R457	
-12	K	NO	47K	NO	47K
-13	K2	NO	NO	47K	47K
-14	K3	47K	NO	47K	NO

TK-3200L

BLOCK DIAGRAM

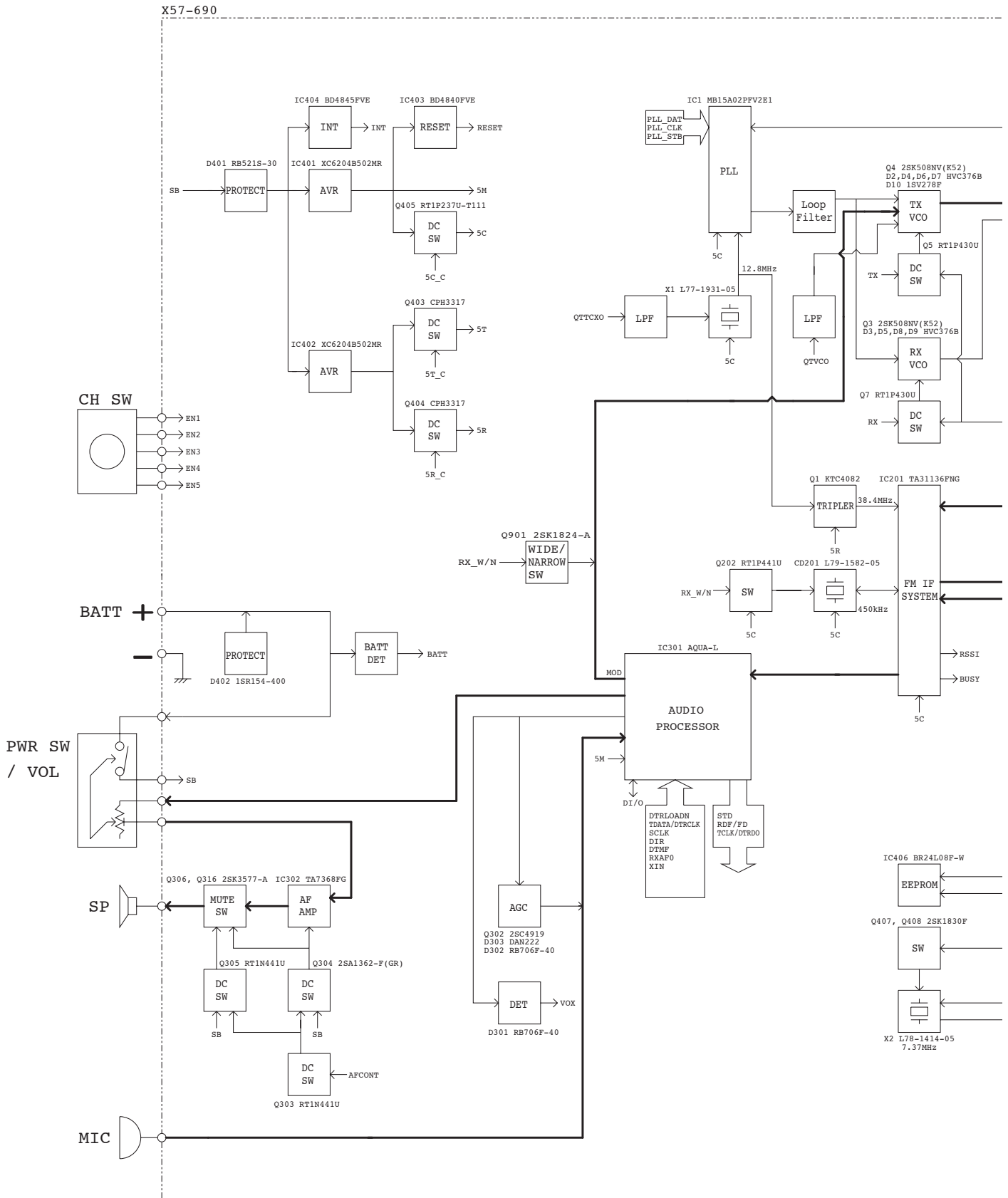

BLOCK DIAGRAM

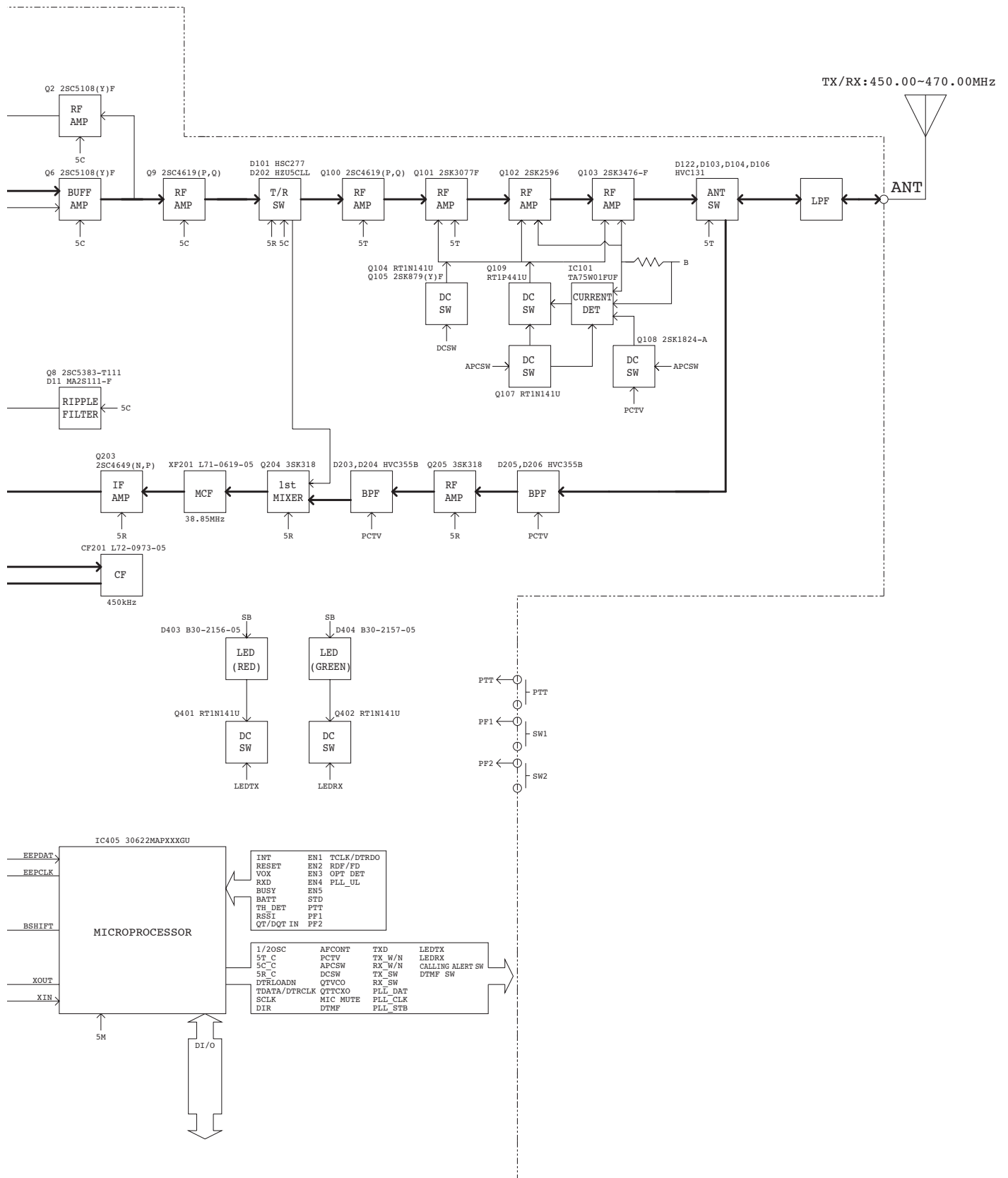

OPTIONAL ACCESSORIES

KSC-35 (RAPID CHARGER)

■ External View



■ Specifications

Charging time KNB-45L : Approx. 180 minutes
 Dimensions (Charger only) 86.3W x 43.2H x 100.0D (mm)
 3-3/8W x 1-45/64 x 4D (inches)
 Weight (Charger only) Approx. 90g / 0.2 lbs

KNB-45L (Li-ion BATTERY PACK)

■ External View



■ Specifications

Voltage 7.4V (3.7V x 2)
 Battery capacity ... 2000mAh

■ Schematic Diagram

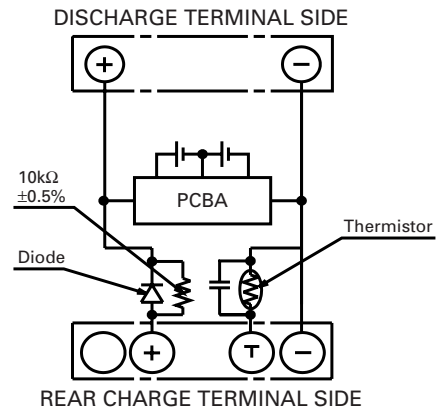

SPECIFICATIONS

General

Frequency Range	450~470MHz
Number of Channels	2 (K) 8 (K2) 15 (K3)
Channel Spacing	25kHz (Wide) 12.5kHz (Narrow)
PLL Channel Stepping	5kHz, 6.25kHz
Operating Voltage	7.5 V DC \pm 20%
Battery Life (5-5-90 duty cycle)	
With KNB-29N battery	Approx.14 hours (Battery Saver off)
	Approx.18 hours (Battery Saver on)
With KNB-45L battery	Approx.17 hours (Battery Saver off)
	Approx.22 hours (Battery Saver on)
Operating Temperature Range	-30°C to +60°C (-22 °F to +140 °F)
Frequency Stability	\pm 2.5ppm (-30°C to +60°C)
Channel Frequency Spread	20MHz
Dimensions and Weight	
(Dimensions not including protrusions)	
Radio Only	54 (2-1/8) W x 122 (4-13/16) H x 21.1 (13/16) D mm (inches)
	160g (0.35 lbs)
With KNB-29N (1500mAh battery)	54 (2-1/8) W x 122 (4-13/16) H x 33 (1-5/16) D mm (inches)
	360g (0.79 lbs)
With KNB-45L (2000mAh battery)	54 (2-1/8) W x 122 (4-13/16) H x 33 (1-5/16) D mm (inches)
	280g (0.62lbs)

Receiver (Measurements made per TIA/EIA-603)

Sensitivity	
EIA 12dB SINAD	0.25 μ V (Wide)/0.28 μ V (Narrow)
Selectivity	70dB (Wide)/60dB (Narrow)
Intermodulation	65dB (Wide)/60dB (Narrow)
Spurious Response	60dB
Audio Power Output	500mW at 8 Ω less than 10% distortion

Transmitter (Measurements made per TIA/EIA-603)

RF Power Output	2W/1W
Spurious and Harmonics	65dB
Modulation	16K0F3E (Wide)/11K0F3E (Narrow)
FM Noise	45dB (Wide)/40dB (Narrow)
Audio Distortion	Less than 5%

Kenwood Corporation

2967-3, Ishikawa-machi, Hachioji-shi, Tokyo, 192-8525 Japan

Kenwood U.S.A. Corporation

P.O. BOX 22745, 2201 East Dominguez Street, Long Beach, CA 90801-5745, U.S.A.

Kenwood Electronics Canada Inc.

6070 Kestrel Road, Mississauga, Ontario, Canada L5T 1S8

Kenwood Electronics Deutschland GmbH

Rembrücker Str. 15, 63150 Heusenstamm, Germany

Kenwood Electronics Belgium N.V.

Leuvensesteenweg 248 J, 1800 Vilvoorde, Belgium

Kenwood Electronics France S.A.

L'Etoile Paris Nord 2, 50 Allée des Impressionnistes, Bp 58416 Villepinte, 95944 Roissy Ch De Gaulle Cedex

Kenwood Electronics UK Limited

KENWOOD House, Dwight Road, Watford, Herts., WD18 9EB United Kingdom

Kenwood Electronics Europe B.V.

Amsterdamseweg 37, 1422 AC Uithoorn, The Netherlands

Kenwood Electronics Italia S.p.A.

Via G. Sirtori, 7/9 20129 Milano, Italy

Kenwood Ibérica, S.A.

Bolivia, 239-08020 Barcelona, Spain

Kenwood Electronics Australia Pty. Ltd.

(A.C.N. 001 499 074)

16 Giffnock Avenue, Centrecourt Estate, North Ryde, N.S.W. 2113 Australia

Kenwood Electronics (Hong Kong) Ltd.

Unit 3712-3724, Level 37, Tower one Metroplaza, 223 Hing Fong Road, Kwai Fong, N.T., Hong Kong

Kenwood Electronics Singapore Pte Ltd

1 Ang Mo Kio Street 63, Singapore 569110

