

UHF FM TRANSCEIVER / UHF 调频对讲机

TK-3230

SERVICE MANUAL / 维修手册

C VERSION

KENWOOD

Kenwood Corporation

© 2007-11 PRINTED IN JAPAN
B51-8808-00 (N) 486

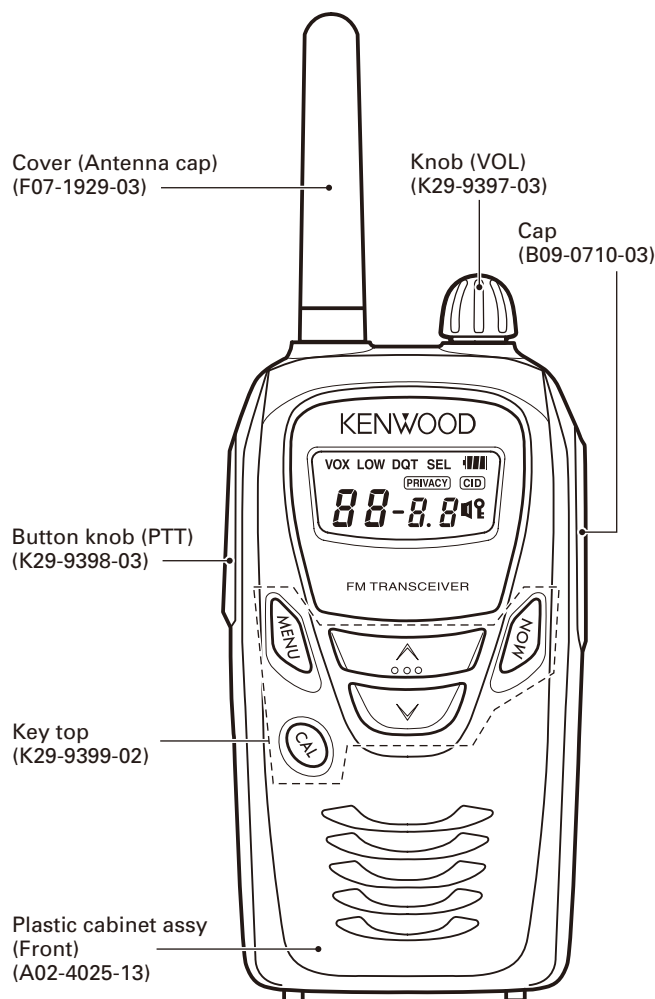

无铅焊接通信产品  
保护环境建伍领先

⚠ 注意：本产品是无铅化焊接产品
在维修时请使用无铅焊锡
和相应的焊接工具
详细事项请访问如下网址了解：
<http://www.kenwoodhk.com.hk/>

This product complies with the **RoHS** directive for the European market.



This product uses Lead Free solder.

GENERAL	2	概 述.....	2
REALIGNMENT	4	模式组合.....	4
CIRCUIT DESCRIPTION	8	电路说明.....	8
SEMICONDUCTOR DATA	15	半导体数据.....	15
COMPONENTS DESCRIPTION	17	元件说明.....	17
PARTS LIST	19	零 件 表.....	19
EXPLODED VIEW	24	部件分解图.....	24
PACKING	25	包 装.....	25
ADJUSTMENT	26	调 整.....	26
PC BOARD		PC 板	
TX-RX UNIT (X57-7330-10)	34	TX-RX 单元 (X57-7330-10).....	34
SCHEMATIC DIAGRAM	38	原 理 图.....	38
BLOCK DIAGRAM	42	方 块 图.....	42
LEVEL DIAGRAM	44	电 平 图.....	44
OPTIONAL ACCESSORIES		可选附件	
KNB-46L, KBH-14, KSC-37	45	KNB-46L, KBH-14, KSC-37	45
SPECIFICATIONS	50	规 格.....	50

Document Copyrights

Copyright 2007 by Kenwood Corporation. All rights reserved.

No part of this manual may be reproduced, translated, distributed, or transmitted in any form or by any means, electronic, mechanical, photocopying, recording, or otherwise, for any purpose without the prior written permission of Kenwood.

Disclaimer

While every precaution has been taken in the preparation of this manual, Kenwood assumes no responsibility for errors or omissions. Neither is any liability assumed for damages resulting from the use of the information contained herein. Kenwood reserves the right to make changes to any products herein at any time for improvement purposes.

文档版权信息

Kenwood Corporation 拥有版权 2007。保留所有权利。

未经 Kenwood 公司预先书面同意，无论出于何种目的，均不得以任何形式或任何方式包括电子、机械、影印、录音或其他方式复制、翻译、分发或传播本手册的任何部分。

免责声明

Kenwood 公司在准备本文档时已采取所有必要的预防措施，恕不对错误或疏漏承担任何责任，也不对因使用本文档中所含的信息而导致的损害负责。Kenwood 公司保留出于改进的需要而随时对文中的产品信息做出更改的权利。

GENERAL / 概述

INTRODUCTION

SCOPE OF THIS MANUAL

This manual is intended for use by experienced technicians familiar with similar types of commercial grade communications equipment. It contains all required service information for the equipment and is current as of the publication date. Changes which may occur after publication are covered by either Service Bulletins or Manual Revisions. These are issued as required.

ORDERING REPLACEMENT PARTS

When ordering replacement parts or equipment information, the full part identification number should be included. This applies to all parts : components, kits, or chassis. If the part number is not known, include the chassis or kit number of which it is a part, and a sufficient description of the required component for proper identification.

PERSONAL SAFETY

The following precautions are recommended for personal safety:

- DO NOT transmit until all RF connectors are verified secure and any open connectors are properly terminated.
- SHUT OFF and DO NOT operate this equipment near electrical blasting caps or in an explosive atmosphere.
- This equipment should be serviced by a qualified technician only.

SERVICE

This transceiver is designed for easy servicing. Refer to the schematic diagrams, printed circuit board views, and alignment procedures contained within.

引言

本手册的范围

本手册是提供给熟悉通信专业并且具有维修经验的技术人员使用的。它包括了维修该设备所需要的全部资料和现行出版日期。在出版后可能发生变动，如果需要，可以参照《维修通报》或《手册修订本》进行补充。

替换零件的订购

当订购替换零件或设备资料时，应注意完整的零件识别号码。所有的零件均有识别号码：元件，组件或机壳。如果不知道零件的号码，为了正确地识别，必须注明此元件所属的机壳或组件的号码，并对元件进行充分的说明。

个人安全

为了个人的安全，请注意下列事项：

- 在没有认真核实所有射频插头之前或有任何一个脱开的插头没有连接到相应端口上的情况下均不要发射。
- 在电爆管附近或在易燃性气体环境中，必须关闭电源，不要操作本设备。
- 本设备只应该由有资格的技术人员进行维修。

维修服务

为了便于维修本设备，建立了完整的维修服务体系，提供了包括原理图，印刷电路板图和调整步骤在内的资料供参考。

REALIGNMENT / 模式组合

1. Getting Acquainted

- ① PTT (Push to Talk) switch
Press and hold, then speak into the speaker area to transmit.
- ② MENU key
Press to perform various functions. Press and hold while switching the power ON to enter Setting Mode.
- ③ CAL key
Press before making a call to alert the other party members, or press to select a unit ID to make a call.
- ④ ^/∇ keys
Press to change the operating channel, to select a menu in Setting Mode, and to perform other functions.
- ⑤ Power switch/Volume control
Turn clockwise to switch the power ON and counter-clockwise to switch the power OFF. Rotate to adjust the volume.
- ⑥ MON key
Press to monitor the current channel for activity.
- ⑦ LED Indicator
Indicates the transceiver status.
- ⑧ SP/MIC jacks
Lift the covers and insert the accessory's plugs here.

1. 介绍

- ① PTT (按下通话) 开关
按住，然后对着扬声器区域讲话来进行发射。
- ② MENU 键
按下可执行各种功能。打开电源时按住可进入设置模式。(经销商须启用设置模式)
- ③ CAL 键
进行呼叫前按下可提醒其他组员，或按下来选择一个单元 ID 进行呼叫。
- ④ ^/∇ 键
按下可改变工作信道、在设置模式下选择菜单、执行其他功能。
- ⑤ 电源开关 / 音量控制
顺时针转动可打开电源，逆时针转动可关闭电源。转动调节音量。
- ⑥ MON 键
按下可监听当前信道的活动状况。
- ⑦ LED 指示灯
显示对讲机状态。
- ⑧ SP/MIC 插孔
提起盖子，将附件的插头在此插入。



2. PC Mode

2-1. Preface

The transceiver is programmed by using a personal computer, a programming interface (KPG-22/22A, USB adapter (KCT-53U)) and programming software (KPG-108D).

The programming software can be used with an IBM PC or compatible. Figure 1 shows the setup of an IBM PC for programming.

2-2. Connection Procedure

1. Connect the transceiver to the personal computer with the interface cable and USB adapter (when the interface cable is KPG-22A, the KCT-53U can be used).

2. PC 模式

2-1. 前言

对讲机采用个人电脑、编程接口 (KPG-22/22A, USB 适配器 (KCT-53U)) 和编程软件 (KPG-108D) 进行编程。

编程软件可以在 IBM PC 或兼容的 PC 上进行使用。图 1 给出了 IBM PC 进行编程的设置。

2-2. 连接操作

1. 使用接口电缆和 USB 适配器将对讲机连接到个人电脑 (接口电缆为 KPG-22A 时, 可以使用 KCT-53U)。

REALIGNMENT / 模式组合

Notes:

- You must install the KCT-53U driver in the computer to used the USB adapter (KCT-53U).
- When using the USB adapter (KCT-53U) for the first time, plug the KCT-53U into a USB port on the computer with the computer power ON.

2. When the POWER is switched on, user mode can be entered immediately. When the PC sends a command, the transceiver enters PC mode.

When data is receiving from the transceiver, the red LED lights.

When data is transmitted by the transceiver, the green LED lights.

Notes :

- The data stored in the personal computer must match Model Name when it is written into EEPROM.
- Do not press the [PTT] key during data transmission or reception.

2-3. KPG-22/KPG-22A Description

(PC programming interface cable : Option)

The KPG-22/22A is required to interface the transceiver with the computer. It has a circuit in its D-sub connector (KPG-22: 25-pin, KPG-22A: 9-pin) case that converts the RS-232C logic level to the TTL level.

The KPG-22/22A connects the SP/MIC connector of the transceiver to the RS-232C serial port of the computer.

2-4. KCT-53U Description (USB adapter : Option)

The KCT-53U is a cable which connects the KPG-22A to a USB port on a computer.

When using the KCT-53U, install the supplied CD-ROM (with driver software) in the computer. The KCT-53U driver runs under Windows 2000 or XP.

2-5. Programming Software Description

The KPG-108D is the programming software for the transceiver supplied on a CD-ROM. The software on this disk allows a user to program the transceiver radios via Programming interface cable (KPG-22).

2-6. Programming with IBM PC

If data is transferred to the transceiver from an IBM PC with the KPG-108D, the data for each set can be modified.

Data can be programmed into the EEPROM in RS-232C format via the SP/MIC jack.

In this mode the PTT line operate as TXD and RXD data lines respectively.

注意:

- 必须在电脑上安装 KCT-53U 驱动程序才能使用 USB 适配器 (KCT-53U)。
- 首次使用 USB 适配器 (KCT-53U) 时, 请在电脑开机的情况下将 KCT-53U 插入电脑的 USB 端口。

2. 对讲机电源打开时, 可以立即进入用户模式。PC 发送指令时, 对讲机进入 PC 模式。

对讲机发送数据时, 红色的 LED 点亮。

对讲机接收数据时, 绿色的 LED 点亮。

注意:

- 个人电脑保存的数据写入 EEPROM 时, 必须与机型相符。
- 请勿在数据发送或接收期间按 [PTT] 键。

2-3. KPG-22/KPG-22A 说明

(PC 编程接口电缆: 选购件)

将对讲机与电脑相连需要 KPG-22/22A。该电缆的 D-sub 连接器 (KPG-22: 25 针, KPG-22A: 9 针) 盒具有将 RS-232C 逻辑电平转换为 TTL 电平的电路。

KPG-22/22A 将对讲机的 SP/MIC 连接器连接到电脑的 RS-232C 串行端口。

2-4. KCT-53U 说明 (USB 适配器: 选购件)

KCT-53U 是将 KPG-22A 连接到电脑 USB 端口的电缆。

使用 KCT-53U 时, 请在电脑上安装附带的 CD-ROM (带有驱动程序软件)。KCT-53U 驱动程序运行于 Windows 2000 或 XP 下。

2-5. 编程软件说明

KPG-108D 是 CD-ROM 附带的用于对讲机的编程软件。该光盘上的软件允许用户通过编程接口电缆 (KPG-22) 对对讲机进行编程。

2-6. 使用 IBM PC 编程

如果使用 KPG-108D 将数据从 IBM PC 传输到对讲机, 则每套对讲机的数据均可修改。

通过 SP/MIC 插孔可以将数据以 RS-232C 格式写入 EEPROM。

在该模式下, PTT 线路分别用作 TXD 和 RXD 数据线路。

REALIGNMENT / 模式组合

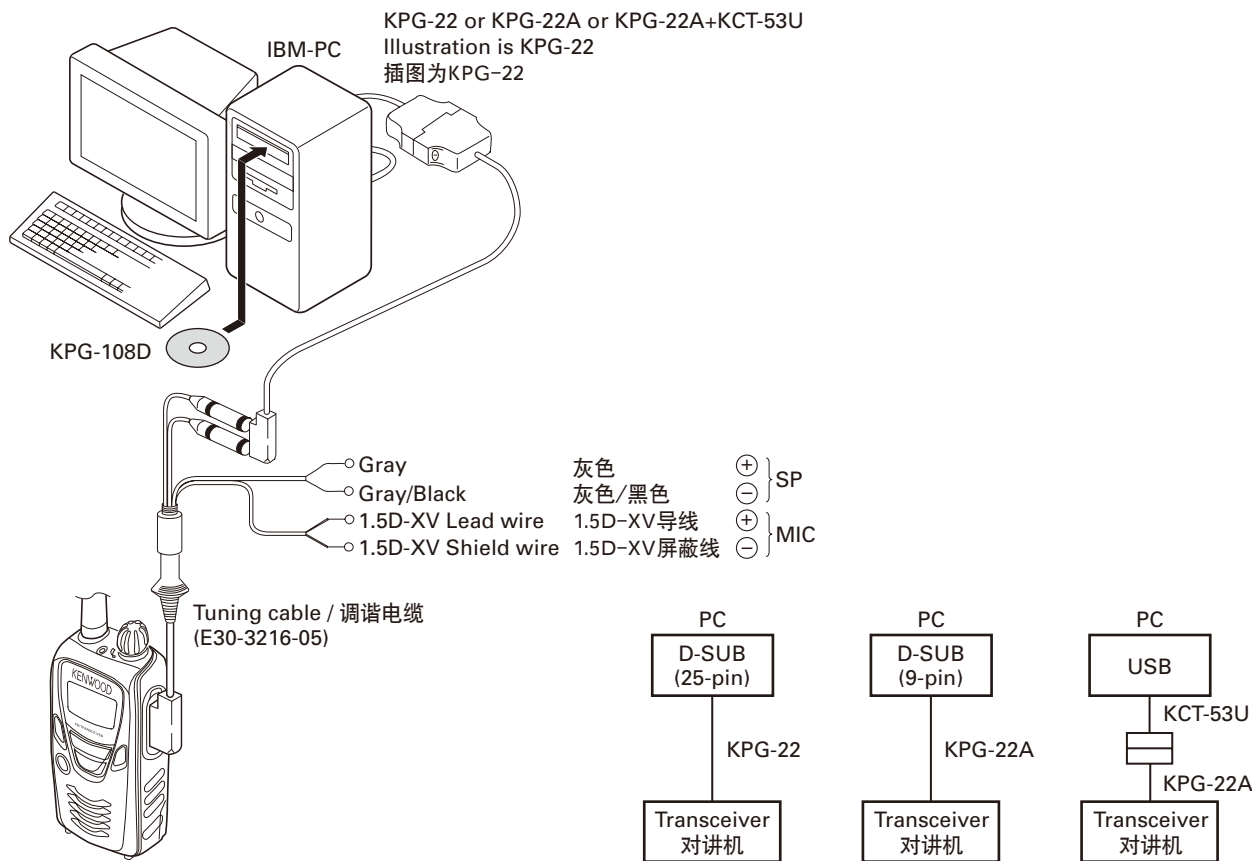

Fig. 1 / 图 1

3. Clone Mode

3-1. Outline

"Clone Mode" copies the transceiver data to another transceiver.

The dealer can copy the transceiver data to another transceiver even without the use of a personal computer.

3-2. Example

The transceiver can copy the programming data to one or more transceivers via RF communication.

The clone source and clone target/s must be in Clone mode.

3-3. Operation

1. To switch the clone target/s to Clone mode, press and hold the [PTT] and [MONI] keys while turning the transceiver power ON.
2. Keep holding [PTT] and [MONI] keys for 1 second. Transceiver sound key on tone and enters Clone mode with "F 9- 1" display.
3. Wait for 2 seconds. Transceiver displays "F 9- 1".
4. Select a channel table number using [UP] (increment channel table) and [DOWN] (decrement channel table) keys.

3. 复制模式

3-1. 概述

"复制模式" 能将对讲机数据复制到其他对讲机。

即使没有使用个人电脑，经销商也能将对讲机数据复制到其他对讲机。

3-2. 实例

通过 RF 通信，对讲机可以将编程数据复制到一台或多台对讲机。

复制源和复制目标必须均处于复制模式。

3-3. 操作

1. 如需将复制目标切换到复制模式，请在打开对讲机电源的同时按住 [PTT] 和 [MONI] 键。
2. 按住 [PTT] 和 [MONI] 键 1 秒钟。对讲机响起键音并进入复制模式，同时显示 "F 9- 1"。
3. 等候 2 秒钟。对讲机显示 "F 9- 1"。
4. 使用 [UP] (增大信道表) 和 [DOWN] (减小信道表) 键选择信道表号。

REALIGNMENT / 模式组合

5. To switch the clone source to Clone mode, press and hold the [PTT] and [MONI] keys while turning the transceiver power ON.
6. Keep holding [PTT] and [MONI] keys for 1 second. Transceiver sound key on tone and enters Clone mode with "E L o n" display.
7. Wait for 2 seconds. Transceiver displays "F 9- i".
8. Select the same channel table number as the clone target/s.
9. Press [PTT] on the clone source to begin data transmission. When the clone target starts to receive data, the LED will light green.
When the clone source finishes sending data, a "confirmation" tone will sound with "E n d" displayed.
If data transmission fails while cloning, an "error" tone will sound from the Target unit with "E r r" displayed.
10. If the cloning fails, no data will be available in the Target unit when it is returned to User mode.
11. When the cloning is successful, the Target unit's "Scan", "Key Lock" and "Super Lock" functions will return to their default values (Scan = OFF, Key Lock = OFF, Super Lock = OFF).
12. After clone has completed, it is necessary for the Target unit to set its required ID Type of ID List for FleetSync. This can be done by using unit's ID List Setting Mode.

Notes:

- The dealer can clone data to two or more transceivers by repeating the above procedures.
- If the transceiver's Clone Mode is configured as "Disabled", the transceiver cannot enter Clone mode.
- The table shown below will cover the frequencies used for wireless cloning.
- A unit cannot be a "Source Unit" if it is unprogrammed. If [PTT] is pressed, an "error" tone will sound.
- Once a unit is set to be the Source, it cannot be a target after the data has been transmitted. This protects the data in the Source unit.
- If the Target unit is cloned unsuccessfully, "error" tone will sound with "E r r" display.
- After 4 seconds, Target unit returns to display "F 9-X X". "xx" means the last selected channel table number.
- The Source unit and Target unit must be of the same model type and destination in order for Clone to operate.
- It is not possible to read/write setup data from the clone source/target when it is in Clone mode. But it will trigger to go to cloning mode (TX) when try to read/write.
- Electronic interface may cause a failure in data transfer during Wireless Clone, such as when waveforms or electromagnetics are being performed at the workbench.
- Clone mode can be used ONLY by the authorized service personnel.
- The Clone mode setting must be configured as "Disable" before being delivered to the end-user.
- When wireless Clone mode is used, the environment must ensure that the radio wave does not leak to outside.
- The transmit output power is automatically set to Low in Clone mode.
- Battery saver function is automatically set to off in Clone mode.

5. 如需将复制源切换到复制模式，请在打开对讲机电源的同时按住 [PTT] 和 [MONI] 键。
6. 按住 [PTT] 和 [MONI] 键 1 秒钟。对讲机响起键音并进入复制模式，同时显示 "E L o n"。
7. 等候 2 秒钟。对讲机显示 "F 9- i"。
8. 选择与复制目标相同的信道表号。
9. 按复制源上的 [PTT] 开始数据发射。复制目标开始接收数据时，LED 将会点亮绿色。
复制源发送数据完成时，将会响起 "确认" 音并显示 "E n d"。
如果复制期间数据发射失败，则复制目标将会响起 "错误" 音并显示 "E r r"。
10. 如果复制失败，则复制目标返回到用户模式时没有任何数据。
11. 复制成功时，复制目标的 "扫描"、"按键锁定" 和 "超级锁定" 功能将会返回到各自的默认值 (扫描 =OFF, 按键锁定 =OFF, 超级锁定 =OFF)。
12. 复制完成后，复制目标需要设置 FleetSync 对应 ID 列表的 ID 类型。
使用对讲机的 ID 列表设置模式即可完成。

注意:

- 通过重复上述操作，经销商可以将数据复制到两台或多台对讲机。
- 如果对讲机的复制模式被配置为 "禁用"，则对讲机无法进入复制模式。
- 下表涵盖无线复制所用的频率。
- 如果未经编程，则对讲机无法成为 "复制源"。此时按 [PTT] 将会响起 "错误" 音。
- 出于保护复制源数据的目的，对讲机一旦被设置为复制源，则发射数据后无法成为复制目标。
- 如果复制目标没有成功复制，则将会响起 "错误" 音并显示 "E r r"。
- 4 秒钟后，复制目标返回 "F 9-X X" 显示。"xx" 表示最新选择的信道表号。
- 为了能够进行复制操作，复制源和复制目标的机型和型号必须相同。
- 处于复制模式时，无法读 / 写复制源 / 目标的设置数据。但在尝试读 / 写时将会触发进入复制模式 (TX)。
- 无线复制期间，电子干扰可能会导致数据传送失败，例如工作台上存在干扰电波或电磁场等。
- 复制模式只能由授权服务人员使用。
- 交付最终用户之前，复制模式设置必须配置为 "禁用"。
- 使用无线复制模式时，必须确保无线电波不会向外部泄漏的环境。
- 在复制模式下，发射输出功率自动设置为低。
- 在复制模式下，电池省电功能自动设置为关。

CIRCUIT DESCRIPTION / 电路说明

Frequency Configuration

频率构成

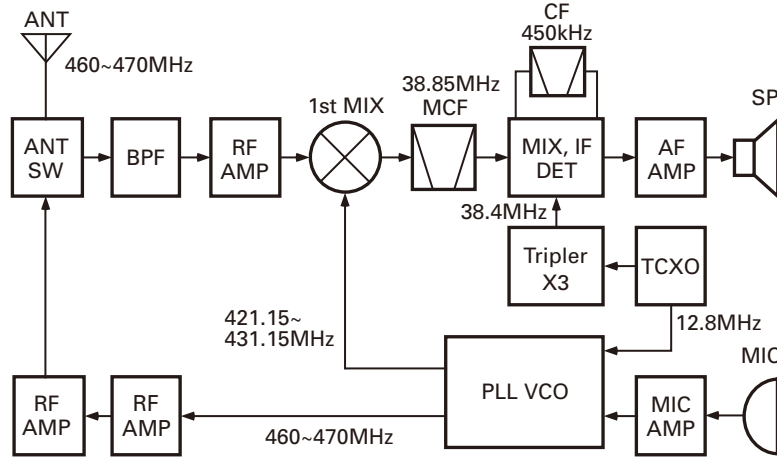

Fig. 1 Frequency configuration / 图 1 频率构成

Reception method	Double super heterodyne	
	1st IF frequency	38.85MHz
	2nd IF frequency	450kHz
Transmission method	VCO direct oscillation amplification	
Modulation	Variable reactance phase modulation	

Table 1 Basic configuration

接收方式	双超外差	
	第一中频	38.85MHz
	第二中频	450kHz
发射方式	VCO 直接振荡放大	
调制	可变电抗相位调制	

表 1 基本构成

Receiver System

■ Front End

The high-frequency signal from the antenna passes through a low-pass filter and a high-frequency switch (D101, D200, D201 and L220) which switches between transmission and reception, and goes to the BPF (L218) to remove unwanted signals. The resulting signal is amplified by high-frequency amplifier (Q204) and goes to the first mixer (Q203).

■ First Mixer

The signal that reaches Q203 is mixed with the first local signal from the VCO to produce a first IF signal (38.85MHz).
 $\text{Receive frequency} - \text{First local frequency} = \text{First IF frequency} = 38.85\text{MHz}$

The first IF signal passes through MCF: XF200 (monolithic crystal filter) to remove unwanted signals.

The first IF signal is amplified by IF amplifier (Q201) and goes to IF IC (IC200).

接收系统

■ 前端

天线的高频信号通过低通滤波器和高频开关 (D101、D200、D201 和 L220) (用于切换发射和接收), 然后进入 BPF (L218) 消除不需要的信号。最终的信号由高频放大器 (Q204) 进行放大, 然后进入第一混频器 (Q203)。

■ 第一混频器

到达 Q203 的信号与来自 VCO 的第一本振信号混频, 进而产生第一中频信号 (38.85MHz)。

(接收信号 - 第一本振信号 = 第一中频 = 38.85MHz)

第一中频信号通过 MCF: XF200 (单片晶体滤波器) 消除不需要的信号。

第一中频信号由中频放大器 (Q201) 进行放大, 然后进入中频 IC (IC200)。

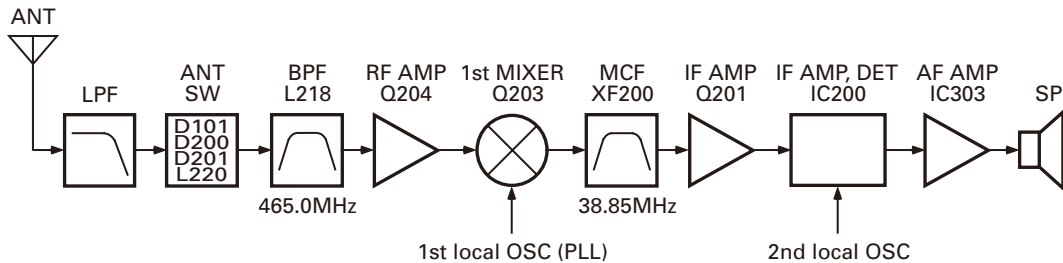

Fig. 2 Receiver section configuration / 图 2 接收部分构成

CIRCUIT DESCRIPTION / 电路说明

Item	Rating
Nominal center frequency (fo)	38.85MHz
Pass bandwidth	±5.0kHz or more at 3dB
Attenuation bandwidth	±18.5kHz or less at 35dB
Ripple	1.0dB or less
Insertion loss	4.0dB or less
Guaranteed attenuation	70dB or more at fo-900kHz
Terminating impedance	610Ω±10% / 3.0pF±0.5pF

Table 2 MCF (L71-0586-05) : TX-RX unit (B/2) XF200

项 目	额 定
标称中心频率 (fo)	38.85MHz
通过带宽	3dB 时 ±5.0kHz 或更大
衰减带宽	35dB 时 ±18.5kHz 或更小
纹波	1.0dB 或更小
插入损耗	4.0dB 或更小
保证衰减	fo-900kHz 时 70dB 或更大
终端阻抗	610 Ω ±10% / 3.0pF ±0.5pF

表 2 MCF(L71-0586-05): TX-RX 单元 (B/2)XF200

Item	Rating
Nominal center frequency (fo)	450kHz
6dB bandwidth	±6.0kHz or more
50dB bandwidth	±12.5kHz or less
Ripple (at 450kHz±4kHz)	2dB or less
Guaranteed attenuation (at 450kHz±100kHz)	35dB or more
Insertion loss	6dB or less
I/O matching impedance	2.0kΩ

Table 3 Ceramic filter (L72-0958-05) : TX-RX unit (B/2) CF200

项 目	额 定
标称中心频率 (fo)	450kHz
6dB 带宽	±6.0kHz 或更大
50dB 带宽	±12.5kHz 或更小
纹波 (450kHz±4kHz 时)	2dB 或更小
保证衰减 (450kHz±100kHz 时)	35dB 或更大
插入损耗	6dB 或更小
I/O 匹配阻抗	2.0k Ω

表 3 陶瓷滤波器 (L72-0958-05): TX-RX 单元 (B/2)CF200

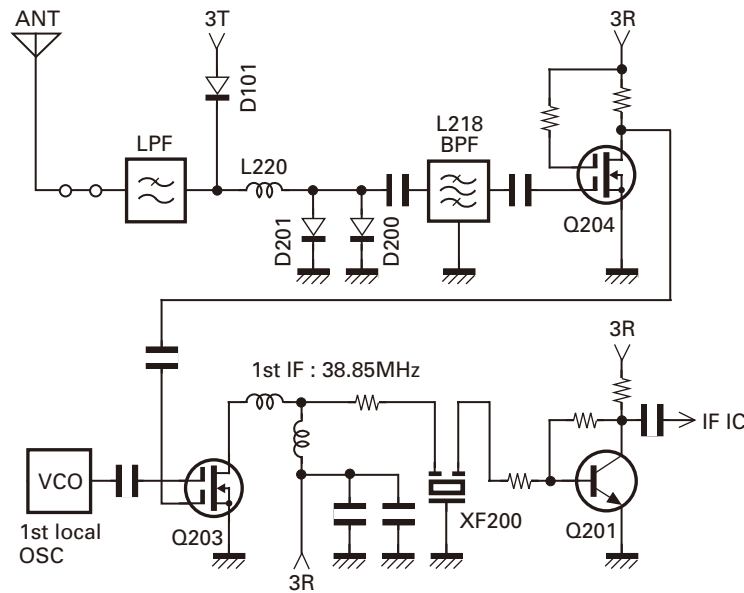

Fig. 3 Receiver circuit / 图 3 接收电路

■ IF Amplifier

The IF circuit is integrated in the FM IC (IC200). The IF IC contains local input, mixer, limiter amplifier, FM DET, and low-frequency amplifier.

The IF signal coming from the IF amplifier (Q201) goes to the IF IC mixer and is mixed with the second local signal (38.4MHz) to produce a second IF signal. (38.85MHz - 38.4MHz = 450kHz)

The tripled PLL reference oscillation (12.8MHz x 3) is used for the second local signal.

■ 中频放大器

中频电路集成在 FM IC (IC200) 内部。中频 IC 内含本地输入、混频器、限幅放大器、FM DET 和低频放大器。

来自中频放大器 (Q201) 的中频信号随后进入中频 IC 并与第二本振信号 (38.4MHz) 混频, 进而产生第二中频信号。(38.85MHz - 38.4MHz = 450kHz)

三倍 PLL 基准振荡 (12.8MHz x 3) 用于第二本振信号。

CIRCUIT DESCRIPTION / 电路说明

The second IF signal passes through ceramic filter (CF200) to remove unwanted signals.

The second IF signal passing through the ceramic filter passes through the limiter amplifier consisting six differential amplifiers and is detected.

The amplified second IF signal is demodulated by the quadrature detector with the ceramic discriminator (CD200). The demodulated signal is routed to the audio circuit.

■ Squelch Circuit

A squelch circuit is provided to prevent no-signal noise or weak signals from outputting to a speaker during transmission.

■ AF Circuit

The FM IC output passes through the base band IC (IC300). The signal then goes through an AF volume control, and is routed to an audio power amplifier (IC303) where it is amplified and output to speaker. This IC have BTL amplifier function. At internal speaker, BTL amplified. At external speaker, IC switch off the 1 channel amplifier by connectors information.

Narrow and wide setting can be made for each channel by switching the demodulation level. The WIDE (low level) and NARROW (high level) data is output from IC403, pin 69. When a Wide (low level) data is received, Q200 turn on. When a NARROW (high level) data is received, Q200 turn off.

Q200 turns off/on with the wide/narrow data and the IC200 detector output level is switched to maintained a constant output level during wide or narrow signals.

第二中频信号通过陶瓷滤波器 (CF200) 消除不需要的信号。通过陶瓷滤波器的第二中频信号随后通过由六个不同放大器组成的限幅放大器并进行检测。

放大后的第二中频信号由积分检波器通过陶瓷鉴频器 (CD200) 进行解调。已解调的信号转发给音频电路。

■ 静噪电路

静噪电路用于防止无信号的噪声或微弱信号输出到扬声器。

■ AF 电路

FM IC 输出信号通过基带 IC (IC300)。随后信号通过 AF 音量调整, 并发送给音频功率放大器 (IC303), 在这里经过放大并输出到扬声器。该 IC 具有 BTL 放大器功能。在内部扬声器, BTL 被放大。在外部扬声器, IC 通过连接器信息关闭 1 信道放大器。

通过切换解调电平, 各个信道均可进行窄宽设置。宽信号 (低电平) 及窄信号 (高电平) 数据从 IC403 (引脚 69) 输出。接收到宽信号 (低电平) 数据时, Q200 打开。接收到窄信号 (高电平) 数据时, Q200 关闭。

在宽或窄信号期间, Q200 随宽 / 窄信号数据打开 / 关闭, IC200 检波器输出电平切换为保持恒定输出电平。

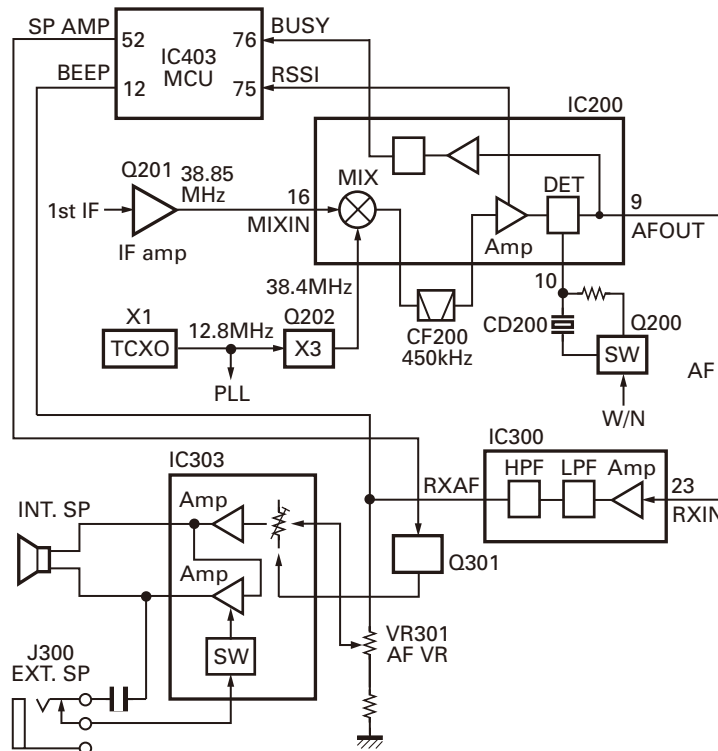

Fig. 4 IF amplifier, Squelch and AF circuits / 图 4 中频放大器, 静噪, AF 电路

CIRCUIT DESCRIPTION / 电路说明

Transmitter System

■ Microphone Amplifier Circuit

The audio signal from the microphone passes through the MIC amplifier (IC302). Then, the signal goes through the base band IC (IC300) that has the 6dB/oct pre-emphasis circuit, band-pass filter (300 to 3kHz), amplifier, and limiter. The distortion components outside the audio band are removed by the splatter filter.

■ Modulation Circuit

The MIC amplifier (IC302) output passes through VR300 for modulation adjustment and goes to the modulation input of the VCO circuit for variable reactance phase modulation.

■ Transmission Output Circuit

The VCO output is amplified by a high-frequency amplifier (Q101, Q103 and Q104), passes through a high-frequency antenna switch, passes through a low-pass filter and goes to the antenna.

The transmission output is about 1.5W with 3.8V DC supply at battery terminal.

■ Low-Pass Filter Circuit

A three-stage Chebyshev type low-pass filter is located between the antenna and transmit/receive switching circuit. It removes harmonic components contained in the transmission output.

发射系统

■ 麦克风放大器电路

麦克风的音频信号通过麦克风放大器 (IC302)。随后信号通过具有 6dB/oct 预加重电路、带通滤波器 (300 ~ 3kHz)、放大器和限幅器的基带 IC (IC300)。音频频带外的失真成分由边带滤波器进行消除。

■ 调制电路

麦克风放大器 (IC302) 输出信号通过 VR300 进行调制调整, 然后进入 VCO 电路的调制输入进行可变电抗相位调制。

■ 发射输出电路

VCO 输出信号由高频放大器 (Q101、Q103 和 Q104) 进行放大, 然后依次通过高频天线开关和低通滤波器并进入天线。

电池端子采用 3.8V 直流供电时, 发射输出功率约为 1.5W。

■ 低通滤波电路

三阶切比雪夫低通滤波器位于天线和发射 / 接收切换电路之间, 能够消除发射输出信号中所带的谐波成分。

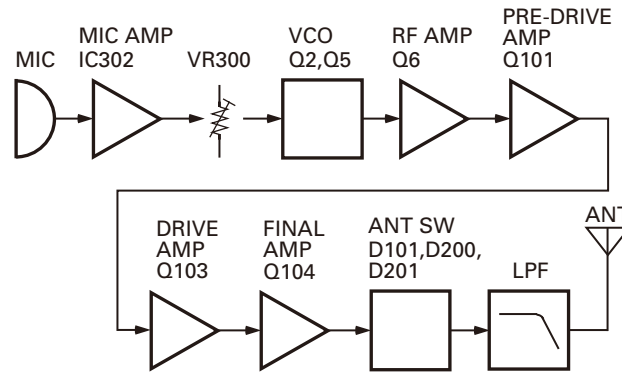

Fig. 5 Transmitter section configuration / 图 5 发射部分构成

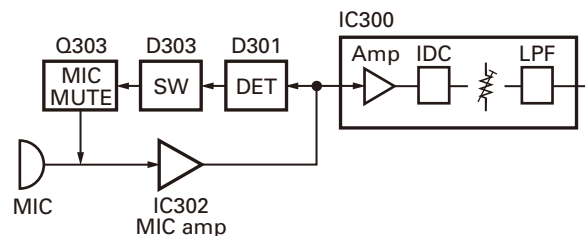

Fig. 6 Microphone amplifier circuit / 图 6 麦克风放大器电路

CIRCUIT DESCRIPTION / 电路说明

PLL System

■ VCO Circuit

The VCO is housed in a shield case.

The VCO circuit consists of a transistor (Q2), a variable capacity diode (D2) for frequency control, a variable capacity diode (D4) for modulation, transmit/receive frequency shift diode (D1), control transistor (Q1) and oscillator buffer amplifier (Q5).

In receive mode, the shift signal T/R goes low, Q1 turns off, and the shift diode (D1) not contact. Q2 produces the first local frequency for reception. (Receive channel frequency - 38.85MHz)

In transmit mode, the shift signal T/R goes high, Q1 turns on and D1 does conducts. Q2 produces about 460~470MHz and the VCO frequency equals the transmit channel frequency.

The 3.0V circuit voltage is produced by ripple removing filter circuit Q4.

PLL 系统

■ VCO 电路

VCO 外嵌屏蔽罩。

VCO 电路由晶体管 (Q2)、用于频率控制的可变电容二极管 (D2)、用于调制的可变电容二极管 (D4)、发射 / 接收频率偏移二极管 (D1)、控制晶体管 (Q1) 和振荡缓冲放大器 (Q5) 组成。

在接收模式下, 移位信号 T/R 变低, Q1 关闭并且二极管 (D1) 不导通。Q2 产生用于接收的第一本振频率。(接收信道频率 - 38.85MHz)

在发射模式下, 移位信号 T/R 变高, Q1 打开并且 D1 导通。Q2 产生 460 ~ 470MHz 的频率并且 VCO 频率与发射信道频率相同。

由纹波消除滤波电路 Q4 产生 3.0V 的电路电压。

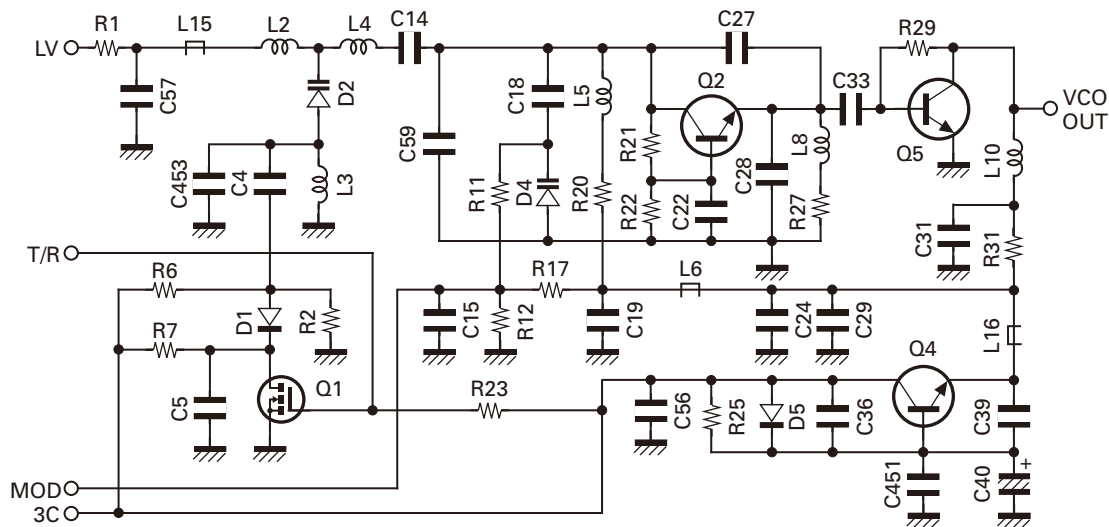

Fig. 7 VCO circuit / 图 7 VCO 电路

■ PLL Circuit

Frequency data is sent to the PLL IC (IC1) from the MCU (IC403) as serial data when the power turns on, when the channel is changed, or when transmission begins. It sets the variable divider in the PLL IC.

The TCXO (X1) produce a 12.8MHz reference frequency. It is divided to produce a 6.25kHz/5kHz PLL comparison frequency in the PLL IC.

This PLL IC can generate a channel step which is twice of the PLL comparison frequency. Hence, the PLL IC can directly generate channel step by 12.5kHz/10kHz. Beside, an external control voltage of TCXO is used to shift TCXO reference frequency by 6.25kHz/5kHz to achieve channel step with 6.25kHz/5kHz generate in the PLL IC.

■ PLL 电路

电源打开时, 信道改变时, 或发射开始时, MCU (IC403) 的频率数据作为串行数据发送到 PLL IC (IC1), 设置 PLL IC 中的可变分频器。

TCXO (X1) 产生 12.8MHz 基准频率, 随后在 PLL IC 中分频产生 6.25kHz/5kHz 的 PLL 比较频率。

该 PLL IC 可以产生两倍于 PLL 比较频率的信道步长。因此, PLL IC 可以直接产生 12.5kHz/10kHz 的信道步长。此外, TCXO 的外部控制电压用于偏移 6.25kHz/5kHz 的 TCXO 基准频率, 进而实现在 PLL IC 中产生 6.25kHz/5kHz 的信道步长。

CIRCUIT DESCRIPTION / 电路说明

The VCO output is divided by the divide ratio set by the divider in the PLL IC to generate 6.25kHz/5kHz. It is compared with the reference comparison frequency by the phase comparator to detect a phase difference.

The charge pump circuit in the PLL IC converts it to a control voltage that can drive the VCO directly.

The control voltage passes through a loop filter which passes low frequency and is applied to the VCO control pin to control the oscillator frequency. The loop filter removes unwanted harmonics and noise contained in the output from the phase comparator and determines PLL response and synchronizing characteristics by the amplitude and phase characteristics (Fig. 8).

■ Unlock Detection Circuit

If the PLL cannot be synchronized for some reason or other when switching the channel or changing between transmission and reception, the PLL IC outputs a low unlock detection signal. This signal goes to the MCU to inhibit transmission when the PLL is unlocked.

VCO 输出信号由 PLL IC 中分频器设置的分频倍率进行分频，进而产生 6.25kHz/5kHz 的频率，随后由相位比较器与基准比较频率进行比较来检测相位差。

PLL IC 中的电荷泵电路将其转换为可以直接驱动 VCO 的控制电压。

控制电压通过环路滤波器，经过低频并应用到 VCO 控制引脚来控制振荡频率。环路滤波器消除相位比较器输出信号中所带的不需要的谐波和噪音，并由振幅及相位特性确定 PLL 响应及同步特性（图 8）。

■ 失锁检测电路

切换信道或在发射与接收之间进行切换时，如果由于某些其他原因造成 PLL 无法同步，则 PLL IC 会输出低失锁检测信号。PLL 失锁时，该信号进入 MCU 禁止发射。

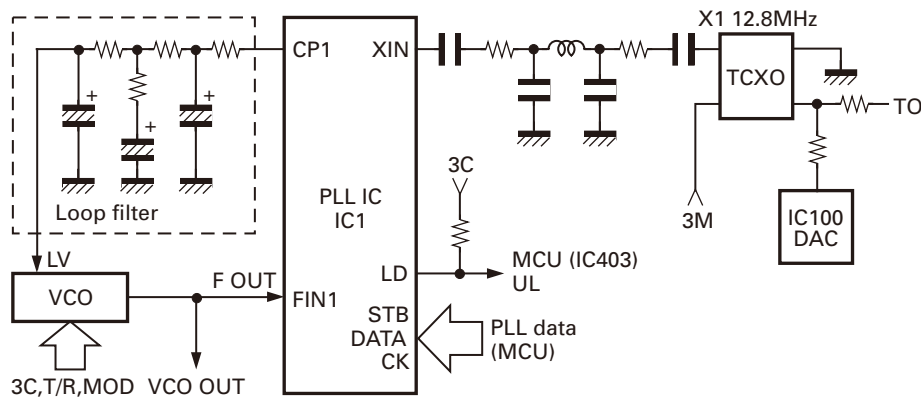

Fig. 8 PLL circuit / 图 8 PLL 电路

Control System

■ Reset Circuit

When a battery voltage is dropped, IC401 is detected low voltage, and this detected signal input to IC403 for stop the MCU function. IC400 is detected the reset voltage.

■ Battery Voltage Detection Circuit

The unit detects a low battery voltage and display the BATT indicator on the LCD. The battery voltage is divided and applied to the analog value input pin (BATT) of the MCU, and converted to a digital signal.

■ Power Supply Circuit

The power supply voltage is maintained to 3.0V by the series regulator (IC404). It is used as MCU power 3M, 3C, 3R and 3T.

The B (battery voltage) is supplied to the RF final transistor Q104.

控制系统

■ 复位电路

电池电压下降时，IC401 检测到低电压并且该检测信号输入到 IC403 用于停止 MCU 功能。IC400 检测复位电压。

■ 电池电压检测电路

本单元检测低电压并在 LCD 上显示 BATT 指示。电池电压随后进行划分并应用到 MCU 的模拟数值输入引脚 (BATT)，然后转换为数字信号。

■ 电源电路

电源电压由串联稳压器 (IC404) 稳压至 3.0V，用作 MCU 电源 3M、3C、3R 和 3T。

B (电池电压) 为 RF 末级晶体管 Q104 供电。

CIRCUIT DESCRIPTION / 电路说明

The transmission power 3T is supplied to the transmission output circuit when the MCU turns Q404 on only in transmit mode.

The reception power 3R is provided to the receive and IF circuits when the MCU turns Q406 on only in receive mode.

The transmission/reception power 3C is supplied to the VCO and PLL circuits when the MCU turns Q405 on in transmit and receive modes.

If no signal is received for 10 seconds, the MCU enters the power save mode, and turns common power 3C and reception power 3R on for one cycle and off for three cycles according to the signals from the MCU to save the battery power.

■ QT/DQT

• Encode (Transmit)

QT/DQT signal is generated by MCU (IC403). Output signal (IC403 pin 18 (TO)) goes to TCXO modulation and VCO modulation (Through the VR300).

• Decode (Receive)

Detected AF signal go to IC300 and then IC301. Function of IC301 is LPF for sub-audible frequency. This signal goes to IC403 pin 77 (TI). IC403 is detected the QT or DQT.

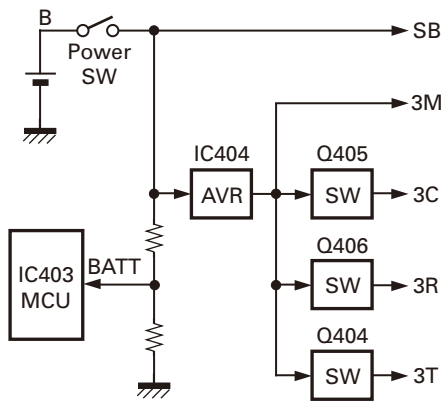

Fig. 9 Reset, Battery voltage detection and Power supply circuits

图 9 复位, 电池电压检测, 电源电路

仅在发射模式下 MCU 打开 Q404 时, 发射电源 3T 才为发射输出电路供电。

仅在接收模式下 MCU 打开 Q406 时, 接收电源 3R 才为接收及中频电路供电。

在发射和接收模式下 MCU 打开 Q405 时, 发射 / 接收电源 3C 为 VCO 及 PLL 电路供电。

如果 10 秒钟内没有接收到任何信号, MCU 进入省电模式, 然后根据 MCU 的信号循环打开公共电源 3C 和接收电源 3R 一段时间长度而后关闭三段长度, 从而达到节省电池电量的目的。

■ QT/DQT

● 编码 (发射)

QT/DQT 信号由 MCU (IC403) 产生。输出信号 (IC403 引脚 18) 进入 TCXO 调制和 VCO 调制 (通过 VR300)。

● 解码 (接收)

检测到的 AF 信号进入 IC300 并随后进入 IC301。IC301 的功能为用于亚音频的 LPF。该信号进入 IC403 引脚 77 (TI)。IC403 检测 QT 或 DQT。

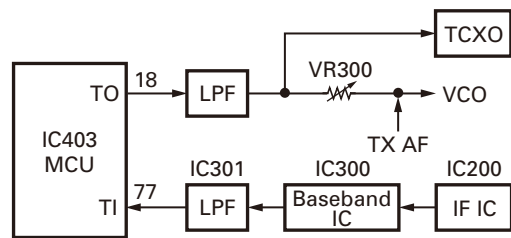

Fig. 10 QT/DQT circuit / 图 10 QT/DQT 电路

SEMICONDUCTOR DATA / 半导体数据

MCU: D338327A22WV (TX-RX unit IC403)

■ Terminal Function

Pin No.	Signal Name	I/O	Function
1	SP DET	I	Head set detect
2	AVSS	-	GND
3	X1	-	
4	X2	-	
5	VSS	-	GND
6	OSC2	-	X'tal (7.3728MHz)
7	OSC1	-	X'tal (7.3728MHz)
8	TEST	I	
9	RESET	-	Reset
10	SCLK	O	Serial clock
11	POW CON	O	Auto power control
12	BEEP	O	Beep output
13	DIR	O	DIR to IC300
14	SDATA	I/O	Serial data
15	TDATA	O	MSK TX data
16	TCLK	I	TCLK from IC300
17	RDF	I	RDF/FD
18	TO	O	QT/DQT output
19	PWM IN	I	PWM data input
20	BOOT	I	BOOT/USER input
21	SAVE	O	Battery save
22	3RC	O	3R control
23	3TC	O	3T control
24	GLLED	O	Green LED
25	RLED	O	Red LED
26	CVCC	-	+3V (Power supply)
27	VSS	-	GND
28~31	V3~V0	-	
32	VCC	O	+3V (Power supply)
33	BACK LT	O	Back light
34~36	COM3~COM1	-	
37	PTT	I	
38	UP	I	
39	DOWN	I	
40	MONI	I	
41	MENU	I	
42	CALL	I	
43	EEPDATA	I/O	EEPROM data
44	EEPCLK	O	EEPROM clock

MCU: D338327A22WV (TX-RX 单元 IC403)

■ 端子功能

管脚号	信号名称	输入/输出	功能
1	SP DET	输入	耳机检测
2	AVSS	-	GND
3	X1	-	
4	X2	-	
5	VSS	-	GND
6	OSC2	-	晶体 (7.3728MHz)
7	OSC1	-	晶体 (7.3728MHz)
8	TEST	输入	
9	RESET	-	复位
10	SCLK	输出	串行时钟
11	POW CON	输出	自动功率控制
12	BEEP	输出	提示音输出
13	DIR	输出	DIR 到 IC300
14	SDATA	输入/输出	串行数据
15	TDATA	输出	MSK TX 数据
16	TCLK	输入	来自 IC300 的 TCLK
17	RDF	输入	RDF/FD
18	TO	输出	QT/DQT 输出
19	PWM IN	输入	PWM 数据输入
20	BOOT	输入	BOOT/USER 输入
21	SAVE	输出	电池节电
22	3RC	输出	3R 控制
23	3TC	输出	3T 控制
24	GLLED	输出	绿色 LED
25	RLED	输出	红色 LED
26	CVCC	-	+3V (电源)
27	VSS	-	GND
28 ~ 31	V3 ~ V0	-	
32	VCC	输出	+3V (电源)
33	BACK LT	输出	背光
34 ~ 36	COM3 ~ COM1	-	
37	PTT	输入	
38	UP	输入	
39	DOWN	输入	
40	MONI	输入	
41	MENU	输入	
42	CALL	输入	
43	EEPDATA	输入/输出	EEPROM 数据
44	EEPCLK	输出	EEPROM 时钟

Pin No.	Signal Name	I/O	Function
45	MIC MUTE	O	MIC mute
46	SHIFT	O	Beat shift
47	PDATA	O	Serial data
48	PCLK	O	Serial clock
49	PEN	O	PLL IC chip select
50	3MSC	O	IC300 power supply
51	PABC	O	Final switch
52	SP AMP	O	AF AMP on/off
53~68	SEG	-	LCD
69	WIDE	O	Wide/Narrow
70	RXD	I	RXD
71	TXD	O	TXD
72	BATT L	I	Battery low
73	AVCC	-	+3V (AD power supply)
74	THP	I	TX thermal input
75	RSSI	I	RSSI input
76	BUSY	I	Squelch input
77	TI	I	QT/DQT input
78	BATT	I	Battery voltage
79	VOX	I	VOX level
80	UL	I	PLL unlock detect

管脚号	信号名称	输入/输出	功能
45	MIC MUTE	输出	麦克风静音
46	SHIFT	输出	拍频偏移
47	PDATA	输出	串行数据
48	PCLK	输出	串行时钟
49	PEN	输出	PLL IC 芯片选择
50	3MSC	输出	IC300 电源
51	PABC	输出	末级开关
52	SP AMP	输出	AF AMP 打开 / 关闭
53 ~ 68	SEG	-	LCD
69	WIDE	输出	宽 / 窄
70	RXD	输入	RXD
71	TXD	输出	TXD
72	BATT L	输入	电池低电量
73	AVCC	-	+3V (AD 电源)
74	THP	输入	TX 热感输入
75	RSSI	输入	RSSI 输入
76	BUSY	输入	静噪输入
77	TI	输入	QT/DQT 输入
78	BATT	输入	电池电压
79	VOX	输入	VOX 电平
80	UL	输入	PLL 失锁检测

FET: RQA0004PXDQS (TX-RX unit Q103)**■ Absolute Maximum Rating (Ta=25°C)**

Item	V _{DSS}	V _{GSS}	I _D	P _D	T _{ch}	T _{stg}
Rating	16V	±5V	0.3A	3W T _c =25°C	150°C	-55~+150°C

FET: RQA0004PXDQS (TX-RX 单元 Q103)**■ 绝对最大额定值 (Ta=25°C)**

项目	V _{DSS}	V _{GSS}	I _D	P _D	T _{ch}	T _{stg}
额定值	16V	±5V	0.3A	3W T _c =25°C	150°C	-55 ~ +150°C

FET: RQA0002DNS (TX-RX unit Q104)**■ Absolute Maximum Rating (Ta=25°C)**

Item	V _{DSS}	V _{GSS}	I _D	P _{ch}	T _{ch}	T _{stg}
Rating	16V	±5V	3.8A	15W T _c =25°C	150°C	-55~+150°C

FET: RQA0002DNS (TX-RX 单元 Q104)**■ 绝对最大额定值 (Ta=25°C)**

项目	V _{DSS}	V _{GSS}	I _D	P _{ch}	T _{ch}	T _{stg}
额定值	16V	±5V	3.8A	15W T _c =25°C	150°C	-55 ~ +150°C

COMPONENTS DESCRIPTION / 元件说明

TX-RX unit (X57-7330-10)

Ref. No.	Part Name	Description
IC1	IC	Phase Locked Loop system
IC100	IC	DAC
IC200	IC	IF System
IC300	IC	Base Band
IC301	IC	Active Filter
IC302	IC	MIC amplifier/ Limiter
IC303	IC	Audio Power Amplifier
IC400	IC	Voltage Detect
IC401	IC	Reset Switch
IC403	IC	MCU
IC404	IC	Voltage Regulator (3V)
IC405	IC	Divider
IC406	IC	EEPROM
Q1	Transistor	DC switch (T/R)
Q2	Transistor	VCO
Q3	Transistor	RF amplifier
Q4	Transistor	Ripple filter
Q5	Transistor	RF buffer amplifier
Q6	Transistor	RF amplifier
Q101	Transistor	TX pre-drive
Q103	FET	TX drive
Q104	FET	TX final
Q200	Transistor	RX W/N Switch
Q201	Transistor	IF amplifier
Q202	Transistor	Tripler
Q203	FET	Mixer
Q204	FET	RF amplifier
Q300,301	FET	Audio mute switch
Q302	FET	VOX switch
Q303	Transistor	MIC mute/AGC
Q400	Transistor	DC switch (Back Light)
Q401	Transistor	DC switch (Busy)
Q402	Transistor	DC switch (TX)
Q403,408	Transistor	Beat shift switch
Q404	Transistor	DC switch (3T)
Q405	Transistor	DC switch (3C)
Q406	Transistor	DC switch (3R)
D1	Diode	Current Steering
D2	Variable capacitance Diode	Frequency control

TX-RX 单元 (X57-7330-10)

有关号码	名称	说明
IC1	IC	锁相环路系统
IC100	IC	DAC
IC200	IC	中频系统
IC300	IC	基带
IC301	IC	有源滤波器
IC302	IC	麦克风放大器 / 限幅器
IC303	IC	音频功率放大器
IC400	IC	电压检测
IC401	IC	复位开关
IC403	IC	MCU
IC404	IC	稳压器 (3V)
IC405	IC	分频器
IC406	IC	EEPROM
Q1	晶体管	直流开关 (T/R)
Q2	晶体管	VCO
Q3	晶体管	RF 放大器
Q4	晶体管	纹波滤波器
Q5	晶体管	RF 缓冲滤波器
Q6	晶体管	RF 放大器
Q101	晶体管	TX 预驱动
Q103	场效应管	TX 驱动
Q104	场效应管	TX 末级
Q200	晶体管	RX W/N 开关
Q201	晶体管	中频放大器
Q202	晶体管	三倍频器
Q203	场效应管	混频器
Q204	场效应管	RF 放大器
Q300, 301	场效应管	音频静音开关
Q302	场效应管	VOX 开关
Q303	晶体管	麦克风静音 /AGC
Q400	晶体管	直流开关 (背光)
Q401	晶体管	直流开关 (繁忙)
Q402	晶体管	直流开关 (TX)
Q403, 408	晶体管	拍频偏移开关
Q404	晶体管	直流开关 (3T)
Q405	晶体管	直流开关 (3C)
Q406	晶体管	直流开关 (3R)
D1	二极管	电流导引
D2	可变电容二极管	频率控制

TK-3230

COMPONENTS DESCRIPTION / 元件说明

Ref. No.	Part Name	Description
D3	Diode	Unlock detect
D4	Variable capacitance Diode	TX modulation
D5	Diode	Current Steering
D6,7	Diode	RF switch
D101,200,201	Diode	Antenna switch
D300	Diode	Switch
D301	Diode	AGC detect
D302	Diode	AF detect
D303	Diode	MIC mute/AGC switch
D304	Diode	Reverse protection
D305	Diode	Surge absorption
D306,307	Zener Diode	Voltage protection
D308	Zener Diode	Surge absorption
D400	LED	LCD Backlight
D401	LED	TX/ BUSY

有关号码	名称	说明
D3	二极管	失锁检测
D4	可变电容二极管	TX 调制
D5	二极管	电流导引
D6, 7	二极管	RF 开关
D101, 200, 201	二极管	天线开关
D300	二极管	开关
D301	二极管	AGC 检测
D302	二极管	AF 检测
D303	二极管	麦克风静音 /AGC 开关
D304	二极管	逆向保护
D305	二极管	电涌吸收
D306, 307	稳压二极管	电压保护
D308	稳压二极管	电涌吸收
D400	LED	LCD 背光
D401	LED	TX/ 繁忙

PARTS LIST / 零件表

* New Parts. Δ indicates safety critical components.

Parts without **Parts No.** are not supplied.

Les articles non mentionnés dans le **Parts No.** ne sont pas fournis.

Teile ohne **Parts No.** werden nicht geliefert.

L : Scandinavia

Y : PX (Far East, Hawaii)

Y : AAFES (Europe)

K : USA

T : England

X : Australia

P : Canada

E : Europe

M : Other Areas

TK-3230 (Y50-6163-01)
TX-RX UNIT (X57-7330-10)

Ref. No.	Address	New parts	Parts No.	Description	Destination
TK-3230					
1	3A	*	A02-3975-33	PLASTIC CABINET ASSY (REAR)	
2	1A	*	A02-4025-13	PLASTIC CABINET ASSY (FRONT)	
4	3B		B09-0710-03	CAP (SP/MIC)	
5	1C	*	B62-2028-00	INSTRUCTION MANUAL	
8	2A		E37-1390-05	PARALLEL CORD (SPEAKER)	
10	2B		F07-1929-03	COVER (ANTENNA CAP)	
12	2B	*	G10-1378-04	FIBROUS SHEET	
16	3D	*	H52-2218-02	ITEM CARTON CASE	
18	1A	*	J19-5508-03	HOLDER (PTT)	
19	2C	*	J29-0736-05	HOOK ASSY ACCESSORY	
21	2B		K29-9397-03	KNOB (VOLUME)	
22	1A		K29-9398-03	BUTTON KNOB (PTT)	
23	2A		K29-9399-02	KEY TOP	
A	2B		N14-0840-05	CIRCULAR NUT	
C	2A,3A		N80-2006-43	PAN HEAD TAPTITE SCREW	
25	2C		N99-2063-05	SCREW SET ACCESSORY	
27	2A		T07-0362-25	SPEAKER	
28	2B		T90-1068-15	ANTENNA ELEMENT	

TX-RX UNIT (X57-7330-10)					
101	2B		B11-1849-03	ILLUMINATION GUIDE (LCD)	
102	1B		B38-0925-05	LCD	
D400			B30-2143-05	LED (YG)	
D401			B30-2278-05	LED (RED/YELLOW)	
C1			CC73HCH1H101J	CHIP C 100PF J	
C2			CS77AA1VR33M	CHIP TNTL 0.33UF 35WV	
C3			CK73HB1H471K	CHIP C 470PF K	
C4,5			CC73HCH1H101J	CHIP C 100PF J	
C6			CS77AA1A2R2M	CHIP TNTL 2.2UF 10WV	
C7-9			CC73HCH1H101J	CHIP C 100PF J	
C10			CK73FB0J106K	CHIP C 10UF K	
C11			CS77CA1V0R1M	CHIP TNTL 0.1UF 35WV	
C12			CC73HCH1H470J	CHIP C 47PF J	
C13			CC73HCH1H101J	CHIP C 100PF J	
C14		*	C93-1724-05	CHIP C 4.2PF	
C15			CC73HCH1H101J	CHIP C 100PF J	
C17			CC73HCH1H101J	CHIP C 100PF J	
C18			CC73HCH1H1R5B	CHIP C 1.5PF B	
C19,20			CK73HB1H471K	CHIP C 470PF K	
C21			CC73HCH1H470J	CHIP C 47PF J	
C22			CK73HB1H471K	CHIP C 470PF K	
C23			CK73HB1C103K	CHIP C 0.010UF K	
C25			CK73HB1H471K	CHIP C 470PF K	
C27			CC73HCH1H150G	CHIP C 15PF G	
C28			CC73HCH1H110G	CHIP C 11PF G	
C29			CC73HCH1H101J	CHIP C 100PF J	
C30			CK73GB1H103K	CHIP C 0.010UF K	

Ref. No.	Address	New parts	Parts No.	Description	Destination
C31,32			CC73HCH1H100D	CHIP C 10PF D	
C33			CC73HCH1H0R5B	CHIP C 0.5PF B	
C34,35			CC73HCH1H100D	CHIP C 10PF D	
C36,37			CC73HCH1H101J	CHIP C 100PF J	
C38			CK73HB1H471K	CHIP C 470PF K	
C39			CC73HCH1H101J	CHIP C 100PF J	
C40			CS77AAQJ220M	CHIP TNTL 22UF 6.3WV	
C41			CC73HCH1H050B	CHIP C 5.0PF B	
C43			CC73HCH1H100D	CHIP C 10PF D	
C44			CC73HCH1H050B	CHIP C 5.0PF B	
C45,46			CK73HB1H471K	CHIP C 470PF K	
C47			CK73HB1A104K	CHIP C 0.10UF K	
C48,49			CK73HB1H471K	CHIP C 470PF K	
C50,51			CC73HCH1H030B	CHIP C 3.0PF B	
C52			CC73HCH1H050B	CHIP C 5.0PF B	
C53			CC73HCH1H080B	CHIP C 8.0PF B	
C54			CC73HCH1H050B	CHIP C 5.0PF B	
C55			CC73HCH1H101J	CHIP C 100PF J	
C57,58			CC73HCH1H101J	CHIP C 100PF J	
C59			CC73HCH1H3R5B	CHIP C 3.5PF B	
C60			CC73HCH1H120J	CHIP C 12PF J	
C100			CK73HB1H471K	CHIP C 470PF K	
C101			CC73HCH1H1R5B	CHIP C 1.5PF B	
C103			CK73HB1A104K	CHIP C 0.10UF K	
C111			CK73HB1A104K	CHIP C 0.10UF K	
C112			CK73HB1H471K	CHIP C 470PF K	
C113			CC73HCH1H150J	CHIP C 15PF J	
C114			CC73HCH1H150G	CHIP C 15PF G	
C116			CK73HB1H471K	CHIP C 470PF K	
C117			CC73HCH1H101J	CHIP C 100PF J	
C119,120			CK73HB1H471K	CHIP C 470PF K	
C121			CC73HCH1H270J	CHIP C 27PF J	
C122			CK73HB1A104K	CHIP C 0.10UF K	
C123			CC73HCH1H270J	CHIP C 27PF J	
C124			CK73HB1H471K	CHIP C 470PF K	
C125			CC73GCH1H050B	CHIP C 5.0PF B	
C126			CK73HB1H471K	CHIP C 470PF K	
C127			CK73HB0J105K	CHIP C 1.0UF K	
C128			CC73GCH1H270J	CHIP C 27PF J	
C129			CK73HB1A104K	CHIP C 0.10UF K	
C130			CK73HB1C103K	CHIP C 0.010UF K	
C131			CK73HB1A104K	CHIP C 0.10UF K	
C132			CK73HB1H471K	CHIP C 470PF K	
C133			CC73HCH1H090B	CHIP C 9.0PF B	
C134			CC73GCH1H101J	CHIP C 100PF J	
C136			CK73HB0J105K	CHIP C 1.0UF K	
C137			CK73HB1C103K	CHIP C 0.010UF K	
C138			CK73HB1A104K	CHIP C 0.10UF K	
C200			CK73HB1H182K	CHIP C 1800PF K	
C202			CK73HB1H271K	CHIP C 270PF K	
C203,204			CK73HB1H102K	CHIP C 1000PF K	
C205			CK73HB1A104K	CHIP C 0.10UF K	
C206			CK73HB1H271K	CHIP C 270PF K	
C207			CK73HB1A104K	CHIP C 0.10UF K	
C208			CC73HCH1H680J	CHIP C 68PF J	
C209			CK73HB1H471K	CHIP C 470PF K	

PARTS LIST / 零件表

TX-RX UNIT (X57-7330-10)

Ref. No.	Address	New parts	Parts No.	Description	Destination	Ref. No.	Address	New parts	Parts No.	Description	Destination
C210			CK73FB0J106K	CHIP C 10UF K		C325			CK73GB0J475K	CHIP C 4.7UF K	
C211			CK73HB1A224K	CHIP C 0.22UF K		C326			CK73HB1A104K	CHIP C 0.10UF K	
C212,213			CK73HB1H471K	CHIP C 470PF K		C327			CK73HB1A683K	CHIP C 0.068UF K	
C215-217			CK73HB1C103K	CHIP C 0.010UF K		C328			CK73GB0J475K	CHIP C 4.7UF K	
C218			CK73HB1H471K	CHIP C 470PF K		C329			CC73HCH1H181J	CHIP C 180PF J	
C219			CK73HB1C103K	CHIP C 0.010UF K		C330,331			CK73HB1A473K	CHIP C 0.047UF K	
C220			CC73HCH1H010B	CHIP C 1.0PF B		C332,333			CK73HB1A104K	CHIP C 0.10UF K	
C221			CK73GB1H183K	CHIP C 0.018UF K		C336			CK73HB1A104K	CHIP C 0.10UF K	
C222			CK73HB1H331K	CHIP C 330PF K		C337			CK73FB1A225K	CHIP C 2.2UF K	
C223			CK73HB1C103K	CHIP C 0.010UF K		C338			CK73HB1C103K	CHIP C 0.010UF K	
C224			CC73HCH1H100D	CHIP C 10PF D		C339			C92-0864-05	CHIP TNL 10UF 10WV	
C225			CC73HCH1H150J	CHIP C 15PF J		C340			CK73HB0J105K	CHIP C 1.0UF K	
C226			CC73HCH1H010B	CHIP C 1.0PF B		C341			CK73HB1H471K	CHIP C 470PF K	
C228			CK73HB1C103K	CHIP C 0.010UF K		C342			CK73HB0J105K	CHIP C 1.0UF K	
C229			CC73HCH1H680J	CHIP C 68PF J		C343			CK73HB1A333K	CHIP C 0.033UF K	
C230,231			CK73HB1C103K	CHIP C 0.010UF K		C345			CK73HB1H471K	CHIP C 470PF K	
C232			CC73HCH1H330J	CHIP C 33PF J		C346			CK73HB1A104K	CHIP C 0.10UF K	
C233			CC73HCH1H121J	CHIP C 120PF J		C348			CK73HB1A104K	CHIP C 0.10UF K	
C234			CK73HB1H471K	CHIP C 470PF K		C349			CK73HB1H102K	CHIP C 1000PF K	
C235			CC73HCH1H330J	CHIP C 33PF J		C350			CS77CPOJ100M	CHIP TNL 10UF 6.3WV	
C236			CC73HCH1H240J	CHIP C 24PF J		C351		*	CK73HB1A154K	CHIP C 0.15UF K	
C237			CC73HCH1H680J	CHIP C 68PF J		C353			CK73HB1H102K	CHIP C 1000PF K	
C239			CC73HCH1H030B	CHIP C 3.0PF B		C354			CS77AB20J101M	CHIP TNL 100UF 6.3WV	
C240			CK73HB1C103K	CHIP C 0.010UF K		C365-367			CC73HCH1H221J	CHIP C 220PF J	
C241,242			CK73HB1H471K	CHIP C 470PF K		C358			CC73HCH1H470J	CHIP C 47PF J	
C243			CC73HCH1H470J	CHIP C 47PF J		C359-361			CC73HCH1H101J	CHIP C 100PF J	
C244-246			CK73HB1H471K	CHIP C 470PF K		C363			CK73HB0J105K	CHIP C 1.0UF K	
C247			CC73HCH1H040B	CHIP C 4.0PF B		C364		*	CC73HCH1H0R3B	CHIP C 0.3PF B	
C248			CK73HB1C103K	CHIP C 0.010UF K		C400			CK73HB1H471K	CHIP C 470PF K	
C250,251			CK73HB1H471K	CHIP C 470PF K		C401			CK73HB0J105K	CHIP C 1.0UF K	
C252,253			CC73HCH1H470J	CHIP C 47PF J		C402			CK73HB1H471K	CHIP C 470PF K	
C254			CK73HB1H471K	CHIP C 470PF K		C404			CK73HB1H471K	CHIP C 470PF K	
C255			CC73HCH1H060B	CHIP C 6.0PF B		C405			CK73FB1A105K	CHIP C 1.0UF K	
C257			CC73HCH1H1R5B	CHIP C 1.5PF B		C408			CK73HB1H471K	CHIP C 470PF K	
C258			CC73HCH1H100D	CHIP C 10PF D		C411			CK73HB1H471K	CHIP C 470PF K	
C259			CK73HB1H471K	CHIP C 470PF K		C412			CS77AA1A100M	CHIP TNL 10UF 10WV	
C261			CC73HCH1H100D	CHIP C 10PF D		C413-415			CK73HB1A104K	CHIP C 0.10UF K	
C262			CC73HCH1H010C	CHIP C 1.0PF C		C417			CK73HB1H471K	CHIP C 470PF K	
C264			CC73HCH1H010B	CHIP C 1.0PF B		C418			CK73HB1A104K	CHIP C 0.10UF K	
C267,268			CK73HB1A104K	CHIP C 0.10UF K		C419			CK73FB0J106K	CHIP C 10UF K	
C301			CK73HB1E682K	CHIP C 6800PF K		C420			CC73HCH1H080B	CHIP C 8.0PF	
C303			CC73HCH1H090B	CHIP C 9.0PF B		C421			CK73HB1H471K	CHIP C 470PF K	
C304			CK73GB1C563K	CHIP C 0.056UF K		C422			CC73HCH1H330J	CHIP C 33PF J	
C306			CK73HB1H681K	CHIP C 680PF K		C423			CC73HCH1H080B	CHIP C 8.0PF B	
C307,308			CK73HB0J105K	CHIP C 1.0UF K		C426			CK73HB1H102K	CHIP C 1000PF K	
C309			CC73HCH1H101J	CHIP C 100PF J		C427			CC73HCH1H330J	CHIP C 33PF J	
C310			CK73HB1C473K	CHIP C 0.047UF K		C428			CC73HCH1H101J	CHIP C 100PF J	
C311			CK73FB0J106K	CHIP C 10UF K		C430			CK73GB1A105K	CHIP C 1.0UF K	
C312			CK73HB1A473K	CHIP C 0.047UF K		C431			CK73HB1C103K	CHIP C 0.010UF K	
C313			CK73FB0J106K	CHIP C 10UF K		C432			CK73HB1C223K	CHIP C 0.022UF K	
C314			CK73HB1H392K	CHIP C 3900PF K		C433			CK73HB1A104K	CHIP C 0.10UF K	
C315			CK73HB1H471K	CHIP C 470PF K		C434			CK73HB1A683K	CHIP C 0.068UF K	
C316			CC73HCH1H221J	CHIP C 220PF J		C437			CK73HB1C103K	CHIP C 0.010UF K	
C317			CK73HB1A473K	CHIP C 0.047UF K		C440			CC73HCH1H101J	CHIP C 100PF J	
C318			CK73HB0J105K	CHIP C 1.0UF K		C442,443			CC73HCH1H101J	CHIP C 100PF J	
C319			CK73HB1H272K	CHIP C 2700PF K		C444			CK73HB1A104K	CHIP C 0.10UF K	
C320			CK73FB0J106K	CHIP C 10UF K		C445			CK73HB1H471K	CHIP C 470PF K	
C321			CK73HB1H471K	CHIP C 470PF K		C446			CK73HB0J105K	CHIP C 1.0UF K	
C322,323			CK73HB1A104K	CHIP C 0.10UF K		C448			CC73GCH1H101J	CHIP C 100PF J	
C324			CC73HCH1H180J	CHIP C 18PF J		C449			CC73HCH1H101J	CHIP C 100PF J	

PARTS LIST / 零件表

TX-RX UNIT (X57-7330-10)

Ref. No.	Address	New parts	Parts No.	Description	Destination	Ref. No.	Address	New parts	Parts No.	Description	Destination
C451			CC73HCH1H101J	CHIP C 100PF J		L401,402			L92-0138-05	CHIP FERRITE	
C453			CC73HCH1H020B	CHIP C 2.0PF B		L403			L92-0140-05	CHIP FERRITE	
C454			CC73HCH1H101J	CHIP C 100PF J		L404-407			L92-0161-05	BEADS CORE	
C455			CK73HB0J105K	CHIP C 1.0UF K		L408			L40-2781-86	SMALL FIXED INDUCTOR (0.27UH)	
C456			CK73HB1A104K	CHIP C 0.10UF K		L409			L40-3363-57	SMALL FIXED INDUCTOR (3.3NH)	
C459			CC73HCH1H050B	CHIP C 5.0PF B		L410			L92-0149-05	CHIP FERRITE	
C460			CK73HB1A104K	CHIP C 0.10UF K		L411			L40-3363-57	SMALL FIXED INDUCTOR (3.3NH)	
C461			CK73HB1H471K	CHIP C 470PF K		L412			L40-2775-57	SMALL FIXED INDUCTOR (27.0NH)	
C464			CK73HB1C103K	CHIP C 0.010UF K		X1			L77-3019-05	TCXO	
C465			CK73HB0J105K	CHIP C 1.0UF K		X400	*		L77-3036-05	CRYSTAL RESONATOR (7.3728MHZ)	
C468			CK73HB1A104K	CHIP C 0.10UF K		XF200			L71-0586-05	MCF (38.85MHZ)	
C470			CK73HB1C183K	CHIP C 0.018UF K		CP400-402			RK74HB1J103J	CHIP-COM 10K J 1/16W	
103	1B		E29-1217-05	INTER CONNECTOR		R1			RK73HB1J103J	CHIP R 10K J 1/16W	
J300			E11-0703-05	PHONE JACK (2.5/3.5)		R2,3			RK73HB1J102J	CHIP R 1.0K J 1/16W	
-			F10-3083-04	SHIELDING CASE		R4			RK73HB1J100J	CHIP R 10 J 1/16W	
F300			F53-0324-05	FUSE(2.5A)		R5			RK73HB1J392J	CHIP R 3.9K J 1/16W	
104	1B		J21-8570-04	MOUNTING HARDWARE (LCD)		R6			RK73HB1J681J	CHIP R 680 J 1/16W	
-			J30-1282-14	SPACER		R7			RK73HB1J473J	CHIP R 47K J 1/16W	
CD200			L79-1866-05	TUNING COIL		R8			RK73HB1J101J	CHIP R 100 J 1/16W	
CF200			L72-0958-05	CERAMIC FILTER		R9			RK73HB1J563J	CHIP R 56K J 1/16W	
L1			L92-0140-05	CHIP FERRITE		R10			RK73HB1J000J	CHIP R 0.0 J 1/16W	
L2			L41-1091-06	SMALL FIXED INDUCTOR (1.0UH)		R11			RK73HB1J473J	CHIP R 47K J 1/16W	
L3			L41-6868-14	SMALL FIXED INDUCTOR (6.8NH)		R12			RK73HB1J183J	CHIP R 18K J 1/16W	
L4	*		L41-3372-43	SMALL FIXED INDUCTOR (33NH)		R13			RK73HB1J000J	CHIP R 0.0 J 1/16W	
L5,6			L41-1091-06	SMALL FIXED INDUCTOR (1.0UH)		R14-16			RK73HB1J101J	CHIP R 100 J 1/16W	
L7			L41-1005-08	SMALL FIXED INDUCTOR (10UH)		R17			RK73HB1J563J	CHIP R 56K J 1/16W	
L8			L41-1091-06	SMALL FIXED INDUCTOR (1.0UH)		R20			RK73HB1J470J	CHIP R 47 J 1/16W	
L10			L40-2775-57	SMALL FIXED INDUCTOR (27.0NH)		R21			RK73HB1J152J	CHIP R 1.5K J 1/16W	
L12			L40-2775-57	SMALL FIXED INDUCTOR (27.0NH)		R22			RK73HB1J562J	CHIP R 5.6K J 1/16W	
L13,14			L40-1275-57	SMALL FIXED INDUCTOR (12.0NH)		R23			RK73HB1J103J	CHIP R 10K J 1/16W	
L15,16			L92-0161-05	BEADS CORE		R24			RK73HB1J000J	CHIP R 0.0 J 1/16W	
L17			L40-1075-57	SMALL FIXED INDUCTOR (10.0NH)		R25			RK73HB1J472J	CHIP R 4.7K J 1/16W	
L101			L40-1575-57	SMALL FIXED INDUCTOR (15.0NH)		R26			RK73HB1J000J	CHIP R 0.0 J 1/16W	
L102			L40-1575-92	SMALL FIXED INDUCTOR (15NH)		R27			RK73GB2A330J	CHIP R 33 J 1/10W	
L103			L40-1875-92	SMALL FIXED INDUCTOR (18NH)		R29			RK73HB1J333J	CHIP R 33K J 1/16W	
L104			L92-0149-05	CHIP FERRITE		R30			RK73HB1J104J	CHIP R 100K J 1/16W	
L105			L40-3363-92	SMALL FIXED INDUCTOR (3.3NH)		R31			RK73HB1J101J	CHIP R 100 J 1/16W	
L106			L41-2263-14	SMALL FIXED INDUCTOR (2.2NH)		R32			RK73HB1J104J	CHIP R 100K J 1/16W	
L107			L92-0149-05	CHIP FERRITE		R34			RK73HB1J221J	CHIP R 220 J 1/16W	
L108			L41-2285-43	SMALL FIXED INDUCTOR (220NH)		R39			RK73HB1J332J	CHIP R 3.3K J 1/16W	
L109			L92-0138-05	CHIP FERRITE		R40			RK73HB1J103J	CHIP R 10K J 1/16W	
L111			L34-4568-05	AIR-CORE COIL		R42,43			RK73HB1J103J	CHIP R 10K J 1/16W	
L112			L92-0161-05	BEADS CORE		R44			RK73HB1J471J	CHIP R 470 J 1/16W	
L201			L40-1091-37	SMALL FIXED INDUCTOR (1.000UH)		R100			RK73HB1J332J	CHIP R 3.3K J 1/16W	
L205			L40-5681-86	SMALL FIXED INDUCTOR (0.56UH)		R107			RK73GB2A393J	CHIP R 39K J 1/10W	
L206			L41-4781-06	SMALL FIXED INDUCTOR (470NH)		R112			RK73HB1J153J	CHIP R 15K J 1/16W	
L208			L40-2285-92	SMALL FIXED INDUCTOR (220NH)		R114			RK73HH1J391D	CHIP R 390 D 1/16W	
L209			L41-3385-39	SMALL FIXED INDUCTOR (0.33UH)		R115			RK73HB1J100J	CHIP R 10 J 1/16W	
L210			L40-2285-92	SMALL FIXED INDUCTOR (220NH)		R119			RK73HB1J220J	CHIP R 22 J 1/16W	
L211			L40-2785-92	SMALL FIXED INDUCTOR (270NH)		R120			RK73HB1J152J	CHIP R 1.5K J 1/16W	
L212			L40-1875-57	SMALL FIXED INDUCTOR (18.0NH)		R122			RK73HB1J682J	CHIP R 6.8K J 1/16W	
L214			L40-2775-57	SMALL FIXED INDUCTOR (27.0NH)		R123			RK73HH1H331D	CHIP R 330 D 1/16W	
L215			L40-3975-57	SMALL FIXED INDUCTOR (39.0NH)		R124			RK73GB2A470J	CHIP R 47 J 1/10W	
L217			L41-1092-44	SMALL FIXED INDUCTOR (1UH)		R126			RK73HB1J152J	CHIP R 1.5K J 1/16W	
L218			L79-1807-05	FILTER		R128			RK73HB1J000J	CHIP R 0.0 J 1/16W	
L219-222			L34-4563-05	AIR-CORE COIL		R129,130			RK73HB1J221J	CHIP R 220 J 1/16W	
L300,301			L92-0138-05	CHIP FERRITE		R131			RK73HB1J471J	CHIP R 470 J 1/16W	
L400			L92-0140-05	CHIP FERRITE		R133			RK73HB1J000J	CHIP R 0.0 J 1/16W	
						R200			RK73HB1J122J	CHIP R 1.2K J 1/16W	

PARTS LIST / 零件表

TX-RX UNIT (X57-7330-10)

Ref. No.	Address	New parts	Parts No.	Description	Destination	Ref. No.	Address	New parts	Parts No.	Description	Destination
R201			RK73HB1J272J	CHIP R 2.7K J 1/16W		R340			RK73HB1J472J	CHIP R 4.7K J 1/16W	
R202			RK73HB1J332J	CHIP R 3.3K J 1/16W		R342,343			RK73HB1J102J	CHIP R 1.0K J 1/16W	
R204			RK73HB1J124J	CHIP R 120K J 1/16W		R344,345			RK73HB1J104J	CHIP R 100K J 1/16W	
R205			RK73HB1J332J	CHIP R 3.3K J 1/16W		R346			RK73HB1J472J	CHIP R 4.7K J 1/16W	
R206			RK73HB1J394J	CHIP R 390K J 1/16W		R347			RK73HB1J560J	CHIP R 56 J 1/16W	
R207			RK73HB1J332J	CHIP R 3.3K J 1/16W		R348			RK73HB1J104J	CHIP R 100K J 1/16W	
R208			RK73HB1J000J	CHIP R 0.0 J 1/16W		R349			RK73HB1J105J	CHIP R 1.0M J 1/16W	
R209			RK73HB1J122J	CHIP R 1.2K J 1/16W		R350			RK73HB1J182J	CHIP R 1.8K J 1/16W	
R211			RK73HB1J222J	CHIP R 2.2K J 1/16W		R351			RK73HB1J472J	CHIP R 4.7K J 1/16W	
R212			RK73HB1J101J	CHIP R 100 J 1/16W		R352			RK73HB1J471J	CHIP R 470 J 1/16W	
R213			RK73HB1J564J	CHIP R 560K J 1/16W		R354			RK73HB1J101J	CHIP R 100 J 1/16W	
R214			RK73HB1J334J	CHIP R 330K J 1/16W		R355			RK73HB1J151J	CHIP R 150 J 1/16W	
R215			RK73HB1J561J	CHIP R 560 J 1/16W		R356,357			RK73HB1J331J	CHIP R 330 J 1/16W	
R216			RK73HB1J101J	CHIP R 100 J 1/16W		R358			RK73HB1J000J	CHIP R 0.0 J 1/16W	
R217			RK73HB1J561J	CHIP R 560 J 1/16W		R359			RK73HB1J104J	CHIP R 100K J 1/16W	
R218			RK73HB1J331J	CHIP R 330 J 1/16W		R360,361			RK73HB1J000J	CHIP R 0.0 J 1/16W	
R219			RK73HB1J224J	CHIP R 220K J 1/16W		R363			RK73HB1J000J	CHIP R 0.0 J 1/16W	
R220			RK73HB1J683J	CHIP R 68K J 1/16W		R365			RK73HB1J560J	CHIP R 56 J 1/16W	
R221			RK73HB1J473J	CHIP R 47K J 1/16W		R400			RK73HB1J000J	CHIP R 0.0 J 1/16W	
R222			RK73HB1J224J	CHIP R 220K J 1/16W		R401			RK73HB1J181J	CHIP R 180 J 1/16W	
R223			RK73HB1J271J	CHIP R 270 J 1/16W		R402,403			RK73HB1J473J	CHIP R 47K J 1/16W	
R224			RK73HB1J000J	CHIP R 0.0 J 1/16W		R404			RK73HB1J101J	CHIP R 100 J 1/16W	
R226			RK73HB1J560J	CHIP R 56 J 1/16W		R405			RK73HB1J473J	CHIP R 47K J 1/16W	
R227			RK73HB1J124J	CHIP R 120K J 1/16W		R406-408			RK73HB1J102J	CHIP R 1.0K J 1/16W	
R228			RK73HB1J104J	CHIP R 100K J 1/16W		R409			RK73HB1J473J	CHIP R 47K J 1/16W	
R230			RK73HB1J273J	CHIP R 27K J 1/16W		R410,411			RK73HB1J101J	CHIP R 100 J 1/16W	
R231			RK73HB1J000J	CHIP R 0.0 J 1/16W		R412			RK73HB1J473J	CHIP R 47K J 1/16W	
R232,233			RK73HB1J564J	CHIP R 560K J 1/16W		R413,414			RK73HB1J102J	CHIP R 1.0K J 1/16W	
R234			RK73HB1J000J	CHIP R 0.0 J 1/16W		R416			RK73HB1J104D	CHIP R 100K D 1/16W	
R300			RK73HB1J153J	CHIP R 15K J 1/16W		R417			RK73HB1J154D	CHIP R 150K D 1/16W	
R302			RK73HB1J562J	CHIP R 5.6K J 1/16W		R418			RK73HB1J000J	CHIP R 0.0 J 1/16W	
R303			RK73HB1J104J	CHIP R 100K J 1/16W		R419-421			RK73HB1J473J	CHIP R 47K J 1/16W	
R304			RK73HB1J333J	CHIP R 33K J 1/16W		R422,423			RK73HB1J393J	CHIP R 39K J 1/16W	
R305			RK73HB1J274J	CHIP R 270K J 1/16W		R424			RK73HB1J101J	CHIP R 100 J 1/16W	
R306			RK73HB1J154J	CHIP R 150K J 1/16W		R425			RK73HB1J393J	CHIP R 39K J 1/16W	
R307			RK73HB1J000J	CHIP R 0.0 J 1/16W		R428			RK73HB1J101J	CHIP R 100 J 1/16W	
R308			RK73HB1J101J	CHIP R 100 J 1/16W		R429,430			RK73HB1J000J	CHIP R 0.0 J 1/16W	
R309,310			RK73HB1J104J	CHIP R 100K J 1/16W		R431			RK73HB1J103J	CHIP R 10K J 1/16W	
R311			RK73HB1J101J	CHIP R 100 J 1/16W		R433			RK73HB1J473J	CHIP R 47K J 1/16W	
R313			RK73HB1J473J	CHIP R 47K J 1/16W		R434			RK73HB1J103J	CHIP R 10K J 1/16W	
R314			RK73HB1J563J	CHIP R 56K J 1/16W		R435			RK73HB1J473J	CHIP R 47K J 1/16W	
R315,316			RK73HB1J153J	CHIP R 15K J 1/16W		R437			RK73HB1J473J	CHIP R 47K J 1/16W	
R317			RK73HB1J333J	CHIP R 33K J 1/16W		R441			RK73HB1J102J	CHIP R 1.0K J 1/16W	
R318			RK73HB1J104J	CHIP R 100K J 1/16W		R442			RK73HB1J680J	CHIP R 68 J 1/16W	
R319			RK73HB1J823J	CHIP R 82K J 1/16W		R443			RK73HB1J102J	CHIP R 1.0K J 1/16W	
R321			RK73HB1J223J	CHIP R 22K J 1/16W		R444			RK73HB1J000J	CHIP R 0.0 J 1/16W	
R322			RK73HB1J183J	CHIP R 18K J 1/16W		R445			RK73HB1J152J	CHIP R 1.5K J 1/16W	
R323			RK73HB1J474J	CHIP R 470K J 1/16W		R446-450			RK73HB1J102J	CHIP R 1.0K J 1/16W	
R324			RK73HB1J153J	CHIP R 15K J 1/16W		R453			RK73HB1J473J	CHIP R 47K J 1/16W	
R325			RK73HB1J331J	CHIP R 330 J 1/16W		R460			RK73HB1J473J	CHIP R 47K J 1/16W	
R327			RK73HB1J683J	CHIP R 68K J 1/16W		R464			RK73HB1J102J	CHIP R 1.0K J 1/16W	
R328			RK73HB1J105J	CHIP R 1.0M J 1/16W		R466			RK73HB1J104J	CHIP R 100K J 1/16W	
R329,330			RK73HB1J104J	CHIP R 100K J 1/16W		R468-471			RK73HB1J000J	CHIP R 0.0 J 1/16W	
R332			RK73HB1J823J	CHIP R 82K J 1/16W		R472			RK73HB1J105J	CHIP R 1.0M J 1/16W	
R333			RK73HB1J682J	CHIP R 6.8K J 1/16W		R473			RK73HB1J184J	CHIP R 180K J 1/16W	
R334			RK73HB1J473J	CHIP R 47K J 1/16W		R474			RK73GB2A000J	CHIP R 0.0 J 1/10W	
R335			RK73HB1J102J	CHIP R 1.0K J 1/16W		R475			RK73HB1J104J	CHIP R 100K J 1/16W	
R336			RK73HB1J223J	CHIP R 22K J 1/16W		R476			RK73HB1J000J	CHIP R 0.0 J 1/16W	
R338			RK73HB1J153J	CHIP R 15K J 1/16W		R479			RK73HB1J182J	CHIP R 1.8K J 1/16W	
R339			RK73HB1J000J	CHIP R 0.0 J 1/16W		R482			RK73HB1J273J	CHIP R 27K J 1/16W	

PARTS LIST / 零件表

TX-RX UNIT (X57-7330-10)

Ref. No.	Address	New parts	Parts No.	Description	Destination	Ref. No.	Address	New parts	Parts No.	Description	Destination
R483			RK73HB1J121J	CHIP R 120 J 1/16W							
R484			RK73HB1J000J	CHIP R 0.0 J 1/16W							
R486			RK73HB1J823J	CHIP R 82K J 1/16W							
R487			RK73HB1J154J	CHIP R 150K J 1/16W							
R490			RK73HB1J473J	CHIP R 47K J 1/16W							
R491			RK73HB1J104J	CHIP R 100K J 1/16W							
R492			RK73HB1J223J	CHIP R 22K J 1/16W							
VR300			R32-0735-05	SEMI FIXED VARIABLE RESISTOR							
VR301			R31-0667-05	VARIABLE RESISTOR							
S1			S70-0414-05	TACT SWITCH							
MIC300			T91-0651-15	MIC ELEMENT							
D1		*	RKS151KJ	DIODE							
D2			1SV270-F	VARIABLE CAPACITANCE DIODE							
D3			MA2S111-F	DIODE							
D4			1SV214-F	VARIABLE CAPACITANCE DIODE							
D5			MA2S111-F	DIODE							
D6,7			HSC277	DIODE							
D101			HVC131	DIODE							
D200,201			HSC277	DIODE							
D300			DA221	DIODE							
D301,302			RB706F-40	DIODE							
D303			DAN222	DIODE							
D304			GN1G	DIODE							
D305-308			KDZ3.3V	ZENER DIODE							
IC1			TB31202FNG	MOS-IC							
IC100			BH2219FVM	ANALOGUE IC							
IC200			TA31136FNG	MOS-IC							
IC300			AK2346	MOS-IC							
IC301			NJM2100V-ZB	MOS-IC							
IC302			TK62012F	MOS-IC							
IC303			LM4865M-N	BI-POLAR IC							
IC400			XC61CN2802N	MOS-IC							
IC401			XC61CN2702N	MOS-IC							
IC403		*	D338327A22WV	MICROCONTROLLER IC							
IC404			BH30FB1WG	MOS-IC							
IC405			TC7W74FU-F	MOS-IC							
IC406			BR24L08FJ-W	ROM IC							
Q1			2SK1824-A	FET							
Q2,3			2SC5488	TRANSISTOR							
Q4			2SC4617(S)	TRANSISTOR							
Q5,6			2SC5066-F(O)	TRANSISTOR							
Q101			2SC5092-F	TRANSISTOR							
Q103		*	RQA0004PXDQS	FET							
Q104			RQA0002DNS	FET							
Q200			KRA304E-P	DIGITAL TRANSISTOR							
Q201,202			2SC4082	TRANSISTOR							
Q203			3SK318	FET							
Q204			3SK294-FP	FET							
Q300-302			2SK1824-A	FET							
Q303			2SC4919	TRANSISTOR							
Q400-402			DTC114EE	DIGITAL TRANSISTOR							
Q403			2SC4919	TRANSISTOR							
Q404-406			KRA305E	DIGITAL TRANSISTOR							
Q408			2SC4919	TRANSISTOR							
TH101			B57331V2104J	THERMISTOR							
TH102			PRF15BC471QB1	THERMISTOR							

TK-3230

EXPLODED VIEW / 部件分解图

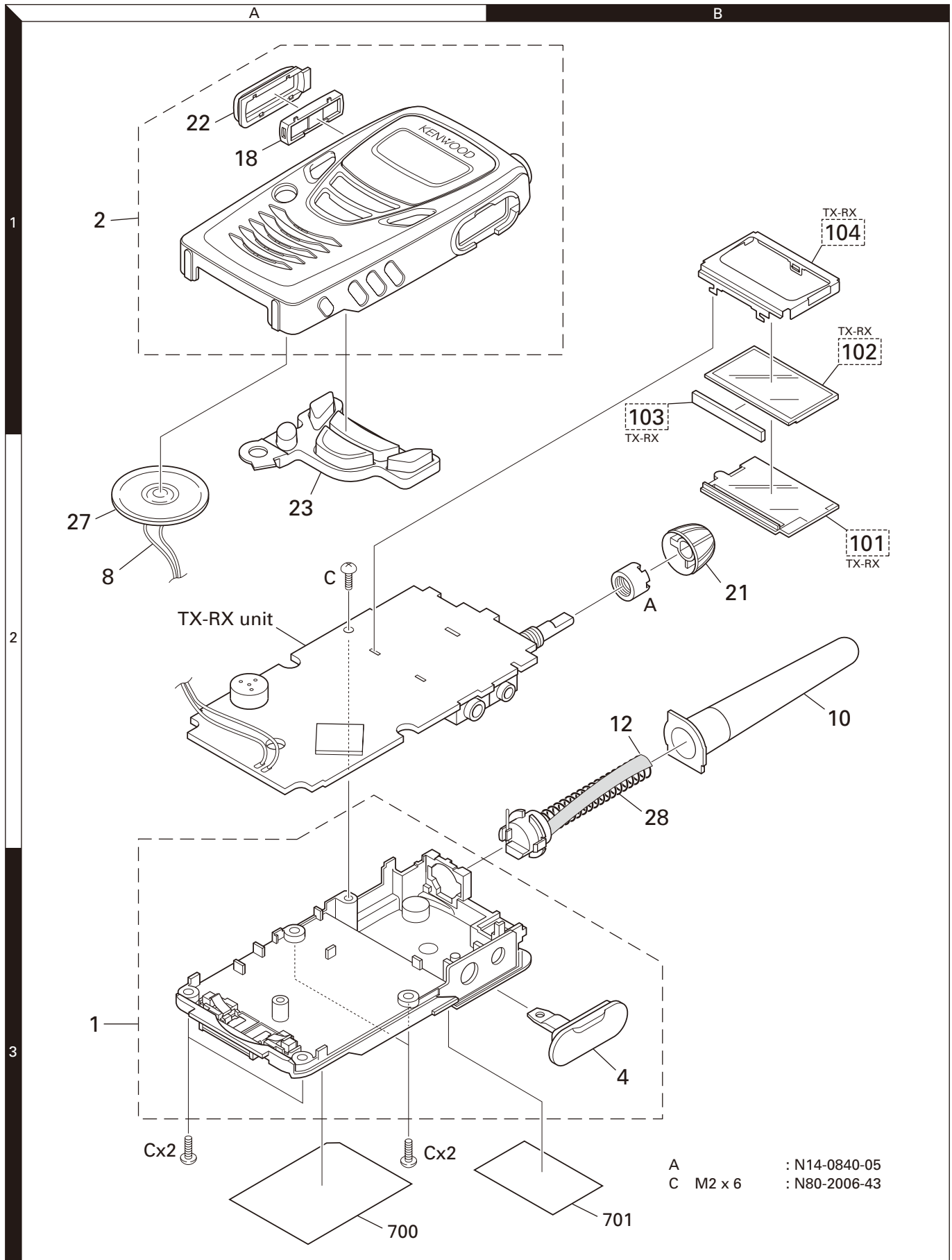

PACKING / 包装

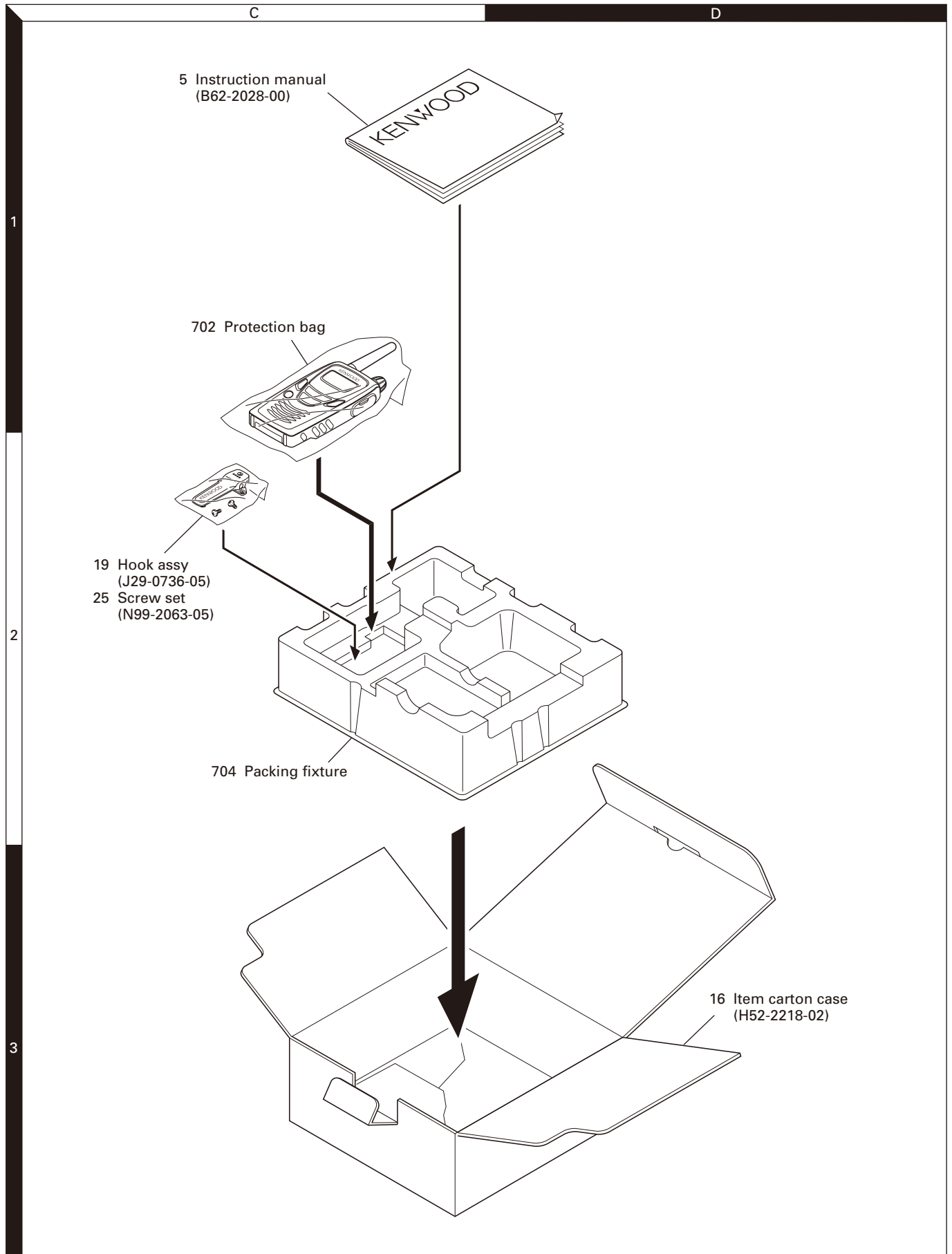

Parts with the exploded numbers larger than 700 are not supplied.

ADJUSTMENT

Required Test Equipment

1. Stabilized Power Supply

- 1) The supply voltage can be changed between 0V and 10V, and the current is 3A or more
- 2) The standard voltage is 3.8V

2. DC Ammeter

- 1) Class 1 ammeter (17 ranges and other features).
- 2) The full scale can be set to either 300mA or 3A.
- 3) A cable of less internal loss must be used.

3. Frequency Counter (f. counter)

- 1) Frequencies of up to 1GHz or so can be measured.
- 2) The sensitivity can be changed to 500MHz or below, and measurements are highly stable and accurate (0.2ppm or so).

4. Power Meter

- 1) Measurable frequency : Up to 600MHz
- 2) Impedance : 50Ω, unbalanced
- 3) Measuring range : Full scale of 3W or so
- 4) A standard cable (5D2W 1m) must be used.

5. RF Voltmeter (RF V.M)

- 1) Measurable frequency : Up to 600MHz or so

6. Linear Detector

- 1) Measurable frequency : Up to 600MHz or so
- 2) Characteristics are flat, and CN is 60dB or more

7. Digital Voltmeter

- 1) Voltage range : FS=10V or so
- 2) Input resistance : 1MΩ or more

8. Oscilloscope

- 1) Measuring range : DC to 30MHz
- 2) Provides highly accurate measurements for 5 to 25MHz.

9. AF Voltmeter (AF V.M)

- 1) Measurable frequency : 50Hz to 1MHz
- 2) Maximum sensitivity : 1mV or more

10. Standard Signal Generator (SSG)

- 1) Maximum frequency : 600MHz or more
- 2) Output : -133dBm/0.05μV to 7dBm/501mV
- 3) Output impedance : 50Ω

11. Dummy Load

- 1) 8Ω, 1W or more

12. AF Generator (AG)

- 1) Frequency range : 100Hz to 100kHz
- 2) Output : 0.5mV to 1V

13. Distortion Meter

- 1) Measurable frequency : 30Hz to 100kHz
- 2) Input level : 50mV to 10Vrms

Service Jig

■ ANT cable (E30-3418-08)

Modify the cable as shown below.

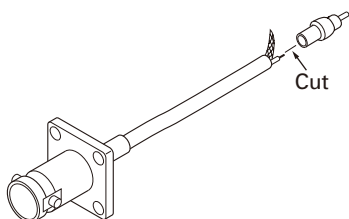

Solder the ANT cable to the ANT terminal on the TX-RX unit.

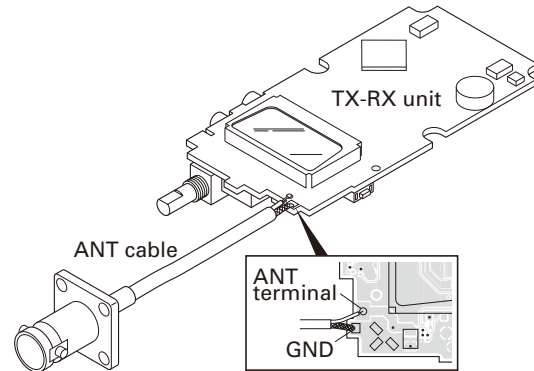

■ Battery jig (W05-1365-00)

Connect the power cable properly between the battery jig installed in the transceiver and the power supply, and be sure output voltage and the power supply polarity prior to switching the power supply ON, otherwise over voltage and reverse connection may damage the transceiver, or the power supply or both.

Note: When using the battery jig, you must measure the voltage at the terminals of the battery jig. Otherwise, a slight voltage drop may occur within the power cable, between the power supply and the battery jig, especially while the transceiver transmits.

Test Signaling

No.	Receive	Transmit
1	None	None
2	None	100Hz Square Wave
3	QT 67.0Hz	QT 67.0Hz
4	QT 151.4Hz	QT 151.4Hz
5	QT 250.3Hz	QT 250.3Hz
6	DQT D023N	DQT D023N
7	DQT D754I	DQT D754I
8	MSK Code (100-1000)	MSK Code (100-1000)
9	None	MSK (1010...)

Test Frequency

No.	Receive (MHz)	Transmit (MHz)
1 (Low)	460.05000	460.10000
2 (High)	469.95000	469.90000
3	460.00000	460.00000
4	460.20000	460.20000
5	460.40000	460.40000
6	460.60000	460.60000

Adjustment Frequency List

CH	Receive (MHz)	Transmit (MHz)
Center	465.05000	465.00000
Frequency Shift 6.25kHz	-	465.00625
Frequency Shift 5.kHz	-	465.00500

调整

所需测试设备

1. 稳定电源

- 1) 电源电压可以在 0V 和 10V 之间切换，并且电流为 3A 或更大
- 2) 标准电压为 3.8V

2. 直流安培表

- 1) 1 级安培表 (17 量程和其他功能)。
- 2) 全刻度可以设置为 300mA 或 3A。
- 3) 必须使用较小内部损耗的电缆。

3. 频率计数器 (f. counter)

- 1) 可以测量最高 1GHz 左右的频率。
- 2) 灵敏度可以切换到 500MHz 或以下，测量结果高度稳定、精确 (0.2ppm 左右)。

4. 功率表

- 1) 可测频率：最高 600MHz
- 2) 阻抗：50 Ω，不平衡
- 3) 测量范围：全刻度 3W 左右
- 4) 必须使用标准电缆 (5D2W 1m)。

5. RF 电压表 (RF V.M)

- 1) 可测频率：最高 600MHz 左右

6. 线性检波器

- 1) 可测频率：最高 600MHz 左右
- 2) 特性固定且 CN 为 60dB 或更大

7. 数字电压表

- 1) 电压范围：FS=10V 左右
- 2) 输入电阻：1M Ω 或更大

8. 示波器

- 1) 测量范围：直流到 30MHz
- 2) 5 ~ 25MHz 之间提供高精度测量。

9. 音频伏特表 (AF V.M)

- 1) 可测频率：50Hz ~ 1MHz
- 2) 最大灵敏度：1mV 或更大

10. 标准信号发生器 (SSG)

- 1) 最大频率：600MHz 或更大
- 2) 输出：-133dBm/0.05 μV ~ 7dBm/501mV
- 3) 输出阻抗：50 Ω

11. 等效负载

- 1) 8 Ω，1W 或更大

12. 音频发生器 (AG)

- 1) 频率范围：100Hz ~ 100kHz
- 2) 输出：0.5mV ~ 1V

13. 失真仪

- 1) 可测频率：30Hz ~ 100kHz
- 2) 输入电平：50mV ~ 10Vrms

维修夹具

■ ANT 电缆 (E30-3418-08)

如下所示修改电缆。

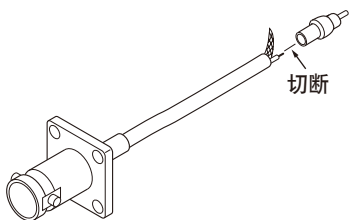

将 ANT 电缆焊接到 TX-RX 单元的 ANT 端子。

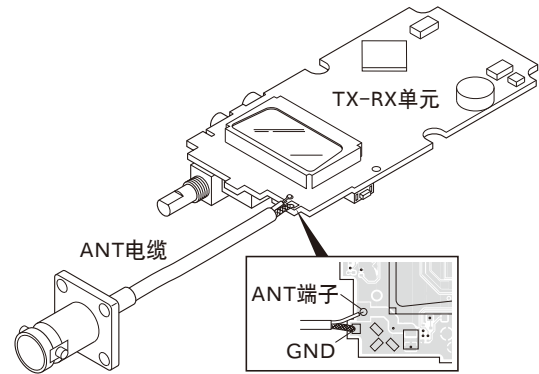

■ 电池夹具 (W05-1365-00)

将电源线正确连接对讲机安装的电池夹具与电源，并且打开电源之前确认输出电压和电源极性，否则过电压和逆向连接可能会损坏对讲机或 / 和电源。

注意：使用电池夹具时，必须测量电池夹具端子处的电压。否则，电源与电池夹具之间的电源线可能会发生微小的压降，尤其是对讲机发射时。

测试信令

号	接收	发射
1	无	无
2	无	100Hz 方波
3	QT 67.0Hz	QT 67.0Hz
4	QT 151.4Hz	QT 151.4Hz
5	QT 250.3Hz	QT 250.3Hz
6	DQT D023N	DQT D023N
7	DQT D754I	DQT D754I
8	MSK 代码 (100-1000)	MSK 代码 (100-1000)
9	无	MSK (1010...)

测试频率

号	接收 (MHz)	发射 (MHz)
1 (低)	460.05000	460.10000
2 (高)	469.95000	469.90000
3	460.00000	460.00000
4	460.20000	460.20000
5	460.40000	460.40000
6	460.60000	460.60000

调整频率表

信道	接收 (MHz)	发射 (MHz)
中心	465.05000	465.00000
频率偏移 6.25kHz	-	465.00625
频率偏移 5. kHz	-	465.00500

ADJUSTMENT

Common Section

Item	Condition	Measurement			Adjustment			Specifications / Remarks
		Test-equipment	Unit	Terminal	Unit	Parts	Method	
1. Setting	1) Set battery jig Battery terminal: 3.8V							
2. VCO lock voltage (Test mode)	1) CH: TX high PTT: ON	Digital voltmeter	TX-RX	LV			Check	2.5V or less
	2) CH: RX high							0.4V or more
	3) CH: RX low							
	4) CH: TX low PTT: ON							

Transmitter Section

Item	Condition	Measurement			Adjustment			Specifications / Remarks	
		Test-equipment	Unit	Terminal	Unit	Parts	Method		
1. Frequency adjustment	1) PC tune CH: TX center PTT: ON	f. counter		ANT Jig cable SP/MIC jack		PC key	Adjust to the center frequency.	Within $\pm 100\text{Hz}$	
2. Frequency shift 6.25kHz	1) PC tune CH: TX 460.00625MHz PTT: ON							Adjust to the desired frequency.	Within $\pm 100\text{Hz}$
3. Frequency shift 5kHz	1) PC tune CH: TX 460.005MHz PTT: ON								
4. High transmit power	1) PC tune CH: TX center	Power meter DC ammeter					Adjust it to 1.5W	$\pm 0.1\text{W}$ Less than 1.6A	
	2) Test mode CH: TX low, high PTT: ON							Check	1.15~1.85W Less than 1.6A
5. Low transmit power	1) PC tune CH: TX center PTT: ON					PC key	Adjust it to 0.55W	$\pm 0.1\text{W}$ Less than 0.9A	
	2) Test mode CH: TX low, high PTT: ON							Check	300~800mW Less than 0.9A
6. DQT balance	1) Test mode CH: TX low SIG: TX 100Hz square wave Linear detector filter LPF: 3kHz PTT: ON	Linear detector Oscilloscope			TX-RX	VR300	Adjust the waveform to square wave.		

调 整

公用部分

项 目	条 件	测 量			调 整			规 格 / 备 注
		测量装置	单元	端子	单元	部件	方 法	
1. 设定	1) 设置电池夹具 BATT 端子电压 : 3.8V							
2. VCO 锁定 电压 (测试模式)	1) CH: TX 高 PTT: 开启	数字电压 表	TX-RX	LV			检查	2. 5V 或更低
	2) CH: RX 高							0. 4V 或更高
	3) CH: RX 低							
	4) CH: TX 低 PTT: 开启							

发射部分

项 目	条 件	测 量			调 整			规 格 / 备 注
		测量装置	单元	端子	单元	部件	方 法	
1. 频率调整	1) PC 同调 CH: TX 中心 PTT: 开启	频率计数 器		ANT 夹 具电缆 SP/MIC 插孔		PC 键	调整到中心频率	±100Hz 以内
2. 频率偏移 6. 25kHz	1) PC 同调 CH: TX 460. 00625MHz PTT: 开启						调整到想要的频率	±100Hz 以内
3. 频率偏移 5kHz	1) PC 同调 CH: TX 460. 005MHz PTT: 开启							
4. 高发射功率	1) PC 同调 CH: TX 中心	功率表 直流安培 表					调整到 1. 5W	±0. 1W 1. 6A 或更低
	2) 测试模式 CH: TX 低, 高 PTT: 开启						检查	1. 15 ~ 1. 85W 1. 6A 或更低
5. 低发射功率	1) PC 同调 CH: TX 中心 PTT: 开启					PC 键	调整到 0. 55W	±0. 1W 0. 9A 或更低
	2) 测试模式 CH: TX 低, 高 PTT: 开启					检查	300 ~ 800mW 0. 9A 或更低	
6. DQT 平衡	1) 测试模式 CH: TX 低 SIG: TX 100Hz 方波 调制分析滤波器 LPF: 3kHz PTT: 开启	线性检波 器 示波器			TX-RX	VR300	将波形调整到方波	

ADJUSTMENT

Item	Condition	Measurement			Adjustment			Specifications / Remarks
		Test-equipment	Unit	Terminal	Unit	Parts	Method	
7. MAX deviation (Wide) (Narrow)	1) PC tune CH: TX center Linear detector filter LPF: 15kHz AG: 1kHz/150mV PTT: ON	Linear detector AG AF V.M		ANT Jig cable SP/MIC jack		PC key	Adjust it to 4.2kHz. ± peak whichever higher	±0.1kHz
							Adjust it to 2.1kHz. ± peak whichever higher	±0.1kHz
8. MIC sensitivity (Wide) (Narrow)	1) Test mode CH: TX low, high Linear detector filter LPF: 15kHz AG: 1kHz/13mV PTT: ON						Check	±2.5~3.8kHz
								±1.1~1.9kHz
9. QT fine deviation	1) PC tune CH: TX center (Wide) QT: 151.4Hz Linear detector filter LPF: 3kHz PTT: ON	Linear detector				PC key	Adjust it to 0.75kHz.	±0.05kHz
	2) PC tune CH: TX center (Narrow) QT: 151.4Hz Linear detector filter LPF: 3kHz PTT: ON						Adjust it to 0.35kHz.	±0.05kHz
10. DQT fine deviation	1) PC tune CH: TX center (Wide) DQT: 023N Linear detector filter LPF: 3kHz PTT: ON						Adjust it to 0.75kHz.	±0.05kHz
	2) PC tune CH: TX center (Narrow) DQT: 023N Linear detector filter LPF: 3kHz PTT: ON						Adjust it to 0.35kHz.	±0.05kHz
11. MSK fine deviation	1) PC tune CH: TX center (Wide) MSK Linear detector filter LPF: 15kHz PTT: ON						Adjust it to 3.0kHz.	±0.1kHz
	2) CH: TX center (Narrow) MSK Linear detector filter LPF: 15kHz PTT: ON						Check	±1.0~±2.0kHz
12. VOX level	1) PC tune AG: 1kHz/40mV	AG				PC key (Start)	Write	
13. Battery indicator level	1) PC tune Battery terminal: 3.3V	Digital voltmeter		Battery terminal				

调 整

项 目	条 件	测 量			调 整			规 格 / 备 注
		测量装置	单元	端子	单元	部件	方 法	
7. 最大频偏 (宽) (窄)	1)PC 同调 CH: TX 中心 调制分析滤波器 LPF: 15kHz AG: 1kHz/150mV PTT: 开启	线性检波器 AG AF V.M		ANT 夹 具电缆 SP/MIC 插孔		PC 键	调整到 4.2kHz。 ± 较高峰值	±0.1kHz
							调整到 2.1kHz。 ± 较高峰值	±0.1kHz
8. 麦克风 灵敏度 (宽) (窄)	1) 测试模式 CH: TX 低, 高 调制分析滤波器 LPF: 15kHz AG: 1kHz/13mV PTT: 开启						检查	±2.5 ~ 3.8kHz
								±1.1 ~ 1.9kHz
9. QT 细频偏	1)PC 同调 CH: TX 中心 (宽) QT: 151.4Hz 调制分析滤波器 LPF: 3kHz PTT: 开启	线性检波器				PC 键	调整到 0.75kHz	±0.05kHz
	2)PC 同调 CH: TX 中心 (窄) QT: 151.4Hz 调制分析滤波器 LPF: 3kHz PTT: 开启						调整到 0.35kHz	±0.05kHz
10. DQT 细频偏	1)PC 同调 CH: TX 中心 (宽) DQT: 023N 调制分析滤波器 LPF: 3kHz PTT: 开启						调整到 0.75kHz	±0.05kHz
	2)PC 同调 CH: TX 中心 (窄) DQT: 023N 调制分析滤波器 LPF: 3kHz PTT: 开启						调整到 0.35kHz	±0.05kHz
11. MSK 细频偏	1)PC 同调 CH: TX 中心 (宽) MSK 调制分析滤波器 LPF: 15kHz PTT: 开启						调整到 3.0kHz	±0.1kHz
	2)CH: TX 中心 (窄) MSK 调制分析滤波器 LPF: 15kHz PTT: 开启						检查	±1.0 ~ ±2.0kHz
12. VOX 电平	1)PC 同调 AG: 1kHz/40mV	AG				PC 键 (开始)	写	
13. 电池指示 电平	1)PC 同调 BATT 端子电压: 3.3V	数字电压 表		BATT 端 子				

ADJUSTMENT

Receiver Section

Item	Condition	Measurement			Adjustment			Specifications / Remarks
		Test-equipment	Unit	Terminal	Unit	Parts	Method	
1. Sensitivity (Wide)	1) Test mode CH: RX low, high SSG output: -117dBm (0.32μV) SSG MOD: 1kHz SSG DEV: ±3kHz	SSG Oscilloscope AF V.M Distortion meter		ANT Jig cable SP/MIC jack			Check	SINAD: 12dB or more
	(Narrow)							
2. Squelch level (open)	1) PC tune CH: RX center (Wide) SSG output: -120dBm SSH MOD: 1kHz SSG DEV: ±3.0kHz					PC key	Adjust to open the squelch.	
	2) PC tune CH: RX center (Narrow) SSG output: -120dBm SSH MOD: 1kHz SSG DEV: ±1.5kHz							

Adjustment Points

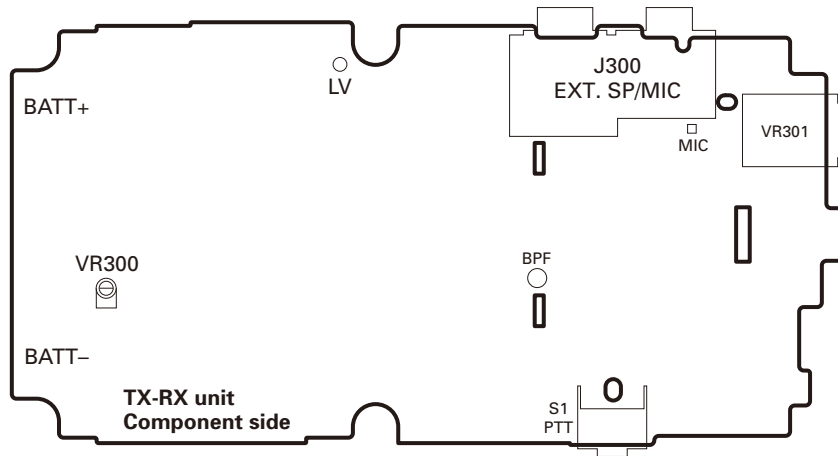

LV: VCO lock voltage measurement
VR300: DQT balance adjustment

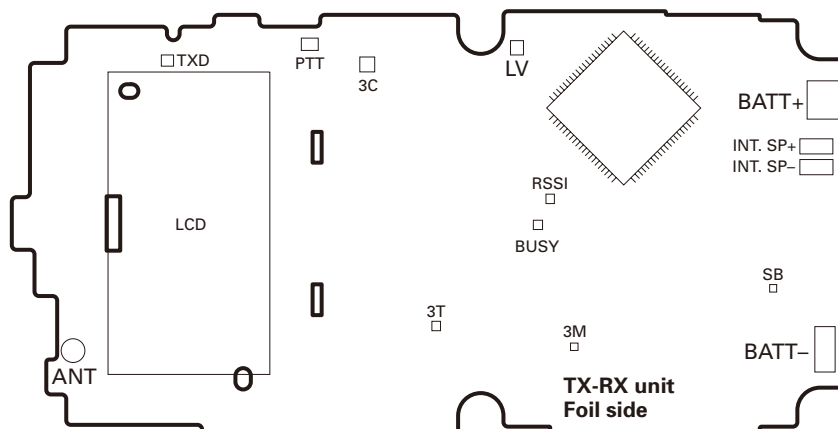

BATT+/-: External power supply
terminal (Fasten it with an alligator clip)

调整

接收部分

项目	条件	测量			调整			规格 / 备注
		测量装置	单元	端子	单元	部件	方法	
1. 灵敏度 (宽)	1) 测试模式 CH: RX 低, 高 SSG 输出: -117dBm (0.32μV) SSG 调制: 1kHz SSG 频偏: ±3kHz	SSG 示波器 AF V.M 失真仪		ANT 夹 具电缆 SP/MIC 插孔			检查	SINAD: 12dB 或更高
(窄)	2) 测试模式 CH: RX 低, 高 SSG 输出: -116dBm (0.35μV) SSG 调制: 1kHz SSG 频偏: ±1.5kHz							
2. 静噪电平 (打开)	1) PC 同调 CH: RX 中心 (宽) SSG 输出: -120dBm SSH 调制: 1kHz SSG 频偏: ±3.0kHz					PC 键	调整到打开静噪	
	2) PC 同调 CH: RX 中心 (窄) SSG 输出: -120dBm SSH 调制: 1kHz SSG 频偏: ±1.5kHz							

调整点

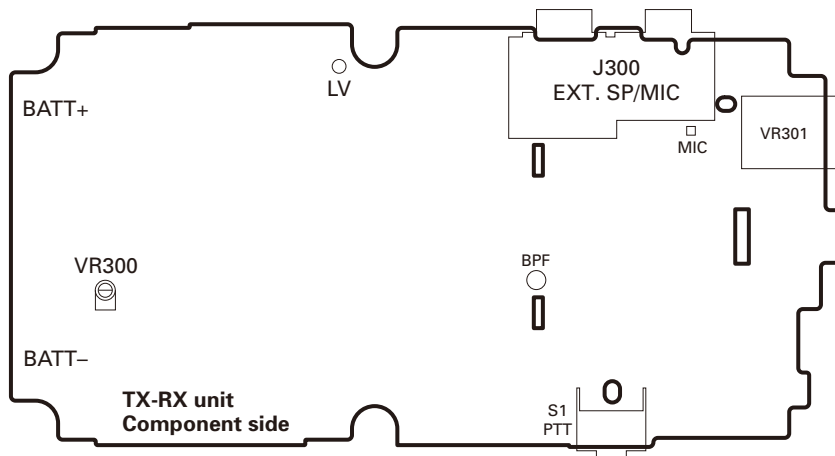

LV: VCO 锁定电压测量
VR300: DQT 平衡调整

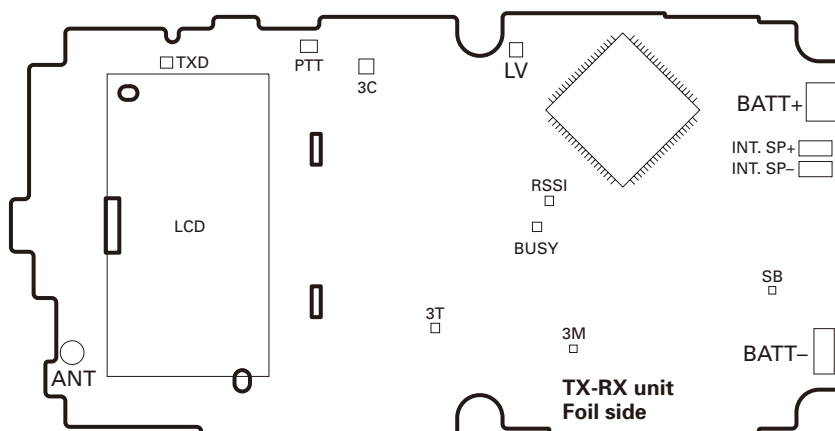

BATT+/-: 外部电源端子
(采用弹簧夹将其固定)

TK-3230 PC BOARD / PC板

TX-RX UNIT (X57-7330-10) Component side view (J79-0103-19)

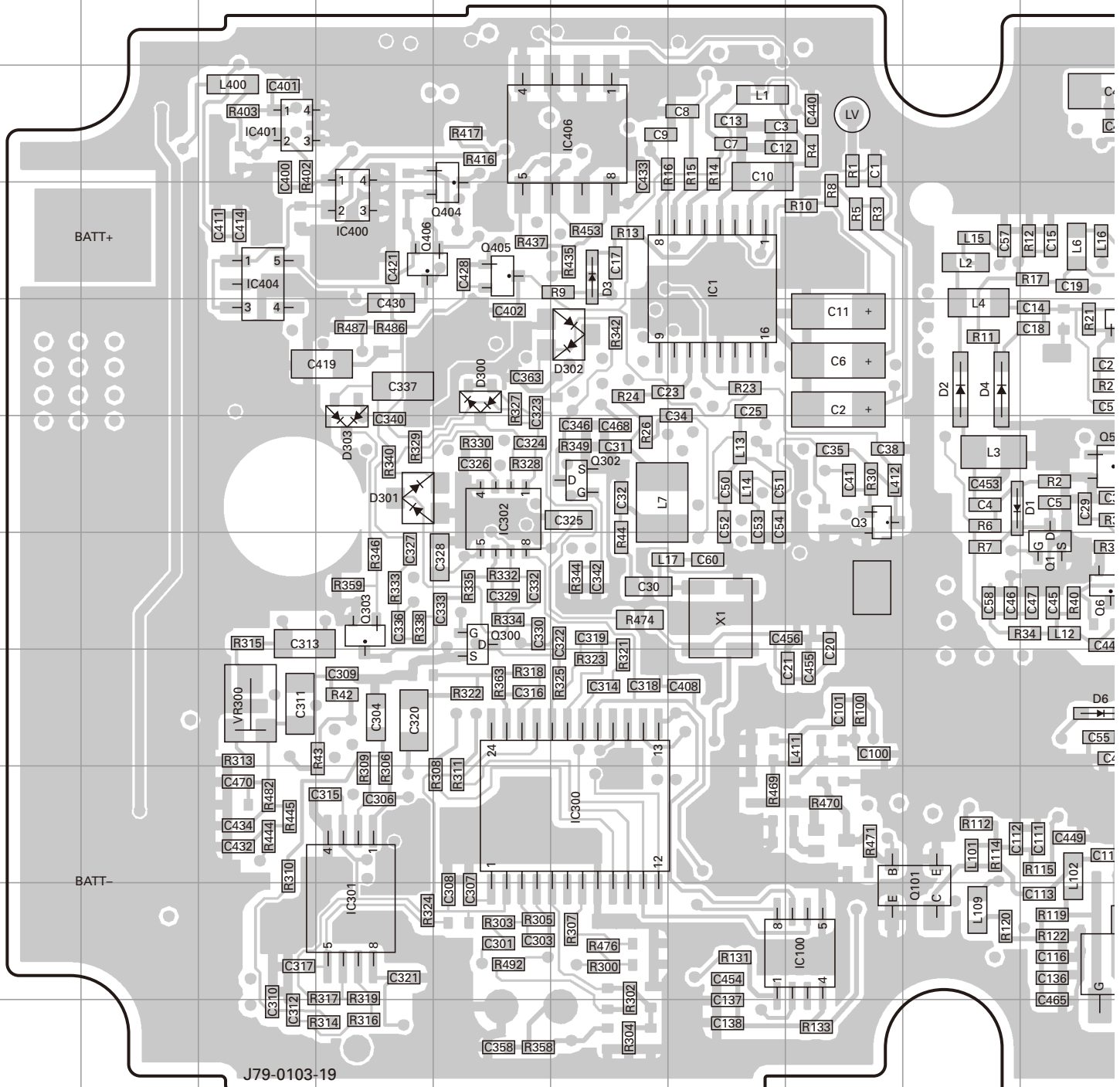

Ref. No.	Address	Ref. No.	Address	Ref. No.	Address	Ref. No.	Address	Ref. No.	Address	Ref. No.	Address
IC1	4G	IC404	4C	Q101	10J	Q300	7E	D3	4F	D300	5E
IC100	10H	IC406	3F	Q103	10J	Q302	6F	D4	5I	D301	6D
IC200	6O	Q1	7J	Q104	10L	Q303	7D	D5	3K	D302	5F
IC300	9F	Q2	5J	Q200	5O	Q404	4E	D6	8J	D303	6D
IC301	10D	Q3	6H	Q201	5M	Q405	4E	D7	8K		
IC302	6E	Q4	3K	Q202	6N	Q406	4D	D101	10P		
IC400	4D	Q5	6J	Q203	8M	D1	6I	D200	10P		
IC401	3C	Q6	7J	Q204	8O	D2	5I	D201	9P		

PC BOARD / PC板 TK-3230

TX-RX UNIT (X57-7330-10) Component side view (J79-0103-19)

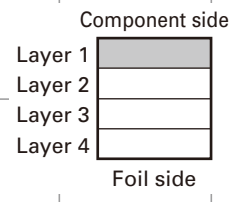
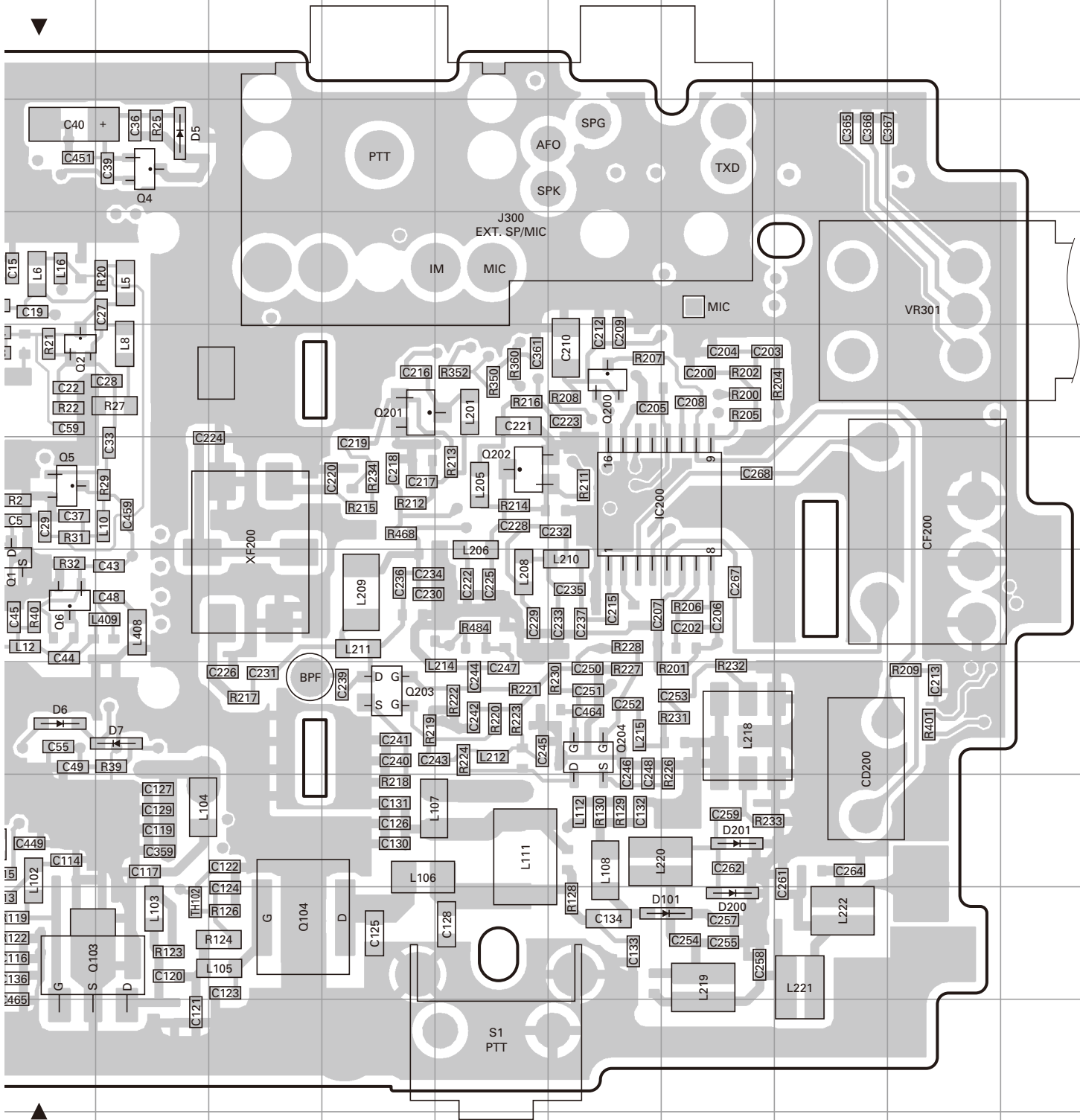

TK-3230 PC BOARD / PC板

TX-RX UNIT (X57-7330-10) Foil side view (J79-0103-19)

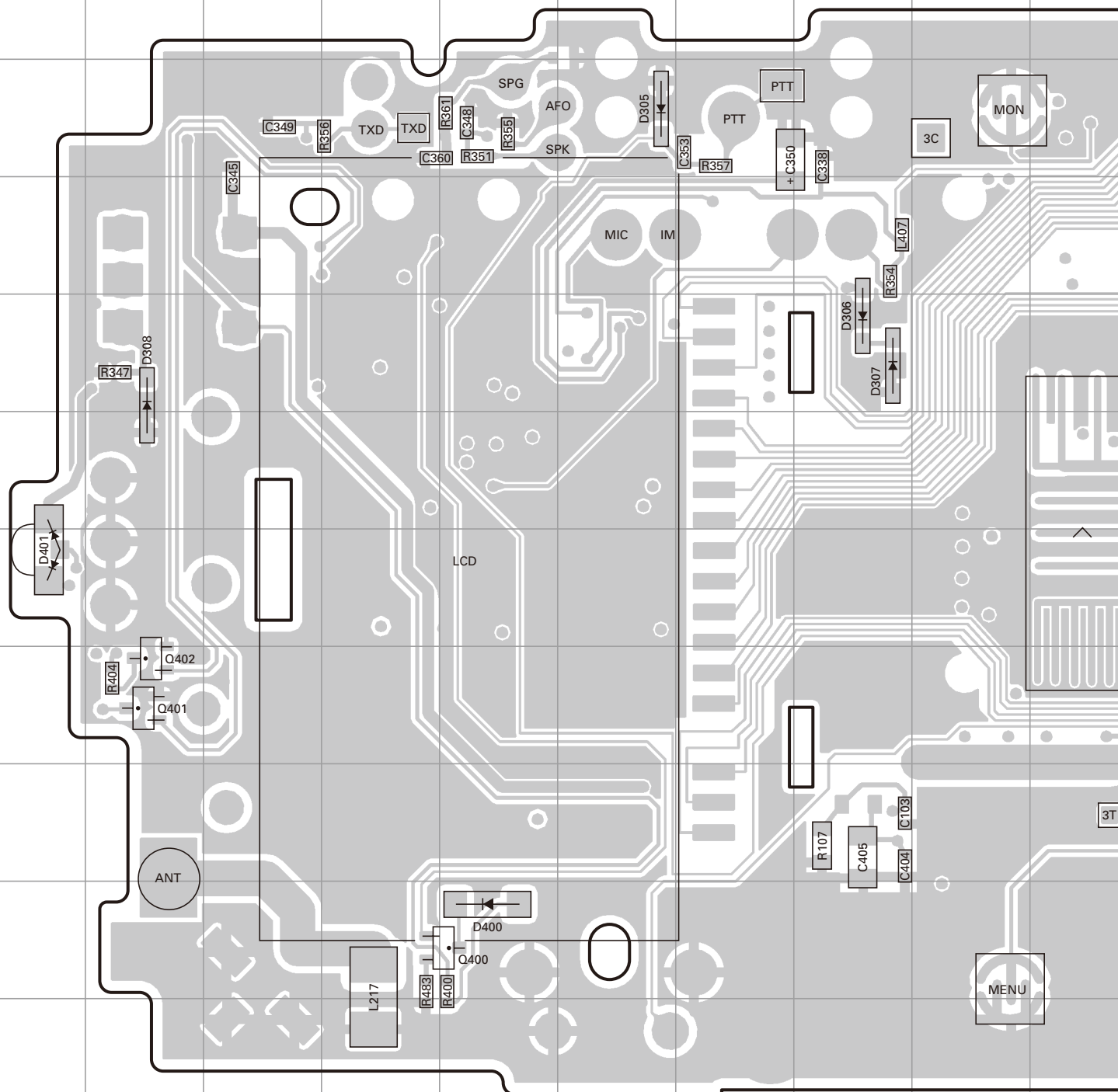

Ref. No.	Address	Ref. No.	Address	Ref. No.	Address
IC303	9Q	Q402	8B	D307	5H
IC403	4N	Q403	6M	D308	5B
IC405	7M	Q408	6N	D400	10E
Q301	8Q	D304	4Q	D401	7A
Q400	10E	D305	3F		
Q401	8B	D306	5H		

PC BOARD / PC板 TK-3230

TX-RX UNIT (X57-7330-10) Foil side view (J79-0103-19)

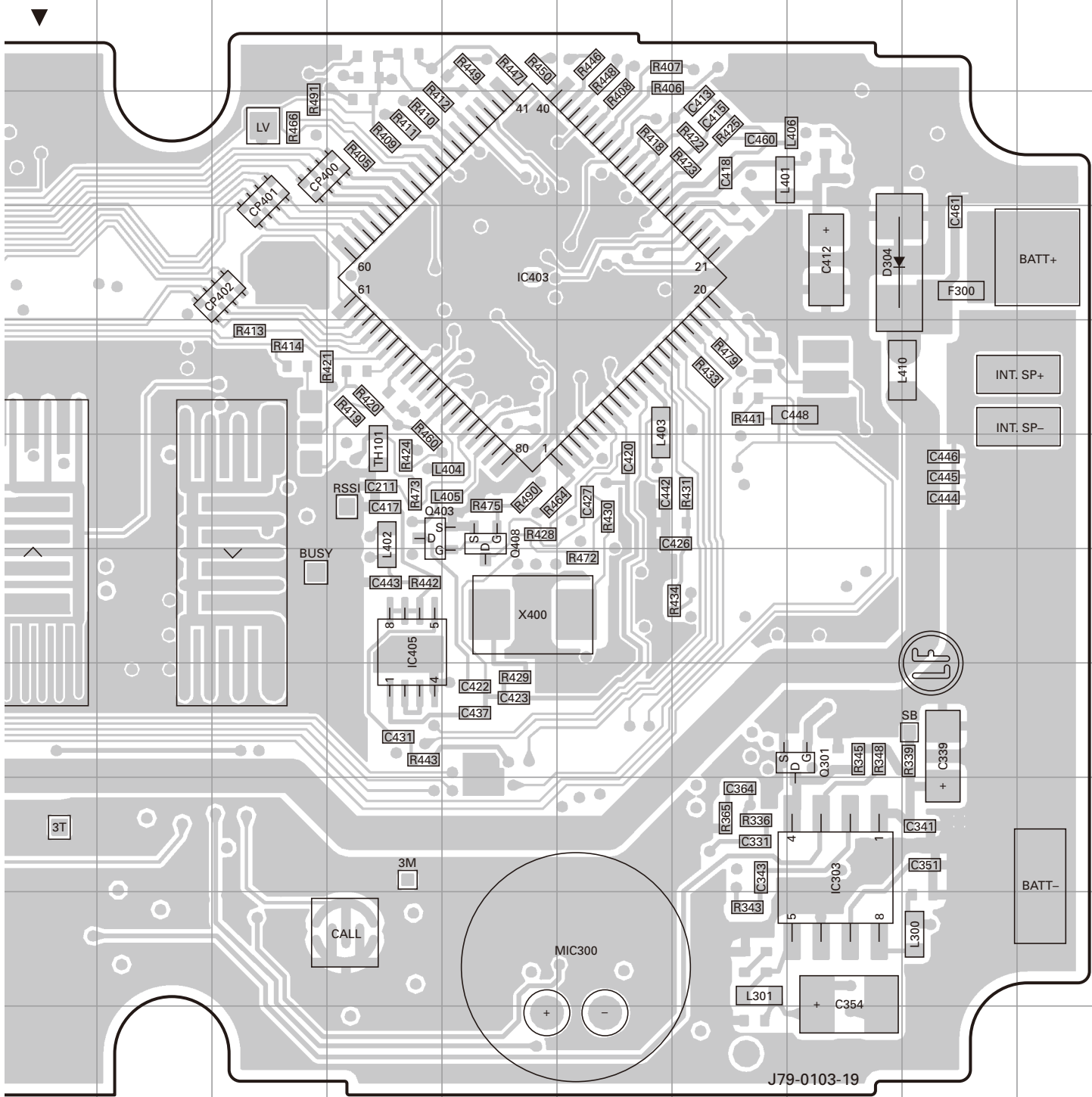

J79-0103-19

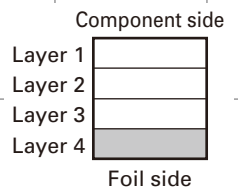

TK-3230 SCHEMATIC DIAGRAM / 原理图

TX-RX UNIT (X57-7330-10)

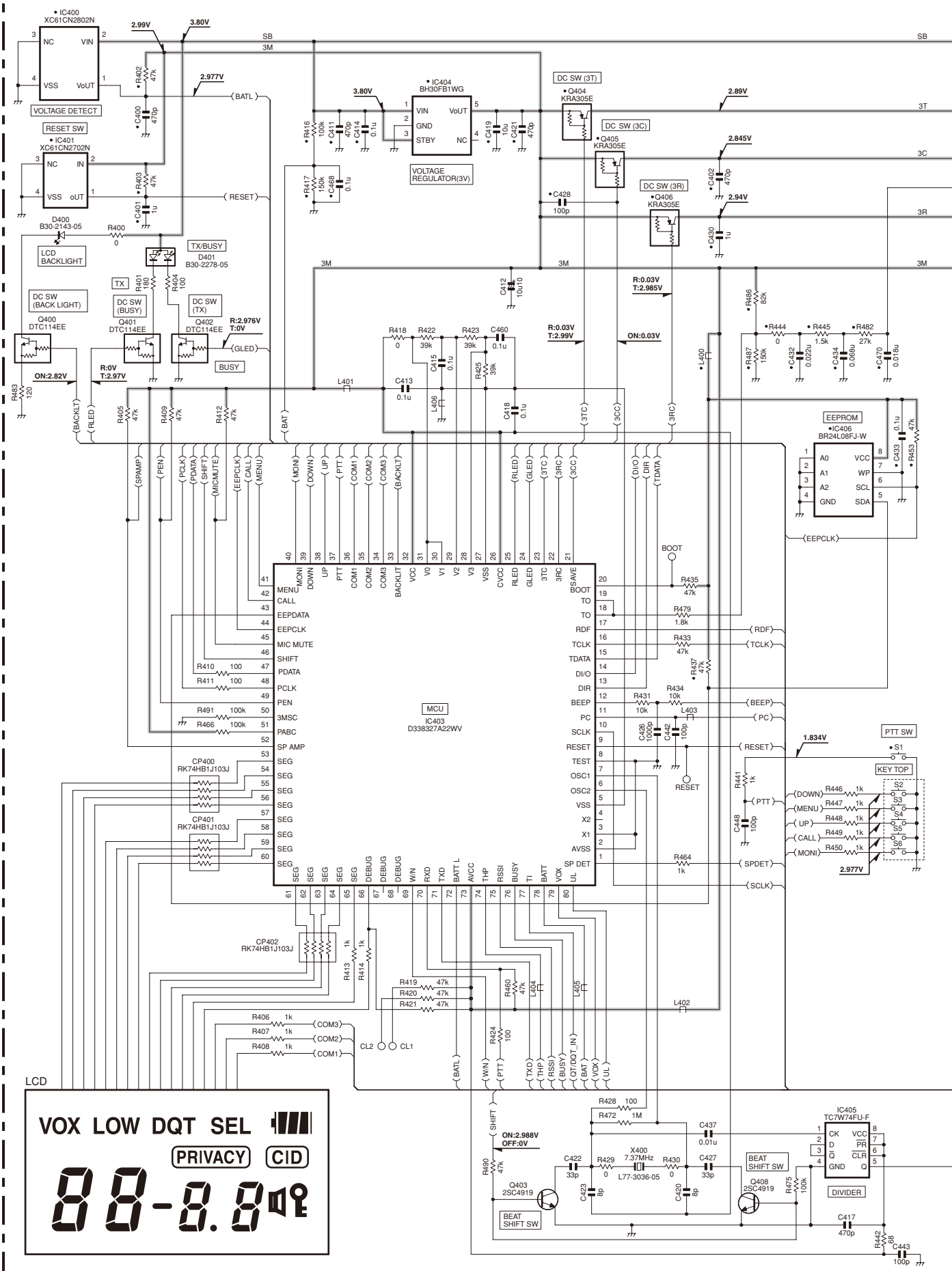

SCHEMATIC DIAGRAM / 原理图 TK-3230

TX-RX UNIT (X57-7330-10)

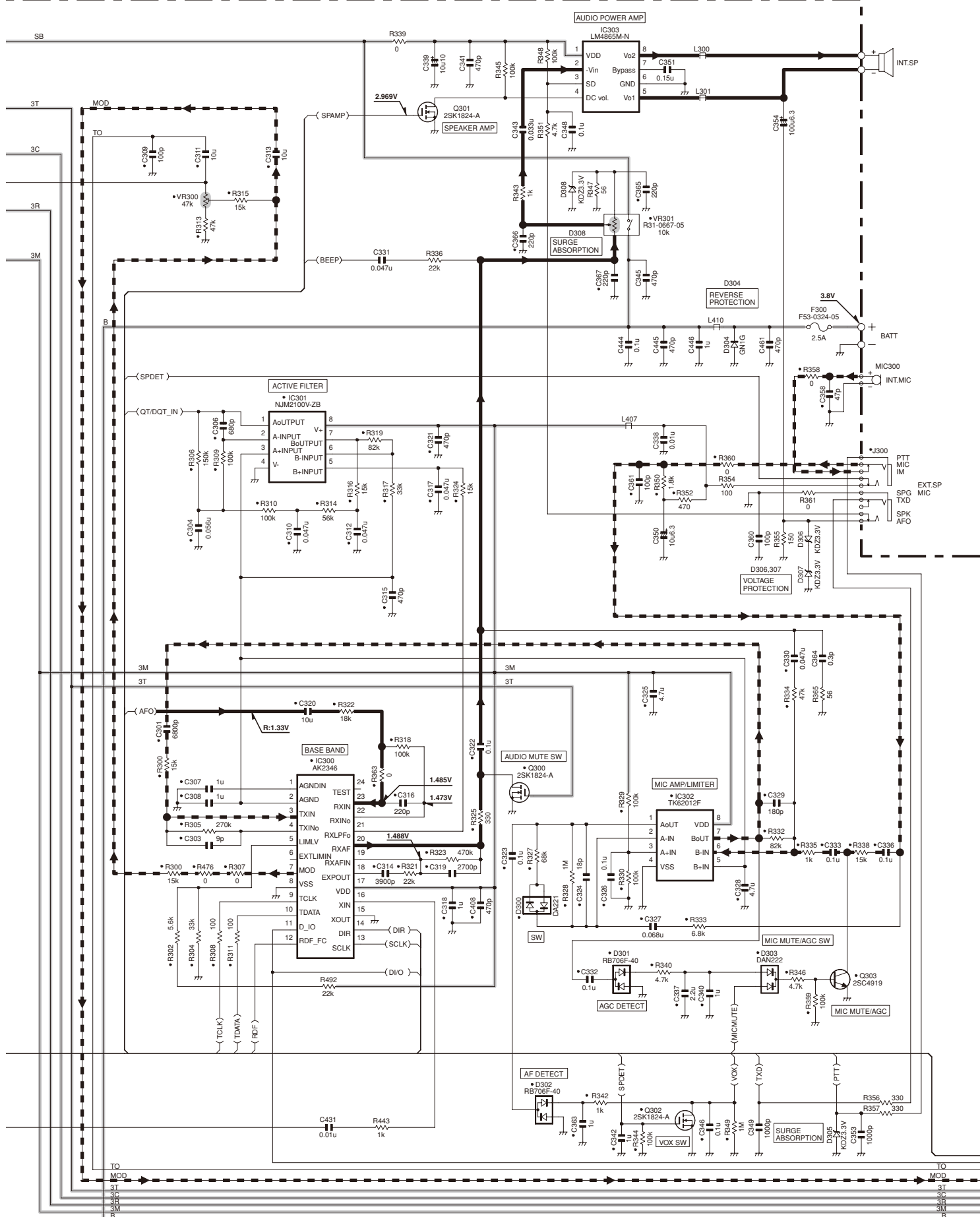

TK-3230 SCHEMATIC DIAGRAM / 原理图

TX-RX UNIT (X57-7330-10)

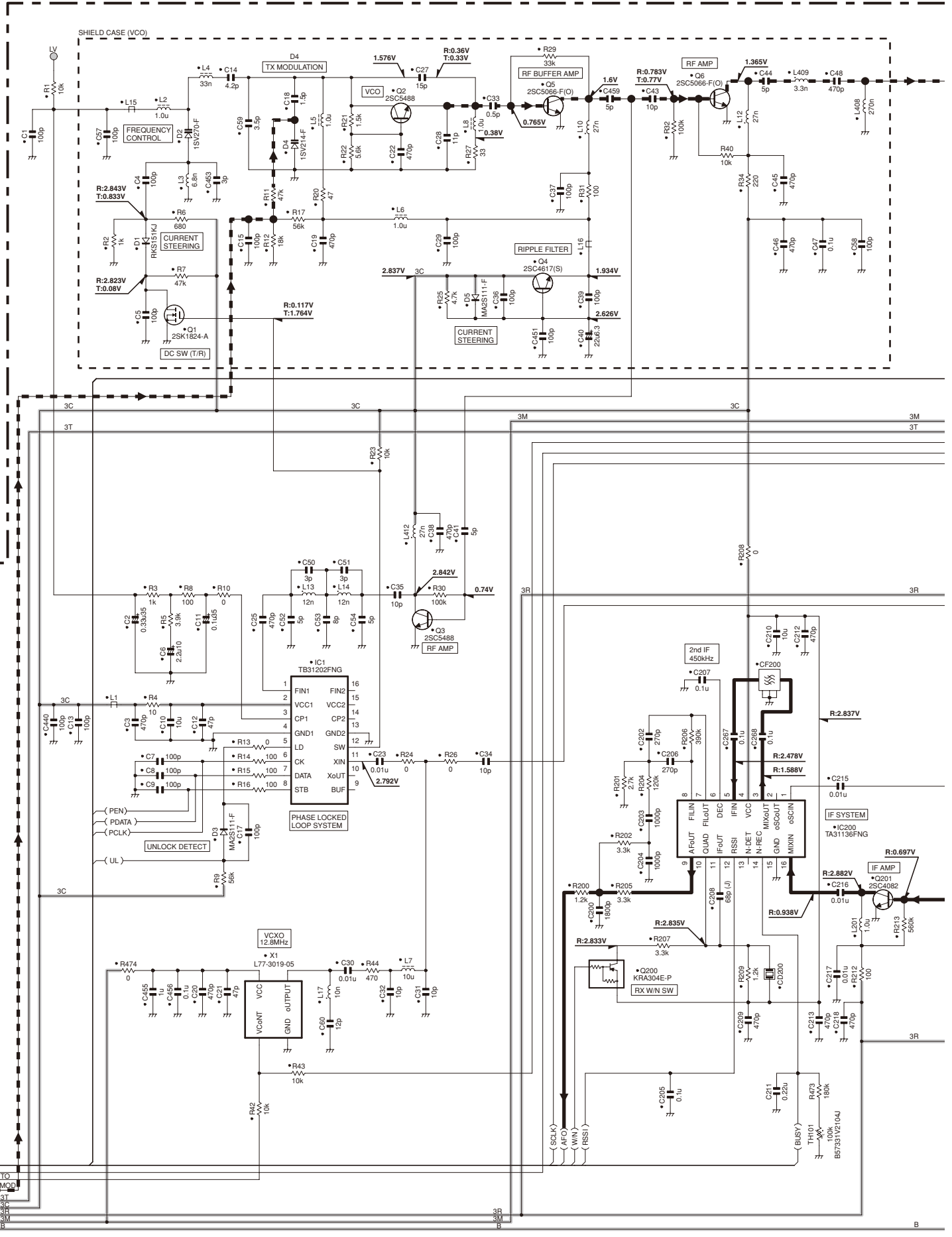

SCHEMATIC DIAGRAM / 原理图 TK-3230

TX-RX UNIT (X57-7330-10)

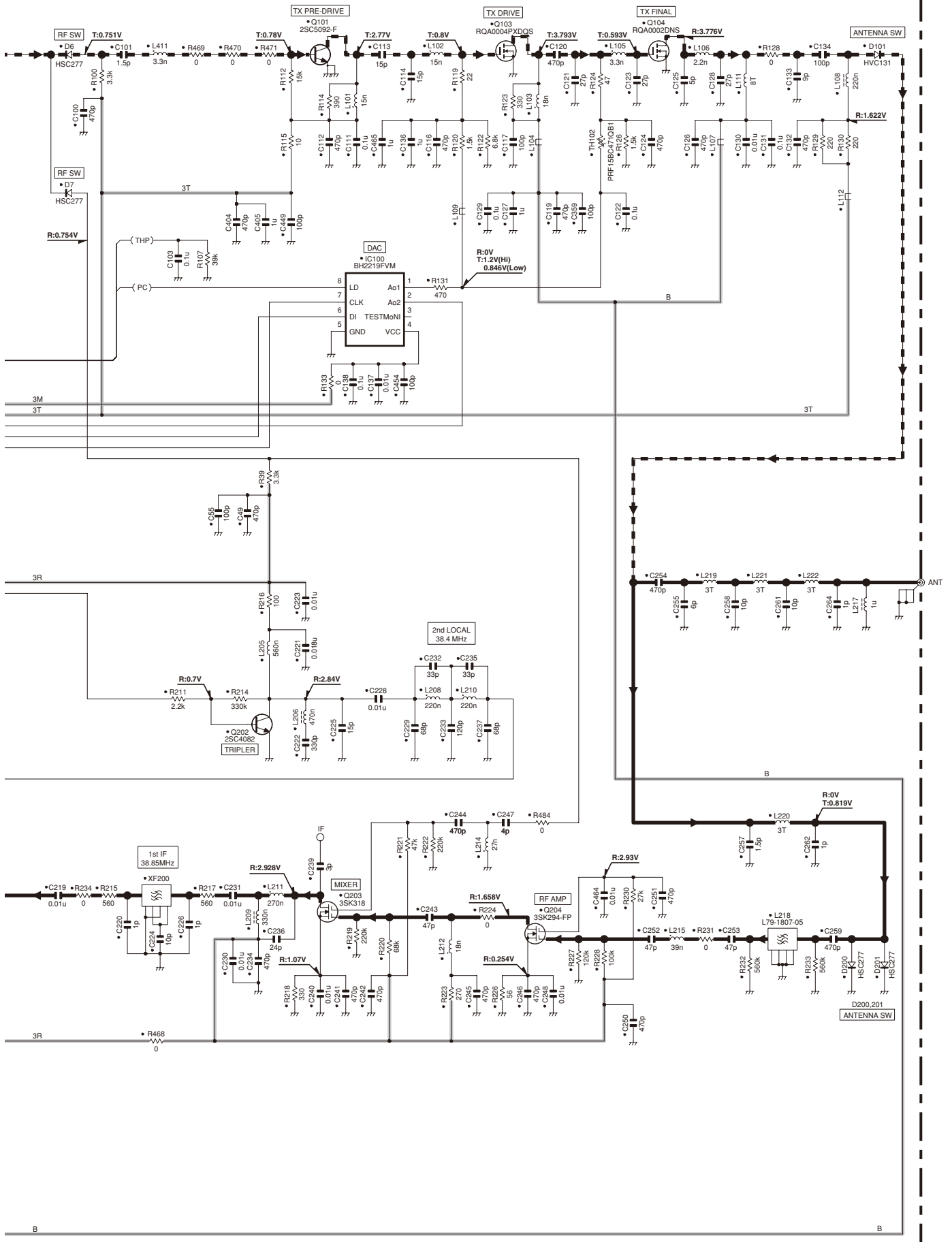

Note : The components marked with a dot (•) are parts of layer 1.

BLOCK DIAGRAM / 方块图

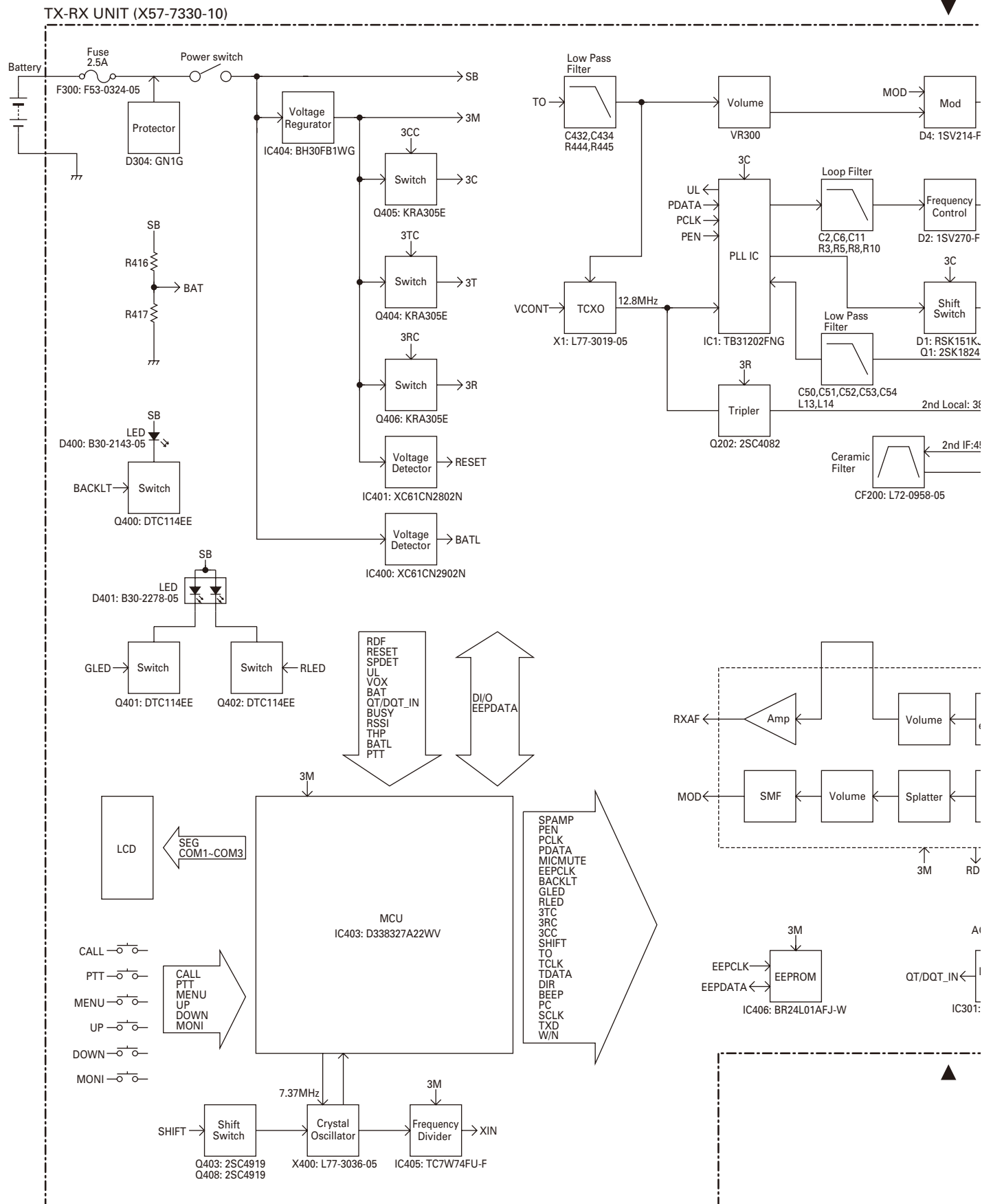

BLOCK DIAGRAM / 方块图

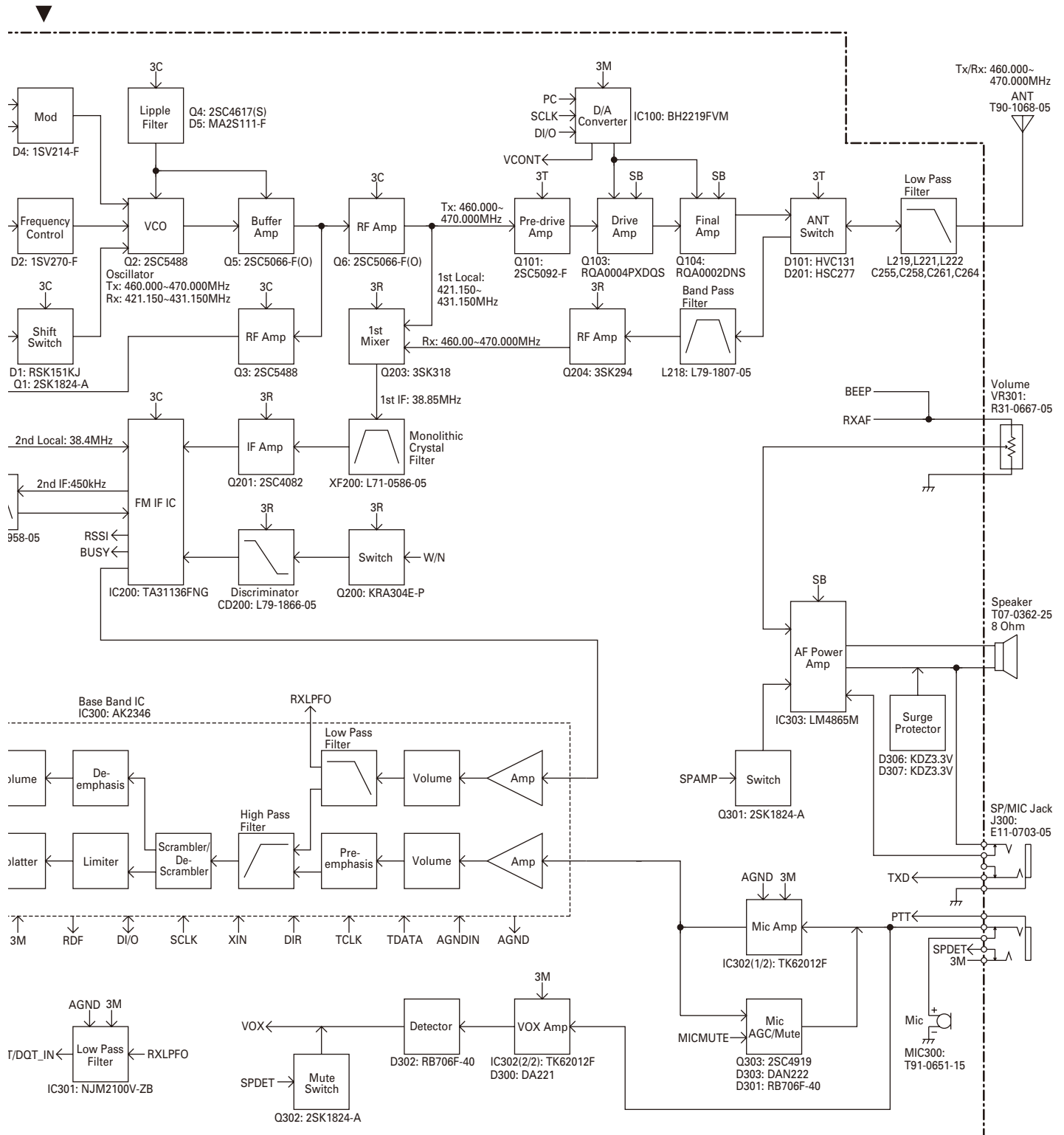

LEVEL DIAGRAM / 电平图

Receiver Section / 接收部分

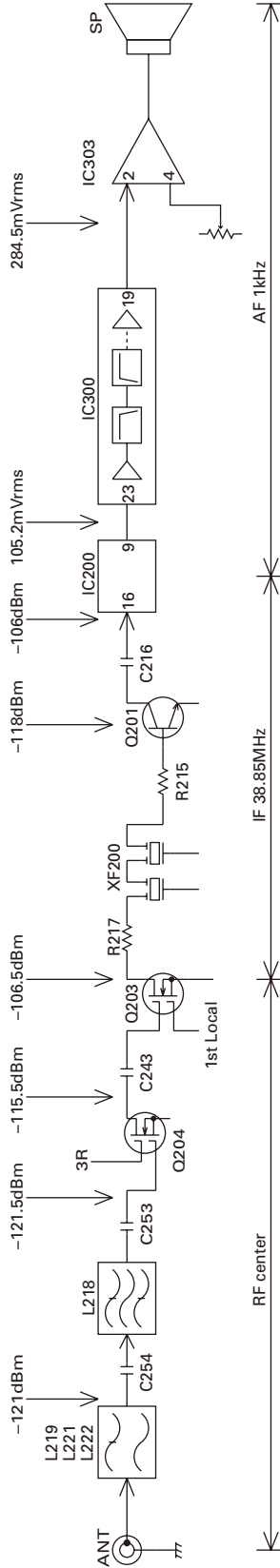

SG output level for obtaining 12dB/SINAD when injected to each point through a 470pF coupling capacitor.
通过470pF耦合电容，用于获得12dB/SINAD时的注入各点的SG输出电平。

Modulate the AF level with a frequency of 1kHz and deviation of 1.5kHz (Narrow), 3kHz (Wide). Then take the signal from the signal generator output when set to -53dBm and obtain the level shown on an AF VTVM when the AF output has been adjusted to 0.63Vrms with the AF vol.

采用1kHz频率和1.5kHz(窄)及3kHz(宽)频偏调制AF电平。随后在设置为-53dBm时采集信号发生器输出的信号，在采用AF音量器将AF输出信号调整到0.63Vrms时获得AF VTVM所示的电平。

Transmitter Section / 发射部分

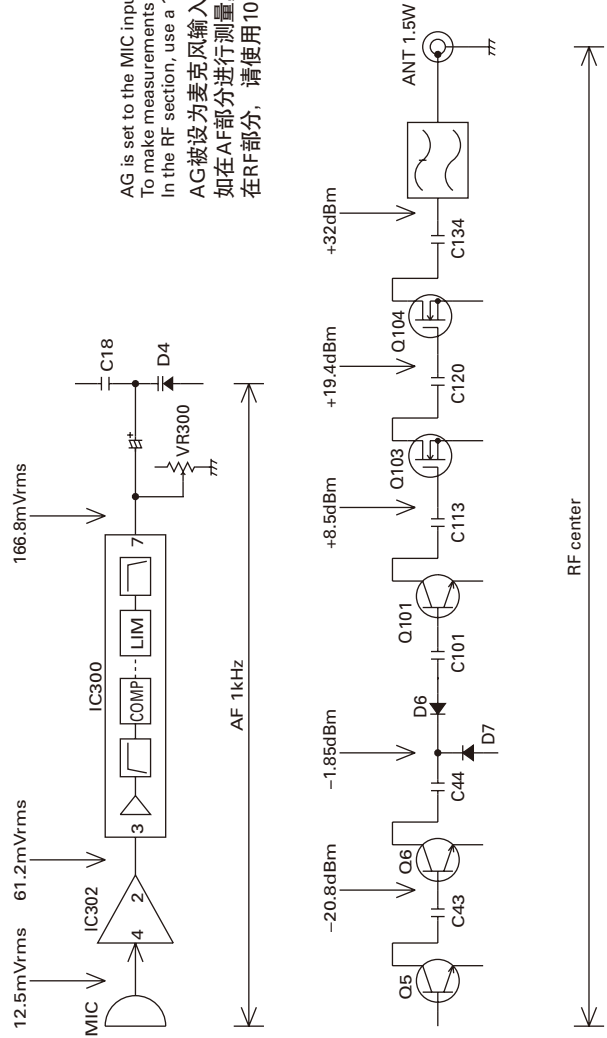

AG is set to the MIC input becomes 3.0kHz DEV. at 1kHz. To make measurements in the AF section, connect the AC level meter. In the RF section, use a 1000pF coupling capacitor.

AG被设为麦克风输入，1kHz时为3.0kHz频偏。如在AF部分进行测量，请连接交流电平表。在RF部分，请使用1000pF耦合电容。

OPTIONAL ACCESSORIES / 可选附件

KNB-46L (Li-ion battery pack / 锂离子电池)

■ External View / 外视图

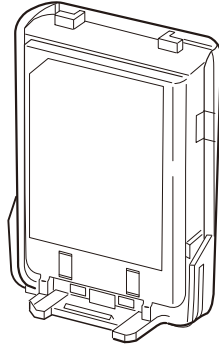

■ Specifications / 规格

Voltage / 电压.....3.7V
 Charging current / 充电电流.....2000mAh

■ Circuit Diagram / 电路图

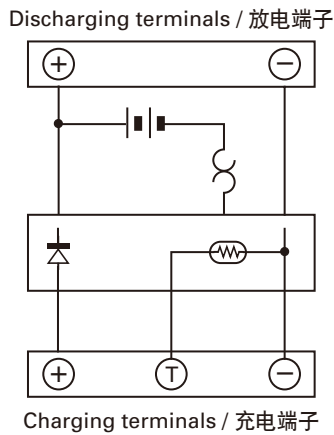

KBH-14 (Belt clip / 皮带夹)

■ External View / 外视图

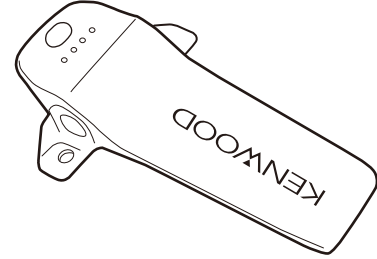

KSC-37 (Rapid charger / 快速充电器)

■ External View / 外视图

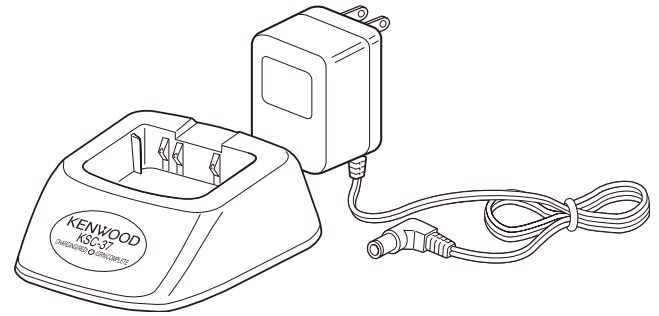

■ Specifications

Charge current 1050mA ± 5%
 Charge voltage (at battery charging terminals) 4.5V ± 1%
 End of charge (current) 200mA ± 20mA
 Rapid charge time Less than 150min
 Low voltage battery charge timer..... 90min
 Rapid charge timer 150min
 Starting charge temperature range 0°C < T < 40°C
 On charge temperature range 0°C < T < 57°C

■ 规格

充电电流 1050mA ± 5%
 充电电压（电池充电端子处）..... 4.5V ± 1%
 充电端（电流）..... 200mA ± 20mA
 快速充电时间..... 少于 150 分
 低压电池充电定时器 90 分钟
 快速充电定时器..... 150 分钟
 开始充电温度范围 0°C < T < 40°C
 充电期间温度范围 0°C < T < 57°C

OPTIONAL ACCESSORY (KSC-37: RAPID CHARGER)

Flow Chart

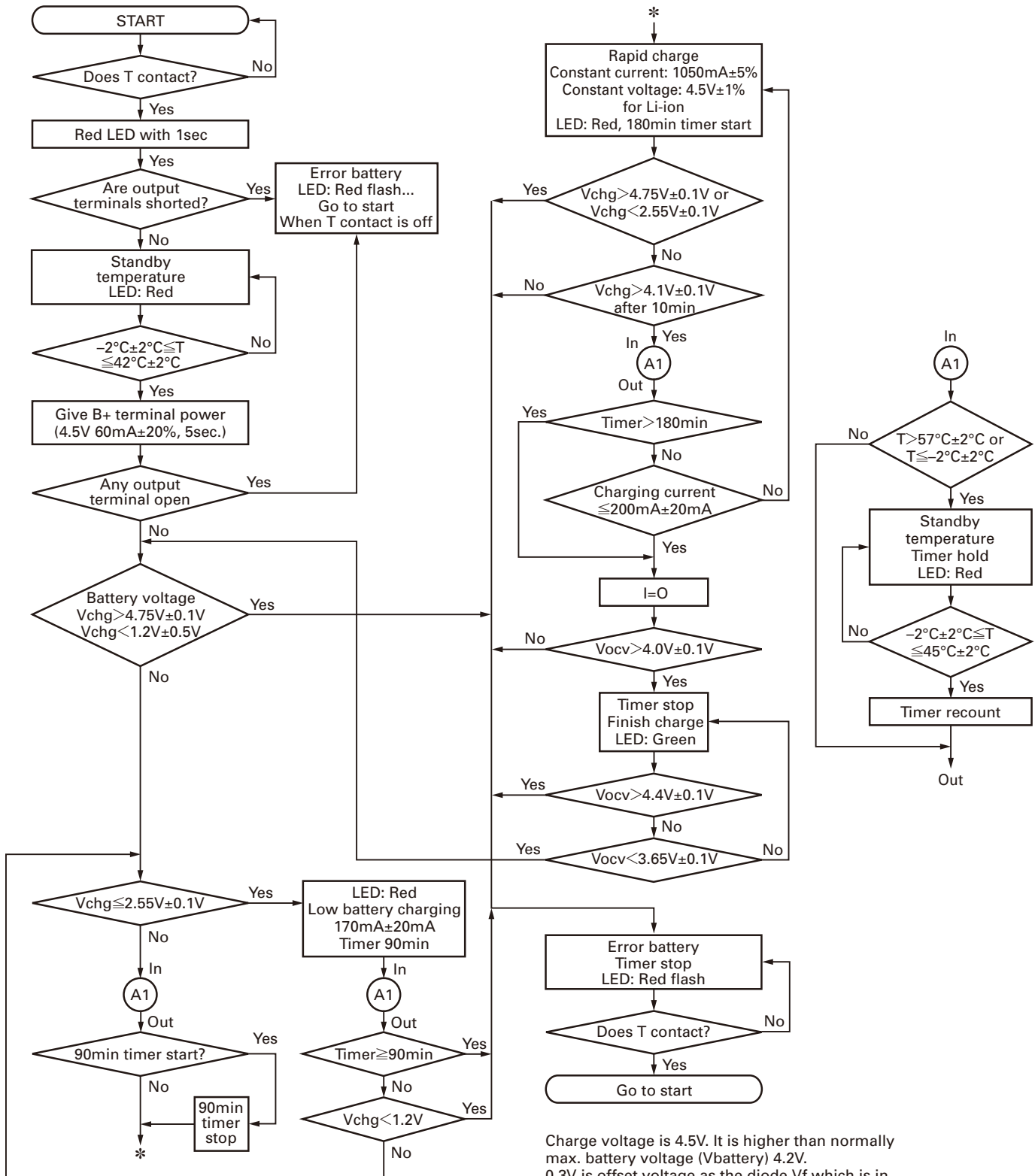

Charge voltage is 4.5V. It is higher than normally max. battery voltage (Vbattery) 4.2V. 0.3V is offset voltage as the diode Vf which is in the battery pack.
 Vchg: Charge voltage at charging (Vbattery+Vf)
 Vocv: Battery voltage at non-charging

可选附件（快速充电器）

流程图

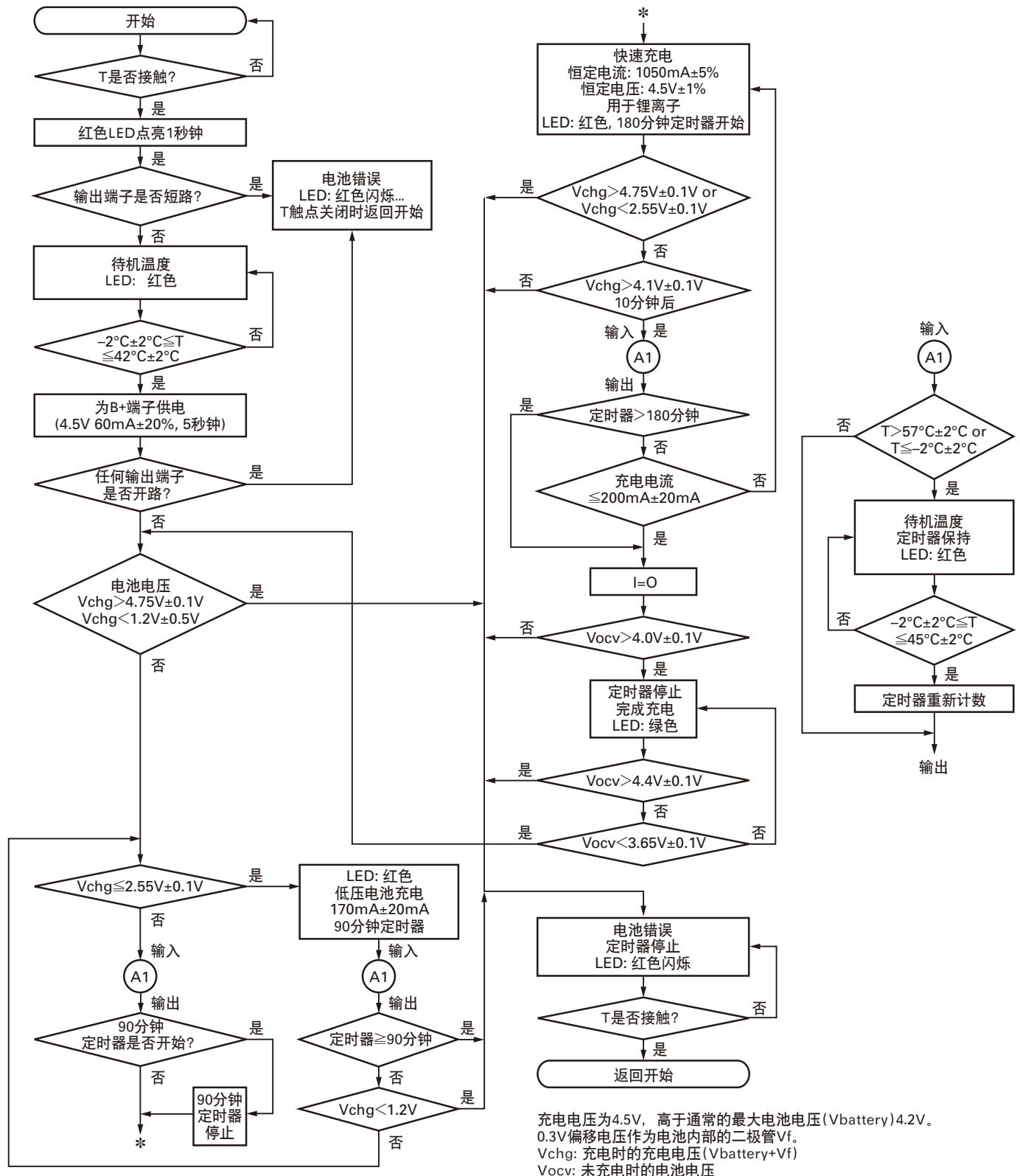

TK-3230

OPTIONAL ACCESSORY / 可选附件 (KSC-37: RAPID CHARGER / 快速充电器)

■ PC Board / 印刷电路板 (Component side view / 元件面视图)

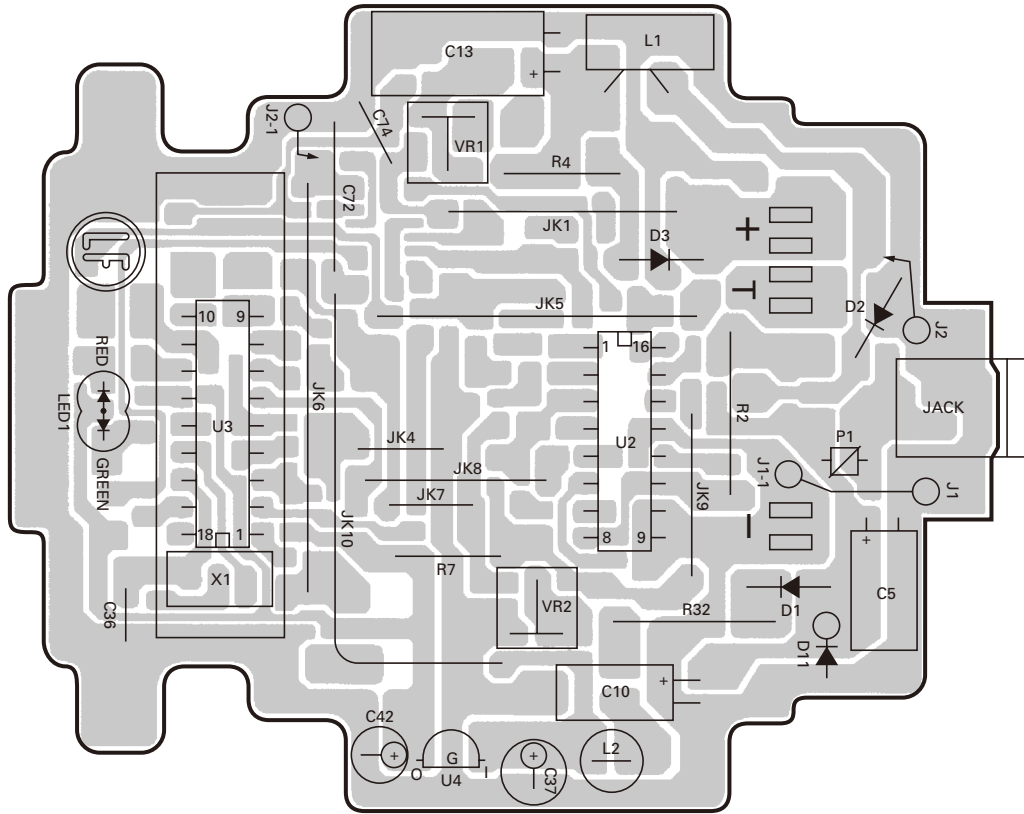

■ PC Board / 印刷电路板 (Foil side view / 铜箔面视图)

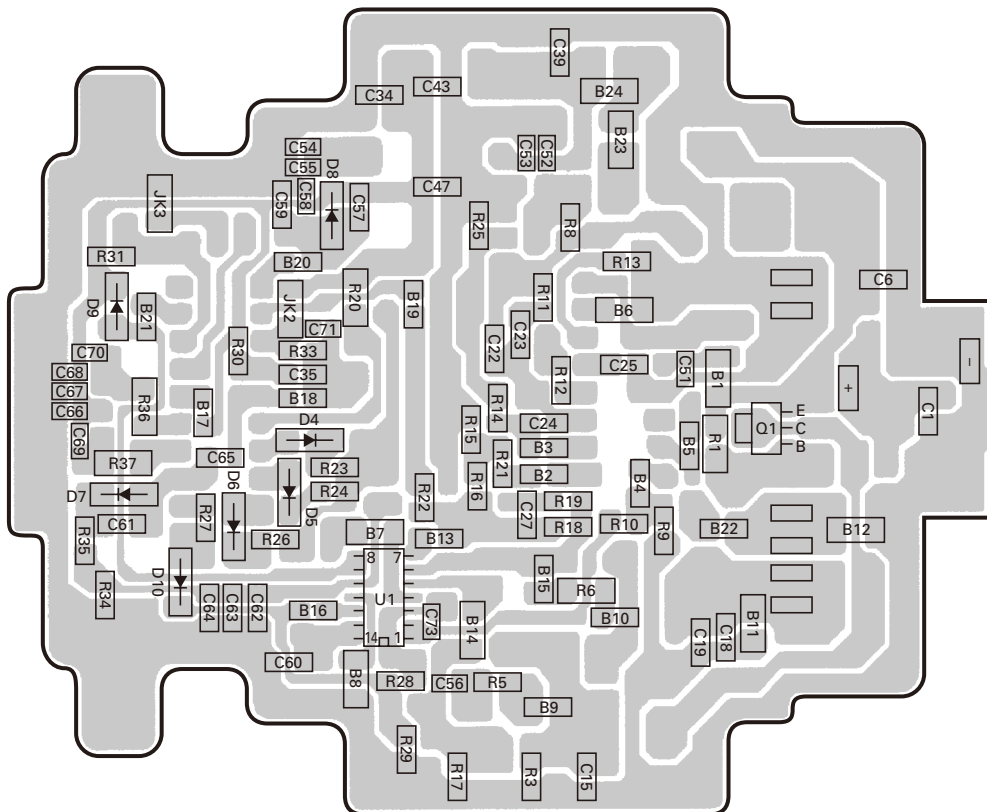

OPTIONAL ACCESSORY / 可选附件 (KSC-37: RAPID CHARGER / 快速充电器)

■ Schematic Diagram / 原理图

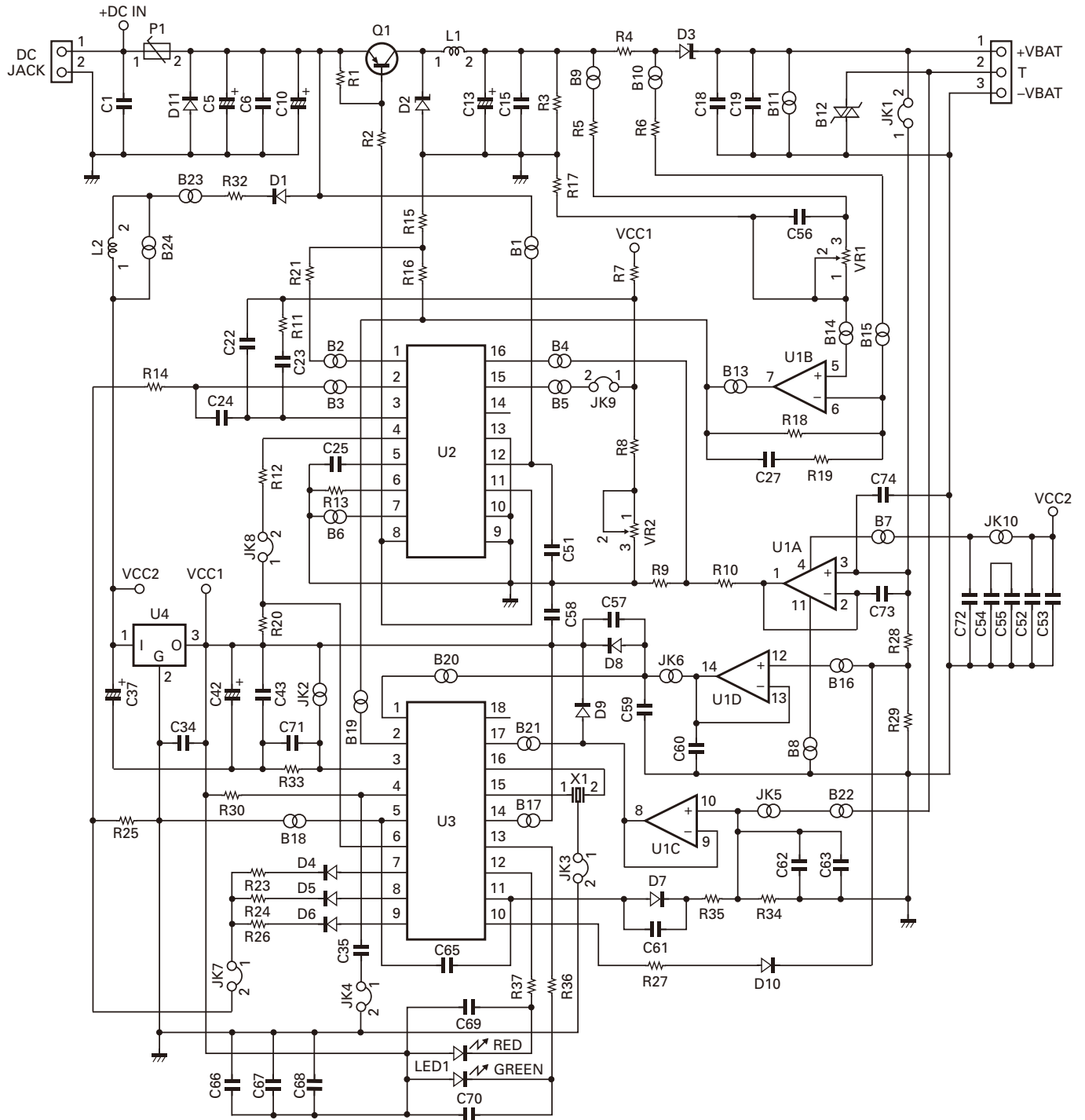

TK-3230

SPECIFICATIONS / 规格

General

Frequency Range.....	460 to 470MHz
Number of Channels.....	16CH
PLL Channel Stepping	6.25kHz, 5kHz
Modulation (Wide/Narrow)	16K0F3E/11K00F3E
RF Output Power (High/Low)	1.5W / 500mW
Operating Voltage	3.8V DC (3.4~4.2V)
Battery Life (5-5-90 Duty Cycle).....	Up to 14 hours (at KNB-46L high power)
Operating Temperature Range	-10°C to +60°C (+14°F to +140°F)
Frequency Stability	±2.5ppm
Dimensions.....	52 (W) x 103.5 (H) x 28.7 (D) mm (155.5mm (H) included antenna) (Projections not included)
Weight.....	Approx. 155g with KNB-46L battery
Standard Load	
Antenna Impedance.....	50Ω
MIC Input.....	2kΩ
AF Output	8Ω

一般

频率范围.....	460 ~ 470MHz
信道数.....	16 信道
PLL 信道步长.....	6.25kHz、5kHz
调制（宽 / 窄）.....	16K0F3E/11K00F3E
RF 输出功率（高 / 低）.....	1.5W / 500mW
工作电压.....	3.8V 直流 (3.4 ~ 4.2V)
电池工作时间（5-5-90 工作循环）.....	最长 14 小时 (KNB-46L 高功率下)
工作温度范围.....	-10°C ~ +60°C
频率稳定性.....	±2.5ppm
尺寸.....	52 (宽) × 103.5 (高) × 28.7 (深) mm (包括天线时为 155.5mm (高)) (未包括凸起部分)
重量.....	约 155g (带有 KNB-46L 电池)
标准负载	
天线阻抗.....	50 Ω
麦克风输入.....	2k Ω
音频输出.....	8 Ω

Kenwood Corporation

2967-3, Ishikawa-machi, Hachioji-shi, Tokyo, 192-8525 Japan

Kenwood U.S.A. Corporation

P.O. BOX 22745, 2201 East Dominguez Street, Long Beach,
CA 90801-5745, U.S.A.

Kenwood Electronics Canada Inc.

6070 Kestrel Road, Mississauga, Ontario, Canada L5T 1S8

Kenwood Electronics Deutschland GmbH

Rembrücker Str. 15, 63150 Heusenstamm, Germany

Kenwood Electronics Belgium N.V.

Leuvensesteenweg 248 J, 1800 Vilvoorde, Belgium

Kenwood Electronics France S.A.

L'Etoile Paris Nord 2, 50 Allée des Impressionnistes,
Bp 58416 Villepinte, 95944 Roissy Ch De Gaulle Cedex

Kenwood Electronics UK Limited

KENWOOD House, Dwight Road, Watford, Herts.,
WD18 9EB United Kingdom

Kenwood Electronics Europe B.V.

Amsterdamseweg 37, 1422 AC Uithoorn, The Netherlands

Kenwood Electronics Italia S.p.A.

Via G. Sirtori, 7/9 20129 Milano, Italy

Kenwood Ibérica, S.A.

Bolivia, 239-08020 Barcelona, Spain

Kenwood Electronics Australia Pty. Ltd.

(A.C.N. 001 499 074)

16 Giffnock Avenue, Centrecourt Estate, North Ryde, N.S.W. 2113 Australia

Kenwood Electronics (Hong Kong) Ltd.

Unit 3712-3724, Level 37, Tower one Metroplaza, 223 Hing Fong Road,
Kwai Fong, N.T., Hong Kong

Kenwood Electronics Singapore Pte Ltd

1 Ang Mo Kio Street 63, Singapore 569110



TK-3230 PC BOARD / PC板

PC BOARD / PC板 TK-3230

TX-RX UNIT (X57-7330-10) Component side view (J79-0103-19)

TX-RX UNIT (X57-7330-10) Component side view (J79-0103-19)

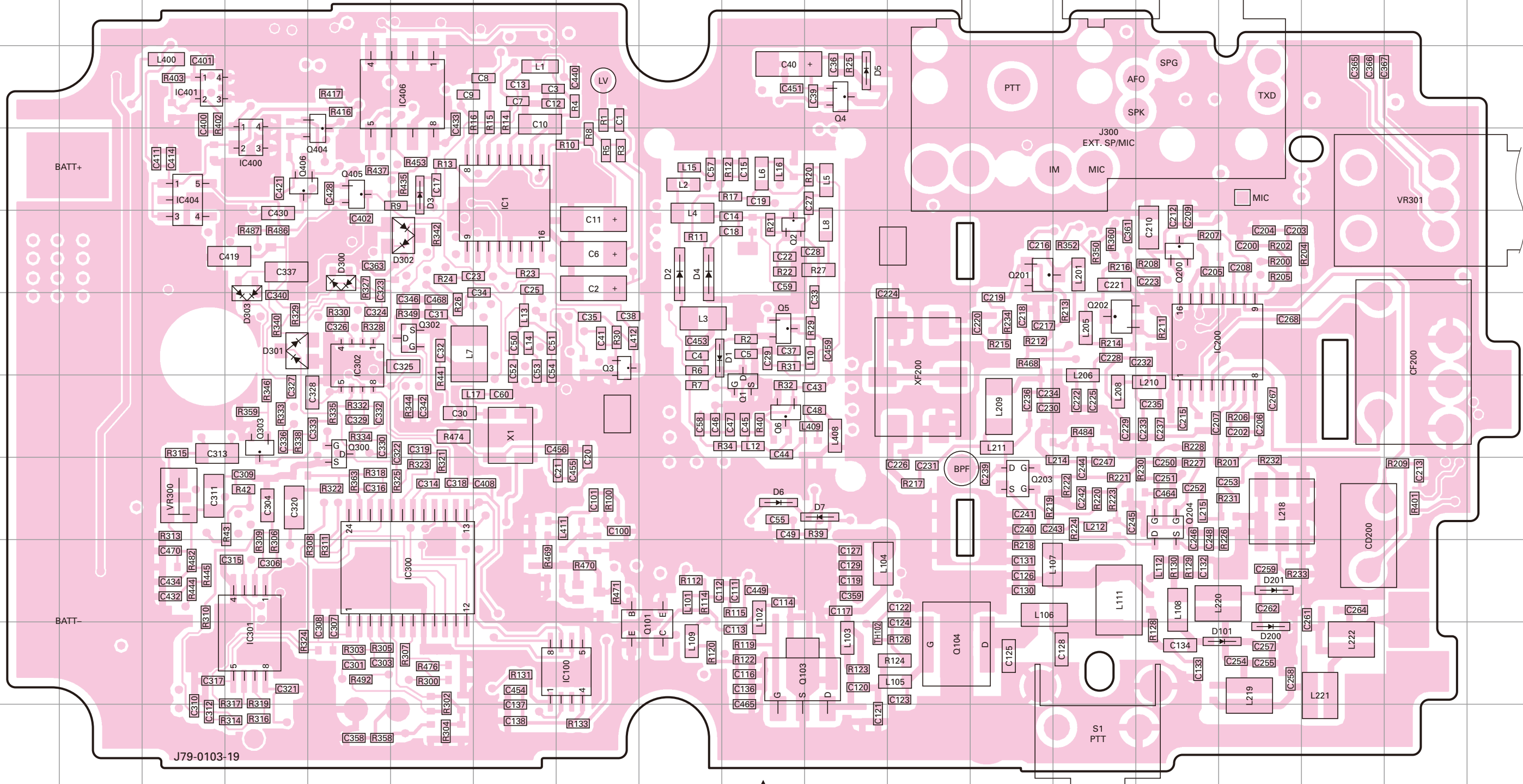

Ref. No.	Address	Ref. No.	Address	Ref. No.	Address	Ref. No.	Address	Ref. No.	Address	Ref. No.	Address
IC1	4G	IC404	4C	Q101	10J	Q300	7E	D3	4F	D300	5E
IC100	10H	IC406	3F	Q103	10J	Q302	6F	D4	5I	D301	6D
IC200	6O	Q1	7J	Q104	10L	Q303	7D	D5	3K	D302	5F
IC300	9F	Q2	5J	Q200	5O	Q404	4E	D6	8J	D303	6D
IC301	10D	Q3	6H	Q201	5M	Q405	4E	D7	8K		
IC302	6E	Q4	3K	Q202	6N	Q406	4D	D101	10P		
IC400	4D	Q5	6J	Q203	8M	D1	6I	D200	10P		
IC401	3C	Q6	7J	Q204	8O	D2	5I	D201	9P		

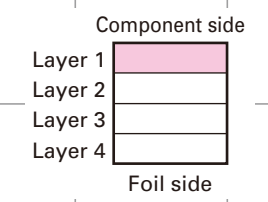

TK-3230 PC BOARD / PC板

PC BOARD / PC板 TK-3230

TX-RX UNIT (X57-7330-10) Foil side view (J79-0103-19)

TX-RX UNIT (X57-7330-10) Foil side view (J79-0103-19)

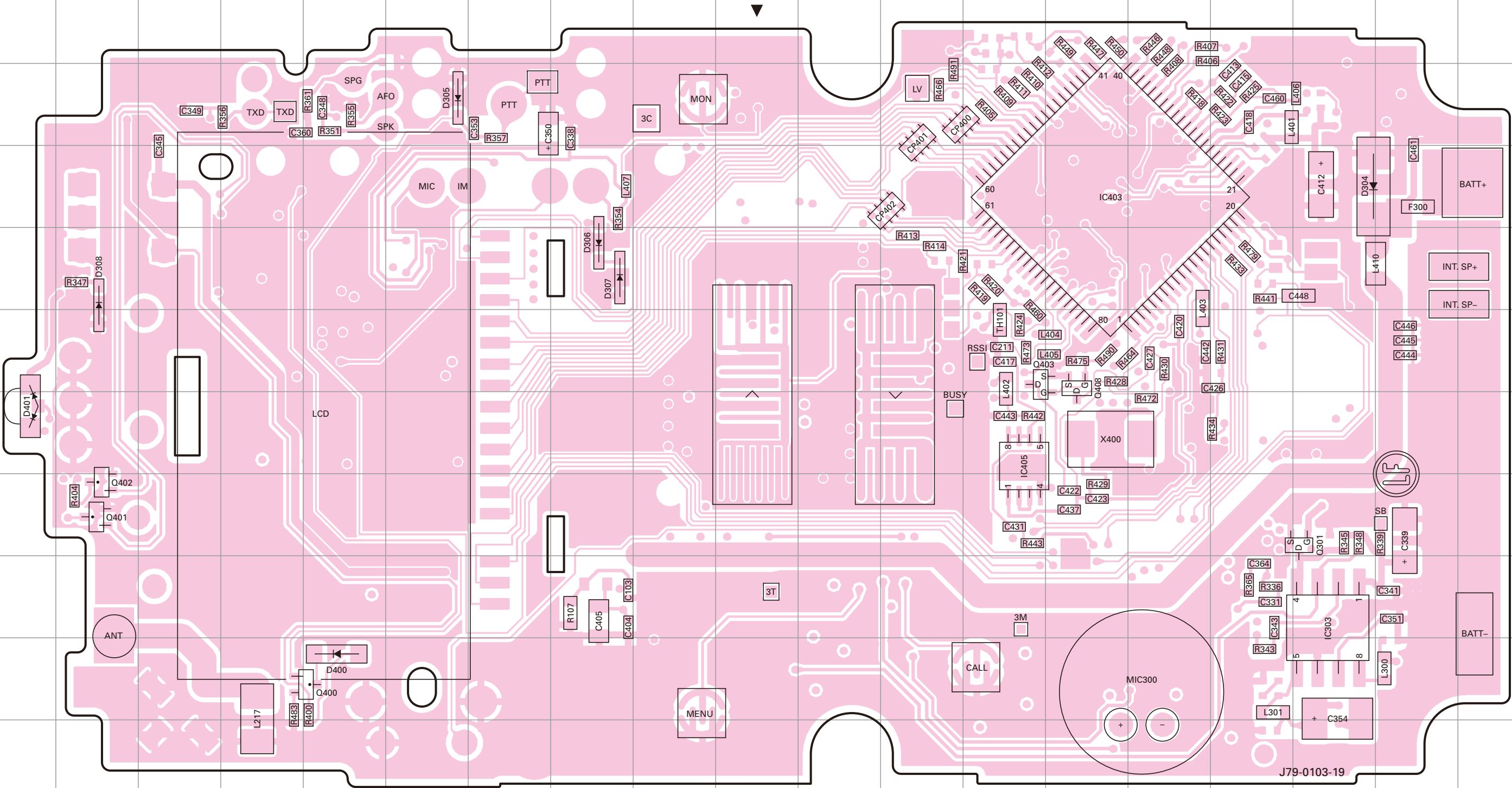

Ref. No.	Address	Ref. No.	Address	Ref. No.	Address
IC303	9Q	Q402	8B	D307	5H
IC403	4N	Q403	6M	D308	5B
IC405	7M	Q408	6N	D400	10E
Q301	8Q	D304	4Q	D401	7A
Q400	10E	D305	3F		
Q401	8B	D306	5H		

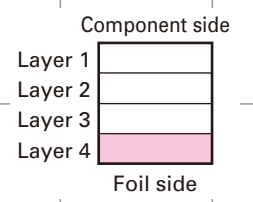

J79-0103-19

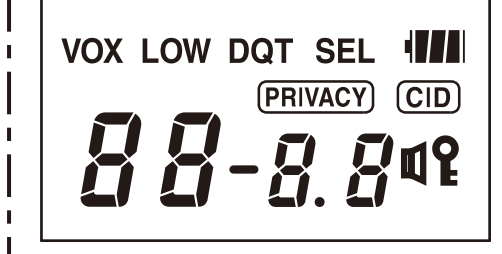
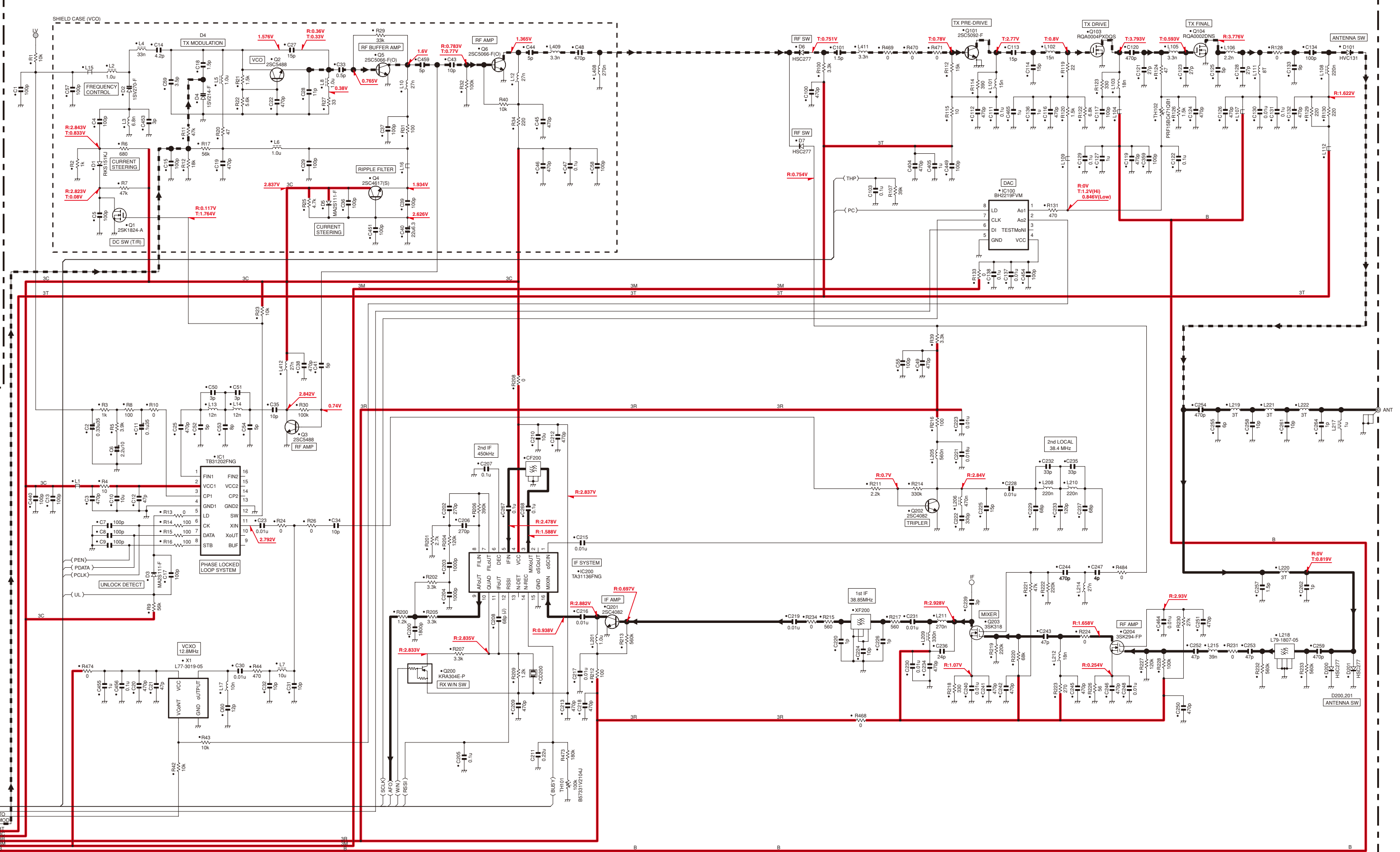
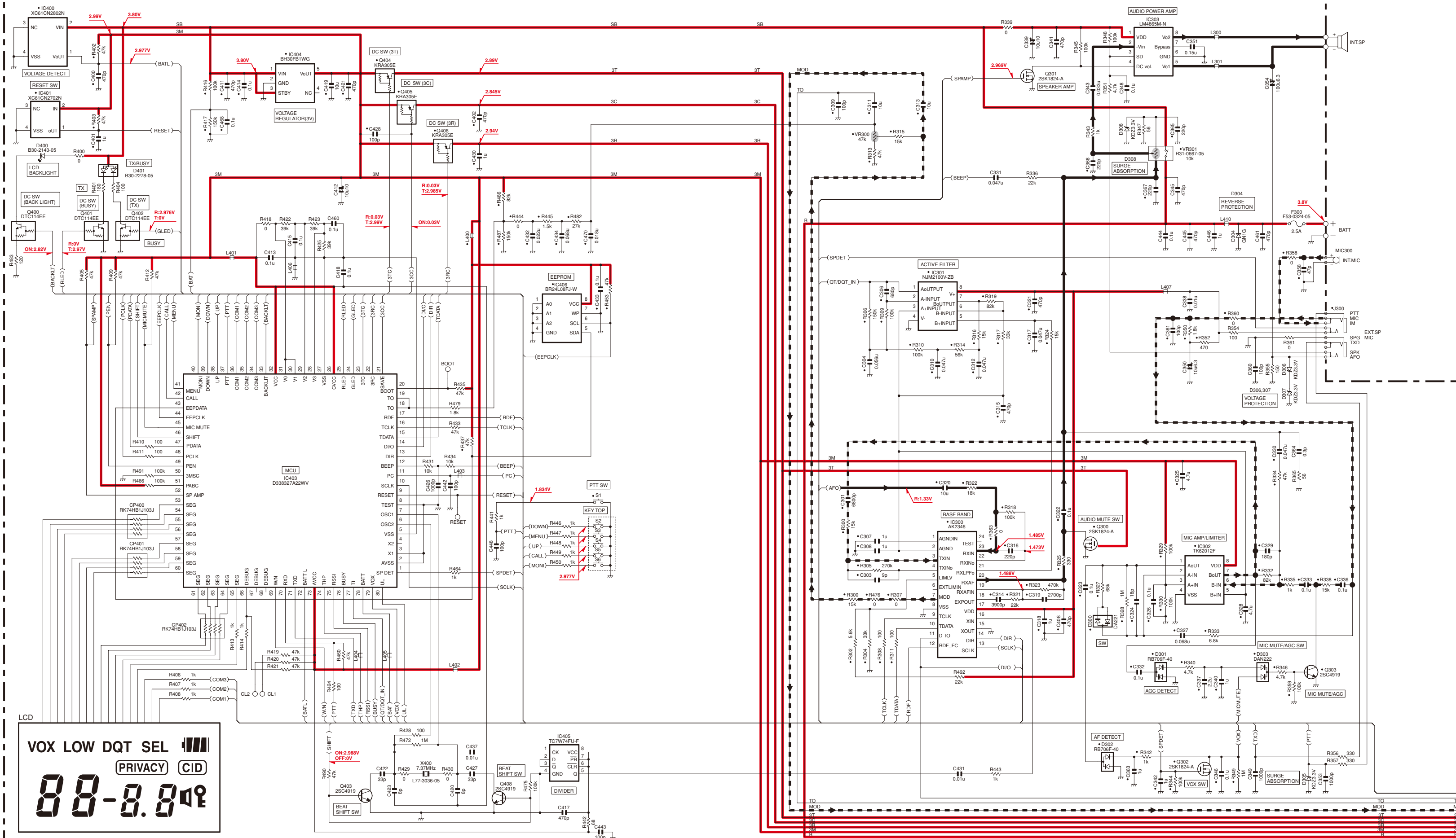

TX-RX UNIT (X57-7330-10)

