

CONTENTS

GENERAL	2
SYSTEM SET-UP	3
REALIGNMENT	3
DISASSEMBLY FOR REPAIR	10
CIRCUIT DESCRIPTION	13
SEMICONDUCTOR DATA	18
COMPONENTS DESCRIPTION	19
PARTS LIST	20
EXPLODED VIEW	27
PACKING	28
ADJUSTMENT	29
PC BOARD	
TX-RX UNIT (X57-7890-71)	34
SCHEMATIC DIAGRAM	38
BLOCK DIAGRAM	44
LEVEL DIAGRAM	46
OPTIONAL ACCESSORIES	
KNB-29N (Ni-MH Battery Pack)	47
KNB-45L (Li-ion Battery Pack)	47
KNB-53N (Ni-MH Battery Pack)	47
KMC-48GPS (GPS Speaker Microphone) ..	47
SPECIFICATIONS	BACK COVER

TK-3310

Document Copyrights

Copyright 2012 by JVC KENWOOD Corporation. All rights reserved.

No part of this manual may be reproduced, translated, distributed, or transmitted in any form or by any means, electronic, mechanical, photocopying, recording, or otherwise, for any purpose without the prior written permission of JVC KENWOOD Corporation.

Disclaimer

While every precaution has been taken in the preparation of this manual, JVC KENWOOD Corporation assumes no responsibility for errors or omissions. Neither is any liability assumed for damages resulting from the use of the information contained herein. JVC KENWOOD Corporation reserves the right to make changes to any products herein at any time for improvement purposes.

Firmware Copyrights

The title to and ownership of copyrights for firmware embedded in Kenwood product memories are reserved for JVC KENWOOD Corporation. Any modifying, reverse engineering, copy, reproducing or disclosing on an Internet website of the firmware is strictly prohibited without prior written consent of JVC KENWOOD Corporation. Furthermore, any reselling, assigning or transferring of the firmware is also strictly prohibited without embedding the firmware in Kenwood product memories.

GENERAL

INTRODUCTION

SCOPE OF THIS MANUAL

This manual is intended for use by experienced technicians familiar with similar types of commercial grade communications equipment. It contains all required service information for the equipment and is current as of the publication date. Changes which may occur after publication are covered by either Service Bulletins or Manual Revisions. These are issued as required.

ORDERING REPLACEMENT PARTS

When ordering replacement parts or equipment information, the full part identification number should be included. This applies to all parts : components, kits, or chassis. If the part number is not known, include the chassis or kit number of which it is a part, and a sufficient description of the required component for proper identification.

PERSONAL SAFETY

The following precautions are recommended for personal safety:

- DO NOT transmit until all RF connectors are verified secure and any open connectors are properly terminated.
- SHUT OFF and DO NOT operate this equipment near electrical blasting caps or in an explosive atmosphere.
- This equipment should be serviced by a qualified technician only.

SERVICE

This transceiver is designed for easy servicing. Refer to the schematic diagrams, printed circuit board views, and alignment procedures contained within.

Model	Type	TX-RX unit	Frequency range	Remarks
TK-3310	X(LMR)	X57-7890-71	RX 450~520MHz TX 450~500MHz	IF1: 38.85MHz LOC: 38.4MHz
	X(CB)		476.4250 ~477.4125MHz	

SYSTEM SET-UP

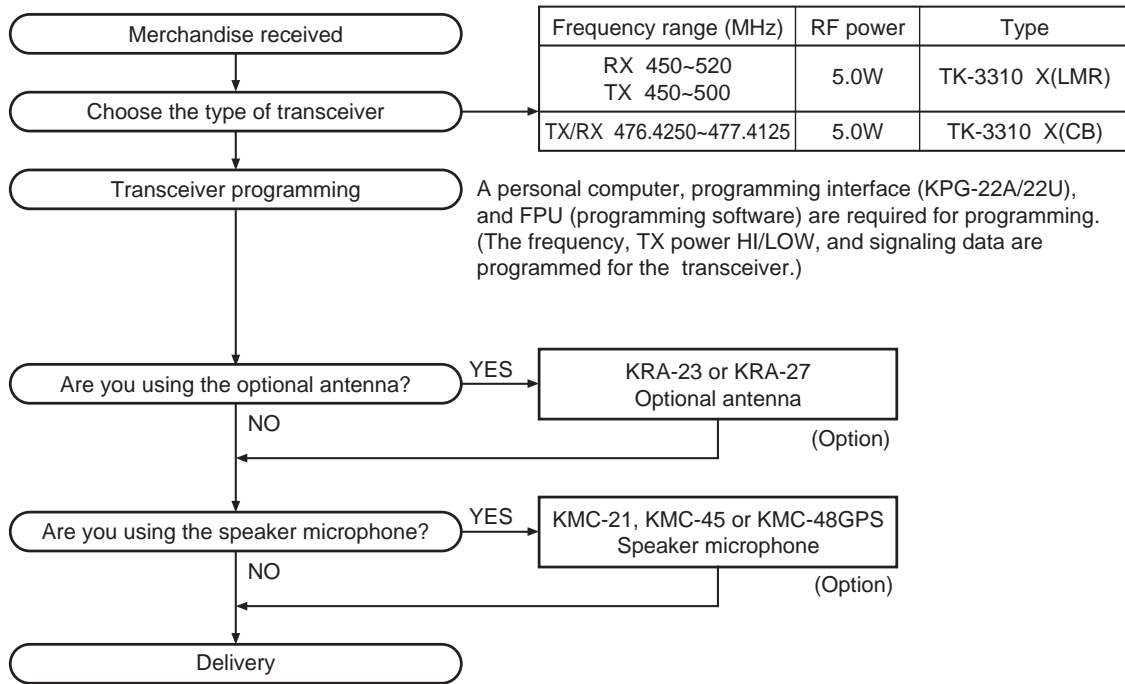

REALIGNMENT

1. Modes

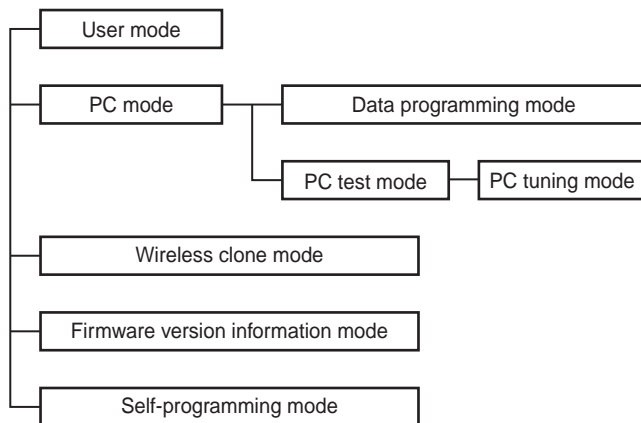

Mode	Function
User mode	For normal use.
PC mode	Used for communication between the transceiver and PC.

Mode	Function
Data programming mode	Used to read and write frequency data and other features to and from the transceiver.
PC test mode	Used to check the transceiver using the PC. This feature is included in the FPU.
Wireless clone mode	Used to transfer programming data from one transceiver to another.
Firmware version information mode	Used to confirm the internal firmware version.
Self-programming mode	You can program the frequency, signaling and other functions using only the transceiver.

2. How to Enter Each Mode

Mode	Operation
User mode	Power ON
PC mode	Received commands from PC
Wireless clone mode	[<B] + Power ON (Two seconds)
Firmware version information mode	[Side1] + [Side2] + Power ON (Two seconds)
Self-programming mode	[S] + Power ON (Two seconds)

REALIGNMENT

3. PC Mode

3-1. Preface

The transceiver is programmed by using a personal computer, a programming interface (KPG-22A/22U, USB adapter (KCT-53U)) and programming software (KPG-152D).

The programming software can be used with a PC. Figure 1 shows the setup of a PC for programming.

3-2. Connection Procedure

1. Connect the transceiver to the personal computer with the interface cable and USB adapter (when the interface cable is KPG-22A, the KCT-53U can be used).

Note:

- You must install the KPG-22U driver in the computer to use the USB programming interface cable (KPG-22U).
 - You must install the KCT-53U driver in the computer to use the USB adapter (KCT-53U).
 - When using the USB adapter (KCT-53U) for the first time, plug the KCT-53U into a USB port on the computer with the computer power ON.
2. When the POWER is switched on, you can immediately enter user mode. When the PC sends a command, the transceiver enters PC mode. When data is transmitting from the transceiver, the red LED lights. When data is receiving by the transceiver, the green LED lights.

Note:

- The data stored in the personal computer must match Model Name and Model Type when it is written into the EEPROM.
- Do not press the [PTT] key during data transmission or reception.

3-3. KPG-22A Description

(PC programming interface cable: Option)

The KPG-22A is required to interface the transceiver with the computer. It has a circuit in its D-sub connector case that converts the RS-232C logic level to the TTL level.

The KPG-22A connects the SP/MIC connector of the transceiver to the RS-232C serial port of the computer.

3-4. KPG-22U Description

(USB programming interface cable: Option)

The KPG-22U is a cable which connects to a USB port on a computer.

When using the KPG-22U, install the supplied CD-ROM (with driver software) in the computer. The KPG-22U driver runs under Windows XP, Vista or 7.

3-5. KCT-53U Description (USB adapter: Option)

The KCT-53U is a cable which connects the KPG-22A to a USB port on a computer.

When using the KCT-53U, install the supplied CD-ROM (with driver software) in the computer. The KCT-53U driver runs under Windows 2000, XP or Vista (32-bit).

3-6. Programming Software KPG-152D Description

The KPG-152D is the programming software for the transceiver supplied on a CD-ROM. This software runs under windows XP, Vista or 7 on a PC. The software on this disk allows a user to program the transceiver via Programming interface cable (KPG-22A/22U).

3-7. Programming with PC

If data is transferred to the transceiver from a PC with the FPU, the data for each set can be modified.

Data can be programmed into the EEPROM in RS-232C format via the SP/MIC jack.

In this mode the PTT line operate as TXD and RXD data lines respectively.

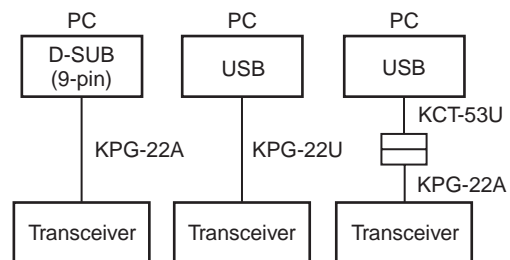
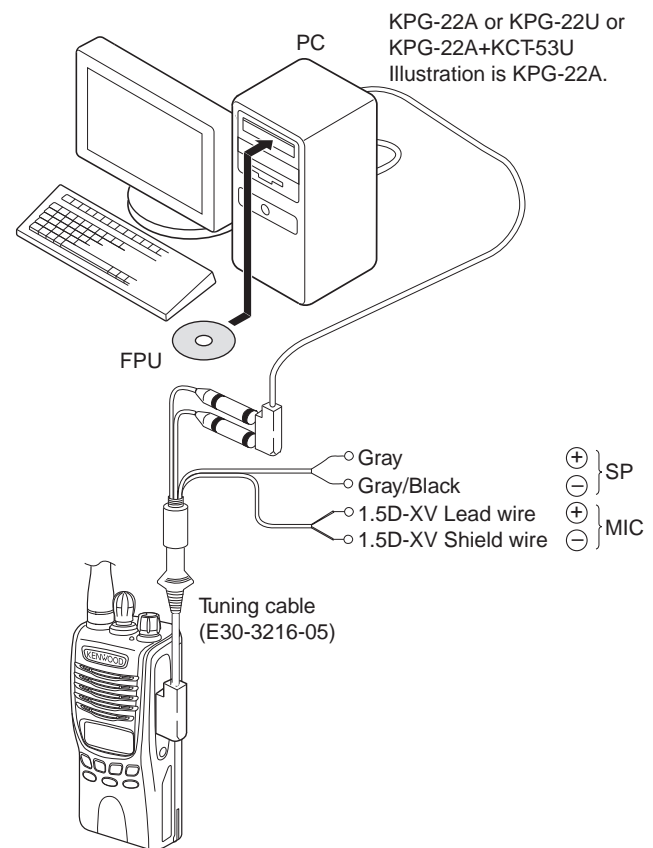

Fig. 1

REALIGNMENT

4. Wireless Clone Mode

4-1. Outline

“Wireless Clone Mode” copies the transceiver data to another transceiver.

The dealer can copy the transceiver data to another transceiver even without the use of a personal computer.

4-2. Example

The transceiver can copy the programming data to one or more transceivers via RF communication.

The clone source and clone target/s must be in wireless clone mode.

4-3. Operation

- To switch the clone target/s to Wireless Clone mode, press and hold the [] key while turning the transceiver power ON.
- Wait for 2 seconds. “CLONE” appears on the LCD, followed by “FRQTBL 1”.
- Select a channel table number using the [Selector] knob.
- To switch the clone source to Wireless Clone mode, press and hold the [] key while turning the transceiver power ON.
- Wait for 2 seconds. “CLONE” appears on the LCD, followed by “FRQTBL 1”.
- Select the same channel table number as the clone target/s.
- Press the [S] key on the clone source to begin data transmission. When the clone target starts to receive data, the green LED will light and “CLONING” will appear on the LCD. The source unit will display “MASTER”.
- When the clone source finishes sending data, a “confirmation” tone will sound and “COMPLETE” will appear on the LCD. If data transmission failed while cloning, the target unit will produce an error tone and “CLONE NG” will appear on the LCD.
- If the cloning fails, no data will be available in the target unit when it is returned to User mode.
- When the cloning is successful, the target unit’s “Scan” and “Key lock” functions will return to their default values (Scan = OFF, Key lock = OFF).
- The source will remain in clone mode after cloning. The target unit will return to user mode after a successful cloning.

Note:

- The dealer can clone data to two or more transceivers by repeating the above procedures.
- If the transceivers wireless clone mode is configured as “Disabled”, the transceiver cannot enter Clone mode.
- The table shown below will cover the frequency tables used for wireless cloning.
- Wireless clone mode cannot be entered in battery low state.
- A unit cannot be a “Source Unit” if it is unprogrammed. If the [S] key is pressed, an “error” tone will sound.
- Once a unit is set to be the source, it cannot be a target after the data has been transmitted. This protects the data in the source unit.
- MSK signaling is used in cloning.

- Electronic interface may cause a failure in data transfer during Wireless Clone, such as when waveforms or electromagnetics are being performed at the workbench.
- Wireless clone mode can be used ONLY by the authorized service personnel.
- The wireless clone mode setting must be configured as “Disable” before being delivered to the end-user.
- To wireless clone, replace the antenna from both the source transceiver and the target transceiver with a dummy load.
- The transmit output power is automatically set to Low in Clone mode.

4-4. Adding the Data Password

If the Data password is set to the transceiver, you must enter the password to activate a clone mode. The maximum length of the password is 6 digits.

The following describes how to enter the password.

- Press and hold the [] key for 2 seconds while turning the transceiver power ON.
- “CLN.LOCK.R”(When the Read authorization password is set to the transceiver.) / “CLN.LOCK.W” (When the Overwrite password is set to the transceiver.) is displayed on the LCD.
- If the [selector] knob is rotated while “CLN.LOCK.R”/ “CLN.LOCK.W” is displayed, the number (0 to 9) flashes on the LCD.

When you press the [C>] key, the currently selected number is determined.

If you press the [A] key, the least digit of the password is deleted.

If you press the [S] key after entering the password in this procedure, “FRQTBL 1” is displayed if the entered password is correct.

If the password is incorrect, “CLN.LOCK.R”/ “CLN.LOCK.W” is redisplayed. (with error tone)

• Clone frequency table

No.	Operating frequency X(LMR): 450-520 (MHz)	Operating frequency X(CB): 476.4250~477.4125 (MHz)		
	Frequency(MHz)	CB CH No.	CH Type	Frequency(MHz)
1	450.000	9	simplex	476.6250
2	452.000	49	simplex	476.6375
3	454.000	10	simplex	476.6500
4	456.000	12	simplex	476.7000
5	458.000	53	simplex	476.7375
6	460.000	14	simplex	476.7500
7	462.000	16	simplex	476.8000
8	464.000	57	simplex	476.8375
9	466.000	18	simplex	476.8500
10	468.000	20	simplex	476.9000
11	470.000	21	simplex	476.9250
12	472.000	24	simplex	477.0000
13	474.000	65	simplex	477.0375
14	476.000	26	simplex	477.0500
15	478.000	28	simplex	477.1000
16	480.000	29	simplex	477.1250
17	482.000	30	simplex	477.1500
18	484.000	39	simplex	477.3750
19	486.000	40	simplex	477.4000
20	488.000	80	simplex	477.4125

REALIGNMENT

5. Self Programming Mode

Write mode for frequency data and signaling, etc. To be used ONLY by the authorized service person maintaining the user's equipment. After programming, reset the FPU to the "Self- Programming" disabled mode. Transceivers CANNOT be delivered to the end-user in the self-programming mode.

5-1. Enter to the Self Programming Mode

Press and hold the [S] key for 2 seconds while turning the transceiver power ON.

When the transceiver enters in the self programming mode, "1- 1" is displayed 2 seconds after "SELF" is displayed.

Note:

This mode (self programming mode) cannot be set when it has been disabled with the FPU.

5-2. Adding the Data Password

If the Data password is set to the transceiver, you must enter the password to activate a self programming mode. The maximum length of the password is 6 digits.

The following describes how to enter the password.

1. Press and hold the [S] key for 2 seconds while turning the transceiver power ON.
2. "SLF.LOCK.R" (When the Read authorization password is set to the transceiver.) / "SLF.LOCK.W" (When the Overwrite password is set to the transceiver.) is displayed on the LCD.
3. If the [selector] knob is rotated while "SLF.LOCK.R"/ "SLF.LOCK.W" is displayed, the number (0 to 9) flashes on the LCD.

When you press the [C>] key, the currently selected number is determined.

If you press the [A] key, the least digit of the password is deleted.

If you press the [S] key after entering the password in this procedure, "SELF" is displayed if the entered password is correct.

If the password is incorrect, "SLF.LOCK.R"/ "SLF.LOCK.W" is redisplayed.

5-3. Channel Selection Mode

In this mode, the Zone or Channel can be selected.

Press and hold the [S] key for 2 seconds while turning the transceiver power ON to enter self programming mode. When the transceiver enters in the self programming mode, the transceiver automatically enters the Channel Selection mode.

2 seconds after displaying "SELF", "1- 1" appears on the LCD.

The setup item for channel selection mode is as follows.

Setup item	Display	Remarks
Select Zone/Channel	>***< - *** *** - >***<	Zone: 1~128 Channel: 1~128

Key operation

Key	Key Function
[Selector]	Toggle between Zone selection and Channel selection
[Side1]	No action
[Side2]	No action
[S]	Enter the Item Setting mode
[A]	Return to the Channel Selection mode
[<B]	Decrement the blinking Zone/Channel number by 1. Press and hold to decrement in steps of 10.
[C>]	Increment the blinking Zone/Channel number by 1. Press and hold to decrement in steps of 10.

Note:

If a non-existing Zone-Channel is selected and the memory for all 128 channels is already filled, an error tone will sound and "MEM.FULL" will appear on the LCD for 2 seconds.

5-4. Item Selection Mode

In this mode, the following items can be selected.

- RX frequency
- RX signaling
- TX frequency
- TX signaling
- RF power Hi/Low (LMR model only)
- Scan Del/Add (LMR model only)
- Beat shift on/off (LMR model only)
- Compander on/off (LMR model only)

When the [S] key is pressed in the Channel Selection mode, the transceiver enters the Item Selection mode.

Key operation

Key	Key Function
[Selector]	The selected item changes
[Side1]	No action
[Side2]	No action
[S]	Enter the Item Setting mode
[A]	Return to the Channel Selection mode
[<B]	Error tone sounds
[C>]	Error tone sounds

REALIGNMENT

5-5. Item Setting Mode

In this mode, the selected item in the Item Selection mode can be programmed.

When the [S] key is pressed in the Item Selection mode, the transceiver enters the Item Setting mode.

The setup items for item setting mode are as follows

Setup item	Display	Remarks
1. RX frequency *1	1. RX FREQ → → ***.*****	Receive frequency X(LMR): 450.00000~520.00000MHz X(CB): 476.42500~477.41250MHz
2. RX signaling *2	2. RX SIG → TONE OFF/ QT ***/./ DQT ***/N/ DQT ***/I	Receive QT/DQT
3. TX frequency *3	3. TX FREQ → → ***.*****	Transmit frequency X(LMR): 450.00000~500.00000MHz X(CB): 476.42500~477.41250MHz
4. TX signaling *4	4. TX SIG → TONE OFF/ QT ***/./ DQT ***/N/ DQT ***/I	Transmit QT/DQT
5. RF power Hi/Low *5	5. PWR ***	HI/LOW
6. Scan Del/Add *5	6. SCN ***	DEL/ADD
7. Beat shift on/off *5	7. SFT ***	ON/OFF
8. Compander on/off *5	8. CMP ***	ON/OFF

*1: The channel frequency step size can be changed only for the LMR model. The CB model has a fixed step size of 12.5 kHz.

*2: The LMR model can select from TONE OFF, QT, DQTN or DQTI if the setting item is RX signaling. The CB model can only select from TONE OFF, QT or DQTN. DQTI is not available on the CB model.

*3: On the CB model, the RX frequency setting value is displayed because the TX frequency cannot be edited.

*4: On the CB model, the RX signaling setting value is displayed because the TX signaling cannot be edited. The LMR model can select from TONE OFF, QT, DQTN or DQTI if the setting item is TX signaling. The CB model can only select from TONE OFF, QT or DQTN. DQTI is not available on the CB model.

*5: Available only on the LMR model.

Key operation

Key	Key Function
[Selector]	Changing the selection item (RX/TX frequency and RX/TX signaling only)
[Side1]	No action
[Side2]	No action
[S]	<ul style="list-style-type: none"> Store the current settings and return to the Item Selection mode without backup. A MHz digit of the frequency blinks. (RX/TX frequency only) The icon of the current signaling configuration blinks. (RX/TX signaling only)
[A]	Abort the current settings and return to the Item Selection mode without backup.
[<B]	Toggle/Decrease the blinking value.
[C>]	Toggle/Increase the blinking value.

5-6. Self Programming Mode flow chart

■ Channel selection mode flow chart

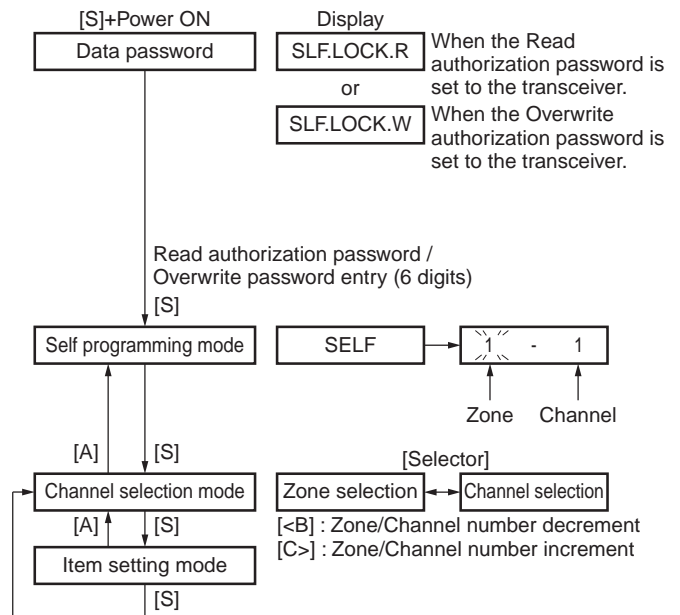

REALIGNMENT

■ Item selection mode flow chart

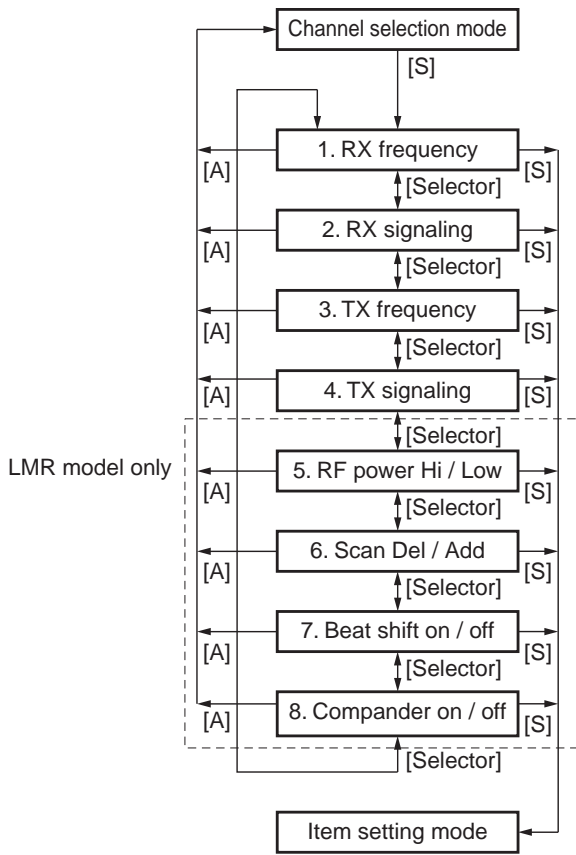

■ Item setting mode flow chart

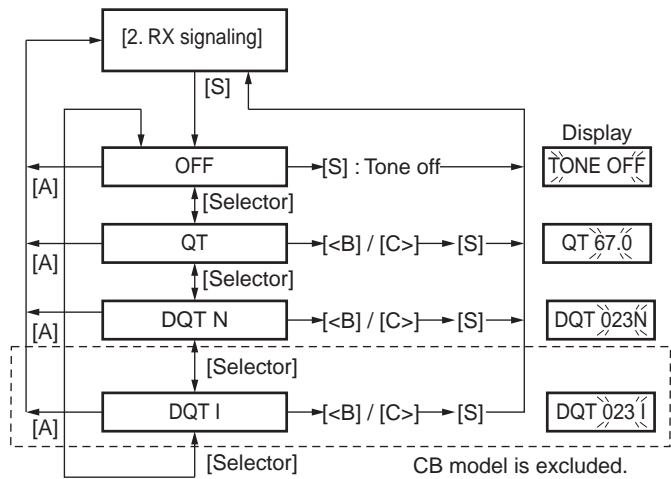
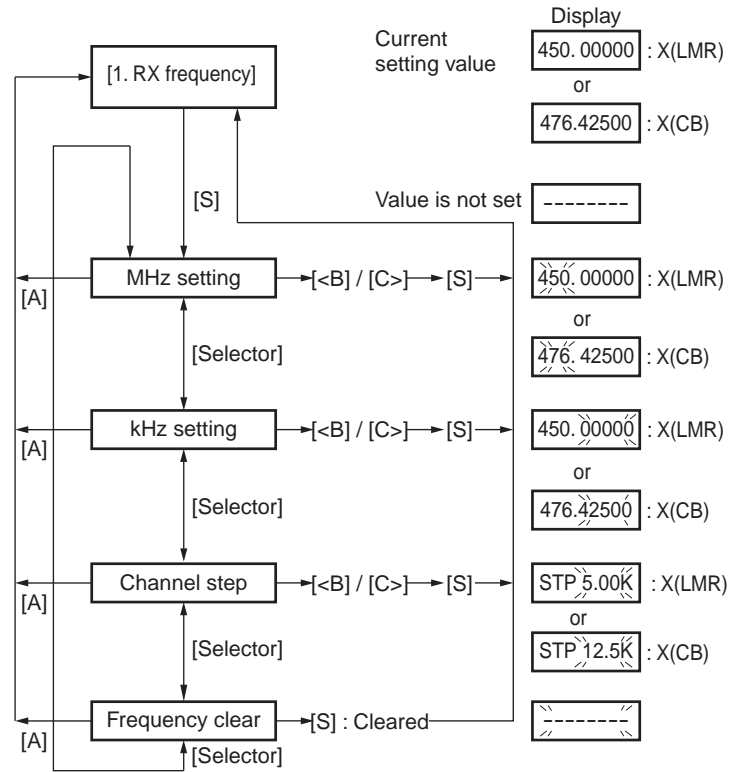

Item setting mode flow chart

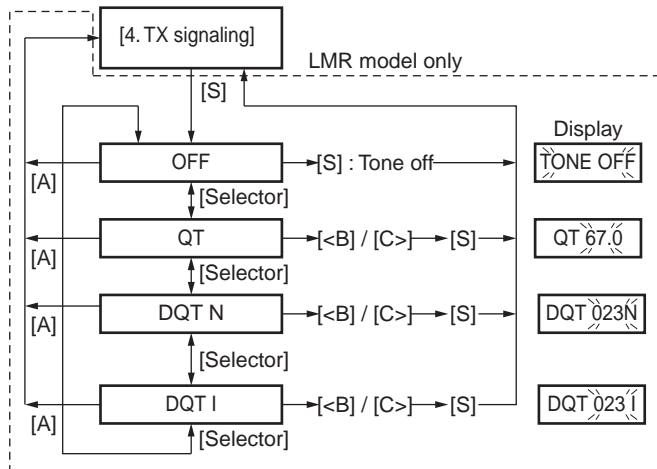
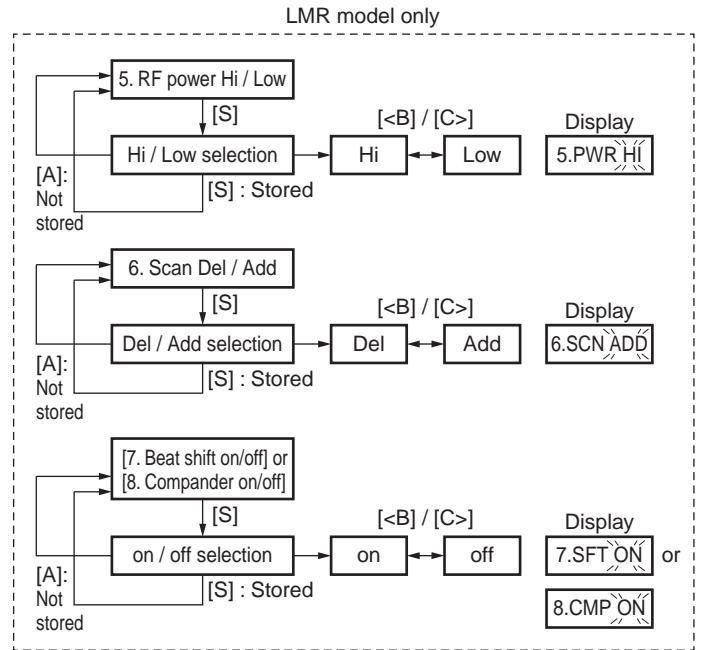
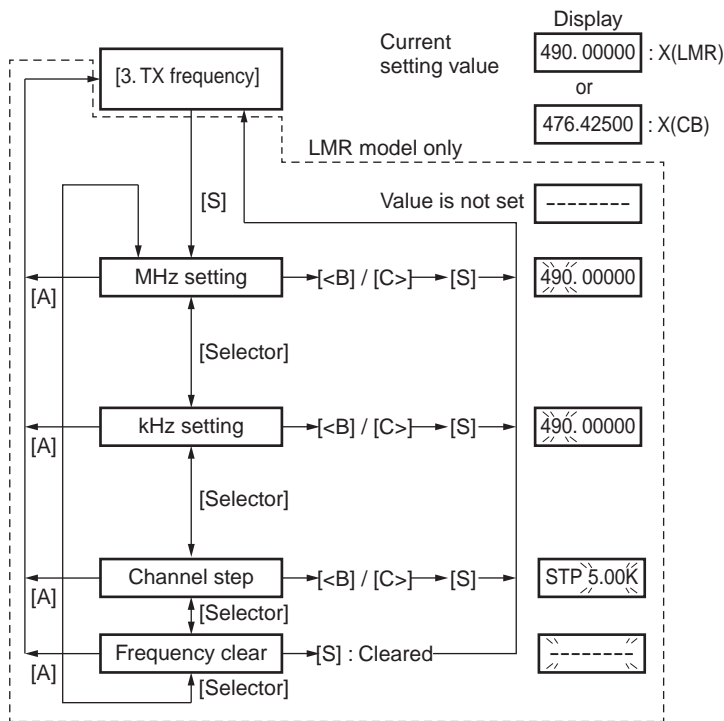

6. Firmware Version Information Mode

Turn the transceiver ON with the [Side1] and [Side2] keys held down. Then, the version is displayed during holding the [Side1] and [Side2] keys.

DISASSEMBLY FOR REPAIR

1. Removing the Case Assembly from the Chassis

1. Remove the selector knob ① and volume knob ②.
2. Remove the two screws ③.
3. Lift and remove the chassis from the case assembly ④.
(Use a flat-blade screwdriver to easily lift the chassis.)

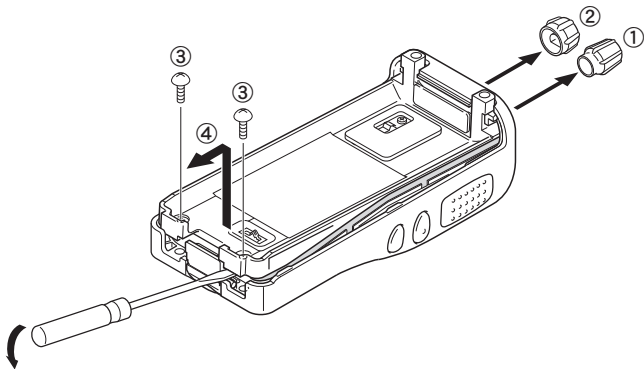

2. Removing the Holder Assembly from the Chassis

1. Remove the holder from the chassis.
Note: Taking care not to cut the speaker and microphone lead.
2. Detach the solder of speaker and microphone lead from the PCB beforehand.
3. Remove the packing ⑤ from the SP/MIC jack of the TX-RX unit.

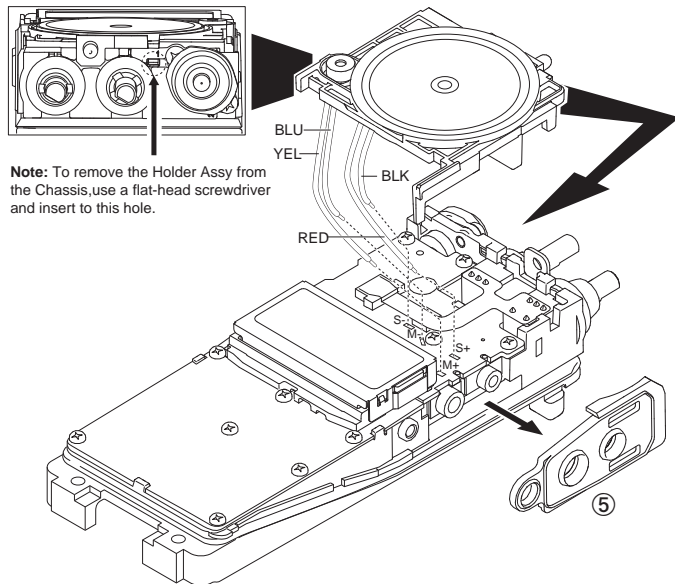

3. Removing the TX-RX unit from the Chassis

1. Remove the eleven screws ⑥ fixing the TX-RX unit.
 2. Remove the solder of the antenna terminal with a soldering iron ⑦.
 3. Remove the solder of the positive terminal with a soldering iron ⑧.
- Note:** You can remove the TX-RX unit from the chassis without removing the solder at the positive terminal. However, in this case, you can not attach the packing (G53-1605-03) that is on the positive terminal to the chassis in assembling. So, it is advisable to remove the solder on the positive terminal first.
4. Remove the FPC from the flat cable connector ⑨.
 5. Lift and remove the TX-RX unit from the chassis ⑩.

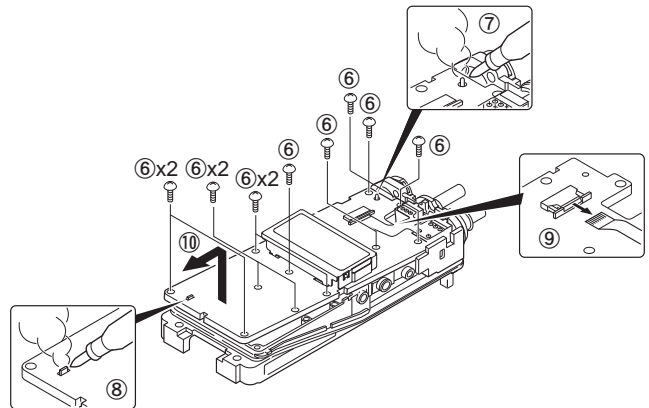

4. Removing the Battery Release Lever from the Case Assembly

1. Press the upper part of the lever toward the inside of the case assembly. One side of the shaft will be removed ①.
 2. Lift and remove the battery release lever from the case assembly ②.
- Note:** Scratch and widen the glue hole if there is difficulty in removing the other end of the shaft.
No glue is required when you reassemble the battery release lever.

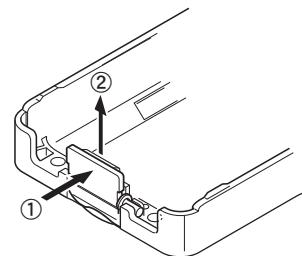

DISASSEMBLY FOR REPAIR

5. Attaching the Battery Release Lever to the Case Assembly

1. Insert one side of the shaft into the hole at the lever fitting section on the case assembly ①.

Caution: The thin spring (G01-4543-14) should be positioned above the two tabs of the lever.

2. Tilt the battery release lever slightly forward ②, so that the thick spring (G01-4542-04) is positioned below the case surface.
3. With the thick spring positioned below the case surface, attach the other side of the shaft to the case assembly by pressing the battery release lever ③ until it snaps into place ④.

Caution: Be careful not to tilt the battery release lever too forward.

If the battery release lever is pushed in this state where the two tabs come below the case surface, there is a possibility of damaging the two tabs.

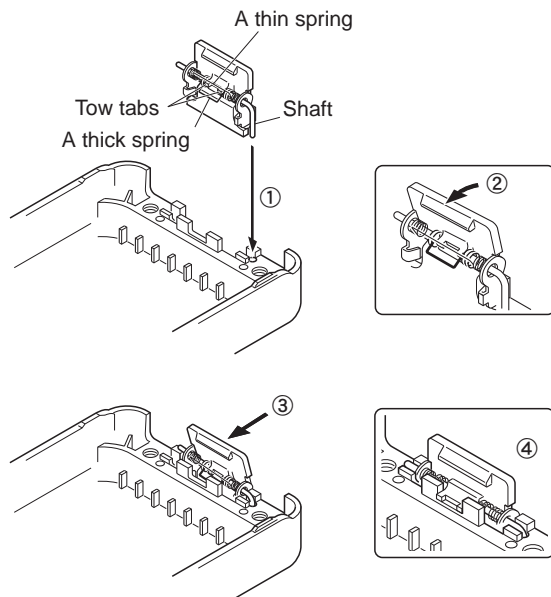

6. Assembling the Battery Release Lever

1. Place the lever ② onto the stopper ①.
2. Place the thick spring ③ onto the lever.
3. Hook the right and left ends of the thin spring ④ onto the tabs of the stopper, then place the thin spring ④ onto the lever ⑤.
4. Slide the shaft through the hole of the stopper and lever ⑥.

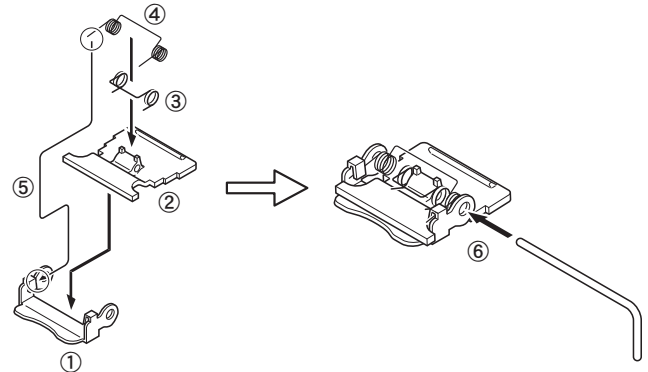

7. Attaching the Positive Terminal to the Chassis

Always attach the positive terminal to the chassis, using the following procedures, before mounting the TX-RX unit onto the chassis.

1. Remove the holder assembly ② from the packing ① of the positive terminal.
2. Mount the packing of the positive terminal into the chassis hole ③.
3. Mount the holder assembly into the packing of the positive terminal ④.

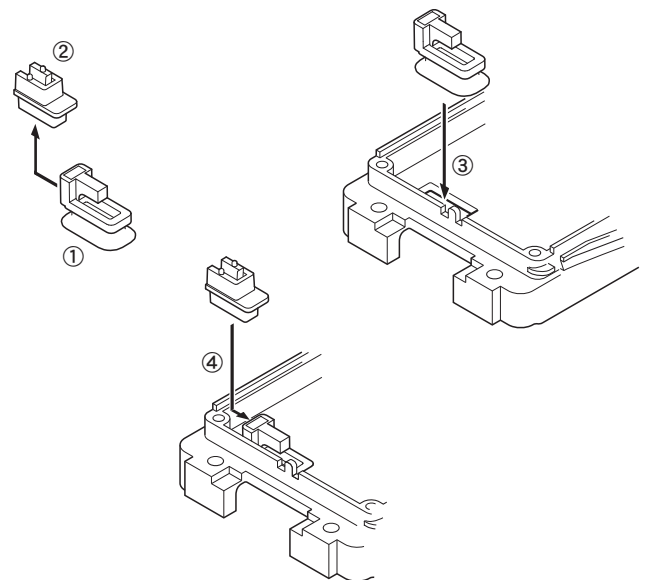

DISASSEMBLY FOR REPAIR

8. Mounting the Chassis to the Case Assembly

1. Confirm that the waterproof packing attached to the circumference of the chassis is securely inserted in the groove of the chassis ①.
2. Insert the upper part of the chassis into the case assembly ②.
3. Press the chassis ③ and the case assembly together to attach them.

Caution: If the packing of the SP/MIC does not come to the correct position after attaching the chassis to the case assembly, reposition the packing with your fingers.

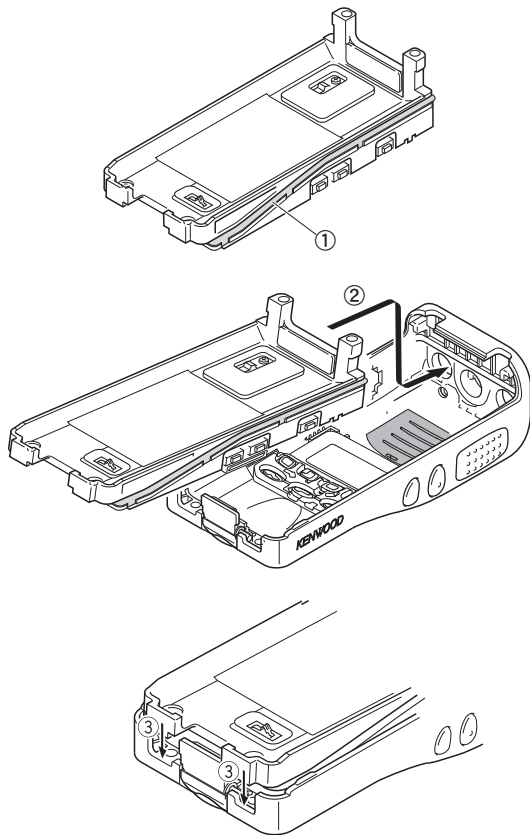

9. Attaching the Antenna Receptacle to the Chassis

Screw the antenna receptacle to the chassis in the order shown in the drawing so that the antenna receptacle comes to the center of the case hole.

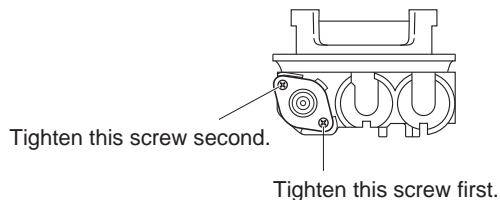

10. The Nuts of the Volume Knob and Channel Knob

Note that the shapes, colors and heights of nuts of the volume knob and channel knob are different from one another. (The nut of volume knob is silver, and the nut of channel knob is gold.)

Use the following jig when removing the nuts of the volume knob and channel knob.

- Jig (Part No.: W05-1012-00)

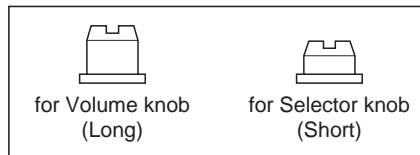

11. Screw sequence for mounting the TX-RX unit to the chassis

Attach the TX-RX unit to the chassis using the screws in the order shown in the drawing below.

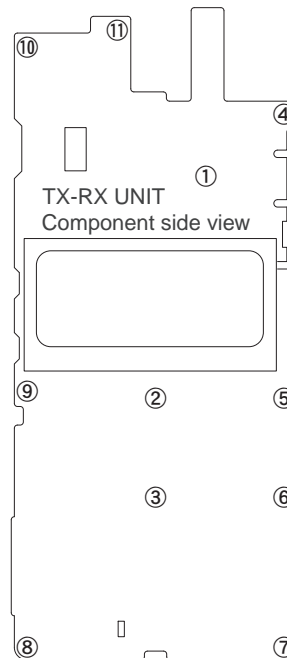

CIRCUIT DESCRIPTION

1. Frequency Configuration

The receiver utilizes double conversion. The first IF is 38.85MHz and the second IF is 450kHz. The first Local oscillator is supplied from the PLL circuit.

The PLL circuit in the transmitter generates the necessary frequencies.

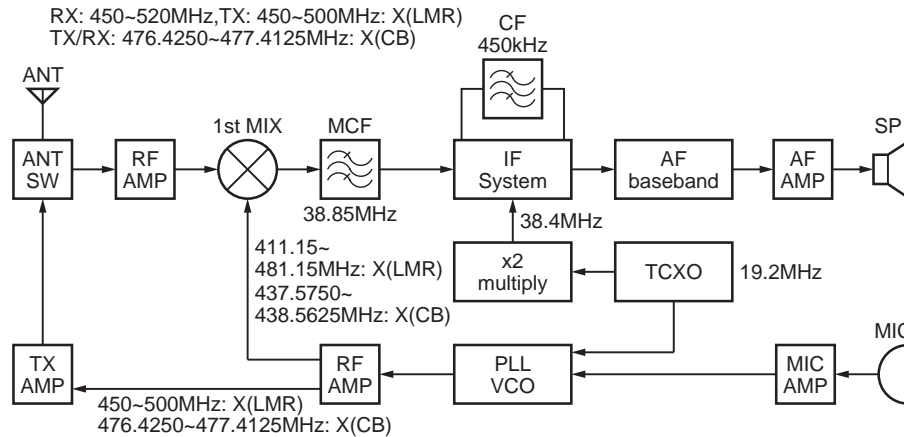

Fig. 1 Frequency configuration

2. Receiver System

The receiver system is shown in Figure 2.

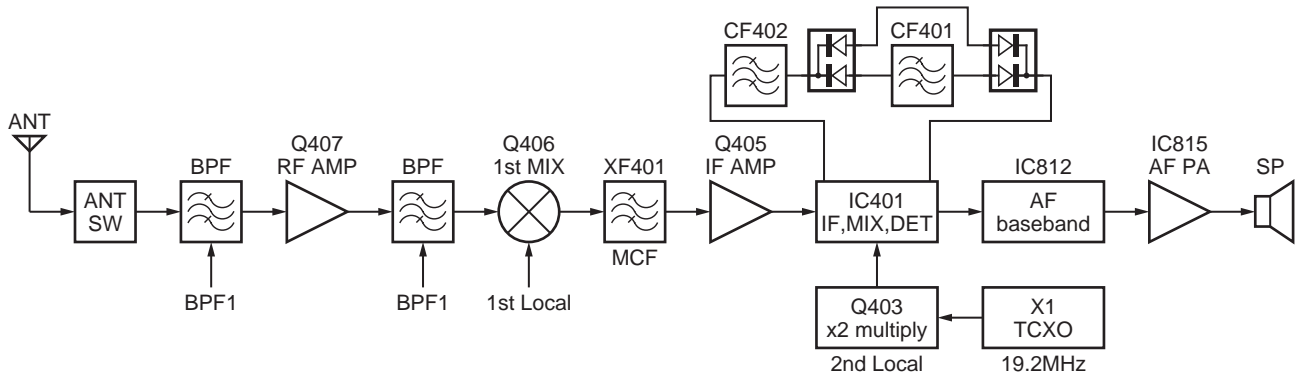

Fig. 2 Receiver system

2-1. Front End (RF Amplifier) Circuit

The signal coming from the antenna passes through the transmit / receive switching diode circuit (D201, D202, D203 and D204) and a BPF (L418 and L419), and is then amplified by the RF amplifier (Q407).

The resulting signal passes through a BPF (L419, L418, L491, L414 and L413) and goes to the mixer. These BPFs are adjusted by variable capacitance diodes (D408, D407, D405, D404 and D403). The input voltage to the variable capacitance diodes is a regulated voltage output from the DC amplifier (IC811).

2-2. First Mixer

The signal from the front end is mixed with the first local oscillator signal generated in the PLL circuit by Q406 to produce a first IF frequency of 38.85MHz.

The resulting signal passes through the XF401 MCF to cut the adjacent spurious and provide the optimum characteristics, such as adjacent frequency selectivity.

CIRCUIT DESCRIPTION

2-3. IF Amplifier Circuit

The first IF signal is passed through a four-pole monolithic crystal filter (XF401) to remove the adjacent channel signal. The filtered first IF signal is amplified by the first IF amplifier (Q405) and is then applied to the IF system IC (IC401).

The IF system IC provides a second mixer, limiting amplifier, quadrature detector and RSSI (Received Signal Strength Indicator). The second mixer mixes the first IF signal with the 38.4MHz signal of the second local oscillator output (Q403) and produces the second IF signal of 450kHz.

The second IF signal is passed through the ceramic filter (Wide: CF402, Narrow: CF401) to remove the adjacent channel signal. The filtered second IF signal is amplified by the limiting amplifier and demodulated by the quadrature detector with the ceramic discriminator (CD401). The demodulated signal is routed to the audio circuit.

2-4. Wide/Narrow Switching Circuit

Wide and narrow settings can be made for each channel by switching the ceramic filters CF401 (narrow).

The second IF signal always passes the ceramic filters CF402 (Wide).

The wide and narrow switching data is output from the MCU (IC820).

D401 and D402 are switched to ceramic filters when a narrow mode is selected.

Q404 turns on/off with the Narrow and the IC401 detector output level is changed to maintain a constant output level during wide or narrow signals.

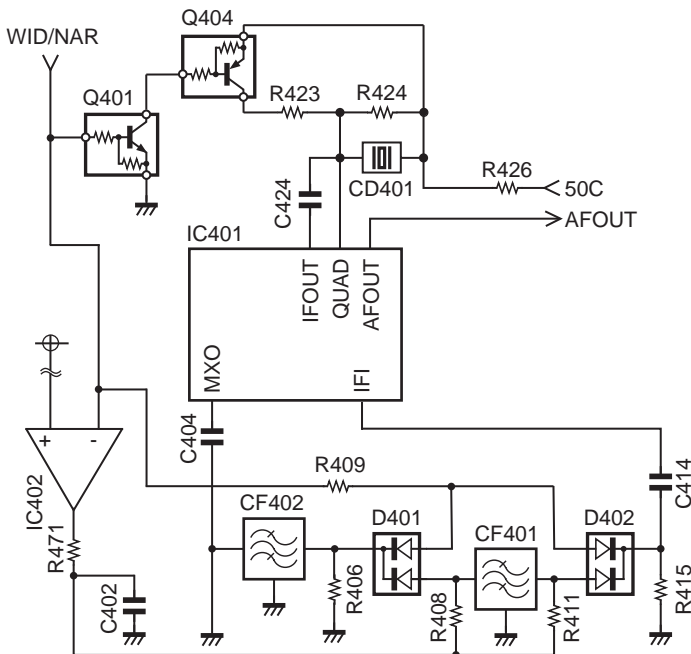

Fig. 3 Wide/Narrow switching circuit

2-5. Audio Amplifier Circuit

The demodulated signal from IC401 is sent to an AF amplifier through baseband IC (IC812), and is routed to an audio power amplifier (IC815) where it is amplified and output to the speaker.

2-6. Squelch Circuit

Part of the AF signal from the IC401 enters the FM system IC (IC401) again, and the noise component is amplified and rectified by a filter and an amplifier to produce a DC voltage corresponding to the noise level.

The DC signal from the FM IC goes to the analog port of the MCU (IC820). IC820 determines whether or not to output sounds from the speaker by checking if the input voltage is higher or lower than the preset value.

To output sounds from the speaker, IC820 sends a high signal to the AF_CONT line and turns IC815 on through Q813, Q814, Q818 and Q819.

3. Transmitter System

3-1. Microphone Amplifier Circuit

The signal from the microphone is limited by the AGC circuit, which is composed of D807, D808, Q810, Q811 and the mute switch (Q809). IC812 is composed of a high-pass filter, low-pass filter and pre-emphasis/IDC circuit.

The signal from the microphone and the low speed data from the MCU (IC820) enter the baseband IC (IC812) and pass through each path and are mixed inside the IC.

The output signal from the baseband IC goes to the VCO modulation input. The other output signal goes to the TCXO modulation input.

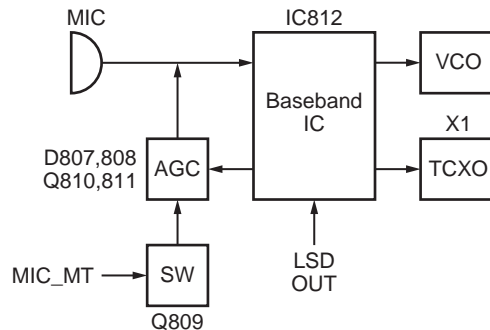

Fig. 4 Microphone amplifier circuit

CIRCUIT DESCRIPTION

3-2. Drive and Final Amplifier Circuit

The signal from the T/R switch (D18 is on) is amplified by the RF AMP (Q201) and pre-drive amplifier (Q203) to 50mW.

The output of the pre-drive amplifier is amplified by the drive amplifier (Q204) and the RF final amplifier (Q205) to 5.0W (1W when the power is low).

The drive amplifier and the RF final amplifier consist of two MOS FET stages.

The output of the RF final amplifier is then passed through the harmonic filter (LPF) and antenna switch (D201 and D202) and is applied to the antenna terminal.

3-3. APC Circuit

The APC circuit always monitors the current flowing through the drive amplifier (Q204) and the RF power amplifier (Q205) and keeps a constant current. The voltage drop at R307, R309 and R310 is caused by the current flowing through the RF final amplifier. This voltage is applied to the differential amplifier IC301 (1/2).

IC301 (2/2) compares the output voltage of IC301 (1/2) with the reference voltage from IC811. The output of IC301 (2/2) controls the VG of the RF power amplifier and the drive amplifier to make both voltages the same.

The change of power high/low is carried out by the change of the reference voltage.

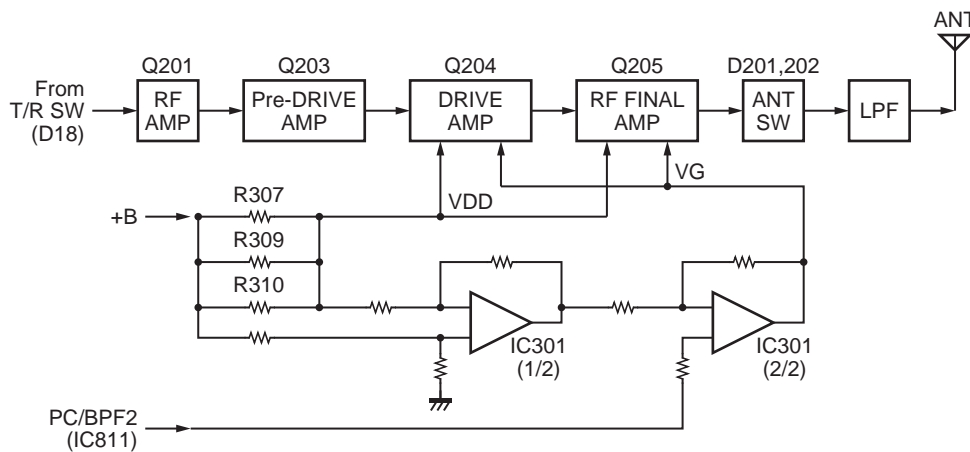

Fig. 5 Drive and final amplifier and APC circuit

4. Frequency Synthesizer Unit

4-1. Frequency synthesizer

The frequency synthesizer consists of the TCXO (X1), VCO, PLL-IC (IC1), and buffer amplifiers.

The TCXO generates 19.2MHz. The frequency stability is 1.5ppm within the temperature range of -30°C to $+60^{\circ}\text{C}$. The frequency tuning and modulation of the TCXO are done to apply voltage to pin 1 of the TCXO. The output of the TCXO is applied to pin 10 of PLL-IC.

The VCO consists of 2 VCO and covers a dual range of 437.5750~438.5625MHz and 476.4250~477.4125MHz: X(CB) or 411.15~481.15MHz and 450~500MHz:X(LMR). The VCO generates 437.5750~438.5625:X(CB) or 411.15~481.15MHz:X(LMR) for providing the first local signal for reception. The operating frequency is generated by Q5 in transmitting mode and Q4 in receiving mode. The oscillation frequency is controlled by applying the VCO control voltage, obtained from the phase comparator (IC1) to the variable capacitance diodes (D6 and D9 in transmitting mode and D10 and D12 in receiving mode)

The TX/RX pin of IC820 goes "high" in transmitting mode, causing Q7 and Q4 to turn off, and Q5 turn on. The TX/RX pin goes "low" in receiving mode.

The output from Q4 and Q5 are amplified by a buffer amplifier (Q8) and Q2, and then sent to the PLL-IC.

The PLL-IC consists of a prescaler, reference divider, phase comparator, and charge pump. The input signal from pin 10 and 17 of the PLL-IC is divided down and compared at the phase comparator. The pulsed output signal of the phase comparator is applied to the charge pump and transformed into a DC signal in the loop filter (LPF). The DC signal is applied to the CV of the VCO and locked to keep the VCO frequency constant.

PLL data is output from PL_STB (pin 20), PL_CLK (pin 8), and PL_DAT (pin 21) of the MCU (IC820). The data is input to the PLL-IC when the channel is changed or transmission is changed to reception and vice versa. PLL lock condition is always monitored by pin 18 (PL_UL) of the MCU. When the PLL is unlocked, PL_UL goes low.

CIRCUIT DESCRIPTION

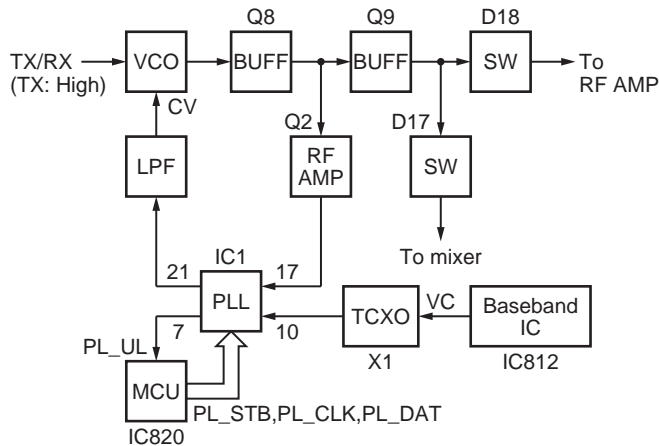

Fig. 6 PLL block diagram

5. Control Circuit

The control consists of the MCU (IC820) and its peripheral circuits. It controls the TX-RX unit. IC820 mainly performs the following;

- 1) Switching between transmission and reception by PTT signal input.
- 2) Reading channel information, frequency, and program data from the memory circuit.
- 3) Sending frequency program data to the PLL.
- 4) Controlling squelch on/off via the DC voltage from the squelch circuit.
- 5) Controlling the audio mute circuit via the decode data input.
- 6) Transmitting tone and encode data.

5-1. Frequency Shift Circuit

The MCU (IC820) and baseband IC (IC812) operates at a clock frequency of 19.2MHz. The oscillator circuit has the baseband IC. This oscillator has a circuit that shifts the frequency via Beat shift switch (Q807).

A beat sound may be able to be evaded if "Beat Shift" is set to ON when it is generated in the internal spurious transmission modulated sound of the transceiver.

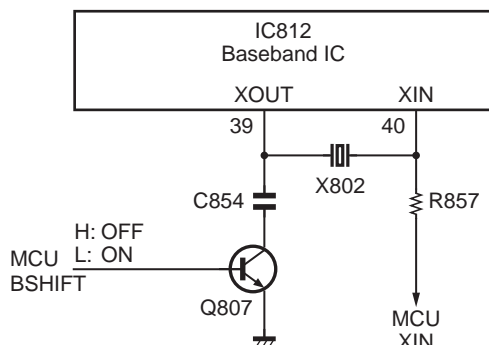

Fig. 7 Frequency shift circuit

5-2. Memory Circuit

The Memory circuit consists of the MCU (IC820) and EEPROM (IC810). The EEPROM has a capacity of 512k bits and stores the channel information, the last channel data, the scan on status, and other parameters.

■ EEPROM

Note:

The EEPROM stores tuning data (Deviation, Squelch, etc.).

Realign the transceiver after replacing the EEPROM.

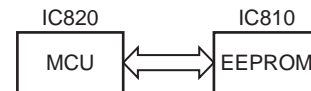

Fig. 8 Memory circuit

5-3. Low Battery Warning

The battery voltage is monitored by the MCU (IC820 pin 63: BATT). When the battery voltage falls below the voltage set by the Low Battery Warning adjustment, the red LED blinks, notifying the operator that it is time to replace the battery (when the always option (default setting) under the Battery Warning function in the FPU is selected). If the battery voltage falls below 5.9V, the transceiver does not transmit and the warning tone beeps while the PTT switch is pressed.

Low battery warning	Battery status
The red LED blinks during transmission.	The battery voltage is low but the transceiver is still usable.
The red LED blinks and the warning tone beeps while the PTT switch is pressed.	The battery voltage is low and the transceiver cannot be used to make calls.

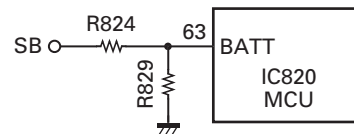

Fig. 9 Low battery warning

CIRCUIT DESCRIPTION

5-4. Key Input

Keys and channel selector circuit.

The signal from the keys and channel selector are directly input to the MCU, as shown in Figure 10.

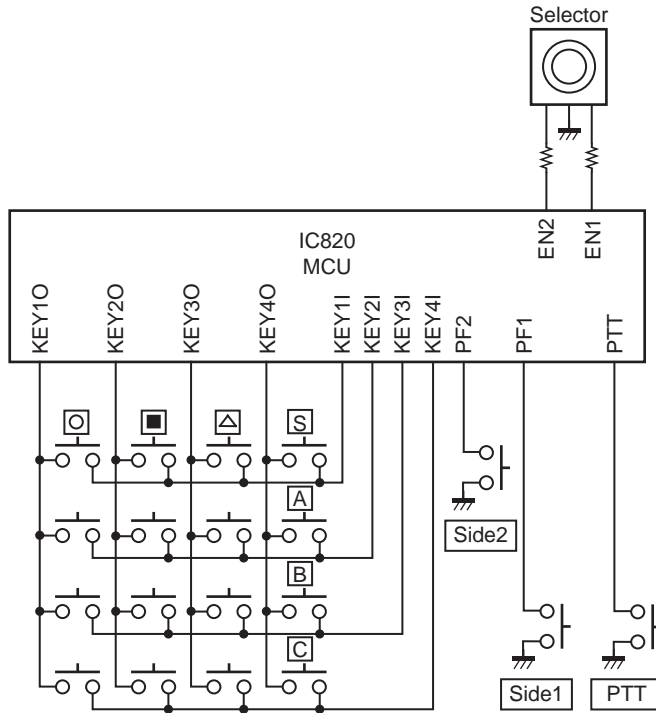

Fig. 10 Key input

6. Signaling Circuit

6-1. Encode

■ Low-speed data (QT, DQT)

Low-speed data is output from pin 2 of the MCU. The signal passes through the low pass CR filter, and goes to the baseband IC (IC812). The signal is mixed with the audio signal and goes to the VCO and TCXO (X1) modulation input after passing through the D/A converter inside the baseband IC (IC812) for BAL adjustment.

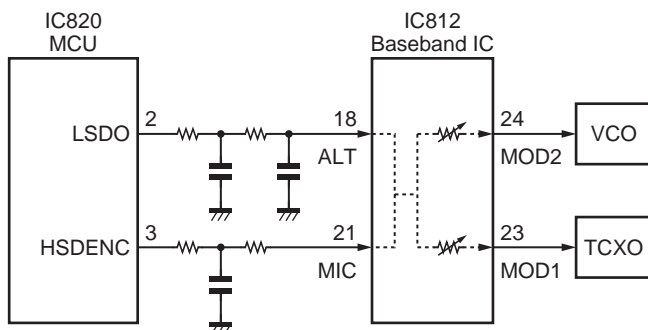

Fig. 11 Encode

■ High-speed data (2-tone)

High-speed data (HSD) is output from pin 3 of the MCU. HSD deviation made by an adjustment in the MCU is passed through the low pass CR filter and then applied to the baseband (IC812).

The signal is mixed with the audio signal and goes to the VCO and TCXO.

■ MSK/DTMF

The MSK/DTMF signal is generated in the baseband IC (IC812). The signal passes through the D/A converter (inside the audio processor: IC812) and is routed to the VCO. When encoding the MSK/DTMF, the microphone input signal is muted.

6-2. Decode

■ QT/DQT

The output signal from the IF IC (IC401) enters the MCU (IC820) through IC812. IC820 determines whether or not the QT or DQT matches the preset value, and controls the AFSW and speaker output sounds according to the squelch results.

■ 2-tone

Part of the received AF signal output from the IF IC (IC401) passes through the baseband IC (IC812) goes to the other AF amplifier IC808, is compared, and then goes to IC820. IC820 checks whether or not the 2-tone data is necessary. If it matches, IC820 carries out a specified operation, such as turning the speaker on.

■ MSK (FleetSync)

The MSK input signal from the IF IC (IC401) goes to IC812. The decoded information is then processed by the MCU.

■ DTMF

The DTMF input signal from the IF IC (IC401) goes to IC812. The decoded information is then processed by the MCU.

7. Power Supply

There are five 5V power supplies and three 3.3V power supplies: 50M, 50V, 50C, 50R, 50T, 33M, 33MS and 33B.

50M and 33M are always output while the power is on.

33MS is always output, but turns off when the power is turned off, to prevent malfunction of the MCU.

50C is a common 5V and is output when SAVE is not set to ON.

50R is 5V for reception and output during reception.

50T is 5V for transmission and output during transmission.

50V is 5V for the SP/MIC connector.

33B is 3.3V for the baseband IC (IC812).

SEMICONDUCTOR DATA

MCU: F363BEDFEKDL (TX-RX unit IC820)

Pin No.	Signal Name	I/O	Function
1	BSHIFT	O	CPU clock frequency shift
2	LSDO	O	QT/DQT output
3	HSDENC	O	2-Tone/BEEP output
4	EN1	I	Encoder detect for direction
5	EN2	I	Pull up for P8_4 (EN2)
6	MODE	I	(Using E8a emulator)
7	NC	-	NC
8	PL_CLK	O	PLL IC clock output
9	RESET	-	Hardware reset input
10	XOUT	-	NC
11	VSS	-	GND
12	XIN	-	Main clock input (19.2MHz)
13	VCC	-	3.3V
14	EMPTT	O	Emergency PTT
15	EN2	I	Encoder interrupt
16	CM_IRQ	I	Baseband IC IRQ
17	INT0	I	Battery low interrupt (4.5V)
18	PL_UL	I	PLL IC unlock input
19	PTT	I	PTT input
20	PL_STB	O	PLL IC STB output
21	PL_DAT	O	PLL IC data output
22	NC		NC
23	33MSC	O	33MS control for switched 33M
24	TXD	O	Serial data (FPU) to PC
25	RXD	I	Serial data (FPU) from PC
26	EM_CLK	O	For E8a emulator
27	APCSW	O	APC enable/disable
28	TX/RX	O	TX/RX switch H: TX, L: RX
29	50VC	O	5V AVR control for GPS MIC option/OPT DET
30	5TC	O	5T control output
31	EP_DTO	O	EEPROM IC data output
32	EP_CLK	O	EEPROM IC clock output
33	CM_DTO	O	Baseband IC data output
34	EMP	O	For FDT tool
35	5RC	O	5R control output
36	EP_WP	O	EEPROM IC write protect output
37	EP_DTI	I	EEPROM IC data input
38	EP_CS	O	EEPROM IC chip select output
39	CE	O	For FDT tool
40	CM_CLK	O	Baseband IC clock output

Pin No.	Signal Name	I/O	Function
41	CM_DTI	I	Baseband IC data input
42	CM_CNS	O	Baseband IC chip select output
43	DC_SW	O	APC voltage discharge switch
44	KEY1O	O	Key matrix output 1
45	KEY2O	O	Key matrix output 2
46	KEY3O	O	Key matrix output 3
47	KEY4O	O	Key matrix output 4
48	KEY1I	I	Key matrix input 1
49	KEY2I	I	Key matrix input 2
50	KEY3I	I	Key matrix input 3
51	KEY4I	I	Key matrix input 4
52	PF1	I	Side key 1 input
53	PF2	I	Side key 2 input
54	LCDBL	O	LCD backlight switch L: ON, H: OFF
55	LC_INH	O	LCD diver IC INH output
56	LC_CLK	O	LCD diver IC clock output
57	LC_DAT	O	LCD diver IC date output
58	LC_CE	O	LCD diver IC chip enable output
59	LC_MOD	O	LCD diver IC mode output
60	HSDDEC	I	2-Tone/5-Tone decode input
61	QT/DQT	I	QT/DQT decode input
62	CVIN	I	VCO lock voltage reading for auto alignment
63	BATT	I	Battery level input
64	VOX	I	VOX level input
65	BUSY	I	RX busy input
66	TH_DET	I	Temperature level input
67	RSSI	I	RSSI input
68	WID/NAR	O	Wide Narrow switch H: WID, L: NAR
69	ASSIST	O	Assist switch
70	AF_MUT	O	Speaker mute output
71	MIC_MT	O	Mic mute output
72	MAN_DN	I	MAN down
73	5CC	O	5C control output
74	LEDBLU	O	Blue LED light control
75	AVSS	-	GND
76	LEDGRN	O	Green LED light control
77	VREF	-	3.3V for A/D reference
78	AVCC	-	3.3V
79	LEDRED	O	Red LED light control
80	OPTDET	I	Option detection input

COMPONENTS DESCRIPTION

TX-RX unit (X57-7890-71)

Ref. No.	Use / Function	Operation / Condition
IC1	PLL IC	TX/RX 1st local
IC2,301	OP amplifier	CVIN/CVADJ amplifier
IC401	FM IC	RX FM system
IC402	Comparator	Narrow filter switching
IC801	5V AVR	50M
IC802	5V AVR	50C
IC803	5V AVR	50V
IC804	3.3V AVR	33M
IC805	Reset IC	Low battery level detector
IC806	3.3V AVR	33B
IC807	Reset IC	MCU reset signal
IC808	OP amplifier	HSD amplifier
IC810	EEPROM	EEPROM
IC811	OP amplifier	RX BPF tuning
IC812	Baseband IC	Audio processor
IC815	AF amplifier	Audio power amplifier
IC817	OP amplifier	VOX signal amplifier
IC820	MCU	Microcontroller unit
IC821	LCD driver	
Q2	RF buffer	PLL-IC input
Q3	Ripple filter	TX/RX VCO
Q4	Oscillator	RX VCO
Q5	Oscillator	TX VCO
Q6	DC switching	TX VCO switching
Q7	DC switching	RX VCO switching
Q8	RF buffer	VCO output
Q9	RF amplifier	VCO output
Q11,12	DC switching	Assist switching
Q201	RF amplifier	TX amplifier
Q203	RF amplifier	Pri-drive amplifier
Q204	FET amplifier	Drive amplifier
Q205	FET amplifier	Final power amplifier
Q301	DC switching	TX FET bias
Q303~306	DC switching	APC circuit
Q401	DC switching	Q404 control
Q403	Doubler	2nd local (19.2MHz x 2)
Q404	DC switching	FM-DET level switching
Q405	IF amplifier	1st IF (38.85MHz)
Q406	Mixer	1st mixer
Q407	RF amplifier	RX (UHF)
Q801	DC switching	Blue LED
Q802	DC switching	50T from 50M
Q803	DC switching	50R from 50M
Q804	DC switching	33MS from 33M

Ref. No.	Use / Function	Operation / Condition
Q805	DC switching	Green/Red LED
Q806	DC switching	MCU clock shift circuit
Q809	DC switching	MIC mute
Q810,811	Amplifier	AGC control
Q813	DC switching	Q814 control
Q814	DC switching	AF power mute
Q815	Level converter	EXT PTT/RXD
Q816	Level converter	EXT TXD
Q817	DC switching	Pop noise mute
Q818,819	AF switching	AF power mute
Q820	DC switching	Q821 control
Q821	DC switching	Backlight LED
Q822	DC switching	EMG PTT
D6,9	Varicap	TX VCO tune
D10,12	Varicap	RX VCO tune
D13	Speed up	Ripple filter
D14	Varicap	TX VCO assist tune
D15	Varicap	RX VCO assist tune
D16	Varicap	Modulation
D17,18	Switching	TX-f/RX 1st local
D201~204	Switching	TX/RX ANT switching
D301	5.1V zone	Over voltage prevention
D401,402	Switching	Narrow filter on/through
D403~405	Varicap	RX RF BPT tune
D407,408	Varicap	RX RF BPT tune
D801	LED (green)	Busy
D803	Protection	Power supply
D804	LED (blue)	Signal
D805	LED (red)	TX
D806	5.1V zener	Over voltage prevention
D807,808	Detection	MIC level
D809,810	Detection	VOX level
D817	Speed up	LCD back light
D818~821	LED (yellow)	Backlight
D824	LED (yellow)	Backlight
D829	Key input detect	Key1I input
D830	Key input detect	Key2I input
D831	Key input detect	Key3I input
D832	Key input detect	Key4I input

TK-3310

PARTS LIST

* New Parts. △ indicates safety critical components.

Parts without **Parts No.** are not supplied.

Les articles non mentionnés dans le **Parts No.** ne sont pas fournis.

Teile ohne **Parts No.** werden nicht geliefert.

L : Scandinavia

K : USA

P : Canada

Y : PX (Far East, Hawaii)

T : England

E : Europe

C : China

X : Australia

M : Other Areas

TK-3310

TX-RX UNIT (X57-7890-71)

Ref. No.	Address	New parts	Parts No.	Description	Destination	Ref. No.	Address	New parts	Parts No.	Description	Destination
TK-3310											
1	1A	*	A02-4188-03	PLASTIC CABINET ASSY		62	1B		T07-0787-05	SPEAKER	
3	2C		B09-0725-03	CAP(SP/MIC) ACCESSORY		63	2D		T90-1039-25	WHIP ANTENNA ACCESSORY	
4	1B	*	B43-1674-04	BADGE(FRONT)		64	1B		T91-0672-05	MIC ELEMENT	
5	1B	*	B43-1676-04	BADGE(REAR)		W1	2A		W02-3748-05	ENCODER(SELECTOR)	
7	1C	*	B62-2443-00	INSTRUCTION MANUAL		66	1C		W08-1249-35	CHARGER ACCESSORY	
9	2A		D10-0649-03	LEVER		67	1D	*	W08-1252-15	AC ADAPTER ACCESSORY	
10	1A		D21-0863-04	SHAFT(LEVER)		-		*	X60-4030-71	SERVICE TX-RX UNIT	
11	1A		D32-0441-13	STOPPER(LEVER)		TX-RX UNIT (X57-7890-71)					
13	2A		E04-0477-15	RF COAXIAL RECEPTACLE(SMA)		101	2B		B11-1876-03	ILLUMINATION GUIDE(LCD)	
14	3A		E23-1253-04	TERMINAL(GND)		102	2B		B11-1877-14	FILTER(LCD)	
15	2A		E23-1254-04	TERMINAL(+VE)		103	2B		B38-0935-05	LCD	
16	1B		E37-1165-15	PROCESSED LEAD WIRE(SP+/RED)		D801			B30-1790-05	LED(BLUE)	
17	1B		E37-1514-05	PROCESSED LEAD WIRE(SP-/BLK)		D804			B30-2314-05	LED(GREEN)	
19	3A		F20-3353-14	INSULATING SHEET(+VE)		D805			B30-2315-05	LED(RED)	
21	2A		G01-4542-04	COIL SPRING		D818-821			B30-2337-05	LED(YELLOW)	
22	2A		G01-4543-14	COIL SPRING		D824			B30-2337-05	LED(YELLOW)	
23	2B		G10-1330-04	FIBROUS SHEET(IC)		C1			CC73HCH1H101J	CHIP C 100PF J	
24	2A		G11-4465-04	RUBBER SHEET(FET)		C3			CC73HCH1H100B	CHIP C 10PF B	
25	2B		G11-4550-04	SHEET(ANT)		C4			CK73HB1H102K	CHIP C 1000PF K	
26	3A		G13-2009-04	CUSHION(CHASSIS)		C5			CC73HCH1H101J	CHIP C 100PF J	
27	3A		G13-2033-04	CUSHION(-VE)		C7			CC73HCH1H100B	CHIP C 10PF B	
28	3A		G13-2034-14	CUSHION(CHASSIS(-))		C8			CC73HCH1H101J	CHIP C 100PF J	
30	3B		G13-2340-14	CUSHION(CF401/402)		C9			CK73HB1E103K	CHIP C 0.010UF K	
31	2B		G13-2358-04	CUSHION(IC820)		C10			CC73HCH1H101J	CHIP C 100PF J	
35	3A		G53-1604-03	PACKING(CHASSIS)		C11			CK73HB1E103K	CHIP C 0.010UF K	
36	2A		G53-1605-03	PACKING(+VE)		C12			CC73HCH1H101J	CHIP C 100PF J	
37	2B		G53-1802-04	PACKING(SMA)		C14			CK73HB1A473K	CHIP C 0.047UF K	
39	2B		G53-1845-03	PACKING(VOL/SELECTOR)		C15			CK73HB1A224K	CHIP C 0.22UF K	
40	1B		G53-1846-03	PACKING(SPK)		C16, 17			CC73HCH1H101J	CHIP C 100PF J	
41	1B		G53-1847-03	PACKING(PHONE)		C18			CK73HB1E103K	CHIP C 0.010UF K	
46	2A		J19-5463-03	HOLDER(+VE)		C19			CC73HCH1H101J	CHIP C 100PF J	
47	2A		J19-5473-03	HOLDER ASSY(+VE)		C20			CK73HB1H471K	CHIP C 470PF K	
48	1B		J19-5545-14	HOLDER ASSY(SPK)		C21			CK73HB1E103K	CHIP C 0.010UF K	
49	2C		J19-5549-03	HOLDER(SP/MIC) ACCESSORY		C24	*		CS77BA1C1R5M	CHIP TNLT 1.5UF 16WV	
50	2C		J29-0734-05	BELT CLIP ACCESSORY		C25			CS77AA1V0R1M	CHIP TNLT 0.1UF 35WV	
52	2A		J82-0127-05	FPC		C27			CK73HB1A224K	CHIP C 0.22UF K	
54	1B		K29-9309-13	KNOB(VOL)		C28			CK73HB1H471K	CHIP C 470PF K	
55	1A		K29-9425-03	BUTTON KNOB(PTT)		C29			CC73HCH1H030B	CHIP C 3.0PF B	
56	1A		K29-9426-03	BUTTON KNOB(SIDE1/SIDE2)		C30			CC73HCH1H080B	CHIP C 8.0PF B	
57	1B		K29-9427-03	KNOB(SELECTOR)		C33			CC73HCH1H080B	CHIP C 8.0PF B	
58	1A		K29-9463-12	KEY TOP(7KEY)		C34			CC73HCH1H100B	CHIP C 10PF B	
A	2A		N14-0848-05	CIRCULAR NUT(SELECTOR)		C35			CK73HB1E103K	CHIP C 0.010UF K	
B	2B		N14-0849-05	CIRCULAR NUT(VOL)		C37, 38			CK73HB1A104K	CHIP C 0.10UF K	
C	2A		N30-2604-48	PAN HEAD MACHINE SCREW(SMA)		C39			CK73HB1H471K	CHIP C 470PF K	
D	3A		N30-2606-48	PAN HEAD MACHINE SCREW		C41			CC73HCH1H101J	CHIP C 100PF J	
E	2B,3A		N83-2005-48	PAN HEAD TAPTITE SCREW		C43			CC73HCH1H101J	CHIP C 100PF J	
60	2C		N99-2046-05	SCREW SET ACCESSORY		C44			CK73HB1H471K	CHIP C 470PF K	
VR1	2A		R31-0676-05	VARIABLE RESISTOR(VOL)		C47			CC73HCH1H470J	CHIP C 47PF J	
						C48			CC73HCH1H090B	CHIP C 9.0PF B	
						C49			CK73HB1H471K	CHIP C 470PF K	
						C50			CK73HB1A104K	CHIP C 0.10UF K	

PARTS LIST

TX-RX UNIT (X57-7890-71)

Ref. No.	Address	New parts	Parts No.	Description	Destination	Ref. No.	Address	New parts	Parts No.	Description	Destination
C51			CC73HCH1H560J	CHIP C 56PF J		C247			CC73GCH1H101J	CHIP C 100PF J	
C53			CC73HCH1H110J	CHIP C 11PF J		C248			CC73GCH1HR75B	CHIP C 0.75PF B	
C55			CK73FB0J106K	CHIP C 10UF K		C249			CC73GCH1H3R5B	CHIP C 3.5PF B	
C57			CC73HCH1H1R5B	CHIP C 1.5PF B		C250			CC73GCH1H060B	CHIP C 6.0PF B	
C58			CC73HCH1H020B	CHIP C 2.0PF B		C253			CC73GCH1H0R3B	CHIP C 0.3PF B	
C59			CC73HCH1H060B	CHIP C 6.0PF B		C255			CC73GCH1H070B	CHIP C 7.0PF B	
C60			CC73HCH1H020B	CHIP C 2.0PF B		C256			CC73GCH1H1R5B	CHIP C 1.5PF B	
C61			CC73HCH1H040B	CHIP C 4.0PF B		C257			CC73GCH1H2R5B	CHIP C 2.5PF B	
C62 ,63			CC73HCH1H101J	CHIP C 100PF J		C258			CC73HCH1H050B	CHIP C 5.0PF B	
C64			CC73HCH1H070B	CHIP C 7.0PF B		C259			CC73GCH1H1R5B	CHIP C 1.5PF B	
C65			CC73HCH1H030B	CHIP C 3.0PF B		C260			CC73GCH1H150J	CHIP C 15PF J	
C66			CC73HCH1H0R3B	CHIP C 0.3PF B		C262,263			CC73GCH1H120J	CHIP C 12PF J	
C67			CC73HCH1H0R5B	CHIP C 0.5PF B		C264			CK73HB1H471K	CHIP C 470PF K	
C68 ,69			CC73HCH1H101J	CHIP C 100PF J		C265			CC73HCH1H040B	CHIP C 4.0PF B	
C70			CK73HB1H471K	CHIP C 470PF K		C266			CK73HB1A105K	CHIP C 1.0UF K	
C71			CC73HCH1H330J	CHIP C 33PF J		C301			CK73HB1A104K	CHIP C 0.10UF K	
C72			CC73HCH1H100B	CHIP C 10PF B		C302			CK73HB1H471K	CHIP C 470PF K	
C73			CC73HCH1H150J	CHIP C 15PF J		C303			CK73FB1C105K	CHIP C 1.0UF K	
C74 ,75			CK73HB1H471K	CHIP C 470PF K		C304			CK73HB1H471K	CHIP C 470PF K	
C76			CK73HB1A104K	CHIP C 0.10UF K		C305			CC73HCH1H101J	CHIP C 100PF J	
C77			CC73HCH1H130J	CHIP C 13PF J		C307			CC73HCH1H470J	CHIP C 47PF J	
C78			CK73HB1A105K	CHIP C 1.0UF K		C308			CC73HCH1H100B	CHIP C 10PF B	
C81			CC73HCH1H010B	CHIP C 1.0PF B		C309			CK73HB1H471K	CHIP C 470PF K	
C85			CC73HCH1H080B	CHIP C 8.0PF B		C311			CK73HB1H471K	CHIP C 470PF K	
C86			CC73HCH1H050B	CHIP C 5.0PF B		C314			CK73HB1H471K	CHIP C 470PF K	
C87			CK73HB1H471K	CHIP C 470PF K		C315			CK73HB1H102K	CHIP C 1000PF K	
C88			CC73HCH1H050B	CHIP C 5.0PF B		C402-407			CK73HB1A104K	CHIP C 0.10UF K	
C201			CC73HCH1H330J	CHIP C 33PF J		C408			CC73HCH1H330J	CHIP C 33PF J	
C203			CK73HB1H471K	CHIP C 470PF K		C409			CK73HB1E103K	CHIP C 0.010UF K	
C204			CK73HB1A104K	CHIP C 0.10UF K		C410			CC73HCH1H560J	CHIP C 56PF J	
C205			CK73HB1H471K	CHIP C 470PF K		C411			CC73HCH1H820J	CHIP C 82PF J	
C209			CC73HCH1H330J	CHIP C 33PF J		C412			CK73HB1H471K	CHIP C 470PF K	
C210			CK73GB1A224K	CHIP C 0.22UF K		C414			CK73HB1A104K	CHIP C 0.10UF K	
C211			CK73HB1H471K	CHIP C 470PF K		C415			CC73HCH1H390J	CHIP C 39PF J	
C212			CK73HB1A105K	CHIP C 1.0UF K		C416			CC73HCH1H820J	CHIP C 82PF J	
C213			CK73HB1H471K	CHIP C 470PF K		C417			CK73HB1H471K	CHIP C 470PF K	
C214			CK73HB1A105K	CHIP C 1.0UF K		C418			CK73HB1A104K	CHIP C 0.10UF K	
C215			CC73HCH1H110J	CHIP C 11PF J		C419			CC73HCH1H560J	CHIP C 56PF J	
C216			CK73HB1A105K	CHIP C 1.0UF K		C420			CK73HB1E1182K	CHIP C 1800PF K	
C217			CC73HCH1H101J	CHIP C 100PF J		C421			CK73HB1H681K	CHIP C 680PF K	
C218			CC73HCH1H130J	CHIP C 13PF J		C422,423			CK73GB0J106K	CHIP C 10UF K	
C219			CK73HB1H471K	CHIP C 470PF K		C424			CC73HCH1H560J	CHIP C 56PF J	
C220			CC73HCH1H150J	CHIP C 15PF J		C425			CK73HB1E103K	CHIP C 0.010UF K	
C221			CK73HB1H471K	CHIP C 470PF K		C426			CK73HB1H471K	CHIP C 470PF K	
C222			CC73HCH1H101J	CHIP C 100PF J		C427			CK73HB1A104K	CHIP C 0.10UF K	
C223-225			CK73HB1H471K	CHIP C 470PF K		C428			CK73HB1A333K	CHIP C 0.033UF K	
C226			CC73HCH1H300J	CHIP C 30PF J		C429			CK73HB1H471K	CHIP C 470PF K	
C227			CC73GCH1H240J	CHIP C 24PF J		C431			CK73HB1A104K	CHIP C 0.10UF K	
C228			CC73GCH1H0R3B	CHIP C 0.3PF B		C433			CK73HB1E103K	CHIP C 0.010UF K	
C229,230			CC73HCH1H151J	CHIP C 150PF J		C435			CK73HB1E103K	CHIP C 0.010UF K	
C233			CK73GB1C104K	CHIP C 0.10UF K		C436			CC73HCH1H020B	CHIP C 2.0PF B	
C234			CK73GB1A105K	CHIP C 1.0UF K		C437			CC73HCH1H220J	CHIP C 22PF J	
C235			CK73HB1E103K	CHIP C 0.010UF K		C439			CK73HB1E103K	CHIP C 0.010UF K	
C236			CC73GCH1H0R3B	CHIP C 0.3PF B		C440,441			CK73HB1H471K	CHIP C 470PF K	
C240			CC73GCH1H2R5B	CHIP C 2.5PF B		C443			CK73HB1E103K	CHIP C 0.010UF K	
C242			CC73GCH1H060B	CHIP C 6.0PF B		C445			CC73HCH1H120J	CHIP C 12PF J	
C243			CC73GCH1H471J	CHIP C 470PF J		C446			CC73HCH1H070B	CHIP C 7.0PF B	
C244			CK73HB1H471K	CHIP C 470PF K		C447			CC73HCH1H1R5B	CHIP C 1.5PF B	
C245			CC73HCH1H090B	CHIP C 9.0PF B		C448			CC73HCH1H050B	CHIP C 5.0PF B	
C246			CC73GCH1H060B	CHIP C 6.0PF B		C449			CK73HB1E103K	CHIP C 0.010UF K	

PARTS LIST

TX-RX UNIT (X57-7890-71)

Ref. No.	Address	New parts	Parts No.	Description	Desti-nation	Ref. No.	Address	New parts	Parts No.	Description	Desti-nation
C450			CC73HCH1H010B	CHIP C 1.0PF B		C858			CK73HB1E682K	CHIP C 6800PF K	
C451,452			CK73HB1H471K	CHIP C 470PF K		C859			CK73HB1A105K	CHIP C 1.0UF K	
C453			CC73HCH1H110J	CHIP C 11PF J		C861			CK73HB1H102K	CHIP C 1000PF K	
C454,455			CK73HB1H471K	CHIP C 470PF K		C863			CK73HB1E103K	CHIP C 0.010UF K	
C457			CC73HCH1H2R5B	CHIP C 2.5PF B		C865			CK73HB1H471K	CHIP C 470PF K	
C458			CC73HCH1H110J	CHIP C 11PF J		C866			CK73GB0J106K	CHIP C 10UF K	
C459			CC73HCH1HR75B	CHIP C 0.75PF B		C869			CK73GB0J106K	CHIP C 10UF K	
C460			CK73HB1H471K	CHIP C 470PF K		C872			CK73HB1H102K	CHIP C 1000PF K	
C461			CC73HCH1H010B	CHIP C 1.0PF B		C873			CK73HB1E103K	CHIP C 0.010UF K	
C462			CK73HB1H471K	CHIP C 470PF K		C874			CK73HB1A104K	CHIP C 0.10UF K	
C463			CC73HCH1H030B	CHIP C 3.0PF B		C876			CK73GB0J106K	CHIP C 10UF K	
C464			CC73HCH1H110J	CHIP C 11PF J		C877			CK73HB1H102K	CHIP C 1000PF K	
C465			CK73HB1H471K	CHIP C 470PF K		C878			CK73HB1H103K	CHIP C 0.010UF K	
C466,467			CC73HCH1H020B	CHIP C 2.0PF B		C879			CK73GB0J106K	CHIP C 10UF K	
C468			CC73HCH1H110J	CHIP C 11PF J		C881			CK73HB1A104K	CHIP C 0.10UF K	
C469			CC73HCH1H020B	CHIP C 2.0PF B		C882			CK73HB1H102K	CHIP C 1000PF K	
C470			CK73HB1H471K	CHIP C 470PF K		C883			CK73HB1H152K	CHIP C 1500PF K	
C474,475			CK73HB1H471K	CHIP C 470PF K		C884			CK73HB1A105K	CHIP C 1.0UF K	
C477			CK73HB1A104K	CHIP C 0.10UF K		C885			CC73HCH1H181J	CHIP C 180PF J	
C478			CK73HB1H471K	CHIP C 470PF K		C886			CC73HCH1H221J	CHIP C 220PF J	
C479			CC73HCH1H0R3B	CHIP C 0.3PF B		C887			CC73HCH1H121J	CHIP C 120PF J	
C480			CC73HCH1H110J	CHIP C 11PF J		C890,891			CK73HB1H391K	CHIP C 390PF K	
C481			CK73HB1H471K	CHIP C 470PF K		C892			CK73HB1A105K	CHIP C 1.0UF K	
C482			CC73HCH1H1R5B	CHIP C 1.5PF B		C893			CK73HB0J475M	CHIP C 4.7UF M	
C484			CC73HCH1H030B	CHIP C 3.0PF B		C894			CK73HB1A105K	CHIP C 1.0UF K	
C485			CC73HCH1H110J	CHIP C 11PF J		C896			CK73HB1A104K	CHIP C 0.10UF K	
C486			CC73HCH1H010B	CHIP C 1.0PF B		C897,898			CK73HB1A474K	CHIP C 0.47UF K	
C487			CC73HCH1H300J	CHIP C 30PF J		C899,900			CK73HB1H471K	CHIP C 470PF K	
C489			CC73HCH1H060B	CHIP C 6.0PF B		C901			CK73HB1A474K	CHIP C 0.47UF K	
C492			CK73HB1H471K	CHIP C 470PF K		C902,903			CK73GB0J225K	CHIP C 2.2UF K	
C495			CK73HB1H471K	CHIP C 470PF K		C904			CK73HB1A474K	CHIP C 0.47UF K	
C496			CK73HB1A104K	CHIP C 0.10UF K		C905,906			CK73HB1H471K	CHIP C 470PF K	
C497			CC73HCH1H2R5B	CHIP C 2.5PF B		C907			CC73HCH1H470J	CHIP C 47PF J	
C803,804			CK73HB1H102K	CHIP C 1000PF K		C909			CK73HB1A104K	CHIP C 0.10UF K	
C806,807			CK73HB1H102K	CHIP C 1000PF K		C910			CK73HB1A683K	CHIP C 0.068UF K	
C808,809			CK73GB1A105K	CHIP C 1.0UF K		C911			CK73GB0J106K	CHIP C 10UF K	
C810,811			CK73HB1H102K	CHIP C 1000PF K		C912			CK73HB1H102K	CHIP C 1000PF K	
C812-816			CK73GB1A105K	CHIP C 1.0UF K		C913			CK73HB1H332K	CHIP C 3300PF K	
C818,819			CK73HB1H102K	CHIP C 1000PF K		C914,915			CK73HB1A105K	CHIP C 1.0UF K	
C821			CK73HB1H102K	CHIP C 1000PF K		C916-919			CK73HB1H102K	CHIP C 1000PF K	
C823			CK73GB1A105K	CHIP C 1.0UF K		C920			CK73GB1A105K	CHIP C 1.0UF K	
C825			CK73HB1A105K	CHIP C 1.0UF K		C921			CC73HCH1H101J	CHIP C 100PF J	
C826			CK73HB1A104K	CHIP C 0.10UF K		C922			CK73HB1A104K	CHIP C 0.10UF K	
C828			CK73GB1A105K	CHIP C 1.0UF K		C923			CK73FB0J106K	CHIP C 10UF K	
C829			CK73HB1E103K	CHIP C 0.010UF K		C924			CC73HCH1H101J	CHIP C 100PF J	
C831			CK73GB0J106K	CHIP C 10UF K		C925			CK73HB1A473J	CHIP C 0.047UF J	
C832			CK73HB1A104K	CHIP C 0.10UF K		C926	*		CS77MCOJ101M	CHIP TNTL 100UF 6.3WV	
C833			CK73HB1H471K	CHIP C 470PF K		C929			CK73HB1H471K	CHIP C 470PF K	
C834			CK73HB1H102K	CHIP C 1000PF K		C930			CK73HB1H102K	CHIP C 1000PF K	
C837			CK73HB1H102K	CHIP C 1000PF K		C931,932			CK73HB1H471K	CHIP C 470PF K	
C840			CK73HB1H332K	CHIP C 3300PF K		C936			CK73HB1H102K	CHIP C 1000PF K	
C842			CK73HB1H392K	CHIP C 3900PF K		C945			CK73HB1A104K	CHIP C 0.10UF K	
C843			CK73HB1H102K	CHIP C 1000PF K		C946			CK73HB1A105K	CHIP C 1.0UF K	
C844			CK73HB1A104K	CHIP C 0.10UF K		C947			CK73HB1H471K	CHIP C 470PF K	
C848			CK73HB1H271K	CHIP C 270PF K		C948,949			CK73HB1H102K	CHIP C 1000PF K	
C849			CK73HB1A104K	CHIP C 0.10UF K		C950			CK73HB0J105K	CHIP C 1.0UF K	
C850			CK73HB1H102K	CHIP C 1000PF K		C951			CK73HB1H102K	CHIP C 1000PF K	
C852			CK73HB1A104K	CHIP C 0.10UF K		C964,965			CK73GB1C225K	CHIP C 2.2UF K	
C854			CC73HCH1H050B	CHIP C 5.0PF B							
C857			CK73HB1H332K	CHIP C 3300PF K							

PARTS LIST

TX-RX UNIT (X57-7890-71)

Ref. No.	Address	New parts	Parts No.	Description	Destination	Ref. No.	Address	New parts	Parts No.	Description	Destination
105	2B		E29-1229-15	INTER CONNECTOR(LCD)		L418,419			L41-8268-14	SMALL FIXED INDUCTOR(8.2NH)	
CN801			E40-6827-05	FLAT CABLE CONNECTOR		L445			L33-2538-05	SMALL FIXED INDUCTOR(91NH)	
J802			E11-0703-05	PHONE JACK(EXT SP/MIC)		L491			L41-8268-14	SMALL FIXED INDUCTOR(8.2NH)	
F801			F53-0324-15	FUSE(2.5A)		L801			L92-0472-05	CHIP FERRITE	
F802			F53-0319-15	FUSE(1A)		L802,803			L92-0161-05	BEADS CORE	
107	2B		G11-4525-14	SHEET(LCD)		X1			L77-3055-05	TCXO(19.2MHZ)	
109	1B		J21-8619-03	MOUNTING HARDWARE(LCD)		X802			L78-1434-05	RESONATOR(19.2MHZ)	
CD401			L79-1866-05	TUNING COIL		XF401			L71-0637-15	MCF(38.85MHZ)	
CF401			L72-1045-05	CERAMIC FILTER(450K)		CP1			RK74HB1J101J	CHIP-COM 100 J 1/16W	
CF402			L72-1010-05	CERAMIC FILTER(450K)		CP802			RK75HA1J102J	CHIP-COM 1.0K J 1/16W	
L1			L41-4795-39	SMALL FIXED INDUCTOR(4.7UH)		CP812			RK75HA1J102J	CHIP-COM 1.0K J 1/16W	
L2			L40-1575-57	SMALL FIXED INDUCTOR(15.0NH)		CP814			RK75HA1J474J	CHIP-COM 470K J 1/16W	
L4			L92-0163-05	BEADS CORE		CP817			RK75HA1J473J	CHIP-COM 47K J 1/16W	
L5			L40-3391-86	SMALL FIXED INDUCTOR(3.3UH)		CP818-821			RK74HB1J103J	CHIP-COM 10K J 1/16W	
L7			L40-1891-86	SMALL FIXED INDUCTOR(1.8UH)		CP823			RK74HB1J103J	CHIP-COM 10K J 1/16W	
L8			L40-3391-86	SMALL FIXED INDUCTOR(3.3UH)		CP826			RK74HB1J103J	CHIP-COM 10K J 1/16W	
L10			L40-2285-92	SMALL FIXED INDUCTOR(220NH)		CP827,828			RK75HA1J473J	CHIP-COM 47K J 1/16W	
L11			L40-1891-86	SMALL FIXED INDUCTOR(1.8UH)		CP836,837			RK75HA1J102J	CHIP-COM 1.0K J 1/16W	
L14			L40-2285-92	SMALL FIXED INDUCTOR(220NH)		CP840-844			RK75HA1J103J	CHIP-COM 10K J 1/16W	
L15			L41-1578-14	SMALL FIXED INDUCTOR(15NH)		CP845,846			RK75HA1J472J	CHIP-COM 4.7K J 1/16W	
L16			L92-0163-05	BEADS CORE		CP847			RK75HA1J473J	CHIP-COM 47K J 1/16W	
L17			L41-1878-14	SMALL FIXED INDUCTOR(18NH)		R1			RK73HB1J000J	CHIP R 0 J 1/16W	
L18 ,19			L40-3391-86	SMALL FIXED INDUCTOR(3.3UH)		R2			RK73HB1J473J	CHIP R 47K J 1/16W	
L20			L40-2775-71	SMALL FIXED INDUCTOR(27NH)		R5			RK73HB1J103J	CHIP R 10K J 1/16W	
L21			L40-2775-57	SMALL FIXED INDUCTOR(27.0NH)		R6			RK73HB1J000J	CHIP R 0 J 1/16W	
L22 ,23			L40-2785-92	SMALL FIXED INDUCTOR(270NH)		R7			RK73HB1J683J	CHIP R 68K J 1/16W	
L25			L40-6865-71	SMALL FIXED INDUCTOR(6.8NH)		R8			RK73HB1J331J	CHIP R 330 J 1/16W	
L27			L40-2275-57	SMALL FIXED INDUCTOR(22.0NH)		R9			RK73HB1J101J	CHIP R 100 J 1/16W	
L201			L40-6865-71	SMALL FIXED INDUCTOR(6.8NH)		R10			RK73HB1J122J	CHIP R 1.2K J 1/16W	
L202			L40-3975-71	SMALL FIXED INDUCTOR(39NH)		R11			RK73HB1J103J	CHIP R 10K J 1/16W	
L203			L40-1275-71	SMALL FIXED INDUCTOR(12NH)		R13			RK73HB1J102J	CHIP R 1.0K J 1/16W	
L204			L40-1575-71	SMALL FIXED INDUCTOR(15NH)		R14			RK73HB1J273J	CHIP R 27K J 1/16W	
L205			L92-0162-05	BEADS CORE		R15 ,16			RK73HB1J100J	CHIP R 10 J 1/16W	
L206			L40-1075-71	SMALL FIXED INDUCTOR(10NH)		R17			RK73HB1J000J	CHIP R 0 J 1/16W	
L207			L34-4574-05	AIR-CORE COIL		R18			RK73HB1J152J	CHIP R 1.5K J 1/16W	
L208			L92-0149-05	CHIP FERRITE		R19			RK73HB1J391J	CHIP R 390 J 1/16W	
L210			L92-0149-05	CHIP FERRITE		R20 -22			RK73HB1J000J	CHIP R 0 J 1/16W	
L211			L34-4565-05	AIR-CORE COIL		R26			RK73HB1J105J	CHIP R 1.0M J 1/16W	
L216			L41-2285-43	SMALL FIXED INDUCTOR(220NH)		R27			RK73HB1J103J	CHIP R 10K J 1/16W	
L217			L34-4564-05	AIR-CORE COIL		R28			RK73HB1J000J	CHIP R 0 J 1/16W	
L218			L40-1863-92	SMALL FIXED INDUCTOR(1.8NH)		R29			RK73HB1J474J	CHIP R 470K J 1/16W	
L219			L34-4563-05	AIR-CORE COIL		R30			RK73HB1J220J	CHIP R 22 J 1/16W	
L220			L34-4565-05	AIR-CORE COIL		R31			RK73HB1J106J	CHIP R 10M J 1/16W	
L221			L34-4564-05	AIR-CORE COIL		R37			RK73HB1J472J	CHIP R 4.7K J 1/16W	
L302			L92-0138-05	CHIP FERRITE		R39			RK73HB1J154J	CHIP R 150K J 1/16W	
L401			L40-1885-92	SMALL FIXED INDUCTOR(180NH)		R40			RK73HB1J104J	CHIP R 100K J 1/16W	
L402			L40-1085-57	SMALL FIXED INDUCTOR(100NH)		R41			RK73HB1J221J	CHIP R 220 J 1/16W	
L403			L40-1591-86	SMALL FIXED INDUCTOR(1.5UH)		R42			RK73HB1J151J	CHIP R 150 J 1/16W	
L406			L92-0138-05	CHIP FERRITE		R43			RK73HB1J104J	CHIP R 100K J 1/16W	
L407			L41-6885-39	SMALL FIXED INDUCTOR(0.68UH)		R44 ,45			RK73HB1J100J	CHIP R 10 J 1/16W	
L408			L40-1575-57	SMALL FIXED INDUCTOR(15.0NH)		R46			RK73HB1J154J	CHIP R 150K J 1/16W	
L409			L40-1085-92	SMALL FIXED INDUCTOR(100NH)		R47			RK73HB1J101J	CHIP R 100 J 1/16W	
L410			L40-1575-57	SMALL FIXED INDUCTOR(15.0NH)		R48			RK73HB1J682J	CHIP R 6.8K J 1/16W	
L411			L40-2775-92	SMALL FIXED INDUCTOR(27NH)		R49			RK73HB1J562J	CHIP R 5.6K J 1/16W	
L413,414			L41-8268-14	SMALL FIXED INDUCTOR(8.2NH)		R50			RK73HB1J220J	CHIP R 22 J 1/16W	
L415			L92-0138-05	CHIP FERRITE		R51			RK73HB1J331J	CHIP R 330 J 1/16W	
L416			L41-2785-14	SMALL FIXED INDUCTOR(270NH)		R52			RK73HB1J222J	CHIP R 2.2K J 1/16W	
						R53			RK73HB1J472J	CHIP R 4.7K J 1/16W	

PARTS LIST

TX-RX UNIT (X57-7890-71)

Ref. No.	Address	New parts	Parts No.	Description	Destination	Ref. No.	Address	New parts	Parts No.	Description	Destination
R56,57			RK73HB1J000J	CHIP R 0 J 1/16W		R416			RK73HB1J561J	CHIP R 560 J 1/16W	
R58			RK73HB1J104J	CHIP R 100K J 1/16W		R417			RK73HB1J684J	CHIP R 680K J 1/16W	
R60			RK73HB1J102J	CHIP R 1.0K J 1/16W		R419			RK73HB1J334J	CHIP R 330K J 1/16W	
R62			RK73HB1J154J	CHIP R 150K J 1/16W		R421,422			RK73HB1J332J	CHIP R 3.3K J 1/16W	
R63			RK73HB1J102J	CHIP R 1.0K J 1/16W		R423			RK73HB1J222J	CHIP R 2.2K J 1/16W	
R67			RK73HB1J103J	CHIP R 10K J 1/16W		R424			RK73HB1J182J	CHIP R 1.8K J 1/16W	
R68			RK73HB1J000J	CHIP R 0 J 1/16W		R425			RK73HB1J000J	CHIP R 0 J 1/16W	
R97			RK73HB1J000J	CHIP R 0 J 1/16W		R426			RK73HB1J100J	CHIP R 10 J 1/16W	
R98			RK73HB1J474J	CHIP R 470K J 1/16W		R427			RK73HB1J823J	CHIP R 82K J 1/16W	
R99			RK73HB1J000J	CHIP R 0 J 1/16W		R428			RK73HB1J000J	CHIP R 0 J 1/16W	
R104,105			RK73HB1J103J	CHIP R 10K J 1/16W		R429			RK73HB1J101J	CHIP R 100 J 1/16W	
R201			RK73HB1J472J	CHIP R 4.7K J 1/16W		R433			RK73HB1J684J	CHIP R 680K J 1/16W	
R203			RK73HB1J102J	CHIP R 1.0K J 1/16W		R434			RK73HB1J391J	CHIP R 390 J 1/16W	
R205			RK73HB1J101J	CHIP R 100 J 1/16W		R435			RK73HB1J391J	CHIP R 390 J 1/16W	
R206			RK73HB1J822J	CHIP R 8.2K J 1/16W		R436			RK73HB1J470J	CHIP R 47 J 1/16W	
R207			RK73HB1J101J	CHIP R 100 J 1/16W		R437			RK73HB1J472J	CHIP R 4.7K J 1/16W	
R209			RK73HB1J101J	CHIP R 100 J 1/16W		R438			RK73HB1J222J	CHIP R 2.2K J 1/16W	
R211			RK73HB1J271J	CHIP R 270 J 1/16W		R439			RK73HB1J391J	CHIP R 390 J 1/16W	
R212			RK73HB1J152J	CHIP R 1.5K J 1/16W		R440			RK73HB1J563J	CHIP R 56K J 1/16W	
R213			RK73HB1J182J	CHIP R 1.8K J 1/16W		R441			RK73HB1J104J	CHIP R 100K J 1/16W	
R214			RK73HB1J220J	CHIP R 22 J 1/16W		R442			RK73HB1J000J	CHIP R 0 J 1/16W	
R215,216			RK73HB1J471J	CHIP R 470 J 1/16W		R443			RK73HB1J563J	CHIP R 56K J 1/16W	
R217			RK73HB1J100J	CHIP R 10 J 1/16W		R444			RK73HB1J104J	CHIP R 100K J 1/16W	
R218			RK73HB1J471J	CHIP R 470 J 1/16W		R445			RK73HB1J000J	CHIP R 0 J 1/16W	
R219			RK73HB1J183J	CHIP R 18K J 1/16W		R446			RK73HB1J474J	CHIP R 470K J 1/16W	
R220			RK73HB1J151J	CHIP R 150 J 1/16W		R447			RK73HB1J222J	CHIP R 2.2K J 1/16W	
R221			RK73HB1J273J	CHIP R 27K J 1/16W		R448			RK73HB1J000J	CHIP R 0 J 1/16W	
R222			RK73HB1J000J	CHIP R 0 J 1/16W		R449			RK73HB1J331J	CHIP R 330 J 1/16W	
R224			RK73HB1J183J	CHIP R 18K J 1/16W		R450,451			RK73HB1J474J	CHIP R 470K J 1/16W	
R226			RK73HB1J150J	CHIP R 15 J 1/16W		R452			RK73HB1J104J	CHIP R 100K J 1/16W	
R227			RK73GB2A000J	CHIP R 0 J 1/10W		R453			RK73HB1J824J	CHIP R 820K J 1/16W	
R228			RK73HB1J183J	CHIP R 18K J 1/16W		R454			RK73HB1J000J	CHIP R 0 J 1/16W	
R231			RK73FB2B000J	CHIP R 0 J 1/8W		R455			RK73HB1J104J	CHIP R 100K J 1/16W	
R232,233			RK73HB1J271J	CHIP R 270 J 1/16W		R456			RK73HB1J154J	CHIP R 150K J 1/16W	
R235			RK73GB2A823J	CHIP R 82K J 1/10W		R457-459			RK73HB1J000J	CHIP R 0 J 1/16W	
R237			RK73HB1J000J	CHIP R 0 J 1/16W		R461,462			RK73HB1J474J	CHIP R 470K J 1/16W	
R239			RK73GB2A000J	CHIP R 0 J 1/10W		R463			RK73HB1J000J	CHIP R 0 J 1/16W	
R301			RK73HB1J000J	CHIP R 0 J 1/16W		R467			RK73HB1J000J	CHIP R 0 J 1/16W	
R303			RK73HB1J561J	CHIP R 560 J 1/16W		R469,470			RK73HB1J333J	CHIP R 33K J 1/16W	
R304			RK73HB1J000J	CHIP R 0 J 1/16W		R471			RK73HB1J272J	CHIP R 2.7K J 1/16W	
R305			RK73HB1J333J	CHIP R 33K J 1/16W		R481			RK73HB1J474J	CHIP R 470K J 1/16W	
R306			RK73HB1J472J	CHIP R 4.7K J 1/16W		R701-704			RK73HB1J473J	CHIP R 47K J 1/16W	
R307			RK73EB2ER39K	CHIP R 0.39 K 1/4W		R705-712			RK73HB1J102J	CHIP R 1.0K J 1/16W	
R308			RK73HB1J182J	CHIP R 1.8K J 1/16W		R713,714			RK73HB1J472J	CHIP R 4.7K J 1/16W	
R309,310			RK73EB2ER39K	CHIP R 0.39 K 1/4W		R802			RK73GB2A221J	CHIP R 220 J 1/10W	
R311,312			RK73HH1J154D	CHIP R 150K D 1/16W		R803			RK73HB1J473J	CHIP R 47K J 1/16W	
R313,314			RK73HH1J474D	CHIP R 470K D 1/16W		R804,805			RK73HB1J104J	CHIP R 100K J 1/16W	
R315			RK73HB1J103J	CHIP R 10K J 1/16W		R806,807			RK73HB1J000J	CHIP R 0 J 1/16W	
R316			RK73HB1J563J	CHIP R 56K J 1/16W		R810			RK73HB1J104J	CHIP R 100K J 1/16W	
R317			RK73HB1J000J	CHIP R 0 J 1/16W		R811			RK73GB2A271J	CHIP R 270 J 1/10W	
R318			RK73HB1J474J	CHIP R 470K J 1/16W		R813			RK73HB1J473J	CHIP R 47K J 1/16W	
R319			RK73HB1J224J	CHIP R 220K J 1/16W		R814-816			RK73HB1J104J	CHIP R 100K J 1/16W	
R320			RK73HB1J105J	CHIP R 1.0M J 1/16W		R817			RK73HB1J223J	CHIP R 22K J 1/16W	
R406			RK73HB1J182J	CHIP R 1.8K J 1/16W		R818			RK73GB2A331J	CHIP R 330 J 1/10W	
R408			RK73HB1J103J	CHIP R 10K J 1/16W		R819,820			RK73HB1J104J	CHIP R 100K J 1/16W	
R409			RK73HB1J153J	CHIP R 15K J 1/16W		R821			RK73HB1J473J	CHIP R 47K J 1/16W	
R410			RK73HB1J334J	CHIP R 330K J 1/16W		R822			RK73HB1J102J	CHIP R 1.0K J 1/16W	
R411			RK73HB1J103J	CHIP R 10K J 1/16W		R824			RK73HH1J824D	CHIP R 820K D 1/16W	
R414			RK73HB1J101J	CHIP R 100 J 1/16W		R829			RK73HH1J394D	CHIP R 390K D 1/16W	
R415			RK73HB1J182J	CHIP R 1.8K J 1/16W		R830			RK73HH1J103D	CHIP R 10K D 1/16W	

PARTS LIST

TX-RX UNIT (X57-7890-71)

Ref. No.	Address	New parts	Parts No.	Description	Destination	Ref. No.	Address	New parts	Parts No.	Description	Destination
R831,832			RK73HB1J000J	CHIP R 0 J 1/16W		R923			RK73HB1J151J	CHIP R 150 J 1/16W	
R835,836			RK73HB1J102J	CHIP R 1.0K J 1/16W		R924			RK73HB1J474J	CHIP R 470K J 1/16W	
R839			RK73HB1J000J	CHIP R 0 J 1/16W		R925			RK73HB1J334J	CHIP R 330K J 1/16W	
R842			RK73HB1J223J	CHIP R 22K J 1/16W		R926			RK73HB1J274J	CHIP R 270K J 1/16W	
R844			RK73HB1J000J	CHIP R 0 J 1/16W		R927			RK73HB1J473J	CHIP R 47K J 1/16W	
R845			RK73HB1J103J	CHIP R 10K J 1/16W		R928			RK73HB1J273J	CHIP R 27K J 1/16W	
R847			RK73HB1J105J	CHIP R 1.0M J 1/16W		R929			RK73HB1J102J	CHIP R 1.0K J 1/16W	
R848			RK73HB1J332J	CHIP R 3.3K J 1/16W		R930			RK73HB1J101J	CHIP R 100 J 1/16W	
R849			RK73HB1J000J	CHIP R 0 J 1/16W		R931			RK73HB1J000J	CHIP R 0 J 1/16W	
R850			RK73HB1J102J	CHIP R 1.0K J 1/16W		R932			RK73HB1J103J	CHIP R 10K J 1/16W	
R852			RK73HB1J104J	CHIP R 100K J 1/16W		R933			RK73HB1J102J	CHIP R 1.0K J 1/16W	
R853			RK73HB1J103J	CHIP R 10K J 1/16W		R934			RK73HB1J472J	CHIP R 4.7K J 1/16W	
R854-856			RK73HB1J000J	CHIP R 0 J 1/16W		R935-937			RK73HB1J103J	CHIP R 10K J 1/16W	
R857			RK73HB1J680J	CHIP R 68 J 1/16W		R952			RK73HB1J331J	CHIP R 330 J 1/16W	
R860			RK73HB1J104J	CHIP R 100K J 1/16W		R953			RK73HB1J472J	CHIP R 4.7K J 1/16W	
R861			RK73HB1J823J	CHIP R 82K J 1/16W		R954,955			RK73HB1J121J	CHIP R 120 J 1/16W	
R863			RK73HB1J103J	CHIP R 10K J 1/16W		R956			RK73HB1J471J	CHIP R 470 J 1/16W	
R865			RK73HB1J223J	CHIP R 22K J 1/16W		R960,961			RK73HB1J000J	CHIP R 0 J 1/16W	
R867,868			RK73HB1J103J	CHIP R 10K J 1/16W		R962			RK73HB1J103J	CHIP R 10K J 1/16W	
R869			RK73HB1J472J	CHIP R 4.7K J 1/16W		R963			RK73HB1J184J	CHIP R 180K J 1/16W	
R871			RK73HB1J104J	CHIP R 100K J 1/16W		R964			RK73HB1J332J	CHIP R 3.3K J 1/16W	
R872			RK73HB1J121J	CHIP R 120 J 1/16W		R965			RK73HB1J000J	CHIP R 0 J 1/16W	
R874			RK73HB1J150J	CHIP R 15 J 1/16W		R967			RK73HB1J000J	CHIP R 0 J 1/16W	
R875			RK73HB1J000J	CHIP R 0 J 1/16W		R968			RK73HB1J102J	CHIP R 1.0K J 1/16W	
R876			RK73HB1J564J	CHIP R 560K J 1/16W		R978			RK73HB1J000J	CHIP R 0 J 1/16W	
R877			RK73HB1J105J	CHIP R 1.0M J 1/16W		R980			RK73HH1J472D	CHIP R 4.7K D 1/16W	
R878			RK73HB1J103J	CHIP R 10K J 1/16W		R981			RK73HB1J000J	CHIP R 0 J 1/16W	
R879-883			RK73HB1J000J	CHIP R 0 J 1/16W		R982			RK73HB1J121J	CHIP R 120 J 1/16W	
R884			RK73HB1J564J	CHIP R 560K J 1/16W		R986			RK73HB1J471J	CHIP R 470 J 1/16W	
R885			RK73HB1J105J	CHIP R 1.0M J 1/16W		R989			RK73HB1J102J	CHIP R 1.0K J 1/16W	
R887			RK73HB1J100J	CHIP R 10 J 1/16W		R991			RK73HB1J472J	CHIP R 4.7K J 1/16W	
R888			RK73HB1J473J	CHIP R 47K J 1/16W		R992			RK73HB1J105J	CHIP R 1.0M J 1/16W	
R890			RK73HB1J153J	CHIP R 15K J 1/16W		R993			RK73HH1J472D	CHIP R 4.7K D 1/16W	
R891			RK73HB1J473J	CHIP R 47K J 1/16W		S1			S70-0414-05	TACT SWITCH	
R892,893			RK73HB1J000J	CHIP R 0 J 1/16W		S2 ,3			S70-0483-05	TACT SWITCH	
R894			RK73HB1J104J	CHIP R 100K J 1/16W		D6			1SV325F	VARIABLE CAPACITANCE DIODE	
R895			RK73HB1J394J	CHIP R 390K J 1/16W		D9 ,10			1SV325F	VARIABLE CAPACITANCE DIODE	
R896			RK73HB1J104J	CHIP R 100K J 1/16W		D12			1SV325F	VARIABLE CAPACITANCE DIODE	
R897			RK73HB1J222J	CHIP R 2.2K J 1/16W		D13			HSC119	DIODE	
R898			RK73HB1J273J	CHIP R 27K J 1/16W		D14 ,15			HVC375B-E	VARIABLE CAPACITANCE DIODE	
R899			RK73HB1J124J	CHIP R 120K J 1/16W		D16			KDV214E-P	DIODE	
R900			RK73HB1J104J	CHIP R 100K J 1/16W		D17			HSC277	DIODE	
R902			RK73HB1J103J	CHIP R 10K J 1/16W		D18			HVC131	DIODE	
R903			RK73HB1J101J	CHIP R 100 J 1/16W		D201,202			HVC131	DIODE	
R904			RK73HB1J474J	CHIP R 470K J 1/16W		D203,204			RN142S	DIODE	
R905			RK73HB1J272J	CHIP R 2.7K J 1/16W		D301			UDZW5.1(B)	ZENER DIODE	
R906			RK73HB1J102J	CHIP R 1.0K J 1/16W		D401,402			KDS121E-P	DIODE	
R907			RK73HB1J272J	CHIP R 2.7K J 1/16W		D403-405			HVC350B	VARIABLE CAPACITANCE DIODE	
R908			RK73HB1J104J	CHIP R 100K J 1/16W		D407,408			HVC350B	VARIABLE CAPACITANCE DIODE	
R909			RK73HB1J105J	CHIP R 1.0M J 1/16W		D409			JDV2S07FS	VARIABLE CAPACITANCE DIODE	
R910,911			RK73HB1J103J	CHIP R 10K J 1/16W		D803			GN1G	DIODE	
R912			RK73HB1J000J	CHIP R 0 J 1/16W		D806			RKZ5.1B2KG	ZENER DIODE	
R913			RK73HB1J182J	CHIP R 1.8K J 1/16W		D807-809			KDR731	DIODE	
R914			RK73HB1J471J	CHIP R 470 J 1/16W		D810			MC2850	DIODE	
R915			RK73HB1J152J	CHIP R 1.5K J 1/16W		D817			DA2S101	DIODE	
R916			RK73HB1J123J	CHIP R 12K J 1/16W		D829-832			1SS388F	DIODE	
R918			RK73HB1J473J	CHIP R 47K J 1/16W							
R919			RK73HB1J682J	CHIP R 6.8K J 1/16W							
R920			RK73HB1J561J	CHIP R 560 J 1/16W							
R921,922			RK73HB1J473J	CHIP R 47K J 1/16W							

TK-3310

PARTS LIST

TX-RX UNIT (X57-7890-71)

Ref. No.	Address	New parts	Parts No.	Description	Destination	Ref. No.	Address	New parts	Parts No.	Description	Destination
IC1			AK1541	MOS-IC		TH201			ERTJ0EV104J	THERMISTOR	
IC2			BD7542FVM	MOS-IC		TH401			NCP18WM224J0S	THERMISTOR	
IC301			NJM2904RB1-ZB	BI-POLAR IC							
IC401			NJM2591V	BI-POLAR IC							
IC402			NJU7108	MOS-IC							
IC801			XC6209B502P-G	MOS-IC							
IC802			XC6209B502M-G	MOS-IC							
IC803			XC6209B502P-G	MOS-IC							
IC804			XC6209B332M-G	MOS-IC							
IC805			XC61CN4502M-G	MOS-IC							
IC806			XC6209B332M-G	MOS-IC							
IC807			XC6120N302N-G	MOS-IC							
IC808			NJM2904RB1-ZB	BI-POLAR IC							
IC810			M95512-RDW6TP	ROM IC							
IC811			HA1630D03MM	MOS-IC							
IC812			CD686AQ3	MOS-IC							
IC815			TA7368FG	MOS-IC							
IC817			TC75S51FE(F)	MOS-IC							
IC820		*	F363BEDFEKDL	MICROCONTROLLER IC							
IC821			NJU6434	MOS-IC							
Q2			2SC5636	TRANSISTOR							
Q3			KTC4075E(Y,GR)	TRANSISTOR							
Q4			MCH3914(8)-H	FET							
Q5			MCH3914(7)-H	FET							
Q6			SSM6L05FU-F	FET							
Q7			SSM3J05FU-F	FET							
Q8 ,9			2SC5636	TRANSISTOR							
Q11			SSM3J05FU-F	FET							
Q12			2SK1824-A	FET							
Q201			2SC5636	TRANSISTOR							
Q203			2SC5455-A	TRANSISTOR							
Q204			RFM01U7P	FET							
Q205			RD07MUS2BT112	FET							
Q301		*	LTC014TEBFS8	TRANSISTOR							
Q303			2SK1824-A	FET							
Q304			LTC014EEBFS8	TRANSISTOR							
Q305			2SK1824-A	FET							
Q306		*	LTA044EEBFS8	TRANSISTOR							
Q401			LTC044EEBFS8	TRANSISTOR							
Q403			KTC4080E-P	TRANSISTOR							
Q404		*	LTA044EEBFS8	TRANSISTOR							
Q405			KTC4080E-P	TRANSISTOR							
Q406			3SK318	FET							
Q407			3SK293-F	FET							
Q801			UPA672T-A	FET							
Q802,803			SSM6L05FU-F	FET							
Q804			SSM3J05FU-F	FET							
Q805			2SK1824-A	FET							
Q807			2SC4919-S	TRANSISTOR							
Q809			KTC4075E(Y,GR)	TRANSISTOR							
Q810			2SC4116(GR)F	TRANSISTOR							
Q811			2SA1586(Y,GR)F	TRANSISTOR							
Q813			LTC014EEBFS8	TRANSISTOR							
Q814			2SB1694	TRANSISTOR							
Q815,816			UPA672T-A	FET							
Q817			LTC044EEBFS8	TRANSISTOR							
Q818,819			2SK3577-A	FET							
Q820			2SC4617(S)	TRANSISTOR							
Q821			2SB1694	TRANSISTOR							
Q822			LTC014EEBFS8	TRANSISTOR							

EXPLODED VIEW

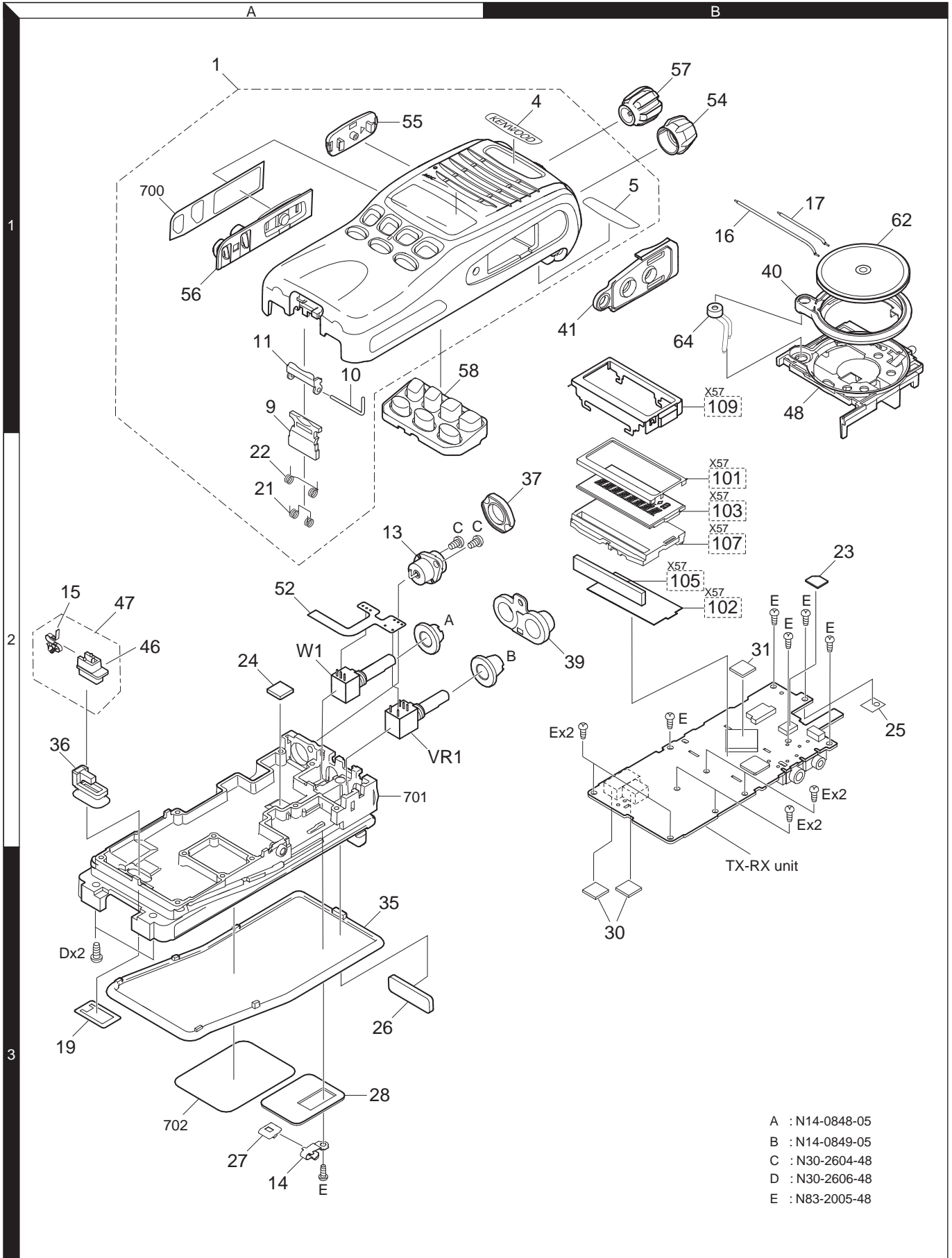

Parts with the exploded numbers larger than 700 are not supplied.

PACKING

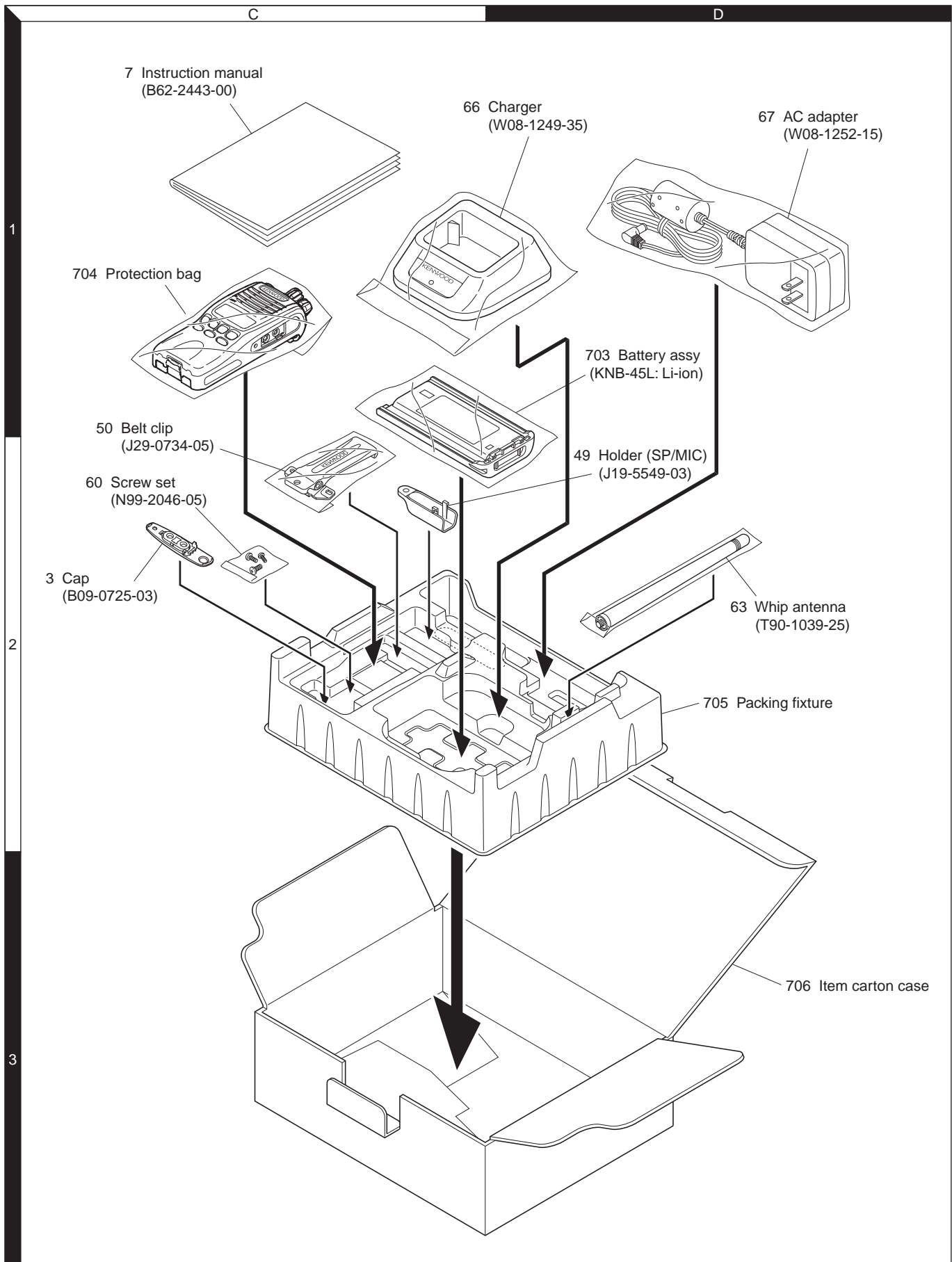

Parts with the exploded numbers larger than 700 are not supplied.

ADJUSTMENT

Test Equipment Required for Alignment

Test Equipment	Major Specifications	
1. Standard Signal Generator (SSG)	Frequency Range Modulation Output	Operational frequency range of the transceiver Frequency modulation and external modulation -127dBm/0.1 μ V to greater than -47dBm/1mV
2. RF Power Meter	Input Impedance Operation Frequency Measurement Range	50 Ω Operational frequency range of the transceiver Vicinity of 10W
3. Deviation Meter	Frequency Range	Operational frequency range of the transceiver
4. Digital Volt Meter (DVM)	Measuring Range Input Impedance	10mV to 10V DC High input impedance for minimum circuit loading
5. Oscilloscope		DC through 30MHz
6. High Sensitivity Frequency Counter	Frequency Range Frequency Stability	10Hz to 1000MHz 0.2ppm or less
7. DC Ammeter		5A
8. AF Volt Meter (AF VM)	Frequency Range Voltage Range	50Hz to 10kHz 1mV to 10V
9. Audio Generator (AG)	Frequency Range Output	50Hz to 5kHz or more 0 to 1V
10. Distortion Meter	Capability Input Level	3% or less at 1kHz 50mV to 10Vrms
11. Spectrum Analyzer	Measuring Range	10kHz to 1GHz or more
12. Tracking Generator	Center frequency Output Voltage	50kHz to 600MHz 100mV or more
13. 8 Ω Dummy Load		Approx. 8 Ω , 3W
14. Regulated Power Supply		5V to 10V, approx. 3A Useful if ammeter equipped

■ Antenna connector adapter

The antenna connector of this transceiver uses an SMA terminal.

Use an antenna connector adapter [SMA(f) – BNC(f) or SMA(f) – N(f)] for adjustment. (The adapter is not provided as an option, so buy a commercially-available one.)

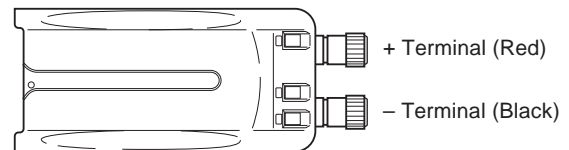

■ Repair Jig (Chassis)

Use jig (part No.: A10-4215-03) for repairing the transceiver. Place the TX-RX unit on the jig and fit it with screws.

The jig facilitates the voltage check and protects the final amplifier FET when the voltage on the flow side of the TX-RX unit is checked during repairs.

■ Battery Jig (W05-1011-00)

Connect the power cable properly between the battery jig installed in the transceiver and the power supply, and be sure output voltage and the power supply polarity prior to switching the power supply ON, otherwise over voltage and reverse connection may damage the transceiver, or the power supply or both.

Note: When using the battery jig, you must measure the voltage at the terminals of the battery jig. Otherwise, a slight voltage drop may occur within the power cable, between the power supply and the battery jig, especially while the transceiver transmits.

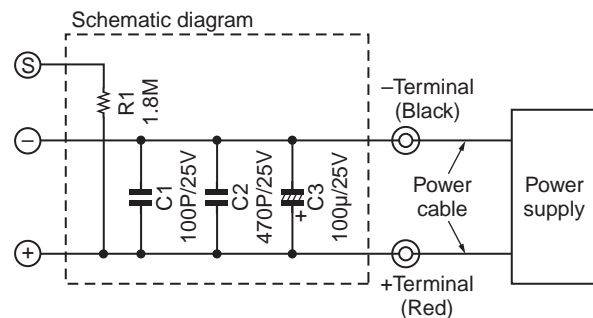

ADJUSTMENT

Frequency and Signaling

The transceiver has been adjusted for the frequencies shown in the following table. When required, re-adjust them following the adjustment procedure to obtain the frequencies you want in actual operation.

■ Frequency (MHz)

Channel No.	RX Frequency	TX Frequency
1	485.05000	485.10000
2	450.05000	450.10000
3	519.95000	519.90000
4	485.00000	485.00000
5	485.20000	485.20000
6	485.40000	485.40000
7~16	-	-

■ Signaling

Signaling No.	RX (Decode)	TX (Encode)
1	None	None
2	None	100Hz Square Wave
3	QT 67.0Hz	QT 67.0Hz
4	QT 151.4Hz	QT 151.4Hz
5	QT 210.7Hz	QT 210.7Hz
6	QT 254.1Hz	QT 254.1Hz
7	DQT D023N	DQT D023N
8	DQT D754I	DQT D754I
9	DTMF (Code: 159D)	DTMF (Code: 159D)
10	None	DTMF (Code: 9)
11	None	MSK (1010)
12	FleetSync (100~1000)	FleetSync (100~1000)
13	None	Single Tone (1000Hz)
14	2-tone (A: 304.7Hz, B: 3106.0Hz)	2-tone (A: 304.7Hz, B: 3106.0Hz)
15	None	DTMF Tone (1477Hz)
16	Single Tone (979.9Hz)	Single Tone (979.9Hz)
17	None	MSK PN9
18	None	DTMF (Code: 3)

Preparations for Tuning the Transceiver

Before attempting to tune the transceiver, connect the unit to a suitable power supply.

Whenever the transmitter is tuned, the unit must be connected to a suitable dummy load (i.e. power meter).

The speaker output connector must be terminated with a 8Ω dummy load and connected to an AC voltmeter and an audio distortion meter or a SINAD measurement meter at all times during tuning.

■ Adjustment frequency (MHz)

TEST CH	RX	TX
Low	450.05000	450.10000
Low'	467.55000	467.60000
Center	485.05000	485.10000
High'	502.55000	502.60000
High	519.95000	519.90000

Adjustment Points

TX-RX UNIT
Component side view

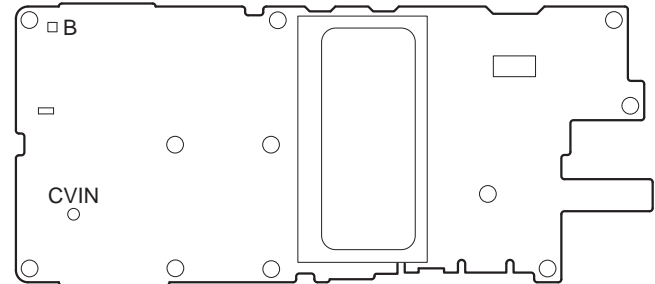

Note: "CVIN" VCO Lock voltage.

ADJUSTMENT

Common Section

Item	Condition	Measurement			Adjustment			Specifications / Remarks
		Test-equipment	Unit	Terminal	Unit	Parts	Method	
1. Setting	1) BATT terminal voltage: 7.5V 2) SSG standard modulation [Wide] MOD: 1kHz, DEV: 3kHz [Narrow] MOD: 1kHz, DEV: 1.5kHz							
2. Receive Assist Voltage	1) (Auto tuning) *Note	Power meter		ANT	TX-RX	FPU		(4.0V±0.1V)
	2) CH: Low	DVM	TX-RX	CVIN			Check	0.6V or more
3. Transmit Assist Voltage	1) (Auto tuning) *Note				TX-RX	FPU		(4.0V±0.1V)
	2) CH: Low PTT: ON						Check	0.6V or more

Note: At test mode, click [Tune Assist Voltage] button in test mode dialog box, then start automatic adjustment of Receive/Transmit assist voltage.

ADJUSTMENT

Transmitter Section

Item	Condition	Measurement			Adjustment			Specifications / Remarks
		Test-equipment	Unit	Terminal	Unit	Parts	Method	
1. Frequency	1) TEST CH: Center PTT: ON	f. counter		ANT	TX-RX	FPU FPU	485.100MHz	±50Hz
2. High Transmit Power	1) TEST CH: Low, Low', Center, High', High (5 points) BATT terminal voltage: 7.5V PTT: ON	Power meter Ammeter					5.0W	±0.1W 2.0A or less
3. Low Transmit Power	1) TEST CH: Low, Low', Center, High', High (5 points) BATT terminal voltage: 7.5V PTT: ON						1.0W	±0.1W 1.0A or less
4. DQT Balance [Wide] 1	1) TEST CH: Low, Low', Center, High', High (5 points) Deviation meter filter LPF: 3kHz HPF: OFF PTT: ON	Power meter Deviation meter Oscilloscope					Make the demodulation wave into square waves.	
5. Maximum Deviation [Wide]	1) TEST CH: Low, Low', Center, High', High (5 points) Deviation meter filter LPF: 15kHz HPF: OFF PTT: ON						4.4kHz (According to the larger +, -)	±80Hz Note: FPU AUTO INPUT 1kHz/150mV
6. DQT Deviation [Wide]	1) TEST CH: 1 Deviation meter filter LPF: 3kHz HPF: OFF PTT: ON						0.75kHz	±40Hz
7. QT Deviation [Wide]	1) TEST CH: 1 Deviation meter filter LPF: 3kHz HPF: OFF PTT: ON						0.75kHz	±40Hz
8. DTMF Deviation [Wide]	1) TEST CH: 1 Deviation meter filter LPF: 15kHz HPF: OFF PTT: ON						3.0kHz	±100Hz
9. MSK Deviation [Wide]	1) TEST CH: 1 Deviation meter filter LPF: 15kHz HPF: OFF PTT: ON						3.0kHz	±100Hz

Note: Regarding deviation alignment item, narrow value is calculated from wide alignment value.

ADJUSTMENT

Receiver Section

Item	Condition	Measurement			Adjustment			Specifications / Remarks
		Test-equipment	Unit	Terminal	Unit	Parts	Method	
1. Sensitivity (Semiauto- matic)	1) TEST CH: Low, Center, High (3 points) SSG output : -90dBm (7.08 μ V) SSG MOD: 3.0kHz	SSG DVM Oscilloscope		ANT		FPU	Press [Start] (Auto tuning)	
2. Open Squelch [Wide]	1) TEST CH: Low, Center, High (3 points) SSG output: -119dBm (0.25 μ V) SSG MOD: 3.0kHz							
[Narrow]	2) TEST CH: Low, Center, High (3 points) SSG output: -119dBm (0.25 μ V) SSG MOD: 1.5kHz							
3. Tight Squelch [Wide]	1) TEST CH: Low, Center, High (3 points) SSG output: -115dBm (0.40 μ V) SSG MOD: 3.0kHz							
[Narrow]	2) TEST CH: Low, Center, High (3 points) SSG output: -114dBm (0.44 μ V) SSG MOD: 1.5kHz							
4. Low RSSI [Wide]	1) TEST CH: Low, Center, High (3 points) SSG output: -120dBm (0.22 μ V) SSG MOD: 3.0kHz							
[Narrow]	2) TEST CH: Low, Center, High (3 points) SSG output: -120dBm (0.22 μ V) SSG MOD: 1.5kHz							
5. High RSSI [Wide]	1) TEST CH: Low, Center, High (3 points) SSG output: -80dBm (22.4 μ V) SSG MOD: 3.0kHz							
[Narrow]	2) TEST CH: Low, Center, High (3 points) SSG output: -80dBm (22.4 μ V) SSG MOD: 1.5kHz							

TK-3310 PC BOARD

TX-RX UNIT (X57-7890-71) Component side view (J79-0288-29)

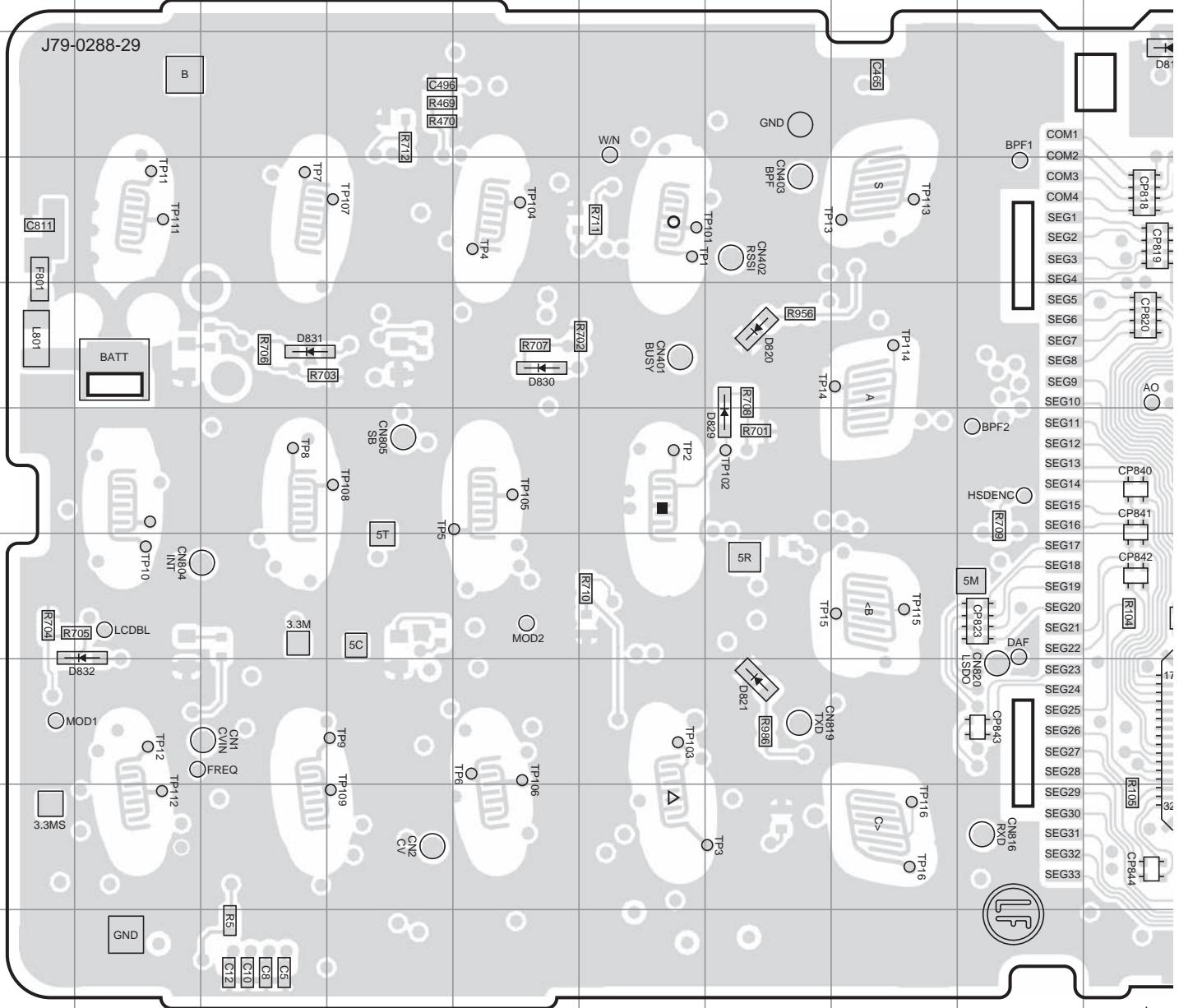

Ref. No.	Address	Ref. No.	Address	Ref. No.	Address	Ref. No.	Address
IC301	3N	Q306	4N	Q818	7P	D820	5G
IC810	4K	Q801	8Q	Q819	8O	D821	8G
IC815	7O	Q805	5P	Q822	4N	D824	3K
IC820	6L	Q813	5P	D801	8R	D829	6G
IC821	8K	Q814	6O	D804	8S	D830	5E
Q303	3M	Q815	9K	D805	8S	D831	5C
Q304	3M	Q816	8M	D818	3L	D832	8B
Q305	3M	Q817	6P	D819	3J		

PC BOARD TK-3310

TX-RX UNIT (X57-7890-71) Component side view (J79-0288-29)

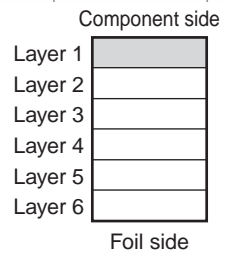
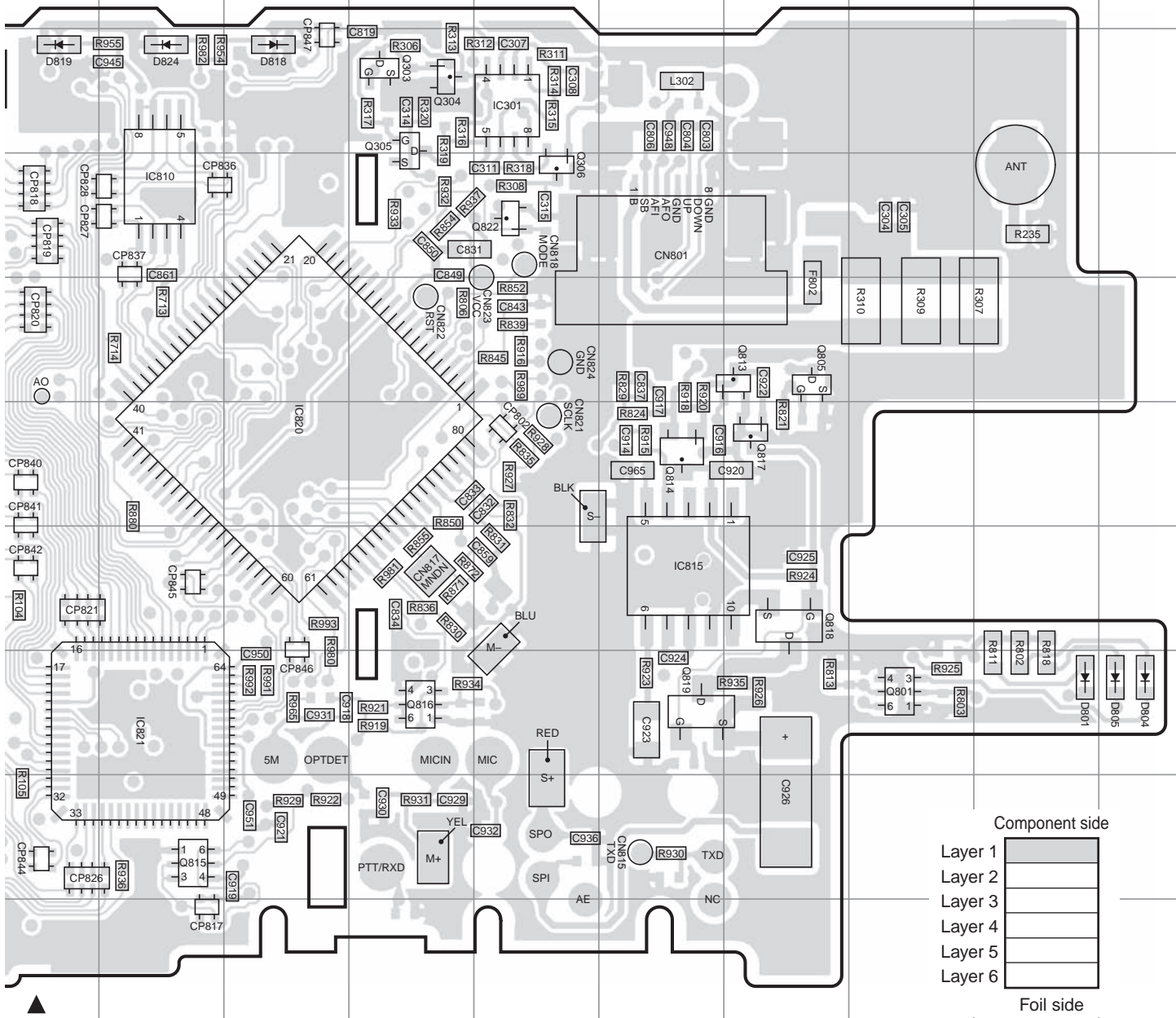

TK-3310 PC BOARD

TX-RX UNIT (X57-7890-71) Foil side view (J79-0288-29)

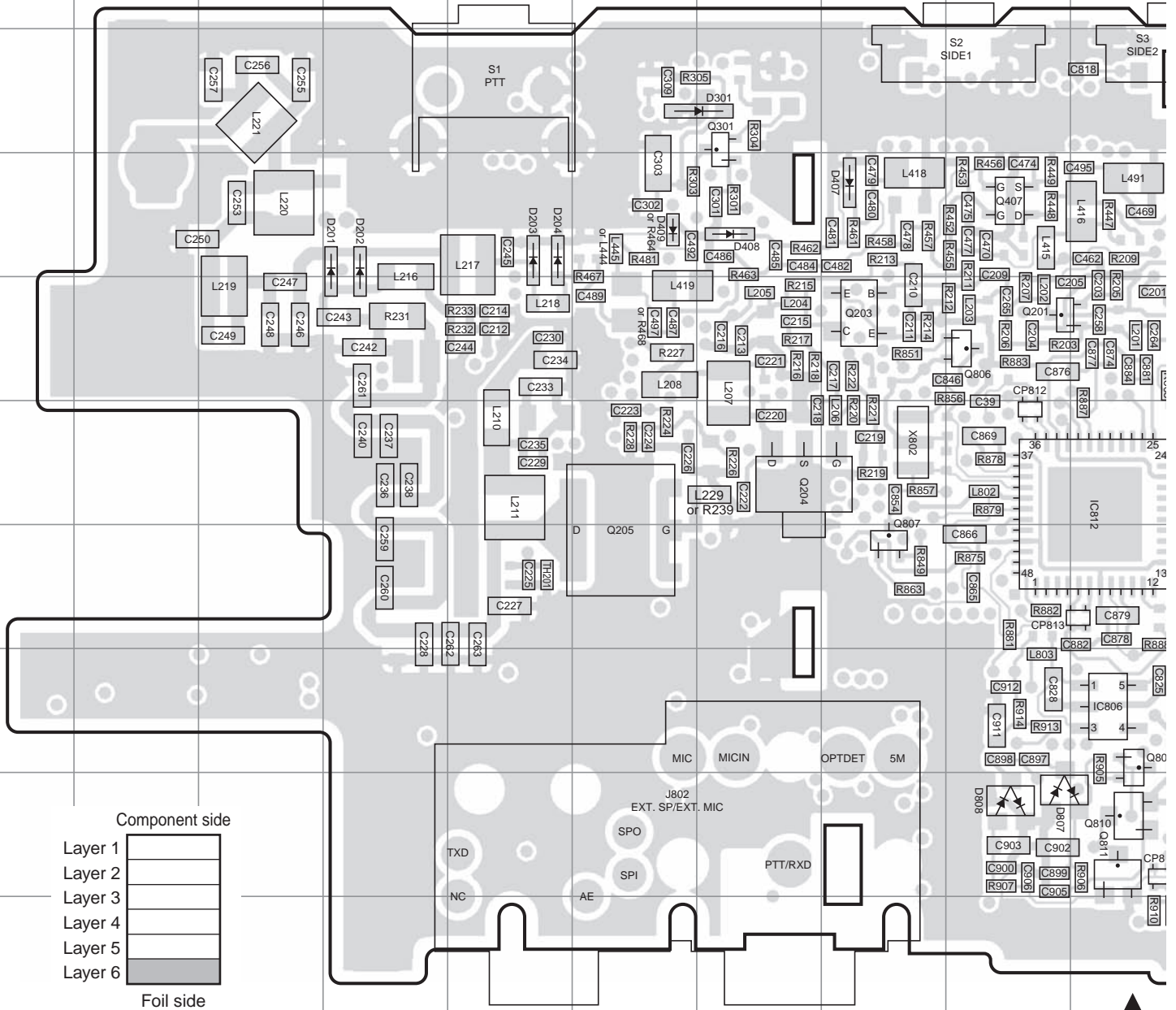

Ref. No.	Address	Ref. No.	Address	Ref. No.	Address	Ref. No.	Address	Ref. No.	Address	Ref. No.	Address	Ref. No.	Address	Ref. No.	Address
IC1	9Q	IC807	7P	Q7	8L	Q401	4N	Q807	7H	D13	7L	D301	3G	D801	3O
IC2	8O	IC808	4L	Q8	7M	Q403	5O	Q809	8J	D14	8N	D401	3O	D802	3O
IC401	5N	IC811	5K	Q9	7N	Q404	4N	Q810	9J	D15	9M	D402	3O	D803	3O
IC402	4O	IC812	6J	Q11	8P	Q405	6N	Q811	9J	D16	8N	D403	3L	D804	3L
IC801	6P	IC817	9K	Q12	9P	Q406	4M	Q820	8R	D17	7M	D404	3L	D810	3L
IC802	7R	Q2	8P	Q201	5I	Q407	4I	Q821	8Q	D18	7M	D405	4K	D811	4K
IC803	6Q	Q3	7M	Q203	5H	Q802	7P	D6	8N	D201	4D	D407	4H	D812	4H
IC804	7Q	Q4	9L	Q204	6G	Q803	7O	D9	8N	D202	4D	D408	4G	D813	4G
IC805	7R	Q5	8M	Q205	7F	Q804	7Q	D10	9M	D203	4E	D409	4F	D814	4F
IC806	8J	Q6	7L	Q301	3G	Q806	5I	D12	10M	D204	4E	D803	3R	D815	3R

PC BOARD TK-3310

TX-RX UNIT (X57-7890-71) Foil side view (J79-0288-29)

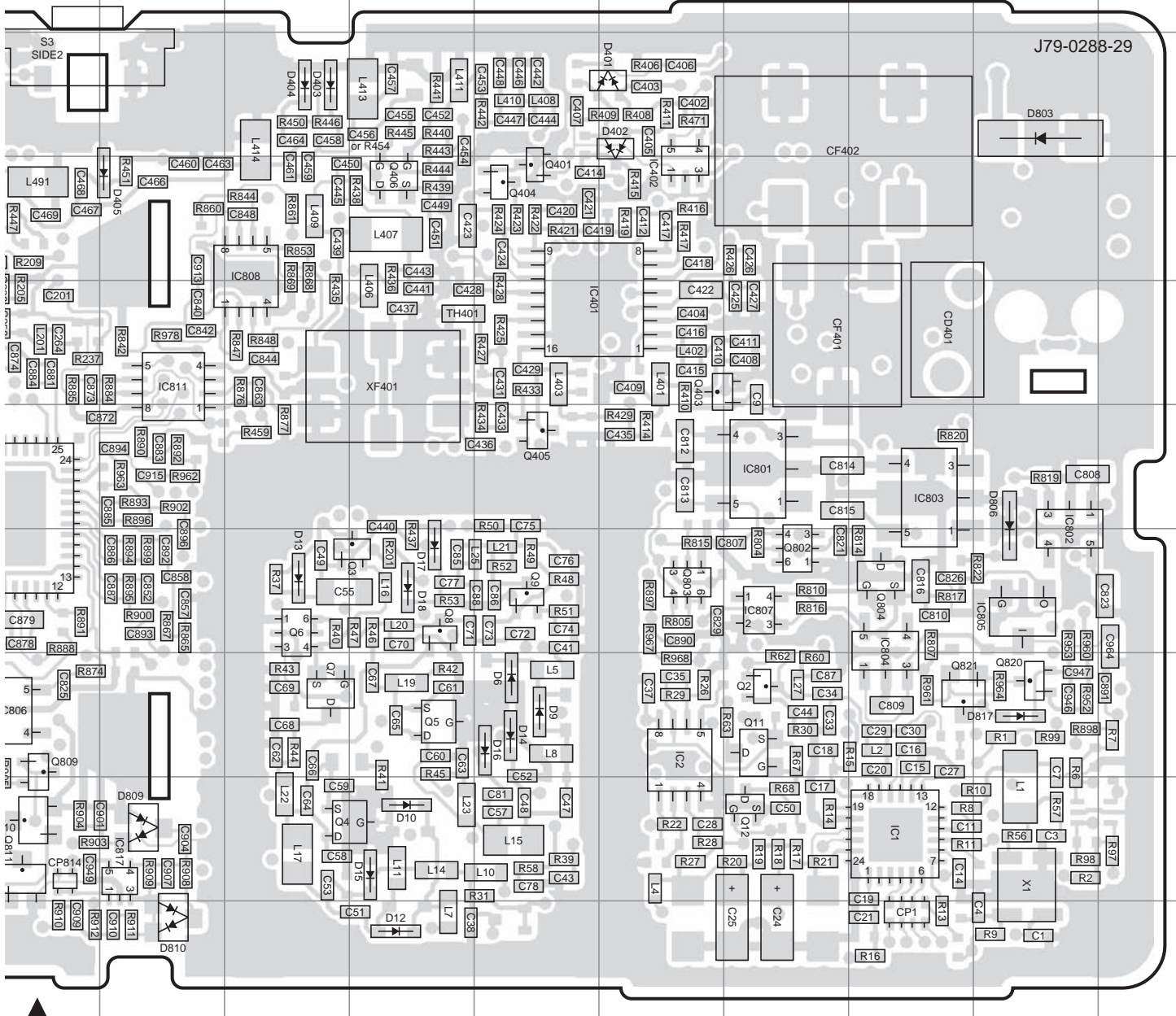

s	Ref. No.	Address
	D806	6R
	D807	9I
	D808	9I
	D809	9K
	D810	10K
	D817	8R

TK-3310 SCHEMATIC DIAGRAM

TX-RX UNIT (X57-7890-71)

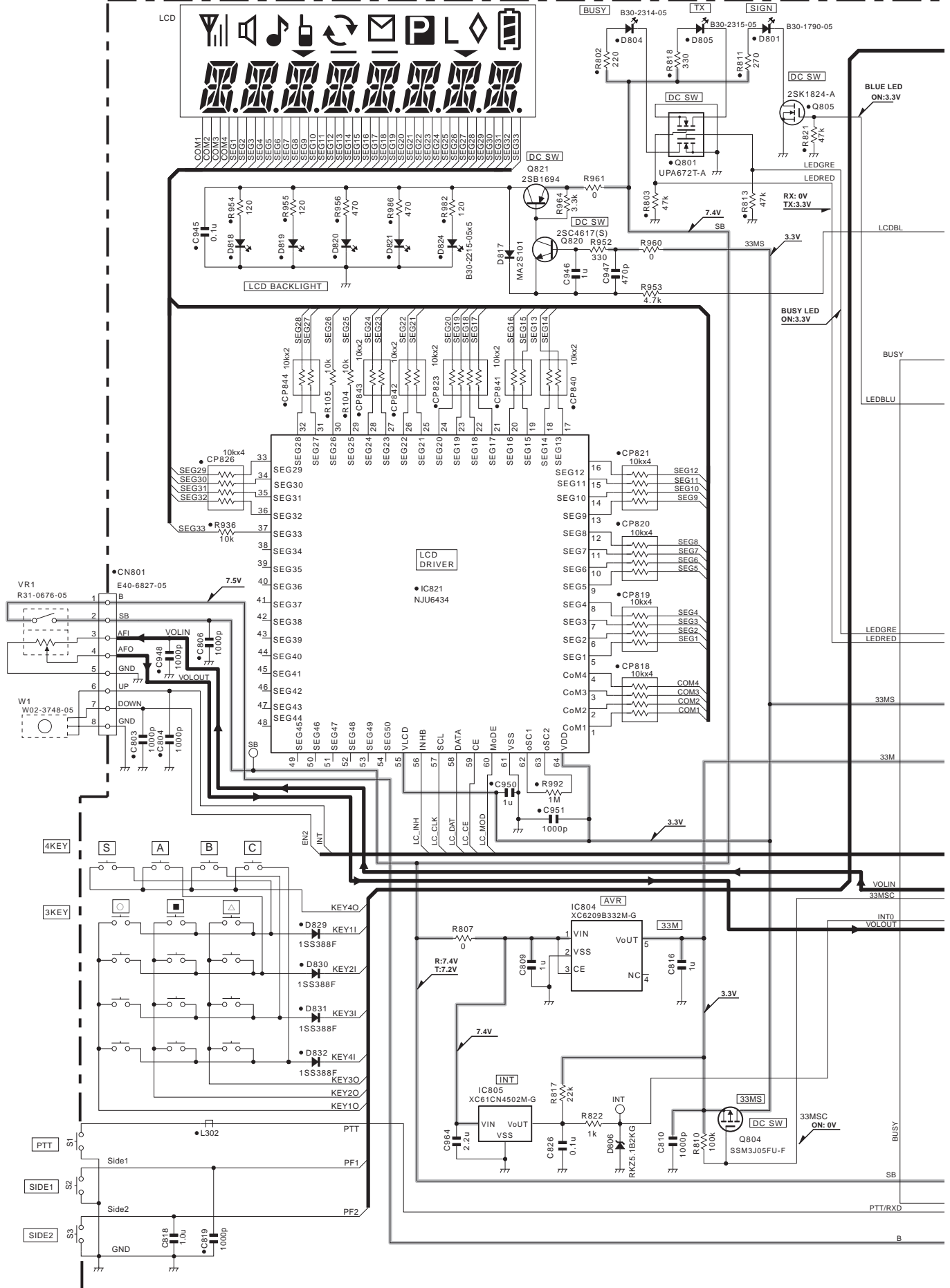

SCHEMATIC DIAGRAM TK-3310

TX-RX UNIT (X57-7890-71)

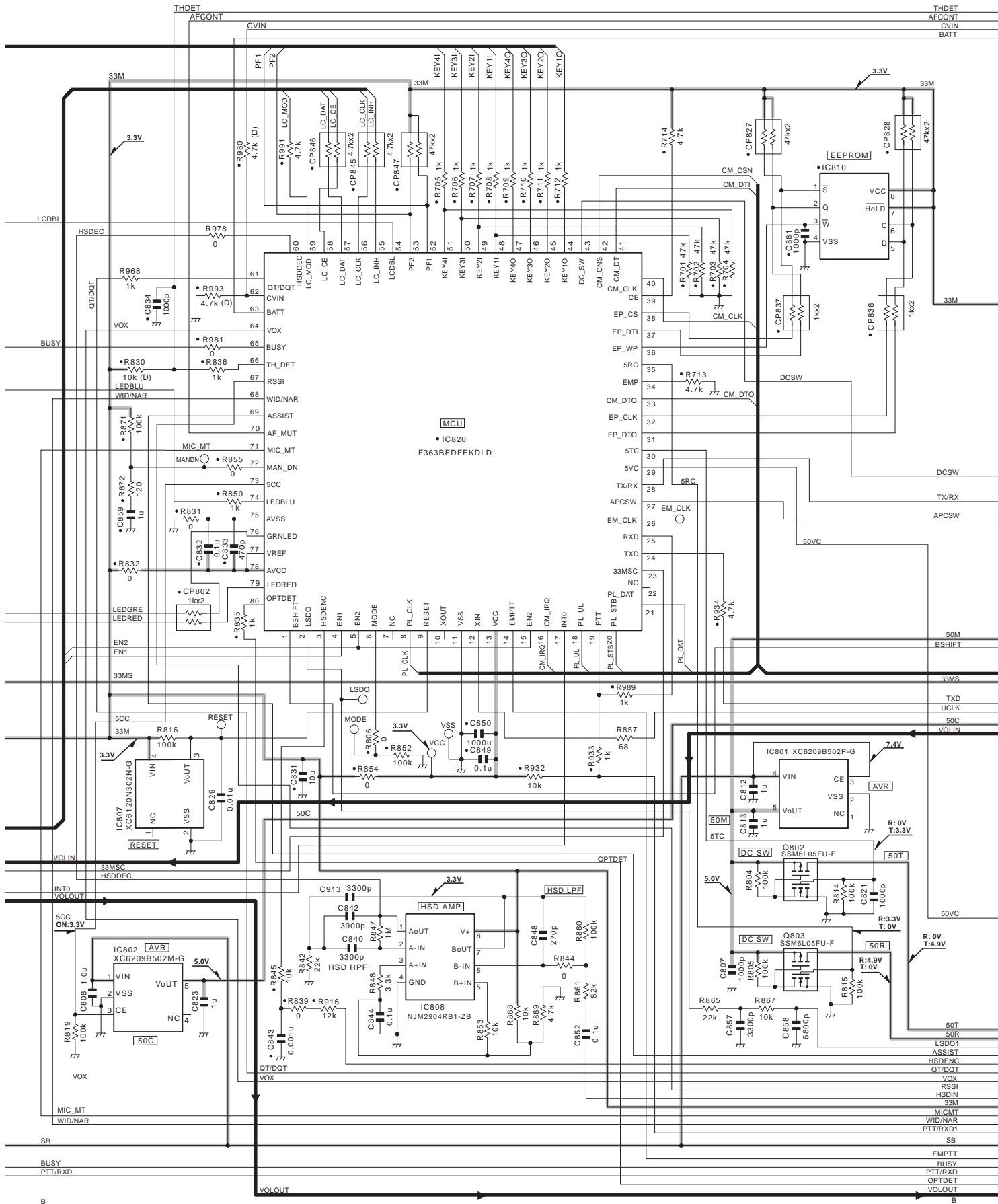

TK-3310 SCHEMATIC DIAGRAM

TX-RX UNIT (X57-7890-71)

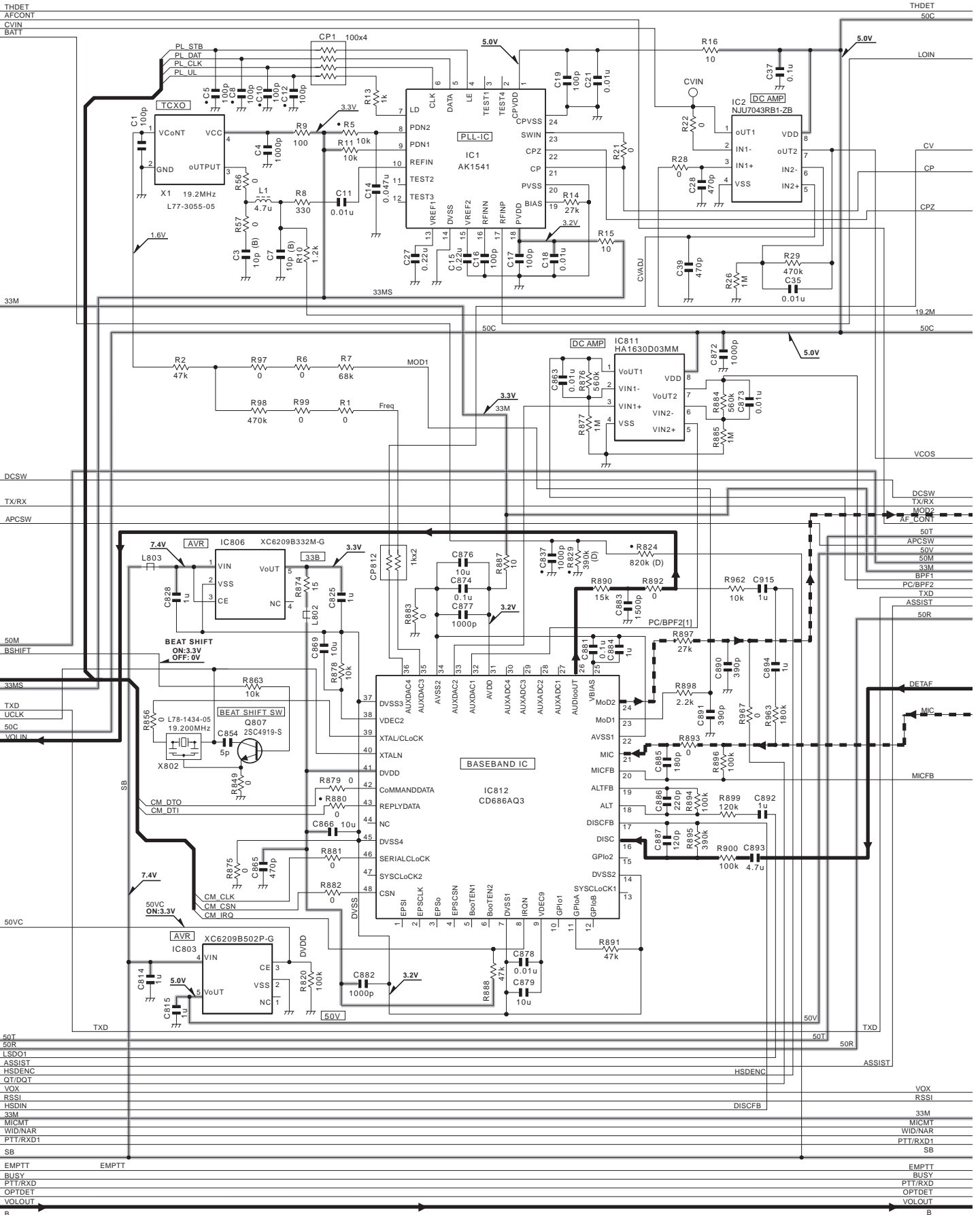

SCHEMATIC DIAGRAM TK-3310

TX-RX UNIT (X57-7890-71)

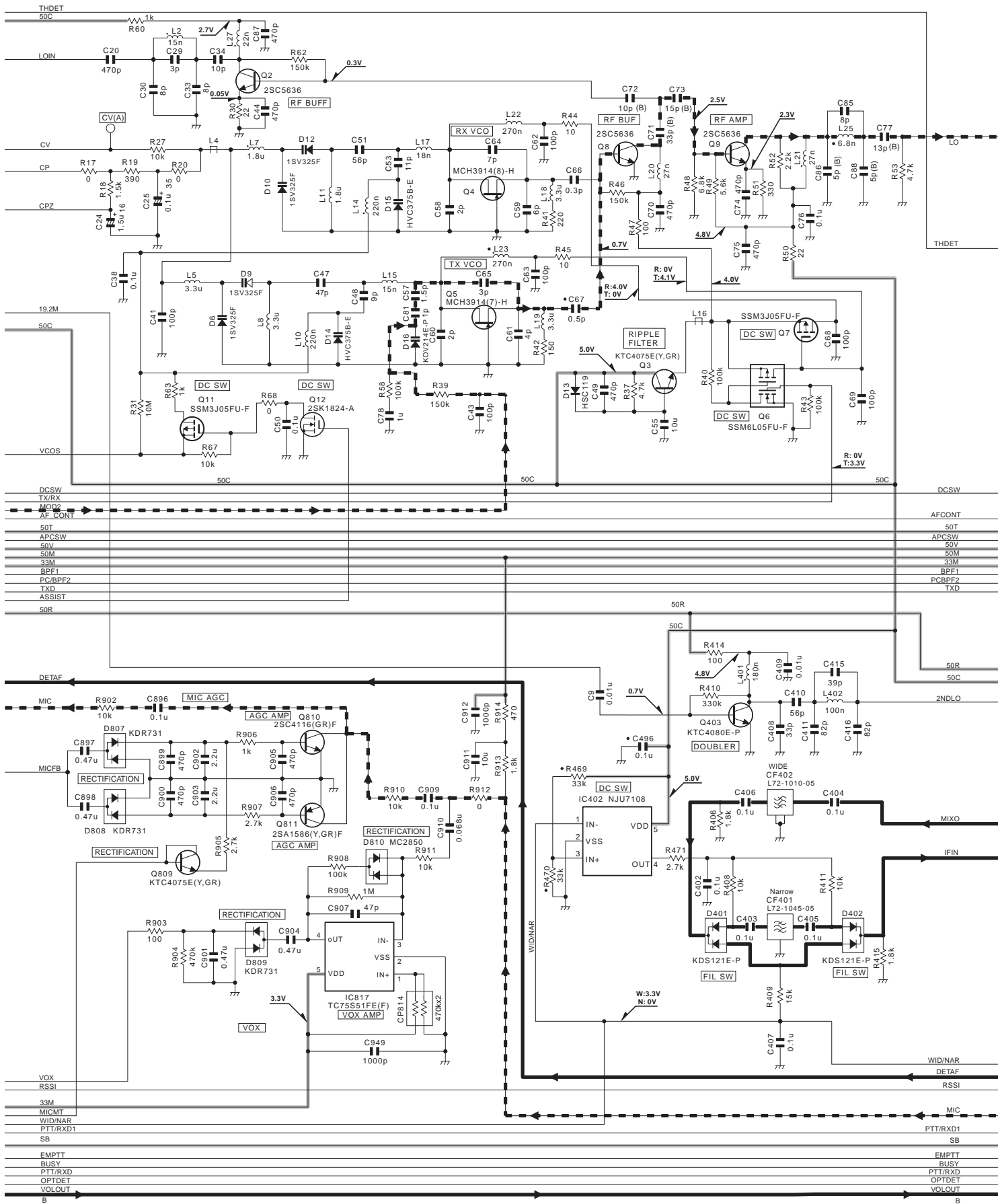

TK-3310 SCHEMATIC DIAGRAM

TX-RX UNIT (X57-7890-71)

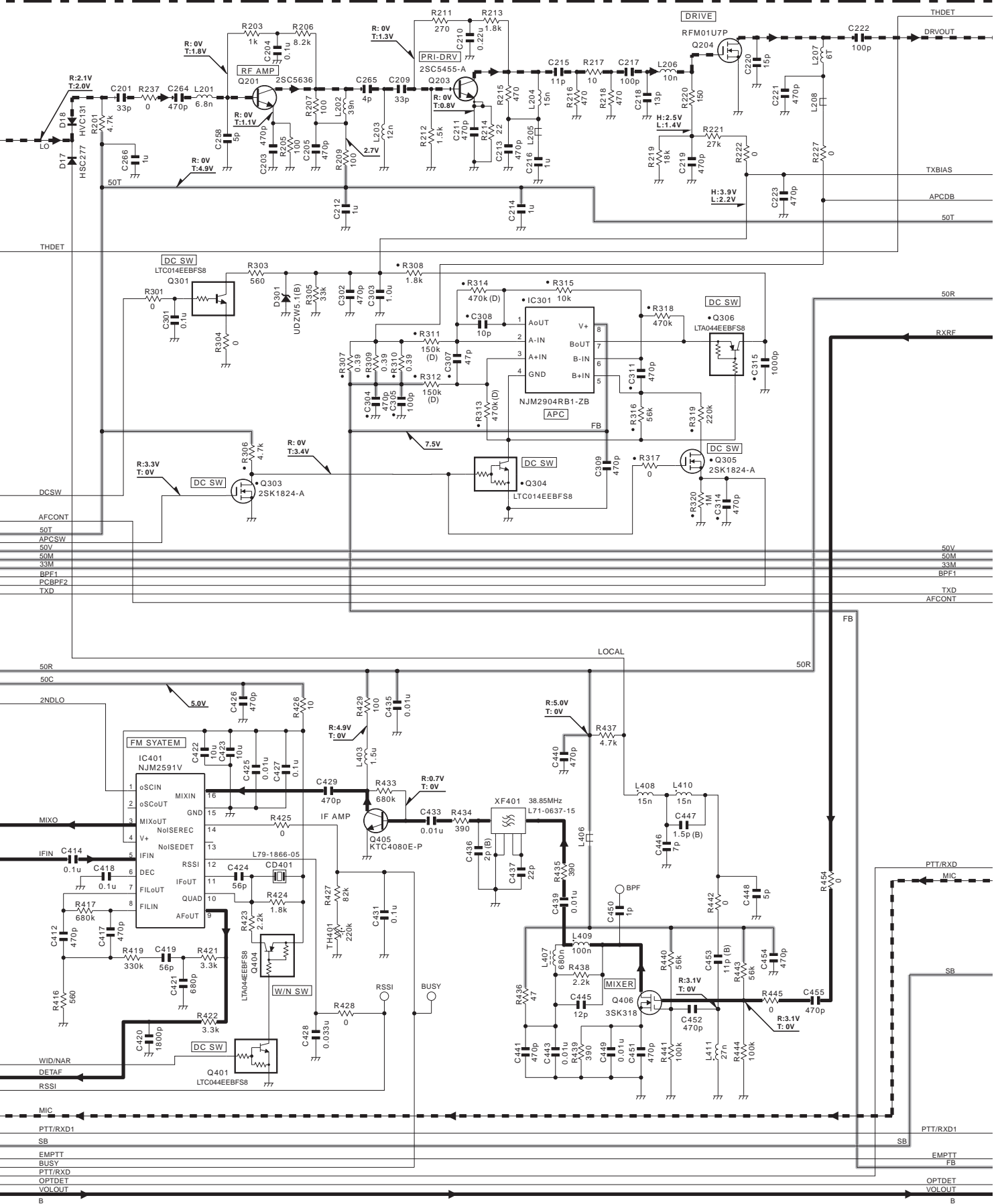

SCHEMATIC DIAGRAM TK-3310

TX-RX UNIT (X57-7890-71)

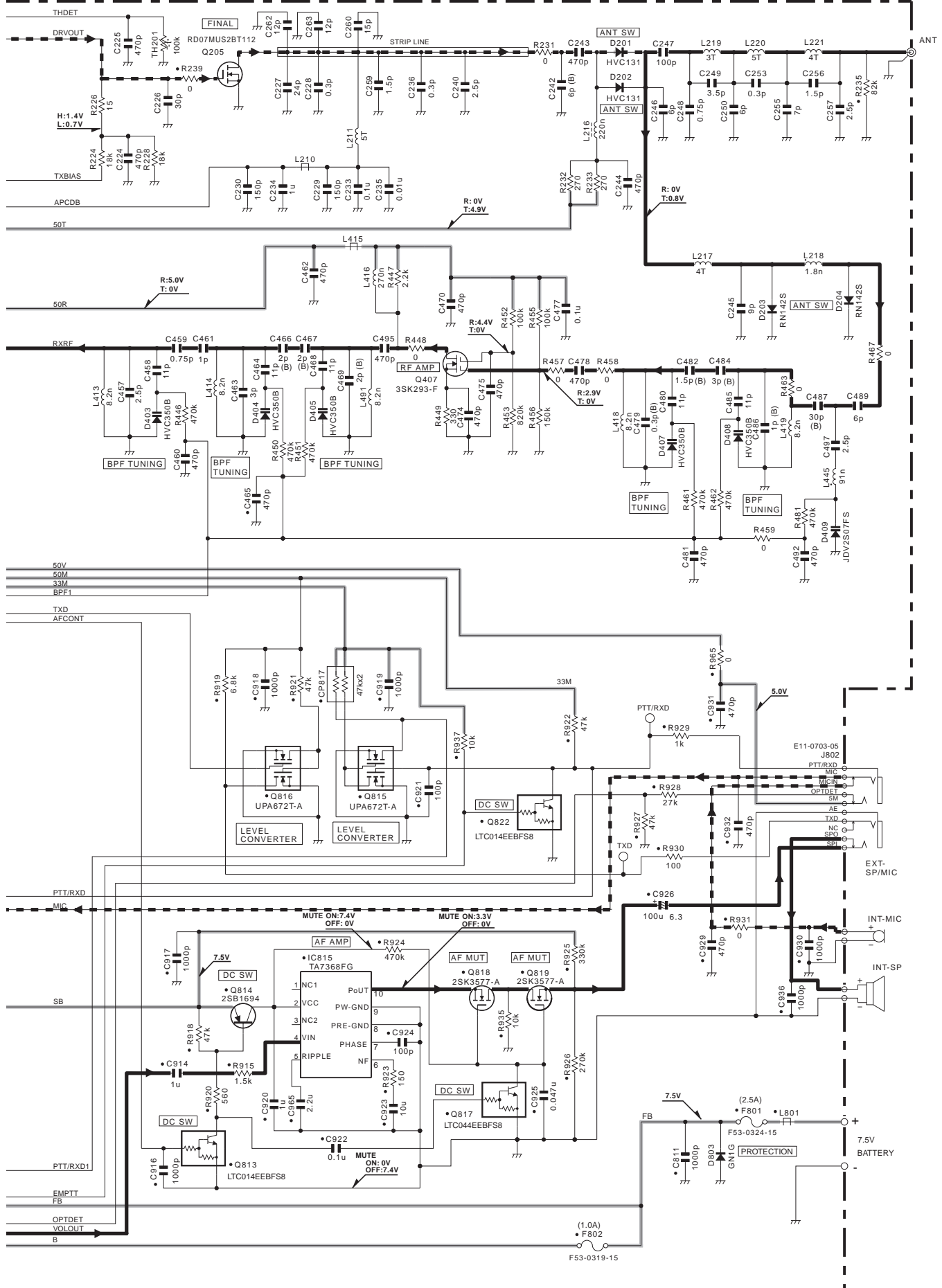

Note : The components marked with a dot (•) are parts of layer 1.

BLOCK DIAGRAM

X57-789

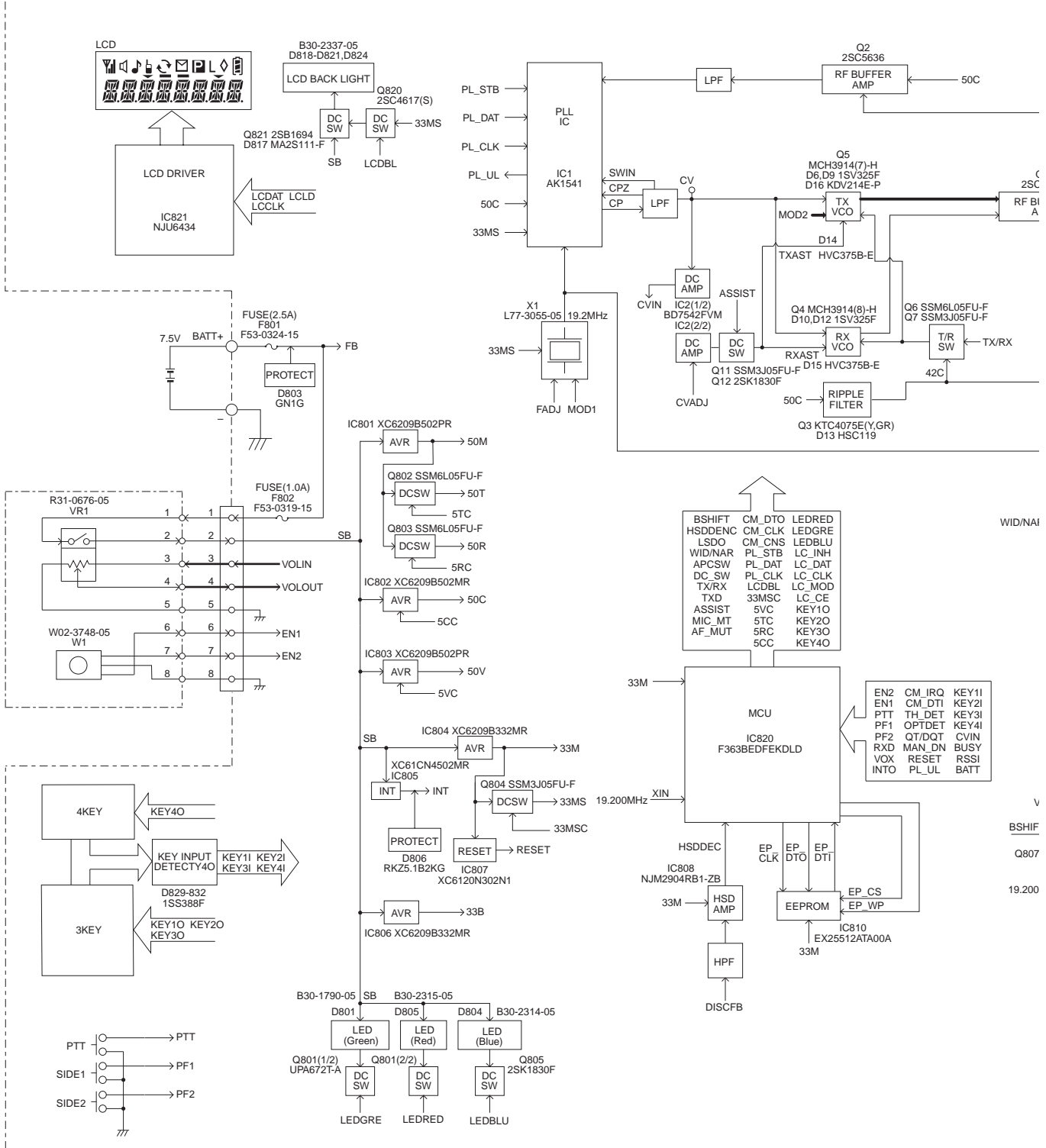

BLOCK DIAGRAM

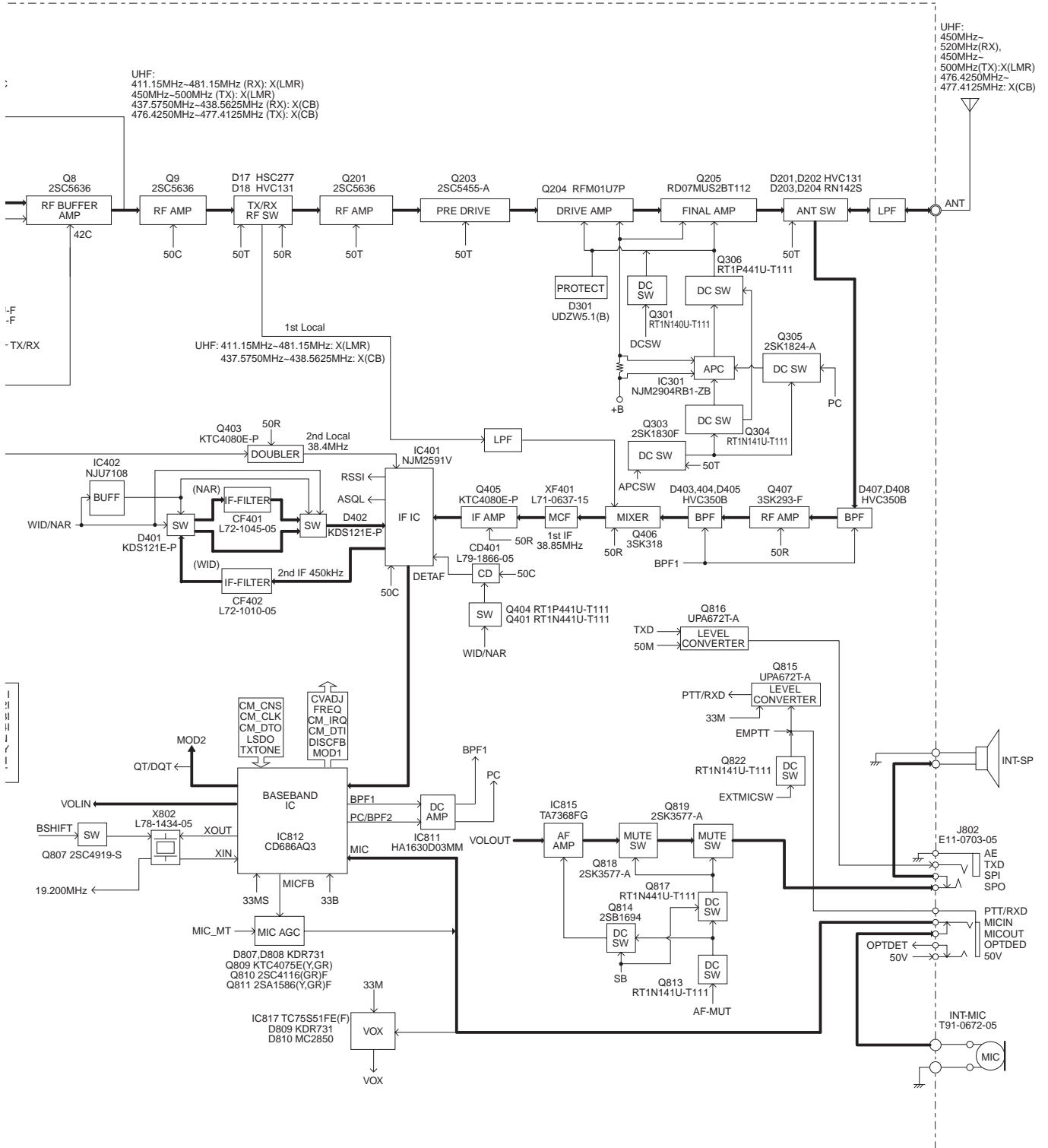

LEVEL DIAGRAM

Receiver Section

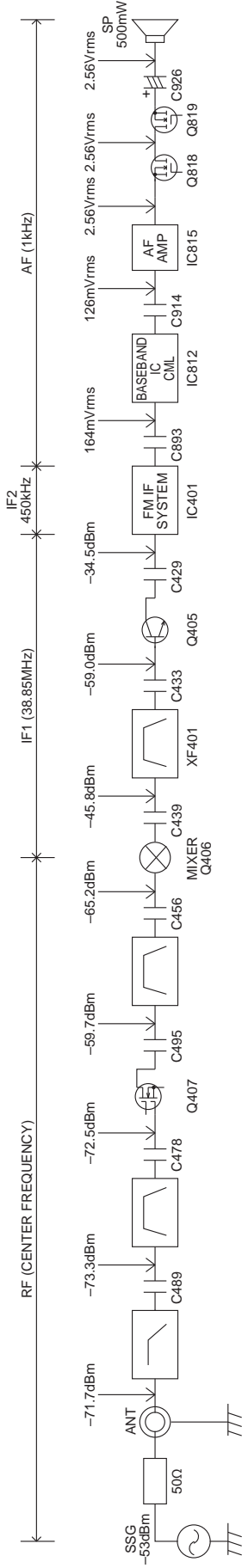

To make measurements in the AF section, connect the AC level meter. (ANT input: -53dBm, 1kHz FM, 1.5kHz Dev (Narrow)). In the RF section, use a high impedance probe. (ANT input: -53dBm, MOD off).

Transmitter Section

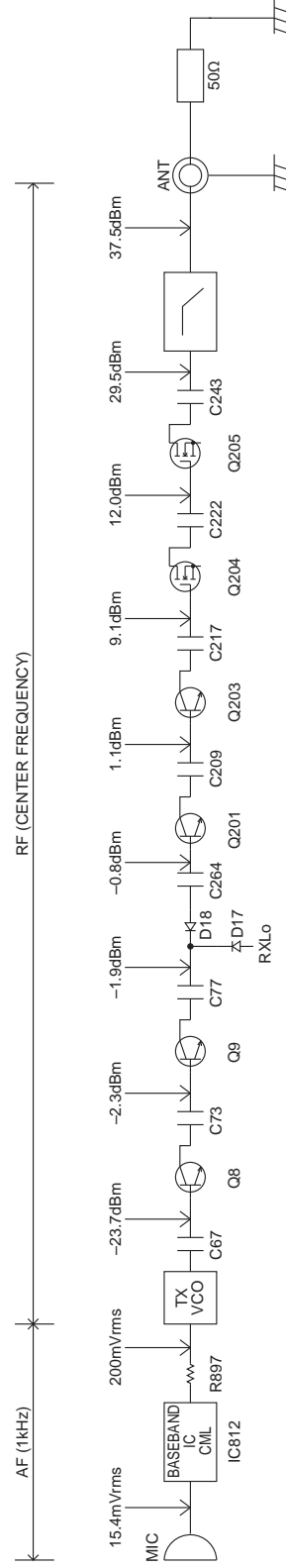

AG is set to the MIC input becomes 1.5kHz Dev, at 1kHz MOD. (Narrow) To make measurements in the AF section, connect the AC level meter. In the RF section, use a 1000pF coupling capacitor.

OPTIONAL ACCESSORIES

KNB-29N (Ni-MH Battery Pack)

■ External View



■ Specifications

Voltage.....7.2V (1.2V x 6)
 Battery capacity.....1500mAh

KNB-53N (Ni-MH Battery Pack)

■ External View



■ Specifications

Voltage.....7.2V (1.2V x 6)
 Battery capacity.....1400mAh

KNB-45L (Li-ion Battery Pack)

■ External View



■ Specifications

Voltage.....7.4V (3.7V x 2)
 Battery capacity.....2000mAh

KMC-48GPS (GPS Speaker Microphone)

■ External View



■ Specifications

Operating temperature range-30°C ~ +60°C
 Microphone impedance 2.2 kΩ (max)
 Speaker impedance..... 16 Ω ± 15 % at 1.2 kHz

SPECIFICATIONS

GENERAL

Frequency Range	450~520MHz (RX),450~500MHz(TX):X(LMR)
	476.4250~477.4125MHz:X(CB)
Channel Spacing	25kHz (Wide) / 12.5kHz (Narrow)
PLL Channel Stepping	5kHz, 6.25kHz
Operating Voltage	7.5 V DC±20%
Battery Life	More than 12 hours at 5 watts (5-5-90 duty cycle, save off) With KNB-45L battery
Operating Temperature Range	-30°C to +60°C
Frequency Stability	±2.5ppm (-30°C to +60°C)
Channel Frequency Spread	70MHz(RX),50MHz(TX)
Dimensions and Weight (Dimensions not included)	
Radio Only	54 W x 122 H x 21 D mm 180g
With KNB-45L (2000mAh battery)	54 W x 122 H x 33.7 D mm 300g

RECEIVER (Measurements made per TIA/EIA-603)

Sensitivity	
EIA 12dB SINAD	0.25µV (Wide) / 0.28µV (Narrow)
Selectivity	70dB (Wide) / 60dB (Narrow)
Intermodulation Distortion	70dB (Wide) / 60dB (Narrow)
Spurious Response	70dB
Audio Output	500mW/8Ω

TRANSMITTER (Measurements made per TIA/EIA-603)

RF Output Power	5W/1W
Spurious Response	70dB
Modulation	16K0F3E (Wide) / 11K0F3E (Narrow)
FM Hum and Noise	45dB (Wide) / 40dB (Narrow)
Modulation Distortion	Less than 5%

Measurements made per TIA/EIA-603 and specifications shown are typical.

JVC KENWOOD Corporation reserves the right to change specifications without prior notice or obligation.

JVC KENWOOD Corporation

3-12, Moriyacho, Kanagawa-ku, Yokohama-shi,
Kanagawa, 221-0022 Japan

Kenwood U.S.A. Corporation

P.O. BOX 22745, 2201 East Dominguez Street, Long Beach,
CA 90801-5745, U.S.A.

Kenwood Electronics Canada Inc.

6070 Kestrel Road, Mississauga, Ontario, Canada L5T 1S8

Kenwood Electronics Deutschland GmbH

Rembrücker Str. 15, 63150 Heusenstamm, Germany

Kenwood Electronics Belgium N.V.

Leuvensesteenweg 248 J, 1800 Vilvoorde, Belgium

Kenwood Electronics France S.A.

L'Etoile Paris Nord 2, 50 Allée des Impressionnistes,
Bp 58416 Villepinte, 95944 Roissy Ch De Gaulle Cedex

Kenwood Electronics UK Limited

Kenwood House, Dwight Road, Watford, Herts.,
WD18 9EB United Kingdom

Kenwood Electronics Europe B.V.

Amsterdamseweg 37, 1422 AC Uithoorn, The Netherlands

Kenwood Electronics Italia S.p.A.

Via G. Sirtori, 7/9 20129 Milano, Italy

Kenwood Ibérica, S.A.

Carretera de Rubi, 88 Planta 1 A 08174 Sant Cugat del Vallès
Barcelona, Spain

Kenwood Electronics Australia Pty. Ltd.

Talavera Business Park Building A, 4 Talavera Road,
North Ryde NSW 2113 Australia

Kenwood Electronics (Hong Kong) Ltd.

Suite 2504, 25/F, Tower 2, Nina Tower, No. 8 Yeung Uk Road,
Tsuen Wan, New Territories, Hong Kong

Kenwood Electronics Singapore Pte Ltd

1 Ang Mo Kio Street 63, Singapore 569110

TK-3310 PC BOARD

PC BOARD TK-3310

**TX-RX UNIT (X57-7890-71)
Component side view (J79-0288-29)**

**TX-RX UNIT (X57-7890-71)
Component side view (J79-0288-29)**

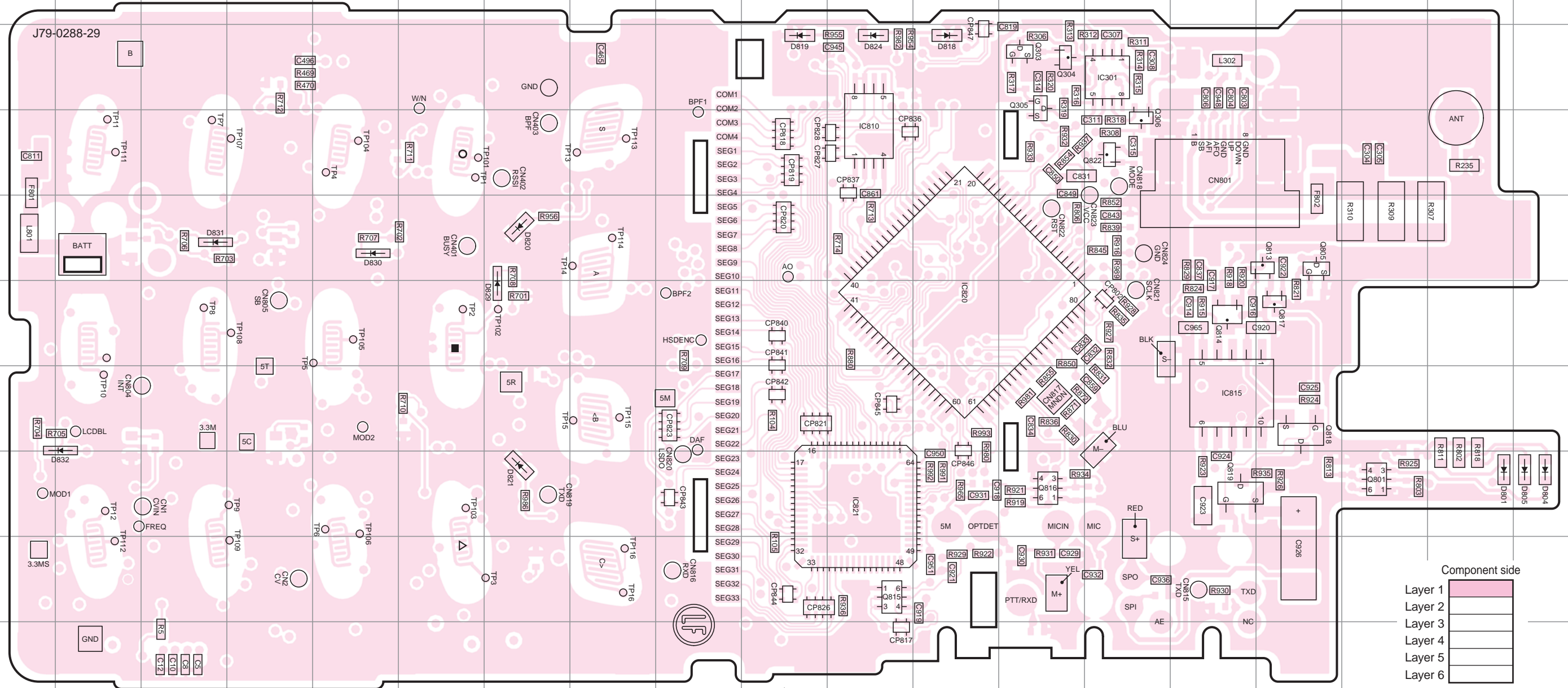

Ref. No.	Address	Ref. No.	Address	Ref. No.	Address	Ref. No.	Address
IC301	3N	Q306	4N	Q818	7P	D820	5G
IC810	4K	Q801	8Q	Q819	8O	D821	8G
IC815	7O	Q805	5P	Q822	4N	D824	3K
IC820	6L	Q813	5P	D801	8R	D829	6G
IC821	8K	Q814	6O	D804	8S	D830	5E
Q303	3M	Q815	9K	D805	8S	D831	5C
Q304	3M	Q816	8M	D818	3L	D832	8B
Q305	3M	Q817	6P	D819	3J		

TK-3310 PC BOARD

PC BOARD TK-3310

TX-RX UNIT (X57-7890-71)
Foil side view (J79-0288-29)

TX-RX UNIT (X57-7890-71)
Foil side view (J79-0288-29)

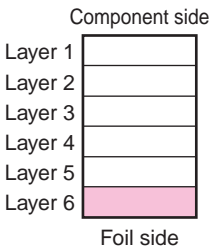
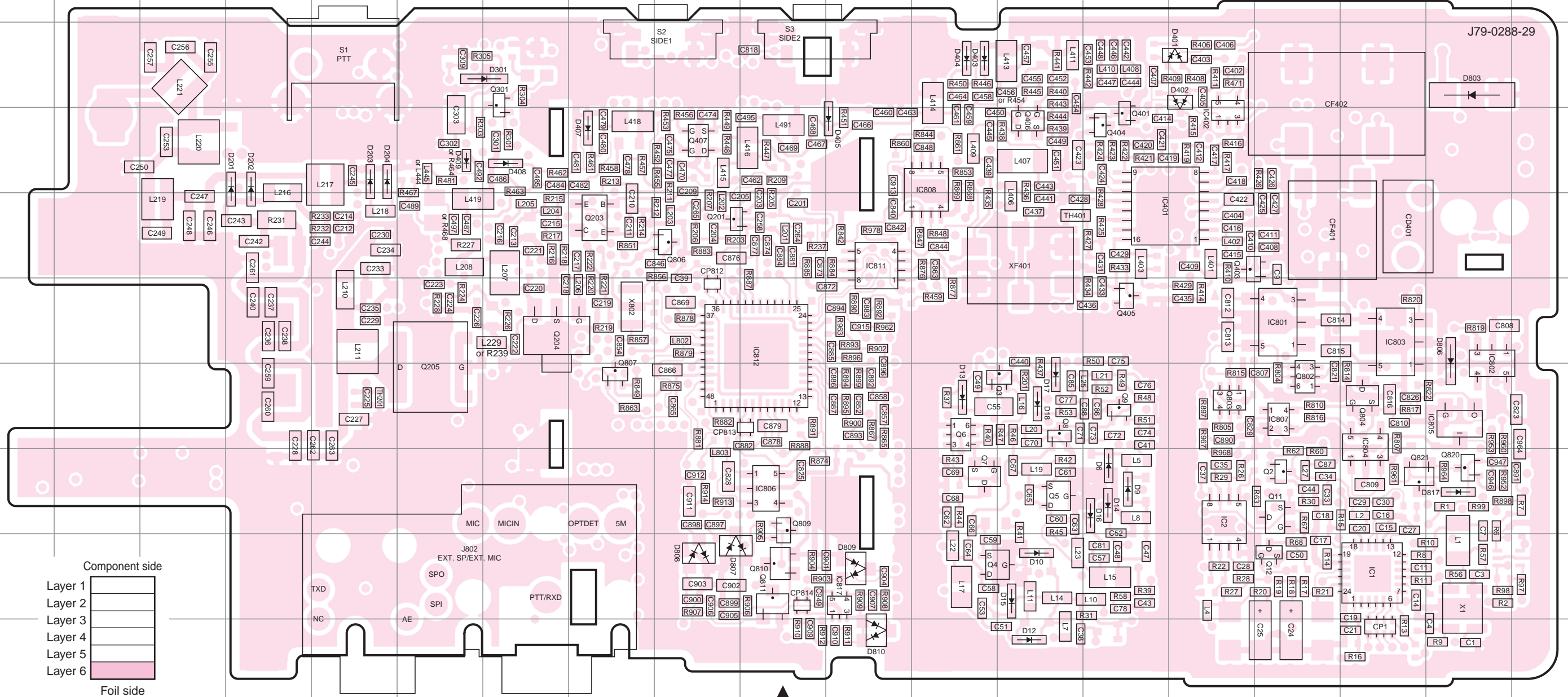

Ref. No.	Address	Ref. No.	Address	Ref. No.	Address	Ref. No.	Address	Ref. No.	Address	Ref. No.	Address	Ref. No.	Address	Ref. No.	Address
IC1	9Q	IC807	7P	Q7	8L	Q401	4N	Q807	7H	D13	7L	D301	3G	D806	6R
IC2	8O	IC808	4L	Q8	7M	Q403	5O	Q809	8J	D14	8N	D401	3O	D807	9I
IC401	5N	IC811	5K	Q9	7N	Q404	4N	Q810	9J	D15	9M	D402	3O	D808	9I
IC402	4O	IC812	6J	Q11	8P	Q405	6N	Q811	9J	D16	8N	D403	3L	D809	9K
IC801	6P	IC817	9K	Q12	9P	Q406	4M	Q820	8R	D17	7M	D404	3L	D810	10K
IC802	7R	Q2	8P	Q201	5I	Q407	4I	Q821	8Q	D18	7M	D405	4K	D817	8R
IC803	6Q	Q3	7M	Q203	5H	Q802	7P	D6	8N	D201	4D	D407	4H		
IC804	7Q	Q4	9L	Q204	6G	Q803	7O	D9	8N	D202	4D	D408	4G		
IC805	7R	Q5	8M	Q205	7F	Q804	7Q	D10	9M	D203	4E	D409	4F		
IC806	8J	Q6	7L	Q301	3G	Q806	5I	D12	10M	D204	4E	D803	3R		

