

UHF FM TRANSCEIVER

# TK-3402(U)/3402

# TK-3407

## SERVICE MANUAL

# KENWOOD

JVCKENWOOD Corporation

© 2012-11 PRINTED IN JAPAN  
B53-7041-00 (Y) 669

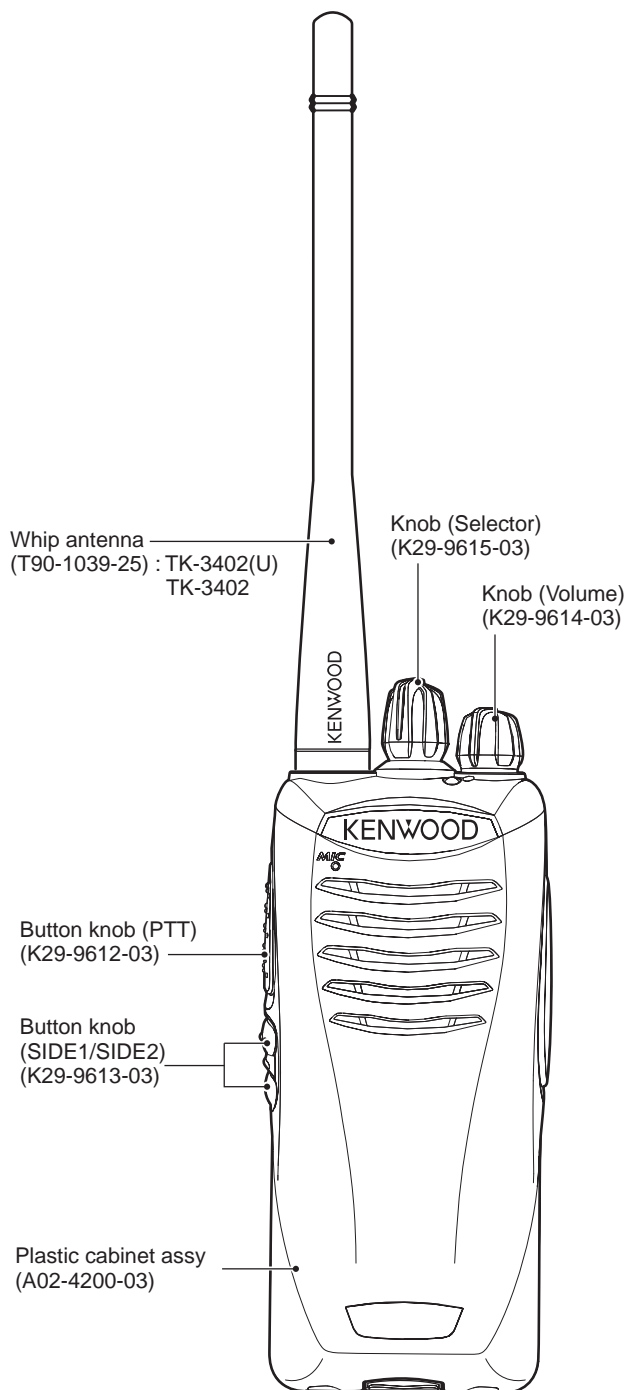

## CONTENTS

GENERAL .....	2
SYSTEM SET-UP .....	3
REALIGNMENT .....	3
DISASSEMBLY FOR REPAIR .....	6
CIRCUIT DESCRIPTION .....	9
SEMICONDUCTOR DATA .....	14
COMPONENTS DESCRIPTION .....	15
PARTS LIST .....	16
EXPLODED VIEW .....	22
PACKING .....	23
ADJUSTMENT .....	25
PC BOARD	
TX-RX UNIT (X57-8320-10) .....	30
SCHEMATIC DIAGRAM .....	34
BLOCK DIAGRAM .....	38
LEVEL DIAGRAM .....	40
SPECIFICATIONS .....	41

# TK-3402(U)/3402/3407

## Document Copyrights

Copyright 2012 by JVC KENWOOD Corporation. All rights reserved.

No part of this manual may be reproduced, translated, distributed, or transmitted in any form or by any means, electronic, mechanical, photocopying, recording, or otherwise, for any purpose without the prior written permission of JVC KENWOOD Corporation.

## Disclaimer

While every precaution has been taken in the preparation of this manual, JVC KENWOOD Corporation assumes no responsibility for errors or omissions. Neither is any liability assumed for damages resulting from the use of the information contained herein. JVC KENWOOD Corporation reserves the right to make changes to any products herein at any time for improvement purposes.

# GENERAL

## INTRODUCTION

### SCOPE OF THIS MANUAL

This manual is intended for use by experienced technicians familiar with similar types of commercial grade communications equipment. It contains all required service information for the equipment and is current as of the publication date. Changes which may occur after publication are covered by either Service Bulletins or Manual Revisions. These are issued as required.

### ORDERING REPLACEMENT PARTS

When ordering replacement parts or equipment information, the full part identification number should be included. This applies to all parts : components, kits, or chassis. If the part number is not known, include the chassis or kit number of which it is a part, and a sufficient description of the required component for proper identification.

## PERSONAL SAFETY

The following precautions are recommended for personal safety:

- DO NOT transmit until all RF connectors are verified secure and any open connectors are properly terminated.
- SHUT OFF and DO NOT operate this equipment near electrical blasting caps or in an explosive atmosphere.
- This equipment should be serviced by a qualified technician only.

## SERVICE

This transceiver is designed for easy servicing. Refer to the schematic diagrams, printed circuit board views, and alignment procedures contained within.

Model	Type	TX-RX unit	Frequency range	Remarks
TK-3402(U)	K	X57-8320-10	450~520MHz	IF1: 50.85MHz LOC: 50.4MHz
TK-3402	K			
TK-3407	M			

# TK-3402(U)/3402/3407

## SYSTEM SET-UP

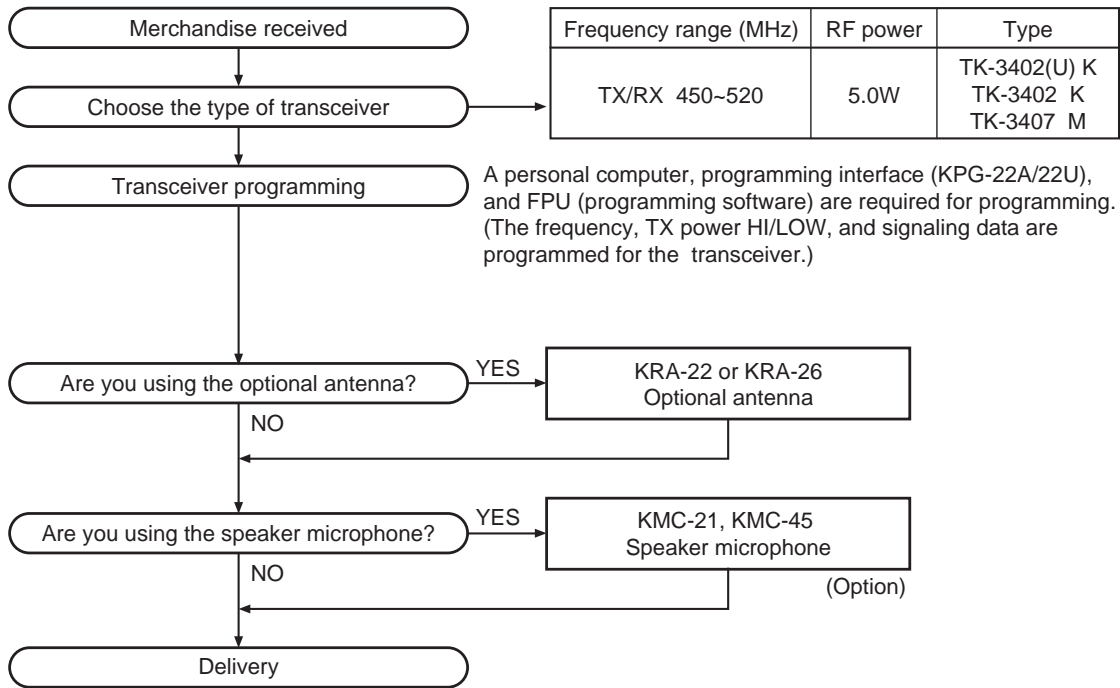

## REALIGNMENT

### 1. Modes

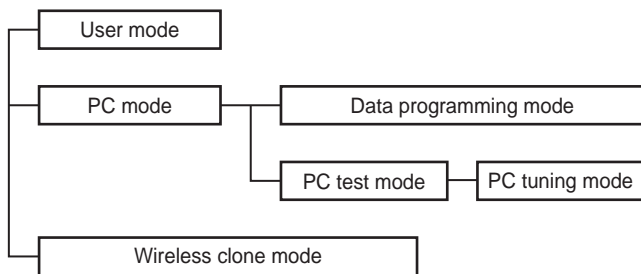

Mode	Function
User mode	For normal use.
PC mode	Used for communication between the transceiver and PC.
Data programming mode	Used to read and write frequency data and other features to and from the transceiver.
PC test mode	Used to check the transceiver using the PC. This feature is included in the FPU.
Wireless clone mode	Used to transfer programming data from one transceiver to another.

### 2. How to Enter Each Mode

Mode	Operation
User mode	Power ON
PC mode	Received commands from PC
Wireless clone mode	[PTT] + [Side] + Power ON (Two seconds)

### 3. PC Mode

#### 3-1. Preface

The transceiver is programmed by using a personal computer, a programming interface (KPG-22A/22U) and FPU programming software.

The programming software can be used with a PC. Figure 1 shows the setup of a PC for programming.

#### 3-2. Connection Procedure

1. Connect the transceiver to the personal computer with the interface cable.

#### Note:

- You must install the KPG-22U driver in the computer to use the USB programming interface cable (KPG-22U).

# TK-3402(U)/3402/3407

## REALIGNMENT

2. When the POWER is switched on, user mode can be entered immediately. When the PC sends a command, the transceiver enters PC mode.

When data is read from the transceiver, the red LED lights.

When data is written to by the transceiver, the green LED lights.

### Note:

- The data stored in the personal computer must match Model Name and Model Type when it is written into EEPROM.
- Do not press the [PTT] key during data transmission or reception.

### 3-3. KPG-22A Description

#### (PC programming interface cable: Option)

The KPG-22A is required to interface the transceiver with the computer. It has a circuit in its D-sub connector (KPG-22A: 9-pin) case that converts the RS-232C logic level to the TTL level.

The KPG-22A connects the SP/MIC connector of the transceiver to the RS-232C serial port of the computer.

### 3-4. KPG-22U Description

#### (USB programming interface cable: Option)

The KPG-22U is a cable which connects to a USB port on a computer.

When using the KPG-22U, install the supplied CD-ROM (with driver software) in the computer. The KPG-22U driver runs under Windows XP, Vista or 7.

### 3-5. Programming Software Description

The FPU is the programming software for the transceiver supplied on a CD-ROM. This software runs under windows XP, Vista or 7 on a PC. The software on this disk allows a user to program the transceiver via Programming interface cable (KPG-22A/22U).

- Use the FPU that matches the market when you first set the market code and model name/frequency data to the service unit. The unit set by mistake cannot be restored.

### • List of FPU for transceiver

Model	Type	FPU
TK-3402(U)	K	KPG-159DN
TK-3402	K	KPG-158D
TK-3407	M	

### 3-6. Programming with PC

If data is transferred to the transceiver from a PC with the FPU, the data for each set can be modified.

Data can be programmed into the EEPROM in RS-232C format via the SP/MIC jack.

In this mode the PTT line operate as TXD and RXD data lines respectively.

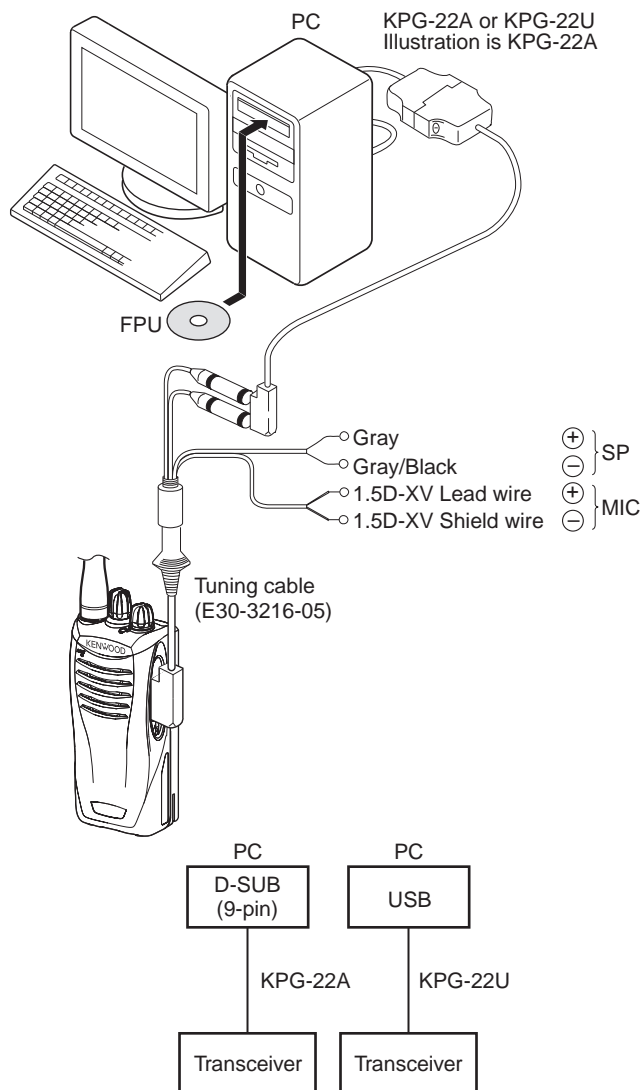

Fig. 1

# TK-3402(U)/3402/3407

## REALIGNMENT

### 4. Wireless Clone Mode

#### 4-1. Outline

“Wireless Clone Mode” copies the transceiver data to another transceiver.

The dealer can copy the transceiver data to another transceiver even without the use of a personal computer.

#### 4-2. Example

The transceiver can copy the programming data to one or more transceivers via RF communication.

The clone source and clone target/s must be in wireless clone mode.

#### 4-3. Operation

1. To switch the clone target/s to Wireless Clone mode, press and hold the [PTT] and [side2] keys while turning the transceiver power ON.
2. Wait for 2 seconds. The LED will light orange and the transceiver will announce “Clone”.
3. Select a channel table number using Side1 (increment channel table) and Side2 (decrement channel table) keys.
4. To switch the clone source to wireless clone mode, press and hold the [PTT] and [side2] keys while turning the transceiver power ON.
5. Wait for 2 seconds. The LED will light orange and the transceiver will announce “Clone”.
6. Select the same channel table number as the clone target/s.
7. Press [PTT] on the clone source to begin data transmission.  
When the clone target starts to receive data, the LED will light green.  
When the clone source finishes sending data, a “confirmation” tone will sound.  
If data transmission fails while cloning, an “error” tone will sound from the target unit.
8. If the cloning fails, no data will be available in the target unit when it is returned to User mode.
9. When the cloning is successful, the target unit’s “Scan” and “Key lock” functions will return to their default values (Scan = OFF, Key lock = OFF).

#### Note:

- The dealer can clone data to two or more transceivers by repeating the above procedures.
- If the transceivers wireless clone Mode is configured as “Disabled”, the transceiver cannot enter Clone mode.
- The table shown below will cover the frequency tables used for wireless cloning.
- Wireless clone mode cannot be entered in battery low state.
- A unit cannot be a “Source Unit” if it is unprogrammed. If [PTT] is pressed, an “error” tone will sound.
- The language used in cloning depends on the “Model type” setting, not the FPU setting.
- Once a unit is set to be the source, it cannot be a target after the data has been transmitted. This protects the data in the source unit.

- Electronic interface may cause a failure in data transfer during Wireless Clone, such as when waveforms or electromagnetics are being performed at the workbench.
- **Wireless clone mode can be used ONLY by the authorized service personnel.**
- **The wireless clone mode setting must be configured as “Disable” before being delivered to the end-user.**
- **To clone, replace the antenna from both the source transceiver and the target transceiver with a dummy load.**
- **The transmit output power is automatically set to Low in clone mode.**

#### • Clone frequency table

No.	Operating frequency 450-520 (MHz)
1	450.000
2	452.000
3	454.000
4	456.000
5	458.000
6	460.000
7	462.000
8	464.000
9	466.000
10	468.000
11	470.000
12	472.000
13	474.000
14	476.000
15	478.000
16	480.000
17	482.000
18	484.000
19	486.000
20	488.000

# TK-3402(U)/3402/3407

## DISASSEMBLY FOR REPAIR

### 1. Removing the Case Assembly from the Chassis

1. Remove the selector knob ① and volume knob ②.
2. Remove the two screws ③.
3. Lift and remove the chassis from the case assembly ④.  
(Use a flat-blade screwdriver to easily lift the chassis.)

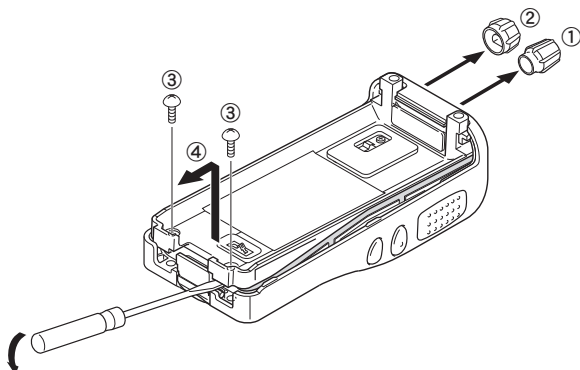

### 2. Removing the Holder Assembly from the Chassis

1. Remove the packing ⑤ from the SMA, volume and selector.
2. Remove the holder from the chassis.  
**Note:** Taking care not to cut the speaker and microphone lead.
3. Detach the solder of speaker and microphone lead from the PCB beforehand.
4. Remove the packing ⑥ from the SP/MIC jack of the TX-RX unit.

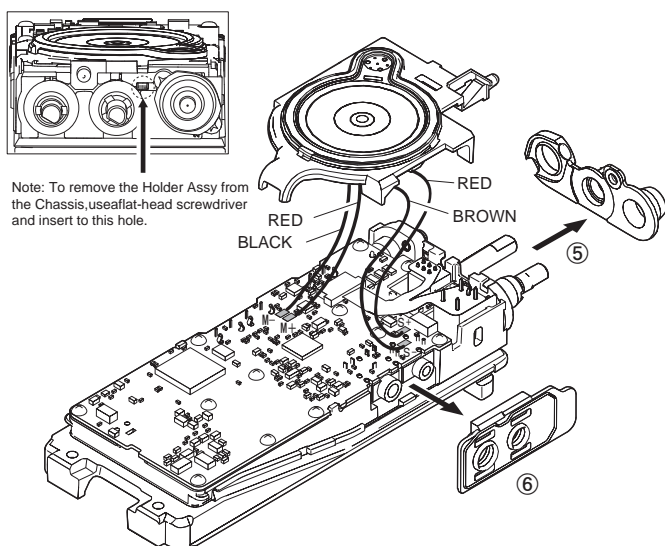

### 3. Removing the TX-RX unit from the Chassis

1. Remove the eleven screws ⑦ fixing the TX-RX unit.
2. Remove the solder of the antenna terminal with a soldering iron ⑧.
3. Remove the solder of the positive terminal with a soldering iron ⑨.  
**Note:** You can remove the TX-RX unit from the chassis without removing the solder at the positive terminal. However, in this case, you can not attach the packing (G53-2218-03) that is on the positive terminal to the chassis in assembling. So, it is advisable to remove the solder on the positive terminal first.
4. Remove the FPC from the flat cable connector ⑩.
5. Lift and remove the TX-RX unit from the chassis ⑪.

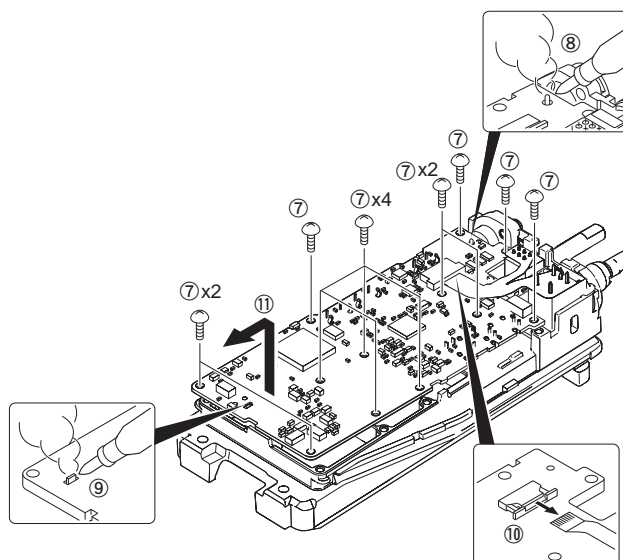

### 4. Removing the Battery Release Lever from the Case Assembly

1. Press the upper part of the lever toward the inside of the case assembly. One side of the shaft will be removed ①.
2. Lift and remove the battery release lever from the case assembly ②.  
**Note:** Scratch and widen the glue hole if there is difficulty in removing the other end of the shaft.  
No glue is required when you reassemble the battery release lever.

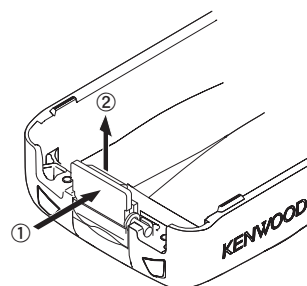

## 5. Attaching the Battery Release Lever to the Case Assembly

1. Insert one side of the shaft into the hole at the lever fitting section on the case assembly ①.  
 Caution: The thin spring (G01-4543-14) should be positioned above the two tabs of the lever.
2. Tilt the battery release lever slightly forward ②, so that the thick spring (G01-4542-04) is positioned below the case surface.
3. With the thick spring positioned below the case surface, attach the other side of the shaft to the case assembly by pressing the battery release lever ③ until it snaps into place ④.

**Caution:** Be careful not to tilt the battery release lever too forward.  
 If the battery release lever is pushed in this state where the two tabs come below the case surface, there is a possibility of damaging the two tabs.

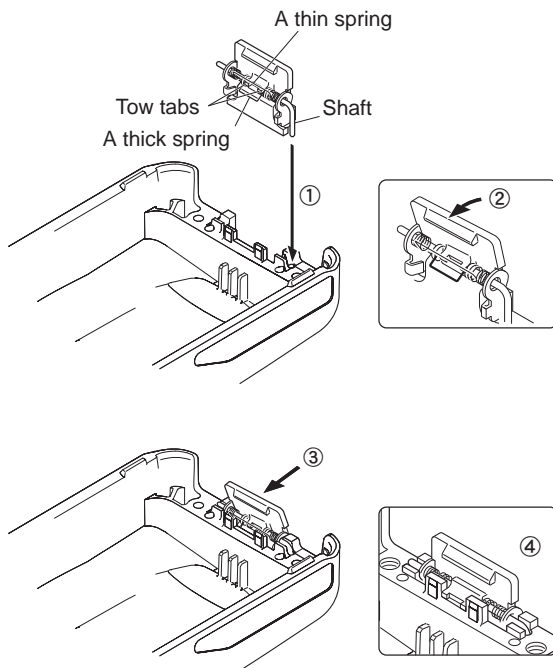

## 6. Assembling the Battery Release Lever

1. Place the lever ② onto the stopper ①.
2. Place the thick spring ③ onto the lever.
3. Hook the right and left ends of the thin spring ④ onto the tabs of the stopper, then place the thin spring ④ onto the lever ⑤.
4. Slide the shaft through the hole of the stopper and lever ⑥.

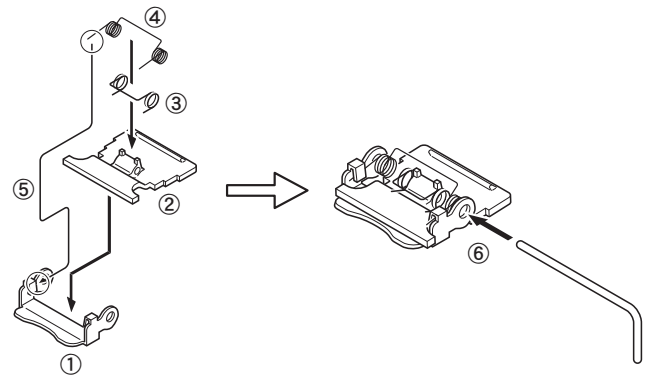

## 7. Attaching the Positive Terminal to the Chassis

Always attach the positive terminal to the chassis, using the following procedures, before mounting the TX-RX unit onto the chassis.

1. Remove the holder assembly ② from the packing ① of the positive terminal.
2. Mount the packing of the positive terminal into the chassis hole ③.
3. Mount the holder assembly into the packing of the positive terminal ④.

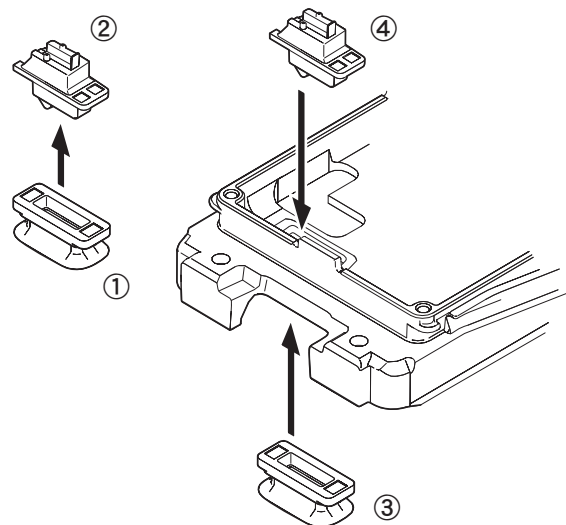



# TK-3402(U)/3402/3407

## DISASSEMBLY FOR REPAIR

### 8. Mounting the Chassis to the Case Assembly

1. Confirm that the waterproof packing attached to the circumference of the chassis is securely inserted in the groove of the chassis ①.
2. Insert the upper part of the chassis into the case assembly ②.
3. Press the chassis ③ and the case assembly together to attach them.

**Caution:** If the packing of the SP/MIC does not come to the correct position after attaching the chassis to the case assembly, reposition the packing with your fingers.

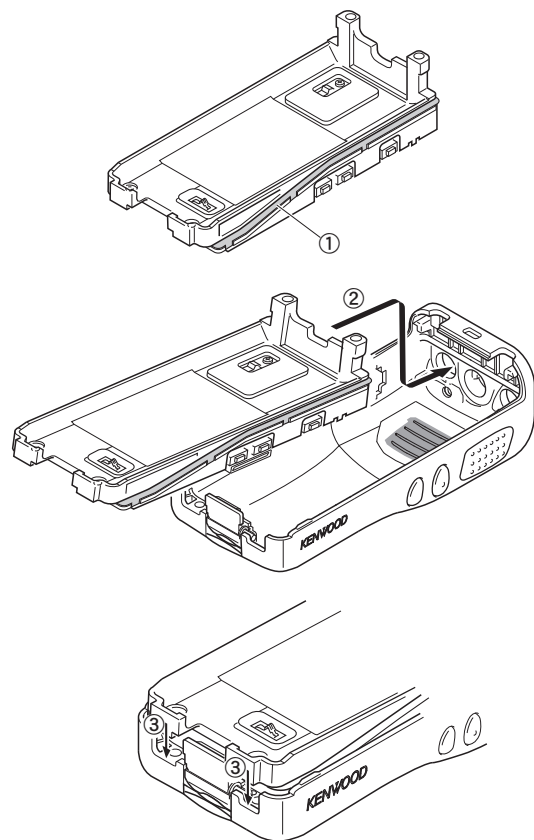

### 10. The Nuts of the Volume Knob and Channel Knob

Note that the shapes, colors and heights of nuts of the volume knob and channel knob are different from one another. (The nut of volume knob is silver, and the nut of channel knob is gold.)

Use the following jig when removing the nuts of the volume knob and channel knob.

- Jig (Part No.: W05-1012-00)

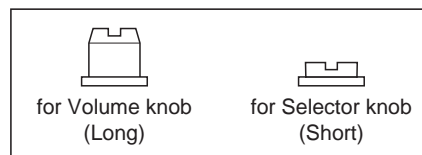

### 9. Attaching the Antenna Receptacle to the Chassis

Screw the antenna receptacle to the chassis in the order shown in the drawing so that the antenna receptacle comes to the center of the case hole.

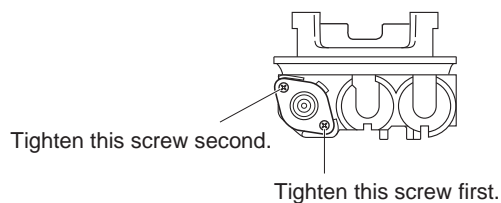



# TK-3402(U)/3402/3407

## CIRCUIT DESCRIPTION

### 1. Frequency Configuration

The receiver utilizes double conversion. The first IF is 50.85MHz and the second IF is 450kHz. The first Local oscillator is supplied from the PLL circuit.

The PLL circuit in the transmitter generates the necessary frequencies. Figure 1 shows the frequencies.

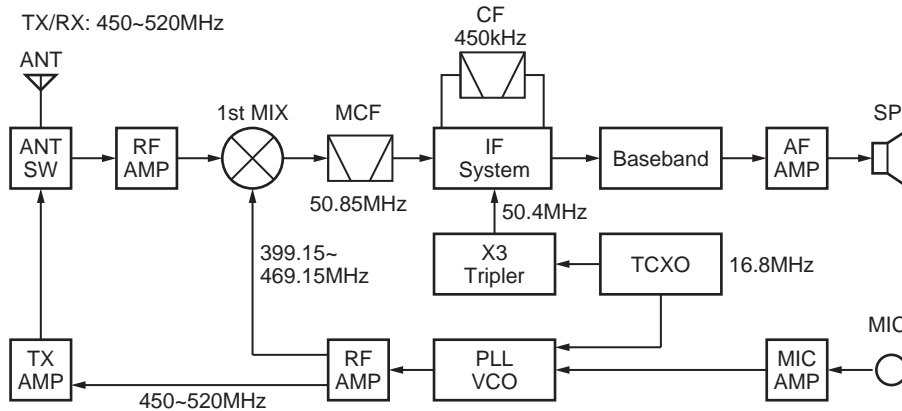

Fig. 1 Frequency configuration

### 2. Receiver System

The receiver system is shown in Figure 2.

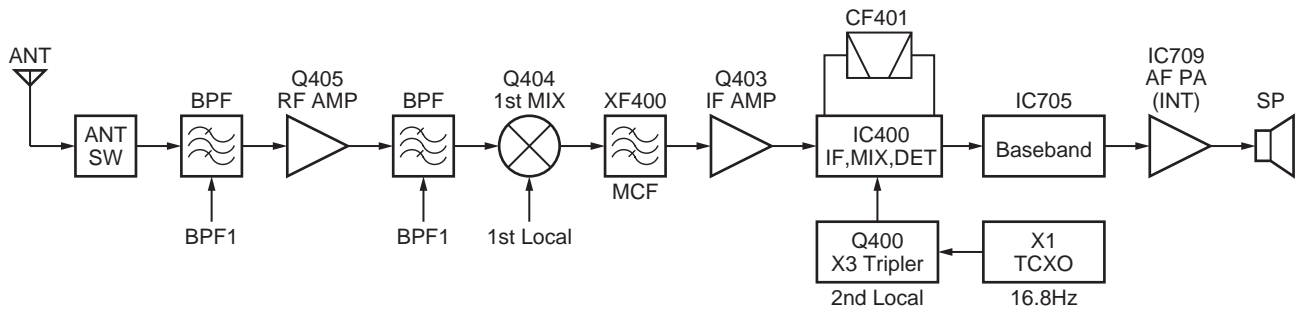

Fig. 2 Receiver system

#### 2-1. Front End (RF Amplifier) Circuit

The signal coming from the antenna passes through the transmit/receive switching diode circuit (D201, D202, D203 and D204) and a BPF (L415 and L416), and is then amplified by the RF amplifier (Q405).

The resulting signal passes through a BPF (L410, L411 and L413) and goes to the mixer. These BPF are adjusted by variable capacitance diodes (D400, D401, D402, D403 and D404). The input voltage to the variable capacitance diode is a regulated voltage output from the DC amplifier (IC704).

#### 2-2. First Mixer

The signal from the front end is mixed with the first local oscillator signal generated in the PLL circuit by Q404 to produce a first IF frequency of 50.85MHz.

The resulting signal passes through the XF400 MCF to cut the adjacent spurious and provide the optimum characteristics, such as adjacent frequency selectivity.

## CIRCUIT DESCRIPTION

### 2-3. IF Amplifier Circuit

The first IF signal is passed through a four-pole monolithic crystal filter (XF400) to remove the adjacent channel signal. The filtered first IF signal is amplified by the first IF amplifier (Q403) and is then applied to the IF system IC (IC400).

The IF system IC provides a second mixer, limiting amplifier, quadrature detector and RSSI (Received Signal Strength Indicator). The second mixer mixes the first IF signal with the 50.85MHz signal of the second local oscillator output (Q403) and produces the second IF signal of 450kHz.

The second IF signal is passed through the ceramic filter (CF401) to remove the adjacent channel signal. The filtered second IF signal is amplified by the limiting amplifier and demodulated by the quadrature detector with the ceramic discriminator (CD400). The demodulated signal is routed to the audio circuit.

### 2-4. Audio Amplifier Circuit

The demodulated signal from IC400 is sent to an AF amplifier through IC705, and is routed to an audio power amplifier (INT:IC709,EXT:IC707) where it is amplified and output to the speaker.

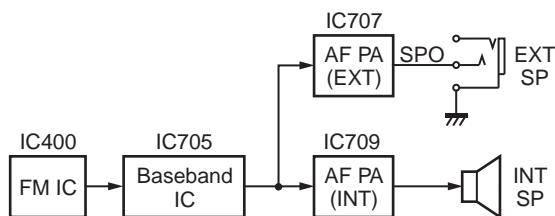

Fig. 3 Audio Amplifier circuit

### 2-5. Squelch Circuit

Part of the AF signal from the IC400 enters the FM IC (IC400) again, and the noise component is amplified and rectified by a filter and an amplifier to produce a DC voltage corresponding to the noise level.

The DC signal from the FM IC goes to the analog port of the MCU (IC702). IC702 determines whether or not to output sounds from the speaker by checking if the input voltage is higher or lower than the preset value.

To output sounds from the speaker, IC702 sends a high signal to the AFSW line and turns IC707 on through Q709, Q710, Q713 and Q716. This explanation is a case of external speaker amplifier. In the case of internal loudspeaker amplifier, IC702 sends a high signal to the AFSW line and turns IC709 on through Q711 and Q714.

## 3. Transmitter System

### 3-1. Microphone Amplifier Circuit

The signal from the microphone is limited by the AGC circuit, which is composed of D700, D701, Q705, Q706 and the mute switch (Q704). IC705 is composed of a high-pass filter, low-pass filter and pre-emphasis/IDC circuit.

The signal from the microphone and the low speed data from the MCU (IC702) enter the baseband IC (IC705) and pass through each path and are mixed inside the IC.

The output signal from the audio processor goes to the VCO modulation input. The other output signal goes to the TCXO modulation input.

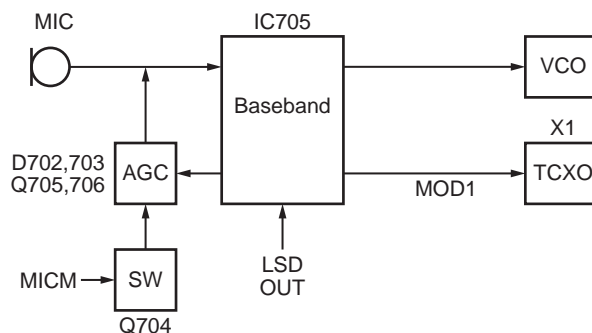

Fig. 4 Microphone amplifier circuit

### 3-2. Drive and Final Amplifier Circuit

The signal from the T/R switch (D15 is on) is amplified by the pre-drive amplifier (Q201) to 20mW.

The output of the pre-drive amplifier is amplified by the drive amplifier (Q206) and the RF final amplifier (Q208) to 5.0W (1W when the power is low).

The drive amplifier and the RF final amplifier consist of two MOS FET stages.

The output of the RF final amplifier is then passed through the harmonic filter (LPF) and antenna switch (D203 and D204) and is applied to the antenna terminal.

### 3-3. APC Circuit

The APC circuit always monitors the current flowing through the drive amplifier (Q206) and the RF power amplifier (Q208) and keeps a constant current. The voltage drop at R230, R231 and R233 is caused by the current flowing through the RF final amplifier. This voltage is applied to the differential amplifier IC200 (1/2).

IC200 (2/2) compares the output voltage of IC200 (1/2) with the reference voltage from IC705(32pin:AUXDAC1). The output of IC200 (2/2) controls the gate bias voltage of the RF power amplifier and the drive amplifier to make both voltages the same.

The change of power high/low is carried out by the change of the reference voltage.

## CIRCUIT DESCRIPTION

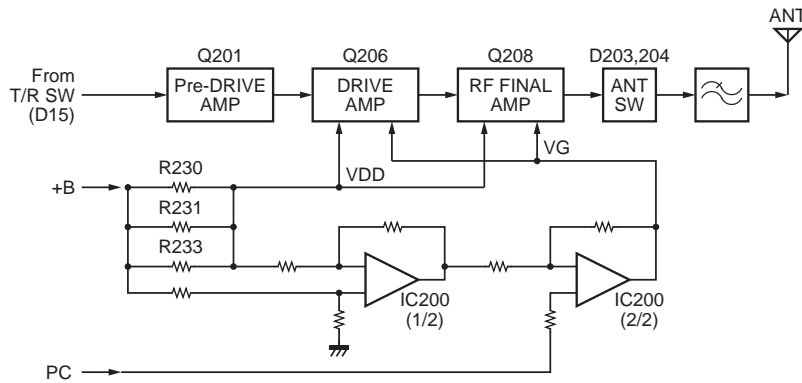

**Fig. 5 Drive and final amplifier and APC circuit**

### 4. Frequency Synthesizer Unit

#### 4-1. Frequency synthesizer

The frequency synthesizer consists of the TCXO (X1), VCO, PLL-IC (IC2), and buffer amplifiers.

The TCXO generates 16.8MHz. The frequency stability is 1.5ppm within the temperature range of  $-30^{\circ}\text{C}$  to  $+60^{\circ}\text{C}$ . The frequency tuning and modulation of the TCXO are done to apply voltage to pin 1 of the TCXO. The output of the TCXO is applied to pin 1 of PLL-IC.

The VCO consists of 2 VCOs and covers a dual range of 399.15~469.15MHz and 450~520MHz. The VCO generates 399.15~469.15MHz for providing the first local signal for reception. The operating frequency is generated by Q6 in transmitting mode and Q5 in receiving mode. The oscillation frequency is controlled by applying the VCO control voltage, obtained from the phase comparator (IC2) to the variable capacitance diodes (D5, D9, D11, and D13 in transmitting mode and D4, D7 and D12 in receiving mode)

The TX/RX pin of IC702 goes "high" in transmitting mode, causing Q8 to turn off, and Q7 turn on. The TX/RX pin goes "low" in receiving mode.

The output from Q5 and Q6 are amplified by a buffer amplifier (Q9) and Q2, and then sent to the PLL-IC. The PLL-IC consists of a prescaler, reference divider, phase comparator, and charge pump. The input signal from pin 1 and 8 of the PLL-IC is divided down and compared at the phase comparator. The pulsed output signal of the phase comparator is applied to the charge pump and transformed into a DC signal in the loop filter (LPF). The DC signal is applied to the CV of the VCO and locked to keep the VCO frequency constant.

PLL data is output from PLL\_LE (pin 72), PLL\_DATA (pin 73) PLL\_CLK (pin 74), and PLL\_PS (pin 70) of the MCU (IC702). The data is input to the PLL-IC when the channel is changed or transmission is changed to reception and vice versa. The PLL lock condition is always monitored by pin 71 (PLL\_LD) of the MCU. When the PLL is unlocked, PLL\_LD goes low.

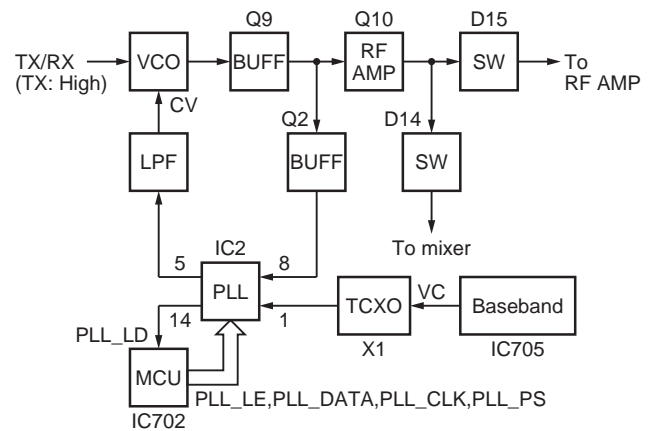

**Fig. 6 PLL block diagram**

### 5. Control Circuit

The control consists of the MCU (IC702) and its peripheral circuits. It controls the TX-RX unit. IC702 mainly performs the following;

- 1) Switching between transmission and reception by PTT signal input.
- 2) Reading channel information, frequency, and program data from the memory circuit.

- 3) Sending frequency program data to the PLL.
- 4) Controlling squelch on/off via the DC voltage from the squelch circuit.
- 5) Controlling the audio mute circuit via the decode data input.
- 6) Transmitting tone and encode data.

# TK-3402(U)/3402/3407

## CIRCUIT DESCRIPTION

### 5-1. Frequency Shift Circuit

The MCU (IC702) and baseband IC (IC705) operates at a clock frequency of 19.2MHz. This oscillator has a circuit that shifts the frequency via Beat shift switch (Q701, Q702).

A beat sound may be able to be evaded from generation if "Beat Shift" is set to ON when it is generated in the internal spurious transmission modulated sound of the transceiver.

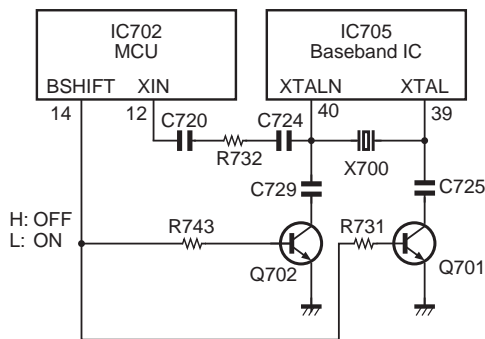

Fig. 7 Frequency shift circuit

### 5-2. Memory Circuit

The Memory circuit consists of the MCU (IC702) and EEPROM (IC700). The EEPROM has a capacity of 64k bits and stores the channel information, the last channel data, the scan on status, and other parameters.

#### ■ EEPROM

##### Note:

The EEPROM stores tuning data (Deviation, Squelch, etc.).

Realign the transceiver after replacing the EEPROM.

### 5-3. Low Battery Warning

The battery voltage is monitored by the MCU (IC702 pin 63: BATT). When the battery voltage falls below the voltage set by the Low Battery Warning adjustment, the red LED blinks, notifying the operator that it is time to replace the battery (when the always option (default setting) under the Battery Warning function in the FPU is selected). If the battery voltage falls below 5.9V, the transceiver does not transmit and the warning tone beeps while the PTT switch is pressed.

### 5-4. Key Input

Keys and channel selector circuit.

The signal from the keys and channel selector are directly input to the MCU, as shown in Figure 10.

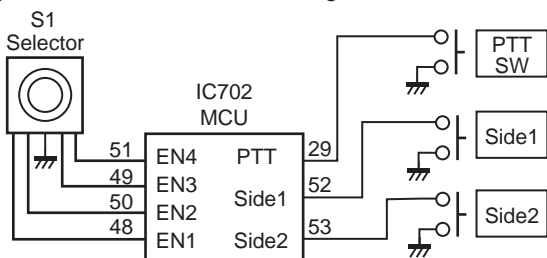

Fig. 8 Key input

## 6. Signaling Circuit

### 6-1. Encode

#### ■ Low-speed data (QT, DQT)

Low-speed data is output from pin2 of the MCU. The signal passes through the low pass CR filter, and goes to the audio processor (IC705). The signal is mixed with the audio signal and goes to the VCO and TCXO (X1) modulation input after passing through the D/A converter inside the audio processor (IC705) for BAL adjustment.

#### ■ High-speed data (2-tone,DTMF)

High-speed data (HSD) is output from pin 3 of the MCU. HSD deviation made by an adjustment in the MCU is passed through the low pass CR filter and then applied to the baseband IC (IC705).

The signal is mixed with the audio signal and goes to the VCO and TCXO. The signal passes through low pass CR filter and D/A converter, and goes to the audio power amplifier. The level is controlled by the MCU.

#### ■ MSK

The MSK signal is generated in the audio processor (IC705). The signal passes through the D/A converter (inside the baseband IC: IC705) and is routed to the VCO. When encoding the MSK, the microphone input signal is muted.

### 6-2. Decode

#### ■ QT/DQT

The output signal from the IF IC (IC400) enters the MCU (IC702) through IC705. IC702 determines whether or not the QT or DQT matches the preset value, and controls the AFSW and speaker output sounds according to the squelch results.

#### ■ 2-tone

Part of the received AF signal output from the IF IC (IC400) passes through the baseband IC (IC705) is compared, and then goes to MCU (IC702). IC702 checks whether or not the 2-tone data is necessary. If it matches, IC702 carries out a specified operation, such as turning the speaker on.

#### ■ MSK (Fleet Sync)

The MSK input signal from the IF IC (IC400) goes to IC705. The decoded information is then processed by the MCU.

#### ■ DTMF

The DTMF input signal from the IF IC (IC400) goes to IC705. The decoded information is then processed by the MCU.

# TK-3402(U)/3402/3407

## CIRCUIT DESCRIPTION

### 7. Power Supply

There are five 5V power supplies and three 3.3V power supplies: 50M, 50V, 50C, 50R, 50T, 33M, 33MS and 33B.

50M and 33M are always output while the power is on.

33MS is always output, but turns off when the power is turned off, to prevent malfunction of the MCU.

50C is a common 5V and is output when SAVE is not set to ON.

50R is 5V for reception and output during reception.

50T is 5V for transmission and output during transmission.

50V is 5V for the SP/MIC connector.

33B is 3.3V for the baseband IC (IC705).

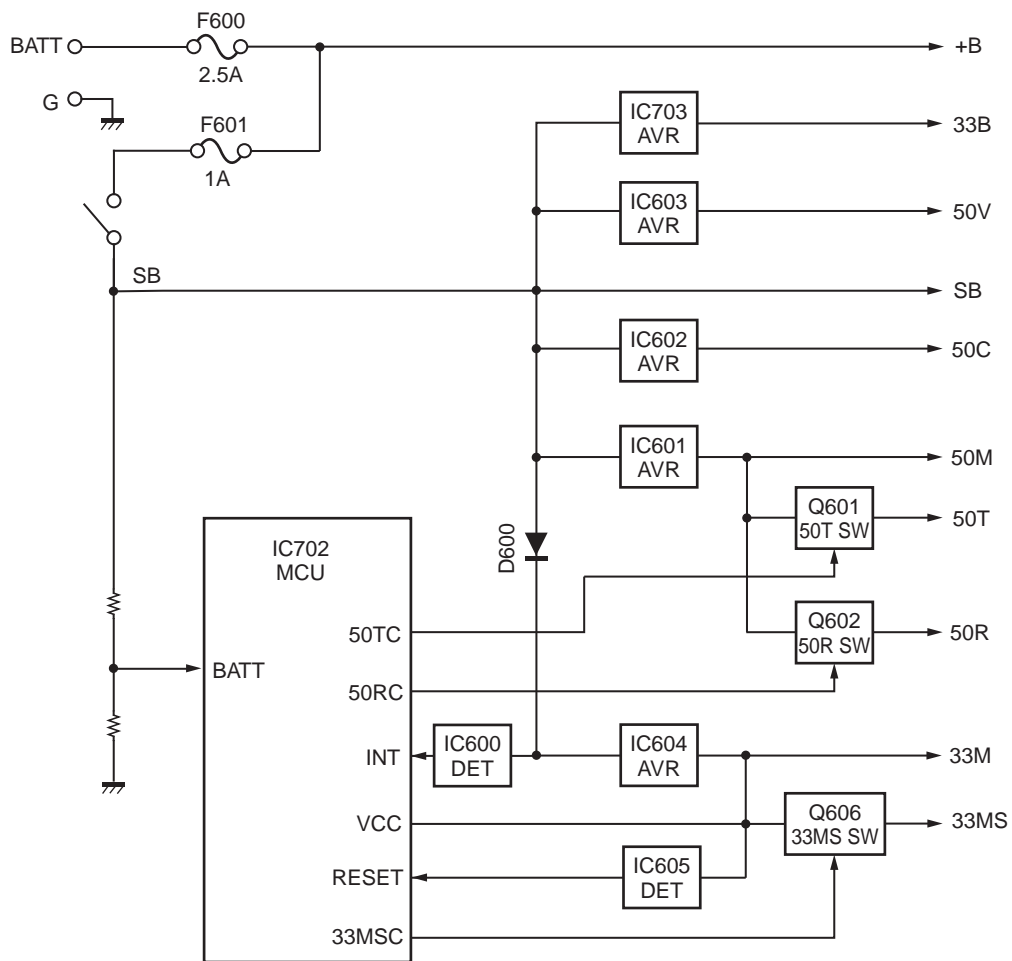

Fig. 9 Power Supply

## SEMICONDUCTOR DATA

## MCU:F363BEDFEKDLF (TX-RX unit IC702)

Pin No.	Signal Name	I/O	Function
1	BLULED	O	Blue LED light control(Hi:LED ON)
2	LSDO	O	QT/DQT output
3	HSDENC	O	2-Tone/BEEP output
4	CML_CSN	O	Chip select for baseband IC
5	SCLK_CML	O	SCLK for baseband IC
6	MODE	I	(Using E8a emulator)
7	SDATA_I_CML	I	REPLY for baseband IC
8	SDATA_O_CML	O	Command for baseband IC
9	RESET	I	MCU reset input
10	XOUT	O	X'TAL (19.2MHz)
11	VSS	-	GND
12	XIN	I	X'TAL (19.2MHz)
13	VCC	-	3.3V
14	BSHIFT	O	MCU clock frequency shift
15	CML_IRQ	I	IRQ for baseband IC
16	INSPMT	O	BTL IC mute
17	INT0	I	Battery low interrupt(4.5V)
18	INSPSW	O	BTL IC supply voltage control
19	NC	O	-
20	5RC	O	5R control output
21	5CC	O	5C control output
22	NC	O	-
23	NC	O	-
24	TXD	O	Serial data (FPU) to PC
25	RXD	I	Serial data (FPU) from PC
26	EM_SCLK	O	For E8a emulator
27	NC	O	-
28	EMPTT	O	Emergency PTT
29	PTT	I	PTT Input
30	NC	O	-
31	50VC	O	5V AVR control for GPS MIC option/OPT DET
32	5TC	O	5T control output
33	NC	O	-
34	EMP	O	For FDT tool
35	LPSW	O	Low power switch (Not used)
36	33MSC	O	33MS control for switched 33M
37	NC	O	-
38	NC	O	-
39	CE	O	For FDT tool
40	MODEL	I	For Model check

Pin No.	Signal Name	I/O	Function
41	OPTDET	I	Option detection
42	GRNLED	O	Green LED light control(Hi:LED ON)
43	REDLED	O	Red LED light control(Hi:LED ON)
44	MIC_MT	O	MIC mute
45	EXTSPSW	O	Speaker mute
46	MINVOL	O	Minimum volume control
47	DICSW	O	APC voltage discharge switch
48	EN1	I	Encoder detection 1
49	EN3	I	Encoder detection 3
50	EN2	I	Encoder detection 2
51	EN4	I	Encoder detection 4
52	PF1	I	Side key1
53	PF2	I	Side key2
54	APC SW	O	APC enable/disable
55	SCLK_EEP	O	Clock for EEPROM
56	SDATA_O_EEP	O	SI for EEPROM
57	ECP_WP	O	Write protect for EEPROM
58	SDATA_I_EEP	I	SO from EEPROM
59	ECP_CS	O	Chip select for EEPROM
60	TH_DET	I	Temperature level input
61	QT/DQT IN	I	QT/DQT decode
62	HSDDEC	I	2-Tone/5-tone decode
63	BATT	I	Battery level input
64	CVIN	I	VCO lock voltage (for auto alignment)
65	BUSY	I	Busy level input
66	RSSI	I	RSSI level input
67	VOX	I	VOX level input
68	NC	O	-
69	NC	O	-
70	PLL_PS	O	Sleep mode function for PLL IC
71	PLL_UL	I	Unlock vorutage from PLL
72	PLL_LE	O	Chip select for PLL IC
73	PLL_DAT	O	Data output for PLL IC
74	PLL_CLK	O	Clock ouput for PLL IC
75	AVSS	-	GND
76	WIDE/NARROW	O	Wide/Narrow switch
77	VREF	-	3.3V for A/D reference
78	AVCC	-	3.3V
79	ASSTSW	O	Assist switch
80	TX/RX	O	TX RX control(Hi: TX , Lo: RX)



# TK-3402(U)/3402/3407

## COMPONENTS DESCRIPTION

### TX-RX unit (X57-8320-10)

Ref. No.	Use / Function	Operation / Condition
IC2	IC	PLL system
IC3	IC	DC AMP(CV)
IC200	IC	DC AMP(APC)
IC400	IC	IF system
IC600	IC	Voltage detector(INT)
IC601	IC	Voltage regulator(50M)
IC602	IC	Voltage regulator(50C)
IC603	IC	Voltage regulator(50V)
IC604	IC	Voltage regulator(33M)
IC605	IC	Voltage detector(reset)
IC700	ROM IC	EEPROM
IC702	MCU	Microprocessor
IC703	IC	Voltage regulator(33B)
IC704	IC	DC AMP(BPF1 tune)
IC705	IC	Baseband system
IC706	IC	DC AMP(VOX)
IC707	IC	AF power amplifier(EXT)
IC708	IC	AF amplifier
IC709	IC	AF power amplifier(INT)
Q1	FET	DC switch(MOD)
Q2	TRANSISTOR	Fin buffer amplifier
Q3	FET	Q1 control
Q4	TRANSISTOR	Ripple filter
Q5	FET	RX-VCO
Q6	FET	TX-VCO
Q7	FET	Q8 control
Q8	FET	T/R VCO DC switch
Q9	TRANSISTOR	Buffer amplifier
Q10	TRANSISTOR	RF amplifier
Q201	TRANSISTOR	Pre-amplifier
Q203	TRANSISTOR	Discharge switch
Q205	FET	APC control switch
Q206	FET	Drive amplifier
Q207	TRANSISTOR	DC switch(APC)
Q208	FET	Final amplifier
Q209	FET	DC switch(Power control)
Q210	TRANSISTOR	DC switch(Power control)
Q400	TRANSISTOR	Tripler(2nd LO)
Q401	TRANSISTOR	Q402 control
Q402	TRANSISTOR	W/N switch
Q403	TRANSISTOR	1st IF amplifier
Q404	FET	1st mixer
Q405	FET	RX RF amplifier
Q600	TRANSISTOR	DC switch(BUSY-LED)
Q601	FET	DC switch(50T)

Ref. No.	Use / Function	Operation / Condition
Q602	FET	DC switch(50R)
Q603	FET	DC switch(MIN-VOL)
Q604,605	TRANSISTOR	DC switch(TX,BLUE-LED)
Q606	FET	DC switch(33MS)
Q701,702	TRANSISTOR	Beat shift switch
Q703	FET	Level shift(TXD)
Q704	TRANSISTOR	MIC mute switch
Q705,706	TRANSISTOR	MIC AGC AMP
Q707	FET	Level shift(RXD)
Q708	TRANSISTOR	DC switch(EXT-PTT)
Q709	TRANSISTOR	Q710 control
Q710	TRANSISTOR	DC switch(IC707 SB)
Q711	TRANSISTOR	Q715 control
Q712	TRANSISTOR	Pop noise mute control
Q713	FET	AF switch(EXT SP)
Q714	TRANSISTOR	DC switch(IC709 SB)
Q715	TRANSISTOR	Q714 control
Q716	FET	AF switch(EXT SP)
D601	LED	GREEN(BUSY)
D602	LED	RED(TX)
D604	LED	BLUE
D1	DIODE	Speed up(PLL UL)
D4	VARIABLE CAPACITANCE DIODE	RX VCO tune
D5	VARIABLE CAPACITANCE DIODE	TX VCO tune
D7	VARIABLE CAPACITANCE DIODE	RX VCO tune
D9	VARIABLE CAPACITANCE DIODE	TX VCO tune
D10	DIODE	Speed up
D11	VARIABLE CAPACITANCE DIODE	TX assist
D12	VARIABLE CAPACITANCE DIODE	RX assist
D13	VARIABLE CAPACITANCE DIODE	MOD
D14 ,15	DIODE	T/R switch
D200	ZENER DIODE	Over voltage protection
D201-204	DIODE	ANT switch
D400-404	VARIABLE CAPACITANCE DIODE	RX BPF tuning
D405	VARIABLE CAPACITANCE DIODE	RX notch tune
D600	DIODE	Voltage drop
D603	DIODE	Voltage prevention
D605	ZENER DIODE	Over voltage protection
D700,701	DIODE	AF detector(MIC)
D702	DIODE	AF detector(VOX)
D703	DIODE	Limiter



# TK-3402(U)/3402/3407

## PARTS LIST

\* New Parts. Δ indicates safety critical components.

Parts without **Parts No.** are not supplied.

Les articles non mentionnés dans le **Parts No.** ne sont pas fournis.

Teile ohne **Parts No.** werden nicht geliefert.

L : Scandinavia

K : USA

P : Canada

Y : PX (Far East, Hawaii)

T : England

E : Europe

C : China

X : Australia

M : Other Areas

### TK-3402(U) / 3402 / 3407

#### TX-RX UNIT (X57-8320-10)

Ref. No.	Address	New parts	Parts No.	Description	Desti-nation
<b>TK-3402(U) / 3402 / 3407</b>					
1	1A	*	A02-4200-03	PLASTIC CABINET ASSY	
2	3A	*	A10-4170-01	CHASSIS	
4	2C	*	B09-0758-03	CAP(EXT SP/MIC) ACCESSORY	
6	1B	*	B43-1686-04	BADGE(FRONT)	
7	1B	*	B43-1687-04	BADGEREAR)	
8	1C	*	B62-2479-00	INSTRUCTION MANUAL ACCESSORY	K,K1
8	1C	*	B62-2480-00	INSTRUCTION MANUAL ACCESSORY	M
9	1A		D10-0649-03	LEVER	
10	1A		D21-0863-04	SHAFT	
11	1A		D32-0441-13	STOPPER	
12	1B	*	D32-0456-03	STOPPER	
13	2B		E04-0477-15	RF COAXIAL RECEPTACLE(SMA)	
14	3B		E23-1253-14	TERMINAL(GROUND)	
15	2A	*	E23-1395-04	TERMINAL(+VE)	
16	2B		E37-1288-05	PARALLELE CORD(SP)	
20	1A		G01-4542-04	COIL SPRING(LEVER)	
21	1A		G01-4543-14	COIL SPRING(STOPPER)	
22	2B		G10-1348-04	FIBROUS SHEET(X57-IC)	
24	2B		G11-4465-04	RUBBER SHEET(Q208)	
25	3B		G13-2009-04	CUSHION(CHASSIS)	
26	3B		G13-2033-04	CUSHION(GROUND)	
27	3B		G13-2034-14	CUSHION(CHASSIS)	
28	2A		G13-2038-34	CUSHION(CHASSIS GROUND)	
29	3A		G13-2039-24	CUSHION(X57)	
30	2A		G13-2107-04	PACKING(CHASSIS)	
31	3A		G53-1604-03	PACKING(SP/MIC)	
32	2B	*	G53-2215-03	PACKING(SP)	
33	2A	*	G53-2216-03	PACKING(VOL/SEL)	
34	2B	*	G53-2217-02	PACKING(+VE)	
35	3A	*	G53-2218-03	PACKING FIXTURE	
41	2C	*	H12-4319-05	PACKING FIXTURE	K,K1
42	3C	*	H52-2589-01	ITEM CARTON CASE	K,K1
43	2C	*	J19-5577-03	HOLDER(SP/MIC) ACCESSORY	
44	2A	*	J19-5578-02	HOLDER(SP)	
45	3A	*	J19-5579-03	HOLDER(+VE)	
46	3A	*	J19-5580-03	HOLDER ASSY	
47	2C	*	J29-0734-15	BELT CLIP ACCESSORY	
48	2B	*	J82-0128-05	FPC(VOL/SEL)	
49	1A	*	J99-0779-04	ADHESIVE SHEET(PTT)	
51	1A	*	K29-9612-03	BUTTON KNOB(PTT)	
52	1A	*	K29-9613-03	BUTTON KNOB(PF)	
53	1A	*	K29-9614-03	KNOB(VOLUME)	
54	1A	*	K29-9615-03	KNOB(SELECTOR)	
A	3A	*	N09-6621-05	PAN HEAD SCREW	
B	2B	*	N14-0849-05	CIRCULAR NUT(VOL)	
C	2B	*	N14-0869-05	CIRCULAR NUT(SEL)	
D	2B	*	N19-2214-05	SPECIAL WASHER(VOL,SEL)	
E	2B	*	N30-2604-48	PAN HEAD MACHINE SCREW	
F	2A,2B	*	N83-2005-48	PAN HEAD TAPTITE SCREW	
55	2C	*	N99-2089-05	SCREW SET ACCESSORY	
VR1	2B		R31-0670-25	VARIABLE RESISTOR	

Ref. No.	Address	New parts	Parts No.	Description	Desti-nation
S1	2B	*	S60-0450-05	ROTARY SWITCH	
56	1A	*	T07-0805-05	SPEAKER	
57	2D		T90-1039-25	WHIP ANTENNA ACCESSORY	K,K1
58	1D		W08-1247-25	AC ADAPTER ACCESSORY	K,K1
59	1D		W08-1249-35	CHARGER ACCESSORY	K,K1

#### TX-RX UNIT (X57-8320-10)

D601			B30-2314-05	LED(GREEN)	
D602			B30-2315-05	LED(RED)	
D604			B30-1790-05	LED(BLUE)	
C2			CK73HB1H271K	CHIP C 270PF	K
C3 ,4			CC73HCH1H101J	CHIP C 100PF	J
C6			CC73HCH1H101J	CHIP C 100PF	J
C7			CC73HCH1H100B	CHIP C 10PF	B
C8			CK73HB1E103K	CHIP C 0.010UF	K
C9			CC73HCH1H101J	CHIP C 100PF	J
C11			CC73HCH1H100B	CHIP C 10PF	B
C13			CC73HCH1H101J	CHIP C 100PF	J
C14			CK73HB1A104K	CHIP C 0.10UF	K
C15 -17			CK73HB1E103K	CHIP C 0.010UF	K
C18			CK73HB1H271K	CHIP C 270PF	K
C19			CK73HB1E103K	CHIP C 0.010UF	K
C21 ,22			CK73HB1H271K	CHIP C 270PF	K
C23			CK73HB1E103K	CHIP C 0.010UF	K
C25			CS77BA21VR33M	CHIP TNTL 0.33UF	35WV
C26			CS77BA1C4R7M	CHIP TNTL 4.7UF	16WV
C27 ,28			CK73HB1H271K	CHIP C 270PF	K
C29			CS77MA1VR22M	CHIP TNTL 0.22UF	35WV
C30			CK73HB1H271K	CHIP C 270PF	K
C31			CS77BA21VR33M	CHIP TNTL 0.33UF	35WV
C33			CK73HB1E103K	CHIP C 0.010UF	K
C34			CK73HB1A104K	CHIP C 0.10UF	K
C35			CC73HCH1H080B	CHIP C 8.0PF	B
C36			CK73HB1A105K	CHIP C 1.0UF	K
C37			CC73HCH1H030B	CHIP C 3.0PF	B
C38			CK73HB1H271K	CHIP C 270PF	K
C40			CC73HCH1H080B	CHIP C 8.0PF	B
C41			CC73HCH1H100C	CHIP C 10PF	C
C42			CK73HB1A104K	CHIP C 0.10UF	K
C43			CK73HB1H271K	CHIP C 270PF	K
C45			CK73HB1H271K	CHIP C 270PF	K
C46			CC73HCH1H560J	CHIP C 56PF	J
C47			CC73HCH1H220J	CHIP C 22PF	J
C48			CC73HCH1H070B	CHIP C 7.0PF	B
C49			CC73HCH1H100C	CHIP C 10PF	C

# TK-3402(U)/3402/3407

## PARTS LIST

TX-RX UNIT (X57-8320-10)

Ref. No.	Address	New parts	Parts No.	Description	Desti-nation	Ref. No.	Address	New parts	Parts No.	Description	Desti-nation
C50 ,51			CK73HB1H271K	CHIP C 270PF K		C265			CC73GCH1H2R5B	CHIP C 2.5PF B	
C54			CC73HCH1HR75B	CHIP C 0.75PF B		C266			CC73GCH1H1R5B	CHIP C 1.5PF B	
C55			CC73HCH1H010B	CHIP C 1.0PF B		C267			CC73GCH1H050B	CHIP C 5.0PF B	
C56			CK73FB0J226M	CHIP C 22UF M		C268			CK73GB1H271K	CHIP C 270PF K	
C57			CC73HCH1H4R5B	CHIP C 4.5PF B		C269			CK73HB1H271K	CHIP C 270PF K	
C58			CC73HCH1H050B	CHIP C 5.0PF B		C270			CC73HCH1H040B	CHIP C 4.0PF B	
C59			CK73HB1A105K	CHIP C 1.0UF K		C271			CC73GCH1H060B	CHIP C 6.0PF B	
C60			CC73HCH1H060B	CHIP C 6.0PF B		C272			CC73GCH1H101J	CHIP C 100PF J	
C61			CC73HCH1H030B	CHIP C 3.0PF B		C273			CC73GCH1HR75B	CHIP C 0.75PF B	
C62			CC73HCH1H050B	CHIP C 5.0PF B		C274			CC73GCH1H020B	CHIP C 2.0PF B	
C63			CC73HCH1H060B	CHIP C 6.0PF B		C275			CC73GCH1H060B	CHIP C 6.0PF B	
C64 ,65			CK73HB1H271K	CHIP C 270PF K		C276			CC73GCH1H0R3B	CHIP C 0.3PF B	
C66			CC73HCH1H0R5B	CHIP C 0.5PF B		C278			CC73GCH1H070B	CHIP C 7.0PF B	
C67			CK73HB1H271K	CHIP C 270PF K		C279			CC73GCH1H010B	CHIP C 1.0PF B	
C68			CC73HCH1H0R3B	CHIP C 0.3PF B		C280			CC73GCH1H3R5B	CHIP C 3.5PF B	
C69			CK73HB1H271K	CHIP C 270PF K		C400,401			CK73HB1A104K	CHIP C 0.10UF K	
C71			CK73HB1H271K	CHIP C 270PF K		C402			CC73HCH1H330J	CHIP C 33PF J	
C72			CC73HCH1H330J	CHIP C 33PF J		C403			CK73HB1E103K	CHIP C 0.010UF K	
C73			CC73HCH1H100B	CHIP C 10PF B		C404			CC73HCH1H220J	CHIP C 22PF J	
C74			CC73HCH1H150J	CHIP C 15PF J		C405			CC73HCH1H820J	CHIP C 82PF J	
C75 ,76			CK73HB1H271K	CHIP C 270PF K		C406			CK73HB1H471K	CHIP C 470PF K	
C77			CK73HB1A104K	CHIP C 0.10UF K		C407			CC73HCH1H390J	CHIP C 39PF J	
C78			CC73HCH1H070B	CHIP C 7.0PF B		C408			CK73HB1A104K	CHIP C 0.10UF K	
C79 ,80			CC73HCH1H050B	CHIP C 5.0PF B		C409			CC73HCH1H820J	CHIP C 82PF J	
C81			CC73HCH1H130J	CHIP C 13PF J		C410			CK73HB1H471K	CHIP C 470PF K	
C200			CK73HB1H271K	CHIP C 270PF K		C411			CK73HB1A104K	CHIP C 0.10UF K	
C202			CK73HB1H271K	CHIP C 270PF K		C412			CC73HCH1H560J	CHIP C 56PF J	
C207			CC73HCH1H100C	CHIP C 10PF C		C413			CK73HB1H182K	CHIP C 1800PF K	
C208			CC73HCH1H200J	CHIP C 20PF J		C414			CK73HB1H681K	CHIP C 680PF K	
C210			CK73GB1A224K	CHIP C 0.22UF K		C415,416			CK73GB0J106K	CHIP C 10UF K	
C211-214			CK73HB1H271K	CHIP C 270PF K		C417			CC73HCH1H560J	CHIP C 56PF J	
C216			CC73HCH1H050B	CHIP C 5.0PF B		C418			CK73HB1E103K	CHIP C 0.010UF K	
C218			CK73HB1A104K	CHIP C 0.10UF K		C419			CK73HB1H271K	CHIP C 270PF K	
C219			CK73HB1H271K	CHIP C 270PF K		C420			CK73HB1A104K	CHIP C 0.10UF K	
C220			CC73HCH1H100C	CHIP C 10PF C		C421			CK73HB1A333K	CHIP C 0.033UF K	
C222			CK73HB1H271K	CHIP C 270PF K		C422			CK73HB1E103K	CHIP C 0.010UF K	
C223			CC73HCH1H100B	CHIP C 10PF B		C423			CK73HB1A104K	CHIP C 0.10UF K	
C224-226			CK73HB1H271K	CHIP C 270PF K		C424			CK73HB1E103K	CHIP C 0.010UF K	
C227			CK73FB1A105K	CHIP C 1.0UF K		C426			CK73HB1E103K	CHIP C 0.010UF K	
C228			CC73HCH1H470J	CHIP C 47PF J		C428			CC73HCH1H010B	CHIP C 1.0PF B	
C229			CK73HB1H271K	CHIP C 270PF K		C429			CC73HCH1H240J	CHIP C 24PF J	
C230			CC73HCH1H470J	CHIP C 47PF J		C430			CC73HCH1H010B	CHIP C 1.0PF B	
C232,233			CK73HB1H271K	CHIP C 270PF K		C431			CK73HB1H271K	CHIP C 270PF K	
C234			CC73HCH1H330J	CHIP C 33PF J		C432			CK73HB1E103K	CHIP C 0.010UF K	
C235			CC73HCH1H470J	CHIP C 47PF J		C433			CK73HB1H271K	CHIP C 270PF K	
C236			CC73HCH1H100B	CHIP C 10PF B		C434			CC73HCH1H010B	CHIP C 1.0PF B	
C239,240			CC73HCH1H151J	CHIP C 150PF J		C435			CK73HB1E103K	CHIP C 0.010UF K	
C241			CC73GCH1H180J	CHIP C 18PF J		C436			CC73HCH1H2R5B	CHIP C 2.5PF B	
C242			CC73GCH1H240J	CHIP C 24PF J		C437			CC73HCH1H130J	CHIP C 13PF J	
C243			CC73GCH1H120J	CHIP C 12PF J		C438			CC73HCH1H050B	CHIP C 5.0PF B	
C244			CC73GCH1H0R3B	CHIP C 0.3PF B		C439			CC73HCH1H020B	CHIP C 2.0PF B	
C245			CK73GB1A105K	CHIP C 1.0UF K		C440			CC73HCH1H1R5B	CHIP C 1.5PF B	
C247			CK73GB1C104K	CHIP C 0.10UF K		C441			CK73HB1E103K	CHIP C 0.010UF K	
C248			CC73GCH1H240J	CHIP C 24PF J		C442			CC73HCH1H010B	CHIP C 1.0PF B	
C249			CK73HB1H471K	CHIP C 470PF K		C443,444			CK73HB1H271K	CHIP C 270PF K	
C250			CK73HB1E103K	CHIP C 0.010UF K		C445			CC73HCH1H020B	CHIP C 2.0PF B	
C252			CK73HB1H271K	CHIP C 270PF K		C446			CK73HB1H271K	CHIP C 270PF K	
C258			CK73HB1H271K	CHIP C 270PF K		C447			CK73GB1H271K	CHIP C 270PF K	
C262			CK73HB1A104K	CHIP C 0.10UF K		C448			CC73HCH1H020B	CHIP C 2.0PF B	
C263			CK73HB1H271K	CHIP C 270PF K		C449			CC73HCH1H110J	CHIP C 11PF J	

# TK-3402(U)/3402/3407

## PARTS LIST

TX-RX UNIT (X57-8320-10)

Ref. No.	Address	New parts	Parts No.	Description	Destination	Ref. No.	Address	New parts	Parts No.	Description	Destination
C450			CC73HCH1H1R5B	CHIP C 1.5PF B		C741			CK73GB0J106K	CHIP C 10UF K	
C451			CK73HB1H271K	CHIP C 270PF K		C742			CK73HB1H271K	CHIP C 270PF K	
C452			CC73HCH1H010B	CHIP C 1.0PF B		C743			CK73HB1H103K	CHIP C 0.010UF K	
C453			CK73HB1H271K	CHIP C 270PF K		C744			CK73GB0J106K	CHIP C 10UF K	
C454			CC73HCH1H3R5B	CHIP C 3.5PF B		C745			CK73HB1A104K	CHIP C 0.10UF K	
C455			CC73HCH1H110J	CHIP C 11PF J		C746			CK73HB1H271K	CHIP C 270PF K	
C456			CC73HCH1H010B	CHIP C 1.0PF B		C747			CK73HB1H152K	CHIP C 1500PF K	
C457			CK73HB1H271K	CHIP C 270PF K		C748			CK73HB1A105K	CHIP C 1.0UF K	
C458			CC73HCH1H1R5B	CHIP C 1.5PF B		C749,750			CC73HCH1H101J	CHIP C 100PF J	
C459			CC73HCH1H110J	CHIP C 11PF J		C751			CC73HCH1H680J	CHIP C 68PF J	
C460			CC73HCH1H020B	CHIP C 2.0PF B		C754			CC73HCH1H101J	CHIP C 100PF J	
C461			CK73HB1H271K	CHIP C 270PF K		C756			CK73HB1A105K	CHIP C 1.0UF K	
C464-466			CK73HB1H271K	CHIP C 270PF K		C757			CK73FB0J226M	CHIP C 22UF M	
C468			CK73HB1A104K	CHIP C 0.10UF K		C758			CK73HB0J475M	CHIP C 4.7UF M	
C469			CK73HB1H271K	CHIP C 270PF K		C759			CK73HB1A105K	CHIP C 1.0UF K	
C470			CC73HCH1H010B	CHIP C 1.0PF B		C760,761			CK73HB1A474K	CHIP C 0.47UF K	
C471			CC73HCH1H110J	CHIP C 11PF J		C762			CK73HB1H271K	CHIP C 270PF K	
C472			CK73HB1H271K	CHIP C 270PF K		C763			CK73HB1A104K	CHIP C 0.10UF K	
C473,474			CC73HCH1H3R5B	CHIP C 3.5PF B		C764,765			CK73HB1H271K	CHIP C 270PF K	
C475			CC73HCH1H110J	CHIP C 11PF J		C766			CK73HB1A474K	CHIP C 0.47UF K	
C476			CC73HCH1H050B	CHIP C 5.0PF B		C767,768			CK73GB0J225K	CHIP C 2.2UF K	
C477			CK73HB1H271K	CHIP C 270PF K		C769			CK73HB1A474K	CHIP C 0.47UF K	
C478			CC73HCH1H300J	CHIP C 30PF J		C770,771			CK73HB1H271K	CHIP C 270PF K	
C480			CC73HCH1H090B	CHIP C 9.0PF B		C772			CC73HCH1H470J	CHIP C 47PF J	
C481			CC73HCH1H050B	CHIP C 5.0PF B		C773,774			CK73HB1H271K	CHIP C 270PF K	
C483			CC73HCH1H040B	CHIP C 4.0PF B		C775			CK73HB1A104K	CHIP C 0.10UF K	
C600,601			CK73GB1A105K	CHIP C 1.0UF K		C777			CK73HB1A683K	CHIP C 0.068UF K	
C602			CK73GB1C225K	CHIP C 2.2UF K		C778			CK73HB1H271K	CHIP C 270PF K	
C603			CK73GB1A105K	CHIP C 1.0UF K		C779			CK73GB0J106K	CHIP C 10UF K	
C604			CK73HB1H271K	CHIP C 270PF K		C780			CK73HB1H271K	CHIP C 270PF K	
C605-607			CK73GB1A105K	CHIP C 1.0UF K		C781			CK73HB1A104K	CHIP C 0.10UF K	
C609-611			CK73HB1H271K	CHIP C 270PF K		C782			CK73HB1H271K	CHIP C 270PF K	
C612			CK73HB1A104K	CHIP C 0.10UF K		C783			CK73GB1A105K	CHIP C 1.0UF K	
C613			CK73HB1H271K	CHIP C 270PF K		C784			CK73GB1C225K	CHIP C 2.2UF K	
C615,616			CK73HB1H271K	CHIP C 270PF K		C785			CK73GB0J225K	CHIP C 2.2UF K	
C618			CK73GB1A105K	CHIP C 1.0UF K		C786			CK73HB1A224K	CHIP C 0.22UF K	
C620			CK73HB1H271K	CHIP C 270PF K		C787			CK73HB1A104K	CHIP C 0.10UF K	
C621			CK73GB1A105K	CHIP C 1.0UF K		C788			CK73FB0J106K	CHIP C 10UF K	
C623-626			CK73HB1H271K	CHIP C 270PF K		C789			CC73HCH1H101J	CHIP C 100PF J	
C628			CK73HB1H271K	CHIP C 270PF K		C790			CK73HB1A473J	CHIP C 0.047UF J	
C629			CK73HB1E103K	CHIP C 0.010UF K		C791			CK73HB1A104K	CHIP C 0.10UF K	
C630-632			CK73HB1H271K	CHIP C 270PF K		C792			CC73HCH1H101J	CHIP C 100PF J	
C700			CK73HB1H271K	CHIP C 270PF K		C794			CK73HB1A683K	CHIP C 0.068UF K	
C704			CK73HB1H102K	CHIP C 1000PF K		C795			CK73GB1A105K	CHIP C 1.0UF K	
C705			CK73HB1A105K	CHIP C 1.0UF K		C798			CK73HB1H271K	CHIP C 270PF K	
C710,711			CK73HB1H271K	CHIP C 270PF K		C801			CK73GB1A105K	CHIP C 1.0UF K	
C717			CK73HB1C123K	CHIP C 0.012UF K		C802			CK73HB1H271K	CHIP C 270PF K	
C718			CK73HB1A104K	CHIP C 0.10UF K		C805,806			CK73HB1H271K	CHIP C 270PF K	
C719			CK73HB1H271K	CHIP C 270PF K		C807			CK73HB1A104K	CHIP C 0.10UF K	
C720			CK73HB1E103K	CHIP C 0.010UF K		C808,809			CK73EB0J476M	CHIP C 47UF M	
C724			CK73HB1E103K	CHIP C 0.010UF K		C813			CK73HB0J475M	CHIP C 4.7UF M	
C725			CC73HCH1H050B	CHIP C 5.0PF B		C814			CK73HB1A104K	CHIP C 0.10UF K	
C729			CC73HCH1H050B	CHIP C 5.0PF B		C815			CK73HB1A105K	CHIP C 1.0UF K	
C730			CK73GB1A105K	CHIP C 1.0UF K		CN600		*	E40-6868-05	FLAT CABLE CONNECTOR	
C732			CK73HB1H271K	CHIP C 270PF K		J601			E11-0703-05	PHONE JACK (EXT SP/MIC)	
C734,735			CK73GB0J106K	CHIP C 10UF K		F600			F53-0324-15	FUSE(2.5A)	
C736			CK73HB1H271K	CHIP C 270PF K		F601			F53-0319-15	FUSE(1A)	
C737			CK73HB1A105K	CHIP C 1.0UF K							
C739			CK73HB1E103K	CHIP C 0.010UF K							
C740			CK73HB1A104K	CHIP C 0.10UF K							

# TK-3402(U)/3402/3407

## PARTS LIST

TX-RX UNIT (X57-8320-10)

Ref. No.	Address	New parts	Parts No.	Description	Desti-nation	Ref. No.	Address	New parts	Parts No.	Description	Desti-nation
CD400			L79-1866-05	TUNING COIL(450KHZ)		CP26			RK75HA1J473J	CHIP-COM 47K J 1/16W	
<b>CF401</b>			L72-0973-05	CERAMIC FILTER(450KHz)		CP27			RK75HA1J474J	CHIP-COM 470K J 1/16W	
L1			L41-4795-39	SMALL FIXED INDUCTOR(4.7UH)		CP28			RK75HA1J103J	CHIP-COM 10K J 1/16W	
L2			L92-0442-05	CHIP FERRITE		R1			RK73HB1J103J	CHIP R 10K J 1/16W	
L3			L92-0163-05	BEADS CORE		R2			RK73HB1J334J	CHIP R 330K J 1/16W	
L4			L40-6865-71	SMALL FIXED INDUCTOR(6.8NH)		R3 -5			RK73HB1J000J	CHIP R 0 J 1/16W	
L7 ,8			L41-1885-53	SMALL FIXED INDUCTOR(0.18UH)		R7			RK73HB1J000J	CHIP R 0 J 1/16W	
L9			L40-2275-71	SMALL FIXED INDUCTOR(22NH)		R8			RK73HB1J331J	CHIP R 330 J 1/16W	
L12			L41-1885-53	SMALL FIXED INDUCTOR(0.18UH)		R9			RK73HB1J000J	CHIP R 0 J 1/16W	
L13 ,14			L41-2285-53	SMALL FIXED INDUCTOR(0.22UH)		R10			RK73HB1J101J	CHIP R 100 J 1/16W	
L15			L41-1578-14	SMALL FIXED INDUCTOR(15NH)		R11			RK73HB1J122J	CHIP R 1.2K J 1/16W	
L16			L41-1878-14	SMALL FIXED INDUCTOR(18NH)		R12			RK73HB1J472J	CHIP R 4.7K J 1/16W	
L17			L92-0163-05	BEADS CORE		R13			RK73HB1J100J	CHIP R 10 J 1/16W	
L18 ,19			L41-2785-53	SMALL FIXED INDUCTOR(0.27UH)		R16 ,17			RK73HB1J000J	CHIP R 0 J 1/16W	
L21			L41-1885-53	SMALL FIXED INDUCTOR(0.18UH)		R18			RK73HB1J681J	CHIP R 680 J 1/16W	
L23			L41-1885-53	SMALL FIXED INDUCTOR(0.18UH)		R19 ,20			RK73HB1J471J	CHIP R 470 J 1/16W	
L24 ,25			L40-2775-71	SMALL FIXED INDUCTOR(27NH)		R21			RK73HB1J105J	CHIP R 1.0M J 1/16W	
L26			L40-8265-71	SMALL FIXED INDUCTOR(8.2NH)		R22			RK73HB1J103J	CHIP R 10K J 1/16W	
L27			L41-1885-53	SMALL FIXED INDUCTOR(0.18UH)		R24			RK73HB1J474J	CHIP R 470K J 1/16W	
L204			L40-6865-71	SMALL FIXED INDUCTOR(6.8NH)		R25			RK73HB1J105J	CHIP R 1.0M J 1/16W	
L205			L40-3375-71	SMALL FIXED INDUCTOR(33NH)		R26			RK73HB1J102J	CHIP R 1.0K J 1/16W	
L206			L92-0162-05	BEADS CORE		R27			RK73HB1J103J	CHIP R 10K J 1/16W	
L207			L40-1275-71	SMALL FIXED INDUCTOR(12NH)		R28			RK73HB1J102J	CHIP R 1.0K J 1/16W	
L208			L34-4574-05	AIR-CORE COIL(6T)		R29			RK73HB1J220J	CHIP R 22 J 1/16W	
L209			L92-0149-05	CHIP FERRITE		R30			RK73HB1J154J	CHIP R 150K J 1/16W	
L211		*	L41-1263-53	SMALL FIXED INDUCTOR(1.2NH)		R31			RK73HB1J563J	CHIP R 56K J 1/16W	
L212			L92-0149-05	CHIP FERRITE		R32			RK73HB1J472J	CHIP R 4.7K J 1/16W	
L213			L34-4565-05	AIR-CORE COIL(5T)		R33			RK73HB1J823J	CHIP R 82K J 1/16W	
L216			L41-2285-43	SMALL FIXED INDUCTOR(220NH)		R34			RK73HB1J104J	CHIP R 100K J 1/16W	
L217			L34-4564-05	AIR-CORE COIL(4T)		R35			RK73HB1J820J	CHIP R 82 J 1/16W	
L218			L34-4563-05	AIR-CORE COIL(3T)		R36			RK73HB1J331J	CHIP R 330 J 1/16W	
L219			L34-4565-05	AIR-CORE COIL(5T)		R37 ,38			RK73HB1J100J	CHIP R 10 J 1/16W	
L220			L34-4564-05	AIR-CORE COIL(4T)		R39			RK73HB1J104J	CHIP R 100K J 1/16W	
L400			L41-1885-53	SMALL FIXED INDUCTOR(0.18UH)		R40			RK73HB1J154J	CHIP R 150K J 1/16W	
L401			L40-1085-71	SMALL FIXED INDUCTOR(100NH)		R41			RK73HB1J101J	CHIP R 100 J 1/16W	
L402			L40-1591-86	SMALL FIXED INDUCTOR(1.5UH)		R42			RK73HB1J682J	CHIP R 6.8K J 1/16W	
L403			L92-0138-05	CHIP FERRITE		R43			RK73HB1J562J	CHIP R 5.6K J 1/16W	
L404			L41-6885-39	SMALL FIXED INDUCTOR(0.68UH)		R44			RK73HB1J220J	CHIP R 22 J 1/16W	
L405			L40-1575-71	SMALL FIXED INDUCTOR(15NH)		R45			RK73HB1J331J	CHIP R 330 J 1/16W	
L406			L41-2785-53	SMALL FIXED INDUCTOR(0.27UH)		R46			RK73HB1J222J	CHIP R 2.2K J 1/16W	
L407			L40-1575-71	SMALL FIXED INDUCTOR(15NH)		R48			RK73HB1J472J	CHIP R 4.7K J 1/16W	
L408			L41-3375-53	SMALL FIXED INDUCTOR(33NH)		R200			RK73HB1J472J	CHIP R 4.7K J 1/16W	
L410,411			L41-8268-14	SMALL FIXED INDUCTOR(8.2NH)		R202			RK73HB1J000J	CHIP R 0 J 1/16W	
L412			L92-0138-05	CHIP FERRITE		R205			RK73HB1J000J	CHIP R 0 J 1/16W	
L413			L41-8268-14	SMALL FIXED INDUCTOR(8.2NH)		R207			RK73HB1J000J	CHIP R 0 J 1/16W	
L414			L41-2785-14	SMALL FIXED INDUCTOR(270NH)		R210			RK73HB1J271J	CHIP R 270 J 1/16W	
L415,416			L41-8268-14	SMALL FIXED INDUCTOR(8.2NH)		R211			RK73HB1J152J	CHIP R 1.5K J 1/16W	
L417			L41-5678-14	SMALL FIXED INDUCTOR(56NH)		R212			RK73HB1J182J	CHIP R 1.8K J 1/16W	
L420			L40-1275-71	SMALL FIXED INDUCTOR(12NH)		R213			RK73HB1J220J	CHIP R 22 J 1/16W	
L600			L92-0472-05	CHIP FERRITE		R214			RK73HB1J561J	CHIP R 560 J 1/16W	
L601			L92-0138-05	CHIP FERRITE		R215			RK73HB1J681J	CHIP R 680 J 1/16W	
L700,701			L92-0161-05	BEADS CORE		R217			RK73HB1J6R8J	CHIP R 6.8 J 1/16W	
X1			L77-3050-05	TCXO(16.8MHZ)		R219			RK73HB1J681J	CHIP R 680 J 1/16W	
X700			L78-1434-05	RESONATOR(19.2MHZ)		R222			RK73HB1J000J	CHIP R 0 J 1/16W	
XF400		*	L71-0682-05	MCF(50.850MHZ)		R223			RK73HB1J561J	CHIP R 560 J 1/16W	
CP1			RK74HB1J101J	CHIP-COM 100 J 1/16W		R224			RK73HB1J151J	CHIP R 150 J 1/16W	
CP20,21			RK75HA1J473J	CHIP-COM 47K J 1/16W		R225			RK73HB1J183J	CHIP R 18K J 1/16W	
CP22			RK75HA1J102J	CHIP-COM 1.0K J 1/16W		R226			RK73HB1J472J	CHIP R 4.7K J 1/16W	
CP23			RK75HA1J473J	CHIP-COM 47K J 1/16W		R227			RK73HB1J273J	CHIP R 27K J 1/16W	
CP24			RK75HA1J102J	CHIP-COM 1.0K J 1/16W		R228			RK73HB1J333J	CHIP R 33K J 1/16W	

If a part reference number is listed in a shaded box, that part does not come with the PCB.

# TK-3402(U)/3402/3407

## PARTS LIST

### TX-RX UNIT (X57-8320-10)

Ref. No.	Address	New parts	Parts No.	Description	Destination	Ref. No.	Address	New parts	Parts No.	Description	Destination
R229			RK73HB1J470J	CHIP R 47 J 1/16W		R609			RK73HB1J102J	CHIP R 1.0K J 1/16W	
R230,231			RK73EB2ER39K	CHIP R 0.39 K 1/4W		R610-613			RK73HB1J104J	CHIP R 100K J 1/16W	
R232			RK73HB1J183J	CHIP R 18K J 1/16W		R614			RK73HH1J824D	CHIP R 820K D 1/16W	
R233			RK73EB2ER39K	CHIP R 0.39 K 1/4W		R615			RK73HH1J394D	CHIP R 390K D 1/16W	
R235			RK73HB1J182J	CHIP R 1.8K J 1/16W		R701,702			RK73HH1J103D	CHIP R 10K D 1/16W	
R236			RK73HB1J150J	CHIP R 15 J 1/16W		R703			RK73HB1J153J	CHIP R 15K J 1/16W	
R237,238			RK73HH1J154D	CHIP R 150K D 1/16W		R705			RK73HB1J103J	CHIP R 10K J 1/16W	
R239			RK73HB1J183J	CHIP R 18K J 1/16W		R708			RK73HB1J102J	CHIP R 1.0K J 1/16W	
R241,242			RK73HH1J474D	CHIP R 470K D 1/16W		R710			RK73HB1J102J	CHIP R 1.0K J 1/16W	
R243			RK73HB1J103J	CHIP R 10K J 1/16W		R711			RK73HH1J103D	CHIP R 10K D 1/16W	
R244			RK73HB1J563J	CHIP R 56K J 1/16W		R712			RK73HB1J473J	CHIP R 47K J 1/16W	
R246			RK73HB1J474J	CHIP R 470K J 1/16W		R715			RK73HB1J102J	CHIP R 1.0K J 1/16W	
R247			RK73HB1J104J	CHIP R 100K J 1/16W		R717			RK73HB1J104J	CHIP R 100K J 1/16W	
R248			RK73HB1J105J	CHIP R 1.0M J 1/16W		R718			RK73HH1J473D	CHIP R 47K D 1/16W	
R249			RK73HB1J271J	CHIP R 270 J 1/16W		R719			RK73HH1J223D	CHIP R 22K D 1/16W	
R250			RK73FB2B000J	CHIP R 0 J 1/8W		R723			RK73HB1J682J	CHIP R 6.8K J 1/16W	
R251			RK73HB1J271J	CHIP R 270 J 1/16W		R724,725			RK73HB1J473J	CHIP R 47K J 1/16W	
R252			RK73GB2A000J	CHIP R 0 J 1/10W		R726			RK73HB1J102J	CHIP R 1.0K J 1/16W	
R253			RK73GB2A823J	CHIP R 82K J 1/10W		R731			RK73HB1J103J	CHIP R 10K J 1/16W	
R254,255			RK73HB1J000J	CHIP R 0 J 1/16W		R732			RK73HB1J680J	CHIP R 68 J 1/16W	
R400			RK73HB1J334J	CHIP R 330K J 1/16W		R733			RK73HB1J103J	CHIP R 10K J 1/16W	
R401			RK73HB1J101J	CHIP R 100 J 1/16W		R734			RK73HB1J472J	CHIP R 4.7K J 1/16W	
R403			RK73HB1J102J	CHIP R 1.0K J 1/16W		R736,737			RK73HB1J102J	CHIP R 1.0K J 1/16W	
R404			RK73HB1J184J	CHIP R 180K J 1/16W		R738			RK73HB1J000J	CHIP R 0 J 1/16W	
R405			RK73HB1J563J	CHIP R 56K J 1/16W		R739,740			RK73HB1J472J	CHIP R 4.7K J 1/16W	
R407,408			RK73HB1J332J	CHIP R 3.3K J 1/16W		R743			RK73HB1J103J	CHIP R 10K J 1/16W	
R409			RK73HB1J222J	CHIP R 2.2K J 1/16W		R744			RK73HB1J150J	CHIP R 15 J 1/16W	
R410			RK73HB1J182J	CHIP R 1.8K J 1/16W		R746			RK73HB1J103J	CHIP R 10K J 1/16W	
R412			RK73HB1J100J	CHIP R 10 J 1/16W		R751			RK73HB1J105J	CHIP R 1.0M J 1/16W	
R413			RK73HB1J104J	CHIP R 100K J 1/16W		R755			RK73HB1J564J	CHIP R 560K J 1/16W	
R415			RK73HB1J101J	CHIP R 100 J 1/16W		R756			RK73HB1J100J	CHIP R 10 J 1/16W	
R418			RK73HB1J334J	CHIP R 330K J 1/16W		R757			RK73HB1J473J	CHIP R 47K J 1/16W	
R419			RK73HB1J121J	CHIP R 120 J 1/16W		R759			RK73HB1J153J	CHIP R 15K J 1/16W	
R420			RK73HB1J101J	CHIP R 100 J 1/16W		R760			RK73HB1J473J	CHIP R 47K J 1/16W	
R421			RK73HB1J470J	CHIP R 47 J 1/16W		R761			RK73HB1J000J	CHIP R 0 J 1/16W	
R422			RK73HB1J472J	CHIP R 4.7K J 1/16W		R762			RK73HB1J104J	CHIP R 100K J 1/16W	
R423			RK73HB1J182J	CHIP R 1.8K J 1/16W		R763			RK73HB1J394J	CHIP R 390K J 1/16W	
R424			RK73HB1J391J	CHIP R 390 J 1/16W		R765			RK73HB1J273J	CHIP R 27K J 1/16W	
R425			RK73HB1J683J	CHIP R 68K J 1/16W		R767			RK73HB1J104J	CHIP R 100K J 1/16W	
R426,427			RK73HB1J104J	CHIP R 100K J 1/16W		R768			RK73HB1J103J	CHIP R 10K J 1/16W	
R428			RK73HB1J563J	CHIP R 56K J 1/16W		R769			RK73HB1J104J	CHIP R 100K J 1/16W	
R429			RK73HB1J000J	CHIP R 0 J 1/16W		R770			RK73HB1J124J	CHIP R 120K J 1/16W	
R430-432			RK73HB1J474J	CHIP R 470K J 1/16W		R772			RK73HB1J154J	CHIP R 150K J 1/16W	
R433			RK73HB1J222J	CHIP R 2.2K J 1/16W		R773			RK73HB1J103J	CHIP R 10K J 1/16W	
R434			RK73HB1J000J	CHIP R 0 J 1/16W		R774			RK73HB1J101J	CHIP R 100 J 1/16W	
R435			RK73HB1J331J	CHIP R 330 J 1/16W		R775			RK73GB2A000J	CHIP R 0 J 1/10W	
R436			RK73HB1J104J	CHIP R 100K J 1/16W		R780			RK73HB1J474J	CHIP R 470K J 1/16W	
R437			RK73HB1J824J	CHIP R 820K J 1/16W		R781			RK73HB1J682J	CHIP R 6.8K J 1/16W	
R438			RK73HB1J104J	CHIP R 100K J 1/16W		R782			RK73HB1J473J	CHIP R 47K J 1/16W	
R439			RK73HB1J154J	CHIP R 150K J 1/16W		R783			RK73HB1J272J	CHIP R 2.7K J 1/16W	
R440			RK73HB1J000J	CHIP R 0 J 1/16W		R784			RK73HB1J102J	CHIP R 1.0K J 1/16W	
R441,442			RK73HB1J474J	CHIP R 470K J 1/16W		R785			RK73HB1J272J	CHIP R 2.7K J 1/16W	
R444			RK73HB1J474J	CHIP R 470K J 1/16W		R786			RK73HB1J104J	CHIP R 100K J 1/16W	
R600			RK73GB2A221J	CHIP R 220 J 1/10W		R787			RK73HB1J105J	CHIP R 1.0M J 1/16W	
R601,602			RK73HB1J104J	CHIP R 100K J 1/16W		R788			RK73HB1J473J	CHIP R 47K J 1/16W	
R603			RK73HB1J101J	CHIP R 100 J 1/16W		R789,790			RK73HB1J103J	CHIP R 10K J 1/16W	
R604			RK73GB2A331J	CHIP R 330 J 1/10W		R792			RK73HB1J471J	CHIP R 470 J 1/16W	
R605			RK73HB1J223J	CHIP R 22K J 1/16W		R793			RK73HB1J182J	CHIP R 1.8K J 1/16W	
R606,607			RK73HB1J104J	CHIP R 100K J 1/16W		R794			RK73HB1J152J	CHIP R 1.5K J 1/16W	
R608			RK73GB2A271J	CHIP R 270 J 1/10W		R795			RK73HB1J473J	CHIP R 47K J 1/16W	



# TK-3402(U)/3402/3407

## PARTS LIST

TX-RX UNIT (X57-8320-10)

Ref. No.	Address	New parts	Parts No.	Description	Destination	Ref. No.	Address	New parts	Parts No.	Description	Destination
R796			RK73HB1J561J	CHIP R 560 J 1/16W		IC708		*	BU7465HFV	MOS-IC	
R800			RK73HB1J183J	CHIP R 18K J 1/16W		IC709		*	NJU7089KV1	MOS-IC	
R801			RK73HB1J151J	CHIP R 150 J 1/16W		Q1		*	SSM3J36TUT	FET	
R802			RK73HB1J474J	CHIP R 470K J 1/16W		Q2			2SC5636	TRANSISTOR	
R803			RK73HB1J391J	CHIP R 390 J 1/16W		Q3			KTK5132E-P	FET	
R804			RK73HB1J124J	CHIP R 120K J 1/16W		Q4			KTC4075E(Y,GR)	TRANSISTOR	
R805,806			RK73HB1J103J	CHIP R 10K J 1/16W		Q5			MCH3914(8)-H	FET	
R807			RK73HB1J183J	CHIP R 18K J 1/16W		Q6			MCH3914(7)-H	FET	
R809			RK73HB1J103J	CHIP R 10K J 1/16W		Q7		*	SSM6L36TU-F	FET	
R810			RK73HB1J334J	CHIP R 330K J 1/16W		Q8		*	SSM3J36TUT	FET	
R811			RK73HB1J274J	CHIP R 270K J 1/16W		Q9 ,10			2SC5636	TRANSISTOR	
R812			RK73HB1J473J	CHIP R 47K J 1/16W		Q201			2SC5455-A	TRANSISTOR	
R813			RK73HB1J823J	CHIP R 82K J 1/16W		Q203			LTC014TEBFS8	TRANSISTOR	
R814			RK73HB1J273J	CHIP R 27K J 1/16W		Q205			KTK5132E-P	FET	
R815			RK73HB1J101J	CHIP R 100 J 1/16W		Q206			RFM01U7P	FET	
R816			RK73HB1J102J	CHIP R 1.0K J 1/16W		Q207			LTC014EEBFS8	TRANSISTOR	
R822			RK73HB1J224J	CHIP R 220K J 1/16W		Q208			RD07MUS2BT112	FET	
R824			RK73HB1J102J	CHIP R 1.0K J 1/16W		Q209		*	SSM3K15AFS-F	FET	
R825			RK73HB1J104J	CHIP R 100K J 1/16W		Q210			LTA044EEBFS8	TRANSISTOR	
R826			RK73HB1J473J	CHIP R 47K J 1/16W		Q400			KTC4080E-P	TRANSISTOR	
S601-603			S70-0414-05	TACT SWITCH		Q401			LTC014EEBFS8	TRANSISTOR	
<b>MIC1</b>			T91-0659-15	MIC ELEMENT		Q402			LTA044EEBFS8	TRANSISTOR	
D1		*	KDS160E-P	DIODE		Q403			KTC4075E(Y,GR)	TRANSISTOR	
D4 ,5			1SV325F	VARIABLE CAPACITANCE DIODE		Q404			3SK318	FET	
D7			1SV325F	VARIABLE CAPACITANCE DIODE		Q405			3SK293-F	FET	
D9			1SV325F	VARIABLE CAPACITANCE DIODE		Q600			LTC014EEBFS8	TRANSISTOR	
D10		*	KDS160E-P	DIODE		Q601,602		*	SSM6L36TU-F	FET	
D11 ,12			HVC375B-E	VARIABLE CAPACITANCE DIODE		Q603		*	SSM3K127TUT	FET	
D13			KDV214E-P	DIODE		Q604,605			LTC014EEBFS8	TRANSISTOR	
D14 ,15			HSC277	DIODE		Q606		*	SSM3J36TUT	FET	
D200			UDZW5.1(B)	ZENER DIODE		Q701,702			KTC4075E(Y,GR)	TRANSISTOR	
D201,202			RN142S	DIODE		Q703			UPA672T-A	FET	
D203,204			HVC131	DIODE		Q704			KTC4075E(Y,GR)	TRANSISTOR	
D400-404			HVC350B	VARIABLE CAPACITANCE DIODE		Q705			2SC4116(GR)F	TRANSISTOR	
D405			JDV2S07FS	VARIABLE CAPACITANCE DIODE		Q706			2SA1586(Y,GR)F	TRANSISTOR	
D600			RB521S-30	DIODE		Q707			UPA672T-A	FET	
D603			GN1G	DIODE		Q708,709			LTC014EEBFS8	TRANSISTOR	
D605			RKZ5.1B2KG	ZENER DIODE		Q710			2SB1694	TRANSISTOR	
D700,701			KDR731	DIODE		Q711			LTC014EEBFS8	TRANSISTOR	
D702			1SS372F	DIODE		Q712			LTC044EEBFS8	TRANSISTOR	
D703			MC2850	DIODE		Q713			2SK3577-A	FET	
IC2			MB15E03SL-E1	MOS-IC		Q714			2SB1132(Q,R)	TRANSISTOR	
IC3			BD7542FVM	MOS-IC		Q715			UMG3N	TRANSISTOR	
IC200			NJM12904RB1	MOS-IC		Q716			2SK3577-A	FET	
IC400			NJM2591V	BI-POLAR IC		TH200			ERTJ0EV104J	THERMISTOR(100K)	
IC600			XC61CN4502M-G	MOS-IC		TH400			NCP18WM224J0S	THERMISTOR(470K)	
IC601			XC6209B502P-G	MOS-IC							
IC602		*	MM1856A50N	BI-POLAR IC							
IC603			XC6209B502P-G	MOS-IC							
IC604		*	MM1856A33N	BI-POLAR IC							
IC605		*	BU4830F	MOS-IC							
IC700			EX25064ATA00A	ROM IC							
IC702			F363BEDFEKDLF	MCU							
IC703		*	MM1856A33N	BI-POLAR IC							
IC704		*	BU7465HFV	MOS-IC							
IC705			CD686AQ3	MOS-IC							
IC706			BU7465HFV	MOS-IC							
IC707			TA7368PL	MOS-IC							

If a part reference number is listed in a shaded box, that part does not come with the PCB.

# TK-3402(U)/3402/3407

## EXPLODED VIEW

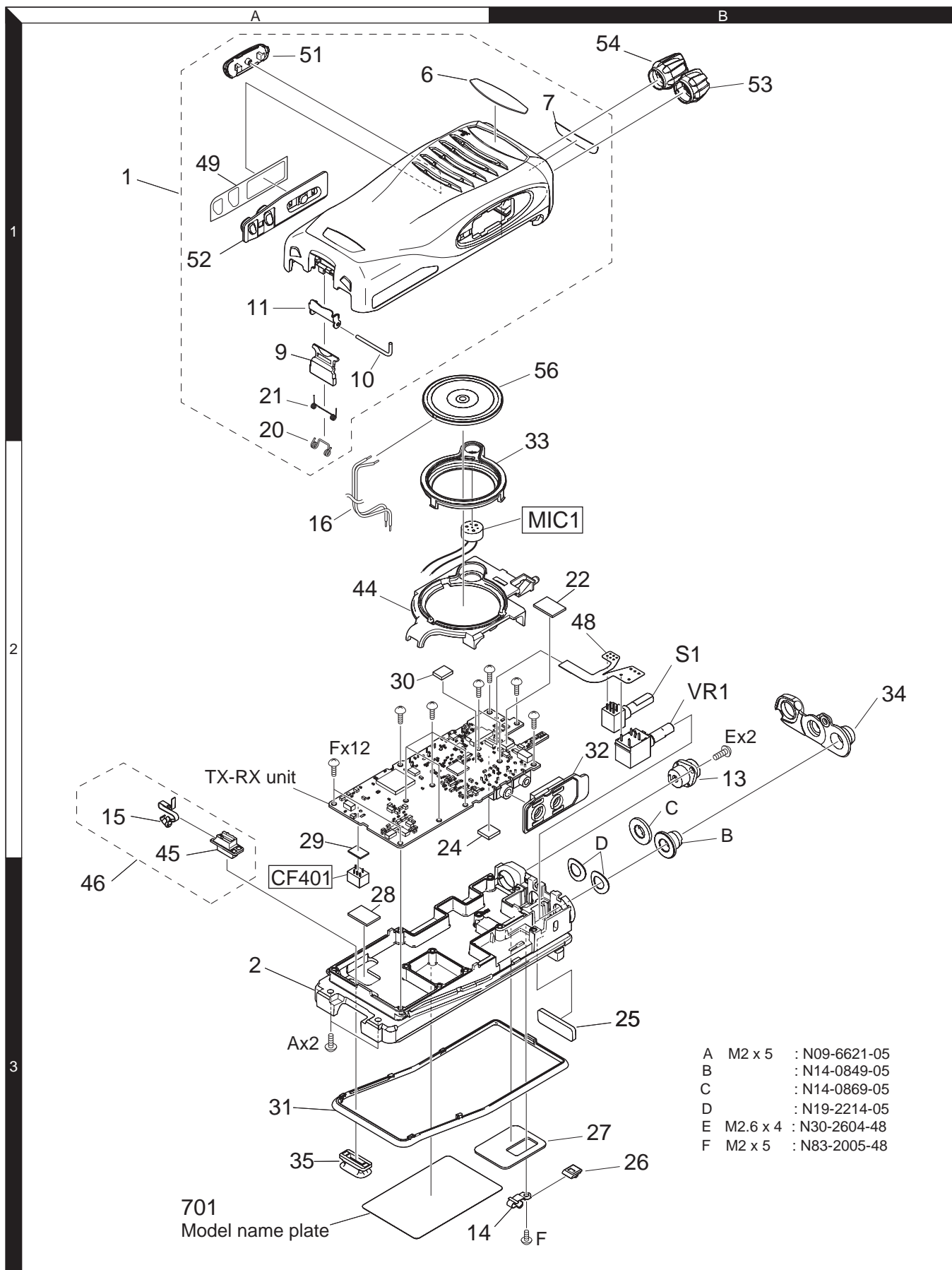



# TK-3402(U)/3402/3407 PACKING(TK-3402(V)/3402)

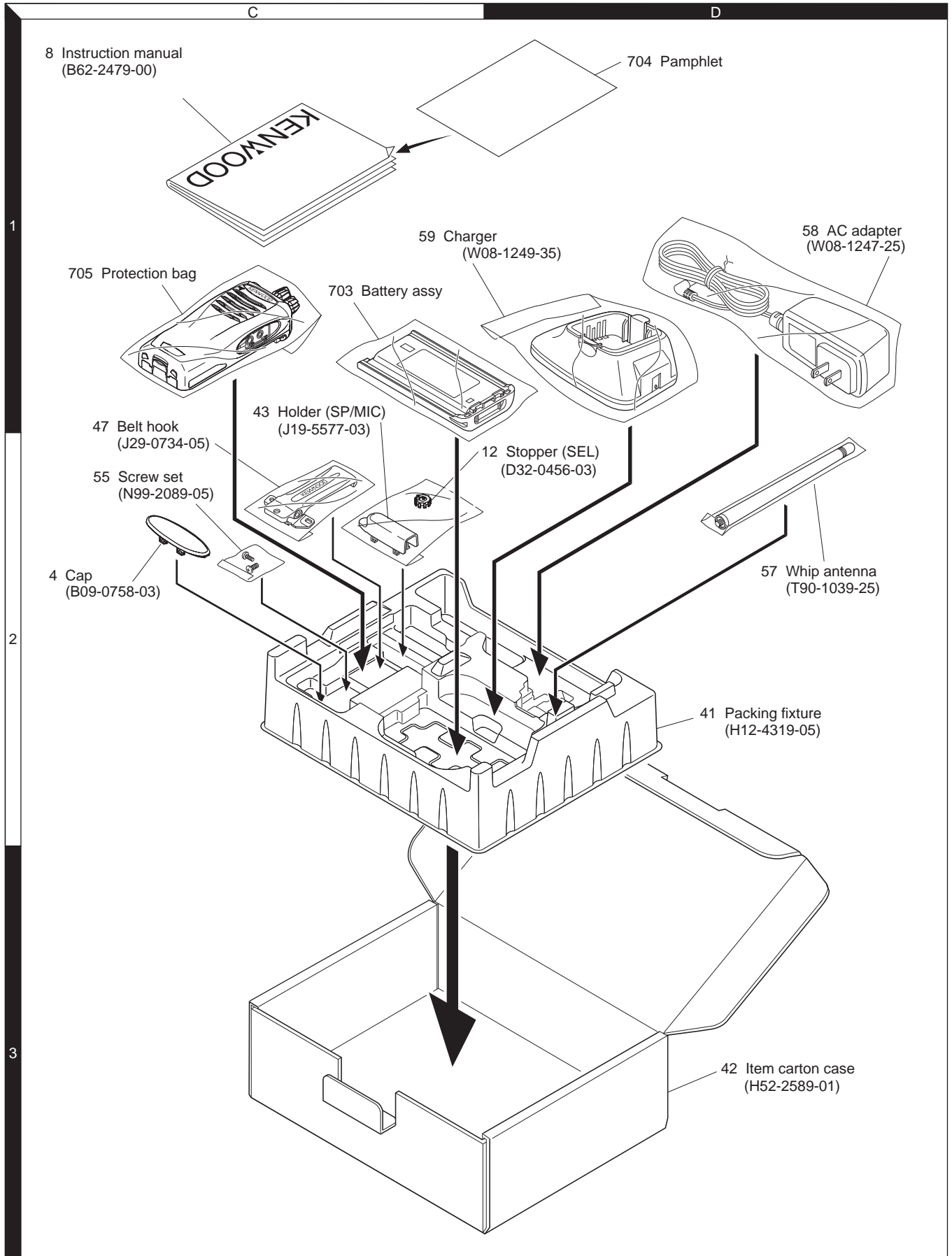

Parts with the exploded numbers larger than 700 are not supplied.

# TK-3402(U)/3402/3407

## PACKING (TK-3407)

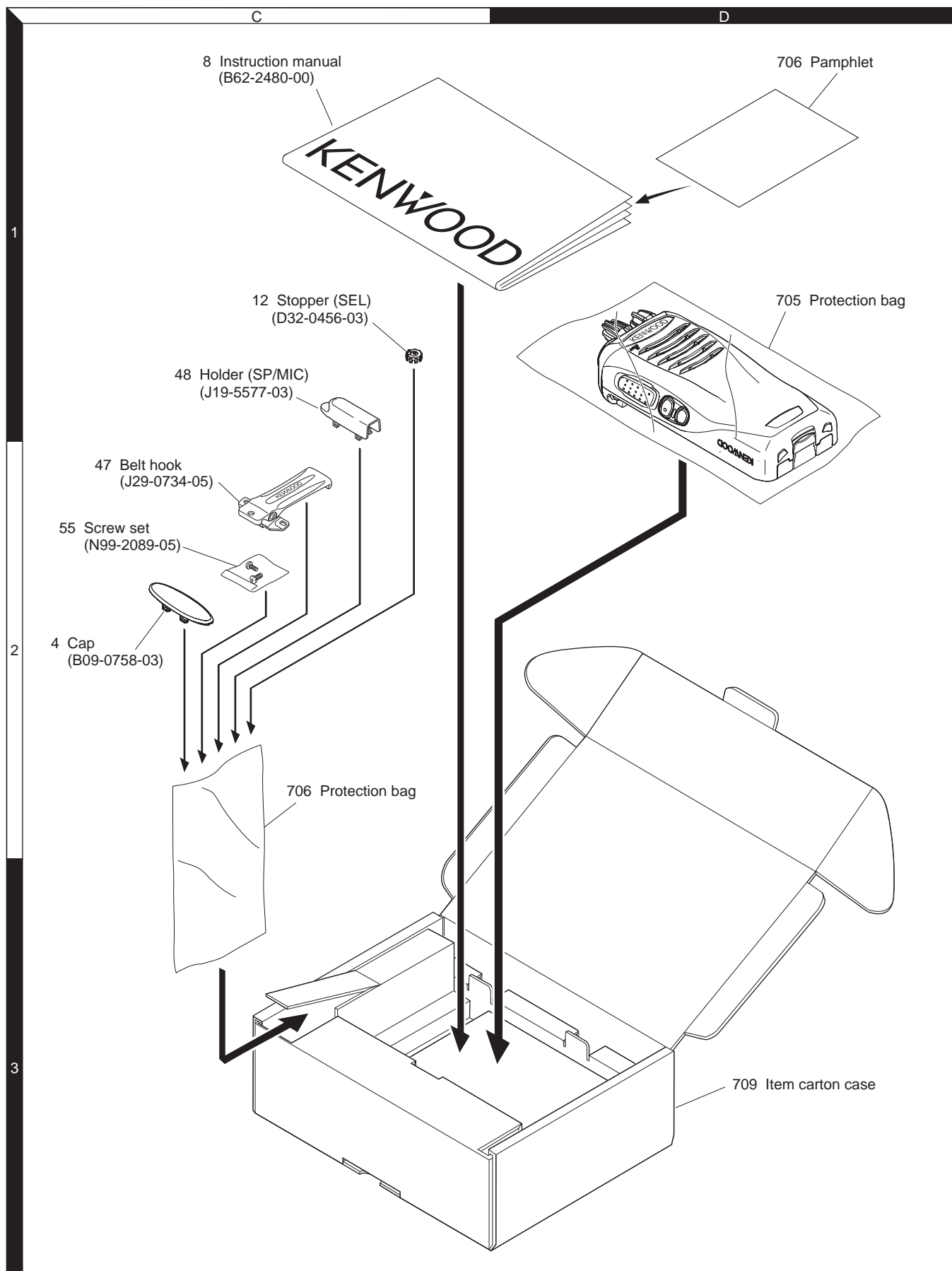

# TK-3402(U)/3402/3407

## ADJUSTMENT

### Test Equipment Required for Alignment

Test Equipment	Major Specifications	
1. Standard Signal Generator (SSG)	Frequency Range Modulation Output	127 to 520MHz Frequency modulation and external modulation -127dBm/0.1μV to greater than -47dBm/1mV
2. RF Power Meter	Input Impedance Operation Frequency Measurement Range	50Ω 127 to 520MHz Vicinity of 10W
3. Deviation Meter	Frequency Range	127 to 520MHz
4. Digital Volt Meter (DVM)	Measuring Range Input Impedance	10mV to 10V DC High input impedance for minimum circuit loading
5. Oscilloscope		DC through 30MHz
6. High Sensitivity Frequency Counter	Frequency Range Frequency Stability	10Hz to 1000MHz 0.2ppm or less
7. DC Ammeter		5A
8. AF Volt Meter (AF VM)	Frequency Range Voltage Range	50Hz to 10kHz 1mV to 10V
9. Audio Generator (AG)	Frequency Range Output	50Hz to 5kHz or more 0 to 1V
10. Distortion Meter	Capability Input Level	3% or less at 1kHz 50mV to 10Vrms
11. Spectrum Analyzer	Measuring Range	10kHz to 1GHz or more
12. Tracking Generator	Center frequency Output Voltage	10kHz to 600MHz 100mV or more
13. 8Ω Dummy Load		Approx. 8Ω, 3W
14. Regulated Power Supply		5V to 10V, approx. 3A Useful if ammeter equipped

#### ■ Antenna connector adapter

The antenna connector of this transceiver uses an SMA terminal.

Use an antenna connector adapter [SMA(f) – BNC(f) or SMA(f) – N(f)] for adjustment. (The adapter is not provided as an option, so buy a commercially-available one.)

#### ■ Repair Jig (Chassis)

Use jig (Chassis) for repairing the transceiver. Place the TX-RX unit on the jig and fit it with screws.

The jig facilitates the voltage check and protects the final amplifier FET when the voltage on the flow side of the TX-RX unit is checked during repairs.

#### ■ Battery Jig (W05-1011-00)

Connect the power cable properly between the battery jig installed in the transceiver and the power supply, and be sure output voltage and the power supply polarity prior to switching the power supply ON, otherwise over voltage and reverse connection may damage the transceiver, or the power supply or both.

**Note:** When using the battery jig, you must measure the voltage at the terminals of the battery jig. Otherwise, a slight voltage drop may occur within the power cable, between the power supply and the battery jig, especially while the transceiver transmits.

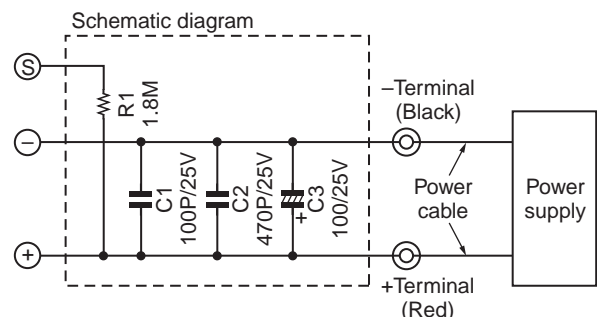
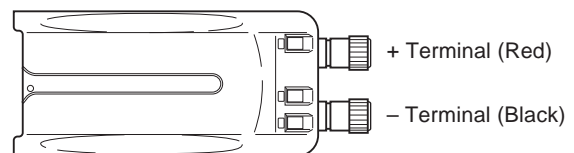

## ADJUSTMENT

### Frequency and Signaling

The transceiver has been adjusted for the frequencies shown in the following table. When required, re-adjust them following the adjustment procedure to obtain the frequencies you want in actual operation.

#### ■ Frequency (MHz)

Channel No.	RX Frequency	TX Frequency
1	485.05000	485.10000
2	450.05000	450.10000
3	519.95000	519.90000
4	485.00000	485.00000
5	485.20000	485.20000
6	485.40000	485.40000
7~16	-	-

#### ■ Signaling

Signaling No.	RX (Decode)	TX (Encode)
1	None	None
2	None	20Hz Square
3	QT 67.0Hz	QT 67.0Hz
4	QT 151.4Hz	QT 151.4Hz
5	QT 210.7Hz	QT 210.7Hz
6	QT 254.1Hz	QT 254.1Hz
7	DQT D023N	DQT D023N
8	DQT D754I	DQT D754I
9	DTMF (Code: 159D)	DTMF (Code: 159D)
10	None	DTMF (Code: 9)
11	None	MSK (1010)
12	FleetSync (100~1000)	FleetSync (100~1000)
13	None	Single Tone (1000Hz)
14	2-Tone A: 304.7Hz, B: 3106.0Hz	2-Tone A: 304.7Hz, duration:1sec B: 3106.0Hz,duration:3sec
15	None	DTMF Tone (1477Hz)
16	Single Tone (979.9Hz)	Single Tone (979.9Hz) Duration:5 sec
17	None	MSK PN9
18	None	DTMF (Code: 3)

### Preparations for Tuning the Transceiver

Before attempting to tune the transceiver, connect the unit to a suitable power supply.

Whenever the transmitter is tuned, the unit must be connected to a suitable dummy load (i.e. power meter).

The speaker output connector must be terminated with a  $8\Omega$  dummy load and connected to an AC voltmeter and an audio distortion meter or a SINAD measurement meter at all times during tuning.

#### ■ Adjustment frequency (MHz)

TEST CH	RX	TX
Low	450.05000	450.10000
Low'	467.55000	467.60000
Center	485.05000	485.10000
High'	502.55000	502.60000
High	519.95000	519.90000

# TK-3402(U)/3402/3407

## ADJUSTMENT

### Common Section

Item	Condition	Measurement			Adjustment			Specifications / Remarks
		Test-equipment	Unit	Terminal	Unit	Parts	Method	
1. Setting	1) Power supply voltage DC power supply terminal : 7.5V							
2. Receive Assist Voltage	1) Auto tuning <b>*Note</b>	Digital Voltage Multimeter	TX-RX	ANT CVIN	TX-RX	FPU		4.0V±0.1V
	2) CH: Low						Check	0.6V or more
3. Transmit Assist Voltage	1) Auto tuning <b>*Note</b>				TX-RX	FPU		4.0V±0.1V
	2) CH: Low						Check	0.6V or more

**\*Note:** At test mode, click [Tune Assist Voltage] button in test mode dialog box, then start automatic adjustment of Receive/Transmit assist voltage.

### Transmitter Section

Item	Condition	Measurement			Adjustment			Specifications / Remarks
		Test-equipment	Unit	Terminal	Unit	Parts	Method	
1. Frequency	1) TEST CH: Center PTT: ON	f. counter		ANT	TX-RX	FPU	485.100MHz	±50Hz
2. High Power	1) TEST CH: Low, Low', Center, High', High (5 points) 2) BATT terminal voltage: 7.5V 3) PTT: ON	Power meter Ammeter				FPU	5.0W	±0.1W 2.0A or less
3. Low Power	1) TEST CH: Low, Center, High (3 points) 2) BATT terminal voltage: 7.5V 3) PTT: ON						1.0W	±0.1W 1.0A or less
4. DQT Balance 2	1) TEST CH: Low, Low', Center, High', High (5 points) 2) Deviation meter filter LPF: 3kHz HPF: OFF 3) PTT: ON	Deviation meter Oscilloscope		ANT			The Deviation of 20Hz frequency is fixed. Change the 1kHz adjustment value to become the same deviation of 20Hz within the specified range.	±0.2dB
5. Maximum Deviation <b>*Note</b>	1) TEST CH: Center, Low, Low', High, High' (5 points) 2) Deviation meter filter LPF: 15kHz HPF: OFF 3) PTT: ON							2.0kHz (According to larger +, -)

# TK-3402(U)/3402/3407

## ADJUSTMENT

Item	Condition	Measurement			Adjustment			Specifications / Remarks
		Test-equipment	Unit	Terminal	Unit	Parts	Method	
6. DQT Deviation <b>*Note</b>	1) TEST CH: Center 2) Deviation meter filter LPF: 3kHz HPF: OFF 3) PTT: ON	Deviation meter Oscilloscope		ANT		FPU	0.35kHz	±40Hz
7. QT Deviation <b>*Note</b>	1) TEST CH: Center 2) Deviation meter filter LPF: 3kHz HPF: OFF 3) PTT: ON						0.35kHz	±40Hz
8. DTMF Deviation <b>*Note</b>	1) TEST CH: Center 2) Deviation meter filter LPF: 15kHz HPF: OFF 3) PTT: ON						1.5kHz	±50Hz
9. MSK Deviation <b>*Note</b>	1) TEST CH: Center 2) Deviation meter filter LPF: 15kHz HPF: OFF 3) PTT: ON						1.5kHz	±50Hz

**\*Note (for the Max Dev, DQT Dev, QT Dev, DTMF Dev and MSK Dev):**

- 1) If select the item without (Wide) or (Narrow), the alignment will be align according to Narrow Band. Wide band will automatically update by calculation using Narrow band value.
- 2) If select the item with (Wide) or (Narrow),
  - (a) If wide band is selected, the alignment only will be done for wide band.
  - (b) If Narrow band is selected, the alignment only will be done for Narrow band.

### Receiver Section

Item	Condition	Measurement			Adjustment			Specifications / Remarks
		Test-equipment	Unit	Terminal	Unit	Parts	Method	
1. Sensitivity (Semiauto-matic)	1) TEST CH: Low, Center, High (3 points) SSG otuput : -90dBm AF Freq : 1kHz Mod Dev : 1.5kHz	SSG Oscilloscope Audio Analyzer		ANT		FPU	Press [Start] (Auto tuning)	

# TK-3402(U)/3402/3407

## ADJUSTMENT

Item	Condition	Measurement			Adjustment			Specifications / Remarks
		Test-equipment	Unit	Terminal	Unit	Parts	Method	
2. Open Squelch [Wide]	1) TEST CH: Low, Center, High (3 points) 2) SSG output: -120dBm SSG MOD: 3.0kHz AF Freq : 1kHz	SSG DVM Oscilloscope		ANT		FPU	Press [Start] (Auto tuning)	
	[Narrow]							
3. Tight Squelch [Wide]	1) TEST CH: Low, Center, High (3 points) 2) SSG output: -115dBm AF Freq : 1kHz Mod Dev : 3.0kHz							
	[Narrow]							
4. Low RSSI <b>*Note</b> [Wide]	1) TEST CH: Low, Center, High (3 points) 2) SSG output: -120dBm AF Freq : 1kHz Mod Dev : 3.0kHz							
	[Narrow]							
5. High RSSI <b>*Note</b> [Wide]	1) TEST CH: Low, Center, High (3 points) 2) SSG output: -80dBm AF Freq : 1kHz Mod Dev : 3.0kHz							
	[Narrow]							

**\*Note**

- 1) If Wide Band RSSI tuning is selected, it will align for the Wide band only.
- 2) If Narrow Band RSSI tuning is selected, Wide band and Narrow band will be align with same tuning value.



# TX-3402(U)/3402/3407 PC BOARD

TX-RX UNIT (X57-8320-10)  
Component side view (J79-0360-09)

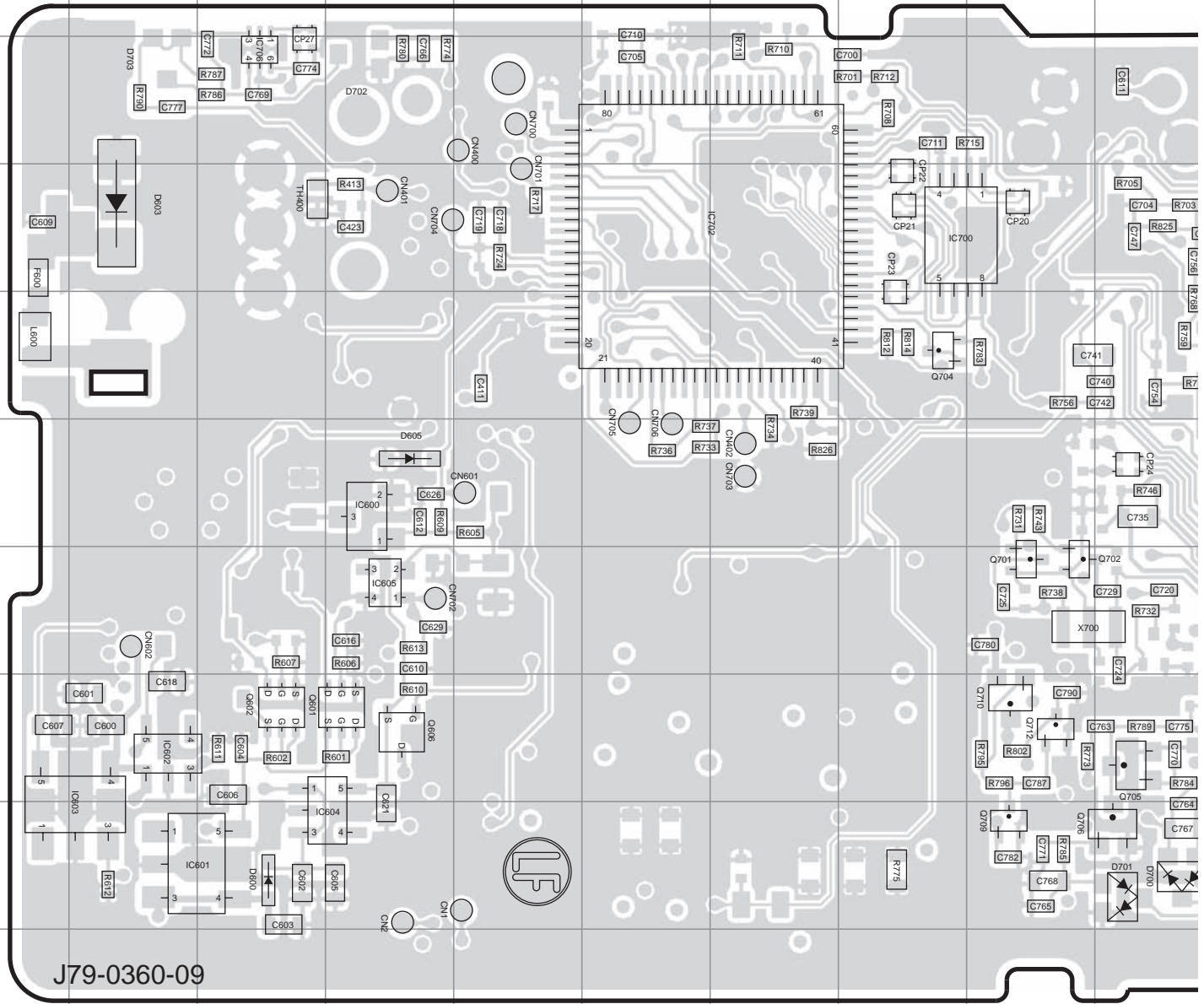

J79-0360-09

Ref. No.	Address	Ref. No.	Address	Ref. No.	Address	Ref. No.	Address	Ref. No.	Address	Ref. No.	Address
D600	9C	D703	3B	IC702	4F	Q600	8M	Q704	5H	Q715	5P
D601	7S	IC200	3N	IC703	5M	Q601	8D	Q705	8J	Q716	8P
D602	7S	IC600	6D	IC705	6K	Q602	8C	Q706	9J		
D603	4B	IC601	9B	IC706	3C	Q603	3O	Q710	8I		
D604	7R	IC602	8B	IC707	7P	Q604	8Q	Q709	9I		
D605	6D	IC603	9B	IC708	6M	Q605	8L	Q711	5P		
D700	9J	IC604	9D	IC709	7O	Q606	8D	Q712	8I		
D701	9J	IC605	7D	Q209	3M	Q701	7I	Q713	8P		
D702	3D	IC700	4H	Q210	4N	Q702	7I	Q714	6O		

# PC BOARD TX-3402(U)/3402/3407

TX-RX UNIT (X57-8320-10)

Component side view (J79-0360-09)

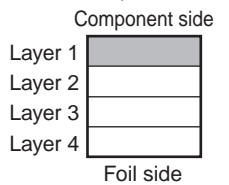
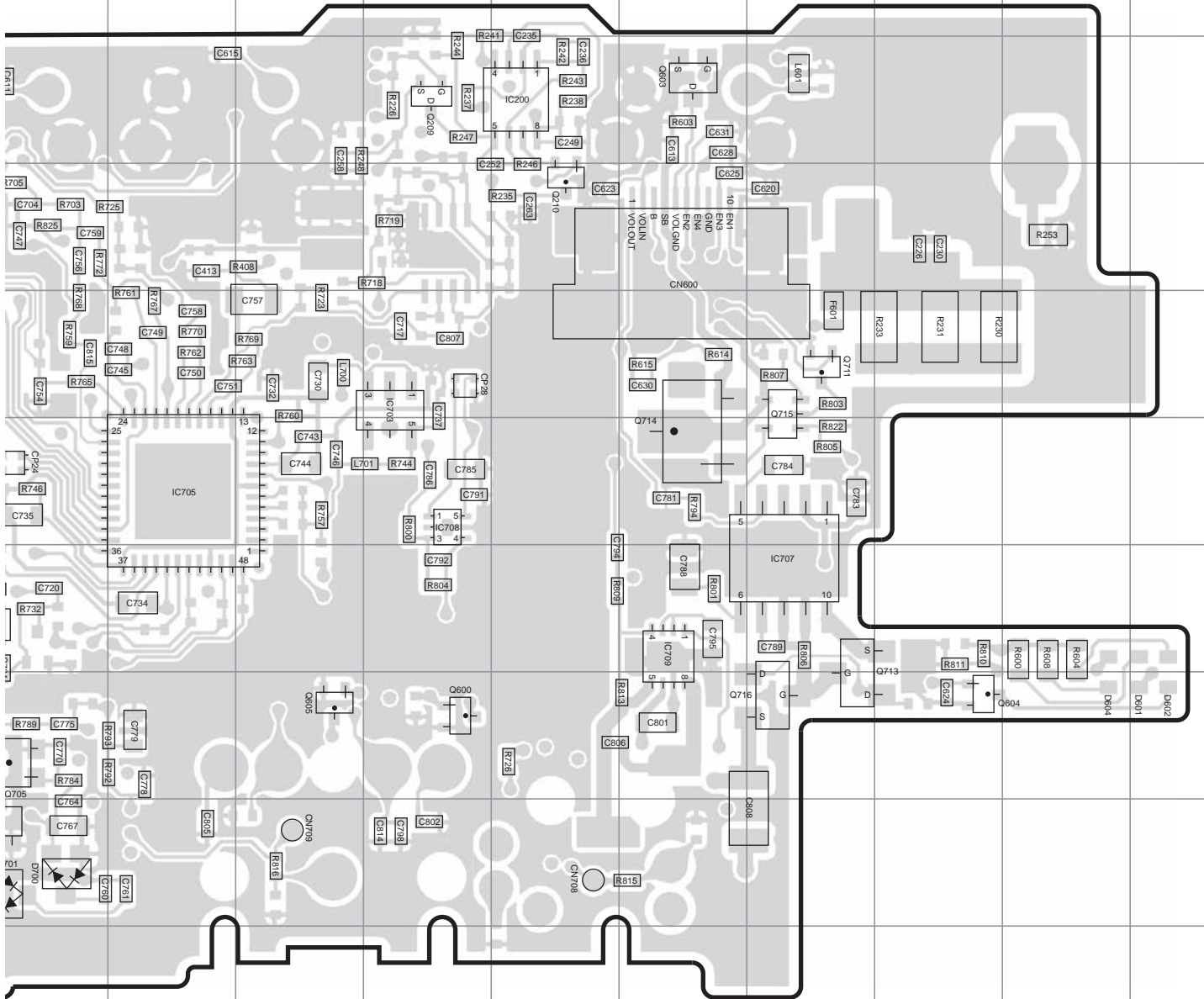

# TX-3402(U)/3402/3407 PC BOARD

TX-RX UNIT (X57-8320-10)  
Foil side view (J79-0360-09)

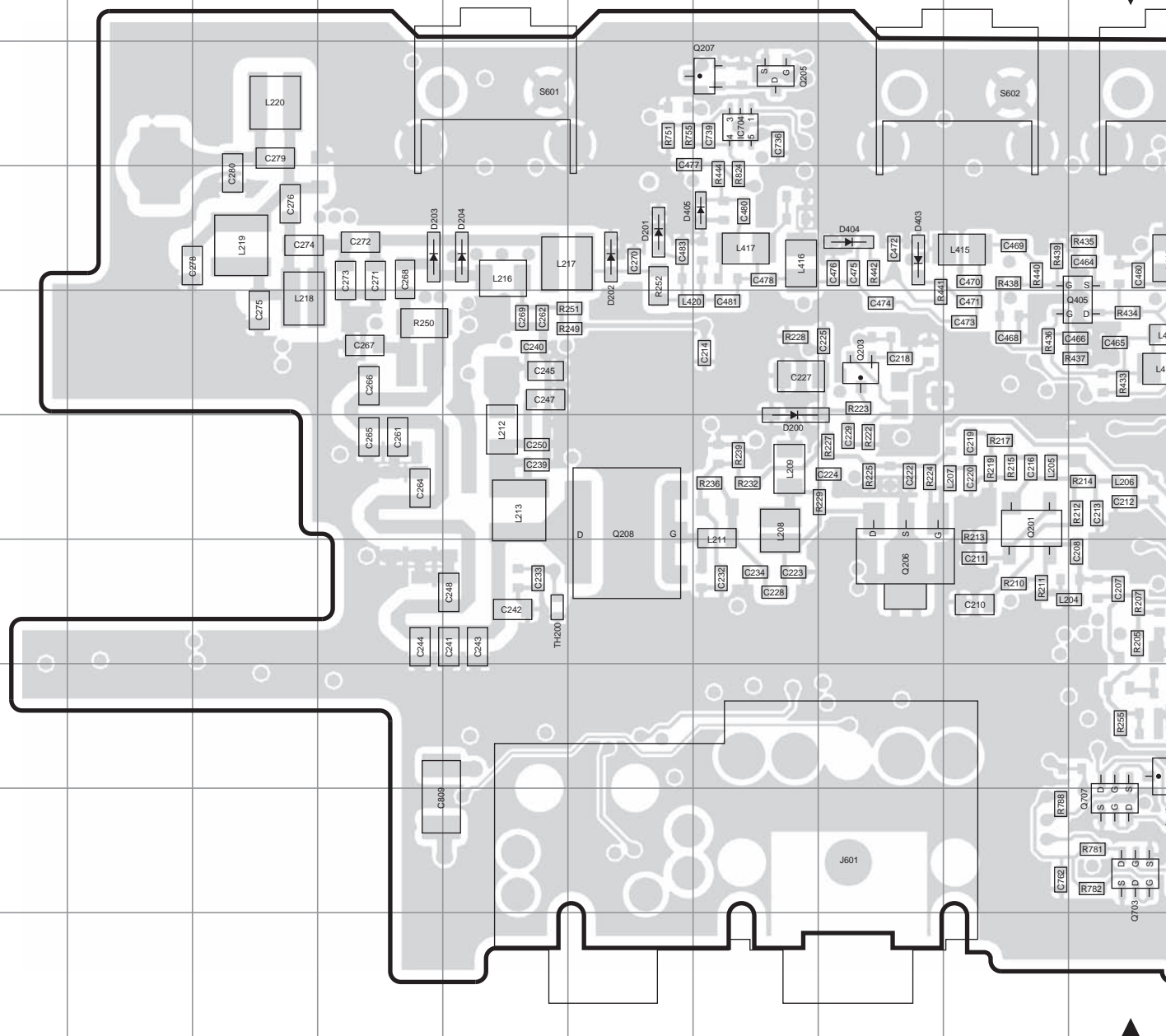

Ref. No.	Address	Ref. No.	Address	Ref. No.	Address	Ref. No.	Address	Ref. No.	Address	Ref. No.	Address
D1	7R	D14	7L	D402	4K	Q2	7O	Q201	6I	Q403	3O
D4	9M	D15	7L	D403	4H	Q3	9O	Q203	5H	Q404	4M
D5	8N	D200	6G	D404	4H	Q4	7N	Q205	3G	Q405	5J
D7	9M	D201	4F	D405	4G	Q5	8L	Q206	7H	Q703	9J
D9	9N	D202	4F	IC2	8Q	Q6	8M	Q207	3G	Q707	9J
D10	7N	D203	4D	IC3	9O	Q7	8N	Q208	6F	Q708	8J
D11	9M	D204	4E	IC400	5O	Q8	7N	Q400	6P		
D12	9L	D400	4L	IC704	3G	Q9	7M	Q401	4P		
D13	9M	D401	4K	Q1	8O	Q10	7M	Q402	3P		

# PC BOARD TX-3402(U)/3402/3407

TX-RX UNIT (X57-8320-10)  
Foil side view (J79-0360-09)

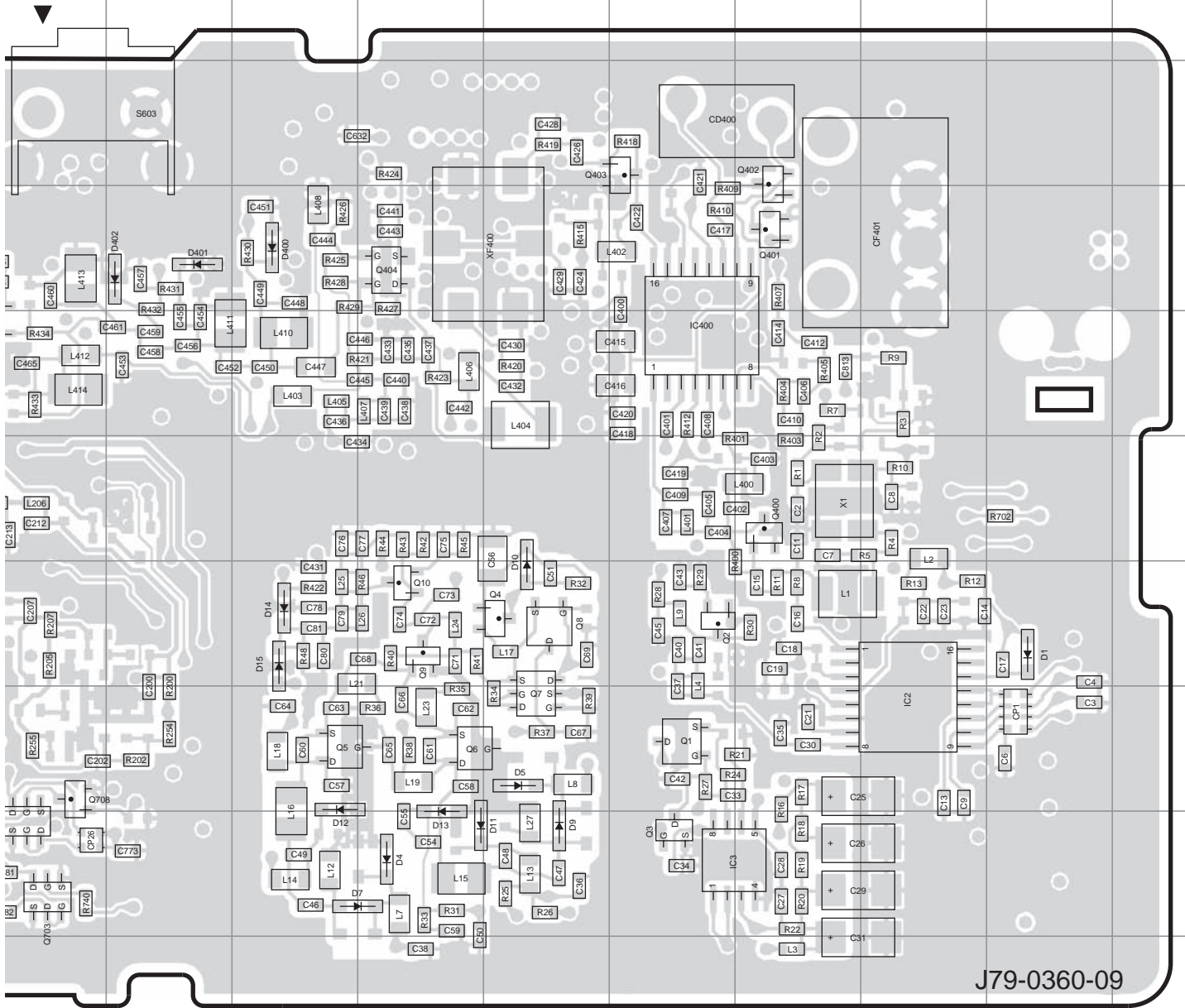

J79-0360-09

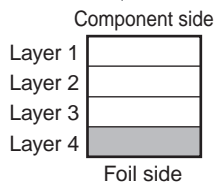



# TK-3402(U)/3402/3407 SCHEMATIC DIAGRAM

TX-RX UNIT(X57-8320-10)

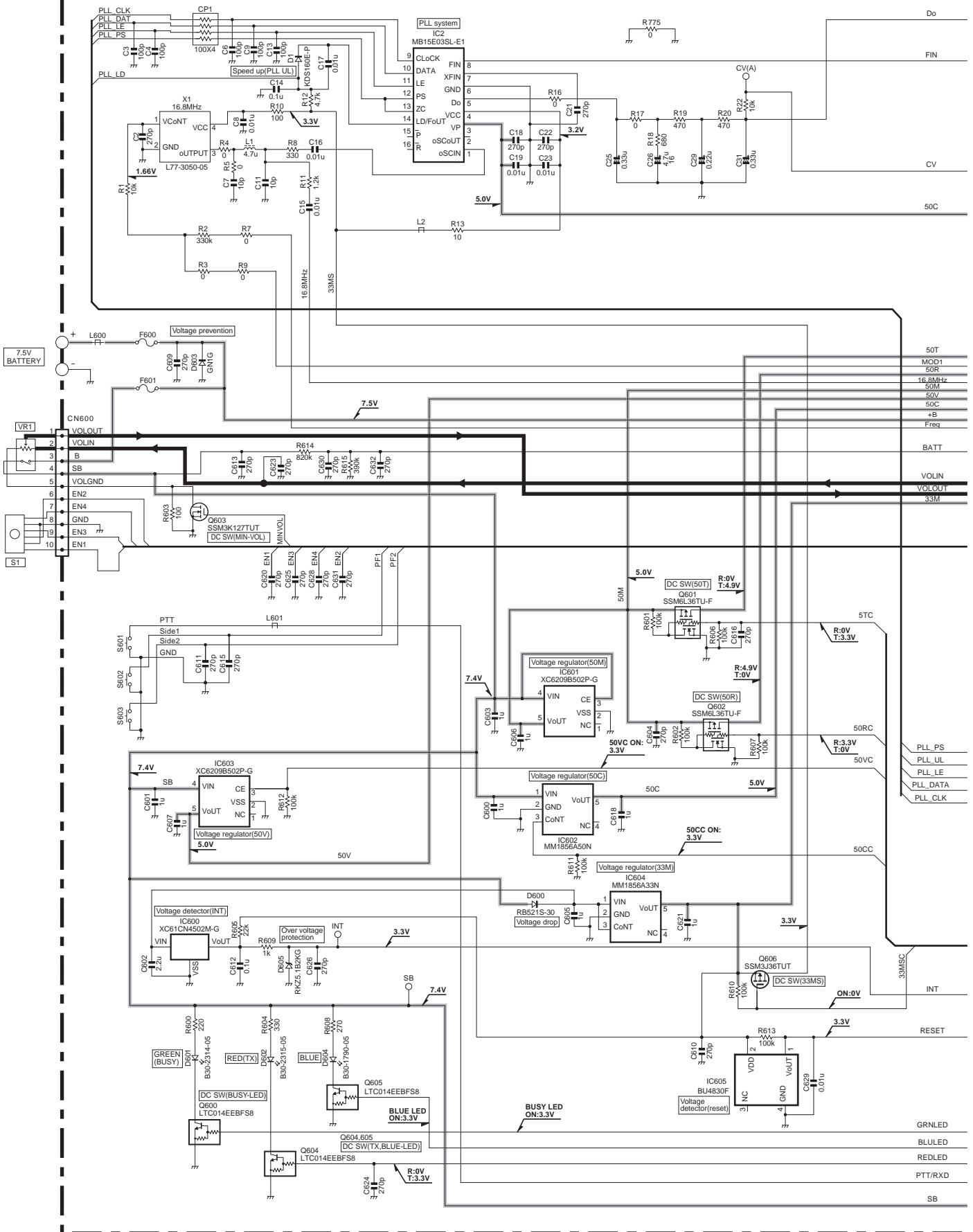

# SCHEMATIC DIAGRAM TK-3402(U)/3402/3407

TX-RX UNIT (X57-8320-10)

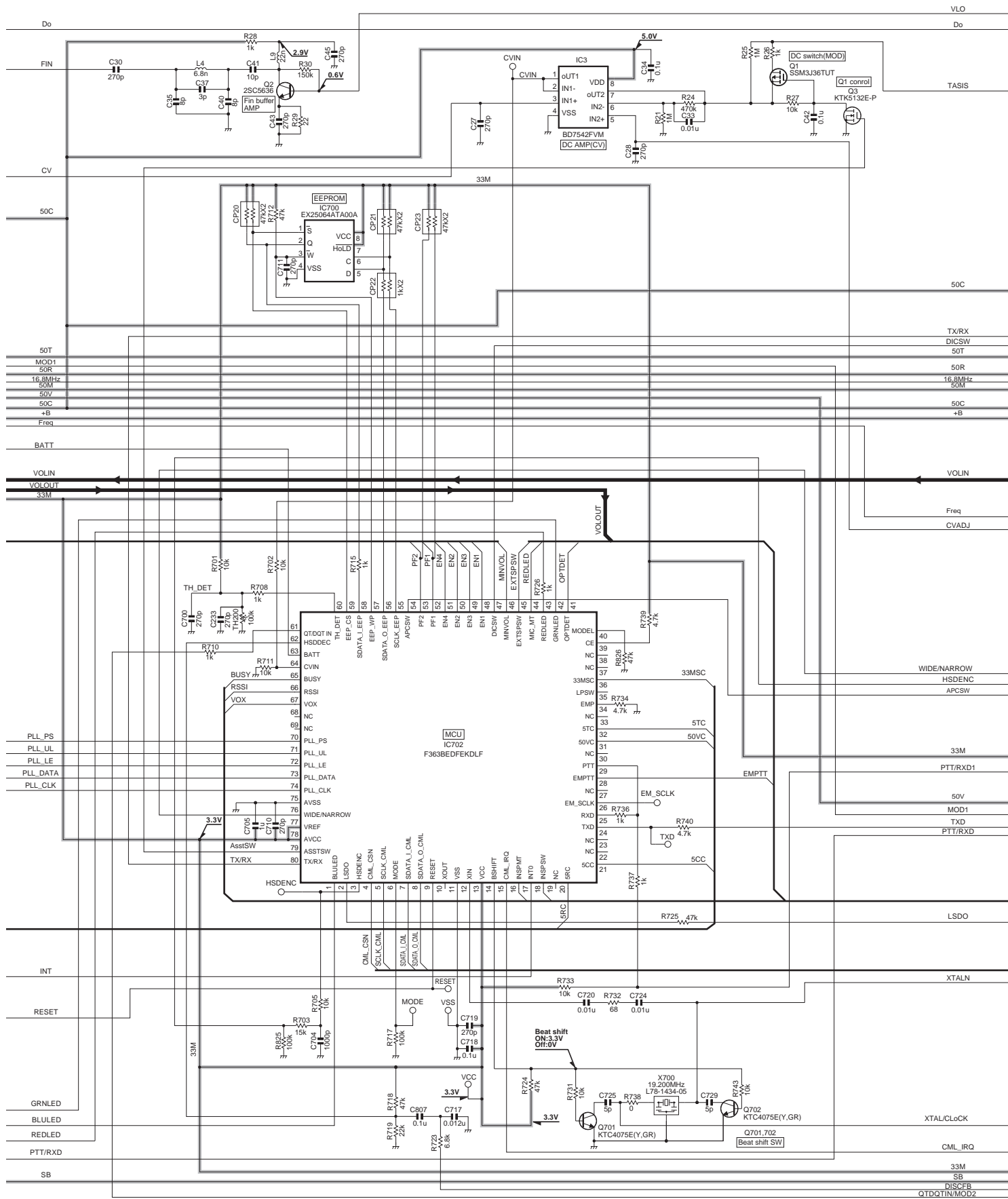

# TK-3402(U)/3402/3407 SCHEMATIC DIAGRAM

TX-RX UNIT (X57-8320-10)

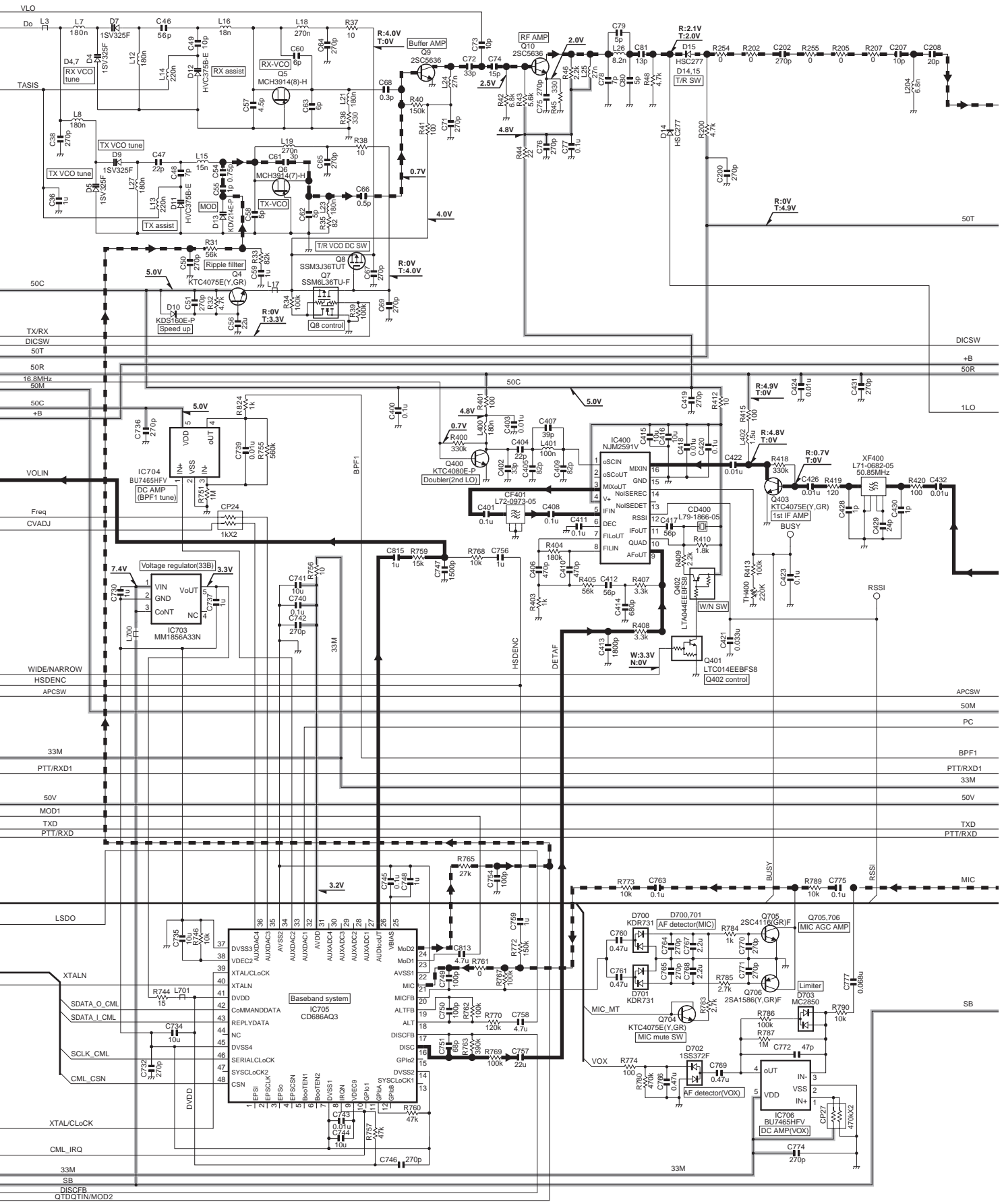





# TK-3402(U)/3402/3407

## BLOCK DIAGRAM

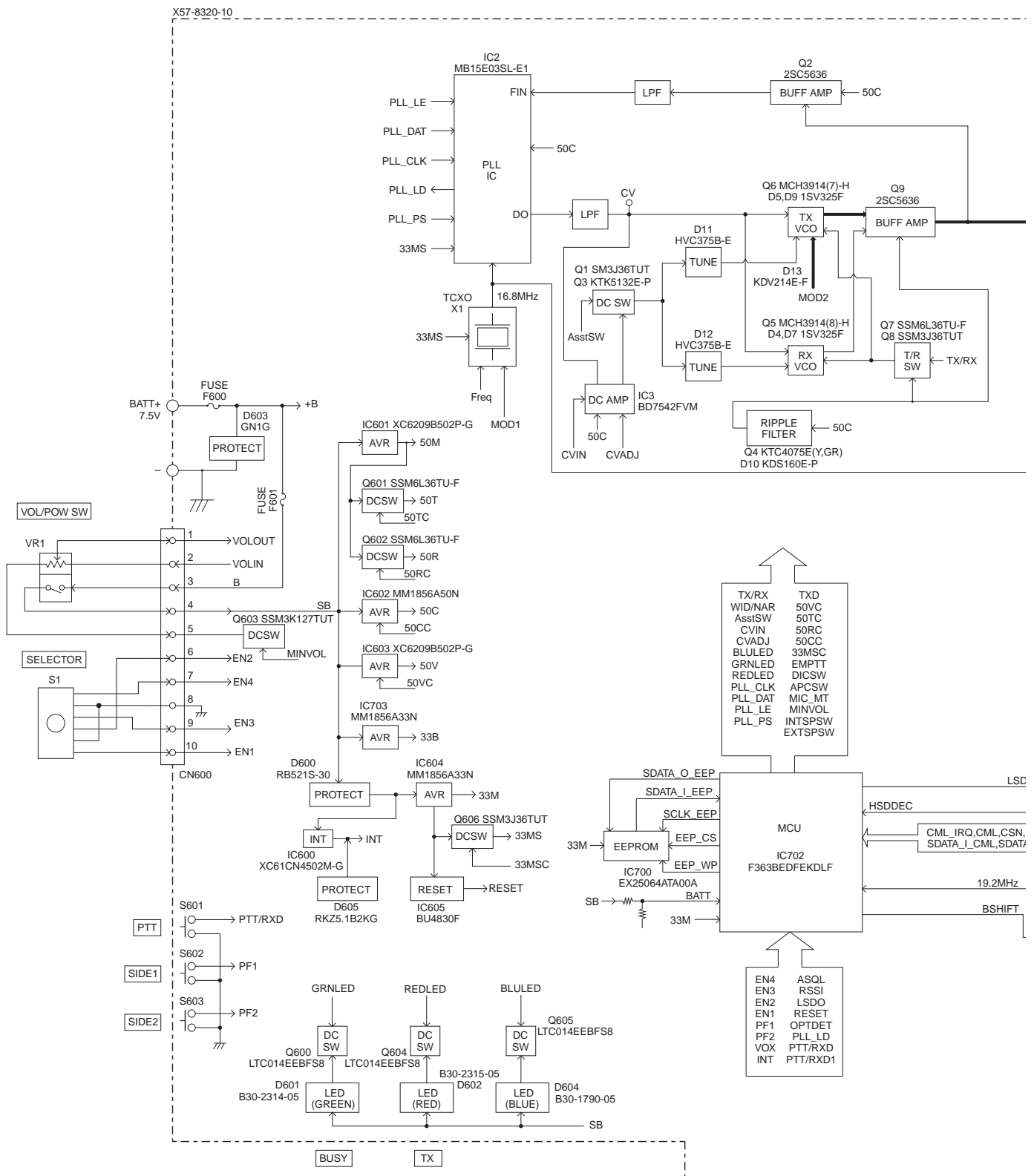

# TK-3402(U)/3402/3407

## BLOCK DIAGRAM

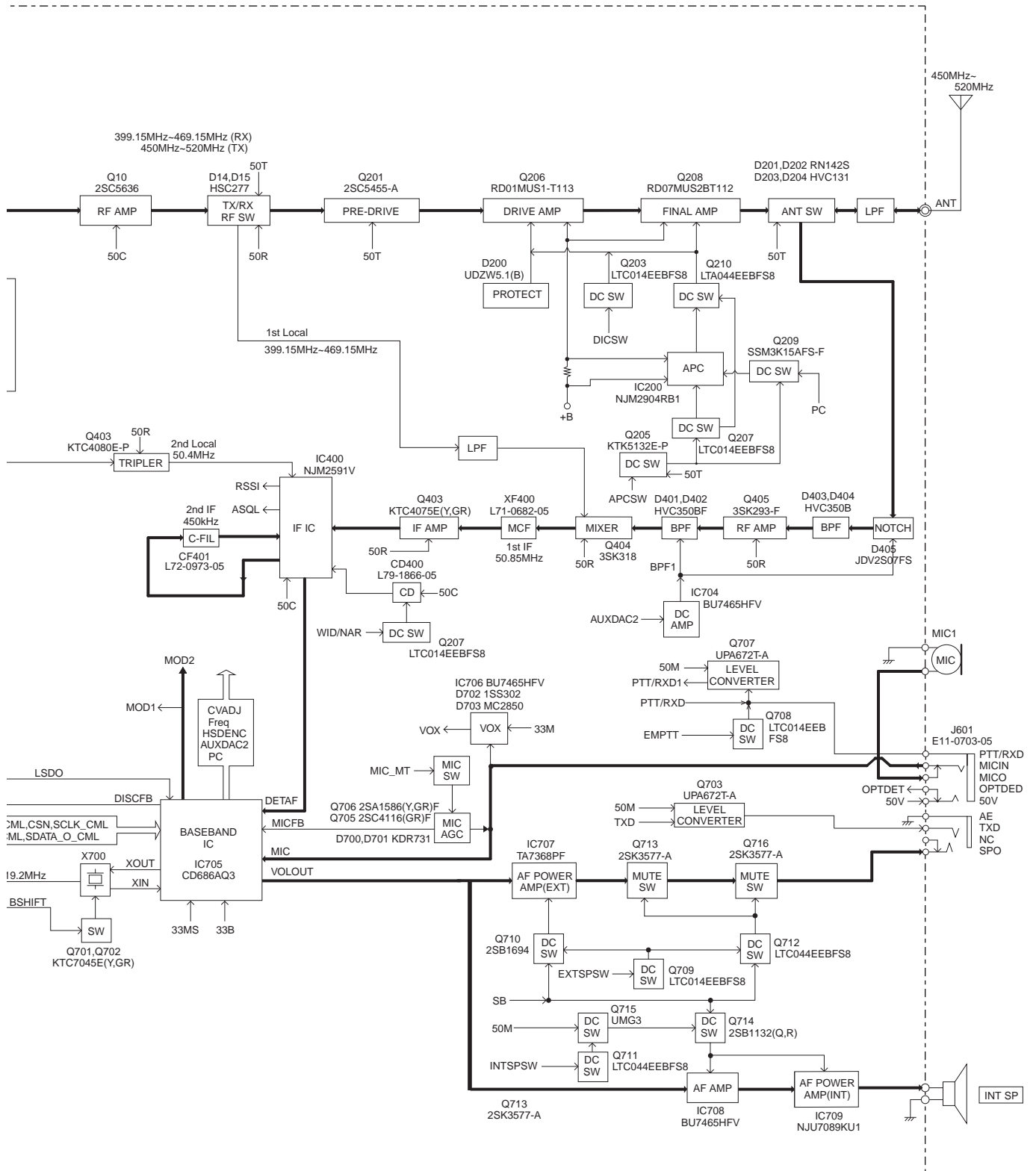

## LEVEL DIAGRAM

### Receiver Section

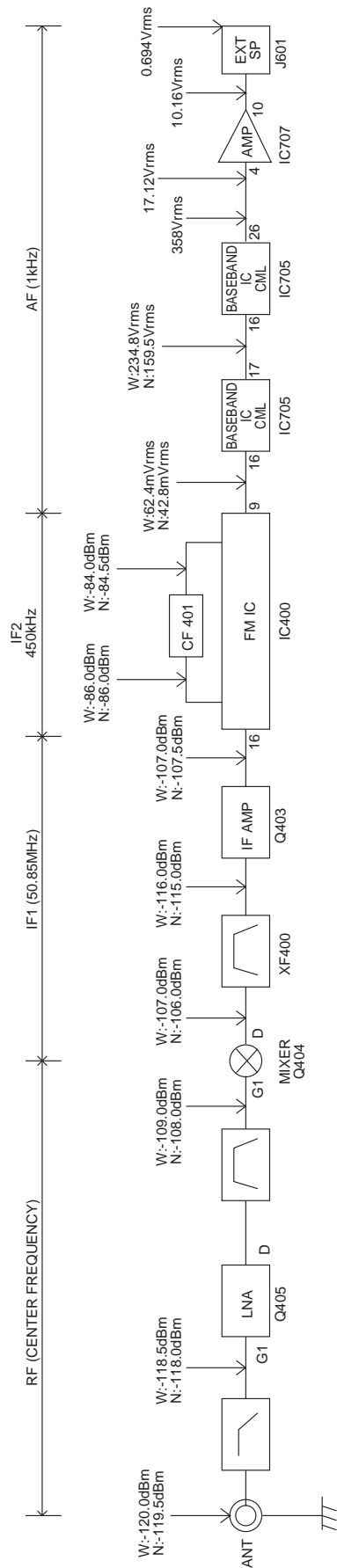

To make measurements in the AF section, connect the AC level meter.  
 (ANT input: -53dBm, 1kHz FM, 1.5kHz Dev (Narrow)).  
 In the RF section, use a high impedance probe. (ANT input: -53dBm, MOD off).

### Transmitter Section

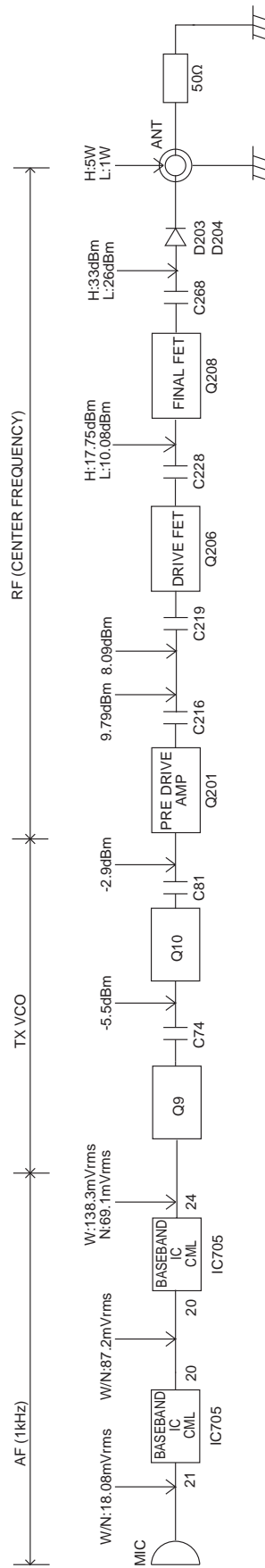

AG is set to the MIC input becomes 1.5kHz Dev, At 1kHz MOD. (Narrow)  
 To make measurements in the AF section, connect the AC level meter.  
 In the RF section, use a 1000pF coupling capacitor.

# TK-3402(U)/3402/3407

## SPECIFICATIONS

### GENERAL

Frequency Range .....	450~520MHz
Number of channels .....	16
Channel Spacing .....	25kHz (Wide) / 12.5kHz (Narrow) ※ TK-3402(U):12.5kHz(Narrow)
PLL Channel Stepping .....	5kHz, 6.25kHz
Operating Voltage .....	7.5 V DC±20%
Battery Life .....	More than 12 hours at 5 watts (5-5-90 duty cycle with KNB-45L battery)
Operating Temperature Range .....	-30°C to +60°C (-22°F to +140°F)
Frequency Stability .....	±2.5ppm (-30°C to +60°C)
Channel Frequency Spread.....	70MHz
Dimensions and Weight (Dimensions not included)	
Radio Only .....	165g(5.8oz)
With KNB-45L (2000mAh battery) .....	54(2.13) W x 122(4.8) H x 33.7(1.32) D mm (in)
	281g(9.9oz)

### RECEIVER (Measurements mode per TIA/EIA-603)

Sensitivity	
EIA 12dB SINAD .....	0.25µV (Wide) / 0.28µV (Narrow)
Adjacent CH Selectivity .....	70dB (Wide) / 60dB (Narrow)
Intermodulation Distortion .....	70dB (Wide) / 60dB (Narrow)
Spurious Response .....	70dB
Audio Output.....	500mW at 8Ω less than 10% distortion (External speaker)
	1.0W at 12Ω less than 10% distortion (Internal speaker)

### TRANSMITTER (Measurements mode per TIA/EIA-603)

RF Output Power .....	5W/1W
Spurious Response .....	70dB
Modulation .....	16K0F3E (Wide) / 11K0F3E (Narrow)
FM Hum and Noise.....	45dB (Wide) / 40dB (Narrow)
Modulation Distortion.....	Less than 5%

Measurements made per TIA/EIA-603 and specifications shown are typical.  
JVC KENWOOD Corporation reserves the right to change specifications without prior notice or obligation.

# TK-3402(U)/3402/3407

## **JVCKENWOOD Corporation**

3-12, Moriyacho, Kanagawa-ku, Yokohama-shi,  
Kanagawa, 221-0022 Japan

### **Kenwood U.S.A. Corporation**

P.O. BOX 22745, 2201 East Dominguez Street, Long Beach,  
CA 90801-5745, U.S.A.

### **Kenwood Electronics Canada Inc.**

6070 Kestrel Road, Mississauga, Ontario, Canada L5T 1S8

### **Kenwood Electronics Deutschland GmbH**

Rembrücker Str. 15, 63150 Heusenstamm, Germany

### **Kenwood Electronics Belgium N.V.**

Leuvensesteenweg 248 J, 1800 Vilvoorde, Belgium

### **Kenwood Electronics France S.A.**

L'Etoile Paris Nord 2, 50 Allée des Impressionnistes,  
Bp 58416 Villepinte, 95944 Roissy Ch De Gaulle Cedex

### **Kenwood Electronics UK Limited**

Kenwood House, Dwight Road, Watford, Herts.,  
WD18 9EB United Kingdom

### **Kenwood Electronics Europe B.V.**

Amsterdamseweg 37, 1422 AC Uithoorn, The Netherlands

### **Kenwood Electronics Italia S.p.A.**

Via G. Sirtori, 7/9 20129 Milano, Italy

### **Kenwood Ibérica, S.A.**

Carretera de Rubi, 88 Planta 1 A 08174 Sant Cugat del Vallès  
Barcelona, Spain

### **JVCKENWOOD Australia Pty. Ltd.**

Talavera Business Park Building A, 4 Talavera Road,  
North Ryde NSW 2113 Australia

### **Kenwood Electronics (Hong Kong) Ltd.**

Suite 2504, 25/F, Tower 2, Nina Tower, No. 8 Yeung Uk Road,  
Tsuen Wan, New Territories, Hong Kong

### **Kenwood Electronics Singapore Pte Ltd**

1 Ang Mo Kio Street 63, Singapore 569110

# TX-3402(U)/3402/3407 PC BOARD

# PC BOARD TX-3402(U)/3402/3407

TX-RX UNIT (X57-8320-10)  
Component side view (J79-0360-09)

TX-RX UNIT (X57-8320-10)  
Component side view (J79-0360-09)

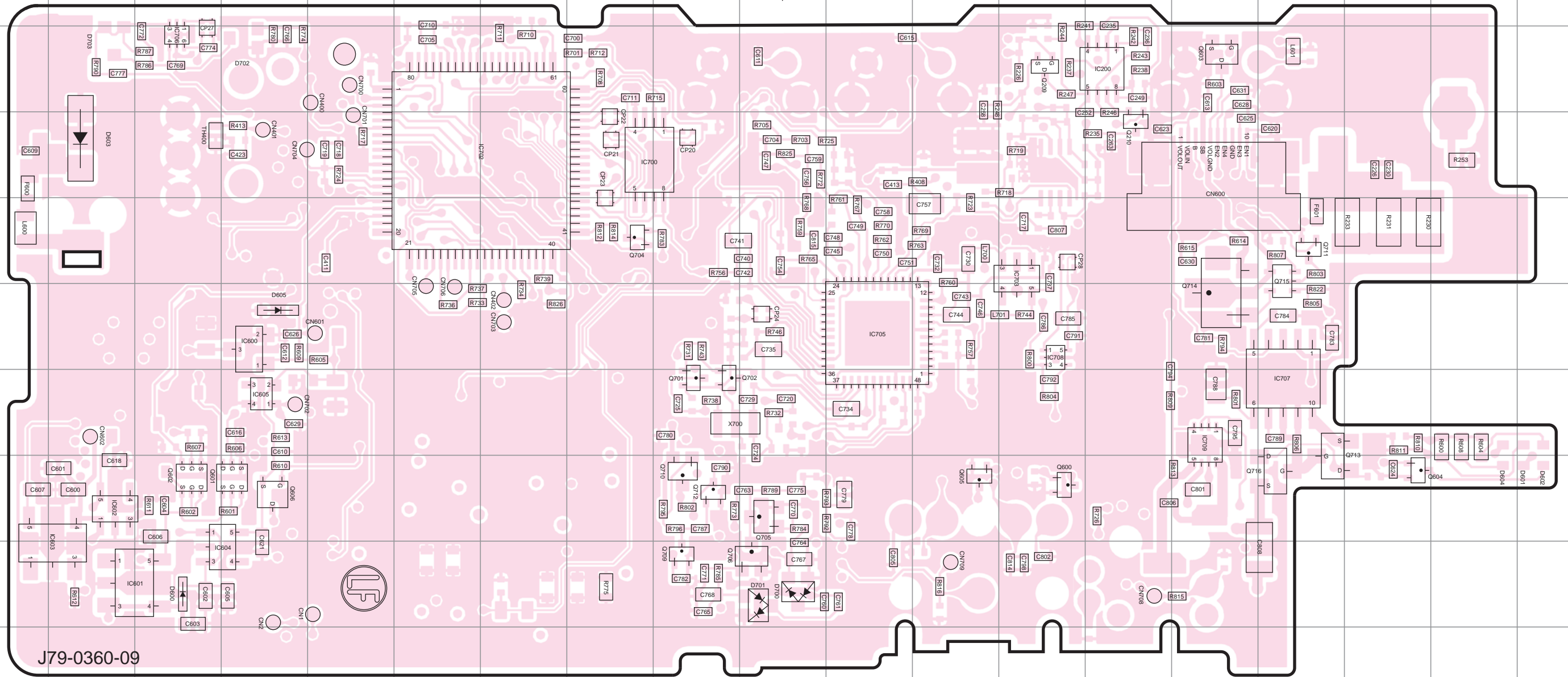

J79-0360-09

Ref. No.	Address	Ref. No.	Address	Ref. No.	Address	Ref. No.	Address	Ref. No.	Address	Ref. No.	Address
D600	9C	D703	3B	IC702	4F	Q600	8M	Q704	5H	Q715	5P
D601	7S	IC200	3N	IC703	5M	Q601	8D	Q705	8J	Q716	8P
D602	7S	IC600	6D	IC705	6K	Q602	8C	Q706	9J		
D603	4B	IC601	9B	IC706	3C	Q603	3O	Q710	8I		
D604	7R	IC602	8B	IC707	7P	Q604	8Q	Q709	9I		
D605	6D	IC603	9B	IC708	6M	Q605	8L	Q711	5P		
D700	9J	IC604	9D	IC709	7O	Q606	8D	Q712	8I		
D701	9J	IC605	7D	Q209	3M	Q701	7I	Q713	8P		
D702	3D	IC700	4H	Q210	4N	Q702	7I	Q714	6O		

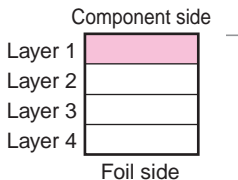



# TX-3402(U)/3402/3407 PC BOARD

# PC BOARD TX-3402(U)/3402/3407

TX-RX UNIT (X57-8320-10)  
Foil side view (J79-0360-09)

TX-RX UNIT (X57-8320-10)  
Foil side view (J79-0360-09)

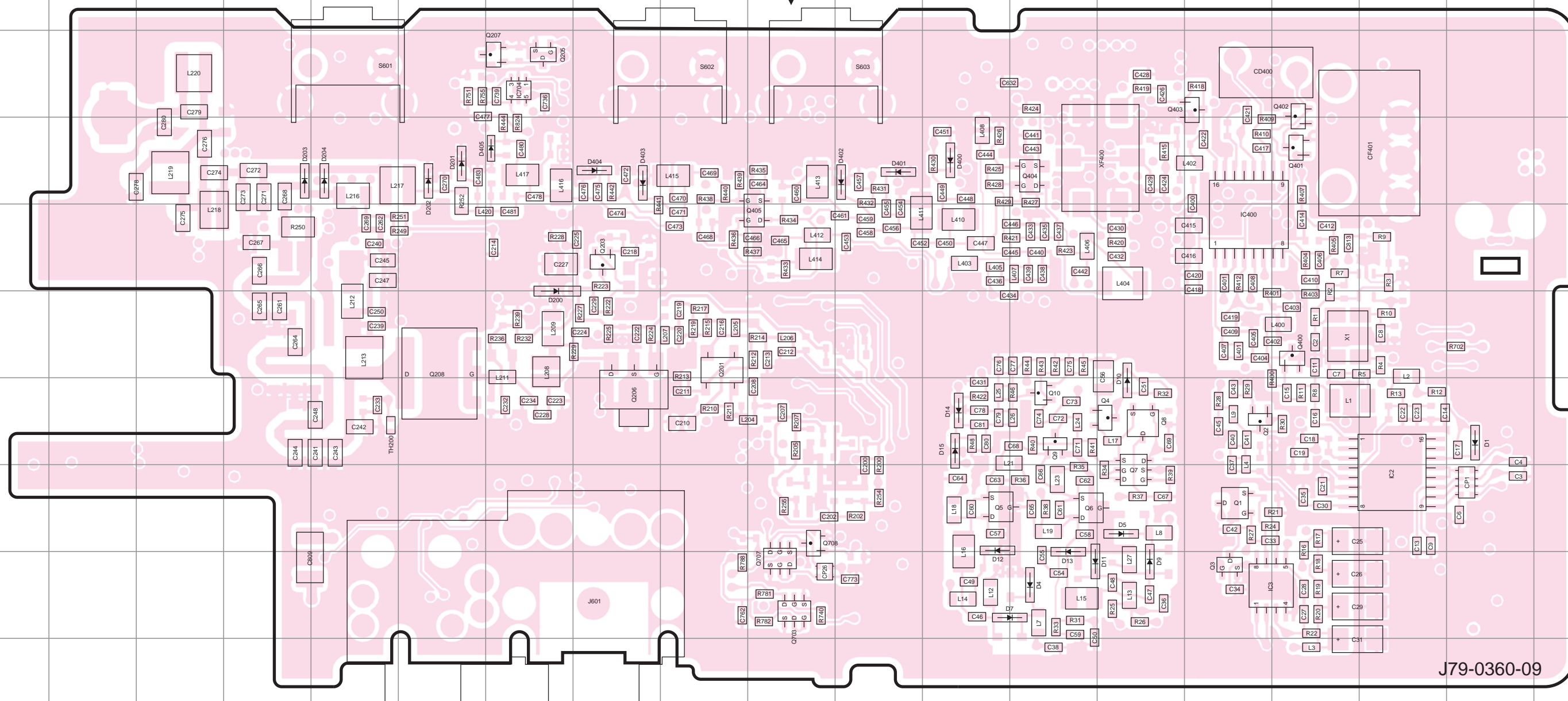

J79-0360-09

Ref. No.	Address	Ref. No.	Address	Ref. No.	Address	Ref. No.	Address	Ref. No.	Address	Ref. No.	Address
D1	7R	D14	7L	D402	4K	Q2	7O	Q201	6I	Q403	3O
D4	9M	D15	7L	D403	4H	Q3	9O	Q203	5H	Q404	4M
D5	8N	D200	6G	D404	4H	Q4	7N	Q205	3G	Q405	5J
D7	9M	D201	4F	D405	4G	Q5	8L	Q206	7H	Q703	9J
D9	9N	D202	4F	IC2	8Q	Q6	8M	Q207	3G	Q707	9J
D10	7N	D203	4D	IC3	9O	Q7	8N	Q208	6F	Q708	8J
D11	9M	D204	4E	IC400	5O	Q8	7N	Q400	6P		
D12	9L	D400	4L	IC704	3G	Q9	7M	Q401	4P		
D13	9M	D401	4K	Q1	8O	Q10	7M	Q402	3P		

