

KENWOOD

Document Copyrights

Copyright 2006 by Kenwood Corporation. All rights reserved.

No part of this manual may be reproduced, translated, distributed, or transmitted in any form or by any means, electronic, mechanical, photocopying, recording, or otherwise, for any purpose without the prior written permission of Kenwood.

Disclaimer

While every precaution has been taken in the preparation of this manual, Kenwood assumes no responsibility for errors or omissions. Neither is any liability assumed for damages resulting from the use of the information contained herein. Kenwood reserves the right to make changes to any products herein at any time for improvement purposes.

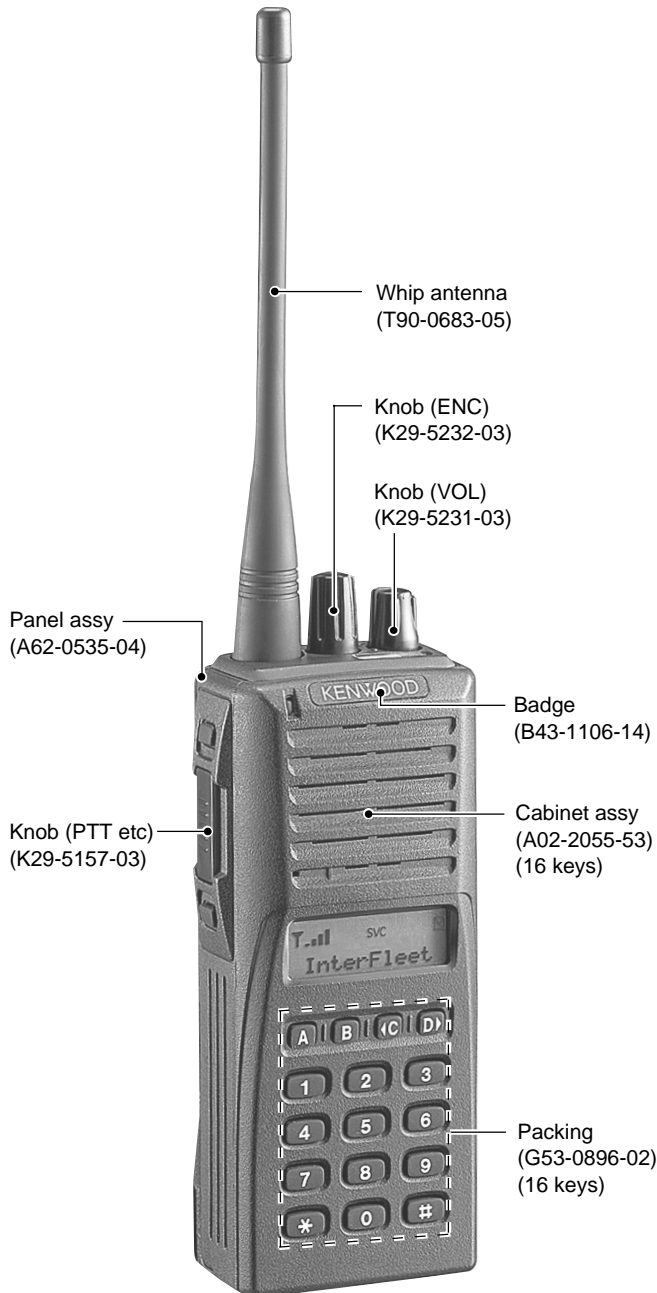

CONTENTS

GENERAL	2
SYSTEM SET-UP	2
OPERATING FEATURES	3
REALIGNMENT	4
CIRCUIT DESCRIPTION	6
SEMICONDUCTOR DATA	11
DESCRIPTION OF COMPONENTS	13
PARTS LIST	14
EXPLODED VIEW	21
PACKING	22
ADJUSTMENT	23
TERMINAL FUNCTION	32
PC BOARD VIEWS	
DISPLAY UNIT (X54-3210-12)	33
TX-RX UNIT (X57-6200-31)	39
SCHEMATIC DIAGRAM	45
BLOCK DIAGRAM	49
LEVEL DIAGRAM	51
OPTIONS	52
SPECIFICATIONS	BACK COVER

CAUTION

When using an external power connector, please use with maximum final module protection of 9V.

GENERAL / SYSTEM SET-UP

INTRODUCTION

SCOPE OF THIS MANUAL

This manual is intended for use by experienced technicians familiar with similar types of commercial grade communications equipment. It contains all required service information for the equipment and is current as of this publication date. Changes which may occur after publication are covered by either Service Bulletins or Manual Revisions, which are issued as required.

- SHUT OFF this equipment when near electrical blasting caps or while in an explosive atmosphere.
- This equipment should be serviced by only qualified technicians.

SERVICE

This radio is designed for easy servicing. Refer to the schematic diagrams, printed circuit board views, and alignment procedures contained within.

ORDERING REPLACEMENT PARTS

When ordering replacement parts or equipment information, the full part identification number should be included. This applies to all parts : components, kits, and chassis. If the part number is not known, include the chassis or kit number of which it is a part and a sufficient description of the required component, for proper identification.

PERSONNEL SAFETY

The following precautions are recommended for personnel safety:

- DO NOT transmit until all RF connectors are secure and any open connectors are properly terminated.

Unit		TX-RX unit	Display unit	Frequency range	Remarks	Charger	Battery
Model & destination							
TK-385	A2	X57-6200-31	X54-3210-12	470~520MHz	1st IF : 44.85MHz LOC : 44.395MHz	Option	Option

SYSTEM SET-UP

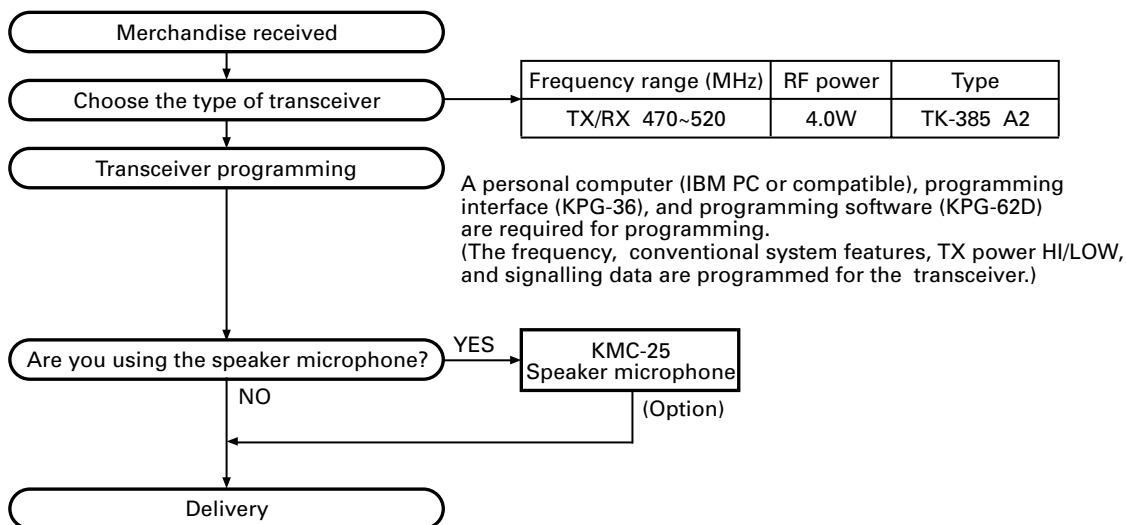

OPERATING FEATURES

1. Operation Features

The TK-385 is a UHF FM Radio designed in both Trunking Mode and Conventional Mode.

2. Transceiver Controls and Indicators

2-1. Physical Layout

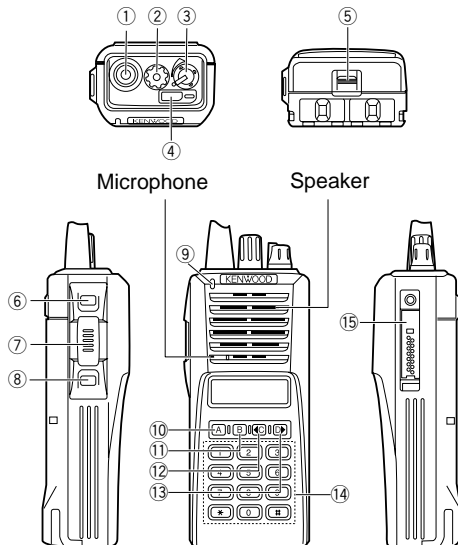

2-2. Panel controls

The key on the top and front panel is momentary-type push buttons. The functions of these keys and knob are explained below.

- ① **Antenna connector**
Connect the antenna here.
- ② **Rotary encoder**
- ③ **POWER switch/ VOLUME control**
Turn clockwise to switch ON the transceiver. Rotate to adjust the volume. Turn counterclockwise fully to switch OFF the transceiver.
- ④ **Auxiliary (orange) key**
- ⑤ **Battery pack release latch**
Pull back on this latch to release the battery pack.
- ⑥ **Call key**
- ⑦ **PTT (Push-To-Talk) switch**
- ⑧ **Clear key**
- ⑨ **Transmit/ Receive indicator**
- ⑩ **A key**
- ⑪ **B key**
- ⑫ **◀C key**
- ⑬ **D▶ key**
- ⑭ **DTMF keypad**
- ⑮ **Universal connector**
Connect the (optional KMC-25) speaker/ microphone here. Otherwise, keep the supplied cover in place.

2-3. Key functions

Trunking mode

- ② **Rotary encoder**
Rotate this encoder to select your desired call address (voice calls) to status (status calls).
- ④ **Auxiliary (orange) key** (default setting: **None**)
Press to activate its auxiliary function.
- ⑥ **Call key**
Press to call the displayed call address.
- ⑦ **PTT (Push-To-Talk) switch**
Press to transmit. Also press to initiate a call if "PTT to Initiate Call" has been programmed.
- ⑧ **Clear key**
Press to end the current call.
- ⑨ **Transmit indicator**
Lights red while transmitting.
- ⑩ **A key** (default setting: **Status/ Stack**)
Press to activate its auxiliary function.
- ⑪ **B key** (default setting: **Redial**)
Press to activate its auxiliary function.
- ⑫ **◀C key** (default setting: **None**)
Press to activate its auxiliary function. Also press to scroll left while viewing stack entries.
- ⑬ **D▶ key** (default setting: **None**)
Press to activate its auxiliary function. Also press to scroll right while viewing stack entries.
- ⑭ **DTMF keypad**
Press to input a call address or dialing function.

Conventional mode

- ② **Rotary encoder**
Rotate this encoder to select your desired channel.
- ⑥ **Call key**
Press to turn the monitor function ON in order to monitor your selected channel.
- ⑦ **PTT (Push-To-Talk) switch**
Press this switch, then speak into the microphone to call a station.
- ⑧ **Clear key**
Press to return to Trunking mode.
- ⑨ **Transmit/ Receive indicator**
Lights green while receiving a signal. Lights red while transmitting.
- ⑩ **A key**
Press to turn Scan ON (or OFF).
- ⑪ **B key**
Press to add/delete channel(s) to/from Scan list.
- ⑬ **D▶ key**
Press to turn the display and keypad backlight ON. The backlight remains ON for 5 seconds.

OPERATING FEATURES / REALIGNMENT

2-4. Display

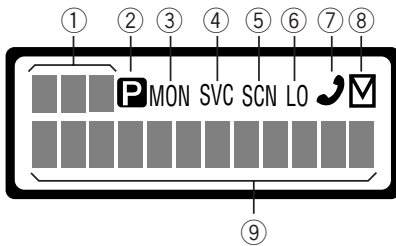

- ① **Sub display**
■■■ displays the strength of received signals.
- ② **Programming indicator**
P appears while in AUX A or Scrambler is being activated.
- ③ **MON (Monitor) indicator**
MON appears while you are monitoring a channel by pressing the Call key. (Conventional Mode only)
- ④ **SVC (Service) indicator**
SVC appears when a control channel is found. It flashes while the transceiver is searching for a control channel.
- ⑤ **SCN (Scan) indicator**
SCN appears while you are scanning. (Conventional Mode only)
- ⑥ **LO indicator**
This icon blinks while in battery warning, if "Always" or "Always W/beep" is selected in the battery warning settings.
- ⑦ **Handset indicator**
☎ flashes when you activate call diversion.
- ⑧ **MAIL indicator**
✉ appears while there is data in the stack. It flashes when there is new data in the stack.
- ⑨ **Alphanumeric display**
■■■■■■■■■■ displays call addresses, the call duration timer, data messages, and the current operating status of the transceiver.

Mode	Function
User mode	For normal use.
Panel test mode	Used by the dealer to check the fundamental characteristics.
Panel tuning mode	Used by the dealer to tune the radio.
PC mode	Used for communication between the radio and PC (IBM compatible).
Data programming mode	Used to read and write frequency data and other features to and from the radio.
PC test mode	Used to check the radio using the PC. This feature is included in the FPU. See panel tuning.
Firmware programming mode	Used when changing the main program of the flash memory.

2. How to Enter Each Mode

Mode	Operation
User mode	Power ON
Panel test mode	[B]+Power ON
PC mode	Received commands from PC
Panel tuning mode	[Panel test mode]+[A]
Firmware programming mode	[A]+Power ON

3. Panel Test Mode

Setting method refer to ADJUSTMENT.

4. Panel Tuning Mode

Setting method refer to ADJUSTMENT.

5. PC Mode

5-1. Preface

The TK-385 transceiver is programmed by using a personal computer, programming interface (KPG-36) and programming software (KPG-62D).

The programming software can be used with an IBM PC or compatible. Figure 1 shows the setup of an IBM PC for programming.

5-2. Connection procedure

1. Connect the TK-385 to the personal computer with the interface cable.
2. When the POWER switch on, user mode can be entered immediately. When PC sends command the radio enter PC mode, and "PROGRAM" is displayed on the LCD. When data transmitting from transceiver, the red LED is blinking. When data receiving to transceiver, the green LED is blinking.

Notes:

- The data stored in the personal computer must match model type, when it is written into the flash memory.
- Change the TK-385 to PC mode, then attach the interface cable.

REALIGNMENT

1. Modes

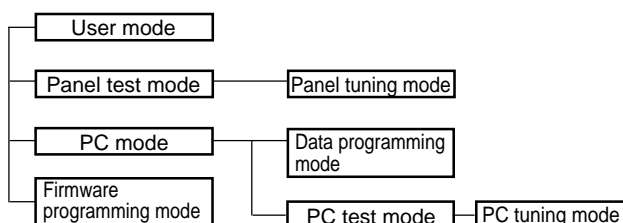

REALIGNMENT

5-3. KPG-36 description

(PC programming interface cable: Option)

The KPG-36 is required to interface the TK-385 to the computer. It has a circuit in its D-subconnector (25-pin) case that converts the RS-232C logic level to the TTL level.

The KPG-36 connects the universal connector of the TK-385 to the computers RS-232C serial port.

5-4. Programming software KPG-62D Description

The KPG-62D is the programming software for the transceiver supplied on three 3.5" floppy disks. This software runs under MS-Windows 95/98 on an IBM-PC or compatible machine.

The data can be input to or read from the transceiver and edited on the screen. The programmed or edited data can be printed out. It is also possible to tune the transceiver.

We recommend that install the KPG-62D for example to hard disk first then use it.

5-5. Programming with IBM PC

If data is transferred to the transceiver from an IBM PC with the KPG-62D, the destination data (basic radio information) for each set can be modified. Normally, it is not necessary to modify the destination data because their values are determined automatically when the frequency range (frequency type) is set.

The values should be modified only if necessary. Data can be programmed into the flash memory in RS-232C format via the universal connector.

KPG-62D instruction manual parts No. : B62-1354-XX

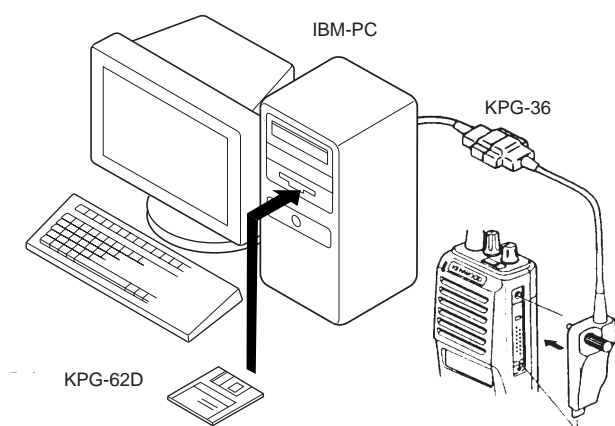

Fig. 1

6. Firmware Programming Mode

6-1. Preface

Flash memory is mounted on the TK-385. This allows the TK-385 to be upgraded when new features are released in the future. (For details on how to obtain the firmware, contact Customer Service.)

6-2. Connection procedure

Connect the TK-385 to the personal computer (IBM PC or compatible) with the interface cable (KPG-36). (Connection is the same as in the PC Mode.)

6-3. Programming

1. Start up the firmware programming software (Fpro.exe).
2. Set the communications speed (normally, 57600 bps) and communications port in the configuration item.
3. Set the firmware to be updated by File name item.
4. Turn the TK-385 power ON with the [A] switch held down. Hold the switch down until the display changes to "PROG 57600". When "PROG 57600" appears, release your finger from the switch.
5. Check the connection between the TK-385 and the personal computer, and make sure that the TK-385 is in the Program mode.
6. Press write button in the window. A window opens on the display to indicate progress of writing. When the TK-385 starts to receive data, the [P] icon is blinking.
7. If writing ends successfully, the LED on the TK-385 lights and the checksum is displayed.
8. If you want to continue programming other TK-385 s, repeat steps 4 to 7.

Notes:

- This mode cannot be entered if the Firmware Programming mode is set to Disable in the Programming software (KPG-62D).
- When programming the firmware, it is recommend to copy the data from the floppy disk to your hard disk before update the radio firmware.
Directry copying from the floppy disk to the radio may not work because the access speed is too slow.

6-4. Function

1. If you press the [Call] switch (top of left side) while "PROG 57600" is displayed, the version is displayed. If you press the [Call] switch again while the version is displayed, "PROG 57600" is redisplayed.
2. If you press the [Clear] switch (bottom of left side) while "PROG 57600" is displayed, the display changes to "PROG 19200" to indicate that the write speed is low speed (19200 bps). If you press the [Clear] switch again while "PROG 19200" is displayed, the display changes to "PROG 38400", and the write speed becomes the middle-speed mode (38400 bps). If you press the [Clear] switch again while "PROG 38400" is displayed, the display returns to "PROG 57600".
3. If you press the [Clear] switch while the version is displayed, the checksum is displayed. If you press the [Clear] switch again while the checksum is displayed, the version is redisplayed.

Note:

Normally, write in the high-speed mode.

CIRCUIT DESCRIPTION

1. Overview

This transceiver is UHF/FM portable transceiver designed to operate in the frequency range of 470 to 520MHz (A2).

2. Circuit Configuration by Frequency

The receiver is a double-conversion superheterodyne with a first intermediate frequency (IF) of 44.85MHz and a second IF of 455kHz. Incoming signals from the antenna are mixed with the local signal from the PLL to produce the first IF of 44.85MHz.

This is then mixed with the 44.395MHz second local oscillator output to produce the 455kHz second IF. This is detected to give the demodulated signal.

The transmit signal frequency is generated by the PLL VCO, and modulated by the signal from the microphone. It is then amplified and sent to the antenna.

3. Receiver System

3-1. RF unit

An incoming RF signal from the antenna terminal is passed through the antenna switch (D12, D14, D15 and D401 are off) and then the bandpass filter (L47,48,49,51,52,54,55,56). The bandpass filter is adjusted by a variable capacitor. The input voltage to the variable capacitor is regulated by the voltage output from the D/A converter (IC8). The signal is amplified by RF amplifier Q24, and passed through the bandpass filter (L29,31,33,34,36) and band-eliminate filter (L27) to remove the spurious signal again. The resulting signal is applied to the first mixer (IC18), where it is mixed with the first local oscillator signal output from the frequency synthesizer to produce the first IF (44.85MHz). The 1st mixer uses the GaAs IC.

3-2. IF unit

The first IF signal is passed through a crystal filter (XF1) to remove a adjacent channel signal. The filtered first IF signal is amplified by the first IF amplifier (Q12) and then applied to the IF system IC (IC12). The IF system IC provides a second mixer, second local oscillator, limiting amplifier, quadrature detector and RSSI (Received Signal Strength Indicator). The second mixer mixes the first IF signal with the 44.395MHz of second local oscillator output (crystal unit X2) and produces the second IF signal of 455kHz.

The second IF signal is passed through the ceramic filter (CF2) to more remove the adjacent channel signal. The filtered second IF signal is amplified by the limiting amplifier and demodulated by the quadrature detector with ceramic discriminator (CD1). The demodulated signal is routed to the audio circuit.

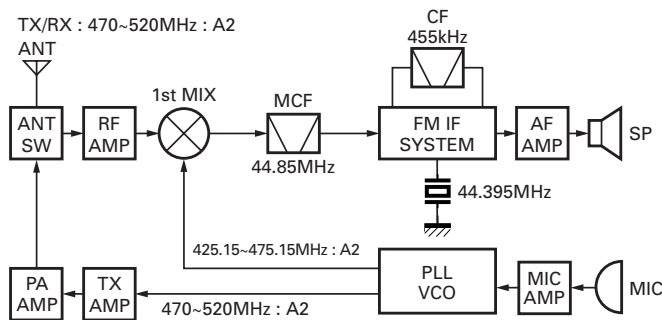

Fig. 1 Frequency configuration

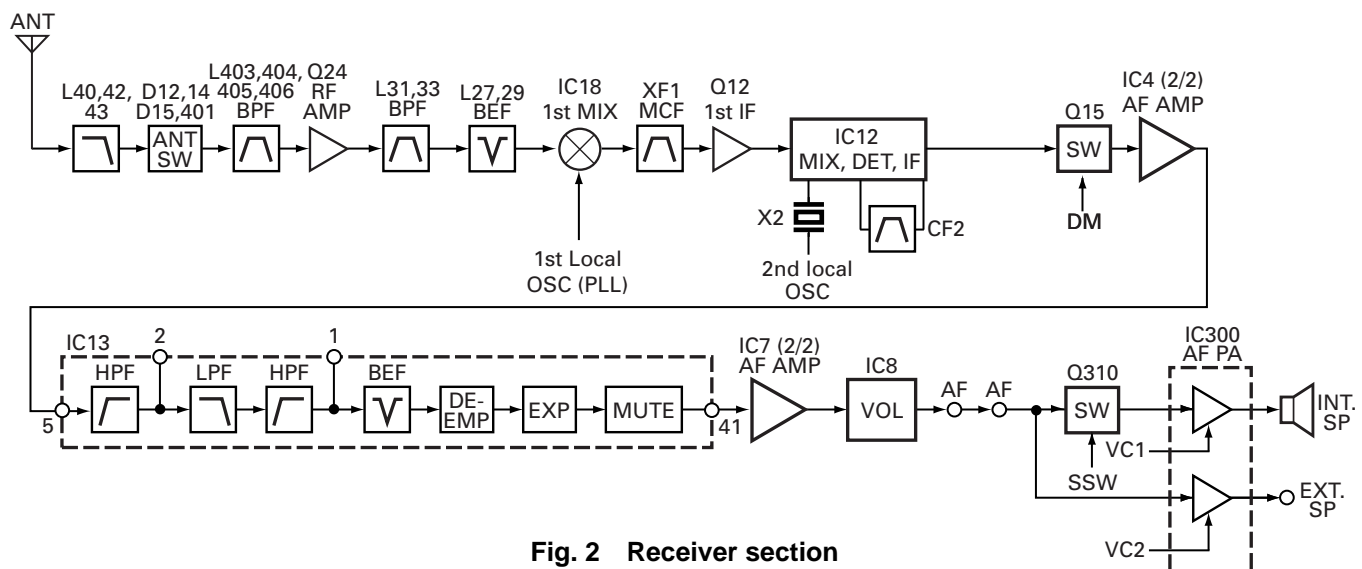

Fig. 2 Receiver section

CIRCUIT DESCRIPTION

3-3. Audio amplifier circuit

The demodulated signal from IC12 goes through the mute switch (Q15) and is amplified by IC4 (2/2), high-pass filtered, low-pass filtered, high-pass filtered, band-eliminate filtered, and de-emphasized by IC13.

The signal then goes through an AF amplifier IC7 (2/2), an electronic volume control (IC8), and an AF switch (Q310 is on), and is routed to audio power amplifier (IC300), where it is amplified and output to the internal speaker.

The audio mute signal (AM) from the shift register becomes Low in the standby and Q304, Q305 which are power supply circuit for IC300 turn off. Also, IC13 is set to the power down mode according to data from microprocessor, and the AF signal is muted. When the audio is output, AM becomes High to turn Q304, Q305 ON, and voltage is supplied to power terminal VP of IC300. Also, IC13 is canceled out of the power down mode.

The speaker is switched by the logic of speaker switching terminal SSW on the universal connector. When SP-MIC is not attached, the logic of SSW becomes High and SW (Q310) is turned ON, and the AF signal is input to both amplifiers of IC300.

When SP-MIC is attached, SSW is connected to GND at inside of SP-MIC. For this reason, Q310 is turned OFF, and the AF signal is input only to amplifier for EXT SP of IC300.

Change of INT/EXT SP refer to Fig. 3.

AM	SSW	VC1	VC2	SP
H	H	H	L	INT
H	L	L	H	EXT
L	H	L	L	MUTE
L	L	L	L	MUTE

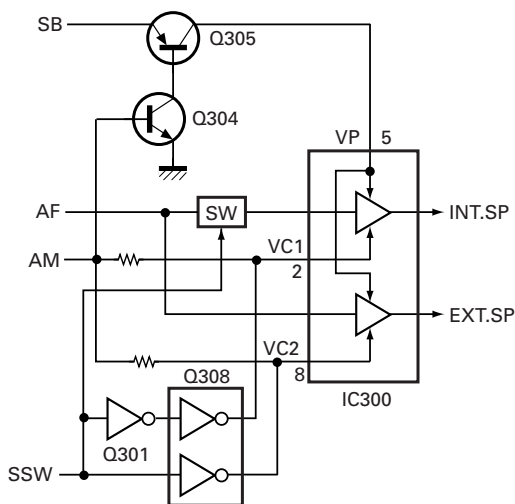

Fig. 3 Audio amplifier circuit

3-4. Squelch circuit

The output from IC12 enters FM IC again, then passed through a band-pass filter. The noise component output from IC12 is amplified by Q4 and rectified by D4 to produce a DC voltage corresponding to the noise level. The DC voltage is sent to the analog port of the CPU (IC19). And IC12 outputs a DC voltage (RSSI) corresponding to the input of the IF amplifier. The CPU reads the RSSI signal via pin 93.

IC19 determines whether to output sounds from the speaker by comparing the input voltage of pin 91 and pin 93 with the preset value.

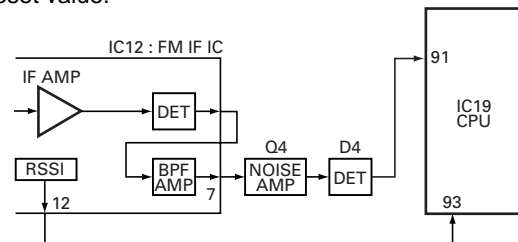

Fig. 4 Squelch circuit

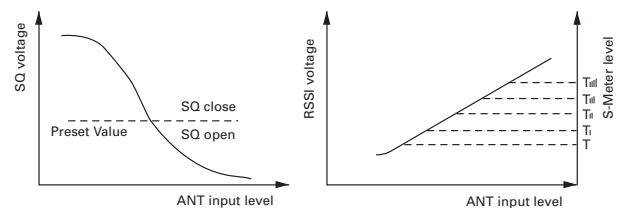

Fig. 5 Squelch and RSSI voltage vs ANT input level

4. Transmitter System

4-1. Microphone amplifier

The signal from the internal microphone goes through the mute switch (Q300).

When the SP-MIC is not attached, the microphone switching terminal (MSW) on the universal connector becomes High, and mute switch (Q300) is turned ON. When the SP-MIC is attached, MSW is connected to GND at inside of SP-MIC. For this reason, Q300 is turned OFF, the internal microphone is muted, and only the input of the external microphone is supplied to the microphone amplifier of the TX-RX unit.

The signal from microphone passes through the limiter circuit in D8, Mic mute switch (Q17 is off in TX) and through the low-pass filter (IC25 : 1/2), the high-pass filter, the ALC circuit, the low-pass filter, the high-pass filter, and pre-emphasis/IDC circuit in IC13. When encoding DTMF, mute switch (Q13) is turned OFF for muting the microphone input signal.

The signal passes through the D/A converter (IC8) for the maximum deviation adjustment, and enters the summing amplifier consisting of IC7 (1/2), and is mixed with the low speed data from the CPU (IC19) and 9600bps DATA from Optional Board Terminal.

CIRCUIT DESCRIPTION

The output signal from the summing amplifier passes through the D/A converter (IC8) again and goes to the VCO modulation input.

The other output signal from the summing amplifier passes through the D/A converter (IC8) again for the BAL adjustment, and the buffer amplifier (IC1 (2/2)), and goes to the VCXO modulation input.

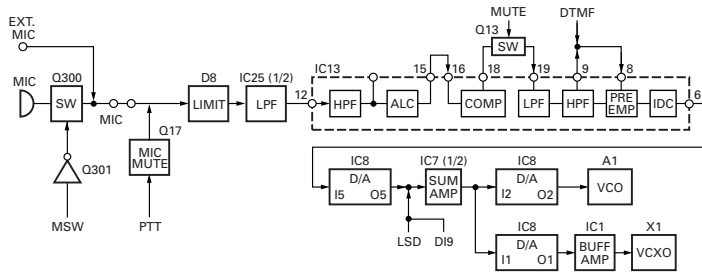

Fig. 6 Microphone amplifier

4-2. Drive and Final amplifier

The signal from the T/R switch (D9 is on) is amplified by the pre-drive (Q18) and drive amplifier (Q20) to 50mW.

The output of the drive amplifier is amplified by the RF power amplifier (IC100) to 4.0W (1W when the power is low). The RF power amplifier consists of two stages MOS FET transistor. The output of the RF power amplifier is then passed through the harmonic filter (LPF) and antenna switch (D12, D401 is on) and applied to the antenna terminal.

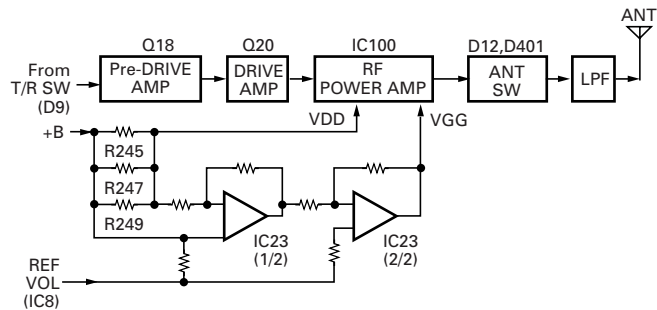

Fig. 7 Drive and final amplifier and APC circuit

4-3. APC circuit

The APC circuit always monitors the current flowing through the RF power amplifier (IC100) and keeps a constant current. The voltage drop at R245, R247 and R249 is caused by the current flowing through the RF power amplifier and this voltage is applied to the differential amplifier (IC23 1/2).

IC23(2/2) compares the output voltage of IC23(1/2) with the reference voltage from IC8, and the output of IC23(2/2) controls the VGG of the RF power amplifier to make the both voltages to same voltage.

The change of power high/low is carried out by the change of the reference voltage. Q22,23 and 25 are turned on in transmit and the APC circuit is active.

5. Frequency Synthesizer Unit

5-1. Frequency synthesizer

The frequency synthesizer consists of the VCXO (X1), VCO (A1), PLL IC(IC14) and buffer amplifiers.

The VCXO generates 16.8MHz. The frequency stability is 1.5ppm within the temperature range of -30 to +60°C. The frequency tuning and modulation of the VCXO are done to apply a voltage to pin 1 of the VCXO. The output of the VCXO is applied to pin 8 of the PLL IC.

The TK-385's VCO consists of 2VCO and covers a dual range of the 425.15~475.15MHz and the 470~520MHz. The VCO generates 425.15~475.15MHz for providing to the first local signal in receive. In TX, the pin 3 of the VCO goes low and the VCO generates 470~520MHz.

The output of the VCO is amplified by the buffer amplifier (Q16) and routed to the pin 5 of the PLL IC. Also the output of the VCO is amplified by the buffer amplifier (Q18) and routed to the next stage according to T/R switch (D9, D23).

The PLL IC consists of a prescaler, fractional divider, reference divider, phase comparator, charge pump. This PLL IC is fractional-N type synthesizer and performs in the 40.50 or 60kHz reference signal which is eighth of the channel step (6.25kHz). The input signal from the pins 5 and 8 of the PLL IC is divided down to the 50kHz and compared at phase comparator. The pulsed output signal of the phase comparator is applied to the charge pump and transformed into DC signal in the loop filter (LPF). The DC signal is applied to the pin 1 of the VCO and locked to keep the VCO frequency constant.

PLL data is output from DT (pin 75). CP (pin 19) and EP (pin 47) of the microprocessor (IC19). The data are input to the PLL IC when the channel is changed or when transmission is changed to reception and vice versa.

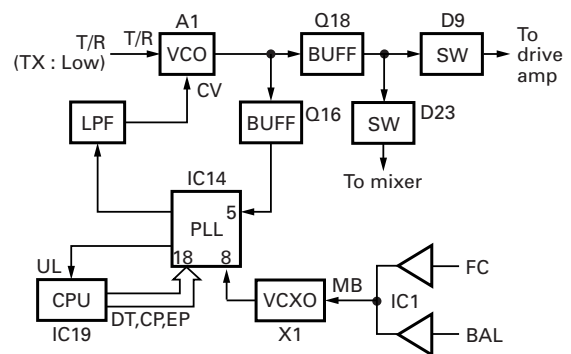

Fig. 8 PLL block diagram

CIRCUIT DESCRIPTION

6. Control Circuit

The control circuit consists of microprocessor (IC19) and its peripheral circuits. It controls the TX-RX unit and transfers data to and from the display unit. IC19 mainly performs the following;

- 1) Switching between transmission and reception by PTT signal input.
- 2) Reading system, group, frequency, and program data from the memory circuit.
- 3) Sending frequency program data to the PLL.
- 4) Controlling squelch on/off by the DC voltage from the squelch circuit.
- 5) Controlling the audio mute circuit by decode data input.
- 6) Transmitting tone and encode data.

6-1. Memory circuit

Memory circuit consists of the CPU (IC19) and a flash memory (IC17).

A flash memory has a capacity of 2M bits and contains the transceiver control program for the CPU and the data for operating features.

This program can be easily downloaded from an external device.

• Flash Memory

Note : The flash memory stores the data containing the FPU (KPG-62D) program, Security Number (MPT Serial Number) and firmware program (User mode, Test mode, Tuning mode, etc.).

This data must be reinstalled when replacing the flash memory.

• EEPROM

Note : The EEPROM stores tuning data (Deviation, Squelch, etc.).

Realign the transceiver after replacing the EEPROM.

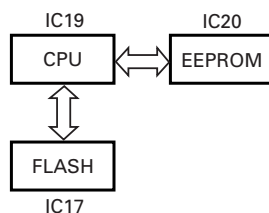

Fig. 9 Memory circuit

6-2. Low battery warning

The battery voltage is monitored by the microprocessor (IC19). When the battery voltage falls below the voltage set by the Low Battery Warning adjustment, the red LED flashes to notify the operator that it is time to replace the battery. If the battery voltage falls even more (approx. 5.8V), a beep sounds and transmission is stopped.

Low battery warning	Battery condition
The red LED flashes during transmission	The battery voltage is low but the transceiver is still usable.
The red LED flashes and continuous beep sounds while PTT pressed	The battery voltage is low and the transceiver is not usable to make calls.

6-3. Key input

If the clock is supplied to CLK terminal when the RES terminal (CPU pin 78) of the decade counter (IC301) is set to Low, Q0 to Q7 become High sequentially. Normally, KI1 and KI2 are Low (pulled down). When any key is pressed, KI1 or KI2 become High. The CPU detects which key is pressed, according to the voltage of KI1 and KI2 and clock timing.

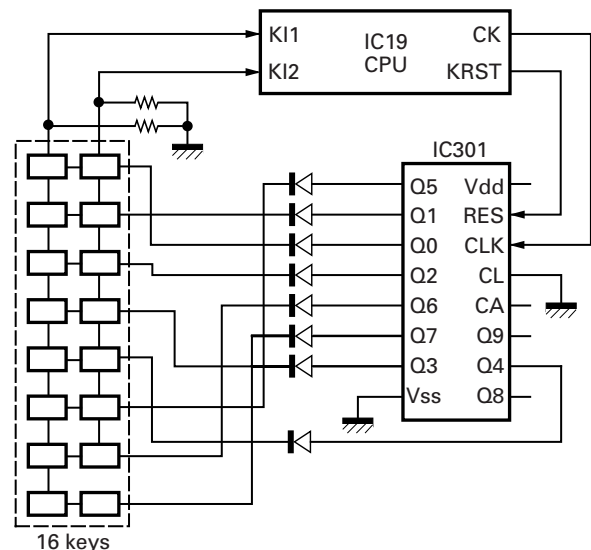

Fig. 10 Key input

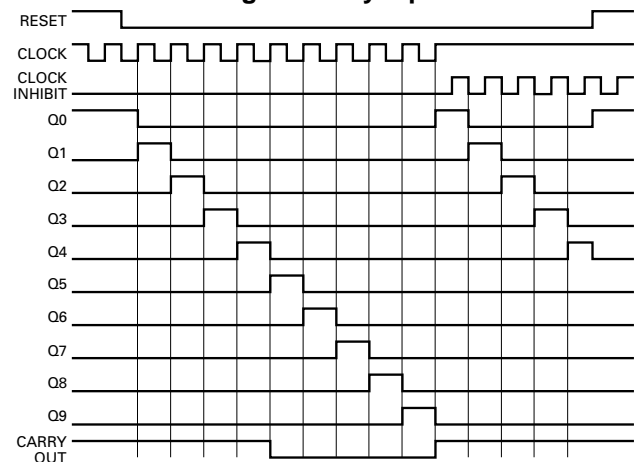

Fig. 11 Decade counter timing chart

CIRCUIT DESCRIPTION

7. Signalling Circuit

7-1. Encode

- **Low-speed data (QT,DQT)**

Low-speed data is output from pin 1 of the CPU. The signal passes through a low-pass CR filter, and goes to the summing amplifier (IC7 1/2). The signal is mixed with the audio signal and goes to the VCO (A1) and VCXO (X1) modulation input after passing through the D/A converter (IC8) for BAL adjustment.

- **High-speed data (DTMF)**

High-speed data is output from pin 2 of the CPU. The signal passes through a low-pass filter consisting of IC10, and provides a TX HSD tone and a RX HSD tone TX HSD deviation making an adjustment by microprocessor is passed through the D/A converter (IC8), and then applied to the audio processor (IC13).

The signal is mixed with the audio signal and goes to the VCO and VCXO, the RX HSD tone is passed a summing amplifier (IC7 2/2), the D/A converter (IC8) for audio control, audio power amplifier and then to the speaker.

- **FFSK**

ESN utilizes 1200bps FFSK signal. FFSK signal is output from pin 6 of IC13. The signal passes through the D/A converter (IC8) for the FFSK deviation adjustment. and is routed to the VCO. When encoding FFSK, the microphone input signal is muted.

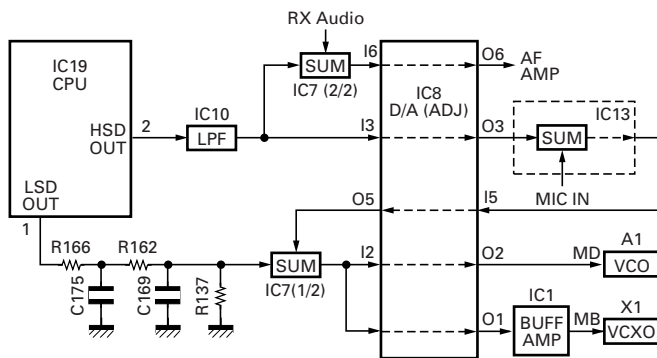

Fig. 12 Encode

7-2. Decode

- **Low-speed data (QT,DQT)**

The demodulated signal from the IF IC (IC12) is amplified by IC4 (2/2) and passes through a low-pass filter (IC11) to remove audio components. The signal is input to pin 95 of the CPU.

The CPU digitizes this signal, performs processing such as DC restoration, and decodes the signal.

- **FFSK**

The FFSK input signal from the IF IC is amplified by IC4 (1/2) and goes to pin 5 of IC13. The signal is demodulated by FFSK demodulator in IC13. The demodulated data goes to the CPU for processing.

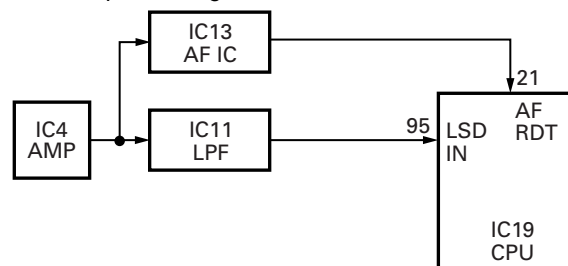

Fig. 13 Decode

8. Power Supply Circuit

Battery +B is supplied via a 3A fuse from the battery terminal connected to the TX-RX unit. After passing through the power switch, power supply (SB) is applied to the three AVRs. IC5 supplies 5V (5M) to the control circuit, and IC9 supplies 5V (5C) to common circuits. IC6 supplies to the TX circuit, the RX circuit and common circuits of needless save mode. During transmission, 5TC becomes Low and Q3 is turned ON to supply 5V (5T) to the TX circuit. During reception, 5RC becomes Low and Q2 is turned ON to supply 5V (5R) to the RX Circuit.

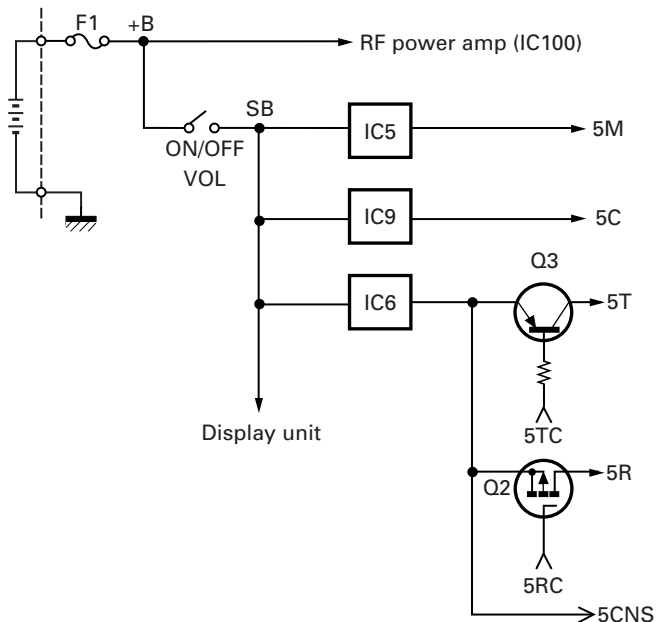

Fig. 14 Power supply circuit

CIRCUIT DESCRIPTION / SEMICONDUCTOR DATA

9. Optional Board Terminal

Terminals for mounting the option board are provided at the bottom edge of the TX-RX unit. The table below shows the correspondence between the board and terminals. R37, R69, R250, R259, R260, R276, R280 may have to be removed depending on the type of option board being used.

Name	Function
SB	Battery (7.5V)
GND	Ground
TXD	Serial data
RXD	Serial data
SQ	Busy: high
LOK	Link acquired : low (TX mode)
DI/ANI	Modulation (ANI) input
DEO	Detect output
TXAI/MUTE	Modulation output from board or mic mute: low
TXAO	Modulation input to board
RXAI	Received signal input to board
RXAO	Received signal output from board
D1	Binary 1
D2	Binary 2
OPT	Scramble, Emergency:low
PTTIN	PTT switch signal input to board (TX:low)
5CNS	Battery (5V)
DI9	9600 bps data input
RXEMAO	Received signal output from board (after de-emphasis)
RXEMAI	Received signal input to board (after de-emphasis)
PTTOUT	PTT switch signal output from board (TX:low)
MONI	Busy:low
LAMP	Busy:low
AAC	Audio Amp Control signal output from board (Busy:high)
Audio Beep	Beep signal output from board.
AUX TXD	Serial data
AUX RXD	Serial data/Option switch port
/EXT SW	

Table 1 Terminal name and function

Microprocessor : 30620M8A-2K9GP (TX-RX UNIT : IC19)

■ Pin function

Pin No.	Port Name	I/O	Function
1	LSDOUT	O	Low speed data output.
2	HSDOUT	O	High speed data output.
3	HSDIN	I	High speed data input.
4	DTMSTD	I	DTMF decode IC data detect input.
5	SELF	I	Self programming mode input.
6	BYTE	I	+5V.
7	CNVSS	I	GND.
8	SFTOE	O	Shift register output enable.
9	LCDCS	O	LCD driver chip select output.
10	RESET	I	Microcomputer reset input.
11	XOUT	-	9.8304MHz (System clock).
12	VSS	-	GND.
13	XIN	-	9.8304MHz (System clock).
14	VCC	-	+5V
15	AUX	I	AUX switch input.
16	AFTRD	I	FFSK modulation data output timing pulse input.
17	AFRTM	I	FFSK demodulation data input timing pulse input.
18	EN2	I	Encoder pulse input 2.
19	PLLCLK	O	PLL IC clock output.
20	BEEP	O	Beep data output.
21	AFRDT	I	FFSK demodulation data input.
22	AFREG1	O	AF IC register switching data output 1.
23	AFREG2	O	AF IC register switching data output 2.
24	EEPDAT	O	EEPROM data output.
25	DACSTB	O	D/A converter IC data strobe output.
26	AFCLR	O	FFSK flame reset output.
27	SAVE	O	Battery save output.
28	LAMP	I	LAMP switch input.
29	AUXTXD	O	External Serial interface output.
30	AUXRXD	I	External Serial interface input.
31	PLLUL	I	PLL unlock detect input.
32	AFFFSKE	O	FFSK modulation enable (Enable active "H").
33	TXD	O	Serial interface output (ex. PC).
34	RXD	I	Serial interface input (ex. PC).
35	AFDAT	O	FFSK data output.
36	PTT	I	PTT switch input.
37	RDY	-	Not used.
38	ALE	-	Not used.
39	HOLD	-	Not used.
40	HLDA	-	Not used.
41	BLCK	-	Not used.
42	RD	-	Flash memory RD bus.
43	BHE	-	Not used.
44	WR	-	Flash memory WR bus.
45	DTMCLK	O	DTMF decode IC clock output.
46	CNTCLK	O	Common clock output.
47	PLLSTB	O	PLL IC data strobe output.
48	CS0	O	Flash memory chip enable.
49	A19	-	Not used.

SEMICONDUCTOR DATA

Pin No.	Port Name	I/O	Function
50-59	A9-A18	-	Flash memory address bus.
60	VCC	-	+5V
61	A8	-	Flash memory address bus.
62	VSS	-	GND.
63-70	A0-A7	-	Flash memory address bus.
71	MONI	I	Monitor switch input.
72	EN4	I	Encoder pulse input 4.
73	EN3	I	Encoder pulse input 3.
74	EN1	I	Encoder pulse input 1.
75	MINDAT	O	Common data output.
76	KEY2	I	Key scan input 2.
77	KEY1	I	Key scan input 1.
78	RESET	O	Key scan IC reset output..
79-86	D0-D7	-	Flash memory data bus.
87	DTMDAT	I	DTMF decode IC data input.
88	PF	I	PF switch input.
89	VOL	I	Volume level input.
90	BATT	I	Battery voltage input.
91	ANLSQL	I	Squelch level input.
92	TEMP	I	Thermistor input.
93	RSSI	I	Received signal strength indicator input (RSSI).
94	AVSS	-	GND.
95	LSDIN	I	Low speed data input.
96	VREF	-	+5V
97	AVCC	-	+5V
98	SFTSTB1	O	Shift register data strobe output.
99	W/N	O	Wide/Narrow switching output.
100	AFSTB	O	AF IC data strobe output.

PLL System : SA7025DK (TX-RX Unit : IC14)

■ Block diagram

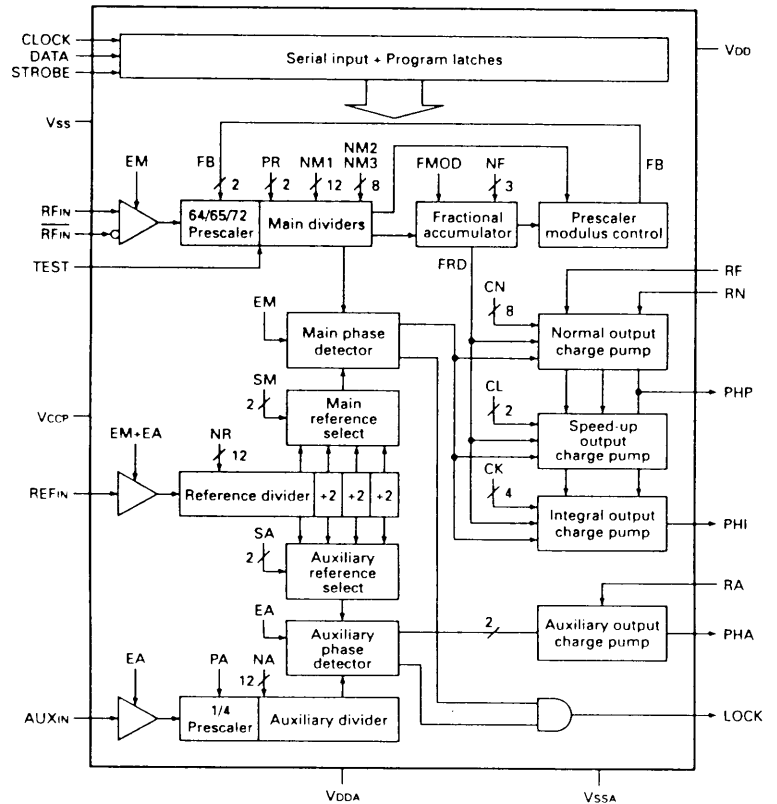

■ Pin description

Pin No.	Symbol	Description
1	CLOCK	Serial clock input.
2	DATA	Serial data input.
3	STROBE	Serial strobe input.
4	Vss	Digital ground.
5	RF _{IN}	Prescaler positive input.
6	R _{FIN}	Prescaler negative input.
7	VCCP	Prescaler positive Supply voltage. This pin supplies power to the prescaler and RF input buffer.
8	REF _{IN}	Reference divider input.
9	RA	Auxiliary current setting; resistor to V _{SSA} .
10	AUX _{IN}	Auxiliary divider input.
11	PHA	Auxiliary phase detector output.
12	VSSA	analog ground.
13	PHI	Integral phase detector output.
14	PHP	Proportional phase detector output.
15	VDDA	Analog supply voltage. This pin supplies power to the charge pumps, Auxiliary prescaler. Auxiliary and Reference buffers.
16	RN	Main current setting; resistor to V _{SSA} .
17	RF	Fractional compensation current setting; resistor to V _{SSA} .
18	LOCK	Lock detector output.
19	TEST	Test pin; connect to V _{DD} .
20	VDD	Digital supply voltage. This pin supplies power to the CMOS digital part of the device.

DESCRIPTION OF COMPONENTS

DISPLAY UNIT (X54-3210-12)

Ref. No.	Use/Function	Operation/Condition
IC300	IC	Audio power amplifier
IC301	IC	Counter /Key scan
Q300	FET	DC switch / INT MIC on/off
Q301	FET	DC switch
Q302	Transistor	DC switch / LED (Red) driver
Q303	Transistor	DC switch / LED (Green) driver
Q304	Transistor	DC switch
Q305	Transistor	Current driver / Audio amp AVR
Q306	Transistor	DC switch
Q307	Transistor	Current driver / LCD back light LED AVR
Q308	FET	DC switch / SP INT/EXT
Q309	Transistor	Temperature compensation
Q310	FET	Mute switch
D300	Zener diode	Surge absorption
D301	LED	LED / Red, Green
D302	Diode	Quick discharge /AF mute
D303	Zener diode	Voltage reference
D304	Diode	Voltage reference
D305~310	LED	LCD back light
D315~318	Diode	Reverse current prevention
D319~321	Zener diode	Surge absorption

TX-RX UNIT (X57-6200-31)

Ref. No.	Use/Function	Operation/Condition
IC1,2	IC	Buffer amplifier
IC3	IC	Voltage detector / Reset
IC4	IC	Buffer amplifier
IC5	IC	Voltage regulator / 5M
IC6	IC	Voltage regulator / 5V
IC7	IC	Buffer amplifier
IC8	IC	D/A converter (Adjustment)
IC9	IC	Voltage regulator / 5C
IC10	IC	Active filter / For HSDout
IC11	IC	Active filter / For LSDin
IC12	IC	FM IF system
IC13	IC	Audio processor
IC14	IC	PLL system
IC16	IC	DTMF decoder
IC17	IC	Flash memory
IC18	IC	Active DBM
IC19	IC	Microprocessor
IC20	IC	EEPROM
IC21,22	IC	Shift register / Output expander
IC23	IC	Comparator (APC)
IC24	IC	Analog switch
IC25	IC	Active filter
Q1	Transistor	Switch
Q2	FET	DC switch / 5R
Q3	Transistor	DC switch / 5T
Q4	Transistor	Noise amplifier / Squelch
Q5	FET	DC switch / Save
Q6	Transistor	2 nd IF W/N switch sets to on when Narrow

Ref. No.	Use/Function	Operation/Condition
Q7	Transistor	2 nd IF W/N switch sets to on when Wide
Q8	Transistor	Ripple filter
Q9	Transistor	DC switch / W/N audio amplitude adjust
Q10	Transistor	AF mute switch
Q11	FET	Mute switch
Q12	Transistor	IF amplifier
Q13	FET	Mute switch / MIC line mute
Q14	FET	DC switch
Q15	FET	DET mute
Q16	Transistor	PLL IC fin amplifier
Q17,18	Transistor	Buffer amplifier
Q19	Transistor	Clock frequency shift
Q20	Transistor	RF amplifier / TX driver
Q21	FET	DC switch
Q22	Transistor	DC switch
Q23	FET	DC switch
Q24	FET	RF amplifier
Q25	Transistor	DC switch
Q26	FET	Mute switch / MIC line mute
D1	Diode	Reverse protection
D2	Diode	Overload protection
D3	Diode	Reverse current protection
D4	Diode	Noise detection
D5	Diode	RF switch (2 nd IF wide/narrow)
D6	Diode	Current steering
D7	Diode	RF switch (2 nd IF wide/narrow)
D8	Diode	Voltage clamp
D9	Diode	TX/RX switch
D10	Diode	Overload protection
D11	Diode	Speed up
D12,14,15	Diode	ANT switch
D16	Diode	Overload protection
D17,18	Diode	Surge absorption
D20,22	Diode	Varactor tuning
D23	Diode	Voltage drop
D24,25	Diode	ANT switch
D401	Diode	ANT switch
D402	Diode	Discharge

SUB UNIT (X58-4590-31)

Ref. No.	Use/Function	Operation/Condition
Q50	FET	VCO oscillation
Q51	FET	DC switch
Q52	FET	VCO oscillation
Q53	Transistor	DC switch
Q54	Transistor	RF Buffer amplifier
D50-D57	Diode	Frequency control
D58	Diode	TX modulation

PARTS LIST

* New Parts. Δ indicates safety critical components.
 Parts without **Parts No.** are not supplied.
 Les articles non mentionnes dans le **Parts No.** ne sont pas fournis.
 Teile ohne **Parts No.** werden nicht geliefert.

L: Scandinavia K: USA P: Canada
 Y: PX (Far East, Hawaii) T: England E: Europe
 Y: AAFES (Europe) X: Australia M: Other Areas

TK-385 DISPLAY UNIT (X54-3210-12)

Ref. No.	Address	New parts	Parts No.	Description	Destination
TK-385					
1	1A		A02-2055-53	CABINET ASSY(16KEYS)	
2	3B		A62-0535-04	PANEL ASSY	
3	2C		B09-0363-03	CAP(SP/MIC) ACSY	
4	2A		B38-0834-05	LCD ASSY	
5	1B		B43-1106-14	BADGE(CABINET ASSY)	
6	2C	*	B62-1551-00	INSTRUCTION MANUAL	
7	3B	*	B72-2034-04	MODEL NAME PLATE	
8	3B		E04-0416-05	RF COAXIAL RECEPTACLE(SMA)	
9	2B		E23-1104-04	TERMINAL(ANT)	
10	3A,3B		E23-1166-04	RELAY TERMINAL	
11	2B		E37-0672-05	FLAT CABLE(CONT-TXRX)	
12	3A		E37-0673-05	LEAD WIRE WITH CONNECTOR(PTT)	
13	1B		E37-0674-15	LEAD WIRE WITH CONNECTOR(SP)	
14	3B		E58-0440-05	SQUARE SOCKET(SP/MIC)	
15	3B		E72-0412-13	TERMINAL BLOCK	
16	2B		F10-2272-03	SHIELDING CASE(DBM)	
17	2A		F10-2310-03	SHIELDING PLATE(LCD)	
18	2A		F10-2340-03	SHIELDING CASE(VCO)	
19	3B		F10-2353-14	SHIELDING PLATE(P-MODULE)	
20	2B		F10-2360-03	SHIELDING CASE(FRONT END)	
21	2B		F10-2373-14	SHIELDING CASE(FE/DBM/VCO)	
22	3B		F20-1181-04	INSULATING SHEET(CHASSIS)	
23	2B		F20-3303-04	INSULATING SHEET(MIC/GND)	
24	1A		G01-0881-04	COIL SPRING(CABINET ASSY)	
25	1B		G09-0418-05	KNOB SPRING(VOL,ENC)	
26	1B		G10-0799-04	FIBROUS SHEET(SP)	
27	3A		G11-2544-04	SHEET(CHASSIS)	
28	3A		G11-2590-04	SHEET(PTT)	
29	2A		G13-1731-04	CUSHION(LCD)	
30	2A		G13-1736-04	CUSHION(VCO SHIELDING CASE)	
31	3B		G13-1762-04	CUSHION(VOL/CHASSIS)	
32	3A		G13-1794-04	CUSHION(MCF)	
33	3A,3B		G13-1834-04	CUSHION(TERMINAL)	
34	3B		G53-0811-03	PACKING(TOP)	
35	1B		G53-0896-02	PACKING(16KEYS)	
36	3A		G53-1510-04	PACKING(BATT+)	
37	3B		G53-1520-24	PACKING(TERMINAL)	
38	2D		H12-3014-02	PACKING FIXTURE	
39	1D		H13-1072-04	CARTON BOARD	
40	3D		H52-1576-02	ITEM CARTON CASE	
41	1A		J19-1572-04	HOLDER(CABINET ASSY)	
42	2B		J21-8398-03	HARDWARE FIXTURE(P-MODULE)	
43	2C		J29-0658-05	HOOK ACSY	
44	3B		J82-0045-05	FPC(VOL,ENC)	
45	3B		J82-0066-05	FPC(SQUARE SOCKET)	
46	1A		K29-5157-03	KNOB(PTT)	
47	1A		K29-5158-03	KEY TOP(PTT)	
48	1A		K29-5165-03	LEVER KNOB(CABINET ASSY)	
49	1B		K29-5231-03	KNOB(VOL)	
50	1B		K29-5232-03	KNOB(ENC)	

Ref. No.	Address	New parts	Parts No.	Description	Destination
A	3B		N14-0569-04	CIRCULAR NUT(VOL,ENC)	
B	3B		N30-2604-46	PAN HEAD MACHINE SCREW(ANT)	
C	3A		N30-2610-46	PAN HEAD MACHINE SCREW(CASE)	
D	2B		N67-2606-46	PAN HEAD SEMS SCREW W(P-MODULE)	
E	3A,3B		N79-2025-46	PAN HEAD TAPTITE SCREW(TERMINAL)	
F	2A,2B		N83-2005-46	PAN HEAD TAPTITE SCREW(UNIT)	
51	2C		N99-2004-05	SCREW SET ACSY	
52	3B		R31-0617-05	VARIABLE RESISTOR(POWER SW/VOL)	
S300	2B		S70-0414-05	TACT SWITCH	
53	1B		T07-0714-05	SPEAKER	
54	2D		T90-0683-05	WHIP ANTENNA ACSY	
MIC300	2B		T91-0579-05	MIC ELEMENT	
55	3B		W02-1814-05	ENCODER	
DISPLAY UNIT (X54-3210-12)					
D301			B30-2019-05	LED(RE/GR)	
D305-310			B30-2171-05	LED	
C301			CC73GCH1H470J	CHIP C 47PF J	
C302			C92-0560-05	CHIP-TAN 10UF 6.3WV	
C304			CK73FB1C474K	CHIP C 0.47UF K	
C305			CC73GCH1H101J	CHIP C 100PF J	
C307			CK73GB1C104K	CHIP C 0.10UF K	
C308			CC73GCH1H101J	CHIP C 100PF J	
C309			CK73FB1C474K	CHIP C 0.47UF K	
C310			CK73GB1C104K	CHIP C 0.10UF K	
C311			CC73GCH1H470J	CHIP C 47PF J	
C312			CK73GB1C104K	CHIP C 0.10UF K	
C313			C92-0628-05	CHIP-TAN 10UF 10WV	
C314			C92-0647-05	CHIP-TAN 3.3UF 4WV	
C315			CC73GCH1H101J	CHIP C 100PF J	
C316,317			CC73GCH1H470J	CHIP C 47PF J	
C318			CC73GCH1H101J	CHIP C 100PF J	
C321-333			CC73GCH1H470J	CHIP C 47PF J	
C335-339			CC73GCH1H470J	CHIP C 47PF J	
C340			CK73GB1E153K	CHIP C 0.015UF K	
C341-344			CC73GCH1H470J	CHIP C 47PF J	
CN300			E40-5891-05	FLAT CABLE CONNECTOR(24P)	
CN301			E40-5892-05	FLAT CABLE CONNECTOR(14P)	
CN302			E40-5662-05	PIN ASSY SOCKET(2P:SP)	
CN303			E40-5887-05	PIN ASSY(4P:PTT)	
CN304			E40-5823-05	FLAT CABLE CONNECTOR(10P:LCD)	
L300,301			L92-0141-05	FERRITE CHIP	
L302,303			L92-0138-05	FERRITE CHIP	
L304,305			L92-0141-05	FERRITE CHIP	
L306,307			L92-0138-05	FERRITE CHIP	
L308,309			L92-0141-05	FERRITE CHIP	
CP300,301			R90-0723-05	MULTI-COMP 47K X2	
CP302,303			R90-0724-05	MULTI-COMP 1K X4	
R300			RK73GB1J103J	CHIP R 10K J 1/16W	
R301			RK73FB2A101J	CHIP R 100 J 1/10W	
R302			RK73GB1J470J	CHIP R 47 J 1/16W	

PARTS LIST

DISPLAY UNIT (X54-3210-12)

TX-RX UNIT (X57-6200-31)

Ref. No.	Address	New parts	Parts No.	Description	Destination	Ref. No.	Address	New parts	Parts No.	Description	Destination
R303			RK73GB1J471J	CHIP R 470 J 1/16W		C12			CK73GB1E103K	CHIP C 0.010UF K	
R304			RK73GB1J182J	CHIP R 1.8K J 1/16W		C13			CC73GCH1H101J	CHIP C 100PF J	
R305			RK73GB1J104J	CHIP R 100K J 1/16W		C14			C92-0628-05	CHIP-TAN 10UF 10WV	
R306			R92-1252-05	CHIP R 0 OHM		C15			C92-0592-05	CHIP-TAN 4.7UF 6.3WV	
R307			RK73GB1J821J	CHIP R 820 J 1/16W		C16			CK73GB1H471K	CHIP C 470PF K	
R308			RK73GB1J153J	CHIP R 15K J 1/16W		C17			C92-0650-05	TANTAL 10UF 6.3WV	
R309			R92-1252-05	CHIP R 0 OHM		C18			CK73FB1C334K	CHIP C 0.33UF K	
R310			RK73GB1J331J	CHIP R 330 J 1/16W		C19			C92-0628-05	CHIP-TAN 10UF 10WV	
R311			RK73GB1J102J	CHIP R 1.0K J 1/16W		C20			CK73GB1C104K	CHIP C 0.10UF K	
R312			RK73GB1J104J	CHIP R 100K J 1/16W		C21			C92-0592-05	CHIP-TAN 4.7UF 6.3WV	
R313,314			RK73GB1J102J	CHIP R 1.0K J 1/16W		C22			CK73GB1H331K	CHIP C 330PF K	
R315			RK73GB1J104J	CHIP R 100K J 1/16W		C23			C92-0592-05	CHIP-TAN 4.7UF 6.3WV	
R316			RK73GB1J473J	CHIP R 47K J 1/16W		C24,25			CK73GB1H471K	CHIP C 470PF K	
R317			RK73GB1J472J	CHIP R 4.7K J 1/16W		C26			CK73GB1E223K	CHIP C 0.022UF K	
R318			RK73GB1J104J	CHIP R 100K J 1/16W		C27-29			CK73GB1H471K	CHIP C 470PF K	
R319-321			RK73GB1J820J	CHIP R 82 J 1/16W		C30			CK73GB1H102K	CHIP C 1000PF K	
R324,325			RK73GB1J102J	CHIP R 1.0K J 1/16W		C31			CK73GB1C104K	CHIP C 0.10UF K	
R326			RK73GB1J124J	CHIP R 120K J 1/16W		C32			CK73FB1A105K	CHIP C 1.0UF K	
R327			RK73GB1J563J	CHIP R 56K J 1/16W		C33,34			CK73GB1H471K	CHIP C 470PF K	
R328			RK73GB1J124J	CHIP R 120K J 1/16W		C35			CK73GB1E103K	CHIP C 0.010UF K	
R331			RK73GB1J103J	CHIP R 10K J 1/16W		C36			CK73GB1C104K	CHIP C 0.10UF K	
R332			RK73GB1J272J	CHIP R 2.7K J 1/16W		C37			CK73GB1H471K	CHIP C 470PF K	
R333			RK73GB1J103J	CHIP R 10K J 1/16W		C38			CK73GB1H102K	CHIP C 1000PF K	
R336			R92-1252-05	CHIP R 0 OHM		C39,40			CK73GB1C104K	CHIP C 0.10UF K	
R337			RK73GB1J472J	CHIP R 4.7K J 1/16W		C41			C92-0713-05	CHIP-TAN 10UF 6.3WV	
R338-341			RK73GB1J101J	CHIP R 100 J 1/16W		C42			CK73GB1H102K	CHIP C 1000PF K	
S301-303			S70-0457-05	TACT SWITCH(PTT)		C43			CK73GB1C333K	CHIP C 0.033UF K	
D300			NNCD6.8G	ZENER DIODE		C44			CK73GB1H471K	CHIP C 470PF K	
D302			1SS373	DIODE		C45			CC73GCH1H100D	CHIP C 10PF D	
D303			015AZ2.4-X	ZENER DIODE		C46			CC73GCH1H121J	CHIP C 120PF J	
D304			MA2S111	DIODE		C47			CK73GB1C104K	CHIP C 0.10UF K	
D315			IMN10	DIODE		C48			CK73GB1H471K	CHIP C 470PF K	
D316,317			MA2S111	DIODE		C49			CK73GB1C104K	CHIP C 0.10UF K	
D318			IMN10	DIODE		C50			CC73GCH1H100D	CHIP C 10PF D	
D319-321			015AZ6.8	ZENER DIODE		C51			CK73GB1E103K	CHIP C 0.010UF K	
IC300			TDA7053AT	IC(AUDIO AMP)		C52			CC73GCH1H271J	CHIP C 270PF J	
IC301			TC74HC4017AF	IC(COUNTER)		C53			CK73GB1H102K	CHIP C 1000PF K	
Q300			2SJ243	FET		C54			CK73GB1E103K	CHIP C 0.010UF K	
Q301			UPA672T	FET		C55			CK73GB1C104K	CHIP C 0.10UF K	
Q302-304			2SC4617(S)	TRANSISTOR		C56			C92-0662-05	CHIP-TAN 15UF 6.3WV	
Q305			2SB798(DL,DK)	TRANSISTOR		C57			CK73GB1H102K	CHIP C 1000PF K	
Q306			2SC4617(S)	TRANSISTOR		C58			CK73GB1H471K	CHIP C 470PF K	
Q307			2SB1132(Q,R)	TRANSISTOR		C59			CK73GB1H222K	CHIP C 2200PF K	
Q308			UPA672T	FET		C60			CK73GB1C273K	CHIP C 0.027UF K	
Q309			2SC4617(S)	TRANSISTOR		C61			CK73GB1C104K	CHIP C 0.10UF K	
Q310			2SK1824	FET		C62			CK73GB1E123K	CHIP C 0.012UF K	
TH300			TN10-3S154JT	THERMISTOR		C63			CK73GB1H122K	CHIP C 1200PF K	
TX-RX UNIT (X57-6200-31)						C64			CK73GB1H102K	CHIP C 1000PF K	
C1			CK73GB1H471K	CHIP C 470PF K		C65,66			CC73GCH1H121J	CHIP C 120PF J	
C2,3			CK73GB1E103K	CHIP C 0.010UF K		C67			CK73GB1C104K	CHIP C 0.10UF K	
C4-6			CK73GB1H471K	CHIP C 470PF K		C68,69			CK73GB1E103K	CHIP C 0.010UF K	
C7,8			CK73GB1E103K	CHIP C 0.010UF K		C70			CK73GB1C104K	CHIP C 0.10UF K	
C9			CK73GB1C104K	CHIP C 0.10UF K		C71			CC73GCH1H220J	CHIP C 22PF J	
C10			CK73GB1E103K	CHIP C 0.010UF K		C72			CK73GB1C683K	CHIP C 0.068UF K	
C11			CK73GB1H471K	CHIP C 470PF K		C73			CC73GCH1H100D	CHIP C 10PF D	
						C74			CK73GB1C104K	CHIP C 0.10UF K	

PARTS LIST

TX-RX UNIT (X57-6200-31)

Ref. No.	Address	New parts	Parts No.	Description	Destination	Ref. No.	Address	New parts	Parts No.	Description	Destination
C75			CK73GB1E103K	CHIP C 0.010UF K		C141			C92-0592-05	CHIP-TAN 4.7UF 6.3WV	
C76			CK73GB1C104K	CHIP C 0.10UF K		C142			CK73GB1H471K	CHIP C 470PF K	
C77			C92-0773-05	CHIP-TAN 15UF 6.3WV		C143			CC73GCH1H100D	CHIP C 10PF D	
C78			CK73GB1H562J	CHIP C 5600PF J		C144			C92-0714-05	CHIP-TAN 4.7UF 6.3WV	
C79			C92-0713-05	CHIP-TAN 10UF 6.3WV		C145			CK73FB1H563K	CHIP C 0.056UF K	
C80			CC73HCH1H101J	CHIP C 100PF J		C146,147			CK73GB1H102K	CHIP C 1000PF K	
C81			CK73GB1H471K	CHIP C 470PF K		C149			CK73GB1H471K	CHIP C 470PF K	
C82			CK73GB1C333K	CHIP C 0.033UF K		C150			CC73GCH1H050B	CHIP C 5.0PF B	
C84			CK73GB1H562J	CHIP C 5600PF J		C152			CC73GCH1H050B	CHIP C 5.0PF B	
C85			CK73GB1H471K	CHIP C 470PF K		C155-157			CK73GB1H471K	CHIP C 470PF K	
C86			CK73GB1H562J	CHIP C 5600PF J		C159			CK73HB1C103K	CHIP C 0.010UF K	
C87			CK73GB1C333K	CHIP C 0.033UF K		C160			CK73GB1C104K	CHIP C 0.10UF K	
C88			CK73GB1C104K	CHIP C 0.10UF K		C161			CC73GCH1H040B	CHIP C 4.0PF B	
C89			CC73GCH1H820J	CHIP C 82PF J		C162			CK73GB1H471K	CHIP C 470PF K	
C90			CC73GCH1H470J	CHIP C 47PF J		C165			CK73GB1E103K	CHIP C 0.010UF K	
C91			CK73GB1H471K	CHIP C 470PF K		C166			CK73HB1C103K	CHIP C 0.010UF K	
C92			C92-0773-05	CHIP-TAN 15UF 6.3WV		C167			CC73GCH1H2R5B	CHIP C 2.5PF B	
C93			CK73GB1H272J	CHIP C 2700PF J		C168			CC73GCH1H070B	CHIP C 7.0PF B	
C95			CK73GB1H471K	CHIP C 470PF K		C169			CK73GB1E103K	CHIP C 0.010UF K	
C96			CC73GCH1H330J	CHIP C 33PF J		C170			CK73HB1C103K	CHIP C 0.010UF K	
C97			CC73GCH1H030B	CHIP C 3.0PF B		C171			CC73GCH1H090B	CHIP C 9.0PF B	
C98,99			CK73GB1H272J	CHIP C 2700PF J		C172			CC73GCH1H050B	CHIP C 5.0PF B	
C100			CK73GB1C104K	CHIP C 0.10UF K		C173			CK73GB1H471K	CHIP C 470PF K	
C101			C92-0656-05	CHIP-TAN 2.2UF 6.3WV		C174			CK73GB1C104K	CHIP C 0.10UF K	
C102			CK73GB1C104K	CHIP C 0.10UF K		C175			CK73GB1H472K	CHIP C 4700PF K	
C103			CC73GCH1H151J	CHIP C 150PF J		C176-180			CK73GB1H471K	CHIP C 470PF K	
C104			CK73GB1H152J	CHIP C 1500PF J		C181			CK73GB1E103K	CHIP C 0.010UF K	
C105			CK73GB1H102K	CHIP C 1000PF K		C182			CC73GCH1H060B	CHIP C 6.0PF B	
C106			CK73GB1E103K	CHIP C 0.010UF K		C183			CC73GCH1H270J	CHIP C 27PF J	
C107			CC73GCH1H030B	CHIP C 3.0PF B		C184			CC73GCH1H680J	CHIP C 68PF J	
C108			C92-0650-05	TANTAL 10UF 6.3WV		C185			CK73GB1H471K	CHIP C 470PF K	
C109			C92-0714-05	CHIP-TAN 4.7UF 6.3WV		C186			CC73GCH1H270J	CHIP C 27PF J	
C110			CK73GB1C104K	CHIP C 0.10UF K		C188,189			CK73GB1H471K	CHIP C 470PF K	
C111			CK73GB1H471K	CHIP C 470PF K		C190			CK73HB1C103K	CHIP C 0.010UF K	
C112			C92-0713-05	CHIP-TAN 10UF 6.3WV		C191,192			CK73GB1H471K	CHIP C 470PF K	
C113,114			CK73GB1C104K	CHIP C 0.10UF K		C193			CC73GCH1H100D	CHIP C 10PF D	
C117,118			CK73GB1C104K	CHIP C 0.10UF K		C194			CC73GCH1H040B	CHIP C 4.0PF B	
C119			CC73GCH1H181J	CHIP C 180PF J		C195			CK73HB1H471K	CHIP C 470PF K	
C120			CK73GB1C473K	CHIP C 0.047UF K		C196			CC73GCH1H040B	CHIP C 4.0PF B	
C121,122			CK73GB1C104K	CHIP C 0.10UF K		C197			CK73FB1C474K	CHIP C 0.47UF K	
C123			CK73GB1E103K	CHIP C 0.010UF K		C198			CC73GCH1H1R5B	CHIP C 1.5PF B	
C124,125			CK73GB1C104K	CHIP C 0.10UF K		C199			CC73GCH1H101J	CHIP C 100PF J	
C126			C92-1366-05	CHIP-TAN 0.47UF 35WV		C200			C92-0565-05	CHIP-TAN 6.8UF 10WV	
C127			C92-0714-05	CHIP-TAN 4.7UF 6.3WV		C202			CK73GB1H471K	CHIP C 470PF K	
C128			CK73GB1C104K	CHIP C 0.10UF K		C203			CC73GCH1H050B	CHIP C 5.0PF B	
C129			CK73GB1H562J	CHIP C 5600PF J		C204			CC73GCH1H1R5B	CHIP C 1.5PF B	
C130			CK73GB1H102K	CHIP C 1000PF K		C205			CC73GCH1H101J	CHIP C 100PF J	
C131			CK73GB1H562J	CHIP C 5600PF J		C207			CC73GCH1H1R5B	CHIP C 1.5PF B	
C133			CC73GCH1H050B	CHIP C 5.0PF B		C208			CK73GB1E103K	CHIP C 0.010UF K	
C134			CK73GB1E153K	CHIP C 0.015UF K		C209			CK73GB1H471K	CHIP C 470PF K	
C135			CK73GB1E103K	CHIP C 0.010UF K		C210			CC73GCH1H3R5B	CHIP C 3.5PF B	
C136			C92-0001-05	CHIP-C 0.1UF 35WV		C211			CK73FB1C474K	CHIP C 0.47UF K	
C137			CK73GB1E103K	CHIP C 0.010UF K		C213			CC73GCH1H101J	CHIP C 100PF J	
C138			CC73GCH1H030B	CHIP C 3.0PF B		C214,215			CC73GCH1H060B	CHIP C 6.0PF B	
C139			CK73GB1H471K	CHIP C 470PF K		C216,217			CC73GCH1H040B	CHIP C 4.0PF B	
C140			CC73GCH1H050B	CHIP C 5.0PF B		C218			CC73GCH1H120J	CHIP C 12PF J	

PARTS LIST

TX-RX UNIT (X57-6200-31)

Ref. No.	Address	New parts	Parts No.	Description	Destination	Ref. No.	Address	New parts	Parts No.	Description	Destination
C219			CC73GCH1H4R5B	CHIP C 4.5PF B		L4			L40-1091-37	SMALL FIXED INDUCTOR(1.0UH)	
C220			CC73GCH1H050B	CHIP C 5.0PF B		L5,6			L92-0138-05	FERRITE CHIP	
C221			CK73GB1H471K	CHIP C 470PF K		L9			L40-1271-36	SMALL FIXED INDUCTOR(12NH)	
C222			CC73GCH1H4R5B	CHIP C 4.5PF B		L10			L40-3971-36	SMALL FIXED INDUCTOR(39NH)	
C223			CC73GCH1H030B	CHIP C 3.0PF B		L11,12			L92-0138-05	FERRITE CHIP	
C224			CC73GCH1H010B	CHIP C 1.0PF B		L13			L40-2271-36	SMALL FIXED INDUCTOR(22NH)	
C225			CC73GCH1H010J	CHIP C 100PF J		L14			L40-1081-36	SMALL FIXED INDUCTOR(100NH)	
C226			CK73GB1H471K	CHIP C 470PF K		L15			L40-1571-36	SMALL FIXED INDUCTOR(15NH)	
C227			CC73GCH1H010B	CHIP C 1.0PF B		L17			L40-1571-36	SMALL FIXED INDUCTOR(15NH)	
C230			CC73GCH1H0R5B	CHIP C 0.5PF B		L18			L39-1272-05	TOROIDAL COIL	
C231			CK73GB1H471K	CHIP C 470PF K		L19			L92-0138-05	FERRITE CHIP	
C232			CC73GCH1H470J	CHIP C 47PF J		L20			L40-1571-36	SMALL FIXED INDUCTOR(15NH)	
C233			CK73GB1H471K	CHIP C 470PF K		L21,22			L39-1272-05	TOROIDAL COIL	
C234			CC73GCH1H080B	CHIP C 8.0PF B		L24			L92-0138-05	FERRITE CHIP	
C236			CC73GCH1H470J	CHIP C 47PF J		L25			L40-2771-36	SMALL FIXED INDUCTOR(27NH)	
C237			CC73GCH1H010B	CHIP C 1.0PF B		L26			L92-0138-05	FERRITE CHIP	
C238			CK73GB1E103K	CHIP C 0.010UF K		L27			L40-3378-67	SMALL FIXED INDUCTOR(33NH)	
C239			CK73GB1H471K	CHIP C 470PF K		L28			L92-0138-05	FERRITE CHIP	
C241			CC73GCH1H090B	CHIP C 9.0PF B		L29			L40-1278-67	SMALL FIXED INDUCTOR(12NH)	
C242,243			CK73GB1H471K	CHIP C 470PF K		L30			L92-0149-05	FERRITE CHIP	
C245			CC73GCH1H3R5B	CHIP C 3.5PF B		L31			L40-1578-67	SMALL FIXED INDUCTOR(15NH)	
C247			CK73GB1H471K	CHIP C 470PF K		L32			L34-4564-05	AIR-CORE COIL(4T)	
C248			CC73GCH1H010B	CHIP C 1.0PF B		L33			L40-2278-67	SMALL FIXED INDUCTOR(22NH)	
C249-253			CK73GB1H471K	CHIP C 470PF K		L34			L40-3378-67	SMALL FIXED INDUCTOR(33NH)	
C254			CC73GCH1H060B	CHIP C 6.0PF B		L35			L40-1085-34	SMALL FIXED INDUCTOR(100NH)	
C255			CC73GCH1H020B	CHIP C 2.0PF B		L36			L40-3378-67	SMALL FIXED INDUCTOR(33NH)	
C256			CC73GCH1H050B	CHIP C 5.0PF B		L37			L34-4564-05	AIR-CORE COIL(4T)	
C257,258			CK73GB1H471K	CHIP C 470PF K		L38			L40-2278-67	SMALL FIXED INDUCTOR(22NH)	
C259			CC73GCH1H010J	CHIP C 100PF J		L39			L40-1871-36	SMALL FIXED INDUCTOR(18NH)	
C261,262			CK73HB1C103K	CHIP C 0.010UF K		L40			L34-4564-05	AIR-CORE COIL(4T)	
C263			CK73GB1H103K	CHIP C 0.010UF K		L41			L40-1071-36	SMALL FIXED INDUCTOR(10NH)	
C264			CC73GCH1H150J	CHIP C 15PF J		L42,43			L34-4564-05	AIR-CORE COIL(4T)	
C265			CK73GB1H103K	CHIP C 0.010UF K		L44			L40-1878-67	SMALL FIXED INDUCTOR(18NH)	
C269			CC73GCH1H030B	CHIP C 3.0PF B		L45			L40-1092-81	SMALL FIXED INDUCTOR	
C276			CC73GCH1H070B	CHIP C 7.0PF B		L46			L40-6878-67	SMALL FIXED INDUCTOR(68NH)	
C401			CK73GB1C104K	CHIP C 0.10UF K		L47			L40-2278-67	SMALL FIXED INDUCTOR(22NH)	
C402			CK73GB1H561K	CHIP C 560PF K		L48-52			L34-4564-05	AIR-CORE COIL(4T)	
C403			CC73GCH1H470J	CHIP C 47PF J		L53			L92-0138-05	FERRITE CHIP	
C404			CC73GCH1H010J	CHIP C 100PF J		L54			L40-1871-36	SMALL FIXED INDUCTOR(18NH)	
C405			C92-0602-05	CHIP-TAN 1.0UF 10WV		L55,56			L40-2271-36	SMALL FIXED INDUCTOR(22NH)	
C407			C92-0714-05	CHIP-TAN 4.7UF 6.3WV		L457,458			L34-4567-05	AIR-CORE COIL(7T)	
C408			CK73HB1A104K	CHIP C 0.10UF K		X1			L77-1789-05	TCXO(16.8MHZ)	
						X2			L77-1760-15	CRYSTAL RESONATOR(44.395MHZ)	
CN1			E40-5823-05	FLAT CABLE CONNECTOR(10P)		X3			L77-1708-05	CRYSTAL RESONATOR(3.579545MHZ)	
CN2			E40-9517-05	PIN ASSY SOCKET(4P)		X4			L78-0462-05	RESONATOR(9.8304MHZ)	
CN3			E40-5890-05	FLAT CABLE CONNECTOR(24P)							
CN4			E23-0342-05	TEST TERMINAL		XF1			L71-0572-05	MCF(44.85MHZ)	
CN5-12			E23-1081-05	TERMINAL							
F1			F53-0130-05	FUSE(3A)		CP1			R90-0724-05	MULTI-COMP 1K X4	
F1			F53-0217-05	FUSE(3A)		CP2			R90-0718-05	MULTI-COMP 4.7K X4	
						CP4,5			R90-0743-05	MULTIPLE RESISTOR 47K X2	
						CP6-21			R90-0741-05	MULTIPLE RESISTOR 1K X2	
CD1			L79-1072-05	TUNING COIL		CP22-24			R90-0743-05	MULTIPLE RESISTOR 47K X2	
CF1			L72-0962-05	CERAMIC FILTER(455KHZ)		R1			RK73GB1J103J	CHIP R 10K J 1/16W	
CF2			L72-0963-05	CERAMIC FILTER(455KHZ)		R2			RK73GB1J473J	CHIP R 47K J 1/16W	
L1			L92-0149-05	FERRITE CHIP		R3			RK73GB1J154J	CHIP R 150K J 1/16W	
L2			L92-0138-05	FERRITE CHIP		R4			RK73GB1J104J	CHIP R 100K J 1/16W	
L3			L40-4791-37	SMALL FIXED INDUCTOR(4.7UH)		R5			RK73HB1J392J	CHIP R 3.9K J 1/16W	

PARTS LIST

TX-RX UNIT (X57-6200-31)

Ref. No.	Address	New parts	Parts No.	Description	Destination	Ref. No.	Address	New parts	Parts No.	Description	Destination
R6,7			RK73GB1J104J	CHIP R 100K J 1/16W		R68			RK73GB1J223J	CHIP R 22K J 1/16W	
R8			RK73HB1J272J	CHIP R 2.7K J 1/16W		R69			R92-1252-05	CHIP R 0 OHM	
R9			RK73HB1J474J	CHIP R 470K J 1/16W		R70			RN73GH1J682D	CHIP R 6.8K D 1/16W	
R10			RK73HB1J392J	CHIP R 3.9K J 1/16W		R71			RK73GB1J183J	CHIP R 18K J 1/16W	
R11			RK73GB1J104J	CHIP R 100K J 1/16W		R72			RK73GB1J155J	CHIP R 1.5M J 1/16W	
R12			RK73GB1J184J	CHIP R 180K J 1/16W		R73			RK73GB1J393J	CHIP R 39K J 1/16W	
R13			RK73GB1J104J	CHIP R 100K J 1/16W		R74			RK73GB1J183J	CHIP R 18K J 1/16W	
R14			R92-1252-05	CHIP R 0 OHM		R75			RN73GH1J683D	CHIP R 68K D 1/16W	
R15			RK73GB1J104J	CHIP R 100K J 1/16W		R76			RK73GB1J474J	CHIP R 470K J 1/16W	
R16,17			RK73GB1J473J	CHIP R 47K J 1/16W		R78			RN73GH1J682D	CHIP R 6.8K D 1/16W	
R18			RK73GB1J154J	CHIP R 150K J 1/16W		R79			RK73GB1J101J	CHIP R 100 J 1/16W	
R19			RK73GB1J104J	CHIP R 100K J 1/16W		R80			RK73GB1J152J	CHIP R 1.5K J 1/16W	
R20			RK73HB1J104J	CHIP R 100K J 1/16W		R81			RK73GB1J220J	CHIP R 22 J 1/16W	
R21			RK73GB1J563J	CHIP R 56K J 1/16W		R83			RK73GB1J184J	CHIP R 180K J 1/16W	
R22,23			RK73GB1J823J	CHIP R 82K J 1/16W		R85			RK73GB1J103J	CHIP R 10K J 1/16W	
R24			RK73GB1J473J	CHIP R 47K J 1/16W		R86			RK73GB1J223J	CHIP R 22K J 1/16W	
R25			RK73HB1J103J	CHIP R 10K J 1/16W		R89			RK73GB1J102J	CHIP R 1.0K J 1/16W	
R26			RK73GB1J473J	CHIP R 47K J 1/16W		R90			RK73GB1J153J	CHIP R 15K J 1/16W	
R27			RK73GB1J332J	CHIP R 3.3K J 1/16W		R91			RK73GB1J473J	CHIP R 47K J 1/16W	
R28			RK73GB1J474J	CHIP R 470K J 1/16W		R93			RK73GB1J822J	CHIP R 8.2K J 1/16W	
R29			RK73GB1J184J	CHIP R 180K J 1/16W		R94			RK73GB1J333J	CHIP R 33K J 1/16W	
R30			RK73GB1J474J	CHIP R 470K J 1/16W		R95			RK73GB1J394J	CHIP R 390K J 1/16W	
R31			RK73GB1J102J	CHIP R 1.0K J 1/16W		R96			RK73HB1J222J	CHIP R 2.2K J 1/16W	
R32			RK73GB1J104J	CHIP R 100K J 1/16W		R97			RK73GB1J151J	CHIP R 150 J 1/16W	
R33			RK73GB1J184J	CHIP R 180K J 1/16W		R100			R92-1252-05	CHIP R 0 OHM	
R34			RK73GB1J683J	CHIP R 68K J 1/16W		R101			RK73GB1J560J	CHIP R 56 J 1/16W	
R35			RK73GB1J220J	CHIP R 22 J 1/16W		R102			RK73GB1J333J	CHIP R 33K J 1/16W	
R36			RK73GB1J154J	CHIP R 150K J 1/16W		R104			RK73GB1J102J	CHIP R 1.0K J 1/16W	
R37			R92-1252-05	CHIP R 0 OHM		R106			RK73GB1J470J	CHIP R 47 J 1/16W	
R38			RK73GB1J101J	CHIP R 100 J 1/16W		R107			RK73GB1J473J	CHIP R 47K J 1/16W	
R39			RK73GB1J472J	CHIP R 4.7K J 1/16W		R109			R92-1252-05	CHIP R 0 OHM	
R40,41			RK73GB1J334J	CHIP R 330K J 1/16W		R110			RK73GB1J220J	CHIP R 22 J 1/16W	
R42,43			RK73GB1J223J	CHIP R 22K J 1/16W		R114			R92-1252-05	CHIP R 0 OHM	
R44			RK73GB1J473J	CHIP R 47K J 1/16W		R115			RK73GB1J184J	CHIP R 180K J 1/16W	
R45			RK73GB1J472J	CHIP R 4.7K J 1/16W		R116			RK73GB1J103J	CHIP R 10K J 1/16W	
R46,47			RK73GB1J223J	CHIP R 22K J 1/16W		R117			RK73GB1J184J	CHIP R 180K J 1/16W	
R48			R92-1252-05	CHIP R 0 OHM		R118			RK73GB1J221J	CHIP R 220 J 1/16W	
R49			RK73GB1J223J	CHIP R 22K J 1/16W		R119			RK73GB1J102J	CHIP R 1.0K J 1/16W	
R50			RN73GH1J913D	CHIP R 91K D 1/16W		R120			RK73GB1J104J	CHIP R 100K J 1/16W	
R51			RN73GH1J683D	CHIP R 68K D 1/16W		R121			RK73GB1J222J	CHIP R 2.2K J 1/16W	
R52			RN73GH1J913D	CHIP R 91K D 1/16W		R122			RK73GB1J221J	CHIP R 220 J 1/16W	
R53			RK73GB1J473J	CHIP R 47K J 1/16W		R125			RK73GB1J124J	CHIP R 120K J 1/16W	
R54			RK73GB1J123J	CHIP R 12K J 1/16W		R126			RK73GB1J470J	CHIP R 47 J 1/16W	
R55			RN73GH1J333D	CHIP R 33K D 1/16W		R127			RK73GB1J103J	CHIP R 10K J 1/16W	
R56			RK73GB1J472J	CHIP R 4.7K J 1/16W		R128			R92-1252-05	CHIP R 0 OHM	
R57			RK73GB1J183J	CHIP R 18K J 1/16W		R129			RK73HB1J104J	CHIP R 100K J 1/16W	
R58			RK73GB1J184J	CHIP R 180K J 1/16W		R130			R92-1252-05	CHIP R 0 OHM	
R59			RK73GB1J564J	CHIP R 560K J 1/16W		R131			RK73GB1J470J	CHIP R 47 J 1/16W	
R60			RK73GB1J123J	CHIP R 12K J 1/16W		R132			RK73GB1J684J	CHIP R 680K J 1/16W	
R61			RK73GB1J103J	CHIP R 10K J 1/16W		R133,134			R92-1368-05	CHIP R 0 OHM	
R62			RN73GH1J913D	CHIP R 91K D 1/16W		R135			RK73GB1J272J	CHIP R 2.7K J 1/16W	
R63			RK73GB1J224J	CHIP R 220K J 1/16W		R136			RK73GB1J122J	CHIP R 1.2K J 1/16W	
R64			RK73GB1J153J	CHIP R 15K J 1/16W		R137			RK73GB1J103J	CHIP R 10K J 1/16W	
R65			RK73GB1J103J	CHIP R 10K J 1/16W		R138			RK73HB1J103J	CHIP R 10K J 1/16W	
R66			R92-1252-05	CHIP R 0 OHM		R140,141			RK73HB1J473J	CHIP R 47K J 1/16W	
R67			RN73GH1J274D	CHIP R 270K D 1/16W		R142,143			RK73HB1J102J	CHIP R 1.0K J 1/16W	

PARTS LIST

TX-RX UNIT (X57-6200-31)

Ref. No.	Address	New parts	Parts No.	Description	Destination	Ref. No.	Address	New parts	Parts No.	Description	Destination
R144			R92-1252-05	CHIP R 0 OHM		R296			RK73GB1J102J	CHIP R 1.0K J 1/16W	
R145-152			RK73HB1J102J	CHIP R 1.0K J 1/16W		R297,298			RK73HB1J473J	CHIP R 47K J 1/16W	
R154			RK73GB1J183J	CHIP R 18K J 1/16W		R299			RK73GB1J101J	CHIP R 100 J 1/16W	
R156			RK73GB1J102J	CHIP R 1.0K J 1/16W		R401			RK73GB1J224J	CHIP R 220K J 1/16W	
R160			RK73GB1J682J	CHIP R 6.8K J 1/16W		R402			RK73GB1J334J	CHIP R 330K J 1/16W	
R162			RK73GB1J103J	CHIP R 10K J 1/16W		R403			RK73GB1J394J	CHIP R 390K J 1/16W	
R163			RK73HB1J103J	CHIP R 10K J 1/16W		R404,405			RK73GB1J104J	CHIP R 100K J 1/16W	
R166			RK73GB1J223J	CHIP R 22K J 1/16W		R406,407			RK73GB1J331J	CHIP R 330 J 1/16W	
R167			R92-1252-05	CHIP R 0 OHM		R408			RK73HB1J473J	CHIP R 47K J 1/16W	
R168			RK73GB1J680J	CHIP R 68 J 1/16W		R410			RK73GB1J183J	CHIP R 18K J 1/16W	
R177			RK73GB1J101J	CHIP R 100 J 1/16W		R411			RK73GB1J472J	CHIP R 4.7K J 1/16W	
R180			RK73GB1J473J	CHIP R 47K J 1/16W		R412			RK73GB1J394J	CHIP R 390K J 1/16W	
R184			RK73GB1J102J	CHIP R 1.0K J 1/16W		R413			RK73HB1J102J	CHIP R 1.0K J 1/16W	
R185			RK73GB1J220J	CHIP R 22 J 1/16W		R414			RK73HB1J331J	CHIP R 330 J 1/16W	
R189			RK73HB1J473J	CHIP R 47K J 1/16W		R415			RK73HB1J184J	CHIP R 180K J 1/16W	
R190			RK73GB1J472J	CHIP R 4.7K J 1/16W		R416,417			RK73GB1J474J	CHIP R 470K J 1/16W	
R195			RK73GB1J222J	CHIP R 2.2K J 1/16W		D1			1SR154-400	DIODE	
R199			RK73HB1J102J	CHIP R 1.0K J 1/16W		D2,3			MA2S111	DIODE	
R202			RK73GB1J271J	CHIP R 270 J 1/16W		D4			RB706F-40	DIODE	
R210			RK73GB1J561J	CHIP R 560 J 1/16W		D5			DAN222	DIODE	
R216			RK73GB1J152J	CHIP R 1.5K J 1/16W		D6			MA2S111	DIODE	
R218			RK73HB1J473J	CHIP R 47K J 1/16W		D7			DAN222	DIODE	
R219			RK73GB1J330J	CHIP R 33 J 1/16W		D8			RB706F-40	DIODE	
R221			RK73HB1J102J	CHIP R 1.0K J 1/16W		D9			MA2S077	DIODE	
R241			RK73GB1J331J	CHIP R 330 J 1/16W		D10			HZU5ALL	DIODE	
R242			R92-1252-05	CHIP R 0 OHM		D11			MA742	DIODE	
R244			RK73GB1J180J	CHIP R 18 J 1/16W		D12			HVC131	DIODE	
R245			RK73EB2ER39K	CHIP R 0.39 K 1/4W		D14,15			HVC131	DIODE	
R247			RK73EB2ER39K	CHIP R 0.39 K 1/4W		D16			HSM88AS	DIODE	
R248			R92-1252-05	CHIP R 0 OHM		D17,18			DA221	DIODE	
R249			RK73EB2ER39K	CHIP R 0.39 K 1/4W		D20			HVC375B	VARIABLE CAPACITANCE DIODE	
R250			R92-1252-05	CHIP R 0 OHM		D22			HVC375B	VARIABLE CAPACITANCE DIODE	
R251-253			RN73GH1J154D	CHIP R 150K D 1/16W		D23			1SS373	DIODE	
R254			RK73GB1J221J	CHIP R 220 J 1/16W		D24,25			MA2S077	DIODE	
R255-257			RN73GH1J154D	CHIP R 150K D 1/16W		D401			HVC131	DIODE	
R258			RK73GB1J221J	CHIP R 220 J 1/16W		D402			MA2S111	DIODE	
R259,260			R92-1252-05	CHIP R 0 OHM		IC1,2			TC75W51FU	IC(BUFFER AMP)	
R261			RK73GB1J103J	CHIP R 10K J 1/16W		IC3			RN5VL42C	IC(VOLTAGE DETECTOR)	
R262			RK73GB1J470J	CHIP R 47 J 1/16W		IC4			TC75W51FU	IC(BUFFER AMP)	
R263,264			RK73GB1J104J	CHIP R 100K J 1/16W		IC5			S-81350HG-KD	IC(VOLTAGE REGULATOR/5M)	
R265			RK73GB1J473J	CHIP R 47K J 1/16W		IC6			NJU7201U50	IC(VOLTAGE REGULATOR/5V)	
R266			R92-1252-05	CHIP R 0 OHM		IC7			TC75W51FU	IC(BUFFER AMP)	
R267			RK73GB1J181J	CHIP R 180 J 1/16W		IC8			M62364FP	IC(D/A CONVERTER)	
R268			RK73GB1J105J	CHIP R 1.0M J 1/16W		IC9			TK11250BM	IC(VOLTAGE REGULATOR/5C)	
R269			RK73GB1J682J	CHIP R 6.8K J 1/16W		IC10			TC75S51F	IC(ACTIVE FILTER)	
R270			R92-1252-05	CHIP R 0 OHM		IC11			TC75W51FU	IC(ACTIVE FILTER)	
R271			RK73GB1J332J	CHIP R 3.3K J 1/16W		IC12			TA31136FN	IC(FM IF)	
R272			R92-1252-05	CHIP R 0 OHM		IC13			TC35453F	IC(AUDIO PROCESSOR)	
R273			RK73GB1J223J	CHIP R 22K J 1/16W		IC14			SA7025DK	IC(PLL SYSTEM)	
R276			R92-1252-05	CHIP R 0 OHM		IC16			LC73872M	IC(DTMF DECODER)	
R277			RK73GB1J223J	CHIP R 22K J 1/16W		IC17			AT29C020-90TI	IC(FLASH MEMORY)	
R279,280			R92-1252-05	CHIP R 0 OHM		IC17			W29C020C90	IC(FLASH MEMORY)	
R282			RK73GB1J223J	CHIP R 22K J 1/16W		IC18			GN2011(Q)	IC(ACTIVE DBM)	
R283			RK73GB1J472J	CHIP R 4.7K J 1/16W		IC19			30620M8A-2K9GP	IC(CPU)	
R284			RK73GB1J221J	CHIP R 220 J 1/16W		IC20			AT2416N10SI2.5	IC(EEPROM)	
R285			R92-1252-05	CHIP R 0 OHM		IC21,22			BU4094BCFV	IC(SHIFT REGISTER)	

PARTS LIST

TX-RX UNIT (X57-6200-31)

SUB UNIT (X58-4590-31)

Ref. No.	Address	New parts	Parts No.	Description	Destination	Ref. No.	Address	New parts	Parts No.	Description	Destination
IC23			NJM2904V	IC(APC)		L58,59			L40-1085-44	SMALL FIXED INDUCTOR(100.0NH)	
IC24			TC7S66FU	IC(ANALOG SWITCH)		L60,61			L40-3391-37	SMALL FIXED INDUCTOR(3.3UH)	
IC25			TC75W51FU	IC(ACTIVE FILTER)		L62			L92-0138-05	FERRITE CHIP	
IC100	2B		M68732SHA	IC(POWER MODULE)		L63			L40-1275-44	SMALL FIXED INDUCTOR(12.0NH)	
Q1			DTC144EE	DIGITAL TRANSISTOR							
Q2			2SJ243	FET		R50			RK73HB1J473J	CHIP R 47K J 1/16W	
Q3			2SA1745(6,7)	TRANSISTOR		R51			RK73HB1J103J	CHIP R 10K J 1/16W	
Q4			2SC4617(S)	TRANSISTOR		R52			RK73HB1J473J	CHIP R 47K J 1/16W	
Q5			2SJ243	FET		R53,54			RK73HB1J101J	CHIP R 100 J 1/16W	
Q6			DTA144EE	DIGITAL TRANSISTOR		R55			RK73HB1J104J	CHIP R 100K J 1/16W	
Q7			DTC144EE	DIGITAL TRANSISTOR		R56			RK73HB1J181J	CHIP R 180 J 1/16W	
Q8			2SC4617(S)	TRANSISTOR		R57			RK73HB1J221J	CHIP R 220 J 1/16W	
Q9,10			DTC144EE	DIGITAL TRANSISTOR		R58			RK73HB1J224J	CHIP R 220K J 1/16W	
Q11			2SK1824	FET		R59			RK73HB1J101J	CHIP R 100 J 1/16W	
Q12			2SC5108(Y)	TRANSISTOR		D50-57			HVC350B	VARIABLE CAPACITANCE DIODE	
Q13-15			2SK1824	FET		D58			HVC351	VARIABLE CAPACITANCE DIODE	
Q16-18			2SC5108(Y)	TRANSISTOR		Q50			2SK508NV(K52)	FET	
Q19			2SC4619	TRANSISTOR		Q51			2SJ243	FET	
Q20			2SC4988	TRANSISTOR		Q52			2SK508NV(K52)	FET	
Q21,22			DTC114EE	DIGITAL TRANSISTOR		Q53			UMC4	TRANSISTOR	
Q23			2SK1824	FET		Q54			2SC5108(Y)	TRANSISTOR	
Q24			3SK239A	FET							
Q25			DTA144EE	DIGITAL TRANSISTOR							
Q26			2SK1824	FET							
TH1			157-302-65801	THERMISTOR							
TH401			157-104-65001	THERMISTOR							
A1:SUB UNIT (VCO) (X58-4590-31)											
The A1 is replaceable as a unit assembly so individual parts are not kept in stock.											
C50			CC73HCH1H470J	CHIP C 47PF J							
C51			CC73HCH1H080B	CHIP C 8.0PF B							
C53			CC73HCH1H0R5B	CHIP C 0.5PF B							
C54			CC73HCH1H020B	CHIP C 2.0PF B							
C55,56			CC73HCH1H060B	CHIP C 6.0PF B							
C57			CK73HB1H102K	CHIP C 1000PF K							
C58			CC73HCH1H0R5B	CHIP C 0.5PF B							
C59			CK73HB1H471K	CHIP C 470PF K							
C60			CC73HCH1H060B	CHIP C 6.0PF B							
C61,62			CK73HB1H102K	CHIP C 1000PF K							
C63			CK73HB1H471K	CHIP C 470PF K							
C64			CC73HCH1H101J	CHIP C 100PF J							
C65			CK73HB1H102K	CHIP C 1000PF K							
C66			CC73HCH1H220J	CHIP C 22PF J							
C67			CC73HCH1H060B	CHIP C 6.0PF B							
C68			CC73HCH1H030B	CHIP C 3.0PF B							
C69			CC73HCH1H080B	CHIP C 8.0PF B							
C70			CC73HCH1H100B	CHIP C 10PF B							
C71			CC73HCH1H0R5B	CHIP C 0.5PF B							
C72,73			CC73HCH1H010B	CHIP C 1.0PF B							
C74			CC73HCH1H040B	CHIP C 4.0PF B							
TC50,51			C05-0384-05	CERAMIC TRIMMER CAP(10PF)							
CN50,51			E40-5622-05	PIN ASSY(3P)							
L50-53			L40-3391-37	SMALL FIXED INDUCTOR(3.3UH)							
L56			L34-4572-05	AIR-CORE COIL							
L57			L34-4573-05	AIR-CORE COIL							

EXPLODED VIEW

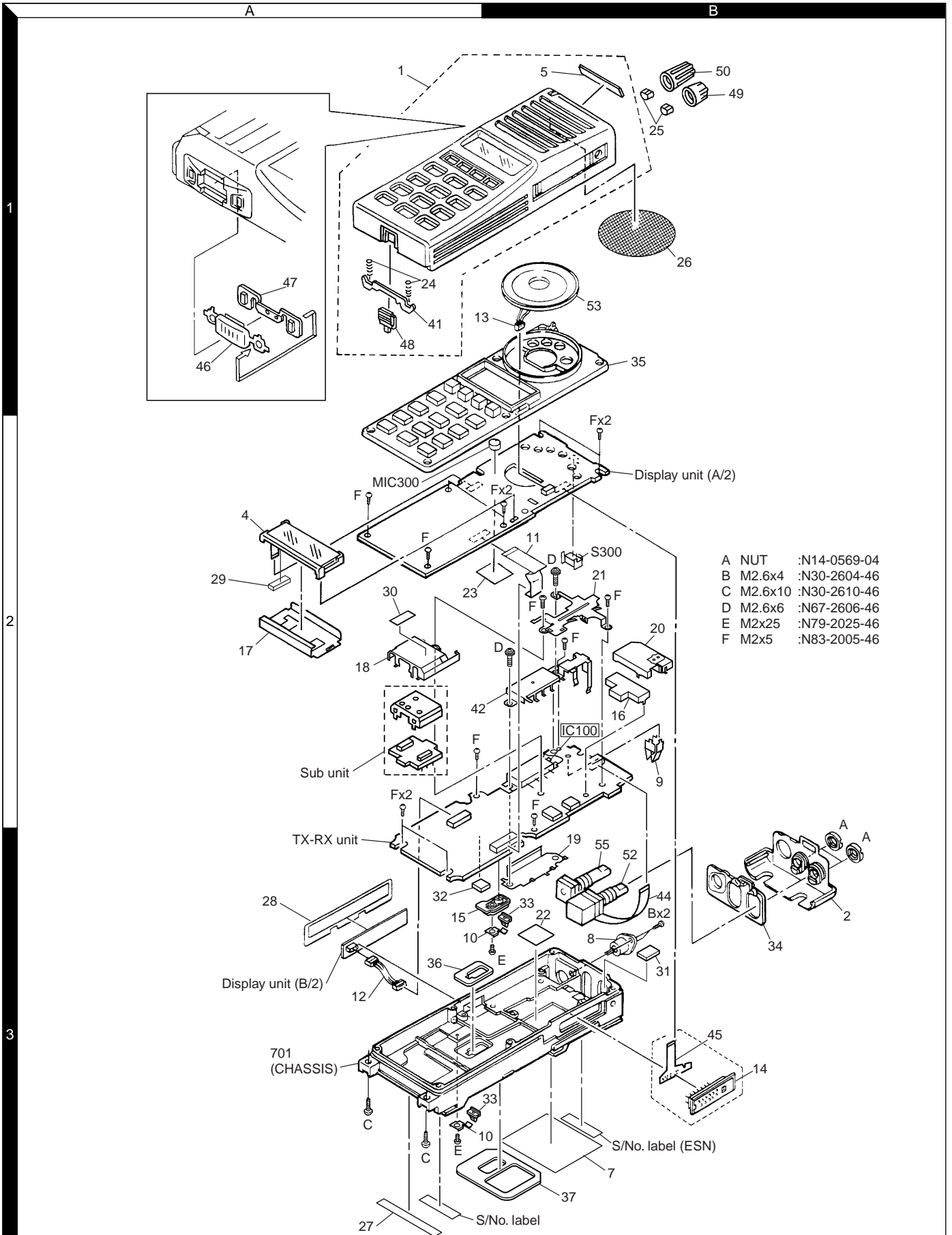

- A NUT :N14-0569-04
- B M2.6x4 :N30-2604-46
- C M2.6x10 :N30-2610-46
- D M2.6x6 :N67-2606-46
- E M2x25 :N79-2025-46
- F M2x5 :N83-2005-46

PACKING

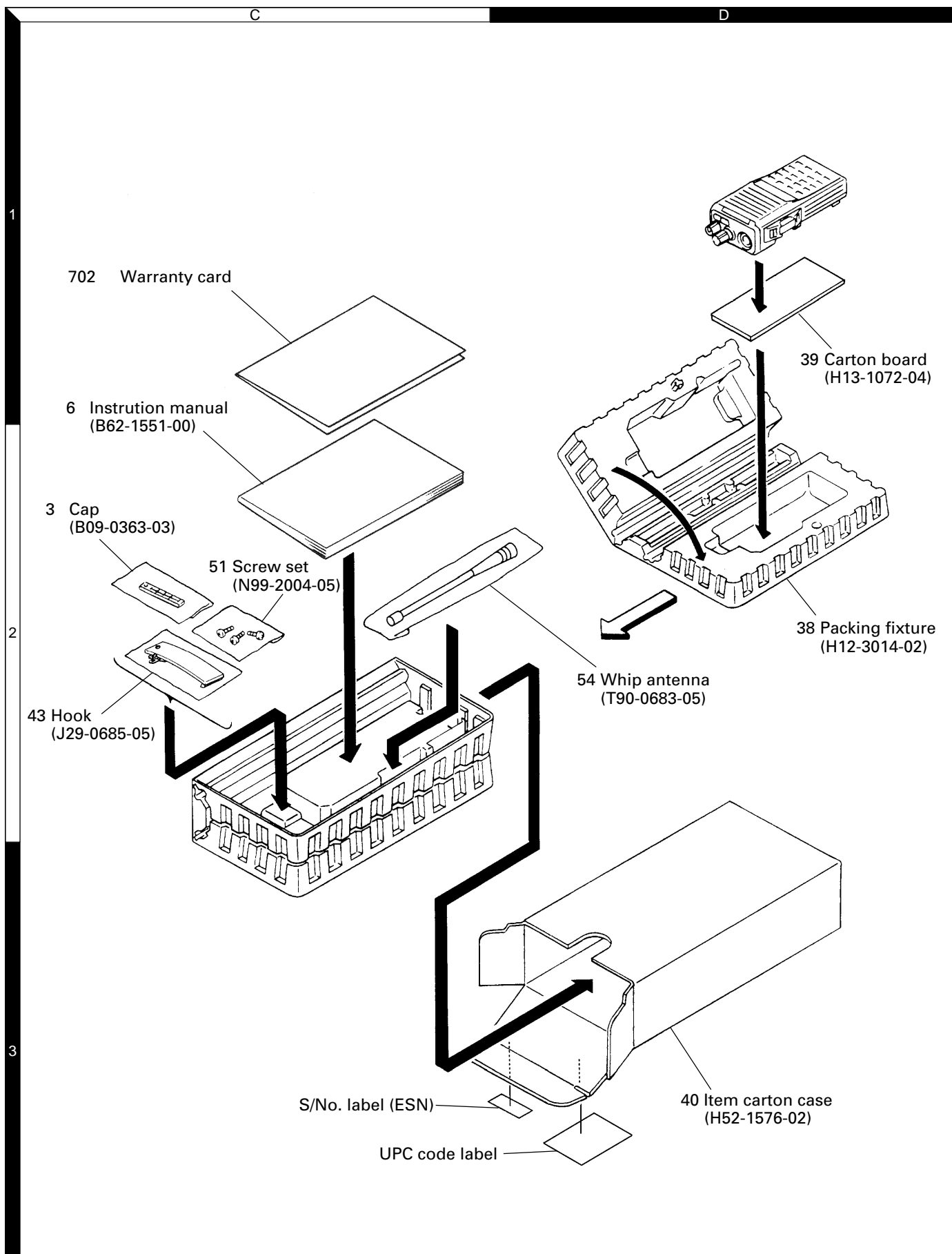

ADJUSTMENT

Test Equipment Required for Alignment

Test Equipment	Major Specifications	
1. Standard Signal Generator (SSG)	Frequency Range Modulation Output	420 to 520MHz Frequency modulation and external modulation. -127dBm/0.1μV to greater than -47dBm/1mV
2. Power Meter	Input Impedance Operation Frequency Measurement Range	50Ω. 420 to 520MHz or more. Vicinity of 10W
3. Deviation Meter	Frequency Range	420 to 520MHz.
4. Digital Volt Meter (DVM)	Measuring Range Input Impedance	10mV to 10V DC High input impedance for minimum circuit loading.
5. Oscilloscope		DC through 30MHz.
6. High Sensitivity Frequency Counter	Frequency Range Frequency Stability	10Hz to 1000MHz. 0.2ppm or less.
7. Ammeter		5A.
8. AF Volt Meter (AF VTVM)	Frequency Range Voltage Range	50Hz to 10kHz. 1mV to 10V.
9. Audio Generator (AG)	Frequency Range Output	50Hz to 5kHz or more. 0 to 1V.
10. Distortion Meter	Capability Input Level	3% or less at 1kHz. 50mV to 10Vrms.
11. Spectrum Analyzer	Measuring Range	DC to 1GHz or more
12. Tracking Generator	Center frequency Output Voltage	50kHz to 600MHz 100mV or more
13. 16Ω Dummy Load		Approx. 16Ω, 3W.
14. Regulated Power Supply		5V to 10V, approx. 5A Useful if ammeter equipped.

■ The following parts are required for adjustment

1. Antenna connector adapter

The antenna connector of this radio uses an SMA terminal.

Use an antenna connector adapter [SMA(f) – BNC(f) or SMA(f) – N(f)] for adjustment. (The adapter is not provided as an option, so buy a commercially-available one.)

Note

When the antenna connector adapter touches the knob, draw out the knob to mount the connector.

2. Universal connector

Use the interface cable (KPG-36) for PC tuning or the lead wire with plug (E30-3287-18) and screw (N08-0535-08) for panel tuning. Connect the plug to the universal connector of the radio and tighten the screw.

The lead wire with plug (E30-3287-18) and screw (N08-0535-08) terminals are as follows. Numbers are universal connector terminal numbers.

Caution

1. When connecting the plug to the universal connector of the radio, a short circuit may occur. To prevent this, be sure to turn the radio POWER switch off.
2. Since the RX AF output is a BTL output, there is a DC component. Isolate this with a capacitor or transformer as shown in the figure.
3. Do not connect an instrument between red or black and GND.

• Universal connector

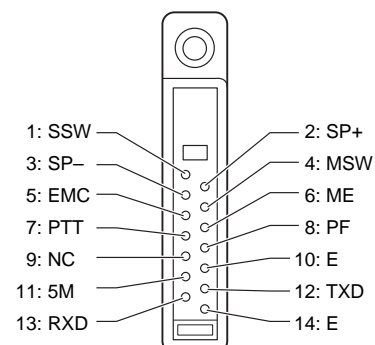

ADJUSTMENT

• Panel tuning

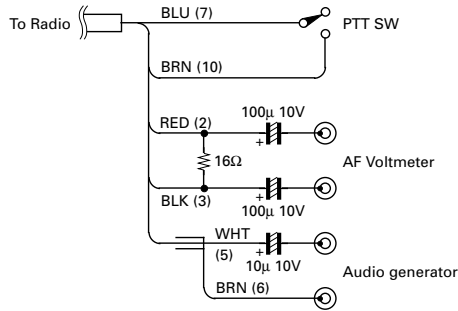
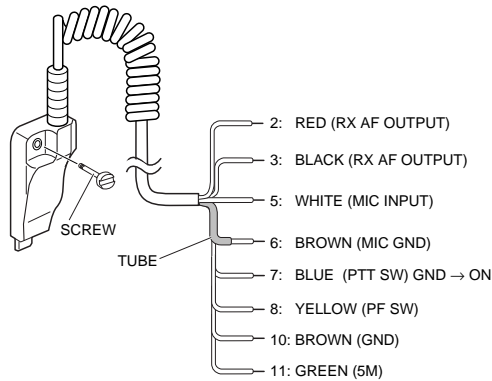

• PC tuning

Connect the wires to the PCB in the connector case of interface cable.

For output the wires out of the connector case, need to process the connector case.

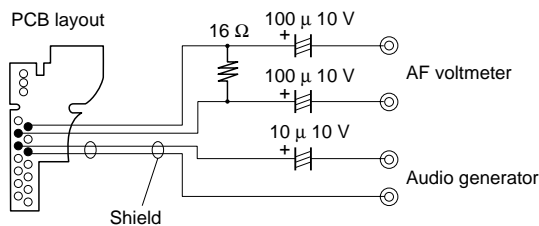
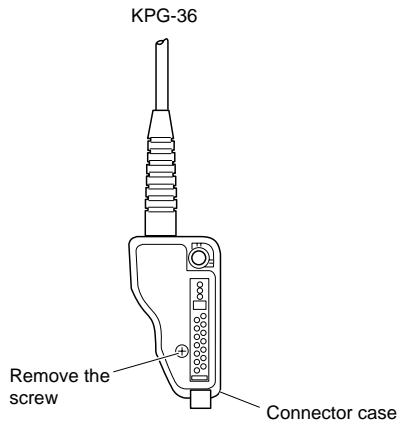

Repair Jig (Chassis)

Use jig (part No.: W05-0825-00) for repairing the TK-385. Place the TX-RX unit on the jig and fit it with 7 screws.

The jig facilitates the voltage check and protects the module when the voltage on the flow side of the TX-RX unit is checked during repairs.

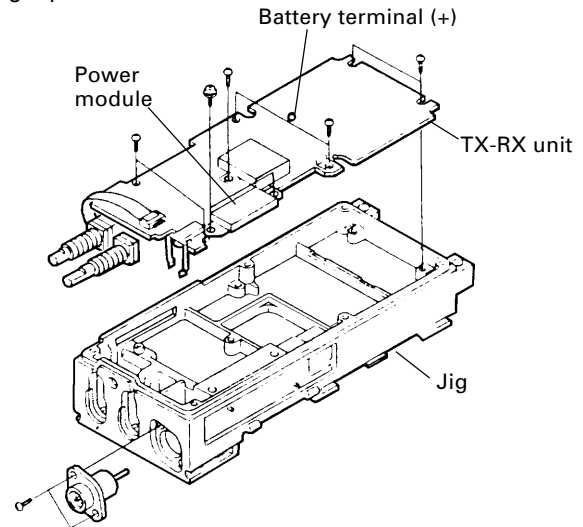

How to Remove the Flat Cable

1. Gently draw out both sides of the connector lever uniformly in the direction of the arrow with tweezers. (CN300, CN301)

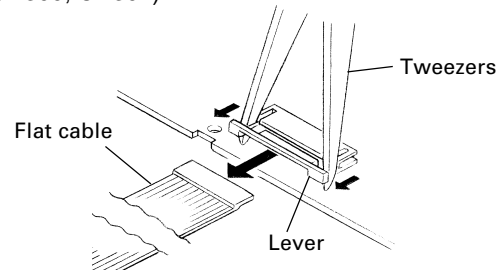

2. Gently rise up the connector lever in the direction of the arrow with a fine regular screwdriver or tweezers. (CN1, CN3, CN304)

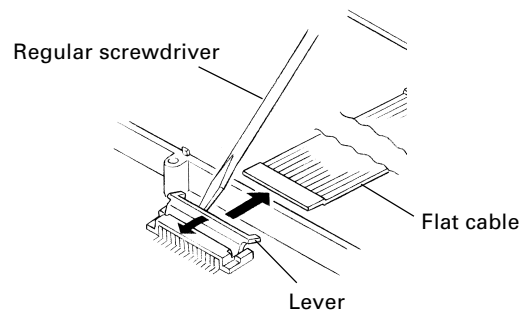

ADJUSTMENT

Test Mode



■ Test mode operating features

This transceiver has a test mode. **To enter test mode, press [B] key and turn power on. Hold [B] key until test channel No. and test signalling No. appears on LCD.** Test mode can be inhibited by programming. To exit test mode, switch the power on again. The following functions are available in test mode.

• Controls

Controls	"FNC" appears	"FNC" not appears
[PTT]	Used when making a transmission.	Used when making a transmission.
[AUX]	Release FNC	Unused
[Call]	Release FNC	Monitor ON and OFF.
[Clear]	Lamp ON/OFF	No Func
[A]	FFSK 1200bps and 2400bps	Sets to the Tuning mode.
[B]	Release FNC	FNC ON.
[C]	Comander function ON and OFF.	RF power HIGH and LOW.
[D]	Beat shift ON and OFF	Changes signalling.
[0] to [9], and [#], [*]	No Func	No Func
[ENCODER]	Release FNC	Changes channel.

• LCD indicator

"SCN"	Unused
" 	Lights at Comander ON.
"LO"	Lights at RF Power Low.
"P"	Unused
"MON"	Lights at monitor ON.
"SVC"	Unlock
" 	Lights at FFSK 2400bps.

• LED indicator

Red LED	Lights during transmission. Blinks at the low battery voltage warning.
Green LED	Lights when there is a carrier.

• Sub LCD indicator

"FNC"	Appears at Function ON.
-------	-------------------------

■ Frequency and signalling

The set has been adjusted for the frequencies shown in the following table. When required, re-adjust them following the adjustment procedure to obtain the frequencies you want in actual operation.

Frequency (MHz) (A2 type)

Channel No.	RX frequency	TX frequency
1	495.05000	495.10000
2	470.05000	470.10000
3	519.95000	519.10000
4	490.00000	490.00000
5	490.20000	490.20000
6	490.40000	490.40000
7 ~ 16	—	—

Signalling

Signalling No.	RX	TX
1	None	None
2	None	100Hz Square wave
3	QT 67.0Hz	QT 67.0Hz
4	QT 151.4Hz	QT 151.4Hz
5	QT 210.7Hz	QT 210.7Hz
6	QT 250.3Hz	QT 250.3Hz
7	DQT 023N	DQT 023N
8	DQT 754I	DQT 754I
9	None	DTMF tone 9
10	None	Single Tone 1200Hz (HSD OUT)
11	None	Single Tone 1200Hz (MODEM OUT)
12	None	Single Tone 1800Hz (MODEM OUT)
13	None	FFSK(PN pattern)
14	FFSK(CODE)	FFSK(CODE)

• Preparations for tuning the transceiver

Before attempting to tune the transceiver, connect the unit to a suitable power supply.

Whenever the transmitter is turned, the unit must be connected to a suitable dummy load (i.e. power meter).

The speaker output connector must be terminated with a 16Ω dummy load and connected to an AC voltmeter and an audio distortion meter or a SINAD measurement meter at all times during tuning.

• Transceiver tuning

(To place transceiver in tuning mode)

Channel appears on LCD. Set channel according to tuning requirements.

ADJUSTMENT

LCD display (Test mode)

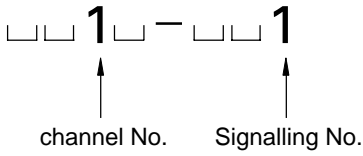

Press [A], now in tuning mode. Use [◀ C] button to write tuning data through tuning modes, and channel selector knob to adjust tuning requirements (1 to 256 appears on LCD).

Use [D ▶] button to select the adjustment item through tuning modes. Use [B] button to adjust 3 or 5 point tuning.

LCD display (Tuning mode)

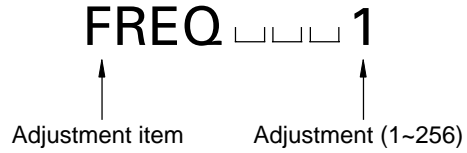

Panel Tuning Mode (A2 Type)

TEST Ch	RX frequency (MHz)	TX frequency (MHz)
L	470.05000	470.10000
L2	478.05000	478.10000
C	495.05000	495.10000
H2	511.95000	511.90000
H	519.95000	519.90000

■ Tuning mode

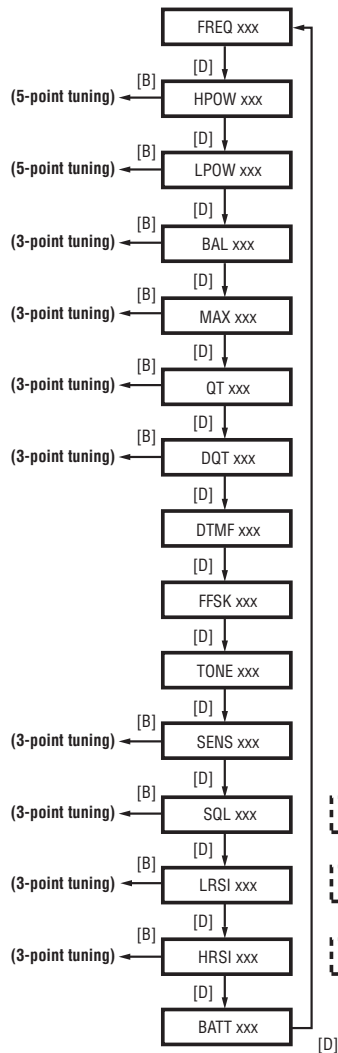

5-point tuning ex. RF Power High

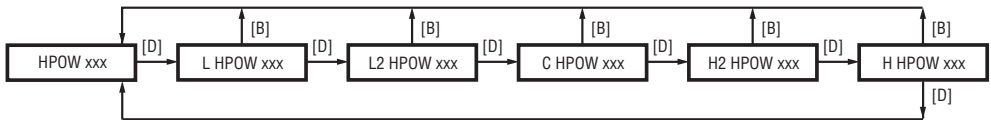

3-point tuning ex. Max Deviation

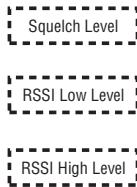
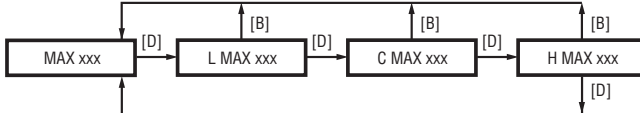

ADJUSTMENT

Common Section

Item	Condition	Measurement			Adjustment			Specifications/ Remark
		Test equipment	Unit	Terminal	Unit	Parts	Method	
1. Setting	1) BATT terminal voltage:7.5V 2) SSG Standard modulation MOD:1kHz, DEV:1.5kHz							
2. VCO lock voltage	[Panel Test Mode] 1) CH-Sig:2-1	Power meter DVM	Panel TX-RX	ANT CV (CN14)			Check	0.8V or more
RX	2) CH-Sig:3-1							4.4V or less
TX	3) CH-Sig:2-1 PTT:ON							0.8V or more
	4) CH-Sig:3-1 PTT:ON							4.4V or less

Transmitter Section [Panel Tuning Mode except when Panel TEST Mode is specified.]

Item	Condition	Measurement			Adjustment			Specifications/ Remark
		Test equipment	Unit	Terminal	Unit	Parts	Method	
1. Frequency Adjust	1) Adj item [FREQ] Adjust [***] PTT:ON	Power meter Am meter	Panel	ANT	Panel	Encoder knob	Center frequency $\pm 100\text{Hz}$ (Note:)After replacing the TCXO (X1), align using KPG-62D.	
2. Max Power Check	1) Adj item [HPOW] Adjust [256] 2) Adj item [L HPOW] → [L2 HPOW] → [C HPOW] → [H2 HPOW] → [H HPOW] Adjust [256] PTT:ON						Check	4.3W or more
3. High Power Adjust	1) Adj item [HPOW] Adjust [***] 2) Adj item [L HPOW] → [L2 HPOW] → [C HPOW] → [H2 HPOW] → [H HPOW] Adjust [***] PTT:ON						Encoder knob	4.0W $\pm 0.1\text{W}$ 2.2A or less
4. High Power Check	[Panel Test Mode] 1) CH-Sig:1-1 PTT:ON 2) CH-Sig:2-1 PTT:ON 3) CH-Sig:3-1 PTT:ON							Check 3.8~4.2W 2.3A or less
5. Low Power Adjust	1) Adj item [LPOW] Adjust [***] 2) Adj item [L LPOW] → [L2 LPOW] → [C LPOW] → [H2 LPOW] → [H LPOW] Adjust [***] PTT:ON					Panel	Encoder knob	0.8W $\pm 0.1\text{W}$ 1.0A or less
6. Low Power Check	[Panel Test Mode] 1) CH-Sig:1-1 Set low power (Push [C]) PTT:ON 2) CH-Sig:2-1 PTT:ON 3) CH-Sig:3-1 PTT:ON							Check 0.5~1.5W 1.2A or less

ADJUSTMENT

Transmitter Section [Panel Tuning Mode except when Panel TEST Mode is specified.]

Item	Condition	Measurement			Adjustment			Specifications/ Remark
		Test equipment	Unit	Terminal	Unit	Parts	Method	
7. DQT Balance Adjust	1) Adj item [BAL] Adjust [***] LPF:3kHz HPF:OFF 2) Adj item [L BAL] → [C BAL] → [H BAL] Adjust [***] PTT:ON	Power meter Dev meter Oscilloscope AG AF VTVM	Panel	ANT universal connector	Panel	Encoder knob	Make the demodulation waves into square waves.	
8. Max DEV Adjust	1) Adj item [MAX] Adjust [***] AG:1kHz / 80mV Dev meter filter LPF:15kHz HPF:OFF 2) Adj item [L MAX] → [C MAX] → [H MAX] Adjust [***] PTT:ON						1.85kHz (According to the larger +,-)	±50Hz
9. MIC Sensitivity Check	[Panel Test Mode] 1) CH-Sig: 1-1 AG:1kHz / 8mV LPF:15kHz PTT:ON						Check	1.2~2.0kHz
10.QT Deviation Adjust	1) Adj item [QT] Adjust [***] LPF:3kHz HPF:OFF 2) Adj item [L QT] → [C QT] → [H QT] Adjust [***] PTT:ON		Panel	ANT universal connector	Panel	Encoder knob	0.35kHz	±50Hz
11.DQT Devition Adjust	1) Adj item [DQT] Adjust [***] LPF:3kHz HPF:OFF 2) Adj item [L DQT] → [C DQT] → [H DQT] Adjust [***] PTT:ON							
12.DTMF Deviation Adjust	1) Adj item [DTMF] Adjust [***] LPF:15kHz HPF:OFF PTT:ON						1.45kHz	±0.05kHz
13.FFSK Deviation Adjust	1) Adj item [FFSK] Adjust [***] LPF:15kHz HPF:OFF PTT:ON						1.45kHz	±0.05kHz

ADJUSTMENT

Transmitter Section [Panel Tuning Mode except when Panel TEST Mode is specified.]

Item	Condition	Measurement			Adjustment			Specifications/ Remark
		Test equipment	Unit	Terminal	Unit	Parts	Method	
14.TONE Deviation Adjust	1) Adj item [TONE] Adjust [***] LPF:15kHz HPF:OFF PTT:ON	Power meter Dev meter Oscilloscope AG AF VTVM	Panel	ANT universal connector	Panel	Encoder knob	1.45kHz	±0.05kHz
15.BATT Detection Writing	1) Adj item [BATT] Adjust [***] PTT:ON	Power meter DVM	Panel	ANT BATT terminal	Panel	Encoder knob	After pressing the PTT switch, confirm that one predeter- mined numeric in the range 1 to 256 appears and then press [C] key. That numeric will be stored in memory.	BATT terminal voltage:6.2V
16.BATT Detection Check	[Panel Test Mode] 1) CH-Sig:1-1 BATT terminal voltage:6.5V PTT:ON 2) BATT terminal voltage:5.7V PTT:ON						Check	No blinking of LED Blinking of LED

ADJUSTMENT

Receiver Section [Panel Tuning Mode except when Panel TEST Mode is specified.]

Item	Condition	Measurement			Adjustment			Specifications/ Remark
		Test equipment	Unit	Terminal	Unit	Parts	Method	
1. Sensitivity Adjust (BPF characteristic)	1) Adj item [SENS] Adjust [***] (A2)	Tracking generator	Panel	ANT	Panel	Encoder knob	Adjustment Low-edge-f Turn the encoder knob to adjust the sensitivity as shown left.(L)	
	2) Low-edge frequency Adj item [L SENS] Spe-Ana setting Center-f : 495MHz Span : 200MHz RBW : 300kHz VBW : 10kHz REF level : -10dBm ATT : 0dB Tra-G setting Input level:-30dBm	Spectrum analyzer	TX-RX	TP (CN13) Need couple capacitor (1000PF)			Adjustment Center-f Turn the encoder knob to adjust the sensitivity as shown left.(C)	
	3) Center frequency Adj item [C SENS]						Adjustment High-edge-f Turn the encoder knob to adjust the sensitivity as shown left.(H)	
	4) High-edge frequency Adj item [H SENS]							
		<p style="text-align: center;">Band Pass Filter Characteristic (A2)</p>						
2. Sensitivity Check	[Panel Test Mode] 1) CH-Sig:1-1 SSG OUT -116dBm (0.355μV) (MOD:1kHz / ±1.5kHz)	SSG AF VTVM Oscilloscope	Panel	ANT Universal connector			Check	12dB SINAD or more
3. Squelch (Preset) Adjust	1) Adj item [SQL] Adjust [***] SSG OUT: 12dB SINAD level					Encoder knob	Adjust to point of opening squelch.	
	2) Adj item [L SQL] → [C SQL] → [H SQL] Adjust [***]							
4. RSSI (Low) Adjust	1) Adj item [LRSI] Adjust [***] SSG OUT: 12dB SINAD level						After input signal from SSG,press [D] key. That numeric will be stored in memory.	
	2) Adj item [L LRSI] → [C LRSI] → [H LRSI] Adjust [***]							
5. Squelch (Preset) Check	[Panel Test Mode] 1) CH-Sig:1-1 SSG OUT: 12dB SINAD level						Check	Squelch must be opened.
	2) SSG OUT:OFF							Squelch must be closed.

ADJUSTMENT

Item	Condition	Measurement			Adjustment			Specifications/ Remark
		Test equipment	Unit	Terminal	Unit	Parts	Method	
6. RSSI (High) Adjust	1) Adj item [HRSI] Adjust [***] SSG OUT: -70dBm (70.7μV)	SSG AF VTVM Oscilloscope	Panel	ANT Universal connector			After input signal from SSG,press [D] key. That numeric will be stored in memory.	
	2) Adj item [L HRSI] → [C HRSI] → [H HRSI] Adjust [***]							

Adjustment points
TX-RX unit (X57-6200-31)
component side view

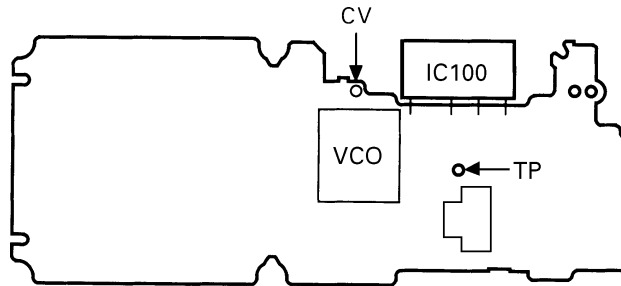

TERMINAL FUNCTION

CN No.	Pin No.	Name	I/O	Function
TX-RX UNIT (X57-6200-31): TX-RX section				
CN1	1	B	O	Power input after passing through the fuse.
	2	B	O	Power input after passing through the fuse.
	3	SB	I	Power output after power switch.
	4	SB	I	Power output after power switch.
	5	5M	O	5V.
	6	VOL	I	Volume level input for audio control.
	7	E	-	GND
	8	EN2	I	Encoder pulse input.
	9	E	-	GND
	10	EN1	I	Encoder pulse input.
CN2 for X54- SW section	1	MON	I	Normally; 5V. MON when connected GND.
	2	LAMP	I	Normally; 5V. LAMP when connected GND.
	3	PTT	I	Normally; 5V. transmit when connected GND.
	4	GND	-	GND
CN3 for X54- Display unit	1	AF	O	Audio output.
	2	AFE	-	Audio GND.
	3	NC	-	Not use.
	4	PF	I	External PF signal input.
	5	CK	O	Clock data output.
	6	RXD	I	Serial control signal input.
	7	TXD	O	Serial control signal output.
	8	DT	O	Data output for LCD driver/decade counter.
	9	KRS	O	Key scan IC reset output.
	10	KI1	I	KEY input
	11	KI2	I	KEY input
	12	GND	-	GND
	13	5M	O	5V.
	14	AM	O	Audio mute signal output. Mute: "L". Unmute: "H"
	15	CS	O	LCD driver chip select output.
	16	NC	-	Not use.
	17	PTT	I	PTT signal input.
	18	AUX	I	AUX key input.
	19	LR	O	TX LED control. Normally: 0V, lighting: 5V.
	20	LG	O	RX LED control. Normally: 0V, lighting: 5V.
	21	LBL	O	Backlight LED control. Normally: 0V, lighting: 5V.
	22	ME	-	MIC GND.
	23	MIC	I	MIC signal input.
	24	SB	O	Power output after power switch.
DISPLAY UNIT (X54-3210-12 A/2) : DISPLAY section				
CN300 for X57- TX-RX unit	1	SB	I	Power input after power switch.
	2	MIC	O	MIC signal output.
	3	ME	-	MIC GND.
	4	LBL	I	Backlight LED control. Normally: 0V, lighting: 5V.
	5	LG	I	RX LED control. Normally: 0V, lighting: 5V.
	6	LR	I	TX LED control. Normally: 0V, lighting: 5V.
	7	AUX	O	AUX key output.
	8	PTT	O	PTT signal output.
	9	NC	-	Not use.
	10	CS	I	LCD driver chip select input.
	11	AM	I	Audio mute signal input. Mute: "L", Unmute: "H"
	12	5M	I	5V.

CN No.	Pin No.	Name	I/O	Function	
	13	GND	-	GND	
	14	KI2	O	KEY output	
	15	KI1	O	KEY output	
	16	KRS	I	Key scan IC reset input	
	17	DT	I	Data input for LCD driver/decade counter.	
	18	TXD	I	Serial control signal input.	
	19	RXD	O	Serial control signal output.	
	20	CK	I	Clock data input.	
	21	PF	O	External PF signal output.	
	22	NC	-	Not use.	
	23	AFE	-	Audio GND.	
	24	AF	I	Audio input.	
	CN301	1	SSW	I	EXT/INT speaker switch input.
		2	SP+	O	BTL output + for external speaker.
3		SP-	O	BTL output - for external speaker.	
4		MSW	I	EXT/INT MIC switch input.	
5		EMC	I	External microphone input.	
6		ME	-	External microphone ground.	
7		PTT	I	External PTT input.	
8		PF	I	Programmable function key input.	
9		NC	-	Not use.	
10		E	-	GND	
11		5M	O	5V output	
12		TXD	O	Serial data output.	
13		RXD	I	Serial data input.	
14		NC (E)	-	Not use (GND)	
CN302	1	SP	O	Output for internal speaker.	
	2	E	-	GND	
CN304	1	NC	-	Not use.	
	2	LEDK	I	Backlight LED control.	
	3	LEDA	O	Backlight LED control.	
	4	VCI	O	LCD power supply.	
	5	SOD	O	Serial data output for LCD driver.	
	6	SID	I	Serial data input for LCD driver.	
	7	SCLK	O	Clock data output for LCD driver.	
	8	CS	O	LCD driver chip select output.	
	9	Vcc	O	5V	
	10	GND	-	GND	
DISPLAY UNIT (X54-3210-12 B/2) : SW section					
CN303 For X57- TX-RX unit	1	MON	O	Normally; 5V..MON when connected GND.	
	2	LAMP	O	Normally; 5V, LAMP when connected GND.	
	3	PTT	O	Normally; 5V, transmit when connected GND.	
	4	GND	-	GND	

DISPLAY UNIT (X54-3210-12) Component Side View

DISPLAY UNIT (X54-3210-12)

Ref. No.	Address
D301	9C
D305	8L
D306	6L
D307	8N
D308	6N
D309	8Q
D310	6Q

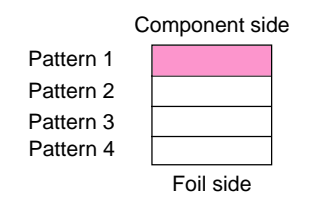
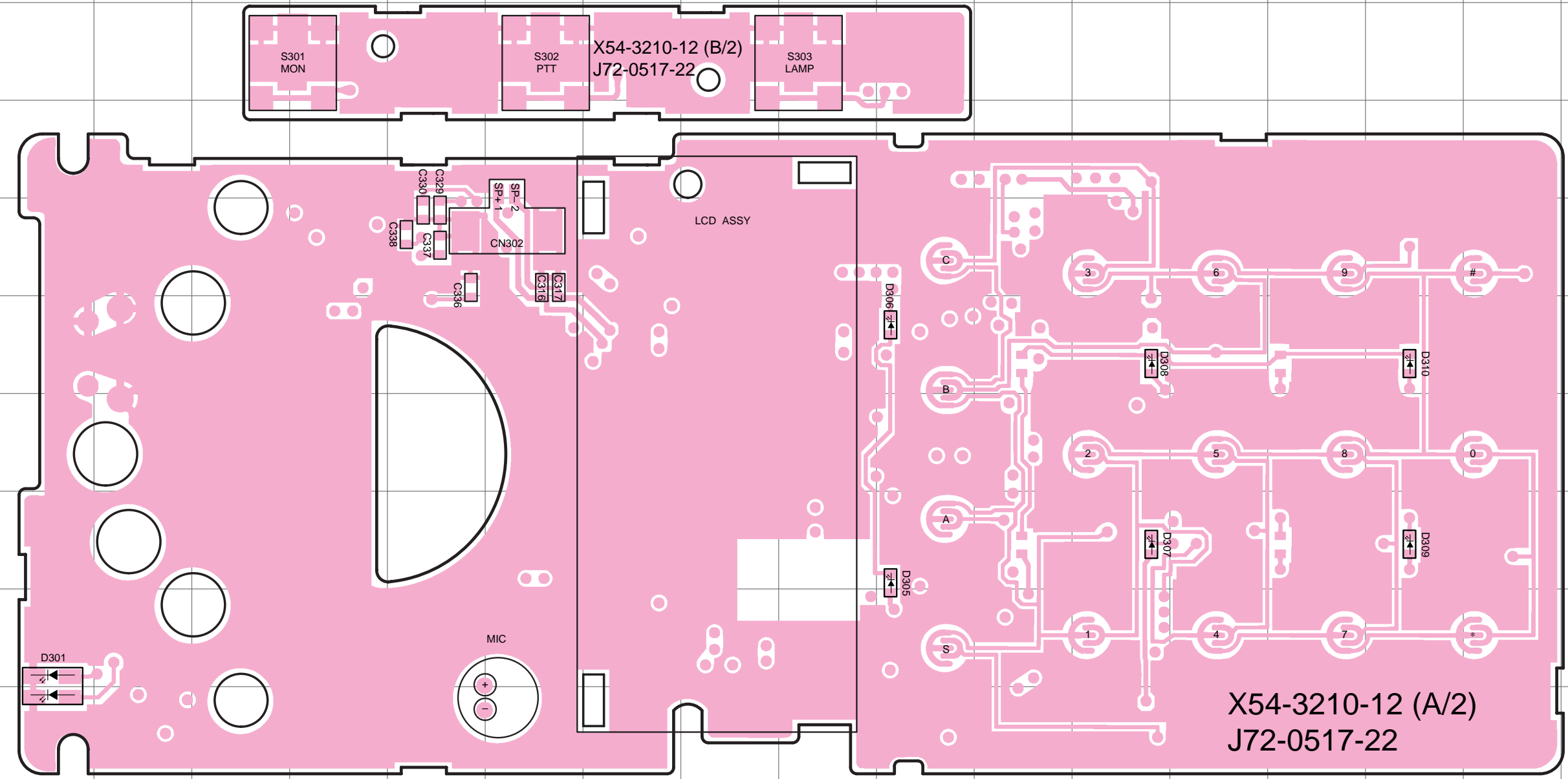

TK-385 PC BOARD VIEW

DISPLAY UNIT (X54-3210-12) Foil Side View

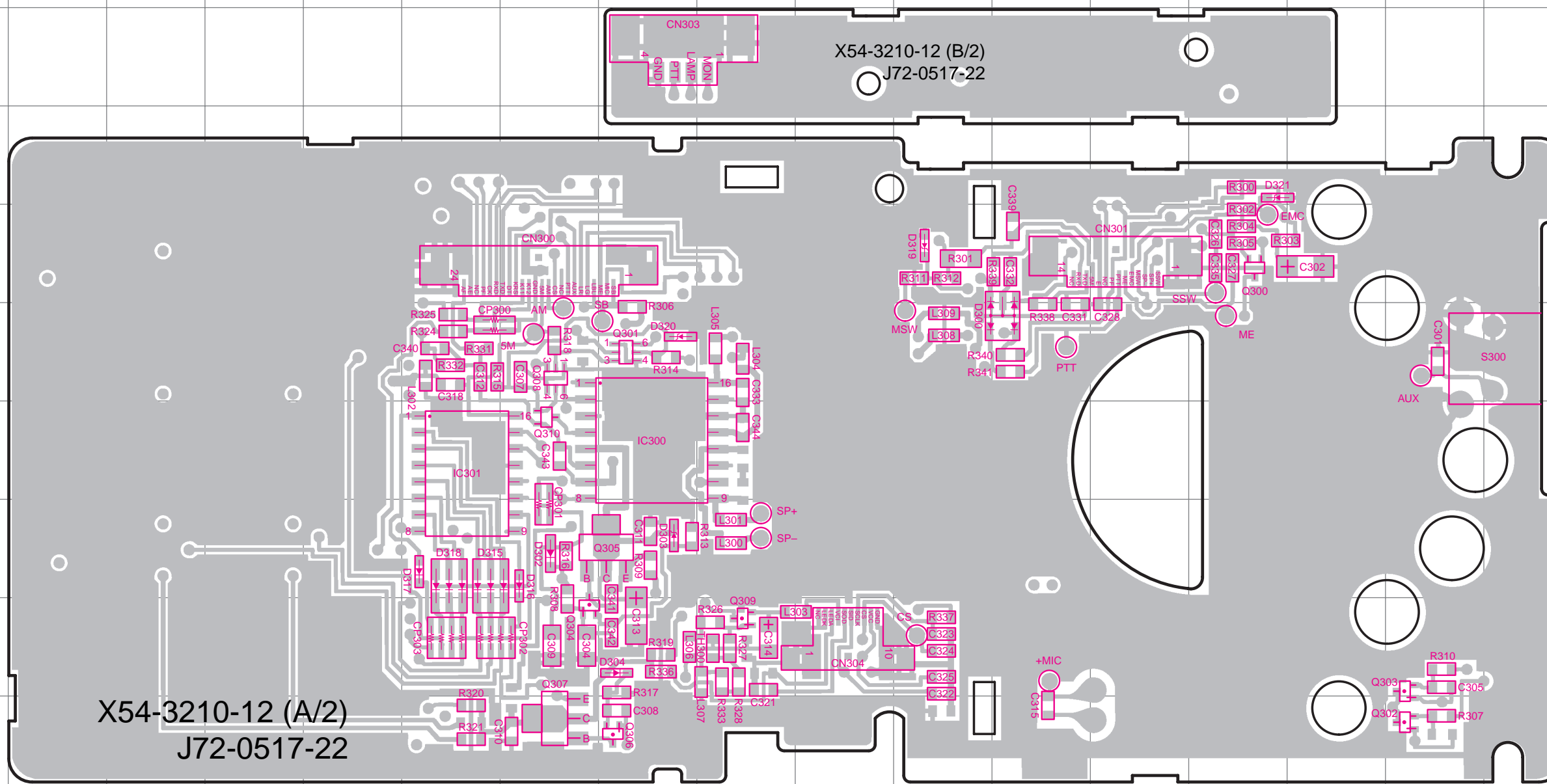

DISPLAY UNIT (X54-3210-12)

Ref. No.	Address
D300	6L
D302	8G
D303	8H
D304	9H
D315	8F
D316	8G
D317	8F
D318	8F
D319	5K
D320	6H
D321	4N
IC300	7H
IC301	7F
Q300	5N
Q301	6H
Q302	10P
Q303	9P
Q304	9G
Q305	8H
Q306	10H
Q307	10G
Q308	6G
Q309	9I
Q310	7G

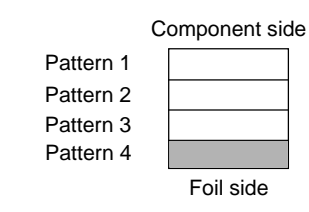
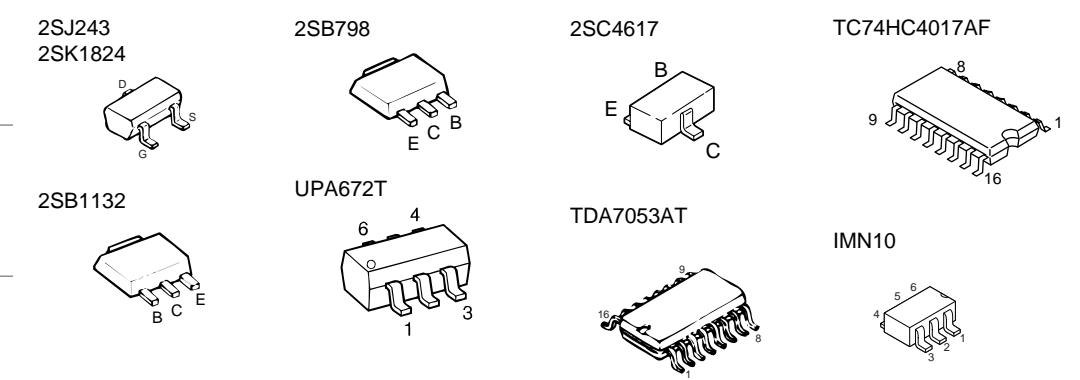

DISPLAY UNIT (X54-3210-12) Component Side + Foil Side View

DISPLAY UNIT (X54-3210-12)

Ref. No.	Address
D300	6H
D301	9C
D302	8M
D303	8L
D304	9L
D305	8L
D306	6L
D307	8N
D308	6N
D309	8Q
D310	6Q
D315	8N
D316	8M
D317	8N
D318	8N
D319	5I
D320	6L
D321	4F
IC300	7L
IC301	7N
Q300	5F
Q301	6L
Q302	10D
Q303	9D
Q304	9M
Q305	8L
Q306	10L
Q307	10M
Q308	6M
Q309	9K
Q310	7M

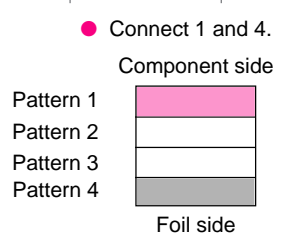
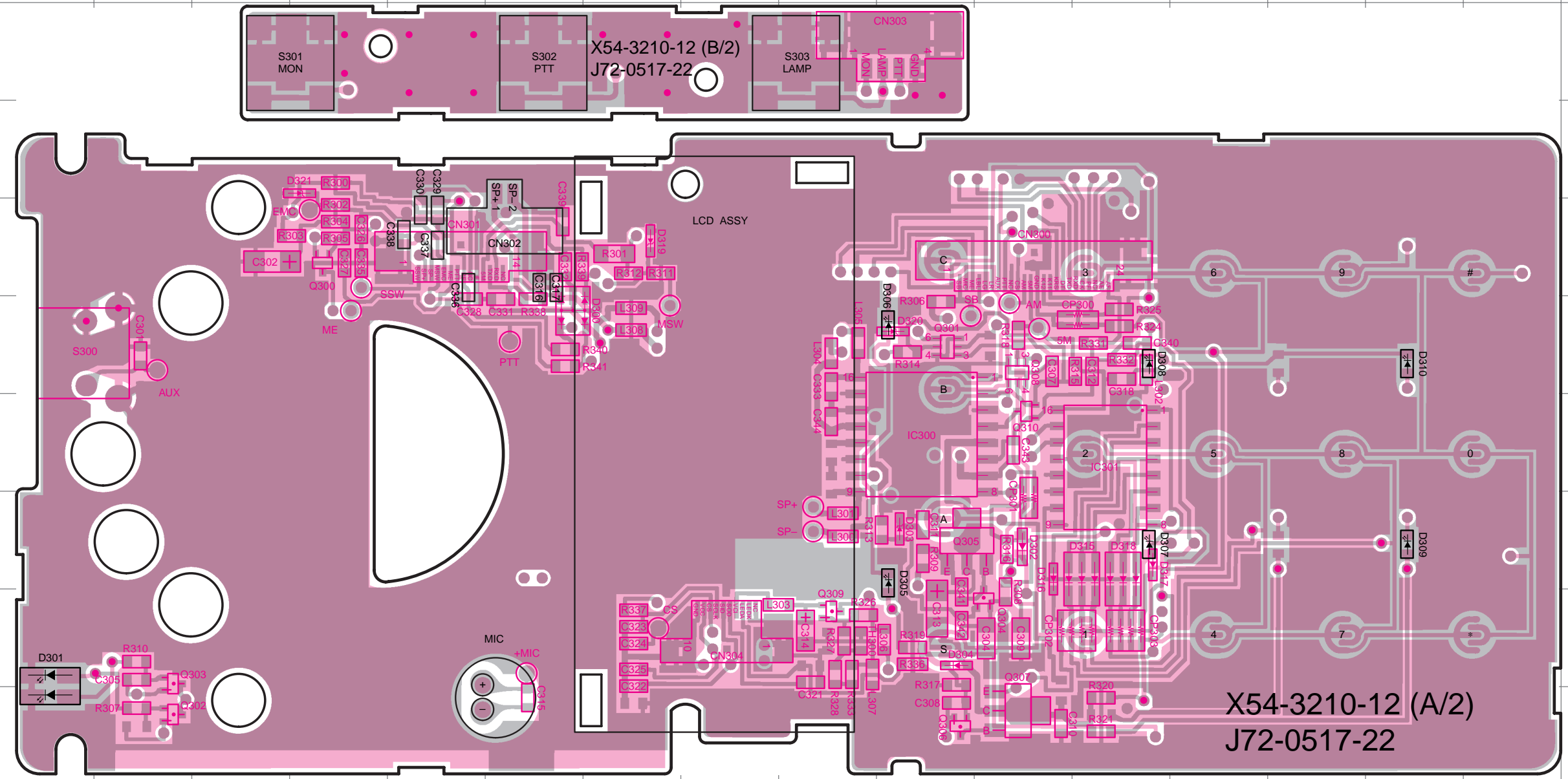

2SJ243
2SK1824

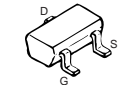

2SB798

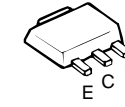

2SC4617

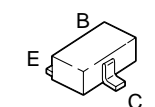

TC74HC4017AF

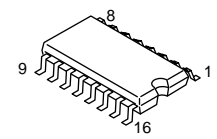

2SB1132

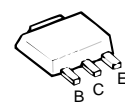

UPA672T

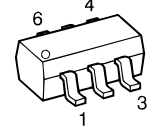

TDA7053AT

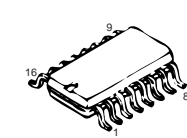

IMN10

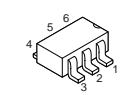

TK-385 PC BOARD VIEW

TX-RX UNIT (X57-6200-31) Component Side View

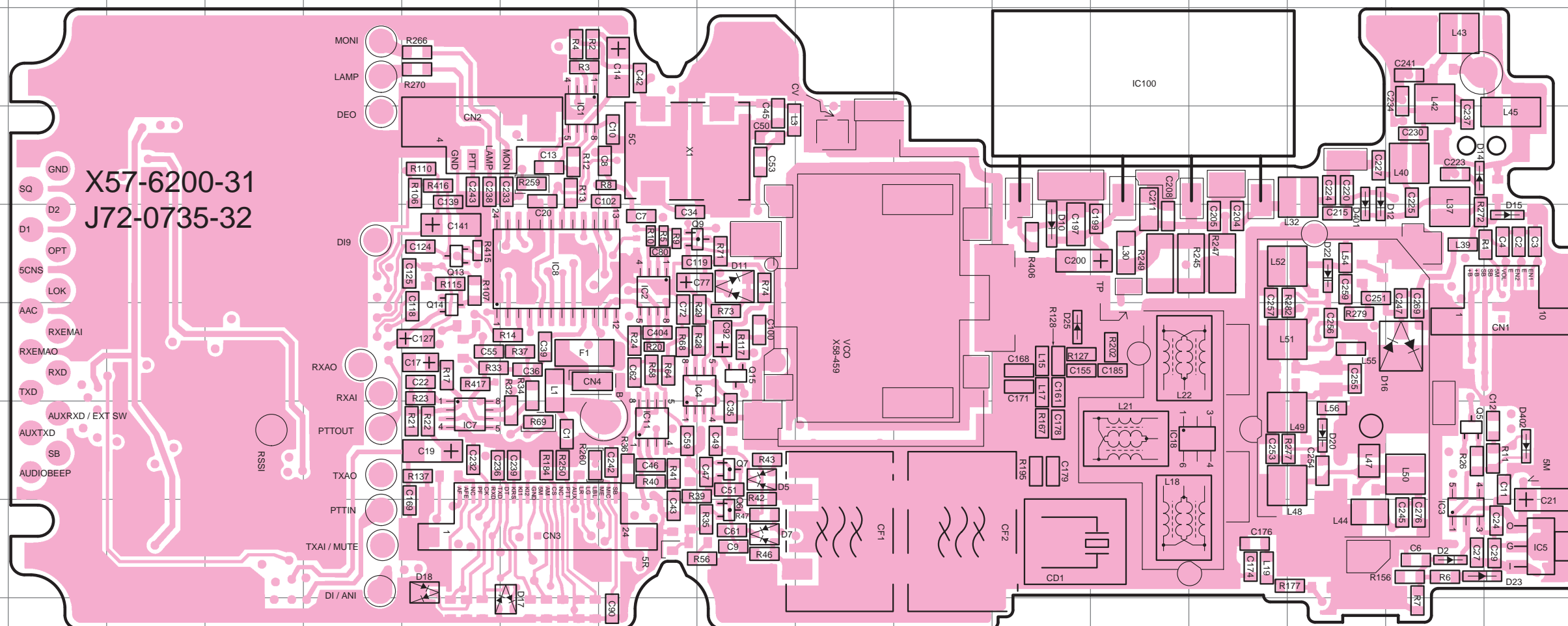

TX-RX UNIT (X57-6200-31)

Ref. No.	Address
D2	8P
D5	7I
D7	8I
D10	5L
D11	5I
D12	4O
D14	4P
D15	5Q
D16	6P
D17	8F
D18	8F
D20	7O
D22	5O
D23	8P
D25	6L
D401	4O
D402	7Q
IC1	4G
IC2	5H
IC3	8P
IC4	6I
IC5	8Q
IC7	7F
IC8	5G
IC11	7H
IC18	7N
Q5	7P
Q6	8I
Q7	7I
Q9	5H
Q13	5F
Q14	5F
Q15	6I

DTA144EE
DTC144EE



2SJ243
2SK1824



S-81350HG-KD



M62364FP

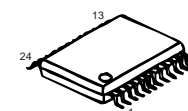

TC75W51FU

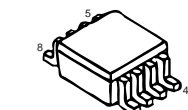

RN5VL42C

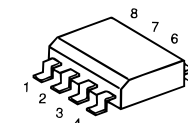

GN2011

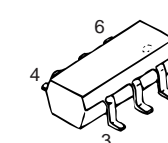

DA221
HSM88AS



MA742



Component side

Pattern 1	
Pattern 2	
Pattern 3	
Pattern 4	
Pattern 5	
Pattern 6	
Foil side	

TX-RX UNIT (X57-6200-31) Foil Side View

TX-RX UNIT (X57-6200-31)

Ref. No.	Address
D1	6L
D3	7L
D4	7L
D6	6J
D8	8O
D9	6H
D24	6H
IC6	6D
IC9	7D
IC10	8N
IC12	8J
IC13	6N
IC14	5J
IC16	3M
IC17	4Q
IC19	7Q
IC20	3Q
IC21	3P
IC22	3Q
IC23	5F
IC24	4M
IC25	8M
Q1	5E
Q2	5D
Q3	6D
Q4	7K
Q8	6J
Q10	7M
Q12	9I
Q16	6J
Q17	6I
Q18	6H
Q19	8Q
Q20	5H
Q21	5G
Q22	5F
Q23	5G
Q24	8E
Q25	5G
Q26	8N

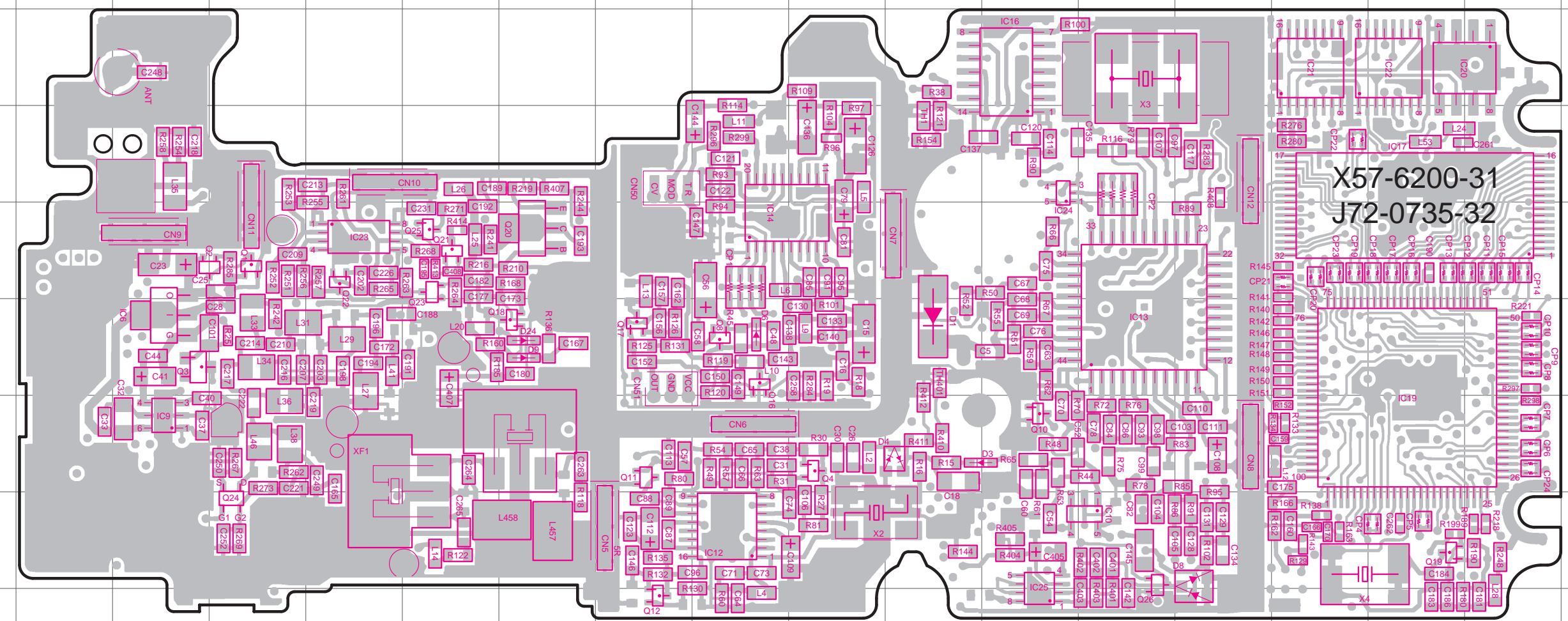

Component side

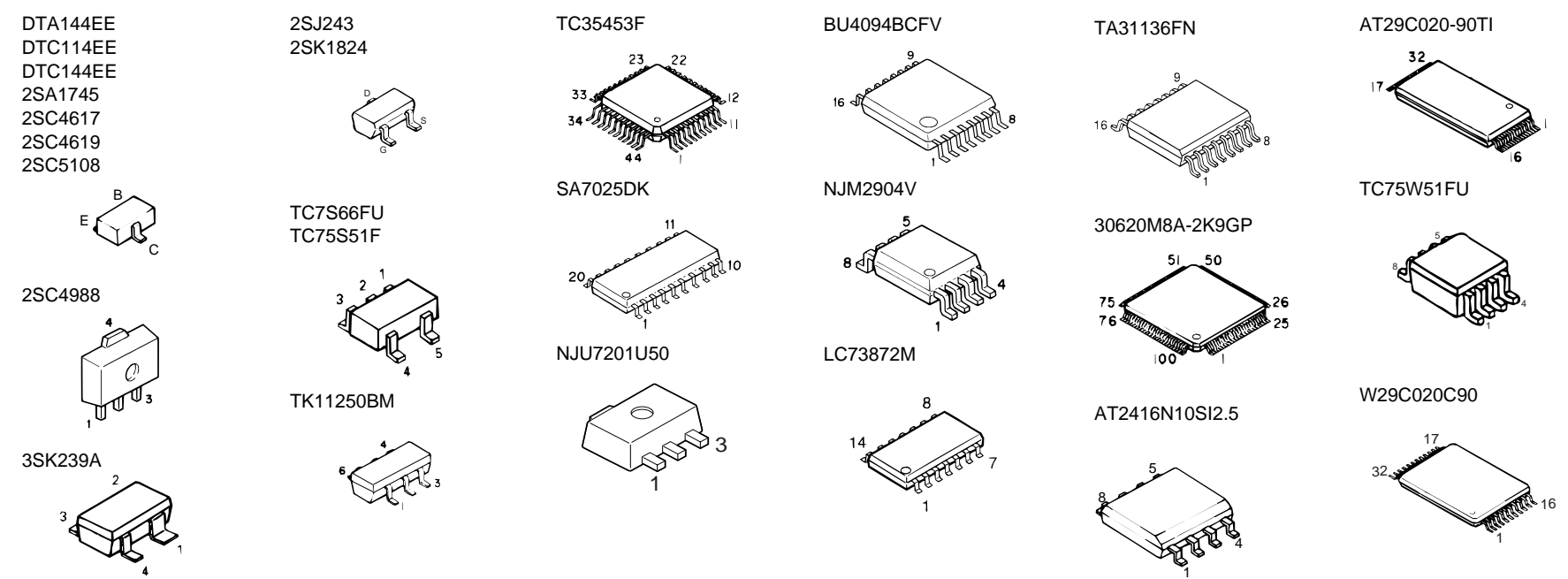
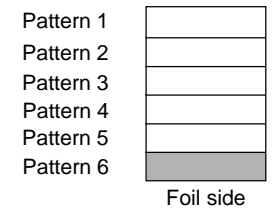

TK-385 PC BOARD VIEW

TX-RX UNIT (X57-6200-31) Component Side + Foil Side View

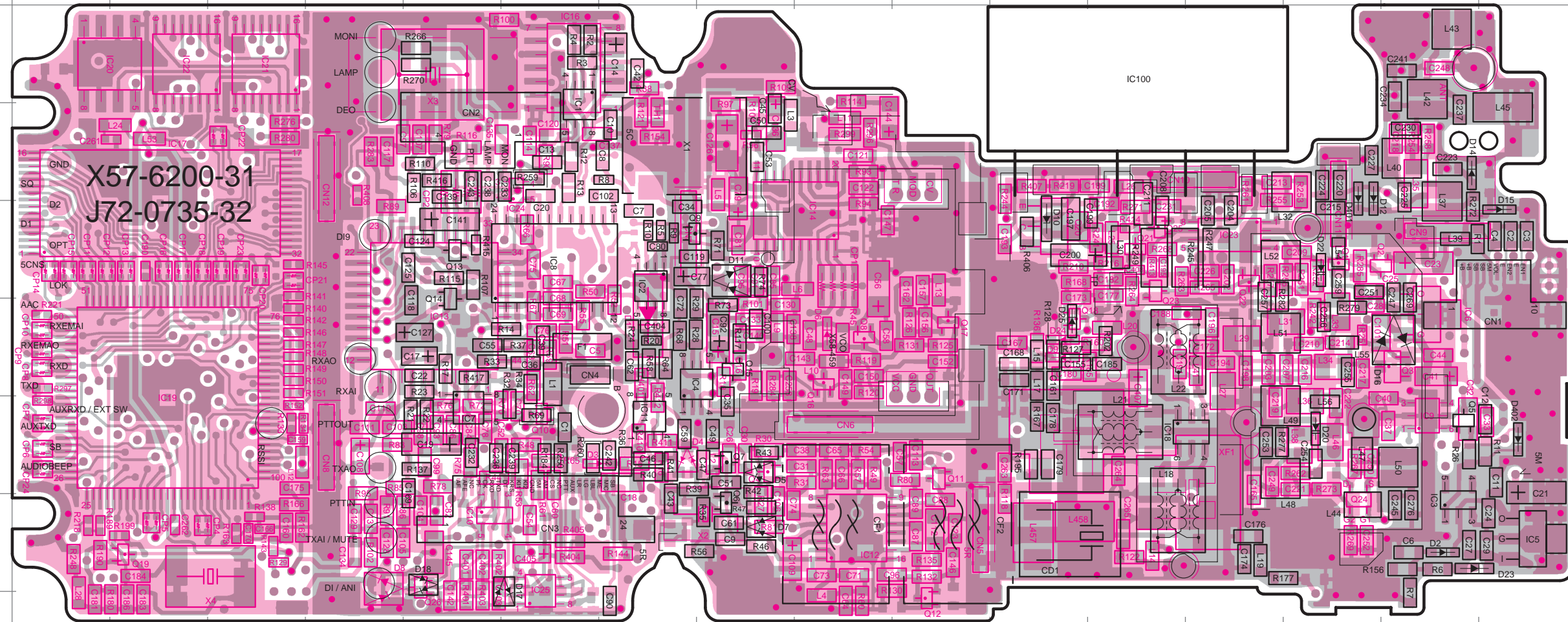

TX-RX UNIT (X57-6200-31)

Ref. No.	Address
D1	6H
D2	8P
D3	7H
D4	7H
D5	7I
D6	6J
D7	8I
D8	8E
D9	6L
D10	5L
D11	5I
D12	4O
D14	4P
D15	5Q
D16	6P
D17	8F
D18	8F
D20	7O
D22	5O
D23	8P
D24	6L
D25	6L
D401	4O
D402	7Q
IC1	4G
IC2	5H
IC3	8P
IC4	6I
IC5	8Q
IC6	6P
IC7	7F
IC8	5G
IC9	7P
IC10	8F
IC11	7H
IC12	8J
IC13	6F
IC14	5J
IC16	3G
IC17	4C
IC18	7N
IC19	7C
IC20	3C
IC21	3D
IC22	3C
IC23	5N
IC24	4G
IC25	8G
Q1	5O
Q2	5P
Q3	6P
Q4	7I
Q5	7P
Q6	8I
Q7	7I
Q8	6J
Q9	5I
Q10	7G
Q11	7K
Q12	9K
Q13	5F
Q14	5F
Q15	6I
Q16	6J
Q18	6L
Q19	8C
Q20	5L
Q21	5M
Q22	5N
Q23	5M
Q24	8O
Q25	5M
Q26	8F

DTA144EE
DTC114EE
DTC144EE
2SA1745
2SC4617
2SC4619
2SC5108

2SJ243
2SK1824

TK11250BM

SA7025DK

NJM2904V

RN5VL42C

DA221
HSM88AS

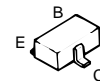
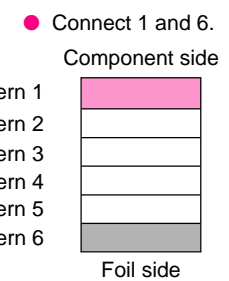

TC7S66FU
TC7S51F

AT29C020-90T1

NJU7201U50

M62364FP

LC73872M

MA742

2SC4988

S-81350HG-KD

TC35453F

BU4094BCFV

TC75W51FU

GN2011

W29C020C90

3SK239A

SCHEMATIC DIAGRAM TK-385

X57-6200-31 TX-RX UNIT

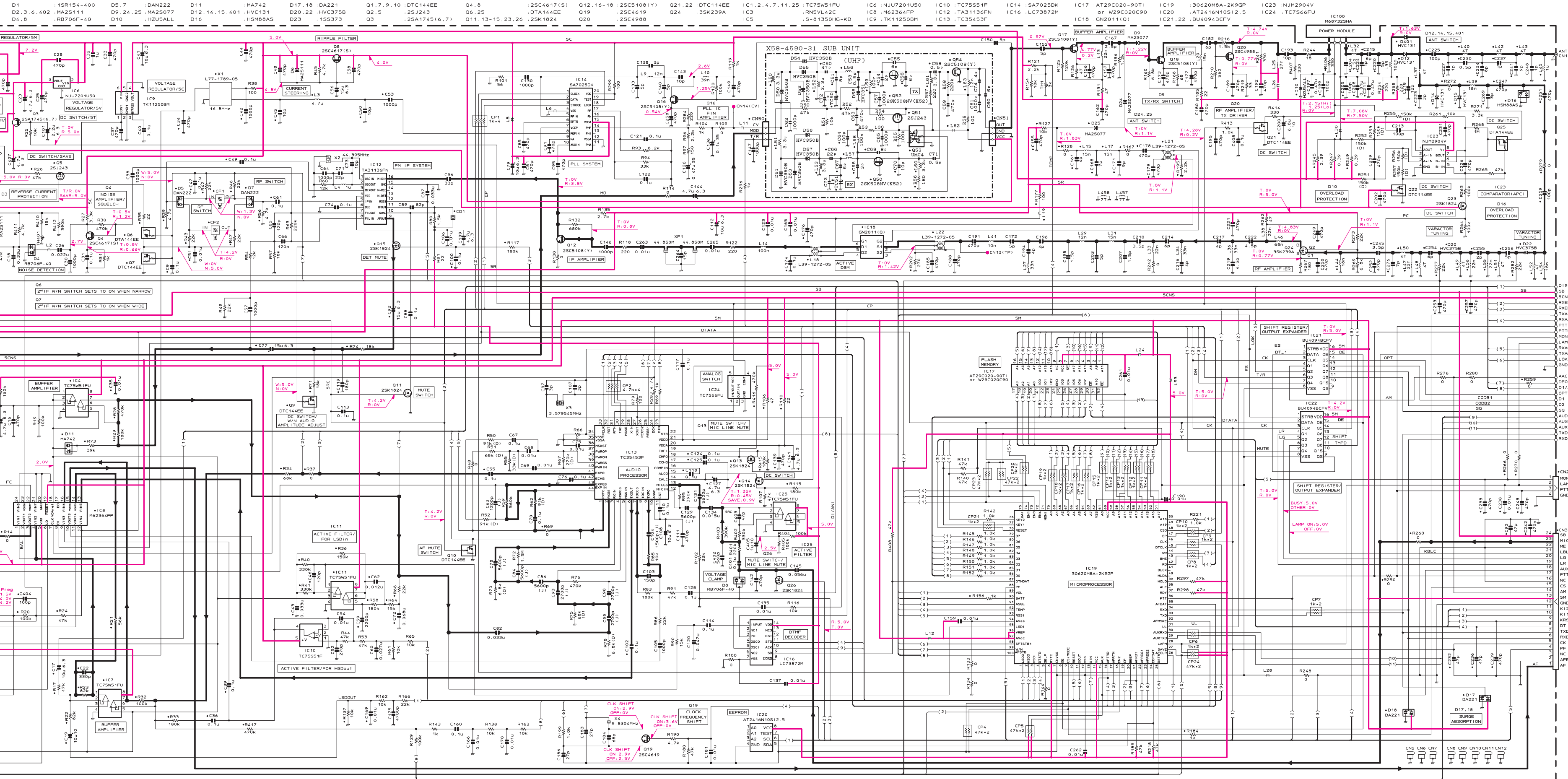

X54-3210-12 B/2 SWITCH SECTION

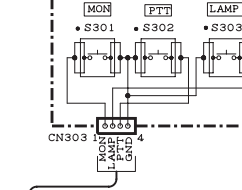

LCD ASSY

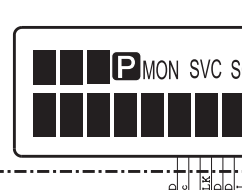

X54-3210-12 A/2 DISPLAY UNIT

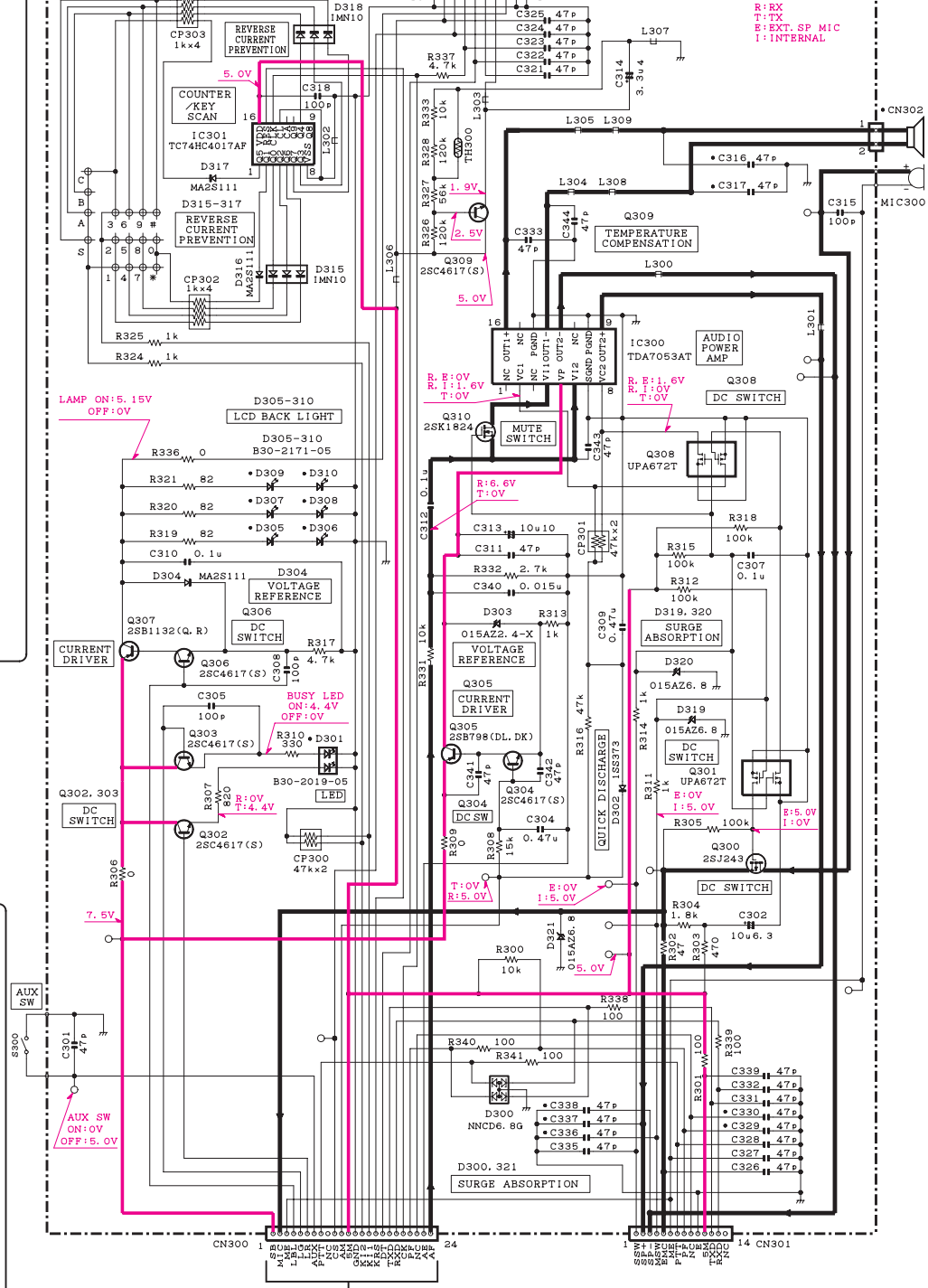

Note) ● Ref. No. : Parts of pattern 1.

TK-385 TK-385

BLOCK DIAGRAM

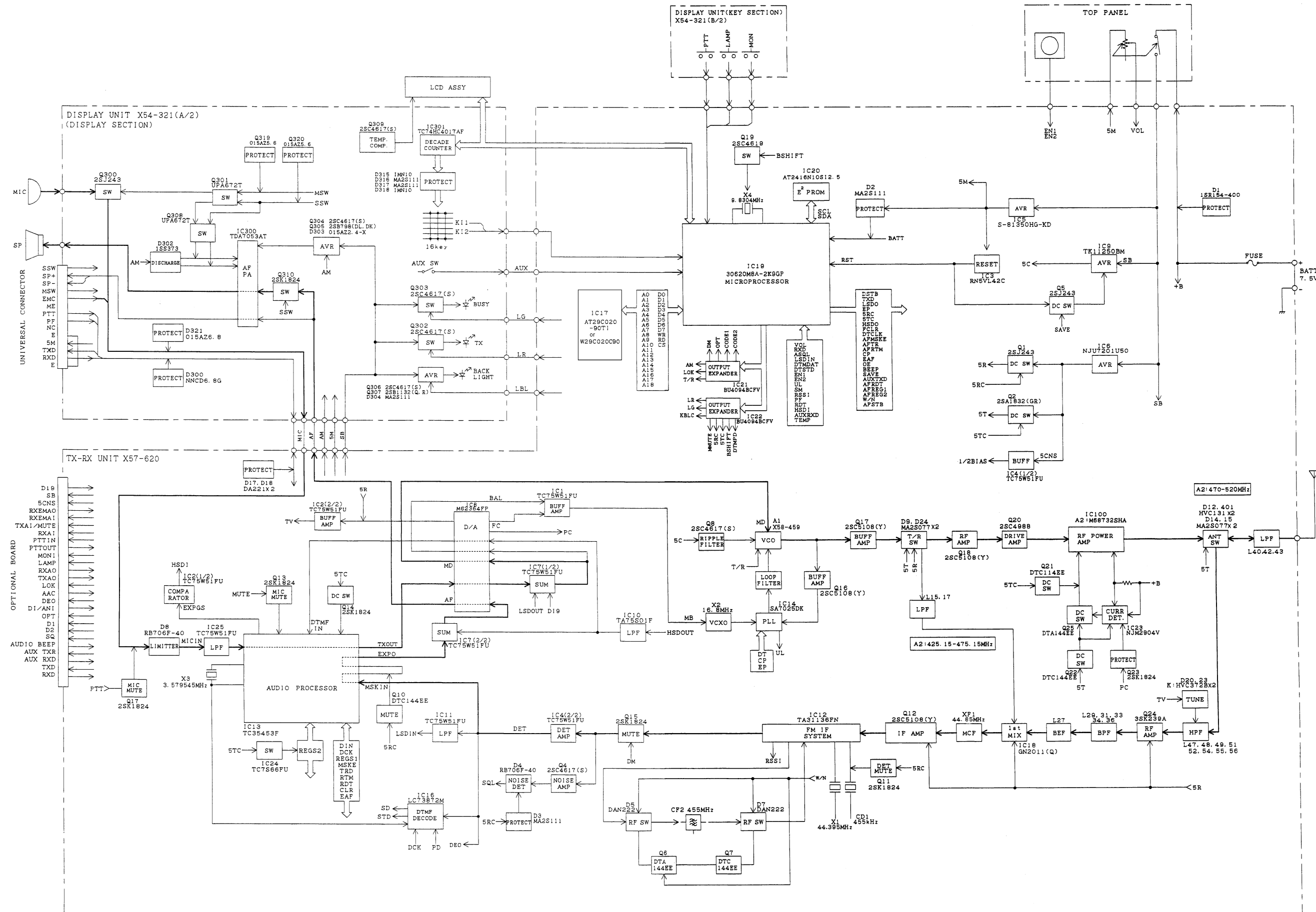

LEVEL DIAGRAM

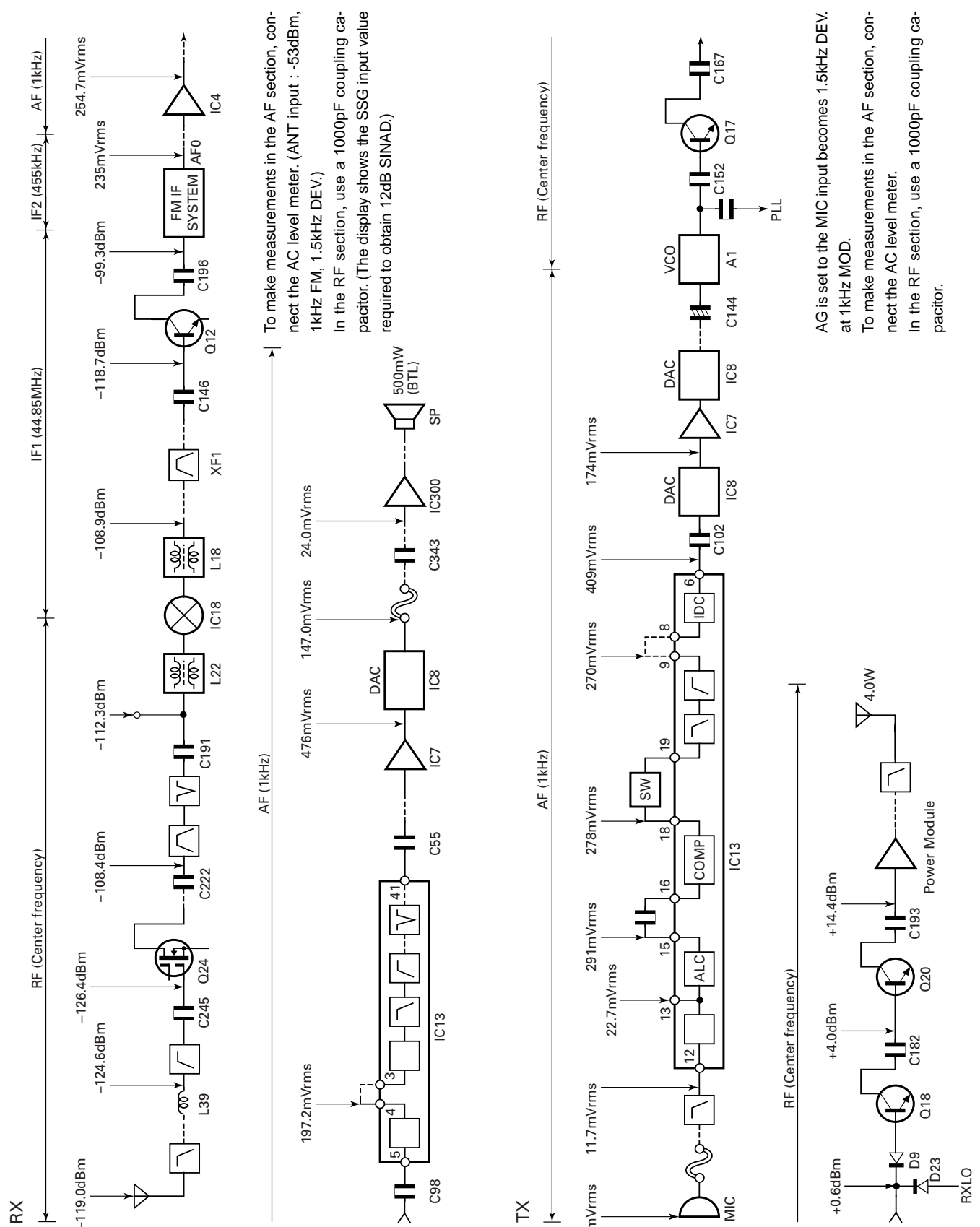

TK-385 TK-385

KNB-16A/17A (Ni-Cd BATTERY) / KPG-36 (PROGRAMMING INTERFACE CABLE) / KSC-19 (CHARGER)

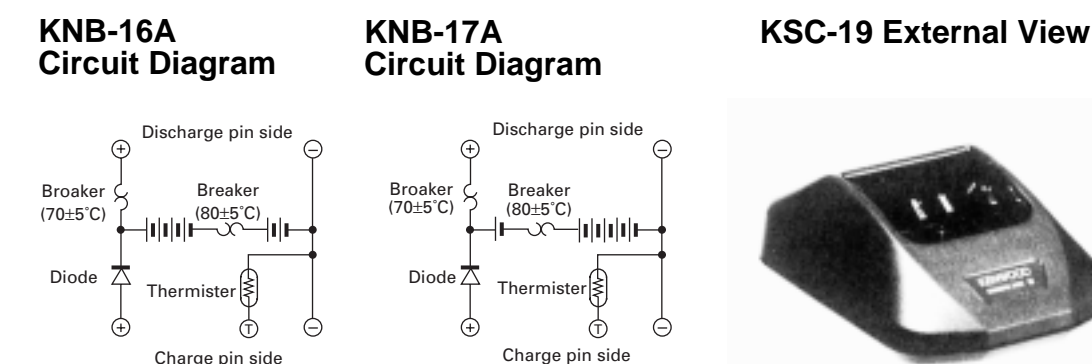

KNB-16A Specifications

Voltage	7.2V (1.2V x 6)
Charging current	1100mAh
Dimensions (mm)	58.0 W x 110.8 H x 17.2 D
(Projections included)	
Charger and charging time	
KSC-19 (Normal Charger)	Approx. 8 hours
KSC-20 (Rapid Charger)	Approx. 1 hour
Weight	180g

KNB-17A Specifications

Voltage	7.2V (1.2V x 6)
Charging current	1500mAh
Dimensions (mm)	58.0 W x 110.8 H x 20.0 D
(Projections included)	
Charger and charging time	
KSC-19 (Normal Charger)	Approx. 8 hours
KSC-20 (Rapid Charger)	Approx. 1.3 hour
Weight	220g

KSC-19 Charging

KNB-16A	
Voltage	7.2V
Battery capacity	1100mAh
Charging time	Approx. 8 hours
KNB-17A	
Voltage	7.2V
Battery capacity	1500mAh
Charging time	Approx. 8 hours

SPECIFICATIONS

General

Frequency Range	
RX, TX	470 to 520MHz
Channel Spacing	12.5kHz (PLL channel stepping 6.25kHz)
Battery Voltage	DC 7.5V \pm 20%
Battery Life	More than 8 hours at 5-5-90 duty cycle with KNB-16A battery More than 10 hours at 5-5-90 duty cycle with KNB-17A battery
Temperature Range	-30°C to +60°C (-22°F to + 140°F)
Dimension and Weight	
With KNB-16A (1100mAh battery)	5.33" (135mm) H x 2.29" (58mm) W x 1.34" (34mm) D 1.01lbs (460g)
	(Dimensions not including protrusions, weight includes antenna and belt hook)

Receiver (Measurements made per TIA/EIA-603)

RF Input Impedance	50 Ω
Sensitivity	
12dB SINAD	0.28 μ V
Selectivity	62dB
Intermodulation	62dB
Spurious (Except for IF 1/2)	70dB
Frequency Stability	\pm 0.00025% (-30°C to +60°C)
Channel Spread	50MHz
Audio Power Output	500mW at 16 Ω less than 5% distortion

Transmitter (Measurements made per TIA/EIA-603)

RF Power Output	
Hi	4W
Low	1W
RF Output Impedance	50 Ω
Spurious	-70dB
Modulation	11K0F3E, 10K5F2D
FM Noise	-40dB
Audio Distortion	Less than 3%
Frequency Stability	\pm 0.00025% (-30°C to +60°C)
Channel Spread	50MHz

KENWOOD CORPORATION

14-6, Dogenzaka 1-chome, Shibuya-ku, Tokyo 150-8501, Japan

KENWOOD SERVICE CORPORATION

P.O. BOX 22745, 2201 East Dominguez Street, Long Beach, CA 90801-5745, U.S.A.

KENWOOD ELECTRONICS CANADA INC.

6070 Kestrel Road, Mississauga, Ontario, Canada L5T 1S8

KENWOOD ELECTRONICS DEUTSCHLAND GMBH

Rembrücker Str. 15, 63150 Heusenstamm, Germany

KENWOOD ELECTRONICS BELGIUM N.V.

Mechelsesteenweg 418 B-1930 Zaventem, Belgium

KENWOOD ELECTRONICS FRANCE S.A.

13, Boulevard Ney, 75018 Paris, France

KENWOOD ELECTRONICS U.K. LIMITED

KENWOOD House, Dwight Road, Watford, Herts., WD1 8EB United Kingdom

KENWOOD ELECTRONICS EUROPE B.V.

Amsterdamseweg 37, 1422 AC Uithoorn, The Netherlands

KENWOOD ELECTRONICS ITALIA S.p.A.

Via G. Sirtori, 7/9 20129 Milano, Italy

KENWOOD IBERICA S.A.

Bolivia, 239-08020 Barcelona, Spain

KENWOOD ELECTRONICS AUSTRALIA PTY. LTD.

(A.C.N. 001 499 074)

16 Giffnock Avenue, Centrecourt Estate, North Ryde, N.S.W. 2113, Australia

KENWOOD ELECTRONICS (HONG KONG) LTD.

Unit 3712-3724, Level 37, Tower one Metroplaza, 223 Hing Fong Road, Kwai Fong, N.T., Hong Kong

KENWOOD ELECTRONICS TECHNOLOGIES(S) PTE LTD.

Sales Marketing Division

1 Ang Mo Kio Street 63, Singapore 569110

