

# TK-5320

## SERVICE MANUAL

### TK-5320 K3,K4

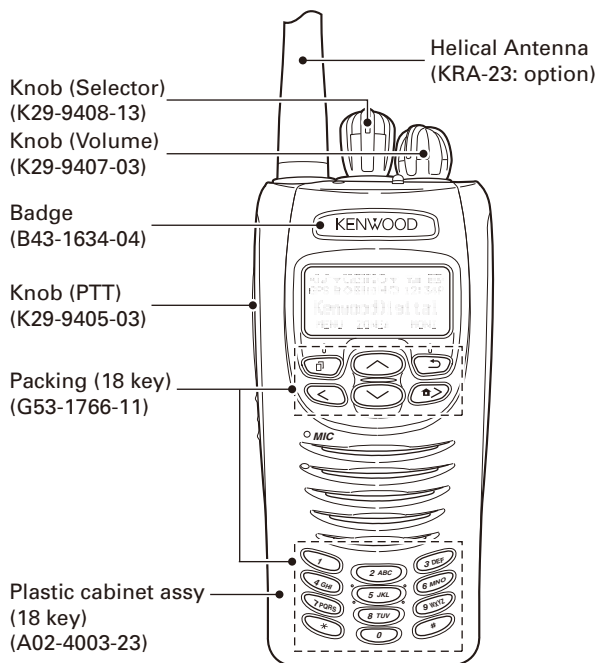

### TK-5320 K,K2

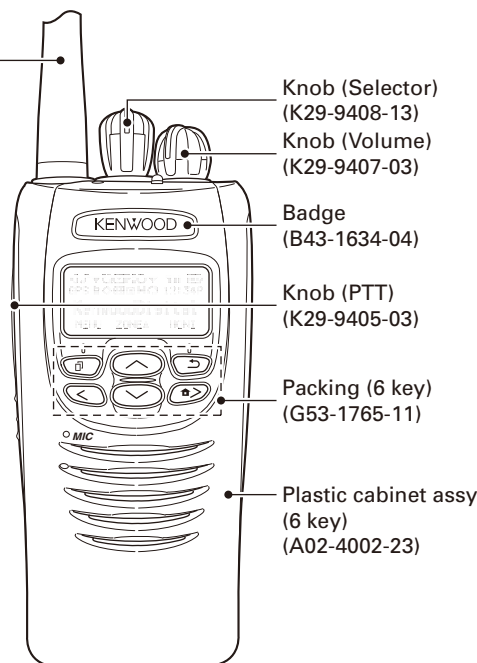

Does not come with antenna. Antenna is available as an option.

## CONTENTS

GENERAL.....	2	TERMINAL FUNCTION .....	56
SYSTEM SET-UP .....	3	PC BOARD	
REALIGNMENT .....	3	CONTROL UNIT (X53-4480-XX).....	64
INSTALLATION.....	5	TX-RX UNIT (X57-7830-XX) .....	68
DISASSEMBLY FOR REPAIR .....	6	INTERCONNECTION DIAGRAM .....	72
CIRCUIT DESCRIPTION .....	10	SCHEMATIC DIAGRAM .....	74
COMPONENTS DESCRIPTION.....	16	BLOCK DIAGRAM .....	88
PARTS LIST .....	18	LEVEL DIAGRAM .....	92
EXPLODED VIEW .....	30	OPTIONAL ACCESSORIES	
PACKING.....	31	KNB-47L (Li-ion Battery Pack) .....	93
TROUBLE SHOOTING .....	32	KNB-48L (Li-ion Battery Pack) .....	93
ADJUSTMENT .....	35	SPECIFICATIONS .....	BACK COVER

## Document Copyrights

Copyright 2009 by Kenwood Corporation. All rights reserved.

No part of this manual may be reproduced, translated, distributed, or transmitted in any form or by any means, electronic, mechanical, photocopying, recording, or otherwise, for any purpose without the prior written permission of Kenwood.

## Disclaimer

While every precaution has been taken in the preparation of this manual, Kenwood assumes no responsibility for errors or omissions. Neither is any liability assumed for damages resulting from the use of the information contained herein. Kenwood reserves the right to make changes to any products herein at any time for improvement purposes.

## Firmware Copyrights

The title to and ownership of copyrights for firmware embedded in Kenwood product memories are reserved for Kenwood Corporation. Any modifying, reverse engineering, copy, reproducing or disclosing on an Internet website of the firmware is strictly prohibited without prior written consent of Kenwood Corporation. Furthermore, any reselling, assigning or transferring of the firmware is also strictly prohibited without embedding the firmware in Kenwood product memories.

Transceivers containing AMBE+2™ Vocoder:

The AMBE+2™ voice coding technology is embedded in the firmware under the license of Digital Voice Systems, Inc.

Transceivers containing IMBE™ Vocoder:

The IMBE™ voice coding technology is embedded in the firmware under the license of Digital Voice Systems, Inc.

# GENERAL

## INTRODUCTION

### SCOPE OF THIS MANUAL

This manual is intended for use by experienced technicians familiar with similar types of commercial grade communications equipment. It contains all required service information for the equipment and is current as of the publication date. Changes which may occur after publication are covered by either Service Bulletins or Manual Revisions. These are issued as required.

### ORDERING REPLACEMENT PARTS

When ordering replacement parts or equipment information, the full part identification number should be included. This applies to all parts : components, kits, or chassis. If the part number is not known, include the chassis or kit number of which it is a part, and a sufficient description of the required component for proper identification.

## PERSONAL SAFETY

The following precautions are recommended for personal safety:

- DO NOT transmit until all RF connectors are verified secure and any open connectors are properly terminated.
- SHUT OFF and DO NOT operate this equipment near electrical blasting caps or in an explosive atmosphere.
- This equipment should be serviced by a qualified technician only.

## SERVICE

This transceiver is designed for easy servicing. Refer to the schematic diagrams, printed circuit board views, and alignment procedures contained within.

## SYSTEM SET-UP

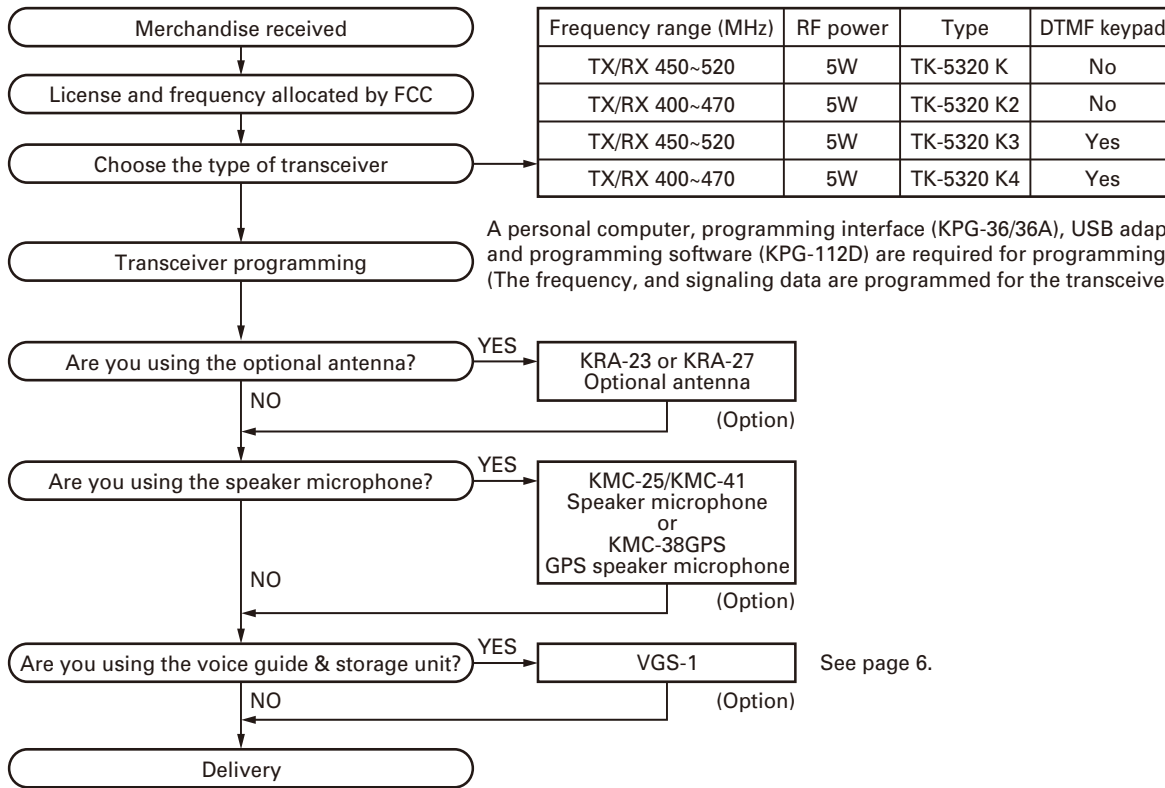

## REALIGNMENT

### 1. Modes

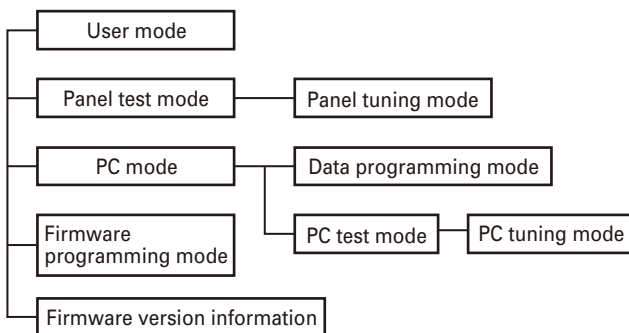

Mode	Function
User mode	For normal use.
Panel test mode	Used by the dealer to check the fundamental characteristics.
Panel tuning mode	Used by the dealer to tune the transceiver.
PC mode	Used for communication between the transceiver and PC.
Data programming mode	Used to read and write frequency data and other features to and from the transceiver.
PC test mode	Used to check the transceiver using the PC. This feature is included in the FPU. See pages 44 to 55.
Firmware programming mode	Used when changing the main program of the flash memory.
Firmware version information	Used to confirm the internal firmware version.

## REALIGNMENT

### 2. How to Enter Each Mode

Mode	Operation
User mode	Power ON
Panel test mode	[>] + Power ON
PC mode	Received commands from PC
Panel tuning mode	Press the [a] key, in Panel test mode
Firmware programming mode	[a] + Power ON
Firmware version information	[Side1] + Power ON

### 3. Panel Test Mode

Setting method refer to ADJUSTMENT.

### 4. Panel Tuning Mode

Setting method refer to ADJUSTMENT.

### 5. PC Mode

#### 5-1. Preface

The transceiver is programmed by using a personal computer, programming interface (KPG-36/36A), USB adapter (KCT-53U) and programming software (KPG-112D).

The programming software can be used with a PC or compatible. Figure 1 shows the setup of a PC for programming.

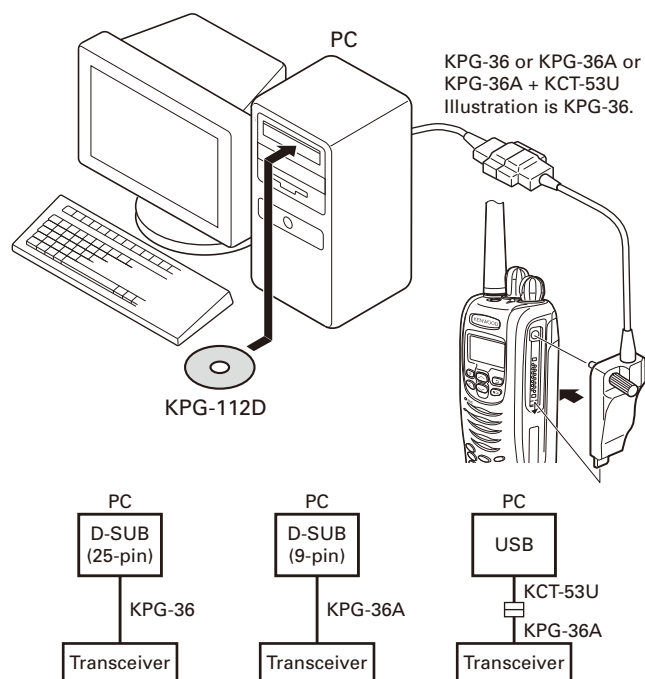

Fig. 1

#### 5-2. Connection procedure

1. Connect the transceiver to the computer using the interface cable and USB adapter (When the interface cable is KPG-36A, the KCT-53U can be used.).

#### Notes:

- You must install the KCT-53U driver in the computer to use the USB adapter (KCT-53U).
- When using the USB adapter (KCT-53U) for the first time, plug the KCT-53U into a USB port on the computer with the computer power ON.

2. When the POWER switch on, user mode can be entered immediately. When PC sends command the transceiver enter PC mode, and "PROGRAM" is displayed on the LCD.

When data transmitting from transceiver, the red LED is lights.

When data receiving to transceiver, the green LED is lights.

#### Note:

The data stored in the computer must match the "Model Name" when it is written into the flash memory.

#### 5-3. KPG-36/KPG-36A description

##### (PC programming interface cable: Option)

The KPG-36/36A is required to interface the transceiver to the computer. It has a circuit in its D-sub connector (KPG-36: 25-pin, KPG-36A: 9-pin) case that converts the RS-232C logic level to the TTL level.

The KPG-36/36A connects the universal connector of the transceiver to the RS-232C serial port of the computer.

#### 5-4. KCT-53U description (USB adapter: Option)

The KCT-53U is a cable which connects the KPG-36A to a USB port on a computer.

When using the KCT-53U, install the supplied CD-ROM (with driver software) in the computer. The KCT-53U driver runs under Windows 2000, XP or Vista (32-bit).

#### 5-5. Programming software KPG-112D description

The KPG-112D is the programming software for the transceiver supplied on a CD-ROM. This software runs under MS-Windows 2000, XP or Vista (32-bit) on a PC.

The data can be input to or read from the transceiver and edited on the screen. The programmed or edited data can be printed out. It is also possible to tune the transceiver.

### 6. Firmware Programming Mode

#### 6-1. Preface

Flash memory is mounted on the transceiver. This allows the transceiver to be upgraded when new features are released in the future. (For details on how to obtain the firmware, contact Customer Service.)

## REALIGNMENT

### 6-2. Connection procedure

Connect the transceiver to the personal computer using the interface cable (KPG-36/36A) and USB adapter (KCT-53U: when the interface cable is KPG-36A, the KCT-53U can be used.). (Connection is the same as in the PC Mode.)

### 6-3. Programming

1. Start up the firmware programming software (Fpro.exe (ver. 4.0 or later)). The Fpro.exe exists in the KPG-112D installed holder.
2. Set the communications speed (normally, 115200 bps) and communications port in the configuration item.
3. Set the firmware to be updated by File name item.
4. Press and hold the [Ⓜ] key while turning the transceiver power ON. Then, the orange LED on the transceiver lights and "PROGRAM 115200" is displayed.
5. Check the connection between the transceiver and the personal computer, and make sure that the transceiver is in the Program mode.
6. Press "write" button in the window. When the transceiver starts to receive data, the [LOADING] display lights.
7. If writing ends successfully, the checksum is calculated and a result is displayed.
8. If you want to continue programming other transceivers, repeat steps 4 to 7.

#### Note:

This mode cannot be entered if the Firmware Programming mode is set to Disable in the Programming software.

### 6-4. Function

1. If you press the [Side2] key while "PROGRAM 115200" is displayed, the display changes to "PROGRAM 19200" (The LED blinks green) to indicate that the write speed is low speed (19200 bps). If you press the [Side2] key again while "PROGRAM 19200" is displayed, the display changes to "PROGRAM 38400" (The LED lights red and orange alternatively). If you press the [Side2] key again while "PROGRAM 38400" is displayed, the display changes to "PROGRAM 57600" (The LED blinks orange). If you press the [Side2] key again while "PROGRAM 57600" is displayed, the display returns to "PROGRAM 115200" (The LED lights orange).
2. If you press the [Side1] key while "PROGRAM 115200" is displayed, the checksum is calculated, and a result is displayed. If you press the [Side1] key again while the checksum is displayed, "PROGRAM 115200" is redisplayed.

#### Note:

Normally, write in the high-speed mode.

## 7. Firmware Version Information

Press and hold the [Side1] key while turning the transceiver power ON and then keep pressing and holding the [Side1] key, the firmware version information appears on the LCD.

## INSTALLATION

### Voice Guide & Storage Unit (VGS-1: Option)

#### ■ Installing the VGS-1 (Voice Guide & Storage Unit) in the transceiver

1. Remove the two screws from the cover.
2. Remove the cover by inserting the tip of a pair of tweezers into the screw hole of the cover and prying it open.

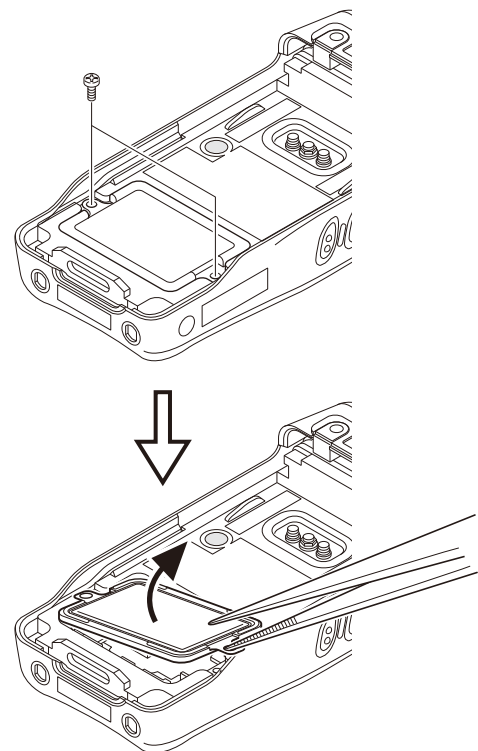

## INSTALLATION

- Remove the OPTION PCB from the connector (CN710) of the Control PCB.

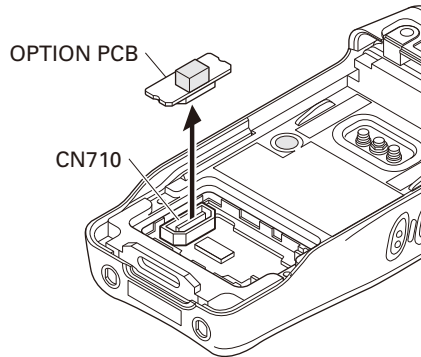

- Attach the flat spring (G02-1846-03) to the VGS-1 as shown in the figure.

**Note:**

Attach the flat spring so that its convex fits the PCB hollow of the VGS-1.

- Attach the cushion (G13-1974-04) to the VGS-1 as shown in the figure.

**Note:**

Be sure not to cover the VGS-1 connector with the cushion.

- Insert the VGS-1 connector into the connector (CN710) of the Control PCB.

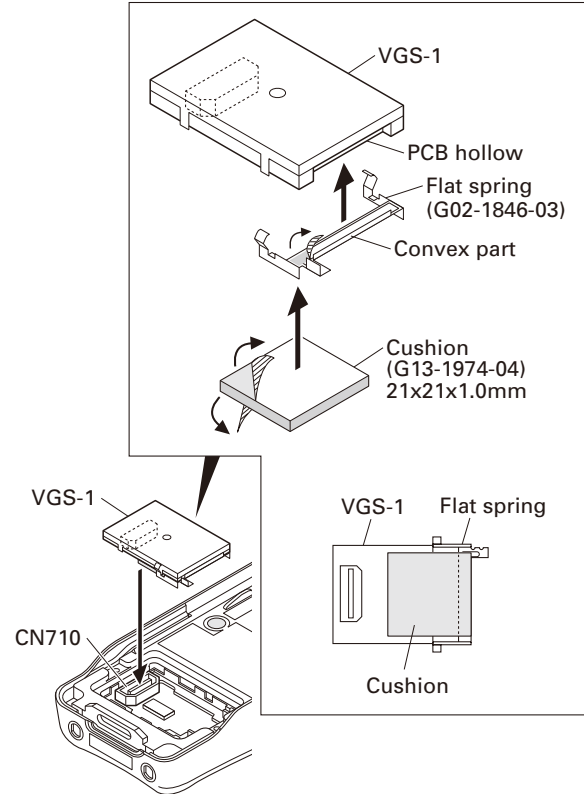

- Reinstall the cover using the two screws removed in step 1.

## DISASSEMBLY FOR REPAIR

### 1. Precautions for Waterproof

- Do not remove the black sheet from the reverse side of the transceiver (refer to the illustration right). Removal of this sheet decreases the waterproof efficiency of the transceiver and may cause malfunctions if water seeps into the transceiver.
- The orange packing material on the reverse side of the transceiver is important with respect to the waterproof efficiency of the transceiver. Do not place stickers or other materials on or around the packing material shown in the figure, or on the reverse side of the battery pack. Doing so will impair the waterproof efficiency of the transceiver and may cause it to break down. Additionally, in order to prevent damage to the packing material, do not allow it to come in contact with foreign materials.

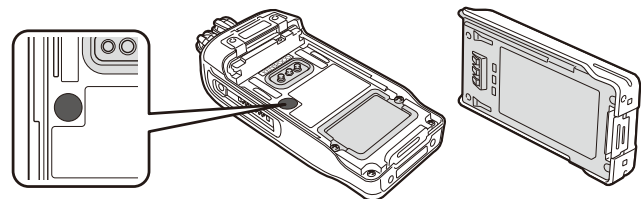

## DISASSEMBLY FOR REPAIR

### 2. Precautions for Disassembly

#### ■ Removing the TX-RX unit from the chassis

1. Remove the cord ASSY from the connector of the TX-RX unit (CN900) ①.
2. Remove the PTT FPC from the connector of the TX-RX unit (CN901) ②.
3. Remove the 14 screws ③.
4. Anchor the screw hole of the TX-RX unit using the tip of a pair of tweezers as shown in the figure. Then, lift the TX-RX unit to remove it from the chassis ④.

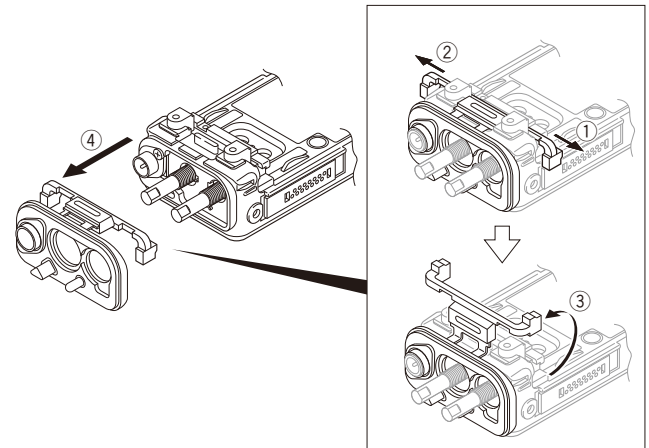
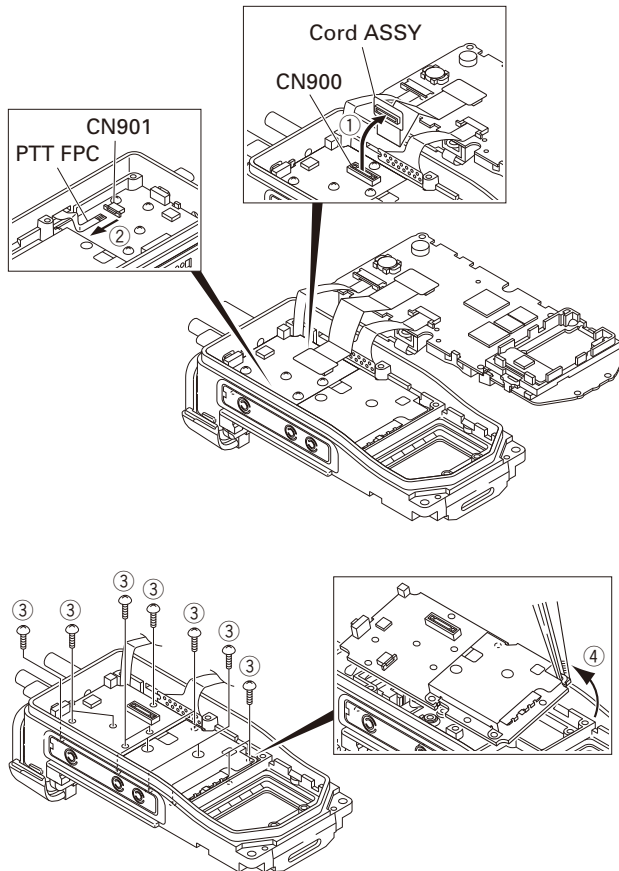

### 3. Precautions for Reassembly

#### ■ Mounting the chassis onto the case

1. Place the key top on the chassis. Then, fit the chassis tightly into the groove of the key top ①.

##### Note:

Confirm that the entire groove of the key top fits to the chassis tightly.

2. Mount the chassis onto the case ②.

##### Note:

After mounting the chassis onto the case, if the 18-key part on the key top or the Auxiliary (Orange) key part of the VOL/CH packing gets stuck inside the case as shown in the figure, return it to the normal position using a soft tipped item (e.g., finger) ③.

Prying it with a pointed metal tool such as forceps, may damage the key top or packing.

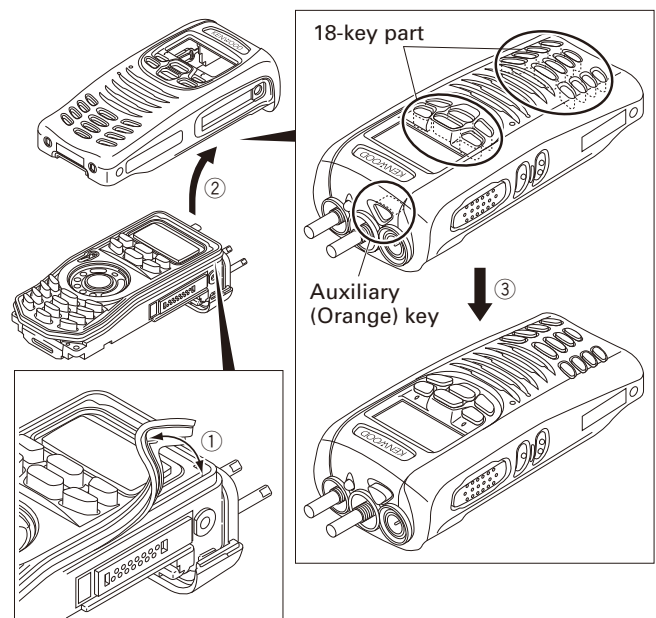

#### ■ Removing the TOP packing (G53-1762-02)

1. Pull the TOP packing to the left to remove the packing that is fit into the left groove of the chassis ①.
2. Pull the TOP packing to the right to remove the packing that is fit into the right groove of the chassis ②.
3. Turn back the TOP packing as shown in the figure ③.
4. Remove the TOP packing ④.

## DISASSEMBLY FOR REPAIR

### ■ Removing the lithium cell (W09-0971-05)

Insert a non-conductive screwdriver to groove of one side of the socket (CN401) and pry the lithium cell up from the socket.

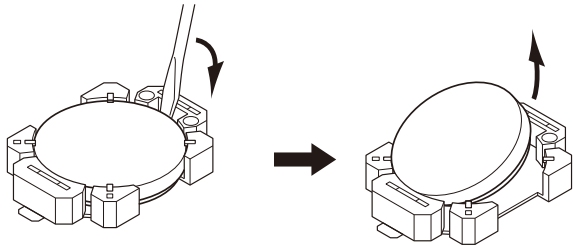

### ■ Installing the lithium cell (W09-0971-05)

Insert a lithium cell into one side of the socket (CN401). Push the lithium cell to insert the lithium cell into the socket.

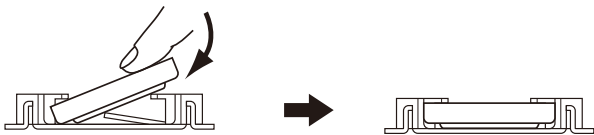

### ■ Affixing the keyboard ASSY (S79-0472-05)

Affix the keyboard ASSY to the Control unit as shown in the figure.

After affixing the keyboard ASSY to the Control unit, confirm that the three positioning holes of the keyboard ASSY and the Control unit are not misaligned.

#### Note:

If the holder (Option board) is removed from the Control unit, it becomes easy to confirm the three positioning holes.

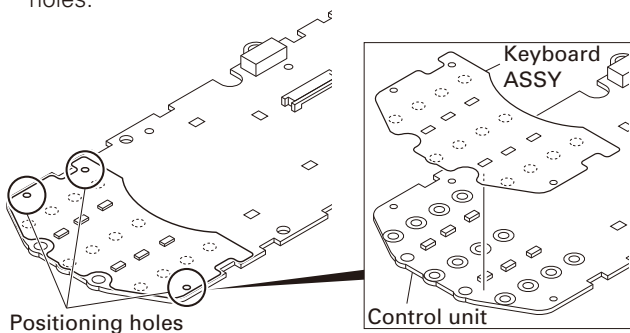

### ■ Inserting the Volume and Channel switch into the chassis

Insert the volume and channel switch into the chassis with the VOL/CH FPC formed as shown in the figure.

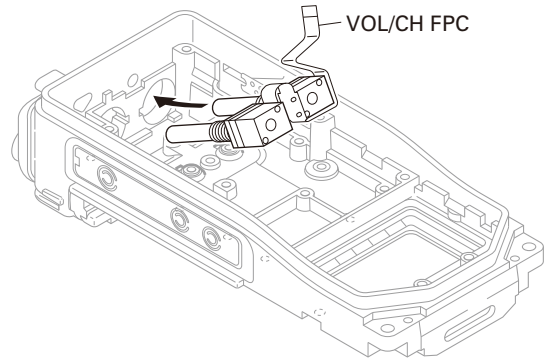

### ■ Forming the VOL/CH FPC, Cord ASSY and Universal connector FPC

Form the VOL/CH FPC, Cord ASSY and Universal connector FPC as shown in the figure.

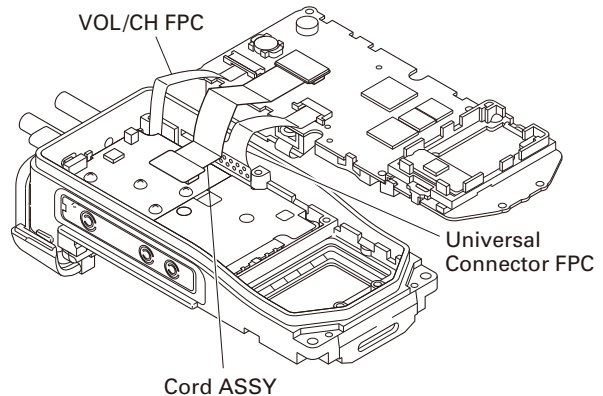

#### Note:

Fold indications are printed on the Cord ASSY and Universal Connector FPC.

"——" line shows creased line on the top.

"- - - -" line shows creased line on the bottom.

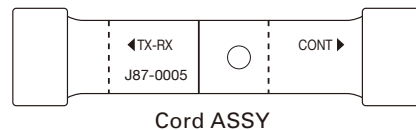

Cord ASSY

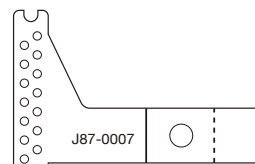

Universal Connector FPC



## DISASSEMBLY FOR REPAIR

### ■ Changing the channel selector from 16-channel operation to free

1. Remove the channel selector knob.
2. Remove the circular nut.
3. Remove the mechanical stopper.
4. Reassemble the circular nut and channel selector knob that were removed in steps 1 and 2, in their original positions.

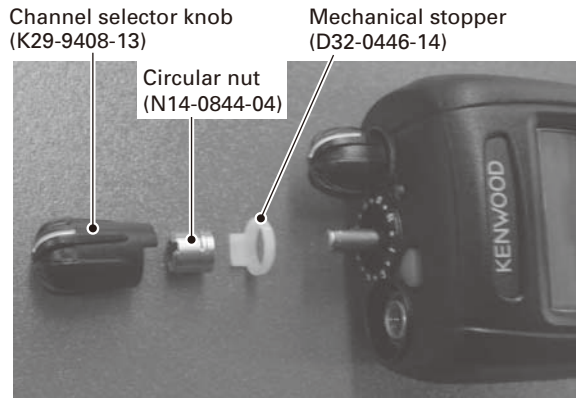

### ■ Assembly Information (Sheet/Cushion)

When "Main Parts" is changed (ordered), "Assembled Sheet / Cushion" should also be changed (ordered) together.

The Sticker and Sheet etc are non-reusable parts. It requires the new one to get the radio's performance after repairs.

For example, when "Plastic Cabinet (A02-4002-23 (6-key)/A02-4003-23 (18-key))" is changed, "Sticker (B42-7296-04)", "Badge (B43-1634-04)" and "Fibrous Sheet (G10-1373-04)" should be ordered and changed together because Sticker (B42-7296-04), Badge (B43-1606-04) and Fibrous Sheet (G10-1373-04) are non-reusable.

Main Parts		Assembled Sheet/ Cushion		
Part Name	Part Number	Part Name	Part Number	Remark
Plastic Cabinet (6-key)	A02-4002-23	Sticker	B42-7443-04	"P25" is printed.
		Badge	B43-1634-04	"KENWOOD" is printed.
Plastic Cabinet (18-key)	A02-4003-23	Fibrous Sheet (SP)	G10-1373-04	
LCD ASSY	B38-0923-05	Adhesive Sheet (LCD)	J99-0714-04	Used for fixing the LCD ASSY on the Illumination Guide (LCD). Also used for fixing the Illumination Guide (LCD) on the Control Unit.
Cord ASSY (50-pin FPC)	X42-3340-10	Cushion (50-pin FPC)	G13-2258-04	
Speaker	T07-0755-15	Rubber Cushion (SP)	G11-4272-14	
		Sheet (SP)	G11-4458-14	Used for stabilizing the waterproof performance. "•" (a hole) on the Sheet (SP) shows the upper side (6-key FPC side).
Switch Unit (6-key FPC)	X41-3720-10	Adhesive Sheet (6-key FPC)	J99-0390-04	Used for fixing the Switch Unit (6-key FPC) from the back side of the Holder (FG-SP) before soldering.
		Adhesive Sheet (6-key FPC)	J99-0712-14	Used for fixing the Switch Unit (6-key FPC) on the Holder (FG-SP).
Switch Unit (PTT FPC)	X41-3710-10	Sheet (PTT)	G11-4428-04	Used for fixing the Push Knob (PTT) on the Switch Unit (PTT FPC) and stabilizing the waterproof performance.
		Adhesive Sheet (PTT FPC)	J99-0711-04	Used for fixing the Switch Unit (PTT FPC) on the Chassis.
Chassis	A10-4111-11	Relay Hardware (VCO-Chassis)	E29-1221-14	Used for stabilizing the shield performance of the VCO.
		Sheet (Air)	G11-4331-04	This sheet is put on the leak check hole. This sheet lets air through, but does not let water through.
		Rubber Sheet (FET)	G11-4429-04	Used for stabilizing the radiation performance of the FET.
		Sheet (Air)	G11-4440-04	This sheet is a protect cover of the sheet (G11-4331-04).
		Cushion (ANT)	G13-2220-04	Used for fixing the Terminal ASSY.
Terminal Block	E72-0425-03	Adhesive Sheet (Terminal Block)	J99-0725-04	Used for fixing the Terminal Block and the Packing (Terminal Block).

## CIRCUIT DESCRIPTION

### 1. Overview

The TK-5320 is a UHF portable transceiver designed to operate in the frequency range of 450 to 520MHz (K,K3) or 400 to 470MHz (K2,K4). The unit consists of receiver, transmitter, phase-locked loop (PLL) frequency synthesizer, base band parts, power supply, and control circuits.

### 2. Frequency Configuration

The receiver is a double-conversion superheterodyne using the first intermediate frequency (IF) of 58.05MHz and the second IF of 450kHz. Incoming signals from the antenna are mixed with the local signal from the PLL circuit to produce the first IF of 58.05MHz. This is then mixed with the 57.6MHz second local oscillator output to produce the 450kHz second IF. The transmit signal frequency is generated by the PLL VCO, and modulated by the signal from the DSP. It is then amplified and fed to the antenna.

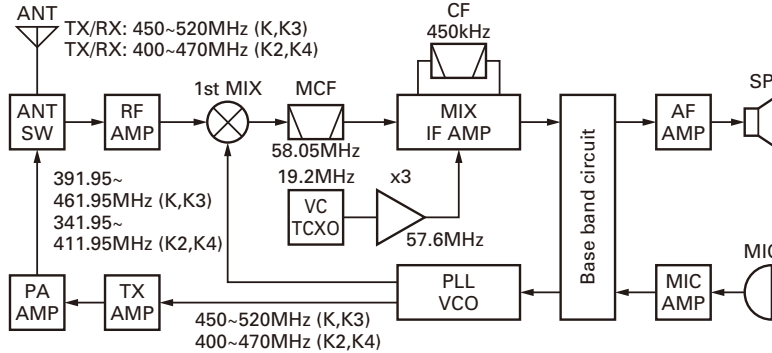

Fig. 1 Frequency configuration

### 3. Receiver System

#### 3-1. RF Circuit

An incoming RF signal from the antenna terminal is passed through the antenna switch (D606, D607, D709, D711) and then the bandpass filter (L721, L722). The bandpass filter is adjusted by a variable capacitor. The input voltage to the variable capacitor is regulated by the voltage output from the D/A converter (IC703). The signal is amplified by an RF amplifier (Q705), and passed through the bandpass filter (L713, L714, L715). The resulting signal is applied to the first mixer (Q703), where it is mixed with the first local oscillator signal output from the frequency synthesizer to produce the first IF (58.05MHz).

#### 3-2. IF Circuit

The first IF signal is passed through a four-pole monolithic crystal filter (XF700) to reject adjacent channel signals. The filtered first IF signal is amplified by the first IF amplifier (Q701) and then applied to the IF system IC (IC701). The IF system IC provides a second mixer, AGC amplifier, and RSSI (Received Signal Strength Indicator).

The second mixer mixes the first IF signal with the 57.6MHz of second local oscillator output and produces the second IF signal of 450kHz.

The second IF signal is passed through the ceramic filter (CF700) to reject the adjacent channel signal. The filtered second IF signal is amplified by the AGC amplifier.

The signal from the AGC amplifier is input to the ASIC (IC108) through the ceramic filter (CF701) and operational amplifier (IC700).

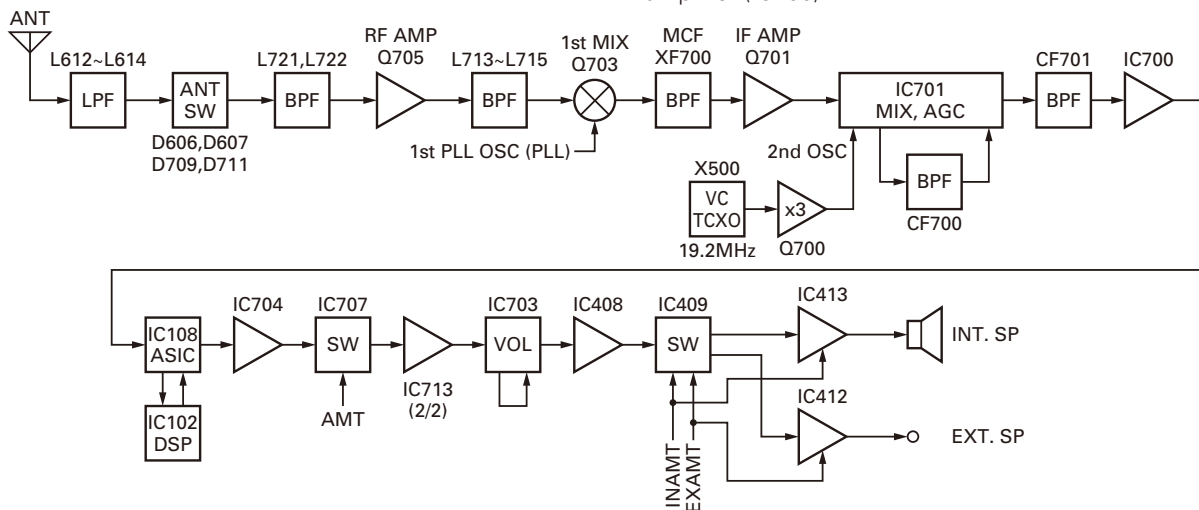

Fig. 2 RF and IF circuit

## CIRCUIT DESCRIPTION

### 3-3. Audio Amplifier Circuit

Audio processing (high-pass filter, low-pass filter, de-emphasized and so on) at FM mode and decoding at P25 mode are processed by DSP. The audio signal from IC108 and IC102 goes through the amplifier (IC704). The signal then goes through a mute switch (IC707), amplifier (IC713), electronic volume control (IC703), and AF amplifier (IC408).

While busy, AMT becomes Low to turn IC707 on, and the signal is fed to the AF switch. While INAMT is High, the AF switch (IC409) selects the internal speaker, and the audio signal is fed to the internal audio power amplifier (IC413), and output to the internal speaker. While EXAMT is High, the AF switch (IC409) selects the external speaker, and the audio signal is fed to the external audio power amplifier (IC412), and output to the external speaker. The power supply for IC413 and IC412 is turned on while INAMT or EX-AMT is High.

The speaker is switched by the logic of the speaker switching terminal SSW on the universal connector. When the SP-MIC is not attached, SSW becomes High. IC108 detects the logic of SSW and activates either INAMT or EX-AMT.

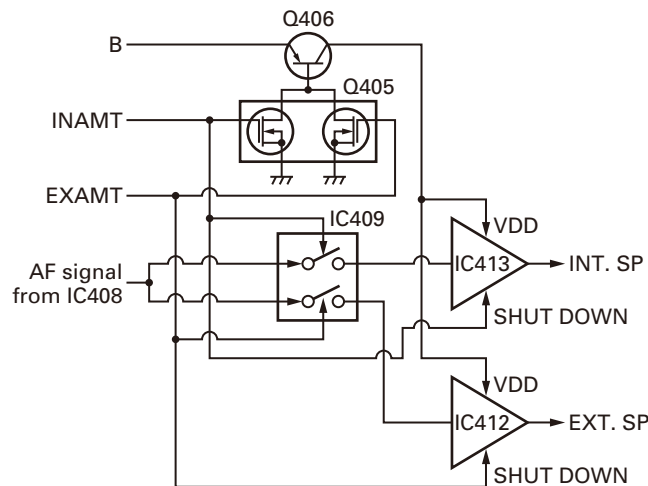

**Fig. 3 Audio amplifier circuit**

### 3-4. Squelch Circuit

It amplifies the demodulated noise signal from IC108 after filtering through the BPF circuit. Then, the amplified signal is converted to a DC signal by the detection circuit. The converted signal is fed back to IC108.

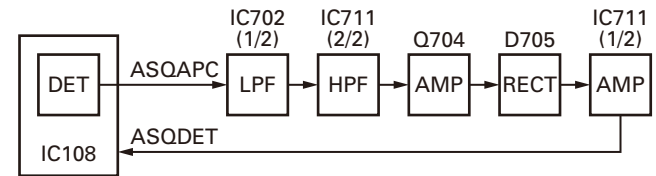

**Fig. 4 Squelch circuit**

## 4. Transmitter System

### 4-1. Audio Band Circuit

The signal from the internal microphone goes through the mute switch (Q5). When the SP-MIC is not attached, the microphone switching terminal (MSW) on the universal connector becomes High, and the mute switch (Q5) is turned on. When the SP-MIC is attached, MSW is connected to GND inside the SP-MIC. For this reason, Q5 is turned off, the internal microphone is muted, and only the input of the external microphone is supplied to the microphone amplifier. The signal from the microphone goes through the mute switch (Q707), and is amplified by IC716 (1/2) and limited by the AGC circuit which is composed of D703, D704, Q705 and Q706.

### 4-2. Base Band Circuit

The audio signal output from the base band circuit is converted to digital data with a sampling frequency of 48kHz. This digital data is sent to the DSP (IC102), and voice signals of 300Hz or lower and frequencies of 3kHz or higher are cut off and an audio range of 300Hz to 3kHz is extracted. The audio signal is then pre-emphasized in FM mode and synthesized with the signals, such as QT and DQT, as required, and is then output from IC108. In Digital mode, the audio signal is converted to the 4-Level FSK base band signal and output from IC108. The DTMF and MSK base band signals are also generated by the DSP and output by IC108.

LPF (IC705) works as a smoothing filter. The DAC (IC703) assigns the base band signal to the VCO and VCTCXO (X500). At this time, the level output according to the transmit carrier is fine-adjusted according to each modulation method.

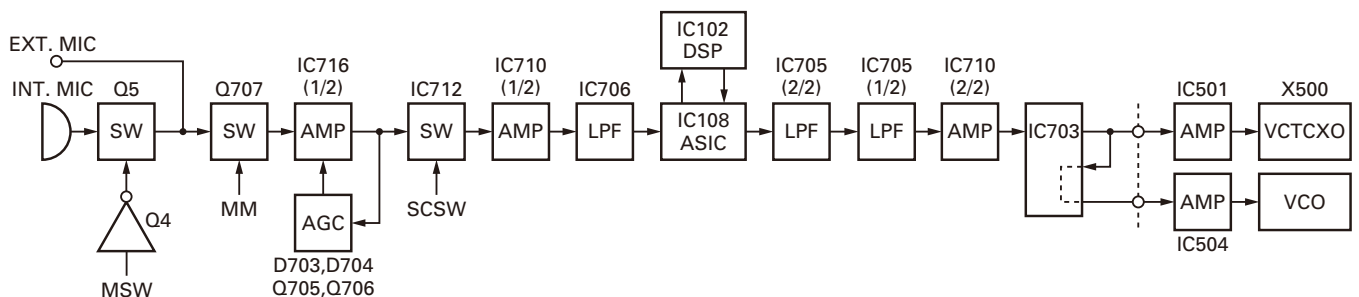

**Fig. 5 Audio band and Base band circuit**

## CIRCUIT DESCRIPTION

### 4-3. VOX

IC716 (2/2) amplifies the audio signal captured in the microphone. The signal is then converted into the DC voltage, rectified by D706. The DC voltage activates the ASIC (IC108), and the VOX starts.

### 4-4. Drive and Final Amplifier

The signal from the T/R switch (D601 is on) is amplified by the drive amplifier (Q601, Q602 and Q603) to 25~27dBm. The output of the drive amplifier is amplified by the RF power amplifier (Q606) to 5.0W (1W when the power is low). The RF power amplifier is MOS FET. The output of the RF power amplifier is then passed through the harmonic filter (LPF) and antenna switch (D606, D607 are on) and applied to the antenna terminal.

### 4-5. APC Circuit

The APC circuit always monitors the current flowing through the RF power amplifier (Q606) and keeps a constant current. The voltage drop at R642, R645 and R647 is caused by the current flowing through the RF power amplifier and this voltage is applied to the differential amplifier (IC600 1/2). IC600 (2/2) compares the output voltage of IC600 (1/2) with the reference voltage from IC108, and the output of IC600 (2/2) controls the VGG of Q602, Q603 and Q606 to make the both voltages the same. The change of power high/low is carried out by the change of the reference voltage. Q607, Q608 and Q610 are turned on and Q604 and Q605 are turned off in transmit and the APC circuit is active.

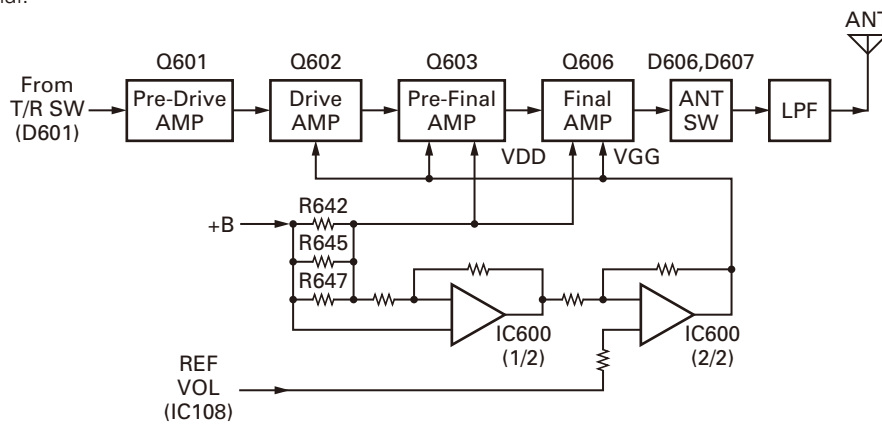

Fig. 6 Drive and final amplifier and APC circuit

## 5. PLL Frequency Synthesizer

### 5-1. VCTCXO (X500)

VCTCXO (X500) generates a reference frequency of 19.2MHz for the PLL frequency synthesizer. This reference frequency is applied to pin 9 of the PLL IC (IC502) and connected to the IF circuit as a 2nd local signal through the Tripler (Q700). The VCTCXO oscillation frequency is determined by the DC voltage of the VC terminal. The VC voltage is fixed to 1.65V by R500 and R501, and supplied to the VC terminal through IC501. The modulation signal is also fed to the VC terminal through IC501.

The frequency adjustment is achieved by switching the ratio of the dividing frequency that is not adjusted by the DC voltage impressed to the VC. The resolution of the adjusting frequency is approximately 4Hz.

### 5-2. VCO

There is a RX VCO and a TX VCO.

The TX VCO (Q509) generates a transmit carrier and the RX VCO (Q508) generates a 1st local signal. For the VCO oscillation frequency, the transmit carrier is 450 to 520MHz (K,K3) or 400 to 470MHz (K2,K4) and the 1st local signal is 391.95 to 461.95MHz (K,K3) or 341.95 to 411.95MHz (K2,K4).

The VCO oscillation frequency is determined by one system of operation switching terminal "T/R" and two systems of voltage control terminals "CV" and "ASSIST".

The operation switching terminal, "T/R", is controlled by the control line (/T\_R) output from the ASIC (IC108). When the /T\_R logic is low, the VCO outputs the transmit carrier and when it is high, it outputs a 1st local receive signal.

The voltage control terminals, "CV" and "ASSIST", are controlled by the PLL IC (IC502) and ASIC (IC108) and the output frequency changes continuously according to the applied voltage. For the modulation input terminal, "VCO\_MOD", the output frequency changes according to the applied voltage. This is used to modulate the VCO output. "VCO\_MOD" works only when "/T\_R" is low.

## CIRCUIT DESCRIPTION

### 5-3. PLL IC (IC502)

The PLL IC compares the differences in phases of the VCO oscillation frequency and the VCTCXO reference frequency, returns the difference to the VCO CV terminal and realizes the "Phase Locked Loop" for the return control. This allows the VCO oscillation frequency to accurately match (lock) the desired frequency.

When the frequency is controlled by the PLL, the frequency convergence time increases as the frequency difference increases when the set frequency is changed. To supplement this, the ASIC is used before control by the PLL IC to bring the VCO oscillation frequency close to the desired frequency. As a result, the VCO CV voltage does not change and is always stable at approximately 2.5V.

The desired frequency is set for the PLL IC by the ASIC (IC108) through the 3-line "SDO1", "SCK1", "/PCS\_RF" serial bus. Whether the PLL IC is locked or not is monitored by the ASIC through the "PLD" signal line. If the VCO is not the desired frequency (unlock), the "PLD" logic is low.

### 5-4. Local Switch (D600, D601)

The connection destination of the signal output from the buffer amplifier (Q600) is changed with the diode switch (D601) that is controlled by the transmission power supply, 50T, and the diode switch (D600) that is controlled by the receive power supply, 50R. If the 50T logic is high, it is connected to a send-side pre-drive (Q601). If the 50T logic is low, it is connected to a receive-side mixer (Q703).

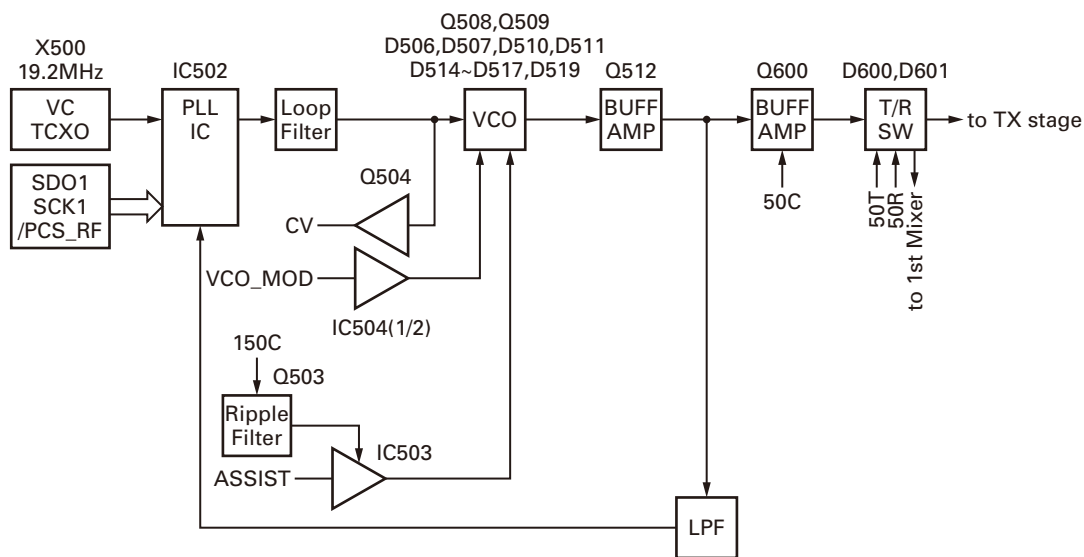

Fig. 7 PLL block diagram

## 6. Control Circuit

The control circuit consists of the ASIC (IC108) and its peripheral circuits. IC108 mainly performs the following;

- 1) Switching between transmission and reception by PTT signal input.
- 2) Reading system, zone, frequency, and program data from the memory circuit.
- 3) Sending frequency program data to the PLL.
- 4) Controlling squelch on/off by the DC voltage from the squelch circuit.
- 5) Controlling the audio mute circuit by decode data input.

### 6-1. ASIC

The ASIC (IC108) is a 32-bit RISC processor, equipped with peripheral function and ADC/DAC.

This ASIC operates at 18.432MHz clock and 3.3V /1.5V DC. It controls the flash memory, SRAM, DSP, the receive circuit, the transmitter circuit, the control circuit, and the display circuit and transfers data to or from an external device.

## CIRCUIT DESCRIPTION

### 6-2. Memory Circuit

The memory circuit consists of the ASIC (IC108) and the SRAM(IC103) and flash memory (IC101). The flash memory has capacity of 32M-bit that contains the transceiver control program for the ASIC and stores the data. It also stores the data for transceiver channels and operating parameter that are written by the FPU. This program can be easily written from external devices. The SRAM has capacity of 1M-bit that contains work area and data area.

#### ■ Flash memory

**Note:** The flash memory stores the data that is written by the FPU (KPG-112D), tuning data (Deviation, Squelch, etc.) ,and firmware program (User mode, Test mode, Tuning mode, etc.). This data must be rewritten when replacing the flash memory.

#### ■ SRAM (Static memory)

**Note:** The SRAM has temporary data area and work area. When the power supply is off, it is backed up by an internal secondary lithium battery. Therefore, the saved data is not lost.

#### ■ Real-time clock

The clock function is based on real-time clock IC (IC106). When the power supply is off, it is backed up by an internal secondary lithium battery.

### 6-3. LCD

The LCD is controlled using the bus lines on the connector (CN1) of the Control unit (X53-448). It corrects the LCD contrast voltage using IC1.

### 6-4. Key Detection Circuit

Keys are detected using the key scan circuit in IC108. The /KEY1\* signals that are normally pulled down go high when any key is pressed.

### 6-5. Low Battery Warning

The battery voltage is divided using R444 and R445 and is detected by the ASIC (IC108). When the battery voltage falls below the voltage set by the Low battery warning adjustment, the red LED blinks to notify the operator that it is time to replace the battery. If the battery voltage falls even more (approx. 5.8V), a beep sounds and transmission stops.

Low battery warning	Battery condition
The red LED blinks during transmission.	The battery voltage is low but the transceiver is still usable.
The red LED blinks and the warning tone beeps while the PTT switch is pressed.	The battery voltage is low and the transceiver is not usable to make calls.

### 6-6. DSP

The DSP circuit consists of a DSP (IC102) and processes the base band signal. The DSP operates on an external clock of 18.432MHz (the same as the IC108), the I/O section operates at 3.3V and the core section operates at 1.5V. The DSP carries out the following processes:

- C4FM processing
- Analog FM pre-emphasis/de-emphasis
- Vocoder processing between audio codec and modulation/demodulation
- CAI processing, such as error correction encoding
- QT/DQT encoding/decoding
- DTMF encoding/decoding
- MSK encoding/decoding
- 2-tone encoding/decoding
- Compressor/expander processing
- Voice scrambler processing
- Transmit/receive audio filtering processing
- Microphone amplifier AGC processing
- Audio mute processing
- Modulation level processing

## 7. Power Supply Circuit

The battery voltage (+B) is provided from the battery terminal on the TX/RX unit (X57). The battery voltage passes through the 2.5A fuse (F900), and goes to the RF final amplifier, AVR ICs (IC902, IC903), and Control unit (X53-448).

In the control unit, +B is connected to the DC/DC (IC407), AVR ICs (IC411, IC708, IC416), and voltage detector IC (IC414). The voltage detector watches the battery voltage. If the battery voltage is 5.6V or higher, the detector outputs High. While the output of IC414 is High, IC416 and Q409 provide 3.1V (31BU) to the backup-section.

When the VOL SW is turned on, SB1 becomes high (battery voltage). The DC/DC (IC407) operates if both SB1 and the output of the detector are high. IC407 outputs 3.8V and it activates IC404 (33M), IC717 (15M), and IC406 (33A). As a result, the ASIC and DSP operate.

The SBC signal becomes High after the ASIC operates, IC708 (5A), Q403 on the Control unit (SB2) and Q901 on the TX-RX unit (SB3) are turned on. IC901 and IC903 operate by turning on these AVR ICs and FET switches.

The 5UC signal becomes High when an option is installed on the universal connector. Then IC411 (50U) operates.

When the /SAVE signal becomes High, IC902 (50C) operates. The output of IC902 is connected to three FET switches (Q902, Q903, Q905). When the SBC signal becomes High, IC903 (33C) operates. The FET switches are controlled by the CPU. Q905 (50T) is turned on in transmit mode. Q902 (50R) and Q903 (50IF) are turned on in receive mode.

When the VOL SW is turned off the /PSW signal becomes Low. After detecting the /PSW signal, the ASIC changes SBC signal to Low. Then the power supplies except IC416 (31BU) stop.

## CIRCUIT DESCRIPTION

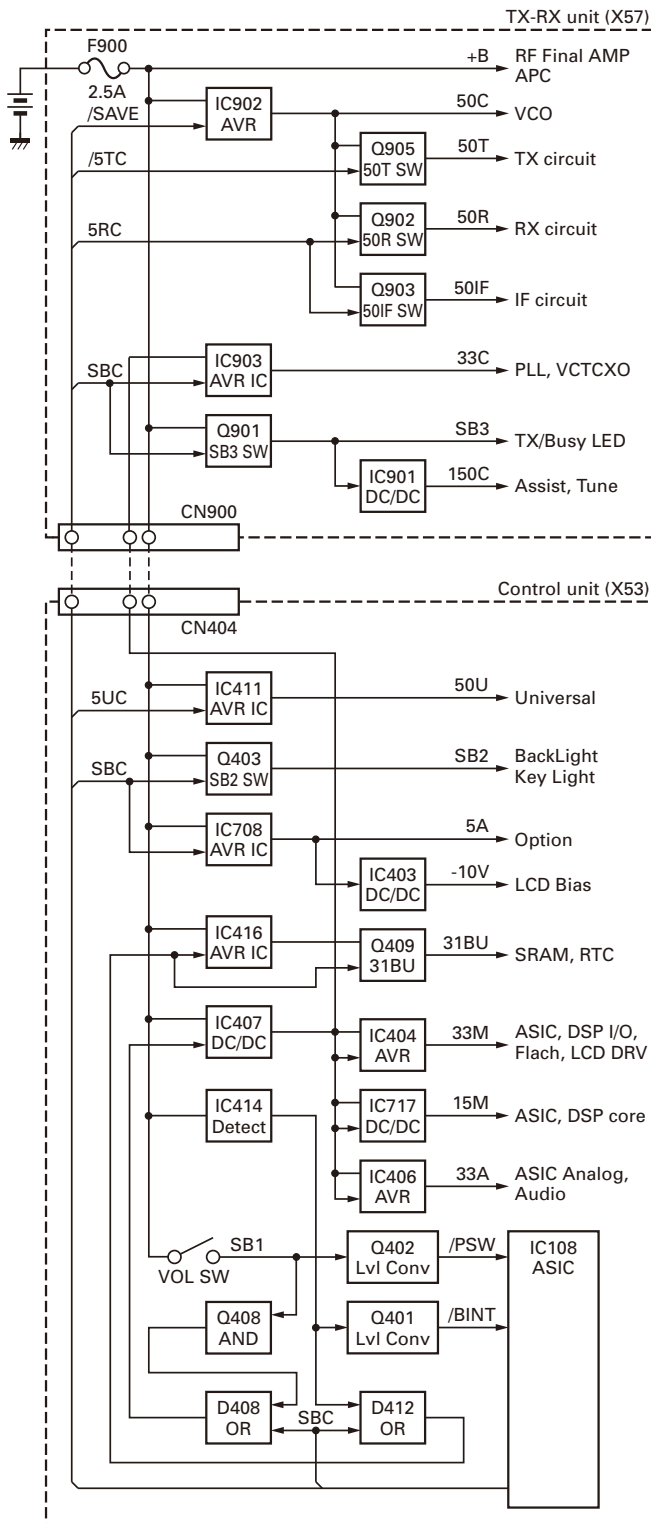

Fig. 8 Power supply circuit

## 8. Signaling Circuit

### 8-1. Encode (QT/DQT/DTMF/2-tone/MSK)

Each signaling data signal of QT, DQT, DTMF, 2-tone and MSK is generated by the DSP circuit, superposed on a modulation signal and output from IC108. The modulation balance of the QT/DQT signal is adjusted by the D/A converter (IC703) and the resulting signal is routed to the modulation input of the VCO and VCXO (X500). Each deviation of the TX QT, DQT, DTMF, 2-tone and MSK tone is adjusted by changing the output level of IC108 and the resulting signal is routed to the VCO and VCXO. The RX DTMF tone is routed to the receive audio signal system, and is output from the speaker.

### 8-2. Decode (QT/DQT/DTMF/2-tone/MSK)

The audio signal is removed from the FM detection signal sent to the DSP circuit and the resulting signal is decoded.

## 9. Compander Circuit

The term "compander" means compressor and expander. The compander reduces noise by utilizing a compressor and an expander. The transceiver contains a DSP (IC102) to perform this operation. The transceiver compander can be turned on or off using the FPU.

## COMPONENTS DESCRIPTION

## Control unit (X53-4480-XX)

Ref. No.	Part Name	Description
IC1	IC	LCD contrast
IC101	IC	FLASH ROM
IC102	IC	DSP
IC103	IC	SRAM
IC104	IC	2 input AND gate
IC105	IC	Reset
IC106	IC	RTC
IC107	IC	Buffer
IC108	IC	ASIC
IC109	IC	2 input AND gate
IC401,402	IC	Bus switch
IC403	IC	Voltage doubling inverter
IC404	IC	Voltage regulator (33M)
IC406	IC	Voltage regulator (33A)
IC407	IC	DC/DC converter
IC408	IC	AF AMP
IC409	IC	AF switch
IC411	IC	Voltage regulator (50U)
IC412,413	IC	Audio AMP
IC414	IC	Reset
IC415	IC	2 input AND gate
IC416	IC	Voltage regulator
IC417,418	IC	Dual bus buffer
IC701	IC	I/O control
IC702	IC	APC LPF
IC703	IC	D/A converter
IC704	IC	RX AF LPF
IC705	IC	Modulation LPF
IC706	IC	MIC AMP
IC707	IC	RX AF switch
IC708	IC	Voltage regulator (5A)
IC709	IC	Sidetone mute
IC710	IC	MOD/MIC summing AMP
IC711	IC	SQL BPF/SQL DC AMP
IC712	IC	MIC switch
IC713	IC	1.65V REF/RX summing AMP
IC714	IC	OPT switch
IC715,716	IC	VOX AMP
IC717	IC	DC/DC converter (15M)
Q1,2	Transistor	LCD backlight switch
Q3	FET	LCD backlight switch
Q4	FET	MIC mute control
Q5	FET	MIC mute switch
Q101,102	Transistor	12key backlight switch

Ref. No.	Part Name	Description
Q103	FET	12key backlight switch
Q401,402	FET	Level converter
Q403	Transistor	SB2 switch
Q404	FET	SB2 switch control
Q405	FET	AF AMP switch
Q406,407	Transistor	Voltage regulator (AF AMP)
Q408,409	Transistor	DC switch
Q410	FET	DC switch
Q411	FET	Level converter
Q412	FET	DC switch control
Q413~415	Transistor	DC switch
Q701	Transistor	OPT switch
Q702	FET	Tone switch
Q703	FET	W/N noise switch
Q704	Transistor	SQL noise AMP
Q705,706	Transistor	MIC AGC
Q707	FET	MIC mute
D1,2	LED	12key backlight
D3,4	LED	LCD backlight
D5,6	LED	12key backlight
D7,8	LED	LCD backlight
D9,10	LED	12key backlight
D11	Diode	LCD backlight switch
D12~16	Diode	Reverse current prevention
D17~21	Zener diode	Surge absorption
D22,23	Diode	Surge absorption
D101	Diode	12key backlight switch
D102	Diode	Reverse current prevention
D401~404	Diode	12key control
D405,406	Diode	DC/DC converter
D407	Diode	Over voltage prevention
D408	Diode	DC/DC converter control
D409,410	Diode	SP control
D411	Diode	RTC BATT control
D412	Diode	DC switch control
D413	Diode	RTC BATT control
D414,415	Diode	Reverse current prevention
D416	Diode	33M control
D417	Diode	33A control
D701	Diode	5A switch
D702	Diode	PLD control
D703,704	Diode	Detector
D705	Diode	Noise detector
D706	Diode	VOX detector
D707	Diode	VOX



## COMPONENTS DESCRIPTION

### TX-RX unit (X57-7830-XX)

Ref. No.	Part Name	Description
IC404	IC	OP AMP (RSSI/VAGC)
IC500	IC	Temperature sensor
IC501	IC	AF AMP for TCXO MOD
IC502	IC	PLL IC
IC503	IC	DC AMP for VCO tune
IC504	IC	OP AMP (VCO MOD/APC)
IC600	IC	Auto power control
IC700	IC	Buffer
IC701	IC	FM IC
IC702,703	IC	DC AMP for BPF
IC900	IC	50T control
IC901	IC	DC/DC converter
IC902	IC	Voltage regulator (50C)
IC903	IC	Voltage regulator (33C)
Q503	Transistor	Ripple filter
Q504	FET	Buffer AMP
Q507	Transistor	Ripple filter
Q508,509	FET	VCO oscillation
Q510,511	FET	T/R switch
Q512,600	Transistor	Buffer AMP
Q601	Transistor	Pre-drive AMP
Q602	FET	Drive AMP
Q603	FET	Pre-final AMP
Q604	Transistor	APC switch
Q605	FET	APC switch
Q606	FET	RF final AMP
Q607	Transistor	APC switch
Q608	FET	APC switch
Q610	Transistor	APC switch
Q700	Transistor	2nd Local tripler
Q701	Transistor	IF AMP
Q703	FET	Mixer
Q704	Transistor	Ripple filter

Ref. No.	Part Name	Description
Q705	FET	RF AMP
Q706	FET	RF AGC
Q900	Transistor	TX/RX LED switch
Q901	FET	SB3 switch
Q902	FET	50R switch
Q903	FET	50IF switch
Q904	FET	DC/DC converter switch
Q905	Transistor	50T switch
D501	Diode	Ripple filter
D505	Diode	Bypass diode
D506,507, D510,511	Variable capaci- tance diode	Frequency control
D514~517	Variable capaci- tance diode	Frequency control
D518	Diode	Ripple filter
D519	Variable capaci- tance diode	TX modulation
D600,601	Diode	Local switch
D604	Zener diode	APC switch
D605	Zener diode	APC protect
D606,607	Diode	Antenna switch
D608	Diode	APC protect
D700	Diode	Ripple filter
D702~704	Variable capaci- tance diode	Vari-cap tune
D705	Diode	RF AGC
D706,708	Variable capaci- tance diode	Vari-cap tune
D709	Diode	Antenna switch
D710	Variable capaci- tance diode	Vari-cap tune
D711	Diode	Antenna switch
D900	LED	TX/RX LED
D901	Diode	Reverse protection
D902	Diode	50T control

# TK-5320

## PARTS LIST

\* New Parts. Δ indicates safety critical components.

Parts without **Parts No.** are not supplied.

Les articles non mentionnés dans le **Parts No.** ne sont pas fournis.

Teile ohne **Parts No.** werden nicht geliefert.

L : Scandinavia

Y : PX (Far East, Hawaii)

Y : AAFES (Europe)

K : USA

T : England

X : Australia

P : Canada

E : Europe

M : Other Areas

### TK-5320

#### CONTROL UNIT (X53-4480-XX)

Ref. No.	Address	New parts	Parts No.	Description	Destination
<b>TK-5320</b>					
1	1B		A02-4002-23	PLASTIC CABINET	K,K2
2	1A		A02-4003-23	PLASTIC CABINET	K3,K4
3	3A		A10-4111-04	CHASSIS	
4	3B		A62-1156-02	PANEL (TOP)	
6	1B,1D		B09-0712-03	CAP ACCESSORY	
7	1A		B11-1853-24	FILTER (LCD)	
8	1A		B11-1854-02	ILLUMINATION GUIDE (LCD)	
9	3B		B11-1855-04	ILLUMINATION GUIDE (TX/BUSY)	
10	1A		B38-0923-05	LCD ASSY	
-			B42-7163-04	STANDARD LABEL	
11	1A	*	B42-7443-04	STICKER (P25)	
12	1B		B43-1634-04	BADGE (KENWOOD)	
13	2D	*	B62-2204-00	INSTRUCTION MANUAL	
15	2B		D32-0446-14	STOPPER (16CH)	
17	2A		E29-1220-04	RELAY HARDWARE (VCO-PCB)	
18	3A		E29-1221-14	RELAY HARDWARE (VCO-CHASS)	
19	3B		E58-0532-05	RECTANGULAR RECEPTACLE (SP/MIC)	
20	3B		E72-0425-03	TERMINAL BLOCK	
22	3A		F07-1931-04	COVER (OP BOARD)	
-			F10-3093-03	SHIELDING COVER (RF)	
23	2A		F10-3106-03	SHIELDING CASE ASSY	
-			F15-1016-04	SHIELDING PLATE (CONT)	
-			F20-3387-04	INSULATING SHEET (ANT)	
-			F20-3390-04	INSULATING SHEET (SHIELD COV)	
24	2A		G02-1836-13	EARTH SPRING (SP)	
-			G02-1837-04	EARTH SPRING (DC/DC)	
-			G02-1848-04	EARTH SPRING	
25	1A		G10-1373-04	FIBROUS SHEET (SP)	
26	2B		G10-1384-14	FIBROUS SHEET (PANEL)	
27	2A		G11-4272-14	RUBBER CUSHION (SP)	
28	3A		G11-4331-04	SHEET (AIR)	
29	3A		G11-4428-04	SHEET (PTT)	
30	3A		G11-4429-04	RUBBER SHEET (FET)	
31	3A		G11-4440-04	SHEET (AIR)	
32	2A		G11-4458-14	SHEET (SP-FRONT)	
33	2A		G11-4459-04	SHEET (TX-RX)	
34	2A		G11-4476-04	SHEET (ECM)	
-			G11-4497-04	SHEET (LCD)	
35	2A		G13-2129-14	CUSHION (TX-RX)	
36	2A,3A		G13-2220-04	CUSHION (ANT/OPB)	
37	2A		G13-2249-04	CUSHION (TX-RX)	
-			G13-2252-04	CONDUCTIVE CUSHION (VGS-1)	
38	2A		G13-2258-04	CUSHION (50PIN FPC)	
39	2A		G13-2265-04	CUSHION (TERMINAL-)	
40	3B		G53-1762-02	PACKING (TOP/BATT)	
41	3B		G53-1763-03	PACKING (TERMINAL)	
42	3A		G53-1764-03	PACKING (OP BOARD)	
43	1B		G53-1765-11	PACKING (6KEYS)	K,K2
44	1A		G53-1766-11	PACKING (12KEY)	K3,K4
45	2B		G53-1768-04	PACKING (VOL/RD-SW)	
46	1B,1D		G53-1769-04	PACKING (CAP) ACCESSORY	
47	2B		G53-1792-04	PACKING (SMA)	

Ref. No.	Address	New parts	Parts No.	Description	Destination
70	1D,2D		H12-4228-12	PACKING FIXTURE	
69	2D		H13-2130-04	CARTON BOARD	
71	3C	*	H52-2338-02	ITEM CARTON CASE	
49	2A		J19-5505-11	HOLDER (FG-SP)	
50	2B		J19-5506-03	HOLDER (VOL/ENC)	
51	2A		J19-5507-02	HOLDER (OPB)	
52	2B		J21-8579-04	MOUNTING HARDWARE (HOLDER)	
53	1C		J29-0730-05	BELT CLIP ACCESSORY	
54	2B		J30-1296-04	SPACER (VOL)	
56	3B		J87-0007-15	FPC (LEAD FREE) (UNIVERSAL)	
-			J87-0028-05	FPC (LEAD FREE) (VOL ENC)	
57	3A		J99-0390-04	ADHESIVE SHEET (6KEY FPC)	
58	3A		J99-0711-04	ADHESIVE SHEET (PTT FPC)	
59	2B		J99-0712-14	ADHESIVE SHEET (6KEY FPC)	
60	1A,2A		J99-0714-04	ADHESIVE SHEET (LCD)	
62	3B		J99-0715-08	ADHESIVE SHEET (UNIVERSAL)	
-			J99-0719-04	ADHESIVE SHEET (SP-SHIELD)	
63	3B		J99-0725-04	ADHESIVE SHEET (T-BLOCK)	
-			J99-0727-04	ADHESIVE SHEET (IP TOP)	
-			J99-0728-04	ADHESIVE SHEET (IP EMG)	
-			J99-0732-04	ADHESIVE SHEET (IP COVER)	
64	3A		K25-2001-03	PUSH KNOB (PTT)	
65	1A		K29-9405-03	KNOB (PTT)	
66	1A		K29-9406-03	BUTTON KNOB (SIDE/PF-KEY)	
67	1B		K29-9407-03	KNOB (VOL)	
68	1B		K29-9408-13	KNOB (ENC)	
A	1B,1D		N08-0564-04	DRESSED SCREW ACCESSORY	
B	3B		N09-2426-14	HEXAGON HEAD SCREW (TERMINAL-)	
C	3A		N09-2440-15	SPECIAL SCREW (CASE/CHASS)	
D	2A,2B		N09-6549-04	STEPPED SCREW (HOLDER)	
E	2B,3A		N09-6554-05	PAN HEAD SCREW (ANT/OPB)	
F	2B		N14-0844-04	CIRCULAR NUT (VOL/RO-SW)	
-			N16-0020-48	SPRING WASHER (IS)	
G	1C		N30-3008-60	PAN HEAD MACHINE SCREW (CLIP)	
H	1A,2A,2B		N83-2005-48	PAN HEAD TAPTITE SCREW (UNIT)	
-			N88-2005-48	FLAT HEAD TAPTITE SCREW (IS)	
72	2A		T07-0755-15	SPEAKER	
73	2A		T91-0575-05	MIC ELEMENT	
75	2A		W09-0971-05	LITHIUM CELL	
77	3A	*	X41-3760-10	SWITCH UNIT	
78	2B	*	X41-3770-10	SWITCH UNIT	
79	2A	*	X42-3380-10	CORD ASSY	
80	2B	*	X60-3910-10	TERMINAL ASSY	
<b>CONTROL UNIT (X53-4480-XX) -10: K,K2 -11: K3,K4</b>					
D1-10			B30-2215-05	LED	K3,K4
D3,4			B30-2215-05	LED	K,K2
D7,8			B30-2215-05	LED	K,K2
C1			CK73HB1A104K	CHIP C 0.10UF K	
C2-6			CK73GB1E105K	CHIP C 1.0UF K	
C7,8			CK73HB1A104K	CHIP C 0.10UF K	

## PARTS LIST

CONTROL UNIT (X53-4480-XX)

Ref. No.	Address	New parts	Parts No.	Description	Desti-nation	Ref. No.	Address	New parts	Parts No.	Description	Desti-nation
C10			CK73HB1A104K	CHIP C 0.10UF K		C421			CK73HB1E682K	CHIP C 6800PF K	
C11			CK73HB0J105K	CHIP C 1.0UF K		C422			CC73HCH1H100C	CHIP C 10PF C	
C12-15			CK73HB1H471K	CHIP C 470PF K		C424,425			CK73HB1A104K	CHIP C 0.10UF K	
C16,17			CC73HCH1H101J	CHIP C 100PF J		C427			CK73HB1E103K	CHIP C 0.010UF K	
C23			CK73HB1H102K	CHIP C 1000PF K		C428			CC73HCH1H030C	CHIP C 3.0PF C	
C24			CC73HCH1H470J	CHIP C 47PF J		C429,430			CK73HB1A104K	CHIP C 0.10UF K	
C25-27			CK73HB1H102K	CHIP C 1000PF K		C431			CK73FB1A106K	CHIP C 10UF K	
C28-34			CC73HCH1H101J	CHIP C 100PF J		C433			CK73FB1A106K	CHIP C 10UF K	
C35			CK73HB1H102K	CHIP C 1000PF K		C435-438			CK73HB1A563K	CHIP C 0.056UF K	
C36			CK73HB1E682K	CHIP C 6800PF K		C439,440			CK73HB1A104K	CHIP C 0.10UF K	
C37			CK73HB1H102K	CHIP C 1000PF K		C441			CK73GB1E105K	CHIP C 1.0UF K	
C38			CC73HCH1H101J	CHIP C 100PF J		C442			CK73HB1H471K	CHIP C 470PF K	
C40			CC73HCH1H221J	CHIP C 220PF J		C443			CK73HB1E103K	CHIP C 0.010UF K	
C41			CC73HCH1H101J	CHIP C 100PF J		C445			CK73HB1H102K	CHIP C 1000PF K	
C101-104			CK73HB1A104K	CHIP C 0.10UF K		C446			CK73GB1E105K	CHIP C 1.0UF K	
C105			CK73HB0J105K	CHIP C 1.0UF K		C447			CK73HB1H102K	CHIP C 1000PF K	
C106			CK73HB1E103K	CHIP C 0.010UF K		C448-450			CK73HB0J105K	CHIP C 1.0UF K	
C107			CK73HB1A104K	CHIP C 0.10UF K	K,K2	C452,453			CK73HB1E103K	CHIP C 0.010UF K	
C107,108			CK73HB1A104K	CHIP C 0.10UF K	K3,K4	C454			CK73GB1E105K	CHIP C 1.0UF K	
C109,110			CK73HB1H102K	CHIP C 1000PF K		C455-457			CK73HB1H471K	CHIP C 470PF K	
C111-113			CK73HB1A104K	CHIP C 0.10UF K		C459			CK73HB1H471K	CHIP C 470PF K	
C114			CK73HB0J105K	CHIP C 1.0UF K	K3,K4	C460			CK73HB1E682K	CHIP C 6800PF K	
C115			CK73HB1H471K	CHIP C 470PF K	K3,K4	C461-463			CK73HB1H471K	CHIP C 470PF K	
C116,117			CK73HB1A104K	CHIP C 0.10UF K		C464			CK73HB1E103K	CHIP C 0.010UF K	
C118,119			CK73HB0J105K	CHIP C 1.0UF K		C465			CK73HB1H102K	CHIP C 1000PF K	
C120,121			CK73HB1A104K	CHIP C 0.10UF K		C466			CK73HB1E682K	CHIP C 6800PF K	
C122-124			CK73HB1E103K	CHIP C 0.010UF K		C467,468			CK73HB1A104K	CHIP C 0.10UF K	
C130			CK73HB1E103K	CHIP C 0.010UF K		C469,470			CK73HB1H102K	CHIP C 1000PF K	
C131			CK73HB1A104K	CHIP C 0.10UF K		C480			CK73HB1E103K	CHIP C 0.010UF K	
C133			CS77CP0J100M	CHIP TNL 10UF 6.3WV		C701			CK73HB1A104K	CHIP C 0.10UF K	
C134			CK73HB1E103K	CHIP C 0.010UF K		C703			CK73GB0J475K	CHIP C 4.7UF K	
C135			CK73HB1H102K	CHIP C 1000PF K		C704,705			CK73HB1A104K	CHIP C 0.10UF K	
C136			CK73HB1E103K	CHIP C 0.010UF K		C706			CC73HCH1H680J	CHIP C 68PF J	
C137			CK73GB1E105K	CHIP C 1.0UF K		C707			CC73HCH1H270J	CHIP C 27PF J	
C138-140			CK73HB1A104K	CHIP C 0.10UF K		C708			CK73HB1A104K	CHIP C 0.10UF K	
C141			CC73HCH1H101J	CHIP C 100PF J		C709			CK73HB0J105K	CHIP C 1.0UF K	
C142			CS77CP0J100M	CHIP TNL 10UF 6.3WV		C710			CK73HB1E103K	CHIP C 0.010UF K	
C143			CK73HB1E103K	CHIP C 0.010UF K		C711			CK73HB1A104K	CHIP C 0.10UF K	
C144			CK73GB1E105K	CHIP C 1.0UF K		C712			CK73HB1E103K	CHIP C 0.010UF K	
C145-148			CK73HB1A104K	CHIP C 0.10UF K		C713			CK73HB1H332K	CHIP C 3300PF K	
C149			CK73HB1E103K	CHIP C 0.010UF K		C714			CK73HB1H122K	CHIP C 1200PF K	
C150			CK73GB1E105K	CHIP C 1.0UF K		C715			CK73HB1A104K	CHIP C 0.10UF K	
C151-155			CK73HB1A104K	CHIP C 0.10UF K		C716			CK73HB1H681K	CHIP C 680PF K	
C156,157			CK73HB1H102K	CHIP C 1000PF K		C717			CK73HB1E103K	CHIP C 0.010UF K	
C158			CK73HB1E103K	CHIP C 0.010UF K		C718			CK73HB1H152K	CHIP C 1500PF K	
C159			CK73HB1A104K	CHIP C 0.10UF K		C719			CK73HB1A104K	CHIP C 0.10UF K	
C160,161			CK73HB1E682K	CHIP C 6800PF K		C720			CK73HB1E103K	CHIP C 0.010UF K	
C401,402			CK73HB1A104K	CHIP C 0.10UF K		C721			CK73HB1A104K	CHIP C 0.10UF K	
C403-405		*	CS77CP1C2R2M	CHIP TNL 2.2UF 16WV		C722			CK73HB1E103K	CHIP C 0.010UF K	
C406			CK73HB0J105K	CHIP C 1.0UF K		C723			CK73HB1A104K	CHIP C 0.10UF K	
C407,408			CK73HB1H102K	CHIP C 1000PF K		C724			CK73HB1E103K	CHIP C 0.010UF K	
C409			CK73HB0J105K	CHIP C 1.0UF K		C725			CC73HCH1E181J	CHIP C 180PF J	
C411,412			CK73HB0J105K	CHIP C 1.0UF K		C726,727			CK73HB1A104K	CHIP C 0.10UF K	
C414			CK73HB0J105K	CHIP C 1.0UF K		C728			CK73HB1H331K	CHIP C 330PF K	
C415		*	CS77BP1A100M	CHIP TNL 10UF 4V		C730			CK73HB1H331K	CHIP C 330PF K	
C416			CK73FB1A106K	CHIP C 10UF K		C731,732			CK73HB1E103K	CHIP C 0.010UF K	
C417			CC73HCH1H221J	CHIP C 220PF J		C734			CK73HB1H102K	CHIP C 1000PF K	
C418			CK73HB1E103K	CHIP C 0.010UF K		C735			CK73HB1H122K	CHIP C 1200PF K	
C419			CK73FB1E475K	CHIP C 4.7UF K		C736,737			CK73HB1A104K	CHIP C 0.10UF K	
C420			CK73HB1E103K	CHIP C 0.010UF K		C738			CK73HB1H102K	CHIP C 1000PF K	

## PARTS LIST

## CONTROL UNIT (X53-4480-XX)

Ref. No.	Address	New parts	Parts No.	Description	Destination	Ref. No.	Address	New parts	Parts No.	Description	Destination
C739			CK73HB1E682K	CHIP C 6800PF K		-			F15-1016-04	SHIELDING PLATE	
C740			CK73HB1H102K	CHIP C 1000PF K		F701			F53-0360-05	FUSE (0.25A/32V)	
C742			CK73GB1E105K	CHIP C 1.0UF K		CN401			J19-5386-05	HOLDER	
C743			CK73HB0J105K	CHIP C 1.0UF K							
C744-746			CK73HB1E103K	CHIP C 0.010UF K							
C747,748			CK73HB1A104K	CHIP C 0.10UF K		L1,2			L92-0408-05	CHIP FERRITE	
C749,750			CC73HCH1H470J	CHIP C 47PF J		L3			L92-0140-05	CHIP FERRITE	
C751			CK73GB1E105K	CHIP C 1.0UF K		L4-7			L92-0408-05	CHIP FERRITE	
C752,753			CC73HCH1H101J	CHIP C 100PF J		L8			L92-0140-05	CHIP FERRITE	
C755			CC73HCH1H470J	CHIP C 47PF J		L101,102			L92-0408-05	CHIP FERRITE	
C756			CK73HB1A104K	CHIP C 0.10UF K		L401			L33-1496-05	SMALL FIXED INDUCTOR (22UH)	
C757,758			CK73GB0J475K	CHIP C 4.7UF K		L402			L92-0467-05	CHIP FERRITE	
C759,760			CK73HB1E103K	CHIP C 0.010UF K		L403			L92-0466-05	CHIP FERRITE	
C761			CC73HCH1H100D	CHIP C 10PF D		L409-411			L92-0467-05	CHIP FERRITE	
C762			CK73HB1A104K	CHIP C 0.10UF K		L701			L92-0140-05	CHIP FERRITE	
C763			CK73HB1E103K	CHIP C 0.010UF K		L702			L92-0162-05	BEADS CORE	
C764			CK73HB1H102K	CHIP C 1000PF K		L704-709			L92-0162-05	BEADS CORE	
C765-767			CK73HB1A104K	CHIP C 0.10UF K		L710-712			L92-0444-05	CHIP FERRITE	
C768			CK73HB1H102K	CHIP C 1000PF K		L713			L92-0163-05	BEADS CORE	
C771			CK73HB1A224K	CHIP C 0.22UF K		L714-717			L92-0444-05	CHIP FERRITE	
C772			CK73HB1E103K	CHIP C 0.010UF K		L718			L92-0408-05	CHIP FERRITE	
C775			CC73HCH1H470J	CHIP C 47PF J		L719			L33-1494-05	SMALL FIXED INDUCTOR (4.7UH)	
C777			CK73HB1H102K	CHIP C 1000PF K		X101			L77-1802-05	CRYSTAL RESONATOR (32768HZ)	
C778			CK73HB0J105K	CHIP C 1.0UF K		X102			L77-3015-05	TCXO (18.432M)	
C779			CK73HB1E103K	CHIP C 0.010UF K		R1			RK73HB1J105J	CHIP R 1.0M J 1/16W	
C780			CK73HB1A224K	CHIP C 0.22UF K		R2			RK73HB1J104J	CHIP R 100K J 1/16W	
C781,782			CK73HB0J105K	CHIP C 1.0UF K		R3			RK73HB1J123J	CHIP R 12K J 1/16W	
C785			CK73HB1A224K	CHIP C 0.22UF K		R4-10			RK73HB1J103J	CHIP R 10K J 1/16W	
C786			CK73HB1E103K	CHIP C 0.010UF K		R11			RK73HB1J104J	CHIP R 100K J 1/16W	
C787			CK73HB0J105K	CHIP C 1.0UF K		R12			RK73HB1J103J	CHIP R 10K J 1/16W	
C788			CC73HCH1H150J	CHIP C 15PF J		R14			RK73HB1J472J	CHIP R 4.7K J 1/16W	
C789			CC73HCH1H680J	CHIP C 68PF J		R15			RK73HB1J000J	CHIP R 0.0 J 1/16W	
C790			CK73HB1A104K	CHIP C 0.10UF K		R16			RK73HB1J331J	CHIP R 330 J 1/16W	
C791			CK73HB1A393K	CHIP C 0.039UF K		R17			RK73HB1J000J	CHIP R 0.0 J 1/16W	
C792			CK73HB0J105K	CHIP C 1.0UF K		R18			RK73HB1J822J	CHIP R 8.2K J 1/16W	
C793,794			CK73HB1A104K	CHIP C 0.10UF K		R19			RK73HB1J471J	CHIP R 470 J 1/16W	
C795			CK73HB1E103K	CHIP C 0.010UF K		R20			RK73HB1J102J	CHIP R 1.0K J 1/16W	
C796			CK73HB1A104K	CHIP C 0.10UF K		R21			RK73HB1J122J	CHIP R 1.2K J 1/16W	
C797			CK73HB0J105K	CHIP C 1.0UF K		R22-24			RK73HB1J102J	CHIP R 1.0K J 1/16W	
C798		*	CS77BP1A100M	CHIP TNL 10UF 4V		R25			RK73HB1J122J	CHIP R 1.2K J 1/16W	
C799			CK73HB1A104K	CHIP C 0.10UF K		R26			RK73HB1J102J	CHIP R 1.0K J 1/16W	
C800			CK73HB1H152K	CHIP C 1500PF K		R27			RK73HB1J104J	CHIP R 100K J 1/16W	
C801			CK73HB1C223K	CHIP C 0.022UF K		R28,29			RK73HB1J102J	CHIP R 1.0K J 1/16W	
C802			CK73HB1E103K	CHIP C 0.010UF K		R30			RK73HB1J101J	CHIP R 100 J 1/16W	
C803			CK73HB1H102K	CHIP C 1000PF K		R31			RK73HB1J102J	CHIP R 1.0K J 1/16W	
C804			CC73HCH1H470J	CHIP C 47PF J		R32-35			RK73HB1J101J	CHIP R 100 J 1/16W	
C805,806			CK73HB1H471K	CHIP C 470PF K		R40			RK73HB1J000J	CHIP R 0.0 J 1/16W	
C808			CK73GB0J475K	CHIP C 4.7UF K		R101,102			RK73HB1J474J	CHIP R 470K J 1/16W	
C809			CK73FB1A106K	CHIP C 10UF K		R103			RK73HB1J102J	CHIP R 1.0K J 1/16W	
C812			CK73HB0J105K	CHIP C 1.0UF K		R105			RK73HB1J104J	CHIP R 100K J 1/16W	
CN1			E40-6755-05	FLAT CABLE CONNECTOR		R106			RK73HB1J472J	CHIP R 4.7K J 1/16W	K3,K4
CN22			E23-1325-05	TERMINAL		R107			RK73HB1J104J	CHIP R 100K J 1/16W	
CN23			E40-6758-05	PIN ASSY		R108			RK73HB1J474J	CHIP R 470K J 1/16W	K3,K4
CN24			E23-1325-05	TERMINAL		R110,111			RK73HB1J104J	CHIP R 100K J 1/16W	
CN403			E40-6813-05	PIN ASSY		R112			RK73HB1J000J	CHIP R 0.0 J 1/16W	K3,K4
CN404			E40-6421-15	PIN ASSY		R113			RK73HB1J104J	CHIP R 100K J 1/16W	
CN405			E40-6754-05	FLAT CABLE CONNECTOR		R114			RK73HB1J331J	CHIP R 330 J 1/16W	K3,K4
CN701			E40-6586-05	SOCKET FOR PIN ASSY		R115			RK73HB1J104J	CHIP R 100K J 1/16W	
CN710			E40-6757-05	PIN ASSY		R116			RK73HB1J473J	CHIP R 47K J 1/16W	
						R117			RK73HB1J000J	CHIP R 0.0 J 1/16W	K3,K4

## PARTS LIST

CONTROL UNIT (X53-4480-XX)

Ref. No.	Address	New parts	Parts No.	Description	Destination	Ref. No.	Address	New parts	Parts No.	Description	Destination
R118			RK73HB1J473J	CHIP R 47K J 1/16W		R431			RK73HB1J474J	CHIP R 470K J 1/16W	
R119			RK73HB1J104J	CHIP R 100K J 1/16W		R432,433			RK73HB1J000J	CHIP R 0.0 J 1/16W	
R120			RK73HB1J474J	CHIP R 470K J 1/16W		R434			RK73HB1J393J	CHIP R 39K J 1/16W	
R121-123			RK73HB1J104J	CHIP R 100K J 1/16W		R435,436			RK73HB1J104J	CHIP R 100K J 1/16W	
R126			RK73HB1J101J	CHIP R 100 J 1/16W		R437			RK73HB1J471J	CHIP R 470 J 1/16W	
R127,128			RK73HB1J000J	CHIP R 0.0 J 1/16W		R438,439			RK73HB1J104J	CHIP R 100K J 1/16W	
R129-131			RK73HB1J101J	CHIP R 100 J 1/16W		R440			RK73HB1J000J	CHIP R 0.0 J 1/16W	
R132,133			RK73HB1J104J	CHIP R 100K J 1/16W		R441			RK73HB1J153J	CHIP R 15K J 1/16W	
R135-137			RK73HB1J104J	CHIP R 100K J 1/16W		R442			RK73HB1J102J	CHIP R 1.0K J 1/16W	
R138			RK73HB1J473J	CHIP R 47K J 1/16W		R443			RK73HB1J474J	CHIP R 470K J 1/16W	
R139			RK73HB1J104J	CHIP R 100K J 1/16W		R444			RK73HB1J564J	CHIP R 560K J 1/16W	
R140			RK73HB1J000J	CHIP R 0.0 J 1/16W		R445			RK73HB1J154J	CHIP R 150K J 1/16W	
R141-143			RK73HB1J104J	CHIP R 100K J 1/16W		R446			RK73HB1J274J	CHIP R 270K J 1/16W	
R144			RK73HB1J471J	CHIP R 470 J 1/16W		R447			RK73HB1J104J	CHIP R 100K J 1/16W	
R145-147			RK73HB1J104J	CHIP R 100K J 1/16W		R448			RK73HB1J103J	CHIP R 10K J 1/16W	
R148			RK73HB1J151J	CHIP R 150 J 1/16W		R449-452			RK73HB1J474J	CHIP R 470K J 1/16W	
R149			RK73HB1J000J	CHIP R 0.0 J 1/16W		R453			RK73HB1J104J	CHIP R 100K J 1/16W	
R150			RK73HB1J102J	CHIP R 1.0K J 1/16W		R454			RK73HB1J474J	CHIP R 470K J 1/16W	
R153,154			RK73HB1J104J	CHIP R 100K J 1/16W		R455			RK73HB1J102J	CHIP R 1.0K J 1/16W	
R155			RK73HB1J473J	CHIP R 47K J 1/16W		R456			RK73HB1J474J	CHIP R 470K J 1/16W	
R156,157			RK73HB1J472J	CHIP R 4.7K J 1/16W		R457,458			RK73HB1J104J	CHIP R 100K J 1/16W	
R158,159			RK73HB1J220J	CHIP R 22 J 1/16W		R459,460			RK73HB1J102J	CHIP R 1.0K J 1/16W	
R160,161			RK73HB1J000J	CHIP R 0.0 J 1/16W		R461			RK73HB1J103J	CHIP R 10K J 1/16W	
R162			RK73HB1J474J	CHIP R 470K J 1/16W		R462			RK73HB1J102J	CHIP R 1.0K J 1/16W	
R163			RK73HB1J104D	CHIP R 100K D 1/16W		R463			RK73HB1J104J	CHIP R 100K J 1/16W	
R165			RK73HB1J102J	CHIP R 1.0K J 1/16W		R464			RK73HB1J474J	CHIP R 470K J 1/16W	
R166			RK73HB1J104J	CHIP R 100K J 1/16W		R465,466			RK73HB1J103J	CHIP R 10K J 1/16W	
R167			RK73HB1J102J	CHIP R 1.0K J 1/16W		R467			RK73HB1J104J	CHIP R 100K J 1/16W	
R168			RK73HB1J000J	CHIP R 0.0 J 1/16W		R468			RK73HB1J000J	CHIP R 0.0 J 1/16W	
R170			RK73HB1J103D	CHIP R 10K D 1/16W		R469			RK73HB1J474J	CHIP R 470K J 1/16W	
R171-173			RK73HB1J000J	CHIP R 0.0 J 1/16W		R470			RK73HB1J183J	CHIP R 18K J 1/16W	
R174-178			RK73HB1J104J	CHIP R 100K J 1/16W		R471			RK73HB1J000J	CHIP R 0.0 J 1/16W	
R180,181			RK73HB1J104J	CHIP R 100K J 1/16W		R472			RK73HB1J223J	CHIP R 22K J 1/16W	
R182			RK73HB1J474J	CHIP R 470K J 1/16W		R473			RK73HB1J332J	CHIP R 3.3K J 1/16W	
R183			RK73HB1J104J	CHIP R 100K J 1/16W		R474,475			RK73HB1J333J	CHIP R 33K J 1/16W	
R184			RK73HB1J473J	CHIP R 47K J 1/16W		R477,478			RK73HB1J000J	CHIP R 0.0 J 1/16W	
R185			RK73HB1J105J	CHIP R 1.0M J 1/16W		R479			RK73HB1J102J	CHIP R 1.0K J 1/16W	
R186			RK73HB1J473J	CHIP R 47K J 1/16W		R481			RK73HB1J474J	CHIP R 470K J 1/16W	
R187			RK73HB1J102J	CHIP R 1.0K J 1/16W		R483			RK73HB1J473J	CHIP R 47K J 1/16W	
R188			RK73HB1J473J	CHIP R 47K J 1/16W		R484			RK73HB1J223J	CHIP R 22K J 1/16W	
R189			RK73HB1J104J	CHIP R 100K J 1/16W		R485			RK73HB1J103J	CHIP R 10K J 1/16W	
R190			RK73HB1J102J	CHIP R 1.0K J 1/16W		R487-490			RK73HB1J223D	CHIP R 22K D 1/16W	
R191			RK73HB1J474J	CHIP R 470K J 1/16W		R491			RK73HB1J104J	CHIP R 100K J 1/16W	
R192			RK73HB1J102J	CHIP R 1.0K J 1/16W		R492			RK73HB1J474J	CHIP R 470K J 1/16W	
R193,194			RK73HB1J104J	CHIP R 100K J 1/16W		R493			RK73HB1J000J	CHIP R 0.0 J 1/16W	
R401			RK73HB1J152J	CHIP R 1.5K J 1/16W	K3,K4	R494-497			RK73HB1J104D	CHIP R 100K D 1/16W	
R402			RK73HB1J151J	CHIP R 150 J 1/16W		R500			RK73HB1J473J	CHIP R 47K J 1/16W	
R403			RK73HB1J152J	CHIP R 1.5K J 1/16W	K3,K4	R501			RK73HB1J222J	CHIP R 2.2K J 1/16W	
R404			RK73HB1J151J	CHIP R 150 J 1/16W		R502,503			RK73HB1J103J	CHIP R 10K J 1/16W	
R405			RK73HB1J152J	CHIP R 1.5K J 1/16W	K3,K4	R504			RK73HB1J102J	CHIP R 1.0K J 1/16W	
R406			RK73HB1J000J	CHIP R 0.0 J 1/16W		R506			RK73HB1J222J	CHIP R 2.2K J 1/16W	
R407,408			RK73HB1J103J	CHIP R 10K J 1/16W		R507-511			RK73HB1J102J	CHIP R 1.0K J 1/16W	
R409			RK73HB1J470J	CHIP R 47 J 1/16W		R512			RK73HB1J101J	CHIP R 100 J 1/16W	
R410-416			RK73HB1J471J	CHIP R 470 J 1/16W		R513-515			RK73HB1J102J	CHIP R 1.0K J 1/16W	
R417			RK73HB1J000J	CHIP R 0.0 J 1/16W		R516			RK73HB1J101J	CHIP R 100 J 1/16W	
R418			RK73HB1J471J	CHIP R 470 J 1/16W		R517			RK73HB1J102J	CHIP R 1.0K J 1/16W	
R419,420			RK73HB1J000J	CHIP R 0.0 J 1/16W		R518			RK73HB1J101J	CHIP R 100 J 1/16W	
R424			RK73HB1J683D	CHIP R 68K D 1/16W		R519-528			RK73HB1J102J	CHIP R 1.0K J 1/16W	
R425			RK73HB1J333D	CHIP R 33K D 1/16W		R529-531			RK73HB1J101J	CHIP R 100 J 1/16W	
R426-429			RK73HB1J000J	CHIP R 0.0 J 1/16W		R532			RK73HB1J102J	CHIP R 1.0K J 1/16W	

## PARTS LIST

### CONTROL UNIT (X53-4480-XX)

Ref. No.	Address	New parts	Parts No.	Description	Destination	Ref. No.	Address	New parts	Parts No.	Description	Destination
R533-535			RK73HB1J101J	CHIP R 100 J 1/16W		R786			RK73HB1J000J	CHIP R 0.0 J 1/16W	
R536-540			RK73HB1J102J	CHIP R 1.0K J 1/16W		R787			RK73HB1J124J	CHIP R 120K J 1/16W	
R541			RK73HB1J101J	CHIP R 100 J 1/16W		R788			RK73HB1J473J	CHIP R 47K J 1/16W	
R543			RK73HB1J101J	CHIP R 100 J 1/16W		R789			RK73HB1J154J	CHIP R 150K J 1/16W	
R544			RK73HB1J102J	CHIP R 1.0K J 1/16W		R790			RK73HB1J102J	CHIP R 1.0K J 1/16W	
R545			RK73HB1J101J	CHIP R 100 J 1/16W		R791			RK73HB1J474J	CHIP R 470K J 1/16W	
R546,547			RK73HB1J102J	CHIP R 1.0K J 1/16W		R793			RK73HB1J102J	CHIP R 1.0K J 1/16W	
R548,549			RK73HB1J473J	CHIP R 47K J 1/16W		R794			RK73HB1J104J	CHIP R 100K J 1/16W	
R550			RK73HB1J000J	CHIP R 0.0 J 1/16W		R795			RK73HB1J000J	CHIP R 0.0 J 1/16W	
R701-707			RK73HB1J000J	CHIP R 0.0 J 1/16W		R796			RK73HB1J333J	CHIP R 33K J 1/16W	
R709-715			RK73HB1J000J	CHIP R 0.0 J 1/16W		R797			RK73HB1J102J	CHIP R 1.0K J 1/16W	
R716			RK73GB2A000J	CHIP R 0.0 J 1/10W		R798			RK73HB1J104J	CHIP R 100K J 1/16W	
R717-722			RK73HB1J104J	CHIP R 100K J 1/16W		R799			RK73HB1J334J	CHIP R 330K J 1/16W	
R723			RK73HB1J105J	CHIP R 1.0M J 1/16W		R800			RK73HB1J474J	CHIP R 470K J 1/16W	
R724			RK73HB1J104J	CHIP R 100K J 1/16W		R801			RK73HB1J473J	CHIP R 47K J 1/16W	
R725			RK73HB1J100J	CHIP R 10 J 1/16W		R802			RK73HB1J474J	CHIP R 470K J 1/16W	
R726			RK73HB1J104J	CHIP R 100K J 1/16W		R803			RK73HB1J103J	CHIP R 10K J 1/16W	
R727-729			RK73HB1J105J	CHIP R 1.0M J 1/16W		R804			RK73HB1J000J	CHIP R 0.0 J 1/16W	
R730			RK73HB1J471J	CHIP R 470 J 1/16W		R805,806			RK73HB1J473J	CHIP R 47K J 1/16W	
R731,732			RK73HB1J105J	CHIP R 1.0M J 1/16W		R807			RK73HB1J102J	CHIP R 1.0K J 1/16W	
R733			RK73HB1J473J	CHIP R 47K J 1/16W		R808			RK73HB1J471J	CHIP R 470 J 1/16W	
R735			RK73HB1J473J	CHIP R 47K J 1/16W		R809			RK73HB1J334J	CHIP R 330K J 1/16W	
R736			RK73HB1J823J	CHIP R 82K J 1/16W		R810			RK73HB1J332J	CHIP R 3.3K J 1/16W	
R737			RK73HB1J153J	CHIP R 15K J 1/16W		R811			RK73HB1J823J	CHIP R 82K J 1/16W	
R738			RK73HB1J563J	CHIP R 56K J 1/16W		R812			RK73HB1J562J	CHIP R 5.6K J 1/16W	
R739			RK73HB1J823J	CHIP R 82K J 1/16W		R813			RK73HB1J273J	CHIP R 27K J 1/16W	
R740			RK73HB1J000J	CHIP R 0.0 J 1/16W		R814			RK73HB1J564J	CHIP R 560K J 1/16W	
R741			RK73HB1J474J	CHIP R 470K J 1/16W		R815			RK73HB1J104J	CHIP R 100K J 1/16W	
R742,743			RK73HB1J103J	CHIP R 10K J 1/16W		R816			RK73HB1J683J	CHIP R 68K J 1/16W	
R744			RK73HB1J223J	CHIP R 22K J 1/16W		R818			RK73HB1J104J	CHIP R 100K J 1/16W	
R745			RK73HB1J682J	CHIP R 6.8K J 1/16W		R819,820			RK73HB1J103J	CHIP R 10K J 1/16W	
R746			RK73HB1J563J	CHIP R 56K J 1/16W		R821			RK73HB1J104J	CHIP R 100K J 1/16W	
R747			RK73HB1J333J	CHIP R 33K J 1/16W		R822,823			RK73HB1J103J	CHIP R 10K J 1/16W	
R748			RK73HB1J103J	CHIP R 10K J 1/16W		R824			RK73HB1J393J	CHIP R 39K J 1/16W	
R749			RK73HB1J472J	CHIP R 4.7K J 1/16W		R825			RK73HB1J104J	CHIP R 100K J 1/16W	
R750			RK73HB1J103J	CHIP R 10K J 1/16W		R826			RK73HB1J334J	CHIP R 330K J 1/16W	
R752			RK73HB1J101J	CHIP R 100 J 1/16W		R827			RK73HB1J184J	CHIP R 180K J 1/16W	
R753			RK73HB1J683J	CHIP R 68K J 1/16W		R828,829			RK73HB1J000J	CHIP R 0.0 J 1/16W	
R754			RK73HB1J564J	CHIP R 560K J 1/16W		R830			RK73HB1J105J	CHIP R 1.0M J 1/16W	
R755			RK73HB1J104J	CHIP R 100K J 1/16W		R831			RK73HB1J474J	CHIP R 470K J 1/16W	
R756			RK73HB1J101J	CHIP R 100 J 1/16W		R832			RK73HB1J473J	CHIP R 47K J 1/16W	
R757			RK73HB1J223J	CHIP R 22K J 1/16W		R833			RK73HB1J684J	CHIP R 680K J 1/16W	
R758			RK73HB1J103J	CHIP R 10K J 1/16W		R834			RK73HB1J000J	CHIP R 0.0 J 1/16W	
R759			RK73HB1J101J	CHIP R 100 J 1/16W		R835			RK73HB1J153J	CHIP R 15K J 1/16W	
R761-764			RK73HB1J223J	CHIP R 22K J 1/16W		R836			RK73HB1J473J	CHIP R 47K J 1/16W	
R765			RK73HB1J334J	CHIP R 330K J 1/16W		R837			RK73HB1J683J	CHIP R 68K J 1/16W	
R766			RK73HB1J000J	CHIP R 0.0 J 1/16W		R838			RK73HB1J564J	CHIP R 560K J 1/16W	
R767			RK73HB1J103J	CHIP R 10K J 1/16W		R839			RK73HB1J333J	CHIP R 33K J 1/16W	
R768			RK73HB1J224J	CHIP R 220K J 1/16W		R840			RK73HB1J123J	CHIP R 12K J 1/16W	
R769,770			RK73HB1J334J	CHIP R 330K J 1/16W		R841			RK73HB1J564J	CHIP R 560K J 1/16W	
R771			RK73HB1J153J	CHIP R 15K J 1/16W		R842			RK73HB1J104J	CHIP R 100K J 1/16W	
R775			RK73HB1J183J	CHIP R 18K J 1/16W		R843			RK73HB1J102J	CHIP R 1.0K J 1/16W	
R777			RK73HB1J473J	CHIP R 47K J 1/16W		R844			RK73HB1J472J	CHIP R 4.7K J 1/16W	
R778			RK73HB1J333J	CHIP R 33K J 1/16W		R845			RK73HB1J104J	CHIP R 100K J 1/16W	
R779			RK73HB1J473J	CHIP R 47K J 1/16W		R846			RK73HB1J471J	CHIP R 470 J 1/16W	
R780			RK73HB1J104J	CHIP R 100K J 1/16W		R847			RK73HB1J182J	CHIP R 1.8K J 1/16W	
R782			RK73HB1J104J	CHIP R 100K J 1/16W		R848			RK73HB1J000J	CHIP R 0.0 J 1/16W	K,K2
R783			RK73HB1J183J	CHIP R 18K J 1/16W		R849,850			RK73HB1J000J	CHIP R 0.0 J 1/16W	K3,K4
R784			RK73HB1J104J	CHIP R 100K J 1/16W		R850			RK73HB1J000J	CHIP R 0.0 J 1/16W	K,K2
R785			RK73HB1J682J	CHIP R 6.8K J 1/16W		R851,852			RK73HB1J683J	CHIP R 68K J 1/16W	

## PARTS LIST

CONTROL UNIT (X53-4480-XX)

TX-RX UNIT (X57-7830-XX)

Ref. No.	Address	New parts	Parts No.	Description	Desti-nation	Ref. No.	Address	New parts	Parts No.	Description	Desti-nation
R853			RK73HB1J000J	CHIP R 0.0 J 1/16W		IC708			XC6209B502PR	MOS-IC	
<b>VR1</b>	2B		S79-0472-05 R31-0666-05	KEYBOARD ASSY VARIABLE RESISTOR	K3,K4	IC709			TC7W53FK (F)	MOS-IC	
<b>S1</b>	2B		S60-0437-05	ROTARY SWITCH		IC710,711			TC75W51FK (F)	MOS-IC	
D11			MA2S111-F	DIODE		IC712			TC7S66FUJ	MOS-IC	
D12-16			1SS416	DIODE		IC713			TC75W51FK (F)	MOS-IC	
D17			EMZ6.8N	ZENER DIODE		IC714			TC7W53FK (F)	MOS-IC	
D18,19			HZC6.8-E	ZENER DIODE		IC715			TC75S51FE (F)	MOS-IC	
D20,21			NNCD6.8G-A	ZENER DIODE		IC716			TC75W51FK (F)	MOS-IC	
D22,23			DA221	DIODE		IC717			XC9235A15CM1	MOS-IC	
D101			MA2S111-F	DIODE	K3,K4	Q1			2SA1362-F (GR)	TRANSISTOR	
D102			1SS416	DIODE		Q2			2SC4617 (S)	TRANSISTOR	
D401-405			1SS388F	DIODE		Q3,4			SSM3K15TE (F)	FET	
D406			HRB0502A	DIODE		Q5			2SJ347F	FET	
D407			MA2S111-F	DIODE		Q101			2SA1832 (GR) F	TRANSISTOR	K3,K4
D408			1SS301F	DIODE		Q102			2SC4617 (S)	TRANSISTOR	K3,K4
D409,410			MA2S111-F	DIODE		Q103			SSM3K15TE (F)	FET	K3,K4
D411			1SS416	DIODE		Q401,402			SSM6N16FE-F	FET	
D412			1SS301F	DIODE		Q403			2SJ648-A	FET	
D413			1SS388F	DIODE		Q404			SSM3K15TE (F)	FET	
D414,415			1SS416	DIODE		Q405			SSM6N16FE-F	FET	
D416,417			1SS388F	DIODE		Q406			2SB1132 (Q,R)	TRANSISTOR	
D701			1SS301F	DIODE		Q407			UMG3N	TRANSISTOR	
D702			MA2S111-F	DIODE		Q408			EMD12	TRANSISTOR	
D703-706			RB706F-40	DIODE		Q409			2SA1955A-F	TRANSISTOR	
D707			DA221	DIODE		Q410			SSM3K15TE (F)	FET	
IC1			NJM2130F3-ZB	BI-POLAR IC		Q411			SSM6N16FE-F	FET	
IC101			<b>Note 1</b>	ROM IC		Q412			SSM3K15TE (F)	FET	
IC102			<b>Note 1</b>	MCU		Q413			2SA1955A-F	TRANSISTOR	
IC103			<b>Note 1</b>	SRAM IC		Q414,415			EMD12	TRANSISTOR	
IC104			TC7SH08FU-F	MOS-IC		Q701			2SA1832 (GR) F	TRANSISTOR	
IC105			XC6109C29ANN	ANALOGUE IC		Q702,703			SSM3K15TE (F)	FET	
IC106			RV5C386A	MOS-IC		Q704			2SC4617 (S)	TRANSISTOR	
IC107			SM5023CNDH-G	MOS-IC		Q705			2SC4738 (GR) F	TRANSISTOR	
IC108			<b>Note 1</b>	MOS-IC		Q706			2SA1832 (GR) F	TRANSISTOR	
IC109			TC7SH08FU-F	MOS-IC		Q707			2SJ243-A	FET	
IC401			TC74LCX245FK	MOS-IC		TH1			ERTJ0EV104H	THERMISTOR	
IC402			TC7WZ245FK-F	MOS-IC		TH701			ERTJ0EV104H	THERMISTOR	
IC403			LM2682MMX	MOS-IC				*	X53-4480-12	CONTROL UNIT	K,K2
IC404			XC6204B332D	MOS-IC				*	X53-4480-13	CONTROL UNIT	K3,K4
IC406			XC6204B332M	MOS-IC		<b>TX-RX UNIT (X57-7830-XX) -10: K,K3 -11: K2,K4</b>					
IC407			LT1616ES6-PBF	ANALOGUE IC		D900			B30-2278-05	LED (RED/YELLOW)	
IC408			TC75S51FE (F)	MOS-IC		C500			CK73HB1A104K	CHIP C	0.10UF K
IC409			TC7W66FK-F	MOS-IC		C501			CC73HCH1H101J	CHIP C	100PF J
IC411			NJM2880U105ZB	ANALOGUE IC		C502			CK73HB1H471K	CHIP C	470PF K
IC412,413			TPA6201A1DRBR	ANALOGUE IC		C503			CK73HB1A104K	CHIP C	0.10UF K
IC414			XC61CC5602NR	MOS-IC		C504			CK73HB1C103K	CHIP C	0.010UF K
IC415			TC7SET08FU-F	MOS-IC		C505			CC73HCH1H101J	CHIP C	100PF J
IC416			S-812C31BPI-G	ANALOGUE IC		C506			CC73HCH1H100C	CHIP C	10PF C
IC417			TC7WH126FK	MOS-IC		C508			CK73HB1C103K	CHIP C	0.010UF K
IC418			TC7WT125FUJ	MOS-IC		C509			CC73HCH1H100C	CHIP C	10PF C
IC701			<b>Note 1</b>	MOS-IC		C511			CK73FB0J106K	CHIP C	10UF K
IC702			TC75W51FK (F)	MOS-IC		C512			CK73HB1C103K	CHIP C	0.010UF K
IC703			M62364FP-F	MOS-IC		C513			CC73HCH1H101J	CHIP C	100PF J
IC704			TC75S51FE (F)	MOS-IC							
IC705			TC75W51FK (F)	MOS-IC							
IC706			TC75S51FE (F)	MOS-IC							
IC707			TC7W53FK (F)	MOS-IC							

If a part reference number is listed in a shaded box, that part does not come with the PCB.

Note 1 : This part cannot be replaced. Therefore, this part is not supplied as a service part.

## PARTS LIST

## TX-RX UNIT (X57-7830-XX)

Ref. No.	Address	New parts	Parts No.	Description	Destination	Ref. No.	Address	New parts	Parts No.	Description	Destination
C514-516			CK73HB1C103K	CHIP C 0.010UF K	K,K3	C586			CC73HCH1H070B	CHIP C 7.0PF B	K,K3
C514,515			CK73HB1C103K	CHIP C 0.010UF K	K2,K4	C586			CC73HCH1H100B	CHIP C 10PF B	K2,K4
C517-519			CC73HCH1H101J	CHIP C 100PF J		C587			CK73HB1H471K	CHIP C 470PF K	
C520			CK73GB1E105K	CHIP C 1.0UF K		C588			CC73HCH1H100B	CHIP C 10PF B	
C521			CC73HCH1H101J	CHIP C 100PF J		C600			CK73HB1A104K	CHIP C 0.10UF K	
C522			CK73HB1A104K	CHIP C 0.10UF K		C601			CC73HCH1H101J	CHIP C 100PF J	
C523,524			CC73HCH1H101J	CHIP C 100PF J		C602			CK73HB1A104K	CHIP C 0.10UF K	
C525			CC73HCH1H470J	CHIP C 47PF J		C603			CC73HCH1H100B	CHIP C 10PF B	
C526			CK73HB1A104K	CHIP C 0.10UF K		C604,605			CK73HB1H471K	CHIP C 470PF K	
C527-529			CC73HCH1H101J	CHIP C 100PF J	K,K3	C607			CC73HCH1H070B	CHIP C 7.0PF B	
C527,528			CC73HCH1H101J	CHIP C 100PF J	K2,K4	C609			CC73GCH1H010B	CHIP C 1.0PF B	K2,K4
C533			CK73HB1H471K	CHIP C 470PF K		C610-612			CK73HB1H471K	CHIP C 470PF K	
C534			CC73HCH1H101J	CHIP C 100PF J		C613			CC73HCH1H040B	CHIP C 4.0PF B	K2,K4
C535			CS77AA1VR15M	CHIP TNL 0.15UF 35WV		C613			CC73HCH1H070B	CHIP C 7.0PF B	K,K3
C536			CC73HCH1H470J	CHIP C 47PF J		C614,615			CK73HB1H471K	CHIP C 470PF K	
C537			CC73HCH1H050B	CHIP C 5.0PF B	K,K3	C617,618			CK73HB1H471K	CHIP C 470PF K	
C539			CS77BA1D100M	CHIP TNL 10UF 20WV		C619			CK73HB1A104K	CHIP C 0.10UF K	
C541			C92-0863-05	CHIP TNL 0.047UF 35WV		C621			CC73HCH1H040B	CHIP C 4.0PF B	K2,K4
C542			C93-0787-05	CERAMIC 0.1UF 50WV		C621			CC73HCH1H150J	CHIP C 15PF J	K,K3
C543			CC73HCH1H030B	CHIP C 3.0PF B	K,K3	C622			CK73HB1H471K	CHIP C 470PF K	
C543			CC73HCH1H040B	CHIP C 4.0PF B	K2,K4	C623			CC73HCH1H120J	CHIP C 12PF J	K2,K4
C545			CK73HB1H471K	CHIP C 470PF K	K2,K4	C623			CC73HCH1H150J	CHIP C 15PF J	K,K3
C546			CK73HB1H472K	CHIP C 4700PF K		C625			CK73HB1H471K	CHIP C 470PF K	
C547			CK73HB1H471K	CHIP C 470PF K	K2,K4	C626			CK73HB1A104K	CHIP C 0.10UF K	
C547,548			CC73HCH1H101J	CHIP C 100PF J	K,K3	C627			CC73HCH1H080B	CHIP C 8.0PF B	K2,K4
C548			CC73HCH1H101J	CHIP C 100PF J	K2,K4	C627			CC73HCH1H100B	CHIP C 10PF B	K,K3
C550			CC73HCH1H050B	CHIP C 5.0PF B		C628			CC73HCH1H100C	CHIP C 10PF C	
C553			CC73HCH1H050B	CHIP C 5.0PF B	K,K3	C629			CK73HB1H471K	CHIP C 470PF K	
C553			CC73HCH1H100B	CHIP C 10PF B	K2,K4	C630			CK73GB1E105K	CHIP C 1.0UF K	
C554			CC73HCH1H470J	CHIP C 47PF J		C631			CS77AA1A6R8M	CHIP TNL 6.8UF 10WV	
C555			CK73HB0J105K	CHIP C 1.0UF K		C632			CK73HB1H471K	CHIP C 470PF K	
C556			CK73HB1H471K	CHIP C 470PF K	K,K3	C634-637			CK73HB1H471K	CHIP C 470PF K	
C556,557			CK73HB1H471K	CHIP C 470PF K	K2,K4	C639			CC73HCH1H330J	CHIP C 33PF J	K2,K4
C557			CC73HCH1H101J	CHIP C 100PF J	K,K3	C639			CC73HCH1H390J	CHIP C 39PF J	K,K3
C561			CK73HB1C103K	CHIP C 0.010UF K	K2,K4	C640			CC73HCH1H470J	CHIP C 47PF J	
C562			CK73HB0J105K	CHIP C 1.0UF K		C641			CC73HCH1H100C	CHIP C 10PF C	
C563			CC73HCH1H101J	CHIP C 100PF J	K2,K4	C642,643			CC73HCH1H151J	CHIP C 150PF J	
C565			CC73HCH1H330J	CHIP C 33PF J		C645			CK73GB1C104K	CHIP C 0.10UF K	
C566			CC73HCH1H680J	CHIP C 68PF J	K,K3	C646			CK73GB1E105K	CHIP C 1.0UF K	
C566			CC73HCH1H820J	CHIP C 82PF J	K2,K4	C647			C93-0941-05	CERAMIC CAP18PF 50V	K,K3
C567			CC73HCH1H0R5B	CHIP C 0.5PF B	K2,K4	C648,649			CK73HB1C103K	CHIP C 0.010UF K	
C568			CC73HCH1H1R5B	CHIP C 1.5PF B	K2,K4	C650			C93-0937-05	CERAMIC CAP12PF 50V	K,K3
C570			CC73HCH1HR75B	CHIP C 0.75PF B		C651			CK73HB1H471K	CHIP C 470PF K	
C571			CC73HCH1H030B	CHIP C 3.0PF B		C653			CK73HB1H471K	CHIP C 470PF K	
C572			CK73FB0J106K	CHIP C 10UF K		C654			C93-0987-05	CERAMIC 0.1UF 50WV	K,K3
C573			CC73HCH1H040B	CHIP C 4.0PF B	K,K3	C660			CC73GCH1H101J	CHIP C 100PF J	
C573			CC73HCH1H060B	CHIP C 6.0PF B	K2,K4	C661			CK73HB1H471K	CHIP C 470PF K	
C574			CC73HCH1H010B	CHIP C 1.0PF B	K,K3	C662			CC73GCH1H010B	CHIP C 1.0PF B	K,K3
C574			CC73HCH1H020B	CHIP C 2.0PF B	K2,K4	C662			CC73GCH1H040B	CHIP C 4.0PF B	K2,K4
C575			CC73HCH1H030B	CHIP C 3.0PF B	K,K3	C663			CC73GCH1H101J	CHIP C 100PF J	
C575			CC73HCH1H060B	CHIP C 6.0PF B	K2,K4	C664			CC73GCH1H040B	CHIP C 4.0PF B	K,K3
C576			CC73HCH1H050B	CHIP C 5.0PF B		C664			CC73GCH1H2R5B	CHIP C 2.5PF B	K2,K4
C577			CK73HB1H471K	CHIP C 470PF K		C665			CC73GCH1H020B	CHIP C 2.0PF B	K,K3
C578			CK73GB0J475K	CHIP C 4.7UF K		C665			CC73GCH1H030B	CHIP C 3.0PF B	K2,K4
C579			CC73HCH1H050B	CHIP C 5.0PF B		C666			CC73GCH1H050B	CHIP C 5.0PF B	K,K3
C580			CK73HB1H471K	CHIP C 470PF K		C666			CC73GCH1H080B	CHIP C 8.0PF B	K2,K4
C581			CC73HCH1H0R5B	CHIP C 0.5PF B		C667			CC73GCH1H1R5B	CHIP C 1.5PF B	K,K3
C582			CK73HB1H471K	CHIP C 470PF K		C667			CC73GCH1H2R5B	CHIP C 2.5PF B	K2,K4
C583			CC73HCH1H0R5B	CHIP C 0.5PF B		C668			CC73GCH1H080B	CHIP C 8.0PF B	K,K3
C584,585			CK73HB1H471K	CHIP C 470PF K		C668			CC73GCH1H100C	CHIP C 10PF C	K2,K4



## PARTS LIST

TX-RX UNIT (X57-7830-XX)

Ref. No.	Address	New parts	Parts No.	Description	Destination	Ref. No.	Address	New parts	Parts No.	Description	Destination
C669			CC73GCH1H040B	CHIP C 4.0PF B	K,K3	C755			CC73HCH1H040B	CHIP C 4.0PF B	K,K3
C669			CC73GCH1H1R5B	CHIP C 1.5PF B	K2,K4	C755			CC73HCH1H050B	CHIP C 5.0PF B	K2,K4
C670			CK73HB1H471K	CHIP C 470PF K		C756			CC73HCH1H090B	CHIP C 9.0PF B	K,K3
C671			CC73HCH1H070B	CHIP C 7.0PF B	K,K2	C756			CK73HB1H471K	CHIP C 470PF K	K2,K4
C671			CC73HCH1H100B	CHIP C 10PF B	K,K3	C758			CK73HB1H471K	CHIP C 470PF K	
C672			CK73HB1H471K	CHIP C 470PF K	K,K2	C759,760			CK73HB1A104K	CHIP C 0.10UF K	
C689-691			CK73HB1A104K	CHIP C 0.10UF K		C761			CK73GB1E105K	CHIP C 1.0UF K	
C692			C93-0951-05	CERAMIC CAP47PF 50V		C764			CC73HCH1H1R5B	CHIP C 1.5PF B	
C700			CC73HCH1H070B	CHIP C 7.0PF B		C765			CK73HB1H471K	CHIP C 470PF K	
C701			CK73HB1C103K	CHIP C 0.010UF K		C766			CK73GB1H104K	CHIP C 0.10UF K	
C702			CC73HCH1H820J	CHIP C 82PF J	K2,K4	C767			CC73HCH1H090B	CHIP C 9.0PF B	K,K3
C703			CK73HB1A104K	CHIP C 0.10UF K		C767			CC73HCH1H120G	CHIP C 12PF G	K2,K4
C704			CC73HCH1H100B	CHIP C 10PF B	K2,K4	C768			CC73HCH1H010B	CHIP C 1.0PF B	
C704			CC73HCH1H470J	CHIP C 47PF J	K,K3	C769			CK73HB1H471K	CHIP C 470PF K	
C705			CK73FB1E475K	CHIP C 4.7UF K		C770			CC73HCH1H030B	CHIP C 3.0PF B	K2,K4
C706			CC73HCH1H100B	CHIP C 10PF B		C770			CC73HCH1H040B	CHIP C 4.0PF B	K,K3
C707			CC73HCH1H680J	CHIP C 68PF J		C771			CK73HB1H471K	CHIP C 470PF K	
C708			CC73HCH1H101J	CHIP C 100PF J		C772			CC73HCH1H090B	CHIP C 9.0PF B	K,K3
C709-711			CK73HB1A104K	CHIP C 0.10UF K		C772			CC73HCH1H120G	CHIP C 12PF G	K2,K4
C712			CC73HCH1H680J	CHIP C 68PF J		C773			CC73HCH1H010B	CHIP C 1.0PF B	K,K3
C713			CK73FB1A106K	CHIP C 10UF K		C773			CC73HCH1H1R5B	CHIP C 1.5PF B	K2,K4
C714			CK73GB1H102K	CHIP C 1000PF K		C774			CC73HCH1H020B	CHIP C 2.0PF B	K2,K4
C715			CC73HCH1H470J	CHIP C 47PF J	K2,K4	C774			CC73HCH1H030B	CHIP C 3.0PF B	K,K3
C715			CK73HB1C103K	CHIP C 0.010UF K	K,K3	C775			CK73HB1H471K	CHIP C 470PF K	
C716			CC73HCH1H820J	CHIP C 82PF J	K,K3	C776			CC73HCH1H090B	CHIP C 9.0PF B	K,K3
C717			CK73HB1C103K	CHIP C 0.010UF K		C776			CC73HCH1H120G	CHIP C 12PF G	K2,K4
C718			CK73HB1A104K	CHIP C 0.10UF K		C777,778			CK73HB1H471K	CHIP C 470PF K	
C719			CK73FB1A106K	CHIP C 10UF K		C779			CK73HB1C103K	CHIP C 0.010UF K	
C720			CC73HCH1H100B	CHIP C 10PF B		C780			CK73GB1H104K	CHIP C 0.10UF K	
C721			CK73HB1A104K	CHIP C 0.10UF K		C782			CC73HCH1H0R5B	CHIP C 0.5PF B	
C722			CC73HCH1H470G	CHIP C 47PF G		C783			CK73GB1E105K	CHIP C 1.0UF K	
C723,724			CK73HB1A104K	CHIP C 0.10UF K		C784-786			CK73HB1H471K	CHIP C 470PF K	
C725			CK73HB1C103K	CHIP C 0.010UF K		C788			CK73GB1H104K	CHIP C 0.10UF K	
C727,728			CK73HB1A104K	CHIP C 0.10UF K		C789			CK73HB1H471K	CHIP C 470PF K	
C729			CK73FB1E474K	CHIP C 0.47UF K		C790			CK73HB1A104K	CHIP C 0.10UF K	
C730			CK73HB1C103K	CHIP C 0.010UF K		C791			CK73HB1H471K	CHIP C 470PF K	
C732			CK73HB1H471K	CHIP C 470PF K		C792			CK73HB1A104K	CHIP C 0.10UF K	
C733,734			CK73HB1C103K	CHIP C 0.010UF K		C794,795			CK73HB1H471K	CHIP C 470PF K	
C735			CC73HCH1H470G	CHIP C 47PF G		C796			CC73HCH1H090B	CHIP C 9.0PF B	K,K3
C736			CK73HB1C103K	CHIP C 0.010UF K		C796			CC73HCH1H110G	CHIP C 11PF G	K2,K4
C737			CC73HCH1H020B	CHIP C 2.0PF B		C798			CC73HCH1H030B	CHIP C 3.0PF B	K2,K4
C738			CC73HCH1H220G	CHIP C 22PF G		C798			CC73HCH1H1R5B	CHIP C 1.5PF B	K,K3
C739			CC73HCH1H060B	CHIP C 6.0PF B		C799			CK73HB1H471K	CHIP C 470PF K	
C740,741			CK73HB1C103K	CHIP C 0.010UF K		C800			CC73HCH1H020B	CHIP C 2.0PF B	K,K3
C742			CK73FB1A475K	CHIP C 4.7UF K		C800			CC73HCH1H1R5B	CHIP C 1.5PF B	K2,K4
C743			CK73HB1C103K	CHIP C 0.010UF K		C801			CK73HB1H471K	CHIP C 470PF K	
C744,745			CK73HB1H471K	CHIP C 470PF K		C802,803			CC73HCH1H040B	CHIP C 4.0PF B	
C746			CC73HCH1H090B	CHIP C 9.0PF B		C804			CC73HCH1H090B	CHIP C 9.0PF B	K,K3
C747			CC73HCH1H100B	CHIP C 10PF B		C804			CC73HCH1H110G	CHIP C 11PF G	K2,K4
C748			CK73HB1H471K	CHIP C 470PF K		C807			CC73HCH1H030B	CHIP C 3.0PF B	K2,K4
C749			CC73HCH1H020B	CHIP C 2.0PF B	K,K3	C807			CC73HCH1H050B	CHIP C 5.0PF B	K,K3
C749			CC73HCH1H040B	CHIP C 4.0PF B	K2,K4	C809			CC73GCH1H180J	CHIP C 18PF J	K,K3
C750			CK73HB1C103K	CHIP C 0.010UF K		C810			CC73HCH1H020B	CHIP C 2.0PF B	K,K3
C751			CC73HCH1H090B	CHIP C 9.0PF B	K2,K4	C810			CC73HCH1H040B	CHIP C 4.0PF B	K2,K4
C751			CC73HCH1H100B	CHIP C 10PF B	K,K3	C811			CC73HCH1H070B	CHIP C 7.0PF B	K2,K4
C752			CK73HB1H471K	CHIP C 470PF K		C811			CC73HCH1H090B	CHIP C 9.0PF B	K,K3
C753			CC73HCH1H020B	CHIP C 2.0PF B	K,K3	C813,814			CC73HCH1H270J	CHIP C 27PF J	K2,K4
C753			CC73HCH1H040B	CHIP C 4.0PF B	K2,K4	C849			CK73HB1H471K	CHIP C 470PF K	
C754			CC73HCH1H030B	CHIP C 3.0PF B	K,K3	C850			CC73HCH1H101J	CHIP C 100PF J	
C754			CC73HCH1H090B	CHIP C 9.0PF B	K2,K4	C900			CK73GB1H102K	CHIP C 1000PF K	

## PARTS LIST

### TX-RX UNIT (X57-7830-XX)

Ref. No.	Address	New parts	Parts No.	Description	Destination	Ref. No.	Address	New parts	Parts No.	Description	Destination
C901,902			CK73HB1H471K	CHIP C 470PF K		L527			L92-0446-05	BEADS CORE	
C903			CK73GB1H471K	CHIP C 470PF K		L528			L40-2775-71	SMALL FIXED INDUCTOR (27NH)	K,K3
C904-908			CC73HCH1H470J	CHIP C 47PF J		L528			L40-3375-71	SMALL FIXED INDUCTOR (33NH)	K2,K4
C910			CC73HCH1H470J	CHIP C 47PF J		L530			L40-5675-57	SMALL FIXED INDUCTOR (56.0NH)	
C912-920			CC73HCH1H470J	CHIP C 47PF J		L598,599			L92-0163-05	BEADS CORE	
C922,923			CC73HCH1H470J	CHIP C 47PF J		L600			L40-2275-92	SMALL FIXED INDUCTOR (22NH)	
C925-943			CC73HCH1H470J	CHIP C 47PF J		L602			L40-1875-92	SMALL FIXED INDUCTOR (18NH)	K,K3
C944			CK73HB1H471K	CHIP C 470PF K		L602			L40-2775-92	SMALL FIXED INDUCTOR (27NH)	K2,K4
C945,946			CC73HCH1H470J	CHIP C 47PF J		L603			L40-1575-92	SMALL FIXED INDUCTOR (15NH)	K,K3
C947			CK73HB1H471K	CHIP C 470PF K		L603			L40-1875-92	SMALL FIXED INDUCTOR (18NH)	K2,K4
C948,949			CK73GB1E105K	CHIP C 1.0UF K		L604			L92-0138-05	CHIP FERRITE	
C950			C92-0765-05	CHIP TNTL 4.7UF 16WV		L605			L40-1275-92	SMALL FIXED INDUCTOR (12NH)	K2,K4
C951			CK73GB1C224K	CHIP C 0.22UF K		L605			L40-6865-92	SMALL FIXED INDUCTOR (6.8NH)	K,K3
C952			CK73HB1H102K	CHIP C 1000PF K		L606			L41-1875-43	SMALL FIXED INDUCTOR (18NH)	
C953			CK73HB1A104K	CHIP C 0.10UF K		L607			L92-0149-05	CHIP FERRITE	
C954			CK73GB1C224K	CHIP C 0.22UF K		L609			L34-4575-05	AIR-CORE COIL	
C955,956			CK73HB1H102K	CHIP C 1000PF K		L610			L92-0149-05	CHIP FERRITE	
C957,958			CK73GB1E105K	CHIP C 1.0UF K		L611			L41-2285-43	SMALL FIXED INDUCTOR (220NH)	
C961			CK73HB1H471K	CHIP C 470PF K		L612-614			L34-4564-05	AIR-CORE COIL	
C962			CC73HCH1E181J	CHIP C 180PF J		L615			L40-1575-57	SMALL FIXED INDUCTOR (15.0NH)	K,K3
C963			CK73GB1E105K	CHIP C 1.0UF K		L615			L40-2275-57	SMALL FIXED INDUCTOR (22.0NH)	K2,K4
C964,965			CK73GB1C224K	CHIP C 0.22UF K		L701			L40-5681-86	SMALL FIXED INDUCTOR (0.56UH)	
C966			CC73HCH1H220J	CHIP C 22PF J		L703			L41-4778-45	SMALL FIXED INDUCTOR (47NH)	
C967			CK73HB1H471K	CHIP C 470PF K		L704			L40-1891-86	SMALL FIXED INDUCTOR (1.8UH)	
C968			CK73GB1C224K	CHIP C 0.22UF K		L705,706			L92-0138-05	CHIP FERRITE	
C969			CK73GB1E105K	CHIP C 1.0UF K		L707			L41-2785-39	SMALL FIXED INDUCTOR (0.27UH)	
C970,971			CK73HB1H102K	CHIP C 1000PF K		L708			L41-5685-39	SMALL FIXED INDUCTOR (0.56UH)	
C972-974			CK73GB1E105K	CHIP C 1.0UF K		L709,710			L40-1575-92	SMALL FIXED INDUCTOR (15NH)	K2,K4
C975			C93-0899-05	CERAMIC CAP9P 50V	K2,K4	L709,710			L40-1875-92	SMALL FIXED INDUCTOR (18NH)	K,K3
C975			C93-0987-05	CERAMIC 0.1UF 50WV	K,K3	L711			L40-2275-92	SMALL FIXED INDUCTOR (22NH)	K,K3
C976			CC73HCH1H470J	CHIP C 47PF J		L711			L40-3375-92	SMALL FIXED INDUCTOR (33NH)	K2,K4
C977			CK73GB1E105K	CHIP C 1.0UF K		L713-715			L41-1078-14	SMALL FIXED INDUCTOR (10NH)	K2,K4
C980			CK73GB1E105K	CHIP C 1.0UF K		L713-715			L41-8268-14	SMALL FIXED INDUCTOR (8.2NH)	K,K3
C981			CK73HB1A474K	CHIP C 0.47UF K		L716			L92-0138-05	CHIP FERRITE	
C987			CC73HCH1H050B	CHIP C 5.0PF B	K2,K4	L717			L41-2285-14	SMALL FIXED INDUCTOR (220NH)	
C988			C93-0945-05	CERAMIC CAP27PF 50V	K2,K4	L720			L40-1075-92	SMALL FIXED INDUCTOR (10NH)	K,K3
C989			C93-0939-05	CERAMIC CAP15PF 50V	K2,K4	L721,722			L41-1078-14	SMALL FIXED INDUCTOR (10NH)	K2,K4
CN600			E23-1326-05	TERMINAL		L721,722			L41-8268-14	SMALL FIXED INDUCTOR (8.2NH)	K,K3
CN601			E23-1167-05	TERMINAL	K2,K4	L723			L34-4564-05	AIR-CORE COIL	
CN737			E40-6358-05	SOCKET FOR PIN ASSY		L725			L40-6865-92	SMALL FIXED INDUCTOR (6.8NH)	K2,K4
CN900			E40-6422-15	SOCKET FOR PIN ASSY		L725			L40-8265-92	SMALL FIXED INDUCTOR (8.2NH)	K,K3
CN901			E40-6752-05	FLAT CABLE CONNECTOR		L726			L41-3378-03	SMALL FIXED INDUCTOR (33NH)	K,K3
CN902			E23-1326-05	TERMINAL		L726			L41-3978-03	SMALL FIXED INDUCTOR (39NH)	K2,K4
F900			F53-0324-05	FUSE (2.5A)		L780			L40-1085-57	SMALL FIXED INDUCTOR (100NH)	
CF700			L72-1017-05	CERAMIC FILTER (450KHZ)		L900			L92-0149-05	CHIP FERRITE	
CF701			L72-1020-05	CERAMIC FILTER (450KHZ)		L901			L33-1462-05	SMALL FIXED INDUCTOR (68UH)	
L500			L41-4795-39	SMALL FIXED INDUCTOR (4.7UH)		L902			L40-2702-86	SMALL FIXED INDUCTOR (27UH)	K2,K4
L503			L92-0163-05	BEADS CORE		L903			L41-6869-16	SMALL FIXED INDUCTOR (6.8NH)	K2,K4
L504			L40-1275-92	SMALL FIXED INDUCTOR (12NH)		X500			L77-3016-05	TCXO (19.2MHZ)	
L508,509			L40-2285-92	SMALL FIXED INDUCTOR (220NH)		XF700			L71-0640-05	MCF (58.05MHZ)	
L514-519			L40-2285-92	SMALL FIXED INDUCTOR (220NH)		R430			RK73GB2A000J	CHIP R 0.0 J 1/10W	
L520			L40-1878-67	SMALL FIXED INDUCTOR (18NH)	K,K3	R431,432			RK73HB1J000J	CHIP R 0.0 J 1/16W	
L520			L40-2278-67	SMALL FIXED INDUCTOR (22NH)	K2,K4	R500,501			RN73HH1J104D	CHIP R 100K D 1/16W	
L521			L40-2278-67	SMALL FIXED INDUCTOR (22NH)	K,K3	R502			RK73HB1J124J	CHIP R 120K J 1/16W	K,K3
L521			L40-2278-67	SMALL FIXED INDUCTOR (22NH)		R503			RK73HB1J100J	CHIP R 10 J 1/16W	
L521			L40-2778-67	SMALL FIXED INDUCTOR (27NH)	K2,K4	R504			RK73HB1J104J	CHIP R 100K J 1/16W	
L522			L40-2285-92	SMALL FIXED INDUCTOR (220NH)		R505			RK73HB1J000J	CHIP R 0.0 J 1/16W	
L523			L92-0446-05	BEADS CORE		R506			RK73HB1J473J	CHIP R 47K J 1/16W	
L524-526			L40-2285-92	SMALL FIXED INDUCTOR (220NH)		R511-514			RK73HB1J100J	CHIP R 10 J 1/16W	

## PARTS LIST

TX-RX UNIT (X57-7830-XX)

Ref. No.	Address	New parts	Parts No.	Description	Desti-nation	Ref. No.	Address	New parts	Parts No.	Description	Desti-nation
R515			RK73HB1J472J	CHIP R 4.7K J 1/16W		R612			RK73HB1J472J	CHIP R 4.7K J 1/16W	
R519			RK73HB1J100J	CHIP R 10 J 1/16W		R613			RK73HB1J000J	CHIP R 0.0 J 1/16W	
R520			RK73HB1J102J	CHIP R 1.0K J 1/16W		R616			RK73HB1J181J	CHIP R 180 J 1/16W	
R522			RK73HB1J100J	CHIP R 10 J 1/16W		R617			RK73HB1J331J	CHIP R 330 J 1/16W	
R523			RK73HB1J102J	CHIP R 1.0K J 1/16W		R618			RK73HB1J220J	CHIP R 22 J 1/16W	
R527			RK73HB1J000J	CHIP R 0.0 J 1/16W		R619			RK73HB1J821J	CHIP R 820 J 1/16W	K2,K4
R529			RK73HB1J102J	CHIP R 1.0K J 1/16W		R620			RK73HB1J000J	CHIP R 0.0 J 1/16W	K,K3
R530			RK73HB1J473J	CHIP R 47K J 1/16W		R620			RK73HB1J5R6J	CHIP R 5.6 J 1/16W	K2,K4
R531			RK73HB1J683J	CHIP R 68K J 1/16W		R621			RK73HB1J821J	CHIP R 820 J 1/16W	K2,K4
R532			RK73HB1J000J	CHIP R 0.0 J 1/16W		R622			RK73HB1J101J	CHIP R 100 J 1/16W	
R533			RK73HH1J184D	CHIP R 180K D 1/16W	K,K3	R623			RK73HB1J103J	CHIP R 10K J 1/16W	K,K3
R533			RK73HH1J224D	CHIP R 220K D 1/16W	K2,K4	R623			RK73HB1J123J	CHIP R 12K J 1/16W	K2,K4
R534			RK73HH1J473D	CHIP R 47K D 1/16W		R624			RK73HB1J333J	CHIP R 33K J 1/16W	K2,K4
R535			RK73HB1J151J	CHIP R 150 J 1/16W		R624			RK73HB1J473J	CHIP R 47K J 1/16W	K,K3
R536			RK73HB1J000J	CHIP R 0.0 J 1/16W		R626			RK73HB1J121J	CHIP R 120 J 1/16W	K,K3
R537			RK73HB1J102J	CHIP R 1.0K J 1/16W		R626			RK73HB1J221J	CHIP R 220 J 1/16W	K2,K4
R538			RK73HH1J391D	CHIP R 390 D 1/16W		R627,628			RK73HB1J000J	CHIP R 0.0 J 1/16W	
R539			RK73HB1J106J	CHIP R 10M J 1/16W		R629			RK73HB1J273J	CHIP R 27K J 1/16W	
R541			RK73HB1J103J	CHIP R 10K J 1/16W		R630			RK73HB1J103J	CHIP R 10K J 1/16W	K2,K4
R546			RK73HB1J104J	CHIP R 100K J 1/16W		R630			RK73HB1J333J	CHIP R 33K J 1/16W	K,K3
R547			RK73HB1J000J	CHIP R 0.0 J 1/16W		R631			RK73HB1J470J	CHIP R 47 J 1/16W	
R548			RK73HB1J104J	CHIP R 100K J 1/16W		R632			RK73HB1J103J	CHIP R 10K J 1/16W	K,K3
R550			RK73HB1J000J	CHIP R 0.0 J 1/16W		R632			RK73HB1J562J	CHIP R 5.6K J 1/16W	K2,K4
R552			RK73HB1J104J	CHIP R 100K J 1/16W	K2,K4	R633			RK73HB1J101J	CHIP R 100 J 1/16W	
R552			RK73HB1J124J	CHIP R 120K J 1/16W	K,K3	R634			RK73HB1J000J	CHIP R 0.0 J 1/16W	
R554,555			RK73HB1J473J	CHIP R 47K J 1/16W		R635			RK73HB1J561J	CHIP R 560 J 1/16W	
R557			RK73HB1J152J	CHIP R 1.5K J 1/16W		R636			RK73HB1J221J	CHIP R 220 J 1/16W	
R558			RK73HB1J474J	CHIP R 470K J 1/16W		R639			RK73HB1J103J	CHIP R 10K J 1/16W	
R559			RK73HH1J181D	CHIP R 180 D 1/16W	K,K3	R641			RK73HB1J103J	CHIP R 10K J 1/16W	
R559			RK73HH1J221D	CHIP R 220 D 1/16W	K2,K4	R642			RK73EB2ER39K	CHIP R 0.39 K 1/4W	
R560			RK73HB1J220J	CHIP R 22 J 1/16W		R644			RK73HB1J220J	CHIP R 22 J 1/16W	K2,K4
R561			RK73HB1J181D	CHIP R 180 D 1/16W	K,K3	R644			RK73HB1J470J	CHIP R 47 J 1/16W	K,K3
R561			RK73HH1J221D	CHIP R 220 D 1/16W	K2,K4	R645			RK73EB2ER39K	CHIP R 0.39 K 1/4W	
R562			RK73HB1J102J	CHIP R 1.0K J 1/16W		R646			RK73HB1J333J	CHIP R 33K J 1/16W	
R563			RK73HB1J473J	CHIP R 47K J 1/16W		R647			RK73EB2ER39K	CHIP R 0.39 K 1/4W	
R564			RK73HB1J154J	CHIP R 150K J 1/16W		R648,649			RK73HH1J154D	CHIP R 150K D 1/16W	
R565			RK73HB1J101J	CHIP R 100 J 1/16W		R650			RK73GB2A000J	CHIP R 0.0 J 1/10W	
R566			RK73HH1J474D	CHIP R 470K D 1/16W		R651-654			RK73HH1J274D	CHIP R 270K D 1/16W	
R567			RK73HB1J472J	CHIP R 4.7K J 1/16W		R655			RK73HB1J103J	CHIP R 10K J 1/16W	
R568			RK73HB1J474J	CHIP R 470K J 1/16W		R656			RK73HB1J563J	CHIP R 56K J 1/16W	
R570,571			RK73HB1J000J	CHIP R 0.0 J 1/16W		R657			RK73HB1J000J	CHIP R 0.0 J 1/16W	
R572			RK73HB1J100J	CHIP R 10 J 1/16W		R658			RK73HB1J182J	CHIP R 1.8K J 1/16W	K,K3
R573			RK73HB1J124J	CHIP R 120K J 1/16W	K2,K4	R658			RK73HB1J821J	CHIP R 820 J 1/16W	K2,K4
R574-576			RK73HB1J000J	CHIP R 0.0 J 1/16W		R659			RK73HB1J474J	CHIP R 470K J 1/16W	
R577			RK73GB2A000J	CHIP R 0.0 J 1/10W		R660			RK73HB1J473J	CHIP R 47K J 1/16W	
R580,581			RK73HB1J000J	CHIP R 0.0 J 1/16W		R661			RK73HB1J104J	CHIP R 100K J 1/16W	
R583			RK73HB1J000J	CHIP R 0.0 J 1/16W	K2,K4	R663			RK73FB2B000J	CHIP R 0.0 J 1/8W	K,K3
R586			RK73HB1J000J	CHIP R 0.0 J 1/16W		R664			RK73HB1J000J	CHIP R 0.0 J 1/16W	
R589,590			RK73HB1J103J	CHIP R 10K J 1/16W		R665,666			RK73HB1J271J	CHIP R 270 J 1/16W	
R599			RK73HB1J104J	CHIP R 100K J 1/16W		R667			RK73EB2E823J	CHIP R 82K J 1/4W	
R600			RK73HB1J102J	CHIP R 1.0K J 1/16W		R669			RK73HB1J471J	CHIP R 470 J 1/16W	K,K3
R601			RK73HB1J183J	CHIP R 18K J 1/16W		R670			RK73HB1J224J	CHIP R 220K J 1/16W	
R602			RK73HB1J124J	CHIP R 120K J 1/16W		R671			RK73GB2A000J	CHIP R 0.0 J 1/10W	
R603			RK73HB1J222J	CHIP R 2.2K J 1/16W		R701			RK73HB1J561J	CHIP R 560 J 1/16W	
R604			RK73HB1J682J	CHIP R 6.8K J 1/16W		R702			RK73HB1J334J	CHIP R 330K J 1/16W	
R605			RK73HB1J103J	CHIP R 10K J 1/16W		R703			RK73HB1J100J	CHIP R 10 J 1/16W	
R606			RK73HB1J331J	CHIP R 330 J 1/16W		R704			RK73HB1J102J	CHIP R 1.0K J 1/16W	
R607			RK73HB1J222J	CHIP R 2.2K J 1/16W		R705			RK73HB1J000J	CHIP R 0.0 J 1/16W	
R608			RK73HB1J470J	CHIP R 47 J 1/16W		R709			RK73HB1J103J	CHIP R 10K J 1/16W	
R610			RK73HB1J472J	CHIP R 4.7K J 1/16W		R710			RK73GB2A000J	CHIP R 0.0 J 1/10W	K,K3

## PARTS LIST

## TX-RX UNIT (X57-7830-XX)

Ref. No.	Address	New parts	Parts No.	Description	Destination	Ref. No.	Address	New parts	Parts No.	Description	Destination
R712			RK73HB1J103J	CHIP R 10K J 1/16W		R785			RK73HB1J105J	CHIP R 1.0M J 1/16W	K2,K4
R714			RK73HB1J100J	CHIP R 10 J 1/16W		R786			RK73HB1J000J	CHIP R 0.0 J 1/16W	
R717			RK73HB1J473J	CHIP R 47K J 1/16W		R788			RK73HB1J104J	CHIP R 100K J 1/16W	K,K3
R718			RK73HB1J183J	CHIP R 18K J 1/16W		R788			RK73HB1J105J	CHIP R 1.0M J 1/16W	K2,K4
R719			RK73HB1J274J	CHIP R 270K J 1/16W		R790			RK73HB1J104J	CHIP R 100K J 1/16W	K,K3
R720			RK73HB1J222J	CHIP R 2.2K J 1/16W		R790			RK73HB1J105J	CHIP R 1.0M J 1/16W	K2,K4
R721			RK73HB1J103J	CHIP R 10K J 1/16W		R791			RK73HB1J000J	CHIP R 0.0 J 1/16W	
R722			RK73HB1J472J	CHIP R 4.7K J 1/16W		R792			RK73HB1J104J	CHIP R 100K J 1/16W	
R724			RK73HB1J104J	CHIP R 100K J 1/16W		R794,795			RK73HB1J103J	CHIP R 10K J 1/16W	
R725			RK73HB1J223J	CHIP R 22K J 1/16W		R796			RK73HB1J000J	CHIP R 0.0 J 1/16W	
R726			RK73HB1J183J	CHIP R 18K J 1/16W		R797			RK73HB1J473J	CHIP R 47K J 1/16W	
R727			RK73HB1J222J	CHIP R 2.2K J 1/16W		R798			RK73HB1J470J	CHIP R 47 J 1/16W	
R728			RK73HB1J221J	CHIP R 220 J 1/16W		R799			RK73HB1J000J	CHIP R 0.0 J 1/16W	
R730			RK73HB1J000J	CHIP R 0.0 J 1/16W		R800			RK73GB2A000J	CHIP R 0.0 J 1/10W	K2,K4
R731			RK73HB1J103J	CHIP R 10K J 1/16W		R900			RK73HB1J391J	CHIP R 390 J 1/16W	
R733			RK73HB1J564J	CHIP R 560K J 1/16W		R901			RK73GB2A000J	CHIP R 0.0 J 1/10W	
R735			RK73HB1J101J	CHIP R 100 J 1/16W		R902			RK73HB1J100J	CHIP R 10 J 1/16W	
R736			RK73HB1J104J	CHIP R 100K J 1/16W		R903			RK73HB1J821J	CHIP R 820 J 1/16W	
R737			RK73HB1J221J	CHIP R 220 J 1/16W		R904			RK73HB1J000J	CHIP R 0.0 J 1/16W	
R738			RK73HB1J272J	CHIP R 2.7K J 1/16W		R905			RK73HB1J330J	CHIP R 33 J 1/16W	
R739			RK73HB1J221J	CHIP R 220 J 1/16W		R906			RK73HB1J474J	CHIP R 470K J 1/16W	
R740			RK73HB1J470J	CHIP R 47 J 1/16W		R907			RK73GB2A100J	CHIP R 10 J 1/10W	
R742			RK73HB1J472J	CHIP R 4.7K J 1/16W		R908			RK73HB1J473J	CHIP R 47K J 1/16W	
R743			RK73HB1J681J	CHIP R 680 J 1/16W		R909			RK73GB2A000J	CHIP R 0.0 J 1/10W	
R744			RK73HB1J221J	CHIP R 220 J 1/16W		R910-912			RK73HB1J474J	CHIP R 470K J 1/16W	
R745			RK73HB1J102J	CHIP R 1.0K J 1/16W		R913			RK73HB1J102J	CHIP R 1.0K J 1/16W	
R746			RK73HB1J104J	CHIP R 100K J 1/16W		R914			RK73HB1J154J	CHIP R 150K J 1/16W	
R747			RK73HB1J154J	CHIP R 150K J 1/16W		R915-917			RK73HB1J474J	CHIP R 470K J 1/16W	
R748			RK73HB1J104J	CHIP R 100K J 1/16W		R918			RK73HB1J102J	CHIP R 1.0K J 1/16W	
R749			RK73HB1J184J	CHIP R 180K J 1/16W	K,K3	R920,921			RK73HB1J473J	CHIP R 47K J 1/16W	
R749			RK73HB1J224J	CHIP R 220K J 1/16W	K2,K4	R922			RK73HB1J102J	CHIP R 1.0K J 1/16W	
R750			RK73GB2A000J	CHIP R 0.0 J 1/10W		R923			RK73HB1J123J	CHIP R 12K J 1/16W	
R752,753			RK73HB1J000J	CHIP R 0.0 J 1/16W		R925			RK73HH1J334D	CHIP R 330K D 1/16W	
R755			RK73HB1J472J	CHIP R 4.7K J 1/16W		R926			RK73HH1J223D	CHIP R 22K D 1/16W	
R757			RK73HB1J104J	CHIP R 100K J 1/16W	K,K3	R927			RK73HB1J102J	CHIP R 1.0K J 1/16W	
R757			RK73HB1J105J	CHIP R 1.0M J 1/16W	K2,K4	R928			RK73HB1J000J	CHIP R 0.0 J 1/16W	
R758			RK73HB1J103J	CHIP R 10K J 1/16W		R929			RK73HB1J102J	CHIP R 1.0K J 1/16W	
R759,760			RK73HB1J104J	CHIP R 100K J 1/16W	K,K3	R931			RK73GB2A000J	CHIP R 0.0 J 1/10W	
R759,760			RK73HB1J105J	CHIP R 1.0M J 1/16W	K2,K4	R932			RK73HB1J104J	CHIP R 100K J 1/16W	
R761			RK73HB1J101J	CHIP R 100 J 1/16W		R933			RK73HB1J102J	CHIP R 1.0K J 1/16W	
R762			RK73HB1J103J	CHIP R 10K J 1/16W		R934			RK73HB1J273J	CHIP R 27K J 1/16W	
R763			RK73HB1J824J	CHIP R 820K J 1/16W		R935			RK73HB1J153J	CHIP R 15K J 1/16W	K2,K4
R764			RK73HB1J104J	CHIP R 100K J 1/16W		R950			RK73HB1J000J	CHIP R 0.0 J 1/16W	K,K3
R765			RK73HB1J000J	CHIP R 0.0 J 1/16W		R951			RK73HB1J000J	CHIP R 0.0 J 1/16W	K2,K4
R768			RK73HB1J000J	CHIP R 0.0 J 1/16W		R954			RK73GB2A000J	CHIP R 0.0 J 1/10W	K2,K4
R769			RK73HB1J103J	CHIP R 10K J 1/16W		R955-958			RK73HB1J000J	CHIP R 0.0 J 1/16W	K2,K4
R770			RK73HB1J680J	CHIP R 68 J 1/16W		S1			S70-0483-05	TACT SWITCH	
R771			RK73HB1J151J	CHIP R 150 J 1/16W	K2,K4	D501			HSC119	DIODE	
R771			RK73HB1J181J	CHIP R 180 J 1/16W	K,K3	D505			DA221	DIODE	
R772			RK73HB1J000J	CHIP R 0.0 J 1/16W		D506,507			1SV325F	VARIABLE CAPACITANCE DIODE	
R773			RK73HB1J824J	CHIP R 820K J 1/16W		D510			1SV290B-F	VARIABLE CAPACITANCE DIODE	K2,K4
R774,775			RK73HB1J104J	CHIP R 100K J 1/16W		D510,511			1SV282-F	VARIABLE CAPACITANCE DIODE	K,K3
R777			RK73HB1J103J	CHIP R 10K J 1/16W		D511			1SV282-F	VARIABLE CAPACITANCE DIODE	K2,K4
R778			RK73HB1J104J	CHIP R 100K J 1/16W		D514-517			1SV282-F	VARIABLE CAPACITANCE DIODE	K,K3
R779			RK73HB1J683J	CHIP R 68K J 1/16W		D514,515			1SV290B-F	VARIABLE CAPACITANCE DIODE	K2,K4
R780			RK73HB1J000J	CHIP R 0.0 J 1/16W		D516,517			1SV282-F	VARIABLE CAPACITANCE DIODE	K2,K4
R781			RK73HB1J182J	CHIP R 1.8K J 1/16W		D518			HSC119	DIODE	
R783			RK73HB1J224J	CHIP R 220K J 1/16W		D519			1SV278F	VARIABLE CAPACITANCE DIODE	
R784			RK73HB1J474J	CHIP R 470K J 1/16W							
R785			RK73HB1J104J	CHIP R 100K J 1/16W	K,K3						

## PARTS LIST

TX-RX UNIT (X57-7830-XX)

Ref. No.	Address	New parts	Parts No.	Description	Destination	Ref. No.	Address	New parts	Parts No.	Description	Destination
D600,601			HSC277	DIODE							
D604			HZU2ALL	ZENER DIODE							
D605			HZU5CLL	ZENER DIODE							
D606,607			HVC131	DIODE							
D608			HSC119	DIODE	K,K3						
D700			HSC119	DIODE							
D702-704			1SV286F	VARIABLE CAPACITANCE DIODE							
D705			HSC119	DIODE							
D706			1SV286F	VARIABLE CAPACITANCE DIODE							
D708			1SV286F	VARIABLE CAPACITANCE DIODE							
D709			HVC131	DIODE							
D710			1SV286F	VARIABLE CAPACITANCE DIODE							
D711			HVC131	DIODE							
D901			1SR154-400	DIODE							
D902			HSC119	DIODE							
IC404			TC75W51FUF	MOS-IC							
IC500			LM73CIMKX-0	MOS-IC							
IC501			TLV2381IDBV	MOS-IC							
IC502			<b>Note 1</b>	MOS-IC							
IC503			TLV2381IDBV	MOS-IC							
IC504			TC75W51FUF	MOS-IC							
IC600			TA75W01FUF	MOS-IC							
IC700			MCP6021-E/OT	MOS-IC							
IC701			TK10931VTL-G	ANALOGUE IC							
IC702,703			TLV2381IDBV	MOS-IC							
IC900			TC75S51FE (F)	MOS-IC							
IC901			XC9101D09AKR	ANALOGUE IC							
IC902			TK11250CUCB	MOS-IC							
IC903			TK71733S	BI-POLAR IC							
Q503			2SC5383-T111	TRANSISTOR							
Q504			2SK879-F (Y)	FET							
Q507			2SC5383-T111	TRANSISTOR							
Q508,509			2SK508NV (K52)	FET							
Q510			SSM6L05FU-F	FET							
Q511			2SJ347F	FET							
Q512			2SC5636	TRANSISTOR							
Q600,601			2SC5636	TRANSISTOR							
Q602			2SK3077F	FET							
Q603			RD01MUS1-T113	FET							
Q604			2SC5383-T111	TRANSISTOR							
Q605			SSM3K15TE (F)	FET							
Q606			RD07MVS1BT122	FET							
Q607		*	DTC144EEB	DIGITAL TRANSISTOR							
Q608			2SK1824-A	FET							
Q610			EMD5	TRANSISTOR							
Q700			2SC5108 (Y) F	TRANSISTOR							
Q701			2SC4215-F (Y)	TRANSISTOR							
Q703			3SK318	FET							
Q704			2SC5383-T111	TRANSISTOR							
Q705			3SK318	FET							
Q706			2SK1830F	FET							
Q900			UMG9N	TRANSISTOR							
Q901-903			SSM6L05FU-F	FET							
Q904			SSM5H01TU-F	FET							
Q905			2SA1955A-F	TRANSISTOR							
TH600			ERTJ0EV104H	THERMISTOR							

**Note 1 : This part cannot be replaced. Therefore, this part is not supplied as a service part.**

## EXPLODED VIEW

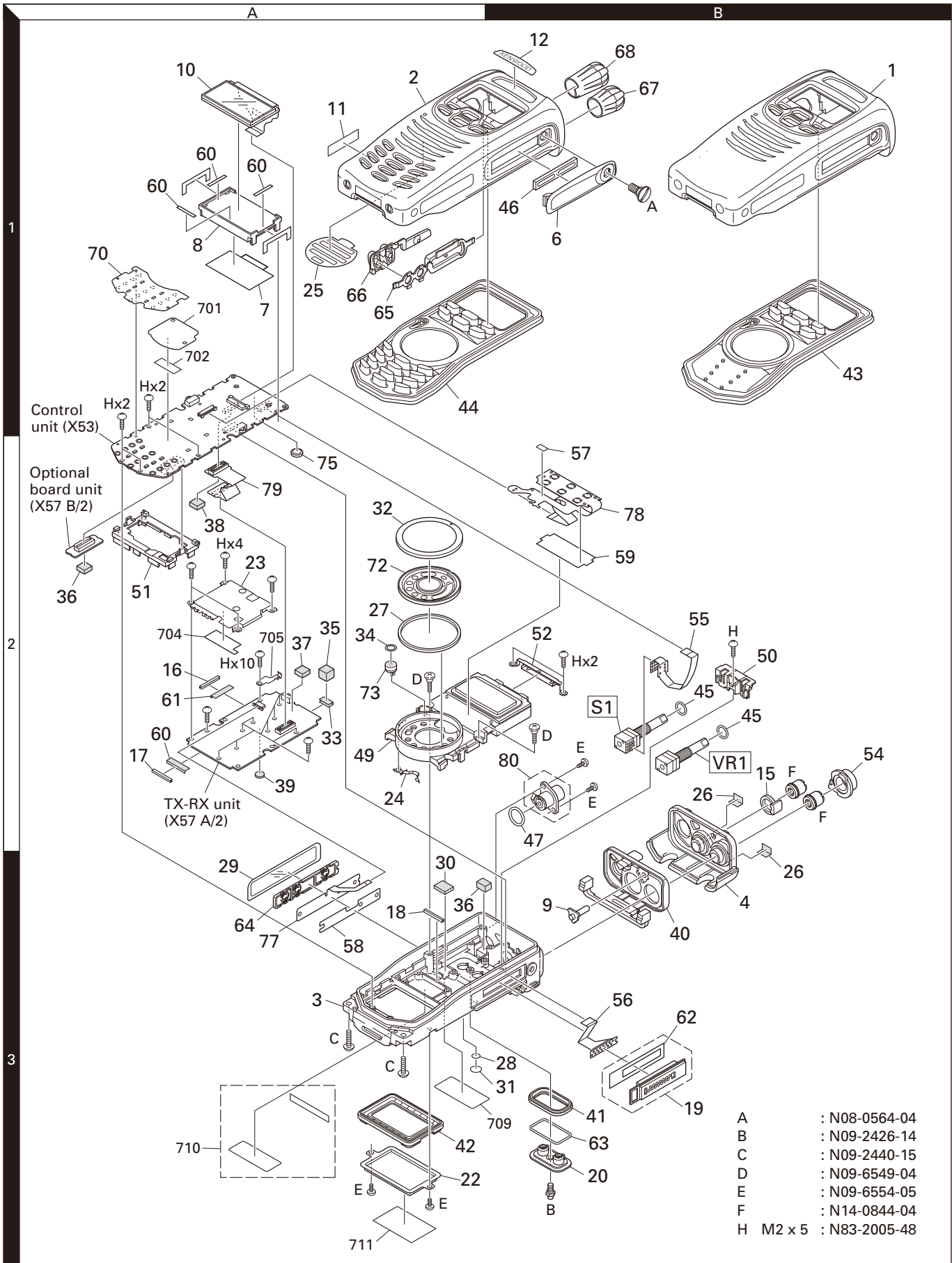

## PACKING

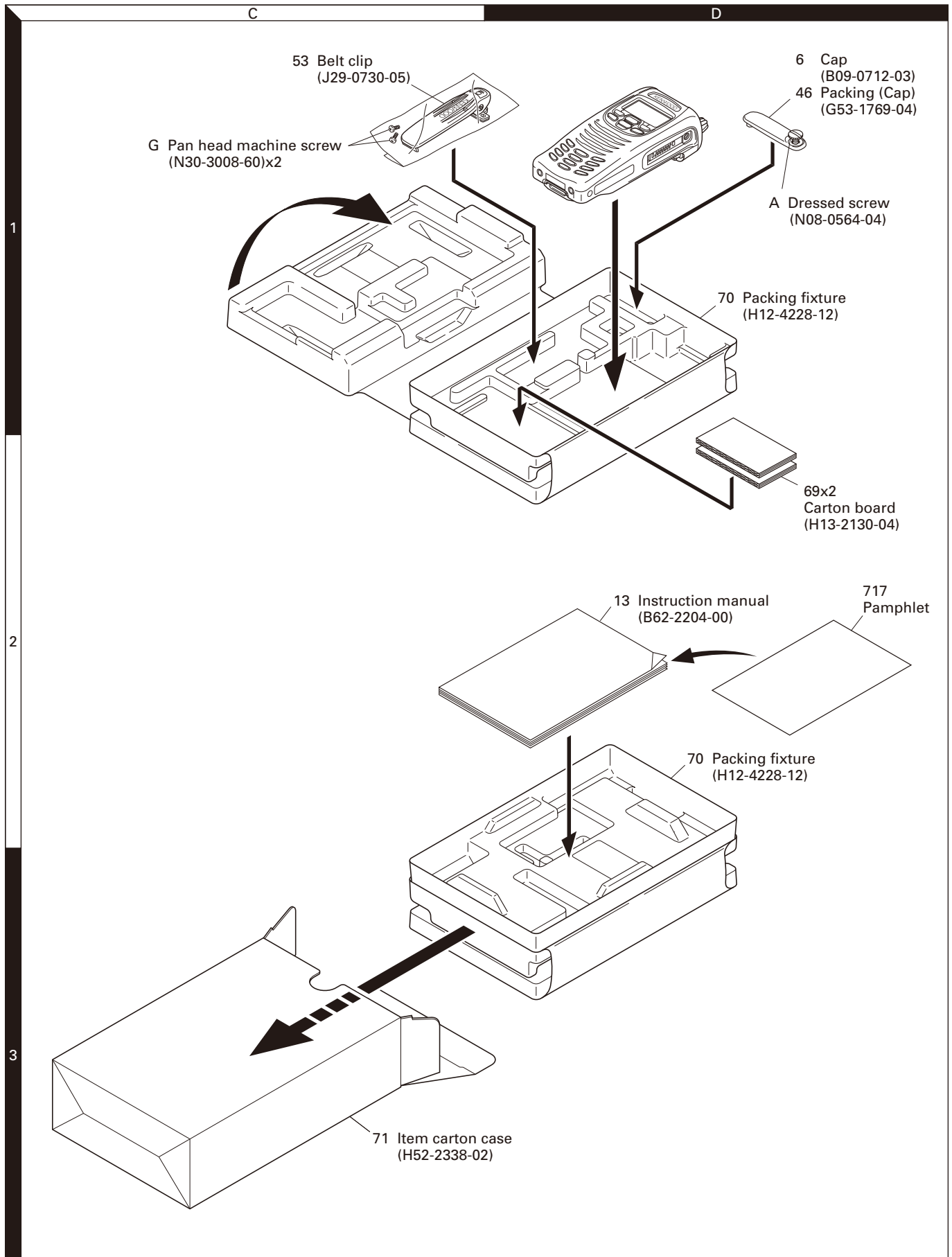

Parts with the exploded numbers larger than 700 are not supplied.

## TROUBLE SHOOTING

### Fault Diagnosis of the BGA (Ball Grid Array) IC

#### ■ Overview

A flowchart for determining whether or not the transceiver can be powered on (the LCD does not function even if the power switch is turned on) due to broken BGA parts.

#### ■ BGA parts

ASIC (IC108), DSP (IC102), FLASH (IC101), SRAM (IC103)

When the BGA IC is problematic, please bring the printed circuit board (X53-4480-12 for 6-key, X53-4480-13 for 18-key) in for service. Various ESN/default adjustment values are written on the printed circuit board for service.

Additionally various ESN stickers are included. (Please refer to pages 34 and 35.)

Button type lithium battery (W09-0971-05) does not belong to the printed circuit board for service. Please use the part which has been attached to the printed circuit board. After the printed circuit board has been readjusted, please attach any ESN stickers to the chassis.

#### ● Checking power supply voltage

Checking voltage	
Points to be checked	Normal voltage
33M IC404 (3 pin)	3.3V
15M IC717 (4 pin)	1.5V
33A IC406 (5 pin)	3.3V
31BU IC416 (3 pin)	3.1V
Power supply of each device is connected through the coil.	
[ASIC]	
33M: L714, 15M: L715, 33A: L716	
[DSP]	
33M: L712, 15M: L711	
[FLASH]	
33M: L717	
[SRAM]	
31BU: L710	

When an abnormal value is confirmed.

#### Checking for an abnormal point

33M has an abnormal voltage.  
[ASIC]  
Remove L714 to check the voltage of the 33M.  
If the voltage becomes normal, the ASIC is broken.  
[DSP]  
Remove L712 to check the voltage of the 33M.  
If the voltage becomes normal, the DSP is broken.  
[FLASH]  
Remove L717 to check the voltage of the 33M.  
If the voltage becomes normal, the FLASH is broken.

15M has an abnormal voltage.  
[ASIC]  
Remove L715 to check the voltage of the 15M.  
If the voltage becomes normal, the ASIC is broken.  
[DSP]  
Remove L711 to check the voltage of the 15M.  
If the voltage becomes normal, the DSP is broken.

#### ● Checking the clock

Checking the clock	
Points to be checked	Normal voltage (3.3V)
18.432MHz ASIC side R158	18.432MHz
ASIC & DSP side R159	18.432MHz
32.768kHz IC106 (1 pin)	32.768kHz

When a normal value is confirmed.

When an abnormal value is confirmed.

33A has an abnormal voltage.  
[ASIC]  
Remove L716 to check the voltage of the 33A.  
If the voltage becomes normal, the ASIC is broken.

#### ● Checking the Reset/Control signal

Checking the control signal input to the ASIC	
Points to be checked	Normal voltage
RESET IC105 (4 pin)	3.3V
/BINT Q401 (6 pin)	3.3V
/PSW Q402 (3 pin)	3.3V

When a normal value is confirmed.

When an abnormal value is confirmed.

31BU has an abnormal voltage.  
[SRAM]  
Remove L710 to check the voltage of the 31BU.  
If the voltage becomes normal, the SRAM is broken.

If the voltage is not corrected, there is a problem other than the BGA parts.

#### Checking the control signal output from the ASIC

Points to be checked	Normal voltage
/FRST C110	3.3V

When a normal value is confirmed.

When an abnormal value is confirmed.

If the /FRST is always 0V, the ASIC is broken.  
If the /FRST repeats 3.3V and 0V at intervals, The ASIC, FLASH and SRAM may be broken.

When a normal value is confirmed.

The BGA parts are not broken.

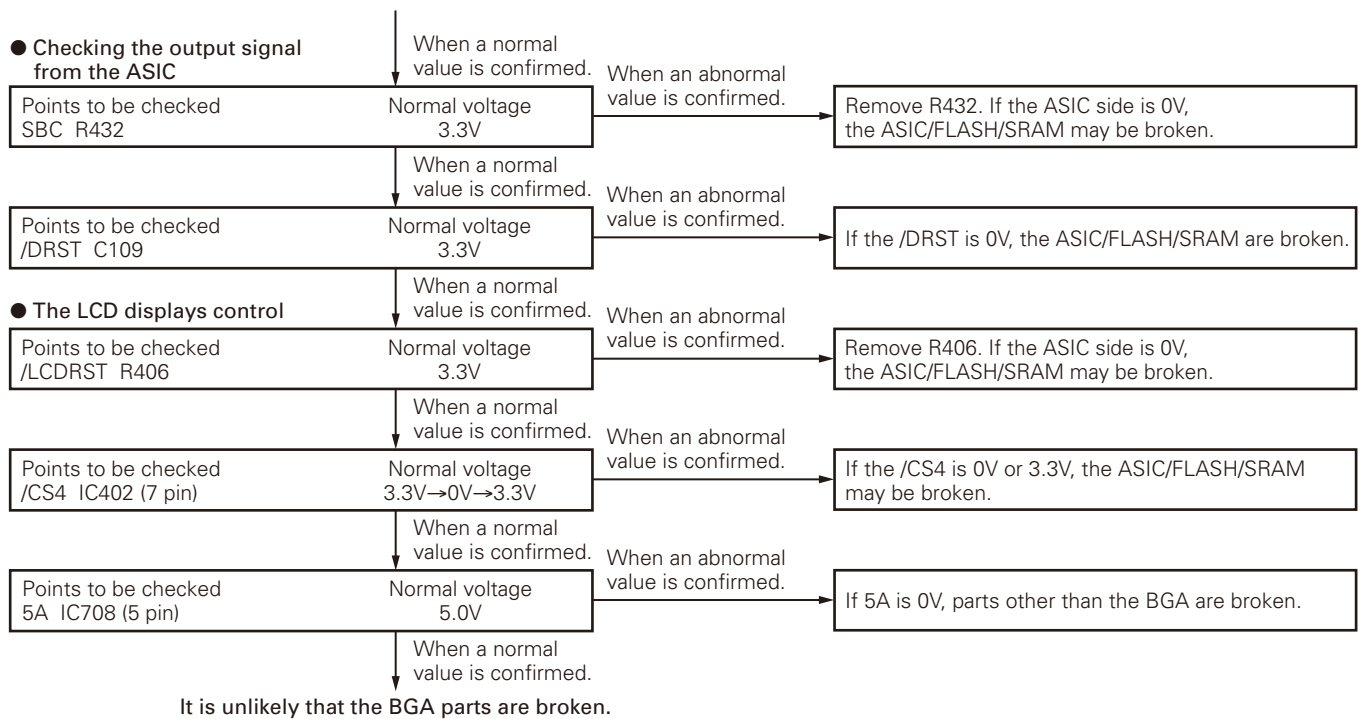
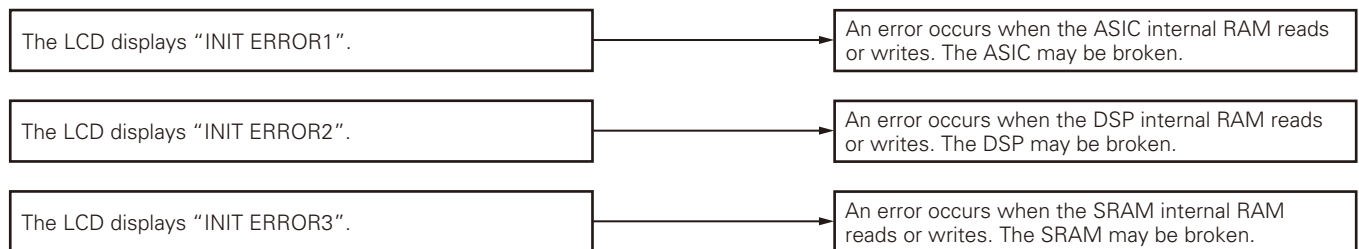

## TROUBLE SHOOTING

● **When an error display appears on the LCD.**■ **Descriptions of signal names**

- |               |   |                     |
|---------------|---|---------------------|
| 1) RST(RESET) | : ASIC reset signal                           | LOW → Reset         |
| 2) /BINT      | : Battery final voltage monitoring            | LOW → Final voltage |
| 3) /PSW       | : Power switch signal                         | LOW → ON            |
| 4) /FRST      | : FLASH reset signal                          | LOW → Reset         |
| 5) SBC        | : Switch B control                            | HIGH → ON           |
| 6) /DRST      | : DSP reset signal                            | LOW → Reset         |
| 7) /LCDRST    | : LCD reset signal                            | LOW → Reset         |
| 8) /CS4       | : LCD controller chip select signal           | LOW → Active        |
| 9) 5A         | : Analog peripheral control 5.0V power supply |                     |

## TROUBLE SHOOTING

### Replacing Control Unit

#### ■ Control unit Information

Model Name	Original Control unit Number	For Service Control unit Number
TK-5320 (K,K2: 6-key)	X53-4480-10	X53-4480-12
TK-5320 (K3,K4: 18-key)	X53-4480-11	X53-4480-13

#### ■ Method of confirming “Original Control unit” and “Service Control unit”

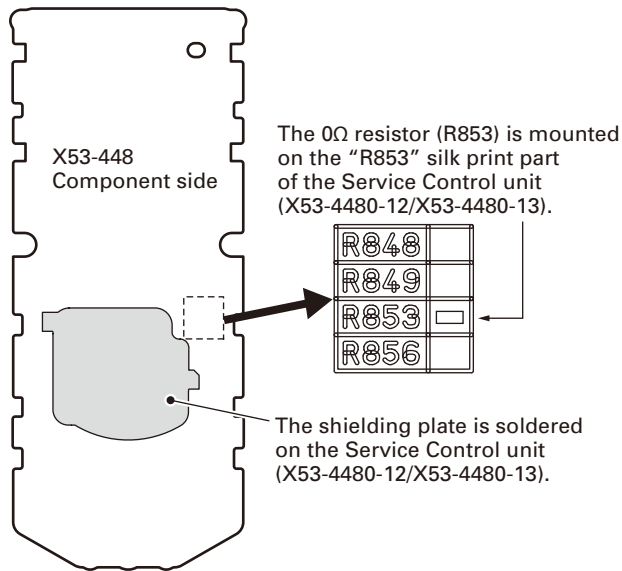

X53-448	R848	R849	R853	R856
0-10	0Ω	(None)	(None)	(None)
0-11	(None)	0Ω	(None)	(None)
0-12	0Ω	(None)	0Ω	(None)
0-13	(None)	0Ω	0Ω	(None)

#### Notes:

- The 0Ω resistor (R848, R849 and R853) is used to differentiate the destination with a visual check. These are not connected with any PCB pattern; they are specifically for production control. There is no need to change the mount of these resistors.
- There is no difference between the schematic diagram of the Service Control unit (X53-4480-12/X53-4480-13) and the schematic diagram of the original Control unit (X53-4480-10/X53-4480-11). (R848, R849 and R853 are connected with GND (ground) only.)

#### ■ Supplied Accessories of “Service Control unit”

Item (Including Parts Number)	Quantity
Control Unit	1
Kenwood ESN Label	1
P25 ESN Label	1
Addendum (B59-2599-XX)	1

#### ■ “Service Control unit” Data

The following data is written on the service unit:

Data Type	Description
Firmware	TK-5320 Firmware.
FPU Data (PC programming mode)	X53-448 (TK-5320).
Various Adjustment Data (PC Test mode)	General adjustment values for the X53-448 (TK-5320).
Kenwood ESN	Model name: [X53-448] TK-52_5320S1K (No DTMF keypad) or TK-52_5320S2K (with DTMF keypad) Type: K The same number as the Kenwood ESN label is written.
P25 ESN	The same number as the P25 ESN

#### ■ After Changing the PCB

- After changing the printed circuit board, write the up-to-date Firmware following the instructions in the “REALIGNMENT - 6.Firmware Programming Mode”.
- Using the KPG-112D, select your desired item (Model Name and Frequency) from the Model> Product Information menu, then use Program> Write to the Transceiver to write the FPU data (PC Programming mode). When writing to the transceiver, a Warning Message, corresponding to the item selected, appears. Click [OK] to continue writing the data.
- Enter Program> Test Mode, then adjust the various adjustment data (PC Test Mode) as described in the “ADJUSTMENT”.
- Attach the new labels corresponding to the new printed circuit board. (Refer to the images on page 36 for label placement.)
- If necessary, write the FPU data used by the customer with the KPG-112D.

## TROUBLE SHOOTING

### Note:

- When a new printed circuit board is used, the Kenwood ESN changes, as does the Transceiver Information display of the KPG-112D, but this does not have any effect on the operation of the transceiver.
- If changing to the original Kenwood ESN and P25 ESN, please contact our service center.

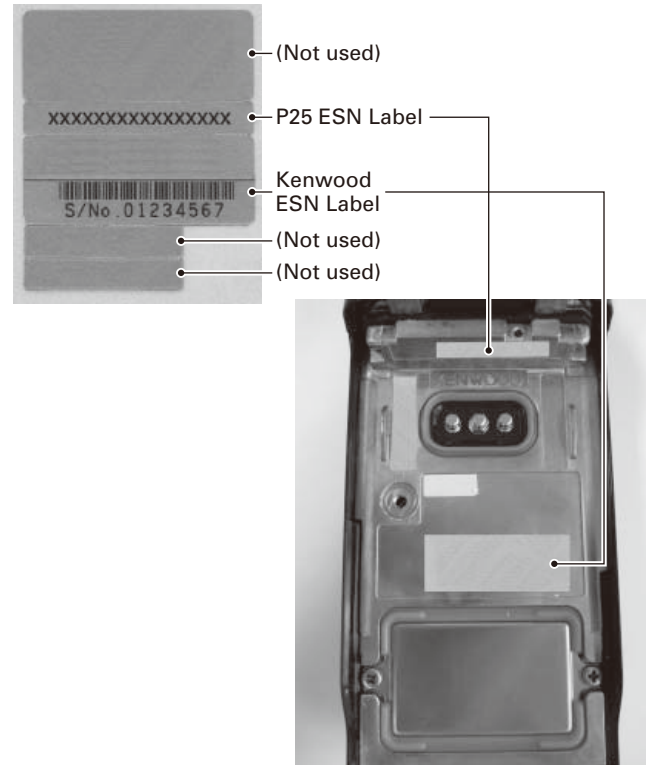

**Note:** A UPC code and UPC barcode is not printed on the Kenwood ESN Label. If necessary, cut the label at the cut-off line and attach only the serial number.

## ADJUSTMENT

### Controls

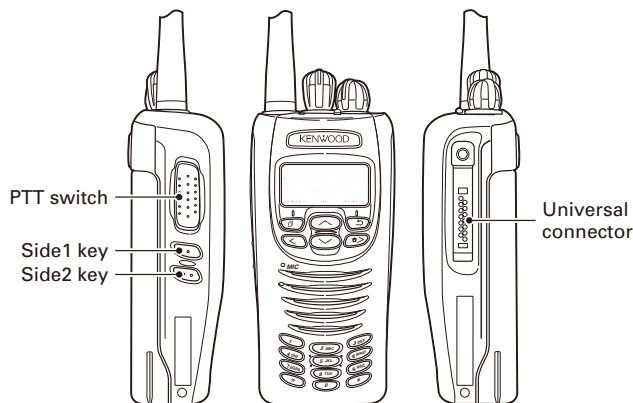
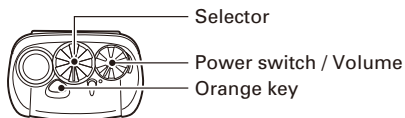

### Panel Test Mode

#### ■ Test mode operation features

This transceiver has a test mode. **To enter test mode, press and hold the [↵] key while turning the transceiver power ON. Before the transceiver enters test mode, the frequency version information appears on the LCD momentarily.** Test mode can be inhibited by programming. To exit test mode, turn the transceiver power OFF. The following functions are available in test mode.

## ADJUSTMENT

### ■ Key operation

Key	"FNC" not appears on the sub LCD display	
	Function	Display
[Selector]	-	-
[^]	Push: Test channel up Hold: Test channel up continuously	Channel No.
[v]	Push: Test channel down Hold: Test channel down continuously	Channel No.
[Side1]	Push: Squelch level up Hold: Squelch off	Squelch level Squelch off: [Squelch off icon] icon appears
[Side2]	Wide/Narrow	Wide: "w" Narrow: "n"
[M]	Shift to panel tuning mode	-
[F]	Function on	"FNC" appears on the sub LCD display
[<]	MSK 1200bps and 2400bps	2400bps: [2400bps icon] icon appears
[*>]	Push: Test signaling up Hold: Test signaling up continuously	Signaling No.
[Orange]	-	-
[PTT]	Transmit	-
[0] to [9] and [#], [*]	Use as the DTMF keypad. If a key is pressed during transmission, the DTMF corresponding to the key that was presses is sent.	-

Key	"FNC" appears on the sub LCD display	
	Function	Display
[Selector]	-	-
[^]	Function off	-
[v]	Analog/P25	Analog: "A" P25: "P"
[Side1]	Function off	-
[Side2]	LCD all lights	LCD all point appears
[M]	High power/Low power	High: "H" Low: "L"
[F]	Function off	-
[<]	Compander on/off	On: [Compander on icon] icon appears
[*>]	Beat shift on/off	On: [Beat shift on icon] icon appears
[Orange]	Function off	-
[PTT]	Transmit	-
[0] to [9] and [#], [*]	Function off	-

### • LED indicator

Red LED Lights during transmission.  
Green LED Lights when there is carrier.

### • Sub LCD indicator

"FNC" Appears at function on.

### • LCD display in panel test mode

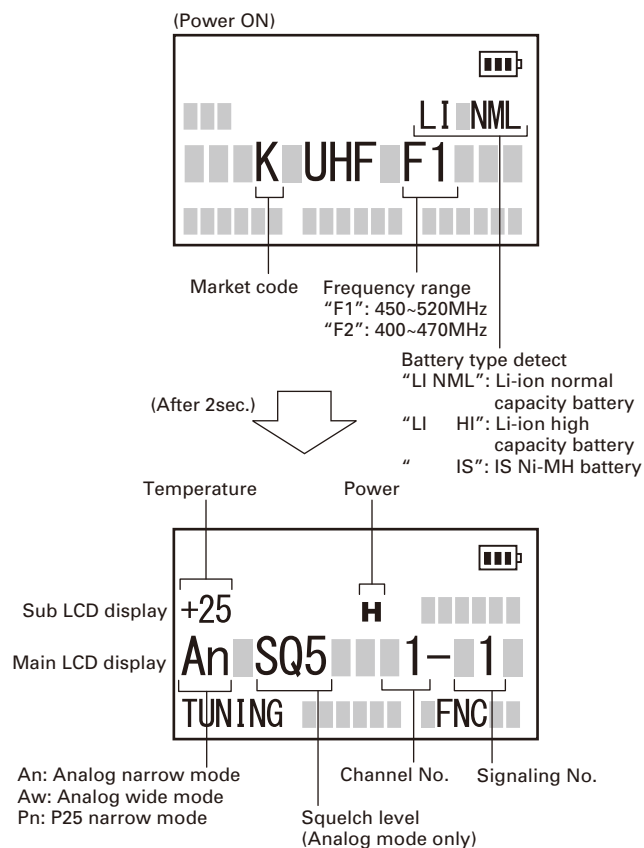

### ■ Frequency and Signaling

The transceiver has been adjusted for the frequencies shown in the following table. When required, readjust them following the adjustment procedure to obtain the frequencies you want in actual operation.

### • Test frequency

CH	K,K3		K2,K4	
	RX (MHz)	TX (MHz)	RX (MHz)	TX (MHz)
1	485.05000	485.10000	435.05000	435.10000
2	450.05000	450.10000	400.05000	400.10000
3	519.95000	519.90000	469.95000	469.90000
4	485.00000	485.00000	435.00000	435.00000
5	485.20000	485.20000	435.20000	435.20000
6	485.40000	485.40000	435.40000	435.40000
7~16	-	-	-	-

# ADJUSTMENT

## • Analog mode signaling

No.	RX	TX
1	None	None
2	None	100Hz Square Wave
4	QT: 67.0Hz	QT: 67.0Hz
5	QT: 151.4Hz	QT: 151.4Hz
6	QT: 210.7Hz	QT: 210.7Hz
7	QT: 254.1Hz	QT: 254.1Hz
8	DQT: D023N	DQT: D023N
9	DQT: D754I	DQT: D754I
10	DTMF: 159D	DTMF: 159D
11	None	DTMF Code 9
12	2-tone: A: 304.7Hz B: 3106.0Hz	2-tone: A: 304.7Hz B: 3106.0Hz
13	Single Tone: 979.9Hz	Single Tone: 979.9Hz
14	None	Single Tone: 1000Hz
15	None	MSK PN9
16	MSK Decode	MSK Encode

## • P25 mode signaling

No.	RX	TX
1	NAC 293	NAC 293
2	NAC 023	NAC 023
3	NAC 5EA	NAC 5EA
4	None	PN9 (Transmitter Pattern)
5	NAC 293	Maximum Deviation Pattern
6	NAC 293	1/3 Deviation Pattern
7	NAC 293	0 Continuous Pattern
8	NAC 293	P25 Fidelity Pattern
9	None	FSW + PN9
10	NAC 293	NAC 293 + 1011Hz Tone Pattern
11	Tone Pattern	NAC 293 + 1011Hz Tone Pattern
12	Silence Pattern (1011Hz)	NAC 293 + Silence Pattern
13	Voice Test Pattern	NAC 293 + Voice Test Pattern
14	Vocoder Loop Test	None

PN9: Pseudo-Random Pattern (for production only)

No.10: For BER (Bit Error Rate) Measurement

The BER value is displayed on the PC Test Mode screen.

## Panel Tuning Mode

### ■ Preparations for tuning the transceiver

Before attempting to tune the transceiver, connect the unit to a suitable power supply.

Whenever the transmitter is turned, the unit must be connected to a suitable dummy load (i.e. power meter).

The speaker output connector must be terminated with a 8Ω dummy load and connected to an AC voltmeter and an audio distortion meter or a SINAD measurement meter at all times during tuning.

### ■ Transceiver tuning (To enter tuning mode)

To enter tuning mode, press the [Ⓜ] key while the transceiver is in test mode. Use the [←] key to write tuning data through tuning modes, and the [↖]/[↘] key to adjust tuning requirements (1 to 4096 appears on the LCD).

Use the [▶] key to select the adjustment item through tuning modes. Use the [→] key to adjust 5 reference level adjustments, and use the [Side2] key to switch between Wide/Narrow.

### • LCD display in panel tuning mode

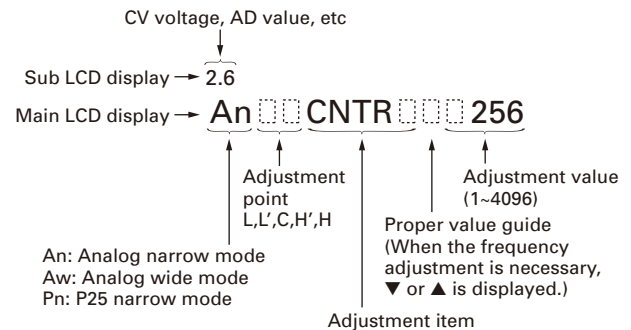

### ■ Key operation

Key	Function	
	Push	Hold (1 second)
[Selector]	-	-
[↖]	Adjustment value up	Continuation up
[↘]	Adjustment value down	Continuation down
[Side1]	Auto adjustment start	-
[Side2]	Wide/Narrow	-
[Ⓜ]	Shift to panel test mode	-
[→]	To enter 5 reference level adjustments	-
[←]	Writes the adjustment value	-
[▶]	Go to next adjustment item	Back to last adjustment item
[Orange]	-	-
[PTT]	Transmit	
[0] to [9] and [#], [*]	-	-

### ■ 5 reference level adjustments frequency

Tuning point	K,K3		K2,K4	
	RX (MHz)	TX (MHz)	RX (MHz)	TX (MHz)
Low	450.05000	450.10000	400.05000	400.10000
Low'	467.55000	467.60000	417.55000	417.60000
Center	485.05000	485.10000	435.05000	435.10000
High'	502.55000	502.60000	452.55000	452.60000
High	519.95000	519.90000	469.95000	469.90000

## ADJUSTMENT

## ■ Adjustment item supplement

Adjustment Item	Description
LCD contrast	The contrast of LCD display can be changed.
Counterclockwise Volume	“Counterclockwise Volume” is adjusted at the minimum volume position. “Clockwise Volume” is adjusted at the maximum volume position. These adjustments can correct the volume variation.
Clockwise Volume	Both “Counterclockwise Volume” and “Clockwise Volume” must be adjusted. (The curve data of volume is applied.)
Receive Assist	The lock voltage of VCO (Receive) is adjusted. This item must be adjusted before all adjustment items for receiver section are adjusted.
Transmit Assist	The lock voltage of VCO (Transmit) is adjusted. This item must be adjusted before all adjustment items for transmitter section are adjusted.
Frequency	Frequency stability is adjusted under receiving condition with SSG. The SSG needs 0.001ppm accuracy so please use a standard oscillator if necessary. This item can be adjusted only in PC Test Mode so that the adjustment value is not changed easily.
RTC	Real-Time Clock (RTC) is adjusted. This item uses the internal clock. (Any measurement equipment is not required.)
High Transmit Power	High Transmit Power is adjusted.
Low Transmit Power	Low Transmit Power is adjusted.
Balance	The transmit audio frequency response is adjusted. This item is adjusted so that the deviation of 2kHz becomes the same deviation of 20Hz. This item must be adjusted before all adjustment items for deviations are adjusted.
Maximum Deviation (P25 Narrow)	Maximum Deviation of P25 (Narrow) is adjusted.
Maximum Deviation (Analog Wide/Narrow)	Maximum Deviation of Analog (Wide/Narrow) is adjusted. This item must be adjusted before all adjustment items for tone deviations are adjusted.
QT Deviation	QT tone deviation is adjusted.
DQT Deviation	DQT tone deviation is adjusted.
DTMF Deviation	DTMF tone deviation is adjusted.
Single Tone Deviation	The deviation of Single Tone used in “2-tone” is adjusted.
MSK Deviation	MSK tone deviation is adjusted.
VOX 1	VOX sensitivity at “VOX 1” is adjusted.
VOX 10	VOX sensitivity at “VOX 10” is adjusted.
Sensitivity 1	Notch filter is adjusted. The performance of Receive Spurious Response is improved.
Sensitivity 2	Band-Pass Filter is adjusted. The performance of Receive Sensitivity is improved.
RSSI Reference	The minimum RSSI level for scan stop is adjusted.
Open Squelch	The squelch level at level “5” is adjusted.
Low RSSI	RSSI display level “  ” is adjusted.
High RSSI	Both “Low RSSI” and “High RSSI” must be adjusted. (The curve data of RSSI level is applied.)
Tight Squelch	The squelch level at level “9” is adjusted.
Battery Warning Level	Battery Warning Level (LED blinking level) is adjusted. Battery Warning Level minus 0.4V is the transmission inhibited level.

## ADJUSTMENT

## ■ Adjustment item and Display

Order	Adjustment item	Main LCD display	Sub LCD display	Aw (Analog Wide)	An (Analog Narrow)	Pn (P25 Narrow)	Adjust item Number
				Adjustment range			
1	LCD contrast	CNTR	-	1 point ADJ			Common Section 2
				1~256			
2	Counterclockwise Volume	VOL1	VOL measurement value	1 point ADJ			Common Section 3
				1~256			
3	Clockwise Volume	VOL2	VOL measurement value	1 point ADJ			Common Section 4
				1~256			
4	Receive Assist	RAST	(CV voltage)	5 point ADJ			Common Section 5
				1~4096			
5	Transmit Assist	TAST	(CV voltage)	5 point ADJ			Common Section 5
				1~4096			
6	RTC (Real-time clock)	RTC	-	1 point ADJ			Common Section 6
				-62~-1/0/+1~+62			
7	High Transmit Power	HIPWR	-	-	5	-	Transmitter Section 1
				1~1024			
8	Low Transmit Power	LOPWR	-	-	5	-	Transmitter Section 2
				1~1024			
9	Balance	BAL	(Encode frequency)	-	5	-	Transmitter Section 3
				1~256			
10	Maximum Deviation (NXDN)	NDEV	-	-	-	5	Transmitter Section 4
				1~1024			
11	Maximum Deviation (Analog)	ADEV	-	5	5	-	Transmitter Section 5
				1~1024			
12	QT Deviation	QT	-	1	1	-	Transmitter Section 6
				1~1024			
13	DQT Deviation	DQT	-	1	1	-	Transmitter Section 7
				1~1024			
14	DTMF Deviation	DTMF	-	1	1	-	Transmitter Section 8
				1~1024			
15	Single Tone Deviation	TONE	-	1	1	-	Transmitter Section 9
				1~1024			
16	MSK Deviation	MSK	-	1	1	-	Transmitter Section 10
				1~1024			
17	VOX1	VOX1	VOX measurement value	1 point ADJ			Transmitter Section 11
				1~256			
18	VOX10	VOX10	VOX measurement value	1 point ADJ			Transmitter Section 12
				1~256			
19	Sensitivity 1	SENS1	(RSSI measurement value)	-	5	-	Receive Section 2
				1~256			
20	Sensitivity 2	SENS2	(RSSI measurement value)	-	5	-	Receive Section 3
				1~256			
21	RSSI Reference	RRSSI	(RSSI measurement value)	5	5	- *1	Receive Section 4
				1~256			

## ADJUSTMENT

Order	Adjustment item	Main LCD display	Sub LCD display	Aw (Analog Wide)	An (Analog Narrow)	Pn (P25 Narrow)	Adjust item Number
				Adjustment range			
22	Open Squelch	SQL	(ASQDET measurement value)	5	5	- *1	Receive Section 5
				1~256			
23	Low RSSI	LRSSI	(RSSI measurement value)	5	5	- *1	Receive Section 6
				1~256			
24	High RSSI	HRSSI	(RSSI measurement value)	5	5	- *1	Receive Section 7
				1~256			
25	Tight Squelch	SQLT	(ASQDET measurement value)	5	5	-	Receive Section 8
				1~256			
26	Battery Warning Level	BATT	(BATT measurement value)	1 point ADJ			Transmitter Section 15
				1~256			

\*1: Because P25 Narrow is adjusted by adjusting Analog Narrow, it is not necessary to adjust P25 Narrow.

### ■ Panel tuning mode flow chart

**Note:** In this Panel tuning mode flow chart, the Adjustment item name is modified.

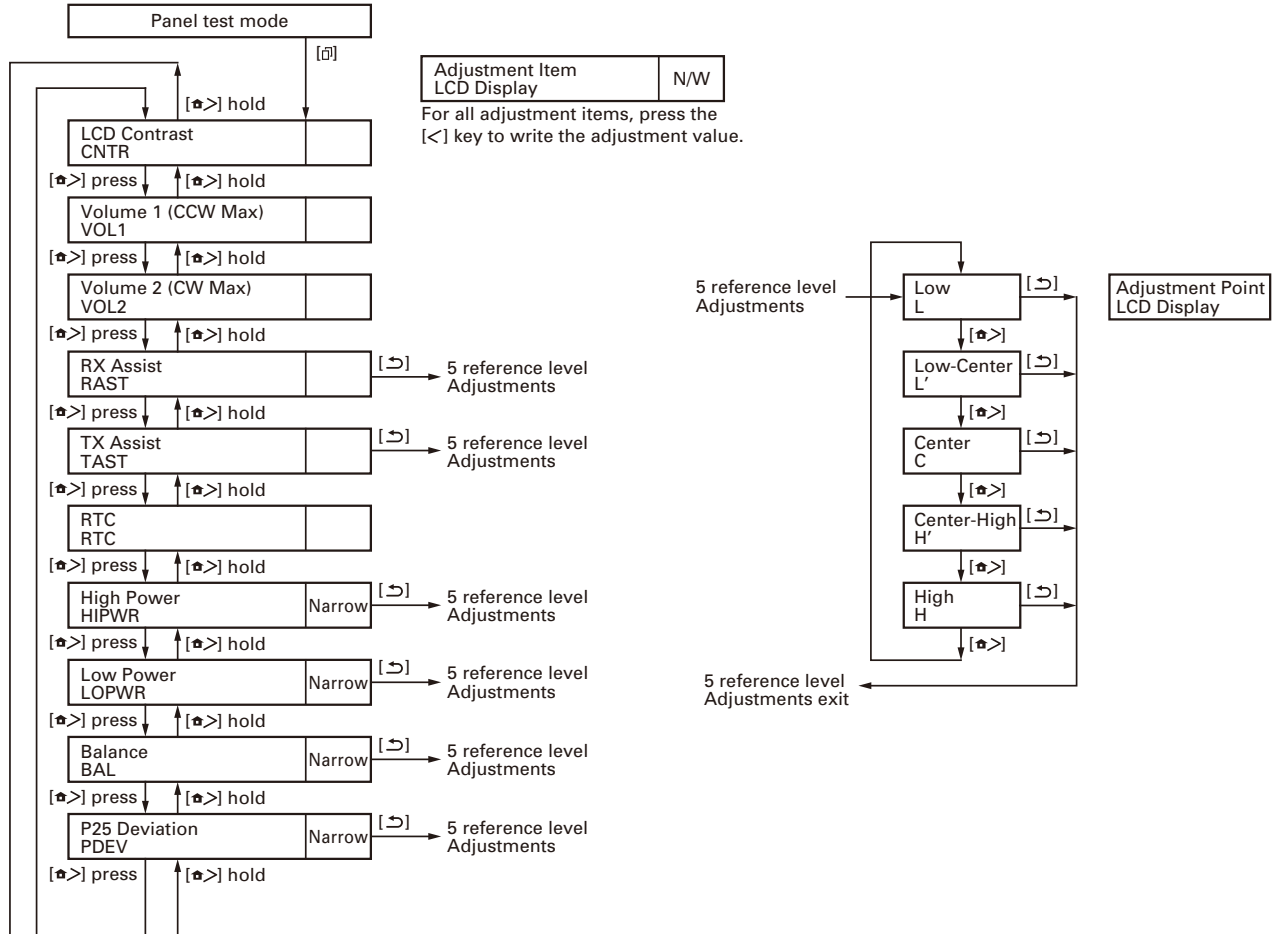



## ADJUSTMENT

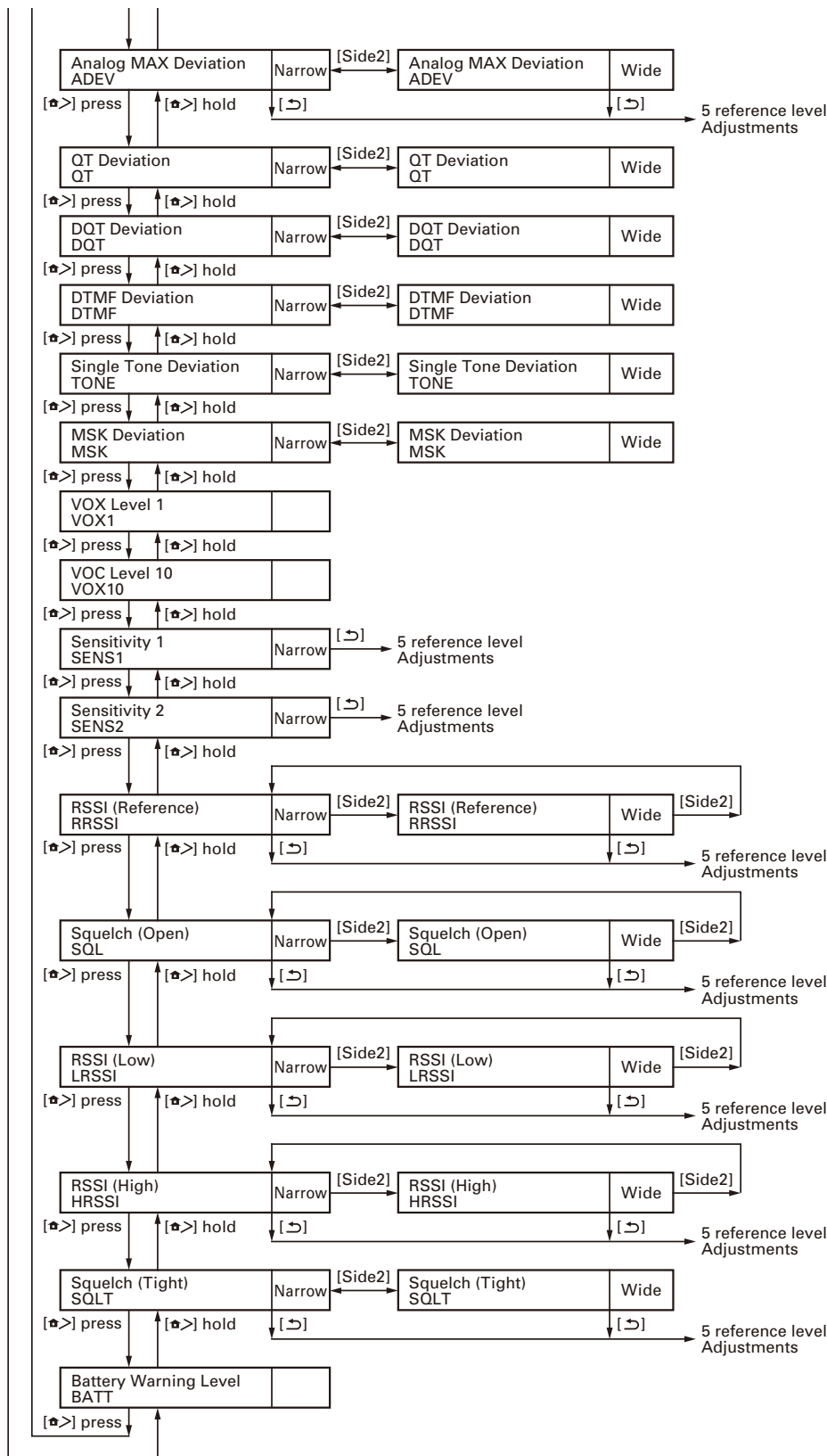

## ADJUSTMENT

### Test Equipment Required for Alignment

Test Equipment	Major Specifications	
1. Standard Signal Generator (SSG)	Frequency Range Modulation Output When performing the Frequency adjustment, the following accuracy is necessary. • 0.001ppm Use a standard oscillator for adjustments, if necessary.	400 to 520MHz Frequency modulation and external modulation -127dBm/0.1μV to greater than -20dBm/22.4mV
2. Power Meter	Input Impedance Operation Frequency Measurement Capability	50Ω 400 to 520MHz Vicinity of 10W
3. Deviation Meter	Frequency Range	400 to 520MHz
4. Digital Volt Meter (DVM)	Measuring Range Input Impedance	10mV to 10V DC High input impedance for minimum circuit loading
5. Oscilloscope		DC through 30MHz
6. High Sensitivity Frequency Counter	Frequency Range Frequency Stability	10Hz to 1000MHz 0.2ppm or less
7. Ammeter		5A
8. AF Volt Meter (AF VTVM)	Frequency Range Voltage Range	50Hz to 10kHz 1mV to 10V
9. Audio Generator (AG)	Frequency Range Output	50Hz to 5kHz or more 0 to 1V
10. Distortion Meter	Capability Input Level	3% or less at 1kHz 50mV to 10Vrms
11. 8Ω Dummy Load		Approx. 8Ω, 3W
12. Regulated Power Supply		5V to 10V, approx. 3A Useful if ammeter equipped

#### ■ Antenna connector adapter

The antenna connector of this transceiver uses an SMA terminal.

Use an antenna connector adapter [SMA(f) – BNC(f) or SMA(f) – N(f)] for adjustment. (The adapter is not provided as an option, so buy a commercially-available one.)

#### ■ Nut wrench

In order to turn the volume nut and the channel selector nut, use a recommendation tool.

KENWOOD part No.: W05-1123-00

#### ■ Battery jig (W05-1370-00)

Connect the power cable properly between the battery jig installed in the transceiver and the power supply, and be sure output voltage and the power supply polarity prior to switching the power supply ON, otherwise over voltage and reverse connection may damage the transceiver, or the power supply or both.

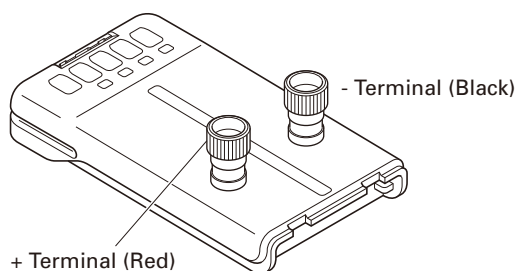

#### Notes:

- When using the battery jig, you must measure the voltage at the terminals of the battery jig. Otherwise, a slight voltage drop may occur within the power cable, between the power supply and the battery jig, especially while the transceiver transmits.
- The battery jig is detected as "Li-ion High Capacity Battery".  
Li-ion High Capacity Battery: R1=1.8MΩ or Open  
Li-ion Normal Capacity Battery: R1=560kΩ

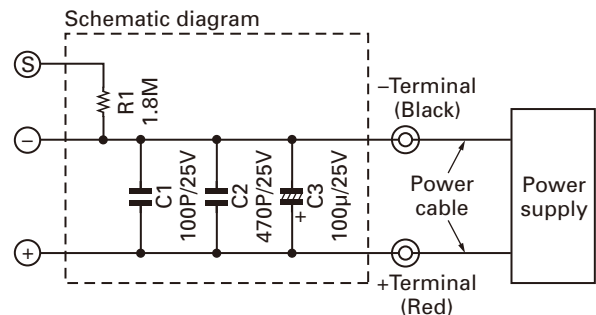

#### ■ C4FM (P25) Deviation Adjustment

1. The transceiver adjusts the deviation between Maximum Deviation (P25) ±1800Hz for the C4FM (P25).
2. The Symbol Rate Pattern is used when adjusting the Maximum Deviation (P25) for the C4FM (P25) (Refer to "P25 mode signaling" described on page 37.). This test signal has a peak deviation equal to  $\pi/2$  1800Hz = 2827Hz.

## ADJUSTMENT

### ■ Universal connector

Use the interface cable (KPG-36/36A) for PC tuning or the lead wire with plug (E30-3287-28) and screw (N08-0535-08) for panel tuning. Connect the plug to the universal connector of the transceiver and tighten the screw.

The lead wire with plug (E30-3287-28) and screw (N08-0535-08) terminals are as follows. Numbers are universal connector terminal numbers.

### Caution

1. When connecting the plug to the universal connector of the transceiver, a short circuit may occur. To prevent this, be sure to turn the transceiver POWER switch off.
2. Since the RX AF output is a BTL output, there is a DC component. Isolate this with a capacitor or transformer as shown in the figure.
3. Do not connect an instrument between red or black and GND.

### • Universal connector

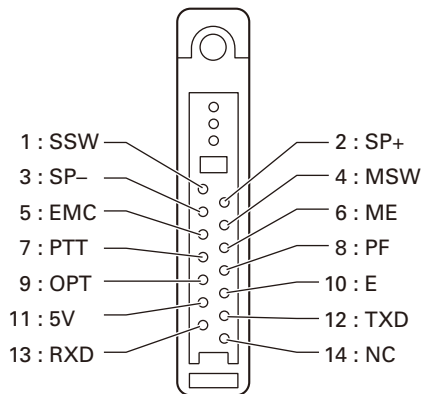

### • Panel tuning

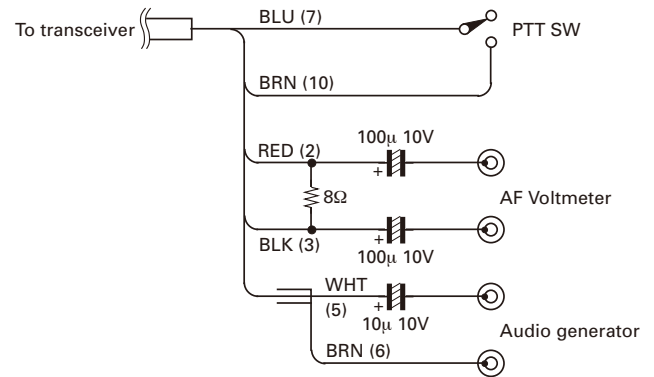
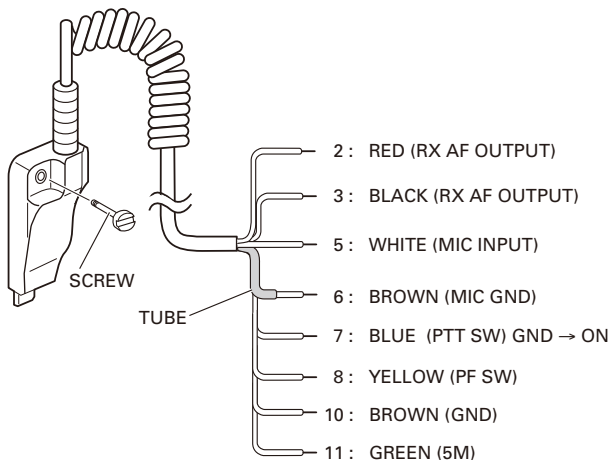

**Note:** Pin 1 (SSW) and Pin 4 (MSW) are connected to Pin 10 (GND) to active External SP and External MIC.

### • PC tuning

Connect the wires to the PCB in the connector case of interface cable.

For output the wires out of the connector case, need to process the connector case.

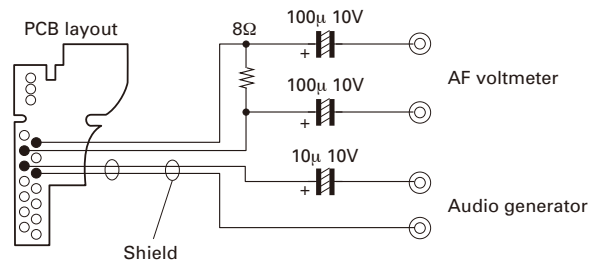
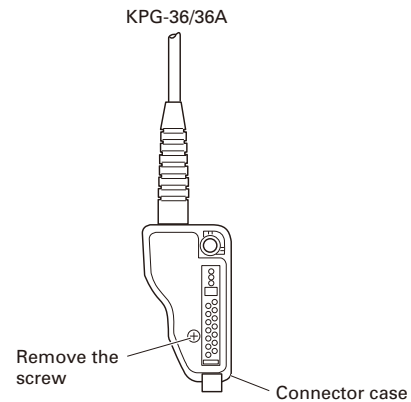

## ADJUSTMENT

## Radio Check Section

Item	Condition		Measurement			Adjustment		Specifications / Remarks	
	Panel test mode	PC test mode	Test-equipment	Unit	Terminal	Unit	Parts		Method
1. Frequency check	1) CH-Sig: 1-1 PTT: ON	1) Test Channel Channel: 1 Test Signaling Mode: Analog Signaling: 1 PTT: Press [Transmit] button.	f. counter	Panel	ANT			Check an internal temperature of radio within 25°C ± 2°C.	+0.05/+0.55ppm +24.25Hz~+266.81Hz @485.1MHz <b>K,K3</b> +21.76Hz~+239.31Hz @435.1MHz <b>K2,K4</b>
2. High power check (Batt: 7.5V)	1) CH-Sig: 1-1 PTT: ON	1) Test Channel Channel: 1 Test Signaling Mode: Analog Signaling: 1 PTT: Press [Transmit] button.	Power meter Ammeter					Check	4.5W~5.5W 2.3A or less
	2) CH-Sig: 2-1 PTT: ON	2) Test Channel Channel: 2 Test Signaling Mode: Analog Signaling: 1 PTT: Press [Transmit] button.							
	3) CH-Sig: 3-1 PTT: ON	3) Test Channel Channel: 3 Test Signaling Mode: Analog Signaling: 1 PTT: Press [Transmit] button.							
3. Low power check (Batt: 7.5V)	1) CH-Sig: 1-1 PTT: ON	1) Test Channel Channel: 1 Test Signaling Mode: Analog Signaling: 1 PTT: Press [Transmit] button.							0.7W~1.2W 1.2A or less
	2) CH-Sig: 2-1 PTT: ON	2) Test Channel Channel: 2 Test Signaling Mode: Analog Signaling: 1 PTT: Press [Transmit] button.							
	3) CH-Sig: 3-1 PTT: ON	3) Test Channel Channel: 3 Test Signaling Mode: Analog Signaling: 1 PTT: Press [Transmit] button.							
4. MIC sensitivity check	1) CH-Sig: 1-1 AG: 1kHz PTT: ON	1) Test Channel Channel: 1 Test Signaling Mode: Analog Signaling: 1 AG: 1kHz PTT: Press [Transmit] button.	Deviation meter Oscilloscope AG AF VTVM		ANT Universal connector			Adjust AG input to get a standard MOD.	12.5mV±5.8mV

## ADJUSTMENT

Item	Condition		Measurement			Adjustment			Specifications / Remarks
	Panel test mode	PC test mode	Test-equipment	Unit	Terminal	Unit	Parts	Method	
5. Sensitivity check	1) CH-Sig: 1-1 SSG output Wide: -117dBm (0.32μV) (MOD: 1kHz/±3kHz) Narrow: -117dBm (0.32μV) (MOD: 1kHz/±1.5kHz)	1) Test Channel Channel: 1 Test Signaling Mode: Analog Signaling: 1 SSG output Wide: -117dBm (0.32μV) (MOD: 1kHz/±3kHz) Narrow: -117dBm (0.32μV) (MOD: 1kHz/±1.5kHz)	SSG AF VTVM Oscilloscope Distortion meter 8Ω Dummy load		ANT Universal connector			Check	12dB SINAD or more

## Common Section

Item	Condition		Measurement			Adjustment			Specifications / Remarks
	Panel tuning mode	PC test mode	Test-equipment	Unit	Terminal	Unit	Parts	Method	
1. Setting	1) DC voltage: 7.5V 2) SSG standard modulation [Wide] MOD: 1kHz, DEV: 3kHz [Narrow] MOD: 1kHz, DEV: 1.5kHz								
2. LCD contrast	1) Adj item: [CNTR] Adjust: [***] Press [◀] key to store the adjustment value.	1) Adj item: [LCD Contrast] Press [Apply] button to store the adjustment value.				Panel	[Panel tuning mode] [∧], [∨]  [PC test mode] [◀], [▶]	Adjust the LCD contrast by looking.	This item is needed when the LCD ASSY (B38-0923-05) is replaced.
3. Counterclockwise Volume	1) Adj item: [VOL1] Adjust: [***]	1) Adj item: [Counterclockwise Volume]						[Panel tuning mode] Turn the volume knob counterclockwise fully. Press [◀] key to store the adjustment value. [PC test mode] Turn the volume knob counterclockwise fully. Press [Apply] button to store the adjustment value.	This item is needed when the variable resistor (R31-0666-05) is replaced.
4. Clockwise Volume	1) Adj item: [VOL2] Adjust: [***]	1) Adj item: [Clockwise Volume]						[Panel tuning mode] Turn the volume knob clockwise fully. Press [◀] key to store the adjustment value. [PC test mode] Turn the volume knob clockwise fully. Press [Apply] button to store the adjustment value.	

## ADJUSTMENT

Item	Condition		Measurement			Adjustment			Specifications / Remarks
	Panel tuning mode	PC test mode	Test-equipment	Unit	Terminal	Unit	Parts	Method	
5. Receive Assist	1) Adj item: [RAST] Adjust: [****] 2) Adj item: [L RAST]→ [L' RAST]→[C RAST]→ [H' RAST]→[H RAST] Adjust: [****] Press [◀] key to store the adjustment value.	1) Adj item: [Receive Assist] 2) Adj item: [Low], [Low'], [Center], [High'], [High] Press [Apply All] button to store the adjustment value.				Panel	[Panel tuning mode] [∧], [∨]  [PC test mode] [◀],[▶]	The sub LCD display and [V] indicator on the PC window shows VCO lock voltage. Change the adjustment value to get VCO lock voltage within the limit of the specified voltage.  <b>Note:</b> Confirm the VCO lock voltage approximately 3 seconds after the adjustment value is changed.	2.5V±0.1V  [PC test mode] Press [Apply All] button to store the adjustment value after all adjustment point was adjusted.
Transmit Assist	1) Adj item: [TAST] Adjust: [****] 2) Adj item: [L TAST]→ [L' TAST]→[C TAST]→ [H' TAST]→[H TAST] Adjust: [****] PTT : ON (RF power is not output.) Press [◀] key to store the adjustment value.	1) Adj item: [Transmit Assist] 2) Adj item: [Low], [Low'], [Center], [High'], [High] PTT: Press [Transmit] button. Press [Apply All] button to store the adjustment value.							
6. RTC oscillation frequency adjust	1) Adj item: [RTC] Adjust: [***]	1) Adj item: [RTC (Real-time clock)]					[Side1]	[Panel tuning mode] Press [Side1] key. After automatic adjustment adjusted value is displayed on the LCD. Press [◀] key to store the adjustment value. [PC test mode] Press [Start] button of "Auto Tuning". Press [Apply] button to store the adjustment value after the automatic adjustment was finished.	
7. Frequency adjust	* The Frequency adjustment can be performed only in PC test mode.	1) Adj item: [Frequency] SSG output : -20dBm (22.4mV) (CW (without modulation))  <b>Caution:</b> Perform the frequency adjustment under the following conditions. • Temperature range of +23°C to +27°C (+73.4°F to +80.6°F). (The temperature is displayed on the Frequency adjustment screen of the KPG-112D and the LCD of the transceiver.) • Use an accuracy of 0.001ppm for the SSG. (Use a standard oscillator if necessary.)	SSG	Panel	ANT			[PC test mode] Press [Start] button of "Auto Tuning". Press [Apply] button to store the adjustment value after the automatic adjustment was finished.	[PC test mode] The value of "IF20" will become around "0" after the adjustment was finished.  <b>Remark:</b> "Frequency" is adjusted under receiving condition with SSG.

## ADJUSTMENT

## Transmitter Section

Item	Condition		Measurement			Adjustment			Specifications / Remarks
	Panel tuning mode	PC test mode	Test-equipment	Unit	Terminal	Unit	Parts	Method	
1. High Transmit Power adjust (Batt: 7.5V)	1) Adj item: [HIPWR] Adjust: [*****] 2) Adj item: [L HIPWR]→ [L' HIPWR]→ [C HIPWR]→ [H' HIPWR]→ [H HIPWR] Adjust: [*****] PTT: ON Press [◀] key to store the adjustment value.	1) Adj item: [High Transmit Power] 2) Adj item: [Low], [Low'], [Center], [High'], [High] PTT: Press [Transmit] button. Press [Apply All] button to store the adjustment value.	Power meter Ammeter	Panel	ANT	Panel	[Panel tuning mode] [∧], [∨]  [PC test mode] [◀],[▶]	5.0W	±0.2W 2.3A or less  [PC test mode] Press [Apply All] button to store the adjustment value after all adjustment point was adjusted.
								0.8W	±0.1W 1.2A or less  [PC test mode] Press [Apply All] button to store the adjustment value after all adjustment point was adjusted.
2. Low Transmit Power adjust (Batt: 7.5V)	1) Adj item: [LOPWR] Adjust: [*****] 2) Adj item: [L LOPWR]→ [L' LOPWR]→ [C LOPWR]→ [H' LOPWR]→ [H LOPWR] Adjust: [*****] PTT: ON Press [◀] key to store the adjustment value.	1) Adj item: [Low Transmit Power] 2) Adj item: [Low], [Low'], [Center], [High'], [High] PTT: Press [Transmit] button. Press [Apply All] button to store the adjustment value.							
3. Balance adjust *2	1) Adj item: [BAL] Adjust: [****] Deviation meter LPF: 3kHz HPF: OFF 2) Adj item: [L BAL]→ [L' BAL]→[C BAL]→ [H' BAL]→[H BAL] Adjust: [****] PTT: ON Press [◀] key to store the adjustment value. Sub LCD: Tone frequency [Side1] key: Press while transmitting to change 20Hz and 2kHz.	1) Adj item: [Balance] Deviation meter LPF : 3kHz HPF : OFF 2) Adj item: [Low], [Low'], [Center], [High'], [High] PTT: Press [Transmit] button. Press [Apply All] button to store the adjustment value. [2kHz Sine Wave Check box]: Check while transmitting change to 2kHz.	Deviation meter Oscilloscope					The Deviation of 20Hz frequency is fixed. Change the 2kHz adjustment value to become the same deviation of 20Hz within the specified range.	2kHz Tone deviation is within ±1.0% of 20Hz tone deviation.  [PC test mode] Press [Apply All] button to store the adjustment value after all adjustment point was adjusted.
*2: Refer to the "Necessary Deviation adjustment item for each signaling and mode" table on page 51. Balance adjustment is common with the adjustment of all signaling deviations.									
4. Maximum Deviation (P25) adjust *3  [Narrow]	1) Adj item: [Pn PDEV] Adjust: [*****] Deviation meter LPF: 3kHz HPF: OFF 2) Adj item: [PnL PDEV]→ [PnL' PDEV]→ [PnC PDEV]→ [PnH' PDEV]→ [PnH PDEV] Adjust: [*****] PTT: ON Press [◀] key to store the adjustment value.	1) Adj item: [Maximum Deviation (P25 Narrow)] Deviation meter LPF: 3kHz HPF: OFF 2) Adj item: [Low], [Low'], [Center], [High'], [High] PTT: Press [Transmit] button. Press [Apply All] button to store the adjustment value.	Deviation meter Oscilloscope	Panel	ANT	Panel	[Panel tuning mode] [∧], [∨]  [PC test mode] [◀],[▶]	2827Hz	2771~2883Hz  [PC test mode] Press [Apply All] button to store the adjustment value after all adjustment point was adjusted.

## ADJUSTMENT

Item	Condition		Measurement			Adjustment			Specifications / Remarks
	Panel tuning mode	PC test mode	Test-equipment	Unit	Terminal	Unit	Parts	Method	
5. Maximum Deviation (Analog) adjust *3 [Narrow]	1) Adj item: [An ADEV] Adjust: [*****] Deviation meter LPF: 15kHz HPF: OFF 2) Adj item: [AnL ADEV]→ [AnL' ADEV]→ [AnC ADEV]→ [AnH' ADEV]→ [AnH ADEV] Adjust: [*****] Press [◀] key to store the adjustment value.	1) Adj item: [Maximum Deviation (Analog Narrow)] Deviation meter LPF: 15kHz HPF: OFF 2) Adj item: [Low], [Low'], [Center], [High'], [High] Press [Apply All] button to store the adjustment value.	Deviation meter Oscilloscope	Panel	ANT	Panel	[Panel tuning mode] [∧], [∨]  [PC test mode] [◀],[▶]	Write the same adjustment value of "P25 Deviation [Narrow]" for each adjustment point. Transmit at each adjustment point and check that the Analog deviation is between 2050Hz and 2150Hz. Deviation meter LPF: 15kHz HPF: OFF [Panel tuning mode] PTT: ON [PC test mode] PTT: Press [Transmit] button	2050~2150Hz  [PC test mode] Press [Apply All] button to store the adjustment value after all adjustment point was adjusted.
[Wide]	1) Adj item: [Aw ADEV] Adjust: [*****] 2) Adj item: [AwL ADEV]→ [AwL' ADEV]→ [AwC ADEV]→ [AwH' ADEV]→ [AwH ADEV] Adjust: [*****] Press [◀] key to store the adjustment value.	1) Adj item: [Maximum Deviation (Analog Wide)] 2) Adj item: [Low], [Low'], [Center], [High'], [High] Press [Apply All] button to store the adjustment value.					Write the same adjustment value of "P25 Deviation [Narrow]" for each adjustment point. Transmit at each adjustment point and check that the Analog deviation is between 4150Hz and 4250Hz. Deviation meter LPF: 15kHz HPF: OFF [Panel tuning mode] PTT: ON [PC test mode] PTT: Press [Transmit] button	4150~4250Hz  [PC test mode] Press [Apply All] button to store the adjustment value after all adjustment point was adjusted.	
*3: Refer to the "Necessary Deviation adjustment item for each signaling and mode" table on page 51. Regarding Maximum Deviation (Analog), it is common with the adjustment of all analog signalings.									
6. QT Deviation adjust *4 [Narrow]	1) Adj item: [An QT] Adjust: [*****] Deviation meter LPF: 3kHz HPF: OFF PTT: ON Press [◀] key to store the adjustment value.	1) Adj item: [QT Deviation (Analog Narrow)] Deviation meter LPF: 3kHz HPF: OFF PTT: Press [Transmit] button. Press [Apply] button to store the adjustment value.	Deviation meter Oscilloscope	Panel	ANT	Panel	[Panel tuning mode] [∧], [∨]  [PC test mode] [◀],[▶]	Write the value as followings. 513 (Reference value)	0.35kHz±0.05kHz
[Wide]	1) Adj item: [Aw QT] Adjust: [*****] PTT: ON Press [◀] key to store the adjustment value.	1) Adj item: [QT Deviation (Analog Wide)] PTT: Press [Transmit] button. Press [Apply] button to store the adjustment value.							0.75kHz±0.05kHz



## ADJUSTMENT

Item	Condition		Measurement			Adjustment			Specifications / Remarks
	Panel tuning mode	PC test mode	Test-equipment	Unit	Terminal	Unit	Parts	Method	
7. DQT Deviation adjust *4  [Narrow]	1) Adj item: [An DQT] Adjust: [*****] Deviation meter LPF: 3kHz HPF: OFF PTT: ON Press [◀] key to store the adjustment value.	1) Adj item: [DQT Deviation (Analog Narrow)] Deviation meter LPF: 3kHz HPF: OFF PTT: Press [Transmit] button. Press [Apply] button to store the adjustment value.	Deviation meter Oscilloscope	Panel	ANT	Panel	[Panel tuning mode] [<], [>]  [PC test mode] [◀],[▶]	Write the value as followings. 415 (Reference value)	0.35kHz±0.05kHz
	[Wide]	1) Adj item: [Aw DQT] Adjust: [*****] PTT: ON Press [◀] key to store the adjustment value.							1) Adj item: [DQT Deviation (Analog Wide)] PTT: Press [Transmit] button. Press [Apply] button to store the adjustment value.
8. DTMF Deviation adjust *4  [Narrow]	1) Adj item: [An DTMF] Adjust: [*****] Deviation meter LPF: 15kHz HPF: OFF PTT: ON Press [◀] key to store the adjustment value.	1) Adj item: [DTMF Deviation (Analog Narrow)] Deviation meter LPF: 15kHz HPF: OFF PTT: Press [Transmit] button. Press [Apply] button to store the adjustment value.						Write the value as followings. 540 (Reference value)	1.25kHz±0.05kHz
	[Wide]	1) Adj item: [Aw DTMF] Adjust: [*****] PTT: ON Press [◀] key to store the adjustment value.							1) Adj item: [DTMF Deviation (Analog Wide)] PTT: Press [Transmit] button. Press [Apply] button to store the adjustment value.
9. Single Tone Deviation adjust *4  [Narrow]	1) Adj item: [An TONE] Adjust: [*****] Deviation meter LPF: 15kHz HPF: OFF PTT: ON Press [◀] key to store the adjustment value.	1) Adj item: [Single Tone Deviation (Analog Narrow)] Deviation meter LPF: 15kHz HPF: OFF PTT: Press [Transmit] button. Press [Apply] button to store the adjustment value.						Write the value as followings. 513 (Reference value)	1.50kHz±0.05kHz
	[Wide]	1) Adj item: [Aw TONE] Adjust: [*****] PTT: ON Press [◀] key to store the adjustment value.							1) Adj item: [Single Tone Deviation (Analog Wide)] PTT: Press [Transmit] button. Press [Apply] button to store the adjustment value.

## ADJUSTMENT

Item	Condition		Measurement			Adjustment			Specifications / Remarks
	Panel tuning mode	PC test mode	Test-equipment	Unit	Terminal	Unit	Parts	Method	
10. MSK Deviation adjust *4 [Narrow]	1) Adj item: [An MSK] Adjust: [****] Deviation meter LPF: 15kHz HPF: OFF PTT: ON Press [<] key to store the adjustment value.	1) Adj item: [MSK Deviation (Analog Narrow)] Deviation meter LPF: 15kHz HPF: OFF PTT: Press [Transmit] button. Press [Apply] button to store the adjustment value.	Deviation meter Oscilloscope	Panel	ANT	Panel	[Panel tuning mode] [<], [>]  [PC test mode] [Left], [Right]	Write the value as followings. 513 (Reference value)	1.50kHz±0.05kHz
[Wide]	1) Adj item: [Aw MSK] Adjust: [****] PTT: ON Press [<] key to store the adjustment value.	1) Adj item: [MSK Deviation (Analog Wide)] PTT: Press [Transmit] button. Press [Apply] button to store the adjustment value.							3.00kHz±0.05kHz
*4: Refer to the "Necessary Deviation adjustment item for each signaling and mode" table on page 51.									
11. VOX1 adjust	1) Adj item: [VOX1] Adjust: [***] AG: 1kHz/45mV at MIC terminal	1) Adj item: [VOX1] AG: 1kHz/45mV at MIC terminal	AG	Panel	Universal connector			[Panel tuning mode] After apply signal from AG, press [<] key to store the adjustment value. [PC test mode] After apply signal from AG, press [Apply] button to store the adjustment value.	
12. VOX10 adjust	1) Adj item: [VOX10] Adjust: [***] AG: 1kHz/3mV at MIC terminal	1) Adj item: [VOX10] AG: 1kHz/3mV at MIC terminal							
13. BATT detection writing	1) Adj item: [BATT] Adjust: [***] PTT: ON	1) Adj item:[Battery Warning Level] PTT: Press [Transmit] button.	Power meter DVM	Panel	ANT BATT terminal			Press the PTT switch or [Transmit] button on the PC window. Apply 6.20V to battery terminal. Confirm that one pre-determined numeric in the range 1 to 256 appears. [Panel tuning mode] Press [<] key to store the adjustment value. [PC test mode] Press [Apply] button to store the adjustment value.	
14. BATT detection check	[Panel test mode] 1) CH-Sig: 1-1 BATT terminal voltage: 6.0V while transmitting	1) Test Channel Channel: 1 Test Signaling Mode: Analog Signaling: 1 BATT terminal voltage: 6.0V while transmitting						Check	The transceiver can transmit with causing the LED to blink.

# ADJUSTMENT

## ■ Necessary Deviation adjustment item for each signaling and mode

The following shows the necessary adjustment items for each signaling deviation. Please read the following table like the following example. In the case of the signaling "QT (Wide)", this signaling is composed of three elements [Balance, Maximum Deviation (Analog Wide) and QT Deviation (Wide)]. Please adjust Balance and Maximum Deviation (Analog Wide) before adjusting QT Deviation (Wide).

Mode	Signaling	Necessary adjustment and order	
		Wide	Narrow
Analog	Audio	Step1. Balance adjust Step2. Maximum Deviation (Analog Wide)	Step1. Balance adjust Step2. Maximum Deviation (Analog Narrow)
	QT	Step1. Balance adjust Step2. Maximum Deviation (Analog Wide) Step3. QT Deviation (Wide)	Step1. Balance adjust Step2. Maximum Deviation (Analog Narrow) Step3. QT Deviation (Narrow)
	DQT	Step1. Balance adjust Step2. Maximum Deviation (Analog Wide) Step3. DQT Deviation (Wide)	Step1. Balance adjust Step2. Maximum Deviation (Analog Narrow) Step3. DQT Deviation (Narrow)
	DTMF	Step1. Balance adjust Step2. Maximum Deviation (Analog Wide) Step3. DTMF Deviation (Wide)	Step1. Balance adjust Step2. Maximum Deviation (Analog Narrow) Step3. DTMF Deviation (Narrow)
	2TONE	Step1. Balance adjust Step2. Maximum Deviation (Analog Wide) Step3. Single Tone Deviation (Analog Wide)	Step1. Balance adjust Step2. Maximum Deviation (Analog Narrow) Step3. Single Tone Deviation (Analog Narrow)
	MSK (FleetSync)	Step1. Balance adjust Step2. Maximum Deviation (Analog Wide) Step3. MSK Deviation (Analog Wide)	Step1. Balance adjust Step2. Maximum Deviation (Analog Narrow) Step3. MSK Deviation (Analog Narrow)
P25	Audio	-	Step1. Balance adjust Step2. Maximum Deviation (P25 Narrow)

- Balance is common with all the above deviation adjustments. If Balance (Transmitter Section 3) has already adjusted, please skip Step1 and adjust from Step2.
- Maximum Deviation (Analog Wide/Narrow) is common with all the analog signaling deviations. If Balance and Maximum Deviation (Analog Wide/Narrow) (Transmitter Section 5) have already adjusted, please skip Step2 and adjust from Step3.

## Receiver Section

Item	Condition		Measurement			Adjustment			Specifications / Remarks
	Panel tuning mode	PC test mode	Test-equipment	Unit	Terminal	Unit	Parts	Method	
1. AF level setting	[Panel test mode] 1) CH-Sig: 1-1 SSG output: -47dBm (1mV) (MOD: 1kHz/±1.5kHz) Wide/Narrow: Narrow Beat Shift: Uncheck Compander: Uncheck	1) Test Channel Channel: 1 Test Signaling Mode: Analog Signaling: 1 Wide/Narrow: Narrow Beat Shift: Uncheck Compander: Uncheck SSG output: -47dBm (1mV) (MOD: 1kHz/±1.5kHz)	SSG DVM AF VTVM Dummy load	Panel	ANT Universal connector	Panel	Volume knob	Turn the Volume knob to obtain 0.63V AF output.	0.63V±0.1V

## ADJUSTMENT

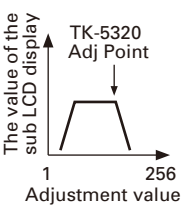
Item	Condition		Measurement			Adjustment			Specifications / Remarks
	Panel tuning mode	PC test mode	Test-equipment	Unit	Terminal	Unit	Parts	Method	
<b>(K,K3) Sensitivity adjust</b>									
2. Sensitivity 1 adjust (K,K3)	1) Adj item: [SENS1] Adjust: [***] 2) Adj item: [L SENS1]→ [L' SENS1]→ [C SENS1]→ [H' SENS1]→ [H SENS1] Adjust: [***] Press [◀] key to store the adjustment value.	1) Adj item: [Sensitivity 1] 2) Adj item: [Low], [Low'], [Center], [High'], [High] Press [Apply All] button to store the adjustment value.	SSG AF VTVM Oscilloscope	Panel	ANT Universal connector	Panel	[Panel tuning mode] [∧], [∨]  [PC test mode] [◀],[▶]	Write the value as followings [L SENS1] / [Low] : 120 [L' SENS1] / [Low'] : 135 [C SENS1] / [Center] : 145 [H' SENS1] / [High'] : 160 [H SENS1] / [High] : 173	
3. Sensitivity 2 adjust (K,K3)	1) Adj item: [SENS2] Adjust: [***] 2) Adj item: [L SENS2]→ [L' SENS2]→ [C SENS2]→ [H' SENS2] Adjust: [***] SSG output: -90dBm (7.08μV) (MOD: 1kHz±1.5kHz) Press [◀] key to store the adjustment value.	1) Adj item: [Sensitivity 2] 2) Adj item: [Low], [Low'], [Center], [High'] SSG output: -90dBm (7.08μV) (MOD: 1kHz±1.5kHz) Press [Apply All] button to store the adjustment value.					(The RSSI level is shown on the sub LCD display and PC window.) 1. Change the adjustment value to get the maximum RSSI level. 2. Increase the adjustment value to seek "TK-5320 ADJ Point" of RSSI level. (Refer to right.)		
	3) Adj item: [H SENS2] Adjust: [***] SSG output: Press [◀] key to store the adjustment value.	3) Adj item: [High] Press [Apply All] button to store the adjustment value.					Write the value as followings. [H SENS2]/[High] : 245		
<b>(K2,K4) Sensitivity adjust</b>									
2. Sensitivity 1 adjust (K2,K4)	1) Adj item: [SENS1] Adjust: [***] 2) Adj item: [L SENS1]→[L' SENS1]→ [L' SENS1]→[C SENS1]→ [H' SENS1] Adjust: [***] Press [◀] key to store the adjustment value.	1) Adj item: [Sensitivity 1] 2) Adj item: [Low], [Low'], [Center], [High'] Press [Apply All] button to store the adjustment value.	SSG AF VTVM Oscilloscope	Panel	ANT Universal connector	Panel	[Panel tuning mode] [∧], [∨]  [PC test mode] [◀],[▶]	Write the value as followings [L SENS1] / [Low]: 100 [L' SENS1] / [Low'] : 115 [C SENS1] / [Center] : 128 [H' SENS1] / [High'] : 142	
	3) Adj item: [H SENS1] Adjust: [***]	3) Adj item: [High]					Increase the adjustment value from 1 to get 12dB SINAD.		
	<b>Caution:</b> Perform the step 3 adjustments of "3. Sensitivity 2 adjust (K2,K4)" before performing the [H SENS1] adjustment.								
	SSG output: -119dBm (0.25μV) (MOD: 1kHz±1.5kHz) Press [◀] key to store the adjustment value.	SSG output: -119dBm (0.25μV) (MOD: 1kHz±1.5kHz) Press [Apply All] button to store the adjustment value.							

## ADJUSTMENT

Item	Condition		Measurement			Adjustment			Specifications / Remarks
	Panel tuning mode	PC test mode	Test-equipment	Unit	Terminal	Unit	Parts	Method	
3. Sensitivity 2 adjust (K2,K4)	1) Adj item: [SENS2] Adjust: [***] 2) Adj item: [L SENS2]→[L' SENS2]→ [C SENS2]→[H' SENS2] Adjust: [***] SSG output: -119dBm (0.25μV) (MOD: 1kHz/±1.5kHz) Press [◀] key to store the adjustment value.	1) Adj item: [Sensitivity 2] 2) Adj item: [Low], [Low'], [Center], [High'] SSG output: -119dBm (0.25μV) (MOD: 1kHz/±1.5kHz) Press [Apply All] button to store the adjustment value.	SSG AF VTVM Oscilloscope	Panel	ANT Universal connector	Panel	[Panel tuning mode] [∧], [∨]	Decrease the adjustment value from 256 to get 12dB SINAD.	
	3) Adj item: [H SENS2] Adjust: [***] Press [◀] key to store the adjustment value.	3) Adj item: [High] Press [Apply All] button to store the adjustment value.					[PC test mode] [◀],[▶]	Write the value as followings. [H SENS2]/[High] : 256	
4. RSSI reference adjust *5  [Analog Narrow]	1) Adj item: [An RRSSI] Adjust: [***] 2) Adj item: [AnL RRSSI]→ [AnL' RRSSI]→ [AnC RRSSI]→ [AnH' RRSSI]→ [AnH RRSSI] Adjust: [***] SSG output: 12dB SINAD level -3dB (MOD: 1kHz/±1.5kHz)	1) Adj item: [RSSI Reference (Analog Narrow)] 2) Adj item: [Low], [Low'], [Center], [High'], [High] SSG output: 12dB SINAD level -3dB (MOD: 1kHz/±1.5kHz)	SSG Distortion meter Oscilloscope				[Panel tuning mode] After input signal from SSG, press [◀] key to store the adjustment value.		
	[Analog Wide]	1) Adj item: [Aw RRSSI] Adjust: [***] 2) Adj item: [AwL RRSSI]→ [AwL' RRSSI]→ [AwC RRSSI]→ [AwH' RRSSI]→[AwH RRSSI] Adjust: [***] SSG output: 12dB SINAD level -3dB (MOD: 1kHz/±3kHz)					1) Adj item: [RSSI Reference (Analog Wide)] 2) Adj item: [Low], [Low'], [Center], [High'], [High] SSG output: 12dB SINAD level -3dB (MOD: 1kHz/±3kHz)		
*5: Because RSSI reference (P25 Narrow) is adjusted by adjusting RSSI reference (Analog Narrow), it is not necessary to adjust RSSI reference (P25 Narrow).									
5. Open Squelch adjust *6 (Squelch level 5 adjust)  [Analog Narrow]	1) Adj item: [An SQL] Adjust: [***] 2) Adj item: [AnL SQL]→ [AnL' SQL]→ [AnC SQL]→ [AnH' SQL]→ [AnH SQL] Adjust: [***] SSG output: 12dB SINAD level +1dB (MOD: 1kHz/±1.5kHz)	1) Adj item: [Open Squelch (Analog Narrow)] 2) Adj item: [Low], [Low'], [Center], [High'], [High] SSG output: 12dB SINAD level +1dB (MOD: 1kHz/±1.5kHz)	SSG Distortion meter Oscilloscope	Panel	ANT Universal connector			[Panel tuning mode] After input signal from SSG, press [◀] key to store the adjustment value.  [PC test mode] After input signal from SSG, press [Apply] button to store the adjustment value.	“Open Squelch” will not be adjusted correctly if MOD and Deviation are wrong.

## ADJUSTMENT

Item	Condition		Measurement			Adjustment			Specifications / Remarks
	Panel tuning mode	PC test mode	Test-equipment	Unit	Terminal	Unit	Parts	Method	
Open Squelch adjust *6 (Squelch level 5 adjust) [Analog Wide]	1) Adj item: [Aw SQL] Adjust: [***] 2) Adj item: [AwL SQL]→ [AwL' SQL]→ [AwC SQL]→ [AwH' SQL]→ [AwH SQL] Adjust: [***] SSG output: 12dB SINAD level +1dB (MOD: 1kHz/±3kHz)	1) Adj item: [Open Squelch (Analog Wide)] 2) Adj item: [Low], [Low'], [Center], [High'], [High] SSG output: 12dB SINAD level +1dB (MOD: 1kHz/±3kHz)	SSG Distortion meter Oscilloscope	Panel	ANT Universal connector			[Panel tuning mode] After input signal from SSG, press [<] key to store the adjustment value.  [PC test mode] After input signal from SSG, press [Apply] button to store the adjustment value.	"Open Squelch" will not be adjusted correctly if MOD and Deviation are wrong.
*6: Because Open Squelch (P25 Narrow) is adjusted by adjusting Open Squelch (Analog Narrow), it is not necessary to adjust Open Squelch (P25 Narrow).									
6. Low RSSI at -118dBm adjust *7 [Analog Narrow]	1) Adj item: [An LRSSI] Adjust: [***] 2) Adj item: [AnL LRSSI]→ [AnL' LRSSI]→ [AnC LRSSI]→ [AnH' LRSSI]→ [AnH LRSSI] Adjust: [***] SSG output: -118dBm (0.28μV) (MOD: 1kHz/±1.5kHz)	1) Adj item: [Low RSSI (Analog Narrow)] 2) Adj item: [Low], [Low'], [Center], [High'], [High] SSG output: -118dBm (0.28μV) (MOD: 1kHz/±1.5kHz)	SSG	Panel	ANT Universal connector			[Panel tuning mode] After input signal from SSG, press [<] key to store the adjustment value.  [PC test mode] After input signal from SSG, press [Apply] button to store the adjustment value.	
[Analog Wide]	1) Adj item: [Aw LRSSI] Adjust: [***] 2) Adj item: [AwL LRSSI]→ [AwL' LRSSI]→ [AwC LRSSI]→ [AwH' LRSSI]→ [AwH LRSSI] Adjust: [***] SSG output: -118dBm (0.28μV) (MOD: 1kHz/±3kHz)	1) Adj item: [Low RSSI (Analog Wide)] 2) Adj item: [Low], [Low'], [Center], [High'], [High] SSG output: -118dBm (0.28μV) (MOD: 1kHz/±3kHz)							
*7: Because Low RSSI at -118dBm (P25 Narrow) is adjusted by adjusting Low RSSI at -118dBm (Analog Narrow), it is not necessary to adjust Low RSSI at -118dBm (P25 Narrow).									
7. High RSSI at -80dBm adjust *8 [Analog Narrow]	1) Adj item: [An HRSSI] Adjust: [***] 2) Adj item: [AnL HRSSI]→ [AnL' HRSSI]→ [AnC HRSSI]→ [AnH' HRSSI]→ [AnH HRSSI] Adjust: [***] SSG output: -80dBm (22.4μV) (MOD: 1kHz/±1.5kHz)	1) Adj item: [High RSSI (Analog Narrow)] 2) Adj item: [Low], [Low'], [Center], [High'], [High] SSG output: -80dBm (22.4μV) (MOD: 1kHz/±1.5kHz)	SSG	Panel	ANT Universal connector			[Panel tuning mode] After input signal from SSG, press [<] key to store the adjustment value.  [PC test mode] After input signal from SSG, press [Apply] button to store the adjustment value.	

## ADJUSTMENT

Item	Condition		Measurement			Adjustment			Specifications / Remarks
	Panel tuning mode	PC test mode	Test-equipment	Unit	Terminal	Unit	Parts	Method	
High RSSI at -80dBm adjust *8  [Analog Wide]	1) Adj item: [Aw HRSSI] Adjust: [***] 2) Adj item: [AwL HRSSI]→ [AwL' HRSSI]→ [AwC HRSSI]→ [AwH' HRSSI]→ [AwH HRSSI] Adjust: [***] SSG output: -80dBm (22.4μV) (MOD: 1kHz/±3kHz)	1) Adj item: [High RSSI (Analog Wide)] 2) Adj item: [Low], [Low'], [Center], [High'], [High] SSG output: -80dBm (22.4μV) (MOD: 1kHz/±3kHz)	SSG	Panel	ANT Universal connector			[Panel tuning mode] After input signal from SSG, press [<] key to store the adjustment value.  [PC test mode] After input signal from SSG, press [Apply] button to store the adjustment value.	
*8: Because High RSSI at -80dBm (P25 Narrow) is adjusted by adjusting High RSSI at -80dBm (Analog Narrow), it is not necessary to adjust High RSSI at -80dBm (P25 Narrow).									
8. Tight Squelch adjust (Squelch level 9 adjust)  [Analog Narrow]	1) Adj item: [An SQLT] Adjust: [***] 2) Adj item: [AnL SQLT]→ [AnL' SQLT]→ [AnC SQLT]→ [AnH' SQLT]→ [AnH SQLT] Adjust: [***] SSG output: 12dB SINAD level +6dB (MOD: 1kHz/±1.5kHz)	1) Adj item: [Tight Squelch (Analog Narrow)] 2) Adj item: [Low], [Low'], [Center], [High'], [High] SSG output: 12dB SINAD level +6dB (MOD: 1kHz/±1.5kHz)	SSG	Panel	ANT Universal connector			[Panel tuning mode] After input signal from SSG, press [<] key to store the adjustment value.  [PC test mode] After input signal from SSG, press [Apply] button to store the adjustment value.	
[Analog Wide]	1) Adj item: [Aw SQLT] Adjust: [***] 2) Adj item: [AwL SQLT]→ [AwL' SQLT]→ [AwC SQLT]→ [AwH' SQLT]→ [AwH SQLT] Adjust: [***] SSG output: 12dB SINAD level +6dB (MOD: 1kHz/±3kHz)	1) Adj item: [Tight Squelch (Analog Wide)] 2) Adj item: [Low], [Low'], [Center], [High'], [High] SSG output: 12dB SINAD level +6dB (MOD: 1kHz/±3kHz)							

# TERMINAL FUNCTION

## Control unit (X53-4480-XX)

Pin No.	Name	I/O	Function
<b>CN1</b>			
1	/CS	O	Chip select output
2	/RES	O	LCD reset output
3	A0	O	Address bus 0 output
4	/WR	O	WR bus output
5	D0	I/O	Data bus 0
6	D1	I/O	Data bus 1
7	D2	I/O	Data bus 2
8	D3	I/O	Data bus 3
9	D4	I/O	Data bus 4
10	D5	I/O	Data bus 5
11	D6	I/O	Data bus 6
12	D7	I/O	Data bus 7
13	VDD	O	3.3V LCD power supply output
14	VSS	-	GND
15	VDD	O	3.3V LCD power supply output
16	V1	-	LCD drive power supply
17	V2	-	LCD drive power supply
18	V3	-	LCD drive power supply
19	V4	-	LCD drive power supply
20	V5	O	LCD drive power supply
<b>CN23</b>			
1	ME	-	Internal MIC GND
2	EMC	I	Internal MIC input
3	SP+	O	BTL output + for internal speaker
4	SP+	O	BTL output + for internal speaker
5	SP-	O	BTL output – for internal speaker
6	SP-	O	BTL output – for internal speaker
7	6_/KEYI1	I	Key matrix input (KEYI1 for 6-key)
8	6_/KEYO2	O	Key matrix output (KEYO2 for 6-key)
9	BL_SB	O	LCD backlight voltage output
10	6_/KEYO0	O	Key matrix output (KEYO0 for 6-key)
11	6_/KEYO1	O	Key matrix output (KEYO1 for 6-key)
12	BL_SB	O	LCD backlight voltage output
13	6_/KEYI0	I	Key matrix input (KEYI0 for 6-key)
14	AGND	-	GND
<b>CN403</b>			
1	33A	O	3.3V for volume level
2	VOL_GND	-	GND for volume level
3	VOL	I	Volume level input for audio control
4	EN3	I	Rotary switch input
5	AGND	-	GND
6	EN4	I	Rotary switch input
7	EN1	I	Rotary switch input
8	EN2	I	Rotary switch input

Pin No.	Name	I/O	Function
9	+B	O	Power output after passing through the fuse
10	SB1	I	Power input after power switch
<b>CN404</b>			
1	LED_G	O	Green LED control output
2	/EMG	I	Emergency (Orange) key input
3	LED_R	O	Red LED control output
4	IFC	I	TX-RX PCB version recognition input
5	/SAVE	O	50C Reg. control output
6	I2CCK	O	TCXO thermometer clock output
7	/5TC	O	50T Reg. switch control output
8	I2CSDA	I/O	TCXO thermometer data input/output
9	SBC	O	SB3 switch control output
10	/T_R	O	TX/RX control output
11	TV2	O	RX tuning voltage 2 output
12	ASSIST	O	VCO tuning voltage output
13	TV1	O	RX tuning voltage 1 output
14	VAGC	I	AGC voltage input
15	5RC	O	50R switch control output
16	TCXO_MOD	O	TCXO modulation output
17	PGND	-	GND
18	RSSI	I	RSSI voltage input
19	PGND	-	GND
20	CV	I	CV voltage input
21	AGND	-	GND
22	NC	-	No connection
23	NC	-	No connection
24	+B	I	Power input after passing through the fuse
25	+B	I	Power input after passing through the fuse
26	+B	I	Power input after passing through the fuse
27	+B	I	Power input after passing through the fuse
28	NC	-	No connection
29	NC	-	No connection
30	AGND	-	GND
31	/PTT	I	PTT input
32	Side_G	O	Key matrix output (SIDE1,2 key)
33	Side_1	I	Key matrix input (SIDE1 key)
34	W_/N	O	W/N control output
35	SDO1	O	PLL serial data output
36	Side_2	I	Key matrix input (SIDE2 key)
37	/PCS_RF	O	PLL enable output
38	/DSW	O	APC voltage discharge switch control output
39	APC	O	APC control voltage output
40	/APCSW	O	APC switch control output
41	VCO_MOD	O	VCO modulation output



# TERMINAL FUNCTION

Pin No.	Name	I/O	Function
42	THP	I	Thermistor voltage input
43	PLD	I	PLL lock detect input
44	38M	O	38M output
45	SCK1	O	PLL clock output
46	GND	-	GND
47	S_DET	I	Battery select input
48	GND	-	GND
49	NC	-	No connection
50	IF_DET	I	IF input
<b>CN405</b>			
1	SSW	I	EXT/INT speaker switch input
2	SP+	O	BTL output + for external speaker
3	SP-	O	BTL output - for external speaker
4	MSW	I	EXT/INT MIC switch input
5	EMC	I	External MIC input
6	ME	-	External MIC GND
7	PTT	I	External PTT input
8	PF	I	Programmable function key input
9	OPT	I/O	Option interface I/O
10	E	-	GND
11	5V	O	5V output
12	TXD	O	Serial data output
13	RXD	I	Serial data input
14	NC	-	No connection
<b>CN701 (for production)</b>			
1~20			
<b>CN710</b>			
1	OPT1	I/O	Refer to "CN710 26-pin connector specification" described on pages 60 to 62.
2	OPT3	I/O	
3	26P_RD	I	
4	26P_TD	O	
5	NC	-	
6	OPT4	O	
7	OPT10	O	
8	OPT5	O	
9	DGND	-	
10	AGND	-	
11	AI	I	
12	AO	O	
13	AGND	-	
14	5V	O	
15	OPT9	I	
16	DTI	I	
17	OPT8	I/O	
18	OPT11	O	
19	OPT7	I/O	

Pin No.	Name	I/O	Function
20	OPT2	I/O	Refer to "CN710 26-pin connector specification" described on pages 60 to 62.
21	TXO	O	
22	RXEO	O	
23	RXEI	I	
24	TXI	I	
25	OPT6	O	
26	POW	O	

## TX-RX unit (X57-7830-XX A/2)

Pin No.	Name	I/O	Function
<b>CN900</b>			
1	LED_G	I	Green LED control input
2	/EMG	O	Emergency (Orange) key output
3	LED_R	I	Red LED control input
4	IFC	O	TX-RX PCB version recognition output
5	/SAVE	I	50C Reg. control input
6	I2CCK	I	TCXO thermometer clock input
7	/5TC	I	50T Reg. switch control input
8	I2CSDA	I/O	TCXO thermometer data input/output
9	SBC	I	SB3 switch control input
10	/T_R	I	TX/RX control input
11	TV2	I	RX tuning voltage 2 input
12	ASSIST	I	VCO tuning voltage input
13	TV1	I	RX tuning voltage 1 input
14	VAGC	O	AGC voltage output
15	5RC	I	50R switch control input
16	TCXO_MOD	I	TCXO modulation input
17	GND	-	GND
18	RSSI	O	RSSI voltage output
19	GND	-	GND
20	CV	O	CV voltage output
21	GND	-	GND
22	NC	-	No connection
23	NC	-	No connection
24	+B	O	Power output after passing through the fuse
25	+B	O	Power output after passing through the fuse
26	+B	O	Power output after passing through the fuse
27	+B	O	Power output after passing through the fuse
28	NC	-	No connection
29	NC	-	No connection
30	GND	-	GND
31	/PTT	O	PTT output

# TERMINAL FUNCTION

Pin No.	Name	I/O	Function
32	Side_G	I	Key matrix input (SIDE1,2 key)
33	Side_1	O	Key matrix output (SIDE1 key)
34	W_N	I	No connection
35	SDO1	I	PLL serial data input
36	Side_2	O	Key matrix output (SIDE2 key)
37	/PCS_RF	I	PLL enable input
38	/DSW	I	APC voltage discharge switch control input
39	APC	I	APC control voltage input
40	/APCSW	I	APC switch control input
41	VCO_MOD	I	VCO modulation input
42	THP	O	Thermistor voltage output
43	PLD	O	PLL lock detect output
44	38M	I	38M input
45	SCK1	I	PLL clock input
46	GND	-	GND
47	S_DET	O	Battery select output
48	GND	-	GND
49	NC	-	No connection
50	IF_DET	O	IF output
<b>CN901</b>			
1	PTT	I	Internal PTT input
2	GND	-	GND
3	Side_G	O	Key matrix output (SIDE1,2 key)
4	Side_1	I	Key matrix input (SIDE1 key)
5	Side_2	I	Key matrix input (SIDE2 key)

## Option Board unit (X57-7830-XX B/2)

Pin No.	Name	I/O	Function
<b>CN737</b>			
1	OPT1	I/O	Refer to "CN737 Option board connector specification" described on page 63.
2	OPT3	I/O	
3	26P_RD	O	
4	26P_TD	I	
5	NC	-	
6	OPT4	I	
7	OPT10	I	
8	OPT5	I	
9	DGND	-	
10	AGND	-	
11	NC	-	
12	NC	-	
13	AGND	-	
14	5V	I	
15	OPT9	O	
16	DTI	O	
17	OPT8	I/O	
18	OPT11	I	
19	OPT7	I/O	
20	OPT2	I/O	
21	TXO	I	
22	RXEO	I	
23	RXEI	O	
24	TXI	O	
25	OPT6	I	
26	POW	I	

## Solder Pad

Name	I/O	Signal Type	Function	Rating and Condition				
				Parameter	Min	Typ	Max	Unit
PTT2	O	Digital	PTT output	[Output] Output Impedance			10k	Ω
PTT1	I	Digital	PTT input	[Input] VIH	2.8		3.3	V
				[Input] VIL	0		0.5	V
MDSW	I	Digital	Man-down switch input	[Input] VIH	2.8		3.3	V
				[Input] VIL	0		0.5	V
GND	-	GND	GND	Allowable current value				mA
TXD	O	Digital	Serial data output	VOH (I <sub>o</sub> =-5mA)	4.0	-	5.3	V
				VOL (I <sub>o</sub> =5mA)	0	-	0.8	V
				Baud Rate			19200	bps
RXD	I	Digital	Serial data input	VIH	2.8	-	5.3	V
				VIL	0	-	0.8	V
				Baud Rate			19200	bps
RSSI	O	Analog	RSSI output	Output Impedance			10k	Ω

# TERMINAL FUNCTION

## Universal Connector

Pin No.	Name	I/O	Signal Type	Function	Rating and Condition				
					Parameter	Min	Typ	Max	Unit
1	SSW	I	Digital	EXT/INT speaker switch input L: External speaker ON H: Internal speaker ON	VIH	2.8	-	5.3	V
					VIL	0	-	0.7	V
2	SP+	O	Analog	BTL output + for external speaker	[8Ω load] Max output power (1kHz, Batt=7.5V)		1.3	1.8	W
					[8Ω load] DC Bias		2.5		V
					[8Ω load] Allowable Frequency	300		3000	Hz
3	SP-	O	Analog	BTL output - for external speaker	[16Ω load] Max output power (1kHz, Batt=7.5V)		0.9	1.4	W
					[16Ω load] DC Bias		2.5		V
					[16Ω load] Allowable Frequency	300		3000	Hz
4	MSW	I	Digital	EXT/INT MIC switch input L: External MIC ON H: Internal MIC ON	VIH	2.8	-	5.3	V
					VIL	0	-	0.5	V
5	EMC	I	Analog	External MIC input	Audio Level (STD deviation)	7.7	12.5	17.3	mV
					DC Bias		3.3		V
					Allowable Frequency	300		3000	Hz
					Input Impedance	-	1.8	-	kΩ
6	ME	-	-	External MIC GND					
7	PTT	I	Digital	External PTT input L: PTT ON	VIH	2.8	-	5.3	V
					VIL	0	-	0.7	V
8	PF	I	Analog	Programmable function key input	V (PF2 key ON)	2.2	-	2.8	V
					V (PF1 key ON)	1.7	-	2.2	V
					V (PF1, PF2 key ON)	1.3	-	1.7	V
9	OPT	I	Digital	Man-down input Programmable active H/L	VIH	2.8	-	5.3	V
					VIL	0	-	0.7	V
10	E	-	-	GND					
11	5V	-	Power	5V power supply output (Output control is FPU programmable)	Output Voltage (Iout=100mA)	4.9	5.0	5.1	V
					Maximum Current	-	-	0.2	A
12	TXD	O	Digital	Serial data output	VOH (Io=-5mA)	4.0	-	5.3	V
					VOL (Io=5mA)	0	-	0.8	V
					Baud Rate			19200	bps
13	RXD	I	Digital	Serial data input	VIH	2.8	-	5.3	V
					VIL	0	-	0.8	V
					Baud Rate			115200	bps
14	NC	-	-	Not used (reserved for future option)					

# TERMINAL FUNCTION

## CN710 26-pin Connector Specification

Pin No.	Name	I/O	Signal Type	Rating and Condition				
				Parameter	Min	Typ	Max	Unit
1	OPT1	I/O	Digital	[Input] VIH	2.8		3.3	V
6	OPT4			[Input] VIL	0		0.5	V
8	OPT5			[Output] VOH	2.8		3.5	V
17	OPT8			[Output] VOL	0		0.5	V
18	OPT11							
2	OPT3	I/O	Digital	[Input] VIH	2.8		3.3	V
19	OPT7			[Input] VIL	0		0.5	V
20	OPT2			[Output] VOH	2.8		3.5	V
25	OPT6			[Output] VOL	0		0.5	V
3	26P_RD	I	Digital	[Input] VIH	2.8		3.3	V
				[Input] VIL	0		0.5	V
				Baud Rate			19200	bps
4	26P_TD	O	Digital	[Output] VOH	2.8		3.5	V
				[Output] VOL	0		0.5	V
				Baud Rate			19200	bps
15	OPT9	I	Analog	Input Amplitude (Square wave)	-	3.3	-	V <sub>p-p</sub>
				Coupling Capacitor	-	0.01	-	μF
				Input Impedance	22k	-	-	Ω
				Allowable Frequency	300	-	3000	Hz
7	OPT10	O	Analog/Digital	Output Amplitude (1kHz, 60% deviation)	0.9	1.3	1.7	V <sub>p-p</sub>
				Coupling Capacitor		0.1		μF
				Output Impedance			22k	Ω
				Allowable Frequency	300		3000	Hz
11	AI	I	Analog	Input Amplitude (1kHz, 60% deviation)	0.3	0.5	0.7	V <sub>p-p</sub>
				Coupling Capacitor	-	0.1	-	μF
				Input Impedance	-	12k	-	Ω
				Allowable Frequency	300	-	3000	Hz
12	AO	O	Analog	Output Amplitude (1kHz, 60% deviation)	30	50	70	mV <sub>p-p</sub>
				Coupling Capacitor	-	0.1	-	μF
				Output Impedance	-	35k	-	Ω
				Allowable Frequency	300		3000	Hz
16	DTI	I	Analog	Input Amplitude (1kHz, 60% deviation)	0.8	1.1	1.4	V <sub>p-p</sub>
				Coupling Capacitor	-	0.1	-	μF
				Input Impedance	22k	-	-	Ω
				Allowable Frequency	300	-	3000	Hz
21	TXO	O	Analog	Output Amplitude (1kHz, 60% deviation) while external MIC	160	260	360	mV <sub>p-p</sub>
				Output Amplitude (1kHz, 60% deviation) while internal MIC	-	130	-	mV <sub>p-p</sub>
				Coupling Capacitor	-	0.1	-	μF
				Output Impedance	-	-	2.2k	Ω
				Allowable Frequency	300		3000	Hz

## TERMINAL FUNCTION

Pin No.	Name	I/O	Signal Type	Rating and Condition				
				Parameter	Min	Typ	Max	Unit
22	RXEO	O	Analog	Output Amplitude (1kHz, 60% deviation)	450	640	830	mVp-p
				Coupling Capacitor	-	0.1	-	μF
				Output Impedance	-	-	2.2k	Ω
				Allowable Frequency	300	-	3000	Hz
23	RXEI	I	Analog	Input Amplitude (1kHz, 60% deviation)	450	640	830	mVp-p
				Coupling Capacitor		0.1		μF
				Input Impedance	22k			Ω
				Allowable Frequency	300		3000	Hz
24	TXI	I	Analog	Input Amplitude (1kHz, 60% deviation) while external MIC	160	260	360	mVp-p
				Input Amplitude (1kHz, 60% deviation) while internal MIC	-	130	-	mVp-p
				Coupling Capacitor	-	0.1	-	μF
				Input Impedance	22k	-	-	Ω
				Allowable Frequency	300	-	3000	Hz
14	5V	O	Power	Output Voltage		5		V
				Output Current			78	mA
26	POW	O	Power	Output Voltage		7.5		V
				Output Current			100	mA
9	DGND	-	GND	Allowable current value (Total current of 3 pins)			100	mA
10	AGND							
13								
5	NC	-	-	-				

### CN710 26-pin Connector Specification

Pin No.	Name	Device	I/O	Connection	Function
1	OPT1	ANI board	O	Aux Input	[COR] Conv/LTR L: Not activity receiving H: Activity receiving [TOR] Conv/LTR L: Not activity receiving H: Activity receiving (Sub Tone or LTR ID is OK) [LOK] Conv L: TX Complete H: Not TX Complete LTR L: TX Link Complete (until TX finishes) H: Not TX Link Complete
		VGS-1	I	BUSY	BUSY indication
2	OPT3	ANI board	I	KEY	TX requirement input
		VGS-1	I	PLAY	PLAY indication
3	26P_RD	ANI board	-	-	-
		VGS-1	I	SO	Serial data input

## TERMINAL FUNCTION

Pin No.	Name	Device	I/O	Connection	Function
4	26P_TD	ANI board	-	-	-
		VGS-1	O	SI	Serial data output
5	NC	-	-	-	-
6	OPT4	ANI board	O	PTT	PTT signal output
		VGS-1	O	EN	Enable
7	OPT10	ANI board	-	-	-
		VGS-1	O	USEL	UART speed select output
8	OPT5	ANI board	O	Emergency	Emergency signal output
		VGS-1	O	RST	Reset output
9	DGND	ANI board	-	A-	GND
		VGS-1	-	DGND	DGND
10	AGND	ANI board	-	A-	GND
		VGS-1	-	AGND	AGND
11	AI	ANI board	-	-	-
		VGS-1	I	AO	VGS Audio input
12	AO	ANI board	-	-	-
		VGS-1	O	AI	VGS Audio output
13	AGND	ANI board	-	A-	GND
		VGS-1	-	AGND	AGND
14	5V	ANI board	-	-	Note: POW and 5V can not be used simultaneously.
		VGS-1	O	5C	5V power supply
15	OPT9	ANI board	I	Sidetone	Sidetone input
		VGS-1	-	-	-
16	DTI	ANI board	I	Data Out	Data signal input
		VGS-1	-	-	-
17	OPT8	ANI board	I	Tone Control	Speaker mute signal input
		VGS-1	-	-	-
18	OPT11	ANI board	O	Man-Down	Man-Down output
		VGS-1	-	-	-
19	OPT7	ANI board	I	MIC Mute	MIC mute signal input
		VGS-1	-	-	-
20	OPT2	ANI board	I	Aux Output	Emergency signal input
		VGS-1	-	-	-
21	TXO	ANI board	-	-	-
		VGS-1	-	-	-
22	RXEO	ANI board	-	-	-
		VGS-1	-	-	-
23	RXEI	ANI board	-	-	-
		VGS-1	-	-	-
24	TXI	ANI board	-	-	-
		VGS-1	-	-	-
25	OPT6	ANI board	-	-	-
		VGS-1	-	-	-
26	POW	ANI board	O	A+	Switched B output
		VGS-1	-	-	Note: POW and 5V can not be used simultaneously.

# TERMINAL FUNCTION

## CN737 Option Board Connector Specification

Pin No.	Name	Device	I/O	Connection	Function
1	OPT1	ANI board	I	Aux Output	[COR] Conv/LTR L: Not activity receiving H: Activity receiving [TOR] Conv/LTR L: Not activity receiving H: Activity receiving (Sub Tone or LTR ID is OK) [LOK] Conv L: TX Complete H: Not TX Complete LTR L: TX Link Complete (until TX finishes) H: Not TX Link Complete
2	OPT3	ANI board	O	KEY	TX requirement output
3	26P_RD	ANI board	-	-	-
4	26P_TD	ANI board	-	-	-
5	NC	-	-	-	-
6	OPT4	ANI board	I	PTT	PTT signal input
7	OPT10	ANI board	-	-	-
8	OPT5	ANI board	I	Emergency	Emergency signal input
9	DGND	ANI board	-	A-	GND
10	AGND	ANI board	-	A-	GND
11	NC	-	-	-	-
12	NC	-	-	-	-
13	AGND	ANI board	-	A-	GND
14	5V	ANI board	-	-	Note: POW and 5V can not be used simultaneously.
15	OPT9	ANI board	O	Sidetone	Sidetone output
16	DTI	ANI board	O	Data Out	Data signal output
17	OPT8	ANI board	O	Tone Control	Speaker mute signal output
18	OPT11	ANI board	I	Man-Down	Man-Down input
19	OPT7	ANI board	O	MIC Mute	MIC mute signal output
20	OPT2	ANI board	O	Aux Output	Emergency signal output
21	TXO	ANI board	-	-	-
22	RXEO	ANI board	-	-	-
23	RXEI	ANI board	-	-	-
24	TXI	ANI board	-	-	-
25	OPT6	ANI board	-	-	-
26	POW	ANI board	I	A+	Switched B input

# TK-5320 PC BOARD

**CONTROL UNIT (X53-4480-XX) -10: K,K2 -11: K3,K4**  
**Component side view (J79-0131-39)**

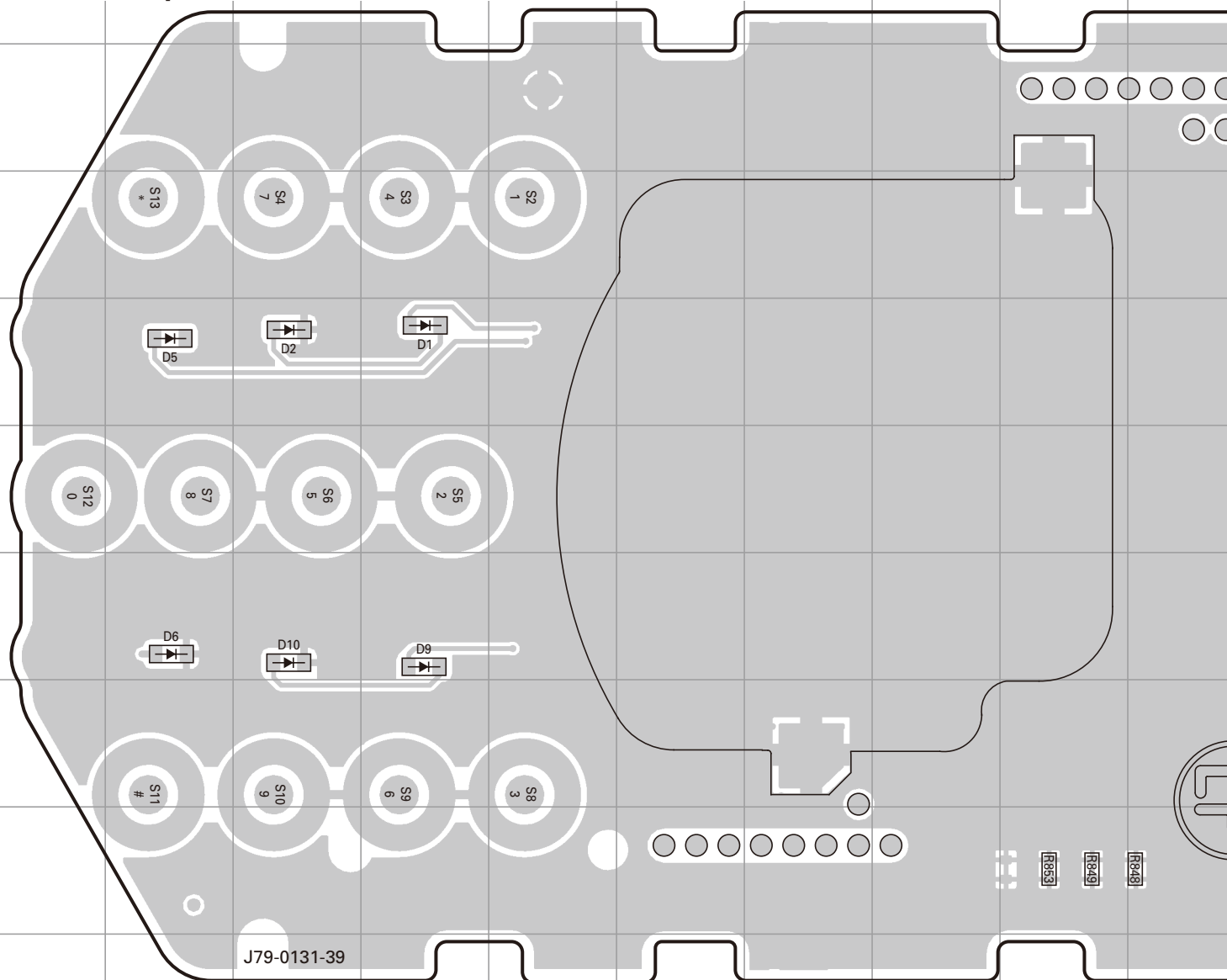

J79-0131-39

Ref. No.	Address	Ref. No.	Address	Ref. No.	Address
IC1	6K	D4	3Q	D14	7M
IC415	8K	D5	5B	D15	7L
Q1	7K	D6	7B	D16	7L
Q2	7L	D7	10O	D17	9L
Q3	6L	D8	10Q	D18	4L
Q4	4L	D9	7D	D19	4L
Q5	4L	D10	7C	D20	8M
D1	5D	D11	7L	D21	8M
D2	5C	D12	7M	D22	8L
D3	3O	D13	7M	D23	9L



# PC BOARD TK-5320

**CONTROL UNIT (X53-4480-XX) -10: K,K2 -11: K3,K4  
Component side view (J79-0131-39)**

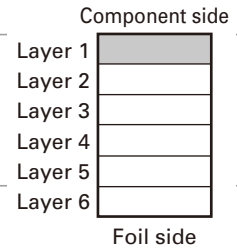
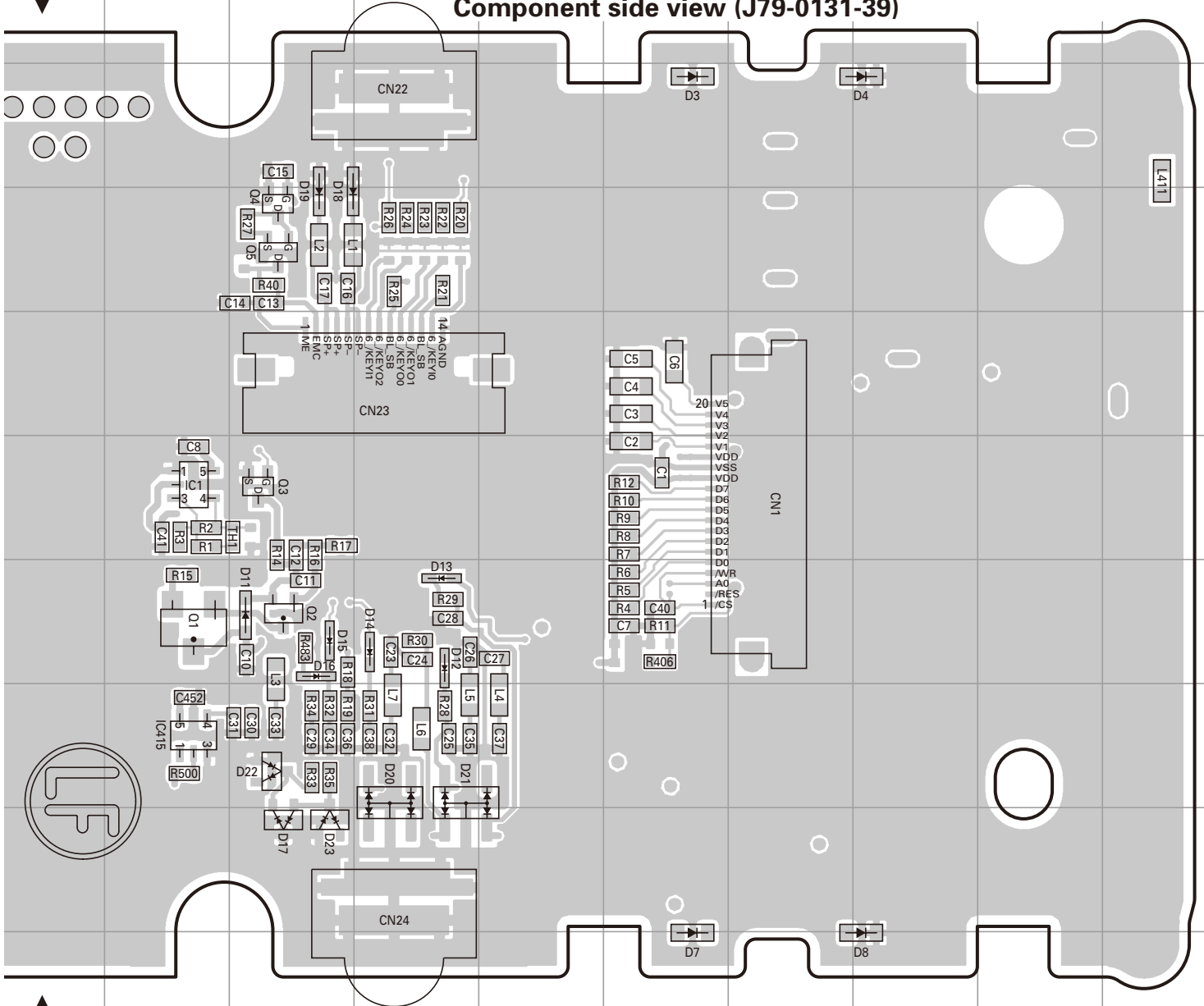

# TK-5320 PC BOARD

**CONTROL UNIT (X53-4480-XX) -10: K,K2 -11: K3,K4**  
**Foil side view (J79-0131-39)**

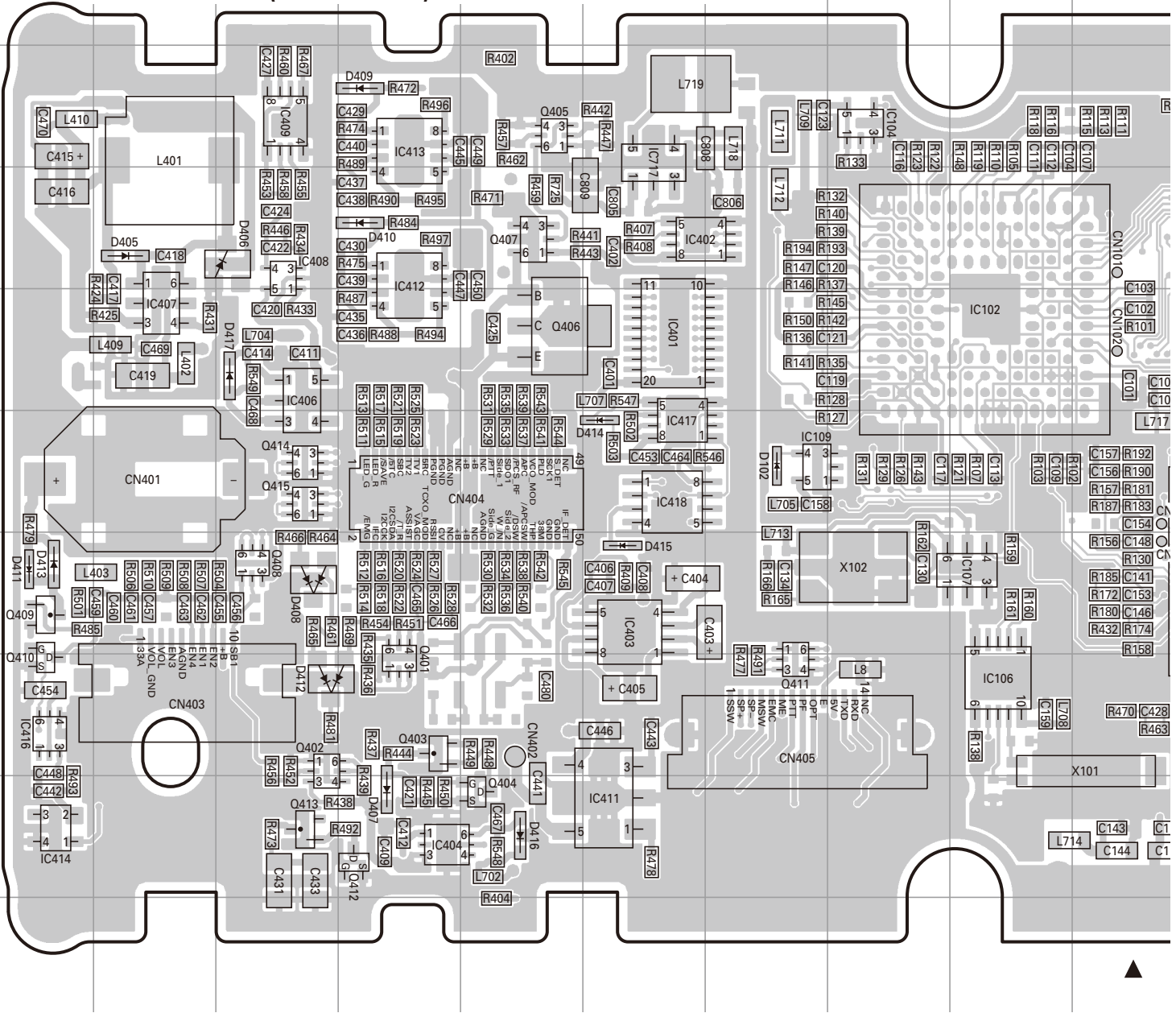

Ref. No.	Address	Ref. No.	Address	Ref. No.	Address	Ref. No.	Address	Ref. No.	Address	Ref. No.	Address	Ref. No.	Address	Ref. No.	Address
IC101	5K	IC404	9D	IC701	7Q	IC713	4Q	Q405	3E	Q702	4R	D405	4B	D417	
IC102	5I	IC406	5C	IC702	5R	IC714	5R	Q406	5E	Q703	6R	D406	4C	D701	
IC103	4K	IC407	5B	IC703	7P	IC715	5P	Q407	4E	Q704	7R	D407	9D	D702	
IC104	3H	IC408	4C	IC704	3P	IC716	5N	Q408	7C	Q705	5O	D408	7C	D703	
IC105	4L	IC409	3C	IC705	9N	IC717	3F	Q409	7A	Q706	5O	D409	3D	D704	
IC106	8I	IC411	9F	IC706	7N	Q101	3K	Q410	8A	Q707	4N	D410	4D	D705	
IC107	7I	IC412	4D	IC707	3P	Q102	3K	Q411	8G	D101	3L	D411	7A	D706	
IC108	7K	IC413	3D	IC708	9Q	Q103	3L	Q412	9D	D102	6G	D412	8C	D707	
IC109	6G	IC414	9A	IC709	4R	Q401	8D	Q413	9C	D401	4M	D413	7A		
IC401	5F	IC416	8A	IC710	6N	Q402	8C	Q414	6C	D402	5M	D414	6F		
IC402	4F	IC417	6F	IC711	6S	Q403	8D	Q415	6C	D403	5M	D415	7F		
IC403	7F	IC418	6F	IC712	6N	Q404	9E	Q701	6Q	D404	5M	D416	9E		

# PC BOARD TK-5320

## CONTROL UNIT (X53-4480-XX) -10: K,K2 -11: K3,K4 Foil side view (J79-0131-39)

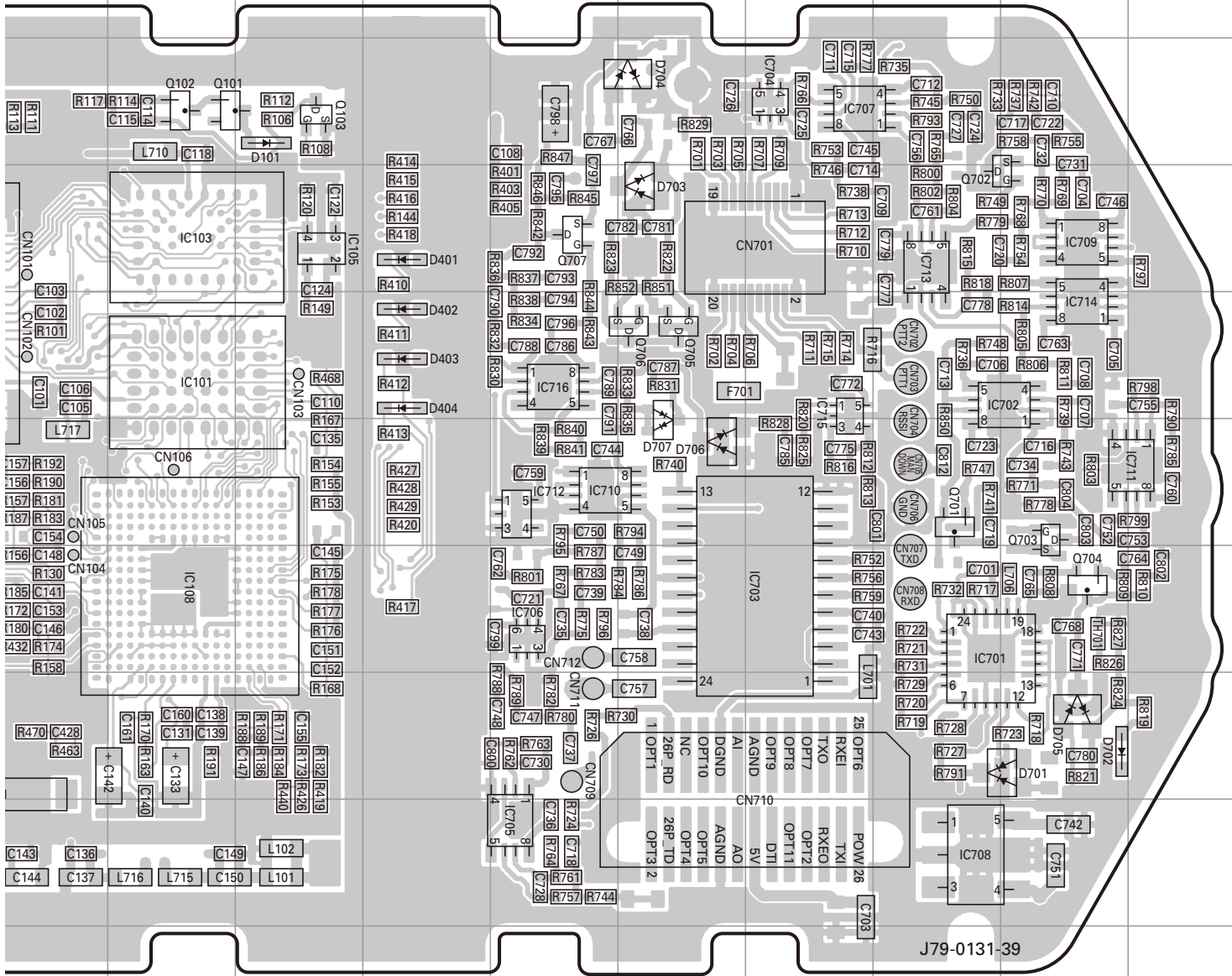

ss	Ref. No.	Address
	D417	5C
	D701	8R
	D702	8R
	D703	4O
	D704	3O
	D705	8R
	D706	6O
	D707	6O

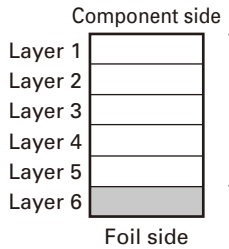

# TK-5320 PC BOARD

TX-RX UNIT (X57-7830-XX) (A/2) -10: K,K3 -11: K2,K4  
 Component side view (J79-0128-39 A/2)

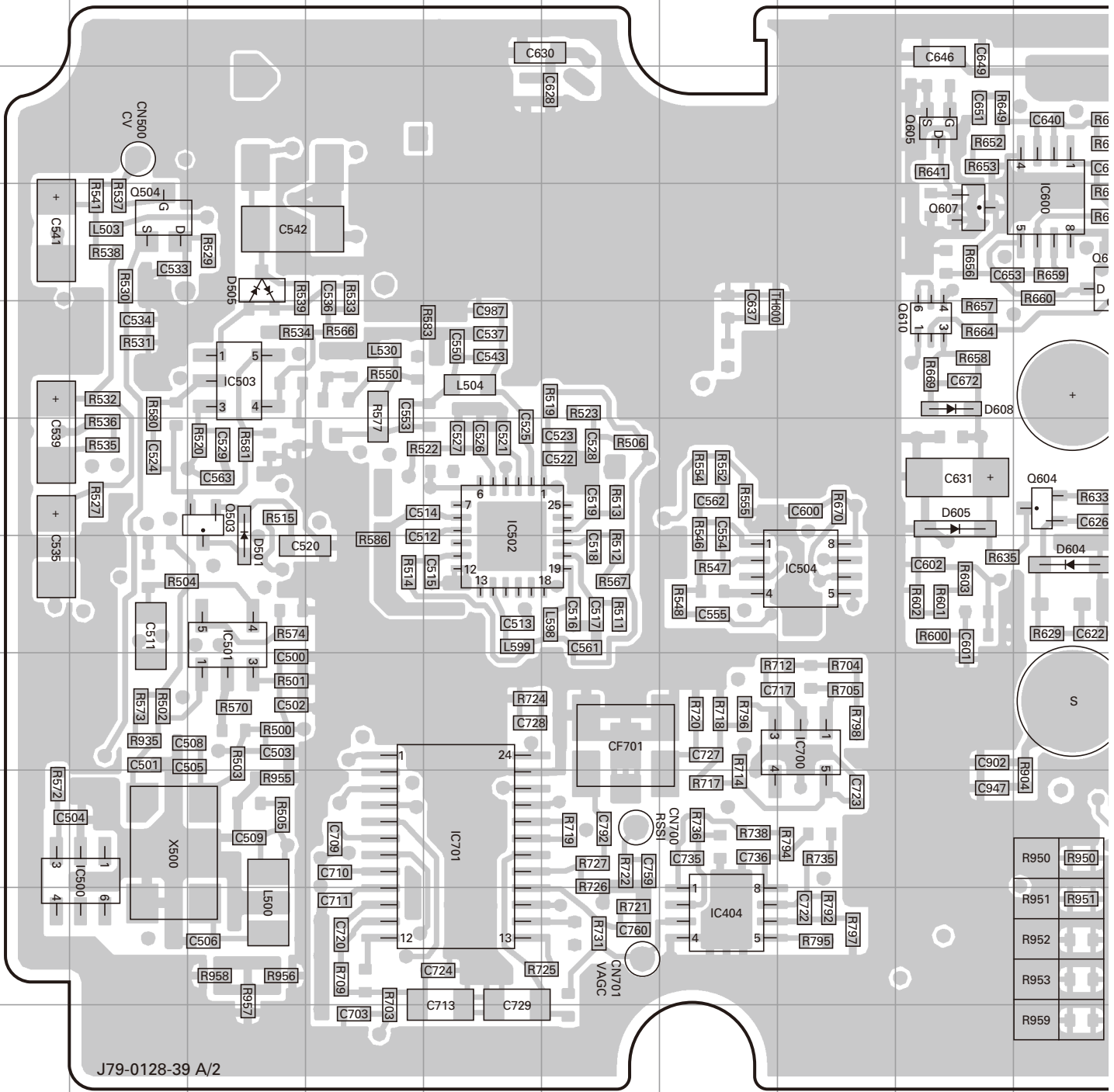

Ref. No.	Address	Ref. No.	Address	Ref. No.	Address	Ref. No.	Address	Ref. No.	Address
IC404	10G	IC700	8H	Q504	4B	Q900	9P	D604	7J
IC500	9B	IC701	9E	Q604	6J	Q901	7N	D605	6I
IC501	7C	IC702	7K	Q605	3I	Q902	7M	D608	5I
IC502	7E	IC900	4P	Q607	4I	Q904	9O	D700	6L
IC503	5C	IC901	9O	Q608	4J	Q905	4N	D900	8P
IC504	7H	IC902	5N	Q610	5I	D501	7C	D901	5M
IC600	4J	Q503	6C	Q704	6L	D505	4C	D902	5P

Market code	R950	R951
K, K3	0	NO
K2, K4	NO	0

# PC BOARD TK-5320

**TX-RX UNIT (X57-7830-XX) (A/2) -10: K,K3 -11: K2,K4**  
**Component side view (J79-0128-39 A/2)**

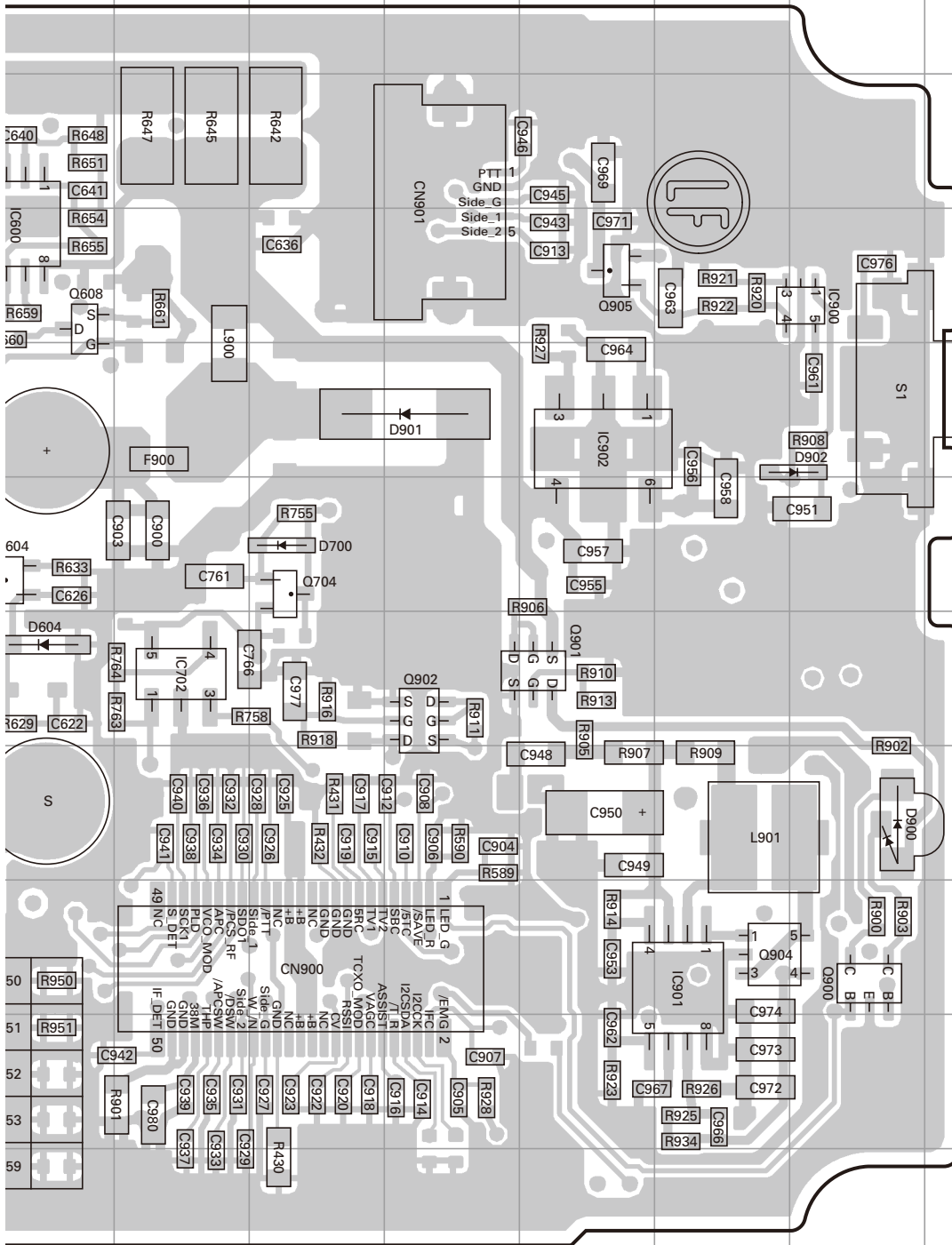

**TX-RX UNIT (X57-7830-XX) (B/2) -10: K,K3 -11: K2,K4**

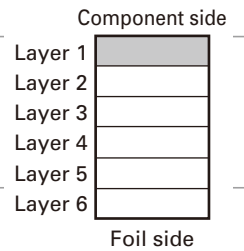
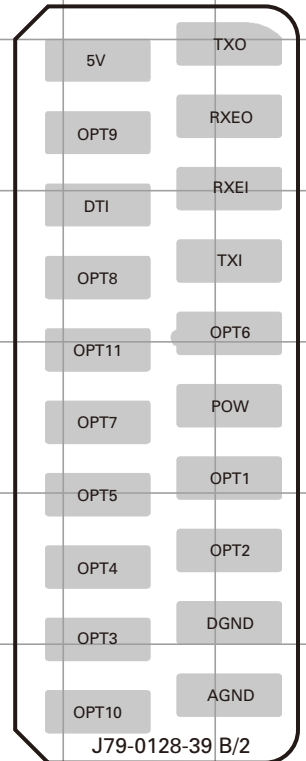

# TK-5320 PC BOARD

**TX-RX UNIT (X57-7830-XX) (A/2) -10: K,K3 -11: K2,K4**  
**Foil side view (J79-0128-39 A/2)**

**TX-RX UNIT  
 (X57-7830-XX) (B/2)  
 -10: K,K3 -11: K2,K4**

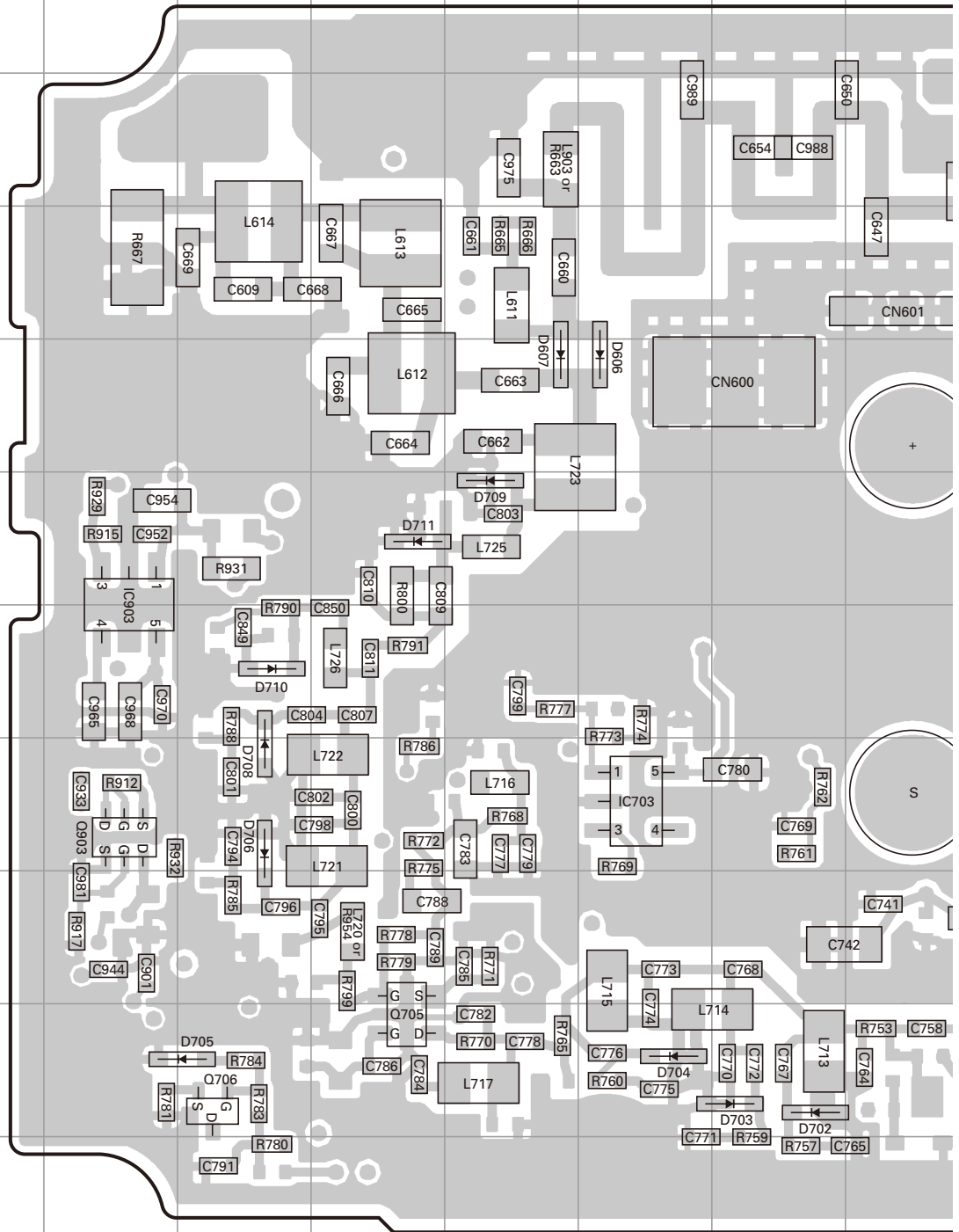
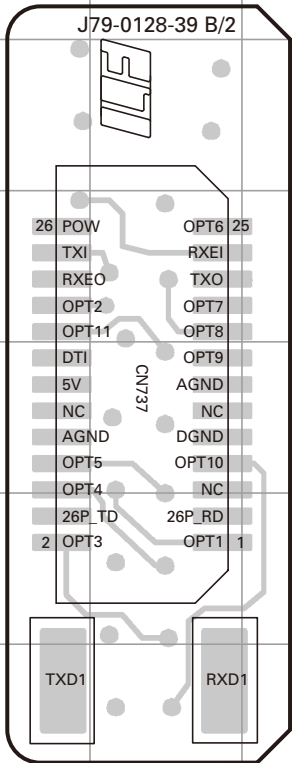

# PC BOARD TK-5320

TX-RX UNIT (X57-7830-XX) (A/2) -10: K,K3 -11: K2,K4  
Foil side view (J79-0128-39 A/2)

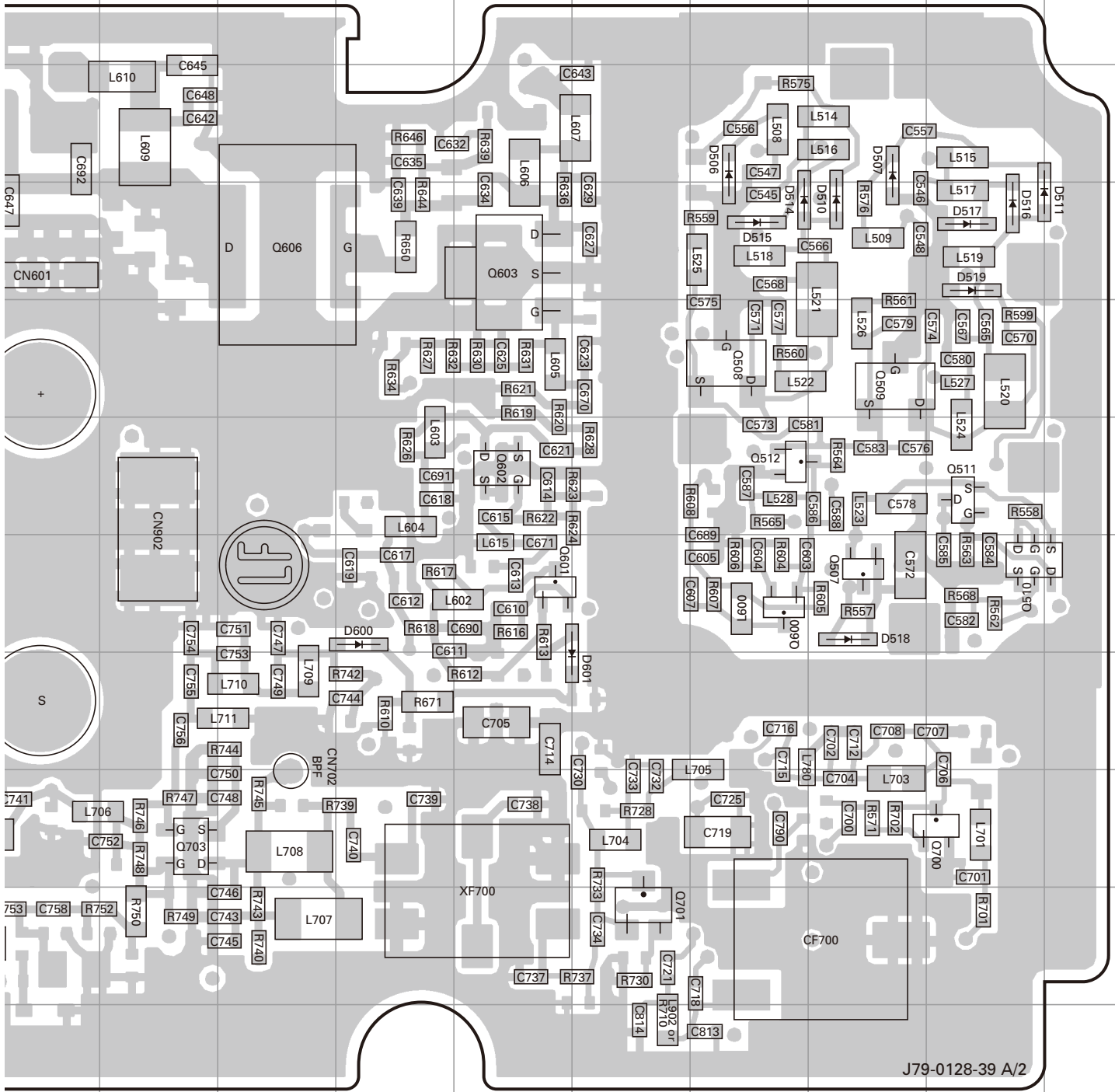

Ref. No.	Address	Ref. No.	Address	Ref. No.	Address	Ref. No.	Address	Ref. No.	Address	Ref. No.	Address
IC703	8H	Q512	6P	Q701	10O	D510	4Q	D519	4R	D704	10H
IC903	7D	Q600	7P	Q703	9K	D511	4S	D600	7M	D705	10E
Q507	7Q	Q601	7N	Q705	10F	D514	4P	D601	8O	D706	8E
Q508	5P	Q602	6N	Q706	10E	D515	4P	D606	5H	D708	8E
Q509	5Q	Q603	4N	Q903	8D	D516	4R	D607	5G	D709	6G
Q510	7R	Q606	4L	D506	3P	D517	4R	D702	10I	D710	7E
Q511	6R	Q700	9R	D507	3Q	D518	7Q	D703	10I	D711	6F

## INTERCONNECTION DIAGRAM

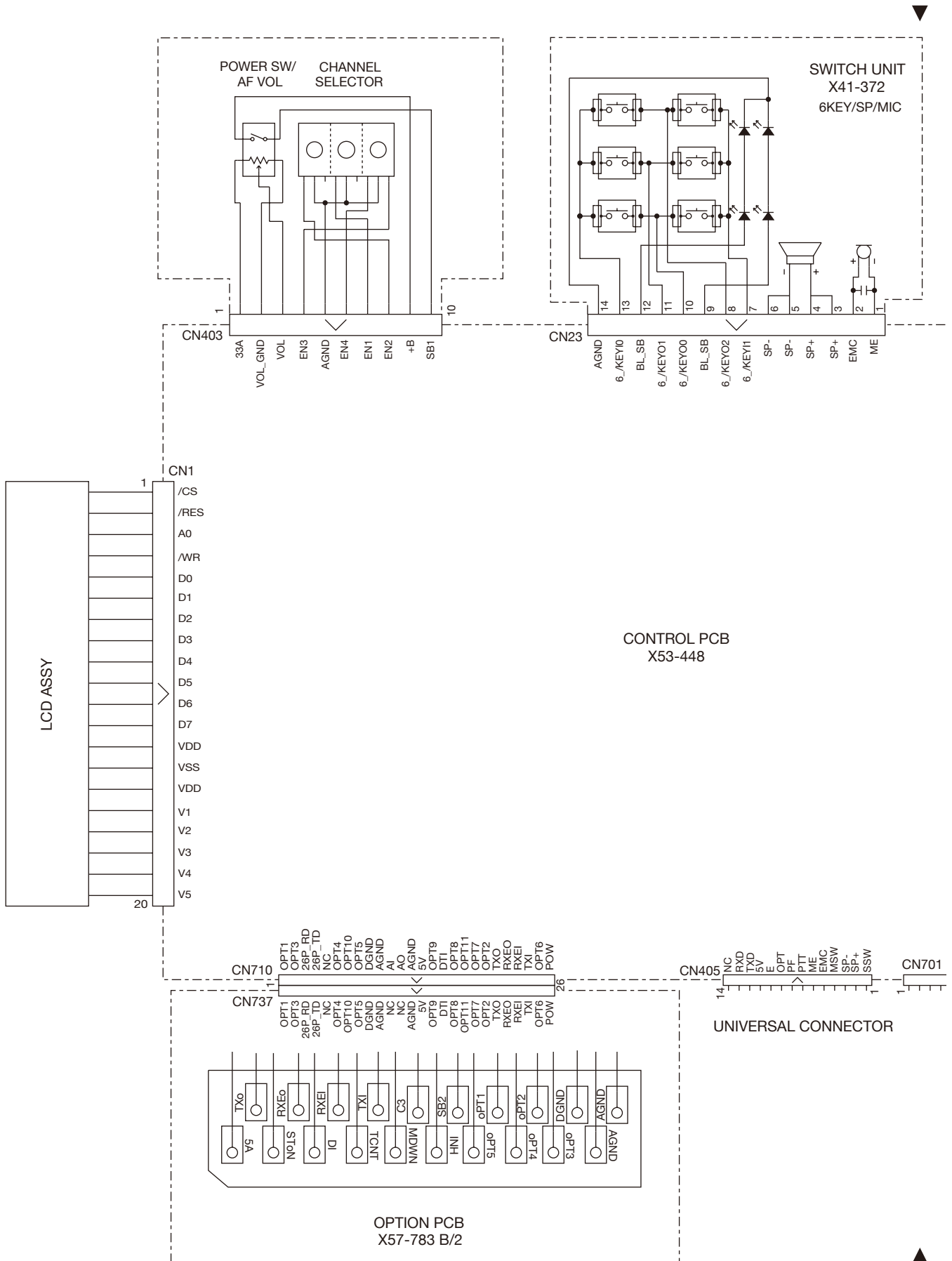



## INTERCONNECTION DIAGRAM

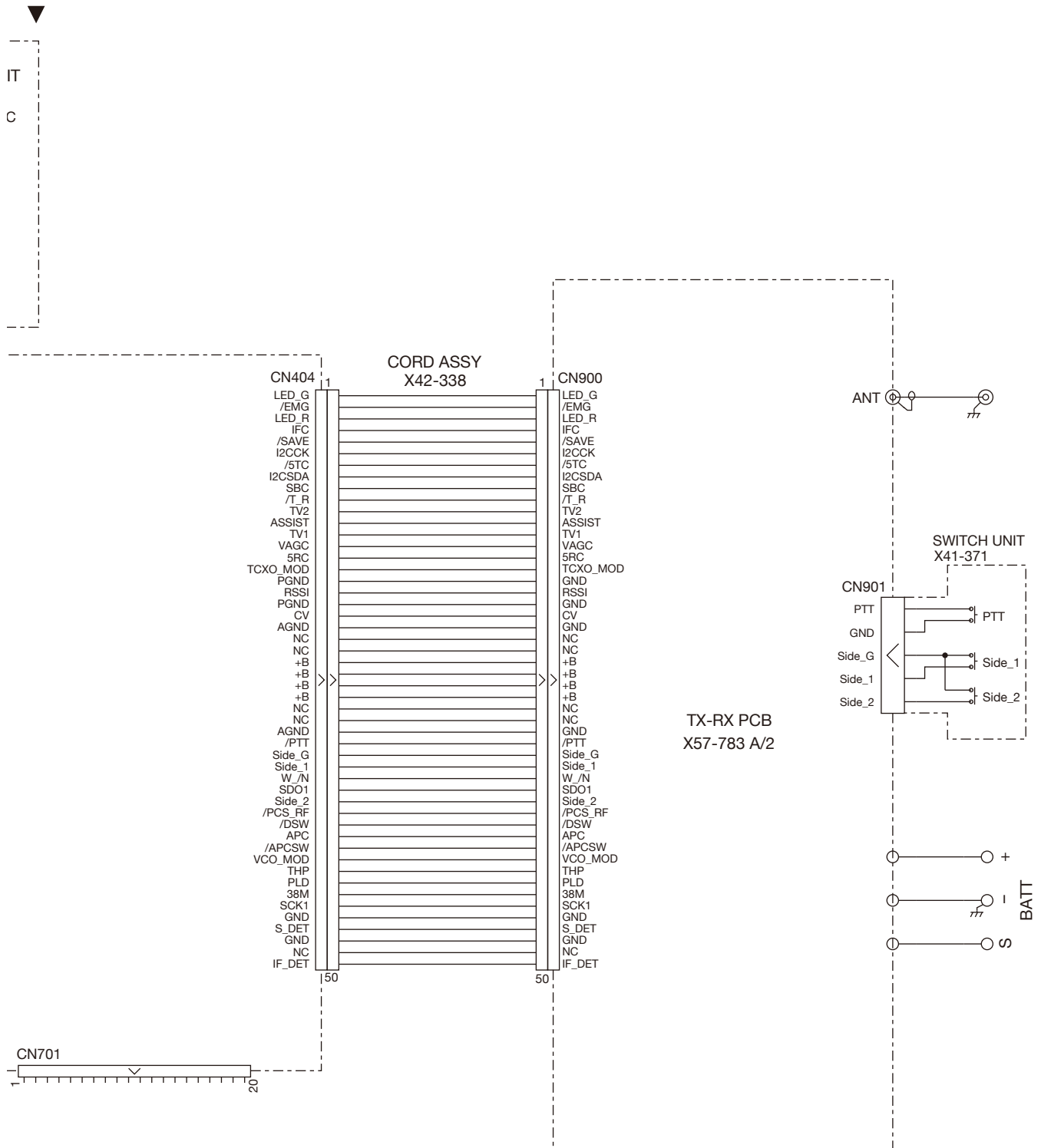

# TK-5320 SCHEMATIC DIAGRAM

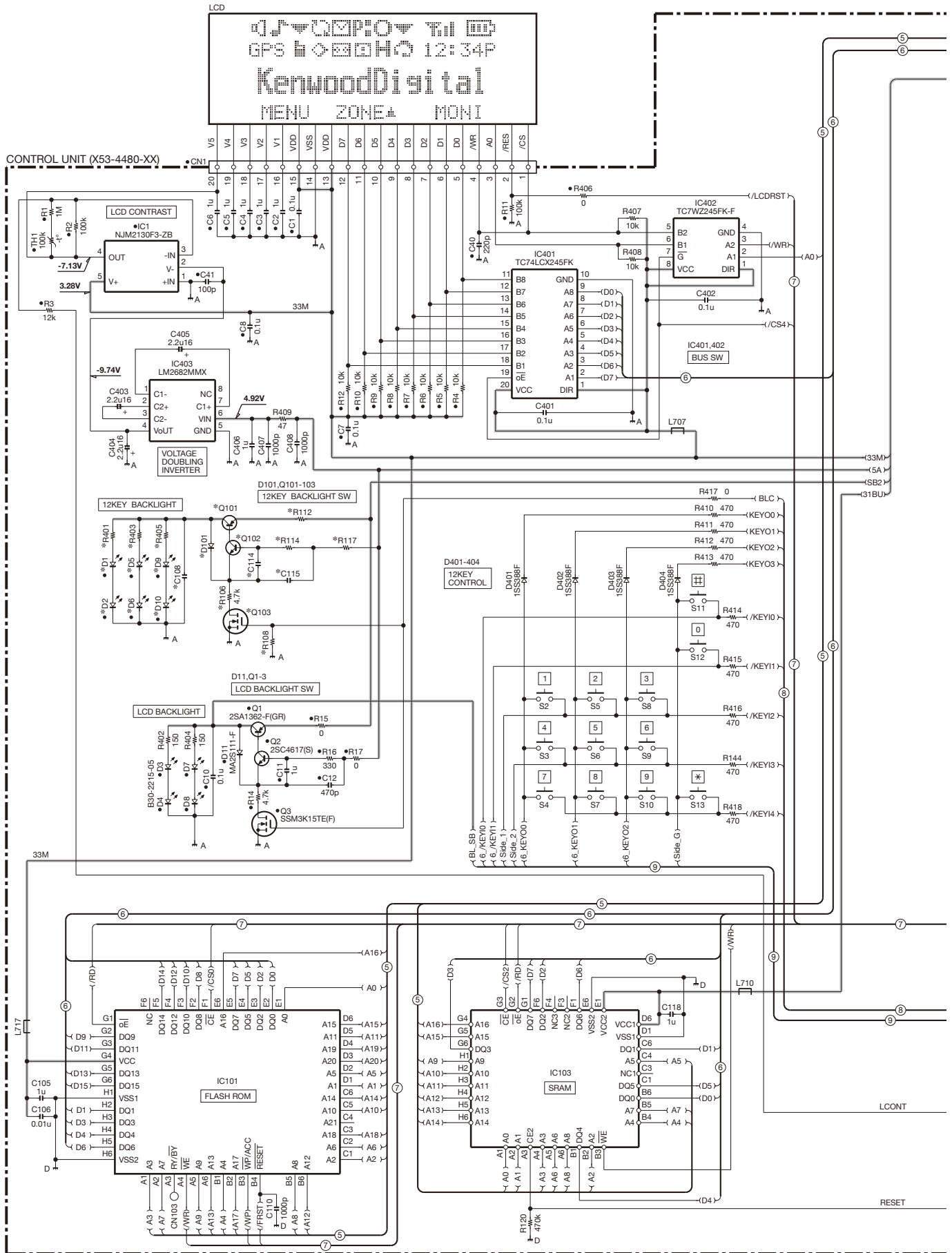

X53-4480-XX	D1	D2	D5	D6	D9	D10	D101	Q101	Q102	Q103	R106	R108	R112	R114	R117	R401	R403	R405	C108	C114	C115	
-10	K,K2	NO	NO	NO	NO	NO	NO	NO	NO	NO	NO	NO	NO	NO	NO	NO	NO	NO	NO	NO	NO	NO
-11	K3,K4	B30-2215-05	B30-2215-05	B30-2215-05	B30-2215-05	B30-2215-05	B30-2215-05	MA2S111-F	2SA1832-GRF	2SC4617(S)	SSM3K15TE(F)	4.7k	470k	0	330	0	1.5k	1.5k	1.5k	0.1u	1u	470p



# TK-5320 SCHEMATIC DIAGRAM

CONTROL UNIT (X53-4480-XX)

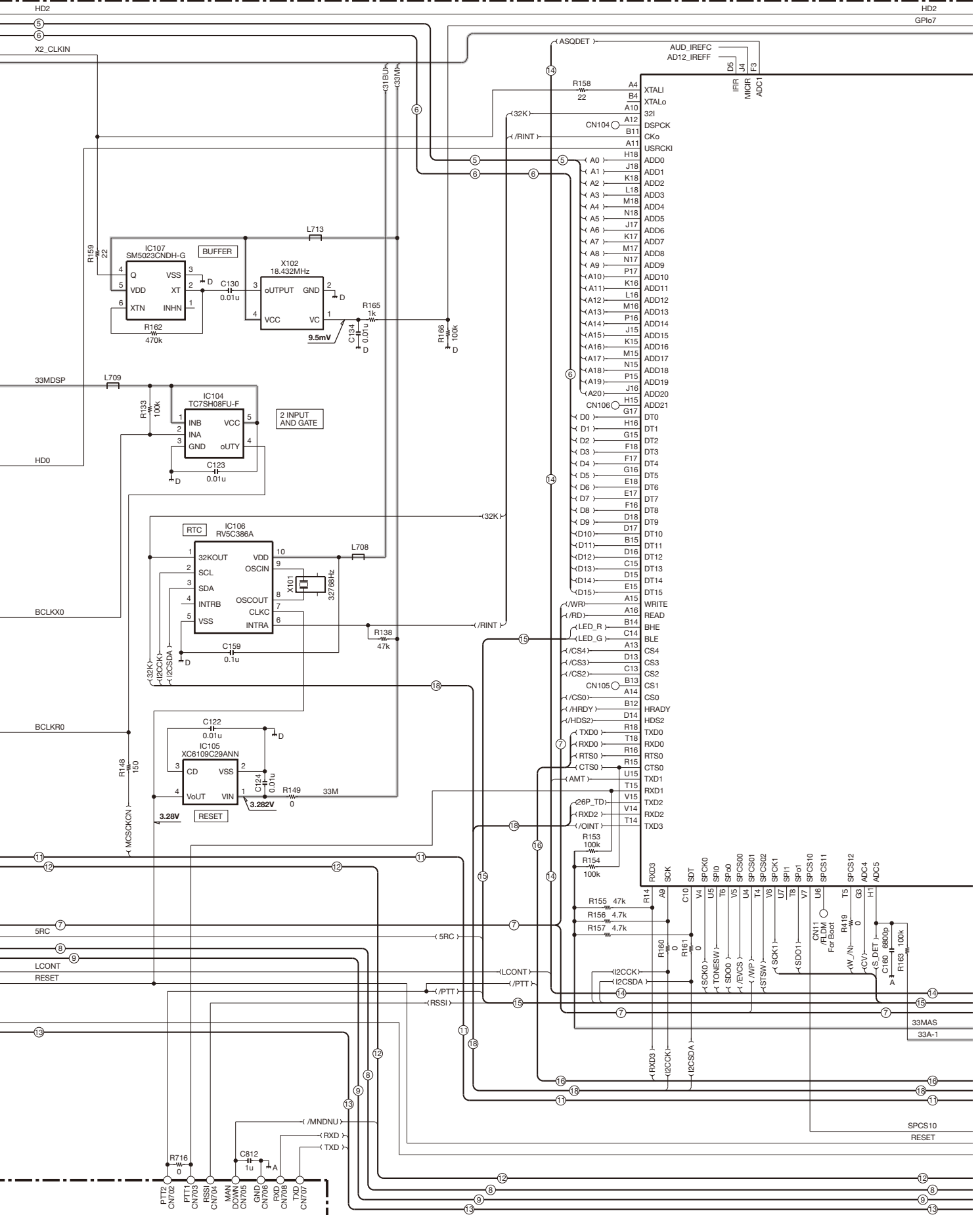

# SCHEMATIC DIAGRAM TK-5320

CONTROL UNIT (X53-4480-XX)

HD2  
GPIO7

HD2  
GPIO7

33A-1

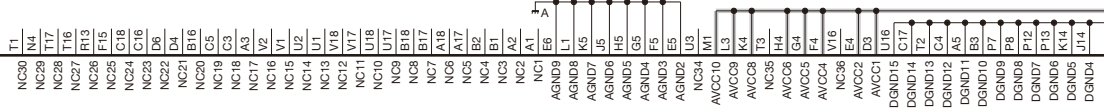

IC108  
ASIC

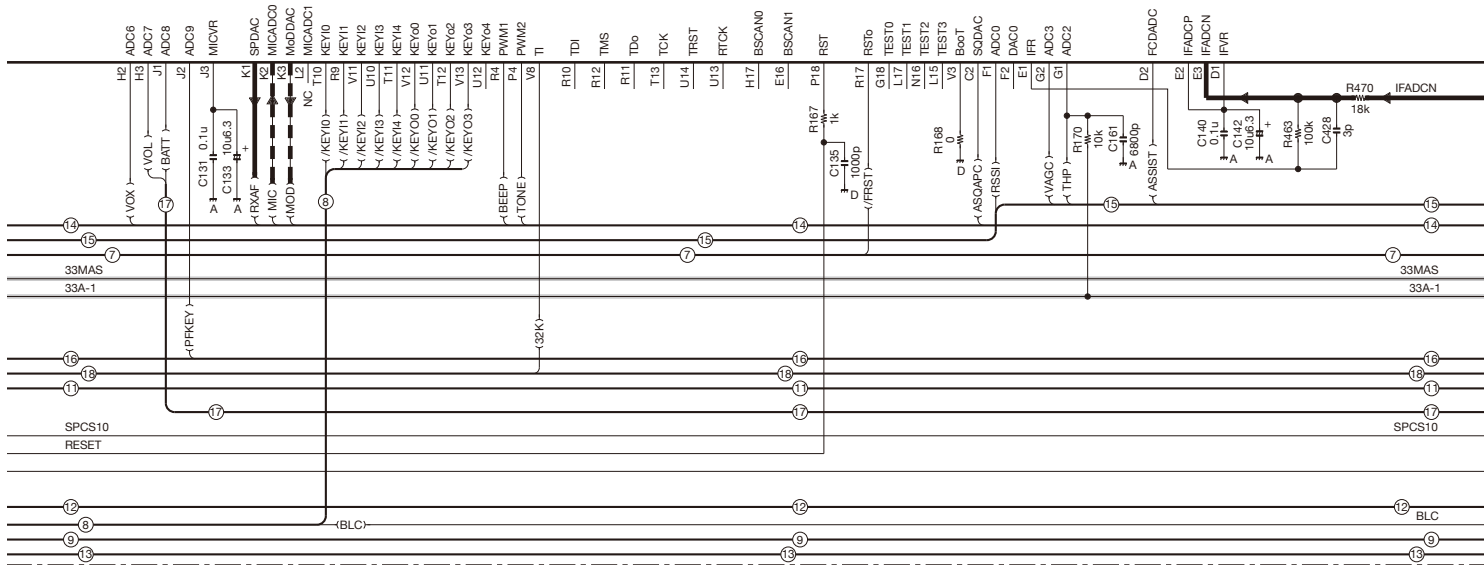

# TK-5320 SCHEMATIC DIAGRAM

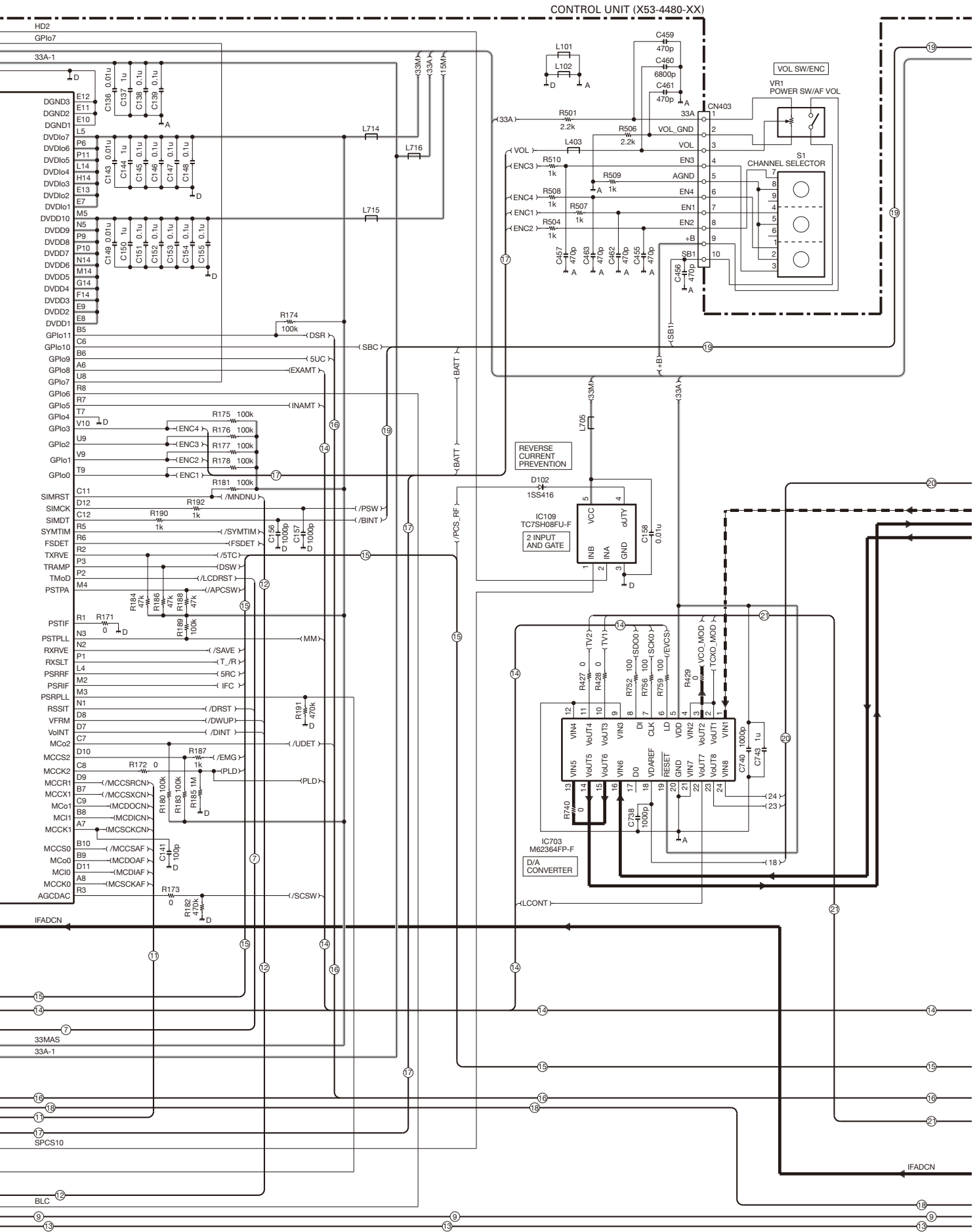

# SCHEMATIC DIAGRAM TK-5320

CONTROL UNIT (X53-4480-XX)

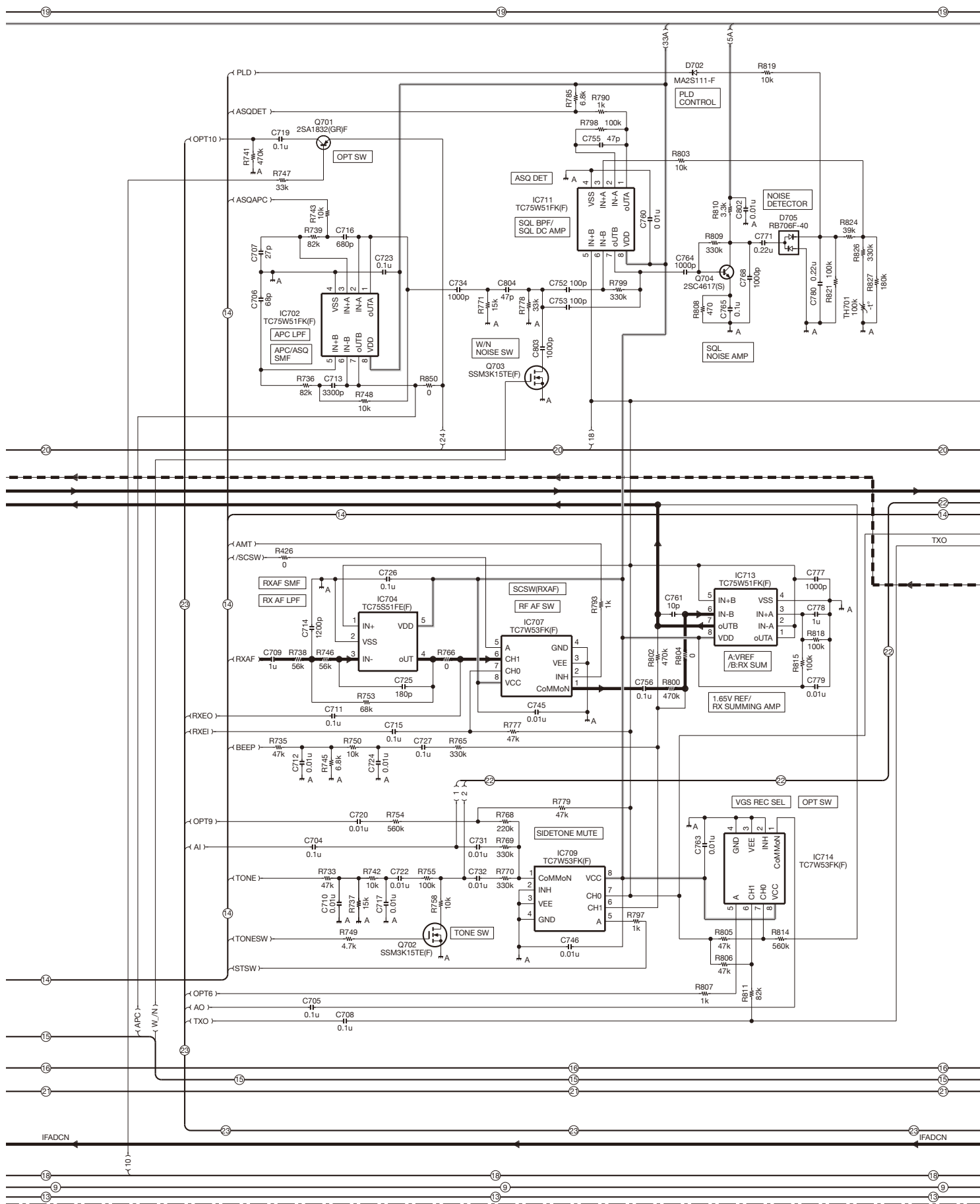

# TK-5320 SCHEMATIC DIAGRAM

CONTROL UNIT (X53-4480-XX)

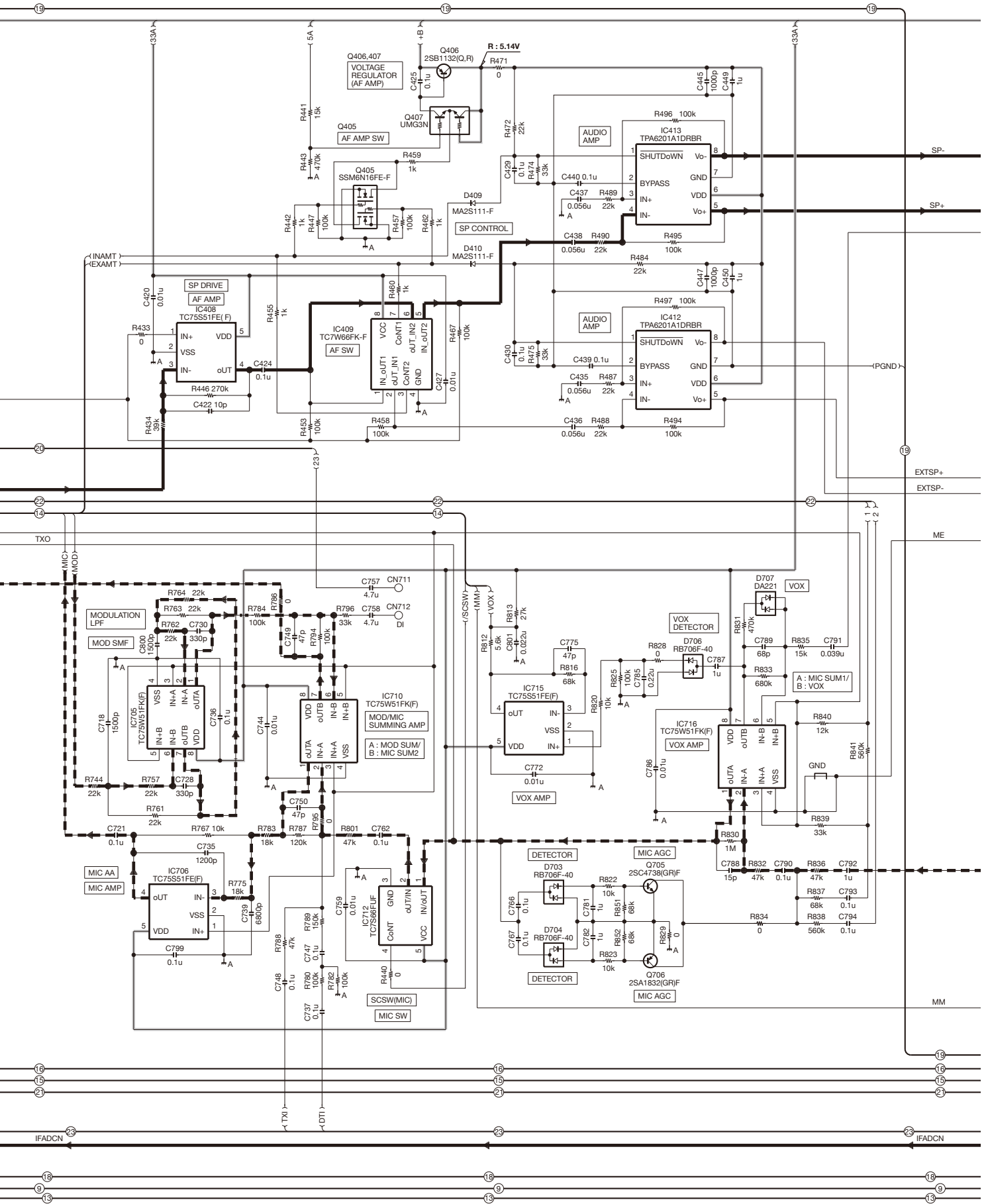



# SCHEMATIC DIAGRAM TK-5320

CONTROL UNIT (X53-4480-XX)

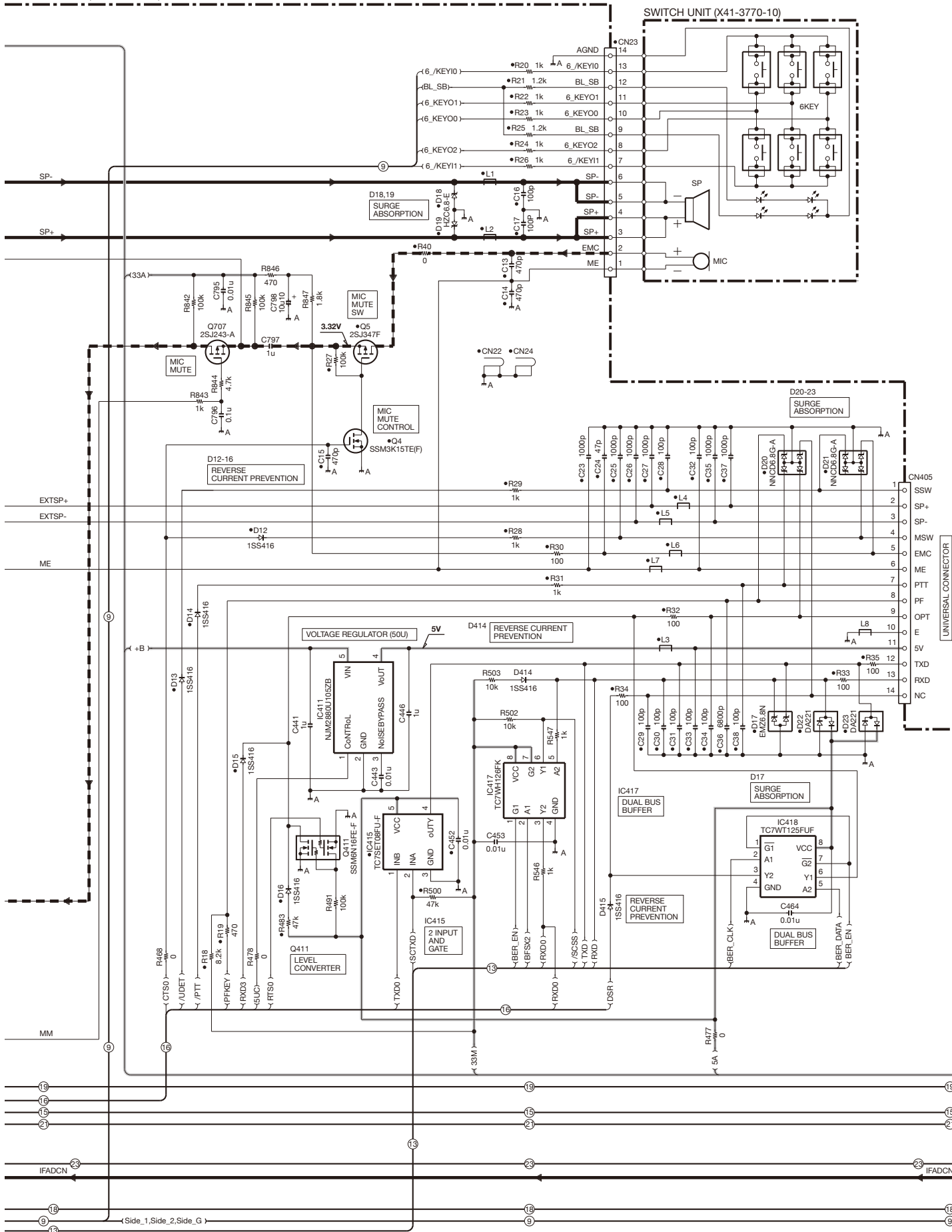

# TK-5320 SCHEMATIC DIAGRAM

CONTROL UNIT (X53-4480-XX)

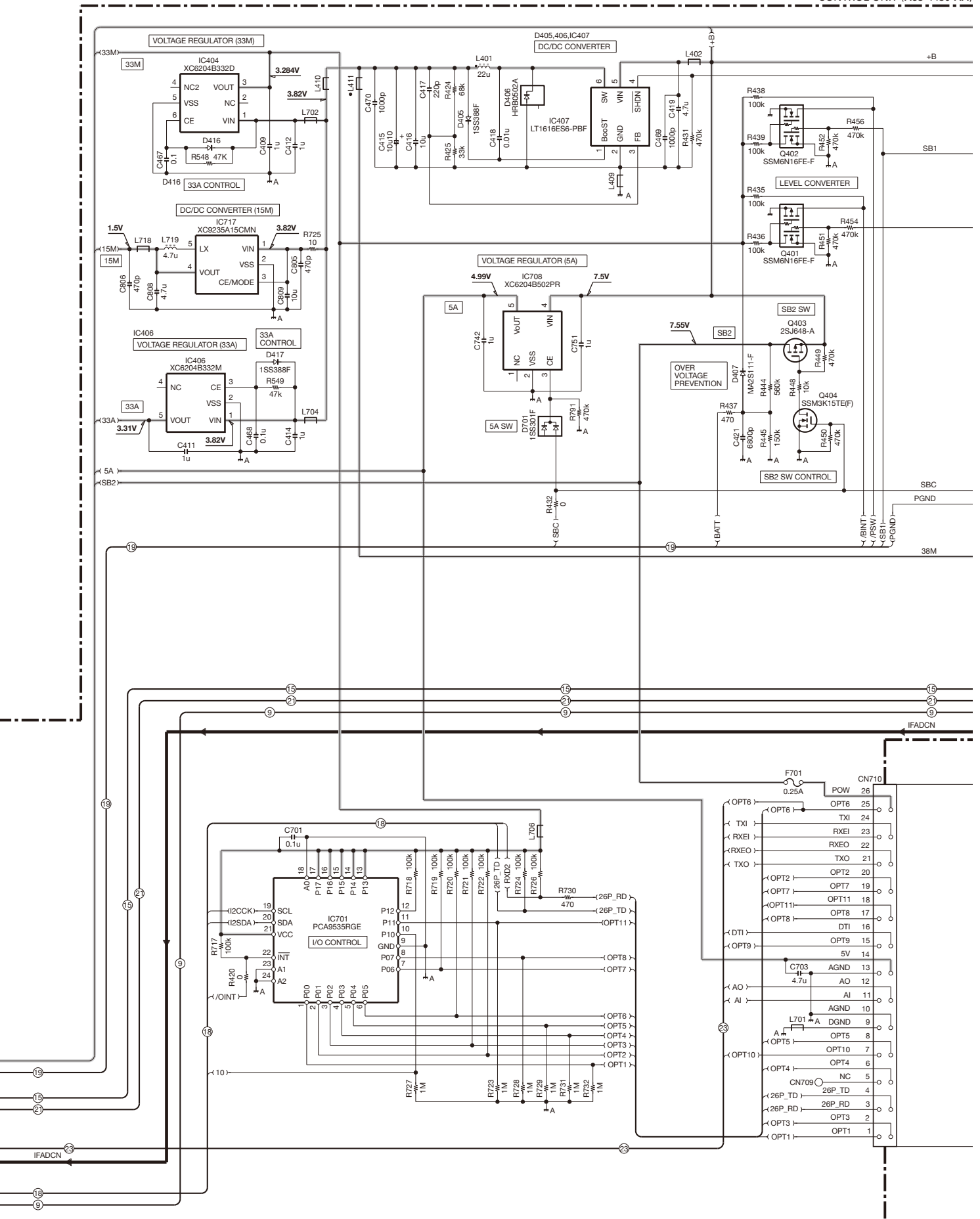

# SCHEMATIC DIAGRAM TK-5320

CONTROL UNIT (X53-4480-XX)

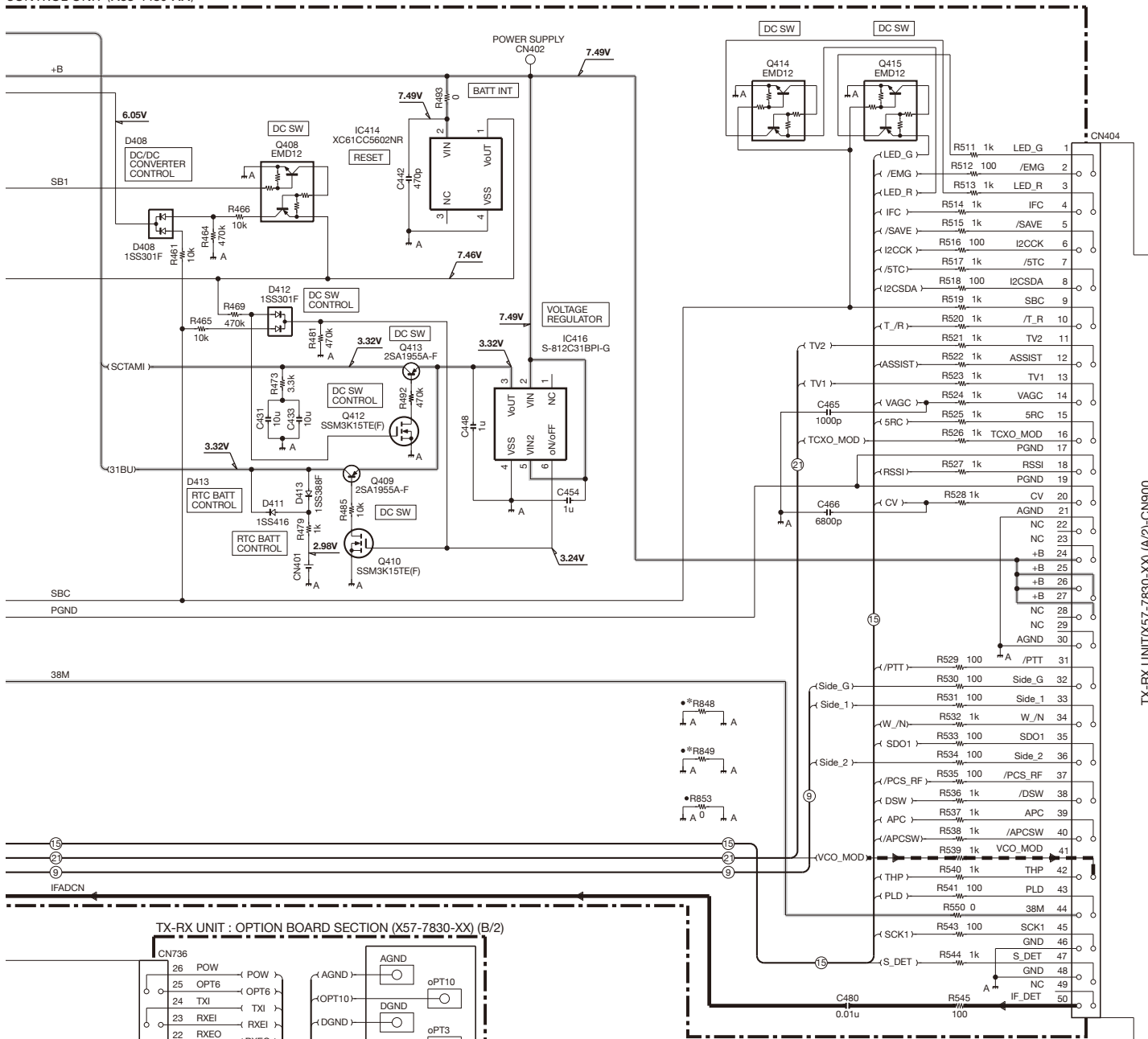

TX-RX UNIT(X57-7830-XX) (A2)-CN900

TX-RX UNIT : OPTION BOARD SECTION (X57-7830-XX) (B/2)

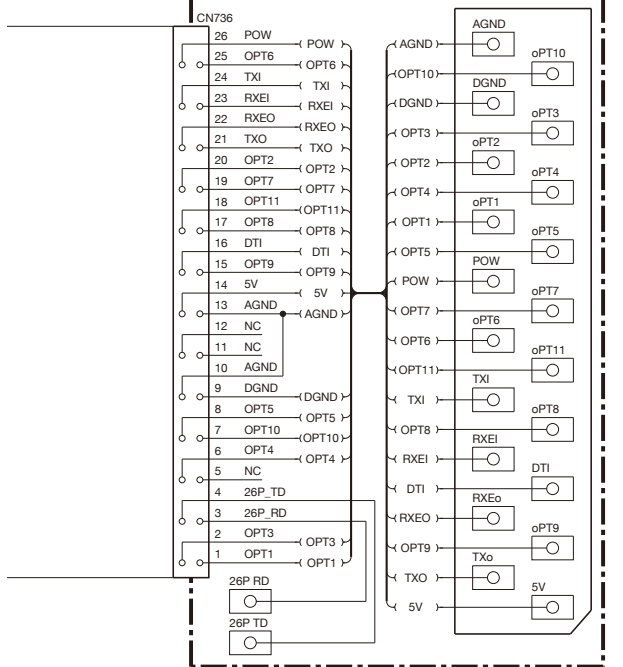

X53-4480-XX	R848	R849
-10	K,K2	0 NO
-11	K3,K4	NO 0

# TK-5320 SCHEMATIC DIAGRAM

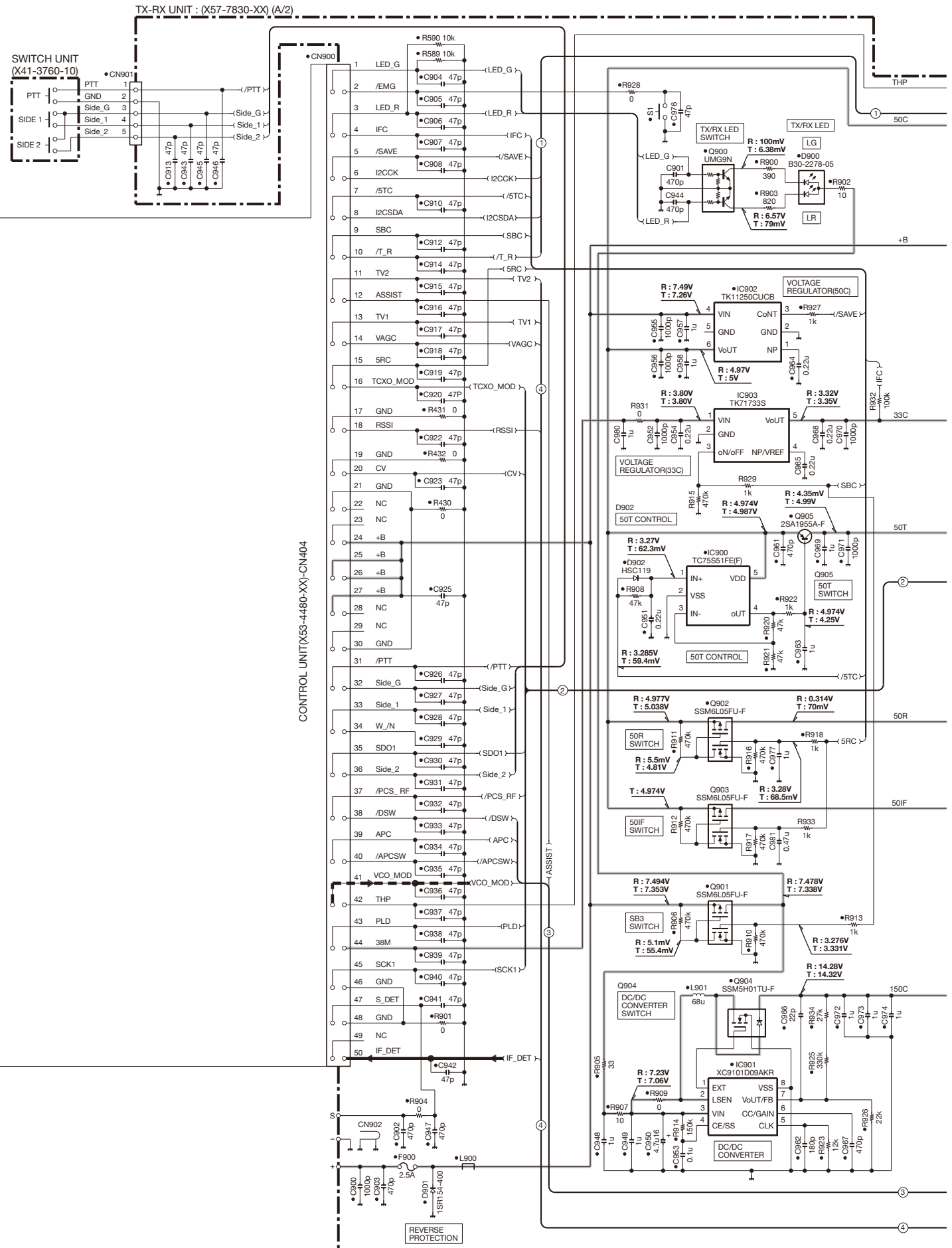

# SCHEMATIC DIAGRAM TK-5320

X57-7830-XX	D510	D514	D515	L520	L521	L528	R502	R533	R552	R559	R561	R573	R583	R935	R955	R956	R957
-10	K,K3	1SV282-F	1SV282-F	18n	22n	27n	120k	180k	120k	180	180	NO	NO	NO	NO	NO	NO
-11	K2,K4	1SV290B-F	1SV290B-F	22n	27n	33n	NO	220k	100k	220	220	120k	0	15k	0	0	0

X57-7830-XX	R958	C516	C529	C537	C543	C545	C547	C553	C557	C561	C563	C566	C567	C568	C573	C574	C575	C586	C987	
-10	K,K3	NO	0.01u	100p	5p	3p	NO	100p	5p	100p	NO	NO	68p	NO	NO	4p	1p	3p	7p	NO
-11	K2,K4	0	NO	NO	NO	4p	470p	470p	10p	470p	0.01u	100p	82p	0.5p	1.5p	6p	2p	6p	10p	5p

TX-RX UNIT (X57-7830-XX) (A/2)

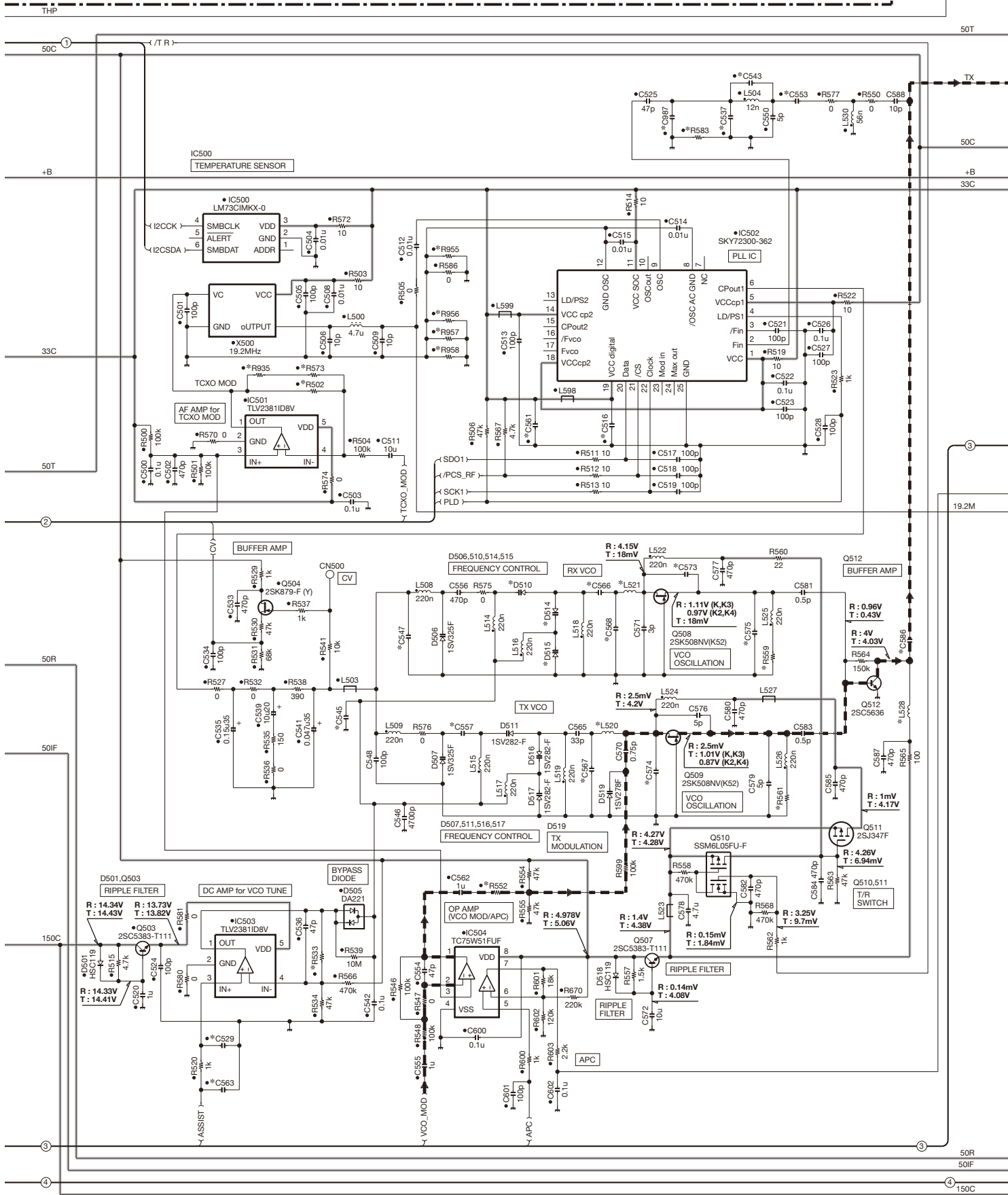

# TK-5320 SCHEMATIC DIAGRAM

X57-7830-XX	D608	CN601	L602	L603	L605	L615	L902	R619	R620	R621	R623	R624	R626	R658	R669	R710	C613	C621	C623	C671	C702	C704	C715	C716	C813	C814
-10	K,K3	HSC119	NO	18n	15n	6.8n	15n	NO	NO	NO	10k	47k	120	1.8k	470	0	7p	15p	15p	7p	NO	47p	0.01u	82p	NO	NO
-11	K2,K4	NO	E23-1167-05	27n	18n	12n	22n	27u	820	5.6	820	12k	33k	220	820	NO	NO	4p	4p	12p	10p	82p	10p	47p	NO	27p

TX-RX UNIT (X57-7830-XX) (A/2)

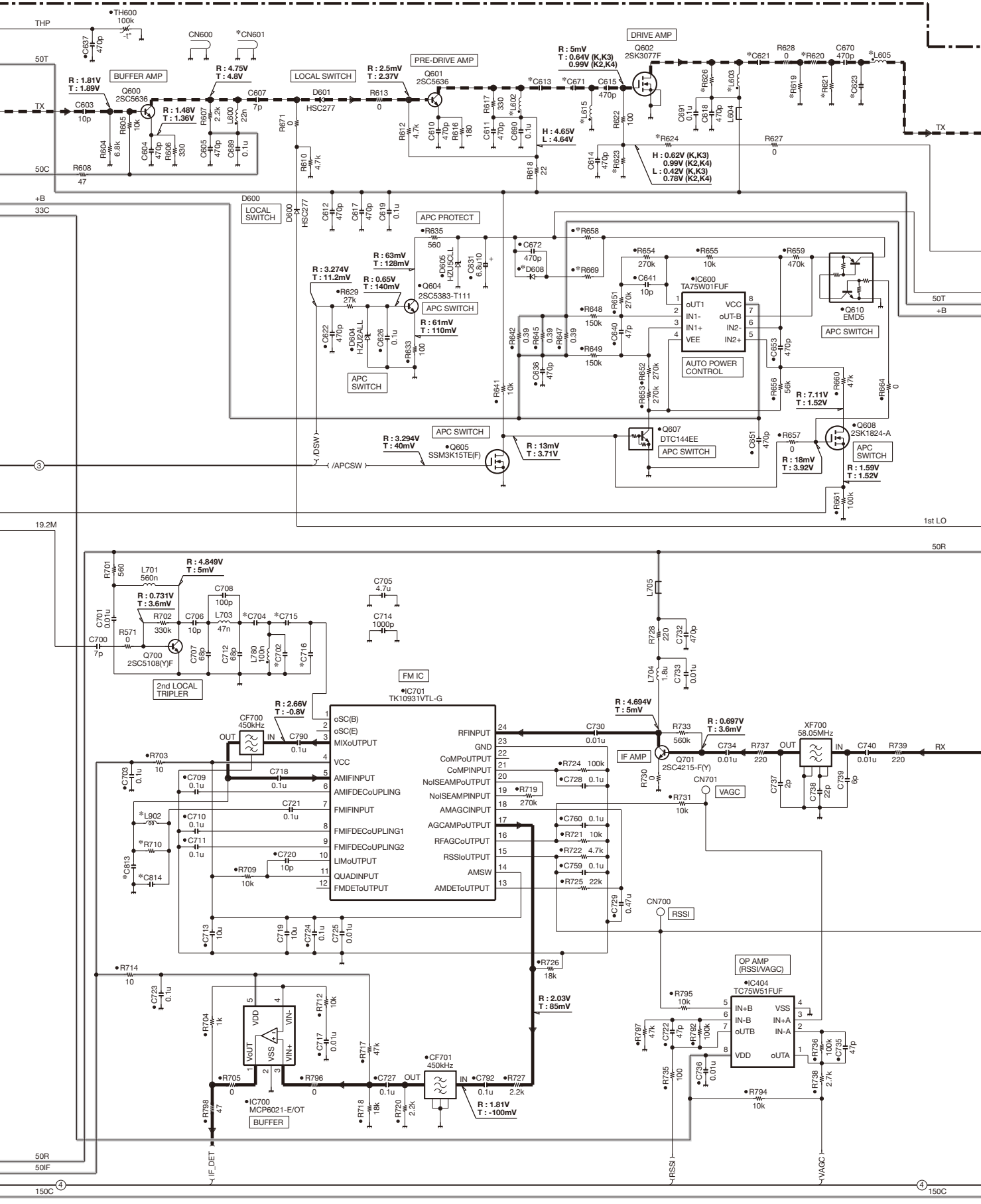

## SCHEMATIC DIAGRAM TK-5320

X57-7830-XX	L709	L710	L711	L713	L714	L715	L720	L721	L722	L725	L726	L903	R630	R632	R644	R663	R749	R757	R759	R760	R771	R785	R788	R790	R800	R950	R951	R954	C609	C627	C639	C647	C650			
-10	K,K3	18n	18n	22n	8.2n	8.2n	10n	8.2n	10n	8.2n	33n	NO	33k	10k	47	0	180k	100k	100k	100k	150	100k	100k	100k	NO	0	NO	0	NO	10p	39p	18p	12p			
-11	K2,K4	15n	15n	33n	10n	10n	NO	10n	10n	6.8n	39n	6.8n	100k	56k	22	NO	220k	1M	1M	1M	180	1M	1M	1M	NO	0	NO	0	1p	8p	33p	NO	NO			
X57-7830-XX	C654	C662	C664	C666	C667	C668	C669	C749	C751	C753	C754	C755	C756	C767	C770	C772	C773	C774	C776	C796	C798	C800	C804	C807	C810	C811	C975	C985	C988	C989						
-10	K,K3	7.5p	1p	4p	2p	5p	1.5p	8p	4p	2p	10p	2p	3p	4p	9p	9p	4p	9p	1p	3p	9p	9p	1.5p	2p	9p	5p	18p	2p	9p	7.5p	NO	NO				
-11	K2,K4	NO	4p	2.5p	3p	8p	2.5p	10p	1.5p	4p	9p	4p	9p	5p	470p	12p	3p	12p	1.5p	2p	12p	11p	3p	1.5p	11p	3p	NO	4p	7p	9p	27p	15p				

TX-RX UNIT (X57-7830-XX) (A/2)

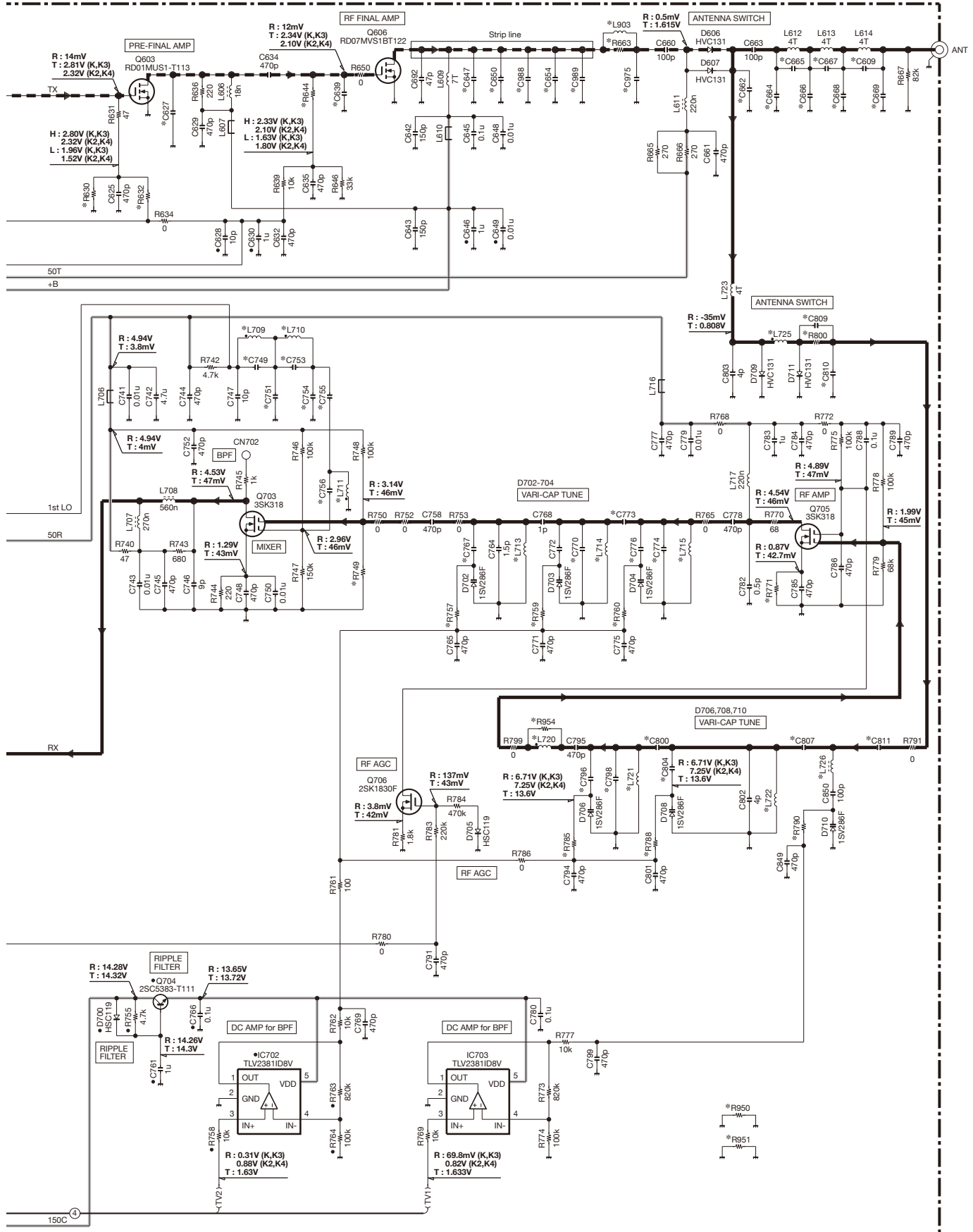

Note : The components marked with a dot (•) are parts of layer 1.

# TK-5320 BLOCK DIAGRAM

## Control unit (X53-4480-XX)

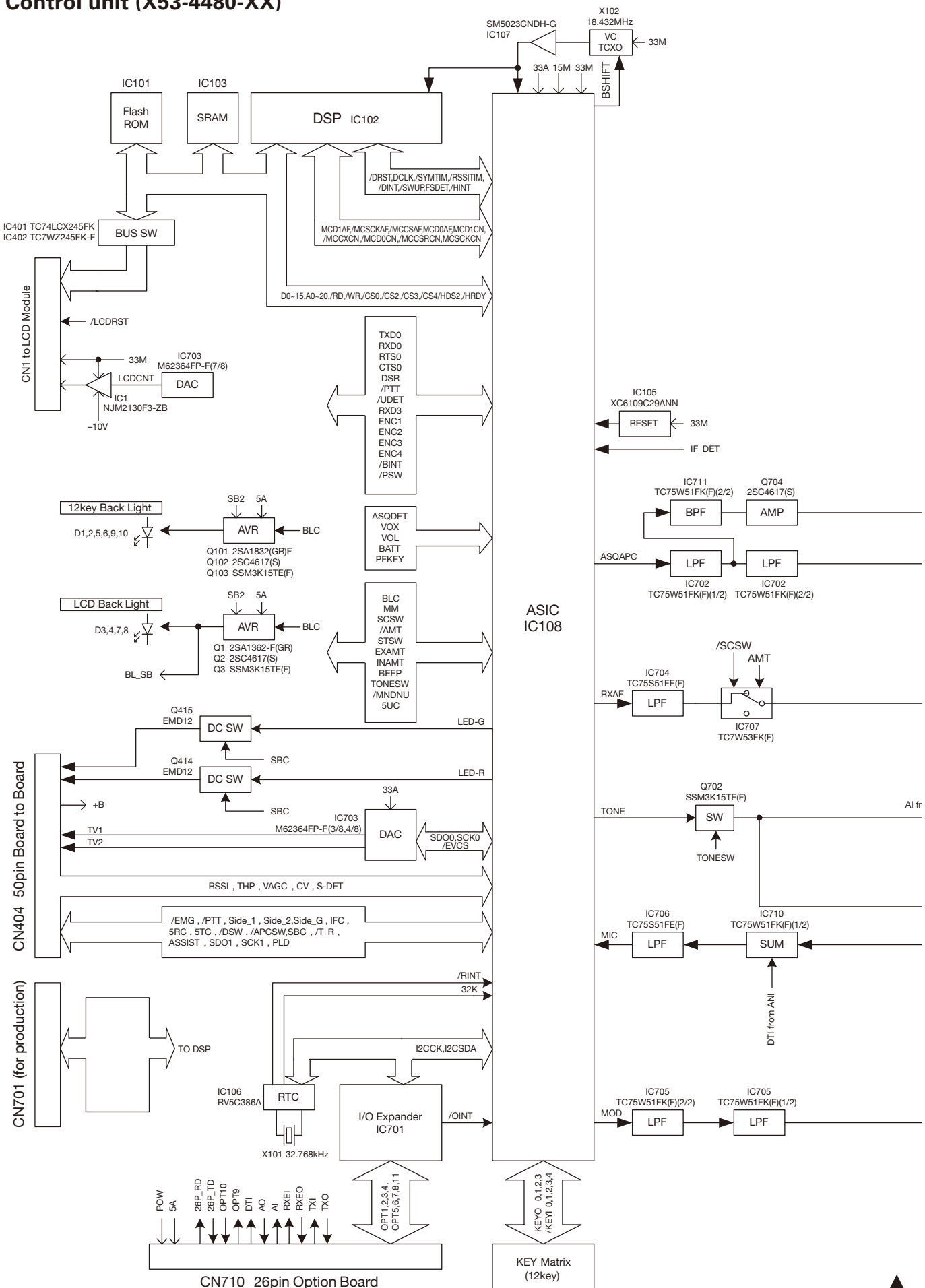



# BLOCK DIAGRAM TK-5320

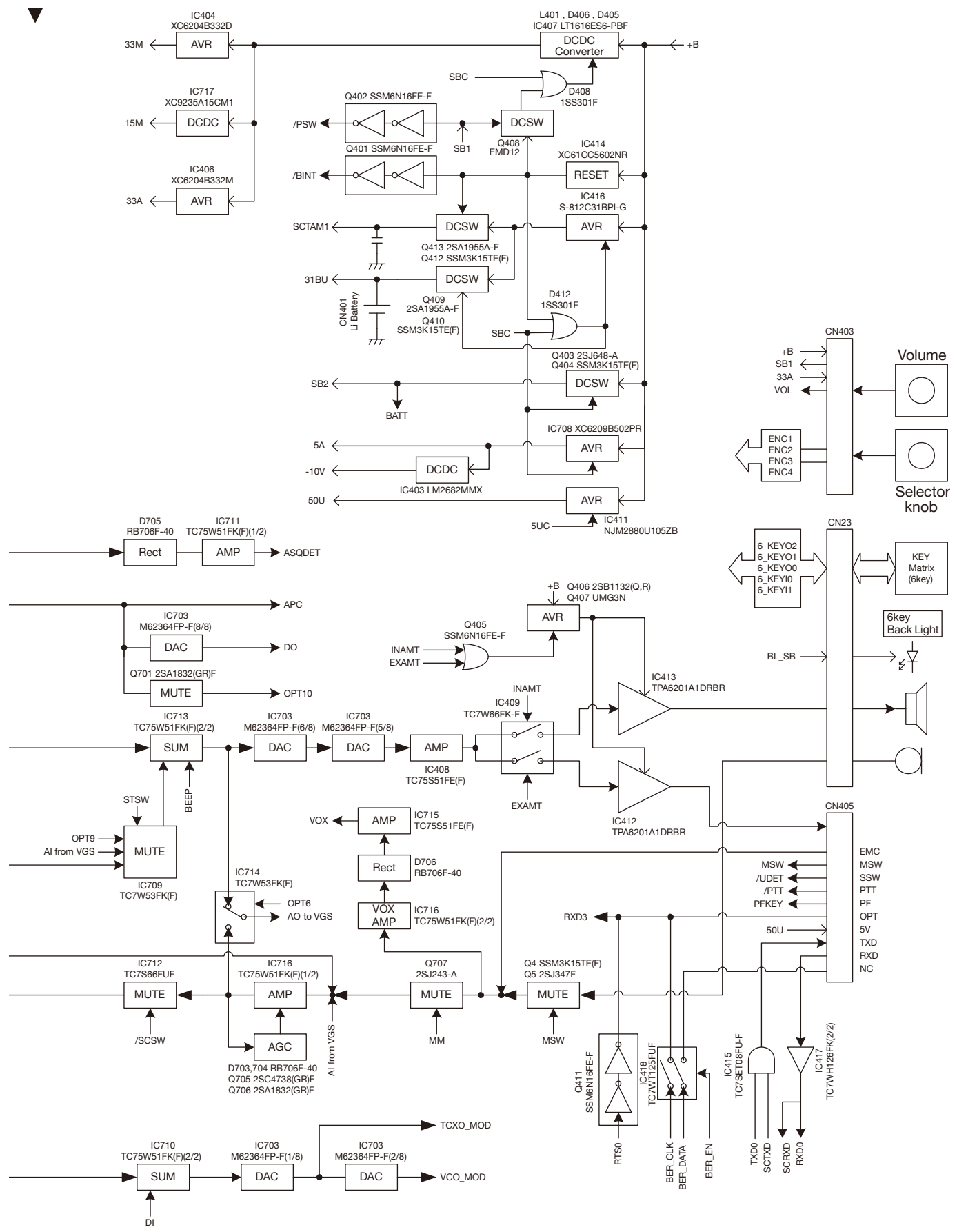

## BLOCK DIAGRAM

### TX-RX unit (X57-7830-XX)

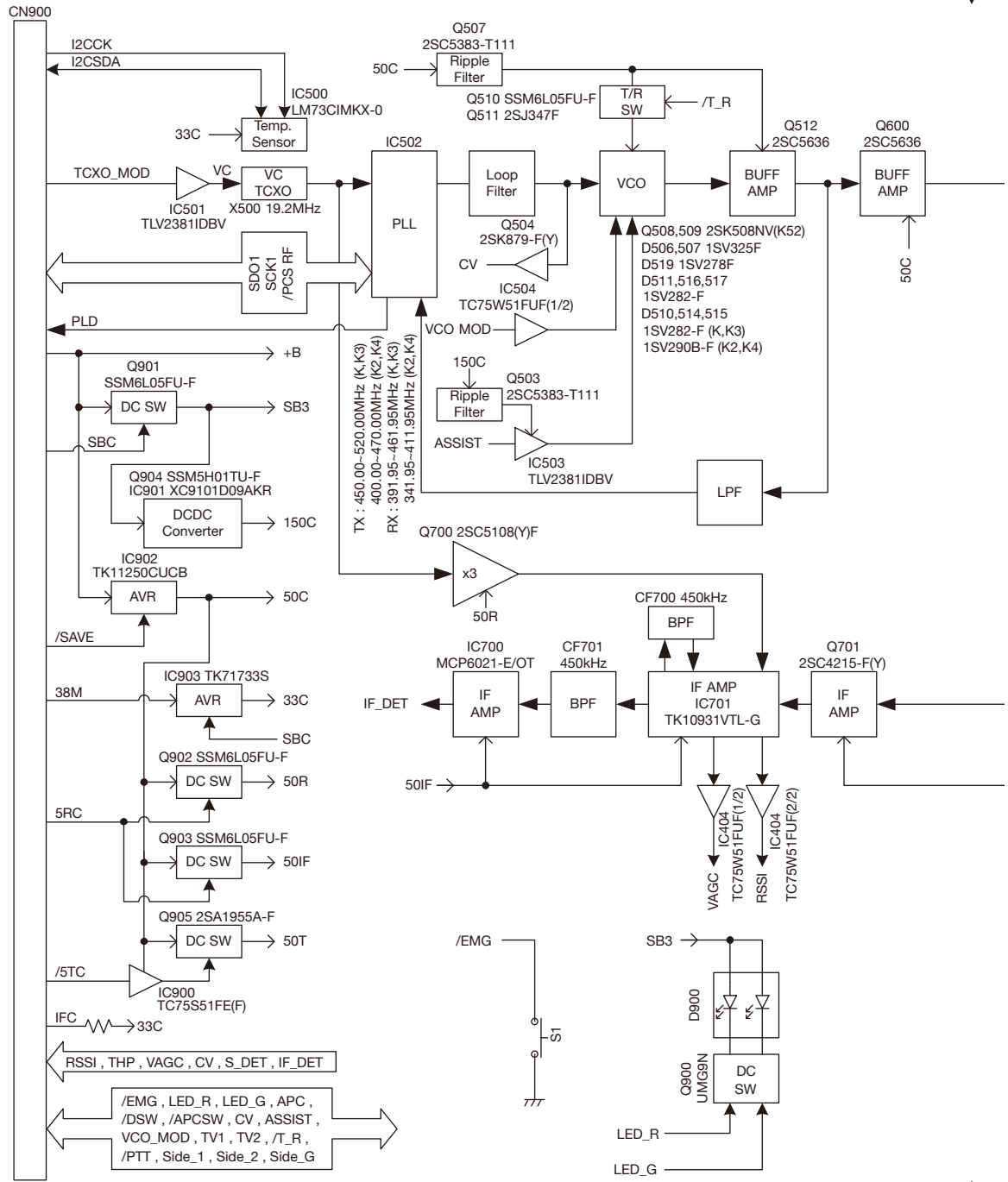

## BLOCK DIAGRAM

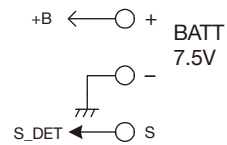
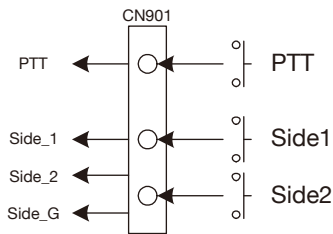
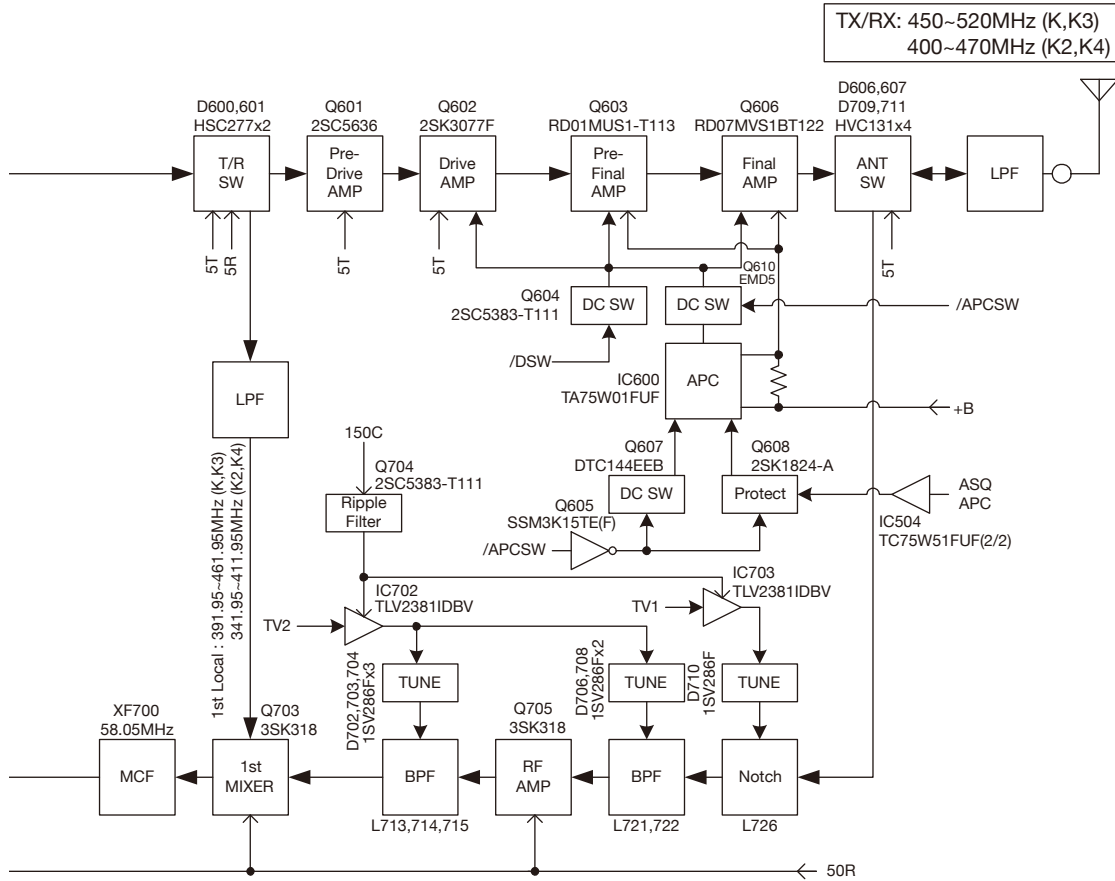

## LEVEL DIAGRAM

### Receiver Section

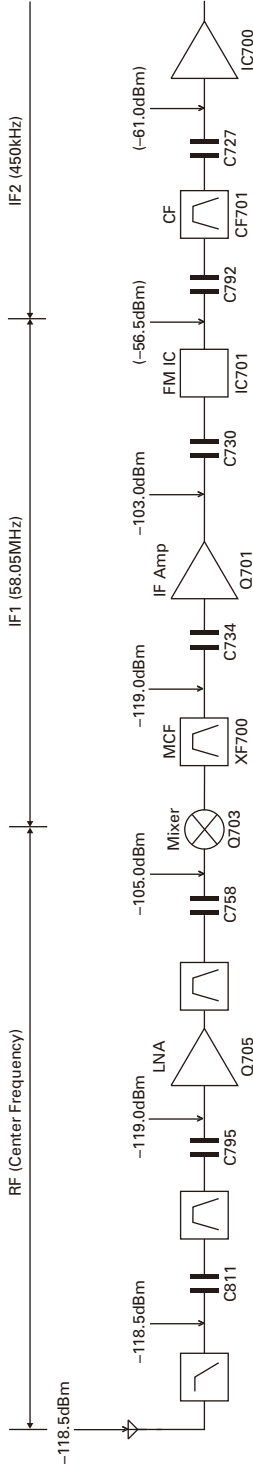

To make measurements in the AF section, connect the AC level meter. (ANT input: -53dB, 1kHz FM, 3kHz DEV (Wide))  
In the RF section, use a 1000pF coupling capacitor.  
(The display shows the SSG input value required to obtain 12dB SINAD without local level.)

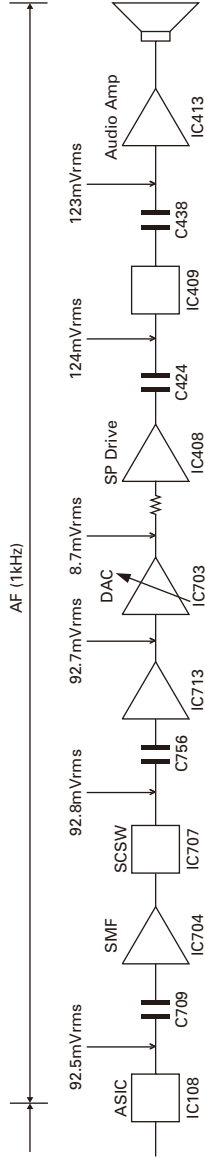

### Transmitter Section

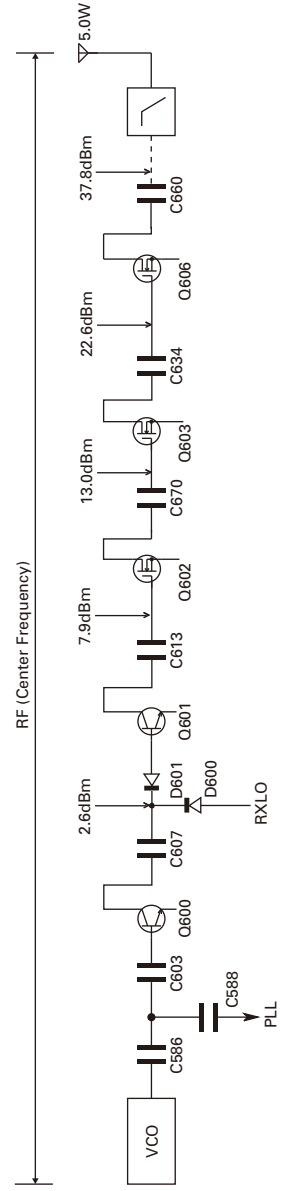
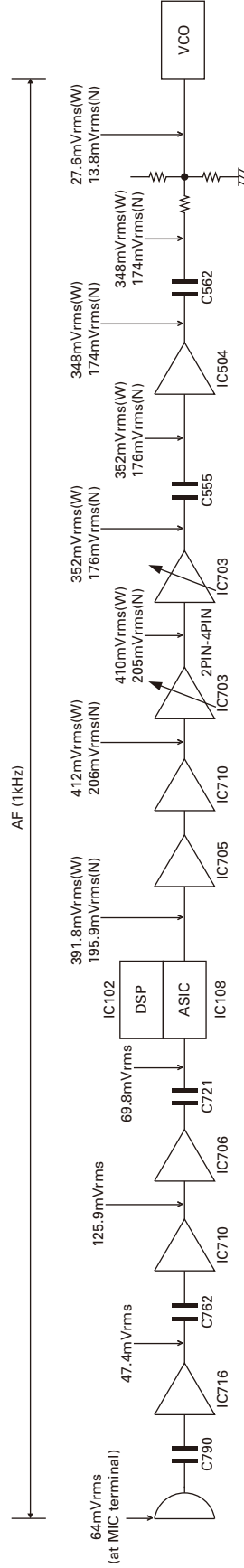

AG is set to the MIC input becomes (3kHz/1.5kHz) at 1kHz MOD (Wide/Narrow).  
To make measurements in the AF section, connect the AC level meter.  
In the RF section, use a 1000pF coupling capacitor.

## OPTIONAL ACCESSORIES

### KNB-47L (Li-ion Battery Pack)

#### ■ External View



#### ■ Specifications

Voltage.....7.4V  
 Battery capacity..... 1950mAh

#### ■ Schematic Diagram

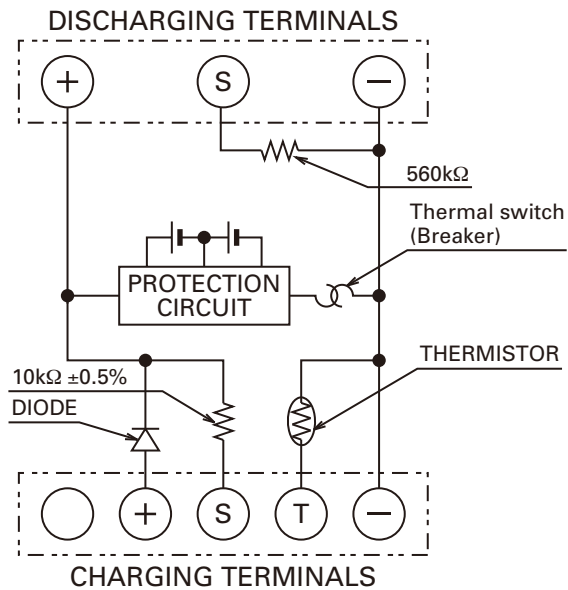

### KNB-48L (Li-ion Battery Pack)

#### ■ External View



#### ■ Specifications

Voltage.....7.4V  
 Battery capacity..... 2550mAh

#### ■ Schematic Diagram

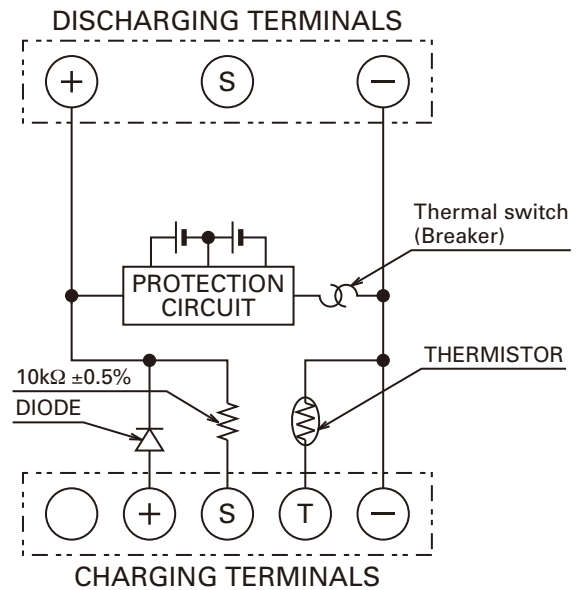

## SPECIFICATIONS

### GENERAL

Models.....	K,K2: Basic Model	K3,K4: w/12-key Model
Frequency Range.....	K,K3: 450~520 MHz	K2,K4: 400~470 MHz
Number of Channels.....	512	
Zones.....	128	
Max. Channels per Zone.....	250	
Channel Spacing.....	Analog: 12.5/25 kHz	Digital: 12.5 kHz
Operating Voltage.....	7.5V DC $\pm$ 20%	
Battery Life (with KNB-48L).....	5-5-90 duty cycle: more than 12.5 hours	10-10-80 duty cycle: more than 8.5 hours
Operating Temperature Range.....	-22°F to +140°F (-30°C to +60°C)	
Frequency Stability.....	$\pm$ 1.0ppm	
Antenna Impedance.....	50 $\Omega$	
Dimensions (W x H x D) (Projections not included)		
Radio only.....	2.28" x 5.02" x 1.63" (58 x 127.5 x 41.3 mm)	
with KNB-47L.....	2.28" x 5.02" x 1.63" (58 x 127.5 x 41.3 mm)	
with KNB-48L.....	2.28" x 5.02" x 1.91" (58 x 127.5 x 48.5 mm)	
Weight		
Radio only.....	9.17 oz (260 g)	
with KNB-47L.....	13.23 oz (375 g)	
with KNB-48L.....	14.29 oz (405 g)	

### RECEIVER

Sensitivity.....	Digital (5% BER): 0.25 $\mu$ V, (1% BER): 0.40 $\mu$ V	
	Analog (12dB SINAD): 0.25 $\mu$ V	
Selectivity.....	Digital: -60dB	Analog @25kHz: -72dB    Analog @12.5kHz: -65dB
Intermodulation Distortion.....	-70dB	
Spurious and Image.....	-75dB	
Audio Distortion.....	Less than 3%	
Audio Output.....	500mW/8 $\Omega$	

### TRANSMITTER

RF Power Output.....	5W/1W	
Spurious and Harmonics.....	70dB	
FM Hum and Noise.....	Analog @25kHz: 45dB	Analog @12.5kHz: 40dB
Audio Distortion.....	Less than 3%	
Modulation.....	16K0F3E, 11K0F3E, 8K10F1E, 8K10F1D	

Analog measurements made per TIA/EIA 603

Digital measurements made per TIA/EIA 102CAAA.

KENWOOD reserves the right to change specifications without prior notice or obligation.

## Kenwood Corporation

2967-3, Ishikawa-machi, Hachioji-shi, Tokyo, 192-8525 Japan

### Kenwood U.S.A. Corporation

P.O. BOX 22745, 2201 East Dominguez Street, Long Beach, CA 90801-5745, U.S.A.

### Kenwood Electronics Canada Inc.

6070 Kestrel Road, Mississauga, Ontario, Canada L5T 1S8

### Kenwood Electronics Deutschland GmbH

Rembrücker Str. 15, 63150 Heusenstamm, Germany

### Kenwood Electronics Belgium N.V.

Leuvensesteenweg 248 J, 1800 Vilvoorde, Belgium

### Kenwood Electronics France S.A.

L'Etoile Paris Nord 2, 50 Allée des Impressionnistes, Bp 58416 Villepinte, 95944 Roissy Ch De Gaulle Cedex

### Kenwood Electronics UK Limited

KENWOOD House, Dwight Road, Watford, Herts., WD18 9EB United Kingdom

### Kenwood Electronics Europe B.V.

Amsterdamseweg 37, 1422 AC Uithoorn, The Netherlands

### Kenwood Electronics Italia S.p.A.

Via G. Sirtori, 7/9 20129 Milano, Italy

### Kenwood Ibérica, S.A.

Bolivia, 239-08020 Barcelona, Spain

### Kenwood Electronics Australia Pty. Ltd.

(A.C.N. 001 499 074)

16 Giffnock Avenue, Centrecourt Estate, North Ryde, N.S.W. 2113 Australia

### Kenwood Electronics (Hong Kong) Ltd.

Unit 3712-3724, Level 37, Tower one Metroplaza, 223 Hing Fong Road, Kwai Fong, N.T., Hong Kong

### Kenwood Electronics Singapore Pte Ltd

1 Ang Mo Kio Street 63, Singapore 569110



# TK-5320 PC BOARD

# PC BOARD TK-5320

CONTROL UNIT (X53-4480-XX) -10: K,K2 -11: K3,K4  
Component side view (J79-0131-39)

CONTROL UNIT (X53-4480-XX) -10: K,K2 -11: K3,K4  
Component side view (J79-0131-39)

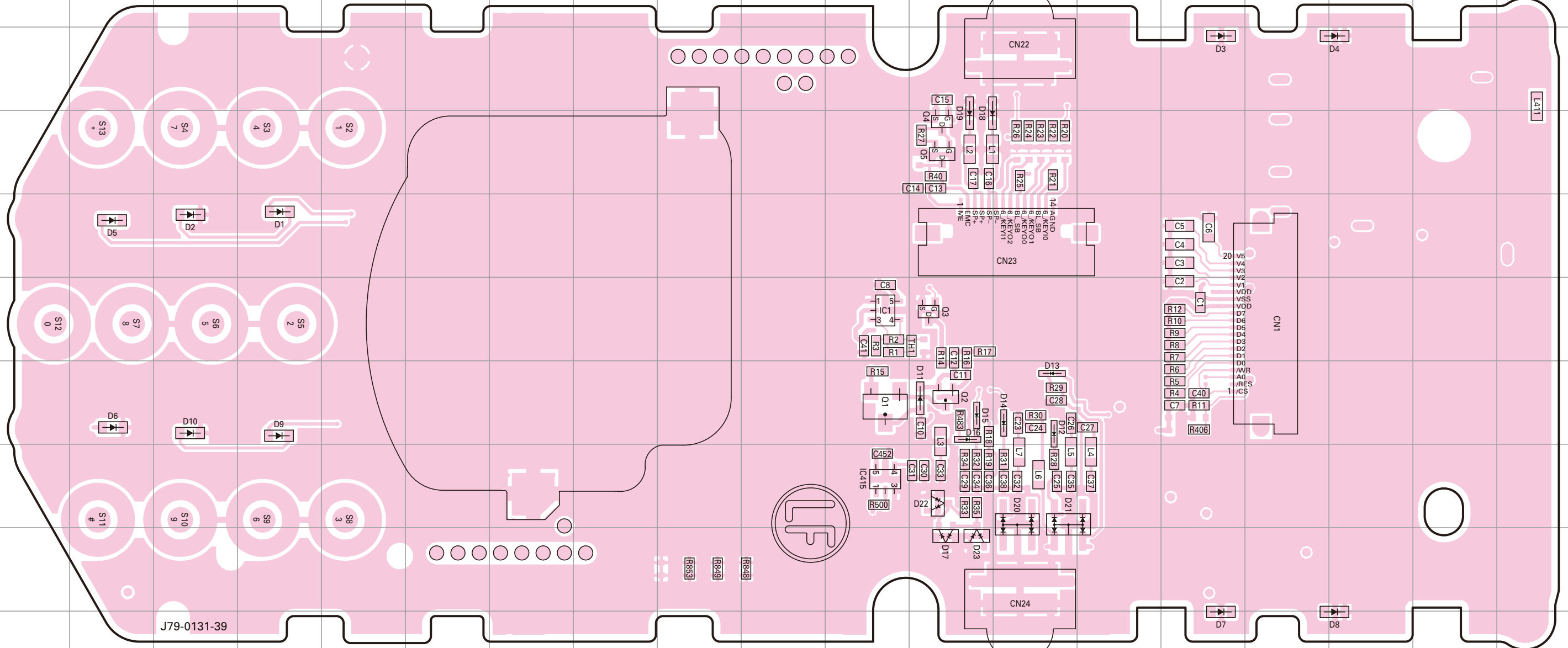

Ref. No.	Address	Ref. No.	Address	Ref. No.	Address
IC1	6K	D4	3Q	D14	7M
IC415	8K	D5	5B	D15	7L
Q1	7K	D6	7B	D16	7L
Q2	7L	D7	10O	D17	9L
Q3	6L	D8	10Q	D18	4L
Q4	4L	D9	7D	D19	4L
Q5	4L	D10	7C	D20	8M
D1	5D	D11	7L	D21	8M
D2	5C	D12	7M	D22	8L
D3	3O	D13	7M	D23	9L

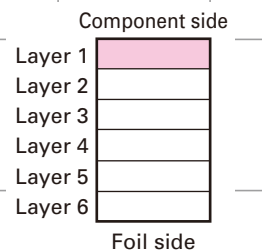

# TK-5320 PC BOARD

# PC BOARD TK-5320

**CONTROL UNIT (X53-4480-XX) -10: K,K2 -11: K3,K4**  
**Foil side view (J79-0131-39)**

**CONTROL UNIT (X53-4480-XX) -10: K,K2 -11: K3,K4**  
**Foil side view (J79-0131-39)**

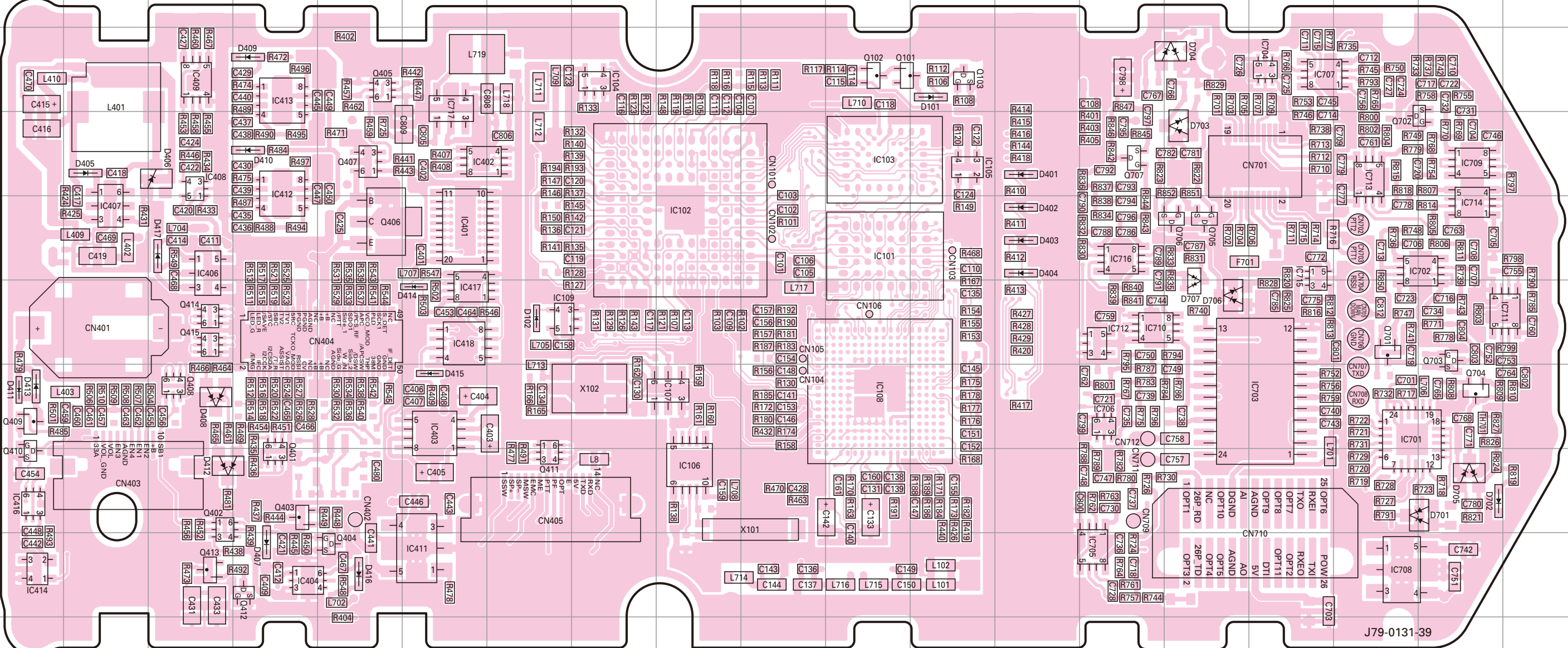

J79-0131-39

Ref. No.	Address	Ref. No.	Address	Ref. No.	Address	Ref. No.	Address	Ref. No.	Address	Ref. No.	Address	Ref. No.	Address	Ref. No.	Address
IC101	5K	IC404	9D	IC701	7Q	IC713	4Q	Q405	3E	Q702	4R	D405	4B	D417	5C
IC102	5I	IC406	5C	IC702	5R	IC714	5R	Q406	5E	Q703	6R	D406	4C	D701	8R
IC103	4K	IC407	5B	IC703	7P	IC715	5P	Q407	4E	Q704	7R	D407	9D	D702	8R
IC104	3H	IC408	4C	IC704	3P	IC716	5N	Q408	7C	Q705	5O	D408	7C	D703	4O
IC105	4L	IC409	3C	IC705	9N	IC717	3F	Q409	7A	Q706	5O	D409	3D	D704	3O
IC106	8I	IC411	9F	IC706	7N	Q101	3K	Q410	8A	Q707	4N	D410	4D	D705	8R
IC107	7I	IC412	4D	IC707	3P	Q102	3K	Q411	8G	D101	3L	D411	7A	D706	6O
IC108	7K	IC413	3D	IC708	9Q	Q103	3L	Q412	9D	D102	6G	D412	8C	D707	6O
IC109	6G	IC414	9A	IC709	4R	Q401	8D	Q413	9C	D401	4M	D413	7A		
IC401	5F	IC416	8A	IC710	6N	Q402	8C	Q414	6C	D402	5M	D414	6F		
IC402	4F	IC417	6F	IC711	6S	Q403	8D	Q415	6C	D403	5M	D415	7F		
IC403	7F	IC418	6F	IC712	6N	Q404	9E	Q701	6Q	D404	5M	D416	9E		

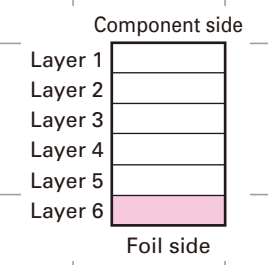



# TK-5320 PC BOARD

# PC BOARD TK-5320

TX-RX UNIT (X57-7830-XX) (A/2) -10: K,K3 -11: K2,K4  
Component side view (J79-0128-39 A/2)

TX-RX UNIT (X57-7830-XX) (A/2) -10: K,K3 -11: K2,K4  
Component side view (J79-0128-39 A/2)

TX-RX UNIT (X57-7830-XX) (B/2) -10: K,K3 -11: K2,K4

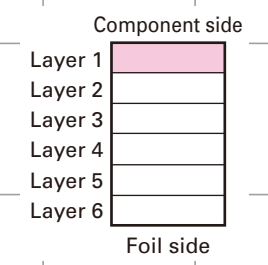
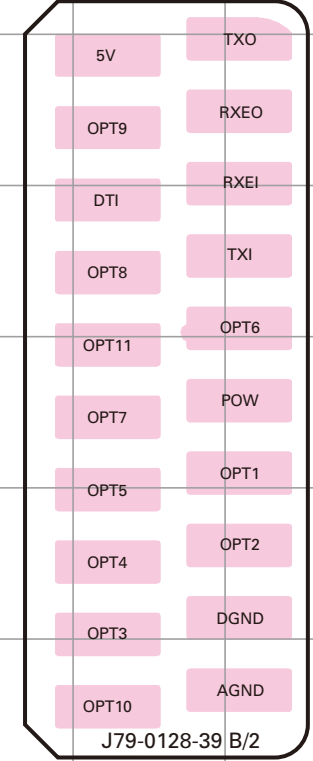
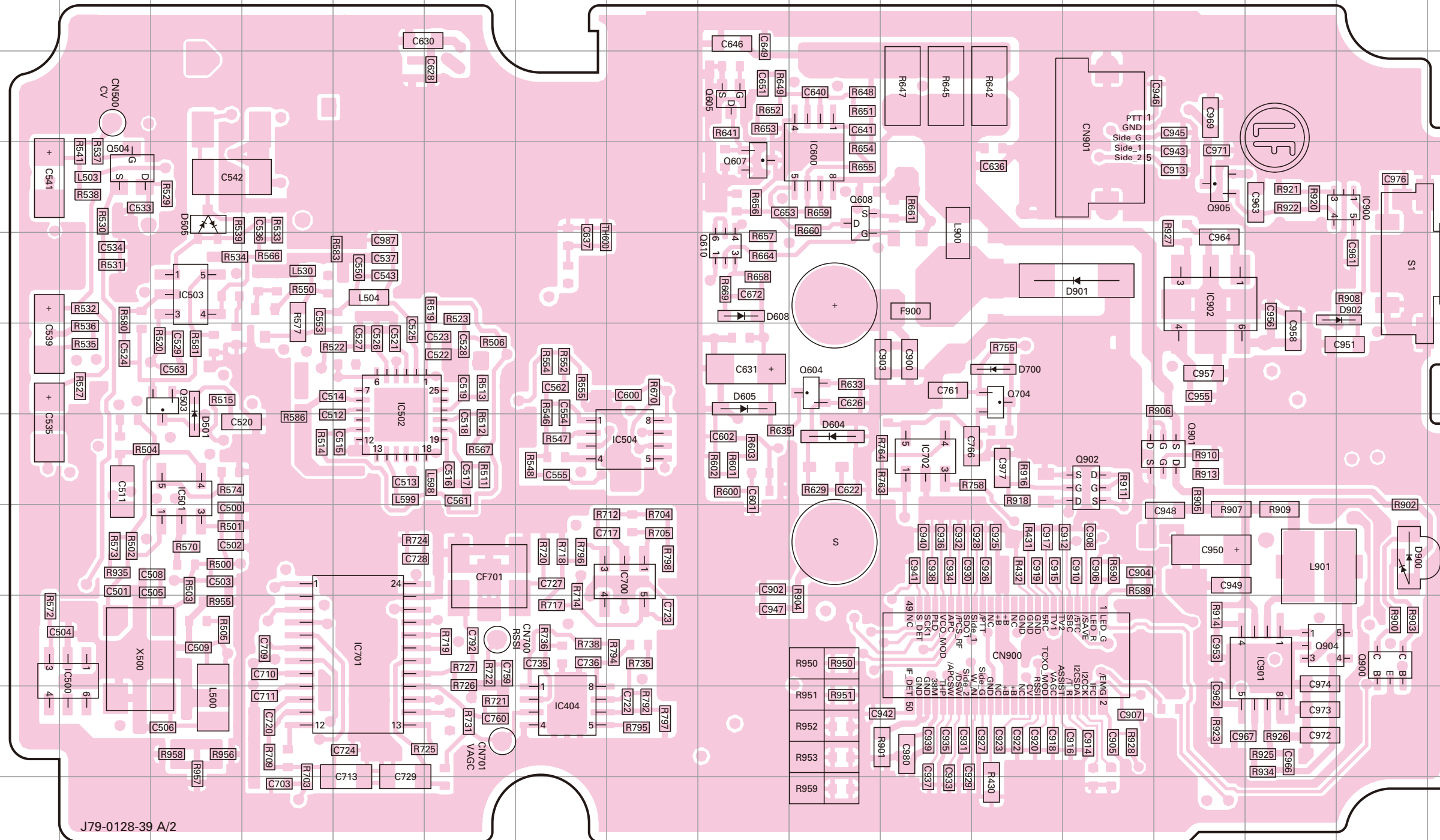

Ref. No.	Address	Ref. No.	Address	Ref. No.	Address	Ref. No.	Address	Ref. No.	Address
IC404	10G	IC700	8H	Q504	4B	Q900	9P	D604	7J
IC500	9B	IC701	9E	Q604	6J	Q901	7N	D605	6I
IC501	7C	IC702	7K	Q605	3I	Q902	7M	D608	5I
IC502	7E	IC900	4P	Q607	4I	Q904	9O	D700	6L
IC503	5C	IC901	9O	Q608	4J	Q905	4N	D900	8P
IC504	7H	IC902	5N	Q610	5I	D501	7C	D901	5M
IC600	4J	Q503	6C	Q704	6L	D505	4C	D902	5P

Market code	R950	R951
K, K3	0	NO
K2, K4	NO	0

# TK-5320 PC BOARD

# PC BOARD TK-5320

**TX-RX UNIT (X57-7830-XX) (A/2) -10: K,K3 -11: K2,K4**  
**Foil side view (J79-0128-39 A/2)**

**TX-RX UNIT (X57-7830-XX) (A/2) -10: K,K3 -11: K2,K4**  
**Foil side view (J79-0128-39 A/2)**

**TX-RX UNIT (X57-7830-XX) (B/2) -10: K,K3 -11: K2,K4**

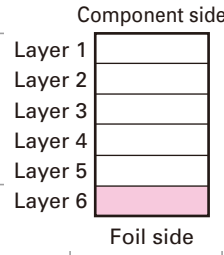
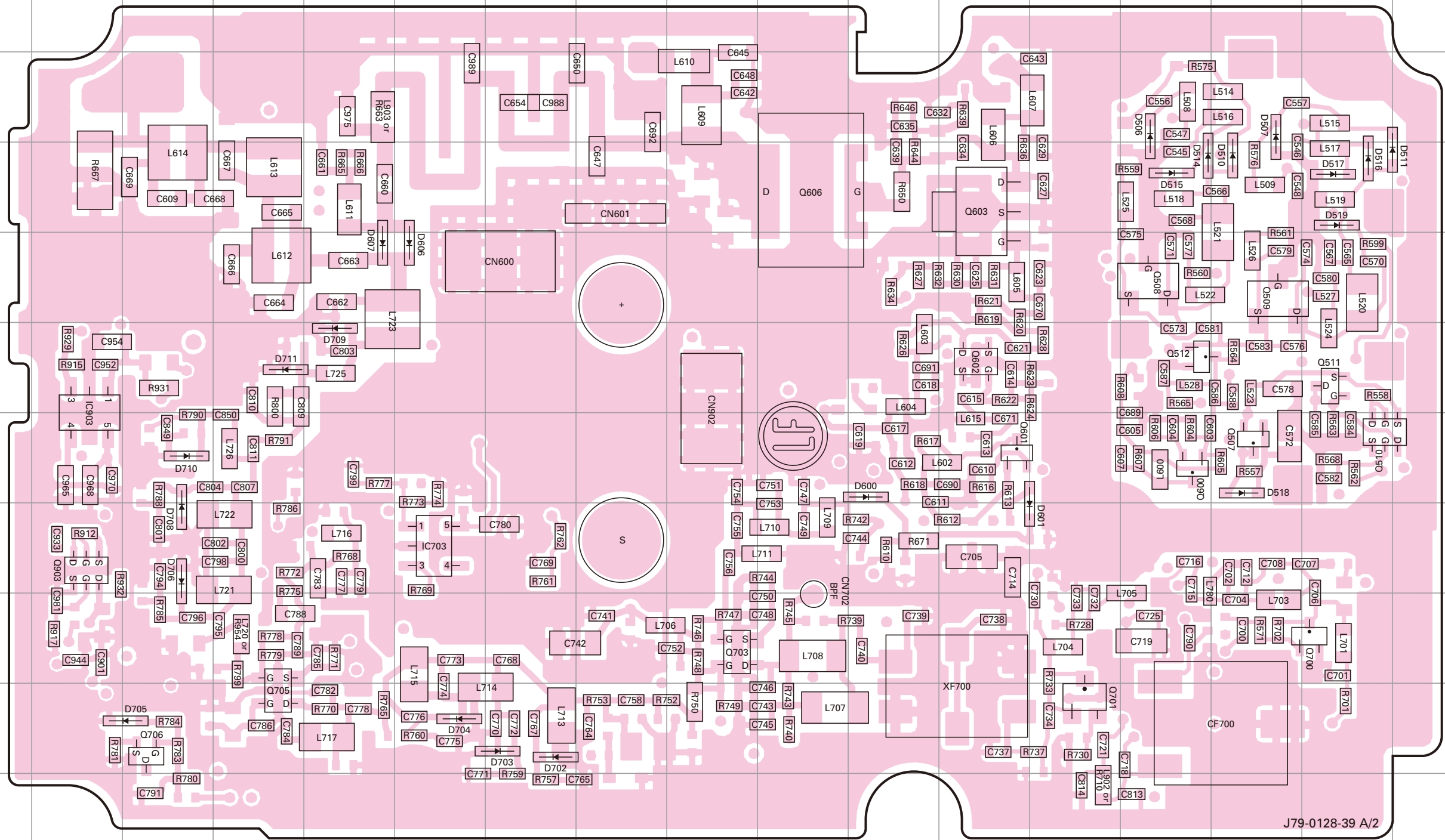
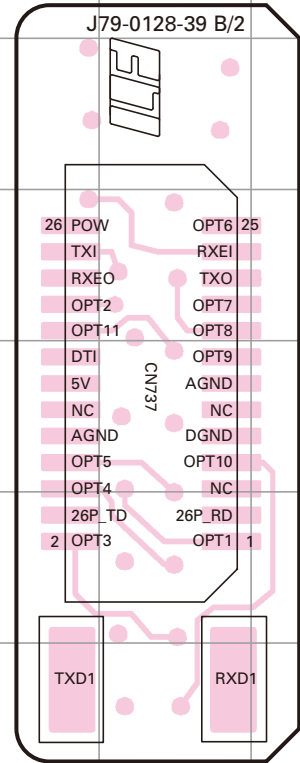

Ref. No.	Address	Ref. No.	Address	Ref. No.	Address	Ref. No.	Address	Ref. No.	Address	Ref. No.	Address
IC703	8H	Q512	6P	Q701	10O	D510	4Q	D519	4R	D704	10H
IC903	7D	Q600	7P	Q703	9K	D511	4S	D600	7M	D705	10E
Q507	7Q	Q601	7N	Q705	10F	D514	4P	D601	8O	D706	8E
Q508	5P	Q602	6N	Q706	10E	D515	4P	D606	5H	D708	8E
Q509	5Q	Q603	4N	Q903	8D	D516	4R	D607	5G	D709	6G
Q510	7R	Q606	4L	D506	3P	D517	4R	D702	10I	D710	7E
Q511	6R	Q700	9R	D507	3Q	D518	7Q	D703	10I	D711	6F

J79-0128-39 A/2

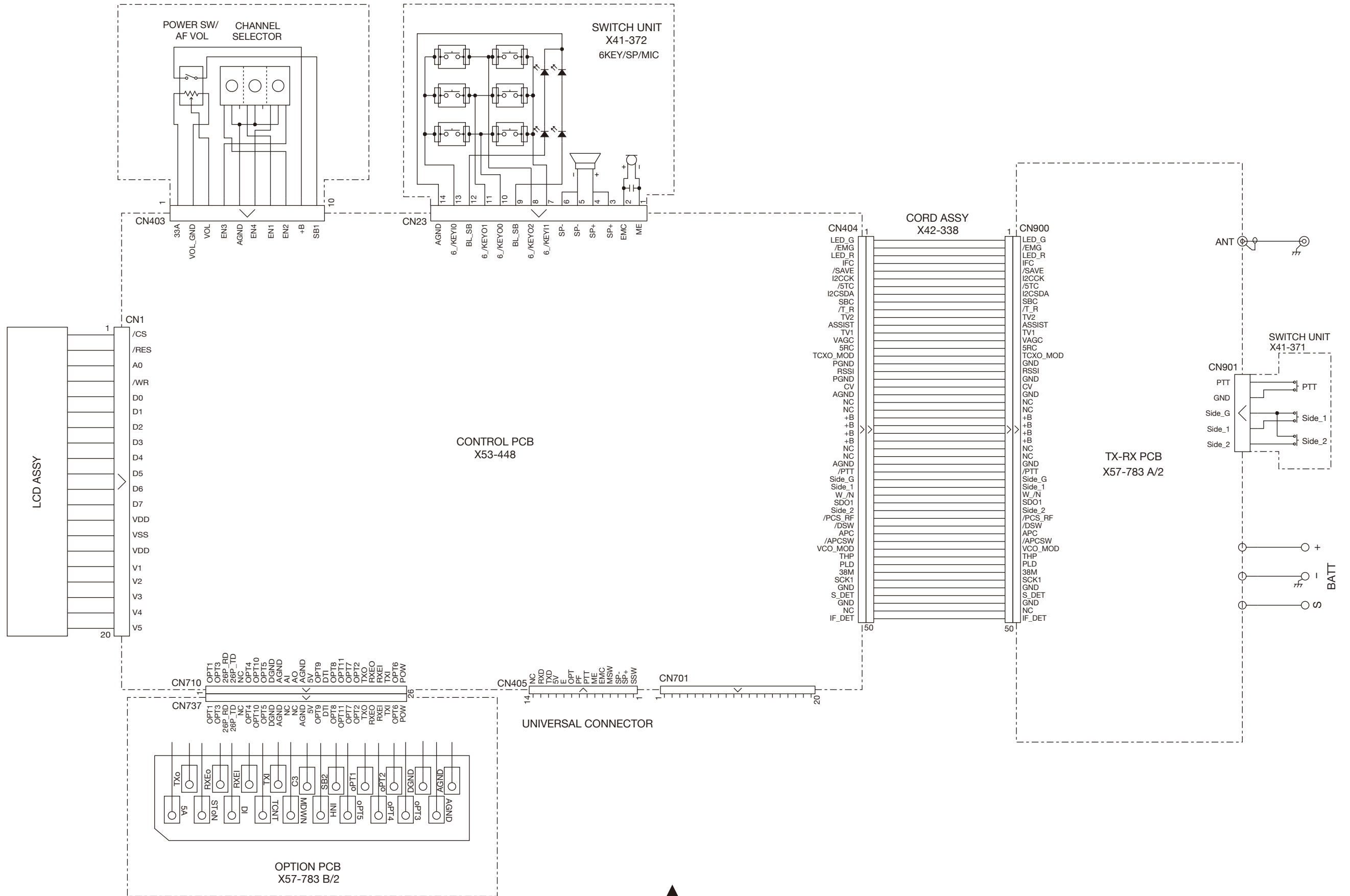



### Control unit (X53-4480-XX)

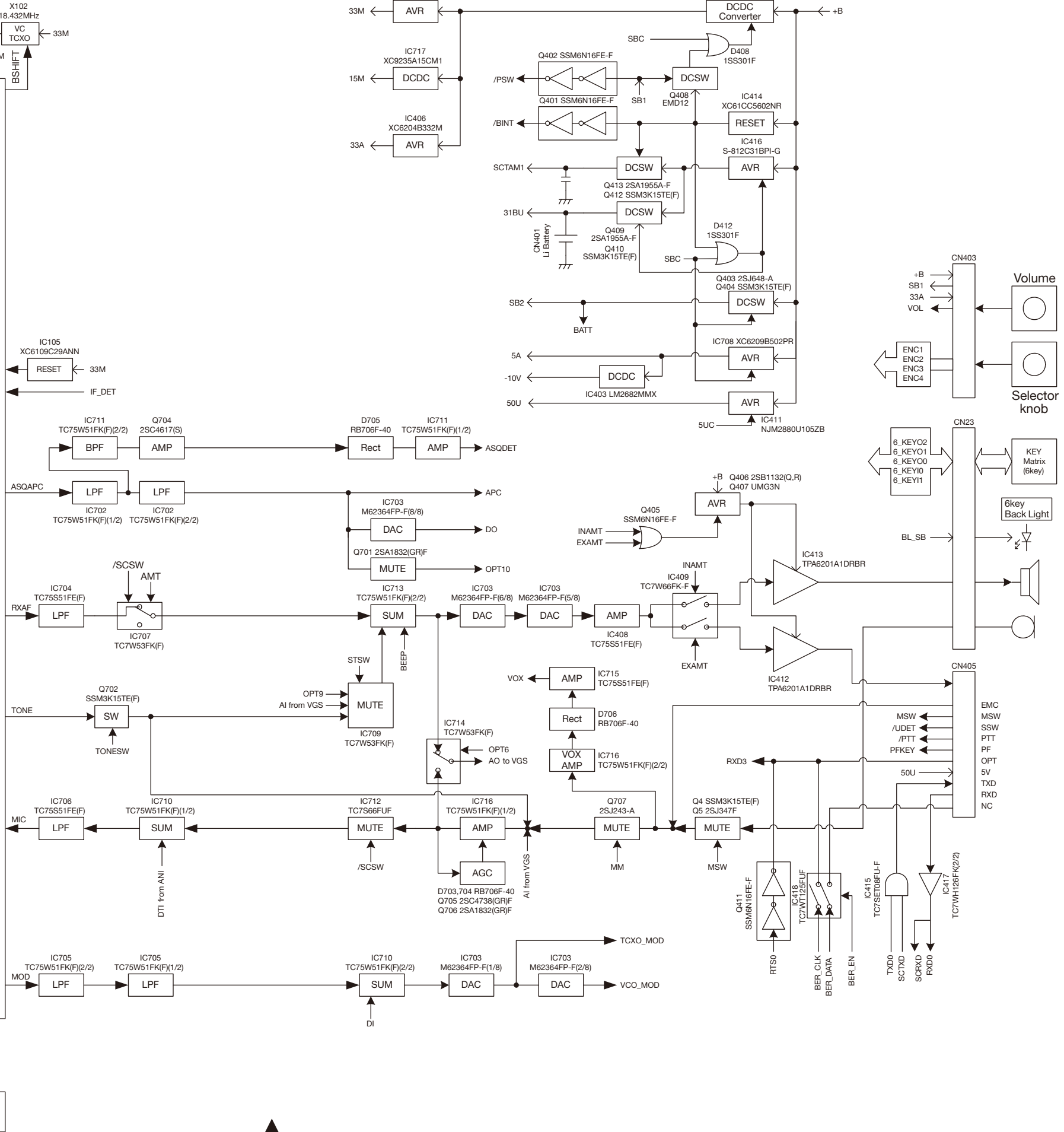
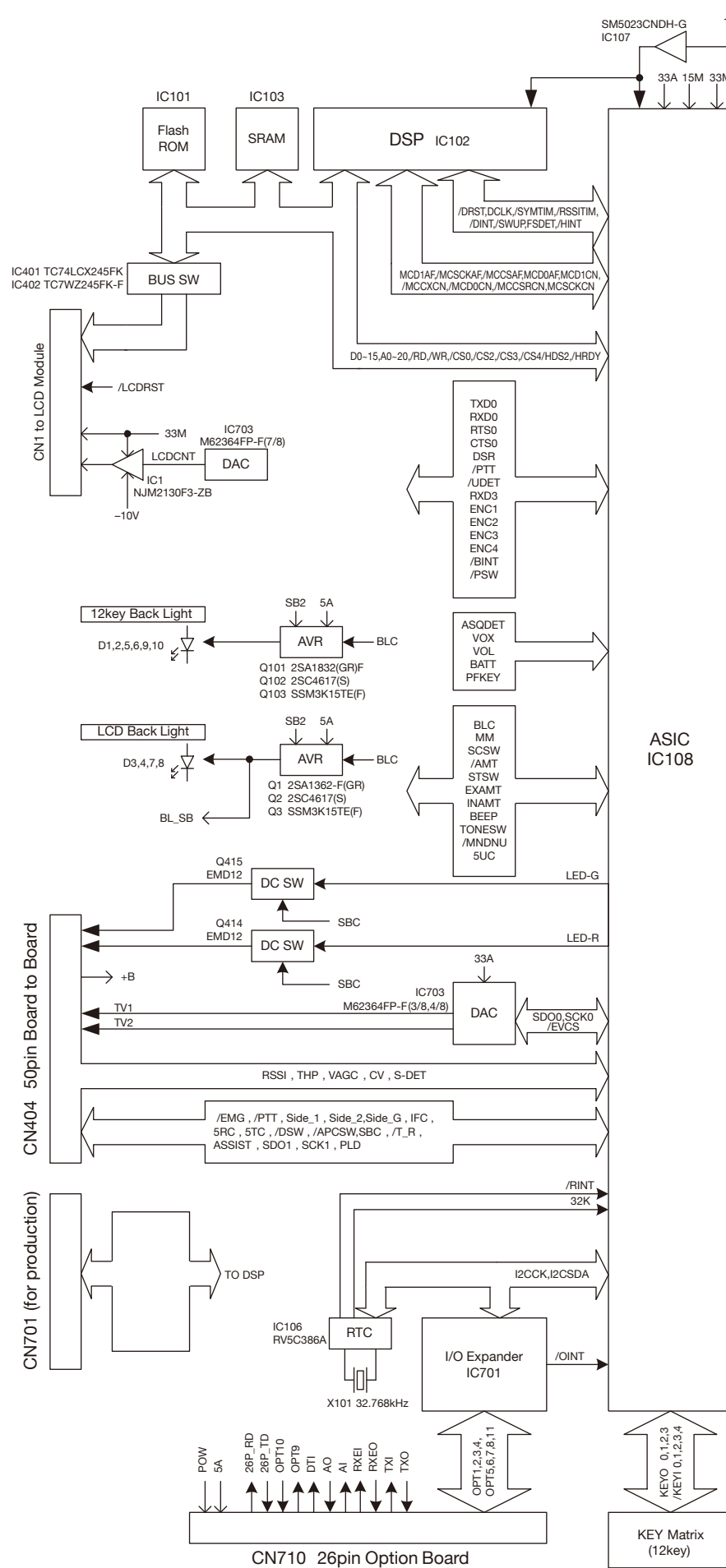

**TX-RX unit (X57-7830-XX)**

