

VHF FM TRANSCEIVER / VHF 调频车载对讲机

# TK-7302

CONNECTION CABLE / 连接电缆

KCT-60

## SERVICE MANUAL / 维修手册

# KENWOOD

Kenwood Corporation

© 2010-4 PRINTED IN CHINA  
B51-8921-00 (N)

C version / C 版本

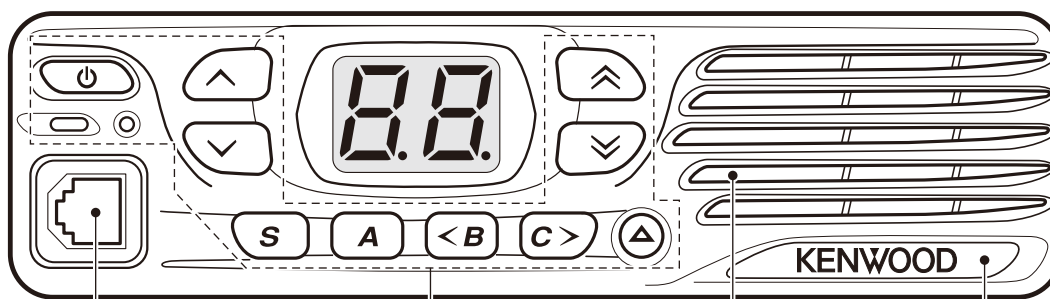

Modular jack / 模块化插孔  
(E58-0535-05)

Key top / 按键  
(K29-9448-01)

Panel assy / 面板组件  
(A62-1171-03)

Badge / 徽章  
(B43-1629-04)

无铅焊接通信产品    
保护环境建伍领先

⚠ 注意：本产品是无铅化焊接产品  
在维修时请使用无铅焊锡  
和相应的焊接工具  
详细事项请访问如下网址了解：  
<http://www.kenwoodhk.com.hk/>

This product complies with the **RoHS** directive for the European market.



This product uses Lead Free solder.

## CONTENTS / 目录

<b>GENERAL</b> .....	<b>3</b>	概 述.....	<b>3</b>
<b>SYSTEM SET-UP</b> .....	<b>5</b>	系统体系.....	<b>5</b>
<b>REALIGNMENT</b> .....	<b>6</b>	模式组合.....	<b>6</b>
<b>INSTALLATION</b> .....	<b>9</b>	安 装.....	<b>9</b>
<b>DISASSEMBLY FOR REPAIR</b> .....	<b>17</b>	维修拆卸.....	<b>17</b>
<b>CIRCUIT DESCRIPTION</b> .....	<b>21</b>	电路说明.....	<b>21</b>
<b>SEMICONDUCTOR DATA</b> .....	<b>30</b>	半导体数据.....	<b>31</b>
<b>COMPONENTS DESCRIPTION</b> .....	<b>32</b>	元件说明.....	<b>33</b>
<b>PARTS LIST</b> .....	<b>34</b>	零 件 表.....	<b>34</b>
<b>EXPLODED VIEW</b> .....	<b>43</b>	部件分解图.....	<b>43</b>
<b>PACKING</b> .....	<b>44</b>	包 装.....	<b>44</b>
<b>ADJUSTMENT</b> .....	<b>45</b>	调 整.....	<b>46</b>
<b>TERMINAL FUNCTION</b> .....	<b>56</b>	端子功能.....	<b>57</b>
<b>PC BOARD</b>		PC 板	
<b>DISPLAY UNIT (X54-3670-20)</b> .....	<b>60</b>	显示单元 (X54-3670-20).....	<b>60</b>
<b>TX-RX UNIT (X57-7683-01)</b> .....	<b>62</b>	TX-RX 单元 (X57-7683-01).....	<b>62</b>
<b>SCHEMATIC DIAGRAM</b> .....	<b>66</b>	原 理 图.....	<b>66</b>
<b>BLOCK DIAGRAM</b> .....	<b>72</b>	方 块 图.....	<b>72</b>
<b>LEVEL DIAGRAM</b> .....	<b>74</b>	电 平 图.....	<b>74</b>
<b>OPTIONAL ACCESSORIES</b>		可选附件	
<b>KCT-60 (CONNECTION CABLE)</b> .....	<b>75</b>	KCT-60( 连接电缆 ).....	<b>75</b>
<b>SPECIFICATIONS</b> .....	<b>75</b>	规 格.....	<b>封底</b>

**Document Copyrights**

Copyright 2010 by Kenwood Corporation. All rights reserved.

No part of this manual may be reproduced, translated, distributed, or transmitted in any form or by any means, electronic, mechanical, photocopying, recording, or otherwise, for any purpose without the prior written permission of Kenwood.

**Disclaimer**

While every precaution has been taken in the preparation of this manual, Kenwood assumes no responsibility for errors or omissions. Neither is any liability assumed for damages resulting from the use of the information contained herein. Kenwood reserves the right to make changes to any products herein at any time for improvement purposes.

**文档版权信息**

Kenwood Corporation 拥有版权 2010。保留所有权利。

未经 Kenwood 公司预先书面同意，无论出于何种目的，均不得以任何形式或任何方式包括电子、机械、影印、录音或其他方式复制、翻译、分发或传播本手册的任何部分。

**免责声明**

Kenwood 公司在准备本文档时已采取所有必要的预防措施，恕不对错误或疏漏承担任何责任，也不对因使用本文中所含的信息而导致的损害负责。Kenwood 公司保留出于改进的需要而随时对文中的产品信息做出更改的权利。

## GENERAL / 概述

### INTRODUCTION

#### SCOPE OF THIS MANUAL

This manual is intended for use by experienced technicians familiar with similar types of commercial grade communications equipment. It contains all required service information for the equipment and is current as of this publication date. Changes which may occur after publication are covered by either Service Bulletins or Manual Revisions, which are issued as required.

#### ORDERING REPLACEMENT PARTS

When ordering replacement parts or equipment information, the full part identification number should be included. This applies to all parts : components, kits, and chassis. If the part number is not known, include the chassis or kit number of which it is a part and a sufficient description of the required component for proper identification.

#### PERSONNEL SAFETY

The following precautions are recommended for personnel safety :

- DO NOT transmit if someone is within two feet (0.6 meter) of the antenna.
- DO NOT transmit until all RF connectors are secure and any open connectors are properly terminated.
- SHUT OFF this equipment when near electrical blasting caps or while in an explosive atmosphere.
- All equipment should be properly grounded before power-up for safe operation.
- This equipment should be serviced by only qualified technicians.

#### PRE-INSTALLATION CONSIDERATIONS

##### 1. UNPACKING

Unpack the radio from its shipping container and check for accessory items. If any item is missing, please contact KENWOOD immediately.

##### 2. PRE-INSTALLATION CHECKOUT

###### 2-1. Introduction

Each radio is adjusted and tested before shipment. However, it is recommended that receiver and transmitter operation be checked for proper operation before installation.

###### 2-2. Testing

The radio should be tested complete with all cabling and accessories as they will be connected in the final installation. Transmitter frequency, deviation, and power output should be checked, as should receiver sensitivity, squelch operation, and audio output. Signalling equipment operation should be verified.

### 引言

#### 本手册的范围

本手册是提供给熟悉通信专业并且具有维修经验的技术人员使用的。它包括了维修该设备所需要的全部资料和现行出版日期。在出版后可能发生变动，如果需要，可以参照《维修通报》或《手册修订本》进行补充。

#### 替换零件的订购

当订购替换零件或设备资料时，应注意完整的零件识别号码。所有的零件均有识别号码：元件，组件或机壳。如果不知道零件的号码，为了正确地识别，必须注明此元件所属的机壳或组件的号码，并对元件进行充分的说明。

#### 个人安全

为了个人的安全，请注意下列事项：

- 如果有人在天线两英尺 (0.6 米) 范围之内时，不要进行发射。
- 在没有认真核实所有射频插头之前或有任何一个脱开的插头没有连接到相应端口上的情况下均不要发射。
- 在电爆管附近或在易燃性气体环境中，必须关闭电源，不要操作本设备。
- 为了操作的安全，在接通电源之前所有设备应该连接地线。
- 本设备只应该由有资格的技术人员进行维修。

#### 安装前条件

##### 1. 开箱

从运输包装中取出本无线电设备并检查附件。如果有任何组件遗失，请立即与 KENWOOD 联系。

##### 2. 安装前检查

###### 2-1. 说明

在运输之前每一台无线电设备均已调整和测试过。但是，在安装之前最好检查接收和发射以便操作正确。

###### 2-2. 测试

无线电设备应该按照电缆和附件最终安装时的连接进行完整的测试。应该检查发射频率，频偏和输出功率，同样应该检查接收灵敏度，静噪和音频输出。应该检验信令操作。

## GENERAL / 概述

### 3. PLANNING THE INSTALLATION

#### 3-1. General

Inspect the vehicle and determine how and where the radio antenna and accessories will be mounted.

Plan cable runs for protection against pinching or crushing wiring, and radio installation to prevent overheating.

#### 3-2. Antenna

The favored location for an antenna is in the center of a large, flat conductive area, usually at the roof center. The trunk lid is preferred, bond the trunk lid and vehicle chassis using ground straps to ensure the lid is at chassis ground.

#### 3-3. Radio

The universal mount bracket allows the radio to be mounted in a variety of ways. Be sure the mounting surface is adequate to support the radio's weight. Allow sufficient space around the radio for air cooling. Position the radio close enough to the vehicle operator to permit easy access to the controls when driving.

#### 3-4. DC Power and wiring

1. This radio may be installed in negative ground electrical systems only. Reverse polarity will cause the cable fuse to blow. Check the vehicle ground polarity before installation to prevent wasted time and effort.
2. Connect the positive power lead directly to the vehicle battery positive terminal. Connecting the Positive lead to any other positive voltage source in the vehicle is not recommended.
3. Connect the ground lead directly to the battery negative terminal.
4. The cable provided with the radio is sufficient to handle the maximum radio current demand. If the cable must be extended, be sure the additional wire is sufficient for the current to be carried and length of the added lead.

### 4. INSTALLATION PLANNING – CONTROL STATIONS

#### 4-1. Antenna system

Control station. The antenna system selection depends on many factors and is beyond the scope of this manual. Your KENWOOD dealer can help you select an antenna system that will best serve your particular needs.

#### 4-2. Radio location

Select a convenient location for your control station radio which is as close as practical to the antenna cable entry point. Secondly, use your system's power supply (which supplies the voltage and current required for your system). Make sure sufficient air can flow around the radio and power supply to allow adequate cooling.

### 3. 安装步骤

#### 3-1. 概述

检查车辆并确认如何以及在何处安装无线电天线和附件。

安排好电缆的位置，避免挤压或碾碎布线，同时无线电设备避免过热。

#### 3-2. 天线

天线的最佳位置应该在一个宽阔，平整导电区域的中心，通常在车顶的中心。行李箱的盖子更好，将地线黏结在行李箱的盖子和车辆的外壳上确保行李箱盖子接地。

#### 3-3. 无线电设备

通用安装托架允许以多种方法安装无线电设备。确认安装的表面足以支撑无线电设备的重量。无线电设备的周围留出适当的空间进行散热。将无线电设备尽可能的安装在靠近车辆操作者的位置上，以便在驾驶时易于控制。

#### 3-4. 直流电源和布线

1. 本无线电设备只能被安装在负极接地电子系统中。反向极性将导致电缆保险丝熔断。在安装之前检查车辆的接地极性，避免工作效率低以及浪费时间。
2. 将电源的正极引线直接连接到车载电池的正极端点上。不要将正极引线与其他正极电压连接。
3. 将接地引线直接与电池的负极连接。
4. 与无线电设备一起提供的电缆适用于所需的最大无线电流。如果电缆必须加长，要确认附加的电线适用于所载的电流和添加引线的长度。

### 4. 安装步骤 – 基站

#### 4-1. 天线系统

基站。天线系统的选择取决于许多因素和本手册的范围。用户的KENWOOD销售商可以帮助用户选择最能满足用户特殊要求的天线系统。

#### 4-2. 无线电位置

为用户的基站无线电设备选择一个方便的位置，此位置应尽量靠近天线电缆输入点。其次，使用用户系统的电源（为用户的系统提供所需的电压和电流）。确认无线电设备周围的空气流通顺畅并且足以使电源冷却。

## GENERAL / 概述

### SERVICE

This radio is designed for easy servicing. Refer to the schematic diagrams, printed circuit board views, and alignment procedures contained in this manual.

### NOTE

If you do not intend to use the 3.5-mm jack for the external speaker, fit the supplied speaker-jack cap to stop dust and sand from getting in.

### 维修服务

为了便于维修本设备，建立了完整的维修服务体系，提供了包括原理图，印刷电路板图和调整步骤在内的资料供参考。

### 注意

如果不打算使用 3.5mm 外部扬声器插孔，请装上附带的扬声器插孔盖，防止灰尘和沙粒进入。

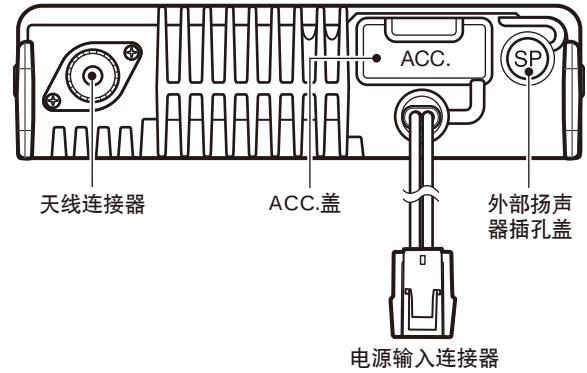
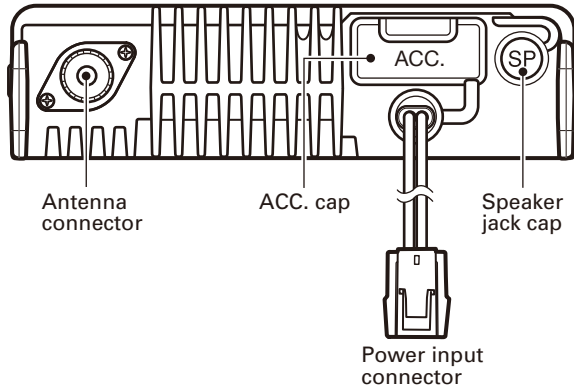

## SYSTEM SET-UP / 系统体系

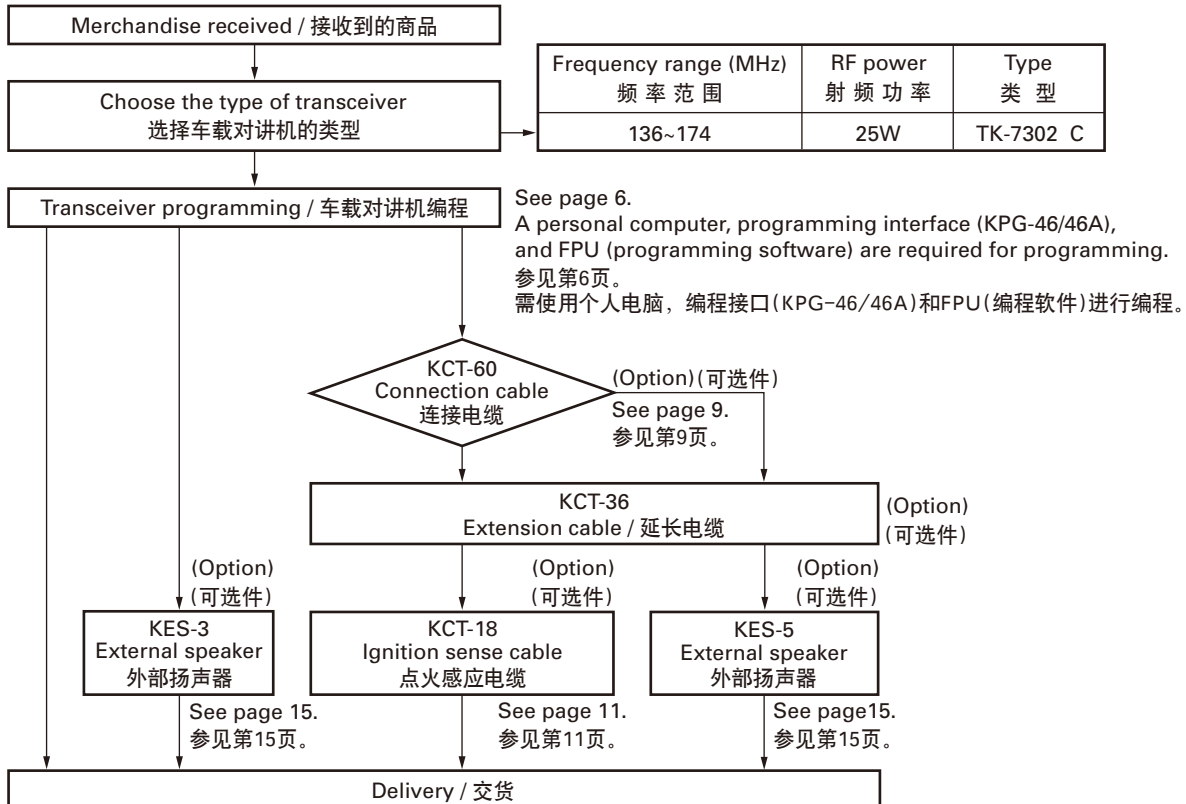

## REALIGNMENT / 模式组合

### 1. Modes

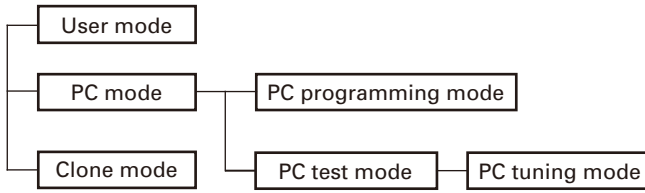

Mode	Function
User mode	For normal use.
PC mode	Used for communication between the transceiver and PC.
PC programming mode	Used to read and write frequency data and other features to and from the transceiver.
PC test mode	Used to check the transceiver using the PC. This feature is included in the FPU.
PC tuning mode	Used to tune the transceiver using the PC.
Clone mode	Used to transfer programming data from one transceiver to another.

### 1. 模式

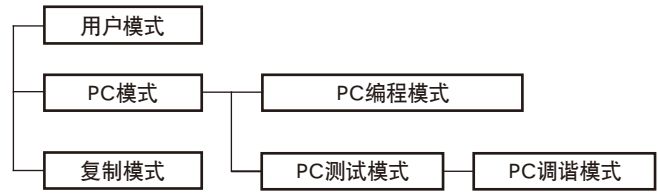

模式	功能
用户模式	一般使用。
PC模式	用于车载对讲机与PC之间的通信。
PC编程模式	用于阅读和写入频率数据以及其他功能。
PC测试模式	用于通过PC检查车载对讲机。该功能内置于FPU中。
PC调谐模式	用于通过PC调谐车载对讲机。
复制模式	用于从一个车载对讲机编程数据复制到另一个车载对讲机。

### 2. How to Enter Each Mode

Mode	Operation
User mode	Power ON
PC mode	Received commands from PC
Clone mode	[≡]+Power ON (Two seconds)

### 2. 如何进入每一种模式

模式	操作
用户模式	接通电源
PC模式	从PC接收指令
复制模式	[≡]+接通电源 (2秒钟)

### 3. PC Mode

#### 3-1. Preface

The transceiver is programmed using a personal computer, a programming interface (KPG-46/46A, USB adapter (KCT-53U)) and FPU (programming software).

The programming software can be used with a PC. Figure 1 shows the setup of a PC for programming.

### 3. PC 模式

#### 3-1. 前言

车载对讲机采用个人电脑、编程接口 (KPG-46/46A, USB 适配器 (KCT-53U)) 和 FPU (编程软件) 进行编程。

编程软件可在 PC 上使用。图 1 说明了 PC 进行编程的设置。

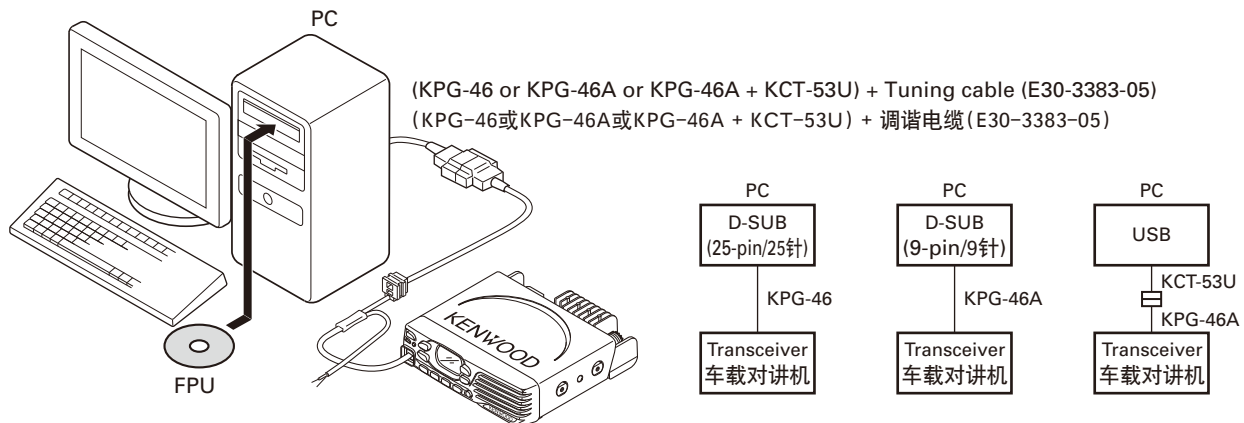

Fig. 1 / 图 1



## REALIGNMENT / 模式组合

### 3-2. Connection procedure

1. Connect the transceiver to the computer using the interface cable and USB adapter (When the interface cable is KPG-46A, the KCT-53U can be used.).

#### Note:

- You must install the KCT-53U driver in the computer to use the USB adapter (KCT-53U).
- When using the USB adapter (KCT-53U) for the first time, plug the KCT-53U into a USB port on the computer with the computer power ON.

2. When the Power is switched on, user mode can be entered immediately. When the PC sends a command, the transceiver enters PC mode, and "Pc" is displayed on the LED.

When data is transmitting from the transceiver, the red LED blinks.

When data is receiving by the transceiver, the green LED blinks.

#### Note:

The data stored in the computer must match the "Model Name" when it is written into the EEPROM.

### 3-3. KPG-46/KPG-46A description (PC programming interface cable: Option)

The KPG-46/46A is required to interface the transceiver to the computer. It has a circuit in its D-sub connector (KPG-46: 25-pin, KPG-46A: 9-pin) case that converts the RS-232C logic level to the TTL level.

The KPG-46/46A connects the 8-pin microphone connector of the transceiver to the RS-232C serial port of the computer.

### 3-4. KCT-53U description (USB adapter: Option)

The KCT-53U is a cable which connects the KPG-46A to a USB port on a computer.

When using the KCT-53U, install the supplied CD-ROM (with driver software) in the computer. The KCT-53U driver runs under Windows 2000 or XP or Vista (32-bit).

### 3-5. FPU (Programming Software) description

The FPU is the programming software for the transceiver supplied on a CD-ROM. This software runs under Windows 2000, XP or Vista (32-bit) on a PC.

The data can be input to or read from the transceiver and edited on the screen. The programmed or edited data can be printed out. It is also possible to tune the transceiver.

#### List of FPU for transceiver

Model	Type	FPU
TK-7302	C	KPG-124D(C)

### 3-2. 连接操作

1. 用接口电缆和 USB 适配器将车载对讲机连接到电脑（接口电缆为 KPG-46A 时，可以使用 KCT-53U）。

#### 注意：

- 必须在电脑上安装 KCT-53U 驱动程序才能使用 USB 适配器 (KCT-53U)。
- 首次使用 USB 适配器 (KCT-53U) 时，请在电脑电源打开的情况下将 KCT-53U 插入电脑的 USB 端口。

2. 电源打开时，可以立即进入用户模式。PC 发出命令时，车载对讲机进入 PC 模式，LED 上显示 "Pc"。  
车载对讲机发送数据时，红色 LED 闪烁。  
车载对讲机接收数据时，绿色 LED 闪烁。

#### 注意：

电脑保存的数据写入 EEPROM 时，必须与“型号名称”相符。

### 3-3. KPG-46/KPG-46A 说明 (PC 编程接口电缆：选购件)

将车载对讲机连接到电脑需要 KPG-46/46A。该电缆的 D-sub 连接器 (KPG-46: 25 针, KPG-46A: 9 针) 盒具有将 RS-232C 逻辑电平转换为 TTL 电平的电路。

KPG-46/46A 将车载对讲机的 8 针麦克风连接器连接到电脑的 RS-232C 串行端口。

### 3-4. KCT-53U 说明 (USB 适配器：选购件)

KCT-53U 是将 KPG-46A 连接到电脑 USB 端口的电缆。

使用 KCT-53U 时，请在电脑上安装附带的 CD-ROM (带有驱动程序软件)。KCT-53U 驱动程序在 Windows 2000、XP 或 Vista (32 位) 下运行。

### 3-5. FPU (编程软件) 说明

FPU 是 CD-ROM 附带的用于车载对讲机的编程软件。

该软件在 PC 的 Windows 2000、XP 或 Vista (32 位) 下运行。可在车载对讲机上写入或读取数据，并可在电脑屏幕上进行编辑。可以打印编程或编辑的数据。此外，还可调谐车载对讲机。

#### 车载对讲机的 FPU 名单

型号	类型	FPU
TK-7302	C	KPG-124D(C)

## REALIGNMENT / 模式组合

## 4. Clone Mode

Programming data can be transferred from one transceiver to another by connecting them via their modular microphone jacks. The operation is as follows (the transmit transceiver is the source and the receive transceiver is a target).

**Note:**

Clone mode should be enabled.

1. Turn the source transceiver power ON with the [M] key held down (2 seconds), "cL" is displayed on the LED.
2. Power on the target transceiver.
3. Connect the cloning cable (No. E30-3382-05) to the modular microphone jacks on the source and target.
4. Press the [S] key on the source transceiver.  
The data of the source is sent to the target. While the source is sending data, red LED will blink. While the target is receiving the data, "Pc" is displayed and green LED will blink. When cloning of data is completed, the source displays "En", and the source red LED turned off, and the target automatically operates in the User mode. The target can then be operated by the same program as the source.
5. The other target can be continuously cloned. Carry out the operation in step 2 to 4.

## 4-1. Adding the data password

If the data password is set in the optional feature menu, you must enter the password (Source transceiver) to activate a clone mode.

You can use 0~9 to configure the password. The maximum length of the password is 6 digits.

1. Turn the source transceiver power ON with the [M] key held down (2 seconds).
2. "PS" is displayed on the LED.
3. If the [A] and [M] keys is pressed while "PS" is displayed, numbers (0 to 9) are displayed flashing. When you press the [C>] key, the currently selected number is determined. If you press the [S] key after entering the password in this procedure, "cL" is displayed if the entered password is correct. If the password is incorrect, "PS" is redisplayed.

## 4. 复制模式

通过模块化麦克风插孔连接车载对讲机，可以将编程数据从一台传输到另一台。具体操作如下（发射车载对讲机是主机，接收车载对讲机是子机）。

**注意：**

应当启用复制模式。

1. 按住 [M] 键 (2 秒) 打开主车载对讲机的电源，LED 上显示 "cL"。
2. 打开子车载对讲机的电源。
3. 将复制电缆 (编号 : E30-3382-05) 连接到主车载对讲机和子车载对讲机上的模块化麦克风插孔。
4. 按主车载对讲机上的 [S] 键。  
主车载对讲机的数据便被发送到子车载对讲机。主车载对讲机发送数据时，红色 LED 将会闪烁。子车载对讲机接收数据时，将显示 "Pc" 且绿色 LED 闪烁。数据复制完成后，主车载对讲机显示 "En"，主车载对讲机的红色 LED 熄灭，子车载对讲机自动以用户模式运行。然后子车载对讲机就可以按与主车载对讲机相同的程序操作。
5. 可以继续对另一台子机进行复制。执行步骤 2 至 4 的操作。

## 4-1. 添加数据密码

如果在可选功能菜单中设置了数据密码，则您必须输入密码（主车载对讲机）方可激活复制模式。

可使用 0 ~ 9 设置密码。密码最大长度为 6 位。

1. 按住 [M] 键 (2 秒) 打开主车载对讲机的电源。
2. LED 上显示 "PS"。
3. 如果在显示 "PS" 时按 [A] 和 [M] 键，数字 (0 到 9) 闪烁显示。按 [C>] 键即可确定当前选择的数字。在此步骤中输入密码后按 [S] 键，如果输入的密码正确，则显示 "cL"。如果密码不正确，则重新显示 "PS"。

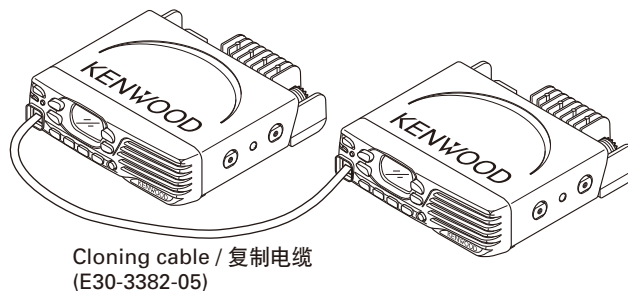
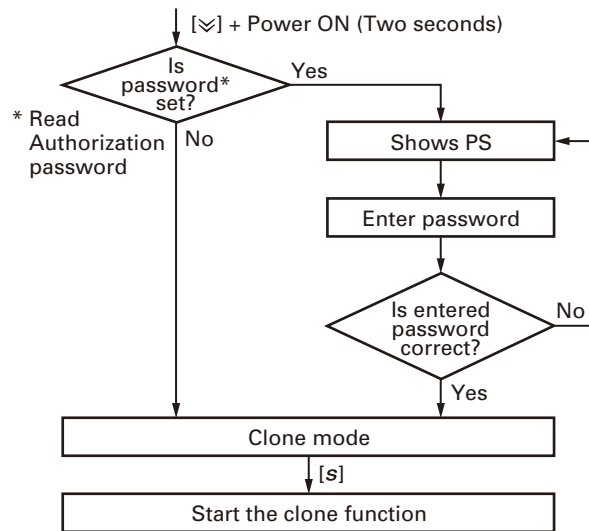

Fig. 2 / 图 2



## REALIGNMENT / 模式组合

## 4-2. Flow chart (Source transceiver)



## 4-2. 流程图 (主车载对讲机)

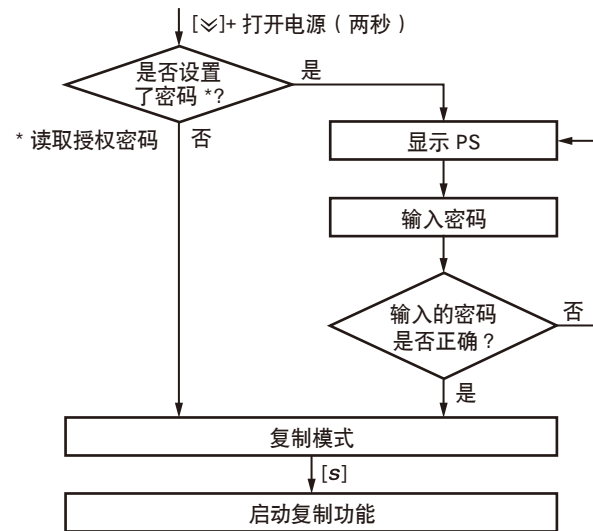

## INSTALLATION / 安装

## 1. Connection Cable (KCT-60: Option)

The KCT-60 connection cable kit is used to connect the transceiver to a Horn alert cable, KCT-18 (Ignition sense cable), KES-5 (External speaker), or through the KCT-36 extension cable.

## 1-1. Installing the KCT-60 (Connection cable) in the transceiver

1. Remove the ACC. cap on the rear of the transceiver.
2. Connect the D-sub connector of the KCT-60 to the D-sub 15-pin terminal of the transceiver.
3. Connect the 15-pin connector of the KCT-60 to a Horn alert cable, KCT-18, KES-5, or through a KCT-36 extension cable.

**Note:** You must set up using the KPG-124D(C).

## 1. 连接电缆 (KCT-60: 选配件)

KCT-60 连接电缆组件用于将车载对讲机连接到喇叭提示电缆、KCT-18(点火感应电缆)、KES-5(外部扬声器), 或通过 KCT-36 延长电缆连接。

## 1-1. 在车载对讲机上安装 KCT-60(连接电缆)

1. 拆下车载对讲机后部的 ACC. 盖。
2. 将 KCT-60 的 D-sub 连接器连接到车载对讲机的 D-sub 15 针端子。
3. 将 KCT-60 的 15 针连接器连接到喇叭提示电缆、KCT-18、KES-5, 或通过 KCT-36 延长电缆。

**注意:** 必须使用 KPG-124D(C) 进行设置。

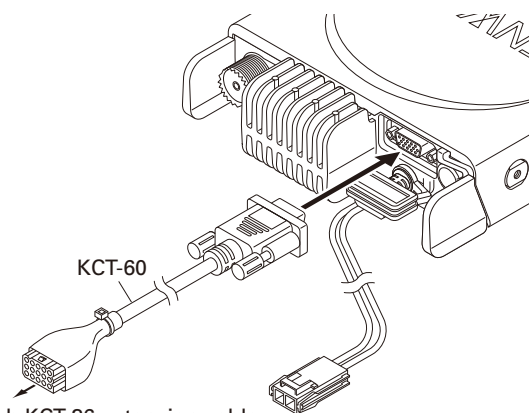

Horn alert cable, KCT-18, KES-5 or through KCT-36 extension cable  
喇叭提示电缆、KCT-18、KES-5或通过KCT-36延长电缆

## INSTALLATION / 安装

### 1-2. Terminal function

D-sub 15-pin Pin No.	Name	Molex 15-pin Pin No.
1	SB	1
2	IGN	2
3	PA or External SP	12
4	DO	4
5	DI	5
6	FNC1	9
7	FNC2	11
8	FNC3	7
9	FNC4	6
10	FNC5	8
11	FNC6	10
12	5C	15
13	HR1	13
14	HR2	14
15	GND	3

### 1-2. 端子功能

D-sub 15 针脚号	名称	Molex 15 针脚号
1	SB	1
2	IGN	2
3	PA 或外部 SP	12
4	DO	4
5	DI	5
6	FNC1	9
7	FNC2	11
8	FNC3	7
9	FNC4	6
10	FNC5	8
11	FNC6	10
12	5C	15
13	HR1	13
14	HR2	14
15	GND	3

## 2. Horn Alert Function

The Horn alert function (max. 2A drive) is enabled by installing the KCT-60 in the transceiver.

### 2-1. Installation Procedure

1. Remove the chip resistor R789 (4.7kΩ) on the TX-RX unit before installing the KCT-60 in the transceiver.

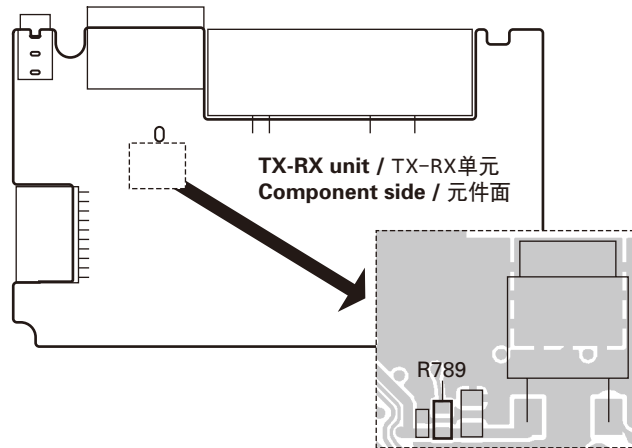

## 2. 喇叭提示功能

在车载对讲机上安装 KCT-60，可使用喇叭提示功能（最大 2A 驱动）。

### 2-1. 安装步骤

1. 在车载对讲机上安装 KCT-60 之前，拆下 TX-RX 单元上的片状电阻器 R789 (4.7kΩ)。

2. Remove the ACC. cap on the rear of the transceiver.
3. Connect the D-sub connector of the KCT-60 to the D-sub 15-pin terminal of the transceiver.
4. Insert the two crimp terminals of the Horn alert cable to pins 13 and 14 of the square plug.
5. Connect the square plug to the 15-pin connector of the KCT-60.

2. 拆下车载对讲机后部的 ACC. 盖。
3. 将 KCT-60 的 D-sub 连接器连接到车载对讲机的 D-sub 15 针端子。
4. 将喇叭提示电缆的两个压接式端子插入方形插头的针脚 13 和 14。
5. 将方形插头连接到 KCT-60 的 15 针连接器。

## INSTALLATION / 安装

6. Connect the remaining two Horn alert cables to your car Horn alert signal control.

The internal FET switch can be controlled by turning the HA function on/off and by using a signaling decode output. The maximum current of HA is 2A. This FET switch is the open drain circuit. Therefore, a DC power supply is necessary to use the HR1. The voltage range is from 5V to 16V.

6. 将剩下的两条喇叭提示电缆连接到汽车的喇叭提示信号控制。

内部 FET 开关可通过打开 / 关闭 HA 功能和使用信令解码输出进行控制。HA 的最大电流为 2A。此 FET 开关属于开漏电路。因此，需 DC 电源方可使用 HR1。电压范围为 5V 至 16V。

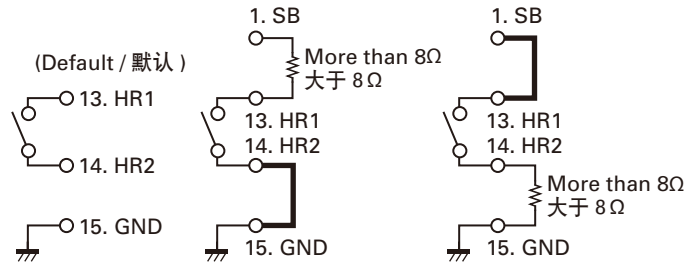

**Note:** You must set up using the KPG-124D(C).

**注意:** 必须使用 KPG-124D(C) 进行设置。

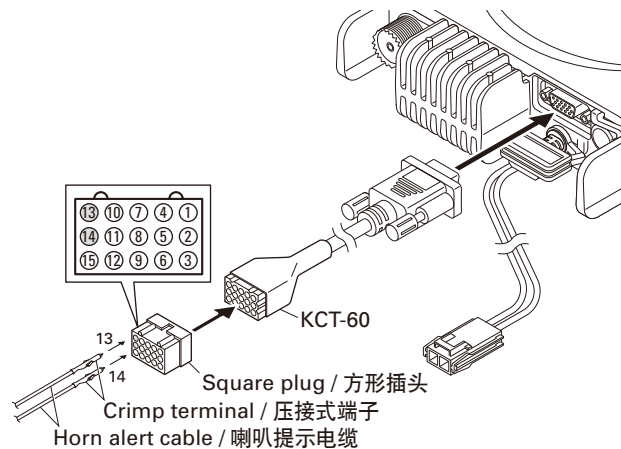

### 3. Ignition Sense Cable (KCT-18: Option)

The KCT-18 is an optional cable for enabling the ignition function. The ignition function lets you turn the transceiver power on and off with the car ignition key.

#### 3-1. Installing the KCT-18 (Ignition sense cable) in the transceiver

- The KCT-18 can be installed in the transceiver by the following two methods (Method A, Method B).  
Method A: The KCT-18 is soldered to the "IGN" pad on the TX-RX unit.  
Method B: The KCT-18 is connected to the 15-pin connector of the KCT-60 connected to the transceiver.

### 3. 点火感应电缆 (KCT-18: 选购件)

KCT-18 为用于启用点火功能的选购电缆。点火功能让您能够通过汽车点火钥匙打开和关闭车载对讲机的电源。

#### 3-1. 在车载对讲机上安装 KCT-18(点火感应电缆)

- KCT-18 可通过以下两种方法安装在车载对讲机上 (方法 A、方法 B)。  
方法 A: 将 KCT-18 焊接到 TX-RX 单元的 "IGN" 盘上。  
方法 B: 将 KCT-18 连接到与车载对讲机相连的 KCT-60 的 15 针连接器上。

## INSTALLATION / 安装

### ■ Installation Procedure: Method A

1. Remove the two screws on both the right and left sides of the transceiver, then remove the cabinet and top packing from the transceiver.
2. Remove the chip resistor R789 (4.7kΩ) on the TX-RX unit.

### ■ 安装步骤：方法 A

1. 卸下车载对讲机左右两侧的两颗螺丝，然后拆下车载对讲机的机壳和顶盖。
2. 拆下 TX-RX 单元上的片状电阻器 R789 (4.7kΩ)。

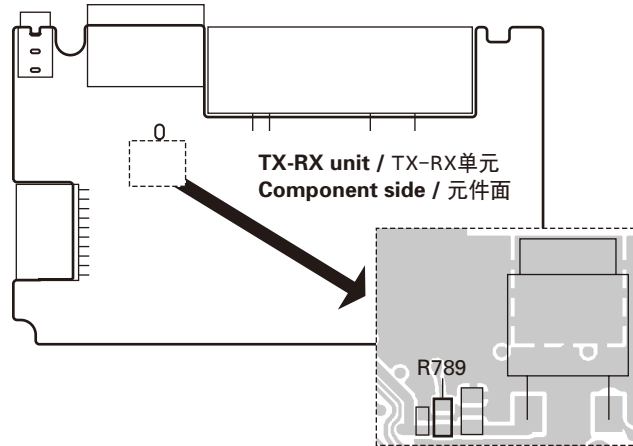

3. Cut the crimp terminal side of the KCT-18 using a pair of nippers or similar tool.

3. 用钳子或类似工具剪切 KCT-18 的压接式端子侧。

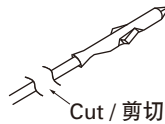

4. Solder the cable side cut in the above step 3 to the "IGN" pad on the TX-RX unit.

4. 将上述步骤 3 中剪切的电缆端焊接到 TX-RX 单元上的 "IGN" 盘。

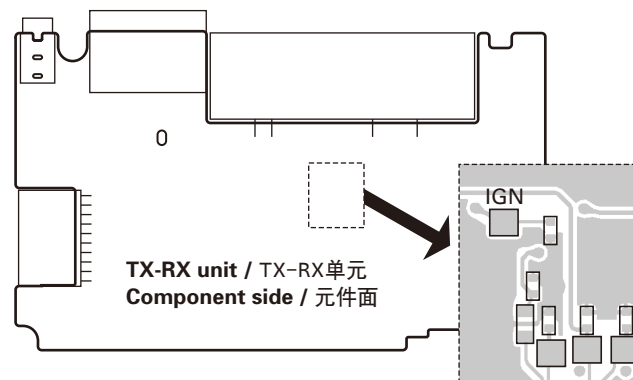

## INSTALLATION / 安装

5. Dress the KCT-18 cable as shown in the figure. The KCT-18 cable needs to pass through one of two indentations located on the rear panel of the transceiver.

5. 如图所示对 KCT-18 电缆进行布线。KCT-18 电缆需要穿过位于车载对讲机后部的两个凹入部之一。

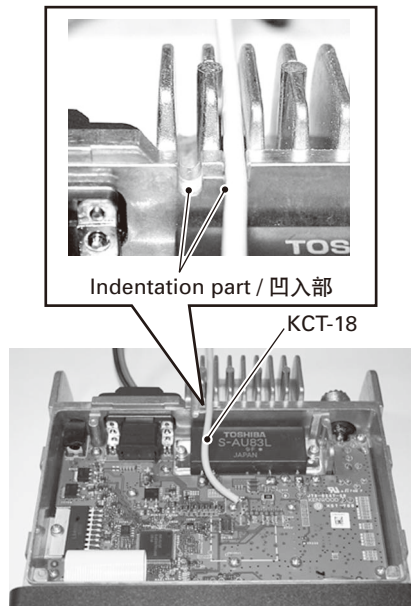

6. Cut off the projection of the top packing using a pair of nippers or similar tool. If the KCT-18 cable is dressed to be routed through the indentations on the right side in step 5, the right side of the projection needs to be cut off. If the KCT-18 cable is dressed to be routed through the indentations on the left side, the left side of the projection needs to be cut off. Following is a figure presenting an example for when the right side of the projection is cut off.

6. 用钳子或类似工具切掉顶盖的突出部。如果在步骤 5 中使 KCT-18 电缆通过右侧的凹入部，则需要切掉突出部的右侧。如果使 KCT-18 电缆通过左侧的凹入部，则需要切掉突出部的左侧。下图显示的是切掉突出部右侧的示例。

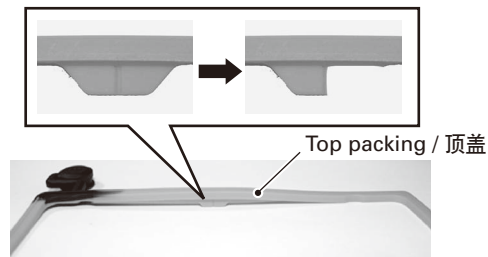

7. Reinstall the top packing. Check the correct fitting of the top packing, then reinstall the cabinet and two screws for the right and left sides.  
8. Connect the other side of the KCT-18 to the ignition line of the car.

7. 重新安装顶盖。检查顶盖装配是否正确，然后，重新安装机壳和左右两侧的两颗螺丝。  
8. 将 KCT-18 的另一端连接到汽车点火线。

## INSTALLATION / 安装

### ■ Installation Procedure: Method B

1. Remove the two screws on both the right and left sides of the transceiver, then remove the cabinet and top packing from the transceiver.
2. Remove the chip resistor R789 (4.7kΩ) on the TX-RX unit.

### ■ 安装步骤：方法 B

1. 卸下车载对讲机左右两侧的两颗螺丝，然后拆下车载对讲机的机壳和顶盖。
2. 拆下 TX-RX 单元上的片状电阻器 R789 (4.7kΩ)。

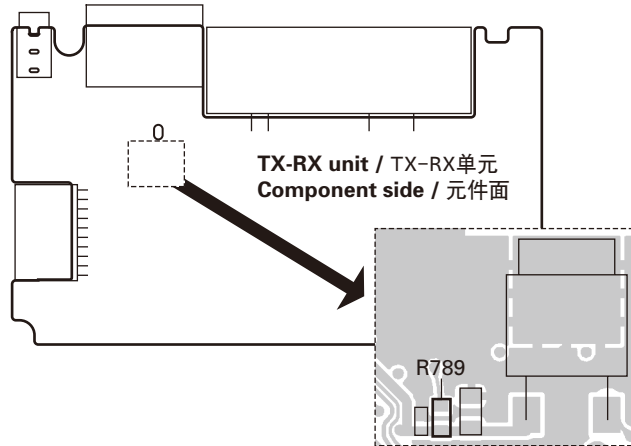

3. Remove the ACC. cap on the rear of the transceiver.
4. Connect the D-sub connector of the KCT-60 to the D-sub 15-pin terminal of the transceiver.
5. Insert the crimp terminal side of the KCT-18 to pin 2 of the square plug.
6. Connect the square plug to the 15-pin connector of the KCT-60.
7. Connect the other side of the KCT-18 to the ignition line of the car.

3. 拆下车载对讲机后部的 ACC. 盖。
4. 将 KCT-60 的 D-sub 连接器连接到车载对讲机的 D-sub 15 针端子。
5. 将 KCT-18 的压接式端子侧插入方形插头的针脚 2。
6. 将方形插头连接到 KCT-60 的 15 针连接器。
7. 将 KCT-18 的另一端连接到汽车点火线。

**Note:** You must set up using the KPG-124D(C).

**注意：**必须使用 KPG-124D(C) 进行设置。

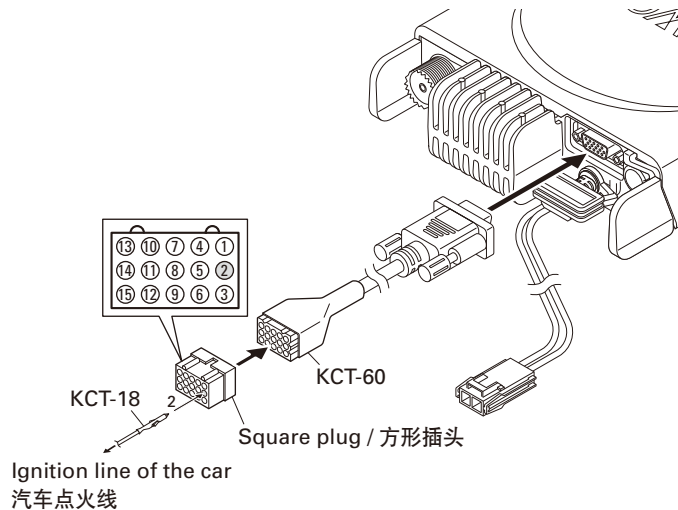



## INSTALLATION / 安装

### 4. External Speaker (Option)

#### 4-1. KES-3

The KES-3 is an external speaker for the 3.5-mm-diameter speaker jack.

##### ■ Connection procedure

1. Remove the speaker-jack cap on the rear of the transceiver.
2. Connect the KES-3 to the 3.5-mm-diameter speaker jack on the rear of the transceiver.

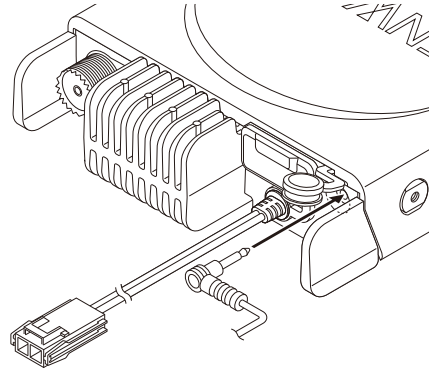

### 4. 外部扬声器（选配件）

#### 4-1. KES-3

KES-3 是用于直径 3.5mm 扬声器插孔的外部扬声器。

##### ■ 连接步骤

1. 拆下车载对讲机后部的扬声器插孔盖。
2. 将 KES-3 连接到车载对讲机后部的直径 3.5mm 扬声器插孔。

#### 4-2. KES-5

External speaker KES-5 can be installed for KCT-60.

##### ■ Connection procedure

1. Remove the ACC. cap on the rear of the transceiver.
2. Connect the D-sub connector of the KCT-60 to the D-sub 15-pin terminal of the transceiver.
3. Insert the two crimp terminals of the KES-5 to pins 3 and 12 of the square plug.
4. Connect the square plug to the 15-pin connector of the KCT-60.

##### Note:

You must set up using the KPG-124D(C).  
Before the external speaker can be used, you must assign one of the keys as "External Speaker", using the KPG-124D(C).

#### 4-2. KES-5

外部扬声器 KES-5 可安装于 KCT-60。

##### ■ 连接步骤

1. 拆下车载对讲机后部的 ACC. 盖。
2. 将 KCT-60 的 D-sub 连接器连接到车载对讲机的 D-sub 15 针端子。
3. 将 KES-5 的两个压接式端子插入方形插头的针脚 3 和 12。
4. 将方形插头连接到 KCT-60 的 15 针连接器。

##### 注意：

必须使用 KPG-124D(C) 进行设置。  
必须使用 KPG-124D(C) 将某个键指定为“外部扬声器”，方可使用外部扬声器。

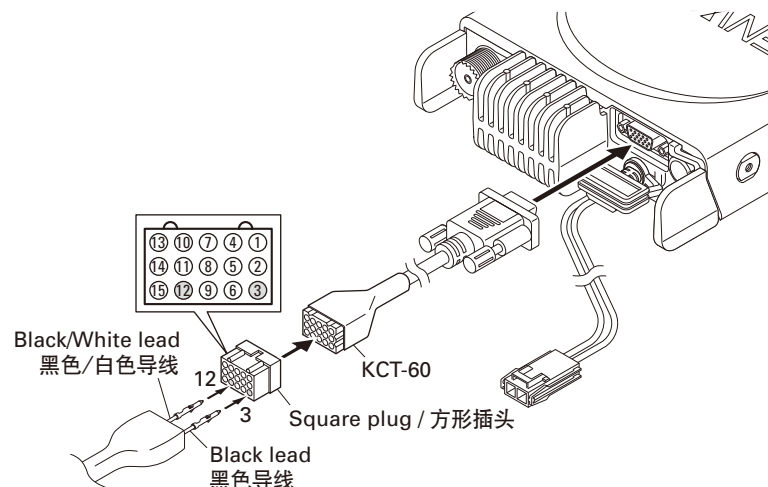

## INSTALLATION / 安装

### 5. GPS Receiver Connection

#### 5-1. Installing the GPS receiver

- Solder each cable of the GPS receiver to the TX-RX unit.
  - Red cable  
The red cable needs to be connected to the solder pad (5M) on the TX-RX unit.
  - Yellow cable  
The yellow cable needs to be connected to the solder pad (RS232C-RXD) on the TX-RX unit.
  - Black cable  
The black cable needs to be connected to the chip capacitor (C842) on the TX-RX unit.

### 5. GPS 接收机连接

#### 5-1. 安装 GPS 接收机

- 将 GPS 接收机的各条电缆焊接到 TX-RX 单元。
  - 红色电缆  
红色电缆需连接到 TX-RX 单元的焊盘 (5M)。
  - 黄色电缆  
黄色电缆需连接到 TX-RX 单元的焊盘 (RS232C-RXD)。
  - 黑色电缆  
黑色电缆需连接到 TX-RX 单元的芯片电容器 (C842)。

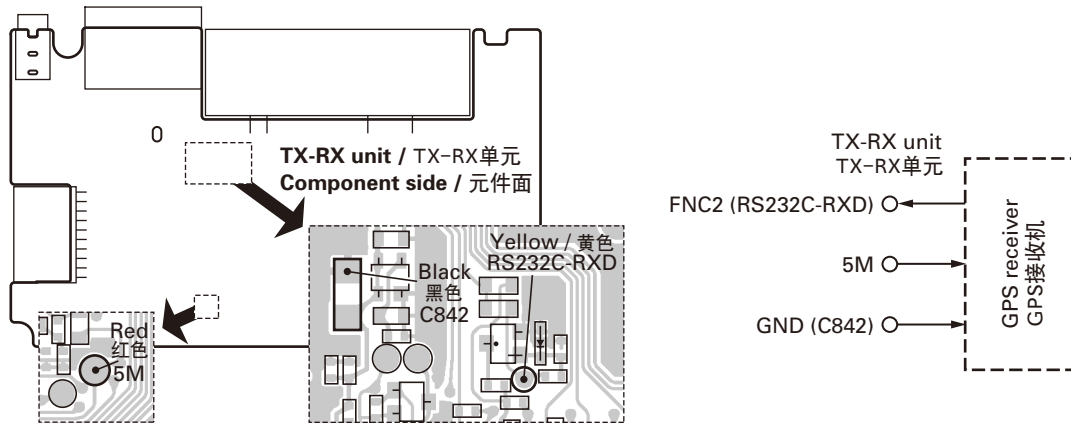

**Note:** You must set up using the KPG-124D(C).

**注意:** 必须使用 KPG-124D(C) 进行设置。

### 6. Extended Function: COM Port 0 and COM Port 1

Location of COM Port 0 and COM Port 1 of the transceiver is shown below.

### 6. 扩展功能：COM 端口 0 和 COM 端口 1

车载对讲机的 COM 端口 0 和 COM 端口 1 的位置如下所示。

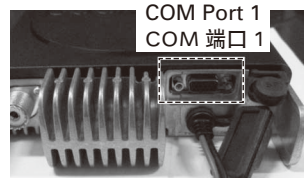
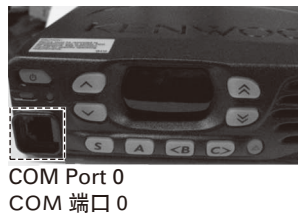

You must configure the transceiver COM Port 0 and COM Port 1 using the KPG-124D(C).

When you set as "Data", the Function port 1 and 2 will be automatically fixed as Input ports. The reason for this is because function port 1 (TXD) and 2 (RXD) share the same circuit path of TXD and RXD line.

必须使用 KPG-124D(C) 配置车载对讲机的 COM 端口 0 和 COM 端口 1。

设置为“数据”时，功能端口 1 和 2 会自动固定为输入端口。这是因为功能端口 1(TXD) 和 2(RXD) 与 TXD 和 RXD 线路共用同一条电路通道。

## DISASSEMBLY FOR REPAIR / 维修拆卸

### 1. Disassembly Procedure

1. When removing the cabinet, first remove the two screws from the right and left with a phillips screwdriver. Then, hook your finger on the edge of the cabinet and pull it out until it is over the chassis protrusion. Remove the cabinet by prying the cabinet as shown below.

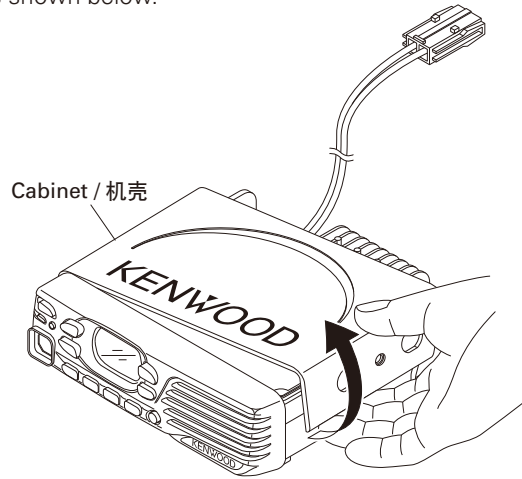

### 1. 拆卸步骤

1. 拆卸机壳时，应先用十字螺丝刀卸下左右两侧的两颗螺丝。然后，用手指勾住机壳边缘将其拉出，直至其位于底座突出部上方。如下图所示撬动机壳将其取下。

2. To remove the panel assembly, first turn the transceiver upside down. Then, insert a flat-head screwdriver into the holes of the chassis and tilt it in the direction as shown by the arrow.

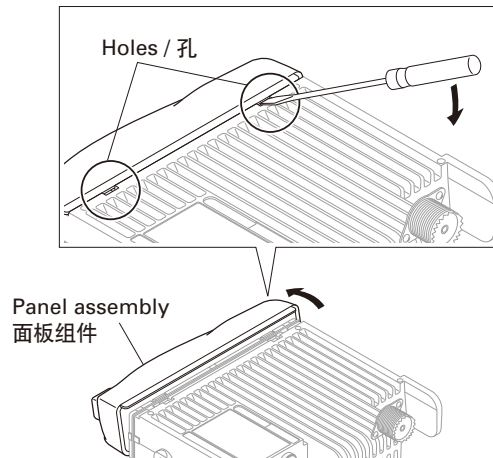

2. 要拆卸面板组件，应先将车载对讲机颠倒放置。然后，将平头螺丝刀插入底座的孔内，使其按箭头所示的方向倾斜。

3. Disconnect the flat cable from connector of the panel assembly.

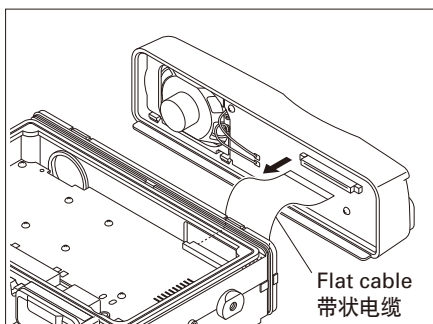

3. 从面板组件的连接器断开带状电缆。

## DISASSEMBLY FOR REPAIR / 维修拆卸

4. To remove the speaker holder, first remove the two screws from the display PCB using a phillips screwdriver. Then, insert a flat-head screwdriver under the tabs of the speaker holder and tilt it in the direction shown by the arrow. Remove the speaker from the front panel by turning it in the direction indicated, together with the speaker holder and display PCB.

4. 要拆下扬声器座，应先用十字螺丝刀拆下显示 PCB 的两颗螺丝。然后，将平头螺丝刀插到扬声器座的凸起下面，使其按箭头所示的方向倾斜。按所示方向转动扬声器，将其连同扬声器座和显示 PCB 一起从前面板上拆下。

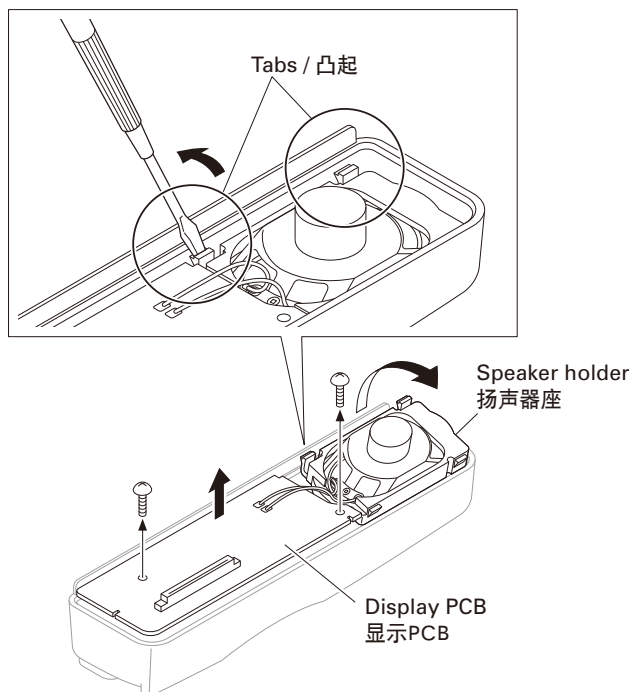

5. When removing the TX-RX PCB, first remove the top packing. Then, remove the 15 screws from the TX-RX PCB, power module, and audio amp. Remove the solder from the antenna hot pin, and the positive terminal of the DC cord.

5. 拆卸 TX-RX PCB 时，应先拆下顶盖。然后，除去天线热端和直流电源线的正极端子的焊锡。拆下 TX-RX PCB、功率模块和音频放大器上的 15 颗螺丝。

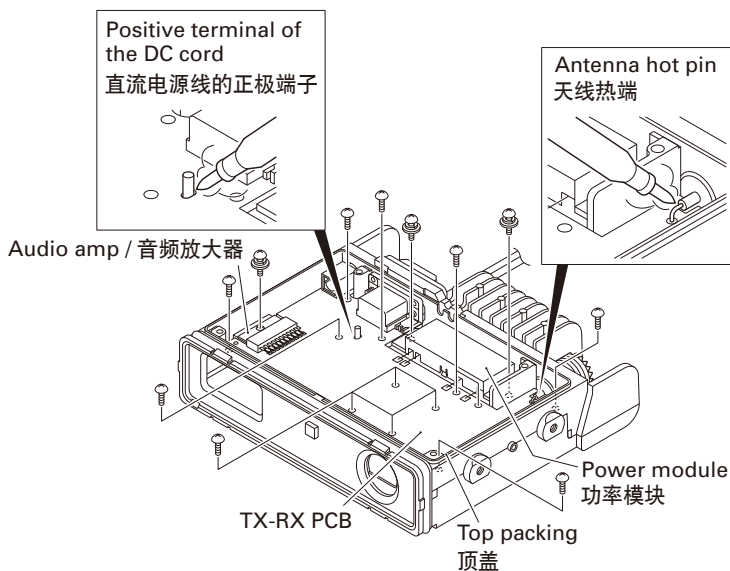

## DISASSEMBLY FOR REPAIR / 维修拆卸

### Note:

When you supply power to the TX-RX PCB after removing the TX-RX PCB from the chassis, solder the positive and ground terminals of the DC cord (Recommendation: E30-3448-25) to the + and GND terminals of the TX-RX PCB.

### 注意:

从底座上拆下 TX-RX PCB 之后对 TX-RX PCB 供电时，将直流电源线（推荐：E30-3448-25）的正极和接地端子焊接到 TX-RX PCB 的 + 和 GND 端子。

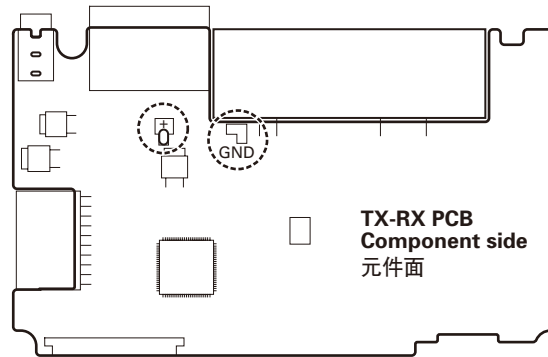

6. Pull it out behind the chassis by rotating the bush ③ of the DC cord 90 degrees in the direction of the arrow after the screw ① in the negative terminal is removed, and the positive terminal ② is removed from the chassis.

6. 拆下负极端子的螺丝①，并从底座上拆下正极端子②之后，将直流电源线的套管③以箭头方向旋转 90 度，将其拉出至底座后面。

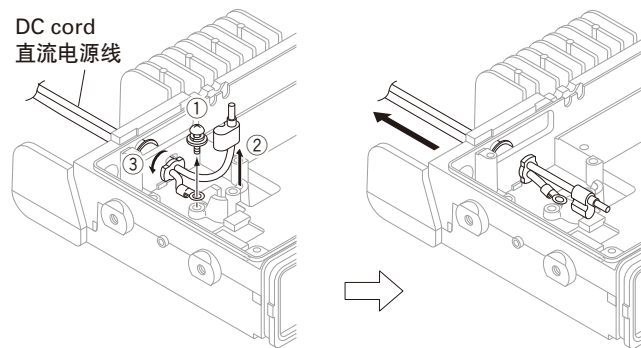

## 2. Precautions for Reassembly

1. When mounting the speaker holder, while suppressing the speaker rear part (shaded area), fix the four tabs of the speaker holder into the hollows of the front panel in order (①, ②, ③, and ④). Then, tighten the two screws of the display PCB.

## 2. 重新组装注意事项

1. 安装扬声器座时，在压住扬声器后部（阴影区域）的同时，按照①，②，③和④的顺序，将扬声器座的四个凸起依次装入前面板的凹槽。然后，旋紧显示 PCB 的两颗螺丝。

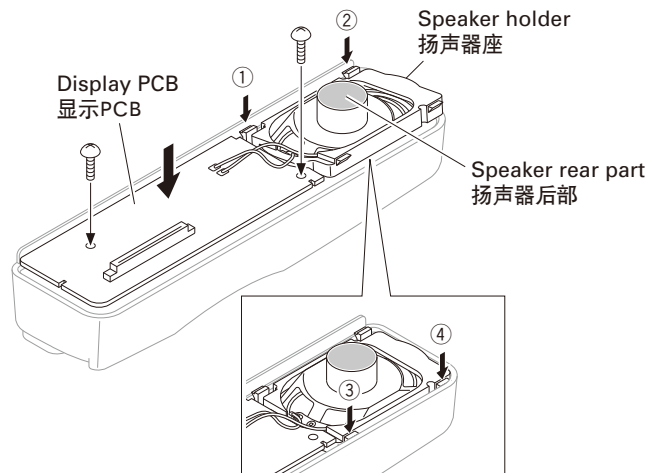

## DISASSEMBLY FOR REPAIR / 维修拆卸

2. When mounting the panel assembly, pass the flat cable through the hole of the chassis as shown below then connect the flat cable to connector of the panel assembly.

2. 安装面板组件时，如下图所示将带状电缆穿过底座的孔，然后将带状电缆连接到面板组件的连接器。

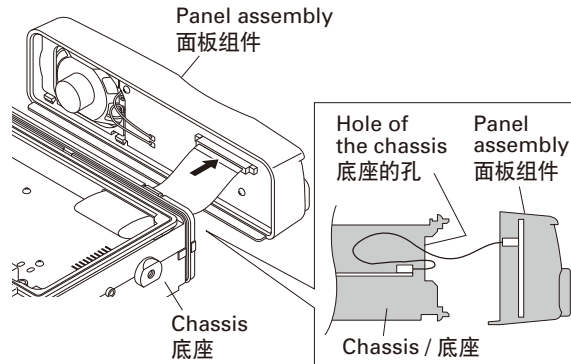

3. Fit the panel assembly into the two tabs of the chassis top side first. Then, fit the panel assembly into the two tabs of the chassis bottom side by turning the panel assembly.

3. 先将面板组件装配到底座顶侧的两个凸起内。然后，再通过转动面板组件，将面板组件装配到底座底侧的两个凸起内。

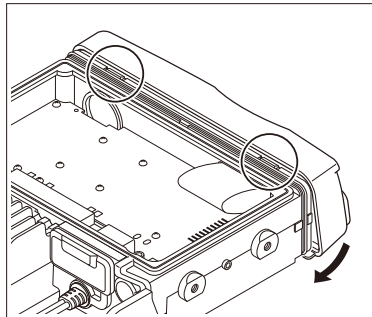

### 3. Correspondence when replacing the LED (B30-2321-05)

When replacing the LED (B30-2321-05), cut the leg of the LED to 4mm (0.16 inch) after installing the Collar (J31-0565-15).

### 3. 更换 LED(B30-2321-05) 时的相应操作

更换 LED(B30-2321-05) 时，安装套圈 (J31-0565-15) 后将 LED 的引线截到 4mm。

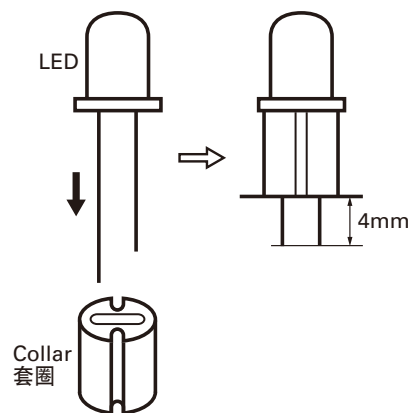



# CIRCUIT DESCRIPTION / 电路说明

## 1. Frequency Configuration

The receiver utilizes double conversion. The first IF is 38.85MHz and the second IF is 450kHz. The first local oscillator signal is supplied from the PLL circuit.

The PLL circuit in the transmitter generates the necessary frequencies. Figure 1 shows the frequencies.

## 1. 频率构成

接收机采用二次转换。第一中频为 38.85MHz，第二中频为 450kHz。第一本地振荡器信号由 PLL 电路提供。

发射机内的 PLL 电路生成必要的频率。图 1 显示了有关频率。

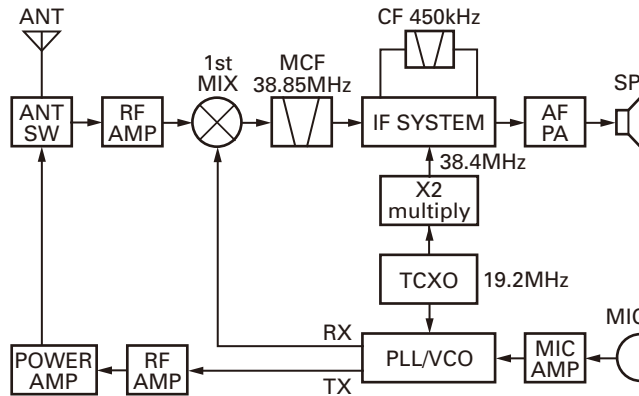

Fig. 1 Frequency configuration / 图 1 频率构成

## 2. Receiver System

The receiver is a double conversion superheterodyne. The frequency configuration is shown in Figure 1.

### 2-1. Front-end RF Amplifier

An incoming signal from the antenna is applied to an RF amplifier (Q506) after passing through the transmit/receive switch circuit (D302, D303, D304 and D305) and BPF (L517, L518 and varactor diodes: D509, D510).

After the signal is amplified (Q506), the signal is filtered by a BPF (L512 and varactor diodes: D508, D506) to eliminate unwanted signals before it is passed to the first mixer.

The voltage of these diodes are controlled by tracking the MCU (IC702) center frequency of the BPF. (See Figure 2)

## 2. 接收机系统

接收机为二次变频超外差方式。频率构成如图 1 所示。

### 2-1. 前端 RF 放大器

来自天线的信号在通过发射 / 接收切换电路 (D302、D303、D304 和 D305) 和 BPF (L517、L518 和 变容二极管 :D509、D510) 之后，被施加到 RF 放大器 (Q506)。

信号被放大之后 (Q506)，在通过第一混频器之前，由 BPF (L512 和变容二极管 :D506、D508) 进行滤波以消除不需要的信号。

通过对 BPF 的 MCU (IC702) 中心频率的跟踪，对这些二极管的电压加以控制。( 参看图 2)

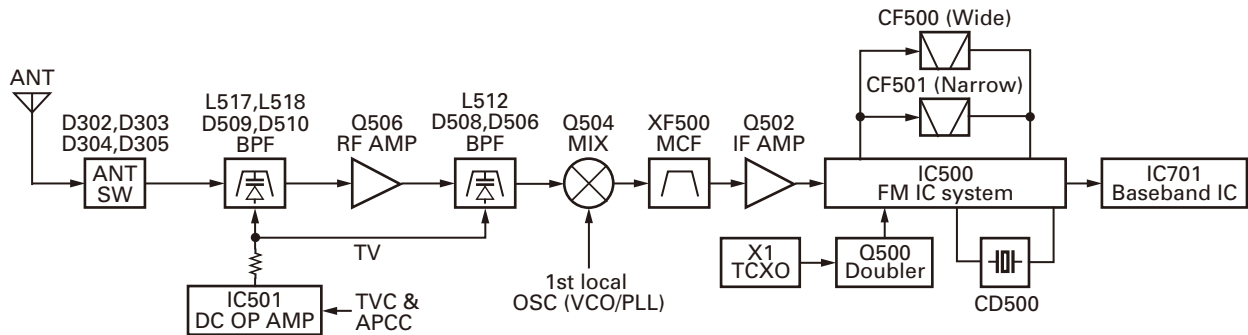

Fig. 2 Receiver System / 图 2 接收机系统

## CIRCUIT DESCRIPTION / 电路说明

## 2-2. First Mixer

The signal from the RF amplifier is heterodyned with the first local oscillator signal from the PLL frequency synthesizer circuit at the first mixer (Q504) to create a 38.85MHz first intermediate frequency (1st IF) signal. The first IF signal is then fed through one pair of monolithic crystal filters (MCF: XF500) to further remove spurious signals.

Item	Rating
Nominal center frequency	38.85MHz
Pass bandwidth	±6.0kHz or more at 3dB
40dB stop bandwidth	±25.0kHz or less
Ripple	1.0dB or less
Insertion loss	4.0dB or less
Guaranteed attenuation	75dB (-900kHz); 50dB (+900kHz)
	Spurious: 40dB or more within $f_o \pm 1\text{MHz}$
Terminal impedance	610Ω// 3.0pF// Coupling Cap 13.0pF

Table 1 Crystal filter (L71-0659-05): XF500

## 2-3. IF Amplifier Circuit

The first IF signal is amplified by Q502, and enters IC500 (FM processing IC). The signal is heterodyned again with a second local oscillator signal within IC500 to create a 450kHz second IF signal. The second IF signal is then fed through a 450kHz ceramic filter (Wide: CF500, Narrow: CF501) to further eliminate unwanted signals before it is amplified and demodulated by the quadrature detector with the ceramic discriminator (CD500).

Item	Rating
Nominal center frequency	450kHz
6dB bandwidth	±6.0kHz or more
50dB bandwidth	±12.5kHz or less
Ripple	2.0dB or less
Insertion loss	6.0dB or less
Guaranteed attenuation	35.0dB or more within $f_o \pm 100\text{kHz}$
Terminal impedance	2.0kΩ

Table 2 Ceramic filter (L72-0993-05): CF500

Item	Rating
Nominal center frequency	450kHz
6dB bandwidth	±4.5kHz or more
50dB bandwidth	±10.0kHz or less
Ripple	2.0dB or less
Insertion loss	6.0dB or less
Guaranteed attenuation	55.0dB or more within $f_o \pm 100\text{kHz}$
Terminal impedance	2.0kΩ

Table 3 Ceramic filter (L72-0959-05): CF501

## 2-2. 第一混频器

RF 放大器的信号与 PLL 频率合成器电路的第一本地振荡器信号在第一混频器 (Q504) 进行外差, 产生 38.85MHz 的第一中频 (1st IF) 信号。第一中频信号随后通过一对单片晶体滤波器 (MCF: XF500) 以进一步消除杂散信号。

项 目	额 定
标称中心频率	38.85MHz
通过带宽	3dB 时 ±6.0kHz 或更大
40dB 阻带宽度	±25.0kHz 或更小
纹波	1.0dB 或更小
插入损耗	4.0dB 或更小
保证衰减	75dB (-900kHz); 50dB (+900kHz)
	杂散: 40dB 或以上, $f_o \pm 1\text{MHz}$ 内
终端阻抗	610Ω // 3.0pF // 耦合电容 13.0pF

表 1 晶体滤波器 (L71-0659-05):XF500

## 2-3. IF 放大器电路

第一 IF 信号由 Q502 放大, 进入 IC500 (FM 处理 IC)。该信号再次与 IC500 内的第二本地振荡器信号进行外差, 产生 450kHz 的第二 IF 信号。第二 IF 信号随后被送到 450kHz 陶瓷滤波器 (宽: CF500, 窄: CF501) 以进一步消除不需要的信号, 然后再由带陶瓷鉴频器的积分检波器 (CD500) 进行放大和解调。

项 目	额 定
标称中心频率	450kHz
6dB 带宽	±6.0kHz 或更大
50dB 带宽	±12.5kHz 或更小
纹波	2.0dB 或更小
插入损耗	6.0dB 或更小
保证衰减	35.0dB 或更大, $f_o \pm 100\text{kHz}$ 内
终端阻抗	2.0kΩ

表 2 陶瓷滤波器 (L72-0993-05): CF500

项 目	额 定
标称中心频率	450kHz
6dB 带宽	±4.5kHz 或更大
50dB 带宽	±10.0kHz 或更小
纹波	2.0dB 或更小
插入损耗	6.0dB 或更小
保证衰减	55.0dB 或更大, $f_o \pm 100\text{kHz}$ 内
终端阻抗	2.0kΩ

表 3 陶瓷滤波器 (L72-0959-05): CF501

## CIRCUIT DESCRIPTION / 电路说明

### 2-4. Wide/Narrow Switching Circuit

The Wide port (pin 99) and Narrow port (pin 98) of the MCU is used to switch between ceramic filters. When the Wide port is high, the ceramic filter switch diodes (D500, D501) cause CF500 to turn on to receive a Wide signal.

When the Narrow port is high, the ceramic filter switch diodes (D500, D501) cause CF501 to turn on to receive a Narrow signal.

### 2-4. 宽 / 窄切换电路

MCU的宽端口（引脚99）和窄端口（引脚98）用于在陶瓷滤波器之间切换。宽端口高时，陶瓷滤波器切换二极管（D500、D501）使CF500打开，接收宽带信号。

窄端口高时，陶瓷滤波器切换二极管（D500、D501）使CF501打开，接收窄带信号。

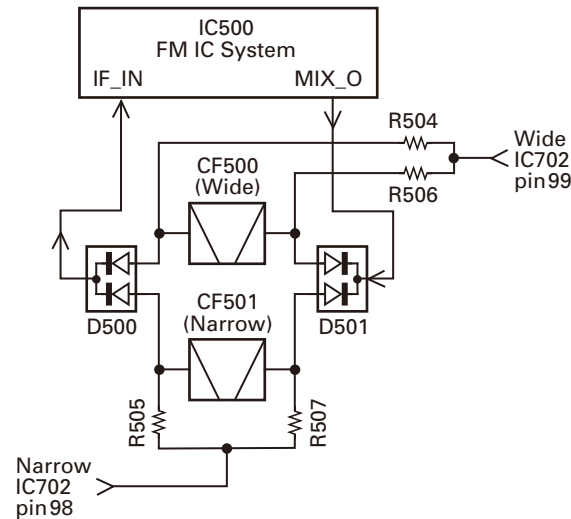

Fig. 3 Wide/Narrow switching circuit / 图3 宽 / 窄切换电路

### 2-5. AF Signal System

The detection signal from the FM IC (IC500) goes to the baseband IC (IC701) DISC input (pin 16) for characterizing the signal.

The AF signal output from IC701 is input to the audio power amplifier (IC705). The AF signal from IC705 switches between the internal speaker and the speaker jack (J701) output.

### 2-5. AF 信号系统

FM IC (IC500) 的检测信号进入基带 IC (IC701) DISC 输入（引脚 16）使信号特性化。

从 IC701 输出的 AF 信号被输入音频功率放大器 (IC705)。IC705 的 AF 信号在内置扬声器和扬声器插孔 (J701) 输出之间切换。

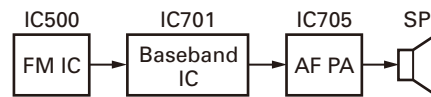

Fig. 4 AF signal system / 图4 AF 信号系统

### 2-6. Squelch Circuit

The detection output from the FM IC (IC500), a voltage is applied to the MCU (IC702). The MCU controls squelch according to the voltage (SQIN) level.

The signal from the RSSI pin of IC500 is monitored.

The electric field strength of the receive signal can be known before the SQIN voltage is input to the MCU, and the scan stop speed is improved.

### 2-6. 静噪电路

来自 FM IC (IC500) 的检测输出，对 MCU (IC702) 施加电压。MCU 根据电压 (SQIN) 电平控制静噪。

监测 IC500 的 RSSI 引脚的信号。

接收信号的电场强度在 SQIN 电压输入 MCU 之前可知，并提高扫描停止速度。

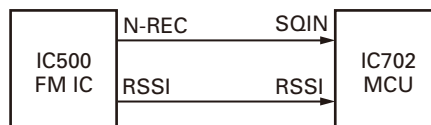

Fig. 5 Squelch circuit / 图5 静噪电路

## CIRCUIT DESCRIPTION / 电路说明

## 3. Transmitter System

## 3-1. Outline

The transmitter circuit produces and amplifies the desired frequency directly. It FM-modulates the carrier signal by means of a varicap diode.

## 3-2. Power Amplifier Circuit

The transmit output signal from the VCO passes through the transmission/reception selection diode (D719) and amplified by Q300. The amplified signal goes to the RF power module (IC301) through a low-pass filter. The low-pass filter removes unwanted high-frequency harmonic components, and the resulting signal goes through the antenna terminal.

## 3-3. APC Circuit

The automatic transmission power control (APC) circuit detects part of a final amplifier output with a coupler circuit and applies a voltage to IC300. IC300 compares the APC control voltage (PC) generated by the baseband IC (IC701) and DC amplifier (IC501) with the detection output voltage. IC300 generates the voltage to control IC301 and stabilizes transmission output.

The APC circuit is configured to protect over current of Q300 and IC301 due to fluctuations of the load at the antenna end and to stabilize transmission output at voltage and temperature variations.

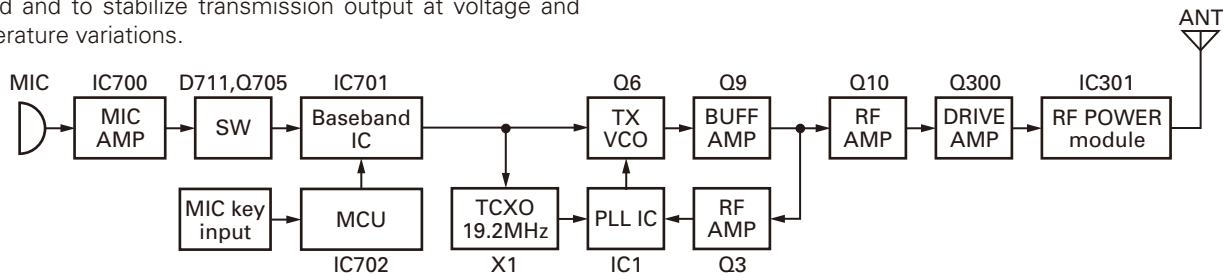

Fig. 6 Transmitter system / 图6 发射机系统

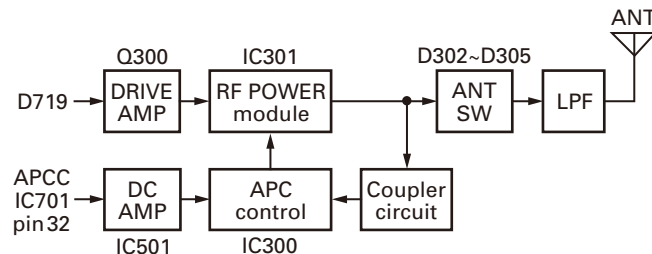

Fig. 7 APC circuit / 图7 APC 电路

## 4. PLL Frequency Synthesizer

The PLL circuit generates the first local oscillator signal for reception and the RF signal for transmission.

## 4-1. PLL Circuit

The frequency step of the PLL circuit is 10 or 12.5kHz.

A 19.2MHz reference oscillator signal is divided at IC1 by a fixed counter to produce the 10 or 12.5kHz reference frequency. The voltage controlled oscillator (VCO) output signal is buffer amplified by Q9, then multiplied by using a doubler and divided by a programmable counter in IC1.

## 3. 发射机系统

## 3-1. 概述

发射机电路直接产生和放大所需的频率。它借助变容二极管对载波信号进行 FM 调制。

## 3-2. 功率放大器电路

VCO 的发射输出信号通过发射 / 接收选择二极管 (D719), 由 Q300 进行放大。放大的信号经低通滤波器进入 RF 功率模块 (IC301)。低通滤波器可消除不必要的高频谱波成分, 产生的信号通过天线端子。

## 3-3. APC 电路

自动发射功率控制 (APC) 电路通过耦合电路检测末级放大器的部分输出, 并对 IC300 施加电压。IC300 将基带 IC (IC701) 和 DC 放大器 (IC501) 生成的 APC 控制电压 (PC) 与检测输出电压进行比较。IC300 生成控制 IC301 并稳定发射输出的电压。

配置 APC 电路是为了保护因天线端负载波动而引起的 Q300 和 IC301 过流, 以及在电压和温度变化时稳定发射输出。

## 4. PLL 频率合成器

PLL 电路生成用于接收的第一本地振荡器信号, 以及用于发射的 RF 信号。

## 4-1. PLL 电路

PLL 电路的频率步长为 10 或 12.5kHz。

19.2MHz 基准振荡器信号在 IC1 处由固定的计数器进行分频, 产生 10 或 12.5kHz 基准频率。压控振荡器 (VCO) 输出信号由 Q9 进行缓冲放大, 然后用倍频器增倍, 由 IC1 中的可编程计数器进行分频。

## CIRCUIT DESCRIPTION / 电路说明

The divided signal is compared in phase with the 10 or 12.5kHz reference signal in the phase comparator in IC1. The output signal from the phase comparator is filtered through a low-pass filter and passed to the VCO to control the oscillator frequency.

### 4-2. VCO Circuit

The operating frequency is generated by Q6 in transmit mode and Q4 in receive mode. The oscillator frequency is controlled by applying the VCO control voltage, obtained from the phase comparator to the varactor diodes (D4 and D14 in transmit mode and D5 and D13 in receive mode) and assist voltage to the (D6, D8 and D9 in transmit mode and D7, D10 and D11 in receive mode).

The TX/RX pin is set high in receive mode causing Q5 to turn off, and turn Q7 on. The TX/RX pin is set low in transmit mode. The outputs from Q4 and Q6 are amplified by Q9 and sent to the RF amplifiers.

分频的信号与 IC1 中的相位比较器内的 10 或 12.5kHz 基准信号进行相位对比。相位比较器的输出信号通过低通滤波器进行滤波，并通过 VCO 对振荡器频率进行控制。

### 4-2. VCO 电路

发射模式下，操作频率由 Q6 产生，接收模式下，操作频率由 Q4 产生。通过对变容二极管（发射模式下 D4 和 D14，接收模式下 D5 和 D13）施加从相位比较器获得的 VCO 控制电压，对（发射模式下 D6、D8 和 D9，接收模式下 D7、D10 和 D11）施加辅助电压，实现对振荡器频率的控制。

在接收模式下 TX/RX 引脚设为高，使 Q5 关闭，Q7 打开。在发射模式下，TX/RX 引脚设为低。Q4 和 Q6 的输出由 Q9 放大并发送到 RF 放大器。

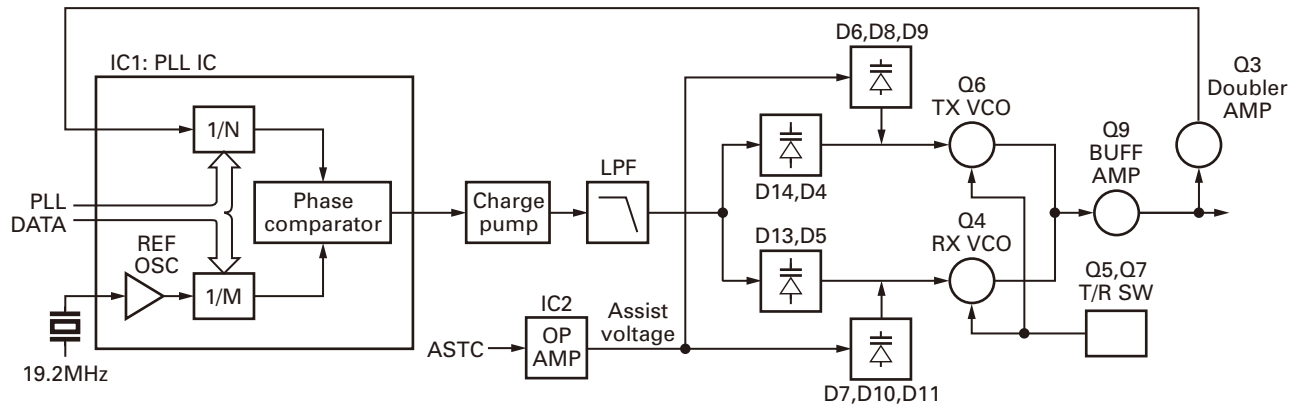

Fig. 8 PLL circuit / 图 8 PLL 电路

### 4-3. Unlock Circuit

During reception, the 9RC signal goes high, the 9TC signal goes low, and Q711 turns on. Q713 turns on and a voltage is applied to the collector (9R). During transmission, the 9RC signal goes low, the 9TC signal goes high and Q712 turns on. Q714 turns on and a voltage is applied to 9T.

The MCU in the control unit monitors the PLL (IC1) LD signal directly. When the PLL is unlocked during transmission, the PLL LD signal goes low. The MCU detects this signal and makes the 9TC signal low. When the 9TC signal goes low, no voltage is applied to 9T, and no signal is transmitted.

### 4-3. 失锁电路

接收期间，9RC 信号变高，9TC 信号变低，Q711 打开。Q713 打开并对集电极 (9R) 施加电压。发射期间，9RC 信号变低，9TC 信号变高，Q712 打开。Q714 打开并对 9T 施加电压。

控制单元的 MCU 直接监测 PLL (IC1) LD 信号。PLL 在发射期间失锁时，PLL LD 信号变低。MCU 检测该信号并使 9TC 信号变低。9TC 信号变低时，不对 9T 施加电压，不发射信号。

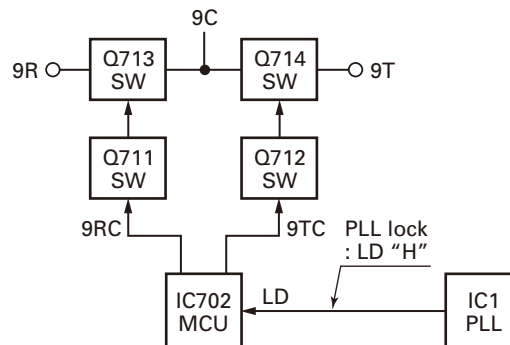

Fig. 9 Unlock circuit / 图 9 失锁电路

## CIRCUIT DESCRIPTION / 电路说明

### 5. Control Circuit

The MCU carries out the following tasks:

- 1) Controls the WIDE, NARROW, TX/RX outputs.
- 2) Controls the Baseband IC (IC701).
- 3) Controls the PLL (IC1).
- 4) Controls the display unit.

### 5. 控制电路

MCU 执行以下任务：

- 1) 控制 WIDE、NARROW、TX/RX 输出。
- 2) 控制基带 IC (IC701)。
- 3) 控制 PLL (IC1)。
- 4) 控制显示单元。

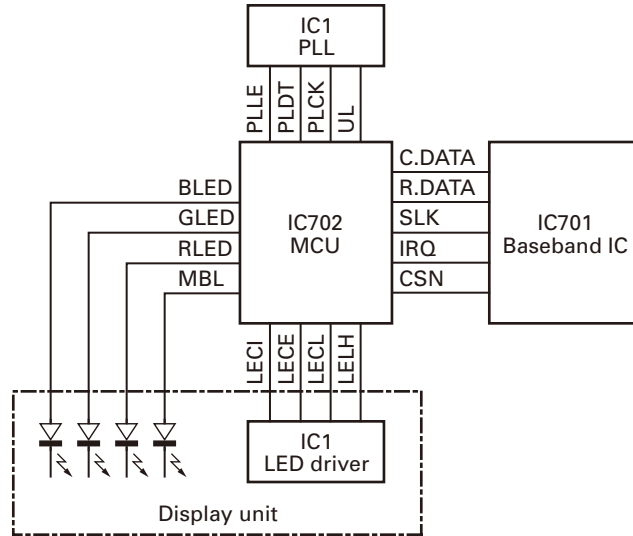

Fig. 10 Control circuit / 图 10 控制电路

### 5-1. Memory Circuit

The transceiver has a 256k-bit EEPROM (IC703). The EEPROM contains adjustment data. The MCU (IC702) controls the EEPROM through three serial data lines.

### 5-1. 存储电路

车载对讲机具有 256k-bit EEPROM (IC703)。EEPROM 含有调整数据。MCU (IC702) 通过三条串行数据线路控制 EEPROM。

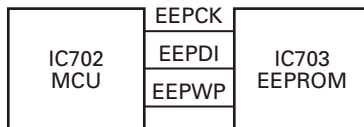

Fig. 11 Memory circuit / 图 11 存储电路

### 5-2. Display Circuit

The MCU (IC702) controls the 7-segment LED Display and LEDs.

When power is on, the MCU will use the MBL line to control the key backlight LEDs.

When the transceiver is busy, the GLED line goes high, Q1 turns on and the green LED (D23) lights after Q7 turns on. In transmit mode, the RLED line goes high, Q2 and Q8 turn on and the red LED (D23) lights.

BLED will be set high when the function select (FPU setting) is on, Q6 turns on and the blue LED (D22) lights.

The dimmer function is controlled by the switch (Q5). The LED driver (IC1) controls the functions of the 7-segment LED through the LEDI, LECE, LECL, LELH lines from the MCU.

### 5-2. 显示电路

MCU (IC702) 控制 7 段 LED 显示和 LED。

电源打开时，MCU 将使用 MBL 线路控制按键背光 LED。

车载对讲机繁忙时，GLED 线路变高，Q1 打开并且绿色 LED (D23) 在 Q7 打开后点亮。在发射模式中，RLED 线路变高，Q2 和 Q8 打开并且红色 LED (D23) 点亮。

功能选择 (FPU 设置) 开启时，BLED 将被设为高，Q6 打开并且蓝色 LED (D22) 点亮。

调光器功能由开关 (Q5) 控制。LED 驱动器 (IC1) 通过 MCU 的 LEDI、LECE、LECL、LELH 线路控制 7 段 LED 的功能。



## CIRCUIT DESCRIPTION / 电路说明

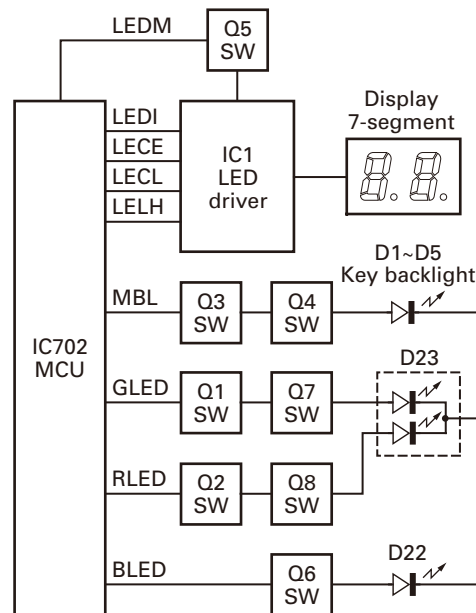

Fig. 12 Display circuit / 图 12 显示电路

## 5-3. Key Matrix Circuit

The front panel has function keys. Each of them is connected to a cross point of a matrix of the KMI1 to KMO3 ports of the MCU. The KMO1 to KMO3 ports are always high, while the KMI1 to KMI3 ports are always low.

The MCU monitors the status of the KMI1 to KMO3 ports. If the state of one of the ports changes, the MCU assumes that the key at the matrix point corresponding to that port has been pressed.

## 5-3. 键矩阵电路

前面板具有功能键。每个键均连接到 MCU 的 KMI1 至 KMO3 端口的矩阵的交叉点。KMO1 至 KMO3 端口始终为高，而 KMI1 至 KMI3 端口始终为低。

MCU 监测 KMI1 至 KMO3 端口的状态。如果某个端口的状态发生改变，则 MCU 认为与该端口对应的矩阵点的按键已经被按下。

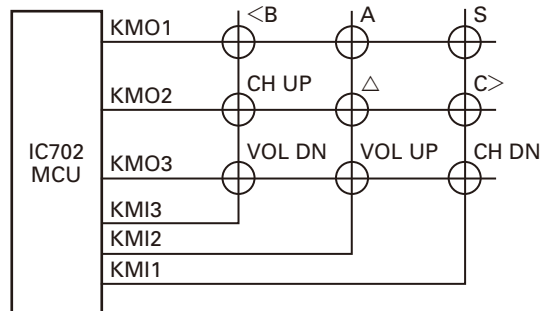

Fig. 13 Key matrix circuit / 图 13 键矩阵电路

## 6. Signaling Circuit

## 6-1. Encode

## ■ Low-speed data (QT, DQT)

Low-speed data is output from pin 1 (LSDO) of the MCU (IC702). The signal passes through a low-pass CR filter. The signal is mixed with the audio signal and goes to the VCO and TCXO (X1) modulation input after signal processing in the baseband IC (IC701).

## 6. 信令电路

## 6-1. 编码

## ■ 低速数据 (QT, DQT)

低速数据从 MCU (IC702) 的引脚 1 (LSDO) 输出。信号通过低通 CR 滤波器。此信号与音频信号混合，在基带 IC (IC701) 中进行信号处理之后，进入 VCO 和 TCXO (X1) 调制输入。

## CIRCUIT DESCRIPTION / 电路说明

### ■ High-speed data (2-tone)

High-speed data (HSD) is output from pin 2 (HSDO) of the MCU.

The signal passes through a low-pass CR filter. TX deviation making an adjustment by MCU is applied to the baseband IC (IC701). The signal is mixed with the audio signal and goes to the VCO and TCXO.

The RX tone is audio output of the baseband IC (IC701) at the same time to audio power amplifier and then to the speaker.

### ■ 高速数据 (2-音)

高速数据 (HSD) 从 MCU 的引脚 2 (HSDO) 输出。

信号通过低通 CR 滤波器。由 MCU 进行调整的 TX 频偏被施加上到基带 IC (IC701)。此信号与音频信号混合，然后送入 VCO 和 TCXO。

RX 音是基带 IC (IC701) 的音频输出，同时进入音频功率放大器，然后再进入扬声器。

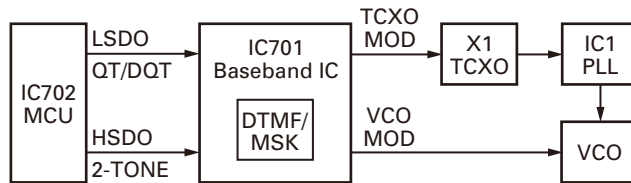

Fig. 14 Encode / 图 14 编码

### ■ MSK / DTMF

MSK and DTMF signal is self generated by the baseband IC (IC701).

The TX deviation adjustment is done by the output gain of the baseband IC (IC701), and is routed to the VCO. When encoding MSK/DTMF, the microphone-input signal is muted.

### ■ MSK/DTMF

MSK 和 DTMF 信号由基带 IC (IC701) 自身生成。

TX 频偏调整由基带 IC (IC701) 的输出增益完成，并被送入 VCO。编码 MSK/DTMF 时，麦克风输入信号被静音。

### 6-2. Decode

#### ■ Low-speed data (QT, DQT)

The demodulated signal from the FM IC (IC500) will input to the baseband IC (IC701) to remove frequencies of 300Hz or more.

The signal is input to pin 88 (LSDI) of the MCU. The MCU digitizes this signal, performs processing such as DC restoration, and decodes the signal.

#### 6-2. 解码

#### ■ 低速数据 (QT, DQT)

FM IC (IC500) 的解调信号将输入到基带 IC (IC701)，以消除 300Hz 或以上的频率。

信号被输入到 MCU 的引脚 88 (LSDI)。MCU 将该信号数字化，进行直流恢复等处理，然后对信号解码。

### ■ High-speed data (2-tone)

The demodulated signal from the FM IC (IC500) is amplified by the baseband IC and passes through a high-pass filter to remove frequencies of 3kHz or more. The MCU digitizes this signal and decodes the signal after receiving the signal at pin 87 (HSDI).

### ■ 高速数据 (2-音)

FM IC (IC500) 的解调信号由基带 IC 放大，并通过高通滤波器以消除 3kHz 或以上的频率。在引脚 87 (HSDI) 接收信号之后，MCU 将该信号数字化并对信号解码。

### ■ MSK / DTMF

The demodulated signal from the FM IC (IC500) will input to the baseband IC (IC701), then the baseband IC will decode and send the decoded information to the MCU by the data line.

The MCU then processes the decoded information.

### ■ MSK/DTMF

FM IC (IC500) 的解调信号将输入到基带 IC (IC701)，然后基带 IC 将进行解码，并由数据线路将解码的信息发送到 MCU。

MCU 随后对已解码信息进行处理。

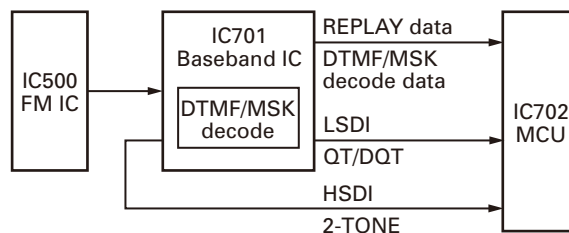

Fig. 15 Decode / 图 15 解码

## CIRCUIT DESCRIPTION / 电路说明

## 7. Power Supply Circuit

When the power switch on the display unit is pressed, the power port on the display unit which is connected to port 17 (POWER), goes low, then port 52 (SBC) goes high, Q719 turns on, SB switch (Q720) turns on and power (SB) is supplied to the transceiver.

When the DC power is supplied to the transceiver, voltage regulator IC (IC707, IC706) will supply into the MCU VDD and reset the voltage detect IC (IC709). IC709 will generate signal (RESET) into the reset terminal on the MCU (IC702) to carry out a power on reset. Also, MCU (IC702) is checking on port 91 (BATT). If DC power is less than about 8.5V, the transceiver is unable to power on.

When the DC power voltage decreases from normal voltage, the INT voltage detector IC (IC708) will set to high on MCU port 18 (INT). If B line becomes less than about 8.5V, MCU will send the backup data to EEPROM (IC703) and go into STOP mode.

This circuit has an overvoltage protection circuit. If a DC voltage of 16V or higher is applied to the base of Q710, this voltage turns Q710 on and sets port 18 (INT) to low. As a result port 78 (SBC) is low, and turns Q719 and Q720 (SB) off.

## 7. 电源电路

按显示单元上的电源开关时，与端口 17 (POWER) 相连的显示单元上的电源端口变低，随后端口 52 (SBC) 变高，Q719 打开，SB 开关 (Q720) 打开，并向车载对讲机提供电源 (SB)。

向车载对讲机提供 DC 电源时，稳压器 IC (IC707、IC706) 将提供到 MCU VDD 并使电压检测 IC (IC709) 复位。IC709 将在 MCU (IC702) 上的复位端子中生成信号 (RESET)，以执行上电复位。此外，MCU (IC702) 对端口 91 (BATT) 进行检查。如果 DC 电源小于约 8.5V，则车载对讲机无法打开电源。

DC 电源电压由正常电压下降时，MCU 端口 18 (INT) 上的 INT 电压检测器 IC (IC708) 将设为高。如果 B 线路变得小于约 8.5V，MCU 将会向 EEPROM (IC703) 发送备份数据并进入 STOP 模式。

此电路具有过电压保护电路。如果对 Q710 的基极施加 16V 或更高的电压，该电压将打开 Q710 并将端口 18 (INT) 设为低。从而使端口 78 (SBC) 较低，并关闭 Q719 和 Q720 (SB)。

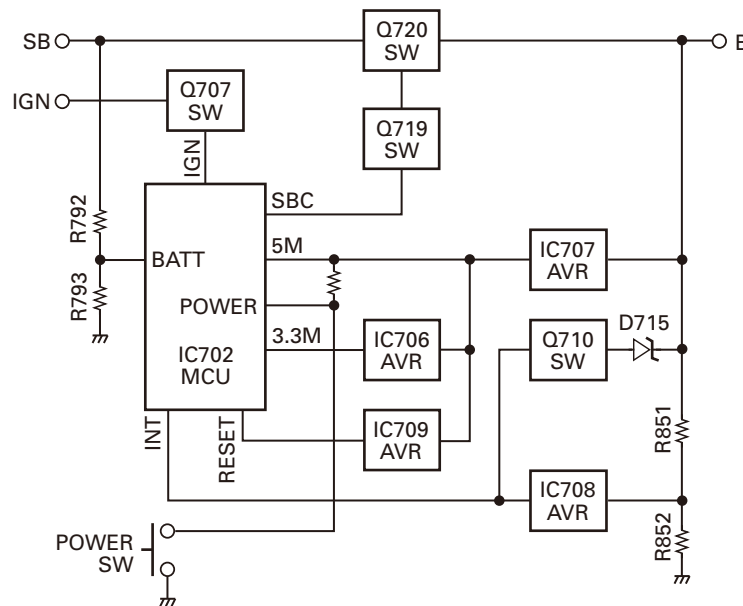

Fig. 16 Power supply circuit / 图 16 电源电路

## SEMICONDUCTOR DATA

## MCU: F364AEDFBKCUE (TX-RX unit IC702)

Pin No.	Name	I/O	Function
1	LSDO	O	QT/DQT output
2	HSDO	O	High speed data output
3	LEDO	O	LED data
4	LECE	O	LED enable
5	LECL	O	LED clock
6	E	-	GND (Only for bus control)
7	CNVSS	I	CNVss for emulator (Hi: boot mode)
8	LELH	O	LED latch
9	LERE	O	LED reset
10	RESET	I	Reset
11	XOUT	O	19.2MHz clock output
12	VSS	-	GND
13	XIN	I	19.2MHz clock input
14	VCC1	-	+5V
15	5CC	O	5C control
16	MKEY	I/O	Microphone key
17	POWKEY	I	Power key input
18	INT	I	MCU stop
19	ASTSW	O	Assist speed up switch
20	BEEP	O	Beep for side tone
21~26	FNC8~FNC3	I/O	Function P8~P3
27	FNC2	I/O	Function P2 / Open drain port
28	FNC1	I/O	Function P1 / Open drain port
29	ETXD	I/O	TXD for emulator
30	ERXD	I/O	RXD for emulator
31	ECLK	-	SCLK for emulator
32	EBSY	-	BUSY for emulator
33	TXD	I/O	To FPU
34	RXD	I/O	From FPU
35	HOOK	I	Hook
36	PTT	I	PTT
37	BSFT	O	Beat shift
38	LPOSW	O	Low power switch for reserve
39	EPM	-	EPM for emulator
40	PLLE	O	PLL enable
41	PLDT	O	PLL data
42	PLCK	O	PLL clock
43	PA	O	Public address (SP2 H: mute / L: unmute)
44	ECE	-	CE for emulator
45	CDATA	O	Command data for Baseband IC
46	RDATA	I	Reply data for Baseband IC
47	SCLK	O	Serial clock for Baseband IC
48	CSN1	O	Chip select for Baseband IC
49	SP MUTE	O	Speaker mute (SP1 H: mute / L: unmute)
50	9RC	O	9R control

Pin No.	Name	I/O	Function
51	9TC	O	9T control
52	SBC	O	SB control
53	3CC	O	3C control
54	PLPS	O	Sleep mode function for PLL IC
55	KSSW	O	Kenwood sound switch
56	AMP SW	O	AF AMP (L: enable / H: disable)
57	EEPWP	O	EEPROM write protect
58	EEPDT	I/O	EEPROM data
59	EEPCK	O	EEPROM clock
60	VCC2	-	+3.3V
61	SCRSW	O	Scrambler switch (Audio path)
62	VSS	-	GND
63	CSN2	O	CSN for Vocoder IC
64	TXRX	O	TX/RX (H: RX / L: TX)
65	LEDM	O	LED dimmer
66	MBL	O	Panel and microphone key backlight
67	NC	I	No connection
68	DST	I	Destination
69	REVP	I	Reverse power
70	FWDP	I	Forward power
71	IRQ2	I	Interrupt request for Vocoder IC
72	IGN	I	Ignition
73	IRQ1	I	Interrupt request for Baseband IC
74	RLED	O	Red LED for TX
75	GLLED	O	Green LED for busy
76	BLED	O	Blue LED for reserve
77~79	KM01~KM03	O	Key matrix output 1~3
80~82	KMI1~KMI3	I	Key matrix input 1~3
83	UL	I	PLL unlock detect
84	AF MUTE	O	AF mute
85	MIC1MUTE	O	Internal microphone mute
86	MIC2 MUTE	O	External microphone mute
87	HSDI	I	High speed data input
88	LSDI	I	Low speed data input: QT/DQT/ (LTR)
89	TEMP2	I	Temperature 2
90	TEMP1	I	Temperature 1
91	BATT	I	Battery voltage
92	RSSI	I	RSSI input
93	SQIN	I	Squelch input
94	AVSS	-	GND
95	CV	I	VCO lock voltage
96	VREF	-	+5V
97	AVCC	-	+5V
98	NARROW	O	Wide/Narrow (Hi: Narrow)
99	WIDE	O	Wide/Narrow (Hi: Wide)
100	HORN	O	Horn alert

## 半导体数据

## MCU: F364AEDFBKCUE(TX-RX 单元 IC702)

管脚号	端口名称	输入/输出	功 能
1	LSDO	输出	QT/DQT 输出
2	HSDO	输出	高速数据输出
3	LEDO	输出	LED 数据
4	LECE	输出	LED 启用
5	LECL	输出	LED 时钟
6	E	-	GND(仅限于总线控制)
7	CNVSS	输入	仿真器的 CNVss(Hi: 引导模式)
8	LELH	输出	LED 闭锁
9	LERE	输出	LED 复位
10	RESET	输入	复位
11	XOUT	输出	19.2MHz 时钟输出
12	VSS	-	GND
13	XIN	输入	19.2MHz 时钟输入
14	VCC1	-	+5V
15	5CC	输出	5C 控制
16	MKEY	输入/输出	麦克风键
17	POWKEY	输入	电源键输入
18	INT	输入	MCU 停止
19	ASTSW	输出	辅助加速开关
20	BEEP	输出	侧音的提示音
21~26	FNC8~FNC3	输入/输出	功能 P8~P3
27	FNC2	输入/输出	功能 P2/ 开漏端口
28	FNC1	输入/输出	功能 P1/ 开漏端口
29	ETXD	输入/输出	仿真器的 TXD
30	ERXD	输入/输出	仿真器的 RXD
31	ECLK	-	仿真器的 SCLK
32	EBSY	-	仿真器的 BUSY
33	TXD	输入/输出	到 FPU
34	RXD	输入/输出	来自 FPU
35	HOOK	输入	挂钩
36	PTT	输入	PTT
37	BSFT	输出	拍频偏移
38	LPOSW	输出	预留的低功率开关
39	EPM	-	仿真器的 EPM
40	PLLE	输出	PLL 启用
41	PLDT	输出	PLL 数据
42	PLCK	输出	PLL 时钟
43	PA	输出	扩音 (SP2 H: 静音 /L: 不静音)
44	ECE	-	仿真器的 CE
45	CDATA	输出	基带 IC 的命令数据
46	RDATA	输入	基带 IC 的回复数据
47	SCLK	输出	基带 IC 的串行时钟
48	CSN1	输出	基带 IC 的芯片选择
49	SP MUTE	输出	扬声器静音 (SP1 H: 静音 /L: 不静音)
50	9RC	输出	9R 控制

管脚号	端口名称	输入/输出	功 能
51	9TC	输出	9T 控制
52	SBC	输出	SB 控制
53	3CC	输出	3C 控制
54	PLPS	输出	PLL IC 的休眠模式功能
55	KSSW	输出	Kenwood 声音开关
56	AMP SW	输出	AF AMP(L: 启用 /H: 禁用)
57	EEPWP	输出	EEPROM 写保护
58	EEPDT	输入/输出	EEPROM 数据
59	EEPCK	输出	EEPROM 时钟
60	VCC2	-	+3.3V
61	SCRSW	输出	扰频器开关 (音频通道)
62	VSS	-	GND
63	CSN2	输出	Vocoder IC 的 CSN
64	TXRX	输出	TX/RX(H: RX/L: TX)
65	LEDM	输出	LED 调光器
66	MBL	输出	面板和麦克风键背光
67	NC	输入	未连接
68	DST	输入	类型选择
69	REVP	输入	反向功率
70	FWDP	输入	前向功率
71	IRQ2	输入	Vocoder IC 的中断请求
72	IGN	输入	点火
73	IRQ1	输入	基带 IC 的中断请求
74	RLED	输出	TX 的红色 LED
75	GLLED	输出	用于繁忙的绿色 LED
76	BLED	输出	预留的蓝色 LED
77~79	KM01~KM03	输出	键矩阵输出 1~3
80~82	KMI1~KMI3	输入	键矩阵输入 1~3
83	UL	输入	PLL 失锁检测
84	AF MUTE	输出	AF 静音
85	MIC1MUTE	输出	内部麦克风静音
86	MIC2 MUTE	输出	外部麦克风静音
87	HSDI	输入	高速数据输入
88	LSDI	输入	低速数据输入: QT/DQT/(LTR)
89	TEMP2	输入	温度 2
90	TEMP1	输入	温度 1
91	BATT	输入	电池电压
92	RSSI	输入	RSSI 输入
93	SQIN	输入	静噪输入
94	AVSS	-	GND
95	CV	输入	VCO 锁定电压
96	VREF	-	+5V
97	AVCC	-	+5V
98	NARROW	输出	宽 / 窄 (Hi: 窄)
99	WIDE	输出	宽 / 窄 (Hi: 宽)
100	HORN	输出	喇叭提示

## COMPONENTS DESCRIPTION

## Display unit (X54-3670-20)

Ref. No.	Part Name	Description
IC1	IC	LED driver
Q1,2	Transistor	TX/BUSY indication LED switch
Q3,4	Transistor	KEY backlight control switch
Q5,9	Transistor	LED dimmer control switch
Q6	Transistor	Indication LED switch
Q7,8	Transistor	TX/BUSY indication LED switch
D1~5	LED	KEY backlight
D20	Diode	Voltage protection
D22	LED	Indication
D23	LED	TX/BUSY indication
D33	Zener diode	Surge protection
D37	LED	LED display

## TX-RX unit (X57-7683-01)

Ref. No.	Part Name	Description
IC1	IC	PLL IC
IC2	IC	Assist filter
IC300	IC	DC AMP (APC)
IC301	IC	Power module
IC500	IC	FM IC
IC501	IC	RF BPF tuning voltage DC AMP
IC700	IC	MIC/MOD AMP
IC701	IC	Baseband IC
IC702	IC	MCU
IC703	IC	EEPROM
IC704	IC	Voltage regulator (9V)
IC705	IC	AF AMP
IC706,710	IC	Voltage regulator (3.3V)
IC707	IC	Voltage regulator (5V)
IC708	IC	Voltage detection (INT)
IC709	IC	Voltage detection (MCU reset)
Q3	Transistor	PLL Fin AMP
Q4	FET	RX VCO
Q5	FET	TX/RX VCO switch
Q6	FET	TX VCO
Q7	Transistor	TX/RX VCO switch
Q8	Transistor	Ripple filter
Q9,10	Transistor	VCO buffer AMP
Q11,12	FET	Assist filter control switch
Q300	Transistor	TX drive AMP
Q500	Transistor	RX 2nd local doubler AMP
Q501	Transistor	Discriminator control switch
Q502	Transistor	IF AMP
Q504	FET	RX 1st mixer
Q506	FET	Front-end LNA
Q507	Transistor	Discriminator control switch
Q510	Transistor	Squelch input control switch

Ref. No.	Part Name	Description
Q511	Transistor	Squelch input switch
Q701	FET	MIC mute switch
Q702	Transistor	MIC mute switch
Q703	Transistor	DET AMP LPF (D-SUB)
Q704	FET	TX/RX switch
Q705	FET	Scrambler switch
Q707	Transistor	Ignition sense control switch
Q710	Transistor	Over voltage detect switch
Q711	Transistor	9R control switch
Q712	Transistor	9T control switch
Q713	Transistor	9R switch
Q714	Transistor	9T switch
Q715,723	FET	SP mute switch
Q717	FET	5C control switch
Q718	FET	3.3C control switch
Q719	Transistor	SB control switch
Q720	FET	SB switch
Q721	Transistor	AF AMP switch
Q722	Transistor	Over voltage detect switch
Q724	FET	Horn alert switch
Q725	Transistor	Horn alert control switch
Q728	Transistor	RS-232C RXD control
Q729	Transistor	PLL IC clock AMP
Q730	Transistor	Baseband IC clock AMP
Q731,732	Transistor	MCU clock AMP
Q733	Transistor	TX/RX Fin filter control
D1	Diode	PLL unlock detection
D4,5,13,14	Variable capacitance diode	Frequency control (TX/RX VCO)
D6~11	Variable capacitance diode	Frequency control (TX/RX VCO)
D12	Variable capacitance diode	Modulation control (TX VCO)
D15~17	Diode	TX/RX Fin filter switch
D300	Zener diode	Voltage protection
D301	Diode	TX power control
D302~305	Diode	ANT switch
D310,311	Zener diode	Voltage protection
D312	Diode	Reverse power rectifier
D313,314	Diode	Power rectifier
D500,501	Diode	W/N CF switch
D506, D508~510	Variable capacitance diode	RF BPF tuning
D700~710	Diode	Surge protection
D711,712	Diode	MIC AMP AGC detection
D715	Zener diode	Voltage protection
D717	Surge absorber	Voltage protection
D718	Diode	Voltage protection
D719,720	Diode	TX/RX band switch



## 元件说明

## 显示单元 (X54-3670-20)

有关号码	零件名称	说明
IC1	IC	LED 驱动器
Q1, 2	晶体管	TX/BUSY 指示 LED 开关
Q3, 4	晶体管	KEY 背光控制开关
Q5, 9	晶体管	LED 调光器控制开关
Q6	晶体管	指示 LED 开关
Q7, 8	晶体管	TX/BUSY 指示 LED 开关
D1~5	LED	KEY 背光
D20	二极管	电压保护
D22	LED	指示
D23	LED	TX/BUSY 指示
D33	稳压二极管	电涌保护
D37	LED	LED 显示

## TX-RX 单元 (X57-7683-01)

有关号码	零件名称	说明
IC1	IC	PLL IC
IC2	IC	辅助滤波器
IC300	IC	直流放大器 (APC)
IC301	IC	功率模块
IC500	IC	FM IC
IC501	IC	RF BPF 调谐电压直流放大器
IC700	IC	MIC/MOD 放大器
IC701	IC	基带 IC
IC702	IC	MCU
IC703	IC	EEPROM
IC704	IC	稳压器 (9V)
IC705	IC	AF 放大器
IC706, 710	IC	稳压器 (3.3V)
IC707	IC	稳压器 (5V)
IC708	IC	电压检测 (INT)
IC709	IC	电压检测 (MCU 复位)
Q3	晶体管	PLL Fin 放大器
Q4	场效应管	RX VCO
Q5	场效应管	TX/RX VCO 开关
Q6	场效应管	TX VCO
Q7	晶体管	TX/RX VCO 开关
Q8	晶体管	纹波滤波器
Q9, 10	晶体管	VCO 缓冲放大器
Q11, 12	场效应管	辅助滤波器控制开关
Q300	晶体管	TX 驱动放大器
Q500	晶体管	RX 第 2 本振倍频放大器
Q501	晶体管	鉴频器控制开关
Q502	晶体管	IF 放大器
Q504	场效应管	RX 第 1 混频器
Q506	场效应管	前端 LNA
Q507	晶体管	鉴频器控制开关
Q510	晶体管	静噪输入控制开关

有关号码	零件名称	说明
Q511	晶体管	静噪输入开关
Q701	场效应管	MIC 静音开关
Q702	晶体管	MIC 静音开关
Q703	晶体管	DET 放大器 LPF(D-SUB)
Q704	场效应管	TX/RX 开关
Q705	场效应管	扰频器开关
Q707	晶体管	点火感应控制开关
Q710	晶体管	过电压检测开关
Q711	晶体管	9R 控制开关
Q712	晶体管	9T 控制开关
Q713	晶体管	9R 开关
Q714	晶体管	9T 开关
Q715, 723	场效应管	SP 静音开关
Q717	场效应管	5C 控制开关
Q718	场效应管	3.3C 控制开关
Q719	晶体管	SB 控制开关
Q720	场效应管	SB 开关
Q721	晶体管	AF 放大器开关
Q722	晶体管	过电压检测开关
Q724	场效应管	喇叭提示开关
Q725	晶体管	喇叭提示控制开关
Q728	晶体管	RS-232C RXD 控制
Q729	晶体管	PLL IC 时钟放大器
Q730	晶体管	基带 IC 时钟放大器
Q731, 732	晶体管	MCU 时钟放大器
Q733	晶体管	TX/RX Fin 滤波器控制
D1	二极管	PLL 失锁检测
D4, 5, D13, 14	可变电容二极管	频率控制 (TX/RX VCO)
D6~11	可变电容二极管	频率控制 (TX/RX VCO)
D12	可变电容二极管	调制控制 (TX VCO)
D15~17	二极管	TX/RX Fin 滤波器开关
D300	稳压二极管	电压保护
D301	二极管	TX 功率控制
D302~305	二极管	天线开关
D310, 311	稳压二极管	电压保护
D312	二极管	反向功率整流器
D313, 314	二极管	功率整流器
D500, 501	二极管	宽 / 窄陶瓷滤波器开关
D506, D508~510	可变电容二极管	RF BPF 调谐
D700~710	二极管	电涌保护
D711, 712	二极管	MIC 放大器 AGC 检测
D715	稳压二极管	电压检测
D717	电涌吸收	电压检测
D718	二极管	电压检测
D719, 720	二极管	TX/RX 波段开关

## PARTS LIST / 零件表

### CAPACITORS

$\frac{C}{1} \frac{C}{2} \frac{45}{3} \frac{TH}{4} \frac{1H}{5} \frac{220}{6} \frac{J}{6}$

- 1 = Type ... ceramic, electrolytic, etc.
- 2 = Shape ... round, square, etc.
- 3 = Temp. coefficient
- 4 = Voltage rating
- 5 = Value
- 6 = Tolerance

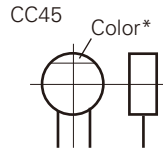

#### • Capacitor value

- 010 = 1pF
- 100 = 10pF
- 101 = 100pF
- 102 = 1000pF = 0.001μF
- 103 = 0.01μF

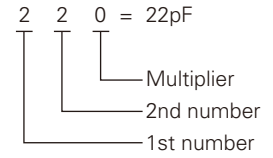

#### • Temperature coefficient

1st Word	C	L	P	R	S	T	U
Color*	Black	Red	Orange	Yellow	Green	Blue	Violet
ppm/°C	0	-80	-150	-220	-330	-470	-750

2nd Word	G	H	J	K	L
ppm/°C	±30	±60	±120	±250	±500

Example : CC45TH = -470±60ppm/°C

#### • Tolerance (More than 10pF)

Code	C	D	G	J	K	M	X	Z	P	No code
(%)	±0.25	±0.5	±2	±5	±10	±20	+40 -20	+80 -20	+100 -0	More than 10μF : -10~+50 Less than 4.7μF : -10~+75

#### (Less than 10pF)

Code	B	C	D	F	G
(pF)	±0.1	±0.25	±0.5	±1	±2

#### • Voltage rating

2nd word \ 1st word	A	B	C	D	E	F	G	H	J	K	V
0	1.0	1.25	1.6	2.0	2.5	3.15	4.0	5.0	6.3	8.0	-
1	10	12.5	16	20	25	31.5	40	50	63	80	35
2	100	125	160	200	250	315	400	500	630	800	-
3	1000	1250	1600	2000	2500	2150	4000	5000	6300	8000	-

#### • Chip capacitors

- (EX)  $\frac{C}{1} \frac{C}{2} \frac{73}{3} \frac{F}{4} \frac{SL}{5} \frac{1H}{6} \frac{000}{7} \frac{J}{7}$  → Refer to the table above.
- 1 = Type
  - 2 = Shape
  - 3 = Dimension
  - 4 = Temp. coefficient
  - 5 = Voltage rating
  - 6 = Value
  - 7 = Tolerance
- (Chip) (CH, RH, UJ, SL)
- (EX)  $\frac{C}{1} \frac{K}{2} \frac{73}{3} \frac{F}{4} \frac{F}{5} \frac{1H}{6} \frac{000}{7} \frac{Z}{7}$
- (Chip) (B, F)

#### • Dimension

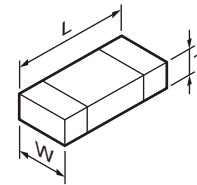

#### Chip capacitor

Code	L	W	T
Empty	5.6±0.5	5.0±0.5	Less than 2.0
A	4.5±0.5	3.2±0.4	Less than 2.0
B	4.5±0.5	2.0±0.3	Less than 2.0
C	4.5±0.5	1.25±0.2	Less than 1.25
D	3.2±0.4	2.5±0.3	Less than 1.5
E	3.2±0.2	1.6±0.2	Less than 1.25
F	2.0±0.3	1.25±0.2	Less than 1.25
G	1.6±0.2	0.8±0.2	Less than 1.0
H	1.0±0.05	0.5±0.05	0.5±0.05

#### Chip resistor

Code	L	W	T
E	3.2±0.2	1.6±0.2	1.0
F	2.0±0.3	1.25±0.2	1.0
G	1.6±0.2	0.8±0.2	0.5±0.1
H	1.0±0.05	0.5±0.05	0.35±0.05

#### • Rating wattage

Code	Wattage	Code	Wattage	Code	Wattage
1J	1/16W	2C	1/6W	3A	1W
2A	1/10W	2E	1/4W	3D	2W
2B	1/8W	2H	1/2W		

### RESISTORS

#### • Chip resistor (Carbon)

- (EX)  $\frac{R}{1} \frac{D}{2} \frac{73}{3} \frac{E}{4} \frac{B}{5} \frac{2B}{6} \frac{000}{7} \frac{J}{7}$
- (Chip) (B, F)

#### • Carbon resistor (Normal type)

- (EX)  $\frac{R}{1} \frac{D}{2} \frac{14}{3} \frac{B}{4} \frac{B}{5} \frac{2C}{6} \frac{000}{7} \frac{J}{7}$

- 1 = Type
- 2 = Shape
- 3 = Dimension
- 4 = Temp. coefficient
- 5 = Rating wattage
- 6 = Value
- 7 = Tolerance

## PARTS LIST / 零件表

\* New Parts. Δ indicates safety critical components.  
 Parts without **Parts No.** are not supplied.  
 Les articles non mentionnés dans le **Parts No.** ne sont pas fournis.  
 Teile ohne **Parts No.** werden nicht geliefert.

**L** : Scandinavia      **K** : USA      **P** : Canada  
**Y** : PX (Far East, Hawaii)      **T** : England      **E** : Europe  
**C** : China      **X** : Australia      **M** : Other Areas

**TK-7302**  
**DISPLAY UNIT (X54-3670-20)**  
**TX-RX UNIT (X57-7683-01)**

Ref. No.	Address	New parts	Parts No.	Description	Destination
<b>TK-7302</b>					
1	1B		A02-4073-21	PLASTIC CABINET	
2	3A		A62-1171-03	PANEL ASSY	
4	2B		B09-0732-03	CAP (D-SUB)	
5	3A		B10-2794-03	FRONT GLASS	
6	3A		B43-1629-04	BADGE	
7	2D	*	B62-2168-10	INSTRUCTION MANUAL	
8	2B		E04-0167-15	RF COAXIAL RECEPTACLE (M)	
9	2A		E23-1344-04	GROUND TERMINAL (AF AMP)	
10	1C		E30-3339-15	DC CORD      ACCESSORY	
11	2B	*	E30-7686-05	DC CORD	
12	2A		E37-1461-05	FLAT CABLE (30P PANEL)	
14	2B		F51-0078-05	FUSE (6X30)	
16	2B		G53-1643-04	PACKING (DC CORD)	
17	2B		G53-1662-04	PACKING (RECEPTACLE)	
18	1B		G53-1819-21	PACKING (CHASSIS)	
19	3A		G53-1820-03	PACKING (PANEL)	
25	3B		J19-5528-03	HOLDER (SPEAKER)	
26	1C		J29-0726-03	BRACKET      ACCESSORY	
28	3A		K29-9448-01	KEY TOP	
A	1A,1B		N35-2604-43	BINDING HEAD MACHINE SCREW	
B	1A,2A,2B		N67-3008-48	PAN HEAD SEMS SCREW	
C	3A,3B		N80-2008-48	PAN HEAD TAPTITE SCREW	
D	2A,2B		N87-2608-48	BRAZIER HEAD TAPTITE SCREW	
30	3D		N99-2039-05	SCREW SET      ACCESSORY	
32	3A		T07-0785-15	SPEAKER	
<b>DISPLAY UNIT (X54-3670-20)</b>					
D1-5			B30-2282-05	LED (Y)	
D22	3A		B30-2321-05	LED (BLUE LED)	
D23	3A		B30-2151-05	LED (RED/GREEN)	
C1			CK73HB1E103K	CHIP C      0.010UF      K	
C8			CC73HCH1H101J	CHIP C      100PF      J	
C9			CK73HB1H102K	CHIP C      1000PF      K	
C10			CK73HB1E103K	CHIP C      0.010UF      K	
C16			CK73HB1E103K	CHIP C      0.010UF      K	
C27			CC73HCH1H101J	CHIP C      100PF      J	
C29-36			CK73HB1H102K	CHIP C      1000PF      K	
C38,39			CC73HCH1H101J	CHIP C      100PF      J	
C40			CK73HB1H102K	CHIP C      1000PF      K	
C41,42			CC73HCH1H101J	CHIP C      100PF      J	
C43-46			CK73HB1H471K	CHIP C      470PF      K	
C47			CK73HB1H102K	CHIP C      1000PF      K	
CN1			E40-6851-05	FLAT CABLE CONNECTOR	
CN2			E23-1262-05	TERMINAL	
J1	3A		E58-0535-05	MODULAR JACK	
101	3A		J31-0565-15	COLLAR	
L1			L92-0138-05	CHIP FERRITE	

Ref. No.	Address	New parts	Parts No.	Description	Destination
CP1			RK74HB1J102J	CHIP-COM 1.0K      J      1/16W	
R1			RK73HB1J101J	CHIP R      100      J      1/16W	
R2			RK73FB2B100J	CHIP R      10      J      1/8W	
R3-8			RK73HB1J102J	CHIP R      1.0K      J      1/16W	
R10,11			RK73HB1J102J	CHIP R      1.0K      J      1/16W	
R12			RK73HB1J122J	CHIP R      1.2K      J      1/16W	
R21			RK73HB1J222J	CHIP R      2.2K      J      1/16W	
R22			RK73HB1J820J	CHIP R      82      J      1/16W	
R23			RK73HB1J121J	CHIP R      120      J      1/16W	
R26,27			RK73HB1J000J	CHIP R      0.0      J      1/16W	
R28,29			RK73HB1J103J	CHIP R      10K      J      1/16W	
R34			RK73HB1J102J	CHIP R      1.0K      J      1/16W	
R35			RK73HB1J223J	CHIP R      22K      J      1/16W	
R36			RK73HB1J822J	CHIP R      8.2K      J      1/16W	
R37,38			RK73HB1J100J	CHIP R      10      J      1/16W	
R39			RK73HB1J150J	CHIP R      15      J      1/16W	
R40			RK73HB1J100J	CHIP R      10      J      1/16W	
R41			RK73HB1J222J	CHIP R      2.2K      J      1/16W	
R42			RK73HB1J102J	CHIP R      1.0K      J      1/16W	
D20			DA221	DIODE	
D33			02DZ6.2F-Y	ZENER DIODE	
D37	3A		HDSP-521A	LED	
IC1			TCA62746AFNAG	MOS-IC	
Q1,2			RT1N441U-T111	TRANSISTOR	
Q3			KRA225S	DIGITAL TRANSISTOR	
Q4			KRC102S-P	DIGITAL TRANSISTOR	
Q5,6			2SC3928A	TRANSISTOR	
Q7,8			RT1P141U-T111	TRANSISTOR	
Q9			2SC3928A	TRANSISTOR	
<b>TX-RX UNIT (X57-7683-01)</b>					
C2			CC73HCH1H101J	CHIP C      100PF      J	
C4			CC73HCH1H101J	CHIP C      100PF      J	
C5			CK73HB1H471K	CHIP C      470PF      K	
C7			CC73HCH1H101J	CHIP C      100PF      J	
C8			CC73GCH1H101J	CHIP C      100PF      J	
C10			CK73HB1A104K	CHIP C      0.10UF      K	
C11			CC73HCH1H101J	CHIP C      100PF      J	
C14			CC73HCH1H101J	CHIP C      100PF      J	
C15			CC73HCH1H080B	CHIP C      8.0PF      B	
C16			CK73HB0J105K	CHIP C      1.0UF      K	
C17,18			CK73HB1A104K	CHIP C      0.10UF      K	
C19,20			CK73HB1E103K	CHIP C      0.010UF      K	
C22			CK73FB0J106K	CHIP C      10UF      K	
C23			CK73HB1A104K	CHIP C      0.10UF      K	
C24			CK73FB0J106K	CHIP C      10UF      K	
C26			CK73HB1C103K	CHIP C      0.010UF      K	
C27			CK73HB1A104K	CHIP C      0.10UF      K	
C29			C92-0863-05	CHIP TNTL      0.047UF      35WV	
C32			CK73HB1H471K	CHIP C      470PF      K	
C34			CK73HB1H471K	CHIP C      470PF      K	
C35			CC73HCH1H060B	CHIP C      6.0PF      B	
C36			CC73GCH1H080B	CHIP C      8.0PF      B	

## PARTS LIST / 零件表

## TX-RX UNIT (X57-7683-01)

Ref. No.	Address	New parts	Parts No.	Description	Destination	Ref. No.	Address	New parts	Parts No.	Description	Destination
C37			CK73HB1H471K	CHIP C 470PF K		C333			CK73HB1H471K	CHIP C 470PF K	
C40			CC73HCH1H390J	CHIP C 39PF J		C336			CK73GB1H221K	CHIP C 220PF K	
C41			CC73HCH1H330J	CHIP C 33PF J		C338			CC73GCH1H220J	CHIP C 22PF J	
C43			CS77CA1V0R1M	CHIP TNTL 0.1UF 35WV		C339			CK73GB1H102K	CHIP C 1000PF K	
C45			CS77BA1E010M	CHIP TNTL 1.0UF 25WV		C340,341			CC73GCH1H101J	CHIP C 100PF J	
C46			CK73HB1H102K	CHIP C 1000PF K		C342			CK73HB1A104K	CHIP C 0.10UF K	
C48			C93-0787-05	CERAMIC 0.1UF 50WV		C344			CK73GB1H102K	CHIP C 1000PF K	
C49			C92-0863-05	CHIP TNTL 0.047UF 35WV		C348			CC73GCH1H470J	CHIP C 47PF J	
C54			CC73HCH1H470J	CHIP C 47PF J		C350			CC73GCH1H220J	CHIP C 22PF J	
C56			CC73HCH1H101J	CHIP C 100PF J		C351			C93-0561-05	CHIP C 12PF J	
C57,58			CK73HB1H102K	CHIP C 1000PF K		C354			CK73HB1A104K	CHIP C 0.10UF K	
C59			CK73FB0J106K	CHIP C 10UF K		C355			CK73GB1H102K	CHIP C 1000PF K	
C61			CC73HCH1H101J	CHIP C 100PF J		C360			CK73GB1H102K	CHIP C 1000PF K	
C62			CC73HCH1H330J	CHIP C 33PF J		C361,362			CK73GB1H103K	CHIP C 0.010UF K	
C63			CC73HCH1H101J	CHIP C 100PF J		C363			CC73GCH1H050B	CHIP C 5.0PF B	
C64			CC73HCH1HR75B	CHIP C 0.75PF B		C364			C93-0562-05	CHIP C 15PF J	
C65,66			CK73HB1H102K	CHIP C 1000PF K		C365,366			C93-0603-05	CHIP C 1000PF K	
C67,68			CK73GB1H102K	CHIP C 1000PF K		C367			CC73GCH1H080B	CHIP C 8.0PF B	
C69			CC73HCH1H3R5B	CHIP C 3.5PF B		C368			CC73GCH1H430J	CHIP C 43PF J	
C70			CC73HCH1H040B	CHIP C 4.0PF B		C372			C93-0562-05	CHIP C 15PF J	
C71,72			CK73GB1H102K	CHIP C 1000PF K		C373			C93-0552-05	CHIP C 2.0PF C	
C73			CC73HCH1H060B	CHIP C 6.0PF B		C374			CM73F2H180J	CHIP C 18PF J	
C74			CC73HCH1H080B	CHIP C 8.0PF B		C376			CK73GB1H102K	CHIP C 1000PF K	
C75			CC73HCH1H040B	CHIP C 4.0PF B		C381			C93-0554-05	CHIP C 4.0PF C	
C76			CC73HCH1H060B	CHIP C 6.0PF B		C383			C93-0562-05	CHIP C 15PF J	
C77			CK73HB1H471K	CHIP C 470PF K		C384			CK73GB1H102K	CHIP C 1000PF K	
C78,79			CC73HCH1H010B	CHIP C 1.0PF B		C391,392			CK73HB1H102K	CHIP C 1000PF K	
C80			CS77BB21C100M	CHIP TNTL 10UF 16WV		C500			CC73HCH1H470J	CHIP C 47PF J	
C81			CK73HB1H102K	CHIP C 1000PF K		C501			CC73HCH1H180J	CHIP C 18PF J	
C82			CK73HB1H471K	CHIP C 470PF K		C504			CK73HB1C103K	CHIP C 0.010UF K	
C83			CK73HB1H102K	CHIP C 1000PF K		C505			CC73HCH1H300J	CHIP C 30PF J	
C84			CC73HCH1H180J	CHIP C 18PF J		C506			CC73HCH1H100B	CHIP C 10PF B	
C85			CC73HCH1H050B	CHIP C 5.0PF B		C508			CC73HCH1H270J	CHIP C 27PF J	
C86			CC73GCH1H050B	CHIP C 5.0PF B		C509			CK73HB1C103K	CHIP C 0.010UF K	
C87-89			CK73HB1H102K	CHIP C 1000PF K		C510-515			CK73HB1A104K	CHIP C 0.10UF K	
C90			CC73GCH1H150J	CHIP C 15PF J		C516			CK73HB1H102K	CHIP C 1000PF K	
C91			CK73HB1H102K	CHIP C 1000PF K		C517			CK73HB1E103K	CHIP C 0.010UF K	
C92			CK73HB1C103K	CHIP C 0.010UF K		C518			CK73HB1H331K	CHIP C 330PF K	
C94			CK73HB1H102K	CHIP C 1000PF K		C519			CK73FB0J106K	CHIP C 10UF K	
C95			CK73HB1A104K	CHIP C 0.10UF K		C520			CK73HB1H331K	CHIP C 330PF K	
C98			CK73GB1H102K	CHIP C 1000PF K		C521,522			CK73HB1A104K	CHIP C 0.10UF K	
C99			CK73HB1H471K	CHIP C 470PF K		C523			CK73GB1C104K	CHIP C 0.10UF K	
C102			CC73HCH1H270J	CHIP C 27PF J		C524			CK73HB1H102K	CHIP C 1000PF K	
C103			CC73HCH1H390J	CHIP C 39PF J		C525			CK73GB0J475K	CHIP C 4.7UF K	
C104			CC73HCH1H060B	CHIP C 6.0PF B		C526			CK73HB1H102K	CHIP C 1000PF K	
C105			CC73HCH1H040B	CHIP C 4.0PF B		C527			CC73HCH1H101J	CHIP C 100PF J	
C106			CC73HCH1H470J	CHIP C 47PF J		C528			CC73GCH1H330J	CHIP C 33PF J	
C300			CC73GCH1H101J	CHIP C 100PF J		C529			CK73HB1E103K	CHIP C 0.010UF K	
C301			CC73HCH1H080B	CHIP C 8.0PF B		C530			CK73HB1A104K	CHIP C 0.10UF K	
C302			CC73HCH1H070B	CHIP C 7.0PF B		C531			CK73HB1H471K	CHIP C 470PF K	
C303			CC73HCH1H090B	CHIP C 9.0PF B		C535			CK73HB1H102K	CHIP C 1000PF K	
C305			CK73HB1H471K	CHIP C 470PF K		C538			CK73HB1E103K	CHIP C 0.010UF K	
C307			CK73HB1H102K	CHIP C 1000PF K		C541			CK73HB1E103K	CHIP C 0.010UF K	
C313			CK73HB1H102K	CHIP C 1000PF K		C543			CC73HCH1H010B	CHIP C 1.0PF B	
C314			CC73HCH1H080B	CHIP C 8.0PF B		C545			CC73HCH1H180J	CHIP C 18PF J	
C315			CK73HB1C223K	CHIP C 0.022UF K		C546			CC73HCH1H070B	CHIP C 7.0PF B	
C316			CC73HCH1H060B	CHIP C 6.0PF B		C550			CK73HB1E103K	CHIP C 0.010UF K	
C317			CS77AA1A4R7M	CHIP TNTL 4.7UF 10WV		C551			CK73GB1A334K	CHIP C 0.33UF K	
C320			CK73GB1H102K	CHIP C 1000PF K		C553			CK73HB1A104K	CHIP C 0.10UF K	
C322			CK73GB1H271K	CHIP C 270PF K		C554			CC73HCH1H080B	CHIP C 8.0PF B	

## PARTS LIST / 零件表

TX-RX UNIT (X57-7683-01)

Ref. No.	Address	New parts	Parts No.	Description	Destination	Ref. No.	Address	New parts	Parts No.	Description	Destination
C555			CK73HB1H102K	CHIP C 1000PF K		C743			CK73HB1C333K	CHIP C 0.033UF K	
C556			CC73HCH1H150G	CHIP C 15PF G		C744			CK73HB1H471K	CHIP C 470PF K	
C557			CK73HB1E103K	CHIP C 0.010UF K		C745			CK73HB1A473J	CHIP C 0.047UF J	
C558			CK73HB1H102K	CHIP C 1000PF K		C746			CK73FB0J106K	CHIP C 10UF K	
C559			CK73GB1H471K	CHIP C 470PF K		C747			CK73HB1A104K	CHIP C 0.10UF K	
C560			CK73HB1H102K	CHIP C 1000PF K		C748			CC73HCH1H390J	CHIP C 39PF J	
C561			CK73HB1H471K	CHIP C 470PF K		C749,750			CK73HB1A104K	CHIP C 0.10UF K	
C562			CK73HB1E103K	CHIP C 0.010UF K		C753			CK73GB0J106K	CHIP C 10UF K	
C563,564			CK73HB1H102K	CHIP C 1000PF K		C754,755			CK73HB1A104K	CHIP C 0.10UF K	
C565			CK73HB1H471K	CHIP C 470PF K		C756			CC73HCH1H391J	CHIP C 390PF J	
C573			CC73HCH1H010B	CHIP C 1.0PF B		C758			CK73HB1H471K	CHIP C 470PF K	
C574			CC73HCH1H560J	CHIP C 56PF J		C760			CK73HB0J105K	CHIP C 1.0UF K	
C575			CC73HCH1H040B	CHIP C 4.0PF B		C762,763			CK73HB1A104K	CHIP C 0.10UF K	
C576			CK73HB1H102K	CHIP C 1000PF K		C764			CK73HB1E103K	CHIP C 0.010UF K	
C577			CC73HCH1H010B	CHIP C 1.0PF B		C765			CK73GB0J106K	CHIP C 10UF K	
C578			CC73HCH1H560J	CHIP C 56PF J		C767			CK73GB1C104K	CHIP C 0.10UF K	
C581			CC73HCH1H1R5B	CHIP C 1.5PF B		C768			CK73GB1H471K	CHIP C 470PF K	
C582			CK73HB1H102K	CHIP C 1000PF K		C769			CK73HB0J105K	CHIP C 1.0UF K	
C583			CK73HB1H471K	CHIP C 470PF K		C770			CK73FB0J106K	CHIP C 10UF K	
C585			CK73HB1A104K	CHIP C 0.10UF K		C771			CC73HCH1H101J	CHIP C 100PF J	
C586			CK73HB1H102K	CHIP C 1000PF K		C772			CK73HB0J105K	CHIP C 1.0UF K	
C587			CK73GB1A105K	CHIP C 1.0UF K		C773			CC73HCH1H101J	CHIP C 100PF J	
C588			CK73HB1H102K	CHIP C 1000PF K		C774			CK73HB0J105K	CHIP C 1.0UF K	
C589			CK73HB1H471K	CHIP C 470PF K		C775			CC73HCH1H271J	CHIP C 270PF J	
C590			CK73HB1H102K	CHIP C 1000PF K		C777			CK73HB0J105K	CHIP C 1.0UF K	
C591			CK73HB1H471K	CHIP C 470PF K		C778			CK73HB1E562K	CHIP C 5600PF K	
C592			CK73GB1A105K	CHIP C 1.0UF K		C779			CK73HB1E103K	CHIP C 0.010UF K	
C593			CC73HCH1H020B	CHIP C 2.0PF B		C780			CK73HB1A683K	CHIP C 0.068UF K	
C594			CC73HCH1H560J	CHIP C 56PF J		C784			CK73GB0J106K	CHIP C 10UF K	
C595			CC73HCH1H030B	CHIP C 3.0PF B		C785			CK73HB1H332K	CHIP C 3300PF K	
C596			CK73HB1H102K	CHIP C 1000PF K		C787			CK73HB1H332K	CHIP C 3300PF K	
C597			CC73HCH1H030B	CHIP C 3.0PF B		C788			CK73HB1A683K	CHIP C 0.068UF K	
C598			CC73HCH1H560J	CHIP C 56PF J		C790			CK73GB1H102K	CHIP C 1000PF K	
C599			CC73HCH1H020B	CHIP C 2.0PF B		C792,793			CK73HB1H102K	CHIP C 1000PF K	
C601			CC73HCH1H040B	CHIP C 4.0PF B		C794			CK73HB1H471K	CHIP C 470PF K	
C602			CC73HCH1H070B	CHIP C 7.0PF B		C795			CK73GB1H102K	CHIP C 1000PF K	
C603			CC73HCH1H180J	CHIP C 18PF J		C796			CK73HB0J105K	CHIP C 1.0UF K	
C606			CK73HB1H471K	CHIP C 470PF K		C797			CK73HB1H102K	CHIP C 1000PF K	
C700-703			CK73HB1H471K	CHIP C 470PF K		C807			CK73HB1H102K	CHIP C 1000PF K	
C704			CK73HB1H102K	CHIP C 1000PF K		C808			CK73HB1A104K	CHIP C 0.10UF K	
C705			CK73HB1H471K	CHIP C 470PF K		C809			CK73GB1C104K	CHIP C 0.10UF K	
C706			CK73HB1H102K	CHIP C 1000PF K		C810			CK73GB1H102K	CHIP C 1000PF K	
C707			CK73HB1H471K	CHIP C 470PF K		C813,814			CK73HB1H102K	CHIP C 1000PF K	
C708			CK73HB1H102K	CHIP C 1000PF K		C816			CK73HB1A104K	CHIP C 0.10UF K	
C709			CK73HB1H471K	CHIP C 470PF K		C817			CK73HB1E103K	CHIP C 0.010UF K	
C711			CK73HB1H471K	CHIP C 470PF K		C819			CS77BB21C220M	CHIP TNTL 22UF 16WV	
C713			CK73HB1H471K	CHIP C 470PF K		C820			CK73HB1H102K	CHIP C 1000PF K	
C715			CK73HB1H471K	CHIP C 470PF K		C821			CK73GB1A105K	CHIP C 1.0UF K	
C717			CK73HB1H471K	CHIP C 470PF K		C822			CK73HB0J105K	CHIP C 1.0UF K	
C719			CK73HB1H471K	CHIP C 470PF K		C824			CS77BB21C220M	CHIP TNTL 22UF 16WV	
C721			CK73HB1H471K	CHIP C 470PF K		C825			CK73HB1A104K	CHIP C 0.10UF K	
C723			CK73HB1H471K	CHIP C 470PF K		C828,829			CK73HB1A104K	CHIP C 0.10UF K	
C725			CK73HB1H471K	CHIP C 470PF K		C831			CK73HB1A104K	CHIP C 0.10UF K	
C727			CK73HB1H471K	CHIP C 470PF K		C832			CK73GB1A224K	CHIP C 0.22UF K	
C729			CK73HB1H471K	CHIP C 470PF K		C833			CK73HB1H102K	CHIP C 1000PF K	
C731,732			CK73HB1H471K	CHIP C 470PF K		C835			CK73GB1H102K	CHIP C 1000PF K	
C735			CK73HB1A104K	CHIP C 0.10UF K		C837,838			CK73HB1H102K	CHIP C 1000PF K	
C736			CK73GB0J475K	CHIP C 4.7UF K		C839			CS77AB21C4R7M	CHIP TNTL 4.7UF 16WV	
C739			CK73GB1C104K	CHIP C 0.10UF K		C840			CK73GB1H102K	CHIP C 1000PF K	
C740			CK73HB1A104K	CHIP C 0.10UF K		C841			CK73GB1A105K	CHIP C 1.0UF K	

## PARTS LIST / 零件表

## TX-RX UNIT (X57-7683-01)

Ref. No.	Address	New parts	Parts No.	Description	Destination	Ref. No.	Address	New parts	Parts No.	Description	Destination
C842			CS77BA1A100M	CHIP TNTL 10UF 10WV		C937			CK73HB1E103K	CHIP C 0.010UF K	
C843			C92-0873-05	ELECTRO 47UF 16WV		C938			CK73HB1H471K	CHIP C 470PF K	
C844			CK73HB1H102K	CHIP C 1000PF K		C939			CK73HB1A104K	CHIP C 0.10UF K	
C845			CK73HB1E103K	CHIP C 0.010UF K		C940			CK73FB0J106K	CHIP C 10UF K	
C846			CK73GB1H102K	CHIP C 1000PF K		C941			CK73HB1H471K	CHIP C 470PF K	
C847			CK73HB1H102K	CHIP C 1000PF K		C942			CC73HCH1H120J	CHIP C 12PF J	
C849			CE32BD1C471M	CHIP EL 470UF 16WV		C945			CK73GB1H471K	CHIP C 470PF K	
C850			CK73GB1H102K	CHIP C 1000PF K		C946			CC73GCH1H240J	CHIP C 24PF J	
C851			CK73GB1A105K	CHIP C 1.0UF K		C947			CK73HB1H102K	CHIP C 1000PF K	
C852			CK73HB1E103K	CHIP C 0.010UF K		C948			CK73GB0J106K	CHIP C 10UF K	
C853,854			CK73HB1H102K	CHIP C 1000PF K		C949			CC73HCH1H120J	CHIP C 12PF J	
C855			CK73GB1H102K	CHIP C 1000PF K		C950			CC73HCH1H101J	CHIP C 100PF J	
C856			CK73HB1A104K	CHIP C 0.10UF K		C952			CC73GCH1H220J	CHIP C 22PF J	
C857			CC73HCH1H220J	CHIP C 22PF J		C953			CK73FB1E225K	CHIP C 2.2UF K	
C858			CK73GB1H221K	CHIP C 220PF K		C954-956			CK73HB1H102K	CHIP C 1000PF K	
C859			CC73HCH1H470J	CHIP C 47PF J		C957			CK73EB1E106K	CHIP C 10UF K	
C860			CC73HCH1H101J	CHIP C 100PF J		C958			CK73HBOJ105K	CHIP C 1.0UF K	
C861			CK73GB1H471K	CHIP C 470PF K		C959-961			CK73HB1H471K	CHIP C 470PF K	
C862			CK73HB1H102K	CHIP C 1000PF K		C964			CK73GB1H102K	CHIP C 1000PF K	
C863			CC73HCH1H220J	CHIP C 22PF J		C966-968			CC73HCH1H470J	CHIP C 47PF J	
C864			CC73GCH1H470J	CHIP C 47PF J		C970			CK73GB1H102K	CHIP C 1000PF K	
C865			CC73HCH1H220J	CHIP C 22PF J		C982			CK73HB1H471K	CHIP C 470PF K	
C866			CK73GB1H102K	CHIP C 1000PF K		C985,986			CK73HB1H471K	CHIP C 470PF K	
C867			CK73GB1H471K	CHIP C 470PF K		CN702			E40-5932-05	SOCKET FOR PIN ASSY	
C868			CK73HB1A334K	CHIP C 0.33UF K		CN724			E40-6847-05	FLAT CABLE CONNECTOR	
C869			CK73GB1H221K	CHIP C 220PF K		J700	1B		E58-0536-05	SUB SOCKET (D)	
C870			CK73HB1H102K	CHIP C 1000PF K		J701	2A		E11-0425-05	3.5D PHONE JACK (3P)	
C874			CK73GB0J105K	CHIP C 1.0UF K		F700			F53-0327-15	FUSE (4A)	
C875-877			CK73HBOJ105K	CHIP C 1.0UF K		CD500			L79-1866-05	TUNING COIL	
C878			CC73HCH1H150J	CHIP C 15PF J		CF500			L72-0993-05	CERAMIC FILTER	
C879			CC73HCH1H220J	CHIP C 22PF J		CF501			L72-0959-05	CERAMIC FILTER	
C880			CK73HB1H102K	CHIP C 1000PF K		L2			L41-4791-08	SMALL FIXED INDUCTOR (4.7NH)	
C881			CK73HBOJ105K	CHIP C 1.0UF K		L3			L92-0442-05	CHIP FERRITE	
C882			CK73GB1A105K	CHIP C 1.0UF K		L4			L92-0443-05	CHIP FERRITE	
C883			CK73HB1A224K	CHIP C 0.22UF K		L7			L92-0163-05	BEADS CORE	
C884			CE32BD1C471M	CHIP EL 470UF 16WV		L9			L92-0163-05	BEADS CORE	
C885,886			CK73GB1H102K	CHIP C 1000PF K		L17			L92-0443-05	CHIP FERRITE	
C887			CK73HB1H102K	CHIP C 1000PF K		L18	*		L41-1588-14	SMALL FIXED INDUCTOR (150NH)	
C889			CK73HB1H102K	CHIP C 1000PF K		L19			L41-1288-14	SMALL FIXED INDUCTOR (120NH)	
C890,891			CK73HB1H471K	CHIP C 470PF K		L20,21			L40-2702-86	SMALL FIXED INDUCTOR (27UH)	
C894			C93-0552-05	CHIP C 2.0PF C		L24			L92-0443-05	CHIP FERRITE	
C898			CK73HB1H102K	CHIP C 1000PF K		L25,26			L40-1085-71	SMALL FIXED INDUCTOR (100NH)	
C915			CK73HB1H102K	CHIP C 1000PF K		L27			L40-1075-71	SMALL FIXED INDUCTOR (10NH)	
C917			CC73HCH1H200J	CHIP C 20PF J		L28			L40-2275-71	SMALL FIXED INDUCTOR (22NH)	
C918			CC73HCH1H121J	CHIP C 120PF J		L29			L40-1001-86	SMALL FIXED INDUCTOR (10UH)	
C919			CC73HCH1H150J	CHIP C 15PF J		L30			L40-4791-86	SMALL FIXED INDUCTOR (4.7UH)	
C920			CK73HB1E103K	CHIP C 0.010UF K		L31,32			L40-1891-86	SMALL FIXED INDUCTOR (1.8UH)	
C921			CK73GB1A105K	CHIP C 1.0UF K		L33			L40-1001-86	SMALL FIXED INDUCTOR (10UH)	
C922			CK73HB1H102K	CHIP C 1000PF K		L34			L40-2702-86	SMALL FIXED INDUCTOR (27UH)	
C923			CK73HB1A104K	CHIP C 0.10UF K		L35			L40-4791-86	SMALL FIXED INDUCTOR (4.7UH)	
C924,925			CK73HBOJ105K	CHIP C 1.0UF K		L36			L40-1891-86	SMALL FIXED INDUCTOR (1.8UH)	
C926,927			CK73HB1H102K	CHIP C 1000PF K		L37			L40-2702-86	SMALL FIXED INDUCTOR (27UH)	
C928			CK73HB1A104K	CHIP C 0.10UF K		L38			L40-1891-86	SMALL FIXED INDUCTOR (1.8UH)	
C929			CK73HB1H102K	CHIP C 1000PF K		L39			L40-6875-71	SMALL FIXED INDUCTOR (68NH)	
C930			CK73HB1A104K	CHIP C 0.10UF K		L300			L40-1875-71	SMALL FIXED INDUCTOR (18NH)	
C931			CK73HB1H102K	CHIP C 1000PF K		L301			L40-1075-71	SMALL FIXED INDUCTOR (10NH)	
C932			CK73HB1A104K	CHIP C 0.10UF K		L302			L40-2275-92	SMALL FIXED INDUCTOR (22NH)	
C933			CK73HB1H102K	CHIP C 1000PF K		L303			L40-1275-92	SMALL FIXED INDUCTOR (12NH)	
C934			CC73HCH1H3R5B	CHIP C 3.5PF B							
C935			CK73HB1H102K	CHIP C 1000PF K							

## PARTS LIST / 零件表

TX-RX UNIT (X57-7683-01)

Ref. No.	Address	New parts	Parts No.	Description	Destination	Ref. No.	Address	New parts	Parts No.	Description	Destination
L304			L40-1575-92	SMALL FIXED INDUCTOR (15NH)		R51			RN73HH1J121D	CHIP R 120 D 1/16W	
L305			L40-1285-92	SMALL FIXED INDUCTOR (120NH)		R52			RK73HB1J102J	CHIP R 1.0K J 1/16W	
L308-310			L92-0179-05	CHIP FERRITE		R53			RK73HB1J273J	CHIP R 27K J 1/16W	
L311			L34-1039-05	AIR-CORE COIL		R54			RK73HB1J000J	CHIP R 0.0 J 1/16W	
L312			L34-4902-05	AIR-CORE COIL		R55			RK73HB1J101J	CHIP R 100 J 1/16W	
L313-315			L34-4903-05	AIR-CORE COIL		R56			RK73HB1J103J	CHIP R 10K J 1/16W	
L316			L34-4902-05	AIR-CORE COIL		R57			RK73HB1J822J	CHIP R 8.2K J 1/16W	
L501			L40-4781-86	SMALL FIXED INDUCTOR (0.47UH)		R58-60			RK73HB1J101J	CHIP R 100 J 1/16W	
L503			L40-5681-86	SMALL FIXED INDUCTOR (0.56UH)		R61			RK73HB1J000J	CHIP R 0.0 J 1/16W	
L504			L40-2775-71	SMALL FIXED INDUCTOR (27NH)		R62			RK73HB1J222J	CHIP R 2.2K J 1/16W	
L505,506			L41-4785-39	SMALL FIXED INDUCTOR (0.47UH)		R63			RK73HB1J472J	CHIP R 4.7K J 1/16W	
L512			L41-5678-14	SMALL FIXED INDUCTOR (56NH)		R64			RK73GB2A472J	CHIP R 4.7K J 1/10W	
L514			L41-6878-45	SMALL FIXED INDUCTOR (68NH)		R65			RK73HB1J103J	CHIP R 10K J 1/16W	
L515			L40-2275-92	SMALL FIXED INDUCTOR (22NH)		R68,69			RK73HB1J000J	CHIP R 0.0 J 1/16W	
L517,518			L41-5678-14	SMALL FIXED INDUCTOR (56NH)		R73			RK73HB1J000J	CHIP R 0.0 J 1/16W	
L700			L92-0443-05	CHIP FERRITE		R74			RK73HB1J560J	CHIP R 56 J 1/16W	
L702			L92-0443-05	CHIP FERRITE		R75-78			RK73HB1J000J	CHIP R 0.0 J 1/16W	
L704			L40-2775-71	SMALL FIXED INDUCTOR (27NH)		R79,80			RK73HB1J153J	CHIP R 15K J 1/16W	
L706			L40-2275-71	SMALL FIXED INDUCTOR (22NH)		R82			RK73HB1J153J	CHIP R 15K J 1/16W	
L707			L40-6875-57	SMALL FIXED INDUCTOR (68.0NH)		R83			RK73FB2B102J	CHIP R 1.0K J 1/8W	
L708			L40-6875-92	SMALL FIXED INDUCTOR (68NH)		R303			RK73HB1J472J	CHIP R 4.7K J 1/16W	
L711,712			L92-0163-05	BEADS CORE		R306			RK73HB1J223J	CHIP R 22K J 1/16W	
L713			L92-0161-05	BEADS CORE		R321			RK73GB2A151J	CHIP R 150 J 1/10W	
X1			L77-3055-05	TCXO (19.2MHZ)		R323			RK73GB2A390J	CHIP R 39 J 1/10W	
XF500			L71-0659-05	MCF (38.85MHZ)		R324			RK73GB2A000J	CHIP R 0.0 J 1/10W	
CP700-702			RK75HA1J102J	CHIP-COM 1.0K J 1/16W		R325			RK73GB2A151J	CHIP R 150 J 1/10W	
CP704-706			RK75HA1J102J	CHIP-COM 1.0K J 1/16W		R327			RK73HB1J101J	CHIP R 100 J 1/16W	
R3			RK73HB1J334J	CHIP R 330K J 1/16W		R329			RK73GB2A470J	CHIP R 47 J 1/10W	
R5-7			RK73HB1J102J	CHIP R 1.0K J 1/16W		R330			RK73HB1J000J	CHIP R 0.0 J 1/16W	
R8			RK73HB1J152J	CHIP R 1.5K J 1/16W		R331			RK73HB1J154J	CHIP R 150K J 1/16W	
R10			RK73HB1J100J	CHIP R 10 J 1/16W		R333,334			RK73HB1J103J	CHIP R 10K J 1/16W	
R12			RK73HB1J100J	CHIP R 10 J 1/16W		R336			RK73HB1J000J	CHIP R 0.0 J 1/16W	
R15			RK73HB1J473J	CHIP R 47K J 1/16W		R338			RK73HB1J153J	CHIP R 15K J 1/16W	
R16			RK73HB1J000J	CHIP R 0.0 J 1/16W		R341			RK73HB1J000J	CHIP R 0.0 J 1/16W	
R20			RK73HB1J102J	CHIP R 1.0K J 1/16W		R342			RK73HB1J104J	CHIP R 100K J 1/16W	
R21			RK73HB1J182J	CHIP R 1.8K J 1/16W		R343			RK73HB1J000J	CHIP R 0.0 J 1/16W	
R22			RK73HB1J000J	CHIP R 0.0 J 1/16W		R345			RK73HB1J104J	CHIP R 100K J 1/16W	
R23			RK73HB1J223J	CHIP R 22K J 1/16W		R346			RK73HB1J473J	CHIP R 47K J 1/16W	
R25			RK73HB1J000J	CHIP R 0.0 J 1/16W		R347			RK73GH2A101D	CHIP R 100 D 1/10W	
R26			RK73HB1J153J	CHIP R 15K J 1/16W		R348			RK73HB1J104J	CHIP R 100K J 1/16W	
R28			RK73HB1J000J	CHIP R 0.0 J 1/16W		R349			RK73HB1J000J	CHIP R 0.0 J 1/16W	
R29			RK73HB1J181J	CHIP R 180 J 1/16W		R352			RK73GH2A680D	CHIP R 68 D 1/10W	
R30			RK73HB1J102J	CHIP R 1.0K J 1/16W		R353			RK73RB2H101J	CHIP R 100 J 1/2W	
R31			RK73HB1J105J	CHIP R 1.0M J 1/16W		R354,355			RK73GB2A000J	CHIP R 0.0 J 1/10W	
R32,33			RK73HB1J000J	CHIP R 0.0 J 1/16W		R357,358			RK73GB2A000J	CHIP R 0.0 J 1/10W	
R34			RK73HB1J222J	CHIP R 2.2K J 1/16W		R361			RK73GH2A121D	CHIP R 120 D 1/10W	
R35			RK73HB1J102J	CHIP R 1.0K J 1/16W		R367			RK73GH2A181D	CHIP R 180 D 1/10W	
R36			RK73HB1J273J	CHIP R 27K J 1/16W		R369,370			RK73HB1J104J	CHIP R 100K J 1/16W	
R37			RK73HB1J103J	CHIP R 10K J 1/16W		R374	2B		R92-1061-05	JUMPER REST 0 OHM	
R38			RK73HB1J000J	CHIP R 0.0 J 1/16W		R375			RK73HB1J104J	CHIP R 100K J 1/16W	
R39			RK73HB1J104J	CHIP R 100K J 1/16W		R376			RK73HB1J103J	CHIP R 10K J 1/16W	
R40			RK73HB1J000J	CHIP R 0.0 J 1/16W		R381			RK73GB2A102J	CHIP R 1.0K J 1/10W	
R41			RK73HB1J393J	CHIP R 39K J 1/16W		R382-384			RK73HB1J000J	CHIP R 0.0 J 1/16W	
R43			RK73HB1J104J	CHIP R 100K J 1/16W		R387,388			RK73HB1J104J	CHIP R 100K J 1/16W	
R45			RK73HB1J473J	CHIP R 47K J 1/16W		R500			RK73HB1J122J	CHIP R 1.2K J 1/16W	
R46			RK73HB1J101J	CHIP R 100 J 1/16W		R501			RK73HB1J334J	CHIP R 330K J 1/16W	
R47			RN73HH1J681D	CHIP R 680 D 1/16W		R502			RK73HB1J101J	CHIP R 100 J 1/16W	
R48			RK73GB2A104J	CHIP R 100K J 1/10W		R503-508			RK73HB1J103J	CHIP R 10K J 1/16W	
R49			RK73HB1J472J	CHIP R 4.7K J 1/16W		R509			RK73GB2A100J	CHIP R 10 J 1/10W	
R50			RN73HH1J271D	CHIP R 270 D 1/16W		R510			RK73HB1J152J	CHIP R 1.5K J 1/16W	



## PARTS LIST / 零件表

## TX-RX UNIT (X57-7683-01)

Ref. No.	Address	New parts	Parts No.	Description	Destination	Ref. No.	Address	New parts	Parts No.	Description	Destination
R511			RK73HB1J104J	CHIP R 100K J 1/16W		R721			RK73HB1J000J	CHIP R 0.0 J 1/16W	
R512			RK73HB1J182J	CHIP R 1.8K J 1/16W		R722			RK73HB1J222J	CHIP R 2.2K J 1/16W	
R513			RK73HB1J224J	CHIP R 220K J 1/16W		R723			RK73HB1J334J	CHIP R 330K J 1/16W	
R515			RK73GB2A472J	CHIP R 4.7K J 1/10W		R724			RK73HB1J000J	CHIP R 0.0 J 1/16W	
R517			RK73HB1J000J	CHIP R 0.0 J 1/16W		R725,726			RK73HH1J473D	CHIP R 47K D 1/16W	
R519			RK73HB1J153J	CHIP R 15K J 1/16W		R727			RK73HB1J473J	CHIP R 47K J 1/16W	
R520			RK73HB1J562J	CHIP R 5.6K J 1/16W		R728-730			RK73HB1J000J	CHIP R 0.0 J 1/16W	
R522			RK73HB1J000J	CHIP R 0.0 J 1/16W		R731			RK73HB1J104J	CHIP R 100K J 1/16W	
R524			RK73HB1J101J	CHIP R 100 J 1/16W		R732			RK73HB1J102J	CHIP R 1.0K J 1/16W	
R525			RK73HB1J000J	CHIP R 0.0 J 1/16W		R733			RK73HB1J103J	CHIP R 10K J 1/16W	
R527			RK73HB1J224J	CHIP R 220K J 1/16W		R734,735			RK73HB1J102J	CHIP R 1.0K J 1/16W	
R528			RK73HB1J000J	CHIP R 0.0 J 1/16W		R736			RK73GB2A000J	CHIP R 0.0 J 1/10W	
R530			RK73HB1J391J	CHIP R 390 J 1/16W		R737			RK73HB1J273J	CHIP R 27K J 1/16W	
R531			RK73HB1J000J	CHIP R 0.0 J 1/16W		R738			RK73HB1J562J	CHIP R 5.6K J 1/16W	
R533			RK73HB1J000J	CHIP R 0.0 J 1/16W		R739			RK73HB1J000J	CHIP R 0.0 J 1/16W	
R534			RK73HB1J331J	CHIP R 330 J 1/16W		R741			RK73HB1J563J	CHIP R 56K J 1/16W	
R537			RK73HB1J683J	CHIP R 68K J 1/16W		R742			RK73HB1J000J	CHIP R 0.0 J 1/16W	
R539			RK73HB1J470J	CHIP R 47 J 1/16W		R743			RK73HB1J104J	CHIP R 100K J 1/16W	
R541			RK73HB1J332J	CHIP R 3.3K J 1/16W		R747			RK73HB1J000J	CHIP R 0.0 J 1/16W	
R543,544			RK73HB1J823J	CHIP R 82K J 1/16W		R748			RK73HB1J104J	CHIP R 100K J 1/16W	
R545			RK73HB1J224J	CHIP R 220K J 1/16W		R749			RK73GB2A100J	CHIP R 10 J 1/10W	
R546			RK73HB1J684J	CHIP R 680K J 1/16W		R751			RK73HB1J104J	CHIP R 100K J 1/16W	
R547			RK73HB1J151J	CHIP R 150 J 1/16W		R752			RK73HB1J101J	CHIP R 100 J 1/16W	
R548			RK73HB1J394J	CHIP R 390K J 1/16W		R753			RK73GB2A104J	CHIP R 100K J 1/10W	
R549			RK73HB1J154J	CHIP R 150K J 1/16W		R754			RK73HB1J104J	CHIP R 100K J 1/16W	
R550			RK73HB1J330J	CHIP R 33 J 1/16W		R755			RK73HB1J101J	CHIP R 100 J 1/16W	
R553			RK73HB1J000J	CHIP R 0.0 J 1/16W		R756			RK73HB1J104J	CHIP R 100K J 1/16W	
R560			RK73HB1J000J	CHIP R 0.0 J 1/16W		R758			RK73HB1J000J	CHIP R 0.0 J 1/16W	
R561			RK73HB1J102J	CHIP R 1.0K J 1/16W		R759			RK73HB1J154J	CHIP R 150K J 1/16W	
R562			RK73HB1J820J	CHIP R 82 J 1/16W		R760			RK73HB1J104J	CHIP R 100K J 1/16W	
R563			RK73HB1J000J	CHIP R 0.0 J 1/16W		R761			RK73HB1J101J	CHIP R 100 J 1/16W	
R564			RK73HB1J223J	CHIP R 22K J 1/16W		R762			RK73HB1J104J	CHIP R 100K J 1/16W	
R565			RK73HB1J221J	CHIP R 220 J 1/16W		R763			RK73HB1J101J	CHIP R 100 J 1/16W	
R566			RK73HB1J104J	CHIP R 100K J 1/16W		R764			RK73HB1J682J	CHIP R 6.8K J 1/16W	
R567			RK73HB1J564J	CHIP R 560K J 1/16W		R765			RK73HB1J000J	CHIP R 0.0 J 1/16W	
R568			RK73HB1J223J	CHIP R 22K J 1/16W		R766			RK73HB1J682J	CHIP R 6.8K J 1/16W	
R569			RK73HB1J104J	CHIP R 100K J 1/16W		R767			RK73HB1J393J	CHIP R 39K J 1/16W	
R570			RK73HB1J683J	CHIP R 68K J 1/16W		R770			RK73GB2A000J	CHIP R 0.0 J 1/10W	
R572			RK73HB1J000J	CHIP R 0.0 J 1/16W		R771			RK73HB1J000J	CHIP R 0.0 J 1/16W	
R573,574			RK73HB1J223J	CHIP R 22K J 1/16W		R773			RK73HB1J472J	CHIP R 4.7K J 1/16W	
R576			RK73HB1J000J	CHIP R 0.0 J 1/16W		R774			RK73HB1J222J	CHIP R 2.2K J 1/16W	
R577			RK73FB28000J	CHIP R 0.0 J 1/8W		R775			RK73HB1J473J	CHIP R 47K J 1/16W	
R589			RK73HB1J000J	CHIP R 0.0 J 1/16W		R776			RK73HB1J103J	CHIP R 10K J 1/16W	
R590			RK73HB1J823J	CHIP R 82K J 1/16W		R778,779			RK73HB1J473J	CHIP R 47K J 1/16W	
R591			RK73HB1J000J	CHIP R 0.0 J 1/16W		R780			RK73HB1J222J	CHIP R 2.2K J 1/16W	
R701			RK73HB1J000J	CHIP R 0.0 J 1/16W		R781			RK73HB1J104J	CHIP R 100K J 1/16W	
R703			RK73HB1J000J	CHIP R 0.0 J 1/16W		R782			RK73HB1J102J	CHIP R 1.0K J 1/16W	
R704			RK73HB1J102J	CHIP R 1.0K J 1/16W		R783			RK73HB1J473J	CHIP R 47K J 1/16W	
R705			RK73HB1J681J	CHIP R 680 J 1/16W		R784			RK73HB1J104J	CHIP R 100K J 1/16W	
R708			RK73HB1J472J	CHIP R 4.7K J 1/16W		R785			RK73HB1J105J	CHIP R 1.0M J 1/16W	
R709			RK73HB1J561J	CHIP R 560 J 1/16W		R786			RK73GB2A102J	CHIP R 1.0K J 1/10W	
R710			RK73GB2A124J	CHIP R 120K J 1/10W		R787			RK73HB1J153J	CHIP R 15K J 1/16W	
R711			RK73HB1J821J	CHIP R 820 J 1/16W		R789			RK73GB2A472J	CHIP R 4.7K J 1/10W	
R712			RK73HB1J561J	CHIP R 560 J 1/16W		R790			RK73HB1J123J	CHIP R 12K J 1/16W	
R713			RK73HB1J104J	CHIP R 100K J 1/16W		R791			RK73HB1J102J	CHIP R 1.0K J 1/16W	
R714,715			RK73HB1J223J	CHIP R 22K J 1/16W		R792			RK73GH2A134D	CHIP R 130K D 1/10W	
R716			RK73HB1J000J	CHIP R 0.0 J 1/16W		R793			RK73GH2A183D	CHIP R 18K D 1/10W	
R718			RK73HB1J104J	CHIP R 100K J 1/16W		R794-797			RK73HB1J102J	CHIP R 1.0K J 1/16W	
R719			RK73HB1J000J	CHIP R 0.0 J 1/16W		R798			RK73GB2A000J	CHIP R 0.0 J 1/10W	
R720			RK73HB1J101J	CHIP R 100 J 1/16W		R799-801			RK73HB1J102J	CHIP R 1.0K J 1/16W	

## PARTS LIST / 零件表

TX-RX UNIT (X57-7683-01)

Ref. No.	Address	New parts	Parts No.	Description	Destination	Ref. No.	Address	New parts	Parts No.	Description	Destination
R802			RK73HB1J000J	CHIP R 0.0 J 1/16W		R930			RK73HB1J223J	CHIP R 22K J 1/16W	
R803			RK73HB1J103J	CHIP R 10K J 1/16W		R931			RK73HB1J103J	CHIP R 10K J 1/16W	
R807,808			RK73HB1J000J	CHIP R 0.0 J 1/16W		R932			RK73HB1J000J	CHIP R 0.0 J 1/16W	
R811			RK73HB1J102J	CHIP R 1.0K J 1/16W		R933			RK73GB2A000J	CHIP R 0.0 J 1/10W	
R812			RK73HB1J473J	CHIP R 47K J 1/16W		R935			RK73HB1J473J	CHIP R 47K J 1/16W	
R815			RK73HB1J102J	CHIP R 1.0K J 1/16W		R938			RK73HB1J000J	CHIP R 0.0 J 1/16W	
R817-819			RK73HB1J000J	CHIP R 0.0 J 1/16W		R939,940			RK73GB2A000J	CHIP R 0.0 J 1/10W	
R820			RK73HB1J473J	CHIP R 47K J 1/16W		R950			RK73HB1J473J	CHIP R 47K J 1/16W	
R821			RK73HB1J471J	CHIP R 470 J 1/16W		R951,952			RK73GB2A000J	CHIP R 0.0 J 1/10W	
R823			RK73GB2A102J	CHIP R 1.0K J 1/10W		R953,954			RK73HB1J000J	CHIP R 0.0 J 1/16W	
R824			RK73HB1J152J	CHIP R 1.5K J 1/16W		R955			RK73HB1J563J	CHIP R 56K J 1/16W	
R825			RK73HB1J473J	CHIP R 47K J 1/16W		R956			RK73HB1J561J	CHIP R 560 J 1/16W	
R826			RK73HB1J223J	CHIP R 22K J 1/16W		R957			RK73HB1J563J	CHIP R 56K J 1/16W	
R827			RK73HB1J473J	CHIP R 47K J 1/16W		R958			RK73HB1J561J	CHIP R 560 J 1/16W	
R829			RK73HB1J000J	CHIP R 0.0 J 1/16W		R959			RK73HB1J184J	CHIP R 180K J 1/16W	
R831,832			RK73HB1J000J	CHIP R 0.0 J 1/16W		R960			RK73HB1J222J	CHIP R 2.2K J 1/16W	
R833-835			RK73HB1J103J	CHIP R 10K J 1/16W		R961			RK73HB1J184J	CHIP R 180K J 1/16W	
R836			RK73HB1J472J	CHIP R 4.7K J 1/16W		R962			RK73HB1J152J	CHIP R 1.5K J 1/16W	
R837			RK73HB1J152J	CHIP R 1.5K J 1/16W		R964			RK73GH2A681D	CHIP R 680 D 1/10W	
R838			RK73HB1J472J	CHIP R 4.7K J 1/16W		R965			RK73HB1J473J	CHIP R 47K J 1/16W	
R839			RK73HB1J473J	CHIP R 47K J 1/16W		R968			RK73HB1J104J	CHIP R 100K J 1/16W	
R840			RK73HB1J683J	CHIP R 68K J 1/16W		R970			RK73HB1J473J	CHIP R 47K J 1/16W	
R841			RK73HB1J473J	CHIP R 47K J 1/16W		R972			RK73HB1J102J	CHIP R 1.0K J 1/16W	
R842			RK73HB1J823J	CHIP R 82K J 1/16W		R973			RK73HB1J100J	CHIP R 10 J 1/16W	
R843			RK73HB1J222J	CHIP R 2.2K J 1/16W		R974			RK73HB1J390J	CHIP R 39 J 1/16W	
R845			RK73HB1J102J	CHIP R 1.0K J 1/16W		R975,976			RK73HB1J151J	CHIP R 150 J 1/16W	
R846			RK73GB2A221J	CHIP R 220 J 1/10W		R977,978			RK73HB1J473J	CHIP R 47K J 1/16W	
R847			RK73HB1J391J	CHIP R 390 J 1/16W		R979-998			RK73HB1J000J	CHIP R 0.0 J 1/16W	
R848			RK73GB2A473J	CHIP R 47K J 1/10W		R999			RK73HB1J473J	CHIP R 47K J 1/16W	
R849			RK73FB2B000J	CHIP R 0.0 J 1/8W		D1			1SS389-F	DIODE	
R850			RK73GB2A334J	CHIP R 330K J 1/10		D4,5			HVC376B	VARIABLE CAPACITANCE DIODE	
R851			RK73HB1J474J	CHIP R 470K J 1/16W		D6-11			1SV325F	VARIABLE CAPACITANCE DIODE	
R852			RK73HB1J564J	CHIP R 560K J 1/16W		D12			1SV278F	VARIABLE CAPACITANCE DIODE	
R853			RK73HB1J000J	CHIP R 0.0 J 1/16W		D13,14			HVC376B	VARIABLE CAPACITANCE DIODE	
R854			RK73GB2A104J	CHIP R 100K J 1/10W		D15-17			HSC277	DIODE	
R855			RK73HB1J101J	CHIP R 100 J 1/16W		D300			UDZW5.1(B)	ZENER DIODE	
R856			RK73HB1J000J	CHIP R 0.0 J 1/16W		D301			1SS355	DIODE	
R857			RK73HB1J102J	CHIP R 1.0K J 1/16W		D302,303			L407CDB	DIODE (50V/1W)	
R858			RK73HB1J332J	CHIP R 3.3K J 1/16W		D304,305			L7091CER	DIODE	
R859-863			RK73HB1J000J	CHIP R 0.0 J 1/16W		D310,311			UDZW3.3(B)	ZENER DIODE	
R867,868			RK73HB1J000J	CHIP R 0.0 J 1/16W		D312			HSC277	DIODE	
R869			RK73HB1J104J	CHIP R 100K J 1/16W		D313,314			MA3J742	DIODE	
R870,871			RK73HB1J000J	CHIP R 0.0 J 1/16W		D500,501			MC2858	DIODE	
R873-876			RK73HB1J000J	CHIP R 0.0 J 1/16W		D506			1SV305F	VARIABLE CAPACITANCE DIODE	
R877			RK73HB1J473J	CHIP R 47K J 1/16W		D508-510			1SV305F	VARIABLE CAPACITANCE DIODE	
R878-881			RK73HB1J105J	CHIP R 1.0M J 1/16W		D700-710			DA221	DIODE	
R882			RK73HB1J823J	CHIP R 82K J 1/16W		D711			MC2858	DIODE	
R883			RK73HB1J000J	CHIP R 0.0 J 1/16W		D712			1SS372F	DIODE	
R884			RK73HB1J472J	CHIP R 4.7K J 1/16W		D715			UDZW18(B)	ZENER DIODE	
R885			RK73GB2A683J	CHIP R 68K J 1/10W		D717			Z5W27V	SURGE ABSORBER	
R886			RK73HB1J823J	CHIP R 82K J 1/16W		D718			MA2S111-F	DIODE	
R887			RK73FB2B000J	CHIP R 0.0 J 1/8W		D719,720			HVC131	DIODE	
R888			RK73GB2A473J	CHIP R 47K J 1/10W		IC1			MB15E03SL-E1	MOS-IC	
R889			RK73GB2A221J	CHIP R 220 J 1/10W		IC2			BD7542FVM	MOS-IC	
R890			RK73HB1J102J	CHIP R 1.0K J 1/16W		IC300			HA17358BFEL-E	MOS-IC	
R891-893			RK73HB1J000J	CHIP R 0.0 J 1/16W		IC301	2B		S-AV33A	MOS-IC	
R894,895			RK73HB1J102J	CHIP R 1.0K J 1/16W		IC500			NJM2591V	BI-POLAR IC	
R896			RK73GB2A000J	CHIP R 0.0 J 1/10W		IC501			HA17358BFEL-E	MOS-IC	
R899			RK73HB1J000J	CHIP R 0.0 J 1/16W		IC700			NJM2100V-ZB	MOS-IC	
R928,929			RK73HB1J472J	CHIP R 4.7K J 1/16W							

If a part reference number is listed in a shaded box, that part does not come with the PCB.

## PARTS LIST / 零件表

## TX-RX UNIT (X57-7683-01)

Ref. No.	Address	New parts	Parts No.	Description	Destination	Ref. No.	Address	New parts	Parts No.	Description	Destination
IC701			CD686Q3	MOS-IC							
IC702		*	F364AEDFBKCUJ	MICROCONTROLLER IC							
IC703			EX24064ASAS0A	ROM IC							
IC704			TA4809BF	ANALOGUE IC							
IC705	2A		LA4600	BI-POLAR IC							
IC706			XC6221B332NR	MOS-IC							
IC707			TA7805FQ	MOS-IC							
IC708			BD4740G	MOS-IC							
IC709			XC6120N402N1	MOS-IC							
IC710			XC6221B332NR	MOS-IC							
Q3			2SC5108(Y)F	TRANSISTOR							
Q4			MCH3914(7)-H	FET							
Q5			2SJ347F	FET							
Q6			MCH3914(7)-H	FET							
Q7			KRX102U	TRANSISTOR							
Q8			KTC4075E(Y,GR)	TRANSISTOR							
Q9,10			2SC5108(Y)F	TRANSISTOR							
Q11			SSM3J05FU-F	FET							
Q12			2SK1830F	FET							
Q300			RD00HVS1-T113	FET							
Q500			2SC5108(Y)F	TRANSISTOR							
Q501			RT1P441U-T111	TRANSISTOR							
Q502			2SC5108(Y)F	TRANSISTOR							
Q504			3SK318	FET							
Q506			3SK318	FET							
Q507			RT1N441U-T111	TRANSISTOR							
Q510			RT1N441U-T111	TRANSISTOR							
Q511			KTC4075E(Y,GR)	TRANSISTOR							
Q701			2SK1830F	FET							
Q702			2SC4919	TRANSISTOR							
Q703			KTC4075E(Y,GR)	TRANSISTOR							
Q704,705			SSM3J05FU-F	FET							
Q707			RT1N440M-T111	TRANSISTOR							
Q710-712			RT1N441U-T111	TRANSISTOR							
Q713,714			2SB1694	TRANSISTOR							
Q715			SSM3K05FU	FET							
Q717,718			SSM3J05FU-F	FET							
Q719			KTC4075E(Y,GR)	TRANSISTOR							
Q720			2SJ645	FET							
Q721			RT1N441U-T111	TRANSISTOR							
Q722			KTC4075E(Y,GR)	TRANSISTOR							
Q723			SSM3K05FU	FET							
Q724			2SJ645	FET							
Q725			KTC4075E(Y,GR)	TRANSISTOR							
Q728			2SC4116(Y)F	TRANSISTOR							
Q729,730			KTC4075E(Y,GR)	TRANSISTOR							
Q731,732			2SC5108(Y)F	TRANSISTOR							
Q733			RT1N441U-T111	TRANSISTOR							
TH300-302			B57331V2104J	THERMISTOR							
TH501			NCP18WM474JOS	THERMISTOR							

## EXPLODED VIEW / 部件分解图

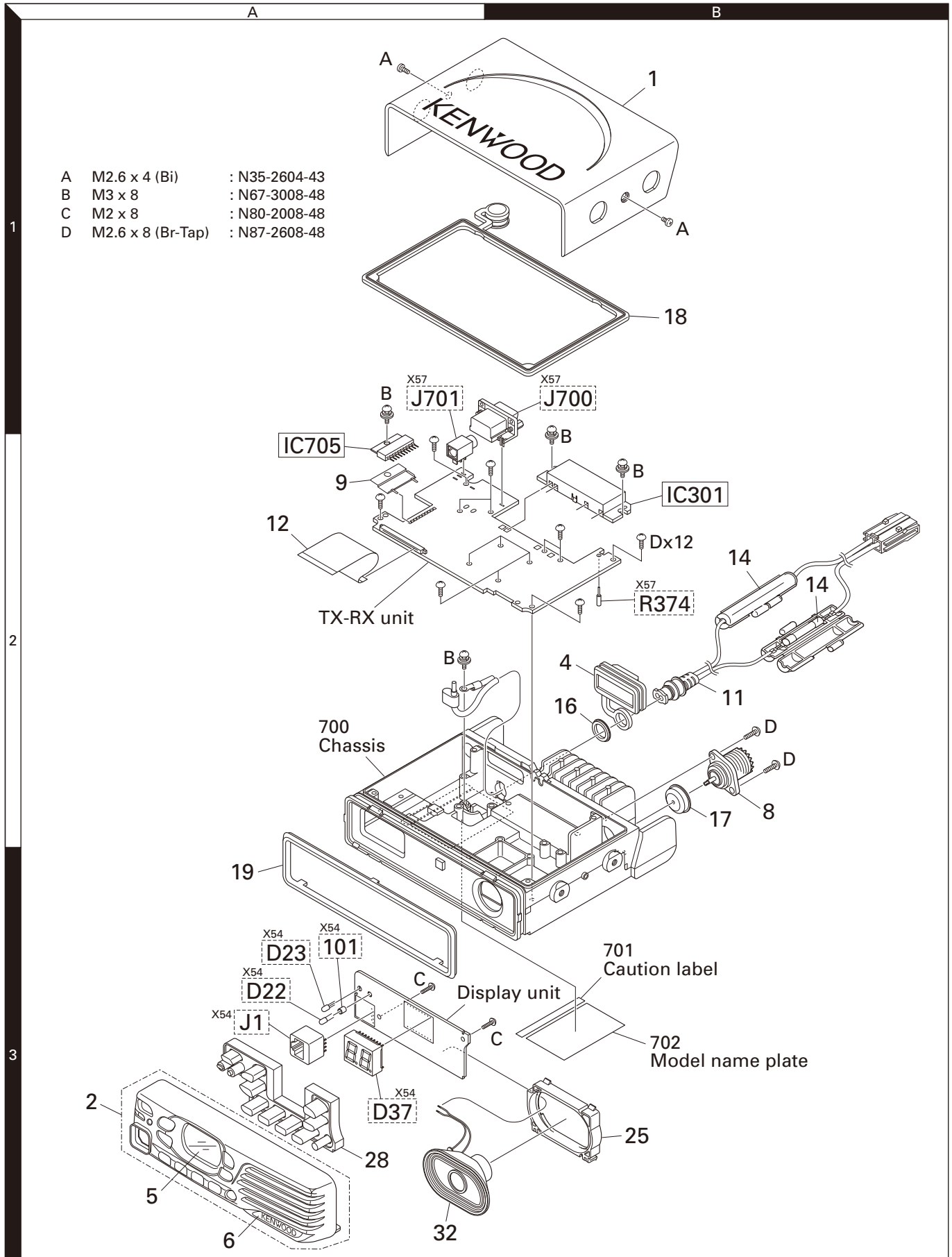

Parts with the exploded numbers larger than 700 are not supplied.  
 If a part reference number is listed in a box on the exploded view of the PCB, that part does not come with the PCB.  
 These parts must be ordered separately.

## PACKING / 包装

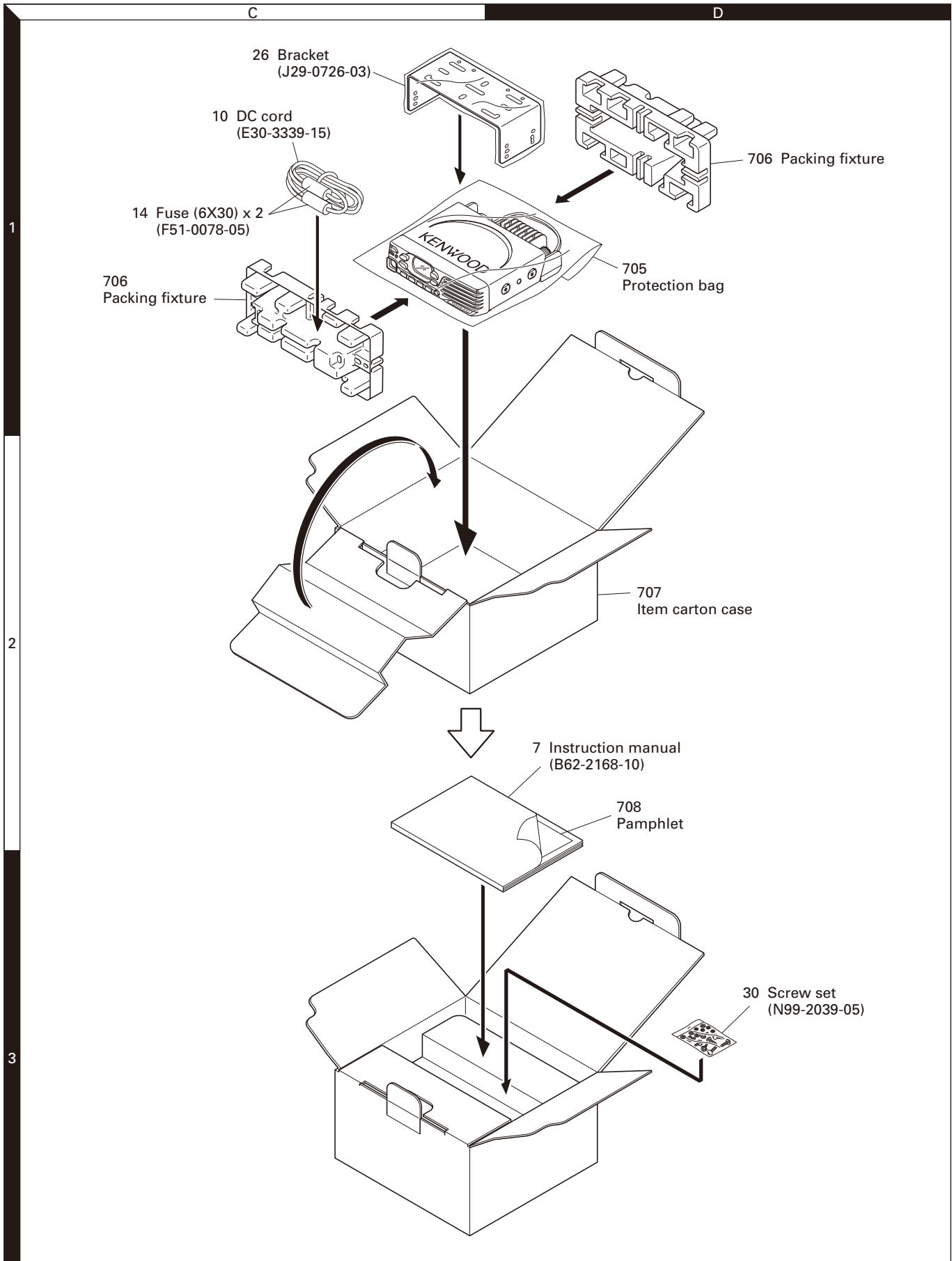

## ADJUSTMENT

### Test Equipment Required for Alignment

Test Equipment	Major Specifications	
1. Standard Signal Generator (SSG)	Frequency Range Modulation Output	136 to 174MHz Frequency modulation and external modulation -127dBm/0.1μV to greater than -7dBm/100mV
2. Power Meter	Input Impedance Operation Frequency Measurement Range	50Ω 136 to 174MHz or more Vicinity of 100W
3. Deviation Meter	Frequency Range	136 to 174MHz
4. Digital Volt Meter (DVM)	Measuring Range Input Impedance	1 to 20V DC High input impedance for minimum circuit loading
5. Oscilloscope		DC through 30MHz
6. High Sensitivity Frequency Counter	Frequency Range Frequency Stability	10Hz to 1000MHz 0.2ppm or less
7. Ammeter		20A or more
8. AF Volt Meter (AF VTVM)	Frequency Range Voltage Range	50Hz to 10kHz 1mV to 3V
9. Audio Generator (AG)	Frequency Range Output	20Hz to 20kHz or more 0 to 1V
10. Distortion Meter	Capability Input Level	3% or less at 1kHz 50mV to 10Vrms
11. 4Ω Dummy Load		Approx. 4Ω, 10W or more
12. Regulated Power Supply		13.6V, approx. 20A (adjustable from 9 to 17V) Useful if ammeter equipped
13. Spectrum Analyzer	Center Frequency	50kHz to 600MHz
14. Tracking Generator	Output Voltage	100mV or more

### Test cable for microphone input (E30-3360-28)

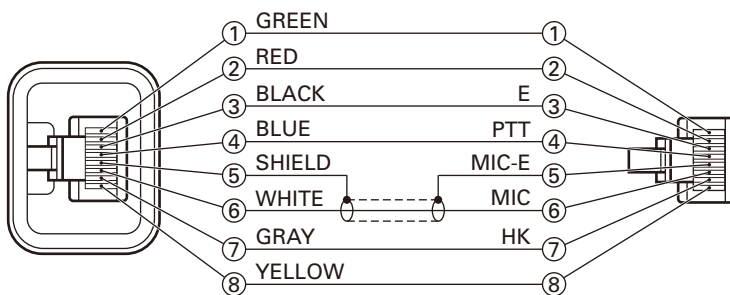

### MIC connector (Front panel view)

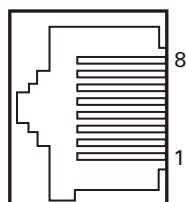

- 1 : MBL
- 2 : SB
- 3 : GND
- 4 : PTT
- 5 : ME
- 6 : MIC
- 7 : HOOK
- 8 : DM

### Tuning cable (E30-3383-05)

Adapter cable (E30-3383-05) is required for injecting an audio if PC tuning is used.  
See "PC Mode" section for the connection.

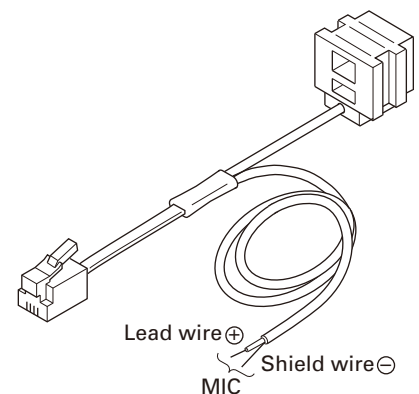

## 调整

### 调整所需的测试设备

测试设备	主要规格	
1. 标准信号发生器 (SSG)	频率范围 调制 输出	136 到 174MHz 调频和外部调制 -127dBm/0.1μV 到大于 -7dBm/100mV
2. 功率计	输入阻抗 操作频率 测量范围	50 Ω 136 到 174MHz 100W 左右
3. 频偏仪	频率范围	136 到 174MHz
4. 数字电压表 (DVM)	测量范围 输入阻抗	直流 1V 到 20V 为最小电路负载高输入阻抗
5. 示波器		直流到 30MHz
6. 高灵敏度频率计数器	频率范围 频率稳定性	10Hz 到 1000MHz 0.2ppm 或更低
7. 电流表		20A 或更高
8. 音频电压表 (AF VTVM)	频率范围 电压范围	50Hz 到 10kHz 1mV 到 3V
9. 音频发生器 (AG)	频率范围 输出	20Hz 到 20kHz 或更高 0V 到 1V
10. 失真测试仪	能力 输入电平	在 1kHz 时 3% 或更低 50mV 到 10Vrms
11. 4Ω 假负载		大约 4Ω, 10W 或更高
12. 可调电源		13.6V, 大约 20A (可调 9 到 17V) 配备了电流表时更好
13. 频谱分析仪	中心频率	50kHz 到 600MHz
14. 轨迹发生器	输出电压	100mV 或更高

### 用于麦克风输入的测试电缆 (E30-3360-28)

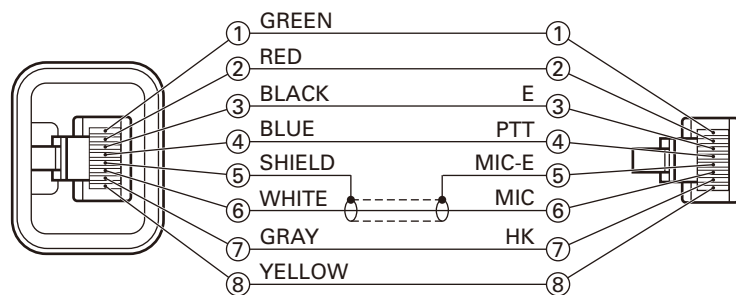

### MIC 连接器 (前面板视图)

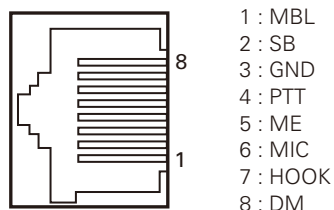

### 调谐电缆 (E30-3383-05)

如果使用 PC 调谐, 则输入音频需要适配器电缆 (E30-3383-05)。有关连接详情, 请参看“PC 模式”。

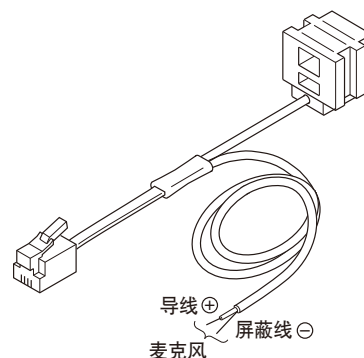



## ADJUSTMENT / 调整

## Test Frequency

Channel	RX (MHz)	TX (MHz)
1	155.05	155.10
2	136.05	136.10
3	173.95	173.90
4	155.00	155.00
5	155.20	155.20
6	155.40	155.40
7~16	-	-

## 测试频率

信道	接收 (MHz)	发射 (MHz)
1	155.05	155.10
2	136.05	136.10
3	173.95	173.90
4	155.00	155.00
5	155.20	155.20
6	155.40	155.40
7~16	-	-

## Test Signaling

No.	RX	TX
1	None	None
2	None	20Hz Square wave
3	QT: 67.0Hz	QT: 67.0Hz
4	QT: 151.4Hz	QT: 151.4Hz
5	QT: 210.7Hz	QT: 210.7Hz
6	QT: 254.1Hz	QT: 254.1Hz
7	DQT: D023N	DQT: D023N
8	DQT: D754I	DQT: D754I
9	DTMF: 159D	DTMF: 159D
10	None	DTMF Code 9
11	None	MSK (1010..)
12	FleetSync: 100-1000	Fleet Sync: 100-1000
13	None	Single Tone : 1000Hz
14	2-Tone A: 304.7Hz, B: 3106.0Hz	2-Tone A: 304.7Hz, B: 3106.0Hz
15	None	DTMF Tone: 1477Hz
16	Single Tone: 979.9Hz	Single Tone: 979.9Hz
17	None	MSK PN9

## 测试信令

编号	接收	发射
1	无	无
2	无	20Hz 方波
3	QT: 67.0Hz	QT: 67.0Hz
4	QT: 151.4Hz	QT: 151.4Hz
5	QT: 210.7Hz	QT: 210.7Hz
6	QT: 254.1Hz	QT: 254.1Hz
7	DQT: D023N	DQT: D023N
8	DQT: D754I	DQT: D754I
9	DTMF: 159D	DTMF: 159D
10	无	DTMF 代码 9
11	无	MSK(1010..)
12	Fleet Sync: 100-1000	Fleet Sync: 100-1000
13	无	单音: 1000Hz
14	2-音 A:304.7Hz, B:3106.0Hz	2-音 A:304.7Hz, B:3106.0Hz
15	无	DTMF 音: 1477Hz
16	单音: 979.9Hz	单音: 979.9Hz
17	无	MSK PN9

## Single or 5 Reference Level Adjustment Frequency

Tuning point	RX (MHz)	TX (MHz)
Low	136.05	136.10
Low'	145.55	145.50
Center	155.05	155.10
High'	164.55	164.50
High	173.95	173.90

## 单点或 5 点参考电平调整频率

调谐点	接收 (MHz)	发射 (MHz)
低	136.05	136.10
低'	145.55	145.50
中心	155.05	155.10
高'	164.55	164.50
高	173.95	173.90

## ADJUSTMENT

## Common Section

Item	Condition	Measurement			Adjustment			Specifications / Remarks
		Test-equipment	Unit	Terminal	Unit	Parts	Method	
1. Setting	1) Power supply voltage DC power supply terminal : 13.6V							
2. Rx Assist (Auto)	1) CH: RX low CH: RX low' CH: RX center CH: RX high' CH: RX high					FPU	"Voltage Level" indicator on the PC window shows VCO lock voltage. Change the adjust- ment value to get VCO lock voltage within the limit of the specified volt- age.	2.5V±0.2V
3. Tx Assist (Auto)	1) CH: TX low CH: TX low' CH: TX center CH: TX high' CH: TX high 2) Transmit						<b>Note:</b> Confirm the VCO lock voltage approxi- mately 3 seconds after the adjustment value is changed.	
4. VCO lock voltage • RX	1) CH: RX low CH: RX low' CH: RX center CH: RX high' CH: RX high	Power meter DVM	TX-RX	LV			Check	2.5V±0.2V
• TX	2) CH: TX low CH: TX low' CH: TX center CH: TX high' CH: TX high 3) Transmit							

## Transmitter Section

Item	Condition	Measurement			Adjustment			Specifications / Remarks
		Test-equipment	Unit	Terminal	Unit	Parts	Method	
1. Frequency (Narrow)	1) TEST CH: TX center 2) Transmit	Frequency counter		ANT		FPU	Adjust to center frequency	Within ±100Hz
2. High Power (Auto) (Narrow)	1) CH: TX low CH: TX low' CH: TX center CH: TX high' CH: TX high 2) Transmit	Power meter Ammeter					25W	±1.0W 8.0A or less

## 调 整

## 共通部分

项 目	条 件	测 量			调 整			规 格 / 备 注
		测量装置	单元	端子	单元	部件	方 法	
1. 设定	1) 电源电压 DC 电源端子：13.6V							
2. 接收辅助 (自动)	1) CH: RX 低 CH: RX 低' CH: RX 中心 CH: RX 高' CH: RX 高					FPU	PC 窗口上的“电压电平”指示显示了 VCO 锁定电压。 更改调整值，以获得指定电压范围内的 VCO 锁定电压。  <b>注意：</b> 在更改调整值约 3 秒后确认 VCO 锁定电压。	2. 5V ± 0.2V
3. 发射辅助 (自动)	1) CH: TX 低 CH: TX 低' CH: TX 中心 CH: TX 高' CH: TX 高 2) 发射							
4. VCO 锁定电压  • 接收	1) CH: RX 低 CH: RX 低' CH: RX 中心 CH: RX 高' CH: RX 高	功率计 DVM	TX-RX	LV			检查	2. 5V ± 0.2V
• 发射	2) CH: TX 低 CH: TX 低' CH: TX 中心 CH: TX 高' CH: TX 高 3) 发射							

## 发射部分

项 目	条 件	测 量			调 整			规 格 / 备 注
		测量装置	单元	端子	单元	部件	方 法	
1. 频率 (窄)	1) 测试 CH: TX 中心 2) 发射	频率计数器		ANT		FPU	调整到中心频率	±100Hz 以内
2. 高功率 (自动) (窄)	1) CH: TX 低 CH: TX 低' CH: TX 中心 CH: TX 高' CH: TX 高 2) 发射	功率计 电流表					25W	±1.0W 8.0A 或更低

## ADJUSTMENT

Item	Condition	Measurement			Adjustment			Specifications / Remarks
		Test-equipment	Unit	Terminal	Unit	Parts	Method	
3. Low Power (Auto) (Narrow)	1) CH: TX low CH: TX low' CH: TX center CH: TX high' CH: TX high 2) Transmit	Power meter Ammeter		ANT		FPU	5W	±0.5W 4.0A or less
4. DQT Balance (Wide)	1) CH: TX low CH: TX low' CH: TX center CH: TX high' CH: TX high 2) Deviation meter filter LPF: 3kHz HPF: OFF 3) Transmit	Deviation meter					The Deviation of 20Hz frequency is fixed. (FL=30, FLC=35, FC=40, FCH=45, FH=50) Change the 1kHz adjustment value to become the same deviation of 20Hz within the specified range.	±0.4dB
5. Maximum Deviation (Wide)	1) CH: TX low CH: TX low' CH: TX center CH: TX high' CH: TX high 2) Deviation meter filter LPF: 15kHz HPF: OFF 3) Transmit	Deviation meter Oscilloscope AG AF VTVM		ANT			4.2kHz (According to the large +, -)	±0.1kHz  <b>Note:</b> FPU auto input 1kHz/50mV
6. MIC sensitivity	1) CH: TX center AG: 1kHz/5mV 2) Deviation meter filter LPF: 15kHz 3) Transmit			ANT MIC			Check	2.2kHz~3.6kHz
7. DQT Deviation (Wide)	1) CH: TX center 2) Deviation meter filter LPF: 3kHz HPF: OFF 3) Transmit			ANT		FPU	0.75kHz	±0.05kHz
8. QT Deviation (Wide)	1) CH: TX center 2) Deviation meter filter LPF: 3kHz HPF: OFF 3) Transmit						0.75kHz	±0.05kHz
9. DTMF Deviation (Wide)	1) CH: TX center 2) Deviation meter filter LPF: 15kHz HPF: OFF 3) Transmit						3.0kHz	±0.1kHz
10. MSK Deviation (Wide)	1) CH: TX center 2) Deviation meter filter LPF: 15kHz HPF: OFF 3) Transmit						3.0kHz	±0.1kHz

## 调 整

项 目	条 件	测 量			调 整			规 格 / 备 注
		测量装置	单元	端子	单元	部件	方 法	
3. 低功率 (自动) (窄)	1) CH: TX 低 CH: TX 低' CH: TX 中心 CH: TX 高' CH: TX 高 2) 发射	功率计 电流表		ANT		FPU	5W	±0.5W 4.0A 或更低
4. DQT 平衡 (宽)	1) CH: TX 低 CH: TX 低' CH: TX 中心 CH: TX 高' CH: TX 高 2) 频偏仪滤波器 LPF: 3kHz HPF: OFF 3) 发射	频偏仪					20Hz 频率的频偏固定。(FL=30, FLC=35, FC=40, FCH=45, FH=50) 更改 1kHz 调整值, 变成指定范围内 20Hz 的相同频偏。	±0.4dB
5. 最大频偏 (宽)	1) CH: TX 低 CH: TX 低' CH: TX 中心 CH: TX 高' CH: TX 高 2) 频偏仪滤波器 LPF: 15kHz HPF: OFF 3) 发射	频偏仪 示波器 AG AF VTVM		ANT			4. 2kHz (按照较大+, -)	±0.1kHz <b>注意:</b> FPU 自动输入 1kHz/50mV
6. MIC 灵敏度	1) CH: TX 中心 AG: 1kHz/5mV 2) 频偏仪滤波器 LPF: 15kHz 3) 发射			ANT MIC			检查	2. 2kHz ~ 3.6kHz
7. DQT 频偏 (宽)	1) CH: TX 中心 2) 频偏仪滤波器 LPF: 3kHz HPF: OFF 3) 发射			ANT		FPU	0.75kHz	±0.05kHz
8. QT 频偏 (宽)	1) CH: TX 中心 2) 频偏仪滤波器 LPF: 3kHz HPF: OFF 3) 发射						0.75kHz	±0.05kHz
9. DTMF 频偏 (宽)	1) CH: TX 中心 2) 频偏仪滤波器 LPF: 15kHz HPF: OFF 3) 发射						3.0kHz	±0.1kHz
10. MSK 频偏 (宽)	1) CH: TX 中心 2) 频偏仪滤波器 LPF: 15kHz HPF: OFF 3) 发射						3.0kHz	±0.1kHz

## ADJUSTMENT

## Receiver Section

Item	Condition	Measurement			Adjustment			Specifications / Remarks
		Test-equipment	Unit	Terminal	Unit	Parts	Method	
1. Rx Sensitivity (Semi-auto)	1) CH: RX low (Wide) CH: RX low' (Wide) CH: RX center (Wide) CH: RX high' (Wide) CH: RX high (Wide) 2) SSG output: -90dBm (7.08 $\mu$ V) Mod: 1kHz Dev: $\pm$ 3.0kHz	SSG Oscilloscope AF VTVM Distortion meter		ANT EXT.SP		FPU	Auto tuning	
2. Squelch open (5) (Wide)	1) CH: RX low CH: RX low' CH: RX center CH: RX high' CH: RX high 2) SSG output: -119dBm (0.25 $\mu$ V) Mod: 1kHz Dev: $\pm$ 3.0kHz						Adjust to open the squelch.	Squelch open
(Narrow)	1) CH: RX low CH: RX low' CH: RX center CH: RX high' CH: RX high 2) SSG output: -119dBm (0.25 $\mu$ V) Mod: 1kHz Dev: $\pm$ 1.5kHz							
3. Squelch tight (Wide)	1) CH: RX low CH: RX low' CH: RX center CH: RX high' CH: RX high 2) SSG output: -114dBm (0.44 $\mu$ V) Mod: 1kHz Dev: $\pm$ 3.0kHz							
(Narrow)	1) CH: RX low CH: RX low' CH: RX center CH: RX high' CH: RX high 2) SSG output: -114dBm (0.44 $\mu$ V) Mod: 1kHz Dev: $\pm$ 1.5kHz							

## 调 整

## 接收部分

项 目	条 件	测 量			调 整			规 格 / 备 注
		测量装置	单元	端子	单元	部件	方 法	
1. 接收灵敏度 (半自动)	1) CH: RX 低 (宽) CH: RX 低' (宽) CH: RX 中心 (宽) CH: RX 高' (宽) CH: RX 高 (宽) 2) SSG 输出: -90dBm (7.08μV) 调制: 1kHz 频偏: ±3.0kHz	SSG 示波器 AF VTVM 失真测试仪		ANT EXT. SP		FPU	自动调谐	
2. 静噪开 (5) (宽)	1) CH: RX 低 CH: RX 低' CH: RX 中心 CH: RX 高' CH: RX 高 2) SSG 输出: -119dBm (0.25μV) 调制: 1kHz 频偏: ±3.0kHz						调整到打开静噪。	静噪开
(窄)	1) CH: RX 低 CH: RX 低' CH: RX 中心 CH: RX 高' CH: RX 高 2) SSG 输出: -119dBm (0.25μV) 调制: 1kHz 频偏: ±1.5kHz							
3. 静噪深 (宽)	1) CH: RX 低 CH: RX 低' CH: RX 中心 CH: RX 高' CH: RX 高 2) SSG 输出: -114dBm (0.44μV) 调制: 1kHz 频偏: ±3.0kHz							
(窄)	1) CH: RX 低 CH: RX 低' CH: RX 中心 CH: RX 高' CH: RX 高 2) SSG 输出: -114dBm (0.44μV) 调制: 1kHz 频偏: ±1.5kHz							



## ADJUSTMENT

Item	Condition	Measurement			Adjustment			Specifications / Remarks
		Test-equipment	Unit	Terminal	Unit	Parts	Method	
4. Low RSSI (Wide)	1) CH: RX low CH: RX low' CH: RX center CH: RX high' CH: RX high 2) SSG output: -119dBm (0.25μV) Mod: 1kHz Dev: ±3.0kHz	SSG Oscillo- scope AF VTVM Distortion meter		ANT EXT.SP		FPU	Auto tuning	
	(Narrow)							
5. High RSSI (Wide)	1) CH: RX low CH: RX low' CH: RX center CH: RX high' CH: RX high 2) SSG output: -80dBm (22.4μV) Mod: 1kHz Dev: ±3.0kHz							
	(Narrow)							

### Adjustment Points

#### ■ Component side

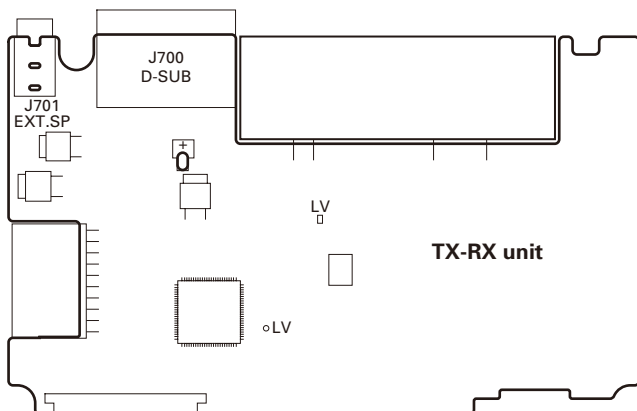

#### ■ Foil side

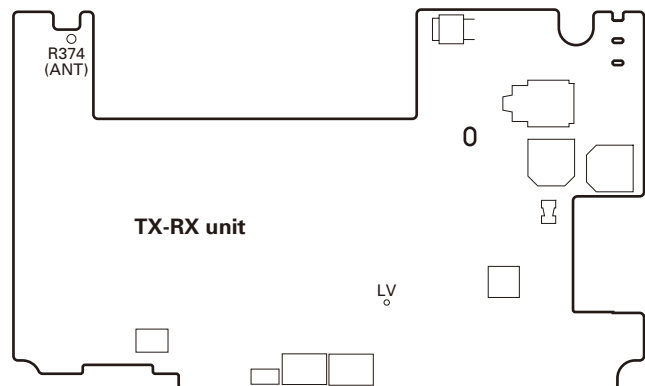

## 调 整

项 目	条 件	测 量			调 整			规 格 / 备 注
		测量装置	单元	端子	单元	部件	方 法	
4. 低 RSSI (宽)	1) CH: RX 低 CH: RX 低' CH: RX 中心 CH: RX 高' CH: RX 高 2) SSG 输出: $-119\text{dBm}$ ( $0.25\mu\text{V}$ ) 调制: 1kHz 频偏: $\pm 3.0\text{kHz}$	SSG 示波器 AF VTVM 失真测试仪		ANT EXT. SP		FPU	自动调谐	
	(窄)							
5. 高 RSSI (宽)	1) CH: RX 低 CH: RX 低' CH: RX 中心 CH: RX 高' CH: RX 高 2) SSG 输出: $-80\text{dBm}$ ( $22.4\mu\text{V}$ ) 调制: 1kHz 频偏: $\pm 3.0\text{kHz}$							
	(窄)							

## 调整点

## ■ 元件面

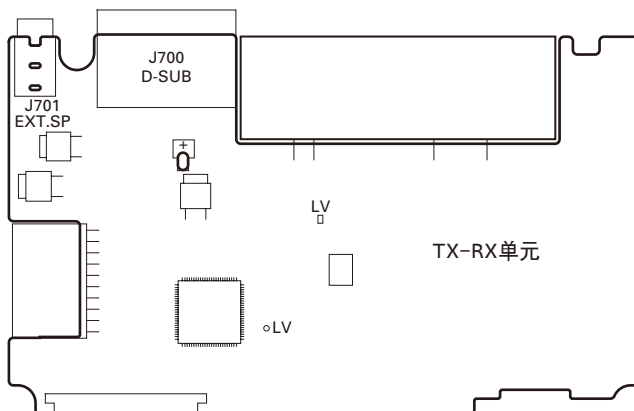

## ■ 箔面

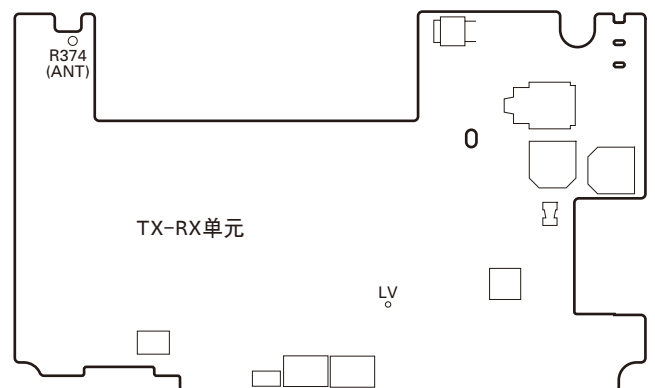

# TERMINAL FUNCTION

## Display unit (X54-3670-20)

Pin No.	Name	I/O	Function
<b>CN1</b>			
1	POWER	O	Detection output of power switch
2	MKEY	I/O	MIC data detection
3	PTT/TXD	I/O	PTT/PC serial data
4	HOOK/RXD	I/O	HOOK/PC serial data
5	ME	-	MIC ground
6	MIC	O	MIC signal output
7	GND	-	Ground
8	NC	-	No connection
9	LELH	I	LED latch input
10	LECL	I	LED clock input
11	LECE	I	LED enable input
12	LEDI	I	LED data input
13	5C	I	5V DC power supply
14	KMI3	O	Key matrix output 3
15	KMI2	O	Key matrix output 2
16	KMI1	O	Key matrix output 1
17	KMO3	I	Key matrix input 3
18	KMO2	I	Key matrix input 2
19	KMO1	I	Key matrix input 1
20	BLED	I	Blue LED control signal input
21	GLED	I	Green LED control signal input
22	RLED	I	Red LED control signal input
23	MBL	I	MIC backlight control signal input
24	LEDM	I	LED dimmer input
25	SP-	I	Speaker input -
26	SP-	I	Speaker input -
27	SP+	I	Speaker input +
28	SP+	I	Speaker input +
29	SB	I	Battery voltage DC supply
30	SB	I	Battery voltage DC supply
<b>J1 (MIC jack)</b>			
1	MBL	O	Backlight of Microphone
2	SB	O	Battery voltage DC supply
3	GND	-	Ground
4	PTT	I	PTT/PC serial data from radio
5	ME	-	MIC ground
6	MIC	I	MIC signal input
7	HOOK	I	HOOK/PC serial data to radio
8	DM	I/O	MIC data detection

## TX-RX unit (X57-7683-01)

Pin No.	Name	I/O	Function
<b>CN702</b>			
1	GND	-	Ground
2	9C	O	9V DC power supply
3	FNC5	I/O	Programmable I/O (programmed by FPU)
4	FNC6	I/O	Programmable I/O (programmed by FPU)
5	FNC2	I/O	Programmable I/O (programmed by FPU)
6	FNC7	I/O	Programmable I/O (programmed by FPU)
7	FNC8	I/O	Programmable I/O (programmed by FPU)
8	FNC3	I/O	Programmable I/O (programmed by FPU)
9	FNC1	I/O	Programmable I/O (programmed by FPU)
10	NC	-	No connection
11	5C	O	5V DC power supply
12	TXAFO	O	TX audio output to scrambler board
13	DATAI	I	External transmit signal input
14	DETO	O	FM detector output
15	NC	-	No connection
16	ALTI	I	External alert tone signal input
17	TXAFI	I	TX audio input from scrambler board
18	RXAFO	O	RX audio output to scrambler board
19	RXAFI	I	RX audio input from scrambler board
20	FNC4	I/O	Programmable I/O (programmed by FPU)
<b>CN724</b>			
1	SB	O	Battery voltage DC supply
2	SB	O	Battery voltage DC supply
3	SP+	O	Speaker output +
4	SP+	O	Speaker output +
5	SP-	O	Speaker output -
6	SP-	O	Speaker output -
7	LEDM	O	LED dimmer output
8	MBL	O	MIC backlight control signal output
9	RLED	O	Red LED control signal output
10	GLED	O	Green LED control signal output
11	BLED	O	Blue LED control signal output
12	KMO1	O	Key matrix output 1
13	KMO2	O	Key matrix output 2
14	KMO3	O	Key matrix output 3
15	KMI1	I	Key matrix input 1
16	KMI2	I	Key matrix input 2
17	KMI3	I	Key matrix input 3
18	5C	O	5V DC power supply

## 端子功能

显示单元 (X54-3670-20)

管脚号	名称	输入/输出	功能
<b>CN1</b>			
1	POWER	输出	电源开关的检测输出
2	MKEY	输入/输出	MIC 数据检测
3	PTT/TXD	输入/输出	PTT/PC 串行数据
4	HOOK/RXD	输入/输出	HOOK/PC 串行数据
5	ME	-	MIC 接地
6	MIC	输出	MIC 信号输出
7	GND	-	接地
8	NC	-	未连接
9	LELH	输入	LED 闭锁输入
10	LECL	输入	LED 时钟输入
11	LECE	输入	LED 启用输入
12	LEDI	输入	LED 数据输入
13	5C	输入	5V DC 电源
14	KMI3	输出	键矩阵输出 3
15	KMI2	输出	键矩阵输出 2
16	KMI1	输出	键矩阵输出 1
17	KMO3	输入	键矩阵输入 3
18	KMO2	输入	键矩阵输入 2
19	KMO1	输入	键矩阵输入 1
20	BLED	输入	蓝色 LED 控制信号输入
21	GLED	输入	绿色 LED 控制信号输入
22	RLED	输入	红色 LED 控制信号输入
23	MBL	输入	MIC 背光控制信号输入
24	LEDM	输入	LED 调光器输入
25	SP-	输入	扬声器输入 -
26	SP-	输入	扬声器输入 -
27	SP+	输入	扬声器输入 +
28	SP+	输入	扬声器输入 +
29	SB	输入	电池电压 DC 电源
30	SB	输入	电池电压 DC 电源
<b>J1 ( MIC 插孔 )</b>			
1	MBL	输出	麦克风的背光
2	SB	输出	电池电压 DC 电源
3	GND	-	接地
4	PTT	输入	来自通信机的 PTT/PC 串行数据
5	ME	-	MIC 接地
6	MIC	输入	MIC 信号输入
7	HOOK	输入	送到通信机的 HOOK/PC 串行数据
8	DM	输入/输出	MIC 数据检测

TX-RX 单元 (X57-7683-01)

管脚号	名称	输入/输出	功能
<b>CN702</b>			
1	GND	-	接地
2	9C	输出	9V DC 电源
3	FNC5	输入/输出	可编程 I/O (由 FPU 编程)
4	FNC6	输入/输出	可编程 I/O (由 FPU 编程)
5	FNC2	输入/输出	可编程 I/O (由 FPU 编程)
6	FNC7	输入/输出	可编程 I/O (由 FPU 编程)
7	FNC8	输入/输出	可编程 I/O (由 FPU 编程)
8	FNC3	输入/输出	可编程 I/O (由 FPU 编程)
9	FNC1	输入/输出	可编程 I/O (由 FPU 编程)
10	NC	-	未连接
11	5C	输出	5V DC 电源
12	TXAFO	输出	对讲频器板的 TX 音频输出
13	DATAI	输入	外部发射信号输入
14	DETO	输出	FM 检测器输出
15	NC	-	未连接
16	ALTI	输入	外部提示音信号输入
17	TXAFI	输入	来自扰频器板的 TX 音频输入
18	RXAFO	输出	对讲频器板的 RX 音频输出
19	RXAFI	输入	来自扰频器板的 RX 音频输入
20	FNC4	输入/输出	可编程 I/O (由 FPU 编程)
<b>CN724</b>			
1	SB	输出	电池电压 DC 电源
2	SB	输出	电池电压 DC 电源
3	SP+	输出	扬声器输出 +
4	SP+	输出	扬声器输出 +
5	SP-	输出	扬声器输出 -
6	SP-	输出	扬声器输出 -
7	LEDM	输出	LED 调光器输出
8	MBL	输出	MIC 背光控制信号输出
9	RLED	输出	红色 LED 控制信号输出
10	GLED	输出	绿色 LED 控制信号输出
11	BLED	输出	蓝色 LED 控制信号输出
12	KMO1	输出	键矩阵输出 1
13	KMO2	输出	键矩阵输出 2
14	KMO3	输出	键矩阵输出 3
15	KMI1	输入	键矩阵输入 1
16	KMI2	输入	键矩阵输入 2
17	KMI3	输入	键矩阵输入 3
18	5C	输出	5V DC 电源

## TERMINAL FUNCTION

Pin No.	Name	I/O	Function
19	LEDI	O	LED data output
20	LECE	O	LED enable output
21	LECL	O	LED clock output
22	LELH	O	LED latch output
23	LERE	O	LED reset output
24	GND	-	Ground
25	MIC	I	MIC signal input
26	ME	-	MIC ground
27	HOOK/RXD	I/O	HOOK/PC serial data
28	PTT/TXD	I/O	PTT/PC serial data
29	MKEY	I/O	MIC data detection
30	POWER	I	Detection input of power switch
<b>J700 (ACC 15-pin)</b>			
1	SB	O	Battery voltage DC supply DC 13.6V±15%, 1.0A max.
2	IGN	I	Ignition sense input, 16.0V max.
3	PA	O	Speaker output
4	DO	O	FM detector output, 500mVp-p
5	DI	I	External transmit signal input 200±50mVp-p
6	FNC1	I/O	Programmable I/O (programmed by FPU) 1.0mA max.
7	FNC2	I/O	Programmable I/O (programmed by FPU) 1.0mA max.
8	FNC3	I/O	Programmable I/O (programmed by FPU) 1.0mA max.
9	FNC4	I/O	Programmable I/O (programmed by FPU) 1.0mA max.
10	FNC5	I/O	Programmable I/O (programmed by FPU) 1.0mA max.
11	FNC6	I/O	Programmable I/O (programmed by FPU) 1.0mA max.
12	5C	O	5V DC power supply, 100mA max.
13	HR1	O	Horn alert signal output, 16.0V/2.0A max.
14	HR2	O	Horn alert signal output, 16.0V/2.0A max.
15	GND	-	Ground

### Function Port Assignment

	Scrambler	
	Name	I/O
FNC1	None	I
FNC2	None	I
FNC3	TXS	O
FNC4	Scrambler	O
FNC5	Scrambler code 1(1)	O
FNC6	Scrambler code 2(2)	O
FNC7	Scrambler code 3(4)	O
FNC8	Scrambler code 4(8)	O
GPS (NMEA)		
	Name	I/O
FNC1	None	O
FNC2	GPS (NMEA input)	I
FNC3	-	-
FNC4	-	-
FNC5	-	-
FNC6	-	-
FNC7	-	-
FNC8	-	-

## 端子功能

管脚号	名称	输入/输出	功能
19	LEDI	输出	LED 数据输出
20	LECE	输出	LED 启用输出
21	LECL	输出	LED 时钟输出
22	LELH	输出	LED 闭锁输出
23	LERE	输出	LED 复位输出
24	GND	-	接地
25	MIC	输入	MIC 信号输入
26	ME	-	MIC 接地
27	HOOK/RXD	输入/输出	HOOK/PC 串行数据
28	PTT/TXD	输入/输出	PTT/PC 串行数据
29	MKEY	输入/输出	MIC 数据检测
30	POWER	输入	电源开关的检测输入
<b>J700(ACC 15 针)</b>			
1	SB	输出	电池电压 DC 电源 DC 13.6V±15%, 最大 1.0A
2	IGN	输入	点火感应输入, 最大 16.0V
3	PA	输出	扬声器输出
4	DO	输出	FM 检测输出, 500mVp-p
5	DI	输入	外部发射信号输入 200±50mVp-p
6	FNC1	输入/输出	可编程 I/O(由 FPU 编程) 最大 1.0mA
7	FNC2	输入/输出	可编程 I/O(由 FPU 编程) 最大 1.0mA
8	FNC3	输入/输出	可编程 I/O(由 FPU 编程) 最大 1.0mA
9	FNC4	输入/输出	可编程 I/O(由 FPU 编程) 最大 1.0mA
10	FNC5	输入/输出	可编程 I/O(由 FPU 编程) 最大 1.0mA
11	FNC6	输入/输出	可编程 I/O(由 FPU 编程) 最大 1.0mA
12	5C	输出	5V DC 电源, 最大 100mA
13	HR1	输出	喇叭提示信号输出, 最大 16.0V/2.0A
14	HR2	输出	喇叭提示信号输出, 最大 16.0V/2.0A
15	GND	-	接地

## 功能端口分配

	扰频器	
	名称	输入/输出
FNC1	无	输入
FNC2	无	输入
FNC3	TXS	输出
FNC4	扰频器	输出
FNC5	扰频器代码 1(1)	输出
FNC6	扰频器代码 2(3)	输出
FNC7	扰频器代码 3(4)	输出
FNC8	扰频器代码 4(8)	输出
	GPS(NMEA)	
	名称	输入/输出
FNC1	无	输出
FNC2	GPS(NMEA 输入)	输入
FNC3	-	-
FNC4	-	-
FNC5	-	-
FNC6	-	-
FNC7	-	-
FNC8	-	-

# TK-7302 PC BOARD / PC板

**DISPLAY UNIT (X54-3670-20) Component side view (J79-0249-19)**

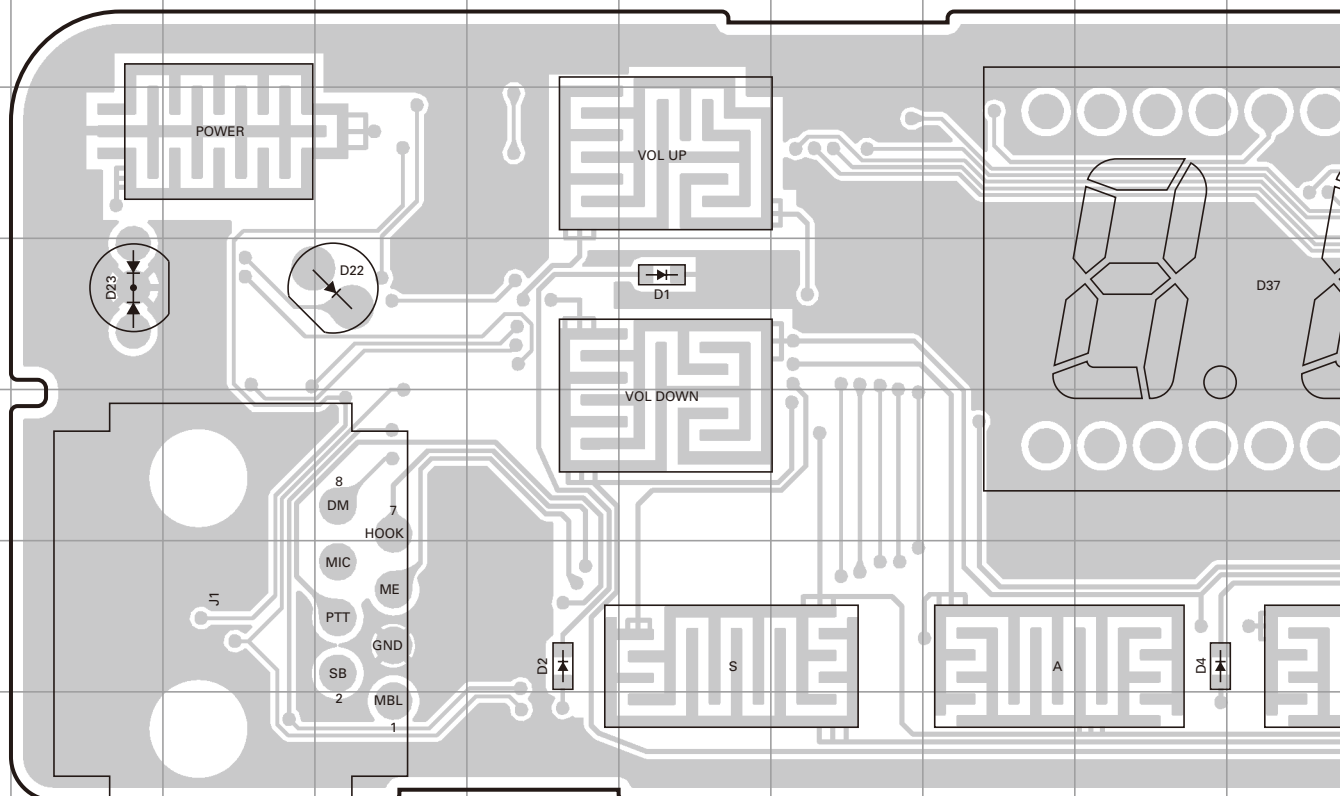

**DISPLAY UNIT (X54-3670-20) Foil side view (J79-0249-19)**

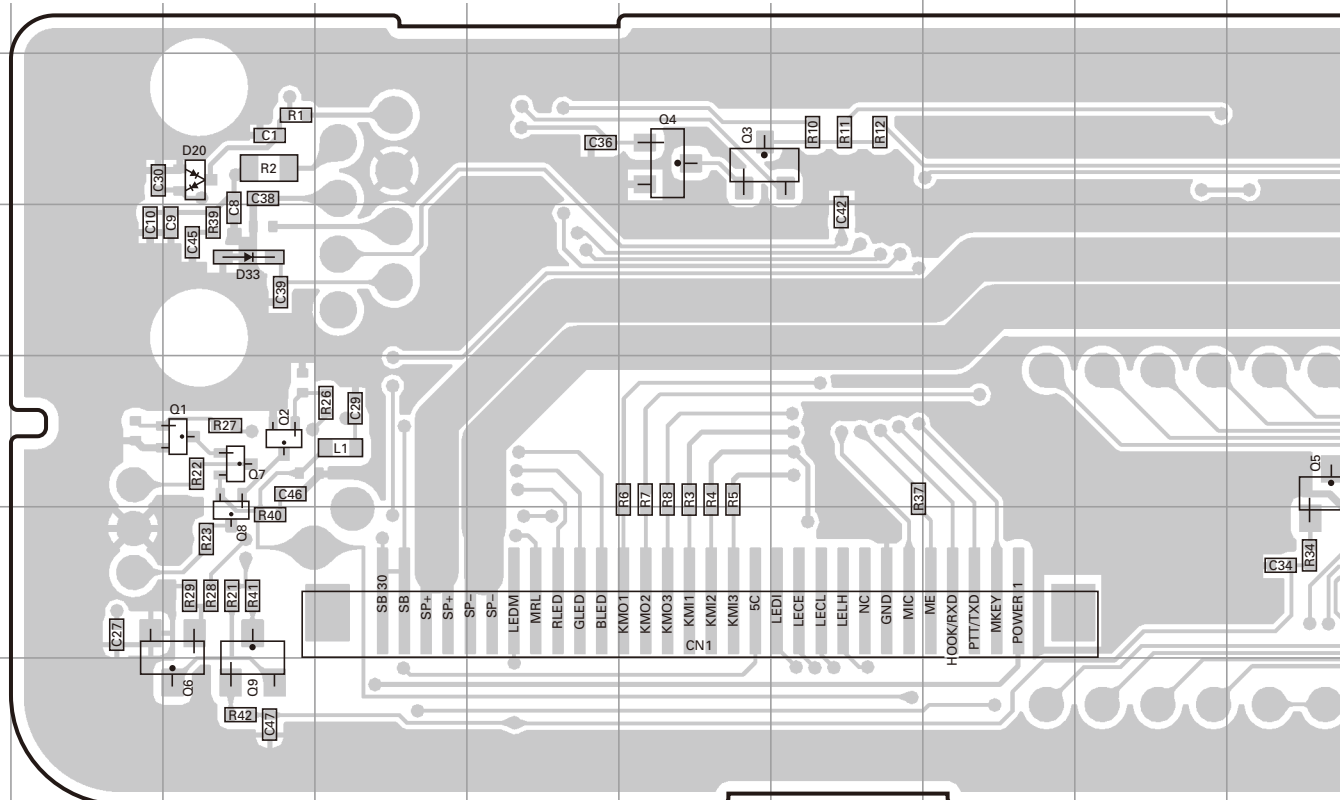



# PC BOARD / PC板 TK-7302

## DISPLAY UNIT (X54-3670-20) Component side view (J79-0249-19)

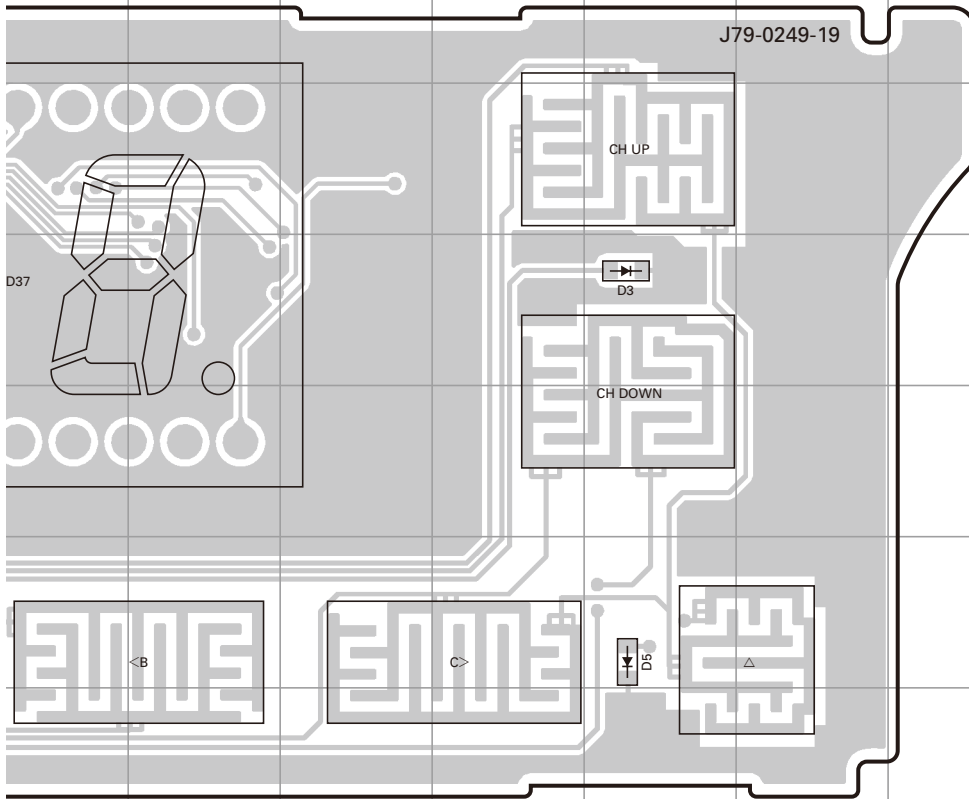

Ref. No.	Address
D1	4F
D2	6E
D3	4N
D4	6I
D5	6N
D22	4D
D23	4B
D37	4J

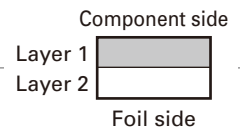

## DISPLAY UNIT (X54-3670-20) Foil side view (J79-0249-19)

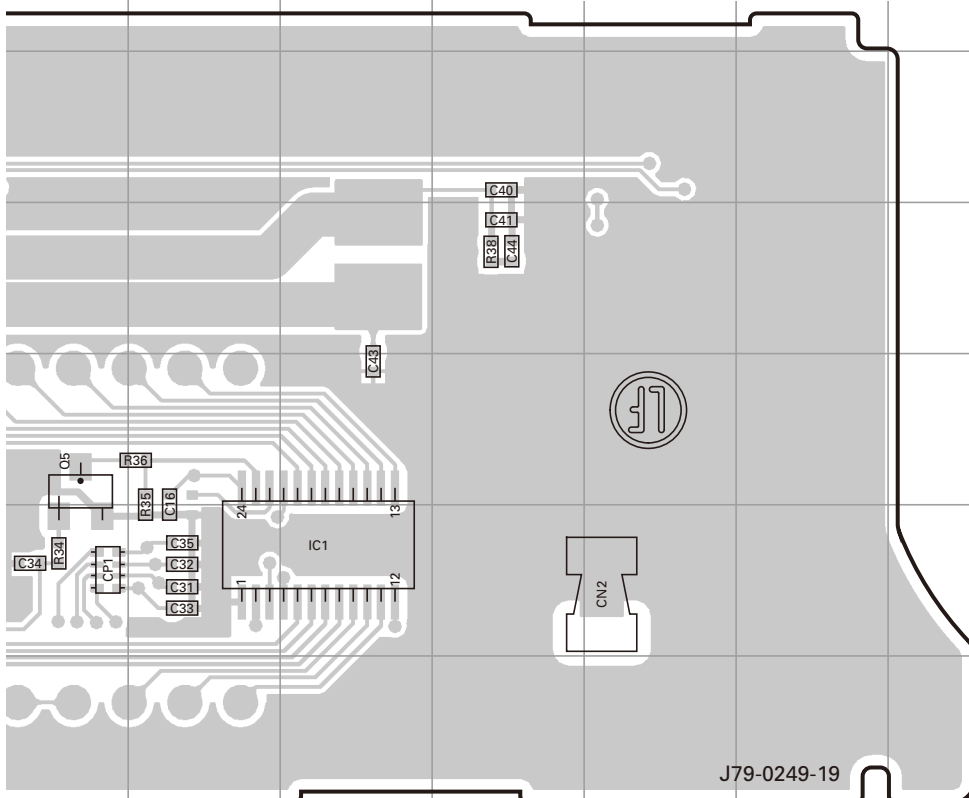

Ref. No.	Address
IC1	12L
Q1	11C
Q2	11C
Q3	9F
Q4	9F
Q5	11J
Q6	13C
Q7	11C
Q8	12C
Q9	13C
D20	9C
D33	10C

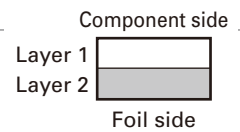

# TK-7302 PC BOARD / PC板

## TX-RX UNIT (X57-7683-01) Component side view (J79-0247-29)

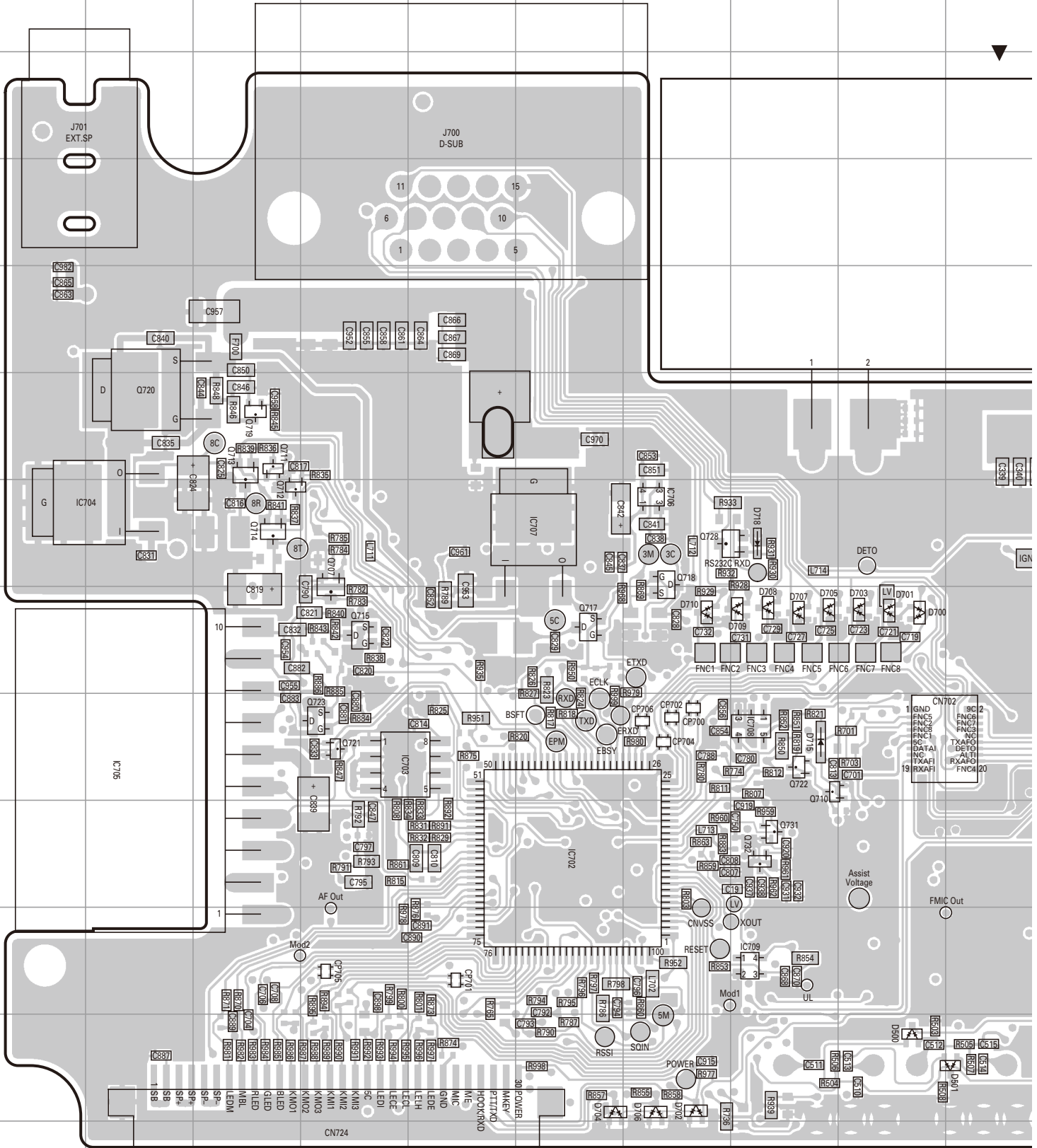

# PC BOARD / PC板 TK-7302

## TX-RX UNIT (X57-7683-01) Component side view (J79-0247-29)

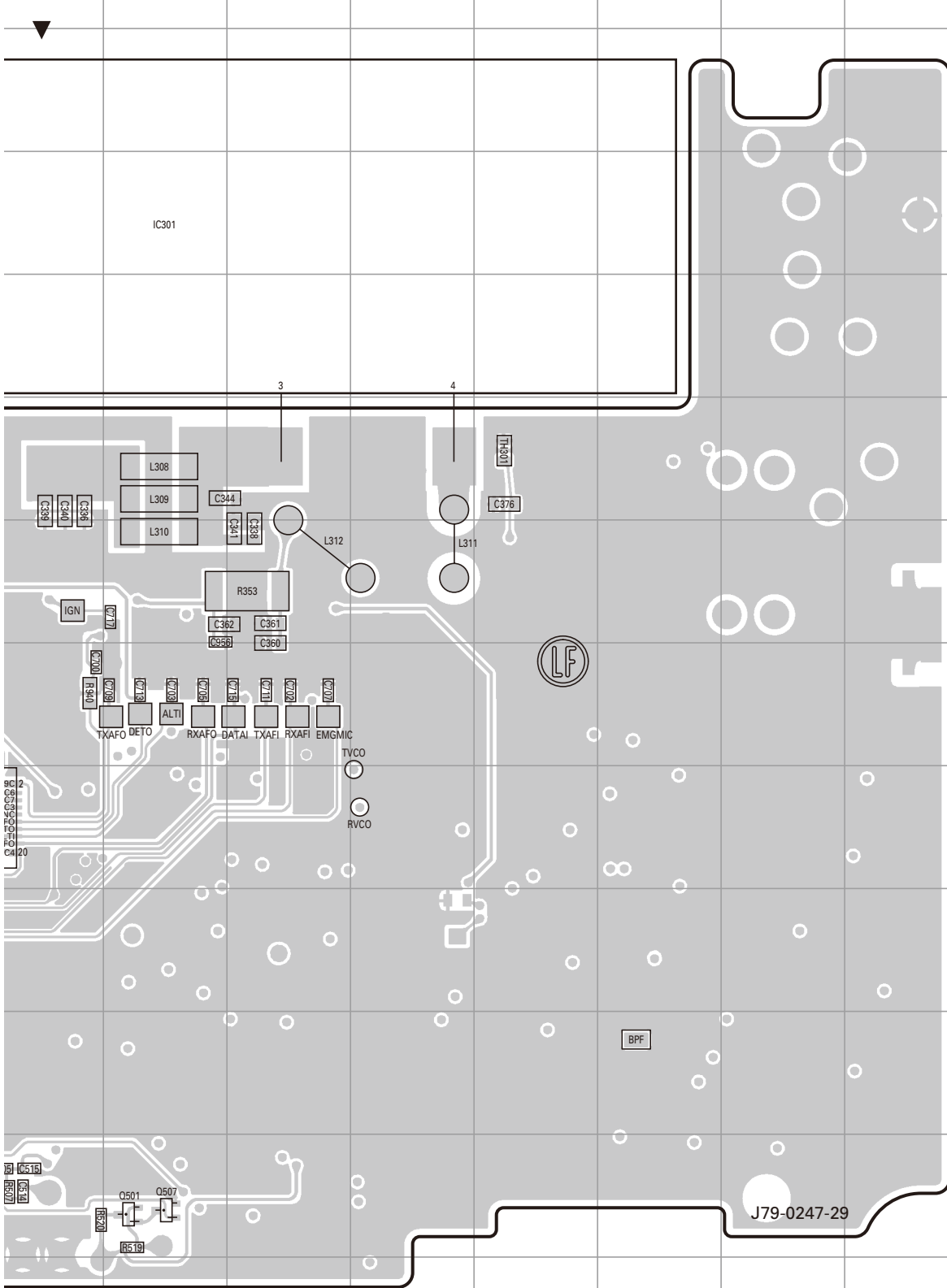

Ref. No.	Address
IC301	4K
IC702	10F
IC703	9D
IC704	7B
IC705	9B
IC706	7G
IC707	7F
IC708	9H
IC709	11H
Q501	12K
Q507	12K
Q707	7D
Q710	9H
Q711	6C
Q712	7C
Q713	6C
Q714	7C
Q715	8D
Q717	8F
Q718	7G
Q719	6C
Q720	6B
Q721	9D
Q722	9H
Q723	9D
Q728	7G
Q731	10H
Q732	10H
D500	12I
D501	12J
D700	8I
D701	8I
D702	12G
D703	8I
D704	12F
D705	8H
D706	12G
D707	8H
D708	8H
D709	8H
D710	8G
D715	9H
D718	7H

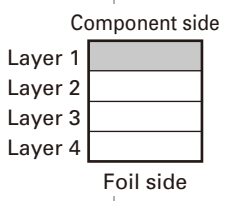

# TK-7302 PC BOARD / PC板

## TX-RX UNIT (X57-7683-01) Foil side view (J79-0247-29)

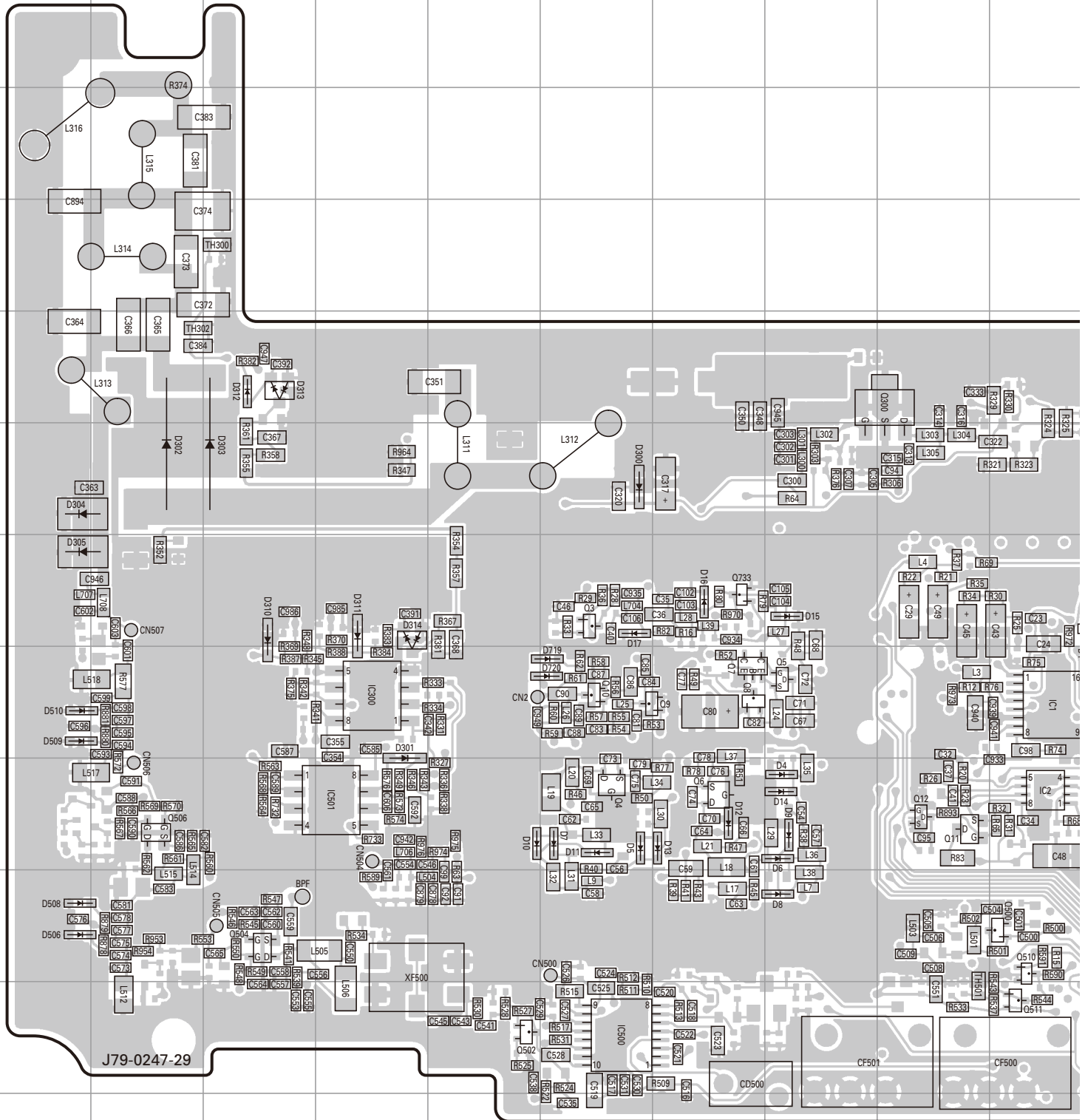





# SCHEMATIC DIAGRAM / 原理图 TK-7302

TX-RX UNIT (X57-7683-01)

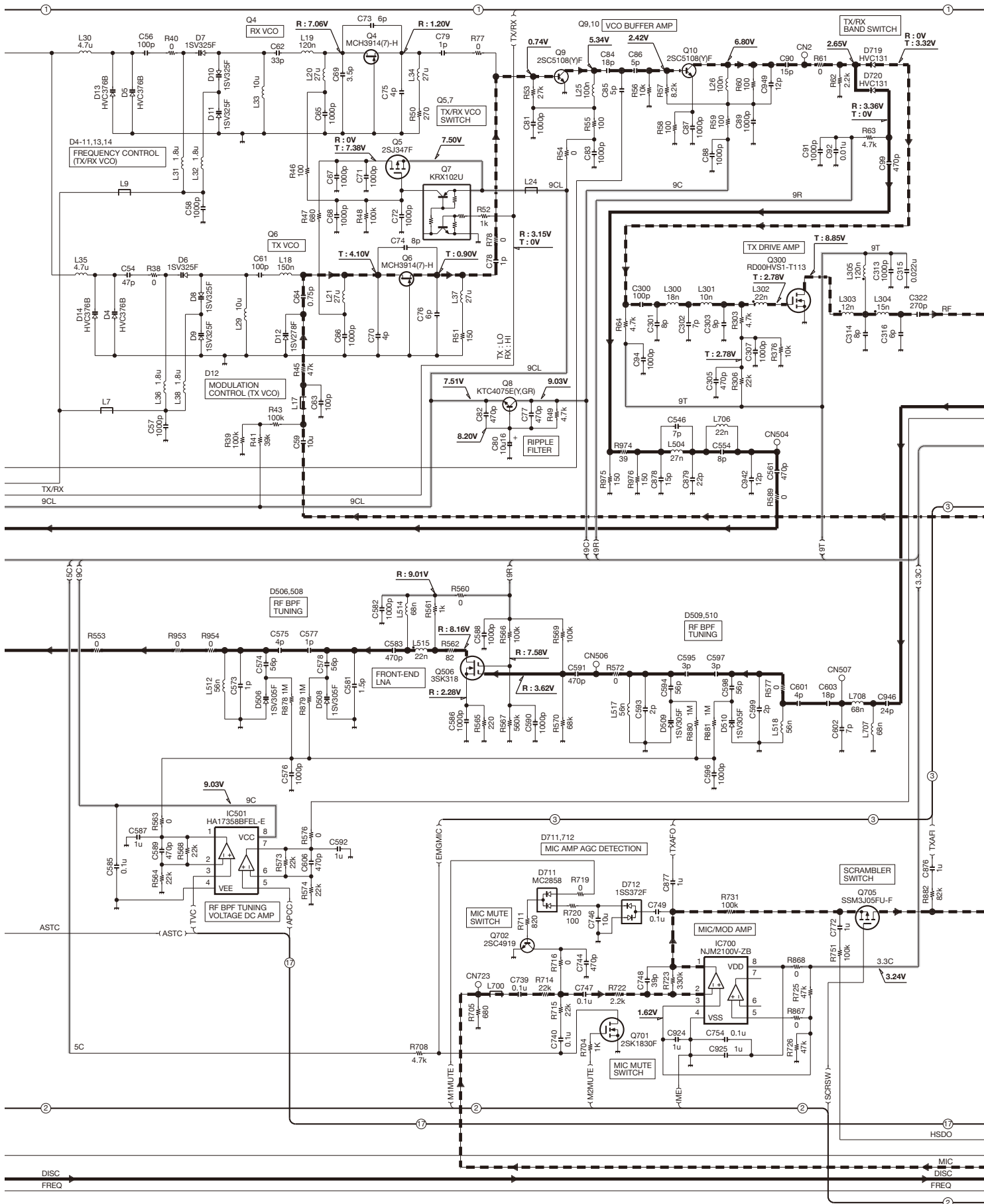





# SCHEMATIC DIAGRAM / 原理图 TK-7302

TX-RX UNIT (X57-7683-01)

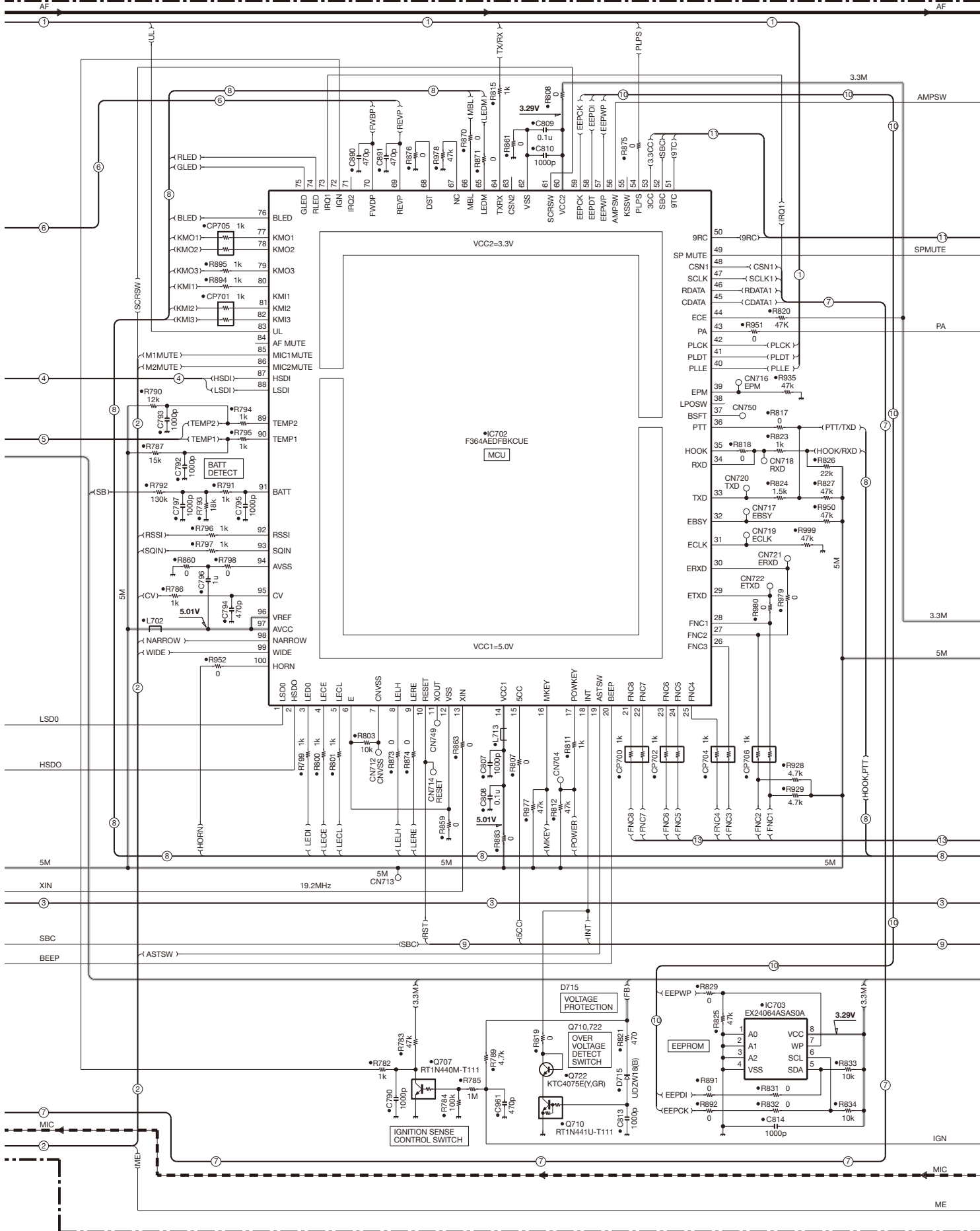

# TK-7302 SCHEMATIC DIAGRAM / 原理图

TX-RX UNIT (X57-7683-01)

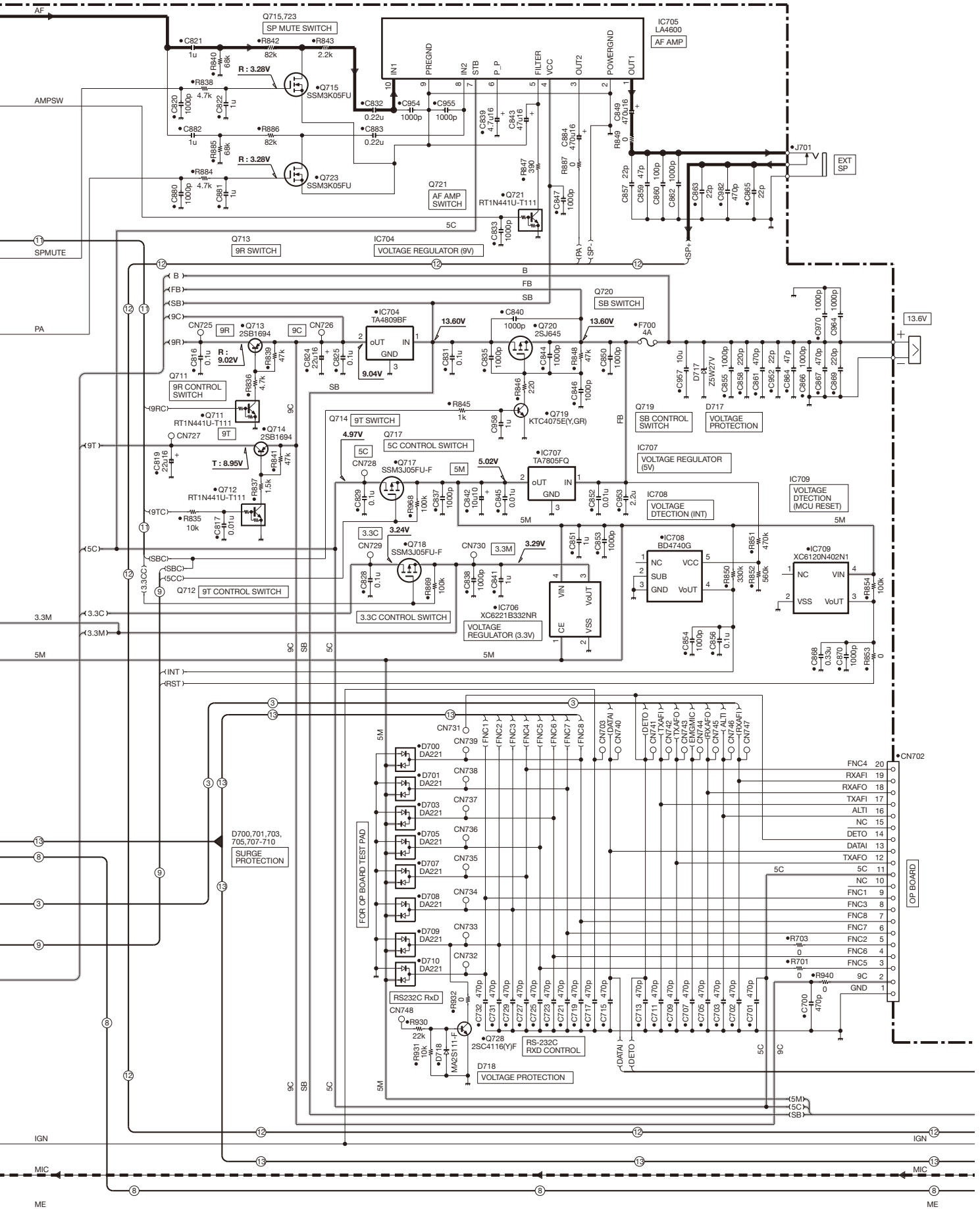

# SCHEMATIC DIAGRAM / 原理图 TK-7302

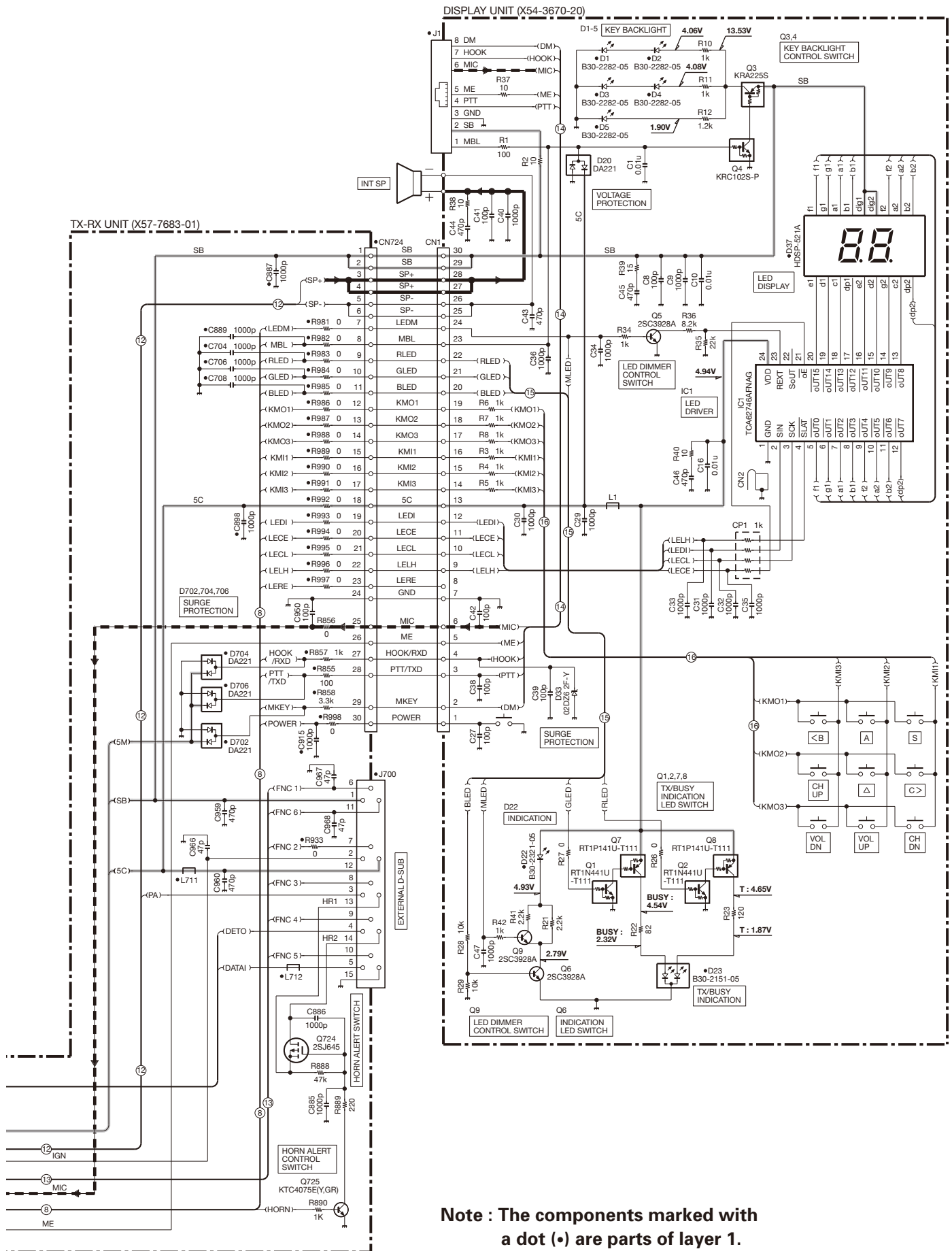

**Note :** The components marked with a dot (•) are parts of layer 1.

## BLOCK DIAGRAM / 方块图

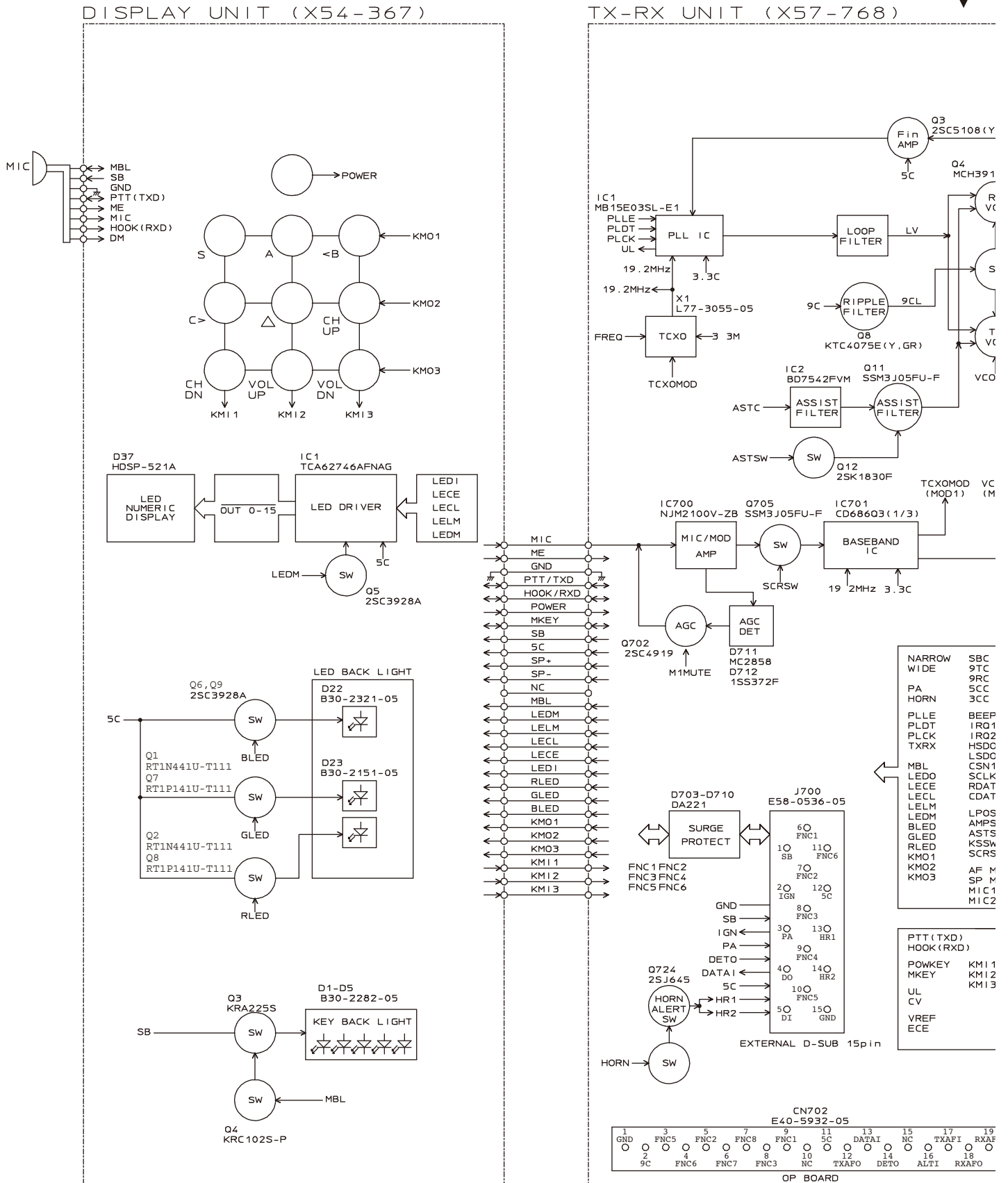



### Receiver Section / 接收部分

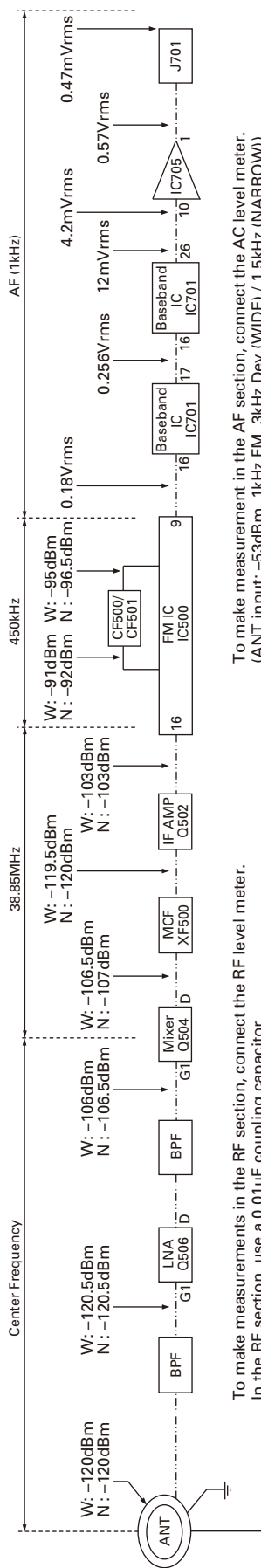

To make measurements in the RF section, connect the RF level meter. In the RF section, use a 0.01 $\mu$ F coupling capacitor. (The display shows the SSG input value required to obtain 12dB SINAD.)

如在RF部分进行测量, 请连接RF电平表。在RF部分, 请使用0.01 $\mu$ F耦合电容。(图中显示获得12dB SINAD所需的SSG输入。)

To make measurements in the AF section, connect the AC level meter. (ANT input: -53dBm, 1kHz FM, 3kHz Dev (WIDE)/1.5kHz (NARROW)) The AF output level is adjusted for a 0.47V/40hm by the front panel AF VOL control.

如在AF部分进行测量, 请连接交流电平表。(ANT输入: -53dBm, 1kHz FM, 3kHz Dev(宽)/1.5kHz(窄)) 通过前面板AF VOL控制, AF输出电平调整为0.47V/40hm。

### Transmitter Section / 发射部分

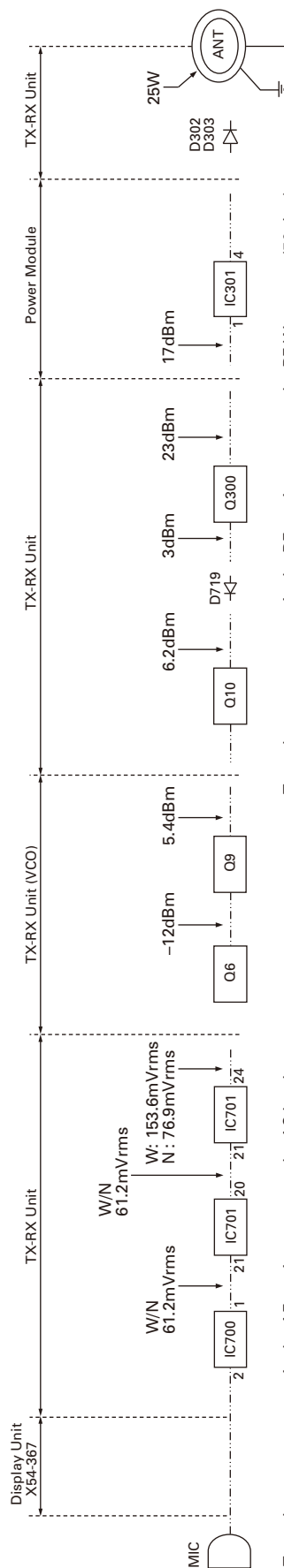

To make measurements in the AF section, connect the AC level meter. AG is set so that MIC input becomes 3kHz/1.5kHz (Wide/Narrow) DEV at 1kHz MOD. 如在AF部分进行测量, 请连接交流电平表。AG被设置成MIC输入从而在1kHz MOD时为3kHz/1.5kHz(宽/窄) DEV。

To make measurements in the RF section, connect the RF Wattmeter (50ohm). 如在RF部分进行测量, 请连接RF功率表(50ohm)。



## OPTIONAL ACCESSORIES / 可选附件

### KCT-60 (Connection Cable / 连接电缆)

#### ■ External View / 外视图



## SPECIFICATIONS

### GENERAL

Frequency Range.....	136~174MHz
Number of Channels.....	16
Zones.....	2
Channel Spacing.....	Wide: 25kHz      Narrow: 12.5kHz
Operating Voltage.....	13.6V DC $\pm$ 15%
Operating Temperature Range.....	-30°C to +60°C
Frequency Stability.....	$\pm$ 2.5ppm
Antenna Impedance.....	50 $\Omega$
Dimensions (W x H x D) (Projections not included).....	160 x 43 x 122.6 mm
Weight.....	1.10kg

### RECEIVER (Measurements made per GB standard)

Sensitivity (EIA 12dB SINAD).....	Wide: 0.28 $\mu$ V	Narrow: 0.35 $\mu$ V
Selectivity.....	Wide: 75dB	Narrow: 65dB
Intermodulation Distortion.....	Wide: 70dB	Narrow: 60dB
Spurious Response.....	75dB	
Audio Output (4 $\Omega$ impedance).....	4W with less than 5% distortion	

### TRANSMITTER (Measurements made per GB standard)

RF Power Output.....	5~25W	
Spurious Response.....	70dB	
FM Hum & Noise.....	Wide: 45dB	Narrow: 40dB
Audio Distortion.....	Wide: Less than 3%	Narrow: Less than 5%
Modulation.....	Wide: 16K0F3E	Narrow: 11K0F3E

## 规 格

## 概 述

频率范围.....	136 ~ 174MHz
信道数量.....	16
区域分区数量.....	2
信道间隔.....	宽 :25kHz 窄 :12.5kHz
工作电源电压.....	13.6V DC $\pm$ 15%
工作温度范围.....	-30°C到 +60°C
频率稳定度.....	$\pm$ 2.5ppm
天线阻抗.....	50 $\Omega$
尺寸(宽 $\times$ 高 $\times$ 长)(未包括凸起部分).....	160 $\times$ 43 $\times$ 122.6 mm
重 量.....	1.10kg

## 接收部 (根据 GB 标准测定)

灵 敏 度(EIA 12dB SINAD) .....	宽 :0.28 $\mu$ V 窄 :0.35 $\mu$ V
选 择 性.....	宽 :75dB 窄 :65dB
互 调.....	宽 :70dB 窄 :60dB
杂散响应抗扰性.....	75dB
音频输出功率.....	4 $\Omega$ 时 4W, 失真低于 5%

## 发射部 (根据 GB 标准测定)

射频功率输出.....	5 ~ 25W
杂散射频分量.....	70dB
FM 噪 音.....	宽 :45dB 窄 :40dB
音频失真.....	宽 : 低于 3% 窄 : 低于 5%
调 制.....	宽 :16K0F3E 窄 :11K0F3E

## Kenwood Corporation

2967-3, Ishikawa-machi, Hachioji-shi, Tokyo, 192-8525 Japan

## Kenwood U.S.A. Corporation

P.O. BOX 22745, 2201 East Dominguez Street, Long Beach, CA 90801-5745, U.S.A.

## Kenwood Electronics Canada Inc.

6070 Kestrel Road, Mississauga, Ontario, Canada L5T 1S8

## Kenwood Electronics Deutschland GmbH

Rembrücker Str. 15, 63150 Heusenstamm, Germany

## Kenwood Electronics Belgium N.V.

Leuvensesteenweg 248 J, 1800 Vilvoorde, Belgium

## Kenwood Electronics France S.A.

L'Etoile Paris Nord 2, 50 Allée des Impressionnistes, Bp 58416 Villepinte, 95944 Roissy Ch De Gaulle Cedex

## Kenwood Electronics UK Limited

KENWOOD House, Dwight Road, Watford, Herts., WD18 9EB United Kingdom

## Kenwood Electronics Europe B.V.

Amsterdamseweg 37, 1422 AC Uithoorn, The Netherlands

## Kenwood Electronics Italia S.p.A.

Via G. Sirtori, 7/9 20129 Milano, Italy

## Kenwood Ibérica, S.A.

Bolivia, 239-08020 Barcelona, Spain

## Kenwood Electronics Australia Pty. Ltd.

Talavera Business Park Building A, 4 Talavera Road, North Ryde NSW 2113 Australia

## Kenwood Electronics (Hong Kong) Ltd.

Unit 3712-3724, Level 37, Tower one Metroplaza, 223 Hing Fong Road, Kwai Fong, N.T., Hong Kong

## Kenwood Electronics Singapore Pte Ltd

1 Ang Mo Kio Street 63, Singapore 569110

DISPLAY UNIT (X54-3670-20) Component side view (J79-0249-19)

DISPLAY UNIT (X54-3670-20) Component side view (J79-0249-19)

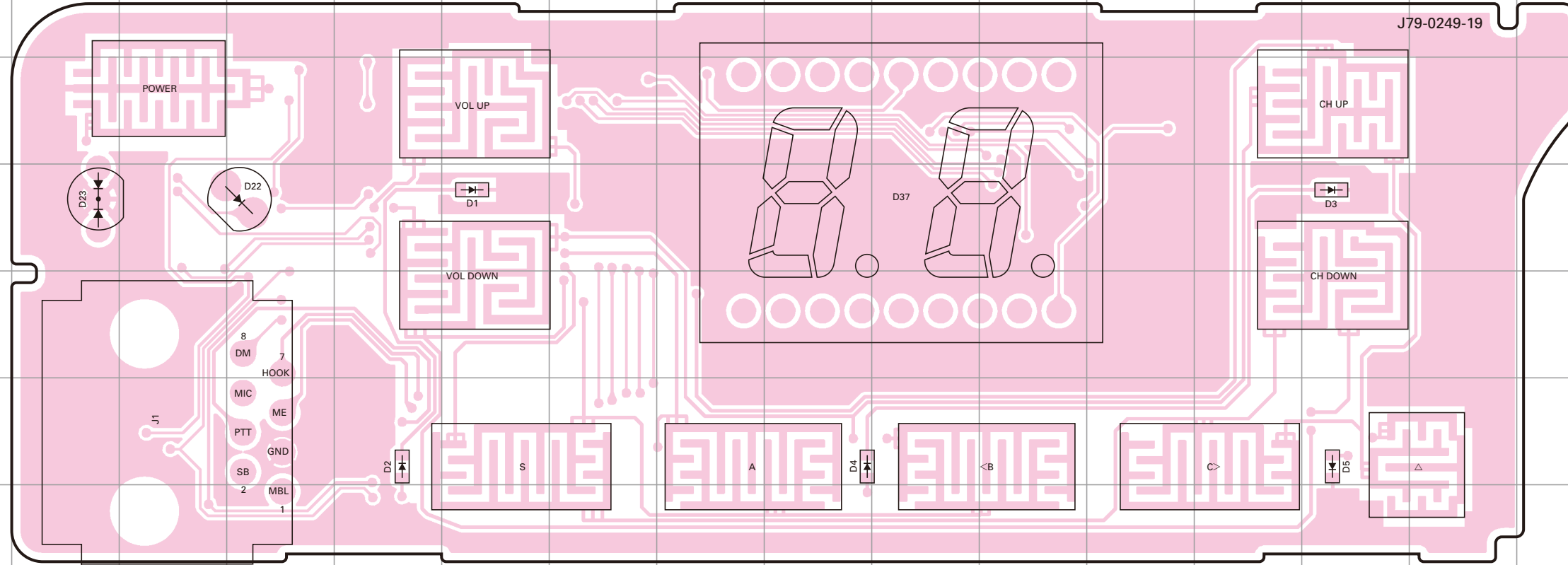

Ref. No.	Address
D1	4F
D2	6E
D3	4N
D4	6I
D5	6N
D22	4D
D23	4B
D37	4J

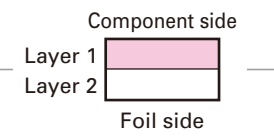

DISPLAY UNIT (X54-3670-20) Foil side view (J79-0249-19)

DISPLAY UNIT (X54-3670-20) Foil side view (J79-0249-19)

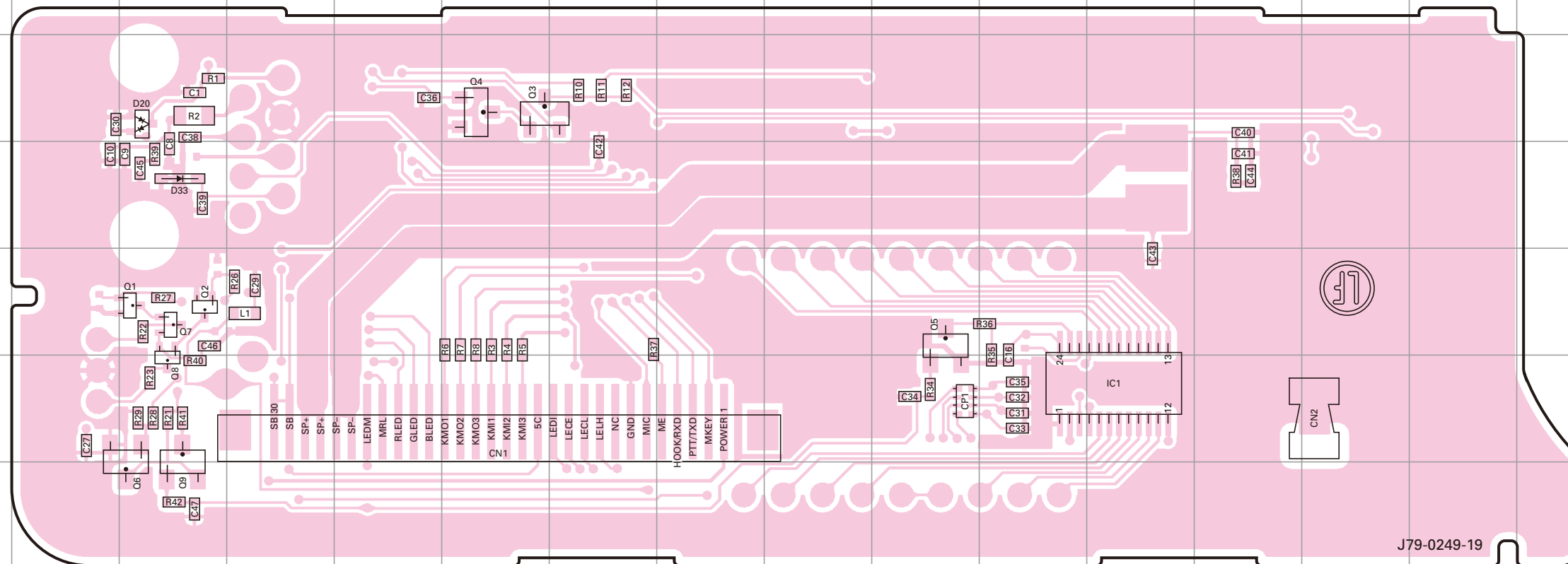

Ref. No.	Address
IC1	12L
Q1	11C
Q2	11C
Q3	9F
Q4	9F
Q5	11J
Q6	13C
Q7	11C
Q8	12C
Q9	13C
D20	9C
D33	10C

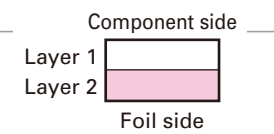

# TK-7302 PC BOARD / PC板

# PC BOARD / PC板 TK-7302

TX-RX UNIT (X57-7683-01) Component side view (J79-0247-29)

TX-RX UNIT (X57-7683-01) Component side view (J79-0247-29)

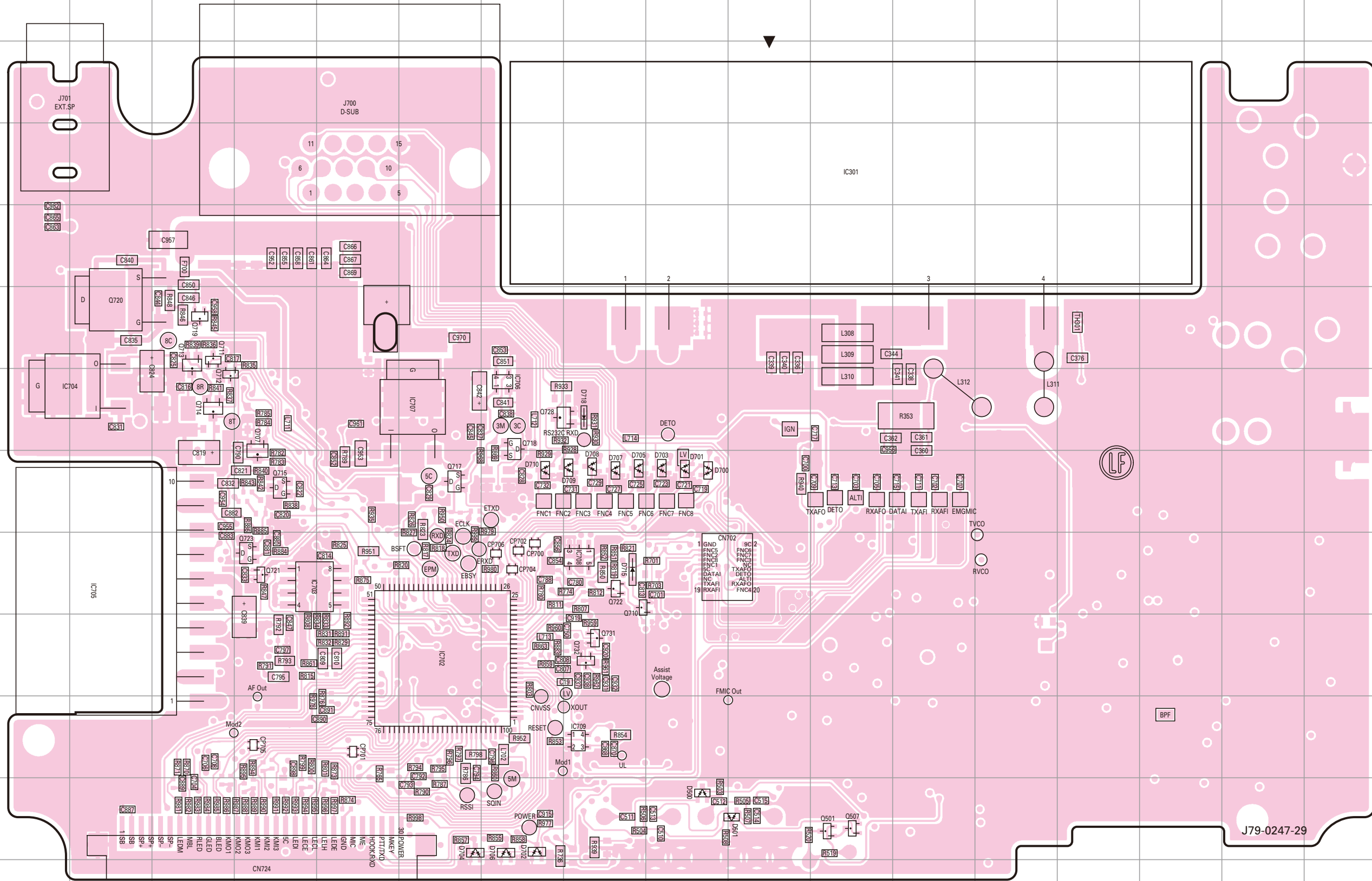

Ref. No.	Address
IC301	4K
IC702	10F
IC703	9D
IC704	7B
IC705	9B
IC706	7G
IC707	7F
IC708	9H
IC709	11H
Q501	12K
Q507	12K
Q707	7D
Q710	9H
Q711	6C
Q712	7C
Q713	6C
Q714	7C
Q715	8D
Q717	8F
Q718	7G
Q719	6C
Q720	6B
Q721	9D
Q722	9H
Q723	9D
Q728	7G
Q731	10H
Q732	10H
D500	12I
D501	12J
D700	8I
D701	8I
D702	12G
D703	8I
D704	12F
D705	8H
D706	12G
D707	8H
D708	8H
D709	8H
D710	8G
D715	9H
D718	7H

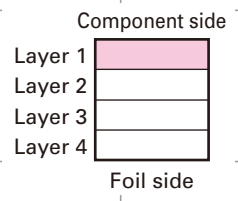

J79-0247-29





