

# KENWOOD

## **Document Copyrights**

Copyright 2006 by Kenwood Corporation. All rights reserved.

No part of this manual may be reproduced, translated, distributed, or transmitted in any form or by any means, electronic, mechanical, photocopying, recording, or otherwise, for any purpose without the prior written permission of Kenwood.

## **Disclaimer**

While every precaution has been taken in the preparation of this manual, Kenwood assumes no responsibility for errors or omissions. Neither is any liability assumed for damages resulting from the use of the information contained herein. Kenwood reserves the right to make changes to any products herein at any time for improvement purposes.



## CONTENTS

<b>GENERAL .....</b>	<b>2</b>	<b>ADJUSTMENT .....</b>	<b>34</b>
<b>SYSTEM SET-UP .....</b>	<b>3</b>	<b>PC BOARD</b>	
<b>OPERATING FEATURES .....</b>	<b>4</b>	<b>DISPLAY UNIT (X54-3400-10) .....</b>	<b>45</b>
<b>REALIGNMENT .....</b>	<b>5</b>	<b>TX-RX UNIT (X57-6580-10) .....</b>	<b>49</b>
<b>INSTALLATION .....</b>	<b>7</b>	<b>SCHEMATIC DIAGRAM .....</b>	<b>55</b>
<b>CIRCUIT DESCRIPTION .....</b>	<b>12</b>	<b>BLOCK DIAGRAM .....</b>	<b>63</b>
<b>SEMICONDUCTOR DATA .....</b>	<b>16</b>	<b>WIRING .....</b>	<b>65</b>
<b>COMPONENTS DESCRIPTION .....</b>	<b>20</b>	<b>TERMINAL FUNCTION .....</b>	<b>66</b>
<b>PARTS LIST .....</b>	<b>22</b>	<b>OPTIONS .....</b>	<b>68</b>
<b>EXPLODED VIEW .....</b>	<b>32</b>	<b>SPECIFICATIONS .....</b>	<b>69</b>
<b>PACKING .....</b>	<b>33</b>		

## GENERAL

### INTRODUCTION

#### SCOPE OF THIS MANUAL

This manual is intended for use by experienced technicians familiar with similar types of commercial grade communications equipment. It contains all required service information for the equipment and is current as of this publication data. Changes which may occur after publication are covered by either Service Bulletins or Manual Revisions. These are issued as required.

### ORDERING REPLACEMENT PARTS

When ordering replacement parts or equipment information, the full part identification number should be included. This applies to all parts : components, kits, and chassis. If the part number is not known, include the chassis or kit number of which it is a part, and a sufficient description of the required component for proper identification.

### PERSONNEL SAFETY

The following precautions are recommended for personnel safety :

- DO NOT transmit if someone is within two feet (0.6 meter) of the antenna.
- DO NOT transmit until all RF connectors are verified secure and any open connectors are properly terminated.
- SHUT OFF and DO NOT operate this equipment near electrical blasting caps or in an explosive atmosphere.
- All equipment should be properly grounded before power-up for safe operation.
- This equipment should be serviced by a qualified technicians only.

### PRE-INSTALLATION CONSIDERNATIONS

#### 1. UNPACKING

Unpack the radio from its shipping container and check for accessory items. If any item is missing, please contact KENWOOD immediately.

#### 2. LICENSING REQUIREMENTS

Federal regulations require a station license for each radio installation (mobile or base) be obtained by the equipment owner. The licensee is responsible for ensuring transmitter power, frequency, and deviation are within the limits permitted by the station license.

Transmitter adjustments may be performed only by a licensed technician holding an FCC first, second or general class commercial radiotelephone operator's license. There is no license required to install or operate the radio.

#### 3. PRE-INSTALLATION CHECKOUT

##### 3-1. Introduction

Each radio is adjusted and tested before shipment. However, it is recommended that receiver and transmitter operation be checked for proper operation before installation.

##### 3-2. Testing

The radio should be tested complete with all cabling and accessories as they will be connected in the final installation. Transmitter frequency, deviation, and power output should be checked, as should receiver sensitivity, squelch operation, and audio output. QT equipment operation should be verified.

### 4. PLANNING THE INSTALLATION

#### 4-1. General

Inspect the vehicle and determine how and where the radio antenna and accessories will be mounted.

Plan cable runs for protection against pinching or crushing wiring, and radio installation to prevent overheating.

#### 4-2. Antenna

The favored location for an antenna is in the center of a large, flat conductive area, usually at the roof center. The trunk lid is preferred, bond the trunk lid and vehicle chassis using ground straps to ensure the lid is at chassis ground.

#### 4-3. Radio

The universal mount bracket allows the radio to be mounted in a variety of ways. Be sure the mounting surface is adequate to support the radio's weight. Allow sufficient space around the radio for air cooling. Position the radio close enough to the vehicle operator to permit easy access to the controls when driving.

#### 4-4. DC Power and wiring

1. This radio may be installed in negative ground electrical systems only. Reverse polarity will cause the cable fuse to blow. Check the vehicle ground polarity before installation to prevent wasted time and effort.
2. Connect the positive power lead directly to the vehicle battery positive terminal. Connecting the Positive lead to any other positive voltage source in the vehicle is not recommended.

---

#### CAUTION

*If DC power is to be controlled by the vehicle ignition switch, a switching relay should be used to switch the positive power lead. The vehicle ignition switch then controls DC to the relay coil.*

---

3. Connect the ground lead directly to the battery negative terminal.
4. The cable provided with the radio is sufficient to handle the maximum radio current demand. If the cable must be extended, be sure the additional wire is sufficient for the current to be carried and length of the added lead.

### 5. INSTALLATION PLANNING – CONTROL STATIONS

#### 5-1. Antenna system

Control station. The antenna system selection depends on many factors and is beyond the scope of this manual. Your KENWOOD dealer can help you select an antenna system that will best serve your particular needs.

## GENERAL / SYSTEM SET-UP

### 5-2. Radio location

Select a convenient location for your control station radio which is as close as practical to the antenna cable entry point. Secondly, use your system's power supply (which supplies the voltage and current required for your system). Make sure sufficient air can flow around the radio and power supply to allow adequate cooling.

### SERVICE

This radio is designed for easy servicing. Refer to the schematic diagrams, printed circuit board views, and alignment procedures contained in this manual.

### SYSTEM SET-UP

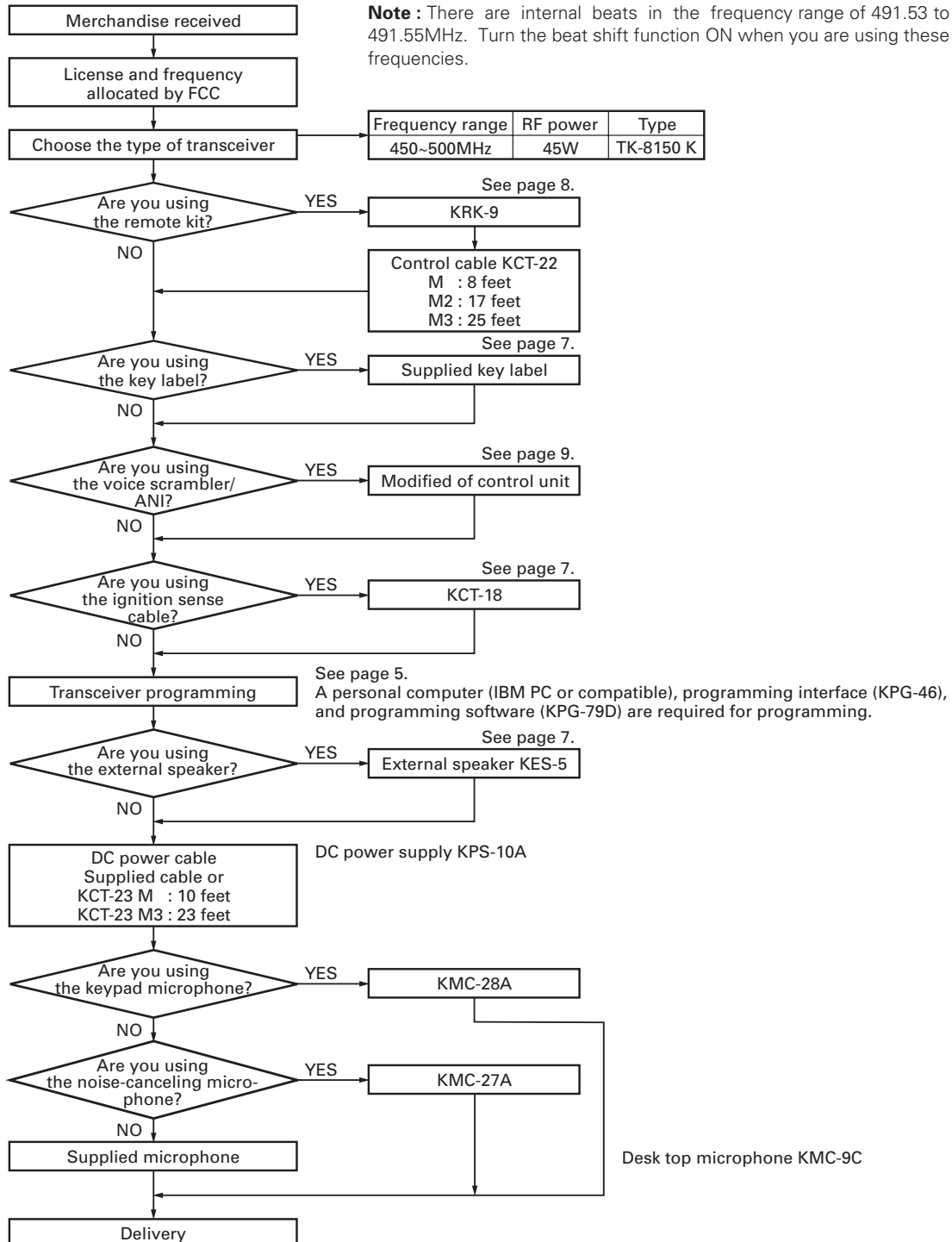

## OPERATING FEATURES

### 1. Controls and Functions

#### 1-1. Front Panel

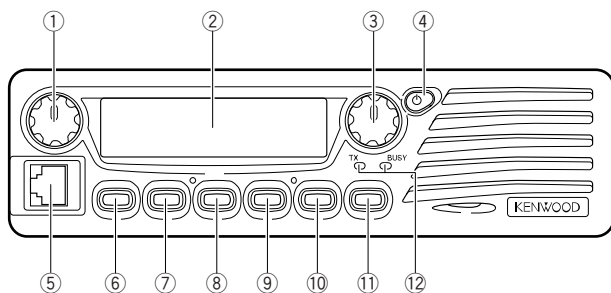

#### 1-2. Microphone

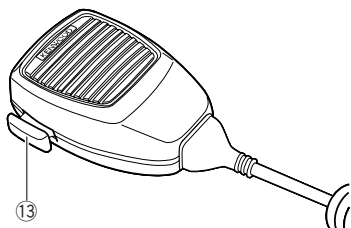

#### ① Volume Control

Rotate to adjust the volume level. Clockwise increases the volume and counterclockwise decreases the volume.

#### ② Display

(See right.)

#### ③ Selector

Rotate to select a Zone or CH/GID (channel/group ID). Clockwise increases the Zone / CH/GID and counterclockwise decreases the Zone / CH/GID. The default setting is CH/GID Up/Down.

#### ④ **⏻ (Power) switch**

Press to switch the transceiver ON. Press and hold for approximately 1 second to switch the transceiver OFF.

#### ⑤ Microphone Jack

Insert the microphone plug into this jack.

#### ⑥ PF1 Key

Press this key to activate its programmable auxiliary function. The default setting is Zone Up.

#### ⑦ PF2 Key

Press this key to activate its programmable auxiliary function. The default setting is Zone Down.

#### ⑧ PF3 Key

Press this key to activate its programmable auxiliary function. The default setting is None.

#### ⑨ PF4 Key

Press this key to activate its programmable auxiliary function. The default setting is None.

#### ⑩ PF5 Key

Press this key to activate its programmable auxiliary function. The default setting is None.

#### ⑪ PF6 Key

Press this key to activate its programmable auxiliary function. The default setting is None.

#### ⑫ TX / BUSY LEDs

The TX LED lights red while transmitting. In Conventional Groups, the BUSY LED lights green while receiving.

#### ⑬ PTT switch

To transmit, press and hold this switch, then speak into the microphone. Release to receive.

#### 1-3. Display

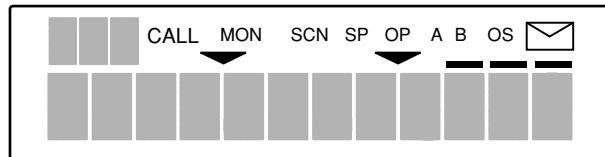

Indicator	Description
	Displays the zone, group ID, and channel numbers. Also displays various functions which have been programmed by your dealer.
CALL	Appears when the squelch opens during a 2-Tone or DTMF call.
MON	Appears when the key programmed as Monitor is pressed.
	Appears when the selected Zone is added to the scan list.
SCN	Appears when you are using Scan mode.
SP	Appears when you are using an external speaker.
OP	Appears when the optional scrambler board is installed and activated.
	Appears when the selected Channel/Group ID is added to the scan list.
A	Appears when the auxiliary A function is activated.
B	Appears when the auxiliary B function is activated.
OS	Appears when Operator Selectable Tone is activated.
	Appears when a FleetSync message is stored in the transceiver memory. Appears and blinks when a new message is received.
	Displays the zone, group ID, and channel numbers. Your dealer can program the zone, group ID, and channel names with up to 12 characters, in place of numbers.

#### 1-4. Rear Panel

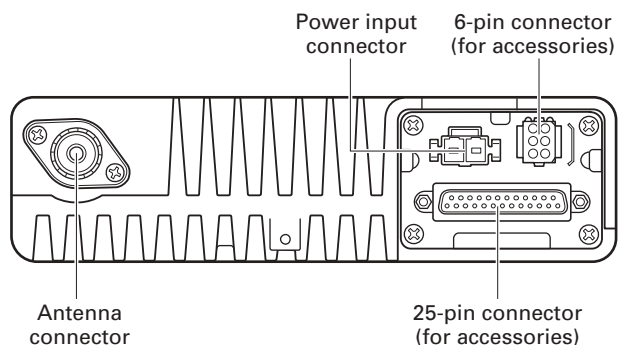

## REALIGNMENT

### 1. Modes

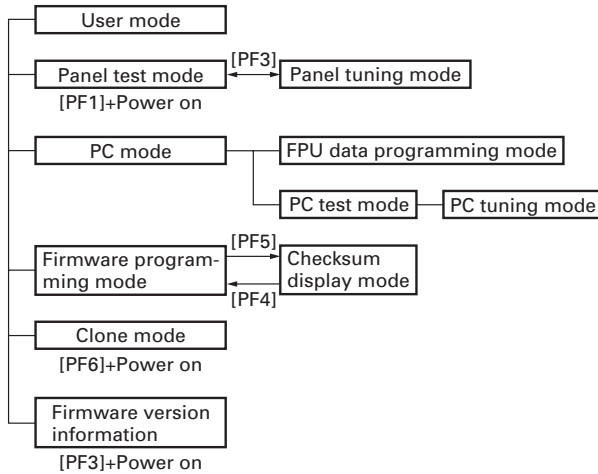

Mode	Function
User mode	For normal use.
Panel test mode	Used by the dealer to check the fundamental characteristics.
Panel tuning mode	Used by the dealer to tune the radio.
PC mode	Used for communication between the radio and PC (IBM compatible).
FPU data programming mode	Used to read and write frequency data and other features to and from the radio.
PC test mode	Used to check the radio using the PC. This feature is included in the FPU. See panel tuning.
Firmware programming mode	Used when changing the main program of the flash memory.
Clone mode	Used to transfer programming data from one radio to another.
Firmware version information	Used to confirm the internal firmware version.

### 2. How to Enter Each Mode

Mode	Operation
User mode	Power ON
Panel test mode	[PF1]+Power ON
Panel tuning mode	[Panel test mode]+[PF3]
PC mode	Received commands from PC
Firmware programming mode	[PF2]+Power ON
Checksum display mode	[Firmware programming mode]+[PF5]
Clone mode	[PF6]+Power ON
Firmware version information	[PF3]+Power ON (one second)

### 3. Panel Test Mode

Setting method refer to "ADJUSTMENT".

### 4. Panel Tuning Mode

Setting method refer to "ADJUSTMENT".

### 5. PC Mode

#### 5-1. Preface

The transceiver is programmed by using a personal computer, programming interface (KPG-46) and programming software (KPG-79D).

The programming software can be used with an IBM PC or compatible. Figure 1 shows the setup of an IBM PC for programming.

#### 5-2. Connection Procedure

1. Connect the transceiver to the personal computer with the interface cable.
2. When the Power switch on, user mode can be entered immediately. When PC sends command the radio enter PC mode, and "PROGRAM" is displayed on the LCD. When data transmitting from transceiver, the red LED is blinking. When data receiving to transceiver, the green LED is blinking.

#### 5-3. KPG-46 Description

##### (PC programming interface cable : Option)

The KPG-46 is required to interface the transceiver to the computer. It has a circuit in its D-subconnector (25-pin) case that converts the RS-232C logic level to the TTL level.

The KPG-46 connects the modular microphone jack of the transceiver to the computers RS-232C serial port.

#### 5-4. Programming Software Description

The KPG-79D programming disk is supplied in 3-1/2" disk format. The software on this disk allows a user to program the transceiver radio via programming interface cable (KPG-46).

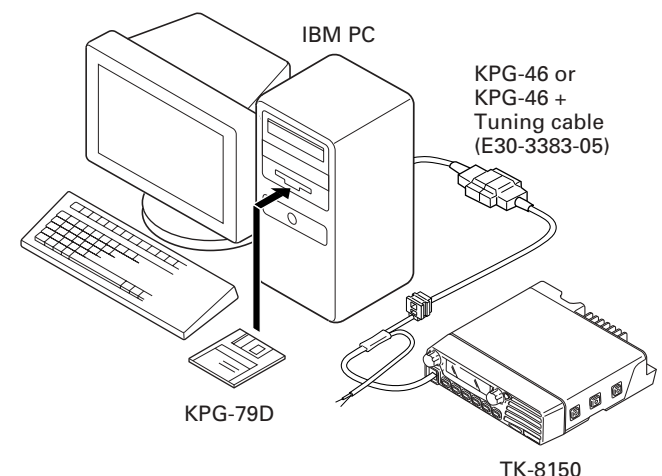

Fig. 1

## REALIGNMENT

### 5-5. Programming With IBM PC

If data is transferred to the transceiver from an IBM PC with the KPG-79D, the destination data (basic radio information) for each set can be modified. Normally, it is not necessary to modify the destination data because their values are determined automatically when the frequency range (frequency type) is set.

The values should be modified only if necessary.

Data can be programmed into the flash memory in RS-232C format via the modular microphone jack.

KPG-79D instruction manual parts No. : B62-1588-XX.

## 6. Firmware Programming Mode

### 6-1. Preface

The TK-8150 uses flash memory to allow it to be easily upgraded when new features are released in the future.

### 6-2. Connection Procedure

Connect the TK-8150 to the personal computer (IBM PC or compatible) with the interface cable (KPG-46). (Connection is the same as in the PC mode.)

#### Note :

You can only program firmware from the 8-pin microphone connector on the front panel. Using the 25-pin logic interface on the rear panel will not work.

### 6-3. Programming

1. Start up the programming software (Fpro. exe).
2. Set the communications speed (normally, 57600 bps) and communications port in the configuration item.
3. Set the firmware to be updated by file name item.
4. Turn ON the transceiver while pressing and holding the [PF2] key. The transceiver enters Firmware programming mode and "PROG 57600". If Firmware programming mode is inhibited by the FPU, the transceiver enters User mode instead.

If the transceiver receives the firmware data from a PC, "PG" appears on the display.

5. Check the connection between the TK-8150 and the personal computer, and make sure that the TK-8150 is in the program mode.
6. Press write button in the window. A window opens on the display to indicate progress of writing.
7. If writing ends successfully, the TX LED on the TK-8150 lights.
8. If you want to continue programming other TK-8150, repeat steps 3 to 6.

#### Note :

This mode cannot be entered if the firmware programming mode is set to disable in the programming software (KPG-79D).

### 6-4. Function

Each time you press the [PF4] key, the data transfer rate alters (19200 / 38400 / 57600 bps).

#### Note :

Normally, write in the high-speed mode (57600 bps).

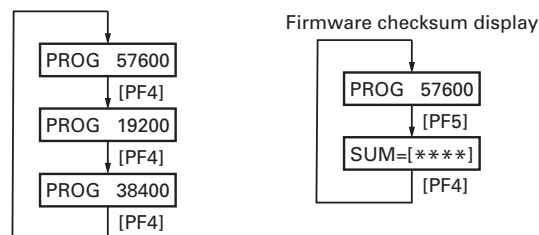

Fig. 2

## 7. Clone Mode

Programming data can be transferred from one radio to another by connecting them via their modular microphone jacks. The operation is as follows (the transmit radio is the master and the receive radio is a slave).

1. Turn the master TK-8150 power ON with the [PF6] key held down. The TK-8150 displays "CLONE". If Firmware programming mode is inhibited by the FPU, the transceiver enters User mode instead.
2. Power on the slave TK-8150.
3. Connect the cloning cable (No. E30-3382-05) to the modular microphone jacks on the master and slave.
4. Press the [PF6] key on the master while the master displays "CLONE". The data of the master is sent to the slave. While the slave is receiving the data, "PROGRAM" is displayed. When cloning of data is completed, the master displays "END", and the slave automatically operates in the User mode. The slave can then be operated by the same program as the master.
5. The other slave can be continuously cloned. When the [PF6] key on the master is pressed while the master displays "END", the master displays "CLONE". Carry out the operation in steps 2 to 4.
6. To end cloning, first you must remove the cloning cable, then switch both master and slave TK-8150s off.

#### Note :

Only the same models can be cloned together.

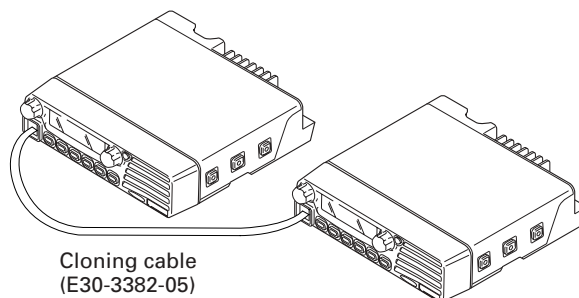

Fig. 3

## 8. Firmware Version Information

This is a mode to confirm the internal firmware version.

1. Turn the transceiver ON while pressing the [PF3] key. The firmware version will appear on the LCD. When you release the [PF3] key, the transceiver automatically enters User mode.

## INSTALLATION

### 1. Installing Name Plate

Punch out the name plate card. Then insert the plates onto the relative function keys.

You can reconfigure the name plates at any time.

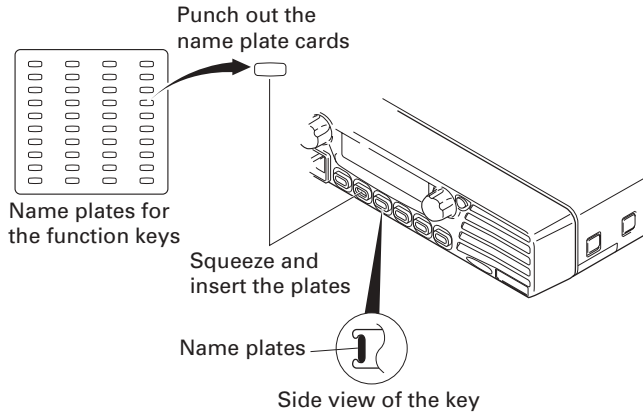

Fig. 1

### 2. Ignition Sense Cable (KCT-18)

The KCT-18 is an optional cable to use the following functions;

#### 2-1. Ignition Function

The ignition function allows you to turn the transceiver's power on and off with the ignition key of your car. When you are driving with the ignition key on, the horn alert function is disabled.

#### 2-2. Timed Power Off Function

The timed power off function turns the transceiver's power off the time specified with the programming software (KPG-79D) after the ignition key is turned off. When you are driving with the ignition key on, the horn alert function is disabled.

The ignition sense function and the timed power off function can be used at the same time.

#### 2-3. Modification

1. Remove the short plug from the accessory connector (6 pins) on the rear of the transceiver.
2. Cut off the end of the protective cover (accessory), insert the KCT-18 into the protective cover, and insert it into pin 1 (IGN) of the short plug.
3. Install the short plug and protective cover on the connector on the rear of the transceiver, then clamp the bottom of the protective cover with the supplied tie wrap.

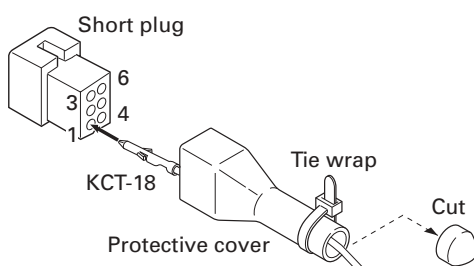

Fig. 2

### 3. External Speaker (KES-5)

The external speaker output from the accessory connector (6 pin) on the rear of the transceiver is 13W/4Ω. Use the KES-5.

#### 3-1. Connection for the KES-5 with the TK-8150

##### ■ When taking the AF output from the accessory connector (6-pin) on the rear of the radio

The following tools are required for changing the connector.

##### • Extracting tool

The following extracting tool is recommended;  
Molex inc. Order No. : J5800-002 (W05-0878-00)

1. Remove the connector with jumper from the external speaker connector on the rear panel of the radio (Fig. 3-1).
- Note :** Save the jumper, which is required when the radio is used without the external speaker.
2. Remove the terminals with the jumper from the connector housing holes number 5 and 6 using the extracting tool.

##### Removing the jumper lead (Fig. 3-2)

- 1) Insert the extracting tool (J5800-002) into the connector while pushing the jumper lead in the direction of (a).
  - 2) Push the extracting tool into collapse the barbs of the crimp terminal.
  - 3) Pull out the lead while continuing to push the extracting tool in the direction (b).
3. Cut off the end of the protection cover, insert the KES-5 speaker cable into the protective cover.
  4. Reinsert the terminal with the black and white stripe lead into hole number 5, and the terminal with the black lead into hole number 4 (Fig. 3-3).
  5. Install the plug and protective cover on the accessory connector on the rear of the transceiver, then clamp the bottom of the protective cover with the supplied tie wrap.

Square-type plug  
(E37-1031-05)

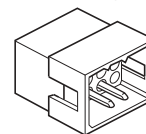

Fig. 3-1

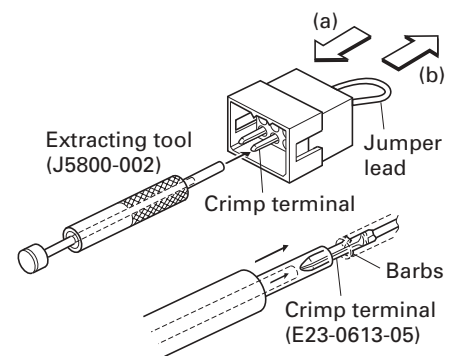

Fig. 3-2

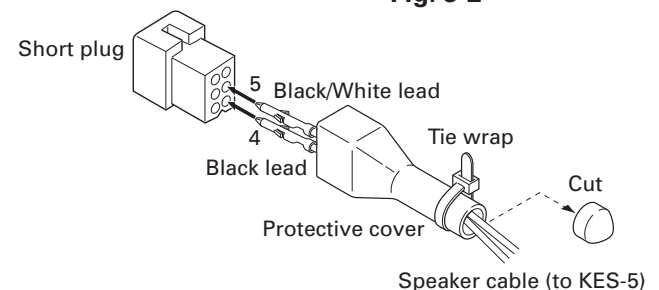

Fig. 3-3



## INSTALLATION

### 4. Use as Public Address Speaker

1. Remove the short plug from the 6-pin accessory connector on the rear of the radio. (Remove the jumpers as described in Section 3-1.)
2. Cut off the end of the protective cover, insert the speaker cable into the protective cover, and insert it into pins 2 and 3.
3. Install the plug and protective cover on the accessory connector on the rear of the transceiver, then clamp the bottom of the protective cover with the supplied tie wrap.
4. If you remove jumper shorting pins 5 and 6, the 20W PA (public address) voice signal is output from pins 2 and 3. (Only when the PA or SP switch is on.)
5. If you use the radio with pins 5 and 6 shorted, the internal speaker is available.

#### Notes :

- Relationship between accessory connector (6-pins) connection and speaker output.
- When pins 5 and 6 are shorted; The internal speaker is used.
- When pins 5 and 6 are open and output is from pins 2 and 3; The 20W external speaker is used.

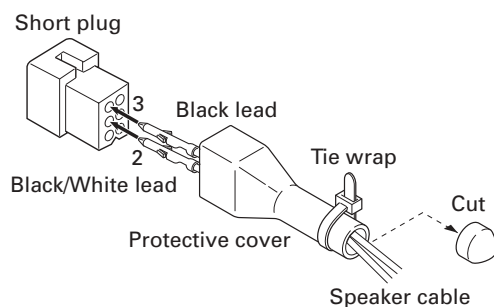

Fig. 4

### 5. Single Control Head Remote Kit (KRK-9) and Control Cable (KCT-22)

1. Lift the tab on the bottom of the transceiver, then pull the panel away from the transceiver.
2. Remove the connector that binds the display unit to the TX-RX unit.
3. As shown in Figure 5-1, make sure that the rubber seal is placed above the cable, then plug the 11-pin connector into the front panel PCB assembly.
4. Also, affix the ground wire to the front panel chassis, as shown in Figure 5-1, with the supplied screw.
5. Choose the remote wire position (right side or left side), then place the seal within the guide rail. Attach and secure the cover using the 2 binding screws.
6. Plug the 12-pin connector (from the rear panel) to the CN902 socket on the display PCB, as shown in Figure 5-2.
7. Push and secure the panel into the chassis so that the 6 tabs on the top and bottom are securely fixed.
8. Plug the connector from the main panel into the CN703 socket (Figure 5-3).
9. Push and secure the main panel so that the 6 tabs on the top and bottom of the panel are securely fixed.

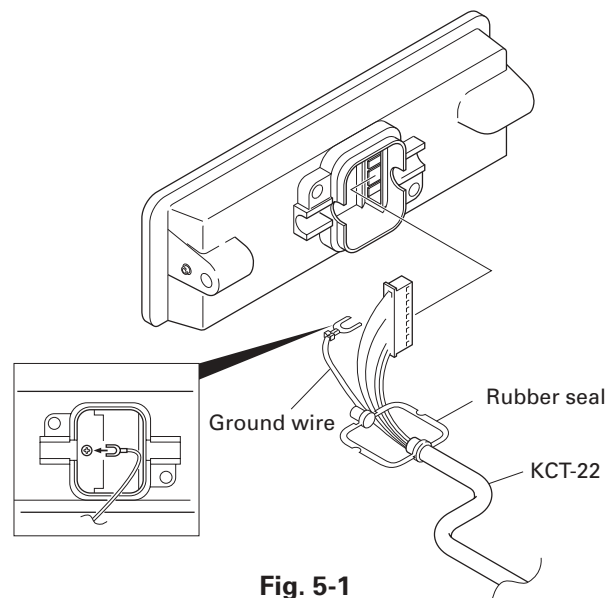

Fig. 5-1

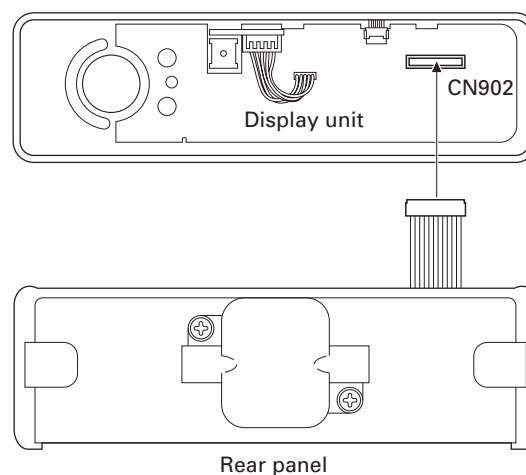

Fig. 5-2

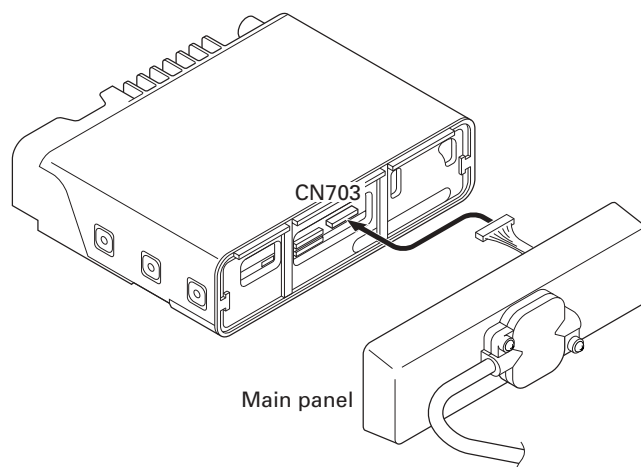

Fig. 5-3

## INSTALLATION

### 6. Optional Board

#### 6-1. Voice Scrambler Board Connection

##### ■ Modification

1. Remove the cabinet and shielding cover from the transceiver.
2. Remove the panel.
3. Delete R798 and R866 on the TX-RX unit.

##### ■ Connection

The functions of pins of CN701 on the foil side of the TX-RX unit are shown in the figure.

Join the CN701 connector to the voice scrambler board via the E37-0808-05 connector cable.

**Note :** You must setup the FPU.

The Voice Scrambler Board is connected subsequent to the de-emphasis circuit.

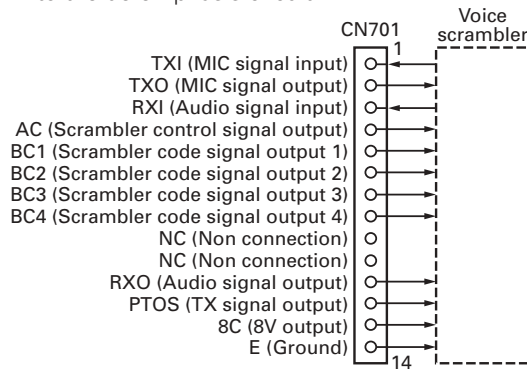

Fig. 6-1 Foil side of the TX-RX unit

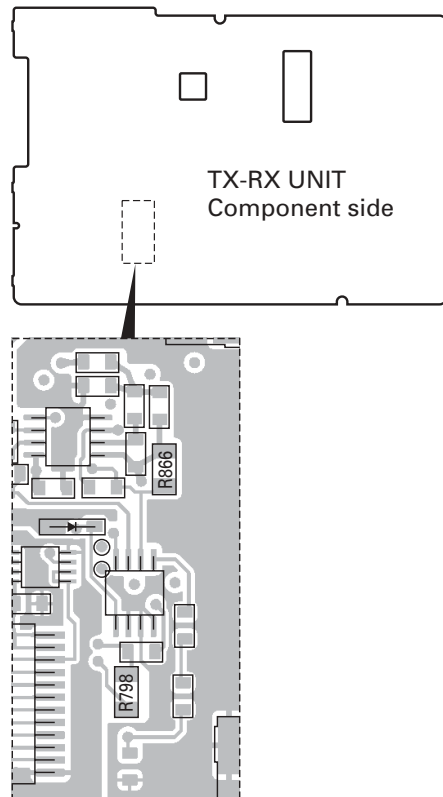

Fig. 6-2

#### 6-2. ANI Board Connection

##### ■ Modification

1. Remove the cabinet and shielding cover from the transceiver.
2. Remove the panel.

##### ■ Connection

Join the CN700 connector to the ANI board via the E37-0808-05 connector cable.

When the ANI board QE-2 is used, you must also use the E37-1075-05 connector.

**Note :** You must setup the FPU.

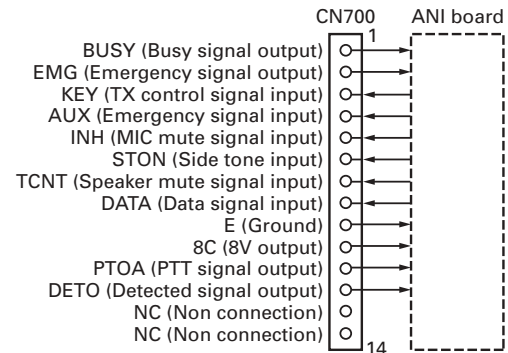
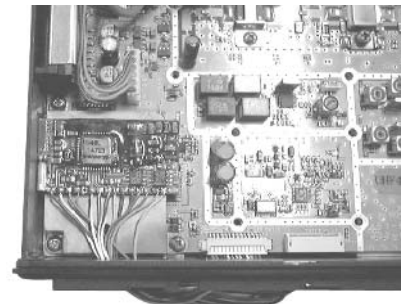

Fig. 6-3 Component side of the TX-RX unit

#### 6-3. Example for Wire Connection

##### ■ Picture (Scrambler board and ANI board)



Top view

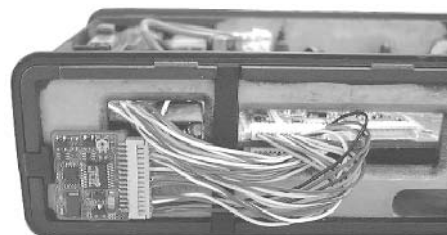

Front view

## INSTALLATION

### 7. Wiring of the Cable for Installing the Built-in Type GPS Unit or Other PC Board

1. Loosen the 2 screws ( ❶ ) to remove the D-sub 25-pin connector.
2. Loosen the 4 screws ( ❷ ) to remove the Hardware fixture.
3. Remove the CN704 connector with the 6-pin lead wire.
4. Take out the Hardware fixture.
5. Cut the packing as shown in the illustration.
7. Tighten the 4 screws to attach the Hardware fixture.
8. Tighten the 2 screws to fix attach D-sub 25-pin connector.

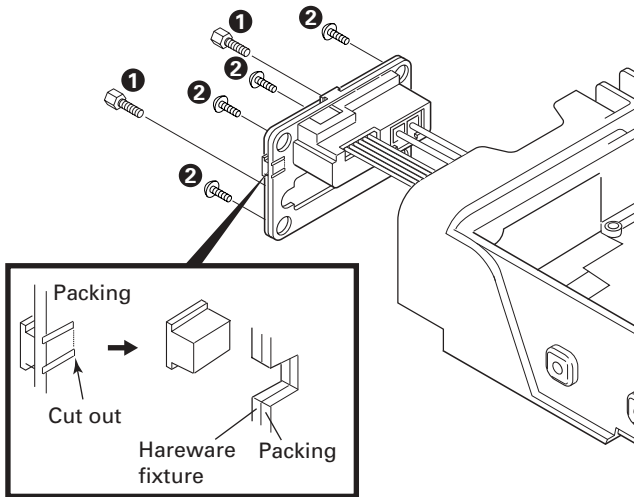

Fig. 7-1

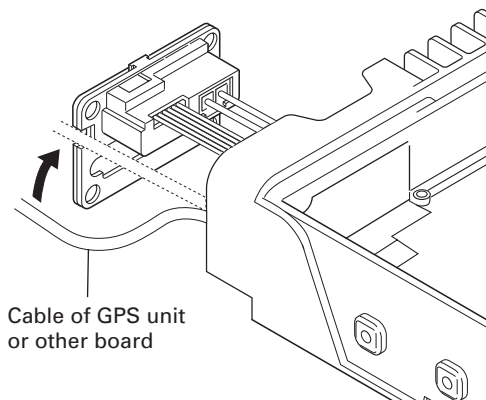

Fig. 7-2

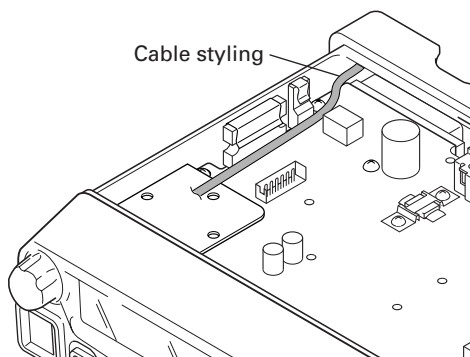

Fig. 7-3

### 8. Horn Alert Function

The HR1 and HR2 pin of the accessory connector (25-pin) on the rear of the transceiver is a relay and maximum current is 1A.

#### 8-1. Modification

1. Remove the cabinet and shielding cover from the transceiver.
2. Remove the panel.
3. Remove the short plug from the 6-pin accessory connector on the rear of the transceiver.
4. Delete R754 on the TX-RX unit.

	Default	Modification
R754	Enable	Disable
State		

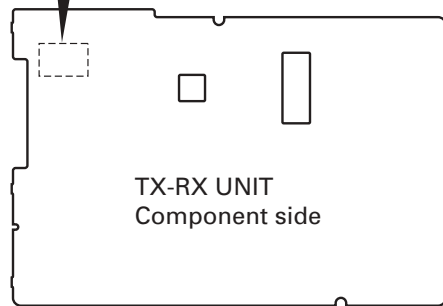
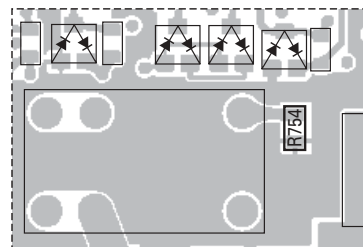

Fig. 8

## INSTALLATION

### 9. Special Instructions for Replacing the Final Amplifier Q5

To replace the Final Amp Q5, ensure to follow the instructions given below:

#### 9-1. C77 and C78 Positions

1. Ensure to solder C77 and C78 to securely contact Q5.  
**Note :** The TX power may vary depending on the position of C77 and C78.

#### 9-2. Soldering

1. Ensure to solder C77 and C78 with the earth spring legs as illustrated in Fig. 9-3.  
**Note :** Use excessive solder to make it thicker than the the electrodes of the chip.
2. Solder the terminals until the electrodes of the chip are fully covered. (Refer to Fig. 9-1.)  
**Note :** Use excessive solder to make it thicker than the the electrodes of the chip. (Refer to Fig. 9-2.)

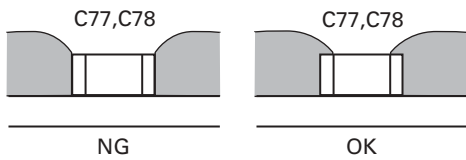

Fig. 9-1

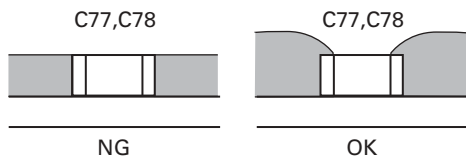

Fig. 9-2

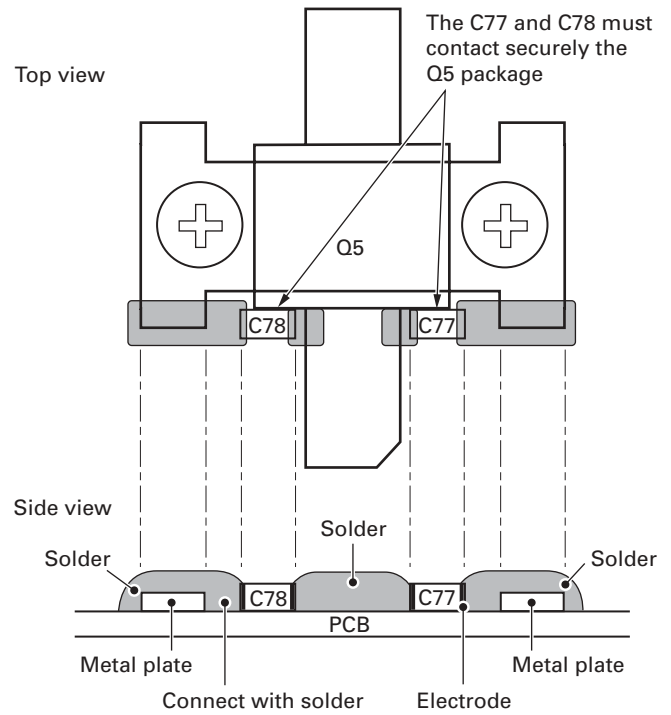

Fig. 9-3

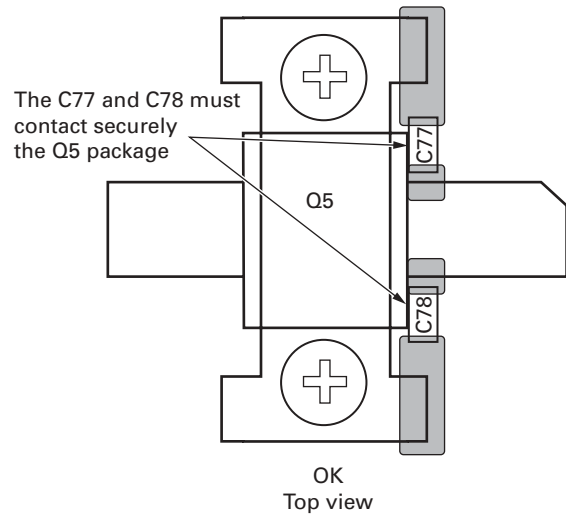

Fig. 9-4

## CIRCUIT DESCRIPTION

### 1. Outline

The TK-8150 is a UHF/FM transceiver designed to operate in the frequency range of 450 to 500MHz. Transmission output power is 45 watts. The maximum channel capacity is 128.

The unit consists of receiver, transmitter, phase-locked loop (PLL) frequency synthesizer, and control circuits.

### 2. Receiver Circuit

The receiver is double conversion superheterodyne, designed to operate in the frequency range of 450MHz to 500MHz.

The receiver circuit consists of the following : 2-1 front-end circuit, 2-2 first mixer, 2-3 IF amplifier circuit, 2-4 audio amplifier circuit, and 2-5 squelch circuit.

#### 2-1. Front-end Circuit

The front-end circuit consists of former BPF (D211 and D212), RF amplifier Q214, and latter BPF (D207, D208, D209 and D210). The BPF covers frequency ranges 450 to 500MHz.

The latter BPF (D207, D208, D209 and D210) attenuates the unwanted signals, and sends only the necessary signal to the first mixer.

#### 2-2. First Mixer

The signal from the BPF is heterodyned with the first local oscillator signal from the PLL frequency synthesizer circuit at the first mixer DBM (Q210, Q211, Q212 and Q213) to become a 73.05MHz first intermediate frequency (IF) signal. The first IF signal is fed through two monolithic crystal filters (XF201; Wide, XF202; Narrow) to further remove spurious signals.

#### 2-3. IF Amplifier

The first IF signal is amplified by Q207 and Q206, and then enters IC201 (FM system IC). The signal is heterodyned again with a second local oscillator signal (73.505MHz) with in IC201 to become a 455kHz second IF signal. The second IF signal is fed through a 455kHz ceramic filters (CF201 and CF203; Wide, CF202 and CF204; Narrow) to further eliminate unwanted signal, and the quadrature detection circuit FM-detects the signal to produce a base-band signal and output it from pin 9.

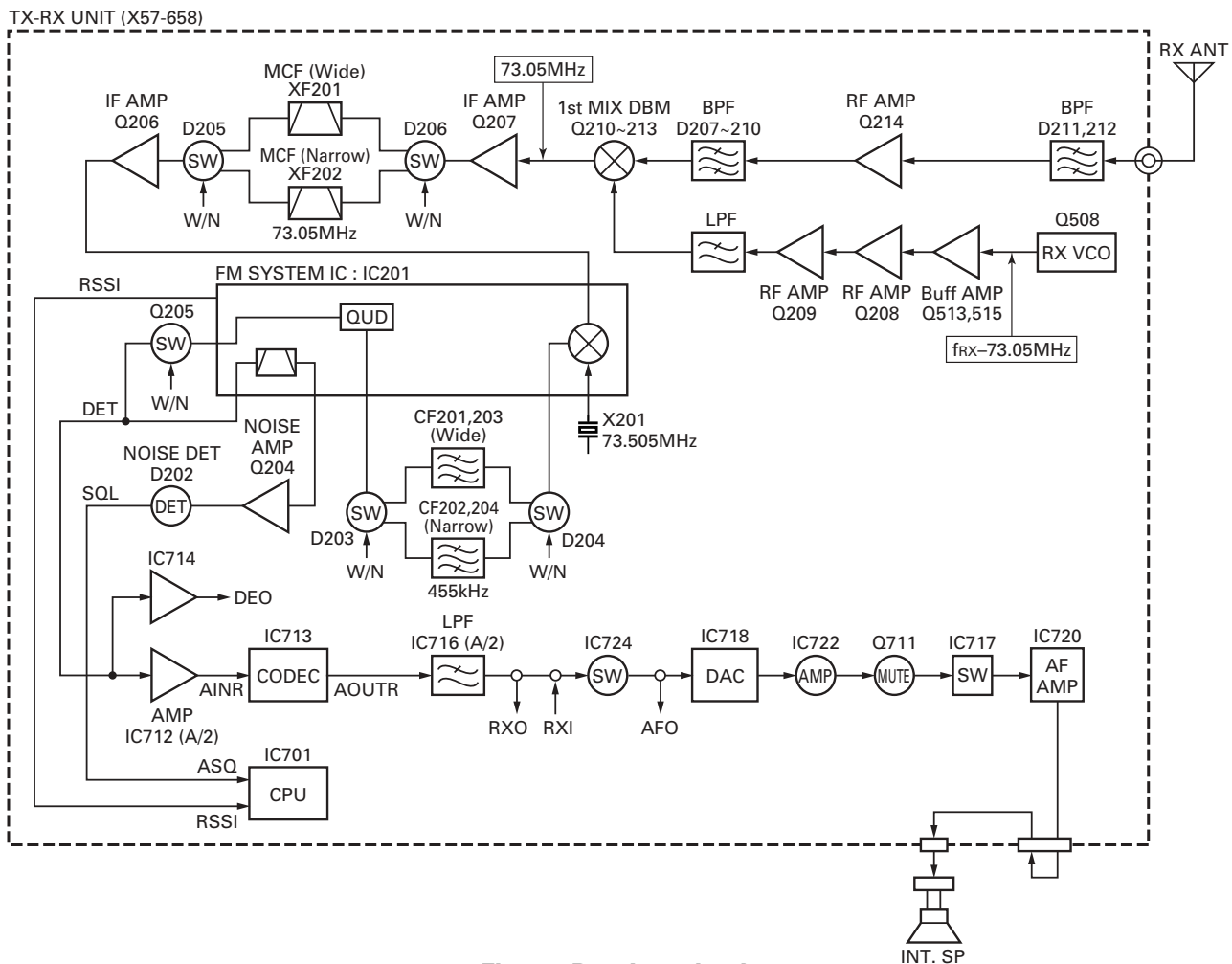

Fig. 1 Receiver circuit

## CIRCUIT DESCRIPTION

### 2-4. Audio Amplifier

The recovered audio signal obtained from IC201 is amplified and anti-aliasing filtered by IC712 (A/2), inputted to the AINR terminal of CODEC IC (IC713), and audio processed by DSP (IC710). The processed audio signal from AOUTR terminal of IC713 is amplified and filtered by IC716 (A/2) to a sufficient level. The audio signal goes to an electronic volume (IC718) and then it passes through the amplifier (IC722), to the input of multiplexer IC (IC717), and is amplified to drive a loudspeaker by an audio power amplifier (IC720). The audio output can be provided to external 4Ω speaker through the 6-pin ACC connector "ES1, ES2" on the rear panel. Q711 is a mute switch.

### 2-5. Squelch Circuit

The output signal from IC201 enters FM IC again, then passed through a band-pass filter.

The noise component output from IC201 is amplified by Q204 and rectified by D202 to produce a DC Voltage corresponding to the noise level. The DC voltage is sent to the analog port of the CPU (IC701).

IC201 outputs a DC voltage (RSSI) corresponding to the input of the IF amplifier.

## 3. Transmitter Circuit

The transmitter circuit consists of the following circuits : 3-1 microphone circuit, 3-2 modulation level adjustment circuit, 3-3 driver and final power amplifier circuit, and 3-4 automatic power control circuit.

### 3-1. Microphone Circuit

The signal from the microphone passes through the mute switch (Q901) and is then routed to the Display unit (X54-340) and TX-RX unit (X57-658). The signal then passes through the AGC circuit to avoid signal distortion.

This circuit consists of IC714, D711, D712, Q707, and Q708. The AGC is operated by controlling the + and – side levels of amplitude using the current obtained by positive and negative detection of the amplified audio signal.

The audio signal is amplified by IC712 (B/2), input to the AINL terminal of CODEC IC (IC713), and audio processed by DSP (IC710). The processed audio signal from the AOUTL terminal of IC713 is amplified and filtered by IC716 (B/2), and amplified by the summing amplifier IC719 (B/2).

### 3-2. Modulation Level Adjustment Circuit

The output of the summing amplifier IC719 (B/2) is passed to an electronic volume (IC718) for maximum deviation adjustment before being applied to a varactor diode in the voltage controlled oscillator VCO.

### 3-3. Driver and Final Power Amplifier Circuit

The transmit signal is generated by the TX VCO (Q507), amplified by Q513 and Q515. This amplified signal is amplified by Q1, Q2, Q3, Q4, and Q5. And this signal is passed to the FINAL stage. The RF power amplifier consists of MOS FET transistor.

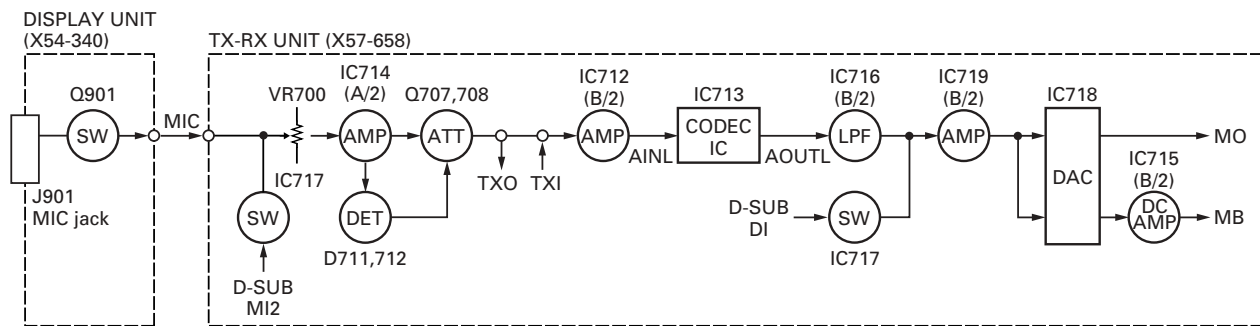

Fig. 2 Microphone circuit

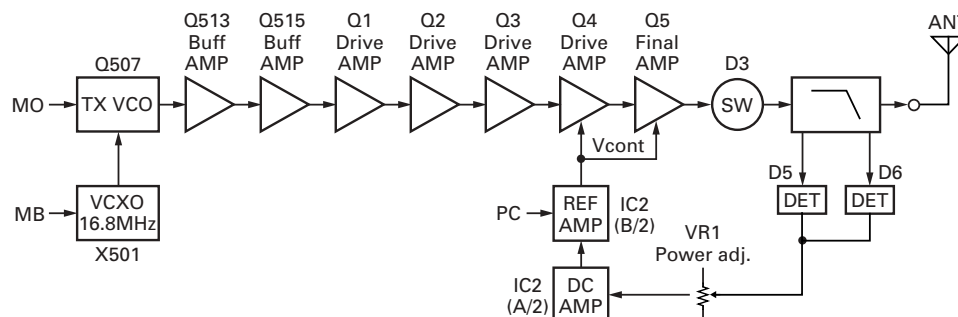

Fig. 3 Drive and final amplifier circuit

## CIRCUIT DESCRIPTION

### 3-4. Automatic Power Control, Circuit and Transmitter

The automatic power control (APC) circuit stabilizes the transmitter output power at a predetermined level, and consists of forward/reflected power detector circuits. The forward/reflected power detector circuits detects forward RF power and reflected RF power to DC voltage, and consists of a C coupling type detection circuit, RF detector D5/D6, and DC amplifier IC2 (A/2).

The voltage comparator (IC2 B/2) compares the voltage obtained by the above detected voltage with a reference voltage, set using the microprocessor and IC718 and IC715.

An APC voltage proportional to the difference between the sensed voltage and the reference voltage appears at the output of IC2. This output voltage controls the gate voltage for the drive amplifier Q4 and final amplifier Q5, which keeps the transmitter output power constant.

### 4. PLL Frequency Synthesizer

The transmit signal and the receive first L.O. signal are generated by the PLL digital frequency synthesizer. The frequency synthesizer consists of a transmitter voltage controlled oscillator (TX VCO; Q507), a receiver voltage controlled oscillator (RX VCO; Q508), a buffer amplifier (Q513 and Q515), an RF amplifier (Q516), a low-pass filter (Q501, Q503 and Q504), a PLL IC (IC501), and TX VCO/RX VCO switches (Q510 and Q511).

In the transmit signal mode, an operating frequency programming data is sent to IC501, from the CPU (IC701), to set the programmable counter within IC501. Q510 is turned on to activate the TX VCO and the output signal of the TX VCO is amplified by Q513 and Q516.

The signal is then divided down in frequency, at the programmable counter in IC501, to 5.0kHz or 6.25kHz which is compared in phase with a 5.0kHz or 6.25kHz reference signal, derived from 16.8MHz VCXO (X501) and a 1/3360 or a 1/

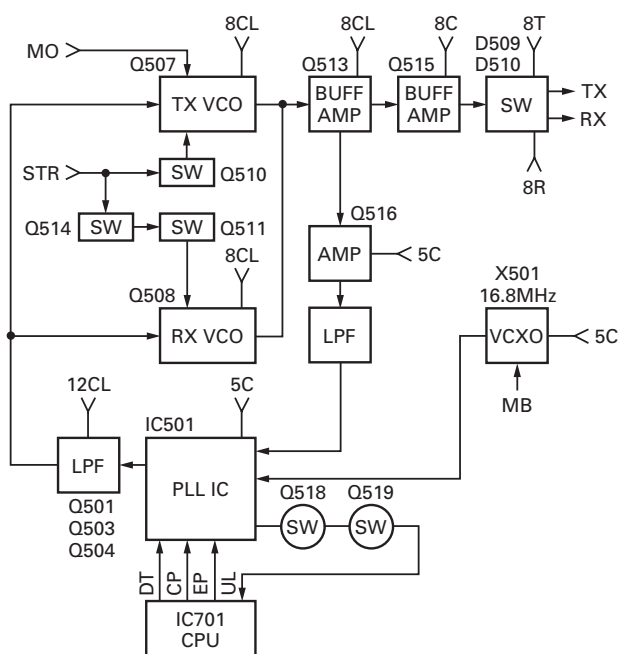

Fig. 4 PLL circuit

2688 fixed counter in IC501, at the phase comparator in IC501. The VCXO operates at 16.8MHz and its frequency stability is maintained within 2.5ppm (temperature range of -30 to +60 degrees).

The phase comparator output signal is fed into a low-pass filter (Q501, Q503 and Q504) before being applied to the TX vco as a frequency control voltage. This low-pass filter's power is supplied by the DC/DC converter (Q502, Q505, Q506, Q509, and Q512). If an unlock condition occurs in the phase locked loop, this condition is detected by Q518 and Q519. This cause the transmitter 8V supply cut off, resulting in the prevention of an unauthorized transmission.

The transmitter modulation signals (processed Mic. audio and sub-audible signalling) are applied to the TX VCO for frequency modulation.

In the receive mode, the VCO is substituted with Q508 (RX VCO) and it generates the receiver first local oscillator signal according to the data sent from the CPU (IC701). The basic operation of the synthesizer remains the same.

### 5. Control Circuit

The control circuit mainly consists of CPU, memory circuit, DSP circuit, and power supply circuit.

#### 5-1. CPU

The CPU (IC701) controls the flash ROM (IC705), the DSP (IC710), the receiver circuit, the transmitter circuit, the control circuit, and the display circuit and transfers data to or from an external device.

#### 5-2. Memory Circuit

IC705 has a flash ROM with a capacity of 4M bits that contains the control program for the CPU, the signal processing program for DSP and data such as channels and operating features.

This program can be easily written from an external devices. Data such as the operating status are programmed into the EEPROM (IC704).

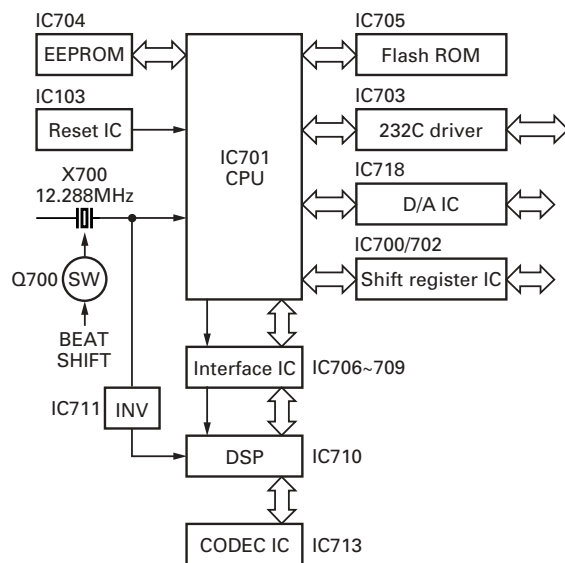

Fig. 5 Control circuit

## CIRCUIT DESCRIPTION

### 5-3. DSP Circuit

The DSP circuit filters transmit/receive audio signal and encode/decode signalling (QT, DQT, MSK, DTMF, 2-Tone, LTR ID). This circuit consists of IC710, IC706, IC707, IC708, IC709 and IC713.

The receive audio signal is converted from analog to digital by IC713 with a sampling frequency of 19.2kHz. The digitized audio signal is sent to DSP (IC710) to process the signalling signal and audio signal. The processed digital audio signal is fed to CODEC (IC713), converted from digital to analog, and the analog signal is output from pin 16 (AOUTR).

The transmit audio signal coming from IC714 (A/2) is amplified by IC712 (B/2), fed to pin 3 (AINL) of CODEC (IC713), and converted from analog to digital at a sampling frequency of 19.2kHz. The digitized transmit audio signal is AGC-processed, pre-emphasized and filtered at 300Hz to 3kHz by DSP (IC710), and the resulting signal is feed back to CODEC (IC713), and converted from digital to analog, and the analog signal is output from pin 15 (AOUTL).

IC706, IC707, IC708 and IC709 are interface IC between the CPU operated at 5.0V and the DSP operated at 3.3V.

### 5-4. Power Supply Circuit

The voltage is always applied from +B. D103 protects IC102 (DFF) against overvoltage.

Pulses from power switch are input to the IC102 clock line and the CPU (IC701). These clock pulses reverse the output High (radio : turn off) → Low (radio : turn on), do not reverse the output Low → High. The CPU (IC701) output the pulse to IC102 set line to reverse the output Low → High.

IGN is input to the IC102 reset line and the CPU (IC701). When the IC102 reset voltage rise, the output goes Low (ra-

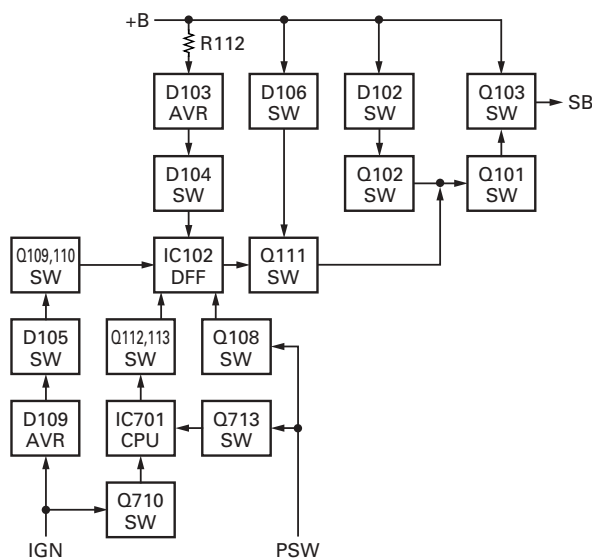

Fig. 6 Power supply circuit

dio : turn on). When IGN falls, the CPU (IC701) output the pulse to IC102 set line to reverse the output Low → High after the programmed time expire (Timed power off function).

If 24V is supplied to the radio by mistake, Q102 turns on, Q101 turns off, the power is forced to be turned off.

This circuit consists of IC104 (8V), IC105 (5V), IC106 (3.3V), IC108 (3.3V) and IC107 (1.8V).

### 6. Display Circuit

The display unit consists of CPU (IC904), LCD assembly, LED, and other components.

Channels are changed by the rotary switch (S1). The up/down signals from the rotary switch enter the CPU (IC904), and converted to a serial data signal, and are sent to the CPU (IC701) in the TX-RX unit. The on/off signals of keys other than the power switch, and the PTT and HOOK signals, are converted to serial data and sent to the CPU (IC701) in the TX-RX unit.

Data is displayed on the 12 digits and 3 digits dot matrix alphanumeric display.

### 7. RS-232C Circuit

The RS-232C circuit connects the RS-232C serial port of a personal computer directly to this model to perform FPU operation (Read and Write). The FPU operation can also be performed by connecting a programming cable (KPG-46) to the local microphone on the front panel. The 232C driver IC (IC703) changes the TTL-232C level. The firmware can only be rewritten with the local microphone on the front panel.

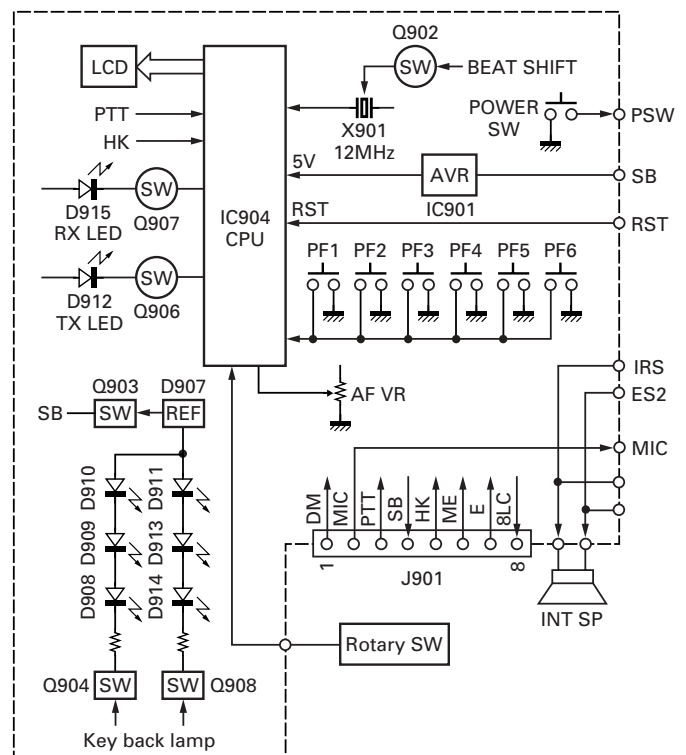

Fig. 7 Display circuit



## SEMICONDUCTOR DATA

## 1. CPU : 30620M8A-5H1GP (TX-RX Unit IC701)

## 1-1. Pin Function

Pin No.	Name	I/O	Function	Pin No.	Name	I/O	Function
1		I/O	Go to port check mode L : Port check mode, H : User mode	39	HOLD	I	Cannot Use (BUS Hold)
2	WN	O	Wide/Narrow H : Narrow, L : Wide	40	HLDA	O	Cannot Use (BUS Hold Status)
3	8RC	O	8R Control H : 8R on, L : 8R off	41	BCLK	O	Cannot Use (Sys Clock Output)
4	INTx	O	INT Request to DSP L : INT request	42	RD	O	Flash ROM : RD, DSP : HDS1
5	STR	O	VCO TX/RX H : TX VCO, L : RX VCO	43	BHE	O	Cannot Use (BUS High Enable)
6	BYTE		+5V	44	WR	O	Flash ROM : WR, DSP : HDS2
7	CNVss		GND	45	SBC	O	SB Control H : SBC off, L : SBC on
8	8TC	O	8T Control H : 8T on, L : 8T off	46	AM	O	Audio Mute H : SP mute, L : SP unmute
9	SFT	O	Beat Shift H : SFT on, L : SFT off	47	HCS	O	DSP HCS
10	RESET		CPU Reset	48	CS0	O	Flash CS
11	Xout		12.288MHz	49~59	A19~A9	O	Cannot Use (Flash ROM Address BUS)
12	Vss		GND	60	Vcc		+5V
13	Xin		12.288MHz	61	A8	O	Cannot Use (Flash ROM Address BUS)
14	Vcc		+5V	62	Vss		GND
15	NMI	I	Not Used	63~70	A7~A0	O	Cannot Use (Flash ROM Address BUS)
16	IGN	I	Ignition Sense H : IGN. Sense off, L : IGN. Sense on	71	PTO	O	Scrambler TX/RX Control H : RX, L : TX
17	PSI	I	Power Down Det L : Power down det	72	PSW	I	Pow. Switch Det H : Inactive, L : Active
18	LD	O	D/A Converter LD	73	Inty	I	INT Request from DSP L : INT request
19	CP	O	PLL IC Clock	74	RS	O	DSP Reset H : DSP reset
20	EP	O	PLL IC Enable	75	SCL	O	EEPROM Clock
21	CONTROL	O	Connect Codec TX Out to speaker line H : Connect, L : Disconnect	76	SDA	I/O	EEPROM Data
22	DT	O	Common Data	77	KEY	I	TX Request from ANI board L : TX request
23	CK	O	Common Clock	78	STB2	O	Shift Register 2 Strobe
24	SOE	O	Shift Register 1 OE	79~86	D7~D0		Cannot Use (Flash ROM Data BUS)
25	STB1	O	Shift Register 1 Strobe	87	PDET	I	Power Det Level
26	AI4	I	AUX Input No.4 H : Inactive, L : Active	88	CDET	I	Power Current Det Level
27	RXD2	I	Head Comm (RXD)	89	TEMP1	I	Power Temp1 Level
28	TXD2	O	Head Comm (TXD)	90	TEMP2	I	Power Temp2 Level
29	TXD1	O	Acc com2 (TXD)	91	ASQ	I	Analog Squelch Level
30	RXD1	I	Acc com2 (RXD)	92	RSSI	I	RSSI Level
31	AI3	I	AUX Input No.3 H : Inactive, L : Active	93	UL	I	Unlock Level
32	AI2	I	AUX Input No.2 H : Inactive, L : Active	94	Avss		GND
33	TXD0	O	Acc com1 (TXD)	95		I	Not Used
34	RXD0	I	Acc com1 (RXD)	96	Vref		+5V
35	AI1	I	AUX Input No.1 H : Inactive, L : Active	97	Avcc		+5V
36		O	Not Used	98	AUX	I	Emergency Channel Request from ANI board L : Channel request
37	RDY	I	Hardware BUS Wait Control	99	INH	I	Audio Inhibit from ANI board H : SP unmute, L : SP mute
38	ALE	O	Cannot Use (Address Latch)	100	TCNT	I	Tone Control from ANI board L : Board tone output request

## SEMICONDUCTOR DATA

## 2. Shift Register 1 : BU4094BCFV (TX-RX Unit IC702)

## 2-1. Pin Function

Pin No.	Port Name	Name	I/O	Function
1	STROBE	STB1	I	From CPU STB1 (Pin No.25)
2	SERIAL IN	DATA	I	From CPU Common Data (Pin No.22)
3	CLOCK	CLK	I	From CPU Common Clock (Pin No.23)
4	Q1	MI2	O	External Mic Mute L : Mute, H : Unmute
5	Q2	DI	O	External Data Line Mute L : Mute, H : Unmute
6	Q3	SP	O	Front SP/EXT SP Change L : Front SP, H : External SP
7	Q4	HR	O	Horn Alert L : Relay off, H : Relay on
8	VSS	VSS		GND
9	Qs	Qs	O	No Connect
10	Qs'	Qs'	O	No Connect
11	Q8	AO4	O	AUX Output No.4 H : AUX Out No.4 on, L : AUX Out No.4 off
12	Q7	AO3	O	AUX Output No.3 H : AUX Out No.3 on, L : AUX Out No.3 off
13	Q6	AO2	O	AUX Output No.2 H : AUX Out No.2 on, L : AUX Out No.2 off
14	Q5	AO1	O	AUX Output No.1 H : AUX Out No.1 on, L : AUX Out No.1 off
15	OUTPUT ENABLE	SOE	I	From CPU SOE (Pin No.24) L → Inactive, H → Active
16	VDD	VDD		+5V

## 3. Shift Register 2 : BU4094BCFV (TX-RX Unit IC700)

## 3-1. Pin Function

Pin No.	Port Name	Name	I/O	Function
1	STROBE	STB2	I	From CPU STB1 (Pin No.21)
2	SERIAL IN	DATA	I	From CPU Common Data (Pin No.22)
3	CLOCK	CLK	I	From CPU Common Clock (Pin No.23)
4	Q1	BC1	O	Scrambler Code 1 (For SCR) L : SCR Code1 off, H : SCR Code1 on
5	Q2	BC2	O	Scrambler Code 2 (For SCR) L : SCR Code2 off, H : SCR Code2 on
6	Q3	BC3	O	Scrambler Code 3 (For SCR) L : SCR Code3 off, H : SCR Code3 on
7	Q4	BC4	O	Scrambler Code 4 (For SCR) L : SCR Code4 off, H : SCR Code4 on
8	VSS	VSS		GND

Pin No.	Port Name	Name	I/O	Function
9	Qs	Qs	O	No Connect
10	Qs'	Qs'	O	No Connect
11	Q8	AC	O	Scrambler ON/OFF (For SCR) L : Scrambler on, H : Scrambler off
12	Q7	BUSY	O	Channel Busy (For ANI) L : Busy, H : Not Busy
13	Q6	EMG	O	Emergency ON/OFF (For ANI) L : Emergency on, H : Emergency off
14	Q5	PTO	O	PTT Output (For ANI) L : PTT on, H : PTT off
15	OUTPUT ENABLE	SOE		GND
16	VDD	VDD		+5V

## 4. D/A Converter : M62364FP (TX-RX Unit IC718)

## 4-1. Pin Function

Pin No.	Name	I/O	Function
1	Vin1	I	AF Volume First IN
2	Vout1	O	AF Volume First OUT
3	Vout2	O	AF Volume Second OUT
4	Vin2	I	AF Volume Second IN (From DAC Pin No.2)
5	VDD		+5V
6	LD	O	From CPU LD(Pin No.18)
7	CK	O	From CPU Common Clock (Pin No.23)
8	DT	O	From CPU Common Data (Pin No.22)
9	Vin3	I	GND
10	Vout3	O	Tune Varicap
11	Vout4	O	Side Tone Out
12	Vin4	I	Side Tone (From Option Board)
13	Vin5	I	
14	Vout5	O	Max Deviation
15	Vout6	O	
16	Vin6	I	DQT Balance
17	Do	O	Open
18	VDAref	I	
19	Reset	I	+5V
20	GND		GND
21	Vin7	I	+5V
22	Vout7	O	Frequency Adjust
23	Vout8	O	Auto Power Control
24	Vin8	I	+5V

## SEMICONDUCTOR DATA

## 5. Display CPU : 30622M4A-443GP (Display Unit IC904)

## 5-1. Pin Function

Pin No.	Name	I/O	Function	Pin No.	Name	I/O	Function
1	DISP	O	LCD Display ON/OFF L : On, H : Off	41	PF3	I	PF3 Key Input
2~5		O	Not used	42	PF4	I	PF4 Key Input
6	BYTE		GND	43	PF5	I	PF5 Key Input
7	CNVss		GND	44	PF6	I	PF6 Key Input
8		O	Not used	45~49		O	Not used
9	SFT	O	Beat Shift L : Shift off, H : Shift on	50	BCK2		PF Key Backlight Control L : Off, H : On
10	RESET		CPU Reset	51	TP3	I	Head Check Mode L : Head check mode, H : Not go to head check mode
11	Xout		12.0MHz	52~56		O	Not used
12	Vss		GND	57	BUSY	O	BUSY LED L : Off, H : On
13	Xin		12.0MHz	58	TX	O	TX LED L : Off, H : On
14	Vcc		+5V	59		O	Not used
15	NMI	I	Not used	60	Vcc		+5V
16~19		O	Not used	61		O	Not used
20	MIC	O	Mic Mute L : Mute, H : Unmute	62	Vss		GND
21,22		O	Not used	63~66		O	Not used
23	DM	I/O	Mic Keypad Data	67	RSW4	I	Rotary SW4
24		O	Not used	68	RSW3	I	Rotary SW3
25	BLC	O	Mic Keypad Backlight Control L : Off, H : On	69	RSW2	I	Rotary SW2
26		O	Not used	70	RSW1	I	Rotary SW1
27	RXD2	I	Body Comm (RXD)	71~81		O	Not used
28	TXD2	O	Body Comm (TXD)	82	LEDK	O	LCD Back Light Control L : Off, H : On
29	TXD1	O	PC Comm (TXD)/connect to PTT	83	DO	O	LCD Data Output
30	RXD1	I	Open (RXD)	84	DI	I	LCD Data Input
31		I	Not used	85	CL	O	LCD Clock
32		O	Not used	86	CE	O	LCD CS
33	TXD0	O	Open (TXD)	87~92		O	Not used
34	RXD0	I	PC Comm (RXD)/connect to HOOK	93	VOL	I	Audio Volume Input
35	HOOK	I	HOOK/connect to RXD0	94	AVss		GND
36	PTT	I	PTT/connect to TXD1	95		O	Not used
37		O	Not used	96	AVref		+5V
38	BCK1	O	PF Key Backlight Control L : Off, H : On	97	AVcc		+5V
39	PF1	I	PF1 Key Input	98~100		O	Not used
40	PF2	I	PF2 Key Input				

## SEMICONDUCTOR DATA

## 6. DSP : 320VC5402PGE (TX-RX Unit IC710)

## 6-1. Pin Function

Pin No.	Name	I/O	Function	Pin No.	Name	I/O	Function
1,2,12,15, 35~38, 71~74,80, 90,110,126, 143,144	NC1~NC18	-	Not used (No connect)	53	BFSX0	I	Frame sync.for transmitter input (LRCK : 19.2kHz)
6,58,69,81, 95,120,124, 135	HD0~HD7	I/O	HPI data bus	54	BFSX1	I	Not used (No connect)
5,7~11,105, 107~109, 131~134, 136~141,	A0~A19	O	Not used (No connect)	55	HRDY	-	Not used (No connect)
13	HAS	I	HPI address strobe (Pull up)	59	BDX0	O	Serial data transmit output
17	HCS	I	HPI chip select	60	BDX1	-	Not used (No connect)
18	HR/W	I	HPI read/write	61	IACK	-	Not used (No connect)
19	READY	I	Data ready (Pull up)	62	HBIL	I	Byte identification (HPI)
20	PS	O	Not used (No connect)	63	NMI	I	Not used (Pull up)
21	DS	O	Not used (No connect)	64	INT0	I	Command interrupt from Host CPU
22	IS	O	Not used (No connect)	65	INT1	I	Not used (Pull up)
23	R/W	O	Not used (No connect)	66	INT2	I	Boot mode select (Pull up)
24	MSTRB	O	Not used (No connect)	67	INT3	I	Not used (Pull up)
25	IOSTRB	O	Not used (No connect)	77	CLKMD1	I	Clock mode select (Pull down)
26	MSC	O	Not used (No connect)	78	CLKMD2	I	Clock mode select (Pull up)
27	XF	O	CODEC control (H : power down, L : active)	79	CLKMD3	I	Clock mode select (Pull down)
28	HOLDA	-	Not used (No connect)	82	TOUT0	-	Not used (No connect)
29	IAQ	-	Not used (No connect)	83	EMU0	I/O	Emulator 0 (to JTAG connector)
30	HOLD	I	Hold (Pull up)	84	EMU1/OFF	I/O	Emulator 1 (to JTAG connector)
31	BIO	I	Serial data synchronize input	85	TDO	O	Test data output (to JTAG connector)
32	MP/MC	I	Not used (Pull down)	86	TDI	I	Test data input (to JTAG connector)
39	HCNTL0	I	HPI control 0	87	TRST	I	Test reset (to JTAG connector)
41	BCLKR0	I	Receive clock output (SCLK : 614.4kHz)	88	TCK	I	Test clock (to JTAG connector)
42	BCLKR1	-	Master clock output (MCLK : 4.9152MHz)	89	TMS	I	Test mode select (to JTAG connector)
43	BFSR0	I	Frame sync. for receiver output (LRCK : 19.2kHz)	92	HPIENA	I	Not used (Pull up)
44	BFSR1	I	Not used (No connect)	94	CLKOUT	O	Not used (No connect)
45	BDR0	I	Serial data receive input	96	X1	-	12.288MHz (System clock)
46	HCNTL1	I	HPI control 1	97	X2/CLKIN	-	12.288MHz (System clock)
47	BDR1	-	Not used (No connect)	98	RS	I	DSP reset input
48	BCLKX0	I	Transmit clock input (SCLK : 614.4kHz)	99~104, 113~119, 121~123	D0~D15	-	Not used (No connect)
49	BCLKX1	O	Not used (No connect)	127	HDS1	I	HPI data strobe1 (Pull up)
51	HINT/TOUT1	O	Interrupt for Host CPU/Boot mode select (Pull up)	129	HDS2	I	HPI data strobe2 (Pull down)
				3,14,34,40, 50,57,70, 76,93,106, 111,128	Vss	-	GND
				4,33,56, 75,112,130	DVDD	-	VDD for I/O pins (+3.3V)
				16,52,68, 91,125,142	CVDD	-	VDD for core CPU (+1.8V)

## COMPONENTS DESCRIPTION

## 1. Display Unit (X54-3400-10)

Ref. No.	Part Name	Description
IC901	IC	Voltage regulator
IC902	IC	Voltage detector
IC904	IC	CPU
Q901	FET	MIC switch
Q902	FET	DC switch
Q903	Transistor	Current driver
Q904~908	Transistor	DC switch
Q909,910	Transistor	Inverter
Q911	Transistor	DC switch
D902~906	Diode	Surge protector
D907	Zener diode	Voltage reference
D908~911	LED	Key backlight
D912	LED	TX light
D913,914	LED	Key backlight
D915	LED	RX light
D916	Zener diode	Surge protector
D917	Varistor	Current protector
D918	Zener diode	Surge protector

## 2. TX-RX Unit (X57-6580-10)

Ref. No.	Part Name	Description
IC2	IC	DC amplifier
IC101	IC	Voltage detector
IC102	IC	D flip-flop
IC103	IC	Voltage detector
IC104~108	IC	Voltage regulator
IC201	IC	FM IF system
IC202	IC	Multiplexer
IC501	IC	PLL
IC700	IC	Shift register
IC701	IC	CPU
IC702	IC	Shift register
IC703	IC	RS232C transceiver
IC704	IC	EEPROM
IC705	IC	Flash ROM
IC706	IC	Bus transceiver
IC707~709	IC	OR gate
IC710	IC	DSP
IC711	IC	Inverter

Ref. No.	Part Name	Description
IC712	IC	AF amplifier
IC713	IC	CODEC
IC714	IC	MIC amplifier/AGC
IC715	IC	Buffer amplifier
IC716	IC	Anti-aliasing filter
IC717	IC	Multiplexer
IC718	IC	D/A converter
IC719	IC	AF amplifier
IC720	IC	Audio power amplifier
IC721	IC	DC amplifier
IC722	IC	AF amplifier
IC723	IC	Voltage regulator
IC724	IC	Multiplexer
IC725	IC	Voltage detector
Q1,2	Transistor	RF amplifier
Q3	FET	RF amplifier
Q4	FET	Drive amplifier
Q5	FET	Final amplifier
Q101	Transistor	DC switch
Q102	Transistor	Switch
Q103	FET	DC switch
Q104~113	Transistor	DC switch
Q201~203	Transistor	W/N switch
Q204	Transistor	Noise amplifier
Q205	Transistor	W/N switch
Q206	Transistor	IF amplifier
Q207	Transistor	Pre IF amplifier
Q208,209	Transistor	RF amplifier
Q210~213	FET	Mixer
Q214	Transistor	RF amplifier
Q501	Transistor	Active filter
Q502	FET	Oscillator
Q503,504	Transistor	Active filter
Q505,506	Transistor	DC switch
Q507	FET	TX oscillator
Q508	FET	RX oscillator
Q509	Transistor	AVR
Q510,511	Transistor	TX/RX switch
Q512	Transistor	Ripple filter
Q513	Transistor	Buffer amplifier

## COMPONENTS DESCRIPTION

Ref. No.	Part Name	Description
Q514	Transistor	Inverter
Q515	Transistor	Buffer amplifier
Q516	Transistor	Amplifier
Q517	Transistor	Ripple filter
Q518~520	Transistor	DC switch
Q521	Transistor	Inverter
Q700	FET	DC switch
Q701~706	Transistor	DC switch
Q707,708	Transistor	MIC gain switch
Q709	Transistor	Inverter
Q710,711	Transistor	DC switch
Q712,713	FET	DC switch
Q714	Transistor	DC switch
Q716	Transistor	DC switch
Q719,720	Transistor	DC switch
D1	Zener diode	Surge protector
D2	Zener diode	Voltage protection
D3,4	Diode	ANT switch
D5,6	Diode	RF detector
D9	Diode	ANT switch
D51	Diode	Surge protector
D101	Diode	Protection of reverse connection
D102,103	Zener diode	Voltage reference
D104~106	Diode	DC switch

Ref. No.	Part Name	Description
D108	Diode	Surge protector
D109	Zener diode	Voltage reference
D201	Diode	DC switch
D202	Diode	Noise detection
D203~206	Diode	Wide/Narrow switch
D207~212	Varicap	BPF tuning
D501~504	Varicap	Frequency control
D505	Diode	Voltage doubler
D506	Varicap	Modulator
D507	Diode	Voltage doubler
D508	Zener diode	Voltage reference
D509,510	Diode	RF switch
D515	Diode	DC switch
D700~703	Diode	Surge protector
D704	Diode	Voltage reduction
D705~709	Diode	Surge protector
D710	Zener diode	Surge protector
D711,712	Diode	AF detector
D714	Diode	DC switch
D715	Zener diode	Surge protector
D717,718	Zener diode	Surge protector
D785~788	Zener diode	Surge protector
D789	Varistor	Current protector
D791	Varistor	Current protector

## PARTS LIST

### CAPACITORS

$\frac{C}{1} \frac{C}{2} \frac{45}{3} \frac{TH}{4} \frac{1H}{5} \frac{220}{6} \frac{J}{6}$

- 1 = Type ... ceramic, electrolytic, etc.
- 2 = Shape ... round, square, etc.
- 3 = Temp. coefficient
- 4 = Voltage rating
- 5 = Value
- 6 = Tolerance

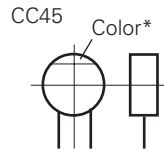

#### • Capacitor value

- 010 = 1pF
- 100 = 10pF
- 101 = 100pF
- 102 = 1000pF = 0.001μF
- 103 = 0.01μF

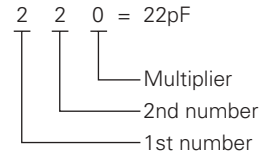

#### • Temperature coefficient

1st Word	C	L	P	R	S	T	U
Color*	Black	Red	Orange	Yellow	Green	Blue	Violet
ppm/°C	0	-80	-150	-220	-330	-470	-750

2nd Word	G	H	J	K	L
ppm/°C	±30	±60	±120	±250	±500

Example : CC45TH = -470±60ppm/°C

#### • Tolerance (More than 10pF)

Code	C	D	G	J	K	M	X	Z	P	No code
(%)	±0.25	±0.5	±2	±5	±10	±20	+40 -20	+80 -20	+100 -0	More than 10μF : -10~+50 Less than 4.7μF : -10~+75

#### (Less than 10pF)

Code	B	C	D	F	G
(pF)	±0.1	±0.25	±0.5	±1	±2

#### • Voltage rating

2nd word \ 1st word	A	B	C	D	E	F	G	H	J	K	V
0	1.0	1.25	1.6	2.0	2.5	3.15	4.0	5.0	6.3	8.0	-
1	10	12.5	16	20	25	31.5	40	50	63	80	35
2	100	125	160	200	250	315	400	500	630	800	-
3	1000	1250	1600	2000	2500	2150	4000	5000	6300	8000	-

### CHIP CAPACITORS

(EX)  $\frac{C}{1} \frac{C}{2} \frac{73}{3} \frac{F}{4} \frac{SL}{5} \frac{1H}{6} \frac{000}{7} \frac{J}{7}$

(Chip) (CH, RH, UJ, SL)

(EX)  $\frac{C}{1} \frac{K}{2} \frac{73}{3} \frac{F}{4} \frac{F}{5} \frac{1H}{6} \frac{000}{7} \frac{Z}{7}$

(Chip) (B, F)

Refer to the table above.

- 1 = Type
- 2 = Shape
- 3 = Dimension
- 4 = Temp. coefficient
- 5 = Voltage rating
- 6 = Value
- 7 = Tolerance

#### • Dimension

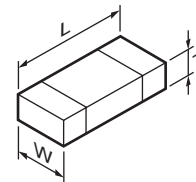

#### Chip capacitor

Code	L	W	T
Empty	5.6±0.5	5.0±0.5	Less than 2.0
A	4.5±0.5	3.2±0.4	Less than 2.0
B	4.5±0.5	2.0±0.3	Less than 2.0
C	4.5±0.5	1.25±0.2	Less than 1.25
D	3.2±0.4	2.5±0.3	Less than 1.5
E	3.2±0.2	1.6±0.2	Less than 1.25
F	2.0±0.3	1.25±0.2	Less than 1.25
G	1.6±0.2	0.8±0.2	Less than 1.0
H	1.0±0.05	0.5±0.05	0.5±0.05

#### Chip resistor

Code	L	W	T
E	3.2±0.2	1.6±0.2	1.0
F	2.0±0.3	1.25±0.2	1.0
G	1.6±0.2	0.8±0.2	0.5±0.1
H	1.0±0.05	0.5±0.05	0.35±0.05

### RESISTORS

#### • Chip resistor (Carbon)

(EX)  $\frac{R}{1} \frac{D}{2} \frac{73}{3} \frac{E}{4} \frac{B}{5} \frac{2B}{6} \frac{000}{7} \frac{J}{7}$

(Chip) (B, F)

#### • Carbon resistor (Normal type)

(EX)  $\frac{R}{1} \frac{D}{2} \frac{14}{3} \frac{B}{4} \frac{B}{5} \frac{2C}{6} \frac{000}{7} \frac{J}{7}$

(Chip) (B, F)

- 1 = Type ... ceramic, electrolytic, etc.
- 2 = Shape ... round, square, etc.
- 3 = Dimension
- 4 = Temp. coefficient
- 5 = Voltage rating
- 6 = Value
- 7 = Tolerance

#### • Rating wattage

Code	Wattage	Code	Wattage	Code	Wattage
1J	1/16W	2C	1/6W	3A	1W
2A	1/10W	2E	1/4W	3D	2W
2B	1/8W	2H	1/2W		

## PARTS LIST

\* New Parts.  $\Delta$  indicates safety critical components.Parts without **Parts No.** are not supplied.Les articles non mentionnés dans le **Parts No.** ne sont pas fournis.Teile ohne **Parts No.** werden nicht geliefert.

L : Scandinavia

Y : PX (Far East, Hawaii)

Y : AAFES (Europe)

K : USA

T : England

X : Australia

P : Canada

E : Europe

M : Other Areas

TK-8150 (Y51-4920-10)

DISPLAY UNIT (X54-3400-10)

Ref. No.	Address	New parts	Parts No.	Description	Destination	Ref. No.	Address	New parts	Parts No.	Description	Destination
<b>TK-8150</b>						<b>DISPLAY UNIT (X54-3400-10)</b>					
1	1B	*	A01-2185-12	CABINET		101	3A	*	B38-0875-05	LCD ASSY	
2	3A	*	A62-1037-03	PANEL ASSY		D908-911			B30-2254-05	LED	
4	1C	*	B11-1297-04	NAME PLATE		D912			B30-2193-05	LED (RED)	
5	1D	*	B62-1619-00	INSTRUCTION MANUAL		D913,914			B30-2254-05	LED	
6	3A	*	B72-2087-04	MODEL NAME PLATE		D915			B30-2194-05	LED (GREEN)	
8	2A		E04-0167-05	RF COAXIAL RECEPTACLE (M)		C901			CC73GCH1H101J	CHIP C 100PF	J
9	1C	*	E30-3478-05	DC CORD ASSY		C902			CK73GB1H102K	CHIP C 1000PF	K
-			E37-0808-05	LEAD WIRE WITH CONNECTOR		C903			CK73GB1H103K	CHIP C 0.010UF	K
11	3A	*	E37-1002-15	LEAD WIRE WITH CONNECTOR (SP)		C904			CK73GB1H102K	CHIP C 1000PF	K
12	1A	*	E37-1003-05	LEAD WIRE WITH CONNECTOR (6P/ACC)		C905,906			CC73GCH1H101J	CHIP C 100PF	J
13	3A	*	E37-1004-05	LEAD WIRE WITH CONNECTOR (TXRX-CONT)		C907			CK73GB1H102K	CHIP C 1000PF	K
14	1B,2C	*	E37-1031-05	LEAD WIRE WITH CONNECTOR (SHORT PLUG)		C909,910			CC73GCH1H101J	CHIP C 100PF	J
15	1A	*	E37-1074-05	LEAD WIRE WITH CONNECTOR (DC CODE)		C911,912			C92-0628-05	CHIP-TAN 10UF	10WV
-		*	E37-1075-05	LEAD WIRE WITH CONNECTOR		C914			CK73GB1H102K	CHIP C 1000PF	K
18	2C		F05-1537-05	FUSE (BLADE) (15A/32V)		C915-917			CC73GCH1H101J	CHIP C 100PF	J
19	2B		F09-0445-05	CAP		C918,919			CK73GB1H103K	CHIP C 0.010UF	K
20	2C	*	F29-0478-05	PROTECTIVE COVER		C921			CK73GB1H103K	CHIP C 0.010UF	K
22	2B		G02-0861-04	FLAT SPRING		C922			CC73GCH1H060B	CHIP C 6.0PF	B
23	2B	*	G02-0894-04	EARTH SPRING		C923			CK73GB1C223K	CHIP C 0.022UF	K
24	2B	*	G02-0896-04	FLAT SPRING		C924			C92-0628-05	CHIP-TAN 10UF	10WV
25	2B	*	G02-0900-04	EARTH SPRING		C925			CK73GB1H102K	CHIP C 1000PF	K
26	2B	*	G02-1801-03	EARTH SPRING		C926,927			CC73GCH1H270J	CHIP C 27PF	J
27	2B	*	G02-1802-04	EARTH SPRING		C928			CK73GB1H103K	CHIP C 0.010UF	K
28	1B	*	G53-1551-02	PACKING		C929,930			CK73GB1H102K	CHIP C 1000PF	K
29	2A	*	G53-1552-03	PACKING		C931			CK73GB1H103K	CHIP C 0.010UF	K
30	1A	*	G53-1554-03	PACKING		C932			CK73GB1H102K	CHIP C 1000PF	K
31	3A	*	G53-1555-04	PACKING		C933			CK73GB1H103K	CHIP C 0.010UF	K
33	3D	*	H52-1921-02	ITEM CARTON CASE		C934,935			CK73GB1H102K	CHIP C 1000PF	K
35	2C		J19-1584-05	HOLDER (MIC)		C938,939			CK73GB1H102K	CHIP C 1000PF	K
36	2B	*	J21-8437-14	HARDWARE FIXTURE		C941,942			CK73GB1H102K	CHIP C 1000PF	K
37	1C	*	J29-0697-03	BRACKET		C943			CK73GB1H103K	CHIP C 0.010UF	K
38	2C		J61-0307-05	BAND		C944			CK73GB1H102K	CHIP C 1000PF	K
40	3A	*	K29-9221-03	KNOB		CN901			E40-5538-05	PIN ASSY	
41	3A	*	K29-9222-02	KEY TOP		CN902			E40-6140-05	PIN ASSY	
A	1B	*	N09-2409-05	HEXAGON HEAD SCREW		CN905			E40-5823-05	FLAT CABLE CONNECTOR	
B	3A		N10-2070-46	HEXAGON NUT		CN906			E40-5752-05	PIN ASSY	
C	1A,2B,3B		N67-3008-46	PAN HEAD SEMS SCREW W		J901			E08-0877-05	MODULAR JACK	
D	3A		N80-2606-46	PAN HEAD TAPTITE SCREW		W1	3A	*	E37-1057-05	LEAD WIRE WITH CONNECTOR	
E	2B,3B		N87-2606-46	BRAZIER HEAD TAPTITE SCREW		L901,902			L40-1095-34	SMALL FIXED INDUCTOR (1UH)	
F	1B	*	N87-2620-46	BRAZIER HEAD TAPTITE SCREW		X901			L77-1863-05	CRYSTAL RESONATOR (12.0MHZ)	
G	1B,2B	*	N87-3008-45	BRAZIER HEAD TAPTITE SCREW		R902			RK73GB1J104J	CHIP R 100K J	1/16W
H	2C	*	N99-2033-05	SCREW SET		R904,905			R92-1252-05	CHIP R 0 OHM J	1/16W
43	3A	*	T07-0738-05	SPEAKER		R906,907			RK73GB1J102J	CHIP R 1.0K J	1/16W
44	1C		T91-0621-15	MICROPHONE		R908			RK73GB1J473J	CHIP R 47K J	1/16W
46	3A	*	X54-3400-10	DISPLAY UNIT		R909			RK73GB1J472J	CHIP R 4.7K J	1/16W
						R910			RK73GB1J104J	CHIP R 100K J	1/16W
						R913			RK73GB1J473J	CHIP R 47K J	1/16W
						R914			RK73GB1J561J	CHIP R 560 J	1/16W
						R915			R92-0670-05	CHIP R 0 OHM	
						R916-918			RK73GB1J473J	CHIP R 47K J	1/16W
						R919			RK73GB1J333J	CHIP R 33K J	1/16W
						R920			RK73FB2A560J	CHIP R 56 J	1/10W



## PARTS LIST

DISPLAY UNIT (X54-3400-10)  
TX-RX UNIT (X57-6580-10)

Ref. No.	Address	New parts	Parts No.	Description	Destination	Ref. No.	Address	New parts	Parts No.	Description	Destination
R922			RK73GB1J333J	CHIP R 33K J 1/16W		C37			CC73GCH1H471J	CHIP C 470PF J	
R923-925			RK73GB1J102J	CHIP R 1.0K J 1/16W		C38			C93-0599-05	CHIP C 470PF K	
R926,927			RK73FB2A151J	CHIP R 150 J 1/10W		C39			CK73GB1H102K	CHIP C 1000PF K	
R928			RK73GB1J102J	CHIP R 1.0K J 1/16W		C40			C93-0562-05	CHIP C 15PF J	
R931			RK73FB2A272J	CHIP R 2.7K J 1/10W		C41			C93-0558-05	CHIP C 8.0PF D	
R932,933			RK73GB1J102J	CHIP R 1.0K J 1/16W		C42,43			C93-0599-05	CHIP C 470PF K	
R934			RK73FB2A272J	CHIP R 2.7K J 1/10W		C45			C93-0599-05	CHIP C 470PF K	
R935-941			RK73GB1J473J	CHIP R 47K J 1/16W		C46,47			CC73GCH1H0R5C	CHIP C 0.5PF C	
R942			RK73GB1J472J	CHIP R 4.7K J 1/16W		C49			CC73GCH1H471J	CHIP C 470PF J	
R943			RK73GB1J333J	CHIP R 33K J 1/16W		C51			CC73GCH1H0R5C	CHIP C 0.5PF C	
R944			RK73GB1J471J	CHIP R 470 J 1/16W		C52			CC73GCH1H020C	CHIP C 2.0PF C	
R945			RK73GB1J6R8J	CHIP R 6.8 J 1/16W		C53			CC73GCH1H471J	CHIP C 470PF J	
R946,947			R92-2021-05	CHIP R 2.2 J 1/2W		C54			C93-0555-05	CHIP C 5.0PF C	
R948			RK73GB1J104J	CHIP R 100K J 1/16W		C55			CC73GCH1H471J	CHIP C 470PF J	
R949			RK73GB1J102J	CHIP R 1.0K J 1/16W		C56,57			C93-0564-05	CHIP C 22PF J	
R950			RK73GB1J224J	CHIP R 220K J 1/16W		C65			CK73GB1H103K	CHIP C 0.010UF K	
R951			RK73GB1J102J	CHIP R 1.0K J 1/16W		C66,67			CK73FB1C474K	CHIP C 0.47UF K	
R952-955			RK73GB1J104J	CHIP R 100K J 1/16W		C69			CK73GB1H103K	CHIP C 0.010UF K	
R956-959			RK73GB1J102J	CHIP R 1.0K J 1/16W		C70			CC73GCH1H471J	CHIP C 470PF J	
R960			RK73GB1J472J	CHIP R 4.7K J 1/16W		C72			C93-0556-05	CHIP C 6.0PF D	
VR901			R31-0630-05	VARIABLE RESISTOR		C73			CC73GCH1H471J	CHIP C 470PF J	
S1	3A	*	S60-0423-05	ROTARY SWITCH		C76			CK73GB1H103K	CHIP C 0.010UF K	
D902-906			DA204U	DIODE		C77			CM73F2H300J	CHIP C 30PF J	
D907			02CZ9.1(X,Y)	ZENER DIODE		C78			CM73F2H300J	CHIP C 30PF J	
D916			02D218(X,Y)	ZENER DIODE		C79			CC73GCH1H471J	CHIP C 470PF J	
D917		*	MINISMD020	VARISTOR		C80			CK73FB1E224K	CHIP C 0.22UF K	
D918			02D218(X,Y)	ZENER DIODE		C81			C93-0552-05	CHIP C 2.0PF C	
IC901			TA7805F	MOS IC		C82			CC73GCH1H471J	CHIP C 470PF J	
IC902			RH5VL42C	MOS IC		C83			C93-0552-05	CHIP C 2.0PF C	
IC904		*	30622M4A-443GP	MPU		C84			CC73GCH1H010C	CHIP C 1.0PF C	
Q901			2SJ243	FET		C85			CC73GCH1H471J	CHIP C 470PF J	
Q902			2SK1824	FET		C88			CC73GCH1H471J	CHIP C 470PF J	
Q903			2SD1760	TRANSISTOR		C89			C93-0554-05	CHIP C 4.0PF C	
Q904-908			DTC114EE	DIGITAL TRANSISTOR		C90			C93-0557-05	CHIP C 7.0PF D	
Q909-911			DTC144EE	DIGITAL TRANSISTOR		C92		*	C90-4085-05	ELECTRO CAP 47UF 20WV	
<b>TX-RX UNIT (X57-6580-10)</b>						C93,94			C90-5299-05	ELECTRO CAP 470UF 25WV	
C1-4			CC73GCH1H471J	CHIP C 470PF J		C99,100			CC73GCH1H471J	CHIP C 470PF J	
C6-9			CC73GCH1H471J	CHIP C 470PF J		C101			C92-0777-05	ELECTRO CAP 1000UF 25WV	
C10			CC73GCH1H080D	CHIP C 8.0PF D		C102			CK73GB1E473J	CHIP C 0.047UF J	
C11-16			CC73GCH1H471J	CHIP C 470PF J		C103			CC73GCH1H471J	CHIP C 470PF J	
C17			CC73GCH1H050C	CHIP C 5.0PF C		C104			CC73GCH1H101J	CHIP C 100PF J	
C18,19			CC73GCH1H471J	CHIP C 470PF J		C105,106			CK73GB1E473J	CHIP C 0.047UF J	
C20			CK73GB1C104K	CHIP C 0.10UF K		C107			CC73GCH1H471J	CHIP C 470PF J	
C21			CC73GCH1H471J	CHIP C 470PF J		C108			C92-0754-05	CHIP-TAN 4.7UF 20WV	
C22			CC73GCH1H120J	CHIP C 12PF J		C109,110			CC73GCH1H471J	CHIP C 470PF J	
C23			CC73GCH1H060D	CHIP C 6.0PF D		C111-113			CK73GB1C104K	CHIP C 0.10UF K	
C24,25			CC73GCH1H471J	CHIP C 470PF J		C114			CC73GCH1H471J	CHIP C 470PF J	
C26			CC73GCH1H080D	CHIP C 8.0PF D		C115			CK73GB1E473J	CHIP C 0.047UF J	
C27,28			CC73GCH1H330J	CHIP C 33PF J		C116			CK73GB1C104K	CHIP C 0.10UF K	
C29			CC73GCH1H471J	CHIP C 470PF J		C117-119			CK73FB1C105K	CHIP C 1.0UF K	
C30			C93-0599-05	CHIP C 470PF K		C120			CK73GB1E473J	CHIP C 0.047UF J	
C31			CC73GCH1H080D	CHIP C 8.0PF D		C121			CK73GB1H102K	CHIP C 1000PF K	
C32			CC73FCH1H180J	CHIP C 18PF J		C122,123			CK73GB1C104K	CHIP C 0.10UF K	
C33			CC73GCH1H471J	CHIP C 470PF J		C124-126			CC73GCH1H101J	CHIP C 100PF J	
C34			CM73F2H300J	CHIP C 30PF J		C127			C92-0585-05	CHIP-TAN 4.7UF 16WV	
C35			CC73FCH1H471J	CHIP C 470PF J		C128-131			C92-0628-05	CHIP-TAN 10UF 10WV	
						C132			CK73GB1H102K	CHIP C 1000PF K	
						C133			C92-0585-05	CHIP-TAN 4.7UF 16WV	
						C134			CK73FB1E224K	CHIP C 0.22UF K	
						C135			C92-0628-05	CHIP-TAN 10UF 10WV	

## PARTS LIST

TX-RX UNIT (X57-6580-10)

Ref. No.	Address	New parts	Parts No.	Description	Desti-nation	Ref. No.	Address	New parts	Parts No.	Description	Desti-nation
C200			CC73GCH1H060D	CHIP C 6.0PF D		C276			CC73GCH1H330J	CHIP C 33PF J	
C201			CK73FB1E224K	CHIP C 0.22UF K		C277			CC73GCH1H020C	CHIP C 2.0PF C	
C202			CK73GB1H102K	CHIP C 1000PF K		C278			CC73GCH1H330J	CHIP C 33PF J	
C203			CK73GB1C104K	CHIP C 0.10UF K		C279-282			CC73GCH1H471J	CHIP C 470PF J	
C204-206			CK73GB1H102K	CHIP C 1000PF K		C283			CC73GCH1H101J	CHIP C 100PF J	
C207			CK73GB1C104K	CHIP C 0.10UF K		C284			CC73GCH1H471J	CHIP C 470PF J	
C208,209			CK73GB1H331K	CHIP C 330PF K		C285			CC73GCH1H470J	CHIP C 47PF J	
C210			CK73GB1H102K	CHIP C 1000PF K		C286			CC73GCH1H1R5C	CHIP C 1.5PF C	
C211			CK73GB1C104K	CHIP C 0.10UF K		C287			CC73GCH1H010C	CHIP C 1.0PF C	
C212			CK73GB1H103K	CHIP C 0.010UF K		C288			CC73GCH1H330J	CHIP C 33PF J	
C213			CC73GCH1H270J	CHIP C 27PF J		C289			CC73GCH1H020C	CHIP C 2.0PF C	
C214			CK73GB1C104K	CHIP C 0.10UF K		C290			CC73GCH1H330J	CHIP C 33PF J	
C215			C92-0560-05	CHIP-TAN 10UF 6.3WV		C292,293			CC73GCH1H471J	CHIP C 470PF J	
C216			CK73GB1C333J	CHIP C 0.033UF J		C294			CC73GCH1H050C	CHIP C 5.0PF C	
C217,218			CK73GB1H103K	CHIP C 0.010UF K		C295			CC73GCH1H070D	CHIP C 7.0PF D	
C219			C92-0560-05	CHIP-TAN 10UF 6.3WV		C297			CK73GB1C104K	CHIP C 0.10UF K	
C220			CK73GB1H103K	CHIP C 0.010UF K		C299-302			CC73GCH1H1R5C	CHIP C 1.5PF C	
C221			CC73GCH1H120J	CHIP C 12PF J		C306			C92-0712-05	CHIP-TAN 22UF 6.3WV	
C222			CC73GCH1H180J	CHIP C 18PF J		C308			CC73GCH1H1R5C	CHIP C 1.5PF C	
C223			CK73GB1H102K	CHIP C 1000PF K		C501			CC73GCH1H471J	CHIP C 470PF J	
C224			CK73GB1H103K	CHIP C 0.010UF K		C502			C92-0560-05	CHIP-TAN 10UF 6.3WV	
C225			CK73GB1C104K	CHIP C 0.10UF K		C503			C92-0514-05	CHIP-TAN 2.2UF 10WV	
C226			CK73GB1H103K	CHIP C 0.010UF K		C504			CK73FB1E104K	CHIP C 0.10UF K	
C227			CC73GCH1H101J	CHIP C 100PF J		C505			CC73GCH1H471J	CHIP C 470PF J	
C228			CC73GCH1H100D	CHIP C 10PF D		C506			C92-0001-05	CHIP C 0.1UF 35WV	
C229-232			CK73GB1H103K	CHIP C 0.010UF K		C507			CK73GB1C104K	CHIP C 0.10UF K	
C234			CC73GCH1H1R5C	CHIP C 1.5PF C		C508			CC73GCH1H471J	CHIP C 470PF J	
C235			CC73GCH1H0R5C	CHIP C 0.5PF C		C509			C92-0657-05	CHIP-TAN 2.2UF 20WV	
C236			CC73GCH1H1R5C	CHIP C 1.5PF C		C510			CC73GCH1H100D	CHIP C 10PF D	
C237			CC73GCH1H101J	CHIP C 100PF J		C511			CC73GCH1H471J	CHIP C 470PF J	
C238			CC73GCH1H471J	CHIP C 470PF J		C512			CK73GB1H103K	CHIP C 0.010UF K	
C239			CC73GCH1H1R5C	CHIP C 1.5PF C		C513			C92-0657-05	CHIP-TAN 2.2UF 20WV	
C240			CC73GCH1H020C	CHIP C 2.0PF C		C514			CC73GCH1H471J	CHIP C 470PF J	
C241,242			CK73GB1H103K	CHIP C 0.010UF K		C515			CK73GB1C104K	CHIP C 0.10UF K	
C244			CC73GCH1H101J	CHIP C 100PF J		C517			CK73GB1C104K	CHIP C 0.10UF K	
C245,246			CK73GB1H103K	CHIP C 0.010UF K		C518			CK73FB1E224K	CHIP C 0.22UF K	
C247			CC73GCH1H101J	CHIP C 100PF J		C519,520			CC73GCH1H471J	CHIP C 470PF J	
C248,249			CC73GCH1H471J	CHIP C 470PF J		C521			C92-0002-05	CHIP-TAN 0.22UF 35WV	
C250			CK73GB1H103K	CHIP C 0.010UF K		C522			CC73GCH1H471J	CHIP C 470PF J	
C251			CC73GCH1H060D	CHIP C 6.0PF D		C523,524			CK73GB1C104K	CHIP C 0.10UF K	
C252			CC73GCH1H080D	CHIP C 8.0PF D		C525			CK73GB1H102K	CHIP C 1000PF K	
C253			CK73GB1H103K	CHIP C 0.010UF K		C526			C92-0628-05	CHIP-TAN 10UF 10WV	
C254,255			CC73GCH1H471J	CHIP C 470PF J		C527			CC73GCH1H050B	CHIP C 5.0PF B	
C256			CC73GCH1H390J	CHIP C 39PF J		C528			CC73GCH1H010B	CHIP C 1.0PF B	
C257			CC73GCH1H090D	CHIP C 9.0PF D		C529			CC73GCH1H100C	CHIP C 10PF C	
C258			CC73GCH1H120J	CHIP C 12PF J		C530			CC73GCH1H150G	CHIP C 15PF G	
C259			CK73GB1H103K	CHIP C 0.010UF K		C531			CK73GB1C104K	CHIP C 0.10UF K	
C260			CK73GB1C104K	CHIP C 0.10UF K		C532			CC73GCH1H090B	CHIP C 9.0PF B	
C261			CC73GCH1H220J	CHIP C 22PF J		C534,535			CC73GCH1H010B	CHIP C 1.0PF B	
C262			CC73GCH1H120J	CHIP C 12PF J		C536			CC73GCH1H150G	CHIP C 15PF G	
C264-266			CK73GB1H103K	CHIP C 0.010UF K		C537			CC73GCH1H120G	CHIP C 12PF G	
C267			CC73GCH1H471J	CHIP C 470PF J		C538			CC73GCH1H050B	CHIP C 5.0PF B	
C268			CC73GCH1H470J	CHIP C 47PF J		C539			CK73GB1C104K	CHIP C 0.10UF K	
C269			CC73GCH1H010C	CHIP C 1.0PF C		C541			CC73GCH1H471J	CHIP C 470PF J	
C270			CC73GCH1H330J	CHIP C 33PF J		C542			CC73GCH1H0R5B	CHIP C 0.5PF B	
C271			CC73GCH1H020C	CHIP C 2.0PF C		C543			CC73GCH1H050B	CHIP C 5.0PF B	
C272			CC73GCH1H330J	CHIP C 33PF J		C544			CC73GCH1H070B	CHIP C 7.0PF B	
C273			CC73GCH1H471J	CHIP C 470PF J		C545			CK73GB1C104K	CHIP C 0.10UF K	
C274			CC73GCH1H470J	CHIP C 47PF J		C546,547			CC73GCH1H060B	CHIP C 6.0PF B	
C275			CC73GCH1H010C	CHIP C 1.0PF C		C548			CC73GCH1H471J	CHIP C 470PF J	

## PARTS LIST

## TX-RX UNIT (X57-6580-10)

Ref. No.	Address	New parts	Parts No.	Description	Destination	Ref. No.	Address	New parts	Parts No.	Description	Destination
C549			CC73GCH1H060B	CHIP C 6.0PF B		C749			CK73GB1H102K	CHIP C 1000PF K	
C550			CC73GCH1H050B	CHIP C 5.0PF B		C750			CK73FB1C105K	CHIP C 1.0UF K	
C551-554			CC73GCH1H471J	CHIP C 470PF J		C751-755			CK73GB1H103K	CHIP C 0.010UF K	
C555,556			CC73GCH1H0R5B	CHIP C 0.5PF B		C756-759			CK73FB1C105K	CHIP C 1.0UF K	
C557			CC73GCH1H471J	CHIP C 470PF J		C760			CC73GCH1H471J	CHIP C 470PF J	
C558			CK73GB1H103K	CHIP C 0.010UF K		C761			CC73GCH1H220J	CHIP C 22PF J	
C559			CK73GB1H102K	CHIP C 1000PF K		C762			CK73GB1H103K	CHIP C 0.010UF K	
C560,561		*	C90-4085-05	ELECTRO CAP 47UF 20WV		C764,765			C92-0501-05	CHIP-TAN 1.5UF 10WV	
C563			CC73GCH1H471J	CHIP C 470PF J		C766			CC73GCH1H151J	CHIP C 150PF J	
C564			CK73GB1H103K	CHIP C 0.010UF K		C767			C92-0628-05	CHIP-TAN 10UF 10WV	
C565			CC73GCH1H060D	CHIP C 6.0PF D		C768,769			CK73GB1C104K	CHIP C 0.10UF K	
C566-572			CC73GCH1H471J	CHIP C 470PF J		C770			C92-0712-05	CHIP-TAN 22UF 6.3WV	
C573			CK73GB1H103K	CHIP C 0.010UF K		C771,772			C92-0628-05	CHIP-TAN 10UF 10WV	
C574			CC73GCH1H471J	CHIP C 470PF J		C773			CC73GCH1H470J	CHIP C 47PF J	
C575			CC73GCH1H040C	CHIP C 4.0PF C		C774			CK73GB1C104K	CHIP C 0.10UF K	
C576			C92-0633-05	CHIP-TAN 22UF 10WV		C775,776			CK73GB1H103K	CHIP C 0.010UF K	
C577			CC73GCH1H060D	CHIP C 6.0PF D		C777			CK73GB1C104K	CHIP C 0.10UF K	
C578			CC73GCH1H471J	CHIP C 470PF J		C778			C92-0628-05	CHIP-TAN 10UF 10WV	
C579			C92-0696-05	CHIP-TAN 47UF 10WV		C779,780			CC73GCH1H101J	CHIP C 100PF J	
C580			CC73GCH1H471J	CHIP C 470PF J		C781,782			C92-0712-05	CHIP-TAN 22UF 6.3WV	
C581			CK73GB1H103K	CHIP C 0.010UF K		C784			CC73GCH1H390J	CHIP C 39PF J	
C584-586			CK73GB1H102K	CHIP C 1000PF K		C785			C92-0712-05	CHIP-TAN 22UF 6.3WV	
C591			C92-0606-05	CHIP-TAN 4.7UF 10WV		C787			CK73GB1H102K	CHIP C 1000PF K	
C593			CK73FB1E683K	CHIP C 0.068UF K		C788			C92-0628-05	CHIP-TAN 10UF 10WV	
C594			CK73GB1H102K	CHIP C 1000PF K		C789			CK73GB1H102K	CHIP C 1000PF K	
C700,701			CK73GB1H103K	CHIP C 0.010UF K		C790			CK73GB1H103K	CHIP C 0.010UF K	
C702			CK73GB1C104K	CHIP C 0.10UF K		C793			CC73GCH1H330J	CHIP C 33PF J	
C703			CC73GCH1H030C	CHIP C 3.0PF C		C794			C92-0628-05	CHIP-TAN 10UF 10WV	
C704,705			CC73GCH1H220J	CHIP C 22PF J		C795			C92-0712-05	CHIP-TAN 22UF 6.3WV	
C706-708			CK73GB1H103K	CHIP C 0.010UF K		C796			CK73GB1H152K	CHIP C 1500PF K	
C709,710			C92-0519-05	CHIP-TAN 1.0UF 25WV		C797-799			CK73GB1H103K	CHIP C 0.010UF K	
C711			CK73FB1C105K	CHIP C 1.0UF K		C800,801			C92-0712-05	CHIP-TAN 22UF 6.3WV	
C712,713			C92-0519-05	CHIP-TAN 1.0UF 25WV		C802			CC73GCH1H680J	CHIP C 68PF J	
C714			CK73GB1C104K	CHIP C 0.10UF K		C803			CK73GB1H122K	CHIP C 1200PF K	
C715			CK73FB1C105K	CHIP C 1.0UF K		C804			CK73GB1H102K	CHIP C 1000PF K	
C716			CK73GB1H103K	CHIP C 0.010UF K		C805			C92-0712-05	CHIP-TAN 22UF 6.3WV	
C717,718			CK73GB1C104K	CHIP C 0.10UF K		C806,807			CK73GB1H103K	CHIP C 0.010UF K	
C719-721			CK73FB1C105K	CHIP C 1.0UF K		C808			C92-0628-05	CHIP-TAN 10UF 10WV	
C722-724			CK73GB1H103K	CHIP C 0.010UF K		C809			C92-0719-05	ELECTRO CAP 47UF 25WV	
C725			CK73FB1C105K	CHIP C 1.0UF K		C810			CK73GB1H102K	CHIP C 1000PF K	
C726			CK73GB1H103K	CHIP C 0.010UF K		C811			CC73GCH1H101J	CHIP C 100PF J	
C727			CK73FB1C105K	CHIP C 1.0UF K		C812			C90-2146-05	ELECTRO CAP 100UF 25WV	
C728			CK73GB1H103K	CHIP C 0.010UF K		C813			CK73GB1C104K	CHIP C 0.10UF K	
C729			CK73GB1H102K	CHIP C 1000PF K		C814			CK73GB1H103K	CHIP C 0.010UF K	
C730,731			CC73GCH1H101J	CHIP C 100PF J		C815,816			CK73GB1C104K	CHIP C 0.10UF K	
C732,733			CK73GB1H102K	CHIP C 1000PF K		C817			CK73GB1H103K	CHIP C 0.010UF K	
C734			CC73GCH1H101J	CHIP C 100PF J		C819			C92-0719-05	ELECTRO CAP 47UF 25WV	
C735,736			CK73GB1H102K	CHIP C 1000PF K		C820			CK73GB1H103K	CHIP C 0.010UF K	
C737			CC73GCH1H101J	CHIP C 100PF J		C822			CK73GB1C104K	CHIP C 0.10UF K	
C738			CK73GB1H102K	CHIP C 1000PF K		C823			CC73GCH1H101J	CHIP C 100PF J	
C739			CK73FB1C105K	CHIP C 1.0UF K		C825-830			CK73GB1H102K	CHIP C 1000PF K	
C740			CK73GB1H102K	CHIP C 1000PF K		C831			CK73GB1C104K	CHIP C 0.10UF K	
C741			CK73GB1H103K	CHIP C 0.010UF K		C832			CC73GCH1H101J	CHIP C 100PF J	
C742			CK73GB1H102K	CHIP C 1000PF K		C833			CK73GB1C104K	CHIP C 0.10UF K	
C743			CK73GB1C104K	CHIP C 0.10UF K		C834			CK73GB1H103K	CHIP C 0.010UF K	
C744			CC73GCH1H101J	CHIP C 100PF J		C835			CC73GCH1H470J	CHIP C 47PF J	
C745			CK73FB1C105K	CHIP C 1.0UF K		C836			C92-0628-05	CHIP-TAN 10UF 10WV	
C746			CC73GCH1H101J	CHIP C 100PF J		C837-839			CK73GB1C104K	CHIP C 0.10UF K	
C747			CK73GB1H103K	CHIP C 0.010UF K		C841			CK73GB1H102K	CHIP C 1000PF K	
C748			CC73GCH1H101J	CHIP C 100PF J		C844			C92-0628-05	CHIP-TAN 10UF 10WV	

## PARTS LIST

TX-RX UNIT (X57-6580-10)

Ref. No.	Address	New parts	Parts No.	Description	Destination	Ref. No.	Address	New parts	Parts No.	Description	Destination
TC501,502			C05-0396-05	CERAMIC TRIMMER CAP (8P)		L518,519			L40-1875-92	SMALL FIXED INDUCTOR (18NH)	
CN102		*	E23-1233-04	TERMINAL		L520			L40-1575-92	SMALL FIXED INDUCTOR (15NH)	
CN201-203			E40-5538-05	PIN ASSY		L700,701			L92-0138-05	FERRITE CHIP	
CN700,701			E40-9370-05	PIN ASSY		L703			L92-0138-05	FERRITE CHIP	
CN703		*	E40-5176-05	PIN ASSY		L704-708			L92-0140-05	FERRITE CHIP	
CN704			E40-3241-05	PIN ASSY							
CN731-766			E23-1081-05	TERMINAL		L710			L92-0140-05	FERRITE CHIP	
CN769-772			E23-1081-05	TERMINAL		L713,714			L40-2275-92	SMALL FIXED INDUCTOR (22NH)	
J700		*	E58-0494-05	SUB SOCKET (D)		X201		*	L77-1737-05	CRYSTAL RESONATOR (73.505MHZ)	
						X501		*	L77-1903-05	VCXO (16.8MHZ/2.5PP)	
						X700			L77-1896-05	CRYSTAL RESONATOR (12.288MHZ)	
F100		*	F53-0278-05	FUSE		XF201			L71-0514-05	MCF (73.05MHZ WIDE)	
						XF202			L71-0515-05	MCF (73.05MHZ NARR)	
CF201			L72-0366-05	CERAMIC FILTER		CP700-715			R90-0740-05	MULTIPLE RESISTOR	
CF202			L72-0376-05	CERAMIC FILTER		R1			RK73GB1J102J	CHIP R 1.0K J 1/16W	
CF203		*	L72-1002-05	CERAMIC FILTER		R3			RK73GB1J222J	CHIP R 2.2K J 1/16W	
CF204			L72-0372-05	CERAMIC FILTER		R4			RK73GB1J220J	CHIP R 22 J 1/16W	
L1,2			L40-1075-92	SMALL FIXED INDUCTOR (10NH)		R5			RK73GB1J103J	CHIP R 10K J 1/16W	
L3			L40-1875-92	SMALL FIXED INDUCTOR (18NH)		R6			RK73GB1J471J	CHIP R 470 J 1/16W	
L4			L40-1075-92	SMALL FIXED INDUCTOR (10NH)		R7			RK73GB1J470J	CHIP R 47 J 1/16W	
L5			L40-1575-92	SMALL FIXED INDUCTOR (15NH)		R8			RK73GB1J222J	CHIP R 2.2K J 1/16W	
L6		*	L41-6865-20	SMALL FIXED INDUCTOR		R9			RK73GB1J470J	CHIP R 47 J 1/16W	
L7,8			L34-4517-05	AIR-CORE COIL		R10			RK73GB1J682J	CHIP R 6.8K J 1/16W	
L9			L34-4523-05	AIR-CORE COIL		R11			RK73GB1J471J	CHIP R 470 J 1/16W	
L10-12			L34-4517-05	AIR-CORE COIL		R12,13			RK73GB1J220J	CHIP R 22 J 1/16W	
L13			L34-4523-05	AIR-CORE COIL		R14			RK73GB1J104J	CHIP R 100K J 1/16W	
L201			L34-4530-05	COIL		R15			RK73GB1J183J	CHIP R 18K J 1/16W	
L202			L40-4785-34	SMALL FIXED INDUCTOR (470NH)		R16			RK73GB1J470J	CHIP R 47 J 1/16W	
L203			L40-1005-34	SMALL FIXED INDUCTOR (10UH)		R17			R92-0670-05	CHIP R 0 OHM	
L204			L40-4772-37	SMALL FIXED INDUCTOR (0.047UH)		R18			R92-1252-05	CHIP R 0 OHM J 1/16W	
L205			L34-4528-05	COIL		R19			RK73FB2A180J	CHIP R 18 J 1/10W	
L206			L34-4529-05	COIL		R20		*	R92-3513-05	RESISTOR 0.003 1W	
L207			L34-4528-05	COIL		R26			RK73FB2A101J	CHIP R 100 J 1/10W	
L208			L34-4529-05	COIL		R27			RK73GB1J154J	CHIP R 150K J 1/16W	
L209			L34-4528-05	COIL		R31			RK73GB1J104J	CHIP R 100K J 1/16W	
L210			L34-4529-05	COIL		R32			R92-1252-05	CHIP R 0 OHM J 1/16W	
L211			L40-1005-34	SMALL FIXED INDUCTOR (10UH)		R34			R92-1252-05	CHIP R 0 OHM J 1/16W	
L212			L40-1875-34	SMALL FIXED INDUCTOR (18NH)		R35			RK73GB1J101J	CHIP R 100 J 1/16W	
L213			L40-3981-37	SMALL FIXED INDUCTOR (0.390UH)		R36			RK73GB1J104J	CHIP R 100K J 1/16W	
L214			L40-2275-34	SMALL FIXED INDUCTOR (22NH)		R37			R92-1213-05	CHIP R 100 J 1/2W	
L215			L40-1281-37	SMALL FIXED INDUCTOR (0.120UH)		R38			RK73GB1J104J	CHIP R 100K J 1/16W	
L216			L40-1575-34	SMALL FIXED INDUCTOR (15NH)		R39			RK73GB1J334J	CHIP R 330K J 1/16W	
L217			L39-1272-05	TOROIDAL COIL		R40			RK73GB1J104J	CHIP R 100K J 1/16W	
L218			L40-1575-34	SMALL FIXED INDUCTOR (15NH)		R41			RK73GB1J473J	CHIP R 47K J 1/16W	
L219			L40-6895-34	SMALL FIXED INDUCTOR (6.8UH)		R42,43			RK73GB1J103J	CHIP R 10K J 1/16W	
L220,221			L39-1272-05	TOROIDAL COIL		R44			R92-1252-05	CHIP R 0 OHM J 1/16W	
L222			L40-1005-34	SMALL FIXED INDUCTOR (10UH)		R45			RK73GB1J104J	CHIP R 100K J 1/16W	
L223			L40-4785-34	SMALL FIXED INDUCTOR (470NH)		R46			R92-1252-05	CHIP R 0 OHM J 1/16W	
L224			L40-2781-37	SMALL FIXED INDUCTOR (0.270UH)		R47			RK73GB1J224J	CHIP R 220K J 1/16W	
L225,226			L40-1275-77	SMALL FIXED INDUCTOR (12NH)		R49			R92-1214-05	CHIP R 120 J 1/2W	
L501			L92-0138-05	FERRITE CHIP		R50			RK73GB1J223J	CHIP R 22K J 1/16W	
L503			L40-5695-34	SMALL FIXED INDUCTOR (5.6UH)		R52			RK73GB1J223J	CHIP R 22K J 1/16W	
L504			L40-1015-34	SMALL FIXED INDUCTOR (100UH)		R59			R92-1061-05	JUMPER REST 0 OHM	
L505,506		*	L41-1098-08	SMALL FIXED INDUCTOR		R61,62			RK73FB2A271J	CHIP R 270 J 1/10W	
L507			L40-1575-92	SMALL FIXED INDUCTOR (15NH)		R63			R92-1252-05	CHIP R 0 OHM J 1/16W	
L508,509		*	L41-1098-08	SMALL FIXED INDUCTOR		R67			R92-1252-05	CHIP R 0 OHM J 1/16W	
L510			L40-1575-92	SMALL FIXED INDUCTOR (15NH)		R101			RK73GB1J474J	CHIP R 470K J 1/16W	
L511			L34-4608-05	AIR-CORE COIL		R102			RK73GB1J394J	CHIP R 390K J 1/16W	
L512		*	L34-4606-05	AIR-CORE COIL		R103			RK73GB1J471J	CHIP R 470 J 1/16W	
L513			L40-1015-34	SMALL FIXED INDUCTOR (100UH)		R104,105			RK73GB1J334J	CHIP R 330K J 1/16W	
L514-517		*	L41-1098-08	SMALL FIXED INDUCTOR							

## PARTS LIST

## TX-RX UNIT (X57-6580-10)

Ref. No.	Address	New parts	Parts No.	Description	Destination	Ref. No.	Address	New parts	Parts No.	Description	Destination
R106			RK73GB1J472J	CHIP R 4.7K J 1/16W		R249			RK73GB1J332J	CHIP R 3.3K J 1/16W	
R107-109			RK73GB1J473J	CHIP R 47K J 1/16W		R250,251			RK73GB1J102J	CHIP R 1.0K J 1/16W	
R110			RK73GB1J472J	CHIP R 4.7K J 1/16W		R252,253			RK73GB1J220J	CHIP R 22 J 1/16W	
R111			RK73GB1J222J	CHIP R 2.2K J 1/16W		R254			RK73GB1J470J	CHIP R 47 J 1/16W	
R112			RK73GB1J102J	CHIP R 1.0K J 1/16W		R255			RK73GB1J821J	CHIP R 820 J 1/16W	
R113			RK73GB1J104J	CHIP R 100K J 1/16W		R256			RK73GB1J5R6J	CHIP R 5.6 J 1/16W	
R114			RK73GB1J473J	CHIP R 47K J 1/16W		R257			RK73GB1J821J	CHIP R 820 J 1/16W	
R115			RK73GB1J104J	CHIP R 100K J 1/16W		R258			RK73GB1J271J	CHIP R 270 J 1/16W	
R116			RK73GB1J473J	CHIP R 47K J 1/16W		R259			RK73GB1J180J	CHIP R 18 J 1/16W	
R117			RK73GB1J103J	CHIP R 10K J 1/16W		R260			RK73GB1J271J	CHIP R 270 J 1/16W	
R118			RK73GB1J104J	CHIP R 100K J 1/16W		R261			RK73GB1J101J	CHIP R 100 J 1/16W	
R119			RK73GB1J102J	CHIP R 1.0K J 1/16W		R262,263			RK73GB1J100J	CHIP R 10 J 1/16W	
R120			RK73GB1J103J	CHIP R 10K J 1/16W		R264			RK73GB1J103J	CHIP R 10K J 1/16W	
R121			RK73GB1J333J	CHIP R 33K J 1/16W		R265,266			RK73GB1J100J	CHIP R 10 J 1/16W	
R122			RK73GB1J472J	CHIP R 4.7K J 1/16W		R267			RK73GB1J101J	CHIP R 100 J 1/16W	
R123			RK73GB1J102J	CHIP R 1.0K J 1/16W		R268,269			RK73GB1J103J	CHIP R 10K J 1/16W	
R124			RK73GB1J333J	CHIP R 33K J 1/16W		R270-273			RK73GB1J221J	CHIP R 220 J 1/16W	
R125			RK73GB1J473J	CHIP R 47K J 1/16W		R274			RK73GB1J102J	CHIP R 1.0K J 1/16W	
R126			R92-1252-05	CHIP R 0 OHM J 1/16W		R275,276			RK73GB1J104J	CHIP R 100K J 1/16W	
R200			R92-0670-05	CHIP R 0 OHM		R277			RK73GB1J331J	CHIP R 330 J 1/16W	
R201			RK73GB1J563J	CHIP R 56K J 1/16W		R279			R92-1252-05	CHIP R 0 OHM J 1/16W	
R202			RK73GB1J393J	CHIP R 39K J 1/16W		R280			RK73GB1J103J	CHIP R 10K J 1/16W	
R203			RK73GB1J104J	CHIP R 100K J 1/16W		R281			RK73GB1J272J	CHIP R 2.7K J 1/16W	
R204			RK73GB1J332J	CHIP R 3.3K J 1/16W		R282			RK73GB1J392J	CHIP R 3.9K J 1/16W	
R205			RK73GB1J102J	CHIP R 1.0K J 1/16W		R283			RK73GB1J104J	CHIP R 100K J 1/16W	
R206			RK73GB1J332J	CHIP R 3.3K J 1/16W		R284			R92-1252-05	CHIP R 0 OHM J 1/16W	
R207			RK73GB1J560J	CHIP R 56 J 1/16W		R286			RK73GB1J224J	CHIP R 220K J 1/16W	
R208			RK73GB1J332J	CHIP R 3.3K J 1/16W		R287			RK73GB1J683J	CHIP R 68K J 1/16W	
R209			RK73GB1J103J	CHIP R 10K J 1/16W		R288			R92-1252-05	CHIP R 0 OHM J 1/16W	
R210			RK73GB1J222J	CHIP R 2.2K J 1/16W		R289			RK73GB1J473J	CHIP R 47K J 1/16W	
R211,212			RK73GB1J334J	CHIP R 330K J 1/16W		R290			RK73GB1J154J	CHIP R 150K J 1/16W	
R213			RK73GB1J273J	CHIP R 27K J 1/16W		R501			RK73GB1J220J	CHIP R 22 J 1/16W	
R214			RK73GB1J153J	CHIP R 15K J 1/16W		R502			RK73GB1J221J	CHIP R 220 J 1/16W	
R215			RK73GB1J682J	CHIP R 6.8K J 1/16W		R503			RK73GB1J102J	CHIP R 1.0K J 1/16W	
R216,217			RK73GB1J223J	CHIP R 22K J 1/16W		R504			RK73GB1J182J	CHIP R 1.8K J 1/16W	
R218			RK73GB1J102J	CHIP R 1.0K J 1/16W		R505-508			RK73GB1J100J	CHIP R 10 J 1/16W	
R219			RK73GB1J682J	CHIP R 6.8K J 1/16W		R509			RK73GB1J104J	CHIP R 100K J 1/16W	
R220			RK73GB1J223J	CHIP R 22K J 1/16W		R510			RK73GB1J103J	CHIP R 10K J 1/16W	
R221			RK73GB1J153J	CHIP R 15K J 1/16W		R511			RK73GB1J474J	CHIP R 470K J 1/16W	
R222			RK73GB1J220J	CHIP R 22 J 1/16W		R512			R92-1252-05	CHIP R 0 OHM J 1/16W	
R223			RK73GB1J103J	CHIP R 10K J 1/16W		R513			RK73EB2B392J	CHIP R 3.9K J 1/8W	
R225			R92-1252-05	CHIP R 0 OHM J 1/16W		R514			RK73GB1J473J	CHIP R 47K J 1/16W	
R226			RK73GB1J102J	CHIP R 1.0K J 1/16W		R515			RK73GB1J100J	CHIP R 10 J 1/16W	
R227			RK73GB1J473J	CHIP R 47K J 1/16W		R516			RK73GB1J470J	CHIP R 47 J 1/16W	
R228-230			RK73GB1J222J	CHIP R 2.2K J 1/16W		R517			RK73GB1J272J	CHIP R 2.7K J 1/16W	
R231			RK73GB1J102J	CHIP R 1.0K J 1/16W		R518			RK73GB1J100J	CHIP R 10 J 1/16W	
R232-234			RK73GB1J222J	CHIP R 2.2K J 1/16W		R519			RK73GB1J151J	CHIP R 150 J 1/16W	
R235			RK73GB1J271J	CHIP R 270 J 1/16W		R520			RK73GB1J122J	CHIP R 1.2K J 1/16W	
R236			RK73GB1J180J	CHIP R 18 J 1/16W		R521			RK73GB1J560J	CHIP R 56 J 1/16W	
R237			RK73GB1J271J	CHIP R 270 J 1/16W		R522			RK73GB1J220J	CHIP R 22 J 1/16W	
R238,239			R92-1252-05	CHIP R 0 OHM J 1/16W		R523			RK73GB1J102J	CHIP R 1.0K J 1/16W	
R240			RK73GB1J332J	CHIP R 3.3K J 1/16W		R524,525			R92-1252-05	CHIP R 0 OHM J 1/16W	
R241			RK73GB1J102J	CHIP R 1.0K J 1/16W		R526			RK73GB1J123J	CHIP R 12K J 1/16W	
R242			RK73GB1J270J	CHIP R 27 J 1/16W		R527			RK73GB1J683J	CHIP R 68K J 1/16W	
R243			RK73GB1J470J	CHIP R 47 J 1/16W		R528			RK73GB1J123J	CHIP R 12K J 1/16W	
R244			RK73GB1J682J	CHIP R 6.8K J 1/16W		R529			RK73GB1J224J	CHIP R 220K J 1/16W	
R245			RK73GB1J330J	CHIP R 33 J 1/16W		R530			RK73GB1J104J	CHIP R 100K J 1/16W	
R246			RK73GB1J102J	CHIP R 1.0K J 1/16W		R531			RK73GB1J152J	CHIP R 1.5K J 1/16W	
R247			RK73GB1J680J	CHIP R 68 J 1/16W		R532			RK73GB1J221J	CHIP R 220 J 1/16W	
R248			RK73GB1J222J	CHIP R 2.2K J 1/16W		R533			RK73GB1J271J	CHIP R 270 J 1/16W	

## PARTS LIST

TX-RX UNIT (X57-6580-10)

Ref. No.	Address	New parts	Parts No.	Description	Desti-nation	Ref. No.	Address	New parts	Parts No.	Description	Desti-nation
R534			RK73GB1J330J	CHIP R 33 J 1/16W		R765			RK73GB1J102J	CHIP R 1.0K J 1/16W	
R535			RK73GB1J221J	CHIP R 220 J 1/16W		R766			RK73GB1J472J	CHIP R 4.7K J 1/16W	
R536			RK73GB1J100J	CHIP R 10 J 1/16W		R767,768			RK73GB1J473J	CHIP R 47K J 1/16W	
R537			RK73GB1J470J	CHIP R 47 J 1/16W		R769			RK73GB1J101J	CHIP R 100 J 1/16W	
R538			R92-1252-05	CHIP R 0 OHM J 1/16W		R770			RK73GB1J473J	CHIP R 47K J 1/16W	
R539-542			RK73GB1J472J	CHIP R 4.7K J 1/16W		R771			RK73GB1J102J	CHIP R 1.0K J 1/16W	
R543			RK73GB1J152J	CHIP R 1.5K J 1/16W		R772			RK73GB1J473J	CHIP R 47K J 1/16W	
R544			RK73GB1J103J	CHIP R 10K J 1/16W		R773			RK73GB1J102J	CHIP R 1.0K J 1/16W	
R545			RK73GB1J224J	CHIP R 220K J 1/16W		R774			RK73GB1J472J	CHIP R 4.7K J 1/16W	
R547			R92-1252-05	CHIP R 0 OHM J 1/16W		R775-777			RK73GB1J473J	CHIP R 47K J 1/16W	
R548			RK73GB1J221J	CHIP R 220 J 1/16W		R778			RK73GB1J102J	CHIP R 1.0K J 1/16W	
R549			RK73GB1J330J	CHIP R 33 J 1/16W		R779,780			RK73GB1J473J	CHIP R 47K J 1/16W	
R550			RK73GB1J180J	CHIP R 18 J 1/16W		R781			RK73GB1J223J	CHIP R 22K J 1/16W	
R551			RK73GB1J470J	CHIP R 47 J 1/16W		R782			RK73GB1J104J	CHIP R 100K J 1/16W	
R552			RK73GB1J223J	CHIP R 22K J 1/16W		R783			RK73GB1J473J	CHIP R 47K J 1/16W	
R553			RK73GB1J153J	CHIP R 15K J 1/16W		R784			RK73GB1J681J	CHIP R 680 J 1/16W	
R554			RK73GB1J103J	CHIP R 10K J 1/16W		R785			RK73GB1J224J	CHIP R 220K J 1/16W	
R555			RK73GB1J472J	CHIP R 4.7K J 1/16W		R786			RK73GB1J684J	CHIP R 680K J 1/16W	
R556			RK73GB1J101J	CHIP R 100 J 1/16W		R787			R92-1252-05	CHIP R 0 OHM J 1/16W	
R557			RK73GB1J100J	CHIP R 10 J 1/16W		R788			RK73GB1J683J	CHIP R 68K J 1/16W	
R558			RK73GB1J152J	CHIP R 1.5K J 1/16W		R789			RK73GB1J183J	CHIP R 18K J 1/16W	
R559			RK73GB1J331J	CHIP R 330 J 1/16W		R793			RK73GB1J102J	CHIP R 1.0K J 1/16W	
R560			RK73GB1J221J	CHIP R 220 J 1/16W		R794			RK73GB1J392J	CHIP R 3.9K J 1/16W	
R561			RK73GB1J151J	CHIP R 150 J 1/16W		R795			RK73GB1J124J	CHIP R 120K J 1/16W	
R562			RK73GB1J221J	CHIP R 220 J 1/16W		R797			RK73GB1J563J	CHIP R 56K J 1/16W	
R563			RK73GB1J330J	CHIP R 33 J 1/16W		R798			R92-0670-05	CHIP R 0 OHM	
R564			RK73GB1J222J	CHIP R 2.2K J 1/16W		R799			RK73GB1J103J	CHIP R 10K J 1/16W	
R565			R92-0670-05	CHIP R 0 OHM		R800			RK73GB1J224J	CHIP R 220K J 1/16W	
R566			RK73GB1J103J	CHIP R 10K J 1/16W		R801,802			RK73GB1J473J	CHIP R 47K J 1/16W	
R568			RK73GB1J104J	CHIP R 100K J 1/16W		R803			RK73GB1J274J	CHIP R 270K J 1/16W	
R569			RK73GB1J103J	CHIP R 10K J 1/16W		R804			RK73GB1J104J	CHIP R 100K J 1/16W	
R570			RK73GB1J224J	CHIP R 220K J 1/16W		R805			RK73GB1J103J	CHIP R 10K J 1/16W	
R571			RK73GB1J103J	CHIP R 10K J 1/16W		R806,807			RK73GB1J473J	CHIP R 47K J 1/16W	
R572			RK73GB1J272J	CHIP R 2.7K J 1/16W		R808			RK73GB1J823J	CHIP R 82K J 1/16W	
R700			RK73GB1J102J	CHIP R 1.0K J 1/16W		R810			RK73GB1J154J	CHIP R 150K J 1/16W	
R701			RK73GB1J473J	CHIP R 47K J 1/16W		R811,812			RK73GB1J104J	CHIP R 100K J 1/16W	
R702			RK73GB1J472J	CHIP R 4.7K J 1/16W		R813			RK73GB1J153J	CHIP R 15K J 1/16W	
R703			R92-1252-05	CHIP R 0 OHM J 1/16W		R814			RK73GB1J103J	CHIP R 10K J 1/16W	
R704			RK73GB1J473J	CHIP R 47K J 1/16W		R815,816			RK73GB1J473J	CHIP R 47K J 1/16W	
R705,706			RK73GB1J152J	CHIP R 1.5K J 1/16W		R817,818			RK73GB1J104J	CHIP R 100K J 1/16W	
R707			RK73GB1J333J	CHIP R 33K J 1/16W		R819			RK73GB1J563J	CHIP R 56K J 1/16W	
R709,710			RK73GB1J473J	CHIP R 47K J 1/16W		R820			RK73GB1J333J	CHIP R 33K J 1/16W	
R711			RK73HB1J101J	CHIP R 100 J 1/16W		R821			RK73GB1J473J	CHIP R 47K J 1/16W	
R713			RK73GB1J473J	CHIP R 47K J 1/16W		R822			RK73GB1J102J	CHIP R 1.0K J 1/16W	
R715			RK73GB1J473J	CHIP R 47K J 1/16W		R823			RK73GB1J224J	CHIP R 220K J 1/16W	
R718			RK73GB1J473J	CHIP R 47K J 1/16W		R824			RK73GB1J153J	CHIP R 15K J 1/16W	
R726,727			RK73GB1J473J	CHIP R 47K J 1/16W		R825			RK73GB1J473J	CHIP R 47K J 1/16W	
R728-731			R92-1252-05	CHIP R 0 OHM J 1/16W		R826			RK73GB1J103J	CHIP R 10K J 1/16W	
R749			RK73GB1J473J	CHIP R 47K J 1/16W		R827			R92-0670-05	CHIP R 0 OHM	
R751			R92-1252-05	CHIP R 0 OHM J 1/16W		R828			RK73GB1J103J	CHIP R 10K J 1/16W	
R752,753			RK73GB1J473J	CHIP R 47K J 1/16W		R829			RK73GB1J102J	CHIP R 1.0K J 1/16W	
R754			R92-1252-05	CHIP R 0 OHM J 1/16W		R831			RK73GB1J104J	CHIP R 100K J 1/16W	
R755,756			RK73GB1J102J	CHIP R 1.0K J 1/16W		R832			RK73GB1J473J	CHIP R 47K J 1/16W	
R757			RK73GB1J473J	CHIP R 47K J 1/16W		R834			RK73GB1J103J	CHIP R 10K J 1/16W	
R758			R92-1252-05	CHIP R 0 OHM J 1/16W		R835			RK73GB1J104J	CHIP R 100K J 1/16W	
R759			RK73GB1J473J	CHIP R 47K J 1/16W		R836			RK73GB1J393J	CHIP R 39K J 1/16W	
R760			RK73GB1J102J	CHIP R 1.0K J 1/16W		R837			RK73GB1J274J	CHIP R 270K J 1/16W	
R761			RK73GB1J473J	CHIP R 47K J 1/16W		R838			RK73GB1J474J	CHIP R 470K J 1/16W	
R762			RK73GB1J102J	CHIP R 1.0K J 1/16W		R839			RK73GB1J104J	CHIP R 100K J 1/16W	
R763,764			RK73GB1J473J	CHIP R 47K J 1/16W		R841			RK73GB1J104J	CHIP R 100K J 1/16W	

## PARTS LIST

## TX-RX UNIT (X57-6580-10)

Ref. No.	Address	New parts	Parts No.	Description	Destination	Ref. No.	Address	New parts	Parts No.	Description	Destination
R842			R92-1252-05	CHIP R 0 OHM J 1/16W		IC103			PST9140NR	MOS IC	
R843-846			RK73GB1J473J	CHIP R 47K J 1/16W		IC104			TA7808S	MOS IC	
R847			RK73GB1J124J	CHIP R 120K J 1/16W		IC105			TA7805F	MOS IC	
R848			RK73GB1J334J	CHIP R 330K J 1/16W		IC106			XC62FP3302P	MOS IC	
R849			RK73GB1J102J	CHIP R 1.0K J 1/16W		IC107			XC62FP1802P	MOS IC	
R850			RK73GB1J103J	CHIP R 10K J 1/16W		IC108			XC62FP3302P	MOS IC	
R851,852			R92-1252-05	CHIP R 0 OHM J 1/16W		IC201			TA31136FN	MOS IC	
R853			RK73GB1J104J	CHIP R 100K J 1/16W		IC202			TC7S66FU	MOS IC	
R854			RK73GB1J474J	CHIP R 470K J 1/16W		IC501	*		ADF4111BRU	MOS IC	
R855			RK73GB1J103J	CHIP R 10K J 1/16W		IC700			BU4094BCFV	MOS IC	
R856			RK73GB1J333J	CHIP R 33K J 1/16W		IC701	*		30620M8A-5H1GP	MPU	
R858			RK73GB1J473J	CHIP R 47K J 1/16W		IC702			BU4094BCFV	MOS IC	
R861,862			RK73GB1J473J	CHIP R 47K J 1/16W		IC703			ADM202EARN	MOS IC	
R863			RK73GB1J683J	CHIP R 68K J 1/16W		IC704	*		AT24128N10SI27	ROM IC	
R864,865			RK73GB1J103J	CHIP R 10K J 1/16W		IC705	*		AT29C040A-12TI	ROM IC	
R866			R92-0670-05	CHIP R 0 OHM		IC706			TC74LVX4245FS	MOS IC	
R867,868			R92-1252-05	CHIP R 0 OHM J 1/16W		IC707-709			TC7WH32FK	MOS IC	
VR1			R12-6427-05	TRIMMING POT. (47K)		IC710			320VC5402PGE	MPU	
VR700			R32-0643-05	SEMI FIXED VARIABLE RESISTOR		IC711			TC7SU04FU	MOS IC	
K700		*	S76-0434-05	RELAY		IC712			TA75W01FU	MOS IC	
D1			ZSA5A27	ZENER DIODE		IC713			AK4550VT	MOS IC	
D2			02DZ6.2(Y)	ZENER DIODE		IC714			TC75W51FU	MOS IC	
D3			MA4PH633	DIODE		IC715,716			TA75W01FU	MOS IC	
D4			XB15A709	DIODE		IC717			BU4053BCFV	MOS IC	
D5,6			MA742	DIODE		IC718			M62364FP	MOS IC	
D9			XB15A709	DIODE		IC719			TC75W51FU	MOS IC	
D51			1SS355	DIODE		IC720			TDA8561Q	BI-POLAR IC	
D101			DSA3A1-FK	DIODE		IC721			LMC7101BIM5	MOS IC	
D102			02DZ18(X,Y)	ZENER DIODE		IC722			TA75S01F	MOS IC	
D103			02DZ15(X,Y)	ZENER DIODE		IC723			NJM78L05UA	BI-POLAR IC	
D104-106			1SS355	DIODE		IC724			TC4W53FU	MOS IC	
D108			DA204U	DIODE		IC725			PST9140NR	MOS IC	
D109		*	02DZ10(Z)	ZENER DIODE		Q1			2SC5110(O)	TRANSISTOR	
D201			1SS355	DIODE		Q2			2SC3356(R24)	TRANSISTOR	
D202			MA742	DIODE		Q3			2SK2596	FET	
D203-206			DAN235E	DIODE		Q4	*		PD55008S	FET	
D207-212		*	1SV279	VARIABLE CAPACITANCE DIODE		Q5	*		RD60HUF1-01	FET	
D501-504			1SV282	VARIABLE CAPACITANCE DIODE		Q101,102			DTC114EE	DIGITAL TRANSISTOR	
D505			1SS388	DIODE		Q103			2SJ506(S)	FET	
D506			1SV278	VARIABLE CAPACITANCE DIODE		Q104,105			DTC114EE	DIGITAL TRANSISTOR	
D507			1SS388	DIODE		Q106,107			2SB1132(Q,R)	TRANSISTOR	
D508		*	02DZ12(Y)	ZENER DIODE		Q108			DTA114EE	DIGITAL TRANSISTOR	
D509,510			HVC131	DIODE		Q109			DTA114YE	DIGITAL TRANSISTOR	
D515			MA2S111	DIODE		Q110			DTC114TE	DIGITAL TRANSISTOR	
D700			1SS355	DIODE		Q111			DTA114EE	DIGITAL TRANSISTOR	
D701-703			DA204U	DIODE		Q112			DTA114YE	DIGITAL TRANSISTOR	
D704			MA2S111	DIODE		Q113			DTC114YE	DIGITAL TRANSISTOR	
D705-709			DA204U	DIODE		Q201			DTC114EE	DIGITAL TRANSISTOR	
D710			02DZ18(X,Y)	ZENER DIODE		Q202			DTA114EE	DIGITAL TRANSISTOR	
D711,712			MA742	DIODE		Q203			DTC114EE	DIGITAL TRANSISTOR	
D714			1SS388	DIODE		Q204			2SC4617(S)	TRANSISTOR	
D715			02DZ18(X,Y)	ZENER DIODE		Q205			DTA144EE	DIGITAL TRANSISTOR	
D717,718			02DZ5.1(Y)	ZENER DIODE		Q206			2SC4215(Y)	TRANSISTOR	
D785-788			02DZ5.1(Y)	ZENER DIODE		Q207			2SC3357	TRANSISTOR	
D789		*	MINISMMDM075/24	VARISTOR		Q208			2SC3356	TRANSISTOR	
D791		*	MINISMMDM110/16	VARISTOR		Q209			2SC3357	TRANSISTOR	
IC2			TA75W01FU	MOS IC		Q210-213			2SK508NV(K52)	FET	
IC101			PST9140NR	MOS IC		Q214			2SC3357	TRANSISTOR	
IC102			TC4013BF(N)	MOS IC		Q501			2SC4116(BL)	TRANSISTOR	
						Q502			2SK1215(E)	FET	

## PARTS LIST

TX-RX UNIT (X57-6580-10)

Ref. No.	Address	New parts	Parts No.	Description	Destination	Ref. No.	Address	New parts	Parts No.	Description	Destination
Q503,504			2SC4116(BL)	TRANSISTOR							
Q505			2SA1832(GR)	TRANSISTOR							
Q506			2SC4738(GR)	TRANSISTOR							
Q507,508			2SK508NV(K52)	FET							
Q509-512			2SC4116(GR)	TRANSISTOR							
Q513			2SC5108(Y)	TRANSISTOR							
Q514			DTC114EE	DIGITAL TRANSISTOR							
Q515,516			2SC5108(Y)	TRANSISTOR							
Q517			2SC4116(GR)	TRANSISTOR							
Q518			2SA1832(GR)	TRANSISTOR							
Q519			DTC144EE	DIGITAL TRANSISTOR							
Q520			2SC4116(GR)	TRANSISTOR							
Q521			DTC144EE	DIGITAL TRANSISTOR							
Q700			2SK1824	FET							
Q701			DTC114EE	DIGITAL TRANSISTOR							
Q702			DTC144EE	DIGITAL TRANSISTOR							
Q703-706			DTD114EK	DIGITAL TRANSISTOR							
Q707			2SC4116(Y)	TRANSISTOR							
Q708			2SA1586(Y,GR)	TRANSISTOR							
Q709			DTC144EE	DIGITAL TRANSISTOR							
Q710			DTC114EE	DIGITAL TRANSISTOR							
Q711			2SD1757K	TRANSISTOR							
Q712			2SJ243	FET							
Q713			2SK1824	FET							
Q714			DTC144EE	DIGITAL TRANSISTOR							
Q716			DTC114EE	DIGITAL TRANSISTOR							
Q719,720			DTC114YE	DIGITAL TRANSISTOR							
TH1			S1R104J475H	THERMISTOR							
TH201			157-503-53006	THERMISTOR							
TH202			157-104-65001	THERMISTOR							



## EXPLODED VIEW

- |   |                     |               |
|---|---------------------|---------------|
| A | :                   | N09-2409-05   |
| B | M7                  | : N10-2070-46 |
| C | M3 x 8              | : N67-3008-46 |
| D | M2.6 x 6            | : N80-2606-46 |
| E | M2.6 x 6 (Br-Tap)   | : N87-2606-46 |
| F | M2.6 x 20 (Br-Tap)  | : N87-2620-46 |
| G | M3 x 8 (Br-Tap) BLK | : N87-3008-45 |

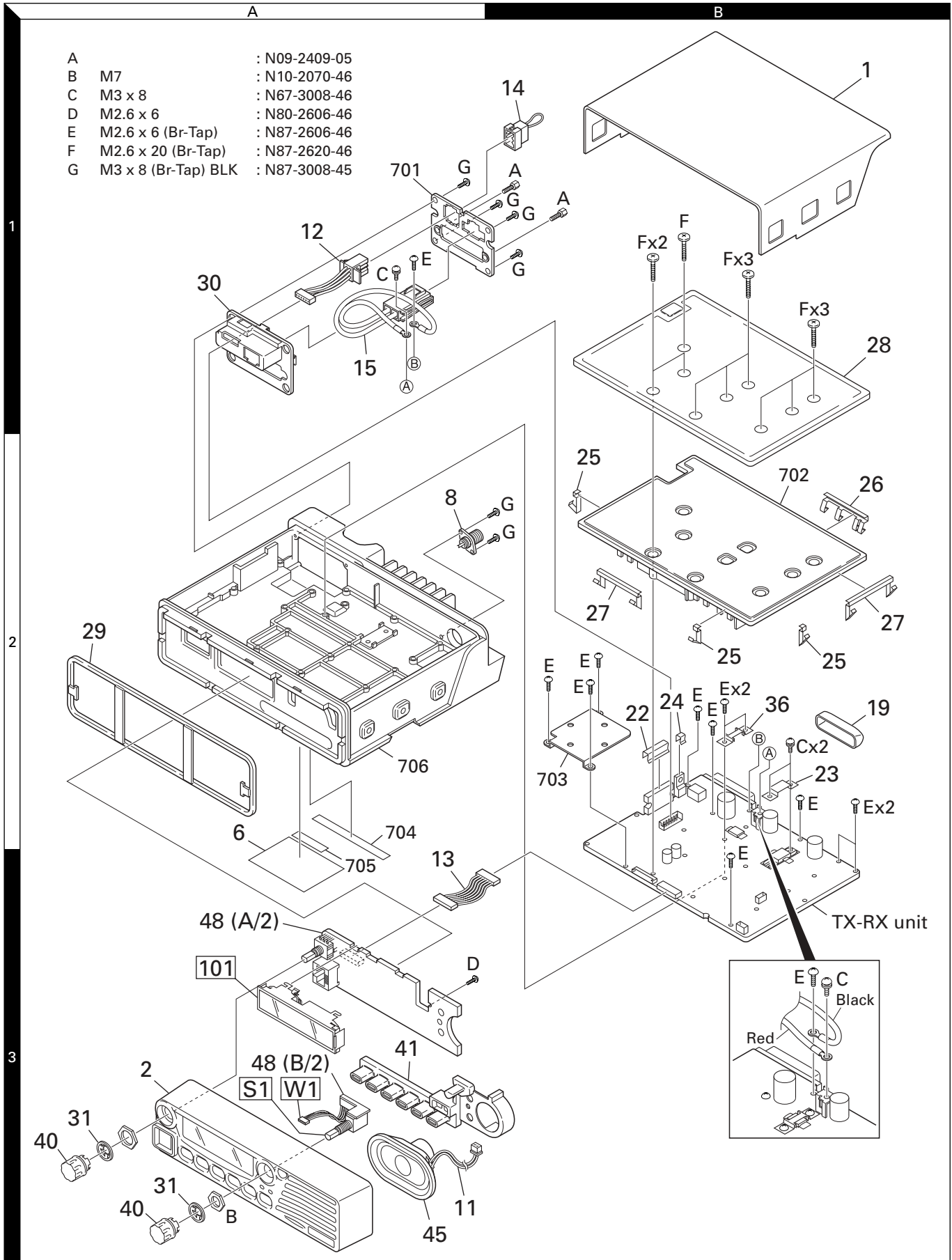

## PACKING

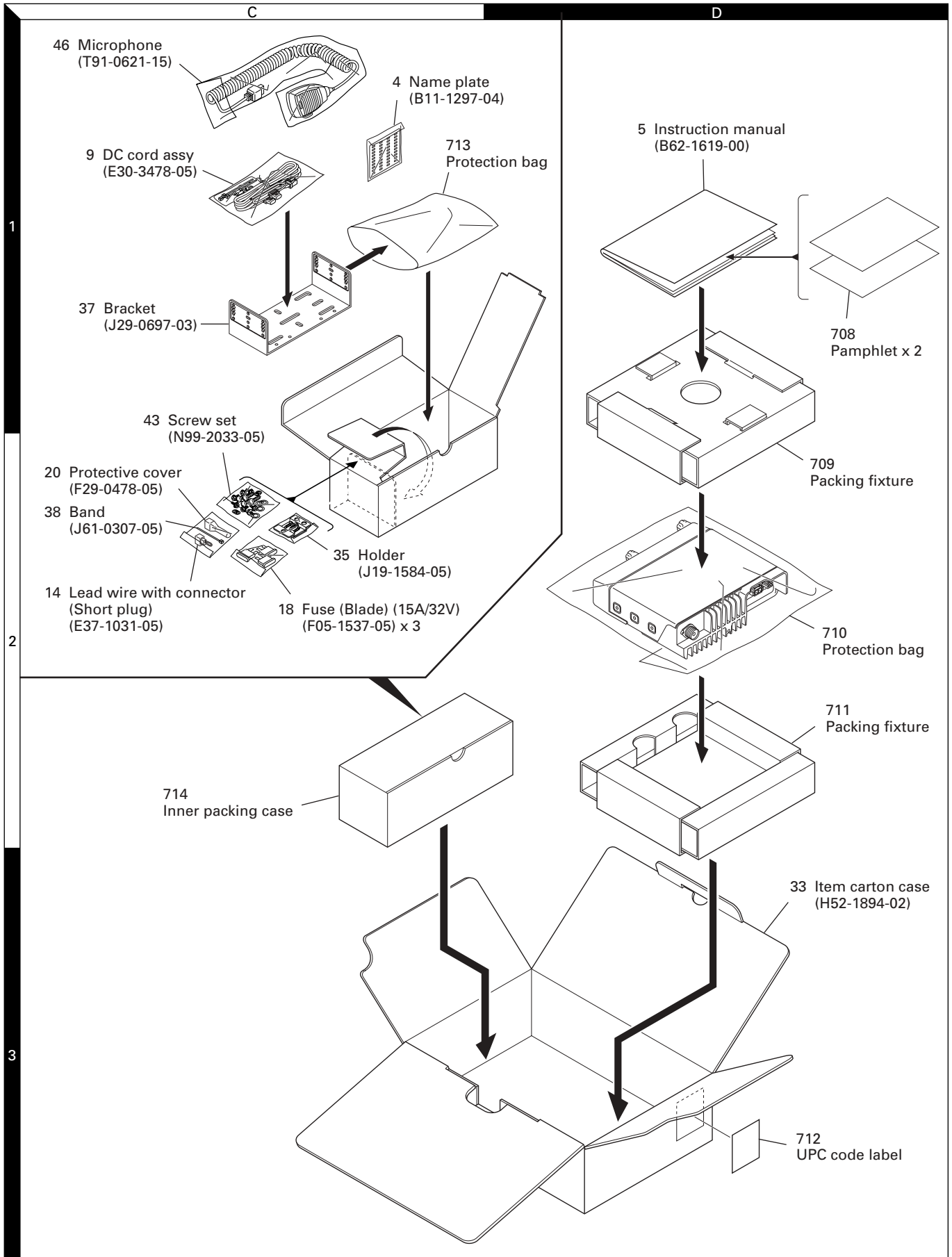

## ADJUSTMENT

### 1. Key Functions

#### 1-1. Front Panel

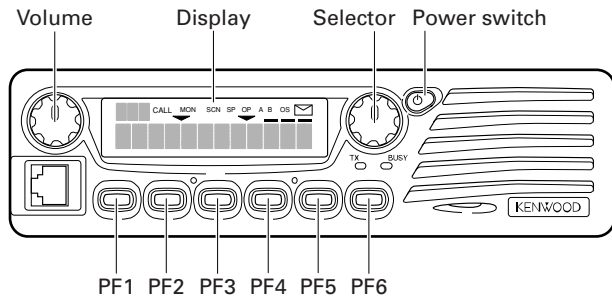

#### 1-2. Panel Test Mode

##### ■ When the Function is Off (▼ does not appear)

Controls	Function
PF1	Test channel down
PF2	Test channel up
PF3	Test mode/Tuning mode changeover
PF4	Noise squelch off
PF5	Wide/Narrow changeover When the narrow is on, □ appears
PF6	After pressing PF6 key, press PF3, PF4, PF5, and PF6 to activate the following functions (See the table below)
Selector knob	Signalling up/down

##### ■ When the Function is On (▼ appears)

Controls	Function
PF1	No function
PF2	No function
PF3	▼ appears on the right side When the Sig No.9 (DTMF) is on, DTMF [9] is transmitted. When the Sig No.12 (MSK) is on, the continuous MSK tone is transmitted.
PF4	Compander on (OP icon appears) / off
PF5	Beat shift on (B icon appears) / off
PF6	MSK speed changeover (1200/2400bps). When MSK speed is 2400 bps, the Mail icon appears.
Selector knob	Test signalling up/down

#### 1-3. Panel Tuning mode

Controls	Function
PF1	Tuning item down
PF2	Tuning item up
PF3	Test mode/Tuning mode changeover
PF4	Noise squelch off
PF5	Wide/Narrow changeover
PF6	Tuning value write→Move to the next tuning item
Selector knob	Tuning value up/down

### 2. Panel Test Mode

The transceiver's transmission output, receiver sensitivity, and other items are measured and QT, DQT, 2-Tone and DTMF signalling is decoded in this mode.

#### 2-1. To Enter the Panel Test Mode

Hold down [PF1] and turn the power switch on to enter this mode. The test frequency channel and test signalling channel will be displayed.

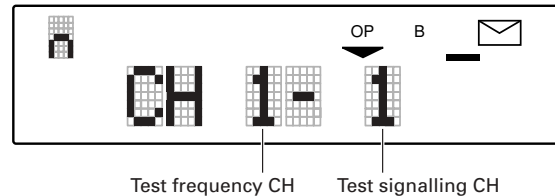

#### 2-2. Test Frequency Channel (MHz)

CH	RX	TX
1/FC	475.15	475.00
2/FL	450.15	450.00
3/FH	499.85	500.00
4	462.55	462.50
5	487.55	487.50
6	475.00	475.00
7	475.20	475.20
8	475.40	475.40

#### 2-3. Test Signalling Channel

No.	Decode	Encode
1	None	None
2	LTR	LTR
3	QT 67Hz	QT 67Hz
4	QT 151.4Hz	QT 151.4Hz
5	QT 210.7Hz	QT 210.7Hz
6	QT 254.1Hz	QT 254.1Hz
7	DQT 023N	DQT 023N
8	DQT 754I	DQT 754I
9	DTMF decode (159D)	DTMF encode (159D)
10	2-Tone decode A : 304.7Hz, B : 3106.0Hz	2-Tone encode A : 304.7Hz, B : 3106.0Hz
11	Single tone 979.9Hz	Single tone 979.9Hz
12	MSK	MSK
13	None	Single tone : 1kHz

### 3. Panel Tuning Mode

The transceiver is adjusted in this mode.

#### 3-1. To Enter the Panel Tuning Mode

Press the [PF3] key in the panel test mode.

The adjustment items, the frequency and signalling, other than the maximum deviation and sensitivity, return to the values that were effective for the test frequency channel and test signalling channel before entering the panel tuning mode.

## ADJUSTMENT

## 3-2. Tuning Item and Display (\*\*\*) : 1~256)

Tuning item	W/N	LCD display	S-LCD	Signalling
Frequency	-	F r e q _ _ _ _ _ * * *		No signalling
TX high power (Low)	-	H i _ P o w e r _ * * *	_ _ L	No signalling
TX high power (Center)	-	H i _ P o w e r _ * * *	_ _ C	No signalling
TX high power (High)	-	H i _ P o w e r _ * * *	_ _ H	No signalling
TX low power (Low)	-	L o _ P o w e r _ * * *	_ _ L	No signalling
TX low power (Center)	-	L o _ P o w e r _ * * *	_ _ C	No signalling
TX low power (High)	-	L o _ P o w e r _ * * *	_ _ H	No signalling
Max. deviation (Low)	Wide	M a x _ D e v _ _ * * *	_ _ L	No signalling
Max. deviation (Center)	Wide	M a x _ D e v _ _ * * *	_ _ C	No signalling
Max. deviation (High)	Wide	M a x _ D e v _ _ * * *	_ _ H	No signalling
Max. deviation (Low)	Narrow	M a x _ D e v _ _ * * *	n _ L	No signalling
Max. deviation (Center)	Narrow	M a x _ D e v _ _ * * *	n _ C	No signalling
Max. deviation (High)	Narrow	M a x _ D e v _ _ * * *	n _ H	No signalling
DQT balance	Wide	D Q T _ B a l _ _ * * *		Square waveform 100Hz
DQT balance	Narrow	D Q T _ B a l _ _ * * *	n _ _	Square waveform 100Hz
QT deviation	Wide	Q T _ D e v _ _ _ * * *		QT : 67.0Hz
QT deviation	Narrow	Q T _ D e v _ _ _ * * *	n _ _	QT : 67.0Hz
DQT deviation	Wide	D Q T _ D e v _ _ * * *		DQT : 023N
DQT deviation	Narrow	D Q T _ D e v _ _ * * *	n _ _	DQT : 023N
LTR code deviation	Wide	L T R _ D e v _ _ * * *		LTR data : Area=0, Goto=12, Home=12, ID=47, Free=25
LTR code deviation	Narrow	L T R _ D e v _ _ * * *	n _ _	LTR data : Area=0, Goto=12, Home=12, ID=47, Free=25
DTMF deviation	Wide	D T M F _ D e v _ * * *		DTMF : 9
DTMF deviation	Narrow	D T M F _ D e v _ * * *	n _ _	DTMF : 9
MSK deviation	Wide	M S K _ D e v _ _ * * *		0xAAA...
MSK deviation	Narrow	M S K _ D e v _ _ * * *	n _ _	0xAAA...
Single tone deviation	Wide	T o n e _ D e v _ * * *		1000Hz
Single tone deviation	Narrow	T o n e _ D e v _ * * *	n _ _	1000Hz
Sensitivity	-	S e n s _ _ _ _ _ * * *	_ _ L	No signalling, Squelch off
Sensitivity	-	S e n s _ _ _ _ _ * * *	_ C L	No signalling, Squelch off
Sensitivity	-	S e n s _ _ _ _ _ * * *	_ _ C	No signalling, Squelch off
Sensitivity	-	S e n s _ _ _ _ _ * * *	_ H C	No signalling, Squelch off
Sensitivity	-	S e n s _ _ _ _ _ * * *	_ _ H	No signalling, Squelch off
Squelch tight	Wide	S q l _ T _ _ _ _ * * *		No signalling
Squelch tight	Narrow	S q l _ T _ _ _ _ * * *	n _ _	No signalling
Squelch open	Wide	S q l _ O _ _ _ _ * * *		No signalling
Squelch open	Narrow	S q l _ O _ _ _ _ * * *	n _ _	No signalling

## ADJUSTMENT

### 3-3. Flow Chart

- ↔ : Use the [PF1] and [PF2] keys.
- : Use the [PF6] key.
- Use the [SELECTOR] knob to set an adjustment value (1 to 256) for each adjustment item.
- Use the [PF6] key to move to the next item.

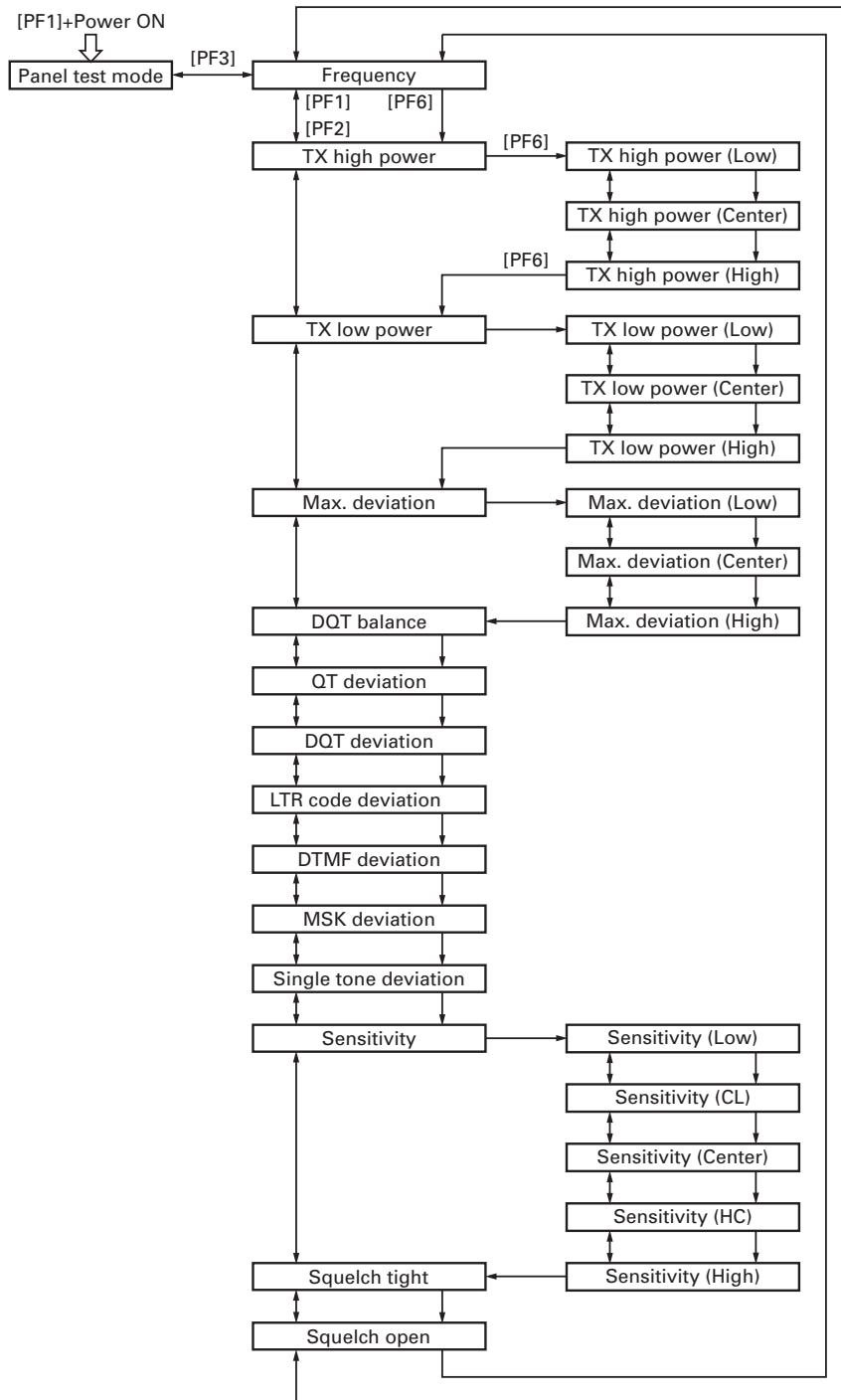

## ADJUSTMENT

### 4. Test Equipment Required for Alignment

Test Equipment	Major Specifications	
1. Standard Signal Generator (SSG)	Frequency Range	400 to 512MHz
	Modulation	Frequency modulation and external modulation
	Output	0.1μV to greater than 1mV
2. Power Meter	Input Impedance	50Ω
	Operation Frequency	400 to 512MHz or more
	Measurement Capability	Vicinity of 50W
3. Deviation Meter	Frequency Range	400 to 512MHz
4. Digital Volt Meter (DVM)	Measuring Range	1 to 20V DC
	Accuracy	High input impedance for minimum circuit loading
5. Oscilloscope		DC through 30MHz
6. High Sensitivity Frequency Counter	Frequency Range	10Hz to 600MHz
	Frequency Stability	0.2ppm or less
7. Ammeter		13A or more
8. AF Volt Meter (AF VTVM)	Frequency Range	50Hz to 10kHz
	Voltage Range	3mV to 3V
9. Audio Generator (AG)	Frequency Range	50Hz to 5kHz
	Output	0 to 1V
10. Distortion Meter	Capability	3% or less at 1kHz
	Input Level	50mV to 10Vrms
11. Voltmeter	Measuring Range	10 to 1.5V DC or less
	Input Impedance	50kΩ/V or greater
12. 4Ω Dummy Load		Approx. 4Ω, 20W
13. Regulated Power Supply		13.6V, approx. 20A (adjustable from 9 to 20V) Useful if ammeter reequipped

#### 4-1. Test Cable for Speaker Output

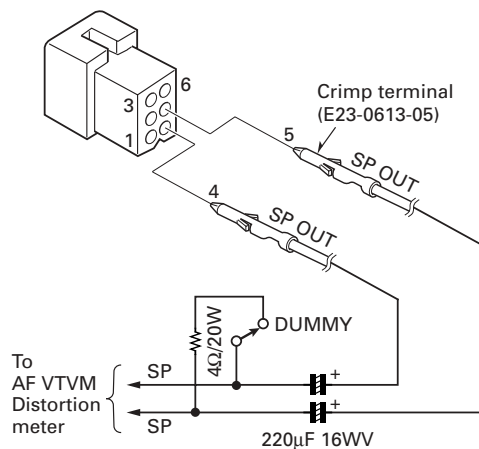

#### 4-2. Repair Jig (Chassis)

To check the voltage on the foil side of the TX-RX unit or to adjust the PLL lock voltage, use the Repair jig (Part No. A10-4065-02).

#### 4-3. Test Cable for Microphone input

The following test cable are recommended.

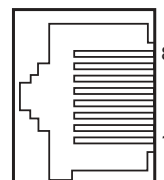
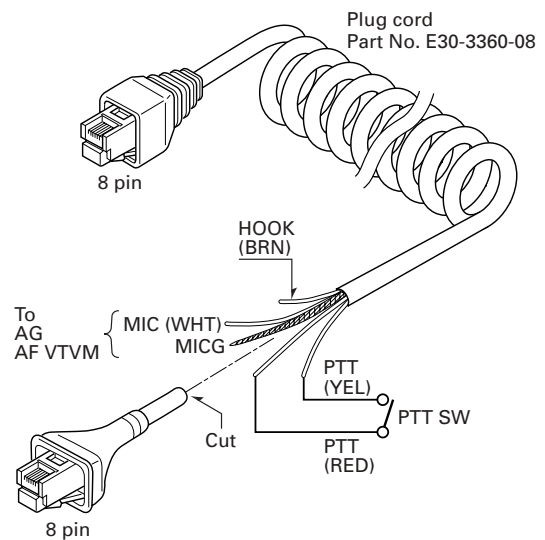

- 1 : NC
- 2 : +B
- 3 : GND
- 4 : PTT/TXD1  
(PC serial data from radio)
- 5 : MIC GND
- 6 : MIC
- 7 : HOOK/RXD1  
(PC serial data to radio)
- 8 : NC

MIC connector (Front panel view)

## ADJUSTMENT

### 5. Warnings When Removing or Installing the Shielding Cover

1. When handling with the shielding cover, do not damage the components on the TX-RX unit.
2. When installing the shielding cover, insert the cover from the rear side.
3. When removing the shielding cover, squeeze the hole marked with an arrow as shown on the diagram and pull it straight up.

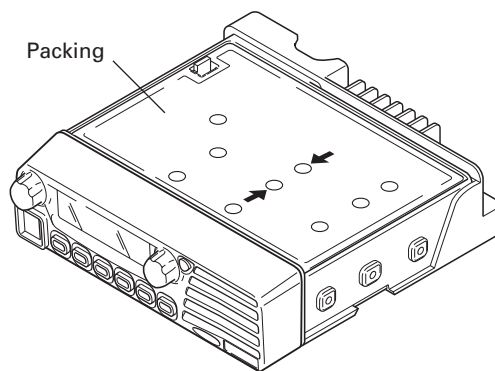

### 6. Common Section

Item	Condition	Measurement			Adjustment			Specifications/Remarks																																																																			
		Test-equipment	Unit	Terminal	Unit	Parts	Method																																																																				
1. Frequency list	<ul style="list-style-type: none"> <li>• Frequency range (MHz) K : 450~500</li> </ul>	<ul style="list-style-type: none"> <li>• Adjustment frequency (MHz)</li> </ul> <table border="1"> <thead> <tr> <th>CH</th> <th>RX</th> <th>TX</th> </tr> </thead> <tbody> <tr><td>1/FC</td><td>475.15</td><td>475.00</td></tr> <tr><td>2/FL</td><td>450.15</td><td>450.00</td></tr> <tr><td>3/FH</td><td>499.85</td><td>500.00</td></tr> <tr><td>4</td><td>462.55</td><td>462.50</td></tr> <tr><td>5</td><td>487.55</td><td>487.50</td></tr> <tr><td>6</td><td>475.00</td><td>475.00</td></tr> <tr><td>7</td><td>475.20</td><td>475.20</td></tr> <tr><td>8</td><td>475.40</td><td>475.40</td></tr> </tbody> </table>	CH	RX	TX	1/FC	475.15	475.00	2/FL	450.15	450.00	3/FH	499.85	500.00	4	462.55	462.50	5	487.55	487.50	6	475.00	475.00	7	475.20	475.20	8	475.40	475.40			<ul style="list-style-type: none"> <li>• Signalling</li> </ul> <table border="1"> <thead> <tr> <th>No.</th> <th>Decode</th> <th>Encode</th> </tr> </thead> <tbody> <tr><td>1</td><td>None</td><td>None</td></tr> <tr><td>2</td><td>LTR</td><td>LTR</td></tr> <tr><td>3</td><td>QT 67Hz</td><td>QT 67Hz</td></tr> <tr><td>4</td><td>QT 151.4Hz</td><td>QT 151.4Hz</td></tr> <tr><td>5</td><td>QT 210.7Hz</td><td>QT 210.7Hz</td></tr> <tr><td>6</td><td>QT 254.1Hz</td><td>QT 254.1Hz</td></tr> <tr><td>7</td><td>DQT 023N</td><td>DQT 023N</td></tr> <tr><td>8</td><td>DQT 754I</td><td>DQT 754I</td></tr> <tr><td>9</td><td>DTMF decode (159D)</td><td>DTMF encode (159D)</td></tr> <tr><td>10</td><td>2-Tone decode A : 304.7Hz, B : 3106.0Hz</td><td>2-Tone encode A : 304.7Hz, B : 3106.0Hz</td></tr> <tr><td>11</td><td>Single tone 979.9Hz</td><td>Single tone 979.9Hz</td></tr> <tr><td>12</td><td>MSK</td><td>MSK</td></tr> <tr><td>13</td><td>None</td><td>Single tone : 1kHz</td></tr> </tbody> </table>	No.	Decode	Encode	1	None	None	2	LTR	LTR	3	QT 67Hz	QT 67Hz	4	QT 151.4Hz	QT 151.4Hz	5	QT 210.7Hz	QT 210.7Hz	6	QT 254.1Hz	QT 254.1Hz	7	DQT 023N	DQT 023N	8	DQT 754I	DQT 754I	9	DTMF decode (159D)	DTMF encode (159D)	10	2-Tone decode A : 304.7Hz, B : 3106.0Hz	2-Tone encode A : 304.7Hz, B : 3106.0Hz	11	Single tone 979.9Hz	Single tone 979.9Hz	12	MSK	MSK	13	None	Single tone : 1kHz	
CH	RX	TX																																																																									
1/FC	475.15	475.00																																																																									
2/FL	450.15	450.00																																																																									
3/FH	499.85	500.00																																																																									
4	462.55	462.50																																																																									
5	487.55	487.50																																																																									
6	475.00	475.00																																																																									
7	475.20	475.20																																																																									
8	475.40	475.40																																																																									
No.	Decode	Encode																																																																									
1	None	None																																																																									
2	LTR	LTR																																																																									
3	QT 67Hz	QT 67Hz																																																																									
4	QT 151.4Hz	QT 151.4Hz																																																																									
5	QT 210.7Hz	QT 210.7Hz																																																																									
6	QT 254.1Hz	QT 254.1Hz																																																																									
7	DQT 023N	DQT 023N																																																																									
8	DQT 754I	DQT 754I																																																																									
9	DTMF decode (159D)	DTMF encode (159D)																																																																									
10	2-Tone decode A : 304.7Hz, B : 3106.0Hz	2-Tone encode A : 304.7Hz, B : 3106.0Hz																																																																									
11	Single tone 979.9Hz	Single tone 979.9Hz																																																																									
12	MSK	MSK																																																																									
13	None	Single tone : 1kHz																																																																									
2. Setting	<ul style="list-style-type: none"> <li>• Receiver section</li> </ul> <p>The indicated SSG output level are for maximum output. Whenever there is no modulation designation, standard modulation (MOD : 1kHz, DEV : 3kHz (Wide), DEV : 1.5kHz (Narrow)) is indicated.</p>		<ul style="list-style-type: none"> <li>• Transmitter section</li> </ul>		<p>When adjusting the PLL lock voltage, you must set the TX POWER value to 0.</p> <p>If you transmit without connecting a 50Ω terminator on the antenna connector, the FET final transistor may be damaged.</p>																																																																						

## ADJUSTMENT

Item	Condition	Measurement			Adjustment			Specifications/Remarks		
		Test-equipment	Unit	Terminal	Unit	Parts	Method			
3. PLL lock voltage	1) CH-SIG : 3-1	DC VM Power meter	TX-RX	CV	TX-RX	TC502	8.2V	±0.1V		
	2) CH-SIG : 3-1 PTT : ON								TC501	
	3) CH-SIG : 2-1								Check	2.0V or more
	4) CH-SIG : 2-1 PTT : ON									
4. Transmit frequency	1) CH-SIG : 1-1 Select Freq_____*** in tuning mode PTT : ON	Power meter f. counter	Rear panel	ANT	Front panel	Selector knob	CH-1 frequency	±50Hz		
5. MCF • Wide	1) CH-SIG : 1-1 Spectrum analyzer Span : 25kHz Scale : 2dB div Center frequency : 73.05MHz Tracking generator Output : -30dBm	Spectrum analyzer  Tracking generator	TX-RX	CN201  CN202	TX-RX	L205 L207 L209	Adjust it to make gain maximum, and make the band flat as shown in the below.			
	• Narrow								1) [PF5] key : Set the narrow "n_ _" appear on the LCD	L206 L208 L210
6. AF coil adjustment	1) CH-SIG : 1-1 SSG output : -20dBm (FM) frequency : 73.05MHz DEV : 1.5kHz MOD : 1kHz SSG signal inject to CN201.	SSG  AF VTVM 4Ω dummy load	TX-RX  Rear panel	CN201  EXT.SP	TX-RX	L201	Maximum audio output level.			



## ADJUSTMENT

Item	Condition	Measurement			Adjustment			Specifications/Remarks			
		Test-equipment	Unit	Terminal	Unit	Parts	Method				
7. TX high power	1) CH-SIG : 3-1 Select __H Hi_Power_*** in tuning mode PTT : ON Keep data at 256	Power meter Ammeter	Rear panel	ANT	TX-RX	VR1	48W	48W±0.5W			
	2) CH-SIG : 2-1 Select __L Hi_Power_*** in tuning mode PTT : ON				Front panel	Selector knob	45W		45W±1W 12A or less		
	3) CH-SIG : 1-1 Select __C Hi_Power_*** in tuning mode PTT : ON										
	4) CH-SIG : 3-1 Select __H Hi_Power_*** in tuning mode PTT : ON										
8. TX low power	1) CH-SIG : 2-1 Select __L Lo_Power_*** in tuning mode PTT : ON				Front panel	Selector knob	15W	15W±1W 12A or less			
	2) CH-SIG : 1-1 Select __C Lo_Power_*** in tuning mode PTT : ON										
	3) CH-SIG : 3-1 Select __H Lo_Power_*** in tuning mode PTT : ON										
9. Maximum deviation • Wide	1) CH-SIG : 2-1 Select __L Max_Dev_*** in tuning mode PTT : ON Deviation meter filter HPF : OFF LPF : 15kHz De-emphasis : OFF AG : 1kHz/50mV	Power meter Deviation meter  AF VTVM AG Oscilloscope	Rear panel  Front panel	ANT  MIC	Front panel	Selector knob	±3.8kHz	±0.1kHz			
	2) CH-SIG : 1-1 Select __C Max_Dev_*** in tuning mode PTT : ON									±3.8kHz	±0.1kHz
	3) CH-SIG : 3-1 Select __H Max_Dev_*** in tuning mode PTT : ON										

## ADJUSTMENT

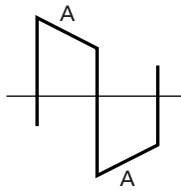
Item	Condition	Measurement			Adjustment			Specifications/Remarks
		Test-equipment	Unit	Terminal	Unit	Parts	Method	
• Narrow	4) CH-SIG : 2-1 [PF5] key : Set the narrow n_L Max_Dev_*** in tuning mode PTT : ON	Power meter Deviation meter	Rear panel	ANT	Front panel	Selector knob	±1.75kHz	±0.05kHz
	5) CH-SIG : 1-1 Select n_C Max_Dev_*** in tuning mode PTT : ON	AF VTVM AG Oscilloscope	Front panel	MIC				
	6) CH-SIG : 3-1 Select n_H Max_Dev_*** in tuning mode PTT : ON							
10. MIC seisitivity (Wide only)	1) CH-SIG : 1-1 PTT : ON Deviation meter filter HPF : OFF LPF : 15kHz De-emphasis : OFF AG : 1kHz/5mV				TX-RX	VR700	Check	2.2~3.7kHz
11. DQT balance • Wide	1) CH-SIG : 1-1 Select DQT_Bal_*** in tuning mode PTT : ON Deviation meter filter HPF : OFF LPF : 3kHz De-emphasis : OFF				Front panel	Selector knob	Wide/Narrow Make the demodulation wave- form neat.	Flat the A parts. 
	• Narrow	2) [PF5] key : Set the narrow n_ DQT_Bal_*** in tuning mode PTT : ON						
12. QT deviation • Wide	1) CH-SIG : 1-3 Select QT_Dev_*** in tuning mode PTT : ON Deviation meter filter HPF : OFF LPF : 3kHz De-emphasis : OFF						±0.75kHz	±0.05kHz
	• Narrow	2) [PF5] key : Set the narrow n_ QT_Dev_*** in tuning mode PTT : ON					±0.35kHz	±0.05kHz

## ADJUSTMENT

Item	Condition	Measurement			Adjustment			Specifications/Remarks
		Test-equipment	Unit	Terminal	Unit	Parts	Method	
13. DQT deviation • Wide	1) CH-SIG : 1-7 Select DQT_Dev_*** in tuning mode PTT : ON Deviation meter filter HPF : OFF LPF : 3kHz De-emphasis : OFF	Power meter Deviation meter	Rear panel	ANT	Front panel	Selector knob	±0.75kHz	±0.05kHz
	• Narrow	2) [PF5] key : Set the narrow n__ DQT_Dev_*** in tuning mode PTT : ON	AF VTVM AG Oscilloscope	Front panel	MIC			±0.35kHz
14. LTR code deviation • Wide	1) CH-SIG : 1-2 Select LTR_Dev_*** in tuning mode PTT : ON Deviation meter filter HPF : OFF LPF : 3kHz De-emphasis : OFF						1.00kHz	±0.05kHz
	• Narrow	2) [PF5] key : Set the narrow n__ LTR_Dev_*** in tuning mode PTT : ON					0.75kHz	±0.05kHz
15. DTMF deviation • Wide	1) CH-SIG : 1-9 Select DTMF_Dev_*** in tuning mode PTT : ON Deviation meter filter HPF : OFF, LPF : 15kHz De-emphasis : OFF						±3.0kHz	±0.1kHz
	• Narrow	2) [PF5] key : Set the narrow n__ DTMF_Dev_*** in tuning mode PTT : ON					±1.5kHz	±0.1kHz
16. MSK deviation • Wide	1) CH-SIG : 1-12 Select MSK_Dev_*** in tuning mode PTT : ON Deviation meter filter HPF : OFF LPF : 15kHz De-emphasis : OFF						±3.0kHz	±0.1kHz
	• Narrow	2) [PF5] key : Set the narrow n__ MSK_Dev_*** in tuning mode PTT : ON					±1.5kHz	±0.05kHz

## ADJUSTMENT

Item	Condition	Measurement			Adjustment			Specifications/Remarks
		Test-equipment	Unit	Terminal	Unit	Parts	Method	
17. Single tone deviation • Wide	1) CH-SIG : 1-11 Select Tone_Dev_*** in tuning mode PTT : ON Deviation meter filter HPF : OFF LPF : 15kHz De-emphasis : OFF	Power meter Deviation meter	Rear panel	ANT	Front panel	Selector knob	±3.0kHz	±0.1kHz
	• Narrow	2) [PF5] key : Set the narrow n_ Tone_Dev_*** in tuning mode PTT : ON	AF VTVM AG Oscilloscope	Front panel	MIC			±1.5kHz
18. Sensitivity	1) CH-SIG : 2-1 Select __L Sens_*** in tuning mode SSG output : -117dBm/0.32μV AF output : 2V/4Ω	SSG  AF VTVM Distortion meter Oscilloscope 4Ω dummy load	Rear panel	ANT  EXT.SP	Front panel	Selector knob	Adjust for maximum SINAD.	SINAD 12dB or more
	2) CH-SIG : 4-1 Select _CL Sens_*** in tuning mode							
	3) CH-SIG : 1-1 Select __C Sens_*** in tuning mode							
	4) CH-SIG : 5-1 Select _HC Sens_*** in tuning mode							
	5) CH-SIG : 3-1 Select __H Sens_*** in tuning mode							
19. Squelch tight • Wide	1) CH-SIG : 1-1 Select Sql_T_*** in tuning mode SSG output : Value when 6dB is added from the sensitivity value of 12dB SINAD.						Adjust to point of opening squelch	Set the value to 255. Adjust the SSG output to "Condition". Then, decrease the value to the point of opening the squelch.
	• Narrow	2) [PF5] key : Set the narrow n_ Sql_T_*** in tuning mode						

## ADJUSTMENT

Item	Condition	Measurement			Adjustment			Specifications/ Remarks
		Test-equipment	Unit	Terminal	Unit	Parts	Method	
20. Squelch open • Wide  • Narrow  • Wide/Narrow	1) CH-SIG : 1-1 Select <code>SqL_O_ _ _ _ ***</code> in tuning mode SSG output : Value when 3dB is subtracted from the sensitivity value of 12dB SINAD.	SSG  AF VTVM Distortion meter Oscilloscope 4Ω dummy load	Rear panel	ANT	Front panel	Selector knob	Adjust to point of opening squelch	Set the value to 255. Adjust the SSG output to "Condition". Then, decrease the value to the point of opening the squelch.
	EXT.SP							
	2) [PF5] key : Set the narrow <code>n_ _</code> <code>SqL_O_ _ _ _ ***</code> in tuning mode SSG output : Value when 4dB is subtracted from the sensitivity value of 12dB SINAD.							
	3) SSG output : OFF					Check	Squelch must be closed.	

**Note** : When you change the Squelch adjustment value, connect all necessary measuring equipment (as stated in the adjustment procedure), then adjust it to the SSG output value.

### 7. Adjustment Points

#### 7-1. Component Side View

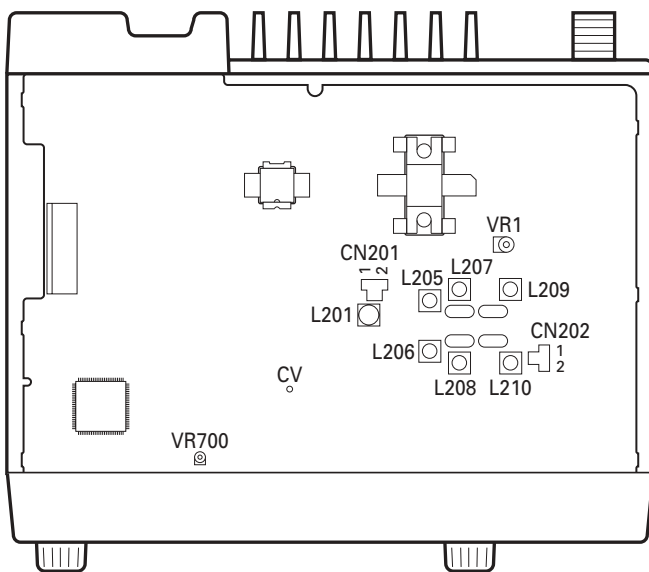

VR1 : TX high power (High)  
VR700 : MIC sensitivity

L201 : AF coil adjustment  
L205,207,209 : MCF (Wide)  
L206,208,210 : MCF (Narrow)

#### 7-2. Foil Side View

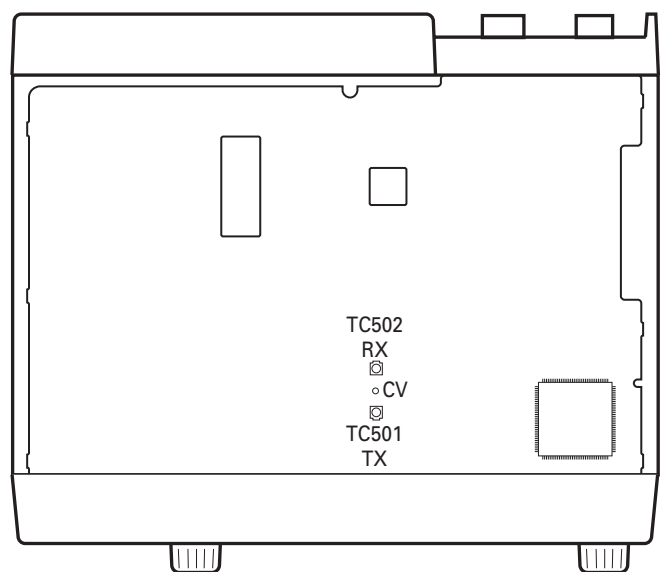

TC501 : PLL lock voltage (TX)  
TC502 : PLL lock voltage (RX)

# TK-8150 PC BOARD

## DISPLAY UNIT (X54-3400-10) Component side view (J72-0840-19)

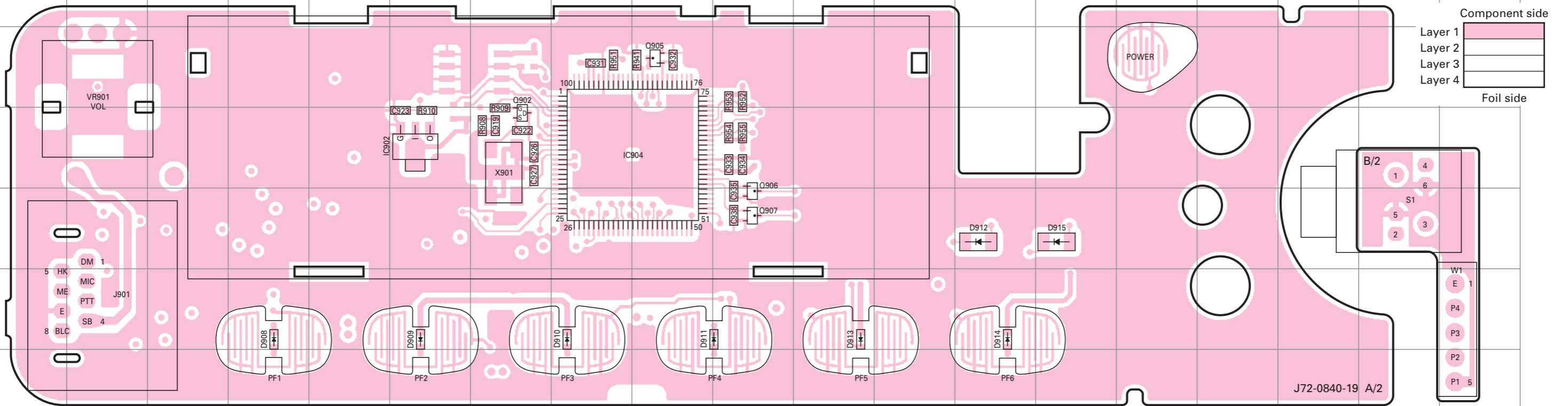

Ref. No.	Address	Ref. No.	Address	Ref. No.	Address	Ref. No.	Address
IC902	3F	Q906	4J	D910	5H	D914	5M
IC904	3I	Q907	4J	D911	5J	D915	4N
Q902	3G	D908	5D	D912	4M		
Q905	2I	D909	5F	D913	5K		

## DISPLAY UNIT (X54-3400-10) Foil side view (J72-0840-19)

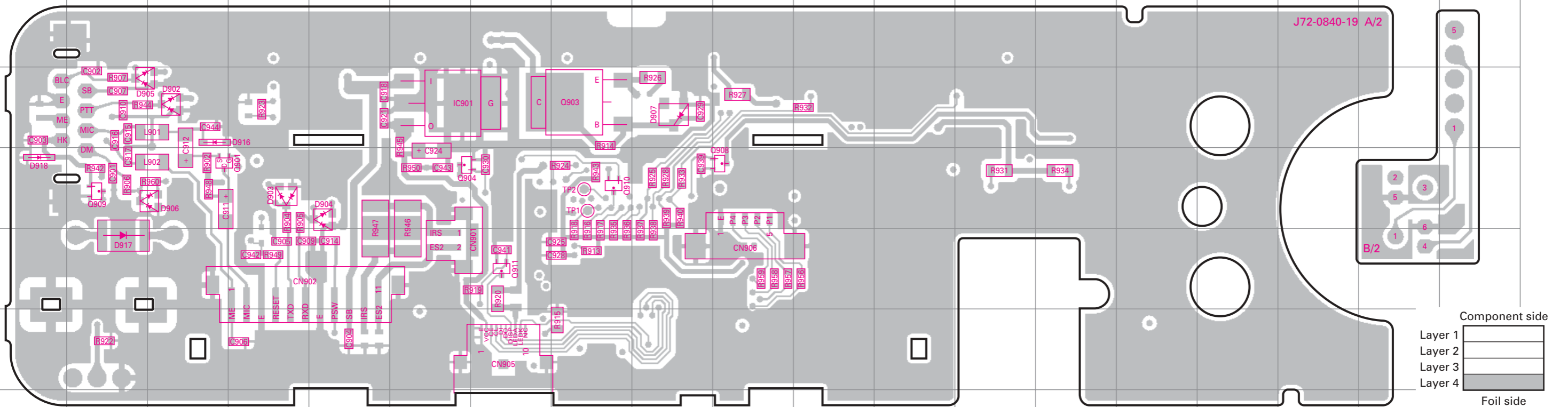

Ref. No.	Address	Ref. No.	Address	Ref. No.	Address	Ref. No.	Address	Ref. No.	Address
IC901	9F	Q908	10J	D902	9C	D906	10C	D918	10A
Q901	10C	Q909	10B	D903	10D	D907	9I		
Q903	9H	Q910	10H	D904	10E	D916	9C		
Q904	10F	Q911	11G	D905	9B	D917	11B		

## DISPLAY UNIT (X54-3400-10) Component side view + Foil side (J72-0840-19)

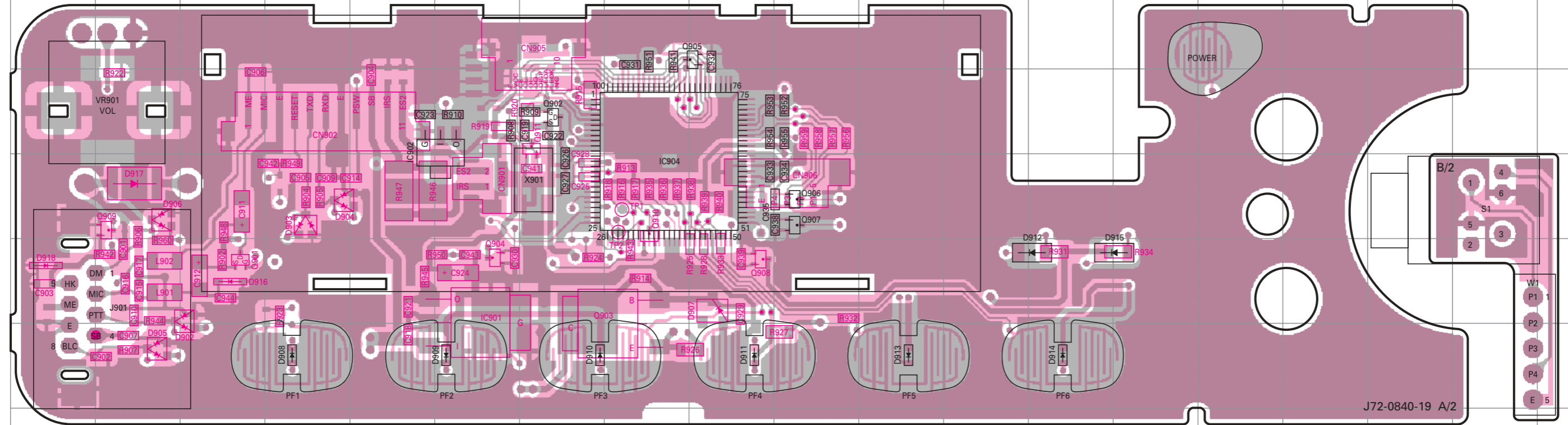

Ref. No.	Address	Ref. No.	Address	Ref. No.	Address	Ref. No.	Address
IC901	5F	Q906	4J	D904	4D	D912	5M
IC902	3F	Q907	4J	D905	6B	D913	6K
IC904	4H	Q908	5I	D906	4B	D914	6M
Q901	5C	Q909	4B	D907	5I	D915	5N
Q902	3G	Q910	4H	D908	6D	D916	5C
Q903	5H	Q911	3G	D909	6F	D917	4B
Q904	5F	D902	5C	D910	6G	D918	5A
Q905	2I	D903	4D	D911	6I		

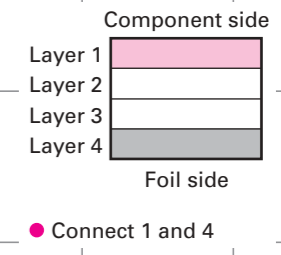

# TK-8150 PC BOARD

## TX-RX UNIT (X57-6580-10) Component side view (J72-0841-19)

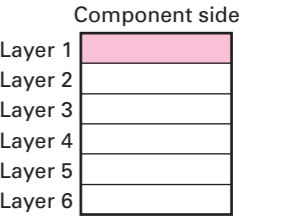

Foil side

Ref. No.	Address	Ref. No.	Address
IC104	4A	Q518	12K
IC105	4C	Q519	12K
IC107	5D	Q520	11I
IC108	6D	Q521	12J
IC201	8I	Q700	9C
IC501	11I	Q702	12D
IC701	11C	Q710	7D
IC702	9D	Q713	12D
IC703	8B	Q716	3E
IC704	12D	Q719	9B
IC705	13C	Q720	9A
IC706	11E	D1	3J
IC707	10E	D3	6Q
IC708	12E	D4	6Q
IC709	12E	D9	7Q
IC716	10E	D101	3F
IC720	6B	D203	8F
IC721	8E	D204	8H
IC724	11F	D207	12Q
Q4	5H	D208	11Q
Q5	5L	D209	11Q
Q103	4D	D210	10Q
Q104	6E	D211	8Q
Q105	5E	D212	8Q
Q106	6E	D505	11G
Q107	5E	D507	11G
Q201	8K	D509	10K
Q202	8K	D510	10K
Q203	9I	D515	12J
Q205	8J	D701	3E
Q210	11O	D703	3C
Q211	11O	D704	10D
Q212	12O	D705	3B
Q213	12O	D707	3C
Q214	9Q	D708	3C
Q501	10I	D709	3B
Q503	10I	D710	2D
Q504	10I	D714	5E
Q505	12G	D715	3D
Q506	12G	D788	10E
Q516	11K	D789	13K

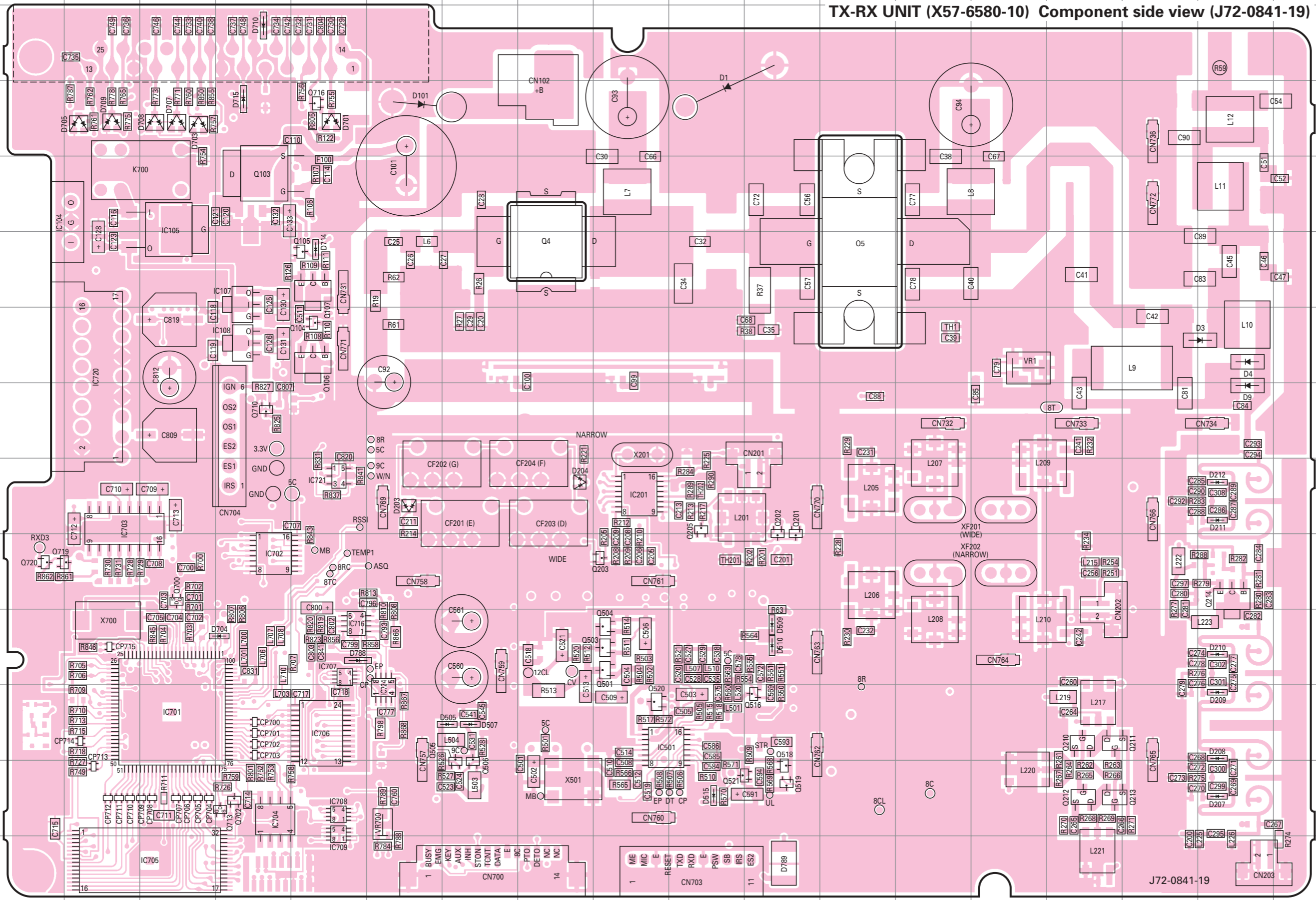

J72-0841-19



## TX-RX UNIT (X57-6580-10) Foil side view (J72-0841-19)

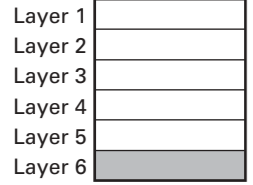

Ref. No.	Address	Ref. No.	Address
IC2	6G	Q517	12G
IC101	6O	Q701	3R
IC102	5P	Q703	3P
IC103	6P	Q704	3Q
IC106	8P	Q705	3P
IC202	9K	Q706	3Q
IC700	12O	Q707	12N
IC710	11Q	Q708	12O
IC711	13R	Q709	10P
IC712	11O	Q711	9Q
IC713	10O	Q712	6Q
IC714	11N	Q714	6Q
IC715	9O	D2	6H
IC717	9R	D5	5B
IC718	9P	D6	4B
IC719	8O	D51	6F
IC722	8Q	D102	4P
IC723	7O	D103	4P
IC725	13O	D104	4P
Q1	6J	D105	4P
Q2	6K	D106	4O
Q3	6M	D108	5P
Q101	4O	D109	5Q
Q102	4P	D201	9I
Q108	4P	D202	9I
Q109	5P	D205	9H
Q110	5P	D206	9E
Q111	4P	D501	11L
Q112	4Q	D502	10L
Q113	4Q	D503	11L
Q204	9J	D504	10L
Q206	8I	D506	11K
Q207	9D	D508	11M
Q208	11G	D700	4R
Q209	11F	D702	3O
Q502	12M	D706	3R
Q507	11K	D711	11N
Q508	10K	D712	11O
Q509	11M	D717	9R
Q510	11J	D718	9R
Q511	9J	D785	13J
Q512	10M	D786	13J
Q513	10J	D787	10N
Q514	10I	D791	3O
Q515	10I		

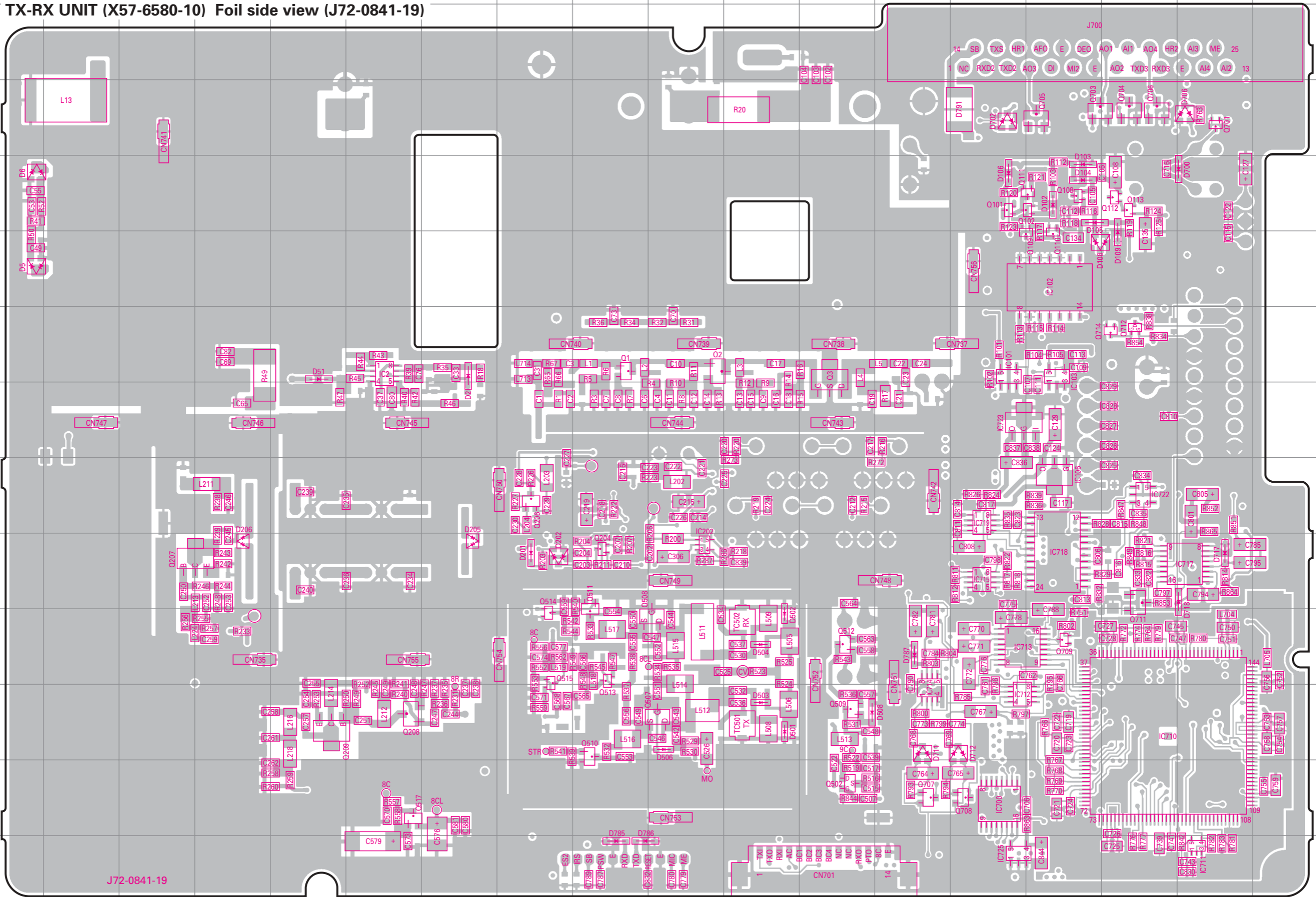

# TK-8150 PC BOARD

## TX-RX UNIT (X57-6580-10) Component side view + Foil side (J72-0841-19)

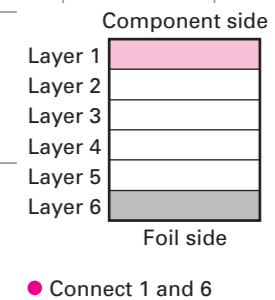

Ref. No.	Address	Ref. No.	Address	Ref. No.	Address
IC2	6M	Q202	8K	D6	4R
IC101	6E	Q203	9I	D9	7Q
IC102	5D	Q204	9J	D51	6N
IC103	6D	Q205	8J	D101	3F
IC104	4A	Q206	8K	D102	4D
IC105	4C	Q207	9P	D103	4D
IC106	8D	Q208	11M	D104	4D
IC107	5D	Q209	11N	D105	4D
IC108	6D	Q210	11O	D106	4E
IC201	8I	Q211	11O	D108	5D
IC202	9I	Q212	12O	D109	5C
IC501	11I	Q213	12O	D201	9K
IC700	12E	Q214	9Q	D202	9K
IC701	11C	O501	10I	D203	8F
IC702	9D	O502	12G	D204	8H
IC703	8B	O503	10I	D205	9L
IC704	12D	O504	10I	D206	9O
IC705	13C	O505	12G	D207	12Q
IC706	11E	O506	12G	D208	11Q
IC707	10E	O507	11I	D209	11Q
IC708	12E	O508	10I	D210	10Q
IC709	12E	O509	11G	D211	8Q
IC710	11C	O510	11J	D212	8Q
IC711	13B	O511	9J	D501	11H
IC712	11E	O512	10G	D502	10H
IC713	10E	O513	10J	D503	11H
IC714	11F	O514	10K	D504	10H
IC715	9E	O515	10K	D505	11G
IC716	10E	O516	11K	D506	11I
IC717	9B	O517	12M	D507	11G
IC718	9D	O518	12K	D508	11G
IC719	8E	O519	12K	D509	10K
IC720	6B	O520	11I	D510	10K
IC721	8E	O521	12J	D515	12J
IC722	8C	Q700	9C	D700	4B
IC723	7E	Q701	3B	D701	3E
IC724	11F	Q702	12D	D702	3E
IC725	13E	Q703	3D	D703	3C
Q1	6J	Q704	3C	D704	10D
Q2	6I	Q705	3D	D705	3B
Q3	6G	Q706	3C	D706	3B
Q4	5H	Q707	12F	D707	3C
Q5	5L	Q708	12E	D708	3C
Q101	4E	Q709	10D	D709	3B
Q102	4D	Q710	7D	D710	2D
Q103	4D	Q711	9C	D711	11F
Q104	6E	Q712	6C	D712	11E
Q105	5E	Q713	12D	D714	5E
Q106	6E	Q714	6C	D715	3D
Q107	5E	Q716	3E	D717	9B
Q108	4D	Q719	9B	D718	9B
Q109	5D	Q720	9A	D785	13J
Q110	5D	D1	3J	D786	13J
Q111	4D	D2	6L	D787	10F
Q112	4C	D3	6Q	D788	10E
Q113	4C	D4	6Q	D789	13K
Q201	8K	D5	5R	D791	3E

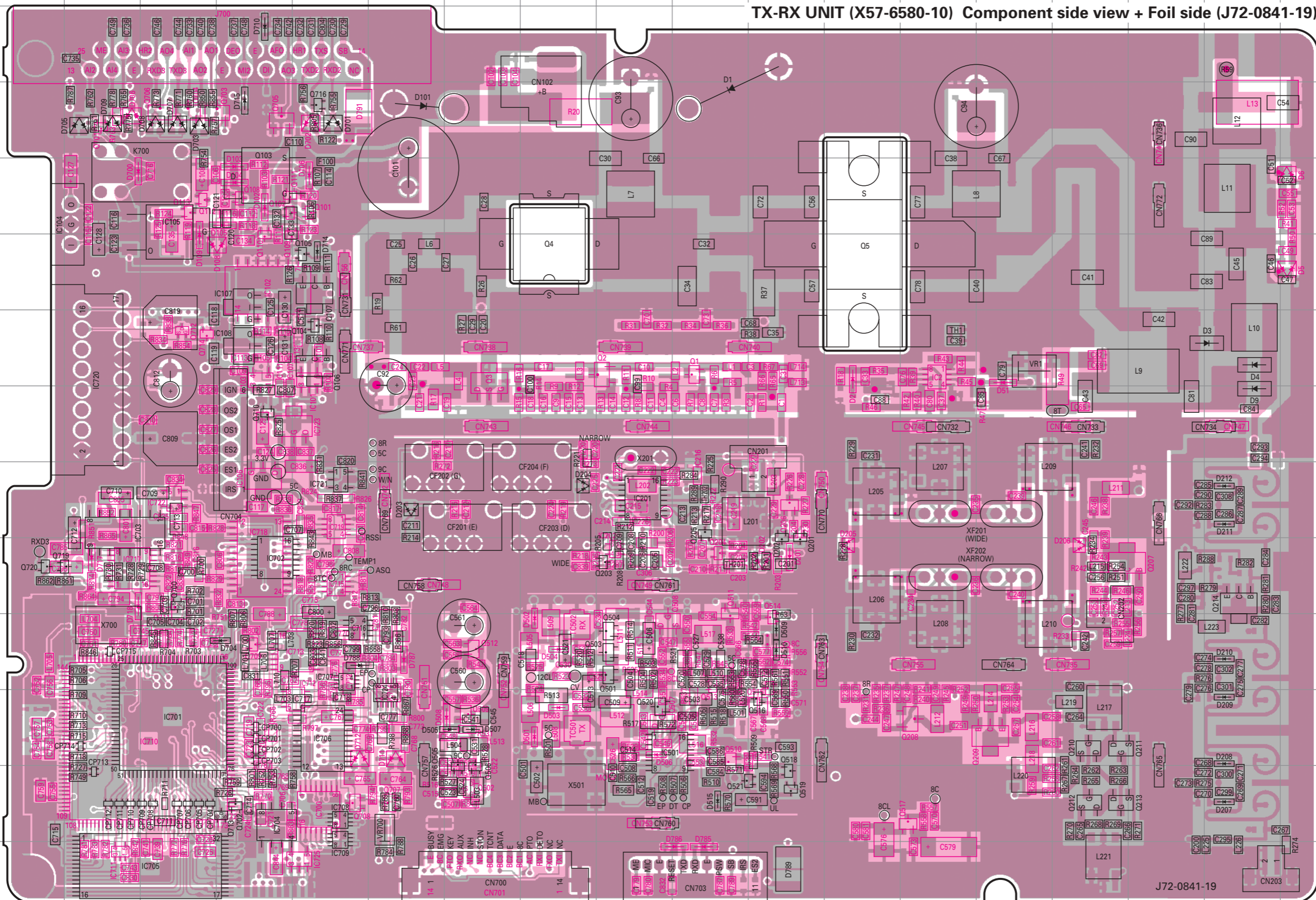

Note : Components marked with a dot (•) are parts of layer 1.

# SCHEMATIC DIAGRAM TK-8150

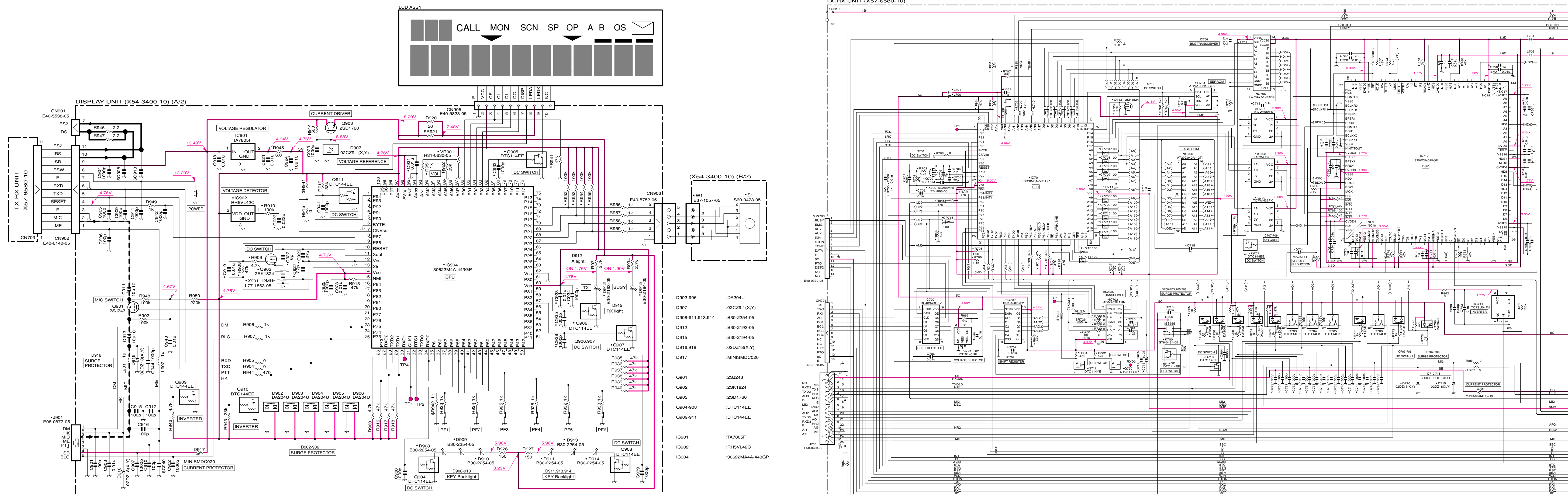

Note : Components marked with a dot (·) are parts of layer 1.

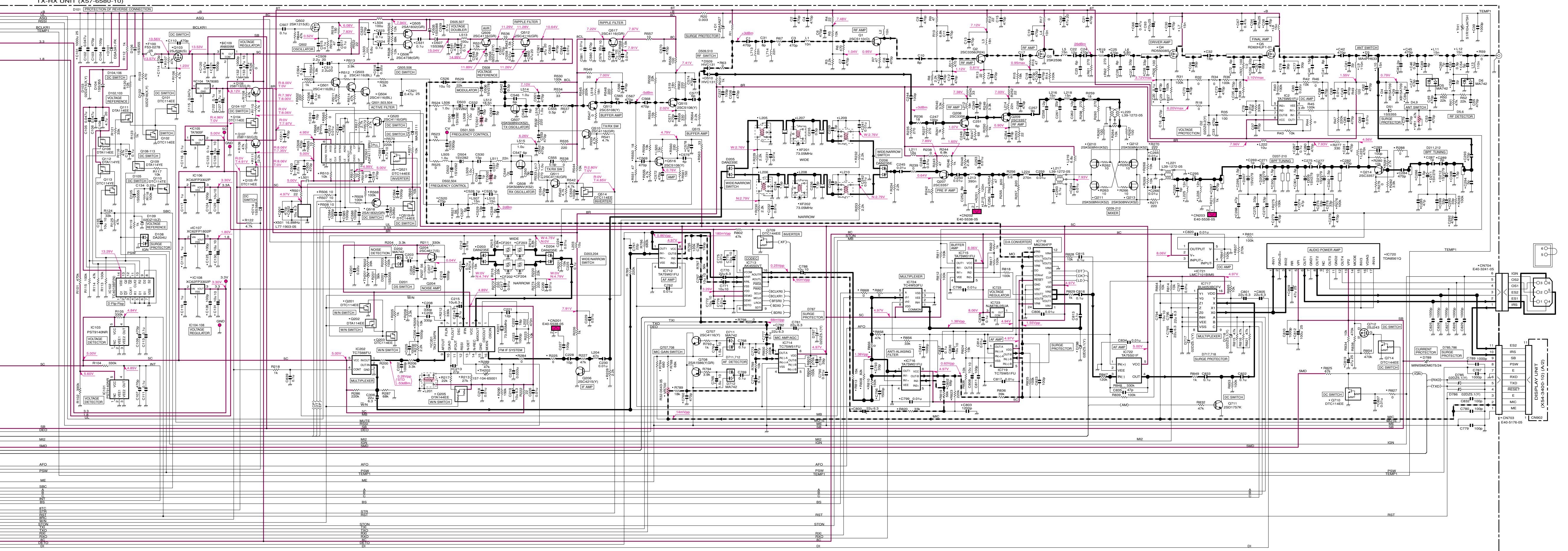

D1	:ZSA5A27
D2	:02D26.2(Y)
D3	:MA4PH633
D4,9	:XB15A709
D5,6,202,711,712	:MA742
D51,104-106,201,700	:1SS355
D101	:DSA3A1-FK
D102,710,715	:02D19(X,Y)
D103	:02D15(X,Y)
D108,701-703,705-709	:DA204U
D109	:02D10(Z)
D203-206	:DAN235E
D207-212	:1SV279
D501-504	:1SV288
D505,507,714,792	:1SS382
D506	:1SV278
D508	:02D12(Y)
D509,510	:HVC131
D515,704	:MA2511(Y)
D717,718,785-788	:02D25.1(Y)
D789	:MINISMMDM075/24
D791	:MINISMMDM110/16
Q1	:2SC5110(O)
Q2	:2SC3356(R24)
Q3	:2SK2596
Q4	:RD50008S
Q5	:RD60HUF-01
Q101,102,104,105, 201,203,514, 701,710,716	:DTC114EE
Q103	:2SJ506(S)
Q106,107	:2SB1132(Q,R)
Q108,111,202	:DTA114EE
Q109,112	:DTA114E
Q110	:DTC114TE
Q113,719,720	:DTC114E
Q204	:2SC4617(S)
Q205	:DTA144EE
Q206	:2SC4215(Y)
Q207,209,214	:2SC3357
Q208	:2SC3356
Q210,213,507,508	:2SK508N(K/S2)
Q501,503,504	:2SC4116(BL)
Q502	:2K1215(E)
Q505,518	:2SA1832(GR)
Q506	:2SC4738(GR)
Q509-512,517,520	:2SC4116(GR)
Q513,515,516	:2SC5108(Y)
Q519,521,702,709,714	:DTC114EE
Q700,713	:2SK1824
Q703-706	:DTD114EK
Q707	:2SC4116(Y)
Q708	:2SA1586(Y,GR)
Q711	:2SD1757K
Q712	:2SJ243
IC2,712,715,716	:TA75W01FU
IC101,103,725	:PST9140NR
IC102	:TC4013B(N)
IC104	:TA7805F
IC105	:TA7805F
IC106,108	:XC62FP3302P
IC107	:XC62FP1802P
IC201	:TA31136FN
IC202	:TC7S66FU
IC501	:ADF4111BRU
IC700,702	:BU4094BCFV
IC701	:30620M9A-SH11GP
IC703	:ADM202EAFRN
IC704	:AT24128N10SI27
IC705	:AT92C040A-12TI
IC706	:TC74LVX244FS
IC707-709	:TC7WH32FK
IC710	:320VC5402PGE
IC711	:TC7SU04FU
IC713	:AK4550VT
IC714,719	:TC7SW51FU
IC717	:BU4053BCFV
IC718	:M62364FP
IC720	:TDAB561Q
IC721	:LMC7101BIM5
IC722	:TA75S01F
IC723	:NUM78L05UA
IC724	:TC4W53FU

# TK-8150 TK-8150

## BLOCK DIAGRAM

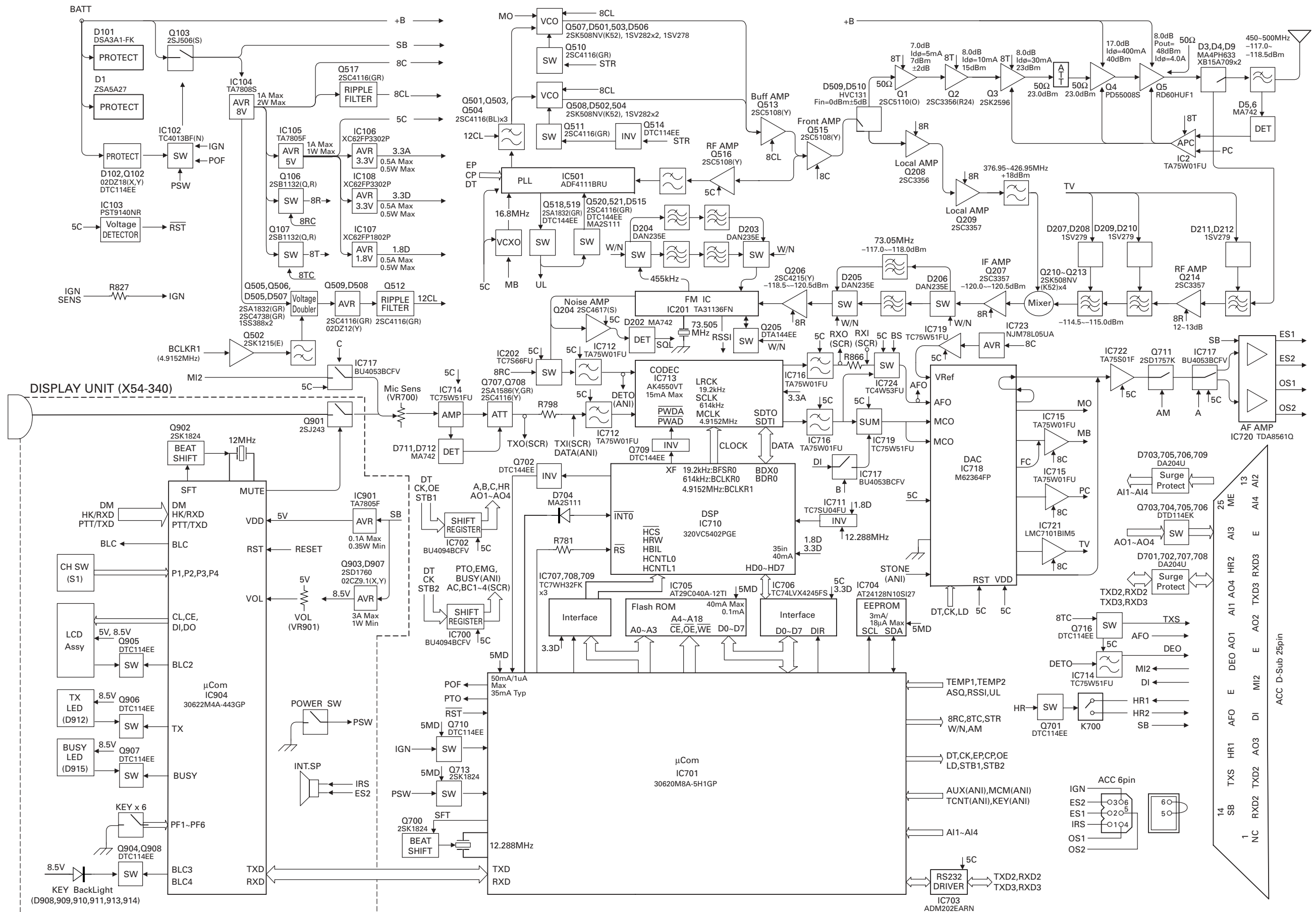

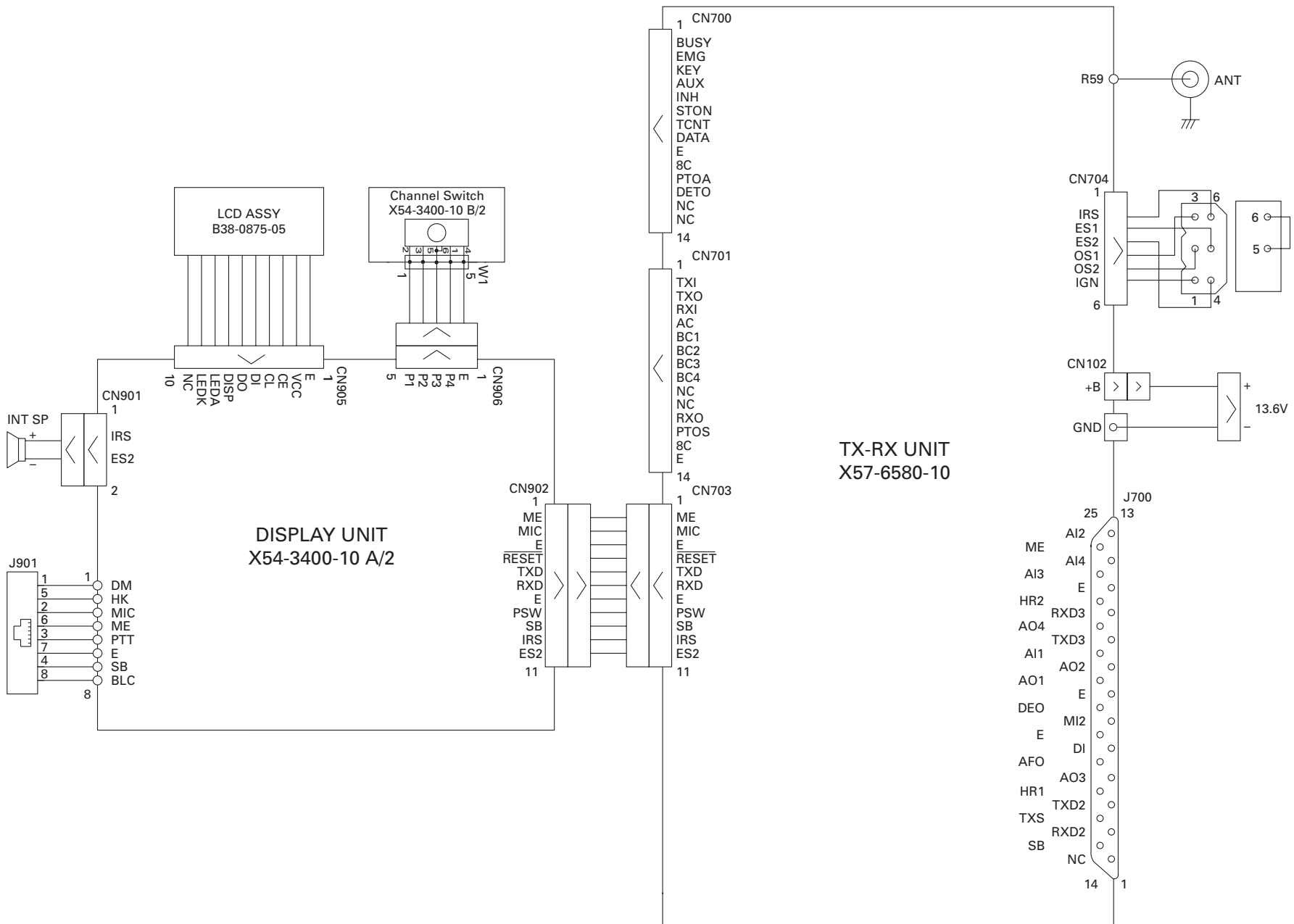

**WIRING**

**TK-8150**

# TERMINAL FUNCTION

## 1. Display Unit (X54-3400-10) (A/2)

Pin No.	Name	Description
<b>CN901 (To remote speaker)</b>		
1	IRS	BTL output for remote speaker output.
2	ES2	BTL output for remote speaker output.
<b>CN902 (To TX-RX unit)</b>		
1	ME	MIC ground.
2	MIC	MIC signal output.
3	E	Ground.
4	RESET	Reset signal input.
5	TXD	Serial data input.
6	RXD	Serial data output.
7	E	Ground.
8	PSW	Power switch control signal output.
9	SB	Power input after power switch (13.6V±15%).
10	IRS	BTL input for remote speaker output.
11	ES2	BTL input for remote speaker output.
<b>CN905 (To LCD assy)</b>		
1	E	Ground.
2	VCC	5V.
3	CE	Enable output for LCD driver.
4	CL	Clock output for LCD driver.
5	DI	Data output for LCD driver.
6	DO	Not used.
7	DISP	Display control signal output. "L" : Display off
8	LEDA	Power output for LCD backlight.
9	LEDK	Ground for LCD backlight. "L" : Backlight on
10	NC	Non connection.
<b>CN906 (To Display unit B/2 : CH SW)</b>		
1	E	Ground.
2	P4	SW position signal input 4.
3	P3	SW position signal input 3.
4	P2	SW position signal input 2.
5	P1	SW position signal input 1.
<b>J901 (MIC jack)</b>		
1	DM	Serial data input for keypad MIC.
2	MIC	MIC signal input.
3	PTT	PTT signal input. "L" : TX, "OPEN" : RX Serial data output.
4	SB	Power output after power switch (13.6V±15%).

Pin No.	Name	Description
5	HK	Hook signal input. "L" : On hook, "H" : Off hook Serial data input.
6	ME	MIC ground.
7	E	Ground.
8	BLC	MIC backlight control signal output. "H" : On, "L" : Off

## 2. Display Unit (X54-3400-10) (B/2)

Pin No.	Name	Description
<b>W1 (To Display unit A/2)</b>		
1	P1	SW position signal output 1.
2	P2	SW position signal output 2.
3	P3	SW position signal output 3.
4	P4	SW position signal output 4.
5	E	Ground.

## 3. TX-RX Unit (X57-6580-10)

Pin No.	Name	Description
<b>CN700 (To ANI board)</b>		
1	BUSY	TX sens signal output Conventional "H" : Not TX, "L" : TX LTR "H" : Not Link complete, "L" : Link complete
2	EMG	Emergency signal output. "L" : Emergency function is operated, "H" : Emergency function is not operated L ≤ 0.05V, H ≥ 4.6V/30kΩ load
3	KEY	TX control signal input. Active low with 47kΩ pull-up to 5V L ≤ 0.8V, H ≥ 2.5V
4	AUX	Emergency signal input. Active low with 47kΩ pull-up to 5V L ≤ 0.8V, H ≥ 2.5V
5	INH	MIC mute signal input. "L" : Mute Active low with 47kΩ pull-up to 5V L ≤ 0.8V, H ≥ 2.5V
6	STON	Side tone input.
7	TCNT	Speaker mute signal input. "L" : Unmute L ≤ 0.8V, H ≥ 2.5V
8	DATA	Data signal input.
9	E	Ground.
10	8C	8V. (CN700 No.10 + CN701 No.13 = 100mA Max.)

# TERMINAL FUNCTION

Pin No.	Name	Description
11	PTOA	PTT signal output. "L" : PTT on, "H" : PTT off L ≤ 0.05V, H ≥ 4.6V/30kΩ load
12	DETO	Detected signal output. DC coupled. Zo ≤ 100Ω Wide : 0.8Vp-p typ., Narrow : 0.7Vp-p typ. (Standard modulation)
13	NC	Non connection.
14	NC	Non connection.
<b>CN701 (To voice scrambler)</b>		
1	TXI	MIC signal input (Capacitor-coupled). Zin = 100kΩ
2	TXO	MIC signal output (Capacitor-coupled). Zo = 1kΩ Wide : 85mVp-p typ., Narrow : 85mVp-p typ. (Standard modulation)
3	RXI	Audio signal input (Capacitor-coupled). Zin = 27kΩ Wide : 1.3Vp-p typ., Narrow : 1.1Vp-p typ. (Standard modulation)
4	AC	Scrambler control signal output. "L" : On, "H" : Off L ≤ 0.05V, H ≥ 4.6V/30kΩ load
5	BC1	Scrambler code signal output 1. L ≤ 0.05V, H ≥ 4.6V/30kΩ load
6	BC2	Scrambler code signal output 2. L ≤ 0.05V, H ≥ 4.6V/30kΩ load
7	BC3	Scrambler code signal output 3. L ≤ 0.05V, H ≥ 4.6V/30kΩ load
8	BC4	Scrambler code signal output 4. L ≤ 0.05V, H ≥ 4.6V/30kΩ load
9	NC	Non connection.
10	NC	Non connection.
11	RXO	Audio signal output. DC coupled. Zo ≤ 100Ω Wide : 1.3Vp-p typ., Narrow : 1.1Vp-p typ. (Standard modulation)
12	PTOS	TX signal output. "L" : TX, "H" : Not TX L ≤ 0.05V, H ≥ 4.6V/30kΩ load
13	8C	8V. (CN700 No.10 + CN701 No.13 = 100mA Max.)
14	E	Ground.
<b>CN703 (To Display unit A/2)</b>		
1	ME	MIC ground.
2	MIC	MIC signal input.
3	E	Ground.
4	RESET	Reset signal output.
5	TXD	Serial data output.

Pin No.	Name	Description
6	RXD	Serial data input.
7	E	Ground.
8	PSW	Power switch control signal input.
9	SB	Power output after power switch (13.6V±15%).
10	IRS	BTL output for remote speaker output.
11	ES2	BTL output for remote speaker output.
<b>CN704 (To ACC 6-pin connector)</b>		
1	IRS	Remote speaker switch.
2	ES1	BTL output for external speaker A.
3	ES2	BTL output for external speaker A.
4	OS1	BTL output for external speaker B (PA).
5	OS2	BTL output for external speaker B (PA).
6	IGN	Ignition sense input.
<b>J700 (ACC 25-pin)</b>		
1	NC	Non connection.
2	RXD2 *	Serial data input 2. RS-232C level. Input voltage range = ±30V max. L ≤ 0.4V, H ≥ 2.4V. Zi ≥ 5kΩ
3	TXD2 *	Serial data output 2. RS-232C level. L ≤ -5V, H ≥ 5V/3kΩ load. Zo ≤ 2kΩ
4	AO3	Auxiliary output 3 (Programmable). Active low open collector (100mA max.) (Default none). L ≤ 0.3V
5	DI	Data signal input (Capacitor-coupled). Z ≥ 10kΩ
6	MI2	External MIC input (Capacitor-coupled). Z = 600Ω
7	E	Ground.
8	AO2	Auxiliary output 2 (Programmable). Active low with 10kΩ pull-up to 5V (100mA max.) (Default none). L ≤ 0.3V, H ≥ 4.8V
9	TXD3 **	Serial data output 3. L ≤ 0.7V, H ≥ 4.2V/25kΩ load. Zo ≤ 1kΩ
10	RXD3 **	Serial data input 3. Input voltage range = +5/0 max. L ≤ 0.8V, H ≥ 4.2V.
11	E	Ground.
12	AI4	Auxiliary input 4 (Programmable). Active low with 47kΩ pull-up to 5V (Default none). L ≤ 0.8V, H ≥ 2.5V
13	AI2	Auxiliary input 2 (Programmable). Active low with 47kΩ pull-up to 5V (Default none). L ≤ 0.8V, H ≥ 2.5V



# TK-8150

## TERMINAL FUNCTION / OPTIONS

Pin No.	Name	Description
14	SB	Power output after power switch. 13.6V±15%, 1.1A max. at 25°C, 0.8A max. at 60°C
15	TXS	TX sense signal output. Active high with 10kΩ pull-up to 5V. L ≤ 0.3V, H ≥ 4.8V
16	HR1	Horn alert signal output 1. 1A max.
17	AFO	Filtered audio output (DC-coupled). Zo ≤ 1KΩ
		PA : MIC signal output. 0.65Vp-p typ. (1kHz/5mV input)
		RX : RX low level output. Wide : 1.3Vp-p typ., Narrow : 1.1Vp-p typ. (Standard modulation)
18	E	Ground.
19	DEO	Detected signal output (Capacitor-coupled).
20	AO1	Auxiliary output 1 (Programmable). Active low with 10kΩ pull-up to 5V (100mA max.) (Default none). L ≤ 0.3V, H ≥ 4.8V
21	AI1	Auxiliary input 1 (Programmable). Active low with 47kΩ pull-up to 5V (Default none). L ≤ 0.8V, H ≥ 2.5V
22	AO4	Auxiliary output 4 (Programmable). Active low open collector (100mA max.) (Default none). L ≤ 0.3V
23	HR2	Horn alert signal output 2. 1A max. (Default ground)
24	AI3	Auxiliary input 3 (Programmable). Active low with 47kΩ pull-up to 5V (Default none). L ≤ 0.8V, H ≥ 2.5V
25	ME	MIC ground.

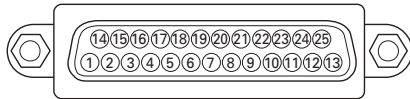

\* and \*\*: Pair

### 4. ACC 6-pin Connector

Pin No.	Name	Description
1	IGN	Ignition sense input.
2	OS2	BTL output for external speaker B (PA).
3	OS1	BTL output for external speaker B (PA).
4	ES2	BTL output for external speaker A.
5	ES1	BTL output for external speaker A.
6	RS1	Remote speaker switch.



### 1. KES-5 (External Speaker)

#### 1-1. External View



#### 1-2. Parts List

\* : New parts

Ref. No.	New parts	Parts No.	Description
	*	A62-1050-08	Panel assy
	*	A82-0050-08	Rear panel
	*	B43-1142-08	Badge
	*	E30-3479-08	Speaker cable
	*	G13-1923-08	Cushion
	*	G53-1553-08	Packing
	*	J29-0699-08	Bracket
	*	N08-0551-08	Dressed screw
	*	N99-2031-08	Screw set
	*	T07-0741-08	Speaker

### 2. KRK-9 (Single Control Head Remote Kit)

#### 1-1. External View

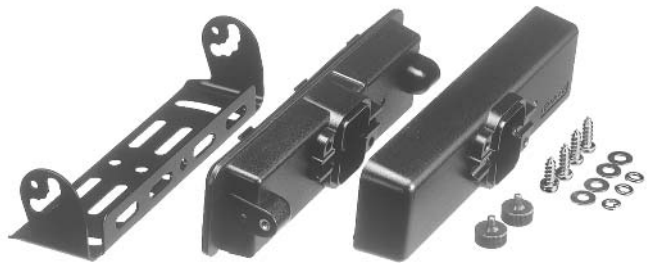

#### 1-2. Parts List

\* : New parts

Ref. No.	New parts	Parts No.	Description
	*	A62-1039-02	Panel
	*	A82-0049-02	Rear panel
	*	E37-1008-05	Lead wire with connector
	*	F07-1865-03	Mold cover
	*	G02-0895-04	Earth spring
	*	G53-1552-03	Packing
	*	J21-8447-04	Hardware fixture
	*	J29-0698-03	Bracket
	*	N08-0550-04	Dressed screw
	*	N87-3008-45	Brazier head taptite screw
	*	N99-2032-05	Screw set

## SPECIFICATIONS

### GENERAL

Frequency Range .....	450~500MHz (K)
Number of Channels (Zone) .....	Conventional CH : Max.128 (1 zone x 128ch~128 zones x 1ch) Trunking ID : Max. 250/zone (max. 32 zones)
Channel Spacing .....	Wide : 25kHz    Narrow : 12.5kHz
Operating Voltage .....	13.6V DC±15%
Current Drain .....	Standby : 0.5A    Receive : 2.3A    Transmit : Less than 13A
Duty Cycle .....	Transmit : 20%
Operating Temperature range .....	-22°F~+140°F (-30°C~+60°C)
Frequency Stability (-22°F~+140°F) .....	±0.00025%
Antenna Impedance .....	50Ω
Dimensions (W x H x D) .....	7-1/12" x 2" x 7" (180mm x 50mm x 170mm)
Weight (net) .....	5.9 lbs (2.7kg)
Band Spread .....	50MHz

### RECEIVER

Sensitivity .....	12dB SINAD : 0.35μV    20dB Quieting : 0.45μV
Selectivity .....	Wide : 80dB (±25kHz)    Narrow : 73dB (±12.5kHz)
Intermodulation .....	Wide : 79dB (±25, 50kHz)    Narrow : 73dB (±12.5, 25kHz)
Spurious Response .....	85dB
External Audio Output .....	12W (@4Ω 3% distortion), 13W (@4Ω 5% distortion)
Internal Audio Output .....	3.2W (@16Ω 3% distortion), 3.5W (@16Ω 5% distortion)

### TRANSMITTER

RF Output Power .....	45 to 15 watts    High : 45 watts    Low : 15 watts
Type of Emission .....	Wide : 16K0F3E, 20K0F1D    Narrow : 11K0F3E, 11K2F1D
Spurious Response .....	75dB
FM Hum & Noise .....	Wide : 48dB    Narrow : 42dB
Microphone Impedance .....	600Ω
Audio Distortion .....	Less than 1% at 1000Hz

Kenwood follows a policy of continuous advancement in development.

For this reason specifications may be changed without notice.

FleetSync™ is a trademark of Kenwood Corporation.

### Applicable MIL-STD

Standard	MIL 810C Methods/Procedures	MIL 810D Methods/Procedures	MIL 810E Methods/Procedures	MIL 810F Methods/Procedures
Low Pressure	500.1/Procedure I	500.2/Procedure I, II	500.3/Procedure I, II	500.4/Procedure I, II
High Temperature	501.1/Procedure I, II	501.2/Procedure I, II Cat. A1	501.3/Procedure I, II Cat. A1	501.4/Procedure I, II
Low Temperature	502.1/Procedure I	502.2/Procedure I, II Cat. C1	502.3/Procedure I, II Cat. C1	502.4/Procedure I, II
Temperature Shock	503.1/Procedure I	503.2/Procedure I Cat. A1,C1	503.3/Procedure I Cat. A1,C1	503.4/Procedure I, II
Solar Radiation	505.1/Procedure I	505.2/Procedure I	505.3/Procedure I	505.4/Procedure I
Rain	506.1/Procedure II	506.2/Procedure II	506.3/Procedure II	506.4/Procedure III
Humidity	507.1/Procedure II	507.2/Procedure II	507.3/Procedure II	507.4
Salt Fog	509.1/Procedure I	509.2/Procedure I	509.3/Procedure I	509.4
Dust	510.1/Procedure I	510.2/Procedure I	510.3/Procedure I	510.4/Procedure I, III
Vibration	514.2/Procedure VIII, X	514.3/Procedure I Cat. 8	514.4/Procedure I Cat. 8	514.5/Procedure I Cat. 20
Shock	516.2/Procedure I, II, III, V	516.3/Procedure I, IV, V	516.4/Procedure I, IV, V	516.5/Procedure I, IV, V

# TK-8150

## **KENWOOD CORPORATION**

2967-3, Ishikawa-machi, Hachioji-shi, Tokyo 192-8525, Japan

### **KENWOOD U.S.A. CORPORATION**

P.O. BOX 22745, 2201 East Dominguez Street, Long Beach, CA 90801-5745, U.S.A.

### **KENWOOD ELECTRONICS CANADA INC.**

6070 Kestrel Road, Mississauga, Ontario, Canada L5T 1S8

### **KENWOOD ELECTRONICS DEUTSCHLAND GMBH**

Rembrücker Str. 15, 63150 Heusenstamm, Germany

### **KENWOOD ELECTRONICS BELGIUM N.V.**

Leuvensesteenweg 248 J, 1800 Vilvoorde, Belgium

### **KENWOOD ELECTRONICS FRANCE S.A.**

13, Boulevard Ney, 75018 Paris, France

### **KENWOOD ELECTRONICS U.K. LIMITED**

KENWOOD House, Dwight Road, Watford, Herts., WD18 9EB United Kingdom

### **KENWOOD ELECTRONICS EUROPE B.V.**

Amsterdamseseweg 37, 1422 AC Uithoorn, The Netherlands

### **KENWOOD ELECTRONICS ITALIA S.p.A.**

Via G. Sirtori, 7/9 20129 Milano, Italy

### **KENWOOD IBERICA S.A.**

Bolivia, 239-08020 Barcelona, Spain

### **KENWOOD ELECTRONICS AUSTRALIA PTY. LTD.**

(A.C.N. 001 499 074)

16 Giffnock Avenue, Centrecourt Estate, North Ryde, N.S.W. 2113 Australia

### **KENWOOD ELECTRONICS (HONG KONG) LTD.**

Unit 3712-3724, Level 37, Tower one Metroplaza, 223 Hing Fong Road, Kwai Fong, N.T., Hong Kong

### **KENWOOD ELECTRONICS TECHNOLOGIES(S) PTE LTD.**

Sales Marketing Division

1 Ang Mo Kio Street 63, Singapore 569110

