

UHF FM TRANSCEIVER

TK-8302/8302H

CONNECTION CABLE

KCT-60

SERVICE MANUAL

KENWOOD

Kenwood Corporation

© 2009-9 PRINTED IN JAPAN
B51-8887-00 (N) 533

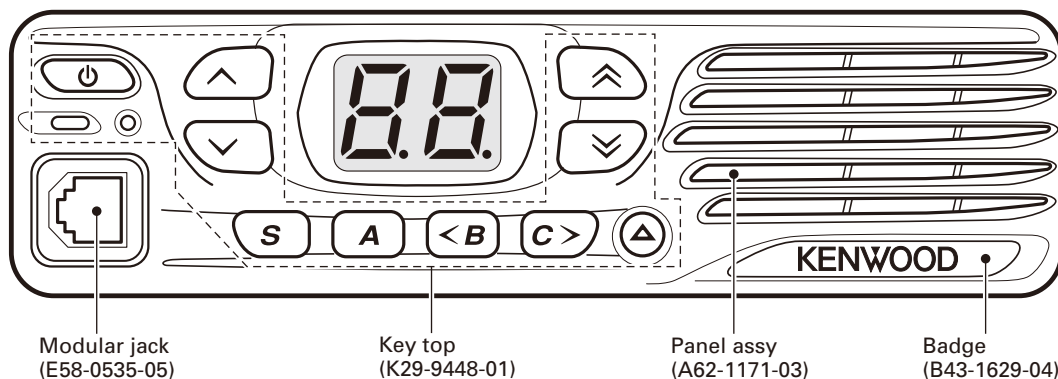

CONTENTS

GENERAL	2	ADJUSTMENT	28
SYSTEM SET-UP	4	TERMINAL FUNCTION	34
REALIGNMENT	4	PC BOARD	
INSTALLATION	6	DISPLAY UNIT (X54-3670-20)	36
DISASSEMBLY FOR REPAIR	8	TX-RX UNIT (X57-7680-XX)	38
CIRCUIT DESCRIPTION	10	SCHEMATIC DIAGRAM	42
SEMICONDUCTOR DATA	15	BLOCK DIAGRAM	48
COMPONENTS DESCRIPTION	16	LEVEL DIAGRAM	50
PARTS LIST	17	OPTIONAL ACCESSORIES	
EXPLODED VIEW	26	KCT-60 (CONNECTION CABLE)	51
PACKING	27	SPECIFICATIONS	BACK COVER

Document Copyrights

Copyright 2009 by Kenwood Corporation. All rights reserved.

No part of this manual may be reproduced, translated, distributed, or transmitted in any form or by any means, electronic, mechanical, photocopying, recording, or otherwise, for any purpose without the prior written permission of Kenwood.

Disclaimer

While every precaution has been taken in the preparation of this manual, Kenwood assumes no responsibility for errors or omissions. Neither is any liability assumed for damages resulting from the use of the information contained herein. Kenwood reserves the right to make changes to any products herein at any time for improvement purposes.

GENERAL

INTRODUCTION

SCOPE OF THIS MANUAL

This manual is intended for use by experienced technicians familiar with similar types of commercial grade communications equipment. It contains all required service information for the equipment and is current as of this publication date. Changes which may occur after publication are covered by either Service Bulletins or Manual Revisions, which are issued as required.

ORDERING REPLACEMENT PARTS

When ordering replacement parts or equipment information, the full part identification number should be included. This applies to all parts : components, kits, and chassis. If the part number is not known, include the chassis or kit number of which it is a part and a sufficient description of the required component for proper identification.

PERSONNEL SAFETY

The following precautions are recommended for personnel safety :

- DO NOT transmit if someone is within two feet (0.6 meter) of the antenna.
- DO NOT transmit until all RF connectors are secure and any open connectors are properly terminated.
- SHUT OFF this equipment when near electrical blasting caps or while in an explosive atmosphere.
- All equipment should be properly grounded before power-up for safe operation.
- This equipment should be serviced by only qualified technicians.

PRE-INSTALLATION CONSIDERATIONS

1. UNPACKING

Unpack the radio from its shipping container and check for accessory items. If any item is missing, please contact KENWOOD immediately.

2. LICENSING REQUIREMENTS

Federal regulations require a station license for each radio installation (mobile or base) be obtained by the equipment owner. The licensee is responsible for ensuring transmitter power, frequency, and deviation are within the limits permitted by the station license.

Transmitter adjustments may be performed only by a licensed technician holding an FCC first, second or general class commercial radiotelephone operator's license. There is no license required to install or operate the radio.

3. PRE-INSTALLATION CHECKOUT

3-1. Introduction

Each radio is adjusted and tested before shipment. However, it is recommended that receiver and transmitter operation be checked for proper operation before installation.

3-2. Testing

The radio should be tested complete with all cabling and accessories as they will be connected in the final installation. Transmitter frequency, deviation, and power output should be checked, as should receiver sensitivity, squelch operation, and audio output. Signalling equipment operation should be verified.

GENERAL

4. PLANNING THE INSTALLATION

4-1. General

Inspect the vehicle and determine how and where the radio antenna and accessories will be mounted.

Plan cable runs for protection against pinching or crushing wiring, and radio installation to prevent overheating.

4-2. Antenna

The favored location for an antenna is in the center of a large, flat conductive area, usually at the roof center. The trunk lid is preferred, bond the trunk lid and vehicle chassis using ground straps to ensure the lid is at chassis ground.

4-3. Radio

The universal mount bracket allows the radio to be mounted in a variety of ways. Be sure the mounting surface is adequate to support the radio's weight. Allow sufficient space around the radio for air cooling. Position the radio close enough to the vehicle operator to permit easy access to the controls when driving.

4-4. DC Power and wiring

1. This radio may be installed in negative ground electrical systems only. Reverse polarity will cause the cable fuse to blow. Check the vehicle ground polarity before installation to prevent wasted time and effort.
2. Connect the positive power lead directly to the vehicle battery positive terminal. Connecting the Positive lead to any other positive voltage source in the vehicle is not recommended.
3. Connect the ground lead directly to the battery negative terminal.
4. The cable provided with the radio is sufficient to handle the maximum radio current demand. If the cable must be extended, be sure the additional wire is sufficient for the current to be carried and length of the added lead.

5. INSTALLATION PLANNING – CONTROL STATIONS

5-1. Antenna system

Control station. The antenna system selection depends on many factors and is beyond the scope of this manual. Your KENWOOD dealer can help you select an antenna system that will best serve your particular needs.

5-2. Radio location

Select a convenient location for your control station radio which is as close as practical to the antenna cable entry point. Secondly, use your system's power supply (which supplies the voltage and current required for your system). Make sure sufficient air can flow around the radio and power supply to allow adequate cooling.

SERVICE

This radio is designed for easy servicing. Refer to the schematic diagrams, printed circuit board views, and alignment procedures contained in this manual.

NOTE

If you do not intend to use the 3.5-mm jack for the external speaker, fit the supplied speaker-jack cap to stop dust and sand from getting in.

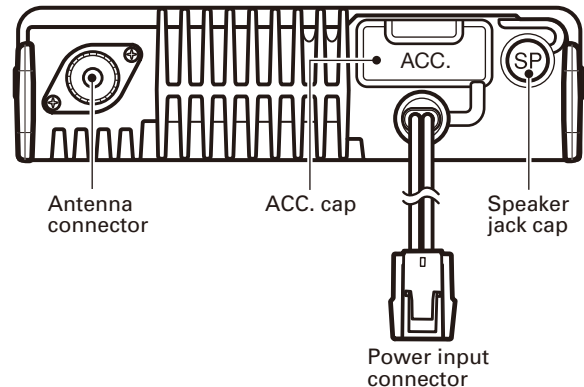

SYSTEM SET-UP

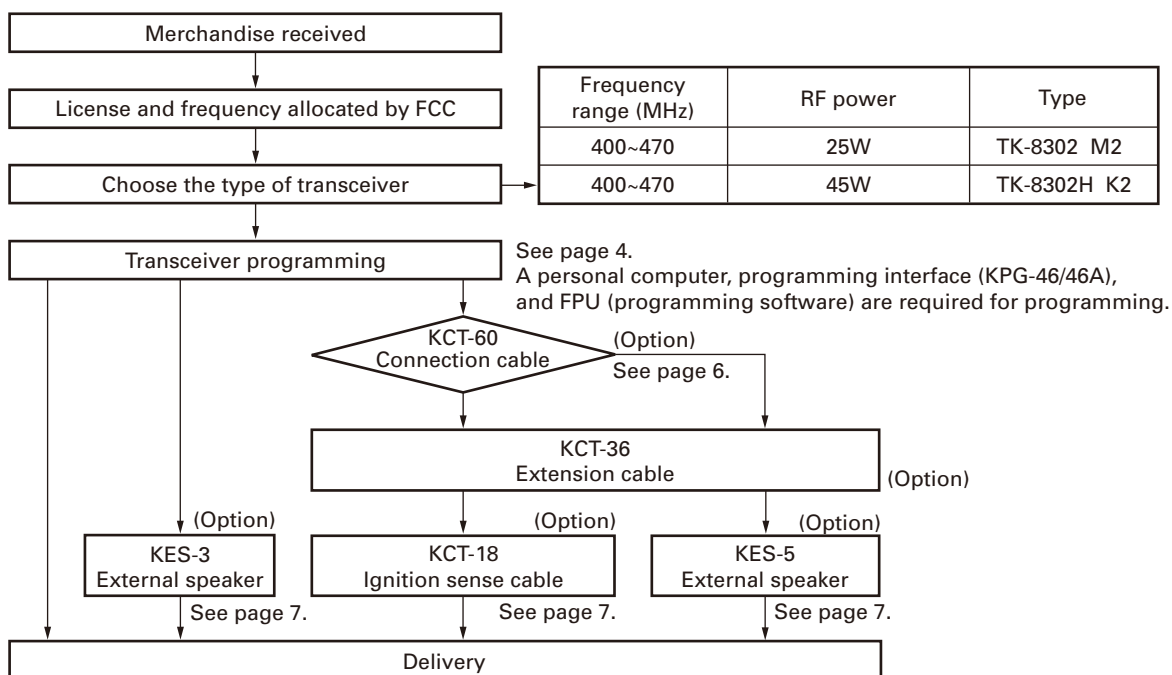

REALIGNMENT

1. Modes

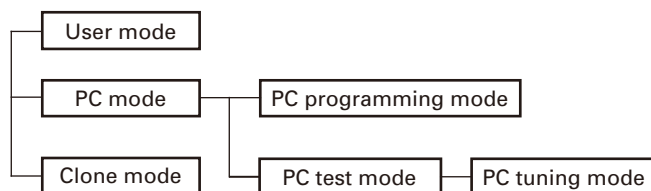

Mode	Function
User mode	For normal use.
PC mode	Used for communication between the transceiver and PC.
PC programming mode	Used to read and write frequency data and other features to and from the transceiver.
PC test mode	Used to check the transceiver using the PC. This feature is included in the FPU.
PC tuning mode	Used to tune the transceiver using the PC.
Clone mode	Used to transfer programming data from one transceiver to another.

2. How to Enter Each Mode

Mode	Operation
User mode	Power ON
PC mode	Received commands from PC
Clone mode	[]+Power ON (Two seconds)

3. PC Mode

3-1. Preface

The transceiver is programmed using a personal computer, a programming interface (KPG-46/46A, USB adapter (KCT-53U)) and FPU (programming software).

The programming software can be used with a PC. Figure 1 shows the setup of a PC for programming.

3-2. Connection procedure

1. Connect the transceiver to the computer using the interface cable and USB adapter (When the interface cable is KPG-46A, the KCT-53U can be used.).

REALIGNMENT

Note:

- You must install the KCT-53U driver in the computer to use the USB adapter (KCT-53U).
 - When using the USB adapter (KCT-53U) for the first time, plug the KCT-53U into a USB port on the computer with the computer power ON.
2. When the Power is switched on, user mode can be entered immediately. When the PC sends a command, the transceiver enters PC mode, and "Pc" is displayed on the LED.
- When data is transmitting from the transceiver, the red LED blinks.
- When data is receiving by the transceiver, the green LED blinks.

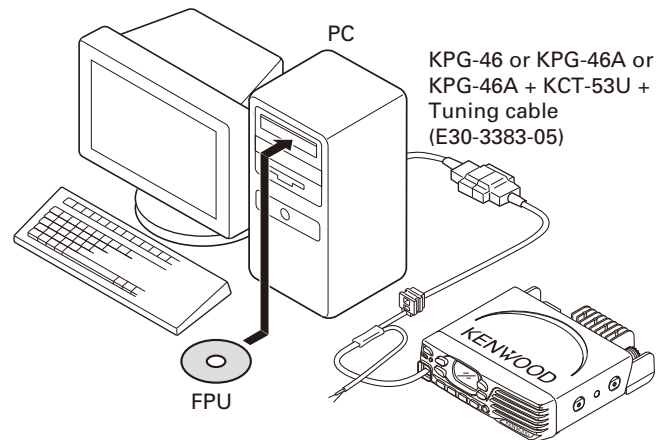

Note:

The data stored in the computer must match the "Model Name" when it is written into the EEPROM.

3-3. KPG-46/KPG-46A description

(PC programming interface cable: Option)

The KPG-46/46A is required to interface the transceiver to the computer. It has a circuit in its D-sub connector (KPG-46: 25-pin, KPG-46A: 9-pin) case that converts the RS-232C logic level to the TTL level.

The KPG-46/46A connects the 8-pin microphone connector of the transceiver to the RS-232C serial port of the computer.

3-4. KCT-53U description (USB adapter: Option)

The KCT-53U is a cable which connects the KPG-46A to a USB port on a computer.

When using the KCT-53U, install the supplied CD-ROM (with driver software) in the computer. The KCT-53U driver runs under Windows 2000 or XP or Vista (32-bit).

3-5. FPU (Programming Software) description

The FPU is the programming software for the transceiver supplied on a CD-ROM. This software runs under Windows 2000, XP or Vista (32-bit) on a PC.

The data can be input to or read from the transceiver and edited on the screen. The programmed or edited data can be printed out. It is also possible to tune the transceiver.

List of FPU for transceiver

Model	Type	FPU
TK-8302	M2	KPG-124D(M)
TK-8302H	K2	KPG-124D(K)

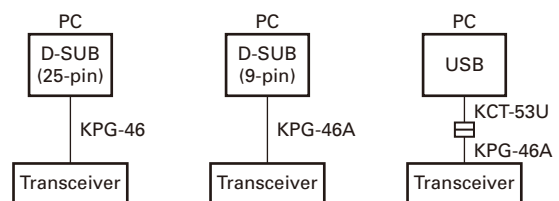

Fig. 1

4. Clone Mode

Programming data can be transferred from one transceiver to another by connecting them via their modular microphone jacks. The operation is as follows (the transmit transceiver is the source and the receive transceiver is a target).

Note :

Clone mode should be enabled.

- Turn the source transceiver power ON with the [M] key held down (2 seconds), "cL" is displayed on the LED.
- Power on the target transceiver.
- Connect the cloning cable (No. E30-3382-05) to the modular microphone jacks on the source and target.
- Press the [s] key on the source transceiver.
The data of the source is sent to the target. While the source is sending data, red LED blinked. While the target is receiving the data, "Pc" is displayed and green LED blinked. When cloning of data is completed, the source displays "En", and the source red LED turned off, and the target automatically operates in the User mode. The target can then be operated by the same program as the source.
- The other target can be continuously cloned. Carry out the operation in step 2 to 4.

REALIGNMENT

4-1. Adding the data password

If the data password is set in the optional feature menu, you must enter the password (Source transceiver) to activate a clone mode.

You can use 0~9 to configure the password. The maximum length of the password is 6 digits.

1. [M]+Power ON.
2. "PS" is displayed on the LED.
3. If the [A] and [M] keys is pressed while "PS" is displayed, numbers (0 to 9) are displayed flashing. When you press the [C>] key, the currently selected number is determined. If you press the [S] key after entering the password in this procedure, "cL" is displayed if the entered password is correct. If the password is incorrect, "PS" is redisplayed.

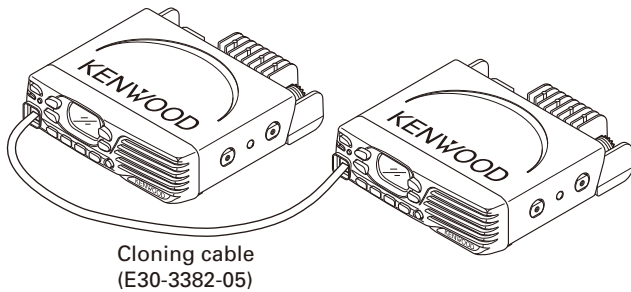
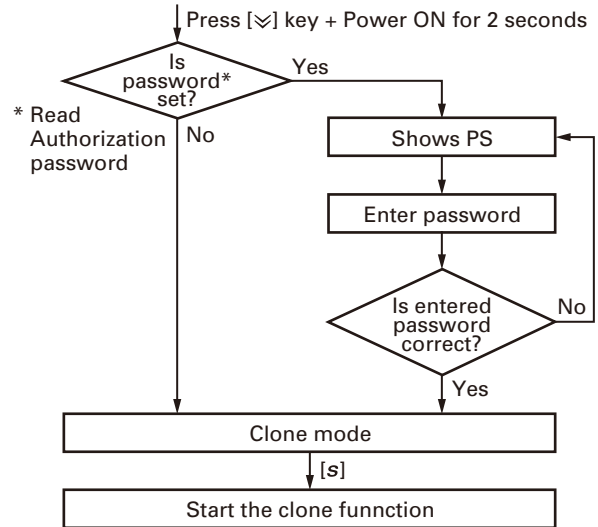

Fig. 2

4-2. Flow chart (Source transceiver)



INSTALLATION

1. Connection Cable (KCT-60: Option)

The KCT-60 connection cable kit is used to connect the transceiver to the KCT-18 (Ignition sense cable), KES-5 (External speaker), or through the KCT-36 extension cable.

1-1. Installing the KCT-60 (Connection cable) in the transceiver

1. Remove the ACC. cap on the rear of the transceiver.
2. Connect the D-sub connector of the KCT-60 to the D-sub 15-pin terminal of the transceiver.
3. Connect the 15-pin connector of the KCT-60 to a KCT-18, KES-5, or through a KCT-36 extension cable.

Note: You must setup using the KPG-124D(K) or KPG-124D(M).

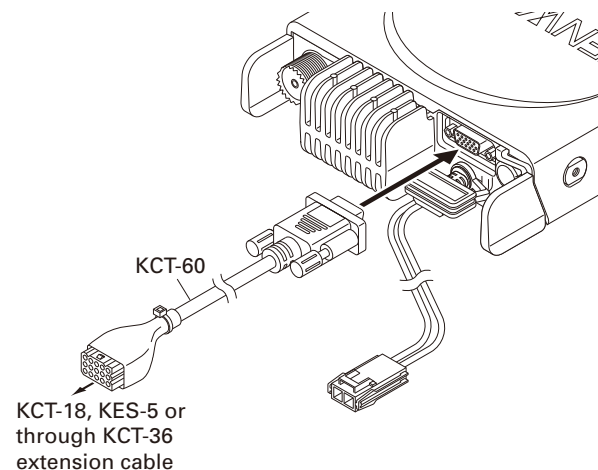

INSTALLATION

1-2. Terminal function

D-sub 15-pin Pin No.	Function	Molex 15-pin Pin No.
1	SB	1
2	IGN	2
3	PA	12
4	DO	4
5	DI	5
6	FNC1	9
7	FNC2	11
8	FNC3	7
9	FNC4	6
10	FNC5	8
11	FNC6	10
12	5C	15
13	HR1	13
14	HR2	14
15	GND	3

2. Ignition Sense Cable (KCT-18: Option)

The KCT-18 is an optional cable for enabling the ignition function. The ignition function lets you turn the power to the transceiver on and off with the car ignition key.

2-1. Installing the KCT-18 (Ignition sense cable) in the transceiver

1. Remove the ACC. cap on the rear of the transceiver.
2. Connect the D-sub connector of the KCT-60 to the D-sub 15-pin terminal of the transceiver.
3. Insert the crimp terminal of the KCT-18 to pin 2 on the 15-pin connector of the KCT-60.

Note: You must setup using the KPG-124D(K) or KPG-124D(M).

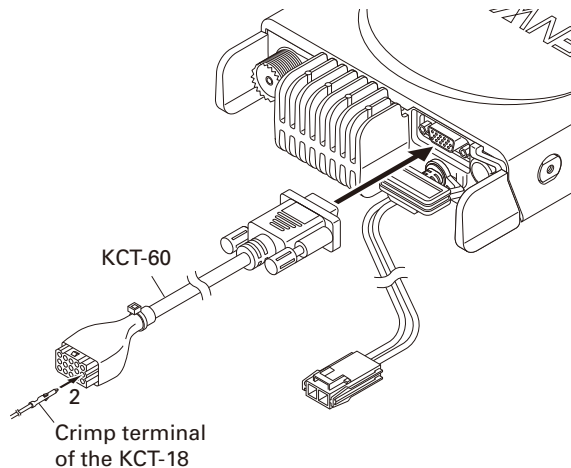

3. External Speaker (Option)

3-1. KES-3

The KES-3 is an external speaker for the 3.5-mm-diameter speaker jack.

■ Connection procedure

1. Remove the speaker-jack cap on the rear of the transceiver.
2. Connect the KES-3 to the 3.5-mm-diameter speaker jack on the rear of the transceiver.

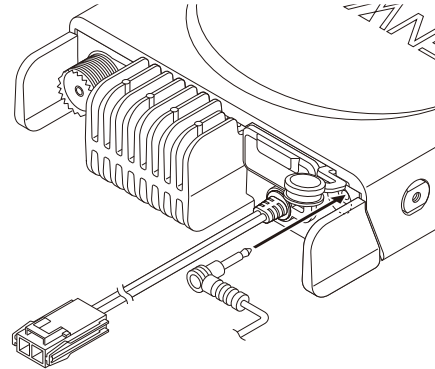

3-2. KES-5

External speaker KES-5 can be installed for KCT-60.

■ Connection procedure

1. Remove the ACC. cap on the rear of the transceiver.
2. Connect the D-sub connector of the KCT-60 to the D-sub 15-pin terminal of the transceiver.
3. Insert two crimp terminals of the KES-5 to pins 3 and 12 on the 15-pin connector of the KCT-60.

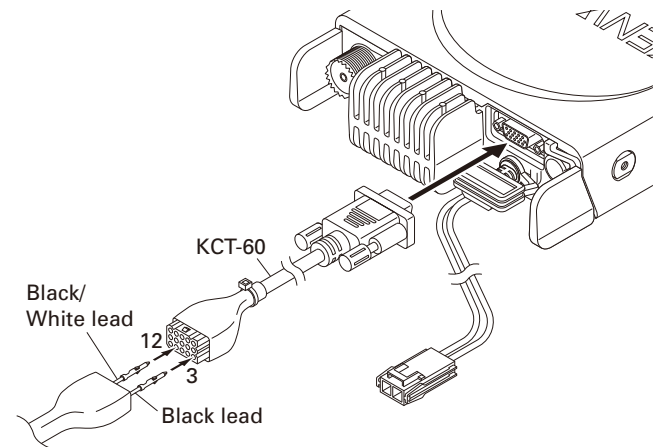

TK-8302/8302H

DISASSEMBLY FOR REPAIR

1. Disassembly Procedure

1. When removing the cabinet, first remove the two screws from the right and left with a phillips screwdriver. Then, hook your finger on the edge of the cabinet and pull it out until it is over the chassis protrusion. Remove the cabinet by prying the cabinet as shown below.

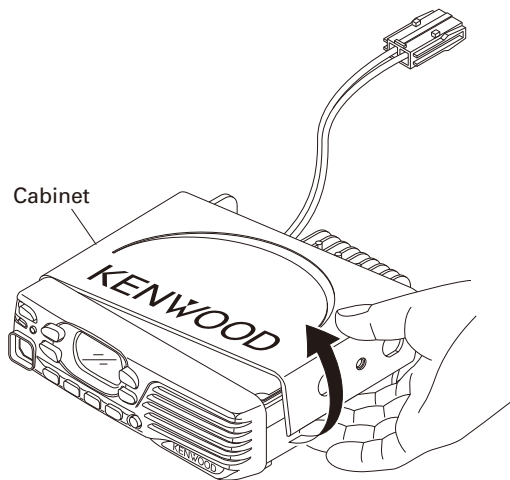

2. To remove the panel assembly, first turn the transceiver upside down. Then, insert a flat-head screwdriver into the holes of the chassis and tilt it in the direction as shown by the arrow.

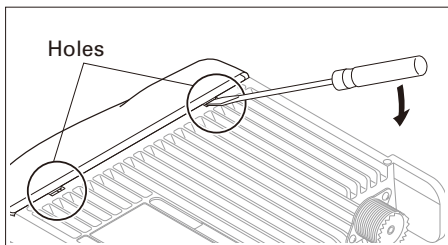

Panel assembly

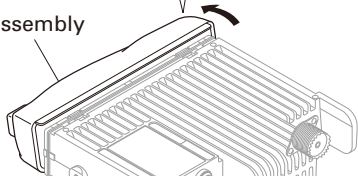

3. Disconnect the flat cable from connector of the panel assembly.

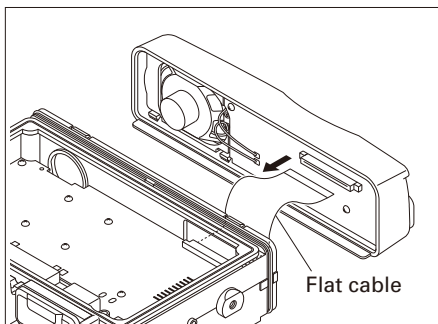

4. To remove the speaker holder, first remove the two screws from the display PCB using a phillips screwdriver. Then, insert a flat-head screwdriver under the tabs of the speaker holder and tilt it in the direction shown by the arrow.

Remove the speaker from the front panel by turning it in the direction indicated, together with the speaker holder and display PCB.

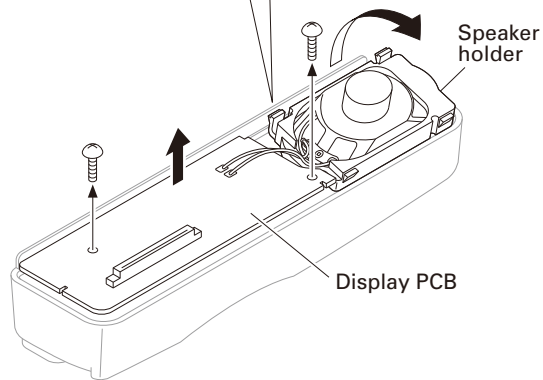
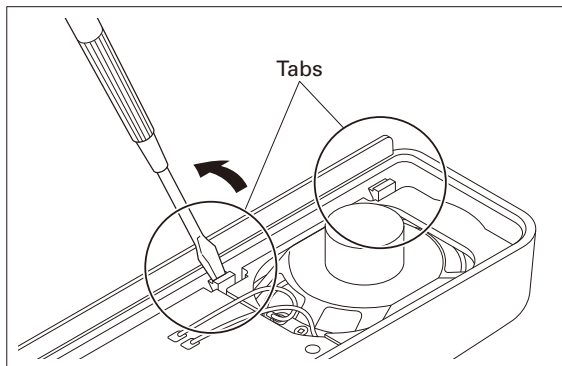

5. When removing the TX-RX PCB, first remove the top packing.

Then, remove the solder of the antenna hot pin and positive terminal of the DC cord. Remove the 15 screws from the TX-RX PCB, power module, and audio amp.

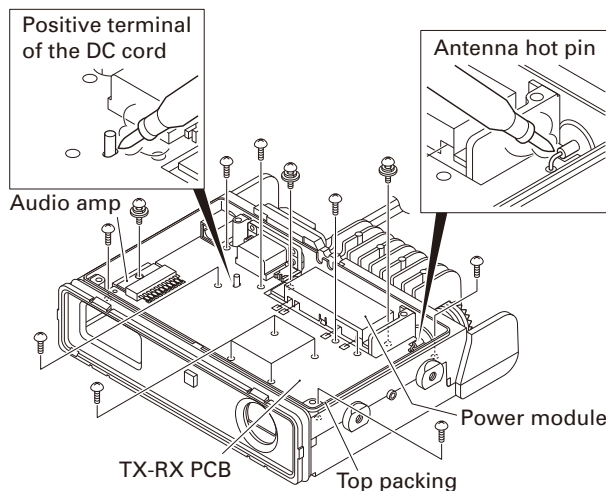

DISASSEMBLY FOR REPAIR

Note:

When you supply power to the TX-RX PCB after removing the TX-RX PCB from the chassis, solder the positive and ground terminals of the DC cord (Recommendation: E30-3448-25) to the + and GND terminals of the TX-RX PCB.

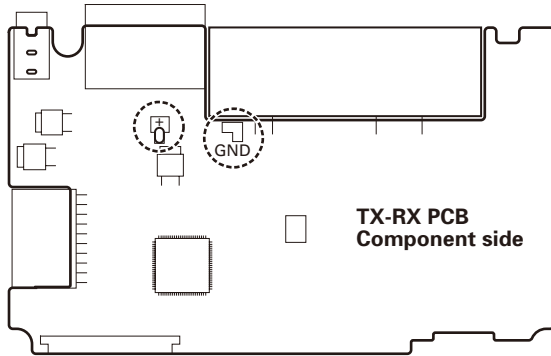

- Pull it out behind the chassis by rotating the bush ③ of the DC cord 90 degrees in the direction of the arrow after the screw ① in the negative terminal is removed, and the positive terminal ② is removed from the chassis.

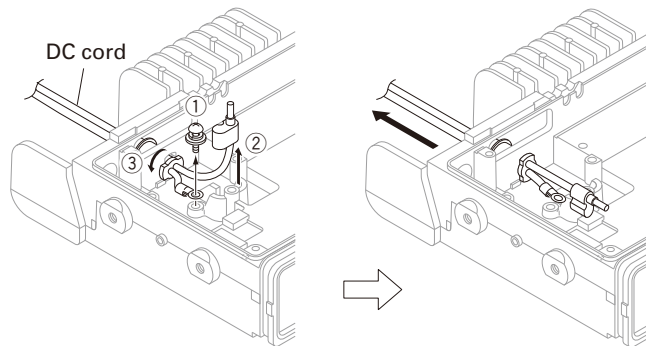

2. Precautions for Reassembly

- When mounting the speaker holder, while suppressing the speaker rear part (shaded area), fix the four tabs of the speaker holder into the hollows of the front panel in order (①, ②, ③, and ④). Then, tighten the two screws of the display PCB.

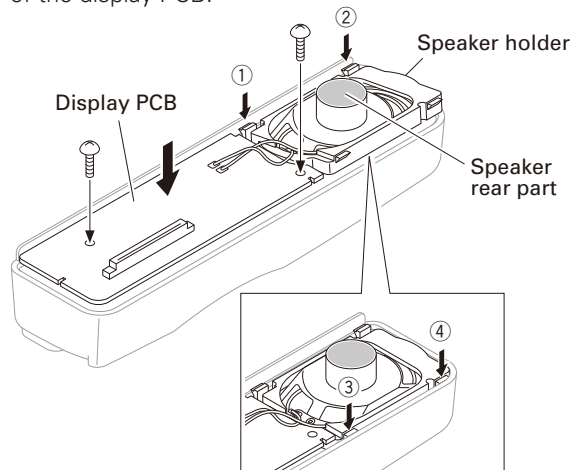

- When mounting the panel assembly, pass the flat cable through the hole of the chassis as shown below then connect the flat cable to connector of the panel assembly.

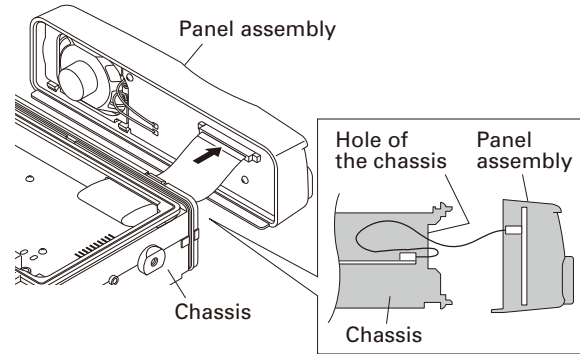

- Fit the panel assembly into the two tabs of the chassis top side first. Then, fit the panel assembly into the two tabs of the chassis bottom side by turning the panel assembly.

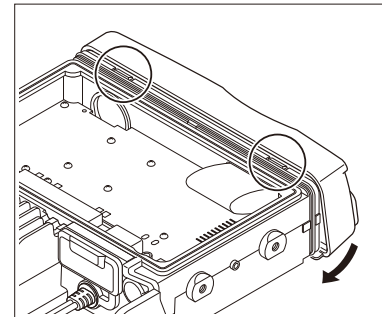

3. Correspondence when replacing the LED (B30-2321-05)

When replacing the LED (B30-2321-05), cut the leg of the LED to 4mm (0.16 inch) after installing the Collar (J31-0565-15).

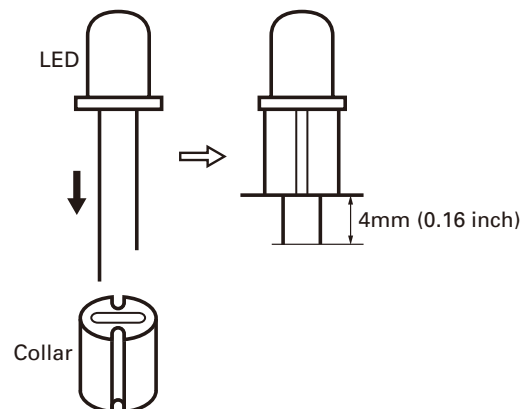

CIRCUIT DESCRIPTION

1. Frequency Configuration

The receiver utilizes double conversion. The first IF is 38.85MHz and the second IF is 450kHz. The first local oscillator signal is supplied from the PLL circuit.

The PLL circuit in the transmitter generates the necessary frequencies. Figure 1 shows the frequencies.

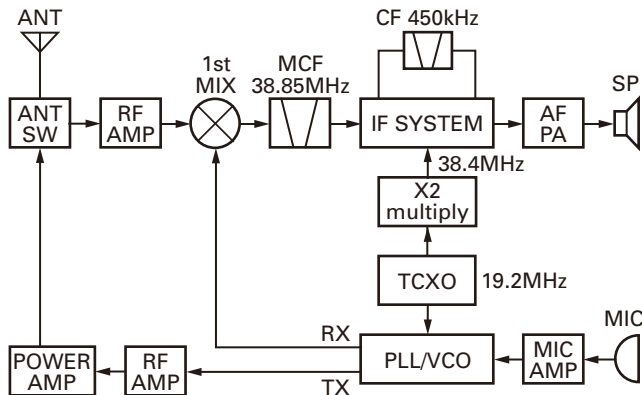

Fig. 1 Frequency configuration

2. Receiver System

The receiver is a double conversion superheterodyne. The frequency configuration is shown in Figure 1.

2-1. Front-end RF Amplifier

An incoming signal from the antenna is applied to an RF amplifier (Q506) after passing through a transmit/receive switch circuit (D302, D303, D304 and D305), BPF (L517, L518 and varactor diodes: D509, D510) and the Notch filter (L519 and varactor diode: D511). The Notch filter function is to eliminate the image frequency.

After the signal is amplified (Q506), the signal is filtered by a BPF (L511, L512, L513 and varactor diodes : D505, D506, D508) to eliminate unwanted signals before it is passed to the first mixer.

The voltage of these diodes are controlled by tracking the MCU (IC702) center frequency of the bandpass filter. (See Figure 2)

2-2. First Mixer

The signal from the RF amplifier is heterodyned with the first local oscillator signal from the PLL frequency synthesizer circuit at the first mixer (Q504) to create a 38.85MHz first intermediate frequency (1st IF) signal. The first IF signal is then fed through one pair of monolithic crystal filters (MCF: XF500) to further remove spurious signals.

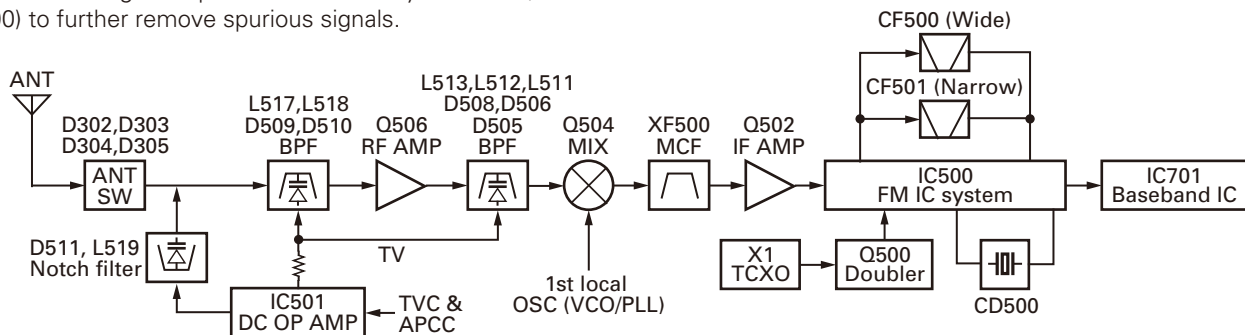

Fig. 2 Receiver System

Item	Rating
Nominal center frequency	38.85MHz
Pass bandwidth	±6.0kHz or more at 3dB
40dB stop bandwidth	±25.0kHz or less
Ripple	1.0dB or less
Insertion loss	4.0dB or less
Guaranteed attenuation	75dB (-900kHz); 50dB (+900kHz)
	Spurious: 40dB or more within fo±1MHz
Terminal impedance	610Ω// 3.0pF// Coupling Cap 13.0pF

Table 1 Crystal filter (L71-0659-05): XF500

2-3. IF Amplifier Circuit

The first IF signal is amplified by Q502, and enters IC500 (FM processing IC). The signal is heterodyned again with a second local oscillator signal within IC500 to create a 450kHz second IF signal. The second IF signal is then fed through a 450kHz ceramic filter (Wide: CF500, Narrow: CF501) to further eliminate unwanted signals before it is amplified and demodulated by the quadrature detector with the ceramic discriminator (CD500).

Item	Rating
Nominal center frequency	450kHz
6dB bandwidth	±6.0kHz or more
50dB bandwidth	±12.5kHz or less
Ripple	2.0dB or less
Insertion loss	6.0dB or less
Guaranteed attenuation	35.0dB or more within fo±100kHz
Terminal impedance	2.0kΩ

Table 2 Ceramic filter (L72-0993-05): CF500

Item	Rating
Nominal center frequency	450kHz
6dB bandwidth	±4.5kHz or more
50dB bandwidth	±10.0kHz or less
Ripple	2.0dB or less
Insertion loss	6.0dB or less
Guaranteed attenuation	55.0dB or more within fo±100kHz
Terminal impedance	2.0kΩ

Table 3 Ceramic filter (L72-0959-05): CF501

CIRCUIT DESCRIPTION

2-4. Wide/Narrow Switching Circuit

The Wide port (pin 99) and Narrow port (pin 98) of the MCU is used to switch between ceramic filters. When the Wide port is high, the ceramic filter switch diodes (D500, D501) cause CF500 to turn on to receive a Wide signal.

When the Narrow port is high, the ceramic filter switch diodes (D500, D501) cause CF501 to turn on to receive a Narrow signal.

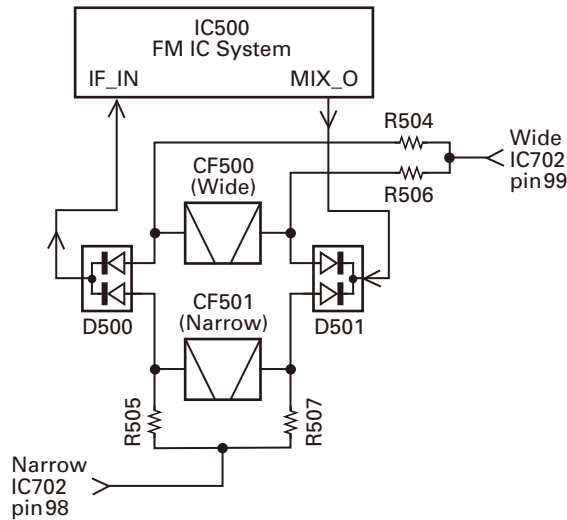

Fig. 3 Wide/Narrow switching circuit

2-5. AF Signal System

The detection signal from the FM IC (IC500) goes to the baseband IC (IC701) DISC input (pin 16) for characterizing the signal.

The AF signal output from IC701 is input to the audio power amplifier (IC705). The AF signal from IC705 switches between the internal speaker and the speaker jack (J701) output.

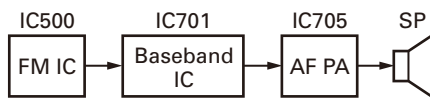

Fig. 4 AF signal system

2-6. Squelch Circuit

The detection output from the FM IC (IC500), a voltage is applied to the MCU (IC702). The MCU controls squelch according to the voltage (SQIN) level.

The signal from the RSSI pin of IC500 is monitored.

The electric field strength of the receive signal can be known before the SQIN voltage is input to the MCU, and the scan stop speed is improved.

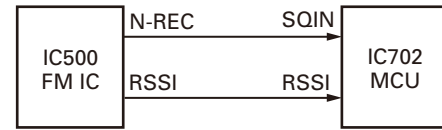

Fig. 5 Squelch circuit

3. Transmitter System

3-1. Outline

The transmitter circuit produces and amplifies the desired frequency directly. It FM-modulates the carrier signal by means of a varicap diode.

3-2. Power Amplifier Circuit

The transmit output signal from the VCO passes through the transmission/reception selection diode (D719) and amplified by Q300. The amplified signal goes to the RF power module (IC301) through a low-pass filter. The low-pass filter removes unwanted high-frequency harmonic components, and the resulting signal goes through the antenna terminal.

3-3. APC Circuit

The automatic transmission power control (APC) circuit detects part of a final amplifier output with a coupler circuit and applies a voltage to IC300. IC300 compares the APC control voltage (PC) generated by the baseband IC (IC701) and DC amplifier (IC501) with the detection output voltage. IC300 generates the voltage to control IC301 and stabilizes transmission output.

The APC circuit is configured to protect over current of Q300 and IC301 due to fluctuations of the load at the antenna end and to stabilize transmission output at voltage and temperature variations.

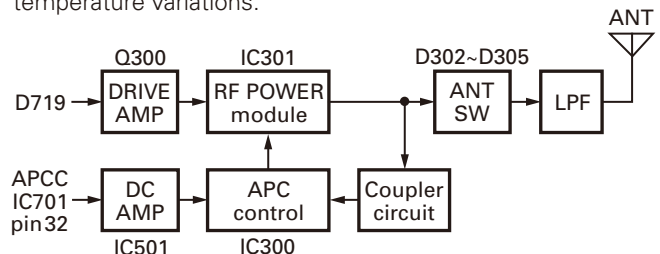

Fig. 7 APC circuit

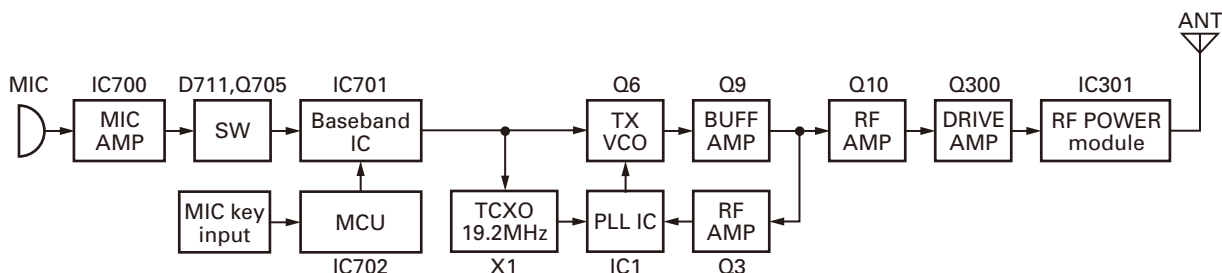

Fig. 6 Transmitter system

CIRCUIT DESCRIPTION

4. PLL Frequency Synthesizer

The PLL circuit generates the first local oscillator signal for reception and the RF signal for transmission.

4-1. PLL Circuit

The frequency step of the PLL circuit is 5 or 6.25kHz.

A 19.2MHz reference oscillator signal is divided at IC1 by a fixed counter to produce the 5 or 6.25kHz reference frequency. The voltage controlled oscillator (VCO) output signal is buffer amplified by Q9, then divided by a programmable counter in IC1.

The divided signal is compared in phase with the 5 or 6.25kHz reference signal in the phase comparator in IC1. The output signal from the phase comparator is filtered

through a low-pass filter and passed to the VCO to control the oscillator frequency.

4-2. VCO Circuit

The operating frequency is generated by Q6 in transmit mode and Q4 in receive mode. The oscillator frequency is controlled by applying the VCO control voltage, obtained from the phase comparator to the varactor diodes (D4 in transmit mode and D5 in receive mode) and assist voltage to the (D6, D8 and D9 in transmit mode and D7, D10 and D11 in receive mode).

The TX/RX pin is set high in receive mode causing Q5 to turn off, and turn Q7 on. The TX/RX pin is set low in transmit mode. The outputs from Q4 and Q6 are amplified by Q9 and sent to the RF amplifiers.

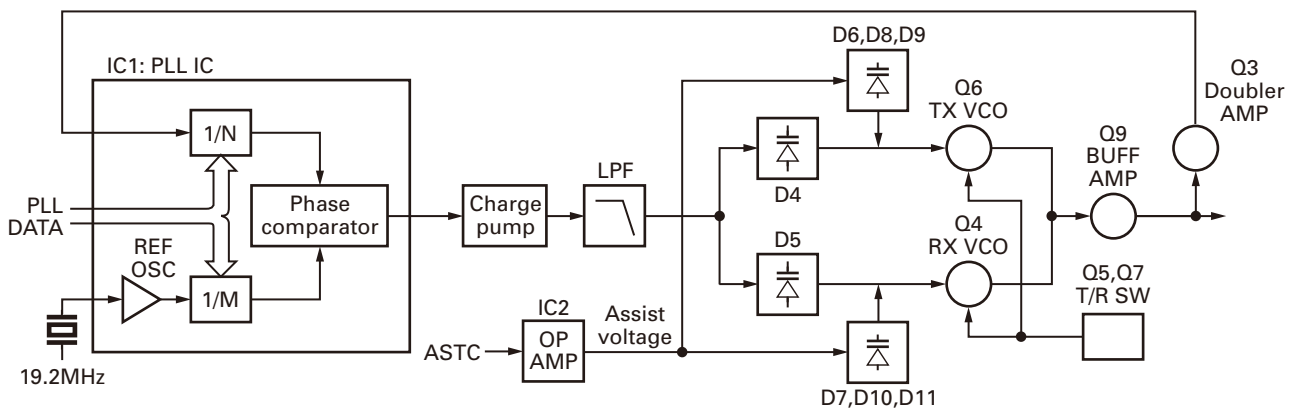

Fig. 8 PLL circuit

4-3. Unlock Circuit

During reception, the 9RC signal goes high, the 9TC signal goes low, and Q711 turns on. Q713 turns on and a voltage is applied to the collector (9R). During transmission, the 9RC signal goes low, the 9TC signal goes high and Q712 turns on. Q714 turns on and a voltage is applied to 9T.

The MCU in the control unit monitors the PLL (IC1) LD signal directly. When the PLL is unlocked during transmission, the PLL LD signal goes low. The MCU detects this signal and makes the 9TC signal low. When the 9TC signal goes low, no voltage is applied to 9T, and no signal is transmitted.

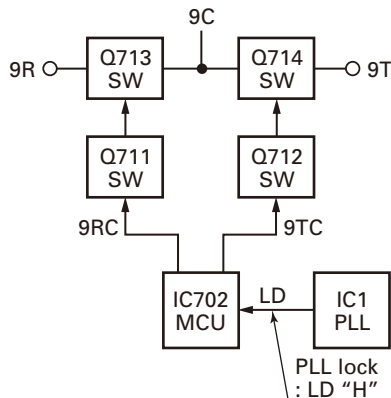

Fig. 9 Unlock circuit

5. Control Circuit

The MCU carries out the following tasks:

- 1) Controls the WIDE, NARROW, TX/RX outputs.
- 2) Controls the baseband IC (IC701).
- 3) Controls the PLL (IC1).
- 4) Controls the display unit

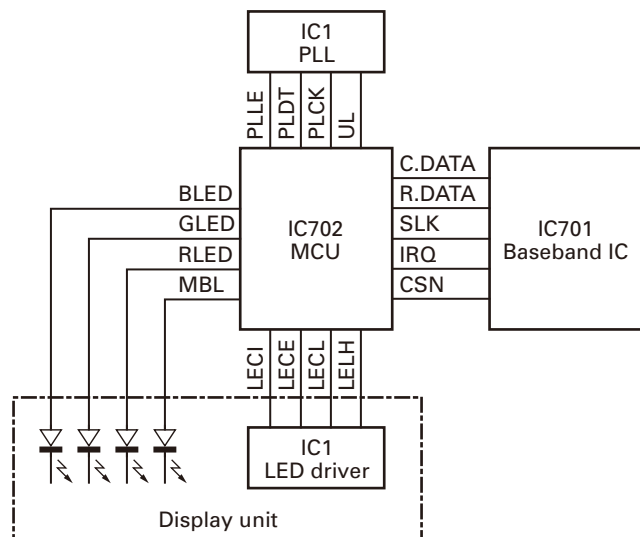

Fig. 10 Control circuit

CIRCUIT DESCRIPTION

5-1. Memory Circuit

The transceiver has a 256k-bit EEPROM (IC703). The EEPROM contains adjustment data. The MCU (IC702) controls the EEPROM through three serial data lines.

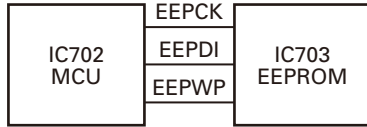

Fig. 11 Memory circuit

5-2. Display Circuit

The MCU (IC702) controls the 7-segment LED Display and LEDs.

When power is on, the MCU will use the MBL line to control the key backlight LEDs.

When the transceiver is busy, the GLED line goes high, Q1 turns on and the green LED (D23) lights after Q7 turns on. In transmit mode, the RLED line goes high, Q2 and Q8 turn on and the red LED (D23) lights.

BLED will be set high when the function select (FPU setting) is on, Q6 turns on and the blue LED (D22) lights.

The dimmer function is controlled by the switch (Q5). The LED driver (IC1) controls the functions of the 7-segment LED through the LEDI, LECE, LECL, LELH lines from the MCU.

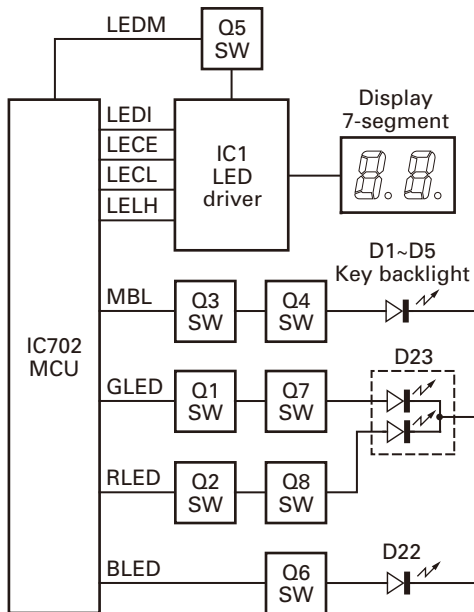

Fig. 12 Display circuit

5-3. Key Matrix Circuit

The TK-8302 front panel has function keys. Each of them is connected to a cross point of a matrix of the KMI1 to KMO3 ports of the MCU. The KMO1 to KMO3 ports are always high, while the KMI1 to KMI3 ports are always low.

The MCU monitors the status of the KMI1 to KMO3 ports. If the state of one of the ports changes, the MCU assumes that the key at the matrix point corresponding to that port has been pressed.

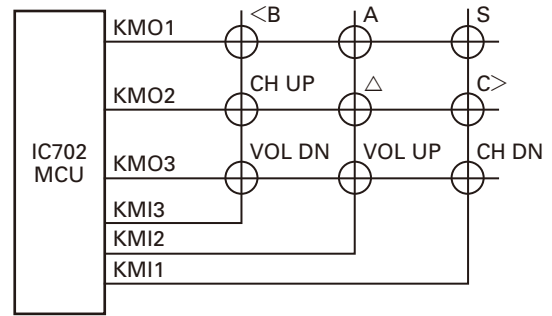

Fig. 13 Key matrix circuit

6. Signaling Circuit

6-1. Encode

■ Low-speed data (QT, DQT)

Low-speed data is output from pin 1 (LSDO) of the MCU (IC702). The signal passes through a low-pass CR filter. The signal is mixed with the audio signal and goes to the VCO and TCXO (X1) modulation input after signal processing in the baseband IC (IC701).

■ High-speed data (2-tone)

High-speed data (HSD) is output from pin 2 (HSDO) of the MCU.

The signal passes through a low-pass CR filter. TX deviation making an adjustment by MCU is applied to the baseband IC (IC701). The signal is mixed with the audio signal and goes to the VCO and TCXO.

The RX tone is audio output of the baseband IC (IC701) at the same time to audio power amplifier and then to the speaker.

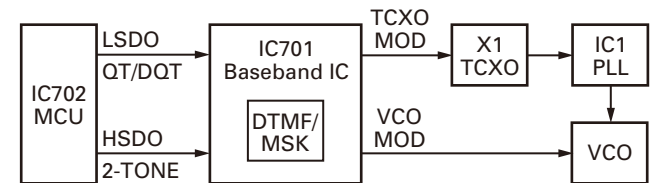

Fig. 14 Encode

■ MSK / DTMF

MSK and DTMF signal is self generated by the baseband IC (IC701).

The TX deviation adjustment is done by the output gain of the baseband IC (IC701), and is routed to the VCO. When encoding MSK/DTMF, the microphone-input signal is muted.

6-2. Decode

■ Low-speed data (QT, DQT)

The demodulated signal from the FM IC (IC500) will input to the baseband IC (IC701) to remove frequencies of 300Hz or more.

The signal is input to pin 88 (LSDI) of the MCU. The MCU digitizes this signal, performs processing such as DC restoration, and decodes the signal.

CIRCUIT DESCRIPTION

High-speed data (2-tone)

The demodulated signal from the FM IC (IC500) is amplified by the baseband IC and passes through a high-pass filter to remove frequencies of 3kHz or more. The MCU digitizes this signal and decodes the signal after receiving the signal at pin 87 (HSDI).

MSK/ DTMF

The demodulated signal from the FM IC (IC500) will input to the baseband IC (IC701), then the baseband IC will decode and send the decoded information to MCU by the data line.

The MCU then processes the decoded information.

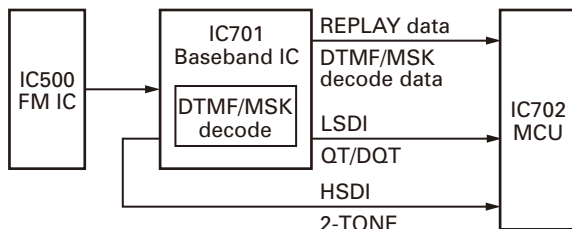

Fig. 15 Decode

7. Power Supply Circuit

When the power switch on the display unit is pressed, the power port on the display unit which is connected to port 17 (POWER), goes low, then port 52 (SBC) goes high, Q719 turns on, SB switch (Q720) turns on and power (SB) is supplied to the transceiver.

When the DC power is supplied to the transceiver, voltage regulator IC (IC707, IC706) will supply into the MCU VDD and reset the voltage detect IC (IC709). IC709 will generate signal (RESET) into the reset terminal on the MCU (IC702) to carry out a power ON reset. Also, MCU (IC702) is checking on port 91 (BATT). If DC power is less than about 8.5V, the transceiver is unable to power on.

When the DC power voltage decreases from normal voltage, the INT voltage detector IC (IC708) will set to high on MCU port 18 (INT). If B line becomes less than about 8.5V, MCU will send the backup data to EEPROM (IC703) and go into STOP mode.

This circuit has an overvoltage protection circuit. If a DC voltage of 16V or higher is applied to the base of Q710, this voltage turns Q710 on and sets port 18 (INT) to low. As a result port 78 (SBC) is low, and turns Q719 and Q720 (SB) off.

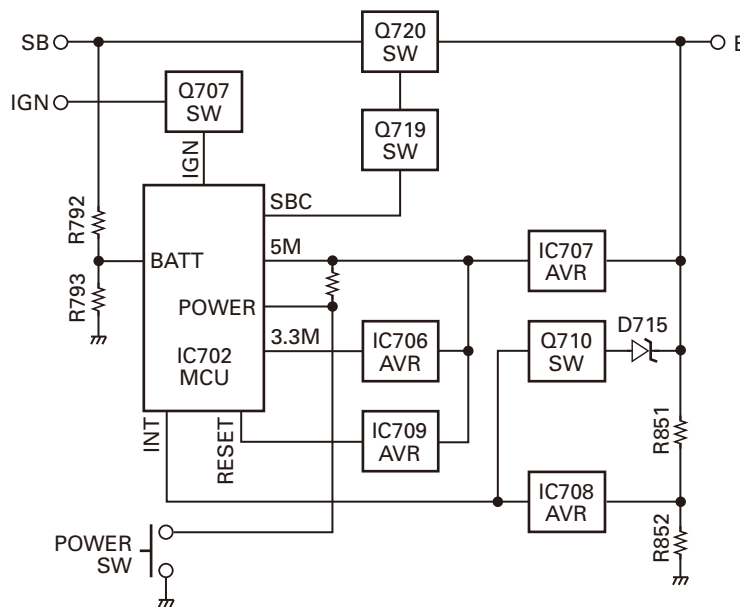

Fig. 16 Power supply circuit

SEMICONDUCTOR DATA

MCU: F364AEDFBKCUB (TX-RX unit IC702)

Pin No.	Name	I/O	Function
1	LSDO	O	QT/DQT output
2	HSDO	O	High speed data output
3	LEDO	O	LED data
4	LECE	O	LED enable
5	LECL	O	LED clock
6	E	-	GND (Only for bus control)
7	CNVSS	I	CNVss for emulator (Hi: boot mode)
8	LELH	O	LED latch
9	LERE	O	LED reset
10	RESET	I	Reset
11	XOUT	O	19.2MHz clock output
12	VSS	-	GND
13	XIN	I	19.2MHz clock input
14	VCC1	-	+5V
15	5CC	O	5C control
16	MKEY	I/O	Mic key
17	POWKEY	I	Power key input
18	INT	I	MCU stop
19	ASTSW	O	Assist speed up switch
20	BEEP	O	Beep for side tone
21~26	FNC8~FNC3	I/O	Function P8~P3
27	FNC2	I/O	Function P2 / Open drain port
28	FNC1	I/O	Function P1 / Open drain port
29	ETXD	I/O	TXD for emulator
30	ERXD	I/O	RXD for emulator
31	ECLK	-	SCLK for emulator
32	EBSY	-	BUSY for emulator
33	TXD	I/O	To FPU
34	RXD	I/O	From FPU
35	HOOK	I	Hook
36	PTT	I	PTT
37	BSFT	O	Beat shift
38	LPOSW	O	Low power switch for reserve
39	EPM	-	EPM for emulator
40	PLLE	O	PLL enable
41	PLDT	O	PLL data
42	PLCK	O	PLL clock
43	PA	O	Public address (SP2 H: mute / L: unmute)
44	ECE	-	CE for emulator
45	CDATA	O	Command data for BASEBAND IC
46	RDATA	I	Reply data for BASEBAND IC
47	SCLK	O	Serial clock for BASEBAND IC
48	CSN1	O	Chip select for BASEBAND IC
49	SP MUTE	O	Speaker mute (SP1 H: mute / L: unmute)
50	9RC	O	9R control

Pin No.	Name	I/O	Function
51	9TC	O	9T control
52	SBC	O	SB control
53	3CC	O	3C control
54	PLPS	O	Sleep mode function for PLL IC
55	KSSW	O	Kenwood sound switch
56	AMP SW	O	AF AMP (L: enable / H: disable)
57	EEPWP	O	EEPROM write protect
58	EEPDT	I/O	EEPROM data
59	EEPCK	O	EEPROM clock
60	VCC2	-	+3.3V
61	SCRSW	O	Scrambler switch (Audio path)
62	VSS	-	GND
63	CSN2	O	CSN for Vocoder IC
64	TXRX	O	TX/RX (H: RX / L: TX)
65	LEDM	O	LED dimmer
66	MBL	O	Pannel and mic key backlight
67	NC	I	No connection
68	DST	I	Destination
69	REVP	I	Reverse power
70	FWDP	I	Forward power
71	IRQ2	I	Interrupt request for Vocoder IC
72	IGN	I	Ignition
73	IRQ1	I	Interrupt request for BASEBAND IC
74	RLED	O	Red LED for TX
75	GLED	O	Green LED for busy
76	BLED	O	Blue LED for reserve
77~79	KM01~KM03	O	Key matrix output 1~3
80~82	KMI1~KMI3	I	Key matrix input 1~3
83	UL	I	PLL unlock detect
84	AF MUTE	O	AF mute
85	MIC1MUTE	O	Internal mic mute
86	MIC2 MUTE	O	External mic mute
87	HSDI	I	High speed data input
88	LSDI	I	Low speed data input: QT/DQT/ (LTR)
89	TEMP2	I	Temperature 2
90	TEMP1	I	Temperature 1
91	BATT	I	Battery voltage
92	RSSI	I	RSSI input
93	SQIN	I	Squelch input
94	AVSS	-	GND
95	CV	I	VCO lock voltage
96	VREF	-	+5V
97	AVCC	-	+5V
98	NARROW	O	Wide/Narrow (Hi: Narrow)
99	WIDE	O	Wide/Narrow (Hi: Wide)
100	HORN	O	Horn alert

TK-8302/8302H

COMPONENTS DESCRIPTION

Display unit (X54-3670-20)

Ref. No.	Part Name	Description
IC1	IC	LED driver
Q1,2	Transistor	TX/BUSY indication LED switch
Q3,4	Transistor	KEY backlight control switch
Q5,9	Transistor	LED dimmer control switch
Q6	Transistor	Indication LED switch
Q7,8	Transistor	TX/BUSY indication LED switch
D1~5	LED	KEY backlight
D20	Diode	Voltage protection
D22	LED	Indication
D23	LED	TX/BUSY indication
D33	Zener diode	Surge protection
D37	LED	LED display

TX-RX unit (X57-7680-XX)

Ref. No.	Part Name	Description
IC1	IC	PLL IC
IC2	IC	Assist filter
IC300	IC	DC AMP (APC)
IC301	IC	Power module
IC500	IC	FM IC
IC501	IC	RF BPF tuning voltage DC AMP
IC700	IC	MIC/MOD AMP
IC701	IC	BASEBAND IC
IC702	IC	MCU
IC703	IC	EEPROM
IC704	IC	Voltage regulator (9V)
IC705	IC	AF AMP
IC706,710	IC	Voltage regulator (3.3V)
IC707	IC	Voltage regulator (5V)
IC708	IC	Voltage detection (INT)
IC709	IC	Voltage detection (MCU reset)
Q3	Transistor	PLL Fin AMP
Q4	FET	RX VCO
Q5	FET	TX/RX VCO switch
Q6	FET	TX VCO
Q7	Transistor	TX/RX VCO switch
Q8	Transistor	Ripple filter
Q9,10	Transistor	VCO buffer AMP
Q11,12	FET	Assist filter control switch
Q300	Transistor	TX drive AMP
Q500	Transistor	RX 2nd local doubler AMP
Q501	Transistor	Discriminator control switch
Q502	Transistor	IF AMP
Q504	FET	RX 1st mixer
Q506	FET	Front-end LNA
Q507	Transistor	Discriminator control switch

Ref. No.	Part Name	Description
Q510	Transistor	Squelch input control switch
Q511	Transistor	Squelch input switch
Q701	FET	MIC mute switch
Q702	Transistor	MIC mute switch
Q703	Transistor	DET AMP LPF (D-SUB)
Q705	FET	Scrambler switch
Q707	Transistor	Ignition sense control switch
Q710	Transistor	Over voltage detect switch
Q711	Transistor	9R control switch
Q712	Transistor	9T control switch
Q713	Transistor	9R switch
Q714	Transistor	9T switch
Q715,723	FET	SP mute switch
Q717	FET	5C control switch
Q718	FET	3.3C control switch
Q719	Transistor	SB control switch
Q720	FET	SB switch
Q721	Transistor	AF AMP switch
Q722	Transistor	Over voltage detect switch
Q724	FET	Horn alert switch
Q725	Transistor	Horn alert control switch
Q728	Transistor	RS-232C RXD control
Q729	Transistor	PLL IC clock AMP
Q730	Transistor	BASEBAND IC clock AMP
Q731,732	Transistor	MCU clock AMP
D1	Diode	PLL unlock detection
D4~11	Variable capacitance diode	Frequency control (TX/RX VCO)
D12	Variable capacitance diode	Modulation control (TX VCO)
D300	Zener diode	Voltage protection
D301	Diode	TX power control
D302~305	Diode	ANT switch
D310,311	Zener diode	Voltage protection
D312	Diode	Reverse power rectifier
D313,314	Diode	Power rectifier
D500,501	Diode	W/N CF switch
D505,506,508~510	Variable capacitance diode	RF BPF tuning
D511	Variable capacitance diode	Front-end notch filter
D700~710	Diode	Surge protection
D711,712	Diode	MIC AMP AGC detection
D715	Zener diode	Voltage protection
D717	Surge absorber	Voltage protection
D718	Diode	Voltage protection
D719,720	Diode	TX/RX band switch

PARTS LIST

CAPACITORS

$\frac{C}{1} \frac{C}{2} \frac{45}{3} \frac{TH}{4} \frac{1H}{5} \frac{220}{6} \frac{J}{7}$

- 1 = Type ... ceramic, electrolytic, etc.
- 2 = Shape ... round, square, etc.
- 3 = Temp. coefficient
- 4 = Voltage rating
- 5 = Value
- 6 = Tolerance

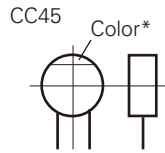

• Capacitor value

- 010 = 1pF
- 100 = 10pF
- 101 = 100pF
- 102 = 1000pF = 0.001μF
- 103 = 0.01μF

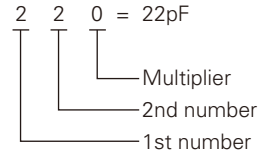

• Temperature coefficient

1st Word	C	L	P	R	S	T	U
Color*	Black	Red	Orange	Yellow	Green	Blue	Violet
ppm/°C	0	-80	-150	-220	-330	-470	-750

2nd Word	G	H	J	K	L
ppm/°C	±30	±60	±120	±250	±500

Example : CC45TH = -470±60ppm/°C

• Tolerance (More than 10pF)

Code	C	D	G	J	K	M	X	Z	P	No code
(%)	±0.25	±0.5	±2	±5	±10	±20	+40 -20	+80 -20	+100 -0	More than 10μF : -10~+50 Less than 4.7μF : -10~+75

(Less than 10pF)

Code	B	C	D	F	G
(pF)	±0.1	±0.25	±0.5	±1	±2

• Voltage rating

2nd word	A	B	C	D	E	F	G	H	J	K	V
0	1.0	1.25	1.6	2.0	2.5	3.15	4.0	5.0	6.3	8.0	-
1	10	12.5	16	20	25	31.5	40	50	63	80	35
2	100	125	160	200	250	315	400	500	630	800	-
3	1000	1250	1600	2000	2500	2150	4000	5000	6300	8000	-

• Chip capacitors

- (EX) $\frac{C}{1} \frac{C}{2} \frac{73}{3} \frac{F}{4} \frac{SL}{5} \frac{1H}{6} \frac{000}{7} \frac{J}{8}$ Refer to the table above.
- 1 = Type
 - 2 = Shape
 - 3 = Dimension
 - 4 = Temp. coefficient
 - 5 = Voltage rating
 - 6 = Value
 - 7 = Tolerance
- (Chip) (CH, RH, UJ, SL)
- (EX) $\frac{C}{1} \frac{K}{2} \frac{73}{3} \frac{F}{4} \frac{F}{5} \frac{1H}{6} \frac{000}{7} \frac{Z}{8}$
- (Chip) (B, F)

• Dimension

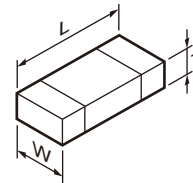

Chip capacitor

Code	L	W	T
Empty	5.6±0.5	5.0±0.5	Less than 2.0
A	4.5±0.5	3.2±0.4	Less than 2.0
B	4.5±0.5	2.0±0.3	Less than 2.0
C	4.5±0.5	1.25±0.2	Less than 1.25
D	3.2±0.4	2.5±0.3	Less than 1.5
E	3.2±0.2	1.6±0.2	Less than 1.25
F	2.0±0.3	1.25±0.2	Less than 1.25
G	1.6±0.2	0.8±0.2	Less than 1.0
H	1.0±0.05	0.5±0.05	0.5±0.05

Chip resistor

Code	L	W	T
E	3.2±0.2	1.6±0.2	1.0
F	2.0±0.3	1.25±0.2	1.0
G	1.6±0.2	0.8±0.2	0.5±0.1
H	1.0±0.05	0.5±0.05	0.35±0.05

RESISTORS

• Chip resistor (Carbon)

- (EX) $\frac{R}{1} \frac{D}{2} \frac{73}{3} \frac{E}{4} \frac{B}{5} \frac{2B}{6} \frac{000}{7} \frac{J}{8}$
- (Chip) (B, F)

• Carbon resistor (Normal type)

- (EX) $\frac{R}{1} \frac{D}{2} \frac{14}{3} \frac{B}{4} \frac{B}{5} \frac{2C}{6} \frac{000}{7} \frac{J}{8}$

- 1 = Type
- 2 = Shape
- 3 = Dimension
- 4 = Temp. coefficient
- 5 = Rating wattage
- 6 = Value
- 7 = Tolerance

• Rating wattage

Code	Wattage	Code	Wattage	Code	Wattage
1J	1/16W	2C	1/6W	3A	1W
2A	1/10W	2E	1/4W	3D	2W
2B	1/8W	2H	1/2W		

TK-8302/8302H

PARTS LIST

* New Parts. Δ indicates safety critical components.

Parts without **Parts No.** are not supplied.

Les articles non mentionnés dans le **Parts No.** ne sont pas fournis.

Teile ohne **Parts No.** werden nicht geliefert.

L : Scandinavia

Y : PX (Far East, Hawaii)

C : China

K : USA

T : England

X : Australia

P : Canada

E : Europe

M : Other Areas

TK-8302/8302H

DISPLAY UNIT (X54-3670-20), TX-RX UNIT (X57-7680-XX)

Ref. No.	Address	New parts	Parts No.	Description	Desti-nation
TK-8302/8302H					
1	1B	*	A02-4073-11	PLASTIC CABINET	
2	3A	*	A62-1171-03	PANEL ASSY	
4	2B	*	B09-0732-03	CAP (D-SUB)	
5	3A	*	B10-2794-03	FRONT GLASS	
6	3A	*	B43-1629-04	BADGE	
7	2D	*	B62-2150-10	INSTRUCTION MANUAL	M2
7	2D	*	B62-2167-10	INSTRUCTION MANUAL	HK2
9	2B		E04-0167-15	RF COAXIAL RECEPTACLE (M)	
10	1C		E30-7523-55	DC CORD ASSY ACCESSORY	
11	2B	*	E30-7684-05	DC CORD	
12	2A	*	E37-1461-05	FLAT CABLE (30P PANEL)	
14	1C		F52-0023-05	FUSE (BLADE TYPE) 10A ACCESSORY	M2
14	1C		F52-0024-05	FUSE (BLADE TYPE) 15A ACCESSORY	HK2
16	2B		G53-1643-04	PACKING (DC CORD)	
17	2B		G53-1662-04	PACKING (RECEPTACLE)	
18	1B	*	G53-1819-21	PACKING (CHASSIS)	
19	3A	*	G53-1820-03	PACKING (PANEL)	
21	1C,1D		H12-3178-05	PACKING FIXTURE	
22	2D	*	H52-2310-12	ITEM CARTON CASE	
24	3D		J19-1584-15	HOLDER (MIC HANGER)	HK2
25	3B	*	J19-5528-03	HOLDER (SPEAKER)	
26	1C		J29-0726-03	BRACKET ACCESSORY	
28	3A	*	K29-9448-01	KEY TOP	
A	1A,1B		N35-2604-43	BINDING HEAD MACHINE SCREW	
B	1A,2A,2B		N67-3008-48	PAN HEAD SEMS SCREW	
C	3A,3B		N80-2008-48	PAN HEAD TAPTITE SCREW	
D	2A,2B		N87-2608-48	BRAZIER HEAD TAPTITE SCREW	
30	3D		N99-2039-05	SCREW SET ACCESSORY	
32	3A	*	T07-0785-05	SPEAKER	
33	2C	*	T91-0624-65	MICROPHONE (KMC-30) ACCESSORY	HK2

Ref. No.	Address	New parts	Parts No.	Description	Desti-nation
CN1		*	E40-6851-05	FLAT CABLE CONNECTOR	
CN2			E23-1262-05	TERMINAL	
J1	3A	*	E58-0535-05	MODULAR JACK	
101	3A	*	J31-0565-15	COLLAR	
L1			L92-0138-05	CHIP FERRITE	
CP1			RK74HB1J102J	CHIP-COM 1.0K J 1/16W	
R1			RK73HB1J101J	CHIP R 100 J 1/16W	
R2			RK73FB2B100J	CHIP R 10 J 1/8W	
R3-8			RK73HB1J102J	CHIP R 1.0K J 1/16W	
R10,11			RK73HB1J102J	CHIP R 1.0K J 1/16W	
R12			RK73HB1J122J	CHIP R 1.2K J 1/16W	
R21			RK73HB1J222J	CHIP R 2.2K J 1/16W	
R22			RK73HB1J820J	CHIP R 82 J 1/16W	
R23			RK73HB1J121J	CHIP R 120 J 1/16W	
R26,27			RK73HB1J000J	CHIP R 0.0 J 1/16W	
R28,29			RK73HB1J103J	CHIP R 10K J 1/16W	
R34			RK73HB1J102J	CHIP R 1.0K J 1/16W	
R35			RK73HB1J223J	CHIP R 22K J 1/16W	
R36			RK73HB1J822J	CHIP R 8.2K J 1/16W	
R37,38			RK73HB1J100J	CHIP R 10 J 1/16W	
R39			RK73HB1J150J	CHIP R 15 J 1/16W	
R40			RK73HB1J100J	CHIP R 10 J 1/16W	
R41			RK73HB1J222J	CHIP R 2.2K J 1/16W	
R42			RK73HB1J102J	CHIP R 1.0K J 1/16W	
D20			DA221	DIODE	
D33			02DZ6.2F-Y	ZENER DIODE	
D37	3A	*	HDSP-521A	LED	
IC1		*	TCA62746AFNAG	MOS-IC	
Q1,2			RT1N441U	TRANSISTOR	
Q3			KRA225S	DIGITAL TRANSISTOR	
Q4			KRC102S-P	DIGITAL TRANSISTOR	
Q5,6			2SC3928A	TRANSISTOR	
Q7,8			RT1P141U	TRANSISTOR	
Q9			2SC3928A	TRANSISTOR	

DISPLAY UNIT (X54-3670-20)

D1-5			B30-2282-05	LED (Y)	
D22	3A	*	B30-2321-05	LED (BLUE LED)	
D23	3A		B30-2151-05	LED (RED/GREEN)	
C1			CK73HB1E103K	CHIP C 0.010UF K	
C8			CC73HCH1H101J	CHIP C 100PF J	
C9			CK73HB1H102K	CHIP C 1000PF K	
C10			CK73HB1E103K	CHIP C 0.010UF K	
C16			CK73HB1E103K	CHIP C 0.010UF K	
C27			CC73HCH1H101J	CHIP C 100PF J	
C29-36			CK73HB1H102K	CHIP C 1000PF K	
C38,39			CC73HCH1H101J	CHIP C 100PF J	
C40			CK73HB1H102K	CHIP C 1000PF K	
C41,42			CC73HCH1H101J	CHIP C 100PF J	
C43-46			CK73HB1H471K	CHIP C 470PF K	
C47			CK73HB1H102K	CHIP C 1000PF K	

TX-RX UNIT (X57-7680-XX) -15: HK2 -23: M2

C2			CC73HCH1H020B	CHIP C 2.0PF B	
C4			CC73HCH1H101J	CHIP C 100PF J	
C5			CK73HB1H471K	CHIP C 470PF K	
C7			CC73HCH1H101J	CHIP C 100PF J	
C8			CC73GCH1H101J	CHIP C 100PF J	
C10			CK73HB1A104K	CHIP C 0.10UF K	
C11			CC73HCH1H101J	CHIP C 100PF J	
C14			CC73HCH1H101J	CHIP C 100PF J	
C15			CC73HCH1H080B	CHIP C 8.0PF B	
C16			CK73HBOJ105K	CHIP C 1.0UF K	
C17,18			CK73HB1A104K	CHIP C 0.10UF K	
C19,20			CK73HB1E103K	CHIP C 0.010UF K	
C22			CK73FBOJ106K	CHIP C 10UF K	
C23			CK73HB1A104K	CHIP C 0.10UF K	
C24			CK73FBOJ106K	CHIP C 10UF K	

PARTS LIST

TX-RX UNIT (X57-7680-XX)

Ref. No.	Address	New parts	Parts No.	Description	Desti-nation	Ref. No.	Address	New parts	Parts No.	Description	Desti-nation
C26			CK73HB1C103K	CHIP C 0.010UF K		C315			CK73HB1C223K	CHIP C 0.022UF K	
C27			CK73HB1A104K	CHIP C 0.10UF K		C316			CC73HCH1H1R5B	CHIP C 1.5PF B	
C28			CC73HCH1H3R5B	CHIP C 3.5PF B		C320			CK73GB1H471K	CHIP C 470PF K	
C29			C92-0863-05	CHIP TNTL 0.047UF 35WV		C322			CK73GB1H271K	CHIP C 270PF K	
C32			CK73HB1H471K	CHIP C 470PF K		C333			CK73HB1H471K	CHIP C 470PF K	
C33			CC73HCH1H020B	CHIP C 2.0PF B		C336			CK73GB1H221K	CHIP C 220PF K	
C34			CC73HCH1H101J	CHIP C 100PF J		C338			CC73GCH1H220J	CHIP C 22PF J	
C35			CC73HCH1H3R5B	CHIP C 3.5PF B		C339			CK73GB1H102K	CHIP C 1000PF K	
C36			CK73GB1H102K	CHIP C 1000PF K		C340,341			CC73GCH1H101J	CHIP C 100PF J	
C37			CK73HB1H471K	CHIP C 470PF K		C342			CK73HB1A104K	CHIP C 0.10UF K	
C41			CC73HCH1H330J	CHIP C 33PF J		C344			CK73GB1H471K	CHIP C 470PF K	
C43			CS77CA1V0R1M	CHIP TNTL 0.1UF 35WV		C348			CC73GCH1H470J	CHIP C 47PF J	
C45			C92-0588-05	CHIP TNTL 1.5UF 16WV		C350			CC73GCH1H220J	CHIP C 22PF J	
C46			CK73HB1H471K	CHIP C 470PF K		C351			C93-0554-05	CHIP C 4.0PF C	
C48			C93-0787-05	CERAMIC 0.1UF 50WV		C353			C93-0552-05	CHIP C 2.0PF C	
C49			C92-0863-05	CHIP TNTL 0.047UF 35WV		C354			CK73HB1A104K	CHIP C 0.10UF K	
C52			CK73HB1H471K	CHIP C 470PF K		C355			CK73GB1H471K	CHIP C 470PF K	
C54			CC73HCH1H470J	CHIP C 47PF J		C360			CK73GB1H471K	CHIP C 470PF K	
C56			CC73HCH1H470J	CHIP C 47PF J		C361,362			CK73GB1H103K	CHIP C 0.010UF K	
C57,58			CK73HB1H471K	CHIP C 470PF K		C363			CC73GCH1H040B	CHIP C 4.0PF B	
C59			CK73FB0J106K	CHIP C 10UF K		C364			C93-0551-05	CHIP C 1.5PF C	M2
C61			CC73HCH1H120J	CHIP C 12PF J		C364			C93-0553-05	CHIP C 3.0PF C	HK2
C62			CC73HCH1H150J	CHIP C 15PF J		C365,366			C93-0603-05	CHIP C 1000PF K	
C63			CC73HCH1H101J	CHIP C 100PF J		C367			CC73GCH1H070B	CHIP C 7.0PF B	
C64			CC73HCH1H0R5B	CHIP C 0.5PF B		C368			CC73GCH1H270J	CHIP C 27PF J	
C65,66			CC73HCH1H101J	CHIP C 100PF J		C372			C93-0552-05	CHIP C 2.0PF C	HK2
C67,68			CK73GB1H471K	CHIP C 470PF K		C372			C93-0554-05	CHIP C 4.0PF C	M2
C69			CC73HCH1H050B	CHIP C 5.0PF B		C373			C93-0550-05	CHIP C 1.0PF C	
C70			CC73HCH1H2R5B	CHIP C 2.5PF B		C374			CM73F2H070D	CHIP C 7.0PF D	
C71,72			CK73GB1H471K	CHIP C 470PF K		C376			CK73GB1H102K	CHIP C 1000PF K	
C73			CC73HCH1H060B	CHIP C 6.0PF B		C381			C93-0551-05	CHIP C 1.5PF C	
C74			CC73HCH1H080B	CHIP C 8.0PF B		C383			C93-0553-05	CHIP C 3.0PF C	
C75			CC73HCH1H050B	CHIP C 5.0PF B		C384			CK73GB1H102K	CHIP C 1000PF K	
C76			CC73HCH1H060B	CHIP C 6.0PF B		C391,392			CK73HB1H471K	CHIP C 470PF K	
C77			CK73HB1H471K	CHIP C 470PF K		C500			CC73HCH1H470J	CHIP C 47PF J	
C78			CC73HCH1H0R3B	CHIP C 0.3PF B		C501			CC73HCH1H180J	CHIP C 18PF J	
C79			CC73HCH1H0R5B	CHIP C 0.5PF B		C503			CK73HB1H561K	CHIP C 560PF K	
C80		*	CS77BB21C100M	CHIP TNTL 10UF 16WV		C504			CK73HB1C103K	CHIP C 0.010UF K	
C81-83			CK73HB1H471K	CHIP C 470PF K		C505			CC73HCH1H300J	CHIP C 30PF J	
C84			CC73HCH1H060B	CHIP C 6.0PF B		C506			CC73HCH1H100B	CHIP C 10PF B	
C85			CC73HCH1H020B	CHIP C 2.0PF B		C508			CC73HCH1H270J	CHIP C 27PF J	
C86			CC73GCH1H020B	CHIP C 2.0PF B		C509			CK73HB1C103K	CHIP C 0.010UF K	
C87-89			CK73HB1H471K	CHIP C 470PF K		C510-515			CK73HB1A104K	CHIP C 0.10UF K	
C90			CC73GCH1H2R5B	CHIP C 2.5PF B		C516			CK73HB1H471K	CHIP C 470PF K	
C91			CK73HB1H471K	CHIP C 470PF K		C517			CK73HB1E103K	CHIP C 0.010UF K	
C92			CK73HB1C103K	CHIP C 0.010UF K		C518			CK73HB1H271K	CHIP C 270PF K	
C94			CK73HB1H471K	CHIP C 470PF K		C519			CK73FB0J106K	CHIP C 10UF K	
C95			CK73HB1A104K	CHIP C 0.10UF K		C520			CK73HB1H271K	CHIP C 270PF K	
C98			CK73GB1H471K	CHIP C 470PF K		C521,522			CK73HB1A104K	CHIP C 0.10UF K	
C99			CK73HB1H471K	CHIP C 470PF K		C523			CK73GB1C104K	CHIP C 0.10UF K	
C100			CC73HCH1H0R5B	CHIP C 0.5PF B		C524			CK73HB1H102K	CHIP C 1000PF K	
C102			CC73HCH1H050B	CHIP C 5.0PF B		C525			CK73GB0J475K	CHIP C 4.7UF K	
C300			CC73GCH1H150J	CHIP C 15PF J		C526			CK73HB1H102K	CHIP C 1000PF K	
C301			CC73HCH1H060B	CHIP C 6.0PF B		C527			CC73HCH1H680J	CHIP C 68PF J	
C302			CC73HCH1H110J	CHIP C 11PF J		C528			CC73GCH1H330J	CHIP C 33PF J	
C303			CC73HCH1H330J	CHIP C 33PF J		C529			CK73HB1E103K	CHIP C 0.010UF K	
C305			CK73HB1H471K	CHIP C 470PF K		C530			CK73HB1A104K	CHIP C 0.10UF K	
C307			CK73HB1H102K	CHIP C 1000PF K		C531			CK73HB1H471K	CHIP C 470PF K	
C313			CK73HB1H471K	CHIP C 470PF K		C535			CK73HB1H471K	CHIP C 470PF K	
C314			CC73HCH1H120J	CHIP C 12PF J		C538			CK73HB1E103K	CHIP C 0.010UF K	

HK2 : TK-8302HK2

M2 : TK-8302M2

PARTS LIST

TX-RX UNIT (X57-7680-XX)

Ref. No.	Address	New parts	Parts No.	Description	Destination	Ref. No.	Address	New parts	Parts No.	Description	Destination
C541			CK73HB1E103K	CHIP C 0.010UF K		C743			CK73HB1C333K	CHIP C 0.033UF K	
C543			CC73HCH1H010B	CHIP C 1.0PF B		C744			CK73HB1H471K	CHIP C 470PF K	
C545			CC73HCH1H180J	CHIP C 18PF J		C745			CK73HB1H271K	CHIP C 270PF K	
C546			CC73HCH1H030B	CHIP C 3.0PF B		C746			CK73FB0J106K	CHIP C 10UF K	
C550			CK73HB1E103K	CHIP C 0.010UF K		C747			CK73HB1A104K	CHIP C 0.10UF K	
C551			CK73GB1A334K	CHIP C 0.33UF K		C748			CC73HCH1H680J	CHIP C 68PF J	
C553			CK73HB1A104K	CHIP C 0.10UF K		C749,750			CK73HB1A104K	CHIP C 0.10UF K	
C554			CC73HCH1H040B	CHIP C 4.0PF B		C751			CC73HCH1H820J	CHIP C 82PF J	
C555			CK73HB1H471K	CHIP C 470PF K		C753			CK73GB0J106K	CHIP C 10UF K	
C556			CC73HCH1H150G	CHIP C 15PF G		C754,755			CK73HB1A104K	CHIP C 0.10UF K	
C557			CK73HB1E103K	CHIP C 0.010UF K		C756			CC73HCH1H391J	CHIP C 390PF J	
C558			CK73HB1H471K	CHIP C 470PF K		C758			CK73HB1H471K	CHIP C 470PF K	
C559			CK73GB1H471K	CHIP C 470PF K		C760			CK73HB0J105K	CHIP C 1.0UF K	
C560,561			CK73HB1H471K	CHIP C 470PF K		C762,763			CK73HB1A104K	CHIP C 0.10UF K	
C562			CK73HB1E103K	CHIP C 0.010UF K		C764			CK73HB1E103K	CHIP C 0.010UF K	
C563-565			CK73HB1H471K	CHIP C 470PF K		C765			CK73GB0J106K	CHIP C 10UF K	
C569			CK73HB1H471K	CHIP C 470PF K		C767			CK73GB1C104K	CHIP C 0.10UF K	
C570			CC73HCH1H680J	CHIP C 68PF J		C768			CK73GB1H471K	CHIP C 470PF K	
C571			CC73HCH1H030B	CHIP C 3.0PF B		C769			CK73HB0J105K	CHIP C 1.0UF K	
C572			CC73HCH1H010B	CHIP C 1.0PF B		C770			CK73FB0J106K	CHIP C 10UF K	
C573			CC73HCH1H040B	CHIP C 4.0PF B		C771			CC73HCH1H101J	CHIP C 100PF J	
C574			CC73HCH1H680J	CHIP C 68PF J		C772			CK73HB0J105K	CHIP C 1.0UF K	
C575			CC73HCH1H020B	CHIP C 2.0PF B		C773			CC73HCH1H101J	CHIP C 100PF J	
C576			CK73HB1H102K	CHIP C 1000PF K		C774			CK73HB0J105K	CHIP C 1.0UF K	
C577			CC73HCH1H010B	CHIP C 1.0PF B		C775			CC73HCH1H391J	CHIP C 390PF J	
C578			CC73HCH1H680J	CHIP C 68PF J		C777			CK73HB0J105K	CHIP C 1.0UF K	
C581			CC73HCH1H030B	CHIP C 3.0PF B		C778			CK73HB1E562K	CHIP C 5600PF K	
C582,583			CK73HB1H471K	CHIP C 470PF K		C779			CK73HB1E103K	CHIP C 0.010UF K	
C585			CK73HB1A104K	CHIP C 0.10UF K		C780			CK73HB1A683K	CHIP C 0.068UF K	
C586			CK73HB1H471K	CHIP C 470PF K		C784			CK73GB0J106K	CHIP C 10UF K	
C587			CK73GB1A105K	CHIP C 1.0UF K		C785			CK73HB1H102K	CHIP C 1000PF K	
C588-591			CK73HB1H471K	CHIP C 470PF K		C787			CK73HB1H332K	CHIP C 3300PF K	
C592			CC73GCH1H471J	CHIP C 470PF J		C788			CK73HB1A683K	CHIP C 0.068UF K	
C593			CC73HCH1H2R5B	CHIP C 2.5PF B		C790			CK73GB1H102K	CHIP C 1000PF K	
C594			CC73HCH1H470J	CHIP C 47PF J		C792-794			CK73HB1H471K	CHIP C 470PF K	
C595			CC73HCH1H040B	CHIP C 4.0PF B		C795			CK73GB1H102K	CHIP C 1000PF K	
C596			CK73HB1H102K	CHIP C 1000PF K		C796			CK73HB0J105K	CHIP C 1.0UF K	
C597			CC73HCH1H050B	CHIP C 5.0PF B		C797			CK73HB1H102K	CHIP C 1000PF K	
C598			CC73HCH1H470J	CHIP C 47PF J		C807			CK73HB1H102K	CHIP C 1000PF K	
C599			CC73HCH1H050B	CHIP C 5.0PF B		C808			CK73HB1A105K	CHIP C 1.0UF K	
C601			CC73HCH1H200G	CHIP C 20PF G		C809			CK73GB1C104K	CHIP C 0.10UF K	
C603			CC73HCH1H080B	CHIP C 8.0PF B		C810			CK73GB1H102K	CHIP C 1000PF K	
C604			CC73HCH1H050B	CHIP C 5.0PF B		C813,814			CK73HB1H102K	CHIP C 1000PF K	
C606			CK73HB1H471K	CHIP C 470PF K		C816			CK73HB1A104K	CHIP C 0.10UF K	
C700-709			CK73HB1H471K	CHIP C 470PF K		C817			CK73HB1E103K	CHIP C 0.010UF K	
C711			CK73HB1H471K	CHIP C 470PF K		C819			CS77AB21C220M	CHIP TNTL 22UF 16WV	
C713			CK73HB1H471K	CHIP C 470PF K		C820			CK73HB1H102K	CHIP C 1000PF K	
C715			CK73HB1H471K	CHIP C 470PF K		C821			CK73GB1A105K	CHIP C 1.0UF K	
C717			CK73HB1H471K	CHIP C 470PF K		C822			CK73HB0J105K	CHIP C 1.0UF K	
C719			CK73HB1H471K	CHIP C 470PF K		C824			CS77AB21C220M	CHIP TNTL 22UF 16WV	
C721			CK73HB1H471K	CHIP C 470PF K		C825			CK73HB1A104K	CHIP C 0.10UF K	
C723			CK73HB1H471K	CHIP C 470PF K		C828,829			CK73HB1A104K	CHIP C 0.10UF K	
C725			CK73HB1H471K	CHIP C 470PF K		C831			CK73HB1A104K	CHIP C 0.10UF K	
C727			CK73HB1H471K	CHIP C 470PF K		C832			CK73GB1A224K	CHIP C 0.22UF K	
C729			CK73HB1H471K	CHIP C 470PF K		C833			CK73HB1H102K	CHIP C 1000PF K	
C731,732			CK73HB1H471K	CHIP C 470PF K		C835			CK73GB1H102K	CHIP C 1000PF K	
C735			CK73HB1A104K	CHIP C 0.10UF K		C837,838			CK73HB1H102K	CHIP C 1000PF K	
C736			CK73GB0J475K	CHIP C 4.7UF K		C839			CS77AB21C4R7M	CHIP TNTL 4.7UF 16WV	
C739			CK73GB1C104K	CHIP C 0.10UF K		C840			CK73GB1H102K	CHIP C 1000PF K	
C740			CK73HB1A104K	CHIP C 0.10UF K		C841			CK73GB1A105K	CHIP C 1.0UF K	

PARTS LIST

TX-RX UNIT (X57-7680-XX)

Ref. No.	Address	New parts	Parts No.	Description	Desti-nation	Ref. No.	Address	New parts	Parts No.	Description	Desti-nation
C842			CS77AA1A100M	CHIP TNTL 10UF 10WV		C939			CK73HB1A104K	CHIP C 0.10UF K	
C843			C92-0873-05	ELECTRO 47UF 16WV		C940			CK73FB0J106K	CHIP C 10UF K	
C844			CK73HB1H102K	CHIP C 1000PF K		C941			CK73HB1H471K	CHIP C 470PF K	
C845			CK73HB1E103K	CHIP C 0.010UF K		C945			CK73GB1H471K	CHIP C 470PF K	
C846			CK73GB1H102K	CHIP C 1000PF K		C947			CK73HB1H471K	CHIP C 470PF K	
C847			CK73HB1H102K	CHIP C 1000PF K		C949			CC73HCH1H2R5B	CHIP C 2.5PF B	
C849		*	C92-0716-05	ELECTRO 220UF 16WV		C950			CC73HCH1H101J	CHIP C 100PF J	
C850			CK73GB1H102K	CHIP C 1000PF K		C952			CC73GCH1H220J	CHIP C 22PF J	
C851			CK73GB1A105K	CHIP C 1.0UF K		C953			CK73FB1E225K	CHIP C 2.2UF K	
C852			CK73HB1E103K	CHIP C 0.010UF K		C954,955			CK73HB1H102K	CHIP C 1000PF K	
C853,854			CK73HB1H102K	CHIP C 1000PF K		C956			CK73HB1H471K	CHIP C 470PF K	
C855			CK73GB1H102K	CHIP C 1000PF K		C957			CK73EB1E106K	CHIP C 10UF K	
C856			CK73HB1A104K	CHIP C 0.10UF K		C958			CK73HB0J105K	CHIP C 1.0UF K	
C857			CC73HCH1H220J	CHIP C 22PF J		CN702			E40-5932-05	SOCKET FOR PIN ASSY	
C858			CK73GB1H221K	CHIP C 220PF K		CN724		*	E40-6847-05	FLAT CABLE CONNECTOR	
C859			CC73HCH1H470J	CHIP C 47PF J		CN751			E23-1262-05	TERMINAL	
C860			CC73HCH1H101J	CHIP C 100PF J		J700	1B	*	E58-0536-05	SUB SOCKET (D)	
C861			CK73GB1H471K	CHIP C 470PF K		J701	2A	*	E11-0425-05	3.5D PHONE JACK (3P)	
C862			CK73HB1H102K	CHIP C 1000PF K		F700			F53-0327-05	FUSE (4A)	
C863			CC73HCH1H220J	CHIP C 22PF J		CD500			L79-1866-05	TUNING COIL	
C864			CC73GCH1H470J	CHIP C 47PF J		CF500			L72-0993-05	CERAMIC FILTER	
C865			CC73HCH1H220J	CHIP C 22PF J		CF501			L72-0959-05	CERAMIC FILTER	
C866			CK73GB1H102K	CHIP C 1000PF K		L2			L41-4791-08	SMALL FIXED INDUCTOR (4.7NH)	
C867			CK73GB1H471K	CHIP C 470PF K		L3			L92-0442-05	CHIP FERRITE	
C868			CK73HB1A334K	CHIP C 0.33UF K		L4			L92-0443-05	CHIP FERRITE	
C869			CK73GB1H221K	CHIP C 220PF K		L5,6			L40-2785-92	SMALL FIXED INDUCTOR (270NH)	
C870			CK73HB1H102K	CHIP C 1000PF K		L7			L92-0163-05	BEADS CORE	
C871			CC73HCH1H010B	CHIP C 1.0PF B		L9			L92-0163-05	BEADS CORE	
C874			CK73GB0J105K	CHIP C 1.0UF K		L11-16			L40-2285-92	SMALL FIXED INDUCTOR (220NH)	
C875-877			CK73HB0J105K	CHIP C 1.0UF K		L17			L92-0443-05	CHIP FERRITE	
C878			CC73HCH1H100D	CHIP C 10PF D		L18,19			L41-2778-14	SMALL FIXED INDUCTOR (27NH)	
C879			CC73HCH1H040B	CHIP C 4.0PF B		L20			L40-2702-86	SMALL FIXED INDUCTOR (27UH)	
C880			CK73HB1H102K	CHIP C 1000PF K		L23			L40-2785-92	SMALL FIXED INDUCTOR (270NH)	
C881			CK73HB0J105K	CHIP C 1.0UF K		L24			L92-0443-05	CHIP FERRITE	
C882			CK73GB1A105K	CHIP C 1.0UF K		L25			L40-3375-71	SMALL FIXED INDUCTOR (33NH)	
C883			CK73HB1A224K	CHIP C 0.22UF K		L26			L40-3975-71	SMALL FIXED INDUCTOR (39NH)	
C884		*	C92-0716-05	ELECTRO 220UF 16WV		L34			L40-2702-86	SMALL FIXED INDUCTOR (27UH)	
C885,886			CK73GB1H102K	CHIP C 1000PF K		L39			L40-1575-71	SMALL FIXED INDUCTOR (15NH)	
C887			CK73HB1H471K	CHIP C 470PF K		L300			L40-6865-71	SMALL FIXED INDUCTOR (6.8NH)	
C889-891			CK73HB1H471K	CHIP C 470PF K		L301			L40-4768-71	SMALL FIXED INDUCTOR (4.7NH)	
C898			CK73HB1H471K	CHIP C 470PF K		L302			L40-8265-92	SMALL FIXED INDUCTOR (8.2NH)	
C915			CK73HB1H471K	CHIP C 470PF K		L303			L40-2775-92	SMALL FIXED INDUCTOR (27NH)	
C917			CC73HCH1H200J	CHIP C 20PF J		L304			L40-1275-92	SMALL FIXED INDUCTOR (12NH)	M2
C918			CC73HCH1H121J	CHIP C 120PF J		L304,305			L40-1275-92	SMALL FIXED INDUCTOR (12NH)	HK2
C919			CC73HCH1H150J	CHIP C 15PF J		L305			L40-1875-92	SMALL FIXED INDUCTOR (18NH)	M2
C920			CK73HB1E103K	CHIP C 0.010UF K		L308-310			L92-0179-05	CHIP FERRITE	
C921			CK73GB1A105K	CHIP C 1.0UF K		L311			L34-1039-05	AIR-CORE COIL	
C922			CK73HB1H102K	CHIP C 1000PF K		L312		*	L34-4902-05	AIR-CORE COIL	
C923			CK73HB1A104K	CHIP C 0.10UF K		L313-315			L34-1039-05	AIR-CORE COIL	
C924,925			CK73HB0J105K	CHIP C 1.0UF K		L316		*	L34-4902-05	AIR-CORE COIL	
C926,927			CK73HB1H102K	CHIP C 1000PF K		L501			L40-4781-86	SMALL FIXED INDUCTOR (0.47UH)	
C928			CK73HB1A104K	CHIP C 0.10UF K		L502			L40-3381-86	SMALL FIXED INDUCTOR (0.33UH)	
C929			CK73HB1H102K	CHIP C 1000PF K		L503			L40-5681-86	SMALL FIXED INDUCTOR (0.56UH)	
C930			CK73HB1A104K	CHIP C 0.10UF K		L504			L40-1875-71	SMALL FIXED INDUCTOR (18NH)	
C931			CK73HB1H102K	CHIP C 1000PF K		L505,506			L41-4785-39	SMALL FIXED INDUCTOR (0.47UH)	
C932			CK73HB1A104K	CHIP C 0.10UF K		L507			L40-1875-71	SMALL FIXED INDUCTOR (18NH)	
C933			CK73HB1H471K	CHIP C 470PF K		L511-513			L41-6868-14	SMALL FIXED INDUCTOR (6.8NH)	
C936			CC73HCH1H020B	CHIP C 2.0PF B		L514		*	L41-2788-45	SMALL FIXED INDUCTOR (270NH)	
C937			CK73HB1E103K	CHIP C 0.010UF K		L515			L40-1875-92	SMALL FIXED INDUCTOR (18NH)	
C938			CK73HB1H471K	CHIP C 470PF K							

HK2 : TK-8302HK2

M2 : TK-8302M2

PARTS LIST

TX-RX UNIT (X57-7680-XX)

Ref. No.	Address	New parts	Parts No.	Description	Destination	Ref. No.	Address	New parts	Parts No.	Description	Destination
L517,518			L41-6868-14	SMALL FIXED INDUCTOR (6.8NH)		R75-78			RK73HB1J000J	CHIP R 0.0 J 1/16W	
L519			L41-8275-45	SMALL FIXED INDUCTOR (82NH)		R81			RK73HB1J000J	CHIP R 0.0 J 1/16W	
L700			L92-0443-05	CHIP FERRITE		R83			RK73FB2B102J	CHIP R 1.0K J 1/8W	
L702			L92-0443-05	CHIP FERRITE		R303			RK73HB1J472J	CHIP R 4.7K J 1/16W	
L705			L40-1575-71	SMALL FIXED INDUCTOR (15NH)		R306			RK73HB1J223J	CHIP R 22K J 1/16W	
L709			L92-0161-05	BEADS CORE		R321			RK73GB2A151J	CHIP R 150 J 1/10W	
L710			L40-2785-92	SMALL FIXED INDUCTOR (270NH)		R323			RK73GB2A390J	CHIP R 39 J 1/10W	
X1		*	L77-3055-05	TCXO (19.2MHZ)		R324			RK73GB2A000J	CHIP R 0.0 J 1/10W	
XF500		*	L71-0659-05	MCF (38.85MHZ)		R325			RK73GB2A151J	CHIP R 150 J 1/10W	
						R327			RK73HB1J101J	CHIP R 100 J 1/16W	
CP700-702			RK75HA1J102J	CHIP-COM 1.0K J 1/16W		R329			RK73GB2A470J	CHIP R 47 J 1/10W	
CP704-706			RK75HA1J102J	CHIP-COM 1.0K J 1/16W		R330			RK73HB1J000J	CHIP R 0.0 J 1/16W	
R3			RK73HB1J823J	CHIP R 82K J 1/16W		R331			RK73HB1J224J	CHIP R 220K J 1/16W	
R5-7			RK73HB1J102J	CHIP R 1.0K J 1/16W		R333,334			RK73HB1J103J	CHIP R 10K J 1/16W	
R8			RK73HB1J152J	CHIP R 1.5K J 1/16W		R336			RK73HB1J000J	CHIP R 0.0 J 1/16W	
R10			RK73HB1J100J	CHIP R 10 J 1/16W		R338			RK73HB1J183J	CHIP R 18K J 1/16W	M2
R12			RK73HB1J100J	CHIP R 10 J 1/16W		R338			RK73HB1J223J	CHIP R 22K J 1/16W	HK2
R15			RK73HB1J473J	CHIP R 47K J 1/16W		R341			RK73HB1J000J	CHIP R 0.0 J 1/16W	
R20			RK73HB1J102J	CHIP R 1.0K J 1/16W		R342			RK73HB1J104J	CHIP R 100K J 1/16W	
R21			RK73HB1J182J	CHIP R 1.8K J 1/16W		R343			RK73HB1J000J	CHIP R 0.0 J 1/16W	
R22			RK73HB1J000J	CHIP R 0.0 J 1/16W		R345			RK73HB1J104J	CHIP R 100K J 1/16W	
R23			RK73HB1J223J	CHIP R 22K J 1/16W		R346			RK73HB1J473J	CHIP R 47K J 1/16W	
R25			RK73HB1J000J	CHIP R 0.0 J 1/16W		R347			RK73GH2A201D	CHIP R 200 D 1/10W	
R26			RK73HB1J153J	CHIP R 15K J 1/16W		R348			RK73HB1J104J	CHIP R 100K J 1/16W	
R27,28			RK73HB1J000J	CHIP R 0.0 J 1/16W		R349			RK73HB1J000J	CHIP R 0.0 J 1/16W	
R29			RK73HB1J181J	CHIP R 180 J 1/16W		R352			RK73GH2A201D	CHIP R 200 D 1/10W	
R30			RK73HB1J000J	CHIP R 0.0 J 1/16W		R353			RK73RB2H101J	CHIP R 100 J 1/2W	
R31			RK73HB1J225J	CHIP R 2.2M J 1/16W		R354,355			RK73GB2A000J	CHIP R 0.0 J 1/10W	
R32,33			RK73HB1J000J	CHIP R 0.0 J 1/16W		R357,358			RK73GB2A000J	CHIP R 0.0 J 1/10W	
R34			RK73HB1J272J	CHIP R 2.7K J 1/16W		R361			RK73GH2A121D	CHIP R 120 D 1/10W	
R35			RK73HB1J102J	CHIP R 1.0K J 1/16W		R367			RK73GH2A181D	CHIP R 180 D 1/10W	
R36			RK73HB1J154J	CHIP R 150K J 1/16W		R369,370			RK73HB1J104J	CHIP R 100K J 1/16W	
R37			RK73HB1J103J	CHIP R 10K J 1/16W		R374	2B		R92-1061-05	JUMPER REST 0 OHM	
R38			RK73HB1J000J	CHIP R 0.0 J 1/16W		R375			RK73HB1J104J	CHIP R 100K J 1/16W	
R39			RK73HB1J473J	CHIP R 47K J 1/16W		R376			RK73HB1J103J	CHIP R 10K J 1/16W	
R40			RK73HB1J000J	CHIP R 0.0 J 1/16W		R381			RK73GB2A102J	CHIP R 1.0K J 1/10W	
R41			RK73HB1J393J	CHIP R 39K J 1/16W		R382-384			RK73HB1J000J	CHIP R 0.0 J 1/16W	
R43			RK73HB1J393J	CHIP R 39K J 1/16W		R387,388			RK73HB1J104J	CHIP R 100K J 1/16W	
R45			RK73HB1J473J	CHIP R 47K J 1/16W		R500			RK73HB1J122J	CHIP R 1.2K J 1/16W	
R46,47			RK73HB1J391J	CHIP R 390 J 1/16W		R501			RK73HB1J334J	CHIP R 330K J 1/16W	
R48			RK73GB2A104J	CHIP R 100K J 1/10W		R502			RK73HB1J101J	CHIP R 100 J 1/16W	
R49			RK73HB1J472J	CHIP R 4.7K J 1/16W		R503-508			RK73HB1J103J	CHIP R 10K J 1/16W	
R50			RK73HB1J680J	CHIP R 68 J 1/16W		R509			RK73GB2A100J	CHIP R 10 J 1/10W	
R51			RK73HB1J101J	CHIP R 100 J 1/16W		R510			RK73HB1J272J	CHIP R 2.7K J 1/16W	
R52			RK73HB1J102J	CHIP R 1.0K J 1/16W		R511			RK73HB1J394J	CHIP R 390K J 1/16W	
R53			RK73HB1J124J	CHIP R 120K J 1/16W		R512			RK73HB1J272J	CHIP R 2.7K J 1/16W	
R54			RK73HB1J000J	CHIP R 0.0 J 1/16W		R513			RK73HB1J394J	CHIP R 390K J 1/16W	
R55			RK73HB1J101J	CHIP R 100 J 1/16W		R515			RK73GB2A472J	CHIP R 4.7K J 1/10W	
R57			RK73HB1J473J	CHIP R 47K J 1/16W		R517			RK73HB1J000J	CHIP R 0.0 J 1/16W	
R58			RK73HB1J100J	CHIP R 10 J 1/16W		R519			RK73HB1J392J	CHIP R 3.9K J 1/16W	
R59			RK73HB1J101J	CHIP R 100 J 1/16W		R520			RK73HB1J272J	CHIP R 2.7K J 1/16W	
R60			RK73HB1J391J	CHIP R 390 J 1/16W		R522			RK73HB1J000J	CHIP R 0.0 J 1/16W	
R61			RK73HB1J000J	CHIP R 0.0 J 1/16W		R524			RK73HB1J101J	CHIP R 100 J 1/16W	
R62			RK73HB1J222J	CHIP R 2.2K J 1/16W		R525			RK73HB1J000J	CHIP R 0.0 J 1/16W	
R63			RK73HB1J472J	CHIP R 4.7K J 1/16W		R527			RK73HB1J224J	CHIP R 220K J 1/16W	
R64			RK73GB2A472J	CHIP R 4.7K J 1/10W		R528			RK73HB1J000J	CHIP R 0.0 J 1/16W	
R65			RK73HB1J103J	CHIP R 10K J 1/16W		R530			RK73HB1J391J	CHIP R 390 J 1/16W	
R68,69			RK73HB1J000J	CHIP R 0.0 J 1/16W		R531			RK73HB1J000J	CHIP R 0.0 J 1/16W	
R73			RK73HB1J000J	CHIP R 0.0 J 1/16W		R532			RK73GB2A000J	CHIP R 0.0 J 1/10W	
R74			RK73HB1J560J	CHIP R 56 J 1/16W		R533			RK73HB1J000J	CHIP R 0.0 J 1/16W	

PARTS LIST

TX-RX UNIT (X57-7680-XX)

Ref. No.	Address	New parts	Parts No.	Description	Desti-nation	Ref. No.	Address	New parts	Parts No.	Description	Desti-nation
R534			RK73HB1J391J	CHIP R 390 J 1/16W		R737			RK73HB1J273J	CHIP R 27K J 1/16W	
R537			RK73HB1J104J	CHIP R 100K J 1/16W		R738			RK73HB1J562J	CHIP R 5.6K J 1/16W	
R539			RK73HB1J470J	CHIP R 47 J 1/16W		R739			RK73HB1J000J	CHIP R 0.0 J 1/16W	
R543,544			RK73HB1J823J	CHIP R 82K J 1/16W		R741			RK73HB1J563J	CHIP R 56K J 1/16W	
R545			RK73HB1J224J	CHIP R 220K J 1/16W		R742			RK73HB1J000J	CHIP R 0.0 J 1/16W	
R546			RK73HB1J684J	CHIP R 680K J 1/16W		R743			RK73HB1J104J	CHIP R 100K J 1/16W	
R547			RK73HB1J151J	CHIP R 150 J 1/16W		R747			RK73HB1J000J	CHIP R 0.0 J 1/16W	
R548			RK73HB1J394J	CHIP R 390K J 1/16W		R748			RK73HB1J104J	CHIP R 100K J 1/16W	
R549			RK73HB1J154J	CHIP R 150K J 1/16W		R749			RK73GB2A000J	CHIP R 0.0 J 1/10W	
R550			RK73HB1J270J	CHIP R 27 J 1/16W		R751			RK73HB1J104J	CHIP R 100K J 1/16W	
R553			RK73HB1J000J	CHIP R 0.0 J 1/16W		R752			RK73HB1J101J	CHIP R 100 J 1/16W	
R554			RK73HB1J105J	CHIP R 1.0M J 1/16W		R753			RK73GB2A104J	CHIP R 100K J 1/10W	
R560			RK73HB1J000J	CHIP R 0.0 J 1/16W		R754			RK73HB1J104J	CHIP R 100K J 1/16W	
R562			RK73HB1J270J	CHIP R 27 J 1/16W		R755			RK73HB1J101J	CHIP R 100 J 1/16W	
R563			RK73HB1J000J	CHIP R 0.0 J 1/16W		R756			RK73HB1J104J	CHIP R 100K J 1/16W	
R564			RK73HB1J223J	CHIP R 22K J 1/16W		R758			RK73HB1J000J	CHIP R 0.0 J 1/16W	
R565			RK73HB1J221J	CHIP R 220 J 1/16W		R759			RK73HB1J154J	CHIP R 150K J 1/16W	
R566			RK73HB1J104J	CHIP R 100K J 1/16W		R760			RK73HB1J104J	CHIP R 100K J 1/16W	
R567			RK73HB1J564J	CHIP R 560K J 1/16W		R761			RK73HB1J101J	CHIP R 100 J 1/16W	
R568			RK73HB1J223J	CHIP R 22K J 1/16W		R762			RK73HB1J104J	CHIP R 100K J 1/16W	
R569			RK73HB1J823J	CHIP R 82K J 1/16W		R763			RK73HB1J101J	CHIP R 100 J 1/16W	
R570			RK73HB1J683J	CHIP R 68K J 1/16W		R764			RK73HB1J682J	CHIP R 6.8K J 1/16W	
R572			RK73HB1J000J	CHIP R 0.0 J 1/16W		R765			RK73HB1J000J	CHIP R 0.0 J 1/16W	
R573,574			RK73HB1J223J	CHIP R 22K J 1/16W		R766			RK73HB1J682J	CHIP R 6.8K J 1/16W	
R576			RK73HB1J000J	CHIP R 0.0 J 1/16W		R767			RK73HB1J393J	CHIP R 39K J 1/16W	
R577			RK73FB2B000J	CHIP R 0.0 J 1/8W		R770			RK73GB2A000J	CHIP R 0.0 J 1/10W	
R579			RK73HB1J104J	CHIP R 100K J 1/16W		R771			RK73HB1J000J	CHIP R 0.0 J 1/16W	
R580			RK73GB2A000J	CHIP R 0.0 J 1/10W		R773			RK73HB1J562J	CHIP R 5.6K J 1/16W	
R589			RK73HB1J000J	CHIP R 0.0 J 1/16W		R774			RK73HB1J222J	CHIP R 2.2K J 1/16W	
R590			RK73HB1J823J	CHIP R 82K J 1/16W		R775			RK73HB1J154J	CHIP R 150K J 1/16W	
R591			RK73HB1J000J	CHIP R 0.0 J 1/16W		R776			RK73HB1J103J	CHIP R 10K J 1/16W	
R701			RK73HB1J000J	CHIP R 0.0 J 1/16W		R778,779			RK73HB1J473J	CHIP R 47K J 1/16W	
R703			RK73HB1J000J	CHIP R 0.0 J 1/16W		R780			RK73HB1J222J	CHIP R 2.2K J 1/16W	
R704			RK73HB1J102J	CHIP R 1.0K J 1/16W		R781			RK73HB1J104J	CHIP R 100K J 1/16W	
R705			RK73HB1J681J	CHIP R 680 J 1/16W		R782			RK73HB1J102J	CHIP R 1.0K J 1/16W	
R708			RK73HB1J472J	CHIP R 4.7K J 1/16W		R783			RK73HB1J473J	CHIP R 47K J 1/16W	
R709			RK73HB1J561J	CHIP R 560 J 1/16W		R784			RK73HB1J104J	CHIP R 100K J 1/16W	
R710			RK73GB2A124J	CHIP R 120K J 1/10W		R785			RK73HB1J105J	CHIP R 1.0M J 1/16W	
R711			RK73HB1J821J	CHIP R 820 J 1/16W		R786			RK73GB2A102J	CHIP R 1.0K J 1/10W	
R712			RK73HB1J561J	CHIP R 560 J 1/16W		R787			RK73HB1J153J	CHIP R 15K J 1/16W	
R713			RK73HB1J104J	CHIP R 100K J 1/16W		R789			RK73GB2A472J	CHIP R 4.7K J 1/10W	
R714,715			RK73HB1J223J	CHIP R 22K J 1/16W		R790			RK73HB1J123J	CHIP R 12K J 1/16W	
R716			RK73HB1J000J	CHIP R 0.0 J 1/16W		R791			RK73HB1J102J	CHIP R 1.0K J 1/16W	
R717			RK73GB2A000J	CHIP R 0.0 J 1/10W		R792			RK73GH2A134D	CHIP R 130K D 1/10W	
R718			RK73HB1J563J	CHIP R 56K J 1/16W		R793			RK73GH2A183D	CHIP R 18K D 1/10W	
R719			RK73HB1J000J	CHIP R 0.0 J 1/16W		R794-797			RK73HB1J102J	CHIP R 1.0K J 1/16W	
R720			RK73HB1J101J	CHIP R 100 J 1/16W		R798			RK73GB2A000J	CHIP R 0.0 J 1/10W	
R722			RK73HB1J222J	CHIP R 2.2K J 1/16W		R799-801			RK73HB1J102J	CHIP R 1.0K J 1/16W	
R723			RK73HB1J334J	CHIP R 330K J 1/16W		R802			RK73HB1J000J	CHIP R 0.0 J 1/16W	
R724			RK73HB1J000J	CHIP R 0.0 J 1/16W		R803			RK73HB1J103J	CHIP R 10K J 1/16W	
R725,726			RK73HH1J473D	CHIP R 47K D 1/16W		R806-808			RK73HB1J000J	CHIP R 0.0 J 1/16W	
R727			RK73HB1J473J	CHIP R 47K J 1/16W		R811			RK73HB1J102J	CHIP R 1.0K J 1/16W	
R728			RK73HB1J000J	CHIP R 0.0 J 1/16W		R812			RK73HB1J473J	CHIP R 47K J 1/16W	
R729			RK73HB1J104J	CHIP R 100K J 1/16W		R815			RK73HB1J102J	CHIP R 1.0K J 1/16W	
R730			RK73HB1J000J	CHIP R 0.0 J 1/16W		R817-819			RK73HB1J000J	CHIP R 0.0 J 1/16W	
R731			RK73HB1J104J	CHIP R 100K J 1/16W		R820			RK73HB1J473J	CHIP R 47K J 1/16W	
R732			RK73HB1J102J	CHIP R 1.0K J 1/16W		R821			RK73HB1J471J	CHIP R 470 J 1/16W	
R733			RK73HB1J103J	CHIP R 10K J 1/16W		R823			RK73GB2A102J	CHIP R 1.0K J 1/10W	
R734,735			RK73HB1J102J	CHIP R 1.0K J 1/16W		R824			RK73HB1J152J	CHIP R 1.5K J 1/16W	
R736			RK73GB2A000J	CHIP R 0.0 J 1/10W		R825			RK73HB1J473J	CHIP R 47K J 1/16W	

HK2 : TK-8302HK2

M2 : TK-8302M2

PARTS LIST

TX-RX UNIT (X57-7680-XX)

Ref. No.	Address	New parts	Parts No.	Description	Destination	Ref. No.	Address	New parts	Parts No.	Description	Destination
R826			RK73HB1J223J	CHIP R 22K J 1/16W		R957			RK73HB1J563J	CHIP R 56K J 1/16W	
R827			RK73HB1J473J	CHIP R 47K J 1/16W		R958			RK73HB1J561J	CHIP R 560 J 1/16W	
R829			RK73HB1J000J	CHIP R 0.0 J 1/16W		R959			RK73HB1J184J	CHIP R 180K J 1/16W	
R831,832			RK73HB1J000J	CHIP R 0.0 J 1/16W		R960			RK73HB1J222J	CHIP R 2.2K J 1/16W	
R833-835			RK73HB1J103J	CHIP R 10K J 1/16W		R961			RK73HB1J184J	CHIP R 180K J 1/16W	
R836			RK73HB1J472J	CHIP R 4.7K J 1/16W		R962			RK73HB1J152J	CHIP R 1.5K J 1/16W	
R837			RK73HB1J152J	CHIP R 1.5K J 1/16W		R963,964			RK73GH2A101D	CHIP R 100 D 1/10W	
R838			RK73HB1J472J	CHIP R 4.7K J 1/16W		R965			RK73HB1J473J	CHIP R 47K J 1/16W	
R839			RK73HB1J473J	CHIP R 47K J 1/16W		R967			RK73HB1J000J	CHIP R 0.0 J 1/16W	
R840			RK73HB1J683J	CHIP R 68K J 1/16W		R968			RK73HB1J104J	CHIP R 100K J 1/16W	
R841			RK73HB1J473J	CHIP R 47K J 1/16W		R971			RK73HB1J000J	CHIP R 0.0 J 1/16W	
R842			RK73HB1J823J	CHIP R 82K J 1/16W		R972			RK73HB1J102J	CHIP R 1.0K J 1/16W	
R843			RK73HB1J222J	CHIP R 2.2K J 1/16W		R973,974			RK73HB1J100J	CHIP R 10 J 1/16W	
R845			RK73HB1J102J	CHIP R 1.0K J 1/16W		R975,976			RK73HB1J471J	CHIP R 470 J 1/16W	
R846			RK73GB2A221J	CHIP R 220 J 1/10W		R977,978			RK73HB1J473J	CHIP R 47K J 1/16W	
R847			RK73HB1J391J	CHIP R 390 J 1/16W		R979-998			RK73HB1J000J	CHIP R 0.0 J 1/16W	
R848			RK73GB2A473J	CHIP R 47K J 1/10W		R999			RK73HB1J473J	CHIP R 47K J 1/16W	
R849			RK73FB2B000J	CHIP R 0.0 J 1/8W		D1	*	1SS389-F	DIODE		
R850			RK73GB2A334J	CHIP R 330K J 1/10W		D4-11		1SV325F	VARIABLE CAPACITANCE DIODE		
R851			RK73HB1J474J	CHIP R 470K J 1/16W		D12		1SV278F	VARIABLE CAPACITANCE DIODE		
R852			RK73HB1J564J	CHIP R 560K J 1/16W		D300		UDZW5.1(B)	ZENER DIODE		
R853			RK73HB1J000J	CHIP R 0.0 J 1/16W		D301		1SS355	DIODE		
R854			RK73GB2A104J	CHIP R 100K J 1/10W		D302,303		L407CDB	DIODE (50V/1W)		
R855			RK73HB1J101J	CHIP R 100 J 1/16W		D304,305		L7091CER	DIODE		
R856			RK73HB1J000J	CHIP R 0.0 J 1/16W		D310,311		UDZW3.3(B)	ZENER DIODE		
R857			RK73HB1J102J	CHIP R 1.0K J 1/16W		D312		HSC277	DIODE		
R858			RK73HB1J332J	CHIP R 3.3K J 1/16W		D313,314	*	HSB88AS-E	DIODE		M2
R859-863			RK73HB1J000J	CHIP R 0.0 J 1/16W		D313,314		MA3J742	DIODE		HK2
R867,868			RK73HB1J000J	CHIP R 0.0 J 1/16W		D500,501		MC2858	DIODE		
R869			RK73HB1J104J	CHIP R 100K J 1/16W		D505,506		1SV305F	VARIABLE CAPACITANCE DIODE		
R870,871			RK73HB1J000J	CHIP R 0.0 J 1/16W		D508-510		1SV305F	VARIABLE CAPACITANCE DIODE		
R873-876			RK73HB1J000J	CHIP R 0.0 J 1/16W		D511		HVC369B	VARIABLE CAPACITANCE DIODE		
R877			RK73HB1J473J	CHIP R 47K J 1/16W		D700-710		DA221	DIODE		
R878,879			RK73HB1J105J	CHIP R 1.0M J 1/16W		D711		MC2858	DIODE		
R880,881			RK73HB1J104J	CHIP R 100K J 1/16W		D712		1SS372F	DIODE		
R882			RK73HB1J823J	CHIP R 82K J 1/16W		D715		UDZW18(B)	ZENER DIODE		
R884			RK73HB1J472J	CHIP R 4.7K J 1/16W		D717		Z5W27V	SURGE ABSORBER		
R885			RK73HB1J683J	CHIP R 68K J 1/16W		D718		MA2S111-F	DIODE		
R886			RK73HB1J823J	CHIP R 82K J 1/16W		D719,720		HVC131	DIODE		
R887			RK73FB2B000J	CHIP R 0.0 J 1/8W		IC1		MB15E03SL-E1	MOS-IC		
R888			RK73GB2A473J	CHIP R 47K J 1/10W		IC2	*	BD7542FVM	MOS-IC		
R889			RK73GB2A221J	CHIP R 220 J 1/10W		IC300	*	HA17358BFEL-E	MOS-IC		
R890			RK73HB1J102J	CHIP R 1.0K J 1/16W		IC301	2B	RA60H40471101	MOS-IC		HK2
R891-893			RK73HB1J000J	CHIP R 0.0 J 1/16W		IC301	2B	S-AU83AL	MOS-IC		M2
R894,895			RK73HB1J102J	CHIP R 1.0K J 1/16W		IC500		TA31136FNG	MOS-IC		
R896			RK73GB2A000J	CHIP R 0.0 J 1/10W		IC501	*	HA17358BFEL-E	MOS-IC		
R899			RK73HB1J000J	CHIP R 0.0 J 1/16W		IC700		NJM2100V-ZB	MOS-IC		
R928,929			RK73HB1J472J	CHIP R 4.7K J 1/16W		IC701	*	CD686Q3	MOS-IC		
R930			RK73HB1J223J	CHIP R 22K J 1/16W		IC702	*	F364AEDFBKUCB	MICROCONTROLLER IC		
R931			RK73HB1J103J	CHIP R 10K J 1/16W		IC703	*	EX24064ASAS0A	ROM IC		
R932			RK73HB1J000J	CHIP R 0.0 J 1/16W		IC704	*	TA4809BF	ANALOGUE IC		
R933			RK73GB2A000J	CHIP R 0.0 J 1/10W	M2	IC705	2A	LA4600	BI-POLAR IC		
R934			RK73GB2A000J	CHIP R 0.0 J 1/10W	HK2	IC706	*	XC6221B332NR	MOS-IC		
R935			RK73HB1J473J	CHIP R 47K J 1/16W		IC707		TA7805FQ	MOS-IC		
R938			RK73HB1J473J	CHIP R 47K J 1/16W		IC708		BD4740G	MOS-IC		
R939,940			RK73GB2A000J	CHIP R 0.0 J 1/10W		IC709	*	XC6120N402N1	MOS-IC		
R950			RK73HB1J473J	CHIP R 47K J 1/16W		IC710	*	XC6221B332NR	MOS-IC		
R951,952			RK73GB2A000J	CHIP R 0.0 J 1/10W		Q3		2SC5108(Y)F	TRANSISTOR		
R955			RK73HB1J563J	CHIP R 56K J 1/16W		Q4	*	MCH3914(7)-H	FET		
R956			RK73HB1J561J	CHIP R 560 J 1/16W							

PARTS LIST

TX-RX UNIT (X57-7680-XX)

Ref. No.	Address	New parts	Parts No.	Description	Destination	Ref. No.	Address	New parts	Parts No.	Description	Destination
Q5			2SJ347F	FET							
Q6		*	MCH3914(7)-H	FET							
Q7			KRX102U	TRANSISTOR							
Q8			KTC4075E(Y,GR)	TRANSISTOR							
Q9,10			2SC5108(Y)F	TRANSISTOR							
Q11			SSM3J05FU-F	FET							
Q12			2SK1830F	FET							
Q300			RD00HVS1-T113	FET							
Q500			2SC5108(Y)F	TRANSISTOR							
Q501			RT1P441U	TRANSISTOR							
Q502			2SC5108(Y)F	TRANSISTOR							
Q504			3SK318	FET							
Q506			3SK318	FET							
Q507			RT1N441U	TRANSISTOR							
Q510			RT1N441U	TRANSISTOR							
Q511			KTC4075E(Y,GR)	TRANSISTOR							
Q701			2SK1830F	FET							
Q702			2SC4919	TRANSISTOR							
Q703			KTC4075E(Y,GR)	TRANSISTOR							
Q705			SSM3J05FU-F	FET							
Q707			KRC414RTK	DIGITAL TRANSISTOR							
Q710-712			RT1N441U	TRANSISTOR							
Q713,714			2SB1694	TRANSISTOR							
Q715			SSM3K05FU	FET							
Q717,718			SSM3J05FU-F	FET							
Q719			KTC4075E(Y,GR)	TRANSISTOR							
Q720			2SJ645	FET							
Q721			RT1N441U	TRANSISTOR							
Q722			KTC4075E(Y,GR)	TRANSISTOR							
Q723			SSM3K05FU	FET							
Q724			2SJ645	FET							
Q725			KTC4075E(Y,GR)	TRANSISTOR							
Q728			2SC4116(Y)F	TRANSISTOR							
Q729,730			KTC4075E(Y,GR)	TRANSISTOR							
Q731,732			2SC5108(Y)F	TRANSISTOR							
TH300-302			B57331V2104J	THERMISTOR							
TH501		*	NCP18WM224JOS	THERMISTOR							

TK-8302/8302H

EXPLODED VIEW

- | | | |
|---|-------------------|---------------|
| A | M2.6 x 4 (Bi) | : N35-2604-43 |
| B | M3 x 8 | : N67-3008-48 |
| C | M2 x 8 | : N80-2008-48 |
| D | M2.6 x 8 (Br-Tap) | : N87-2608-48 |

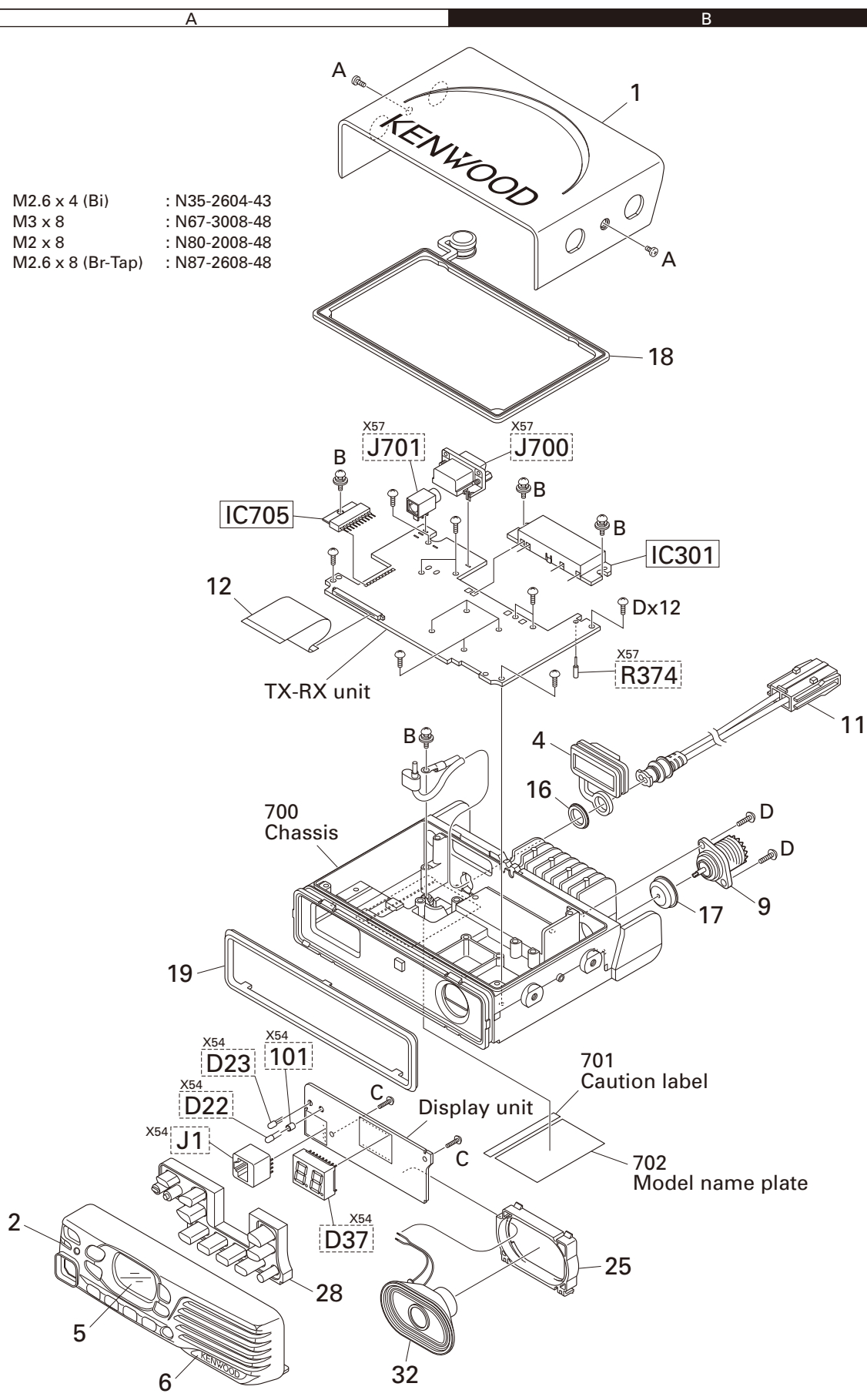

26 Parts with the exploded numbers larger than 700 are not supplied.
 If a part reference number is listed in a box on the exploded view of the PCB, that part does not come with the PCB.
 These parts must be ordered separately.

PACKING

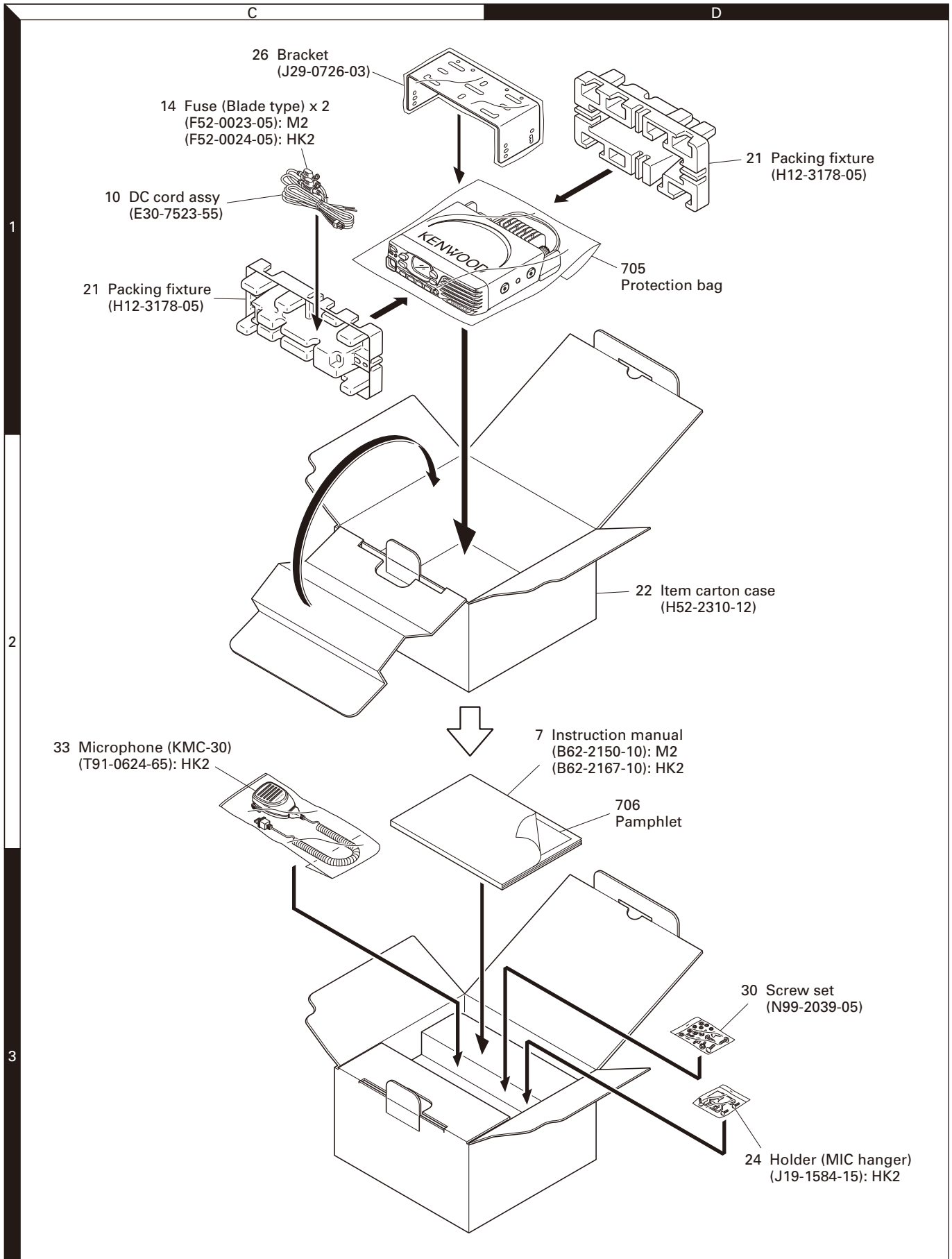

Parts with the exploded numbers larger than 700 are not supplied.

ADJUSTMENT

Test Equipment Required for Alignment

Test Equipment	Major Specifications	
1. Standard Signal Generator (SSG)	Frequency Range Modulation Output	400 to 520MHz Frequency modulation and external modulation -127dBm/0.1μV to greater than -7dBm/100mV
2. Power Meter	Input Impedance Operation Frequency Measurement Range	50Ω 400 to 520MHz or more Vicinity of 100W
3. Deviation Meter	Frequency Range	400 to 520MHz
4. Digital Volt Meter (DVM)	Measuring Range Input Impedance	1 to 20V DC High input impedance for minimum circuit loading
5. Oscilloscope		DC through 30MHz
6. High Sensitivity Frequency Counter	Frequency Range Frequency Stability	10Hz to 1000MHz 0.2ppm or less
7. Ammeter		20A or more
8. AF Volt Meter (AF VTVM)	Frequency Range Voltage Range	50Hz to 10kHz 1mV to 3V
9. Audio Generator (AG)	Frequency Range Output	20Hz to 20kHz or more 0 to 1V
10. Distortion Meter	Capability Input Level	3% or less at 1kHz 50mV to 10Vrms
11. 4Ω Dummy Load		Approx. 4Ω, 10W or more
12. Regulated Power Supply		13.6V, approx. 20A (adjustable from 9 to 17V) Useful if ammeter equipped
13. Spectrum Analyzer	Center Frequency	50kHz to 600MHz
14. Tracking Generator	Output Voltage	100mV or more

Test cable for microphone input (E30-3360-28)

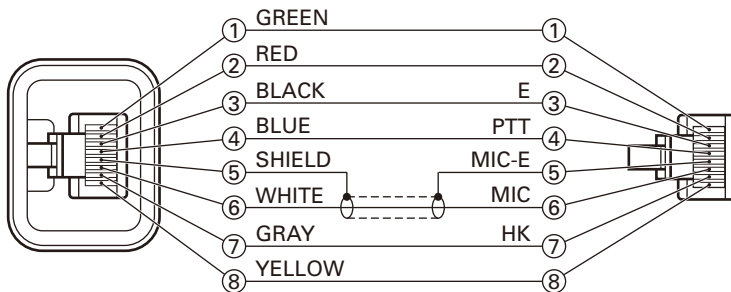

MIC connector (Front panel view)

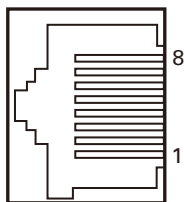

- 1 : MBL
- 2 : SB
- 3 : GND
- 4 : PTT
- 5 : ME
- 6 : MIC
- 7 : HOOK
- 8 : DM

Tuning cable (E30-3383-05)

Adapter cable (E30-3383-05) is required for injecting an audio if PC tuning is used.
See "PC Mode" section for the connection.

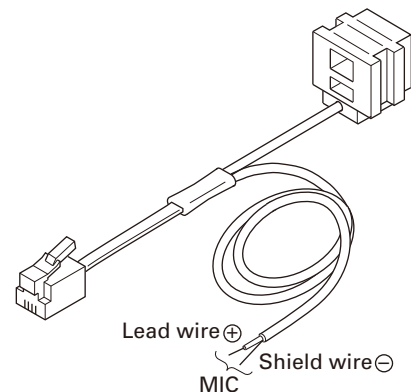

ADJUSTMENT

Test Frequency

Channel	RX (MHz)	TX (MHz)
1	435.05	435.10
2	400.05	400.10
3	469.95	469.90
4	435.00	435.00
5	435.20	435.20
6	435.40	435.40

Test Signaling

	RX	TX
1	None	None
2	None	20Hz Square wave
3	QT: 67.0Hz	QT: 67.0Hz
4	QT: 151.4Hz	QT: 151.4Hz
5	QT: 210.7Hz	QT: 210.7Hz
6	QT: 254.1Hz	QT: 254.1Hz
7	DQT: D023N	DQT: D023N
8	DQT: D754I	DQT: D754I
9	DTMF: 159D	DTMF: 159D
10	None	DTMF Code 9
11	None	MSK (1010..)
12	FleetSync: 100-1000	Fleet Sync: 100-1000
13	None	Single Tone : 1000Hz
14	2-Tone A: 304.7Hz, B: 3106.0Hz	2-Tone A: 304.7Hz, B: 3106.0Hz
15	None	DTMF Tone: 1477Hz
16	Single Tone: 979.9Hz	Single Tone: 979.9Hz
17	None	MSK PN9

Single or 5 Reference Level Adjustment Frequency

Tuning point	RX (MHz)	TX (MHz)
Low	400.05	400.10
Low'	417.55	417.50
Center	435.05	435.10
High'	452.55	452.50
High	469.95	469.90

Adjustment Points

■ Component side

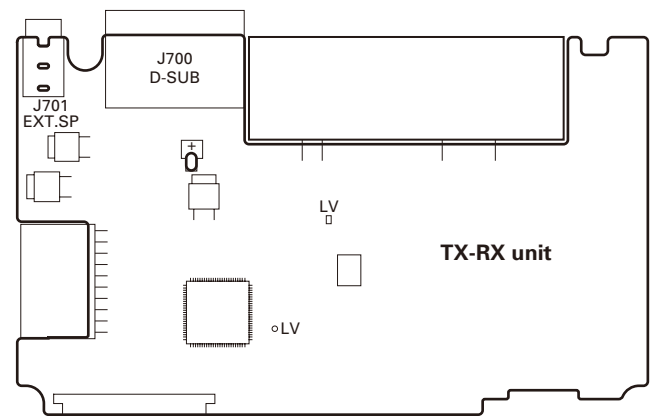

■ Foil side

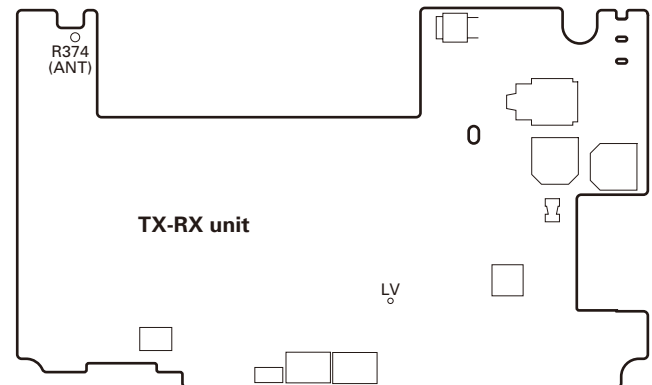

TK-8302/8302H

ADJUSTMENT

Common Section

Item	Condition	Measurement			Adjustment			Specifications / Remarks
		Test-equipment	Unit	Terminal	Unit	Parts	Method	
1. Setting	1) Power supply voltage DC power supply terminal : 13.6V							
2. Rx Assist (Auto)	1) CH: RX low CH: RX low' CH: RX center CH: RX high' CH: RX high					FPU	"Voltage Level" indicator on the PC window shows VCO lock voltage. Change the adjust- ment value to get VCO lock voltage within the limit of the specified volt- age. Note: Confirm the VCO lock voltage approxi- mately 3 seconds after the adjustment value is changed.	2.5V±0.2V
3. Tx Assist (Auto)	1) CH: TX low CH: TX low' CH: TX center CH: TX high' CH: TX high 2) Transmit							
4. VCO lock voltage • RX • TX	1) CH: RX low CH: RX low' CH: RX center CH: RX high' CH: RX high	Power meter DVM	TX-RX	LV			Check	2.5V±0.2V
	2) CH: TX low CH: TX low' CH: TX center CH: TX high' CH: TX high 3) Transmit							

Transmitter Section

Item	Condition	Measurement			Adjustment			Specifications / Remarks
		Test-equipment	Unit	Terminal	Unit	Parts	Method	
1. Frequency (Narrow)	1) TEST CH: TX center 2) Transmit	Frequency counter		ANT		FPU	Adjust to center frequency	Within ±100Hz
2. High Power (Auto) (Narrow) • TK-8302 • TK-8302H	1) CH: TX low CH: TX low' CH: TX center CH: TX high' CH: TX high 2) Transmit	Power meter Ammeter					25W	±1.0W 8.0A or less
							low, low', center, high': 45W high: 40W	±2.0W 14.0A or less

ADJUSTMENT

Item	Condition	Measurement			Adjustment			Specifications / Remarks
		Test-equipment	Unit	Terminal	Unit	Parts	Method	
3. Low Power (Auto) (Narrow) • TK-8302 • TK-8302H	1) CH: TX low CH: TX low' CH: TX center CH: TX high' CH: TX high 2) Transmit	Power meter Ammeter		ANT		FPU	5W	±0.5W 4.0A or less
							25W	±1.0W 8.0A or less
4. DQT Balance (Wide)	1) CH: TX low CH: TX low' CH: TX center CH: TX high' CH: TX high 2) Deviation meter filter LPF: 3kHz HPF: OFF 3) Transmit	Deviation meter					The Deviation of 20Hz frequency is fixed. (FL=30, FLC=35, FC=40, FCH=45, FH=50) Change the 1kHz adjustment value to become the same deviation of 20Hz within the specified range.	±0.4dB
5. Maximum Deviation (Wide)	1) CH: TX low CH: TX low' CH: TX center CH: TX high' CH: TX high 2) Deviation meter filter LPF: 15kHz HPF: OFF 3) Transmit	Deviation meter Oscilloscope AG AF VTVM		ANT			4.4kHz (According to the large +, -)	±0.1kHz Note: FPU auto input 1kHz/50mV
6. MIC sensitivity	1) CH: TX center AG: 1kHz/5mV 2) Deviation meter filter LPF: 15kHz 3) Transmit			ANT MIC			Check	2.2kHz~3.6kHz
7. DQT Deviation (Wide)	1) CH: TX center 2) Deviation meter filter LPF: 3kHz HPF: OFF 3) Transmit			ANT		FPU	0.75kHz	±0.05kHz
8. QT Deviation (Wide)	1) CH: TX center 2) Deviation meter filter LPF: 3kHz HPF: OFF 3) Transmit						0.75kHz	±0.05kHz
9. DTMF Deviation (Wide)	1) CH: TX center 2) Deviation meter filter LPF: 15kHz HPF: OFF 3) Transmit						3.0kHz	±0.1kHz
10. MSK Deviation (Wide)	1) CH: TX center 2) Deviation meter filter LPF: 15kHz HPF: OFF 3) Transmit						3.0kHz	±0.1kHz

ADJUSTMENT

Receiver Section

Item	Condition	Measurement			Adjustment			Specifications / Remarks
		Test-equipment	Unit	Terminal	Unit	Parts	Method	
1. RX Sensitivity (Semi-auto)	1) CH: RX low (Wide) CH: RX low' (Wide) CH: RX center (Wide) CH: RX high' (Wide) CH: RX high (Wide) 2) SSG output: -90dBm (7.08μV) Mod: 1kHz Dev: ±3.0kHz	SSG Oscilloscope AF VTVM Distortion meter		ANT Ext.SP		FPU	Auto tuning	
2. Squelch open (5) (Wide)	1) CH: RX low CH: RX low' CH: RX center CH: RX high' CH: RX high 2) SSG output: -120dBm (0.22μV) Mod: 1kHz Dev: ±3.0kHz						Adjust to open the squelch.	Squelch open
(Narrow)	1) CH: RX low CH: RX low' CH: RX center CH: RX high' CH: RX high 2) SSG output: -120dBm (0.22μV) Mod: 1kHz Dev: ±1.5kHz							
3. Squelch tight (Wide)	1) CH: RX low CH: RX low' CH: RX center CH: RX high' CH: RX high 2) SSG output: -115dBm (0.4μV) Mod: 1kHz Dev: ±3.0kHz							
(Narrow)	1) CH: RX low CH: RX low' CH: RX center CH: RX high' CH: RX high 2) SSG output: -115dBm (0.4μV) Mod: 1kHz Dev: ±1.5kHz							
4. Low RSSI (Wide)	1) CH: RX low CH: RX low' CH: RX center CH: RX high' CH: RX high 2) SSG output: -120dBm (0.22μV) Mod: 1kHz Dev: ±3.0kHz						Auto tuning	

ADJUSTMENT

Item	Condition	Measurement			Adjustment			Specifications / Remarks
		Test-equipment	Unit	Terminal	Unit	Parts	Method	
Low RSSI (Narrow)	1) CH: RX low CH: RX low' CH: RX center CH: RX high' CH: RX high 2) SSG output: -120dBm (0.22μV) Mod: 1kHz Dev: ±1.5kHz	SSG Oscillo- scope AF VTVM Distortion meter		ANT Ext.SP		FPU	Auto tuning	
5. High RSSI (Wide)	1) CH: RX low CH: RX low' CH: RX center CH: RX high' CH: RX high 2) SSG output: -80dBm (22.4μV) Mod: 1kHz Dev: ±3.0kHz							
(Narrow)	1) CH: RX low CH: RX low' CH: RX center CH: RX high' CH: RX high 2) SSG output: -80dBm (22.4μV) Mod: 1kHz Dev: ±1.5kHz							

TERMINAL FUNCTION

Display unit (X54-3670-20)

Pin No.	Name	I/O	Function
CN1			
1	POWER	O	Detection output of power switch
2	MKEY	I/O	MIC data detection
3	PTT/TXD	I/O	PTT/PC serial data
4	HOOK/RXD	I/O	HOOK/PC serial data
5	ME	-	MIC ground
6	MIC	O	MIC signal output
7	GND	-	Ground
8	NC	-	No connection
9	LELH	I	LED latch input
10	LECL	I	LED clock input
11	LECE	I	LED enable input
12	LEDI	I	LED data input
13	5C	I	5V DC power supply
14	KMI3	O	Key matrix output 3
15	KMI2	O	Key matrix output 2
16	KMI1	O	Key matrix output 1
17	KMO3	I	Key matrix input 3
18	KMO2	I	Key matrix input 2
19	KMO1	I	Key matrix input 1
20	BLED	I	Blue LED control signal input
21	GLED	I	Green LED control signal input
22	RLED	I	Red LED control signal input
23	MBL	I	MIC backlight control signal input
24	LEDM	I	LED dimmer input
25	SP-	I	Speaker input -
26	SP-	I	Speaker input -
27	SP+	I	Speaker input +
28	SP+	I	Speaker input +
29	SB	I	Battery voltage DC supply
30	SB	I	Battery voltage DC supply
J1 (MIC jack)			
1	MBL	O	Backlight of Microphone
2	SB	O	DC Power output
3	GND	-	Ground
4	PTT	I	PTT/ PC serial data from radio
5	ME	-	MIC ground
6	MIC	I	MIC signal input
7	HOOK	I	HOOK/ PC serial data to radio
8	DM	I/O	MIC data detection

TX-RX unit (X57-7680-XX)

Pin No.	Name	I/O	Function
CN702			
1	GND	-	Ground
2	9C	O	9V DC power supply
3	FNC5	I/O	Programmable I/O (programmed by FPU)
4	FNC6	I/O	Programmable I/O (programmed by FPU)
5	FNC2	I/O	Programmable I/O (programmed by FPU)
6	FNC7	I/O	Programmable I/O (programmed by FPU)
7	FNC8	I/O	Programmable I/O (programmed by FPU)
8	FNC3	I/O	Programmable I/O (programmed by FPU)
9	FNC1	I/O	Programmable I/O (programmed by FPU)
10	NC	-	No connection
11	5C	O	5V DC power supply
12	TXAFO	O	TX audio output to scrambler board
13	DATAI	I	External transmit signal input
14	DETO	O	FM detector output
15	NC	-	No connection
16	ALTI	I	External alert tone signal input
17	TXAFI	I	TX audio input from scrambler board
18	RXAFO	O	RX audio output to scrambler board
19	RXAFI	I	RX audio input from scrambler board
20	FNC4	I/O	Programmable I/O (programmed by FPU)
CN724			
1	SB	O	Battery voltage DC supply
2	SB	O	Battery voltage DC supply
3	SP+	O	Speaker output +
4	SP+	O	Speaker output +
5	SP-	O	Speaker output -
6	SP-	O	Speaker output -
7	LEDM	O	LED dimmer output
8	MBL	O	MIC backlight control signal output
9	RLED	O	Red LED control signal output
10	GLED	O	Green LED control signal output
11	BLED	O	Blue LED control signal output
12	KMO1	O	Key matrix output 1
13	KMO2	O	Key matrix output 2
14	KMO3	O	Key matrix output 3
15	KMI1	I	Key matrix input 1
16	KMI2	I	Key matrix input 2
17	KMI3	I	Key matrix input 3
18	5C	O	5V DC power supply

TERMINAL FUNCTION

Pin No.	Name	I/O	Function
19	LEDI	O	LED data output
20	LECE	O	LED enable output
21	LECL	O	LED clock output
22	LELH	O	LED latch output
23	LERE	O	LED reset output
24	GND	-	Ground
25	MIC	I	MIC signal input
26	ME	-	MIC ground
27	HOOK/RXD	I/O	HOOK/PC serial data
28	PTT/TXD	I/O	PTT/PC serial data
29	MKEY	I/O	MIC data detection
30	POWER	I	Detection input of power switch
J700 (ACC 15-pin)			
1	SB	O	Battery voltage DC supply
2	IGN	I	Ignition sense input
3	PA	O	Speaker output
4	DO	O	FM detector output
5	DI	I	External transmit signal input
6	FNC1	I/O	Programmable I/O (programmed by FPU)
7	FNC2	I/O	Programmable I/O (programmed by FPU)
8	FNC3	I/O	Programmable I/O (programmed by FPU)
9	FNC4	I/O	Programmable I/O (programmed by FPU)
10	FNC5	I/O	Programmable I/O (programmed by FPU)
11	FNC6	I/O	Programmable I/O (programmed by FPU)
12	5C	O	5V DC power supply
13	HR1	O	Horn alert signal output
14	HR2	O	Horn alert signal output
15	GND	-	Ground

Function Port Assignment

	Scrambler	
	Name	I/O
FNC1	None	I
FNC2	None	I
FNC3	TXS	O
FNC4	Scrambler	O
FNC5	Scrambler code 1(1)	O
FNC6	Scrambler code 2(2)	O
FNC7	Scrambler code 3(4)	O
FNC8	Scrambler code 4(8)	O
GPS (NMEA)		
	Name	I/O
FNC1	None	O
FNC2	GPS (NMEA input)	I
FNC3	-	-
FNC4	-	-
FNC5	-	-
FNC6	-	-
FNC7	-	-
FNC8	-	-

TK-8302/8302H PC BOARD

DISPLAY UNIT (X54-3670-20) Component side view (J79-0249-19)

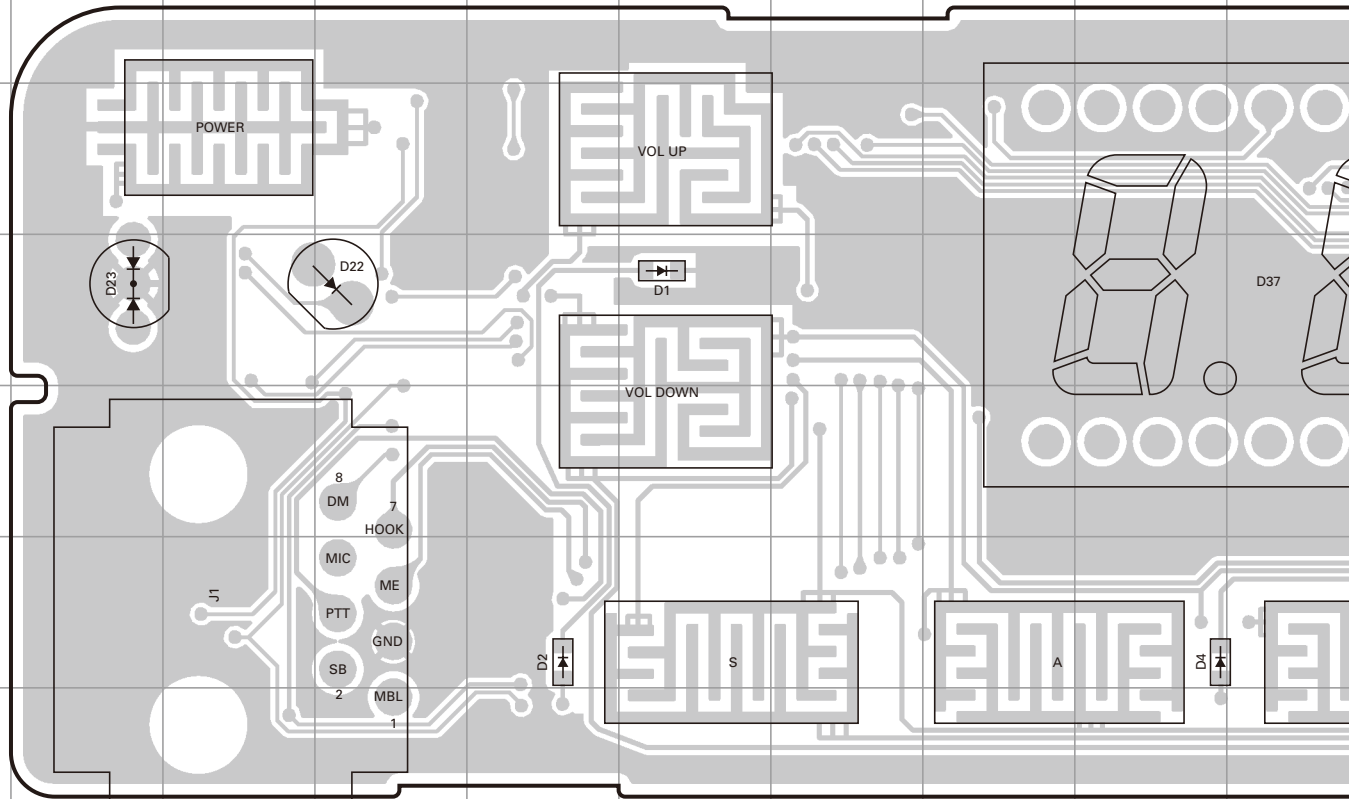

DISPLAY UNIT (X54-3670-20) Foil side view (J79-0249-19)

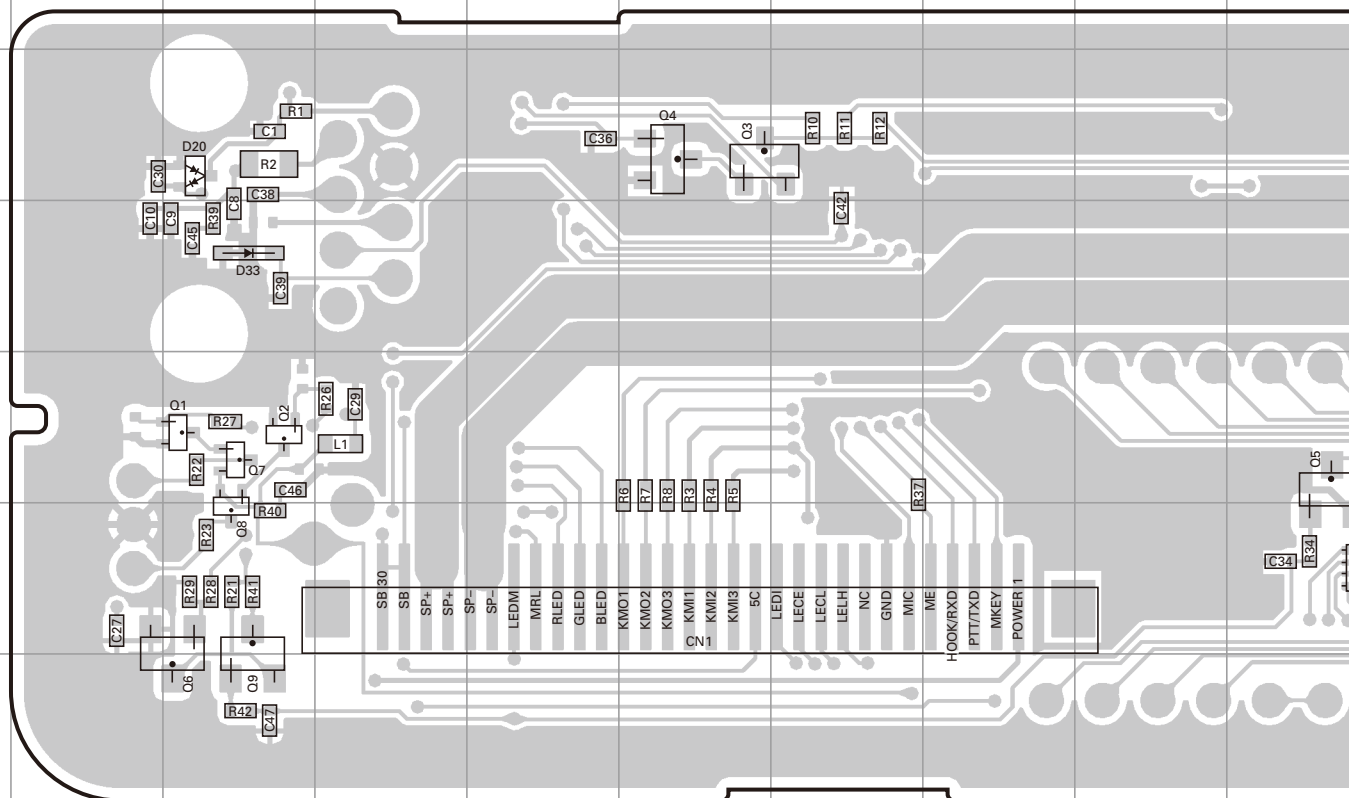

PC BOARD TK-8302/8302H

DISPLAY UNIT (X54-3670-20) Component side view (J79-0249-19)

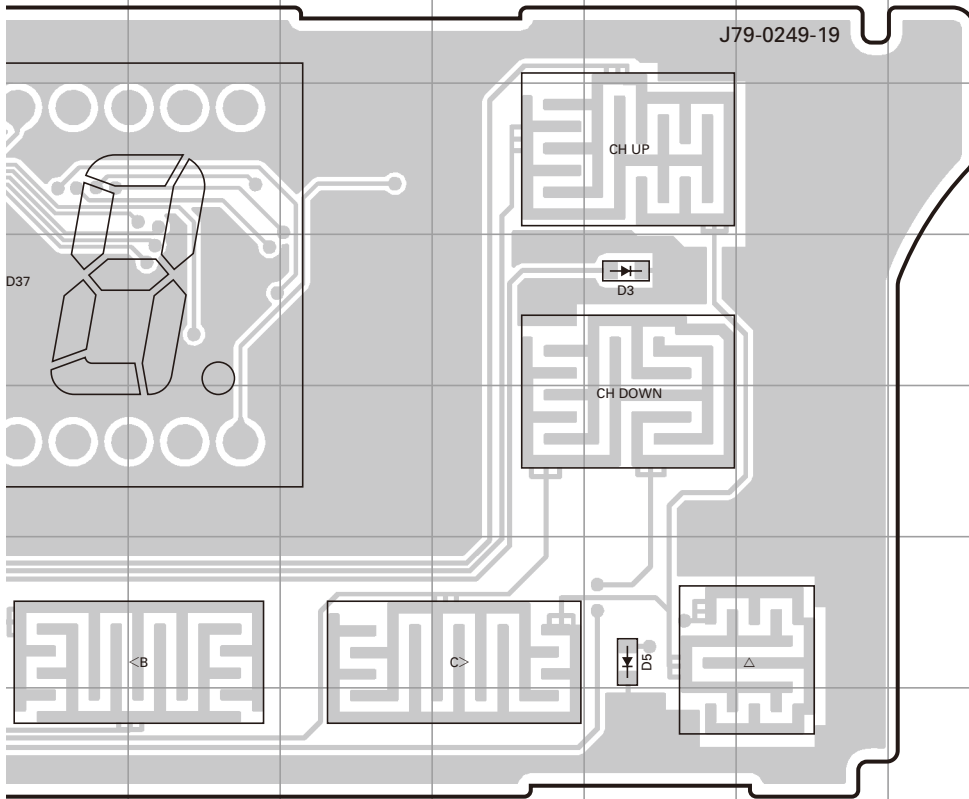

Ref. No.	Address
D1	4F
D2	6E
D3	4N
D4	6I
D5	6N
D22	4D
D23	4B
D37	4J

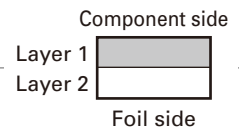

DISPLAY UNIT (X54-3670-20) Foil side view (J79-0249-19)

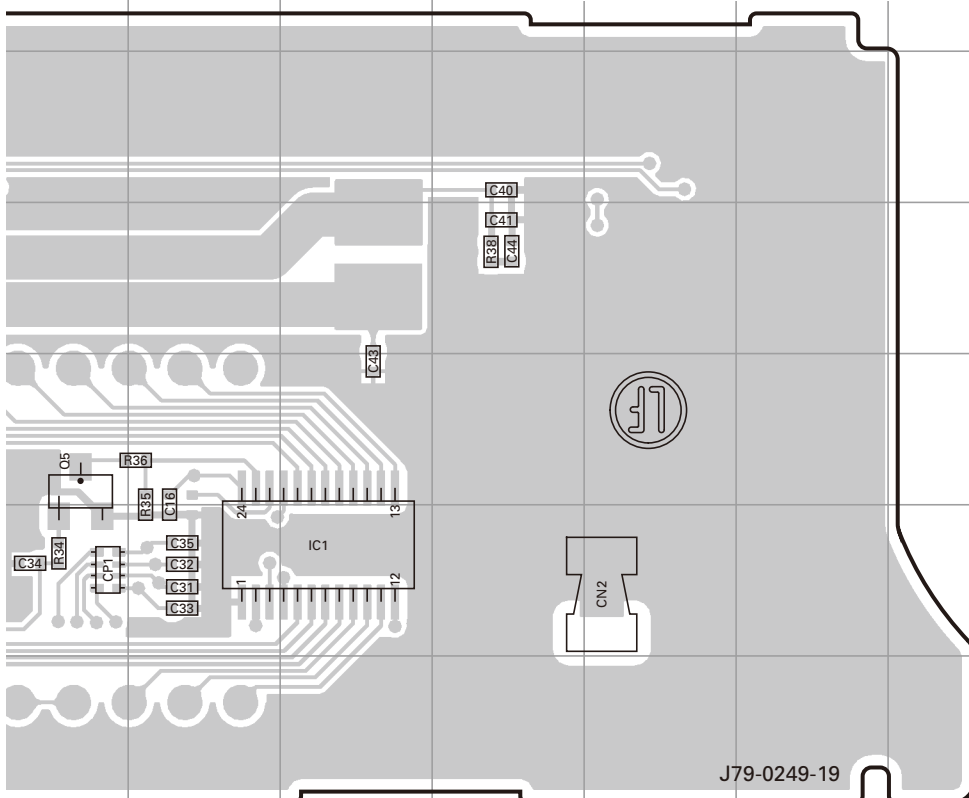

Ref. No.	Address
IC1	12L
Q1	11C
Q2	11C
Q3	9F
Q4	9F
Q5	11J
Q6	13C
Q7	11C
Q8	12C
Q9	13C
D20	9C
D33	10C

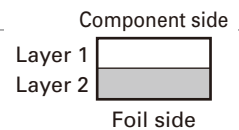

TK-8302/8302H PC BOARD

TX-RX UNIT (X57-7680-XX) -15: TK-8302H K2 -23: TK-8302 M2
Component side view (J79-0247-09)

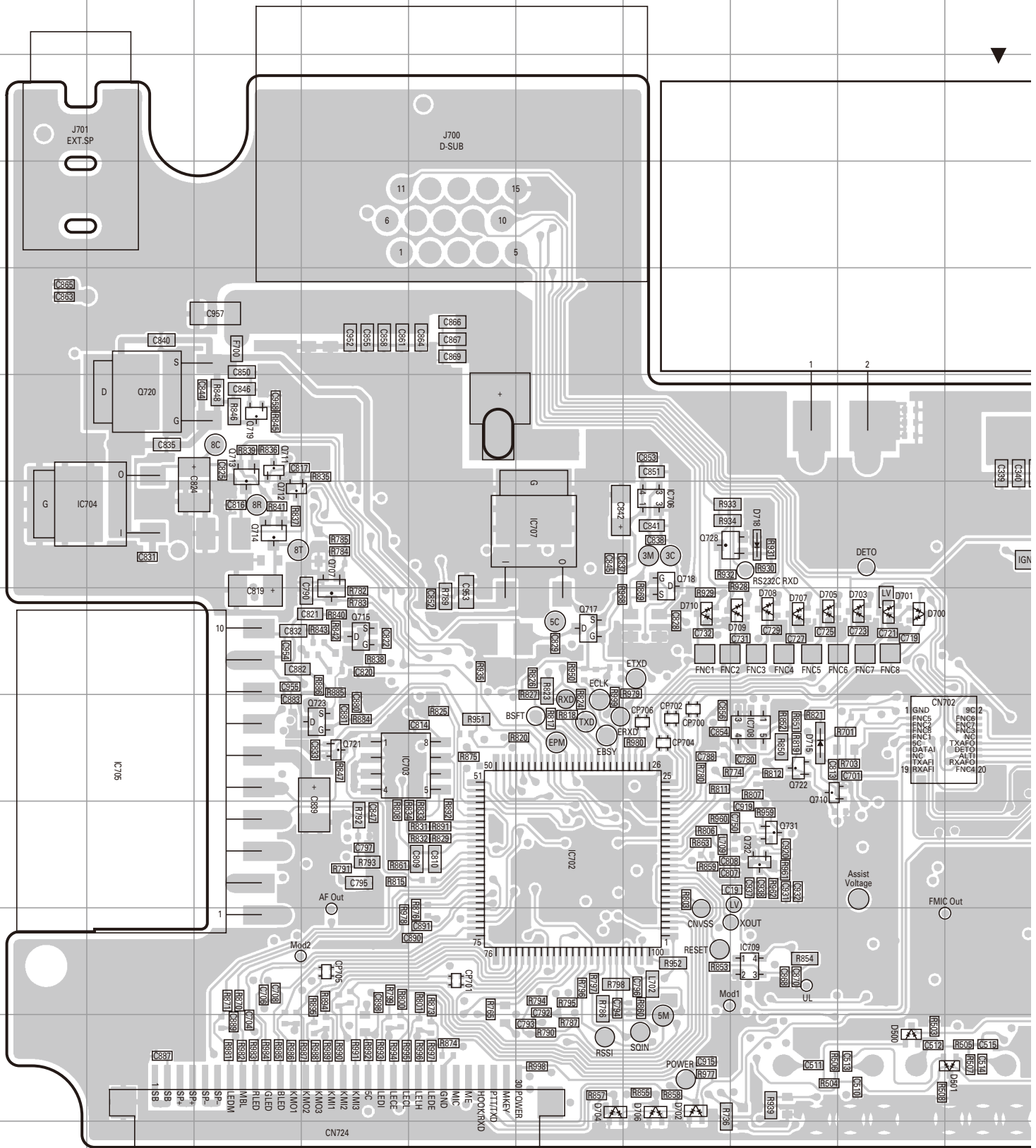

PC BOARD TK-8302/8302H

TX-RX UNIT (X57-7680-XX) -15: TK-8302H K2 -23: TK-8302 M2
Component side view (J79-0247-09)

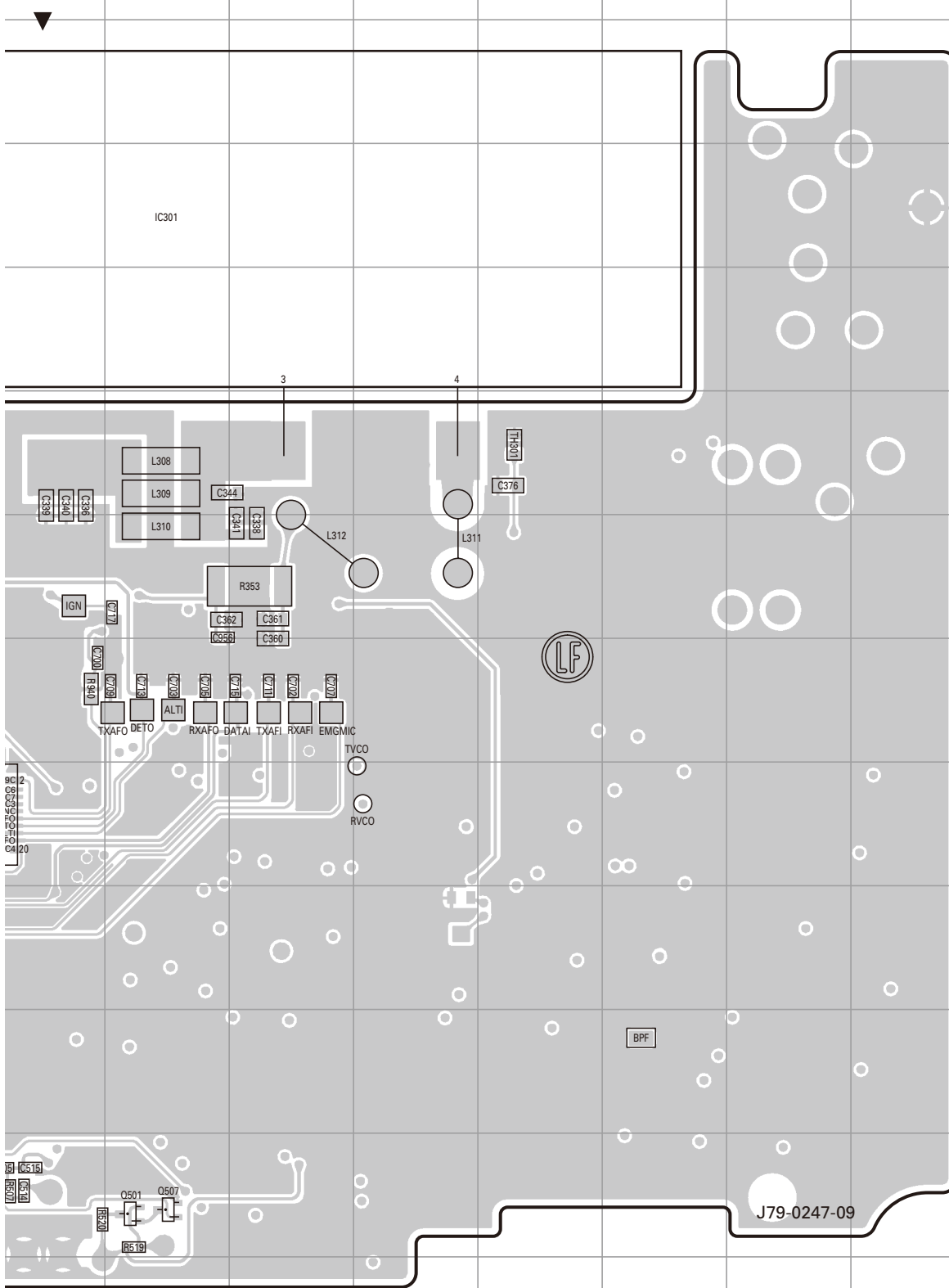

Ref. No.	Address
IC301	4K
IC702	10F
IC703	9D
IC704	7B
IC705	9B
IC706	7G
IC707	7F
IC708	9H
IC709	11H
Q501	12K
Q507	12K
Q707	7D
Q710	9H
Q711	6C
Q712	7C
Q713	6C
Q714	7C
Q715	8D
Q717	8F
Q718	7G
Q719	6C
Q720	6B
Q721	9D
Q722	9H
Q723	9D
Q728	7G
Q731	10H
Q732	10H
D500	12I
D501	12J
D700	8I
D701	8I
D702	12G
D703	8I
D704	12F
D705	8H
D706	12G
D707	8H
D708	8H
D709	8H
D710	8G
D715	9H
D718	7H

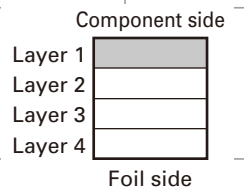

PC BOARD TK-8302/8302H

TX-RX UNIT (X57-7680-XX) -15: TK-8302H K2 -23: TK-8302 M2
Foil side view (J79-0247-09)

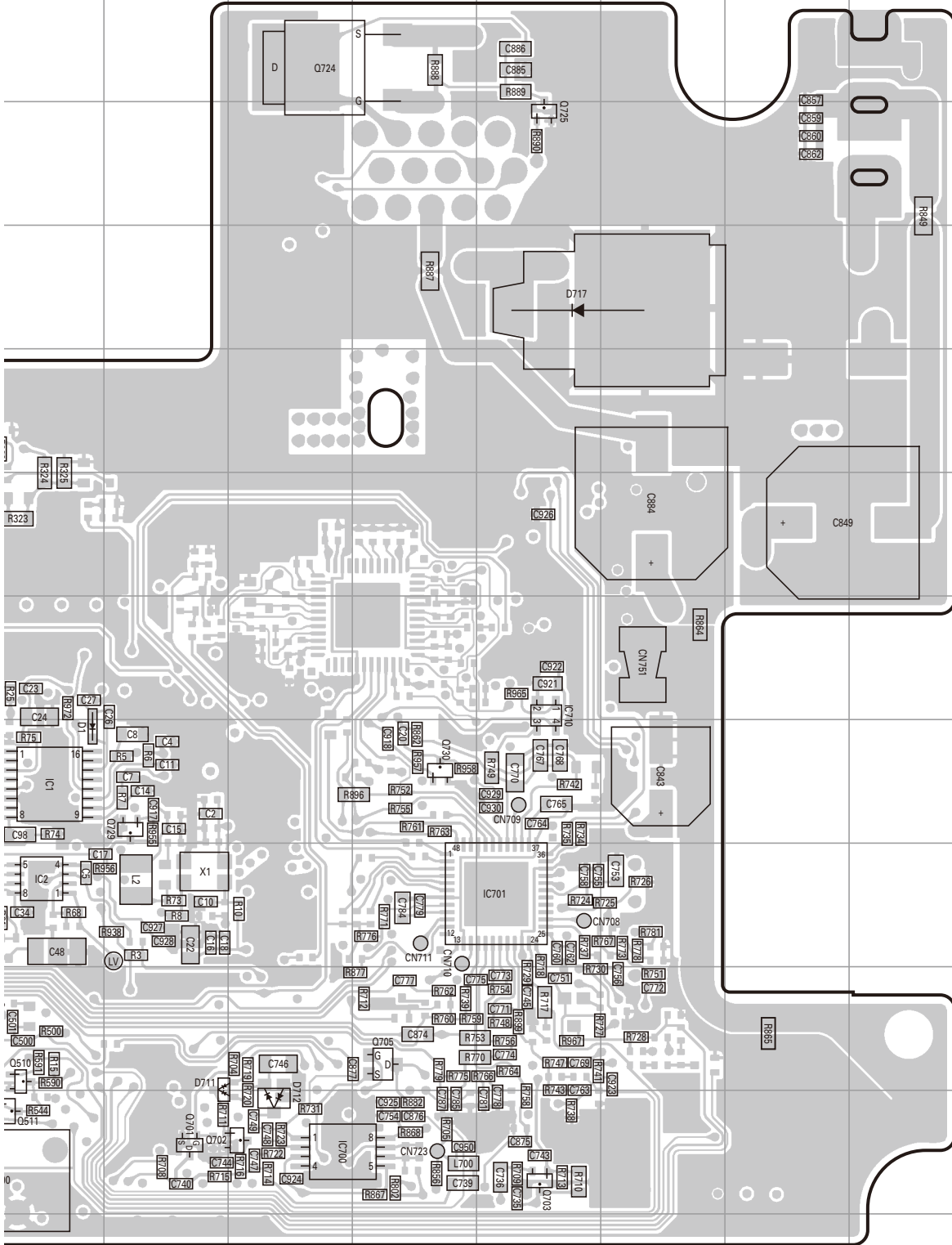

Ref. No.	Address	Ref. No.	Address
IC1	9J	D1	9J
IC2	10J	D4	10H
IC300	9D	D5	10F
IC500	12F	D6	10H
IC700	12L	D8	11H
IC701	10N	D9	10H
IC710	8N	D10	10E
Q3	8F	D11	10F
Q4	10F	D12	10G
Q5	9H	D300	7F
Q6	10G	D301	9D
Q7	9G	D302	7B
Q8	9G	D303	7C
Q9	9G	D304	7A
Q10	9F	D305	8A
Q11	10I	D310	8C
Q12	10I	D311	8D
Q300	6I	D312	6C
Q500	11J	D313	6C
Q502	12E	D314	8D
Q504	11C	D505	11B
Q506	10B	D506	11A
Q510	11J	D508	11A
Q511	12J	D509	9A
Q701	12K	D510	9A
Q702	12L	D511	8A
Q703	12N	D711	11K
Q705	11M	D712	12L
Q724	3L	D717	5N
Q725	4N	D719	9F
Q729	9K	D720	9F
Q730	9M		

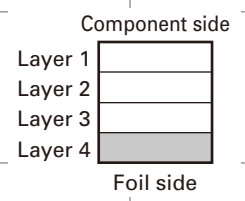

TK-8302/8302H SCHEMATIC DIAGRAM

TX-RX UNIT (X57-7680-XX)

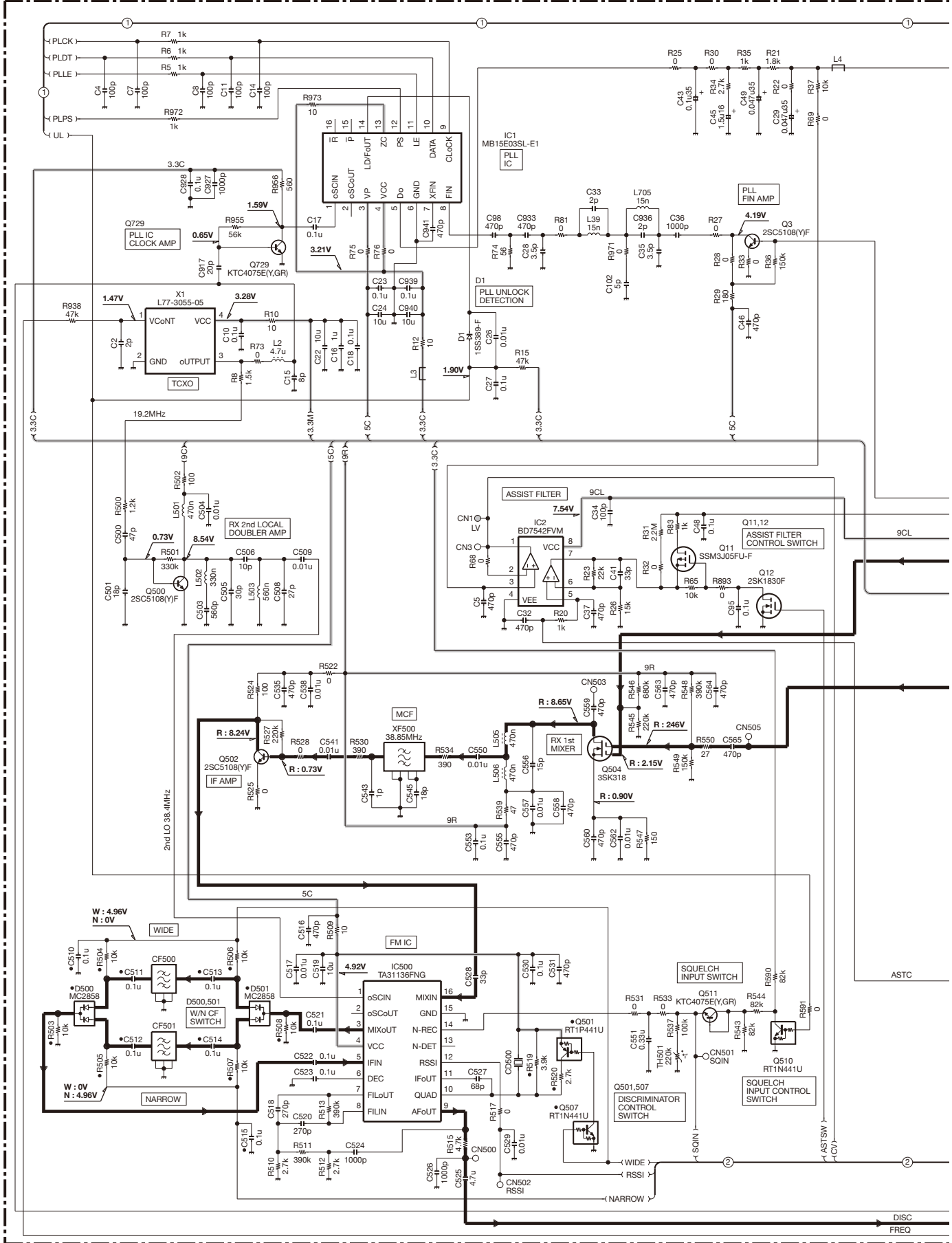

SCHEMATIC DIAGRAM TK-8302/8302H

TX-RX UNIT (X57-7680-XX)

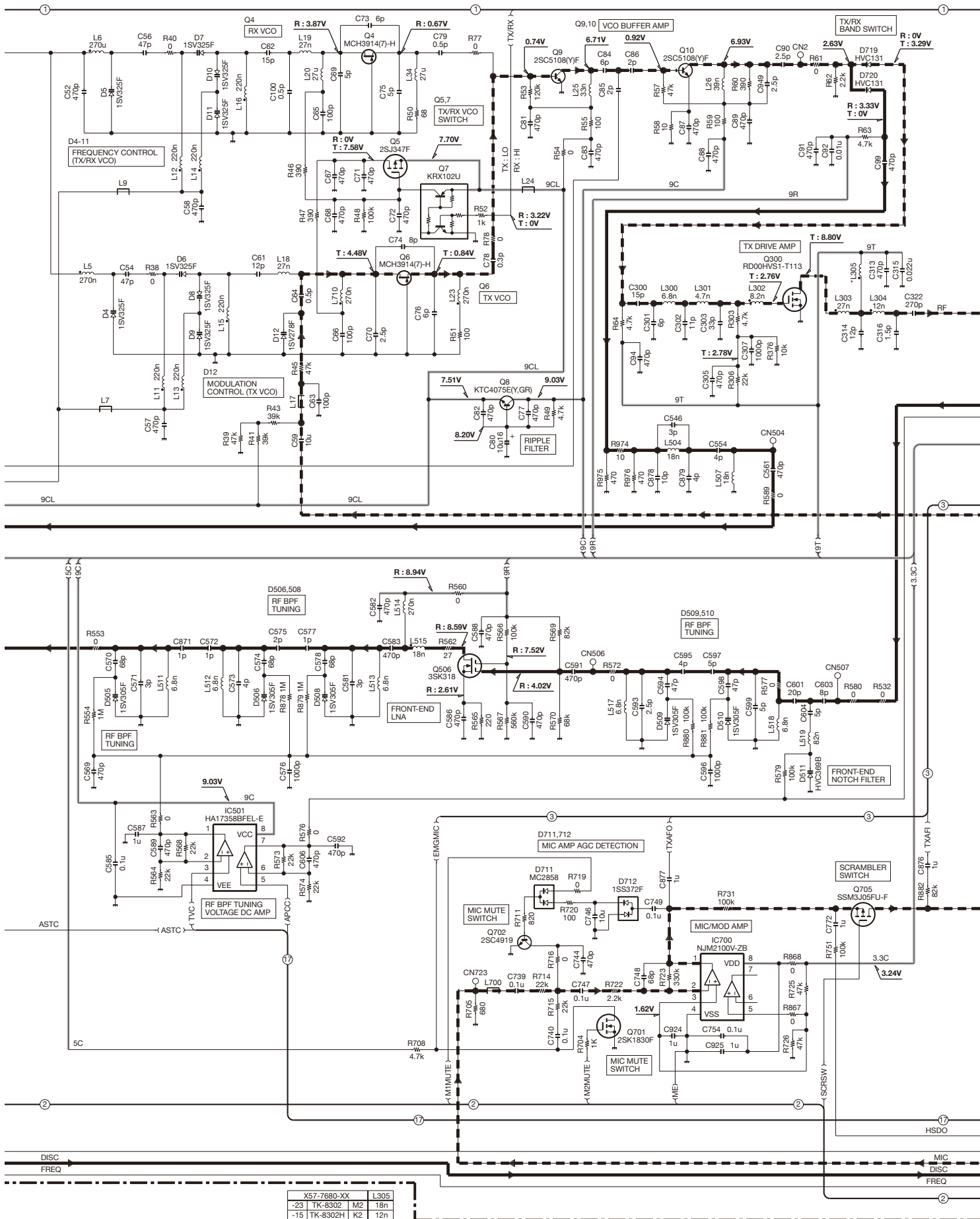

X57-7680-XX	L305
-23 TK-8302 M2	18n
-15 TK-8302H K2	12n

TK-8302/8302H SCHEMATIC DIAGRAM

TX-RX UNIT (X57-7680-XX)

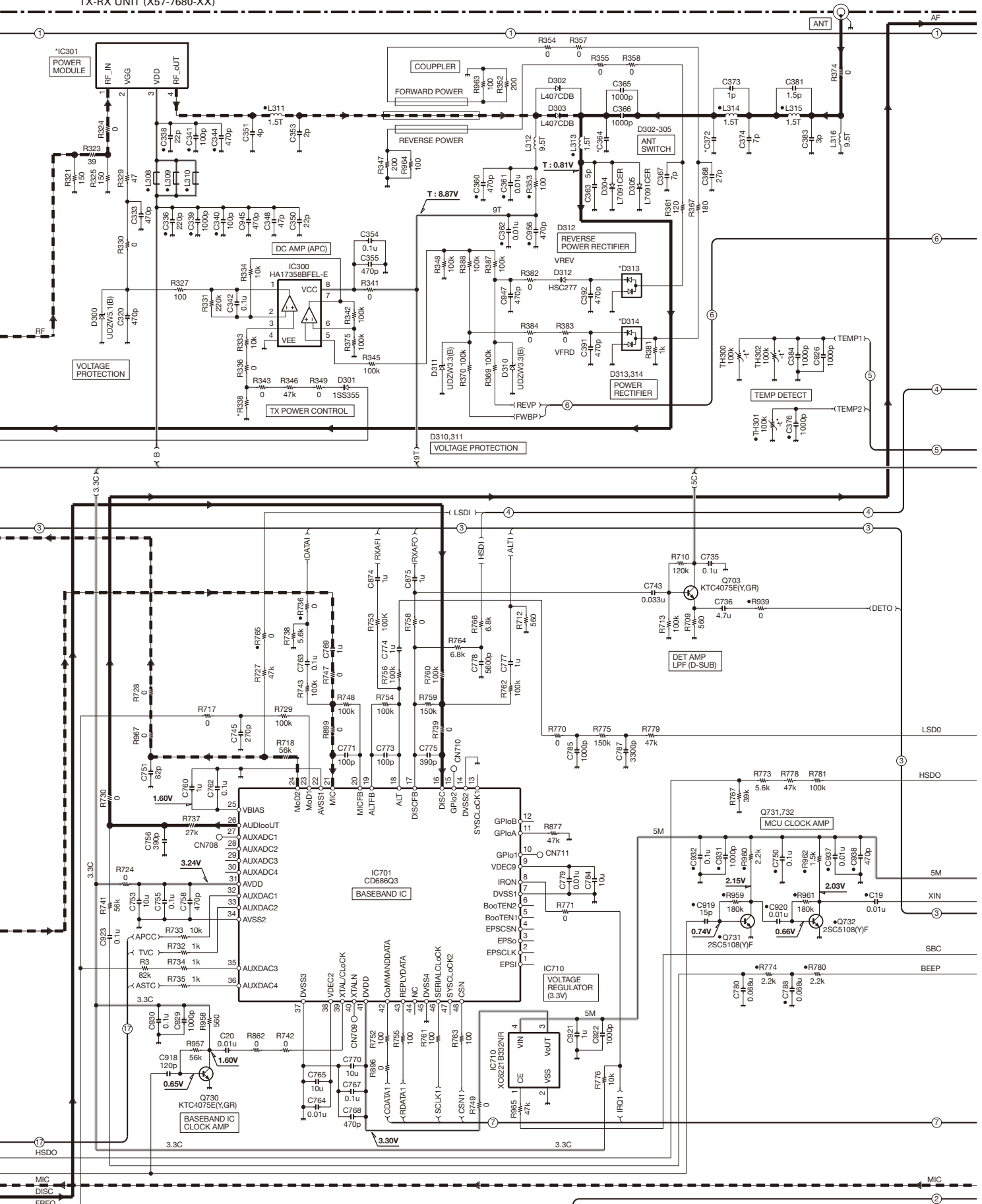

X57-7680-XX	IC301	R338	C364	C372	D313	D314
-23 TK-8302	M2	S-AU83AL	18k	1.5p	4p	HSB88AS-E
-15 TK-8302H	K2	RA60H40471101	22k	3p	2p	MA3J742

SCHEMATIC DIAGRAM TK-8302/8302H

TX-RX UNIT (X57-7680-XX)

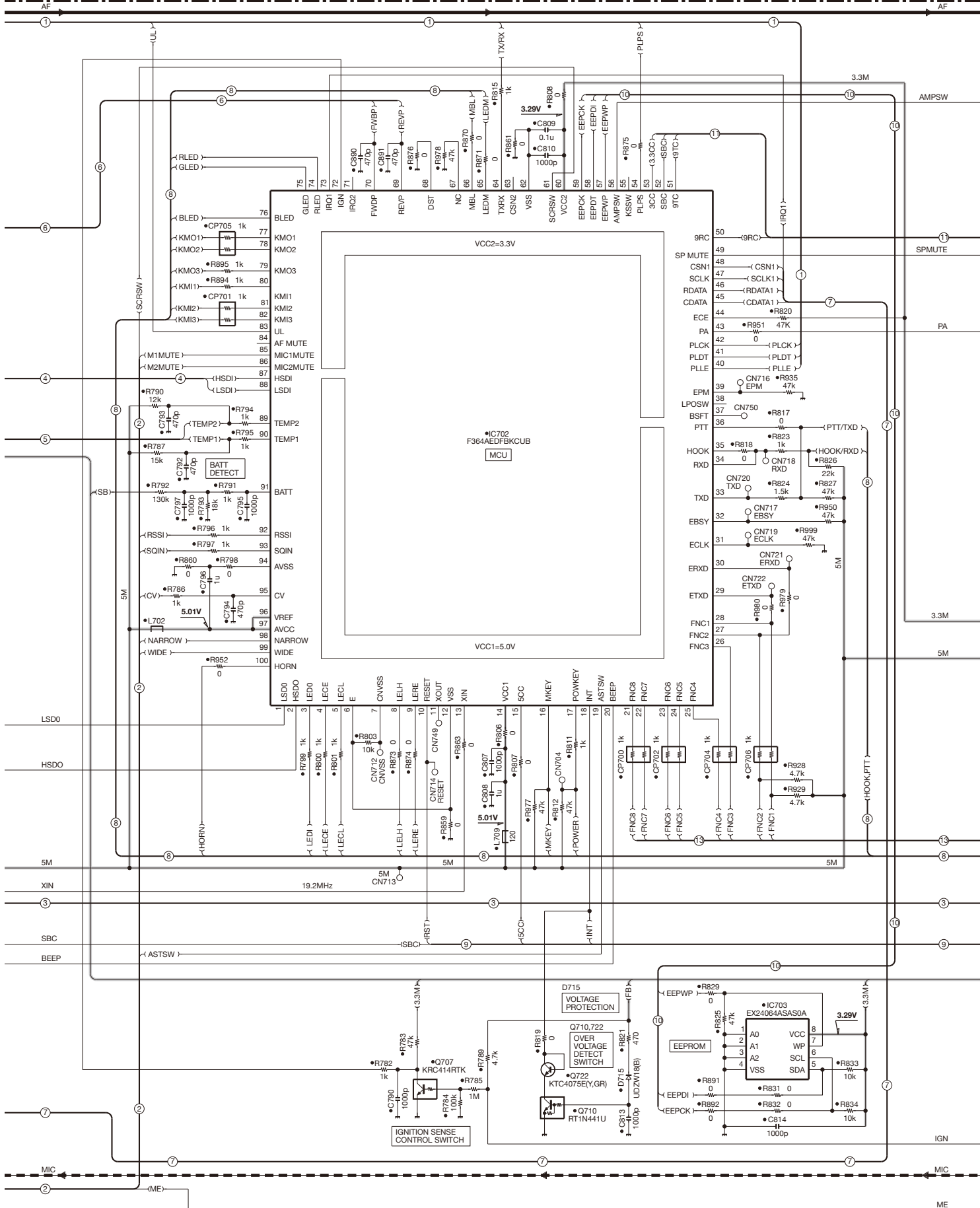

TK-8302/8302H SCHEMATIC DIAGRAM

TX-RX UNIT (X57-7680-XX)

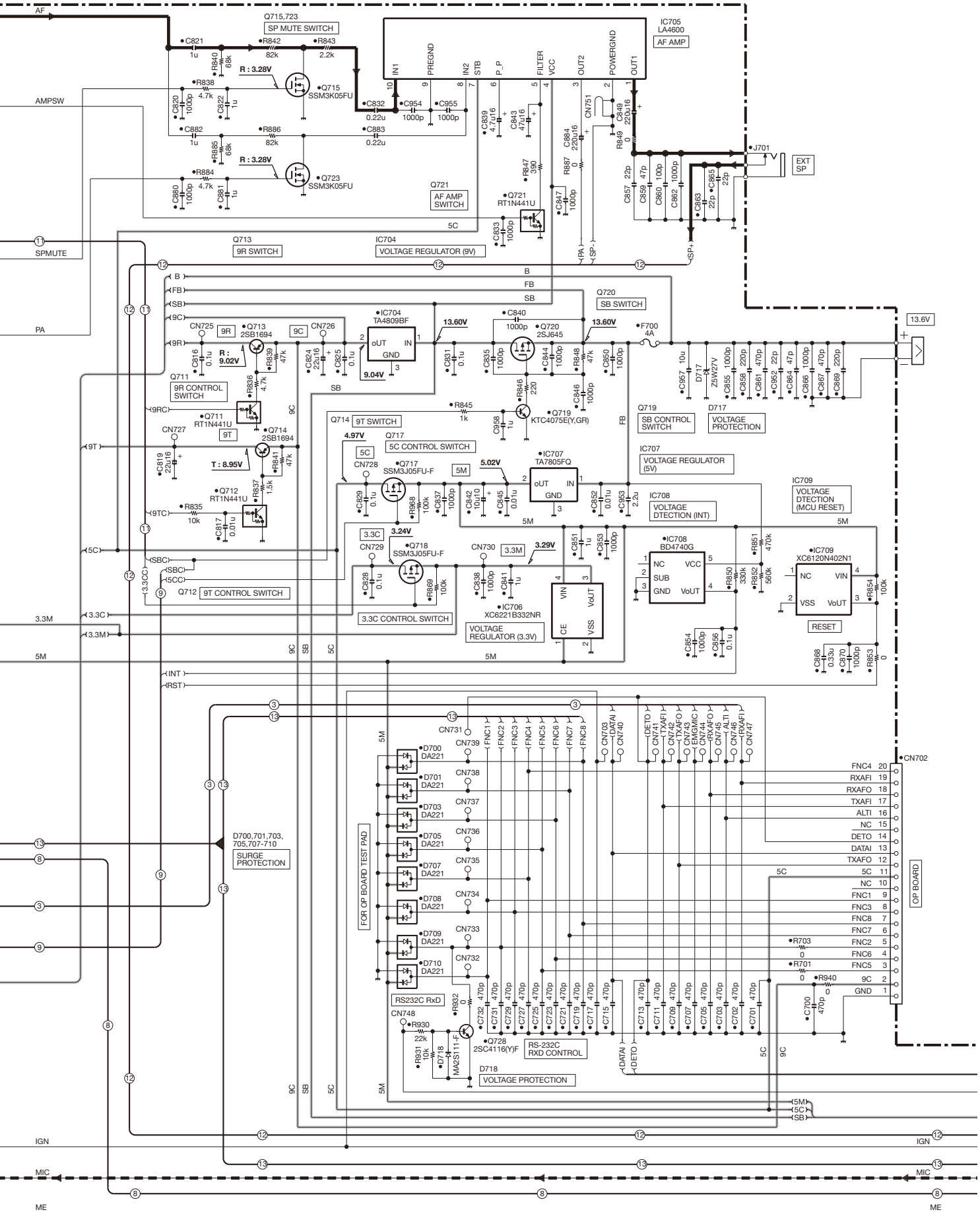

SCHEMATIC DIAGRAM TK-8302/8302H

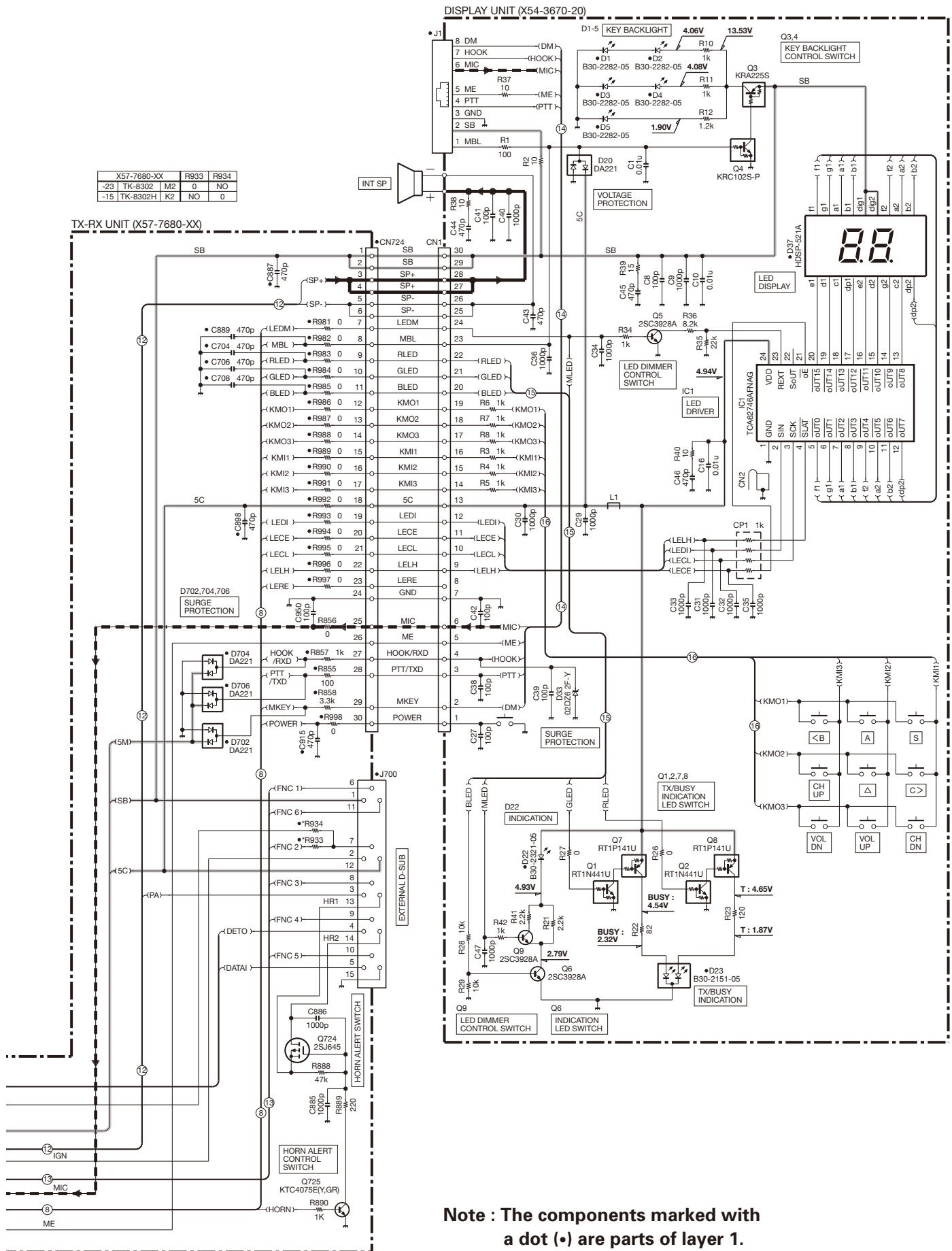

Note : The components marked with a dot (•) are parts of layer 1.

BLOCK DIAGRAM

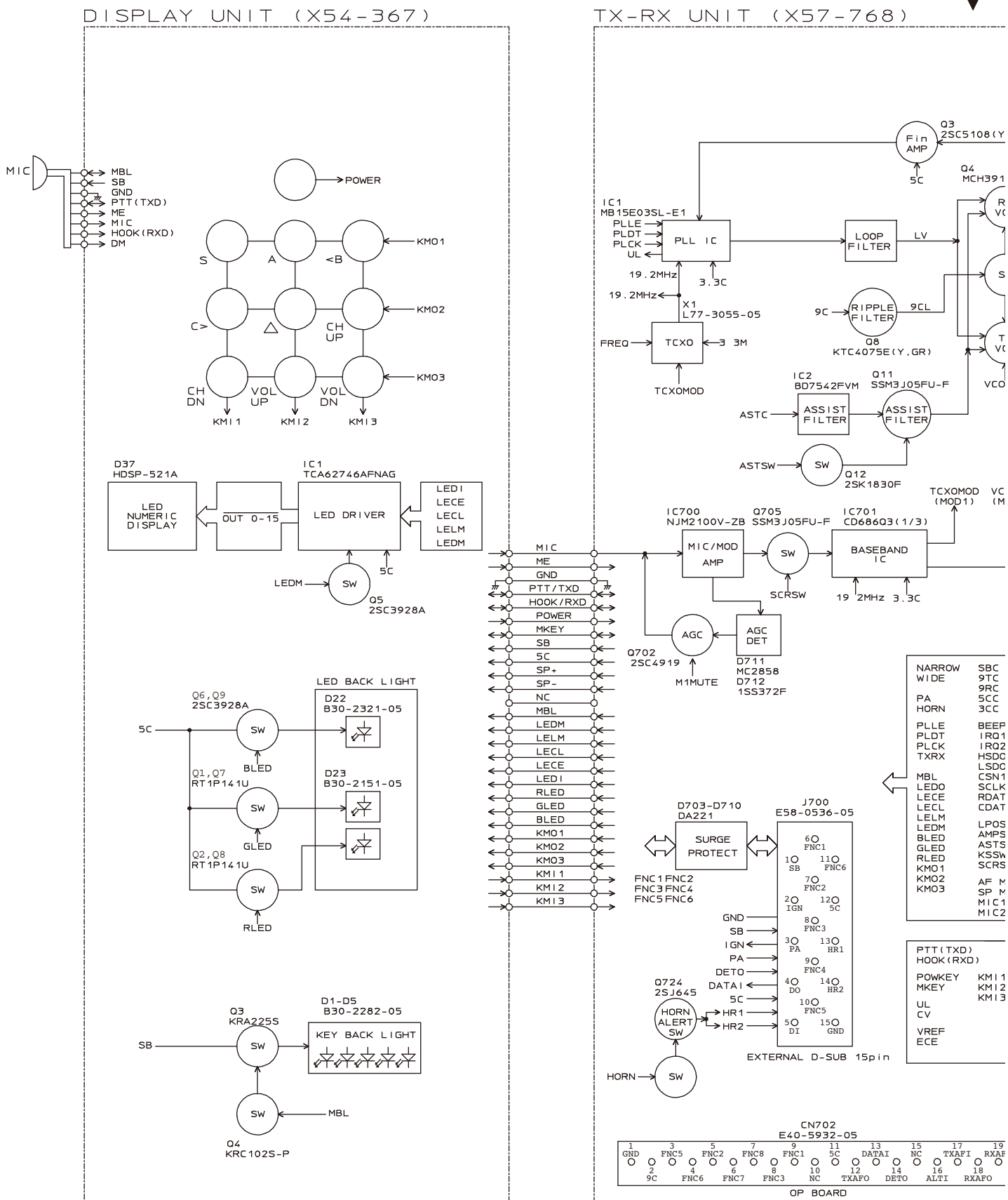

LEVEL DIAGRAM

Receiver Section

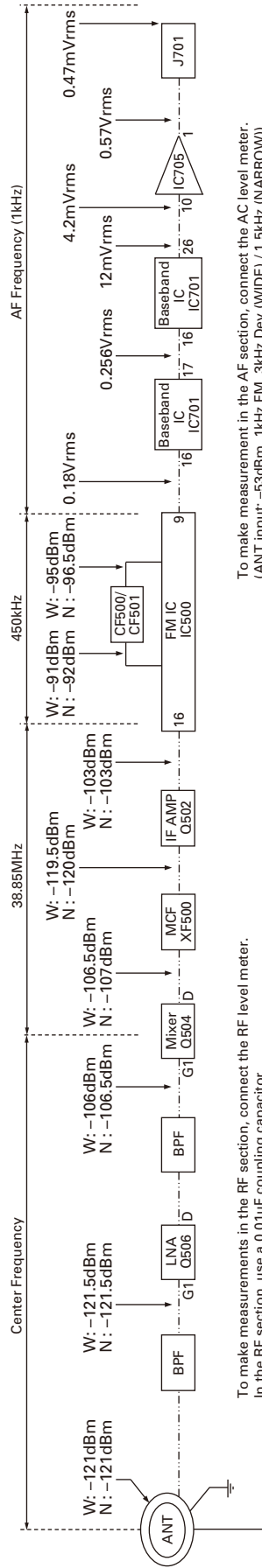

To make measurements in the RF section, connect the RF level meter. In the RF section, use a 0.01µF coupling capacitor. (The display shows the SSG input value required to obtain 12dB SINAD.)

To make measurement in the AF section, connect the AC level meter. (ANT input: -53dBm, 1kHz FM, 3kHz Dev (WIDE) / 1.5kHz (NARROW)) The AF output level is adjusted for a 0.47V/40hm by the front panel AF VOL control.

Transmitter Section

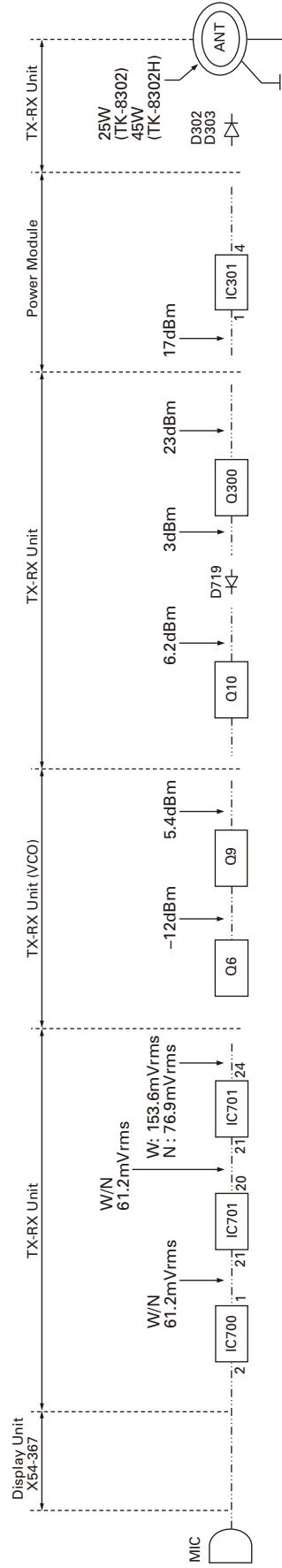

To make measurements in the AF section, connect the AC level meter. AG is set so that MIC input becomes 3kHz/1.5kHz (Wide/Narrow) DEV at 1kHz MOD.

To make measurements in the RF section, connect the RF Wattmeter (50ohm).

OPTIONAL ACCESSORIES

KCT-60 (Connection Cable)

■ External View



TK-8302/8302H

SPECIFICATIONS

GENERAL

Frequency Range.....	400 to 470MHz
Number of Channels.....	16
Zones.....	2
Channel Spacing.....	Wide: 25kHz Narrow: 12.5kHz
Operating Voltage.....	13.6V DC \pm 15%
Operating Temperature Range.....	-30°C to +60°C (-22°F to +140°F)
Frequency Stability.....	\pm 2.5ppm
Antenna Impedance.....	50 Ω
Dimensions (W x H x D) (Projections not included).....	160 (6.30) W x 43 (1.69) H x 122.6 (4.83) D mm (inches)
Weight (net).....	1.10kg (2.4 lbs)

RECEIVER (Measurements made per EIA/TIA-603)

Sensitivity (12dB SINAD).....	Wide: 0.28 μ V Narrow: 0.35 μ V
Selectivity.....	Wide: 75dB Narrow: 65dB
Intermodulation Distortion.....	Wide: 70dB Narrow: 60dB
Spurious Response.....	75dB
Audio Output (4 Ω impedance).....	4W with less than 5% distortion

TRANSMITTER (Measurements made per EIA/TIA-603)

RF Power Output	
TK-8302.....	5~25W (High: 25W, Low: 5W)
TK-8302H.....	5~45W (High: 45W, Low: 25W)
Spurious Response.....	70dB
FM Hum & Noise.....	Wide: 45dB Narrow: 40dB
Audio Distortion.....	Wide: Less than 3% Narrow: Less than 5%
Modulation.....	Wide: 16K0F3E Narrow: 11K0F3E

Kenwood Corporation

2967-3, Ishikawa-machi, Hachioji-shi, Tokyo, 192-8525 Japan

Kenwood U.S.A. Corporation

P.O. BOX 22745, 2201 East Dominguez Street, Long Beach, CA 90801-5745, U.S.A.

Kenwood Electronics Canada Inc.

6070 Kestrel Road, Mississauga, Ontario, Canada L5T 1S8

Kenwood Electronics Deutschland GmbH

Rembrücker Str. 15, 63150 Heusenstamm, Germany

Kenwood Electronics Belgium N.V.

Leuvensesteenweg 248 J, 1800 Vilvoorde, Belgium

Kenwood Electronics France S.A.

L'Etoile Paris Nord 2, 50 Allée des Impressionnistes, Bp 58416 Villepinte, 95944 Roissy Ch De Gaulle Cedex

Kenwood Electronics UK Limited

KENWOOD House, Dwight Road, Watford, Herts., WD18 9EB United Kingdom

Kenwood Electronics Europe B.V.

Amsterdamseweg 37, 1422 AC Uithoorn, The Netherlands

Kenwood Electronics Italia S.p.A.

Via G. Sirtori, 7/9 20129 Milano, Italy

Kenwood Ibérica, S.A.

Bolivia, 239-08020 Barcelona, Spain

Kenwood Electronics Australia Pty. Ltd.

(A.C.N. 001 499 074)

16 Giffnock Avenue, Centrecourt Estate, North Ryde, N.S.W. 2113 Australia

Kenwood Electronics (Hong Kong) Ltd.

Unit 3712-3724, Level 37, Tower one Metroplaza, 223 Hing Fong Road, Kwai Fong, N.T., Hong Kong

Kenwood Electronics Singapore Pte Ltd

1 Ang Mo Kio Street 63, Singapore 569110



DISPLAY UNIT (X54-3670-20) Component side view (J79-0249-19)

DISPLAY UNIT (X54-3670-20) Component side view (J79-0249-19)

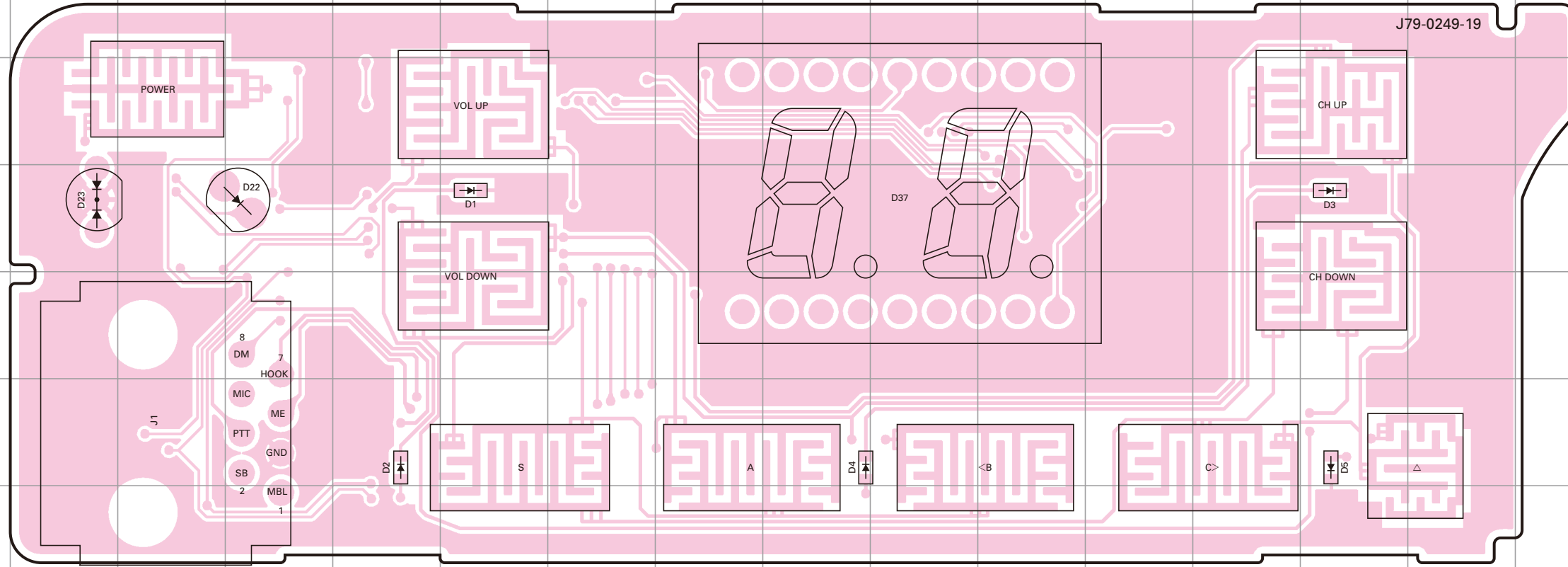

Ref. No.	Address
D1	4F
D2	6E
D3	4N
D4	6I
D5	6N
D22	4D
D23	4B
D37	4J

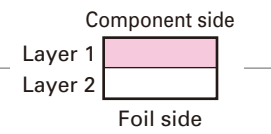

DISPLAY UNIT (X54-3670-20) Foil side view (J79-0249-19)

DISPLAY UNIT (X54-3670-20) Foil side view (J79-0249-19)

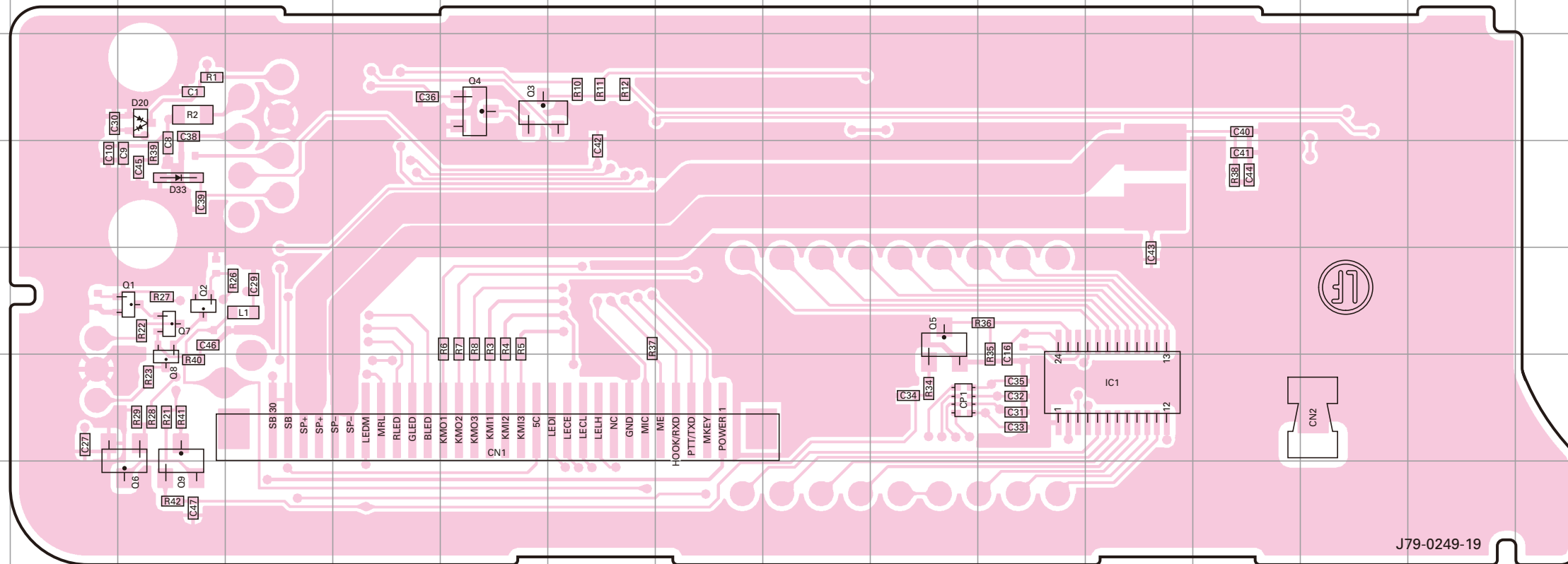

Ref. No.	Address
IC1	12L
Q1	11C
Q2	11C
Q3	9F
Q4	9F
Q5	11J
Q6	13C
Q7	11C
Q8	12C
Q9	13C
D20	9C
D33	10C

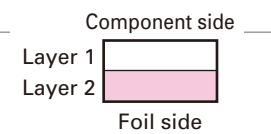

TK-8302/8302H PC BOARD

PC BOARD TK-8302/8302H

TX-RX UNIT (X57-7680-XX) -15: TK-8302H K2 -23: TK-8302 M2
Component side view (J79-0247-09)

TX-RX UNIT (X57-7680-XX) -15: TK-8302H K2 -23: TK-8302 M2
Component side view (J79-0247-09)

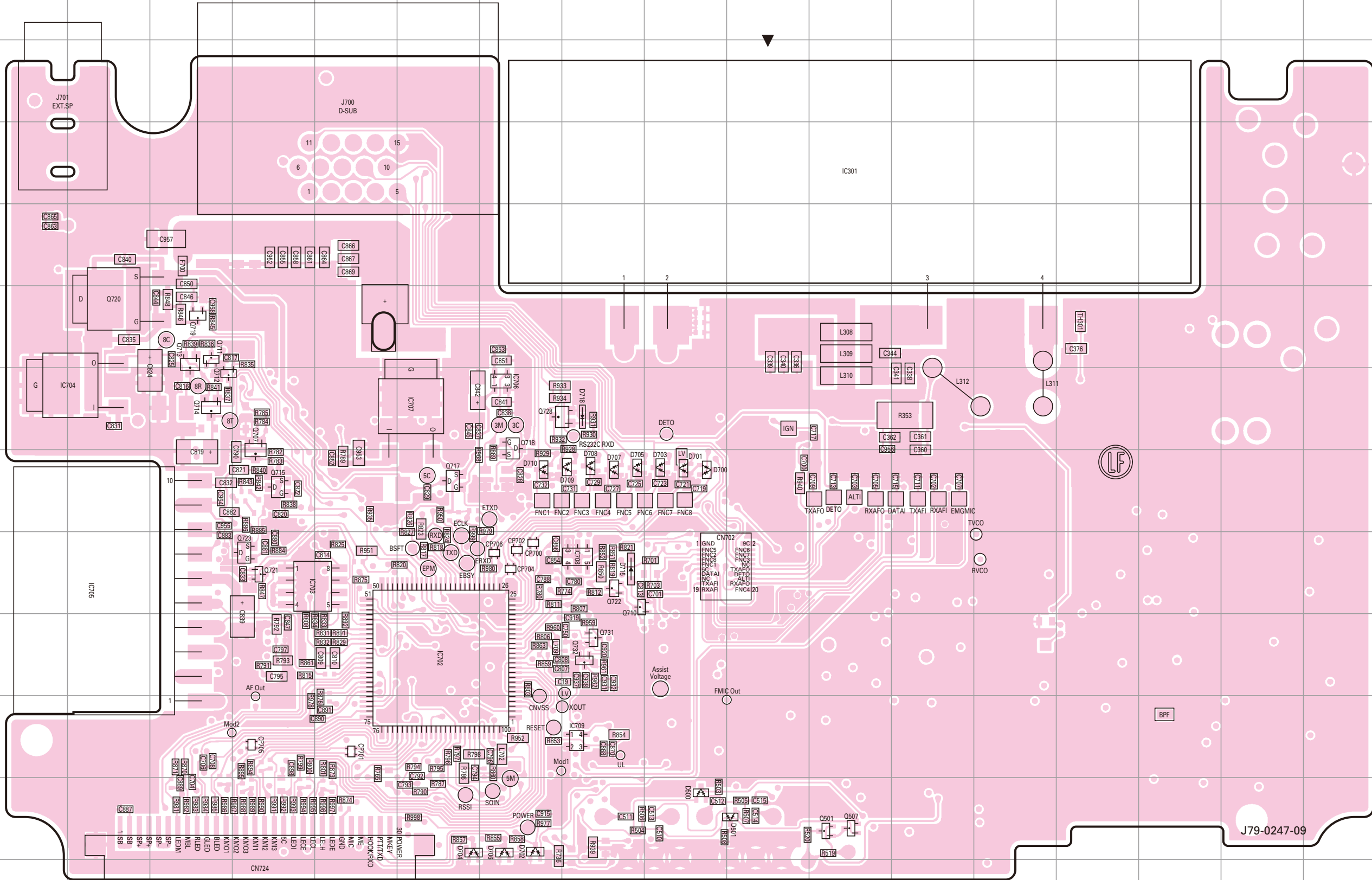

Ref. No.	Address
IC301	4K
IC702	10F
IC703	9D
IC704	7B
IC705	9B
IC706	7G
IC707	7F
IC708	9H
IC709	11H
Q501	12K
Q507	12K
Q707	7D
Q710	9H
Q711	6C
Q712	7C
Q713	6C
Q714	7C
Q715	8D
Q717	8F
Q718	7G
Q719	6C
Q720	6B
Q721	9D
Q722	9H
Q723	9D
Q728	7G
Q731	10H
Q732	10H
D500	12I
D501	12J
D700	8I
D701	8I
D702	12G
D703	8I
D704	12F
D705	8H
D706	12G
D707	8H
D708	8H
D709	8H
D710	8G
D715	9H
D718	7H

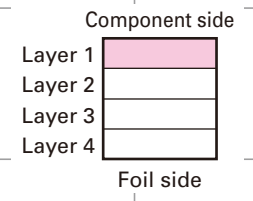

J79-0247-09

TK-8302/8302H PC BOARD

PC BOARD TK-8302/8302H

TX-RX UNIT (X57-7680-XX) -15: TK-8302H K2 -23: TK-8302 M2
Foil side view (J79-0247-09)

TX-RX UNIT (X57-7680-XX) -15: TK-8302H K2 -23: TK-8302 M2
Foil side view (J79-0247-09)

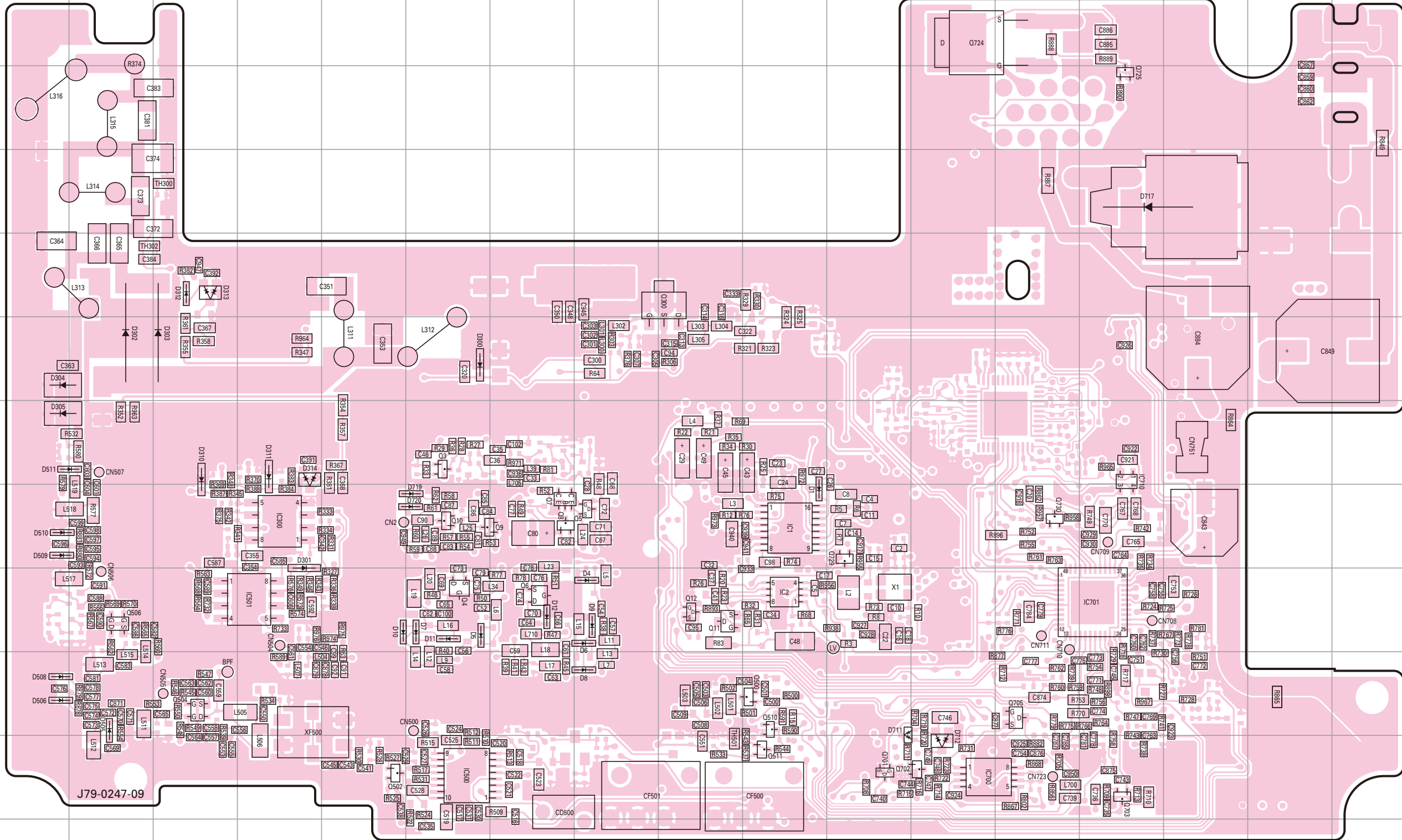

Ref. No.	Address	Ref. No.	Address
IC1	9J	D1	9J
IC2	10J	D4	10H
IC300	9D	D5	10F
IC500	12F	D6	10H
IC501	10D	D7	10F
IC700	12L	D8	11H
IC701	10N	D9	10H
IC710	8N	D10	10E
Q3	8F	D11	10F
Q4	10F	D12	10G
Q5	9H	D300	7F
Q6	10G	D301	9D
Q7	9G	D302	7B
Q8	9G	D303	7C
Q9	9G	D304	7A
Q10	9F	D305	8A
Q11	10I	D310	8C
Q12	10I	D311	8D
Q300	6I	D312	6C
Q500	11J	D313	6C
Q502	12E	D314	8D
Q504	11C	D505	11B
Q506	10B	D506	11A
Q510	11J	D508	11A
Q511	12J	D509	9A
Q701	12K	D510	9A
Q702	12L	D511	8A
Q703	12N	D711	11K
Q705	11M	D712	12L
Q724	3L	D717	5N
Q725	4N	D719	9F
Q729	9K	D720	9F
Q730	9M		

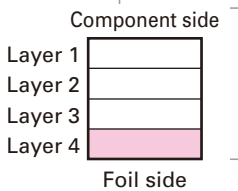

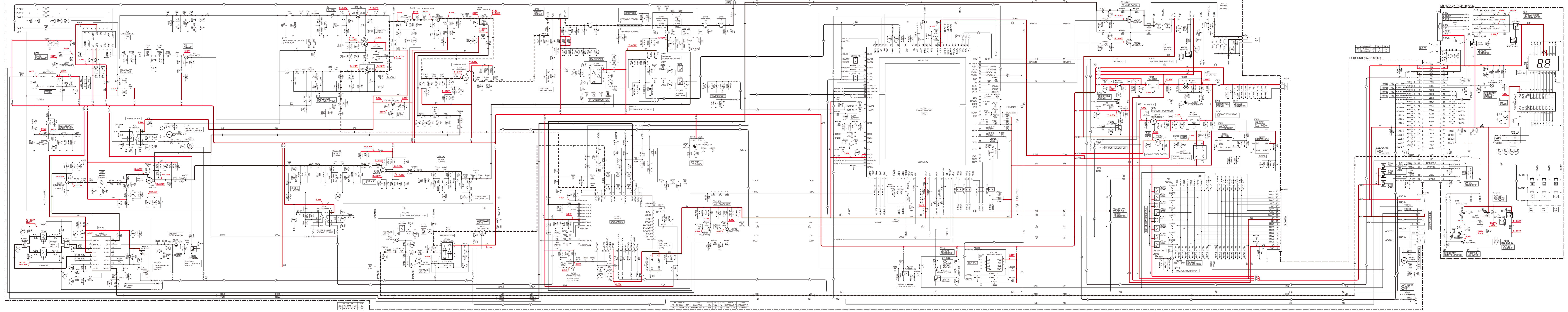

DISPLAY UNIT (X54-367)

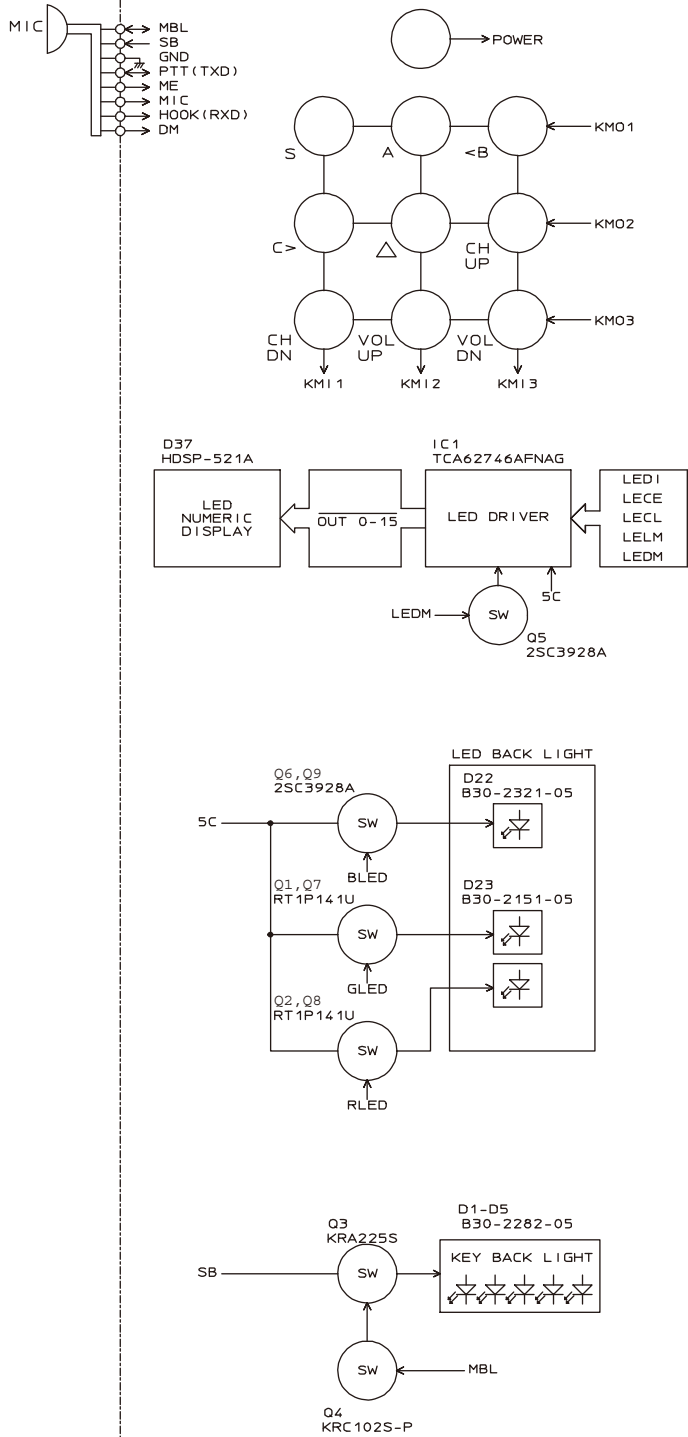

TX-RX UNIT (X57-768)

