

UHF FM TRANSCEIVER / UHF 调频车载对讲机

# TK-8360

SERVICE MANUAL / 维修手册

C version / C 版本

# KENWOOD

Kenwood Corporation

© 2011-3 PRINTED IN JAPAN  
B51-8965-00 (Y)

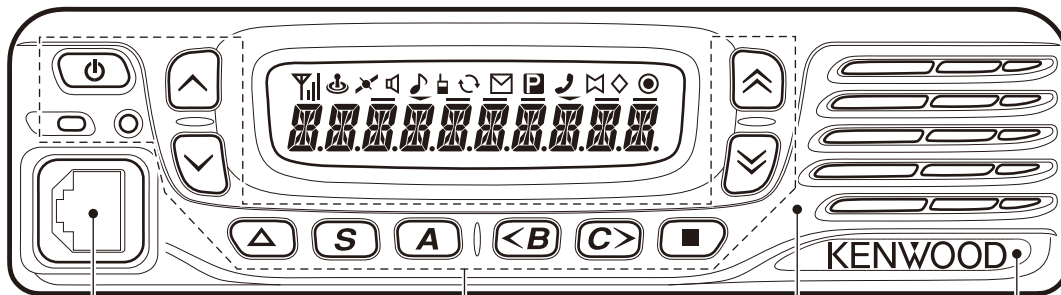

Modular jack / 模块化插孔  
(E58-0535-05)

Key top / 按键  
(K29-9479-01)

Panel assy / 面板组件  
(A62-1180-13)

Badge / 徽章  
(B43-1650-04)

无铅焊接通信产品  

保护环境建伍领先

⚠注意：本产品是无铅化焊接产品  
在维修时请使用无铅焊锡  
和相应的焊接工具  
详细事项请访问如下网址了解：  
<http://www.kenwoodhk.com.hk/>

This product complies with the **RoHS** directive for the European market.



This product uses Lead Free solder.

<b>GENERAL</b> .....	<b>3</b>	概 述.....	3
<b>SYSTEM SET-UP</b> .....	<b>5</b>	系统体系.....	5
<b>REALIGNMENT</b> .....	<b>5</b>	模式组合.....	6
<b>INSTALLATION</b> .....	<b>10</b>	安 装.....	10
<b>DISASSEMBLY FOR REPAIR</b> .....	<b>19</b>	维修拆卸.....	19
<b>CIRCUIT DESCRIPTION</b> .....	<b>23</b>	电路说明.....	23
<b>SEMICONDUCTOR DATA</b> .....	<b>32</b>	半导体数据.....	32
<b>COMPONENTS DESCRIPTION</b> .....	<b>35</b>	元件说明.....	35
<b>PARTS LIST</b> .....	<b>38</b>	零 件 表.....	38
<b>EXPLODED VIEW</b> .....	<b>48</b>	部件分解图.....	48
<b>PACKING</b> .....	<b>49</b>	包 装.....	49
<b>ADJUSTMENT</b> .....	<b>50</b>	调 整.....	51
<b>TERMINAL FUNCTION</b> .....	<b>68</b>	端子功能.....	68
<b>PC BOARD</b>		印刷电路板	
<b>DISPLAY UNIT (X54-3740-20)</b> .....	<b>72</b>	显示单元 (X54-3740-20).....	72
<b>TX-RX UNIT (X57-8020-23)</b> .....	<b>74</b>	收发单元 (X57-8020-23).....	74
<b>SCHEMATIC DIAGRAM</b> .....	<b>78</b>	原 理 图.....	78
<b>BLOCK DIAGRAM</b> .....	<b>84</b>	方 块 图.....	84
<b>LEVEL DIAGRAM</b> .....	<b>86</b>	电 平 图.....	86
<b>SPECIFICATIONS</b> .....	<b>87</b>	规 格.....	封底

## Document Copyrights

Copyright 2011 by Kenwood Corporation. All rights reserved.

No part of this manual may be reproduced, translated, distributed, or transmitted in any form or by any means, electronic, mechanical, photocopying, recording, or otherwise, for any purpose without the prior written permission of Kenwood.

## Disclaimer

While every precaution has been taken in the preparation of this manual, Kenwood assumes no responsibility for errors or omissions. Neither is any liability assumed for damages resulting from the use of the information contained herein. Kenwood reserves the right to make changes to any products herein at any time for improvement purposes.

## 文档版权信息

Kenwood Corporation 拥有版权 2011。保留所有权利。

未经 Kenwood 公司预先书面同意，无论出于何种目的，均不得以任何形式或任何方式包括电子、机械、影印、录音或其他方式复制、翻译、分发或传播本手册的任何部分。

## 免责声明

Kenwood 公司在准备本文档时已采取所有必要的预防措施，恕不对错误或疏漏承担任何责任，也不对因使用本文中所含的信息而导致的损害负责。Kenwood 公司保留出于改进的需要而随时对文中的产品信息做出更改的权利。

# GENERAL / 概述

## INTRODUCTION

### SCOPE OF THIS MANUAL

This manual is intended for use by experienced technicians familiar with similar types of commercial grade communications equipment. It contains all required service information for the equipment and is current as of the publication date. Changes which may occur after publication are covered by either Service Bulletins or Manual Revisions. These are issued as required.

### ORDERING REPLACEMENT PARTS

When ordering replacement parts or equipment information, the full part identification number should be included. This applies to all parts : components, kits, or chassis. If the part number is not known, include the chassis or kit number of which it is a part, and a sufficient description of the required component for proper identification.

### PERSONAL SAFETY

The following precautions are recommended for personal safety:

- DO NOT transmit if someone is within two feet (0.6 meter) of the antenna.
- DO NOT transmit until all RF connectors are secure and any open connectors are properly terminated.
- SHUT OFF this equipment when near electrical blasting caps or while in an explosive atmosphere.
- All equipment should be properly grounded before powerup for safe operation.
- This equipment should be serviced by only qualified technicians.

## PRE-INSTALLATION CONSIDERATIONS

### 1. UNPACKING

Unpack the radio from its shipping container and check for accessory items. If any item is missing, please contact KENWOOD immediately.

### 2. PRE-INSTALLATION CHECKOUT

#### 2-1. Introduction

Each radio is adjusted and tested before shipment. However, it is recommended that receiver and transmitter operation be checked for proper operation before installation.

#### 2-2. Testing

The radio should be tested complete with all cabling and accessories as they will be connected in the final installation. Transmitter frequency, deviation, and power output should be checked, as should receiver sensitivity, squelch operation, and audio output. Signalling equipment operation should be verified.

## 引言

### 本手册的范围

本手册是提供给熟悉通信专业并且具有维修经验的技术人员使用的。它包括了维修该设备所需要的全部资料和现行出版日期。在出版后可能发生变动，如果需要，可以参照《维修通报》或《手册修订本》进行补充。

### 替换零件的订购

当订购替换零件或设备资料时，应注意完整的零件识别号码。所有的零件均有识别号码：元件，组件或机壳。如果不知道零件的号码，为了正确地识别，必须注明此元件所属的机壳或组件的号码，并对元件进行充分的说明。

### 个人安全

为了个人的安全，请注意下列事项：

- 如果有人在天线两英尺 (0.6 米) 范围之内时，不要进行发射。
- 在没有认真核实所有射频插头之前或有任何一个脱开的插头没有连接到相应端口上的情况下均不要发射。
- 在电爆管附近或在易燃性气体环境中，必须关闭电源，不要操作本设备。
- 为了操作的安全，在接通电源之前所有设备应该连接地线。
- 本设备只应该由有资格的技术人员进行维修。

### 安装前条件

#### 1. 开箱

从运输包装中取出本无线电设备并检查附件。如果有任何组件遗失，请立即与 KENWOOD 联系。

#### 2. 安装前检查

##### 2-1. 说明

在运输之前每一台无线电设备均已调整和测试过。但是，在安装之前最好检查接收和发射以便操作正确。

##### 2-2. 测试

无线电设备应该按照电缆和附件最终安装时的连接进行完整的测试。应该检查发射频率，频偏和输出功率，同样应该检查接收灵敏度，静噪和音频输出。应该检验信令操作。

## GENERAL / 概述

### 3. PLANNING THE INSTALLATION

#### 3-1. General

Inspect the vehicle and determine how and where the radio antenna and accessories will be mounted.

Plan cable runs for protection against pinching or crushing wiring, and radio installation to prevent overheating.

#### 3-2. Antenna

The favored location for an antenna is in the center of a large, flat conductive area, usually at the roof center. The trunk lid is preferred, bond the trunk lid and vehicle chassis using ground straps to ensure the lid is at chassis ground.

#### 3-3. Radio

The universal mount bracket allows the radio to be mounted in a variety of ways. Be sure the mounting surface is adequate to support the radio's weight. Allow sufficient space around the radio for air cooling. Position the radio close enough to the vehicle operator to permit easy access to the controls when driving.

#### 3-4. DC Power and wiring

1. This radio may be installed in negative ground electrical systems only. Reverse polarity will cause the cable fuse to blow. Check the vehicle ground polarity before installation to prevent wasted time and effort.
2. Connect the positive power lead directly to the vehicle battery positive terminal. Connecting the Positive lead to any other positive voltage source in the vehicle is not recommended.
3. Connect the ground lead directly to the battery negative terminal.
4. The cable provided with the radio is sufficient to handle the maximum radio current demand. If the cable must be extended, be sure the additional wire is sufficient for the current to be carried and length of the added lead.

### 4. INSTALLATION PLANNING – CONTROL STATIONS

#### 4-1. Antenna system

Control station. The antenna system selection depends on many factors and is beyond the scope of this manual. Your KENWOOD dealer can help you select an antenna system that will best serve your particular needs.

#### 4-2. Radio location

Select a convenient location for your control station radio which is as close as practical to the antenna cable entry point. Secondly, use your system's power supply (which supplies the voltage and current required for your system). Make sure sufficient air can flow around the radio and power supply to allow adequate cooling.

### 3. 安装步骤

#### 3-1. 概述

检查车辆并确认如何以及在何处安装无线电天线和附件。

安排好电缆的位置，避免挤压或碾碎布线，同时无线电设备避免过热。

#### 3-2. 天线

天线的最佳位置应该在一个宽阔，平整导电区域的中心，通常在车顶的中心。行李箱的盖子更好，将地线黏结在行李箱的盖子和车辆的外壳上确保行李箱盖子接地。

#### 3-3. 无线电设备

通用安装托架允许以多种方法安装无线电设备。确认安装的表面足以支撑无线电设备的重量。无线电设备的周围留出适当的空间进行散热。将无线电设备尽可能的安装在靠近车辆操作者的位置上，以便在驾驶时易于控制。

#### 3-4. 直流电源和布线

1. 本无线电设备只能被安装在负极接地电子系统中。反向极性将导致电缆保险丝熔断。在安装之前检查车辆的接地极性，避免工作效率低以及浪费时间。
2. 将电源的正极引线直接连接到车载电池的正极端点上。不要将正极引线与其他正极电压连接。
3. 将接地引线直接与电池的负极连接。
4. 与无线电设备一起提供的电缆适用于所需的最大无线电电流。如果电缆必须加长，要确认附加的电线适用于所载的电流和添加引线的长度。

### 4. 安装步骤 - 基站

#### 4-1. 天线系统

基站。天线系统的选择取决于许多因素和本手册的范围。用户的KENWOOD销售商可以帮助用户选择最能满足用户特殊要求的天线系统。

#### 4-2. 无线电位置

为用户的基站无线电设备选择一个方便的位置，此位置应尽量靠近天线电缆输入点。其次，使用用户系统的电源（为用户的系统提供所需的电压和电流）。确认无线电设备周围的空气流通顺畅并且足以使电源冷却。

## GENERAL / 概述

### SERVICE

This radio is designed for easy servicing. Refer to the schematic diagrams, printed circuit board views, and alignment procedures contained in this manual.

### NOTE

If you do not intend to use the speaker 3.5-mm jack and the D-sub 15-pin connector, fit the supplied speaker-jack cap and ACC cap to stop dust and sand from getting in.

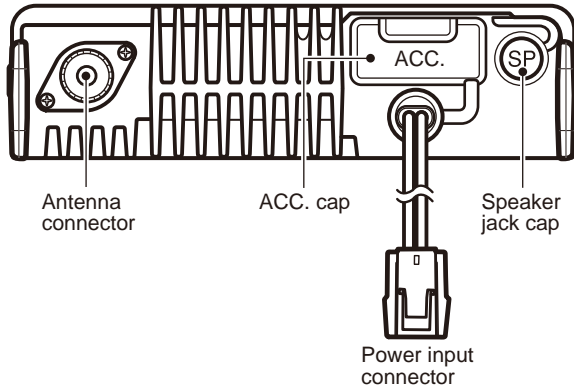

### 维修服务

为了便于维修本设备，建立了完整的维修服务体系，提供了包括原理图，印刷电路板图和调整步骤在内的资料供参考。

### 注意

如果不打算使用 3.5mm 扬声器插孔和 15 针 D-sub 连接器，请装上附带的扬声器插孔盖和 ACC. 盖，防止灰尘和沙粒进入。

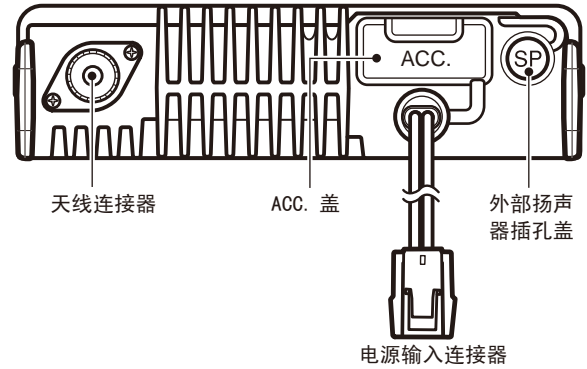

## SYSTEM SET-UP / 系统体系

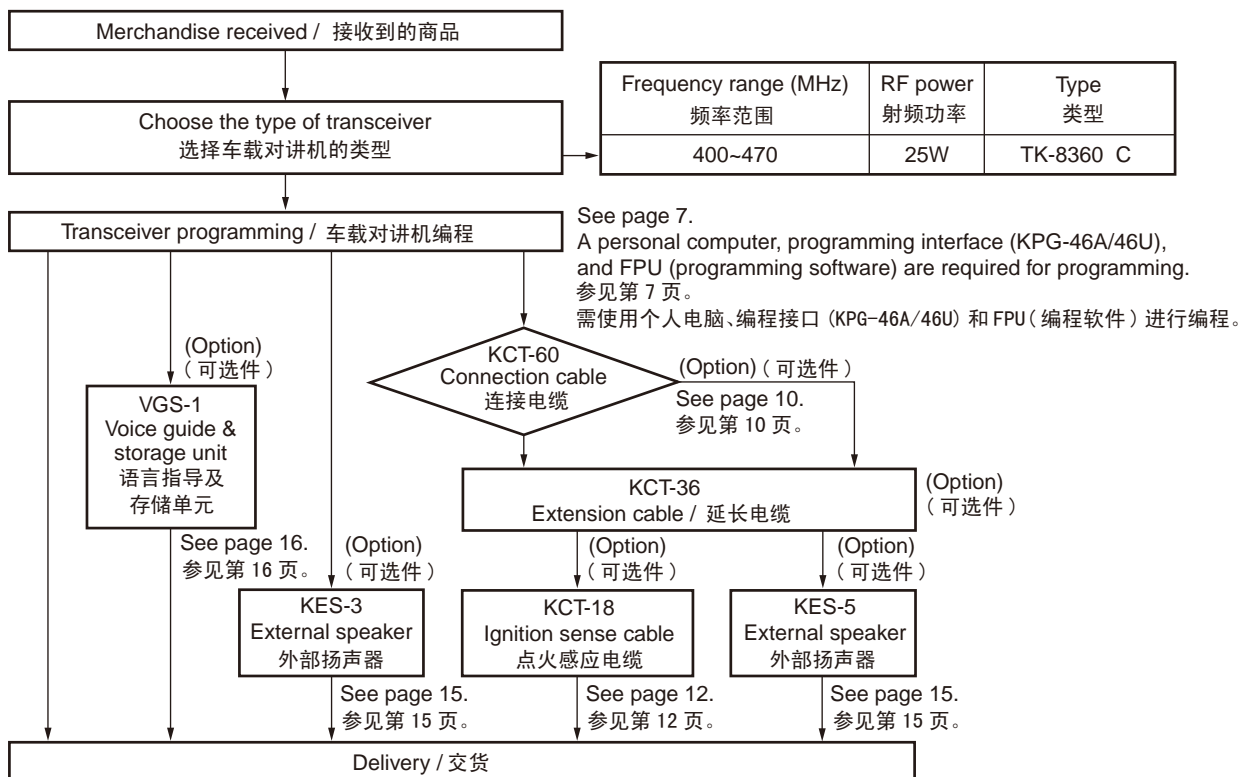

## REALIGNMENT / 模式组合

## 1. Modes

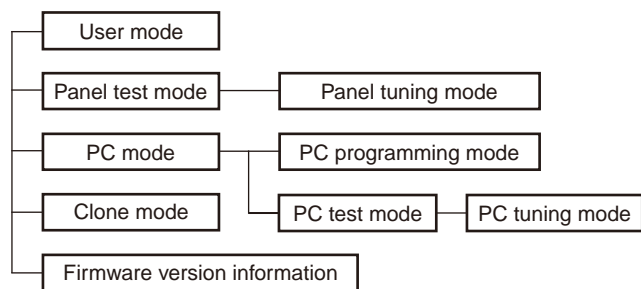

Mode	Function
User mode	For normal use.
Panel test mode	Use by the dealer to check the fundamental characteristics.
Panel tuning mode	Used by the dealer to tune the transceiver.
PC mode	Used for communication between the transceiver and PC.
PC programming mode	Used to read and write frequency data and other features to and from the transceiver.
PC test mode	Used to check the transceiver using the PC. This feature is included in the FPU.
PC tuning mode	Used to tune the transceiver using the PC.
Clone mode	Used to transfer programming data from one transceiver to another.
Firmware version information	Used to confirm the internal firmware version.

## 2. How to Enter Each Mode

Mode	Operation
User mode	Power ON
Panel test mode	[A]+Power ON
Panel tuning mode	Panel test mode+[s]
PC mode	Received commands from PC
Clone mode	[<B]+Power ON (One second)
Firmware version information	[Δ]+Power ON

## 3. Panel Test Mode

Setting method refer to ADJUSTMENT.

## 4. Panel Tuning Mode

Setting method refer to ADJUSTMENT.

## 1. 模式

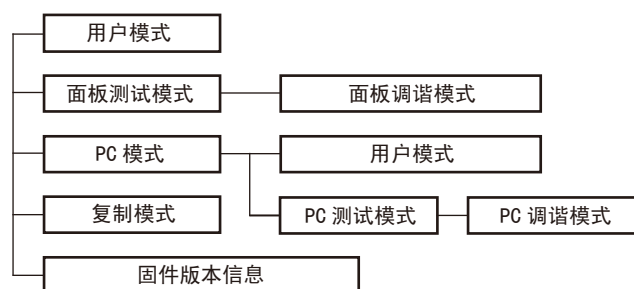

模式	功能
用户模式	一般使用。
面板测试模式	用于经销商检查基本功能。
面板调谐模式	用于经销商调整车载对讲机指标。
PC 模式	用于车载对讲机与 PC 之间的通信。
PC 编程模式	用于阅读和写入频率数据以及其他功能。
PC 测试模式	用于通过 PC 检查车载对讲机。该功能内置于 FPU 中。
PC 调谐模式	用于通过 PC 调谐车载对讲机。
复制模式	用于从一个车载对讲机编程数据复制到另一个车载对讲机。
固件版本信息	用于确认内部固件版本。

## 2. 如何进入每一种模式

模式	操作
用户模式	接通电源
面板测试模式	[ A ]+ 接通电源
面板调谐模式	面板测试模式 + [ s ]
PC 模式	从 PC 接收指令
复制模式	[ < B ]+ 接通电源 (1 秒钟)
固件版本信息	[ Δ ]+ 接通电源

## 3. 关于面板测试模式

关于设定方式，参见调整。

## 4. 关于面板调谐模式

关于设定方式，参见调整。



# REALIGNMENT / 模式组合

## 5. PC Mode

### 5-1. Preface

The transceiver is programmed using a personal computer, a programming interface (KPG-46A/46U, USB adapter (KCT-53U)) and FPU (programming software).

The programming software can be used with a PC. Figure 1 shows the setup of a PC for programming.

### 5-2. Connection procedure

1. Connect the transceiver to the computer using the interface cable and USB adapter (When the interface cable is KPG-46A, the KCT-53U can be used.).

#### Note:

- You must install the KPG-46U driver in the computer to use the USB programming interface cable (KPG-46U).
- You must install the KCT-53U driver in the computer to use the USB adapter (KCT-53U).
- When using the USB adapter (KCT-53U) for the first time, plug the KCT-53U into a USB port on the computer with the computer power ON.

2. When the Power is switched on, user mode can be entered immediately. When the PC sends a command, the transceiver enters PC mode, and "PROGRAM" is displayed on the LCD.

When data is transmitting from the transceiver, the red LED blinks.

When data is receiving by the transceiver, the green LED blinks.

#### Note:

The data stored in the computer must match the "Model Name" when it is written into the EEPROM.

### 5-3. KPG-46A description

#### (PC programming interface cable: Option)

The KPG-46A is required to interface the transceiver to the computer. It has a circuit in its D-sub connector (KPG-46A: 9-pin) case that converts the RS-232C logic level to the TTL level.

The KPG-46A connects the 8-pin microphone connector of the transceiver to the RS-232C serial port of the computer.

### 5-4. KPG-46U description

#### (USB programming interface cable: Option)

The KPG-46U is a cable which connects to a USB port on a computer.

When using the KPG-46U, install the supplied CD-ROM (with driver software) in the computer. The KPG-46U driver runs under Windows XP, Vista or 7.

### 5-5. KCT-53U description (USB adapter: Option)

The KCT-53U is a cable which connects the KPG-46A to a USB port on a computer.

When using the KCT-53U, install the supplied CD-ROM (with driver software) in the computer. The KCT-53U driver runs under Windows 2000, XP or Vista (32-bit).

## 5. PC 模式

### 5-1. 前言

车载对讲机采用个人电脑、编程接口 (KPG-46A/46U, USB 适配器 (KCT-53U)) 和 FPU (编程软件) 进行编程。

编程软件可在 PC 上使用。图 1 说明了 PC 进行编程的设置。

### 5-2. 连接操作

1. 用接口电缆和 USB 适配器将车载对讲机连接到电脑 (接口电缆为 KPG-46A 时, 可以使用 KCT-53U)。

#### 注意:

- 必须在电脑上安装 KPG-46U 驱动程序才能使用 USB 编程接口电缆 (KPG-46U)。
- 必须在电脑上安装 KCT-53U 驱动程序才能使用 USB 适配器 (KCT-53U)。
- 首次使用 USB 适配器 (KCT-53U) 时, 请在电脑电源打开的情况下将 KCT-53U 插入电脑的 USB 端口。

2. 电源打开时, 可以立即进入用户模式。PC 发出命令时, 车载对讲机进入 PC 模式, LCD 上显示 "PROGRAM"。

车载对讲机发送数据时, 红色 LED 闪烁。

车载对讲机接收数据时, 绿色 LED 闪烁。

#### 注意:

电脑保存的数据写入 EEPROM 时, 必须与 "型号名称" 相符。

### 5-3. KPG-46A 说明 (PC 编程接口电缆: 选购件)

将车载对讲机连接到电脑需要 KPG-46A。该电缆的 D-sub 连接器 (KPG-46A: 9 针) 盒具有将 RS-232C 逻辑电平转换为 TTL 电平的电路。

KPG-46A 将车载对讲机的 8 针麦克风连接器连接到电脑的 RS-232C 串行端口。

### 5-4. KPG-46U 说明 (USB 编程接口电缆: 选购件)

KPG-46U 是连接到电脑 USB 端口的电缆。

使用 KPG-46U 时, 请在电脑上安装附带的 CD-ROM (带有驱动程序)。KPG-46U 驱动程序可以在 Windows XP、Vista 或 7 下运行。

### 5-5. KCT-53U 说明 (USB 适配器: 选购件)

KCT-53U 是将 KPG-46A 连接到电脑 USB 端口的电缆。

使用 KCT-53U 时, 请在电脑上安装附带的 CD-ROM (带有驱动程序)。KCT-53U 驱动程序在 Windows 2000、XP 或 Vista (32 位) 下运行。

## REALIGNMENT / 模式组合

## 5-6. FPU (Programming Software) description

The FPU is the programming software for the transceiver supplied on a CD-ROM. This software runs under Windows XP, Vista or 7 on a PC.

The data can be input to or read from the transceiver and edited on the screen. The programmed or edited data can be printed out. It is also possible to tune the transceiver.

## List of FPU for transceiver

Model	Type	FPU
TK-8360	C	KPG-135D(C)

## 5-6. FPU (编程软件) 说明

FPU 是 CD-ROM 附带的用于车载对讲机的编程软件。

该软件在 PC 的 Windows XP, Vista 或 7 下运行。

可在车载对讲机上写入或读取数据，并可在电脑屏幕上进行编辑。可以打印编程或编辑的数据。此外，还可调谐车载对讲机。

## 车载对讲机的 FPU 名单

型号	类型	FPU
TK-8360	C	KPG-135D(C)

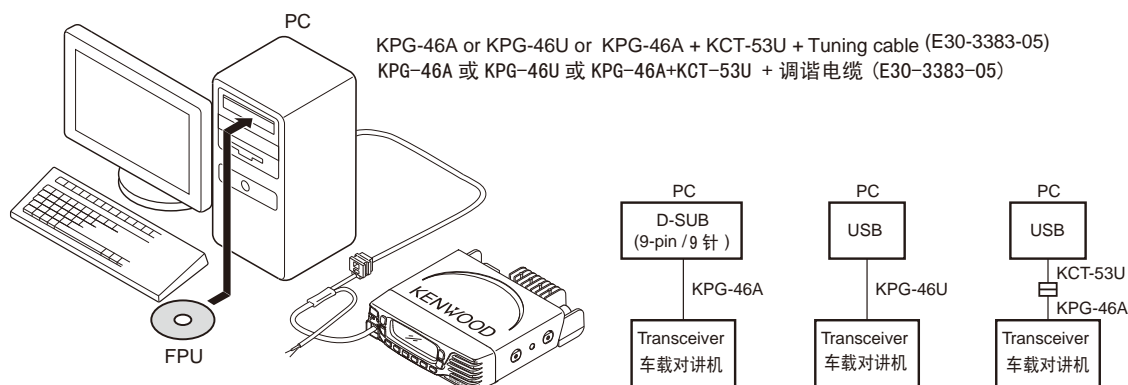

Fig. 1 / 图 1

## 6. Clone Mode

Programming data can be transferred from one transceiver to another by connecting them via their modular microphone jacks. The operation is as follows (the transmit transceiver is the source and the receive transceiver is a target).

## Note :

Clone mode should be enabled.

1. Turn the source transceiver power ON with the [**B**] key held down (1 second), "CLONE MODE" is displayed on the LCD.
2. Power on the target transceiver.
3. Connect the cloning cable (No. E30-3382-05) to the modular microphone jacks on the source and target.
4. Press the [**s**] key on the source transceiver.

The data of the source is sent to the target. While the source is sending data, red LED blinked. While the target is receiving the data, "PROGRAM" is displayed and green LED blinked. When cloning of data is completed, the source displays "END", and the source red LED turned off, and the target automatically operates in the User mode. The target can then be operated by the same program as the source.

5. The other target can be continuously cloned. Carry out the operation in step 2 to 4.

## 6. 复制模式

通过模块化麦克风插孔连接车载对讲机，可以将编程数据从一台传输到另一台。具体操作如下（发射车载对讲机是主机，接收车载对讲机是子机）。

## 注意：

应当启用复制模式。

1. 按住 [**B**] 键 (1 秒) 打开主机的电源, LCD 上显示 "CLONE MODE".
2. 打开子机的电源.
3. 将复制电缆 (编号: E30-3382-05) 连接到主机和子机上的模块化麦克风插孔.
4. 按主机上的 [**s**] 键.  
主机的数据便被发送到子机。主机发送数据时, 红色 LED 将会闪烁。子机接收数据时, 将显示 "PROGRAM" 且绿色 LED 闪烁。数据复制完成后, 主机显示 "END", 主机的红色 LED 熄灭, 子机自动以用户模式运行。然后子机就可以按与主机相同的程序操作.
5. 可以继续对另一台子机进行复制。执行步骤 2 至 4 的操作.



## REALIGNMENT / 模式组合

### 6-1. Adding the data password

If the read authorization password is set in the optional feature menu, you must enter the password (Source transceiver) to activate a clone mode.

You can use 0-9 to configure the password. The maximum length of the password is 6 digits.

1. [**B**]+Power ON.
2. "CLONE LOCK" is displayed on the LCD.
3. If the [**△**] and [**▽**] keys is pressed while "CLONE LOCK" is displayed, numbers (0 to 9) are displayed flashing. When you press the [**C**>] key, the currently selected number is determined. If you press the [**S**] key after entering the password in this procedure, "CLONE MODE" is displayed if the entered password is correct. If the password is incorrect, "CLONE LOCK" is redisplayed.

### 6-1. 添加数据密码

如果在可选功能菜单中设置了读取授权密码，则您必须输入密码（主机）方可激活复制模式。

可使用 0 ~ 9 设置密码。密码最大长度为 6 位。

1. [**B**] + 接通电源。
2. LCD 上显示 "CLONE LOCK"。
3. 如果在显示 "CLONE LOCK" 时按 [**△**] 和 [**▽**] 键，数字 (0 到 9) 闪烁显示。按 [**C**>] 键即可确定当前选择的数字。在此步骤中输入密码后按 [**S**] 键，如果输入的密码正确，则显示 "CLONE MODE"。如果密码不正确，则重新显示 "CLONE LOCK"。

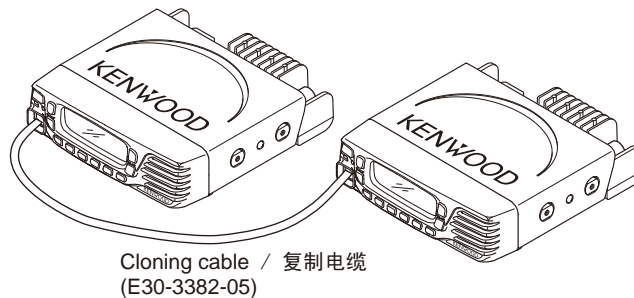
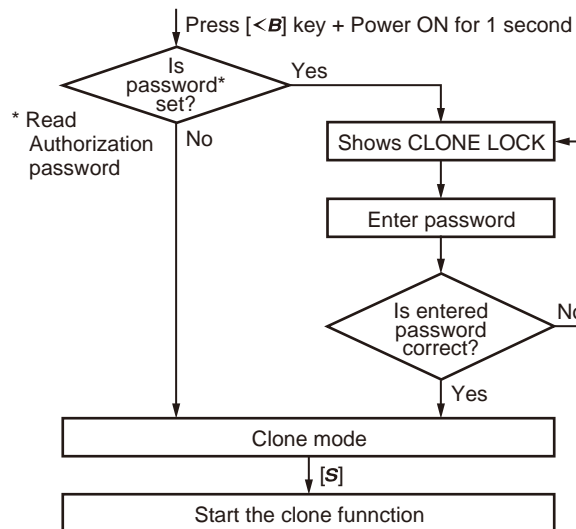
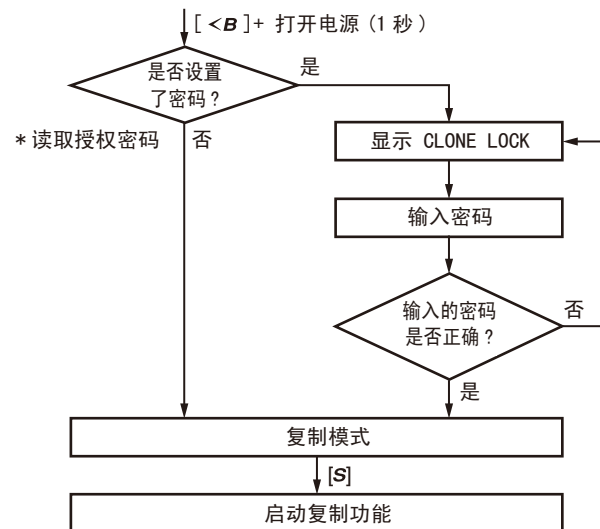

Fig. 2 / 图 2

### 6-2. Flow chart (Source transceiver)



### 6-2. 流程图（主车载对讲机）



## 7. Firmware Version Information

Press and hold the [**△**] key while turning the transceiver power ON and then keep pressing and holding the [**△**] key, the firmware version information appears on the LCD.

## 7. 固件版本信息

打开车载对讲机电源时按住 [**△**] 键，然后一直按住 [**△**] 键，LCD 上便出现固件版本信息。

## INSTALLATION / 安装

### 1. Connection Cable (KCT-60: Option)

The KCT-60 connection cable kit is used to connect the transceiver to a Horn alert cable, KCT-18 (Ignition sense cable), KES-5 (External speaker), or through the KCT-36 extension cable.

#### 1-1. Installing the KCT-60 (Connection cable) in the transceiver

1. Remove the ACC. cap on the rear of the transceiver.
2. Connect the D-sub connector of the KCT-60 to the D-sub 15-pin terminal of the transceiver.
3. Connect the 15-pin connector of the KCT-60 to a Horn alert cable, KCT-18, KES-5, or through a KCT-36 extension cable.

**Note:** You must setup using the KPG-135D(C).

### 1. 连接电缆 (KCT-60: 选配件)

KCT-60 连接电缆组件用于将车载对讲机连接到喇叭提示电缆、KCT-18 (点火感应电缆)、KES-5 (外部扬声器), 或通过 KCT-36 延长电缆连接。

#### 1-1. 在车载对讲机上安装 KCT-60 (连接电缆)

1. 拆下车载对讲机后部的 ACC. 盖。
2. 将 KCT-60 的 D-sub 连接器连接到车载对讲机的 D-sub 15 针端子。
3. 将 KCT-60 的 15 针连接器连接到喇叭提示电缆、KCT-18、KES-5, 或通过 KCT-36 延长电缆。

**注意:** 必须使用 KPG-135D(C) 进行设置。

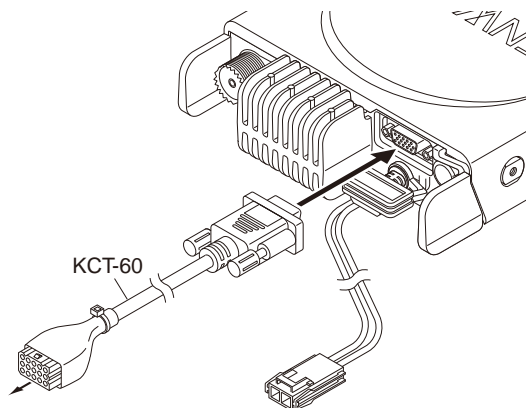

Horn alert cable, KCT-18, KES-5 or through KCT-36 extension cable  
喇叭提示电缆、KCT-18、KES-5 或通过 KCT-36 延长电缆

#### 1-2. Terminal function

D-sub 15-pin Pin No.	Function	Molex 15-pin Pin No.
1	SB	1
2	IGN	2
3	PA or EXT-SP	12
4	DO	4
5	DI	5
6	FNC1	9
7	FNC2	11
8	FNC3	7
9	FNC4	6
10	FNC5	8
11	FNC6	10
12	5C	-
13	HR1	13
14	HR2	14
15	GND	3

#### 1-2. 端子功能

D-sub 15 针脚号	名称	Molex 15 针脚号
1	SB	1
2	IGN	2
3	PA or EXT-SP	12
4	DO	4
5	DI	5
6	FNC1	9
7	FNC2	11
8	FNC3	7
9	FNC4	6
10	FNC5	8
11	FNC6	10
12	5C	-
13	HR1	13
14	HR2	14
15	GND	3

## INSTALLATION / 安装

### 2. Horn Alert Function

The Horn alert function (max. 2A drive) is enabled by installing the KCT-60 in the transceiver.

#### 2-1. Installation Procedure

1. Remove the chip resistor R863 (4.7kΩ) on the TX-RX unit before installing the KCT-60 in the transceiver.

#### Combination of Horn alert function and Ignition function

R863	KCT-18	Horn alert function	Ignition function	
Present	Absent	Always inactive	Inactive	Default
Absent	Present	Active when ignition is off	Active	
Absent	Absent	Always active	Transceiver cannot be turned on if the ignition function is set	
Present	Present	Do not use this configuration	Do not use this configuration	

### 2. 喇叭提示功能

在车载对讲机上安装 KCT-60，可使用喇叭提示功能（最大 2A 驱动）。

#### 2-1. 安装步骤

1. 在车载对讲机上安装 KCT-60 之前，拆下收发单元上的片状电阻器 R863 (4.7kΩ)。

#### 喇叭提示功能和点火功能的组合

R863	KCT-18	喇叭提示功能	点火功能	
装有	没有	一直无效	无效	默认
没有	装有	点火器关闭状态时有效。	有效	
没有	没有	一直有效	如果点火功能设置有效时车载对讲机不能开机。	
装有	装有	请勿使用这个设置。	请勿使用这个设置。	

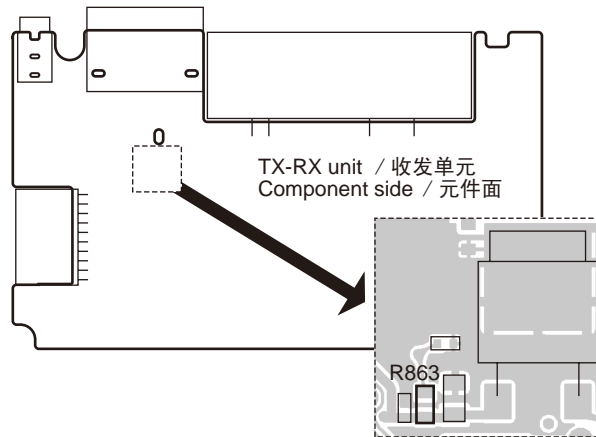

2. Remove the ACC. cap on the rear of the transceiver.
3. Connect the D-sub connector of the KCT-60 to the D-sub 15-pin terminal of the transceiver.
4. Insert the two crimp terminals of the Horn alert cable to pins 13 and 14 of the square plug.
5. Connect the square plug to the 15-pin connector of the KCT-60.
6. Connect the remaining two Horn alert cables to your car Horn alert signal control.

The internal FET switch can be controlled by turning the HA function on/off and by using a signaling decode output. The maximum current of HA is 2A. This FET switch is the open drain circuit. Therefore, a DC power supply is necessary to use the HR1. The voltage range is from 5V to 16V.

2. 拆下车载对讲机后部的 ACC. 盖。
3. 将 KCT-60 的 D-sub 连接器连接到车载对讲机的 D-sub 15 针端子。
4. 将喇叭提示电缆的两个压接式端子插入方形插头的针脚 13 和 14。
5. 将方形插头连接到 KCT-60 的 15 针连接器。
6. 将剩下的两条喇叭提示电缆连接到汽车的喇叭提示信号控制。

内部 FET 开关可通过打开 / 关闭 HA 功能和使用信令解码输出进行控制。HA 的最大电流为 2A。此 FET 开关属于开漏电路。因此，需 DC 电源方可使用 HR1。电压范围为 5V 至 16V。

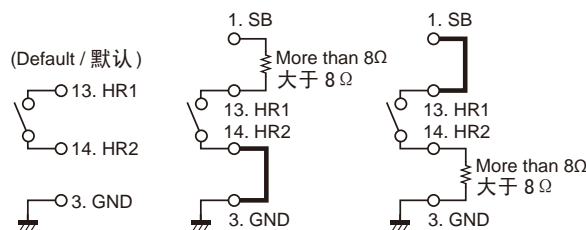

## INSTALLATION / 安装

**Note:** You must set up using the KPG-135D(C).

注意：必须使用 KPG-135D(C) 进行设置。

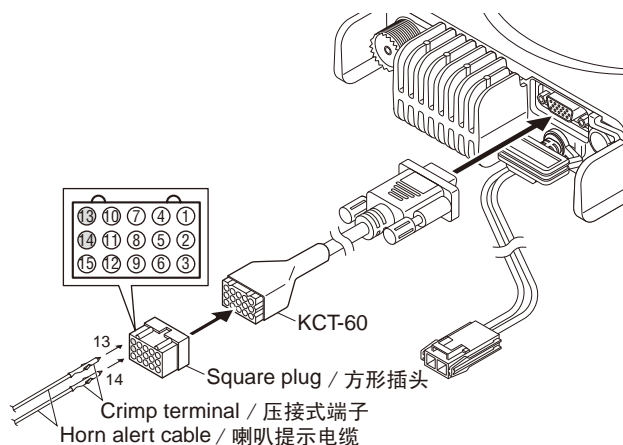

### 3. Ignition Sense Cable (KCT-18: Option)

The KCT-18 is an optional cable for enabling the ignition function. The ignition function lets you turn the transceiver power on and off with the car ignition key.

### 3. 点火感应电缆（KCT-18：选配件）

KCT-18 为用于启用点火功能的选配件。点火功能让您能够通过汽车点火钥匙打开和关闭车载对讲机的电源。

#### 3-1. Installing the KCT-18 (Ignition sense cable) in the transceiver

1. The KCT-18 can be installed in the transceiver by the following two methods (Method A, Method B).

Method A: The KCT-18 is soldered to the "IGN" pad on the TX-RX unit.

Method B: The KCT-18 is connected to the 15-pin connector of the KCT-60 connected to the transceiver.

#### 3-1. 在车载对讲机上安装 KCT-18（点火感应电缆）

1. KCT-18 可通过以下两种方法安装在车载对讲机上（方法 A、方法 B）。

方法 A: 将 KCT-18 焊接到收发单元的“IGN”盘上。

方法 B: 将 KCT-18 连接到与车载对讲机相连的 KCT-60 的 15 针连接器上。

#### ■ Installation Procedure: Method A

1. Remove the two screws on both the right and left sides of the transceiver, then remove the cabinet and top packing from the transceiver.
2. Remove the chip resistor R863 (4.7kΩ) on the TX-RX unit.

#### ■ 安装步骤：方法 A

1. 卸下车载对讲机左右两侧的两颗螺丝，然后拆下车载对讲机的机壳和顶盖。
2. 拆下收发单元上的片状电阻器 R863 (4.7kΩ)。

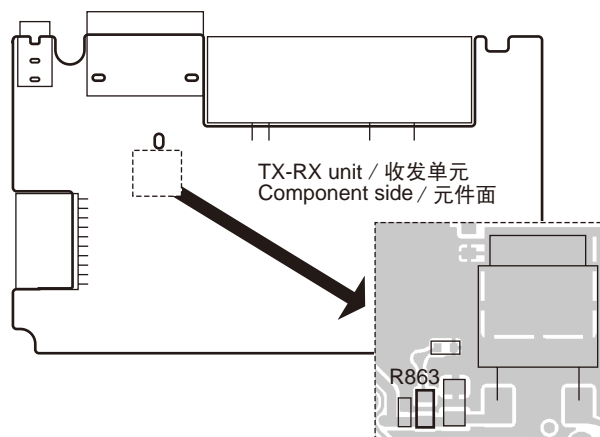

# INSTALLATION / 安装

3. Cut the crimp terminal side of the KCT-18 using a pair of nippers or similar tool.

3. 用钳子或类似工具剪切 KCT-18 的压接式端子侧。

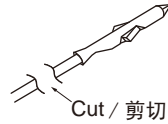

4. Solder the cable side cut in the above step 3 to the "IGN" pad on the TX-RX unit.

4. 将上述步骤 3 中剪切的电缆端焊接到收发单元上的 "IGN" 盘。

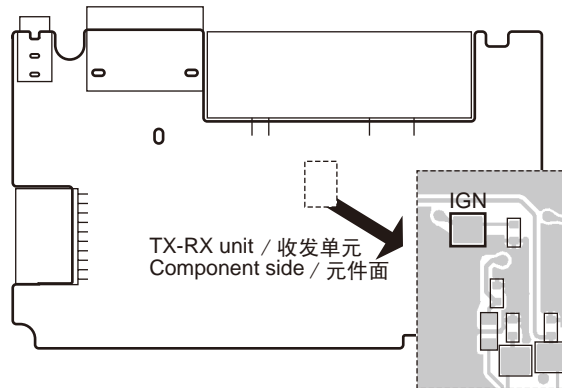

5. Dress the KCT-18 cable as shown in the figure. The KCT-18 cable needs to pass through one of two indentations located on the rear panel of the transceiver.

5. 如图所示对 KCT-18 电缆进行布线。KCT-18 电缆需要穿过位于车载对讲机后部的两个凹入部之一。

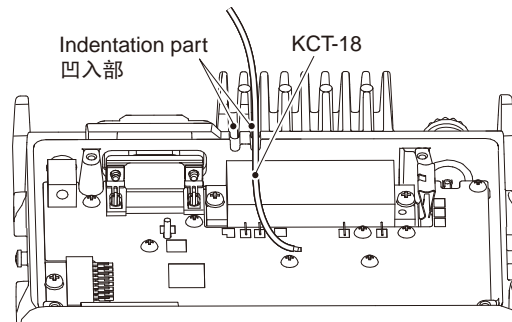

6. Cut off the projection of the top packing using a pair of nippers or similar tool.

6. 用钳子或类似工具切掉顶盖的突出部。

If the KCT-18 cable is dressed to be routed through the indentations on the right side in step 5, the right side of the projection needs to be cut off. If the KCT-18 cable is dressed to be routed through the indentations on the left side, the left side of the projection needs to be cut off. Following is a figure presenting an example for when the right side of the projection is cut off.

如果在步骤 5 中使 KCT-18 电缆通过右侧的凹入部，则需要切掉突出部的右侧。如果使 KCT-18 电缆通过左侧的凹入部，则需要切掉突出部的左侧。

下图显示的是切掉突出部右侧的示例。



7. Reinstall the top packing. Check the correct fitting of the top packing, then reinstall the cabinet and two screws for the right and left sides.

7. 重新安装顶盖。检查顶盖装配是否正确，然后，重新安装机壳和左右两侧的两颗螺丝。

8. Connect the other side of the KCT-18 to the ignition line of the car.

8. 将 KCT-18 的另一端连接到汽车点火线。

## INSTALLATION / 安装

### ■ Installation Procedure: Method B

1. Remove the two screws on both the right and left sides of the transceiver, then remove the cabinet and top packing from the transceiver.
2. Remove the chip resistor R863 (4.7kΩ) on the TX-RX unit.

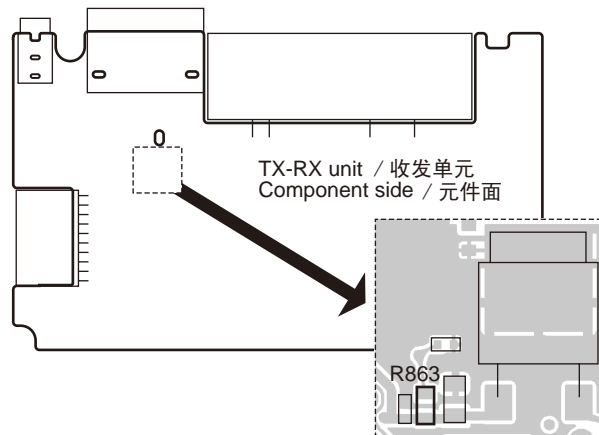

### ■ 安装步骤：方法 B

1. 卸下车载对讲机左右两侧的两颗螺丝，然后拆下车载对讲机的机壳和顶盖。
2. 拆下收发单元上的片状电阻器 R863 (4.7kΩ)。

3. Remove the ACC. cap on the rear of the transceiver.
4. Connect the D-sub connector of the KCT-60 to the D-sub 15-pin terminal of the transceiver.
5. Insert the crimp terminal side of the KCT-18 to pin 2 of the square plug.
6. Connect the square plug to the 15-pin connector of the KCT-60.
7. Connect the other side of the KCT-18 to the ignition line of the car.

3. 拆下车载对讲机后部的 ACC. 盖。
4. 将 KCT-60 的 D-sub 连接器连接到车载对讲机的 D-sub 15 针端子。
5. 将 KCT-18 的压接式端子侧插入方形插头的针脚 2。
6. 将方形插头连接到 KCT-60 的 15 针连接器。
7. 将 KCT-18 的另一端连接到汽车点火线。

**Note:** You must set up using the KPG-135D(C).

**注意：** 必须使用 KPG-135D (C) 进行设置。

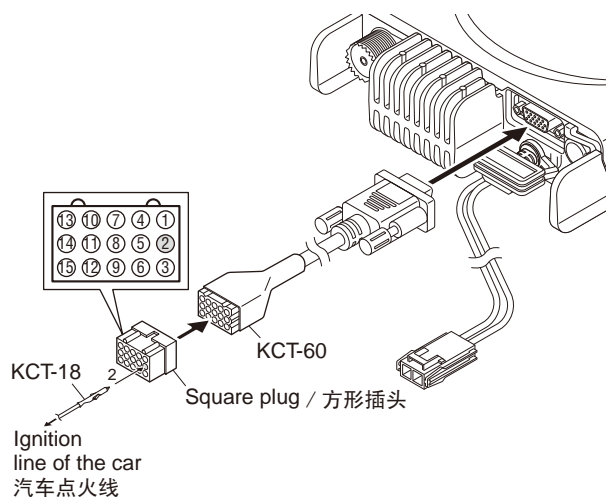



# INSTALLATION / 安装

## 4. External Speaker (Option)

### 4-1. KES-3

The KES-3 is an external speaker for the 3.5-mm-diameter speaker jack.

#### ■ Connection procedure

1. Remove the speaker-jack cap on the rear of the transceiver.
2. Connect the KES-3 to the 3.5-mm-diameter speaker jack on the rear of the transceiver.

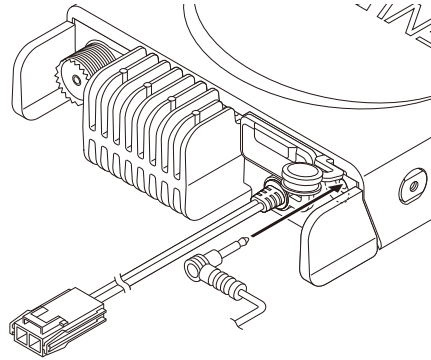

## 4. 外部扬声器（选购件）

### 4-1. KES-3

KES-3 是用于直径 3.5mm 扬声器插孔的外部扬声器。

#### ■ 连接步骤

1. 拆下车载对讲机后部的扬声器插孔盖。
2. 将 KES-3 连接到车载对讲机后部的直径 3.5mm 扬声器插孔。

### 4-2. KES-5

External speaker KES-5 can be installed for KCT-60.

#### ■ Connection procedure

1. Remove the ACC. cap on the rear of the transceiver.
2. Connect the D-sub connector of the KCT-60 to the D-sub 15-pin terminal of the transceiver.
3. Insert the two crimp terminals of the KES-5 to pins 3 and 12 of the square plug.
4. Connect the square plug to the 15-pin connector of the KCT-60.

#### Note:

You must set up using the KPG-135D(C).  
Before the external speaker can be used, you must assign one of the keys as "External Speaker", using the KPG-135D(C).

### 4-2. KES-5

外部扬声器 KES-5 可安装于 KCT-60。

#### ■ 连接步骤

1. 拆下车载对讲机后部的 ACC. 盖。
2. 将 KCT-60 的 D-sub 连接器连接到车载对讲机的 D-sub 15 针端子。
3. 将 KES-5 的两个压接式端子插入方形插头的针脚 3 和 12。
4. 将方形插头连接到 KCT-60 的 15 针连接器。

#### 注意：

必须使用 KPG-135D(C) 进行设置。  
必须使用 KPG-135D(C) 将某个键指定为“外部扬声器”，方可使用外部扬声器。

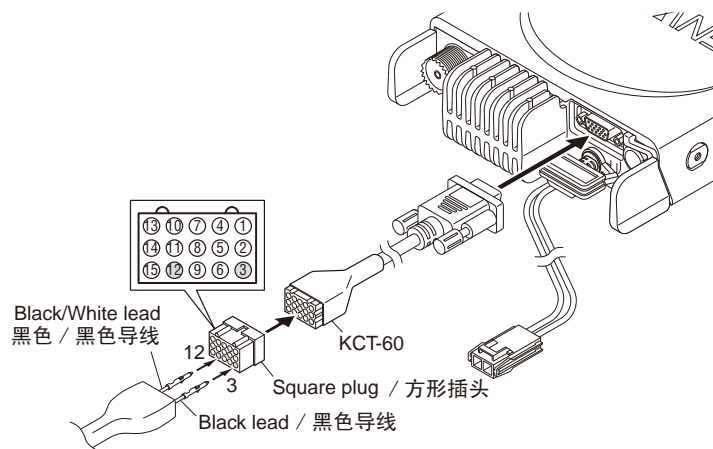

## INSTALLATION / 安装

### 5. Voice Guide & Storage Unit (VGS-1: Option)

#### 5-1. Installing the VGS-1 unit in the transceiver

1. Remove the two screws on both sides of the transceiver, then remove the cabinet and top packing from the transceiver.
2. Remove the cover fitted into the TX-RX unit connector (CN700).
3. Attach two cushions to VGS-1
4. Insert the VGS-1 connector (CN1) into the TX-RX unit connector (CN700).

**Note:** You must set up using the KPG-135D(C).

### 5. 语言指导及存储单元 (VGS-1: 选配件)

#### 5-1. 在车载对讲机中安装 VGS-1 单元

1. 卸下车载对讲机左右两侧的两颗螺丝，然后拆下车载对讲机的机壳和顶盖。
2. 取下收发单元连接器 (CN700) 上的所有盖子。
3. 如图所示，将缓冲垫安装到 VGS-1 上。
4. 将 VGS-1 连接器 (CN1) 插入收发单元连接器 (CN700)。

注意：必须使用 KPG-135D (C) 进行设置。

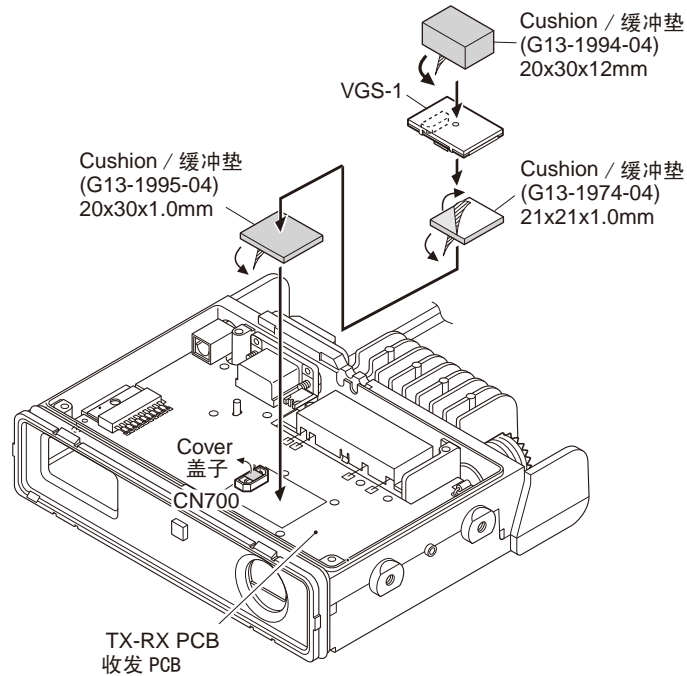

# INSTALLATION / 安装

## 6. GPS Receiver Connection

### 6-1. Installing the GPS receiver

1. Solder each cable of the connector cables to the TX-RX unit.

- Red cable

The red cable needs to be connected to the solder pad (5M) on the TX-RX unit.

- Yellow cable

The yellow cable needs to be connected to the solder pad GPS (RS-232C-RXD) on the TX-RX unit.

- Black cable

The black cable needs to be connected to the solder pad (GND) on the TX-RX unit.

## 6. GPS 接收机连接

### 6-1. 安装 GPS 接收机

1. 将 GPS 接收机的各条电缆焊接到收发单元。

- 红色电缆

红色电缆需连接到收发单元的焊盘 (5M)。

- 黄色电缆

黄色电缆需连接到收发单元的焊盘 GPS (RS-232C-RXD)。

- 黑色电缆

黑色电缆需连接到收发单元的焊盘 (GND)。

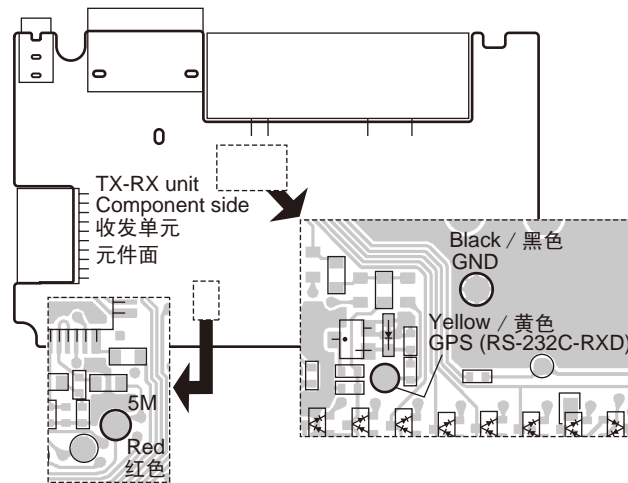

**Note:** You must set up using the KPG-135D(C).

注意：必须使用 KPG-135D(C) 进行设置。

## 7. Extended Function: COM Port 0 and COM Port 1

Location of COM Port 0 and COM Port 1 of the transceiver is shown below.

## 7. 扩展功能：COM 端口 0 和 COM 端口 1

车载对讲机的 COM 端口 0 和 COM 端口 1 的位置如下所示。

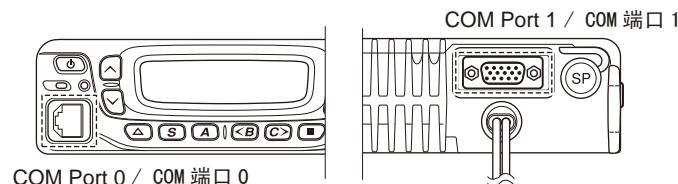

You must configure the transceiver COM Port 0 and COM Port 1 using the KPG-135D(C).

When set as "Data", the Function port 1 and 2 will be automatically fixed as Input ports. The reason for this is because function port 1 (TXD) and 2 (RXD) share the same circuit path of TXD and RXD line.

必须使用 KPG-135D(C) 配置车载对讲机的 COM 端口 0 和 COM 端口 1。

设置为“数据”时，功能端口 1 和 2 会自动固定为输入端口。这是因为功能端口 1 (TXD) 和 2 (RXD) 与 TXD 和 RXD 线路共用同一条电路通道。

## INSTALLATION / 安装

## 8. Changing Serial Port Level

## 8-1. Change FNC2 (RXD) of D-SUB 15-pin connector from TTL level to RS-232C level

FNC2 (RXD) of D-SUB 15-pin connector is configured at the TTL level as the default value. But you can change this serial port level to RS-232C level by configuring the port.

Remove the R726 chip jumper and solder the clip jumper to R727.

## 8-2. Change FNC1 (TXD) and FNC2 (RXD) of D-SUB 15-pin connector from TTL level to RS-232C level

FNC1 (TXD) and FNC2 (RXD) of D-SUB 15-pin connector are configured at the TTL level as the default value. But you can change these serial port level to RS-232C level through the RS-232C level converter IC (IC700) by configuring the port.

Remove the R760 and R761 chip jumpers and solder the chip jumpers to R752, R753, R767 and R768.

## 8. 改变串行接口电平

## 8-1. 将 FNC2 (RXD) 的 D-SUB 15 针连接器从 TTL 电平转换到 RS-232C 电平

FNC2 (RXD) 的 D-SUB 15 针连接器被默认设置在 TTL 电平。但可以通过端口设置将此串行接口换到 RS-232C 电平。

从 R726 跳线至 R727。

## 8-2. 将 D-SUB 15 针连接器的 FNC1 (TXD) 和 FNC2 (RXD) 从 TTL 电平转换到 RS-232C 电平

D-SUB 15 针连接器的 FNC1 (TXD) 和 FNC2 (RXD) 默认设置在 TTL 电平。但可以通过端口设置将这些串行端口电平通过 RS-232C 档位转换器 IC (IC700) 转换至 RS-232C 电平。

从 R760 和 R761 跳线至 R752, R753, R767 和 R768。

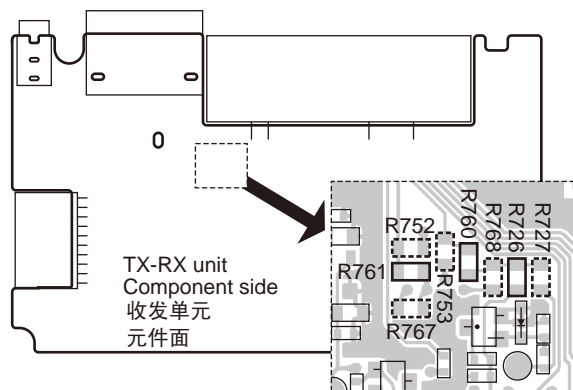

## ■ In the case of 8-1.

## [TTL level]

R726, R760 and R761: 0Ω chip jumper.  
R727, R752, R753, R767 and R768: open.

## [RS-232C level]

R727, R760 and R761: 0Ω chip jumper.  
R726, R752, R753, R767 and R768: open.

## ■ In the case of 8-2.

## [TTL level]

R726, R760 and R761: 0Ω chip jumper.  
R727, R752, R753, R767 and R768: open.

## [RS-232C level]

R726, R752, R753, R767 and R768: 0Ω chip jumper.  
R727, R760 and R761: Open.

## ■ 8-1 の場合

## [TTL 电平]

R726, R760 和 R761: 0Ω 贴片电阻。  
R727, R752, R753, R767 和 R768: 断开。

## [RS-232C 电平]

R727, R760 和 R761: 0Ω 贴片电阻。  
R726, R752, R753, R767 和 R768: 断开。

## ■ 8-2 の場合

## [TTL 电平]

R726, R760 和 R761: 0Ω 贴片电阻。  
R727, R752, R753, R767 和 R768: 断开。

## [RS-232C 电平]

R726, R752, R753, R767 和 R768: 0Ω 贴片电阻。  
R727, R760 和 R761: 断开。

# DISASSEMBLY FOR REPAIR / 维修拆卸

## 1. Disassembly Procedure

1. When removing the cabinet, first remove the two screws from the right and left with a phillips screwdriver. Then, hook your finger on the edge of the cabinet and pull it out until it is over the chassis protrusion. Remove the cabinet by prying the cabinet as shown below.

## 1. 拆卸步骤

1. 拆卸机壳时，应先用十字螺丝刀卸下左右两侧的两颗螺丝。然后，用手指勾住机壳边缘将其拉出，直至其位于底座突出部上方。如下图所示撬动机壳将其取下。

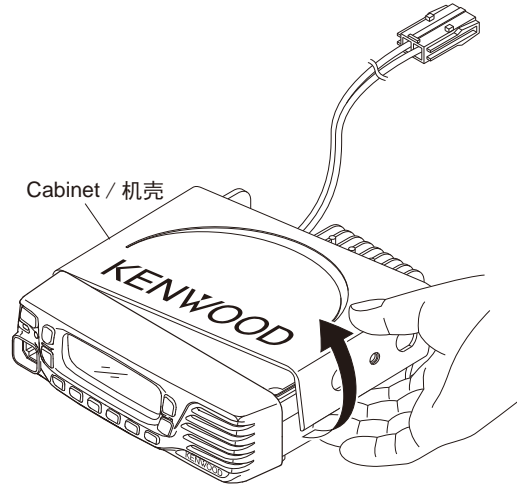

2. To remove the panel assembly, first turn the transceiver upside down. Then, insert a flat-head screwdriver into the holes of the chassis and tilt it in the direction as shown by the arrow.

2. 要拆卸面板组件，应先将车载对讲机颠倒放置。然后，将一字螺丝刀插入底座的孔内，使其按箭头所示的方向倾斜。

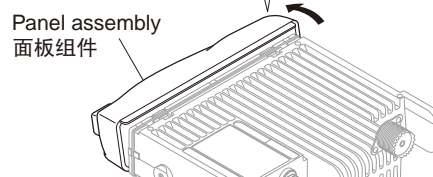
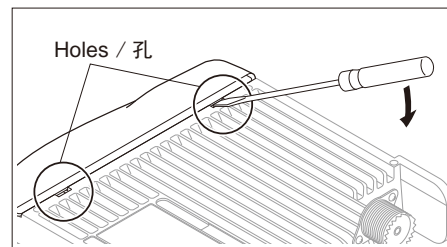

3. Disconnect the flat cable from connector of the panel assembly.

3. 从面板组件的连接器断开带状电缆。

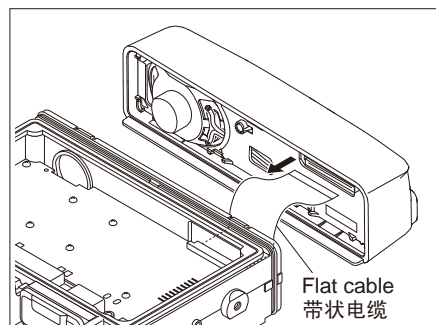

## DISASSEMBLY FOR REPAIR / 维修拆卸

4. Hook the finger to hole and while pulling the speaker holder to this side, expand the panel side of ① to ③, and remove the speaker holder from the front panel.

4. 拇指放入如图所示的洞孔中，然后同时拉起扬声器座和拉开面板的①到③处，就可以从面板上卸下扬声器座。

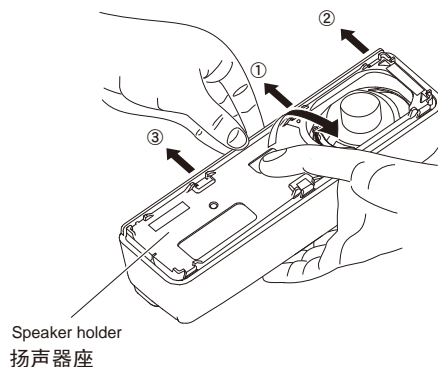

5. When removing the TX-RX PCB, first remove the top packing. Then, remove the solder of the antenna hot pin and positive terminal of the DC cord. Remove the 15 screws from the TX-RX PCB, power module, and audio amp.

5. 拆卸收发 PCB 时，应先拆下顶盖。然后，除去天线热端和直流电源线的正极端子的焊锡。拆下收发 PCB、功率模块和音频放大器上的 15 颗螺丝。

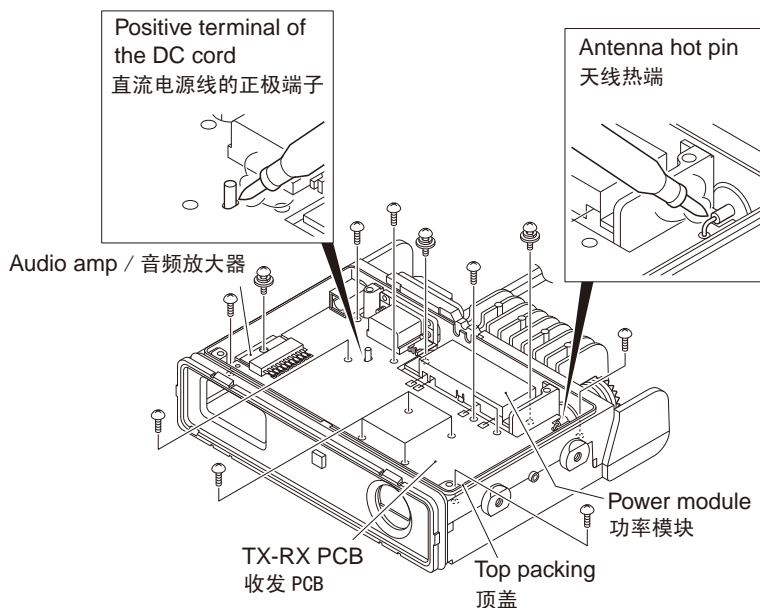

### Note:

When you supply power to the TX-RX PCB after removing the TX-RX PCB from the chassis, solder the positive and ground terminals of the DC cord (Recommendation: E30-3448-25) to the + and GND terminals of the TX-RX PCB.

### 注意：

从底座上拆下收发 PCB 之后对收发 PCB 供电时，将直流电源线（推荐：E30-3448-25）的正极和接地端子焊接到收发 PCB 的 + 和 GND 端子。



## DISASSEMBLY FOR REPAIR / 维修拆卸

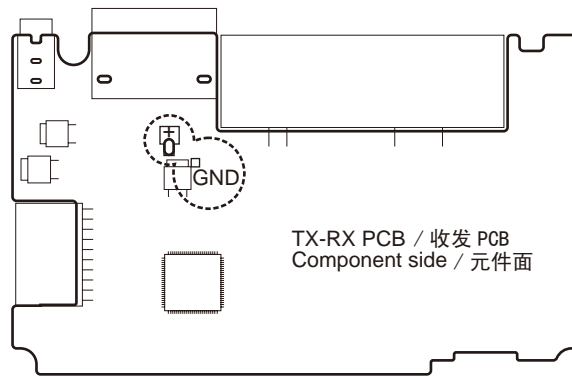

6. Pull it out behind the chassis by rotating the bush ③ of the DC cord 90 degrees in the direction of the arrow after the screw ① in the negative terminal is removed, and the positive terminal ② is removed from the chassis.

6. 拆下负极端子的螺丝①，并从底座上拆下正极端子②之后，将直流电源线的套管③以箭头方向旋转 90 度，将其拉出至底座后面。

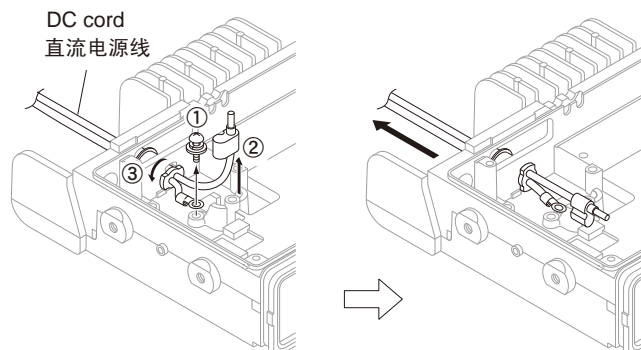

## 2. Precautions for Reassembly

1. The tab from ① to ③ is applied the front panel first. And, ④ to ⑥ tabs inside the front panel is pushed.

## 2. 重新组装注意事项

1. 首先放下①到③的凸起部，然后再按住④到⑥的凸起部。

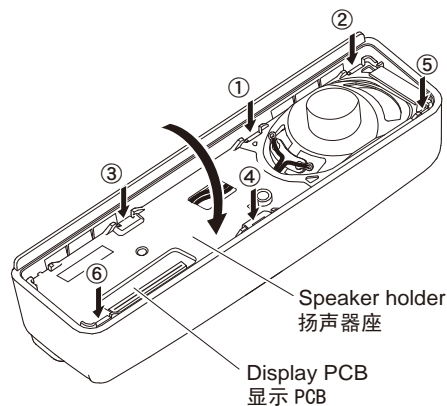

## DISASSEMBLY FOR REPAIR / 维修拆卸

2. When mounting the panel assembly, pass the flat cable through the hole of the chassis as shown below then connect the flat cable to connector of the panel assembly.

2. 安装面板组件时，如下图所示将带状电缆穿过底座的孔，然后将带状电缆连接到面板组件的连接器。

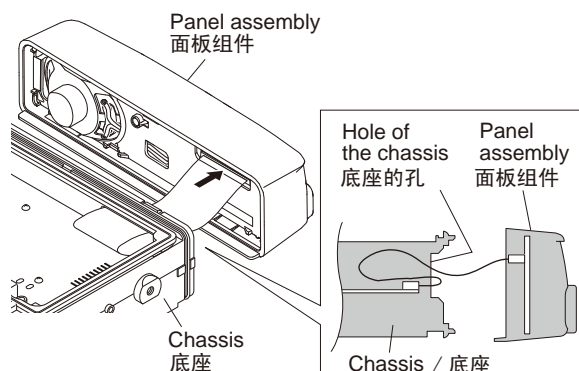

3. Fit the panel assembly into the two tabs of the chassis top side first. Then, fit the panel assembly into the two tabs of the chassis bottom side by turning the panel assembly.

3. 先将面板组件装配到底座顶侧的两个凸起内。然后，再通过转动面板组件，将面板组件装配到底座底侧的两个凸起内。

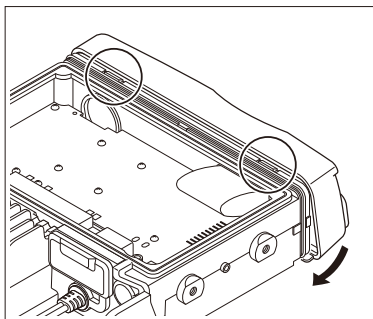

### 3. Correspondence when replacing the LED (D22 and D23)

When replacing the LED (D22 and D23), it makes it to length.

### 3. 更换 LED (D22 和 D23) 时的相应操作

更换 LED (D22 和 D23) 时，将 LED 的引线截到如下图所的尺寸。

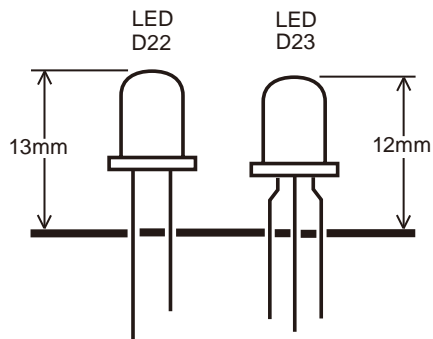

# CIRCUIT DESCRIPTION / 电路说明

## 1. Frequency Configuration

The receiver utilizes double conversion. The first IF is 38.85MHz and the second IF is 450kHz. The first local oscillator signal is supplied from the PLL circuit.

The PLL circuit in the transmitter generates the necessary frequencies. Figure 1 shows the frequencies.

## 1. 频率构成

接收机采用二次转换。第一中频为 38.85MHz，第二中频为 450kHz。第一本地振荡器信号由 PLL 电路提供。

发射机内的 PLL 电路生成必要的频率。图 1 显示了有关频率。

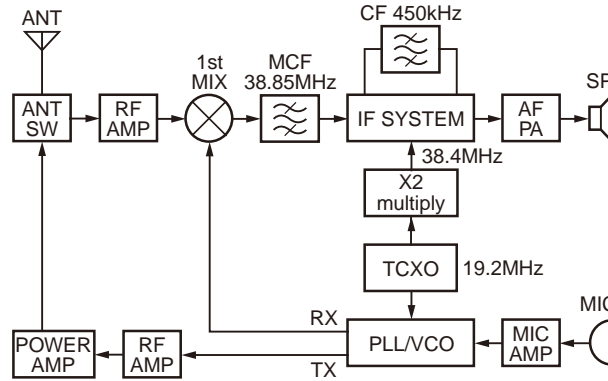

Fig. 1 Frequency configuration / 图 1 频率构成

## 2. Receiver System

The receiver is a double conversion superheterodyne.

The frequency configuration is shown in Figure 1.

## 2. 接收机系统

接收机为二次变频超外差方式。

频率构成如图 1 所示。

### 2-1. Front-end RF Amplifier

An incoming signal from the antenna is applied to an RF amplifier (Q511) after passing through the transmit/receive switch circuit (D303, D304, D307 and D311), BPF (L518, L519 and varactor diodes: D506, D507) and the Notch filter (L523 and varactor diode: D508). The Notch filter function is to eliminate the image frequency.

After the signal is amplified (Q511), the signal is filtered by the bandpass (L512, L513, L514 and varactor diodes: D503, D504, D505) to eliminate unwanted signals before it is passed to the first mixer.

The voltage of these diodes are controlled by tracking the MCU (IC704) center frequency of the bandpass filter. (See Figure 2)

### 2-1. 前端 RF 放大器

来自天线的信号在通过发射 / 接收切换电路 (D303、D304、D307 和 D311) 和 BPF (L518、L519 和变容二极管 :D506、D507) 和陷波滤波器 (L523 和变容二极管 :D508) 之后, 被施加到 RF 放大器 (Q511)。

信号被放大之后 (Q511), 在通过第一混频器之前, 由 BPF (L513 和变容二极管 :D504、D505) 进行滤波以消除不需要的信号。

通过对 BPF 的 MCU (IC704) 中心频率的跟踪, 对这些二极管的电压加以控制。(参看图 2)

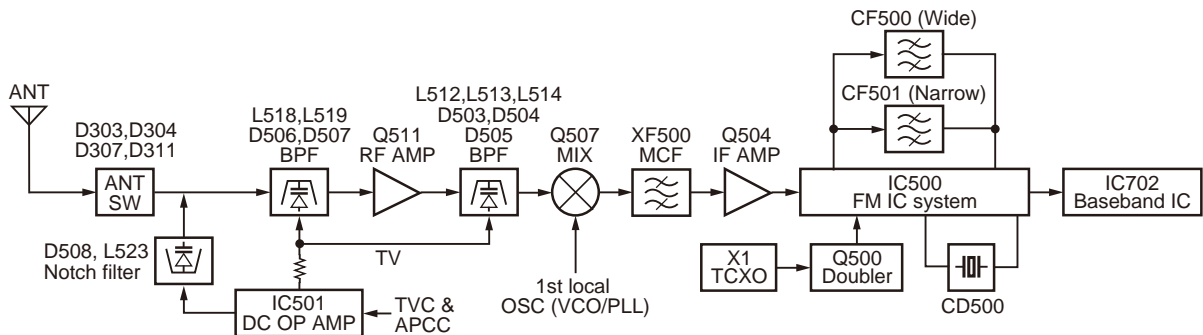

Fig. 2 Receiver System / 图 2 接收机系统

## CIRCUIT DESCRIPTION / 电路说明

## 2-2. First Mixer

The signal from the RF amplifier is heterodyned with the first local oscillator signal from the PLL frequency synthesizer circuit at the first mixer (Q507) to create a 38.85MHz first intermediate frequency (1st IF) signal. The first IF signal is then fed through one pair of monolithic crystal filters (MCF: XF500) to further remove spurious signals.

Item	Rating
Nominal center frequency	38.85MHz
Pass bandwidth	$\pm 6.0\text{kHz}$ or more at 3dB
40dB stop bandwidth	$\pm 25.0\text{kHz}$ or less
Ripple	1.0dB or less
Insertion loss	4.0dB or less
Guaranteed attenuation	75dB (-900kHz); 50dB (+900kHz)
	Spurious: 40dB or more within $f_o \pm 1\text{MHz}$
Terminal impedance	$610\Omega // 3.0\text{pF} // \text{Coupling Cap } 13.0\text{pF}$

Table 1 Crystal filter (L71-0659-05): XF500

## 2-3. IF Amplifier Circuit

The first IF signal is amplified by Q504, and enters IC500 (FM processing IC). The signal is heterodyned again with a second local oscillator signal within IC500 to create a 450kHz second IF signal. The second IF signal is then fed through a 450kHz ceramic filter (Wide: CF500, Narrow: CF501) to further eliminate unwanted signals before it is amplified and demodulated by the quadrature detector with the ceramic discriminator (CD500).

Item	Rating
Nominal center frequency	450kHz
6dB bandwidth	$\pm 6.0\text{kHz}$ or more
50dB bandwidth	$\pm 12.5\text{kHz}$ or less
Ripple	2.0dB or less
Insertion loss	6.0dB or less
Guaranteed attenuation	35.0dB or more within $f_o \pm 100\text{kHz}$
Terminal impedance	$2.0\text{k}\Omega$

Table 2 Ceramic filter (L72-0993-05): CF500

Item	Rating
Nominal center frequency	450kHz
6dB bandwidth	$\pm 4.5\text{kHz}$ or more
50dB bandwidth	$\pm 10.0\text{kHz}$ or less
Ripple	2.0dB or less
Insertion loss	6.0dB or less
Guaranteed attenuation	60.0dB or more within $f_o \pm 100\text{kHz}$
Terminal impedance	$2.0\text{k}\Omega$

Table 3 Ceramic filter (L72-0999-05): CF501

## 2-2. 第一混频器

RF 放大器的信号与 PLL 频率合成器电路的第一本地振荡器信号在第一混频器 (Q507) 进行外差, 产生 38.85MHz 的第一中频 (1st IF) 信号。第一中频信号随后通过一对单片晶体滤波器 (MCF: XF500) 以进一步消除杂散信号。

项 目	额 定
标称中心频率	38.85MHz
通过带宽	3dB 时 $\pm 6.0\text{kHz}$ 或更大
40dB 阻带宽度	$\pm 25.0\text{kHz}$ 或更小
纹波	1.0dB 或更小
插入损耗	4.0dB 或更小
保证衰减	75dB (-900kHz); 50dB (+900kHz)
	杂散: 40dB 或以上, $f_o \pm 1\text{MHz}$ 内
终端阻抗	$610\Omega // 3.0\text{pF} // \text{耦合电容 } 13.0\text{pF}$

表 1 晶体滤波器 (L71-0659-05): XF500

## 2-3. IF 放大器电路

第一 IF 信号由 Q504 放大, 进入 IC500 (FM 处理 IC)。该信号再次与 IC500 内的第二本地振荡器信号进行外差, 产生 450kHz 的第二 IF 信号。第二 IF 信号随后被送到 450kHz 陶瓷滤波器 (宽: CF500, 窄: CF501) 以进一步消除不需要的信号, 然后再由带陶瓷鉴频器的积分检波器 (CD500) 进行放大和解调。

项 目	额 定
标称中心频率	450kHz
6dB 带宽	$\pm 6.0\text{kHz}$ 或更大
50dB 带宽	$\pm 12.5\text{kHz}$ 或更小
纹波	2.0dB 或更小
插入损耗	6.0dB 或更小
保证衰减	35.0dB 或更大, $f_o \pm 100\text{kHz}$ 内
终端阻抗	$2.0\text{k}\Omega$

表 2 陶瓷滤波器 (L72-0993-05): CF500

项 目	额 定
标称中心频率	450kHz
6dB 带宽	$\pm 4.5\text{kHz}$ 或更大
50dB 带宽	$\pm 10.0\text{kHz}$ 或更小
纹波	2.0dB 或更小
插入损耗	6.0dB 或更小
保证衰减	60.0dB 或更大, $f_o \pm 100\text{kHz}$ 内
终端阻抗	$2.0\text{k}\Omega$

表 3 陶瓷滤波器 (L72-0999-05): CF501

## CIRCUIT DESCRIPTION / 电路说明

### 2-4. Wide/Narrow Switching Circuit

The Wide port (pin 99) and Narrow port (pin 98) of the MCU is used to switch between ceramic filters. When the Wide port is high, the ceramic filter switch diodes (D500, D501) cause CF500 to turn on to receive a Wide signal.

When the Narrow port is high, the ceramic filter switch diodes (D500, D501) cause CF501 to turn on to receive a Narrow signal.

### 2-4. 宽 / 窄切换电路

MCU 的宽端口（引脚 99）和窄端口（引脚 98）用于在陶瓷滤波器之间切换。宽端口高时，陶瓷滤波器切换二极管（D500、D501）使 CF500 打开，接收宽带信号。

窄端口高时，陶瓷滤波器切换二极管（D500、D501）使 CF501 打开，接收窄带信号。

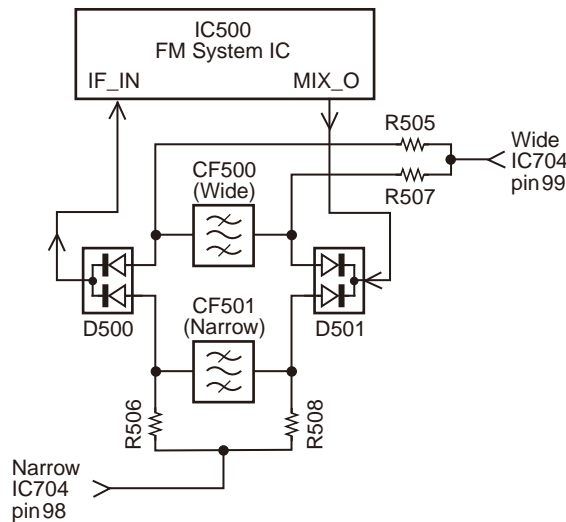

Fig. 3 Wide/Narrow switching circuit / 图 3 宽 / 窄切换电路

### 2-5. AF Signal System

The detection signal from the FM IC (IC500) goes to the baseband IC (IC702) DISC input (pin 16) for characterizing the signal.

The AF signal output from IC702 is input to the audio power amplifier (IC706). The AF signal from IC706 switches between the internal speaker and the speaker jack (J701) output.

### 2-5. AF 信号系统

FM IC (IC500) 的检测信号进入基带 IC (IC702) DISC 输入（引脚 16）使信号特性化。

从 IC702 输出的 AF 信号被输入音频功率放大器（IC706）。IC706 的 AF 信号在内置扬声器和扬声器插孔（J701）输出之间切换。

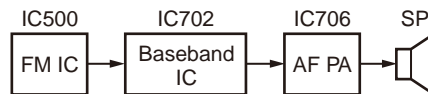

Fig. 4 AF signal system / 图 4 AF 信号系统

### 2-6. Squelch Circuit

The detection output from the FM IC (IC500), a voltage is applied to the MCU (IC704). The MCU controls squelch according to the voltage (SQIN) level.

The signal from the RSSI pin of IC500 is monitored.

The electric field strength of the receive signal can be known before the SQIN voltage is input to the MCU, and the scan stop speed is improved.

### 2-6. 静噪电路

来自 FM IC (IC500) 的检测输出，对 MCU (IC704) 施加电压。MCU 根据电压 (SQIN) 电平控制静噪。

监测 IC500 的 RSSI 引脚的信号。

接收信号的电场强度在 SQIN 电压输入 MCU 之前可知，并提高扫描停止速度。

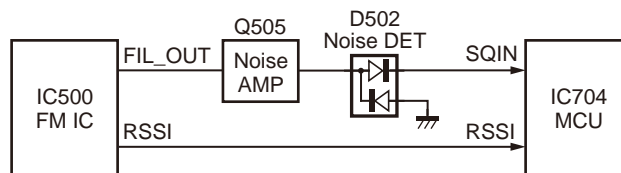

Fig. 5 Squelch circuit / 图 5 静噪电路

## CIRCUIT DESCRIPTION / 电路说明

## 3. Transmitter System

## 3-1. Outline

The transmitter circuit produces and amplifies the desired frequency directly. It FM-modulates the carrier signal by means of a varicap diode.

## 3-2. Power Amplifier Circuit

The transmit output signal from the VCO passes through the transmission/reception selection diode (D17) and amplified by Q300. The amplified signal goes to the RF power module (IC300) through a low-pass filter. The lowpass filter removes unwanted high-frequency harmonic components, and the resulting signal goes through the antenna terminal.

## 3-3. APC Circuit

The automatic transmission power control (APC) circuit detects part of a final amplifier output with a coupler circuit and applies a voltage to IC301. IC301 compares the APC control voltage (PC) generated by the baseband IC (IC702) and DC amplifier (IC501) with the detection output voltage. IC301 generates the voltage to control IC300 and stabilizes transmission output.

The APC circuit is configured to protect over current of Q300 and IC300 due to fluctuations of the load at the antenna end and to stabilize transmission output at voltage and temperature variations.

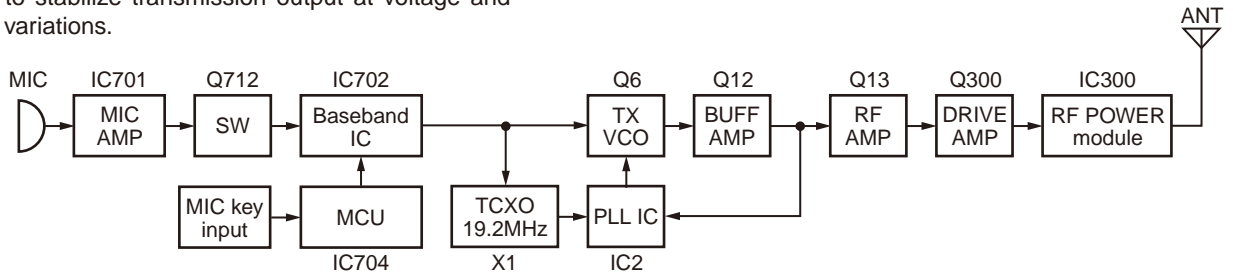

Fig. 6 Transmitter system / 图 6 发射机系统

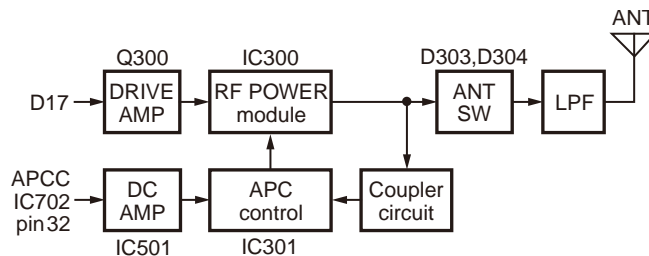

Fig. 7 APC circuit / 图 7 APC 电路

## 4. PLL Frequency Synthesizer

The PLL circuit generates the first local oscillator signal for reception and the RF signal for transmission.

## 4-1. PLL Circuit

The frequency step of the PLL circuit is 5, 6.25, 10 or 12.5kHz.

A 19.2MHz reference oscillator signal is divided at IC2 by a fixed counter to produce the 5, 6.25, 10 or 12.5kHz reference frequency. The voltage controlled oscillator (VCO) output signal is buffer amplified by Q12, then divided by a programmable counter in IC2.

## 3. 发射机系统

## 3-1. 概述

发射机电路直接产生和放大所需的频率。它借助变容二极管对载波信号进行 FM 调制。

## 3-2. 功率放大器电路

VCO 的发射输出信号通过发射 / 接收选择二极管 (D17), 由 Q300 进行放大。放大的信号经低通滤波器进入 RF 功率模块 (IC300)。低通滤波器可消除不必要的高频谐波成分, 产生的信号通过天线端子。

## 3-3. APC 电路

自动发射功率控制 (APC) 电路通过耦合电路检测末级放大器的部分输出, 并对 IC301 施加电压。IC301 将基带 IC (IC702) 和 DC 放大器 (IC501) 生成的 APC 控制电压 (PC) 与检测输出电压进行比较。IC301 生成控制 IC300 并稳定发射输出的电压。

配置 APC 电路是为了保护因天线端负载波动而引起的 Q300 和 IC300 过流, 以及在电压和温度变化时稳定发射输出。

## 4. PLL 频率合成器

PLL 电路生成用于接收的第一本地振荡器信号, 以及用于发射的 RF 信号。

## 4-1. PLL 电路

PLL 电路的频率步长为 5, 6.25, 7.5, 10, 12.5 或 15kHz。

19.2MHz 基准振荡器信号在 IC2 处由固定的计数器进行分频, 产生基准频率。压控振荡器 (VCO) 输出信号由 Q12 进行缓冲放大, 然后用倍频器增倍, 由 IC2 中的可编程计数器进行分频。



## CIRCUIT DESCRIPTION / 电路说明

The divided signal is compared in phase with the reference signal in the phase comparator in IC2. The output signal from the phase comparator is filtered through a low-pass filter and passed to the VCO to control the oscillator frequency.

### 4-2. VCO Circuit

The operating frequency is generated by Q6 in transmit mode and Q8 in receive mode. The oscillator frequency is controlled by applying the VCO control voltage, obtained from the phase comparator to the varactor diodes (D7 in transmit mode and D9 in receive mode) and assist voltage to the (D10, D12 and D13 in transmit mode and D11, D14 and D15 in receive mode).

The TX/RX pin is set high in receive mode causing Q7 to turn off, and turn Q10 on. The TX/RX pin is set low in transmit mode. The outputs from Q8 and Q6 are amplified by Q12 and sent to the RF amplifiers.

分频的信号与 IC2 中的相位比较器内的基准信号进行相位对比。相位比较器的输出信号通过低通滤波器进行滤波，并通过 VCO 对振荡器频率进行控制。

### 4-2. VCO 电路

发射模式下，操作频率由 Q6 产生，接收模式下，操作频率由 Q8 产生。通过对变容二极管（发射模式下 D6 和 D7，接收模式下 D8 和 D9）施加从相位比较器获得的 VCO 控制电压，对（发射模式下 D10、D12 和 D13，接收模式下 D11、D14 和 D15）施加辅助电压，实现对振荡器频率的控制。

在接收模式下 TX/RX 引脚设为高，使 Q7 关闭，Q10 打开。在发射模式下，TX/RX 引脚设为低。Q8 和 Q6 的输出由 Q12 放大并发送到 RF 放大器。

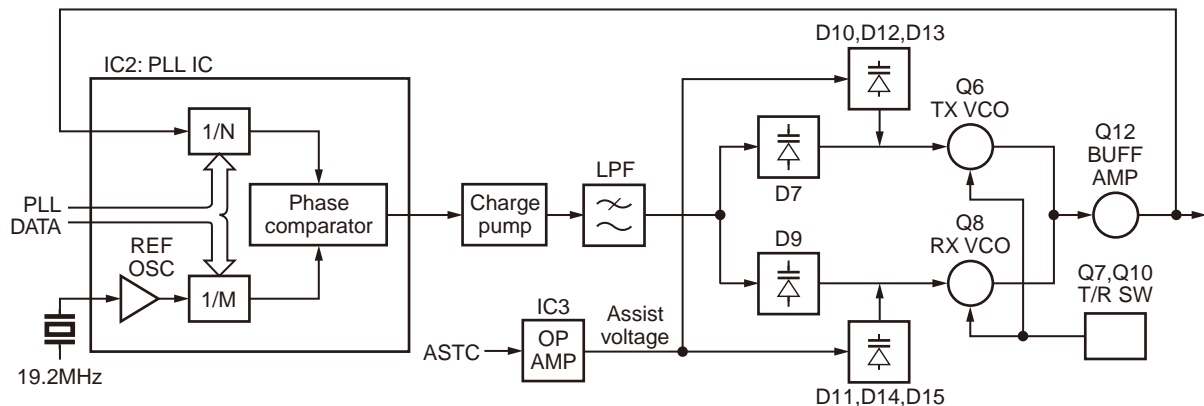

Fig. 8 PLL circuit / 图 8 PLL 电路

### 4-3. Unlock Circuit

During reception, the 9RC signal goes high, the 9TC signal goes low, and Q400 turns on. Q402 turns on and a voltage is applied to the collector (9R). During transmission, the 9RC signal goes low, the 9TC signal goes high and Q401 turns on. Q403 turns on and a voltage is applied to 9T.

The MCU in the control unit monitors the PLL (IC2) LD signal directly. When the PLL is unlocked during transmission, the PLL LD signal goes low. The MCU detects this signal and makes the 9TC signal low. When the 9TC signal goes low, no voltage is applied to 9T, and no signal is transmitted.

### 4-3. 失锁电路

接收期间，9RC 信号变高，9TC 信号变低，Q400 打开。Q402 打开并对集电极 (9R) 施加电压。发射期间，9RC 信号变低，9TC 信号变高，Q401 打开。Q403 打开并对 9T 施加电压。

控制单元的 MCU 直接监测 PLL (IC2) LD 信号。PLL 在发射期间失锁时，PLL LD 信号变低。MCU 检测该信号并使 9TC 信号变低。9TC 信号变低时，不对 9T 施加电压，不发射信号。

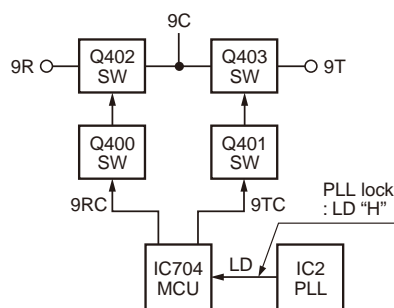

Fig. 9 Unlock circuit / 图 9 失锁电路

## CIRCUIT DESCRIPTION / 电路说明

### 5. Control Circuit

The MCU carries out the following tasks:

- 1) Controls the WIDE, NARROW, TX/RX outputs.
- 2) Controls the Baseband IC (IC702).
- 3) Controls the PLL (IC2).
- 4) Controls the display unit.

### 5. 控制电路

MCU 执行以下任务：

- 1) 控制 WIDE、NARROW、TX/RX 输出。
- 2) 控制基带 IC (IC702)。
- 3) 控制 PLL (IC1)。
- 4) 控制显示单元。

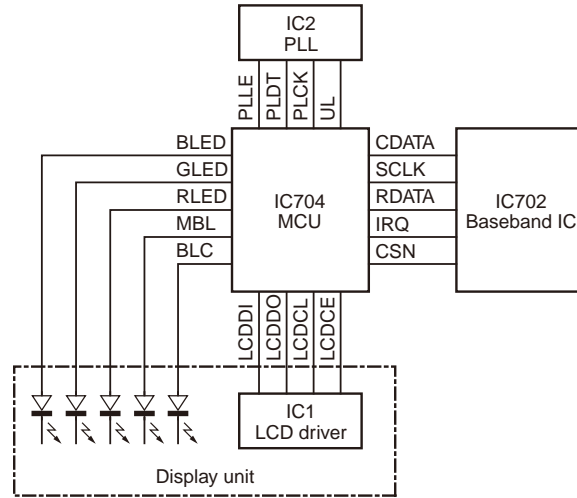

Fig. 10 Control circuit / 图 10 控制电路

### 5-1. Memory Circuit

The transceiver has a 512k-bit EEPROM (IC705). The EEPROM contains adjustment data. The MCU (IC704) controls the EEPROM through three serial data lines.

### 5-1. 存储电路

车载对讲机具有 256k-bit EEPROM (IC705)。EEPROM 含有调整数据。MCU (IC704) 通过三条串行数据线路控制 EEPROM。

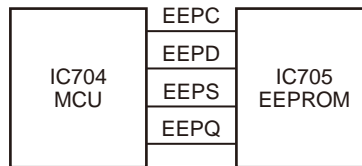

Fig. 11 Memory circuit / 图 11 存储电路

### 5-2. Display Circuit

The MCU (IC704) controls the LCD display and LEDs.

When power is on, the MCU will use the MBL line and the BLC line to control the key backlight LEDs and LCD backlight LEDs.

When the transceiver is busy, the GLED line goes high, Q6 turns on and the green LED (D23) lights after Q5 turns on. In transmit mode, the RLED line goes high, Q3 and Q4 turn on and the red LED (D23) lights.

BLED will be set high when the function select (FPU setting) is on, Q2 turns on and the blue LED (D22) lights.

The LCD driver (IC1) controls the functions of the LCD through the LCDDI, LCDDO, LCDCL, LCDCE lines from the MCU.

### 5-2. 显示电路

MCU (IC704) 控制 LCD 显示和 LED。

电源打开时，MCU 将使用 MBL 线路和 BLC 线路控制按键背光 LED 和 LCD 背光 LED。

车载对讲机繁忙时，GLED 线路变高，Q6 打开并且绿色 LED (D23) 在 Q5 打开后点亮。在发射模式中，RLED 线路变高，Q3 和 Q4 打开且红色 LED (D23) 点亮。

功能选择 (FPU 设置) 开启时，BLED 将被设为高，Q2 打开且蓝色 LED (D22) 点亮。

LCD 驱动器 (IC1) 通过 MCU 的 LCDDI、LCDDO、LCDCL、LCDCE 线路控制 LCD 的功能。

## CIRCUIT DESCRIPTION / 电路说明

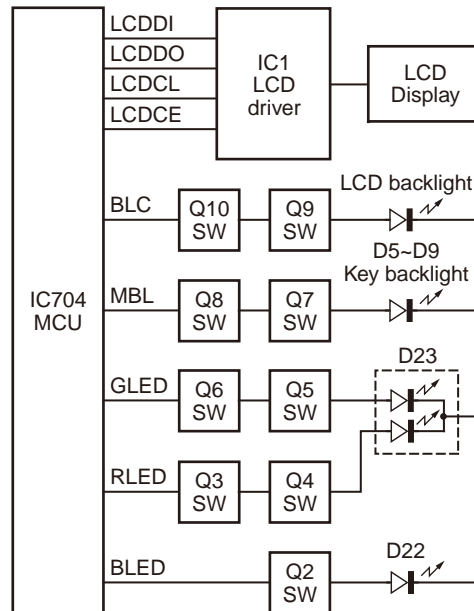

Fig. 12 Display circuit / 图 12 显示电路

## 5-3. Key Matrix Circuit

The front panel has function keys. Each of them is connected to a cross point of a matrix of the KMI1 to KMO3 ports of the LCD driver. The KMO1 to KMO3 ports are always high, while the KMI1 to KMI3 ports are always low.

The LCD driver monitors the status of the KMI1 to KMO3 ports. If the state of one of the ports changes, the LCD driver assumes that the key at the matrix point corresponding to that port has been pressed.

## 5-3. 键矩阵电路

前面板具有功能键。每个键均连接到 LCD 驱动器的 KMI1 至 KMO3 端口的矩阵的交叉点。KMO1 至 KMO3 端口始终为高，而 KMI1 至 KMI3 端口始终为低。

LCD 驱动器监测 KMI1 至 KMO3 端口的状态。如果某个端口的状态发生改变，则 LCD 驱动器认为与该端口对应的矩阵点的按键已经被按下。

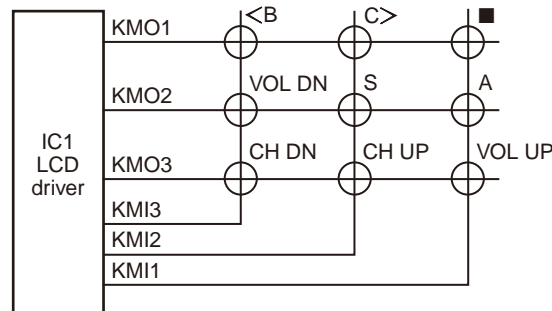

Fig. 13 Key matrix circuit / 图 13 键矩阵电路

## CIRCUIT DESCRIPTION / 电路说明

## 6. Signaling Circuit

## 6-1. Encode

## ■ Low-speed data (QT, DQT)

Low-speed data is output from pin 26 (LSDO) of the MCU (IC704). The signal passes through a low-pass CR filter. The signal is mixed with the audio signal and goes to the VCO and TCXO (X1) modulation input after signal processing in the baseband IC (IC702).

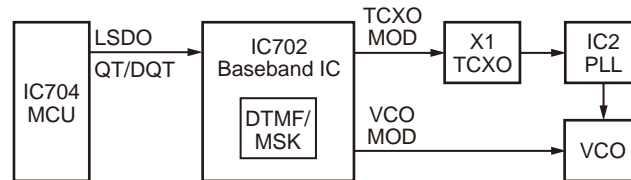

Fig. 14 Encode / 图 14 编码

## ■ MSK / DTMF

MSK and DTMF signal is self generated by the baseband IC (IC702).

The TX deviation adjustment is done by the output gain of the baseband IC (IC702), and is routed to the VCO. When encoding MSK/DTMF, the microphone-input signal is muted.

## 6-2. Decode

## ■ Low-speed data (QT, DQT)

The demodulated signal from the FM IC (IC500) will input to the baseband IC (IC702) to remove frequencies of 300Hz or more.

The signal is input to pin 88 (LSDI) of the MCU. The MCU digitizes this signal, performs processing such as DC restoration, and decodes the signal.

## ■ MSK/ DTMF

The demodulated signal from the FM IC (IC500) will input to the baseband IC (IC702), then the baseband IC will decode and send the decoded information to the MCU by the data line.

The MCU then processes the decoded information.

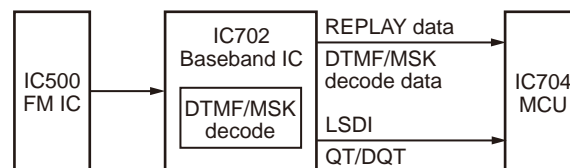

Fig. 15 Decode / 图 15 解码

## 6. 信令电路

## 6-1. 编码

## ■ 低速数据 (QT, DQT)

低速数据从 MCU (IC704) 的引脚 26 (LSDO) 输出。信号通过低通 CR 滤波器。此信号与音频信号混合，在基带 IC (IC702) 中进行信号处理之后，进入 VCO 和 TCXO (X1) 调制输入。

## ■ MSK/DTMF

MSK 和 DTMF 信号由基带 IC (IC702) 自身生成。TX 频偏调整由基带 IC (IC702) 的输出增益完成，并被送入 VCO。编码 MSK/DTMF 时，麦克风输入信号被静音。

## 6-2. 解码

## ■ 低速数据 (QT, DQT)

FM IC (IC500) 的解调信号将输入到基带 IC (IC702)，以消除 300Hz 或以上的频率。

信号被输入到 MCU 的引脚 88 (LSDI)。MCU 将该信号数字化，进行直流恢复等处理，然后对信号解码。

## ■ MSK/DTMF

FM IC (IC500) 的解调信号将输入到基带 IC (IC702)，然后基带 IC 将进行解码，并由数据线路将解码的信息发送到 MCU。MCU 随后对已解码信息进行处理。

## CIRCUIT DESCRIPTION / 电路说明

## 7. Power Supply Circuit

When the power switch on the display unit is pressed, the power port on the display unit which is connected to port 17 (POWER), goes low, then port 52 (SBC) goes high, Q406 turns on, SB switch (Q407) turns on and power (SB) is supplied to the transceiver.

When the DC power is supplied to the transceiver, voltage regulator IC (IC401, IC402) will supply into the MCU VDD and reset the voltage detect IC (IC404). IC404 will generate signal (RESET) into the reset terminal on the MCU (IC704) to carry out a power on reset. Also, MCU (IC704) is checking on port 91 (BATT). If DC power is less than about 8.5V, the transceiver is unable to power on.

When the DC power voltage decreases from normal voltage, the INT voltage detector IC (IC403) will set to high on MCU port 18 (INT). If B line becomes less than about 8.5V, MCU will send the backup data to EEPROM (IC705) and go into STOP mode.

This circuit has an overvoltage protection circuit. If a DC voltage of 16V or higher is applied to the base of Q717, this voltage turns Q717 on and sets port 18 (INT) to low. As a result port 78 (SBC) is low, and turns Q406 and Q407 (SB) off.

## 7. 电源电路

按显示单元上的电源开关时，与端口 17 (POWER) 相连的显示单元上的电源端口变低，随后端口 52 (SBC) 变高，Q406 打开，SB 开关 (Q407) 打开，并向车载对讲机提供电源 (SB)。

向车载对讲机提供 DC 电源时，稳压器 IC (IC401、IC402) 将提供到 MCU VDD 并使电压检测 IC (IC404) 复位。IC404 将在 MCU (IC704) 上的复位端子中生成信号 (RESET)，以执行上电复位。此外，MCU (IC704) 对端口 91 (BATT) 进行检查。如果 DC 电源小于约 8.5V，则车载对讲机无法打开电源。

DC 电源电压由正常电压下降时，MCU 端口 18 (INT) 上的 INT 电压检测器 IC (IC403) 将设为高。如果 B 线路变得小于约 8.5V，MCU 将会向 EEPROM (IC705) 发送备份数据并进入 STOP 模式。

此电路具有过电压保护电路。如果对 Q717 的基极施加 16V 或更高的电压，该电压将打开 Q717 并将端口 18 (INT) 设为低。从而使端口 78 (SBC) 较低，并关闭 Q406 和 Q407 (SB)。

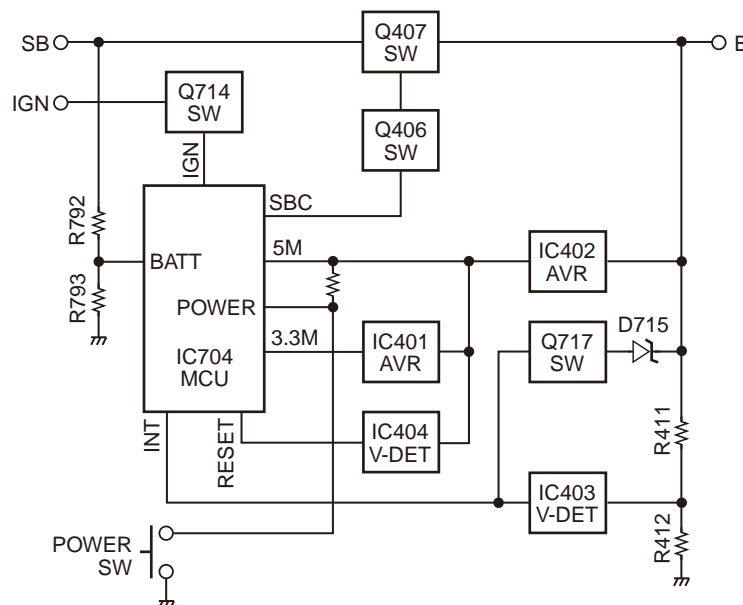

Fig. 16 Power supply circuit / 图 16 电源电路

MCU: F3650TDFBKEBA (TX-RX unit IC704)

Pin No.	Name	I/O	Function
1	FREQ	O	Frequency alignment
2	HSDO	O	High speed data output
3	LCDDO	O	LCD data output
4	LCDCOE	O	LCD enable
5	HSDI	I	High speed data input
6	E	-	GND (Only for bus control)
7	CNVSS	I	CNVSS for emulator (H: boot mode)
8	LCDDI	I	LCD data input
9	LCDCO	O	LCD clock output
10	RESET	I	Reset
11	XOUT	O	11.0592MHz clock output
12	VSS	-	GND
13	XIN	I	11.0592MHz clock input
14	VCC1	-	+5V
15	5CC	O	5C control
16	MKEY	I/O	Mic key detect
17	POWKEY	I	Power key detect
18	INT	I	MCU stop
19	ASTSW	O	Assist speed up switch control
20	BEEP	O	Beep for side tone
21	FNC8	I/O	Function port 8
22	FNC7	I/O	Function port 7 (REC/SRC)
23	FNC6	I/O	Function port 6
24	FNC5	I/O	Function port 5
25	FNC4	I/O	Function port 4
26	LSDO	O	Low speed data output
27	SI	I	Serial data input for VGS
28	SO	O	Serial data output for VGS
29	FNC1	I/O	Function port 1 (TXD to COM port 1)
30	FNC2	I/O	Function port 2 (RXD from COM port 1)
31	ECLK	-	SCLK for emulator
32	FNC3/ EBSY	I/O	Function port 3 / BUSY for emulator
33	TXD	I/O	TXD to FPU
34	RXD	I/O	RXD from FPU
35	HOOK	I	Hook
36	PTT	I	PTT
37	BSFT	O	Beat shift (L: beat shift ON)
38	LPOSW	O	No use
39	EPM	-	EPM for emulator
40	PLLE	O	PLL lock enable
41	PLDT	O	PLL data output
42	PLCK	O	PLL clock output

MCU: F3650TDFBKEBA (收发单元 IC704)

管脚号	端口名称	输入/输出	功能
1	FREQ	输出	频率控制
2	HSDO	输出	高速数据
3	LCDDO	输出	LCD 数据
4	LCDCOE	输出	LCD 启用
5	HSDI	输入	高速数据
6	E	-	GND (仅限于总线控制)
7	CNVSS	输入	类型选择
8	LCDDI	输入	LCD 数据
9	LCDCO	输出	LCD 时钟
10	RESET	输入	MCU 复位
11	XOUT	输出	11.0592MHz 时钟输出
12	VSS	-	接地
13	XIN	输入	11.0592MHz 时钟输入
14	VCC1	-	+5V
15	5CC	输出	5C 控制
16	MKEY	输入/输出	麦克风键
17	POWKEY	输入	电源键输入
18	INT	输入	MCU 停止
19	ASTSW	输出	辅助加速开关
20	BEEP	输出	侧音的提示音
21	FNC8	输入/输出	功能 P8
22	FNC7	输入/输出	功能 P7 (REC/SRC)
23	FNC6	输入/输出	功能 P6
24	FNC5	输入/输出	功能 P5
25	FNC4	输入/输出	功能 P4
26	LSDO	输出	低速数据
27	SI	输入	串行数据输入 (VGS)
28	SO	输出	串行数据输出 (VGS)
29	FNC1	输入/输出	功能 P1/(TXD COM1)
30	FNC2	输入/输出	功能 P2/(RXD COM1)
31	ECLK	-	类型选择
32	FNC3/ EBSY	输入/输出	功能 P3
33	TXD	输入/输出	到 FPU
34	RXD	输入/输出	来自 FPU
35	HOOK	输入	挂钩
36	PTT	输入	PTT 键
37	BSFT	输出	拍频偏移
38	LPOSW	输出	未使用
39	EPM	-	类型时钟
40	PLLE	输出	PLL 启用
41	PLDT	输出	PLL 数据
42	PLCK	输出	PLL 时钟



## SEMICONDUCTOR DATA / 半导体数据

Pin No.	Name	I/O	Function
43	PA	O	Public address control
44	CE	-	CE for emulator
45	CDATA	O	Command data output for baseband IC
46	RDATA	I	Reply data input for baseband IC
47	SCLK	O	Serial clock output for baseband IC
48	CSN1	O	Chip select for baseband IC
49	SP MUTE	O	Speaker mute control
50	9RC	O	9R control
51	9TC	O	9T control
52	SBC	O	SB control
53	3CC	O	3C control
54	PLPS	O	Sleep mode function for PLL IC
55	EEPS	O	EEPROM chip select
56	AMPSW	O	AF AMP switch control (L: enable / H: disable)
57	EEPQ	I	EEPROM serial data input
58	EEPD	O	EEPROM serial data output
59	EEPC	O	EEPROM serial clock output
60	VCC2	-	+3.3V
61	SCRSW	O	Scrambler switch control (Audio path)
62	VSS	-	GND
63	NC	-	No connection
64	TXRX	O	TX/RX (H: RX / L: TX)
65	BLC	O	LCD backlight control
66	MBL	O	Panel and mic key backlight control
67	NC	-	No connection
68	DST	I	Destination
69	NC	-	No connection
70	NC	-	No connection
71	STSW	O	Side tone switch control for VGS playback
72	IGN	I	Ignition
73	IRQ1	I	Interrupt request for baseband IC
74	RLED	O	Red LED for TX
75	GLLED	O	Green LED for busy
76	BLED	O	Blue LED for VGS writing and signaling
77	VGSRX	O	VGS recording switch control for RX
78	NC	-	No connection
79	NC	-	No connection
80	EMG	I	Emergency key detect
81	NC	-	No connection
82	NC	-	No connection
83	UL	I	PLL unlock detect
84	DMUTE	O	Det mute control

管脚号	端口名称	输入 / 输出	功 能
43	PA	输出	扩音
44	CE	-	类型启用
45	CDATA	输出	基带 IC 的命令数据
46	RDATA	输入	基带 IC 的回复数据
47	SCLK	输出	基带 IC 的串行时钟
48	CSN1	输出	基带 IC 的芯片选择
49	SP MUTE	输出	扬声器静音
50	9RC	输出	9R 控制
51	9TC	输出	9T 控制
52	SBC	输出	SB 控制
53	3CC	输出	3C 控制
54	PLPS	输出	PLL 省电状态控制
55	EEPS	输出	EEPROM 启用
56	AMPSW	输出	AF 放大器 (L: 启用 / H: 禁用)
57	EEPQ	输入	EEPROM 数据
58	EEPD	输出	EEPROM 数据
59	EEPC	输出	EEPROM 时钟
60	VCC2	-	+3.3V
61	SCRSW	输出	扰频器开关
62	VSS	-	接地
63	NC	-	未连接
64	TXRX	输出	收发切换 (H: RX / L: TX)
65	BLC	输出	LCD 背光控制
66	MBL	输出	键背光控制
67	NC	-	未连接
68	DST	输入	类型选择
69	NC	-	未连接
70	NC	-	未连接
71	STSW	输出	侧音的提示音
72	IGN	输入	点火
73	IRQ1	输入	基带 IC 的中断请求
74	RLED	输出	TX 的红色 LED
75	GLLED	输出	用于繁忙的绿色 LED
76	BLED	输出	预留的蓝色 LED
77	VGSRX	输出	VGS 音频控制
78	NC	-	未连接
79	NC	-	未连接
80	EMG	输入	EMG 键
81	NC	-	未连接
82	NC	-	未连接
83	UL	输入	PLL 失锁检测
84	DMUTE	输出	检测静音

## SEMICONDUCTOR DATA / 半导体数据

Pin No.	Name	I/O	Function
85	MIC1MUTE	O	Internal mic mute control
86	MIC2MUTE	O	External mic mute control
87	HSDI	I	No use
88	LSDI	I	Low speed data input: QT/DQT/(LTR)
89	TEMP2	I	Temperature 2 data input
90	TEMP1	I	Temperature 1 data input
91	BATT	I	Battery voltage input
92	RSSI	I	RSSI input
93	SQIN	I	Squelch input
94	AVSS	-	GND
95	CV	I	VCO lock voltage detect
96	VREF	-	+5V
97	AVCC	-	+5V
98	NARROW	O	Wide/Narrow control (Hi: Narrow)
99	WIDE	O	Wide/Narrow control (Hi: Wide)
100	HORN	O	Horn alert switch control

管脚号	端口名称	输入/输出	功 能
85	MIC1MUTE	输出	内部麦克风静音
86	MIC2MUTE	输出	外部麦克风静音
87	HSDI	输入	未使用
88	LSDI	输入	低速数据
89	TEMP2	输入	温度 2
90	TEMP1	输入	温度 1
91	BATT	输入	电池电压
92	RSSI	输入	RSSI 输入
93	SQIN	输入	静噪输入
94	AVSS	-	接地
95	CV	输入	VCO 锁定电压
96	VREF	-	+5V
97	AVCC	-	+5V
98	NARROW	输出	宽 / 窄控制 (H: 窄)
99	WIDE	输出	宽 / 窄控制 (H: 宽)
100	HORN	输出	喇叭提示

## COMPONENTS DESCRIPTION / 元件说明

## Display unit (X54-3740-20)

Ref. No.	Part Name	Description
IC1	IC	LCD driver
Q2	Transistor	Indication LED (BLUE) switch
Q3	Transistor	TX LED switch control
Q4	Transistor	TX LED switch
Q5	Transistor	BUSY LED switch
Q6	Transistor	BUSY LED switch control
Q7	Transistor	KEY backlight switch
Q8	Transistor	KEY backlight switch control
Q9	Transistor	LCD backlight switch control
Q10	Transistor	LCD backlight switch
D1	Zener diode	Surge protection
D2	Diode	Voltage protection
D5~9	LED	KEY backlight
D10	Diode	Voltage protection
D11~21	LED	LCD backlight
D22	LED	Indication (BLUE)
D23	LED	TX/BUSY indication
D24	LED	LCD backlight

## 显示单元 (X54-3740-20)

有关号码	零件名称	说明
IC1	IC	LCD 驱动
Q2	晶体管	蓝色 LED 开关
Q3	晶体管	TX LED 开关控制
Q4	晶体管	TX LED 开关
Q5	晶体管	BUSY LED 开关
Q6	晶体管	BUSY LED 开关控制
Q7	晶体管	键背光开关
Q8	晶体管	键背光开关控制
Q9	晶体管	LCD 背光开关控制
Q10	晶体管	LCD 背光开关
D1	稳压二极管	电涌保护
D2	二极管	电压保护
D5 ~ 9	LED	键背光
D10	二极管	电压保护
D11 ~ 21	LED	LCD 背光
D22	LED	LED/ 蓝色
D23	LED	LED/ 红色 / 绿色
D24	LED	LCD 背光

## TX-RX unit (X57-8020-23)

Ref. No.	Part Name	Description
IC1	IC	DC AMP (frequency)
IC2	IC	PLL IC
IC3	IC	Assist filter
IC300	IC	Power module
IC301	IC	DC AMP (APC)
IC400	IC	Voltage regulator (9V)
IC401	IC	Voltage regulator (3.3V)
IC402	IC	Voltage regulator (5V)
IC403	IC	Voltage detection (INT)
IC404	IC	Voltage detection (reset)
IC500	IC	FM SYSTEM IC
IC501	IC	RX BPF/ APC DC AMP
IC700	IC	RS-232C driver
IC701	IC	MIC MOD AMP
IC702	IC	Baseband IC
IC703	IC	Voltage regulator (3.3V)
IC704	IC	MCU
IC705	IC	EEPROM

## 收发单元 (X57-8020-23)

有关号码	零件名称	说明
IC1	IC	直流放大器
IC2	IC	PLL 系统
IC3	IC	辅助滤波器
IC300	IC	功率模块
IC301	IC	直流放大器 (APC)
IC400	IC	稳压器 /9V
IC401	IC	稳压器 /3.3V
IC402	IC	稳压器 /5V
IC403	IC	稳压器 /INT
IC404	IC	稳压器 / 复位
IC500	IC	FM 系统
IC501	IC	直流放大器
IC700	IC	RS-232C 驱动
IC701	IC	MIC 调制放大器
IC702	IC	基带 IC
IC703	IC	稳压器 /3.3V
IC704	IC	微处理器
IC705	IC	EEPROM

## COMPONENTS DESCRIPTION / 元件说明

Ref. No.	Part Name	Description
IC706	IC	AF power AMP
IC707,708	IC	Option setting switch
IC709	IC	HSD BPF/COMP
IC710	IC	MOD/ Option setting switch
Q1	Transistor	Buffer AMP (PLL IC clock)
Q4	FET	Assist filter switch
Q5	FET	Assist filter switch control
Q6	FET	TX VCO
Q7	Transistor	TX/RX VCO switch
Q8	FET	RX VCO
Q10	Transistor	T/R VCO switch
Q11	Transistor	Ripple filter
Q12	Transistor	Buffer AMP
Q13	Transistor	RF AMP
Q300	Transistor	TX drive AMP
Q400	Transistor	9R switch control
Q401	Transistor	9T switch control
Q402	Transistor	9R switch
Q403	Transistor	9T switch
Q404	FET	5C switch
Q405	FET	3.3C switch
Q406	Transistor	SB switch
Q407	FET	SB switch control
Q500	Transistor	Doubler (2nd local)
Q502	Transistor	W/N switch
Q503	Transistor	W/N switch control
Q504	Transistor	IF AMP
Q505	Transistor	Squelch noise AMP
Q506	Transistor	Squelch input switch
Q507	FET	1st mixer
Q508	Transistor	Squelch input switch
Q511	FET	RF AMP
Q700	Transistor	RS-322C RXD buffer
Q702	FET	Horn alert switch
Q703	Transistor	MIC mute switch
Q704	FET	MIC mute switch
Q705	Transistor	Horn alert switch control
Q708	Transistor	DET AMP (D-SUB)
Q709	FET	TX/RX switch

有关号码	零件名称	说明
IC706	IC	AF 功率放大器
IC707, 708	IC	外部开关
IC709	IC	HSD BPF/COMP
IC710	IC	MOD/ 外部开关
Q1	晶体管	射频缓冲放大器 (PLL IC 时钟)
Q4	场效应管	辅助滤波器开关
Q5	场效应管	辅助滤波器开关控制
Q6	场效应管	TX VCO 振荡器
Q7	晶体管	收发直流开关
Q8	场效应管	RX VCO 振荡器
Q10	晶体管	收发直流开关
Q11	晶体管	纹波滤波器
Q12	晶体管	射频缓冲放大器
Q13	晶体管	射频放大器
Q300	晶体管	驱动放大器
Q400	晶体管	9R 电压控制
Q401	晶体管	9T 电压控制
Q402	晶体管	9R 直流开关
Q403	晶体管	9T 直流开关
Q404	场效应管	5C 直流开关
Q405	场效应管	3.3C 直流开关
Q406	晶体管	SB 直流开关
Q407	场效应管	SB 电压控制
Q500	晶体管	倍频器 (第二本地)
Q502	晶体管	宽 / 窄开关
Q503	晶体管	宽 / 窄开关控制
Q504	晶体管	IF 放大器
Q505	晶体管	静噪噪声放大器
Q506	晶体管	静噪开关
Q507	场效应管	混频器
Q508	晶体管	静噪开关
Q511	场效应管	射频放大器
Q700	晶体管	RS-232C RXD 控制
Q702	场效应管	喇叭提示开关
Q703	晶体管	麦克风静音开关
Q704	场效应管	麦克风静音开关
Q705	晶体管	喇叭提示开关控制
Q708	晶体管	检测放大器 (D-SUB)
Q709	场效应管	收发开关

## COMPONENTS DESCRIPTION / 元件说明

Ref. No.	Part Name	Description
Q710	Transistor	Baseband IC clock AMP
Q712	FET	Option switch
Q713	FET	DET mute switch
Q714	Transistor	IGN switch
Q715	Transistor	Beet shift switch
Q716,717	Transistor	Over voltage detect switch
Q718,719	FET	SP mute
Q720	Transistor	AF AMP switch
D1	Diode	PLL unlock detect
D7	Variable capacitance diode	TX VCO frequency
D9	Variable capacitance diode	RX VCO frequency
D10	Variable capacitance diode	RX VCO assist
D11	Variable capacitance diode	TX VCO assist
D12,13	Variable capacitance diode	RX VCO assist
D14,15	Variable capacitance diode	TX VCO assist
D16	Variable capacitance diode	Modulation
D17,18	Diode	TX/RX RF switch
D300	Zener diode	Voltage protection
D301	Diode	TX power control
D302	Diode	Reverse power detection
D303,304	Diode	ANT switch
D305,306	Diode	RF power detection
D307	Diode	ANT switch
D309,310	Zener diode	Voltage protection
D311	Diode	ANT switch
D400	Surge absorber	Voltage protection
D500,501	Diode	W/N CF switch
D502	Diode	Squelch detection
D503~507	Variable capacitance diode	RF BPF tuning
D508	Variable capacitance diode	RX notch tuning
D700~711	Diode	Surge protection
D712,713	Diode	MIC AGC detection
D715	Zener diode	Voltage drop
D716	Diode	Speed up (DET mute)

有关号码	零件名称	说明
Q710	晶体管	基带 IC 时钟放大器
Q712	场效应管	外部开关
Q713	场效应管	检测静音开关
Q714	晶体管	IGN 开关
Q715	晶体管	拍频偏移开关
Q716, 717	晶体管	过电压检测开关
Q718, 719	场效应管	扬声器静音开关
Q720	晶体管	AF 放大器开关
D1	二极管	PLL 失锁检测
D7	可变电容二极管	频率控制 /TX VCO
D9	可变电容二极管	频率控制 /RX VCO
D10	可变电容二极管	RX VCO 辅助
D11	可变电容二极管	TX VCO 辅助
D12, 13	可变电容二极管	RX VCO 辅助
D14, 15	可变电容二极管	TX VCO 辅助
D16	可变电容二极管	调制器
D17, 18	二极管	收发开关
D300	稳压二极管	电涌保护
D301	二极管	功率整流器
D302	二极管	反向功率检测
D303, 304	二极管	天线开关
D305, 306	二极管	功率整流器
D307	二极管	天线开关
D309, 310	稳压二极管	电压保护
D311	二极管	天线开关
D400	电涌吸收	电压保护
D500, 501	二极管	宽 / 窄滤波器开关
D502	二极管	静噪检测
D503 ~ 507	可变电容二极管	RX BPF 调谐
D508	可变电容二极管	接收陷波调谐
D700 ~ 711	二极管	电涌保护
D712, 713	二极管	麦克风 AGC 检测
D715	稳压二极管	电压检测
D716	二极管	加速 (检测静音)

## PARTS LIST / 零件表

### CAPACITORS

CC 45 TH 1H 220 J  
 1 2 3 4 5 6

- 1 = Type ... ceramic, electrolytic, etc.
- 2 = Shape ... round, square, etc.
- 3 = Temp. coefficient
- 4 = Voltage rating
- 5 = Value
- 6 = Tolerance

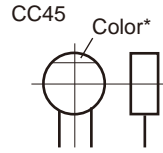

#### • Capacitor value

- 010 = 1pF
- 100 = 10pF
- 101 = 100pF
- 102 = 1000pF = 0.001mF
- 103 = 0.01mF

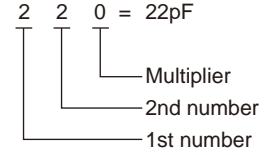

#### • Temperature coefficient

1st Word	C	L	P	R	S	T	U
Color*	Black	Red	Orange	Yellow	Green	Blue	Violet
ppm/°C	0	-80	-150	-220	-330	-470	-750

2nd Word	G	H	J	K	L
ppm/°C	±30	±60	±120	±250	±500

Example : CC45TH = -470±60ppm/°C

#### • Tolerance (More than 10pF)

Code	C	D	G	J	K	M	X	Z	P	No code
(%)	±0.25	±0.5	±2	±5	±10	±20	+40 -20	+80 -20	+100 -0	More than 10mF : -10~+50 Less than 4.7mF : -10~+75

#### (Less than 10pF)

Code	B	C	D	F	G
(pF)	±0.1	±0.25	±0.5	±1	±2

#### • Voltage rating

2nd word 1st word	A	B	C	D	E	F	G	H	J	K	V
0	1.0	1.25	1.6	2.0	2.5	3.15	4.0	5.0	6.3	8.0	-
1	10	12.5	16	20	25	31.5	40	50	63	80	35
2	100	125	160	200	250	315	400	500	630	800	-
3	1000	1250	1600	2000	2500	2150	4000	5000	6300	8000	-

#### • Chip capacitors

- (EX) CC 73 F SL 1H 000 J  
 1 2 3 4 5 6 7
- (Chip) (CH, RH, UJ, SL)
- (EX) CK 73 F F 1H 000 Z  
 1 2 3 4 5 6 7
- (Chip) (B, F)
- Refer to the table above.
- 1 = Type
  - 2 = Shape
  - 3 = Dimension
  - 4 = Temp. coefficient
  - 5 = Voltage rating
  - 6 = Value
  - 7 = Tolerance

#### • Dimension

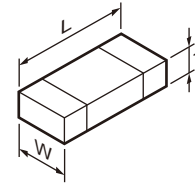

#### Chip capacitor

Code	L	W	T
Empty	5.6±0.5	5.0±0.5	Less than 2.0
A	4.5±0.5	3.2±0.4	Less than 2.0
B	4.5±0.5	2.0±0.3	Less than 2.0
C	4.5±0.5	1.25±0.2	Less than 1.25
D	3.2±0.4	2.5±0.3	Less than 1.5
E	3.2±0.2	1.6±0.2	Less than 1.25
F	2.0±0.3	1.25±0.2	Less than 1.25
G	1.6±0.2	0.8±0.2	Less than 1.0
H	1.0±0.05	0.5±0.05	0.5±0.05

### RESISTORS

#### • Chip resistor (Carbon)

- (EX) RD 73 E B 2B 000 J  
 1 2 3 4 5 6 7
- (Chip) (B, F)

#### • Carbon resistor (Normal type)

- (EX) RD 14 B B 2C 000 J  
 1 2 3 4 5 6 7

- 1 = Type
- 2 = Shape
- 3 = Dimension
- 4 = Temp. coefficient
- 5 = Rating wattage
- 6 = Value
- 7 = Tolerance

#### Chip resistor

Code	L	W	T
E	3.2±0.2	1.6±0.2	1.0
F	2.0±0.3	1.25±0.2	1.0
G	1.6±0.2	0.8±0.2	0.5±0.1
H	1.0±0.05	0.5±0.05	0.35±0.05

#### • Rating wattage

Code	Wattage	Code	Wattage	Code	Wattage
1J	1/16W	2C	1/6W	3A	1W
2A	1/10W	2E	1/4W	3D	2W
2B	1/8W	2H	1/2W		



## PARTS LIST / 零件表

\* New Parts. Δ indicates safety critical components.

Parts without **Parts No.** are not supplied.Les articles non mentionnés dans le **Parts No.** ne sont pas fournis.

Teile ohne Parts No. werden nicht geliefert.

L : Scandinavia

Y : PX (Far East, Hawaii)

C : China

K : USA

T : England

X : Australia

P : Canada

E : Europe

M : Other Areas

TK-8360  
DISPLAY UNIT (X54-3740-20)

Ref. No.	Address	New parts	Parts No.	Description	Destination	Ref. No.	Address	New parts	Parts No.	Description	Destination
<b>TK-8360</b>						C6			CK73HB1H471K	CHIP C 470PF	K
1	1B		A02-4073-21	PLASTIC CABINET		C7			CK73HB1H102K	CHIP C 1000PF	K
2	2B		A10-4129-01	CHASSIS		C8			CK73HB1H221K	CHIP C 220PF	K
3	3A		A62-1180-13	PANEL ASSY		C9			CK73HB1H471K	CHIP C 470PF	K
5	2B		B09-0732-03	CAP(D-SUB)		C10			CK73HB1H102K	CHIP C 1000PF	K
7	3A		B43-1650-04	BADGE		C11			CK73HB1H221K	CHIP C 220PF	K
8	2D		B62-2280-00	INSTRUCTION MANUAL(E/C) ACCESSORY		C12			CC73HCH1H101J	CHIP C 100PF	J
10	2B		E04-0167-15	RF COAXIAL RECEPTACLE(M)		C13			CK73HB1E103K	CHIP C 0.010UF	K
11	2B		E23-1346-04	GROUND TERMINAL(CLIP)		C14 ,15			CK73HB1H102K	CHIP C 1000PF	K
12	1C		E30-3339-15	DC CORD ASSY ACCESSORY		C20			CC73HCH1H101J	CHIP C 100PF	J
13	2B		E30-7686-05	DC CORD		C21			CK73HB1E103K	CHIP C 0.010UF	K
14	2A		E37-1461-05	FLAT CABLE		C22			CK73HB1H221K	CHIP C 220PF	K
16	2B,1C		F51-0078-05	FUSE(10A)		C23			CK73HB1H102K	CHIP C 1000PF	K
18	3B		G13-2363-04	CUSHION		C24			CK73HB1E103K	CHIP C 0.010UF	K
19	2B		G53-1643-04	PACKING(DC CORD)		C25 ,26			CK73HB1H471K	CHIP C 470PF	K
20	2B		G53-1662-04	PACKING(RECEPTACLE)		C27 ,28			CK73HB1A105K	CHIP C 1.0UF	K
21	1B		G53-1819-21	PACKING(CHASSIS)		C29 -31			CK73HB1H102K	CHIP C 1000PF	K
22	2A		G53-1820-03	PACKING(PANEL)		C32 ,33			CK73HB1C473K	CHIP C 0.047UF	K
23	3A		G53-1858-03	PACKING(SP)		103	2A		E29-1231-15	INTER CONNECTOR(LCD)	
29	3A		J19-5542-02	HOLDER(SP)		CN1			E40-6851-05	FLAT CABLE CONNECTOR(30P)	
30	1C		J29-0726-03	BRACKET ACCESSORY		J1	3A		E58-0535-05	MODULAR JACK(MIC)	
32	3A		K29-9479-01	KEY TOP		104	3A		F20-3383-04	INSULATING SHEET	
A	1A,1B		N35-2604-43	BINDING HEAD MACHINE SCREW		105	2A		J21-8629-03	MOUNTING HARDWARE(LCD)	
B	1A,1B,2B		N67-3008-48	PAN HEAD SEMS SCREW		L1			L92-0138-05	CHIP FERRITE	
C	2B		N87-2608-48	BRAZIER HEAD TAPTITE SCREW		CP1			RK74HB1J102J	CHIP-COM 1.0K	J 1/16W
34	3D		N99-2039-05	SCREW SET ACCESSORY		R1			RK73HB1J100J	CHIP R 10	J 1/16W
36	3A		T07-0785-15	SPEAKER		R2 -4			RK73HB1J103J	CHIP R 10K	J 1/16W
<b>DISPLAY UNIT (X54-3740-20)</b>						R5			RK73HB1J102J	CHIP R 1.0K	J 1/16W
101	2A		B11-1885-03	ILLUMINATION GUIDE		R6			RK73HB1J150J	CHIP R 15	J 1/16W
102	2A		B38-0936-05	LCD		R7			RK73HB1J000J	CHIP R 0	J 1/16W
D5 -9			B30-2337-05	LED(YELLOW)		R8			RK73FB2B000J	CHIP R 0	J 1/8W
D11 -21			B30-2337-05	LED(YELLOW)		R9			RK73HB1J000J	CHIP R 0	J 1/16W
D22	3A		B30-2321-05	LED(BLUE LED)		R12			RK73HB1J101J	CHIP R 100	J 1/16W
D23	3A		B30-2151-05	LED(RED/GREEN)		R14			RK73HB1J122J	CHIP R 1.2K	J 1/16W
D24			B30-2337-05	LED(YELLOW)		R15			RK73HB1J000J	CHIP R 0	J 1/16W
C1			CC73HCH1H101J	CHIP C 100PF	J	R17			RK73HB1J000J	CHIP R 0	J 1/16W
C2 ,3			CK73HB1H221K	CHIP C 220PF	K	R18			RK73HB1J181J	CHIP R 180	J 1/16W
C4			CC73HCH1H101J	CHIP C 100PF	J	R19			RK73HB1J820J	CHIP R 82	J 1/16W
C5			CK73HB1H221K	CHIP C 220PF	K	R20			RK73HB1J000J	CHIP R 0	J 1/16W
D1			UDZW6.2(B)	ZENER DIODE		R22			RK73HB1J000J	CHIP R 0	J 1/16W
D2			DA221	DIODE		R23			RK73HB1J473J	CHIP R 47K	J 1/16W
D10			MC2850	DIODE		R24 ,25			RK73HB1J103J	CHIP R 10K	J 1/16W
IC1			LC75857W-E	MOS-IC		R26			RK73HB1J123J	CHIP R 12K	J 1/16W
						R27			RK73HB1J473J	CHIP R 47K	J 1/16W
						R28 ,29			RK73HB1J151J	CHIP R 150	J 1/16W
						R30 ,31			RK73HB1J121J	CHIP R 120	J 1/16W
						R32			RK73HB1J103J	CHIP R 10K	J 1/16W
						R33			RK73HB1J000J	CHIP R 0	J 1/16W
						R34 -37			RK73HB1J151J	CHIP R 150	J 1/16W

## PARTS LIST / 零件表

DISPLAY UNIT (X54-3740-20)

TX-RX UNIT (X57-8020-23)

Ref. No.	Address	New parts	Parts No.	Description	Destination	Ref. No.	Address	New parts	Parts No.	Description	Destination
Q2 ,3			RT1N141U-T111	TRANSISTOR		C83 ,84			CC73HCH1H101J	CHIP C 100PF J	
Q4 ,5			RT1P141U-T111	TRANSISTOR		C85 ,86			CK73GB1H471K	CHIP C 470PF K	
Q6			RT1N141U-T111	TRANSISTOR		C87			CC73HCH1H050B	CHIP C 5.0PF B	
Q7			KRA225S	TRANSISTOR		C88			CC73HCH1H2R5B	CHIP C 2.5PF B	
Q8			RT1N141C-T112	TRANSISTOR		C89 ,90			CK73GB1H471K	CHIP C 470PF K	
Q9			RN47A4-F	TRANSISTOR		C91			CC73HCH1H060B	CHIP C 6.0PF B	
Q10			2SB1132(Q,R)	TRANSISTOR		C92			CC73HCH1H080B	CHIP C 8.0PF B	
						C93 ,94			CC73HCH1H050B	CHIP C 5.0PF B	
						C95			CK73HB1H471K	CHIP C 470PF K	
						C96			CC73HCH1H0R5B	CHIP C 0.5PF B	
<b>TX-RX UNIT (X57-8020-23)</b>											
C1			CK73HB1H471K	CHIP C 470PF K		C97			CC73HCH1H0R3B	CHIP C 0.3PF B	
C2			CC73HCH1H020B	CHIP C 2.0PF B		C98			CS77BB21C100M	CHIP TNTL 10UF 16WV	
C5 ,6			CC73HCH1H101J	CHIP C 100PF J		C99 -101			CK73HB1H471K	CHIP C 470PF K	
C7			CK73HB1H102K	CHIP C 1000PF K		C102			CC73HCH1H060B	CHIP C 6.0PF B	
C8 ,9			CK73HB1A104K	CHIP C 0.10UF K		C103			CC73HCH1H020B	CHIP C 2.0PF B	
C10			CC73HCH1H101J	CHIP C 100PF J		C104			CC73GCH1H020B	CHIP C 2.0PF B	
C11			CC73GCH1H101J	CHIP C 100PF J		C105-107			CK73HB1H471K	CHIP C 470PF K	
C12			CC73HCH1H200J	CHIP C 20PF J		C108			CC73HCH1H0R5B	CHIP C 0.5PF B	
C14			CC73HCH1H101J	CHIP C 100PF J		C109			CK73HB1H471K	CHIP C 470PF K	
C16			CC73HCH1H101J	CHIP C 100PF J		C110			CC73GCH1H020B	CHIP C 2.0PF B	
C17			CC73HCH1H080B	CHIP C 8.0PF B		C111			CK73HB1E103K	CHIP C 0.010UF K	
C19			CK73FB0J106K	CHIP C 10UF K		C112,113			CK73HB1H471K	CHIP C 470PF K	
C21			CK73HB1A104K	CHIP C 0.10UF K		C114			CK73FB0J226M	CHIP C 22UF M	
C22			CK73HB0J105K	CHIP C 1.0UF K		C300			CC73GCH1H120J	CHIP C 12PF J	
C23 ,24			CK73HB1A104K	CHIP C 0.10UF K		C301			CC73HCH1H070B	CHIP C 7.0PF B	
C25			CK73FB0J106K	CHIP C 10UF K		C302			CC73HCH1H150J	CHIP C 15PF J	
C27			CK73HB1A104K	CHIP C 0.10UF K		C303			CK73HB1H471K	CHIP C 470PF K	
C28			CK73FB0J106K	CHIP C 10UF K		C304			CC73HCH1H120J	CHIP C 12PF J	
C29			CK73HB1H471K	CHIP C 470PF K		C305			CK73HB1H102K	CHIP C 1000PF K	
C30			CK73HB1E103K	CHIP C 0.010UF K		C308			CC73HCH1H120J	CHIP C 12PF J	
C31			CK73HB1A104K	CHIP C 0.10UF K		C309			CK73HB1H471K	CHIP C 470PF K	
C32 ,33			CK73HB1H471K	CHIP C 470PF K		C310			CC73HCH1H3R5B	CHIP C 3.5PF B	
C35			CC73HCH1H3R5B	CHIP C 3.5PF B		C311			CK73HB1E223K	CHIP C 0.022UF K	
C36			CK73HB1H471K	CHIP C 470PF K		C312			CC73GCH1H470J	CHIP C 47PF J	
C42			CS77CA1V0R1M	CHIP TNTL 0.1UF 35WV		C314			CK73GB1H471K	CHIP C 470PF K	
C43			CC73HCH1H101J	CHIP C 100PF J		C319			CK73HB1H471K	CHIP C 470PF K	
C44			CC73HCH1H020B	CHIP C 2.0PF B		C321			CC73HCH1H101J	CHIP C 100PF J	
C47			CK73HB1H471K	CHIP C 470PF K		C322			CK73GB1H221K	CHIP C 220PF K	
C48			C92-0588-05	CHIP TNTL 1.5UF 16WV		C324			CC73GCH1H220J	CHIP C 22PF J	
C49			CC73HCH1H050B	CHIP C 5.0PF B		C325			CK73GB1H102K	CHIP C 1000PF K	
C50			CK73GB1H471K	CHIP C 470PF K		C326,327			CC73GCH1H101J	CHIP C 100PF J	
C52			CC73HCH1H330J	CHIP C 33PF J		C328			CK73HB1A104K	CHIP C 0.10UF K	
C53			CC73HCH1H020B	CHIP C 2.0PF B		C330			CK73GB1H471K	CHIP C 470PF K	
C56			CC73HCH1H3R5B	CHIP C 3.5PF B		C331			CC73GCH1H101J	CHIP C 100PF J	
C57			C92-0863-05	CHIP TNTL 0.047UF 35WV		C332			CK73GB1H471K	CHIP C 470PF K	
C59			CK73HB1H471K	CHIP C 470PF K		C333			CC73GCH1H470J	CHIP C 47PF J	
C61			C92-0863-05	CHIP TNTL 0.047UF 35WV		C334			CC73GCH1H220J	CHIP C 22PF J	
C63			C93-0787-05	CHIP C 0.1UF J		C335			C93-0554-05	CHIP C 4.0PF C	
C65			CK73HB1A104K	CHIP C 0.10UF K		C338			CK73HB1A104K	CHIP C 0.10UF K	
C66			CK73HB1H471K	CHIP C 470PF K		C339			CK73GB1H471K	CHIP C 470PF K	
C68			CC73HCH1H680J	CHIP C 68PF J		C340			C93-0552-05	CHIP C 2.0PF C	
C70			CC73HCH1H470J	CHIP C 47PF J		C342			CK73HB1H471K	CHIP C 470PF K	
C72			CK73HB1H471K	CHIP C 470PF K		C343			CK73GB1H471K	CHIP C 470PF K	
C74			CK73HB1H471K	CHIP C 470PF K		C345			CK73GB1H103K	CHIP C 0.010UF K	
C75			CK73FB0J106K	CHIP C 10UF K		C346,347			CK73HB1H471K	CHIP C 470PF K	
C77			CC73HCH1H120J	CHIP C 12PF J		C348			CK73GB1H103K	CHIP C 0.010UF K	
C79			CC73HCH1H150J	CHIP C 15PF J		C349			CK73HB1H471K	CHIP C 470PF K	
C80			CC73HCH1H101J	CHIP C 100PF J		C350			CC73GCH1H040B	CHIP C 4.0PF B	
C81			CC73HCH1H0R5B	CHIP C 0.5PF B		C351			C93-0553-05	CHIP C 3.0PF C	
C82			CC73HCH1HR75B	CHIP C 0.75PF B		C352,353			C93-0603-05	CHIP C 1000PF K	

## PARTS LIST / 零件表

TX-RX UNIT (X57-8020-23)

Ref. No.	Address	New parts	Parts No.	Description	Desti-nation	Ref. No.	Address	New parts	Parts No.	Description	Desti-nation
C354			CC73GCH1H070B	CHIP C 7.0PF B		C524			CK73GB1C104K	CHIP C 0.10UF K	
C355			CC73GCH1H270J	CHIP C 27PF J		C525			CK73HB1H102K	CHIP C 1000PF K	
C356			C93-0556-05	CHIP C 6.0PF D		C527			CK73HB1E562K	CHIP C 5600PF K	
C358			CM73F2H100D	CHIP C 10PF D		C528			CC73HCH1H820J	CHIP C 82PF J	
C361			C93-0550-05	CHIP C 1.0PF C		C529			CC73HCH1H330J	CHIP C 33PF J	
C363			C93-0557-05	CHIP C 7.0PF D		C530			CK73HB1E103K	CHIP C 0.010UF K	
C364			CK73GB1H102K	CHIP C 1000PF K		C531			CK73HB1A104K	CHIP C 0.10UF K	
C366			CK73GB1H102K	CHIP C 1000PF K		C532			CK73HB1H471K	CHIP C 470PF K	
C367			CK73HB1H102K	CHIP C 1000PF K		C533			CK73HB1A104K	CHIP C 0.10UF K	
C401			CK73HB1A104K	CHIP C 0.10UF K		C535			CK73HB1H102K	CHIP C 1000PF K	
C402			CK73HB1E103K	CHIP C 0.010UF K		C537			CK73HB1A104K	CHIP C 0.10UF K	
C404			CS77BB21C220M	CHIP TNTL 22UF 16WV		C538			CK73HB1H471K	CHIP C 470PF K	
C406			CS77BB21C220M	CHIP TNTL 22UF 16WV		C540			CK73HB1H102K	CHIP C 1000PF K	
C407			CK73HB1A104K	CHIP C 0.10UF K		C541,542			CK73HB1E103K	CHIP C 0.010UF K	
C410-412			CK73HB1A104K	CHIP C 0.10UF K		C543			CK73HB1E223K	CHIP C 0.022UF K	
C414			CK73HB0J105K	CHIP C 1.0UF K		C544			CC73HCH1H010B	CHIP C 1.0PF B	
C415			CK73GB1H102K	CHIP C 1000PF K		C545			CC73HCH1H180J	CHIP C 18PF J	
C416,417			CK73HB1H102K	CHIP C 1000PF K		C546			CC73HCH1H100D	CHIP C 10PF D	
C418			CK73GB1A105K	CHIP C 1.0UF K		C549			CK73HB0J224K	CHIP C 0.22UF K	
C419			CK73GB1H102K	CHIP C 1000PF K		C550			CK73HB1A104K	CHIP C 0.10UF K	
C420			CS77BA1A100M	CHIP TNTL 10UF 10WV		C551			CK73HB1E103K	CHIP C 0.010UF K	
C421			CK73HB1H102K	CHIP C 1000PF K		C552			CK73HB1H471K	CHIP C 470PF K	
C422			CK73HB1E103K	CHIP C 0.010UF K		C553			CC73HCH1H150G	CHIP C 15PF G	
C423,424			CK73GB1H102K	CHIP C 1000PF K		C554			CC73HCH1H030B	CHIP C 3.0PF B	
C425			CK73HB1E103K	CHIP C 0.010UF K		C555			CK73HB1E103K	CHIP C 0.010UF K	
C426			CK73GB1A105K	CHIP C 1.0UF K		C556			CK73HB1H471K	CHIP C 470PF K	
C427			CK73HB1H102K	CHIP C 1000PF K		C557			CK73GB1H471K	CHIP C 470PF K	
C428			CK73FB1E225K	CHIP C 2.2UF K		C558			CK73HB1H471K	CHIP C 470PF K	
C429			CK73EB1E106K	CHIP C 10UF K		C559			CK73HB1E103K	CHIP C 0.010UF K	
C430			CK73HB1H102K	CHIP C 1000PF K		C560			CK73HB1H471K	CHIP C 470PF K	
C433			CK73HB1A104K	CHIP C 0.10UF K		C561			CC73HCH1H040B	CHIP C 4.0PF B	
C434			CK73GB1H102K	CHIP C 1000PF K		C562,563			CK73HB1H471K	CHIP C 470PF K	
C435			CK73GB1H221K	CHIP C 220PF K		C565			CK73HB1H471K	CHIP C 470PF K	
C436			CK73GB1H471K	CHIP C 470PF K		C566			CC73HCH1H680J	CHIP C 68PF J	
C437			CC73GCH1H220J	CHIP C 22PF J		C567			CC73HCH1H030B	CHIP C 3.0PF B	
C438			CK73GB1H471K	CHIP C 470PF K		C568			CC73HCH1H010B	CHIP C 1.0PF B	
C439			CC73GCH1H470J	CHIP C 47PF J		C569			CC73HCH1H0R5B	CHIP C 0.5PF B	
C440			CK73GB1H471K	CHIP C 470PF K		C570			CC73HCH1H040B	CHIP C 4.0PF B	
C442			CC73GCH1H101J	CHIP C 100PF J		C571			CC73HCH1H680J	CHIP C 68PF J	
C443			CK73GB1H102K	CHIP C 1000PF K		C572			CC73HCH1H020B	CHIP C 2.0PF B	
C444			CK73HB1A334K	CHIP C 0.33UF K		C573			CK73HB1H102K	CHIP C 1000PF K	
C445			CC73GCH1H470J	CHIP C 47PF J		C574			CC73HCH1H010B	CHIP C 1.0PF B	
C446			CK73GB1H471K	CHIP C 470PF K		C575			CC73HCH1H680J	CHIP C 68PF J	
C447			CK73GB1H221K	CHIP C 220PF K		C578			CC73HCH1H030B	CHIP C 3.0PF B	
C448			CK73GB1H471K	CHIP C 470PF K		C579,580			CK73HB1H471K	CHIP C 470PF K	
C449			CK73HB1H102K	CHIP C 1000PF K		C582			CK73HB1A104K	CHIP C 0.10UF K	
C500			CC73HCH1H470J	CHIP C 47PF J		C583			CK73HB1H471K	CHIP C 470PF K	
C502			CC73HCH1H101J	CHIP C 100PF J		C585-589			CK73HB1H471K	CHIP C 470PF K	
C504			CK73GB1E103K	CHIP C 0.010UF K		C590			CC73HCH1H2R5B	CHIP C 2.5PF B	
C505			CC73HCH1H470J	CHIP C 47PF J		C591			CC73GCH1H471J	CHIP C 470PF J	
C506			CC73HCH1H160J	CHIP C 16PF J		C592			CC73HCH1H470J	CHIP C 47PF J	
C508			CC73HCH1H270J	CHIP C 27PF J		C593			CC73HCH1H040B	CHIP C 4.0PF B	
C509			CK73HB1E103K	CHIP C 0.010UF K		C594			CK73HB1H102K	CHIP C 1000PF K	
C510-515			CK73HB1A104K	CHIP C 0.10UF K		C595			CC73HCH1H4R5B	CHIP C 4.5PF B	
C517			CK73HB1H471K	CHIP C 470PF K		C596			CC73HCH1H470J	CHIP C 47PF J	
C518			CK73HB1E103K	CHIP C 0.010UF K		C597			CC73HCH1H040B	CHIP C 4.0PF B	
C519			CK73HB1H221K	CHIP C 220PF K		C600			CC73HCH1H200G	CHIP C 20PF G	
C520			CK73FB0J106K	CHIP C 10UF K		C602			CC73HCH1H080B	CHIP C 8.0PF B	
C521			CK73HB1H221K	CHIP C 220PF K		C603			CC73HCH1H050B	CHIP C 5.0PF B	
C522,523			CK73HB1A104K	CHIP C 0.10UF K		C605			CC73HCH1H040B	CHIP C 4.0PF B	

## PARTS LIST / 零件表

## TX-RX UNIT (X57-8020-23)

Ref. No.	Address	New parts	Parts No.	Description	Destination	Ref. No.	Address	New parts	Parts No.	Description	Destination
C607			CK73HB1H471K	CHIP C 470PF K		C792			CC73HCH1H391J	CHIP C 390PF J	
C700-704			CC73HCH1H101J	CHIP C 100PF J		C793			CK73HB1H471K	CHIP C 470PF K	
C705			CK73HB1H471K	CHIP C 470PF K		C794			CK73HB1A104K	CHIP C 0.10UF K	
C706			CC73HCH1H101J	CHIP C 100PF J		C795			CK73HB0J105K	CHIP C 1.0UF K	
C707,708			CK73HB1H471K	CHIP C 470PF K		C796			CK73HB1E103K	CHIP C 0.010UF K	
C709			CC73HCH1H101J	CHIP C 100PF J		C797			CK73HB1A104K	CHIP C 0.10UF K	
C710			CK73HB1H471K	CHIP C 470PF K		C799-801			CK73HB1A104K	CHIP C 0.10UF K	
C712			CK73HB1H471K	CHIP C 470PF K		C802			CK73HB1E103K	CHIP C 0.010UF K	
C714			CK73HB1H471K	CHIP C 470PF K		C803			CK73HB0J105K	CHIP C 1.0UF K	
C716			CK73HB1H471K	CHIP C 470PF K		C804			CK73GB0J106K	CHIP C 10UF K	
C717			CC73HCH1H101J	CHIP C 100PF J		C807			CK73GB1C104K	CHIP C 0.10UF K	
C718			CK73HB1H471K	CHIP C 470PF K		C808			CK73GB1H471K	CHIP C 470PF K	
C720			CK73HB1H471K	CHIP C 470PF K		C809			CK73HB0J105K	CHIP C 1.0UF K	
C722			CK73HB1H471K	CHIP C 470PF K		C810			CC73HCH1H101J	CHIP C 100PF J	
C723			CC73HCH1H101J	CHIP C 100PF J		C811			CK73FB0J106K	CHIP C 10UF K	
C724			CK73HB1H471K	CHIP C 470PF K		C812			CK73HB0J105K	CHIP C 1.0UF K	
C726			CK73HB1H471K	CHIP C 470PF K		C813			CC73HCH1H101J	CHIP C 100PF J	
C728			CK73HB1H471K	CHIP C 470PF K		C814			CK73HB0J105K	CHIP C 1.0UF K	
C730			CK73HB1H471K	CHIP C 470PF K		C815			CC73HCH1H151J	CHIP C 150PF J	
C732			CK73HB1H471K	CHIP C 470PF K		C816			CK73HB0J105K	CHIP C 1.0UF K	
C734			CK73HB1H471K	CHIP C 470PF K		C818			CK73FB0J106K	CHIP C 10UF K	
C735			CC73HCH1H101J	CHIP C 100PF J		C819			CK73HB1E103K	CHIP C 0.010UF K	
C736			CK73HB1H471K	CHIP C 470PF K		C820			CK73GB1H104K	CHIP C 0.10UF K	
C738			CK73HB1H471K	CHIP C 470PF K		C821			CK73GB0J106K	CHIP C 10UF K	
C739			CC73HCH1H101J	CHIP C 100PF J		C822			CK73FB0J226M	CHIP C 22UF M	
C740			CK73HB1H471K	CHIP C 470PF K		C823			CK73GB1A105K	CHIP C 1.0UF K	
C742,743			CC73HCH1H470J	CHIP C 47PF J		C824			CK73HB1H102K	CHIP C 1000PF K	
C744			CK73HB1H471K	CHIP C 470PF K		C826			CK73HB1A683K	CHIP C 0.068UF K	
C745			CC73HCH1H470J	CHIP C 47PF J		C829			CK73HB1H682K	CHIP C 6800PF K	
C746			CK73HB1H471K	CHIP C 470PF K		C832			CK73GB1H102K	CHIP C 1000PF K	
C747			CK73GB1H102K	CHIP C 1000PF K		C834			CK73HB1H332K	CHIP C 3300PF K	
C748			CK73GB1A105K	CHIP C 1.0UF K		C836			CK73HB1E103K	CHIP C 0.010UF K	
C749			CK73HB0J105K	CHIP C 1.0UF K		C838			CC73HCH1H101J	CHIP C 100PF J	
C752			CK73HB0J105K	CHIP C 1.0UF K		C840,841			CK73HB1H471K	CHIP C 470PF K	
C754			CK73GB1H102K	CHIP C 1000PF K		C842			CK73GB1H102K	CHIP C 1000PF K	
C755			CK73HB0J105K	CHIP C 1.0UF K		C843			CK73HB0J105K	CHIP C 1.0UF K	
C756			CK73GB1C104K	CHIP C 0.10UF K		C844			CK73HB1H102K	CHIP C 1000PF K	
C758			CK73HB1A104K	CHIP C 0.10UF K		C848			CC73HCH1H180G	CHIP C 18PF B	
C761			CK73HB1H471K	CHIP C 470PF K		C849			CC73HCH1H0R3B	CHIP C 0.3PF B	
C762,763			CK73GB1E105K	CHIP C 1.0UF K		C851			CC73HCH1H180G	CHIP C 18PF G	
C764			CK73HB1A104K	CHIP C 0.10UF K		C852			CK73HB1H102K	CHIP C 1000PF K	
C765			CK73FB0J106K	CHIP C 10UF K		C853			CK73HB1A105K	CHIP C 1.0UF K	
C766			CK73HB1A104K	CHIP C 0.10UF K		C854			CK73GB1C104K	CHIP C 0.10UF K	
C767,768			CK73GB1E105K	CHIP C 1.0UF K		C855			CK73GB1H102K	CHIP C 1000PF K	
C769			CK73HB1A104K	CHIP C 0.10UF K		C858-861			CK73HB1H102K	CHIP C 1000PF K	
C771			CC73HCH1H680J	CHIP C 68PF J		C862,863			CK73GB1A105K	CHIP C 1.0UF K	
C772			CK73HB1A104K	CHIP C 0.10UF K		C864,865			CK73HB0J105K	CHIP C 1.0UF K	
C773			CK73HB0J105K	CHIP C 1.0UF K		C866			CK73HB1A224K	CHIP C 0.22UF K	
C774,775			CK73HB1A104K	CHIP C 0.10UF K		C867			CK73GB1C224K	CHIP C 0.22UF K	
C777			CK73HB1A104K	CHIP C 0.10UF K		C869			CK73HB1H102K	CHIP C 1000PF K	
C778			CK73HB0J105K	CHIP C 1.0UF K		C871			CS77BA1C4R7M	CHIP TNL 4.7UF 16WV	
C779			CK73HB1A104K	CHIP C 0.10UF K		C872			C92-0873-05	ELECTRO 47UF 16WV	
C780			CK73GB0J475K	CHIP C 4.7UF K		C873			CE32BD1C471M	CHIP EL 470UF 16WV	
C784			CK73HB1A104K	CHIP C 0.10UF K		C874			CK73HB1H102K	CHIP C 1000PF K	
C785			CK73HB1C333K	CHIP C 0.033UF K		C875			CE32BD1C471M	CHIP EL 470UF 16WV	
C786			CC73HCH1H121J	CHIP C 120PF J		C876			CC73HCH1H220J	CHIP C 22PF J	
C788			CK73HB1H102K	CHIP C 1000PF K		C877			CC73HCH1H470J	CHIP C 47PF J	
C789			CK73HB1H222K	CHIP C 2200PF K		C880			CC73HCH1H101J	CHIP C 100PF J	
C790			CK73GB0J106K	CHIP C 10UF K		C881			CK73HB1H471K	CHIP C 470PF K	
C791			CK73HB1A104K	CHIP C 0.10UF K		C882			CC73HCH1H220J	CHIP C 22PF J	

## PARTS LIST / 零件表

TX-RX UNIT (X57-8020-23)

Ref. No.	Address	New parts	Parts No.	Description	Desti-nation	Ref. No.	Address	New parts	Parts No.	Description	Desti-nation
C883			CK73HB1H471K	CHIP C 470PF K		L512-514			L41-6868-14	SMALL FIXED INDUCTOR(6.8NH)	
C884			CC73HCH1H220J	CHIP C 22PF J		L515			L41-2788-45	SMALL FIXED INDUCTOR(270NH)	
C885			CK73HB1H471K	CHIP C 470PF K		L516			L40-1875-92	SMALL FIXED INDUCTOR(18NH)	
C886			CK73HB1A104K	CHIP C 0.10UF K		L518,519			L41-6868-14	SMALL FIXED INDUCTOR(6.8NH)	
C887			CK73HB1E103K	CHIP C 0.010UF K		L523			L41-8275-45	SMALL FIXED INDUCTOR(82NH)	
C888,889			CK73HB1H471K	CHIP C 470PF K		L700,701			L92-0163-05	BEADS CORE	
C890			CC73HCH1H121J	CHIP C 120PF J		L702			L92-0443-05	CHIP FERRITE	
C891			CK73HB1A104K	CHIP C 0.10UF K		L704			L92-0443-05	CHIP FERRITE	
C893			CK73HB1A104K	CHIP C 0.10UF K		L706			L92-0161-05	BEADS CORE	
C894			CK73HB1H103K	CHIP C 0.010UF K		L707-712			L92-0163-05	BEADS CORE	
C895			CK73HB1H102K	CHIP C 1000PF K		X1			L77-3055-05	TCXO(19.2MHZ)	
C896			CK73HB1E103K	CHIP C 0.010UF K		X700			L77-1950-05	CRYSTAL RESONATOR(11.0592MHZ)	
C897			CK73HB1H471K	CHIP C 470PF K		XF500			L71-0659-05	MCF(38.85MHZ)	
C900			CC73HCH1H101J	CHIP C 100PF J							
C902			CC73HCH1H101J	CHIP C 100PF J		CP700-703			RK74HA1J102J	CHIP-COM 1.0K J 1/16W	
CN700			E40-6361-05	PIN ASSY		CP704			RK74HA1J101J	CHIP-COM 100 J 1/16W	
CN701			E40-6847-05	FLAT CABLE CONNECTOR		R1			RK73HB1J473J	CHIP R 47K J 1/16W	
J700	1B		E58-0536-05	D-SUB SOCKET(15P)		R3			RK73HB1J100J	CHIP R 10 J 1/16W	
J701	1B		E11-0425-05	3.5D PHONE JACK(3P)		R5			RK73HB1J103J	CHIP R 10K J 1/16W	
F400			F53-0327-15	FUSE(4A)		R6 -8			RK73HB1J102J	CHIP R 1.0K J 1/16W	
CD500			L79-1866-05	TUNING COIL(450KHZ)		R9			RK73HB1J000J	CHIP R 0 J 1/16W	
CF500			L72-0993-05	CERAMIC FILTER(450KHZ/WID)		R10			RK73HB1J152J	CHIP R 1.5K J 1/16W	
CF501			L72-0999-05	CERAMIC FILTER(450KHZ/NAR)		R11			RK73HB1J223J	CHIP R 22K J 1/16W	
L2			L41-1591-08	SMALL FIXED INDUCTOR(1.5NH)		R12			RK73HB1J000J	CHIP R 0 J 1/16W	
L3			L92-0442-05	CHIP FERRITE		R13			RK73HB1J563J	CHIP R 56K J 1/16W	
L5			L40-1575-71	SMALL FIXED INDUCTOR(15NH)		R14			RK73HB1J000J	CHIP R 0 J 1/16W	
L8			L40-1575-71	SMALL FIXED INDUCTOR(15NH)		R15			RK73HB1J104J	CHIP R 100K J 1/16W	
L9			L92-0443-05	CHIP FERRITE		R16			RK73HB1J561J	CHIP R 560 J 1/16W	
L11			L40-2785-92	SMALL FIXED INDUCTOR(270NH)		R17			RK73HB1J100J	CHIP R 10 J 1/16W	
L13			L40-2785-92	SMALL FIXED INDUCTOR(270NH)		R19 ,20			RK73HB1J000J	CHIP R 0 J 1/16W	
L15 ,16			L92-0163-05	BEADS CORE		R21			RK73HB1J100J	CHIP R 10 J 1/16W	
L19			L40-2285-92	SMALL FIXED INDUCTOR(220NH)		R22			RK73HB1J102J	CHIP R 1.0K J 1/16W	
L22 -24			L40-2285-92	SMALL FIXED INDUCTOR(220NH)		R23			RK73HB1J100J	CHIP R 10 J 1/16W	
L26			L40-2285-92	SMALL FIXED INDUCTOR(220NH)		R24			RK73HB1J183J	CHIP R 18K J 1/16W	
L28			L40-2285-92	SMALL FIXED INDUCTOR(220NH)		R25			RK73HB1J560J	CHIP R 56 J 1/16W	
L29			L92-0443-05	CHIP FERRITE		R26			RK73HB1J000J	CHIP R 0 J 1/16W	
L31 ,32			L41-2778-14	SMALL FIXED INDUCTOR(27NH)		R30			RK73HB1J472J	CHIP R 4.7K J 1/16W	
L33			L40-2702-86	SMALL FIXED INDUCTOR(27UH)		R33 ,34			RK73HB1J000J	CHIP R 0 J 1/16W	
L35			L40-2285-92	SMALL FIXED INDUCTOR(220NH)		R36			RK73HB1J102J	CHIP R 1.0K J 1/16W	
L37			L40-2785-92	SMALL FIXED INDUCTOR(270NH)		R39 ,40			RK73HB1J000J	CHIP R 0 J 1/16W	
L39			L40-2702-86	SMALL FIXED INDUCTOR(27UH)		R41			RK73HB1J223J	CHIP R 22K J 1/16W	
L40			L92-0443-05	CHIP FERRITE		R42			RK73HB1J272J	CHIP R 2.7K J 1/16W	
L41			L40-3375-71	SMALL FIXED INDUCTOR(33NH)		R44			RK73HB1J153J	CHIP R 15K J 1/16W	
L42			L40-3975-71	SMALL FIXED INDUCTOR(39NH)		R45			RK73HB1J102J	CHIP R 1.0K J 1/16W	
L300,301			L40-6865-71	SMALL FIXED INDUCTOR(6.8NH)		R46 ,47			RK73HB1J000J	CHIP R 0 J 1/16W	
L302			L40-3363-92	SMALL FIXED INDUCTOR(3.3NH)		R50			RK73HB1J225J	CHIP R 2.2M J 1/16W	
L303			L40-3975-92	SMALL FIXED INDUCTOR(39NH)		R51			RK73HB1J000J	CHIP R 0 J 1/16W	
L304			L40-1875-92	SMALL FIXED INDUCTOR(18NH)		R52			RK73HB1J182J	CHIP R 1.8K J 1/16W	
L305			L40-2775-92	SMALL FIXED INDUCTOR(27NH)		R53			RK73FB2B102J	CHIP R 1.0K J 1/8W	
L307-309			L92-0179-05	CHIP FERRITE		R54 ,55			RK73HB1J000J	CHIP R 0 J 1/16W	
L310			L34-4902-05	AIR-CORE COIL		R56 ,57			RK73HB1J103J	CHIP R 10K J 1/16W	
L311			L34-1039-05	AIR-CORE COIL		R58 ,59			RK73HB1J000J	CHIP R 0 J 1/16W	
L313-315			L34-1039-05	AIR-CORE COIL		R61			RK73HB1J000J	CHIP R 0 J 1/16W	
L316			L34-4902-05	AIR-CORE COIL		R62			RK73HB1J473J	CHIP R 47K J 1/16W	
L500,501			L40-4781-86	SMALL FIXED INDUCTOR(0.47UH)		R63			RK73HB1J000J	CHIP R 0 J 1/16W	
L503			L40-4781-86	SMALL FIXED INDUCTOR(0.47UH)		R64 ,65			RK73HB1J393J	CHIP R 39K J 1/16W	
L504			L40-1875-71	SMALL FIXED INDUCTOR(18NH)		R66			RK73HB1J473J	CHIP R 47K J 1/16W	
L508			L40-1875-71	SMALL FIXED INDUCTOR(18NH)		R67 ,68			RN73HH1J391D	CHIP R 390 D 1/16W	
L509,510			L41-4785-39	SMALL FIXED INDUCTOR(0.47UH)		R69			RK73GB2A104J	CHIP R 100K J 1/10W	
						R70			RK73HB1J472J	CHIP R 4.7K J 1/16W	



## PARTS LIST / 零件表

## TX-RX UNIT (X57-8020-23)

Ref. No.	Address	New parts	Parts No.	Description	Destination	Ref. No.	Address	New parts	Parts No.	Description	Destination
R71			RN73HH1J680D	CHIP R 68 D 1/16W		R502			RK73HB1J824J	CHIP R 820K J 1/16W	
R72			RN73HH1J101D	CHIP R 100 D 1/16W		R503			RK73HB1J101J	CHIP R 100 J 1/16W	
R73			RK73HB1J102J	CHIP R 1.0K J 1/16W		R504-508			RK73HB1J103J	CHIP R 10K J 1/16W	
R74 ,75			RK73HB1J000J	CHIP R 0 J 1/16W		R510			RK73HB1J103J	CHIP R 10K J 1/16W	
R76			RK73HB1J104J	CHIP R 100K J 1/16W		R511			RK73GB2A100J	CHIP R 10 J 1/10W	
R77			RK73HB1J000J	CHIP R 0 J 1/16W		R512			RK73HB1J182J	CHIP R 1.8K J 1/16W	
R78			RK73HB1J151J	CHIP R 150 J 1/16W		R513			RK73HB1J823J	CHIP R 82K J 1/16W	
R80			RK73HB1J104J	CHIP R 100K J 1/16W		R515			RK73HB1J564J	CHIP R 560K J 1/16W	
R81 ,82			RK73HB1J100J	CHIP R 10 J 1/16W		R516			RK73GB2A472J	CHIP R 4.7K J 1/10W	
R83			RK73HB1J391J	CHIP R 390 J 1/16W		R518			RK73HB1J000J	CHIP R 0 J 1/16W	
R84			RK73HB1J000J	CHIP R 0 J 1/16W		R520			RK73HB1J332J	CHIP R 3.3K J 1/16W	
R85			RK73HB1J222J	CHIP R 2.2K J 1/16W		R521			RK73HB1J222J	CHIP R 2.2K J 1/16W	
R86			RK73HB1J472J	CHIP R 4.7K J 1/16W		R522			RK73HB1J102J	CHIP R 1.0K J 1/16W	
R87			RK73GB2A472J	CHIP R 4.7K J 1/10W		R523			RK73HB1J000J	CHIP R 0 J 1/16W	
R88 ,89			RK73HB1J474J	CHIP R 470K J 1/16W		R524			RK73HB1J103J	CHIP R 10K J 1/16W	
R300			RK73HB1J472J	CHIP R 4.7K J 1/16W		R525			RK73HB1J000J	CHIP R 0 J 1/16W	
R301			RK73HB1J273J	CHIP R 27K J 1/16W		R526			RK73HB1J474J	CHIP R 470K J 1/16W	
R302			RK73HB1J103J	CHIP R 10K J 1/16W		R527			RK73HB1J101J	CHIP R 100 J 1/16W	
R309,310			RK73GB2A100J	CHIP R 10 J 1/10W		R528			RK73HB1J224J	CHIP R 220K J 1/16W	
R311			RK73GB2A121J	CHIP R 120 J 1/10W		R529			RK73HB1J000J	CHIP R 0 J 1/16W	
R313			RK73HB1J101J	CHIP R 100 J 1/16W		R530			RK73HB1J560J	CHIP R 56 J 1/16W	
R315			RK73GB2A470J	CHIP R 47 J 1/10W		R531			RK73HB1J391J	CHIP R 390 J 1/16W	
R316			RK73HB1J000J	CHIP R 0 J 1/16W		R533			RK73HB1J102J	CHIP R 1.0K J 1/16W	
R317			RK73HB1J224J	CHIP R 220K J 1/16W		R534			RK73HB1J391J	CHIP R 390 J 1/16W	
R319,320			RK73HB1J103J	CHIP R 10K J 1/16W		R536			RK73HB1J223J	CHIP R 22K J 1/16W	
R321			RK73HB1J000J	CHIP R 0 J 1/16W		R537			RK73HB1J563J	CHIP R 56K J 1/16W	
R323			RK73HB1J183J	CHIP R 18K J 1/16W		R538			RK73HB1J470J	CHIP R 47 J 1/16W	
R324			RK73HB1J000J	CHIP R 0 J 1/16W		R540,541			RK73HB1J823J	CHIP R 82K J 1/16W	
R326			RK73HB1J473J	CHIP R 47K J 1/16W		R542			RK73HB1J224J	CHIP R 220K J 1/16W	
R328,329			RK73HB1J000J	CHIP R 0 J 1/16W		R543			RK73HB1J684J	CHIP R 680K J 1/16W	
R330,331			RK73HB1J104J	CHIP R 100K J 1/16W		R545			RK73HB1J151J	CHIP R 150 J 1/16W	
R333			RK73HB1J104J	CHIP R 100K J 1/16W		R546			RK73HB1J823J	CHIP R 82K J 1/16W	
R334			RK73GH2A201D	CHIP R 200 D 1/10W		R547			RK73HB1J394J	CHIP R 390K J 1/16W	
R335			RK73GH2A101D	CHIP R 100 D 1/10W		R548			RK73HB1J154J	CHIP R 150K J 1/16W	
R336,337			RK73HB1J104J	CHIP R 100K J 1/16W		R549			RK73HB1J270J	CHIP R 27 J 1/16W	
R339			RK73GH2A101D	CHIP R 100 D 1/10W		R550,551			RK73HB1J000J	CHIP R 0 J 1/16W	
R340,341			RK73HB1J000J	CHIP R 0 J 1/16W		R552			RK73HB1J105J	CHIP R 1.0M J 1/16W	
R342			RK73HB1J104J	CHIP R 100K J 1/16W		R557,558			RK73HB1J105J	CHIP R 1.0M J 1/16W	
R343			RK73GH2A201D	CHIP R 200 D 1/10W		R561			RK73HB1J000J	CHIP R 0 J 1/16W	
R344			RK73HB1J000J	CHIP R 0 J 1/16W		R563			RK73HB1J270J	CHIP R 27 J 1/16W	
R345			RK73RB2H101J	CHIP R 100 J 1/2W		R564			RK73HB1J000J	CHIP R 0 J 1/16W	
R346			RK73GB2A102J	CHIP R 1.0K J 1/10W		R565			RK73HB1J223J	CHIP R 22K J 1/16W	
R348-351			RK73GB2A000J	CHIP R 0 J 1/10W		R566			RK73HB1J221J	CHIP R 220 J 1/16W	
R352			RK73GH2A121D	CHIP R 120 D 1/10W		R567			RK73HB1J104J	CHIP R 100K J 1/16W	
R353			RK73GH2A181D	CHIP R 180 D 1/10W		R568			RK73HB1J564J	CHIP R 560K J 1/16W	
R358	2B		R92-1061-05	JUMPER REST 0 OHM		R569			RK73HB1J223J	CHIP R 22K J 1/16W	
R400			RK73HB1J103J	CHIP R 10K J 1/16W		R570			RK73HB1J823J	CHIP R 82K J 1/16W	
R401			RK73HB1J472J	CHIP R 4.7K J 1/16W		R571			RK73HB1J683J	CHIP R 68K J 1/16W	
R402			RK73HB1J152J	CHIP R 1.5K J 1/16W		R572			RK73HB1J000J	CHIP R 0 J 1/16W	
R403,404			RK73HB1J473J	CHIP R 47K J 1/16W		R573,574			RK73HB1J223J	CHIP R 22K J 1/16W	
R405,406			RK73HB1J104J	CHIP R 100K J 1/16W		R575			RK73HB1J000J	CHIP R 0 J 1/16W	
R407			RK73HB1J102J	CHIP R 1.0K J 1/16W		R576,577			RK73HB1J104J	CHIP R 100K J 1/16W	
R408			RK73GB2A221J	CHIP R 220 J 1/10W		R578			RK73FB2B000J	CHIP R 0 J 1/8W	
R409			RK73GB2A473J	CHIP R 47K J 1/10W		R579			RK73GB2A000J	CHIP R 0 J 1/10W	
R410			RK73GB2A334J	CHIP R 330K J 1/10W		R580			RK73HB1J104J	CHIP R 100K J 1/16W	
R411			RK73HB1J474J	CHIP R 470K J 1/16W		R581			RK73GB2A000J	CHIP R 0 J 1/10W	
R412			RK73HB1J564J	CHIP R 560K J 1/16W		R582			RK73HB1J471J	CHIP R 470 J 1/16W	
R413			RK73HB1J000J	CHIP R 0 J 1/16W		R583			RK73HB1J100J	CHIP R 10 J 1/16W	
R414			RK73HB1J474J	CHIP R 470K J 1/16W		R584			RK73HB1J471J	CHIP R 470 J 1/16W	
R500			RK73HB1J000J	CHIP R 0 J 1/16W		R586			RK73HB1J000J	CHIP R 0 J 1/16W	



## PARTS LIST / 零件表

TX-RX UNIT (X57-8020-23)

Ref. No.	Address	New parts	Parts No.	Description	Desti-nation	Ref. No.	Address	New parts	Parts No.	Description	Desti-nation
R700			RK73HB1J223J	CHIP R 22K J 1/16W		R801			RK73HB1J562J	CHIP R 5.6K J 1/16W	
R701			RK73HB1J103J	CHIP R 10K J 1/16W		R802			RK73HB1J000J	CHIP R 0 J 1/16W	
R703			RK73HB1J000J	CHIP R 0 J 1/16W		R803			RK73HB1J563J	CHIP R 56K J 1/16W	
R707			RK73HB1J102J	CHIP R 1.0K J 1/16W		R804,805			RK73HB1J000J	CHIP R 0 J 1/16W	
R708			RK73HB1J101J	CHIP R 100 J 1/16W		R806,807			RK73HB1J104J	CHIP R 100K J 1/16W	
R709			RK73HB1J102J	CHIP R 1.0K J 1/16W		R809,810			RK73HB1J000J	CHIP R 0 J 1/16W	
R710,711			RK73HB1J000J	CHIP R 0 J 1/16W		R811			RK73HB1J104J	CHIP R 100K J 1/16W	
R713			RK73HB1J000J	CHIP R 0 J 1/16W		R813			RK73HB1J104J	CHIP R 100K J 1/16W	
R718			RK73HB1J000J	CHIP R 0 J 1/16W		R814			RK73HB1J101J	CHIP R 100 J 1/16W	
R721-723			RK73HB1J000J	CHIP R 0 J 1/16W		R815			RK73GB2A000J	CHIP R 0 J 1/10W	
R724			RK73GB2A000J	CHIP R 0 J 1/10W		R816			RK73HB1J104J	CHIP R 100K J 1/16W	
R725			RK73HB1J000J	CHIP R 0 J 1/16W		R817			RK73GB2A104J	CHIP R 100K J 1/10W	
R726			RK73GB2A000J	CHIP R 0 J 1/10W		R818			RK73HB1J104J	CHIP R 100K J 1/16W	
R728			RK73HB1J472J	CHIP R 4.7K J 1/16W		R819			RK73HB1J101J	CHIP R 100 J 1/16W	
R730			RK73HB1J681J	CHIP R 680 J 1/16W		R820			RK73HB1J000J	CHIP R 0 J 1/16W	
R733			RK73GB2A000J	CHIP R 0 J 1/10W		R823			RK73HB1J124J	CHIP R 120K J 1/16W	
R734			RK73HB1J102J	CHIP R 1.0K J 1/16W		R824			RK73HB1J000J	CHIP R 0 J 1/16W	
R735			RK73GB2A473J	CHIP R 47K J 1/10W		R825			RK73HB1J104J	CHIP R 100K J 1/16W	
R736			RK73HB1J821J	CHIP R 820 J 1/16W		R826			RK73HB1J101J	CHIP R 100 J 1/16W	
R737			RK73HB1J000J	CHIP R 0 J 1/16W		R827			RK73HB1J104J	CHIP R 100K J 1/16W	
R738			RK73GB2A221J	CHIP R 220 J 1/10W		R829			RK73HB1J101J	CHIP R 100 J 1/16W	
R739			RK73HB1J223J	CHIP R 22K J 1/16W		R830			RK73GB2A100J	CHIP R 10 J 1/10W	
R741			RK73HB1J223J	CHIP R 22K J 1/16W		R831			RK73HB1J473J	CHIP R 47K J 1/16W	
R742			RK73HB1J823J	CHIP R 82K J 1/16W		R832			RK73HB1J472J	CHIP R 4.7K J 1/16W	
R743			RK73HB1J561J	CHIP R 560 J 1/16W		R840			RK73HB1J473J	CHIP R 47K J 1/16W	
R744			RK73HB1J102J	CHIP R 1.0K J 1/16W		R841			RK73HB1J000J	CHIP R 0 J 1/16W	
R745,746			RK73HB1J000J	CHIP R 0 J 1/16W		R842			RK73HB1J103J	CHIP R 10K J 1/16W	
R747			RK73HB1J101J	CHIP R 100 J 1/16W		R843			RK73HB1J393J	CHIP R 39K J 1/16W	
R748			RK73HB1J123J	CHIP R 12K J 1/16W		R845			RK73GB2A000J	CHIP R 0 J 1/10W	
R749			RK73HB1J000J	CHIP R 0 J 1/16W		R846			RK73HB1J562J	CHIP R 5.6K J 1/16W	
R750			RK73HB1J105J	CHIP R 1.0M J 1/16W		R849			RK73HB1J682J	CHIP R 6.8K J 1/16W	
R751			RK73HB1J000J	CHIP R 0 J 1/16W		R850			RK73HB1J102J	CHIP R 1.0K J 1/16W	
R754			RK73HB1J123J	CHIP R 12K J 1/16W		R851			RK73HB1J223J	CHIP R 22K J 1/16W	
R755			RK73HB1J154J	CHIP R 150K J 1/16W		R852			RK73HB1J473J	CHIP R 47K J 1/16W	
R756			RK73HB1J103J	CHIP R 10K J 1/16W		R853			RK73HB1J332J	CHIP R 3.3K J 1/16W	
R757			RK73HB1J222J	CHIP R 2.2K J 1/16W		R854,855			RK73HB1J473J	CHIP R 47K J 1/16W	
R760,761			RK73GB2A000J	CHIP R 0 J 1/10W		R856			RK73HB1J222J	CHIP R 2.2K J 1/16W	
R762			RK73HB1J334J	CHIP R 330K J 1/16W		R857,858			RK73HB1J104J	CHIP R 100K J 1/16W	
R763			RK73HB1J154J	CHIP R 150K J 1/16W		R859			RK73HB1J105J	CHIP R 1.0M J 1/16W	
R765			RK73HB1J103J	CHIP R 10K J 1/16W		R860			RK73GB2A102J	CHIP R 1.0K J 1/10W	
R769			RK73HB1J000J	CHIP R 0 J 1/16W		R861			RK73HB1J153J	CHIP R 15K J 1/16W	
R772			RK73GB2A000J	CHIP R 0 J 1/10W		R863			RK73GB2A472J	CHIP R 4.7K J 1/10W	
R773			RK73HB1J000J	CHIP R 0 J 1/16W		R864			RK73HB1J123J	CHIP R 12K J 1/16W	
R774			RK73HB1J561J	CHIP R 560 J 1/16W		R866,867			RK73HB1J102J	CHIP R 1.0K J 1/16W	
R775			RK73HB1J000J	CHIP R 0 J 1/16W		R868			RK73HB1J000J	CHIP R 0 J 1/16W	
R776			RK73GB2A124J	CHIP R 120K J 1/10W		R869			RK73GH2A134D	CHIP R 130K D 1/10W	
R779,780			RK73HB1J473D	CHIP R 47K D 1/16W		R870			RK73GH2A183D	CHIP R 18K D 1/10W	
R781			RK73HB1J183J	CHIP R 18K J 1/16W		R871			RK73GB2A000J	CHIP R 0 J 1/10W	
R782			RK73HB1J104J	CHIP R 100K J 1/16W		R872-874			RK73HB1J102J	CHIP R 1.0K J 1/16W	
R785			RK73HB1J000J	CHIP R 0 J 1/16W		R875			RK73GB2A000J	CHIP R 0 J 1/10W	
R786			RK73HB1J473J	CHIP R 47K J 1/16W		R876-878			RK73HB1J102J	CHIP R 1.0K J 1/16W	
R787			RK73HB1J333J	CHIP R 33K J 1/16W		R879			RK73HB1J000J	CHIP R 0 J 1/16W	
R788			RK73HB1J000J	CHIP R 0 J 1/16W		R880			RK73HB1J154J	CHIP R 150K J 1/16W	
R789			RK73HB1J563J	CHIP R 56K J 1/16W		R881			RK73HB1J000J	CHIP R 0 J 1/16W	
R790			RK73HB1J000J	CHIP R 0 J 1/16W		R883			RK73HB1J000J	CHIP R 0 J 1/16W	
R791			RK73HB1J223J	CHIP R 22K J 1/16W		R885			RK73HB1J102J	CHIP R 1.0K J 1/16W	
R792			RK73HB1J561J	CHIP R 560 J 1/16W		R886			RK73HB1J000J	CHIP R 0 J 1/16W	
R793			RK73HB1J103J	CHIP R 10K J 1/16W		R887			RK73HB1J102J	CHIP R 1.0K J 1/16W	
R794,795			RK73HB1J102J	CHIP R 1.0K J 1/16W		R888			RK73HB1J000J	CHIP R 0 J 1/16W	
R799			RK73HB1J273J	CHIP R 27K J 1/16W		R889			RK73HB1J102J	CHIP R 1.0K J 1/16W	

## PARTS LIST / 零件表

## TX-RX UNIT (X57-8020-23)

Ref. No.	Address	New parts	Parts No.	Description	Destination	Ref. No.	Address	New parts	Parts No.	Description	Destination
R893,894			RK73HB1J000J	CHIP R 0 J 1/16W		D700			DA2S101	DIODE	
R895			RK73HB1J102J	CHIP R 1.0K J 1/16W		D701-711			DA221	DIODE	
R896			RK73HB1J000J	CHIP R 0 J 1/16W		D712			MC2858-T111	DIODE	
R897,898			RK73HB1J473J	CHIP R 47K J 1/16W		D713			1SS372F	DIODE	
R899-902			RK73HB1J000J	CHIP R 0 J 1/16W		D715			UDZW18(B)	ZENER DIODE	
R905			RK73GB2A000J	CHIP R 0 J 1/10W		D716			DA2S101	DIODE	
R906,907			RK73HB1J473J	CHIP R 47K J 1/16W		IC1			TC75S51FE(F)	MOS-IC	
R908,909			RK73HB1J472J	CHIP R 4.7K J 1/16W		IC2			MB15E03SL-E1	MOS-IC	
R910			RK73HB1J471J	CHIP R 470 J 1/16W		IC3			BD7542FVM	MOS-IC	
R911			RK73HB1J152J	CHIP R 1.5K J 1/16W		<b>IC300</b>	2B		S-AU83AL	POWER MODULE	
R912			RK73GB2A102J	CHIP R 1.0K J 1/10W		IC301			HA17358BFEL-E	MOS-IC	
R913			RK73HB1J473J	CHIP R 47K J 1/16W		IC400			TA4809BF	ANALOGUE IC	
R914-917			RK73HB1J000J	CHIP R 0 J 1/16W		IC401			XC6221B332N-G	MOS-IC	
R918			RK73HB1J223J	CHIP R 22K J 1/16W		IC402			TA7805F-NQ	MOS-IC	
R919			RK73HB1J473J	CHIP R 47K J 1/16W		IC403			BD4740G	MOS-IC	
R920			RK73HB1J472J	CHIP R 4.7K J 1/16W		IC404			XC6120N402N-G	MOS-IC	
R921			RK73HB1J473J	CHIP R 47K J 1/16W		IC500			UA31136L	MOS-IC	
R923			RK73HB1J472J	CHIP R 4.7K J 1/16W		IC501			HA17358BFEL-E	MOS-IC	
R924,925			RK73HB1J473J	CHIP R 47K J 1/16W		IC700			ADM202EARNZ	MOS-IC	
R927,928			RK73HB1J473J	CHIP R 47K J 1/16W		IC701			NJM2100V-ZB	MOS-IC	
R929,930			RK73HB1J472J	CHIP R 4.7K J 1/16W		IC702			CD686AQ3	MOS-IC	
R931,932			RK73HB1J224J	CHIP R 220K J 1/16W		IC703			XC6221B332N-G	MOS-IC	
R933,934			RK73HB1J823J	CHIP R 82K J 1/16W		IC704			F3650TDFBKEBA	MCU	
R935,936			RK73HB1J222J	CHIP R 2.2K J 1/16W		IC705			EX25512ATA00A	ROM IC	
R938			RK73HB1J391J	CHIP R 390 J 1/16W		<b>IC706</b>	1A		LA4600	BI-POLAR IC	
R940-942			RK73FB2B000J	CHIP R 0 J 1/8W		IC707			TC7S66FUF	MOS-IC	
R943			RK73HB1J104J	CHIP R 100K J 1/16W		IC708			TC4W53FU-F	MOS-IC	
R944			RK73HB1J473J	CHIP R 47K J 1/16W		IC709			NJM2746RB1-ZB	ANALOGUE IC	
R945			RK73HB1J103J	CHIP R 10K J 1/16W		IC710			TC7W53FK(F)	MOS-IC	
R947			RK73HB1J103J	CHIP R 10K J 1/16W		Q1			KTC4075E(Y,GR)	TRANSISTOR	
R948			RK73HB1J684J	CHIP R 680K J 1/16W		Q4			SSM3J05FU-F	FET	
R949			RK73HB1J394J	CHIP R 390K J 1/16W		Q5			2SK1830F	FET	
R950			RK73HB1J105J	CHIP R 1.0M J 1/16W		Q6			MCH3914(7)-H	FET	
R951			RK73HB1J332J	CHIP R 3.3K J 1/16W		Q7			2SJ347F	FET	
R952			RK73HB1J101J	CHIP R 100 J 1/16W		Q8			MCH3914(7)-H	FET	
R953			RK73HB1J103J	CHIP R 10K J 1/16W		Q10			KRX102U	TRANSISTOR	
R954			RK73HB1J332J	CHIP R 3.3K J 1/16W		Q11			KTC4075E(Y,GR)	TRANSISTOR	
R955			RK73HB1J472J	CHIP R 4.7K J 1/16W		Q12, 13			2SC5108(Y)F	TRANSISTOR	
R956,957			RK73HB1J223J	CHIP R 22K J 1/16W		Q300			RD00HVS1-T113	FET	
R960			RK73HB1J000J	CHIP R 0 J 1/16W		Q400,401			RT1N141U-T111	TRANSISTOR	
R962			RK73HB1J823J	CHIP R 82K J 1/16W		Q402,403			2SB1694	TRANSISTOR	
D1			1SS389-F	DIODE		Q404,405			SSM3J05FU-F	FET	
D7			1SV325F	VARIABLE CAPACITANCE DIODE		Q406			KTC4075E(Y,GR)	TRANSISTOR	
D9 -15			1SV325F	VARIABLE CAPACITANCE DIODE		Q407			2SJ645	FET	
D16			1SV278F	VARIABLE CAPACITANCE DIODE		Q500			2SC5108(Y)F	TRANSISTOR	
D17, 18			HVC131	DIODE		Q502			RT1P441U-T111	TRANSISTOR	
D300			UDZW5.1(B)	ZENER DIODE		Q503			RT1N441U-T111	TRANSISTOR	
D301			1SS355	DIODE		Q504			2SC5108(Y)F	TRANSISTOR	
D302			HSC277	DIODE		Q505			2SC2412K	TRANSISTOR	
D303,304			L407CDB	DIODE		Q506			KTC4075E(Y,GR)	TRANSISTOR	
D305,306			HSB88AS-E	DIODE		Q507			3SK318	FET	
D307			RKP350KV	DIODE		Q508			RT1N141U-T111	TRANSISTOR	
D309,310			UDZW3.3(B)	ZENER DIODE		Q511			3SK318	FET	
D311		*	L709CER-T	DIODE		Q700			2SC4116(Y)F	TRANSISTOR	
D400			Z5W27V	SURGE ABSORBER		Q702			2SJ645	FET	
D500,501			MC2858-T111	DIODE		Q703			2SC4919-S	TRANSISTOR	
D502			HSB88AS-E	DIODE		Q704			2SK1830F	FET	
D503-507			1SV305F	VARIABLE CAPACITANCE DIODE		Q705			KTC4075E(Y,GR)	TRANSISTOR	
D508			HVC369B	VARIABLE CAPACITANCE DIODE		Q708			KTC4075E(Y,GR)	TRANSISTOR	
						Q709			SSM3J05FU-F	FET	

## PARTS LIST / 零件表

TX-RX UNIT (X57-8020-23)

Ref. No.	Address	New parts	Parts No.	Description	Destination	Ref. No.	Address	New parts	Parts No.	Description	Destination
Q710			KTC4075E(Y,GR)	TRANSISTOR							
Q712			SSM3J05FU-F	FET							
Q713			2SK1824-A	FET							
Q714			RT1N440M-T111	TRANSISTOR							
Q715			DTC114YEB	DIGITAL TRANSISTOR							
Q716			KTC4075E(Y,GR)	TRANSISTOR							
Q717			RT1N441U-T111	TRANSISTOR							
Q718,719			SSM3K05FU	FET							
Q720			RT1N141U-T111	TRANSISTOR							
TH300-302			B57331V2104J	THERMISTOR							
TH501			NCP18WB473J0S	THERMISTOR							

## EXPLODED VIEW / 部件分解图

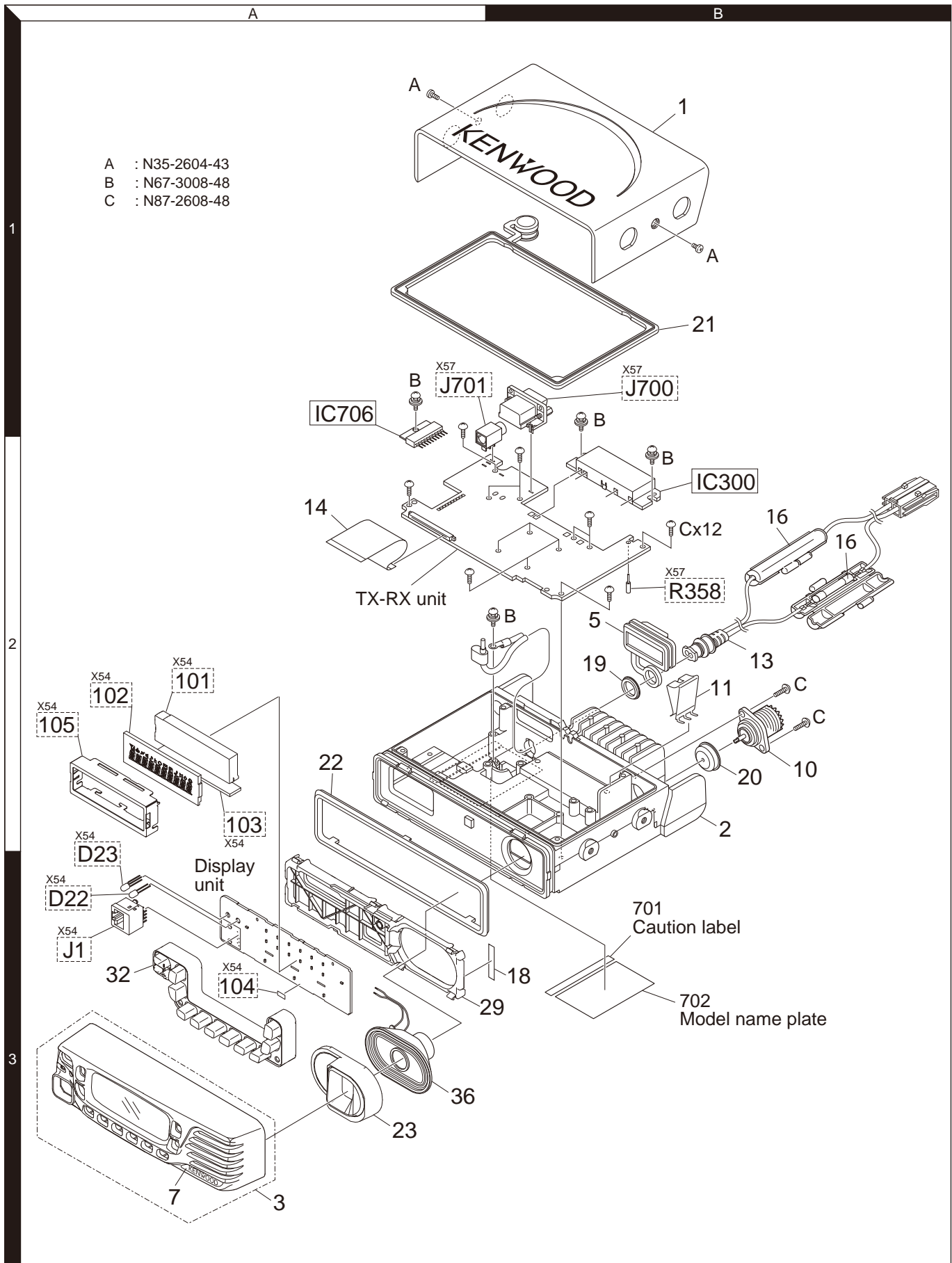

48 Parts with the exploded numbers larger than 700 are not supplied. / 编号大于 700 的零件未提供分解图。  
 If a part reference number is listed in a box on the exploded view of the PCB, that part does not come with the PCB. These parts must be ordered separately. / 维修部件的 PCB 板里不含方里的文字所表示的零件。这些零件必需另外购买。

## PACKING / 包装

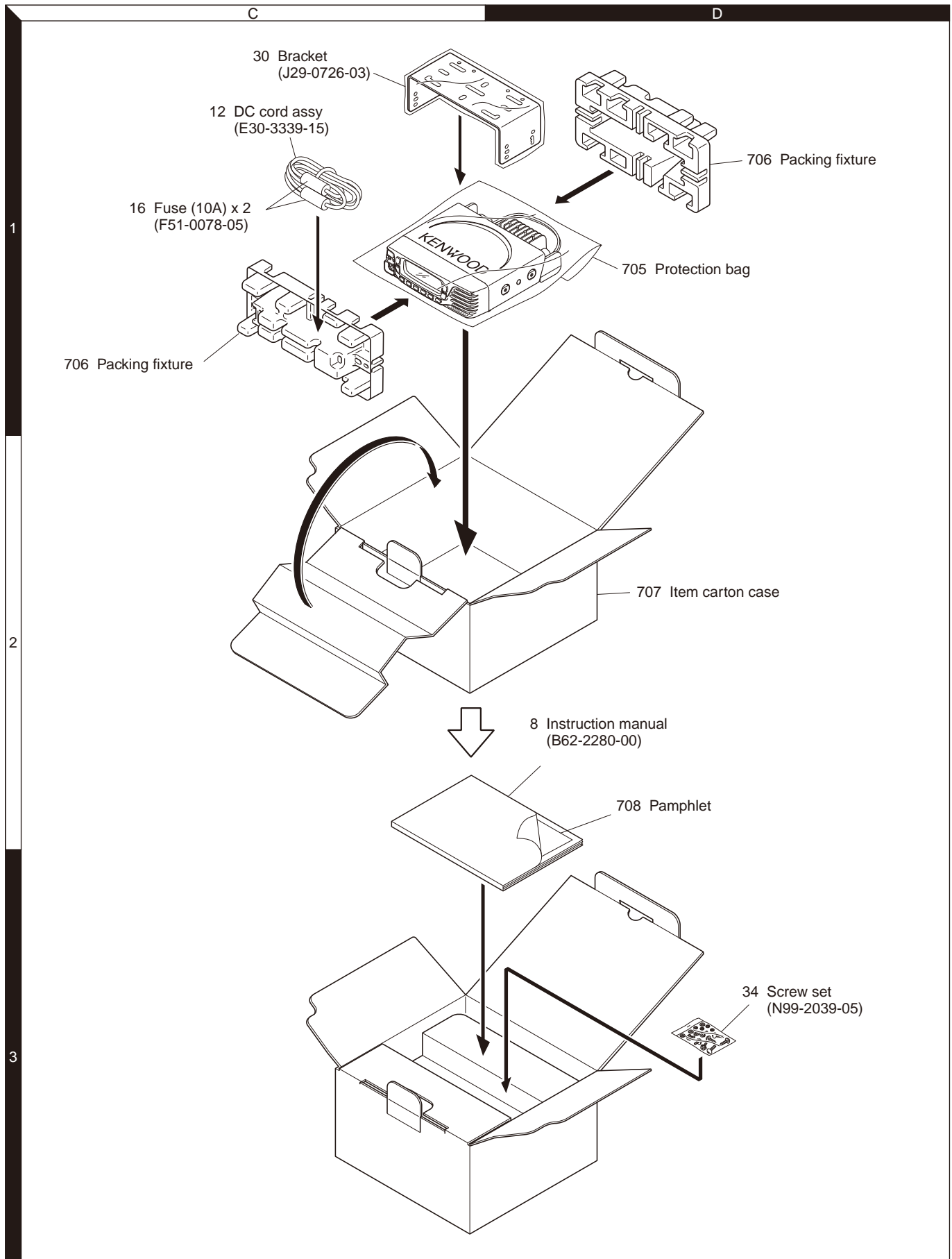

Parts with the exploded numbers larger than 700 are not supplied. / 编号大于 700 的零件未提供分解图。

## ADJUSTMENT

### Controls

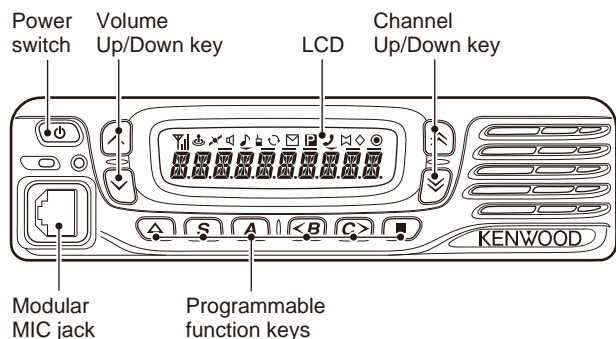

### ■ Preparations for checking/tuning the transceiver

Before attempting to check/tune the transceiver, connect the unit to a suitable power supply.

Whenever the transmitter is turned on, the unit must be connected to a suitable dummy load (i.e. power meter).

The speaker output connector must be terminated with an 4Ω dummy load and connected to an AC voltmeter and an audio distortion meter or a SINAD measurement meter at all times during checking/tuning.

### Panel Test Mode

#### ■ Test mode operation features

This transceiver has a test mode. To enter test mode, press and hold the [A] key while turning the transceiver power ON. Before the transceiver enters test mode, the frequency version information appears on the LCD momentarily. Test mode can be inhibited by programming. To exit test mode, turn the transceiver power OFF. The following functions are available in test mode.

#### ■ Key operation

Key	“-” not appears	
	Function	Display
[S]	Shifts to Panel tuning mode	-
[A]	Function on	“-” appears
[<B]	MSK 1200bps and 2400bps	2400bps: ☒ icon appears
[C>]	Test signaling CH up	Signaling No.
[^]/[v]	Test frequency CH up/down	Channel No.
[^]/[v]	Volume up/down	-
[Δ]	Squelch on/off	🔊
[■]	Narrow/Wide	Narrow: “N”, Wide: “W”
<b>Microphone key</b>		
[PTT]	Transmit	-
[0] to [9] and [#], [*]	Use as the DTMF keypad. If a key is pressed during transmission, the DTMF corresponding to the key that was presses is sent.	-

Key	“-” appears	
	Function	Display
[S]	High power / Low power	Low: “- -” icon appears
[A]	Function off	-
[<B]	Compander on/off	On: 🎧 icon appears
[C>]	Beat shift on/off	On: ⬠ icon appears
[^]/[v]	Function off	-
[^]/[v]	Function off	-
[Δ]	Squelch level 0	On: 🗨 icon appears
[■]	LCD all lights	LCD all point appears
<b>Microphone key</b>		
[PTT]	Transmit	-
[0] to [9] and [#], [*]	Function off	-

#### • LED indicator

Red LED Lights during transmission.  
Green LED Lights when there is carrier.

#### • LCD display in panel test mode

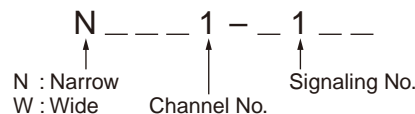

#### ■ Frequency and Signaling

The transceiver has been adjusted for the frequencies shown in the following table. When required, readjust them following the adjustment procedure to obtain the frequencies you want in actual operation.

#### • Frequency (MHz)

Channel	RX Frequency	TX Frequency
1	435.05000	435.10000
2	400.05000	400.10000
3	469.95000	469.90000
4	435.00000	435.00000
5	435.20000	435.20000
6	435.40000	435.40000
7~16	-	-



## 调整

## 控制

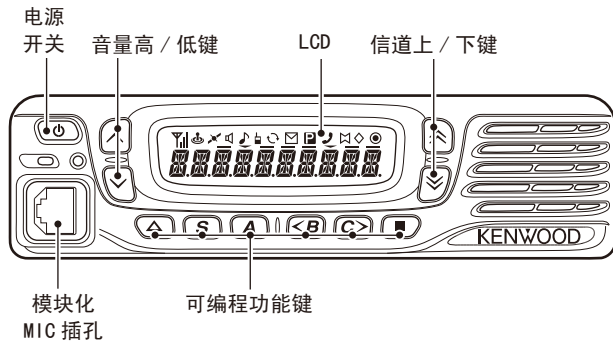

## ■准备检查和调谐车载对讲机的

在尝试调谐车载对讲机前，请将车载对讲机连接到合适的电源上。

发射打开时，车载对讲机必须连接到合适的等效负载上（如功率表）。

扬声器输出连接器必须端接  $4\Omega$  的等效负载，调谐期间，必须始终连接到交流电压表和音频失真仪或 SINAD 测量仪表上。

## 面板测试模式

## ■测试模式操作功能

本对讲机有测试模式。如需进入测试模式，请在打开对讲机电源的同时按住 [A] 键。对讲机进入测试模式之前，LCD 上短时间出现频率版本信息。可以通过编程禁用测试模式。如需退出测试模式，请关闭对讲机电源。在测试模式可以使用下列功能。

## ■键操作

键	“—” 不出现	
	功能	显示
[S]	换到面板调谐模式	-
[A]	功能关	显示“—”
[<B]	MSK 1200bps 和 2400bps	2400bps: <input checked="" type="checkbox"/> 图标出现
[C>]	测试信令 CH 上调	信令号
[^]/[v]	测试频率 CH 上调/下调	信道号
[^]/[v]	音量升高/降低	-
[Δ]	静噪打开/关闭	🔊
[■]	窄/宽	窄：“N”，宽：“W”
麦克风键		
[PTT]	发射	-
[0] 至 [9] 和 [#], [*]	用作 DTMF 键盘。如果在发射时按下某个键，则发送与按下的键对应的 DTMF。	-

键	“—” 出现	
	功能	显示
[S]	高功率/低功率	低：“--”图标出现
[A]	功能关	-
[<B]	压缩扩展器打开/关闭	开：图标出现
[C>]	拍频偏移打开/关闭	开：图标出现
[^]/[v]	功能关	-
[^]/[v]	功能关	-
[Δ]	静噪电平 0	开：图标出现
[■]	LCD 全亮	LCD 全点显示
麦克风键		
[PTT]	发射	-
[0] 至 [9] 和 [#], [*]	功能关	-

## • LED 指示灯

红色 LED 发射时点亮。低电池电压警告时闪烁。  
绿色 LED 有载波时点亮。

## • 面板测试模式时的 LCD 显示

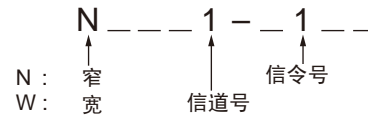

## ■频率和信令

已经根据下表所示的频率调整了设置。需要时，按调整步骤重新调整，以获得实际操作时想要的频率。

## • 频率 (MHz)

信道	接收频率	发射频率
1	435.05000	435.10000
2	400.05000	400.10000
3	469.95000	469.90000
4	435.00000	435.00000
5	435.20000	435.20000
6	435.40000	435.40000
7 ~ 16	-	-

## ADJUSTMENT

### • Signaling

Signaling No.	RX (Decode)	TX (Encode)
1	None	None
2	None	20Hz Square Wave
4	QT: 67.0Hz	QT: 67.0Hz
5	QT: 151.4Hz	QT: 151.4Hz
6	QT: 210.7Hz	QT: 210.7Hz
7	QT: 254.1Hz	QT: 254.1Hz
8	DQT: D023N	DQT: D023N
9	DQT: D754I	DQT: D754I
10	DTMF (CODE: 159D)	DTMF (CODE: 159D)
11	None	DTMF (CODE: 9)
12	None	MSK (1010..)
13	FleetSync: 100-1000	Fleet Sync: 100-1000
14	None	Single Tone (1000Hz)
16	None	Single Tone (1477Hz)
18	None	MSK PN9

### Panel Tuning Mode

#### ■ Transceiver tuning

(To place transceiver in tuning mode)

Press [S] key, now in tuning mode. Use [<B] key to write tuning data through tuning modes, and [↗]/[↘] to adjust tuning requirements (1 to 70/256/1024/4096 appears on LCD).

Use [C>] key to select the adjustment item through tuning modes. Use [A] key to adjust 5 reference level adjustments, and use [■] key to switch between Wide/Narrow.

Channel appears on LCD. Set channel according to tuning requirements.

#### • LCD display in panel tuning mode

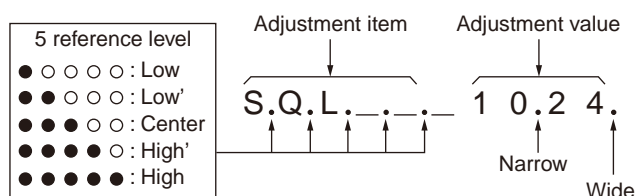

### ■ Key operation

Key	Function	
	Push	Hold (1 second)
[S]	End of panel tuning mode	-
[A]	To enter 5 reference level adjustments	-
[<B]	Writes the adjustment value	-
[C>]	Go to next adjustment item	Back to last adjustment item
[↗]/[↘]	Adjustment value up/down	Continuation up/down
[^]/[v]	Volume level up/down	Continuation up/down
[Δ]	Squelch on/off	-
[■]	Selects Narrow, Wide	-

### ■ 5 reference level adjustments frequency (MHz)

TEST CH	RX	TX
Low	400.05000	400.10000
Low'	417.55000	417.60000
Center	435.05000	435.10000
High'	452.55000	452.60000
High	469.95000	469.90000

### ■ Adjustment item and Display

(\*\*\*1: 1~1024, \*\*\*4: 1~4048,

Only Frequency: 1~256, Only DQT Balance: 1~70)

Order	Adjustment item	Display
1	RX Assist	RXASS ***1
2	TX Assist	TXASS ***1
3	Frequency	FREQ **2
4	High Power	HPOW ***1
5	Low Power	LPOW ***1
6	DQT Balance	BAL *7
7	Max Deviation	DEV ***4
8	DQT Deviation	DQT ***4
9	QT Deviation	QT ***4
10	DTMF Deviation	DTMF ***4
11	MSK Deviation	MSK ***4
12	Sensitivity (Semi-auto)	SENS1 ***1
13	Sensitivity (Not used)	SENS2 ***1
14	Squelch Open (5)	SQL ***1
15	Squelch tight	SQLT ***1
16	Low RSSI	LRSSI ***1
17	High RSSI	HRSSI ***1

## 调整

## • 信令

信令号	接收 (解码)	发射 (编码)
1	无	无
2	无	20Hz 方波
4	QT: 67.0Hz	QT: 67.0Hz
5	QT: 151.4Hz	QT: 151.4Hz
6	QT: 210.7Hz	QT: 210.7Hz
7	QT: 254.1Hz	QT: 254.1Hz
8	DQT: D023N	DQT: D023N
9	DQT: D754I	DQT: D754I
10	DTMF (代码: 159D)	DTMF (代码: 159D)
11	无	DTMF (代码 9)
12	无	MSK (1010. .)
13	Fleet Sync: 100-1000	Fleet Sync: 100-1000
14	无	单音 (1000Hz)
16	无	单音 (1477Hz)
18	无	MSK PN9

## 面板调谐模式

## ■ 车载对讲机调谐

(要使车载对讲机进入调谐模式)

按 [S] 键, 现在处于调谐模式。用 [<B] 键写入调谐模式的调谐数据, 用 [↗]/[↘] 调整调谐要求 (1 ~ 70/256/1024/4096 出现在 LCD 上)。

用 [C>] 键选择调谐模式的调整项目。用 [A] 键调整 5 点基准电平调节, 然后用 [■] 键切换宽/窄。

信道出现在 LCD 上。根据调谐要求设置信道。

## • 面板调谐模式时的 LCD 显示

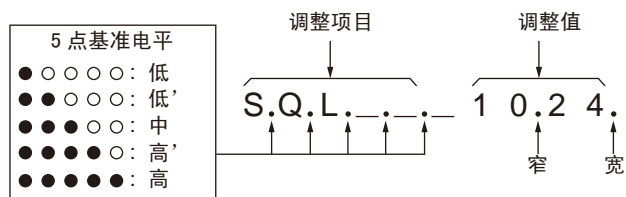

## ■ 键操作

键	功 能	
	按 下	按住 (1 秒钟)
[S]	结束面板调谐模式	-
[A]	进入 5 点基准电平调节	-
[<B]	写入调整值	-
[C>]	转到下一调整项目	返回到最后调整的项目
[↗]/[↘]	调整值增大 / 减小	连续增加 / 减小
[^]/[v]	音量升高 / 降低	连续升高 / 降低
[△]	静噪打开 / 关闭	-
[■]	择窄、宽	-

## ■ 5 点基准电平调整频率 (MHz)

测试信道	接 收	发 射
低	400.05000	400.10000
低'	417.55000	417.60000
中	435.05000	435.10000
高'	452.55000	452.60000
高	469.95000	469.90000

## ■ 调整项目和显示

(\*\*\*1: 1 ~ 1024, \*\*\*4: 1 ~ 4048,

仅频率: 1 ~ 256, 仅 DQT 平衡: 1 ~ 70)

顺 序	调 整 项 目	显 示
1	接收辅助	RXASS ***1
2	发射辅助	TXASS ***1
3	频率	FREQ **2
4	高功率	HPOW ***1
5	低功率	LPOW ***1
6	DQT 平衡	BAL *7
7	最大频偏	DEV ***4
8	DQT 频偏	DQT ***4
9	QT 频偏	QT ***4
10	DTMF 频偏	DTMF ***4
11	MSK 频偏	MSK ***4
12	灵敏度 (半自动)	SENS1 ***1
13	灵敏度 (未使用)	SENS2 ***1
14	静噪开 (5)	SQL ***1
15	静噪深	SQLT ***1
16	低 RSSI	LRSSI ***1
17	高 RSSI	HRSSI ***1

## ADJUSTMENT

### ■ Flow chart

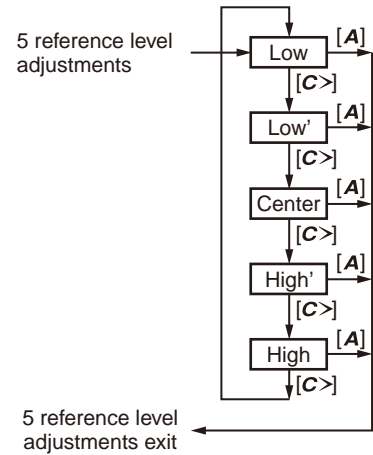
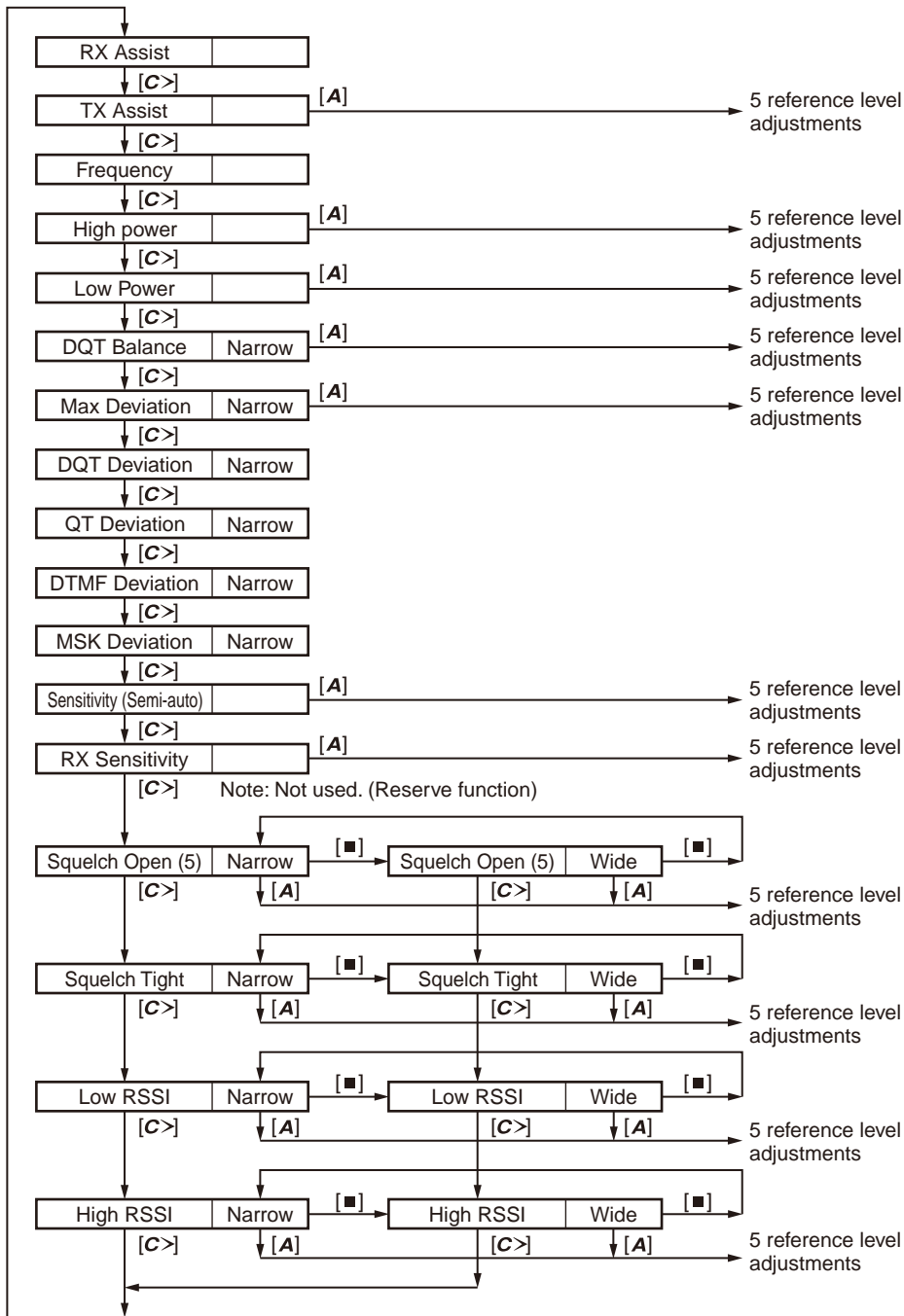

## 调整

■ 流程图

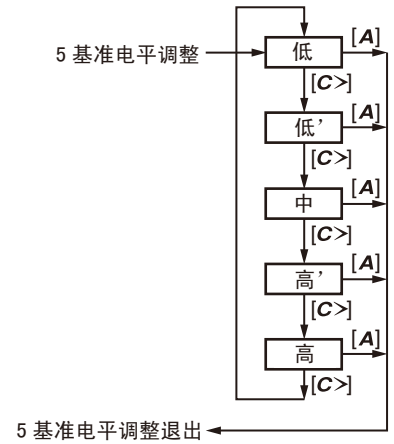
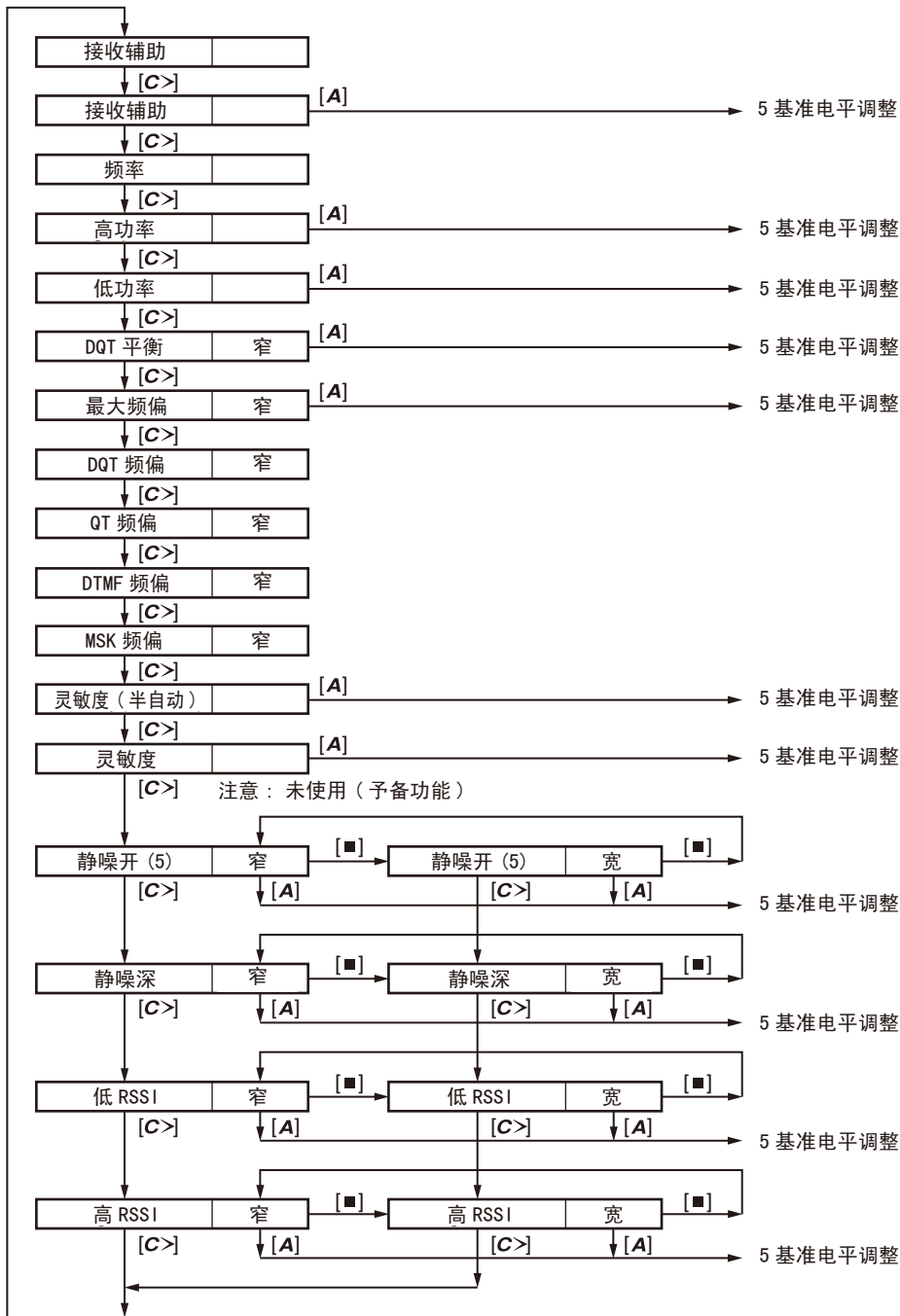

## ADJUSTMENT

### Test Equipment Required for Alignment

Test Equipment	Major Specifications	
1. Standard Signal Generator (SSG)	Frequency Range Modulation Output	400 to 470MHz Frequency modulation and external modulation -127dBm/0.1μV to greater than -7dBm/100mV
2. Power Meter	Input Impedance Operation Frequency Measurement Range	50Ω 400 to 470MHz or more Vicinity of 100W
3. Deviation Meter	Frequency Range	400 to 470MHz
4. Digital Volt Meter (DVM)	Measuring Range Input Impedance	1 to 20V DC High input impedance for minimum circuit loading
5. Oscilloscope		DC through 30MHz
6. High Sensitivity Frequency Counter	Frequency Range Frequency Stability	10Hz to 1000MHz 0.2ppm or less
7. Ammeter		20A or more
8. AF Volt Meter (AF VTVM)	Frequency Range Voltage Range	50Hz to 10kHz 1mV to 3V
9. Audio Generator (AG)	Frequency Range Output	20Hz to 20kHz or more 0 to 1V
10. Distortion Meter	Capability Input Level	3% or less at 1kHz 50mV to 10Vrms
11. 4Ω Dummy Load		Approx. 4Ω, 10W or more
12. Regulated Power Supply		13.6V, approx. 20A (adjustable from 9 to 17V) Useful if ammeter equipped
13. Spectrum Analyzer	Center Frequency	50kHz to 600MHz
14. Tracking Generator	Output Voltage	100mV or more

### Test cable for microphone input (E30-3360-28)

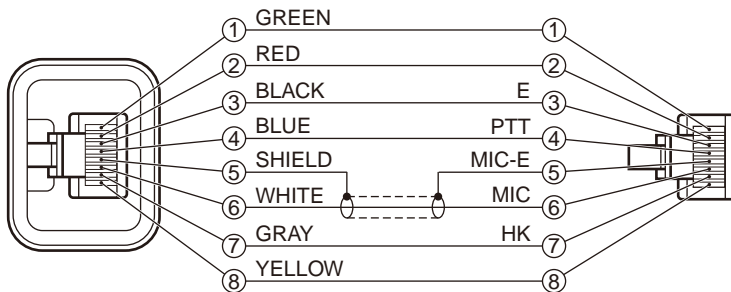

### MIC connector (Front panel view)

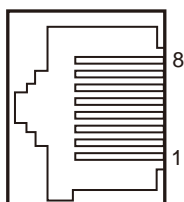

- 1 : MBL
- 2 : SB
- 3 : GND
- 4 : PTT
- 5 : ME
- 6 : MIC
- 7 : HOOK
- 8 : DM

### Tuning cable (E30-3383-05)

Adapter cable (E30-3383-05) is required for injecting an audio if PC tuning is used.  
See "PC Mode" section for the connection.

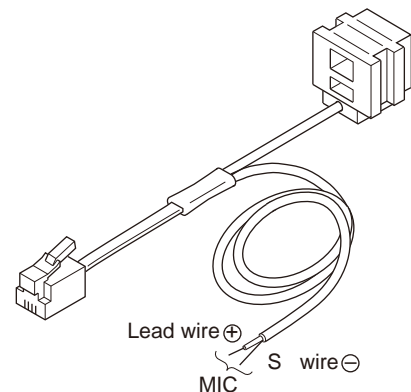



## 调整

## 调整所需的测试设备

测试设备	主要规格	
1. 标准信号发生器 (SSG)	频率范围 调制 输出	400 到 470MHz 调频和外部调制 -127dBm/0.1 $\mu$ V 到大于 -7dBm/100mV
2. 功率计	输入阻抗 操作频率 测量范围	50 $\Omega$ 400 到 470MHz 100W 左右
3. 频偏仪	频率范围	400 到 470MHz
4. 数字电压表 (DVM)	测量范围 输入阻抗	直流 1V 到 20V 为最小电路负载高输入阻抗
5. 示波器		直流到 30MHz
6. 高灵敏度频率计数器	频率范围 频率稳定性	10Hz 到 1000MHz 0.2ppm 或更低
7. 电流表		20A 或更高
8. 音频电压表 (AF VTVM)	频率范围 电压范围	50Hz 到 10kHz 1mV 到 3V
9. 音频发生器 (AG)	频率范围 输出	20Hz 到 20kHz 或更高 0V 到 1V
10. 失真测试仪	能力 输入电平	在 1kHz 时 3% 或更低 50mV 到 10Vrms
11. 4 $\Omega$ 假负载		大约 4 $\Omega$ , 10W 或更高
12. 可调电源		13.6V, 大约 20A (可调 9 到 17V) 配备了电流表时更好
13. 频谱分析仪	中心频率	50kHz 到 600MHz
14. 轨迹发生器	输出电压	100mV 或更高

## 用于麦克风输入的测试电缆 (E30-3360-28)

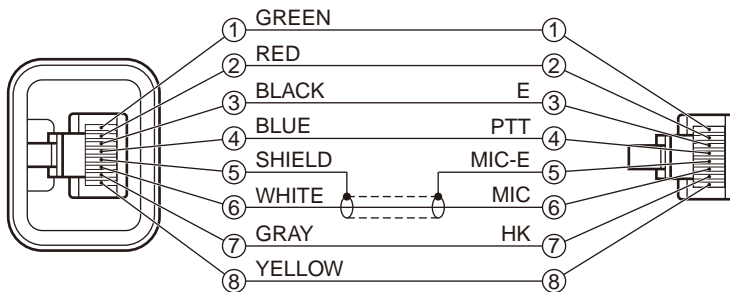

## 调谐电缆 (E30-3383-05)

如果使用 PC 调谐, 则输入音频需要适配器电缆 (E30-3383-05)。有关连接详情, 请参看“PC 模式”。

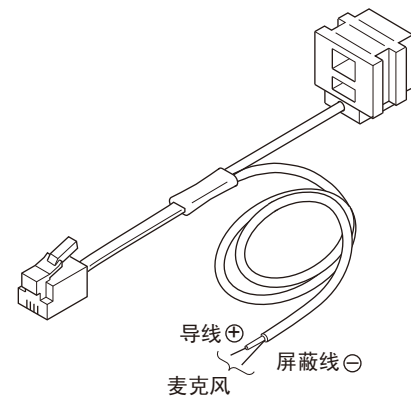

## MIC 连接器 (前面板视图)

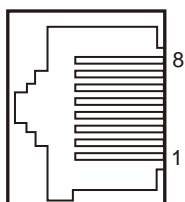

- 1: MBL
- 2: SB
- 3: GND
- 4: PTT
- 5: ME
- 6: MIC
- 7: HOOK
- 8: DM

## ADJUSTMENT

## Common Section

Item	Condition		Measurement			Adjustment			Specifications / Remarks
	Panel tuning mode	PC test mode	Test-equipment	Unit	Terminal	Unit	Parts	Method	
1. Setting	1) Power supply voltage DC power supply terminal: 13.6V 2) SSG standard modulation [Wide] MOD: 1kHz, DEV: 3kHz [Narrow] MOD: 1kHz, DEV: 1.5kHz								
2. Receive Assist Voltage (Automatic)	1) Adj item: [RXASS] Adjust: [****] 2) TEST CH: Low, Low', Center, High', High (5 points) 3) Press [<B] key to store the adjustment value.	1) (Auto tuning)*	Power meter				FPU	"Voltage Level" indicator on PC window shows VCO lock voltage. Change the adjustment value to get VCO lock voltage within the limit of the specified voltage.  <b>Note:</b> Confirm the VCO lock voltage approximately 3 seconds after the adjustment value is changed.	2.5V±0.2V
3. Transmit Assist Voltage (Automatic)	1) Adj item: [TXASS] Adjust: [****] 2) TEST CH: Low, Low', Center, High', High (5 points) 3) PTT: ON 4) Press [<B] key to store the adjustment value.	1) (Auto tuning)* 2) Transmit							
4. VCO Lock Voltage Check	1) Adj item: [RXASS] Adjust: [****] 2) TEST CH: Low, Low', Center, High', High (5 points)	1) TEST CH: Low, Low', Center, High', High (5 points)	Power meter DVM	TX-RX	LV			Check	2.5V±0.2V
• RX									
• TX	3) Adj item: [TXASS] Adjust: [****] 4) TEST CH: Low, Low', Center, High', High (5 points) 5) Transmit	2) TEST CH: Low, Low', Center, High', High (5 points) 3) Transmit							

\*: At test mode, click [Tune Assist Voltage] button in test mode dialog box, then start automatic adjustment of Receive/Transmit assist voltage.

## Transmitter Section

Item	Condition		Measurement			Adjustment			Specifications / Remarks
	Panel tuning mode	PC test mode	Test-equipment	Unit	Terminal	Unit	Parts	Method	
1. Frequency	1) Adj item: [FREQ] Adjust: [***] 2) PTT: ON 3) Press [<B] key to store the adjustment value.	1) TEST CH: TX center 2) Transmit	Frequency counter		ANT		[Panel tuning mode] [↗],[↘]  [PC test mode] FPU	Adjust to center frequency	Within ±100Hz
2. High Transmit Power	1) Adj item: [HPOW] Adjust: [****] 2) TEST CH: Low, Low', Center, High', High (5 points) 3) PTT: ON 4) Press [<B] key to store the adjustment value.	1) TEST CH: Low, Low', Center, High', High (5 points) 2) Transmit	Power meter Ammeter					25W	±1.0W 8.0A or less

## 调整

## 共通部分

项目	条件		测量			调整			规格 / 备注
	面板调谐模式	PC 测试模式	测量装置	单元	端子	单元	部件	方法	
1. 设定	1) 电源电压 DC 电源端子 : 13. 6V 2) SSG 标准调制 [ 宽 ] MOD: 1kHz, DEV: 3kHz [ 窄 ] MOD: 1kHz, DEV: 1. 5kHz								
2. 接收辅助电压 (自动)	1) 调整项目 : [RXASS] 调整 : [****] 2) 测试信道 : 低, 低', 中, 高', 高 (5 点) 3) 按 [ <B ] 键储存调整值。	1) (自动调谐)*	功率计				FPU	PC 窗口上的“电压电平”指示显示了 VCO 锁定电压。 更改调整值, 以获得指定电压范围内的 VCO 锁定电压。  注意 : 在更改调整值约 3 秒后确认 VCO 锁定电压。	2. 5V ± 0. 2V
3. 发射辅助电压 (自动)	1) 调整项目 : [TXASS] 调整 : [****] 2) 测试信道 : 低, 低', 中, 高', 高 (5 点) 3) PTT: 开启 4) 按 [ <B ] 键储存调整值。	1) (自动调谐)* 2) 发射							
4. VCO 锁定电压检查  • 接收	1) 调整项目 : [RXASS] 调整 : [****] 2) 测试信道 : 低, 低', 中, 高', 高 (5 点)	1) 测试信道 : 低, 低', 中, 高', 高 (5 点)	功率计 DVM	收发	LV			检查	2. 5V ± 0. 2V
• 发射	3) 调整项目 : [TXASS] 调整 : [****] 4) 测试信道 : 低, 低', 中, 高', 高 (5 点) 5) PTT: 开启	2) 测试信道 : 低, 低', 中, 高', 高 (5 点) 3) 发射							

\*: 在测试模式的时, 点击测试模式的对话框里的 [ 调整辅助电压 ] 按钮就会开始自动调整接收 / 发射辅助电压。

## 发射部分

项目	条件		测量			调整			规格 / 备注
	面板调谐模式	PC 测试模式	测量装置	单元	端子	单元	部件	方法	
1. 频率	1) 调整项目 : [FREQ] 调整 : [***] 2) PTT: 开启 3) 按 [ <B ] 键储存调整值。	1) 测试信道 : TX 中 2) 发射	频率计数器		ANT		[ 面板调谐模式 ] [ <A ], [ <V ]  [ PC 测试模式 ] FPU	调整到中心频率	± 100Hz 以内
2. 高功率	1) 调整项目 : [HPOW] 调整 : [****] 2) 测试信道 : 低, 低', 中, 高', 高 (5 点) 3) PTT: 开启 4) 按 [ <B ] 键储存调整值。	1) 测试信道 : 低, 低', 中, 高', 高 (5 点) 2) 发射	功率计 电流表					25W	± 1. 0W 8. 0A 或更低

## ADJUSTMENT

Item	Condition		Measurement			Adjustment			Specifications / Remarks
	Panel tuning mode	PC test mode	Test-equipment	Unit	Terminal	Unit	Parts	Method	
3. Low Transmit Power	1) Adj item: [LPOW] Adjust: [****] 2) TEST CH: Low, Low', Center, High', High (5 points) 3) PTT: ON 4) Press [<B] key to store the adjustment value.	1) TEST CH: Low, Low', Center, High', High (5 points) 2) Transmit	Power meter Ammeter		ANT		[Panel tuning mode] [<A],[<M]  [PC test mode] FPU	5W	±0.5W 4.0A or less
4. DQT Balance (Narrow)	1) Adj item: [BAL] Adjust: [**] 2) TEST CH: Low, Low', Center, High', High (5 points) 3) Deviation meter filter LPF: 3kHz HPF: OFF 4) PTT: ON Output 20Hz 5) Press [■] key during PTT ON. Output 1kHz 6) Press [<B] key to store the adjustment value.	1) TEST CH: Low, Low', Center, High', High (5 points) 2) Deviation meter filter LPF: 3kHz HPF: OFF 3) Transmit	Deviation meter		ANT			The Deviation of 20Hz frequency is fixed. (FL=30, FLC=35, FC=40, FCH=45, FH=50) Change the 1kHz adjustment value to become the same deviation of 20Hz within the specified range.	±0.4dB
5. Maximum Deviation (Narrow)	1) Adj item: [DEV] Adjust: [****] 2) TEST CH: Low, Low', Center, High', High (5 points) 3) Deviation meter filter LPF: 15kHz HPF: OFF 4) PTT: ON 5) Press [<B] key to store the adjustment value.	1) TEST CH: Low, Low', Center, High', High (5 points) 2) Deviation meter filter LPF: 15kHz HPF: OFF 3) Transmit	Deviation meter Oscilloscope AG AF VTVM		ANT			2.2kHz (According to the large +, -)	±0.05kHz  <b>Note:</b> FPU auto input 1kHz/50mV
6. MIC Sensitivity Check	1) Adj item: [DEV] Adjust: [****] 2) TEST CH: Center 3) Deviation meter filter LPF: 15kHz HPF: OFF AG: 1kHz/5mV 4) PTT: ON	1) TEST CH: Center 2) Deviation meter filter LPF: 15kHz HPF: OFF AG: 1kHz/5mV 3) Transmit			ANT MIC			Check	1.1kHz~1.8kHz

## 调整

项目	条件		测量			调整			规格 / 备注
	面板调谐模式	PC 测试模式	测量装置	单元	端子	单元	部件	方法	
3. 低功率	1) 调整项目:[LPow] 调整:[****] 2) 测试信道:低,低', 中,高',高(5点) 3) PTT: 开启 4) 按[<B]键储存调整值。	1) 测试信道:低,低', 中,高',高(5点) 2) 发射	功率计 电流表		ANT		[面板调谐模式] [<][>]  [PC测试模式] FPU	5W	±0.5W 4.0A 或更低
4. DQT 平衡 (窄)	1) 调整项目:[BAL] 调整:[**] 2) 测试信道:低,低', 中,高',高(5点) 3) 频偏仪滤波器 LPF:3kHz HPF:OFF 4) PTT: 开启 输出 20Hz 5) 按住 PTT 键时再按 [■]键就会输出 1kHz 音频。 6) 按[<B]键储存调整值。	1) 测试信道:低,低', 中,高',高(5点) 2) 频偏仪滤波器 LPF:3kHz HPF:OFF 3) 发射	频偏仪		ANT			20Hz 频率的 频偏固定。 (FL=30, FLC=35, FC=40, FCH=45, FH=50) 更改 1kHz 调整值, 变成指定范围内 20Hz 的相同频偏。	±0.4dB
5. 最大频偏 (窄)	1) 调整项目:[DEV] 调整:[****] 2) 测试信道:低,低', 中,高',高(5点) 3) 频偏仪滤波器 LPF:15kHz HPF:OFF 4) PTT: 开启 5) 按[<B]键储存调整值。	1) 测试信道:低,低', 中,高',高(5点) 2) 频偏仪滤波器 LPF:15kHz HPF:OFF 3) 发射	频偏仪 示波器 AG AF VTVM		ANT			2.2kHz (按照较大+, -)	±0.05kHz  注意: FPU 自动输入 1kHz/50mV
6. MIC 灵敏度 检查	1) 调整项目:[DEV] 调整:[****] 2) 测试信道:中 3) 频偏仪滤波器 LPF:15kHz HPF:OFF AG:1kHz/5mV 4) PTT: 开启	1) 测试信道:中 2) 频偏仪滤波器 LPF:15kHz HPF:OFF AG:1kHz/5mV 3) 发射			ANT MIC			检查	1.1kHz ~ 1.8kHz

## ADJUSTMENT

Item	Condition		Measurement			Adjustment			Specifications / Remarks
	Panel tuning mode	PC test mode	Test-equipment	Unit	Terminal	Unit	Parts	Method	
7. DQT Deviation (Narrow)	1) Adj item: [DQT] Adjust: [****] 2) TEST CH: Center 3) Deviation meter filter LPF: 3kHz HPF: OFF 4) PTT: ON 5) Press [<B] key to store the adjust- ment value.	1) TEST CH: Center 2) Deviation meter filter LPF: 3kHz HPF: OFF 3) Transmit	Deviation meter Oscillo- scope AG AF VTVM		ANT		[Panel tuning mode] [<],[>]  [PC test mode] FPU	0.35kHz	±0.05kHz
8. QT Deviation (Narrow)	1) Adj item: [QT] Adjust: [****] 2) TEST CH: Center 3) Deviation meter filter LPF: 3kHz HPF: OFF 4) PTT: ON 5) Press [<B] key to store the adjust- ment value.	1) TEST CH: Center 2) Deviation meter filter LPF: 3kHz HPF: OFF 3) Transmit						0.35kHz	±0.05kHz
9. DTMF Deviation (Narrow)	1) Adj item: [DTMF] Adjust: [****] 2) TEST CH: Center 3) Deviation meter filter LPF: 15kHz HPF: OFF 4) PTT: ON 5) Press [<B] key to store the adjust- ment value.	1) TEST CH: Center 2) Deviation meter filter LPF: 15kHz HPF: OFF 3) Transmit						1.5kHz	±0.05kHz
10. MSK Deviation (Narrow)	1) Adj item: [MSK] Adjust: [****] 2) TEST CH: Center 3) Deviation meter filter LPF: 15kHz HPF: OFF 4) PTT: ON 5) Press [<B] key to store the adjust- ment value.	1) TEST CH: Center 2) Deviation meter filter LPF: 15kHz HPF: OFF 3) Transmit						1.5kHz	±0.05kHz

## 调整

项目	条件		测量			调整			规格 / 备注
	面板调谐模式	PC 测试模式	测量装置	单元	端子	单元	部件	方法	
7. DQT 频偏 (窄)	1) 调整项目:[DQT] 调整:[****] 2) 测试信道:中 3) 频偏仪滤波器 LPF:3kHz HPF:OFF 4) PTT: 开启 5) 按 [ <b>&lt;B</b> ] 键储存调整值。	1) 测试信道:中 2) 频偏仪滤波器 LPF:3kHz HPF:OFF 3) 发射	频偏仪 示波器 AG AF VTVM		ANT		[面板调谐模式] [↵][↶]  [PC 测试模式] FPU	0.35kHz	±0.05kHz
8. QT 频偏 (窄)	1) 调整项目:[QT] 调整:[****] 2) 测试信道:中 3) 频偏仪滤波器 LPF:3kHz HPF:OFF 4) PTT: 开启 5) 按 [ <b>&lt;B</b> ] 键储存调整值。	1) 测试信道:中 2) 频偏仪滤波器 LPF:3kHz HPF:OFF 3) 发射						0.35kHz	±0.05kHz
9. DTMF 频偏 (窄)	1) 调整项目:[DTMF] 调整:[****] 2) 测试信道:中 3) 频偏仪滤波器 LPF:15kHz HPF:OFF 4) PTT: 开启 5) 按 [ <b>&lt;B</b> ] 键储存调整值。	1) 测试信道:中 2) 频偏仪滤波器 LPF:15kHz HPF:OFF 3) 发射						1.5kHz	±0.05kHz
10. MSK 频偏 (窄)	1) 调整项目:[MSK] 调整:[****] 2) 测试信道:中 3) 频偏仪滤波器 LPF:15kHz HPF:OFF 4) PTT: 开启 5) 按 [ <b>&lt;B</b> ] 键储存调整值。	1) 测试信道:中 2) 频偏仪滤波器 LPF:15kHz HPF:OFF 3) 发射						1.5kHz	±0.05kHz



## ADJUSTMENT

## Receiver Section

Item	Condition		Measurement			Adjustment			Specifications / Remarks
	Panel tuning mode	PC test mode	Test-equipment	Unit	Terminal	Unit	Parts	Method	
1. Sensitivity (Semiauto- matic)	1) Adj item: [SENS1] Adjust: [****] 2) TEST CH: Low, Low', Center, High', High (5 points) 3) SSG output : -90dBm (7.08μV)	1) TEST CH: Low, Low', Center, High', High (5 points) 2) SSG output : -90dBm (7.08μV)	SSG Oscillo- scope AF VTVM Distortion meter		ANT Ext.SP			[Panel tuning mode] After input signal from SSG, press [<B>] key to store the adjustment value.  [PC test mode] After input signal from SSG, press [Apply] button to store the adjust- ment value.	
(Manual)	4) Adj item: [SENS2]  <b>Note:</b> Adj item [SENS2] is not used. If you mistakenly ad- just "SENS2", readjust "SENS1" again.								
2. Open Squelch (5) (Narrow)	1) Adj item: [SQL] Adjust: [****] 2) TEST CH: Low, Low', Center, High', High (5 points) 3) SSG output Low, Low', Center : -120dBm (0.22μV) High', High : -121dBm (0.20μV)	1) TEST CH: Low, Low', Center, High', High (5 points) 2) SSG output Low, Low', Center : -120dBm (0.22μV) High', High : -121dBm (0.20μV)							Squelch open
(Wide)	1) Adj item: [SQL] Adjust: [****] 2) TEST CH: Low, Low', Center, High', High (5 points) 3) SSG output Low, Low', Center : -120dBm (0.22μV) High', High : -121dBm (0.20μV)	1) TEST CH: Low, Low', Center, High', High (5 points) 2) SSG output Low, Low', Center : -120dBm (0.22μV) High', High : -121dBm (0.20μV)							
3. Tight Squelch (Narrow)	1) Adj item: [SQLT] Adjust: [****] 2) TEST CH: Low, Low', Center, High', High (5 points) 3) SSG output Low, Low', Center : -115dBm (0.40μV) High', High : -116dBm (0.35μV)	1) TEST CH: Low, Low', Center, High', High (5 points) 2) SSG output Low, Low', Center : -115dBm (0.40μV) High', High : -116dBm (0.35μV)							
(Wide)	1) Adj item: [SQLT] Adjust: [****] 2) TEST CH: Low, Low', Center, High', High (5 points) 3) SSG output Low, Low', Center : -115dBm (0.40μV) High', High : -116dBm (0.35μV)	1) TEST CH: Low, Low', Center, High', High (5 points) 2) SSG output Low, Low', Center : -115dBm (0.40μV) High', High : -116dBm (0.35μV)							

## 调整

## 接收部分

项 目	条 件		测 量			调 整			规格 / 备注
	面板调谐模式	PC 测试模式	测量装置	单元	端子	单元	部件	方 法	
1. 灵敏度 (半自动)	1) 调整项目 : [SENS1] 调整 : [****] 2) 测试信道 : 低, 低', 中, 高', 高 (5 点) 3) SSG 输出 : -90dBm (7.08 $\mu$ V)	1) 测试信道 : 低, 低', 中, 高', 高 (5 点) 2) SSG 输出 : -90dBm (7.08 $\mu$ V)	SSG 示波器 AF VTVM 失真测试仪		ANT Ext. SP			[ 面板调谐模式 ] 从 SSG 输入信号之 后, 按 [ <B ] 键储 存调整值。  [PC 测试模式] 从 SSG 输入信号之 后, 按 [Apply] 键 储存调整值。	
(手动)	4) 调整项目 : [SENS2]  注意 : 调整项目 [SENS2] 未使用。 如果错误调整了 “SENS2” 的时候, 需 要再次调整 “SENS1”。								
2. 静噪开 (5) (窄)	1) 调整项目 : [SQL] 调整 : [****] 2) 测试信道 : 低, 低', 中, 高', 高 (5 点) 3) SSG 输出 低, 低' : -120dBm (0.22 $\mu$ V) 中, 高', 高 : -121dBm (0.20 $\mu$ V)	1) 测试信道 : 低, 低', 中, 高', 高 (5 点) 2) SSG 输出 低, 低' : -120dBm (0.22 $\mu$ V) 中, 高', 高 : -121dBm (0.20 $\mu$ V)							静噪开
(宽)	1) 调整项目 : [SQL] 调整 : [****] 2) 测试信道 : 低, 低', 中, 高', 高 (5 点) 3) SSG 输出 低, 低' : -120dBm (0.22 $\mu$ V) 中, 高', 高 : -121dBm (0.20 $\mu$ V)	1) 测试信道 : 低, 低', 中, 高', 高 (5 点) 2) SSG 输出 低, 低' : -120dBm (0.22 $\mu$ V) 中, 高', 高 : -121dBm (0.20 $\mu$ V)							
3. 静噪深 (窄)	1) 调整项目 : [SQLT] 调整 : [****] 2) 测试信道 : 低, 低', 中, 高', 高 (5 点) 3) SSG 输出 低, 低' : -115dBm (0.40 $\mu$ V) 中, 高', 高 : -116dBm (0.35 $\mu$ V)	1) 测试信道 : 低, 低', 中, 高', 高 (5 点) 2) SSG 输出 低, 低' : -115dBm (0.40 $\mu$ V) 中, 高', 高 : -116dBm (0.35 $\mu$ V)							
(宽)	1) 调整项目 : [SQLT] 调整 : [****] 2) 测试信道 : 低, 低', 中, 高', 高 (5 点) 3) SSG 输出 低, 低' : -115dBm (0.40 $\mu$ V) 中, 高', 高 : -116dBm (0.35 $\mu$ V)	1) 测试信道 : 低, 低', 中, 高', 高 (5 点) 2) SSG 输出 低, 低' : -115dBm (0.40 $\mu$ V) 中, 高', 高 : -116dBm (0.35 $\mu$ V)							

## ADJUSTMENT

Item	Condition		Measurement			Adjustment			Specifications / Remarks
	Panel tuning mode	PC test mode	Test-equipment	Unit	Terminal	Unit	Parts	Method	
4. Low RSSI (Narrow)	1) Adj item: [LRSSI] Adjust: [****] 2) TEST CH: Low, Low', Center, High', High (5 points) 3) SSG output : -120dBm (0.22μV)	1) TEST CH: Low, Low', Center, High', High (5 points) 2) SSG output : -120dBm (0.22μV)	SSG Oscilloscope AF VTVM Distortion meter		ANT Ext.SP			[Panel tuning mode] After input signal from SSG, press [ <b>&lt;B&gt;</b> ] key to store the adjustment value.  [PC test mode] After input signal from SSG, press [Apply] button to store the adjustment value.	
	(Wide)	1) Adj item: [LRSSI] Adjust: [****] 2) TEST CH: Low, Low', Center, High', High (5 points) 3) SSG output : -120dBm (0.22μV)							
5. High RSSI (Narrow)	1) Adj item: [HRSSI] Adjust: [****] 2) TEST CH: Low, Low', Center, High', High (5 points) 3) SSG output : -70dBm (70.8μV)	1) TEST CH: Low, Low', Center, High', High (5 points) 2) SSG output : -70dBm (70.8μV)							
	(Wide)	1) Adj item: [HRSSI] Adjust: [****] 2) TEST CH: Low, Low', Center, High', High (5 points) 3) SSG output : -70dBm (70.8μV)							1) TEST CH: Low, Low', Center, High', High (5 points) 2) SSG output : -70dBm (70.8μV)

### Adjustment Points

#### ■ Component side

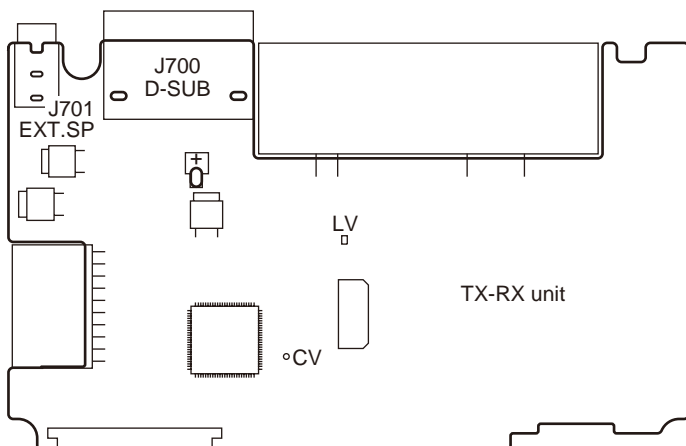

#### ■ Foil side

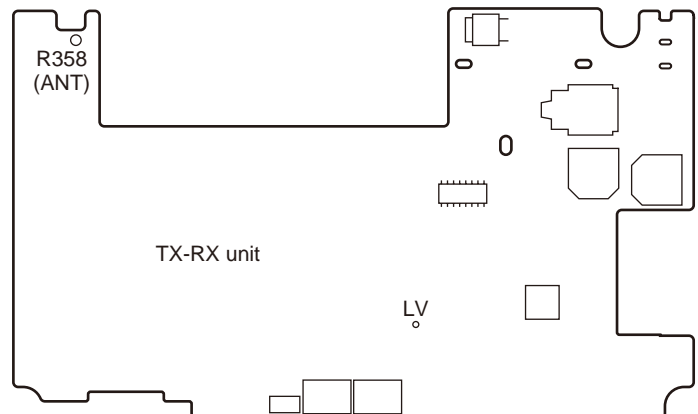

## 调整

项目	条件		测量			调整			规格 / 备注
	面板调谐模式	PC 测试模式	测量装置	单元	端子	单元	部件	方法	
4. 低 RSSI (窄)	1) 调整项目 : [LRSSI] 调整 : [****] 2) 测试信道 : 低, 低', 中, 高', 高 (5 点) 3) SSG 输出 :-120dBm (0.22 $\mu$ V)	1) 测试信道 : 低, 低', 中, 高', 高 (5 点) 2) SSG 输出 :-120dBm (0.22 $\mu$ V)	SSG 示波器 AF VTVM 失真测试仪		ANT Ext. SP			[ 面板调谐模式 ] 从 SSG 输入信号之 后, 按 [ <B ] 键储 存调整值。  [ PC 测试模式 ] 从 SSG 输入信号之 后, 按 [ Apply ] 键 储存调整值。	
	(宽)	1) 调整项目 : [LRSSI] 调整 : [****] 2) 测试信道 : 低, 低', 中, 高', 高 (5 点) 3) SSG 输出 :-120dBm (0.22 $\mu$ V)							
5. 高 RSSI (窄)	1) 调整项目 : [HRSSI] 调整 : [****] 2) 测试信道 : 低, 低', 中, 高', 高 (5 点) 3) SSG 输出 :-70dBm (70.8 $\mu$ V)	1) 测试信道 : 低, 低', 中, 高', 高 (5 点) 2) SSG 输出 :-70dBm (70.8 $\mu$ V)							
	(宽)	1) 调整项目 : [HRSSI] 调整 : [****] 2) 测试信道 : 低, 低', 中, 高', 高 (5 点) 3) SSG 输出 :-70dBm (70.8 $\mu$ V)							1) 测试信道 : 低, 低', 中, 高', 高 (5 点) 2) SSG 输出 :-70dBm (70.8 $\mu$ V)

## 调整点

## ■ 元件面

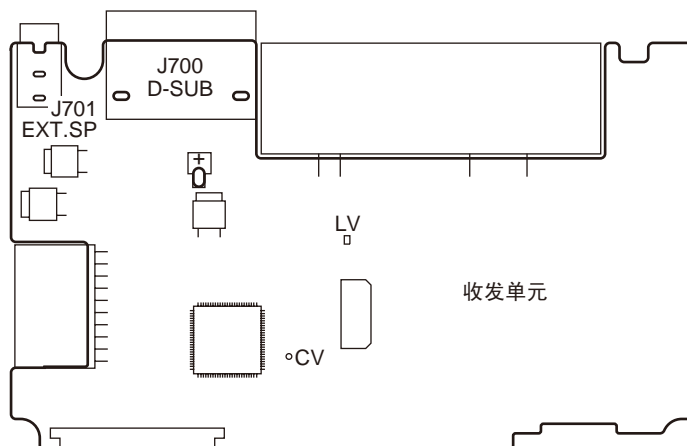

## ■ 箔面

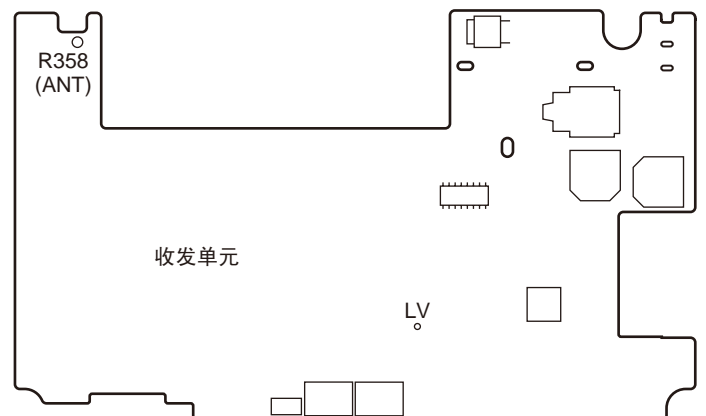

## TERMINAL FUNCTION / 端子功能

## Display unit (X54-3740-20)

Pin No.	Name	I/O	Function
<b>CN1 (to TX-RX unit CN701)</b>			
1	POWER	O	Detection output of power switch
2	MKEY	I/O	MIC data detection
3	PTT/TXD	I/O	PTT/PC serial data
4	HOOK/ RXD	I/O	HOOK/PC serial data
5	ME	-	MIC ground
6	MIC	O	MIC signal output
7	GND	-	Ground
8	GND	-	Ground
9	LCDDO	O	LCD data output
10	LCCL	I	LCD clock input
11	LCCE	I	LCD enable input
12	LCDDI	I	LCD data input
13	5C	I	5V DC power supply
14	GND	-	Ground
15	GND	-	Ground
16	EMG	O	Emergency key detection
17	GND	-	Ground
18	NC	-	No connection
19	GND	-	Ground
20	BLED	I	Blue LED control signal input
21	GLED	I	Green LED control signal input
22	RLED	I	Red LED control signal input
23	MBL	I	MIC backlight control signal input
24	BLC	I	LCD backlight control signal input
25	SP-	I	Speaker input -
26	SP-	I	Speaker input -
27	SP+	I	Speaker input +
28	SP+	I	Speaker input +
29	SB	I	Battery voltage DC supply
30	SB	I	Battery voltage DC supply
<b>J1 (MIC jack)</b>			
1	MBL	O	MIC backlight control
2	SB	O	Battery voltage DC supply
3	GND	-	Ground
4	PTT	I/O	PTT/ PC serial data from radio
5	ME	-	MIC ground
6	MIC	I	MIC signal input
7	HOOK	I	HOOK/ PC serial data to radio
8	DM	I/O	MIC data detection

## 显示单元 (X54-3740-20)

管脚号	名称	输入/输出	功能
<b>CN1 (至收发单元 CN701)</b>			
1	POWER	输出	电源开关的检测
2	MKEY	输入/输出	MIC 数据检测
3	PTT/TXD	输入/输出	PTT/PC 串行数据
4	HOOK/RXD	输入/输出	HOOK/PC 串行数据
5	ME	-	MIC 接地
6	MIC	输出	MIC 信号
7	GND	-	接地
8	GND	-	接地
9	LCDDO	输出	LCD 数据
10	LCCL	输入	LCD 时钟
11	LCCE	输入	LCD 启用
12	LCDDI	输入	LCD 数据
13	5C	输入	5V
14	GND	-	接地
15	GND	-	接地
16	EMG	输出	EMG 键
17	GND	-	接地
18	NC	-	未连接
19	GND	-	接地
20	BLED	输入	蓝色 LED 控制信号
21	GLED	输入	绿色 LED 控制信号
22	RLED	输入	红色 LED 控制信号
23	MBL	输入	MIC 背光控制信号
24	BLC	输入	LCD 背光控制信号
25	SP-	输入	扬声器 -
26	SP-	输入	扬声器 -
27	SP+	输入	扬声器 +
28	SP+	输入	扬声器 +
29	SB	输入	电池电压 DC 电源
30	SB	输入	电池电压 DC 电源
<b>J1 (MIC 插孔)</b>			
1	MBL	输出	麦克风的背光
2	SB	输出	电池电压 DC 电源
3	GND	-	接地
4	PTT	输入/输出	来自通信机的 PTT/PC 串行数据
5	ME	-	MIC 接地
6	MIC	输入	MIC 信号输入
7	HOOK	输入	送到通信机的 HOOK/PC 串行数据
8	DM	输入/输出	MIC 数据检测

# TERMINAL FUNCTION / 端子功能

## TX-RX unit (X57-8020-23)

Pin No.	Name	I/O	Function
<b>CN700 (Board to Board)</b>			
1	OPT1	I/O	VGS busy signal input (VGS-1) Scrambler code select 1 (Scrambler board)
2	OPT3	I/O	VGS playback signal input (VGS-1) Scrambler code select 2 (Scrambler board)
3	SI	I	Serial data input (VGS-1)
4	SO	I/O	Serial data output (VGS-1) PTT input (Scrambler board)
5	CK	O	Serial clock output (VGS-1)
6	OPT4	O	VGS enable output (VGS-1) Echo PTT output (Scrambler board)
7	USEL	-	Ground
8	OPT5	O	VGS reset signal output (VGS-1) Scrambler code select 8 (Scrambler board)
9	GND	-	Ground
10	GND	-	Ground
11	AI	I	VGS audio input (VGS-1)
12	AO	O	VGS audio output (VGS-1)
13	GND	-	Ground
14	5C	O	5V DC power supply (VGS-1)
15	STON	I	Side tone input (VGS-1)
16	DTI	I	Data signal input (VGS-1)
17	TCTL	-	No connection
18	NC	-	No connection
19	AUDI H	-	No connection
20	OPT2	O	Scrambler Clear/Code select (Scrambler board)
21	TXO	O	MIC signal output (Scrambler board)
22	RXEO	O	Audio signal output (Scrambler board)
23	RXEI	I	Audio signal input (Scrambler board)
24	TXI	I	MIC signal input (Scrambler board)
25	OPT6	O	Scrambler code select 4 (Scrambler board)
26	9C	O	9V DC power supply (Scrambler board)
<b>CN701 (to Display unit CN1)</b>			
1	SB	O	Battery voltage DC supply
2	SB	O	Battery voltage DC supply
3	SP+	O	Speaker output +
4	SP+	O	Speaker output +
5	SP-	O	Speaker output -
6	SP-	O	Speaker output -
7	BLC	O	LCD backlight control signal output
8	MBL	O	MIC backlight control signal output
9	RLED	O	Red LED control signal output

## 收发单元 (X57-8020-23)

管脚号	名称	输入/输出	功能
<b>CN700 (基板对基板连接)</b>			
1	OPT1	输入/输出	VGS-1 繁忙指示 选择 1
2	OPT3	输入/输出	VGS-1 放指示 选择 2
3	SI	输入	VGS-1 串行数据输入
4	SO	输入/输出	VGS-1 串行数据输出 PTT 信号
5	CK	输出	VGS-1 时钟
6	OPT4	输出	VGS-1 启用 Echo-PTT 信号
7	USEL	输出	VGS-1 UART 速度选择
8	OPT5	输出	VGS-1 复位 选择 8
9	GND	-	接地
10	GND	-	接地
11	AI	输入	VGS-1 音频输入
12	AO	输出	VGS-1 音频输出
13	GND	-	接地
14	5C	输出	5V
15	STON	输入	VGS-1 侧音
16	DTI	输入	VGS-1 数据信号
17	TCTL	-	未连接
18	NC	-	未连接
19	AUDI H	-	未连接
20	OPT2	输出	选择
21	TXO	输出	麦克风信号输出
22	RXEO	输出	音频输出输出
23	RXEI	输入	音频输入
24	TXI	输入	麦克风信号输出
25	OPT6	输出	选择 4
26	9C	输出	9V
<b>CN701 (至显示单元 CN1)</b>			
1	SB	输出	电池电压 DC 电源
2	SB	输出	电池电压 DC 电源
3	SP+	输出	扬声器 +
4	SP+	输出	扬声器 +
5	SP-	输出	扬声器 -
6	SP-	输出	扬声器 -
7	BLC	输出	LCD 背光控制信号
8	MBL	输出	MIC 背光控制信号
9	RLED	输出	红色 LED 控制信号

## TERMINAL FUNCTION / 端子功能

Pin No.	Name	I/O	Function
10	GLED	O	Green LED control signal output
11	BLED	O	Blue LED control signal output
12	GND	-	Ground
13	NC	-	No connection
14	GND	-	Ground
15	EMG	I	Emergency key detection
16	GND	-	Ground
17	GND	-	Ground
18	5C	O	5V DC power supply
19	LCDDI	O	LCD data output
20	LCCE	O	LCD enable output
21	LCCL	O	LCD clock output
22	LCDDO	I	LCD data input
23	GND	-	Ground
24	GND	-	Ground
25	MIC	I	MIC signal input
26	ME	-	MIC ground
27	HOOK/ RXD	I/O	HOOK/PC serial data
28	PTT/TXD	I/O	PTT/PC serial data
29	MKEY	I/O	MIC data detection
30	POWER	I	Detection input of power switch
<b>J700 (ACC 15-pin)</b>			
1	SB	O	Battery voltage DC supply, DC 13.6V±15%, 1.0A max
2	IGN	I	Ignition sense input, 16.0V max
3	PA	O	Speaker output
4	DETO	O	FM detector output, 500mVp-p
5	DATAI	I	External transmit signal input, 200±50mVp-p
6	FNC1	I/O	Programmable I/O (programmed by FPU), 1.0mA max
7	FNC2	I/O	Programmable I/O (programmed by FPU), 1.0mA max
8	FNC3	I/O	Programmable I/O (programmed by FPU), 1.0mA max
9	FNC4	I/O	Programmable I/O (programmed by FPU), 1.0mA max
10	FNC5	I/O	Programmable I/O (programmed by FPU), 1.0mA max
11	FNC6	I/O	Programmable I/O (programmed by FPU), 1.0mA max
12	5C	O	5V DC power supply, 100mA max
13	HR1	O	Horn alert signal output, 16.0V/2.0A max
14	HR2	O	Horn alert signal output, 16.0V/2.0A max
15	GND	-	Ground

管脚号	名称	输入/输出	功能
10	GLED	输出	绿色 LED 控制信
11	BLED	输出	蓝色 LED 控制信号
12	GND	-	接地
13	NC	-	未连接
14	GND	-	接地
15	EMG	输入	EMG 键
16	GND	-	接地
17	GND	-	接地
18	5C	输出	5V
19	LCDDI	输出	LCD 数据
20	LCCE	输出	LCD 启用
21	LCCL	输出	LCD 时钟
22	LCDDO	输入	LCD 数据
23	GND	-	接地
24	GND	-	接地
25	MIC	输入	MIC 信号
26	ME	-	MIC 接地
27	HOOK/RXD	输入/输出	HOOK/PC 串行数据
28	PTT/TXD	输入/输出	PTT/PC 串行数据
29	MKEY	输入/输出	MIC 数据检测
30	POWER	输入	电源开关的检测
<b>J700 (ACC 15 针)</b>			
1	SB	输出	电池电压 DC 电源 DC 13.6V±15%, 最大 1.0A
2	IGN	输入	点火感应输入, 最大 16.0V
3	PA	输出	扬声器输出
4	DETO	输出	FM 检测输出, 500mVp-p
5	DATAI	输入	外部发射信号输入 200±50mVp-p
6	FNC1	输入/输出	可编程 I/O (由 FPU 编程) 最大 1.0mA
7	FNC2	输入/输出	可编程 I/O (由 FPU 编程) 最大 1.0mA
8	FNC3	输入/输出	可编程 I/O (由 FPU 编程) 最大 1.0mA
9	FNC4	输入/输出	可编程 I/O (由 FPU 编程) 最大 1.0mA
10	FNC5	输入/输出	可编程 I/O (由 FPU 编程) 最大 1.0mA
11	FNC6	输入/输出	可编程 I/O (由 FPU 编程) 最大 1.0mA
12	5C	输出	5V DC 电源, 最大 100mA
13	HR1	输出	喇叭提示信号输出, 最大 16.0V/2.0A
14	HR2	输出	喇叭提示信号输出, 最大 16.0V/2.0A
15	GND	-	接地



# TERMINAL FUNCTION / 端子功能

## Function Port Assignment

	Scrambler	
	Name	I/O
FNC1	-	-
FNC2	-	-
FNC3	None	O
FNC4	Scrambler	O
FNC5	Scrambler code 1(1)	O
FNC6	Scrambler code 2(2)	O
FNC7	Scrambler code 3(4)	O
FNC8	Scrambler code 4(8)	O
	GPS (NMEA)	
	Name	I/O
FNC1	None	O
FNC2	GPS (NMEA input)	I
FNC3	-	-
FNC4	-	-
FNC5	-	-
FNC6	-	-
FNC7	-	-
FNC8	-	-

## 功能端口分配

	扰频器	
	名称	输入 / 输出
FNC1	-	-
FNC2	-	-
FNC3	无	输出
FNC4	扰频器	输出
FNC5	扰频器代码 1 (1)	输出
FNC6	扰频器代码 2 (3)	输出
FNC7	扰频器代码 3 (4)	输出
FNC8	扰频器代码 4 (8)	输出
	GPS (NMEA)	
	名称	输入 / 输出
FNC1	无	输出
FNC2	GPS (NMEA 输入)	输入
FNC3	-	-
FNC4	-	-
FNC5	-	-
FNC6	-	-
FNC7	-	-
FNC8	-	-



DISPLAY UNIT (X54-3740-20) Component side view (J79-0297-09)

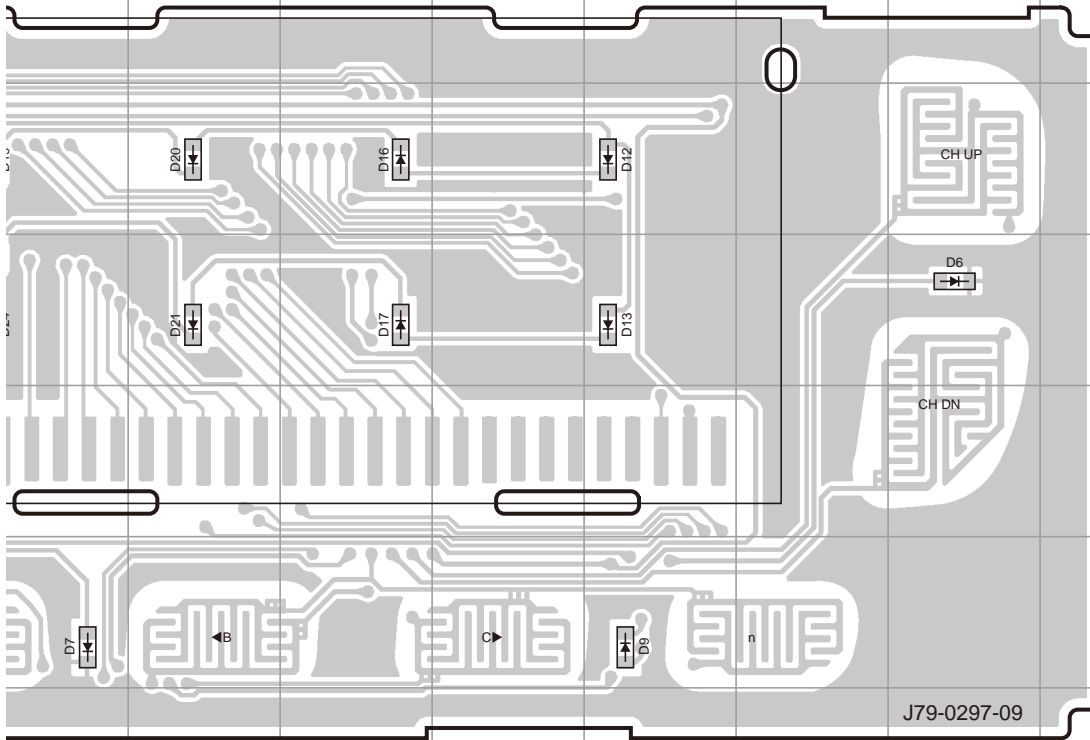

Ref. No.	Address	Ref. No.	Address
D5	4E	D16	3L
D6	4P	D17	4L
D7	6J	D18	4H
D8	6G	D19	3J
D9	6N	D20	3K
D11	3G	D21	4K
D12	3N	D22	4C
D13	4N	D23	4B
D14	4G	D24	4J
D15	3H		

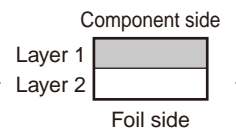

DISPLAY UNIT (X54-3740-20) Foil side view (J79-0297-09)

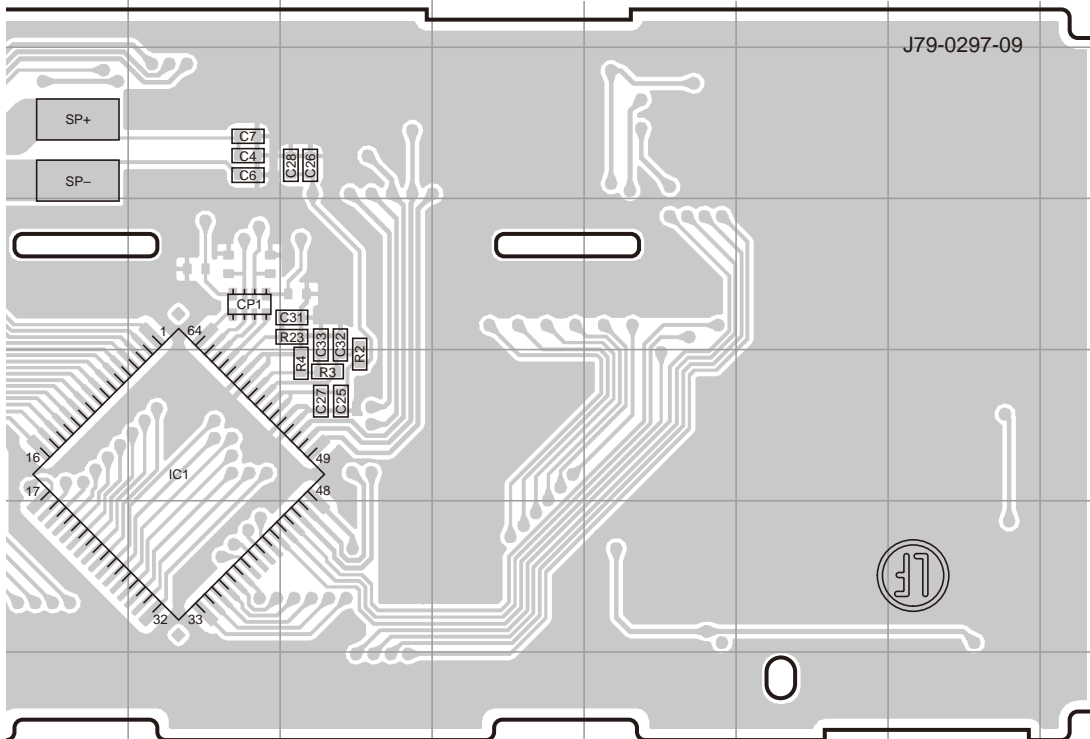

Ref. No.	Address
IC1	11K
Q2	11C
Q3	11B
Q4	11C
Q5	12B
Q6	12B
Q7	10E
Q8	11E
Q9	11E
Q10	11F
D1	10C
D2	9B
D10	11G

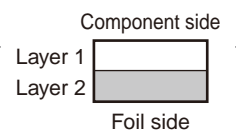



# PC BOARD / 印刷电路板 TK-8360

## TX-RX UNIT (X57-8020-23) Component side view (J79-0296-09)

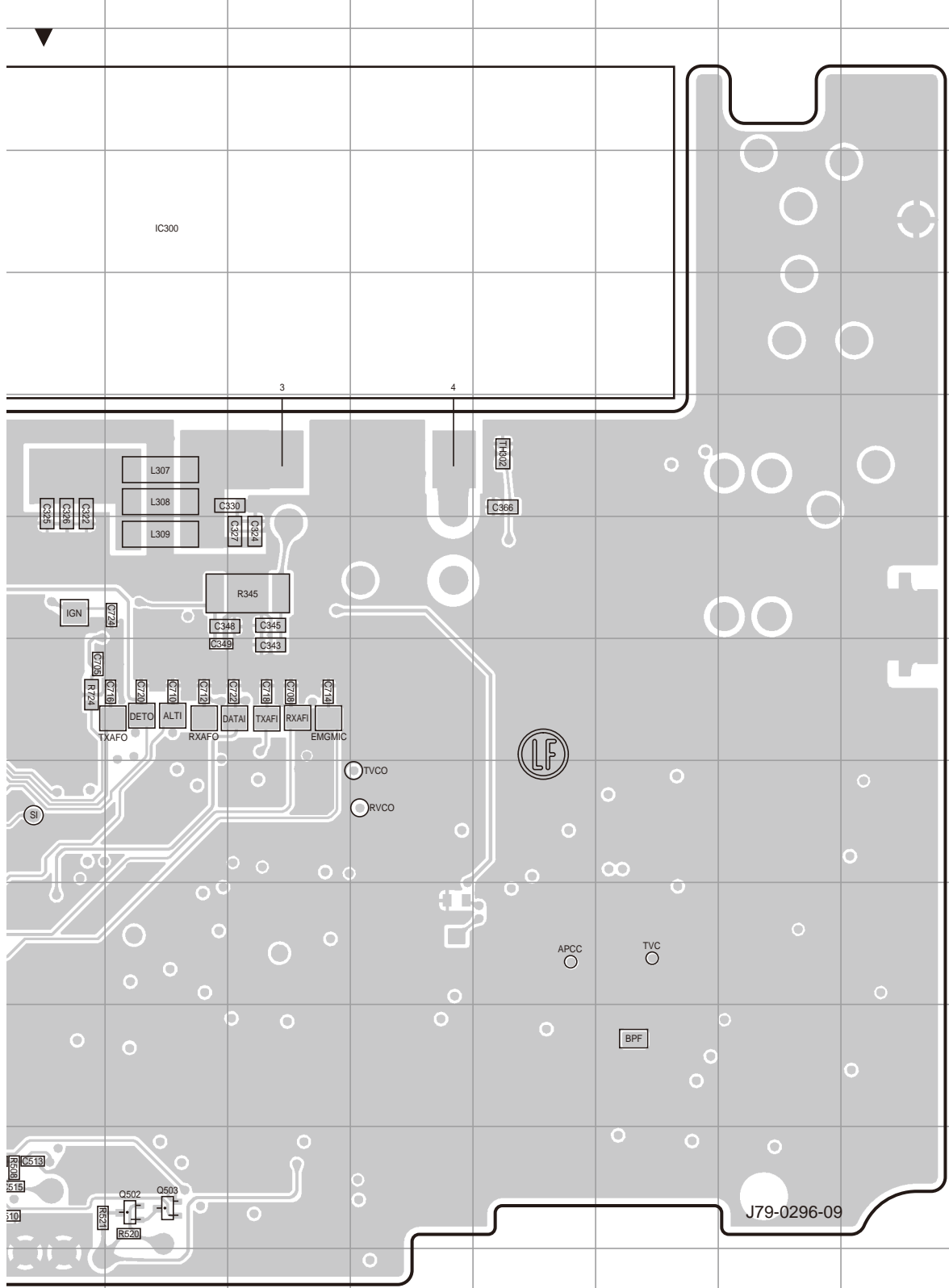

Ref. No.	Address
IC300	4K
IC400	7B
IC401	7G
IC402	7F
IC403	9H
IC404	11H
IC704	10F
IC705	9D
IC706	9B
IC708	12I
IC709	11E
Q400	6C
Q401	7C
Q402	7C
Q403	7C
Q404	8F
Q405	8G
Q406	6C
Q407	6B
Q502	12K
Q503	12K
Q700	7H
Q714	8D
Q715	10H
Q716	9H
Q717	9H
Q718	8D
Q719	9D
Q720	9D
D500	12I
D501	12J
D700	7H
D701	8I
D702	8I
D703	12G
D704	8I
D705	8H
D706	8H
D707	12F
D708	8H
D709	12G
D710	8H
D711	8G
D715	9H

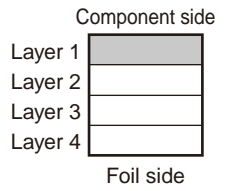

# TK-8360 PC BOARD / 印刷电路板

## TX-RX UNIT (X57-8020-23) Foil side view (J79-0296-09)

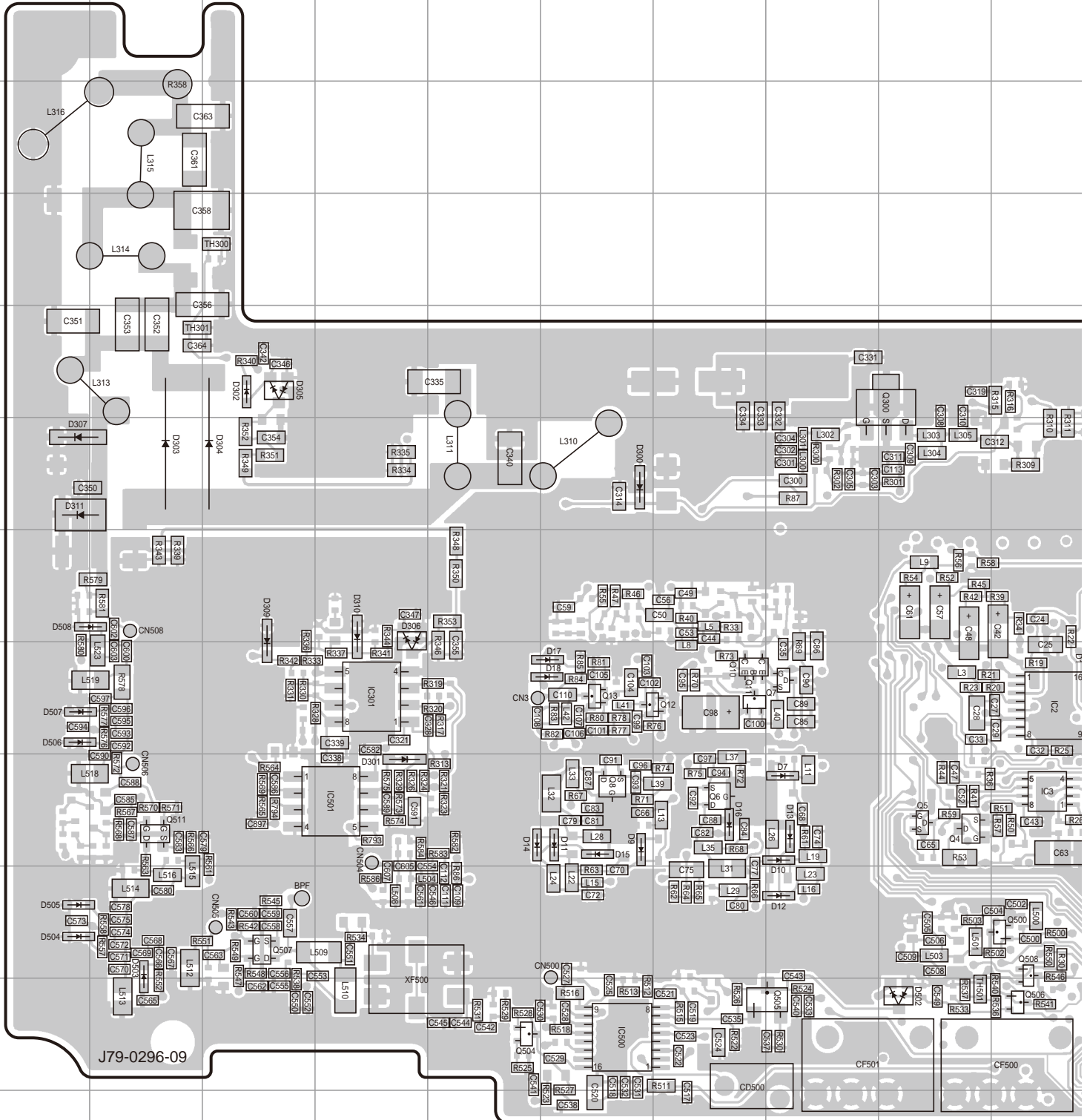





# TK-8360 SCHEMATIC DIAGRAM / 原理图

TX-RX UNIT (X57-8020-23)

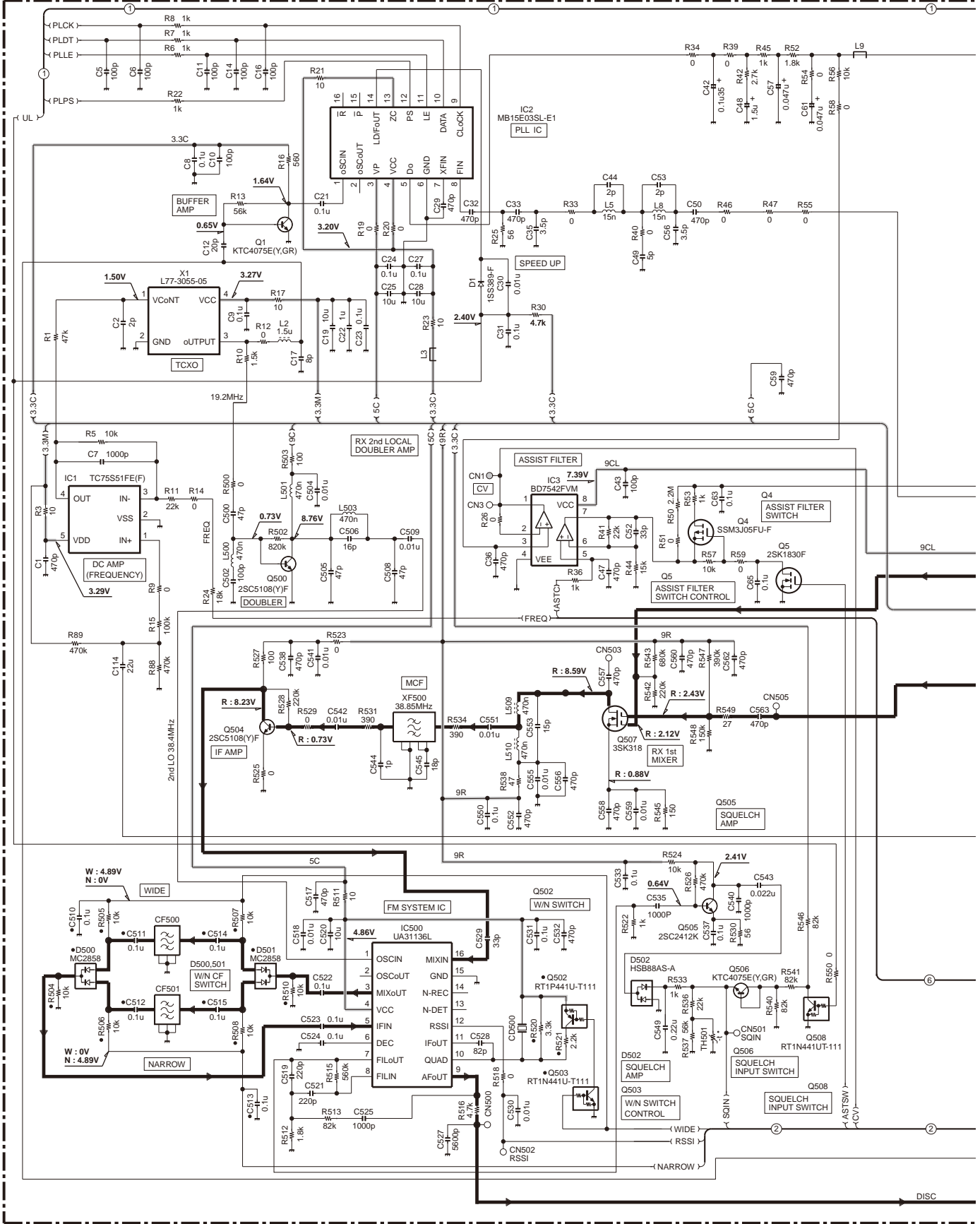



# TK-8360 SCHEMATIC DIAGRAM / 原理图

TX-RX UNIT (X57-8020-23)

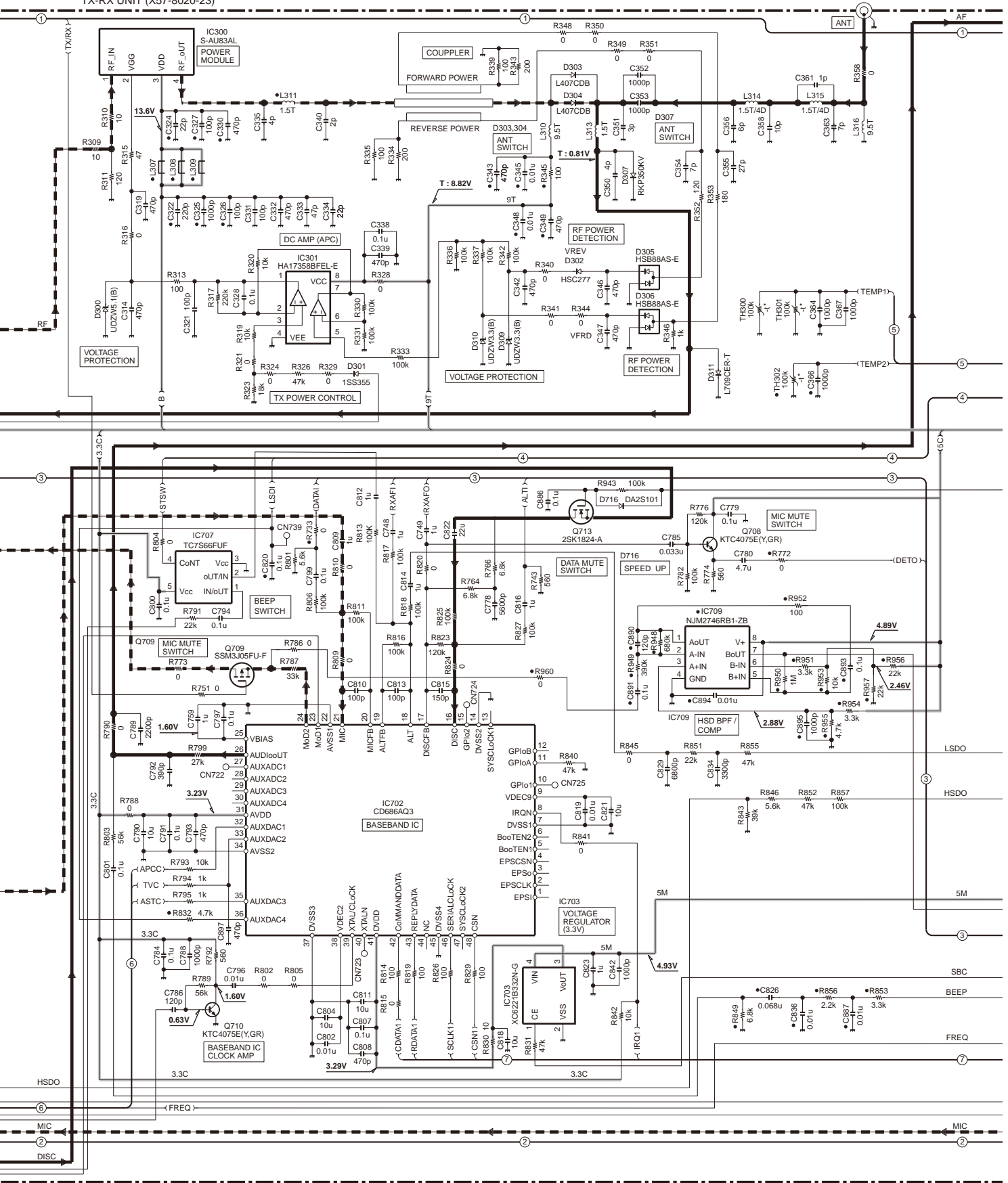

# SCHEMATIC DIAGRAM / 原理图

# TK-8360

TX-RX UNIT (X57-8020-23)

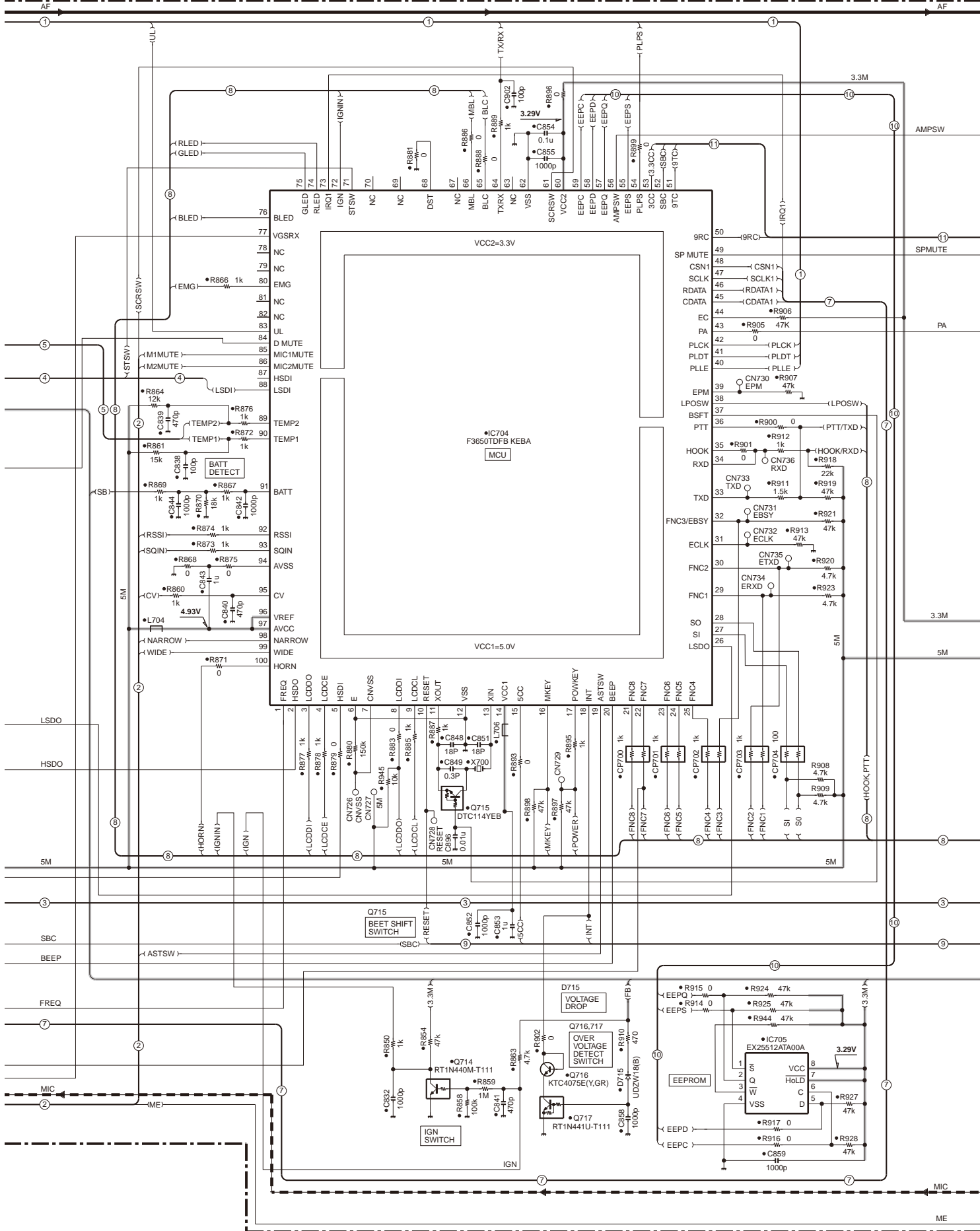



# SCHEMATIC DIAGRAM / 原理图

# TK-8360

Note : The components marked with a dot (•) are parts of layer 1.

注意: 标有点号 (•) 的零件为第一层的零件。

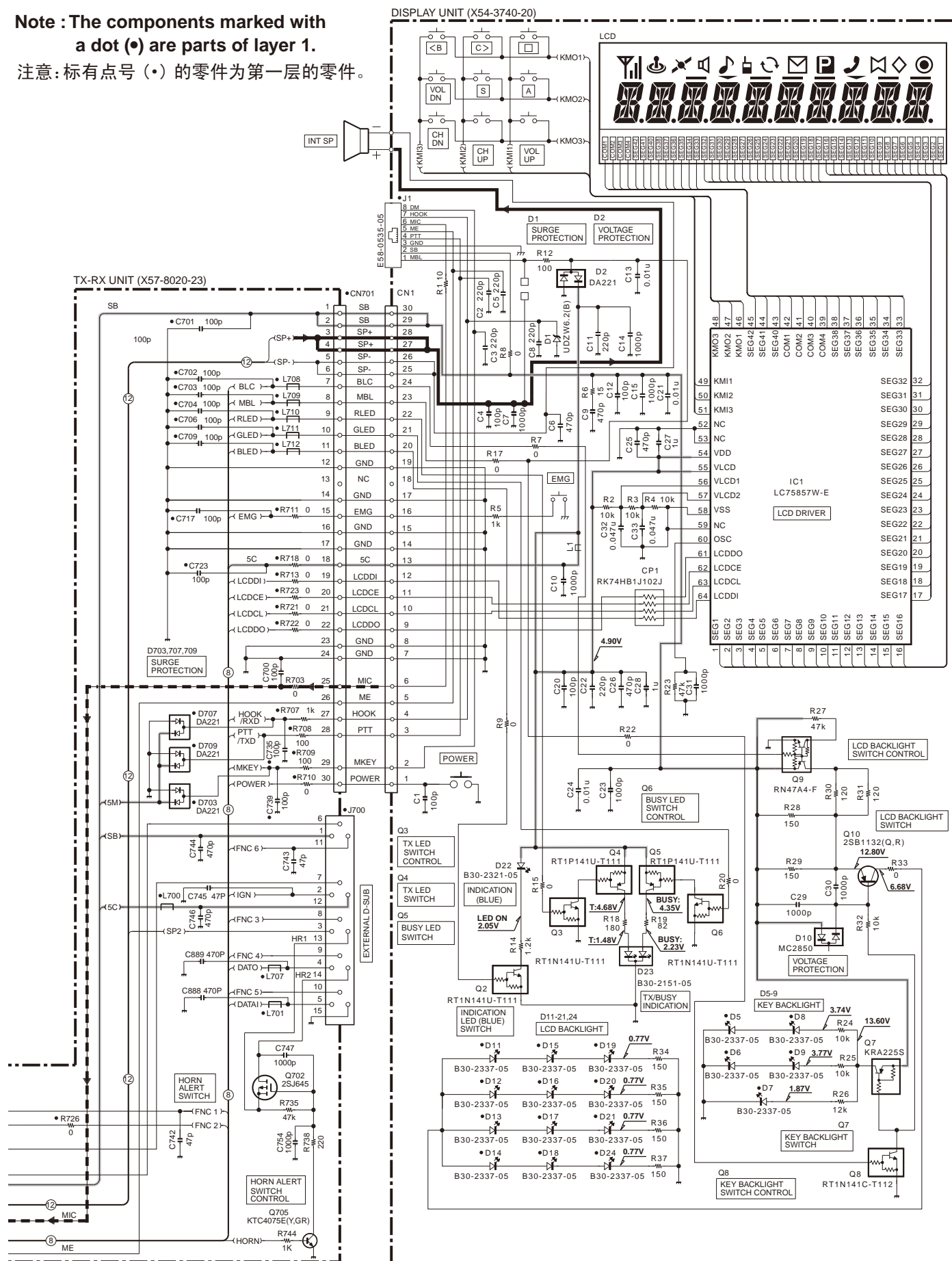



## BLOCK DIAGRAM / 方块图

DISPLAY UNIT (X54-374)

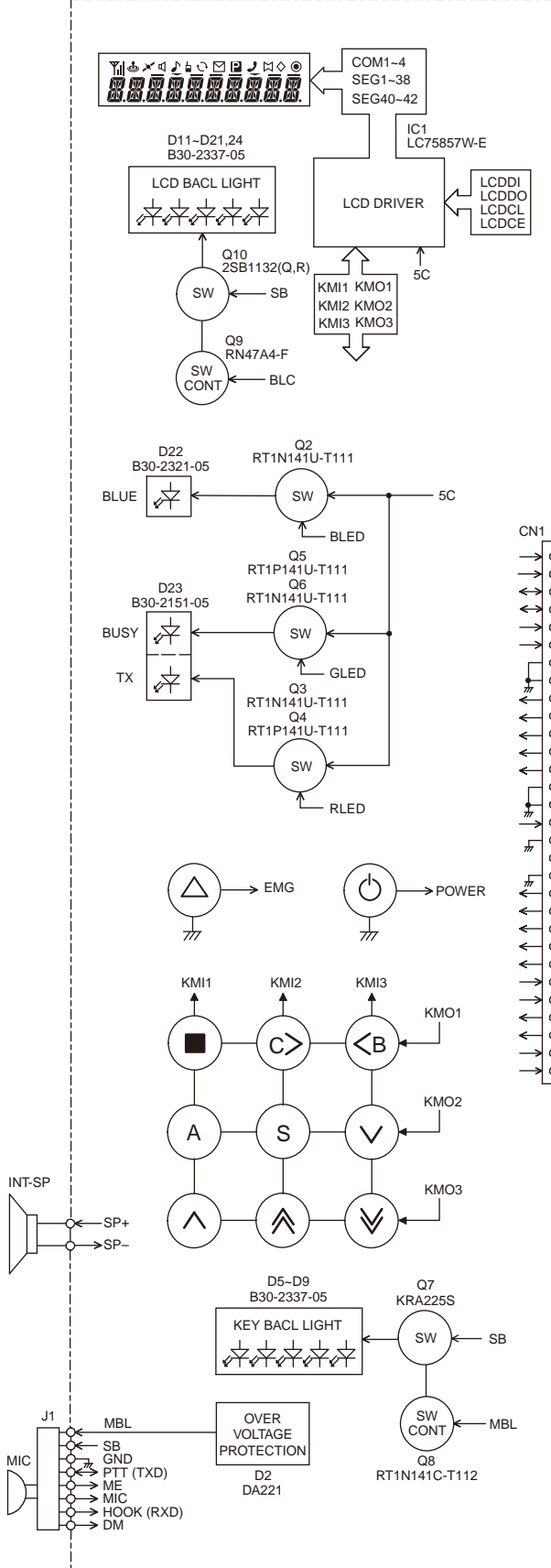

TX-RX UNIT (X57-802)

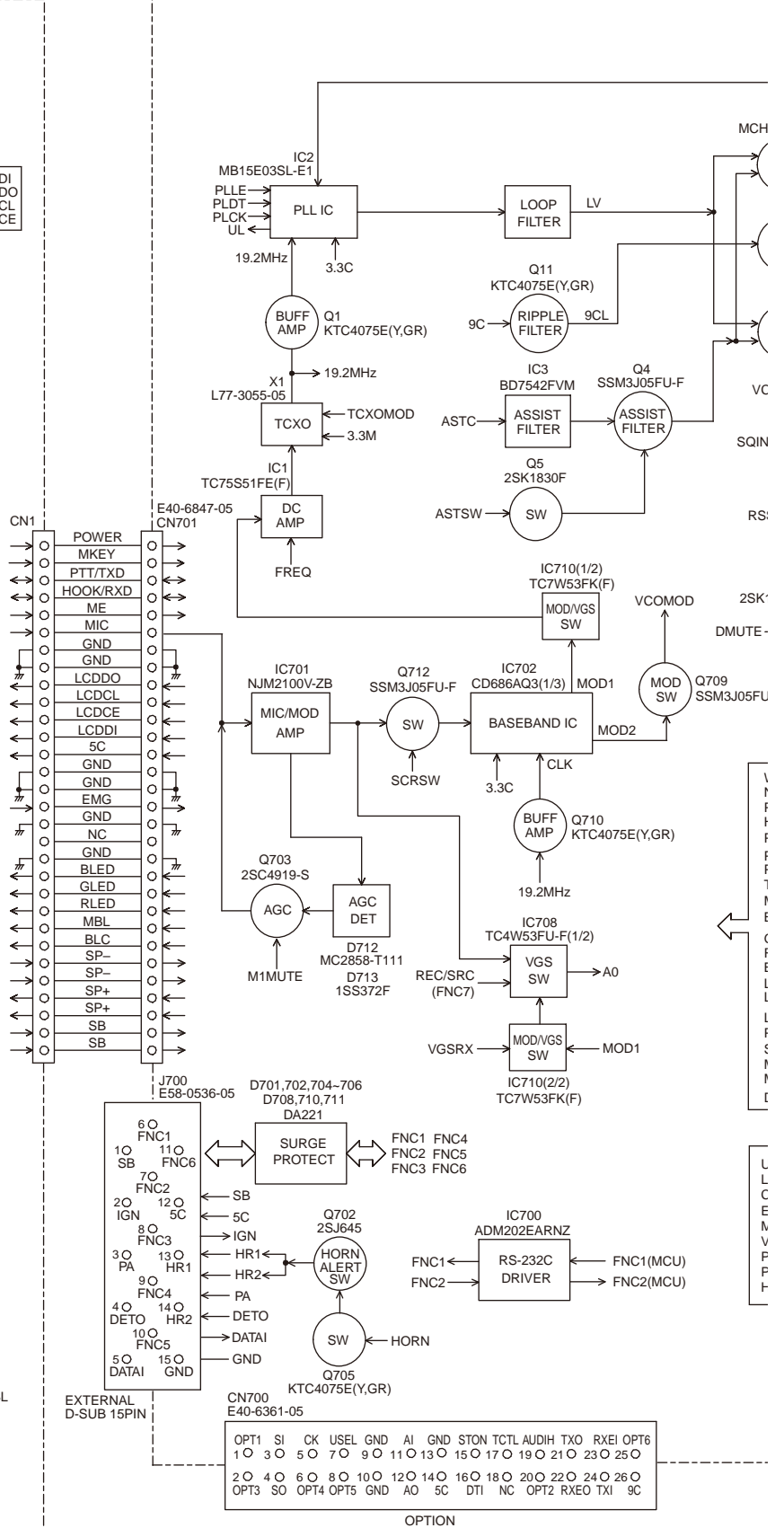





## LEVEL DIAGRAM / 电平图

### Receiver Section / 接收部分

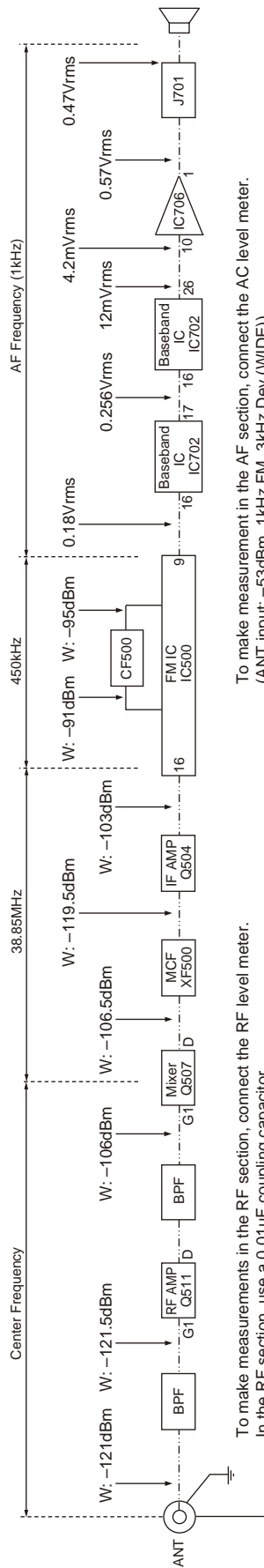

To make measurements in the RF section, connect the RF level meter. In the RF section, use a  $0.01\mu\text{F}$  coupling capacitor. (The display shows the SSG input value required to obtain 12dB SINAD.)

如在 RF 部分进行测量, 请连接 RF 电表。 (图中显示获得 12dB SINAD 所需的 SSG 输入。)

To make measurement in the AF section, connect the AC level meter. (ANT input:  $-53\text{dBm}$ ,  $1\text{kHz}$  FM,  $3\text{kHz}$  Dev (WIDE)) The AF output level is adjusted for a  $0.47\text{V}/4\Omega$  by the front panel AF VOL control.

如在 AF 部分进行测量, 请连接交流电表。 (ANT 输入:  $-53\text{dBm}$ ,  $1\text{kHz}$  FM,  $3\text{kHz}$  Dev (宽)) 通过前面板 AF VOL 控制, AF 输出电平调整为  $0.47\text{V}/4\Omega$ 。

### Transmitter Section / 发射部分

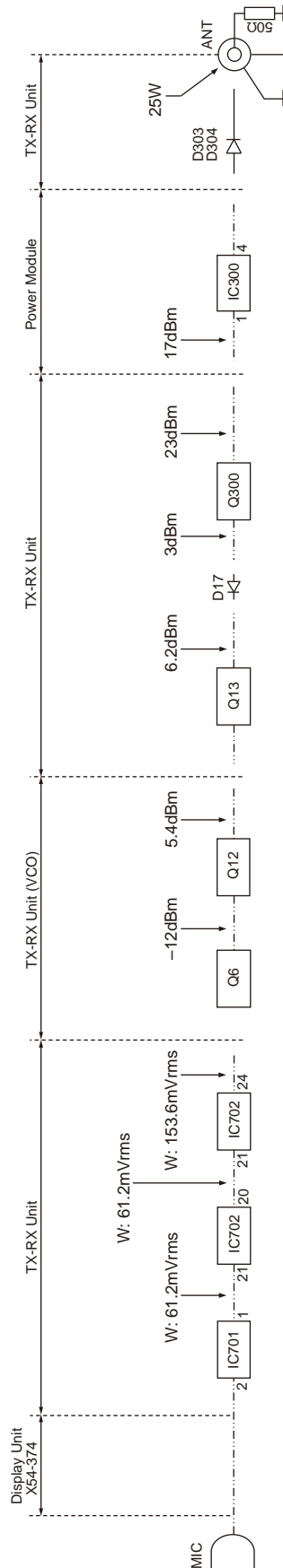

To make measurements in the AF section, connect the AC level meter. AG is set so that MIC input becomes  $3\text{kHz}$  (Wide) DEV at  $1\text{kHz}$  MOD. 如在 AF 部分进行测量, 请连接交流电表。 AG 被设置成 MIC 输入从而在  $1\text{kHz}$  MOD 时为  $3\text{kHz}$  (宽) DEV。

To make measurements in the RF section, connect the RF Wattmeter (500). 如在 RF 部分进行测量, 请连接 RF 功率表 (500)。

# SPECIFICATIONS

## GENERAL

Frequency Range .....	400 to 470MHz
Number of Channels.....	128
Zones.....	128
Channel Spacing .....	Wide: 25kHz    Narrow: 12.5kHz
Operating Voltage .....	13.6V DC $\pm$ 15%
Operating Temperature Range .....	-30°C to +60°C
Frequency Stability .....	$\pm$ 2.5ppm
Antenna Impedance .....	50 $\Omega$
Dimensions (W x H x D) (Projections not included).....	160 x 43 x 136 mm
Weight (net) .....	1.2kg

## RECEIVER (Measurements made per China GB standard)

Sensitivity (12dB SINAD).....	Wide: 0.28 $\mu$ V    Narrow: 0.35 $\mu$ V
Selectivity .....	Wide: 75dB    Narrow: 65dB
Intermodulation Distortion .....	Wide: 70dB    Narrow: 65dB
Spurious Response .....	75dB
Audio Output (4 $\Omega$ impedance).....	4W with less than 5% distortion

## TRANSMITTER (Measurements made per China GB standard)

RF Power Output .....	5-25W (High: 25W, Low: 5W)
Spurious Response .....	70dB
FM Hum & Noise .....	Wide: 45dB    Narrow: 40dB
Audio Distortion .....	Wide: Less than 3%    Narrow: Less than 5%
Modulation .....	Wide: 16K0F3E    Narrow: 11K0F3E

Measurements made per China GB standard and specifications shown are typical.  
Kenwood reserves the right to change specifications without prior notice or obligation.

## 规 格

## 概 述

频率范围 .....	400 ~ 470MHz
信道数量 .....	128
区域分区数量 .....	128
信道间隔 .....	宽 : 25kHz      窄 : 12.5kHz
工作电源电压 .....	13.6V DC $\pm$ 15%
工作温度范围 .....	-30°C 到 +60°C
频率稳定度 .....	$\pm$ 2.5ppm
天线阻抗 .....	50 $\Omega$
尺寸 (宽 $\times$ 高 $\times$ 长) (未包括凸起部分) .....	160 $\times$ 43 $\times$ 136 mm
重 量 .....	1.2kg

## 接收部 (根据中国 GB 标准测定)

灵 敏 度 (EIA 12dB SINAD) .....	宽 : 0.28 $\mu$ V      窄 : 0.35 $\mu$ V
选 择 性 .....	宽 : 75dB      窄 : 65dB
互调抑制 .....	宽 : 70dB      窄 : 65dB
杂散响应 .....	75dB
音频输出功率 .....	4 $\Omega$ 时 4W, 失真低于

## 发射部 (根据中国 GB 标准测定)

射频功率输出 .....	5 ~ 25W
杂散射频分量 .....	70dB
调频噪声 .....	宽 : 45dB      窄 : 40dB
音频失真 .....	宽 : 低于 3%      窄 : 低于 5%
调 制 .....	宽 : 16K0F3E      窄 : 11K0F3E

依据中国 GB 标准获得的测量值和所示规格均为典型值。  
建伍公司有权变更技术规格，恕不预先通知。

## Kenwood Corporation

2967-3, Ishikawa-machi, Hachioji-shi, Tokyo, 192-8525 Japan

## Kenwood U.S.A. Corporation

P.O. BOX 22745, 2201 East Dominguez Street, Long Beach,  
CA 90801-5745, U.S.A.

## Kenwood Electronics Canada Inc.

6070 Kestrel Road, Mississauga, Ontario, Canada L5T 1S8

## Kenwood Electronics Deutschland GmbH

Rembrücker Str. 15, 63150 Heusenstamm, Germany

## Kenwood Electronics Belgium N.V.

Leuvensesteenweg 248 J, 1800 Vilvoorde, Belgium

## Kenwood Electronics France S.A.

L' Etoile Paris Nord 2, 50 Allée des Impressionnistes,  
Bp 58416 Villepinte, 95944 Roissy Ch De Gaulle Cedex

## Kenwood Electronics UK Limited

KENWOOD House, Dwight Road, Watford, Herts.,  
WD18 9EB United Kingdom

## Kenwood Electronics Europe B.V.

Amsterdamseweg 37, 1422 AC Uithoorn, The Netherlands

## Kenwood Electronics Italia S.p.A.

Via G. Sirtori, 7/9 20129 Milano, Italy

## Kenwood Ibérica, S.A.

Bolivia, 239-08020 Barcelona, Spain

## Kenwood Electronics Australia Pty. Ltd.

Talavera Business Park Building A, 4 Talavera Road,  
North Ryde NSW 2113 Australia

## Kenwood Electronics (Hong Kong) Ltd.

Suite 2504, 25/F, Tower 2, Nina Tower, No. 8 Yeung Uk Road,  
Tsuen Wan, New Territories, Hong Kong

## Kenwood Electronics Singapore Pte Ltd

1 Ang Mo Kio Street 63, Singapore 569110



TX-RX UNIT (X57-8020-23) Component side view (J79-0296-09)

TX-RX UNIT (X57-8020-23) Component side view (J79-0296-09)

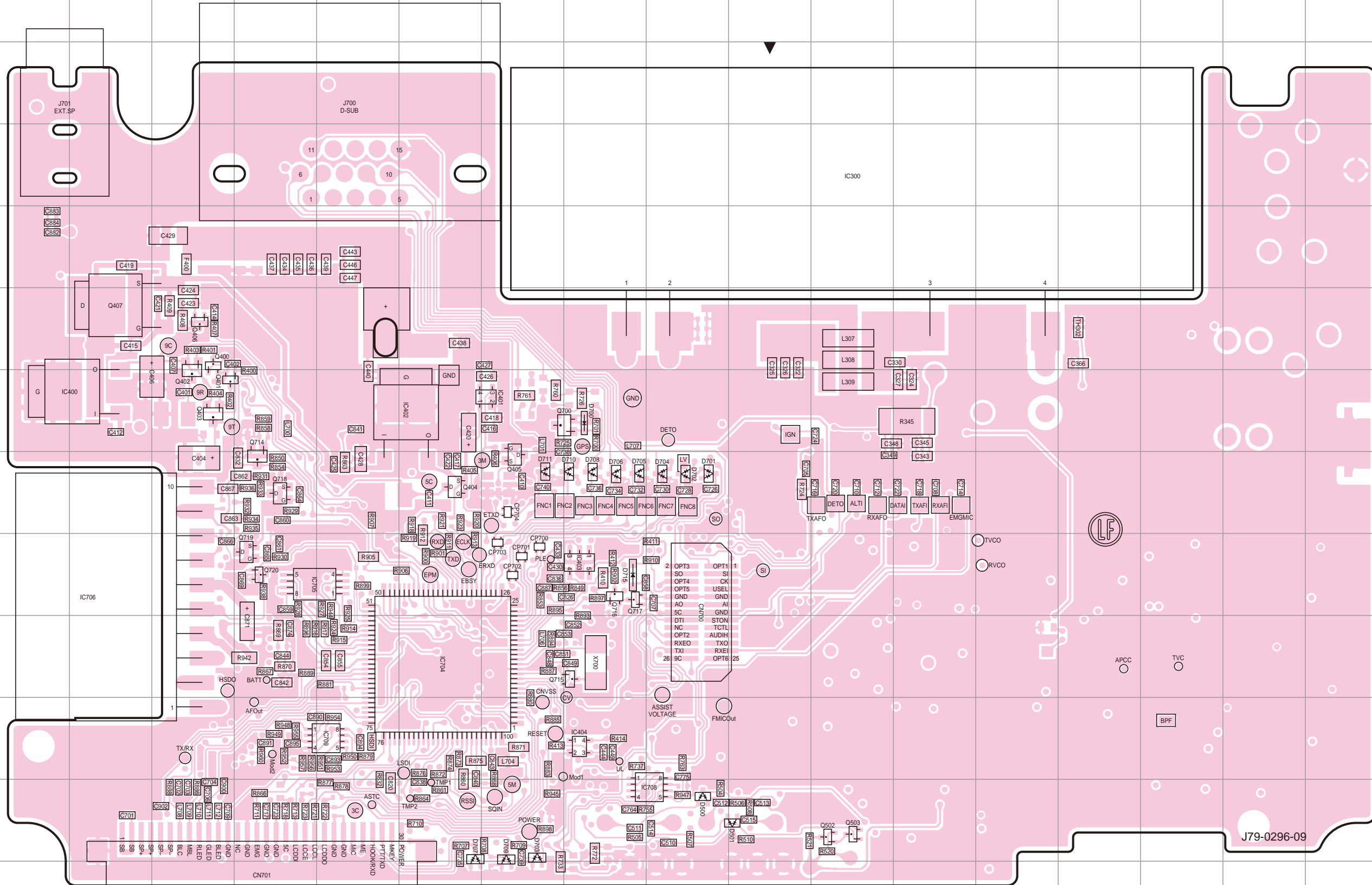

Ref. No.	Address
IC300	4K
IC400	7B
IC401	7G
IC402	7F
IC403	9H
IC404	11H
IC704	10F
IC705	9D
IC706	9B
IC708	12I
IC709	11E
Q400	6C
Q401	7C
Q402	7C
Q403	7C
Q404	8F
Q405	8G
Q406	6C
Q407	6B
Q502	12K
Q503	12K
Q700	7H
Q714	8D
Q715	10H
Q716	9H
Q717	9H
Q718	8D
Q719	9D
Q720	9D
D500	12I
D501	12J
D700	7H
D701	8I
D702	8I
D703	12G
D704	8I
D705	8H
D706	8H
D707	12F
D708	8H
D709	12G
D710	8H
D711	8G
D715	9H

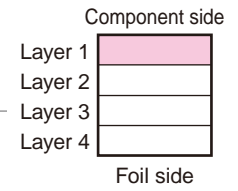

J79-0296-09



# TK-8360 PC BOARD / 印刷电路板

# PC BOARD / 印刷电路板 TK-8360

TX-RX UNIT (X57-8020-23) Foil side view (J79-0296-09)

TX-RX UNIT (X57-8020-23) Foil side view (J79-0296-09)

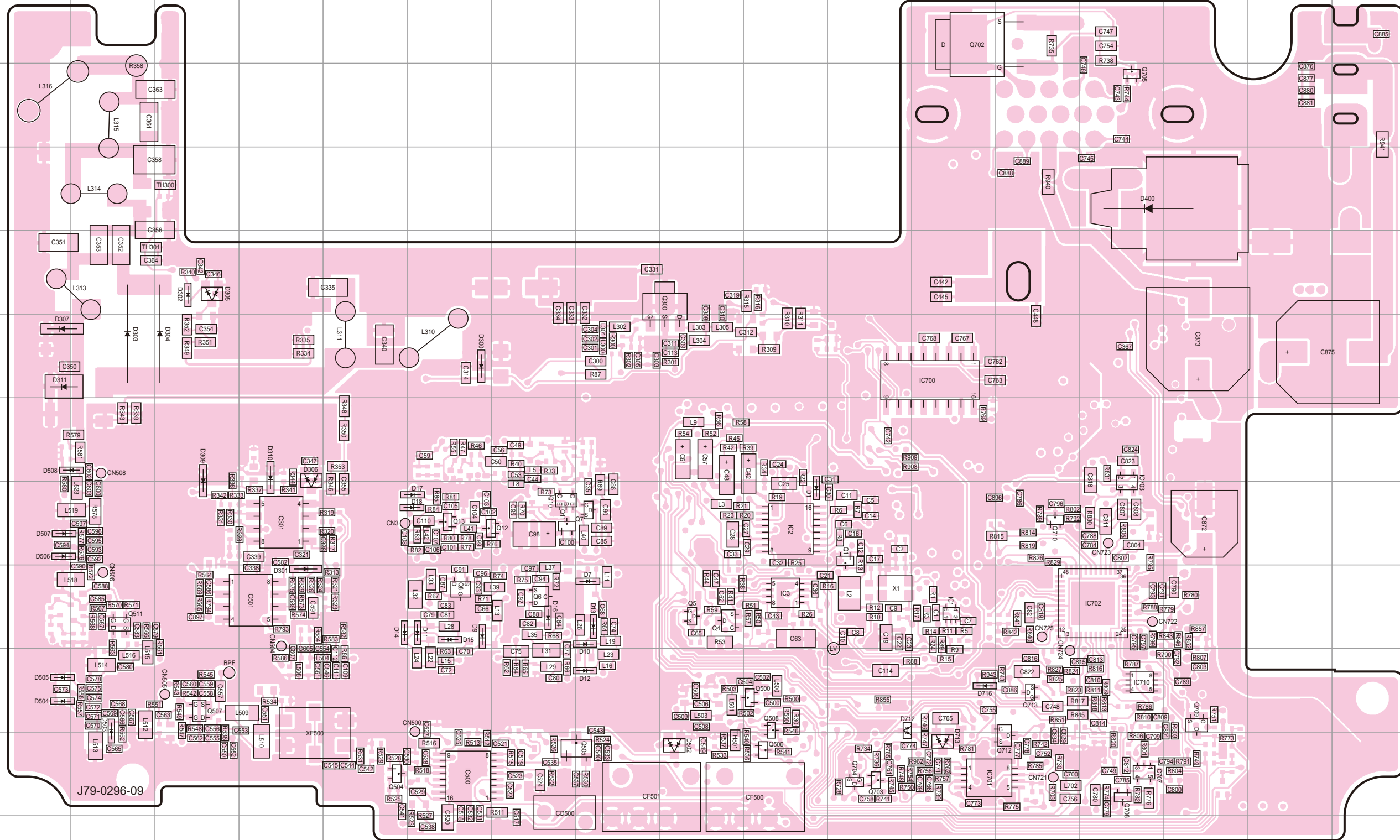

Ref. No.	Address	Ref. No.	Address
IC1	10L	Q713	11M
IC2	9J	D1	9J
IC3	10J	D7	10H
IC301	9D	D9	10F
IC500	12F	D10	10H
IC501	10D	D11	10F
IC700	7L	D12	11H
IC701	12L	D13	10H
IC702	10N	D14	10E
IC703	9N	D15	10F
IC707	12N	D16	10G
IC710	11N	D17	9F
Q1	9K	D18	9F
Q4	10I	D300	7F
Q5	10I	D301	10D
Q6	10G	D302	6C
Q7	9H	D303	7B
Q8	10F	D304	7C
Q10	9G	D305	6C
Q11	9G	D306	8D
Q12	9G	D307	7A
Q13	9F	D309	8C
Q300	6I	D310	8D
Q500	11J	D311	7A
Q504	12E	D400	5N
Q505	12H	D502	12I
Q506	12J	D503	11B
Q507	11C	D504	11A
Q508	11J	D505	11A
Q511	10B	D506	9A
Q702	3L	D507	9A
Q703	12K	D508	8A
Q704	12K	D712	11K
Q705	4N	D713	12L
Q708	12N	D716	11L
Q709	11O		
Q710	9M		
Q712	12M		

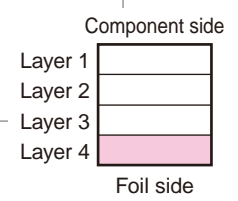



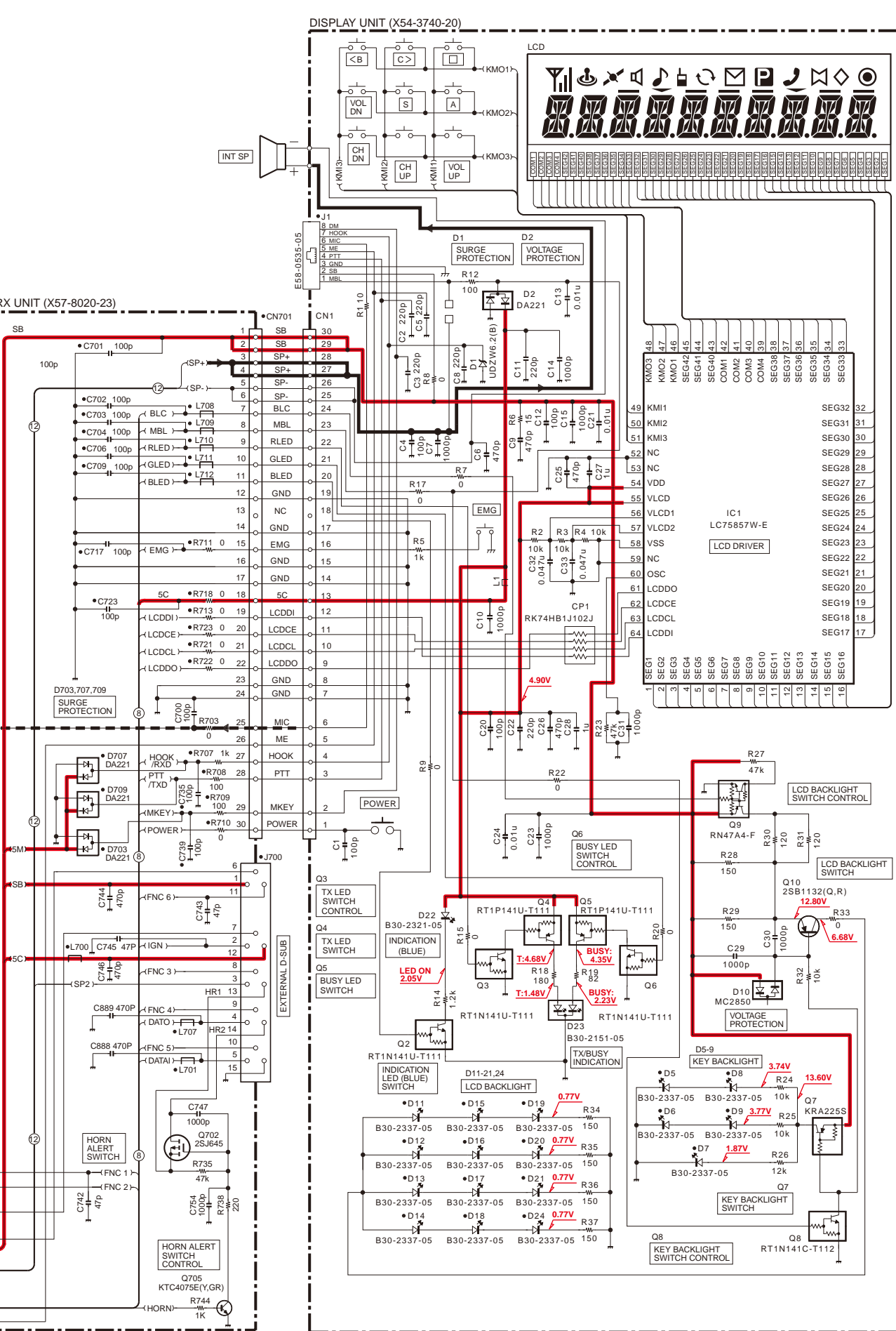
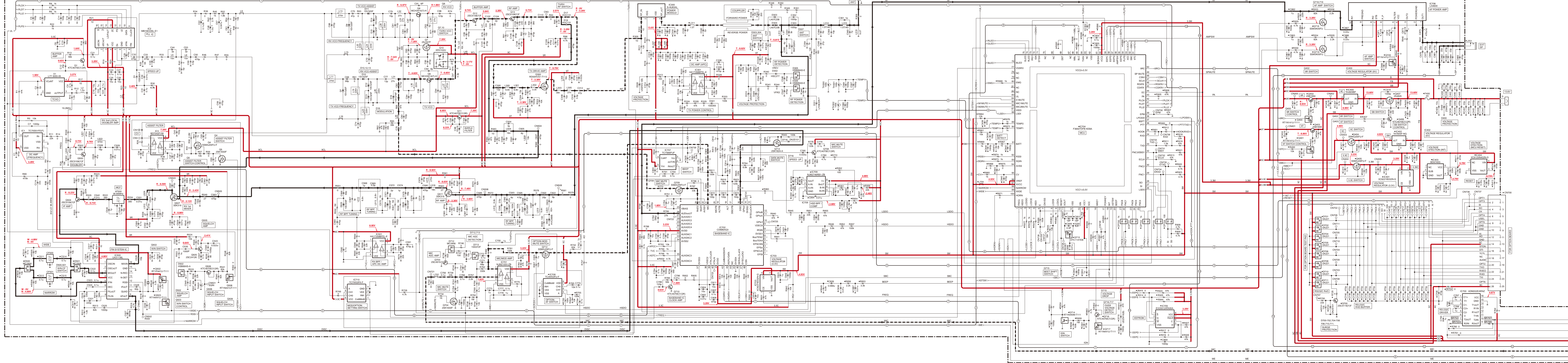



DISPLAY UNIT (X54-374)

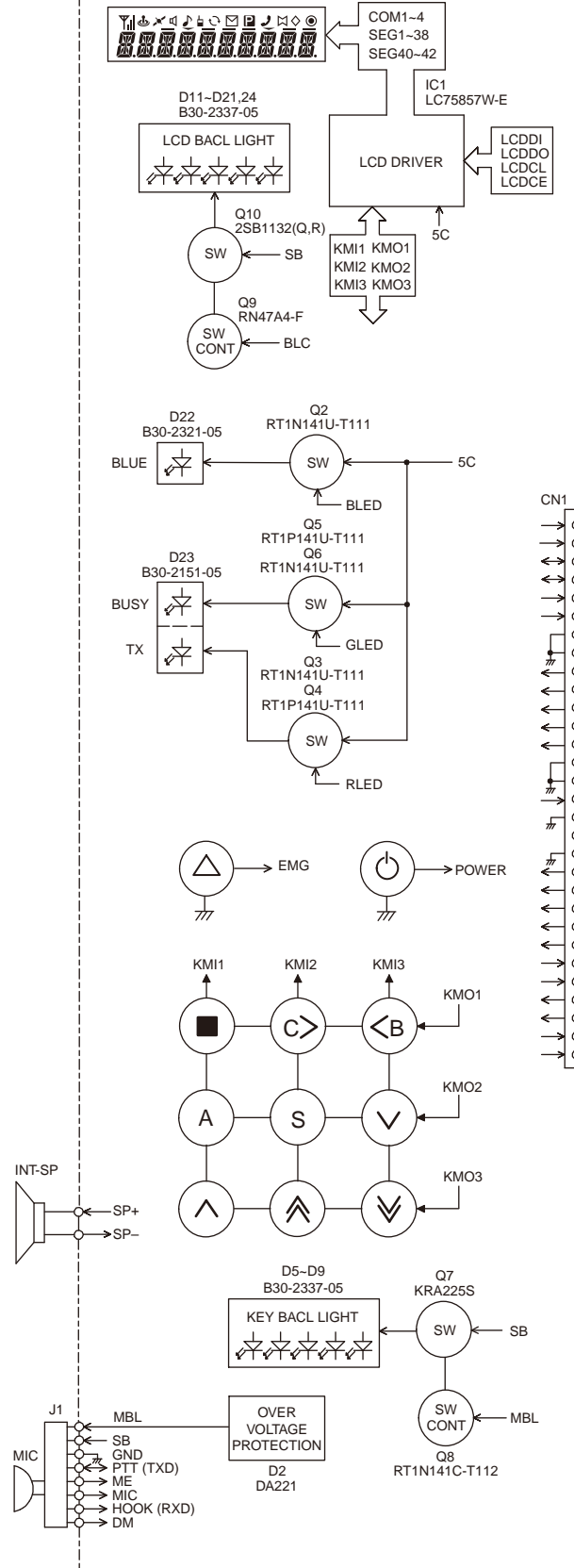

TX-RX UNIT (X57-802)

