

CONTENTS

GENERAL	2	ADJUSTMENT	32
OPERATING FEATURES	3	PC BOARD VIEWS	
REALIGNMENT	4	PLL/VCO (X58-4722-70)	40
INSTALLATION	6	TX-RX UNIT (X57-6152-70) (A/2)	41
CIRCUIT DESCRIPTION	13	TX-RX UNIT (X57-6152-70) (B/2)	47
SEMICONDUCTOR DATA	18	SCHEMATIC DIAGRAM	51
DESCRIPTION OF COMPONENTS	19	BLOCK DIAGRAM	59
PARTS LIST	21	LEVEL DIAGRAM	62
EXPLODED VIEW	30	TERMINAL FUNCTION	64
PACKING	31	SPECIFICATIONS	65

GENERAL

INTRODUCTION

SCOPE OF THIS MANUAL

This manual is intended for use by experienced technicians familiar with similar types of commercial grade communications equipment. It contains all required service information for the equipment and is current as of the publication data. Changes which may occur after publication are covered by either Service Bulletins or Manual Revisions. These are issued as required.

ORDERING REPLACEMENT PARTS

When ordering replacement parts or equipment information, the full part identification number should be included. This applies to all parts : components, kits, or chassis. If the part number is not known, include the chassis or kit number of which it is a part, and a sufficient description of the required component for proper identification.

PERSONNEL SAFETY

The following precautions are recommended for personnel safety :

- DO NOT transmit if someone is within two feet (0.6 meter) of the antenna.
- DO NOT transmit until all RF connectors are verified secure and any open connectors are properly terminated.
- SHUT OFF and DO NOT operate this equipment near electrical blasting caps or in an explosive atmosphere.
- All equipment should be properly grounded before power-up for safe operation.
- This equipment should be serviced by a qualified technician only.

PRE-INSTALLATION CONSIDERNATIONS

1. UNPACKING

Unpack the radio from its shipping container and check for accessory items. If any item is missing, please contact KENWOOD immediately.

2. PRE-INSTALLATION CHECKOUT

2-1. Introduction

Each radio is adjusted and tested before shipment. However, it is recommended that receiver and transmitter operation be checked for proper operation before installation.

2-2. Testing

The radio should be tested complete with all cabling and accessories as they will be connected in the final installation. Transmitter frequency, deviation, and power output should be checked, as should receiver sensitivity, squelch operation, and audio output. QT equipment operation should be verified.

3. PLANNING THE INSTALLATION

3-1. General

Inspect the vehicle and determine how and where the radio antenna and accessories will be mounted.

Plan cable runs for protection against pinching or crushing wiring, and radio installation to prevent overheating.

3-2. Antenna

The favored location for an antenna is in the center of a large, flat conductive area, usually at the roof center. The trunk lid is preferred, bond the trunk lid and vehicle chassis using ground straps to ensure the lid is at chassis ground.

3-3. Radio

The universal mount bracket allows the radio to be mounted in a variety of ways. Be sure the mounting surface is adequate to support the radio's weight. Allow sufficient space around the radio for air cooling. Position the radio close enough to the vehicle operator to permit easy access to the controls when driving.

3-4. DC Power and wiring

1. This radio may be installed in negative ground electrical systems only. Reverse polarity will cause the cable fuse to blow. Check the vehicle ground polarity before installation to prevent wasted time and effort.
2. Connect the positive power lead directly to the vehicle battery positive terminal. Connecting the Positive lead to any other positive voltage source in the vehicle is not recommended.
3. Connect the ground lead directly to the battery negative terminal.
4. The cable provided with the radio is sufficient to handle the maximum radio current demand. If the cable must be extended, be sure the additional wire is sufficient for the current to be carried and length of the added lead.

GENERAL / OPERATING FEATURES

4. INSTALLATION PLANNING – CONTROL STATIONS

4-1. Antenna system

Control station. The antenna system selection depends on many factors and is beyond the scope of this manual. Your KENWOOD dealer can help you select an antenna system that will best serve your particular needs.

4-2. Radio location

Select a convenient location for your control station radio which is as close as practical to the antenna cable entry point. Secondly, use your system's power supply (which supplies the voltage and current required for your system). Make sure sufficient air can flow around the radio and power supply to allow adequate cooling.

SERVICE

This radio is designed for easy servicing. Refer to the schematic diagrams, printed circuit board views, and alignment procedures contained in this manual.

Note

When you modify your radio as described in system set-up, take the following precaution.

The rating of pin 7 (SB) of the accessory connector cable (KCT-19) on the rear of the radio is 13.6V (0.75A). Insert a 1A fuse if you use the SB pin for external equipment.

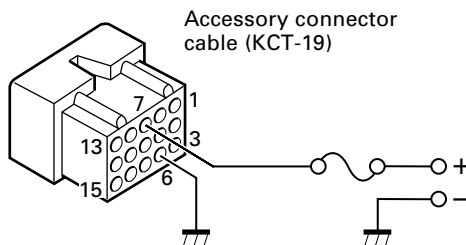

If you do not intend to use the 3.5-mm jack for the external speaker, fit the supplied speaker-jack cap (B09-0235-05) to stop dust and sand getting in.

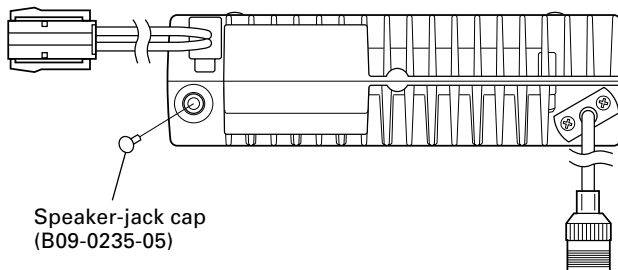

OPERATING FEATURES

1. Transceiver Controls and Indicators (Fig. 1)

1-1. The Basics

Features listed in this section are available for both Trunking and Conventional modes. Mode specific features can be found in their corresponding sections in this manual.

• Front panel

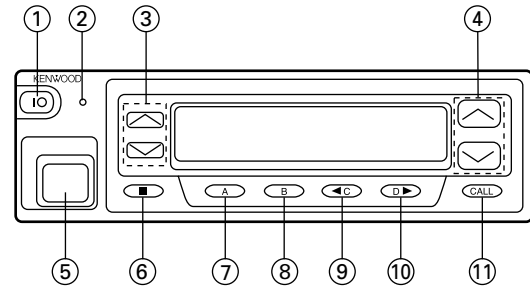

Fig. 1

① IO (Power) switch

Press to switch the transceiver ON (or OFF).

② Transmit/Receive indicator

③ ^/∨ (Volume) keys

④ ^/∨ (Control) keys

⑤ Microphone jack

Insert the microphone plug into this connector.

⑥ ■ key

⑦ A key

⑧ B key

⑨ ◀ C key

⑩ ▶ D key

⑪ CALL key

1-2. Trunking Mode

• Key functions

The numbers correspond to the Figure 1.

② Transmit indicator

Lights red while transmitting.

④ ^/∨ (Control) keys

Press these keys to select your desired call address (voice calls) or status (status calls).

⑥ ■ key

Press to end the current call.

⑦ A key (default setting : Status/Stack)

Press to activate its auxiliary function below.

⑧ B key (default setting : Redial)

Press to activate its auxiliary function below.

OPERATING FEATURES / REALIGNMENT

- ⑨ ◀ **C key (Default setting : None)**
Press to activate its auxiliary function below. Also press to scroll left while viewing stack entries.
- ⑩ ▶ **D key (Default setting : None)**
Press to activate its auxiliary function below. Also press to scroll right while viewing stack entries.
- ⑪ **CALL key**
Press to call the displayed call address.

• **Display**

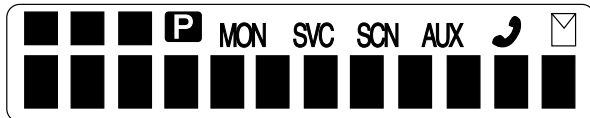

Fig. 2

■■■ displays the strength of received signals, the output power (high or low), status numbers, and received call types.

SVC appears when a control channel is found. It flashes while the transceiver is searching for a control channel.

☎ flashes when you activate call diversion.

✉ appears while there is data in the stack. It flashes when there is new data in the stack.

■■■■■■■■■■■■■■■■■■■■ displays call addresses, the call duration timer, data messages, and the current operating status of the transceiver.

1-3. Conventional Mode

• **Key functions**

The numbers correspond to the Figure 1.

- ② **Transmit/Receive indicator**
Lights red while transmitting.
Lights green while receiving a signal.
- ④ ^/∨ **(Control) keys**
Press these keys to select your desired channel.
- ⑥ ■ **key**
Press to return to Trunking mode.
- ⑦ **A key**
Press to turn Scan ON (or OFF).
- ⑧ **B key**
Press to add/remove channels to/from Scan.
- ⑪ **CALL key**
Press to turn the squelch OFF in order to monitor your selected channel.

• **Display (Refer to Figure 2)**

■■■ displays the strength of received signals.

MON appears while you are monitoring a channel by pressing the CALL key.

SCN appears while you are scanning.

■■■■■■■■■■■■■■■■■■■■ displays channel numbers and the current operating status of the transceiver.

REALIGNMENT

1. Modes

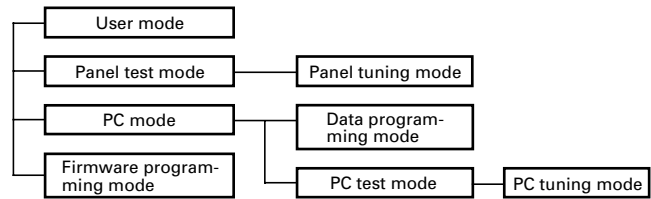

Mode	Function
User mode	For normal use.
Panel test mode	Used by the dealer to check the fundamental characteristics.
Panel tuning mode	Used by the dealer to tune the radio.
PC mode	Used for communication between the radio and PC (IBM compatible).
Data programming mode	Used to read and write frequency data and other features to and from the radio.
PC test mode	Used to check the radio using the PC. This feature is included in the FPU. See panel tuning.
Firmware programming mode	Used when changing the main program of the flash memory.

2. How to Enter Each Mode

Mode	Operation
User mode	Power ON
Panel test mode	[B]+Power ON
PC mode	Received commands from PC
Panel tuning mode	[Panel test mode]+[A]
Firmware programming mode	[A]+Power ON

3. Panel Test Mode

Setting method refer to ADJUSTMENT.

4. Panel Tuning Mode

Setting method refer to ADJUSTMENT.

REALIGNMENT

5. PC Mode

5-1. Preface

The TK-885 transceiver is programmed by using a personal computer, programming interface (KPG-46) and programming software (KPG-62D).

The programming software can be used with an IBM PC or compatible. Figure 1 shows the setup of an IBM PC for programming.

5-2. Connection Procedure

1. Connect the TK-885 to the personal computer with the interface cable.
2. When the Power switch on, user mode can be entered immediately. When PC sends command the radio enter PC mode, and "PROGRAM" is displayed on the LCD. When data transmitting from transceiver, the red LED is blinking. When data receiving to transceiver, the green LED is blinking.

Notes :

- The data stored in the personal computer must match model type, when it is written into the flash memory.
- Change the TK-885 to PC mode, then attach the interface cable.

5-3. KPG-46 Description

(PC programming interface cable : Option)

The KPG-46 is required to interface the TK-885 to the computer. It has a circuit in its D-subconnector (25-pin) case that converts the RS-232C logic level to the TTL level.

The KPG-46 connects the modular microphone jack of the TK-885 to the computers RS-232C serial port.

5-4. Programming Software KPG-62D Description

The KPG-62D is the programming software for the transceiver supplied on two 3.5" floppy disks. This software runs under MS-Windows 95/98 on an IBM-PC or compatible machine.

The data can be input to or read from the transceiver and edited on the screen. The programmed or edited data can be printed out. It is also possible to tune the transceiver.

We recommend that install the KPG-62D for example to hard disk first then use it.

5-5. Programming With IBM PC

If data is transferred to the transceiver from an IBM PC with the KPG-62D, the destination data (basic radio information) for each set can be modified. Normally, it is not necessary to modify the destination data because their values are determined automatically when the frequency range (frequency type) is set.

The values should be modified only if necessary.

Data can be programmed into the flash memory in RS-232C format via the modular microphone jack.

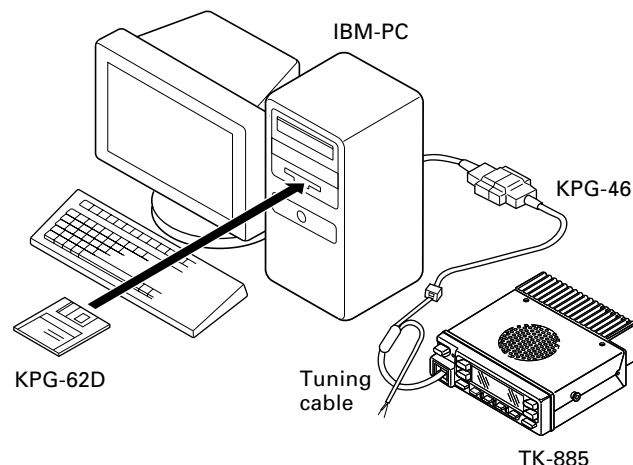

Fig. 1

6. Firmware Programming Mode

6-1. Preface

Flash memory is mounted on the TK-885. This allows the TK-885 to be upgraded when new features are released in the future. (For details on how to obtain the firmware, contact Customer Service.)

6-2. Connection Procedure

Connect the TK-885 to the personal computer (IBM PC or compatible) with the interface cable (KPG-46). (Connection is the same as in the PC Mode.)

6-3. Programming

1. Start up the programming software (Fpro. exe).
2. Set the communications speed (normally, 57600 bps) and communications port in the configuration item.
3. Set the firmware to be updated by File name item.
4. Turn the TK-885 Power ON with the [A] switch held down. Hold the switch down until the display changes to "PROG 57600". When "PROG 57600" appears, release your finger from the switch.
5. Check the connection between the TK-885 and the personal computer, and make sure that the TK-885 is in the Program mode.
6. Press write button in the window. A window opens on the display to indicate progress of writing. When the TK-885 starts to receive data, the  icon is blinking.
7. If writing ends successfully, the LED on the TK-885 lights and the checksum is displayed.
8. If you want to continue programming other TK-885, repeat steps 4 to 7.

REALIGNMENT / INSTALLATION

Notes :

- This mode cannot be entered if the Firmware programming mode is set to Disable in the Programming software (KPG-62D).
- When programming the firmware, it is recommend to copy the data from the floppy disk to your hard disk before update the radio firmware.
Directly copying from the floppy disk to the radio may not work because the access speed is too slow.

6-4. Function

1. If you press the [■] switch while "PROG 57600" is displayed, the version is displayed. If you press the [■] switch again while the version is displayed, "PROG 57600" is redisplayed.
2. If you press the [D▶] switch while "PROG 57600" is displayed, the display changes to "PROG 19200" to indicate that the write speed is low speed (19200 bps). If you press the [D▶] switch again while "PROG 19200" is displayed, the display changes to "PROG 38400", and the write speed becomes the middle speed (38400 bps). If you press the [D▶] switch again while "PROG 38400" is displayed, the display returns to "PROG 57600".
3. If you press the [D▶] switch while the version is displayed, the checksum is displayed. If you press the [D▶] switch again while the checksum is displayed, the version is redisplayed.

Note :

Normally, write in the high-speed mode.

INSTALLATION

1. Accessory Connection Cable (KCT-19 : Option)

The KCT-19 is an accessory connection cable for connecting external equipment. The connector has 15 pins and the necessary signal lines are selected for use.

1-1. Installing the KCT-19 in the transceiver

1. Remove the upper and lower half of the transceiver case, and lift the DC cord bushing (❶) from the chassis.
2. Remove the pad as shown in Figure 1 (❷).
3. Insert the KCT-19 cable (❸) into the chassis (❹).
The wire harness band (❺) must be inside the chassis.
4. Replace the DC cord bushing (❻).
5. Connect the KCT-19 to the TX-RX unit (A/2) as shown in Figure 2 (❼).
6. Connect the KCT-19 to the external accessory by inserting the crimp terminal (❸) into the square plug (❾), both of which are supplied with the KCT-19.

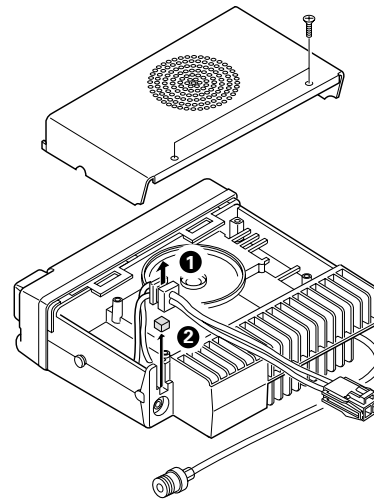

Fig. 1

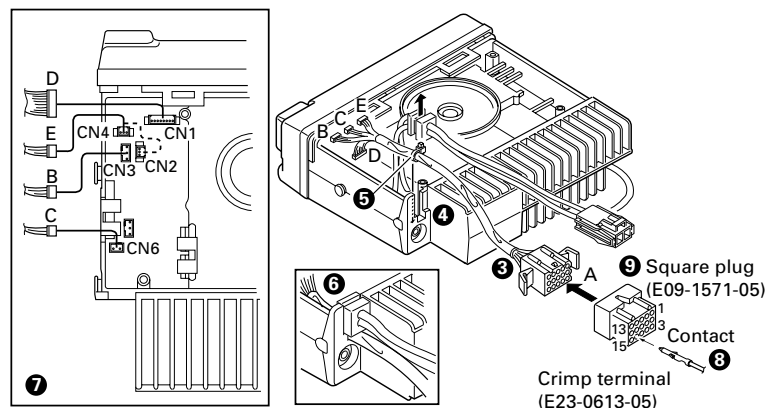

Fig. 2

INSTALLATION

1-2. KCT-19 Accessory Port Function

No. (A)	No. (B,C,D,E)	Name	Function	Note
1	D-2	AHK	No function.	
2	D-5	ME	Microphone ground.	*1
		AM	Speaker audio mute input.	
3	D-3	IGN	Ignition sense input.	
4	D-1	DEO	Receiver detector output.	
5	D-6	MI	External microphone input.	*1
		TXS	Transmitter sense output.	
6	B-2	E	Ground.	
7	B-3	SB	Switched B+, DC 13.6V output. Maximum 0.75A	
8	D-7	PTT	No function.	
9	D-4	DI	Data modulation input.	
10	B-1	HOR	Horn alert/call output.	
11	D-8	SQ	No function.	
12	C-1	SP	Speaker audio output.	
13	E-1	CN2 and CN4	LOK	No function. *1 *2
		CN2	AM	Speaker mute input.
14	E-2	CN4	RXD	Serial control data input. *2
		CN2	MM	MIC mute input, active high.
15	E-3	CN4	TXD	Serial control data output. *2
		CN2	DTC	No function.
		*1	LOK	No function.
		TXS	No function.	
		FSW	Foot switch input, active low	

Note

*1 : The functions of A-2, A-5, A-13 (when connector E is connected to CN2), and A-15 (when connector E is connected to CN2) are changed as described in the jumper chart.

*2 : The functions of A-13, A-14 and A-15 are changed if the connector E is connected to CN2 or CN4 of the radio.

No.	CN2	CN4
E-1	LOK/AM	LOK
E-2	MM	RXD
E-3	LOK/DTC/TXS/FSW	TXD

· Connect CN6 of the radio to connector C of the KCT-19 instead of to the internal speaker connector, if use external speaker.

1-3. Data Equipment Connection

The jumpers must be set to either one for each function. Otherwise, the radio will not work properly.

ME/AM

R12 (0Ω)	R167 (0Ω)	Function / Default	
Yes	No	AM	Default
No	Yes	ME	

MI/TXS

R94 (0Ω)	R24 (0Ω)	Function / Default	
Yes	No	TXS	Default
No	Yes	MI	

LOK/AM

R5 (0Ω)	R6 (0Ω)	Function / Default	
Yes	No	AM	
No	Yes	LOK	Default

DTC/LOK/TXS/FSW

R168 (0Ω)	R84 (0Ω)	R51 (0Ω)	R13 (0Ω)	Function / Default	
No	No	No	Yes	LOK	
Yes	No	No	No	DTC	Default
No	No	Yes	No	TXS	
No	Yes	No	No	FSW	

Note : The following parts are not installed at the time of shipping; R5,R13,R24,R51,R84,R167

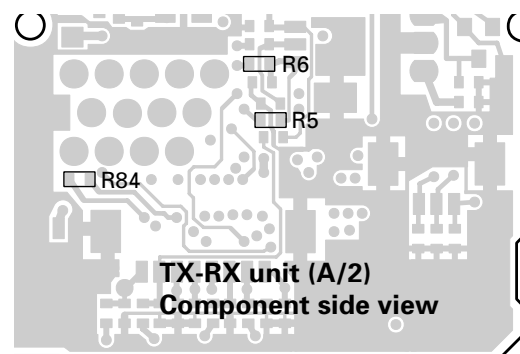
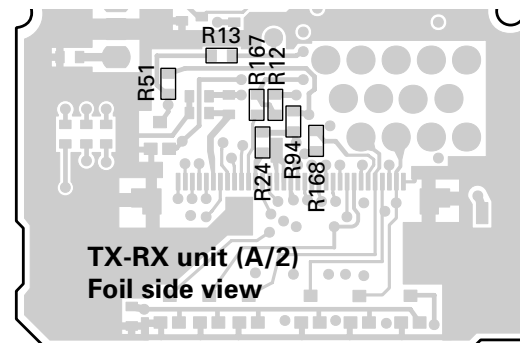

Fig. 3

INSTALLATION

2. Accessory Terminal (TX-RX Unit)

2-1. External Connector Accessory Terminal Method

Connector No.	Pin No.	Pin name	I/O	Function
CN1	1	DEO	O	Detect signal output. (Output level : 250mVrms; standard modulation)
	2	AHK	I	No function.
	3	IGN	I	Ignition sense input.
	4	DI	I	External modulation signal input.
	5	ME	-	MIC earth.
		AM	I	Audio mute signal input.
	6	MI	I	Internal MIC input.
		TXS	O	No function.
7	PTT	I	No function.	
8	SQ	O	No function.	
CN2	1	AM	I	Audio mute signal input.
		LOK	O	No function.
	2	MM	I	MIC mute input.
	3	DTC	I	No function.
		TXS	O	No function.
		FSW	I	Foot switch signal input. Foot sw on : L, Foot sw off : H
	LOK	O	No function.	
CN3	1	HOR	O	Horn alert signal output. Signal output for horn relay drive (open collector). L level during horn drive : Max. sink current 100mA. L level when AUX A is on.
	2	E	-	Earth.
	3	SB	O	Power output after power switch (DC 13.6V±15%, 0.75A max.).
CN4	1	LOK	O	No function.
	2	RXD	I	Serial data input 1.
	3	TXD	O	Serial data output 1.
CN5	1	PA	O	Relay for PA function in KAP-1 control signal. PA on : H, PA off : L
	2	SPO	O	Audio signal input from KAP-1.
	3	SPI	I	Audio signal output to KAP-1.
CN6	1	SP	O	Output for internal/external speaker.
	2	E	-	Earth.

3. Optional Board Terminal

Terminal is for mounting the option board are provided at the control and TX-RX unit. The table below shows the correspondence between the board and terminals. Disconnect R529 and R571 in control unit when the scrambler board is attached.

The table below shown the differences between the schematic terminals and the PC board terminals.

Schematic diagram			PC board view	
Name	I/O	Function	Name	Unit
SB	O	Switched B+ (13.6V, 0.75A)	SB	TX-RX
5C	O	5C	5C	TX-RX
GND	-	Earth	E	TX-RX
DEO	O	Detect signal output (Output level : 250mVrms; standard modulation)	DEO	TX-RX
RXAI	I	RX audio input	RXAI	Control
RXAO	O	RX audio output	RXAO	Control
TXAI	I	TX audio input	TXAI	Control
TXAO	O	TX audio output	TXAO	Control
LOK	O	No function	LOK	TX-RX
OPT	O	Option board select.	OP	TX-RX
CODE1	O	Option code 1 (for voice scrambler code 1)	C1	TX-RX
CODE2	O	Option code 1 (for voice scrambler code 2)	C2	TX-RX
CODE3	O	Option code 1 (for voice scrambler code 3)	C3	TX-RX
CODE4	O	Option code 1 (for voice scrambler code 4)	C4	TX-RX
SQ	O	No function	SQ	TX-RX
TXD1	O	Serial data output 1	TD1	TX-RX
RXD1	I	Serial data input 1	RD1	TX-RX
TXD2	O	Serial data output 2	TD2	TX-RX
RXD2	I	Serial data input 2	RD2	TX-RX
RSSI	O	Receive signal strength indication	RSSI	TX-RX
PTT	I	PTT	PTT	Control
MPTT	I	MIC PTT	MPTT	Control
FSW	I	Foot switch input	FW	TX-RX

INSTALLATION

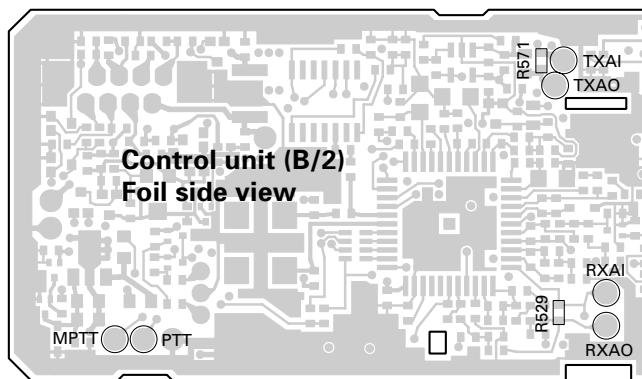
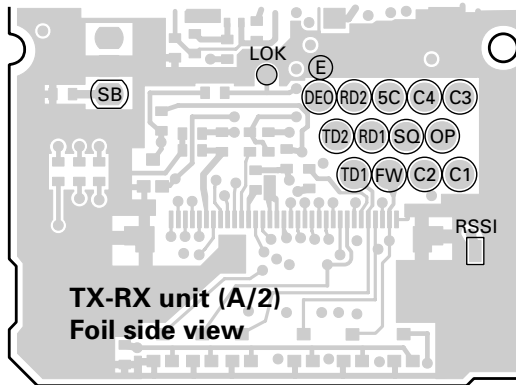

Fig. 4

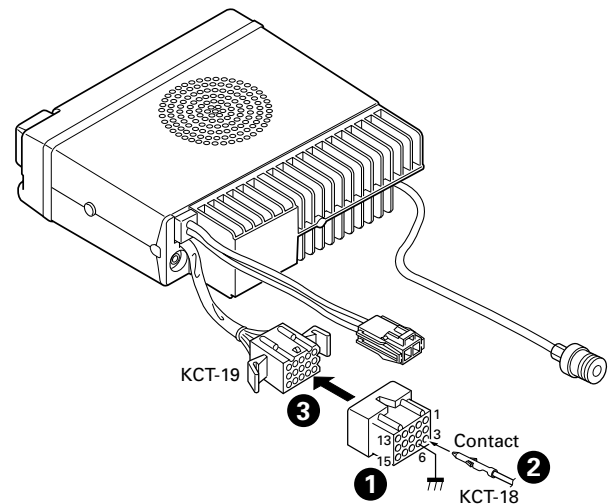

Fig. 5

4. Ignition Sense Cable (KCT-18 : Option)

The KCT-18 is an optional cable for enabling the ignition function. The ignition function lets you turn the power to the transceiver on and off with the car ignition key.

If you use the Horn Alert function or the Manual Relay function, you can turn the function off while driving with the ignition key.

4-1. Connecting the KCT-18 to the Transceiver

1. Install the KCT-19 in the transceiver. (See the KCT-19 section.)
2. Insert the KCT-18 lead terminal (2) into pin 3 of the square plug (1) supplied with the KCT-19, then insert the square plug into the KCT-19 connector (3).

4-2. Modifying the Transceiver

Modify the transceiver as follows to turn the power or the Horn Alert or Manual Relay function on and off with the ignition key.

1. Remove the lower half of the transceiver case.
2. Set jumper resistors (0Ω) R151 and R152 of the TX-RX unit (A/2) as shown in Table 1.

Operation when KCT-18 is connected	R151	R152
KCT-18 cannot be connected	Enable	Enable
Power on/off and Horn Alert or AUX-A on/off	Disable	Enable
Horn Alert or AUX-A on/off, Timed power off	Enable	Disable
Power cannot be turned on	Disable	Disable

Table 1 R151 and R152 setup chart

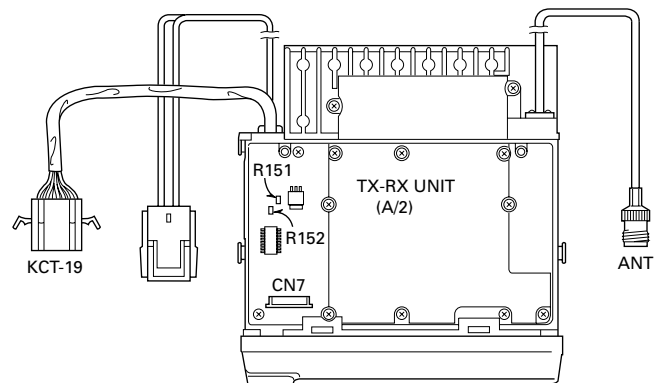

Fig. 6

INSTALLATION

5. Optional Voice Scrambler Function

You can use the voice scrambler in the following two configurations.

- Assign this function to the Scrambler key by using the programming software (KPG-62D).
When the Scrambler key is pressed, the [] indicator appears, and the optional (scrambler) function is enabled. When the key is pressed again, the [] indicator goes off and the function is disabled.
- Using the KPG-62D, you can set the voice scrambler to be always active, without pressing a key. The operator cannot switch off the voice scrambler.

5-1. Configuring a Scrambler Code

The scrambler code cannot be changed using the transceiver keys. Only one scrambler code can be set into the transceiver. If you want to change the code, you must use the KPG-62D to reconfigure the scrambler code.

5-2. Voice Scrambler Board Connection

• Modification

- Remove the upper half of the case of the TK-885.
- Remove R529 and R571 on the Control unit (X57-615 B/2).

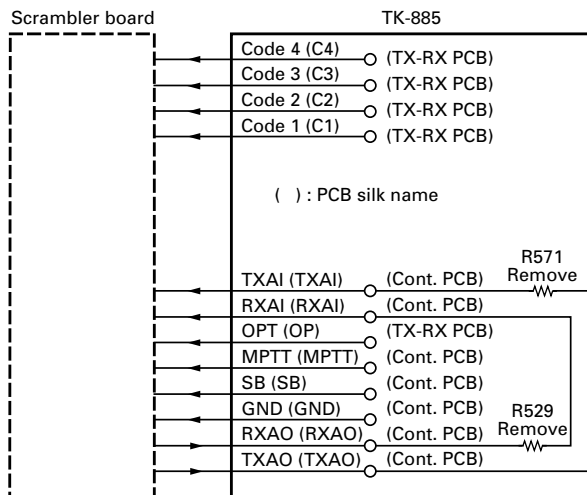

Fig 7

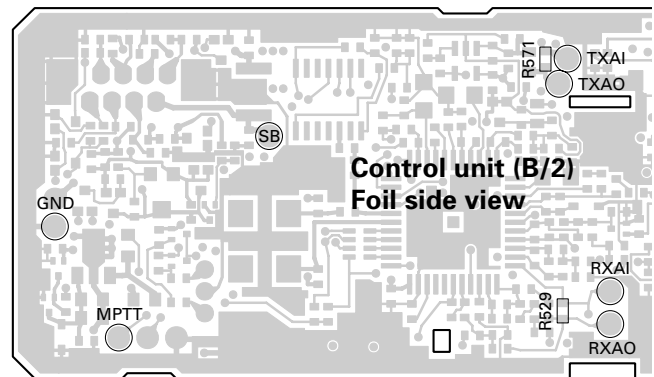
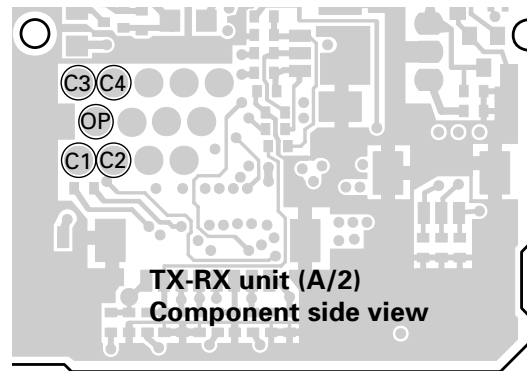

Fig. 8

6. PA/HA Unit (KAP-1 : Option)

6-1. Installing the KAP-1 in the Transceiver

The Horn Alert (max. 2A drive) and Public Address functions are enabled by inserting the KAP-1 W1 (3P; white/black/red) into CN3 on the TX-RX unit, inserting W2 (3P; green) into CN5 on the TX-RX unit, and connecting the KCT-19 (option) to CN2 and CN3 of the KAP-1.

• Installation procedure

- Open the upper case of the transceiver.
- Insert the two cables (❶) with connectors from the KAP-1 switch unit into the connectors on the transceiver.
- Secure the switch unit board to the chassis with a screw (❸). The notch (❷) in the board must be placed at the front left side.
- Attach the cushion on the top of the KAP-1 switch unit.

INSTALLATION

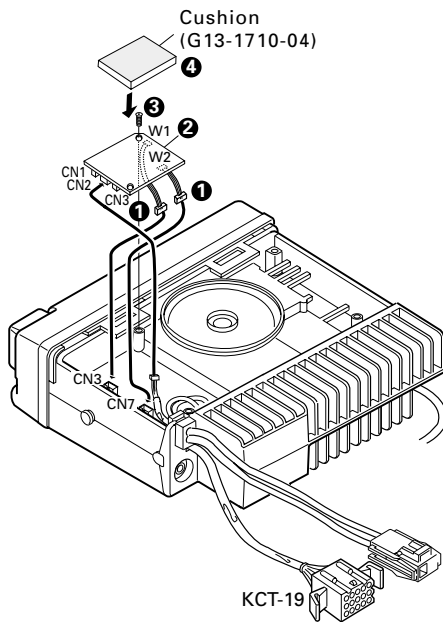

Fig. 9

6-2. Modifying the Transceiver

• Horn alert

The signal from pin 4 of IC7 on the TX-RX unit turns Q4 and Q6 on and off and drives KAP-1 HA relay to drive the horn with a maximum of 2A.

The default output is HR1. The relay open output can be obtained between HR1 and HR2 by removing R1 in the KAP-1.

	R1	Output form
HR1 (Default)	Enable	
HR2	Disable	

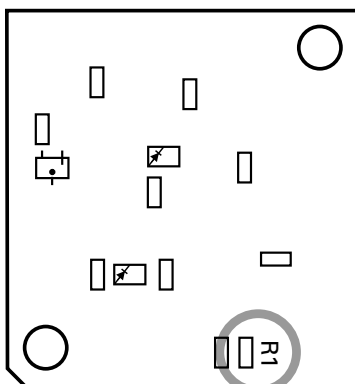

Fig. 10 KAP-1 foil side view

• Public address

The signal from pin 13 of IC7 on the TX-RX unit drives PA relay in the KAP-1 and switches the audio power amplifier output between the external PA system (through KCT-19) and internal and external speakers.

To use the PA function, R109 on the TX-RX unit must be removed.

	R109
Use the PA function	No
Do not use the PA function	Yes

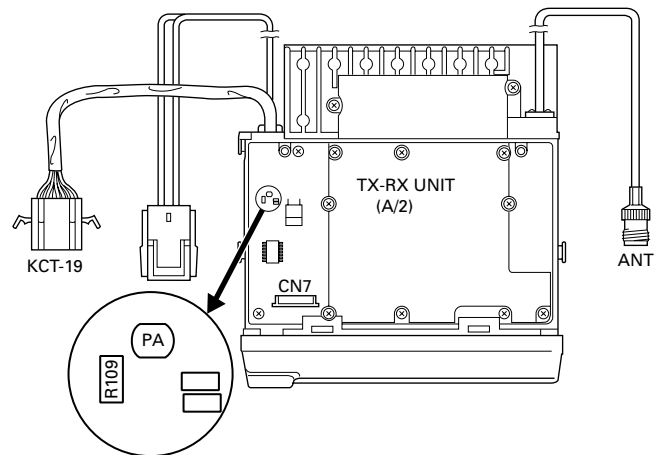

Fig. 11

7. Fitting the Control Panel Upside Down

The TK-885 control panel can be fitted upside down, so the transceiver can be mounted with its internal speaker (in the upper half of the case) facing down in your car.

1. Remove the control panel and the TX-RX unit (B/2) control section. (Fig. 12)

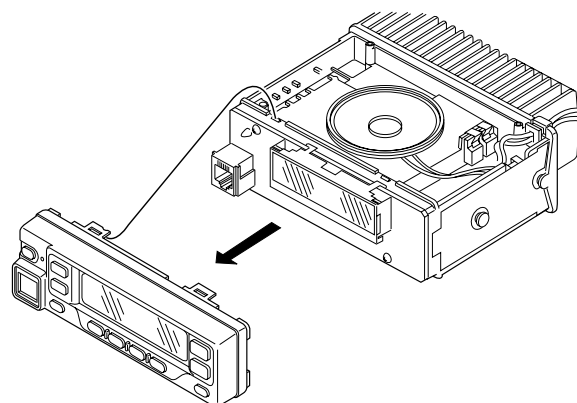

Fig. 12

INSTALLATION

2. Fold the flat cable (❶) in the opposite direction (❷).
3. Rotate the control section (❸) 180 degrees (❹).
4. Insert the flat cable into the control section connector, CN502 (❺).
5. Mount the control section on the transceiver (❻).

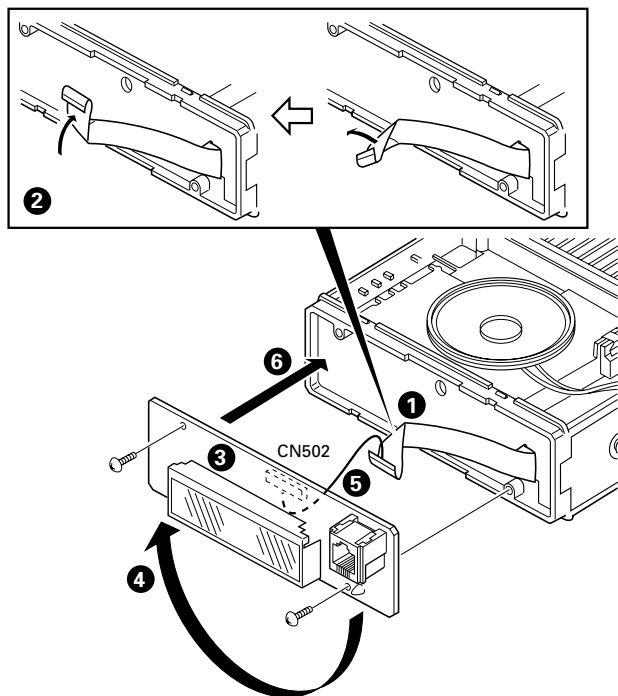

Fig. 13

6. Rotate the control panel 180 degrees and mount it on the transceiver. Refit the two halves of the case to complete installation. (Fig. 14)

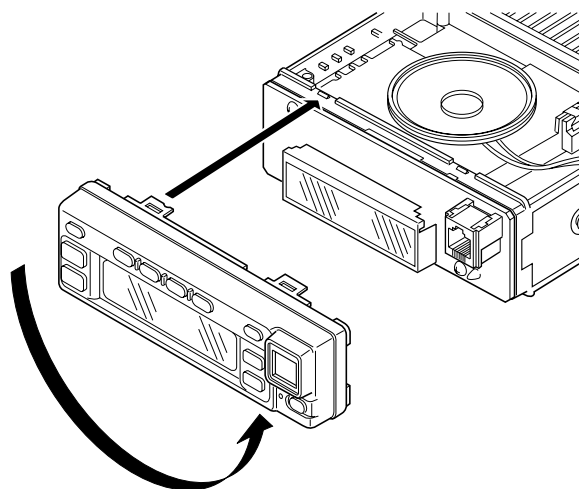

Fig. 14

8. External Speaker

8-1. KES-3 : Option

The KES-3 is an external speaker for the 3.5-mm-diameter speaker jack.

• Connection procedure

1. Connect the KES-3 to the 3.5-mm-diameter speaker jack on the rear of the transceiver.

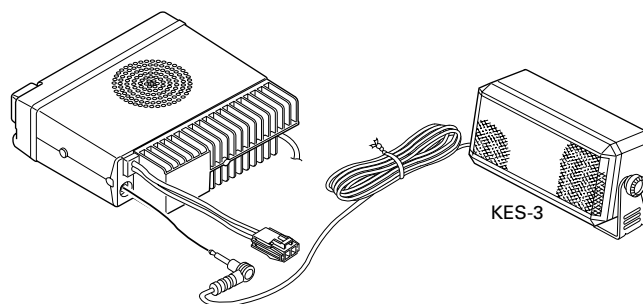

Fig. 15

8-2. KES-4 : Option

The KES-4 is an external speaker used with the accessory connection cable.

• Connection procedure

1. Install the KCT-19 in the transceiver. (See the KCT-19 section.)
2. Insert the crimp terminal into the square plug supplied with the KCT-19.
3. Connect CN5 of the transceiver to connector C of the KCT-19 instead of to the internal speaker connector.

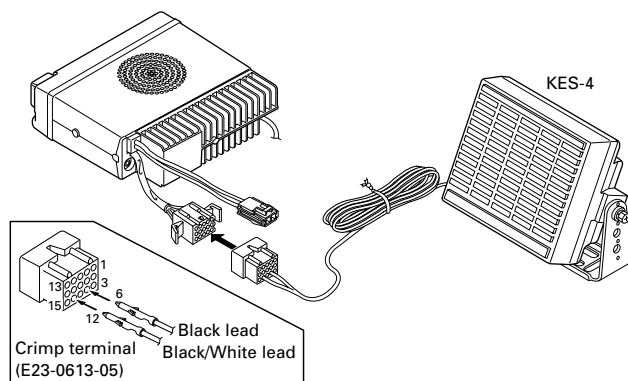

Fig. 16

CIRCUIT DESCRIPTION

Frequency Configuration

The TX-RX unit incorporates a VCO, based on a fractional N type PLL synthesizer system, that allows a channel step of 6.25 and 12.5kHz to be selected. The incoming signal from the antenna is mixed with a first local oscillation frequency to produce a first intermediate frequency of 44.85MHz.

The signal is then mixed with a second local oscillation frequency of 44.395MHz to produce a second intermediate frequency of 455kHz. This is called a double-conversion system. The TX-RX unit contains a wide/narrow CFs. The transmit signal is produced by the PLL circuit for direction oscillation and division. The signal output from the VCO is amplified by a straight amplifier and transmitted.

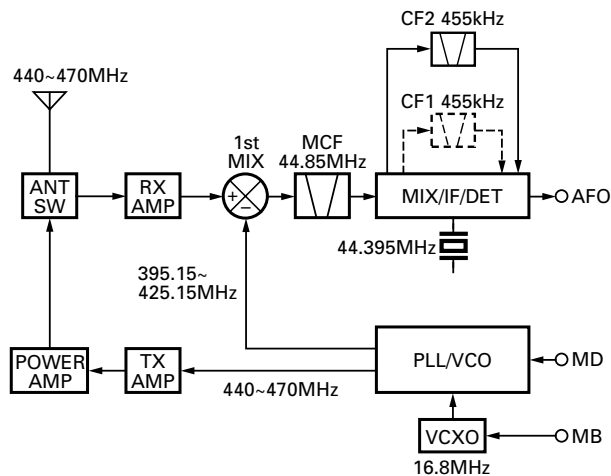

Fig. 1 Frequency configuration

Receiver System

■ Outline

The incoming signal from the antenna passes through a low-pass filter and a transmission/reception selection diode switch (D209) and goes to the front end of the receiver. The front-end filter is a variable BPF consisting of two two-pole helical resonators and eight varicap diodes (D203, D204, D205, D206, D212, D213, D214, D215) to eliminate unwanted out-of-band signal components. The low-noise amplifier (LNA) (Q201) uses a bipolar transistor to achieve wide-band and low-distortion amplification.

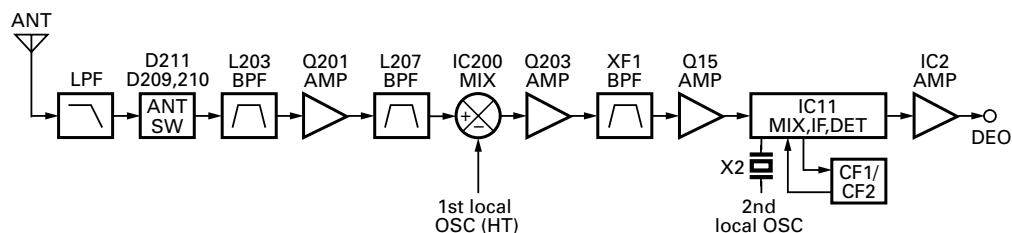

Fig. 2 Receiver system

The signal passes through a BPF and is down-converted with the first local signal by IC200, then converted to the first IF signal of 44.85MHz. The first local signal passes through an LPF and an attenuator to eliminate unwanted harmonics components and implement the optimum input level to the mixer, then enters IC200. A DBM is used as a mixer to achieve a high potential.

The signal output from the mixer is amplified by an intermediate frequency amplifier and input to two MCFs (XF1). The signal is amplified by another intermediate amplifier and goes to the FM IF IC (IC11). The first intermediate frequency signal is mixed with the second local signal of 44.395MHz to produce the second IF signal of 455kHz.

The unwanted near-by signal components are then eliminated by a ceramic filter (CF2) and the resulting signal goes back to the FM IF IC. The signal is quadrature-detected in the IC to produce an audio signal, which is amplified by a DET amplifier (IC2) and output to the control unit.

■ AF Signal System

The detection signal (DEO) from the TX-RX unit goes to the audio processor (IC504) of the control unit. The signal passes through a filter in the audio processor to adjust the gain, and is output to IC502. IC502 sums the AF signal and the DTMF signal and returns the resulting signal to the TX-RX unit. The signal (AFO) sent to the TX-RX unit is input to the D/A converter (IC5). The AFO output level is adjusted by the D/A converter. The signal output from the D/A converter is added with the BEEP signal (BPO) and the resulting signal is input to the audio power amplifier (IC10). The AF signal from IC10 switches between the internal speaker and speaker jack (J1) output.

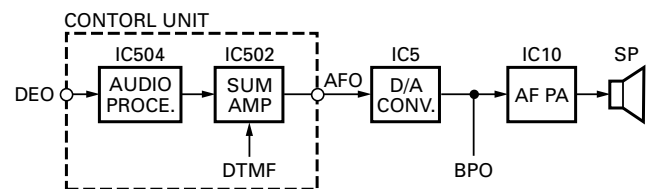

Fig. 3 AF signal system

CIRCUIT DESCRIPTION

■ Squelch Circuit

The detection output from the FM IF IC (IC11) is amplified by IC2 and the signal (DEO) is sent to the control unit. The signal passes through a high-pass filter and a noise amplifier (Q503) in the control unit to detect noise. A voltage is applied to the CPU (IC511). The CPU controls squelch according to the voltage (ASQ) level. The signal from the RSSI pin of IC11 is monitored. The electric field strength of the receive signal can be known before the ASQ voltage is input to the CPU, and the scan stop speed is improved.

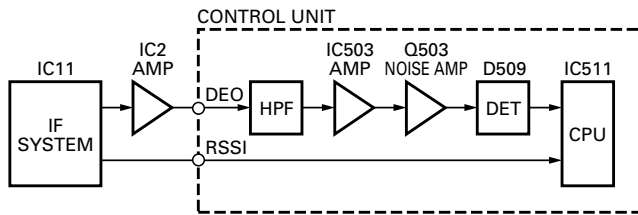

Fig. 4 Squelch circuit

Transmitter System

■ Outline

The transmitter circuit produces and amplifies the desired frequency directly. It FM-modulates the carrier signal by means of a varicap diode.

■ VCO/PLL Circuit

The TK-885 has a VCO for the transmitter and a VCO for the receiver in a sub-unit (A1). They are housed in a solid shielded case and connected to the TX-RX unit through CN101. One of the VCOs is selected with an ST signal. A filtered low-noise power supply is used for the VCOs and varicap diodes.

The VCO for the transmitter is described below. It is designed so that Q103 turns on with a prescribed frequency when a reverse bias is applied to D102 and D104 by using the control voltage (CV) through CN101. The control voltage is changed by turning the trimmer capacitor (TC109). The output from Q103 is applied to the buffer amplifier (Q106) to generate a VCO output signal. This signal is used as a drive input signal or a local signal of the first mixer.

Since a signal output from Q106 is input to the PLL IC, it passes through CN101 and buffer amplifier (Q300) and goes to the PLL IC (IC300). The modulation signal from CN101 is applied to D105 and passes through C113 to modulate the carrier.

The PLL IC uses a fractional N type synthesizer to improve the C/N ratio and lock-up speed. The VCO output signal input to the pin 5 of the PLL IC is divided to produce a comparison frequency according to a channel step. This signal is compared with the reference frequency which is output from the VCXO (X1). VCXO provides 16.8MHz, 2.5ppm (-30 to +60°C) and guarantees stable performance when the temperature changes. The output signal from the phase comparator passes through a charge pump and an external active LPF (Q301, Q302) in the PLL IC to generate a DC VCO control voltage CV. Serial data (DT, CK, EP) are output from the CPU (IC511) and shift register (IC8) in the control unit to control the PLL IC. The PLL lock status is always monitored by the CPU.

■ Unlock Circuit

During reception, the T/R signal goes high, the KEY signal goes low, and Q10 turns on. Q11 turns on and a voltage is applied to the collector (8R). During transmission, the T/R signal goes low, the KEY signal goes high and Q13 turns on. Q12 turns on and a voltage is applied to 8T.

The CPU in the control unit monitors the PLL (IC300) LD signal directly. The CPU detects this signal and makes the KEY signal low. When the KEY signal goes low, no voltage is applied to 8T, and no signal is transmitted.

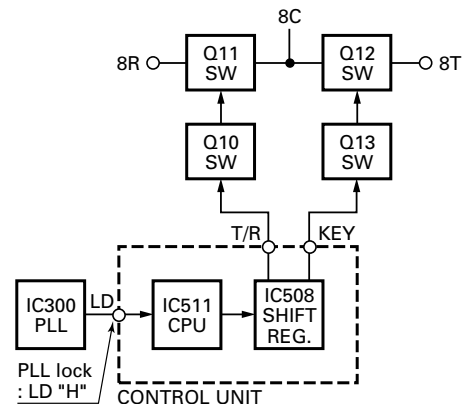

Fig. 6 Unlock circuit

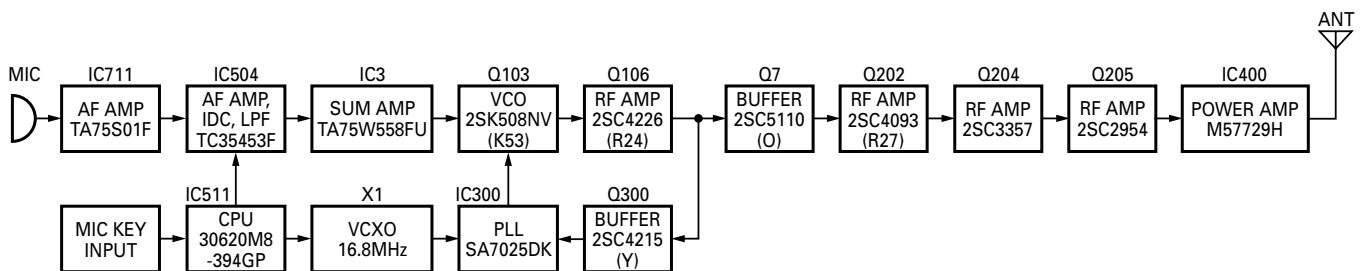

Fig. 5 Transmitter system

CIRCUIT DESCRIPTION

■ Power Amplifier Circuit

The transmit output signal from the VCO is amplified to a specified level of the power module (IC400) by the drive block (Q202, Q204, Q205). The amplified signal passes through the transmission/reception selection diode (D209) and goes to a low-pass filter. The low-pass filter removes unwanted high-frequency harmonic components, and the resulting signal is goes the antenna terminal.

■ APC Circuit

The automatic transmission power control (APC) circuit detects part of a power module output with a diode (D27, D30) and applies a voltage to Q21. Q21 compares the APC control voltage (PC) generated by the D/A converter (IC5) and DC amplifier (IC6) with the detection output voltage to control Q19 and Q20, generates DB voltage from B voltage, and stabilizes transmission output.

Q17 turns the PC signal on or off using 8T so that the circuit works only during transmission. With stability at low power in mind, Q29 turns off to optimize the detection voltage.

The APC circuit is configured to protect overcurrent of the power module due to fluctuations of the load at the antenna end and to stabilize transmission output at voltage and temperature variations.

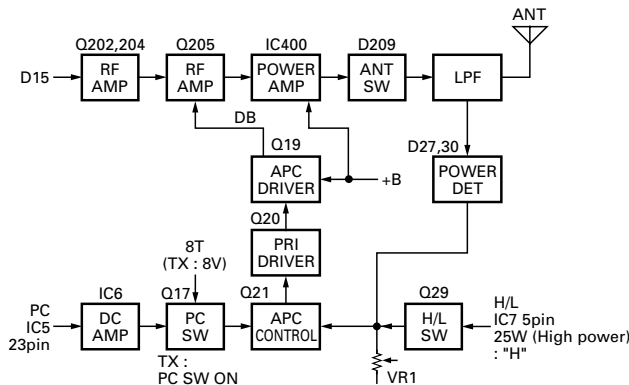

Fig. 7 APC circuit

Control Circuit

The CPU carries out the following tasks:

- 1) Controls the shift register (IC7, IC8, IC508) AF MUTE, T/R KEY outputs.
- 2) Adjusts the AF signal level of the audio processor (IC504) and turns the filter select compounder on or off.
- 3) Controls the DTMF decoder (IC507).
- 4) Controls the LCD assembly display data.
- 5) Controls the PLL (IC300).
- 6) Controls the D/A converter (IC5) and adjusts the volume, modulation and transmission power.

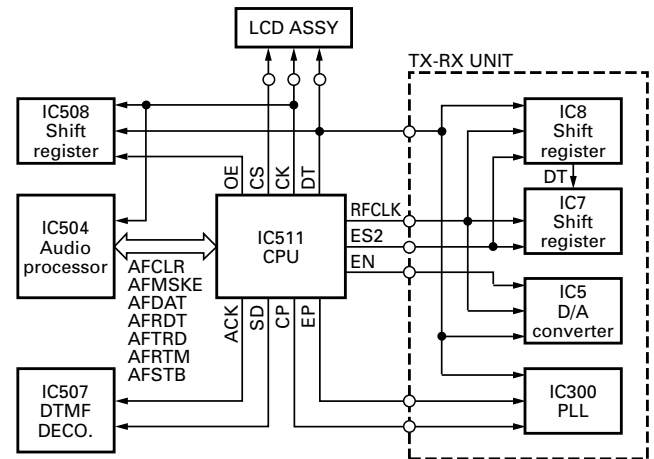

Fig. 8 Control circuit

■ Memory Circuit

Memory circuit consists of the CPU (IC511) and a flash memory (IC510). A flash memory has a capacity of 2M bits (256k x 8) and contains the transceiver control program for the CPU and the data for operating features.

This program can be easily downloaded from an external device. The CPU (IC511) controls the flash memory through an external address bus and an external data bus. The CPU controls the EEPROM (IC512) through two serial data lines.

• Flash Memory

Note: The flash memory stores the data containing the FPU (KPG-62D) program, Security Number (MPT Serial Number), and firmware program (User mode, Test mode, Tuning mode, etc.).

This data must be reinstalled when replacing the flash memory.

• EEPROM

Note: The EEPROM stores tuning data (Deviation, Squelch, etc.).

Realign the transceiver after replacing the EEPROM.

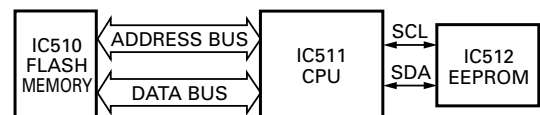

Fig. 9 Memory circuit

CIRCUIT DESCRIPTION

■ Display Circuit

The CPU (IC511) controls the shift register (IC508) and display LEDs. When the LG line goes high when the transceiver is busy, Q508 turns on and the green LED on D511 lights. In transmit mode, the LR line goes high, Q509 turns on and the red light lights. Backlighting LEDs for the key operation unit (D512~D517) and LCD are provided.

When the KBLC line goes high, Q512 turns on, then Q513 turns on, and the key illumination LED lights. A voltage is applied to the LEDA line to turn on the LCD backlight.

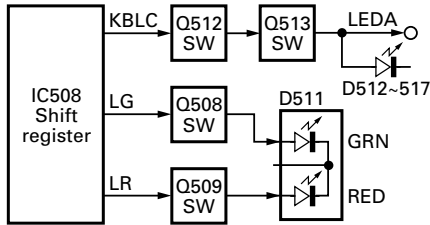

Fig. 10 Display circuit

■ Encode

The QT, DQT signals are output from LSDO of the CPU (IC511) and go to the D/A converter (IC5) of the TX-RX unit. The DTMF and single tone signals are output from HSDO of the CPU and goes to the audio processor (IC504). An MSK signal is output from the audio processor according to the data (AFDAT) from the CPU. The signal is summed with a MIC/MSK signal by the audio processor (IC504), and the resulting signal passes through an analog switch (IC506) and goes to the TX-RX unit (MO).

MO is summed with the external pin DI line by the summing amplifier (IC3) and the resulting signal goes to the D/A converter (IC5). The D/A converter (IC5) adjusts the MO level and the balance between the MO and TO levels. Part of a TO signal is summed with an output signal from pin 3 (MO) of IC5 and the resulting signal goes to the MD pin of the VCO. This signal is applied to a varicap diode in the VCO for direct FM modulation.

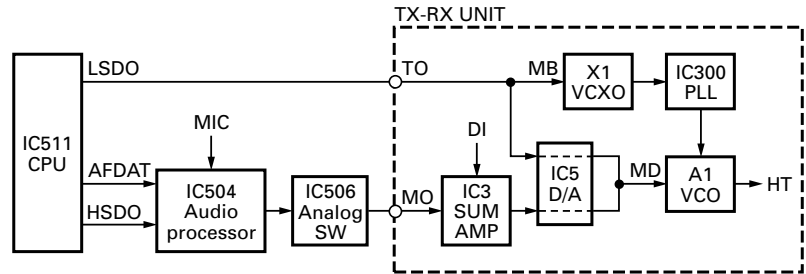

Fig. 12 Encode

■ Key Matrix Circuit

The TK-885 front panel has ten keys. Each of them is connected to a cross point of a matrix of the KEY1 to KEY7 ports of the microprocessor. The KEY5 to KEY7 ports are always high, while the KEY1 to KEY4 ports are always low.

The microprocessor monitors the status of the KEY1 to KEY7 ports. If the state of one of the ports changes, the microprocessor assumes that the key at the matrix point corresponding to that port has been pressed. Unused points (KEY1 to KEY7) are also used for foot switch (FSW) input.

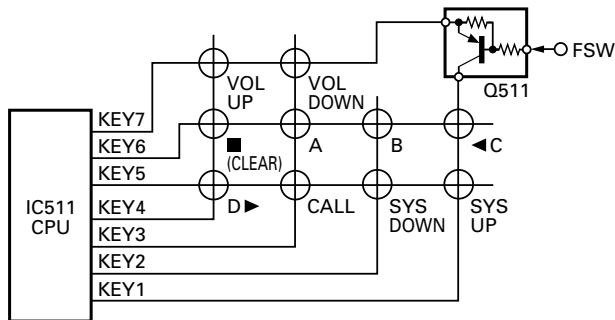

Fig. 11 Key matrix circuit

■ Decode

The signal (DEO) detected by the TX-RX unit passes through two low-pass filters of IC501, goes to LSDI of the CPU (IC511) to decode QT, DQT.

The MSK signal passes through IC504. IC504 includes band-pass filter and MSK decoder, converts the input signal into a square waveform (0 and 5V). This square waveform is then fed to AFRDT line of CPU (IC511).

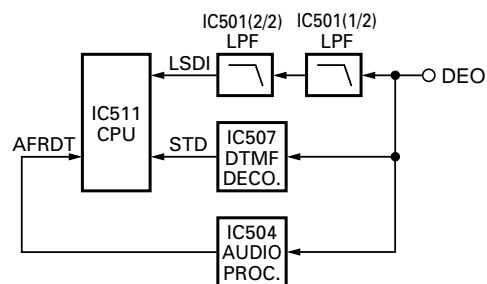

Fig. 13 Decode

CIRCUIT DESCRIPTION

■ D/A Converter

The D/A converter (IC5) is used to adjust TONE and MO modulation, beep, AF volume, TV voltage, FC reference voltage, and PC POWER CONTROL voltage level.

Adjustment values are sent from the CPU as serial data. The D/A converter has a resolution of 256 and the following relationship is valid:

$$\text{D/A output} = (\text{Vin} - \text{VDAREF}) / 256 \times n + \text{VDAREF}$$

Vin: Analog input

VDAREF: D/A reference voltage

n: Serial data value from the microprocessor (CPU)

■ Horn Control

The horn switch, consisting of Q4, Q5, and Q6, controls the horn relay. It is supplied by the dealer to provide the external horn alert function.

Q5 disables horn alert, turning on when its base is high, to inhibit the function. Normally, the output from IC7 is low, and Q6 is off; the base of Q4 is about 0V and Q4 is off. When horn alert is enabled, the output from IC7 goes high and Q6 turns on. The base current flows through R58 to Q4 to turn Q4 on. Q4 can sink a maximum of 100mA. If the operational KAP-1 is used, it can drive up to 2A.

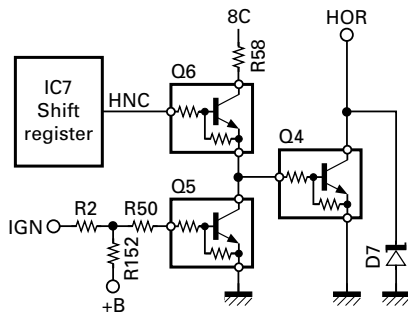

Fig. 14 Horn control

■ PA Switch

If the optional KAP-1 is used, the PA (Public Address) function becomes available. In this case, the signal flow changes as follows;

"PA2"	Q507	SW.A	SW.B	SW.D	Public address
L	L	L	H	H	OFF
H	H	H	L	L	ON

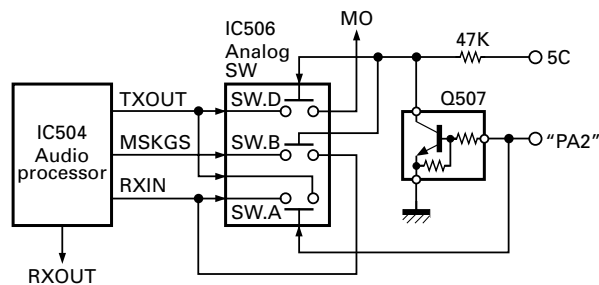

Fig. 15 PA switch

Power Supply Circuit

When the POWER switch on the control unit is pressed, the PSW signal is inverted by Q26 and sent to a flip-flop IC (IC15). This IC outputs a control signal when the PSW goes low. When the power turns on, pin 1 of IC15 outputs a low signal and Q30 turns on. The base of Q28 goes high, Q28 turns on, SB SW (Q27) turns on and power (SB) is supplied to the set.

This circuit has an over-voltage protection circuit. If a DC voltage of 20V or higher is applied to the power cable, D34 turns on and a voltage is applied to the base of Q31. This voltage turns Q31 on and turns Q28 and SBSW off. This circuit has a TIMED POWER OFF (TOF) function which can be programmed by software.

It is controlled through pin 6 of IC7. When the TOF line goes high, Q22 turns on and then Q25 turns on. Pin 6 of IC15 goes high, then pin 1 goes high to turn Q27 off.

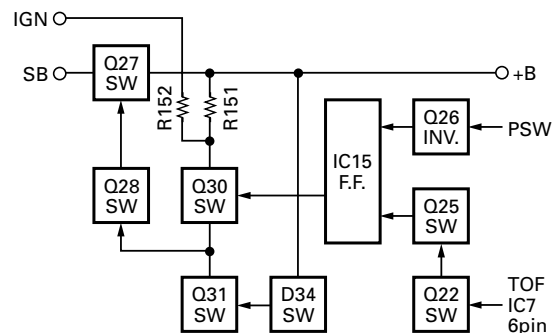

Fig. 16 Power supply circuit

SEMICONDUCTOR DATA

Microprocessor : 30620M8-394GP (TX-RX Unit IC511)

■ Terminal function

Pin No.	Name	I/O	Function
1	LSDOUT	O	Low speed data output.
2	HSDOUT	O	High speed data output.
3	HSDIN	I	High speed data input.
4	DTMSTD	I	DTMF decode IC data detect input.
5	SELF	I	No function.
6	BYTE	I	+5V.
7	CNVSS	I	GND.
8	SFTOE	O	Shift register output enable.
9	LCDCS	O	LCD driver chip select output.
10	RESET	I	Microcomputer reset input.
11	XOUT	-	9.8304MHz (System clock).
12	VSS	-	GND.
13	XIN	-	9.8304MHz (System clock).
14	VCC	-	+5V.
15	IGN	I	Ignition input.
16	AFTRD	I	FFSK modulation data output timing pulse input.
17	AFRTM	I	FFSK demodulation data input timing pulse input.
18	MICDAT	O	MIC key data output.
19	CP	O	PLL IC clock output.
20	BEEP	O	Beep data output.
21	AFRDT	I	FFSK demodulation data input.
22	AFREG1	O	AF IC register switching data output 1.
23	AFREG2	O	AF IC register switching data output 2.
24	EEPDAT	O	EEPROM data output.
25	EN	O	D/A converter IC data strobe output.
26	AFCLR	O	FFSK flame reset output.
27	RXCOM2	I	External hook input / External serial interface input.
28	TXCOM2	I/O	External PTT input / External serial interface output.
29	TXCOM1	O	External serial interface output.
30	RXCOM1	I	External serial interface input.
31	LD	I	PLL unlock detect input.
32	AFMSKE	O	FFSK modulation enable. (Enable active "H")
33	TXD	O	Serial interface output.
34	HOOK	I	Hook input / Serial interface input.
35	AFDAT	O	FFSK data output.
36	RFCLK	O	Common clock output. (TX-RX unit)
37	RDY	-	Not used.
38	ALE	-	Not used.
39	HOLD	-	Not used.
40	HLDA	-	Not used.
41	BLCK	-	Not used.
42	RD	-	Flash memory RD bus.
43	BHE	-	Not used.
44	WR	-	Flash memory WR bus.
45	DTMCLK	O	DTMF decode IC clock output.
46	CNTCLK	O	Common clock output. (Control unit)

Pin No.	Name	I/O	Function
47	EP	O	PLL IC data strobe output.
48	CSO	O	Flash memory chip enable.
49	A19	-	Not used.
50~59	A18~A9	-	Flash memory address bus.
60	VCC	-	+5V.
61	A8	-	Flash memory address bus.
62	VSS	-	GND.
63~70	A7~A0	-	Flash memory address bus.
71~74	KEY1~KEY4	I/O	Key matrix data input/output 1~4.
75	MINDAT	O	Common data output.
76~78	KEY5~KEY7	I	Key matrix data input 5~7.
79~86	D7~D0	-	Flash memory data bus.
87	DTMDAT	I	DTMF decode IC data input.
88	AUXDTC	I	External DTC input.
89	MICBLC	O	MIC back light control output.
90	POWSW	I	Power switch input.
91	ANLSQL	I	Squelch level input.
92	PTT	I	PTT switch input.
93	RSSI	I	Received signal strength indicator input.
94	AVSS	-	GND.
95	LSDIN	I	Low speed data input.
96	VREF	-	+5V.
97	AVCC	-	+5V.
98	ES1	O	Shift register data strobe output. (Control unit)
99	ES2	O	Shift register data strobe output. (TX-RX unit)
100	AFSTB	O	AF IC data strobe output.

Shift Register : BU4094BCFV

■ Terminal function (TX-RX unit IC508)

Pin No.	Port	Name	Function
1	ES	ES1	Strobe
2	DT	DAT	Data
3	CK		Clock
4	Q1	LEDR	Red LED. H : ON, L : OFF
5	Q2	LEDG	Green LED. H : ON, L : OFF
6	Q3	KEYBLT	Key back light. H : ON, L : OFF
7	Q4	MMUTE	MIC mute. H: Mute, L : Unmute
8	VSS		GND
9			NC
10			NC
11	Q8	PA2	Public address control 2. H : ON, L : OFF
12	Q7	BSHIFT	Beat shift. H : ON, L : OFF
13	Q6	KEY	TX power switching. H : TX, L : RX
14	Q5	T/R	TX/RX switching. H : RX, L : TX
15	OE		Output enable
16	VDC		+5V

SEMICONDUCTOR DATA / DESCRIPTION OF COMPONENTS

■ Terminal function (TX-RX unit IC8)

Pin No.	Port	Name	Function
1	STB	ES	Strobe
2	SI	DT	DATA
3	CLK	CK	Clock
4	Q1	AM1	Audio mute 1. H : Mute, L : Unmute
5	Q2	LOK	No function
6	Q3	STR	VCO shift switching. H : TX, L : RX
7	Q4	DM	Dead mute. H : RX, L : TX
8	VSS		GND
9	QS		IC7 data output
10			NC
11	Q8	SQ	No function
12	Q7	CODE2	Option board data 2. H : ON, L : OFF
13	Q6	CODE1	Option board data 1. H : ON, L : OFF
14	Q5	OPT	Option board control. H : ON, L : OFF / Auxiliary B.
15	OE		Output
16	VDC		+5V.

■ Terminal function (TX-RX unit IC7)

Pin No.	Port	Name	Function
1	STB	ES	Strobe
2	SI	DT	Data
3	CLK	CK	Clock
4	Q1	HORN	Horn alert. H : ON, L : OFF / Auxiliary A. H : ON, L : OFF
5	Q2	HL	RF power switching. H : High, L : Low
6	Q3	TIMOFF	Timed power off. H : Power off
7	Q4	CODE3	Option board data 1. H : ON, L : OFF
8	VSS		GND
9			NC
10			NC
11	Q8	W/N	No function
12	Q7		NC
13	Q6	PA1	Public address 1. H : ON, L : OFF
14	Q5	CODE4	Option board data 1. H : ON, L : OFF
15	OE		Output enable
16	VDC		+5V

DESCRIPTION OF COMPONENTS

TX-RX Unit (X57-6152-70) (A/2)

Ref. No.	Use / Function	Operation / Condition
IC1	DC amp	FC, TCXO control
IC2	DET amp	External DEO, internal DEO
IC3	Amp/Summing amp	DI / DI and MO addition
IC4	Analog switch	DI switch
IC5	A/D converter	PC, TV, FC, AFO, BEEP, TO, MO control
IC6	DC amp	PC, TV
IC7	Shift register	HNC, H/L, TOF, CODE3, CODE4, PA control
IC8	Shift register	AM, LOK, STR, DM, OPT, CODE1, CODE2 control
IC9	5V AVR	External 5C
IC10	AF power amp	
IC11	FM IF DET	Quadrature detector, 2nd mixer, OSC, IF amplifier, RSSI
IC12	5V AVR	5C
IC13	9V AVR	9C
IC14	8V AVR	8C
IC15	Flip-flop	Power on/off control
IC200	Mixer	DBM
IC300	PLL	Reference 16.8MHz. PLL lock : LD "H"
IC400	Power module	RF power 25W
IC401	Short protection	
Q1	DC switch	When PTT on CN1 is "H", DI on CN1 is muted
Q2	Ripple filter	8CL
Q3	Ripple filter	9CL
Q4	HOR switch	IGN
Q5	HOR SW control	IGN
Q6	HOR SW control	Active while HNC is "H"
Q7	Buffer amp	HT
Q8	AF mute	Active while AM1 is "H"
Q9	AF mute	Active while power switch is off
Q10	8R SW control	Active while T/R is "H"
Q11	8R switch	Active while Q10 is active
Q12	8T switch	Active while Q13 is active
Q13	8T SW control	Active while KEY is "H"
Q15	IF amp	44.85MHz
Q16	AF switch	No function
Q17	PC switch	Active while TX
Q18	DET mute	Active while KEY is "H"
Q19	APC	APC driver
Q20	APC	APC predriver
Q21	APC control	
Q22	TOF switch	Active while TOF is "H"
Q23,24	W/N switch	No function
Q25	TOF switch	Active while Q22 is on
Q26	Inverter	Active while power switch is "L"

DESCRIPTION OF COMPONENTS

Ref. No.	Use / Function	Operation / Condition
Q27	SB switch	Active while Q28 is on
Q28	SB SW control	Active while Q30 is on, and Q31 is off
Q29	H/L switch	Active while RF power is High
Q30	SB SW control	Active while power switch is on
Q31	SB SW control	Active while power supply voltage is more than 20V
Q32	DET mute	Active while TX
Q201	RF amp	Low noise amplifier
Q202	RF amp	Power module predrive
Q203	Pre IF amp	44.85MHz
Q204,205	RF amp	Power module drive
Q300	Buffer amp	PLL
Q301,302	Active filter	
Q401	Short protection	Power module protection
Q402,403	W/N switch	No function
D1~6	Protection	
D7	HOR protection	
D8,9	Protection	
D11	AF mute	
D12~14	Protection	
D15	HT switch	
D16	Reverse protection	
D17	Protection	
D20	Reverse protection	IGN
D21	Protection	5V (IGN)
D22,23	W/N switch	No function
D24	Over current protection	
D26	Reverse protection	
D27	Power detection	
D28	Protection	
D30	Power detection	
D31	Reverse protection	
D32	Surge absorption	B
D34	Protection	Active while power supply voltage is more than 20V
D35	Charge	DEO
D37	Reverse protection	
D200	Large input protection	
D203~206	BPF tune	
D207	Usable temperature range	
D209	ANT switch	Active while TX
D210,211	ANT switch	
D212~215	BPF tune	

Control Unit (X57-6152-70) (B/2)

Ref. No.	Use / Function	Operation / Condition
IC501	LPF, amplification	LSD
IC502	Amplification	AF, HSD
IC503	Reference voltage/ Buffer amp	ASQ

Ref. No.	Use / Function	Operation / Condition
IC504	Audio processor	Compander, MIC amplifier, ALC, Modem, AF filter, IDC
IC506	Analog switch	MO, DEO, EMG, MI switch
IC507	DTMF decoder	No function
IC508	Shift register	LR, LG, KBLC, MM1, T/R, KEY, BSFT, PA2 output
IC509	Reset	Low voltage output when powering up
IC510	Flash ROM	
IC511	CPU	
IC512	EEPROM	
IC513	5V AVR	5C (Control unit)
IC710	Buffer amp	HSD
IC711	Buffer amp	MIC
Q501	MIC mute	Active while MM is "H" and MM1 is "H"
Q502	AF mute	Active while KEY is "H"
Q503	Noise amp	
Q507	Inverter	PA2 H/L switch
Q508	LED switch (Green)	Active while LG is "H", active while RX
Q509	LED switch (Red)	Active while LR is "H", active while TX
Q510	Clock switch shift	Clock shift is on while BSFT is "H"
Q511	FSW switch	Foot switch is on while FSW is "L"
Q512,513	Key backlight switch	Active while KBLC is "H"
Q515	Keybacklight switch	
D501	Surge absorption	BLC
D502	Over current protection	PSB
D503	Surge absorption	CM
D504	Surge absorption	PTT/TXD
D505	Surge absorption	HOOK/RXD
D507	MIC mute	MM/MM1
D508	Limiter	MIC
D509	Limiter	ASQ
D510	Reverse current protection	C575 charge
D511	BUSY/TX LED	Lights green while busy, red while TX
D512~517	Key backlight	Active while KBLC is "H"
D518	Current regulation	Key backlight
D520	Discharge	Speed up

VCO Unit (X58-4722-70)

Ref. No.	Use / Function	Operation / Condition
Q101	Oscillator	RX
Q102	Inverter	Active while ST is "H", active while TX
Q103	Oscillator	TX
Q104	TX/RX switch	Active while ST is "H", active while TX
Q105	TX/RX switch	Active while Q102 is off
Q106	Buffer amp	
D101	RX VCO	
D102	TX VCO	
D103	RX VCO	
D104	TX VCO	
D105	Modulation	

PARTS LIST

CAPACITORS

CC 45 TH 1H 220 J
 1 2 3 4 5 6

- 1 = Type ... ceramic, electrolytic, etc.
- 2 = Shape ... round, square, ect.
- 3 = Temp. coefficient
- 4 = Voltage rating
- 5 = Value
- 6 = Tolerance

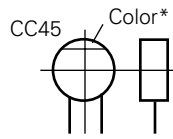

• Capacitor value

- 010 = 1pF
- 100 = 10pF
- 101 = 100pF
- 102 = 1000pF = 0.001μF
- 103 = 0.01μF

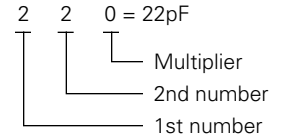

• Temperature coefficient

1st Word	C	L	P	R	S	T	U
Color*	Black	Red	Orange	Yellow	Green	Blue	Violet
ppm/°C	0	-80	-150	-220	-330	-470	-750

2nd Word	G	H	J	K	L
ppm/°C	±30	±60	±120	±250	±500

Example : CC45TH = -470 ± 60ppm/°C

• Tolerance (More than 10pF)

Code	C	D	G	J	K	M	X	Z	P	No code
(%)	±0.25	±0.5	±2	±5	±10	±20	+40 -20	+80 -20	+100 -0	More than 10μF -10 ~ +50 Less than 4.7μF -10 ~ +75

(Less than 10pF)

Code	B	C	D	F	G
(pF)	±0.1	±0.25	±0.5	±1	±2

• Voltage rating

2nd word \ 1st word	A	B	C	D	E	F	G	H	J	K	V
0	1.0	1.25	1.6	2.0	2.5	3.15	4.0	5.0	6.3	8.0	-
1	10	12.5	16	20	25	31.5	40	50	63	80	35
2	100	125	160	200	250	315	400	500	630	800	-
3	1000	1250	1600	2000	2500	3150	4000	5000	6300	8000	-

• Chip capacitors

(EX) C C 7 3 F S L 1 H 0 0 0 J
 1 2 3 4 5 6 7

(Chip) (CH, RH, UJ, SL)

(EX) C K 7 3 F F 1 H 0 0 0 Z
 1 2 3 4 5 6 7

(Chip) (B, F)

Refer to the table above.

- 1 = Type
- 2 = Shape
- 3 = Dimension
- 4 = Temp. coefficient
- 5 = Voltage rating
- 6 = Value
- 7 = Tolerance

Dimension (Chip capacitors)

Dimension code	L	W	T
Empty	5.6 ± 0.5	5.0 ± 0.5	Less than 2.0
A	4.5 ± 0.5	3.2 ± 0.4	Less than 2.0
B	4.5 ± 0.5	2.0 ± 0.3	Less than 2.0
C	4.5 ± 0.5	1.25 ± 0.2	Less than 1.25
D	3.2 ± 0.4	2.5 ± 0.3	Less than 1.5
E	3.2 ± 0.2	1.6 ± 0.2	Less than 1.25
F	2.0 ± 0.3	1.25 ± 0.2	Less than 1.25
G	1.6 ± 0.2	0.8 ± 0.2	Less than 1.0
H	1.0 ± 0.05	0.5 ± 0.05	0.5 ± 0.05

RESISTORS

• Chip resistor (Carbon)

(EX) R D 7 3 E B 2 B 0 0 0 J
 1 2 3 4 5 6 7

(Chip) (B, F)

• Carbon resistor (Normal type)

(EX) R D 1 4 B B 2 C 0 0 0 J
 1 2 3 4 5 6 7

- 1 = Type ... ceramic, electrolytic, etc.
- 2 = Shape ... round, square, ect.
- 3 = Dimension
- 4 = Temp. coefficient
- 5 = Voltage rating
- 6 = Value
- 7 = Tolerance

Dimension

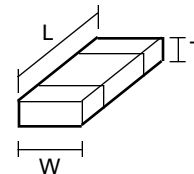

Dimension (Chip resistor)

Dimension code	L	W	T
E	3.2 ± 0.2	1.6 ± 0.2	1.0
F	2.0 ± 0.3	1.25 ± 0.2	1.0
G	1.6 ± 0.2	0.8 ± 0.2	0.5 ± 0.1
H	1.0 ± 0.05	0.5 ± 0.05	0.35 ± 0.05

Rating wattage

Code	Wattage	Code	Wattage	Code	Wattage
1J	1/16W	2C	1/6W	3A	1W
2A	1/10W	2E	1/4W	3D	2W
2B	1/8W	2H	1/2W		

PARTS LIST

*New Parts. ⚠ indicates safety critical components.

Parts without **Parts No.** are not supplied.

Les articles non mentionnés dans le **Parts No.** ne sont pas fournis.

Teile ohne **Parts No.** werden nicht geliefert.

L : Scandinavia

Y : PX (Far East, Hawaii)

Y : AAFES (Europe)

K : USA

T : England

X : Australia

P : Canada

E : Europe

M : Other Areas

TK-885

TX-RX UNIT (X57-6152-70)

Ref. No.	Address	New parts	Parts No.	Description	Destination
TK-885					
1	1A		A01-2165-13	CABINET (UPPER)	
2	2A		A01-2166-13	CABINET (LOWER)	
3	2A		A62-0642-03	PANEL ASSY	
5	1D		B09-0235-05	CAP ACC	
6	2B		B38-0835-05	LCD ASSY	
7	1A,1B		B42-2455-04	STICKER	
8	2D	*	B62-1262-00	INSTRUCTION MANUAL	
9	1C	*	B72-1709-04	MODEL NAME PLATE	
11	1C		E30-3031-15	ANTENNA CABLE	
12	1D		E30-3339-05	DC CORD ACC	
13	1C		E30-3340-05	DC CORD (RADIO)	
14	2B		E37-0789-05	FLAT CABLE (CONT-TX/RX)	
15	1B		E37-0790-25	LEAD WIRE WITH CONNECTOR (SP)	
17	2B		F10-2234-04	SHIELDING COVER (AF,APC)	
18	2B		F10-2280-02	SHIELDING COVER (TX/RX)	
19	1C		F10-2354-03	SHIELDING PLATE (POWER MODULE)	
20	2C		F10-2355-04	SHIELDING COVER (POWER MODULE)	
21	2B		F10-2371-04	SHIELDING COVER (TX/RX)	
22	2C		F12-0462-04	CONDUCTIV SHEET	
23	2B		F20-1192-04	INSULATING SHEET (DISPLAY)	
24	1D		F51-0016-05	FUSE (6*30)	
25	1B,1C		G02-0791-04	FLAT SPRING (AF,APC)	
26	1B		G02-0841-14	FLAT SPRING (TX/RX-CHASSIS)	
28	1B,1C		G10-1221-04	FIBROUS SHEET (CHASSIS)	
29	1B		G10-1222-14	FIBROUS SHEET (CABINET)	
30	1A,2A,2B		G10-1223-14	FIBROUS SHEET (CHASSIS)	
31	1C		G13-1468-04	CUSHION (DC CORD)	
32	1B		G13-1690-04	CUSHION (SPEAKER)	
33	2C		G53-0796-04	PACKING (PHONE JACK)	
35	3D		H10-6618-12	POLYSTYRENE FOAMED FIXTURE	
36	2E		H10-6619-12	POLYSTYRENE FOAMED FIXTURE	
37	1E		H12-1391-03	INNER PACKING CASE	
39	2E		H25-0720-04	PROTECTION BAG (200X350)	
40	3E	*	H52-1572-02	ITEM CARTON CASE	
42	1D		J19-1584-05	MIC HANGER ACC	
43	1D		J29-0627-23	BRACKET ACC	
45	2B		K29-5422-02	KEY TOP	
A	1A,2A		N33-2606-45	OVAL HEAD MACHINE SCREW	
B	2C		N67-3008-46	PAN HEAD SEMS SCREW	
C	2B,1C		N87-2606-46	BRAZIER HEAD TAPTITE SCREW	
D	2B		N87-2612-46	BRAZIER HEAD TAPTITE SCREW	
47	2D		N99-0395-05	SCREW SET	
49	1B		T07-0246-05	SPEAKER	
51	1D		T91-0621-05	MICROPHONE ACC	
TX-RX UNIT (X57-6152-70)					
D511			B30-2151-05	LED (TX/BUSY)	
D512-517			B30-2171-05	LED	
C1-15			CK73GB1H102K	CHIP C 1000PF K	
C16			C92-0507-05	CHIP-TAN 4.7UF 6.3WV	

Ref. No.	Address	New parts	Parts No.	Description	Destination
C17			C92-0628-05	CHIP-TAN 10UF 10WV	
C18			C92-0507-05	CHIP-TAN 4.7UF 6.3WV	
C19			CC73GCH1H100D	CHIP C 10PF D	
C20			CK73GB1E103K	CHIP C 0.010UF K	
C21,22			CK73GB1H102K	CHIP C 1000PF K	
C23			C92-0507-05	CHIP-TAN 4.7UF 6.3WV	
C24			CK73GB1H102K	CHIP C 1000PF K	
C25			C92-0507-05	CHIP-TAN 4.7UF 6.3WV	
C27			CK73GB1H102K	CHIP C 1000PF K	
C28			CC73GCH1H470J	CHIP C 47PF J	
C29			C92-0628-05	CHIP-TAN 10UF 10WV	
C30			CK73GB1H102K	CHIP C 1000PF K	
C31			C92-0628-05	CHIP-TAN 10UF 10WV	
C32			CC73GCH1H220J	CHIP C 22PF J	
C33			CK73GB1E103K	CHIP C 0.010UF K	
C34			C92-0505-05	CHIP-TAN 10UF 16WV	
C35			CK73GB1E103K	CHIP C 0.010UF K	
C36			C92-0628-05	CHIP-TAN 10UF 10WV	
C37			C92-1341-05	ELECTRO 100UF 16WV	
C38			C92-0505-05	CHIP-TAN 10UF 16WV	
C39			CK73GB1E103K	CHIP C 0.010UF K	
C40			CK73GB1H102K	CHIP C 1000PF K	
C41			C92-1341-05	ELECTRO 100UF 16WV	
C42			C92-0546-05	CHIP-TAN 68UF 6.3WV	
C43			CK73GB1E103K	CHIP C 0.010UF K	
C44			CK73GB1H102K	CHIP C 1000PF K	
C45			C92-0507-05	CHIP-TAN 4.7UF 6.3WV	
C46			C92-0004-05	CHIP-TAN 1.0UF 16WV	
C47			CK73GB1H102K	CHIP C 1000PF K	
C48			CK73FF1C105Z	CHIP C 1.0UF Z	
C49			CK73GB1H102K	CHIP C 1000PF K	
C51,52			CK73GB1H102K	CHIP C 1000PF K	
C54			CK73GB1C104K	CHIP C 0.10UF K	
C55			CC73GCH1H020C	CHIP C 2.0PF C	
C56			CK73GB1H471K	CHIP C 470PF K	
C57			CK73GB1E103K	CHIP C 0.010UF K	
C58			CK73GB1H471K	CHIP C 470PF K	
C59			CK73GB1H102K	CHIP C 1000PF K	
C60			CK73GB1H471K	CHIP C 470PF K	
C61			CK73GB1E103K	CHIP C 0.010UF K	
C62			CC73GCH1H020C	CHIP C 2.0PF C	
C63			CK73FB1E103K	CHIP C 0.010UF K	
C64			CK73GB1E103K	CHIP C 0.010UF K	
C65			CK73GB1C104K	CHIP C 0.10UF K	
C66			CC73GCH1H470J	CHIP C 47PF J	
C67			CK73GB1H471K	CHIP C 470PF K	
C68			CK73GB1C104K	CHIP C 0.10UF K	
C69			CC73GCH1H151J	CHIP C 150PF J	
C70			C92-0719-05	ELECTRO 47UF 25WV	
C71			CK73GB1C104K	CHIP C 0.10UF K	
C72,73			CK73GB1H102K	CHIP C 1000PF K	
C74			C92-0719-05	ELECTRO 47UF 25WV	
C75			C92-0044-05	CHIP-ELE 47UF 10WV	
C76			CK73GB1H102K	CHIP C 1000PF K	
C77			C92-0719-05	ELECTRO 47UF 25WV	

PARTS LIST

TX-RX UNIT (X57-6152-70)

Ref. No.	Address	New parts	Parts No.	Description	Desti-nation	Ref. No.	Address	New parts	Parts No.	Description	Desti-nation
C78			CK73GB1E103K	CHIP C 0.010UF K		C156,157			CK73GB1E103K	CHIP C 0.010UF K	
C79			C92-0722-05	ELECTRO 470UF 25WV		C158,159			CC73GCH1H050C	CHIP C 5.0PF C	
C80			CK73GB1C104K	CHIP C 0.10UF K		C160			CK73GB1C104K	CHIP C 0.10UF K	
C84			CC73GCH1H120J	CHIP C 12PF J		C161			CC73GCH1H101J	CHIP C 100PF J	
C88			CK73GB1E103K	CHIP C 0.010UF K		C162			C92-0585-05	CHIP-TAN 4.7UF 16WV	
C89			CK73GB1H471K	CHIP C 470PF K		C164,165			CK73GB1H471K	CHIP C 470PF K	
C90			CK73GB1H102K	CHIP C 1000PF K		C166			CK73GB1C104K	CHIP C 0.10UF K	
C91,92			CK73GB1E103K	CHIP C 0.010UF K		C167			CC73GCH1H100D	CHIP C 10PF D	
C93			CK73GB1H102K	CHIP C 1000PF K		C173			C92-0543-05	CHIP-TAN 3.3UF 10WV	
C94			CK73GB1H471K	CHIP C 470PF K		C174			C92-0038-05	CHIP-ELE 22UF 16WV	
C96			CC73GCH1H180J	CHIP C 18PF J		C175			CK73GB1H102K	CHIP C 1000PF K	
C97			CK73GB1H102K	CHIP C 1000PF K		C176			C92-0712-05	CHIP-TAN 22UF 6.3WV	
C98			CC73GCH1H150J	CHIP C 15PF J		C178,179			CC73GCH1H220J	CHIP C 22PF J	
C99			CK73GB1H102K	CHIP C 1000PF K		C195-198			CK73GB1H102K	CHIP C 1000PF K	
C100			C92-0628-05	CHIP-TAN 10UF 10WV		C200			CK73GB1H102K	CHIP C 1000PF K	
C101			CK73GB1H102K	CHIP C 1000PF K		C204			CC73GCH1H150J	CHIP C 15PF J	
C102			CC73GCH1H270J	CHIP C 27PF J		C205,206			CC73GCH1H101J	CHIP C 100PF J	
C103			CK73GB1C104K	CHIP C 0.10UF K		C207			CK73GB1H471K	CHIP C 470PF K	
C104			CK73GB1E103K	CHIP C 0.010UF K		C209			CC73GCH1H080D	CHIP C 8.0PF D	
C105,106			C92-0516-05	CHIP-TAN 4.7UF 16WV		C211,212			CK73GB1H471K	CHIP C 470PF K	
C107			C92-0628-05	CHIP-TAN 10UF 10WV		C214,215			CK73GB1H471K	CHIP C 470PF K	
C108			CK73GB1C104K	CHIP C 0.10UF K		C216			CK73GB1E103K	CHIP C 0.010UF K	
C109			CK73GB1H471K	CHIP C 470PF K		C217			CK73GB1H102K	CHIP C 1000PF K	
C111,112			CK73GB1H471K	CHIP C 470PF K		C218			CC73GCH1H150J	CHIP C 15PF J	
C113			CK73GB1E103K	CHIP C 0.010UF K		C219			CC73GCH1H391J	CHIP C 390PF J	
C114			C92-0543-05	CHIP-TAN 3.3UF 10WV		C220,221			CK73GB1H471K	CHIP C 470PF K	
C115			CK73GB1H102K	CHIP C 1000PF K		C224			CC73GCH1H020C	CHIP C 2.0PF C	
C116			C92-0712-05	CHIP-TAN 22UF 6.3WV		C225			CK73GB1H471K	CHIP C 470PF K	
C117			CK73GB1E103K	CHIP C 0.010UF K		C227			CK73GB1H471K	CHIP C 470PF K	
C118			CK73GB1C104K	CHIP C 0.10UF K		C229			CK73GB1H471K	CHIP C 470PF K	
C119			C92-0543-05	CHIP-TAN 3.3UF 10WV		C230,231			CK73GB1C104K	CHIP C 0.10UF K	
C120			CK73GB1H102K	CHIP C 1000PF K		C233			CK73GB1E103K	CHIP C 0.010UF K	
C121			C92-0628-05	CHIP-TAN 10UF 10WV		C234			CK73GB1H471K	CHIP C 470PF K	
C123			CK73GB1C104K	CHIP C 0.10UF K		C235			CC73GCH1H020C	CHIP C 2.0PF C	
C124			CK73FB1E103K	CHIP C 0.010UF K		C236			CK73GB1H471K	CHIP C 470PF K	
C125			CK73GB1H471K	CHIP C 470PF K		C239-241			CK73GB1E103K	CHIP C 0.010UF K	
C126			CK73GB1C104K	CHIP C 0.10UF K		C243			CK73GB1E103K	CHIP C 0.010UF K	
C127			CK73GB1E103K	CHIP C 0.010UF K		C244			CK73GB1H471K	CHIP C 470PF K	
C128			CK73FB1H471K	CHIP C 470PF K		C245			CC73GCH1H050C	CHIP C 5.0PF C	
C129			CK73GB1E103K	CHIP C 0.010UF K		C246-250			CK73GB1H471K	CHIP C 470PF K	
C130			CK73GB1H102K	CHIP C 1000PF K		C251			CC73GCH1H070D	CHIP C 7.0PF D	
C131			CK73GB1H471K	CHIP C 470PF K		C252			CK73GB1H471K	CHIP C 470PF K	
C132			CK73GB1C104K	CHIP C 0.10UF K		C253			CK73FF1C105Z	CHIP C 1.0UF Z	
C133			C92-0720-05	ELECTRO 100UF 25WV		C254			CC73FCH1H390J	CHIP C 39PF J	
C134			CK73FB1E224K	CHIP C 0.22UF K		C255,256			CK73GB1H471K	CHIP C 470PF K	
C135			CK73GB1H102K	CHIP C 1000PF K		C257			C92-0719-05	ELECTRO 47UF 25WV	
C136			CK73FB1E224K	CHIP C 0.22UF K		C258			CK73GB1C104K	CHIP C 0.10UF K	
C137			CK73GB1H471K	CHIP C 470PF K		C260			CK73GB1H471K	CHIP C 470PF K	
C138			CC73FCH1HOR5B	CHIP C 0.5PF B		C261			CK73GB1C104K	CHIP C 0.10UF K	
C139			CC73FCH1H020B	CHIP C 2.0PF B		C262			C92-0719-05	ELECTRO 47UF 25WV	
C140-143			CK73GB1H471K	CHIP C 470PF K		C263			CK73GB1H471K	CHIP C 470PF K	
C144			CK73GB1H102K	CHIP C 1000PF K		C264			CK73GB1C104K	CHIP C 0.10UF K	
C145,146			CK73GB1H471K	CHIP C 470PF K		C266			C93-0551-05	CHIP C 1.5PF C	
C147			CC73FCH1HOR5B	CHIP C 0.5PF B		C267			C93-0603-05	CHIP C 1000PF K	
C148			CK73GB1H102K	CHIP C 1000PF K		C268			CC73FCH1H060D	CHIP C 6.0PF D	
C149			CC73FCH1H1R5B	CHIP C 1.5PF B		C269			C93-0556-05	CHIP C 6.0PF D	
C150			CC73GCH1H220J	CHIP C 22PF J		C270			C93-0550-05	CHIP C 1.0PF C	
C151			CK73GB1H102K	CHIP C 1000PF K		C272			C93-0560-05	CHIP C 10PF D	
C153,154			CK73GB1E103K	CHIP C 0.010UF K		C273			C93-0557-05	CHIP C 7.0PF D	
C155			CK73GB1H102K	CHIP C 1000PF K		C274			CC73GCH1H070D	CHIP C 7.0PF D	

PARTS LIST

TX-RX UNIT (X57-6152-70)

Ref. No.	Address	New parts	Parts No.	Description	Destination	Ref. No.	Address	New parts	Parts No.	Description	Destination
C275			CC73GCH1H040C	CHIP C 4.0PF C		C525			CK73GB1H103K	CHIP C 0.010UF K	
C277			CC73GCH1H080D	CHIP C 8.0PF D		C526			CK73GB1C104K	CHIP C 0.10UF K	
C279			CK73GB1E103K	CHIP C 0.010UF K		C527			CK73GB1C683K	CHIP C 0.068UF K	
C281			CC73GCH1H080D	CHIP C 8.0PF D		C528			CK73GB1H102K	CHIP C 1000PF K	
C282,283			CK73GB1H471K	CHIP C 470PF K		C529			CK73GB1H562J	CHIP C 5600PF J	
C284-286			CC73GCH1H101J	CHIP C 100PF J		C531			CK73GB1H562J	CHIP C 5600PF J	
C287			CK73GB1H471K	CHIP C 470PF K		C533			CK73GB1H562J	CHIP C 5600PF J	
C290			CC73GCH1H080D	CHIP C 8.0PF D		C535			CK73GB1H102K	CHIP C 1000PF K	
C292			CM73F2H0R5C	CHIP C 0.5PF C		C536			CC73GCH1H030C	CHIP C 3.0PF K	
C293-295			CC73GCH1H220J	CHIP C 22PF J		C537			CK73GB1H272K	CHIP C 2700PF K	
C296			C92-0555-05	CHIP-TAN 0.047UF 35WV		C539			CK73GB1H272K	CHIP C 2700PF K	
C303			C92-0565-05	CHIP-TAN 6.8UF 10WV		C540			CC73GCH1H271J	CHIP C 270PF J	
C304-306			CK73GB1H102K	CHIP C 1000PF K		C541			CC73GCH1H100D	CHIP C 10PF D	
C307			CC73GCH1H060D	CHIP C 6.0PF D		C542			CC73GCH1H271J	CHIP C 270PF J	
C309			CC73GCH1H120J	CHIP C 12PF J		C543			CK73GB1H272K	CHIP C 2700PF K	
C311			CC73GCH1H060D	CHIP C 6.0PF D		C544			CC73GCH1H030C	CHIP C 3.0PF C	
C312			CC73GCH1H040C	CHIP C 4.0PF C		C545			CK73GB1H102K	CHIP C 1000PF K	
C313			CK73GB1H102K	CHIP C 1000PF K		C546			CK73GB1H122K	CHIP C 1200PF K	
C314			C92-0555-05	CHIP-TAN 0.047UF 35WV		C547			CK73GB1H102K	CHIP C 1000PF K	
C315,316			CK73GB1C104K	CHIP C 0.10UF K		C548			C92-0712-05	CHIP-TAN 22UF 6.3WV	
C317			CK73GB1H102K	CHIP C 1000PF K		C549,550			CK73GB1C104K	CHIP C 0.10UF K	
C318,319			CK73GB1C104K	CHIP C 0.10UF K		C552			CK73GB1C333K	CHIP C 0.033UF K	
C320			C92-0004-05	CHIP-TAN 1.0UF 16WV		C553			CK73GB1H472K	CHIP C 4700PF K	
C321			CC73GCH1H060D	CHIP C 6.0PF D		C554-558			CK73GB1C104K	CHIP C 0.10UF K	
C322			C92-0004-05	CHIP-TAN 1.0UF 16WV		C559			CK73GB1H102K	CHIP C 1000PF K	
C325			C92-0002-05	CHIP-TAN 0.22UF 35WV		C560			C92-0507-05	CHIP-TAN 4.7UF 6.3WV	
C326			CK73FB1C154K	CHIP C 0.15UF K		C561			CK73GB1H102K	CHIP C 1000PF K	
C330,331			CC73GCH1H1R5C	CHIP C 1.5PF C		C562,563			CK73GB1H472K	CHIP C 4700PF K	
C405-407			CC73GCH1H220J	CHIP C 22PF J		C564			CK73GB1E223K	CHIP C 0.022UF K	
C409			CC73GCH1H220J	CHIP C 22PF J		C565			CK73GB1H102K	CHIP C 1000PF K	
C414			CK73GB1H471K	CHIP C 470PF K		C566			CC73GCH1H101J	CHIP C 100PF J	
C419			CC73GCH1H220J	CHIP C 22PF J		C567			CK73GB1E223K	CHIP C 0.022UF K	
C422			CK73GB1H102K	CHIP C 1000PF K		C568			C92-0712-05	CHIP-TAN 22UF 6.3WV	
C423			C92-0628-05	CHIP-TAN 10UF 10WV		C569			CC73GCH1H470J	CHIP C 47PF J	
C429			C92-0628-05	CHIP-TAN 10UF 10WV		C570,571			CK73GB1C104K	CHIP C 0.10UF K	
C430,431			CC73GCH1H220J	CHIP C 22PF J		C572			CK73FB1H563K	CHIP C 0.056UF K	
C435			CC73FCH1H220J	CHIP C 22PF J		C574			CK73GB1C104K	CHIP C 0.10UF K	
C442-448			CC73GCH1H220J	CHIP C 22PF J		C575			CK73FB1C334K	CHIP C 0.33UF K	
C455			C92-0628-05	CHIP-TAN 10UF 10WV		C576			CK73GB1C473K	CHIP C 0.047UF K	
C456			CE04EW1A101M	ELECTRO 100UF 10WV		C577			CK73GB1C104K	CHIP C 0.10UF K	
C501			CK73GB1H471K	CHIP C 470PF K		C578			CK73GB1H103K	CHIP C 0.010UF K	
C502			CC73GCH1H221J	CHIP C 220PF J		C579			CK73GB1H472K	CHIP C 4700PF K	
C503,504			CK73GB1H471K	CHIP C 470PF K		C580			CK73GB1H102K	CHIP C 1000PF K	
C505			CK73GB1C683K	CHIP C 0.068UF K		C581			CK73GB1H103K	CHIP C 0.010UF K	
C506			CK73GB1E123K	CHIP C 0.012UF K		C582,583			CK73GB1C104K	CHIP C 0.10UF K	
C508			CK73GB1C104K	CHIP C 0.10UF K		C584			CK73GB1H471K	CHIP C 470PF K	
C509			CK73GB1H222K	CHIP C 2200PF K		C592			CK73GB1C104K	CHIP C 0.10UF K	
C510			C92-0507-05	CHIP-TAN 4.7UF 6.3WV		C593			CK73GB1H103K	CHIP C 0.010UF K	
C511			CK73GB1H103K	CHIP C 0.010UF K		C594,595			CC73GCH1H270J	CHIP C 27PF J	
C512			CK73GB1H471K	CHIP C 470PF K		C596			CC73GCH1H680J	CHIP C 68PF J	
C513			CK73GB1H102K	CHIP C 1000PF K		C597			CK73GB1H103K	CHIP C 0.010UF K	
C514			CK73GB1H152K	CHIP C 1500PF K		C598,599			CC73GCH1H101J	CHIP C 100PF J	
C515			CK73GB1C104K	CHIP C 0.10UF K		C600,601			CK73GB1H102K	CHIP C 1000PF K	
C516,517			CK73GB1H103K	CHIP C 0.010UF K		C602			CK73GB1H103K	CHIP C 0.010UF K	
C518			CK73GB1H102K	CHIP C 1000PF K		C603			CK73GB1C104K	CHIP C 0.10UF K	
C519			C92-0507-05	CHIP-TAN 4.7UF 6.3WV		C604			C92-0566-05	CHIP-TAN 10UF 6.3WV	
C520			CC73GCH1H221J	CHIP C 220PF J		C605			CK73GB1C104K	CHIP C 0.10UF K	
C521,522			CK73GB1C104K	CHIP C 0.10UF K		C606			CK73GB1H332K	CHIP C 3300PF K	
C523			CK73GB1H103K	CHIP C 0.010UF K		C607			CK73GB1H103K	CHIP C 0.010UF K	
C524			CK73GB1C104K	CHIP C 0.10UF K		C608			CK73GB1H392K	CHIP C 3900PF K	

PARTS LIST

TX-RX UNIT (X57-6152-70)

Ref. No.	Address	New parts	Parts No.	Description	Desti-nation	Ref. No.	Address	New parts	Parts No.	Description	Desti-nation
C609,610			CK73GB1H103K	CHIP C 0.010UF K		L218			L40-6871-34	SMALL FIXED INDUCTOR (68NH)	
C613			C92-0606-05	CHIP-TAN 4.7UF 10WV		L219			L40-1071-34	SMALL FIXED INDUCTOR (10NH)	
C614			CK73GB1H102K	CHIP C 1000PF K		L220			L34-4478-05	AIR-CORE COIL	
C616			CK73GB1H102K	CHIP C 1000PF K		L221			L34-1195-05	AIR-CORE COIL	
C617			CC73GCH1H101J	CHIP C 100PF J		L222			L34-1052-05	AIR-CORE COIL	
C620			CC73GCH1H101J	CHIP C 100PF J		L223			L34-0908-05	AIR-CORE COIL	
C622,623			CK73GB1H102K	CHIP C 1000PF K		L224			L34-1052-05	AIR-CORE COIL	
C624			CC73GCH1H101J	CHIP C 100PF J		L225			L92-0179-05	FERRITE CHIP	
C625			CK73GB1H102K	CHIP C 1000PF K		L227			L40-1085-54	SMALL FIXED INDUCTOR (100NH)	
C626			CC73GCH1H101J	CHIP C 100PF J		L228			L40-8281-37	SMALL FIXED INDUCTOR (0.820UH)	
C627			CK73GB1H102K	CHIP C 1000PF K		L302			L92-0148-05	FERRITE CHIP	
C628			CC73GCH1H101J	CHIP C 100PF J		L303			L40-2275-34	SMALL FIXED INDUCTOR (22NH)	
C629			CK73GB1C104K	CHIP C 0.10UF K		L305,306			L40-1575-92	SMALL FIXED INDUCTOR (15NH)	
C630			CK73GB1H102K	CHIP C 1000PF K		L400,401			L92-0179-05	FERRITE CHIP	
C631-634			CC73GCH1H101J	CHIP C 100PF J		L501-508			L92-0138-05	FERRITE CHIP	
C710			CK73GB1C104K	CHIP C 0.10UF K		X1			L77-1777-05	TCXO (16.8M)	
C711,712			CK73GB1H222K	CHIP C 2200PF K		X2			L77-1762-05	CRYSTAL RESONATOR (44.395MHZ)	
C713			CK73GB1H102K	CHIP C 1000PF K		X501			L77-1708-05	CRYSTAL RESONATOR (3.579545MHZ)	
C714			CC73GCH1H331J	CHIP C 330PF J		X502			L78-0462-05	RESONATOR (9.8304M/8*2.5)	
C715			CK73GB1H102K	CHIP C 1000PF K		XF1			L71-0572-05	MCF (44.85MHZ ±5K)	
C716			CK73FB1H273K	CHIP C 0.027UF K		CP501			R90-0724-05	MULTI-COMP 1K X4	
C718			C92-0712-05	CHIP-TAN 22UF 6.3WV		R1			RK73GB1J102J	CHIP R 1.0K J 1/16W	
C720			CC73GCH1H470J	CHIP C 47PF J		R2			R92-1252-05	CHIP R 0 OHM	
C721-723			CC73GCH1H221J	CHIP C 220PF J		R3,4			RK73GB1J102J	CHIP R 1.0K J 1/16W	
C724			CK73GB1E123K	CHIP C 0.012UF K		R6,7			R92-1252-05	CHIP R 0 OHM	
C726			CK73GB1C104K	CHIP C 0.10UF K		R8			RK73GB1J102J	CHIP R 1.0K J 1/16W	
CN1			E40-5737-05	PIN ASSY8P		R9			R92-1252-05	CHIP R 0 OHM	
CN2			E40-5738-05	PIN ASSY3P		R10,11			RK73GB1J102J	CHIP R 1.0K J 1/16W	
CN3			E40-3247-05	PIN ASSY3P		R12			R92-1252-05	CHIP R 0 OHM	
CN4			E40-5738-05	PIN ASSY3P		R14			RK73GB1J473J	CHIP R 47K J 1/16W	
CN5			E40-3247-05	PIN ASSY3P		R15			RK73GB1J103J	CHIP R 10K J 1/16W	
CN6			E40-3246-05	PIN ASSY2P		R16			RK73GB1J184J	CHIP R 180K J 1/16W	
CN7			E40-5982-05	FLAT CABLE CONNECTOR		R17,18			R92-1252-05	CHIP R 0 OHM	
CN501			E40-5823-05	FLAT CABLE CONNECTOR		R19			RK73GB1J153J	CHIP R 15K J 1/16W	
CN502			E40-5982-05	FLAT CABLE CONNECTOR		R20			RK73GB1J104J	CHIP R 100K J 1/16W	
J1	2C		E11-0442-05	3.5D PHONE JACK (3P)		R21			RK73GB1J563J	CHIP R 56K J 1/16W	
J501	1B		E08-0877-05	MODULAR JACK		R22			RK73GB1J104J	CHIP R 100K J 1/16W	
-			J31-0543-05	COLLAR (LH-5-1.5)		R23			RK73GB1J184J	CHIP R 180K J 1/16W	
CF1			L72-0372-05	CERAMIC FILTER		R25			RK73GB1J394J	CHIP R 390K J 1/16W	
CF2			L72-0376-05	CERAMIC FILTER		R26			RK73GB1J104J	CHIP R 100K J 1/16W	
L1			L40-1005-34	SMALL FIXED INDUCTOR (10UH)		R27			RK73GB1J473J	CHIP R 47K J 1/16W	
L2			L92-0138-05	FERRITE CHIP		R28			R92-1252-05	CHIP R 0 OHM	
L3			L40-3975-44	SMALL FIXED INDUCTOR (39.0NH)		R29			RK73GB1J220J	CHIP R 22 J 1/16W	
L4			L40-8272-37	SMALL FIXED INDUCTOR (0.082UH)		R30			RK73GB1J224J	CHIP R 220K J 1/16W	
L5			L40-1092-34	SMALL FIXED INDUCTOR		R31			RK73GB1J104J	CHIP R 100K J 1/16W	
L6			L34-4459-05	COIL		R32			RK73GB1J474J	CHIP R 470K J 1/16W	
L7			L40-8281-37	SMALL FIXED INDUCTOR (0.820UH)		R33			RK73GB1J562J	CHIP R 5.6K J 1/16W	
L8			L92-0138-05	FERRITE CHIP		R34			R92-1252-05	CHIP R 0 OHM	
L9			L40-1875-44	SMALL FIXED INDUCTOR (18.0NH)		R35			RK73GB1J223J	CHIP R 22K J 1/16W	
L10			L92-0191-05	FERRITE CHIP		R36			RK73GB1J103J	CHIP R 10K J 1/16W	
L203			L79-1750-05	HELICAL BLOCK		R37			R92-1252-05	CHIP R 0 OHM	
L205			L40-1071-34	SMALL FIXED INDUCTOR (10NH)		R39			RK73GB1J101J	CHIP R 100 J 1/16W	
L206			L40-1571-34	SMALL FIXED INDUCTOR (15NH)		R40			RK73GB1J152J	CHIP R 1.5K J 1/16W	
L207			L79-1750-05	HELICAL BLOCK		R41			RK73GB1J122J	CHIP R 1.2K J 1/16W	
L208			L40-1875-92	SMALL FIXED INDUCTOR (18NH)		R42			RK73GB1J104J	CHIP R 100K J 1/16W	
L210-212			L39-1272-05	TOROIDAL COIL		R44			RK73GB1J154J	CHIP R 150K J 1/16W	
L214			L40-1071-34	SMALL FIXED INDUCTOR (10NH)		R45			RK73GB1J104J	CHIP R 100K J 1/16W	
L216,217			L40-1571-34	SMALL FIXED INDUCTOR (15NH)		R46			RK73GB1J223J	CHIP R 22K J 1/16W	
						R47			RK73GB1J473J	CHIP R 47K J 1/16W	
						R48			RK73GB1J122J	CHIP R 1.2K J 1/16W	

PARTS LIST

TX-RX UNIT (X57-6152-70)

Ref. No.	Address	New parts	Parts No.	Description	Destination	Ref. No.	Address	New parts	Parts No.	Description	Destination
R49			RK73GB1J102J	CHIP R 1.0K J 1/16W		R138			RK73FB2A100J	CHIP R 10 J 1/10W	
R50			RK73GB1J103J	CHIP R 10K J 1/16W		R139			R92-0670-05	CHIP R 0 OHM	
R52			R92-1252-05	CHIP R 0 OHM		R140			R92-1252-05	CHIP R 0 OHM	
R53			RK73GB1J274J	CHIP R 270K J 1/16W		R141			RK73GB1J104J	CHIP R 100K J 1/16W	
R54			RK73GB1J104J	CHIP R 100K J 1/16W		R142			R92-0699-05	CHIP R 10 J 1/2W	
R56			RK73GB1J103J	CHIP R 10K J 1/16W		R143			RK73GB1J102J	CHIP R 1.0K J 1/16W	
R57			RK73GB1J473J	CHIP R 47K J 1/16W		R144			RK73GB1J223J	CHIP R 22K J 1/16W	
R58			RK73GB1J102J	CHIP R 1.0K J 1/16W		R145			RK73GB1J104J	CHIP R 100K J 1/16W	
R59			R92-1252-05	CHIP R 0 OHM		R146			R92-1215-05	CHIP R 470 J 1/2W	
R60			RK73GB1J472J	CHIP R 4.7K J 1/16W		R147			RK73FB2A223J	CHIP R 22K J 1/10W	
R61			RK73GB1J822J	CHIP R 8.2K J 1/16W		R148			RK73FB2A472J	CHIP R 4.7K J 1/10W	
R62			RK73GB1J221J	CHIP R 220 J 1/16W		R149			RK73FB2A103J	CHIP R 10K J 1/10W	
R63			R92-1252-05	CHIP R 0 OHM		R150			R92-0670-05	CHIP R 0 OHM	
R65			R92-1252-05	CHIP R 0 OHM		R151-153			R92-1252-05	CHIP R 0 OHM	
R66			RK73GB1J392J	CHIP R 3.9K J 1/16W		R154			RK73GB1J103J	CHIP R 10K J 1/16W	
R67,68			RK73GB1J101J	CHIP R 100 J 1/16W		R155			RK73GB1J333J	CHIP R 33K J 1/16W	
R69			RK73GB1J222J	CHIP R 2.2K J 1/16W		R156			RK73GB1J471J	CHIP R 470 J 1/16W	
R70-73			R92-1252-05	CHIP R 0 OHM		R157			RK73GB1J101J	CHIP R 100 J 1/16W	
R74			RK73GB1J473J	CHIP R 47K J 1/16W		R158,159			RK73FB2A562J	CHIP R 5.6K J 1/10W	
R75			RK73GB1J221J	CHIP R 220 J 1/16W		R162			RK73GB1J122J	CHIP R 1.2K J 1/16W	
R76			RK73GB1J153J	CHIP R 15K J 1/16W		R163			RK73GB1J104J	CHIP R 100K J 1/16W	
R77			RK73GB1J333J	CHIP R 33K J 1/16W		R164			RK73GB1J474J	CHIP R 470K J 1/16W	
R79			RK73GB1J150J	CHIP R 15 J 1/16W		R165			R92-0670-05	CHIP R 0 OHM	
R80			RK73GB1J473J	CHIP R 47K J 1/16W		R168			R92-1252-05	CHIP R 0 OHM	
R81,82			RK73GB1J561J	CHIP R 560 J 1/16W		R169			RK73GB1J104J	CHIP R 100K J 1/16W	
R83			RK73GB1J150J	CHIP R 15 J 1/16W		R170			R92-1252-05	CHIP R 0 OHM	
R85			RK73GB1J152J	CHIP R 1.5K J 1/16W		R176			R92-0670-05	CHIP R 0 OHM	
R86			R92-1252-05	CHIP R 0 OHM		R181,182			R92-0679-05	CHIP R 0 OHM	
R89			R92-1252-05	CHIP R 0 OHM		R200-202			R92-0670-05	CHIP R 0 OHM	
R90			RK73GB1J2R2J	CHIP R 2.2 J 1/16W		R203			RK73FB2A102J	CHIP R 1.0K J 1/10W	
R91			RK73GB1J472J	CHIP R 4.7K J 1/16W		R204,205			RK73FB2A100J	CHIP R 10 J 1/10W	
R94			R92-1252-05	CHIP R 0 OHM		R206			RK73FB2A102J	CHIP R 1.0K J 1/10W	
R96			RK73GB1J331J	CHIP R 330 J 1/16W		R209,210			RK73GB1J104J	CHIP R 100K J 1/16W	
R97,98			RK73GB1J473J	CHIP R 47K J 1/16W		R211			RK73GB1J332J	CHIP R 3.3K J 1/16W	
R99			RK73GB1J152J	CHIP R 1.5K J 1/16W		R212,213			RK73GB1J102J	CHIP R 1.0K J 1/16W	
R100			RK73GB1J331J	CHIP R 330 J 1/16W		R214			RK73GB1J101J	CHIP R 100 J 1/16W	
R104			R92-1252-05	CHIP R 0 OHM		R215			RK73GB1J100J	CHIP R 10 J 1/16W	
R106			R92-1252-05	CHIP R 0 OHM		R217,218			RK73GB1J104J	CHIP R 100K J 1/16W	
R107			RK73GB1J473J	CHIP R 47K J 1/16W		R220			RK73GB1J271J	CHIP R 270 J 1/16W	
R109			R92-0670-05	CHIP R 0 OHM		R221			RK73GB1J222J	CHIP R 2.2K J 1/16W	
R110			RK73GB1J470J	CHIP R 47 J 1/16W		R223			RK73GB1J102J	CHIP R 1.0K J 1/16W	
R111,112			RK73GB1J472J	CHIP R 4.7K J 1/16W		R224,225			R92-1252-05	CHIP R 0 OHM	
R113			R92-1252-05	CHIP R 0 OHM		R226			RK73GB1J682J	CHIP R 6.8K J 1/16W	
R114			RK73GB1J392J	CHIP R 3.9K J 1/16W		R227			R92-1252-05	CHIP R 0 OHM	
R115			R92-1252-05	CHIP R 0 OHM		R228			RK73GB1J102J	CHIP R 1.0K J 1/16W	
R116			RK73GB1J473J	CHIP R 47K J 1/16W		R230			RK73GB1J682J	CHIP R 6.8K J 1/16W	
R119			RK73GB1J103J	CHIP R 10K J 1/16W		R231			RK73GB1J103J	CHIP R 10K J 1/16W	
R120			RK73GB1J392J	CHIP R 3.9K J 1/16W		R232			R92-1252-05	CHIP R 0 OHM	
R121,122			RK73GB1J472J	CHIP R 4.7K J 1/16W		R233			RK73GB1J470J	CHIP R 47 J 1/16W	
R123			RK73GB1J153J	CHIP R 15K J 1/16W		R234			RK73GB1J150J	CHIP R 15 J 1/16W	
R124-126			RK73GB1J223J	CHIP R 22K J 1/16W		R235			RK73GB1J152J	CHIP R 1.5K J 1/16W	
R127			RK73FB2A273J	CHIP R 27K J 1/10W		R236			RK73GB1J101J	CHIP R 100 J 1/16W	
R128			RK73GB1J223J	CHIP R 22K J 1/16W		R237			RK73GB1J471J	CHIP R 470 J 1/16W	
R129			RK73GB1J100J	CHIP R 10 J 1/16W		R238			RK73GB1J221J	CHIP R 220 J 1/16W	
R130,131			RK73GB1J223J	CHIP R 22K J 1/16W		R239			RK73GB1J100J	CHIP R 10 J 1/16W	
R132			RK73GB1J104J	CHIP R 100K J 1/16W		R240			RK73GB1J222J	CHIP R 2.2K J 1/16W	
R133			RK73GB1J153J	CHIP R 15K J 1/16W		R241			RK73GB1J100J	CHIP R 10 J 1/16W	
R134			RK73GB1J473J	CHIP R 47K J 1/16W		R242			RK73GB1J681J	CHIP R 680 J 1/16W	
R135			R92-1214-05	CHIP R 120 J 1/2W		R243			RK73GB1J331J	CHIP R 330 J 1/16W	
R137			RK73GB1J473J	CHIP R 47K J 1/16W		R244			RK73GB1J152J	CHIP R 1.5K J 1/16W	

PARTS LIST

TX-RX UNIT (X57-6152-70)

Ref. No.	Address	New parts	Parts No.	Description	Desti-nation	Ref. No.	Address	New parts	Parts No.	Description	Desti-nation
R245			R92-0685-05	CHIP R 22 J 1/2W		R524			RN73GH1J274D	CHIP R 270K D 1/16W	
R250			R92-1252-05	CHIP R 0 OHM		R525			RK73GB1J823J	CHIP R 82K J 1/16W	
R251			RK73GB1J474J	CHIP R 470K J 1/16W		R526			RK73GB1J104J	CHIP R 100K J 1/16W	
R255-257			R92-1252-05	CHIP R 0 OHM		R527			RK73GB1J103J	CHIP R 10K J 1/16W	
R258			RK73GB1J222J	CHIP R 2.2K J 1/16W		R528			RK73GB1J153J	CHIP R 15K J 1/16W	
R300			RK73GB1J560J	CHIP R 56 J 1/16W		R529			R92-1252-05	CHIP R 0 OHM	
R301-303			RK73GB1J102J	CHIP R 1.0K J 1/16W		R530			RK73GB1J394J	CHIP R 390K J 1/16W	
R304			R92-1252-05	CHIP R 0 OHM		R531			RK73GB1J473J	CHIP R 47K J 1/16W	
R305			RK73GB1J103J	CHIP R 10K J 1/16W		R532			RK73GB1J394J	CHIP R 390K J 1/16W	
R306			RK73GB1J471J	CHIP R 470 J 1/16W		R533			R92-1252-05	CHIP R 0 OHM	
R307			R92-1252-05	CHIP R 0 OHM		R535			RK73GB1J155J	CHIP R 1.5M J 1/16W	
R308			RK73GB1J101J	CHIP R 100 J 1/16W		R536			RN73GH1J682D	CHIP R 6.8K D 1/16W	
R309			RK73GB1J683J	CHIP R 68K J 1/16W		R537,538			RK73GB1J473J	CHIP R 47K J 1/16W	
R310			RK73GB1J103J	CHIP R 10K J 1/16W		R540			RK73GB1J474J	CHIP R 470K J 1/16W	
R311			RK73GB1J271J	CHIP R 270 J 1/16W		R541			RK73GB1J274J	CHIP R 270K J 1/16W	
R312			RK73GB1J332J	CHIP R 3.3K J 1/16W		R542			RN73GH1J683D	CHIP R 68K D 1/16W	
R313			RK73GB1J103J	CHIP R 10K J 1/16W		R544			RK73GB1J101J	CHIP R 100 J 1/16W	
R314			RK73GB1J273J	CHIP R 27K J 1/16W		R545			RK73GB1J182J	CHIP R 1.8K J 1/16W	
R315			RK73GB1J472J	CHIP R 4.7K J 1/16W		R546			RK73GB1J224J	CHIP R 220K J 1/16W	
R316,317			R92-1252-05	CHIP R 0 OHM		R547			RK73GB1J103J	CHIP R 10K J 1/16W	
R318			RK73GB1J221J	CHIP R 220 J 1/16W		R548			RK73GB1J183J	CHIP R 18K J 1/16W	
R319			RK73GB1J102J	CHIP R 1.0K J 1/16W		R550			RN73GH1J682D	CHIP R 6.8K D 1/16W	
R320			R92-1252-05	CHIP R 0 OHM		R551			RK73GB1J223J	CHIP R 22K J 1/16W	
R400			R92-0670-05	CHIP R 0 OHM		R552			RK73GB1J334J	CHIP R 330K J 1/16W	
R402			R92-0670-05	CHIP R 0 OHM		R553			RK73GB1J102J	CHIP R 1.0K J 1/16W	
R403			R92-1252-05	CHIP R 0 OHM		R554			RK73GB1J332J	CHIP R 3.3K J 1/16W	
R406			RK73GB1J394J	CHIP R 390K J 1/16W		R555			RK73GB1J394J	CHIP R 390K J 1/16W	
R408			R92-1252-05	CHIP R 0 OHM		R556			RK73GB1J223J	CHIP R 22K J 1/16W	
R411			RK73GB1J472J	CHIP R 4.7K J 1/16W		R558			R92-1252-05	CHIP R 0 OHM	
R413			RK73GB1J473J	CHIP R 47K J 1/16W		R562			RK73GB1J273J	CHIP R 27K J 1/16W	
R414			R92-1252-05	CHIP R 0 OHM		R564			R92-1252-05	CHIP R 0 OHM	
R415			RK73GB1J103J	CHIP R 10K J 1/16W		R566			RK73GB1J470J	CHIP R 47 J 1/16W	
R416			RK73GB1J822J	CHIP R 8.2K J 1/16W		R567			RK73GB1J220J	CHIP R 22 J 1/16W	
R417			RK73GB1J122J	CHIP R 1.2K J 1/16W		R568			RK73GB1J473J	CHIP R 47K J 1/16W	
R418			RK73GB1J473J	CHIP R 47K J 1/16W		R569			RK73GB1J333J	CHIP R 33K J 1/16W	
R419			R92-1252-05	CHIP R 0 OHM		R571,572			R92-1252-05	CHIP R 0 OHM	
R420,421			R92-0670-05	CHIP R 0 OHM		R573			RK73GB1J104J	CHIP R 100K J 1/16W	
R422			R92-1252-05	CHIP R 0 OHM		R574			RK73GB1J473J	CHIP R 47K J 1/16W	
R501			RK73GB1J472J	CHIP R 4.7K J 1/16W		R575			RK73GB1J103J	CHIP R 10K J 1/16W	
R502			RK73GB1J184J	CHIP R 180K J 1/16W		R576			RK73GB1J473J	CHIP R 47K J 1/16W	
R503			RK73GB1J223J	CHIP R 22K J 1/16W		R577			RK73GB1J153J	CHIP R 15K J 1/16W	
R504			RK73GB1J184J	CHIP R 180K J 1/16W		R579			R92-1252-05	CHIP R 0 OHM	
R505			RK73GB1J102J	CHIP R 1.0K J 1/16W		R580			RK73GB1J103J	CHIP R 10K J 1/16W	
R506			R92-1252-05	CHIP R 0 OHM		R581			RK73GB1J472J	CHIP R 4.7K J 1/16W	
R507,508			RK73GB1J154J	CHIP R 150K J 1/16W		R582			R92-1252-05	CHIP R 0 OHM	
R509			RK73GB1J103J	CHIP R 10K J 1/16W		R584			R92-1252-05	CHIP R 0 OHM	
R510			RK73GB1J105J	CHIP R 1.0M J 1/16W		R585,586			RK73GB1J473J	CHIP R 47K J 1/16W	
R511			RK73GB1J102J	CHIP R 1.0K J 1/16W		R587			R92-1252-05	CHIP R 0 OHM	
R512			RK73GB1J681J	CHIP R 680 J 1/16W		R588			RK73GB1J473J	CHIP R 47K J 1/16W	
R513			R92-1252-05	CHIP R 0 OHM		R589			R92-1368-05	CHIP R 0 OHM	
R514			RK73GB1J102J	CHIP R 1.0K J 1/16W		R590-600			RK73HB1J102J	CHIP R 1.0K J 1/16W	
R515			RN73GH1J913D	CHIP R 91K D 1/16W		R601-603			R92-1368-05	CHIP R 0 OHM	
R516			RK73GB1J102J	CHIP R 1.0K J 1/16W		R608-610			RK73HB1J102J	CHIP R 1.0K J 1/16W	
R517			RK73GB1J103J	CHIP R 10K J 1/16W		R611			R92-1252-05	CHIP R 0 OHM	
R518			RN73GH1J333D	CHIP R 33K D 1/16W		R612			RK73GB1J224J	CHIP R 220K J 1/16W	
R519			RN73GH1J913D	CHIP R 91K D 1/16W		R613			RK73HB1J102J	CHIP R 1.0K J 1/16W	
R520			RN73GH1J683D	CHIP R 68K D 1/16W		R614			R92-1252-05	CHIP R 0 OHM	
R521			RK73GB1J105J	CHIP R 1.0M J 1/16W		R615			RK73HB1J102J	CHIP R 1.0K J 1/16W	
R522			RN73GH1J913D	CHIP R 91K D 1/16W		R616			RK73GB1J473J	CHIP R 47K J 1/16W	
R523			RK73GB1J154J	CHIP R 150K J 1/16W		R617,618			RK73HB1J102J	CHIP R 1.0K J 1/16W	

PARTS LIST

TX-RX UNIT (X57-6152-70)

Ref. No.	Address	New parts	Parts No.	Description	Destination	Ref. No.	Address	New parts	Parts No.	Description	Destination
R619			R92-1252-05	CHIP R 0 OHM		D1-6			DA204U	DIODE	
R620			RK73HB1J102J	CHIP R 1.0K J 1/16W		D1-6			HSB123	DIODE	
R621			R92-1252-05	CHIP R 0 OHM		D7			02DZ20(Y,Z)	ZENER DIODE	
R622,623			RK73HB1J102J	CHIP R 1.0K J 1/16W		D8,9			DA204U	DIODE	
R624			R92-1252-05	CHIP R 0 OHM		D8,9			HSB123	DIODE	
R625-627			RK73HB1J102J	CHIP R 1.0K J 1/16W		D11			DAN202U	DIODE	
R628,629			R92-1368-05	CHIP R 0 OHM		D12-14			DA204U	DIODE	
R630			RK73HB1J102J	CHIP R 1.0K J 1/16W		D12-14			HSB123	DIODE	
R631			R92-1368-05	CHIP R 0 OHM		D15			DAN235E	DIODE	
R632			RK73HB1J102J	CHIP R 1.0K J 1/16W		D16			1SS355	DIODE	
R633			R92-1368-05	CHIP R 0 OHM		D17			DA204U	DIODE	
R634			RK73HB1J102J	CHIP R 1.0K J 1/16W		D17			HSB123	DIODE	
R635			R92-1368-05	CHIP R 0 OHM		D20			1SS355	DIODE	
R636,637			RK73HB1J102J	CHIP R 1.0K J 1/16W		D21			02DZ5.6(X,Y)	ZENER DIODE	
R638			R92-1368-05	CHIP R 0 OHM		D22,23			DAN235E	DIODE	
R639			RK73HB1J102J	CHIP R 1.0K J 1/16W		D24			MINISMD075-02	VARISTOR	
R640			R92-1368-05	CHIP R 0 OHM		D26			1SS355	DIODE	
R641			RK73HB1J102J	CHIP R 1.0K J 1/16W		D27			HSM88AS	DIODE	
R642			R92-1368-05	CHIP R 0 OHM		D28			02DZ15(X,Y)	ZENER DIODE	
R643			RK73HB1J102J	CHIP R 1.0K J 1/16W		D30			HSM88AS	DIODE	
R644			R92-1368-05	CHIP R 0 OHM		D31			1SS355	DIODE	
R645			RK73GB1J472J	CHIP R 4.7K J 1/16W		D32			22ZR-10D	SURGE ABSORBER	
R646,647			RK73HB1J102J	CHIP R 1.0K J 1/16W		D34			02DZ18(X,Y)	ZENER DIODE	
R649			RK73HB1J102J	CHIP R 1.0K J 1/16W		D35			MA742	DIODE	
R650-652			R92-1368-05	CHIP R 0 OHM		D37			DSA3A1	DIODE	
R653,654			RK73HB1J102J	CHIP R 1.0K J 1/16W		D200			HSM88AS	DIODE	
R655-657			R92-1368-05	CHIP R 0 OHM		D203-206			MA2S377	VARIABLE CAPACITANCE DIODE	
R658			RK73HB1J472J	CHIP R 4.7K J 1/16W		D207			HSB123	DIODE	
R659-666			R92-1368-05	CHIP R 0 OHM		D209			MA4PH633	DIODE	
R667,668			RK73GB1J181J	CHIP R 180 J 1/16W		D210,211			XB15A709	DIODE	
R670			RK73GB1J473J	CHIP R 47K J 1/16W		D212-215			MA2S377	VARIABLE CAPACITANCE DIODE	
R672,673			RK73GB1J473J	CHIP R 47K J 1/16W		D501			DA204U	DIODE	
R674			RK73FB2A222J	CHIP R 2.2K J 1/10W		D501			HSB123	DIODE	
R675			RK73GB1J473J	CHIP R 47K J 1/16W		D502			MINISMD075-02	VARISTOR	
R676			RK73GB1J103J	CHIP R 10K J 1/16W		D503-505			DA204U	DIODE	
R677			RK73GB1J223J	CHIP R 22K J 1/16W		D503-505			HSB123	DIODE	
R678			RK73GB1J103J	CHIP R 10K J 1/16W		D507			DAN202U	DIODE	
R679			RK73FB2A390J	CHIP R 39 J 1/10W		D508,509			MA742	DIODE	
R680			RK73FB2A222J	CHIP R 2.2K J 1/10W		D510			HSC119	DIODE	
R682			RK73GB1J473J	CHIP R 47K J 1/16W		D518			02DZ9.1(X,Y)	ZENER DIODE	
R683			RK73GB1J103J	CHIP R 10K J 1/16W		D520			MA2S111	DIODE	
R701			RK73GB1J102J	CHIP R 1.0K J 1/16W		IC1			TA75W01FU	MOS IC	
R702			RK73GB1J101J	CHIP R 100 J 1/16W		IC2,3			TA75W558FU	MOS IC	
R705,706			RK73GB1J473J	CHIP R 47K J 1/16W		IC4			TC4S66F	MOS IC	
R710,711			RK73GB1J104J	CHIP R 100K J 1/16W		IC5			M62363FP	MOS IC	
R712,713			RK73GB1J473J	CHIP R 47K J 1/16W		IC6			TA75W01FU	MOS IC	
R714			RK73GB1J103J	CHIP R 10K J 1/16W		IC7,8			BU4094BCFV	MOS IC	
R716			RK73GB1J472J	CHIP R 4.7K J 1/16W		IC9			TA78L05F	MOS IC	
R718			RK73GB1J154J	CHIP R 150K J 1/16W		IC10			LA4422	BI-POLAR IC	
R719			RK73GB1J103J	CHIP R 10K J 1/16W		IC11			TA31136FN	MOS IC	
R720			RK73GB1J683J	CHIP R 68K J 1/16W		IC12			TA78L05F	MOS IC	
R721			RK73GB1J334J	CHIP R 330K J 1/16W		IC13			AN8009M	MOS IC	
R722			RK73FB2A680J	CHIP R 68 J 1/10W		IC14			TA7808S	MOS IC	
R723			R92-1252-05	CHIP R 0 OHM		IC15			TC4013BF(N)	MOS IC	
R724			RK73GB1J472J	CHIP R 4.7K J 1/16W		IC200			GN2011(Q)	MOS IC	
R725			RK73GB1J153J	CHIP R 15K J 1/16W		IC300			SA7025DK	MOS IC	
R726			R92-1252-05	CHIP R 0 OHM		IC400	1C		M57729H-22	POWER MODULE	
R727			RK73GB1J472J	CHIP R 4.7K J 1/16W		IC401			NJM2904V	MOS IC	
R730			RK73GB1J472J	CHIP R 4.7K J 1/16W		IC501			TA75W558FU	MOS IC	
VR1			R32-0668-05	SEMI FIXED VARIABLE RESISTOR		IC502			TC75W51FU	MOS IC	

PARTS LIST

TX-RX UNIT (X57-6152-70)
PLL/VCO (X58-4722-70)

Ref. No.	Address	New parts	Parts No.	Description	Destination	Ref. No.	Address	New parts	Parts No.	Description	Destination
IC503			TA75W558FU	MOS IC		PLL/VCO (X58-4722-70)					
IC504			TC35453F	MOS IC		C102			CK73GB1H471K	CHIP C 470PF	K
IC506			BU4066BCFV	MOS IC		C104			CC73GCH1H100D	CHIP C 10PF	D
IC507			LC73872M	MOS IC		C105			CC73GCH1H070B	CHIP C 7.0PF	B
IC508			BU4094BCFV	MOS IC		C107			CC73GCH1H120J	CHIP C 12PF	J
IC509			RH5VL42C	MOS IC		C108			CC73GCH1HR75B	CHIP C 0.75PF	B
IC510			AT29C020-90TI	ROM IC		C110			CC73GCH1H080B	CHIP C 8.0PF	B
IC511			30620M8-394GP	MPU		C111			CC73GCH1H050B	CHIP C 5.0PF	B
IC512			AT2416N10SI2.5	ROM IC		C113			CC73GCH1H0R5B	CHIP C 0.5PF	B
IC513			TA78L05F	MOS IC		C114,115			CC73GCH1H040B	CHIP C 4.0PF	B
IC710,711			TA75S01F	MOS IC		C116			CC73GCH1H060B	CHIP C 6.0PF	B
Q1			2SK1824	FET		C117			CK73GB1H471K	CHIP C 470PF	K
Q2,3			2SC2412K(S)	TRANSISTOR		C118			CC73GCH1H090B	CHIP C 9.0PF	B
Q4			DT1144EK	DIGITAL TRANSISTOR		C119,120			CK73GB1H471K	CHIP C 470PF	K
Q5,6			DTC114EE	DIGITAL TRANSISTOR		C121			CC73GCH1H070B	CHIP C 7.0PF	B
Q7			2SC5110(O)	TRANSISTOR		C122			CC73GCH1H0R5B	CHIP C 0.5PF	B
Q8			DTC363EU	DIGITAL TRANSISTOR		C123			CK73GB1H471K	CHIP C 470PF	K
Q9			DTA114YUA	DIGITAL TRANSISTOR		C124			CC73GCH1HR75B	CHIP C 0.75PF	B
Q10			DT1144EE	DIGITAL TRANSISTOR		C125			CC73GCH1H040B	CHIP C 4.0PF	B
Q11			2SA1362(Y)	TRANSISTOR		C126,127			CK73GB1H471K	CHIP C 470PF	K
Q12			2SB1132(Q,R)	TRANSISTOR		C128			CK73FB1E104K	CHIP C 0.10UF	K
Q13			DTC114EE	DIGITAL TRANSISTOR		C129			CK73GB1H471K	CHIP C 470PF	K
Q15			2SC2059K(P)	TRANSISTOR		TC106			C05-0384-05	CERAMIC TRIMMER CAP (10PF)	
Q16			DTC144EE	DIGITAL TRANSISTOR		TC109			C05-0384-05	CERAMIC TRIMMER CAP (10PF)	
Q17			2SC2412K(S)	TRANSISTOR		CN101			E40-5699-05	PIN ASSY	
Q18			2SK1824	FET		-			F10-2279-04	SHIELDING CASE	
Q19			2SD2394	TRANSISTOR		L101-104			L40-1595-34	SMALL FIXED INDUCTOR (1.5UH)	
Q20			2SB1188(Q)	TRANSISTOR		L105			L40-2278-67	SMALL FIXED INDUCTOR (22NH)	
Q21			FMW1	TRANSISTOR		L106			L40-1878-67	SMALL FIXED INDUCTOR (18NH)	
Q22			DTC114EE	DIGITAL TRANSISTOR		L107,108			L40-1098-76	SMALL FIXED INDUCTOR (1UH)	
Q23			DTA114EE	DIGITAL TRANSISTOR		L109,110			L40-1595-34	SMALL FIXED INDUCTOR (1.5UH)	
Q24			DTC144EE	DIGITAL TRANSISTOR		L111			L33-0751-05	SMALL FIXED INDUCTOR	
Q25,26			DTA114EE	DIGITAL TRANSISTOR		R101,102			RK73GB1J101J	CHIP R 100 J 1/16W	
Q27			2SA1641(S,T)	TRANSISTOR		R103			RK73GB1J104J	CHIP R 100K J 1/16W	
Q28,29			DTC114EE	DIGITAL TRANSISTOR		R104			RK73GB1J101J	CHIP R 100 J 1/16W	
Q30			DTA114EE	DIGITAL TRANSISTOR		R105			RK73GB1J154J	CHIP R 150K J 1/16W	
Q31			DTC114EE	DIGITAL TRANSISTOR		R106			RK73GB1J101J	CHIP R 100 J 1/16W	
Q32			2SK1824	FET		R107-110			RK73GB1J103J	CHIP R 10K J 1/16W	
Q201			2SC3357	TRANSISTOR		R111			RK73GB1J470J	CHIP R 47 J 1/16W	
Q202			2SC4093(R27)	TRANSISTOR		R112			RK73GB1J151J	CHIP R 150 J 1/16W	
Q203,204			2SC3357	TRANSISTOR		R113			RK73GB1J181J	CHIP R 180 J 1/16W	
Q205			2SC2954	TRANSISTOR		R114			RK73GB1J470J	CHIP R 47 J 1/16W	
Q300			2SC4215(Y)	TRANSISTOR		R115			RK73GB1J103J	CHIP R 10K J 1/16W	
Q301,302			2SC3722K(S)	TRANSISTOR		R116			RK73GB1J392J	CHIP R 3.9K J 1/16W	
Q401-403			DTC114EE	DIGITAL TRANSISTOR		R117			RK73GB1J101J	CHIP R 100 J 1/16W	
Q501			DTC314TU	DIGITAL TRANSISTOR		R118-120			R92-1252-05	CHIP R 0 OHM	
Q502			DTC144EE	DIGITAL TRANSISTOR		D101-104			1SV283	VARIABLE CAPACITANCE DIODE	
Q503			2SC4617(S)	TRANSISTOR		D105			1SV214	VARIABLE CAPACITANCE DIODE	
Q507			DTC144EE	DIGITAL TRANSISTOR		Q101			2SK508NV(K52)	FET	
Q508,509			2SC4617(S)	TRANSISTOR		Q102			DTC114EUA	DIGITAL TRANSISTOR	
Q510			2SC4619	TRANSISTOR		Q103			2SK508NV(K52)	FET	
Q511			DTA144WE	DIGITAL TRANSISTOR		Q104,105			2SC4081	TRANSISTOR	
Q512			DTC114EE	DIGITAL TRANSISTOR		Q106			2SC4226(R24)	TRANSISTOR	
Q513			2SC2873(Y)	TRANSISTOR							
Q515			DTC114EE	DIGITAL TRANSISTOR							

EXPLODED VIEW

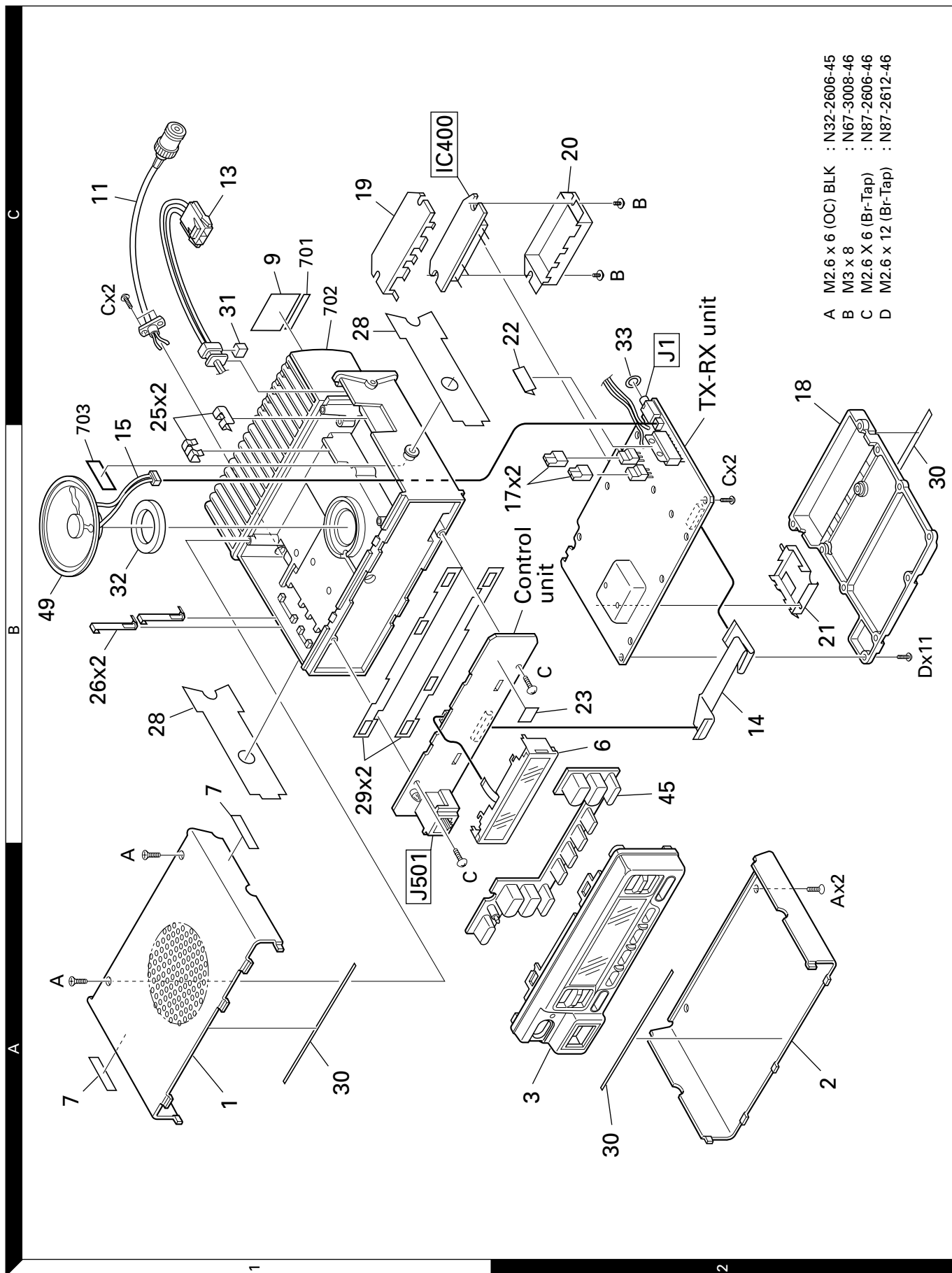

- A M2.6 x 6 (OC) BLK : N32-2606-45
- B M3 x 8 : N67-3008-46
- C M2.6 X 6 (Br-Tap) : N87-2606-46
- D M2.6 x 12 (Br-Tap) : N87-2612-46

PACKING

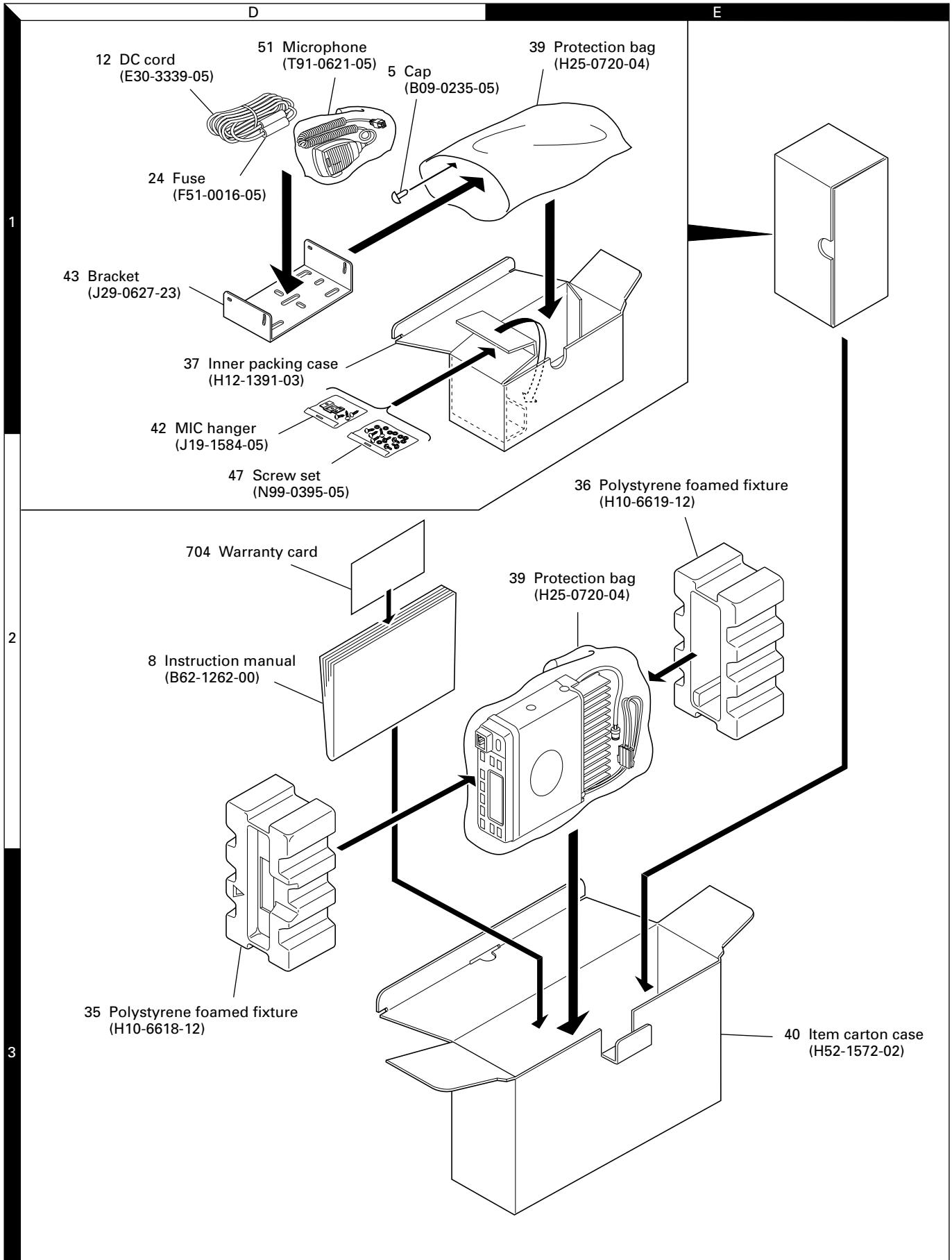

Parts with the exploded numbers larger than 700 are not supplied.

ADJUSTMENT

Test Mode

■ Test Mode Operating Features

This transceiver has a test mode. **To enter test mode, press [B] key and turn power on. Hold [B] key until test channel No. and test signalling No. appears on LCD.**

Test mode can be inhibited by programming. To exit test mode, switch the power on again. The following functions are available in test mode.

• Controls ("FCN" appears)

[PTT]	Used when making a transmission.
[■]	Function off.
[A]	FFSK 1200 bps and 2400 bps.
[B]	Shift off.
[◀C]	Compander function on and off.
[D▶]	Beat shift on and off.
[CALL]	Monitor on and off.
[System Up/Down]	Shift off.
[Volume Up/Down]	Volume up/down.

• Controls ("FCN" not appears)

[PTT]	Used when making a transmission.
[■]	Function off.
[A]	Sets to the tuning mode.
[B]	Shift on.
[◀C]	RF power high and low.
[D▶]	Changes signalling.
[CALL]	Monitor on and off.
[System Up/Down]	Changes channel.
[Volume Up/Down]	Volume up/down.

Note : If a [A], [B], [◀C], [D▶] key is pressed during transmission, the DTMF corresponding to the key that was pressed is sent.

• LCD indicator

"SCN"	Unused
"J"	Lights at compander on.
"AUX"	Unused.
"P"	Lights at RF power low.
"MON"	Lights at monitor on.
"SVC"	Unlock.
"☐"	Lights at FFSK 2400 bps.

• LED indicator

Red LED	Lights during transmission.
Green LED	Lights when there is a carrier.

• Sub LCD indicator

"FCN"	Appears at shift on.
-------	----------------------

■ Frequency and Signalling

The set has been adjusted for the frequencies shown in the following table. When required, re-adjust them following the adjustment procedure to obtain the frequencies you want in actual operation.

• Frequency (MHz)

Channel No.	RX	TX
1	455.05000	455.10000
2	440.05000	440.10000
3	469.95000	469.90000
4	455.00000	455.00000
5	455.20000	455.20000
6	455.40000	455.40000
7~16	-	-

• Signalling

Signalling No.	RX	TX
1	None	None
2	None	100Hz square
3	QT 67.0Hz	QT 67.0Hz
4	QT 151.4Hz	QT 151.4Hz
5	QT 210.7Hz	QT 210.7Hz
6	QT 250.3Hz	QT 250.3Hz
7	DQT 023N	DQT 023N
8	DQT 754I	DQT 754I
9	None	DTMF tone 9
10	None	Single tone 1200Hz (HSD out)
11	None	Single tone 1200Hz (MODEM out)
12	None	Single tone 1800Hz (MODEM out)
13	None	FFSK (PN pattern)
14	FFSK code	FFSK code

■ Preparations for Tuning the Transceiver

Before attempting to tune the transceiver, connect the unit to a suitable power supply.

Whenever the transmitter is turned, the unit must be connected to a suitable dummy load (i.e. power meter).

The speaker output connector must be terminated with a 4Ω dummy load and connected to an AC voltmeter and an audio distortion meter or a SINAD measurement meter at all times during tuning.

■ Transceiver Tuning

(To place transceiver in tuning mode)

Channel appears on LCD. Set channel according to tuning requirements.

LCD display (Test mode)

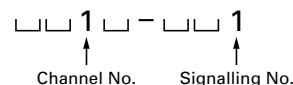

ADJUSTMENT

Press [A], now in tuning mode. Use [◀C] button to write tuning data through tuning modes, and [System Up/Down] to adjust tuning requirements (1 to 256 appears on LCD).

Use [D▶] button to select the adjustment item through tuning modes. Use [B] button to adjust 3 or 5-point tuning.

LCD display (Tuning mode)

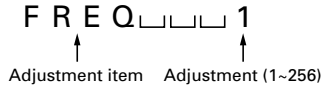

• Panel Tuning Mode (MHz)

Test channel	RX frequency	TX frequency
L	440.05000	440.10000
L2	447.55000	447.60000
C	455.05000	455.10000
H2	462.55000	462.60000
H	469.95000	469.90000

• Tuning flow

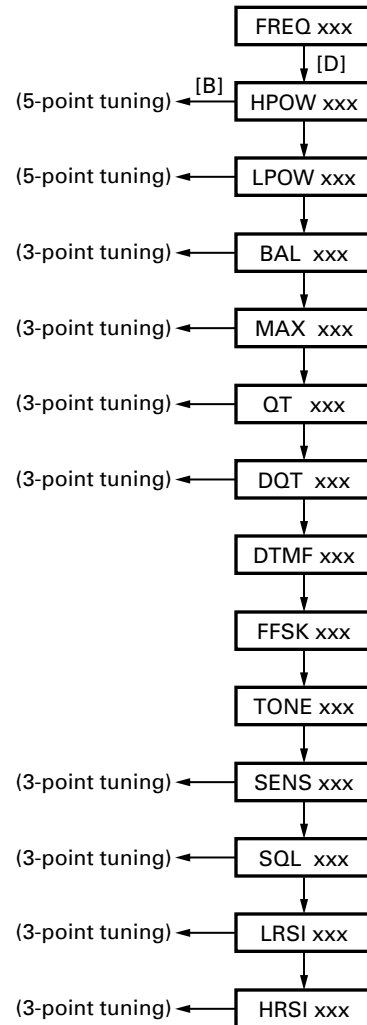

• 5-point tuning (ex. RF power high)

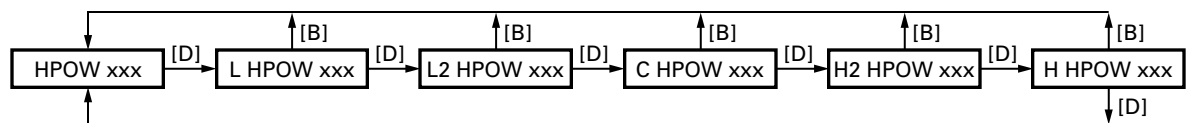

• 3-point tuning (ex. Maximum deviation)

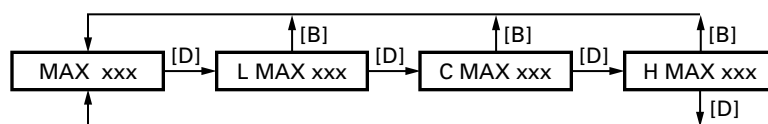

ADJUSTMENT

Test Equipment Required for Alignment

Test Equipment	Major Specifications	
1. Standard Signal Generator (SSG)	Frequency Range Modulation Output	400 to 470MHz Frequency modulation and external modulation -127dBm/0.1μV to greater than -7dBm/100mV
2. Power Meter	Input Impedance Operation Frequency Measurement Capability	50Ω 400 to 470MHz or more Vicinity of 50W
3. Deviation Meter	Frequency Range	400 to 470MHz
4. Digital Volt Meter (DVM)	Measuring Range Accuracy	1 to 20V DC High input impedance for minimum circuit loading
5. Oscilloscope		DC through 30MHz
6. High Sensitivity Frequency Counter	Frequency Range Frequency Stability	10Hz to 1000MHz 0.2ppm or less
7. Ammeter		20A
8. AF Volt Meter (AF VTVM)	Frequency Range Voltage Range	50Hz to 10kHz 1mV to 3V
9. Audio Generator (AG)	Frequency Range Output	20Hz to 20kHz or more 0 to 1V
10. Distortion Meter	Capability Input Level	3% or less at 1kHz 50mV to 10Vrms
11. 4Ω Dummy Load		Approx. 4Ω, 10W
12. Regulated Power Supply		13.6V, approx. 20A (adjustable from 9 to 20V) Useful if ammeter required

Tuning cable (E30-3383-05)

Adapter cable (E30-3383-05) is required for injecting an audio if PC tuning is used. See "PC Mode" section for the connection.

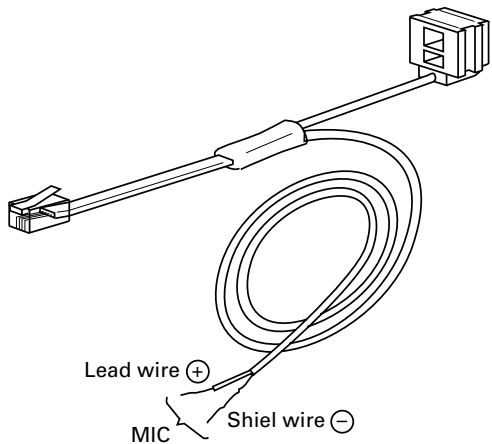

Test cable for microphone input (E30-3360-08)

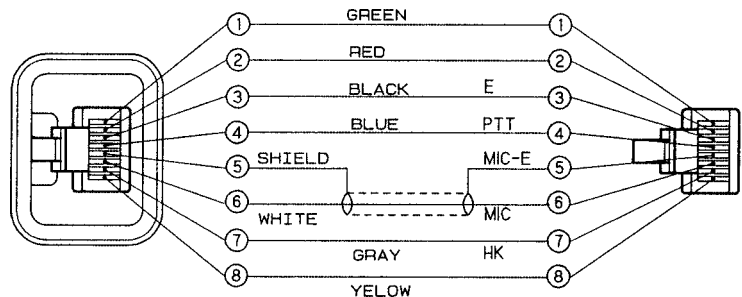

MIC connector (Front view)

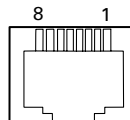

- 1 : BLC
- 2 : PSB
- 3 : E
- 4 : PTT
- 5 : ME
- 6 : MIC
- 7 : HOOK
- 8 : CM

ADJUSTMENT

Adjustment Location

■ Switch

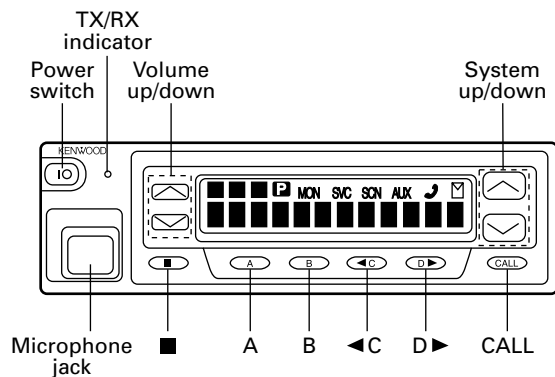

■ Note

• Flash memory

The firmware program (User mode, Test mode, Tuning mode, etc.), the data programmed and security number (MPT serial number) by the FPU (KPG-62D) for the flash memory, is stored in memory. When parts are changed, program the data again.

• EEPROM

The tuning data (Deviation, Squelch, etc.) for the EEPROM, is stored in memory. When parts are changed, readjust the transceiver.

■ Adjustment Point

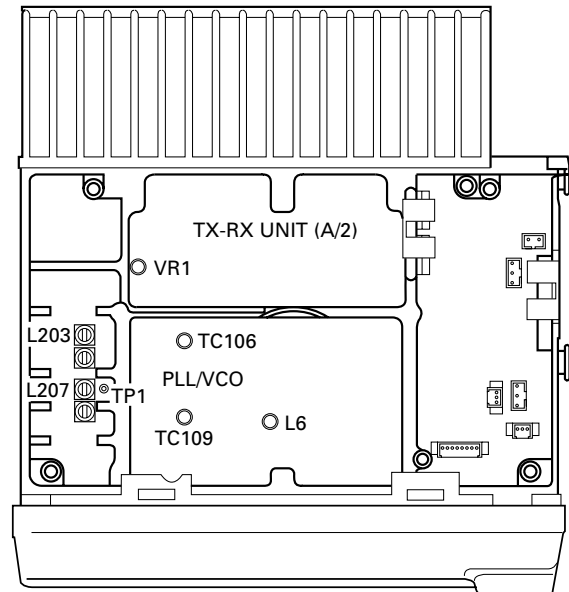

■ Repair Jig (Chassis)

Use jig (Part No. : A10-4010-02) for repairing the TK-885. The jig facilitates the voltage check when the voltage on the component side TX-RX unit is checked during repairs.

Common Section

Item	Condition	Measurement			Adjustment			Specifications/Remarks
		Test-equipment	Unit	Terminal	Unit	Parts	Method	
1. PLL lock voltage	1) Set test mode CH : CH3 - Sig1 PTT : OFF (Receive) PTT : ON (Transmit)	DVM Power meter	TX-RX (A/2)	TP1	PLL	TC106	1.5V (Receive)	±0.1V
	TC109					1.5V (Transmit)		
	2) CH : CH2 - Sig1 PTT : OFF (Receive) PTT : ON (Transmit)						Check	8.0V or less

ADJUSTMENT

Receiver Section

Item	Condition	Measurement			Adjustment			Specifications/Remarks	
		Test-equipment	Unit	Terminal	Unit	Parts	Method		
1. Discriminator	1) Set test mode CH : CH1 - Sig1 SSG output : -53dBm AF : 1.4V/4Ω	SSG AF VTVM Oscilloscope	Rear panel	ANT ACC (EXT.SP)	TX-RX (A/2)	L6	AF output voltage maximum.		
2. Sensitivity	1) Set test mode Select "SENS" in tuning mode. "L SENS" SSG freq' : 440.050MHz SSG output : -118dBm/0.31μV SSG MOD : 1.5kHz AF output : 1V/4Ω	SSG AF VTVM Distortion meter Oscilloscope AG		ANT ACC (EXT.SP)			Adjust for maximum SINAD.		
	2) "C SENS" SSG freq' : 455.050MHz								
	3) "H SENS" SSG freq' : 469.950MHz								
3. Squelch	1) Set test mode Select "L SQL" in tuning mode. SSG freq' : 440.050MHz SSG output : Sensitivity value of 12dB SINAD. SSG MOD : 1.5kHz							Squelch must be closed once. Then adjust for squelch open point.	
	2) "C SQL" SSG freq' : 455.050MHz								
	3) "H SQL" SSG freq' : 469.950MHz								
4. RSSI (Low)	1) Set test mode Select "L LRSI" in tuning mode. SSG freq' : 440.050MHz SSG output : Sensitivity value of 12dB SINAD. SSG MOD : 1.5kHz					Writing values only.			
	2) "C LRSI" SSG freq' : 455.050MHz								
	3) "H LRSI" SSG freq' : 469.950MHz								
5. RSSI (High)	1) Set test mode Select "L HRSI" in tuning mode. SSG freq' : 440.050MHz SSG output : -70dBm SSG MOD : 1.5kHz					Writing values only.			
	2) "C HRSI" SSG freq' : 455.050MHz								
	3) "H HRSI" SSG freq' : 469.950MHz								
6. Squelch check	1) Set test mode CH : CH1 - Sig1 SSG freq' : 455.050MHz SSG output : 15dB SINAD level					Check	Squelch must be opened.		
	2) SSG output : OFF						Squelch must be closed.		

ADJUSTMENT

Item	Condition	Measurement			Adjustment			Specifications/Remarks
		Test-equipment	Unit	Terminal	Unit	Parts	Method	
7. QT check	1) Set test mode CH : CH1 - Sig5 SSG freq' : 455.050MHz SSG MOD INT : 1kHz EXT : 151.4Hz SSG system MOD DEV : ±1.85kHz SSG output : 12dB SINAD level	SSG AF VTVM Distortion meter Oscilloscope AG	Rear panel	ANT ACC (EXT.SP)			Check	Squelch must be opened.
	2) CH : CH1 - Sig4 CH1 - Sig6 CH1 - Sig7							Squelch must be closed.

Transmitter Section

Item	Condition	Measurement			Adjustment			Specifications/Remarks		
		Test-equipment	Unit	Terminal	Unit	Parts	Method			
1. Frequency	1) Set test mode Select "FREQ" in tuning mode. PTT : ON	Power meter F. counter	Rear panel	ANT			Check	455.100MHz±100Hz		
2. Power output	1) Maximum power Set test mode Select "HPOW" in tuning mode. "H HPOW 256" PTT : ON						TX-RX (A/2)	VR1	26.0W	±0.5W
3. High power	1) Set test mode Select "HPOW" in tuning mode. "L HPOW" PTT : ON								25.0W	±1.0W
	2) "L2 HPOW" PTT : ON									
	3) "C HPOW" PTT : ON									
	4) "H2 HPOW" PTT : ON									
	5) "H HPOW" PTT : ON									
4. Low power	1) Set test mode Select "LPOW" in tuning mode. "L LPOW" PTT : ON	Power meter					5.0W	±0.5W		
	2) "L2 LPOW" PTT : ON									
	3) "C LPOW" PTT : ON									
	4) "H2 LPOW" PTT : ON									
	5) "H LPOW" PTT : ON									

ADJUSTMENT

Item	Condition	Measurement			Adjustment			Specifications/Remarks
		Test-equipment	Unit	Terminal	Unit	Parts	Method	
5. Power check	1) Set test mode CH : CH1 - Sig1 CH2 - Sig1 CH3 - Sig1 PTT : ON	Power meter Ammeter		ANT DC IN			Check	25W±1W, 8A or less
6. Modulation balance	1) Set test mode MIC input : OFF Select "BAL" in tuning mode. "L BAL" Deviation meter filter LPF : 15kHz HPF : OFF De-emphasis : OFF	Power meter Deviation meter Oscilloscope AF VTVM AG	Rear panel Front panel	ANT MIC			Make the de-modulation waveform near.	
	2) "C BAL" PTT : ON							
	3) "H BAL" PTT : ON							
7. Maximum deviation	1) Set test mode Connect AG to the MIC terminal. Select "MAX" in tuning mode. "L MAX" AG : 1kHz/40mV Deviation meter filter LPF : 15kHz HPF : OFF De-emphasis : OFF PTT : ON						2.05kHz (According to the larger +, -)	±0Hz, -50Hz
	2) "C MAX" PTT : ON							
	3) "H MAX" PTT : ON							
8. MIC sensitivity check	1) Set test mode CH : CH1 - Sig1 AG : 1kHz/4mV PTT : ON						Check	±1.5kHz±0.05kHz
9. QT deviation	1) Set test mode Select "QT" in tuning mode. "L QT" Deviation meter filter LPF : 3kHz HPF : OFF PTT : ON						0.35kHz	±50Hz
	2) "C QT" PTT : ON							
	3) "H QT" PTT : ON							

ADJUSTMENT

Item	Condition	Measurement			Adjustment			Specifications/Remarks
		Test-equipment	Unit	Terminal	Unit	Parts	Method	
10. DQT deviation	1) Set test mode Select "DQT" in tuning mode. "L DQT" Deviation meter filter LPF : 3kHz HPF : OFF PTT : ON	Power meter Deviation meter Oscilloscope	Rear panel	ANT			0.35kHz	±50Hz
	2) "C DQT" PTT : ON	AF VTVM AG	Front panel	MIC				
	3) "H DQT" PTT : ON							
11. DTMF deviation	1) Set test mode Select "DTMF" in tuning mode. Deviation meter filter LPF : 15kHz HPF : OFF PTT : ON							
12. FFSK deviation	1) Set test mode Select "FFSK" in tuning mode. Deviation meter filter LPF : 15kHz HPF : OFF PTT : ON					1.5kHz	±0.1kHz	
13. TONE deviation	1) Set test mode Select "TONE" in tuning mode. Deviation meter filter LPF : 15kHz HPF : OFF PTT : ON					1.5kHz	±0.1kHz	

PC BOARD VIEWS TK-885

PLL/VCO (X58-4722-70) Component side view

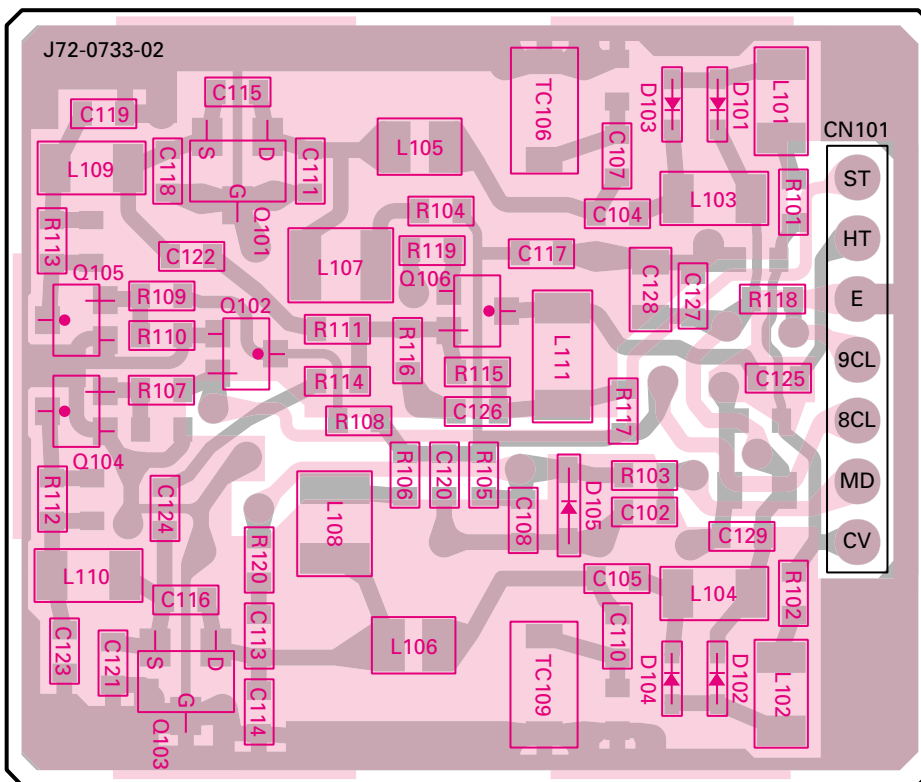

PLL/VCO (X58-4722-70) Foil side view

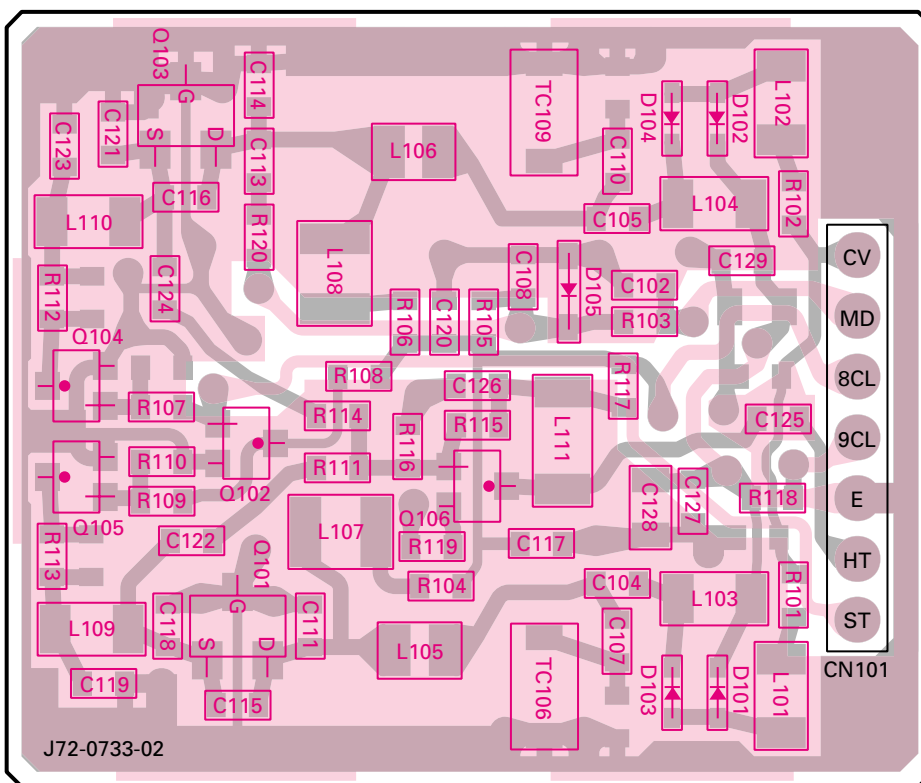

Component side
 Foil side

TK-885 PC BOARD VIEW

TX-RX UNIT (X57-6152-70) (A/2) Component side view

Ref. No.	Address	Ref. No.	Address	Ref. No.	Address	Ref. No.	Address	Ref. No.	Address
IC5	10M	Q6	10S	Q203	13F	D9	12M	D205	11B
IC10	8R	Q8	8O	Q300	9F	D11	9M	D206	11C
IC11	12J	Q10	7M	Q301	11G	D12	12M	D211	5E
IC14	6O	Q13	7M	Q302	11F	D13	13M	D212	8B
IC300	10H	Q16	11J	Q401	7H	D14	12N	D213	9C
IC400	2I	Q17	6G	Q402	10O	D32	4Q	D214	11B
IC401	7G	Q19	4O	Q403	10O	D37	5P	D215	12C
Q4	11R	Q21	7F	D7	10R	D203	9B		
Q5	10R	Q32	11J	D8	13M	D204	9D		

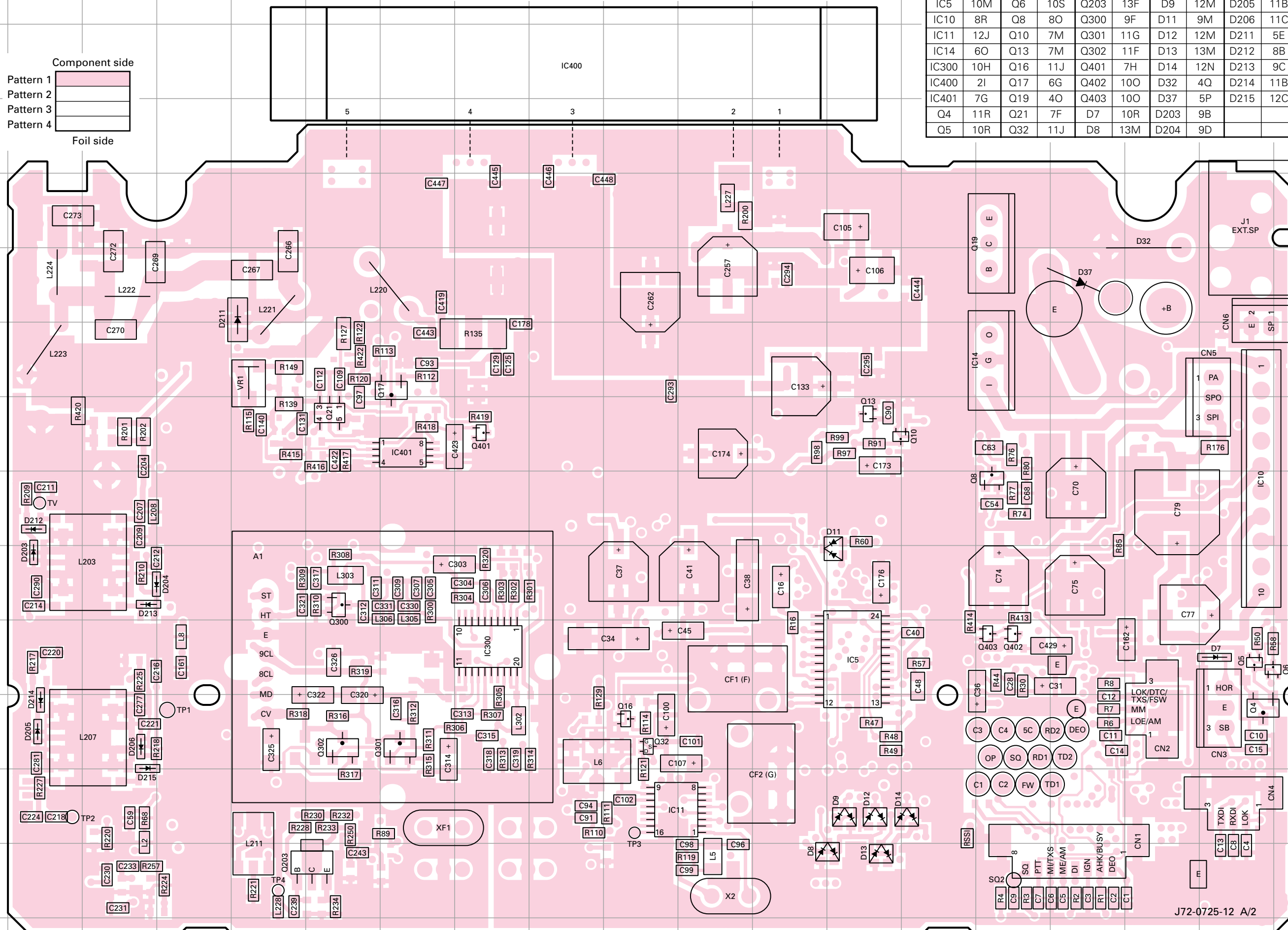
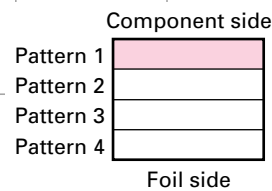

J72-0725-12 A/2

TX-RX UNIT (X57-6152-70) (A/2) Foil side view

Ref. No.	Address	Ref. No.	Address	Ref. No.	Address	Ref. No.	Address	Ref. No.	Address	Ref. No.	Address	Ref. No.	Address
IC1	9M	IC13	6G	Q11	7G	Q26	10C	Q205	7J	D17	13D	D30	6R
IC2	13G	IC15	9C	Q12	7H	Q27	7D	D1	13D	D20	8C	D31	8C
IC3	10E	IC200	12Q	Q15	12K	Q28	7D	D2	13C	D21	8B	D34	8C
IC4	9E	IC400	2K	Q18	11J	Q29	6N	D3	13C	D22	11I	D35	12F
IC6	6M	Q1	8E	Q20	5G	Q30	8D	D4	13C	D23	11H	D200	9R
IC7	9G	Q2	9J	Q22	9C	Q31	8C	D5	13E	D24	7E	D207	7L
IC8	10G	Q3	9I	Q23	10J	Q201	10Q	D6	12C	D26	9B	D209	5N
IC9	8D	Q7	10N	Q24	10J	Q202	7M	D15	11N	D27	6P	D210	6O
IC12	9H	Q9	8B	Q25	9C	Q204	7L	D16	7B	D28	8B		

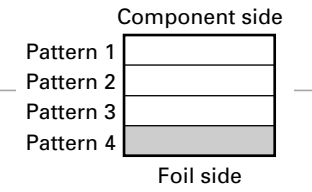

J72-0725-12 A/2

TK-885 PC BOARD VIEW

TX-RX UNIT (X57-6152-70) (A/2) Component side view + Foil side

Ref. No.	Address	Ref. No.	Address	Ref. No.	Address	Ref. No.	Address	Ref. No.	Address	Ref. No.	Address	Ref. No.	Address	Ref. No.	Address
IC1	9G	IC14	6O	Q8	8O	Q22	9Q	Q203	13F	D5	13O	D21	8R	D200	9B
IC2	13M	IC15	9R	Q9	8R	Q23	10J	Q204	7H	D6	12Q	D22	11K	D203	9B
IC3	10O	IC200	12C	Q10	7M	Q24	10J	Q205	7J	D7	10R	D23	11L	D204	9D
IC4	9O	IC300	10H	Q11	7M	Q25	9Q	Q300	9F	D8	13M	D24	7O	D205	11B
IC5	10M	IC400	2I	Q12	7L	Q26	10Q	Q301	11G	D9	12M	D26	9R	D206	11C
IC6	6G	IC401	7G	Q13	7M	Q27	7P	Q302	11F	D11	9M	D27	6D	D207	7H
IC7	9M	Q1	8O	Q15	12I	Q28	7P	Q401	7H	D12	12M	D28	8R	D209	5F
IC8	10M	Q2	9J	Q16	11J	Q29	6F	Q402	10O	D13	13M	D30	6B	D210	6E
IC9	8P	Q3	9K	Q17	6G	Q30	8P	Q403	10O	D14	12N	D31	8Q	D211	5E
IC10	8R	Q4	11R	Q18	11J	Q31	8Q	D1	13P	D15	11F	D32	4Q	D212	8B
IC11	12J	Q5	10R	Q19	4O	Q32	11J	D2	13Q	D16	7R	D34	8Q	D213	9C
IC12	9L	Q6	10S	Q20	5M	Q201	10C	D3	13Q	D17	13P	D35	12N	D214	11B
IC13	6M	Q7	10F	Q21	7F	Q202	7G	D4	13Q	D20	8O	D37	5P	D215	12C

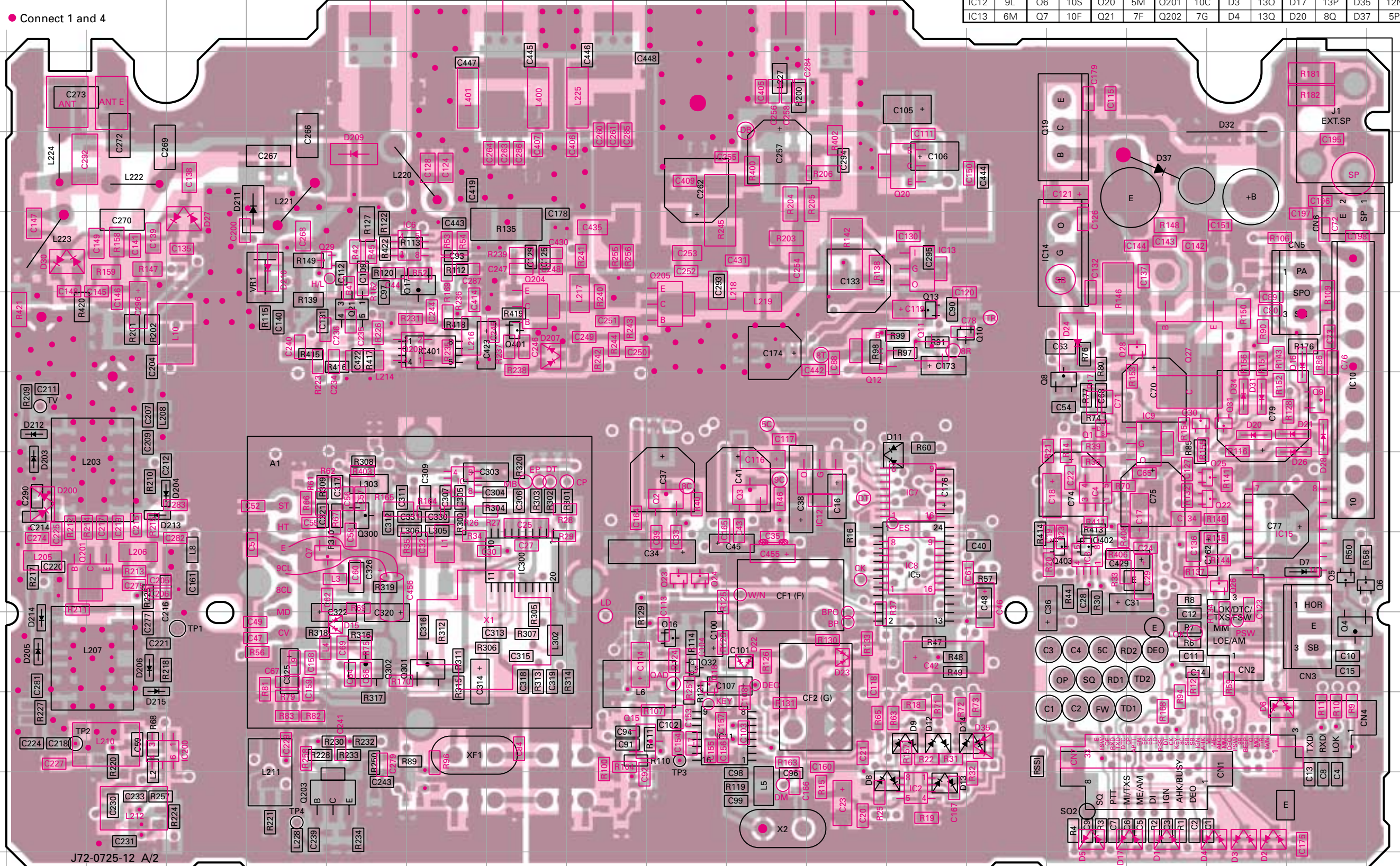
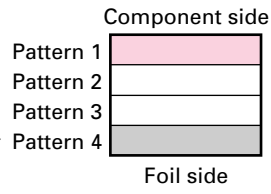

TX-RX UNIT (X57-6152-70) (B/2) Component side view

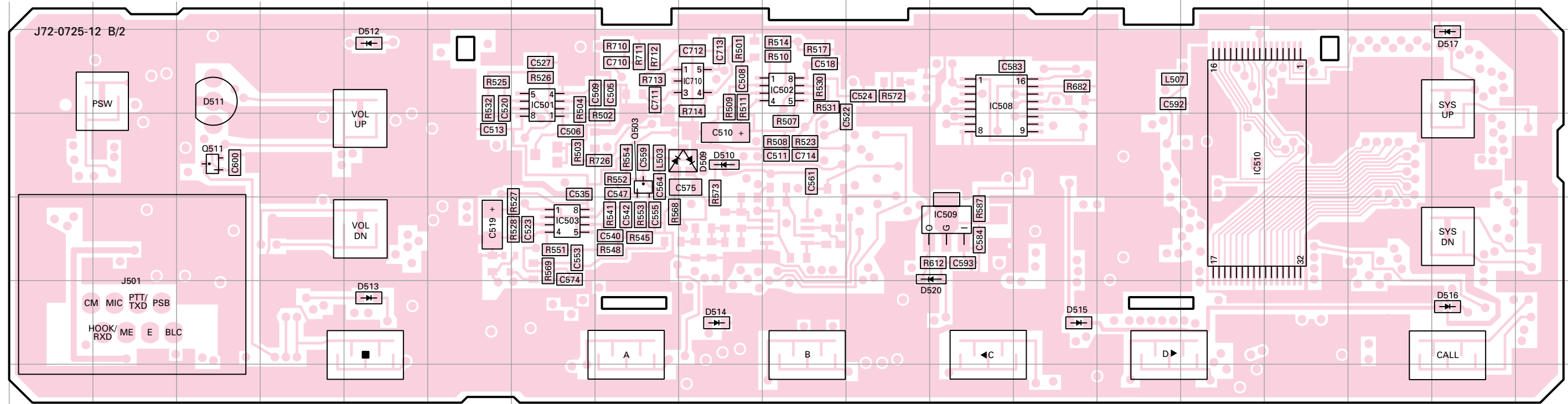

Ref. No.	Address	Ref. No.	Address	Ref. No.	Address	Ref. No.	Address	Ref. No.	Address	Ref. No.	Address
IC501	2G	IC508	2L	IC710	2I	D509	3I	D512	2E	D515	5M
IC502	2J	IC509	4L	Q503	3H	D510	3I	D513	5E	D516	5R
IC503	4G	IC510	3O	Q511	3C	D511	2C	D514	5I	D517	2R

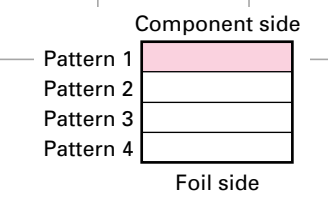

TX-RX UNIT (X57-6152-70) (B/2) Foil side view

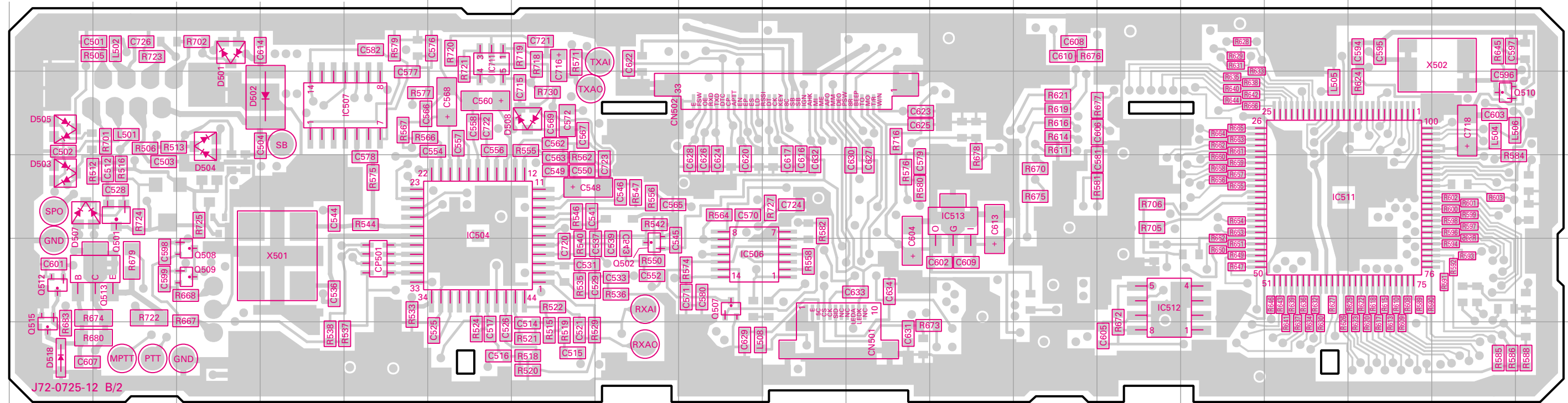

Ref. No.	Address	Ref. No.	Address	Ref. No.	Address	Ref. No.	Address	Ref. No.	Address	Ref. No.	Address
IC504	10F	IC511	10P	IC711	7F	Q507	11I	Q510	9R	Q515	12A
IC506	11I	IC512	11N	Q501	10B	Q508	11C	Q512	11A	D501	8C
IC507	9E	IC513	10L	Q502	11H	Q509	11C	Q513	11B	D502	9D
										D505	9A
										D518	12A

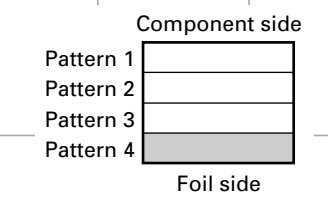

TK-885 PC BOARD VIEW

TX-RX UNIT (X57-6152-70) (B/2) Component side view + Foil side

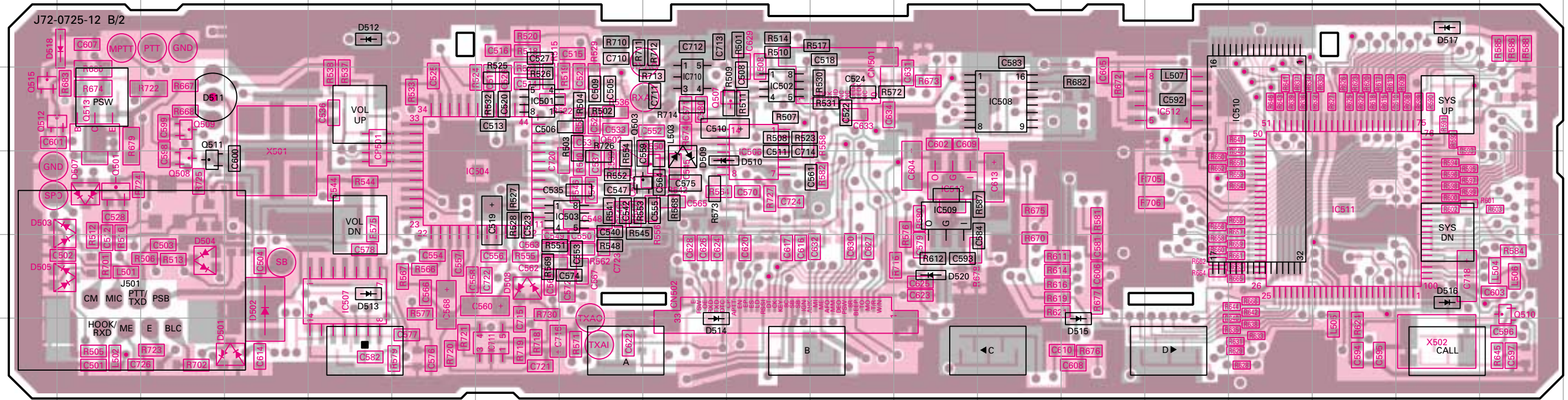

Ref. No.	Address	Ref. No.	Address	Ref. No.	Address	Ref. No.	Address	Ref. No.	Address	Ref. No.	Address	Ref. No.	Address
IC501	3G	IC509	4L	Q501	4B	Q511	4C	D504	5C	D512	2E	D520	5L
IC502	3J	IC510	3P	Q502	4I	Q512	3A	D505	5B	D513	5E		
IC503	4H	IC511	4Q	Q503	4H	Q513	3B	D507	4B	D514	6I		
IC504	4G	IC512	3O	Q507	3J	Q515	3A	D508	5G	D515	6N		
IC506	4J	IC513	4L	Q508	4C	D501	6D	D509	4I	D516	5R		
IC507	5E	IC710	3I	Q509	3C	D502	5D	D510	4J	D517	2R		
IC508	3M	IC711	6G	Q510	5S	D503	4B	D511	3C	D518	2B		

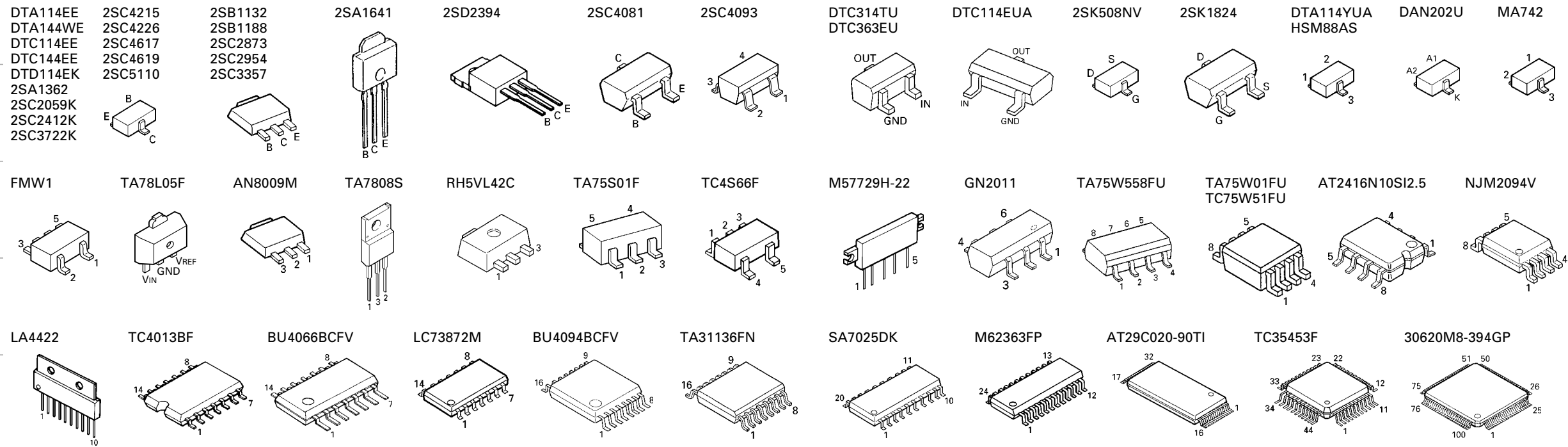
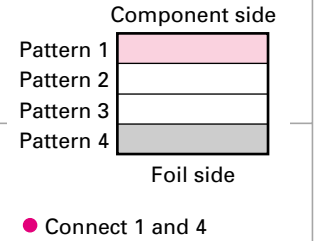

TK-885 SCHEMATIC DIAGRAM

X57-6152-70 CONTROL UNIT

Note: Components marked with a dot (·) are parts of pattern 1.

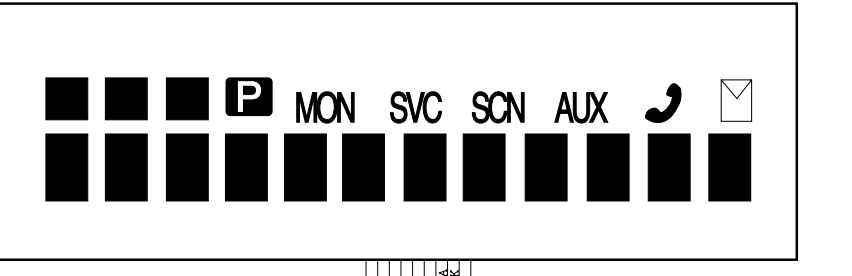
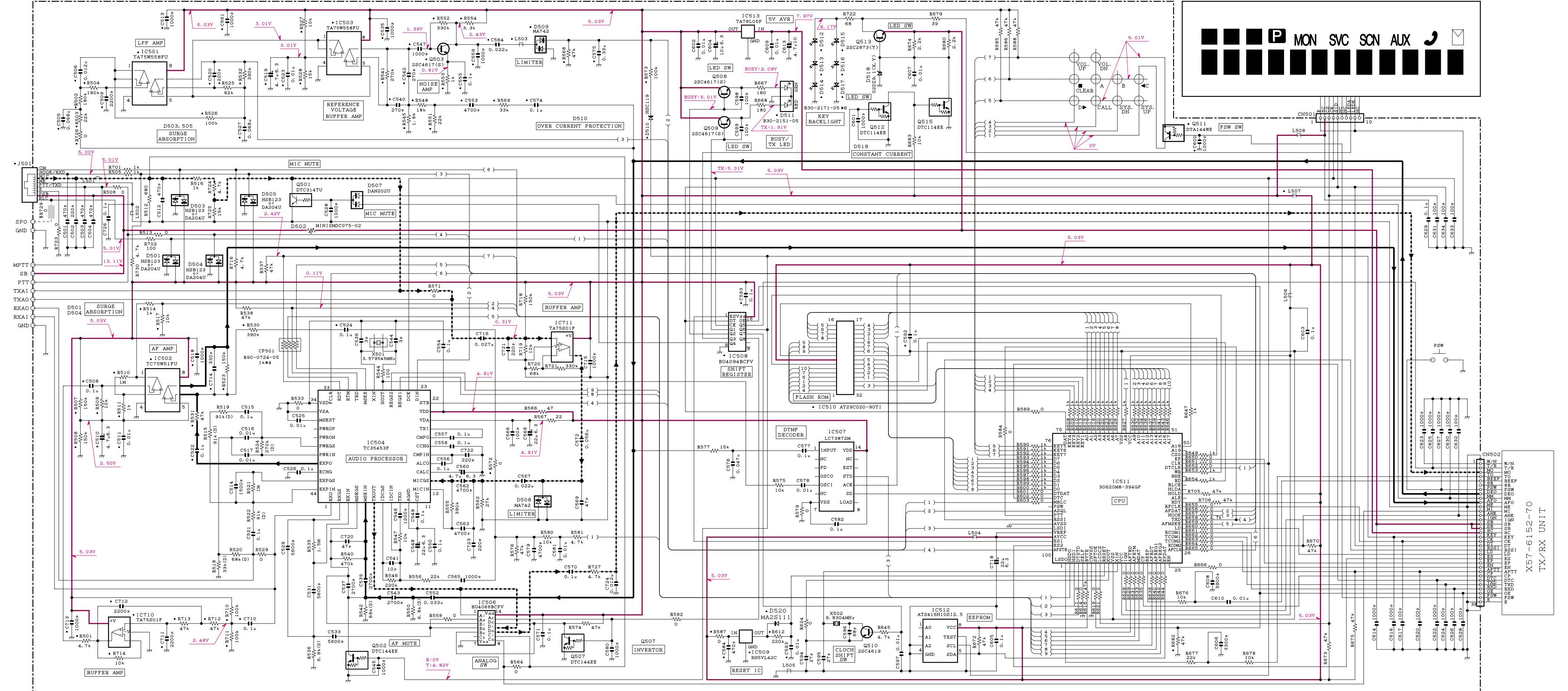

- D501, 503-505 : HSB123 or DA204U
- D507 : DAN202U
- D510 : HSC119
- D512-517 : B30-2171-05
- D520 : MA2S111
- Q501 : DTC314TU
- Q503, 508, 509 : 2SC4617(S)
- Q511 : DTA144WE
- Q513 : 2SC2873(Y)
- IC501, 503 : TA75W58FU
- IC504 : TC35453P
- IC507 : LC73872M
- IC509 : RH5V142C
- IC511 : 30620M8-394GP
- IC513 : TA78L05F
- IC502 : TC75W51FU
- IC506 : BU4066BCFV
- IC508 : BU4094BCFV
- IC510 : AT29C020-90T1
- IC512 : AT2416N10S12.5
- IC710, 711 : TA75S01F
- D502 : MINISMDC075-02
- D508, 509 : MA742
- D511 : B30-2151-05
- D518 : 02DZ9.1(X,Y)
- Q502, 507 : DTC144EE
- Q510 : 2SC4619
- Q512, 515 : DTC114EE

X57-6152-70 TX/RX UNIT

BLOCK DIAGRAM

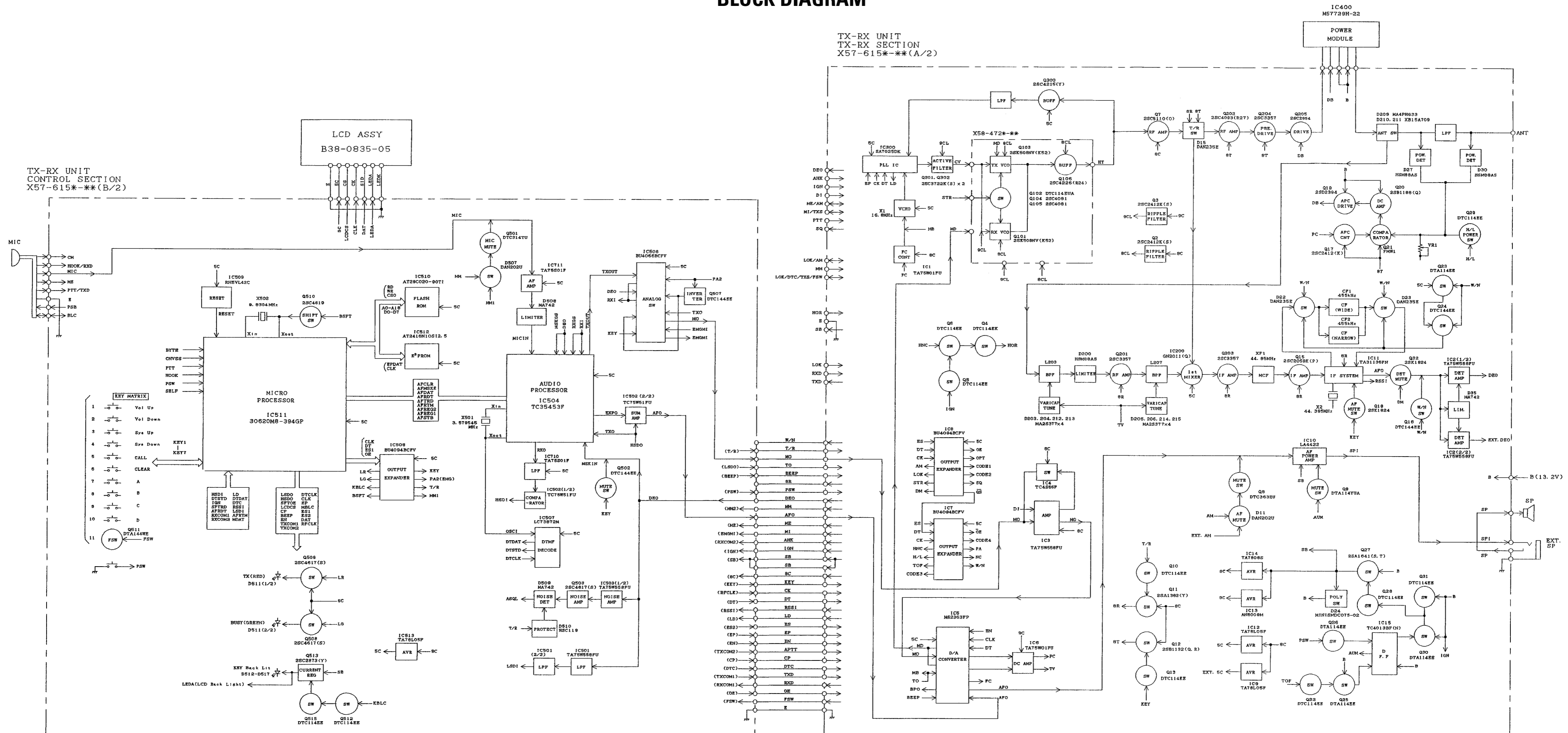

TK-885 TK-885

LEVEL DIAGRAM

Receiver Section

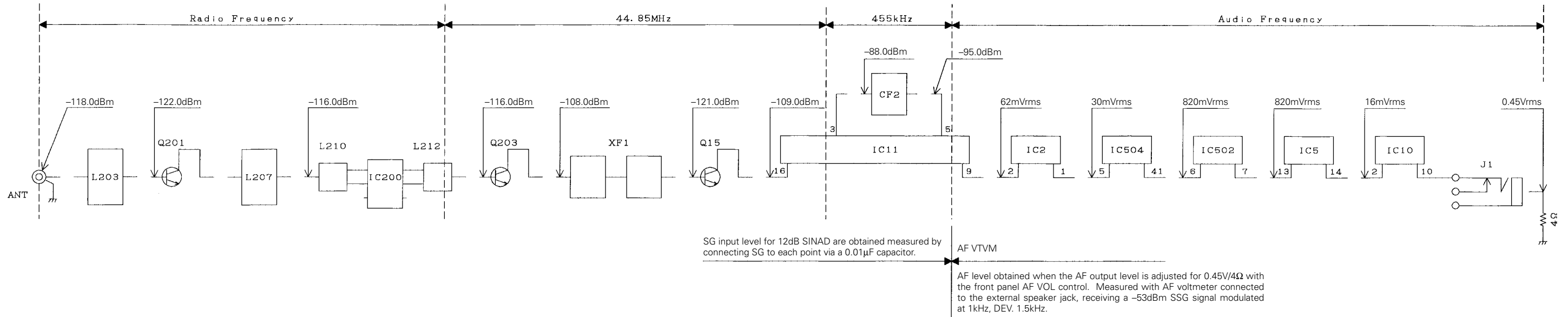

Transmitter Section

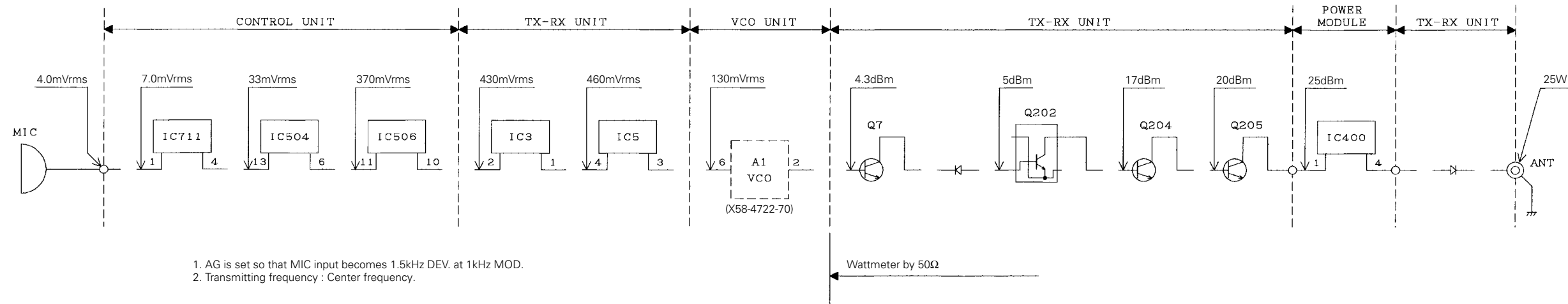

1. AG is set so that MIC input becomes 1.5kHz DEV. at 1kHz MOD.
2. Transmitting frequency : Center frequency.

TERMINAL FUNCTION

CN7 (TX-RX Unit) ↔ CN502 (Control Unit)

Pin No.	Name	Function
1	W/N	No function.
2	T/R	TX/RX switch. H : Receive
3	MO	Modulation signal.
4	TO	Low speed data signal.
5	BEEP	Beep.
6	8R	NC (8V)
7	PSW	Power switch.
8	DEO	Receive signal to control unit.
9	MM	MIC mute. H : MIC mute
10	AFO	Receive signal from control unit.
11	ME	MIC ground.
12	MI	External MIC.
13	AHK	Hook signal. H : Off hook
14	IGN	Ignition signal.
15	SB	13.6V.
16	SB	13.6V.
17	8C	8V.
18	KEY	TX signal.
19	CK	Shift register clock.
20	DT	PLL/Shift register/DA converter data.
21	RSSI	RSSI signal.
22	LD	PLL unlock detection.
23	ES	Shift register enable.
24	EP	PLL enable signal.
25	EN	DA converter enable signal.
26	APTT	No function.
27	CP	PLL clock.
28	DTC	No function.
29	TXD	Serial data
30	RXD	Serial data.
31	OE	Serial data.
32	FSW	Foot switch signal.
33	E	Ground.

CN101 (VCO) ↔ TX-RX Unit

Pin No.	Name	Function
1	ST	Switched transmit input. H : Transmit
2	HT	RF output.
3	E	Ground.
4	9CL	9V input.
5	8CL	8V input.
6	MD	Modulation input.
7	CV	Control voltage input.

CN501 (Control Unit)

Pin No.	Name	Function
1	E	Ground.
2	5C	Logic power (5V).
3	CS	Chip selector signal. L : Option
4	CK	Serial clock signal.
5	SID	Serial data input.
6	(NC)	Unused terminal.
7	(NC)	Unused terminal.
8	LED(A)	LED anode terminal.
9	LED(K)	LED cathode terminal.
10	NC	Unused terminal.

J501 (Control Unit)

Pin No.	Name	Function
1	BLC	MIC key backlight control.
2	PSB	13.6V.
3	E	Ground.
4	PTT/TXD	PTT.
5	ME	MIC ground.
6	MIC	MIC signal input.
7	HOOK/RXD	Hook detection
8	CM	MIC data detection.

SPECIFICATIONS

GENERAL

Frequency Range	450 to 470MHz
Number of Channels	Trunking mode : Maximum 1023 channels Conventional mode : Maximum 32 channels
Channel Spacing	12.5kHz
Input Voltage	13.6V negative ground
Current Drain	0.4A on standby 1.0A on receive 8A on transmit
Temperature Range	-30°C to +60°C (-22°F to +140°F)
Frequency Stability	±2.5ppm from -30°C to +60°C
Dimensions & Weight	140 (5.51) W x 40 (1.58) H x 145 (5.73) D mm (inch), 0.94kg (2.07 lbs)

RECEIVER (Measurements made par EIA standard EIA/TIA 603)

RF Input Impedance	50Ω
Sensitivity	0.35μV
Adjacent Channel Selectivity	67dB
Intermodulation Rejection	65dB
Spurious and Image Rejection	80dB
Audio Power Output	4W at 4Ω less than 10% distortion
Channel Frequency Spread	20MHz

TRANSMITTER (Measurements made par EIA standard EIA/TIA 603)

RF Power Output	25W
Spurious and Harmonics	70dB
Modulation Limiting	±2.5kHz at 12.5kHz
FM Noise	40dB
Microphone Impedance	600Ω
Audio Distortion	Less than 3% at 1000Hz
Channel Frequency Spread	20MHz

TK-885

KENWOOD CORPORATION

14-6, Dogenzaka 1-chome, Shibuya-ku, Tokyo 150-8501, Japan

KENWOOD SERVICE CORPORATION

P.O. BOX 22745, 2201 East Dominguez Street, Long Beach, CA 90801-5745, U.S.A.

KENWOOD ELECTRONICS CANADA INC.

6070 Kestrel Road, Mississauga, Ontario, Canada L5T 1S8

KENWOOD ELECTRONICS DEUTSCHLAND GMBH

Rembrücker Str. 15, 63150 Heusenstamm, Germany

KENWOOD ELECTRONICS BELGIUM N.V.

Mechelsesteenweg 418 B-1930 Zaventem, Belgium

KENWOOD ELECTRONICS FRANCE S.A.

13, Boulevard Ney, 75018 Paris, France

KENWOOD ELECTRONICS U.K. LIMITED

KENWOOD House, Dwight Road, Watford, Herts., WD1 8EB United Kingdom

KENWOOD ELECTRONICS EUROPE B.V.

Amsterdamseweg 37, 1422 AC Uithoorn, The Netherlands

KENWOOD ELECTRONICS ITALIA S.p.A.

Via G. Sirtori, 7/9 20129 Milano, Italy

KENWOOD IBERICA S.A.

Bolivia, 239-08020 Barcelona, Spain

KENWOOD ELECTRONICS AUSTRALIA PTY. LTD.

(A.C.N. 001 499 074)

16 Giffnock Avenue, North Ryde, N.S.W. 2113 Australia

KENWOOD ELECTRONICS (HONG KONG) LTD.

Unit 3712-3724, Level 37, Tower one Metroplaza, 223 Hing Fong Road, Kwai Fong, N.T., Hong Kong

KENWOOD ELECTRONICS TECHNOLOGIES(S) PTE LTD.

Sales Marketing Division

1 Ang Mo Kio Street 63, Singapore 569110