

KENWOOD

Document Copyrights

Copyright 2006 by Kenwood Corporation. All rights reserved.

No part of this manual may be reproduced, translated, distributed, or transmitted in any form or by any means, electronic, mechanical, photocopying, recording, or otherwise, for any purpose without the prior written permission of Kenwood.

Disclaimer

While every precaution has been taken in the preparation of this manual, Kenwood assumes no responsibility for errors or omissions. Neither is any liability assumed for damages resulting from the use of the information contained herein. Kenwood reserves the right to make changes to any products herein at any time for improvement purposes.

文档版权信息

Kenwood Corporation 拥有版权 2006。保留所有权利。

未经 Kenwood 公司预先书面同意，无论出于何种目的，均不得以任何形式或任何方式包括电子、机械、影印、录音或其他方式复制、翻译、分发或传播本手册的任何部分。

免责声明

Kenwood 公司在准备本文档时已采取所有必要的预防措施，恕不对错误或疏漏承担任何责任，也不对因使用本文中所含的信息而导致的损害负责。Kenwood 公司保留出于改进的需要而随时对文中的产品信息做出更改的权利。

TK-90

SERVICE MANUAL / 维修手册

KENWOOD

Kenwood Corporation

© 2006-4 PRINTED IN JAPAN
B51-8757-00 (N) 781

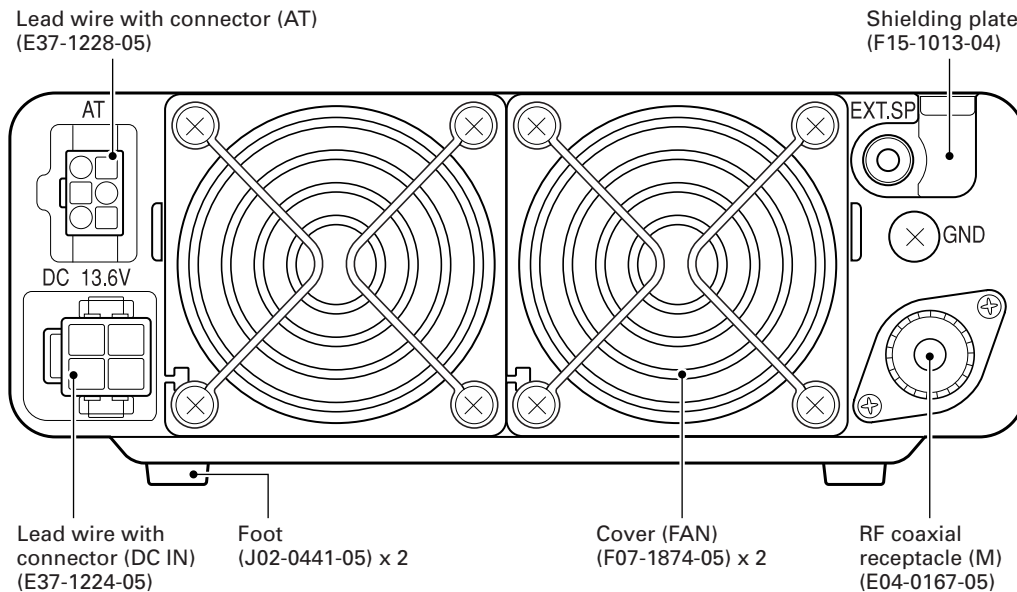
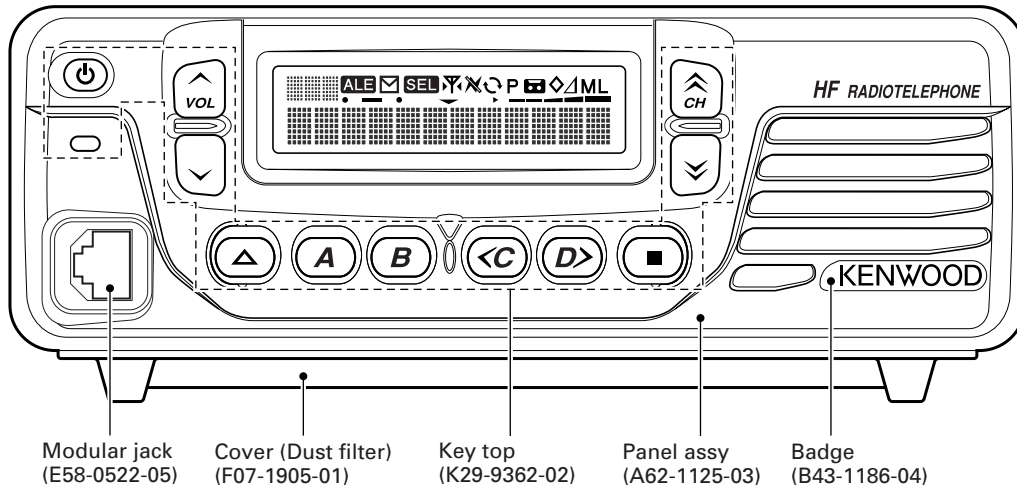

无铅焊接通信产品  
 保护环境建伍领先

⚠ 注意：本产品是无铅化焊接产品
 在维修时请使用无铅焊锡
 和相应的焊接工具
 详细事项请访问如下网址了解：
<http://www.kenwoodhk.com.hk/>



This product uses Lead Free solder.

CONTENTS / 目录

GENERAL	3	概 述	3
SYSTEM SET-UP	4	系统体系	4
REALIGNMENT	5	模式组合	5
INSTALLATION	12	安 装	12
DISASSEMBLY FOR REPAIR	17	维修拆卸	17
CIRCUIT DESCRIPTION	18	电路说明	18
COMPONENTS DESCRIPTION	31	元件说明	31
SEMICONDUCTOR DATA	40	半导体数据	40
PARTS LIST	47	零 件 表	47
EXPLODED VIEW	64	部件分解图	64
PACKING	65	包 装	65
ADJUSTMENT	66	调 整	66
TERMINAL FUNCTION	87	端子功能	87
PC BOARD		PC板	
FINAL UNIT (X45-3780-20)	92	FINAL单元 (X45-3780-20)	92
DISPLAY UNIT (X54-3560-20)	96	DISPLAY单元 (X54-3560-20)	96
TX-RX UNIT (X57-7210-20)	98	TX-RX单元 (X57-7210-20)	98
INTERCONNECTION DIAGRAM	102	互连图	102
SCHEMATIC DIAGRAM		原 理 图	
FINAL UNIT (X45-3780-20)	104	FINAL单元 (X45-3780-20)	104
DISPLAY UNIT (X54-3560-20)	106	DISPLAY单元 (X54-3560-20)	106
TX-RX UNIT (X57-7210-20)	108	TX-RX单元 (X57-7210-20)	108
BLOCK DIAGRAM	112	方 块 图	112
LEVEL DIAGRAM	114	电 平 图	114
SPECIFICATIONS	116	规 格	117

GENERAL / 概述

INTRODUCTION

SCOPE OF THIS MANUAL

This manual is intended for use by experienced technicians familiar with similar types of commercial grade communications equipment. It contains all required service information for the equipment and is current as of the publication date. Changes which may occur after publication are covered by either Service Bulletins or Manual Revisions. These are issued as required.

ORDERING REPLACEMENT PARTS

When ordering replacement parts or equipment information, the full part identification number should be included. This applies to all parts : components, kits, or chassis. If the part number is not known, include the chassis or kit number of which it is a part, and a sufficient description of the required component for proper identification.

PERSONAL SAFETY

The following precautions are recommended for personal safety:

- DO NOT transmit until all RF connectors are verified secure and any open connectors are properly terminated.
- SHUT OFF and DO NOT operate this equipment near electrical blasting caps or in an explosive atmosphere.
- This equipment should be serviced by a qualified technician only.

SERVICE

This transceiver is designed for easy servicing. Refer to the schematic diagrams, printed circuit board views, and alignment procedures contained within.

List of Service Manual

Title	Parts Number	Remarks
KAT-1	B51-8304-00	Automatic antenna tuner
KRK-5/6DH	B51-8445-20	Remote kit
KCT-31	B51-8573-00	Interface cable
VGS-1	B51-8669-00	Voice guide & strage unit
KMC-35/36	B51-8697-00	Microphone

引言

本手册的范围

本手册是提供给熟悉通信专业并且具有维修经验的技术人员使用的。它包括了维修该设备所需要的全部资料和现行出版日期。在出版后可能发生变动,如果需要,可以参照《维修通报》或《手册修订本》进行补充。

替换零件的订购

当订购替换零件或设备资料时,应注意完整的零件识别号码。所有的零件均有识别号码:元件,组件或机壳。如果不知道零件的号码,为了正确地识别,必须注明此元件所属的机壳或组件的号码,并对元件进行充分的说明。

个人安全

为了个人的安全,请注意下列事项:

- 在没有认真核实所有射频插头之前或有任何一个脱开的插头没有连接到相应端口上的情况下都不要发射。
- 在电爆管附近或在易燃性气体环境中,必须关闭电源,不要操作本设备。
- 本设备只应该由有资格的技术人员进行维修。

维修服务

为了便于维修本设备,建立了完整的维修服务体系,提供了包括原理图,印刷电路板图和调整步骤在内的资料供参考。

SYSTEM SET-UP / 系统体系

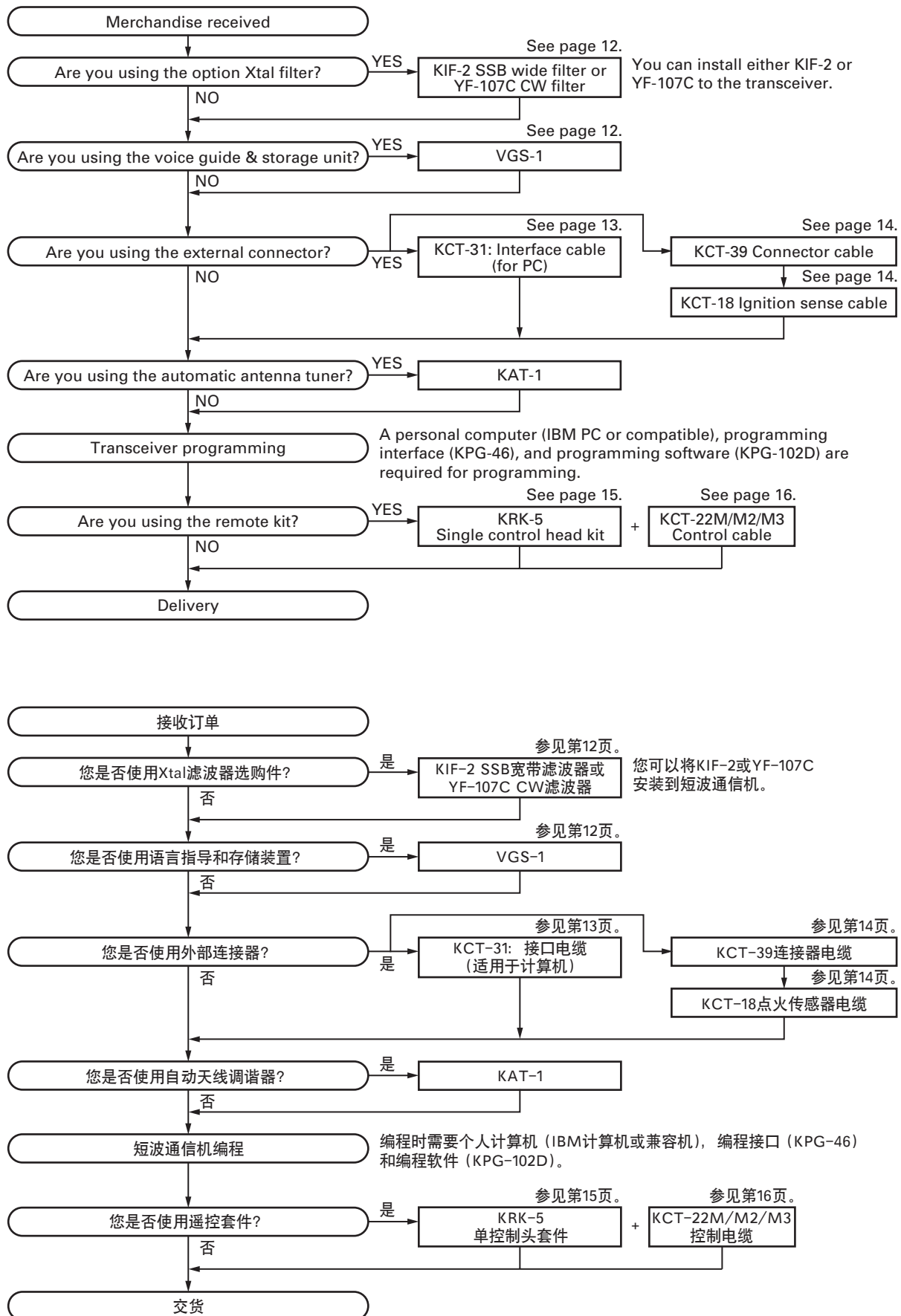

REALIGNMENT / 模式组合

1. Modes

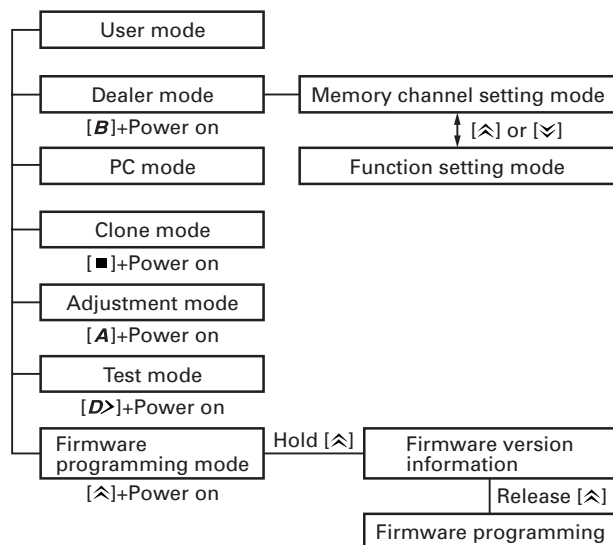

Mode	Function
User mode	For normal use.
Dealer mode	You can program the memory channel and other function using only the transceiver.
PC mode	Used for communication between the transceiver and PC (IBM compatible).
Clone mode	Used to transfer memory channel data from one transceiver to another.
Adjustment mode	Used by the dealer to tune the transceiver.
Test mode	Used by the dealer to check the fundamental characteristics.
Firmware programming mode	Used when changing the main program of the flash memory.

2. How to Enter Each Mode

Mode	Operation
User mode	Power ON
Dealer mode	[B] + Power ON
PC mode	Received commands from PC
Clone mode	[■] + Power ON
Adjustment mode	[A] + Power ON
Test mode	[D>] + Power ON
Firmware programming mode	[↖] + Power ON

3. Test Mode

Setting method refer to ADJUSTMENT.

4. Adjustment Mode

Setting method refer to ADJUSTMENT.

1. 模式

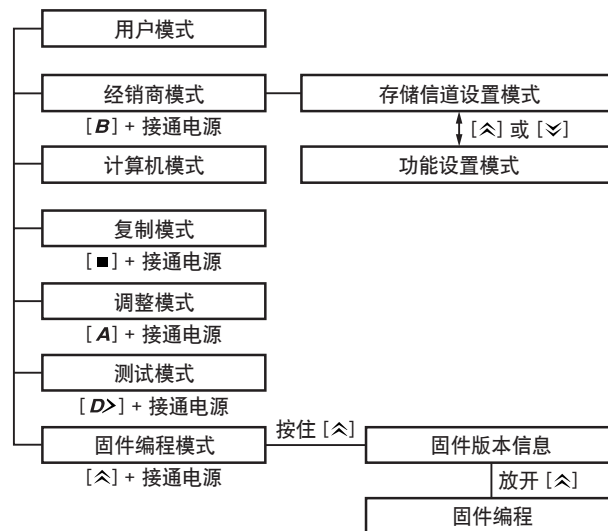

模式	功能
用户模式	一般使用。
经销商模式	您可以只使用短波通信机自身来编程存储信道和其他功能。
计算机模式	用于短波通信机与计算机 (IBM兼容机) 之间的通信。
复制模式	用于从一个短波通信机编程数据复制到另一个短波通信机。
调整模式	用于经销商调整短波通信机指标。
测试模式	用于经销商检查基本功能。
固件编程模式	当改变Flash Rom中操作主程序时使用。

2. 如何进入每一种模式

模式	操作
用户模式	接通电源
经销商模式	[B] + 接通电源
计算机模式	从计算机接收指令
复制模式	[■] + 接通电源
调整模式	[A] + 接通电源
测试模式	[D>] + 接通电源
固件编程模式	[↖] + 接通电源

3. 关于面板测试模式

关于设定方式, 参见调整。

4. 关于面板调谐模式

关于设定方式, 参见调整。

REALIGNMENT / 模式组合

5. PC Mode

5-1. Preface

The transceiver is programmed by using a personal computer, programming interface (KPG-46) and programming software (KPG-102D).

The programming software can be used with an IBM PC or compatible. Figure 1 shows the setup of an IBM PC for programming.

5-2. Connection procedure

1. Connect the transceiver to the personal computer with the interface cable.
2. When the POWER switch on, user mode can be entered immediately. When PC sends command the transceiver enter PC mode, and "PROGRAM" is displayed on the LCD.

When data transmitting from transceiver, the red LED is lights.

When data receiving to transceiver, the green LED is lights.

Note:

The data stored in the personal computer must match model type, when it is written into the EEPROM.

5-3. KPG-46 description

(PC programming interface cable: Option)

The KPG-46 is required to interface the transceiver to the computer. It has a circuit in its D-sub connector (25-pin) case that converts the RS-232C logic level to the TTL level.

The KPG-46 connects the MIC connector of the transceiver to the computers RS-232C serial port.

5-4. Programming software KPG-102D description

The KPG-102D is the programming software for the transceiver supplied on a CD-ROM. This software runs under MS-Windows 98, ME, Windows 2000 or XP on an IBM-PC or compatible machine.

The data can be input to or read from the transceiver and edited on the screen. The programmed or edited data can be printed out. It is also possible to tune the transceiver.

5. 计算机模式

5-1. 前言

短波通信机使用计算机、编程电缆 (KPG-46) 和编程软件 (KPG-102D) 进行编程。

IBM计算机或兼容机可以使用编程软件。图1显示IBM计算机编程的设置。

5-2. 连接步骤

1. 使用编程电缆将短波通信机与计算机连接。
2. 当接通电源时, 立即进入用户模式。当计算机发出指令使短波通信机进入计算机模式时, "PROGRAM" 出现在显示器上。
短波通信机正在发送数据时, 红色的LED点亮。
短波通信机正在接收数据时, 绿色的LED点亮。

注意:

储存在计算机内的数据在写入短波通信机的存储器中时必须与短波通信机的型号相匹配。

5-3. KPG-46说明

(计算机编程电缆: 可选项)

KPG-46用于将短波通信机与计算机连接。在其D型副插座 (25芯) 中有一个电平转换电路, 此电路可以把RS-232C逻辑电平转换为TTL电平。

KPG-46将短波通信机的MIC连接器连接到电脑的RS-232C串行端口。

5-4. 编程软件说明

KPG-102D是短波通信机的编程软件。此软件的运行环境为IBM-PC机或兼容机的Windows 98、ME、Windows 2000或XP。

数据可以被输入到短波通信机或从短波通信机中读取数据, 并且在屏幕上进行编辑。已被编程或编辑的数据可以打印出来。也可以调整短波通信机的指标。

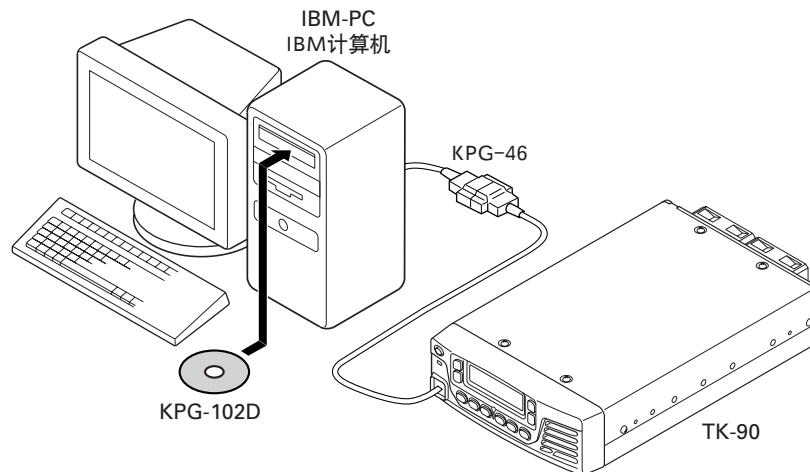

Fig. 1 / 图1

REALIGNMENT / 模式组合

6. Firmware Programming Mode

6-1. Summary

The flash memory within the microcomputer of the transceiver can be upgraded when new features are added or existing specifications are modified.

6-2. Connection

Use the KPG-46 interface cable to connect the microphone terminal of the transceiver and the COM terminal of the PC.

6-3. Programming

1. Run the PC firmware programming software (Fpro.exe).
2. Set the communication baud rate to 19,200 bps. (Do not use other baud rates, as they cannot be used for communications.)
3. Select the new firmware file.
4. While press the [↵] key, turn the transceiver power on. "PROG 19200" will appear on the transceiver display.
5. Confirm the connection between the transceiver and the PC.
6. Press the "Write" button on the PC screen. "PG" will appear on the transceiver display when data reception begins.
7. When data reception has completed, the transceiver will calculate the checksum and indicate the results.
8. To repeat the data writing process on additional transceivers, repeat steps 4 to 7.

Notes:

- The TK-90 hardware can use only a baud rate of 19,200 bps for communications.
- The transceiver baud rate cannot be changed.
- A communication error where occur and programming cannot be performed if the firmware programming software (Fpro.exe) is set to a baud rate other than 19,200 bps.
- It takes approximately 2 1/2 minutes to reprogram a single transceiver.

6-4. Function

1. While "PROG 19200" appears on the display, you can calculate the checksum by pressing the [A] key. The results will be indicated on the display.
2. While the checksum results are displayed, press the [A] key again to return the display to "PROG 19200".

7. Clone Mode

Memory channel data can be transferred from one radio to another by connecting them via their MIC connectors. The operation is as follows (the transmit radio is the source and the receive radio is a target).

The "password" of description by explanation of 1. to 6. are "Read Authorization Password".

1. Turn the source transceiver power ON with the [■] key held down. The transceiver displays "CLONE".
2. Power on the target transceiver.
3. Connect the cloning cable (part No. E30-3382-05) to the MIC connectors on the source and target.

6. 固件编程模式

6-1. 概述

添加了新的特性或修改了当前规格时,可以升级短波通信机微处理器内部的闪存。

6-2. 连接

使用KPG-46接口电缆连接短波通信机的麦克风端子和计算机的COM端子。

6-3. 编程

1. 运行计算机固件编程软件 (Fpro.exe)。
2. 将通信波特率设为19,200 bps。(请勿使用其他波特率,否则无法进行通信。)
3. 选择新的固件文件。
4. 按 [↵] 键时,打开短波通信机电源。
短波通信机显示屏上将出现 "PROG 19200"。
5. 确认短波通信机和计算机的连接。
6. 按计算机屏幕上的 "写入" 按钮。数据接收开始时,短波通信机显示屏上将出现 "PG"。
7. 数据接收完成时,短波通信机将核对校验码并指示结果。
8. 如需在其他短波通信机上重复数据写入操作,请重复步骤4~7。

注意:

- TK-90硬件仅可以使用19,200 bps波特率进行通信。
- 短波通信机波特率无法更改。
- 如果固件编程软件 (Fpro.exe) 设为除19,200 bps以外的波特率,则会发生通信错误且无法进行编程。
- 重新编程单台短波通信机大约需要2.5分钟。

6-4. 功能

1. 显示屏上出现 "PROG 19200" 时,您可以按 [A] 键核对校验码。显示屏上将会指示结果。
2. 显示校验和结果时,再次按 [A] 键将显示屏返回至 "PROG 19200"。

7. 复制模式

通过MIC连接器连接短波通信机,可以将存储信道数据从一台短波通信机传输到另一台短波通信机。具体操作如下(发射机是主机,接收机是子机)。

说明1~6所描述的 "密码" 是 "读取授权密码"。

1. 按住 [■] 键打开主短波通信机的电源。短波通信机显示 "CLONE"。
2. 打开子短波通信机的电源。
3. 将复制电缆 (零件号E30-3382-05) 连接到主、子短波通信机的MIC连接器上。

REALIGNMENT / 模式组合

- Press the [■] key on the source while the source displays "CLONE". The data of the source is sent to the target. While the target is receiving the data, "PROGRAM" is displayed. When cloning of data is completed, the source displays "END", and the target automatically operates in the User mode. The target can then be operated by the same memory channel as the source.
- The other target can be continuously cloned. When the [■] key on the source is pressed while the source displays "END", the source displays "CLONE". Carry out the operation in step 2 to 4.

Note:

Cannot be cloned if the password (over write password) is programmed to the target.

- 主短波通信机显示“CLONE”时,按主短波通信机上的[■]键。主短波通信机的数据便被发送到子短波通信机。子短波通信机正在接收数据时,显示“PROGRAM”。数据复制完成后,主短波通信机显示“END”,子短波通信机自动按用户模式操作。此时,子短波通信机即可按照与主短波通信机相同的存储信道进行操作。
- 可以继续对另一台子短波通信机进行复制。主短波通信机显示“END”时,如果按主短波通信机上的[■]键,则主短波通信机显示“CLONE”。执行步骤2~4的操作。

注意:

如果子短波通信机编程设有密码(改写密码),则无法复制。

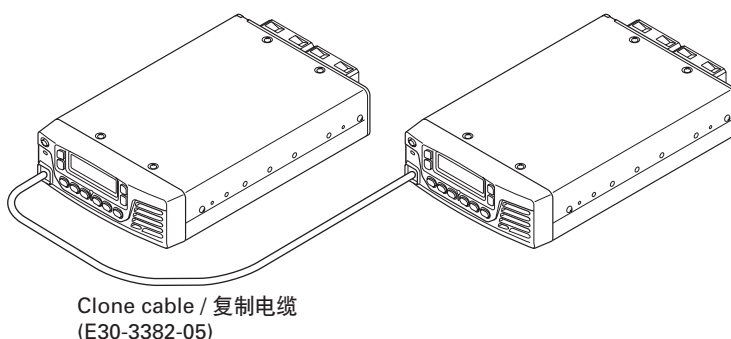

Fig. 2 / 图2

8. Dealer Mode

This mode allows you to write the memory channel data and functions to the equipment. This mode is to be used ONLY by authorized service personnel who are maintaining the user's equipment. After programming, reset the FPU to disable "Channel setting" and "Function setting". Transceivers CANNOT be delivered to the end-user with dealer mode enabled.

8-1. Entering dealer mode

- Press and hold the [B] key while turning the power on.
- When dealer mode is enabled, "DEALER MODE" appears on the display.

Note:

Dealer mode (Channel setting and Function setting) cannot be set when it has been disabled by the FPU.

8-2. Flow chart

■ Dealer mode

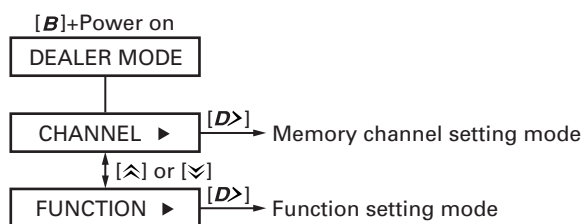

8. 经销商模式

该模式允许您将存储信道数据和功能写入设备。该模式只能由维护用户设备的授权服务人员使用。编程后,请复位FPU以禁用“信道设置”和“功能设置”。短波通信机不能以经销商模式启用的状态交付最终用户。

8-1. 进入经销商模式

- 电源打开时,按住 [B] 键。
- 经销商模式启用时,显示屏上出现“DEALER MODE”。

注意:

如果FPU已经禁用经销商模式(信道设置和功能设置),则不能设置经销商模式。

8-2. 流程图

■ 经销商模式

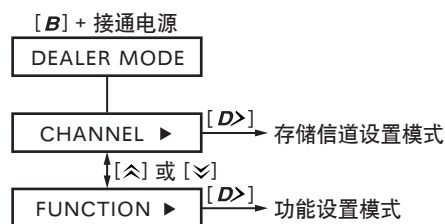

REALIGNMENT / 模式组合

Memory channel setting mode

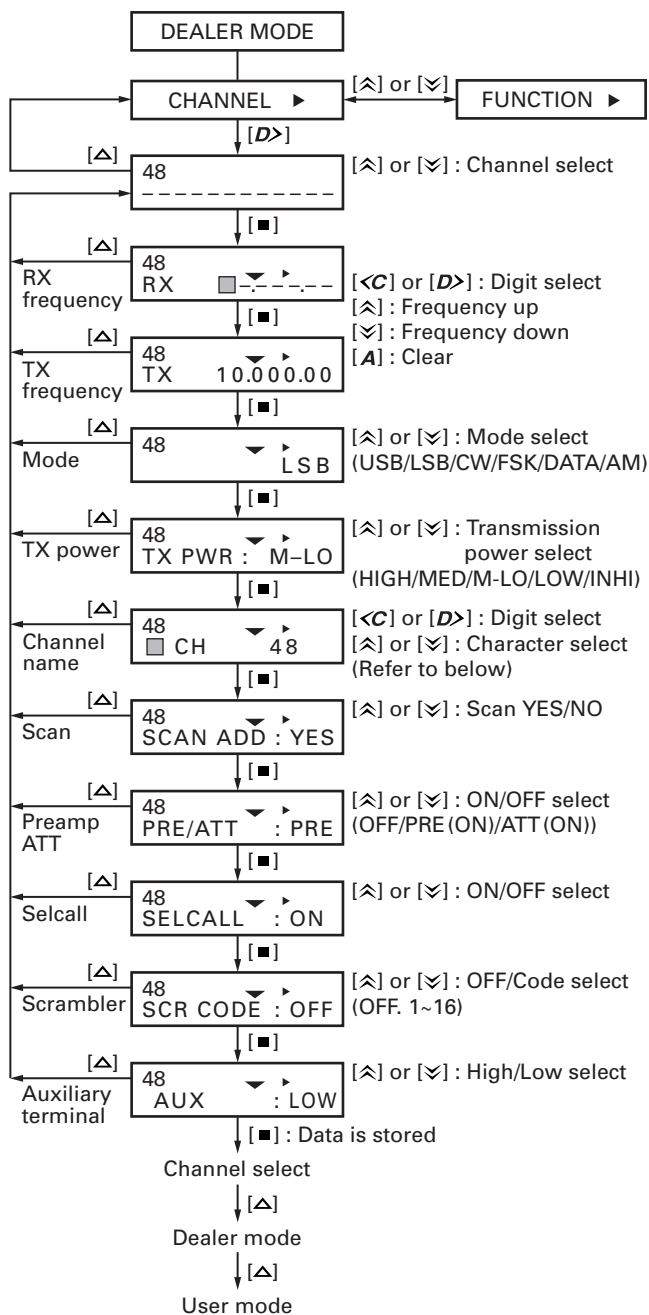

存储信道设置模式

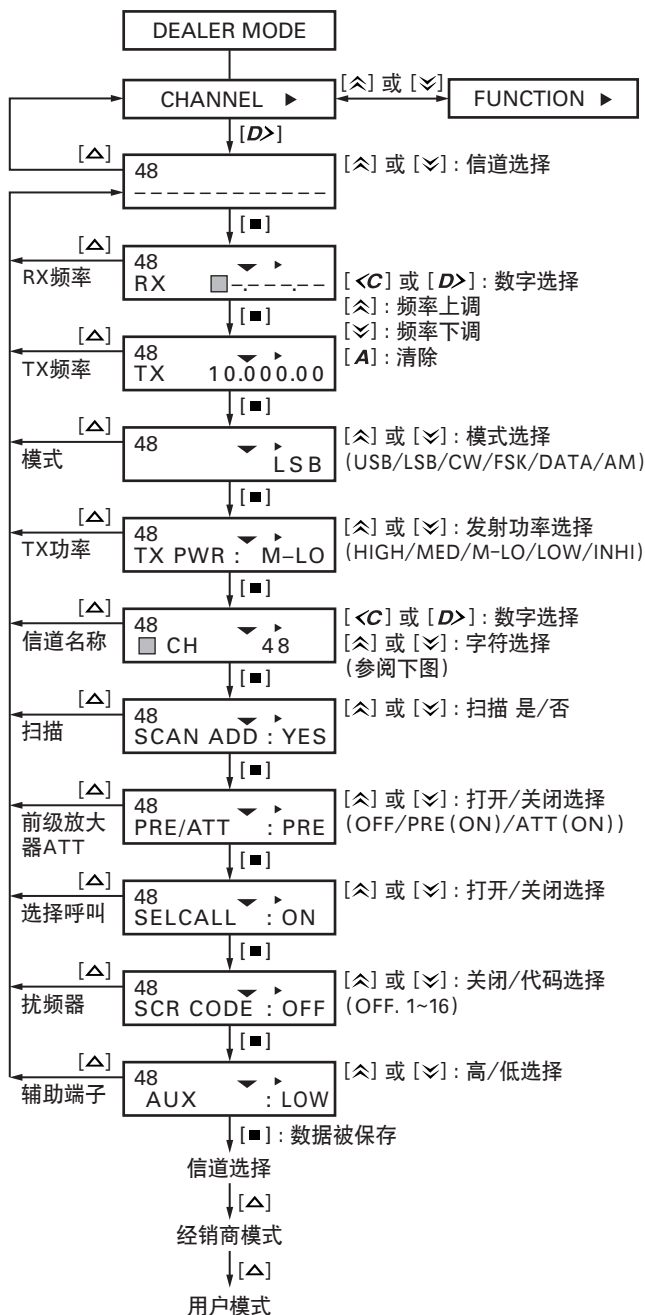

Character pattern / 字符图案

Capital letter alphabet / 大写字母

ABCDEFGHIJKLM
NOPQRSTUVWXYZ

Lower-case letter alphabet / 小写字母

abcdefghijklmnop
qrstuvwxyz

Numeric / 数字

0123456789

Symbol / 符号

!"#\$%&'()*+,-
./:;<=>?@
[]^_`{|}~

REALIGNMENT / 模式組合

■ Function setting mode

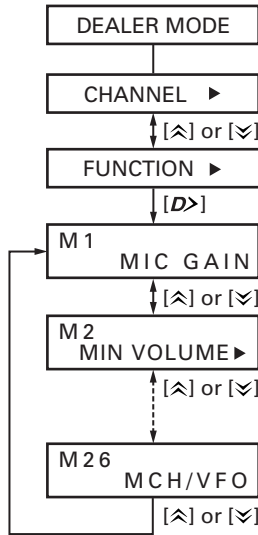

• Operation example

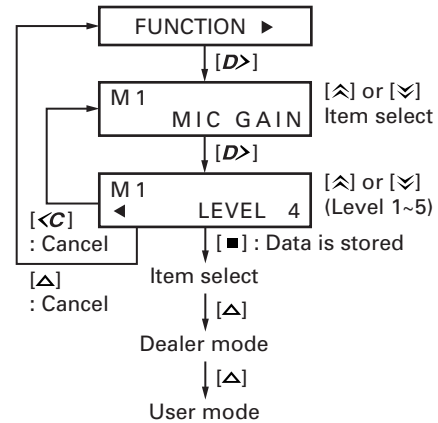

• Menu list

Menu No.	Item	Display	Set Value
1	Mic Gain Level	MIC GAIN	1 to 5
2	Minimum Volume	MIN VOLUME	0 to 31
3	Ignition Sense	IGNIT SENSE	OFF / TYPE 1 (Ignition and Switch) / TYPE 2 (Ignition Only)
4	Scan Resume	SCAN RESUME	CO (Carrier Operate) / TO (Time Operate)
5	Time Operated Wait	TO WAIT	3 sec to 10 sec
6	Dropout Delay Time	DROP DELAY	0 sec to 300 sec
7	Scan Resume after Transmit	SCAN-RSM TX	ON / OFF
8	Dwell Time	DWELL TIME	0 sec to 300 sec
9	Revert Channel	REVERT CH	TYPE 1 (Selected) / TYPE 2 (Selected + Talkback) / TYPE 3 (Preferred Channel) / TYPE 4 (Preferred Channel + Talkback)
10	Preferred Channel Scan Interval	P-SCN INTVL	1 to 5
11	Preferred Channel	PREF CH	NONE / Programmed channel
12	Time-out Timer	TOT	OFF / 3 min / 5 min / 10 min / 20 min / 30 min
13	Transmit Power for VFO Mode	VFO TX PWR	HIGH / MEDIUM / MEDIUM LOW / LOW / INHIBIT
14	IF Filter SSB	IF-FIL SSB	BUILT-IN / OPTION
15	IF Filter DATA	IF-FIL DATA	BUILT-IN / OPTION
16	IF Filter FSK	IF-FIL FSK	BUILT-IN / OPTION
17	CW Break-in	BREAK-IN	ON / OFF
18	CW Break-in Delay Time	CW DELAY	FULL / 50 ms to 1000 ms (50 ms step)
19	DI Level	DI LEVEL	0 to 9
20	DEO Level	DEO LEVEL	0 to 9
21	FSK Reverse	FSK REVERS	NORMAL / REVERSE
22	DATA Sideband	DATA S-BAND	USB / LSB
23	FSK Transmit Polarity	POLARITY	NORMAL / REVERSE
24	FSK Transmit Shift Frequency	FSK SHIFT	170Hz / 200Hz / 425Hz / 850Hz
25	FSK Receive Tone Frequency	FSK TONE	1275Hz / 2125Hz
26	VFO Mode / Channel Mode	MCH/VFO	VFO / M CH

REALIGNMENT / 模式组合

■ 功能设置模式

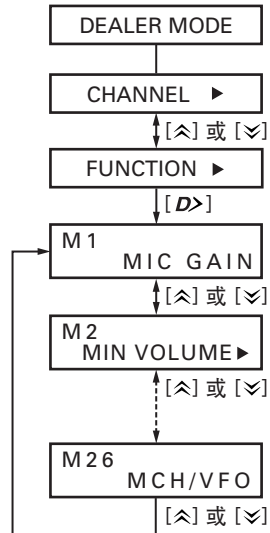

● 操作实例

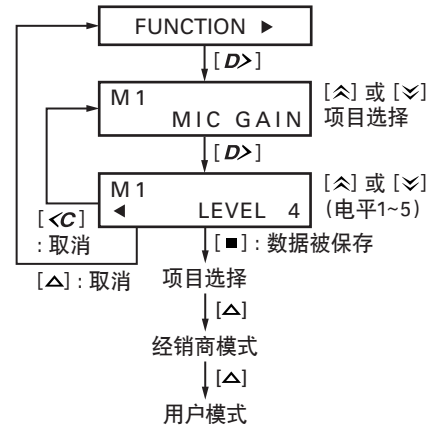

● 菜单列表

菜单号	项目	显示	设置值
1	麦克风增益电平	MIC GAIN	1~5
2	最小音量	MIN VOLUME	0~31
3	点火传感	IGNIT SENSE	OFF / TYPE 1 (点火和开关) / TYPE 2 (仅点火)
4	扫描恢复	SCAN RESUME	CO (载波操作) / TO (时间操作)
5	时间操作等待	TO WAIT	3~10秒
6	失落延迟时间	DROP DELAY	0~300秒
7	发射后扫描恢复	SCAN-RSM TX	ON / OFF
8	停留时间	DWELL TIME	0~300秒
9	返回信道	REVERT CH	TYPE 1 (选择) / TYPE 2 (选择+当前通话) / TYPE 3 (首选信道) / TYPE 4 (首选信道+当前通话)
10	首选信道扫描间隔	P-SCN INTVL	1~5
11	首选信道	PREF CH	NONE / 编程信道
12	超时定时器	TOT	OFF / 3分钟 / 5分钟 / 10分钟 / 20分钟 / 30分钟
13	VFO模式的发射功率	VFO TX PWR	HIGH / MEDIUM / MEDIUM LOW / LOW / INHIBIT
14	中频滤波器SSB	IF-FIL SSB	BUILT-IN / OPTION
15	中频滤波器数据	IF-FIL DATA	BUILT-IN / OPTION
16	中频滤波器FSK	IF-FIL FSK	BUILT-IN / OPTION
17	CW插入	BREAK-IN	ON / OFF
18	CW插入延迟时间	CW DELAY	FULL / 50~1000毫秒 (50毫秒步长)
19	数据输入电平	DI LEVEL	0~9
20	解调输出电平	DEO LEVEL	0~9
21	FSK反转	FSK REVERS	NORMAL / REVERSE
22	数据边带	DATA S-BAND	USB / LSB
23	FSK发射极性	POLARITY	NORMAL / REVERSE
24	FSK发射偏移频率	FSK SHIFT	170Hz / 200Hz / 425Hz / 850Hz
25	FSK接收音频率	FSK TONE	1275Hz / 2125Hz
26	VFO模式/信道模式	MCH/VFO	VFO / M CH

1. Voice Guide & Storage Unit (VGS-1)

1. Remove the top case (8 screws) (①).
2. Loosen the 3 screws (②) to remove the shield cover (③).
3. Use the 2 rubber cushions shown illustration and attach them to the VGS-1 (④).
4. Plug the VGS-1 into the CN11 connector of the PC board, pressing down on the top of the VGS-1 until secure (⑤).

1. 语音指导及存储单元 (VGS-1)

1. 取出上盖 (8颗螺丝) (①)。
2. 松开3颗螺丝 (②), 取出屏蔽盖 (③)。
3. 将图示的2个橡胶垫安装到VGS-1 (④)。
4. 将VGS-1插入PC板的CN11连接器, 然后向下按VGS-1的顶部, 确保连接牢固 (⑤)。

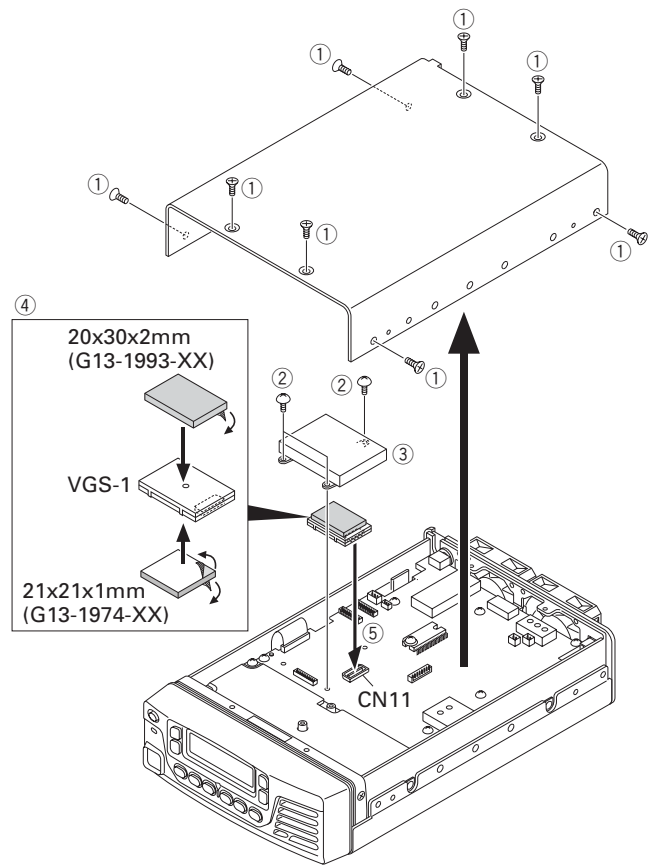

Fig. 1 / 图1

2. Optional Filter (KIF-2 or YF-107C)

2-1. Removing the TX-RX unit

1. Remove the 6-pin connector from inside the chassis by pushing on the stopper with a small screwdriver or other implement (①).
2. Pull the CN236, CN14, CN16, and CN17 connectors from the unit (②, ③, ④).
3. Remove the 14 screws (⑤) from the unit.

2. 选件滤波器 (KIF-2或YF-107C)

2-1. 取下TX-RX单元

1. 使用小型螺丝刀或其他工具推动卡子, 从机壳中取下6针连接器 (①)。
2. 从单元中拉出CN236、CN14、CN16和CN17连接器 (②, ③, ④)。
3. 从单元取下14颗螺丝 (⑤)。

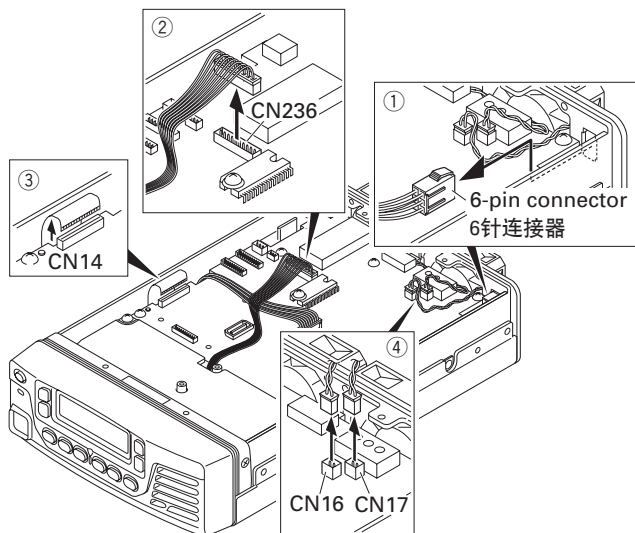

Fig. 2-1 / 图2-1

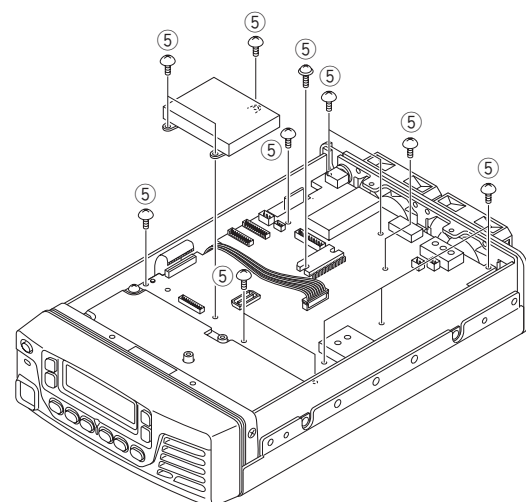

Fig. 2-2 / 图2-2

INSTALLATION / 安装

2-2. Installing the optional filter

1. Insert the optional filter onto the unit and solder it in place.

Note:

After installing the TX-RX unit into the chassis, push the W321 and W702 cables in between the chassis and optional filter. If the cables are not correctly placed, the W702 cable may become wedged between the optional filter and the top case when the top case is replaced.

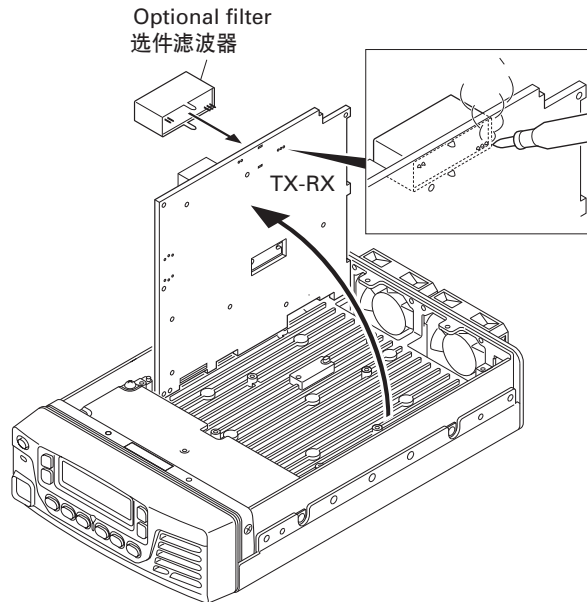

Fig. 2-3 / 图2-3

2-2. 安装选件滤波器

1. 将选件滤波器插入单元并焊接到位。

注意:

将TX-RX单元安装到机壳后, 请将W321和W702推入机壳和选件滤波器之间。如果没有正确放置电缆, 则放置顶盖时可能将W702电缆嵌入选件滤波器和顶盖之间。

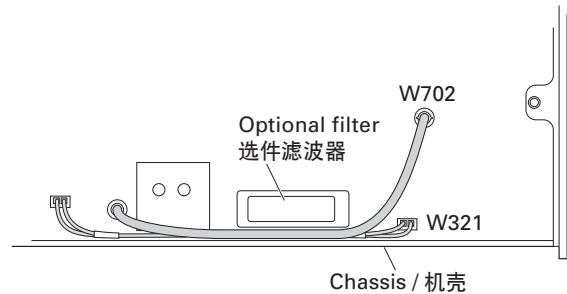

Fig. 2-4 / 图2-4

3. Interface Cable for PC (KCT-31)

1. Remove the black cover (①) from the rear of the chassis.
2. Attach the large and small 3-pin connectors of the KCT-31 to the CN7 and CN8 terminals of the unit. (The 8-pin connector of the KCT-31 is not used.)
3. Route the KCT-31 cable as shown in the figure below (②).
4. The cable tie (③) must be inside the chassis.

3. 用于计算机的接口电缆 (KCT-31)

1. 从机壳底部取下黑色盖 (①)。
2. 将KCT-31的大小3针连接器安装到单元的CN7和CN8端子。(KCT-31的8针连接器尚未使用。)
3. 如下图所示对KCT-31电缆进行布线 (②)。
4. 一定要使电缆线束 (③) 处于底架的里边。

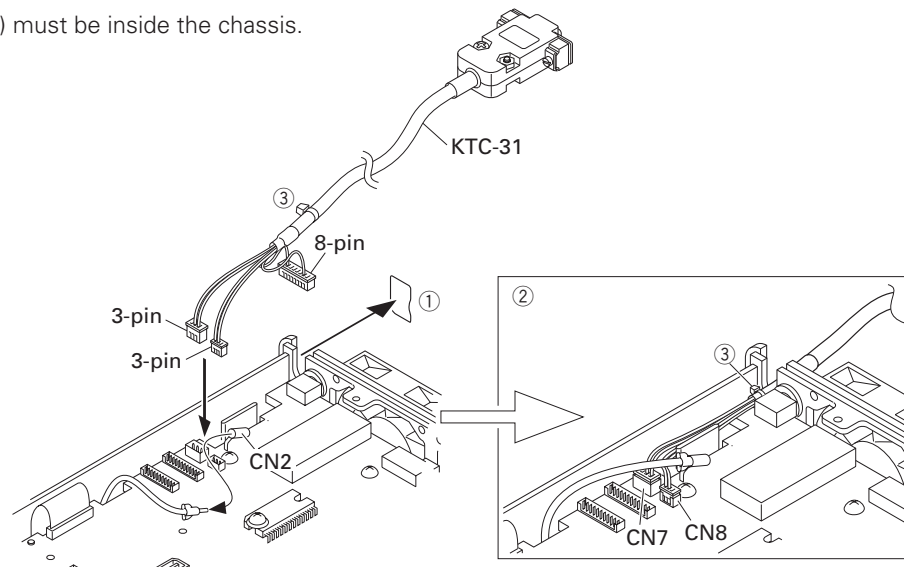

Fig. 3 / 图3

INSTALLATION / 安装

4. Connection Cable (KCT-39)

1. Remove the black cover (①) from the rear of the chassis.
2. Attach the KCT-39 connectors to the CN9 and CN10 terminals of the unit.
3. Route the KCT-39 cable as shown in the figure below (②).
4. The cable tie (③) must be inside the chassis.

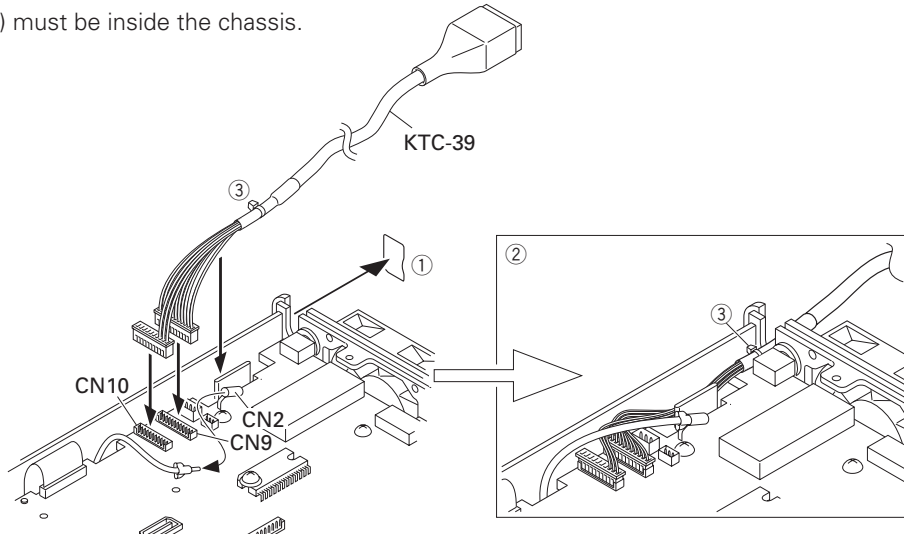

Fig. 4 / 图4

4. 连接电缆 (KCT-39)

1. 从机壳底部取下黑色盖 (①)。
2. 将KCT-39连接器安装到单元的CN9和CN10端子。
3. 如下图所示对KCT-39电缆进行布线 (②)。
4. 一定要使电缆线束 (③) 处于底架的里边。

5. Ignition Sense Cable (KCT-18)

The KCT-18 is an optional cable for enabling the ignition function. The ignition function lets you turn the power to the transceiver on and off with the car ignition key.

5-1. Connecting the KCT-18 to the transceiver

1. Install the KCT-39 in the transceiver. (See the KCT-39 section)
2. Insert the KCT-18 lead terminal (②) into pin 2 of the square plug (①) supplied with the KCT-39, then insert the square plug into the KCT-39 connector (③).

5. 点火传感器电缆 (KCT-18)

KCT-18是用于点火功能的选件电缆。点火功能可以使得你用汽车点火钥匙来开启和关闭短波通信机的电源。

5-1. 把KCT-18连接到短波通信机

1. 在短波通信机上安装KCT-39。(参见KCT-39部分)
2. 将KCT-18的引线头 (②) 插入KCT-39方形插头 (①) 的管脚2上, 然后将方形插头插入KCT-39连接器 (③)。

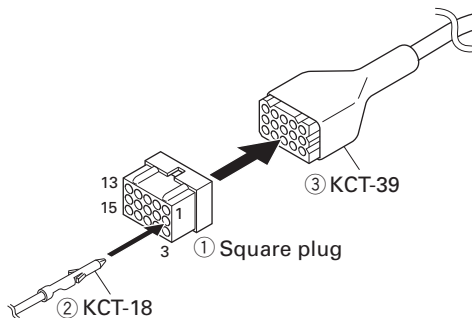
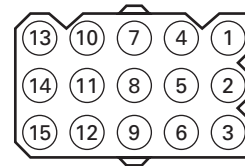

Fig. 5 / 图5

■ Accessory Port Function / 附件端口功能



No.	Color	Internal connector	Name	号	色	内部连接器	名称
1	Red	CN9-1	KEY	1	红	CN9-1	KEY
2	Pink	CN10-1	IGN	2	桃	CN10-1	IGN
3	Black	CN9-3	GND	3	黑	CN9-3	GND
4	Brown	CN10-3	DEO	4	茶	CN10-3	DEO
5	Orange	CN10-2	DI	5	橙	CN10-2	DI
6	Yellow	CN9-8	DPTT	6	黄	CN9-8	DPTT
7	Green	CN9-7	RTK	7	绿	CN9-7	RTK
8	Blue	CN9-9	GND	8	青	CN9-9	GND
9	Purple	CN9-12	AUX3	9	紫	CN9-12	AUX3
10	Gray	CN9-10	AUX1	10	灰	CN9-10	AUX1
11	White	CN9-11	AUX2	11	白	CN9-11	AUX2
12	NC	NC		12	NC	NC	
13	NC	NC		13	NC	NC	
14	Sky blue	CN9-6	RXD1	14	天蓝	CN9-6	RXD1
15	Turquoise	CN9-5	TXD1	15	青绿	CN9-5	TXD1

INSTALLATION / 安装

6. Single Control Head Kit (KRK-5)

The KRK-5 remote kit is used to remotely operate the transceiver. The KRK-5 is connected to the transceiver's front panel an optional KCT-22M (8 feet), KCT-22M2 (17 feet), or KCT-22M3 (25 feet) control cable.

6-1. Installing the KRK-5 Main Panel onto the Transceiver

1. Remove the upper case, lower case and front panel of the transceiver.
2. Insert the lead wire with connector (W601) of the TX-RX unit (X57-721) into the connector (CN4) of the KRK-5 (①).
3. Install the KRK-5 main panel on the transceiver using four screws (②).

Note:

Take care that the lead wire with connector (W601) is not caught when fitting the KRK-5 main panel on the transceiver.

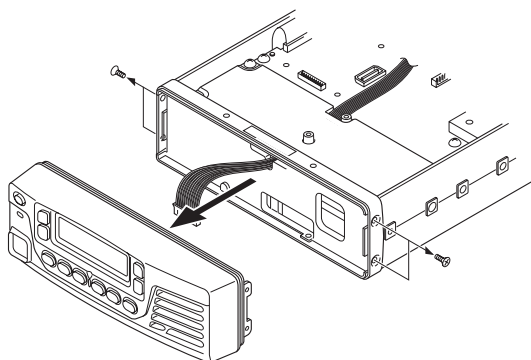

6. 单控制头套件 (KRK-5)

KRK-5遥控套件用于远程操作短波通信机。通过KCT-22M (8英尺)、KCT-22M2 (17英尺) 或KCT-22M3 (25英尺) 控制电缆将KRK-5连接至短波通信机的前面板。

6-1. 将KRK-5主控制盘安装到短波通信机上

1. 取下短波通信机的顶盖、底盖和前面板。
2. 使用TX-RX单元 (X57-721) 连接器 (W601) 将导线插入KRK-5的连接器 (CN4) (①)。
3. 使用4颗螺丝将KRK-5主控制盘安装到短波通信机上 (②)。

注意:

将KRK-5主控制盘安装到短波通信机上时, 请勿卡住带有连接器 (W601) 的导线。

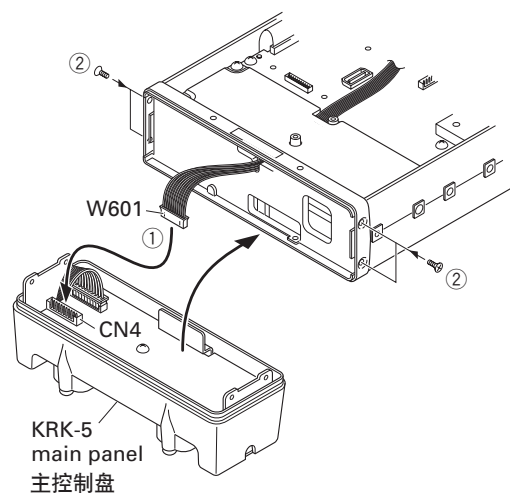

Fig. 6-1 / 图6-1

6-2. Installing the KRK-5 Rear Panel onto the Front Panel

1. Remove three screws (③) on the KRK-5 rear panel, then remove the KRK-5 sub panel.
2. Insert the lead wire with connector (W102) of the KRK-5 into the connector (CN2) of the front panel (④).
3. Install the KRK-5 sub panel onto the sub panel of the front panel.
4. Install the KRK-5 sub panel to the sub panel of the front panel kit using four screws (⑤).
5. Reinstall the KRK-5 rear panel using three screws removed in step 1.

6-2. 将KRK-5后面板安装到短波通信机前面板上

1. 取下KRK-5后面板上的3颗螺丝 (③), 然后取下KRK-5副板。
2. 使用KRK-5的连接器 (W102) 将导线插入前面板的连接器 (CN2) (④)。
3. 将KRK-5副板安装到前面板的副板上。
4. 使用4颗螺丝将KRK-5副板安装到前面板套件的副板上 (⑤)。
5. 使用步骤1中取下的3颗螺丝重新安装KRK-5后面板。

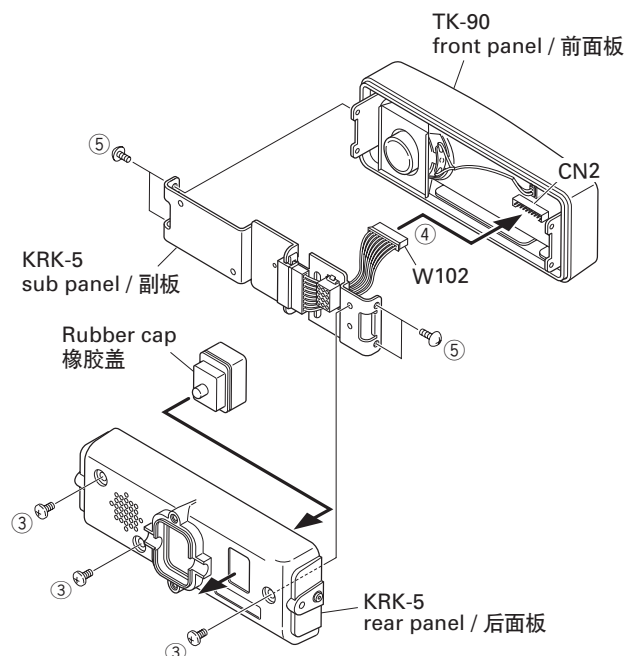

Fig. 6-2 / 图6-2

INSTALLATION / 安装

6-3. Control Cable (KCT-22) Connection

1. Insert one connector of the control cable to the transceiver (with KRK-5) and the other to the display (⑥).
2. Connect the cable to the GND terminal with the screw (⑦) supplied with the control cable.
3. Secure the one connector of the control cable to the KRK-5 main panel with two screws (⑧) according to the installation condition of the transceiver.
4. Secure the control cable to the KRK-5 main panel with the cable fitting (J21-4354-04) and two screws (⑨) supplied with the KRK-5.
5. Secure the other connector of the control cable to the display with two screws (⑩) in the same way.

6-3. 控制电缆 (KCT-22) 连接

1. 将控制电缆的一个连接器插入短波通信机 (带有KRK-5), 另一个插入显示屏 (⑥)。
2. 使用随控制电缆提供的螺丝 (⑦) 将电缆连接到GND端子。
3. 根据短波通信机的安装情况, 使用2颗螺丝 (⑧) 将控制电缆的一个连接器固定到KRK-5主控制盘。
4. 使用随KRK-5提供的电缆配件 (J21-4354-04) 和2颗螺丝 (⑨) 将控制电缆固定到KRK-5主控制盘。
5. 按照相同的方式使用2颗螺丝 (⑩) 将控制电缆的另一个连接器固定到显示屏。

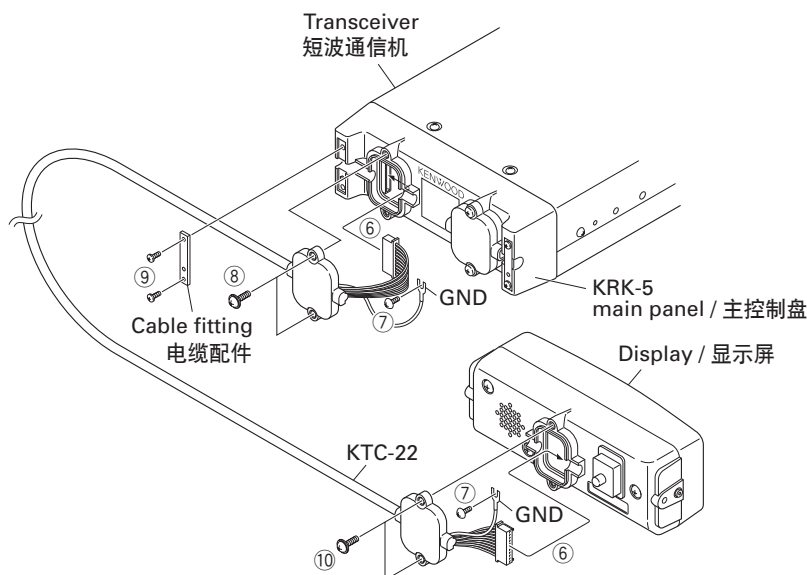

Fig. 6-3 / 图6-3

6-4. Display Installation

1. Install the display with the angle bracket (J29-0648-03) (⑪) and two screws (N08-0526-04) (⑫) supplied with the KRK-5.

6-4. 显示屏的安装

1. 使用随KRK-5提供的角撑架 (J29-0648-03) (⑪) 和2颗螺丝 (N08-0526-04) (⑫) 安装显示屏。

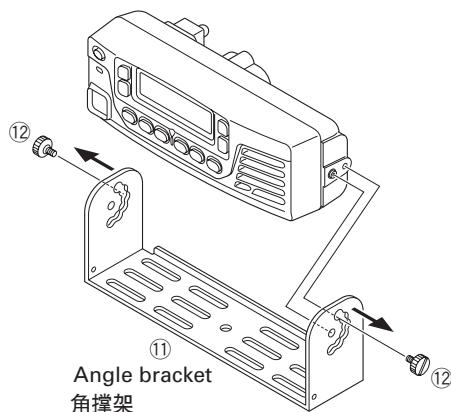

Fig. 6-4 / 图6-4

DISASSEMBLY FOR REPAIR / 维修拆卸

1. Installing the Sub-Panel

Installation of the sub-panel into the front panel can be difficult, so please follow the instructions below for installation procedures.

1. Tilt the sub-panel at an angle of 45° (①).
2. Insert the sub-panel at the center of the front panel (②) before sliding it into place.
3. Slide the sub-panel to the right (③).
4. Press the left side of the sub-panel into the front panel to complete the installation (④).

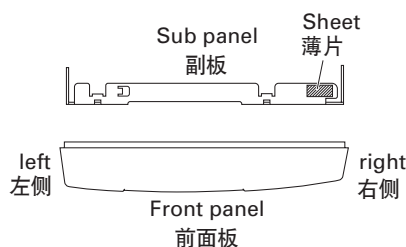

1. 安装副板

将副板安装到前面板较为困难, 请按照下列说明进行安装操作。

1. 呈45°角倾斜副板(①)。
2. 滑动副板之前, 请将其插入前面板的中央(②)。
3. 向右滑动副板(③)。
4. 将副板左侧按入前面板, 完成安装(④)。

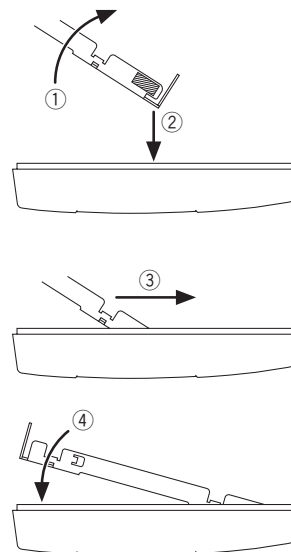

Fig. 1 / 图1

2. Removing and Cleaning the Dust Filter

The dust filter is used as the air intake for cooling of the unit.

When the dust filter becomes dirty, remove the 3 screws (①) holding it in place, wash the groove of the dust filter with water, and dry it well before reinstalling it.

2. 取出并清洁滤尘器

滤尘器是用于冷却装置的进风口。

滤尘器变脏时, 请取下将其固定的3颗螺丝(①), 用清水冲洗滤尘器的凹槽并将其晾干, 然后重新安装。

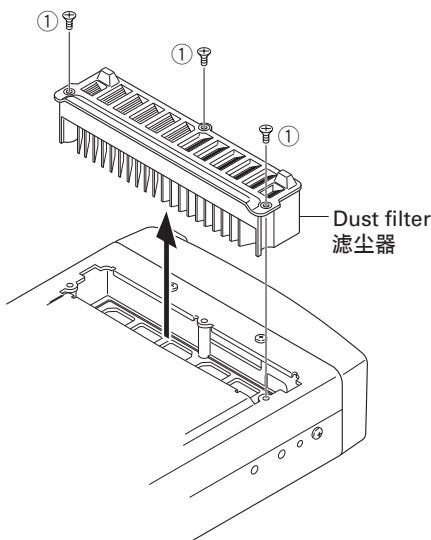

Fig. 2 / 图2

CIRCUIT DESCRIPTION / 电路说明

Frequency Composition

This transceiver operates with double conversion frequency composition.

频率构成

本短波通信机的工作采用二次变频的频率构成。

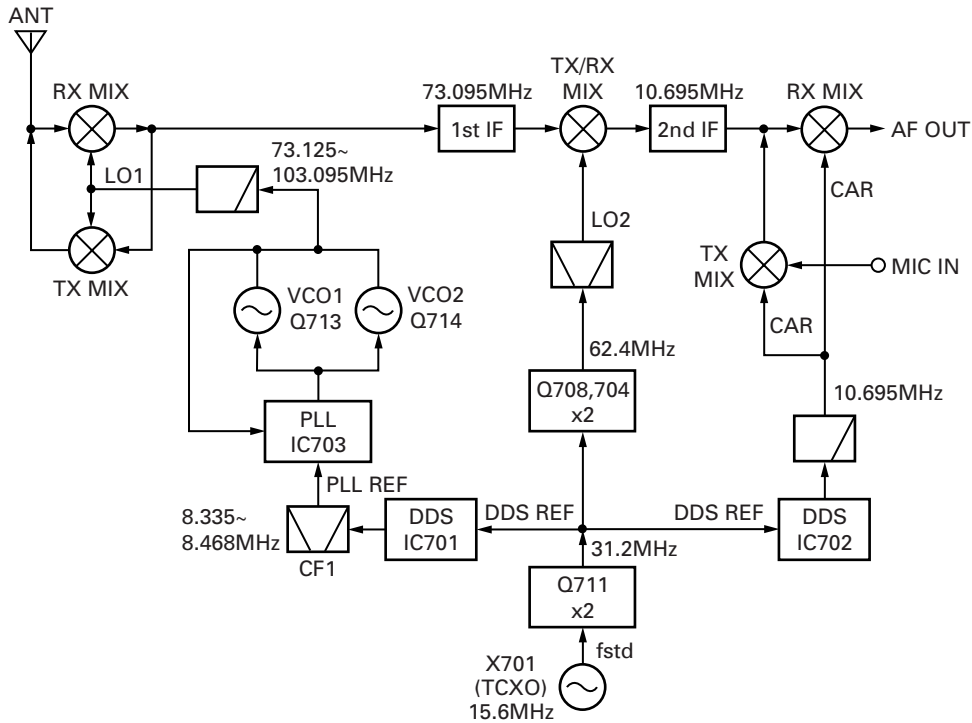

Fig. 1 Frequency composition / 图1 频率构成

Reference Signal Generator

TCXO is used for the reference frequency, fstd, which controls the PLL, and is oscillating 15.6MHz. This reference signal goes through the buffer amplifier (Q709) and is doubled (to 31.2MHz) by the frequency multiplier (Q711). This doubled signal is used as DDS (IC701) for a reference signal of PLL from the first local oscillator and as the reference signal of DDS for CARs (IC702).

The doubled signal is further doubled with Q708 and Q704, and released from the second local oscillator (LO2: 62.4MHz).

■ LO1

The output from the DDS (IC701) (8.340MHz~8.459MHz) goes through ceramic filter CF701 and is input into the PLL IC (IC703). The input signal is demultiplied by 8 (R) in the PLL IC (IC703) and becomes the comparison frequency f_0 which is 1.041MHz~1.058MHz. VCO oscillates at 73.125MHz~103.095MHz, and is input into the 6th pin of the PLL IC, and then demultiplied to 1/N in the PLL IC. It is then compared with the comparison frequency f_0 by the phase comparator which locks the frequency and yields the LO1 output frequency.

基准信号发生器

TCXO用于控制PLL的基准频率fstd并且是振荡的15.6MHz频率。该基准信号通过缓冲放大器(Q709)并由倍频器(Q711)放大一倍(至31.2MHz)。该倍频信号用作DDS(IC701),来自本振的PLL基准信号,并用作CARs(IC702)的DDS基准信号。

倍频信号随后由Q708和Q704再次放大一倍,并从第二级本振输出(LO2: 62.4MHz)。

■ LO1

DDS (IC701) (8.340MHz~8.459MHz) 的输出信号通过陶瓷滤波器CF701并输入至PLL IC (IC703)。输入信号在PLL IC (IC703) 内进行8 (R) 分频并成为1.041MHz~1.058MHz之间的比较频率 f_0 。VCO在73.125MHz~103.095MHz之间振荡并输入至PLL IC的第6个引脚,然后在PLL IC内进行N分频。接着通过锁定频率并产生LO1输出频率的相位比较器与比较频率 f_0 进行比较。

CIRCUIT DESCRIPTION / 电路说明

With the DDS (IC701), the output frequency is swept with the formula: $f_{\text{DDS STEP}} [\text{Hz}] = 10 \times R/N$, when at 10Hz Step, and with the formula: $f_{\text{DDS STEP}} [\text{Hz}] = 1 \times R/N$, when at 1Hz STEP. Therefore, LO1 covers the frequency range of 73.125 MHz~103.095MHz in 10Hz or 1Hz steps.

The PLL output created is amplified with amplifier Q706, passes through the BPF, the ATT, and the LPF, and is output as LO1.

LO2

LO2 outputs 62.4MHz which is the reference frequency, 15.6MHz, multiplied by 4.

The reference oscillation circuit output goes through buffer Q709, is multiplied at doubler Q711, and becomes 31.2MHz. Because this signal is also used as the DDS reference frequency, it is resistively distributed. The signal is then multiplied by doublers Q708 and Q704, the higher harmonic component is removed by the BPF, and it is output as LO2.

CAR

A carrier of 10.695MHz is used by the modulator and the demodulator generated by the DDS (IC702). The DDS output signal goes through the buffer (Q712) and LPF, and is sent to the modulator and the demodulator.

在DDS (IC701) 内, 使用公式扫视输出频率, 处于10Hz步进时, 采用公式 $f_{\text{DDS STEP}} [\text{Hz}] = 10 \times R/N$, 处于1Hz步进时, 采用公式 $f_{\text{DDS STEP}} [\text{Hz}] = 1 \times R/N$, 因此, LO1涵盖73.125MHz~103.095MHz的范围, 步进为10Hz或1Hz。

产生的PLL输出经由放大器Q706进行放大, 然后通过BPF、ATT和LPF并作为LO1进行输出。

LO2

LO2输出62.4MHz的基准频率, 是15.6MHz的4倍。

基准振荡电路的输出信号通过缓冲器Q709并在倍频器Q711内进行放大成为31.2MHz。由于该信号还用作DDS基准频率, 因此其耐分流。然后信号由倍频器Q708和Q704再次放大, 较高的谐波部分将由BPF清除并作为LO2输出。

CAR

调制器和检波器使用的10.695MHz载波由DDS (IC702) 产生。DDS输出信号通过缓冲器 (Q712) 和LPF并发送至调制器和检波器。

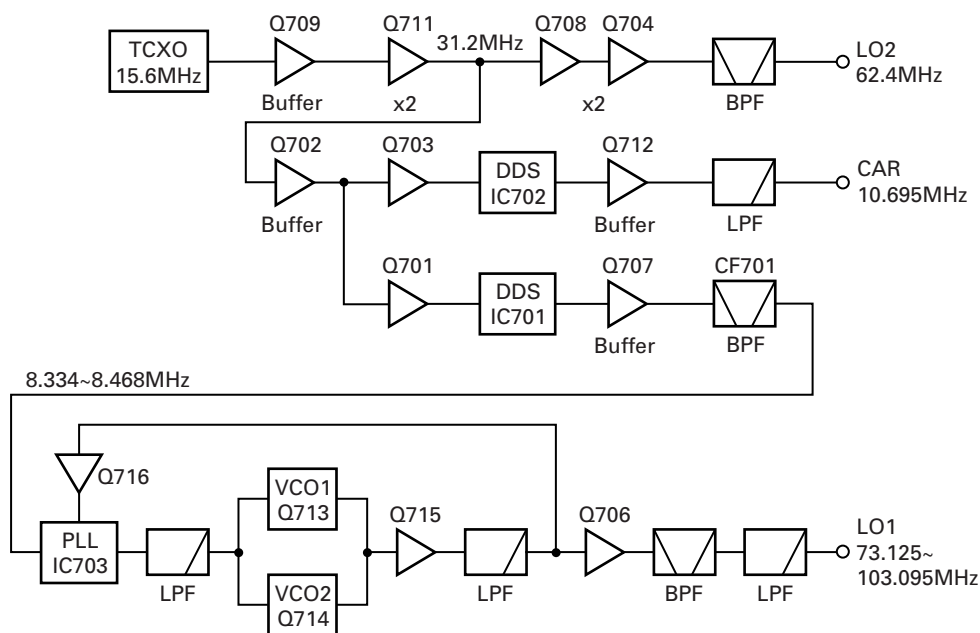

Fig. 2 Reference signal generator block diagram / 图2 基准信号发生器结构图

CIRCUIT DESCRIPTION / 电路说明

Receive Circuit

The receive circuit is a double conversion structure with first IF: 73.095MHz and second IF: 10.695MHz.

■ From Antenna to Preamplifier

The received signal from the antenna terminal is passed into the Final unit (X45-378), the surge trap (D3), the transmit/receive switching relay (K1), and the image signal eliminating filter, and is then output to the TX-RX unit (X57-721).

The signal from the Final unit CN1 is input into TX-RX unit CN1. It is then passed through the attenuator circuit (K1: default setting 20dB, the image signal eliminating filter, the surge absorption limiter, and is then input into the bandpass filter circuit. The bandpass filter circuit is divided into 8 frequency ranges. A breakdown of the frequencies is shown in table 1. This bandpass filter passes not only the received signal but also the transmit signal at the time of transmission.

After the bandpass filter circuit, there is a preamp (Q103) with approximately a 10dB gain. This preamp can be turned ON/OFF using the FPU. It is then passed through a local oscillator signal eliminating filter, and input into the first mixer.

■ From First Mixer, RF Output (Receive Second IF: 10.695MHz)

The signal input into the first mixer is converted to the first IF frequency (73.095MHz). The first mixer uses a high-performance circuit with quad-connects JFETs (Q105, 106, 108, 109). Its dynamic range characteristics is therefore equal a to high-class model. The next step, MCF, uses 2, 2-pole MCFs. By passing not only the received signal but also the transmitted signal through this narrow-band MCF, nearby spurious signals are reduced. The signal input/output terminals TP1 (CN4) and TP2 (CN5) for MFC adjustment are located on the print base.

The signals which passed through MCF are amplified with the receiving first IF amplifier (Q183) which is gain controlled (AGC), and are then converted to receiving second IF (10.695 MHz) at the receiving second mixer. This mixer employs passive type which uses a diode and is a dual-directional circuit which converts not only received signal frequencies but also transmitted signal frequencies.

Band 频段	Filter range 滤波器范围
1	30kHz~1.605MHz
2	1.605MHz~2.5MHz
3	2.5~4.1MHz
4	4.1~7.5MHz
5	7.5~10.5MHz
6	10.5~14.5MHz
7	14.5~21.5MHz
8	21.5~30.0MHz

Table 1 BPF range
表1 带通滤波器范围

接收电路

接收电路为带有第一中频73.095MHz和第二中频10.695MHz的二次变频结构。

■ 从天线至前置放大器

从天线端子接收的信号依次通过Final单元 (X45-378)、电涌滤波器 (D3)、发射/接收转换继电器 (K1) 和镜象信号消除滤波器, 然后输出至TX-RX单元 (X57-721)。

Final单元CN1的信号输入至发射接收单元CN1。然后通过衰减器电路 (K1: 默认设置20dB)、镜象信号消除滤波器、电涌吸收限幅器并输入至带通滤波器电路。带通滤波器分为8个频率范围。频率的衰减参见表1。该带通滤波器不仅能够通过接收信号, 还能够通过发射信号。

经过带通滤波器电路后, 进入10dB左右增益的前置放大器 (Q103)。该前置放大器可以使用FPU进行打开/关闭。然后通过本地振荡器信号消除滤波器并输入至第一混频器。

■ 来自第一混频器, 射频单元输出 (接收第二中频10.695MHz)

输入至第一混频器的信号被转换为第一中频 (73.095MHz)。第一混频器使用带有四连接JFET (Q105, 106, 108, 109) 的高性能电路。因此, 其动态范围特性等同于高级机型。接下来的MCF使用两个双极MCF。不仅能够通过接收的信号, 而且还能够通过窄带MCF的发射信号, 从而降低周围的杂散信号。在压印基座上带有用于MFC调节的信号输入/输出端子TP1 (CN4) 和 TP2 (CN5)。

通过MCF的信号经由接收的第一中频放大器 (Q183) (受增益控制 (AGC)) 放大, 然后在接收的第二混频器处转换为接收的第二中频 (10.695MHz)。该混频器采用使用二极管的被动式设计和双向电路, 不仅能够转换接收的信号频率还能转换发射信号频率。

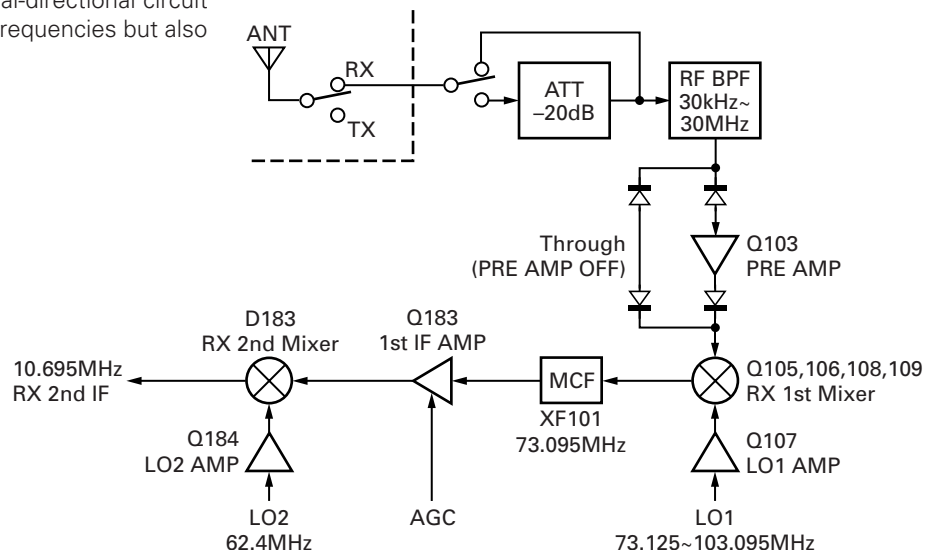

Fig. 3 From antenna to TX-RX unit / 图3 从天线至TX-RX单元

CIRCUIT DESCRIPTION / 电路说明

■ Receiving IF Filter

The 10.695MHz received signal converted at the second mixer is amplified by the gain-controlled (AGC) second IF amplifier (Q185). Q185 also functions as a noise blanker gate. When blanking, the pulse voltage of the noise component is added to the Q185 source terminal, and Q185 turns OFF. It is then passed through a narrow band IF filter, eliminating unnecessary signal components.

The default IF filters installed are for SSB (XF252: 2.4kHz band) and AM (XF251: 6kHz band). On the TX-RX unit print board, there is space for installing an optional filter. A CW filter (YF-107C: 500Hz band) or SSB filter (KIF-2: 2.7kHz band) can be installed as an optional filter.

Signals which are passed through the IF filter are amplified with the IF amplifier (Q251), and are then input into the gain-controlled (AGC) second IF amplifier (Q451 and Q455).

■ 接收中频滤波器

在第二混频器处转换的接收信号10.695MHz经由增益控制 (AGC) 的第二中频放大器 (Q185) 进行放大。消声时, 噪音部分的脉冲电压被添加至Q185源极且Q185关闭。然后通过10.695MHz窄带中频滤波器消除不需要的信号部分。

标配安装的中频滤波器适用于SSB (XF252: 2.4kHz频带) 和调幅 (XF251: 6kHz频带)。在TX-RX单元的印刷板上, 预留了用于安装滤波器选配件的空间。选配的滤波器可以安装CW滤波器 (YF-107C: 500Hz频带) 和SSB滤波器 (KIF-2: 2.7kHz频带)。

通过中频滤波器的信号经由中频放大器 (Q251) 放大, 然后输入至增益控制 (AGC) 的第二中频放大器 (Q451和Q455)。

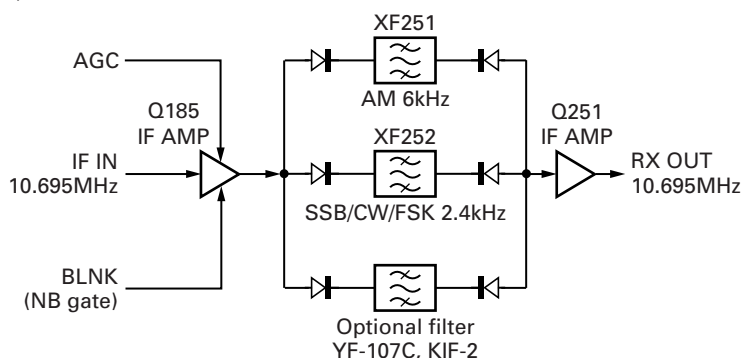

Fig. 4 Receiving IF filter / 图4 接收中频滤波器

Item	Rating
Nominal center frequency	10.695MHz
Center frequency deviation	Within $\pm 150\text{Hz}$ at 6dB
Pass bandwidth and Attenuation bandwidth	2.2kHz or more at 6dB 3.0kHz or less at 20dB 5.2kHz or less at 60dB
Ripple	2dB or less
Insertion loss	6dB or less
Guaranteed attenuation	80dB or more within $\pm 5\sim 1000\text{kHz}$
Terminal impedance	$1.0\text{k}\Omega \pm 5\%$ / $7\text{pF} \pm 5\%$
Temperature range	$-20^\circ\text{C} \sim +70^\circ\text{C}$

Table 2 MCF (L71-0604-15): XF252

项目	规格
标称中心频率	10.695MHz
中心频率频偏	在6dB, $\pm 150\text{Hz}$ 以内
通过带幅及衰减带幅	在6dB, 2.2kHz或更高 在20dB, 3.0kHz或更低 在60dB, 5.2kHz或更低
脉动	2dB或更低
插入损耗	6dB或更低
保证衰减量	在 $\pm 5\sim 1000\text{kHz}$ 以内, 80dB或更高
终端阻抗	$1.0\text{k}\Omega \pm 5\%$ / $7\text{pF} \pm 5\%$
温度范围	$-20^\circ\text{C} \sim +70^\circ\text{C}$

表2 MCF (L71-0604-15): XF252

Item	Rating
Nominal center frequency	10.695MHz
Center frequency deviation	Within $\pm 100\text{Hz}$ (25°C , 6dB)
Pass bandwidth	500Hz or more (6dB)
Insertion loss	$9\text{dB} \pm 3\text{dB}$
Ripple	2dB or less
Guaranteed attenuation	80dB or more within $\pm 2\sim 1000\text{kHz}$
Terminal impedance	800Ω / 2pF

Table 3 MCF (YF-107C): CW optional filter

项目	规格
标称中心频率	10.695MHz
中心频率频偏	$\pm 100\text{Hz}$ 以内 (25°C , 6dB)
通过带幅	500Hz或更高 (6dB)
插入损耗	$9\text{dB} \pm 3\text{dB}$
脉动	2dB或更低
保证衰减量	在 $\pm 2\sim 1000\text{kHz}$ 以内, 80dB或更高
终端阻抗	800Ω / 2pF

表3 MCF (YF-107C): CW滤波器 (选件)

CIRCUIT DESCRIPTION / 电路说明

Item	Rating
Nominal center frequency	10.695MHz
Center frequency deviation	Within $\pm 150\text{Hz}$ at 6dB
Pass bandwidth and	2.7kHz or more at 6dB
Attenuation bandwidth	4.4Hz or less at 20dB
	6.2kHz or less at 60dB
Ripple	2dB or less
Insertion loss	7dB or less
Guaranteed attenuation	80dB or more within $\pm 6\sim 1000\text{kHz}$
Terminal impedance	$800\Omega / 2.0\text{pF}$
Temperature range	$-20^{\circ}\text{C}\sim +70^{\circ}\text{C}$

Table 4 MCF (KIF-2): SSB WIDE optional filter

项 目	规 格
标称中心频率	10.695MHz
中心频率频偏	在6dB, $\pm 150\text{Hz}$ 以内
通过带幅及	在6dB, 2.7kHz或更高
衰减带幅	在20dB, 4.4kHz或更低
	在60dB, 6.2kHz或更低
脉动	2dB或更低
插入损耗	7dB或更低
保证衰减量	在 $\pm 6\sim 1000\text{kHz}$ 以内, 80dB或更高
终端阻抗	$800\Omega / 2.0\text{pF}$
温度范围	$-20^{\circ}\text{C}\sim +70^{\circ}\text{C}$

表4 MCF (KIF-2): SSB宽带滤波器 (选件)

■ From the Receiving Second IF Amplifier to Detection

The diode (D452) between Q451 and Q455 is a pin diode. The received total gain (AGC operation start level) is determined by the current passed through this diode. The current value can be set using the adjustment menu. The transistor (Q456) connected to the source of Q455 is a switch to mute the IF signal during transmission.

The IF signal amplified with Q451 and Q455 is detected with IC451 during SSB/CW/FSK mode and converted into an AF signal. AM mode is detected with D454 after passing through the Q457 buffer. Some amount of DC bias is applied to D454 to reduce the distortion when the signal is small.

■ AGC Circuit

The output signals of Q457 are also input into the AGC circuit. The IF signal is input into the voltage double rectifier (D453) and converted into DC voltage there. This voltage is added to the base of Q453.

The base voltage of Q453 changes depending on the amplitude (input level of receiving signal) of the IF signal. Fluctuations of the base current change the AGC voltage, control the gain of the AGC IF amplifier (Q183, Q451 and Q455) and maintain the IF signal level input into the detection circuit.

■ 从接收的第二中频放大器至检测

Q451和Q455之间的二极管 (D452) 是插脚二极管。接收到的总增益 (AGC操作启动电平) 由通过该二极管的电流来确定。电流值可以使用调节菜单进行设置。连接至Q455源极的晶体管 (Q456) 是发射期间中频信号静音的开关。

由Q451和Q455放大的中频信号在SSB/CW/FSK模式期间通过IC451进行检测, 并转换为音频信号。通过Q457缓冲器后, D454检测到调幅模式。一定程度的直流偏置将添加至D454, 从而减小信号较小时的失真。

■ AGC电路

Q457的输出信号也会输入至AGC电路。中频信号输入至双电压整流器 (D453) 并在此转换为直流电压。该电压被添加至Q453基极。

Q453的基极电压取决于中频信号的振幅 (接收信号的输入电平)。基极电流的波动能够改变AGC电压, 控制AGC中频放大器 (Q183、Q451和Q455) 的增益并保持输入至检测电路的中频信号的电平。

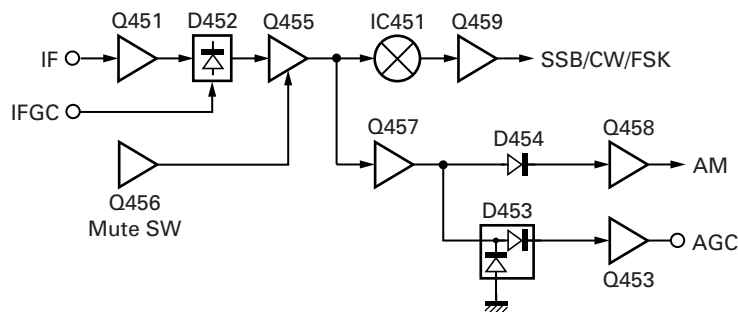

Fig. 5 From the receiving second IF amplifier to detection and AGC circuit

图5 从接收的第二中频放大器至检测和AGC电路

CIRCUIT DESCRIPTION / 电路说明

■ From Detection Circuit to Speaker Output

The detected audio signal is input into the multiplexer (IC452). The multiplexer, depending on the mode at the time, switches the detection circuit output, and the signal is amplified and filtered at the multiple returning amplifier circuit (IC453). It is then sent by the analog switch IC (IC551) to the speaker output route and VGS-1, etc.

IC551 output is passed through the mute switch (Q460) and is input into the electric volume (IC555). IC555 changes the level, depending on the speaker output. The output from IC555 is passed through the mute circuit (Q523) and the audio frequency characteristics switch (Q521), and is then power-amplified at the audio power amplifier IC (IC521), passed through the pin-jack (J1), is sent from CN236 to the Display unit, and is output from the built-in speaker.

■ Audio Frequency Switching by Mode

The switch circuit (Q521) is added so that while in SSB mode, the high-pitch range can be suppressed to prevent exhausting the listener's ears, and while in AM mode, the high-pitch range sound can be expressed. Therefore, the sound in AM mode and in other modes are different.

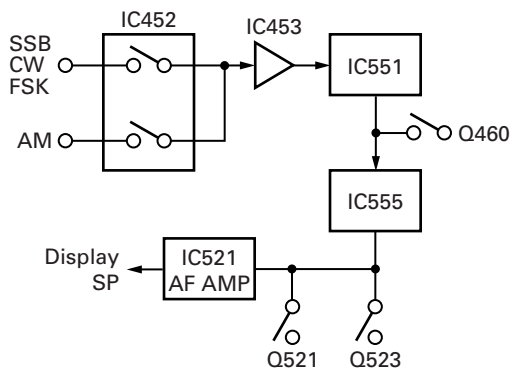

Fig. 6 From detection circuit to speaker output
图6 从检测电路至扬声器输出

Transmission Circuit

■ From Microphone Terminal to Output for Modulation

This transceiver's transmission section operates with the frequencies consisting of double super heterodyne, transmission first IF: 10.695MHz and transmission second IF: 73.095MHz.

The Audio signal (AF signal) input from the microphone terminal is relayed at the Display unit (X54-356) and input into the TX-RX unit (X57-721).

The AF signal input into the TX-RX unit is amplified by the MIC AMP IC (IC605), and the level is adjusted by the DA converter (IC554) according to the microphone gain set in the firmware. The AF signal is then split as a signal for modulation to the 1st AF ALC amplifier (IC602) and a microphone signal for VOX operation to the VOX AMP (IC604).

The first AF ALC amplifier detects its output with D605 and D606, and restricts the input signal with Q605 and Q606. This prevents SSB over-modulation and restricts the VGS-1 (option) recording input level.

■从检测电路至扬声器输出

检测到的音频信号被输入至多路复用器 (IC452)。多路复用器 (取决于当时的模式) 转换检测电路输出, 信号在多用放大器回路 (IC453) 进行放大和过滤。然后由模拟转换IC (IC551) 发送至扬声器输出线路和VGS-1等。

IC551输出信号通过静音开关 (Q460) 并输入至电子音量 (IC555)。IC555根据扬声器输出改变电平。IC555的输出信号通过静音电路 (Q523) 和音频特性开关 (Q521), 然后在音频功率放大器IC (IC521) 进行功率放大并通过管脚插口 (J1), 接着从CN236 发送至显示单元并从内置扬声器输出。

■通过模式进行音频转换

增加了转换电路 (Q521), 使得在SSB模式下可以抑制高音范围, 从而避免听者耳朵疲劳; 在调幅模式下可以表现高音范围的声音。因此, 调幅模式和其他模式下的声音存在差异。

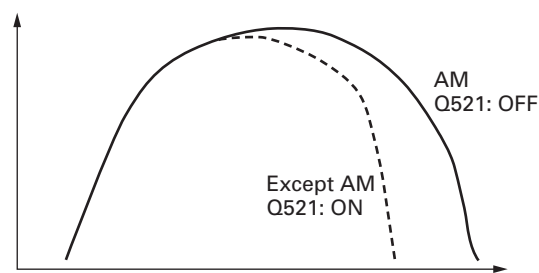

Fig. 7 Audio frequency switching by mode
图7 通过模式进行音频转换

发射电路

■麦克风端子至调制输出

本对讲机的发射部分使用二次超外差、发射第一中频10.695 MHz和发射第二中频73.095MHz组成的频率进行操作。

麦克风端子输入的音频信号在Display单元 (X54-356) 进行中继, 然后输入至TX-RX单元 (X57-721)。

输入至TX-RX单元的音频信号通过MIC AMP IC (IC605) 进行放大, 并根据固件中设置的麦克风增益由DA转换器 (IC554) 调节电平。接着, 音频信号分离为进入第一个AF ALC放大器 (IC602) 进行调制的信号和进入VOX AMP (IC604) 进行VOX操作的麦克风信号。

第一个AF ALC放大器通过D605和D606检测其输出, 并通过Q605和Q606限制输入信号。该步骤能够避免SSB过度调制以及限制VGS-1 (选件) 录音输入电平。

CIRCUIT DESCRIPTION / 电路说明

Connected to the first AF ALC amplifier output, switching to the second AF ALC amplifier (IC602), are the recording output for VGS-1, the play input, and the I/O circuit for the scrambler circuit.

The second AF ALC amplifier does not operate for ALC when it is SSB. It instead operates to prevent AM over-modulation. The AF signal which went through the second AF ALC amplifier should reach appropriate modulation sensitivity by DA Converter (IC554).

It then goes through buffer amplifier (Q255) and into the balanced modulator (IC251).

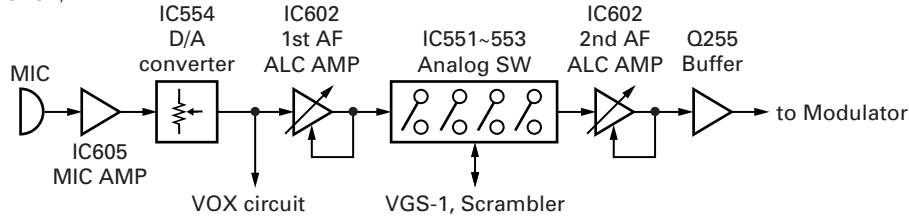

Fig. 8 From microphone terminal to output for modulation / 图8 麦克风端子至调制输出

■ Modulation Circuit

The AF signal input into the balanced modulator (IC251) in USB mode is modulated with a 10.6965MHz carrier and becomes a DSB signal. (LSB: 10.6935MHz, AM: 10.695MHz, FSK changes depending on the shift width and tone setting.)

The signal modulated to DSB is amplified by IF amplifier (Q253), goes through SSB IF filter (XF252), attenuates unnecessary side band component, and becomes the first IF frequency SSB signal.

In AM mode, by adding direct voltage to the modulation signal, it breaks down the balanced modulator, and by emitting the carrier, generates an AM signal. The AM-modulated signal is amplified by the IF amplifier (Q253), goes through AM IF filter (XF251), and attenuates the out-of-band modulation component.

In CW and FSK mode, the carrier signal is generated in the same way as in AM mode, by adding direct voltage to the modulation signal terminal.

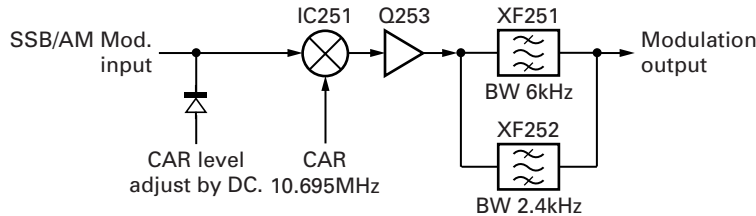

Fig. 9 Modulation circuit / 图9 调制电路

■ From Modulation Circuit to Drive Output

The transmission signal which passed through the first IF filter (10.695MHz) is amplified at the second gate of the IF amplifier (Q186). While being sent, ALC voltage is added to control the gain.

The transmission signal from the IF amplifier (Q186) is passed through the buffer (Q187) and the first transmission mixer (D183), and is converted to the second IF frequency, 73.095MHz.

The transmission signal is then amplified by the IF amplifier (Q182) where the total gain (resulting from the Final unit frequency characteristics) is corrected for each transmission frequency by the TGC (Transmission Gain Control).

连接至第一个AF ALC放大器输出以及切换至第二个AF ALC放大器 (IC602) 的是VGS-1的录音输出、播放输入和扰频电路的I/O电路。

使用SSB时,第二个AF ALC放大器不会用作ALC,其作用为避免调幅过度调制。通过第二个AF ALC放大器的音频信号当经由DA转换器 (IC554) 达到适当的调制灵敏度。

然后通过缓冲放大器 (Q255) 并进入平衡调制器 (IC251)。

■ 调制电路

在USB模式下,输入至平衡调制器 (IC251) 的音频信号使用 10.6965MHz载波进行平衡调制,并变成DSB信号。(LSB: 10.6935MHz, AM: 10.695MHz, FSK的变化取决于偏移宽度和音设置。)

调制成DSB的信号经由中频放大器 (Q253) 进行放大,然后通过SSB中频滤波器 (XF252) 衰减不需要的边带部分,成为第一个中频SSB信号。

在调幅模式下,通过将直流电压添加至调制信号,打破平衡调制器的平衡,并通过发射载波产生调幅信号。调幅调制信号经由中频放大器 (Q253) 进行放大,然后通过调幅中频滤波器 (XF251) 并衰减频带外的调制部分。

在CW模式和FSK模式下,通过将直流电压添加至调制信号端子,生成载波信号的方法与调幅模式下相同。

■ 从调制电路至驱动输出

通过第一中频滤波器的发射信号 (10.695MHz) 由中频放大器 (Q186) 的第二栅极进行放大。发送过程中,通过添加ALC电压控制增益。

中频放大器 (Q186) 的发射信号通过缓冲器 (Q187) 和第一发射混频器 (D183),然后转换为第二中频73.095MHz。

发射信号由中频放大器 (Q182) 进行放大。在中频放大器 (Q182) 内,由TGC (发射增益控制) 为各个发射频率校正总增益 (因Final单元频率特性所致)。

CIRCUIT DESCRIPTION / 电路说明

The signal passed through the IF amplifier loses all unnecessary signals other than the second IF signal at the MCF (XF101). Here, it is inserted into the second transmission mixer (IC101) and is converted to the transmission frequency signal.

The signal from the second transmission mixer (IC101) passes through the receiving circuit BPF, becomes amplified at the drive amplifier (Q3), and is sent from CN1 to the Final unit.

在MCF (XF101) 内, 通过中频放大器的信号去掉第二中频信号之外的所有不需信号, 然后在此进入第二发射混频器 (IC101) 并转换为发射频率的发射信号。

第二发射混频器 (IC101) 的信号通过接收电路BPF, 然后在驱动放大器 (Q3) 内进行放大并从CN1发送至Final单元。

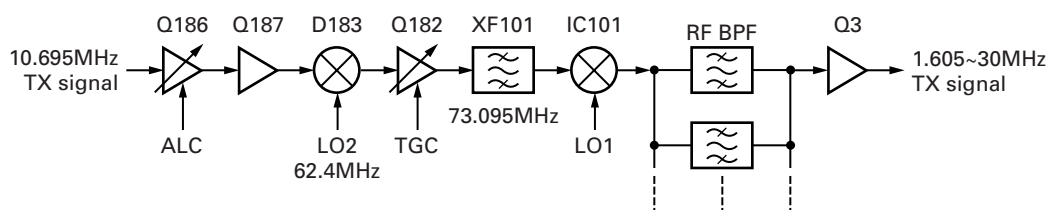

Fig. 10 From modulation circuit to drive output / 图10 从调制电路至驱动输出

■ Control Circuit

1) ALC Circuit

This is the feedback loop circuit for avoiding raising of the transmission power above the specified value. It monitors the forward wave detection voltage (VSF) detected at the final unit, lowers the first IF amplifier gain so as not to exceed the specified value, and controls the antenna end transmission power.

The VSF voltage is added to the base of Q363 and the POC voltage (Power Control Voltage) is added to the emitter. If the VSF voltage generated by the transmit power becomes POC + approximately 0.7V, the Q363 collector current runs and the collector voltage decreases from 5.6V. Q365, D370, Q366, and D372 convert the voltage change to the correct control voltage, change the first IF amplifier Q186 second gate bias, and control it so that the transmit power is not over the specified value.

2) Power Control Circuit

By lowering the ALC circuit POC voltage, the VSF voltage where ALC starts being active becomes lowered. By doing this, the transmission power can be lowered as well. However, in this condition, the ALC starts becoming active when the microphone input level is low.

Therefore, the IF amplifier (Q186) gain should be lowered in accordance with the POC. By making the ALC voltage default value (the voltage when transmitting no signal) variable depending on the set transmission power, the IF amplifier (Q186) gain is changed at the same time.

■ From Drive Output to Antenna

The transmission signal sent from CN2 of the TX-RX unit (X57-721) to CN2 of the Final unit (X45-378) is amplified for its power by the pre-drive amplifier (Q1), the drive amplifier (Q2 and Q3), and the final amplifier (Q4 and Q5). The higher harmonic wave is then removed with a LPF of the specified frequency band, and the transmission signal passes through traveling wave, reflecting wave detection circuit, and transmission/receive switching relay and is sent to the antenna terminal.

■ 控制电路

1) ALC电路

该电路为反馈回路, 能够避免发射功率高于规定值。该电路可以监控末级单元检测到的行进波检测电压 (VSF), 降低超出规定值的第一中频放大器增益以及控制天线端的发射功率。

将VSF电压添加至Q363基极以及将POC电压 (功率控制电压) 添加至发射极。如果由发射功率产生的VSF电压变为POC + 0.7V左右, 则Q363控制器电流出现且控制器电压从5.6V开始下降。Q365、D370、Q366和D372将电压变化转换为校正控制电压, 改变第一中频放大器Q186的第二栅极偏压, 并根据不超出规定值的原则进行控制。

2) 功率控制电路

通过降低ALC电路的POC电压, ALC开始激活时的VSF电压将会降低, 从而降低发射功率。但是, 此时如果麦克风输入电平为低, 则ALC开始激活。

因而应当根据POC降低中频放大器 (Q186) 增益。通过根据设置的发射功率设置ALC电压默认值 (没有发射信号时的电压) 变量, 能够同时改变中频放大器 (Q186) 增益。

■ 从驱动输出至天线

从TX-RX单元 (X57-721) CN2发送至Final单元 (X45-378) CN2的发射信号经由前置驱动放大器 (Q1)、驱动放大器 (Q2和Q3) 以及末级放大器 (Q4和Q5) 依次放大其功率。然后, 由指定频带的LPF消除较高的谐波, 发射信号依次通过行波、反射波检测电路以及发射/接收转换继电器, 发送至天线端子。

CIRCUIT DESCRIPTION / 电路说明

The idling current adjusting trimmer potentiometer is adjusted as VR1 for the pre-drive, VR2 for drive Q2, VR3 for drive Q3, and the final steps Q4 and Q5 are adjusted to VR4. Although a FET is used for the drive amplifier, because the FET's V_{th} characteristics vary greatly, the drive step idling current is adjusted separately for Q2 and Q3. Please note that the same hfe rank transistor is used for the final steps, Q4 and Q5.

The LPF circuit of this transceiver divides the frequency band of 1.605~30MHz into 7 (6 in previous models), and ensures a higher harmonic wave attenuation within the band range.

Thermistor (TH1 and TH2) for temperature protection detection converts temperature change to voltage, is output from CN4's TH1 and TH2 terminals to the TX-RX unit, and controls the fan motor and power down.

In transmit power detection, the voltage at coil L8 is detected at D7 for traveling wave and D6 for reflecting wave, output from CN4 to the TX-RX unit as VSF and VSR signals, and is used for transmission output control. The current running in the drive circuit is detected at R1 as ID+ and ID-, and the current running in the final step circuit is detected at R3 as IC+ and IC-. Each signal goes from CN4 to the TX-RX unit and is used for transmission output control.

For the pre-drive for excess current protection, chip fuse F1 (5A) for the drive circuit, chip fuse F2 (10A) for the power switch Q7 protection, and blade-type fuse F3 (4A) for the external antenna tuner power are used.

The DC power supply coming in from the power connector into the transceiver is divided into 2 lines of 14V and 14S. A 14V power supply which does not go through the main power switch FET (Q7) is added to the final step transistor Q4 and Q5's power supply and from CN3 to the MCU in the TX-RX unit.

The main power switch FET (Q7) is controlled by Q8 and is turned ON/OFF. The PSC signal from the TX-RX unit is applied to Q8, and when the PSC signal is High, Q7 is ON and a current of approximately 5A goes through Q7.

Power supply 14S, which went through Q7, becomes the power supply for the pre-drive and drive. 14S becomes an 8V power supply of 8A at IC2, and is used for the final transistor base bias. 8A is supplied from CN3 to the TX-RX unit. 14S becomes an 8V power supply of 8D at IC1, and the power supply 14AF which came through the choke coil L29, from CN3 to the TX-RX unit.

For the relay for LPF (K101~K702), the controlling IC (IC3), FEN, CLK, and DAT control signals from the TX-RX unit come through CN4. IC3's 5V power supply is also generated at the TX-RX unit and is supplied from CN4's 5A terminal.

根据VR1对应前置驱动放大器、VR2对应驱动器Q2、VR3对应驱动器Q3、VR4对应末级放大器Q4和Q5的原则调节静态电流微调电位器。尽管驱动放大器均使用FET,但是由于FET的 V_{th} 特性差异很大,驱动放大器静态电流必须对Q2和Q3进行单独调节。请注意,末级放大器Q4和Q5晶体管的hfe等级相同。

本短波通信机的LPF电路将1.605~30MHz的频带分为7个(以前机型为6),确保频带范围内较高的谐波衰减。

用于温度保护检测的热敏电阻(TH1和TH2)将温度变化转换为电压变化,然后从CN4的TH1和TH2端子输出至TX-RX单元并控制风扇马达和断电。

在发射功率检测方面,在行波的D7和反射波的D6检测线圈L8的电压,作为VSF和VSR信号从CN4输出至TX-RX单元并用于发射输出控制。

驱动电路中出现的电流在R1处检测为ID+和ID-,末级电路中出现的电流在R3处检测为IC+和IC-。每个信号从CN4进入TX-RX单元并用于发射输出控制。

就用于过载电流保护的前置驱动而言,驱动电路使用片状保险丝F1(5A),电源开关Q7保护使用片状保险丝F2(10A),外部天线调谐功率使用叶片式保险丝F3(4A)。

从电源接口进入短波通信机的直流电源分离为14V和14S两条线路。未经过主电源开关FET(Q7)的14V电源被添加至末级晶体管Q4和Q5的电源,并从CN3进入TX-RX单元的MCU。

主电源开关FET(Q7)由Q8控制开关。TX-RX单元的PSC信号应用于Q8,当PSC信号为高电平时,Q7开启,5A左右的电流通过Q7。

通过Q7的14S电源成为前置驱动和驱动的电源。在IC2处,14S变为8V、8A电源并用于末级晶体管基极偏压。从CN3向TX-RX单元提供8A电流。在IC1处,14S变为8V、8D电源,并通过扼流线圈L29的14AF电源从CN3提供至TX-RX单元。

就LPF(K101~K702)的继电器而言,控制来自TX-RX单元的IC(IC3)、FEN、CLK和DAT的控制信号通过CN4。IC3的5V电源同时在TX-RX单元生成并由CN4的5A端子供电。

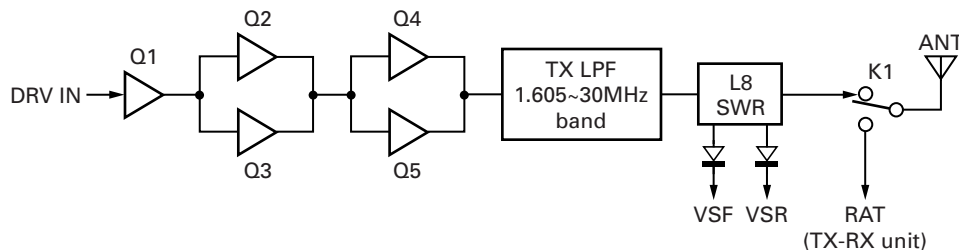

Fig. 11 From drive output to antenna / 图11 从驱动输出至天线

CIRCUIT DESCRIPTION / 电路说明

■ Protection Circuit

1) Current Protection

Even with a load whose VSWR is relatively in good condition, there may be cases where the consumption current increases. This is the protection circuit which detects such current and makes sure the current consumption is less than the specified amount. It includes the circuit which detects the current of the Final unit and the circuit which detects the current of the drive step and prevents currents that exceed a certain level.

The final side detects the voltage difference occurring at both ends of R3, the current detection resistance, and the drive step detects the voltage difference occurring at R1. When the difference becomes a certain value or larger at the TX-RX unit op-amp (IC361, IC362), the IF amplifier (Q186) gain is controlled using the ALC circuit and excess current is suppressed.

2) SWR Protection

When there is a problem with the antenna load impedance, the transmission circuit may become damaged. By lowering the power according to the VSWR deterioration, this circuit is protected from damaging devices.

The reflected wave detection voltage VSR responding to the reflected power exceeds a certain value at the final unit. By using the function to lower the ALC circuit gain, the reflected power is controlled so as to not to be yielded again.

When the VSR for the op-amp (IC362) reversed input and the SWR protection controlling voltage (PRO) for forward input are connected, and when the VSR which exceeds the PRO occurs, this op-amp output is also connected to the ALC circuit and is controlled by lowering the IF amplifier (Q186) gain.

■ Attached Circuit

1) High-boost Circuit

Because the SSB modulation frequency characteristics are flat, the signal is transmitted with the frequency characteristics of the microphone itself. Due to their structure, waterproof microphone's high pitch sound tends to be lowered. To correct this, a high-boost circuit for emphasizing high pitch sound is included.

The microphone amplifier (IC605) gain and frequency characteristics are switched at Q607 and Q608. When high-boost is ON, high-gain yields 3dB octave low-cut characteristics. By combining this with the IF filter for SSB (XF252), a modulation frequency of 2~2.5kHz is emphasized.

Thus, the practical sound quality difference from non-waterproof microphones is lessened.

2) VOX Circuit with Anti-VOX

The signal from the microphone passes through the microphone amplifier (IC605) and DA converter IC (IC554), is input to the VOX amplifier (IC604), is tested for VOX sensitivity at IC554, passes through the buffer amplifier (IC603), is detected by the detector (D604), and changes to a DC level.

The received signal coming in from the speakers is amplified to an appropriate level at the anti VOX amplifier (IC605), is tested for anti VOX sensitivity at the DA converter IC (IC554), passes through buffer amplifier (IC603), is detected by the detector (D603), and changes to a DC level.

■ 保护电路

1) 电流保护

即使负载状况相对良好的VSWR, 也会出现消耗电流增加的情况。该保护电路可以检测此类电流并确保电流消耗低于规定值。该保护电路包括检测Final单元电流的电路, 以及检测驱动部分电流的电路, 避免电流超出相应范围。

Final单元检测R3处(电流检测电阻)两侧的电压差, 驱动部分检测R1处的电压差。在TX-RX单元放大器(IC361, IC362)处的电压差为某个值或较大时, 使用ALC电路控制中频放大器(Q186)增益, 超出部分的电流即被抑制。

2) SWR保护电路

天线负载阻抗出现故障时, 发射电路可能受损。该电路能够根据VSWR损耗降低功率, 达到避免设备损坏的目的。

响应反射功率的反射波检测电压VSR在Final单元可能超出某个值。通过使用降低ALC电路增益的功能, 可以控制反射功率不再产生。

放大器(IC362)的VSR反向输入而正向输入的SWR保护控制电压(PRO)已经连接时, 以及发生超出PRO的VSR时, 该放大器输出也会连接至ALC电路, 并通过再次降低中频放大器(Q186)进行控制。

■ 附属电路

1) 高频补偿电路

由于SSB调制频率特性较为平坦, 因此使用麦克风自身的频率特性发射信号。由于其自身结构所限, 防水麦克风的高音趋向降低。为了校正该现象, 短波通信机内置了增强高音的高频补偿电路。

麦克风放大器(IC605)增益和频率特性在Q607和Q608处进行转换。高频补偿开启时, 高频增益产生3dB八度音阶低频切除特性。通过结合SSB的中频滤波器(XF252), 增强2~2.5kHz的调制频率。

因此, 与非防水麦克风之间的实际音质差异得以减少。

2) 带有抗防VOX功能的VOX电路

来自麦克风的信号通过麦克风放大器(IC605)和DA转换器IC(IC554), 然后输入至VOX放大器(IC604)并在IC554处检测VOX灵敏度, 接着通过缓冲放大器(IC603)并由检波器(D604)进行检测, 随后改变为直流电平。

从扬声器接收的信号在防VOX放大器(IC605)处放大为合适的电平并在DA转换器IC(IC554)处检测防VOX灵敏度, 接着通过缓冲放大器(IC603)并由检波器(D603)进行检测, 随后改变为直流电平。

CIRCUIT DESCRIPTION / 电路说明

The VOX circuit gives priority to what goes over a specified value by the use of a flip-flop IC (IC601). Setting values are set for the speaker output and microphone input levels separately. The level which first exceeds the threshold is given priority.

If input from microphones exceeds the level set in the VOX sensitivity before output from speakers exceeds the specified value set in the anti-VOX sensitivity, transmission status is yielded. Even if the input from the microphone becomes less than the VOX sensitivity, the transmission condition is maintained for the delay time.

When sound is output from the speakers and the output is more than the anti-VOX specified value, the setting can be made so that the status is not changed to transmission even with any amount of input into the microphone, or so that VOX does not activate with the sound of transceiver itself.

The VOX delay time is set and controlled by the MCU software.

3) DI Circuit

This is an external input circuit for when modulating signal other than from the microphone terminal, such as when using the optional KCT-39. The sensitivity is the same as a microphone, but because a trimmer potentiometer (VR852) is included for input, it can therefore support a wide range of input levels.

Digital Control Circuit

■ Outline

The digital control circuit consists of the main MCU at its center, the EEPROM (IC854), and the reset IC (IC856 and IC857). (Please refer to the block diagram.)

■ Main MCU

The main MCU (IC855) operates at a power supply voltage of 5V and a clock frequency of 11.0592MHz. The EEPROM is connected to the main MCU for backup. The power supply voltage monitoring circuit including the reset circuit are also connected.

通过使用触发器IC (IC601), VOX电路将优先权给予超出规定值的情况。单独设置扬声器输出电平和麦克风输入电平的设置值。首先超出阈值的电平具有优先权。

扬声器的输出超出防VOX灵敏度中设置的规定值之前, 如果麦克风的输入超出VOX灵敏度中设置的电平, 则产生发射状态。即使麦克风的输入低于VOX灵敏度, 仍然在延迟时间内保持发射状态。

从扬声器输出声音且输出超出防VOX规定值时, 可以进行设置, 使得无论输入麦克风的电平如何均不会转换为发射状态, 或者使得出现对讲机自身的声音时不激活VOX。

VOX延迟时间由MCU软件进行设置和控制。

3) DI电路

该电路为外部输入电路, 适用于麦克风端子以外的调制信号时(如使用KCT-39选购件时)。灵敏度与麦克风相同, 但是由于内置了用于输入的微调电位器 (VR852), 因此能够支持大范围的输入电平。

数字控制电路

■ 概述

数字控制电路由核心的主MCU、EEPROM (IC854) 和复位IC (IC856和IC857) 组成。(请参阅结构图)

■ 主MCU

主MCU (IC855) 以5V的电压和11.0592MHz的时钟频率进行工作。与主MCU连接了用于备份的EEPROM。同时还连接了包括复位电路在内的电压监控电路。

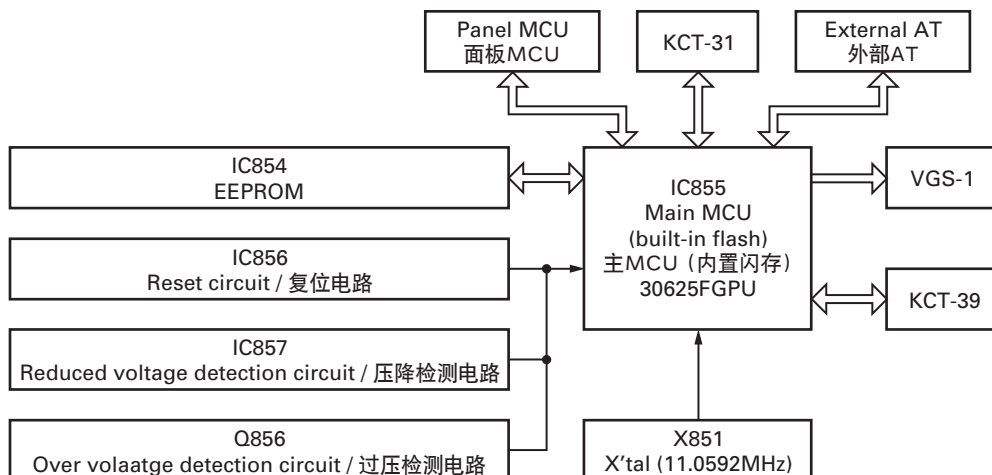

Fig. 12 Digital control circuit block diagram / 图12 数字控制电路结构图

CIRCUIT DESCRIPTION / 电路说明

Display Section

The display section consists of a MCU for the panel and the peripheral circuit, an LCD display, and LEDs for the backlight. Communication with the main MCU is performed with the TXD and RXD lines. In order to avoid voltage drop, buffer ICs are inserted into both the TX-RX unit and the Display unit on the TXD and RXD lines.

■ Panel MCU Circuit

The 8D power supply sent from the main unit is converted to 5V by the 5V AVR (IC1) to use as the power supply for the digital section. For the MCU clock (CLK), 14.756MHz (X1) is used. The reset signal is performed by the reset IC (IC5).

■ LCD Driver

LC75810 is the LCD driver. Because of the IC specification, the 8V power supply for the LCD needs to be applied after VDD (5V). Therefore, switching circuits for turning the 8V power supply on after 5V was emitted (Q4 and Q5) are provided.

■ LED Section

12 LEDs are used for the LCD backlight which can be controlled with 3 settings: Bright, Low, Off. The keypad light uses a tact switch with the LEDs and is controlled with 2 settings: On and Off. On is used with both the Bright and Low settings, and Off is used when the backlight is off. When Busy or TX, the LED used is D7, which includes 2 LEDs. The MCU controls the on/off setting of these LEDs.

显示部分

显示部分包括面板的MCU和外围电路、液晶显示屏、背光LED。通过TXD线和RXD线实现与主MCU的通信。为了避免电压下降，TXD线和RXD线的缓冲IC被嵌入到TX-RX单元和Display单元。

■ 面板MCU电路

主单元发送的8D电源由5V AVR (IC1) 转换为5V并将其用作数字部分的电源。对于MCU时钟 (CLK) 而言,则使用14.756MHz (X1)。复位信号通过复位IC (IC5) 实现。

■ 显示驱动器

LC75810为显示驱动器。由于IC规格所限,VDD (5V) 之后,液晶显示屏需要使用8V电源,因此,提供从5V切换至8V的电源转换电路 (Q4和Q5)。

■ 液晶显示屏部分

液晶显示屏背光使用12个LED,可以通过3种设置进行控制:亮、暗、关。键盘照明使用带有LED的触摸开关,通过2种设置进行控制:开和关。背光为亮和暗设置时,键盘照明使用开设置;背光为关设置时,键盘照明使用关设置。繁忙或发射期间,使用的LED为包括两个LED的LED (D7) 且由MCU控制这些LED的开关设置。

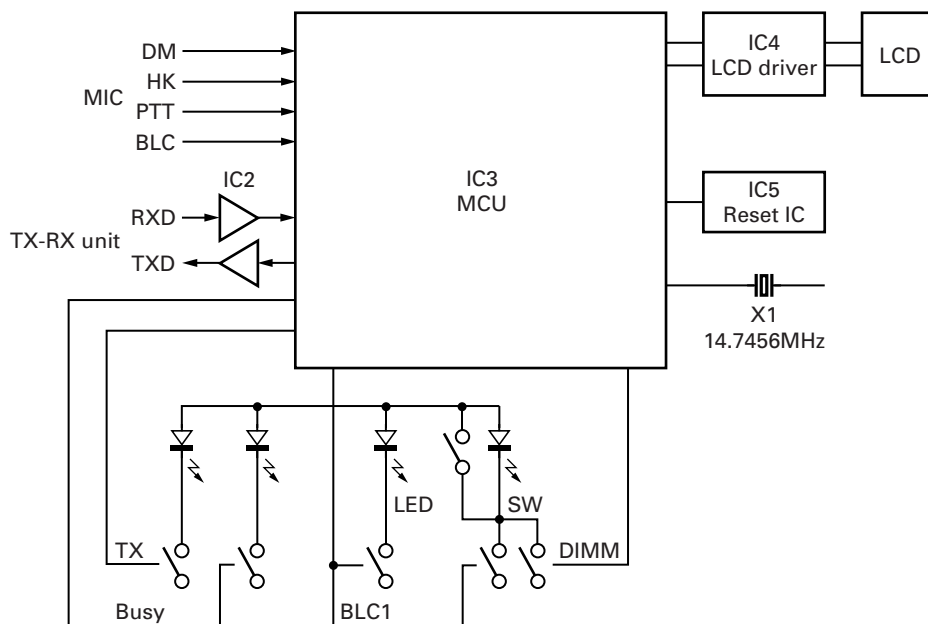

Fig. 13 Display circuit / 图13 显示电路

CIRCUIT DESCRIPTION / 电路说明

SELCALL Operation

The SELCALL signal is passed through FSK IC for demodulation NJM2211M (IC865). When the SELCALL function is on, Q859 is turned ON by MCU signal and power is supplied to the SELCALL circuit. The receive detection signal is always connected to the SELCALL circuit input section buffer (IC863), and is output to the FSK demodulator (IC865, 2 pin).

■ Receive (NJM2211M Operation)

The FSK signal mean frequency, f_0 (2210Hz), is the center of the shift frequency (2295Hz and 2125Hz). When changing the value in the adjustment mode, the SELADJ signal is output from the MCU and IC865 becomes the mean frequency setting mode. NJM2211M is a PLL IC, and locks within the range of $f_0 \pm \Delta f$. While locked, the LOW level signal is output to the FSL terminal. The output, in the range of $f_0 + \Delta f$ (High: 5V) and $f_0 - \Delta f$ (Low: 0V) is sent to the FSD terminal. The FSD signal while IC865 is locked (FSL=Low) is analyzed by the MCU. The lock range Δf is determined by the circuit constant, and is set at approximately 170Hz.

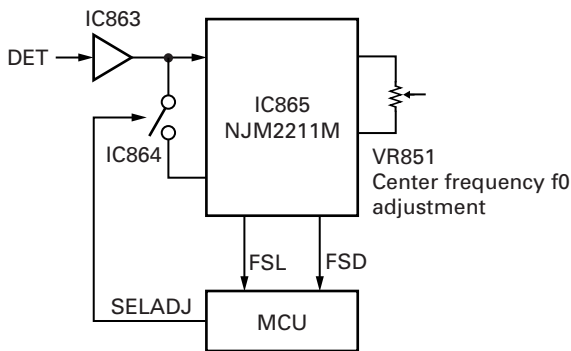

Fig. 14 SELCALL operation (RX)

图14 选择呼叫操作 (接收)

■ Transmission

Transmission is implemented by shifting the carrier frequency (CAR). The DDS IC (IC702) has 2 registers (FREQ0 and FREQ1), each of which can retain different frequency data. Selection of these frequencies is possible by changing the applied voltage at the FSELECT terminal (10 pin). The MCU writes data at 2125Hz and 2295Hz to DDS. The FSEL data is changed according to the FSK signal, generating the FSK transmission signal.

In the case of SELCALL, the FSK shift volume is fixed at a value of 170Hz. In the case of RTTY operation, the FSEL terminal is connected to the external terminal (RTK) via the analog switch IC (IC851), and shifts the frequency according to the signal from RTK.

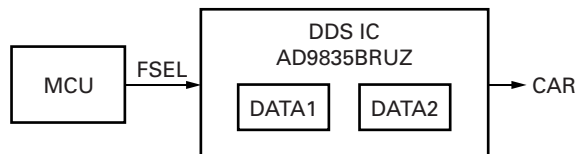

Fig. 16 SELCALL operation (TX) / 图16 选择呼叫操作 (发射)

选择呼叫操作

选择呼叫信号通过用于解调的FSK IC NJM2211M (IC865)。选择呼叫功能开启时, Q859通过MCU信号开启并对选择呼叫电路供电。接收检测信号始终连接至选择呼叫电路的输入部分缓冲器,且该IC863的输出信号被输入至FSK解调器 (IC865, 2针)。

■接收 (NJM2211M操作)

FSK信号平均频率 f_0 (2210Hz) 是偏移频率 (2295Hz和2125Hz)的中间频率。在调节模式下改变数值时, MCU输出SELADJ信号, IC865成为中间频率设置模式。NJM2211M为PLL IC并锁定于 $f_0 \pm \Delta f$ 的范围内; 当其锁定时, 低电平信号输出至FSL端子。在 $f_0 + \Delta f$ (高: 5V) 和 $f_0 - \Delta f$ (低: 0V) 的范围内, 输出信号发送至FSD端子。由MCU分析IC865锁定 (FSL为低电平) 时的FSD信号。锁定范围 Δf 由电路常数决定, 其值设置在170Hz左右。

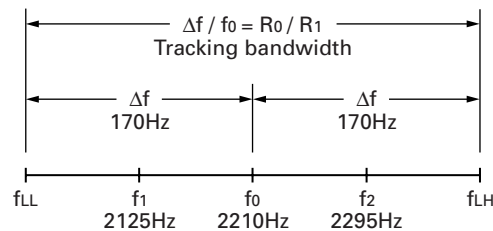

Fig. 15 / 图15

■发射

发射通过载波频率 (CAR) 偏移实现。DDS IC (IC702) 带有2个寄存器 (FREQ0和FREQ1), 各个寄存器可以保留不同的频率数据。通过在FSELECT端子 (10针) 改变外加电压实现此类频率的选择。MCU会将2125Hz的数据和2295Hz的数据写入DDS。FSEL数据根据FSK信号进行改变, 并由之产生FSK发射信号。

在选择呼叫的情况下, FSK偏移量为170Hz的固定值且无法改变。在无线电传操作的情况下, FSEL端子通过模拟转换IC (IC851) 连接至外部端子 (RTK), 并根据来自RTK的信号改变频率。

COMPONENTS DESCRIPTION / 元件说明

1. Final Unit (X45-3780-20)

Ref. No.	Use / Function	Operation / Condition
IC1	AVR	8V for digital circuit
IC2	AVR	8V for analogue circuit
IC3	Extended I/O	LPF control signal (Serial → Parallel)
Q1	Amplifier	Pre-drive amplifier
Q2,3	Amplifier	Drive amplifier
Q4,5	Amplifier	Final amplifier
Q6	Bias control	Final (Q4,5) stage bias current control
Q7	Switching	14S
Q8	Switching	Q7 gate bias control
Q9	Driver	Transmission/reception relay (K1) control
Q10~13	Driver	LPF changeover relay control
D1,2	Temperature compensation	Final (Q4,5) stage bias current control
D3	Surge absorption	Antenna
D6	High-frequency rectification	Reflected wave detection
D7	High-frequency rectification	Forward wave detection
D8	Surge absorption	Power supply surge protection
D9	Surge absorption	ANT changeover relay
D101	Surge absorption	Relay (K102)
D201	Surge absorption	Relay (K202)
D301	Surge absorption	Relay (K302)
D401	Surge absorption	Relay (K402)
D501	Surge absorption	Relay (K502)
D601	Surge absorption	Relay (K602)
D701	Surge absorption	Relay (K702)

2. Display Unit (X54-3560-20)

Ref. No.	Use / Function	Operation / Condition
IC1	AVR	5V for display circuit
IC2	AND gate	Buffer
IC3	MCU	Panel microcomputer
IC4	LCD driver	
IC5	Reset IC	Reset signal for ECU
Q2	Switching	Backlight control
Q4	Switching	8D switch control
Q5	Switching	8D switch
Q6,7	Switching	Surge prevention

1. Final单元 (X45-3780-20)

有关号码	使用 / 功能	操作 / 状态
IC1	AVR	用于数字电路的8V
IC2	AVR	用于模拟电路的8V
IC3	扩展I/O	LPF控制信号(串行→并行)
Q1	放大器	预驱动放大器
Q2,3	放大器	驱动放大器
Q4,5	放大器	末级放大器
Q6	偏置控制	末级(Q4,5)偏置电流控制
Q7	转换	14S
Q8	转换	Q7栅偏置控制
Q9	驱动器	发射/接收继电器(K1)控制
Q10~13	驱动器	LPF转换继电器控制
D1,2	温度补偿	末级(Q4,5)偏置电流控制
D3	电涌吸收	天线
D6	高频校正	反射波检测
D7	高频校正	前向波检测
D8	电涌吸收	电源电涌保护
D9	电涌吸收	ANT转换中继
D101	电涌吸收	继电器(K102)
D201	电涌吸收	继电器(K202)
D301	电涌吸收	继电器(K302)
D401	电涌吸收	继电器(K402)
D501	电涌吸收	继电器(K502)
D601	电涌吸收	继电器(K602)
D701	电涌吸收	继电器(K702)

2. Display单元 (X54-3560-20)

有关号码	使用 / 功能	操作 / 状态
IC1	AVR	用于显示电路的5V
IC2	AND栅	缓冲器
IC3	MCU	面板微处理器
IC4	LCD驱动	
IC5	复位IC	用于ECU的复位信号
Q2	转换	背光控制
Q4	转换	8D开关控制
Q5	转换	8D开关
Q6,7	转换	电涌预防

COMPONENTS DESCRIPTION / 元件说明

Ref. No.	Use / Function	Operation / Condition
Q9	Switching	TX indication LED switch
Q10	Switching	Busy indication LED switch
Q11~14	Switching	Dimmer control
D1,2	1.8V zener diode	Voltage protection
D3~5	Limiter	Surge prevention
D6	Limiter	Voltage protection
D7	LED	TX/Busy indication
D8~19	LED	LCD backlight

有关号码	使用 / 功能	操作 / 状态
Q9	转换	TX指示LED开关
Q10	转换	繁忙指示LED开关
Q11~14	转换	调光器控制
D1,2	1.8V稳压二极管	电压保护
D3~5	限幅器	电涌预防
D6	限幅器	电压保护
D7	LED	TX/繁忙指示
D8~19	LED	LCD背光

3. TX-RX Unit (X57-7210-20)

Ref. No.	Use / Function	Operation / Condition
IC1	Shift register	Q0: L when BPF4 is selected Q1: L when BPF5 is selected Q2: L when BPF6 is selected Q3: L when BPF3 is selected Q4: L when BPF1 is selected Q5: L when BPF7 is selected Q6: L when BPF8 is selected Q7: L when BPF2 is selected Q8: L when FAN1 is selected Q9: L when FAN2 is selected Q10: H when ATT is ON Q11: H when preamplifier is ON
IC101	Mixer	Transmission mixer
IC251	Mixer IC	TX modulator
IC361	OP amplifier	Final current protection
IC362	OP amplifier	Drive current protection VSWR protection
IC363	A/D	Electrical volume
IC421	Shift register	Q0: TX boost Q1: FSK select Q2: NC Q3: AM control Q4: OP filter loss Q5: AGC slow switch Q6: AGC off switch Q7: VGS-1 switch Q8: ALE switch Q9: IF filter select signal (Option) Q10: IF filter select signal (2.4k) Q11: IF filter select signal (6k)
IC422	Analog switch	AGC time constant changeover

3. TX-RX单元 (X57-7210-20)

有关号码	使用 / 功能	操作 / 状态
IC1	移位寄存器	Q0: 选择BPF4时为低 Q1: 选择BPF5时为低 Q2: 选择BPF6时为低 Q3: 选择BPF3时为低 Q4: 选择BPF1时为低 Q5: 选择BPF7时为低 Q6: 选择BPF8时为低 Q7: 选择BPF2时为低 Q8: 选择FAN1时为低 Q9: 选择FAN2时为低 Q10: ATT开启时为高 Q11: 前级放大器开启时为高
IC101	混频器	发射混频器
IC251	混频器IC	TX调制器
IC361	OP放大器	末级电流保护
IC362	OP放大器	驱动电流保护 VSWR保护
IC363	A/D	电子音量
IC421	移位寄存器	Q0: TX增高 Q1: FSK选择 Q2: 未连接 Q3: AM控制 Q4: OP滤波器损耗 Q5: AGC慢速开关 Q6: AGC关闭开关 Q7: VGS-1开关 Q8: ALE开关 Q9: 中频滤波器选择信号 (选件) Q10: 中频滤波器选择信号 (2.4k) Q11: 中频滤波器选择信号 (6k)
IC422	模拟开关	AGC时间常数转换

COMPONENTS DESCRIPTION / 元件说明

Ref. No.	Use / Function	Operation / Condition
IC423	OP amplifier	Buffer for S-meter voltage
IC451	Mixer IC	Demodulator
IC452	Multiplexer	Detect signal select
IC453	OP amplifier	Detect signal buffer Ref voltage
IC454	5V AVR	For analogue circuit
IC521	AF amplifier	Audio amplifier
IC551~553	Analog switch	Audio signal select
IC554	A/D	Electrical volume 1: DEO output 2: No use 3: MOD signal 4: AM AGC 5: Anti VOX level 6: DI level 7: MIC sense 8: VOX sense
IC555	A/D	Electrical volume 1: Audio output level 2: Beep level 3: Side tone level 4: Emergency tone level 5: VGS-1 monitor level 6: VGS-1 signal for DEO 7: Reserved 8: No use
IC601	NOR	VOX control
IC602	OP amplifier	AGC amplifier for MOD
IC603	OP amplifier	For VOX function
IC604	DI amplifier	Amplifier for DI/VOX
IC605	MIC amplifier	Amplifier for MIC/ANTI VOX
IC606	Buffer	Buffer for UART signal
IC701	DDS	LO1-PLL reference signal is generated
IC702	DDS	CAR signal generation
IC703	PLL	LO1 control
IC704	5V AVR	For PLL circuit
IC851	Analog switch	RTK control switch
IC852	OP amplifier	Buffer for DEO signal
IC853	5V AVR	5V for VGS-1
IC854	EEPROM	EEPROM
IC855	MCU	Main microcomputer
IC856	Reset IC	CPU reset signal

有关号码	使用 / 功能	操作 / 状态
IC423	OP放大器	信号强度表电压的缓冲器
IC451	混频器IC	解调器
IC452	多路器	检测信号选择
IC453	OP放大器	检测信号缓冲器 基准电压
IC454	5V AVR	用于模拟电路
IC521	AF放大器	音频放大器
IC551~553	模拟开关	音频信号选择
IC554	A/D	电子音量 1: DEO输出 2: 未使用 3: MOD信号 4: AM AGC 5: 防VOX电平 6: DI电平 7: 麦克风感应 8: VOX感应
IC555	A/D	电子音量 1: 音频输出电平 2: 提示音电平 3: 侧音电平 4: 紧急报警音电平 5: VGS-1监控电平 6: 用于DEO的VGS-1信号 7: 预留 8: 未使用
IC601	NOR	VOX控制
IC602	OP放大器	用于MOD的AGC放大器
IC603	OP放大器	用于VOX功能
IC604	DI放大器	用于DI/VOX的放大器
IC605	MIC放大器	用于麦克风/防VOX的放大器
IC606	缓冲器	用于UART信号的缓冲器
IC701	DDS	产生LO1-PLL基准信号
IC702	DDS	CAR信号产生
IC703	PLL	LO1控制
IC704	5V AVR	用于PLL电路
IC851	模拟开关	RTK控制开关
IC852	OP放大器	用于DEO信号的缓冲器
IC853	5V AVR	用于VGS-1的5V
IC854	EEPROM	EEPROM
IC855	MCU	主微处理器
IC856	复位IC	CPU复位信号

COMPONENTS DESCRIPTION / 元件说明

Ref. No.	Use / Function	Operation / Condition
IC857	Reset IC	Back up indicate signal
IC859	5V AVR	5V for CPU
IC861	5V AVR	5V for option board
IC863	OP amplifier	Buffer for Selcall/option
IC864	OP amplifier	Selcall function
IC865	FSK tone decoder	For selcall function
Q1	Switching	Receiving RATB power supply control (ON during reception)
Q2	Switching	ON during TX
Q3	Amplifier	Transmission drive output amplifier
Q4	Mute switch	Mute reception path during transmission (ON during reception)
Q5~12	Switching	BPF selection (ON when selected)
Q13	Switching	ATT changeover relay control (OFF when ATT is ON)
Q101	Switching	ON when preamplifier is ON
Q102	Switching	OFF when preamplifier is OFF
Q103	Amplifier	Preamplifier
Q104	Switching	Preamplifier power supply control (ON when preamplifier ON)
Q105,106	Mixer	Receiving first mixer
Q107	Amplifier	RX LO1 amplifier
Q108,109	Mixer	Receiving first mixer
Q110	Switching	Preamplifier
Q181	Switching	Transmission IF mute control (Mute when ON)
Q182	Amplifier	Transmission IF amplifier
Q183	Amplifier	Receiving IF amplifier (Controlled by AGC)
Q184	Amplifier	LO2 amplifier
Q185	Amplifier	2nd IF amplifier (Controlled by AGC)
Q186	Amplifier	ALC amplifier for TX
Q187	Buffer	ALC buffer for TX
Q251	Amplifier	2nd IF amplifier for receiving
Q252	Switching	Correction IF filter loss
Q253	Amplifier	Amplifier for TX
Q254	Buffer	CAR input buffer
Q255	Buffer	MOD input buffer
Q311	Switching	RXB power supply generation switch
Q312	Switching	TXB power supply generation switch
Q313	Switching	RXB power supply generation switch
Q321	Buffer	NB input buffer

有关号码	使用 / 功能	操作 / 状态
IC857	复位IC	备份指示信号
IC859	5V AVR	用于CPU的5V
IC861	5V AVR	用于可选板的5V
IC863	OP放大器	选择呼叫/选购件的缓冲器
IC864	OP放大器	选择呼叫功能
IC865	FSK音解码器	用于选择呼叫功能
Q1	转换	接收RATB电源控制 (接收期间开启)
Q2	转换	TX期间开启
Q3	放大器	发射驱动输出放大器
Q4	静音开关	发射期间的静音接收路径 (接收期间开启)
Q5~12	转换	BPF选择 (选择时开启)
Q13	转换	ATT转换中继控制 (ATT开启时关闭)
Q101	转换	前级放大器开启时开启
Q102	转换	前级放大器关闭时关闭
Q103	放大器	前级放大器
Q104	转换	前级放大器电源控制 (前级放大器开启时开启)
Q105,106	混频器	接收的第一混频器
Q107	放大器	RX LO1放大器
Q108,109	混频器	接收的第一混频器
Q110	转换	前级放大器
Q181	转换	发射中频静音控制 (开启时静音)
Q182	放大器	发射中频放大器
Q183	放大器	接收的中频放大器 (由AGC控制)
Q184	放大器	LO2放大器
Q185	放大器	第二中频放大器 (由AGC控制)
Q186	放大器	用于TX的ALC放大器
Q187	缓冲器	用于TX的ALC缓冲器
Q251	放大器	用于接收的第二中频放大器
Q252	转换	校正中频滤波器损耗
Q253	放大器	用于TX的放大器
Q254	缓冲器	CAR输入缓冲器
Q255	缓冲器	MOD输入缓冲器
Q311	转换	RXB电源产生开关
Q312	转换	TXB电源产生开关
Q313	转换	RXB电源产生开关
Q321	缓冲器	NB输入缓冲器

COMPONENTS DESCRIPTION / 元件说明

Ref. No.	Use / Function	Operation / Condition
Q322	Amplifier	IF amplifier for NB circuit
Q323	Differential amplifier	IF amplifier for NB circuit
Q324	Amplifier	NB AGC control amplifier
Q325	Amplifier	IF amplifier for NB circuit
Q326	Switching	Generate IF mute signal
Q327	Buffer	Buffer for NB IF signal
Q329	Switching	Generate IF mute signal
Q361	Switching	AM time constant
Q362	Switching	CKY control
Q363	Comparator	Comparator
Q364	Switching	CKY control
Q365,366	Amplifier	ALC voltage control
Q421	Switching	AMB switch
Q423	LPF	Side tone LPF
Q451	Amplifier	AGC 2nd IF amplifier for RX
Q452	Inverter	For IF amplifier mute switch
Q453	Amplifier	AGC voltage control
Q454	Switching	AGC-OFF switch
Q455	Amplifier	AGC 2nd IF amplifier
Q456	Switching	IF amplifier mute switch
Q457	Buffer	Buffer for 2nd IF signal
Q458	Buffer	Output buffer for AM detection signal
Q459	Amplifier	Output amplifier for detection signal
Q460	Switching	Detection signal mute switch
Q521	Switching	Detection signal mute switch
Q522	Ripple filter	For audio amplifier VCC
Q523	Switching	Cutoff frequency switch
Q524	Switching	Audio amplifier mute switch
Q601,602	Switching	Audio AGC voltage
Q603	Switching	VOX switch
Q604	Switching	VOX function control signal
Q605,606	Switching	Audio AGC voltage
Q607,608	Switching	MIC boost switch
Q609	Switching	DI mute switch
Q610	Switching	MIC mute switch
Q701	Amplifier	IC701 CLK input amplifier
Q702	Buffer	31.2MHz buffer
Q703	Amplifier	IC702 CLK input amplifier
Q704	Doubler	15.6MHz x 2
Q706	Amplifier	LO1 output amplifier
Q707	Buffer	DDS output buffer

有关号码	使用 / 功能	操作 / 状态
Q322	放大器	用于NB电路的中频放大器
Q323	差分放大器	用于NB电路的中频放大器
Q324	放大器	NB AGC控制放大器
Q325	放大器	用于NB电路的中频放大器
Q326	转换	产生中频静音信号
Q327	缓冲器	用于NB中频信号的缓冲器
Q329	转换	产生中频静音信号
Q361	转换	AM时间常数
Q362	转换	CKY控制
Q363	比较器	比较器
Q364	转换	CKY控制
Q365,366	放大器	ALC电压控制
Q421	转换	AMB开关
Q423	LPF	侧音LPF
Q451	放大器	用于RX的AGC第二个中频放大器
Q452	变换器	用于中频放大器静音开关
Q453	放大器	AGC电压控制
Q454	转换	AGC-OFF开关
Q455	放大器	AGC第二中频放大器
Q456	转换	中频放大器静音开关
Q457	缓冲器	用于第二中频信号的缓冲器
Q458	缓冲器	用于AM检测信号的输出缓冲器
Q459	放大器	用于检测信号的输出放大器
Q460	转换	检测信号静音开关
Q521	转换	检测信号静音开关
Q522	纹波滤波器	用于音频放大器VCC
Q523	转换	截止频率开关
Q524	转换	音频放大器静音开关
Q601,602	转换	音频AGC电压
Q603	转换	VOX开关
Q604	转换	VOX功能控制信号
Q605,606	转换	音频AGC电压
Q607,608	转换	麦克风增高开关
Q609	转换	DI静音开关
Q610	转换	克风静音开关
Q701	放大器	IC701 CLK输入放大器
Q702	缓冲器	31.2MHz缓冲器
Q703	放大器	IC702 CLK输入放大器
Q704	倍频器	15.6MHz x 2
Q706	放大器	LO1输出放大器
Q707	缓冲器	DDS输出缓冲器

COMPONENTS DESCRIPTION / 元件说明

Ref. No.	Use / Function	Operation / Condition
Q708	Doubler	31.2MHz x 2
Q709	Buffer	15.6MHz buffer
Q711	Doubler	15.6MHz x 2
Q712	Buffer	DDS output buffer
Q713	VCO1	Oscillation FET
Q714	VCO2	Oscillation FET
Q715	Amplifier	VCO output amplifier
Q716	Amplifier	PLL-fin amplifier
Q717	Ripple filter	Ripple filter for VCO power supply
Q718,719	Switching	VCO select switch
Q720	Ripple filter	Ripple filter for VCO power supply
Q851,852	Inverter	TS signal for KAT-1
Q853,854	Inverter	TT signal for KAT-1
Q855	Inverter	IGN control switch
Q856	Switching	Power supply voltage protection
Q858	Switching	Selcall function adjust mode
Q859	Switching	Selcall function
Q991,992	Switching	FAN control switch
Q993	inverter	PTT signal
Q994,995	Switching	FAN control switch
D1~4	Limiter	Over input protection
D5	Switching	ON when receiving over 1.605MHz is selected
D6	Switching	ON when receiving under 1.605MHz is selected
D7	Switching	ON during transmission
D8	Switching	ON when receiving over 1.605MHz is selected
D9	Switching	ON when BPF of 10.5~14.5MHz is selected
D10	Switching	1/2: ON when BPF of 14.5~21.5MHz is selected 2/2: ON when BPF of 4.1~7.5MHz is selected
D11	Switching	1/2: ON when BPF of 1.605~2.5MHz is selected 2/2: ON when BPF of 2.5~4.1MHz is selected
D12	Switching	1/2: ON when BPF of 7.5~10.5MHz is selected 2/2: ON when BPF of 21.5~30MHz is selected

有关号码	使用 / 功能	操作 / 状态
Q708	倍频器	31.2MHz x 2
Q709	缓冲器	15.6MHz缓冲器
Q711	倍频器	15.6MHz x 2
Q712	缓冲器	DDS输出缓冲器
Q713	VCO1	振荡FET
Q714	VCO2	振荡FET
Q715	放大器	VCO输出放大器
Q716	放大器	PLL-fin放大器
Q717	纹波滤波器	用于VCO电源的纹波滤波器
Q718,719	转换	VCO选择开关
Q720	纹波滤波器	用于VCO电源的纹波滤波器
Q851,852	变换器	用于KAT-1的TS信号
Q853,854	变换器	用于KAT-1的TT信号
Q855	变换器	IGN控制开关
Q856	转换	电源电压保护
Q858	转换	选择呼叫功能调整模式
Q859	转换	选择呼叫功能
Q991,992	转换	FAN控制开关
Q993	变换器	PTT信号
Q994,995	转换	FAN控制开关
D1~4	限幅器	过度输入保护
D5	转换	选择了接收超过1.605MHz时开启
D6	转换	选择了接收低于1.605MHz时开启
D7	转换	发射期间开启
D8	转换	选择了接收超过1.605MHz时开启
D9	转换	选择了10.5~14.5MHz的BPF时开启
D10	转换	1/2: 选择了14.5~21.5MHz的BPF时开启 2/2: 选择了4.1~7.5MHz的BPF时开启
D11	转换	1/2: 选择了1.605~2.5MHz的BPF时开启 2/2: 选择了2.5~4.1MHz的BPF时开启
D12	转换	1/2: 选择了7.5~10.5MHz的BPF时开启 2/2: 选择了21.5~30MHz的BPF时开启

COMPONENTS DESCRIPTION / 元件说明

Ref. No.	Use / Function	Operation / Condition
D13	Switching	ON when receiving under 1.605MHz is selected
D14	Switching	ON when BPF of 10.5~14.5MHz is selected
D15	Switching	ON when BPF of 2.5~4.1MHz is selected
D16	Switching	ON when BPF of 4.1~7.5MHz is selected
D17	Switching	ON when BPF of 7.5~10.5MHz is selected
D18	Switching	ON when BPF of 1.605~2.5MHz is selected
D19	Switching	ON when BPF of 14.5~21.5MHz is selected
D20	Switching	ON when BPF of 21.5~30MHz is selected
D21	Surge absorption	For ATT changeover relay
D101	Switching	ON during transmission
D102	Switching	ON when receiving preamplifier is ON
D103	Switching	ON when receiving preamplifier is OFF
D104	Switching	1/2: ON when receiving preamplifier is OFF 2/2: ON when receiving preamplifier is ON
D105	Switching	LO1 path transmission/reception changeover
D106	Switching	73.095MHz IF path transmission/reception changeover
D107	Switching	IF path transmission/reception changeover
D181	Reverse current prevention	AGC voltage control
D182	Switching	IF path transmission/reception changeover
D183	Mixer	RX 2nd / TX mixer
D184,185	Switching	IF path transmission/reception changeover
D186	Switching	On when mute If amplifier
D187	Reverse current prevention	AGC voltage control
D251	Switching	ON when option filter is selected

有关号码	使用 / 功能	操作 / 状态
D13	转换	选择了接收低于1.605MHz时开启
D14	转换	选择了10.5~14.5MHz的BPF时开启
D15	转换	选择了2.5~4.1MHz的BPF时开启
D16	转换	选择了4.1~7.5MHz的BPF时开启
D17	转换	选择了7.5~10.5MHz的BPF时开启
D18	转换	选择了1.605~2.5MHz的BPF时开启
D19	转换	选择了14.5~21.5MHz的BPF时开启
D20	转换	选择了21.5~30MHz的BPF时开启
D21	电涌吸收	用于ATT转换继电器
D101	转换	发射期间开启
D102	转换	接收的前级放大器开启时开启
D103	转换	接收的前级放大器关闭时开启
D104	转换	1/2: 接收的前级放大器关闭时开启 2/2: 接收的前级放大器开启时开启
D105	转换	LO1路径发射/接收转换
D106	转换	73.095MHz中频路径发射/接收转换
D107	转换	中频路径发射/接收转换
D181	逆向电流预防	AGC电压控制
D182	转换	中频路径发射/接收转换
D183	混频器	RX第二/TX混频器
D184,185	转换	中频路径发射/接收转换
D186	转换	中频放大器静音时开启
D187	逆向电流预防	AGC电压控制
D251	转换	选择了滤波器选购件时开启

COMPONENTS DESCRIPTION / 元件说明

Ref. No.	Use / Function	Operation / Condition
D252	Switching	1/2: ON when AM mode is selected 2/2: ON when 2.4kHz SSB filter is selected
D253	Switching	ON when option filter is selected
D254	Switching	ON when AM mode is selected
D255	Switching	ON when AM mode is selected IF path transmission/reception changeover
D256	Switching	ON when SSB mode is selected IF path transmission/reception changeover
D257	Switching	ON when option filter is selected IF path transmission/reception changeover
D258	Switching	ON when option filter is selected
D259	Switching	ON during transmission
D260	Reverse current prevention	AM mixer balance
D261	Temperature compensation	AM mixer balance
D321	Rectification	NB voltage generation
D361	5.1V zener diode	Over input protection
D362	5.6V zener diode	Voltage shift
D363	Reverse current prevention	Over input protection
D364	5.6V zener diode	Over input protection
D365~369	Reverse current prevention	Reverse current prevention
D370	3.9V Zener diode	Voltage shift
D371,372	Reverse current prevention	Reverse current prevention
D373	Temperature compensation	Temperature compensation
D374	Reverse current prevention	Reverse current prevention
D451	Reverse current prevention	RBK signal
D452	PIN diode	IF gain control
D453	Rectification	AGC control voltage generation
D454	Rectification	AM detection
D521,522	Reverse current prevention	Time constant

有关号码	使用 / 功能	操作 / 状态
D252	转换	1/2: 选择了AM模式时开启 2/2: 选择了2.4kHz SSB滤波器时 开启
D253	转换	选择了滤波器选购件时开启
D254	转换	选择了AM模式时开启
D255	转换	选择了AM模式时开启 中频路径发射/接收转换
D256	转换	选择了SSB模式时开启 中频路径发射/接收转换
D257	转换	选择了滤波器选购件时开启 中频路径发射/接收转换
D258	转换	选择了滤波器选购件时开启
D259	转换	发射期间开启
D260	逆向电流预防	AM混频器平衡
D261	温度补偿	AM混频器平衡
D321	校正	NB电压产生
D361	5.1V稳压二极管	过度输入保护
D362	5.6V稳压二极管	电压偏移
D363	逆向电流预防	过度输入保护
D364	5.6V稳压二极管	过度输入保护
D365~369	逆向电流预防	逆向电流预防
D370	3.9V稳压二极管	电压偏移
D371,372	逆向电流预防	逆向电流预防
D373	温度补偿	温度补偿
D374	逆向电流预防	逆向电流预防
D451	逆向电流预防	RBK信号
D452	PIN二极管	中频增益控制
D453	校正	AGC控制电压产生
D454	校正	AM检测
D521,522	逆向电流预防	时间常数

COMPONENTS DESCRIPTION / 元件说明

Ref. No.	Use / Function	Operation / Condition
D601,602	Reverse current prevention	Audio AGC
D603,604	Attenuator	VOX voltage control
D605,606	Reverse current prevention	Audio AGC
D607,608	Reverse current prevention	Mute circuit
D609,610	Varistor	Surge prevention
D611,612	Poly-switch	Current limit
D613,614	Varistor	Surge prevention
D701,702	Variable capacitance diode	VCO oscillation frequency variance
D703	Reverse current prevention	Unlock signal
D704	Switching	ON when VCO1 is selected
D705	Switching	ON when VCO2 is selected
D851,852	Varistor	Surge prevention
D853	Poly-switch	Current limit
D854	Varistor	Surge prevention
D855,856	Limiter	Over input protection
D857	Varistor	Current limit
D858,859	Reverse current prevention	Low active
D860	Limiter	Over input protection
D861	Reverse current prevention	Low active
D862,863	Varistor	Surge prevention
D864	Limiter	Over input protection
D865~867	Varistor	Surge prevention
D868	18V zener diode	Voltage shift
D869	Reverse current prevention	EEPROM writing time
D870	Reverse current prevention	Frequency select
D871	Reverse current prevention	Surge prevention
D872	Limiter	Surge prevention
D991,992	Reverse current prevention	FAN

有关号码	使用 / 功能	操作 / 状态
D601,602	逆向电流预防	音频AGC
D603,604	衰减器	VOX电压控制
D605,606	逆向电流预防	音频AGC
D607,608	逆向电流预防	静音电路
D609,610	变阻器	电涌预防
D611,612	高分子聚合保护开关	电流限幅
D613,614	变阻器	电涌预防
D701,702	可变电容二极管	VCO振荡频率偏差
D703	逆向电流预防	失锁信号
D704	转换	选择了VCO1时开启
D705	转换	选择了VCO2时开启
D851,852	变阻器	电涌预防
D853	高分子聚合保护开关	电流限幅
D854	变阻器	电涌预防
D855,856	限幅器	过度输入保护
D857	变阻器	电流限幅
D858,859	逆向电流预防	低激活
D860	限幅器	过度输入保护
D861	逆向电流预防	低激活
D862,863	变阻器	电涌预防
D864	限幅器	过度输入保护
D865~867	变阻器	电涌预防
D868	18V稳压二极管	电压偏移
D869	逆向电流预防	EEPROM写入时间
D870	逆向电流预防	频率选择
D871	逆向电流预防	电涌预防
D872	限幅器	电涌预防
D991,992	逆向电流预防	风扇

SEMICONDUCTOR DATA / 半导体数据

1. Main Microcomputer: 30625FGPUKBEC
(TX-RX unit IC855)

Pin No.	Port Name	I/O	Function
1	VREF	I	A/D converter, D/A converter reference voltage input
2	AVCC	I	Power source input for A/D converter
3	PDA	O	PLL IC data
4	PCK	O	PLL IC clock
5	PEN	O	PLL IC enable
6	DEN1	O	DDS IC1 enable
7	DEN2	O	DDS IC2 enable
8	VCO1	O	VCO1 changeover instruction
9	VCO2	O	VCO2 changeover instruction
10	UL	I	Unlock detect
11	VEN	O	VGS-1 enable output
12	VRST	O	VGS-1 reset output
13	BYTE	I	External data bus change input
14	CNVSS	I	Processor mode change input
15	VPLY	I	VGS-1 PLAY input
16	VBSY	I	VGS-1 BUSY input
17	RESET	I	Reset input
18	XOUT	O	Main clock output
19	VSS	I	GND
20	XIN	I	Main clock input
21	VCC1	I	Power supply input
22	NMI	I	NC
23	BKC	I	Decrease voltage interruption input
24	BOVR	I	Overvoltage interruption input
25	STPC	I	Return interruption input by serial data
26	BSFT	O	Reserve
27	BEEP	O	Beep encode output
28	AGCSW	O	AGC voltage discharge control
29	TONE	O	Side tone encode output
30,31	NC	I	NC
32	DATA	O	Common serial data output
33	CLK	O	Common serial data input
34	RXD2	I	Common serial data input for ALE unit
35	TXD2	O	Common serial data output for ALE unit
36	TXD1	O	Serial data output (PC command)
37	VCC1	I	Power supply input
38	RXD1	I	Serial data input (PC command / GPS)
39	VSS	I	GND
40	WCLK	I	Serial clock input for flash ROM
41	WBSY	O	BUSY input for flash ROM
42	TXD0	O	Serial data output (To panel MCU)

1. 主微处理器: 30625FGPUKBEC
(TX-RX单元IC855)

管脚号	端口名称	输入/输出	功能
1	VREF	输入	模数转换器, 数模转换器基准电压输入
2	AVCC	输入	用于模数转换器的电源输入
3	PDA	输出	PLL IC数据
4	PCK	输出	PLL IC时钟
5	PEN	输出	PLL IC启用
6	DEN1	输出	DDS IC1启用
7	DEN2	输出	DDS IC2启用
8	VCO1	输出	VCO1转换指示
9	VCO2	输出	VCO2转换指示
10	UL	输入	失锁检测
11	VEN	输出	VGS-1启用输出
12	VRST	输出	VGS-1复位输出
13	BYTE	输入	外部数据总线更改输入
14	CNVSS	输入	处理器模式更改输入
15	VPLY	输入	VGS-1播放输入
16	VBSY	输入	VGS-1繁忙输入
17	RESET	输入	复位输入
18	XOUT	输出	主时钟输出
19	VSS	输入	GND
20	XIN	输入	主时钟输入
21	VCC1	输入	电源输入
22	NMI	输入	未连接
23	BKC	输入	降压中断输入
24	BOVR	输入	过压中断输入
25	STPC	输入	通过串行数据返回中断输入
26	BSFT	输出	预留
27	BEEP	输出	提示音编码输出
28	AGCSW	输出	AGC电压放电控制
29	TONE	输出	侧音编码输出
30,31	NC	输入	未连接
32	DATA	输出	通用串行数据输出
33	CLK	输出	通用串行数据输入
34	RXD2	输入	用于ALE单元的通用串行数据输入
35	TXD2	输出	用于ALE单元的通用串行数据输出
36	TXD1	输出	串行数据输出 (计算机命令)
37	VCC1	输入	电源输入
38	RXD1	输入	串行数据输入 (计算机命令/GPS)
39	VSS	输入	GND
40	WCLK	输入	用于闪存ROM的串行时钟输入
41	WBSY	输出	用于闪存ROM的繁忙输入
42	TXD0	输出	串行数据输出 (至面板MCU)

SEMICONDUCTOR DATA / 半导体数据

Pin No.	Port Name	I/O	Function
43	RXD0	I	Serial data input (From panel MCU)
44	RBK	O	RF blanking control
45	ABK	O	Audio blanking control
46	AMU	O	Audio mute control
47	TXC	O	Transmission power supply control
48	CKY	O	Transmission power output control
49	MMU2	O	DI audio mute control
50	MMU1	O	Microphone audio mute control
51	SELC	O	SELCALL power source ON/OFF control
52	WEPM	I	EPM input for flash ROM
53	NC	O	NC
54~56	IEN1~IEN3	O	A/D converter IC (TX-RX unit) enable
57	IEN4	O	Expansion I/O IC (TX-RX unit) enable
58	REN	O	Expansion I/O IC (TX-RX unit) enable
59,60	NC	O	NC
61	WCE	I	WCE input for flash ROM
62	PSENSE	I	NC
63	VOXS	O	VOX circuit changeover data output control
64	VOXO	I	VOX transmission instruction
65	TTI	I	TT signal input (For Auto antenna tuner)
66	TSI	I	TS signal input (For Auto antenna tuner)
67	TTO	O	TT signal output (For Auto antenna tuner)
68	TSO	O	TS signal output (For Auto antenna tuner)
69	NC	O	NC
70	KEY	I	CW key input
71	DPTT	I	DATA PTT input
72~74	AUX1~AUX3	I/O	Programmable AUX terminal 1~3
75	FSL	I	Detection input of FSK
76	SELADJ	O	Center frequency adjustment control of FSK modem
77	SELRX	I	SELCALL receive data input
78	SELTX	O	SELCALL transmit data output
79	FEN	O	Expansion I/O IC (Final unit) enable
80	PSC	O	Power switch control
81~84	TYP0~TYP3	I	Destination port 0~3
85	VCC2	I	Power supply input
86	NC	O	NC
87	VSS	I	GND
88	EEN	O	EEPROM enable
89	EDA	I	EEPROM data input
90	ECK	O	EEPROM clock output
91	ESI	O	EEPROM data output
92	CTS2	I	ALE unit flow control input
93	RTS2	O	ALE unit flow control output

管脚号	端口名称	输入/输出	功能
43	RXD0	输入	串行数据输入 (来自面板MCU)
44	RBK	输出	RF消隐控制
45	ABK	输出	音频消隐控制
46	AMU	输出	音频静音控制
47	TXC	输出	发射电源控制
48	CKY	输出	发射功率输出控制
49	MMU2	输出	DI音频静音控制
50	MMU1	输出	麦克风音频静音控制
51	SELC	输出	选择呼叫电源开启/关闭控制
52	WEPM	输入	用于闪存ROM的EPM输入
53	NC	输出	未连接
54~56	IEN1~IEN3	输出	模数转换器IC (TX-RX单元) 启用
57	IEN4	输出	扩展I/O IC (TX-RX单元) 启用
58	REN	输出	扩展I/O IC (TX-RX单元) 启用
59,60	NC	输出	未连接
61	WCE	输入	用于闪存ROM的WCE输入
62	PSENSE	输入	未连接
63	VOXS	输出	VOX电路转换数据输出控制
64	VOXO	输入	VOX发射指示
65	TTI	输入	TT信号输入 (用于自动天线调谐器)
66	TSI	输入	TS信号输入 (用于自动天线调谐器)
67	TTO	输出	TT信号输出 (用于自动天线调谐器)
68	TSO	输出	TS信号输出 (用于自动天线调谐器)
69	NC	输出	未连接
70	KEY	输入	CW键输入
71	DPTT	输入	数据PTT输入
72~74	AUX1~AUX3	输入/输出	可编程AUX端子1~3
75	FSL	输入	FSK的检测输入
76	SELADJ	输出	FSK调制解调器的中心频率调整控制
77	SELRX	输入	选择呼叫接收数据输入
78	SELTX	输出	选择呼叫发射数据输出
79	FEN	输出	扩展I/O IC (Final单元) 启用
80	PSC	输出	电源开关控制
81~84	TYP0~TYP3	输入	目的端口0~3
85	VCC2	输入	电源输入
86	NC	输出	未连接
87	VSS	输入	GND
88	EEN	输出	EEPROM启用
89	EDA	输入	EEPROM数据输入
90	ECK	输出	EEPROM时钟输出
91	ESI	输出	EEPROM数据输出
92	CTS2	输入	ALE单元流量控制输入
93	RTS2	输出	ALE单元流量控制输出

SEMICONDUCTOR DATA / 半导体数据

Pin No.	Port Name	I/O	Function
94	APTT	I	PTT instruction input from ALE
95	AAMU	I	Reserve
96	FSINT	I	FSK signal reception interruption input
97	PWS	I	Power switch line input
98	IGN	I	Ignition sense input
99	AMMU	I	Reserve
100	ADCD	I	ALE detect input
101	ABSY	I	ALE BUSY input
102	ARST	O	ALE reset output
103	BIO	I/O	Reserve
104	BAUD	O	ALE unit baud rate change
105	ASQC	O	Squelch state notification to ALE unit
106	ASENS	I	ALE unit attach judgement
107	ALE1	I	Reserve
108	SCR	O	Scrambler ON/OFF
109	SCRT	O	Scrambler circuit connection (transmission system) control
110	SCRR	O	Scrambler circuit connection (reception system) control
111	VGSRREC	O	VGS-1 recording route connection (reception system) control
112	VGSTREC	O	VGS-1 recording route connection (transmission system) control
113	VGSTPLY	O	VGS-1 playing route connection (transmission system) control
114	ALEMOD	O	ALE voice modulation route connection control
115	EMRMOD	O	Background Tone modulation route connection control
116	CODE1	O	Scrambler code setting 1
117	CODE2	O	Scrambler code setting 2
118	CODE4	O	Scrambler code setting 4
119	CODE8	O	Scrambler code setting 8
120	SM	I	S-meter voltage input
121	FIL1	I	Option filter installed and classification judgement voltage input
122,123	TH2, TH1	I	Final unit temperature detection voltage input 2, 1
124	VSF	I	Forward signal voltage input
125,126	NC	I	NC
127	AVSS	I	GND
128	NC	I	NC

管脚号	端口名称	输入/输出	功能
94	APTT	输入	来自ALE的PTT指示输入
95	AAMU	输入	预留
96	FSINT	输入	FSK信号接收中断输入
97	PWS	输入	电源开关线路输入
98	IGN	输入	点火传感器输入
99	AMMU	输入	预留
100	ADCD	输入	ALE检测输入
101	ABSY	输入	ALE繁忙输入
102	ARST	输出	ALE复位输出
103	BIO	输入/输出	预留
104	BAUD	输出	ALE单元波特率更改
105	ASQC	输出	向ALE单元通知静噪状态
106	ASENS	输入	ALE单元安装判断
107	ALE1	输入	预留
108	SCR	输出	扰频器开启/关闭
109	SCRT	输出	扰频器电路连接 (发射系统) 控制
110	SCRR	输出	扰频器电路连接 (接收系统) 控制
111	VGSRREC	输出	VGS-1录音路线连接 (接收系统) 控制
112	VGSTREC	输出	VGS-1录音路线连接 (发射系统) 控制
113	VGSTPLY	输出	VGS-1播放路线连接 (发射系统) 控制
114	ALEMOD	输出	ALE语音调制路线连接控制
115	EMRMOD	输出	背景音调制路线连接控制
116	CODE1	输出	扰频器代码设置1
117	CODE2	输出	扰频器代码设置2
118	CODE4	输出	扰频器代码设置4
119	CODE8	输出	扰频器代码设置8
120	SM	输入	信号强度表电压输入
121	FIL1	输入	安装的滤波器选配件和分类判断 电压输入
122,123	TH2, TH1	输入	Final单元温度检测电压输入2, 1
124	VSF	输入	前向信号电压输入
125,126	NC	输入	未连接
127	AVSS	输入	GND
128	NC	输入	未连接

SEMICONDUCTOR DATA / 半导体数据

2. Extended I/O Port

2-1. TX-RX unit IC1: BU2099FV

Pin No.	Port Name	Pin Name	Function	Active level	Condition
6	Q0	BPF4	4.1~7.5MHz BPF	L	L: Selection
7	Q1	BPF5	7.5~10.5MHz BPF	L	L: Selection
8	Q2	BPF6	10.5~14.5MHz BPF	L	L: Selection
9	Q3	BPF3	2.5~4.1MHz BPF	L	L: Selection
10	Q4	BPF1	30k~1.605MHz BPF	L	L: Selection
11	Q5	BPF7	14.5~21.5MHz BPF	L	L: Selection
12	Q6	BPF8	21.5~30MHz BPF	L	L: Selection
13	Q7	BPF2	1.605~2.5MHz BPF	L	L: Selection
14	Q8	FANH	Fan motor control	L	L: High speed
15	Q9	FANL	Fan motor control	L	L: Low speed
16	Q10	ATT	Attenuator ON/OFF	H	H: Attenuator ON
17	Q11	Pre	Preamplifier ON/OFF	H	H: Preamp ON

2-2. TX-RX unit IC421: BU2099FV

Pin No.	Port Name	Pin Name	Function	Active level	Condition
6	Q0	TXEQ	Equalizer for transmission (High boost)	H	H: Mic High Boost ON
7	Q1	FSKS	FSK Key route changeover (Enable/Disable of RTK)	H	H: Selcall functional OFF
8	Q2	SCC	NC	L	
9	Q3	AMC	Power source of AM mode detection output	L	L: AM mode
10	Q4	OP500	IF filter passing loss compensation	L	L: CW filter selection
11	Q5	AGCSLOW	AGC time constant changeover	H	H: AGC slow
12	Q6	AGCOFF	AGC circuit OFF/ON	H	H: AGC reference adjustment mode
13	Q7	5DSW	VGS-1 / GPS unit power source ON/OFF	H	H: VGS-1/GPS unit is used
14	Q8	ALE5DSW	ALE power source ON/OFF	H	H: ALE is used
15	Q9	FILT3	IF Filter 3 selection	L	L: Option filter selection
16	Q10	FILT2	IF Filter 2 selection	L	L: Built-in SSB filter selection
17	Q11	FILT1	IF Filter 1 selection	L	L: Built-in AM filter selection

2-3. FINAL unit IC3: BU2099FV

Pin No.	Port Name	Pin Name	Function	Active level	Condition
6	Q0	NC			
7	Q1	NC			
8	Q2	NC			
9	Q3	NC			
10	Q4	NC			
11	Q5	LPF1	1.605~2.5MHz LPF	L	L: Selection
12	Q6	LPF2	2.5~3.45MHz LPF	L	L: Selection
13	Q7	LPF3	3.45~5.5MHz LPF	L	L: Selection
14	Q8	LPF4	5.5~8.2MHz LPF	L	L: Selection
15	Q9	LPF5	8.2~12.1MHz LPF	L	L: Selection
16	Q10	LPF6	12.1~18.1MHz LPF	L	L: Selection
17	Q11	LPF7	18.1~30.0MHz LPF	L	L: Selection

2. 扩展I/O端口

2-1. TX-RX单元IC1: BU2099FV

管脚号	端口名称	管脚名称	功 能	激活电平	状 态
6	Q0	BPF4	4.1~7.5MHz BPF	L	L: 选择
7	Q1	BPF5	7.5~10.5MHz BPF	L	L: 选择
8	Q2	BPF6	10.5~14.5MHz BPF	L	L: 选择
9	Q3	BPF3	2.5~4.1MHz BPF	L	L: 选择
10	Q4	BPF1	30k~1.605MHz BPF	L	L: 选择
11	Q5	BPF7	14.5~21.5MHz BPF	L	L: 选择
12	Q6	BPF8	21.5~30MHz BPF	L	L: 选择
13	Q7	BPF2	1.605~2.5MHz BPF	L	L: 选择
14	Q8	FANH	风扇马达控制	L	L: 高速
15	Q9	FANL	风扇马达控制	L	L: 低速
16	Q10	ATT	衰减器开启/关闭	H	H: 衰减器开启
17	Q11	Pre	前级放大器开启/关闭	H	H: 前级放大器开启

2-2. TX-RX单元IC421: BU2099FV

管脚号	端口名称	管脚名称	功 能	激活电平	状 态
6	Q0	TXEQ	用于发射的均衡器(高频补偿)	H	H: 麦克风高频补偿开启
7	Q1	FSKS	FSK键路线转换(RTK启用/禁用)	H	H: 选择呼叫功能关闭
8	Q2	SCC	未连接	L	
9	Q3	AMC	AM模式检测输出的电源	L	L: AM模式
10	Q4	OP500	中频滤波器通过损耗补偿	L	L: 选择CW滤波器
11	Q5	AGCSLOW	AGC时间常数转换	H	H: AGC慢速
12	Q6	AGCOFF	AGC电路关闭/开启	H	H: AGC基准调整模式
13	Q7	5DSW	VGS-1/GPS单元电源开启/关闭	H	H: 使用VGS-1/GPS单元
14	Q8	ALE5DSW	ALE电源开启/关闭	H	H: 使用ALE
15	Q9	FILT3	选择中频滤波器3	L	L: 选择滤波器选购件
16	Q10	FILT2	选择中频滤波器2	L	L: 选择内置SSB滤波器
17	Q11	FILT1	选择中频滤波器1	L	L: 选择内置AM滤波器

2-3. FINAL单元IC3: BU2099FV

管脚号	端口名称	管脚名称	功 能	激活电平	状 态
6	Q0	NC			
7	Q1	NC			
8	Q2	NC			
9	Q3	NC			
10	Q4	NC			
11	Q5	LPF1	1.605~2.5MHz LPF	L	L: 选择
12	Q6	LPF2	2.5~3.45MHz LPF	L	L: 选择
13	Q7	LPF3	3.45~5.5MHz LPF	L	L: 选择
14	Q8	LPF4	5.5~8.2MHz LPF	L	L: 选择
15	Q9	LPF5	8.2~12.1MHz LPF	L	L: 选择
16	Q10	LPF6	12.1~18.1MHz LPF	L	L: 选择
17	Q11	LPF7	18.1~30.0MHz LPF	L	L: 选择

SEMICONDUCTOR DATA / 半导体数据

3. Panel Microcomputer: 30302MAP150GU (Display unit IC3)

Pin No.	Port Name	I/O	Function
1~4	NC	O	NC
5	SHIFT	O	NC
6	BYTE	I	External data bus changeover input
7	CNVSS	I	Processor mode changeover input
8,9	NC	O	NC
10	RST	I	Reset input
11	XOUT	O	Main clock output (14.7456MHz)
12	VSS	I	GND
13	XIN	I	Main clock input (14.7456MHz)
14	VCC1	I	Power source input
15	NMI	I	NMI interruption input
16	BLC2	O	MIC backlight control
17	BLC1	O	Key & LCD backlight control
18	DIMM	O	Dimmer control
19	GRE	O	LED green
20	RED	O	LED red
21	NC	O	NC
22	LCK	O	LCD serial clock
23	LDT	O	LCD serial data
24	LCS	O	LCD chip select
25	LRES	O	LCD reset
26	NC	O	NC
27	RXD2	I	Serial data input (From main MCU)
28	TXD2	O	Serial data output (To main MCU)
29	PTT/TXD1	O	NMI interruption input
30	NC	I	NC
31	DM	I/O	MIC keypad detection control
32,33	NC	I	NC
34	RXD0	I	Serial data input (Communication with microphone connector)
35~59	NC	O	NC
60	VCC2	I	Power source input
61	NC	O	NC
62	VSS	I	GND
63~82	NC	O	NC
83	S10	I	Front panel key (∨)
84	S9	I	Front panel key (∧)
85	S8	I	Front panel key (■)
86	S7	I	Front panel key (D>)
87	S6	I	Front panel key (<C)
88	S5	I	Front panel key (B)
89	S4	I	Front panel key (A)

3. 面板微处理器: 30302MAP150GU (Display单元IC3)

管脚号	端口名称	输入/输出	功能
1~4	NC	输出	未连接
5	SHIFT	输出	未连接
6	BYTE	输入	外部数据总线转换输入
7	CNVSS	输入	处理器模式转换输入
8,9	NC	输出	未连接
10	RST	输入	复位输入
11	XOUT	输出	主时钟输出 (14.7456MHz)
12	VSS	输入	GND
13	XIN	输入	主时钟输入 (14.7456MHz)
14	VCC1	输入	电源输入
15	NMI	输入	NMI中断输入
16	BLC2	输出	麦克风背光控制
17	BLC1	输出	按键及LCD背光控制
18	DIMM	输出	调光器控制
19	GRE	输出	绿色LED
20	RED	输出	红色LED
21	NC	输出	未连接
22	LCK	输出	LCD串行时钟
23	LDT	输出	LCD串行数据
24	LCS	输出	LCD芯片选择
25	LRES	输出	LCD复位
26	NC	输出	未连接
27	RXD2	输入	串行数据输入 (来自主MCU)
28	TXD2	输出	串行数据输出 (至主MCU)
29	PTT/TXD1	输出	NMI中断输入
30	NC	输入	未连接
31	DM	输入/输出	麦克风键盘检测控制
32,33	NC	输入	未连接
34	RXD0	输入	串行数据输入 (与麦克风连接器通信)
35~59	NC	输出	未连接
60	VCC2	输入	电源输入
61	NC	输出	未连接
62	VSS	输入	GND
63~82	NC	输出	未连接
83	S10	输入	前面板按键 (∨)
84	S9	输入	前面板按键 (∧)
85	S8	输入	前面板按键 (■)
86	S7	输入	前面板按键 (D>)
87	S6	输入	前面板按键 (<C)
88	S5	输入	前面板按键 (B)
89	S4	输入	前面板按键 (A)

SEMICONDUCTOR DATA / 半导体数据

Pin No.	Port Name	I/O	Function
90	S3	I	Front panel key (Δ)
91	S2	I	Front panel key (∇)
92	S1	I	Front panel key (\wedge)
93	NC	O	NC
94	AVSS	I	GND
95	NC	O	NC
96	VREF	I	AD converter reference power source
97	AVCC	I	Power source input (Analog)
98~100	NC	O	NC

管脚号	端口名称	输入/输出	功能
90	S3	输入	前面板按键 (Δ)
91	S2	输入	前面板按键 (∇)
92	S1	输入	前面板按键 (\wedge)
93	NC	输出	未连接
94	AVSS	输入	GND
95	NC	输出	未连接
96	VREF	输入	模数转换器基准电源
97	AVCC	输入	电源输入 (模拟)
98~100	NC	输出	未连接

4. DDS: AD9835BRUZ (TX-RX unit IC701,702)

4-1. Block Diagram / 方块图

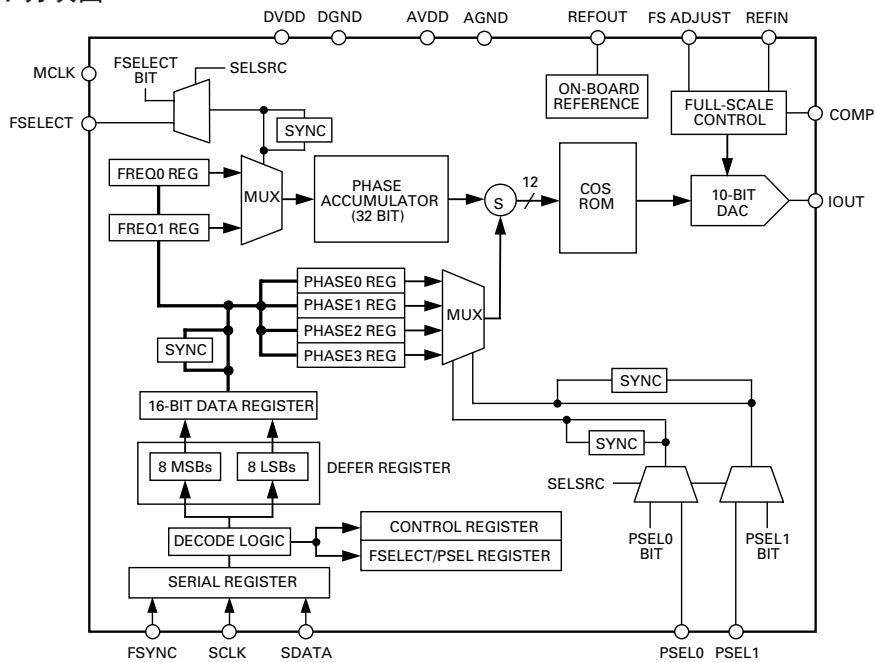

5. FSK Tone Decoder / FSK音调解码器: NJM2211M (TX-RX unit IC865)

5-1. Terminal Connection / 端子连接

5-2. Block Diagram / 方块图

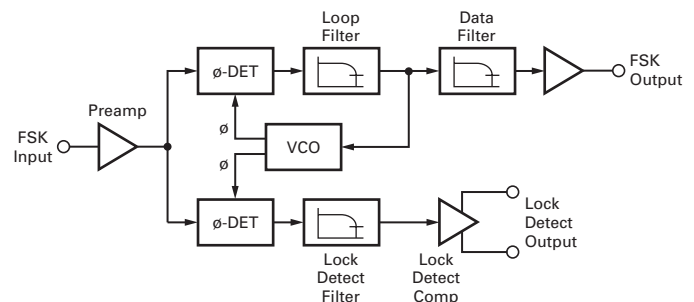
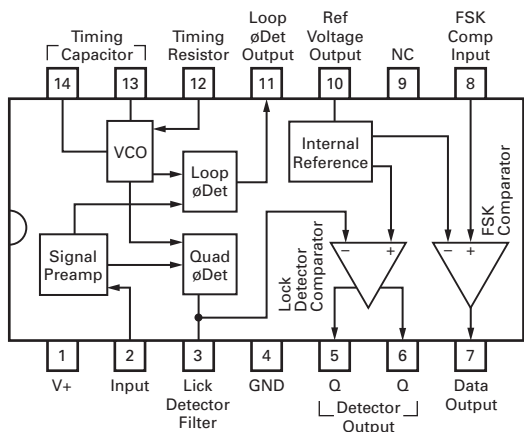

PARTS LIST / 零件表

* New Parts. Δ indicates safety critical components.Parts without **Parts No.** are not supplied.Les articles non mentionnés dans le **Parts No.** ne sont pas fournis.Teile ohne **Parts No.** werden nicht geliefert.

L : Scandinavia

Y : PX (Far East, Hawaii)

Y : AAFES (Europe)

K : USA

T : England

X : Australia

P : Canada

E : Europe

M : Other Areas

TK-90 (Y52-3290-20)

FINAL UNIT (X45-3780-20)

Ref. No.	Address	New parts	Parts No.	Description	Destination	Ref. No.	Address	New parts	Parts No.	Description	Destination
TK-90						FINAL UNIT (X45-3780-20)					
1	1B	*	A01-2199-02	METALLIC CABINET (TOP)		C1			C92-0777-05	ELECTRO	1000UF 25WV
2	2A	*	A01-2200-02	METALLIC CABINET (BOTTOM)		C2		*	CD04AH1E471M	ELECTRO	470UF 25WV
3	3A	*	A62-1125-03	PANEL ASSY		C3			C91-2691-05	CERAMIC	470PF 250WV
5	3A	*	B43-1186-04	BADGE		C4			C92-0777-05	ELECTRO	1000UF 25WV
6	1D	*	B62-1866-00	INSTRUCTION MANUAL		C5,6		*	CD04AH1E471M	ELECTRO	470UF 25WV
8	2B		E04-0167-05	RF COAXIAL RECEPTACLE (M)		C10			CK73GB1H103K	CHIP C	0.010UF K
9	2B		E23-1164-04	EARTH LUG (ANT)		C11,12			CC73FCH1H820J	CHIP C	82PF J
10	2C		E30-3489-05	DC CORD ACCESSORY		C13,14			CK73FB1H103K	CHIP C	0.010UF K
-			E37-0877-05	COAXIAL CABLE (DRIVE)		C15			CK73FB1E104K	CHIP C	0.10UF K
-			E37-0881-05	COAXIAL CABLE (RAT)		C16			CK73GB1H102K	CHIP C	1000PF K
-		*	E37-1227-05	LEAD WIRE WITH CONNECTOR (DISP-TXRX)		C17			CK73FB1E104K	CHIP C	0.10UF K
14	1B	*	E37-1228-05	LEAD WIRE WITH CONNECTOR (AT)		C18			CK73GB1H102K	CHIP C	1000PF K
-		*	E37-1229-05	FLAT CABLE (FINAL-TXRX)		C19-22			CK73FB1H103K	CHIP C	0.010UF K
-		*	E37-1230-05	LEAD WIRE WITH CONNECTOR (FINAL-TXRX)		C23,24			CC73FCH1H221J	CHIP C	220PF J
17	3B	*	E37-1231-05	LEAD WIRE WITH CONNECTOR (SPEAKER)		C25			CK73GB1H102K	CHIP C	1000PF K
20	1B		F07-1874-05	COVER (FAN)		C26			CK73FB1E104K	CHIP C	0.10UF K
21	3A	*	F07-1905-01	COVER (DUST FILTER)		C27			CK73GB1H102K	CHIP C	1000PF K
22	1B,2B		F09-0478-05	FANMOTOR		C28,29			CK73FB1E104K	CHIP C	0.10UF K
23	2B	*	F15-1013-04	SHIELDING PLATE		C30			CK73FB1H103K	CHIP C	0.010UF K
24	2C	*	F52-0038-05	FUSE (BLADE TYPE) (4A)		C31			CM73F2H102J	CHIP C	1000PF J
25	2C		F52-0044-05	FUSE (BLADE TYPE) (25A/32V)		C32-39			C93-0716-05	CHIP C	3300PF K
27	2B		G02-0896-04	FLAT SPRING (FINAL)		C42			CM73F2H151J	CHIP C	150PF J
28	2A,3A		G10-1635-04	FIBROUS SHEET		C44			CK73GB1H102K	CHIP C	1000PF K
30	3A	*	G13-2120-04	CUSHION (LCD FRAME)		C45			CK73FB1E104K	CHIP C	0.10UF K
31	3B	*	G13-2121-04	CUSHION (SPEAKER)		C46		*	CE32CL1E330M	CHIP EL	33UF 25WV
32	1B	*	G13-2127-04	CUSHION (EXT SP)		C47			CK73FB1E104K	CHIP C	0.10UF K
33	1B	*	G13-2160-05	CONDUCTIVE CUSHION (CABINET)		C48			CK73GB1H102K	CHIP C	1000PF K
34	3A	*	G53-1698-03	PACKING (PANEL)		C49-51			CK73FB1E104K	CHIP C	0.10UF K
36	3B		J02-0441-05	FOOT		C52,53			C93-0553-05	CHIP C	3.0PF C
37	2C	*	J02-1302-04	FOOT ACCESSORY		C54			CC73GCH1H221J	CHIP C	220PF J
38	3B		J19-5464-13	HOLDER (SPEAKER)		C55			CC73GCH1H470J	CHIP C	47PF J
-			J61-0307-05	BAND (TXRX)		C56			CC73FCH1H560J	CHIP C	56PF J
41	3A	*	K29-9362-02	KEY TOP		C57			CC73GCH1H221J	CHIP C	220PF J
A	1B	*	N09-2477-05	SEMS SCREW		C58			CK73GB1H103K	CHIP C	0.010UF K
B	1B		N15-1040-48	FLAT WASHER		C59			CC73GCH1H121J	CHIP C	120PF J
C	2A,2B	*	N32-3006-48	FLAT HEAD MACHINE SCREW		C60			CC73GCH1H560J	CHIP C	56PF J
D	3A,1B	*	N33-3006-43	OVAL HEAD MACHINE SCREW		C61		*	CE32CL1HR47M	CHIP EL	0.47UF 50WV
E	3A	*	N35-3008-43	BINDING HEAD MACHINE SCREW		C62			CM73F2H561J	CHIP C	560PF J
F	1B		N35-4010-48	BINDING HEAD MACHINE SCREW		C63			CK73FB1E104K	CHIP C	0.10UF K
G	1B	*	N66-2610-48	PAN HEAD SEMS SCREW		C64			CK73GB1H102K	CHIP C	1000PF K
H	3B		N67-2608-48	PAN HEAD SEMS SCREW		C65			CK73FB1H103K	CHIP C	0.010UF K
J	3A,3B	*	N82-2608-48	BINDING HEAD TAPTITE SCREW		C66-68			CK73FB1E104K	CHIP C	0.10UF K
K	3B		N87-2606-48	BRAZIER HEAD TAPTITE SCREW		C69,70		*	CE32CL1V100M	CHIP EL	10UF 35WV
L	1A,2A,2B		N87-2608-48	BRAZIER HEAD TAPTITE SCREW		C71,72			CK73FB1E104K	CHIP C	0.10UF K
45	3B		T07-0757-05	SPEAKER		C73,74		*	CE32CL1V100M	CHIP EL	10UF 35WV
						C75			CK73FB1E104K	CHIP C	0.10UF K
						C76			CK73GB1H103K	CHIP C	0.010UF K
						C77			CK73GB1H102K	CHIP C	1000PF K
						C78			CK73GB1H103K	CHIP C	0.010UF K
						C79			CK73GB1H102K	CHIP C	1000PF K
						C80,81			CK73GB1H103K	CHIP C	0.010UF K
						C82			CK73FB1E104K	CHIP C	0.10UF K
						C101			CM73F2H102J	CHIP C	1000PF J
						C103			CC45FSL2H221JN	CERAMIC	220PF J

PARTS LIST / 零件表

FINAL UNIT (X45-3780-20)

Ref. No.	Address	New parts	Parts No.	Description	Destination	Ref. No.	Address	New parts	Parts No.	Description	Destination
C105,106			CM73F2H102J	CHIP C 100PF J		C714			CK73FB1H103K	CHIP C 0.010UF K	
C107			CM73F2H681J	CHIP C 680PF J		TC1			C05-0370-05	CERAMIC TRIMMER CAPACITOR	
C108			CC45FSL2H101JN	CERAMIC 100PF J		CN1,2			E04-0154-05	PIN SOCKET	
C109			CM73F2H821J	CHIP C 820PF J		CN3		*	E41-0933-05	PIN ASSY	
C114			CK73FB1H103K	CHIP C 0.010UF K		CN4		*	E41-1391-05	FLAT CABLE CONNECTOR	
C201			CM73F2H821J	CHIP C 820PF J		CN6			E41-0927-05	PIN ASSY	
C202			CC45FSL2H181JN	CERAMIC 180PF J		CN9		*	E23-1310-05	TEST TERMINAL	
C203,204			CM73F2H821J	CHIP C 820PF J		W1		*	E37-1275-05	PROCESSED LEAD WIRE (ANTENNA)	
C205			CM73F2H561J	CHIP C 560PF J		W2	2B		E37-1224-05	LEAD WIRE WITH CONNECTOR (DC IN)	
C206,207			CC45FSL2H391JN	CERAMIC 390PF J		F3	3A	*	F52-0038-05	FUSE (BLADE TYPE) (4A/32V)	
C214			CK73FB1H103K	CHIP C 0.010UF K		F1			F53-0328-05	FUSE (5A)	
C301			CC45FSL2H471JN	CERAMIC 470PF J		F2		*	F53-0391-05	FUSE (UL,CSA) (10A 60V)	
C302			C93-0572-05	CHIP C 100PF J		CN7,8			J13-0410-05	FUSE HOLDER	
C303			CM73F2H821J	CHIP C 820PF J		-		*	L92-0104-05	TROIDAL CORE	
C305			CC45FSL2H331JN	CERAMIC 330PF J		-		*	L92-0107-05	TROIDAL CORE	
C307			CC45FSL2H331JN	CERAMIC 330PF J		-		*	L92-0108-05	TROIDAL CORE	
C308			CC45FSL2H271JN	CERAMIC 270PF J		L1			L39-1483-05	TOROIDAL COIL	
C309,310			CC45FSL2H391JN	CERAMIC 390PF J		L2			L39-1257-05	TOROIDAL COIL	
C311			CC45FSL2H221JN	CERAMIC 220PF J		L3			L39-1450-05	TOROIDAL COIL	
C314			CK73FB1H103K	CHIP C 0.010UF K		L4			L39-0480-15	TOROIDAL COIL	
C401			CC45FSL2H391JN	CERAMIC 390PF J		L5			L39-1252-15	TOROIDAL COIL	
C403			C93-0569-05	CHIP C 56PF J		L6			L33-0651-05	CHOKE COIL	
C405			CC45FSL2H331JN	CERAMIC 330PF J		L7			L33-0625-15	TOROIDAL COIL	
C406			CC45FSL2H271JN	CERAMIC 270PF J		L8			L39-0480-15	TOROIDAL COIL	
C407			CC45FSL2H151JN	CERAMIC 150PF J		L11			L41-2285-33	SMALL FIXED INDUCTOR (0.22UH)	
C408			CC45FSL2H271JN	CERAMIC 270PF J		L12			L41-4785-33	SMALL FIXED INDUCTOR (0.47UH)	
C409			CC45FSL2H181JN	CERAMIC 180PF J		L13-19			L92-0445-05	CHIP FERRITE	
C410			CC45FSL2H331JN	CERAMIC 330PF J		L20,21		*	L41-1025-27	SMALL FIXED INDUCTOR (1000UH)	
C412			CC45FSL2H121JN	CERAMIC 120PF J		L22		*	L41-2785-09	SMALL FIXED INDUCTOR (270NH)	
C414			CK73FB1H103K	CHIP C 0.010UF K		L23			L41-4705-33	SMALL FIXED INDUCTOR (47UH)	
C501			CC45FSL2H271JN	CERAMIC 270PF J		L24,25			L92-0131-05	CHIP FERRITE	
C502			C93-0566-05	CHIP C 33PF J		L26			L41-4795-33	SMALL FIXED INDUCTOR (4.7UH)	
C504			CC45FSL2H271JN	CERAMIC 270PF J		L27,28			L92-0131-05	CHIP FERRITE	
C505			CC45FSL2H181JN	CERAMIC 180PF J		L29		*	L33-1990-05	CHOKE COIL	
C506,507			C93-0568-05	CHIP C 47PF J		L30,31			L92-0131-05	CHIP FERRITE	
C508			CC45FSL2H331JN	CERAMIC 330PF J		L32			L92-0445-05	CHIP FERRITE	
C509			C93-0567-05	CHIP C 39PF J		L101		*	L39-1500-05	TOROIDAL COIL	
C510			CC45FSL2H101JN	CERAMIC 100PF J		L102			L39-0459-05	TOROIDAL COIL	
C511			C93-0572-05	CHIP C 100PF J		L104			L41-4705-33	SMALL FIXED INDUCTOR (47UH)	
C512			CC45FSL2H151JN	CERAMIC 150PF J		L201			L39-0459-05	TOROIDAL COIL	
C514			CK73FB1H103K	CHIP C 0.010UF K		L202		*	L39-1501-05	TOROIDAL COIL	
C601			CC45FSL2H121JN	CERAMIC 120PF J		L204			L41-4705-33	SMALL FIXED INDUCTOR (47UH)	
C602			C93-0558-05	CHIP C 8.0PF D		L301		*	L39-1502-05	TOROIDAL COIL	
C603			CC45FSL2H121JN	CERAMIC 120PF J		L302			L39-1457-05	TOROIDAL COIL	
C604			C93-0572-05	CHIP C 100PF J		L303		*	L39-1504-05	TOROIDAL COIL	
C606			C93-0571-05	CHIP C 82PF J		L304			L41-4705-33	SMALL FIXED INDUCTOR (47UH)	
C607			CC45FSL2H151JN	CERAMIC 150PF J		L401			L39-1223-05	TOROIDAL COIL	
C609			C93-0572-05	CHIP C 100PF J		L402			L39-1258-05	TOROIDAL COIL	
C610			C93-0566-05	CHIP C 33PF J		L403			L39-1221-05	TOROIDAL COIL	
C612			C93-0569-05	CHIP C 56PF J		L404			L41-4705-33	SMALL FIXED INDUCTOR (47UH)	
C613			C93-0571-05	CHIP C 82PF J		L501		*	L39-1503-05	TOROIDAL COIL	
C614			CK73FB1H103K	CHIP C 0.010UF K		L502			L39-1221-05	TOROIDAL COIL	
C701			CC45FSL2H101JN	CERAMIC 100PF J		L503			L34-1279-05	AIR-CORE COIL	
C702			C93-0563-05	CHIP C 18PF J		L504			L41-4705-33	SMALL FIXED INDUCTOR (47UH)	
C704			CC45FSL2H151JN	CERAMIC 150PF J		L601			L39-1221-05	TOROIDAL COIL	
C705			C93-0561-05	CHIP C 12PF J		L602		*	L34-4812-05	AIR-CORE COIL	
C706			CC45FSL2H680JN	CERAMIC 68PF J		L603		*	L34-4813-05	AIR-CORE COIL	
C707			C93-0555-05	CHIP C 5.0PF C		L604			L41-4705-33	SMALL FIXED INDUCTOR (47UH)	
C708,709			CC45FSL2H121JN	CERAMIC 120PF J							
C710,711			C93-0564-05	CHIP C 22PF J							

PARTS LIST / 零件表

FINAL UNIT (X45-3780-20)
DISPLAY UNIT (X54-3560-20)

Ref. No.	Address	New parts	Parts No.	Description	Desti-nation	Ref. No.	Address	New parts	Parts No.	Description	Desti-nation
L701			L34-1281-05	AIR-CORE COIL		D101			1SS355	DIODE	
L702			L34-1282-05	AIR-CORE COIL		D201			1SS355	DIODE	
L703			L34-1359-05	AIR-CORE COIL		D301			1SS355	DIODE	
L704			L41-3305-33	SMALL FIXED INDUCTOR (33UH)		D401			1SS355	DIODE	
L705			L92-0131-05	CHIP FERRITE		D501			1SS355	DIODE	
R1		*	RS14DB3DR22J	FL-PROOF RS 0.22 J 2W		D601			1SS355	DIODE	
R2			RS14DB3A4R7J	FL-PROOF RS 4.7 J 1W		D701			1SS355	DIODE	
R3	3B	*	R92-3615-05	METAL FILM RESISTOR (0.01 30W)		IC1,2		*	TA7808SQ	BI-POLAR IC	
R11			RK73FB2B560J	CHIP R 56 J 1/8W		IC3			BU2099FV	MOS-IC	
R12			RK73FB2B472J	CHIP R 4.7K J 1/8W		Q1	3A		RD06HHF1	FET (PRE DRIVE)	
R13,14			RK73FB2B561J	CHIP R 560 J 1/8W		Q2,Q3	3A,3B		RD16HHF1	FET (DRIVE)	
R15			RK73GB2A562J	CHIP R 5.6K J 1/10W		Q4,Q5	3B		2SC2879A(O,Y)	TRANSISTOR (FINAL)	
R16,17			RK73FB2B2R2J	CHIP R 2.2 J 1/8W		Q6	3A		2SC3421-Q(Y)	TRANSISTOR	
R18,19			RK73FB2B561J	CHIP R 560 J 1/8W		Q7		*	SI7445DP-E3	FET	
R20		*	RK73SB3A331J	CHIP R 330 J 1W		Q8			DTC114EKA	DIGITAL TRANSISTOR	
R21			RK73FB2B472J	CHIP R 4.7K J 1/8W		Q9		*	RN47A4-F	TRANSISTOR	
R22			RK73FB2B2R2J	CHIP R 2.2 J 1/8W		Q10-12			FMA5A	TRANSISTOR	
R23		*	RK73SB3A331J	CHIP R 330 J 1W		Q13			DTB113EK	DIGITAL TRANSISTOR	
R24			RK73FB2B472J	CHIP R 4.7K J 1/8W		TH1,2		*	NCP18XW153J0S	THERMISTOR	
R25			RK73FB2B2R2J	CHIP R 2.2 J 1/8W		-			212-1021-05	INSULATING TUBE (D1)	
R26			RK73FB2B391J	CHIP R 390 J 1/8W		DISPLAY UNIT (X54-3560-20)					
R27			RK73GB2A562J	CHIP R 5.6K J 1/10W		101	3B		B11-1825-04	FILTER	
R28			RK73FB2B391J	CHIP R 390 J 1/8W		D7			B30-2151-05	LED (RED/GREEN)	
R29			RK73GB2A562J	CHIP R 5.6K J 1/10W		D8-19			B30-2281-05	LED (Y)	
R30,31		*	RK73SB3A5R6J	CHIP R 5.6 J 1W		ED1	3B		B38-0914-05	LCD	
R32,33		*	RK73SB3A2R7J	CHIP R 2.7 J 1W		C4			CK73GB1H102K	CHIP C 1000PF K	
R34		*	RK73EB2E150J	CHIP R 15 J 1/4W		C7			CK73GB1H102K	CHIP C 1000PF K	
R35,36		*	RK73SB3A5R6J	CHIP R 5.6 J 1W		C9			CK73GB1H102K	CHIP C 1000PF K	
R37,38		*	RK73SB3A2R7J	CHIP R 2.7 J 1W		C11			CK73GB1H222K	CHIP C 2200PF K	
R39		*	RK73EB2E150J	CHIP R 15 J 1/4W		C13			CK73GB1H104K	CHIP C 0.10UF K	
R40			RK73GB2A391J	CHIP R 390 J 1/10W		C15			CK73GB1H102K	CHIP C 1000PF K	
R41			RK73GB2A4R7J	CHIP R 4.7 J 1/10W		C16-18			CC73GCH1H101J	CHIP C 100PF J	
R42,43		*	RK73PB2H270J	CHIP R 27 J 1/2W		C19			CK73GB1H102K	CHIP C 1000PF K	
R44			RK73GB2A223J	CHIP R 22K J 1/10W		C20			CK73GB1E105K	CHIP C 1.0UF K	
R45			RK73GB2A103J	CHIP R 10K J 1/10W		C21,22			CC73GCH1H101J	CHIP C 100PF J	
R46			RK73GB2A562J	CHIP R 5.6K J 1/10W		C23			CK73GB1H104K	CHIP C 0.10UF K	
R47			RK73GB2A822J	CHIP R 8.2K J 1/10W		C24			CK73GB1H103K	CHIP C 0.010UF K	
R48			RK73GB2A562J	CHIP R 5.6K J 1/10W		C25		*	CE32CL1C100M	CHIP EL 10UF 16WV	
R49			RK73GB2A822J	CHIP R 8.2K J 1/10W		C26			CK73GB1E105K	CHIP C 1.0UF K	
R51-53			RK73GB2A101J	CHIP R 100 J 1/10W		C28		*	CE32CL1C100M	CHIP EL 10UF 16WV	
R54-60			RK73GB2A470J	CHIP R 47 J 1/10W		C29			CK73GB1H102K	CHIP C 1000PF K	
R61,62			RK73FB2B104J	CHIP R 100K J 1/8W		C30			CK73GB1H104K	CHIP C 0.10UF K	
R65,66			RK73EB2E000J	CHIP R 0.0 J 1/4W		C31,32			CC73GCH1H100D	CHIP C 10PF D	
R67,68			RK73FB2B561J	CHIP R 560 J 1/8W		C33			CK73GB1H103K	CHIP C 0.010UF K	
R69			RK73FB2B560J	CHIP R 56 J 1/8W		C34-37			CK73GB1H102K	CHIP C 1000PF K	
VR1-4		*	R32-0752-05	SEMI FIXED VARIABLE RESISTOR		C38,39			CK73GB1E105K	CHIP C 1.0UF K	
K1			S51-1420-05	RELAY		C40		*	CE32CL1C100M	CHIP EL 10UF 16WV	
K101,102			S76-0423-05	RELAY		C41			CK73GB1E105K	CHIP C 1.0UF K	
K201,202			S76-0423-05	RELAY		C42-45			CK73GB1H103K	CHIP C 0.010UF K	
K301,302			S76-0423-05	RELAY		C46			CC73GCH1H471J	CHIP C 470PF J	
K401,402			S76-0423-05	RELAY		C47			CK73GB1H472K	CHIP C 4700PF K	
K501,502			S76-0423-05	RELAY		102	3B		E29-1202-04	INTER CONNECTOR	
K601,602			S76-0423-05	RELAY		CN1		*	E41-2077-05	PIN ASSY	
K701,702			S51-1420-05	RELAY		CN2		*	E41-2559-05	PIN ASSY	
D1,2		*	MA2B027(B)	VARISTOR		J1	3B		E58-0522-05	MODULAR JACK	
D3			DSA301LA	DIODE							
D6,7		*	1SS348-F	DIODE							
D8			ZSH5MA27	SURGE ABSORBER							
D9			1SS355	DIODE							

If a part reference number is listed in a shaded box, that part does not come with the PCB.

PARTS LIST / 零件表

DISPLAY UNIT (X54-3560-20)

TX-RX UNIT (X57-7210-20)

Ref. No.	Address	New parts	Parts No.	Description	Destination
103	3B		J19-5467-03	HOLDER	
104	3B		J21-8470-03	MOUNTING HARDWARE	
105	3B	*	J31-0558-05	COLLAR	
L1,2			L41-1095-33	SMALL FIXED INDUCTOR (1.0UH)	
L3			L41-1005-27	SMALL FIXED INDUCTOR (10UH)	
L4,5			L41-1095-33	SMALL FIXED INDUCTOR (1.0UH)	
L6			L41-1005-27	SMALL FIXED INDUCTOR (10UH)	
L8,9			L41-1005-27	SMALL FIXED INDUCTOR (10UH)	
X1			L77-1956-05	CRYSTAL RESONATOR (14.7456MHZ)	
CP1,2		*	RK74GB1J102J	CHIP-COM 1.0K J 1/16W	
CP3-7		*	RK74GA1J101J	CHIP-COM 100 J 1/16W	
R1-6			RK73FB2B000J	CHIP R 0.0 J 1/8W	
R7			RK73FB2B101J	CHIP R 100 J 1/8W	
R8-11			RK73FB2B000J	CHIP R 0.0 J 1/8W	
R12,13			RK73GB2A101J	CHIP R 100 J 1/10W	
R15			RK73FB2B391J	CHIP R 390 J 1/8W	
R17			RK73FB2B391J	CHIP R 390 J 1/8W	
R19			RK73FB2B391J	CHIP R 390 J 1/8W	
R20			RK73GB2A473J	CHIP R 47K J 1/10W	
R21			RK73GB2A102J	CHIP R 1.0K J 1/10W	
R22			RK73GB2A101J	CHIP R 100 J 1/10W	
R23			RK73GB2A000J	CHIP R 0.0 J 1/10W	
R24			RK73GB2A102J	CHIP R 1.0K J 1/10W	
R25			RK73GB2A472J	CHIP R 4.7K J 1/10W	
R27,28			RK73GB2A103J	CHIP R 10K J 1/10W	
R29			RK73FB2B821J	CHIP R 820 J 1/8W	
R31			RK73GB2A333J	CHIP R 33K J 1/10W	
R32			RK73GB2A473J	CHIP R 47K J 1/10W	
R33			RK73GB2A101J	CHIP R 100 J 1/10W	
R34,35			RK73GB2A473J	CHIP R 47K J 1/10W	
R37			RK73FB2B000J	CHIP R 0.0 J 1/8W	
R38			RK73GB2A000J	CHIP R 0.0 J 1/10W	
R39			RK73FB2B471J	CHIP R 470 J 1/8W	
R40			RK73FB2B271J	CHIP R 270 J 1/8W	
R41			RK73GB2A471J	CHIP R 470 J 1/10W	
R42			RK73GB2A102J	CHIP R 1.0K J 1/10W	
R43			RK73GB2A473J	CHIP R 47K J 1/10W	
R44			RK73GB2A102J	CHIP R 1.0K J 1/10W	
R45			RK73GB2A103J	CHIP R 10K J 1/10W	
R46-49			RK73GB2A474J	CHIP R 470K J 1/10W	
R50			RK73GB2A103J	CHIP R 10K J 1/10W	
R51			RK73GB2A101J	CHIP R 100 J 1/10W	
R52			RK73GB2A102J	CHIP R 1.0K J 1/10W	
R53			RK73FB2B471J	CHIP R 470 J 1/8W	
R54			RK73GB2A000J	CHIP R 0.0 J 1/10W	
R55			RK73FB2B151J	CHIP R 150 J 1/8W	
R58			RK73FB2B471J	CHIP R 470 J 1/8W	
R59			RK73GB2A473J	CHIP R 47K J 1/10W	
R60			RK73FB2B151J	CHIP R 150 J 1/8W	
R61			RK73FB2B471J	CHIP R 470 J 1/8W	
R62			RK73FB2B151J	CHIP R 150 J 1/8W	
R64			RK73FB2B471J	CHIP R 470 J 1/8W	
R65			RK73FB2B151J	CHIP R 150 J 1/8W	
R66			RK73GB2A000J	CHIP R 0.0 J 1/10W	
R67			RK73GB2A271J	CHIP R 270 J 1/10W	
R70			RK73GB2A102J	CHIP R 1.0K J 1/10W	
R71			RK73FB2B000J	CHIP R 0.0 J 1/8W	
R72-75			RK73GB2A472J	CHIP R 4.7K J 1/10W	
R76			RK73GB2A103J	CHIP R 10K J 1/10W	

Ref. No.	Address	New parts	Parts No.	Description	Destination
S1-11		*	S70-0896-05	TACT SWITCH	
D1,2		*	EDZ18B	ZENER DIODE	
D3-5			AVRM1608080MAA	VARISTOR	
D6			DA221	DIODE	
IC1			XC6201P502PR	MOS-IC	
IC2			TC7WT125FUF	MOS-IC	
IC3		*	30302MAP150GU	MICROCONTROLLER IC	
IC4			LC75810T-8726	MOS-IC	
IC5			S-80942CNNBG9C	MOS-IC	
Q2			DTC114EE	DIGITAL TRANSISTOR	
Q4			DTC114EE	DIGITAL TRANSISTOR	
Q5			12A02CH	TRANSISTOR	
Q6,7			DTC144EE	DIGITAL TRANSISTOR	
Q9-14			DTC114EE	DIGITAL TRANSISTOR	
TH1		*	NCP18XH103JOS	THERMISTOR	
TX-RX UNIT (X57-7210-20)					
C1			CC73GCH1H180J	CHIP C 18PF J	
C2			CK73GB1H102K	CHIP C 1000PF K	
C3		*	CD04AH1E471M	ELECTRO 470UF 25VV	
C4			CC73GCH1H390J	CHIP C 39PF J	
C5			CK73GB1E105K	CHIP C 1.0UF K	
C6			CK73GB1H104K	CHIP C 0.10UF K	
C7			CC73GCH1H470J	CHIP C 47PF J	
C9			CK73GB1H104K	CHIP C 0.10UF K	
C10			CC73GCH1H070B	CHIP C 7.0PF B	
C11			CC73GCH1H470J	CHIP C 47PF J	
C12			CK73GB1H104K	CHIP C 0.10UF K	
C13			CK73GB1H103K	CHIP C 0.010UF K	
C14			CK73EB1H104K	CHIP C 0.10UF K	
C15			CK73GB1H102K	CHIP C 1000PF K	
C16			CK73GB1H104K	CHIP C 0.10UF K	
C17			CK73EB1H104K	CHIP C 0.10UF K	
C18			CK73GB1H104K	CHIP C 0.10UF K	
C19			CK73GB1H103K	CHIP C 0.010UF K	
C20			CK73GB1H102K	CHIP C 1000PF K	
C21			CK73GB1H104K	CHIP C 0.10UF K	
C22			CK73GB1H103K	CHIP C 0.010UF K	
C23			CC73GCH1H270J	CHIP C 27PF J	
C24			CK73GB1H102K	CHIP C 1000PF K	
C25			CK73GB1H103K	CHIP C 0.010UF K	
C26			CC73GCH1H150J	CHIP C 15PF J	
C27		*	CE32CL1C100M	CHIP EL 10UF 16WV	
C28			CK73GB1H103K	CHIP C 0.010UF K	
C29			CK73GB1H102K	CHIP C 1000PF K	
C30,31			CK73GB1H104K	CHIP C 0.10UF K	
C32			CK73GB1E105K	CHIP C 1.0UF K	
C33			CK73GB1H102K	CHIP C 1000PF K	
C37		*	CC73GCH1H152J	CHIP C 1500PF J	
C38			CK73GB1H104K	CHIP C 0.10UF K	
C39		*	CC73GCH1H222J	CHIP C 2200PF J	
C40		*	CC73GCH1H152J	CHIP C 1500PF J	
C41-45		*	CC73GCH1H222J	CHIP C 2200PF J	
C46		*	CC73GCH1H122J	CHIP C 1200PF J	
C47			CK73GB1H104K	CHIP C 0.10UF K	
C48		*	CC73GCH1H182J	CHIP C 1800PF J	
C49			CK73GB1H104K	CHIP C 0.10UF K	

PARTS LIST / 零件表

TX-RX UNIT (X57-7210-20)

Ref. No.	Address	New parts	Parts No.	Description	Desti-nation	Ref. No.	Address	New parts	Parts No.	Description	Desti-nation
C50			CC73GCH1H821J	CHIP C 820PF J		C124			CC73GCH1H060B	CHIP C 6.0PF B	
C51			CK73GB1H104K	CHIP C 0.10UF K		C125			CC73GCH1H151J	CHIP C 150PF J	
C52			CC73GCH1H681J	CHIP C 680PF J		C126			CK73GB1H103K	CHIP C 0.010UF K	
C53			CK73GB1H104K	CHIP C 0.10UF K		C127			CC73GCH1H471J	CHIP C 470PF J	
C54			CC73GCH1H471J	CHIP C 470PF J		C128			CC73GCH1H180J	CHIP C 18PF J	
C55			CK73GB1H104K	CHIP C 0.10UF K		C129			CK73GB1H103K	CHIP C 0.010UF K	
C56			CC73GCH1H331J	CHIP C 330PF J		C130			CC73GCH1H680J	CHIP C 68PF J	
C57			CK73GB1H104K	CHIP C 0.10UF K		C133,134			CK73GB1H103K	CHIP C 0.010UF K	
C58			CC73GCH1H221J	CHIP C 220PF J		C135			CK73GB1H104K	CHIP C 0.10UF K	
C59			CK73GB1H104K	CHIP C 0.10UF K		C137			CK73GB1H103K	CHIP C 0.010UF K	
C60			CC73GCH1H221J	CHIP C 220PF J		C138,139			CK73GB1H104K	CHIP C 0.10UF K	
C61			CC73GCH1H102J	CHIP C 1000PF J		C142			CK73GB1H102K	CHIP C 1000PF K	
C62		*	CC73GCH1H222J	CHIP C 2200PF J		C144,145			CK73GB1H102K	CHIP C 1000PF K	
C63-68			CC73GCH1H102J	CHIP C 1000PF J		C146,147			CK73GB1H103K	CHIP C 0.010UF K	
C69		*	CC73GCH1H152J	CHIP C 1500PF J		C148			CK73GB1H102K	CHIP C 1000PF K	
C70			CC73GCH1H560J	CHIP C 56PF J		C149			CK73GB1H104K	CHIP C 0.10UF K	
C71			CC73GCH1H680J	CHIP C 68PF J		C151,152			CK73GB1H102K	CHIP C 1000PF K	
C72		*	CC73GCH1H561J	CHIP C 560PF J		C154			CC73GCH1H030B	CHIP C 3.0PF B	
C73			CC73GCH1H331J	CHIP C 330PF J		C155			CC73GCH1H471J	CHIP C 470PF J	
C74			CC73GCH1H101J	CHIP C 100PF J		C156		*	CE32CL1C100M	CHIP EL 10UF 16WV	
C75			CC73GCH1H151J	CHIP C 150PF J		C157			CK73GB1H104K	CHIP C 0.10UF K	
C76			CC73GCH1H102J	CHIP C 1000PF J		C158			CK73GB1H102K	CHIP C 1000PF K	
C77			CK73GB1H103K	CHIP C 0.010UF K		C159			CK73GB1H103K	CHIP C 0.010UF K	
C78-83			CC73GCH1H102J	CHIP C 1000PF J		C160			CK73GB1H102K	CHIP C 1000PF K	
C84			CK73GB1E105K	CHIP C 1.0UF K		C161			CK73GB1H103K	CHIP C 0.010UF K	
C85		*	CC73GCH1H122J	CHIP C 1200PF J		C164			CC73GCH1H020B	CHIP C 2.0PF B	
C86,87			CK73GB1H104K	CHIP C 0.10UF K		C165			CK73GB1H102K	CHIP C 1000PF K	
C88		*	CC73GCH1H182J	CHIP C 1800PF J		C166			CC73GCH1H010B	CHIP C 1.0PF B	
C89			CK73GB1H104K	CHIP C 0.10UF K		C167			CC73GCH1H040B	CHIP C 4.0PF B	
C90			CC73GCH1H821J	CHIP C 820PF J		C169			CK73GB1H102K	CHIP C 1000PF K	
C91			CK73GB1H104K	CHIP C 0.10UF K		C170			CC73GCH1H090B	CHIP C 9.0PF B	
C92			CC73GCH1H681J	CHIP C 680PF J		C181			CK73GB1H103K	CHIP C 0.010UF K	
C93			CK73GB1H104K	CHIP C 0.10UF K		C182			CK73GB1H102K	CHIP C 1000PF K	
C94			CC73GCH1H471J	CHIP C 470PF J		C184			CK73GB1H103K	CHIP C 0.010UF K	
C95			CK73GB1H104K	CHIP C 0.10UF K		C185			CC73GCH1H030B	CHIP C 3.0PF B	
C96			CC73GCH1H331J	CHIP C 330PF J		C186			CK73GB1H104K	CHIP C 0.10UF K	
C97			CK73GB1H104K	CHIP C 0.10UF K		C187			CK73GB1H102K	CHIP C 1000PF K	
C98			CC73GCH1H221J	CHIP C 220PF J		C188-190			CK73GB1H103K	CHIP C 0.010UF K	
C99			CK73GB1H104K	CHIP C 0.10UF K		C191			CC73GCH1H030B	CHIP C 3.0PF B	
C100		*	CC73GCH1H222J	CHIP C 2200PF J		C192,193			CK73GB1H102K	CHIP C 1000PF K	
C101			CK73GB1H103K	CHIP C 0.010UF K		C194			CK73GB1H104K	CHIP C 0.10UF K	
C102			CK73GB1H104K	CHIP C 0.10UF K		C196			CK73GB1H103K	CHIP C 0.010UF K	
C104			CK73GB1E105K	CHIP C 1.0UF K		C197,198			CK73GB1H102K	CHIP C 1000PF K	
C105,106			CK73GB1H104K	CHIP C 0.10UF K		C200			CK73GB1H103K	CHIP C 0.010UF K	
C107			CK73GB1H103K	CHIP C 0.010UF K		C202			CK73GB1H102K	CHIP C 1000PF K	
C108			CS77CA1C100M	CHIP-TAN 10UF 16WV		C203			CK73GB1H103K	CHIP C 0.010UF K	
C109			CK73GB1H102K	CHIP C 1000PF K		C204			CC73GCH1H020B	CHIP C 2.0PF B	
C110			CK73GB1H104K	CHIP C 0.10UF K		C205			CK73GB1H103K	CHIP C 0.010UF K	
C111			CK73GB1H102K	CHIP C 1000PF K		C207			CK73GB1H102K	CHIP C 1000PF K	
C112			CK73GB1H104K	CHIP C 0.10UF K		C208			CK73GB1H103K	CHIP C 0.010UF K	
C113			CK73GB1H103K	CHIP C 0.010UF K		C209			CC73GCH1H090B	CHIP C 9.0PF B	
C114			CK73GB1E105K	CHIP C 1.0UF K		C210			CC73GCH1H220J	CHIP C 22PF J	
C115,116			CK73GB1H104K	CHIP C 0.10UF K		C211-213			CK73GB1H103K	CHIP C 0.010UF K	
C117			CK73GB1H103K	CHIP C 0.010UF K		C216			CK73GB1H103K	CHIP C 0.010UF K	
C118			CK73GB1H104K	CHIP C 0.10UF K		C217			CC73GCH1H331J	CHIP C 330PF J	
C119			CC73GCH1H101J	CHIP C 100PF J		C219			CK73GB1H103K	CHIP C 0.010UF K	
C120		*	CE32CL1C100M	CHIP EL 10UF 16WV		C220			CC73GCH1H270J	CHIP C 27PF J	
C121			CC73GCH1H680J	CHIP C 68PF J		C221,222			CK73GB1H104K	CHIP C 0.10UF K	
C122			CK73GB1H104K	CHIP C 0.10UF K		C224-228			CK73GB1H103K	CHIP C 0.010UF K	
C123			CK73GB1H103K	CHIP C 0.010UF K		C229			CK73GB1H104K	CHIP C 0.10UF K	

PARTS LIST / 零件表

TX-RX UNIT (X57-7210-20)

Ref. No.	Address	New parts	Parts No.	Description	Destination	Ref. No.	Address	New parts	Parts No.	Description	Destination
C230,231			CK73GB1H103K	CHIP C 0.010UF K		C372			CC73GCH1H471J	CHIP C 470PF J	
C232			CK73GB1H102K	CHIP C 1000PF K		C373			CK73GB1H103K	CHIP C 0.010UF K	
C233			CK73GB1H103K	CHIP C 0.010UF K		C374			CK73GB1E105K	CHIP C 1.0UF K	
C234			CK73GB1H102K	CHIP C 1000PF K		C375		*	CK73GB1H473K	CHIP C 0.047UF K	
C235			CC73GCH1H220J	CHIP C 22PF J		C376			CK73GB1H104K	CHIP C 0.10UF K	
C236			CC73GCH1H050B	CHIP C 5.0PF B		C377,378			CK73GB1H103K	CHIP C 0.010UF K	
C237,238			CK73GB1H103K	CHIP C 0.010UF K		C379			CC73GCH1H101J	CHIP C 100PF J	
C239			CC73GCH1H680J	CHIP C 68PF J		C380			CK73GB1E105K	CHIP C 1.0UF K	
C251			CC73GCH1H010B	CHIP C 1.0PF B		C381			C92-0870-05	CHIP-TAN 4.7UF 16WV	
C252			CC73GCH1H050B	CHIP C 5.0PF B		C382		*	CE32CL1C100M	CHIP EL 10UF 16WV	
C253-258			CK73GB1H103K	CHIP C 0.010UF K		C383			CS77CA1C100M	CHIP-TAN 10UF 16WV	
C262			CC73GCH1H200J	CHIP C 20PF J		C421		*	CS77AA1C2R2M	CHIP-TAN 2.2UF 16WV	
C266-272			CK73GB1H103K	CHIP C 0.010UF K		C422			CK73GB1H104K	CHIP C 0.10UF K	
C274			CK73GB1H103K	CHIP C 0.010UF K		C423			CK73GB1H103K	CHIP C 0.010UF K	
C275			CC73GCH1H010B	CHIP C 1.0PF B		C424			CS77CA1VR22M	CHIP-TAN 0.22UF 35WV	
C276			CC73GCH1H050B	CHIP C 5.0PF B		C425			CK73GB1H103K	CHIP C 0.010UF K	
C277-285			CK73GB1H103K	CHIP C 0.010UF K		C426			CS77CA1C010M	CHIP-TAN 1.0UF 16WV	
C286,287			CK73GB1H104K	CHIP C 0.10UF K		C427			CK73GB1H104K	CHIP C 0.10UF K	
C288		*	CE32CL1C100M	CHIP EL 10UF 16WV		C428			CS77CA1C100M	CHIP-TAN 10UF 16WV	
C289			CK73GB1H103K	CHIP C 0.010UF K		C429			C92-0870-05	CHIP-TAN 4.7UF 16WV	
C290,291			CK73GB1H104K	CHIP C 0.10UF K		C430			CK73GB1E105K	CHIP C 1.0UF K	
C292		*	CE32CL1C100M	CHIP EL 10UF 16WV		C431			CK73GB1H104K	CHIP C 0.10UF K	
C293			CK73GB1H104K	CHIP C 0.10UF K		C432			CK73GB1H103K	CHIP C 0.010UF K	
C294			CK73GB1H103K	CHIP C 0.010UF K		C433		*	CK73GB1H223K	CHIP C 0.022UF K	
C295			CK73GB0J475K	CHIP C 4.7UF K		C434			CK73GB1E105K	CHIP C 1.0UF K	
C296			CK73GB1E105K	CHIP C 1.0UF K		C435-438			CK73GB1H103K	CHIP C 0.010UF K	
C297			CK73GB0J475K	CHIP C 4.7UF K		C439			CK73GB1E105K	CHIP C 1.0UF K	
C311,312			CK73GB1H102K	CHIP C 1000PF K		C440			CK73GB1H104K	CHIP C 0.10UF K	
C313		*	CE32CL1C100M	CHIP EL 10UF 16WV		C441			CK73GB1E105K	CHIP C 1.0UF K	
C314,315			CK73GB1H104K	CHIP C 0.10UF K		C451			CK73GB1H103K	CHIP C 0.010UF K	
C316			CK73GB1H103K	CHIP C 0.010UF K		C452			CK73GB1H104K	CHIP C 0.10UF K	
C321			CK73GB1H102K	CHIP C 1000PF K		C453,454			CK73GB1H103K	CHIP C 0.010UF K	
C322,323			CK73GB1H103K	CHIP C 0.010UF K		C455			CC73GCH1H050B	CHIP C 5.0PF B	
C324			CK73GB1H102K	CHIP C 1000PF K		C456			CC73GCH1H390J	CHIP C 39PF J	
C325			CK73GB1H103K	CHIP C 0.010UF K		C457			CK73GB1H103K	CHIP C 0.010UF K	
C326			CC73GCH1H020B	CHIP C 2.0PF B		C458			CK73GB1H104K	CHIP C 0.10UF K	
C327			CK73GB1H102K	CHIP C 1000PF K		C459,460			CK73GB1H103K	CHIP C 0.010UF K	
C328			CC73GCH1H090B	CHIP C 9.0PF B		C461			CK73GB1H102K	CHIP C 1000PF K	
C329			CK73GB1H103K	CHIP C 0.010UF K		C462			CC73GCH1H050B	CHIP C 5.0PF B	
C331			CK73GB1H103K	CHIP C 0.010UF K		C463			CC73GCH1H221J	CHIP C 220PF J	
C333			CK73GB1A474K	CHIP C 0.47UF K		C464			CK73GB1H103K	CHIP C 0.010UF K	
C334			CK73GB1H103K	CHIP C 0.010UF K		C465			CC73GCH1H390J	CHIP C 39PF J	
C336,337			CK73GB1H103K	CHIP C 0.010UF K		C466			CK73GB1H103K	CHIP C 0.010UF K	
C339,340			CK73GB1H103K	CHIP C 0.010UF K		C467			CC73GCH1H470J	CHIP C 47PF J	
C341			CC73GCH1H101J	CHIP C 100PF J		C468			CC73GCH1H150J	CHIP C 15PF J	
C342			CK73GB1H102K	CHIP C 1000PF K		C469			CK73GB1H103K	CHIP C 0.010UF K	
C344			CK73GB1E105K	CHIP C 1.0UF K		C470			CK73GB1H102K	CHIP C 1000PF K	
C345,346			CK73GB1H103K	CHIP C 0.010UF K		C471			CC73GCH1H470J	CHIP C 47PF J	
C347		*	CE32BM1E470M	CHIP EL 47UF 25WV		C472			CK73GB1H104K	CHIP C 0.10UF K	
C348			CK73GB1H102K	CHIP C 1000PF K		C473			CC73GCH1H030B	CHIP C 3.0PF B	
C349			CK73GB1E105K	CHIP C 1.0UF K		C474			CK73GB1H104K	CHIP C 0.10UF K	
C361			CK73GB1H103K	CHIP C 0.010UF K		C475			CK73GB1E105K	CHIP C 1.0UF K	
C362			CK73GB1E105K	CHIP C 1.0UF K		C476			CK73GB1H103K	CHIP C 0.010UF K	
C363,364			CK73GB1H103K	CHIP C 0.010UF K		C477			CE32BM1C101M	CHIP EL 100UF 16WV	
C365			CS77CA1ER47M	CHIP-TAN 0.47UF 25WV		C478			CK73GB1H104K	CHIP C 0.10UF K	
C367		*	CE32CL1C100M	CHIP EL 10UF 16WV		C479			CC73GCH1H221J	CHIP C 220PF J	
C368			CK73GB1H104K	CHIP C 0.10UF K		C480			CC73GCH1H220J	CHIP C 22PF J	
C369			CK73GB1E105K	CHIP C 1.0UF K		C481			CK73GB1H102K	CHIP C 1000PF K	
C370			CK73GB1H103K	CHIP C 0.010UF K		C482			CC73GCH1H101J	CHIP C 100PF J	
C371		*	CK73GB1H473K	CHIP C 0.047UF K		C483			CK73GB0J475K	CHIP C 4.7UF K	

PARTS LIST / 零件表

TX-RX UNIT (X57-7210-20)

Ref. No.	Address	New parts	Parts No.	Description	Desti-nation	Ref. No.	Address	New parts	Parts No.	Description	Desti-nation
C484			CK73GB1H103K	CHIP C 0.010UF K		C631			CK73GB1E105K	CHIP C 1.0UF K	
C485-487			CK73GB1E105K	CHIP C 1.0UF K		C632		*	CE32CL1C100M	CHIP EL 10UF 16WV	
C488			CK73GB1H103K	CHIP C 0.010UF K		C633-636			CK73GB1E105K	CHIP C 1.0UF K	
C489,490			CK73GB1E105K	CHIP C 1.0UF K		C639			CK73GB1H104K	CHIP C 0.10UF K	
C491			CK73GB1H104K	CHIP C 0.10UF K		C640			CK73GB1H332K	CHIP C 3300PF K	
C492,493			CK73GB1E105K	CHIP C 1.0UF K		C643,644			CC73GCH1H471J	CHIP C 470PF J	
C494			CK73GB1H103K	CHIP C 0.010UF K		C645,646			CK73GB1E105K	CHIP C 1.0UF K	
C495			CS77CA1C100M	CHIP-TAN 10UF 16WV		C647,648			CC73GCH1H101J	CHIP C 100PF J	
C496,497			CK73GB1E105K	CHIP C 1.0UF K		C651			CK73GB1H103K	CHIP C 0.010UF K	
C498			CC73GCH1H101J	CHIP C 100PF J		C656			CK73GB1H102K	CHIP C 1000PF K	
C499			CK73GB1E105K	CHIP C 1.0UF K		C657		*	CE32CL1C100M	CHIP EL 10UF 16WV	
C500			CS77CA1C100M	CHIP-TAN 10UF 16WV		C658			CK73GB1H102K	CHIP C 1000PF K	
C501,502			CK73GB1H103K	CHIP C 0.010UF K		C659			CK73GB1H103K	CHIP C 0.010UF K	
C503			CC73GCH1H471J	CHIP C 470PF J		C662			CC73GCH1H470J	CHIP C 47PF J	
C504			CK73GB1E105K	CHIP C 1.0UF K		C663			CC73GCH1H270J	CHIP C 27PF J	
C521			CK73GB1E105K	CHIP C 1.0UF K		C664			CS77CA1C100M	CHIP-TAN 10UF 16WV	
C522,523			CK73GB1H104K	CHIP C 0.10UF K		C701			CK73GB1H102K	CHIP C 1000PF K	
C524			CK73GB1H103K	CHIP C 0.010UF K		C702			CK73FB1A475K	CHIP C 4.7UF K	
C525			CK73GB1H104K	CHIP C 0.10UF K		C703		*	CE32CL1C100M	CHIP EL 10UF 16WV	
C526		*	CD04AH1E221M	ELECTRO 220UF 25WV		C704,705			CK73GB1H103K	CHIP C 0.010UF K	
C527-530			CK73GB1H103K	CHIP C 0.010UF K		C706			CK73GB1H102K	CHIP C 1000PF K	
C532			CK73GB1H103K	CHIP C 0.010UF K		C707			CC73GCH1H560J	CHIP C 56PF J	
C533			CK73GB1H332K	CHIP C 3300PF K		C708			CK73GB1H103K	CHIP C 0.010UF K	
C534		*	CD04AH1E471M	ELECTRO 470UF 25WV		C709			CK73GB1H104K	CHIP C 0.10UF K	
C536		*	CD04AH1E471M	ELECTRO 470UF 25WV		C710			CC73GCH1H680J	CHIP C 68PF J	
C537			CK73FB1E104K	CHIP C 0.10UF K		C711			CC73GCH1H120J	CHIP C 12PF J	
C538,539		*	CE32BM1E470M	CHIP EL 47UF 25WV		C712		*	CK73GB1H473K	CHIP C 0.047UF K	
C541		*	CD04AH1E101M	ELECTRO 100UF 25WV		C713			CK73GB1H103K	CHIP C 0.010UF K	
C542			CK73FB1H103K	CHIP C 0.010UF K		C714			CC73GCH1H271J	CHIP C 270PF J	
C543			CK73GB1E105K	CHIP C 1.0UF K		C715			CC73GCH1H080B	CHIP C 8.0PF B	
C545			CK73FB1H103K	CHIP C 0.010UF K		C716			CK73GB1H103K	CHIP C 0.010UF K	
C546			CK73GB1E105K	CHIP C 1.0UF K		C718			CK73GB1H102K	CHIP C 1000PF K	
C547			CK73GB1H104K	CHIP C 0.10UF K		C719			CC73GCH1H100D	CHIP C 10PF D	
C548			CK73GB1H102K	CHIP C 1000PF K		C721			CC73GCH1H220J	CHIP C 22PF J	
C549		*	CK73GB1H223K	CHIP C 0.022UF K		C722			CC73GCH1H271J	CHIP C 270PF J	
C550			CK73GB1H103K	CHIP C 0.010UF K		C723			CC73GCH1H270J	CHIP C 27PF J	
C551-554			CK73GB1E105K	CHIP C 1.0UF K		C724			CC73GCH1H120J	CHIP C 12PF J	
C557-559			CK73GB1E105K	CHIP C 1.0UF K		C725			CK73GB1H103K	CHIP C 0.010UF K	
C560		*	CE32CL1C100M	CHIP EL 10UF 16WV		C726			CK73FB1A475K	CHIP C 4.7UF K	
C561			CK73GB1E105K	CHIP C 1.0UF K		C727			CC73GCH1H470J	CHIP C 47PF J	
C562			CE32BM1C101M	CHIP EL 100UF 16WV		C728			CK73GB1H103K	CHIP C 0.010UF K	
C563-567			CK73GB1E105K	CHIP C 1.0UF K		C729			CK73GB1H104K	CHIP C 0.10UF K	
C601			CK73GB1E105K	CHIP C 1.0UF K		C730			CC73GCH1H680J	CHIP C 68PF J	
C602,603		*	CK73GB1C225K	CHIP C 2.2UF K		C731			CC73GCH1H330J	CHIP C 33PF J	
C604			CK73GB1H104K	CHIP C 0.10UF K		C732			CK73GB1H102K	CHIP C 1000PF K	
C605,606			CK73GB1E105K	CHIP C 1.0UF K		C734			CK73GB1H102K	CHIP C 1000PF K	
C607		*	CE32CL1C100M	CHIP EL 10UF 16WV		C735			CC73GCH1H220J	CHIP C 22PF J	
C608			CC73GCH1H100D	CHIP C 10PF D		C736			CK73GB1H472K	CHIP C 4700PF K	
C609			CK73GB1E105K	CHIP C 1.0UF K		C737			CK73GB1H103K	CHIP C 0.010UF K	
C610		*	CE32CL1C100M	CHIP EL 10UF 16WV		C739			CK73GB1H102K	CHIP C 1000PF K	
C611			CK73GB1E105K	CHIP C 1.0UF K		C740			CC73GCH1H151J	CHIP C 150PF J	
C612			CK73GB1H102K	CHIP C 1000PF K		C743			CK73FB1A475K	CHIP C 4.7UF K	
C613		*	CK73GB1H223K	CHIP C 0.022UF K		C744			CK73GB1H104K	CHIP C 0.10UF K	
C614			CC73GCH1H100D	CHIP C 10PF D		C745			CK73GB1H102K	CHIP C 1000PF K	
C615-617			CK73GB1E105K	CHIP C 1.0UF K		C746,747			CK73GB1H472K	CHIP C 4700PF K	
C618-620			CK73GB1H104K	CHIP C 0.10UF K		C748		*	CK73GB1H473K	CHIP C 0.047UF K	
C621-626			CK73GB1E105K	CHIP C 1.0UF K		C749			CK73GB1H472K	CHIP C 4700PF K	
C627,628			CC73GCH1H101J	CHIP C 100PF J		C751			CK73GB1H102K	CHIP C 1000PF K	
C629			CK73GB1E105K	CHIP C 1.0UF K		C752			CK73GB1H103K	CHIP C 0.010UF K	
C630		*	CE32CL1C100M	CHIP EL 10UF 16WV		C756			CK73GB1H102K	CHIP C 1000PF K	

PARTS LIST / 零件表

TX-RX UNIT (X57-7210-20)

Ref. No.	Address	New parts	Parts No.	Description	Destination	Ref. No.	Address	New parts	Parts No.	Description	Destination
C757			CK73GB1H103K	CHIP C 0.010UF K		C831			CC73GCH1H101J	CHIP C 100PF J	
C760			CC73GCH1H101J	CHIP C 100PF J		C832			CK73GB1H102K	CHIP C 1000PF K	
C761			CK73GB1H472K	CHIP C 4700PF K		C833			CC73GCH1H270J	CHIP C 27PF J	
C762			CC73GCH1H101J	CHIP C 100PF J		C834		*	CE32CL1C100M	CHIP EL 10UF 16WV	
C764-766			CK73GB1H103K	CHIP C 0.010UF K		C835			CK73GB1H102K	CHIP C 1000PF K	
C767		*	CK73GB1H473K	CHIP C 0.047UF K		C836			CC73GCH1H120J	CHIP C 12PF J	
C768			CC73GCH1H470J	CHIP C 47PF J		C837			CK73GB1E105K	CHIP C 1.0UF K	
C769			CK73GB1H103K	CHIP C 0.010UF K		C838			CK73GB1H102K	CHIP C 1000PF K	
C771			CC73GCH1H471J	CHIP C 470PF J		C839			CK73GB1H472K	CHIP C 4700PF K	
C772			CK73GB1H103K	CHIP C 0.010UF K		C840			CC73GCH1H270J	CHIP C 27PF J	
C773			CC73GCH1H470J	CHIP C 47PF J		C841			CK73GB1H104K	CHIP C 0.10UF K	
C774			CK73FB1A475K	CHIP C 4.7UF K		C842,843			CK73GB1E105K	CHIP C 1.0UF K	
C775			CK73GB1H104K	CHIP C 0.10UF K		C844		*	CE32CL1C100M	CHIP EL 10UF 16WV	
C776			CK73GB1H102K	CHIP C 1000PF K		C845,846			CK73GB1H102K	CHIP C 1000PF K	
C777			CC73GCH1H270J	CHIP C 27PF J		C847			CK73GB1E105K	CHIP C 1.0UF K	
C778			CC73GCH1H101J	CHIP C 100PF J		C848		*	CE32BM1E470M	CHIP EL 47UF 25WV	
C779			CC73GCH1H681J	CHIP C 680PF J		C849,850			CK73GB1H472K	CHIP C 4700PF K	
C780			CC73GCH1H820J	CHIP C 82PF J		C853			CK73GB1H104K	CHIP C 0.10UF K	
C781			CC73GCH1H391J	CHIP C 390PF J		C856			CK73GB1H104K	CHIP C 0.10UF K	
C782			CK73GB1H103K	CHIP C 0.010UF K		C857			CC73GCH1H471J	CHIP C 470PF J	
C783			CC73GCH1H471J	CHIP C 470PF J		C858-860			CK73GB1H102K	CHIP C 1000PF K	
C784			CK73GB1H104K	CHIP C 0.10UF K		C866			CK73GB1H103K	CHIP C 0.010UF K	
C785			CC73GCH1H390J	CHIP C 39PF J		C867,868			CK73GB1E105K	CHIP C 1.0UF K	
C786			CK73GB1H103K	CHIP C 0.010UF K		C869,870			CC73GCH1H101J	CHIP C 100PF J	
C787			CK73FB1A475K	CHIP C 4.7UF K		C871			CK73GB1E105K	CHIP C 1.0UF K	
C788		*	CK73GB1H473K	CHIP C 0.047UF K		C873			CK73GB1H102K	CHIP C 1000PF K	
C789,790			CK73GB1H103K	CHIP C 0.010UF K		C874		*	CE32CL1C100M	CHIP EL 10UF 16WV	
C791			CC73GCH1H040B	CHIP C 4.0PF B		C875			CK73GB1E105K	CHIP C 1.0UF K	
C792			CC73GCH1H121J	CHIP C 120PF J		C876			CK73GB1H103K	CHIP C 0.010UF K	
C793			CC73GCH1H820J	CHIP C 82PF J		C877			CK73GB1H104K	CHIP C 0.10UF K	
C795			CK73GB1H103K	CHIP C 0.010UF K		C878			CK73GB1E105K	CHIP C 1.0UF K	
C797			CC73GCH1H390J	CHIP C 39PF J		C879		*	CE32CL1C100M	CHIP EL 10UF 16WV	
C798			CK73GB1H103K	CHIP C 0.010UF K		C880			CK73GB1E105K	CHIP C 1.0UF K	
C799			CC73GCH1H060B	CHIP C 6.0PF B		C881			CC73GCH1H101J	CHIP C 100PF J	
C800			CC73GCH1H050B	CHIP C 5.0PF B		C882			CK73GB1H102K	CHIP C 1000PF K	
C801			CC73GCH1H391J	CHIP C 390PF J		C883-885			CC73GCH1H101J	CHIP C 100PF J	
C802			CK73GB1H103K	CHIP C 0.010UF K		C886			CK73GB1H102K	CHIP C 1000PF K	
C803		*	CK73GB1H473K	CHIP C 0.047UF K		C887			CC73GCH1H101J	CHIP C 100PF J	
C804		*	CK73GB1H333K	CHIP C 0.033UF K		C888			CK73GB1E105K	CHIP C 1.0UF K	
C805			CC73GCH1H330J	CHIP C 33PF J		C889			CC73GCH1H101J	CHIP C 100PF J	
C806			CC73GCH1H180J	CHIP C 18PF J		C890-894			CK73GB1E105K	CHIP C 1.0UF K	
C807			CC73GCH1H120J	CHIP C 12PF J		C896			CK73GB1H104K	CHIP C 0.10UF K	
C808		*	CC73GCH1H561J	CHIP C 560PF J		C897			CK73GB1E105K	CHIP C 1.0UF K	
C809			CC73GCH1H471J	CHIP C 470PF J		C898			CK73GB1H102K	CHIP C 1000PF K	
C810			CS77CA1A3R3M	CHIP-TAN 3.3UF 10WV		C899			CK73GB1H104K	CHIP C 0.10UF K	
C811			CC73GCH1H330J	CHIP C 33PF J		C900,901			CK73GB1H102K	CHIP C 1000PF K	
C812			CC73GCH1H820J	CHIP C 82PF J		C902,903			CK73GB1E105K	CHIP C 1.0UF K	
C813			CC73GCH1H270J	CHIP C 27PF J		C904-909			CK73GB1H102K	CHIP C 1000PF K	
C814			CK73GB1H104K	CHIP C 0.10UF K		C910			CK73GB1E105K	CHIP C 1.0UF K	
C815			CC73GCH1H331J	CHIP C 330PF J		C911			CK73GB1H102K	CHIP C 1000PF K	
C816,817			CC73GCH1H150J	CHIP C 15PF J		C912			CK73GB1E105K	CHIP C 1.0UF K	
C818			CS77AA1DR68M	CHIP-TAN 0.68UF 20WV		C913			CK73GB1H102K	CHIP C 1000PF K	
C819			CK73FB1A475K	CHIP C 4.7UF K		C914-919			CK73GB1H104K	CHIP C 0.10UF K	
C820			CK73GB1H472K	CHIP C 4700PF K		C920,921			CK73GB1H102K	CHIP C 1000PF K	
C821			CK73GB1H102K	CHIP C 1000PF K		C922			CK73GB1E105K	CHIP C 1.0UF K	
C822,823			CC73GCH1H090B	CHIP C 9.0PF B		C923			CE32BM1C101M	CHIP EL 100UF 16WV	
C824			CK73GB1H104K	CHIP C 0.10UF K		C924			CK73GB1H102K	CHIP C 1000PF K	
C825			CK73GB1H472K	CHIP C 4700PF K		C925			CK73GB1E105K	CHIP C 1.0UF K	
C826-829			CK73GB1H102K	CHIP C 1000PF K		C926			CK73GB1H102K	CHIP C 1000PF K	
C830			CK73GB1H472K	CHIP C 4700PF K		C928			CK73GB1H102K	CHIP C 1000PF K	

PARTS LIST / 零件表

TX-RX UNIT (X57-7210-20)

Ref. No.	Address	New parts	Parts No.	Description	Desti-nation	Ref. No.	Address	New parts	Parts No.	Description	Desti-nation
C929			CK73GB1E105K	CHIP C 1.0UF K		CN236		*	E41-0936-05	PIN ASSY	
C930-935			CC73GCH1H101J	CHIP C 100PF J		J1			E11-0455-05	3.5D PHONE JACK (3P)	
C936			CC73GCH1H150J	CHIP C 15PF J		W321			E37-0884-05	LEAD WIRE WITH CONNECTOR	
C937,938			CC73GCH1H471J	CHIP C 470PF J		W551		*	E37-1225-05	LEAD WIRE WITH CONNECTOR	
C939		*	CE32BM1E470M	CHIP EL 47UF 25WV		W701		*	E37-1222-05	LEAD WIRE WITH MINIPIN PLUG	
C940			CC73GCH1H101J	CHIP C 100PF J		W702		*	E37-1223-05	LEAD WIRE WITH MINIPIN PLUG	
C941			CC73GCH1H471J	CHIP C 470PF J		F311			F53-0128-05	FUSE	
C942			CK73GB1E105K	CHIP C 1.0UF K		CF701		*	L72-1026-05	CERAMIC FILTER	
C944			CC73GCH1H150J	CHIP C 15PF J		L1			L41-2785-08	SMALL FIXED INDUCTOR (270NH)	
C945			CK73GB1H104K	CHIP C 0.10UF K		L2			L41-1085-33	SMALL FIXED INDUCTOR (0.1UH)	
C946,947			CK73GB1H102K	CHIP C 1000PF K		L3			L41-4705-33	SMALL FIXED INDUCTOR (47UH)	
C950			CK73GB1H104K	CHIP C 0.10UF K		L4		*	L41-1001-34	SMALL FIXED INDUCTOR (10UH)	
C951			CK73GB1H102K	CHIP C 1000PF K		L5			L41-4705-33	SMALL FIXED INDUCTOR (47UH)	
C952			CK73GB1H103K	CHIP C 0.010UF K		L6		*	L41-2785-09	SMALL FIXED INDUCTOR (270NH)	
C953			CK73GB1H104K	CHIP C 0.10UF K		L7,8		*	L41-1025-27	SMALL FIXED INDUCTOR (1000UH)	
C954-957			CK73GB1H102K	CHIP C 1000PF K		L9			L41-1585-08	SMALL FIXED INDUCTOR (150NH)	
C958			CK73GB1E105K	CHIP C 1.0UF K		L11		*	L41-1025-27	SMALL FIXED INDUCTOR (1000UH)	
C959,960			CK73GB1H102K	CHIP C 1000PF K		L13			L41-5695-09	SMALL FIXED INDUCTOR (5.6UH)	
C961		*	CE32BM1E470M	CHIP EL 47UF 25WV		L14		*	L41-1025-27	SMALL FIXED INDUCTOR (1000UH)	
C962			CK73GB1H102K	CHIP C 1000PF K		L15,16			L41-6895-09	SMALL FIXED INDUCTOR (6.8UH)	
C964,965			CK73GB1H102K	CHIP C 1000PF K		L17			L41-2295-09	SMALL FIXED INDUCTOR (2200NH)	
C966		*	CE32CL1C100M	CHIP EL 10UF 16WV		L18			L41-1595-09	SMALL FIXED INDUCTOR (1500NH)	
C967			CK73GB1H102K	CHIP C 1000PF K		L19			L41-1095-09	SMALL FIXED INDUCTOR (1000NH)	
C968			CK73GB1E105K	CHIP C 1.0UF K		L20			L41-4785-08	SMALL FIXED INDUCTOR (470NH)	
C969			CK73GB1H102K	CHIP C 1000PF K		L21			L41-3985-08	SMALL FIXED INDUCTOR (390NH)	
C971,972			CK73GB1H103K	CHIP C 0.010UF K		L22			L41-2785-08	SMALL FIXED INDUCTOR (270NH)	
C973			CK73GB0J475K	CHIP C 4.7UF K		L23			L41-1885-08	SMALL FIXED INDUCTOR (180NH)	
C974			CK73GB1H104K	CHIP C 0.10UF K		L24			L41-5695-09	SMALL FIXED INDUCTOR (5.6UH)	
C975			CK73GB0J475K	CHIP C 4.7UF K		L25		*	L41-1025-27	SMALL FIXED INDUCTOR (1000UH)	
C976,977			CK73GB1E105K	CHIP C 1.0UF K		L26		*	L41-4795-09	SMALL FIXED INDUCTOR (4.7UH)	
C978			CK73GB1H104K	CHIP C 0.10UF K		L27			L41-6885-09	SMALL FIXED INDUCTOR (680NH)	
C980		*	CK73GB1H333K	CHIP C 0.033UF K		L28			L41-1895-09	SMALL FIXED INDUCTOR (1800NH)	
C981		*	CE32CL1C100M	CHIP EL 10UF 16WV		L29			L41-1295-09	SMALL FIXED INDUCTOR (1200NH)	
C982,983			CK73GB1H104K	CHIP C 0.10UF K		L30			L41-2795-09	SMALL FIXED INDUCTOR (2700NH)	
C984		*	CC73GCH1H222J	CHIP C 2200PF J		L31			L41-2295-09	SMALL FIXED INDUCTOR (2200NH)	
C985			CK73GB1H153K	CHIP C 0.015UF K		L32		*	L41-1025-27	SMALL FIXED INDUCTOR (1000UH)	
C986			CK73GB1H822K	CHIP C 8200PF K		L33			L41-2295-09	SMALL FIXED INDUCTOR (2200NH)	
C987			CK73GB1H392K	CHIP C 3900PF K		L34			L41-1595-09	SMALL FIXED INDUCTOR (1500NH)	
C988-990		*	CC73GCH1H222J	CHIP C 2200PF J		L35			L41-1095-09	SMALL FIXED INDUCTOR (1000NH)	
C991,992			CK73FB1E104K	CHIP C 0.10UF K		L36			L41-4785-08	SMALL FIXED INDUCTOR (470NH)	
C993		*	CC73GCH1H222J	CHIP C 2200PF J		L37			L41-3985-08	SMALL FIXED INDUCTOR (390NH)	
C994,995			CK73GB1H103K	CHIP C 0.010UF K		L38			L41-2785-08	SMALL FIXED INDUCTOR (270NH)	
C996		*	CC73GCH1H222J	CHIP C 2200PF J		L39			L41-1885-08	SMALL FIXED INDUCTOR (180NH)	
C997		*	CC73GCH1H182J	CHIP C 1800PF J		L40		*	L41-1001-34	SMALL FIXED INDUCTOR (10UH)	
C998			CK73GB1E105K	CHIP C 1.0UF K		L101		*	L41-1025-27	SMALL FIXED INDUCTOR (1000UH)	
TC702,703			C05-0384-05	CERAMIC TRIMMER CAP (10PF)		L102			L41-1015-33	SMALL FIXED INDUCTOR (100UH)	
CN1,2			E04-0191-05	PIN SOCKET		L103		*	L41-1025-27	SMALL FIXED INDUCTOR (1000UH)	
CN4,5		*	E41-1505-05	PIN ASSY		L104			L41-1015-33	SMALL FIXED INDUCTOR (100UH)	
CN6,7		*	E41-2558-05	PIN ASSY		L105			L39-1476-05	TOROIDAL COIL	
CN8		*	E40-6683-05	PIN ASSY		L106		*	L39-1499-05	TOROIDAL COIL	
CN9		*	E40-6653-05	PIN ASSY		L107		*	L41-1025-27	SMALL FIXED INDUCTOR (1000UH)	
CN10		*	E40-6682-05	PIN ASSY		L108,109			L41-2785-08	SMALL FIXED INDUCTOR (270NH)	
CN11			E40-6357-05	PIN ASSY		L110			L41-1015-33	SMALL FIXED INDUCTOR (100UH)	
CN12		*	E41-0933-05	PIN ASSY		L111			L39-1480-05	TOROIDAL COIL	
CN13		*	E40-6654-05	PIN ASSY		L112			L39-1476-05	TOROIDAL COIL	
CN14		*	E41-1391-05	FLAT CABLE CONNECTOR		L113			L41-3385-33	SMALL FIXED INDUCTOR (0.33UH)	
CN15		*	E41-1395-05	FLAT CABLE CONNECTOR		L115			L39-1480-05	TOROIDAL COIL	
CN16,17		*	E41-2077-05	PIN ASSY		L116			L41-4785-33	SMALL FIXED INDUCTOR (0.47UH)	
CN157			E41-1377-05	FLAT CABLE CONNECTOR							

PARTS LIST / 零件表

TX-RX UNIT (X57-7210-20)

Ref. No.	Address	New parts	Parts No.	Description	Destination	Ref. No.	Address	New parts	Parts No.	Description	Destination
L117			L41-1015-33	SMALL FIXED INDUCTOR (100UH)		L723			L41-2295-33	SMALL FIXED INDUCTOR (2.2UH)	
L118,119			L41-4705-33	SMALL FIXED INDUCTOR (47UH)		L724,725			L41-2295-09	SMALL FIXED INDUCTOR (2200NH)	
L120			L34-4709-05	COIL		L726,727			L41-1005-08	SMALL FIXED INDUCTOR (10UH)	
L121		*	L41-1001-34	SMALL FIXED INDUCTOR (10UF)		L728			L41-1015-33	SMALL FIXED INDUCTOR (100UH)	
L122-124		*	L34-4818-05	COIL		L729		*	L34-4816-05	COIL	
L181		*	L34-4818-05	COIL		L730			L41-1015-33	SMALL FIXED INDUCTOR (100UH)	
L182-184			L41-4785-33	SMALL FIXED INDUCTOR (0.47UH)		L731		*	L34-4816-05	COIL	
L186			L41-4785-33	SMALL FIXED INDUCTOR (0.47UH)		L732			L41-2288-09	SMALL FIXED INDUCTOR (220NH)	
L187			L41-4705-33	SMALL FIXED INDUCTOR (47UH)		L733			L41-1888-09	SMALL FIXED INDUCTOR (180NH)	
L188			L39-1480-05	TOROIDAL COIL		L734			L41-8285-33	SMALL FIXED INDUCTOR (0.82UH)	
L189			L41-4785-33	SMALL FIXED INDUCTOR (0.47UH)		L735,736			L41-2205-33	SMALL FIXED INDUCTOR (22UH)	
L190			L39-1480-05	TOROIDAL COIL		L737			L41-5685-33	SMALL FIXED INDUCTOR (0.56UH)	
L192			L41-1015-33	SMALL FIXED INDUCTOR (100UH)		L738			L41-1005-33	SMALL FIXED INDUCTOR (10UH)	
L195			L41-4795-33	SMALL FIXED INDUCTOR (4.7UH)		L739			L41-4705-33	SMALL FIXED INDUCTOR (47UH)	
L196,197			L41-4705-33	SMALL FIXED INDUCTOR (47UH)		L740			L41-1095-33	SMALL FIXED INDUCTOR (1.0UH)	
L198,199			L41-1015-33	SMALL FIXED INDUCTOR (100UH)		L741		*	L41-1001-34	SMALL FIXED INDUCTOR (10UH)	
L200			L41-4795-33	SMALL FIXED INDUCTOR (4.7UH)		L742			L41-3975-33	SMALL FIXED INDUCTOR (0.039UH)	
L201			L41-2295-33	SMALL FIXED INDUCTOR (2.2UH)		L851		*	L41-1001-28	SMALL FIXED INDUCTOR (10UH)	
L251			L41-1015-33	SMALL FIXED INDUCTOR (100UH)		L852		*	L41-1001-34	SMALL FIXED INDUCTOR (10UH)	
L252		*	L41-1805-33	SMALL FIXED INDUCTOR (18UH)		L853		*	L41-1001-28	SMALL FIXED INDUCTOR (10UH)	
L253-255			L41-1015-33	SMALL FIXED INDUCTOR (100UH)		L854		*	L41-1001-34	SMALL FIXED INDUCTOR (10UF)	
L256			L41-1005-33	SMALL FIXED INDUCTOR (10UH)		L855			L41-1015-27	SMALL FIXED INDUCTOR (100UH)	
L257,258			L41-4705-33	SMALL FIXED INDUCTOR (47UH)		L856,857		*	L41-1001-28	SMALL FIXED INDUCTOR (10UH)	
L259			L41-1015-33	SMALL FIXED INDUCTOR (100UH)		L858			L41-4705-33	SMALL FIXED INDUCTOR (47UH)	
L260		*	L41-1001-34	SMALL FIXED INDUCTOR (10UH)		L859			L92-0149-05	CHIP FERRITE	
L261		*	L41-1805-33	SMALL FIXED INDUCTOR (18UH)		X701		*	L77-1820-15	TCXO (15.600MHZ)	
L321			L41-4705-33	SMALL FIXED INDUCTOR (47UH)		X851			L77-1950-05	CRYSTAL RESONATOR (11.0592MHZ)	
L322			L41-1085-33	SMALL FIXED INDUCTOR (0.1UH)		XF101			L71-0605-05	MCF (73.095MHZ)	
L323			L41-2285-33	SMALL FIXED INDUCTOR (0.22UH)		XF251			L71-0433-15	MCF (10.695MHZ)	
L324		*	L41-1025-27	SMALL FIXED INDUCTOR (1000U)		XF252		*	L71-0604-15	CRYSTAL FILTER (10.695MHZ)	
L325			L41-4705-33	SMALL FIXED INDUCTOR (47UH/)		CP1,2		*	RK74GB1J103J	CHIP-COM 10K J 1/16W	
L326,327		*	L34-4817-05	COIL		CP421,422		*	RK74GB1J103J	CHIP-COM 10K J 1/16W	
L361-363			L41-1015-33	SMALL FIXED INDUCTOR (100UH)		CP851		*	RK74GB1J473J	CHIP-COM 47K J 1/16W	
L451,452			L34-4710-05	COIL		CP853		*	RK74GB1J473J	CHIP-COM 47K J 1/16W	
L453		*	L41-1025-27	SMALL FIXED INDUCTOR (1000UH)		CP855		*	RK74GB1J473J	CHIP-COM 47K J 1/16W	
L454			L41-3305-33	SMALL FIXED INDUCTOR (33UH)		CP856			RK74GB1J101J	CHIP-COM 100 J 1/16W	
L551,552			L41-1015-33	SMALL FIXED INDUCTOR (100UH)		CP857			RK74GA1J473J	CHIP-COM 47K J 1/16W	
L601,602			L41-1015-33	SMALL FIXED INDUCTOR (100UH)		CP858-860			RK74GB1J101J	CHIP-COM 100 J 1/16W	
L603			L41-1095-33	SMALL FIXED INDUCTOR (1.0UH)		CP861		*	RK74GA1J101J	CHIP-COM 100 J 1/16W	
L701			L41-1015-33	SMALL FIXED INDUCTOR (100UH)		CP862		*	RK74GB1J102J	CHIP-COM 1.0K J 1/16W	
L702			L41-8275-33	SMALL FIXED INDUCTOR (0.082UH)		CP863		*	RK74GA1J101J	CHIP-COM 100 J 1/16W	
L703			L41-1085-33	SMALL FIXED INDUCTOR (0.1UH)		CP864-871			RK74GB1J101J	CHIP-COM 100 J 1/16W	
L704			L41-8275-33	SMALL FIXED INDUCTOR (0.082UH)		CP872		*	RK74GB1J102J	CHIP-COM 1.0K J 1/16W	
L705			L41-1015-33	SMALL FIXED INDUCTOR (100UH)		CP873			RK74GA1J102J	CHIP-COM 1.0K J 1/16W	
L706			L41-4785-33	SMALL FIXED INDUCTOR (0.47UH)		CP874-876		*	RK74GA1J101J	CHIP-COM 100 J 1/16W	
L707			L41-2275-33	SMALL FIXED INDUCTOR (0.022UH)		CP877			RK74GA1J102J	CHIP-COM 1.0K J 1/16W	
L708			L41-8285-33	SMALL FIXED INDUCTOR (0.82UH)		CP878			RK74GB1J101J	CHIP-COM 100 J 1/16W	
L709			L41-2275-33	SMALL FIXED INDUCTOR (0.022UH)		CP880			RK74GA1J473J	CHIP-COM 47K J 1/16W	
L710			L41-3375-33	SMALL FIXED INDUCTOR (0.033UH)		R1			RK73GB2A821J	CHIP R 820 J 1/10W	
L711			L41-4785-33	SMALL FIXED INDUCTOR (0.47UH)		R2			RK73GB2A6R8J	CHIP R 6.8 J 1/10W	
L713			L41-3975-33	SMALL FIXED INDUCTOR (0.039UH)		R3			RK73EB2E471J	CHIP R 470 J 1/4W	
L714			L41-1015-33	SMALL FIXED INDUCTOR (100UH)		R4			RK73GB2A821J	CHIP R 820 J 1/10W	
L715			L41-1085-33	SMALL FIXED INDUCTOR (0.1UH)		R5			RK73EB2E560J	CHIP R 56 J 1/4W	
L716			L41-1095-33	SMALL FIXED INDUCTOR (1.0UH)		R6			RK73GB2A103J	CHIP R 10K J 1/10W	
L717			L41-1015-33	SMALL FIXED INDUCTOR (100UH)		R7			RK73GB2A102J	CHIP R 1.0K J 1/10W	
L718			L41-1005-33	SMALL FIXED INDUCTOR (10UH)		R8			RK73FB2B100J	CHIP R 10 J 1/8W	
L719			L41-1595-33	SMALL FIXED INDUCTOR (1.5UH)		R9			RK73GB2A473J	CHIP R 47K J 1/10W	
L720			L41-8285-33	SMALL FIXED INDUCTOR (0.82UH)		R10			RK73GB2A102J	CHIP R 1.0K J 1/10W	
L721			L41-1015-33	SMALL FIXED INDUCTOR (100UH)		R11			RK73GB2A681J	CHIP R 680 J 1/10W	
L722			L41-6885-33	SMALL FIXED INDUCTOR (0.68UH)		R12			RK73GB2A103J	CHIP R 10K J 1/10W	

PARTS LIST / 零件表

TX-RX UNIT (X57-7210-20)

Ref. No.	Address	New parts	Parts No.	Description	Desti-nation	Ref. No.	Address	New parts	Parts No.	Description	Desti-nation
R13			RK73GB2A273J	CHIP R 27K J 1/10W		R151			RK73GB2A000J	CHIP R 0.0 J 1/10W	
R14			RK73GB2A681J	CHIP R 680 J 1/10W		R152,153			RK73GB2A331J	CHIP R 330 J 1/10W	
R15			RK73GB2A101J	CHIP R 100 J 1/10W		R154			RK73GB2A000J	CHIP R 0.0 J 1/10W	
R16			RK73GB2A222J	CHIP R 2.2K J 1/10W		R155			RK73GB2A101J	CHIP R 100 J 1/10W	
R17			RK73GB2A151J	CHIP R 150 J 1/10W		R157			RK73GB2A561J	CHIP R 560 J 1/10W	
R18,19			RK73FB2B560J	CHIP R 56 J 1/8W		R158			RK73GB2A470J	CHIP R 47 J 1/10W	
R20			RK73GB2A101J	CHIP R 100 J 1/10W		R181			RK73GB2A331J	CHIP R 330 J 1/10W	
R21			RK73GB2A472J	CHIP R 4.7K J 1/10W		R182			RK73GB2A000J	CHIP R 0.0 J 1/10W	
R22			RK73GB2A103J	CHIP R 10K J 1/10W		R183			RK73GB2A331J	CHIP R 330 J 1/10W	
R23			RK73GB2A472J	CHIP R 4.7K J 1/10W		R184			RK73GB2A101J	CHIP R 100 J 1/10W	
R25,26			RK73GB2A103J	CHIP R 10K J 1/10W		R185			RK73GB2A681J	CHIP R 680 J 1/10W	
R27-34			RK73FB2B470J	CHIP R 47 J 1/8W		R186			RK73GB2A331J	CHIP R 330 J 1/10W	
R35			RK73GB2A330J	CHIP R 33 J 1/10W		R187			RK73GB2A474J	CHIP R 470K J 1/10W	
R37			RK73GB2A471J	CHIP R 470 J 1/10W		R188			RK73GB2A000J	CHIP R 0.0 J 1/10W	
R38-43			RK73GB2A330J	CHIP R 33 J 1/10W		R189			RK73GB2A393J	CHIP R 39K J 1/10W	
R44-51			RK73FB2B470J	CHIP R 47 J 1/8W		R190			RK73GB2A153J	CHIP R 15K J 1/10W	
R52			RK73FB2B000J	CHIP R 0.0 J 1/8W		R192			RK73GB2A223J	CHIP R 22K J 1/10W	
R53			RK73GB2A560J	CHIP R 56 J 1/10W		R193			RK73GB2A100J	CHIP R 10 J 1/10W	
R54			RK73GB2A221J	CHIP R 220 J 1/10W		R194			RK73GB2A681J	CHIP R 680 J 1/10W	
R100,101			RK73GB2A103J	CHIP R 10K J 1/10W		R195			RK73GB2A682J	CHIP R 6.8K J 1/10W	
R103			RK73FB2B221J	CHIP R 220 J 1/8W		R196			RK73GB2A000J	CHIP R 0.0 J 1/10W	
R104,105			RK73FB2B121J	CHIP R 120 J 1/8W		R197			RK73GB2A331J	CHIP R 330 J 1/10W	
R106			RK73GB2A101J	CHIP R 100 J 1/10W		R198			RK73GB2A223J	CHIP R 22K J 1/10W	
R107			RK73FB2B101J	CHIP R 100 J 1/8W		R199			RK73GB2A100J	CHIP R 10 J 1/10W	
R108			RK73GB2A470J	CHIP R 47 J 1/10W		R200			RK73GB2A102J	CHIP R 1.0K J 1/10W	
R109			RK73GB2A682J	CHIP R 6.8K J 1/10W		R201			RK73GB2A101J	CHIP R 100 J 1/10W	
R110			RK73GB2A820J	CHIP R 82 J 1/10W		R202			RK73GB2A000J	CHIP R 0.0 J 1/10W	
R111			RK73FB2B221J	CHIP R 220 J 1/8W		R203			RK73GB2A102J	CHIP R 1.0K J 1/10W	
R112			RK73GB2A681J	CHIP R 680 J 1/10W		R204			RK73GB2A100J	CHIP R 10 J 1/10W	
R113			RK73FB2B471J	CHIP R 470 J 1/8W		R205			RK73GB2A330J	CHIP R 33 J 1/10W	
R114			RK73GB2A102J	CHIP R 1.0K J 1/10W		R206			RK73GB2A273J	CHIP R 27K J 1/10W	
R115			RK73GB2A332J	CHIP R 3.3K J 1/10W		R207			RK73GB2A103J	CHIP R 10K J 1/10W	
R116			RK73GB2A473J	CHIP R 47K J 1/10W		R208			RK73GB2A000J	CHIP R 0.0 J 1/10W	
R117			RK73GB2A102J	CHIP R 1.0K J 1/10W		R209			RK73GB2A102J	CHIP R 1.0K J 1/10W	
R118			RK73GB2A103J	CHIP R 10K J 1/10W		R211,212			RK73GB2A220J	CHIP R 22 J 1/10W	
R119			RK73GB2A471J	CHIP R 470 J 1/10W		R213			RK73GB2A331J	CHIP R 330 J 1/10W	
R120			RK73GB2A000J	CHIP R 0.0 J 1/10W		R214			RK73GB2A180J	CHIP R 18 J 1/10W	
R121			RK73GB2A102J	CHIP R 1.0K J 1/10W		R215			RK73GB2A331J	CHIP R 330 J 1/10W	
R122			RK73FB2B561J	CHIP R 560 J 1/8W		R216			RK73GB2A102J	CHIP R 1.0K J 1/10W	
R123			RK73GB2A103J	CHIP R 10K J 1/10W		R217			RK73GB2A470J	CHIP R 47 J 1/10W	
R124			RK73GB2A102J	CHIP R 1.0K J 1/10W		R218			RK73GB2A102J	CHIP R 1.0K J 1/10W	
R125			RK73GB2A331J	CHIP R 330 J 1/10W		R219			RK73GB2A101J	CHIP R 100 J 1/10W	
R126			RK73GB2A472J	CHIP R 4.7K J 1/10W		R220			RK73GB2A104J	CHIP R 100K J 1/10W	
R127			RK73GB2A000J	CHIP R 0.0 J 1/10W		R221			RK73GB2A393J	CHIP R 39K J 1/10W	
R128,129			RK73GB2A221J	CHIP R 220 J 1/10W		R222			RK73GB2A332J	CHIP R 3.3K J 1/10W	
R130,131			RK73GB2A222J	CHIP R 2.2K J 1/10W		R223			RK73GB2A330J	CHIP R 33 J 1/10W	
R132			RK73GB2A120J	CHIP R 12 J 1/10W		R224			RK73GB2A104J	CHIP R 100K J 1/10W	
R134,135			RK73GB2A100J	CHIP R 10 J 1/10W		R226			RK73GB2A101J	CHIP R 100 J 1/10W	
R136			RK73GB2A271J	CHIP R 270 J 1/10W		R227			RK73GB2A470J	CHIP R 47 J 1/10W	
R137			RK73GB2A220J	CHIP R 22 J 1/10W		R228			RK73GB2A331J	CHIP R 330 J 1/10W	
R138,139			RK73GB2A100J	CHIP R 10 J 1/10W		R229			RK73GB2A152J	CHIP R 1.5K J 1/10W	
R140			RK73GB2A471J	CHIP R 470 J 1/10W		R230			RK73GB2A151J	CHIP R 150 J 1/10W	
R141			RK73GB2A681J	CHIP R 680 J 1/10W		R231			RK73GB2A223J	CHIP R 22K J 1/10W	
R142			RK73GB2A103J	CHIP R 10K J 1/10W		R232			RK73GB2A331J	CHIP R 330 J 1/10W	
R144			RK73GB2A333J	CHIP R 33K J 1/10W		R233			RK73GB2A681J	CHIP R 680 J 1/10W	
R145			RK73GB2A100J	CHIP R 10 J 1/10W		R234			RK73GB2A223J	CHIP R 22K J 1/10W	
R146			RK73GB2A332J	CHIP R 3.3K J 1/10W		R235			RK73GB2A102J	CHIP R 1.0K J 1/10W	
R147			RK73GB2A102J	CHIP R 1.0K J 1/10W		R236			RK73GB2A682J	CHIP R 6.8K J 1/10W	
R148			RK73GB2A331J	CHIP R 330 J 1/10W		R237			RK73GB2A102J	CHIP R 1.0K J 1/10W	
R149,150			RK73GB2A102J	CHIP R 1.0K J 1/10W		R239			RK73GB2A102J	CHIP R 1.0K J 1/10W	

PARTS LIST / 零件表

TX-RX UNIT (X57-7210-20)

Ref. No.	Address	New parts	Parts No.	Description	Destination	Ref. No.	Address	New parts	Parts No.	Description	Destination
R240			RK73GB2A470J	CHIP R 47 J 1/10W		R324			RK73GB2A154J	CHIP R 150K J 1/10W	
R243			RK73GB2A104J	CHIP R 100K J 1/10W		R325			RK73GB2A273J	CHIP R 27K J 1/10W	
R244			RK73GB2A330J	CHIP R 33 J 1/10W		R326			RK73GB2A103J	CHIP R 10K J 1/10W	
R245			RK73GB2A180J	CHIP R 18 J 1/10W		R327,328			RK73GB2A101J	CHIP R 100 J 1/10W	
R251,252			RK73GB2A561J	CHIP R 560 J 1/10W		R329			RK73GB2A102J	CHIP R 1.0K J 1/10W	
R253			RK73GB2A101J	CHIP R 100 J 1/10W		R330			RK73GB2A221J	CHIP R 220 J 1/10W	
R254			RK73GB2A152J	CHIP R 1.5K J 1/10W		R331			RK73GB2A102J	CHIP R 1.0K J 1/10W	
R255			RK73GB2A332J	CHIP R 3.3K J 1/10W		R332,333			RK73GB2A103J	CHIP R 10K J 1/10W	
R256			RK73GB2A182J	CHIP R 1.8K J 1/10W		R334			RK73GB2A101J	CHIP R 100 J 1/10W	
R257			RK73GB2A101J	CHIP R 100 J 1/10W		R335			RK73GB2A473J	CHIP R 47K J 1/10W	
R258			RK73GB2A561J	CHIP R 560 J 1/10W		R336			RK73GB2A683J	CHIP R 68K J 1/10W	
R259,260			RK73GB2A101J	CHIP R 100 J 1/10W		R337			RK73GB2A103J	CHIP R 10K J 1/10W	
R261			RK73GB2A391J	CHIP R 390 J 1/10W		R338			RK73GB2A223J	CHIP R 22K J 1/10W	
R262			RK73GB2A000J	CHIP R 0.0 J 1/10W		R339			RK73GB2A102J	CHIP R 1.0K J 1/10W	
R264			RK73GB2A391J	CHIP R 390 J 1/10W		R341			RK73GB2A103J	CHIP R 10K J 1/10W	
R265			RK73GB2A000J	CHIP R 0.0 J 1/10W		R342			RK73GB2A152J	CHIP R 1.5K J 1/10W	
R266			RK73GB2A561J	CHIP R 560 J 1/10W		R343			RK73GB2A103J	CHIP R 10K J 1/10W	
R267,268			RK73GB2A152J	CHIP R 1.5K J 1/10W		R344			RK73GB2A333J	CHIP R 33K J 1/10W	
R269			RK73GB2A182J	CHIP R 1.8K J 1/10W		R345			RK73GB2A221J	CHIP R 220 J 1/10W	
R271			RK73GB2A471J	CHIP R 470 J 1/10W		R346			RK73GB2A102J	CHIP R 1.0K J 1/10W	
R272			RK73GB2A101J	CHIP R 100 J 1/10W		R347			RK73GB2A104J	CHIP R 100K J 1/10W	
R273			RK73GB2A273J	CHIP R 27K J 1/10W		R348			RK73GB2A101J	CHIP R 100 J 1/10W	
R274			RK73GB2A103J	CHIP R 10K J 1/10W		R349			RK73GB2A681J	CHIP R 680 J 1/10W	
R275			RK73GB2A471J	CHIP R 470 J 1/10W		R352			RK73GB2A102J	CHIP R 1.0K J 1/10W	
R276			RK73GB2A101J	CHIP R 100 J 1/10W		R353,354			RK73GB2A000J	CHIP R 0.0 J 1/10W	
R277			RK73GB2A150J	CHIP R 15 J 1/10W		R360			RK73GB2A102J	CHIP R 1.0K J 1/10W	
R278			RK73GB2A152J	CHIP R 1.5K J 1/10W		R361			RK73GB2A331J	CHIP R 330 J 1/10W	
R279			RK73GB2A470J	CHIP R 47 J 1/10W		R362			RK73GB2A333J	CHIP R 33K J 1/10W	
R280			RK73GB2A471J	CHIP R 470 J 1/10W		R363			RK73GB2A101J	CHIP R 100 J 1/10W	
R281			RK73GB2A101J	CHIP R 100 J 1/10W		R364			RK73GB2A683J	CHIP R 68K J 1/10W	
R283			RK73GB2A102J	CHIP R 1.0K J 1/10W		R365,366			RK73GB2A223J	CHIP R 22K J 1/10W	
R284			RK73GB2A471J	CHIP R 470 J 1/10W		R367			RK73GB2A153J	CHIP R 15K J 1/10W	
R285			RK73GB2A102J	CHIP R 1.0K J 1/10W		R368			RK73GB2A223J	CHIP R 22K J 1/10W	
R286			RK73GB2A152J	CHIP R 1.5K J 1/10W		R369-371			RK73GB2A104J	CHIP R 100K J 1/10W	
R287			RK73GB2A471J	CHIP R 470 J 1/10W		R372			RK73GB2A224J	CHIP R 220K J 1/10W	
R288			RK73GB2A224J	CHIP R 220K J 1/10W		R373,374			RK73GB2A000J	CHIP R 0.0 J 1/10W	
R290			RK73GB2A334J	CHIP R 330K J 1/10W		R375			RK73GB2A104J	CHIP R 100K J 1/10W	
R291			RK73GB2A560J	CHIP R 56 J 1/10W		R376			RK73GB2A103J	CHIP R 10K J 1/10W	
R292			RK73GB2A331J	CHIP R 330 J 1/10W		R377			RK73GB2A334J	CHIP R 330K J 1/10W	
R293			RK73GB2A101J	CHIP R 100 J 1/10W		R379			RK73GB2A333J	CHIP R 33K J 1/10W	
R294,295			RK73GB2A224J	CHIP R 220K J 1/10W		R380			RK73GB2A331J	CHIP R 330 J 1/10W	
R296			RK73GB2A472J	CHIP R 4.7K J 1/10W		R381			RK73GB2A332J	CHIP R 3.3K J 1/10W	
R297			RK73GB2A102J	CHIP R 1.0K J 1/10W		R382			RK73GB2A561J	CHIP R 560 J 1/10W	
R298			RK73GB2A101J	CHIP R 100 J 1/10W		R383			RK73GB2A222J	CHIP R 2.2K J 1/10W	
R299			RK73GB2A102J	CHIP R 1.0K J 1/10W		R384			RK73GB2A473J	CHIP R 47K J 1/10W	
R300			RK73GB2A184J	CHIP R 180K J 1/10W		R385			RK73GB2A101J	CHIP R 100 J 1/10W	
R301			RK73GB2A101J	CHIP R 100 J 1/10W		R386			RK73GB2A331J	CHIP R 330 J 1/10W	
R302			RK73GB2A471J	CHIP R 470 J 1/10W		R387			RK73GB2A473J	CHIP R 47K J 1/10W	
R303			RK73GB2A473J	CHIP R 47K J 1/10W		R388			RK73GB2A102J	CHIP R 1.0K J 1/10W	
R304			RK73GB2A472J	CHIP R 4.7K J 1/10W		R389			RK73GB2A473J	CHIP R 47K J 1/10W	
R311			RK73GB2A473J	CHIP R 47K J 1/10W		R390			RK73GB2A331J	CHIP R 330 J 1/10W	
R312			RK73GB2A103J	CHIP R 10K J 1/10W		R391			RK73GB2A105J	CHIP R 1.0M J 1/10W	
R313			RK73GB2A102J	CHIP R 1.0K J 1/10W		R392			RK73GB2A274J	CHIP R 270K J 1/10W	
R314			RK73GB2A103J	CHIP R 10K J 1/10W		R393			RK73GB2A331J	CHIP R 330 J 1/10W	
R315			RK73GB2A102J	CHIP R 1.0K J 1/10W		R394			RK73GB2A105J	CHIP R 1.0M J 1/10W	
R316			RK73GB2A103J	CHIP R 10K J 1/10W		R395			RK73GB2A272J	CHIP R 2.7K J 1/10W	
R317			RK73GB2A473J	CHIP R 47K J 1/10W		R396			RK73GB2A473J	CHIP R 47K J 1/10W	
R319			RK73GB2A473J	CHIP R 47K J 1/10W		R397			RK73GB2A394J	CHIP R 390K J 1/10W	
R321,322			RK73GB2A101J	CHIP R 100 J 1/10W		R398			RK73GB2A330J	CHIP R 33 J 1/10W	
R323			RK73GB2A471J	CHIP R 470 J 1/10W		R399			RK73GB2A102J	CHIP R 1.0K J 1/10W	

PARTS LIST / 零件表

TX-RX UNIT (X57-7210-20)

Ref. No.	Address	New parts	Parts No.	Description	Destination	Ref. No.	Address	New parts	Parts No.	Description	Destination
R400			RK73GB2A822J	CHIP R 8.2K J 1/10W		R468			RK73GB2A104J	CHIP R 100K J 1/10W	
R401			RK73GB2A473J	CHIP R 47K J 1/10W		R469			RK73GB2A331J	CHIP R 330 J 1/10W	
R402,403			RK73GB2A333J	CHIP R 33K J 1/10W		R470			RK73GB2A103J	CHIP R 10K J 1/10W	
R404			RK73GB2A473J	CHIP R 47K J 1/10W		R471			RK73GB2A470J	CHIP R 47 J 1/10W	
R405			RK73GB2A393J	CHIP R 39K J 1/10W		R472			RK73GB2A222J	CHIP R 2.2K J 1/10W	
R406			RK73GB2A561J	CHIP R 560 J 1/10W		R473			RK73GB2A470J	CHIP R 47 J 1/10W	
R407			RK73GB2A333J	CHIP R 33K J 1/10W		R474			RK73GB2A101J	CHIP R 100 J 1/10W	
R408			RK73GB2A473J	CHIP R 47K J 1/10W		R475			RK73GB2A474J	CHIP R 470K J 1/10W	
R409			RK73GB2A333J	CHIP R 33K J 1/10W		R476			RK73GB2A562J	CHIP R 5.6K J 1/10W	
R410			RK73GB2A473J	CHIP R 47K J 1/10W		R477			RK73GB2A470J	CHIP R 47 J 1/10W	
R411			RK73GB2A474J	CHIP R 470K J 1/10W		R478			RK73GB2A471J	CHIP R 470 J 1/10W	
R412			RK73GB2A682J	CHIP R 6.8K J 1/10W		R479			RK73GB2A331J	CHIP R 330 J 1/10W	
R413			RK73GB2A561J	CHIP R 560 J 1/10W		R480			RK73GB2A222J	CHIP R 2.2K J 1/10W	
R414			RK73GB2A822J	CHIP R 8.2K J 1/10W		R481			RK73GB2A104J	CHIP R 100K J 1/10W	
R415			RK73GB2A104J	CHIP R 100K J 1/10W		R482			RK73GB2A274J	CHIP R 270K J 1/10W	
R416			RK73GB2A330J	CHIP R 33 J 1/10W		R483			RK73GB2A000J	CHIP R 0.0 J 1/10W	
R417			RK73GB2A822J	CHIP R 8.2K J 1/10W		R484			RK73GB2A470J	CHIP R 47 J 1/10W	
R418			RK73GB2A334J	CHIP R 330K J 1/10W		R485,486			RK73GB2A474J	CHIP R 470K J 1/10W	
R419			RK73GB2A104J	CHIP R 100K J 1/10W		R487			RK73GB2A101J	CHIP R 100 J 1/10W	
R420			RK73GB2A561J	CHIP R 560 J 1/10W		R488			RK73GB2A222J	CHIP R 2.2K J 1/10W	
R421			RK73GB2A123J	CHIP R 12K J 1/10W		R489			RK73GB2A331J	CHIP R 330 J 1/10W	
R422			RK73GB2A101J	CHIP R 100 J 1/10W		R491			RK73GB2A681J	CHIP R 680 J 1/10W	
R424			RK73GB2A102J	CHIP R 1.0K J 1/10W		R492			RK73GB2A471J	CHIP R 470 J 1/10W	
R425			RK73GB2A000J	CHIP R 0.0 J 1/10W		R493			RK73GB2A104J	CHIP R 100K J 1/10W	
R426,427			RK73GB2A473J	CHIP R 47K J 1/10W		R494			RK73GB2A473J	CHIP R 47K J 1/10W	
R428			RK73GB2A274J	CHIP R 270K J 1/10W		R495			RK73GB2A104J	CHIP R 100K J 1/10W	
R429			RK73GB2A102J	CHIP R 1.0K J 1/10W		R496			RK73GB2A100J	CHIP R 10 J 1/10W	
R430			RK73GB2A103J	CHIP R 10K J 1/10W		R497			RK73GB2A103J	CHIP R 10K J 1/10W	
R431			RK73GB2A000J	CHIP R 0.0 J 1/10W		R498			RK73GB2A473J	CHIP R 47K J 1/10W	
R432			RK73GB2A101J	CHIP R 100 J 1/10W		R499			RK73GB2A103J	CHIP R 10K J 1/10W	
R433			RK73GB2A472J	CHIP R 4.7K J 1/10W		R500			RK73GB2A223J	CHIP R 22K J 1/10W	
R434			RK73GB2A223J	CHIP R 22K J 1/10W		R501,502			RK73GB2A472J	CHIP R 4.7K J 1/10W	
R435			RK73GB2A331J	CHIP R 330 J 1/10W		R503			RK73GB2A101J	CHIP R 100 J 1/10W	
R436			RK73GB2A472J	CHIP R 4.7K J 1/10W		R505			RK73GB2A103J	CHIP R 10K J 1/10W	
R437			RK73GB2A223J	CHIP R 22K J 1/10W		R506			RK73GB2A682J	CHIP R 6.8K J 1/10W	
R438			RK73GB2A822J	CHIP R 8.2K J 1/10W		R507			RK73GB2A000J	CHIP R 0.0 J 1/10W	
R439			RK73GB2A184J	CHIP R 180K J 1/10W		R508			RK73GB2A103J	CHIP R 10K J 1/10W	
R440			RK73GB2A333J	CHIP R 33K J 1/10W		R521			RK73GB2A151J	CHIP R 150 J 1/10W	
R441			RK73GB2A102J	CHIP R 1.0K J 1/10W		R523			RK73GB2A682J	CHIP R 6.8K J 1/10W	
R442			RK73GB2A103J	CHIP R 10K J 1/10W		R524			RK73GB2A223J	CHIP R 22K J 1/10W	
R443			RK73GB2A223J	CHIP R 22K J 1/10W		R525,526			RK73GB2A103J	CHIP R 10K J 1/10W	
R444			RK73GB2A000J	CHIP R 0.0 J 1/10W		R527			RK73GB2A223J	CHIP R 22K J 1/10W	
R445			RK73GB2A101J	CHIP R 100 J 1/10W		R528			RK73GB2A104J	CHIP R 100K J 1/10W	
R446			RK73GB2A000J	CHIP R 0.0 J 1/10W		R529			RK73GB2A563J	CHIP R 56K J 1/10W	
R447			RK73GB2A103J	CHIP R 10K J 1/10W		R530,531			RK73GB2A104J	CHIP R 100K J 1/10W	
R451,452			RK73GB2A332J	CHIP R 3.3K J 1/10W		R532			RK73GB2A333J	CHIP R 33K J 1/10W	
R453			RK73GB2A104J	CHIP R 100K J 1/10W		R533,534			RK73GB2A473J	CHIP R 47K J 1/10W	
R454			RK73GB2A393J	CHIP R 39K J 1/10W		R535			RK73FB2B4R7J	CHIP R 4.7 J 1/8W	
R455			RK73GB2A101J	CHIP R 100 J 1/10W		R536			RK73GB2A221J	CHIP R 220 J 1/10W	
R456			RK73GB2A331J	CHIP R 330 J 1/10W		R537			RK73GB2A103J	CHIP R 10K J 1/10W	
R457			RK73GB2A103J	CHIP R 10K J 1/10W		R538			RK73GB2A333J	CHIP R 33K J 1/10W	
R458			RK73GB2A470J	CHIP R 47 J 1/10W		R539			RK73GB2A102J	CHIP R 1.0K J 1/10W	
R459			RK73GB2A000J	CHIP R 0.0 J 1/10W		R541			RK73GB2A391J	CHIP R 390 J 1/10W	
R460			RK73GB2A223J	CHIP R 22K J 1/10W		R543			RK73GB2A000J	CHIP R 0.0 J 1/10W	
R461			RK73GB2A102J	CHIP R 1.0K J 1/10W		R544			RK73GB2A223J	CHIP R 22K J 1/10W	
R462			RK73GB2A222J	CHIP R 2.2K J 1/10W		R545			RK73GB2A333J	CHIP R 33K J 1/10W	
R463			RK73GB2A101J	CHIP R 100 J 1/10W		R546			RK73GB2A103J	CHIP R 10K J 1/10W	
R464			RK73GB2A104J	CHIP R 100K J 1/10W		R547			RK73EB2E000J	CHIP R 0.0 J 1/4W	
R465,466			RK73GB2A472J	CHIP R 4.7K J 1/10W		R548			RK73GB2A103J	CHIP R 10K J 1/10W	
R467			RK73GB2A393J	CHIP R 39K J 1/10W		R551			RK73GB2A104J	CHIP R 100K J 1/10W	

PARTS LIST / 零件表

TX-RX UNIT (X57-7210-20)

Ref. No.	Address	New parts	Parts No.	Description	Destination	Ref. No.	Address	New parts	Parts No.	Description	Destination
R553			RK73GB2A101J	CHIP R 100 J 1/10W		R628			RK73GB2A103J	CHIP R 10K J 1/10W	
R554			RK73GB2A223J	CHIP R 22K J 1/10W		R629			RK73GB2A105J	CHIP R 1.0M J 1/10W	
R555			RK73GB2A473J	CHIP R 47K J 1/10W		R630			RK73GB2A102J	CHIP R 1.0K J 1/10W	
R556			RK73GB2A104J	CHIP R 100K J 1/10W		R631-634			RK73GB2A103J	CHIP R 10K J 1/10W	
R557			RK73GB2A101J	CHIP R 100 J 1/10W		R635			RK73GB2A123J	CHIP R 12K J 1/10W	
R558,559			RK73GB2A104J	CHIP R 100K J 1/10W		R636			RK73GB2A101J	CHIP R 100 J 1/10W	
R560			RK73GB2A101J	CHIP R 100 J 1/10W		R637,638			RK73GB2A103J	CHIP R 10K J 1/10W	
R561			RK73GB2A104J	CHIP R 100K J 1/10W		R639,640			RK73GB2A101J	CHIP R 100 J 1/10W	
R562			RK73GB2A101J	CHIP R 100 J 1/10W		R641			RK73GB2A104J	CHIP R 100K J 1/10W	
R563			RK73GB2A183J	CHIP R 18K J 1/10W		R642			RK73GB2A154J	CHIP R 150K J 1/10W	
R564			RK73GB2A103J	CHIP R 10K J 1/10W		R643			RK73GB2A101J	CHIP R 100 J 1/10W	
R565			RK73GB2A822J	CHIP R 8.2K J 1/10W		R644			RK73GB2A224J	CHIP R 220K J 1/10W	
R566			RK73GB2A104J	CHIP R 100K J 1/10W		R645			RK73GB2A103J	CHIP R 10K J 1/10W	
R567			RK73GB2A101J	CHIP R 100 J 1/10W		R646			RK73GB2A153J	CHIP R 15K J 1/10W	
R568			RK73GB2A822J	CHIP R 8.2K J 1/10W		R647			RK73GB2A101J	CHIP R 100 J 1/10W	
R569			RK73GB2A104J	CHIP R 100K J 1/10W		R648			RK73GB2A104J	CHIP R 100K J 1/10W	
R570			RK73GB2A101J	CHIP R 100 J 1/10W		R649			RK73GB2A474J	CHIP R 470K J 1/10W	
R571			RK73GB2A104J	CHIP R 100K J 1/10W		R650			RK73GB2A104J	CHIP R 100K J 1/10W	
R572			RK73GB2A101J	CHIP R 100 J 1/10W		R651			RK73GB2A101J	CHIP R 100 J 1/10W	
R574			RK73GB2A104J	CHIP R 100K J 1/10W		R652			RK73GB2A224J	CHIP R 220K J 1/10W	
R575			RK73GB2A223J	CHIP R 22K J 1/10W		R653			RK73GB2A472J	CHIP R 4.7K J 1/10W	
R578			RK73GB2A102J	CHIP R 1.0K J 1/10W		R654			RK73GB2A103J	CHIP R 10K J 1/10W	
R579			RK73GB2A472J	CHIP R 4.7K J 1/10W		R657-661			RK73GB2A103J	CHIP R 10K J 1/10W	
R580			RK73GB2A122J	CHIP R 1.2K J 1/10W		R666,667			RK73GB2A472J	CHIP R 4.7K J 1/10W	
R581			RK73GB2A103J	CHIP R 10K J 1/10W		R670			RK73GB2A223J	CHIP R 22K J 1/10W	
R582			RK73GB2A473J	CHIP R 47K J 1/10W		R671			RK73GB2A681J	CHIP R 680 J 1/10W	
R583			RK73GB2A472J	CHIP R 4.7K J 1/10W		R672			RK73GB2A472J	CHIP R 4.7K J 1/10W	
R584			RK73GB2A102J	CHIP R 1.0K J 1/10W		R674			RK73GB2A103J	CHIP R 10K J 1/10W	
R585			RK73GB2A122J	CHIP R 1.2K J 1/10W		R675,676			RK73GB2A101J	CHIP R 100 J 1/10W	
R586			RK73GB2A474J	CHIP R 470K J 1/10W		R679,680			RK73GB2A224J	CHIP R 220K J 1/10W	
R590			RK73GB2A102J	CHIP R 1.0K J 1/10W		R681			RK73GB2A104J	CHIP R 100K J 1/10W	
R591			RK73GB2A122J	CHIP R 1.2K J 1/10W		R685			RK73GB2A000J	CHIP R 0.0 J 1/10W	
R593			RK73GB2A473J	CHIP R 47K J 1/10W		R701			RK73GB2A100J	CHIP R 10 J 1/10W	
R594			RK73GB2A563J	CHIP R 56K J 1/10W		R702			RK73GB2A560J	CHIP R 56 J 1/10W	
R595			RK73GB2A000J	CHIP R 0.0 J 1/10W		R703			RK73GB2A823J	CHIP R 82K J 1/10W	
R596,597			RK73GB2A474J	CHIP R 470K J 1/10W		R704			RK73GB2A224J	CHIP R 220K J 1/10W	
R598,599			RK73GB2A153J	CHIP R 15K J 1/10W		R706			RK73GB2A331J	CHIP R 330 J 1/10W	
R601			RK73GB2A102J	CHIP R 1.0K J 1/10W		R707			RK73GB2A271J	CHIP R 270 J 1/10W	
R602			RK73GB2A103J	CHIP R 10K J 1/10W		R708			RK73GB2A470J	CHIP R 47 J 1/10W	
R603,604			RK73GB2A151J	CHIP R 150 J 1/10W		R709			RK73GB2A102J	CHIP R 1.0K J 1/10W	
R605			RK73GB2A223J	CHIP R 22K J 1/10W		R710			RK73GB2A180J	CHIP R 18 J 1/10W	
R606			RK73GB2A101J	CHIP R 100 J 1/10W		R711			RK73GB2A271J	CHIP R 270 J 1/10W	
R607			RK73GB2A103J	CHIP R 10K J 1/10W		R712,713			RK73GB2A102J	CHIP R 1.0K J 1/10W	
R608			RK73GB2A101J	CHIP R 100 J 1/10W		R714			RK73GB2A392J	CHIP R 3.9K J 1/10W	
R609			RK73GB2A474J	CHIP R 470K J 1/10W		R715			RK73GB2A103J	CHIP R 10K J 1/10W	
R610			RK73GB2A101J	CHIP R 100 J 1/10W		R716			RK73GB2A100J	CHIP R 10 J 1/10W	
R611,612			RK73GB2A332J	CHIP R 3.3K J 1/10W		R717			RK73GB2A823J	CHIP R 82K J 1/10W	
R613,614			RK73GB2A223J	CHIP R 22K J 1/10W		R718			RK73GB2A100J	CHIP R 10 J 1/10W	
R615			RK73GB2A564J	CHIP R 560K J 1/10W		R720			RK73GB2A561J	CHIP R 560 J 1/10W	
R616			RK73GB2A105J	CHIP R 1.0M J 1/10W		R721			RK73GB2A271J	CHIP R 270 J 1/10W	
R617			RK73GB2A474J	CHIP R 470K J 1/10W		R722			RK73GB2A331J	CHIP R 330 J 1/10W	
R618			RK73GB2A222J	CHIP R 2.2K J 1/10W		R725			RK73GB2A102J	CHIP R 1.0K J 1/10W	
R619			RK73GB2A103J	CHIP R 10K J 1/10W		R726			RK73GB2A393J	CHIP R 39K J 1/10W	
R620			RK73GB2A105J	CHIP R 1.0M J 1/10W		R727			RK73GB2A682J	CHIP R 6.8K J 1/10W	
R621			RK73GB2A103J	CHIP R 10K J 1/10W		R729,730			RK73GB2A102J	CHIP R 1.0K J 1/10W	
R622			RK73GB2A683J	CHIP R 68K J 1/10W		R731			RK73GB2A331J	CHIP R 330 J 1/10W	
R623			RK73GB2A103J	CHIP R 10K J 1/10W		R732			RK73GB2A101J	CHIP R 100 J 1/10W	
R624,625			RK73GB2A151J	CHIP R 150 J 1/10W		R736			RK73GB2A822J	CHIP R 8.2K J 1/10W	
R626			RK73GB2A104J	CHIP R 100K J 1/10W		R737			RK73GB2A153J	CHIP R 15K J 1/10W	
R627			RK73GB2A102J	CHIP R 1.0K J 1/10W		R738			RK73GB2A470J	CHIP R 47 J 1/10W	

PARTS LIST / 零件表

TX-RX UNIT (X57-7210-20)

Ref. No.	Address	New parts	Parts No.	Description	Destination	Ref. No.	Address	New parts	Parts No.	Description	Destination
R739			RK73GB2A271J	CHIP R 270 J 1/10W		R811			RK73GB2A473J	CHIP R 47K J 1/10W	
R740			RK73GB2A153J	CHIP R 15K J 1/10W		R850			RK73GB2A000J	CHIP R 0.0 J 1/10W	
R741			RK73GB2A682J	CHIP R 6.8K J 1/10W		R851,852			RK73GB2A101J	CHIP R 100 J 1/10W	
R742			RK73GB2A392J	CHIP R 3.9K J 1/10W		R853,854			RK73GB2A472J	CHIP R 4.7K J 1/10W	
R744			RK73GB2A331J	CHIP R 330 J 1/10W		R855,856			RK73GB2A101J	CHIP R 100 J 1/10W	
R746			RK73GB2A271J	CHIP R 270 J 1/10W		R857,858			RK73FB2B000J	CHIP R 0.0 J 1/8W	
R747			RK73GB2A153J	CHIP R 15K J 1/10W		R863-871			RK73GB2A101J	CHIP R 100 J 1/10W	
R748			RK73GB2A682J	CHIP R 6.8K J 1/10W		R872			RK73GB2A104J	CHIP R 100K J 1/10W	
R749			RK73GB2A101J	CHIP R 100 J 1/10W		R874			RK73GB2A471J	CHIP R 470 J 1/10W	
R750			RK73GB2A180J	CHIP R 18 J 1/10W		R877			RK73GB2A471J	CHIP R 470 J 1/10W	
R751			RK73GB2A100J	CHIP R 10 J 1/10W		R880			RK73GB2A105J	CHIP R 1.0M J 1/10W	
R752			RK73GB2A271J	CHIP R 270 J 1/10W		R881			RK73GB2A104J	CHIP R 100K J 1/10W	
R753			RK73GB2A101J	CHIP R 100 J 1/10W		R882			RK73GB2A103J	CHIP R 10K J 1/10W	
R754			RK73GB2A822J	CHIP R 8.2K J 1/10W		R895			RK73GB2A102J	CHIP R 1.0K J 1/10W	
R755			RK73GB2A153J	CHIP R 15K J 1/10W		R896			RK73GB2A104J	CHIP R 100K J 1/10W	
R757			RK73GB2A000J	CHIP R 0.0 J 1/10W		R897			RK73GB2A101J	CHIP R 100 J 1/10W	
R758			RK73GB2A470J	CHIP R 47 J 1/10W		R900			RK73GB2A101J	CHIP R 100 J 1/10W	
R759			RK73GB2A391J	CHIP R 390 J 1/10W		R901,902			RK73GB2A473J	CHIP R 47K J 1/10W	
R761			RK73GB2A560J	CHIP R 56 J 1/10W		R906,907			RK73GB2A102J	CHIP R 1.0K J 1/10W	
R762			RK73GB2A470J	CHIP R 47 J 1/10W		R909			RK73GB2A104J	CHIP R 100K J 1/10W	
R763			RK73GB2A473J	CHIP R 47K J 1/10W		R910			RK73GB2A473J	CHIP R 47K J 1/10W	
R764			RK73GB2A102J	CHIP R 1.0K J 1/10W		R911-913			RK73GB2A101J	CHIP R 100 J 1/10W	
R765			RK73GB2A181J	CHIP R 180 J 1/10W		R914			RK73GB2A104J	CHIP R 100K J 1/10W	
R766			RK73GB2A331J	CHIP R 330 J 1/10W		R915			RK73GB2A101J	CHIP R 100 J 1/10W	
R767,768			RK73GB2A101J	CHIP R 100 J 1/10W		R916			RK73GB2A473J	CHIP R 47K J 1/10W	
R769			RK73GB2A470J	CHIP R 47 J 1/10W		R917			RK73GB2A101J	CHIP R 100 J 1/10W	
R770			RK73GB2A224J	CHIP R 220K J 1/10W		R918			RK73GB2A471J	CHIP R 470 J 1/10W	
R772			RK73GB2A104J	CHIP R 100K J 1/10W		R919			RK73GB2A104J	CHIP R 100K J 1/10W	
R774			RK73GB2A101J	CHIP R 100 J 1/10W		R920,921			RK73GB2A473J	CHIP R 47K J 1/10W	
R775,776			RK73GB2A391J	CHIP R 390 J 1/10W		R926,927			RK73GB2A473J	CHIP R 47K J 1/10W	
R777			RK73GB2A470J	CHIP R 47 J 1/10W		R930			RK73GB2A104J	CHIP R 100K J 1/10W	
R778			RK73GB2A000J	CHIP R 0.0 J 1/10W		R933			RK73GB2A823J	CHIP R 82K J 1/10W	
R779			RK73GB2A221J	CHIP R 220 J 1/10W		R945			RK73PB2H560J	CHIP R 56 J 1/2W	
R780			RK73GB2A180J	CHIP R 18 J 1/10W		R948			RK73GB2A101J	CHIP R 100 J 1/10W	
R781,782			RK73GB2A221J	CHIP R 220 J 1/10W		R951			RK73GB2A471J	CHIP R 470 J 1/10W	
R783,784			RK73GB2A180J	CHIP R 18 J 1/10W		R952			RK73GB2A103J	CHIP R 10K J 1/10W	
R785			RK73FB2B000J	CHIP R 0.0 J 1/8W		R954			RK73GB2A471J	CHIP R 470 J 1/10W	
R786			RK73GB2A391J	CHIP R 390 J 1/10W		R956			RK73GB2A102J	CHIP R 1.0K J 1/10W	
R787			RK73FB2B000J	CHIP R 0.0 J 1/8W		R958			RK73GB2A102J	CHIP R 1.0K J 1/10W	
R788			RK73GB2A391J	CHIP R 390 J 1/10W		R960			RK73GB2A101J	CHIP R 100 J 1/10W	
R789			RK73GB2A153J	CHIP R 15K J 1/10W		R961			RK73GB2A103J	CHIP R 10K J 1/10W	
R790			RK73GB2A682J	CHIP R 6.8K J 1/10W		R962			RK73FB2B000J	CHIP R 0.0 J 1/8W	
R791			RK73GB2A103J	CHIP R 10K J 1/10W		R963			RK73GB2A474J	CHIP R 470K J 1/10W	
R792,793			RK73GB2A102J	CHIP R 1.0K J 1/10W		R964,965			RK73GB2A472J	CHIP R 4.7K J 1/10W	
R794			RK73GB2A101J	CHIP R 100 J 1/10W		R966			RK73GB2A474J	CHIP R 470K J 1/10W	
R795			RK73GB2A471J	CHIP R 470 J 1/10W		R967			RK73GB2A393J	CHIP R 39K J 1/10W	
R796			RK73GB2A472J	CHIP R 4.7K J 1/10W		R968			RK73GB2A104J	CHIP R 100K J 1/10W	
R797			RK73GB2A560J	CHIP R 56 J 1/10W		R969			RK73GB2A394J	CHIP R 390K J 1/10W	
R798			RK73GB2A470J	CHIP R 47 J 1/10W		R970			RK73GB2A000J	CHIP R 0.0 J 1/10W	
R799			RK73GB2A153J	CHIP R 15K J 1/10W		R971			RK73GB2A223J	CHIP R 22K J 1/10W	
R800			RK73GB2A682J	CHIP R 6.8K J 1/10W		R972			RK73GB2A332J	CHIP R 3.3K J 1/10W	
R801			RK73GB2A271J	CHIP R 270 J 1/10W		R973-976			RK73GB2A473J	CHIP R 47K J 1/10W	
R802			RK73GB2A180J	CHIP R 18 J 1/10W		R977			RK73GB2A103J	CHIP R 10K J 1/10W	
R803			RK73GB2A470J	CHIP R 47 J 1/10W		R979-982			RK73GB2A473J	CHIP R 47K J 1/10W	
R804			RK73GB2A560J	CHIP R 56 J 1/10W		R983,984			RK73GB2A472J	CHIP R 4.7K J 1/10W	
R805			RK73GB2A271J	CHIP R 270 J 1/10W		R985-989			RK73GB2A473J	CHIP R 47K J 1/10W	
R806,807			RK73GB2A471J	CHIP R 470 J 1/10W		R990			RK73FB2B100J	CHIP R 10 J 1/8W	
R808			RK73GB2A000J	CHIP R 0.0 J 1/10W		R991		*	RK73SB3A680J	CHIP R 68 J 1W	
R809			RK73GB2A102J	CHIP R 1.0K J 1/10W		R992			RK73EB2E560J	CHIP R 56 J 1/4W	
R810			RK73GB2A151J	CHIP R 150 J 1/10W		R993		*	RK73SB3A680J	CHIP R 68 J 1W	

PARTS LIST / 零件表

TX-RX UNIT (X57-7210-20)

Ref. No.	Address	New parts	Parts No.	Description	Destination	Ref. No.	Address	New parts	Parts No.	Description	Destination
R994			RK73EB2E560J	CHIP R 56 J 1/4W		D704,705			HSC277	DIODE	
R995,996			RK73GB2A182J	CHIP R 1.8K J 1/10W		D851,852			AVRM1608080MAA	VARISTOR	
R997-999			RK73FB2B100J	CHIP R 10 J 1/8W		D853			MINISMDC020F	VARISTOR	
VR251,252		*	R32-0328-05	SEMI FIXED VARIABLE RESISTOR		D854			AVRM1608080MAA	VARISTOR	
VR361,362		*	R32-0328-05	SEMI FIXED VARIABLE RESISTOR		D855,856			DA221	DIODE	
VR851,852		*	R32-0328-05	SEMI FIXED VARIABLE RESISTOR		D857			AVRM1608080MAA	VARISTOR	
K1			S51-1428-05	RELAY		D858,859		*	1SS400	DIODE	
D1			V08(G)	DIODE		D860			DA221	DIODE	
D2,3			RLS245	DIODE		D861		*	1SS400	DIODE	
D4			V08(G)	DIODE		D862,863			AVRM1608080MAA	VARISTOR	
D5,6			HVC131	DIODE		D864			DA221	DIODE	
D7			LFB01	DIODE		D865-867			AVRM1608080MAA	VARISTOR	
D8,9			HVC131	DIODE		D868		*	EDZ18B	ZENER DIODE	
D10-12		*	1SV312-F	DIODE		D869			RB521S-30	DIODE	
D13			HVC131	DIODE		D870-872		*	1SS400	DIODE	
D14-20			HSC277	DIODE		D991,992		*	1SS400	DIODE	
D21		*	1SS400	DIODE		IC1			BU2099FV	MOS-IC	
D101-103			HSC277	DIODE		IC101		*	TA4107F-F	MOS-IC	
D104		*	1SV312-F	DIODE		IC251			NJM2594V	ANALOGUE IC	
D105-107			DAN235E	DIODE		IC361			BA10358FV	MOS-IC	
D181		*	1SS400	DIODE		IC362			BA10324AFV	MOS-IC	
D182			DAN235E	DIODE		IC363			M62364FP-F	MOS-IC	
D183			HSB88WS	DIODE		IC421			BU2099FV	MOS-IC	
D184,185			DAN235E	DIODE		IC422			BU4066BCFV	MOS-IC	
D186,187		*	1SS400	DIODE		IC423		*	NJM2100V-ZB	MOS-IC	
D251			HSC277	DIODE		IC451		*	TA4101F-F	ANALOGUE IC	
D252		*	1SV312-F	DIODE		IC452			TC7W53FK(F)	MOS-IC	
D253			RN731V	DIODE		IC453		*	NJM2100V-ZB	MOS-IC	
D254			HSC277	DIODE		IC454			XC6201P502PR	MOS-IC	
D255-257		*	1SV312-F	DIODE		IC521	1B	*	BA5415A	BI-POLAR IC	
D258			HSC277	DIODE		IC551-553			BU4066BCFV	MOS-IC	
D259			HVC131	DIODE		IC554,555			M62364FP-F	MOS-IC	
D260,261			HSC277	DIODE		IC601			TC4001BFT	MOS-IC	
D321			RB706F-40	DIODE		IC602		*	NJM2100V-ZB	MOS-IC	
D361		*	EDZ5.1B	ZENER DIODE		IC603			BA10358FV	MOS-IC	
D362		*	015AZ5.6(X)F	ZENER DIODE		IC604,605		*	NJM2100V-ZB	MOS-IC	
D363		*	1SS400	DIODE		IC606			TC7WT125FUF	MOS-IC	
D364		*	015AZ5.6(X)F	ZENER DIODE		IC701,702		*	AD9835BRUZ	MOS-IC	
D365			1SS388F	DIODE		IC703		*	LMX2306TMX/NP	ANALOGUE IC	
D366,367		*	1SS400	DIODE		IC704			XC6201P502PR	MOS-IC	
D368,369			1SS388F	DIODE		IC851			TC7S66FUF	MOS-IC	
D370		*	015AZ3.9(X)F	ZENER DIODE		IC852			NJM2107F-ZB	ANALOGUE IC	
D371-373		*	1SS400	DIODE		IC853			TK11250CUCB	MOS-IC	
D374			1SS388F	DIODE		IC854			AT25128A10SU27	ROM IC	
D451		*	1SS400	DIODE		IC855		*	30625FGPUKBEC	MICROPROCESSOR IC	
D452			RN731V	DIODE		IC856,857			S-80942CNNBG9C	MOS-IC	
D453,454			HSM88AS-E	DIODE		IC859		*	XC6202P502FR	MOS-IC	
D521,522		*	1SS400	DIODE		IC861			TK11250CUCB	MOS-IC	
D601,602			MA3J742	DIODE		IC863		*	NJM2100V-ZB	MOS-IC	
D603,604		*	1SS400	DIODE		IC864		*	TC7W66FK-F	MOS-IC	
D605,606			MA3J742	DIODE		IC865			NJM2211M	MOS-IC	
D607,608		*	1SS400	DIODE		Q1		*	HN7G01FU-F(A)	TRANSISTOR	
D609,610			AVRM1608080MAA	VARISTOR		Q2			DTC114EE	DIGITAL TRANSISTOR	
D611		*	MINISMDC05002F	VARISTOR		Q3			2SK2596	FET	
D612			MINISMDC020F	VARISTOR		Q4			2SD1757K	TRANSISTOR	
D613,614			AVRM1608080MAA	VARISTOR		Q5-13			DTA123YE	DIGITAL TRANSISTOR	
D701,702		*	KV1470-G	VARIABLE CAPACITANCE DIODE		Q101			2SK1830F	FET	
D703		*	1SS400	DIODE		Q102		*	RN47A5-F	TRANSISTOR	
						Q103			2SC3356-A(R24)	TRANSISTOR	
						Q104		*	HN7G01FU-F(A)	TRANSISTOR	

PARTS LIST / 零件表

TX-RX UNIT (X57-7210-20)

Ref. No.	Address	New parts	Parts No.	Description	Desti-nation	Ref. No.	Address	New parts	Parts No.	Description	Desti-nation
Q105,106			2SK508NV(K53)	FET		Q855			DTC114TE	DIGITAL TRANSISTOR	
Q107			2SK2596	FET		Q856			DTC114EE	DIGITAL TRANSISTOR	
Q108,109			2SK508NV(K53)	FET		Q858			DTC114EE	DIGITAL TRANSISTOR	
Q110		*	RN47A5-F	TRANSISTOR		Q859			DTA114EE	DIGITAL TRANSISTOR	
Q181			DTC114EE	DIGITAL TRANSISTOR		Q991,992			2SD1757K	TRANSISTOR	
Q182,183		*	3SK317-E	FET		Q993			2SK1830F	FET	
Q184			2SC3356-A(R24)	TRANSISTOR		Q994,995			DTA114EE	DIGITAL TRANSISTOR	
Q185,186		*	3SK317-E	FET		TH184		*	NCP18XF101J0S	THERMISTOR	
Q187			2SC4617(R)	TRANSISTOR		TH185		*	NCP18XW332J0S	THERMISTOR	
Q251			2SC3356-A(R24)	TRANSISTOR		TH251		*	NCP18XF101J0S	THERMISTOR	
Q252			DTC114EE	DIGITAL TRANSISTOR		TH252,253		*	NCP18XQ471J0S	THERMISTOR	
Q253-255			2SC4617(R)	TRANSISTOR		TH255			NCP18XQ102J0S	THERMISTOR	
Q311,312		*	HN7G01FU-F(A)	TRANSISTOR		TH361		*	NCP18XW153J0S	THERMISTOR	
Q313			DTC114EE	DIGITAL TRANSISTOR		TH451			NCP18XM472J0S	THERMISTOR	
Q321			2SC4617(R)	TRANSISTOR		TH551		*	NCP18WB473J0S	THERMISTOR	
Q322			2SC3356-A(R24)	TRANSISTOR							
Q323			UMX2N	TRANSISTOR							
Q324			2SK1830F	FET							
Q325-327			2SC4617(Q)	TRANSISTOR							
Q329			DTA114EE	DIGITAL TRANSISTOR							
Q361			DTC114EE	DIGITAL TRANSISTOR							
Q362		*	RN47A5-F	TRANSISTOR							
Q363,364			2SC4617(R)	TRANSISTOR							
Q365		*	2SK208-F(GR)	FET							
Q366			2SC4617(R)	TRANSISTOR							
Q421			DTA114EE	DIGITAL TRANSISTOR							
Q423			2SC4617(R)	TRANSISTOR							
Q451		*	3SK317-E	FET							
Q452			2SK1830F	FET							
Q453			2SC4617(R)	TRANSISTOR							
Q454			DTC114EE	DIGITAL TRANSISTOR							
Q455		*	3SK317-E	FET							
Q456			DTC114EE	DIGITAL TRANSISTOR							
Q457-459			2SC4617(R)	TRANSISTOR							
Q460			2SK1830F	FET							
Q521			2SK1830F	FET							
Q522		*	2SC5566-E	TRANSISTOR							
Q523,524			2SK1830F	FET							
Q601			2SC4116(Y)F	TRANSISTOR							
Q602			2SA1586(Y,GR)F	TRANSISTOR							
Q603			DTA114EE	DIGITAL TRANSISTOR							
Q604			2SC4617(R)	TRANSISTOR							
Q605			2SC4116(Y)F	TRANSISTOR							
Q606			2SA1586(Y,GR)F	TRANSISTOR							
Q607		*	RN1701-F	TRANSISTOR							
Q608			DTC114EE	DIGITAL TRANSISTOR							
Q609,610			2SK1830F	FET							
Q701-704			2SC4617(R)	TRANSISTOR							
Q706			2SC4649(N,P)	TRANSISTOR							
Q707-709			2SC4617(R)	TRANSISTOR							
Q711,712			2SC4617(R)	TRANSISTOR							
Q713,714			2SK508NV(K52)	FET							
Q715,716			2SC4649(N,P)	TRANSISTOR							
Q717			2SC4617(R)	TRANSISTOR							
Q718,719			DTC114EE	DIGITAL TRANSISTOR							
Q720		*	2SC5566-E	TRANSISTOR							
Q851			DTA143EE	DIGITAL TRANSISTOR							
Q852			DTC143EE	DIGITAL TRANSISTOR							
Q853			DTA143EE	DIGITAL TRANSISTOR							
Q854			DTC143EE	DIGITAL TRANSISTOR							

EXPLODED VIEW / 部件分解图

A	: N09-2477-05
B	∅4 (FW) : N15-1040-48
C	M3 x 6 (F) : N32-3006-48
D	M3 x 6 (OC) : N33-3006-43
E	M3 x 8 (Bi) : N35-3008-43
F	M4 x 10 (Bi) : N35-4010-48
G	M2.6 x 10 : N66-2610-48
H	M2.6 x 8 : N67-2608-48
J	M2.6 x 8 : N82-2608-48
K	M2.6 x 6 (Br-Tap) : N87-2606-48
L	M2.6 x 8 (Br-Tap) : N87-2608-48

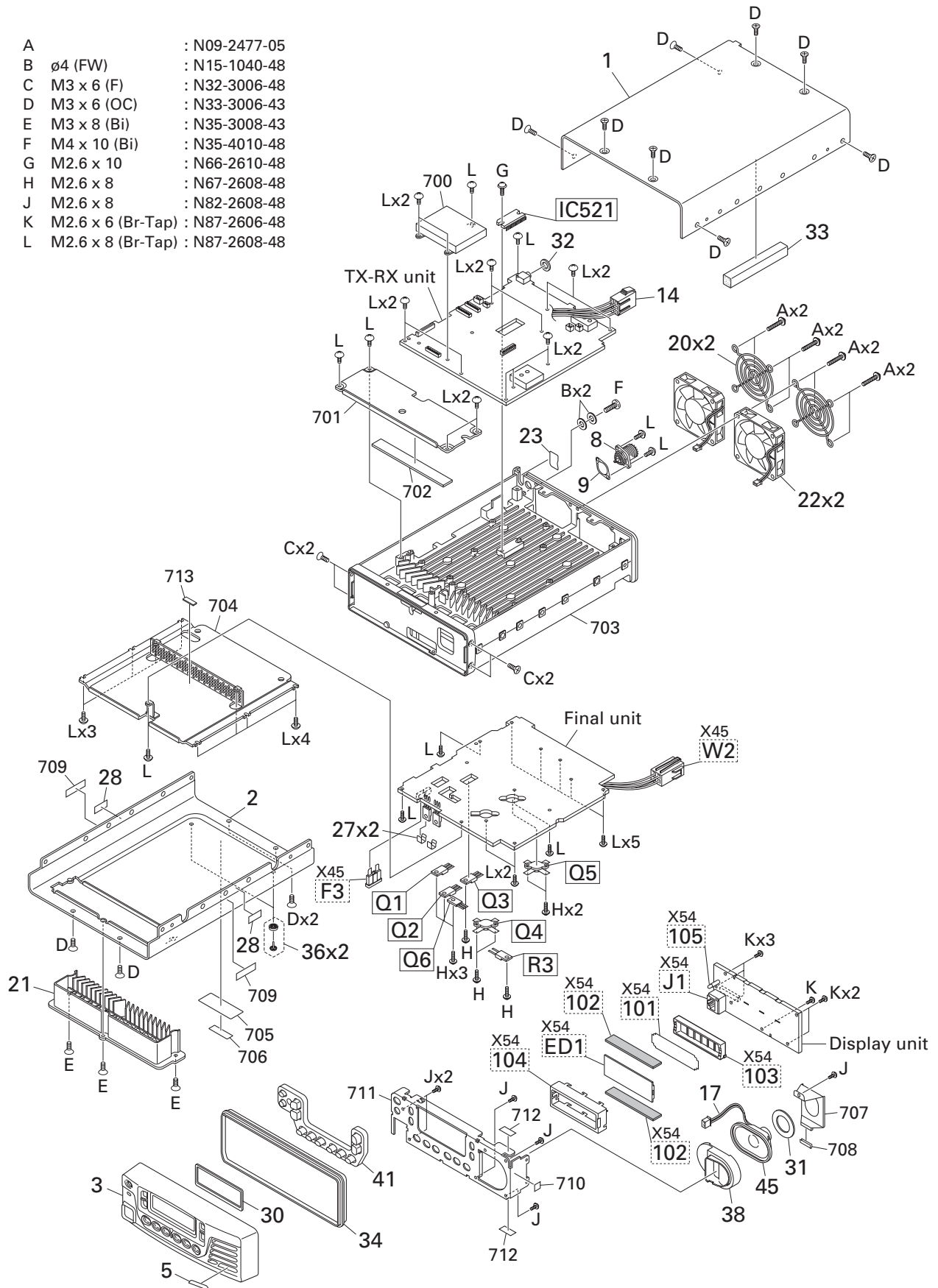

64 Parts with the exploded numbers larger than 700 are not supplied.
 If a part reference number is listed in a box on the exploded view of the PCB, that part does not come with the PCB. These parts must be ordered separately.

PACKING / 包装

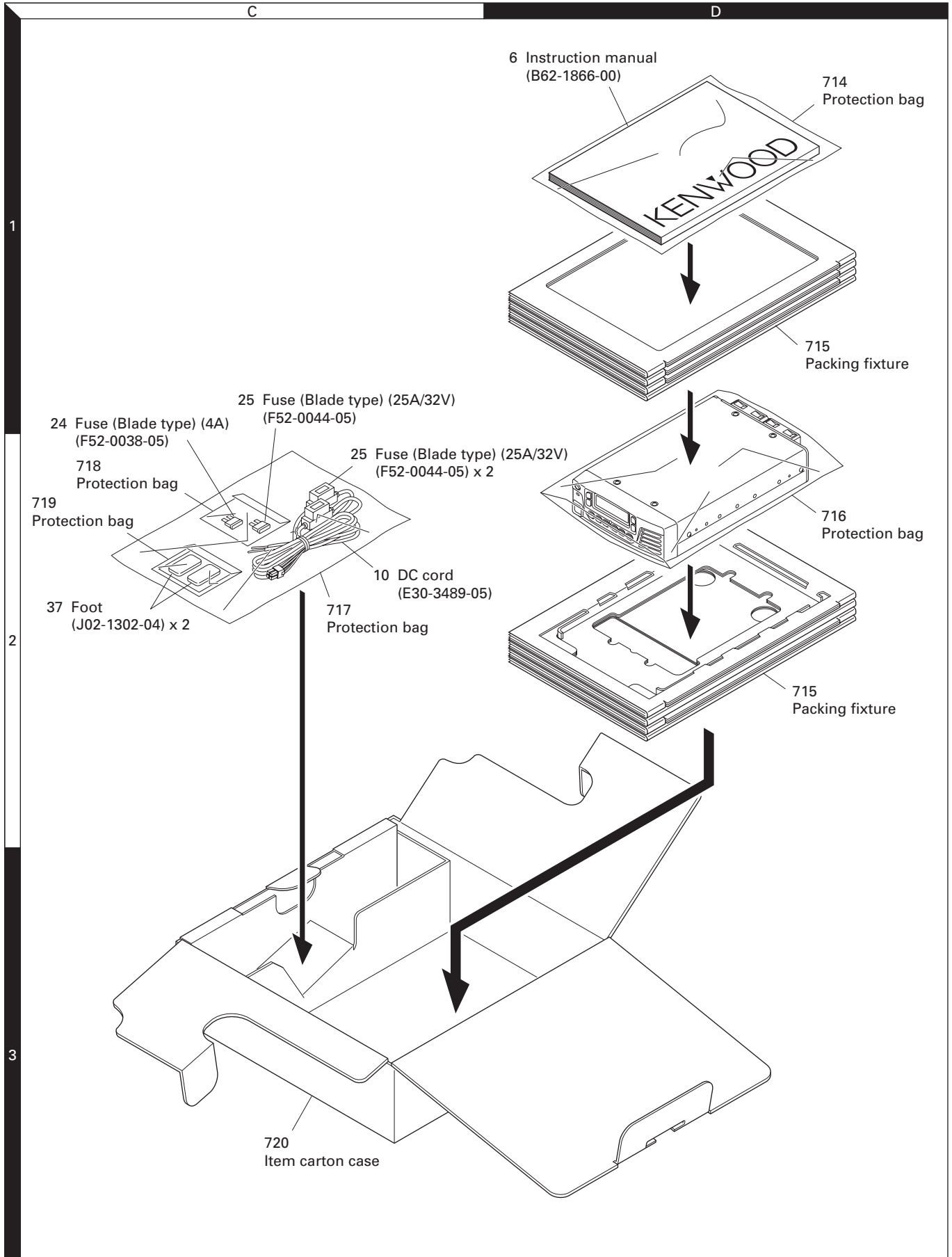

Parts with the exploded numbers larger than 700 are not supplied.

Required Test Equipment**1. DC Voltmeter (DC V.M)**

- 1) Input resistance : More than 1M Ω
- 2) Voltage range : 1.5 to 1000V AC/DC

Note: A high-recision multimeter may be used. However, accurate readings can not be obtained for high-impedance circuits.

2. DC Ammeter

- 1) Current range : 100mA, 1.5A, 30A, high-precision ammeter may be used.

3. RF VTVM (RF V.M)

- 1) Input impedance : 1M Ω and less than 3pF, min.
- 2) Voltage range : 10mV to 300V
- 3) Frequency range : 10kHz to 500MHz

4. AF Voltmeter (AF V.M)

- 1) Frequency range : 50Hz to 10kHz
- 2) Input resistance : 1M Ω or greater
- 3) Voltage range : 10mV to 30V

5. AF Generator (AG)

- 1) Frequency range : 200Hz to 5kHz
- 2) Output : 1mV or less to 1V, low distortion

6. AF Dummy Load (DM. SP)

- 1) Impedance : 4 Ω
- 2) Dissipation : 5W or greater

7. Oscilloscope

Requires high sensitivity, and external synchronization capability (150MHz or greater).

8. Standard Signal Generator (SSG)

- 1) Frequency range : 50kHz to 30MHz
- 2) Output : -133dBm/0.1 μ V to 7dBm/1V
- 3) Output impedance : 50 Ω
- 4) AM modulation can be possible

Note : Generator must be frequency stable.

9. Frequency Counter (f. counter)

- 1) Minimum input voltage : 50mV
- 2) Frequency range : 150MHz or greater

10. Noise Generator (Noise G.)

Must generate ignition noise containing harmonics beyond 30MHz.

11. Audio Analyzer**12. RF Dummy Load**

- 1) Impedance : 150 Ω and 50 Ω
- 2) Dissipation : 150W or greater

13. Power Meter

- 1) Impedance : 50 Ω
- 2) Dissipation : 200W continuous or greater
- 3) Frequency limits : 30MHz or greater

14. Spectrum Analyzer

- 1) Frequency range : 100kHz to 140MHz or greater
- 2) Bandwidth : 1kHz to 3MHz

15. Tracking Generator**16. Directional Coupler****17. Monitor Receiver****18. Microphone**

KMC-30, KMC-32, KMC-35 or KMC-36

19. Distortion Meter**20. Double Signal Pad (50 Ω)****所需测试设备****1. 直流电压表 (DC V.M)**

- 1) 输入电阻: 1M Ω 以上
- 2) 电压范围: 1.5~1000V 交流/直流

注意: 可以使用高精度万用表。但是对于高阻抗电路而言, 无法获得精确的读数。

2. 直流安培表

- 1) 电流范围: 100mA, 1.5A, 30A, 可以使用高精度安培表。

3. RF VTVM (RF V.M)

- 1) 输入阻抗: 1M Ω 及最小低于3pF
- 2) 电压范围: 10mV~300V
- 3) 频率范围: 10kHz~500MHz

4. 音频伏特表 (AF V.M)

- 1) 频率范围: 50Hz~10kHz
- 2) 输入电阻: 1M Ω 或更高
- 3) 电压范围: 10mV~30V

5. 音频发生器 (AG)

- 1) 频率范围: 200Hz~5kHz
- 2) 输出: 1mV或低于1V, 低失真

6. 音频等效负载 (DM. SP)

- 1) 阻抗: 4 Ω
- 2) 耗散: 5W或更高

7. 示波器

需要高灵敏度和外部同步能力 (150MHz或更高)

8. 标准信号发生器 (SSG)

- 1) 频率范围: 50kHz~30MHz
- 2) 输出: -133dBm/0.1 μ V~7dBm/1V
- 3) 输出阻抗: 50 Ω
- 4) 可以进行AM调制

注意: 发生器的频率必须稳定。

9. 频率计数器 (f. counter)

- 1) 最小输入电压: 50mV
- 2) 频率范围: 150MHz或更高

10. 噪音发生器 (Noise G.)

必须产生包含超过30MHz谐波的点火噪音。

11. 音频分析器**12. RF等效负载**

- 1) 阻抗: 150 Ω 和50 Ω
- 2) 耗散: 150W或更高

13. 功率表

- 1) 阻抗: 50 Ω
- 2) 耗散: 连续200W或更高
- 3) 频率界限: 30MHz或更高

14. 频谱分析器

- 1) 频率范围: 100kHz~140MHz或更高
- 2) 带宽: 1kHz~3MHz

15. 跟踪发生器**16. 定向耦合器****17. 监控接收器****18. 麦克风**

MC-30, KMC-32, KMC-35或KMC-36

19. 失真仪**20. 并置信号器具 (50 Ω)**

ADJUSTMENT / 调整

Test Mode

This mode allows you to test the reception sensitivity and transmission output, etc.

■ Entering Test Mode

1. Press and hold the [D>] key while turning the power on.
2. When dealer mode is enabled, "TEST MODE" appears on the display.

Note:

Test mode cannot be set when it has been disabled by the FPU.

■ Operations in the Test Mode

• Switching between the Memory Channel Mode and the VFO Mode

Press the [Δ] key for one second.

• Channel up/down (Memory Channel Mode)

The [↗] key or the [↘] key.

• Frequency up/down (VFO Mode)

The [↗] key or the [↘] key.

• Select the digit to change the frequency (VFO Mode)

1. Press the [Δ] key to select a digit of the current frequency to be increased or decreased.
2. Select a digit of the frequency to increase or decrease with the [C<] and [D>] keys. (The selected digit blinks).
3. Press the [Δ] key to confirm a digit of the frequency to be increased or decreased.

Note:

The frequency can be also changed with the [↗] and [↘] keys even when a digit to be increased or decreased is being selected.

When "Minimum Volume Type" is set to "Lowest Limit" in the FPU, the volume cannot be decreased lower than the value set for the Minimum Volume in both the adjustment mode and the test mode.

■ Operations of Keys in the Test Mode

Key	Operation
[Δ]	Hold: Switching between the Memory Channel Mode and VFO Mode Press: Starts selecting the VFO frequency increase/decrease step (Exit: [Δ])
[A]	Mode Select
[B]	Starting the Squelch Level Adjust (Exit: [Δ])
[C<]	Selecting the transmission output
[D>]	PRE AMP/ATT on/off
[■]	Enters the User Menu Mode (Exit: [Δ])

■ Exiting the Test Mode

Turn off the power switch to exit the Test Mode.

测试模式

该模式用于测试接收灵敏度和发射输出等。

■ 进入测试模式

1. 电源打开时, 按住 [D>] 键。
2. 经销商模式启用时, 显示屏上出现 "TEST MODE"。

注意:

如果FPU已经禁用经销商模式, 则不能设置测试模式。

■ 测试模式中的操作

● 在存储信道模式和VFO模式之间切换

按 [Δ] 键1秒钟。

● 信道上调/下调 (存储信道模式)

[↗] 键或 [↘] 键。

● 频率上调/下调 (VFO模式)

[↗] 键或 [↘] 键

● 通过切换频率位数更改频率 (VFO模式)

1. 按 [Δ] 键闪烁当前频率位数。
2. 按 [C<] 键和 [D>] 键移动光标来选择要增大或减小的频率位数。
3. 按 [Δ] 键确认要增大或减小的频率位数。

注意:

即使光标正处于要增大或减小的频率位数, 按 [↗] 键和 [↘] 键仍然可以更改频率。

当FPU里的“最小音量类型”被设定到“最小限度”时, 在调整模式和测试模式下音量都不能被降低到低于设定的最小音量值。

■ 测试模式中的按键操作

键	操 作
[Δ]	按住: 在存储信道模式和VFO模式之间切换 按: 开始选择VFO频率增大/减小步长 (退出: [Δ])
[A]	模式选择
[B]	开始静噪电平调整 (退出: [Δ])
[C<]	选择发射输出
[D>]	PRE AMP/ATT打开/关闭
[■]	开始用户菜单模式 (退出: [Δ])

■ 退出测试模式

关闭电源开关即可退出测试模式。

ADJUSTMENT

Adjustment Mode

■ Outline

1. You can adjust the transceiver in adjustment mode (adjustment using the panel keys) or with manual adjustment (turning a coil and a trimmer, etc.). The adjustment mode has 48 items (Menu No. 1 to 48) and all adjustment data is stored in the EEPROM (X57-721 : IC854).
2. Enter adjustment mode and change each setting data.
3. New data will be written the EEPROM by performing Menu No. 48 writing.

2. Select adjustment mode Menu No.
Press the [↗] or [↘] key to change the Menu No.
3. Change adjustment mode setting data
Setting data can be changed with [←C] or [D→] key.
4. Write adjustment mode data
Press [↗] or [↘] key on Menu No. 48.

■ Operation procedures in adjustment mode

1. How to start the adjustment mode
Turn the transceiver ON while pressing the [A] key, to enter adjustment mode and the Menu No. appears on the display.

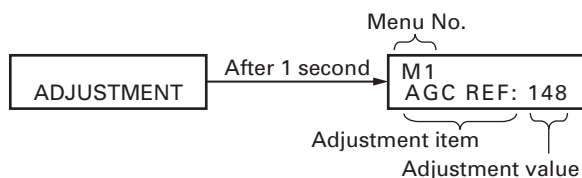

Note:

When the power is turned OFF in the middle in the adjustment mode, it is canceled.

This mode cannot be set when it has been disabled with the FPU.

When "Minimum Volume Type" is set to "Lowest Limit" in the FPU, the volume cannot be decreased lower than the value set for the Minimum Volume in both the adjustment mode and the test mode.

■ Adjustment menu list (Menu 1 to 48)

Menu No.	Item	Display	Condition			Alignment Item	Initial value	Method
			Frequency	Mode	RX or TX			
1	Receive AGC Reference	AGC REF: * * *	13.2MHz	USB	RX	AGC	147	DAC AGC data by [←C] or [D→] key
2	IF Gain	IFG: * * * * *	13.2MHz	USB	RX	IFGC	30	DAC I F AGC data by [←C] or [D→] key
3	S-meter (S1)	SSB S1: * * *	13.2MHz	USB	RX	-	-	One push [←C] or [D→] key to get ADC SM
4	S-meter (S3)	SSB S3: * * *	13.2MHz		RX	-	-	
5	S-meter (S5)	SSB S5: * * *	13.2MHz		RX	-	-	
6	SelCall	SELCALL: - - -	13.2MHz	USB	RX	-	-	Hardware alignment
7	Power Gain Control Reference	PGC REF: * * *	13.1MHz	USB	TX	PGC (100W)	85	DAC PGC data by [←C] or [D→] key
8	CAR (USB)	SUP USB: * * *	13.1MHz	USB	TX	-	-	Hardware alignment
9	Suppression (LSB)	SUP LSB: * * *	13.1MHz	LSB	TX	-	-	Hardware alignment
10	Tracking Gain Control Reference (Band 4)	TGC REF: * * *	13.1MHz	USB	TX	TGC (TX4)	150	DAC TGC data by [←C] or [D→] key
11	Carrier (USB)	U CAR : * * *	13.1MHz	USB	TX	LO1 CAR	±0	Carrier data by [←C] or [D→] key
12	Frequency (LSB)	L CAR : * * *	13.1MHz	LSB	TX	LO1 CAR	±0	Carrier data by [←C] or [D→] key
13	CW Carrier level	CW CAR: * * *	13.1MHz	CW	TX	CAR (CW)	190	DAC CAR data by [←C] or [D→] key
14	AM Carrier level	AM CAR: * * *	13.1MHz	AM	TX	CAR (AM)	190	DAC CAR data by [←C] or [D→] key
15	Null Point Adjustment	NULL : * * *	2.1MHz	CW	TX	-	-	Hardware alignment
16	Power Control (100W)	POC100W: * * *	13.1MHz	CW	TX	POC (100W)	185	DAC POC data by [←C] or [D→] key
17	RF Mater (100W)	RFM100W: * * *	13.1MHz	CW	TX	-	-	One push [←C] or [D→] key to get ADC RFM
18	Power Control (50W)	POC 50W: * * *	13.1MHz	CW	TX	POC (50W)	115	DAC POC data by [←C] or [D→] key
19	RF Mater (50W)	RFM 50W: * * *	13.1MHz	CW	TX	-	-	One push [←C] or [D→] key to get ADC RFM

调整

调整模式

■概述

- 您可以在调整模式下 (使用面板按钮调整) 或通过手动调整 (转动线圈或微调电容器等) 对短波通信机进行调整。调整模式具有48个项目 (菜单号1~48) 且所有调整数据均保存在EEPROM (X57-721: IC854) 中。
- 进入调整模式并更改各个设置数据。
- 执行菜单号48写入操作, 将新数据写入EEPROM。

■调整模式下的操作步骤

- 如何启动调整模式
 - 按住 [A] 键时打开短波通信机, 进入调整模式, 显示屏上出现菜单号。



- 选择调整模式的菜单号
按 [↵] 或 [↵] 键更改菜单号。
- 更改调整模式的设置数据
按 [◀] 或 [▶] 键可以更改设置数据。
- 写入调整模式的数据
在菜单号48上按 [↵] 或 [↵] 键。

注意:

如果调整模式过程中关闭电源, 则将取消调整模式。
如果FPU已经禁用该模式, 则不能设置该模式。
当FPU里的“最小音量类型”被设定到“最小限度”时, 在调整模式和测试模式下音量都不能被降低到低于设定的最小音量值。

■调整菜单 (菜单1~48)

菜单号	对应项目	显示	条件			调整项目	初始值	方式
			频率	模式	RX或TX			
1	接收AGC参考电平	AGC REF: ***	13.2MHz	USB	RX	AGC	147	通过 [◀] 或 [▶] 键选择DAC AGC数据
2	中频增益	IFG: *** **	13.2MHz	USB	RX	IFGC	30	通过 [◀] 或 [▶] 键选择DAC IF AGC数据
3	S-表 (S1)	SSB S1: ***	13.2MHz	USB	RX	-	-	按一下 [◀] 或 [▶] 键获取ADC SM
4	S-表 (S3)	SSB S3: ***	13.2MHz		RX	-	-	
5	S-表 (S5)	SSB S5: ***	13.2MHz		RX	-	-	
6	选呼	SELCALL: ---	13.2MHz	USB	RX	-	-	硬件校准
7	功率增益控制 参考电平	PGC REF: ***	13.1MHz	USB	TX	PGC (100W)	85	通过 [◀] 或 [▶] 键选择DAC PGC数据
8	载波抑制 (USB)	SUP USB: ***	13.1MHz	USB	TX	-	-	硬件校准
9	载波抑制 (LSB)	SUP LSB: ***	13.1MHz	LSB	TX	-	-	硬件校准
10	统调增益控制 参考电平 (频带4)	TGC REF: ***	13.1MHz	USB	TX	TGC (TX4)	150	通过 [◀] 或 [▶] 键选择DAC TGC数据
11	载波频率 (USB)	U CAR : ***	13.1MHz	USB	TX	LO1 CAR	±0	通过 [◀] 或 [▶] 键选择载波数据
12	载波频率 (LSB)	L CAR : ***	13.1MHz	LSB	TX	LO1 CAR	±0	通过 [◀] 或 [▶] 键选择载波数据
13	CW载波电平	CW CAR: ***	13.1MHz	CW	TX	CAR (CW)	190	通过 [◀] 或 [▶] 键选择DAC CAR数据
14	AM载波电平	AM CAR: ***	13.1MHz	AM	TX	CAR (AM)	190	通过 [◀] 或 [▶] 键选择DAC CAR数据
15	零点调整	NULL : ***	2.1MHz	CW	TX	-	-	硬件校准
16	功率控制 (100W)	POC100W: ***	13.1MHz	CW	TX	POC (100W)	185	通过 [◀] 或 [▶] 键选择DAC POC数据
17	射频表 (100W)	RFM100W: ***	13.1MHz	CW	TX	-	-	按一下 [◀] 或 [▶] 键获取 ADC RFM
18	功率控制 (50W)	POC 50W: ***	13.1MHz	CW	TX	POC (50W)	115	通过 [◀] 或 [▶] 键选择DAC POC数据
19	射频表 (50W)	RFM 50W: ***	13.1MHz	CW	TX	-	-	按一下 [◀] 或 [▶] 键获取 ADC RFM

ADJUSTMENT

Menu No.	Item	Display	Condition			Alignment Item	Initial value	Method
			Frequency	Mode	RX or TX			
20	Power Control (25W)	POC 25W: ***	13.1MHz	CW	TX	POC (25W)	75	DAC_POC data by [◀C] or [D▶] key
21	RF Mater (25W)	RFM 25W: ***	13.1MHz	CW	TX	-	-	One push [◀C] or [D▶] key to get ADC_RFM
22	Power Control (10W)	POC 10W: ***	13.1MHz	CW	TX	POC (10W)	37	DAC_POC data by [◀C] or [D▶] key
23	RF Mater (10W)	RFM 10W: ***	13.1MHz	CW	TX	-	-	One push [◀C] or [D▶] key to get ADC_RFM
24	Power Control (5W)	POC 5W: ***	13.1MHz	CW	TX	POC (5W)	20	DAC_POC data by [◀C] or [D▶] key
25	RF Mater (5W)	RFM 5W: ***	13.1MHz	CW	TX	-	-	One push [◀C] or [D▶] key to get ADC_RFM
26	Mic Sense	SSB MOD: ***	13.1MHz	USB	TX	MOD_2 (SSB)	128	DAC_MOD data by [◀C] or [D▶] key
27	Power (50W)	PGC 50W: ***	13.1MHz	USB	TX	PGC (50W)	122	DAC_PGC data by [◀C] or [D▶] key
28	Tracking (25W)	PGC 25W: ***	13.1MHz	USB	TX	PGC (25W)	132	DAC_PGC data by [◀C] or [D▶] key
29	Gain (10W)	PGC 10W: ***	13.1MHz	USB	TX	PGC (10W)	144	DAC_PGC data by [◀C] or [D▶] key
30	Control (5W)	PGC 5W: ***	13.1MHz	USB	TX	PGC (5W)	151	DAC_PGC data by [◀C] or [D▶] key
31	Frequency (Band 1)	TGC TX1: ***	2.1MHz	USB	TX	TGC (TX1)	150	DAC_MOD data by [◀C] or [D▶] key
32	Tracking (Band 2)	TGC TX2: ***	4.1MHz	USB	TX	TGC (TX2)	150	DAC_MOD data by [◀C] or [D▶] key
33	Gain (Band 3)	TGC TX3: ***	7.1MHz	USB	TX	TGC (TX3)	150	DAC_MOD data by [◀C] or [D▶] key
34	Control (Band 5)	TGC TX5: ***	21.1MHz	USB	TX	TGC (TX5)	150	DAC_MOD data by [◀C] or [D▶] key
35	(Band 6)	TGC TX6: ***	25.1MHz	USB	TX	TGC (TX6)	150	DAC_MOD data by [◀C] or [D▶] key
36	(Band 7)	TGC TX7: ***	28.1MHz	USB	TX	TGC (TX7)	150	DAC_MOD data by [◀C] or [D▶] key
37	AM Modulation Sensitivity	AM MOD : ***	13.1MHz	AM	TX	MOD_2 (AM)	70	DAC_MOD data by [◀C] or [D▶] key
38	AM Maximum Sensitivity	AM MAX : ***	13.1MHz	AM	TX	AMM	128	DAC_AMM data by [◀C] or [D▶] key
39	Over-current Protection (Final)	PRO FIN: ***	1.7MHz	CW	TX	POC	190	Hardware alignment
40	Over-current Protection (Drive)	PRO DRV: ***	18MHz	CW	TX	POC	190	Hardware alignment
41	VSWR Protection	SWR PRO: ***	13.1MHz	CW	TX	PRO	60	DAC_PRO data by [◀C] or [D▶] key
42	Slow Fan-speed Check	FANSLOW: ---	13.2MHz	USB	RX	-	-	Check only
43	Fast Fan-speed Check	FANFAST: ---	13.2MHz	USB	RX	-	-	Check only
44	Carrier Frequency for Option filter (USB)	U CAR2 : 000	13.1MHz	USB	TX	LO1 CAR	±0	Skip
45	Carrier Frequency for Option filter (LSB)	L CAR2 : 000	13.1MHz	LSB	TX	LO1 CAR	±0	Skip
46	Checksum	SUM = ****			RX	-	-	Check only
47	Display Test	ALL Display			RX	-	-	Check only
48	Write	WRITE TO ROM			RX	-	-	EEPROM write by [◀C] or [D▶] key

13.1MHz is TX alignment standard frequency.

13.2MHz is RX alignment standard frequency.

调 整

菜单号	对应项目	显示	条 件			调整项目	初始 值	方 式
			频 率	模 式	RX或TX			
20	功率控制 (25W)	POC 25W: ***	13.1MHz	CW	TX	POC (25W)	75	通过 [C] 或 [D] 键选择DAC POC数据
21	射频表 (25W)	RFM 25W: ***	13.1MHz	CW	TX	-	-	按一下 [C] 或 [D] 键获取 ADC RFM
22	功率控制 (10W)	POC 10W: ***	13.1MHz	CW	TX	POC (10W)	37	通过 [C] 或 [D] 键选择DAC POC数据
23	射频表 (10W)	RFM 10W: ***	13.1MHz	CW	TX	-	-	按一下 [C] 或 [D] 键获取 ADC RFM
24	功率控制 (5W)	POC 5W: ***	13.1MHz	CW	TX	POC (5W)	20	通过 [C] 或 [D] 键选择DAC POC数据
25	射频表 (5W)	RFM 5W: ***	13.1MHz	CW	TX	-	-	按一下 [C] 或 [D] 键获取 ADC RFM
26	麦克风灵敏度	SSB MOD: ***	13.1MHz	USB	TX	MOD_2 (SSB)	128	通过 [C] 或 [D] 键选择DAC MOD数据
27	功率统	PGC 50W: ***	13.1MHz	USB	TX	PGC (50W)	122	通过 [C] 或 [D] 键选择DAC PGC数据
28	调增益	PGC 25W: ***	13.1MHz	USB	TX	PGC (25W)	132	通过 [C] 或 [D] 键选择DAC PGC数据
29	控制	PGC 10W: ***	13.1MHz	USB	TX	PGC (10W)	144	通过 [C] 或 [D] 键选择DAC PGC数据
30		PGC 5W: ***	13.1MHz	USB	TX	PGC (5W)	151	通过 [C] 或 [D] 键选择DAC PGC数据
31	频率统	TGC TX1: ***	2.1MHz	USB	TX	TGC (TX1)	150	通过 [C] 或 [D] 键选择DAC MOD数据
32	调增益	TGC TX2: ***	4.1MHz	USB	TX	TGC (TX2)	150	通过 [C] 或 [D] 键选择DAC MOD数据
33	控制	TGC TX3: ***	7.1MHz	USB	TX	TGC (TX3)	150	通过 [C] 或 [D] 键选择DAC MOD数据
34		TGC TX5: ***	21.1MHz	USB	TX	TGC (TX5)	150	通过 [C] 或 [D] 键选择DAC MOD数据
35		TGC TX6: ***	25.1MHz	USB	TX	TGC (TX6)	150	通过 [C] 或 [D] 键选择DAC MOD数据
36		TGC TX7: ***	28.1MHz	USB	TX	TGC (TX7)	150	通过 [C] 或 [D] 键选择DAC MOD数据
37	调幅灵敏度	AM MOD: ***	13.1MHz	AM	TX	MOD_2 (AM)	70	通过 [C] 或 [D] 键选择DAC MOD数据
38	调幅最大灵敏度	AM MAX: ***	13.1MHz	AM	TX	AMM	128	通过 [C] 或 [D] 键选择DAC AMM数据
39	过流保护 (末级)	PRO FIN: ***	1.7MHz	CW	TX	POC	190	硬件校准
40	过流保护 (驱动)	PRO DRV: ***	18MHz	CW	TX	POC	190	硬件校准
41	电压驻波比保护	SWR PRO: ***	13.1MHz	CW	TX	PRO	60	通过 [C] 或 [D] 键选择DAC PRO数据
42	慢风扇速度检查	FANSLOW: ---	13.2MHz	USB	RX	-	-	仅检测
43	快风扇速度检查	FANFAST: ---	13.2MHz	USB	RX	-	-	仅检测
44	可选滤波器的 载波频率 (USB)	U CAR2: 000	13.1MHz	USB	TX	LO1 CAR	±0	跳过
45	可选滤波器的 载波频率 (LSB)	L CAR2: 000	13.1MHz	LSB	TX	LO1 CAR	±0	跳过
46	校验和	SUM = ****			RX	-	-	仅检测
47	显示测试	ALL Display			RX	-	-	仅检测
48	写入	WRITE TO ROM			RX	-	-	通过 [C] 或 [D] 键进行EEPROM写入

13.1MHz是TX对应的标准频率。

13.2MHz是RX对应的标准频率。

ADJUSTMENT

Common Section

Item	Condition	Measurement			Adjustment			Specifications/Remarks
		Test-equipment	Unit	Terminal	Unit	Parts	Method	
1. Setting	1) Connect the DC cord to the DC power supply. DC IN : DC 13.6V							
2. Checksum	1) Menu No. : 46						Check	Checksum appears.
3. Display test	1) Menu No. : 47						Check	LCD all segments light.

PLL Section

Item	Condition	Measurement			Adjustment			Specifications/Remarks
		Test-equipment	Unit	Terminal	Unit	Parts	Method	
1. LO2 (62.4MHz) frequency	1) Display f. : 13.200MHz Mode : USB Disconnect the cable from LO2 and insert a cable from the frequency counter. After the adjustment, connect the cable to LO2.	f. counter	TX-RX	LO2			Check	62.40000MHz Note : Do not make the LO2 (62.4MHz) frequency adjustment.
2. LO2 level	1) Display f. : 13.200MHz Mode : USB Disconnect the cable from LO2 and insert a cable from the oscilloscope. After the adjustment, connect the cable to LO2.	Spectrum analyzer			TX-RX	L731 L729	Level max. ± 15.6 MHz spurious minimum	-15dBm or more 60dBc or less
3. Lock voltage	1) VCO1 Display f. : 14.999MHz Mode : USB	DC V.M		CV	TX-RX	TC703	4.20V	± 0.05 V
	Display f. : 30.000kHz						Check	0.2~1.0V
	2) VCO2 Display f. : 30.000MHz Mode : USB				TX-RX	TC702	4.20V	± 0.05 V
	Display f. : 14.500MHz						Check	0.2~1.0V

调 整

公用部分

项 目	条 件	测 量			调 整			规 格 / 备 注
		测量装置	单元	端子	单元	部件	方 法	
1. 设定	1) 将直流电线连接到直流电源。 DC IN : 直流13.6V							
2. 校验和	1) 菜单号 : 46						检查	校验码出现。
3. 显示测试	1) 菜单号 : 47						检查	LCD所有段点亮。

PLL部分

项 目	条 件	测 量			调 整			规 格 / 备 注
		测量装置	单元	端子	单元	部件	方 法	
1. LO2 (62.4MHz) 频率	1) 显示频率 : 13.200MHz 模式 : USB 断开LO2的电缆并插入频率计数器的电缆。 调整后, 将电缆连接到LO2。	频率计数器	TX-RX	LO2			检查	62.40000MHz 注意 : 请勿进行LO2 (62.4MHz) 频率调整。
2. LO2电平	1) 显示频率 : 13.200MHz 模式 : USB 断开LO2的电缆并插入示波器的电缆。 调整后, 将电缆连接到LO2。	频谱 分析器			TX-RX	L731 L729	最大电平。 ± 15.6MHz最小虚拟	-15dBm或更高 60dBc或更低
3. 锁定电压	1) VCO1 显示频率 : 14.999MHz 模式 : USB 显示频率 : 30.000kHz	DC V.M		CV	TX-RX	TC703	4.20V	± 0.05V
							检查	0.2~1.0V
	TX-RX				TC702	4.20V	± 0.05V	
						检查	0.2~1.0V	
	2) VCO2 显示频率 : 30.000MHz 模式 : USB 显示频率 : 14.500MHz							

ADJUSTMENT

MCF Section

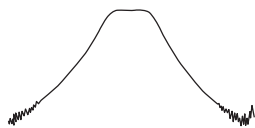
Item	Condition	Measurement			Adjustment			Specifications/Remarks
		Test-equipment	Unit	Terminal	Unit	Parts	Method	
1. TX MCF (73.095MHz)	1) Display f. : 13.200MHz Mode : USB Spectrum analyzer setting Center f. : 73.095MHz Frequency span : 100kHz Xdb/DIV : 10dB RBW : 300Hz VBW : 100Hz Disconnect the cable from CN2 (DRV). Transmit After the adjustment, connect the cable to CN2.	Tracking generator Spectrum analyzer	TX-RX	CN4 (TP1) CN5 (TP2)	TX-RX	L122 L123 L124	Adjust the coils to obtain the frequency response as shown.	
2. RX MCF	1) After the adjustment of TX MCF.					L120 L181		

Receiver Section

Item	Condition	Measurement			Adjustment			Specifications/Remarks
		Test-equipment	Unit	Terminal	Unit	Parts	Method	
<ul style="list-style-type: none"> To terminate the adjustment menu in the middle, save your settings with Menu No. 48. 								
1. Receive AGC reference	1) Menu No. : 1 (13.2MHz, USB) SSG output : OFF	DC V.M	TX-RX	AGC		[<C>] or [D>]	Set the adjustment value within the limit of the specified voltage.	2.8V±0.05V
2. RF IF gain	1) Display f. : 14.200MHz Mode : USB PRE-AMP : ON AGC : FAST *AF output : 0.45V/4Ω (LV7) SSG f. : 13.201MHz SSG output : -115dBm (0.398μV)	SSG Oscilloscope AF V.M DM. SP	Rear panel	ANT EXT.SP	TX-RX	L451 L452	AF output max.	
3. IF gain	1) Menu No. : 2 (13.2MHz, USB) SSG f. : 13.201MHz SSG output : OFF					[<C>] or [D>]	Check the adjustment value (A) displayed on the left side of the display.	<div style="border: 1px solid black; padding: 5px; width: fit-content; margin: 0 auto;"> M2 IFG : 048 033 A </div>
	2) SSG output : -107dBm (1.0μV)						Change the adjustment value (B) displayed on the right side of the display by pressing the [<C>] or [D>] keys so that adjustment value (A) increase by 5 (A+5).	<div style="border: 1px solid black; padding: 5px; width: fit-content; margin: 0 auto;"> M2 IFG : 053 033 A+5 B </div>

调 整

MCF部分

项 目	条 件	测 量			调 整			规 格 / 备 注
		测量装置	单元	端子	单元	部件	方 法	
1. TX MCF (73.095MHz)	1) 显示频率：13.200MHz 模式：USB 频谱分析器设定 中心频率：73.095MHz 频率间隔：100kHz Xdb/DIV：10dB RBW：30kHz VBW：30kHz 断开CN2 (CRV) 的电缆。 发射 调整后，将电缆连接到CN2。	跟踪 发生器 频谱 分析器	TX-RX	CN4 (TP1) CN5 (TP2)	TX-RX	L122 L123 L124	调整线圈，获取如同 所示的频率响应。	
2. RX MCF	1) TX MCF调整后。					L120 L181		

接收部分

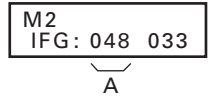
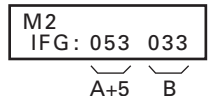
项 目	条 件	测 量			调 整			规 格 / 备 注
		测量装置	单元	端子	单元	部件	方 法	
● 如需在调整过程中结束调整菜单，请使用菜单号48保存设置。								
1. 接收AGC 参考电平	1) 菜单号：1 (13.2MHz, USB) SSG输出：OFF	DC V.M	TX-RX	AGC		[<C>]或 [D>]	在规定电压范围内 设置调整值。	2.8V ± 0.05V
2. RF中频 增益	1) 显示频率：14.200MHz 模式：USB PRE-AMP：ON AGC：FAST *AF输出：0.45V/4Ω (LV7) SSG频率：13.201MHz SSG输出 ：-115dBm (0.398μV)	SSG 示波器 AF V.M DM. SP	后面板	ANT EXT.SP	TX-RX	L451 L452	最大AF输出	
3. 中频增益	1) 菜单号：2 (13.2MHz, USB) SSG频率：13.201MHz SSG输出：OFF					[<C>]或 [D>]	检查显示屏左侧显示的调整值 (A)。	
	2) SSG输出：-107dBm (1.0μV)						通过按 [<C>] 或 [D>] 键将调整值 (A) 增加5 (A+5)， 更改显示屏右侧显示的调整值 (B)。	

*：当音量不能降低时，请确认“最小音量”值。
当FPU里的“最小音量类型”被设定到“最小限度”时，音量不能被降低到低于设定的“最小音量”值。

ADJUSTMENT

Item	Condition	Measurement			Adjustment			Specifications/Remarks			
		Test-equipment	Unit	Terminal	Unit	Parts	Method				
4. S/N • 550kHz	1) Display f. : 550kHz Mode : AM PRE-AMP : ON *AF output : 0.45V/4Ω (LV7) SSG f. : 550kHz SSG output : -79dBm (25μV) MOD : 1kHz, 60%	SSG Oscilloscope AF V.M Distortion meter DM. SP Audio analyzer	Rear panel	ANT EXT.SP							
	2) MOD : OFF						Check	-10dB or less			
	• 13.2MHz				3) Display f. : 14.200MHz Mode : DATA PRE-AMP : ON *AF output : 0.45V/4Ω (LV7) SSG f. : 13.201MHz SSG output : -121dBm (0.2μV)						
					4) SSG output : OFF			Check	-10dB or less		
	• PRE-AMP gain				5) Display f. : 13.200MHz Mode : DATA PRE-AMP : ON *AF output : 0.45V/4Ω (LV7) SSG f. : 13.201MHz SSG output : -118dBm (0.28μV)					Set SINAD at 0dB.	
					6) PRE-AMP : OFF			Check	-(5~15)dB		
	• RF ATT				7) Display f. : 13.200MHz Mode : DATA ATT : OFF *AF output : 0.2V/4Ω SSG f. : 13.201MHz SSG output : -116dBm (0.35μV)					AF level = A	
					8) ATT : ON SSG output : -96dBm (3.54μV)			Check for AF level	A±2dB		
5. S-meter (S1)	1) Menu No. : 3 (13.2MHz, USB) SSG f. : 13.201MHz SSG output : -107dBm (1μV)					[<C] or [D>]	1 push	S-meter lights up to S1 level.			
	(S3)	2) Menu No. : 4 (13.2MHz, USB) SSG output : -81dBm (19.9μV)						S-meter lights up to S3 level.			
	(S5)	3) Menu No. : 5 (13.2MHz, USB) SSG output : -41dBm (1.99mV)						S-meter lights up to S5 level. (Lights up all)			
6. Selcall	1) Menu No. : 6 (13.2MHz, USB)	f. counter	TX-RX	FRQ	TX-RX	VR851	2210Hz	±3Hz			

调 整

项 目	条 件	测 量			调 整			规 格 / 备 注			
		测量装置	单元	端子	单元	部件	方 法				
4. S/N ● 550kHz	1) 显示频率：550kHz 模式：AM PRE-AMP：ON *AF输出：0.45V/4Ω (LV7) SSG频率：550kHz SSG输出：-79dBm (25μV) 调制：1kHz, 60%	SSG 示波器 AF V.M 失真仪 DM. SP 音频 分析器	后面板	ANT EXT.SP							
	2) 调制：OFF						检查	-10dB或更低			
	● 13.2MHz				3) 显示频率：14.200MHz 模式：DATA PRE-AMP：ON *AF输出：0.45V/4Ω (LV7) SSG频率：13.201MHz SSG输出：-121dBm (0.2μV)						
					4) SSG输出：OFF			检查	-10dB或更低		
	● PRE-AMP 增益				5) 显示频率：13.200MHz 模式：DATA PRE-AMP：ON *AF输出：0.45V/4Ω (LV7) SSG频率：13.201MHz SSG输出：-118dBm (0.28μV)					将SINAD设为0dB。	
					6) PRE-AMP：OFF			检查	-(5~15)dB		
	● RF ATT				7) 显示频率：13.200MHz 模式：DATA ATT：OFF *AF输出：0.2V/4Ω SSG频率：13.201MHz SSG输出：-116dBm (0.35μV)					AF电平 = A	
					8) ATT：ON SSG输出：-96dBm (3.54μV)					AF电平检查	A ± 2dB
5. S-表 (S1)	1) 菜单号：3 (13.2MHz, USB) SSG频率：13.201MHz SSG输出：-107dBm (1μV)					[<C]或 [D>] 按一下	信号强度表增亮到S1电平。				
	(S3)	2) 菜单号：4 (13.2MHz, USB) SSG输出：-81dBm (19.9μV)					信号强度表增亮到S3电平。				
	(S5)	3) 菜单号：5 (13.2MHz, USB) SSG输出：-41dBm (1.99mV)					信号强度表增亮到S5电平。 (全亮)				
6. 选呼	1) 菜单号：6 (13.2MHz, USB)	频率计数器	TX-RX	FRQ	TX-RX	VR851	2210Hz	± 3Hz			

*：当音量不能降低时，请确认“最小音量”值。
当FPU里的“最小音量类型”被设定到“最小限度”时，音量不能被降低到低于设定的“最小音量”值。

ADJUSTMENT

Item	Condition	Measurement			Adjustment			Specifications/Remarks
		Test-equipment	Unit	Terminal	Unit	Parts	Method	
7. NB gain	1) Display f. : 13.200MHz Mode : USB PRE-AMP : ON AGC : FAST NB : ON SSG f. : 13.201MHz SSG output : -103dBm (1.58μV)	DC V.M SSG Oscilloscope AF V.M DM. SP	TX-RX Rear panel	NB ANT EXT.SP	TX-RX	L326 L327	Voltage min.	4.5V or less
	2) NB : OFF→ON	Noise G.					Adjust output of noise generator to S2, and check.	Decrease pulsed noise.
8. VGS-1 (Option)	1) Disconnect the antenna cable from the transceiver. Connect the VGS-1 to CN11 on the TX-RX unit. Display f. : 13.900MHz Mode : USB Vol : MIN					[PF]	1 push	The display frequency can be heard vocally.
	2) Connect a microphone to the MIC jack.					[CH1]	Hold down [CH1] key, and talk into the microphone for approximately 5 seconds.	
							Press the [CH1] key again.	The recorded voice message is played back.

Transmitter Section

Item	Condition	Measurement			Adjustment			Specifications/Remarks
		Test-equipment	Unit	Terminal	Unit	Parts	Method	
1. Final idling current	1) Test mode Display f. : 13.1MHz Mode : USB Final unit VR1 to VR4 : MIN Transmit	Ammeter	Rear panel	DC IN	Final		Check the default current (Ii) of DC IN.	
						VR1	Ii + 300mA = A	±10mA
						VR2	A + 400mA = B	
						VR3	B + 400mA = C	
						VR4	C + 500mA	
2. Current protection pre-adjust	1) Display f. : 13.1MHz Mode : USB Transmit	DC V.M	TX-RX		TX-RX	VR361 VR362	Turn to the left completely.	
3. Power gain control reference	1) Menu No. : 7 (13.1MHz, USB) Transmit			PGC		[<C] or [D>]	Set the adjustment value within the limit of the specified voltage.	2.5V±0.1V

调 整

项 目	条 件	测 量			调 整			规 格 / 备 注
		测量装置	单元	端子	单元	部件	方 法	
7. NB增益	1) 显示频率：13.200MHz 模式：USB PRE-AMP：ON AGC：FAST NB：ON SSG频率：13.201MHz SSG输出：-103dBm (1.58μV)	DC V.M SSG 示波器 AF V.M DM. SP	TX-RX 后面板	NB ANT EXT.SP	TX-RX	L326 L327	最小电压	4.5V或更低
	2) NB：OFF→ON	Noise G.					将噪音发生器的输出调整到S2并进行检查。	降低脉冲噪声。
8. VGS-1 (选购件)	1) 断开短波通信机的天线电缆。 将VGS-1连接到TX-RX单元上的CN11。 显示频率：13.900MHz 模式：USB Vol：MIN					[PF]	按一下	可以听到语音报告的显示频率。
	2) 将麦克风连接到麦克风插孔。					[CH1]	按住 [CH1] 键, 然后向麦克风讲话5秒钟左右。	
							再次按 [CH1] 键。	播放录制的语音消息。

发射部分

项 目	条 件	测 量			调 整			规 格 / 备 注
		测量装置	单元	端子	单元	部件	方 法	
1. 末级静态 电流	1) 测试模式 显示频率：13.1MHz 模式：USB Final单元VR1~VR4：MIN 发射	电流表	后面板	DC IN	Final		检查DC IN的默认电流 (Ii)。	± 10mA
						VR1	$I_i + 300\text{mA} = A$	
						VR2	$A + 400\text{mA} = B$	
						VR3	$B + 400\text{mA} = C$	
						VR4	$C + 500\text{mA}$	
2. 电流保护 预调整	1) 显示频率：13.1MHz 模式：USB 发射	DC V.M	TX-RX		TX-RX	VR361 VR362	完全转到左边。	
3. 功率增益 控制参考 电平	1) 菜单号：7 (13.1MHz, USB) 发射			PGC		[<C]或 [D>]	在规定电压范围内 设置调整值。	2.5V ± 0.1V

ADJUSTMENT

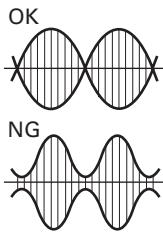
Item	Condition	Measurement			Adjustment			Specifications/Remarks
		Test-equipment	Unit	Terminal	Unit	Parts	Method	
4. Tracking gain control reference (Band 4)	1) Menu No. : 10 (13.1MHz, USB) MIC input : 1kHz, 7mV Transmit	Spectrum analyzer AG	TX-RX	CN2 DRV		[<C] or [D>]	-9dBm	±0.5dB
5. Carrier frequency (USB, LSB)	1) Menu No. : 11 (USB), 12 (LSB) (13.1MHz) MIC input : 350Hz, 7mV 2700Hz, 7mV Transmit						Change the adjustment values to get the waveform as shown.	
6. CW carrier level	1) Menu No. : 13 (13.1MHz, CW) Transmit						0dBm	±0.5dB
7. AM carrier level	1) Menu No. : 14 (13.1MHz, AM) Transmit						Same as display value of menu No. 13 (CW carrier level).	
8. Null point adjustment	1) Menu No. : 15 (2.1MHz, CW) Transmit	DC V.M	Final	VSR	Final	TC1	Voltage min.	0.2V or less
9. Power control (100W)	1) Menu No. : 16 (13.1MHz, CW) Transmit	Power meter	Rear panel	ANT		[<C] or [D>]	100W	±2W
RF meter (100W)	1) Menu No. : 17 (13.1MHz, CW) Transmit						1 push while transmitting	Lights up all
10. Power control (50W)	1) Menu No. : 18 (13.1MHz, CW) Transmit						50W	±2W
RF meter (50W)	1) Menu No. : 19 (13.1MHz, CW) Transmit						1 push while transmitting	Lights up all
11. Power control (25W)	1) Menu No. : 20 (13.1MHz, CW) Transmit						25W	±1W
RF meter (25W)	1) Menu No. : 21 (13.1MHz, CW) Transmit						1 push while transmitting	Lights up all
12. Power control (10W)	1) Menu No. : 22 (13.1MHz, CW) Transmit						10W	±1W
RF meter (10W)	1) Menu No. : 23 (13.1MHz, CW) Transmit						1 push while transmitting	Lights up all

调 整

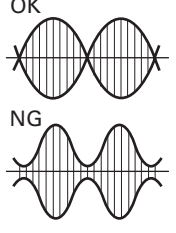
项 目	条 件	测 量			调 整			规 格 / 备 注
		测量装置	单元	端子	单元	部件	方 法	
4. 统调增益 控制参考 电平 (频带4)	1) 菜单号 : 10 (13.1MHz, USB) MIC输入 : 1kHz, 7mV 发射	频谱 分析器 AG	TX-RX	CN2 DRV		[<C>或 <D>]	-9dBm	± 0.5dB
5. 载波频率 (USB, LSB)	1) 菜单号 : 11 (USB), 12 (LSB) (13.1MHz) MIC输入 : 350Hz, 7mV 2700Hz, 7mV 发射						更改调整值, 获取 如图所示的波形。	
6. CW 载波电平	1) 菜单号 : 13 (13.1MHz, CW) 发射						0dBm	± 0.5dB
7. AM 载波电平	1) 菜单号 : 14 (13.1MHz, AM) 发射						与菜单第13条 (CW载波电平) 的 显示值相同。	
8. 零点调整	1) 菜单号 : 15 (2.1MHz, CW) 发射	DC V.M	Final	VSR	Final	TC1	最小电压	0.2V或更低
9. 功率控制 (100W)	1) 菜单号 : 16 (13.1MHz, CW) 发射	功率计	后面板	ANT		[<C>或 <D>]	100W	± 2W
射频表 (100W)	1) 菜单号 : 17 (13.1MHz, CW) 发射						发射期间按一下	全亮
10. 功率控制 (50W)	1) 菜单号 : 18 (13.1MHz, CW) 发射						50W	± 2W
射频表 (50W)	1) 菜单号 : 19 (13.1MHz, CW) 发射						发射期间按一下	全亮
11. 功率控制 (25W)	1) 菜单号 : 20 (13.1MHz, CW) 发射						25W	± 1W
射频表 (25W)	1) 菜单号 : 21 (13.1MHz, CW) 发射						发射期间按一下	全亮
12. 功率控制 (10W)	1) 菜单号 : 22 (13.1MHz, CW) 发射						10W	± 1W
射频表 (10W)	1) 菜单号 : 23 (13.1MHz, CW) 发射						发射期间按一下	全亮

ADJUSTMENT

Item	Condition	Measurement			Adjustment			Specifications/Remarks
		Test-equipment	Unit	Terminal	Unit	Parts	Method	
13. Power control (5W)	1) Menu No. : 24 (13.1MHz, CW) Transmit	Power meter	Rear panel	ANT		[<C] or [D>]	5W	±0.5W
RF meter (5W)	1) Menu No. : 25 (13.1MHz, CW) Transmit						1 push while transmitting	Lights up all
14. Carrier suppression (USB, LSB)	1) Menu No. : 8 (USB), 9 (LSB) (13.1MHz) Transmit	Power meter Spectrum analyzer			TX-RX	VR251 (USB) VR252 (LSB)	Carrier level min.	40dBc or more
15. Mic sense	1) Menu No. : 26 (13.1MHz, USB) MIC input : 1kHz, 7mV Transmit	Power meter AG				[<C] or [D>]	60W	±2W
16. Power tracking gain control (5W)	1) Menu No. : 30 (13.1MHz, USB) MIC input : 1kHz, 7mV Transmit						3W	±0.3W
(10W)	2) Menu No. : 29 Transmit						6W	±0.6W
(25W)	3) Menu No. : 28 Transmit						15W	±1.5W
(50W)	4) Menu No. : 27 Transmit						30W	±3W
17. Frequency tracking gain control (Band 1)	1) Menu No. : 31 (2.1MHz, USB) MIC input : 1kHz, 7mV Transmit						60W	±10W
(Band 2)	2) Menu No. : 32 (4.1MHz, USB) Transmit							
(Band 3)	3) Menu No. : 33 (7.1MHz, USB) Transmit							
(Band 5)	4) Menu No. : 34 (21.1MHz, USB) Transmit							
(Band 6)	5) Menu No. : 35 (25.1MHz, USB) Transmit							
(Band 7)	6) Menu No. : 36 (28.1MHz, USB) Transmit							

调 整

项 目	条 件	测 量			调 整			规 格 / 备 注
		测量装置	单元	端子	单元	部件	方 法	
13. 功率控制 (5W)	1) 菜单号 : 24 (13.1MHz, CW) 发射	功率计	后面板	ANT		[<C]或 [D>]	5W	± 0.5W
射频表 (5W)	1) 菜单号 : 25 (13.1MHz, CW) 发射						发射期间按一下	全亮
14. 载波抑制 (USB, LSB)	1) 菜单号 : 8 (USB), 9 (LSB) (13.1MHz) 发射	功率计 频谱 分析器			TX-RX	VR251 (USB) VR252 (LSB)	最小载波电平	40dBc或更高
15. 麦克风 灵敏度	1) 菜单号 : 26 (13.1MHz, USB) MIC输入 : 1kHz, 7mV 发射	功率计 AG				[<C]或 D>]	60W	± 2W
16. 功率统调 增益控制 (5W)	1) 菜单号 : 30 (13.1MHz, USB) MIC输入 : 1kHz, 7mV 发射						3W	± 0.3W
(10W)	2) 菜单号 : 29 发射						6W	± 0.6W
(25W)	3) 菜单号 : 28 发射						15W	± 1.5W
(50W)	4) 菜单号 : 27 发射						30W	± 3W
17. 频率统调 增益控制 (频带1)	1) 菜单号 : 31 (2.1MHz, USB) MIC输入 : 1kHz, 7mV 发射						60W	± 10W
(频带2)	2) 菜单号 : 32 (4.1MHz, USB) 发射							
(频带3)	3) 菜单号 : 33 (7.1MHz, USB) 发射							
(频带5)	4) 菜单号 : 34 (21.1MHz, USB) 发射							
(频带6)	5) 菜单号 : 35 (25.1MHz, USB) 发射							
(频带7)	6) 菜单号 : 36 (28.1MHz, USB) 发射							

ADJUSTMENT

Item	Condition	Measurement			Adjustment			Specifications/Remarks	
		Test-equipment	Unit	Terminal	Unit	Parts	Method		
17. AM modulation sensitivity	1) Menu No. : 37 (13.1MHz, AM) MIC input : 1kHz, 7mV Transmit	Modulation analyzer AG Power meter	Rear panel	ANT		[<C] or [D>]	Modulation 60%	±2%	
18. AM maximum sensitivity	1) Menu No. 38 (13.1MHz, AM) MIC input : 1kHz, 20mV Transmit						90%	±5%	
19. Over-current protection (Final)	1) Menu No. : 39 (1.7MHz, CW) Transmit	DC V.M Power meter	TX-RX			[<C] or [D>]	120W		
				TP2	TX-RX		VR362	5V	±0.2V
20. Over-current protection (Drive)	1) Menu No. : 40 (18MHz, CW) Transmit					[<C] or [D>]	120W		
				TP4	TX-RX	VR361	5V	±0.2V	
21. VSWR protection	1) Menu No. : 41 (13.1MHz, CW) Transmit	150Ω dummy load Through type power meter	Rear panel	ANT		[<C] or [D>]	40W	±2W	
22. Slow fan-speed check	1) Menu No. : 42 (13.2MHz, USB)							Check	Fan turns slowly
23. Fast fan-speed check	2) Menu No. : 43 (13.2MHz, USB)								Fan turns fast
24. Carrier frequency for option filter (USB)	1) Menu No. : 44						Not adjust	Skip	
	(LSB) 2) Menu No. : 45								

调 整

项 目	条 件	测 量			调 整			规 格 / 备 注				
		测量装置	单元	端子	单元	部件	方 法					
17. 调幅灵敏度	1) 菜单号 : 37 (13.1MHz, AM) MIC输入 : 1kHz, 7mV 发射	调制 分析器 AG 功率计	后面板	ANT		[<C]或 [D>]	调制60%	± 2%				
18. 调幅最大灵敏度	1) 菜单号 38 (13.1MHz, AM) MIC输入 : 1kHz, 20mV 发射						90%	± 5%				
19. 过流保护 (末级)	1) 菜单号 : 39 (1.7MHz, CW) 发射	DC V.M 功率计	TX-RX			[<C]或 [D>]	120W					
							TP2	TX-RX	VR362	5V	± 0.2V	
20. 过流保护 (驱动)	1) 菜单号 : 40 (18MHz, CW) 发射									[<C]或 [D>]	120W	
											TP4	TX-RX
21. 电压驻波 比保护	1) 菜单号 : 41 (13.1MHz, CW) 发射	150Ω 等效负载 直通型 功率表	后面板	ANT		[<C]或 [D>]					40W	± 2W
22. 慢风扇 速度检查	1) 菜单号 : 42 (13.2MHz, USB)											
23. 快风扇 速度检查	2) 菜单号 : 43 (13.2MHz, USB)									风扇快速运转		
24. 可选 滤波器的 载波频率 (USB)	1) 菜单号 : 44						不调整	跳过				
(LSB)	2) 菜单号 : 45											

ADJUSTMENT / 调整

Adjustment Points / 调整点

■ TX-RX UNIT (Component side view)

TX-RX单元 (元件面视图)

- L120, L181: RX MCF
- L122~L124: TX MCF (73.095MHz)
- L326, L327: NB gain / NB增益
- L729, L731: LO2 level / LO2电平
- L451, L452: RF IF gain / RF中频增益
- TC702: Lock voltage (VCO2) / 锁定电压 (VCO2)
- TC703: Lock voltage (VCO1) / 锁定电压 (VCO1)
- VR251 (USB), VR252 (LSB): Carrier suppression
载波抑制
- VR361, VR362: Current protection pre-adjust
电流保护预调整
- VR362: Over-current protection (Final)
过流保护 (末级)
- VR361: Over-current protection (Drive)
过流保护 (驱动)
- VR851: Selcall / 选呼

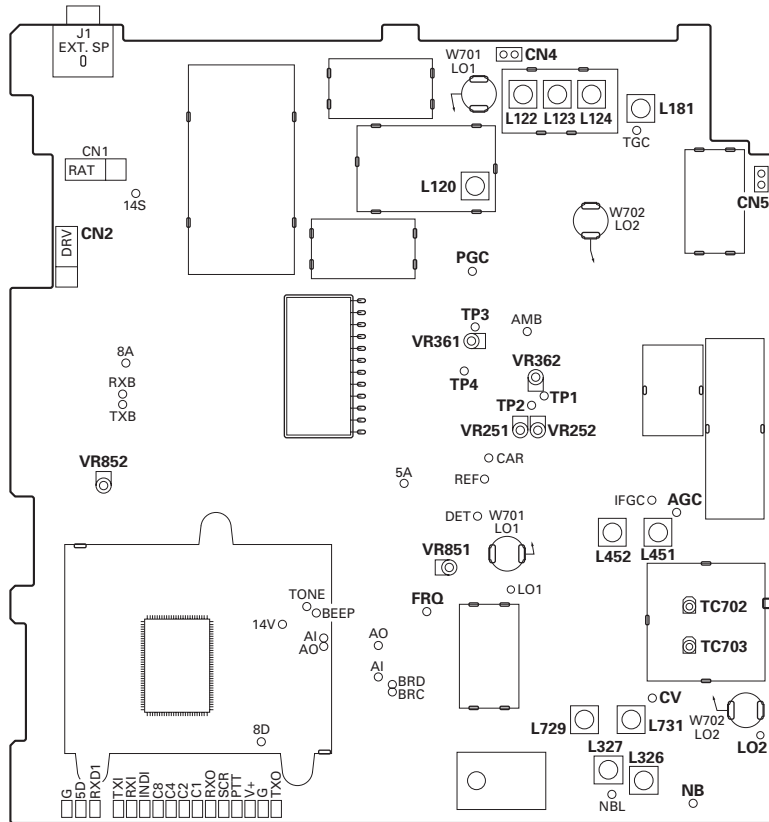

■ FINAL UNIT (Component side view)

FINAL单元 (元件面视图)

- VR1~VR4: Final idling current / 末级静态电流
- TC1: Null point adjustment / 零点调整

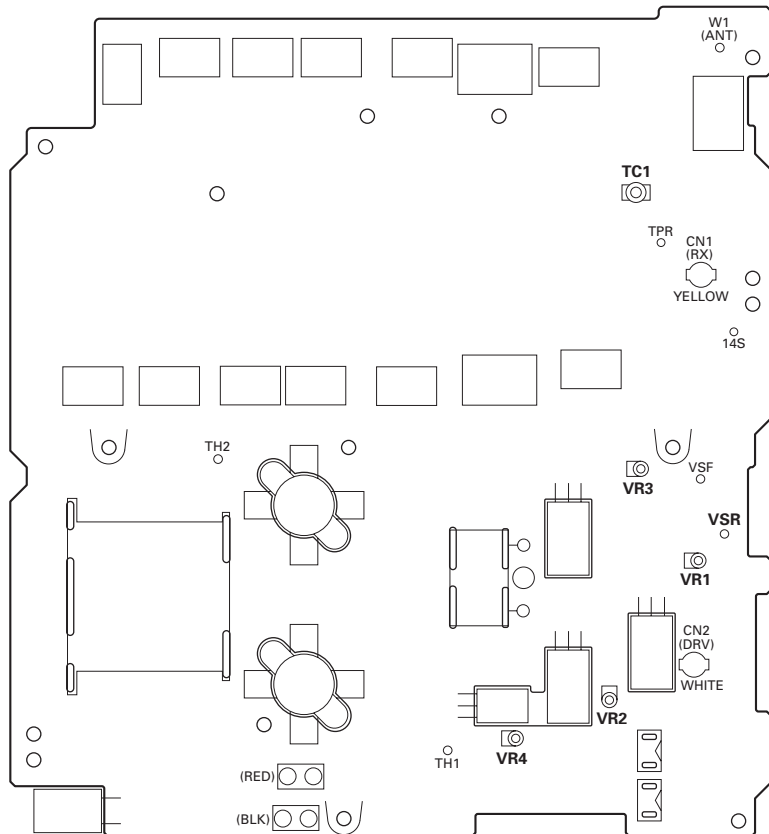

TERMINAL FUNCTION / 端子功能

Final Unit (X45-3780-20)

Pin No.	Name	I/O	Function
CN3 (to TX-RX unit)			
1	8D	I	8V AVR output for digital circuit
2	8A	I	8V AVR output for analogue circuit
3	14S	I	Switched 13.6V
4	14V	I	13.6V
5	14AF	I	Switched 13.6V for audio amplifier
6	14AG	I	GND for audio amplifier
7	GND	-	GND
8	GND	-	GND
CN4 (to TX-RX unit)			
1	GND	-	GND
2	DAT	I	Data for shift-register in Final unit
3	CLK	I	CLK for shift-register in Final unit
4	FEN	I	EN for shift-register in Final unit
5	PSC	I	Power supply switch control signal
6	TH1	O	Thermal protect detection voltage 1
7	TH2	O	Thermal protect detection voltage 2
8	NC	-	
9	VSF	O	Forward power detected voltage
10	VSR	O	Reflected power detected voltage
11	NC	-	
12	ID+	O	Drive current detection positive
13	ID-	O	Drive current detection negative
14	NC	-	
15	IC+	O	Final transistor current detection positive
16	IC-	O	Final transistor current detection negative
17	NC	-	
18	TXB	I	TX 8V
19	NC	-	
20	5A	I	5V for Final unit
21	NC	-	
22	GND	-	GND
CN6 (to CN for AT)			
1	14AT	O	Power supply for EXT. AT
2	GND	-	GND

Display Unit (X54-3560-20)

Pin No.	Name	I/O	Function
CN1 (to Internal SP)			
1	SPG	-	Speaker GND

Final单元 (X45-3780-20)

管脚号	名称	输入/输出	功 能
CN3 (至TX-RX单元)			
1	8D	输入	用于数字电路的8V AVR输出
2	8A	输入	用于模拟电路的8V AVR输出
3	14S	输入	切换13.6V
4	14V	输入	13.6V
5	14AF	输入	用于音频放大器的切换13.6V
6	14AG	输入	音频放大器接地
7	GND	-	GND
8	GND	-	GND
CN4 (至TX-RX单元)			
1	GND	-	GND
2	DAT	输入	用于Final单元移位寄存器的数据
3	CLK	输入	用于Final单元移位寄存器的时钟
4	FEN	输入	用于Final单元移位寄存器的启用
5	PSC	输入	电源开关控制信号
6	TH1	输出	过热保护检测电压1
7	TH2	输出	过热保护检测电压2
8	NC	-	未连接
9	VSF	输出	前向功率检测电压
10	VSR	输出	反射功率检测电压
11	NC	-	未连接
12	ID+	输出	驱动电流检测正极
13	ID-	输出	驱动电流检测负极
14	NC	-	未连接
15	IC+	输出	末级晶体管电流检测正极
16	IC-	输出	末级晶体管电流检测负极
17	NC	-	未连接
18	TXB	输入	TX 8V
19	NC	-	未连接
20	5A	输入	用于Final单元的5V
21	NC	-	未连接
22	GND	-	GND
CN6 (至连接器用于天线调谐器)			
1	14AT	输出	用于EXT. AT的电源
2	GND	-	GND

Display单元 (X54-3560-20)

管脚号	名称	输入/输出	功 能
CN1 (至内置扬声器)			
1	SPG	-	扬声器接地

TERMINAL FUNCTION / 端子功能

Pin No.	Name	I/O	Function
2	SP	O	Speaker output
CN2 (to TX-RX unit)			
1	ME	O	GND for MIC
2	MIC	O	MIC input signal
3	E	-	GND
4	8D	I	8V for circuit in Display unit
5	PSENSE	O	Panel connect check signal
6	RXD0	I	Data input (UART)
7	PS	O	Power control signal
8	TXD0	O	Data output (UART)
9	SB	I	Switched 13.6V
10	SP	I	Audio signal to internal speaker
11	SPG	I	GND for internal speaker
J1 (to MIC)			
1	DM	I/O	MIC data detection
2	HK	I	Data input for FPU
3	MIC	I	MIC signal input
4	ME	I	MIC GND
5	PTT	I/O	MIC standby signal (PTT) / Data output for FPU
6	E	-	GND
7	SB	O	Switched 13.6V for MIC
8	BLC	O	MIC backlight control

管脚号	名称	输入/输出	功 能
2	SP	输出	扬声器输出
CN2 (至TX-RX单元)			
1	ME	输出	麦克风接地
2	MIC	输出	麦克风输入信号
3	E	-	GND
4	8D	输入	用于Display单元电路的8V
5	PSENSE	输出	面板连接检测信号
6	RXD0	输入	数据输入 (UART)
7	PS	输出	功率控制信号
8	TXD0	输出	数据输出 (UART)
9	SB	输入	切换13.6V
10	SP	输入	至内置扬声器的音频信号
11	SPG	输入	内置扬声器接地
J1 (至麦克风)			
1	DM	输入/输出	麦克风数据检测
2	HK	输入	用于FPU的数据输入
3	MIC	输入	麦克风信号输入
4	ME	输入	麦克风GND
5	PTT	输入/输出	麦克风待机信号 (PTT)/用于FPU的数据输出
6	E	-	GND
7	SB	输出	用于麦克风的切换13.6V
8	BLC	输出	麦克风背光控制

TX-RX Unit (X57-7210-20)

Pin No.	Name	I/O	Function
CN6 (to CN for AT)			
1	TT	I/O	External antenna tuner in/through control
2	TS	I/O	External antenna tuner tuning start control
3	GND	-	GND
CN7 (for KCT-31)			
1	NC	-	
2	GND	-	GND
3	SB	O	Switched 13.6V
CN8 (for KCT-31)			
1	NC	-	
2	RXD1	I	Data input
3	TXD1	O	Data output
CN9 (for KCT-39)			
1	KEY	I	KEY signal input
2	NC	-	
3	GND	-	GND

TX-RX单元 (X57-7210-20)

管脚号	名称	输入/输出	功 能
CN6 (至连接器用于天线调谐器)			
1	TT	输入/输出	外部天线调谐器输入/通过控制
2	TS	输入/输出	外部天线调谐器调谐启动控制
3	GND	-	GND
CN7 (用于KCT-31)			
1	NC	-	未连接
2	GND	-	GND
3	SB	输出	切换13.6V
CN8 (用于KCT-31)			
1	NC	-	未连接
2	RXD1	输入	数据输入
3	TXD1	输出	数据输出
CN9 (用于KCT-39)			
1	KEY	输入	KEY信号输入
2	NC	-	未连接
3	GND	-	GND

TERMINAL FUNCTION / 端子功能

Pin No.	Name	I/O	Function
4	NC	-	
5	TXD1	O	Data output
6	RXD1	I	Data input
7	RTK	I	RTTY control
8	DPTT	I	Data PTT signal input
9	GND	-	GND
10	AUX1	I/O	
11	AUX2	I/O	
12	AUX3	I/O	
CN10 (for KCT-39)			
1	IGN	I	Ignition sense signal input H: Power on
2	DI	I	Modulation signal input (TX by DPTT)
3	DEO	O	Detect signal output
4~11	NC	-	
CN11 (for VGS-1)			
1	VBSY	I	VGS-1 busy signal
2	VPLY	I	VGS-1 play signal
3	SO	-	NC
4	DATA	O	Data signal output for VGS-1
5	CLK	-	CLK for VGS-1
6	VEN	-	Enable signal for VGS-1
7	USEL	-	NC
8	VRST	O	VGS-1 reset signal
9	DGND	-	DGND
10	AGND	-	GND
11	VAI	I	VGS-1 audio input
12	VAO	O	VGS-1 audio output
13	AGND	-	GND
14	5D	O	Switched 5V for VGS-1
15~26	NC	-	
CN12 (to Final unit)			
1	8D	I	8V AVR output for digital circuit
2	8A	I	8V AVR output for analogue circuit
3	14S	I	Switched 13.6V
4	14V	I	13.6V
5	14AF	I	Switched 13.6V for audio amplifier
6	14AG	I	GND for audio amplifier
7	GND	-	GND
8	GND	-	GND
CN13 (to Option)			
1	TXAO	O	TX audio signal output (TXI)

管脚号	名称	输入/输出	功 能
4	NC	-	未连接
5	TXD1	输出	数据输出
6	RXD1	输入	数据输入
7	RTK	输入	RTTY控制
8	DPTT	输入	数据PTT信号输入
9	GND	-	GND
10	AUX1	输入/输出	
11	AUX2	输入/输出	
12	AUX3	输入/输出	
CN10 (用于KCT-39)			
1	IGN	输入	点火传感器信号输入 H: 打开电源
2	DI	输入	调制信号输入 (通过DPTT的TX)
3	DEO	输出	检测信号输出
4~11	NC	-	未连接
CN11 (用于VGS-1)			
1	VBSY	输入	VGS-1繁忙信号
2	VPLY	输入	VGS-1播放信号
3	SO	-	未连接
4	DATA	输出	用于VGS-1的数据信号输出
5	CLK	-	用于VGS-1的时钟
6	VEN	-	用于VGS-1的启用信号
7	USEL	-	未连接
8	VRST	输出	VGS-1复位信号
9	DGND	-	DGND
10	AGND	-	GND
11	VAI	输入	VGS-1音频输入
12	VAO	输出	VGS-1音频输出
13	AGND	-	GND
14	5D	输出	用于VGS-1的切换5V
15~26	NC	-	未连接
CN12 (至Final单元)			
1	8D	输入	用于数字电路的8V AVR输出
2	8A	输入	用于模拟电路的8V AVR输出
3	14S	输入	切换13.6V
4	14V	输入	13.6V
5	14AF	输入	用于音频放大器的切换13.6V
6	14AG	输入	音频放大器接地
7	GND	-	GND
8	GND	-	GND
CN13 (至选购件)			
1	TXAO	输出	TX音频信号输出 (TXI)

TERMINAL FUNCTION / 端子功能

Pin No.	Name	I/O	Function
2	RXAO	O	RX audio signal output (RXI)
3	INDI	I	NC (INDI)
4	CODE8	O	Code 8 (C8)
5	CODE4	O	Code 4 (C4)
6	CODE2	O	Code 2 (C2)
7	CODE1	O	Code 1 (C1)
8	RXAI	I	RX audio signal input (RXO)
9	SCR	O	Enable signal for option (SCR) H: Active
10	PTT	O	PTT signal (PTT) L: TX
11	8D	O	8V for option (V+)
12	GND	-	GND (G)
13	TXAI	I	TX audio signal input (TXO)
14	NC	-	
CN14 (to Final unit)			
1	GND	-	GND
2	NC	-	NC
3	5A	O	5V for Final unit
4	NC	-	NC
5	TXB	O	TX 8V
6	NC	-	
7	IC-	I	Final transistor current detection negative
8	IC+	I	Final transistor current detection positive
9	NC	-	
10	ID-	I	Drive current detection negative
11	ID+	I	Drive current detection positive
12	NC	-	
13	VSR	I	Reflected power detected voltage
14	VSF	I	Forward power detected voltage
15	NC	-	
16	TH2	I	Thermal protect detection voltage 2
17	TH1	I	Thermal protect detection voltage 1
18	PSC	-	Power supply switch control signal
19	FEN	O	EN for shift-register in Final unit
20	CLK	O	CLK for shift-register in Final unit
21	DATA	O	Data for shift-register in Final unit
22	GND	-	GND
CN15 (to ALE unit)			
1	GND	-	Reserved:
2	AO	O	Reserved: ALE audio output
3	AI	I	Reserved: ALE audio input
4	5BTT	O	Reserved: 5V for battery charge

管脚号	名称	输入/输出	功 能
2	RXAO	输出	RX音频信号输出 (RXI)
3	INDI	输入	未连接 (INDI)
4	CODE8	输出	代码8 (C8)
5	CODE4	输出	代码4 (C4)
6	CODE2	输出	代码2 (C2)
7	CODE1	输出	代码1 (C1)
8	RXAI	输入	RX音频信号输入 (RXO)
9	SCR	输出	选购件的启用信号 (SCR) H: 活动
10	PTT	输出	PTT信号 (PTT) L: TX
11	8D	输出	用于选购件的8V (V+)
12	GND	-	GND (G)
13	TXAI	输入	TX音频信号输入 (TXO)
14	NC	-	未连接
CN14 (至Final单元)			
1	GND	-	GND
2	NC	-	未连接
3	5A	输出	用于Final单元的5V
4	NC	-	未连接
5	TXB	输出	TX 8V
6	NC	-	未连接
7	IC-	输入	末级晶体管电流检测负极
8	IC+	输入	末级晶体管电流检测正极
9	NC	-	未连接
10	ID-	输入	驱动电流检测负极
11	ID+	输入	驱动电流检测正极
12	NC	-	未连接
13	VSR	输入	反射功率检测电压
14	VSF	输入	前向功率检测电压
15	NC	-	未连接
16	TH2	输入	过热保护检测电压2
17	TH1	输入	过热保护检测电压1
18	PSC	-	电源开关控制信号
19	FEN	输出	用于Final单元移位寄存器的启用
20	CLK	输出	用于Final单元移位寄存器的时钟
21	DATA	输出	用于Final单元移位寄存器的数据
22	GND	-	GND
CN15 (至ALE单元)			
1	GND	-	预留:
2	AO	输出	预留: ALE音频输出
3	AI	输入	预留: ALE音频输入
4	5BTT	输出	预留: 用于电池充电器的5V

TERMINAL FUNCTION / 端子功能

Pin No.	Name	I/O	Function
5	A5A	O	Reserved: Switched 5V for ALE
6	NC	-	Reserved:
7	DGND	-	Reserved: DGND
8	BRDAT	I	Reserved: TP (Bit error rate data)
9	BRCLK	I	Reserved: TP (Bit error rate clock)
10	ALE2	-	Reserved:
11	ALE1	-	Reserved:
12	ASENSE	I	Reserved: ALE unit detection
13	ASQC	O	Reserved: Squelch control signal for ALE
14	BAUD	O	Reserved: Baud selection signal
15	BIO	-	Reserved:
16	ARST	O	Reserved: ALE reset signal
17	ABSY	I	Reserved: ALE busy signal
18	DCD	I	Reserved: Data carrier detection
19	AMMU	I	Reserved: ALE MIC mute signal
20	AAMU	I	Reserved: ALE audio mute signal
21	APTT	I	Reserved: ALE standby signal
22	TXC	O	Reserved: TX control signal
23	RTS2	O	Reserved: Request to send signal for ALE
24	CTS2	I	Reserved: Clear to send signal for ALE
25	TXD2	O	Reserved: Data output for ALE
26	RXD2	I	Reserved: Data input for ALE
CN16 (for FAN1)			
1	FAN+	O	FAN1+
2	FAN-	O	FAN1-
CN17 (for FAN2)			
1	FAN+	O	FAN2+
2	FAN-	O	FAN2-
CN236 (to Display unit)			
1	SPG	-	GND for internal speaker
2	SP	O	Audio signal to internal speaker
3	SB	O	Switched 13.6V
4	TXD0	O	Data output (UART)
5	PS	I	Power control signal
6	RXD0	I	Data input (UART)
7	PSENSE	I	NC
8	8D	O	8V for circuit in display
9	E	-	GND
10	MIC	I	MIC input signal
11	ME	-	GND for MIC

管脚号	名称	输入/输出	功 能
5	A5A	输出	预留: 用于ALE的切换5V
6	NC	-	预留:
7	DGND	-	预留: DGND
8	BRDAT	输入	预留: TP (比特误码率数据)
9	BRCLK	输入	预留: TP (比特误码率时钟)
10	ALE2	-	预留:
11	ALE1	-	预留:
12	ASENSE	输入	预留: ALE单元检测
13	ASQC	输出	预留: 用于ALE的静音控制信号
14	BAUD	输出	预留: 波特选择信号
15	BIO	-	预留:
16	ARST	输出	预留: ALE复位信号
17	ABSY	输入	预留: ALE繁忙信号
18	DCD	输入	预留: 数据载波检测
19	AMMU	输入	预留: ALE麦克风静音信号
20	AAMU	输入	预留: ALE音频静音信号
21	APTT	输入	预留: ALE待机信号
22	TXC	输出	预留: TX控制信号
23	RTS2	输出	预留: 用于ALE的发送信号请求
24	CTS2	输入	预留: 用于ALE的发送信号清除
25	TXD2	输出	预留: 用于ALE的数据输出
26	RXD2	输入	预留: 用于ALE的数据输入
CN16 (用于FAN1)			
1	FAN+	输出	FAN1+
2	FAN-	输出	FAN1-
CN17 (用于FAN2)			
1	FAN+	输出	FAN2+
2	FAN-	输出	FAN2-
CN236 (至Display单元)			
1	SPG	-	内置扬声器接地
2	SP	输出	至内置扬声器的音频信号
3	SB	输出	切换13.6V
4	TXD0	输出	数据输出 (UART)
5	PS	输入	功率控制信号
6	RXD0	输入	数据输入 (UART)
7	PSENSE	输入	未连接
8	8D	输出	用于显示电路的8V
9	E	-	GND
10	MIC	输入	麦克风输入信号
11	ME	-	麦克风接地

TK-90 PC BOARD / PC板

FINAL UNIT (X45-3780-20) Component side view (J79-0008-09)

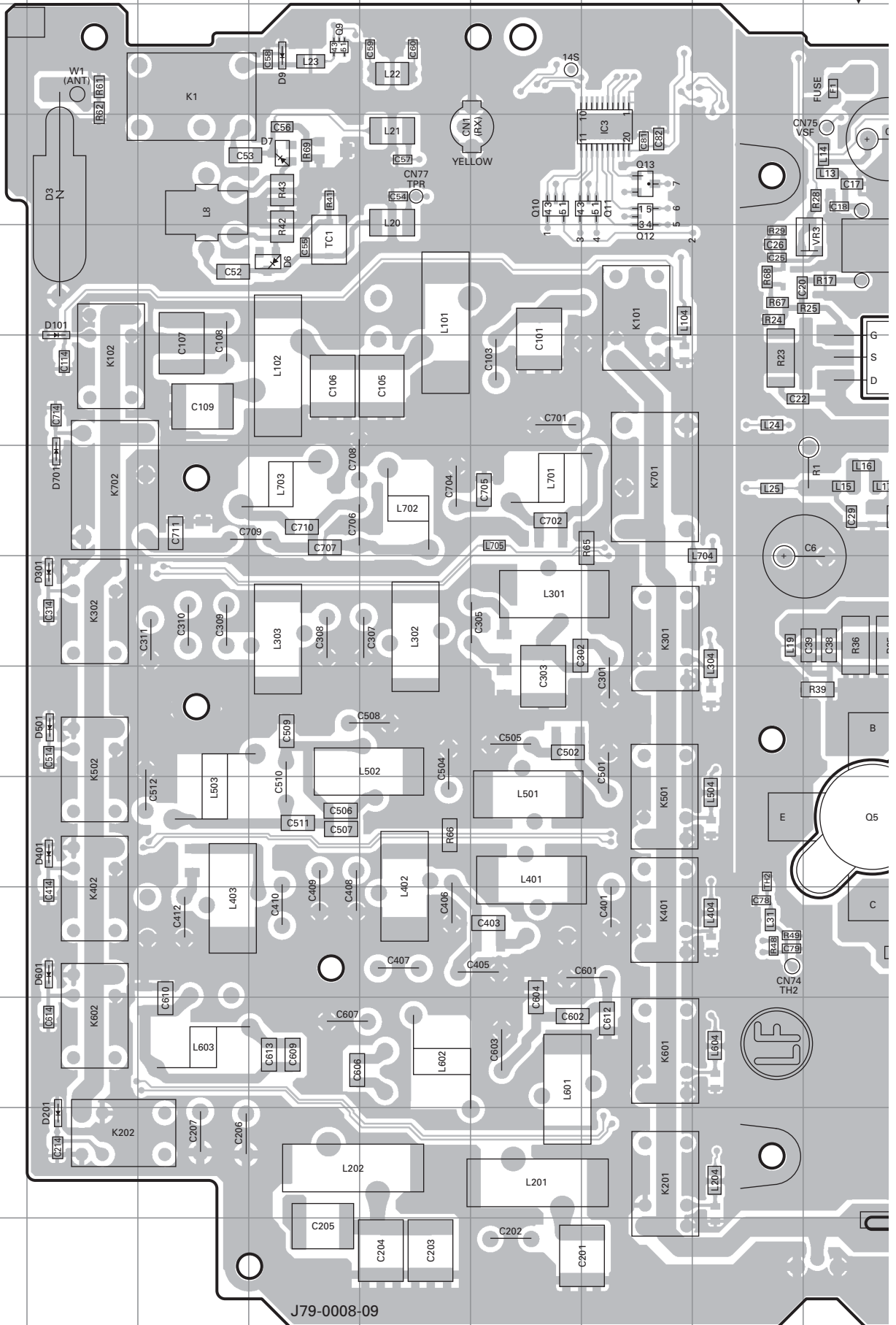

PC BOARD / PC板 TK-90

FINAL UNIT (X45-3780-20) Component side view (J79-0008-09)

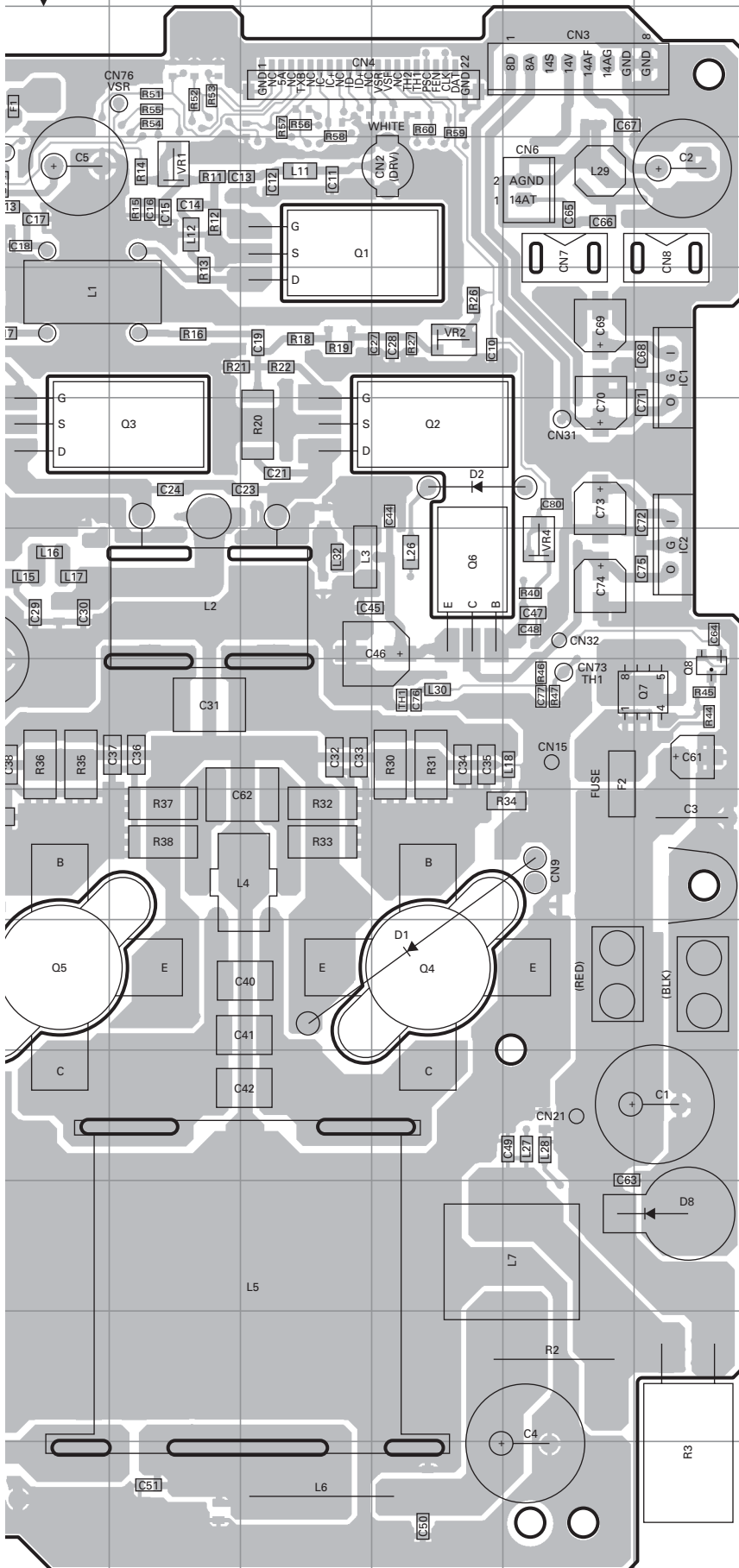

Ref. No.	Address
IC1	40
IC2	60
IC3	3H
Q1	3L
Q2	5M
Q3	5K
Q4	9M
Q5	9J
Q6	6M
Q7	7O
Q8	7O
Q9	2E
Q10	3G
Q11	3H
Q12	3H
Q13	3H
D1	9M
D2	5M
D3	3C
D6	4E
D7	3E
D8	11O
D9	2E
D101	4C
D201	12C
D301	7C
D401	9C
D501	8C
D601	10C
D701	6C

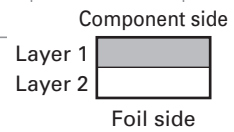

TK-90 PC BOARD / PC板

PC BOARD / PC板 TK-90

FINAL UNIT (X45-3780-20) Component side view (J79-0008-09)

FINAL UNIT (X45-3780-20) Component side view (J79-0008-09)

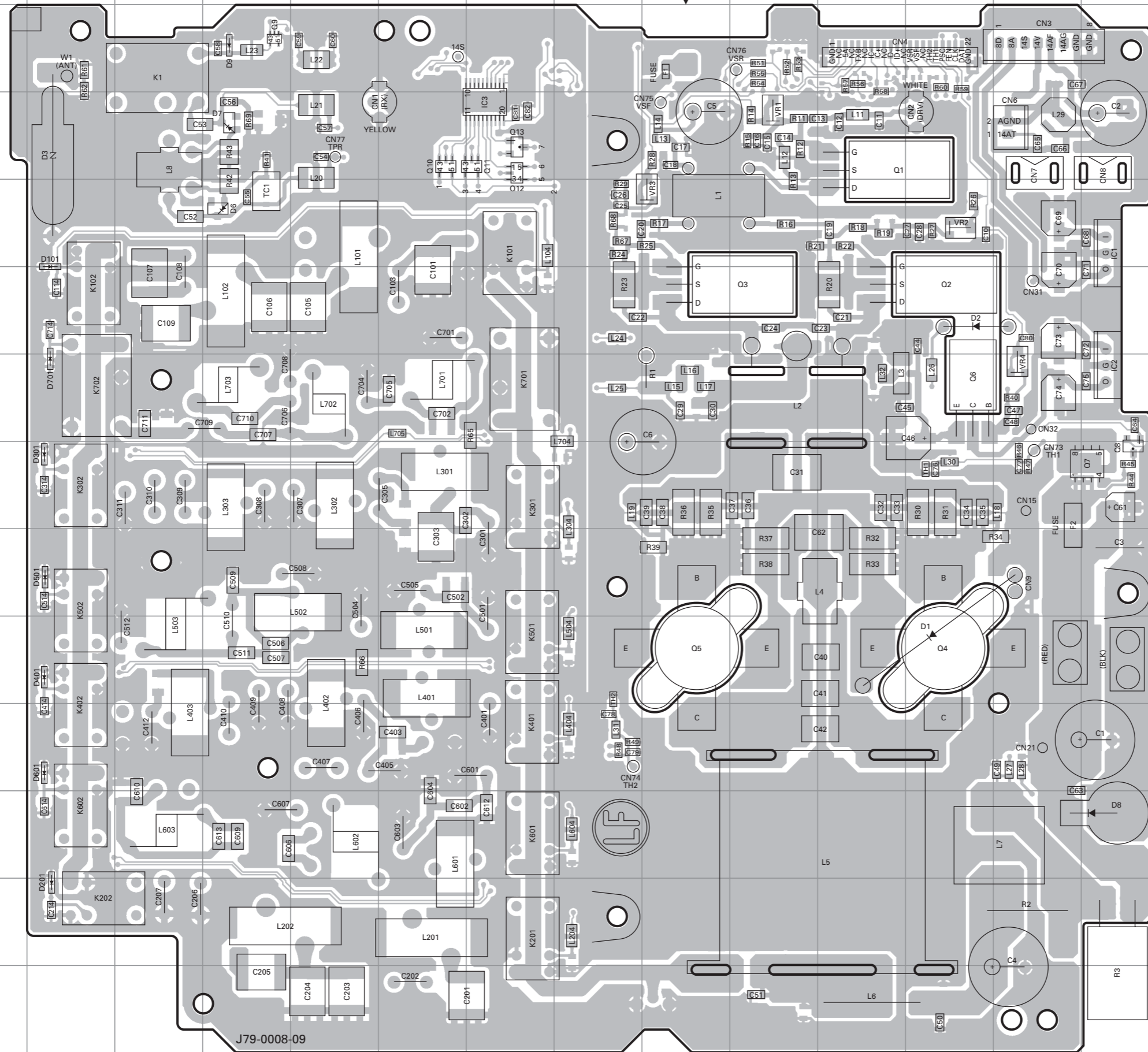

Ref. No.	Address
IC1	40
IC2	60
IC3	3H
Q1	3L
Q2	5M
Q3	5K
Q4	9M
Q5	9J
Q6	6M
Q7	70
Q8	70
Q9	2E
Q10	3G
Q11	3H
Q12	3H
Q13	3H
D1	9M
D2	5M
D3	3C
D6	4E
D7	3E
D8	110
D9	2E
D101	4C
D201	12C
D301	7C
D401	9C
D501	8C
D601	10C
D701	6C

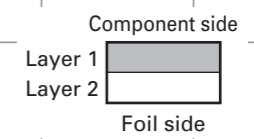

J79-0008-09

TK-90 PC BOARD / PC板

FINAL UNIT (X45-3780-20) Foil side view (J79-0008-09)

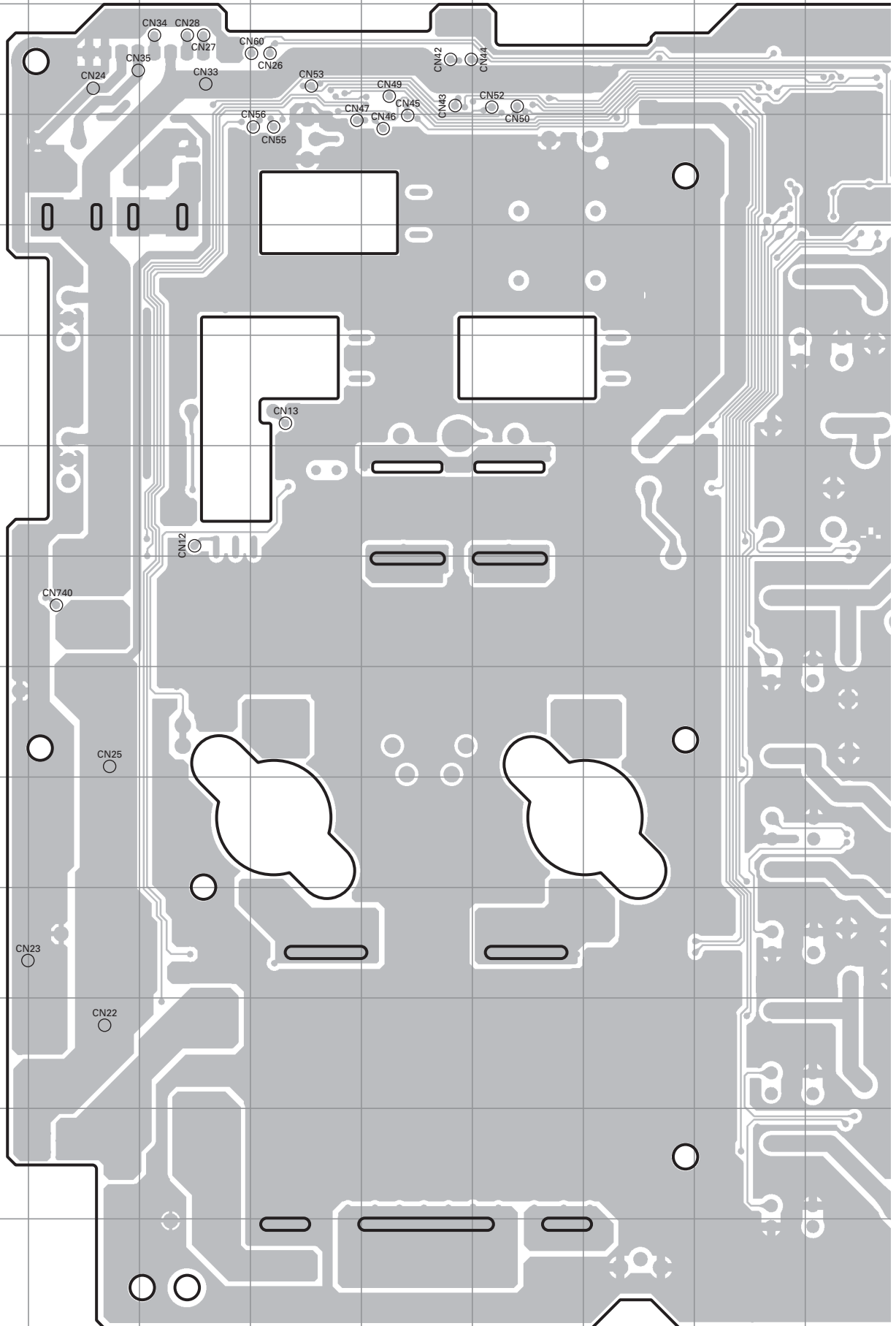

PC BOARD / PC板 TK-90

FINAL UNIT (X45-3780-20) Foil side view (J79-0008-09)

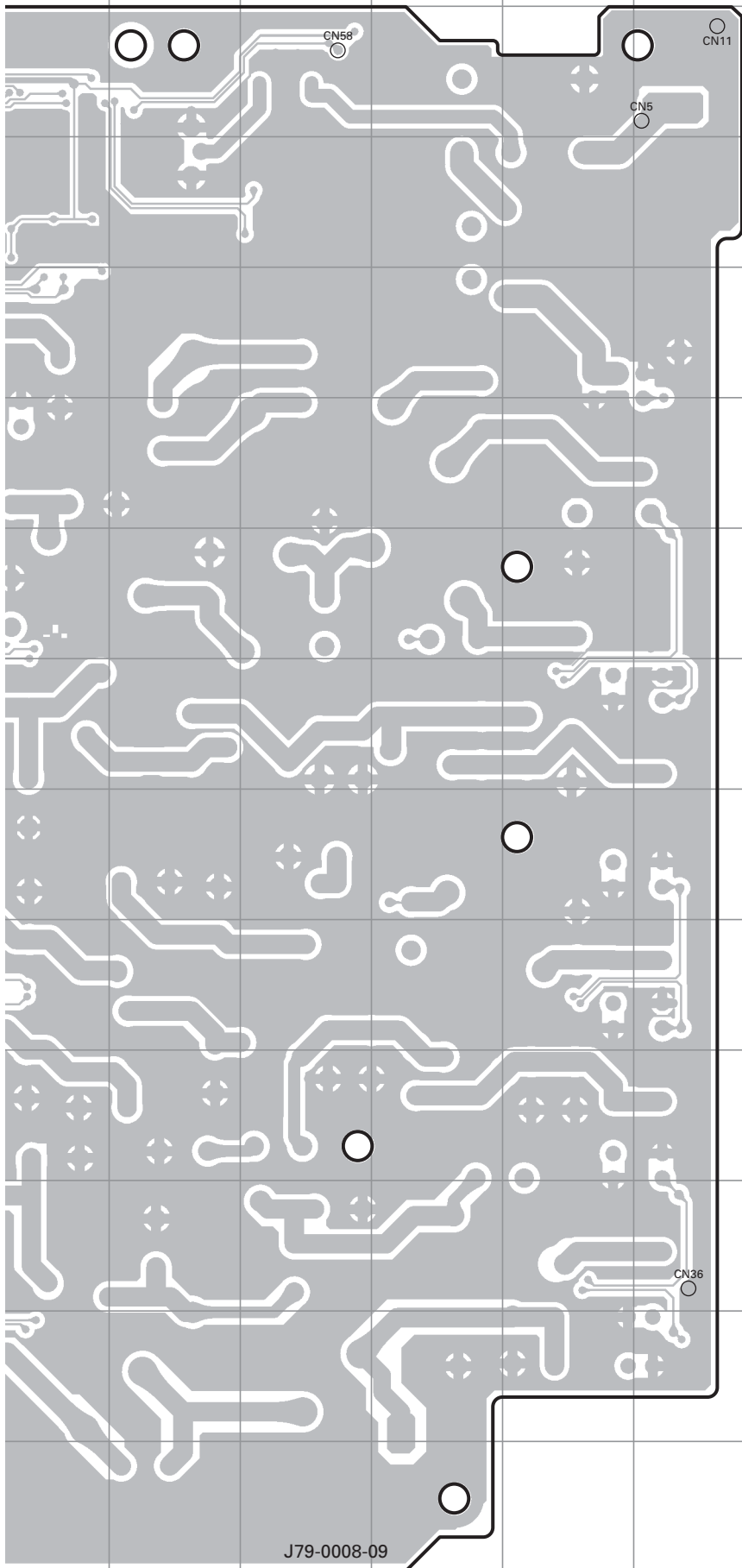

J79-0008-09

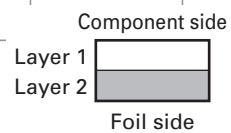

1
2
3
4
5
6
7
8
9
10
11
12
13
14

TK-90 PC BOARD / PC板

PC BOARD / PC板 TK-90

FINAL UNIT (X45-3780-20) Foil side view (J79-0008-09)

FINAL UNIT (X45-3780-20) Foil side view (J79-0008-09)

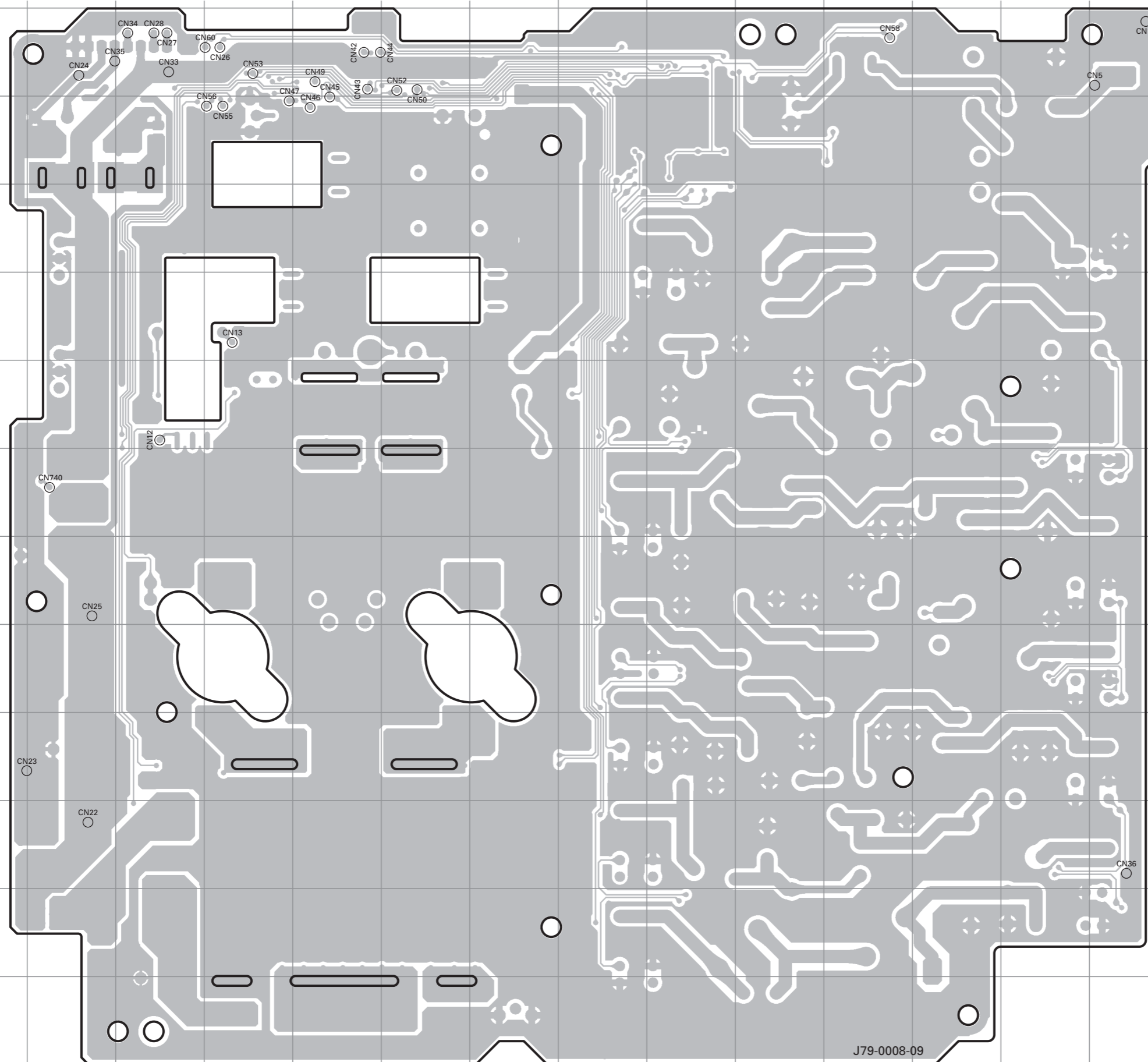

J79-0008-09

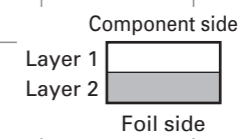

TK-90 PC BOARD / PC板

DISPLAY UNIT (X54-3560-20) Component side view (J79-0009-09)

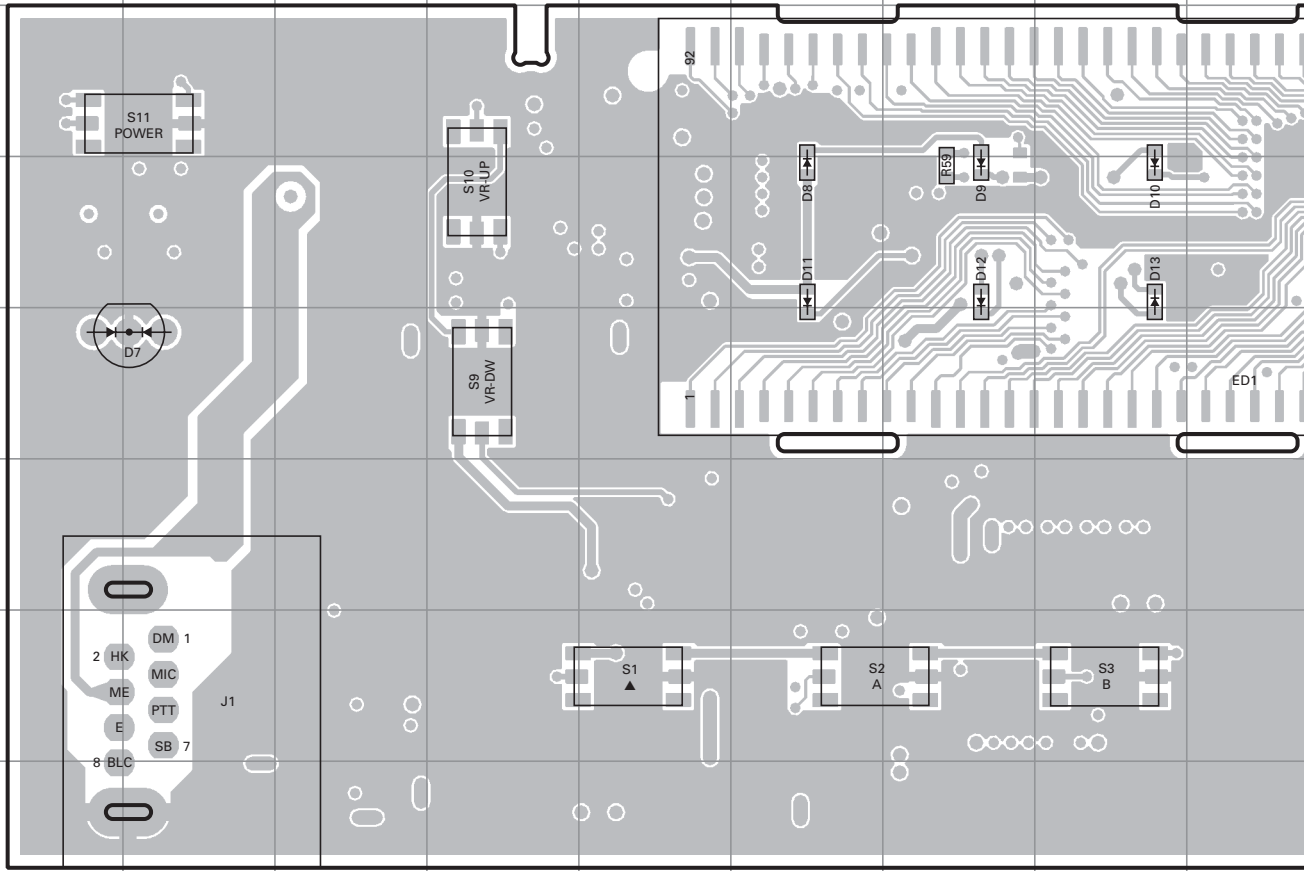

DISPLAY UNIT (X54-3560-20) Foil side view (J79-0009-09)

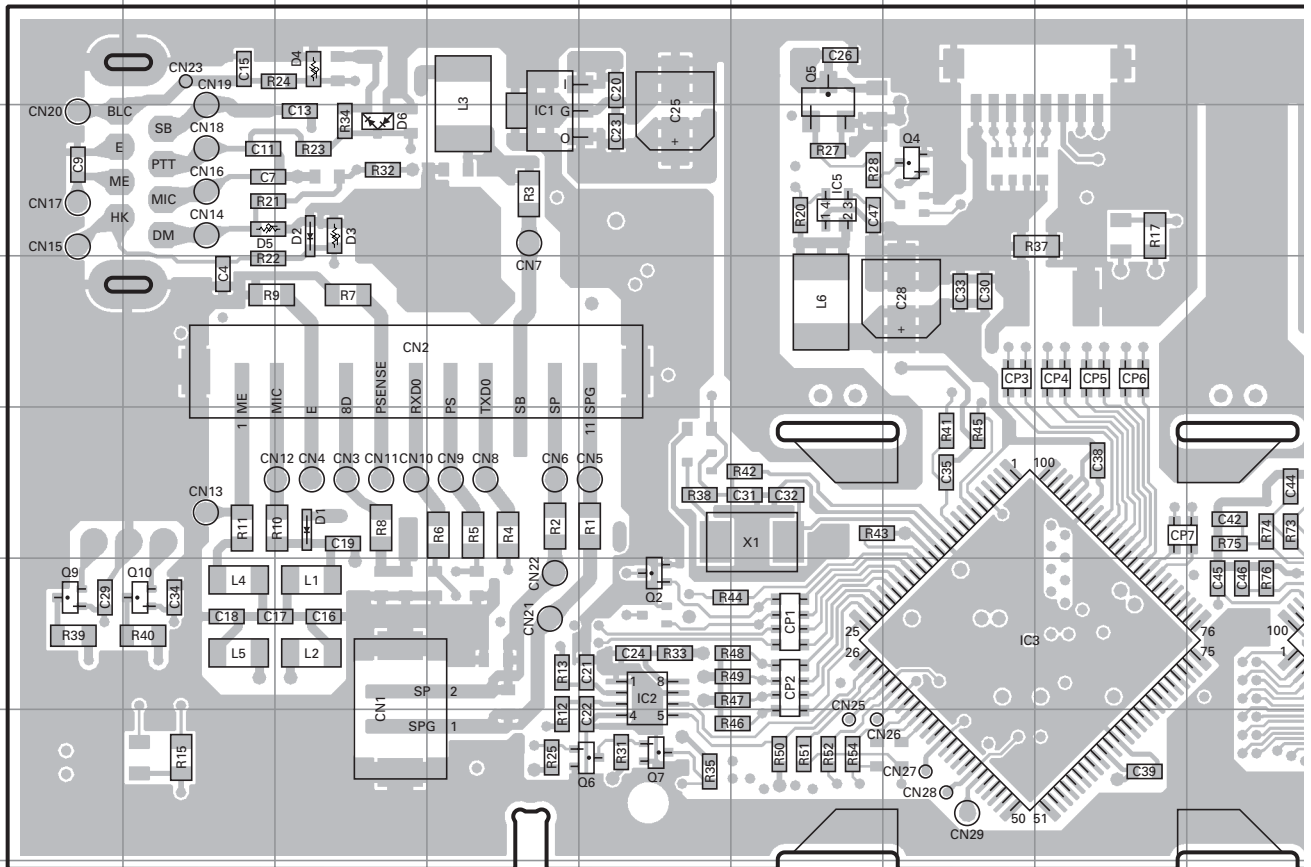

PC BOARD / PC板 TK-90

DISPLAY UNIT (X54-3560-20) Component side view (J79-0009-09)

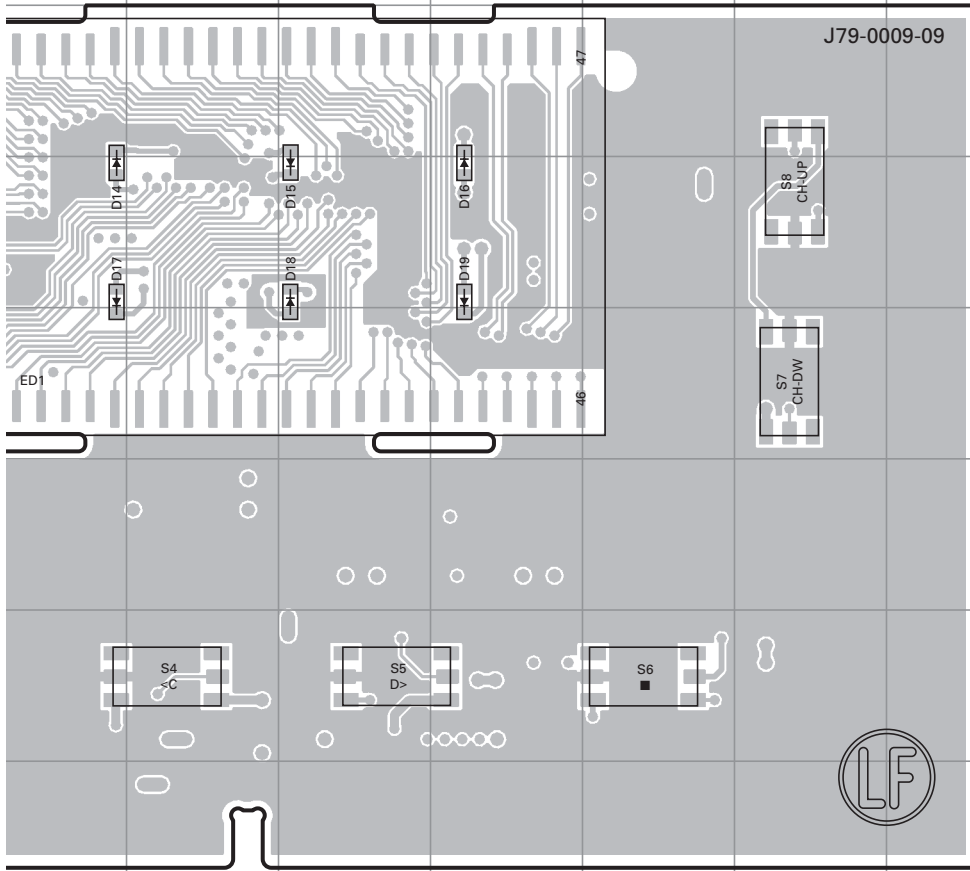

Ref. No.	Address
D7	4C
D8	3G
D9	3H
D10	3I
D11	3G
D12	3H
D13	3I
D14	3J
D15	3L
D16	3M
D17	3J
D18	3L
D19	3M

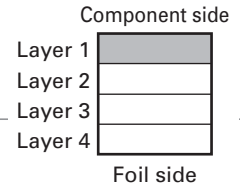

DISPLAY UNIT (X54-3560-20) Foil side view (J79-0009-09)

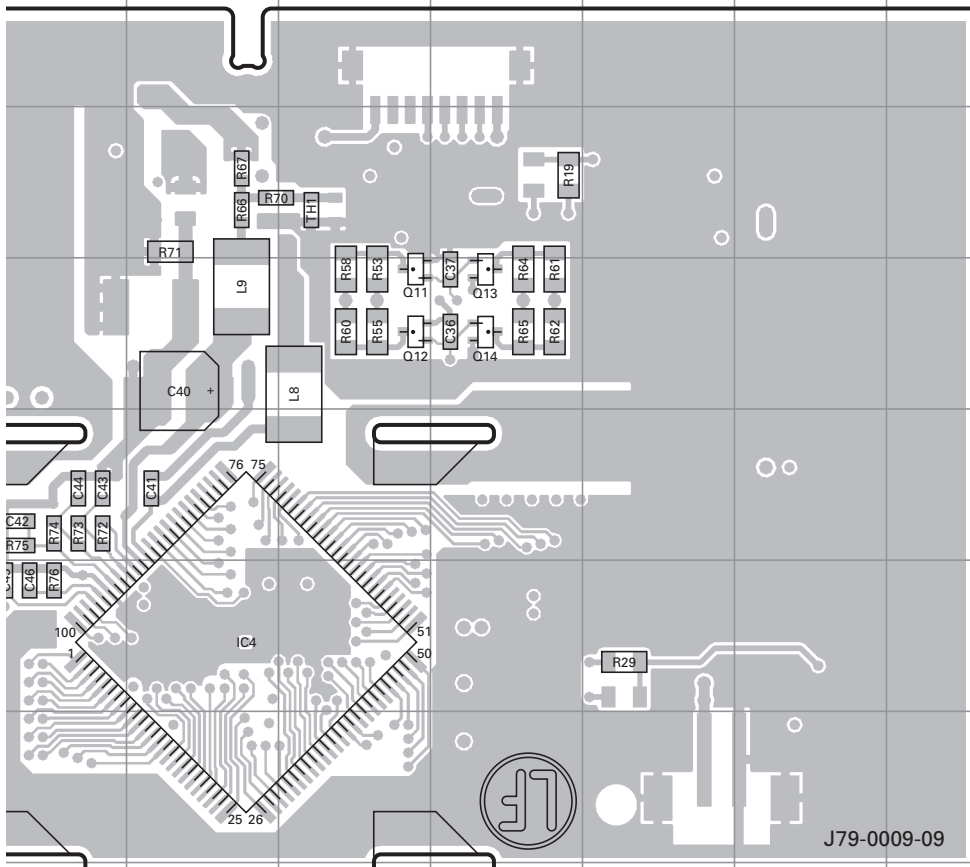

Ref. No.	Address	Ref. No.	Address
IC1	9E	Q10	12C
IC2	12F	Q11	10L
IC3	12H	Q12	10L
IC4	12K	Q13	10M
IC5	9G	Q14	10M
Q2	12F	D1	11D
Q4	9H	D2	9D
Q5	8G	D3	9D
Q6	13F	D4	8D
Q7	13F	D5	9C
Q9	12B	D6	9D

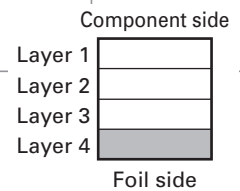

TK-90 PC BOARD / PC板

PC BOARD / PC板 TK-90

DISPLAY UNIT (X54-3560-20) Component side view (J79-0009-09)

DISPLAY UNIT (X54-3560-20) Component side view (J79-0009-09)

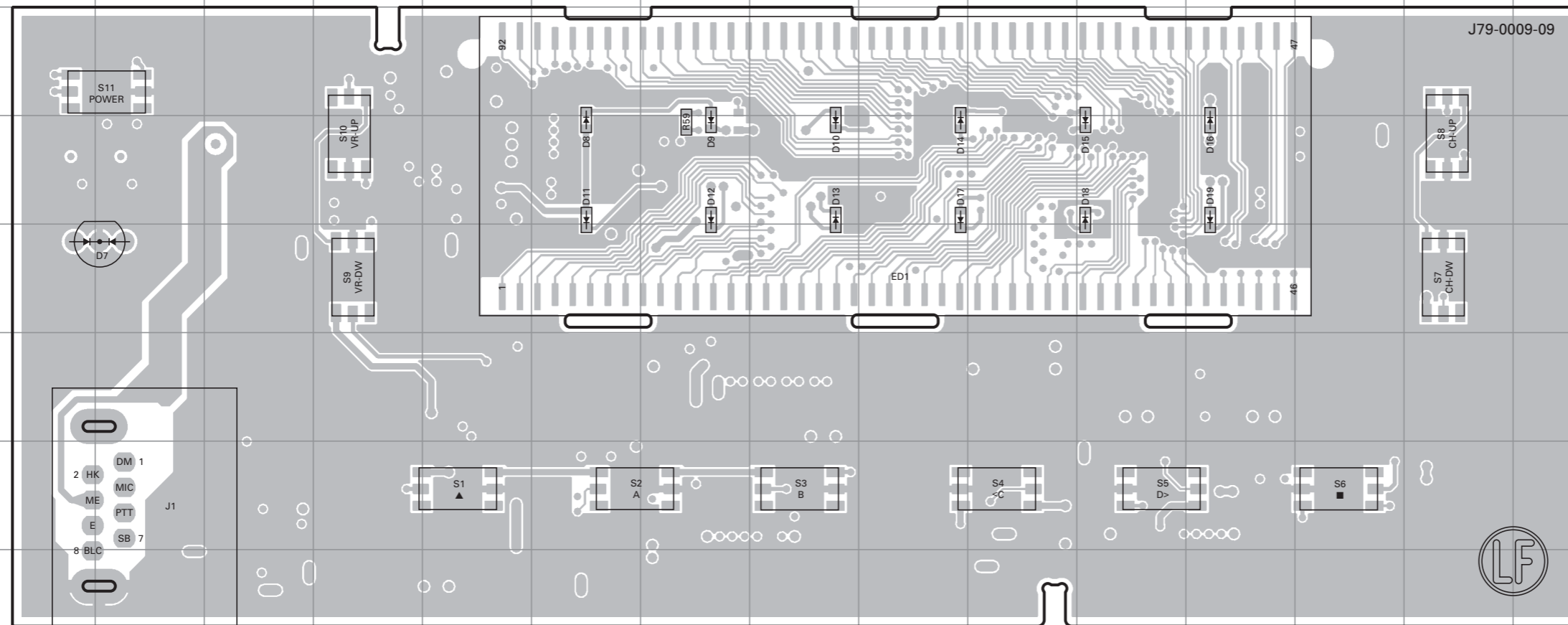

Ref. No.	Address
D7	4C
D8	3G
D9	3H
D10	3I
D11	3G
D12	3H
D13	3I
D14	3J
D15	3L
D16	3M
D17	3J
D18	3L
D19	3M

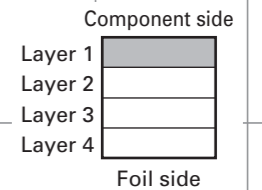

DISPLAY UNIT (X54-3560-20) Foil side view (J79-0009-09)

DISPLAY UNIT (X54-3560-20) Foil side view (J79-0009-09)

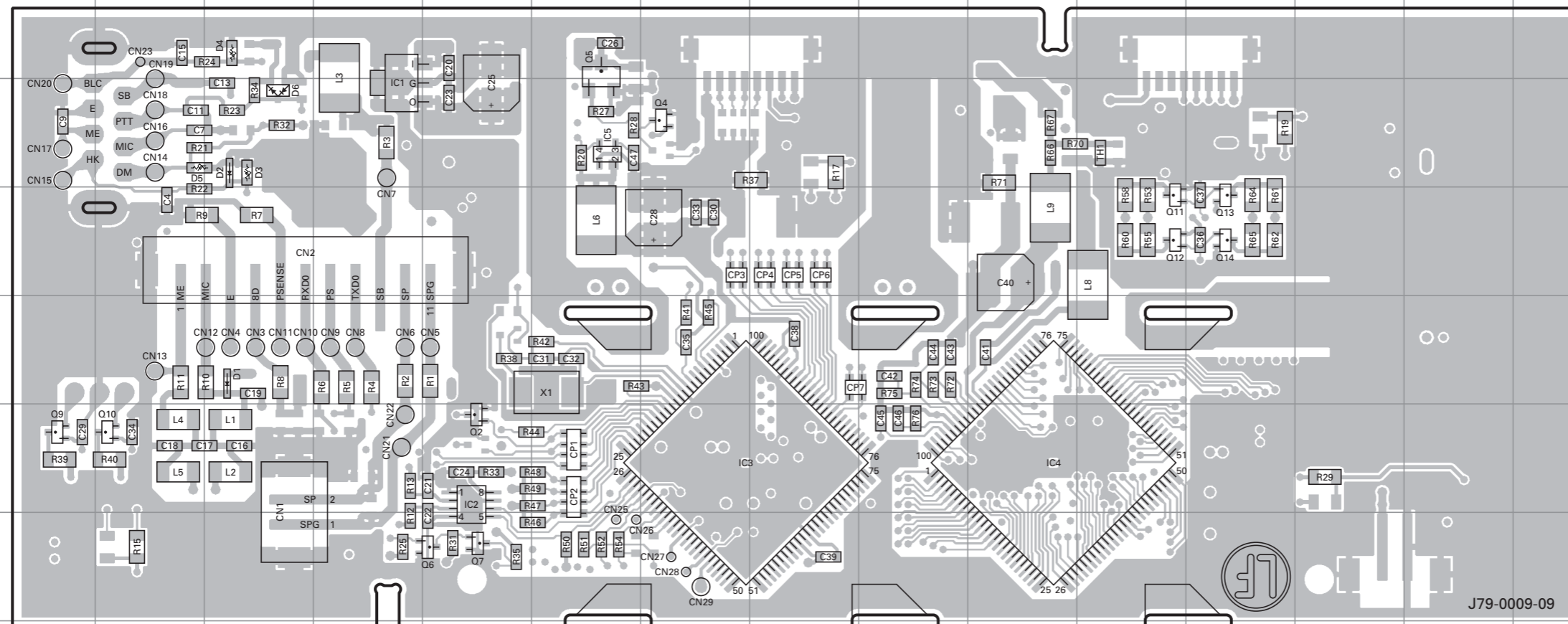

Ref. No.	Address	Ref. No.	Address
IC1	9E	Q10	12C
IC2	12F	Q11	10L
IC3	12H	Q12	10L
IC4	12K	Q13	10M
IC5	9G	Q14	10M
Q2	12F	D1	11D
Q4	9H	D2	9D
Q5	8G	D3	9D
Q6	13F	D4	8D
Q7	13F	D5	9C
Q9	12B	D6	9D

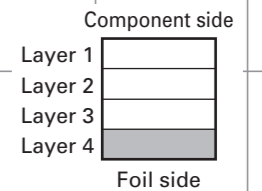

TK-90 PC BOARD / PC板

TX-RX UNIT (X57-7210-20) Component side view (J79-0007-09)

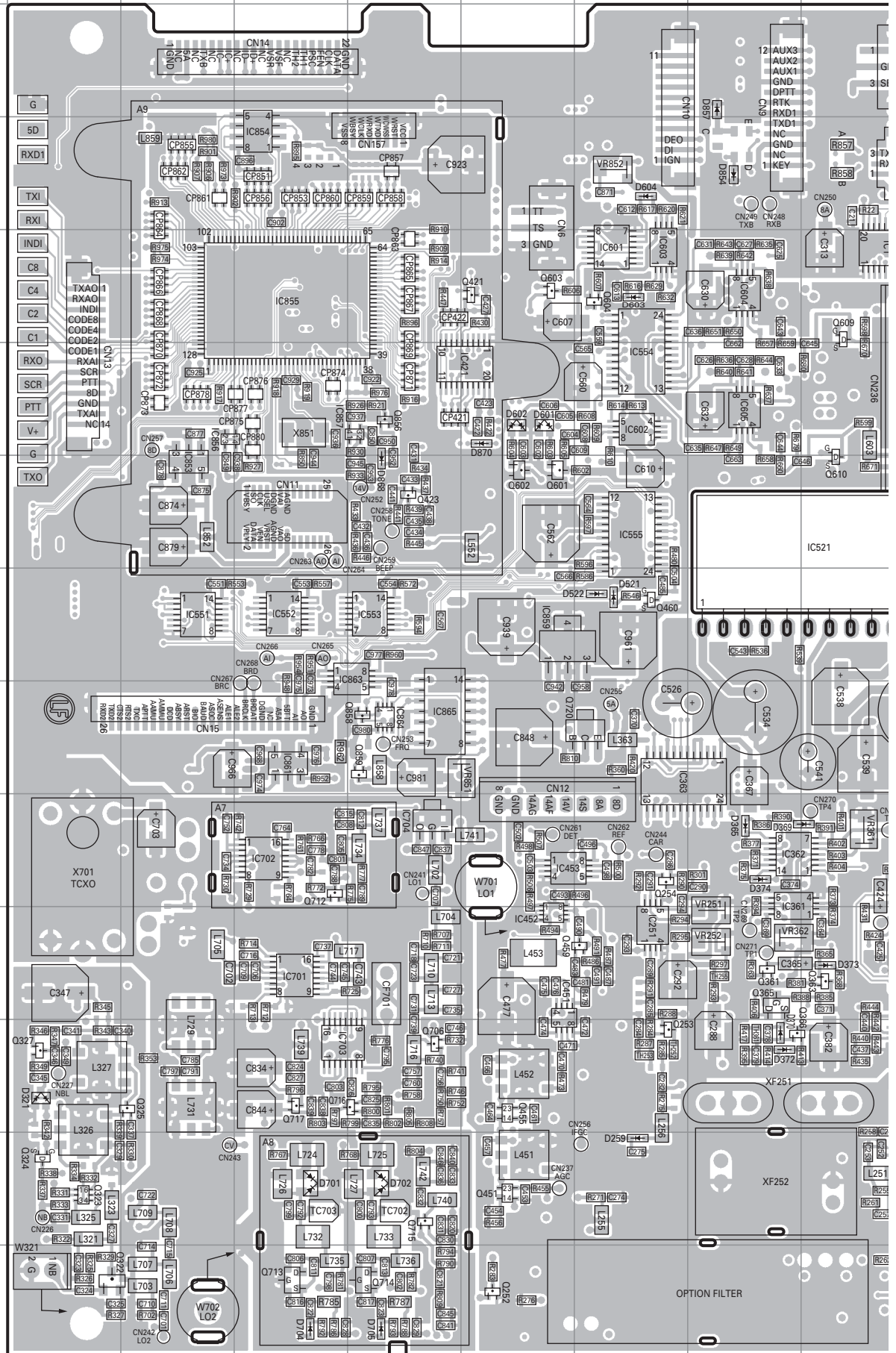

TX-RX UNIT (X57-7210-20) Component side view (J79-0007-09)

TX-RX UNIT (X57-7210-20) Component side view (J79-0007-09)

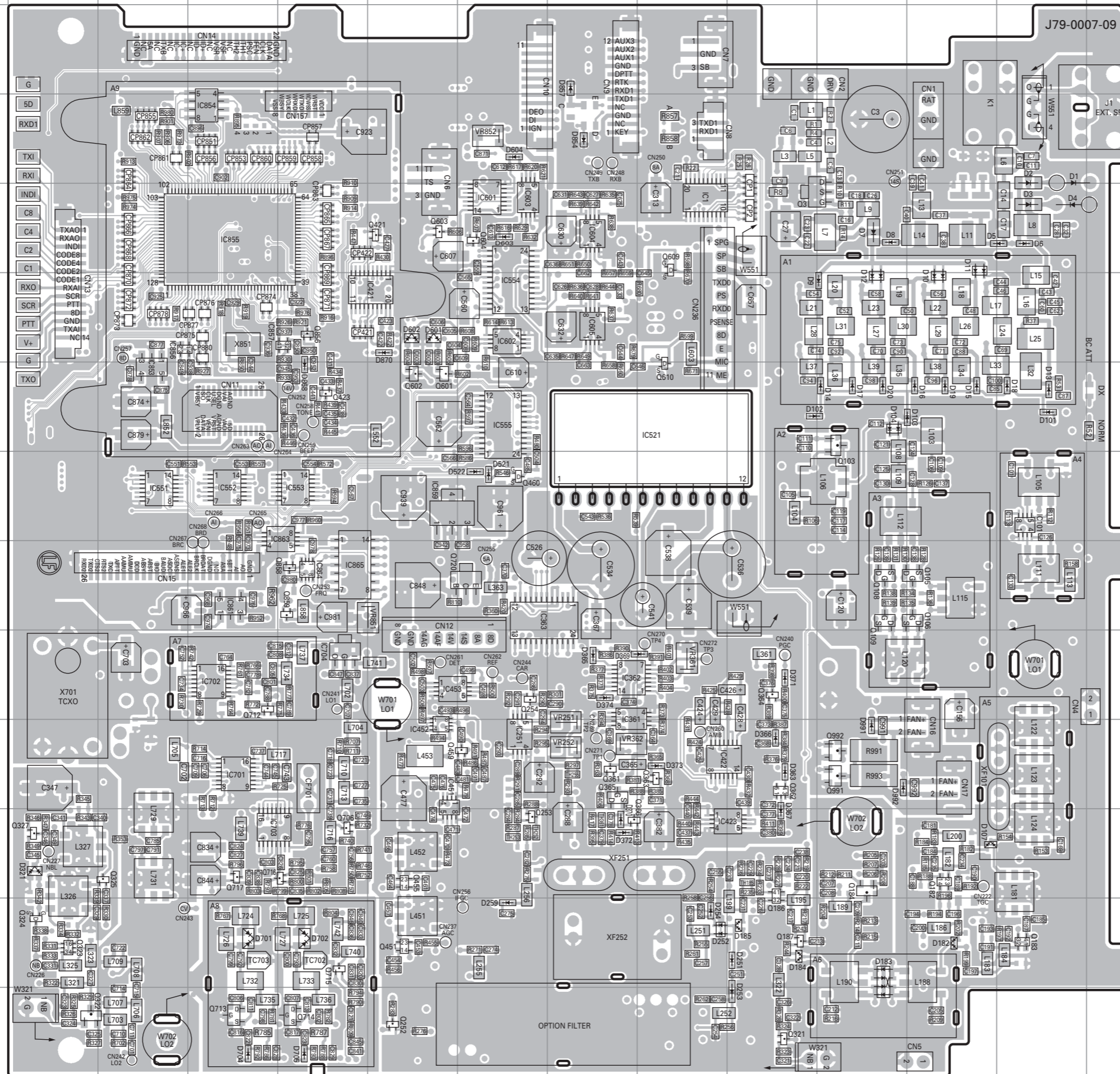

Ref. No.	Address	Ref. No.	Address	Ref. No.	Address
IC1	4J	Q187	12K	D7	4L
IC101	7N	Q252	13G	D8	4L
IC251	10H	Q253	11H	D9	5L
IC361	9I	Q254	9H	D10	5M
IC362	9I	Q321	13K	D11	4M
IC363	8H	Q322	13C	D12	5L
IC421	5G	Q323	12C	D13	6N
IC422	10J	Q324	12C	D14	6L
IC423	11K	Q325	11D	D15	6M
IC451	10G	Q327	11C	D16	6M
IC452	10G	Q361	10I	D17	6L
IC453	9G	Q362	10K	D18	6N
IC521	6J	Q363	10J	D19	6M
IC551	7D	Q364	9K	D20	6L
IC552	7E	Q365	10I	D101	6N
IC553	7F	Q366	11I	D102	6K
IC554	5H	Q421	4G	D103	6M
IC555	6H	Q423	6F	D104	6L
IC601	4H	Q451	12G	D107	11M
IC602	5H	Q455	11G	D182	12M
IC603	4H	Q459	10H	D183	12L
IC604	4I	Q460	7H	D184	12K
IC605	5I	Q601	6G	D185	12K
IC701	10E	Q602	6G	D251	12K
IC702	9E	Q603	4G	D252	12J
IC703	11E	Q604	4H	D253	13K
IC704	9F	Q609	4J	D254	12J
IC853	6D	Q610	6J	D259	12H
IC854	3E	Q706	11F	D321	11C
IC855	4E	Q712	9E	D363	10K
IC856	5D	Q713	13E	D365	9I
IC857	5F	Q714	13F	D366	10K
IC859	7G	Q715	12F	D367	11K
IC861	8E	Q716	11F	D369	9J
IC863	7F	Q717	11E	D370	11I
IC864	8F	Q720	8H	D371	9K
IC865	8F	Q856	5F	D372	11I
Q3	4K	Q858	8F	D373	10J
Q103	6L	Q859	8F	D374	9I
Q105	8M	Q991	10L	D521	7H
Q106	8M	Q992	10L	D522	7H
Q108	8L	D1	3N	D601	5G
Q109	8L	D2	3N	D602	5G
Q182	11M	D3	4N	D603	4H
Q183	12N	D4	4N	D604	3H
Q184	11L	D5	4N	D701	12E
Q186	11K	D6	4N	D702	12F
				D704	13E
				D705	13F
				D854	3I
				D857	2I
				D868	6F
				D870	5G
				D991	10L
				D992	10L

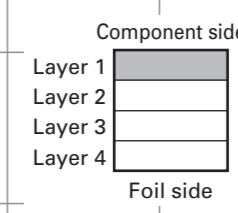

TK-90 PC BOARD / PC板

TX-RX UNIT (X57-7210-20) Foil side view (J79-0007-09)

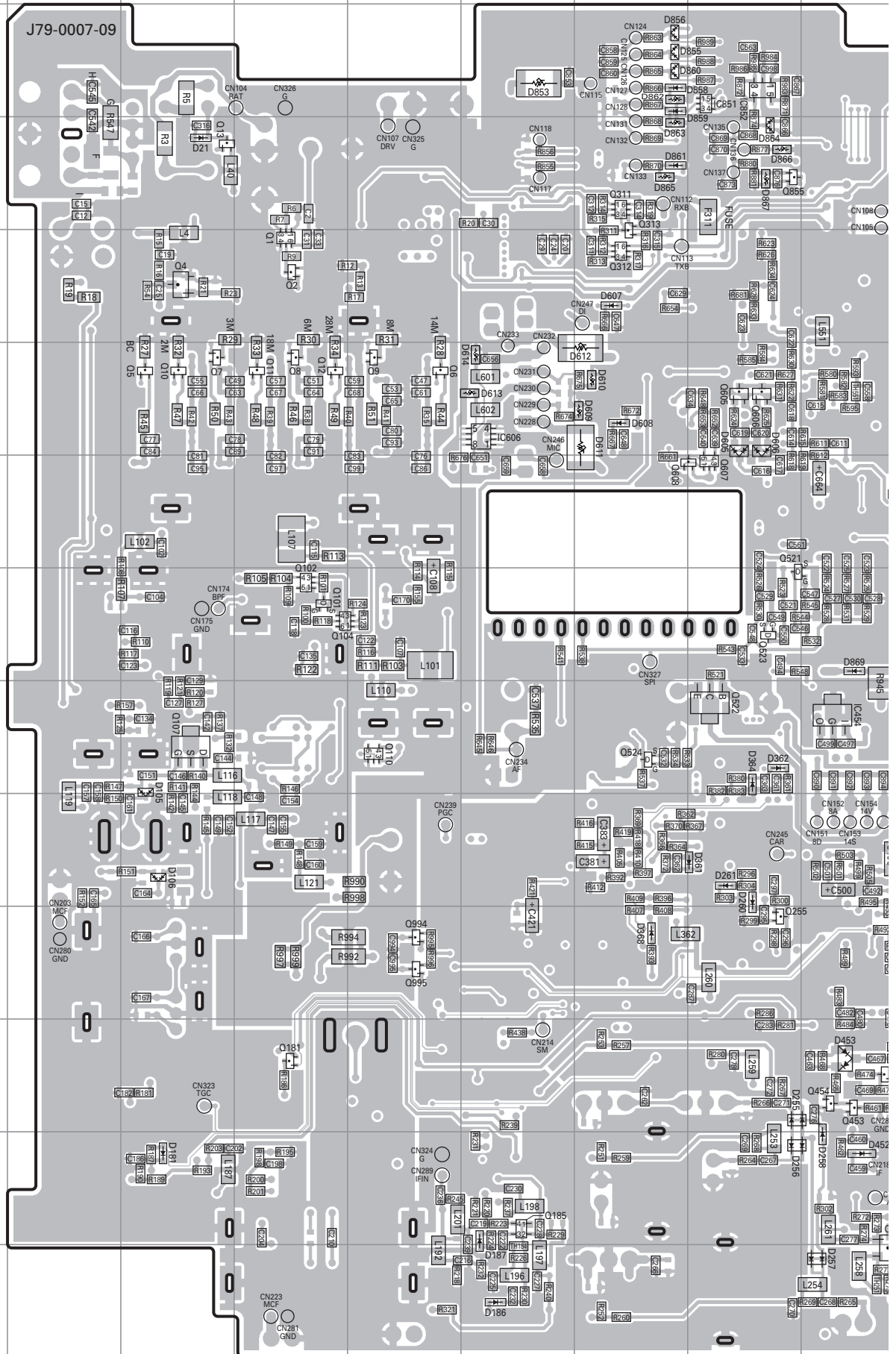

PC BOARD / PC板 TK-90

TX-RX UNIT (X57-7210-20) Foil side view (J79-0007-09)

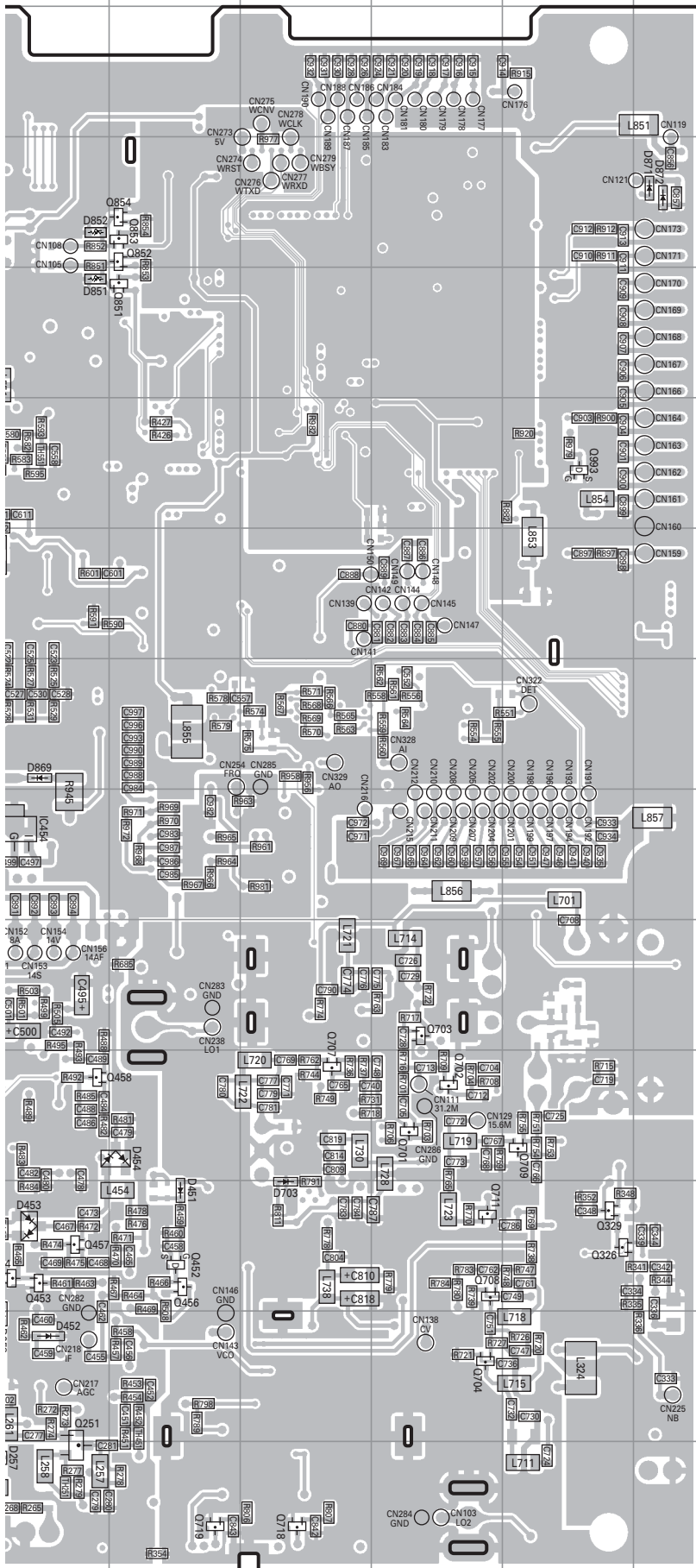

Ref. No.	Address	Ref. No.	Address	Ref. No.	Address
IC454	8J	Q522	8I	D361	9I
IC606	5G	Q523	7I	D362	8I
IC851	2I	Q524	8H	D364	8I
IC852	2I	Q605	5I	D368	10H
Q1	4E	Q606	5I	D451	11K
Q2	4E	Q607	6I	D452	12J
Q4	4D	Q608	6I	D453	11J
Q5	5D	Q701	10M	D454	10K
Q6	5F	Q702	10M	D605	5I
Q7	5D	Q703	9M	D606	5I
Q8	5E	Q704	12M	D607	4H
Q9	5F	Q707	10L	D608	5H
Q10	5D	Q708	11M	D609	5H
Q11	5E	Q709	10N	D610	5H
Q12	5E	Q711	11M	D611	5H
Q13	3D	Q718	13L	D612	5H
Q101	7E	Q719	13K	D613	5G
Q102	7E	Q851	4K	D614	5G
Q104	7E	Q852	3K	D703	11L
Q107	8D	Q853	3K	D851	4J
Q110	8F	Q854	3K	D852	3J
Q181	11E	Q855	3I	D853	2G
Q185	12G	Q993	5N	D855	2H
Q251	13J	Q994	10F	D856	2H
Q255	10I	Q995	10F	D858	2H
Q311	3H	D21	3D	D859	2H
Q312	4H	D105	8D	D860	2H
Q313	4H	D106	9D	D861	3H
Q326	11N	D181	12D	D862	2H
Q329	11N	D186	13G	D863	3H
Q452	11K	D187	12G	D864	3I
Q453	11J	D255	11I	D865	3H
Q454	11J	D256	12I	D866	3I
Q456	11K	D257	13J	D867	3I
Q457	11J	D258	12J	D869	7J
Q458	10J	D260	9I	D871	3O
Q521	7I	D261	9I	D872	3O

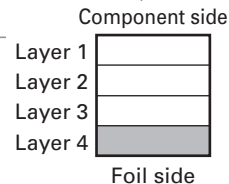

TK-90 PC BOARD / PC板

TX-RX UNIT (X57-7210-20) Foil side view (J79-0007-09)

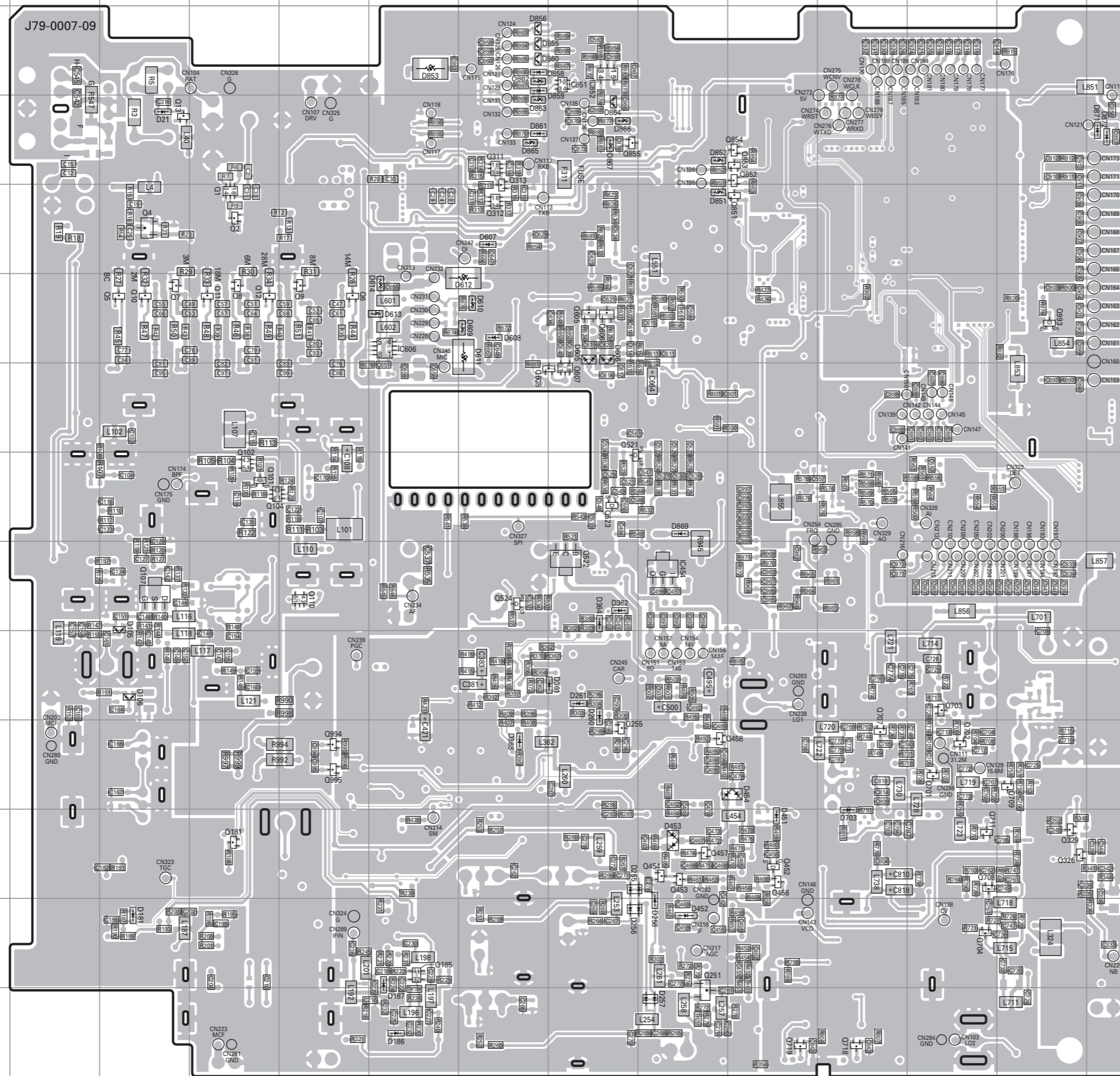

PC BOARD / PC板 TK-90

TX-RX UNIT (X57-7210-20) Foil side view (J79-0007-09)

Ref. No.	Address	Ref. No.	Address	Ref. No.	Address
IC454	8J	Q522	8I	D361	9I
IC606	5G	Q523	7I	D362	8I
IC851	2I	Q524	8H	D364	8I
IC852	2I	Q605	5I	D368	10H
Q1	4E	Q606	5I	D451	11K
Q2	4E	Q607	6I	D452	12J
Q4	4D	Q608	6I	D453	11J
Q5	5D	Q701	10M	D454	10K
Q6	5F	Q702	10M	D605	5I
Q7	5D	Q703	9M	D606	5I
Q8	5E	Q704	12M	D607	4H
Q9	5F	Q707	10L	D608	5H
Q10	5D	Q708	11M	D609	5H
Q11	5E	Q709	10N	D610	5H
Q12	5E	Q711	11M	D611	5H
Q13	3D	Q718	13L	D612	5H
Q101	7E	Q719	13K	D613	5G
Q102	7E	Q851	4K	D614	5G
Q104	7E	Q852	3K	D703	11L
Q107	8D	Q853	3K	D851	4J
Q110	8F	Q854	3K	D852	3J
Q181	11E	Q855	3I	D853	2G
Q185	12G	Q993	5N	D855	2H
Q251	13J	Q994	10F	D856	2H
Q255	10I	Q995	10F	D858	2H
Q311	3H	D21	3D	D859	2H
Q312	4H	D105	8D	D860	2H
Q313	4H	D106	9D	D861	3H
Q326	11N	D181	12D	D862	2H
Q329	11N	D186	13G	D863	3H
Q452	11K	D187	12G	D864	3I
Q453	11J	D255	11I	D865	3H
Q454	11J	D256	12I	D866	3I
Q456	11K	D257	13J	D867	3I
Q457	11J	D258	12J	D869	7J
Q458	10J	D260	9I	D871	3O
Q521	7I	D261	9I	D872	3O

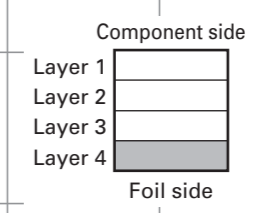

INTERCONNECTION DIAGRAM / 互连图

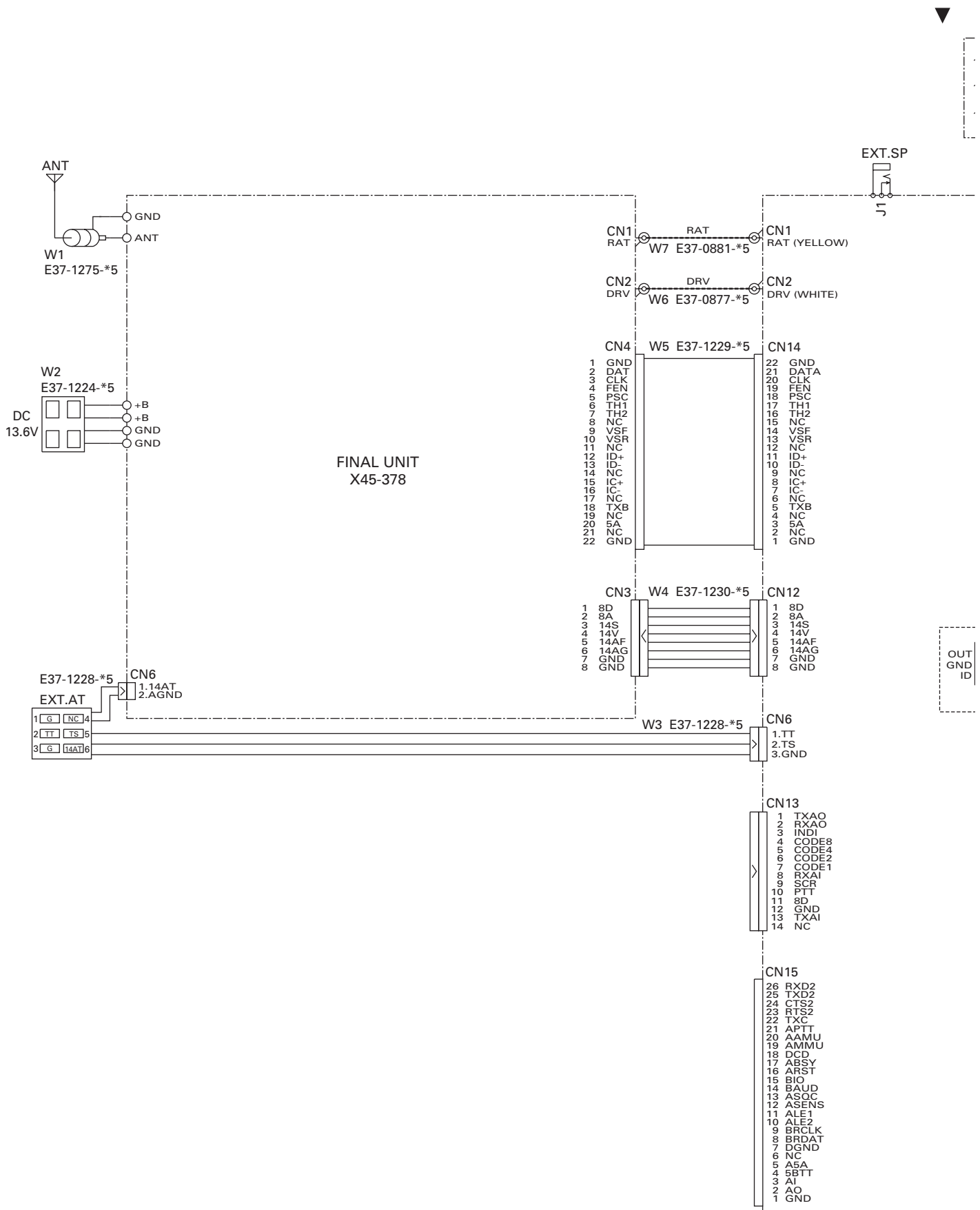

INTERCONNECTION DIAGRAM / 互连图

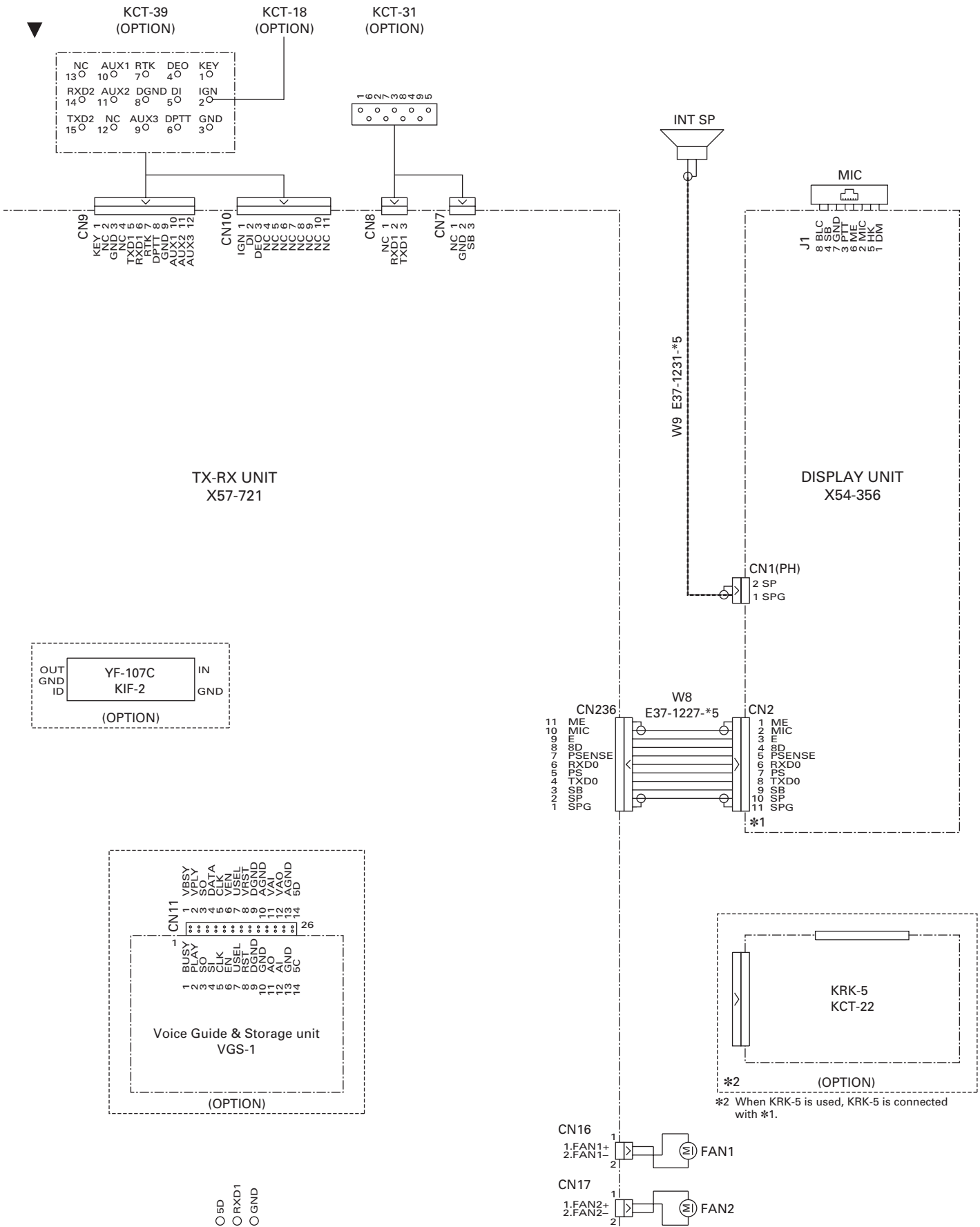

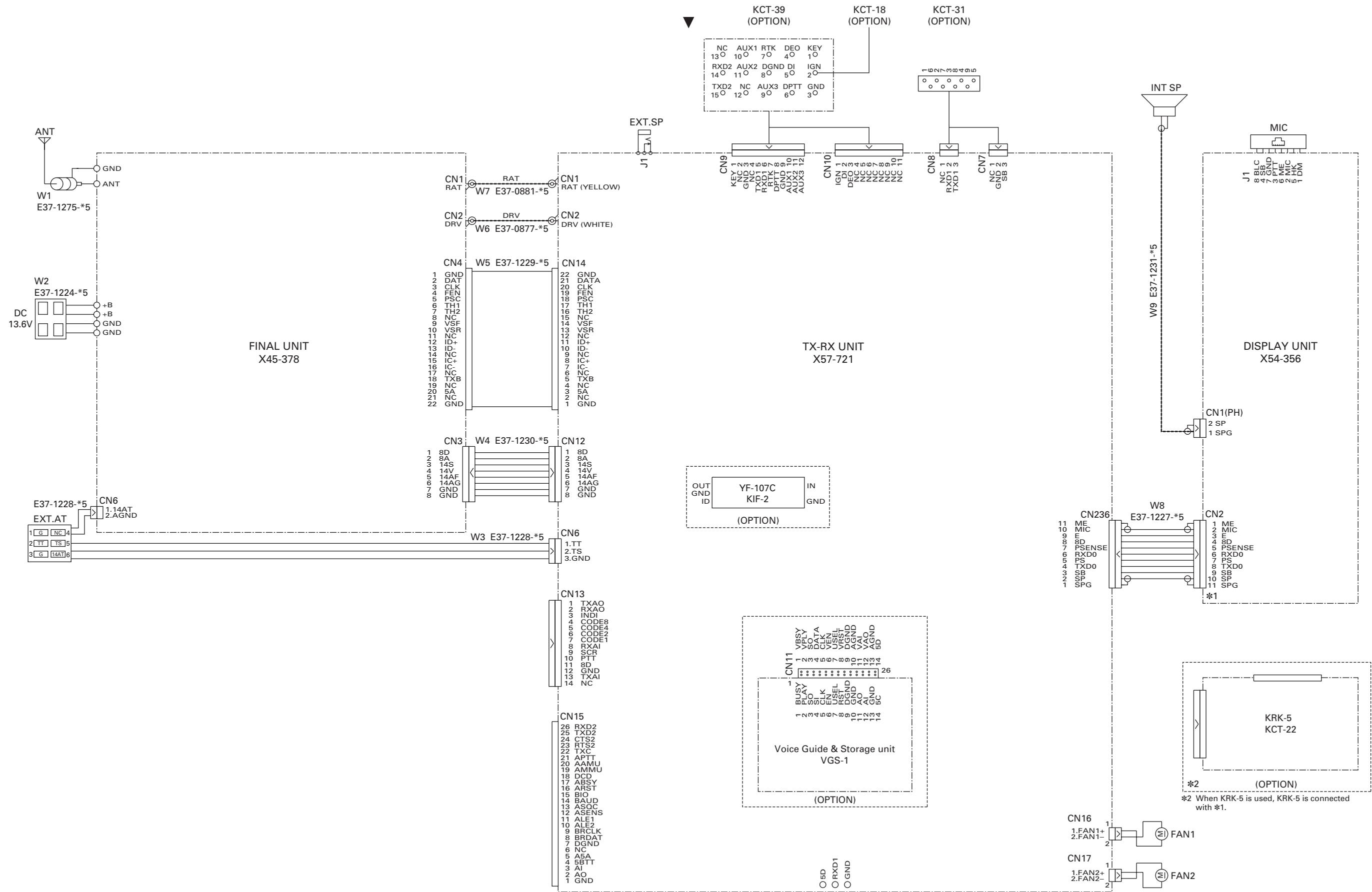

TK-90 SCHEMATIC DIAGRAM / 原理图

FINAL UNIT (X45-3780-20)

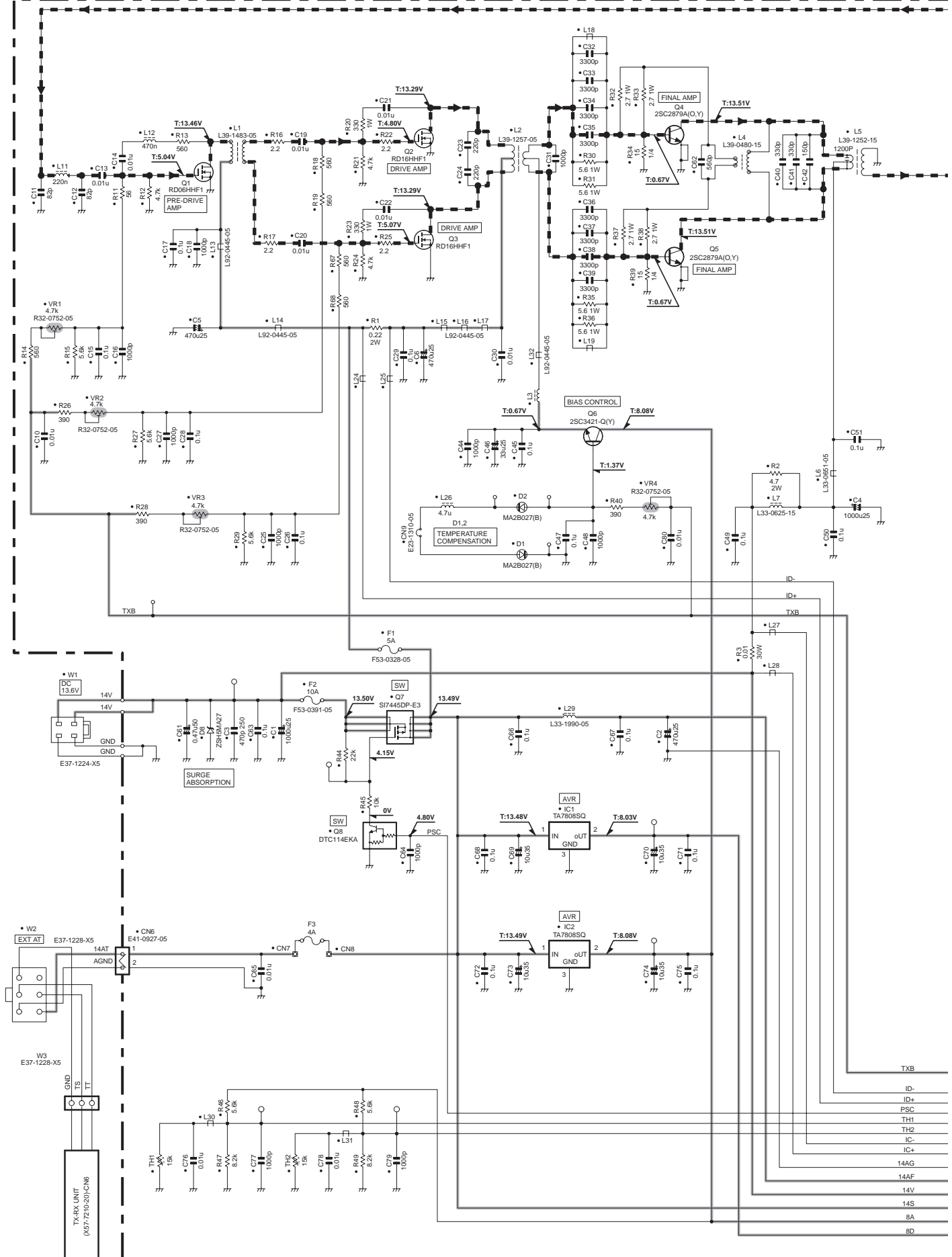

SCHEMATIC DIAGRAM / 原理图 TK-90

FINAL UNIT (X45-378020)

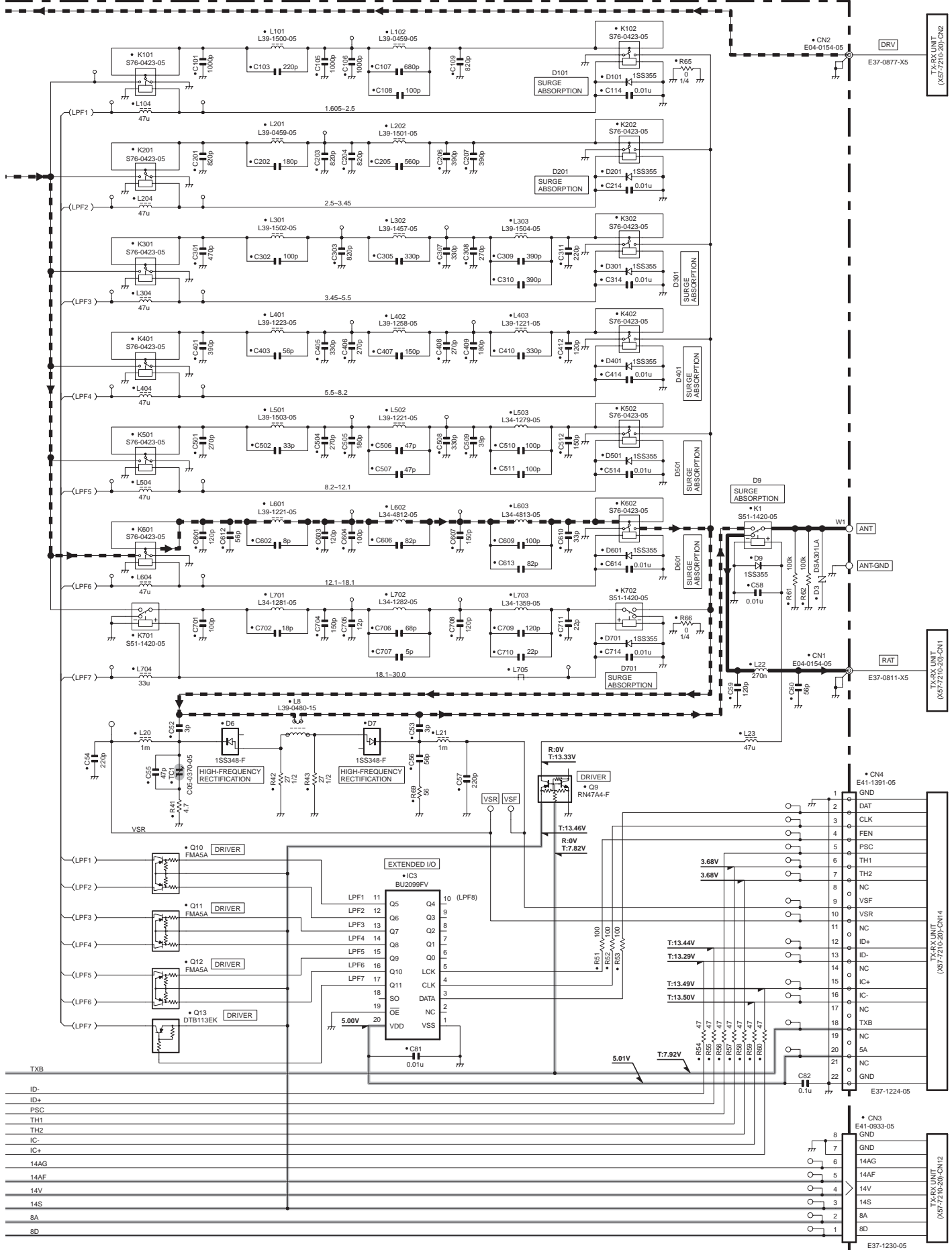

Note : The components marked with a dot (•) are parts of layer 1.

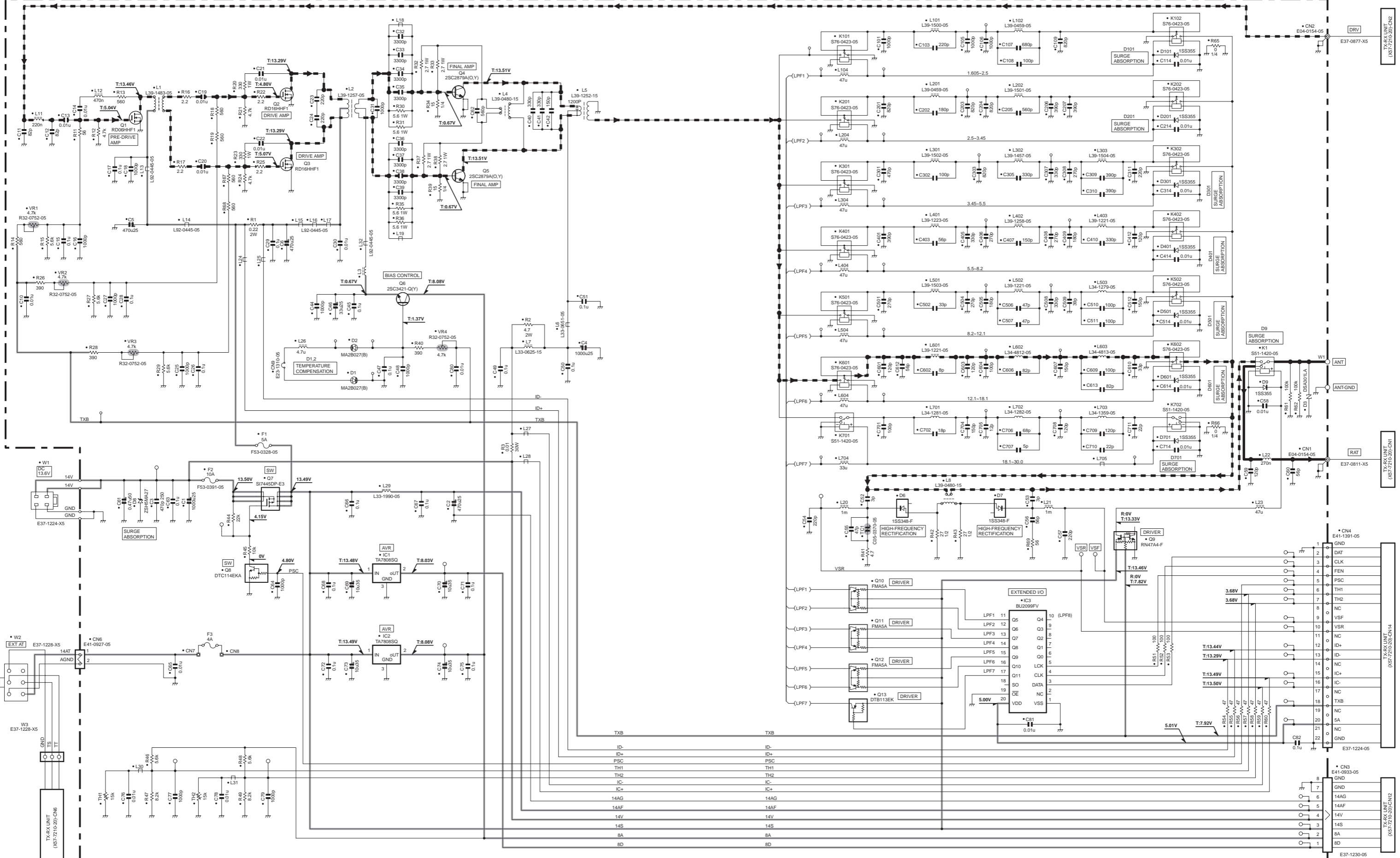

TXRX UNIT (X45-3780-20)

TXRX UNIT (X45-3780-20)

TXRX UNIT (X45-3780-20)

TXRX UNIT (X45-3780-20)

TXRX UNIT (X45-3780-20)

TK-90 SCHEMATIC DIAGRAM / 原理图

DISPLAY UNIT(X54-3560-20)

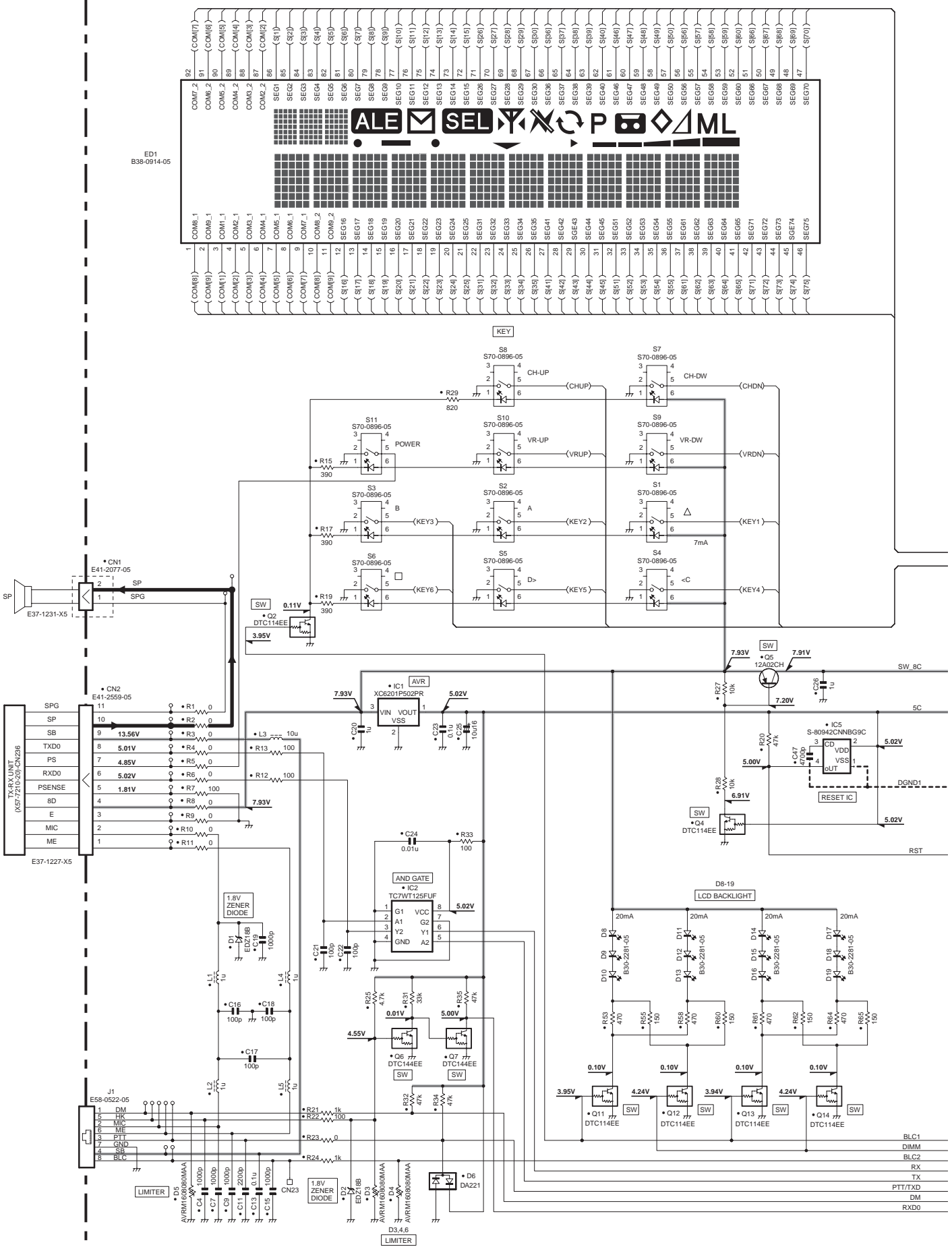

SCHEMATIC DIAGRAM / 原理图 TK-90

DISPLAY UNIT (X54-3560-20)

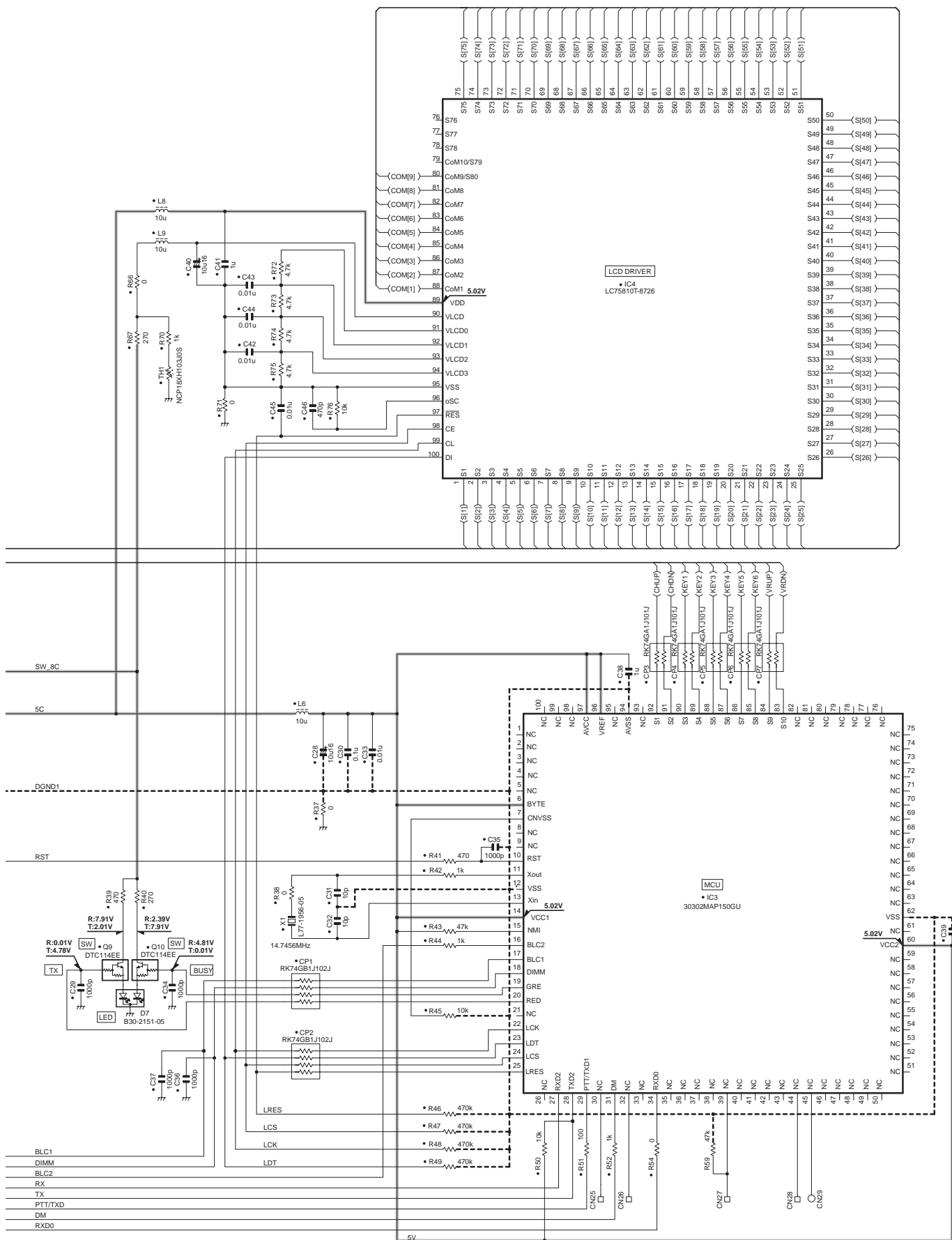

Note : The components marked with a dot (•) are parts of layer 1.

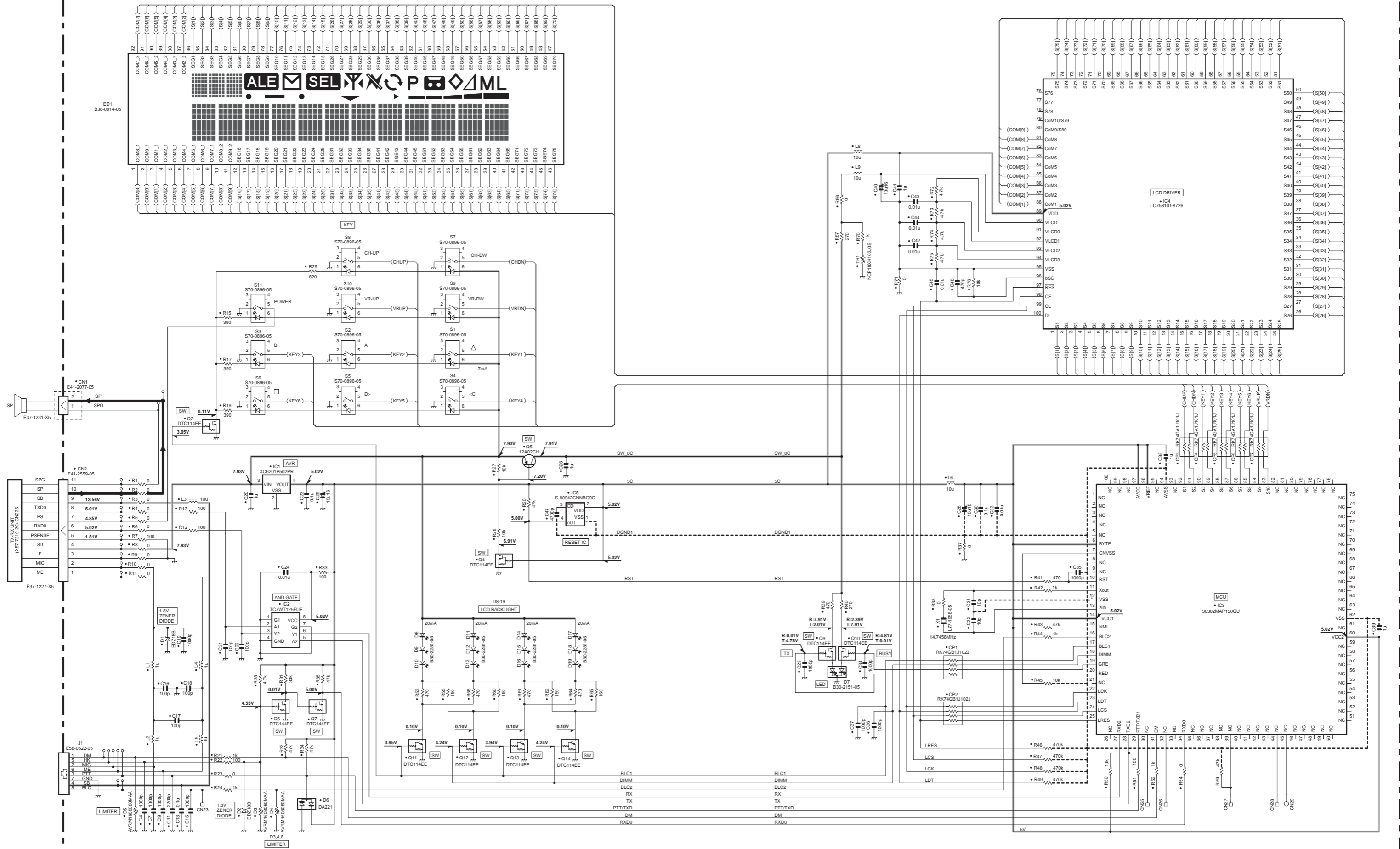

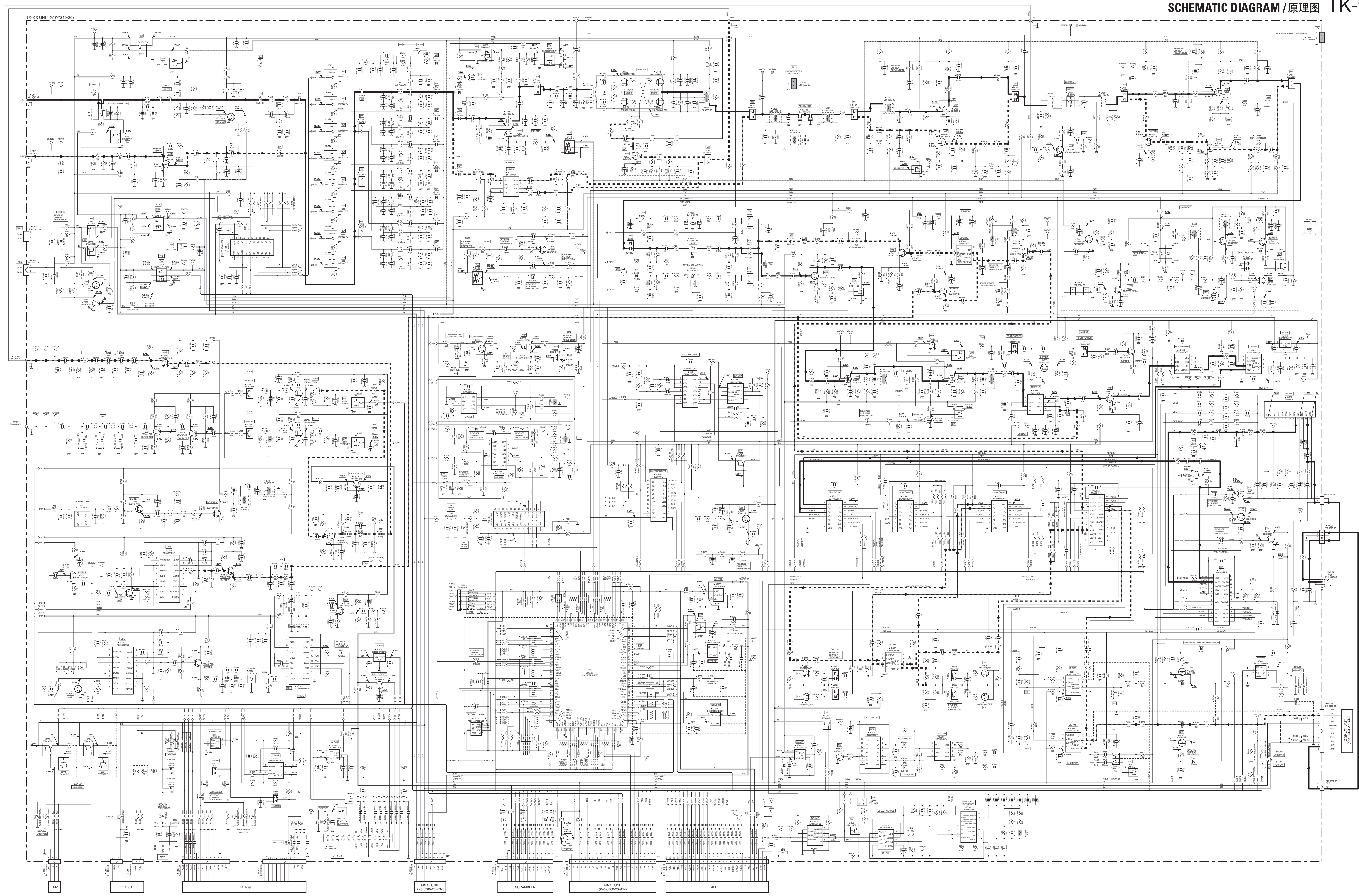

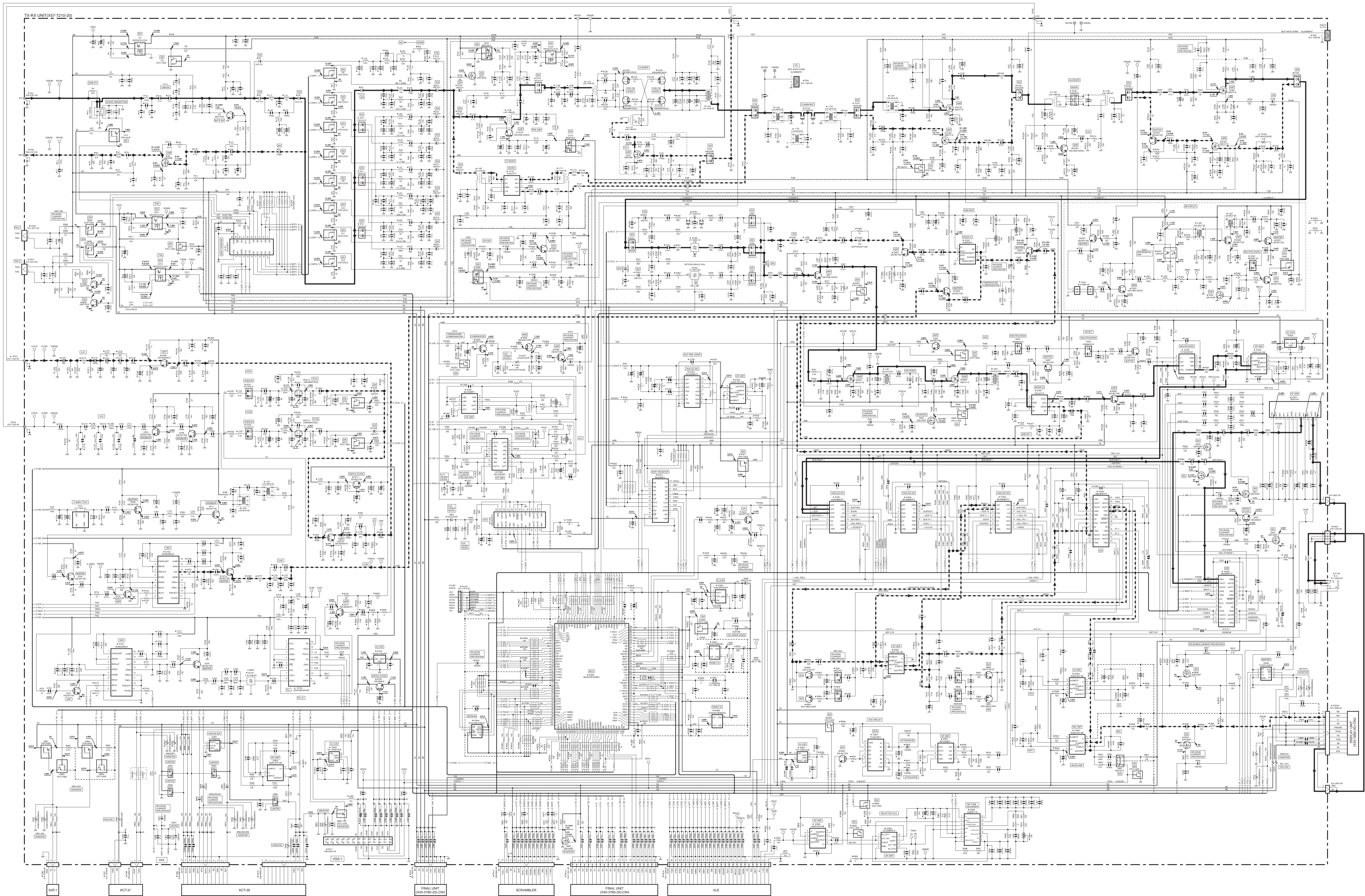

BLOCK DIAGRAM / 方块图

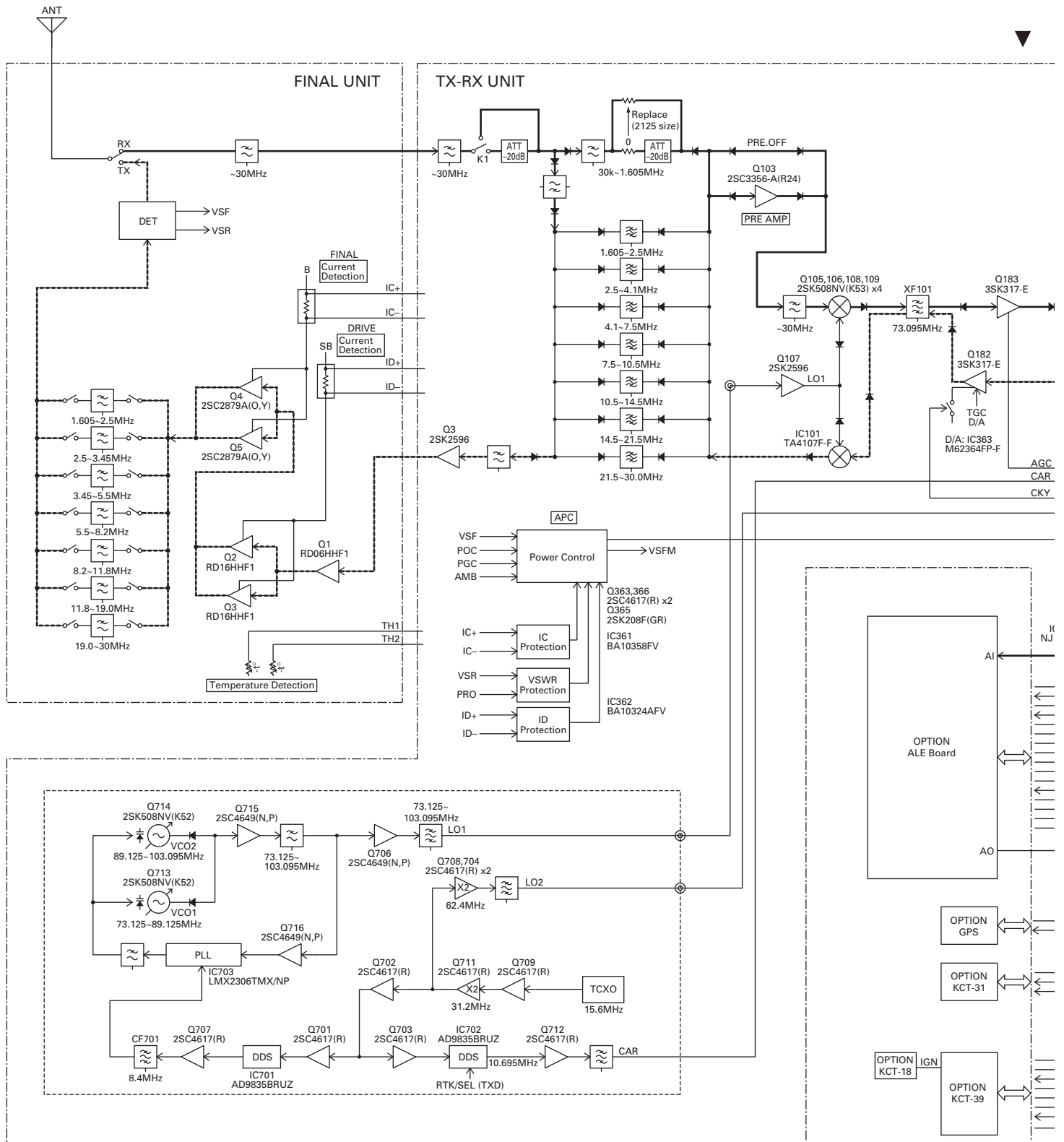

BLOCK DIAGRAM / 方块图

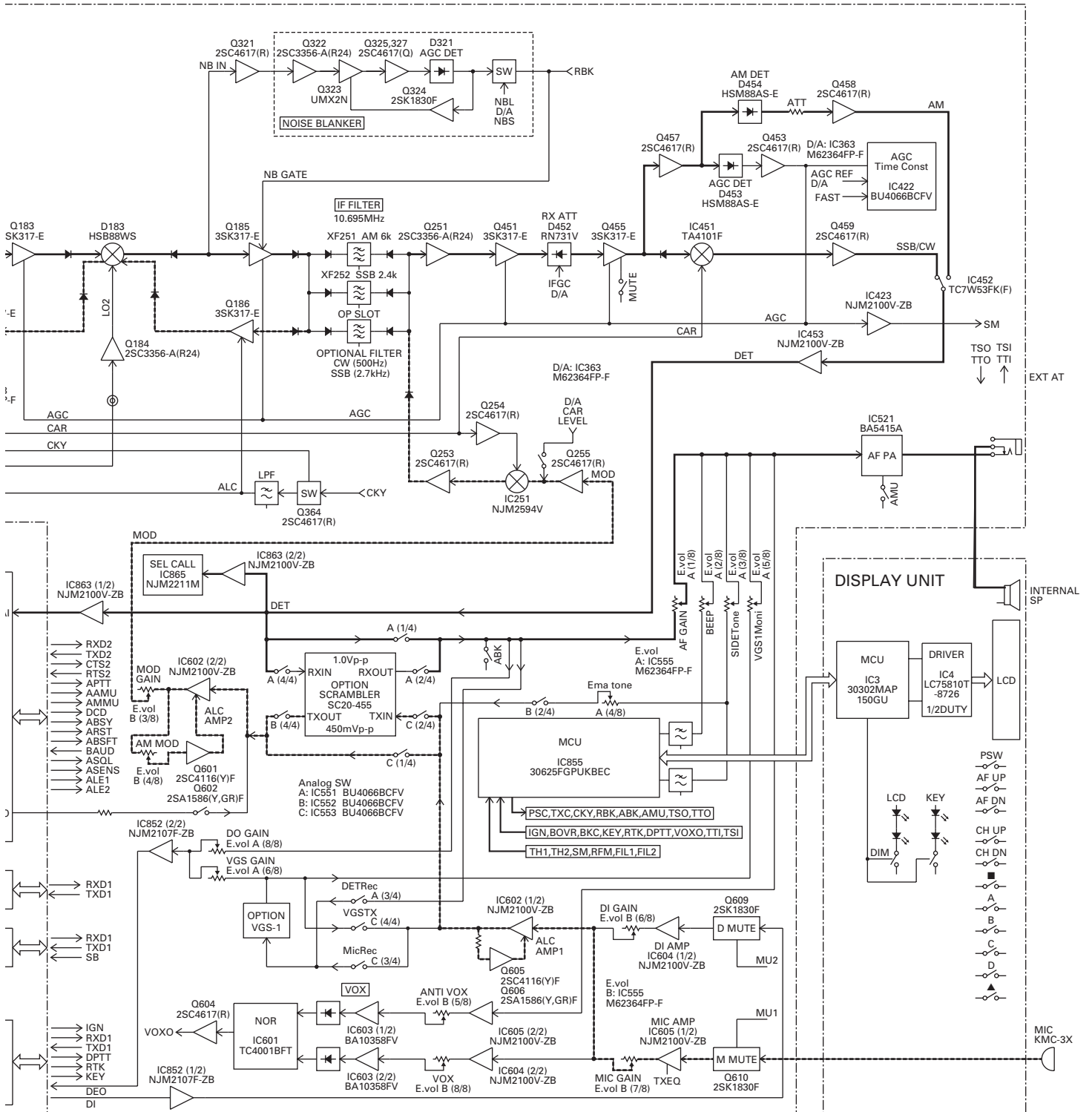

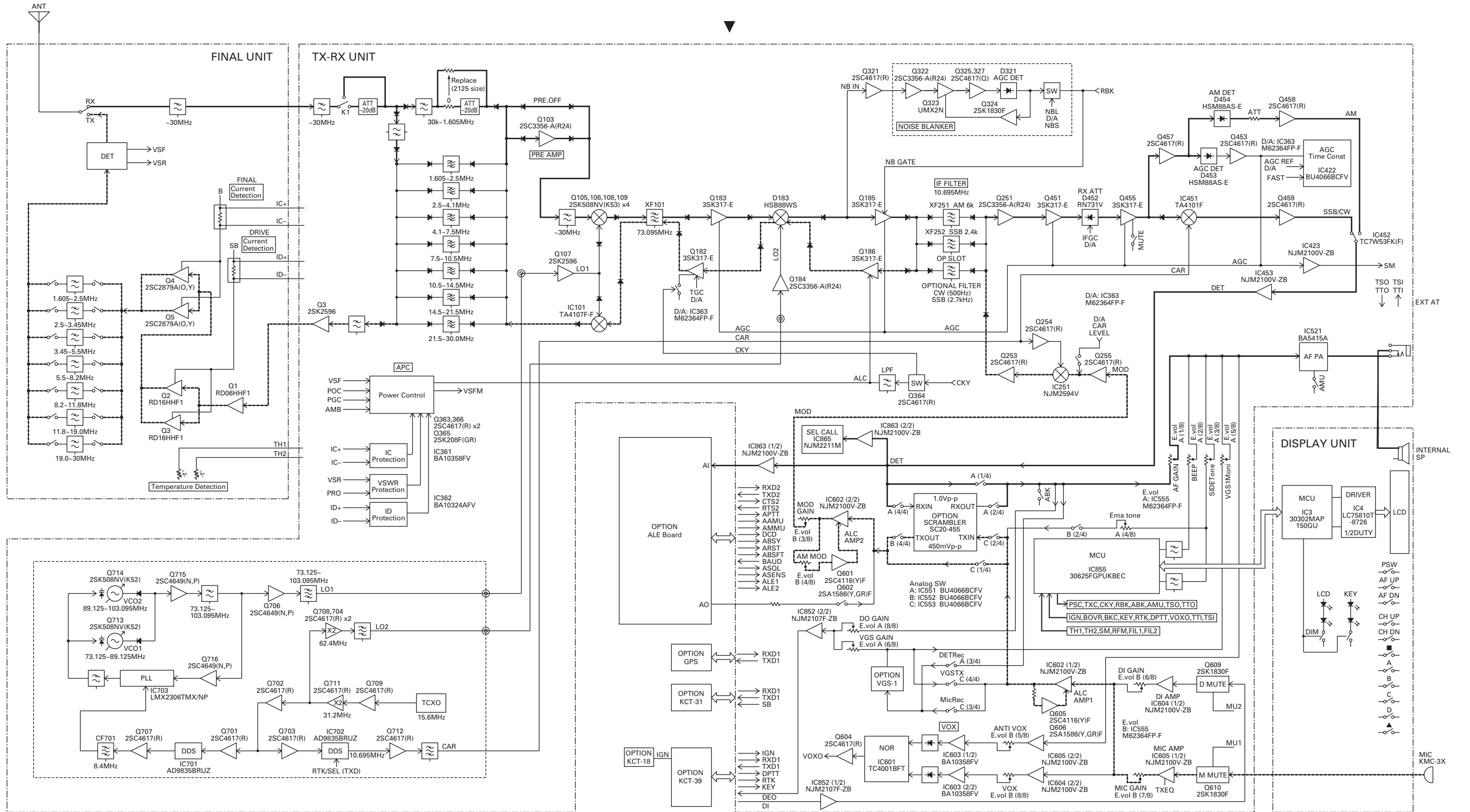

LEVEL DIAGRAM / 电平图

Receiver Section / 接收部

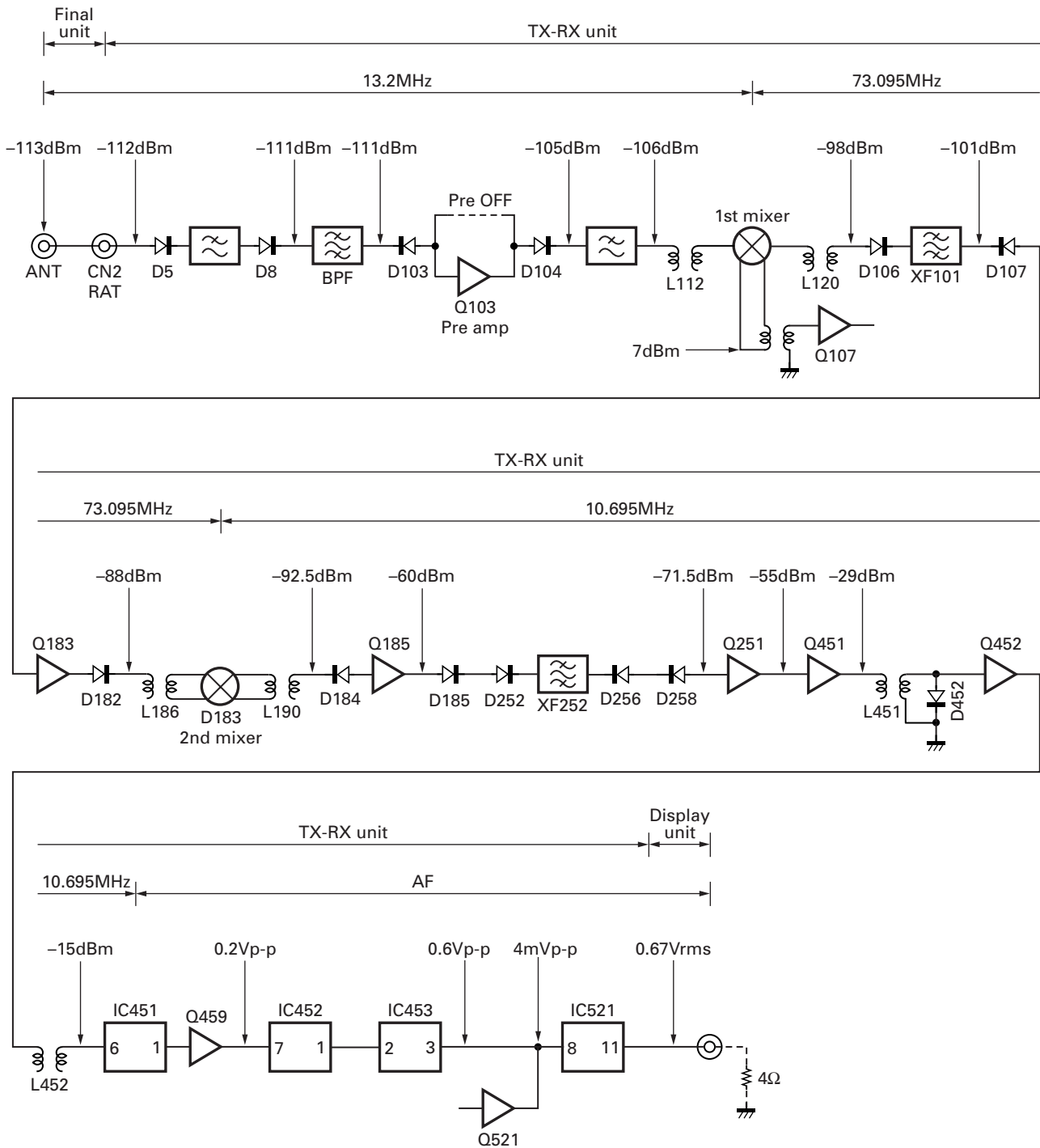

Measuring equipment

Spectrum analyzer
Oscilloscope
SSG

测量装置

频谱分析器
示波器
SSG

Measuring condition

RX frequency: 13.2MHz
Mode: USB (Pre amp: ON)
Antenna input: -113dBm
Audio output: Level 8
DEO output: Level 4
External speaker output : 4Ω terminated

测量条件

接收频率: 13.2MHz
模式: USB (前级放大器: 打开)
天线输入: -113dBm
音频输出: 电平8
DEO输出: 电平4
外部扬声器输出: 4Ω终端

LEVEL DIAGRAM / 电平图

Transmitter Section / 发射部

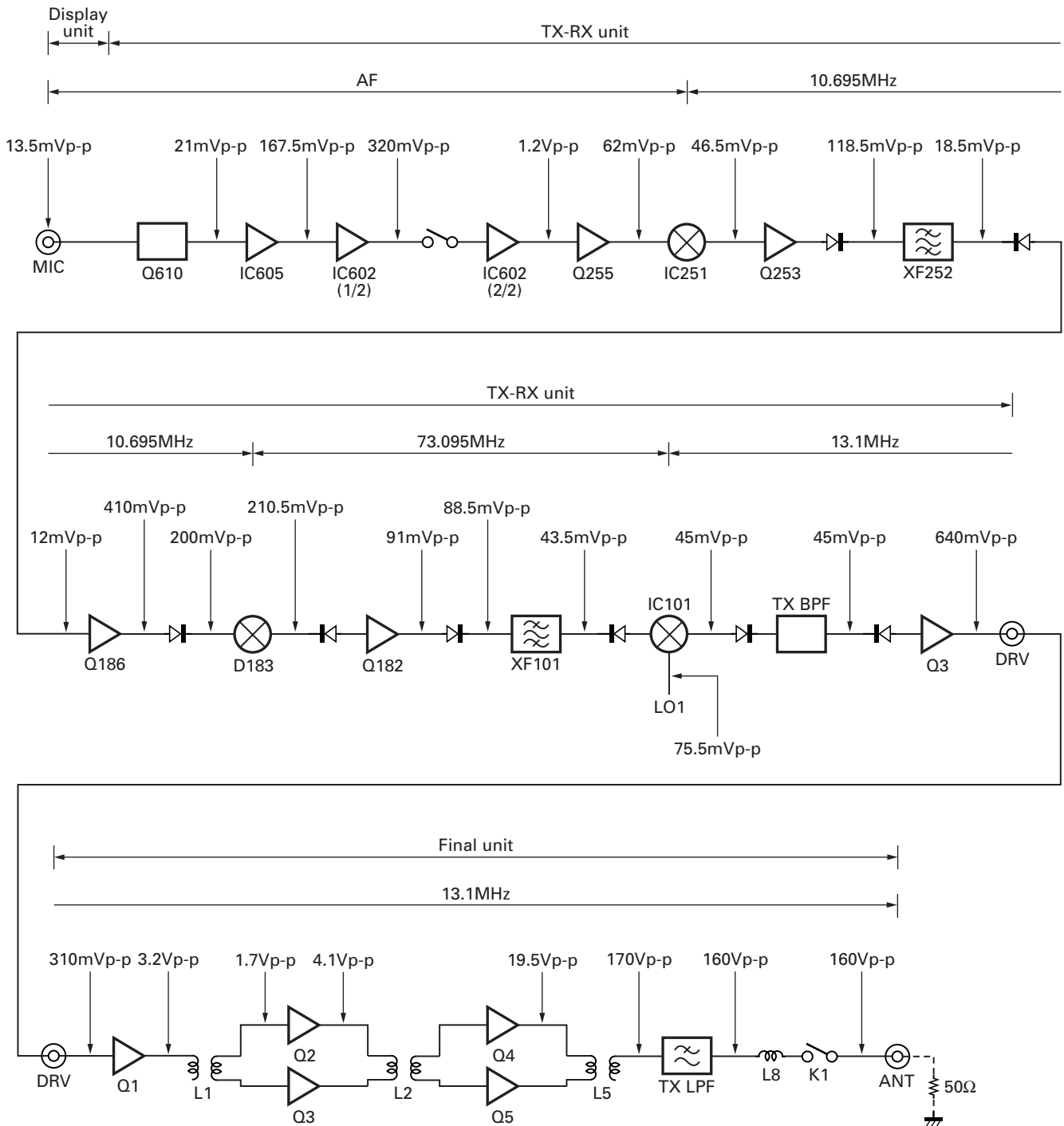

Measuring equipment

Oscilloscope
Audio generator (AG)

测量装置

示波器
音频发生器 (AG)

Measuring condition

TX frequency: 13.1MHz
Power: High
Microphone input: 7mV (TX power: 60W)
Mode: USB

测量条件

发射频率: 13.1MHz
功率: 高
麦克风输入: 7mV (发射功率: 60W)
模式: USB

SPECIFICATIONS

GENERAL

TX Frequency Range	1.8~30.0MHz
Guarantee Frequency Range	1.8~2.4MHz, 3.5~4.5MHz, 6.0~8.0MHz 11.0~14.5MHz, 16.0~21.5MHz, 24.0~30.0MHz
RX Frequency Range	0.5~30.0MHz
Number of Channels	300 Channels
Emission Type	J3E, J2B* (SSB) A1A (CW) A3E (AM) F1B (FSK)
	*: ALE mode
Operating Temperature	-20°C~+60°C
Operating Voltage	13.6V±15%
Frequency Stability	±0.5ppm (-10°C~+50°C) ±1.0ppm (-20°C~+60°C)
Current Drain	20.5A (TX), 1.2A (Stand-by)
Antenna Impedance	50Ω
Dimensions (W x H x D) Projections not included	
Radio only	179 x 60 x 276mm
Remote Panel	179 x 60 x 58mm
Weight	3.5kg

RECEIVER

Sensitivity	
SSB/CW/FSK	4μV (0.5~1.605MHz), 0.25μV (1.605~30.0MHz)
AM	32μV (0.5~1.605MHz), 2.5μV (1.605~30.0MHz)
Selectivity	
SSB/CW/FSK	2.2kHz (-6dB), 4.8kHz (-60dB)
With KIF-2	2.7kHz (-6dB), 6.2kHz (-60dB)
AM	5.0kHz (-6dB), 40.0kHz (-60dB)
Spurious Response	
IF Image Rejection	70dB
IF Rejection	80dB
Audio Output	3.5W (4Ω/10% distortion)

TRANSMITTER

Power Output	
SSB/CW/FSK	100W / 50W / 25W / 5W
AM	25W / 5W
Spurious Emission	-46dB
Carrier Suppression	40dB
Unwanted Sideband Suppression	50dB (1.0kHz tone)
Microphone Impedance	600Ω

规 格

概 述

发射频率范围	1.8~30.0MHz
保证频率范围	1.8~2.4MHz, 3.5~4.5MHz, 6.0~8.0MHz 11.0~14.5MHz, 16.0~21.5MHz, 24.0~30.0MHz
接收频率范围	0.5~30.0MHz
频道数	300
发射体制	J3E, J2B* (SSB) A1A (CW) A3E (AM) F1B (FSK)
	* : ALE方式
温度范围	- 20℃到 + 60℃
操作电压	直流13.6V ± 15%
频率稳定性	± 0.5ppm (- 10℃到 + 50℃) ± 1.0ppm (- 20℃到 + 60℃)
电流消耗	20.5A (发射), 1.2A (待机)
阻 抗	50Ω
尺寸 (宽 × 高 × 长) 未包括凸起部分	
通信机	179 x 60 x 276mm
遥控盘	179 x 60 x 58mm
重量 (净重)	3.5kg

接收部

灵敏度	
SSB/CW/FSK	4μV (0.5~1.605MHz), 0.25μV (1.605~30.0MHz)
AM	32μV (0.5~1.605MHz), 2.5μV (1.605~30.0MHz)
选择性	
SSB/CW/FSK	2.2kHz (- 60dB), 4.8kHz (- 60dB)
KIF-2	2.7kHz (- 60dB), 6.2kHz (- 60dB)
AM	5.0kHz (- 60dB), 40.0kHz (- 60dB)
杂散响应抗扰性	
中频镜像抑制	70dB
中频抑制	80dB
音频功率输出	3.5W (4Ω/10%失真)

发射部

功率输出	
SSB/CW/FSK	100W / 50W / 25W / 5W
AM	25W / 5W
杂散发射	- 46dB
载波抑制	40dB
无用边带抑制	50dB (1.0kHz音)
麦克风阻抗	600Ω

Kenwood Corporation

2967-3, Ishikawa-machi, Hachioji-shi, Tokyo, 192-8525 Japan

Kenwood U.S.A. Corporation

P.O. BOX 22745, 2201 East Dominguez Street, Long Beach,
CA 90801-5745, U.S.A.

Kenwood Electronics Canada Inc.

6070 Kestrel Road, Mississauga, Ontario, Canada L5T 1S8

Kenwood Electronics Deutschland GmbH

Rembrücker Str. 15, 63150 Heusenstamm, Germany

Kenwood Electronics Belgium N.V.

Leuvensesteenweg 248 J, 1800 Vilvoorde, Belgium

Kenwood Electronics France S.A.

L'Etoile Paris Nord 2, 50 Allée des Impressionnistes,
Bp 58416 Villepinte, 95944 Roissy Ch De Gaulle Cedex

Kenwood Electronics UK Limited

KENWOOD House, Dwight Road, Watford, Herts.,
WD18 9EB United Kingdom

Kenwood Electronics Europe B.V.

Amsterdamseweg 37, 1422 AC Uithoorn, The Netherlands

Kenwood Electronics Italia S.p.A.

Via G. Sirtori, 7/9 20129 Milano, Italy

Kenwood Ibérica, S.A.

Bolivia, 239-08020 Barcelona, Spain

Kenwood Electronics Australia Pty. Ltd.

(A.C.N. 001 499 074)

16 Giffnock Avenue, Centrecourt Estate, North Ryde, N.S.W. 2113 Australia

Kenwood Electronics (Hong Kong) Ltd.

Unit 3712-3724, Level 37, Tower one Metroplaza, 223 Hing Fong Road,
Kwai Fong, N.T., Hong Kong

Kenwood Electronics Singapore Pte Ltd

1 Ang Mo Kio Street 63, Singapore 569110

