

KENWOOD

SERVICE MANUAL

VHF DIGITAL TRANSCEIVER

TK-D240, TK-D240(V)

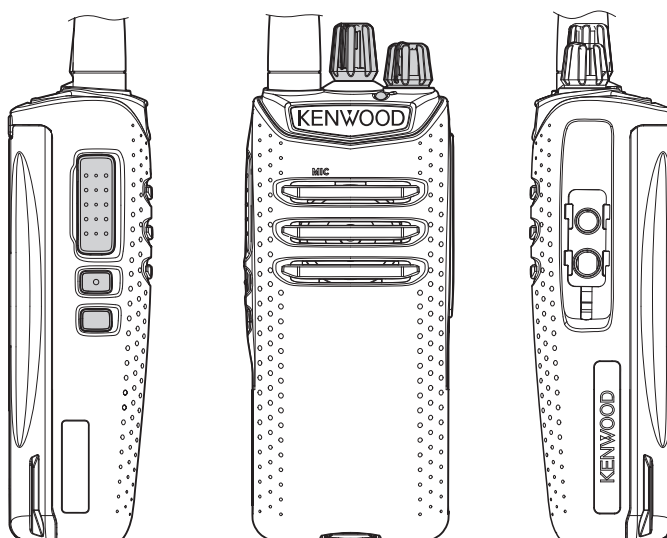

TABLE OF CONTENTS

1	PRECAUTION.....	1-5
2	SPECIFIC SERVICE INSTRUCTIONS.....	1-5
3	DISASSEMBLY.....	1-16
4	ADJUSTMENT.....	1-19
5	TROUBLESHOOTING.....	1-46

This product complies with the RoHS directive for the European market.



This product uses Lead Free solder.

Document Copyrights

Copyright 2015 by JVC KENWOOD Corporation. All rights reserved.

No part of this manual may be reproduced, translated, distributed, or transmitted in any form or by any means, electronic, mechanical, photocopying, recording, or otherwise, for any purpose without the prior written permission of JVC KENWOOD Corporation.

Disclaimer

While every precaution has been taken in the preparation of this manual, JVC KENWOOD Corporation assumes no responsibility for errors or omissions. Neither is any liability assumed for damages resulting from the use of the information contained herein.

JVC KENWOOD Corporation reserves the right to make changes to any products herein at any time for improvement purposes.

Firmware Copyrights

The title to and ownership of copyrights for firmware embedded in KENWOOD product memories are reserved for JVC KENWOOD Corporation. Any modifying, reverse engineering, copy, reproducing or disclosing on an Internet website of the firmware is strictly prohibited without prior written consent of JVC KENWOOD Corporation. Furthermore, any reselling, assigning or transferring of the firmware is also strictly prohibited without embedding the firmware in KENWOOD product memories.

Transceivers containing AMBE+2™ Vocoder: The AMBE+2™ voice coding technology is embedded in the firmware under the license of Digital Voice Systems, Inc.

SPECIFICATION

(K,M TYPE)

GENERAL		
Frequency Range		136~174MHz
Number of Channels		32 ch / 2 zones (Max. 16 ch/ zone)
Channel Spacing	Analog	25 / 12.5 kHz
	Digital	12.5 kHz
Operating Voltage		7.5V DC \pm 20%
Battery Life (5-5-90, battery saver off)	Analog / Digital	Approx. 11.5 / 13.5 hrs w/ /KNB-45L
		Approx. 14 / 17 hrs w/ /KNB-69L
		Approx. 8 / 10 hrs w/ /KNB-53N
Operating Temperature Range		-22°F~+140°F (-30°C ~ +60°C) with KNB-45L / 69L: +14°F~+140°F (-10 °C ~ +60 °C)
Frequency Stability		\pm 2.0ppm
Antenna Impedance		50 Ω
Dimensions (W x H x D) (Projections not included)	w/ Battery	2.13 x 4.78 x 1.33 in. (54 x 121.4 x 33.8 mm) (w/ KNB-45L)
		2.13 x 4.78 x 1.49 in. (54 x 121.4 x 37.8 mm) (w/ KNB-69L)
		2.13 x 4.78 x 1.33 in. (54 x 121.4 x 33.8 mm) (w/ KNB-53N)
Weight (net)	w/ Battery	10.0 oz (285 g) (w/ KNB-45L)
		10.9 oz (310 g) (w/ KNB-69L)
		12.7 oz (360 g) (w/ KNB-53N)
RECEIVER		
Sensitivity	Digital 1 % BER	0.45 μ V
	Digital 5 % BER	0.3 μ V
	Analog (12dB SINAD)	0.25 μ V
Adjacent Channel Selectivity	Analog @ 25 / 12.5 kHz	74 dB / 68 dB
Intermodulation Distortion	Analog	72dB
Spurious Response	Analog	70dB
Audio Distortion		Less than 10%
Audio Output		1W/12 Ω (Internal speaker) 500mW/8 Ω (External output)
TRANSMITTER		
RF Power Output	High/Low	5W/1W
Spurious Response		70dB
FM Hum & Noise	Analog @ 25 / 12.5 kHz	45 / 40 dB
Audio Distortion		Less than 2%
Emission Designator		16K0F3E, 14K0F2D, 11K0F3E, 7K50F2D, 7K60FXE, 7K60FXD

Specifications shown are typical.

Analog 25 kHz is not included in the models sold in the USA or US territories.

Analog measurements accord with TIA 603. Digital measurements accord with EN 300 113.

JVC KENWOOD Corporation reserves the right to change specifications without prior notice or obligation.

(E,E2 TYPE)

GENERAL		
Frequency Range		136~174MHz
Number of Channels		32 ch / 2 zones (Max. 16 ch/ zone)
Channel Spacing	Analogue	25 / 20 / 12.5 kHz
	Digital	12.5 kHz
Operating Voltage		7.5V DC \pm 20%
Battery Life (5-5-90, battery saver off)	Analogue / Digital	Approx. 11.5 / 13.5 hrs w/ /KNB-45L
		Approx. 14 / 17 hrs w/ /KNB-69L
		Approx. 8 / 10 hrs w/ /KNB-53N
Operating Temperature Range		-30°C ~ +60°C with KNB-45L / 69L: -10 °C ~ +60 °c
Frequency Stability		\pm 2.0ppm
Antenna Impedance		50 Ω
Dimensions (W x H x D) (Projections not included)	w/ Battery	54 x 121.4 x 33.8 mm (w/ KNB-45L)
		54 x 121.4 x 37.8 mm (w/ KNB-69L)
		54 x 121.4 x 33.8 mm (w/ KNB-53N)
Weight (net)	w/ Battery	285 g (w/ KNB-45L)
		310 g (w/ KNB-69L)
		360 g (w/ KNB-53N)
RECEIVER		
Sensitivity	Digital 1 % BER	-1 dB μ V (0.45 μ V)
	Digital 5 % BER	-4.5 dB μ V (0.3 μ V)
	Analogue (20 dB SINAD) @ 25 / 20 / 12.5 kHz	-3 dB μ V (0.35 μ V) / -3 dB μ V (0.35 μ V) / -1 dB μ V (0.45 μ V)
Adjacent Channel Selectivity	Analogue @ 25 / 20 / 12.5 kHz	74 dB / 72 dB / 67 dB
Intermodulation Distortion	Analogue	65dB
Spurious Response	Analogue	70dB
Audio Distortion		Less than 10%
Audio Output		1W/12 Ω (Internal speaker) 500mW/8 Ω (External output)
TRANSMITTER		
RF Power Output	High/Low	5W/1W
Spurious Response		<1 GHz \leq -36 dBm, 1 GHz - 4 GHz \leq -30 dBm
FM Hum & Noise	Analogue @ 25 / 20 / 12.5 kHz	45 / 45 / 40 dB
Audio Distortion		Less than 2%
Emission Designator		16K0F3E, 14K0F2D, 14K0F3E, 12K0F2D, 8K50F3E, 7K50F2D, 7K60FXE, 7K60FXD

Specifications shown are typical.

Analogue measurements accord with TIA 603, EN 300 086 & 219. Digital measurements accord with EN 300 113.

JVC KENWOOD Corporation reserves the right to change specifications without prior notice or obligation.

SECTION 1 PRECAUTION

This service manual does not describe PRECAUTION.

SECTION 2 SPECIFIC SERVICE INSTRUCTIONS

2.1 SYSTEM SET-UP

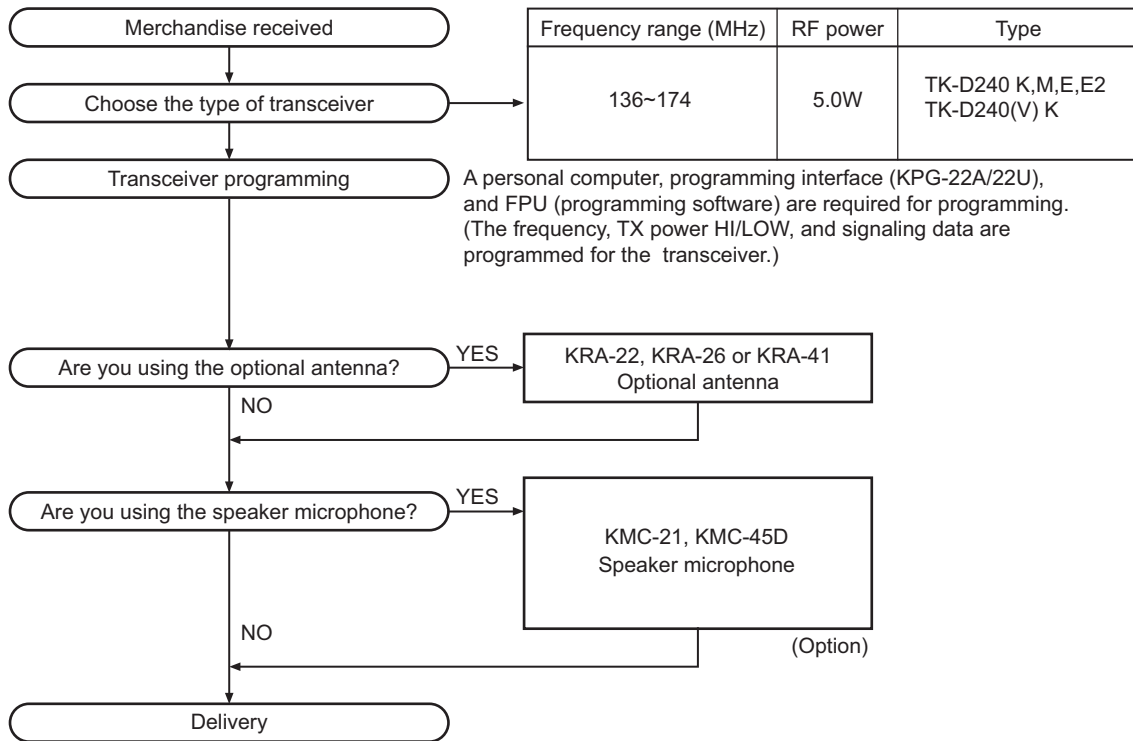

2.2 REALIGNMENT

2.2.1 Modes

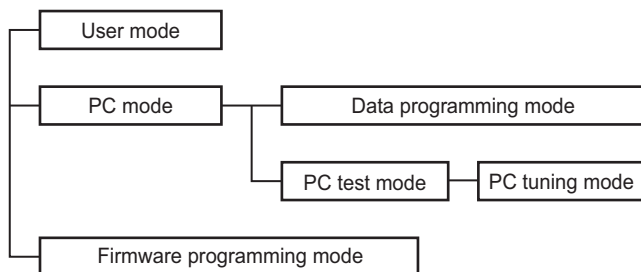

Mode	Function
User mode	For normal use.
PC mode	Used to communication between the transceiver and PC.
PC programming mode	Used to read and write frequency data and other features to and from the transceiver.
PC test mode	Used to check the transceiver using the PC. This feature is included in the FPU.

Mode	Function
PC tuning mode	Used to tune the transceiver using the PC.
Firmware programming mode	Used when changing the main program of the flash memory.

2.2.2 How to Enter Each Mode

Mode	Operation
User mode	Power ON
PC mode	Received commands from PC
Firmware programming mode	[Side2] + Power ON (Two seconds)

2.2.3 PC Mode

2.2.3.1 Preface

The transceiver is programmed by using a personal computer, a programming interface (KPG-22A/22U) and the FPU (programming software).

The programming software can be used with a PC. Figure 1 shows the setup of a PC for programming.

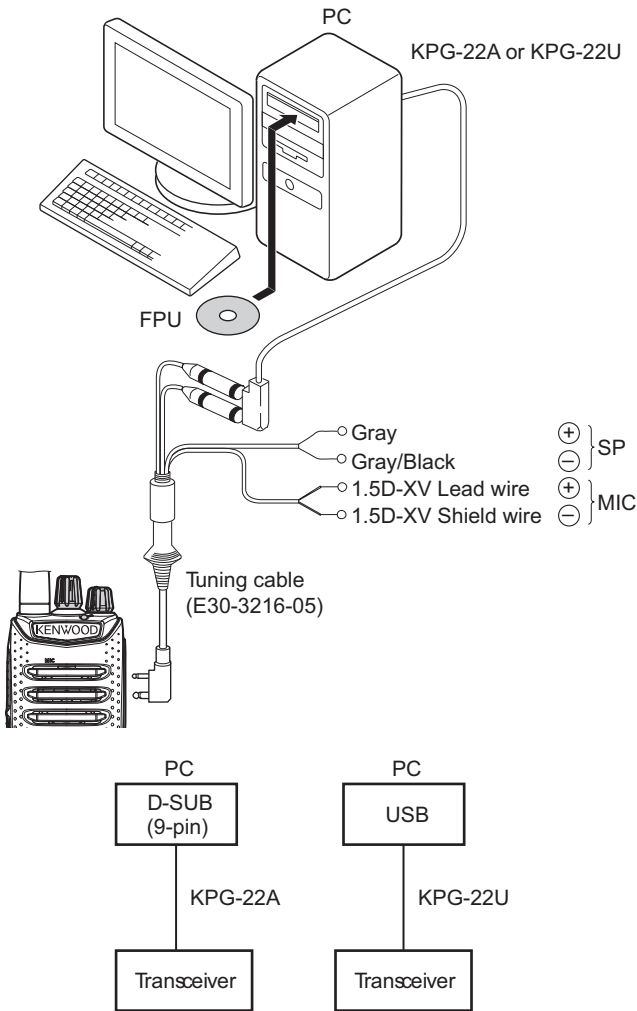

Fig.1

2.2.3.2 Connection procedure

- (1) Connect the transceiver to the computer using the interface cable.

Note:

You must install the KPG-22U driver in the computer to use the USB programming interface cable (KPG-22U).

- (2) When the Power is switched on, you can immediately enter user mode. When the PC sends a command, the transceiver enters PC mode.

When data is transmitting from the transceiver, the red LED lights.

When data is being received by the transceiver, the green LED lights.

Note:

- The data stored in the computer must match the "Model Name and Model Type" when it is written into the Flash memory.
- Do not press the [PTT] key during data transmission or reception.

2.2.3.3 KPG-22A description (PC programming interface cable: Option)

The KPG-22A is required to interface the transceiver with the computer. It has a circuit in its D-sub connector (KPG-22A: 9-pin) case that converts the RS-232C logic level to the TTL level.

The KPG-22A connects the SP/MIC connector of the transceiver to the RS-232C serial port of the computer.

2.2.3.4 KPG-22U description (USB programming interface cable: Option)

The KPG-22U is a cable which connects to a USB port on a computer.

When using the KPG-22U, install the supplied CD-ROM (with driver software) in the computer. The KPG-22U driver runs under Windows XP, Vista, 7, 8 or 8.1.

The latest version of the USB driver is available for download from the following URL:

<http://www.kenwood.com/usb-com/>

(This URL may change without notice.)

2.2.3.5 Programming software: KPG-166D (Ver. 2.00 or later) description

The FPU is the programming software for the transceiver supplied on a CD-ROM. This software runs under Windows XP, Vista, 7, 8 or 8.1 on a PC. The software on this disk allows a user to program the transceiver via the Programming interface cable (KPG-22A/22U).

2.2.3.6 Programming with a PC

If data is transferred to the transceiver from a PC with the FPU, the data for each set can be modified.

Data can be programmed into the Flash memory in RS-232C format via the SP/MIC jack.

In this mode, the PTT line operate as TXD and RXD data lines, respectively.

2.2.4 Firmware Programming Mode

2.2.4.1 Preface

Flash memory is mounted on the transceiver. This allows the transceiver to be upgraded when new features are released in the future. (For details on how to obtain the firmware, contact Customer Service.)

2.2.4.2 Connection procedure

Connect the transceiver to the personal computer using the interface cable (KPG-22A/22U).

(Connection is the same as in the PC Mode.)

2.2.4.3 Programming

[Firmware upgrade in User Mode]

- (1) Start up the firmware programming software (Updater).
- (2) Set the communications speed (normally, 115200 bps) and communications port in the configuration item.
- (3) Power On the transceiver in User mode.
- (4) Press "write" button in the window. When the transceiver starts to receive data, the orange LED turns to green.
- (5) If writing ends successfully, the green LED turns to red.

Note:

- It is not necessary to enable the Firmware Programming mode in the Programming software.
- Normally, write in the high-speed mode.

[Firmware upgrade in Firmware Programming Mode]

- (1) Start up the firmware programming software (Updater).
- (2) Set the communications speed (normally, 115200 bps) and communications port in the configuration item.
- (3) Press and hold the [Side2] key while turning the transceiver power ON. Then, the orange LED turns on.

- (4) Press "write" button in the window. When the transceiver starts to receive data, the orange LED turns to green.
- (5) If writing ends successfully, the green LED turns to red.

Note:

- This mode cannot be entered if the Firmware Programming mode is set to Disable in the Programming software.
- Normally, write in the high-speed mode.

2.3 CIRCUIT DESCRIPTION

2.3.1 Frequency Configuration

The receiver utilizes double conversion. The first IF is 49.95MHz and the second IF is 450kHz. The first Local oscillator is supplied from the PLL circuit.

The PLL circuit in the transmitter generates the necessary frequencies. Figure 1 shows the frequencies.

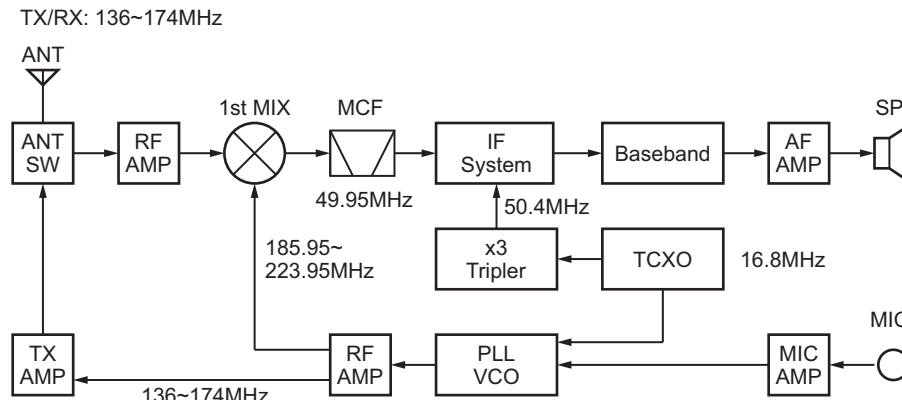

Fig.1 Frequency configuration

2.3.2 Receiver System

The receiver system is shown in Figure 2.

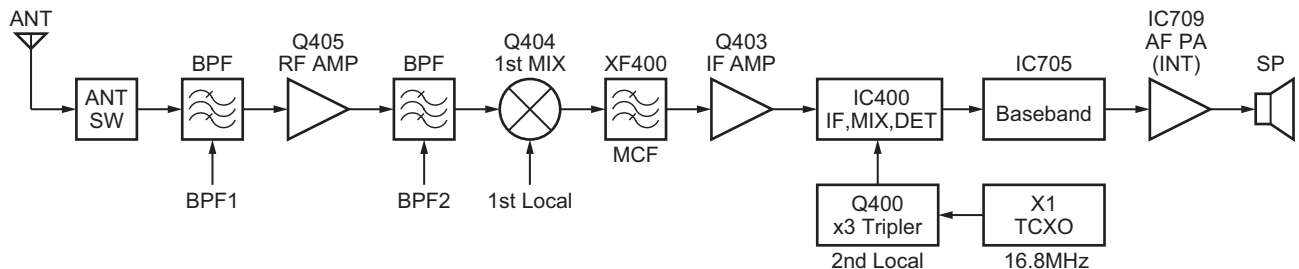

Fig.2 Receiver system

2.3.2.1 Front End (RF Amplifier) Circuit

The signal coming from the antenna passes through the transmit/receive switching diode circuit (D201, D202, D203 and D204) and a BPF (L415 and L416), and is then amplified by the RF amplifier (Q405).

The resulting signal passes through a BPF (L411 and L414) and goes to the mixer. The BPF is adjusted by variable capacitance diodes (D401, D402, D403 and D404). The input voltage to the variable capacitance diodes is the regulated voltage output from the DC amplifier (IC704, IC721).

2.3.2.2 First Mixer

The signal from the front end is mixed with the first local oscillator signal generated in the PLL circuit by Q404 to produce the first IF frequency of 49.95MHz.

The resulting signal passes through the XF400 MCF to cut the adjacent spurious and provide optimum characteristics, such as adjacent frequency selectivity.

2.3.2.3 IF Amplifier Circuit

The first IF signal is passed through a four-pole monolithic crystal filter (XF400) to remove the adjacent channel signal. The filtered first IF signal is amplified by the first IF amplifier (Q403) and is then applied to the IF system IC (IC400).

The IF system IC provides a second mixer, AGC+BPF, PLL FM detector, noise squelch and RSSI circuit.

The second mixer mixes the first IF signal (49.95MHz) with the signal of the second local oscillator output (Q400) and produces the second IF signal of 450kHz.

The second IF signal is passed through the internal bandpass filter of the IF system IC to remove the adjacent channel signal. The filtered second IF signal is amplified by the limiting amplifier and demodulated by the internal discriminator of the IF system IC.

The demodulated signal is routed to the audio circuit.

2.3.2.4 Audio Amplifier Circuit

The demodulated signal from IC400 is sent to an AF amplifier through IC705, and is routed to an audio power amplifier (INT:IC709, EXT:IC707) where it is amplified and output to the speaker.

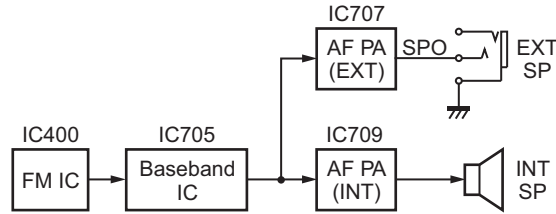

Fig.3 Audio amplifier circuit

2.3.2.5 Squelch Circuit

Part of the AF signal from the IC400 enters the FM IC (IC400) again, and the noise component is amplified and rectified by a filter and an amplifier to produce a DC voltage corresponding to the noise level.

There are 2 noise filters. Analog Narrow band and DMR band will share the same noise filter (W_N control is Low) whereas analog wide 5k band and analog wide 4k band will use another noise filter (W_N control is HIGH).

The selection of different noise filter is by 2 multiplexer (IC719 and IC720).

The DC signal from the FM IC goes to the analog port of the MCU (IC710). IC710 determines whether or not to output sounds from the speaker by checking if the input voltage is higher or lower than the preset value.

To output sounds from the speaker, IC710 sends a high signal to the EXTSPSW line and turns IC707 on through Q709, Q710, Q713 and Q716. This explanation is for the external speaker amplifier. For the internal loudspeaker amplifier, IC710 sends a high signal to the INTSPSW line and turns IC709 on through Q711 and Q714.

2.3.3 Transmitter System

2.3.3.1 Microphone Amplifier Circuit

The signal from the microphone is limited by the AGC circuit, which is composed of D700, D701, Q705, Q706 and the mute switch (Q704). IC705 is composed of a high-pass filter, low-pass filter and pre-emphasis/IDC circuit.

The signal from the microphone and the low speed data from the MCU (IC710) enter the baseband IC (IC705) and pass through each path and are mixed inside the IC.

The output signal from the audio processor MOD2 goes to the VCO modulation input. The other output signal from MOD1 goes to the TCXO modulation input.

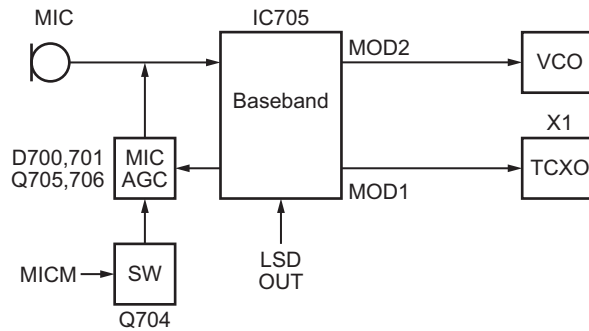

Fig.4 Microphone amplifier circuit

2.3.3.2 Drive and Final Amplifier Circuit

The signal from the T/R switch (D15 is on) is amplified by the pre-drive amplifier (Q201).

The output of the pre-drive amplifier is amplified by the drive amplifier (Q206) and the RF final amplifier (Q208) to 5.0W (1W when the power is low).

The drive amplifier and the RF final amplifier consist of two MOS FET stages.

The output of the RF final amplifier is then passed through the antenna switch (D203 and D204) and harmonic filter (LPF) and is applied to the antenna terminal.

2.3.4 Frequency Synthesizer Unit

2.3.4.1 Frequency synthesizer

The frequency synthesizer consists of the TCXO (X1), VCO, PLL-IC (IC2), and buffer amplifiers.

The TCXO generates 16.8MHz. The frequency stability of TCXO is 2ppm within the temperature range of -30°C to +60°C. The frequency tuning and modulation of the TCXO are done to apply voltage to pin 1 of the TCXO. The TCXO output is applied to pin 10 of the PLL-IC.

The VCO consists of 2 VCOs and covers a dual range of 185.95~223.95MHz and 136~174MHz. The VCO generates 185.95~223.95MHz to provide the first local signal for reception. The operating frequency is generated by Q6 in transmitting mode and Q5 in receiving mode. The oscillation frequency is controlled by applying the VCO control voltage the variable capacitance diodes (D3,D9,D11,D13 and D17 while transmitting and D4,D8,D12 and D16 while receiving).

The TX/RX pin of IC710 goes "high" in transmission mode, causing Q8 to turn off, and Q7 turn on. The TX/RX pin goes "low" in reception mode.

The output from Q5 and Q6 are amplified by a buffer amplifier (Q9) and are then sent to the PLL-IC. The PLL-IC consists of an 18-bit delta signal modulator, prescaler, reference divider, phase comparator, and charge pump.

The input signal from pin 10 and 17 of the PLL-IC is divided down and compared at the phase comparator. The pulse output signal of the phase comparator is applied to the charge pump and transformed into a DC signal in the loop filter (LPF). The DC signal is applied to the CV of the VCO and is locked to keep the VCO frequency constant.

PLL data is output from PLL_LE (pin 87), PLL_DATA (pin 86) and PLL_CLK (pin 88) of the MCU (IC710). The data is input to the PLL-IC when the channel is changed or when transmission is changed to reception and vice-versa. The PLL lock condition is always monitored by pin 71 (PLL_LD) of the MCU. When the PLL is unlocked, PLL_LD goes low.

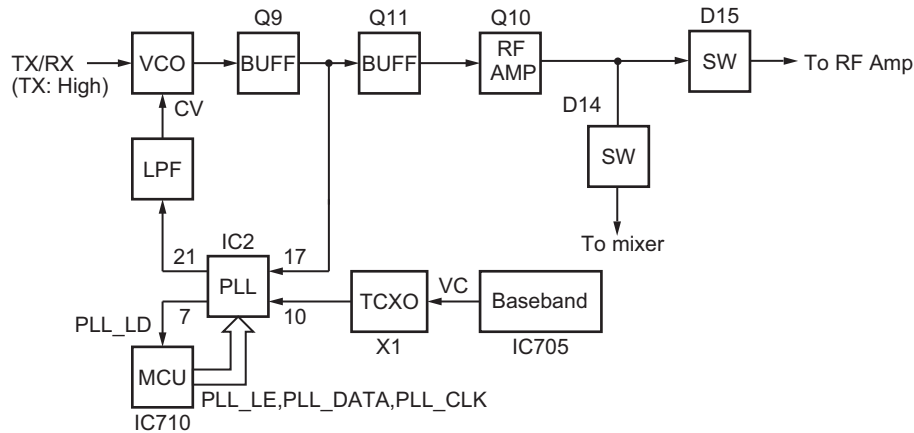

Fig.6 PLL block diagram

2.3.5 Control Circuit

The control consists of the MCU (IC710) and its peripheral circuits. It controls the Main unit. IC710 mainly performs the following;

- (1) Switching between transmission and reception via the PTT signal input.
- (2) Reading channel information, frequency, and program data from the memory circuit.
- (3) Sending frequency program data to the PLL.
- (4) Controlling squelch on/off via the DC voltage from the squelch circuit.
- (5) Controlling the audio mute circuit via the decode data input.
- (6) Transmitting tone and encode data.

2.3.5.1 Frequency Shift Circuit

The MCU (IC710) and baseband IC (IC705) operate at a clock frequency of 19.2MHz.

This oscillator frequency can be shifted by pin 8 of the MCU (IC710). When pin 8 is set to high, the beat shift function is ON.

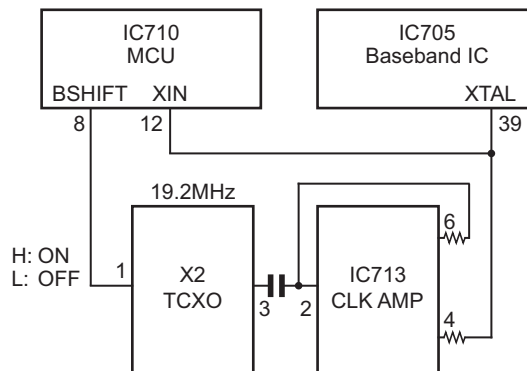

Fig.7 Frequency shift circuit

2.3.5.2 Memory Circuit

The Memory circuit consists of the MCU (IC710) and Flash memory (IC700). The Flash memory has a capacity of 4M-bit and stores the channel information, the last channel data, the scan on status, and other parameters.

2.3.5.3 Low Battery Warning

The battery voltage is monitored by the MCU (IC710 pin 33: BATT). When the battery voltage falls below 7.0V approximately, the red LED blinks, notifying the operator that it is time to replace the battery (When "Always" option (default setting) under the Battery Warning function in the FPU is selected).

If the battery voltage falls below 5.8V approximately, the transceiver does not transmit and a warning tone beeps when the PTT switch is pressed (When the Battery Warning Tone is selected in the FPU).

2.3.5.4 Key Input

Keys and channel selector circuit.

The signal from the keys and channel selector are directly input to the MCU, as shown in Figure 8.

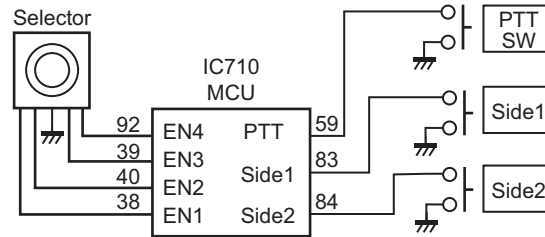

Fig.8 Key input

2.3.6 Signaling Circuit

2.3.6.1 Encode

■ Low-speed data (QT, DQT)

Low-speed data is output from pin 29 of the MCU. The signal passes through the low pass CR filter, and goes to the audio processor (IC705). The signal is mixed with the audio signal and goes to the VCO and TCXO (X1) modulation input after passing through the D/A converter inside the audio processor (IC705) for BAL adjustment.

■ High-speed data (2-tone,DTMF)

High-speed data (HSD) is output from pin 30 of the MCU. HSD deviation made by an adjustment in the MCU is passed through the low pass CR filter and is then mixed with the microphone signal before being applied to the baseband IC (IC705).

The output of the baseband IC, MOD1 and MOD2, will be fed into the TCXO and VCO respectively.

■ MSK (Fleet Sync/MDC-1200)

The MSK signal is generated in the audio processor (IC705). The signal passes through the D/A converter (inside the baseband IC: IC705) and is routed to the VCO. When encoding the MSK, the microphone input signal is muted.

2.3.6.2 Decode

■ QT/DQT

The output signal from the FM IC (IC400) enters the MCU (IC710) through IC705. IC710 determines whether or not the QT or DQT matches the preset value, and controls the AFSW and speaker output sounds according to the squelch results.

■ 2-tone

Part of the received AF signal output from the FM IC (IC400) passes through the baseband IC (IC705), and is compared and output from MOD2 before going to the MCU (IC710). IC710 checks whether or not the 2-tone data is necessary. If it matches, IC710 carries out a specified operation, such as turning the speaker on.

■ MSK (Fleet Sync)

The MSK input signal from the FM IC (IC400) goes to IC705. The decoded information is then processed by the MCU.

■ DTMF

The DTMF input signal from the FM IC (IC400) goes to IC705. The decoded information is then processed by the MCU.

2.3.7 Power Supply

There are five 5V power supplies and five 3.3V power supplies: 50M, 50V, 50C, 50R, 50T, 33M, 33MS, 33B, 33R and 33MD. 33MS is always output, but turns off when the power is turned off, to prevent a malfunction of the MCU.

50C is a common 5V.

50R is 5V for reception and is output during reception.

50T is 5V for transmission and is output during transmission.

50V is 5V for the SP/MIC connector.

33B is 3.3V for the baseband IC (IC705) digital supply.

33C is 3.3V for the IF IC (IC400).

33MD is 3.3V for the MCU digital supply.

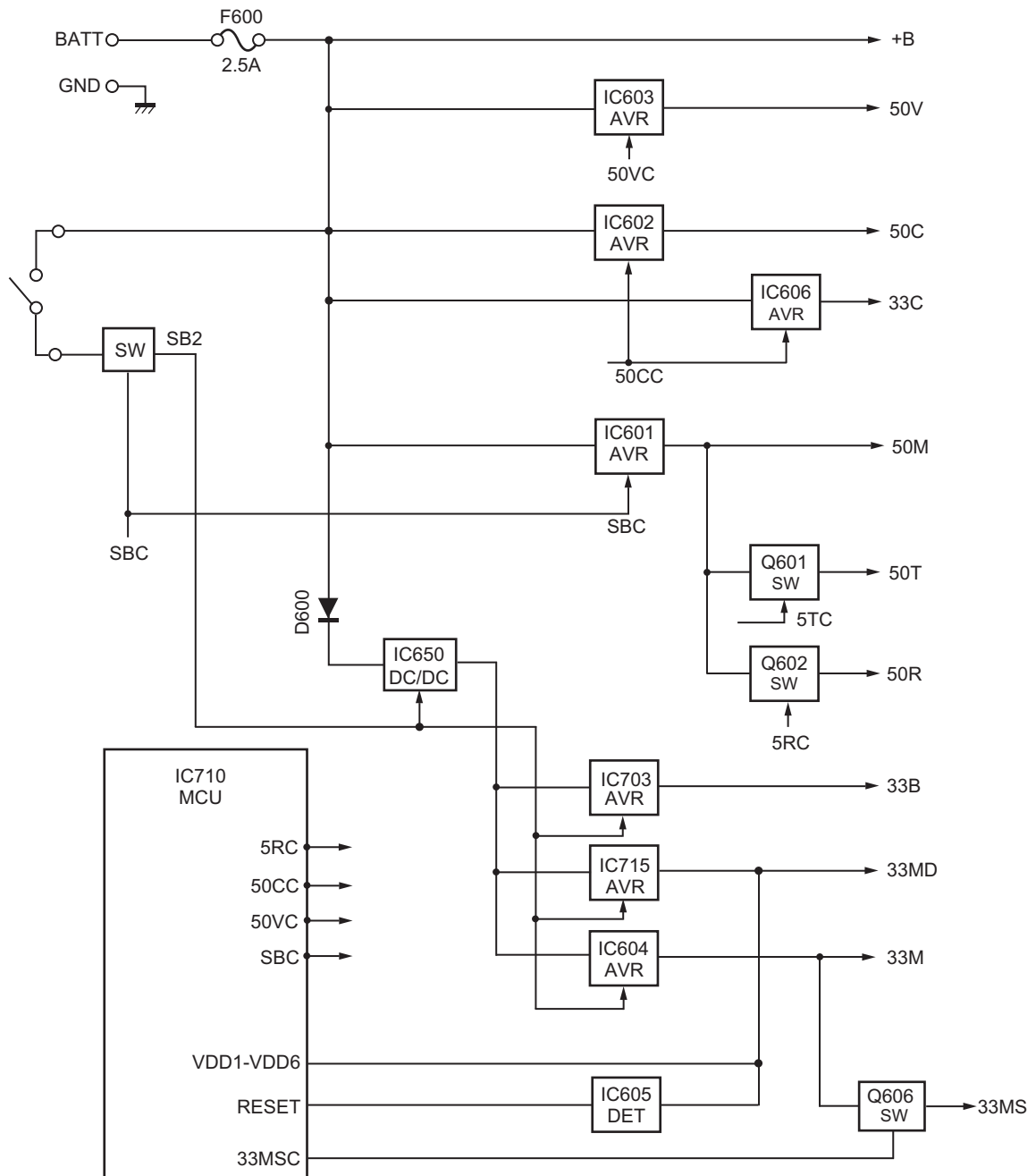

Fig.9 Power supply

2.3.8 DMR Receiving

2.3.8.1 For Digital Data Mode

The demodulated signal from IC400 (Pin13) is fed into the baseband IC (Pin 16) for DMR decoding. The decoded digital data will pass to the MCU through the C-BUS. The MCU determines whether or not to output sound from the speaker by checking if the data matches.

2.3.8.2 For Digital Voice Mode

If the digital data matches in the MCU, the digital voice payload data will go into the Vocoder in the MCU for conversion to PCM. The PCM data will go to the baseband IC through the SPI input, where it will be converted to analog by the DAC. Analog voice will be filtered and finally sent to the audio amplifier.

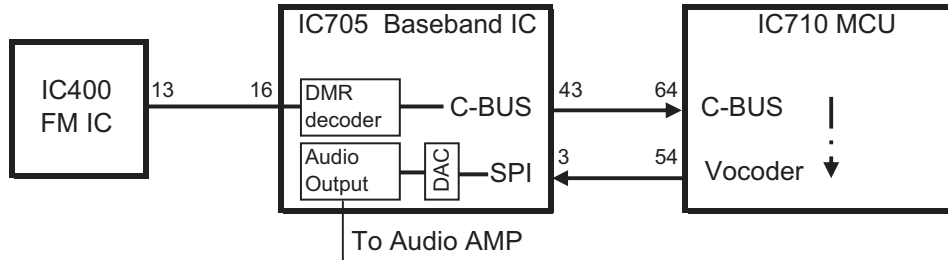

Fig.10 DMR receiver system

2.3.9 DMR Transmitting

2.3.9.1 For Digital Data Mode

The digital data will be generated by the MCU, where it will be passed to the baseband IC, through the C-BUS for the encoding process. The encoded data will finally transmit through the TCXO and VCO modulation.

2.3.9.2 For Digital Voice Mode

The analog voice from the microphone will go to the ADC (after the audio filter) to convert to PCM data. The PCM data will be sent to the Vocoder through the SPI output. The Vocoder will convert the PCM to DMR protocol, where it will be sent to the baseband through the C-BUS. In the baseband IC, the data will be encoded and finally transmitted through the TCXO and VCO modulation.

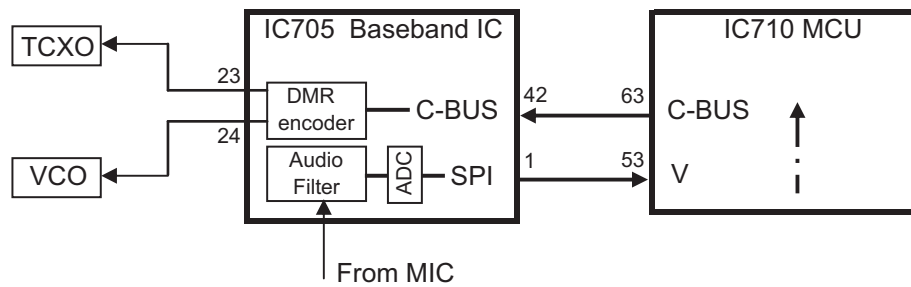

Fig.11 DMR transmit system

2.4 SEMICONDUCTOR DATA

2.4.1 MCU: 2F405VGT6KGEA (Main unit IC710)

Pin No.	Name	I/O	Function
1	MINVOL	O	Minimum volume control
2	NC(TR_GPIO1)	-	No connection
3	NC(TR_GPIO2)	-	No connection
4	NC(TR_GPIO3)	-	No connection
5	NC(TR_GPIO4)	-	No connection
6	VBAT	-	3.3V
7	BLUELED	O	Blue LED Control
8	BSHIFT	O	MCU Clock frequency Shift
9	INTSPMT	O	Internal Speaker Mute
10	VSS	-	GND
11	VDD	-	33MD
12	XIN	I	Clock input (19.2MHz)
13	NC	-	No connection
14	RESET	I	RESET
15	HSDI	I	Tone decode

Pin No.	Name	I/O	Function
16	LSDI	I	QT/DQT decode
17	VOX	I	VOX
18	EMPTT	O	Emergency PTT
19	VDD	-	33MD
20	VSSA	-	GND
21	VREF+	-	33M
22	VDDA	-	33M
23	5CC	O	5C Control
24	CVIN	I	VCO Lock Voltage IN
25	FLDM	I	Force Flash Load Mode
26	TH_DET2	I	Thermistor DET (Temperature detection for RX)
27	VSS	-	GND
28	VDD	-	33MD
29	LSDO	O	QT/DQT OUT
30	HSDENC	O	BEEP / HSD OUT
31	CURR	I	Transmit current Level Input

Pin No.	Name	I/O	Function
32	1PINDET	I	External MIC detection
33	BATT	I	Battery Level Input
34	RSSI	I	RSSI Input
35	BUSY	I	BUSY Input
36	TH_DET1	I	Thermistor DET (Temperature detection for TX)
37	33MSC	O	33M Swith Control
38	EN1	I	Encoder Input 1
39	EN3	I	Encoder Input 3
40	EN2	I	Encoder Input 2
41	GRNLED	O	Green LED Control
42	MIC_MT	O	MIC Mute
43	EXTSPMT	O	Speaker Mute
44	ASSTSW	O	Assist Switch
45	SBC	O	SB switch control
46	INSPSW	O	Internal Speaker Switch
47	TEST_TX	O	
48	TEST_RX	I	
49	VCAP_1	-	2.2uF
50	VDD	-	33MD
51	CML_SSOUT	I	SPI chip select for baseband IC
52	CML_EPSCLK	I	Clock for SPI
53	CML_EPSO	O	SPI output
54	CML_EPSI	I	SPI input
55	FM_RSTN	O	Hradwear reset for FM IC
56	FM_CSN	O	Chip select for FM IC
57	FM_SCLK	O	Clock for FM IC
58	FM_SDATA	I/O	Data I/O for FM IC
59	PTT	I	PTT key
60	TR_SQ	O	TOR/COR selectable
61	5RC	O	5RC
62	CML_RST	O	Reset for CML
63	CML_CDATA	O	Command for baseband IC
64	CML_RDATA	I	REPLY for baseband IC
65	CML_SCLK	O	SCLK for baseband IC
66	CML_CSN	O	Chip select for baseband IC
67	TX/RX	O	VCO TX RX Swith
68	TXD	O	Serial Data to MIC JACK
69	RXD	I	Serial Data from MIC JACK
70	SB_DET	I	Power switch detect
71	PLL_LD	I	UL for PLL
72	SWDIO	I/O	
73	VCAP_2	-	2.2uF
74	VSS	-	GND
75	VDD	-	33MD
76	SWCLK	I/O	

Pin No.	Name	I/O	Function
77	F_CS	O	Chip Select for Flash
78	F_SCLK	O	Clock for Flash
79	F_DATAI	I	DATA Input to Flash
80	F_DATAO	O	DATA Output for Flash
81	F_WP	O	Write protect for Flash memory
82	50VC	O	5V AVR Control for GPS MIC
83	PF1	I	Programmable Function Key Input 1
84	PF2	I	Programmable Function Key Input 2
85	SYSCLK2	I	CML System clock 2
86	PLL_DATA	O	Data output for PLL
87	PLL_LE	O	Chip Select for PLL
88	PLL_CLK	O	Clock for PLL
89	SWO	O	
90	SRST	I	
91	OPTDET	I	Option Detection
92	EN4	I	Encoder Input 4
93	REDLED	O	RED LED Control
94	BOOT0	-	
95	W_N	O	RX Wide Narrow Band Switch
96	FM_PDN	O	Power down port for LDO of FM IC
97	INT	I	Low Battery Interrupt
98	CML_IRQ	I	Interrupt request for baseband IC
99	VSS	-	GND
100	VDD	-	33MD

2.5 COMPONENTS DESCRIPTION

2.5.1 Main unit (XC1-1162-70)

Ref. No.	Part Name	Description
IC1	IC	DC amplifier (FREQ/MOD)
IC2	IC	PLL System
IC3	IC	DC amplifier (CV)
IC400	IC	IF System
IC600	IC	Voltage detector (INT)
IC601	IC	Voltage regulator (50M)
IC602	IC	Voltage regulator (50C)
IC603	IC	Voltage regulator (50V)
IC604	IC	Voltage regulator (33M)
IC605	IC	Voltage detector (Reset)
IC606	IC	Voltage regulator (33C)
IC650	IC	DC/DC converter
IC700	IC	Flash memory
IC703	IC	Voltage regulator (33B)
IC704	IC	DC amplifier (BPF tune or APC)

Ref. No.	Part Name	Description
IC705	IC	Baseband system
IC706	IC	DC amplifier (VOX)
IC707	IC	AF power amplifier (EXT)
IC708	IC	AF amplifier
IC709	IC	AF power amplifier (INT)
IC710	IC	MCU
IC713	IC	Clock buffer amplifier
IC715	IC	Voltage regulator (33MD)
IC717	IC	Audio buffer amplifier
IC719,720	IC	Wide/Narrow multiplexer
IC721	IC	DC amplifier(BPF tune)
IC832	IC	AF amplifier
Q1	FET	DC switch(Assist)
Q3	FET	Q1 control
Q4	Transistor	Rippler filter
Q5	FET	RX VCO
Q6	FET	TX VCO
Q7	FET	Q8 control
Q8	FET	TX/RX VCO DC switch
Q9	Transistor	Buffer amplifier
Q10,11	Transistor	RF amplifier
Q201	Transistor	Pre-drive amplifier
Q206	FET	Drive amplifier
Q208	FET	Final amplifier
Q290	FET	DC switch(CURR)
Q291	FET	DC switch(BATT)
Q297	Transistor	DC switch(PC)
Q298	Transistor	Q290/Q291 control
Q400	Transistor	Tripler(2nd local)
Q403	Transistor	1st IF amplifier
Q404	FET	1st mixer
Q405	FET	RX RF amplifier
Q600	Transistor	DC switch (BUSY LED)
Q601	FET	DC switch (50T)
Q602	FET	DC switch (50R)
Q603	FET	DC switch (MIN VOL)
Q604	Transistor	DC switch (RED LED)
Q605	Transistor	DC switch (BLUE LED)
Q606	FET	DC switch (33MS)
Q620	Transistor	DC switch(INT)
Q703	FET	Level shift (TXD)
Q704	Transistor	MIC mute switch
Q705,706	Transistor	MIC AGC amplifier

Ref. No.	Part Name	Description
Q707	Transistor	Level shift(RXD)
Q708	Transistor	DC switch (EXT PTT)
Q709	Transistor	Q710 control
Q710	Transistor	Ripple filter
Q711	Transistor	Q715 control
Q712	Transistor	Pop noise mute control
Q713	FET	AF switch (EXT SP)
Q714	Transistor	DC switch (IC709 SB)
Q715	Transistor	Q714 control
Q716	FET	AF switch (EXT SP)
D3	Variable capacitance diode	TX VCO tune
D4	Variable capacitance diode	RX VCO tune
D8	Variable capacitance diode	RX VCO tune
D9	Variable capacitance diode	TX VCO tune
D10	Diode	Speed up
D11	Variable capacitance diode	TX assist
D12	Variable capacitance diode	RX assist
D13	Variable capacitance diode	Modulation
D14, 15	Diode	TX/RX switch
D16	Variable capacitance diode	RX assist
D17	Variable capacitance diode	TX assist
D201~204	Diode	Antenna switch
D401~404	Variable capacitance diode	RX BPF tuning
D405	Variable capacitance diode	RX notch tune
D600	Diode	Voltage drop
D601	LED	Green (BUSY)
D602	LED	Red (TX)
D603	Diode	Voltage prevention
D604	LED	Blue
D605	Zener diode	Over voltage protection
D620	Diode	DC switch(SBC2)
D630	Diode	DC switch(INT)
D700, 701	Diode	AF detector (MIC)
D702	Diode	AF detector (VOX)
D703	Diode	Limiter
D754	Diode	1 pin detection

2.6 TERMINAL FUNCTION

2.6.1 Main unit (XC1-1162-70)

Pin No.	Name	I/O	Function
CN600			
1	VOLOUT	O	Volume output to audio amplifier
2	VOLIN	I	Volume level input for audio control
3	SB	I	Power input after power switch
4	SB	I	Connect to pin 3
5	B	O	Voltage output after passing through the R620
6	B	O	Connect to pin 5
7	VOLGND	-	GND for volume level
8	EN2	I	Rotary switch input
9	EN4	I	Rotary switch input
10	GND	-	GND
11	EN3	I	Rotary switch input
12	EN1	I	Rotary switch input

2.6.2 SP/MIC Connector Specification

Pin No.	Name	I/O	Signal Type	Function
1	PTT/RXD	I	Digital	PTT/RXD input
2	MICI	I	Analog	External MIC input
3	MIC	O	Analog	Internal MIC output
4	OPTDET	I	Digital	External option detection
5	50V	O	Power	DC 5V output
6	AE	-	GND	GND
7	TXD	O	Digital	TXD output
8	NC	-	-	No connection
9	DET	I	Digital	External Speaker detection
10	SPO	O	Analog	Internal audio output

SECTION 3 DISASSEMBLY

3.1 Precautions for Disassembly

3.1.1 Removing the Case Assembly from the Chassis

- (1) Remove the selector knob <1> and volume knob <2>.
- (2) Remove the two screws <3>.
- (3) Lift and remove the chassis from the case assembly <4>.
(Use a flat-blade screwdriver to easily lift the chassis.)

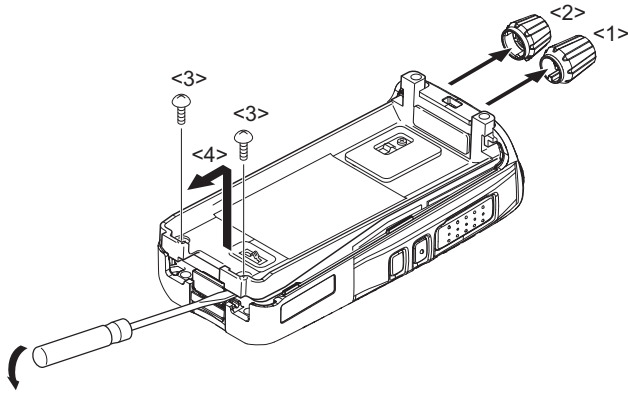

3.1.2 Removing the Holder Assembly from the Chassis

- (1) Remove the packing <5> from the SMA, volume and selector.
- (2) Remove the holder from the chassis.

Note:

Take care to not cut the speaker and microphone leads.

- (3) Detach the solder of the speaker and microphone leads from the PCB beforehand.
- (4) Remove the packing <6> from the SP/MIC jack of the Main unit.

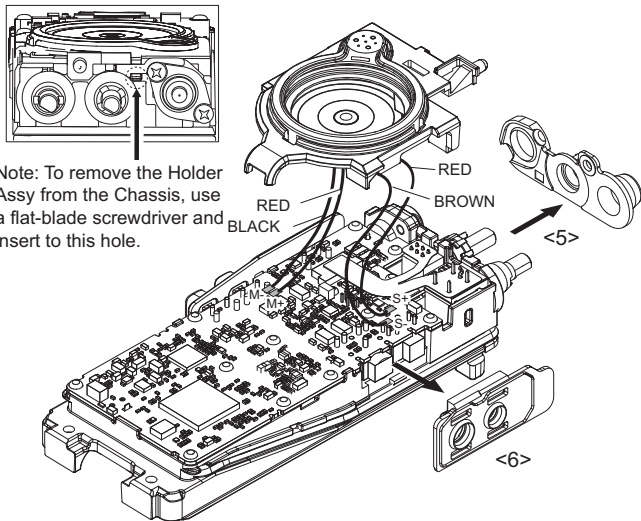

Note: To remove the Holder Assy from the Chassis, use a flat-blade screwdriver and insert to this hole.

Note:

You can remove the Main unit from the chassis without removing the solder at the positive terminal. However, in this case, you cannot attach the packing (G53-2218-03) that is on the positive terminal to the chassis during assembly. So, we advise you to remove the solder on the positive terminal first.

- (4) Remove the FPC from the flat cable connector <10>.
- (5) Lift and remove the Main unit from the chassis <11>.

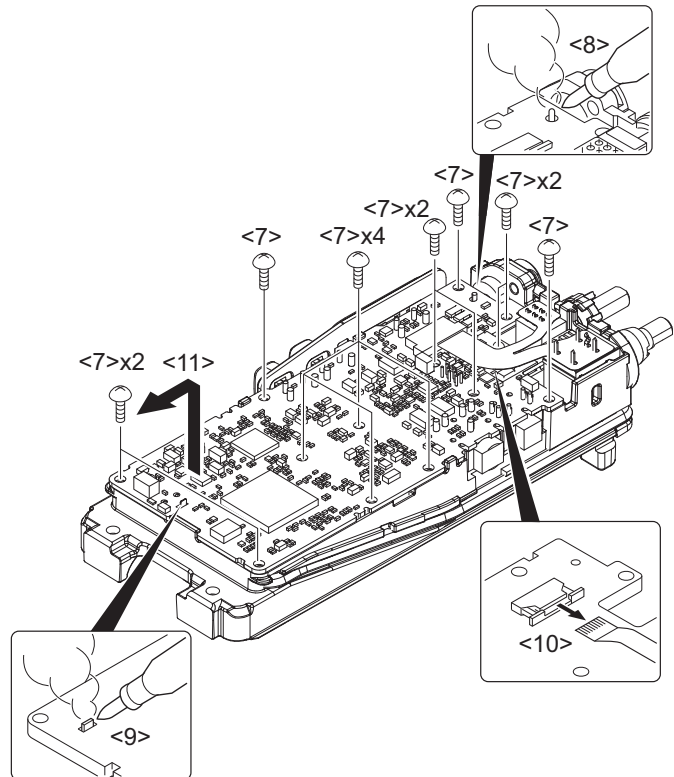

3.1.4 Removing the Battery Release Lever from the Case Assembly

- (1) Press the upper part of the lever toward the inside of the case assembly. One side of the shaft will be removed <1>.
- (2) Lift and remove the battery release lever from the case assembly <2>.

Note:

Scratch and widen the glue hole if you are having difficulty removing the other end of the shaft. No glue is required when you reassemble the battery release lever.

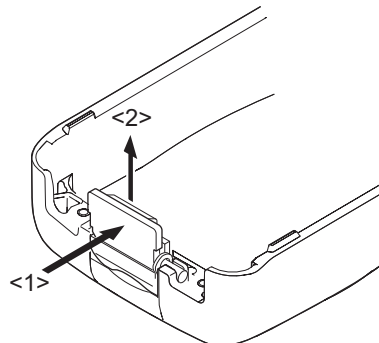

3.2 Precautions for Reassembly

3.2.1 Attaching the Battery Release Lever to the Case Assembly

- (1) Insert one side of the shaft into the hole at the lever fitting section on the case assembly <1>.

Caution:

Position the thin spring (G01-4543-14) above the two tabs of the lever.

- (2) Tilt the battery release lever slightly forward <2>, so that the thick spring (G01-4542-04) is positioned below the case surface.
- (3) With the thick spring positioned below the case surface, attach the other side of the shaft to the case assembly by pressing the battery release lever <3> until it snaps into place <4>.

Caution:

Be careful to not tilt the battery release lever too far forward. If the battery release lever is pushed in this state where the two tabs come below the case surface, there is a possibility of damaging the two tabs.

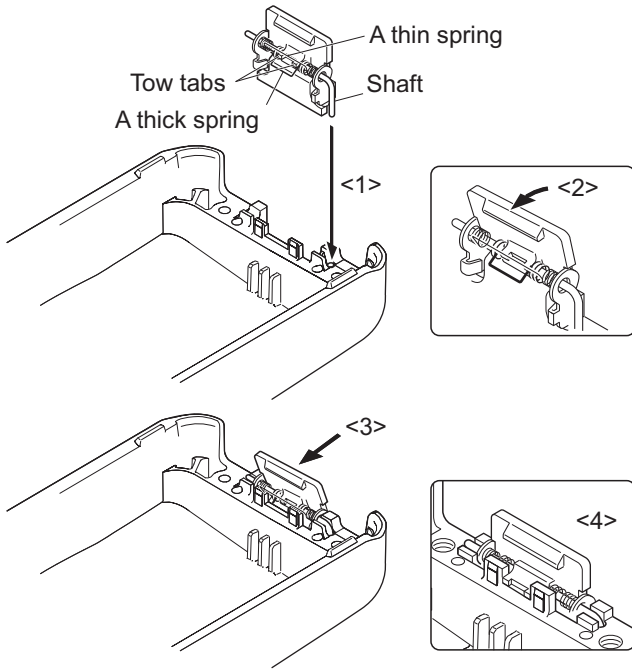

3.2.2 Assembling the Battery Release Lever

- (1) Place the lever <2> onto the stopper <1>.
- (2) Place the thick spring <3> onto the lever.
- (3) Hook the right and left ends of the thin spring <4> onto the tabs of the stopper, then place the thin spring onto the lever <5>.
- (4) Slide the shaft through the hole of the stopper and lever <6>.

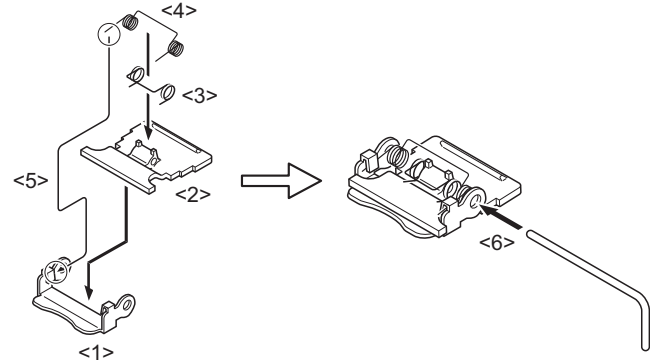

3.2.3 Attaching the Positive Terminal to the Chassis

Always attach the positive terminal to the chassis using the following procedures, before mounting the Main unit onto the chassis.

- (1) Remove the holder assembly <2> from the packing <1> of the positive terminal.
- (2) Mount the packing of the positive terminal into the chassis hole <3>.
- (3) Mount the holder assembly into the packing of the positive terminal <4>.

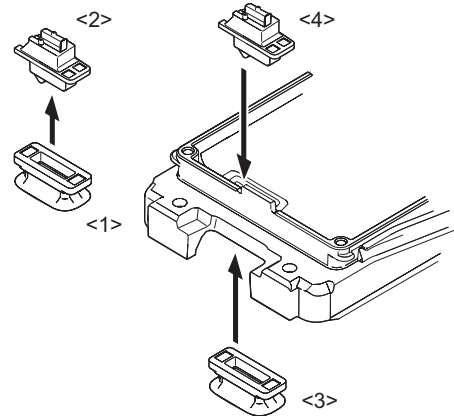

3.2.4 Mounting the Chassis to the Case Assembly

- (1) Confirm that the waterproof packing attached to the circumference of the chassis is securely inserted in the groove of the chassis <1>.
- (2) Insert the upper part of the chassis into the case assembly <2>.
- (3) Press the chassis <3> and the case assembly together to attach them.

Caution:

If the packing of the SP/MIC is not at the correct position after attaching the chassis to the case assembly, reposition the packing with your fingers.

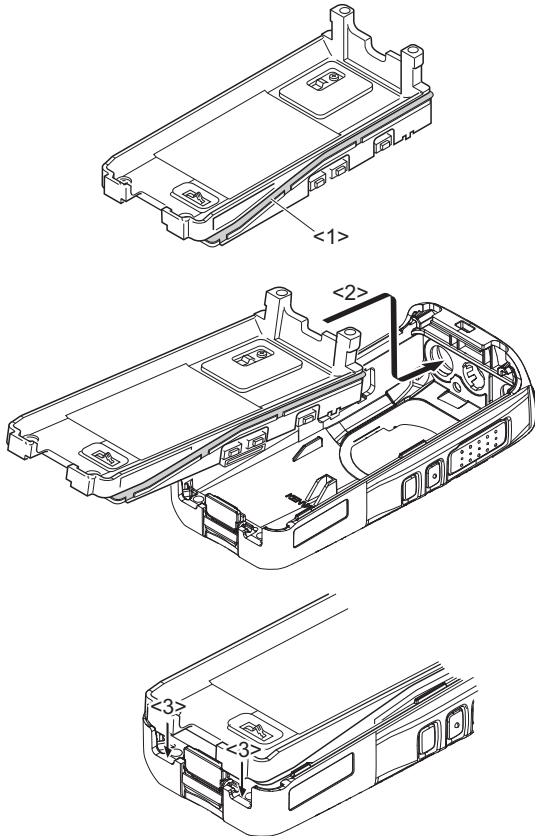

3.2.6 The Nuts of the Volume Knob and Channel Knob

Note that the shape, color and height of the nuts of the volume knob and channel knob are different from one another. (The nut of volume knob is silver, and the nut of channel knob is gold.)

Use the following jig when removing the nuts of the volume knob and channel knob:

- Jig (Part No.: W05-1012-00)

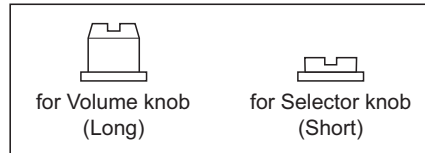

3.2.5 Attaching the Antenna Receptacle to the Chassis

Screw the antenna receptacle to the chassis in the order shown in the drawing so that the antenna receptacle comes to the center of the case hole.

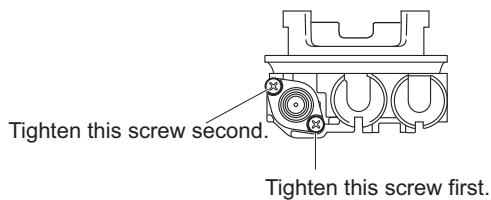

SECTION 4 ADJUSTMENT

4.1 K,M TYPE Test Equipment Required for Alignment

Test Equipment	Major Specifications	
1. Standard Signal Generator (SSG)	Frequency Range	100 to 520MHz
	Modulation	Frequency modulation and external modulation
	Output	-127dBm/0.1μV to greater than -47dBm/1mV
2. Power Meter	Input Impedance	50Ω
	Operation Frequency	100 to 520MHz
	Measuring Range	Vicinity of 10W
3. Deviation Meter	Frequency Range	100 to 520MHz
4. Digital Volt Meter (DVM)	Measuring Range	10mV to 10V DC
	Input Impedance	High input impedance for minimum circuit loading
5. Oscilloscope		DC through 30MHz
6. High Sensitivity Frequency Counter	Frequency Range	10Hz to 1000MHz
	Frequency Stability	0.2ppm or less
7. Ammeter		5A
8. AF Volt Meter (AF VM)	Frequency Range	50Hz to 10kHz
	Voltage Range	1mV to 10V
9. Audio Generator (AG)	Frequency Range	50Hz to 5kHz or more
	Output	0 to 1V
10. Distortion Meter	Capability	3% or less at 1kHz
	Input Level	50mV to 10Vrms
11. 8Ω Dummy Load		Approx. 8Ω, 3W
12. Regulated Power Supply		5V to 10V, approx. 3A Useful if ammeter equipped

*The test equipment which is not used for adjustment is contained in this table.

■Antenna connector adapter

The antenna connector of this transceiver uses an SMA terminal.

Use an antenna connector adapter [SMA(f) - BNC(f) or SMA(f) - N(f)] for adjustment. (The adapter is not provided as an option, so buy a commercially-available one.)

■Repair Jig (Chassis)

Use jig (Chassis) for repairing the transceiver. Place the Main unit on the jig and fit it with screws.

The jig facilitates the voltage check and protects the final amplifier FET when the voltage on the flow side of the Main unit is checked during repairs.

■Battery Jig (W05-1011-00)

Connect the power cable properly between the battery jig installed in the transceiver and the power supply, and be sure output voltage and the power supply polarity prior to switching the power supply ON, otherwise over voltage and reverse connection may damage the transceiver, or the power supply or both.

Note:

When using the battery jig, you must measure the voltage at the terminals of the battery jig. Otherwise, a slight voltage drop may occur within the power cable, between the power supply and the battery jig, especially while the transceiver transmits.

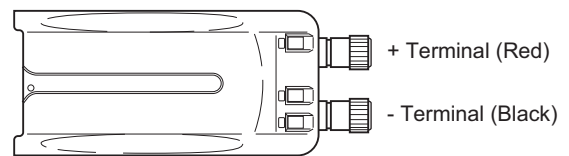

Schematic diagram

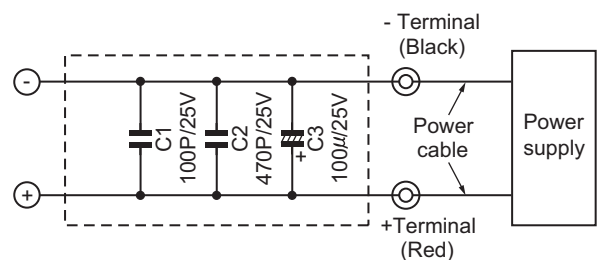

4.2 Frequency and Signaling

The transceiver has been adjusted for the frequencies shown in the following table. When required, readjust them following the adjustment procedure to obtain the frequencies you want in actual operation.

■Test frequency

CH	RX (MHz)	TX (MHz)
1	155.05000	155.10000
2	136.05000	136.10000
3	173.95000	173.90000
4	155.00000	155.00000
5	155.20000	155.20000
6	155.40000	155.40000
7~16	-	-

■Analog mode signaling

No.	RX	TX
1	None	None
2	None	100Hz Square Wave
3	QT 67.0 Hz	QT 67.0 Hz
4	QT 151.4 Hz	QT 151.4 Hz
5	QT 210.7 Hz	QT 210.7 Hz
6	QT 254.1 Hz	QT 254.1 Hz
7	DQT D023N	DQT D023N
8	DQT D754I	DQT D754I
9	DTMF Decode (CODE: 159D)	DTMF Encode (CODE: 159D)
10	None	DTMF Encode (CODE: 9)
11	Single Tone: 979.9Hz	Single Tone: 979.9Hz
12	None	Single Tone: 1000Hz
13	None	MSK PN9
14	MSK Decode	MSK Encode

■DMR mode signaling

No.	RX	TX
1	CC 00 Burst	CC 00 Burst
2	PN9 Continuous Pattern	PN9 Continuous Pattern
3	CC 00 Burst	Maximum Deviation Continuous Pattern
5	CC 00 Burst	0 Continuous Pattern
6	SYNC (Each slot) + PN9 Burst Pattern	SYNC (Each slot) + PN9 Burst Pattern

4.3 Preparations for Tuning the Transceiver

Before attempting to tune the transceiver, connect the unit to a suitable power supply.

Whenever the transmitter is tuned, the unit must be connected to a suitable dummy load (i.e. power meter).

The speaker output connector must be terminated with a 8Ω dummy load and connected to an AC voltmeter and an audio distortion meter or a SINAD measurement meter at all times during tuning.

■5 reference level adjustments frequency

Tuning point	RX (MHz)	TX (MHz)
Low	136.05000	136.10000
Low'	145.55000	145.60000
Center	155.05000	155.10000
High'	164.55000	164.60000
High	173.95000	173.90000

PN9:Pseudo-Random Pattern (for production only)

4.3.1 Adjustment item supplement

Adjustment Item	Description
Receive Assist	The lock voltage of VCO (Receive) is adjusted. This item must be adjusted before all adjustment items for receiver section are adjusted.
Transmit Assist	The lock voltage of VCO (Transmit) is adjusted. This item must be adjusted before all adjustment items for transmitter section are adjusted.
Frequency	The Transmit Frequency is adjusted.
Ramp Offset	Adjust this item to the optimal Ramp voltage.
High Transmit Power	High Transmit Power is adjusted.
Low Transmit Power	Low Transmit Power is adjusted.
Balance	The transmit audio frequency response is adjusted. This item is adjusted so that the deviation of 2kHz becomes the same deviation of 20Hz. This item must be adjusted before all adjustment items for deviations are adjusted.
Maximum Deviation (DMR)	Maximum Deviation of DMR is adjusted.
Maximum Deviation (Analog Wide/ Narrow)	Maximum Deviation of Analog (Wide/ Narrow) is adjusted. This item must be adjusted before all adjustment items for tone deviations are adjusted.
QT Deviation	QT tone deviation is adjusted.
DQT Deviation	DQT tone deviation is adjusted.
Single Tone Deviation	The deviation of Single Tone used in "2-tone" is adjusted.
VOX 1	VOX 1 Level is adjusted.
VOX 10	VOX 10 Level is adjusted.
Sensitivity 1	Band-Pass Filter is adjusted. The performance of Receive Sensitivity is improved.
Sensitivity 2	Band-Pass Filter is adjusted. The performance of the interfering wave is improved.
RSSI Reference	The minimum RSSI level for scan stop is adjusted.

Adjustment Item	Description
Open Squelch	The squelch level at level "5" is adjusted.
Low RSSI	RSSI display level is adjusted.
High RSSI	Both "Low RSSI" and "High RSSI" must be adjusted. (The curve data of RSSI level is applied.)
Tight Squelch	The squelch level at level "9" is adjusted.
Battery Warning Level	Battery Warning Level (LED blinking level) is adjusted. Battery Warning Level minus 0.4V is the transmission inhibited level.

4.3.2 Adjustment item

Order	Adjustment item	Aw (Analog Wide)	An (Analog Narrow)	Dn (DMR)	Adjust item Number
		Adjustment range			
1	Receive Assist	5 point ADJ			Common Section 1
		1 ~ 1024			
2	Transmit Assist	5 point ADJ			Common Section 2
		1 ~ 1024			
3	Frequency	1 point ADJ			Common Section 3
		1 ~ 1024			
4	Ramp Offset	5 point ADJ			Transmitter Section 1
		1 ~ 512			
5	High Transmit Power	-	5	-	Transmitter Section 2
		1 ~ 1024			
6	Low Transmit Power	-	5	-	Transmitter Section 3
		1 ~ 1024			
7	Balance	-	5	-	Transmitter Section 4
		1 ~ 70			
8	Maximum Deviation (DMR)	-	-	5	Transmitter Section 5
		1 ~ 1024			
9	Maximum Deviation (Analog)	5	5	-	Transmitter Section 6
		1 ~ 1024			
10	QT Deviation	1	1	-	Transmitter Section 7
		1 ~ 1024			
11	DQT Deviation	1	1	-	Transmitter Section 8
		1 ~ 1024			
12	Single Tone Deviation	1	1	-	Transmitter Section 9
		1 ~ 1024			
13	VOX 1	1 point ADJ			Transmitter Section 10
		1 ~ 4096			
14	VOX 10	1 point ADJ			Transmitter Section 11
		1 ~ 4096			
15	Sensitivity 1	-	5	-	Receive Section 2
		1 ~ 1024			
16	Sensitivity 2	-	5	-	Receive Section 3
		1 ~ 1024			
17	RSSI Reference	-	5	-	Receive Section 4
		1 ~ 1024			

Order	Adjustment item	Aw (Analog Wide)	An (Analog Narrow)	Dn (DMR)	Adjust item Number
		Adjustment range			
18	Open Squelch	5	5	5	Receive Section 5
		1 ~ 1024			
19	Low RSSI	-	5	-	Receive Section 6
		1 ~ 1024			
20	High RSSI	-	5	-	Receive Section 7
		1 ~ 1024			
21	Tight Squelch	5	5	-	Receive Section 8
		1 ~ 1024			
22	Battery Warning Level	1 point ADJ			Transmitter Section 12
		1 ~ 4096			
23	DTMF Deviation	1	1	-	Transmitter Section 14
		1 ~ 1024			
24	MSK Deviation	1	1	-	Transmitter Section 15
		1 ~ 1024			

4.4 Radio check Section

Item	Condition	Measurement			Adjustment			Specifications /Remarks
	PC test mode	Test- equipment	Unit	Terminal	Unit	Parts	Method	
1. Frequency check	1)Test Channel Channel: 1 Test Signaling Mode: Analog Signaling: 1 PTT: Press [Transmit] button.	f. counter	Panel	ANT			Check	155.099767~ 155.100233M Hz (±1.5ppm@ 155.1MHz)
2. High power check (Battery voltage: 7.5V)	1)Test Channel Channel: 1 Test Signaling Mode: Analog Signaling: 1 PTT: Press [Transmit] button.	Power meter Ammeter	Panel	ANT			Check	4.0W~6.0W 2.3A or less
	2)Test Channel Channel: 2 Test Signaling Mode: Analog Signaling: 1 PTT: Press [Transmit] button.	Power meter Ammeter	Panel	ANT			Check	4.0W~6.0W 2.3A or less
	3)Test Channel Channel: 3 Test Signaling Mode: Analog Signaling: 1 PTT: Press [Transmit] button.	Power meter Ammeter	Panel	ANT			Check	4.0W~6.0W 2.3A or less

Item	Condition	Measurement			Adjustment			Specifications /Remarks
	PC test mode	Test-equipment	Unit	Terminal	Unit	Parts	Method	
3. Low power check (Battery voltage: 7.5V)	1)Test Channel Channel: 1 Test Signaling Mode: Analog Signaling: 1 PTT: Press [Transmit] button.	Power meter Ammeter	Panel	ANT			Check	0.75W~1.25W 1.2A or less
	2)Test Channel Channel: 2 Test Signaling Mode: Analog Signaling: 1 PTT: Press [Transmit] button.	Power meter Ammeter	Panel	ANT			Check	0.75W~1.25W 1.2A or less
	3)Test Channel Channel: 3 Test Signaling Mode: Analog Signaling: 1 PTT: Press [Transmit] button.	Power meter Ammeter	Panel	ANT			Check	0.75W~1.25W 1.2A or less
4. MIC sensitivity check	1)Test Channel Channel: 1 Test Signaling Mode: Analog Signaling: 1 AG: 1kHz PTT: Press [Transmit] button.	Deviation meter Oscilloscope AG AF VM	Panel	ANT SP/MIC connector			Adjust AG input to get a standard MOD.	15.0mV ±7.0mV
5. Sensitivity check	1)Test Channel Channel: 1 Test Signaling Mode: Analog Signaling: 1 SSG output Wide: -115dBm (0.40μV) (MOD: 1kHz/±3kHz) Narrow: -115dBm (0.40μV) (MOD: 1kHz/±1.5kHz)	SSG AF VTVM Oscilloscope Distortion meter 8Ω Dummy load	Panel	ANT SP/MIC connector			Check	12dB SINAD or more

4.5 Common Section

Item	Condition	Measurement			Adjustment			Specifications /Remarks
	PC test mode	Test-equipment	Unit	Terminal	Unit	Parts	Method	
1. Setting	1) BATT terminal voltage:7.5V 2) SSG standard modulation [Wide] MOD:1kHz,DEV:3kHz [Narrow] MOD:1kHz,DEV:1.5kHz							
2. Receive Assist	1) Adj item: [Receive Assist] 2) Adj item: [Low], [Low'], [Center], [High'], [High] Press [Apply All] button to store the adjustment value.				Panel	[FPU] [<][>]	[V] indicator on the PC window shows VCO lock voltage. Change the adjustment value to get VCO lock voltage within the limit of the specified voltage. Note: Confirm the VCO lock voltage approximately 3 seconds after the adjustment value is changed.	2.4~2.6V Press [Apply All] button to store the adjustment value after all adjustment point have been adjusted.

Item	Condition	Measurement			Adjustment			Specifications /Remarks
	PC test mode	Test-equipment	Unit	Terminal	Unit	Parts	Method	
3. Transmit Assist	1) Adj item: [Transmit Assist] 2) Adj item: [Low], [Low'], [Center], [High'], [High] PTT: Press [Transmit] button. Press [Apply All] button to store the adjustment value.				Panel	FPU [<][>]	[V] indicator on the PC window shows VCO lock voltage. Change the adjustment value to get VCO lock voltage within the limit of the specified voltage. Note: Confirm the VCO lock voltage approximately 3 seconds after the adjustment value is changed.	2.4~2.6V Press [Apply All] button to store the adjustment value after all adjustment point have been adjusted.
4. Frequency	1) Adj item: [Frequency] PTT: Press [Transmit] button. Press [Apply] button to store the adjustment value. 2) Adj item: [High]	f. counter	Panel	ANT		[FPU] [<][>]	155.100MHz	155.099767~155.100233MHz (±1.5ppm@155.1MHz)

4.6 Transmitter Section

Item	Condition	Measurement			Adjustment			Specifications /Remarks
	PC test mode	Test-equipment	Unit	Terminal	Unit	Parts	Method	
1. Ramp Offset	1) Adj item: [Ramp Offset] 2) Adj item: [Low], [Low'], [Center], [High'], [High]		Panel		Panel	[FPU] [<][>]	Write the value as followings. 1 Press [Apply All] button to store the adjustment value after all adjustment points have been adjusted.	
2. High transmit power (Battery voltage : 7.5V)	1) Adj item: [High Transmit Power] 2) Adj item: [Low], [Low'], [Center], [High'], [High] PTT: Press [Transmit] button. Press [Apply All] button to store the adjustment value.	Power meter Ammeter	Panel	ANT	Panel	[FPU] [<][>]	5.0W	±0.2W 2.0A or less Press [Apply] button to store the adjustment value whenever each adjustment points have been adjusted.
3. Low transmit power (Battery voltage :7.5V)	1) Adj item: [Low Transmit Power] 2) Adj item: [Low], [Low'], [Center], [High'], [High] PTT: Press [Transmit] button. Press [Apply All] button to store the adjustment value.	Power meter Ammeter	Panel	ANT	Panel	[FPU] [<][>]	1.0W	±0.05W 1.0A or less Press [Apply] button to store the adjustment value whenever each adjustment points have been adjusted.

Item	Condition	Measurement			Adjustment			Specifications /Remarks
	PC test mode	Test-equipment	Unit	Terminal	Unit	Parts	Method	
4. Balance 1 *1 *2	1) Adj item: [Balance] Deviation meter LPF : 3kHz HPF : OFF 2) Adj item: [Low], [Low'], [Center], [High'], [High] PTT: Press [Transmit] button. Press [Apply All] button to store the adjustment value. [2kHz Sine Wave Check box]: Check while transmitting change to 2kHz.	Deviation meter Oscilloscope	Panel	ANT	Panel	[FPU] [<][>]	The Deviation of 20Hz frequency is fixed. Change the 2kHz adjustment value to become the same deviation of 20Hz within the specified range.	2kHz Tone deviation is within ± 0.2 dB of 20Hz tone deviation. Press [Apply All] button to store the adjustment value after all adjustment points have been adjusted.
4. Balance 2 *1 *2	1) Adj item: [Balance] Deviation meter LPF : 3kHz HPF : OFF 2) Adj item: [Low], [Low'], [Center], [High'], [High] PTT: Press [Transmit] button. Press [Apply All] button to store the adjustment value. [Square Wave Check box]: Check while transmitting change to Square Wave.	Deviation meter Oscilloscope	Panel	ANT	Panel	[FPU] [<][>]	Make the demodulation wave into square wave.	
<p>*1 : Refer to the "4.6.1 Necessary Deviation adjustment item for each signaling and mode" table. Balance adjustment is common with the adjustment of all signaling deviations. *2 :Only 1 Balance needs to be adjusted (either Balance 1 or Balance 2).</p>								
5. Maximum Deviation (DMR) *2	1) Adj item: [Maximum Deviation (DMR)] Deviation meter LPF : 3kHz HPF : OFF 2) Adj item: [Low], [Low'], [Center], [High'], [High] PTT: Press [Transmit] button. Press [Apply All] button to store the adjustment value.	Deviation meter Oscilloscope	Panel	ANT	Panel	[FPU] [<][>]	2749Hz	2695~2803Hz Press [Apply All] button to store the adjustment value after all adjustment points have been adjusted.

Item	Condition	Measurement			Adjustment			Specifications /Remarks
	PC test mode	Test-equipment	Unit	Terminal	Unit	Parts	Method	
6. Maximum deviation (Analog) *2	1) Adj item: [Maximum Deviation (Analog Narrow)] Deviation meter LPF : 15kHz HPF : OFF 2) Adj item: [Low], [Low'], [Center], [High'], [High] PTT: Press [Transmit] button. Press [Apply All] button to store the adjustment value.	Deviation meter Oscilloscope	Panel	ANT	Panel	[FPU] [<][>]	2100Hz Write the same adjustment value of "[Maximum Deviation (DMR)]" for each adjustment point. Transmit at each adjustment point and check that the Analog deviation is between 2050Hz and 2150Hz. Deviation meter LPF : 15kHz HPF : OFF [Panel tuning mode] PTT: ON [PC test mode] PTT: Press [Transmit] button	2050~2150Hz Press [Apply All] button to store the adjustment value after all adjustment points have been adjusted.
	1) Adj item: [Maximum Deviation (Analog Wide)] 2) Adj item: [Low], [Low'], [Center], [High'], [High] PTT: Press [Transmit] button. Press [Apply All] button to store the adjustment value.	Deviation meter Oscilloscope	Panel	ANT	Panel	[FPU] [<][>]	4200Hz Write the same adjustment value of "[Maximum Deviation (DMR)]" for each adjustment point. Transmit at each adjustment point and check that the Analog deviation is between 4150Hz and 4250Hz. Deviation meter LPF : 15kHz HPF : OFF [Panel tuning mode] PTT: ON [PC test mode] PTT: Press [Transmit] button	4150~4250Hz Press [Apply All] button to store the adjustment value after all adjustment points have been adjusted.
*2: Refer to the "4.6.1 Necessary Deviation adjustment item for each signaling and mode" table. Regarding Maximum Deviation (Analog), it is common with the adjustment of all analog signalings.								
7. QT Deviation *3	1) Adj item: [QT Deviation (Analog Narrow)] Deviation meter LPF : 3kHz HPF : OFF 2) Adj item: [Low], [Low'], [Center], [High'], [High] PTT: Press [Transmit] button. Press [Apply] button to store the adjustment value.	Deviation meter Oscilloscope	Panel	ANT	Panel	[FPU] [<][>]	0.35kHz	0.35kHz ±0.05kHz
	1) Adj item: [QT Deviation(Analog Wide)] 2) Adj item: [Low], [Low'], [Center], [High'], [High] PTT: Press [Transmit] button. Press [Apply] button to store the adjustment value.	Deviation meter Oscilloscope	Panel	ANT	Panel	[FPU] [<][>]	0.75kHz	0.75kHz ±0.05kHz

Item	Condition	Measurement			Adjustment			Specifications /Remarks
	PC test mode	Test-equipment	Unit	Terminal	Unit	Parts	Method	
8. DQT Deviation *3	1) Adj item: [DQT Deviation (Analog Narrow)] Deviation meter LPF : 3kHz HPF : OFF 2) Adj item: [Low], [Low'], [Center], [High'], [High] PTT: Press [Transmit] button. Press [Apply] button to store the adjustment value.	Deviation meter Oscilloscope	Panel	ANT	Panel	[FPU] [<][>]	0.35kHz	0.35kHz ±0.05kHz
	1) Adj item: [DQT Deviation(Analog Wide)] 2) Adj item: [Low], [Low'], [Center], [High'], [High] PTT: Press [Transmit] button. Press [Apply] button to store the adjustment value.	Deviation meter Oscilloscope	Panel	ANT	Panel	[FPU] [<][>]	0.75kHz	0.75kHz ±0.05kHz
9. Single Tone Deviation *3	1) Adj item: [Single Tone Deviation (Analog Narrow)] Deviation meter LPF : 15kHz HPF : OFF 2) Adj item: [Low], [Low'], [Center], [High'], [High] PTT: Press [Transmit] button. Press [Apply] button to store the adjustment value.	Deviation meter Oscilloscope	Panel	ANT	Panel	[FPU] [<][>]	1.50kHz	1.50kHz ±0.05kHz
	1) Adj item: [Single Tone Deviation (Analog Wide)] 2) Adj item: [Low], [Low'], [Center], [High'], [High] PTT: Press [Transmit] button. Press [Apply] button to store the adjustment value.	Deviation meter Oscilloscope	Panel	ANT	Panel	[FPU] [<][>]	3.00kHz	3.00kHz ±0.05kHz
*3: Refer to the "4.6.1 Necessary Deviation adjustment item for each signaling and mode" table.								
10.VOX 1	1) Adj item: [VOX 1] AG : 1kHz/45mV at MIC terminal Press [Apply] button to store the adjustment value.	AG AF VM	Panel		Panel		After apply signal from AG,press [Apply] button to store the adjustment value.	
11.VOX 10	1) Adj item: [VOX 10] AG : 1kHz/3mV at MIC terminal Press [Apply] button to store the adjustment value.	AG AF VM	Panel		Panel		After apply signal from AG,press [Apply] button to store the adjustment value.	
12. Battery warning level writing	1) Adj item: [Battery Warning Level] PTT: Press [Transmit] button.	Power meter DVM	Panel	ANT BATT terminal			Press the PTT switch or [Transmit] button on the PC window. Apply 6.20V to battery terminal. Confirm that one pre-determined numeric in the range 1 to 4096 appears. Press [Apply] button to store the adjustment value.	

Item	Condition	Measurement			Adjustment			Specifications /Remarks
	PC test mode	Test-equipment	Unit	Terminal	Unit	Parts	Method	
13. Battery warning level check	1) Test Channel Channel: 1 Test Signaling Mode: Analog Signaling: 1 BATT terminal voltage: 6.0V while transmitting	Power meter DVM	Panel	ANT BATT terminal			Check	The transceiver can transmit with causing the LED to blink.
14. DTMF Deviation	1) Adj item: [DTMF Deviation (Analog Narrow)] Deviation meter LPF : 15kHz HPF : OFF 2) Adj item: [Low], [Low'], [Center], [High'], [High] PTT: Press [Transmit] button. Press [Apply] button to store the adjustment value.	Deviation meter Oscilloscope	Panel	ANT	Panel	[FPU] [<][>]	1.25kHz	1.25kHz ±0.05kHz
	1) Adj item: [DTMF Deviation (Analog Wide)] 2) Adj item: [Low], [Low'], [Center], [High'], [High] PTT: Press [Transmit] button. Press [Apply] button to store the adjustment value.	Deviation meter Oscilloscope	Panel	ANT	Panel	[FPU] [<][>]	2.50kHz	2.50kHz ±0.05kHz
15. MSK Deviation	1) Adj item: [MSK Deviation (Analog Narrow)] Deviation meter LPF : 15kHz HPF : OFF 2) Adj item: [Low], [Low'], [Center], [High'], [High] PTT: Press [Transmit] button. Press [Apply] button to store the adjustment value.	Deviation meter Oscilloscope	Panel	ANT	Panel	[FPU] [<][>]	1.50kHz	1.50kHz ±0.05kHz
	1) Adj item: [MSK Deviation (Analog Wide)] 2) Adj item: [Low], [Low'], [Center], [High'], [High] PTT: Press [Transmit] button. Press [Apply] button to store the adjustment value.	Deviation meter Oscilloscope	Panel	ANT	Panel	[FPU] [<][>]	3.00kHz	3.00kHz ±0.05kHz

4.6.1 Necessary Deviation adjustment item for each signaling and mode

The following shows the necessary adjustment items for each signaling deviation. Please read the following table like the following example. In the case of the signaling "QT (Analog Wide)", this signaling is composed of three elements [Balance, Maximum Deviation (Analog Wide) and QT Deviation (Analog Wide)]. Please adjust Balance and Maximum Deviation (Analog Wide) before adjusting QT Deviation (Analog Wide).

Mode	Signaling	Necessary adjustment and order	
		Wide	Narrow
Analog	Audio	1. Balance 2. Maximum Deviation [Analog Wide]	1. Balance 2. Maximum Deviation [Analog Narrow]
	QT	1. Balance 2. Maximum Deviation [Analog Wide] 3. QT Deviation [Analog Wide]	1. Balance 2. Maximum Deviation [Analog Narrow] 3. QT Deviation [Analog Narrow]
	DQT	1. Balance 2. Maximum Deviation [Analog Wide] 3. DQT Deviation [Analog Wide]	1. Balance 2. Maximum Deviation [Analog Narrow] 3. DQT Deviation [Analog Narrow]
	2TONE	1. Balance 2. Maximum Deviation [Analog Wide] 3. Single Tone Deviation [Analog Wide]	1. Balance 2. Maximum Deviation [Analog Narrow] 3. Single Tone Deviation [Analog Narrow]
	DTMF	1. Balance 2. Maximum Deviation [Analog Wide] 3. DTMF Deviation [Analog Wide]	1. Balance 2. Maximum Deviation [Analog Narrow] 3. DTMF Deviation [Analog Narrow]
	MSK	1. Balance 2. Maximum Deviation [Analog Wide] 3. MSK Deviation [Analog Wide]	1. Balance 2. Maximum Deviation [Analog Narrow] 3. MSK Deviation [Analog Narrow]
DMR	Audio	-	1. Balance 2. Maximum Deviation [DMR]

- Balance is common with all the above deviation adjustments. If Balance (Transmitter Section 4) has already adjusted, please skip Step1 and adjust from Step2.
- Maximum Deviation (Analog Wide/Analog Narrow) is common with all the analog signaling deviations. If Balance and Maximum Deviation (Analog Wide/Analog Narrow) (Transmitter Section 6) have already adjusted, please skip Step2 and adjust from Step3.

4.7 Receiver Section

Item	Condition	Measurement			Adjustment			Specifications /Remarks
		Test-equipment	Unit	Terminal	Unit	Parts	Method	
1. AF level setting	1) Test Channel Channel: 1 Test Signaling Mode: Analog Signaling: 1 Wide/Narrow: Narrow Beat Shift: Uncheck Compander: Uncheck SSG output:-47dBm (1mV) (MOD:1kHz/±1.5kHz)	SSG DVM AF VM Dummy load		ANT SP/MIC connec- tor		Vol- ume knob	Turn the Volume knob to obtain 1.0V AF output.	1.0V±0.2V
2. Sensitivity 1 (SENS1)	1) Adj item: [Sensitivity 1] 2) Adj item:[Low], [Low'], [Center], [High'], [High] Press [Apply All] button to store the adjustment value.	SSG DVM AF VM Dummy load		ANT SP/MIC connec- tor		[FPU] [<][>] Preset value Low : 50 Low' : 180 Center : 350 High' : 480 High : 600	Press [Start] button of "Auto Tuning", or increase the adjustment value from the preset value to get the maximum RSSI level. SSG output: -100dBm (2.24μV) (MOD: 1kHz/±1.5kHz) Press [Apply All] button to store the adjustment value after all adjustment points have been adjusted.	RSSI Peak Caution: Perform the adjustment of "3. Sensitivity 2" before performing this adjustment.
3. Sensitivity 2 (SENS2)	1) Adj item: [Sensitivity 2] 2) Adj item:[Low], [Low'], [Center], [High'], [High] Press [Apply All] button to store the adjustment value.	SSG DVM AF VM Dummy load		ANT SP/MIC connec- tor		[FPU] [<][>] Low : 100 Low' : 240 Center : 365 High' : 430 High : 520	Write Preset value. (Fixed value)	
4.* RSSI Reference	1) Adj item: [RSSI Reference (Analog Narrow)] 2) Adj item:[Low], [Low'], [Center], [High'], [High] SSG output: 12dB SINAD level -3dB (MOD:1kHz/±1.5kHz)	SSG DVM AF VM Dummy load		ANT SP/MIC connec- tor		[FPU] [<][>]	After input signal from SSG, press [Apply] button to store the adjustment value.	*: Because RSSI Reference (Analog Wide and DMR) is adjusted by adjusting RSSI Reference (Analog Narrow), it is not necessary to adjust RSSI Reference (Analog Wide and DMR).
5. Open Squelch (DMR)	1) Adj item:[Open Squelch (DMR)] 2) Adj item:[Low], [Low'], [Center], [High'], [High] Reference SSG output: 12dB SINAD level@Analog Narrow -3dB (CW (without modulation))	SSG Distortion meter Oscilloscope		ANT SP/MIC connec- tor		[FPU] [<][>]	After input signal from SSG, press [Apply] button to store the adjustment value.	

Item	Condition	Measurement			Adjustment			Specifications /Remarks
		Test-equipment	Unit	Terminal	Unit	Parts	Method	
5. Open Squelch (Analog Narrow)	1) Adj item: [Open Squelch (Analog Narrow)] 2) Adj item:[Low], [Low'], [Center], [High'], [High] SSG output: 12dB SINAD level +1dB (MOD:1kHz/±1.5kHz)	SSG Distortion meter Oscilloscope		ANT SP/MIC connector		[FPU] [<][>]	After input signal from SSG, press [Apply] button to store the adjustment value.	
5. Open Squelch (Analog Wide)	1) Adj item: [Open Squelch (Analog wide)] 2) Adj item:[Low], [Low'], [Center], [High'], [High] SSG output: 12dB SINAD level +1dB (MOD:1kHz/±3.0kHz)	SSG Distortion meter Oscilloscope		ANT SP/MIC connector		[FPU] [<][>]	After input signal from SSG, press [Apply] button to store the adjustment value.	
6.* Low RSSI	1) Adj item:[Low RSSI (Analog Narrow)] 2) Adj item:[Low], [Low'], [Center], [High'], [High] SSG output :-118dBm (0.28uV) (MOD:1kHz/±1.5kHz)	SSG Distortion meter Oscilloscope		ANT SP/MIC connector		[FPU] [<][>]	After input signal from SSG, press [Apply] button to store the adjustment value.	*: Because Low RSSI at -118dBm (Analog Wide and DMR) is adjusted by adjusting Low RSSI at -118dBm (Analog Narrow), it is not necessary to adjust Low RSSI at -118dBm (Analog Wide and DMR).
7.* High RSSI	1) Adj item: [High RSSI (Analog Narrow)] 2) Adj item: [Low], [Low'], [Center], [High'], [High] SSG output : -80dBm (22.4uV) (MOD:1kHz/±1.5kHz)	SSG Distortion meter Oscilloscope		ANT SP/MIC connector		[FPU] [<][>]	After input signal from SSG, press [Apply] button to store the adjustment value.	*: Because High RSSI at -80dBm (Analog Wide and DMR) is adjusted by adjusting High RSSI at -80dBm (Analog Narrow), it is not necessary to adjust High RSSI at -80dBm (Analog Wide and DMR).
8. Tight Squelch (Analog Narrow)	1) Adj item: [Open Squelch (Analog Narrow)] 2) Adj item:[Low], [Low'], [Center], [High'], [High] SSG output: 12dB SINAD level +5dB (MOD:1kHz/±1.5kHz)	SSG Distortion meter Oscilloscope		ANT SP/MIC connector		[FPU] [<][>]	After input signal from SSG, press [Apply] button to store the adjustment value.	
8. Tight Squelch (Analog Wide)	1) Adj item: [Open Squelch (Analog wide)] 2) Adj item:[Low], [Low'], [Center], [High'], [High] SSG output: 12dB SINAD level +5dB (MOD:1kHz/±3.0kHz)	SSG Distortion meter Oscilloscope		ANT SP/MIC connector		[FPU] [<][>]	After input signal from SSG, press [Apply] button to store the adjustment value.	

4.8 E,E2 TYPE

Test Equipment Required for Alignment

Test Equipment	Major Specifications	
1. Standard Signal Generator (SSG)	Frequency Range	100 to 520MHz
	Modulation	Frequency modulation and external modulation
	Output	-127dBm/0.1 μ V to greater than -47dBm/1mV
2. Power Meter	Input Impedance	50 Ω
	Operation Frequency	100 to 520MHz
	Measuring Range	Vicinity of 10W
3. Deviation Meter	Frequency Range	100 to 520MHz
4. Digital Volt Meter (DVM)	Measuring Range	10mV to 10V DC
	Input Impedance	High input impedance for minimum circuit loading
5. Oscilloscope		DC through 30MHz
6. High Sensitivity Frequency Counter	Frequency Range	10Hz to 1000MHz
	Frequency Stability	0.2ppm or less
7. Ammeter		5A
8. AF Volt Meter (AF VM)	Frequency Range	50Hz to 10kHz
	Voltage Range	1mV to 10V
9. Audio Generator (AG)	Frequency Range	50Hz to 5kHz or more
	Output	0 to 1V
10. Distortion Meter	Capability	3% or less at 1kHz
	Input Level	50mV to 10Vrms
11. 8 Ω Dummy Load		Approx. 8 Ω , 3W
12. Regulated Power Supply		5V to 10V, approx. 3A Useful if ammeter equipped

*The test equipment which is not used for adjustment is contained in this table.

■Antenna connector adapter

The antenna connector of this transceiver uses an SMA terminal.

Use an antenna connector adapter [SMA(f) - BNC(f) or SMA(f) - N(f)] for adjustment. (The adapter is not provided as an option, so buy a commercially-available one.)

■Repair Jig (Chassis)

Use jig (Chassis) for repairing the transceiver. Place the Main unit on the jig and fit it with screws.

The jig facilitates the voltage check and protects the final amplifier FET when the voltage on the flow side of the Main unit is checked during repairs.

■Battery Jig (W05-1011-00)

Connect the power cable properly between the battery jig installed in the transceiver and the power supply, and be sure output voltage and the power supply polarity prior to switching the power supply ON, otherwise over voltage and reverse connection may damage the transceiver, or the power supply or both.

Note:

When using the battery jig, you must measure the voltage at the terminals of the battery jig. Otherwise, a slight voltage drop may occur within the power cable, between the power supply and the battery jig, especially while the transceiver transmits.

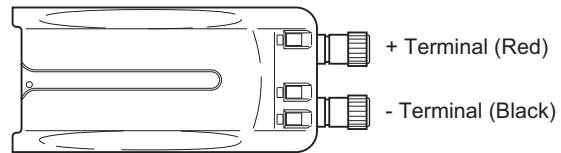

Schematic diagram

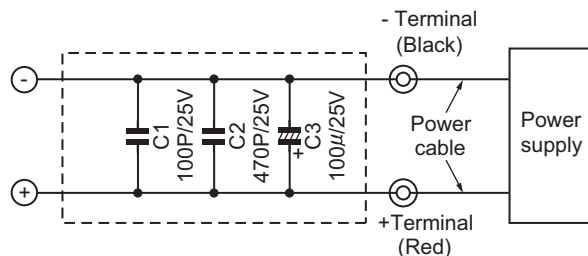

4.9 Frequency and Signaling

The transceiver has been adjusted for the frequencies shown in the following table. When required, readjust them following the adjustment procedure to obtain the frequencies you want in actual operation.

■Test frequency

CH	RX (MHz)	TX (MHz)
1	155.05000	155.10000
2	136.05000	136.10000
3	173.95000	173.90000
4	155.00000	155.00000
5	155.20000	155.20000
6	155.40000	155.40000
7~16	-	-

■Analog mode signaling

No.	RX	TX
1	None	None
2	None	100Hz Square Wave
3	QT 67.0 Hz	QT 67.0 Hz
4	QT 151.4 Hz	QT 151.4 Hz
5	QT 210.7 Hz	QT 210.7 Hz
6	QT 254.1 Hz	QT 254.1 Hz
7	DQT D023N	DQT D023N
8	DQT D754I	DQT D754I
9	DTMF Decode (CODE: 159D)	DTMF Encode (CODE: 159D)
10	None	DTMF Encode (CODE: 9)
11	Single Tone: 979.9Hz	Single Tone: 979.9Hz
12	None	Single Tone: 1000Hz
13	None	MSK PN9
14	MSK Decode	MSK Encode

■DMR mode signaling

No.	RX	TX
1	CC 00 Burst	CC 00 Burst
2	PN9 Continuous Pattern	PN9 Continuous Pattern
3	CC 00 Burst	Maximum Deviation Continuous Pattern
5	CC 00 Burst	0 Continuous Pattern
6	SYNC (Each slot) + PN9 Burst Pattern	SYNC (Each slot) + PN9 Burst Pattern

4.10 Preparations for Tuning the Transceiver

Before attempting to tune the transceiver, connect the unit to a suitable power supply.

Whenever the transmitter is tuned, the unit must be connected to a suitable dummy load (i.e. power meter).

The speaker output connector must be terminated with a 8Ω dummy load and connected to an AC voltmeter and an audio distortion meter or a SINAD measurement meter at all times during tuning.

■5 reference level adjustments frequency

Tuning point	RX (MHz)	TX (MHz)
Low	136.05000	136.10000
Low'	145.55000	145.60000
Center	155.05000	155.10000
High'	164.55000	164.60000
High	173.95000	173.90000

PN9:Pseudo-Random Pattern (for production only)

4.10.1 Adjustment item supplement

Adjustment Item	Description
Receive Assist	The lock voltage of VCO (Receive) is adjusted. This item must be adjusted before all adjustment items for receiver section are adjusted.
Transmit Assist	The lock voltage of VCO (Transmit) is adjusted. This item must be adjusted before all adjustment items for transmitter section are adjusted.
Frequency	The Transmit Frequency is adjusted.
Ramp Offset	Adjust this item to the optimal Ramp voltage.
High Transmit Power	High Transmit Power is adjusted.
Low Transmit Power	Low Transmit Power is adjusted.
Balance	The transmit audio frequency response is adjusted. This item is adjusted so that the deviation of 2kHz becomes the same deviation of 20Hz. This item must be adjusted before all adjustment items for deviations are adjusted.
Maximum Deviation (DMR)	Maximum Deviation of DMR is adjusted.
Maximum Deviation (Analog Wide 5k/ Wide 4k/ Narrow)	Maximum Deviation of Analog (Wide 5k/ Wide 4k/ Narrow) is adjusted. This item must be adjusted before all adjustment items for tone deviations are adjusted.
QT Deviation	QT tone deviation is adjusted.
DQT Deviation	DQT tone deviation is adjusted.
Single Tone Deviation	The deviation of Single Tone used in "5-tone" is adjusted.
VOX 1	VOX 1 Level is adjusted.
VOX 10	VOX 10 Level is adjusted.
Sensitivity 1	Band-Pass Filter is adjusted. The performance of Receive Sensitivity is improved.
Sensitivity 2	Band-Pass Filter is adjusted. The performance of the interfering wave is improved.
RSSI Reference	The minimum RSSI level for scan stop is adjusted.

Adjustment Item	Description
Open Squelch	The squelch level at level "5" is adjusted.
Low RSSI	RSSI display level is adjusted.
High RSSI	Both "Low RSSI" and "High RSSI" must be adjusted. (The curve data of RSSI level is applied.)
Tight Squelch	The squelch level at level "9" is adjusted.
Battery Warning Level	Battery Warning Level (LED blinking level) is adjusted. Battery Warning Level minus 0.4V is the transmission inhibited level.

4.10.2 Adjustment item

Order	Adjustment item	Aw	As	An	Dn	Adjust item Number
		(Analog Wide 5k)	(Analog Wide 4k)	(Analog Narrow)	(DMR)	
		Adjustment range				
1	Receive Assist	5 point ADJ				Common Section 1
		1 ~ 1024				
2	Transmit Assist	5 point ADJ				Common Section 2
		1 ~ 1024				
3	Frequency	1 point ADJ				Common Section 3
		1 ~ 1024				
4	Ramp Offset	5 point ADJ				Transmitter Section 1
		1 ~ 512				
5	High Transmit Power	-	-	5	-	Transmitter Section 2
		1 ~ 1024				
6	Low Transmit Power	-	-	5	-	Transmitter Section 3
		1 ~ 1024				
7	Balance	-	-	5	-	Transmitter Section 4
		1 ~ 70				
8	Maximum Deviation (DMR)	-	-	-	5	Transmitter Section 5
		1 ~ 1024				
9	Maximum Deviation (Analog)	5	5	5	-	Transmitter Section 6
		1 ~ 1024				
10	QT Deviation	1	1	1	-	Transmitter Section 7
		1 ~ 1024				
11	DQT Deviation	1	1	1	-	Transmitter Section 8
		1 ~ 1024				
12	Single Tone Deviation	1	1	1	-	Transmitter Section 9
		1 ~ 1024				
13	VOX 1	1 point ADJ				Transmitter Section 10
		1 ~ 4096				
14	VOX 10	1 point ADJ				Transmitter Section 11
		1 ~ 4096				
15	Sensitivity 1	-	-	5	-	Receive Section 2
		1 ~ 1024				
16	Sensitivity 2	-	-	5	-	Receive Section 3
		1 ~ 1024				

Order	Adjustment item	Aw (Analog Wide 5k)	As (Analog Wide 4k)	An (Analog Narrow)	Dn (DMR)	Adjust item Number
		Adjustment range				
17	RSSI Reference	-	-	5	-	Receive Section 4
		1 ~ 1024				
18	Open Squelch	5	5	5	5	Receive Section 5
		1 ~ 1024				
19	Low RSSI	-	-	5	-	Receive Section 6
		1 ~ 1024				
20	High RSSI	-	-	5	-	Receive Section 7
		1 ~ 1024				
21	Tight Squelch	5	5	5	-	Receive Section 8
		1 ~ 1024				
22	Battery Warning Level	1 point ADJ				Transmitter Section 12
		1 ~ 4096				
23	DTMF Deviation	1	1	1	-	Transmitter Section 14
		1 ~ 1024				
24	MSK Deviation	1	1	1	-	Transmitter Section 15
		1 ~ 1024				

4.11 Radio check Section

Item	Condition	Measurement			Adjustment			Specifications /Remarks
	PC test mode	Test- equipment	Unit	Terminal	Unit	Parts	Method	
1. Frequency check	1)Test Channel Channel: 1 Test Signaling Mode: Analog Signaling: 1 PTT: Press [Transmit] button.	f. counter	Panel	ANT			Check	155.099767~ 155.100233M Hz (±1.5ppm@ 155.1MHz)
2. High power check (Battery voltage: 7.5V)	1)Test Channel Channel: 1 Test Signaling Mode: Analog Signaling: 1 PTT: Press [Transmit] button.	Power meter Ammeter	Panel	ANT			Check	4.0W~6.0W 2.3A or less
	2)Test Channel Channel: 2 Test Signaling Mode: Analog Signaling: 1 PTT: Press [Transmit] button.	Power meter Ammeter	Panel	ANT			Check	4.0W~6.0W 2.3A or less
	3)Test Channel Channel: 3 Test Signaling Mode: Analog Signaling: 1 PTT: Press [Transmit] button.	Power meter Ammeter	Panel	ANT			Check	4.0W~6.0W 2.3A or less

Item	Condition	Measurement			Adjustment			Specifications /Remarks
	PC test mode	Test-equipment	Unit	Terminal	Unit	Parts	Method	
3. Low power check (Battery voltage: 7.5V)	1)Test Channel Channel: 1 Test Signaling Mode: Analog Signaling: 1 PTT: Press [Transmit] button.	Power meter Ammeter	Panel	ANT			Check	0.75W~1.25W 1.2A or less
	2)Test Channel Channel: 2 Test Signaling Mode: Analog Signaling: 1 PTT: Press [Transmit] button.	Power meter Ammeter	Panel	ANT			Check	0.75W~1.25W 1.2A or less
	3)Test Channel Channel: 3 Test Signaling Mode: Analog Signaling: 1 PTT: Press [Transmit] button.	Power meter Ammeter	Panel	ANT			Check	0.75W~1.25W 1.2A or less
4. MIC sensitivity check	1)Test Channel Channel: 1 Test Signaling Mode: Analog Signaling: 1 AG: 1kHz PTT: Press [Transmit] button.	Deviation meter Oscilloscope AG AF VM	Panel	ANT SP/MIC connector			Adjust AG input to get a standard MOD.	15.0mV ±7.0mV
5. Sensitivity check	1)Test Channel Channel: 1 Test Signaling Mode: Analog Signaling: 1 SSG output Wide 5k: -115dBm (0.40μV) (MOD: 1kHz/±3kHz) Wide 4k: -115dBm (0.40μV) (MOD: 1kHz/±2.4kHz) Narrow: -115dBm (0.40μV) (MOD: 1kHz/±1.5kHz)	SSG AF VTVM Oscilloscope Distortion meter 8Ω Dummy load	Panel	ANT SP/MIC connector			Check	12dB SINAD or more

4.12 Common Section

Item	Condition	Measurement			Adjustment			Specifications /Remarks
	PC test mode	Test-equipment	Unit	Terminal	Unit	Parts	Method	
1. Setting	1) BATT terminal voltage:7.5V 2) SSG standard modulation [Wide 5k] MOD:1kHz,DEV:3kHz [Wide 4k] MOD:1kHz,DEV:2.4kHz [Narrow] MOD:1kHz,DEV:1.5kHz							
2. Receive Assist	1) Adj item: [Receive Assist] 2) Adj item: [Low], [Low'], [Center], [High'], [High] Press [Apply All] button to store the adjustment value.				Panel	[FPU] [<][>]	[V] indicator on the PC window shows VCO lock voltage. Change the adjustment value to get VCO lock voltage within the limit of the specified voltage. Note: Confirm the VCO lock voltage approximately 3 seconds after the adjustment value is changed.	2.4~2.6V Press [Apply All] button to store the adjustment value after all adjustment point have been adjusted.

Item	Condition	Measurement			Adjustment			Specifications /Remarks
	PC test mode	Test-equipment	Unit	Terminal	Unit	Parts	Method	
3. Transmit Assist	1) Adj item: [Transmit Assist] 2) Adj item: [Low], [Low'], [Center], [High'], [High] PTT: Press [Transmit] button. Press [Apply All] button to store the adjustment value.				Panel	FPU [<][>]	[V] indicator on the PC window shows VCO lock voltage. Change the adjustment value to get VCO lock voltage within the limit of the specified voltage. Note: Confirm the VCO lock voltage approximately 3 seconds after the adjustment value is changed.	2.4~2.6V Press [Apply All] button to store the adjustment value after all adjustment point have been adjusted.
4. Frequency	1) Adj item: [Frequency] PTT: Press [Transmit] button. Press [Apply] button to store the adjustment value. 2) Adj item: [High]	f. counter	Panel	ANT		[FPU] [<][>]	155.100MHz	155.099767~155.100233MHz (±1.5ppm@155.1MHz)

4.13 Transmitter Section

Item	Condition	Measurement			Adjustment			Specifications /Remarks
	PC test mode	Test-equipment	Unit	Terminal	Unit	Parts	Method	
1. Ramp Offset	1) Adj item: [Ramp Offset] 2) Adj item: [Low], [Low'], [Center], [High'], [High]		Panel		Panel	[FPU] [<][>]	Write the value as followings. 1 Press [Apply All] button to store the adjustment value after all adjustment points have been adjusted.	
2. High transmit power (Battery voltage : 7.5V)	1) Adj item: [High Transmit Power] 2) Adj item: [Low], [Low'], [Center], [High'], [High] PTT: Press [Transmit] button. Press [Apply All] button to store the adjustment value.	Power meter Ammeter	Panel	ANT	Panel	[FPU] [<][>]	5.0W	±0.2W 2.0A or less Press [Apply] button to store the adjustment value whenever each adjustment points have been adjusted.
3. Low transmit power (Battery voltage :7.5V)	1) Adj item: [Low Transmit Power] 2) Adj item: [Low], [Low'], [Center], [High'], [High] PTT: Press [Transmit] button. Press [Apply All] button to store the adjustment value.	Power meter Ammeter	Panel	ANT	Panel	[FPU] [<][>]	1.0W	±0.05W 1.0A or less Press [Apply] button to store the adjustment value whenever each adjustment points have been adjusted.
4. Balance *1 *2	1) Adj item: [Balance] Deviation meter LPF : 3kHz HPF : OFF 2) Adj item: [Low], [Low'], [Center], [High'], [High] PTT: Press [Transmit] button. Press [Apply All] button to store the adjustment value. [2kHz Sine Wave Check box]: Check while transmitting change to 2kHz.	Deviation meter Oscilloscope	Panel	ANT	Panel	[FPU] [<][>]	The Deviation of 20Hz frequency is fixed. Change the 2kHz adjustment value to become the same deviation of 20Hz within the specified range.	2kHz Tone deviation is within ±0.2dB of 20Hz tone deviation. Press [Apply All] button to store the adjustment value after all adjustment points have been adjusted.

Item	Condition	Measurement			Adjustment			Specifications /Remarks
	PC test mode	Test-equipment	Unit	Terminal	Unit	Parts	Method	
4. Balance 2 *1 *2	1) Adj item: [Balance] Deviation meter LPF : 3kHz HPF : OFF 2) Adj item: [Low], [Low'], [Center], [High'], [High] PTT: Press [Transmit] button. Press [Apply All] button to store the adjustment value. [Square Wave Check box]: Check while transmitting change to Square Wave.	Deviation meter Oscilloscope	Panel	ANT	Panel	[FPU] [<][>]	Make the demodulation wave into square wave.	
<p>*1 : Refer to the "4.13.1 Necessary Deviation adjustment item for each signaling and mode" table. Balance adjustment is common with the adjustment of all signaling deviations. *2 :Only 1 Balance needs to be adjusted (either Balance 1 or Balance 2).</p>								
5. Maximum Deviation (DMR) *2	1) Adj item: [Maximum Deviation (DMR)] Deviation meter LPF : 3kHz HPF : OFF 2) Adj item: [Low], [Low'], [Center], [High'], [High] PTT: Press [Transmit] button. Press [Apply All] button to store the adjustment value.	Deviation meter Oscilloscope	Panel	ANT	Panel	[FPU] [<][>]	2749Hz	2695~2803Hz Press [Apply All] button to store the adjustment value after all adjustment points have been adjusted.

Item	Condition	Measurement			Adjustment			Specifications /Remarks
	PC test mode	Test-equipment	Unit	Terminal	Unit	Parts	Method	
6. Maximum deviation (Analog) *2	1) Adj item: [Maximum Deviation (Analog Narrow)] Deviation meter LPF : 15kHz HPF : OFF 2) Adj item: [Low], [Low'], [Center], [High'], [High] PTT: Press [Transmit] button. Press [Apply All] button to store the adjustment value.	Deviation meter Oscilloscope	Panel	ANT	Panel	[FPU] [<][>]	2100Hz Write the same adjustment value of "[Maximum Deviation (DMR)]" for each adjustment point. Transmit at each adjustment point and check that the Analog deviation is between 2050Hz and 2150Hz. Deviation meter LPF : 15kHz HPF : OFF [Panel tuning mode] PTT: ON [PC test mode] PTT: Press [Transmit] button	2050~2150Hz Press [Apply All] button to store the adjustment value after all adjustment points have been adjusted.
	1)Adj item: [Maximum Deviation (Analog Wide 4k)] 2)Adj item: [Low], [Low'], [Center], [High'], [High] PTT: Press [Transmit] button. Press [Apply All] button to store the adjustment value.	Deviation meter Oscilloscope	Panel	ANT	Panel	[FPU] [<][>]	3360Hz Write the same adjustment value of "[Maximum Deviation (DMR)]" for each adjustment point. Transmit at each adjustment point and check that the Analog deviation is between 3310Hz and 3410Hz. Deviation meter LPF : 15kHz HPF : OFF [Panel tuning mode] PTT: ON [PC test mode] PTT: Press [Transmit] button	3310~3410Hz Press [Apply All] button to store the adjustment value after all adjustment points have been adjusted.
	1) Adj item: [Maximum Deviation (Analog Wide 5k)] 2) Adj item: [Low], [Low'], [Center], [High'], [High] PTT: Press [Transmit] button. Press [Apply All] button to store the adjustment value.	Deviation meter Oscilloscope	Panel	ANT	Panel	[FPU] [<][>]	4200Hz Write the same adjustment value of "[Maximum Deviation (DMR)]" for each adjustment point. Transmit at each adjustment point and check that the Analog deviation is between 4150Hz and 4250Hz. Deviation meter LPF : 15kHz HPF : OFF [Panel tuning mode] PTT: ON [PC test mode] PTT: Press [Transmit] button	4150~4250Hz Press [Apply All] button to store the adjustment value after all adjustment points have been adjusted.

Item	Condition	Measurement			Adjustment			Specifications /Remarks
	PC test mode	Test-equipment	Unit	Terminal	Unit	Parts	Method	
*2: Refer to the "4.13.1 Necessary Deviation adjustment item for each signaling and mode" table. Regarding Maximum Deviation (Analog), it is common with the adjustment of all analog signalings.								
7. QT Deviation *3	1) Adj item: [QT Deviation (Analog Narrow)] Deviation meter LPF : 3kHz HPF : OFF 2) Adj item: [Low], [Low'], [Center], [High'], [High] PTT: Press [Transmit] button. Press [Apply] button to store the adjustment value.	Deviation meter Oscilloscope	Panel	ANT	Panel	[FPU] [<<][>]	0.35kHz	0.35kHz ±0.05kHz
	1) Adj item: [QT Deviation (Analog Wide 4k)] 2) Adj item: [Low], [Low'], [Center], [High'], [High] PTT: Press [Transmit] button. Press [Apply] button to store the adjustment value.	Deviation meter Oscilloscope	Panel	ANT	Panel	[FPU] [<<][>]	0.60kHz	0.60kHz ±0.05kHz
	1) Adj item: [QT Deviation(Analog Wide 5k)] 2) Adj item: [Low], [Low'], [Center], [High'], [High] PTT: Press [Transmit] button. Press [Apply] button to store the adjustment value.	Deviation meter Oscilloscope	Panel	ANT	Panel	[FPU] [<<][>]	0.75kHz	0.75kHz ±0.05kHz
8. DQT Deviation *3	1) Adj item: [DQT Deviation (Analog Narrow)] Deviation meter LPF : 3kHz HPF : OFF 2) Adj item: [Low], [Low'], [Center], [High'], [High] PTT: Press [Transmit] button. Press [Apply] button to store the adjustment value.	Deviation meter Oscilloscope	Panel	ANT	Panel	[FPU] [<<][>]	0.35kHz	0.35kHz ±0.05kHz
	1) Adj item: [DQT Deviation (Analog Wide 4k)] 2) Adj item: [Low], [Low'], [Center], [High'], [High] PTT: Press [Transmit] button. Press [Apply] button to store the adjustment value.	Deviation meter Oscilloscope	Panel	ANT	Panel	[FPU] [<<][>]	0.60kHz	0.60kHz ±0.05kHz
	1) Adj item: [DQT Deviation(Analog Wide 5k)] 2) Adj item: [Low], [Low'], [Center], [High'], [High] PTT: Press [Transmit] button. Press [Apply] button to store the adjustment value.	Deviation meter Oscilloscope	Panel	ANT	Panel	[FPU] [<<][>]	0.75kHz	0.75kHz ±0.05kHz

Item	Condition	Measurement			Adjustment			Specifications /Remarks
	PC test mode	Test-equipment	Unit	Terminal	Unit	Parts	Method	
9. Single Tone Deviation *3	1) Adj item: [Single Tone Deviation (Analog Narrow)] Deviation meter LPF : 15kHz HPF : OFF 2) Adj item: [Low], [Low'], [Center], [High'], [High] PTT: Press [Transmit] button. Press [Apply] button to store the adjustment value.	Deviation meter Oscilloscope	Panel	ANT	Panel	[FPU] [<][>]	1.50kHz	1.50kHz ±0.05kHz
	1) Adj item: [Single Tone Deviation (Analog Wide 4k)] 2) Adj item: [Low], [Low'], [Center], [High'], [High] PTT: Press [Transmit] button. Press [Apply] button to store the adjustment value.	Deviation meter Oscilloscope	Panel	ANT	Panel	[FPU] [<][>]	2.40kHz	2.40kHz ±0.05kHz
	1) Adj item: [Single Tone Deviation (Analog Wide 5k)] 2) Adj item: [Low], [Low'], [Center], [High'], [High] PTT: Press [Transmit] button. Press [Apply] button to store the adjustment value.	Deviation meter Oscilloscope	Panel	ANT	Panel	[FPU] [<][>]	3.00kHz	3.00kHz ±0.05kHz
*3: Refer to the "4.13.1 Necessary Deviation adjustment item for each signaling and mode" table.								
10.VOX 1	1) Adj item: [VOX 1] AG : 1kHz/45mV at MIC terminal Press [Apply] button to store the adjustment value.	AG AF VM	Panel		Panel		After apply signal from AG,press [Apply] button to store the adjustment value.	
11.VOX 10	1) Adj item: [VOX 10] AG : 1kHz/3mV at MIC terminal Press [Apply] button to store the adjustment value.	AG AF VM	Panel		Panel		After apply signal from AG,press [Apply] button to store the adjustment value.	
12. Battery warning level writing	1) Adj item: [Battery Warning Level] PTT: Press [Transmit] button.	Power meter DVM	Panel	ANT BATT terminal			Press the PTT switch or [Transmit] button on the PC window. Apply 6.20V to battery terminal. Confirm that one predetermined numeric in the range 1 to 4096 appears. Press [Apply] button to store the adjustment value.	
13. Battery warning level check	1) Test Channel Channel: 1 Test Signaling Mode: Analog Signaling: 1 BATT terminal voltage: 6.0V while transmitting	Power meter DVM	Panel	ANT BATT terminal			Check	The transceiver can transmit with causing the LED to blink.

Item	Condition	Measurement			Adjustment			Specifications /Remarks
	PC test mode	Test-equipment	Unit	Terminal	Unit	Parts	Method	
14. DTMF Deviation	1) Adj item: [DTMF Deviation (Analog Narrow)] Deviation meter LPF : 15kHz HPF : OFF 2) Adj item: [Low], [Low'], [Center], [High'], [High] PTT: Press [Transmit] button. Press [Apply] button to store the adjustment value.	Deviation meter Oscilloscope	Panel	ANT	Panel	[FPU] [<][>]	1.25kHz	1.25kHz ±0.05kHz
	1) Adj item: [DTMF Deviation (Analog Wide 4k)] 2) Adj item: [Low], [Low'], [Center], [High'], [High] PTT: Press [Transmit] button. Press [Apply] button to store the adjustment value.	Deviation meter Oscilloscope	Panel	ANT	Panel	[FPU] [<][>]	2.00kHz	2.00kHz ±0.05kHz
	1) Adj item: [DTMF Deviation (Analog Wide 5k)] 2) Adj item: [Low], [Low'], [Center], [High'], [High] PTT: Press [Transmit] button. Press [Apply] button to store the adjustment value.	Deviation meter Oscilloscope	Panel	ANT	Panel	[FPU] [<][>]	2.50kHz	2.50kHz ±0.05kHz
15. MSK Deviation	1) Adj item: [MSK Deviation (Analog Narrow)] Deviation meter LPF : 15kHz HPF : OFF 2) Adj item: [Low], [Low'], [Center], [High'], [High] PTT: Press [Transmit] button. Press [Apply] button to store the adjustment value.	Deviation meter Oscilloscope	Panel	ANT	Panel	[FPU] [<][>]	1.50kHz	1.50kHz ±0.05kHz
	1) Adj item: [MSK Deviation (Analog Wide 4k)] 2) Adj item: [Low], [Low'], [Center], [High'], [High] PTT: Press [Transmit] button. Press [Apply] button to store the adjustment value.	Deviation meter Oscilloscope	Panel	ANT	Panel	[FPU] [<][>]	2.40kHz	2.40kHz ±0.05kHz
	1) Adj item: [MSK Deviation (Analog Wide 5k)] 2) Adj item: [Low], [Low'], [Center], [High'], [High] PTT: Press [Transmit] button. Press [Apply] button to store the adjustment value.	Deviation meter Oscilloscope	Panel	ANT	Panel	[FPU] [<][>]	3.00kHz	3.00kHz ±0.05kHz

4.13.1 Necessary Deviation adjustment item for each signaling and mode

The following shows the necessary adjustment items for each signaling deviation. Please read the following table like the following example. In the case of the signaling "QT (Analog Wide 5k)", this signaling is composed of three elements [Balance, Maximum Deviation (Analog Wide 5k) and QT Deviation (Analog Wide 5k)]. Please adjust Balance and Maximum Deviation (Analog Wide 5k) before adjusting QT Deviation (Analog Wide 5k).

Mode	Signaling	Necessary adjustment and order		
		Wide 5k	Wide 4k	Narrow
Analog	Audio	1. Balance 2. Maximum Deviation [Analog Wide 5k]	1. Balance 2. Maximum Deviation [Analog Wide 4k]	1. Balance 2. Maximum Deviation [Analog Narrow]
	QT	1. Balance 2. Maximum Deviation [Analog Wide 5k] 3. QT Deviation [Analog Wide 5k]	1. Balance 2. Maximum Deviation [Analog Wide 4k] 3. QT Deviation [Analog Wide 4k]	1. Balance 2. Maximum Deviation [Analog Narrow] 3. QT Deviation [Analog Narrow]
	DQT	1. Balance 2. Maximum Deviation [Analog Wide 5k] 3. DQT Deviation [Analog Wide 5k]	1. Balance 2. Maximum Deviation [Analog Wide 4k] 3. DQT Deviation [Analog Wide 4k]	1. Balance 2. Maximum Deviation [Analog Narrow] 3. DQT Deviation [Analog Narrow]
	5STONE	1. Balance 2. Maximum Deviation [Analog Wide 5k] 3. Single Tone Deviation [Analog Wide 5k]	1. Balance 2. Maximum Deviation [Analog Wide 4k] 3. Single Tone Deviation [Analog Wide 4k]	1. Balance 2. Maximum Deviation [Analog Narrow] 3. Single Tone Deviation [Analog Narrow]
	DTMF	1. Balance 2. Maximum Deviation [Analog Wide 5k] 3. DTMF Deviation [Analog Wide 5k]	1. Balance 2. Maximum Deviation [Analog Wide 4k] 3. DTMF Deviation [Analog Wide 4k]	1. Balance 2. Maximum Deviation [Analog Narrow] 3. DTMF Deviation [Analog Narrow]
	MSK	1. Balance 2. Maximum Deviation [Analog Wide 5k] 3. MSK Deviation [Analog Wide 5k]	1. Balance 2. Maximum Deviation [Analog Wide 4k] 3. MSK Deviation [Analog Wide 4k]	1. Balance 2. Maximum Deviation [Analog Narrow] 3. MSK Deviation [Analog Narrow]
DMR	Audio	-	-	1. Balance 2. Maximum Deviation [DMR]

- Balance is common with all the above deviation adjustments. If Balance (Transmitter Section 4) has already adjusted, please skip Step1 and adjust from Step2.
- Maximum Deviation (Analog Wide 5k/Analog Wide 4k/Analog Narrow) is common with all the analog signaling deviations. If Balance and Maximum Deviation (Analog Wide 5k/Analog Wide 4k/Analog Narrow) (Transmitter Section 6) have already adjusted, please skip Step2 and adjust from Step3.

4.14 Receiver Section

Item	Condition	Measurement			Adjustment			Specifications /Remarks
		Test-equipment	Unit	Terminal	Unit	Parts	Method	
1. AF level setting	1) Test Channel Channel: 1 Test Signaling Mode: Analog Signaling: 1 Wide 5k/Wide 4k/ Narrow: Narrow Beat Shift: Uncheck Compander: Uncheck SSG output:-47dBm (1mV) (MOD:1kHz/±1.5kHz)	SSG DVM AF VM Dummy load		ANT SP/MIC connec- tor		Vol- ume knob	Turn the Volume knob to obtain 1.0V AF output.	1.0V±0.2V
2. Sensitivity 1 (SENS1)	1) Adj item: [Sensitivity 1] 2) Adj item:[Low], [Low'], [Center], [High'], [High] Press [Apply All] button to store the adjustment value.	SSG DVM AF VM Dummy load		ANT SP/MIC connec- tor		[FPU] [<][>] Preset value Low : 50 Low' : 180 Center : 350 High' : 480 High : 600	Increase the adjustment value from the preset value to the first 12dB SINAD point with SSG level -118dBm.	12dBSINAD Adjust@-118dBm Caution: Perform the adjustment of "3. Sensitivity 2" before performing this adjustment.
3. Sensitivity 2 (SENS2)	1) Adj item: [Sensitivity 2] 2) Adj item:[Low], [Low'], [Center], [High'], [High] Press [Apply All] button to store the adjustment value.	SSG DVM AF VM Dummy load		ANT SP/MIC connec- tor		[FPU] [<][>] Low : 100 Low' : 240 Center : 365 High' : 430 High : 520	Write Preset value. (Fixed value)	
4.* RSSI Reference	1) Adj item: [RSSI Reference (Analog Narrow)] 2) Adj item:[Low], [Low'], [Center], [High'], [High] SSG output:12dB SINAD level -3dB (MOD:1kHz/±1.5kHz)	SSG DVM AF VM Dummy load		ANT SP/MIC connec- tor		[FPU] [<][>]	After input signal from SSG, press [Apply] button to store the adjustment value.	*: Because RSSI Reference (Analog Wide 5k, Analog Wide 4k and DMR) is adjusted by adjusting RSSI Reference (Analog Narrow), it is not necessary to adjust RSSI Reference (Analog Wide 5k, Analog Wide 4k and DMR).
5. Open Squelch (DMR)	1) Adj item:[Open Squelch (DMR)] 2) Adj item:[Low], [Low'], [Center], [High'], [High] Reference SSG output: 12dB SINAD level@Analog Narrow -3dB (CW (without modulation))	SSG Distortion meter Oscilloscope		ANT SP/MIC connec- tor		[FPU] [<][>]	After input signal from SSG, press [Apply] button to store the adjustment value.	
5. Open Squelch (Analog Narrow)	1) Adj item: [Open Squelch (Analog Narrow)] 2) Adj item:[Low], [Low'], [Center], [High'], [High] SSG output:12dB SINAD level +1dB (MOD:1kHz/±1.5kHz)	SSG Distortion meter Oscilloscope		ANT SP/MIC connec- tor		[FPU] [<][>]	After input signal from SSG, press [Apply] button to store the adjustment value.	

Item	Condition	Measurement			Adjustment			Specifications /Remarks
		Test-equipment	Unit	Terminal	Unit	Parts	Method	
5. Open Squelch (Analog Wide 4k)	1) Adj item: [Open Squelch (Analog Wide 4k)] 2) Adj item:[Low], [Low'], [Center], [High'], [High] SSG output:12dB SINAD level +1dB (MOD:1kHz/±2.4kHz)	SSG Distortion meter Oscilloscope		ANT SP/MIC connector		[FPU] [<][>]	After input signal from SSG, press [Apply] button to store the adjustment value.	
5. Open Squelch (Analog Wide 5k)	1) Adj item: [Open Squelch (Analog Wide 5k)] 2) Adj item:[Low], [Low'], [Center], [High'], [High] SSG output:12dB SINAD level +1dB (MOD:1kHz/±3.0kHz)	SSG Distortion meter Oscilloscope		ANT SP/MIC connector		[FPU] [<][>]	After input signal from SSG, press [Apply] button to store the adjustment value.	
6.* Low RSSI	1) Adj item:[Low RSSI (Analog Narrow)] 2) Adj item:[Low], [Low'], [Center], [High'], [High] SSG output :-118dBm (0.28uV) (MOD:1kHz/±1.5kHz)	SSG Distortion meter Oscilloscope		ANT SP/MIC connector		[FPU] [<][>]	After input signal from SSG, press [Apply] button to store the adjustment value.	*: Because Low RSSI at -118dBm (Analog Wide 5k, Wide 4k and DMR) is adjusted by adjusting Low RSSI at -118dBm (Analog Narrow), it is not necessary to adjust Low RSSI at -118dBm (Analog Wide 5k, Wide 4k and DMR).
7.* High RSSI	1) Adj item: [High RSSI (Analog Narrow)] 2) Adj item: [Low], [Low'], [Center], [High'], [High] SSG output : -80dBm (22.4uV) (MOD:1kHz/±1.5kHz)	SSG Distortion meter Oscilloscope		ANT SP/MIC connector		[FPU] [<][>]	After input signal from SSG, press [Apply] button to store the adjustment value.	*: Because High RSSI at -80dBm (Analog Wide 5k, Wide 4k and DMR) is adjusted by adjusting High RSSI at -80dBm (Analog Narrow), it is not necessary to adjust High RSSI at -80dBm (Analog Wide 5k, Wide 4k and DMR).
8. Tight Squelch (Analog Narrow)	1) Adj item: [Open Squelch (Analog Narrow)] 2) Adj item:[Low], [Low'], [Center], [High'], [High] SSG output:12dB SINAD level +5dB (MOD:1kHz/±1.5kHz)	SSG Distortion meter Oscilloscope		ANT SP/MIC connector		[FPU] [<][>]	After input signal from SSG, press [Apply] button to store the adjustment value.	
8. Tight Squelch (Analog Wide 4k)	1) Adj item: [Open Squelch (Analog Wide 4k)] 2) Adj item:[Low], [Low'], [Center], [High'], [High] SSG output:12dB SINAD level +5dB (MOD:1kHz/±2.4kHz)	SSG Distortion meter Oscilloscope		ANT SP/MIC connector		[FPU] [<][>]	After input signal from SSG, press [Apply] button to store the adjustment value.	
8. Tight Squelch (Analog Wide 5k)	1) Adj item: [Open Squelch (Analog Wide 5k)] 2) Adj item:[Low], [Low'], [Center], [High'], [High] SSG output:12dB SINAD level +5dB (MOD:1kHz/±3.0kHz)	SSG Distortion meter Oscilloscope		ANT SP/MIC connector		[FPU] [<][>]	After input signal from SSG, press [Apply] button to store the adjustment value.	

SECTION 5 TROUBLESHOOTING

5.1 Replacing Main Unit

■ Main unit Information

Model Name	Original Main unit Number	Service Unit Number (XCA-***)
TK-D240 K	XC1-1162-70	XCA-001E-00S (Main Unit Number: XC1-1162-71)
TK-D240 M	XC1-1162-70	XCA-001E-00S (Main Unit Number: XC1-1162-71)
TK-D240 E	XC1-1162-70	XCA-001E-00S (Main Unit Number: XC1-1162-71)
TK-D240 E2	XC1-1162-70	XCA-001E-00S (Main Unit Number: XC1-1162-71)
TK-D240V K	XC1-1162-70	XCA-001E-00S (Main Unit Number: XC1-1162-71)

■ Supplied Accessories of "Service Main unit"

Item (Including Parts Number)	Quantity
Main Unit (XC1-1162-71)	1

■ "Service Main unit" Data

The following data is written on the service Main unit:

Data Type	Description
Firmware	TK-D240/D340 Firmware
FPU Data (PC programming mode)	XC1-116 (TK-D240) E type data.
KENWOOD ESN	Model name: TK-D240 Type: E The same number as a the Model Name Plate label is written.

■ After Changing the PCB

- (1) Using the KPG-166D, select your desired item (Model Name and Frequency) from the Model> Product Information menu, then use Program> Write Data to the Transceiver to write the FPU data (PC Programming mode). When writing to the transceiver, a Warning Message, corresponding to the item selected, appears. Click [OK] to continue writing the data.
- (2) Enter Program> Test Mode, then adjust the various adjustment data (PC Test Mode) as described in the "SECTION 4 ADJUSTMENT".
- (3) If necessary, write the FPU data used by the customer with the KPG-166D.

Note:

- When a new printed circuit board is used, the KENWOOD ESN changes, as does the Transceiver Information display of the KPG-166D, but this does not have any effect on the operation of the transceiver.
- If changing to the original ESN, please contact our service center.

SCHEMATIC DIAGRAM
■ MAIN UNIT (XC1-1162-70)

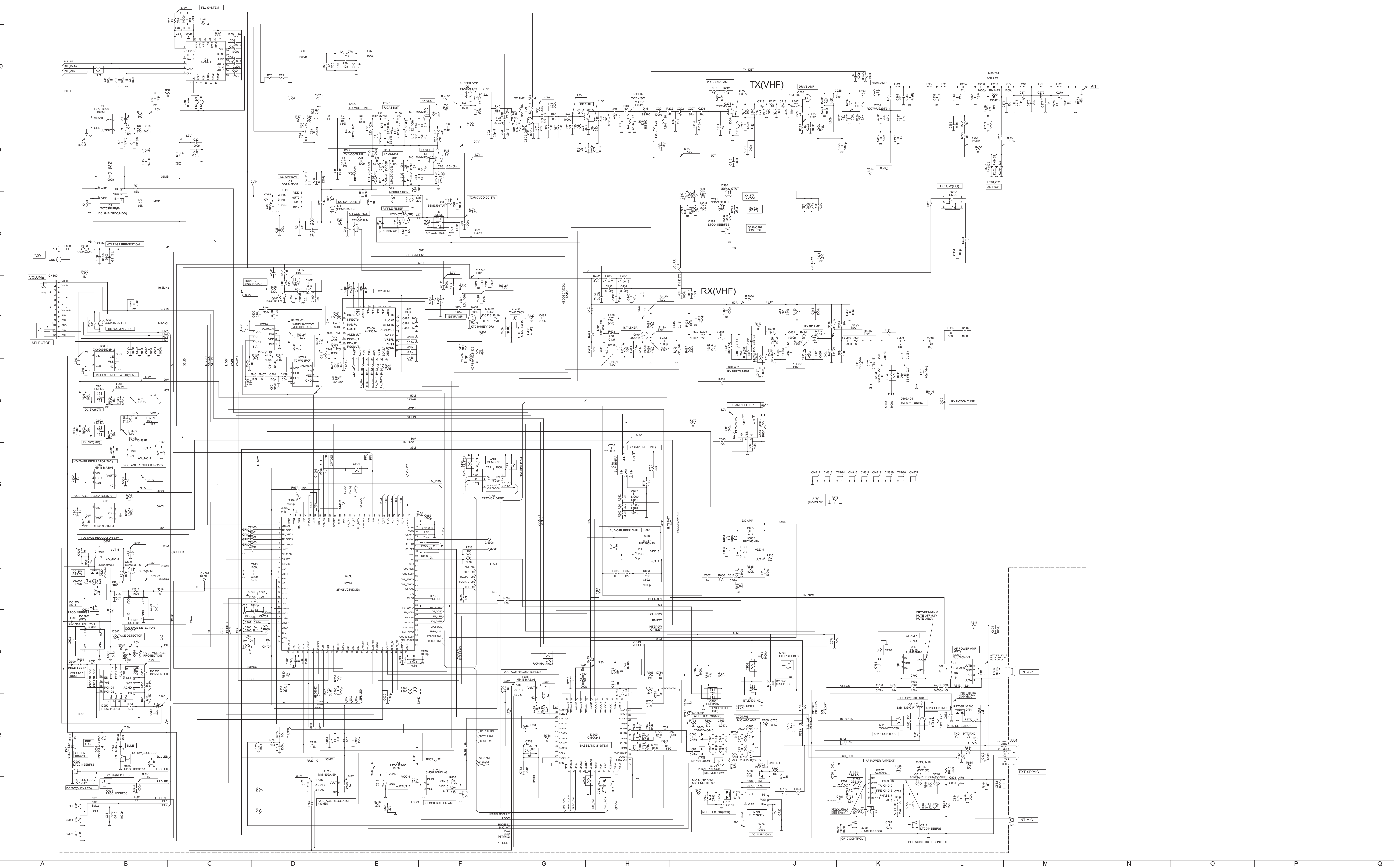

MEMO

LEVEL DIAGRAM

Receiver Section

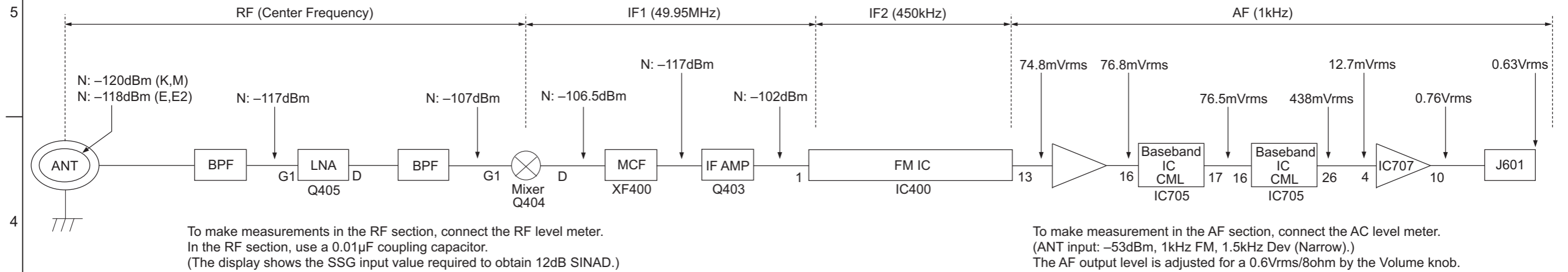

Transmitter Section

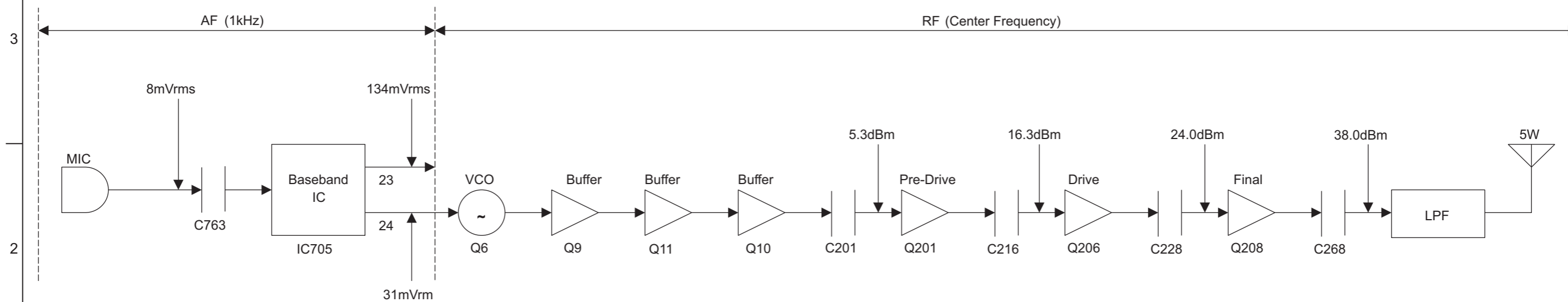

MIC input : 1.5kHz DEV.(Narrow) at 1kHz MOD
 Transmitting frequency : Center frequency

BLOCK DIAGRAM

MAIN UNIT

5

4

3

2

1

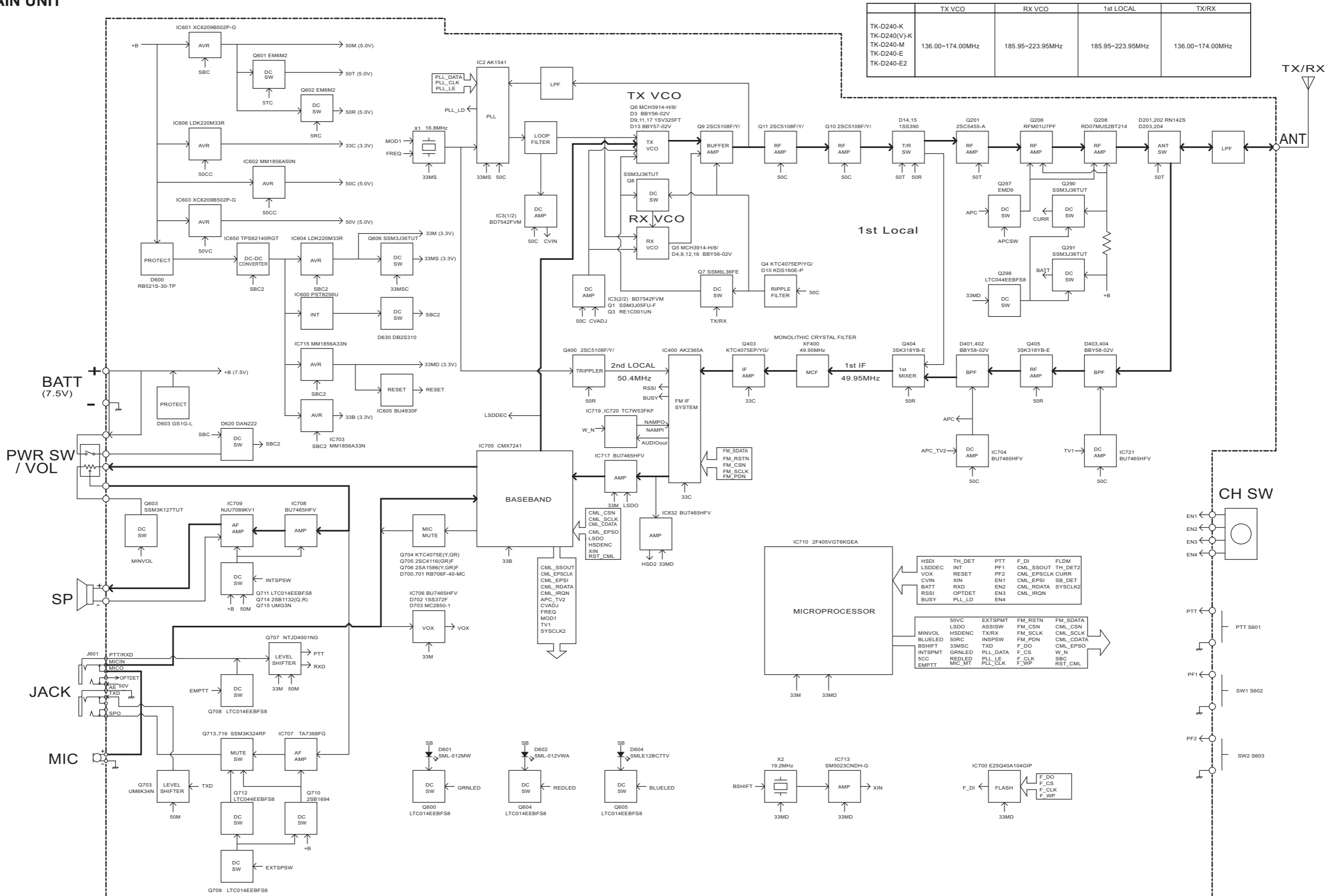

PARTS LIST

[TK-D240,TK-D240(V)]

* SAFETY PRECAUTION

Parts identified by the \triangle symbol are critical for safety. Replace only with specified part numbers.

* BEWARE OF BOGUS PARTS

Parts that do not meet specifications may cause trouble in regard to safety and performance. We recommend that genuine parts be used.

* (x_) in a description column shows the number of the used part.

- Contents -

Exploded view of general assembly and parts list	3-2
Electrical parts list	3-4
Packing materials and accessories parts list	3-10

Exploded view of general assembly and parts list

Block No.M1MM

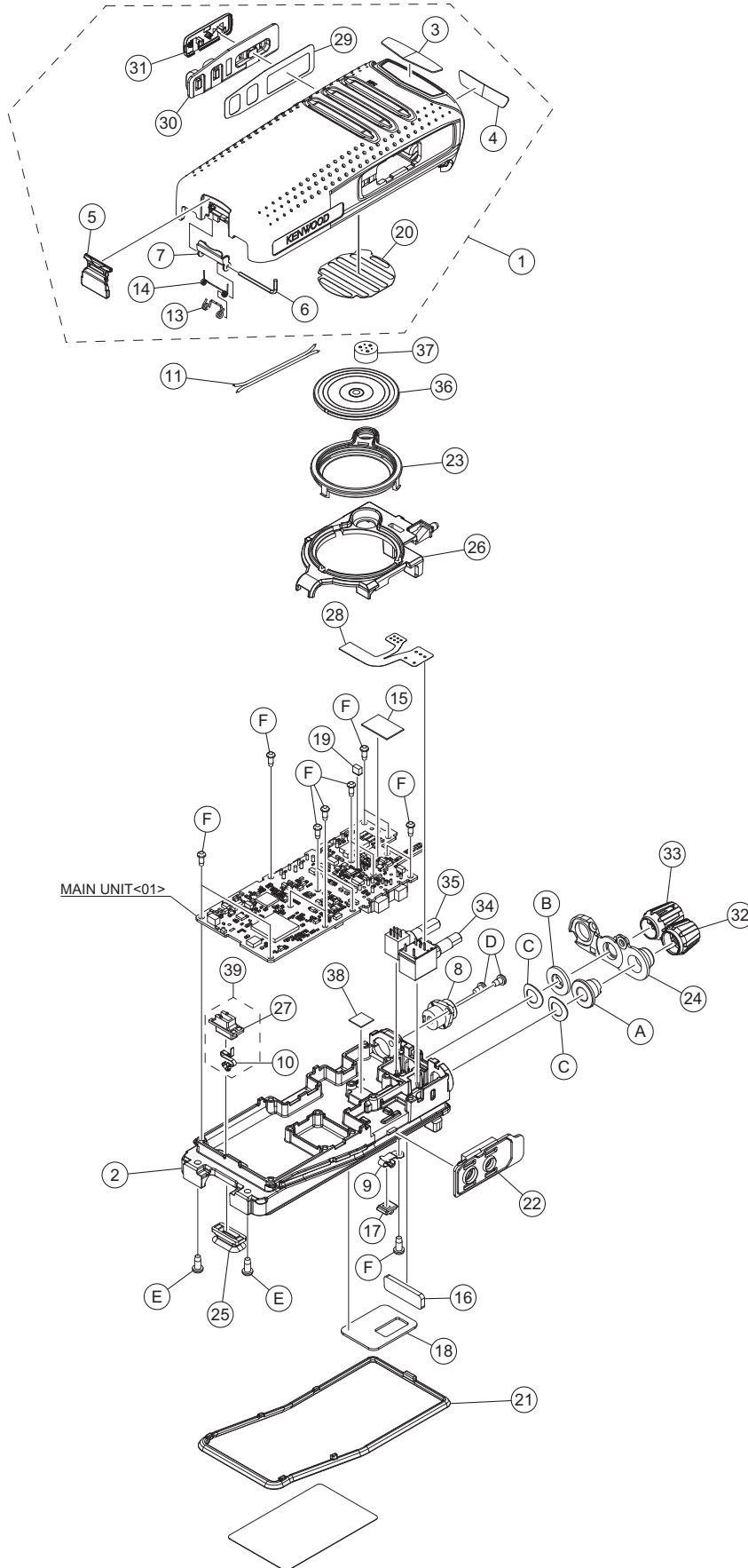

General assembly

Block No. [M][1][M][M]

△ Symbol No.	Part No.	Part Name	Description	Local
1	A0C-0117-00	P.CABINET ASSEMBLY		
2	A1A-0029-00	CHASSIS		
3	B4D-0034-00	BADGE	FRONT	
4	B4D-0035-00	BADGE	REAR	
5	D10-0649-03	LEVER		
6	D21-0863-04	SHAFT		
7	D32-0441-13	STOPPER		
8	E04-0477-15	C.RECEPTACLE-SM		
9	E23-1253-24	TERMINAL	GROUND	
10	E23-1395-04	TERMINAL		
11	E37-1288-05	PARALLEL CORD	SP	
13	G01-4543-14	COIL SPRING	STOPPER	
14	G01-4542-04	COIL SPRING	LEVER	
15	G10-1348-04	FIBROUS SHEET	PCB AMP	
16	G13-2009-04	CUSHION	CHASSIS	
17	G13-2033-04	CUSHION	GROUND	
18	G13-2034-24	CUSHION	CHASSIS(-)	
19	G13-2448-04	CUSHION	PCB,SP	
20	G1A-0033-00	FIBROUS SHEET	SP	
21	G53-1604-03	PACKING	CHASSIS	
22	G53-2215-03	PACKING	SP/MIC	
23	G53-2216-03	PACKING	SP	
24	G53-2217-02	PACKING	VOL/CH	
25	G53-2218-03	PACKING	TERMINAL	
26	J19-5578-22	HOLDER	SP	
27	J19-5579-03	HOLDER		
28	J87-0054-05	FPC(LEAD FREE)	VOL/CH	
29	J9K-0012-00	ADHESIVE SHEET	PTT	
30	K2K-0187-00	BUTTON KNOB	MONI/PF	
31	K2K-0188-00	BUTTON KNOB	PTT	
32	K2K-0189-00	KNOB	VOL	
33	K2K-0190-00	KNOB	CH	
34	R31-0670-35	V RESISTOR	VOL	
35	S60-0450-05	ROTARY SWITCH	CH	
36	T0H-0011-00	SPEAKER		
37	T91-0659-15	MIC ELEMENT		
38	G11-4465-04	RUBBER SHEET	FET	
39	J19-5580-03	HOLDER ASSEMBLY		
A	N14-0849-05	CIRCULAR NUT	VOL	
B	N14-0869-05	CIRCULAR NUT	CH	
C	N19-2214-05	SPECIAL WASHER	VOL/CH(x2)	
D	N30-2604-48	P.HEAD M.SCREW	RF RECE(x2)	
E	N09-6621-05	PAN HEAD SCREW	CH(x2)	
F	N83-2005-48	P.HEAD T.SCREW	PCB,TERM(x14)	
-	XCA-001E-00S	MAIN UNIT	SERVICE UNIT	

Electrical parts list

MAIN UNIT

XC1-1162-70

Block No. [0][1]

△ Symbol No.	Part No.	Part Name	Description	Local
IC1	TC75S51FEF	IC		
IC2	AK1541	IC		
IC3	BD7542FVM	IC		
IC400	AK2365A	IC		
IC600	PST8256U	IC		
IC601	XC6209B502P-G	IC		
IC602	MM1856A50N	IC		
IC603	XC6209B502P-G	IC		
IC604	LDK220M33R	IC		
IC605	BU4830F	IC		
IC606	LDK220M33R	IC		
IC650	TPS62140RGT	IC		
IC700	E25Q40A104GIP	IC		
IC703	MM1856A33N	IC		
IC704	BU7465HFV	IC		
IC705	CMX7241	IC		
IC706	BU7465HFV	IC		
IC707	TA7368FG	IC		
IC708	BU7465HFV	IC		
IC709	NJU7089KV1	IC		
IC710	2F405VGT6KGEA	IC		
IC713	SM5023CNDH-G	IC		
IC715	MM1856A33N	IC		
IC717	BU7465HFV	IC		
IC719	TC7W53FKF	IC		
IC720	TC7W53FKF	IC		
IC721	BU7465HFV	IC		
IC832	BU7465HFV	IC		
Q1	SSM3J05FU-F	FET		
Q3	RE1C001UN	FET		
Q4	KTC4075EP/YG/	TRANSISTOR		
Q5	MCH3914-H/8/	FET		
Q6	MCH3914-H/8/	FET		
Q7	EM6M2	FET		
Q8	SSM3J36TUT	FET		
Q9	2SC5108F/Y/	TRANSISTOR		
Q10	2SC5108F/Y/	TRANSISTOR		
Q11	2SC5108F/Y/	TRANSISTOR		
Q201	2SC5455-A	TRANSISTOR		
Q206	RFM01U7PF	FET		
Q208	RD07MUS2BT214	FET		
Q290	SSM3J36TUT	FET		
Q291	SSM3J36TUT	FET		
Q297	EMD9	TRANSISTOR		
Q298	LTC044EEBFS8	DIGI TRANSISTOR		
Q400	2SC5108F/Y/	TRANSISTOR		
Q403	KTC4075EP/YG/	TRANSISTOR		
Q404	3SK318YB-E	FET		
Q405	3SK318YB-E	FET		
Q600	LTC014EEBFS8	DIGI TRANSISTOR		
Q601	EM6M2	FET		
Q602	EM6M2	FET		
Q603	SSM3K127TUT	FET		
Q604	LTC014EEBFS8	DIGI TRANSISTOR		
Q605	LTC014EEBFS8	DIGI TRANSISTOR		
Q606	SSM3J36TUT	FET		
Q620	LTC044EEBFS8	DIGI TRANSISTOR		
Q703	UM6K34N	FET		
Q704	KTC4075EP/YG/	TRANSISTOR		
Q705	2SC4116F/G/	TRANSISTOR		
Q706	2SA1586F/YG/	TRANSISTOR		
Q707	NTJD4001NG	FET		
Q708	LTC014EEBFS8	DIGI TRANSISTOR		
Q709	LTC014EEBFS8	DIGI TRANSISTOR		
Q710	2SB1694	TRANSISTOR		
Q711	LTC014EEBFS8	DIGI TRANSISTOR		
Q712	LTC044EEBFS8	DIGI TRANSISTOR		
Q713	SSM3K324RF	FET		
Q714	2SB1132(Q,R)	TRANSISTOR		

△ Symbol No.	Part No.	Part Name	Description	Local
Q715	UMG3N	DIGI TR ARRAY		
Q716	SSM3K324RF	FET		
D3	BBY56-02V	VARI CAP DIODE		
D4	BBY56-02V	VARI CAP DIODE		
D8	BBY56-02V	VARI CAP DIODE		
D9	1SV325F	VARI CAP DIODE		
D10	KDS160E-P	DIODE		
D11	1SV325F	VARI CAP DIODE		
D12	BBY56-02V	VARI CAP DIODE		
D13	BBY57-02V	VARI CAP DIODE		
D14	1SS390	DIODE		
D15	1SS390	DIODE		
D16	BBY56-02V	VARI CAP DIODE		
D17	1SV325F	VARI CAP DIODE		
D201	RN142S	DIODE		
D202	RN142S	DIODE		
D203	RN142S	DIODE		
D204	RN142S	DIODE		
D401	BBY58-02V	VARI CAP DIODE		
D402	BBY58-02V	VARI CAP DIODE		
D403	BBY58-02V	VARI CAP DIODE		
D404	BBY58-02V	VARI CAP DIODE		
D405	BBY58-02V	VARI CAP DIODE		
D600	RB521S-30-TP	DIODE		
D601	SML-512MW	LED		
D602	SML-512VWA	LED		
D603	GS1G-L	DIODE		
D604	SMLE12BC7TV	LED		
D605	UDZW5.1B	ZENER DIODE		
D620	DAN222	DIODE ARRAY		
D630	DB2S310	SCHOTTKY DIODE		
D700	RB706F-40-MC	DIODE		
D701	RB706F-40-MC	DIODE		
D702	1SS372F	SCHOTTKY DIODE		
D703	MC2850-1	DIODE ARRAY		
D754	RB706F-40-MC	DIODE		
C1	CK73HBB1H102K	C CAPACITOR	1000pF 50V K	
C5	CK73HBB1H102K	C CAPACITOR	1000pF 50V K	
C6	CC73HCH1H101J	C CAPACITOR	100pF 50V J	
C7	CC73HCH1H100B	C CAPACITOR	10pF 50V B	
C8	CK73HBB1E103K	C CAPACITOR	0.01uF 25V K	
C9	CC73HCH1H101J	C CAPACITOR	100pF 50V J	
C11	CC73HCH1H100B	C CAPACITOR	10pF 50V B	
C13	CC73HCH1H101J	C CAPACITOR	100pF 50V J	
C15	CK73HBB1E103K	C CAPACITOR	0.01uF 25V K	
C16	CK73HBB1E103K	C CAPACITOR	0.01uF 25V K	
C18	CK73HBB1H102K	C CAPACITOR	1000pF 50V K	
C19	CK73HBB1E103K	C CAPACITOR	0.01uF 25V K	
C22	CK73HBB1H102K	C CAPACITOR	1000pF 50V K	
C23	CK73HBB1E103K	C CAPACITOR	0.01uF 25V K	
C26	CS77AAV1ER47M	TA E CAPACITOR	0.47uF 25V M	
C27	CK73HBB1H102K	C CAPACITOR	1000pF 50V K	
C28	CK73HBB1H102K	C CAPACITOR	1000pF 50V K	
C29	CC730AD1H683J	C CAPACITOR	0.068uF 50V J	
C30	CK73HBB1H102K	C CAPACITOR	1000pF 50V K	
C31	CK73HBB1H102K	C CAPACITOR	1000pF 50V K	
C32	CK73HBB1H102K	C CAPACITOR	1000pF 50V K	
C33	CC73HCH1H330J	C CAPACITOR	33pF 50V J	
C34	CK73HBB1A104K	C CAPACITOR	0.1uF 10V K	
C35	CC73HCH1H180G	C CAPACITOR	18pF 50V G	
C36	CC730AD1H104J	C CAPACITOR	0.1uF 50V J	
C37	CC73HCH1H120G	C CAPACITOR	12pF 50V G	
C38	CK73HBB1H102K	C CAPACITOR	1000pF 50V K	
C39	CK73GB0J106K	C CAPACITOR	10uF 6.3V K	
C40	CC73HCH1H180G	C CAPACITOR	18pF 50V G	
C42	CK73HBB1A104K	C CAPACITOR	0.1uF 10V K	
C46	CC73HCH1H101J	C CAPACITOR	100pF 50V J	
C47	CC73HCH1H101J	C CAPACITOR	100pF 50V J	
C54	CC73HCH1HR75B	C CAPACITOR	0.75pF 50V B	
C56	CS77PBQ1C100M	TA E CAPACITOR	10uF 16V M	
C57	CC73HCH1H080B	C CAPACITOR	8pF 50V B	
C58	CC73HCH1H150G	C CAPACITOR	15pF 50V G	
C60	CC73HCH1H100B	C CAPACITOR	10pF 50V B	
C61	CC73HCH1H120G	C CAPACITOR	12pF 50V G	

△ Symbol No.	Part No.	Part Name	Description	Local	△ Symbol No.	Part No.	Part Name	Description	Local
C64	CK73HBB1E103K	C CAPACITOR	0.01uF 25V K		C285	CC73GCH1H070B	C CAPACITOR	7pF 50V B	
C65	CK73HBB1E103K	C CAPACITOR	0.01uF 25V K		C290	CK73HBB1E103K	C CAPACITOR	0.01uF 25V K	
C66	CC73HCH1H0R5B	C CAPACITOR	0.5pF 50V B		C291	CK73HBB1E103K	C CAPACITOR	0.01uF 25V K	
C67	CK73HBB1H102K	C CAPACITOR	1000pF 50V K		C304	CC73HCH1H101J	C CAPACITOR	100pF 50V J	
C68	CC73HCH1H0R5B	C CAPACITOR	0.5pF 50V B		C400	CK73HBB1A104K	C CAPACITOR	0.1uF 10V K	
C69	CK73HBB1H102K	C CAPACITOR	1000pF 50V K		C402	CC73HCH1H330J	C CAPACITOR	33pF 50V J	
C71	CK73HBB1H102K	C CAPACITOR	1000pF 50V K		C403	CK73HBB1E103K	C CAPACITOR	0.01uF 25V K	
C72	CC73HCH1H220G	C CAPACITOR	22pF 50V G		C404	CC73HCH1H180J	C CAPACITOR	18pF 50V J	
C74	CK73HBB1H102K	C CAPACITOR	1000pF 50V K		C405	CC73HCH1H820J	C CAPACITOR	82pF 50V J	
C75	CK73HBB1H102K	C CAPACITOR	1000pF 50V K		C406	CK73HB1H271K	C CAPACITOR	270pF 50V K	
C76	CK73HBB1H102K	C CAPACITOR	1000pF 50V K		C407	CC73HCH1H390J	C CAPACITOR	39pF 50V J	
C77	CK73HBB1A104K	C CAPACITOR	0.1uF 10V K		C409	CC73HCH1H820J	C CAPACITOR	82pF 50V J	
C79	CC73HCH1H100B	C CAPACITOR	10pF 50V B		C410	CK73HB1H271K	C CAPACITOR	270pF 50V K	
C80	CC73HCH1H180J	C CAPACITOR	18pF 50V J		C412	CC73HCH1H101J	C CAPACITOR	100pF 50V J	
C82	CC73HCH1H101J	C CAPACITOR	100pF 50V J		C413	CK73HB1H182K	C CAPACITOR	1800pF 50V K	
C83	CK73HBB1H102K	C CAPACITOR	1000pF 50V K		C414	CK73HBB1H681K	C CAPACITOR	680pF 50V K	
C84	CK73HB1H103K	C CAPACITOR	10000pF 50V K		C415	CK73GB0J106K	C CAPACITOR	10uF 6.3V K	
C85	CK73HB1A473K	C CAPACITOR	0.04uF 10V K		C416	CK73GB0J106K	C CAPACITOR	10uF 6.3V K	
C86	CK73HBB1E103K	C CAPACITOR	0.01uF 25V K		C419	CK73HBB1H102K	C CAPACITOR	1000pF 50V K	
C87	CK73HBB1H102K	C CAPACITOR	1000pF 50V K		C421	CK73HB1A333K	C CAPACITOR	0.033uF 10V K	
C88	CK73HBB1H102K	C CAPACITOR	1000pF 50V K		C422	CK73HBB1E103K	C CAPACITOR	0.01uF 25V K	
C89	CK73HB1A224K	C CAPACITOR	0.22uF 10V K		C424	CK73HBB1E103K	C CAPACITOR	0.01uF 25V K	
C90	CK73HB1A224K	C CAPACITOR	0.22uF 10V K		C425	CK73HBB1H102K	C CAPACITOR	1000pF 50V K	
C92	CC73HCH1H220G	C CAPACITOR	22pF 50V G		C426	CK73HBB1E103K	C CAPACITOR	0.01uF 25V K	
C93	CC73HCH1H120G	C CAPACITOR	12pF 50V G		C428	CC73HCH1H040B	C CAPACITOR	4pF 50V B	
C94	CC73HCH1H120G	C CAPACITOR	12pF 50V G		C429	CC73HCH1H150G	C CAPACITOR	15pF 50V G	
C95	CC73HCH1H100B	C CAPACITOR	10pF 50V B		C430	CC73HCH1H040B	C CAPACITOR	4pF 50V B	
C96	CK73HBB1H102K	C CAPACITOR	1000pF 50V K		C431	CK73HBB1H102K	C CAPACITOR	1000pF 50V K	
C97	CC73HCH1H220G	C CAPACITOR	22pF 50V G		C432	CK73HBB1E103K	C CAPACITOR	0.01uF 25V K	
C98	CK73HBB1H102K	C CAPACITOR	1000pF 50V K		C433	CK73HBB1H102K	C CAPACITOR	1000pF 50V K	
C100	CC73HCH1H680G	C CAPACITOR	68pF 50V G		C434	CC73HCH1H120G	C CAPACITOR	12pF 50V G	
C101	CC73HCH1H101J	C CAPACITOR	100pF 50V J		C435	CK73HBB1E103K	C CAPACITOR	0.01uF 25V K	
C102	CC73HCH1H020B	C CAPACITOR	2pF 50V B		C436	CC73HCH1H060B	C CAPACITOR	6pF 50V B	
C104	CK73HBB1H102K	C CAPACITOR	1000pF 50V K		C437	CC73HCH1H120G	C CAPACITOR	12pF 50V G	
C105	CK73HBB1H102K	C CAPACITOR	1000pF 50V K		C438	CC73HCH1H220G	C CAPACITOR	22pF 50V G	
C106	CC73HCH1H180J	C CAPACITOR	18pF 50V J		C439	CC73HCH1H060B	C CAPACITOR	6pF 50V B	
C200	CK73HBB1H102K	C CAPACITOR	1000pF 50V K		C440	CC73HCH1H120G	C CAPACITOR	12pF 50V G	
C201	CK73HBB1H102K	C CAPACITOR	1000pF 50V K		C441	CK73HBB1E103K	C CAPACITOR	0.01uF 25V K	
C202	CC73HCH1H470J	C CAPACITOR	47pF 50V J		C442	CC73HCH1H010B	C CAPACITOR	1pF 50V B	
C207	CC73HCH1H390J	C CAPACITOR	39pF 50V J		C443	CK73HBB1H102K	C CAPACITOR	1000pF 50V K	
C208	CC73HCH1H390J	C CAPACITOR	39pF 50V J		C444	CK73HBB1H102K	C CAPACITOR	1000pF 50V K	
C210	CK73HB1A224K	C CAPACITOR	0.22uF 10V K		C445	CC73HCH1H020B	C CAPACITOR	2pF 50V B	
C211	CK73HBB1H102K	C CAPACITOR	1000pF 50V K		C446	CK73HBB1H102K	C CAPACITOR	1000pF 50V K	
C212	CK73HBB1H102K	C CAPACITOR	1000pF 50V K		C447	CK73HBB1H102K	C CAPACITOR	1000pF 50V K	
C213	CK73HBB1H102K	C CAPACITOR	1000pF 50V K		C448	CC73HCH1H0R5B	C CAPACITOR	0.5pF 50V B	
C214	CK73HBB1H102K	C CAPACITOR	1000pF 50V K		C449	CC73HCH1H010B	C CAPACITOR	1pF 50V B	
C216	CC73HCH1H390J	C CAPACITOR	39pF 50V J		C453	CK73HBB1H102K	C CAPACITOR	1000pF 50V K	
C219	CC73HCH1H300J	C CAPACITOR	30pF 50V J		C454	CC73HCH1H020B	C CAPACITOR	2pF 50V B	
C220	CC73HCH1H180J	C CAPACITOR	18pF 50V J		C455	CC73HCH1H680G	C CAPACITOR	68pF 50V G	
C222	CK73HBB1H102K	C CAPACITOR	1000pF 50V K		C457	CK73HBB1H102K	C CAPACITOR	1000pF 50V K	
C224	CK73HBB1H102K	C CAPACITOR	1000pF 50V K		C458	CC73HCH1H1R5B	C CAPACITOR	1.5pF 50V B	
C228	CC73HCH1H680J	C CAPACITOR	68pF 50V J		C459	CC73HCH1H330G	C CAPACITOR	33pF 50V G	
C229	CK73HBB1H102K	C CAPACITOR	1000pF 50V K		C460	CC73HCH1H0R5B	C CAPACITOR	0.5pF 50V B	
C232	CK73HBB1H102K	C CAPACITOR	1000pF 50V K		C461	CK73HBB1H102K	C CAPACITOR	1000pF 50V K	
C233	CK73HBB1H102K	C CAPACITOR	1000pF 50V K		C464	CK73HBB1H102K	C CAPACITOR	1000pF 50V K	
C239	CC73HCH1H220G	C CAPACITOR	22pF 50V G		C465	CK73HBB1H102K	C CAPACITOR	1000pF 50V K	
C240	CC73HCH1H151J	C CAPACITOR	150pF 50V J		C466	CK73HBB1H102K	C CAPACITOR	1000pF 50V K	
C245	CK73GXR1A105K	C CAPACITOR	1uF 10V K		C468	CK73HBB1A104K	C CAPACITOR	0.1uF 10V K	
C247	CK73GBB1C104K	C CAPACITOR	0.1uF 16V K		C469	CK73HBB1H102K	C CAPACITOR	1000pF 50V K	
C259	CC73GCH1H070B	C CAPACITOR	7pF 50V B		C470	CC73HCH1HR75B	C CAPACITOR	0.75pF 50V B	
C262	CK73HBB1A104K	C CAPACITOR	0.1uF 10V K		C471	CC73HCH1H240G	C CAPACITOR	24pF 50V G	
C264	CC73HCH1H820J	C CAPACITOR	82pF 50V J		C472	CK73HBB1H102K	C CAPACITOR	1000pF 50V K	
C268	CK73GBB1H102K	C CAPACITOR	1000pF 50V K		C474	CC73HCH1H010B	C CAPACITOR	1pF 50V B	
C269	CK73HBB1H102K	C CAPACITOR	1000pF 50V K		C475	CC73HCH1H100B	C CAPACITOR	10pF 50V B	
C270	CC73HCH1H220G	C CAPACITOR	22pF 50V G		C478	CC73HCH1H120G	C CAPACITOR	12pF 50V G	
C271	CC73GCH1H180G	C CAPACITOR	18pF 50V G		C484	CC73HCH1H070B	C CAPACITOR	7pF 50V B	
C272	CK73GBB1H102K	C CAPACITOR	1000pF 50V K		C485	CK73HBB1H102K	C CAPACITOR	1000pF 50V K	
C273	CC73GCH1H100C	C CAPACITOR	10pF 50V C		C486	CK73GB0J106K	C CAPACITOR	10uF 6.3V K	
C274	CC73GCH1H180G	C CAPACITOR	18pF 50V G		C487	CK73HBB1A104K	C CAPACITOR	0.1uF 10V K	
C275	CC73GCH1H200J	C CAPACITOR	20pF 50V J		C488	CK73HB1A224K	C CAPACITOR	0.22uF 10V K	
C276	CC73GCH1H060B	C CAPACITOR	6pF 50V B		C489	CK73HB1A105K	C CAPACITOR	1uF 10V K	
C277	CC73GCH1H030B	C CAPACITOR	3pF 50V B		C491	CK73HB1A105K	C CAPACITOR	1uF 10V K	
C278	CC73GCH1H220J	C CAPACITOR	22pF 50V J		C492	CC73HCH1H101J	C CAPACITOR	100pF 50V J	
C279	CC73GCH1H070B	C CAPACITOR	7pF 50V B		C493	CC73HCH1H101J	C CAPACITOR	100pF 50V J	
C280	CC73GCH1H100C	C CAPACITOR	10pF 50V C		C494	CK73HB1A224K	C CAPACITOR	0.22uF 10V K	
C282	CC73GCH1H820J	C CAPACITOR	82pF 50V J		C495	CK73HBB1A104K	C CAPACITOR	0.1uF 10V K	
C283	CC73GCH1H080B	C CAPACITOR	8pF 50V B		C496	CK73GB0J106K	C CAPACITOR	10uF 6.3V K	
C284	CC73GCH1H120J	C CAPACITOR	12pF 50V J		C497	CK73HBB1A104K	C CAPACITOR	0.1uF 10V K	

△ Symbol No.	Part No.	Part Name	Description	Local	△ Symbol No.	Part No.	Part Name	Description	Local
C499	CK73HBB1H102K	C CAPACITOR	1000pF 50V K		C772	CC73HCH1H470J	C CAPACITOR	47pF 50V J	
C500	CK73HBB1A104K	C CAPACITOR	0.1uF 10V K		C773	CK73HBB1H102K	C CAPACITOR	1000pF 50V K	
C501	CK73HBB1H681K	C CAPACITOR	680pF 50V K		C774	CK73HBB1H102K	C CAPACITOR	1000pF 50V K	
C504	CC73HCH1H101J	C CAPACITOR	100pF 50V J		C775	CK73HBB1A104K	C CAPACITOR	0.1uF 10V K	
C508	CK73HBB1A104K	C CAPACITOR	0.1uF 10V K		C777	CK73HB1A105K	C CAPACITOR	1uF 10V K	
C600	CK73GXR1A105K	C CAPACITOR	1uF 10V K		C778	CK73HBB1H102K	C CAPACITOR	1000pF 50V K	
C601	CK73GXR1A105K	C CAPACITOR	1uF 10V K		C779	CK73HB0J475M	C CAPACITOR	4.7uF 6.3V M	
C602	CK73HB1A105K	C CAPACITOR	1uF 10V K		C780	CK73HBB1H102K	C CAPACITOR	1000pF 50V K	
C603	CK73GXR1A105K	C CAPACITOR	1uF 10V K		C781	CK73HBB1A104K	C CAPACITOR	0.1uF 10V K	
C604	CK73HBB1H102K	C CAPACITOR	1000pF 50V K		C782	CK73HBB1H102K	C CAPACITOR	1000pF 50V K	
C605	CK73GXR1A105K	C CAPACITOR	1uF 10V K		C783	CK73GXR1A105K	C CAPACITOR	1uF 10V K	
C606	CK73GXR1A105K	C CAPACITOR	1uF 10V K		C784	CK73GXR1C225K	C CAPACITOR	2.2uF 16V K	
C607	CK73GXR1A105K	C CAPACITOR	1uF 10V K		C785	CK73GB0J106K	C CAPACITOR	10uF 6.3V K	
C609	CK73HBB1H102K	C CAPACITOR	1000pF 50V K		C786	CK73HB1A224K	C CAPACITOR	0.22uF 10V K	
C610	CK73HBB1H102K	C CAPACITOR	1000pF 50V K		C787	CK73HBB1A104K	C CAPACITOR	0.1uF 10V K	
C611	CK73HBB1H102K	C CAPACITOR	1000pF 50V K		C788	CK73FXR0J226M	C CAPACITOR	22uF 6.3V M	
C612	CK73HBB1A104K	C CAPACITOR	0.1uF 10V K		C789	CC73HCH1H101J	C CAPACITOR	100pF 50V J	
C615	CK73HBB1H102K	C CAPACITOR	1000pF 50V K		C790	CK73HB1A473K	C CAPACITOR	0.047uF 10V K	
C616	CK73HBB1H102K	C CAPACITOR	1000pF 50V K		C791	CK73HBB1A104K	C CAPACITOR	0.1uF 10V K	
C618	CK73GXR1A105K	C CAPACITOR	1uF 10V K		C792	CC73HCH1H101J	C CAPACITOR	100pF 50V J	
C620	CK73HBB1H102K	C CAPACITOR	1000pF 50V K		C794	CK73HBB1A683K	C CAPACITOR	0.068uF 10V K	
C621	CK73GBB0J225K	C CAPACITOR	2.2uF 6.3V K		C795	CK73GXR1A105K	C CAPACITOR	1uF 10V K	
C623	CK73HBB1H102K	C CAPACITOR	1000pF 50V K		C796	CK73HBB1A104K	C CAPACITOR	0.1uF 10V K	
C624	CK73HBB1H102K	C CAPACITOR	1000pF 50V K		C798	CK73HBB1H102K	C CAPACITOR	1000pF 50V K	
C625	CK73HBB1H102K	C CAPACITOR	1000pF 50V K		C801	CK73GXR1A105K	C CAPACITOR	1uF 10V K	
C626	CK73HBB1H102K	C CAPACITOR	1000pF 50V K		C802	CK73HBB1H102K	C CAPACITOR	1000pF 50V K	
C627	CK73HBB1H102K	C CAPACITOR	1000pF 50V K		C805	CK73HBB1H102K	C CAPACITOR	1000pF 50V K	
C628	CK73HBB1H102K	C CAPACITOR	1000pF 50V K		C806	CK73HBB1H102K	C CAPACITOR	1000pF 50V K	
C629	CK73HBB1E103K	C CAPACITOR	0.01uF 25V K		C808	CK73EXR0J476M	C CAPACITOR	47uF 6.3V M	
C630	CK73HBB1H102K	C CAPACITOR	1000pF 50V K		C809	CK73EXR0J476M	C CAPACITOR	47uF 6.3V M	
C631	CK73HBB1H102K	C CAPACITOR	1000pF 50V K		C812	CK73HBB1H102K	C CAPACITOR	1000pF 50V K	
C650	CK73FB1C106K	C CAPACITOR	10uF 16V K		C814	CK73HBB1A104K	C CAPACITOR	0.1uF 10V K	
C651	CK73FB1C106K	C CAPACITOR	10uF 16V K		C815	CK73HB1A105K	C CAPACITOR	1uF 10V K	
C652	CK73HBB1H332K	C CAPACITOR	3300pF 50V K		C818	CK73HB1H103K	C CAPACITOR	10000pF 50V K	
C653	CK73HB1E104K	C CAPACITOR	0.10uF 25V K		C819	CK73HBB1H332K	C CAPACITOR	3300pF 50V K	
C655	CK73FB0J226M	C CAPACITOR	22uF 6.3V M		C820	CK73HBB1H332K	C CAPACITOR	3300pF 50V K	
C700	CK73HBB1H102K	C CAPACITOR	1000pF 50V K		C832	CK73HB1A105K	C CAPACITOR	1uF 10V K	
C703	CC73HCH1H471J	C CAPACITOR	470pF 50V J		C835	CK73HBB1A104K	C CAPACITOR	0.1uF 10V K	
C704	CK73HBB1H102K	C CAPACITOR	1000pF 50V K		C836	CK73HB1A105K	C CAPACITOR	1uF 10V K	
C711	CK73HBB1H102K	C CAPACITOR	1000pF 50V K		C840	CK73HBB1E103K	C CAPACITOR	0.01uF 25V K	
C718	CK73HBB1A104K	C CAPACITOR	0.1uF 10V K		C841	CK73HB1H272K	C CAPACITOR	2700pF 50V K	
C719	CK73HBB1H102K	C CAPACITOR	1000pF 50V K		C842	CK73HBB1H332K	C CAPACITOR	3300pF 50V K	
C720	CK73GXR1A105K	C CAPACITOR	1uF 10V K		C851	CK73HBB1A104K	C CAPACITOR	0.1uF 10V K	
C723	CK73GBB0J225K	C CAPACITOR	2.2uF 6.3V K		C852	CK73HBB1H102K	C CAPACITOR	1000pF 50V K	
C730	CK73GXR1A105K	C CAPACITOR	1uF 10V K		C853	CK73HBB1A104K	C CAPACITOR	0.1uF 10V K	
C732	CK73HBB1H102K	C CAPACITOR	1000pF 50V K		C882	CK73HB1A105K	C CAPACITOR	1uF 10V K	
C734	CK73GB0J106K	C CAPACITOR	10uF 6.3V K		C885	CK73HBB1E103K	C CAPACITOR	0.01uF 25V K	
C735	CK73GB0J106K	C CAPACITOR	10uF 6.3V K		C886	CK73HBB1H102K	C CAPACITOR	1000pF 50V K	
C736	CK73HBB1H102K	C CAPACITOR	1000pF 50V K		C905	CK73HBB1A104K	C CAPACITOR	0.1uF 10V K	
C737	CK73HB1A105K	C CAPACITOR	1uF 10V K		C906	CK73HB1H103K	C CAPACITOR	10000pF 50V K	
C738	CS77MA0J470M	TA E CAPACITOR	47uF 6.3V M		C907	CK73HB1H103K	C CAPACITOR	10000pF 50V K	
C740	CK73HBB1A104K	C CAPACITOR	0.1uF 10V K		C908	CK73HXROJ105K	C CAPACITOR	1uF 6.3V K	
C741	CK73GB0J106K	C CAPACITOR	10uF 6.3V K		C909	CK73HBB1A104K	C CAPACITOR	0.1uF 10V K	
C742	CK73HBB1H102K	C CAPACITOR	1000pF 50V K		C910	CK73HB0J225K	C CAPACITOR	2.2uF 6.3V K	
C743	CK73HB1H103K	C CAPACITOR	10000pF 50V K		C911	CK73HBB1A104K	C CAPACITOR	0.1uF 10V K	
C744	CK73GB0J106K	C CAPACITOR	10uF 6.3V K		C912	CK73HB0J225K	C CAPACITOR	2.2uF 6.3V K	
C745	CK73HBB1A104K	C CAPACITOR	0.1uF 10V K		C913	CK73HBB1A104K	C CAPACITOR	0.1uF 10V K	
C747	CK73HBB1H152K	C CAPACITOR	1500pF 50V K		C914	CK73HB1H103K	C CAPACITOR	10000pF 50V K	
C748	CK73HB1A105K	C CAPACITOR	1uF 10V K		C915	CK73HB1H103K	C CAPACITOR	10000pF 50V K	
C749	CC73HCH1H101J	C CAPACITOR	100pF 50V J		C924	CK73GXR1A105K	C CAPACITOR	1uF 10V K	
C750	CC73HCH1H101J	C CAPACITOR	100pF 50V J		C925	CK73HB1A105K	C CAPACITOR	1uF 10V K	
C751	CC73HCH1H151J	C CAPACITOR	150pF 50V J		C970	CK73HBB1H102K	C CAPACITOR	1000pF 50V K	
C754	CC73HCH1H101J	C CAPACITOR	100pF 50V J		C971	CK73HBB1A104K	C CAPACITOR	0.1uF 10V K	
C756	CK73HB1A105K	C CAPACITOR	1uF 10V K		C972	CK73HBB1H102K	C CAPACITOR	1000pF 50V K	
C758	CK73HB0J475M	C CAPACITOR	4.7uF 6.3V M		C980	CS77FAV0J101M	TA E CAPACITOR	100uF 6.3V M	
C759	CK73HB1A105K	C CAPACITOR	1uF 10V K		C981	CK73HB0J475M	C CAPACITOR	4.7uF 6.3V M	
C760	CK73HB1A474K	C CAPACITOR	0.47uF 10V K		C982	CK73HXROJ105K	C CAPACITOR	1uF 6.3V K	
C761	CK73HB1A474K	C CAPACITOR	0.47uF 10V K		C983	CK73HBB1H102K	C CAPACITOR	1000pF 50V K	
C762	CK73HBB1H102K	C CAPACITOR	1000pF 50V K		C984	CK73HBB1H102K	C CAPACITOR	1000pF 50V K	
C763	CK73HB1A473K	C CAPACITOR	0.047uF 10V K		C985	CK73HBB1H102K	C CAPACITOR	1000pF 50V K	
C764	CK73HBB1H102K	C CAPACITOR	1000pF 50V K		C986	CK73HBB1H102K	C CAPACITOR	1000pF 50V K	
C765	CK73HBB1H102K	C CAPACITOR	1000pF 50V K		C989	CK73HBB1A104K	C CAPACITOR	0.1uF 10V K	
C766	CK73HB1A474K	C CAPACITOR	0.47uF 10V K		C999	CK73HBB1A104K	C CAPACITOR	0.1uF 10V K	
C767	CK73GBB0J225K	C CAPACITOR	2.2uF 6.3V K						
C768	CK73GBB0J225K	C CAPACITOR	2.2uF 6.3V K		R1	RK73HB1J223J	MG RESISTOR	22kΩ 1/16W J	
C769	CK73HB1A474K	C CAPACITOR	0.47uF 10V K		R2	RK73HB1J103J	MG RESISTOR	10kΩ 1/16W J	
C770	CK73HBB1H102K	C CAPACITOR	1000pF 50V K		R7	RK73HB1J683J	MG RESISTOR	68kΩ 1/16W J	
C771	CK73HBB1H102K	C CAPACITOR	1000pF 50V K		R8	RK73HB1J331J	MG RESISTOR	330Ω 1/16W J	

△ Symbol No.	Part No.	Part Name	Description	Local	△ Symbol No.	Part No.	Part Name	Description	Local
R9	RK73HB1J683J	MG RESISTOR	68kΩ 1/16W J		R293	RK73HH1J824D	MG RESISTOR	820kΩ 1/16W D	
R10	RK73HB1J101J	MG RESISTOR	100Ω 1/16W J		R295	RK73HB1J274J	MG RESISTOR	270kΩ 1/16W J	
R11	RK73HB1J122J	MG RESISTOR	1.2kΩ 1/16W J		R296	RK73HB1J224J	MG RESISTOR	220kΩ 1/16W J	
R13	RK73HB1J100J	MG RESISTOR	10Ω 1/16W J		R301	RK73EB2ER39J	MG RESISTOR	0.39Ω J	
R16	RK73HB1J000J	MG RESISTOR	0Ω 1/16W J		R302	RK73EB2ER39J	MG RESISTOR	0.39Ω J	
R17	RK73HB1J000J	MG RESISTOR	0Ω 1/16W J		R303	RK73EB2ER39J	MG RESISTOR	0.39Ω J	
R18	RK73HB1J222J	MG RESISTOR	2.2kΩ 1/16W J		R314	RK73HB1J000J	MG RESISTOR	0Ω 1/16W J	
R19	RK73HB1J151J	MG RESISTOR	150Ω 1/16W J		R320	RK73HB1J000J	MG RESISTOR	0Ω 1/16W J	
R21	RK73HB1J333J	MG RESISTOR	33kΩ 1/16W J		R323	RK73HB1J102J	MG RESISTOR	1kΩ 1/16W J	
R22	RK73HB1J103J	MG RESISTOR	10kΩ 1/16W J		R324	RK73HB1J472J	MG RESISTOR	4.7kΩ 1/16W J	
R23	RK73HB1J470J	MG RESISTOR	47Ω 1/16W J		R400	RK73HB1J334J	MG RESISTOR	330kΩ 1/16W J	
R24	RK73HB1J223J	MG RESISTOR	22kΩ 1/16W J		R401	RK73HB1J101J	MG RESISTOR	100Ω 1/16W J	
R25	RK73HB1J106J	MG RESISTOR	10MΩ 1/16W J		R403	RK73HB1J102J	MG RESISTOR	1kΩ 1/16W J	
R26	RK73HB1J102J	MG RESISTOR	1kΩ 1/16W J		R404	RK73HB1J564J	MG RESISTOR	560kΩ 1/16W J	
R27	RK73HB1J103J	MG RESISTOR	10kΩ 1/16W J		R405	RK73HB1J224J	MG RESISTOR	220kΩ 1/16W J	
R29	RK73HB1J000J	MG RESISTOR	0Ω 1/16W J		R407	RK73HB1J332J	MG RESISTOR	3.3kΩ 1/16W J	
R30	RK73HB1J184J	MG RESISTOR	180kΩ 1/16W J		R408	RK73HB1J332J	MG RESISTOR	3.3kΩ 1/16W J	
R31	RK73HB1J473J	MG RESISTOR	47kΩ 1/16W J		R409	RK73HB1J563J	MG RESISTOR	56kΩ 1/16W J	
R32	RK73HB1J152J	MG RESISTOR	1.5kΩ 1/16W J		R412	RK73HB1J100J	MG RESISTOR	10Ω 1/16W J	
R33	RK73HB1J473J	MG RESISTOR	47kΩ 1/16W J		R413	RK73HB1J184J	MG RESISTOR	180kΩ 1/16W J	
R34	RK73HB1J104J	MG RESISTOR	100kΩ 1/16W J		R414	RK73HB1J101J	MG RESISTOR	100Ω 1/16W J	
R35	RK73HB1J271J	MG RESISTOR	270Ω 1/16W J		R417	RK73HB1J684J	MG RESISTOR	680kΩ 1/16W J	
R36	RK73HB1J271J	MG RESISTOR	270Ω 1/16W J		R418	RK73HB1J334J	MG RESISTOR	330kΩ 1/16W J	
R37	RK73HB1J220J	MG RESISTOR	22Ω 1/16W J		R419	RK73HB1J221J	MG RESISTOR	220Ω 1/16W J	
R38	RK73HB1J220J	MG RESISTOR	22Ω 1/16W J		R420	RK73HB1J101J	MG RESISTOR	100Ω 1/16W J	
R40	RK73HB1J154J	MG RESISTOR	150kΩ 1/16W J		R421	RK73HB1J470J	MG RESISTOR	47Ω 1/16W J	
R41	RK73HB1J101J	MG RESISTOR	100Ω 1/16W J		R422	RK73HB1J472J	MG RESISTOR	4.7kΩ 1/16W J	
R42	RK73HB1J103J	MG RESISTOR	10kΩ 1/16W J		R423	RK73HB1J681J	MG RESISTOR	680Ω 1/16W J	
R43	RK73HB1J103J	MG RESISTOR	10kΩ 1/16W J		R424	RK73HB1J331J	MG RESISTOR	330Ω 1/16W J	
R44	RK73HB1J470J	MG RESISTOR	47Ω 1/16W J		R425	RK73HB1J104J	MG RESISTOR	100kΩ 1/16W J	
R45	RK73HB1J391J	MG RESISTOR	390Ω 1/16W J		R426	RK73HB1J154J	MG RESISTOR	150kΩ 1/16W J	
R46	RK73HB1J222J	MG RESISTOR	2.2kΩ 1/16W J		R427	RK73HB1J224J	MG RESISTOR	220kΩ 1/16W J	
R48	RK73HB1J472J	MG RESISTOR	4.7kΩ 1/16W J		R428	RK73HB1J104J	MG RESISTOR	100kΩ 1/16W J	
R51	RK73HB1J102J	MG RESISTOR	1kΩ 1/16W J		R429	RK73HB1J220J	MG RESISTOR	22Ω 1/16W J	
R52	RK73HB1J100J	MG RESISTOR	10Ω 1/16W J		R433	RK73HB1J102J	MG RESISTOR	1kΩ 1/16W J	
R53	RK73HB1J000J	MG RESISTOR	0Ω 1/16W J		R434	RK73HB1J680J	MG RESISTOR	68Ω 1/16W J	
R54	RK73HB1J103J	MG RESISTOR	10kΩ 1/16W J		R435	RK73HB1J221J	MG RESISTOR	220Ω 1/16W J	
R55	RK73HB1J273J	MG RESISTOR	27kΩ 1/16W J		R436	RK73HH1J393D	MG RESISTOR	39kΩ 1/16W D	
R56	RK73HB1J100J	MG RESISTOR	10Ω 1/16W J		R437	RK73HH1J683D	MG RESISTOR	68kΩ 1/16W D	
R58	RK73HB1J103J	MG RESISTOR	10kΩ 1/16W J		R438	RK73HB1J124J	MG RESISTOR	120kΩ 1/16W J	
R60	RK73HB1J103J	MG RESISTOR	10kΩ 1/16W J		R439	RK73HB1J154J	MG RESISTOR	150kΩ 1/16W J	
R61	RK73HB1J822J	MG RESISTOR	8.2kΩ 1/16W J		R440	RK73HB1J000J	MG RESISTOR	0Ω 1/16W J	
R62	RK73HB1J221J	MG RESISTOR	220Ω 1/16W J		R441	RK73HH1J473D	MG RESISTOR	47kΩ 1/16W D	
R63	RK73HB1J470J	MG RESISTOR	47Ω 1/16W J		R442	RK73HB1J000J	MG RESISTOR	0Ω 1/16W J	
R65	RK73HB1J222J	MG RESISTOR	2.2kΩ 1/16W J		R443	RK73HB1J000J	MG RESISTOR	0Ω 1/16W J	
R66	RK73HB1J101J	MG RESISTOR	100Ω 1/16W J		R446	RK73GB2A000J	MG RESISTOR	0Ω 1/10W J	
R67	RK73HB1J101J	MG RESISTOR	100Ω 1/16W J		R448	RK73HB1J000J	MG RESISTOR	0Ω 1/16W J	
R68	RK73HB1J680J	MG RESISTOR	68Ω 1/16W J		R449	RK73HB1J224J	MG RESISTOR	220kΩ 1/16W J	
R69	RK73HB1J101J	MG RESISTOR	100Ω 1/16W J		R450	RK73HB1J000J	MG RESISTOR	0Ω 1/16W J	
R70	RK73HB1J000J	MG RESISTOR	0Ω 1/16W J		R451	RK73HB1J000J	MG RESISTOR	0Ω 1/16W J	
R71	RK73HB1J000J	MG RESISTOR	0Ω 1/16W J		R452	RK73HB1J000J	MG RESISTOR	0Ω 1/16W J	
R200	RK73HB1J472J	MG RESISTOR	4.7kΩ 1/16W J		R453	RK73HB1J000J	MG RESISTOR	0Ω 1/16W J	
R201	RK73HB1J121J	MG RESISTOR	120Ω 1/16W J		R454	RK73HB1J000J	MG RESISTOR	0Ω 1/16W J	
R202	RK73HB1J560J	MG RESISTOR	56Ω 1/16W J		R455	RK73HB1J104J	MG RESISTOR	100kΩ 1/16W J	
R203	RK73HB1J121J	MG RESISTOR	120Ω 1/16W J		R457	RK73HB1J000J	MG RESISTOR	0Ω 1/16W J	
R210	RK73HB1J220J	MG RESISTOR	22Ω 1/16W J		R458	RK73HB1J561J	MG RESISTOR	560Ω 1/16W J	
R211	RK73HB1J102J	MG RESISTOR	1kΩ 1/16W J		R459	RK73HB1J332J	MG RESISTOR	3.3kΩ 1/16W J	
R212	RK73HB1J152J	MG RESISTOR	1.5kΩ 1/16W J		R460	RK73HB1J105J	MG RESISTOR	1MΩ 1/16W J	
R213	RK73HB1J220J	MG RESISTOR	22Ω 1/16W J		R461	RK73HB1J124J	MG RESISTOR	120kΩ 1/16W J	
R214	RK73HB1J561J	MG RESISTOR	560Ω 1/16W J		R464	RK73HB1J102J	MG RESISTOR	1kΩ 1/16W J	
R215	RK73HB1J561J	MG RESISTOR	560Ω 1/16W J		R600	RK73GB2A221J	MG RESISTOR	220Ω 1/10W J	
R217	RK73HB1J100J	MG RESISTOR	10Ω 1/16W J		R601	RK73HB1J104J	MG RESISTOR	100kΩ 1/16W J	
R219	RK73HB1J561J	MG RESISTOR	560Ω 1/16W J		R602	RK73HB1J104J	MG RESISTOR	100kΩ 1/16W J	
R224	RK73HB1J470J	MG RESISTOR	47Ω 1/16W J		R603	RK73HB1J101J	MG RESISTOR	100Ω 1/16W J	
R225	RK73HB1J562J	MG RESISTOR	5.6kΩ 1/16W J		R604	RK73GB2A331J	MG RESISTOR	330Ω 1/10W J	
R227	RK73HB1J682J	MG RESISTOR	6.8kΩ 1/16W J		R605	RK73HB1J223J	MG RESISTOR	22kΩ 1/16W J	
R229	RK73HB1J391J	MG RESISTOR	390Ω 1/16W J		R606	RK73HB1J103J	MG RESISTOR	10kΩ 1/16W J	
R232	RK73HB1J682J	MG RESISTOR	6.8kΩ 1/16W J		R607	RK73HB1J103J	MG RESISTOR	10kΩ 1/16W J	
R236	RK73HB1J100J	MG RESISTOR	10Ω 1/16W J		R608	RK73GB2A271J	MG RESISTOR	270Ω 1/10W J	
R239	RK73HB1J562J	MG RESISTOR	5.6kΩ 1/16W J		R609	RK73HB1J102J	MG RESISTOR	1kΩ 1/16W J	
R240	RK73GB2A000J	MG RESISTOR	0Ω 1/10W J		R610	RK73HB1J104J	MG RESISTOR	100kΩ 1/16W J	
R249	RK73HB1J680J	MG RESISTOR	68Ω 1/16W J		R611	RK73HB1J104J	MG RESISTOR	100kΩ 1/16W J	
R251	RK73HB1J680J	MG RESISTOR	68Ω 1/16W J		R612	RK73HB1J104J	MG RESISTOR	100kΩ 1/16W J	
R252	RK73GB2A000J	MG RESISTOR	0Ω 1/10W J		R613	RK73HB1J104J	MG RESISTOR	100kΩ 1/16W J	
R253	RK73GB2A823J	MG RESISTOR	82kΩ 1/10W J		R616	RK73HB1J000J	MG RESISTOR	0Ω 1/16W J	
R290	RK73HH1J394D	MG RESISTOR	390kΩ 1/16W D		R620	RK73HB1J102J	MG RESISTOR	1kΩ 1/16W J	
R291	RK73HH1J824D	MG RESISTOR	820kΩ 1/16W D		R621	RK73HB1J393J	MG RESISTOR	39kΩ 1/16W J	
R292	RK73HH1J394D	MG RESISTOR	390kΩ 1/16W D		R622	RK73HB1J473J	MG RESISTOR	47kΩ 1/16W J	

△ Symbol No.	Part No.	Part Name	Description	Local	△ Symbol No.	Part No.	Part Name	Description	Local
R623	RK73HB1J472J	MG RESISTOR	4.7kΩ 1/16W J		R817	RK73HB1J000J	MG RESISTOR	0Ω 1/16W J	
R624	RK73HB1J683J	MG RESISTOR	68kΩ 1/16W J		R824	RK73HB1J102J	MG RESISTOR	1kΩ 1/16W J	
R650	RK73HH1J183D	MG RESISTOR	18kΩ 1/16W D		R825	RK73HB1J104J	MG RESISTOR	100kΩ 1/16W J	
R651	RK73HH1J683D	MG RESISTOR	68kΩ 1/16W D		R826	RK73HB1J104J	MG RESISTOR	100kΩ 1/16W J	
R653	RK73HB1J000J	MG RESISTOR	0Ω 1/16W J		R828	RK73HB1J273J	MG RESISTOR	27kΩ 1/16W J	
R654	RK73FB2B000J	MG RESISTOR	0Ω 1/8W J		R830	RK73HB1J102J	MG RESISTOR	1kΩ 1/16W J	
R701	RK73HH1J103D	MG RESISTOR	10kΩ 1/16W D		R831	RK73HH1J104D	MG RESISTOR	100kΩ 1/16W D	
R702	RK73HH1J103D	MG RESISTOR	10kΩ 1/16W D		R835	RK73HB1J103J	MG RESISTOR	10kΩ 1/16W J	
R703	RK73HB1J153J	MG RESISTOR	15kΩ 1/16W J		R836	RK73HB1J822J	MG RESISTOR	8.2kΩ 1/16W J	
R705	RK73HB1J103J	MG RESISTOR	10kΩ 1/16W J		R837	RK73HB1J223J	MG RESISTOR	22kΩ 1/16W J	
R708	RK73HB1J102J	MG RESISTOR	1kΩ 1/16W J		R838	RK73HB1J824J	MG RESISTOR	820kΩ 1/16W J	
R709	RK73HB1J222J	MG RESISTOR	2.2kΩ 1/16W J		R840	RK73HB1J472J	MG RESISTOR	4.7kΩ 1/16W J	
R711	RK73HH1J103D	MG RESISTOR	10kΩ 1/16W D		R841	RK73HB1J473J	MG RESISTOR	47kΩ 1/16W J	
R712	RK73HB1J473J	MG RESISTOR	47kΩ 1/16W J		R842	RK73HB1J272J	MG RESISTOR	2.7kΩ 1/16W J	
R718	RK73HB1J820J	MG RESISTOR	82Ω 1/16W J		R844	RK73HH1J473D	MG RESISTOR	47kΩ 1/16W D	
R720	RK73HB1J000J	MG RESISTOR	0Ω 1/16W J		R845	RK73HH1J473D	MG RESISTOR	47kΩ 1/16W D	
R722	RK73HB1J000J	MG RESISTOR	0Ω 1/16W J		R850	RK73GB2A000J	MG RESISTOR	0Ω 1/10W J	
R723	RK73HB1J000J	MG RESISTOR	0Ω 1/16W J		R852	RK73HB1J123J	MG RESISTOR	12kΩ 1/16W J	
R725	RK73HB1J473J	MG RESISTOR	47kΩ 1/16W J		R853	RK73HB1J123J	MG RESISTOR	12kΩ 1/16W J	
R726	RK73HB1J102J	MG RESISTOR	1kΩ 1/16W J		R857	RK73HB1J100J	MG RESISTOR	10Ω 1/16W J	
R736	RK73HB1J101J	MG RESISTOR	100Ω 1/16W J		R862	RK73HB1J471J	MG RESISTOR	470Ω 1/16W J	
R737	RK73HB1J101J	MG RESISTOR	100Ω 1/16W J		R863	RK73HB1J102J	MG RESISTOR	1kΩ 1/16W J	
R738	RK73HB1J473J	MG RESISTOR	47kΩ 1/16W J		R877	RK73HB1J102J	MG RESISTOR	1kΩ 1/16W J	
R740	RK73HB1J472J	MG RESISTOR	4.7kΩ 1/16W J		R881	RK73HB1J473J	MG RESISTOR	47kΩ 1/16W J	
R744	RK73HB1J150J	MG RESISTOR	15Ω 1/16W J		R885	RK73HB1J103J	MG RESISTOR	10kΩ 1/16W J	
R746	RK73HB1J222J	MG RESISTOR	2.2kΩ 1/16W J		R886	RK73HB1J104J	MG RESISTOR	100kΩ 1/16W J	
R748	RK73HB1J000J	MG RESISTOR	0Ω 1/16W J		R887	RK73HB1J563J	MG RESISTOR	56kΩ 1/16W J	
R751	RK73HB1J104J	MG RESISTOR	100kΩ 1/16W J		R888	RK73HB1J102J	MG RESISTOR	1kΩ 1/16W J	
R752	RK73HB1J000J	MG RESISTOR	0Ω 1/16W J		R901	RK73HB1J473J	MG RESISTOR	47kΩ 1/16W J	
R755	RK73HB1J563J	MG RESISTOR	56kΩ 1/16W J		R902	RK73HB1J473J	MG RESISTOR	47kΩ 1/16W J	
R756	RK73HB1J473J	MG RESISTOR	4.7kΩ 1/16W J		R903	RK73HB1J220J	MG RESISTOR	22Ω 1/16W J	
R757	RK73HB1J473J	MG RESISTOR	47kΩ 1/16W J		R904	RK73HB1J221J	MG RESISTOR	220Ω 1/16W J	
R759	RK73HB1J153J	MG RESISTOR	15kΩ 1/16W J		R905	RK73HB1J474J	MG RESISTOR	470kΩ 1/16W J	
R762	RK73HB1J104J	MG RESISTOR	100kΩ 1/16W J		R907	RK73HB1J000J	MG RESISTOR	0Ω 1/16W J	
R763	RK73HB1J104J	MG RESISTOR	100kΩ 1/16W J		R960	RK73HB1J000J	MG RESISTOR	0Ω 1/16W J	
R765	RK73HB1J273J	MG RESISTOR	27kΩ 1/16W J		R970	RK73HB1J000J	MG RESISTOR	0Ω 1/16W J	
R766	RK73HB1J222J	MG RESISTOR	2.2kΩ 1/16W J		R977	RK73HB1J103J	MG RESISTOR	10kΩ 1/16W J	
R767	RK73HB1J104J	MG RESISTOR	100kΩ 1/16W J		R978	RK73HB1J103J	MG RESISTOR	10kΩ 1/16W J	
R768	RK73HB1J103J	MG RESISTOR	10kΩ 1/16W J		R979	RK73HB1J103J	MG RESISTOR	10kΩ 1/16W J	
R769	RK73HB1J104J	MG RESISTOR	100kΩ 1/16W J		R980	RK73HB1J103J	MG RESISTOR	10kΩ 1/16W J	
R770	RK73HB1J124J	MG RESISTOR	120kΩ 1/16W J		R999	RK73HB1J473J	MG RESISTOR	47kΩ 1/16W J	
R772	RK73HB1J154J	MG RESISTOR	150kΩ 1/16W J		L1	LR77Z0AE4R7J	CHIP INDUCTOR	4.7uH	
R773	RK73HB1J103J	MG RESISTOR	10kΩ 1/16W J		L2	LB73G0BJ-001	CHIP FERRITE		
R774	RK73HB1J101J	MG RESISTOR	100Ω 1/16W J		L3	LB73H0AV-003	CHIP FERRITE		
R775	RK73HB1J000J	MG RESISTOR	0Ω 1/16W J		L4	LK73H0AM27NJ	M.CHIP INDUCTOR	27nH	
R780	RK73HB1J474J	MG RESISTOR	470kΩ 1/16W J		L7	LK73G0AQ100K	M.CHIP INDUCTOR	10uH	
R781	RK73HB1J682J	MG RESISTOR	6.8kΩ 1/16W J		L8	LK73G0AQ100K	M.CHIP INDUCTOR	10uH	
R782	RK73HB1J473J	MG RESISTOR	47kΩ 1/16W J		L13	L41-2285-53	CHIP INDUCTOR		
R783	RK73HB1J272J	MG RESISTOR	2.7kΩ 1/16W J		L14	L41-2285-53	CHIP INDUCTOR		
R784	RK73HB1J123J	MG RESISTOR	12kΩ 1/16W J		L15	L41-3978-08	CHIP INDUCTOR		
R785	RK73HB1J273J	MG RESISTOR	27kΩ 1/16W J		L16	L41-2278-08	CHIP INDUCTOR		
R786	RK73HB1J104J	MG RESISTOR	100kΩ 1/16W J		L17	LB73H0AV-003	CHIP FERRITE		
R787	RK73HB1J105J	MG RESISTOR	1MΩ 1/16W J		L18	L41-2285-53	CHIP INDUCTOR		
R788	RK73HB1J473J	MG RESISTOR	47kΩ 1/16W J		L19	L41-2285-53	CHIP INDUCTOR		
R789	RK73HB1J103J	MG RESISTOR	10kΩ 1/16W J		L21	LK73G0AQ3R3K	M.CHIP INDUCTOR	3.3uH	
R790	RK73HB1J103J	MG RESISTOR	10kΩ 1/16W J		L23	LK73G0AQ3R3K	M.CHIP INDUCTOR	3.3uH	
R792	RK73HB1J471J	MG RESISTOR	470Ω 1/16W J		L24	LK73H0AM82NJ	M.CHIP INDUCTOR	82nH	
R793	RK73HB1J182J	MG RESISTOR	1.8kΩ 1/16W J		L25	LK73H0AMR10J	M.CHIP INDUCTOR	0.1uH	
R794	RK73HB1J152J	MG RESISTOR	1.5kΩ 1/16W J		L27	LK73H0AM56NJ	M.CHIP INDUCTOR	56nH	
R795	RK73HB1J473J	MG RESISTOR	47kΩ 1/16W J		L28	LK73H0AM56NJ	M.CHIP INDUCTOR	56nH	
R796	RK73HB1J561J	MG RESISTOR	560Ω 1/16W J		L29	LK73H0AM82NJ	M.CHIP INDUCTOR	82nH	
R799	RK73HB1J104J	MG RESISTOR	100kΩ 1/16W J		L30	L41-2285-53	CHIP INDUCTOR		
R800	RK73HB1J183J	MG RESISTOR	18kΩ 1/16W J		L31	L41-2285-53	CHIP INDUCTOR		
R801	RK73HB1J101J	MG RESISTOR	100Ω 1/16W J		L204	LK73H0AM33NJ	M.CHIP INDUCTOR	33nH	
R802	RK73HB1J474J	MG RESISTOR	470kΩ 1/16W J		L205	LK73H0AMR10J	M.CHIP INDUCTOR	0.1uH	
R803	RK73HB1J331J	MG RESISTOR	330Ω 1/16W J		L206	LB73H0AV-002	CHIP FERRITE		
R804	RK73HB1J124J	MG RESISTOR	120kΩ 1/16W J		L207	LK73H0AM39NJ	M.CHIP INDUCTOR	39nH	
R805	RK73HB1J000J	MG RESISTOR	0Ω 1/16W J		L208	LR79Z0DC45N5J	CHIP INDUCTOR	45.5nH	
R806	RK73HB1J103J	MG RESISTOR	10kΩ 1/16W J		L209	LB73F0AW-002	CHIP FERRITE		
R807	RK73HB1J332J	MG RESISTOR	3.3kΩ 1/16W J		L212	LB73F0AW-002	CHIP FERRITE		
R809	RK73HB1J103J	MG RESISTOR	10kΩ 1/16W J		L213	LR79Z0DD43N6J	CHIP INDUCTOR	43.6nH	
R810	RK73HB1J334J	MG RESISTOR	330kΩ 1/16W J		L216	L41-2295-39	CHIP INDUCTOR		
R811	RK73HB1J274J	MG RESISTOR	270kΩ 1/16W J		L217	LR79Z0DC45N5J	CHIP INDUCTOR	45.5nH	
R812	RK73HB1J473J	MG RESISTOR	47kΩ 1/16W J		L218	LR79Z0DD27N4J	CHIP INDUCTOR	27.4nH	
R813	RK73HB1J823J	MG RESISTOR	82kΩ 1/16W J		L219	LR79Z0DD43N6J	CHIP INDUCTOR	43.6nH	
R814	RK73HB1J273J	MG RESISTOR	27kΩ 1/16W J		L220	LR79Z0DD37N7J	CHIP INDUCTOR	37.7nH	
R815	RK73HB1J101J	MG RESISTOR	100Ω 1/16W J		L221	LR79Z0DD12N2J	CHIP INDUCTOR	12.2nH	
R816	RK73HB1J102J	MG RESISTOR	1kΩ 1/16W J						

△ Symbol No.	Part No.	Part Name	Description	Local
L222	LR79Z0DD21N9J	CHIP INDUCTOR	21.9nH	
L223	LR79Z0DD27N4J	CHIP INDUCTOR	27.4nH	
L400	L41-1885-53	CHIP INDUCTOR		
L401	LK73H0AMR10J	M.CHIP INDUCTOR	0.1uH	
L402	LK73G0AQ1R5K	M.CHIP INDUCTOR	1.5uH	
L403	LB73G0BD-005	CHIP FERRITE		
L404	LR77Z0AER56J	CHIP INDUCTOR	0.56uH	
L405	LK73H0AM27NJ	M.CHIP INDUCTOR	27nH	
L406	L41-2785-53	CHIP INDUCTOR		
L407	LK73H0AM27NJ	M.CHIP INDUCTOR	27nH	
L408	L41-1285-53	CHIP INDUCTOR		
L409	L41-2285-14	CHIP INDUCTOR		
L411	L41-6878-14	CHIP INDUCTOR		
L412	LB73G0BD-005	CHIP FERRITE		
L414	L41-6878-14	CHIP INDUCTOR		
L415	L41-8278-14	CHIP INDUCTOR		
L416	L41-6878-14	CHIP INDUCTOR		
L600	L92-0472-05	CHIP FERRITE		
L601	LB73G0BD-005	CHIP FERRITE		
L650	LB73G0CQ-001	CHIP FERRITE		
L651	L33-3034-05	CHIP INDUCTOR		
L652	LB73G0CQ-001	CHIP FERRITE		
L653	LB73G0CQ-001	CHIP FERRITE		
L700	LB73H0AV-001	CHIP FERRITE		
L701	LB73H0AV-001	CHIP FERRITE		
L702	LB73H0AV-001	CHIP FERRITE		
L703	LB73H0AV-003	CHIP FERRITE		
L901	LB73H0AV-003	CHIP FERRITE		
L902	LB73H0AV-003	CHIP FERRITE		
L903	LB73H0AV-003	CHIP FERRITE		
L904	LK73H0AM56NJ	M.CHIP INDUCTOR	56nH	
CN600	E40-6922-05	F.C.CONNECTOR		
CN912	E23-1167-05	TERMINAL		
CN913	E23-1167-05	TERMINAL		
CN914	E23-1167-05	TERMINAL		
CN915	E23-1167-05	TERMINAL		
CN916	E23-1167-05	TERMINAL		
CN918	E23-1167-05	TERMINAL		
CN919	E23-1167-05	TERMINAL		
CN920	E23-1167-05	TERMINAL		
CN921	E23-1167-05	TERMINAL		
CP1	RK74HA1J101J	NET RESISTOR	100Ω 1/16W J	
CP20	RK74HA1J473J	NET RESISTOR	47kΩ 1/16W J	
CP21	RK74HA1J473J	NET RESISTOR	47kΩ 1/16W J	
CP23	RK74HA1J473J	NET RESISTOR	47kΩ 1/16W J	
CP24	RK74HA1J102J	NET RESISTOR	1kΩ 1/16W J	
CP25	RK74HA1J473J	NET RESISTOR	47kΩ 1/16W J	
CP26	RK74HA1J103J	NET RESISTOR	10kΩ 1/16W J	
CP27	RK74HA1J474J	NET RESISTOR	470kΩ 1/16W J	
CP28	RK74HA1J103J	NET RESISTOR	10kΩ 1/16W J	
CP401	RK74HA1J104J	NET RESISTOR	100kΩ 1/16W J	
CP402	RK74HA1J474J	NET RESISTOR	470kΩ 1/16W J	
F600	FZA10AW-2R5	FUSE (CC)	2.5A	
F701	FZA10BH-R315	FUSE (CC)	0.315A	
J601	E11-0703-05	PHONE JACK		
S601	S70-0414-05	TACTILE PUSH SW		
S602	S70-0414-05	TACTILE PUSH SW		
S603	S70-0414-05	TACTILE PUSH SW		
TH200	ERTJ0EV104J	THERMISTOR		
TH400	NCP18WM224J03	THERMISTOR		
TH401	ERTJ0EV104J	THERMISTOR		
X1	L77-3128-05	TCXO		
X2	L77-3129-05	TCXO		
XF400	L71-0655-05	MCF		

Packing materials and accessories parts list (TK-D240_K,TK-D240_E,TK-D240V_K)

Block No.M2MM

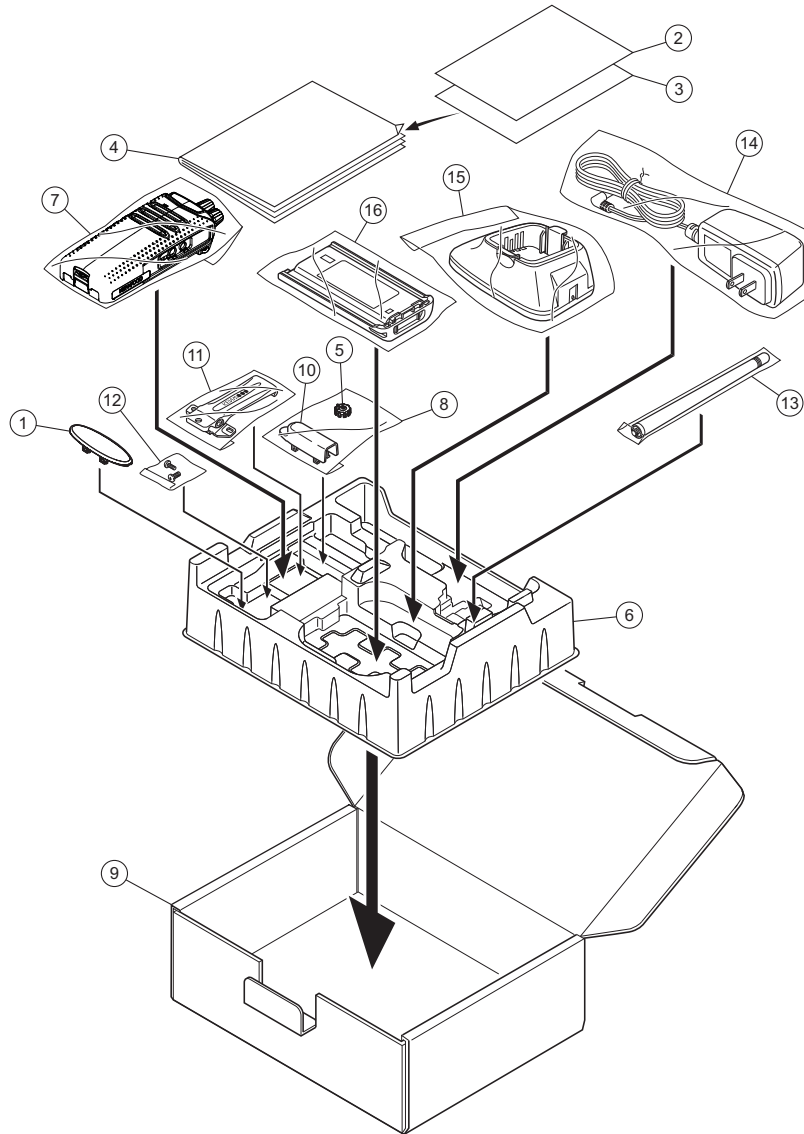

Packing and accessories

Block No. [M][2][M][M]

Symbol No.	Part No.	Part Name	Description	Local
1	B0K-0032-00	CAP		
2	-----	PAMPHLET		D240_K,D240V_K
3	-----	PAMPHLET	ROHS2	D240_E
4	B5A-0929-00	INST.MANUAL		D240_K,D240V_K
4	B5A-0930-00	INST.MANUAL		D240_E
5	D32-0456-03	STOPPER		
6	H12-4319-05	PACKING FIXTURE	ACC	
7	-----	PROTECTION BAG		
8	-----	PROTECTION BAG		
9	H52-2589-01	ITEM CARTON	ACC	D240_K,D240V_K
9	H52-2588-01	ITEM CARTON	NO ACC	D240_E
10	J19-5577-03	HOLDER		
11	J29-0734-15	HOOK ASSEMBLY		
12	N99-2089-05	SCREW SET		
13	T90-1036-15	HELICAL ANTENNA		D240_K,D240V_K
14	W08-1247-25	AC ADAPTER (CC)		D240_K,D240V_K
14	W08-1246-25	AC ADAPTER (CC)	KSC-35SE	D240_E
15	W08-1249-45	CHARGER (CC)	KSC-35S	
16	W0K-0020-00	LI-ION BAT.P(CC)	45L TWS	

Packing materials and accessories parts list (TK-D240_M,TK-D240_E2)

Block No.M3MM

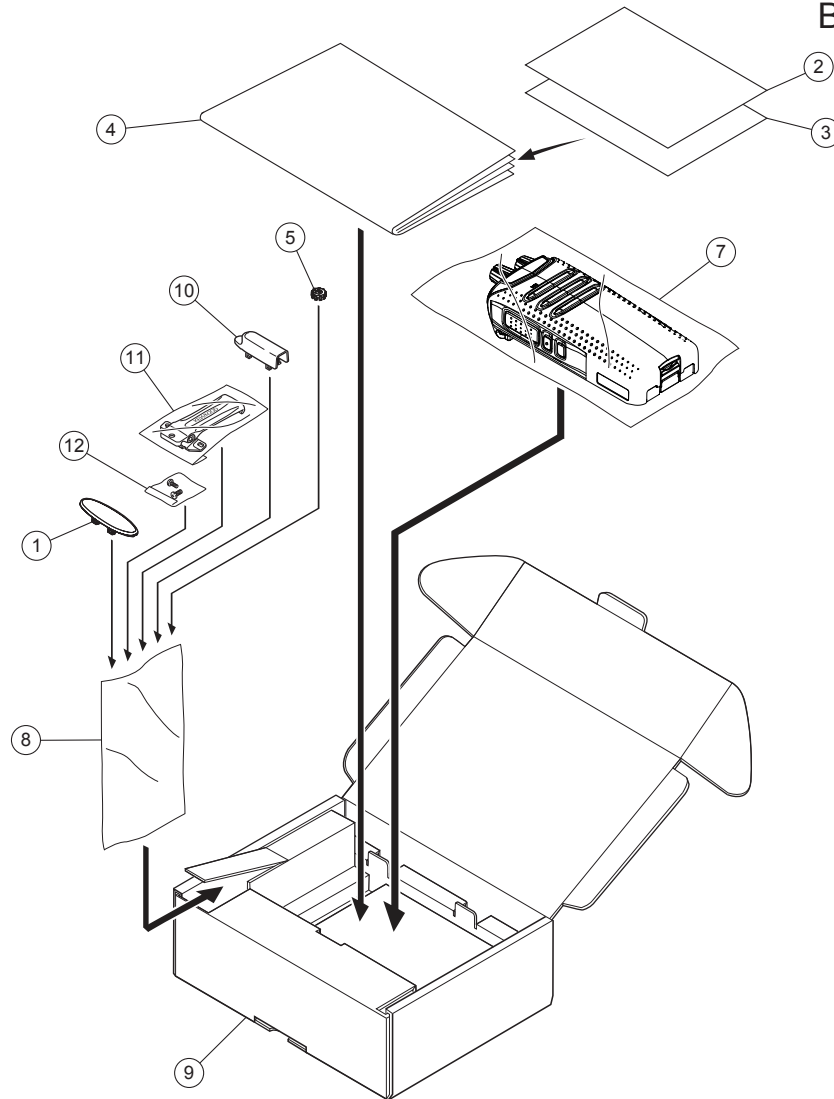

Packing and accessories

Block No. [M][3][M][M]

△ Symbol No.	Part No.	Part Name	Description	Local
1	B0K-0032-00	CAP		
2	-----	PAMPHLET		D240_M
3	-----	PAMPHLET	ROHS2	D240_E2
4	B5A-0931-00	INST.MANUAL		D240_M
4	B5A-0930-00	INST.MANUAL		D240_E2
5	D32-0456-03	STOPPER		
7	-----	PROTECTION BAG		
8	-----	PROTECTION BAG		
9	H52-2588-01	ITEM CARTON	NO ACC	
10	J19-5577-03	HOLDER		
11	J29-0734-15	HOOK ASSEMBLY		
12	N99-2089-05	SCREW SET		



KENWOOD

JVC KENWOOD Corporation
Communications Systems Business Unit

(No.RA035<Rev.001>)

Printed in Japan
VSE