**CONTENTS**

MAINTENANCE AND ADJUSTMENT	2	TX-RX UNIT (X57-3470-10)	93
INSTALLATION INSTRUCTIONS	5	FINAL UNIT (X45-3370-10)	101
CIRCUIT DESCRIPTION	7	SCHEMATIC DIAGRAM	105
DESCRIPTION OF COMPONENTS	27	MAT-100 (AUTOMATIC ANTENNA TUNER)	
PARTS LIST	33	Circuit Description	108
EXPLODED VIEW	63	Block Diagram	122
PACKING	65	Description of Components	123
ADJUSTMENT	66	Parts List	124
LEVEL DIAGRAM	76	Exploded View	129
BLOCK DIAGRAM	77	PC Board View	
TERMINAL FUNCTION	81	LED UNIT (W02-0844-08)	130
CIRCUIT DIAGRAMS / PC BOARD VIEWS		ANT MODULE UNIT (W02-0883-08)	131
LCD ASS'Y (B38-0324-05)	83	Schematic Diagram	133
VCO (X58-3720-10)	83	Installation Instructions	136
DC-DC (X59-1100-00)	84	Manual Tuning	140
FAM & TEMP PROTECTION (X59-3370-00)	84	Specifications	141
VCO (X59-3440-00)	84	SPECIFICATIONS	BACK COVER
CONTROL UNIT (X53-3280-10)	85		

TKM-707

MAINTENANCE AND ADJUSTMENT

Service

Your SSB radiotelephone has been factory aligned and tested to specification before shipment. Under normal circumstances the SSB radiotelephone will operate in accordance with these instructions. All adjustable trimmers and coils in your SSB radiotelephone has been adjusted at the factory and should only be readjusted by a qualified technician with proper test equipment. Attempting service or alignment without factory authorization can void the SSB radiotelephone's warranty.

When operated properly, the SSB radiotelephone will provide many years of service without requiring realignment. The information in this section gives some general service procedures which can be accomplished without sophisticated test equipment.

Should it ever become necessary to return the equipment to your dealer or service center for repair, pack it in its original box and packing, and include a full description of the problems involved. Also include your telephone number. You need not return accessory items unless directly related to the service problem.

Service note :

If you desire to correspond on a technical or operational problem, please make your note short, complete, and to the point, and PLEASE make it readable.

Please list: Model and Serial Number

The problem you are having.

Please give sufficient detail to diagnose. Information such as other equipment in the station, meter readings and anything else you feel might be useful in attempting diagnosis .

Caution :

Do not pack the equipment in crushed newspapers for shipment. Extensive damage may result during shipment.

Notes :

1. Record the Date of Purchase, Serial Number and Dealer from whom purchased.
2. For your own information, retain a written record of any maintenance performed on the unit.
3. When claiming warranty service, a photocopy of the bill of sale, or other proof of purchase showing the date of sale must accompany the radio.

MAINTENANCE AND ADJUSTMENT

Adjustment

1-1. Cover removal

Before removing the cover, turn the DC power supply's power switch OFF and disconnect the power cable.
Do not pinch wiring when opening or closing cases.

Remove the top cover (8 screws), and the bottom cover (4 screws) from radiotelephone.

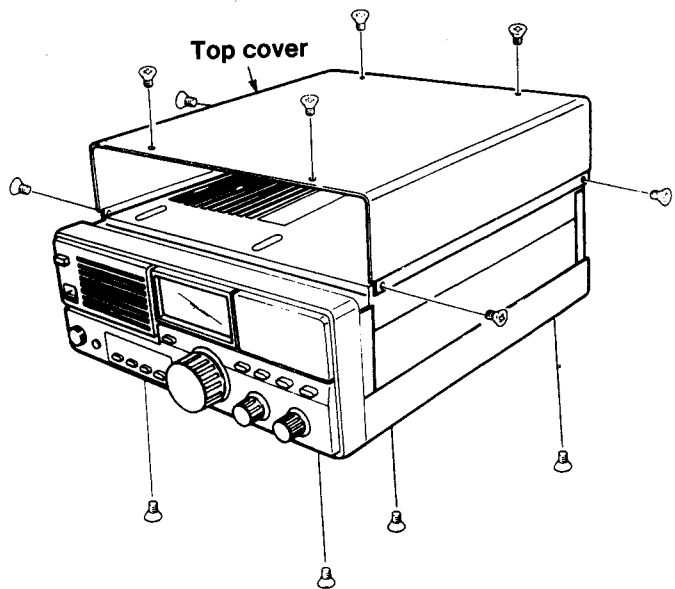

1-2. Sub chassis removal

Remove the 4 screws as shown in the diagram.
Open in a counterclockwise direction.

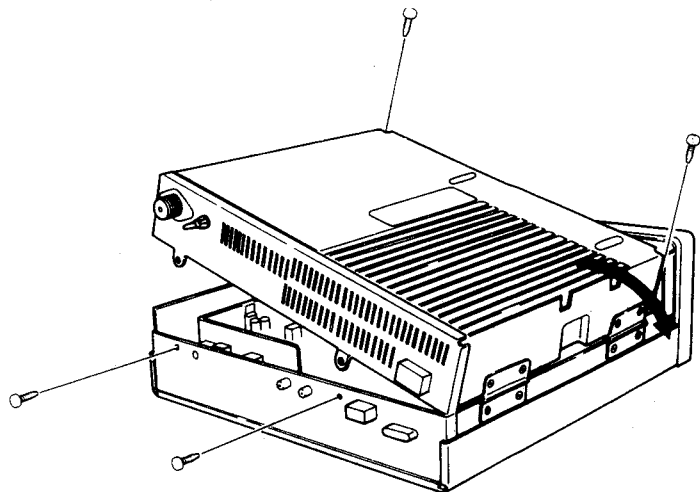

1-3. Beep tone level

Turn VR7 to the desired BEEP tone level.

1-4. Alarm tone level

1. Press the ALARM key to select the ALARM TEST mode.
2. Turn VR6 to the desired ALARM tone level.

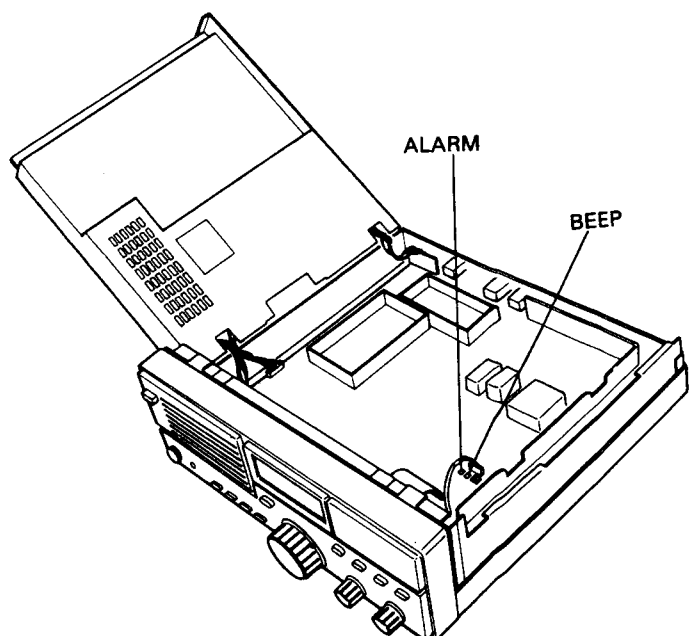

TKM-707

MAINTENANCE AND ADJUSTMENT

1-5. Microphone connector

Front view

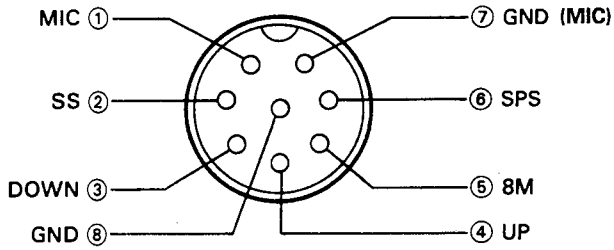

- ① MIC Impedance approx. 600Ω
- ② SS Stand-by switch
- ③ DOWN Frequency or Memory channel number decrease
- ④ UP Frequency or Memory channel number increase
- ⑤ 8M 8V(Max.100mA)
- ⑥ SPS Receive audio output
- ⑦ GND(MIC) Mic ground
- ⑧ GND Ground

1-6. 13.6 VDC Power input connector

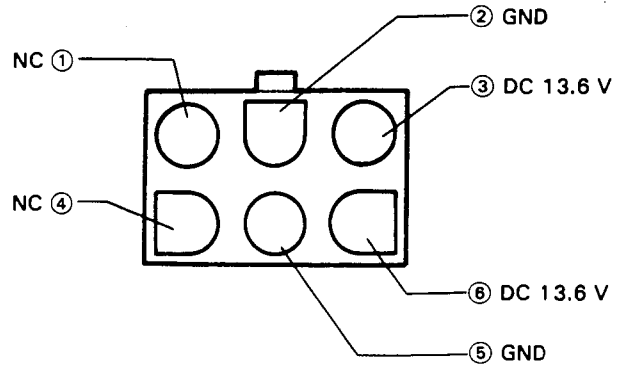

1-7. Antenna coupler connector

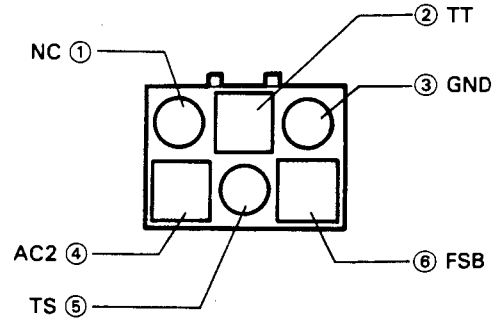

- ① NC Not used
- ② TT Control signal input/output
- ③ GND Ground
- ④ AC2 Antenna current input
- ⑤ TS Control signal input/output
- ⑥ FSB Power output for antenna coupler

INSTALLATION INSTRUCTIONS

Mounting bracket

When installing the SSB radiotelephone in a vessel consider the ease of operation and safety when selecting the location for the mounting bracket.

1. Install the bracket using the supplied flat washers and self tapping screws, or spring washers and bolts (4 each). You may attach the supplied rubber cushion to the bracket.

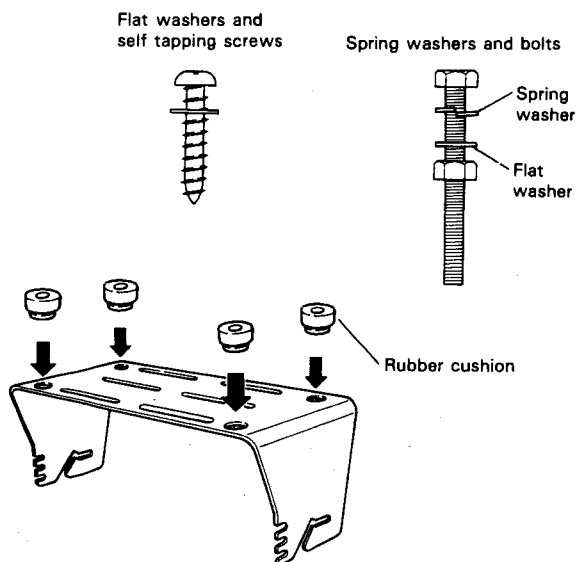

2. Attach the supplied metal fittings with the 4 flat head screws to the side of the radiotelephone.

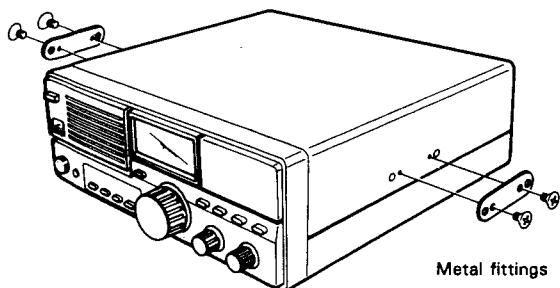

3. Attach the supplied shoulder bolt loosely 3,4 mm away to the side of the radiotelephone.

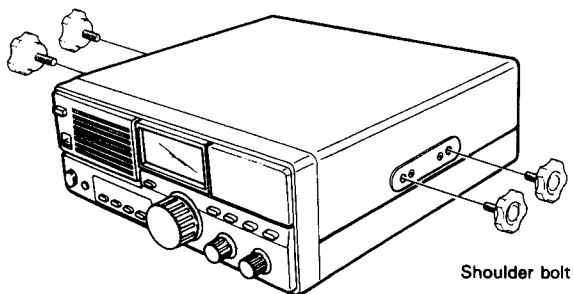

4. Align the grooves in the bracket with the rear shoulder bolts and slide the radiotelephone to the rear .

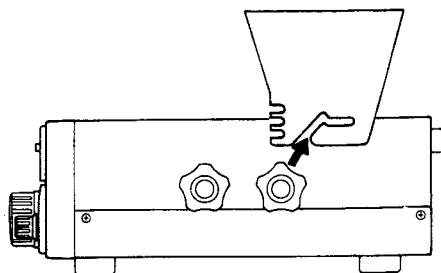

5. The angle of the bracket may be adjusted to three of possible viewing angles. Select the desired angle.

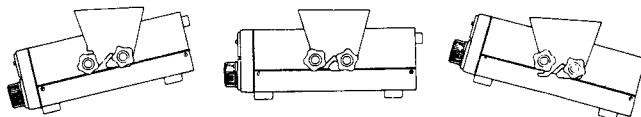

6. Hold the radiotelephone in place and tighten the shoulder bolt with knob.

Microphone hanger

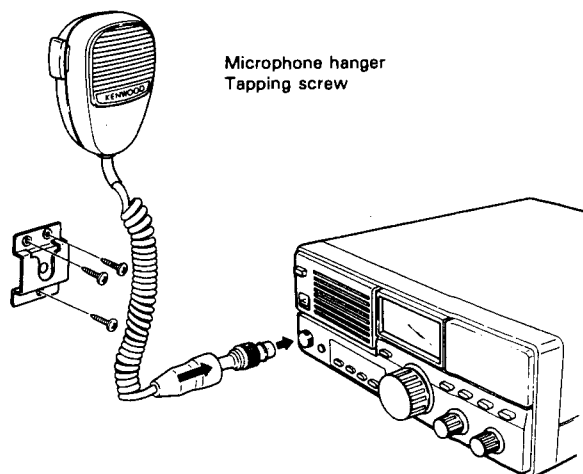

TKM-707

INSTALLATION INSTRUCTIONS

Connection

This radiotelephone requires a maximum of 30 A at 13.6VDC \pm 15% when transmitting at full power. Do not exceed the length of the supplied power cable.

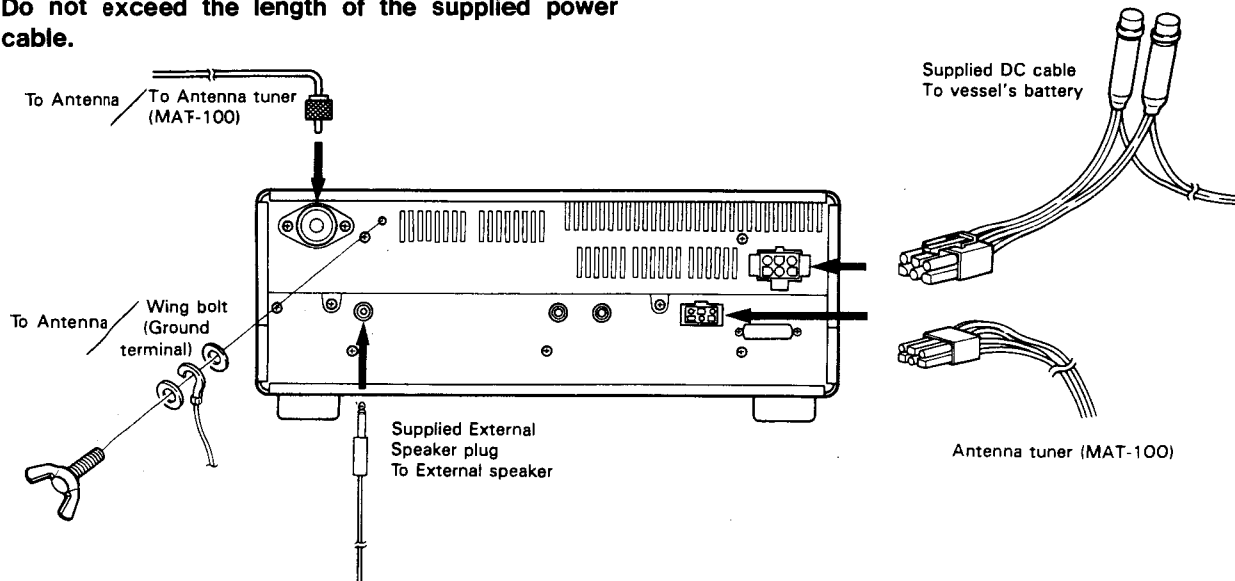

Without antenna coupler

The type of antenna that is used will greatly affect the performance of the equipment. Use a properly adjusted antenna, of good quality, to enable your equipment to perform at its best. The antenna input impedance is 50 ohms. Use 50 ohm coaxial cable such as RG-8U or 8D-2V for this connection. If the antenna is far from the transceiver the use of low loss coaxial cable, such as RG-8U is recommended. Match the impedance of the coaxial cable and that of the antenna so that the SWR is less than 1.5. The protection circuit in the transceiver will activate if the SWR is particularly poor (greater than 3). High SWR values will cause the transmitter output to drop.

With antenna coupler

A wire antenna must be in the range from 2 to 24 MHz and having a total length of 12 to 23 meters. When the radiotelephone is operated only on low frequencies, a longer antenna is preferable. The antenna should be erected as high as possible. The insulator should be able to withstand high transmitter power levels without leakage.

Typical installation and connection

Connect the Antenna connector of the radiotelephone to the RF IN jack with the coaxial cable, such as RG-8U are recommended. Connect the 6P connector of the supplied control cable to the radiotelephone. Please refer to the MAT-100 Instruction Manual to connect with the cable to the MAT-100.

CIRCUIT DESCRIPTION

Frequency Configuration

The TKM-707 operates as a double conversion system for both transmission and reception. (See Figure 1.)

• Receiver system

The receive signal from the ANT terminal passes through the final unit and the TX-RX unit LPF and is applied directly to mixers Q9 and Q10 (2SK125-5). Here the signal is mixed with the first local oscillator frequency (71.395~101.295 MHz) from the PLL in order to generate the first IF signal of 71.295 MHz. The receive frequency may be fine tuned with the clarifier by varying the first local oscillator frequency.

The 71.295 MHz first IF signal passes through a monolithic filter (MCF) and is mixed with the second local oscillator frequency (60.6 MHz) by MIX FETs Q13 and Q14 (2SK520(K44)) to generate a 10.695 MHz second IF signal. The second local oscillator signal is generated by the TX-RX unit Q90 and Q91 (2SC2714(Y)) and is then doubled by Q56 (2SC2714(Y)).

The second IF signal (10.695 MHz) passes through a crystal filter, and is then applied to IC2 : KCD03 where the signal is demodulated. The demodulated audio output is amplified by the AF preamplifier and power amplifier to drive the speaker.

• Transmitter system

The audio signal from the microphone is amplified by mic amplifiers Q37 and Q38 : 2SC3324(G), and is then combined with the carrier oscillator in the balanced modulator, (IC6 : μ PC1037A) to generate the TX first IF (10.695 MHz).

In the H3E mode, a carrier signal is added to the TX first IF (10.695 MHz). The TX first IF is then mixed with the second local oscillator frequency (60.6 MHz) by IC7 : SN16913P in the same manner as the receiver system, to produce a 71.295 MHz signal. This signal is then mixed with the PLL first local oscillator frequency in order to generate a transmit signal.

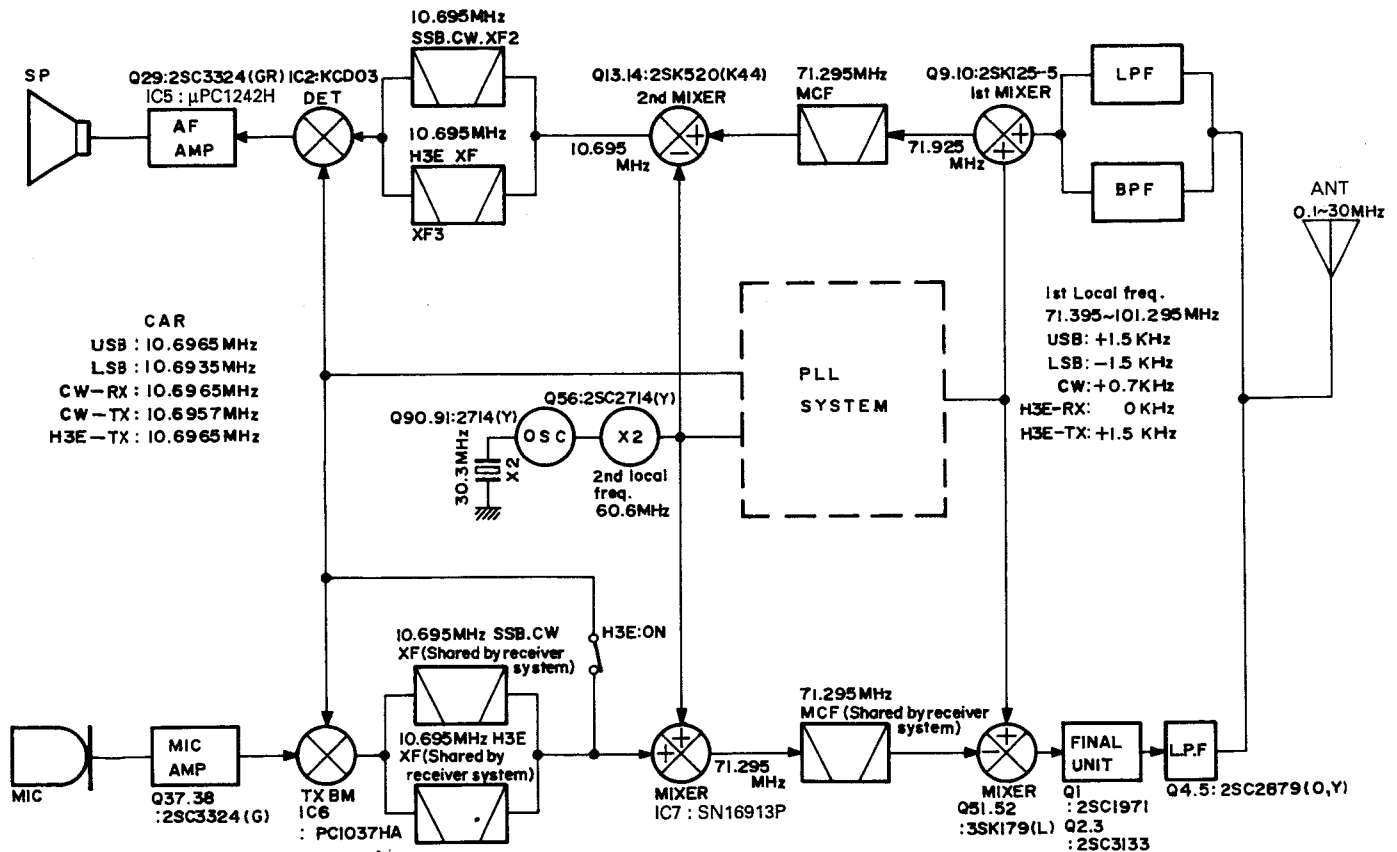

Fig. 1 Frequency configuration

CIRCUIT DESCRIPTION

PLL (Phase Locked Loop)

The TKM-707 PLL is divided into a HET loop and a CAR loop. The HET loop consists of loop A and loop B, and the CAR loop consists of loop C. Figures 2 and 3 show a block diagram of the HET and CAR loops. The following paragraphs describe loops A, B, and C.

The reference frequency for loops A, B, and C is 10.1 MHz. This frequency is generated by dividing the 30.3 MHz reference oscillation frequency by 3. Therefore, the frequency accuracy of the HET and CAR is determined by the 30.3 MHz oscillation circuit.

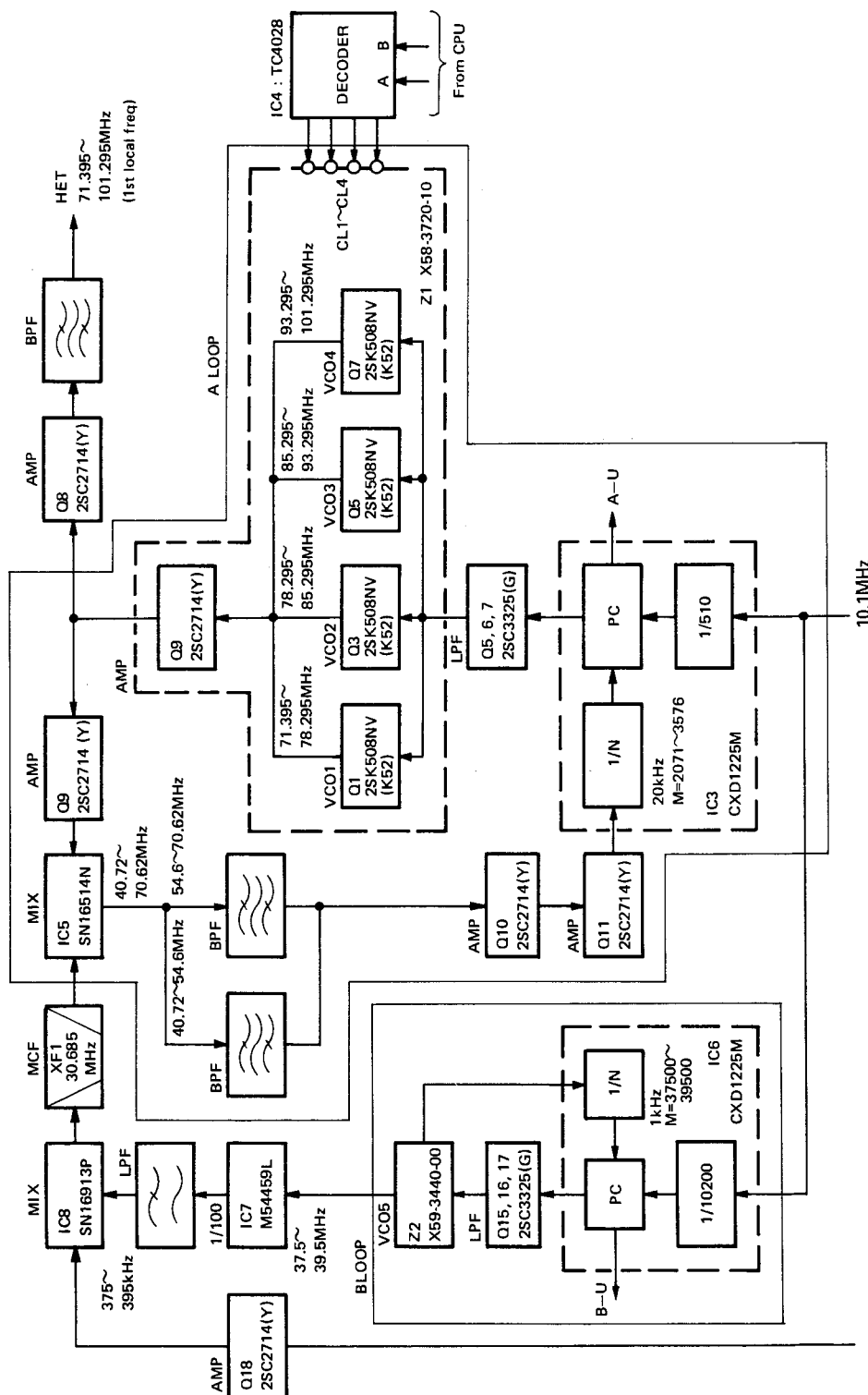

Fig. 2 Block diagram of PLL HET loop

CIRCUIT DESCRIPTION

Loop B generates a 37.5~39.5 MHz signal via IC6 (CXD1225M) with a 1 kHz comparison frequency. The 37.5~39.5 MHz signal is generated by VCO6 (X59-3440-00), then divided by 100 in IC7 : M54459L to generate a 10 Hz steps. Fine-frequency adjustment by means of the clarifier is added to loop B under microprocessor control. The 375~395 kHz output signal that was divided by 100 by IC7 is mixed with the 30.3 MHz signal by IC8 : SN16913P in order to generate a 30.675~30.695 MHz signal. This frequency passes through MCF (XF1; 30.685 MHz) and enters IC5 (SN76514N).

Loop A generates a 71.395~101.295 MHz signal via IC3 (CXD1225M) with a comparison frequency of 20 kHz. This signal becomes the HET oscillator signal. The loop A VCO (X58-3720-10) consists of four separate VCO circuits which are selected by IC4 (TC4028) according to the control data from the microprocessor. (See Table 1.) Part of the loop A VCO output passes through the buffer amplifier of Q9 : 2SC2714(Y) and is applied to IC5. The signal is then mixed with the signal from loop B in IC5 : SN76514N (40.72~70.62 MHz). The resulting 40.72~70.62 MHz signal passes through BPF1 and BPF2. VCO1 and VCO2 pass the signal through BPF1, and VCO3 and VCO4 pass it through BPF2. The signal passing through the BPF is amplified by Q10 and Q11 : 2SC2714(Y) and is then applied to PLL IC3 (CXD1225M).

Loop C generates a 59.3~59.7 MHz via IC9 (CXD1225M) with a 2 kHz comparison. This VCO output is divided by 100 by IC10 : M54459L, and is mixed with 10.1 MHz by IC11 : SN16913P to generate a 10.693~10.697 MHz signal. The 10.693~10.697 MHz signal passes through ceramic filter CF1 to become the CAR signal. The CAR signal changes with the mode. It is amplified by Q27 and is then sent to the TX-RX unit.

Frequency Function		0.1~7MHz	7~14MHz	14~22MHz	22~30MHz
		Microprocessor control signal	V1	0	1
	V2	0	0	1	1
VCO		VCO1	VCO2	VCO3	VCO4
BPF		BPF1	BPF1	BPF2	BPF2

Table 1 Switching of Loop A VCO and BPF

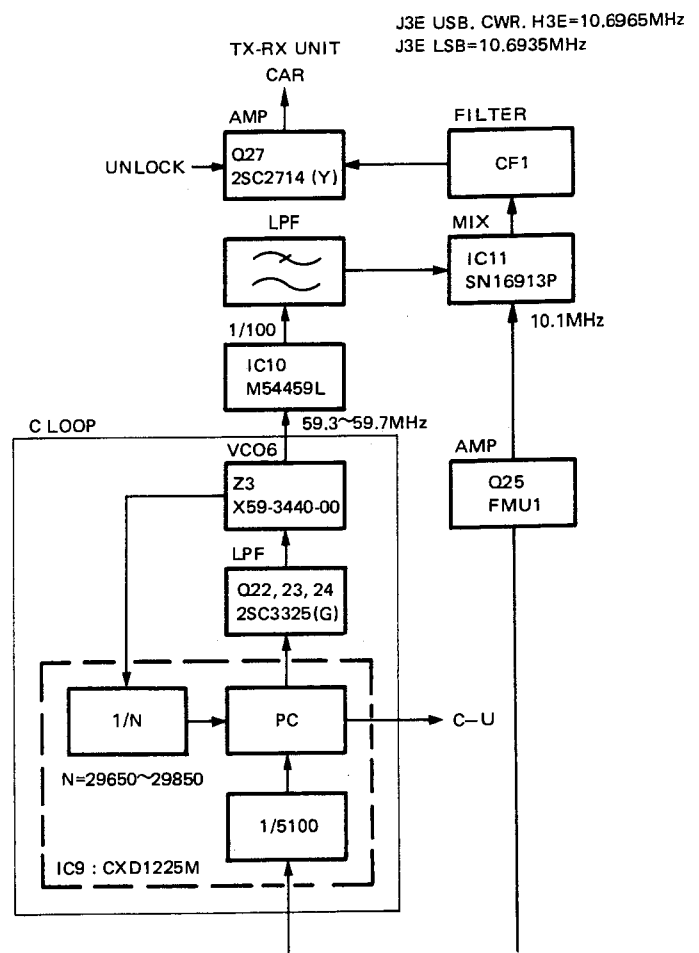

Fig. 3 Block diagram of PLL CAR loop

CIRCUIT DESCRIPTION

• CAR stop circuit in AM receive mode

In the CW and SSB modes, the 8 V DC power for the last mixer IC (IC11 : SN16913P) of the CAR loop is supplied through Q26 : 2SC2712(Y). In the H3E receive mode, 8 V is applied to pin 3 of the TX-RX unit shift register IC10 (TC9174F) according to the data supplied from the microprocessor. The 8 V is supplied to the control unit via the CAR coaxial cable.

This sets Q28 : DTC114EK on, changes Q26 from on to off, disables IC11, and stops CAR.

• Unlock circuit

Normally 8 V (8C) is fed to the HET and CAR transistors Q8 and Q27 via Q21. (Q21 is on.) When any of the PLL loops (loop A, B, and C) should unlock, pin 8 of the corresponding PLL IC (IC3, IC6, IC9 : CXD1225M) will go H (5V). This causes Q19 to switch on, and Q20 and Q21 to switch off. This action causes the voltage applied to Q8 and Q27 to be removed. Meanwhile Q29 switches on, and LED D10 turns on to indicate the unlocked state.

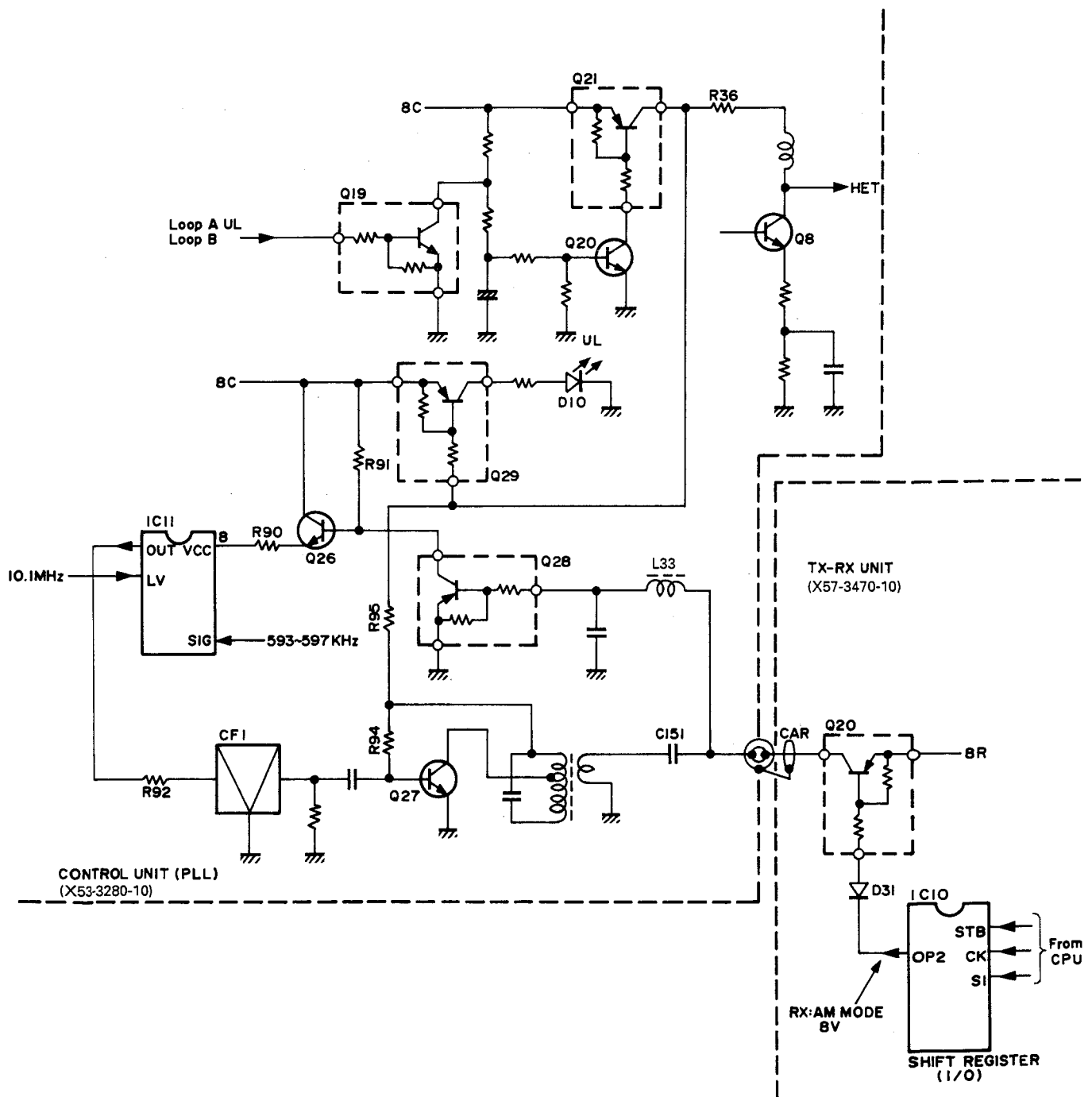

Fig. 4 CAR stop circuit in AM receive mode and PLL unlock circuit

CIRCUIT DESCRIPTION

Control Unit

• Control unit configuration

The main LSI chips in the control unit include CPU : IC302, ROM : IC310, EEPROM : IC311, and extended I/O IC : IC300.

The CPU reads the program from the ROM, reads/writes memory channel data to EEPROM, and inputs and outputs signals from the CPU ports or extended I/O IC ports.

The address signal (8 low-order bits) required for the CPU to access the ROM, EEPROM, and extended I/O IC is multiplexed with other data and output to the bus line. The address is maintained for the necessary period of time by latching IC303.

The chip select (CS) signal, which selects a the desired device (ROM, EEPROM, etc.), is supplied to each device by decoding the address signal by IC304 : TC74HC138AF.

• Bus operation

The ROM (IC310), EEPROM (IC311), and extended I/O IC (IC300) are connected to the CPU (IC302) via the bus line. When the CPU accesses these ICs (IC310, IC311, and IC300), the address signals (A13 to A15) output from the CPU are decoded by IC304, and the IC is specified by the CS signal. IC310 (ROM) uses the CPU address signal A15 as a CS signal.

Table 2 is a truth table for IC304.

This bus is a multiplexed bus onto which an address code and data are output alternately. Therefore, when the CPU accesses one of the ICs, the necessary address signal is latched by IC303.

This latch uses the positive pulse applied to the ALE pin, after the CPU outputs an address.

INPUT			OUTPUT							
A	B	C	\bar{Y}_0	\bar{Y}_1	\bar{Y}_2	\bar{Y}_3	\bar{Y}_4	\bar{Y}_5	\bar{Y}_6	\bar{Y}_7
0	0	0	0	1	1	1	1	1	1	1
0	0	1	1	0	1	1	1	1	1	1
0	1	0	1	1	0	1	1	1	1	1
0	1	1	1	1	1	0	1	1	1	1
1	0	0	1	1	1	1	0	1	1	1
1	0	1	1	1	1	1	1	0	1	1
1	1	0	1	1	1	1	1	1	0	1
1	1	1	1	1	1	1	1	1	1	0

Table 2 Truth table for IC304 : TC74HC138AF

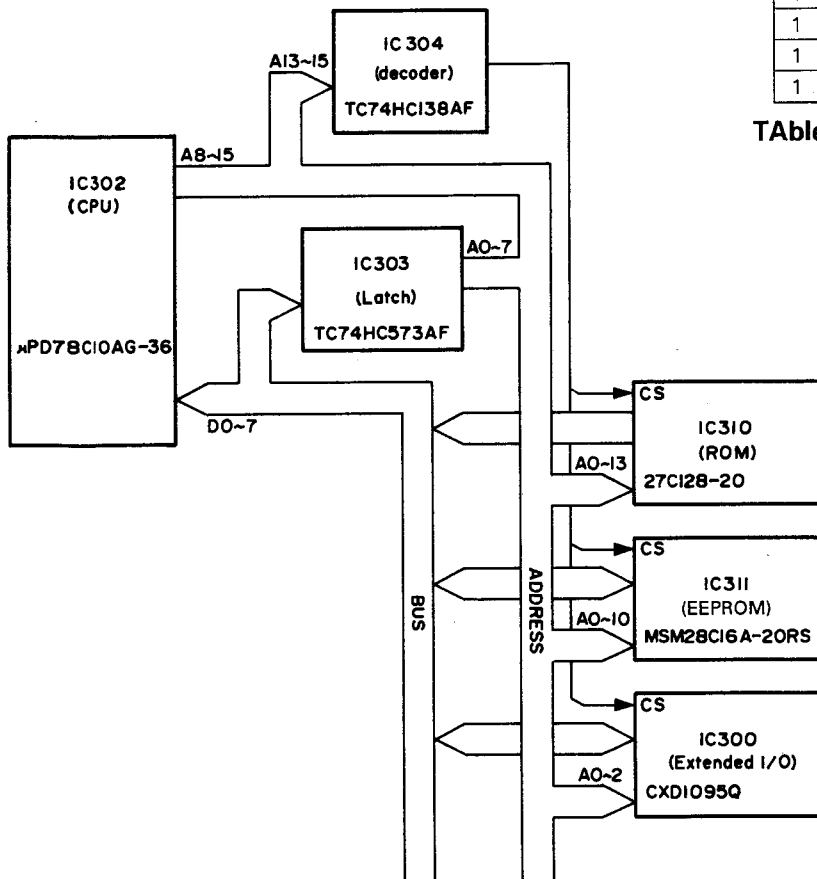

Fig. 5 Control unit block diagram

TKM-707

CIRCUIT DESCRIPTION

- Key scan**

Active L pulses are output from S0 (PC0 pin 11) to S6 (PC7 pin 18), in the order listed, and input through ports K0 (PB3 pin 5) to K4 (PB7 pin 9). Which switch has been pressed is determined by finding where the lines intersect on the matrix.

matrix	Scan input				
	K0	K1	K2	K3	K4
S0	ENT	ITU	3	2	1
S1	SCN	NB	6	5	4
S2	C/FUNC	0	9	8	7
S3	TUNE	SQL	TX-FREQ	MODE	2182
S4	ALARM	A/B/ITU	MEMO/DIAL	DIMMER	
S5					
S6	DIP1	DIP2	DIP3	DIP4	
S7	D311	D312	D313	D314	

- Display**

The CPU calculates the display data and transfers 112-bit serial data to the LCD module. The LCD driver IC in the LCD module lights the LCD dynamically with 50% duty cycle.

Figure 6 shows the serial data waveform.

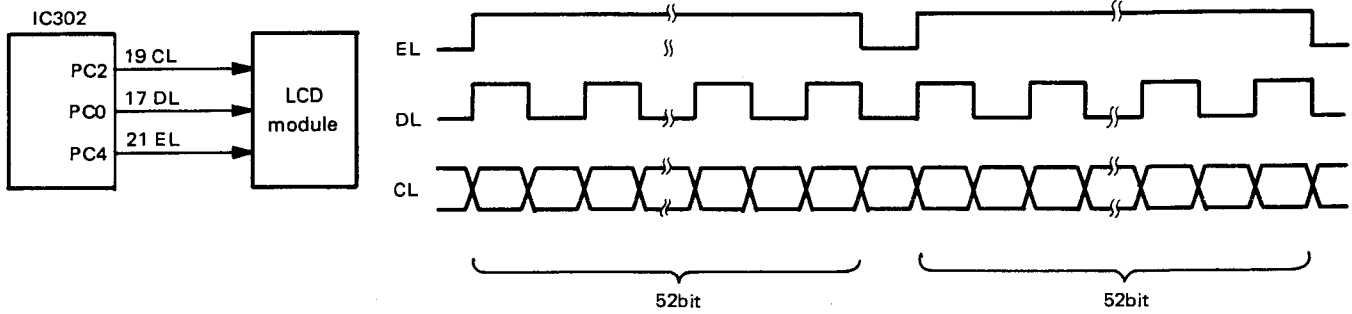

Fig. 6 Serial data waveform

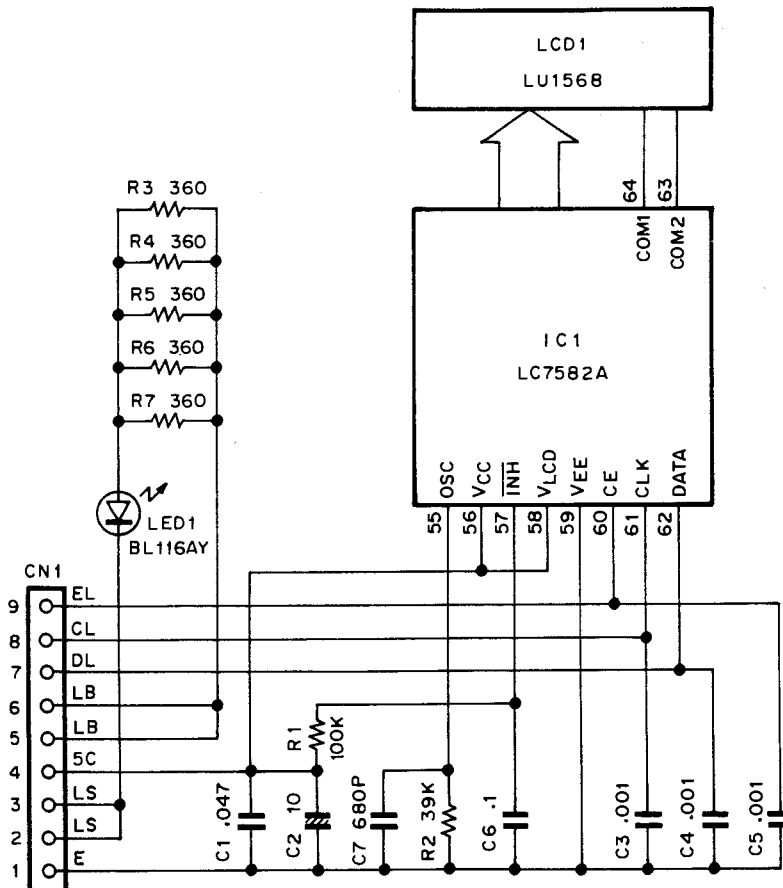

Fig. 7 LCD module circuit diagram

CIRCUIT DESCRIPTION

• Backup

The TKM-707 backs up data in two ways. The first is a semipermanent backup that backs up memory channel data in the nonvolatile memory EEPROM. The second is a lithium cell that backs up the operation status in the CPU RAM.

The CPU backup is performed by monitoring the CB (13.6 V) line. If the voltage falls below the prescribed level, the CPU STOP pin is activated and CPU power consumption is reduced. When the power consumption is low, the CPU stops generating clock signal, which places each port is at a high impedance level.

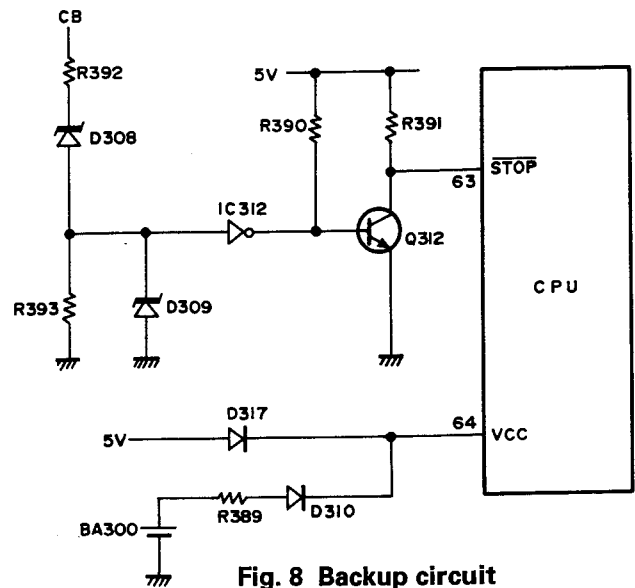

Fig. 8 Backup circuit

• System reset circuit

IC305 (M51951BML) is the system reset IC that monitors the power supply voltage. If the voltage falls below the prescribed level, it outputs a reset signal to the main CPU to stop execution and inhibit memory write functions.

If the power supply voltage again exceeds the prescribed level when the power is on, the reset signal is released, the main CPU is initialized, and execution is resumed after the time constant of R375 and C379 has elapsed.

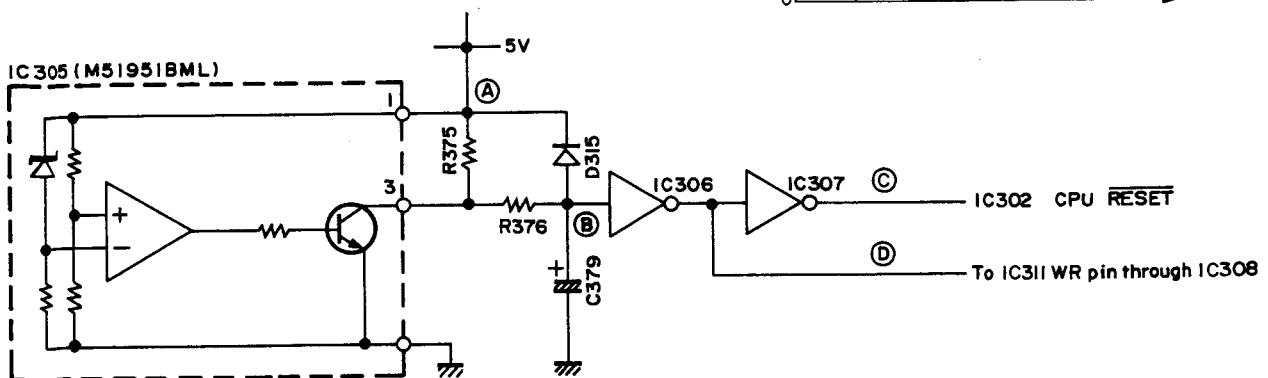
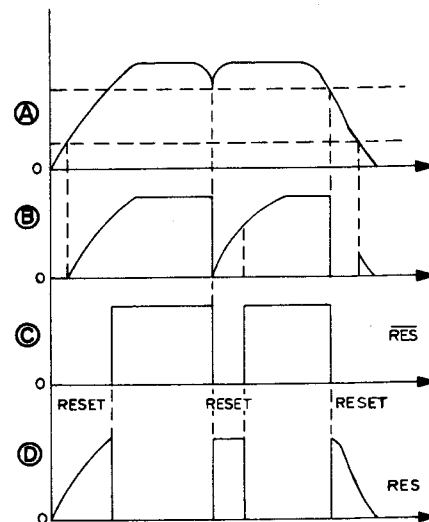

Fig. 9 Reset circuit and timing chart

CIRCUIT DESCRIPTION

• Clarifier

When the clarifier knob is turned a DC voltage corresponding to the rotation angle is produced. The input voltage is A/D converted by the CPU and PLL data is controlled.

The data is controlled in the CPU so that the curve

shown in Figure 10-2 is obtained. Operation of the circuit is improved by enlarging the zero area at the center of the rotation angle.

The zero point of the clarifier is adjusted by setting the knob to the mechanical center, then setting zero with VR303.

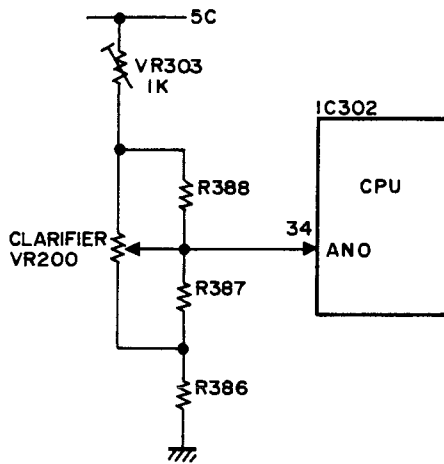

Fig. 10-1 Clarifier circuit

Fine adjustment frequency

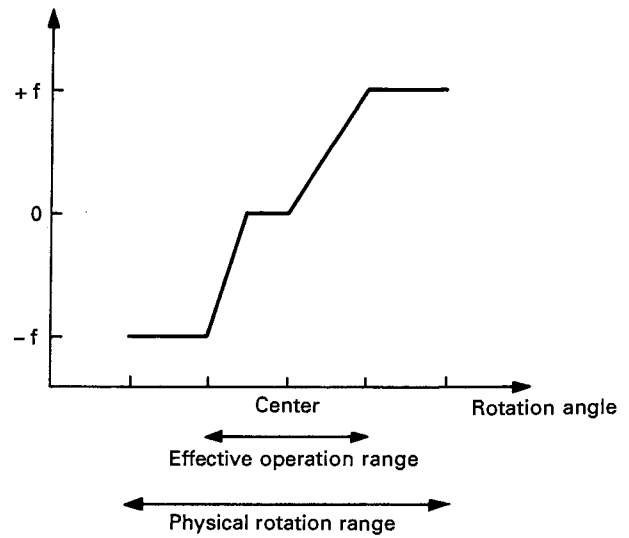

Fig. 10-2

• Encoder

When the encoder is turned, a pulse having a 90-degree phase shift is input to the CPU. The EN1 pulse is applied to PC3 of pin 20 and INT1 of pin 26. The CPU detects the trailing edge of the waveform via PC3 and the leading edge by INT1 and begins interrupt operation. It checks PC1 of pin 18, judges the rotational direction, counts 1, then performs up/down processing of the frequency and channel data.

Since the encoder is a mechanical device, it produces chattering, but it is designed not to malfunction by software means.

• Receive signal switching

The MU signal switches the AF signal and the BLK signal switches the RF signal.

When switching from one PLL loop to another an active H-pulse is generated to suppress any noise.

In the TX mode and during memory write operation, the MU signal is output continuously to cut off the audio.

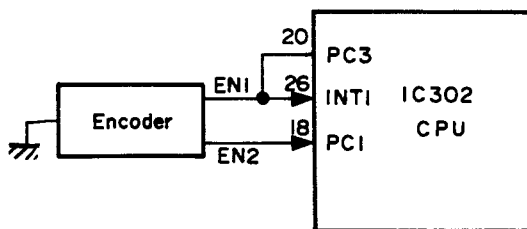

Fig. 11 Encoder circuit

CIRCUIT DESCRIPTION

• Squelch control

The CPU inputs the SQL SW status by means of a key scan.

When the SQL SW is off, the SQS signal goes L to

open squelch.

When the SQL SW is on and the VSQ signal is H, the SQS signal goes H to close squelch. If the VSQ signal is L, the SQS signal goes L.

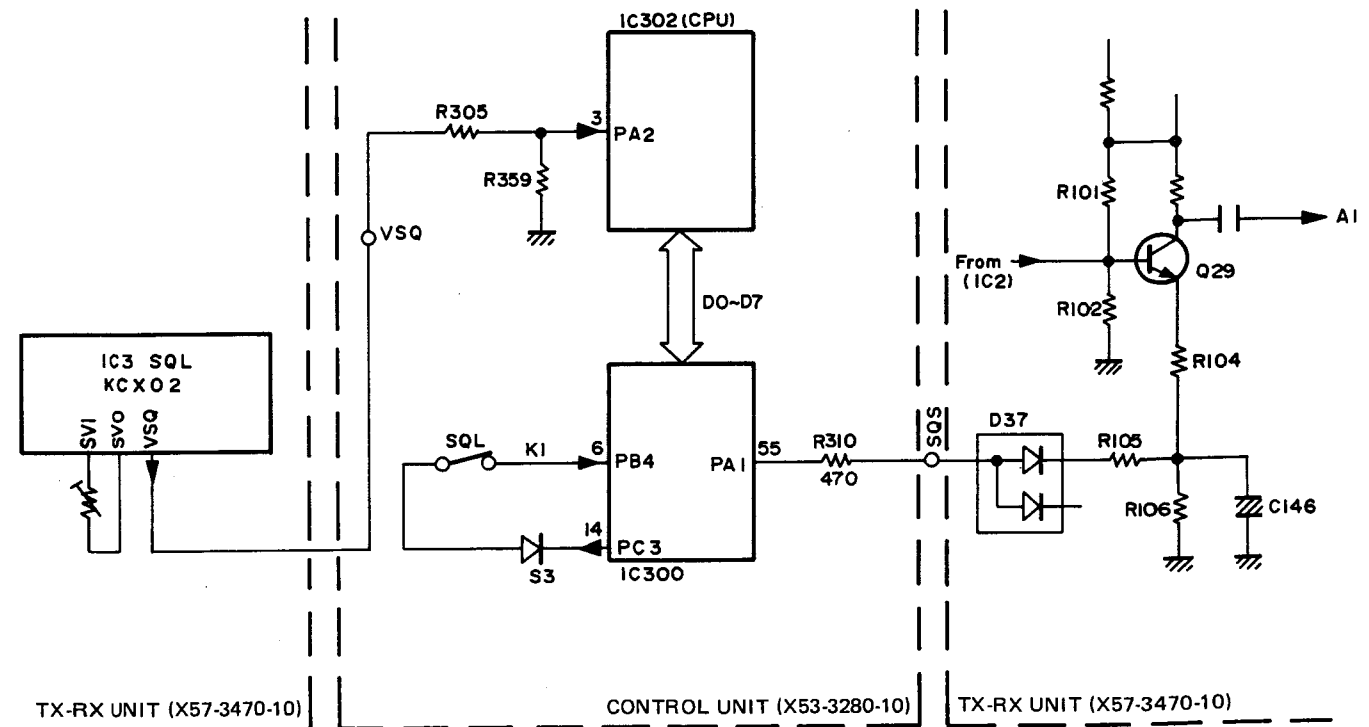

Fig. 12 Squelch control circuit

• Noise blanker switching

The CPU inputs the NB SW status by key scan.

When the NB SW is pressed, the display changes from OFF to NB1 to NB2 to OFF, and the NB1/NB2 port is controlled as listed in Table 3.

When the display is NB2, both NB1 and NB2 operate.

Display	NB1	NB2
OFF	L	L
NB1	H	L
NB2	H	H

Table 3

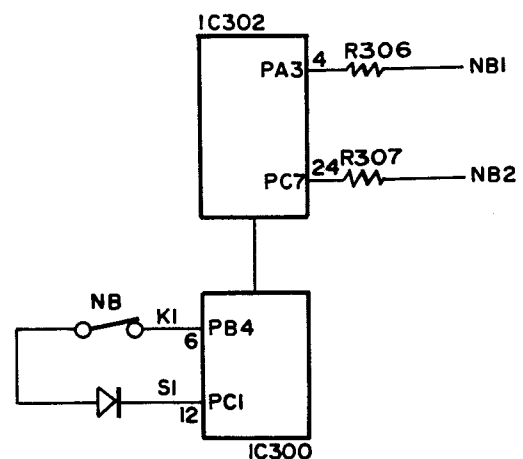

Fig. 13 Noise blanker switching circuit

TKM-707

CIRCUIT DESCRIPTION

• Dimmer

Each time the DIMMER SW is pressed, it changes from MAX to MEDIUM to MIN to OFF to MAX. Table 4 lists the PA4 to PA6 outputs.

Brightness	PA6	PA5	PA4
MAX	L	L	H
MED	L	H	L
MIN	H	L	L
OFF	L	L	L

Table 4

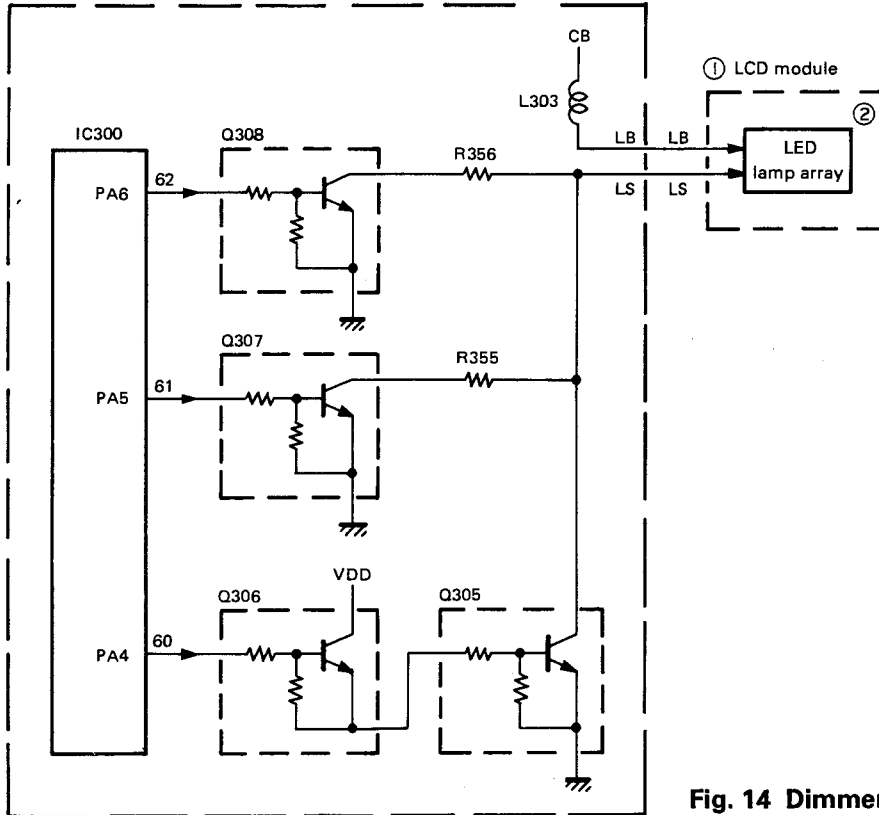

Fig. 14 Dimmer circuit

• Tone output

The 1300/2200 Hz alarm tone is obtained by generating a pseudo sine wave via D/A means and passing it through the LPF.

The 1300 Hz tone has a step waveform with a 1/13 cycle, and the 2200 Hz tone has a step waveform with a 1/8 cycle.

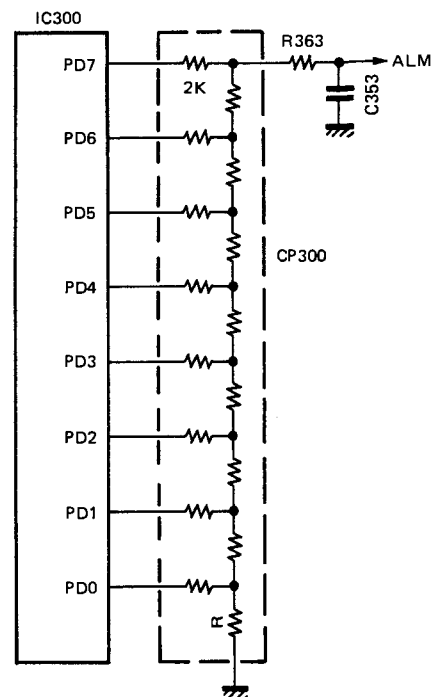

Fig. 15 Tone output circuit

CIRCUIT DESCRIPTION

• Terminal functions

1) CXD1095Q : Control unit IC300

Port name	Pin No.	Name	I/O	Function/operation
PA0	54	MU	O	AF mute. During memory input.
PA1	55	SQS	O	Squelch control. When squelch is closed.
PA2	56	HRL	O	HS relay control. When the speaker is switched to the external speaker.
PA3	59	TTO	O	Through instruction. When through operation is instructed to AT.
PA4	60	DM2	O	Dimmer control. See page 16.
PA5	61	DM1	O	
PA6	62	DM0	O	
PA7	63		O	
PB0	64	PTT	I	MIC PTT. When PTT SW is on.
PB1	3		I	Unused.
PB2	4		I	Unused.
PB3	5	K0	I	Key scan output. When SW is pressed.
PB4	6	K1	I	
PB5	7	K2	I	
PB6	8	K3	I	
PB7	9	K4	I	
PC0	11	S0	O	Key scan output. When the key scan strobe pulse output.
PC1	12	S1	O	
PC2	13	S2	O	
PC3	14	S3	O	
PC4	15	S4	O	
PC5	16	S5	O	
PC6	17	S6	O	
PC7	18	S7	O	
PD0	20		O	Tone D/A. When alarm tone is output.
PD1	21		O	
PD2	22		O	
PD3	23		O	
PD4	24		O	
PD5	27		O	
PD6	28		O	
PD7	29		O	
PE0	49	DS	O	Serial data.
PE1	50	CS	O	Serial CK.
PE2	52	ES2	O	Enable.
PE3	53	ES1	O	
Vss	10			GND.
Vss	25			GND.
VDD	26			Power input pin.
D0	30			Bus pin.
D1	31			Bus pin.
D2	32			Bus pin.
D3	35			Bus pin.
D4	36			Bus pin.
D5	37			Bus pin.
D6	38			Bus pin.
D7	39			Bus pin.
CLR	40			Unused. Fixed to H for data write.
ODEON	41			Unused. Fixed to H for data write.
Vss	42			GND.
WR	43			Strobe input for data write.
RD	44			Strobe input for data read.

CIRCUIT DESCRIPTION

Port name	Pin No.	Name	I/O	Function/Operation
CS	45			Chip select input.
A0	46			Address input for selection of port and control register.
A1	47			Address input for selection of port and control register.
A2	48			Address input for selection of port and control register.
Vss	57			GND.
VDD	58			Power input pin.

2) μ PD78C10AG-36 : Control unit IC302

Port name	Pin No.	Name	I/O	Function/Operation
PC0	17	DL	O	Serial data for LCD.
PC1	18	EN2	I	Encoder CK2.
PC2	19	CL	O	Serial CK for LCD.
PC3	20	EN1	I	Encoder CK1.
PC4	21	EL	O	LCD enable.
PC5	22	KEY	I	Key. When marked.
PC6	23	BZ	O	Buzzer.
PC7	24	NB2	O	NB switching. When NB2 operates.
PD0	55	D0	I/O	Bus.
PD1	56	D1	I/O	Bus.
PD2	57	D2	I/O	Bus.
PD3	58	D3	I/O	Bus.
PD4	59	D4	I/O	Bus.
PD5	60	D5	I/O	Bus.
PD6	61	D6	I/O	Bus.
PD7	62	D7	I/O	Bus.
PF0	47	A8	O	Address.
PF1	48	A9	O	Address.
PF2	49	A10	O	Address.
PF3	50	A11	O	Address.
PF4	51	A12	O	Address.
PF5	52	A13	O	Address.
PF6	53	A14	O	Address.
PF7	54	A15	O	Address.
MNI	25		I	Unused.
INT1	26	EN1	I	Encoder CK1.
AN0	34	CL2	I	Clarifier.
AN1	35	M	I	Level meter.
AN2	36	PLSB	I	LSB correction.
AN3	37	PUSB	I	USB correction.
AN4	38	DLY	I	Delay VR.
AN5	39		I	Unused.
AN6	40	UP	I	MIC UP. When SW is on.
AN7	41	DW	I	MIC DOWN. When SW is on.
PA0	1	STT	O	TX 8T switching. In TX mode.
PA1	2	BLK	O	RF mute. When PLL is switched.
PA2	3	VSQ	I	Audio squelch. When an audio signal is present.
PA3	4	NB1	O	NB switching. When NB1 and NB2 operate.
PA4	5	TSO	O	AT tune start.
PA5	6	TTI	I	AT tune end.
PA6	7	V2	O	VCO switching.
PA7	8	V1	O	
PB0	9	EP2	O	PLL IC enable.
PB1	10	EP3	O	
PB2	11	EP1	O	

CIRCUIT DESCRIPTION

Port name	Pin No.	Name	I/O	Function/Operation
PB3	12	CP	O	Serial CK for PLL IC.
PB4	13	DP	O	Serial data for PLL IC.
PB5	14	STR	O	RX 8R switching. In RX mode.
PB6	15		O	Unused.
PB7	16	TSI	O	AT through response.
MODE 1	27		I	Specify the size of the external memory. Fixed to H level.
RESET	28		I	Reset input. Usually H.
MODE 0	29		I	Specify the size of the external memory. Fixed to H level.
X2	30		I	Crystal connection pin for internal clock generation.
X1	31		I	Crystal connection pin for internal clock generation.
Vss	32		I	GND.
A Vss	33		I	A/D converter GND pin.
VAREF	42		I	A/D converter reference voltage input pin.
A Vdd	43		I	A/D converter power pin.
RD	44		O	Strobe signal output for external memory read operation.
WR	45		O	Strobe signal output for external memory write operation.
ALE	46		O	Strobe signal to externally latch the low-order address output to pins PD0 to PD7 to access the external memory.
STOP	63		I	Control input pin in the hardware stop mode.
VDD	64		I	Go L for backup.

3) TC9174F : TX-RX unit IC9

Port name	Pin No.	Name	I/O	Function/Operation
OP1	2	B8	O	BPF switching signal.
OP2	3	B7	O	
OP3	4	B6	O	
OP4	5	B5	O	
OP5	6	B4	O	
OP6	7	B3	O	
OP7	8	B2	O	
OP8	9	B1	O	
OP9	10		O	Unused.
OP10	11	TUNE	O	Power control at AT. During tune transmission.

4) TC9174F : TX-RX unit IC10

Port name	Pin No.	Name	I/O	Function/Operation
OP1	2		O	Unused.
OP2	3	AM	O	In H3E mode.
OP3	4	CW	O	In CW mode.
OP4	5	ALS	O	Alarm tone mute. When alarm tone is output.
OP5	6	FL3	O	LPF switching signal.
OP6	7	FL2	O	
OP7	8	FL1	O	
OP8	9		O	Unused.
OP9	10	M-POW	O	Power control.
OP10	11	L-POW	O	

CIRCUIT DESCRIPTION

Receiving Circuit Configuration

BPF NO.	Frequency (MHz)
B1	0.1~1.5999
B2	1.6~2.9999
B3	3.0~4.9999
B4	5.0~6.9999
B5	7.0~8.9999
B6	9.0~13.9999
B7	14.0~17.9999
B8	18.0~29.9999

Table 5 Receiving bandpass filter table

- **Automatic gain control (AGC) circuit**

The output of final-stage intermediate-frequency (IF) amplifier Q15 (3SK131(M)) is amplified by IF hybrid IC2 (KCD03) to produce an AGC voltage with a voltage doubler rectifier. This AGC voltage is fed to a two-stage IF amplifier in IC2 and the second gates of FETs Q12 and Q15 (3SK131(M)) to control the gain.

- **Squelch circuit**

The detected output of IC2 is partially sent to hybrid IC3 (KCX02) and is used as a squelch circuit signal. A high or low digital VSQ signal is output from hybrid IC3, then input to the CPU. The CPU outputs an SQS signal and mutes it using audio frequency (AF) preamplifier Q29 (2SC3324(G)) for squelch control.

- **Noise blanker (NB) circuit**

The input of the NB circuit is extracted from the outputs of second-stage RX mix FETs Q13 and Q14 (2SK520(K44)) and is applied to the NB hybrid IC1 (KCX01). The input signal is amplified and detected by IC1 then output as a noise blanking signal. The operation of IF amplifier Q15 (3SK131(M)) is stopped by NB switching transistor Q16. Noise components are then eliminated.

NB1 is used for short-duration pulses such as ignition noise. NB7 is used for longer-duration, long duration pulse noise such as the woodpecker.

Transmitting Circuit Configuration

The transmitter utilizes a double-conversion system. An audio signal from the microphone is amplified by microphone amplifiers Q37 and Q38 (2SC3324(G)) and modulated by double-balanced mixer (BM) IC6 (μ PC1037A). The modulated output is converted to a DSB signal, passed through 10.695 MHz single-side-band (SSB) filter XF2, then converted to an SSB signal. The SSB signal is then amplified by TX IF amplifier Q45 (3SK131(M)) in the first stage. An ALC voltage is applied to the second gate of Q45 by a dual MOS FET IF amplifier to control the transmitter output.

Audio signals in the H3E mode are also modulated, like an SSB signal, passed through a filter, then amplified by Q45. A carrier signal is added to the amplified signal by a circuit consisting of Q48 and Q49 producing an H3E signal.

The 10.695 MHz signal amplified by Q45 is mixed with a 60.6 MHz signal by second-stage mixer IC7 (SN16913P), then converted to a 71.295 MHz signal. Spurious components in the 71.295 MHz signal are eliminated by a monolithic crystal filter (MCF) (XF1). The resultant signal is amplified by dual gate MOS FET amplifier Q50 (3SK129(L)). When a high SWR is felt at the antenna, the ALC2 voltage at the second gate of Q50 is reduced and the transmitting output level is lowered to protect the transistor in the final stage. The amplified transmitting IF signal is input to a double-balanced mixer consisting of FETs Q51 and Q52 (3SK179(L)), then converted to the desired transmitting frequency. The converted signal is passes through a low-pass filter to eliminate higher harmonic components and is then amplified to the signal level required for a final-stage drive circuit by transistor Q53 (2SC2053).

The drive output is sent to the final-stage unit and amplified to a sufficient output level by wideband pre-drive amplifier Q1 (2SC1971), wideband push-pull drive amplifiers Q2 and Q3 (2SC3133), and wideband push-pull amplifiers Q4 and Q5 (2SC2879(O,Y)) in the final stage.

Pre-drive amplifier Q1 has a fixed bias and is thermally coupled with diode D1. The bias currents of drive amplifiers Q2 and Q3 and final-stage amplifiers Q4 and Q5 are adjusted by VR1 and VR2. Diode D2 is thermally coupled with Q2, D3 with Q4, and D4 with Q6. Diodes D1 through D4 compensate for the temperature in each stage and prevent thermal runaway.

CIRCUIT DESCRIPTION

The outputs of Q4 and Q5 in the final stages pass through low-pass filters for each band to eliminate higher harmonic components. The low-pass filter output passes through transmit relay K115 and is applied to the antenna terminal. The ALC voltage is detected by L121, and the antenna current is detected by L123.

For bandwidth information, the 3-bit information items (FL1 through FL3) sent from the TX-RX unit are converted to 7 bits by decoder IC101. Q107 through Q113 turn on and relays K101 through K114 are changed over for bandwidth selection. The bandwidth information can be checked by checking that test points LPF1 through LPF7 are high (5 V). The band select relay can also be checked by checking that LPF1B through LPF7B

are 5 V. The table 6 outlines the bandwidth information.

Transmission and reception can be checked when test points TX and RX are 5 V.

FL1	FL2	FL3	LPF NO.	Frequency (MHz)
H	H	H	1	1.6050~2.9999
L	H	H	2	3.0000~4.9999
H	L	H	3	5.0000~6.9999
L	L	H	4	7.0000~8.9999
H	H	L	5	9.0000~13.9999
L	H	L	6	14.0000~17.9999
H	L	L	7	18.0000~27.9999

Table 6 Bandwidth information

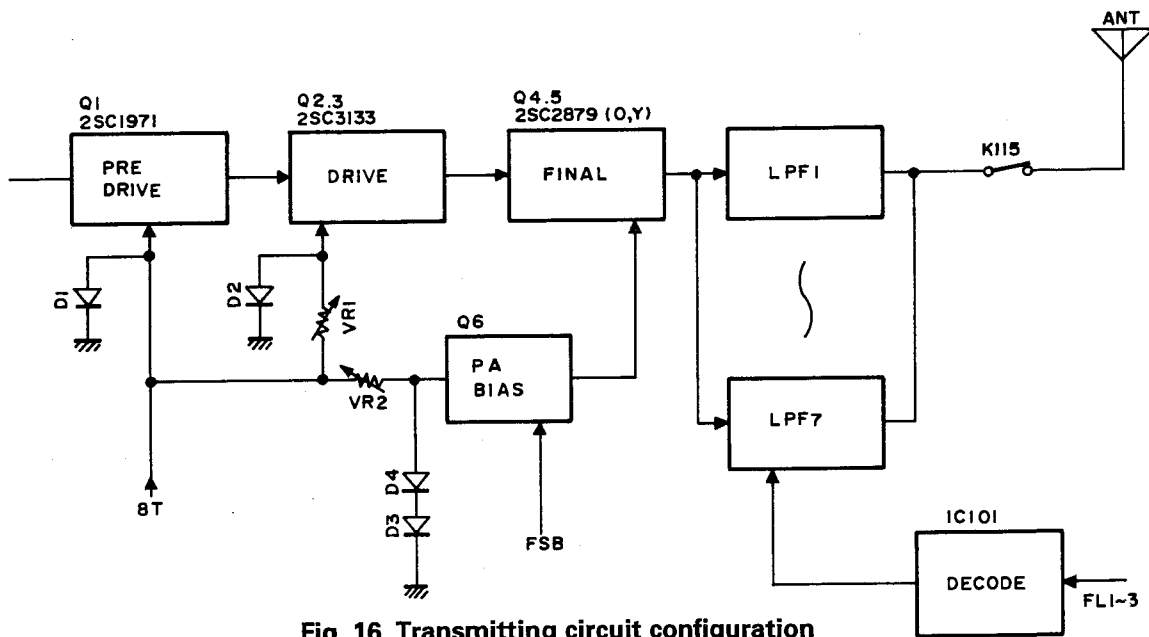

Fig. 16 Transmitting circuit configuration

• ALC voltage detector and antenna current detector circuits

The ALC voltage is detected by L121. Forward waves are detected by D102, converted to an AC voltage, then sent to the TX-RX unit. The voltage is approximately 10 V in the low- to high-band range with respect to the 47 kΩ load of R112. Reflected waves are detected by D101 and sent to the TX-RX unit. The

reflected waves are adjusted by TC101 so that the VSR voltage is minimum (approximately 0.5 V) when a 4 MHz frequency is output at 110 W.

For antenna current detection, the voltage detected by L123 is detected by D103 and fed to the TX-RX unit. The voltage is approximately 6 V in the low- to high-band range with respect to the 47 kΩ load.

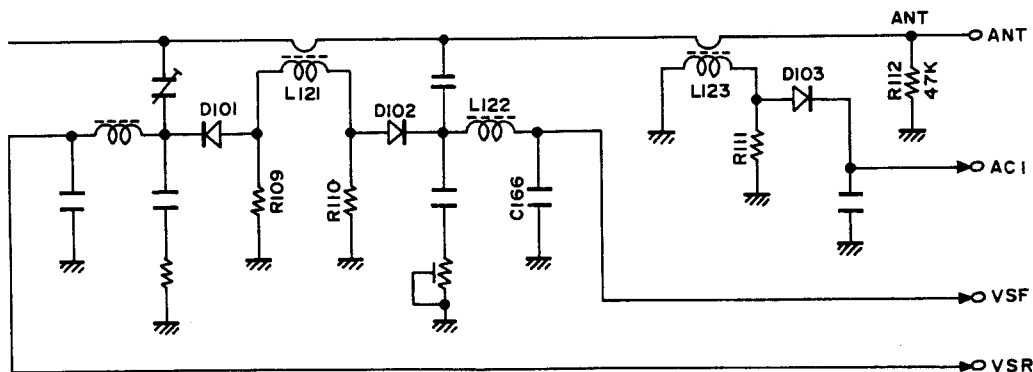

Fig. 17 ALC voltage and antenna current detection

CIRCUIT DESCRIPTION

Protection Circuit Configuration

The final stage has a temperature protection circuit consisting of fan module unit Z1 and an overvoltage protection circuit consisting of D6, Q7, and Q8.

• Temperature protection circuit

When the heat sink temperature rises and the temperature of thermistor TH1 (10 kΩ) exceeds approximately 55 degrees C, comparator IC1 (b/2) of the fan

module (X59-3370-00) is activated, switching transistor Q1 on, and fan motor M1 is driven.

When the heat sink temperature becomes still higher and the thermistor temperature exceeds 90 degrees C, comparator IC1 (a/2) is activated and the output goes high (approximately 7 V). The power select circuit is then activated reducing the output power to approximately 30 W.

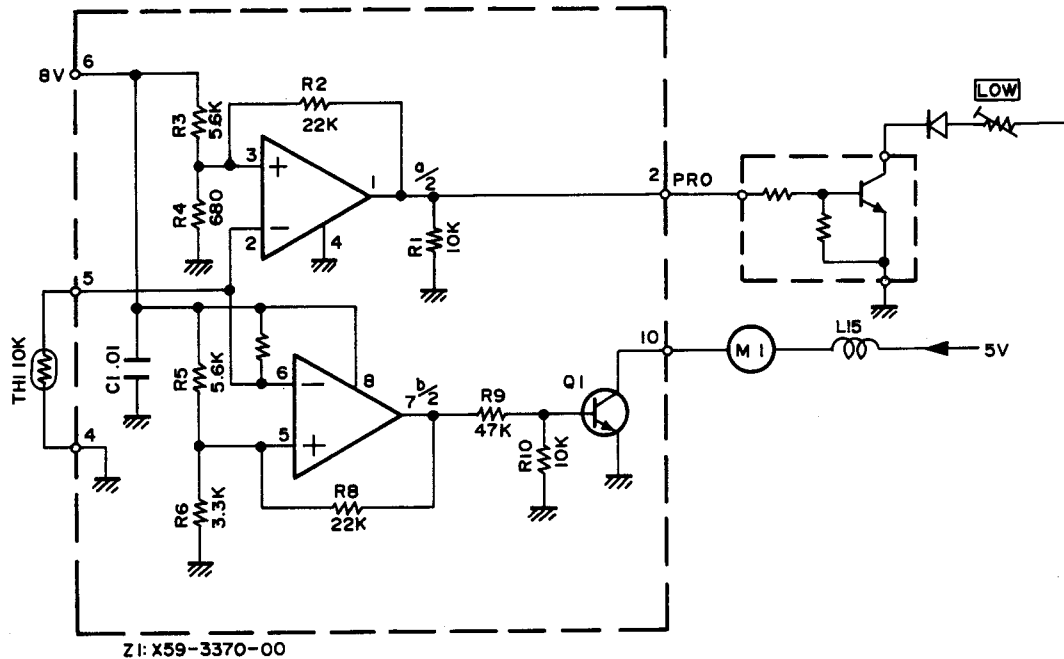

Fig. 18 Temperature protection circuit

• Overvoltage protection circuit

When the supply voltage exceeds approximately 20 V, the base of switching transistor Q7 goes high turning it on; which in turn turns on Q8. As a result, relay K1 connected to the POWER switch is set off and the power is switched off.

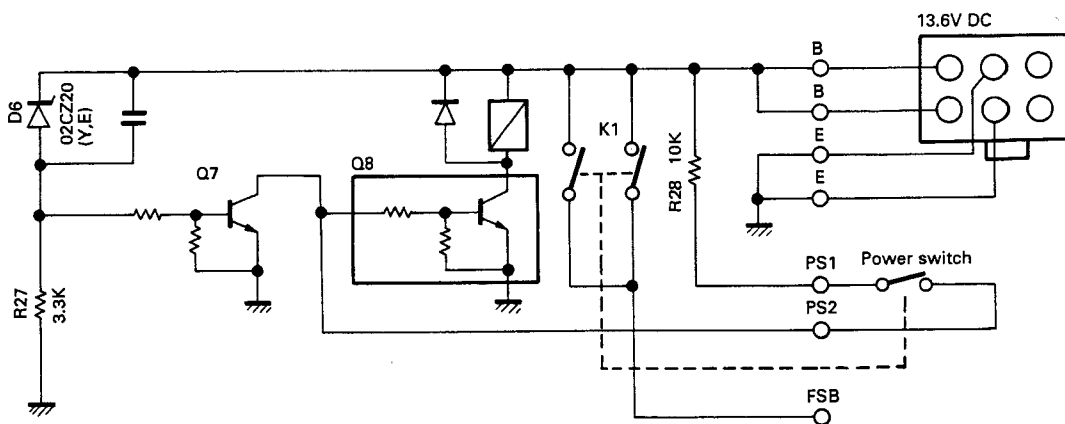

Fig. 19 Overvoltage protection circuit

CIRCUIT DESCRIPTION

• Receiving front end protection circuit

The voltage (8 V) from 8R turns Q104 on, turns Q103 on, (2SA1362(Y)), which then sets receiving select relay K116 on during reception. Therefore, the signal from the ANT terminal is sent to the RA terminal via relay K116.

When a HF signal exceeding approximately 10 W is input to the ANT terminal during reception, forward

waves are detected by D101. This signal level is enough to turn Q106 (2SC2712(Y)) on; which turns Q105 (DTA144) off, then on. Q104 (DTD114EK) then changes from on to off, and Q103 changes from on to off. Thus, receiving select relay K116 is not activated, so the high-frequency power is not fed to the RA terminal to protect the receiving front end.

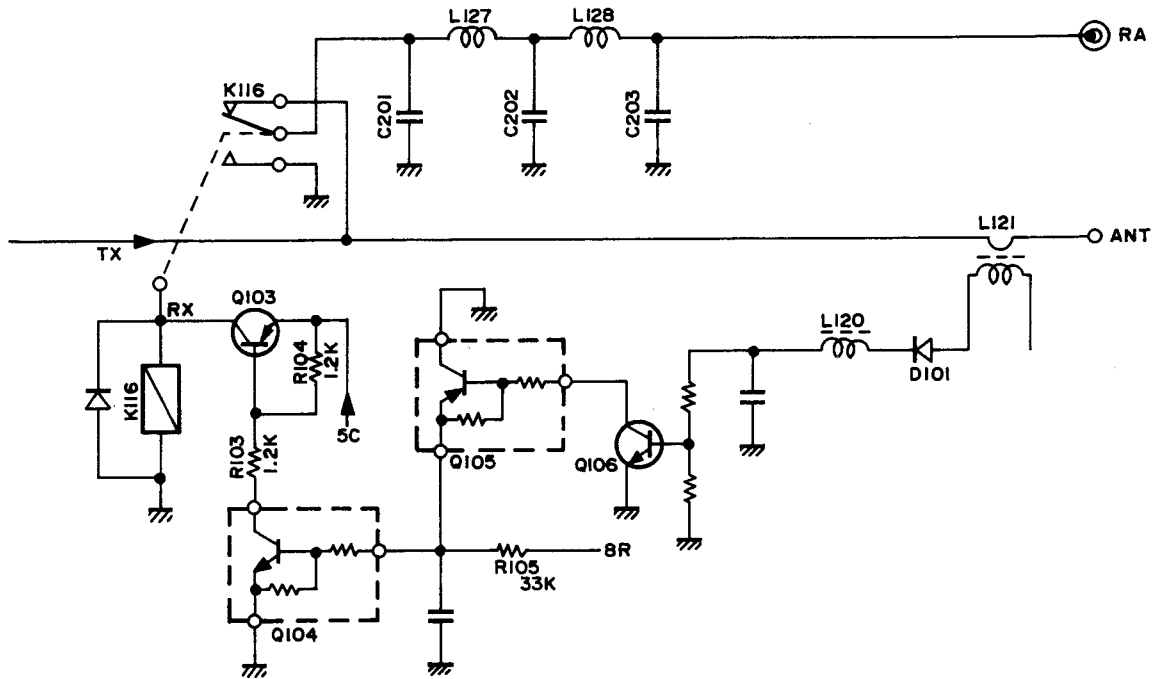

Fig. 20 Receiving front end protection circuit

MIC terminal

See Figure 21 and Table 7.

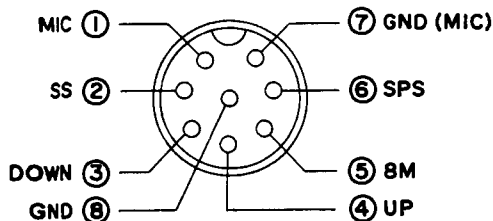

Fig. 21 MIC pin (Viewed from front panel)

Pin No.	Pin Name	Description
①	MIC	MIC impedance approx. 600Ω
②	SS	STANDBY switch.
③	DOWN	Frequency and channel number decrement.
④	UP	Frequency and channel number increment.
⑤	8M	BV (100mA [MAX]).
⑥	SPS	Receiving audio output.
⑦	GND (MIC)	Ground for MIC.
⑧	GND	Ground.

Table 7 MIC pin description

CIRCUIT DESCRIPTION

• When using handset instead of microphone

1) Connecting the handset

Connect an 8-pin MIC plug (E07-0852-15) to the handset as shown in Figure 22. Add a resistor (100 k Ω) in series to pin 3 (DOWN line). Then, connect the resistor to the off hook switch. Now when the handset is lifted, the off hook circuit is activated. The off hook switch operation is described below. (See Figures 23 and 24.)

The DOWN line is connected to the A/D input terminal of the CPU. The CPU judges whether the A/D input terminal output is a DOWN switch signal or handset off hook switch signal in accordance with the DOWN line level. When the handset off hook switch is detected as being on, the APO signal goes high. Internal and external speaker outputs are then cut off irrespective of the SP switch setting.

2) Using the handset

1. Connect an 8-pin MIC plug to the handset as described above.
2. Insert the connected 8-pin MIC plug into the MIC jack on the front panel.
3. When the handset is placed on a hanger as shown in Figure 23, the received tone is heard from an internal or external speaker (the SP switch is activated). The handset speaker is cut off.
4. When the handset is removed from the hanger as shown in Figure 24, the internal or external speaker is cut off (the SP switch is deactivated). The received tone is heard from the handset speaker.
5. When the PTT switch of the handset is pressed, the set enters the transmission mode.
6. Speak over the handset microphone.
7. When the PTT switch is released the set enters the reception mode.

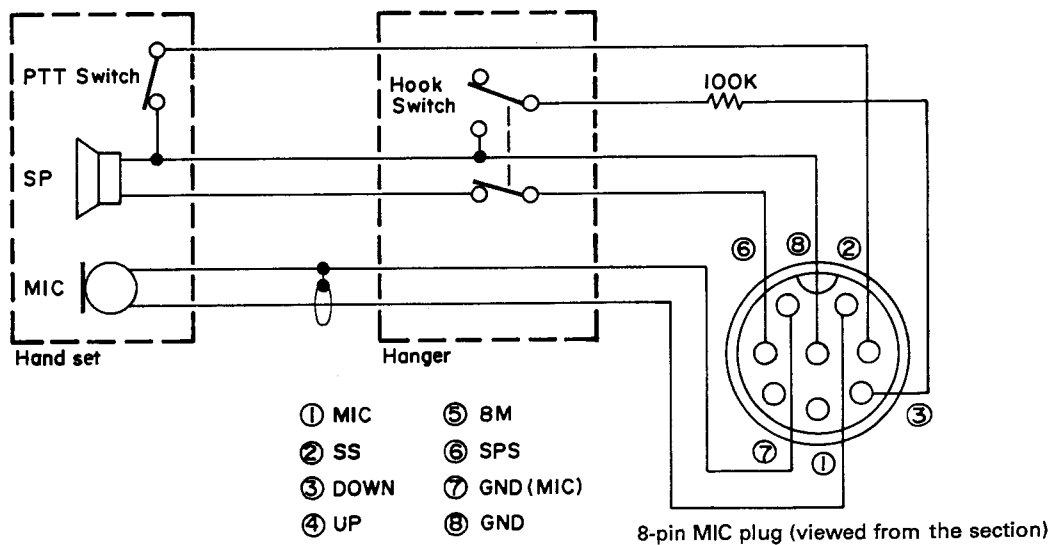

Fig. 22 Handset connection

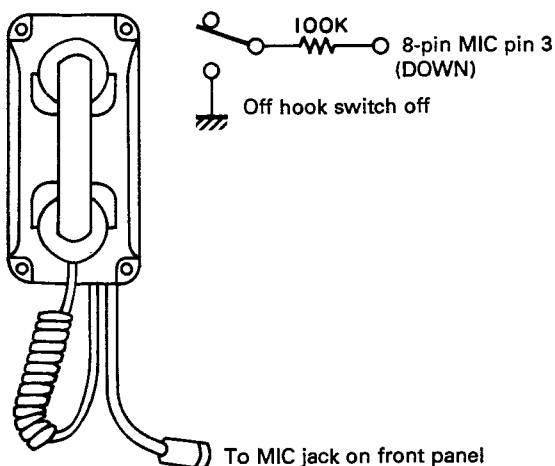

Fig. 23 When placing handset on hanger

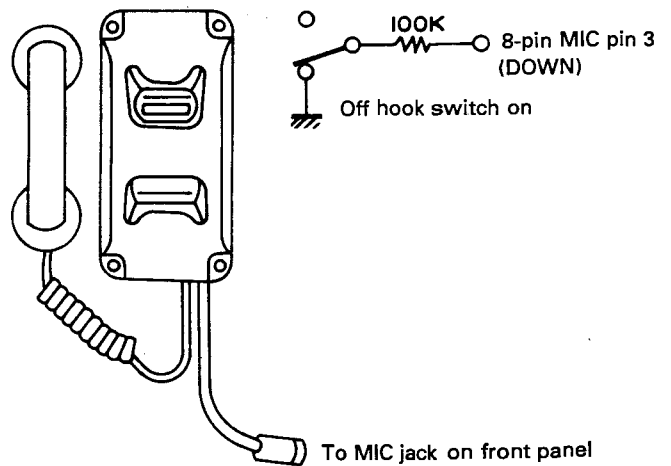

Fig. 24 When removing handset from hanger

CIRCUIT DESCRIPTION

Antenna Current Level Meter Selection

• Preparations

1. Remove the upper and lower case fastening screws.
2. Remove the fastening screws of the heat sink covering the top of the set and push the heat sink down to the left.
3. The TX-RX unit (X57-3470-10) is under the heat sink, so sliding switch S1 of the unit can now be seen.

When connecting an antenna coupler, set slide switch S1 of the TX-RX unit (X57-3470-10) to EXT. Now the current of the antenna connected to the antenna coupler can be detected. The detected current can be displayed by using a level meter. When sliding switch S1 is set to INT, the current of the antenna connected to the ANT terminal of the set is detected. The detected current is also displayed by using a level meter.

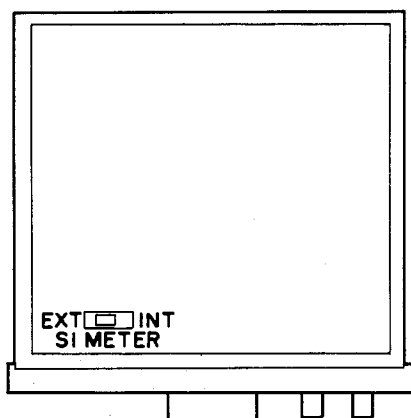

Fig. 25 Antenna current detector circuit selection (Viewed from the panel top)

Operation Mode

The operation mode consists of user and dealer modes. They differ in specifications for reset and memory channel entry. Memory channel operation will be described first.

• User mode

This mode is selected by users. Only a receiving frequency can be written into the memory channel. Memory channels written in the dealer mode cannot be overwritten.

• Dealer mode

This mode is used when dealers write the transmitting and receiving frequencies assigned to users into the memory channel. For M type radios, the mode is returned to the user mode after programming is completed. For K type, the mode is set to the dealer mode at the factory.

Setting of Functions by Diode Removal

As Table 8 outlines, functions can be set with diodes D311 through D314 of the control unit (X53-3280-10).

• Function setting

1. Set the POWER switch to OFF.
2. Set the diode corresponding to the desired function.
3. Set the POWER switch to ON.

• Description of table 8

When D311 is removed, the ALARM key on the front panel is ineffective.

When D312 is removed, a wave-type least significant bit (LSB) can be sent.

When D313 is removed, the frequency selected in the DIAL mode can be sent.

When D314 is removed, a wave-type H3E signal can be sent.

Ref. No.	Function	Diode provided	
		Yes	No
D311	Alarm key	Valid	Invalid
D312	LSB sending	Impossible	Possible
D313	Dial mode sending	Impossible	Possible
D314	H3E sending	Impossible	Possible

Table 8 Setting of functions with diodes

Setting of Functions with DIP Switch

As Table 9 outlines, functions can be set with DIP switches S301 of the control unit (X53-3280-10).

• Function setting

1. Set the POWER switch to OFF.
2. Set the DIP switch corresponding to the desired function.
3. Set the POWER switch to ON.

• Description of table 9

When Switch 1 is set to ON, operation is set in the user mode. When it is set to OFF, operation is set in the dealer mode.

Switches 2 and 3 must remain set to ON.

When switch 4 is set to ON, the destination is set to America. When it is set to OFF, the destination is set to other foreign countries.

1) For America (K type)

A frequency has been preset to memory groups A and B. Factory setting is as follows:

- Switch 1 : OFF
- Switch 2 : ON
- Switch 3 : ON
- Switch 4 : ON

CIRCUIT DESCRIPTION

2) For other foreign countries (M type)

A frequency has not been preset to memory groups A and B. Factory setting is as follows:

- Switch 1 : ON
- Switch 2 : ON
- Switch 3 : ON
- Switch 4 : OFF

Switch No.	Function	Switch setting	
		ON	OFF
1	Operation mode	User	Dealer
4	Destination	America	Other foreign countries

Table 9 Setting of functions with DIP switches

Reset

• How to reset

1. Set the POWER switch to OFF.
2. Set the POWER switch to ON while pressing the keys listed in Table 10.

• Description of table 10

When the system is reset in the dealer and user modes with the ENT key, the initial mode is entered with the memory backed up.

When the system is reset in the user mode with the C/FUNC key, only the memory channel written in the user mode is cleared. The initial mode is then entered.

1) For foreign countries' destination (except America)

When the system is reset in the dealer mode with the C/FUNC key, all memory channels are cleared. The initial mode is then entered.

2) For American destination

When the system is reset in the dealer mode, with the C/FUNC key, the preset channel is set in the initial mode. Other memory channels are cleared. The initial mode is then entered.

Operation mode	Key used	Write data		
		Preset channel	Dealer write channel	User write channel
Dealer mode	ENT	Back up	Back up	Back up
	C/F	Set	Cleared	Cleared
User mode	ENT	Back up	Back up	Back up
	C/F	Back up	Back up	Cleared

Table 10 Reset

Memory

• Before memory write

Reset the system as follows before writing the memory:

1. Set the set in the dealer mode.
2. Set the POWER switch to ON while pressing the C/FUNC key.

• Memory write

Write the memory in accordance with the Operation Manual (write the memory while the set is in dealer mode). Receiving and transmitting frequencies can be written in the dealer mode.

• After memory write

After memory write is completed, set the set in the user mode. The memory written in the dealer mode cannot be rewritten.

• The ALARM key is ineffective

(See Setting of Functions by Diode Removal.)

• Wave-type LSB and H3E signals can be sent

(See Setting of Functions by Diode Removal.)

• A frequency can be sent in the dial mode

(See Setting of Functions by Diode Removal.)

• Destination selection

See Setting of Functions with DIP Switches.

DESCRIPTION OF COMPONENTS

FINAL UNIT (X45-3370-10)

Component	Use/Function	Operation/Condition/Compatibility
IC1	8V AVR	Input 13.6V, output 8V.
IC2	5V AVR	Input 13.6V, output 5V.
IC101	Band data decode	See to circuit description.
Q1	Pre drive amplifier	Wide freq. amplifier.
Q2, 3	Drive amplifier	Pushpull amplifier.
Q4, 5	Final amplifier	Pushpull amplifier.
Q6	Bias voltage supply to Q4, 5.	Current amplifier when transmit.
Q7	Over voltage detection	Turn on when voltage (approx. 20V or more).
Q8	Power switch relay control	On when power switch is turned on.
Q101, 102	TX/RX select relay switch	Turn ON when transmit (TX terminal : 5V).
Q103, 104	TX/RX select relay switch	Turn ON when receive (RX terminal : 5V).
Q105	RX protection circuit switch	Turn ON when operate to protection circuit (Normally OFF).
Q106	RX protection circuit detection	
Q107	LPF select relay switch	Turn ON 5~6.9999MHz (LPF3B terminal : 5V).
Q108	LPF select relay switch	Turn ON 18~29.9999MHz (LPF7B terminal : 5V).
Q109	LPF select relay switch	Turn ON 9~13.9999MHz (LPF5B terminal : 5V).
Q110	LPF select relay switch	Turn ON 7~8.9999MHz (LPF4B terminal : 5V).
Q111	LPF select relay switch	Turn ON 14~17.9999MHz (LPF6B terminal : 5V).
Q112	LPF select relay switch	Turn ON ~2.9999MHz (LPF1B terminal : 5V).
Q113	LPF select relay switch	Turn ON 3~4.9999MHz (LPF2B terminal : 5V).
Q114	LPF select relay switch	Turn ON 14~17.9999MHz (LPF6 terminal : 5V).
Q115	LPF select relay switch	Turn ON 18~29.9999MHz (LPF7 terminal : 5V).
Q116	LPF select relay switch	Turn ON ~2.9999MHz (LPF1 terminal : 5V).
Q117	LPF select relay switch	Turn ON 3~4.9999MHz (LPF2 terminal : 5V).
Q118	LPF select relay switch	Turn ON 9~13.9999MHz (LPF5 terminal : 5V).
Q119	LPF select relay switch	Turn ON 5~6.9999MHz (LPF3 terminal : 5V).
Q120	LPF select relay switch	Turn ON 7~8.9999MHz (LPF4 terminal : 5V).
D1	Temperature compensation of Q1 bias current	Temperature compensation of pre drive transistor Q1.
D2	Temperature compensation of Q2, 3 bias current	Temperature compensation of drive transistor Q2.
D3	Temperature compensation of Q4, 5 bias current	Temperature compensation of final transistor Q4.
D4	Q6 temperature compensation	Temperature compensation of final bias transistor Q6.
D5	Power supply reverse current protection	Power voltage supply.
D6	AVR	Over voltage protection.
D7	Surge absorb for relay	Relay for power switch.
D8	Surge absorb for moter	Fan motor.
D101	Reflection wave rectifier	RF rectifier.
D102	Foward wave rectifier	RF rectifier.
D103	Antenna current rectifier	RF rectifier.
D104	Lightning surge protection	Surge absorb to ANT terminal.
D105	Surge absorb for relay	For transmit relay.
D106	Surge absorb for relay	For receive relay.
D107	Surge absorb for relay	5~6.9999MHz. LPF relay.
D108	Surge absorb for relay	18~29.9999MHz. LPF relay.
D109	Surge absorb for relay	9~13.9999MHz. LPF relay.
D110	Surge absorb for relay	7~8.9999MHz. LPF relay.
D111	Surge absorb for relay	14~17.9999MHz. LPF relay.
D112	Surge absorb for relay	0.1000~2.9999MHz. LPF relay.
D113	Surge absorb for relay	3~4.9999MHz. LPF relay.
TH1	Temperature protection detection	Approx 55°C when fan motor operates. Approx 45°C when fan motor stoped. Approx 90°C when RF power droped. Approx 80°C when RF power recovered.

DESCRIPTION OF COMPONENTS

CONTROL UNIT (X53-3280-10)

Component	Use/Function	Operation/Condition/Compatibility																																				
IC1	5V AVR	Input 8V, output 5V.																																				
IC2	Divided 1/3	5 : Output 10.1MHz 10 : Input 30.3MHz																																				
IC3	A loop PLL IC	5 : Ref. input 10.1MHz 7 : VCO locked voltage output. 8 : "H" when unlocked 11 : VCO input 40.72~70.62MHz.																																				
IC4	VCO select decoder	<table border="1"> <thead> <tr> <th colspan="2">Control data</th> <th colspan="4">VCO switching</th> </tr> <tr> <th>V1</th> <th>V2</th> <th>VCO1</th> <th>VCO2</th> <th>VCO3</th> <th>VCO4</th> </tr> </thead> <tbody> <tr> <td>L</td> <td>L</td> <td>ON</td> <td>OFF</td> <td>OFF</td> <td>OFF</td> </tr> <tr> <td>H</td> <td>L</td> <td>OFF</td> <td>ON</td> <td>OFF</td> <td>OFF</td> </tr> <tr> <td>L</td> <td>H</td> <td>OFF</td> <td>OFF</td> <td>ON</td> <td>OFF</td> </tr> <tr> <td>H</td> <td>H</td> <td>OFF</td> <td>OFF</td> <td>OFF</td> <td>ON</td> </tr> </tbody> </table>	Control data		VCO switching				V1	V2	VCO1	VCO2	VCO3	VCO4	L	L	ON	OFF	OFF	OFF	H	L	OFF	ON	OFF	OFF	L	H	OFF	OFF	ON	OFF	H	H	OFF	OFF	OFF	ON
Control data		VCO switching																																				
V1	V2	VCO1	VCO2	VCO3	VCO4																																	
L	L	ON	OFF	OFF	OFF																																	
H	L	OFF	ON	OFF	OFF																																	
L	H	OFF	OFF	ON	OFF																																	
H	H	OFF	OFF	OFF	ON																																	
IC5	A loop MIXER	5 : Input 71.395~101.295MHz 11 : Input 30.675~30.695MHz 13 : Output 40.72~70.62MHz																																				
IC6	B loop PLL IC	5 : Ref. input 10.1MHz 7 : VCO lock voltage output 8 : "H" when unlocked. 13 : VCO input 37.5~39.5MHz																																				
IC7	Divided 1/100	4 : Input 37.5~39.5MHz 8 : Output 375~395kHz																																				
IC8	MIXER	1 : Output 30.675~30.695MHz 2 : Input 30.3MHz 5 : Input 375~395kHz																																				
IC9	C loop PLL IC	5 : Ref. input 10.1MHz 7 : VCO lock voltage output 8 : "H" when unlocked 11 : VCO input 59.3~59.7MHz																																				
IC10	Divided 1/100	4 : Input 59.3~59.7MHz 8 : Output 593~597kHz																																				
IC11	MIXER	1 : Output 10.693~10.697MHz 2 : Input 10.1MHz 5 : Input 593~597kHz																																				
IC300	I/O Expander																																					
IC301	5V AVR	Input 13.6V (CB line), output 5V.																																				
IC302	CPU	8bit microprocessor																																				
IC303	Address latch	Latched an address signal for multiplex bus.																																				
IC304	Address decoder	Chip select signal occur.																																				
IC305	System reset	Watch a 13.8V voltage, reset signal occur to CPU.																																				
IC306	System reset wave form																																					
IC307	Inverter	Inverted reset signal.																																				
IC308	OR gate	Make a logic that can not be memory writing when reset operation.																																				
IC310	EPROM	Memorized program.																																				
IC311	EEPROM	Keep to memory channel data.																																				
IC312	Back-up signal wave form																																					
Q1	Ref buffer amplifier	30.3MHz.																																				
Q2, 3	Ref amplifier	30.3MHz.																																				
Q4	Ref. buffer amplifier	10.1MHz.																																				
Q5~7	A loop active filter																																					
Q8	HET amplifier	71.395~101.295MHz.																																				
Q9	Buffer amplifier	71.395~101.295MHz.																																				
Q10, 11	A loop PLL IF amplifier	40.72~70.62MHz.																																				
Q12, 13	A loop B.P.F select switch	ON A loop operative to VCO3 or VCO4.																																				
Q14	A loop B.P.F select switch	ON A loop operative to VCO1 or VCO2.																																				
Q15~17	B loop active filter																																					
Q18	Buffer amplifier	30.3MHz.																																				
Q19~21	Unlock switching	ON when unlocked. Normally OFF.																																				
Q22~24	C loop active filter																																					
Q25	Buffer amplifier	10.1MHz.																																				
Q26	Carrier output switching	OFF when H3E received.																																				
Q27	CAR amplifier	10.693~10.697MHz.																																				
Q28	CAR output amplifier switching	ON when unlocked.																																				
Q29	LED indicator switch	ON when unlocked.																																				
Q300	Tuning start indication switch	ON when tuning start. Normally OFF.																																				
Q301	Tuning finished response switch	ON when tuning finished. Normally OFF.																																				
Q302	Tuning through indication switch	ON when tuning through. Normally OFF.																																				

DESCRIPTION OF COMPONENTS

Component	Use/Function	Operation/Condition/Compatibility
Q303	Tuning through response switch	ON when tuning through. Normally OFF.
Q304	STBY switch	ON in transmit. OFF in received.
Q305, 306	Dimmer switch	ON : 'H'.
Q307	Dimmer switch	ON : 'MED'.
Q308	Dimmer switch	ON : LOW.
Q309	LB AVR protection	LB AVR. Output approx 10.5V.
Q310	LB AVR protection	ON when LB AVR output is shorted.
Q311	KEY switch	MARK : ON SPACE : OFF.
Q312	Back-up switch	ON when back-up mode. Normally OFF.
D1	Reverse current protection	
D2, 3	A loop B.P.F select switch	ON when operative to A loop VCO1 or VCO2.
D4, 5	A loop B.P.F select switch	ON when operative to A loop VCO3 or VCO4.
D6	Reverse current protection	
D7	B loop VCO vari-cap	
D8	Reverse current protection	
D9	C loop VCO vari-cap	
D301	LB AVR ref.	
D302~306	Reverse current protection	RF feed back of another circuit when using scan signal.
D307	CPU input port protection	
D308	Voltage detection for back-up	
D309	IC312 port protection	
D310	Reverse current protection	Charge protection of the lithium battery when normal operation.
D311~314	Function setting	See to circuit description.
D315	Discharge value select	Occur to reset signal quickly when power supply is turned OFF.
D316	Level shift	IC301 output calibration.
D317	Reverse current protection	Protect for back-up current that draw to unwanted circuit.

TX-RX UNIT (X57-3470-10)

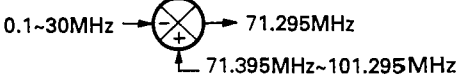
Component	Use/Function	Operation/Condition/Compatibility
IC1	Noise blanker	
IC2	IF	10.695MHz IF 2nd stage. SSB, AM detection with AGC amplifier.
IC3	Squelch	
IC4(1/2)	S-meter amplifier	
IC5	Audio power amplifier	
IC6	Transmit balanced modulator	5 : MIC input 3 : Output 7 : Carrier input
IC7	Transmit 1st mixer	1 : Output 71.295MHz 2 : Local input 60.6MHz 5 : IF input 10.695MHz
IC8(1/2)	ALC amplifier	Controlled ALC voltage by FWD voltage.
IC8(2/2)	ALC amplifier	Protect for Q50 G2 voltage dropped when abnormal.
IC9	Receive B.P.F select	Converted to parallel data from serial data.
IC10	Select	MODE, RF power select. Converted to parallel data from serial data of L.P.F information.
IC11	8V AVR	Input SB line output 8V.
Q1	BPF8 switching	Turn ON when received 18.0000~30.0000MHz.
Q2	BPF7 switching	Turn ON when received 14.0000~17.9999MHz.
Q3	BPF6 switching	Turn ON when received 9.0000~13.9999MHz.
Q4	BPF5 switching	Turn ON when received 7.0000~8.9999MHz.
Q5	BPF4 switching	Turn ON when received 5.0000~6.9999MHz.
Q6	BPF3 switching	Turn ON when received 3.0000~4.9999MHz.
Q7	BPF2 switching	Turn ON when received 1.6000~2.9999MHz.
Q8	BPF1 switching	Turn ON when received 0.1~1.5999MHz.
Q9, 10	Receive 1st mixer	
Q11	1st mixer switching	Turn ON in received.
Q12	1st IF amplifier	71.295MHz.

DESCRIPTION OF COMPONENTS

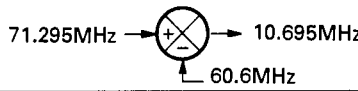
Component	Use/FUction	Operation/Condition/Compatibility
Q13, 14	Receive 2nd mixer	
Q15	2nd IF amplifier	10.695MHz.
Q16	2nd IF amplifier switching	Normaly turn ON. Turn OFF when, NB GATE is LOW, BLK is HI.
Q17	2nd IF amplifier switching	Turn ON when BLK is 'H'.
Q18	NB1 switching	Turn ON when NB1 operates.
Q19	NB2 switching	Turn ON when NB2 operates.
Q20	H3E receive +B voltage switching	Turn ON when H3E received (8V).
Q21	H3E receive +B voltage switching	Turn ON when H3E received.
Q24	Filter switching	
Q25	AMB switching	Turn ON when H3E mode.
Q26	SCB switching	Turn OFF when H3E mode normaly 8V.
Q27	H3E DET switching	Turn OFF when H3E mode.
Q28	AGC switching	Turn ON when H3E mode.
Q29	AF pre-amplifier	
Q30	Mute switching	ON in mute squelch is turned on. Normaly OFF.
Q31	Alarm switching	OFF in alarm is turned on. Normaly on.
Q32	Alarm switching	ON in alarm is turned on.
Q33	Alarm switching	
Q34	Alarm amplifier	
Q35	Internal speaker switching	ON when internal speaker is turned OFF.
Q36	RELAY switching	Turn ON when transmit.
Q37, 38	Mic amplifier	
Q39	Mic switching	ON when alarm operation.
Q40	Mic amplifier mute	Turn ON when CW mode (8V).
Q44	CAR switching	Turn ON when received.
Q45	Transmit IF amplifier	10.695MHz.
Q47	Transmit IF amplifier switch	Turn ON when transmit (8V). Occur to keying timing.
Q48	H3E CAR switching	Turn ON when H3E transmissstion.
Q49	CAR amplifier	H3E carrier. 60.6MHz.
Q50	Transmit IF amplifer	71.295MHz.
Q51, 52	Transmit 2nd mixer	71.295MHz → Transmit freq.
Q53	Transmit RF amplifier	
Q54	HET amplifier.	71.395~101.295MHz.
Q55	REF buffer amplifier	30.3MHz.
Q56	Doubler	30.3 X 2=60.6MHz.
Q57	2nd HET amplifier	60.6MHz.
Q58	Temperature protection switch	Turn ON temperature protection operation. Normaly OFF.
Q59	Reflection ALC amplifier	
Q60	8R switching	Turn ON when receive (8V).
Q64	8R switching	Turn ON when receive.
Q65	8R switching	Turn OFF when receive.
Q66	8T switching	Turn ON when transmit (8V).
Q67	8T switching	Turn ON when transmit.
Q68	8T switching	Turn OFF when transmit.
D1~4	Front-end protection	
D5, 6	BPF8 switching	Turn ON when received 18.0000~30.0000MHz.
D7, 8	BPF7 switching	Turn ON when received 14.0000~17.9999MHz.
D9, 10	BPF6 switching	Turn ON when received 9.0000~13.9999MHz.
D11, 12	BPF5 switching	Turn ON when received 7.0000~8.9999MHz.
D13, 14	BPF4 switching	Turn ON when received 5.0000~6.9999MHz.
D15, 16	BPF3 switching	Turn ON when received 3.0000~4.9999MHz.

DESCRIPTION OF COMPONENTS

Component	Use/Function	Operation/Condition/Compatibility
D17, 18	BPF2 switching	Turn ON when received 1.6000~2.9999MHz.
D19, 20	BPF1 switching	Turn ON when received 0.1~1.5999MHz.
D21, 22	Voltage shift	NB1, NB2 switch.
D24, 25	MCF switching	Select between receive & transmit.
D26, 33	Crystal filter switching	Select between receive & transmit.
D27~30	Crystal filter switching	Select between J3E CW mode & H3E.
D31~35	Reverse current protection	
D36	Switching	S-meter time-constant select.
D37	Reverse current protection	SQL.
D38		MUTE.
D39	Surge voltage absorb for relay.	Speaker relay.
D45	Reverse current protection	EXT ALC.
D46	ALC protection	EXT ALC.
D47	Relay terminal protection	
D48~51	Reverse current protection	MIC terminal (8V line).
D52	Crystal filter switching	
D53, 54	CAR switching	Turn ON when, carrier into BM.
D57	Reverse current protection	8T.
D58	Reverse current protection	
D59, 60	H3E CAR switching	Turn ON when H3E transmit. H3E CAR amplifier input.
D64~66	H3E CAR switching	Turn ON when H3E transmit. H3E CAR amplifier output.
D67	1st local switching	TX-RX switching.
D68	2nd local switching	
D69	Reverse current protection	LOW PWR ALC1, 2.
D70	Reverse current protection	MED PWR ALC1, 2.
D71, 72	Reverse current protection	
D73	Voltage regulator	For DC-DC converter.
D74	Voltage regulator	Voltage supply for IC9, 10 (5V).
D75	Reverse current protection	S-meter, antenna current.

VCO (X58-3720-10) CONTROL UNIT

Component	Use/Function	Operation/Condition/Compatibility
Q1	VCO1	71.395~78.295MHz.
Q2	VCO1 switching	Turn ON when VCO1 operates.
Q3	VCO2	78.295~85.295MHz.
Q4	VCO2 switching	Turn ON when VCO2 operates.
Q5	VCO3	85.295~93.295MHz.
Q6	VCO3 switching	Turn ON when VCO3 operates.
Q7	VCO4	93.295~101.295MHz.
Q8	VCO4 switching	Turn ON when VCO4 operates.
Q9	VCO buffer amplifier	71.395~101.295MHz.
D1	VCO1 vari-cap	
D2	VCO1 switching	Turn ON when VCO1 operates.
D3	VCO2 vari-cap	
D4	VCO2 switching	Turn ON when VCO2 operates.
D5	VCO3 vari-cap	
D6	VCO3 switching	Turn ON when VCO3 operates.
D7	VCO4 vari-cap	
D8	VCO4 switching	Turn ON when VCO4 operates.

TKM-707

DESCRIPTION OF COMPONENTS

DC-DC (X59-1110-00) TX-RX UNIT

Component	Use/Function	Operation/Condition/Compatibility
Q1	Multi-vibrator	Supplies approx. 19kHz square wave.
Q2	Multi-vibrator	
D1	Voltage multiplying current	

VCO1 (X59-3440-00) CONTROL UNIT

Component	Use/Function	Operation/Condition/Compatibility
Q1	VCO	30~110MHz.
Q2	VCO buffer	

FAN & TEMP PRO (X59-3370-00) FINAL UNIT

Component	Use/Function	Operation/Condition/Compatibility
IC1(1/2)	Temperature protection	"H" level : 7V, temperature of heatsink increase over 90°C.
IC1(2/2)		"H" level : 7V, temperature of heatsink increase over 55°C.
Q1	Switching	Turn ON when IC1(2/2) operates fan starter.

PARTS LIST

CAPACITORS

CC 45 TH 1H 220 J
 1 2 3 4 5 6

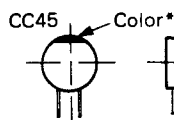

Capacitor value

- 0 1 0 = 1pF
- 1 0 0 = 10pF
- 1 0 1 = 100pF
- 1 0 2 = 1000pF = 0.001μF

1 0 3 = 0.01μF

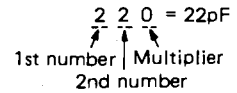

- 1 = Type ceramic, electrolytic, etc.
- 2 = Shape round, square, etc.
- 3 = Temp. coefficient
- 4 = Voltage rating
- 5 = Value
- 6 = Tolerance

Temperature Coefficient

1st Word	C	L	P	R	S	T	U
Color*	Black	Red	Orange	Yellow	Green	Blue	Violet
ppm/°C	0	-80	-150	-220	-330	-470	-750

2nd Word	G	H	J	K	L
ppm/°C	± 30	± 60	± 120	± 250	± 500

Example CC45TH = -470±60 ppm/°C

Tolerance

Code (%)	C	D	G	J	K	M	X	Z	P	No code
	± 0.25	± 0.5	± 2	± 5	± 10	± 20	+ 40 - 20	+ 80 - 20	+ 100 - 0	10μF-10~+50 4.7μF-10~+75

Code (pF)	B	C	D	F	G
	± 0.1	± 0.25	± 0.5	± 1	± 2

Less than 10 pF

Rating voltage

2nd word												
1st word	A	B	C	D	E	F	G	H	J	K	V	
0	1.0	1.25	1.6	2.0	2.5	3.15	4.0	5.0	6.3	8.0	-	
1	10	12.5	16	20	25	31.5	40	50	63	80	35	
2	100	125	160	200	250	315	400	500	630	800	-	
3	1000	1250	1600	2000	2500	3150	4000	5000	6300	8000	-	

Chip capacitors

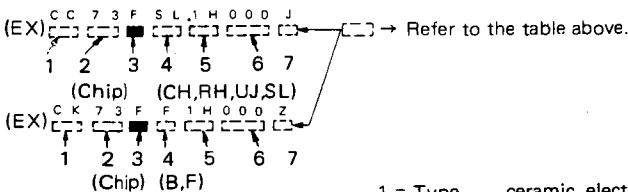

Dimension

Dimension code	L	W	T
Empty	5.6 ± 0.5	5.0 ± 0.5	Less than 2.0
E	3.2 ± 0.2	1.6 ± 0.2	Less than 1.25
F	2.0 ± 0.3	1.25 ± 0.2	Less than 1.25

Dimension

Dimension code	L	W	T	Wattage
E	3.2 ± 0.2	1.6 ± 0.2	0.57	2B
F	2.0 ± 0.3	1.25 ± 0.2	0.45	2A

Rating wattage

Cord	Wattage	Cord	Wattage	Cord	Wattage
2A	1/10W	2E	1/4W	3A	1W
2B	1/8W	2H	1/2W	3D	2W
2C	1/6W				

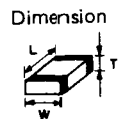

RESISTORS

Chip resistor (Carbon)

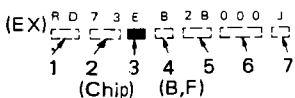

Carbon resistor (Normal type)

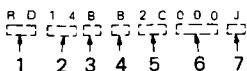

- 1 = Type ceramic, electrolytic, etc.
- 2 = Shape round, square, etc.
- 3 = Dimension
- 4 = Temp. coefficient
- 5 = Voltage rating
- 6 = Value
- 7 = Tolerance.

TKM-707

PARTS LIST

* New Parts

Parts without Parts No. are not supplied.

Les articles non mentionnes dans le Parts No. ne sont pas fournis.

Telle ohne Parts No. werden nicht geliefert.

RADIOTELEPHONE

Ref. No.	Address	New Parts	Parts No.	Description	Desti- nation	Re- marks
参照番号	位 置	新	部 品 番 号	部 品 名 / 規 格	仕 向	備 考
TKM-707						
1	1B	*	A01-1086-02	METALLIC CABINET		
2	3B	*	A01-1088-02	METALLIC CABINET		
5	2A	*	A20-7045-13	PANEL ASSY		
6	2A	*	A20-7061-04	PANEL ASSY (DRESSING PANEL)		
9	1D	*	A23-1518-03	REAR PANEL (TOP)		
10	2D	*	A23-1520-03	REAR PANEL (BOTTOM)		
-		*	A20-7043-03	PANEL		
-		*	A21-1536-04	DRESSING PANEL		
		*	B40-7609-04	MODEL NAME PLATE		
		*	B42-3378-04	LABEL (PANEL)		
		*	B42-3380-04	LABEL (BEHIND OF KYE PAD)		
11	2A	*	B09-0320-04	CAP (PHONES)		
12	2A	*	B10-1129-14	FRONT GLASS		
17	2B	*	B42-3381-04	LABEL (HEAT SINK)		
-		*	B46-0420-00	WARRANTY CARD	K	
-		*	B50-8321-00	INSTRUCTION MANUAL		
-		*	B59-0420-00	SUB-INSTRUCTION MANUAL		
		*	E12-0001-15	PHONE PLUG (ACSY)		
		*	E30-2194-05	DC POWER CORD		
		*	E31-3303-05	CONNECTING WIRE (REF)		
		*	E31-6115-05	CONNECTING WIRE (25P)		
		*	E31-6116-05	CONNECTING WIRE (27P)		
		*	E31-6117-05	CONNECTING WIRE (CAR)		
		*	E31-6118-05	CONNECTING WIRE (HET)		
		*	F05-3034-05	FUSE (30A ACSY)		
19	2D	*	F20-1005-04	INSULATING BOARD (FINAL)		
		*	F06-4027-05	FUSE (4A)		
		*	G02-0593-04	LEAF SPRING		
22	2C	*	G02-0594-04	LEAF SPRING		
23	1B, 3B	*	G10-0676-04	NON-WOVEN FABRIC (CABINET)		
26	2B	*	G13-0684-04	CUSHION (HEAT SINK)		
27	3B	*	G13-0942-04	CUSHION (LOWER CABINET)		
-		*	G10-0691-04	NON-WOVEN FABRIC (PANEL)		
-		*	G10-0693-04	NON-WOVEN FABRIC (PANEL)		
		*	H13-0836-14	PROTECTION PLATE		
-		*	H01-8298-04	ITEM CARTON BOX (INSIDE)		
-		*	H03-2806-04	OUTER PACKING CASE		
-		*	H10-2680-02	POLYSTYRENE FOAMED FIXTURE(F)		
-		*	H10-2681-02	POLYSTYRENE FOAMED FIXTURE(R)		
-		*	H20-1410-03	PROTECTION COVER		
-		*	H25-0029-04	PROTECTION BAG (FUSE, PLUG)		
-		*	H25-0079-04	PROTECTION BAG (MIC)		
-		*	H25-0096-04	PROTECTION BAG (WING SCREW)		
-		*	H25-0112-04	PROTECTION BAG (DC CORD)		
-		*	H25-0116-04	PROTECTION BAG		
		*	J02-0451-05	FOOT (BRACKET, ACSY)		
		*	J13-0413-05	FUSE HOLDER		
		*	J19-1376-15	MIC HANGER (A)		
		*	J29-0446-02	BRACKET		
		*	J30-0557-04	SPACER (BRACKET, ACSY)		

E: Scandinavia & Europe K: USA P: Canada W: Europe

U: PX(Far East, Hawaii) T: England M: Other Areas

UE: AAFES(Europe) X: Australia

 indicates safety critical components.

PARTS LIST

× New Parts

Parts without Parts No. are not supplied.

Les articles non mentionnés dans le Parts No. ne sont pas fournis.

Teile ohne Parts No. werden nicht geliefert.

RADIOTELEPHONE

FINAL UNIT (X45-3370-10)

Ref. No. 参照番号	Address 位置	New Parts 新	Parts No. 部品番号	Description 部品名 / 規格	Desti- nation 仕向	Re- marks 備考
30	3B		J02-0323-05	FOOT		
32	2A		J31-0141-04	SPACER RING (MIC)		
33	2C		J50-0401-05	HINGE		
-			J61-0307-05	WIRE BAND		
40	2A		K29-4519-04	KNØB (POWER SW)		
41	2A	*	K29-4538-03	KNØB (MAIN DIAL)		
42	2A	*	K29-4539-04	KNØB		
43	2A	*	K29-4540-14	KNØB		
44	2B	*	K29-4542-04	KNØB (RUBBER KYE)		
A	1D, 2D	*	N09-2078-05	SCREW		
B	1C, 1D	*	N09-2079-05	SCREW		
C	1B, 3B	*	N09-2083-05	FLAT SCREW		
D	2A, 2C	*	N09-2084-05	SEMUSE SCREW (M3X6)		
E	2A, 1B		N32-3006-46	FLAT SCREW		
F	2A		N35-3006-46	BINDING SCREW (PANEL, ETC)		
G	2D	*	N52-2608-60	TAPPING SCREW (BLADE FUSE)		
H	2C, 2D		N87-3006-46	TAPTITE SCREW (SHIELD COVER)		
J	2C		N88-3006-46	TAPTITE SCREW (HINGE)		
-		*	N08-0521-05	DRESSED SCREW (BRACKET M5X10)		
-		*	N09-2080-05	WING SCREW (M4X10 ACSY)		
-		*	N09-2106-05	SCREW (FOR MIC HANGER, ACSY)		
-		*	N15-1040-60	FLAT WASHER (ACSY)		
-		*	N32-3006-41	FLAT SCREW (FOR BRACKET)		
-		*	N99-0341-05	SCREW SET		
50	2A	*	T07-0227-25	LOUDSPEAKER (FULLRANGE)		
-		*	T91-0388-05	MICROPHONE		
53	1C	*	X45-3370-10	FINAL UNIT		
54	2B, 3C	*	X53-3280-10	CONTROL UNIT		
55	2C, 2D	*	X57-3470-10	TX-RX UNIT		
FINAL UNIT (X45-3370-10)						
C1			CK73FB1H561K	CHIP C	560PF	K
C2			CK73FB1H103K	CHIP C	0.010UF	K
C3	, 4		CK73FB1H223K	CHIP C	0.022UF	K
C5	, 6		CK73FB1H102K	CHIP C	1000PF	K
C7			CK73FB1H223K	CHIP C	0.022UF	K
C8	, 9		CK73FB1H103K	CHIP C	0.010UF	K
C10		*	CC45SL2H471J	CERAMIC	470PF	J
C11	, 12		C91-1004-05	CERAMIC	0.0068UF	J
C13	, 14		CM73F2H122J	CHIP C	1200PF	J
C15	-18	*	CC45SL2H221J	CERAMIC	220PF	J
C19			CE04EW1E101M	ELECTRO	100UF	25WV
C20			CK73EB1H473K	CHIP C	0.047UF	K
C21			CK73FB1H103K	CHIP C	0.010UF	K
C22			CK73EB1H473K	CHIP C	0.047UF	K
C23			CK73FB1H223K	CHIP C	0.022UF	K
C24			C91-0119-05	CERAMIC	0.047UF	K
C25			CE04EW1C100M	ELECTRO	10UF	16WV
C26			CK73FB1H223K	CHIP C	0.022UF	K
C27			CE04EW1E101M	ELECTRO	100UF	25WV
C28			CK73FB1H223K	CHIP C	0.022UF	K
C29			CK73FB1H102K	CHIP C	1000PF	K
C30			C91-0119-05	CERAMIC	0.047UF	K
C31			CE04EW1C100M	ELECTRO	10UF	16WV
C32	-37		CK73FB1H103K	CHIP C	0.010UF	K

E: Scandinavia & Europe K: USA P: Canada W: Europe

U: PX(Far East Hawaii) T: England M: Other Areas

UE: AAFES(Europe) X: Australia

▲ indicates safety critical components.

PARTS LIST

* New Parts

Parts without Parts No. are not supplied.

Les articles non mentionnes dans le Parts No. ne sont pas fournis.

Teile ohne Parts No. werden nicht geliefert.

FINAL UNIT (X45-3370-10)

Ref. No. 参照番号	Address 位置	New Parts 新	Parts No. 部品番号	Description 部品名 / 規格	Desti- nation 仕向	Re- marks 備考
C38			CK73EB1H473K	CHIP C 0.047UF K		
C40			C90-0817-05	ELECTRØ 1000UF 16WV		
C41			CK73EB1H473K	CHIP C 0.047UF K		
C42			CK73FB1H223K	CHIP C 0.022UF K		
C43			CE04EW1E470M	ELECTRØ 47UF 25WV		
C44			CK73EB1H473K	CHIP C 0.047UF K		
C45			CE04EW1E470M	ELECTRØ 47UF 25WV		
C46			CK73FB1H223K	CHIP C 0.022UF K		
C47, 48			CE04EW1E470M	ELECTRØ 47UF 25WV		
C49			CK73EB1H473K	CHIP C 0.047UF K		
C50 -57			CK73FB1H103K	CHIP C 0.010UF K		
C58			CK73EB1H473K	CHIP C 0.047UF K		
C59			CK45F1H103Z	CERAMIC 0.010UF Z		
C60, 61			CK73EB1H104K	CHIP C 0.10UF K		
C62		*	C90-2125-05	ELECTRØ 68UF 20WV		
C101		*	CC45SL2H331J	CERAMIC 330PF J		
C102		*	CC45SL2H271J	CERAMIC 270PF J		
C103		*	CC45SL2H471J	CERAMIC 470PF J		
C104, 105			CM93D2H561J	MICA 560PF J		
C106, 107		*	CC45SL2H271J	CERAMIC 270PF J		
C108, 109			CM93D2H681J	MICA 680PF J		
C110		*	CC45SL2H221J	CERAMIC 220PF J		
C111			CM93D2H561J	MICA 560PF J		
C112		*	CC45SL2H271J	CERAMIC 270PF J		
C113, 114			CC45SL2H331J	CERAMIC 330PF J		
C115			CC45SL2H150J	CERAMIC 15PF J		
C116			CC45SL2H270J	CERAMIC 27PF J		
C117			CM93D2H821J	MICA 820PF J		
C118		*	CC45SL2H221J	CERAMIC 220PF J		
C119		*	CC45SL2H271J	CERAMIC 270PF J		
C120		*	CC45SL2H471J	CERAMIC 470PF J		
C121		*	CC45SL2H151J	CERAMIC 150PF J		
C122, 123			CC45SL2H331J	CERAMIC 330PF J		
C124		*	CC45SL2H470J	CERAMIC 47PF J		
C125		*	CC45SL2H391J	CERAMIC 390PF J		
C126		*	CC45SL2H181J	CERAMIC 180PF J		
C127		*	CC45SL2H121J	CERAMIC 120PF J		
C128		*	CC45SL2H181J	CERAMIC 180PF J		
C129			CC45SL2H331J	CERAMIC 330PF J		
C130		*	CC45SL2H271J	CERAMIC 270PF J		
C131			CC45SL2H330J	CERAMIC 33PF J		
C132		*	CC45SL2H390J	CERAMIC 39PF J		
C133		*	CC45SL2H471J	CERAMIC 470PF J		
C134		*	CC45SL2H680J	CERAMIC 68PF J		
C135			CC45SL2H101J	CERAMIC 100PF J		
C136			CC45SL2H331J	CERAMIC 330PF J		
C137		*	CC45SL2H181J	CERAMIC 180PF J		
C138			CC45SL2H270J	CERAMIC 27PF J		
C139			CC45SL2H331J	CERAMIC 330PF J		
C140		*	CC45SL2H470J	CERAMIC 47PF J		
C141		*	CC45SL2H271J	CERAMIC 270PF J		
C142		*	CC45SL2H121J	CERAMIC 120PF J		
C143			CC45SL2H220J	CERAMIC 22PF J		
C144			CC45SL2H270J	CERAMIC 27PF J		
C145, 146		*	CC45SL2H121J	CERAMIC 120PF J		

E: Scandinavia & Europe K: USA P: Canada W: Europe

U: PX(Far East, Hawaii) T: England M: Other Areas

UE: AAFES(Europe) X: Australia

⚠ indicates safety critical components.

PARTS LIST

* New Parts

Parts without Parts No. are not supplied.

Les articles non mentionnes dans le Parts No. ne sont pas fournis.

Teile ohne Parts No. werden nicht geliefert.

FINAL UNIT (X45-3370-10)

Ref. No. 参照番号	Address 位置	New Parts 新	Parts No. 部品番号	Description 部品名 / 規格	Desti- nation 仕向	Re- marks 備考
C147			CC45SL2H180J	CERAMIC 18PF J		
C148		*	CC45SL2H820J	CERAMIC 82PF J		
C149			CC45SL2H220J	CERAMIC 22PF J		
C150		*	CC45SL2H680J	CERAMIC 68PF J		
C151			CC45SL2H180J	CERAMIC 18PF J		
C152		*	CC45SL2H151J	CERAMIC 150PF J		
C153		*	CC45SL2H560J	CERAMIC 56PF J		
C154		*	CC45SL2H470J	CERAMIC 47PF J		
C155			CC45SL2H150J	CERAMIC 15PF J		
C156-159			CK73FB1H103K	CHIP C 0.010UF K		
C160			CE04EW1H010M	ELECTRO 1.0UF 50WV		
C161, 162			CK73FB1H103K	CHIP C 0.010UF K		
C163			CC73FSL1H101J	CHIP C 100PF J		
C164			CC73FCH1H560J	CHIP C 56PF J		
C165			CC73FCH1H030C	CHIP C 3PF C		
C166-200			CK73FB1H103K	CHIP C 0.010UF K		
C201			CC73FSL1H101J	CHIP C 100PF J		
C202			CC73FSL1H181J	CHIP C 180PF J		
C203			CC73FCH1H390J	CHIP C 39PF J		
C204			CM93D2H102J	MICA 1000PF J		
TC101			C05-0350-05	TRIMMING * 20PF		
A1 -4		*	E31-6102-05	CONNECTING WIRE (RA)		
A5			E23-0467-05	TERMINAL		
A10:			E23-0616-04	TERMINAL (ANT)		
CN1			E23-0467-05	TERMINAL		
			E40-3238-05	PIN CONNECTOR 3P		
CN2			E40-3237-05	PIN CONNECTOR 2P		
CN3			E40-3243-05	PIN CONNECTOR 8P		
CN4			E40-3239-05	PIN CONNECTOR 4P		
CN5			E04-0157-05	RF COAXIAL CABLE JACK (P0)		
CN6			E40-3237-05	PIN CONNECTOR 2P		
CN7			E40-0211-05	PIN CONNECTOR 2P		
CN101			E04-0157-05	RF COAXIAL CABLE JACK (RA)		
CN102			E40-3239-05	PIN CONNECTOR 4P		
CN103			E40-3242-05	PIN CONNECTOR 7P		
J1	1D		E04-0167-05	ANT RECEPTACLE (ANT)		
W2		*	E31-6083-05	CONNECTING WIRE (DI)		
W3		*	E31-6107-05	CONNECTING WIRE (FUSE)		
W4 ,5		*	E31-6105-05	CONNECTING WIRE (+B)		
W6		*	E31-6106-05	CONNECTING WIRE (DC CONNECTOR)		
W101		*	E31-6085-05	CONNECTING WIRE (PI)		
A6	1C	*	F01-0974-01	HEAT SINK		
A8	1C	*	F20-1038-04	INSULATING BOARD		
A9			F20-0078-05	INSULATING BOARD (Q1)		
A10	1C		F29-0014-05	INSULATOR (Q1)		
M1	1C	*	F09-0425-05	HEAD PROTECTOR		
A13 ,14	2C		G02-0574-04	LEAF SPRING (IC1)		
100	1C		J32-0916-04	STUD (Q4)		
-			J61-0307-05	WIRE BAND		
A11 ,12	1C	*	J42-0461-05	POWER CORD BUSHING		
L1			L40-1501-14	SMALL FIXED INDUCTOR 15UH		
L2			L40-3391-14	SMALL FIXED INDUCTOR 3.3UH		
L3		*	L39-0481-05	TOROIDAL COIL		

E: Scandinavia & Europe K: USA P: Canada W: Europe

U: PX(Far East, Hawaii) T: England M: Other Areas

UE: AAFES(Europe) X: Australia

△ indicates safety critical components.

PARTS LIST

* New Parts

Parts without Parts No. are not supplied.

Les articles non mentionnés dans le Parts No. ne sont pas fournis.

Teile ohne Parts No. werden nicht geliefert.

FINAL UNIT (X45-3370-10)

Ref. No. 参照番号	Address 位置	New Parts 新	Parts No. 部品番号	Description 部品名 / 規格	Desti- nation 仕向	Re- marks 備考
L4 -6			L33-0699-05	CHOKE COIL		
L7			L19-0342-05	BALUN TRANSFORMER		
L8 ,9			L33-0699-05	CHOKE COIL		
L10		*	L39-0482-05	TOROIDAL COIL		
L11			L39-0431-05	TOROIDAL COIL		
L12			L33-0651-05	CHOKE COIL		
L13			L33-0625-15	CHOKE COIL		
L14			L15-0016-05	LOW-FREQUENCY CHOKE COIL		
L15			L40-1011-14	SMALL FIXED INDUCTOR 100UH		
L16			L33-0699-05	CHOKE COIL		
L101			L39-0461-05	TOROIDAL COIL		
L102			L39-0459-05	TOROIDAL COIL		
L103		*	L39-0474-05	TOROIDAL COIL		
L104		*	L39-0475-05	TOROIDAL COIL		
L105		*	L39-0467-05	TOROIDAL COIL		
L106		*	L39-0468-05	TOROIDAL COIL		
L107, 108		*	L39-0469-05	TOROIDAL COIL		
L109		*	L39-0471-05	TOROIDAL COIL		
L110, 111		*	L39-0470-05	TOROIDAL COIL		
L112		*	L34-1283-05	COIL		
L113		*	L34-1284-05	COIL		
L114		*	L34-1283-05	COIL		
L115		*	L34-1285-05	COIL		
L116		*	L34-1286-05	COIL		
L117		*	L34-1285-05	COIL		
L118		*	L34-1287-05	COIL		
L119		*	L34-1288-05	COIL		
L120			L40-1021-14	SMALL FIXED INDUCTOR 1MH		
L121		*	L39-0480-05	TOROIDAL COIL		
L122			L40-1021-14	SMALL FIXED INDUCTOR 1MH		
L123		*	L39-0472-05	TOROIDAL COIL		
L124			L40-2201-14	SMALL FIXED INDUCTOR 22UH		
L125			L40-2201-13	SMALL FIXED INDUCTOR 22UH		
L126			L40-2201-14	SMALL FIXED INDUCTOR 22UH		
L127, 128			L34-1035-05	COIL		
A	1D	*	N09-2078-05	SCREW (ANT)		
F	1C		N35-3006-46	BINDING SCREW (FAN)		
H	1C, 2D		N87-3006-46	TAPTITE SCREW		
K	1C	*	N09-2076-05	SCREW (M2.6, Q1)		
L	1C	*	N09-2077-05	SCREW (M3, Q2-6)		
R1			RK73FB2A821J	CHIP R 820	J	
R2			RK73FB2A5R6J	CHIP R 5.6	J 1/10W	
R3			RK73FB2A821J	CHIP R 820	J	
R4			RK73FB2A560J	CHIP R 56	J 1/10W	
R5			RK73FB2A331J	CHIP R 330	J 1/10W	
R6			RK73FB2A681J	CHIP R 680	J 1/10W	
R7			RK73FB2A331J	CHIP R 330	J 1/10W	
R8 ,9		*	R92-1243-05	CARBON R 8.2	J 1/2	
R10 ,11		*	R92-1242-05	CARBON R 6.8	J 1/4	
R12 ,13		*	R92-0696-05	CARBON R 33	J 1/4	
R14 ,15		*	RS14DB3A101J	FL-PROOF RS 100	J 1W	
R16 -19		*	RS14DB3D4R7J	FL-PROOF RS 4.7	J 2W	
R20 ,21			RS14DB3A150J	FL-PROOF RS 15	J 1W	
R22 ,23			RS14DB3A3R3J	FL-PROOF RS 3.3	J 1W	
R24			RS14DB3A100J	FL-PROOF RS 10	J 1W	

E: Scandinavia & Europe K: USA P: Canada W: Europe

U: PX(Far East, Hawaii) T: England M: Other Areas

UE: AAFES(Europe) X: Australia

▲ indicates safety critical components.

PARTS LIST

* New Parts

Parts without Parts No. are not supplied.

Les articles non mentionnés dans le Parts No. ne sont pas fournis.

Teile ohne Parts No. werden nicht geliefert.

FINAL UNIT (X45-3370-10)

CONTROL UNIT (X53-3280-10)

Ref. No. 参照番号	Address 位置	New Parts 新	Parts No. 部品番号	Description 部品名 / 規格	Desti- nation 仕向	Re- marks 備考
R25		*	R92-1253-05	CARBON R 82 J 1/2		
R26		*	RK73FB2A561J	CHIP R 560 J 1/10W		
R27		*	RK73FB2A332J	CHIP R 3.3K J 1/10W		
R28		*	RK73FB2A103J	CHIP R 10K J 1/10W		
R29		*	R92-0670-05	CHIP R 0 OHM		
R101-104			RK73FB2A122J	CHIP R 1.2K J 1/10W		
R105			RK73FB2A333J	CHIP R 33K J 1/10W		
R106			RK73FB2A103J	CHIP R 10K J 1/10W		
R107			RK73FB2A563J	CHIP R 56K J 1/10W		
R108			RK73FB2A100J	CHIP R 10 J 1/10W		
R109		*	R92-0696-05	CARBON R 33 J 1/4		
R110		*	R92-1244-05	CARBON R 27 J 1/4		
R111		*	R92-1245-05	CARBON R 47 J 1/4		
R112		*	R92-1246-05	CARBON R 47K J 1/4		
R113-126		*	RK73FB2A122J	CHIP R 1.2K J 1/10W		
R127-129			RK73FB2A472J	CHIP R 4.7K J 1/10W		
VR1		*	R12-0442-05	TRIM POT. 220		
VR2		*	R12-1431-05	TRIM POT. 1K		
VR101		*	R12-0431-05	TRIM POT. 100		
W104		*	R92-1061-05	JUMPER REST 0 OHM		
K1		*	S51-2423-05	RELAY (POWER)		
K101-115		*	S51-1440-05	RELAY		
K116		*	S51-1441-05	RELAY (RA)		
D1		*	KB-365	VARISTOR		
D2 -4		*	KB-162	VARISTOR		
D5		*	SG-5L(R)	DIODE		
D6		*	02C220(Y,Z)	CHIP ZENER DIODE		
D7 ,8		*	DLS1585	CHIP DIODE		
D101-103			1SS101	DIODE		
D104			DSA301LA-S	DIODE		
D105-113			DLS1585	CHIP DIODE		
IC1			UPC78M08H	IC(VOLTAGE REGULATOR/ +8V)		
IC2			UPC78M05H	IC(VOLTAGE REGULATOR/ +5V)		
IC101		*	TC4028BF	IC(BCD-TO-DECIMAL DECODER)		
Q1		*	2SC1971	TRANSISTOR		
Q2 ,3		*	2SC3133	TRANSISTOR		
Q4 ,5		*	2SC2879(Q,Y)	TRANSISTOR		
Q6		*	2SD1406(Y)	TRANSISTOR		
Q7			DTC124EK	DIGITAL TRANSISTOR		
Q8			DTD114EK	DIGITAL TRANSISTOR		
Q101			2SA1362(Y)	CHIP TRANSISTOR		
Q102			DTD114EK	DIGITAL TRANSISTOR		
Q103			2SA1362(Y)	CHIP TRANSISTOR		
Q104			DTD114EK	DIGITAL TRANSISTOR		
Q105			DTA144EK	DIGITAL TRANSISTOR		
Q106			2SC2712(Y)	CHIP TRANSISTOR		
Q107-113			2SA1362(Y)	CHIP TRANSISTOR		
Q114-120			DTD114EK	DIGITAL TRANSISTOR		
TH1	1C		5TP41L	THERMISTOR 10K		
Z1		*	X59-3370-00	MODULE UNIT(FAN PROTECTION)		
CONTROL UNIT (X53-3280-10)						
A200	2B	*	B38-0324-05	LCD ASSY		
D10			B30-0880-05	LED		

E: Scandinavia & Europe K: USA P: Canada W: Europe

U: PX(Far East, Hawaii) T: England M: Other Areas

UE: AAFES(Europe) X: Australia

⚠ indicates safety critical components.

PARTS LIST

× New Parts

Parts without Parts No. are not supplied.

Les articles non mentionnés dans le Parts No. ne sont pas fournis.

Teile ohne Parts No. werden nicht geliefert.

CONTROL UNIT (X53-3280-10)

Ref. No. 参照番号	Address 位置	New Parts 新	Parts No. 部品番号	Description 部品名 / 規格	Desti- nation 仕 向	Re- marks 備考
C1			CK73FB1H102K	CHIP C 1000PF K		
C2			CE04EW1C101M	ELECTRO 100UF 16WV		
C3			CE04EW1C470M	ELECTRO 47UF 16WV		
C4	-7		CK73FB1H102K	CHIP C 1000PF K		
C8	,9		CC73FCH1H100D	CHIP C 10PF D		
C10			CK73FB1H223K	CHIP C 0.022UF K		
C11			CC73FCH1H220J	CHIP C 22PF J		
C12			CK73FB1H223K	CHIP C 0.022UF K		
C13			CE04EW1C470M	ELECTRO 47UF 16WV		
C14	,15		CC73FCH1H470J	CHIP C 47PF J		
C16			CK73FB1H102K	CHIP C 1000PF K		
C17			CK73FB1H223K	CHIP C 0.022UF K		
C18			CK73FB1H102K	CHIP C 1000PF K		
C19			CK73EB1H104K	CHIP C 0.10UF K		
C20			CK73FB1H223K	CHIP C 0.022UF K		
C21			CE04EW1C470M	ELECTRO 47UF 16WV		
C22			CK73FB1H103K	CHIP C 0.010UF K		
C23	,24		C92-0004-05	CHIP-TAN 1UF 16WV		
C25			C91-1102-05	FILM 0.10UF J		
C26			CK73FB1H103K	CHIP C 0.010UF K		
C27			CE04EW1A221M	ELECTRO 220UF 10WV		
C28			CK73FB1H103K	CHIP C 0.010UF K		
C29			CE04EW1A221M	ELECTRO 220UF 10WV		
C30			CK73FB1H223K	CHIP C 0.022UF K		
C31			CE04EW1C470M	ELECTRO 47UF 16WV		
C32	,33		CK73FB1H102K	CHIP C 1000PF K		
C34			CK73FB1H103K	CHIP C 0.010UF K		
C35			CC73FCH1H470J	CHIP C 47PF J		
C36			CC73FSL1H391J	CHIP C 390PF J		
C37			CC73FCH1H470J	CHIP C 47PF J		
C38			CC73FCH1H330J	CHIP C 33PF J		
C39			CC73FCH1H060D	CHIP C 6PF D		
C40			CC73FCH1H470J	CHIP C 47PF J		
C41			CC73FCH1H180J	CHIP C 18PF J		
C42			CC73FCH1H270J	CHIP C 27PF J		
C43			CK73FB1H102K	CHIP C 1000PF K		
C44			CK73FB1H103K	CHIP C 0.010UF K		
C45			CK73FB1H102K	CHIP C 1000PF K		
C46	-49		CK73FB1H103K	CHIP C 0.010UF K		
C50			CK73FB1H223K	CHIP C 0.022UF K		
C51	-53		CK73FB1H103K	CHIP C 0.010UF K		
C54			CC73FCH1H390J	CHIP C 39PF J		
C55			CC73FSL1H181J	CHIP C 180PF J		
C56			CC73FCH1H270J	CHIP C 27PF J		
C57			CC73FCH1H680J	CHIP C 68PF J		
C58			CC73FCH1H560J	CHIP C 56PF J		
C59			CC73FCH1H270J	CHIP C 27PF J		
C60			CC73FCH1H100D	CHIP C 10PF D		
C61			CC73FCH1H390J	CHIP C 39PF J		
C62	,63		CC73FCH1H180J	CHIP C 18PF J		
C64	,65		CK73FB1H103K	CHIP C 0.010UF K		
C66			CC73FCH1H470J	CHIP C 47PF J		
C67			CC73FSL1H271J	CHIP C 270PF J		
C68			CC73FCH1H330J	CHIP C 33PF J		
C69			CC73FCH1H820J	CHIP C 82PF J		

E: Scandinavia & Europe K: USA P: Canada W: Europe

U: PX(Far East, Hawaii) T: England M: Other Areas

UE: AAFES(Europe) X: Australia

⚠ indicates safety critical components.

PARTS LIST

* New Parts

Parts without Parts No. are not supplied.

Les articles non mentionnés dans le Parts No. ne sont pas fournis.

Teile ohne Parts No. werden nicht geliefert.

CONTROL UNIT (X53-3280-10)

Ref. No. 参照番号	Address 位置	New Parts 新	Parts No. 部品番号	Description 部品名 / 規格	Desti- nation 仕向	Re- marks 備考
C70			CC73FCH1H680J	CHIP C 68PF J		
C71			CC73FCH1H220J	CHIP C 22PF J		
C72			CC73FCH1H180J	CHIP C 18PF J		
C73			CC73FCH1H270J	CHIP C 27PF J		
C74			CC73FCH1H330J	CHIP C 33PF J		
C75			CC73FCH1H220J	CHIP C 22PF J		
C76, 77			CK73FB1H103K	CHIP C 0.010UF K		
C78			CC73FCH1H470J	CHIP C 47PF J		
C79			CK73FB1H103K	CHIP C 0.010UF K		
C80			CK73FB1H102K	CHIP C 1000PF K		
C81			CC73FCH1H060D	CHIP C 6PF D		
C82			CK73FB1H103K	CHIP C 0.010UF K		
C83			CK73FB1H102K	CHIP C 1000PF K		
C84			CC73FSL1H101J	CHIP C 100PF J		
C85			CK73FB1H223K	CHIP C 0.022UF K		
C86			CK73FB1H102K	CHIP C 1000PF K		
C87			CK73EB1H104K	CHIP C 0.10UF K		
C88			CK73FB1H223K	CHIP C 0.022UF K		
C89			CE04EW1C470M	ELECTRO 47UF 16WV		
C90			CK73FB1H103K	CHIP C 0.010UF K		
C91			CK73EB1H104K	CHIP C 0.10UF K		
C92			CK73FB1H103K	CHIP C 0.010UF K		
C93			CE04EW1C470M	ELECTRO 47UF 16WV		
C94			CK73FB1H102K	CHIP C 1000PF K		
C95			CC73FCH1H330J	CHIP C 33PF J		
C96			CC73FCH1H120J	CHIP C 12PF J		
C97			CC73FCH1H220J	CHIP C 22PF J		
C98			CC73FCH1H470J	CHIP C 47PF J		
C99			CE04EW1C101M	ELECTRO 100UF 16WV		
C100			CK73FB1H223K	CHIP C 0.022UF K		
C101, 102			CK73FB1H102K	CHIP C 1000PF K		
C103			CK73FB1H103K	CHIP C 0.010UF K		
C104			CK73FB1H223K	CHIP C 0.022UF K		
C105			CK73FB1H681K	CHIP C 680PF K		
C106			CK73FB1H102K	CHIP C 1000PF K		
C107			CK73FB1H681K	CHIP C 680PF K		
C108			CK73FB1H103K	CHIP C 0.010UF K		
C109			CK73FB1H102K	CHIP C 1000PF K		
C110			CC73FSL1H101J	CHIP C 100PF J		
C111, 112			CK73FB1H103K	CHIP C 0.010UF K		
C113			CK73FB1H223K	CHIP C 0.022UF K		
C114-116			CK73FB1H103K	CHIP C 0.010UF K		
C117			CE04EW1HR47M	ELECTRO 0.47UF 50WV		
C118			CK73FB1H102K	CHIP C 1000PF K		
C119			CK73EB1H104K	CHIP C 0.10UF K		
C120			CK73FB1H223K	CHIP C 0.022UF K		
C121			CE04EW1C470M	ELECTRO 47UF 16WV		
C122			CK73FB1H103K	CHIP C 0.010UF K		
C123			CK73EB1H104K	CHIP C 0.10UF K		
C124			CK73FB1H103K	CHIP C 0.010UF K		
C125			CE04EW1C470M	ELECTRO 47UF 16WV		
C126			CK73FB1H102K	CHIP C 1000PF K		
C127			CC73FCH1H180J	CHIP C 18PF J		
C128			CC73FCH1H050C	CHIP C 5PF C		
C129			CC73FCH1H220J	CHIP C 22PF J		

E: Scandinavia & Europe K: USA P: Canada W: Europe

U: PX(Far East, Hawaii) T: England M: Other Areas

UE: AAFES(Europe) X: Australia

⚠ indicates safety critical components.

PARTS LIST

× New Parts

Parts without Parts No. are not supplied.

Les articles non mentionnés dans le Parts No. ne sont pas fournis.

Teile ohne Parts No. werden nicht geliefert.

CONTROL UNIT (X53-3280-10)

Ref. No. 参照番号	Address 位置	New Parts 新	Parts No. 部品番号	Description 部品名 / 規格	Desti- nation 仕 向	Re- marks 備考
C130			CC73FCH1H470J	CHIP C 47PF J		
C131			CE04EW1C101M	ELECTRO 100UF 16WV		
C132			CK73FB1H223K	CHIP C 0.022UF K		
C133, 134			CK73FB1H102K	CHIP C 1000PF K		
C135			CK73FB1H103K	CHIP C 0.010UF K		
C136			CK73FB1H223K	CHIP C 0.022UF K		
C137			CK73FB1H471K	CHIP C 470PF K		
C138			CK73FB1H821K	CHIP C 820PF K		
C139			CK73FB1H471K	CHIP C 470PF K		
C140			CK73FB1H103K	CHIP C 0.010UF K		
C141, 142			CK73FB1H102K	CHIP C 1000PF K		
C143			CC73FSL1H101J	CHIP C 100PF J		
C144-147			CK73FB1H103K	CHIP C 0.010UF K		
C148			CK73FB1H223K	CHIP C 0.022UF K		
C149			CC73FCH1H220J	CHIP C 22PF J		
C150			CK73FB1H223K	CHIP C 0.022UF K		
C151			CK73FB1H103K	CHIP C 0.010UF K		
C152, 153			CK73FB1H223K	CHIP C 0.022UF K		
C200-205			CK73FB1H471K	CHIP C 470PF K		
C206-212			CK73FB1H103K	CHIP C 0.010UF K		
C300			CK73FB1H103K	CHIP C 0.010UF K		
C302-307			CK73FB1H103K	CHIP C 0.010UF K		
C308			CK73FB1H471K	CHIP C 470PF K		
C309			CK73FB1H103K	CHIP C 0.010UF K		
C310			CK73FB1H471K	CHIP C 470PF K		
C311-314			CK73FB1H103K	CHIP C 0.010UF K		
C315-318			CK73FB1H471K	CHIP C 470PF K		
C319			CK73FB1H103K	CHIP C 0.010UF K		
C320			CK73FB1H223K	CHIP C 0.022UF K		
C321			CK73FB1H103K	CHIP C 0.010UF K		
C322			CE04EW1C470M	ELECTRO 47UF 16WV		
C323-326			CK73FB1H103K	CHIP C 0.010UF K		
C327-337			CK73FB1H102K	CHIP C 1000PF K		
C338			CK73FB1H223K	CHIP C 0.022UF K		
C339			CK73FB1H103K	CHIP C 0.010UF K		
C340			CK73FB1H223K	CHIP C 0.022UF K		
C341			CK73FB1H103K	CHIP C 0.010UF K		
C342			CK73FB1H102K	CHIP C 1000PF K		
C343			CK73FB1H103K	CHIP C 0.010UF K		
C344			CK73FB1H102K	CHIP C 1000PF K		
C345			CK73FB1H103K	CHIP C 0.010UF K		
C346			CK73FB1H102K	CHIP C 1000PF K		
C347			CK73FB1H103K	CHIP C 0.010UF K		
C348			CK73FB1H223K	CHIP C 0.022UF K		
C349			CE04EW1C470M	ELECTRO 47UF 16WV		
C350			CK73FB1H103K	CHIP C 0.010UF K		
C351			CE04EW1C470M	ELECTRO 47UF 16WV		
C352, 353			CK73FB1H102K	CHIP C 1000PF K		
C354-356			CK73FB1H103K	CHIP C 0.010UF K		
C357-361			CK73FB1H102K	CHIP C 1000PF K		
C362, 363			CC73FCH1H100D	CHIP C 10PF D		
C364			C90-2041-05	TANTAL 10UF 10WV		
C365			CK73FB1H103K	CHIP C 0.010UF K		
C366			CE04EW1C470M	ELECTRO 47UF 16WV		
C367-373			CK73FB1H103K	CHIP C 0.010UF K		

E: Scandinavia & Europe K: USA P: Canada W: Europe

U: PX(Far East, Hawaii) T: England M: Other Areas

UE: AAFES(Europe) X: Australia

⚠ indicates safety critical components.

PARTS LIST

* New Parts

Parts without Parts No. are not supplied.

Les articles non mentionnes dans le Parts No. ne sont pas fournis.

Teile ohne Parts No. werden nicht geliefert.

CONTROL UNIT (X53-3280-10)

Ref. No. 参照番号	Address 位置	New Parts 新	Parts No. 部品番号	Description 部品名 / 規格	Desti- nation 仕向	Re- marks 備考
C374			CK73FB1H102K	CHIP C 1000PF K		
C375			CK73FB1H103K	CHIP C 0.010UF K		
C376			CE04EW1C470M	ELECTRO 47UF 16WV		
C377, 378			CK73FB1H103K	CHIP C 0.010UF K		
C379			C92-0008-05	CHIP TAN 3.3UF 16WV		
C380			CE04EW1C101M	ELECTRO 100UF 16WV		
C381, 382			CK73FB1H103K	CHIP C 0.010UF K		
C383			CE04EW1C470M	ELECTRO 47UF 16WV		
C384			CK73FB1H103K	CHIP C 0.010UF K		
C386			CK73FB1H223K	CHIP C 0.022UF K		
C387			CE04EW1C470M	ELECTRO 47UF 16WV		
C388, 389			CK73FB1H103K	CHIP C 0.010UF K		
C390			CE04EW1C470M	ELECTRO 47UF 16WV		
C391			CK73FB1H103K	CHIP C 0.010UF K		
C392-413			CK73FB1H102K	CHIP C 1000PF K		
C414			CE04EW1C470M	ELECTRO 47UF 16WV		
C415, 416			CK73FB1H103K	CHIP C 0.010UF K		
C417			CE04EW1C470M	ELECTRO 47UF 16WV		
C418			CK73FB1H103K	CHIP C 0.010UF K		
A201			E23-0623-04	TERMINAL (MIC)		
CN1 -3			E04-0157-05	RF COAXIAL CABLE JACK A		
CN200		*	E40-5340-05	PIN CONNECTOR (27P)		
CN202		*	E40-5341-05	PIN CONNECTOR		
CN206			E40-3299-05	PIN CONNECTOR (2P)		
CN300		*	E40-3853-05	PIN CONNECTOR (25P)		
CN301		*	E40-3855-05	PIN CONNECTOR (27P)		
CN302			E02-2015-05	IC SOCKET (IC310)		
J200			E06-0858-15	8P METAL SOCKET (MIC)		
J201		*	E11-0440-05	PHONE JACK		
TP1 ,2			E23-0465-05	TERMINAL		
TP4			E23-0465-05	TERMINAL		
W200		*	E31-6111-05	CONNECTING WIRE		
W201		*	E31-6112-05	CONNECTING WIRE		
W202		*	E31-6113-05	CONNECTING WIRE		
A1 ,2			F11-0881-14	SHIELDING COVER		
CF1			L72-0369-05	CERAMIC FILTER 10.695MHZ		
L1			L40-1011-48	SMALL FIXED INDUCTOR 100UH		
L2			L40-6892-48	SMALL FIXED INDUCTOR 6.8UH		
L3			L40-1011-48	SMALL FIXED INDUCTOR 100UH		
L4			L40-6882-48	SMALL FIXED INDUCTOR 0.68UH		
L5			L40-1082-48	SMALL FIXED INDUCTOR 0.1UHH		
L6			L40-8272-48	SMALL FIXED INDUCTOR 82NH		
L7			L40-5672-48	SMALL FIXED INDUCTOR 56NH		
L8		*	L40-3982-48	SMALL FIXED INDUCTOR 0.39UH		
L9			L40-4782-48	SMALL FIXED INDUCTOR 0.47UH		
L10			L40-3382-48	SMALL FIXED INDUCTOR 0.33UH		
L11 -13			L40-2782-48	SMALL FIXED INDUCTOR 0.27UH		
L14			L40-2282-48	SMALL FIXED INDUCTOR 0.22UH		
L15			L40-1582-48	SMALL FIXED INDUCTOR 0.15UH		
L19			L40-2782-48	SMALL FIXED INDUCTOR 0.27UH		
L20			L40-1011-48	SMALL FIXED INDUCTOR 100UH		
L21		*	L34-4220-05	COIL		
L22			L40-1001-48	SMALL FIXED INDUCTOR 10UH		
L23 ,24			L40-2211-48	SMALL FIXED INDUCTOR 220UH		

E: Scandinavia & Europe K: USA P: Canada W: Europe

U: PX(Far East, Hawaii) T: England M: Other Areas

UE: AAFES(Europe) X: Australia

⚠ indicates safety critical components.

PARTS LIST

* New Parts

Parts without Parts No. are not supplied.

Les articles non mentionnes dans le Parts No. ne sont pas fournis.

Teile ohne Parts No. werden nicht geliefert.

CONTROL UNIT (X53-3280-10)

Ref. No. 参照番号	Address 位置	New Parts 新	Parts No. 部品番号	Description 部品名 / 規格	Desti- nation 仕 向	Re- marks 備考
L25 ,26		*	L34-4219-05	COIL		
L27			L40-1011-48	SMALL FIXED INDUCTOR 100UH		
L28		*	L34-4221-05	COIL		
L29			L40-1001-48	SMALL FIXED INDUCTOR 10UH		
L30 ,31		*	L40-1511-48	SMALL FIXED INDUCTOR 150UH		
L32			L30-0281-15	IFT		
L33			L40-2211-48	SMALL FIXED INDUCTOR 220UH		
L300			L40-2211-14	SMALL FIXED INDUCTOR 220UH		
L302			L40-1011-14	SMALL FIXED INDUCTOR 100UH		
L303,304			L40-1011-13	SMALL FIXED INDUCTOR 100UH		
L305,306			L40-1011-48	SMALL FIXED INDUCTOR 100UH		
L307-311			L40-1011-14	SMALL FIXED INDUCTOR 100UH		
X300			L77-1380-05	CRYSTAL RESONATOR 11.0592MHZ		
XF1		*	L71-0404-05	CRYSTAL FILTER 30.685MHZ		
CP300			R90-0598-05	MULTI-COMP 10K/20K		
CP301			R90-0455-05	MULTI-COMP 4.7KX8 J 1/4W		
R1			RK73FB2A102J	CHIP R 1.0K J 1/10W		
R2			RK73FB2A473J	CHIP R 47K J 1/10W		
R3			RK73FB2A223J	CHIP R 22K J 1/10W		
R4			RK73FB2A561J	CHIP R 560 J 1/10W		
R5			RK73FB2A101J	CHIP R 100 J 1/10W		
R6			RK73FB2A154J	CHIP R 150K J 1/10W		
R7			RK73FB2A121J	CHIP R 120 J 1/10W		
R8			RK73FB2A122J	CHIP R 1.2K J 1/10W		
R9			RK73FB2A393J	CHIP R 39K J 1/10W		
R10			RK73FB2A102J	CHIP R 1.0K J 1/10W		
R11 ,12			RK73FB2A101J	CHIP R 100 J 1/10W		
R13 -16			RK73FB2A681J	CHIP R 680 J 1/10W		
R17			RK73FB2A101J	CHIP R 100 J 1/10W		
R18			RK73FB2A332J	CHIP R 3.3K J 1/10W		
R19			RK73FB2A103J	CHIP R 10K J 1/10W		
R20			RK73FB2A224J	CHIP R 220K J 1/10W		
R21			RK73FB2A332J	CHIP R 3.3K J 1/10W		
R22			RK73FB2A152J	CHIP R 1.5K J 1/10W		
R23			RK73FB2A221J	CHIP R 220 J 1/10W		
R24			RK73FB2A470J	CHIP R 47 J 1/10W		
R25 ,26			RK73FB2A104J	CHIP R 100K J 1/10W		
R27			RK73FB2A181J	CHIP R 180 J 1/10W		
R28			RK73FB2A330J	CHIP R 33 J 1/10W		
R29			RK73FB2A562J	CHIP R 5.6K J 1/10W		
R30			RK73FB2A103J	CHIP R 10K J 1/10W		
R31			RK73FB2A100J	CHIP R 10 J 1/10W		
R32			RK73FB2A101J	CHIP R 100 J 1/10W		
R33			RK73FB2A471J	CHIP R 470 J 1/10W		
R34			RK73FB2A100J	CHIP R 10 J 1/10W		
R35			RK73FB2A471J	CHIP R 470 J 1/10W		
R36			RK73FB2A330J	CHIP R 33 J 1/10W		
R37			RK73FB2A103J	CHIP R 10K J 1/10W		
R38			RK73FB2A223J	CHIP R 22K J 1/10W		
R39			RK73FB2A471J	CHIP R 470 J 1/10W		
R40 ,41			RK73FB2A101J	CHIP R 100 J 1/10W		
R42			RK73FB2A471J	CHIP R 470 J 1/10W		
R43			RK73FB2A151J	CHIP R 150 J 1/10W		
R44 -47			RK73FB2A152J	CHIP R 1.5K J 1/10W		

E: Scandinavia & Europe K: USA P: Canada W: Europe

U: PX(Far East, Hawaii) T: England M: Other Areas

UE: AAFES(Europe) X: Australia

⚠ indicates safety critical components.

PARTS LIST

× New Parts

Parts without Parts No. are not supplied.

Les articles non mentionnés dans le Parts No. ne sont pas fournis.

Teile ohne Parts No. werden nicht geliefert.

CONTROL UNIT (X53-3280-10)

Ref. No. 参照番号	Address 位置	New Parts 新	Parts No. 部品番号	Description 部品名 / 規格	Desti- nation 仕向	Re- marks 備考
R48			RK73FB2A151J	CHIP R 150 J 1/10W		
R49			RK73FB2A471J	CHIP R 470 J 1/10W		
R50			RK73FB2A332J	CHIP R 3.3K J 1/10W		
R51			RK73FB2A123J	CHIP R 12K J 1/10W		
R52			RK73FB2A331J	CHIP R 330 J 1/10W		
R53			RK73FB2A102J	CHIP R 1.0K J 1/10W		
R54			RK73FB2A101J	CHIP R 100 J 1/10W		
R55			RK73FB2A272J	CHIP R 2.7K J 1/10W		
R56			RK73FB2A822J	CHIP R 8.2K J 1/10W		
R57			RK73FB2A331J	CHIP R 330 J 1/10W		
R58			RK73FB2A821J	CHIP R 820 J		
R59	,60		RK73FB2A101J	CHIP R 100 J 1/10W		
R61			RK73FB2A682J	CHIP R 6.8K J 1/10W		
R62			RK73FB2A102J	CHIP R 1.0K J 1/10W		
R63			RK73FB2A683J	CHIP R 68K J 1/10W		
R64			RK73FB2A221J	CHIP R 220 J 1/10W		
R65			RK73FB2A152J	CHIP R 1.5K J 1/10W		
R66	,67		RK73FB2A103J	CHIP R 10K J 1/10W		
R68			RK73FB2A223J	CHIP R 22K J 1/10W		
R69			RK73FB2A103J	CHIP R 10K J 1/10W		
R70			RK73FB2A223J	CHIP R 22K J 1/10W		
R71			RK73FB2A102J	CHIP R 1.0K J 1/10W		
R72			RK73FB2A101J	CHIP R 100 J 1/10W		
R73			RK73FB2A102J	CHIP R 1.0K J 1/10W		
R74			RK73FB2A101J	CHIP R 100 J 1/10W		
R75			RK73FB2A221J	CHIP R 220 J 1/10W		
R76			RK73FB2A471J	CHIP R 470 J 1/10W		
R77			RK73FB2A683J	CHIP R 68K J 1/10W		
R78			RK73FB2A471J	CHIP R 470 J 1/10W		
R79	,80		RK73FB2A103J	CHIP R 10K J 1/10W		
R81			RK73FB2A102J	CHIP R 1.0K J 1/10W		
R82			RK73FB2A473J	CHIP R 47K J 1/10W		
R83			RK73FB2A152J	CHIP R 1.5K J 1/10W		
R84			RK73FB2A221J	CHIP R 220 J 1/10W		
R85	,86		RK73FB2A103J	CHIP R 10K J 1/10W		
R87			RK73FB2A223J	CHIP R 22K J 1/10W		
R88			RK73FB2A101J	CHIP R 100 J 1/10W		
R89			RK73FB2A102J	CHIP R 1.0K J 1/10W		
R90			RK73FB2A101J	CHIP R 100 J 1/10W		
R91			RK73FB2A682J	CHIP R 6.8K J 1/10W		
R92			RK73FB2A101J	CHIP R 100 J 1/10W		
R93			RK73FB2A102J	CHIP R 1.0K J 1/10W		
R94			RK73FB2A334J	CHIP R 330K J 1/10W		
R95			RK73FB2A102J	CHIP R 1.0K J 1/10W		
R96			RK73FB2A471J	CHIP R 470 J 1/10W		
R97			RK73FB2A221J	CHIP R 220 J 1/10W		
R98			RK73FB2A102J	CHIP R 1.0K J 1/10W		
R200,201			RK73FB2A471J	CHIP R 470 J 1/10W		
R202,203			R92-1213-05			
R302,303			RK73FB2A101J	CHIP R 100 J 1/10W		
R304,305			RK73FB2A471J	CHIP R 470 J 1/10W		
R306,307			RK73FB2A102J	CHIP R 1.0K J 1/10W		
R308-317			RK73FB2A471J	CHIP R 470 J 1/10W		
R318,319			R92-1213-05			
R320			RK73FB2A471J	CHIP R 470 J 1/10W		

E: Scandinavia & Europe K: USA P: Canada W: Europe

U: PX(Far East, Hawaii) T: England M: Other Areas

UE: AAFES(Europe) X: Australia

⚠ indicates safety critical components.

PARTS LIST

* New Parts

Parts without Parts No. are not supplied.

Les articles non mentionnes dans le Parts No. ne sont pas fournis.

Teile ohne Parts No. werden nicht geliefert.

CONTROL UNIT (X53-3280-10)

Ref. No. 参照番号	Address 位置	New Parts 新	Parts No. 部品番号	Description 部品名 / 規格	Desti- nation 仕向	Re- marks 備考
R321			RK73FB2A103J	CHIP R 10K J 1/10W		
R322			RK73FB2A471J	CHIP R 470 J 1/10W		
R323, 324			RK73FB2A473J	CHIP R 47K J 1/10W		
R325-340			RK73FB2A471J	CHIP R 470 J 1/10W		
R341			RK73FB2A101J	CHIP R 100 J 1/10W		
R342			RK73FB2A471J	CHIP R 470 J 1/10W		
R343			RK73FB2A101J	CHIP R 100 J 1/10W		
R344			RK73FB2A471J	CHIP R 470 J 1/10W		
R345			RK73FB2A101J	CHIP R 100 J 1/10W		
R346-354			RK73FB2A103J	CHIP R 10K J 1/10W		
R355		*	RK73EB2B560J	CHIP R 56 J 1/8W		
R356			RK73FB2A271J	CHIP R 270 J 1/10W		
R357, 358			RK73FB2A472J	CHIP R 4.7K J 1/10W		
R359			RK73FB2A223J	CHIP R 22K J 1/10W		
R360			RK73FB2A103J	CHIP R 10K J 1/10W		
R361			RK73FB2A471J	CHIP R 470 J 1/10W		
R362			RK73FB2A223J	CHIP R 22K J 1/10W		
R363			RK73FB2A472J	CHIP R 4.7K J 1/10W		
R364-370			RK73FB2A471J	CHIP R 470 J 1/10W		
R371-374			RK73FB2A103J	CHIP R 10K J 1/10W		
R375			RK73FB2A273J	CHIP R 27K J 1/10W		
R376			RK73FB2A220J	CHIP R 22 J 1/10W		
R377, 378			RK73FB2A101J	CHIP R 100 J 1/10W		
R379			RK73FB2A104J	CHIP R 100K J 1/10W		
R380-383			RK73FB2A101J	CHIP R 100 J 1/10W		
R384			RK73FB2A103J	CHIP R 10K J 1/10W		
R385			RK73FB2A473J	CHIP R 47K J 1/10W		
R386			RK73FB2A182J	CHIP R 1.8K J 1/10W		
R389			RK73FB2A473J	CHIP R 47K J 1/10W		
R390, 391			RK73FB2A103J	CHIP R 10K J 1/10W		
R392			RK73FB2A472J	CHIP R 4.7K J 1/10W		
R393			RK73FB2A223J	CHIP R 22K J 1/10W		
VR200		*	R01-3437-05	TRIM POT. 10K-U		
VR201		*	R01-3436-05	TRIM POT. 10K-B		
VR301-303		*	R12-6469-05	TRIM POT. 4.7K		
S201-215			S50-1426-05	SENSITIVE SWITCH		
S216-220			S40-2441-15	PUSH SWITCH		
S221			S40-2440-15	PUSH SWITCH (SP OFF)		
S222-224			S40-2441-15	PUSH SWITCH		
S225			S40-2453-05	PUSH SWITCH (POWER)		
S226			S40-2441-15	PUSH SWITCH		
S301			S59-4401-05	DIP SWITCH		
D1			1SS184	CHIP DIODE		
D2 -5			RLS135	CHIP DIODE		
D6			1SS184	CHIP DIODE		
D7			1SV166	CHIP DIODE		
D8			1SS184	CHIP DIODE		
D9			1SV166	CHIP DIODE		
D301			02CZ11Y	ZENER DIODE(11V)		
D302, 303			1SS184	CHIP DIODE		
D304-306			1SS272	CHIP DIODE		
D307		*	02CZ4.7Y	ZENER DIODE(4.7V)		
D308		*	02CZ5.6Y	ZENER DIODE(5.6V)		
D309			02CZ5.1X, Y	ZENER DIODE(5.1V)		

E: Scandinavia & Europe K: USA P: Canada W: Europe

U: PX(Far East, Hawaii) T: England M: Other Areas

UE: AAFES(Europe) X: Australia

⚠ indicates safety critical components.

PARTS LIST

* New Parts

Parts without Parts No. are not supplied.

Les articles non mentionnés dans le Parts No. ne sont pas fournis.

Teile ohne Parts No. werden nicht geliefert.

CONTROL UNIT (X53-3280-10)

Ref. No. 参照番号	Address 位置	New Parts 新	Parts No. 部品番号	Description 部品名 / 規格	Desti- nation 仕向	Re- marks 備考
D310			1SS181	CHIP DIODE		
D311-314			1SS133	CHIP DIODE		
D315			1SS184	CHIP DIODE		
D316, 317			1SS181	CHIP DIODE		
IC1		*	UPC78N05H	IC(5V AVR)		
IC2		*	HD74LS290FP	IC(DIVIDER)		
IC3			CXD1225M	IC(PLL SYNTHESIZER)		
IC4		*	TC4028BF	IC(BCD-TO-DECIMAL DECODER)		
IC5			SN76514N	IC(MIXER)		
IC6			CXD1225M	IC(PLL SYNTHESIZER)		
IC7			M54459L	IC(PRE SCALER)		
IC8			SN16913P	IC(DUBLE BALANCED MIXERS)		
IC9			CXD1225M	IC(PLL SYNTHESIZER)		
IC10			M54459L	IC(PRE SCALER)		
IC11			SN16913P	IC(DUBLE BALANCED MIXERS)		
IC300		*	CXD1095Q	IC(I/O)		
IC301		*	UPC78N05H	IC(5V AVR)		
IC302		*	UPD78C10AGQ-36	IC(CPU)		
IC303			TC74HC573AF	IC(LATCH)		
IC304			TC74HC138AF	IC(DECODER)		
IC305			M51951BML	IC(SYSTEM RESET)		
IC306		*	TC4S584F	IC(INVERTER)		
IC307			TC4SU69F	IC(INVERTER GATE)		
IC308		*	TC4S71F	IC		
IC310		*	27C128-20JBF1	IC(EPR0M)		
IC311		*	MSM28C16A-20RS	IC(E PROM)		
IC312		*	TC4S584F	IC		
Q1 -3			2SC2714(Y)	CHIP TRANSISTOR		
Q4			FMU1	CHIP TRANSISTOR		
Q5 -7			2SC3324(G)	CHIP TRANSISTOR		
Q8 -11			2SC2714(Y)	CHIP TRANSISTOR		
Q12			DTC114EK	DIGITAL TRANSISTOR		
Q13			2SC2712(Y)	CHIP TRANSISTOR		
Q14			FMC2	CHIP TRANSISTOR		
Q15 -17			2SC3324(G)	CHIP TRANSISTOR		
Q18			2SC2714(Y)	CHIP TRANSISTOR		
Q19			DTC114EK	DIGITAL TRANSISTOR		
Q20			2SC2712(Y)	CHIP TRANSISTOR		
Q21			DTA114EK	DIGITAL TRANSISTOR		
Q22 -24			2SC3324(G)	CHIP TRANSISTOR		
Q25			FMU1	CHIP TRANSISTOR		
Q26			2SC2712(Y)	CHIP TRANSISTOR		
Q27			2SC2714(Y)	CHIP TRANSISTOR		
Q28			DTC114EK	DIGITAL TRANSISTOR		
Q29			DTA114EK	DIGITAL TRANSISTOR		
Q300			DTC143EK	DIGITAL TRANSISTOR		
Q301			DTA143EK	DIGITAL TRANSISTOR		
Q302			DTC143EK	DIGITAL TRANSISTOR		
Q303			DTA143EK	DIGITAL TRANSISTOR		
Q304			DTC114EK	DIGITAL TRANSISTOR		
Q305		*	DTD123EK	DIGITAL TRANSISTOR		
Q306-308			DTC114EK	DIGITAL TRANSISTOR		
Q309			2SD1624S	CHIP TRANSISTOR		
Q310			2SC2712(Y)	CHIP TRANSISTOR		
Q311			DTA143EK	DIGITAL TRANSISTOR		

E: Scandinavia & Europe K: USA P: Canada W: Europe

U: PX(Far East, Hawaii) T: England M: Other Areas

UE: AAFES(Europe) X: Australia

▲ indicates safety critical components.

PARTS LIST

* New Parts

Parts without Parts No. are not supplied.

Les articles non mentionnes dans le Parts No. ne sont pas fournis.

Teile ohne Parts No. werden nicht geliefert.

CONTROL UNIT (X53-3280-10)

TX-RX UNIT (X57-3470-10)

Ref. No. 参照番号	Address 位置	New Parts 新	Parts No. 部品番号	Description 部品名 / 規格	Desti- nation 仕 向	Re- marks 備考
Q312			2SC2712(Y)	CHIP TRANSISTOR		
BA300		*	W09-0625-05	LITHIUM BATTERY		
S200		*	W02-0877-05	ENCODER		
Z1		*	X58-3720-10	SUB UNIT (VCO)		
Z2 ,3		*	X59-3440-00	MODULE UNIT (VCO)		
TX-RX UNIT (X57-3470-10)						
C1			CK73EB1H104K	CHIP C 0.10UF K		
C2			CC73FSL1H101J	CHIP C 100PF J		
C3			CC73FSL1H181J	CHIP C 180PF J		
C4			CC73FCH1H820J	CHIP C 82PF J		
C5			CK73FB1H223K	CHIP C 0.022UF K		
C6			CK73FB1H103K	CHIP C 0.010UF K		
C7			CK73FB1H682K	CHIP C 6800PF K		
C8 ,9			CK73EB1H104K	CHIP C 0.10UF K		
C10			CC73FSL1H121J	CHIP C 120PF J		
C11 ,12			CC73FCH1H820J	CHIP C 82PF J		
C13			CC73FSL1H221J	CHIP C 220PF J		
C14			CK73FB1H681K	CHIP C 680PF K		
C15			CC73FSL1H151J	CHIP C 150PF J		
C16 ,17			CK73EB1H104K	CHIP C 0.10UF K		
C18			CC73FSL1H331J	CHIP C 330PF J		
C19			CC73FCH1H390J	CHIP C 39PF J		
C20			CC73FSL1H331J	CHIP C 330PF J		
C21			CC73FSL1H391J	CHIP C 390PF J		
C22			CC73FSL1H181J	CHIP C 180PF J		
C23			CK73FB1H222K	CHIP C 2200PF K		
C24 ,25			CK73EB1H104K	CHIP C 0.10UF K		
C26			CC73FSL1H331J	CHIP C 330PF J		
C27			CC73FCH1H820J	CHIP C 82PF J		
C28			CC73FSL1H181J	CHIP C 180PF J		
C29			CC73FSL1H331J	CHIP C 330PF J		
C30			CK73FB1H102K	CHIP C 1000PF K		
C31			CC73FSL1H271J	CHIP C 270PF J		
C32 ,33			CK73EB1H104K	CHIP C 0.10UF K		
C34			CK73FB1H471K	CHIP C 470PF K		
C35			CC73FCH1H560J	CHIP C 56PF J		
C36			CC73FSL1H331J	CHIP C 330PF J		
C37			CK73FB1H471K	CHIP C 470PF K		
C38			CK73FB1H152K	CHIP C 1500PF K		
C39			CC73FSL1H391J	CHIP C 390PF J		
C40			CK73EB1H104K	CHIP C 0.10UF K		
C46			CK73EB1H104K	CHIP C 0.10UF K		
C47			CK73FB1H561K	CHIP C 560PF K		
C48			CC73FSL1H101J	CHIP C 100PF J		
C49			CK73FB1H471K	CHIP C 470PF K		
C50			CK73FB1H681K	CHIP C 680PF K		
C51			CK73FB1H392K	CHIP C 3900PF K		
C52			CK73FB1H471K	CHIP C 470PF K		
C53			CK73EB1H104K	CHIP C 0.10UF K		
C54			CK73FB1H821K	CHIP C 820PF K		
C55			CC73FSL1H221J	CHIP C 220PF J		
C56			CK73FB1H561K	CHIP C 560PF K		
C57			CK73FB1H152K	CHIP C 1500PF K		

E: Scandinavia & Europe K: USA P: Canada W: Europe

U: PX(Far East, Hawaii) T: England M: Other Areas

UE: AAFES(Europe) X: Australia

⚠ indicates safety critical components.

PARTS LIST

× New Parts

Parts without Parts No. are not supplied.

Les articles non mentionnés dans le Parts No. ne sont pas fournis.

Teile ohne Parts No. werden nicht geliefert.

TX-RX UNIT (X57-3470-10)

Ref. No. 参照番号	Address 位置	New Parts 新	Parts No. 部品番号	Description 部品名 / 規格	Desti- nation 仕向	Re- marks 備考
C58			CK73FB1H472K	CHIP C 4700PF K		
C59			CK73FB1H102K	CHIP C 1000PF K		
C60 -62			CK73EB1H104K	CHIP C 0.10UF K		
C63			CK73FB1H152K	CHIP C 1500PF K		
C64			CC73FSL1H391J	CHIP C 390PF J		
C65			CK73FB1H102K	CHIP C 1000PF K		
C66 -68			CK73EB1H104K	CHIP C 0.10UF K		
C69			CK73FB1H222K	CHIP C 2200PF K		
C70			CK73FB1H681K	CHIP C 680PF K		
C71			CK73FB1H152K	CHIP C 1500PF K		
C72 ,73			CK73EB1H104K	CHIP C 0.10UF K		
C74			CC73FSL1H101J	CHIP C 100PF J		
C75			CC73FSL1H151J	CHIP C 150PF J		
C76			CC73FCH1H680J	CHIP C 68PF J		
C77			CK73FB1H102K	CHIP C 1000PF K		
C78 -80			CK73EB1H104K	CHIP C 0.10UF K		
C86			CK73FB1H103K	CHIP C 0.010UF K		
C87			CK73EB1H104K	CHIP C 0.10UF K		
C88			CK73FB1H102K	CHIP C 1000PF K		
C89			CK73FB1H103K	CHIP C 0.010UF K		
C90 ,91			CK73FB1H102K	CHIP C 1000PF K		
C92 -94			CC73FCH1H010C	CHIP C 1PF C		
C96			CK73FB1H103K	CHIP C 0.010UF K		
C97			CK73FB1H102K	CHIP C 1000PF K		
C98			CC73FCH1H010C	CHIP C 1PF C		
C99			CK73EB1H104K	CHIP C 0.10UF K		
C100, 101			CK73FB1H102K	CHIP C 1000PF K		
C102			CK73FB1H103K	CHIP C 0.010UF K		
C103, 104			CK73FB1H102K	CHIP C 1000PF K		
C105-107			CK73FB1H103K	CHIP C 0.010UF K		
C108			CK73FB1H223K	CHIP C 0.022UF K		
C109			CK73FB1H103K	CHIP C 0.010UF K		
C110			CK73FB1H102K	CHIP C 1000PF K		
C111-120			CK73FB1H103K	CHIP C 0.010UF K		
C121, 122			CC73FCH1H020C	CHIP C 2.0PF C		
C126-131			CK73FB1H103K	CHIP C 0.010UF K		
C132			CK73EB1H104K	CHIP C 0.10UF K		
C133, 134			CE04EW1C100M	ELECTRØ 10UF 16WV		
C135			CK73EB1H104K	CHIP C 0.10UF K		
C136			CK73EB1H473K	CHIP C 0.047UF K		
C137			CK73FB1H223K	CHIP C 0.022UF K		
C138, 139			CK73FB1H103K	CHIP C 0.010UF K		
C140			CE04EW1C100M	ELECTRØ 10UF 16WV		
C141			C90-2041-05	TANTAL 10UF 10WV		
C142			C92-0003-05	CHIP TAN 0.47UF 25WV		
C143, 144			CK73FB1H103K	CHIP C 0.010UF K		
C145			CE04EW1C100M	ELECTRØ 10UF 16WV		
C146			CE04EW1C220M	ELECTRØ 22UF 16WV		
C147			CE04EW1C470M	ELECTRØ 47UF 16WV		
C148			CK73EB1H104K	CHIP C 0.10UF K		
C150			CE04EW1C220M	ELECTRØ 22UF 16WV		
C151, 152			CE04EW1C470M	ELECTRØ 47UF 16WV		
C154			CK73FB1H102K	CHIP C 1000PF K		
C155, 156			CE04EW1C470M	ELECTRØ 47UF 16WV		
C157			CE04EW1C471M	ELECTRØ 470UF 16WV		

E: Scandinavia & Europe K: USA P: Canada W: Europe

U: PX(Far East, Hawaii) T: England M: Other Areas

UE: AAFES(Europe) X: Australia

⚠ indicates safety critical components.

PARTS LIST

Parts without Parts No. are not supplied.

Les articles non mentionnes dans le Parts No. ne sont pas fournis.

Teile ohne Parts No. werden nicht geliefert.

TX-RX UNIT (X57-3470-10)

Ref. No. 参照番号	Address 位置	New Parts 新	Parts No. 部品番号	Description 部品名 / 規格	Desti- nation 仕向	Re- marks 備考
C158			CE04EW1C220M	ELECTRØ 22UF 16WV		
C159			CE04EW1C470M	ELECTRØ 47UF 16WV		
C160			C90-2076-05	ELECTRØ 560UF 10WV		
C161			C90-2045-05	ELECTRØ 2.2UF 25WV		
C162			CK73FB1H223K	CHIP C 0.022UF K		
C163			CK73FB1H332K	CHIP C 3300PF K		
C166			CQ92M1H104K	MYLAR 0.10UF K		
C167			CK73FB1H103K	CHIP C 0.010UF K		
C169, 170			CK73FB1H103K	CHIP C 0.010UF K		
C171			CK73FB1H222K	CHIP C 2200PF K		
C172, 173			CK73FB1H103K	CHIP C 0.010UF K		
C174			CK73EB1H104K	CHIP C 0.10UF K		
C175			CE04EW1C470M	ELECTRØ 47UF 16WV		
C176, 177			CK73FB1H103K	CHIP C 0.010UF K		
C178-180			CK73FB1H102K	CHIP C 1000PF K		
C181, 182			CK73FB1H103K	CHIP C 0.010UF K		
C186, 187			CK73FB1H103K	CHIP C 0.010UF K		
C188			CC73FSL1H101J	CHIP C 100PF J		
C189			CE04EW1C470M	ELECTRØ 47UF 16WV		
C190			CE04EW1H2R2M	ELECTRØ 2.2UF 50WV		
C192			CE04EW1H2R2M	ELECTRØ 2.2UF 50WV		
C193			CK73FB1H103K	CHIP C 0.010UF K		
C194			CE04EW1C100M	ELECTRØ 10UF 16WV		
C195			CK73EB1H104K	CHIP C 0.10UF K		
C196			CE04EW1C470M	ELECTRØ 47UF 16WV		
C197			CE04EW1H2R2M	ELECTRØ 2.2UF 50WV		
C198			CE04EW1C100M	ELECTRØ 10UF 16WV		
C199			CE04EW1C470M	ELECTRØ 47UF 16WV		
C200			CK73FB1H223K	CHIP C 0.022UF K		
C206-208			CK73FB1H103K	CHIP C 0.010UF K		
C209			CC73FCH1H470J	CHIP C 47PF J		
C210, 211			CK73FB1H103K	CHIP C 0.010UF K		
C212			CC73FCH1H470J	CHIP C 47PF J		
C213			CC73FCH1H220J	CHIP C 22PF J		
C214			CK73FB1H223K	CHIP C 0.022UF K		
C215, 216			CK73FB1H103K	CHIP C 0.010UF K		
C217			CK73FB1H102K	CHIP C 1000PF K		
C218-220			CK73FB1H103K	CHIP C 0.010UF K		
C221, 222			C92-0004-05	CHIP-TAN 1UF 16WV		
C223			CK73FB1H103K	CHIP C 0.010UF K		
C224			CK73FB1H223K	CHIP C 0.022UF K		
C225			CC73FCH1H470J	CHIP C 47PF J		
C226, 227			CK73FB1H103K	CHIP C 0.010UF K		
C228			CK73FB1H102K	CHIP C 1000PF K		
C229, 230			CC73FCH1H470J	CHIP C 47PF J		
C231			CK73FB1H103K	CHIP C 0.010UF K		
C232			CK73FB1H102K	CHIP C 1000PF K		
C233-236			CK73FB1H103K	CHIP C 0.010UF K		
C237			CK73FB1H102K	CHIP C 1000PF K		
C238-240			CK73FB1H103K	CHIP C 0.010UF K		
C241			CK73FB1H102K	CHIP C 1000PF K		
C244-246			CK73FB1H102K	CHIP C 1000PF K		
C247, 248			CK73FB1H103K	CHIP C 0.010UF K		
C249			CC73FSL1H101J	CHIP C 100PF J		
C250			CC73FCH1H080D	CHIP C 8PF D		

E: Scandinavia & Europe K: USA P: Canada W: Europe

U: PX(Far East, Hawaii) T: England M: Other Areas

UE: AAFES(Europe) X: Australia

▲ indicates safety critical components.

PARTS LIST

× New Parts

Parts without Parts No. are not supplied.

Les articles non mentionnés dans le Parts No. ne sont pas fournis.

Teile ohne Parts No. werden nicht geliefert.

TX-RX UNIT (X57-3470-10)

Ref. No. 参照番号	Address 位置	New Parts 新	Parts No. 部品番号	Description 部品名 / 規格	Desti- nation 仕 向	Re- marks 備考
C251, 252			CK73FB1H103K	CHIP C 0.010UF K		
C253			CC73FCH1H150J	CHIP C 15PF J		
C255			CC73FCH1H030C	CHIP C 3PF C		
C256			CK73EB1H104K	CHIP C 0.10UF K		
C257			CK73FB1H332K	CHIP C 3300PF K		
C258			CK73FB1H222K	CHIP C 2200PF K		
C259			CC73FSL1H151J	CHIP C 150PF J		
C260			CC73FCH1H120J	CHIP C 12PF J		
C261			CC73FSL1H221J	CHIP C 220PF J		
C262			CC73FCH1H470J	CHIP C 47PF J		
C263-265			CK73EB1H104K	CHIP C 0.10UF K		
C266			CK73EB1H473K	CHIP C 0.047UF K		
C267			CK73EB1H104K	CHIP C 0.10UF K		
C268			CC73FCH1H560J	CHIP C 56PF J		
C269			CC73FCH1H820J	CHIP C 82PF J		
C270			CC73FSL1H391J	CHIP C 390PF J		
C271			CK73FB1H102K	CHIP C 1000PF K		
C272			CC73FSL1H101J	CHIP C 100PF J		
C273			CK73FB1H102K	CHIP C 1000PF K		
C274			CC73FCH1H050C	CHIP C 5PF C		
C275			CC73FCH1H040C	CHIP C 4PF C		
C276			CC73FCH1H270J	CHIP C 27PF J		
C277			CC73FCH1H100D	CHIP C 10PF D		
C278			CC73FCH1H150J	CHIP C 15PF J		
C279			CK73FB1H103K	CHIP C 0.010UF K		
C280			CC73FCH1H060D	CHIP C 6PF D		
C286			CC73FCH1H060D	CHIP C 6PF D		
C287			CC73FCH1H220J	CHIP C 22PF J		
C288, 289			CK73FB1H103K	CHIP C 0.010UF K		
C290			CC73FCH1H080D	CHIP C 8PF D		
C291			CK73FB1H103K	CHIP C 0.010UF K		
C292			CC73FCH1H0R5C	CHIP C 0.5PF C		
C293			CC73FCH1H080D	CHIP C 8PF D		
C294-297			CK73FB1H103K	CHIP C 0.010UF K		
C298			CE04EW1H2R2M	ELECTRØ 2.2UF 50WV		
C299-301			CK73FB1H103K	CHIP C 0.010UF K		
C302			CC73FSL1H471J	CHIP C 47PF J		
C303			CK73FB1H103K	CHIP C 0.010UF K		
C304			C90-2041-05	TANTAL 10UF 10WV		
C305			CE04EW1C100M	ELECTRØ 10UF 16WV		
C306			CE04EW1C470M	ELECTRØ 47UF 16WV		
C307			CE04EW1C221M	ELECTRØ 220UF 16WV		
C308			CK73FB1H223K	CHIP C 0.022UF K		
C309-311			CE04EW1C470M	ELECTRØ 47UF 16WV		
C312			CK73FB1H223K	CHIP C 0.022UF K		
C313			CE04EW1C101M	ELECTRØ 100UF 16WV		
C314, 315			CK73FB1H102K	CHIP C 1000PF K		
C316			CE04EW1C101M	ELECTRØ 100UF 16WV		
C317-320			CK73FB1H103K	CHIP C 0.010UF K		
C326-332			CK73FB1H103K	CHIP C 0.010UF K		
C342			CK73FB1H102K	CHIP C 1000PF K		
C333			CK73FB1H223K	CHIP C 0.022UF K		
C335-341			CK73FB1H103K	CHIP C 0.010UF K		
C344-346			CK73FB1H103K	CHIP C 0.010UF K		
C347-350			CK73FB1H471K	CHIP C 470PF K		
C351, 352			CK73FB1H103K	CHIP C 0.010UF K		

E: Scandinavia & Europe K: USA P: Canada W: Europe

U: PX(Far East, Hawaii) T: England M: Other Areas

UE: AAFES(Europe) X: Australia

⚠ indicates safety critical components.

PARTS LIST

* New Parts

Parts without Parts No. are not supplied.

Les articles non mentionnés dans le Parts No. ne sont pas fournis.

Teile ohne Parts No. werden nicht geliefert.

TX-RX UNIT (X57-3470-10)

Ref. No. 参照番号	Address 位置	New Parts 新	Parts No. 部品番号	Description 部品名 / 規格	Desti- nation 仕向	Re- marks 備考
C353-355 C356 C357-360 C366,367 C368			CK73FB1H223K CE04EW1E4R7M CK73FB1H103K CK73FB1H103K CK73FB1H223K	CHIP C 0.022UF K ELECTRO 4.7UF 25WV CHIP C 0.010UF K CHIP C 0.010UF K CHIP C 0.022UF K		
C369-376			CK73FB1H103K	CHIP C 0.010UF K		
CN1 -5 CN6 CN7 CN8 CN9			E04-0157-05 E40-3242-05 E40-3243-05 E40-3240-05 E40-3238-05	RF COAXIAL CABLE JACK A PIN CONNECTOR 7P PIN CONNECTOR 8P PIN CONNECTOR 5P PIN CONNECTOR 3P		
CN10 CN11,12 CN17 J1 ,2 J4		*	E40-5339-05 E40-3238-05 E40-3303-05 E13-0166-05 E11-0414-05	PIN CONNECTOR 25P PIN CONNECTOR 3P PIN CONNECTOR 6P PHONE JACK (RELAY,ALC) PHONE JACK (EXT.SP)		
TP1 ,2 TP3 -5 W1		*	E04-0154-05 E23-0465-05 E31-6101-05	RF COAXIAL CONNECTOR TERMINAL CONNECTING WIRE (AT CONNECT)		
A1 A2 A3 A4	2D	*	F01-0975-04 F11-1072-14 F11-1014-04 F11-1071-14	HEAT SINK SHIELDING COVER (FRONT) SHIELDING COVER (HET) SHIELDING COVER (BPF)		
A5 ,6 J5	2D	*	G02-0574-04 J13-0071-05	LEAF SPRING (IC5,9) FUSE HOLDER		
L1 ,2 L3 L4 -6 L7 L8			L40-2782-48 L33-0695-05 L40-2292-48 L40-1011-48 L40-3382-48	SMALL FIXED INDUCTOR 0.27UH CHOKE COIL 1MH SMALL FIXED INDUCTOR 2.2UH SMALL FIXED INDUCTOR 100UH SMALL FIXED INDUCTOR 0.33UH		
L9 L10 ,11 L12 L13 L14			L40-2282-48 L40-4782-48 L33-0695-05 L40-1011-48 L40-6882-48	SMALL FIXED INDUCTOR 0.22UH SMALL FIXED INDUCTOR 0.47UH CHOKE COIL 1MH SMALL FIXED INDUCTOR 100UH SMALL FIXED INDUCTOR 0.68UH		
L15 -17 L18 L19 L20 L24			L40-4782-48 L33-0695-05 L40-1011-48 L40-6882-48 L40-6882-48	SMALL FIXED INDUCTOR 0.47UH CHOKE COIL 1MH SMALL FIXED INDUCTOR 100UH SMALL FIXED INDUCTOR 0.68UH SMALL FIXED INDUCTOR 0.68UH		
L25 L26 L27 L28 L29 ,30			L40-1092-48 L40-6882-48 L33-0695-05 L40-1011-48 L40-1092-48	SMALL FIXED INDUCTOR 1UH SMALL FIXED INDUCTOR 0.68UH CHOKE COIL 1MH SMALL FIXED INDUCTOR 100UH SMALL FIXED INDUCTOR 1UH		
L31 L32 L33 L34 L35 -38		*	L40-1292-48 L40-1092-48 L33-0695-05 L40-1011-48 L40-1592-48	SMALL FIXED INDUCTOR 1.2UH SMALL FIXED INDUCTOR 1UH CHOKE COIL 1MH SMALL FIXED INDUCTOR 100UH SMALL FIXED INDUCTOR 1.5UH		
L39 L40			L33-0695-05 L40-1011-48	CHOKE COIL 1MH SMALL FIXED INDUCTOR 100UH		

E: Scandinavia & Europe K: USA P: Canada W: Europe

U: PX(Far East, Hawaii) T: England M: Other Areas

UE: AAFES(Europe) X: Australia

⚠ indicates safety critical components.

PARTS LIST

* New Parts

Parts without Parts No. are not supplied.

Les articles non mentionnés dans le Parts No. ne sont pas fournis.

Teile ohne Parts No. werden nicht geliefert.

TX-RX UNIT (X57-3470-10)

Ref. No. 参照番号	Address 位置	New Parts 新	Parts No. 部品番号	Description 部品名 / 規格	Desti- nation 仕向	Re- marks 備考
L44			L40-2292-48	SMALL FIXED INDUCTOR 2.2UH		
L45		*	L40-1592-48	SMALL FIXED INDUCTOR 1.5UH		
L46 ,47			L40-2292-48	SMALL FIXED INDUCTOR 2.2UH		
L48			L33-0695-05	CHOKE COIL 1MH		
L49			L40-2211-48	SMALL FIXED INDUCTOR 220UH		
L50			L40-3392-48	SMALL FIXED INDUCTOR 3.3UH		
L51			L40-2292-48	SMALL FIXED INDUCTOR 2.2UH		
L52			L40-2211-48	SMALL FIXED INDUCTOR 220UH		
L53 ,54			L33-0695-05	CHOKE COIL 1MH		
L55			L40-6892-48	SMALL FIXED INDUCTOR 6.8UH		
L56			L40-4792-48	SMALL FIXED INDUCTOR 4.7UH		
L57			L33-0695-05	CHOKE COIL 1MH		
L58			L40-2782-48	SMALL FIXED INDUCTOR 0.27UH		
L59			L40-2282-48	SMALL FIXED INDUCTOR 0.22UH		
L60		*	L39-0483-05	TOROIDAL COIL		
L64			L40-1011-48	SMALL FIXED INDUCTOR 100UH		
L65		*	L34-4212-05	COIL 71.295MHZ		
L66 ,67		*	L34-4213-05	COIL 71.295MHZ		
L68		*	L34-4214-05	COIL 71.295MHZ		
L69			L34-4209-05	COIL 71.295MHZ		
L70		*	L34-4216-05	COIL 10.695MHZ		
L71			L30-0281-15	IFT 10.695MHZ		
L72 -74			L40-4701-48	SMALL FIXED INDUCTOR 47UH		
L75			L15-0016-05	LOW-FREQUENCY CHOKE COIL		
L76			L40-1011-48	SMALL FIXED INDUCTOR 100UH		
L77 ,78			L40-4701-48	SMALL FIXED INDUCTOR 47UH		
L79			L30-0281-15	IFT 10.695MHZ		
L80		*	L34-4217-05	COIL 71.295MHZ		
L83			L40-6892-48	SMALL FIXED INDUCTOR 6.8UH		
L84		*	L34-4218-05	COIL 71.295MHZ		
L85			L39-0432-05	TOROIDAL COIL		
L86		*	L39-0483-05	TOROIDAL COIL		
L87			L40-3382-48	SMALL FIXED INDUCTOR 0.33UH		
L88			L40-2782-48	SMALL FIXED INDUCTOR 0.27UH		
L89			L40-1092-48	SMALL FIXED INDUCTOR 1UH		
L90		*	L39-0483-05	TOROIDAL COIL		
L91			L40-1011-48	SMALL FIXED INDUCTOR 100UH		
L92			L40-1082-48	SMALL FIXED INDUCTOR 0.1UH		
L93			L40-8272-48	SMALL FIXED INDUCTOR 82NH		
L94			L40-5682-48	SMALL FIXED INDUCTOR 0.56UH		
L95			L34-0904-05	COIL		
L96			L40-1082-48	SMALL FIXED INDUCTOR 0.1UH		
L97			L40-2292-48	SMALL FIXED INDUCTOR 2.2UH		
L99 ,100		*	L34-4215-05	COIL 60.6MHZ		
L101			L34-2271-05	TUNING COIL 60.6MHZ		
L105,106			L40-1011-48	SMALL FIXED INDUCTOR 100UH		
L107			L33-0695-05	CHOKE COIL 1MH		
L108-116			L40-1011-48	SMALL FIXED INDUCTOR 100UH		
X1		*	L77-1426-05	CRYSTAL RESONATOR 30.3MHZ		
XF1		*	L71-0402-05	MCF 70.295MHZ		
XF2			L71-0249-05	CRYSTAL FILTER SSB		
XF3		*	L71-0403-05	CRYSTAL FILTER AM		
M	2C,2D		N32-3006-41	FLAT HEAD MACHINE SCREW		

E: Scandinavia & Europe K: USA P: Canada W: Europe

U: PX(Far East, Hawaii) T: England M: Other Areas

UE: AAFES(Europe) X: Australia

△ indicates safety critical components

PARTS LIST

× New Parts

Parts without Parts No. are not supplied.

Les articles non mentionnés dans le Parts No. ne sont pas fournis.

Teile ohne Parts No. werden nicht geliefert.

TX-RX UNIT (X57-3470-10)

Ref. No. 参照番号	Address 位置	New Parts 新	Parts No. 部品番号	Description 部品名 / 規格	Desti- nation 仕 向	Re- marks 備考
R1			RK73FB2A471J	CHIP R 470 J 1/10W		
R2			RK73FB2A473J	CHIP R 47K J 1/10W		
R3			RK73FB2A101J	CHIP R 100 J 1/10W		
R4			RK73FB2A473J	CHIP R 47K J 1/10W		
R5			RK73FB2A101J	CHIP R 100 J 1/10W		
R6			RK73FB2A473J	CHIP R 47K J 1/10W		
R7			RK73FB2A101J	CHIP R 100 J 1/10W		
R8			RK73FB2A473J	CHIP R 47K J 1/10W		
R9			RK73FB2A101J	CHIP R 100 J 1/10W		
R10			RK73FB2A473J	CHIP R 47K J 1/10W		
R11			RK73FB2A101J	CHIP R 100 J 1/10W		
R12			RK73FB2A473J	CHIP R 47K J 1/10W		
R13			RK73FB2A101J	CHIP R 100 J 1/10W		
R14			RK73FB2A473J	CHIP R 47K J 1/10W		
R15			RK73FB2A101J	CHIP R 100 J 1/10W		
R17 ,18			RK73FB2A101J	CHIP R 100 J 1/10W		
R19			R92-0670-05	CHIP R 0 ΩHM		
R20			RK73FB2A473J	CHIP R 47K J 1/10W		
R21			RK73FB2A471J	CHIP R 470 J 1/10W		
R22 ,23			RK73FB2A681J	CHIP R 680 J 1/10W		
R24			RK73FB2A331J	CHIP R 330 J 1/10W		
R25			RK73FB2A471J	CHIP R 470 J 1/10W		
R26			RK73FB2A152J	CHIP R 1.5K J 1/10W		
R27			RK73FB2A330J	CHIP R 33 J 1/10W		
R28 -32			RK73FB2A102J	CHIP R 1.0K J 1/10W		
R33			RK73FB2A473J	CHIP R 47K J 1/10W		
R34			RK73FB2A104J	CHIP R 100K J 1/10W		
R35			RK73FB2A474J	CHIP R 470K J 1/10W		
R36			RK73FB2A471J	CHIP R 470 J 1/10W		
R37			RK73FB2A101J	CHIP R 100 J 1/10W		
R38			RK73FB2A471J	CHIP R 470 J 1/10W		
R39			RK73FB2A102J	CHIP R 1.0K J 1/10W		
R40			RK73FB2A681J	CHIP R 680 J 1/10W		
R41 ,42			RK73FB2A222J	CHIP R 2.2K J 1/10W		
R46			RK73FB2A681J	CHIP R 680 J 1/10W		
R47			RK73FB2A101J	CHIP R 100 J 1/10W		
R48			RK73FB2A222J	CHIP R 2.2K J 1/10W		
R49			RK73FB2A103J	CHIP R 10K J 1/10W		
R50			RK73FB2A472J	CHIP R 4.7K J 1/10W		
R51			RK73FB2A333J	CHIP R 33K J 1/10W		
R52			RK73FB2A104J	CHIP R 100K J 1/10W		
R53			RK73FB2A471J	CHIP R 470 J 1/10W		
R54			RK73FB2A104J	CHIP R 100K J 1/10W		
R55			RK73FB2A101J	CHIP R 100 J 1/10W		
R56			RK73FB2A472J	CHIP R 4.7K J 1/10W		
R57			RK73FB2A471J	CHIP R 470 J 1/10W		
R58			RK73FB2A103J	CHIP R 10K J 1/10W		
R59			RK73FB2A222J	CHIP R 2.2K J 1/10W		
R60 ,61			R92-0670-05	CHIP R 0 ΩHM		
R62 ,63			RK73FB2A472J	CHIP R 4.7K J 1/10W		
R64			RK73FB2A332J	CHIP R 3.3K J 1/10W		
R65			RK73FB2A101J	CHIP R 100 J 1/10W		
R66			RK73FB2A103J	CHIP R 10K J 1/10W		
R67			RK73FB2A332J	CHIP R 3.3K J 1/10W		
R68			RK73FB2A102J	CHIP R 1.0K J 1/10W		

E: Scandinavia & Europe K: USA P: Canada W: Europe

U: PX(Far East, Hawaii) T: England M: Other Areas

UE: AAFES(Europe) X: Australia

⚠ indicates safety critical components.

PARTS LIST

× New Parts

Parts without Parts No. are not supplied.

Les articles non mentionnés dans le Parts No. ne sont pas fournis.

Teile ohne Parts No. werden nicht geliefert.

TX-RX UNIT (X57-3470-10)

Ref. No. 参照番号	Address 位置	New Parts 新	Parts No. 部品番号	Description 部品名 / 規格	Desti- nation 仕向	Re- marks 備考
R69 ,70			RK73FB2A472J	CHIP R 4.7K J 1/10W		
R71 ,72			RK73FB2A103J	CHIP R 10K J 1/10W		
R73 ,74			RK73FB2A332J	CHIP R 3.3K J 1/10W		
R75			RK73FB2A101J	CHIP R 100 J 1/10W		
R76 ,77			RK73FB2A222J	CHIP R 2.2K J 1/10W		
R78			RK73FB2A103J	CHIP R 10K J 1/10W		
R79 ,80			RK73FB2A471J	CHIP R 470 J 1/10W		
R86 ,87			RK73FB2A101J	CHIP R 100 J 1/10W		
R88 ,89			RK73FB2A153J	CHIP R 15K J 1/10W		
R90			RK73FB2A103J	CHIP R 10K J 1/10W		
R92			RK73FB2A103J	CHIP R 10K J 1/10W		
R93			RK73FB2A471J	CHIP R 470 J 1/10W		
R94			RK73FB2A105J	CHIP R 1.0M J 1/10W		
R95			RK73FB2A123J	CHIP R 12K J 1/10W		
R96			RK73FB2A103J	CHIP R 10K J 1/10W		
R97			RK73FB2A224J	CHIP R 220K J 1/10W		
R98			RK73FB2A103J	CHIP R 10K J 1/10W		
R99			RK73FB2A564J	CHIP R 560K J 1/10W		
R100			RK73FB2A102J	CHIP R 1.0K J 1/10W		
R101			RK73FB2A473J	CHIP R 47K J 1/10W		
R102			RK73FB2A123J	CHIP R 12K J 1/10W		
R103			RK73FB2A472J	CHIP R 4.7K J 1/10W		
R104			RK73FB2A271J	CHIP R 270 J 1/10W		
R105			RK73FB2A222J	CHIP R 2.2K J 1/10W		
R106			RK73FB2A272J	CHIP R 2.7K J 1/10W		
R107			RK73FB2A332J	CHIP R 3.3K J 1/10W		
R108			RK73FB2A472J	CHIP R 4.7K J 1/10W		
R109			RK73FB2A222J	CHIP R 2.2K J 1/10W		
R110			RK73FB2A333J	CHIP R 33K J 1/10W		
R112			RK73FB2A104J	CHIP R 100K J 1/10W		
R113			RK73FB2A102J	CHIP R 1.0K J 1/10W		
R114			RK73FB2A331J	CHIP R 330 J 1/10W		
R115			RK73FB2A562J	CHIP R 5.6K J 1/10W		
R116			RK73FB2A153J	CHIP R 15K J 1/10W		
R117			RK73FB2A105J	CHIP R 1.0M J 1/10W		
R118			RK73FB2A101J	CHIP R 100 J 1/10W		
R119			RK73FB2A562J	CHIP R 5.6K J 1/10W		
R120			RK73FB2A333J	CHIP R 33K J 1/10W		
R126			RK73FB2A103J	CHIP R 10K J 1/10W		
R127,128			RK73FB2A473J	CHIP R 47K J 1/10W		
R129			RK73FB2A152J	CHIP R 1.5K J 1/10W		
R130			RK73FB2A223J	CHIP R 22K J 1/10W		
R132-134			RK73FB2A472J	CHIP R 4.7K J 1/10W		
R135			RK73FB2A102J	CHIP R 1.0K J 1/10W		
R136			RK73FB2A104J	CHIP R 100K J 1/10W		
R137			RK73FB2A223J	CHIP R 22K J 1/10W		
R138			RK73FB2A472J	CHIP R 4.7K J 1/10W		
R139			RK73FB2A471J	CHIP R 470 J 1/10W		
R140			RK73FB2A102J	CHIP R 1.0K J 1/10W		
R141			RK73FB2A471J	CHIP R 470 J 1/10W		
R142			RK73FB2A101J	CHIP R 100 J 1/10W		
R143			RK73FB2A104J	CHIP R 100K J 1/10W		
R144			RK73FB2A473J	CHIP R 47K J 1/10W		
R145			RK73FB2A102J	CHIP R 1.0K J 1/10W		

E: Scandinavia & Europe K: USA P: Canada W: Europe

U: PX(Far East, Hawaii) T: England M: Other Areas

UE: AAFES(Europe) X: Australia

▲ indicates safety critical components.

PARTS LIST

* New Parts

Parts without Parts No. are not supplied.

Les articles non mentionnés dans le Parts No. ne sont pas fournis.

Teile ohne Parts No. werden nicht geliefert.

TX-RX UNIT (X57-3470-10)

Ref. No. 参照番号	Address 位置	New Parts 新	Parts No. 部品番号	Description 部品名 / 規格	Desti- nation 仕向	Re- marks 備考
R146			RK73FB2A151J	CHIP R 150 J 1/10W		
R147, 148			RK73FB2A471J	CHIP R 470 J 1/10W		
R149			RK73FB2A472J	CHIP R 4.7K J 1/10W		
R150			RK73FB2A101J	CHIP R 100 J 1/10W		
R151			RK73FB2A332J	CHIP R 3.3K J 1/10W		
R152, 153			RK73FB2A224J	CHIP R 220K J 1/10W		
R154, 155			RK73FB2A222J	CHIP R 2.2K J 1/10W		
R156			RK73FB2A471J	CHIP R 470 J 1/10W		
R157			RK73FB2A222J	CHIP R 2.2K J 1/10W		
R158			RK73FB2A471J	CHIP R 470 J 1/10W		
R159			RK73FB2A102J	CHIP R 1.0K J 1/10W		
R160			RK73FB2A472J	CHIP R 4.7K J 1/10W		
R164			R92-0670-05	CHIP R 0 0HM		
R165			RK73FB2A102J	CHIP R 1.0K J 1/10W		
R166			RK73FB2A182J	CHIP R 1.8K J 1/10W		
R167			RK73FB2A102J	CHIP R 1.0K J 1/10W		
R168			RK73FB2A103J	CHIP R 10K J 1/10W		
R169			RK73FB2A223J	CHIP R 22K J 1/10W		
R170			RK73FB2A562J	CHIP R 5.6K J 1/10W		
R171			RK73FB2A101J	CHIP R 100 J 1/10W		
R172			RK73FB2A472J	CHIP R 4.7K J 1/10W		
R176			RK73FB2A471J	CHIP R 470 J 1/10W		
R177			RK73FB2A103J	CHIP R 10K J 1/10W		
R178			RK73FB2A101J	CHIP R 100 J 1/10W		
R179			RK73FB2A332J	CHIP R 3.3K J 1/10W		
R180			RK73FB2A563J	CHIP R 56K J 1/10W		
R181			RK73FB2A472J	CHIP R 4.7K J 1/10W		
R182			RK73FB2A333J	CHIP R 33K J 1/10W		
R183			RK73FB2A472J	CHIP R 4.7K J 1/10W		
R184			R92-0670-05	CHIP R 0 0HM		
R185			RK73FB2A103J	CHIP R 10K J 1/10W		
R186			RK73FB2A154J	CHIP R 150K J 1/10W		
R187			RK73FB2A102J	CHIP R 1.0K J 1/10W		
R188			RK73FB2A222J	CHIP R 2.2K J 1/10W		
R189			RK73FB2A391J	CHIP R 390 J 1/10W		
R190			RK73FB2A681J	CHIP R 680 J 1/10W		
R191			RK73FB2A471J	CHIP R 470 J 1/10W		
R192-194			RK73FB2A102J	CHIP R 1.0K J 1/10W		
R195			RK73FB2A471J	CHIP R 470 J 1/10W		
R196			RK73FB2A472J	CHIP R 4.7K J 1/10W		
R197			RK73FB2A101J	CHIP R 100 J 1/10W		
R198			RK73FB2A391J	CHIP R 390 J 1/10W		
R199			RK73FB2A101J	CHIP R 100 J 1/10W		
R200			RK73FB2A471J	CHIP R 470 J 1/10W		
R206			RK73FB2A221J	CHIP R 220 J 1/10W		
R207			RK73FB2A103J	CHIP R 10K J 1/10W		
R208-211			RK73FB2A330J	CHIP R 33 J 1/10W		
R212, 213			RK73FB2A104J	CHIP R 100K J 1/10W		
R214			RK73FB2A101J	CHIP R 100 J 1/10W		
R215			RK73FB2A102J	CHIP R 1.0K J 1/10W		
R216			RK73FB2A332J	CHIP R 3.3K J 1/10W		
R217			RK73FB2A561J	CHIP R 560 J 1/10W		
R218			RK73FB2A681J	CHIP R 680 J 1/10W		
R219			RK73FB2A4R7J	CHIP R 4.7 J 1/10W		
R220			RK73FB2A100J	CHIP R 10 J 1/10W		

E: Scandinavia & Europe K: USA P: Canada W: Europe

U: PX(Far East, Hawaii) T: England M: Other Areas

UE: AAFES(Europe) X: Australia

⚠ indicates safety critical components.

PARTS LIST

× New Parts

Parts without Parts No. are not supplied.

Les articles non mentionnés dans le Parts No. ne sont pas fournis.

Teile ohne Parts No. werden nicht geliefert.

TX-RX UNIT (X57-3470-10)

Ref. No. 参照番号	Address 位置	New Parts 新	Parts No. 部品番号	Description 部品名 / 規格	Desti- nation 仕向	Re- marks 備考
R221			RK73FB2A680J	CHIP R 68 J 1/10W		
R222			RK73FB2A472J	CHIP R 4.7K J 1/10W		
R223			RK73FB2A681J	CHIP R 680 J 1/10W		
R224			RK73FB2A220J	CHIP R 22 J 1/10W		
R225			RK73FB2A221J	CHIP R 220 J 1/10W		
R226			RK73FB2A330J	CHIP R 33 J 1/10W		
R227			RK73FB2A102J	CHIP R 1.0K J 1/10W		
R228			RK73FB2A222J	CHIP R 2.2K J 1/10W		
R229			RK73FB2A102J	CHIP R 1.0K J 1/10W		
R230			RK73FB2A102J	CHIP R 1.0K J 1/10W		
R231			RK73FB2A334J	CHIP R 330K J 1/10W		
R232, 233			RK73FB2A102J	CHIP R 1.0K J 1/10W		
R234			RK73FB2A334J	CHIP R 330K J 1/10W		
R235			RK73FB2A221J	CHIP R 220 J 1/10W		
R236			RK73FB2A472J	CHIP R 4.7K J 1/10W		
R237			RK73FB2A103J	CHIP R 10K J 1/10W		
R238			RK73FB2A471J	CHIP R 470 J 1/10W		
R240			RK73FB2A101J	CHIP R 100 J 1/10W		
R246			RK73FB2A222J	CHIP R 2.2K J 1/10W		
R247			RK73FB2A221J	CHIP R 220 J 1/10W		
R248			RK73FB2A223J	CHIP R 22K J 1/10W		
R249			RK73FB2A683J	CHIP R 68K J 1/10W		
R250			RK73FB2A473J	CHIP R 47K J 1/10W		
R251			RK73FB2A223J	CHIP R 22K J 1/10W		
R252			RK73FB2A473J	CHIP R 47K J 1/10W		
R253			RK73FB2A333J	CHIP R 33K J 1/10W		
R254, 255			RK73FB2A104J	CHIP R 100K J 1/10W		
R256			RK73FB2A223J	CHIP R 22K J 1/10W		
R257			RK73FB2A153J	CHIP R 15K J 1/10W		
R258			RK73FB2A224J	CHIP R 220K J 1/10W		
R259			RK73FB2A474J	CHIP R 470K J 1/10W		
R260			RK73FB2A223J	CHIP R 22K J 1/10W		
R261			RK73FB2A104J	CHIP R 100K J 1/10W		
R262, 263			RK73FB2A102J	CHIP R 1.0K J 1/10W		
R264			RK73FB2A101J	CHIP R 100 J 1/10W		
R265			RK73FB2A334J	CHIP R 330K J 1/10W		
R266			RK73FB2A472J	CHIP R 4.7K J 1/10W		
R267			RK73FB2A332J	CHIP R 3.3K J 1/10W		
R268			RK73FB2A103J	CHIP R 10K J 1/10W		
R269			RK73FB2A152J	CHIP R 1.5K J 1/10W		
R270-272			RK73FB2A103J	CHIP R 10K J 1/10W		
R273			RK73FB2A152J	CHIP R 1.5K J 1/10W		
R274, 275			RK73FB2A103J	CHIP R 10K J 1/10W		
R277-279			RK73FB2A471J	CHIP R 470 J 1/10W		
R280			RK73FB2A153J	CHIP R 15K J 1/10W		
R286, 287			RK73FB2A471J	CHIP R 470 J 1/10W		
R289			RK73FB2A471J	CHIP R 470 J 1/10W		
R292-296			RK73FB2A471J	CHIP R 470 J 1/10W		
R298			RK73FB2A103J	CHIP R 10K J 1/10W		
R299			RK73FB2A332J	CHIP R 3.3K J 1/10W		
VR3		*	R12-6475-05	TRIMMING POT. 47K		
VR4		*	R12-6471-05	TRIM POT. 10K		
VR5		*	R12-3126-05	TRIM POT. 10K		
VR6 -8		*	R12-6475-05	TRIMMING POT. 47K		
VR9		*	R12-3126-05	TRIM POT. 10K		

E: Scandinavia & Europe K: USA P: Canada W: Europe

U: PX(Far East, Hawaii) T: England M: Other Areas

UE: AAFES(Europe) X: Australia

△ indicates safety critical components.

PARTS LIST

* New Parts

Parts without Parts No. are not supplied.

Les articles non mentionnes dans le Parts No. ne sont pas fournis.

Telle ohne Parts No. werden nicht geliefert.

TX-RX UNIT (X57-3470-10)

Ref. No. 参照番号	Address 位置	New Parts 新	Parts No. 部品番号	Description 部品名 / 規格	Desti- nation 仕 向	Re- marks 備考
VR10		*	R12-6471-05	TRIM POT. 10K		
VR11		*	R12-6465-05	TRIMMING POT.1K		
VR12,13		*	R12-6471-05	TRIM POT. 10K		
VR14,15		*	R12-6475-05	TRIMMING POT.47K		
VR17		*	R12-6477-05	TRIMMING POT.100K		
VR18		*	R12-6473-05	TRIMMING POT.22K		
VR19,20		*	R12-6471-05	TRIM POT. 10K		
K1			S51-1428-05	RELAY		
S1			S31-1411-05	SLIDE SWITCH (METER)		
D1			V08(G)	DIODE		
D2		*	RLS245	CHIP DIODE		
D3			V08(G)	DIODE		
D4		*	RLS245	CHIP DIODE		
D5 -20			RLS135	CHIP DIODE		
D21 ,22			1SS226	CHIP DIODE		
D24 -30			1SS268	CHIP DIODE		
D31 ,32			1SS184	CHIP DIODE		
D33			1SS268	CHIP DIODE		
D34 -36			1SS184	CHIP DIODE		
D37 ,38			1SS181	CHIP DIODE		
D39			DLS1585	CHIP DIODE		
D45			1SS184	CHIP DIODE		
D46		*	O2CZ9.1(X,Y)	ZENER DIODE(9.1V)		
D47		*	RLS245	CHIP DIODE		
D48			DLS1585	CHIP DIODE		
D49 -51			1SS184	CHIP DIODE		
D52 -54			DLS1585	CHIP DIODE		
D57 ,58			1SS184	CHIP DIODE		
D59 ,60			DLS1585	CHIP DIODE		
D64 -66			1SS184	CHIP DIODE		
D67 ,68			1SS268	CHIP DIODE		
D69 -72			1SS184	CHIP DIODE		
D73			O2CZ6.2(Y,Z)	ZENER DIODE(6.2V)		
D74			O2CZ5.1X,Y	ZENER DIODE(5.1V)		
D75			1SS184	CHIP DIODE		
IC1		*	KCX01	IC(NB HIC)		
IC2		*	KCD03	IC(IF HIC)		
IC3		*	KCX02	IC(SQL HIC)		
IC4			NJM2904M	IC(OP AMP X2)		
IC5			UPC1242H	IC(AF POWER AMP)		
IC6			UPC1037HA	IC(DUBBLE BALANCE MODULATOR)		
IC7			SN16913P	IC(DUBLE BALANCED MIXERS)		
IC8			NJM2904M	IC(OP AMP X2)		
IC9 ,10			TC9174F	IC(CMOS I/O)		
IC11			UPC78M08H	IC(8V AVR)		
Q1 -8		*	DTB143EK	DIGITAL TRANSISTOR		
Q9 ,10			2SK125-5	FET		
Q11			FMC3	DIGITAL TRANSISTOR		
Q12			3SK131(M)	CHIP FET		
Q13 ,14			2SK520(K44)	CHIP FET		
Q15			3SK131(M)	CHIP FET		
Q16			2SC2712(Y)	CHIP TRANSISTOR		
Q17 -19			DTC114EK	DIGITAL TRANSISTOR		
Q20			DTA114EK	DIGITAL TRANSISTOR		

E: Scandinavia & Europe K: USA P: Canada W: Europe

U: PX(Far East, Hawaii) T: England M: Other Areas

UE: AAFES(Europe) X: Australia

⚠ indicates safety critical components.

PARTS LIST

* New Parts

Parts without Parts No. are not supplied.

Les articles non mentionnés dans le Parts No. ne sont pas fournis.

Teile ohne Parts No. werden nicht geliefert.

TX-RX UNIT (X57-3470-10)

VCO (X58-3720-10)

Ref. No. 参照番号	Address 位置	New Parts 新	Parts No. 部品番号	Description 部品名 / 規格	Desti- nation 仕向	Re- marks 備考
Q21			DTC114EK	DIGITAL TRANSISTOR		
Q24			FMC3	DIGITAL TRANSISTOR		
Q25			DTA114EK	DIGITAL TRANSISTOR		
Q26			FMC3	DIGITAL TRANSISTOR		
Q27			DTC114EK	DIGITAL TRANSISTOR		
Q28			DTA114EK	DIGITAL TRANSISTOR		
Q29			2SC3324(G)	CHIP TRANSISTOR		
Q30			2SD1757(K)	CHIP TRANSISTOR		
Q31 , 32			DTC114EK	DIGITAL TRANSISTOR		
Q33 , 34			2SC2712(Y)	CHIP TRANSISTOR		
Q35		*	DTD143EK	DIGITAL TRANSISTOR		
Q36		*	2SC3649(S,T)	CHIP TRANSISTOR		
Q37 , 38			2SC3324(G)	CHIP TRANSISTOR		
Q39			DTC114EK	DIGITAL TRANSISTOR		
Q40			DTA114EK	DIGITAL TRANSISTOR		
Q44			DTC114EK	DIGITAL TRANSISTOR		
Q45			3SK131(M)	CHIP FET		
Q47			2SA1162(Y)	CHIP TRANSISTOR		
Q48			DTA114EK	DIGITAL TRANSISTOR		
Q49			2SC2714(Y)	CHIP TRANSISTOR		
Q50 -52			3SK179(L)	CHIP FET		
Q53 , 54			2SC2053	TRANSISTOR		
Q55 -57			2SC2714(Y)	CHIP TRANSISTOR		
Q58			DTC114EK	DIGITAL TRANSISTOR		
Q59			2SC2712(Y)	CHIP TRANSISTOR		
Q60			2SA1213(Y)	CHIP TRANSISTOR		
Q64			2SC2712(Y)	CHIP TRANSISTOR		
Q65			DTC114EK	DIGITAL TRANSISTOR		
Q66			2SA1213(Y)	CHIP TRANSISTOR		
Q67			2SC2712(Y)	CHIP TRANSISTOR		
Q68			DTC114EK	DIGITAL TRANSISTOR		
TH1			112-502-2	THERMISTOR 5K		
TH2			112-103-2	THERMISTOR 10K		
TH3			112-502-2	THERMISTOR 5K		
TH4			112-501-2	THERMISTOR 500		
Z1		*	X59-1100-00	MODULE UNIT (DC-DC CONV.)		
C95			CK73FB1H102K	CHIP C 1000PF K		
VCO (X58-3720-10)						
C1			CK73FB1H102K	CHIP C 1000PF K		
C2			CC73FCH1H330J	CHIP C 33PF J		
C3			CC73FCH1H100D	CHIP C 10PF D		
C4			CC73FCH1H010C	CHIP C 1.0PF C		
C5			CC73FCH1H070D	CHIP C 7PF D		
C6			CC73FCH1H200J	CHIP C 20PF J		
C7			CC73FCH1H120J	CHIP C 12PF J		
C8			CK73FB1H102K	CHIP C 1000PF K		
C9			CC73FCH1H050C	CHIP C 5PF C		
C10 , 11			CK73FB1H102K	CHIP C 1000PF K		
C12			CC73FCH1H270J	CHIP C 27PF J		
C13			CC73FCH1H100D	CHIP C 10PF D		
C14			CC73FCH1H020C	CHIP C 2PF C		
C15			CC73FCH1H090D	CHIP C 9PF D		
C16			CC73FCH1H180J	CHIP C 18PF J		

E: Scandinavia & Europe K: USA P: Canada W: Europe

U: PX(Far East, Hawaii) T: England M: Other Areas

UE: AAFES(Europe) X: Australia

⚠ indicates safety critical components.

PARTS LIST

× New Parts

Parts without Parts No. are not supplied.

Les articles non mentionnés dans le Parts No. ne sont pas fournis.

Teile ohne Parts No. werden nicht geliefert.

VCO (X58-3720-10)

Ref. No. 参照番号	Address 位置	New Parts 新	Parts No. 部品番号	Description 部品名 / 規格	Desti- nation 仕 向	Re- marks 備考
C17			CC73FCH1H090D	CHIP C 9PF D		
C18			CK73FB1H102K	CHIP C 1000PF K		
C19			CC73FCH1H050C	CHIP C 5PF C		
C20 ,21			CK73FB1H102K	CHIP C 1000PF K		
C22			CC73FCH1H240J	CHIP C 24PF J		
C23			CC73FCH1H100D	CHIP C 10PF D		
C25			CC73FCH1H080D	CHIP C 8PF D		
C26			CC73FCH1H160J	CHIP C 16PF J		
C27			CC73FCH1H120J	CHIP C 12PF J		
C28			CK73FB1H102K	CHIP C 1000PF K		
C29			CC73FCH1H050C	CHIP C 5PF C		
C30 ,31			CK73FB1H102K	CHIP C 1000PF K		
C32			CC73FCH1H240J	CHIP C 24PF J		
C33			CC73FCH1H100D	CHIP C 10PF D		
C35			CC73FCH1H070D	CHIP C 7PF D		
C36			CC73FCH1H120J	CHIP C 12PF J		
C37			CC73FCH1H080D	CHIP C 8PF D		
C38			CK73FB1H102K	CHIP C 1000PF K		
C39			CC73FCH1H050C	CHIP C 5PF C		
C40 -48			CK73FB1H102K	CHIP C 1000PF K		
TC1 -4			C05-0345-05	TRIMMING CAP 10PF		
CN1			E40-5211-05	PIN CONNECTOR (8P)		
A1		*	F10-1419-04	SHIELDING PLATE		
A2		*	F10-1420-04	SHIELDING PLATE		
A3		*	G13-0954-04	FORMED PLATE		
L1		*	L33-0729-05	CHOKE COIL		
L2		*	L34-2360-05	COIL		
L3		*	L33-0729-05	CHOKE COIL		
L4		*	L34-2359-05	COIL		
L5		*	L33-0729-05	CHOKE COIL		
L6		*	L34-2359-05	COIL		
L7		*	L33-0729-05	CHOKE COIL		
L8		*	L34-2358-05	COIL		
			N30-2604-41	PAN HEAD MACHINE SCREW		
R1			RK73FB2A682J	CHIP R 6.8K J 1/10W		
R2			RK73FB2A271J	CHIP R 270 J 1/10W		
R3			RK73FB2A332J	CHIP R 3.3K J 1/10W		
R4			RK73FB2A682J	CHIP R 6.8K J 1/10W		
R5			RK73FB2A271J	CHIP R 270 J 1/10W		
R6			RK73FB2A332J	CHIP R 3.3K J 1/10W		
R7			RK73FB2A682J	CHIP R 6.8K J 1/10W		
R8			RK73FB2A271J	CHIP R 270 J 1/10W		
R9			RK73FB2A332J	CHIP R 3.3K J 1/10W		
R10			RK73FB2A682J	CHIP R 6.8K J 1/10W		
R11			RK73FB2A271J	CHIP R 270 J 1/10W		
R12			RK73FB2A332J	CHIP R 3.3K J 1/10W		
R13 ,14			RK73FB2A472J	CHIP R 4.7K J 1/10W		
R15			RK73FB2A560J	CHIP R 56 J 1/10W		
R16			RK73FB2A471J	CHIP R 470 J 1/10W		
R17			RK73FB2A332J	CHIP R 3.3K J 1/10W		

E: Scandinavia & Europe K: USA P: Canada W: Europe

U: PX(Far East, Hawaii) T: England M: Other Areas

UE: AAFES(Europe) X: Australia

▲ indicates safety critical components.

PARTS LIST

× New Parts

Parts without Parts No. are not supplied.

Les articles non mentionnés dans le Parts No. ne sont pas fournis.

Teile ohne Parts No. werden nicht geliefert.

VCO (X58-3720-10)

DC-DC (X59-1100-00)

FAN & TEMP PROTECTION (X59-3370-00)

VCO (X59-3440-00)

Ref. No. 参照番号	Address 位置	New Parts 新	Parts No. 部品番号	Description 部品名 / 規格	Desti- nation 仕向	Re- marks 備考
D1			1SV166	CHIP DIODE		
D2			RLS135	CHIP DIODE		
D3			1SV166	CHIP DIODE		
D4			RLS135	CHIP DIODE		
D5			1SV166	CHIP DIODE		
D6			RLS135	CHIP DIODE		
D7			1SV166	CHIP DIODE		
D8			RLS135	CHIP DIODE		
Q1			2SK508NV(K52)	CHIP FET		
Q2			DTC114EK	DIGITAL TRANSISTOR		
Q3			2SK508NV(K52)	CHIP FET		
Q4			DTC114EK	DIGITAL TRANSISTOR		
Q5			2SK508NV(K52)	CHIP FET		
Q6			DTC114EK	DIGITAL TRANSISTOR		
Q7			2SK508NV(K52)	CHIP FET		
Q8			DTC114EK	DIGITAL TRANSISTOR		
Q9			2SC2714(Y)	CHIP TRANSISTOR		
DC-DC (X59-1100-00)						
C1	.2		CK73FB1H222K	CHIP C 2200PF K		
			E23-0471-05	TERMINAL		
JR1	-3		R92-0670-05	CHIP R 0 OHM		
R1			RK73FB2A272J	CHIP R 2.7K J 1/10W		
R2	.3		RK73FB2A223J	CHIP R 22K J 1/10W		
R4			RK73FB2A473J	CHIP R 47K J 1/10W		
R5			RK73FB2A471J	CHIP R 470 J 1/10W		
D1			1SS226	CHIP DIODE		
Q1	.2		2SC2712(Y)	CHIP TRANSISTOR		
Q3			2SA1162(Y)	CHIP TRANSISTOR		
FAN & TEMP PROTECTION (X59-3370-00)						
C1			CK73FB1H103K	CHIP C 0.010UF K		
			E23-0471-05	TERMINAL		
R1			RK73FB2A103J	CHIP R 10K J 1/10W		
R2			RK73FB2A223J	CHIP R 22K J 1/10W		
R3			RK73FB2A562J	CHIP R 5.6K J 1/10W		
R4			RK73FB2A681J	CHIP R 680 J 1/10W		
R5			RK73FB2A562J	CHIP R 5.6K J 1/10W		
R6			RK73FB2A332J	CHIP R 3.3K J 1/10W		
R7			RK73FB2A562J	CHIP R 5.6K J 1/10W		
R8			RK73FB2A223J	CHIP R 22K J 1/10W		
R9, W1, 2			R92-0670-05	CHIP R 0OHM		
1C1			NJM2904M	IC(OP AMP X2)		
Q1			DTD123EK	DIGITAL TRANSISTOR		
VCO (X59-3440-00)						
C1			CC73FCH1H080D	CHIP C 8PF D		
C2			CK73FB1H102K	CHIP C 1000PF K		
C3			CC73FCH1H030C	CHIP C 3PF C		
C4			CK73FB1H103K	CHIP C 0.010UF K		
			E23-0471-05	TERMINAL		
L1			L40-1011-48	SMALL FIXED INDUCTOR 100UH		

E: Scandinavia & Europe K: USA P: Canada W: Europe

U: PX(Far East, Hawaii) T: England M: Other Areas

UE: AAFES(Europe) X: Australia

△ indicates safety critical components.

TKM-707

PARTS LIST

* New Parts

Parts without Parts No. are not supplied.

Les articles non mentionnés dans le Parts No. ne sont pas fournis.

Teile ohne Parts No. werden nicht geliefert.

VCO (X59-3440-00)

Ref. No. 参照番号	Address 位置	New Parts 新	Parts No. 部品番号	Description 部品名 / 規格	Desti- nation 仕向	Re- marks 備考
R1			RK73FB2A334J	CHIP R 330K J 1/10W		
R2			RK73FB2A151J	CHIP R 150 J 1/10W		
R3			RK73FB2A330J	CHIP R 33 J 1/10W		
R4			RK73FB2A224J	CHIP R 220K J 1/10W		
R5			RK73FB2A470J	CHIP R 47 J 1/10W		
R6			RK73FB2A101J	CHIP R 100 J 1/10W		
R7			RK73FB2A102J	CHIP R 1.0K J 1/10W		
Q1			2SK210(GR)	CHIP FET		
Q2			2SC2714(Y)	CHIP TRANSISTOR		

E: Scandinavia & Europe K: USA P: Canada W: Europe

U: PX(Far East, Hawaii) T: England M: Other Areas

UE: AAFES(Europe) X: Australia

 indicates safety critical components.

EXPLODED VIEW

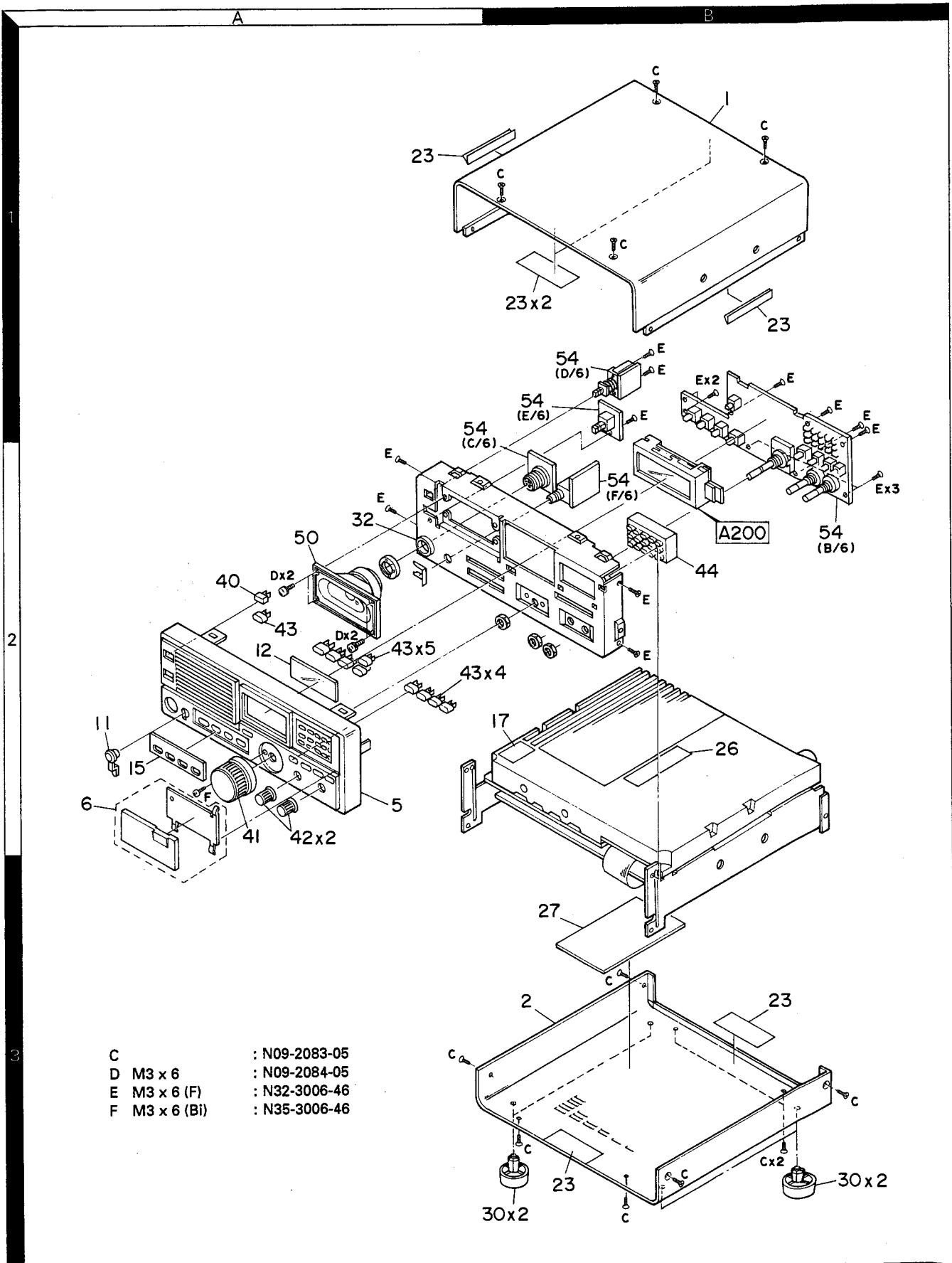

TKM-707

EXPLODED VIEW

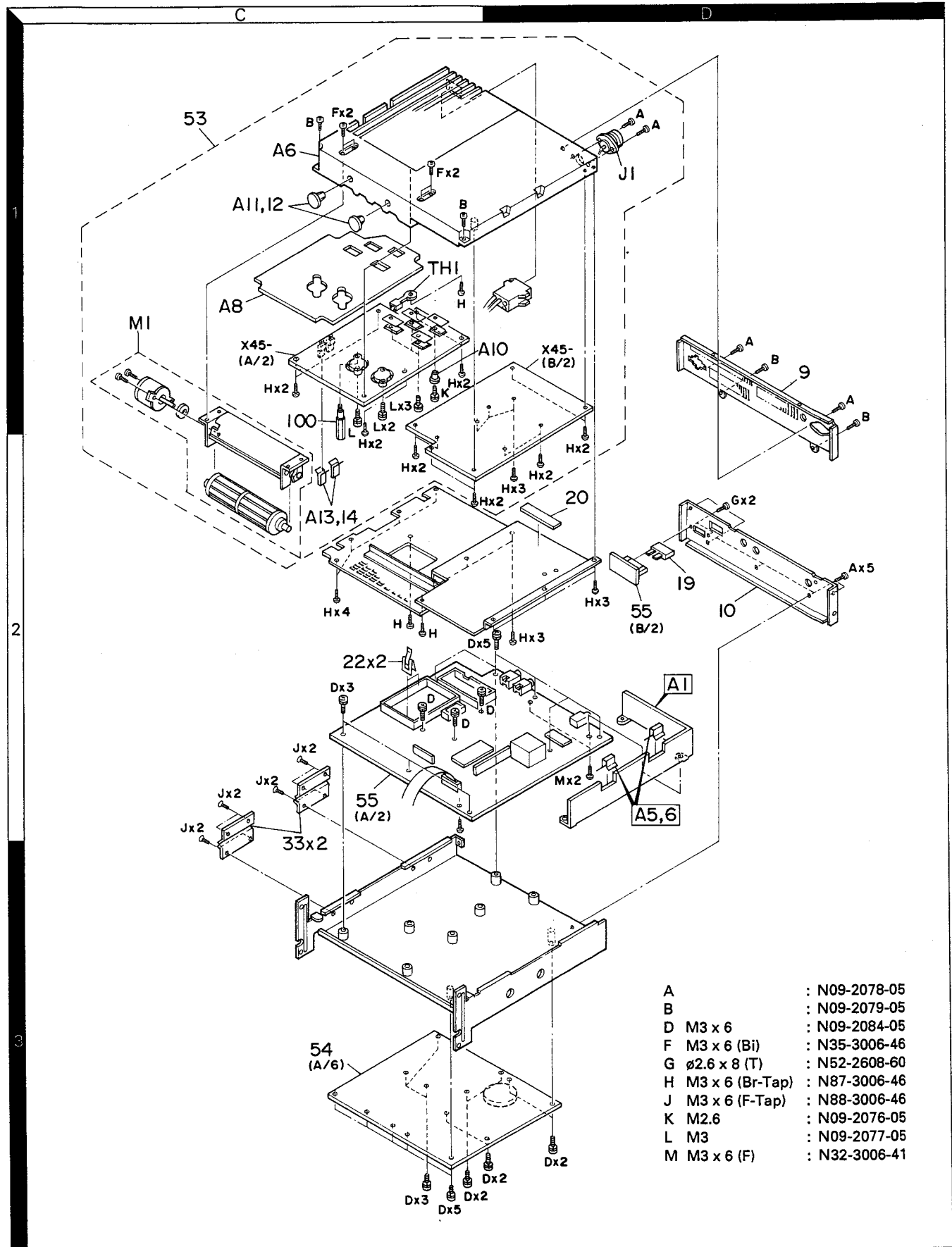

PACKING

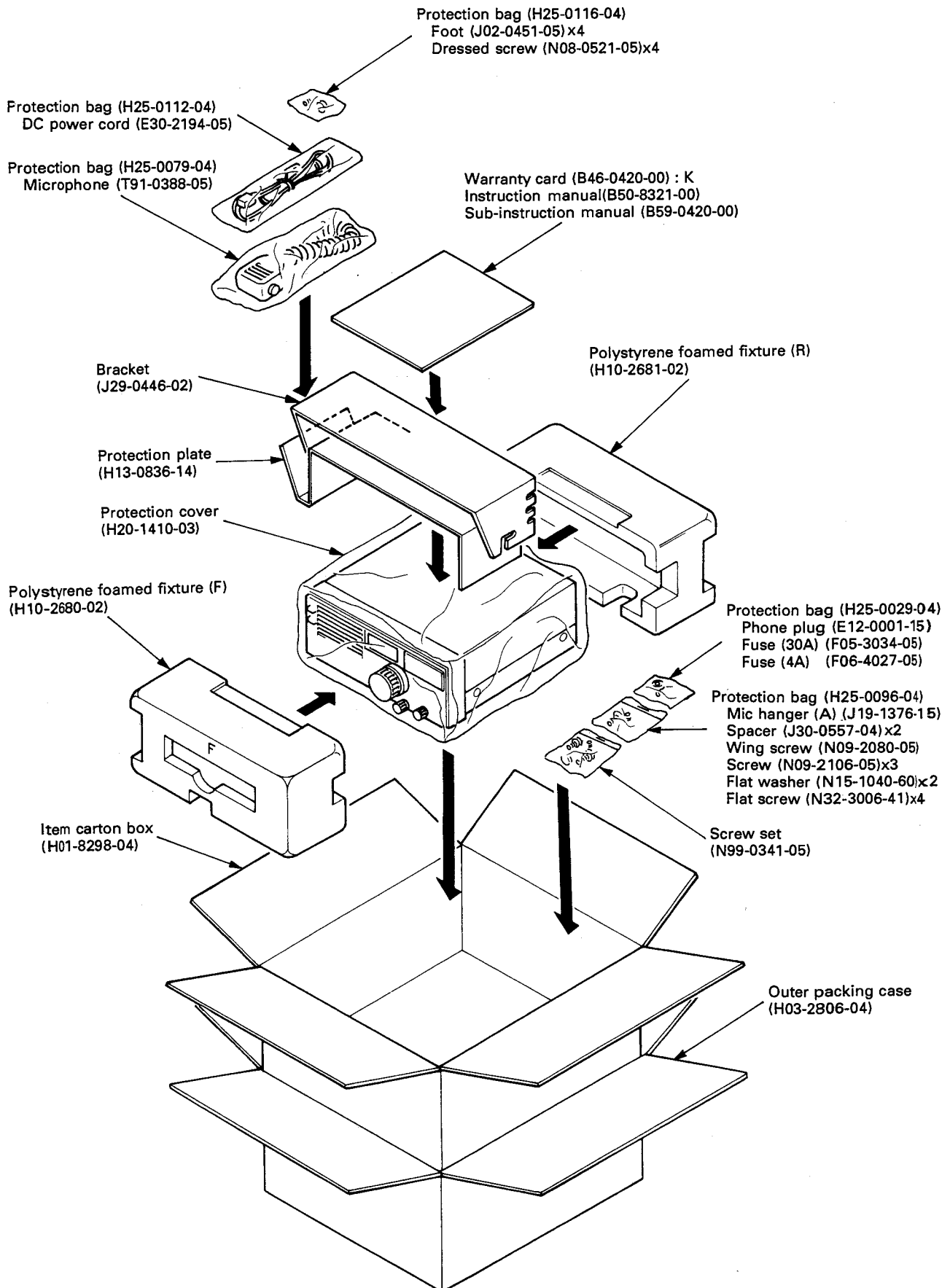

TKM-707

ADJUSTMENT

Front Panel

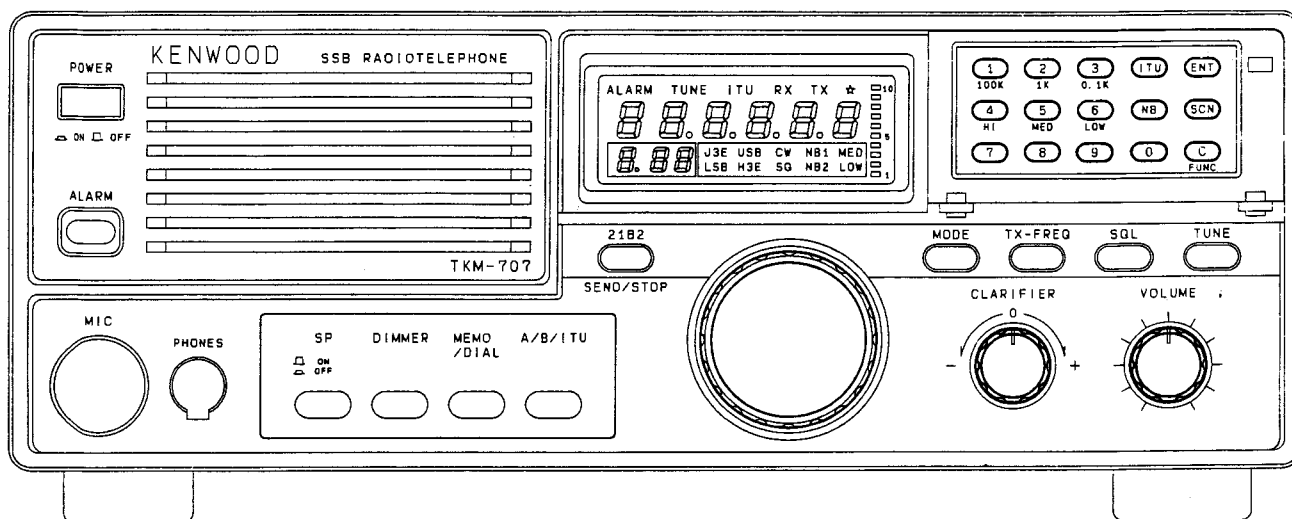

Rear Panel

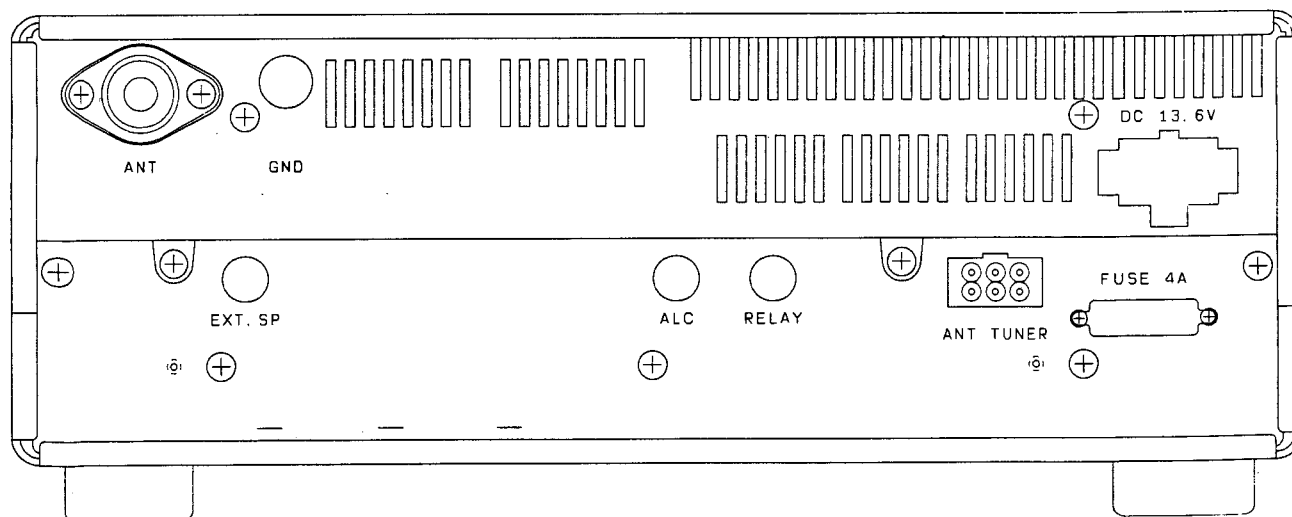

ADJUSTMENT

FCC Requirements

The FCC requires that the deviation and frequency of the transceiver be checked annually.

Precautions

The inherent quality of the solid-state components used in this transceiver provides many years of continuous use. Take the following precautions to prevent damage to the transceiver.

- Never key the transmitter unless an antenna or suitable dummy load is connected to the transceiver's antenna receptacle.
- Ensure that the input voltage does not exceed 16V DC or fall below 11V DC.

Test Applications

- Performance test : conducted to check overall transceiver operation. This should be performed before transceiver sale/installation.
- Alignment : conducted if the transceiver fails the performance test or if a critical electrical component has been replaced. KENWOOD recommends that alignment be performed whenever maintenance is performed.

Test Equipment

The following test equipment, or its equivalent, is necessary for TKM-707 maintenance.

Test Equipment Required for Alignment

No.	Test Equipment	Major Specifications
1	Standard Signal Generator (SSG)	Frequency Range Modulation Output 0.5 to 30 MHz. AM or external modulation. 0.1 μ V to greater than 1 mV.
2	Power Meter	Input Impedance Operation Frequency Measurement Capability 50 Ω . 0.5 to 30 MHz or more. Vicinity 200 W.
3	Directional coupler	Operation Frequency 0.5 to 30 MHz.
4	Digital Volt Meter (DVM)	Measuring Range Accuracy 20V DC. High input impedance for minimum circuit loading.
5	Oscilloscope	DC through 30 MHz.
6	High Sensitivity Frequency Counter	Frequency Range Frequency Stability 10 Hz to 100 MHz. 0.2 ppm or less.
7	Ammeter	30A.
8	AF Volt Meter (AF VTVM)	Frequency Range Voltage Range 50 Hz to 10 kHz. 3 mV to 3 V.
9	Audio Generator (AG) QTY : 2	Frequency Range Output 50 Hz to 5 kHz or more. 1 and 1 V.
10	RF Volt Meter (RF VTVM)	Frequency Range Voltage Range Impedance 10 kHz to 500 MHz. 10 mV to 300 V. 1 M Ω and less than 3 pF, min.
11	Voltmeter	Measuring Range Input Impedance 10 to 1.5 V DC or less. 50 k Ω /V or greater.
12	Dummy Load	Approx. 4 Ω , 5 W.
13	Regulated Power Supply	13.6 V approx. 30 A (adjustable from 11 to 16 V). Useful if ammeter equipped.

TKM-707

ADJUSTMENT

Alignment

The TKM-707 alignment points are shown in figure. After connecting test equipment, ensure that the supply voltage is 13.6V.

Top view

TX-RX unit (X57-3470-10)

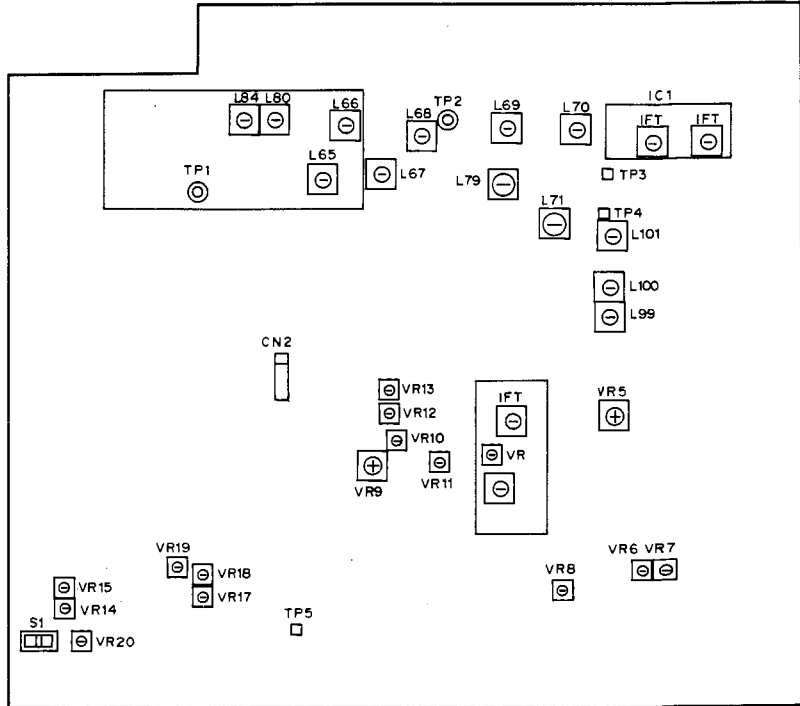

Bottom view

Control unit (X53-3280-10)

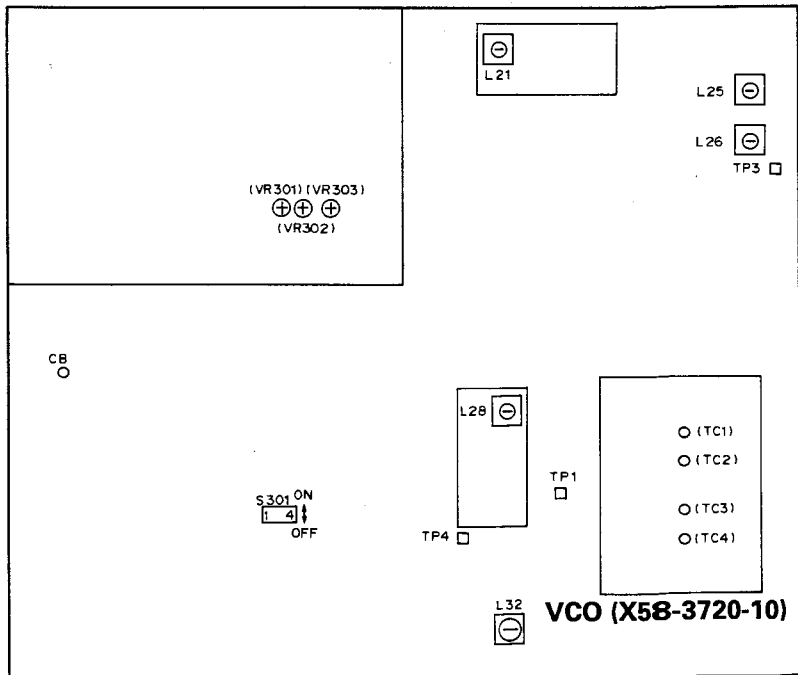

ADJUSTMENT

Preparations

1. Remove the screws from the top and bottom of the case to expose the bottom of the set. (The control unit (x53-3280-10) can be seen.)
2. Check that the POWER switch is set to OFF.
3. Change DIP switch S301's No.1 of the control unit from ON to OFF. (The operation mode changes from the user mode to the dealer mode.)

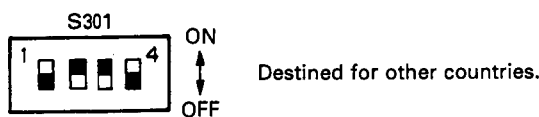
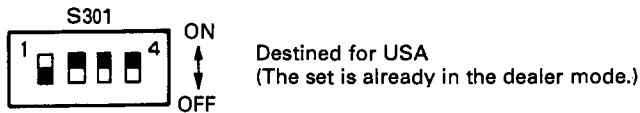

Indicates the switch setting position (OFF).

4. Set the POWER switch to ON while holding the ENT key down. (Microcomputer reset)
5. Write the receive and transmit frequencies to the memory channel as follows:

Memorize the required receive and transmit frequencies on the memory channel during adjustment. Memorized frequencies and modes are as follows:
 2.100.0 MHz USB
 4.100.0 MHz USB

Write the memory in the following order:

- 1) Press the MEMO/DIAL key to enter the memory mode.
- 2) Press the ENT key to enter the memory entry mode. A vacant channel display is shown below.

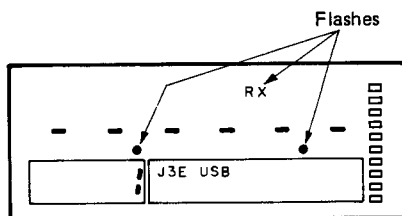

- 3) Rotate the channel selector to select the desired memory channel (vacant channel) on which no frequency has been memorized.

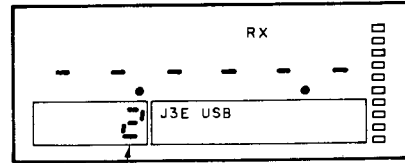

Rotate the channel selector until the desired memory channel appears.

- 4) Enter the receive frequency sequentially from the high-order digit from the numeric keypad. Example: When memorizing 2.100.0 MHz, enter 2, 1, 0, 0, 0 in this sequence.

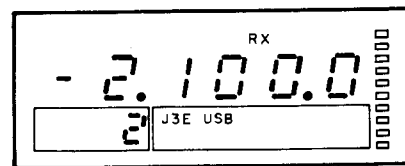

- 5) Press the MODE key to set the desired USB mode.
- 6) Press the ENT key to store the RX data into the selected memory channel.
- 7) The display panel is shown below.

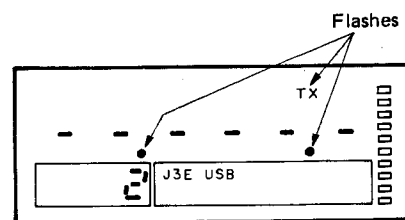

- 8) Enter the transmit frequency sequentially from the high-order digit from the numeric keypad. Enter the same 2.100.0 MHz frequency as the receive frequency.

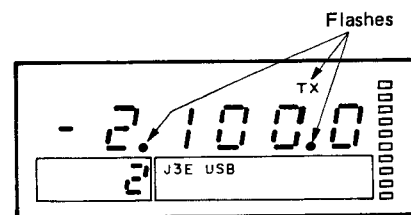

- 9) Press the ENT key.

Writing the 2.100.0 MHz frequency and USB mode to a certain memory channel is completed. Write other frequencies and modes to vacant channels in the same way as the above.

ADJUSTMENT

PLL Adjustment

1. PLL C-Loop (carrier) Check and Adjustment

1-1. Voltage-controlled oscillator (VCO) check

1. Connect a digital voltmeter to the TP4 terminal of the control unit.
2. Press the MEMO/DIAL key to enter the memory mode.
3. Turn the channel selector and read the selected 2.100.0 MHz USB.
4. Check that the display frequency is 2.100.0 USB and that the voltage is 3 to 5 V.
5. Set the mode to 2.100.0 LSB with the MODE key. Check that the voltage is 0.3 to 0.5 V lower than the USB voltage.

1-2. Output level adjustment

1. Connect an RF voltmeter to the TP5 terminal of the control unit.
2. Turn L32's core of the control unit in the direction in which it is inserted until the output becomes 0.35 Vrms. (Specification: 0.35 ± 0.03 Vrms)

2. Clarifier Adjustment

1. Set the clarifier control on the front panel to the center click position.
2. Turn VR303 of the control unit until symbol ★ on the LCD display disappears.
3. Check that the same width to center clock position of clarifier control when clarifier control is turned right and left position. (Until symbol ★ on the LCD display disappears.)

3. PLL B-Loop Check

1. Connect a digital voltmeter to the TP2 terminal of the control unit.
2. With the set in the memory mode, press the MEMO/DIAL key to enter the dial mode.
3. Enter 2.100.0 from the numeric keypad, then press the ENT key.
A beep sounds, and the frequency becomes 2.100.0 MHz.
Press the MODE key to enter the USB mode.
4. Check that the voltage at TP2 is 1.5 to 3.0 V.
5. Turn the channel selector until the frequency is 2.099.9 MHz.
6. Check that the voltage at TP2 is 5.5 to 7.0 V.

4. PLL MCF Adjustment

1. Connect an RF voltmeter to the TP3 terminal of the control unit.
2. Alternately turn L25 and L26 of the control unit until they are maximum. (Specification: 30 to 40 mV)

5. PLL A-Loop Check

1. Connect a digital voltmeter to the TP1 terminal of the control unit.
2. Press the MEMO/DIAL key to enter the dial mode.
3. Enter 22.000.0 MHz from the numeric keypad, then press the ENT key.
Press the MODE key to enter the USB mode.
4. Check that the voltage at TP1 is 1.5 to 2.5V.
If the voltage at TP1 is unable to 1.5 to 2.5V, adjustment are as follows :
Enter 29.999.9 MHz from the numeric keypad, then press the ENT key.
Press the MODE key to enter the USB mode.
Turn TC4 of the X58-3720-10 in the control unit until the voltage is 6.5 ± 0.1 V.
5. Enter 14.000.0 MHz from the numeric keypad, then press the ENT key.
Press the MODE key to enter the USB mode.
6. Check that the voltage at TP1 is 1.5 to 2.5V.
If the voltage at TP1 is unable to 1.5 to 2.5V, adjustment are as follows :
Enter 21.999.9 MHz from the numeric keypad, then press the ENT key.
Press the MODE key to enter the USB mode.
Turn TC3 of the X58-3720-10 in the control unit until the voltage is 6.5 ± 0.1 V.
7. Enter 7.000.0 MHz from the numeric keypad, then press the ENT key.
Press the MODE key to enter the USB mode.
8. Check that the voltage at TP1 is 1.5 to 2.5V.
If the voltage at TP1 is unable to 1.5 to 2.5V, adjustment are as follows :
Enter 13.999.9 MHz from the numeric keypad, then press the ENT key.
Press the MODE key to enter the USB mode.
Turn TC2 of the X58-3720-10 in the control unit until the voltage is 6.5 ± 0.1 V.
9. Enter 0.100.0 MHz from the numeric keypad, then press the ENT key.
Press the MODE key to enter the USB mode.

ADJUSTMENT

10. Check that the voltage at TP1 is 1.5 to 2.5V.
 If the voltage at TP1 is unable to 1.5 to 2.5V, adjustment are as follows :
 Enter 6.999.9 MHz from the numeric keypad, then press the ENT key.
 Press the MODE key to enter the USB mode.
 Turn TC1 of the X58-3720-10 in the control unit until the voltage is $6.5 \pm 0.1V$.

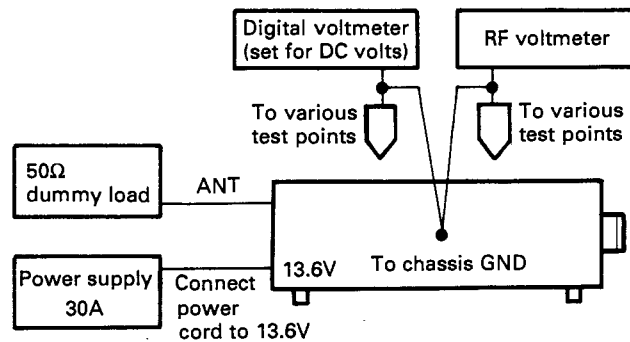

Receiver Adjustment

1. Second HET Adjustment (HET2: 60.6 MHz)

1. Connect an RF voltmeter to the TP4 terminal of the TX-RX unit.
2. Set that the memorizing frequency is 2.100.0 MHz, the mode is USB.
3. Turn L101 of the TX-RX unit until the peak level is 0.45 to 0.65 Vrms.

2. Reference Frequency Check

1. Connect a frequency counter to the TP4 terminal of the TX-RX unit.
2. Check that the frequency is within 60.600.0 MHz \pm 10 Hz.

Note : Adjust the frequency when the frequency counter power switch is turned on after warm-up 10 minutes later.

3. MCF Adjustment

1. Connect a tracking generator to the TP1 terminal of the TX-RX unit.
2. Connect a spectrum analyzer to the TP2 terminal of the TX-RX unit.
3. Remove coaxial cable connector CN2 (HET) from the TX-RX unit.

Spectrum analyzer specifications:

Center frequency	71.295 MHz
Span	50 kHz
Reference level	-30 dBm
TG level	-20 dBm, 2 dB/div

4. Adjust the waveforms and gain in the order of L65, L68, L67, and L66 of the TX-RX unit.
 Set the L66's core always inside.

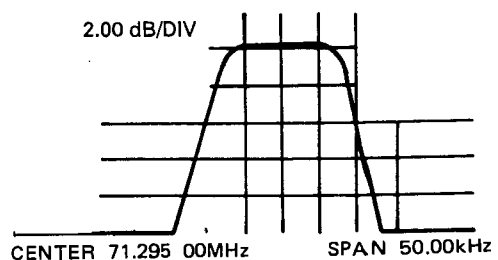

ADJUSTMENT

4. Receiving Amplifier Adjustment

1. Connect SSG to the ANT terminal.
2. Connect an AF voltmeter, an oscilloscope, and a 4Ω dummy load to the EXT. SP terminal.

SSG specifications:

Receiving frequency	2.101.0 MHz
Level	-113 dBm (0.5 μV)
Mode	CW

3. Set that the memorizing frequency is 2.100.0 MHz, the mode is USB.
4. Turn the two IFTs of the TX-RX unit IC2, and turn L69, L70, and L71 of the TX-RX unit until the AF output is maximum.

5. S-meter Adjustment

1. Connect SSG to the ANT terminal.
2. Connect a digital voltmeter to the TP5 terminal of the TX-RX unit.

SSG specifications:

Receiving frequency	2.101.0 MHz
Level	RF OUT OFF
Mode	CW

3. Set that the memorizing frequency is 2.100.0 MHz, the mode is USB.

5-1. S-meter zero-point adjustment (S-0)

1. Turn VR3 of the TX-RX unit until the voltage at the TP5 terminal is 0.1 V (Specification: 0.1 V ± 0.02 V)

5-2. S-meter eight-point adjustment (S-8)

SSG specifications:

Receiving frequency	2.101.0 MHz
Level	-73 dBm (50 μV)

1. Set that the memorizing frequency is 2.100.0 MHz, the mode is USB.
2. Turn VR4 of the TX-RX unit until the LCD on the panel indicates that a "9-point bar indicator" goes off.

5-3. S-meter one-point adjustment (S-1)

SSG specifications:

Receiving frequency	2.101.0 MHz
Level	-103 dBm (1.58 μV)

1. Set that the memorizing frequency is 2.100.0 MHz, the mode is USB.
2. Turn the VR control of the TX-RX unit IC2 until the LCD on the panel indicates that a "1-point bar indicator" goes on.

5-4. Zero- and eight-point checks

1. Set that the memorizing frequency is 2.100.0 MHz, the mode is USB, and the SSG frequency is 2.101.0 MHz.

• SSG level: RF OUT OFF

1. Check that the voltage at the TP5 terminal of the TX-RX unit is 0.08 to 0.15 V.

• SSG level: -73 dBm (50 μV)

1. Check that the LCD on the panel indicates a "8-point bar" indicator goes on.

Note: If the checks in steps 5-4 are incorrect, make the adjustments outlined in steps 5-1 through 5-3 again.

6. NB Adjustment

1. Connect SSG to the ANT terminal.
2. Connect an analog voltmeter to the TP3 terminal of the TX-RX unit.

SSG specifications:

Frequency	2.101.0 MHz
Level	-93 dBm (5 μV)

Set that the memorizing frequency is 2.100.0 MHz and that the mode is USB.

3. Turn the two IFTs of the TX-RX unit IC1 until the voltage at the TP3 terminal is minimum. (Reference level: Approx. 3.25V)
4. SSG specifications:

Frequency	2.101.0 MHz
Level	RF OUT OFF

 Check that the voltage at the TP3 terminal of the TX-RX unit increases approximately 5.45 V.

7. Squelch Adjustment

1. Set that the receiving frequency is free and that the mode is USB.
2. Turn VR5 of the TX-RX unit counterclockwise as far as it will go. (Preset)
3. Set the SQL switch on the front panel to ON, then slowly turn VR5 until it is set to the threshold position.

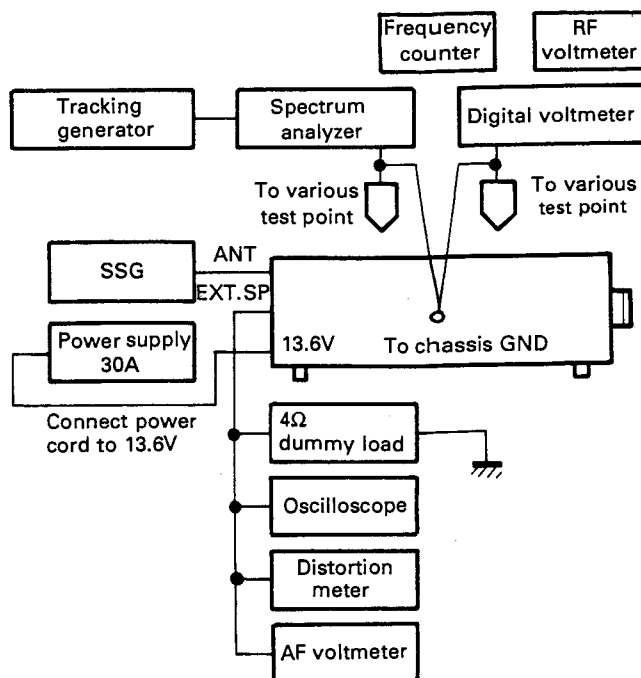

ADJUSTMENT

Transmitter Adjustment

1. Setting

1. Remove the coaxial plug (DO) of the TX-RX unit from the printed circuit board, then connect a RF voltmeter to the coaxial plug.

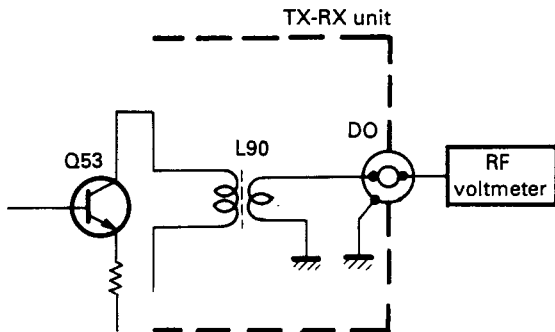

2. Set VR10 of the TX-RX unit to the center position.
3. Press the 2182 key to select the desired emergency channel (2.182.0 MHz), and press the MODE key to enter the H3E mode.
4. Insert a MIC or STBY switch into the microphone connector, then place the set in the transmit mode.
5. Turn L79, L80, and L84 of the TX-RX unit until the RF voltmeter (50 Ω terminated) reading is maximum. (Specification: 0.5 Vrms or more.)

2. Carrier Level Adjustment

1. Connect the control cable of the antenna coupler MAT-100.
2. Connect an RF voltmeter to the DO terminal of the TX-RX unit as described in step 1.
Set that the memorizing frequency is 2.100.0 MHz and that the mode is USB.
Press the TUNE key to enter the transmit mode.
3. Turn VR10 of the TX-RX unit until the RF voltmeter reading is 8 dBm. (Specification: 8 ± 0.5 dBm)
Return to receive mode automatically after transmitting 15 seconds.

Note: After adjustment is completed, remove the coaxial plug (DO) of the TX-RX unit from the RF voltmeter, then insert the coaxial plug into the coaxial socket on the printed circuit board.

3. Transmission Output Adjustment

1. Connect a power meter to the ANT terminal.
2. Connect the two audio generator to the microphone connector. Also, connect an AF voltmeter to check the AG output.
AG1 specifications:
Frequency 400Hz
Level 50 mV
AG2 specifications:
Frequency 1800 Hz
Level 50mV
3. Set that the memorizing frequency is 2.100.0 MHz and that the mode is USB.

3-1. High Power Adjustment

1. Place the set in the transmit mode.
2. Turn VR14 of the TX-RX unit until the power is 75 W. (Specification: 75 ± 5 W)
3. After adjustment is completed, return the set to the receive mode.

3-2. MED Power Adjustment

1. Press the FUNC and 5 keys sequentially, then set the power medium (during reception).
2. Place the set in the transmit mode.
3. Turn VR17 of the TX-RX unit until the power is 40 W. (Specification: 40 ± 5 W)
4. After adjustment is completed, return the set to the receive mode.

3-3. Low Power Adjustment

1. Press the FUNC and 6 keys sequentially, then set the power low (during reception).
2. Place the set in the transmit mode.
3. Turn VR18 of the TX-RX unit until the power is 20 W. (Specification: 20 ± 3 W)
4. After adjustment is completed, return the set to the receive mode.
5. Press the FUNC and 4 keys sequentially, then return the power from low to high.

4. MIC Sensitivity Adjustment

1. Connect a power meter to the ANT terminal.
2. Connect an AG to the microphone connector, then connect an AF voltmeter to check the AG output.
AG specifications:
Frequency 1 kHz
Level 5 mV
3. Set that the memorizing frequency is 2.100.0 MHz and that the mode is USB.
4. Place the set in the transmit mode.
5. Turn VR9 of the TX-RX unit until the power is 50 W. (Specification: 50 ± 5 W)
6. Return the set to the receive mode.

ADJUSTMENT

5. Transmitting Meter Adjustment

1. Make the adjustments outlined in steps 4-1 through 4-4 above. Except AG frequency : 1 kHz, level : 50 mV.
2. Check that the S1's switch position is INT side of the TX-RX unit. If S1 is unable to INT position, change S1's position to INT.
3. Place the set in the transmit mode.
4. Turn VR20 of the TX-RX unit until the LCD transmitting meter reads that a "8-point bar indicator" goes on.
5. Return the set to the receive mode.
6. Replace the S1's position after adjusted.

6. H3E Carrier Level Adjustment

1. Connect a power meter to the ANT terminal.
2. Press the 2182 key to select the desired emergency channel (2.182.0 MHz), and press the MODE key to enter the H3E mode.
3. Place the set in the transmit mode.
4. Turn VR11 of the TX-RX unit until the power is 45 W. (Specification: $45W \pm 5 W$)

7. Protection Adjustment

1. Connect a DC ammeter (30 A range) in series to the (+) DC line.
2. Strap the ANT terminal with a check jig.
3. Connect an audio generator to the microphone connector. Also, connect an AF voltmeter to check the AG output.
AG specifications:
Frequency 1 kHz
Level 50 mV
4. Set that the memorizing frequency is 4.100.0 MHz and that the mode is USB.
5. Place the set in the transmit mode.
6. Turn VR15 of the TX-RX unit until the ammeter reading is 16 A. (Specification: $16 \pm 0.5 A$)
7. After adjustment is completed, return the set to the receive mode.

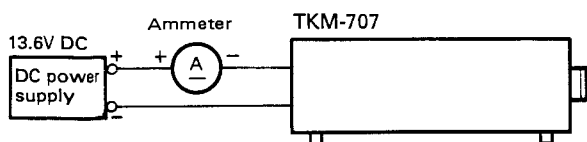

8. Carrier Suppression Adjustment

1. Connect a power meter to the ANT terminal via a directional coupler.
2. Connect a spectrum analyzer to one side of the directional coupler.
3. Set that the memorizing frequency is 2.100.0 MHz and that the mode is USB.
4. Place the set in the transmit mode.
5. Turn VR12 and VR13 of the TX-RX unit until the spectrum analyzer reading is minimum.
Specification: 60 dB-lower than full power in the USB mode (MIC input frequency : 1 kHz, level : 50 mV)
6. Return the set to the receive mode.

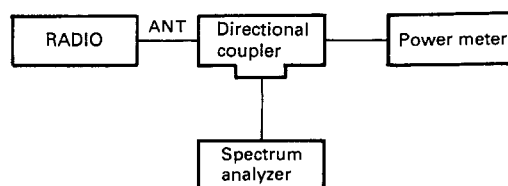

9. Transmitting Frequency Characteristic Adjustment

1. Connect a power meter to the ANT terminal via a directional coupler.
2. Connect an oscilloscope to one side of the directional coupler.
3. Connect the two audio generators to Microphone connector. Also, connect an AF voltmeter to check the AG output.
AG specifications:
AG1 frequency 350 Hz
Output 5 mV
AG2 frequency 2700 Hz
Output 5 mV
4. Set that the memorizing frequency is 2.100.0 MHz and that the mode is USB.
5. Place the set in the transmit mode.
6. Turn VR301 of the control unit until the waveform is crossed.



ADJUSTMENT

7. Press the MODE key to enter the LSB mode.
8. Check that the transmitting frequency is 2.100.0 MHz and that the mode is LSB.
9. Place the set in the transmit mode.
10. Turn VR302 of the control unit until the waveform is crossed.
11. Return the set to the receive mode.

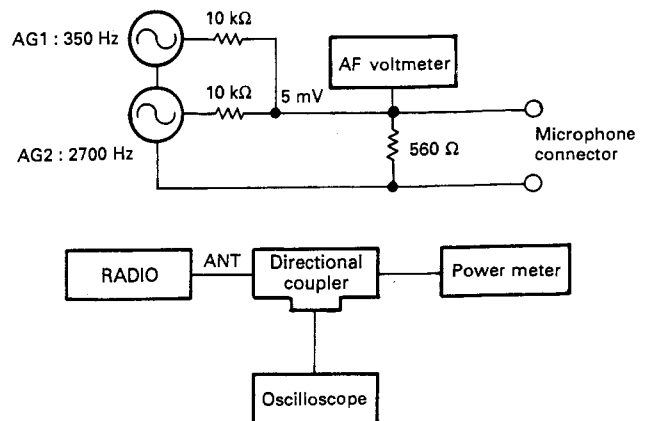

10. Alarm Tone Adjustment

1. Remove the coaxial plug (DO) of the TX-RX unit from the printed circuit board, then connect an RF voltmeter to the coaxial plug.
2. Press the ALARM and 2182 keys at the same time.
3. Turn VR8 of the TX-RX unit until the RF voltmeter reading is 8 dBm. (Specification: 8 ± 0.5 dBm)
4. Press the 2182 key to stop the tone, and transmit mode.

Note: After adjustment is completed, remove the coaxial plug (DO) of the TX-RX unit from the RF voltmeter, then insert the coaxial plug into the coaxial socket on the printed circuit board.

11. Tuning Power Adjustment

1. Connect a power meter to the ANT terminal.
2. Connect the control cable of the antenna coupler MAT-100 (rear panel).
3. Press the MEMO/DIAL key to enter the memory mode.
4. Set that the memorizing frequency is 2.100.0 MHz and that the mode is USB.
5. Press the TONE key to place the set in the transmit mode.
6. Turn VR19 of the TX-RX unit until the power is 10 W. (Specification: 10 ± 1 W)
7. Return to receive mode automatically after transmitting 15 seconds.

12. After adjustment is completed, perform the following:

• Erase the memorized frequencies and modes

Only the transmitting/receiving frequencies below those memorized for adjustment must be erased.
2.100.0 USB, 4.100.0 USB

1. Press the MEMO/DIAL key to enter the memory mode.
2. Press the ENT key to select the memory entry mode.
3. Turn the encoder and set it to the memory channel to be erased.
4. Press the O key.
5. Press the ENT key.

The frequencies and modes of the memory channel that was used for adjustment are then erased.

Note: Return the DIP switch S301 to original position (before factory setup position).

Destined for USA No.1 : OFF, No.2 to 4 : ON
Destined for other countries No.1 to 3 : ON, No.4 : OFF

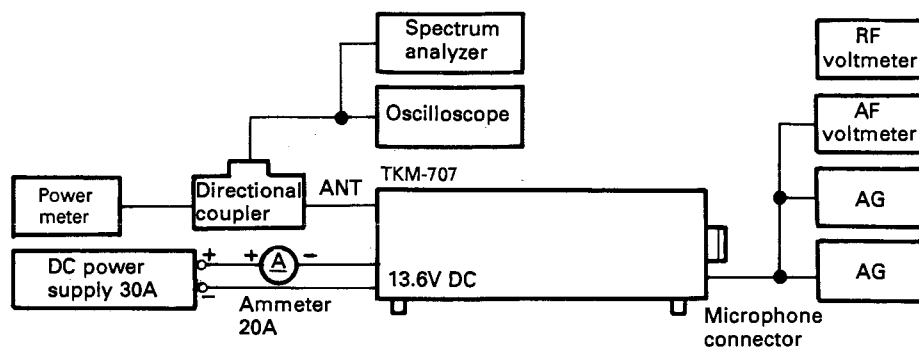

LEVEL DIAGRAM

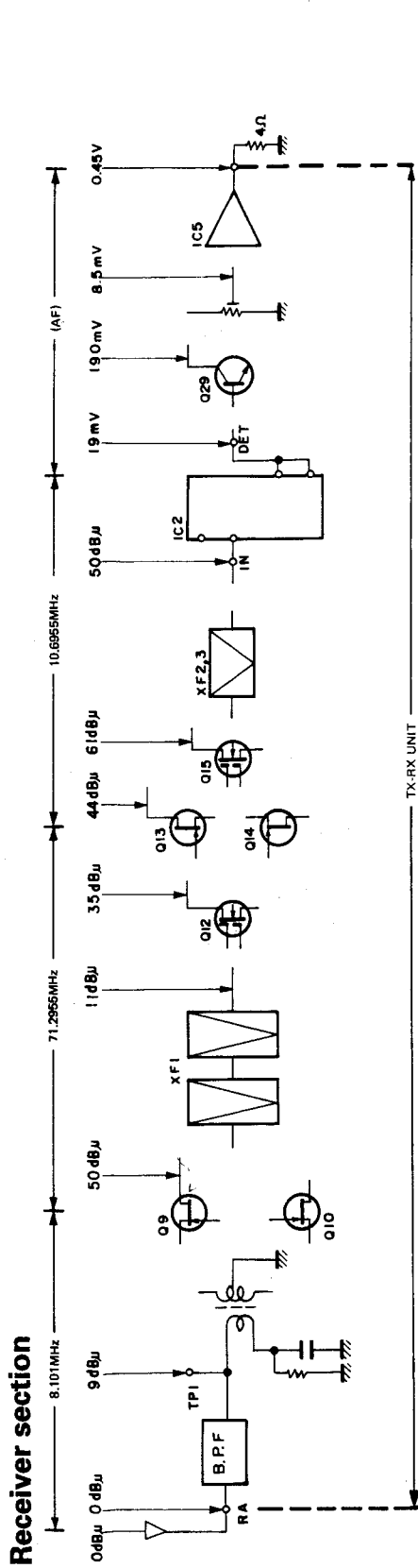

1. These SSG signal level values are necessary in order to obtain the same level of audio output (with the AF VR fixed) when 0.45V/8Ω audio signals are obtained (using the AF GAIN VR) from 8.100MHz, 0dBμ signal input from antenna.
2. SSG output was measured, using a 0.01μF capacitor for RF and IF circuit.
3. SSG output was measured, using a 10μF electrolytic capacitor for AF circuit.

Freq : 8.100MHz
 Mode : J3E USB
 SSG out : 0dBμ
 AF out : 0.45V/8Ω

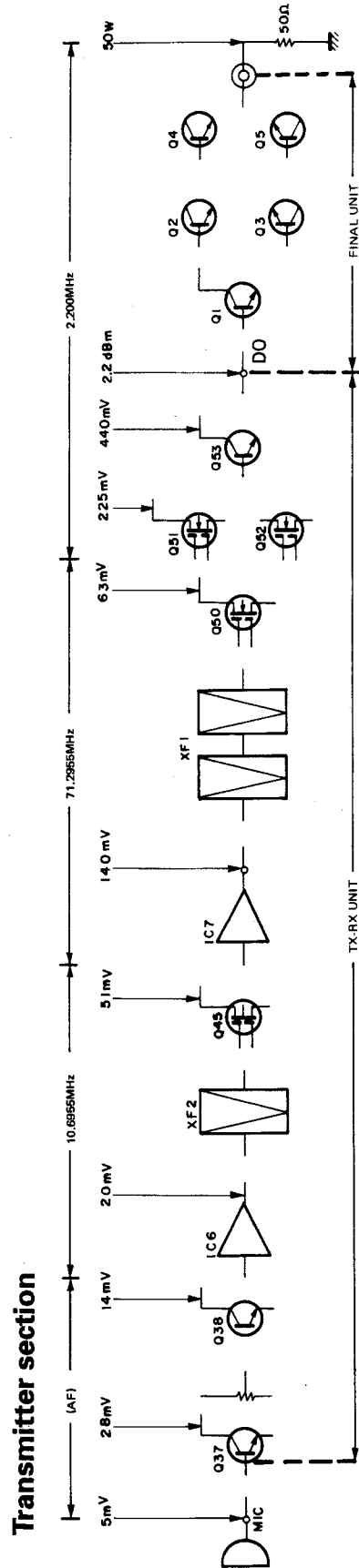

1. Freq : 2.200MHz
2. Mode : J3E USB
3. The high frequency circuits measured with a power meter in USB mode. (50Ω terminated to DO terminal on the TX-RX unit)
4. The audio input voltages are necessary to that output almost reaches saturation (AG : 1kHz 5mV single tone).

TKM-707 TKM-707

BLOCK DIAGRAM

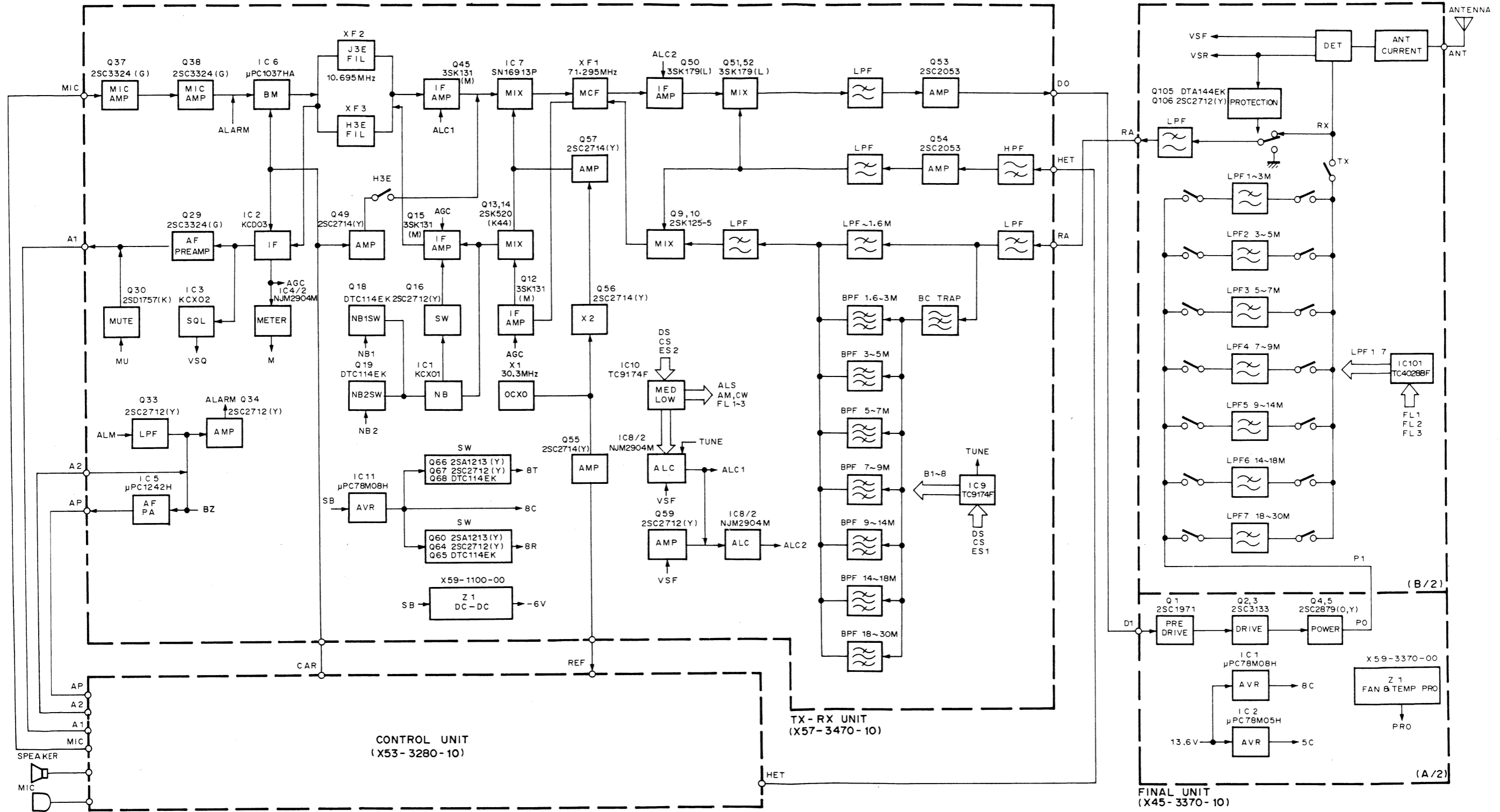

TERMINAL FUNCTION

Connector No.	Terminal		Terminal function
	No.	Name	
FINAL UNIT (X45-3370-10) (A/2)			
CN1	1	PS1	Power switch 1.
	2	PS2	Power switch 2.
	3	NC	Not used.
CN2	1	M+	Fan motor control signal
	2	M-	Fan motor control signal.
CN3	1	CB	Common +B.
	2	8C	Common +8V.
	3	SB	Switched +B (+13.6V).
	4	NC	Not used.
	5	8T	TX +8V.
	6	8R	RX +8V.
	7	PRO	Protection.
	8	E	GND
CN4	1	E	GND
	2	5C	Common +5V.
	3	8T	TX +8V.
	4	8R	RX +8V.
CN5		PO	RF power output.
W2		DI	Drive input.
W3	1	FSB	Final switched +B.
	2	FSB	Final switched +B.
	3	SB	Switched +B (+13.6V).
	4	SB	Switched +B (+13.6V).
	5	E	GND
	6	E	GND
W6		B	+B (+13.6V).
		B	+B (+13.6V).
		E	GND
		E	GND
FINAL UNIT (X45-3370-10) (B/2)			
CN101		RA	Receive antenna.
CN102	1	E	GND
	2	5C	Common +5V.
	3	8T	TX +8V.
	4	8R	RX +8V.
CN103	1	AC1	Antenna current protection.
	2	VSF	VSWR (Forward).
	3	E	GND
	4	VSR	VSWR (Reflection).
	5	FL3	Final band information 3.
	6	FL2	Final band information 2.
	7	FL1	Final band information 1.
W101		PI	RF power input.
		ANT	Antenna.
		E	GND
CONTROL UNIT (X53-3280-10) (A/6)			
CN1		REF	30.6MHz.
CN2		HET	1st local.
CN3		CAR	Carrier.
CN300	1	E	GND
	2	8C	Common +8V.
	3	DLY	Delay volume.
	4	TT	Antenna tuner signal.
	5	STR	Receive STBY.
	6	TS	Antenna tuner signal
	7	STT	Transmit STBY.
	8	BLK	Blanking signal.

Connector No.	Terminal		Terminal function	
	No.	Name		
	9	VSQ	Voice SQL output.	
	10	NB1	Noise blanker 1 switch.	
	11	BZ	Buzzer signal.	
	12	NB2	Noise blanker 2 switch.	
	13	ALM	Alarm signal.	
	14	KEY	Key.	
	15	MU	Audio mute.	
	16	SQS	Squelch switching.	
	17	M	Meter.	
	18	DS	Serial-parallel converter IC data.	
	19	CS	Serial-parallel converter IC clock.	
	20	ES2	Serial-parallel converter IC enable 2.	
	21	ES1	Serial-parallel converter IC enable 1.	
	22	NC	Not used.	
	23	SS	STBY switch.	
	24	APO	Audio power output control.	
	25	CB	Common +B.	
	CN301	1	NC	Not used.
		2	NC	Not used.
		3	UP	MIC up.
		4	DW	MIC down.
		5	K0	Key scan input.
		6	K1	Key scan input.
		7	K2	Key scan input.
		8	K3	Key scan input.
9		K4	Key scan input.	
10		E	GND	
11		S0	Key scan output.	
12		S1	Key scan output.	
13		S2	Key scan output.	
14		S3	Key scan output.	
15		S4	Key scan output.	
16		S5	Key scan output.	
17		5V	+5V.	
18		EN1	Encoder clock 1.	
19		LS	Dimmer switch for LCD illumination.	
20		EN2	Encoder clock 2.	
21		EL	LCD enable.	
22		CL3	Clarifier volume.	
23		CL	LCD clock.	
24		CL2	Clarifier volume.	
25		DL	LCD data.	
26		CL1	Clarifier volume.	
27		LB	+B for LCD illumination.	
CONTROL UNIT (X53-3280-10) (B/6)				
CN200	1	NC	Not used.	
	2	NC	Not used.	
	3	UP	MIC up.	
	4	DW	MIC down.	
	5	K0	Key scan input.	
	6	K1	Key scan input.	
	7	K2	Key scan input.	
	8	K3	Key scan input.	
	9	K4	Key scan input.	
	10	E	GND	
	11	S0	Key scan output.	
	12	S1	Key scan output.	
	13	S2	Key scan output.	
	14	S3	Key scan output.	
	15	S4	Key scan output.	
	16	S5	Key scan output.	
	17	5V	+5V.	

TERMINAL FUNCTION

Connector No.	Terminal		Terminal function
	No.	Name	
	18	EN1	Encoder clock 1.
	19	LS	Dimmer switch for LCD illumination.
	20	EN2	Encoder clock 2.
	21	EL	LCD enable.
	22	CL3	Clarifier volume.
	23	CL	LCD clock.
	24	CL2	Clarifier volume.
	25	DL	LCD data.
	26	CL1	Clarifier volume.
	27	LB	+B for LCD illumination.
CN202		5V	+5V.
		LS	Dimmer switch for LCD illumination.
		EL	LCD enable.
		CL	LCD clock.
		DL	LCD data.
		LB	+B for LCD illumination.
		E	GND
W200	1	A1	AF VOL.
	2	A2	AF VOL.
	3	E	GND
W201	1	DW	MIC down.
	2	E	GND
	3	UP	MIC up.
W202	1	K0	Key scan output.
	2	S4	Key scan input.
	3	SPS	Switched speaker.
	4	ESP	External speaker.
CONTROL UNIT (X53-3280-10) (C/6)			
W201	1	DW	MIC down.
	2	E	GND
	3	UP	MIC up.
	4	8M	MIC connector +8V.
	5	SPS	Switched speaker.
	6	E	GND
	7	MIC	MIC
	8	SS	STBY switch.
CONTROL UNIT (X53-3280-10) (D/6)			
CN206	1	PS1	Power switch 1.
	2	PS2	Power switch 2.
CONTROL UNIT (X53-3280-10) (E/6)			
W202	1	S4	Key scan input.
	2	K0	Key scan output.
	3	NC	Not used.
CONTROL UNIT (X53-3280-10) (F/6)			
W202	1	AP	Audio power.
	2	E	GND
	3	ESP	External speaker output.
	4	ESP	External speaker output.
	5	SPS	Switched speaker.
	6	SPS	Switched speaker.
	7	E	GND
TX-RX UNIT (X57-3470-10) (A/2)			
CN1		RA	Receive antenna.
CN2		HET	1st local.
CN3		CAR	Carrier.
CN4		REF	30.6MHz.
CN5		DO	Drive output.

Connector No.	Terminal		Terminal function
	No.	Name	
CN6	1	AC1	Antenna current protection.
	2	VSF	VSWR (Forward).
	3	E	GND
	4	VSR	VSWR (Reflection).
	5	FL3	Final band information 3.
	6	FL2	Final band information 2.
	7	FL1	Final band information 1.
CN7	1	CB	Common +B.
	2	8C	Common +8V.
	3	SB	Switched +B (+13.6V).
	4	NC	Not used.
	5	8T	TX +8V.
	6	8R	RX +8V.
	7	PRO	Protection.
	8	E	GND
CN8	1	8M	MIC connector +8V.
	2	SPS	Switched speaker.
	3	E	GND
	4	MIC	MIC
	5	SS	STBY switch.
CN9	1	ESP	External speaker.
	2	E	GND
	3	AP	Audio power.
CN10	1	E	GND
	2	8C	Common +8V.
	3	DLY	Delay volume.
	4	TT	Antenna tuner signal.
	5	STR	Receive STBY.
	6	TS	Antenna tuner signal
	7	STT	Transmit STBY.
	8	BLK	Blanking signal.
	9	VSQ	Voice SQL output.
	10	NB1	Noise blanker 1 switch.
	11	BZ	Buzzer signal.
	12	NB2	Noise blanker 2 switch.
	13	ALM	Alarm signal.
	14	KEY	Key.
	15	MU	Audio mute.
	16	SQS	Squelch switching.
	17	M	Meter.
	18	DS	Serial-parallel converter IC data.
	19	CS	Serial-parallel converter IC clock.
	20	ES2	Serial-parallel converter IC enable 2.
	21	ES1	Serial-parallel converter IC enable 1.
	22	NC	Not used.
	23	SS	STBY switch.
	24	APO	Audio power output control.
	25	CB	Common +B.
CN11	1	A1	AF VOL.
	2	A2	AF VOL.
	3	E	GND
CN12	1	AC2	
	2	TS	Antenna tuner signal.
	3	TT	Antenna tuner signal.
TX-RX UNIT (X57-3470-10) (B/2)			
CN17	1	E	GND
	2	E	GND
	3	SB	Switched +B (+13.6V).
	4	SB	Switched +B (+13.6V).
	5	FSB	Final switched +B.
	6	FSB	Final switched +B.

LCD ASS'Y (B38-0324-05) Component side view

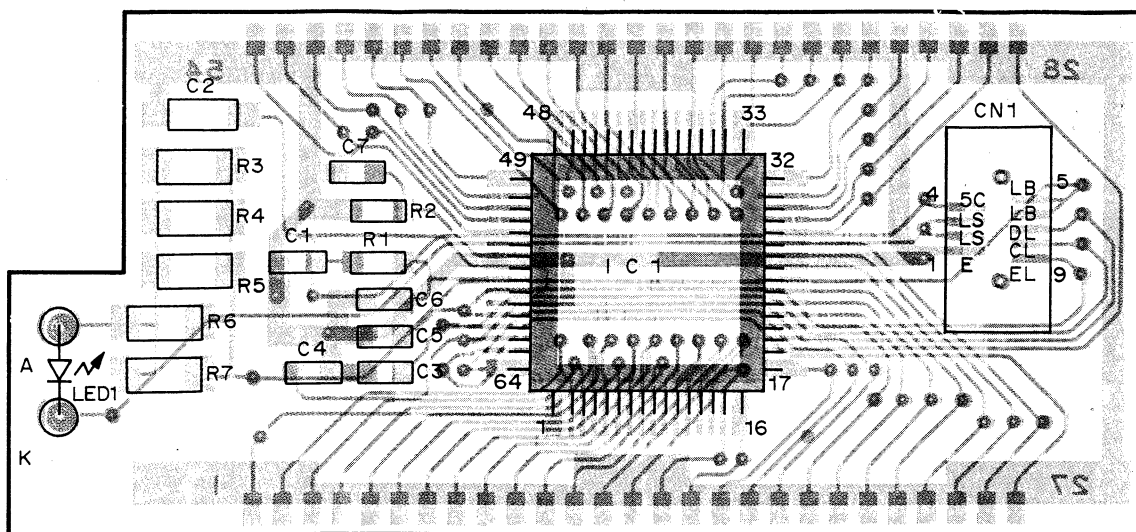

IC1 : LC7582A
LED1 : BL116AY

VCO (X58-3720-10) Component side view

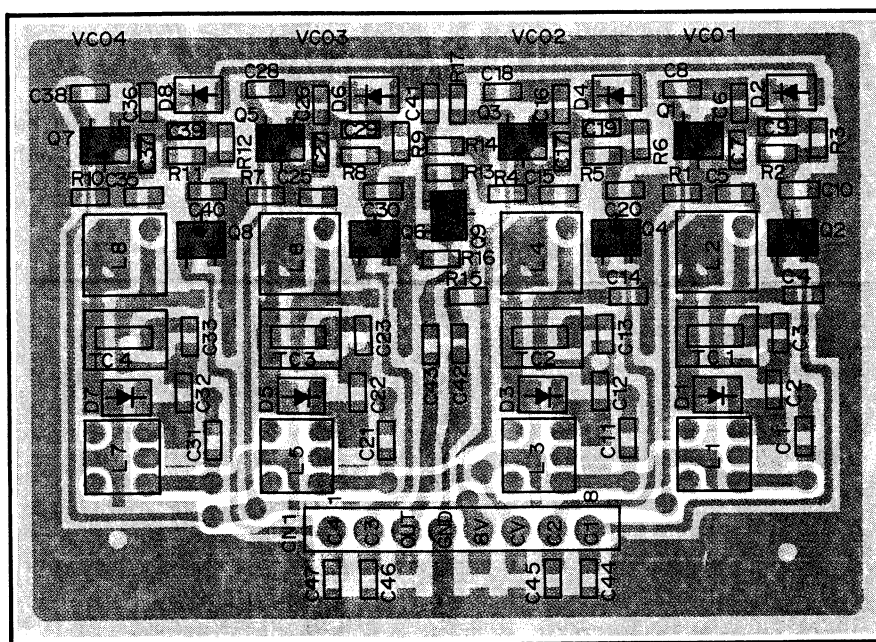

Q1, 3, 5, 7 : 2SK508NV(K52) Q2, 4, 6, 8 : DTC114EK Q9 : 2SC2714(Y)
D1, 3, 5, 7 : 1SV166 D2, 4, 6, 8 : RLS135

2SA1162
2SC2712
2SC2714
DTC114EK
DTD123EK



2SK508NV



2SK210



NJM2904M

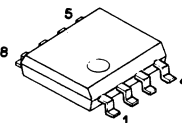

LC7582A

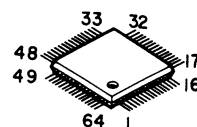

PC BOARD VIEWS TKM-707

DC-DC (X59-1100-00) Component side view

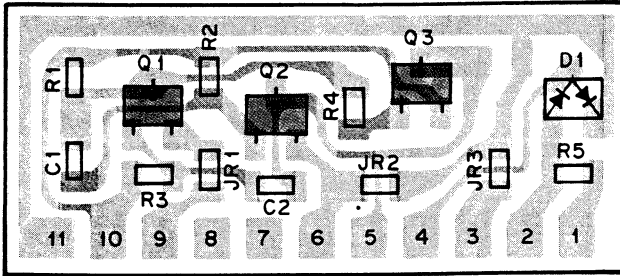

Q1,2 : 2SC2712(Y) Q3 : 2SA1162(Y)
D1 : 1SS226

FAN & TEMP PROTECTION (X59-3370-00) Component side view

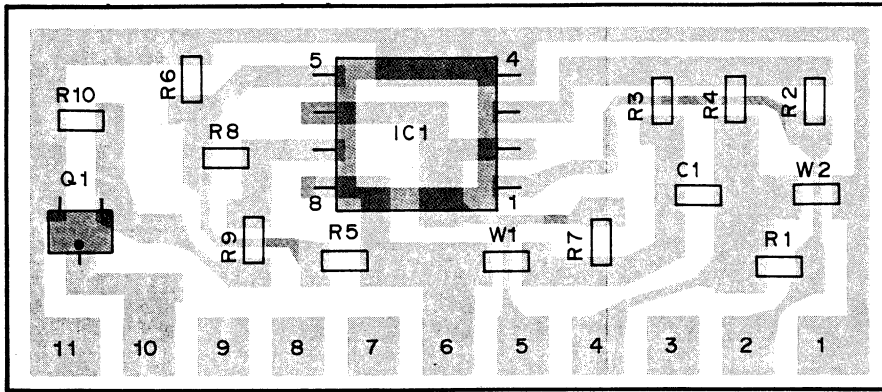

IC1 : NJM2904M
Q1 : DTD123EK

R10 : Not used

VCO (X59-3440-00) Component side view

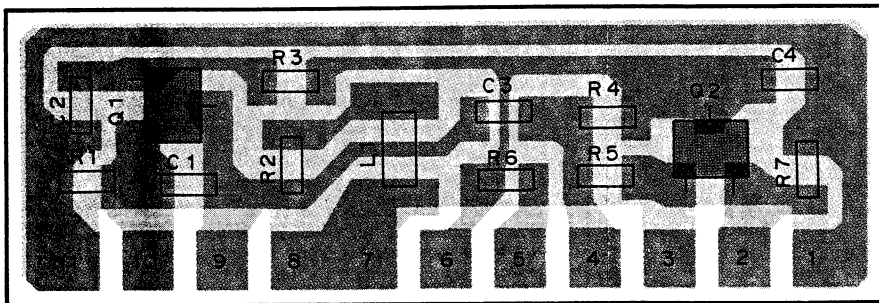

Q1 : 2SK210(GR) Q2 : 2SC2714(Y)

NIT (X53-3280-10) Foil side view

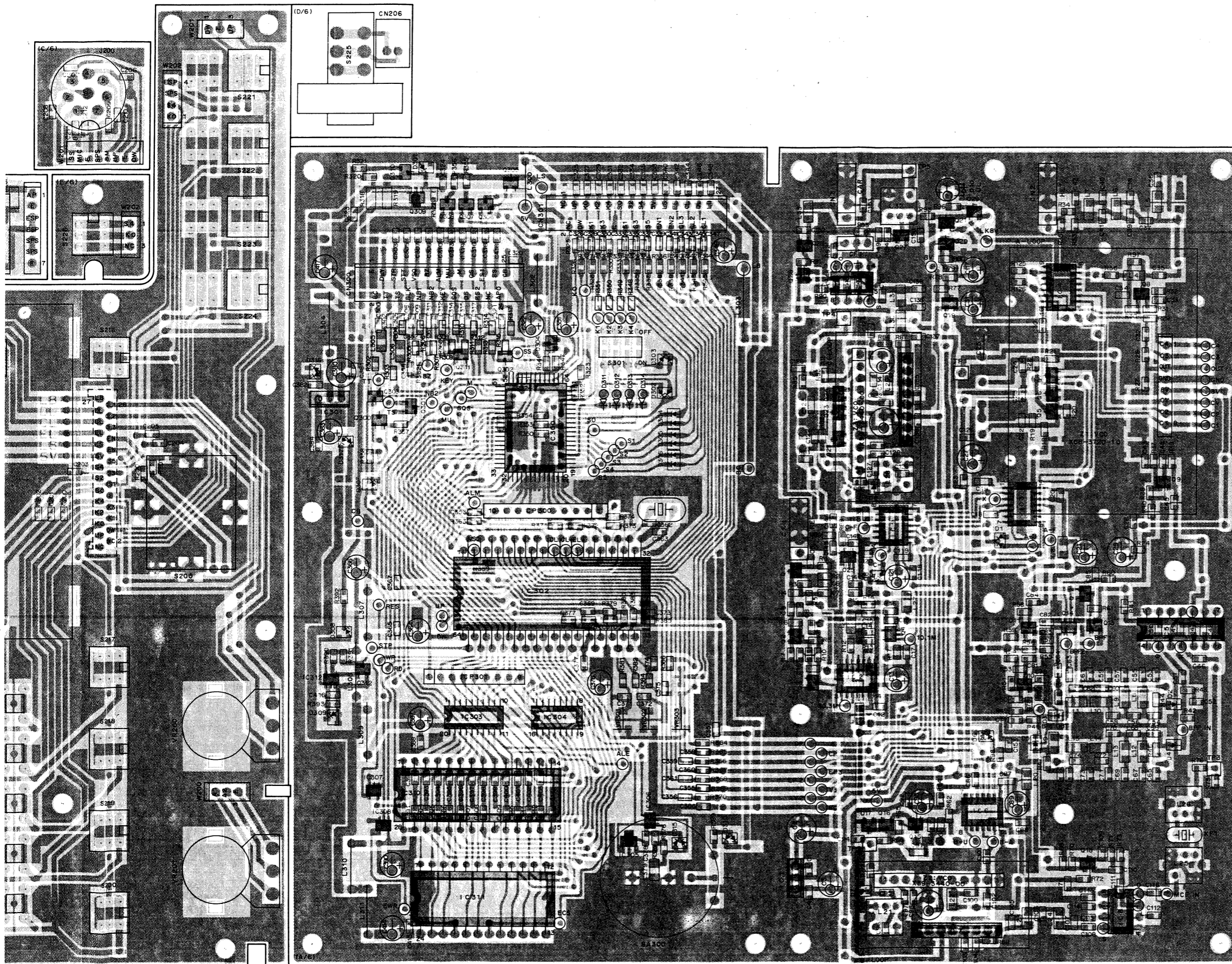

2SC2712
2SC2714
2SC3324
DTA114EK
DTA143EK
DTC114EK
DTC143EK
DTD123EK



2SD1624S

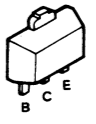

μPC78N05H

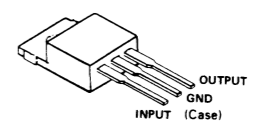

M51951BML

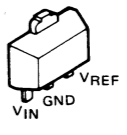

FMC2
FMU1

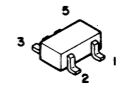

TC4S71F
TC4S584F
TC4SU69F



M54459L

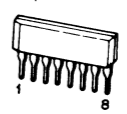

SN16913P

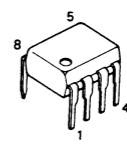

CXD1225M

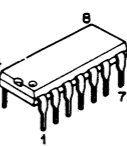

SN76514N

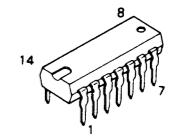

HD74LS290FP

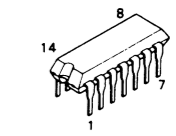

TC74HC138AF
TC4028BF

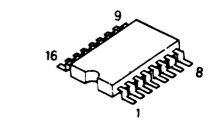

TC74HC573AF

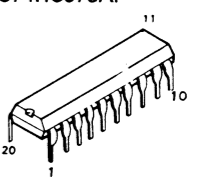

MSM28C16A-20RS

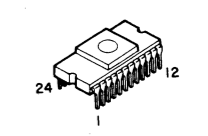

27C128-20JBF1

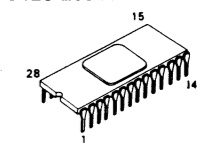

μPD78C10AGQ-36

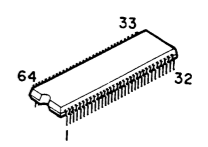

CXD1095Q

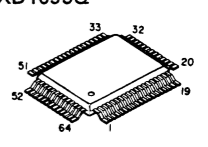

CIRCUIT DIAGRAM TKM-707

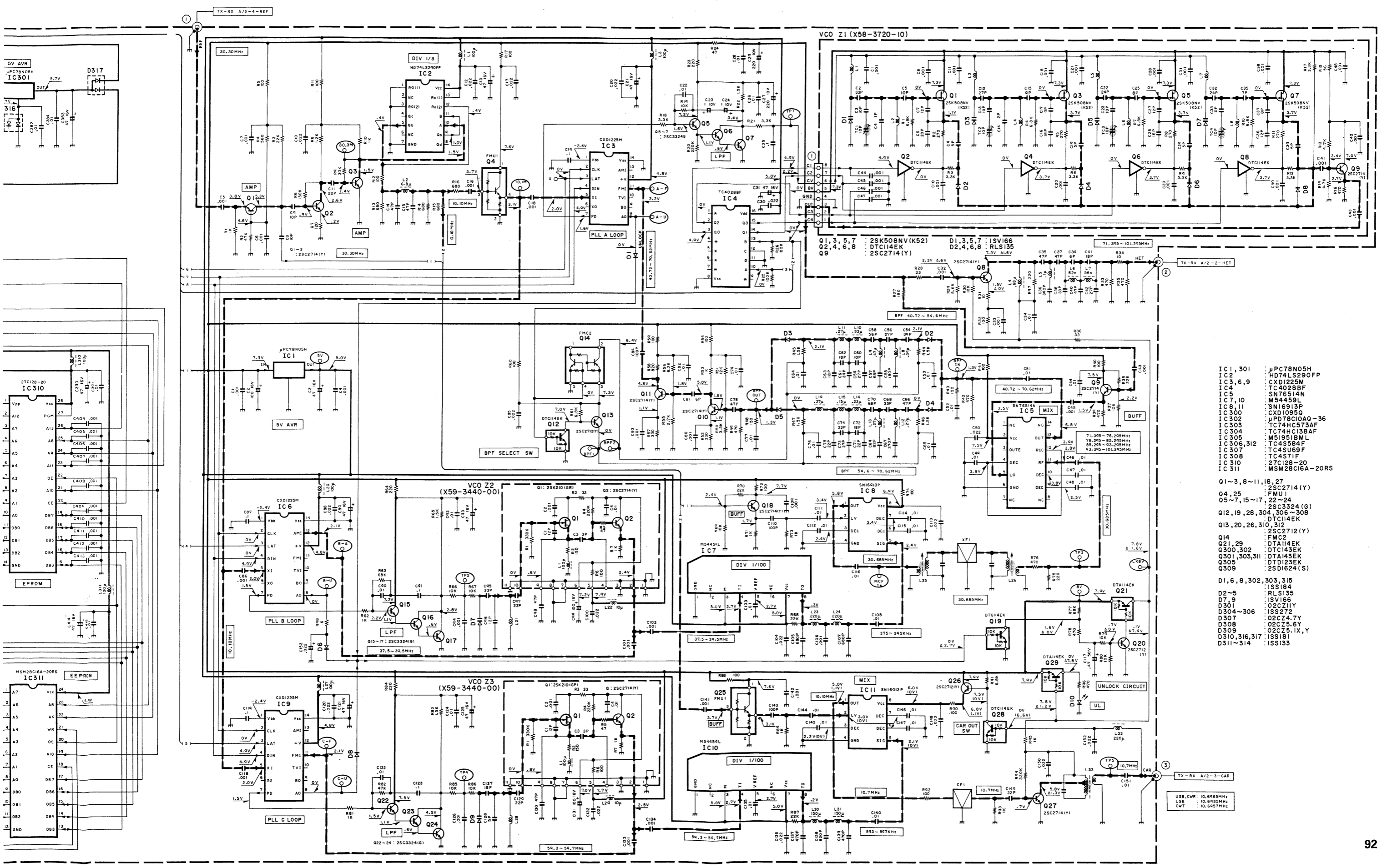

- | | |
|-------------|------------------|
| IC 1, 301 | : JPC78N05H |
| IC 2 | : HD74LS290FP |
| IC 3, 6, 9 | : CXD1225M |
| IC 4 | : TC4028BF |
| IC 5 | : SN76514N |
| IC 7, 10 | : M54459L |
| IC 8, 11 | : SN16913P |
| IC 300 | : CXD1095Q |
| IC 302 | : JPD78C10A0-36 |
| IC 303 | : TC74HC573AF |
| IC 304 | : TC74HC138AF |
| IC 305 | : M51951BML |
| IC 306, 312 | : TC48584F |
| IC 307 | : TC48569F |
| IC 308 | : TC4871F |
| IC 310 | : 27C128-20 |
| IC 311 | : MSM28C16A-20RS |
-
- | | |
|---------------------------|--------------|
| Q1-3, 8-11, 18, 27 | : 2SC2714(Y) |
| Q4, 25 | : FMU1 |
| Q5-7, 15-17, 22-24 | : 2SC3324(G) |
| Q12, 19, 28, 304, 306-308 | : DT144EK |
| Q13, 20, 26, 310, 312 | : 2SC2712(Y) |
| Q14 | : FMC2 |
| Q21, 29 | : DT144EK |
| Q300, 302 | : DT143EK |
| Q301, 303, 311 | : DT143EK |
| Q305 | : DT123EK |
| Q309 | : 2SD1624(S) |
-
- | | |
|-------------------------|---------------|
| D1, 6, 8, 302, 303, 315 | : ISS184 |
| D2-5 | : RLS135 |
| D7-9 | : ISV166 |
| D301 | : Q2C211Y |
| D304-306 | : ISS272 |
| D307 | : Q2C24.7Y |
| D308 | : Q2C25.6Y |
| D309 | : Q2C25.1X, Y |
| D310, 316, 317 | : ISS181 |
| D311-314 | : ISS133 |

TKM-707 PC BOARD VIEWS

TX-RX UNIT (X57-3470-10) - Component side view

2SA1162
2SC2712
2SC2714
2SC3324
2SD1757
DTA114EK
DTB143EK
DTC114EK
DTD143EK

μPC78M08H

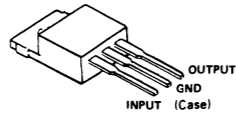

μPC1242H

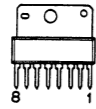

2SC2053

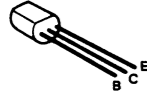

μPC1037HA

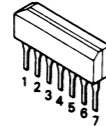

2SA1213
2SC3649



SN16913P

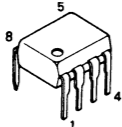

2SK125-5

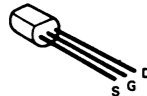

NJM2904M

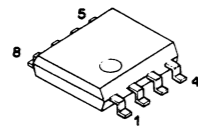

2SK520



TC9174F

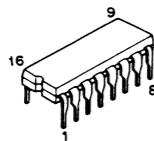

3SK131
3SK179

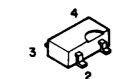

FMC3

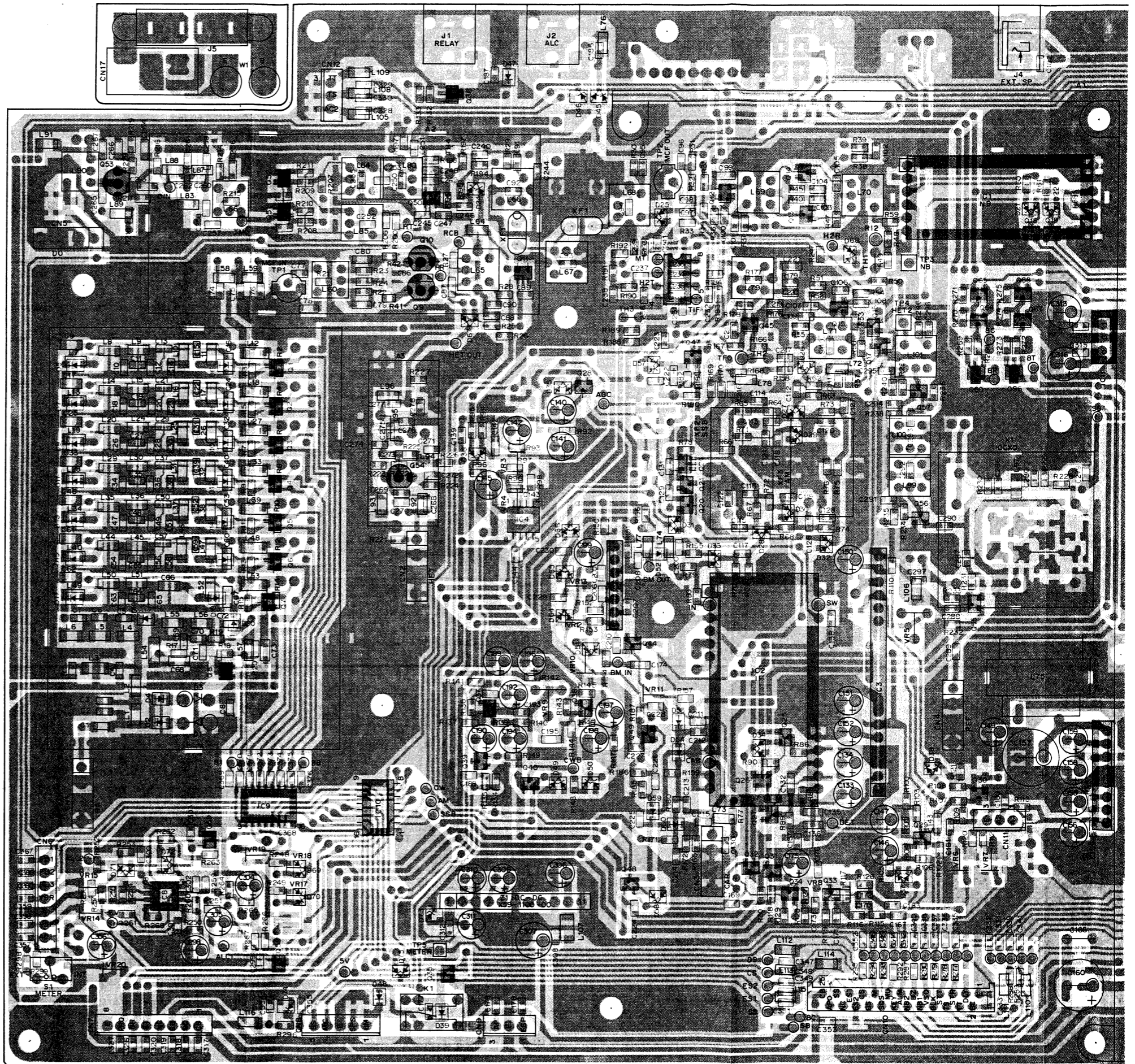
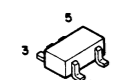

TX-RX UNIT (X57-3470-10) Foil side view

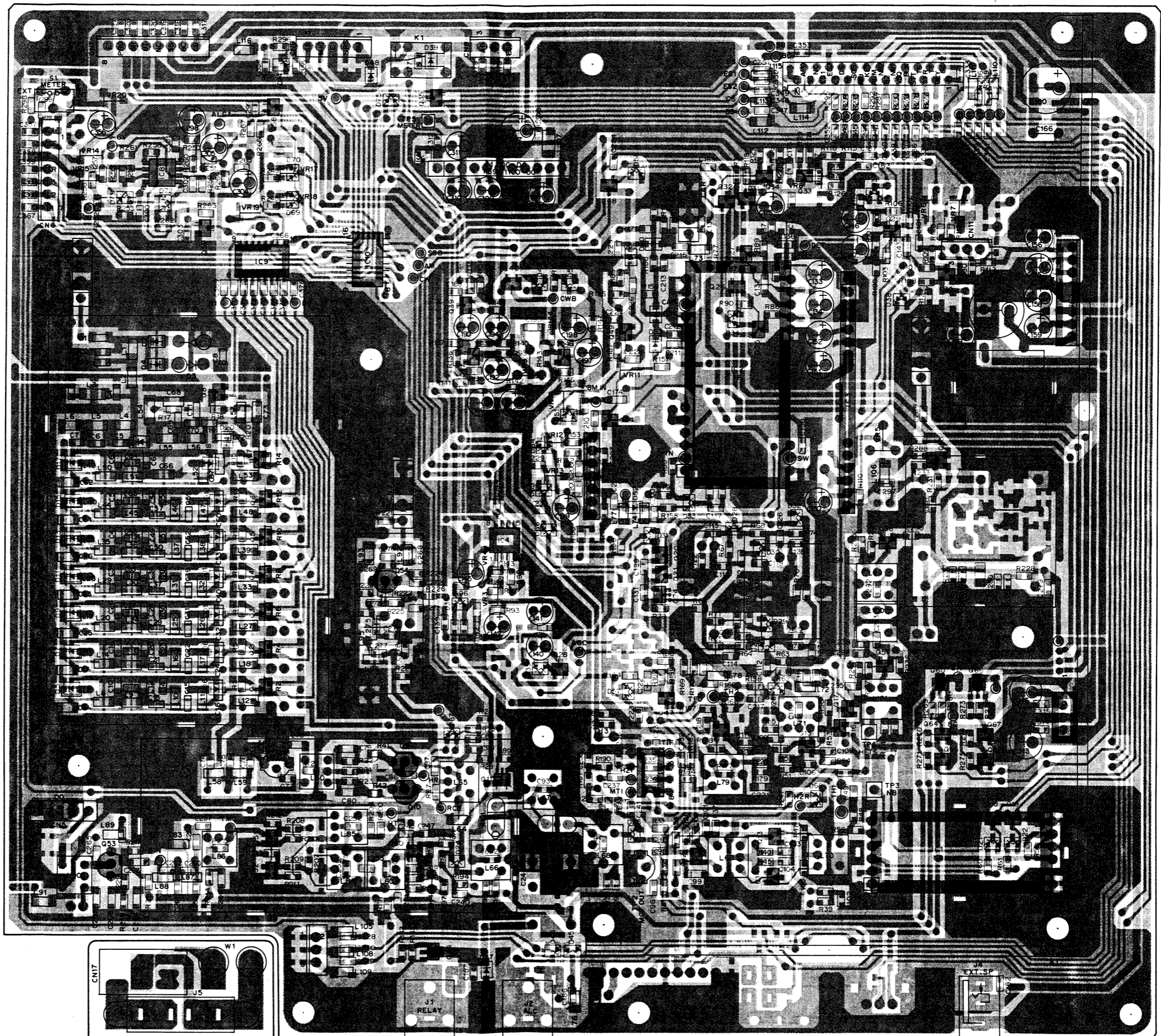
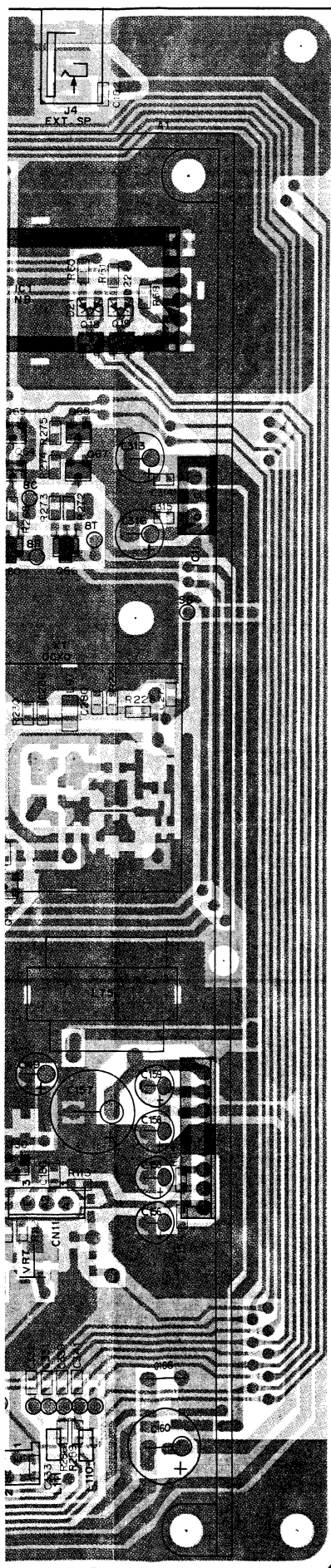

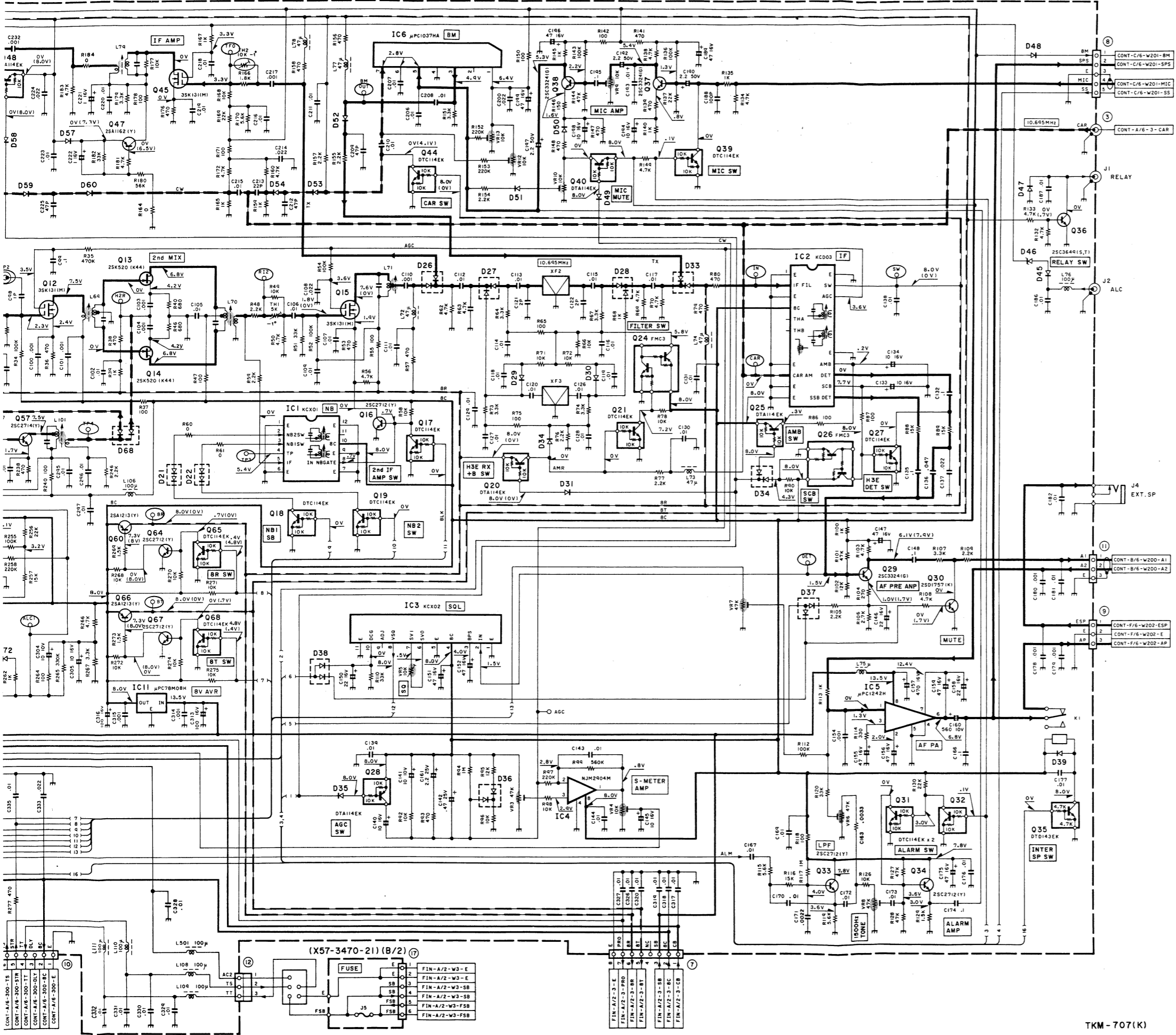

TKM-707(K)

FINAL UNIT (X45-3370-10) Foil side view

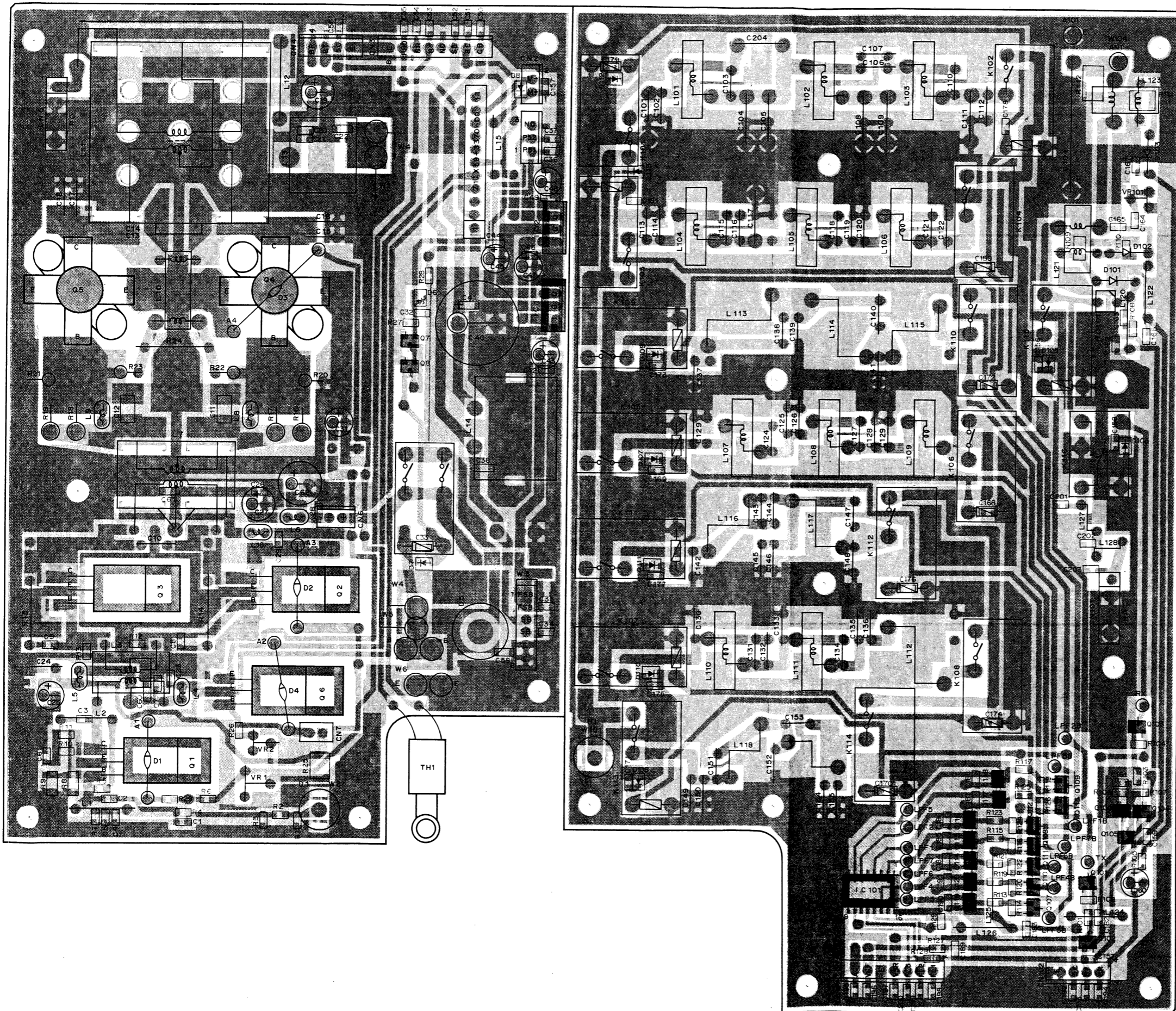

2SA1362
2SC2712
DTA114EK
DTC124EK
DTD114EK



2SC1971
2SC3133

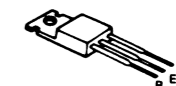

2SD1406

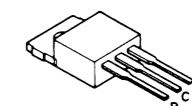

2SC2879

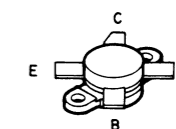

μPC78M05H
μPC78M08H

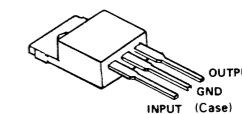

TC4028BF

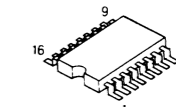

FINAL UNIT (X45-3370-10)(A/2)

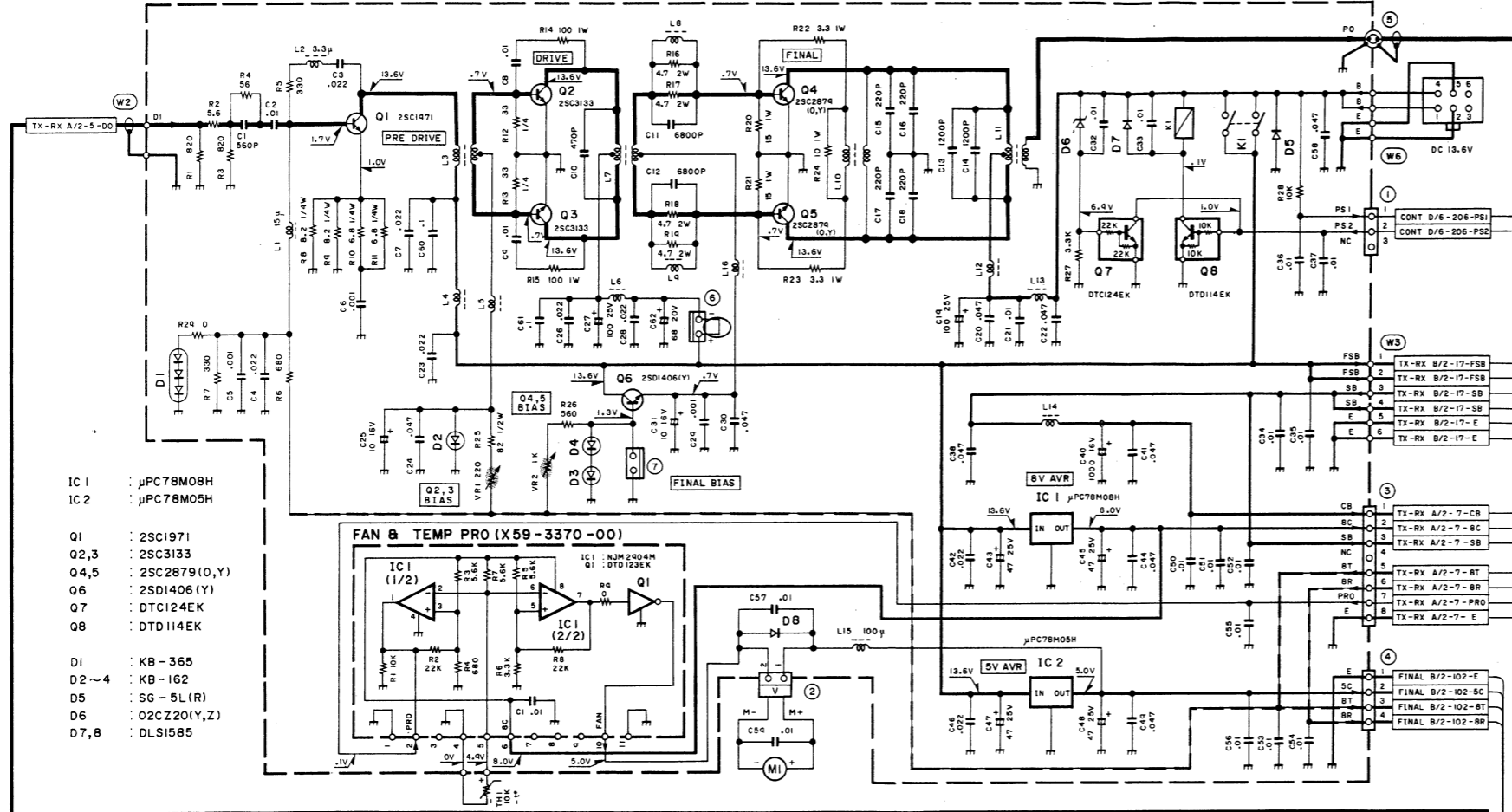

FINAL UNIT (X45-3370-10)(B/2)

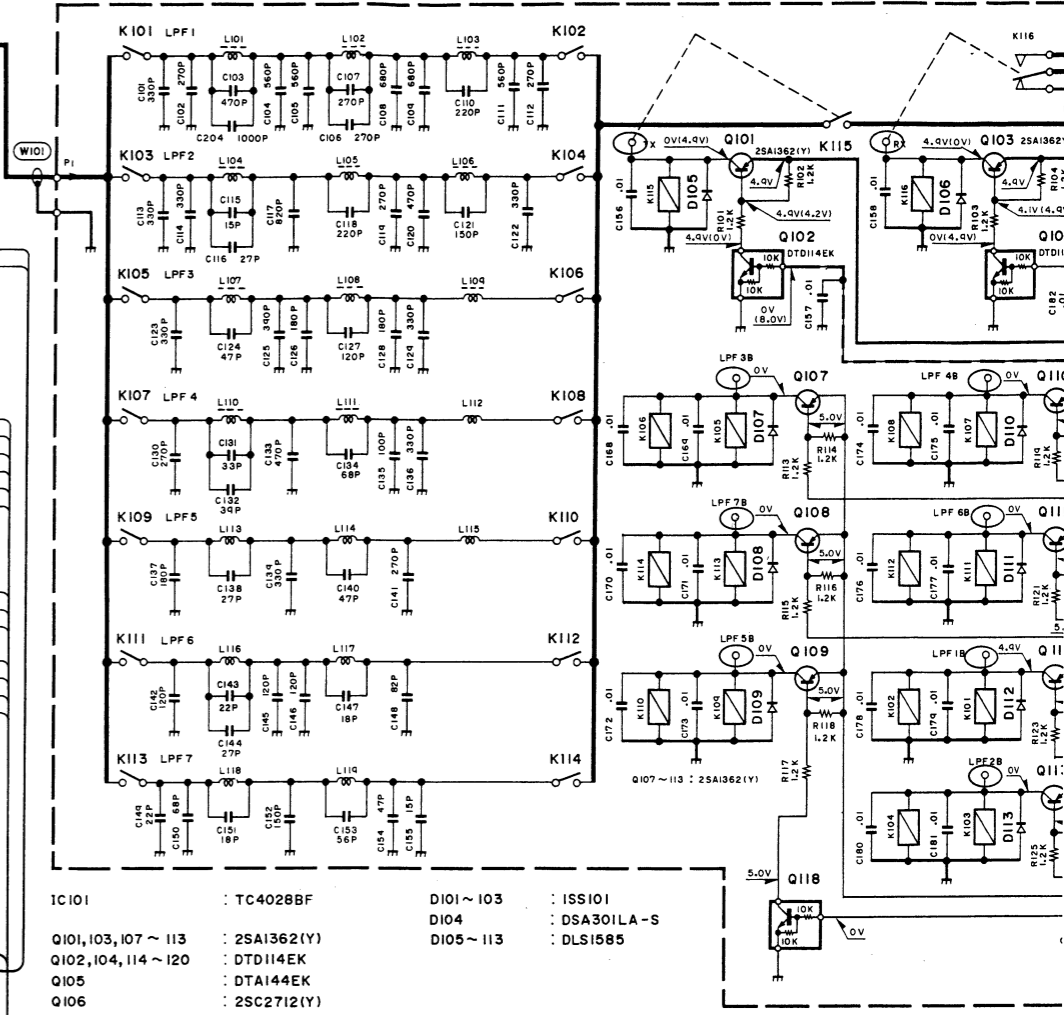

CONTROL UNIT (X53-3280-10)(B/6)

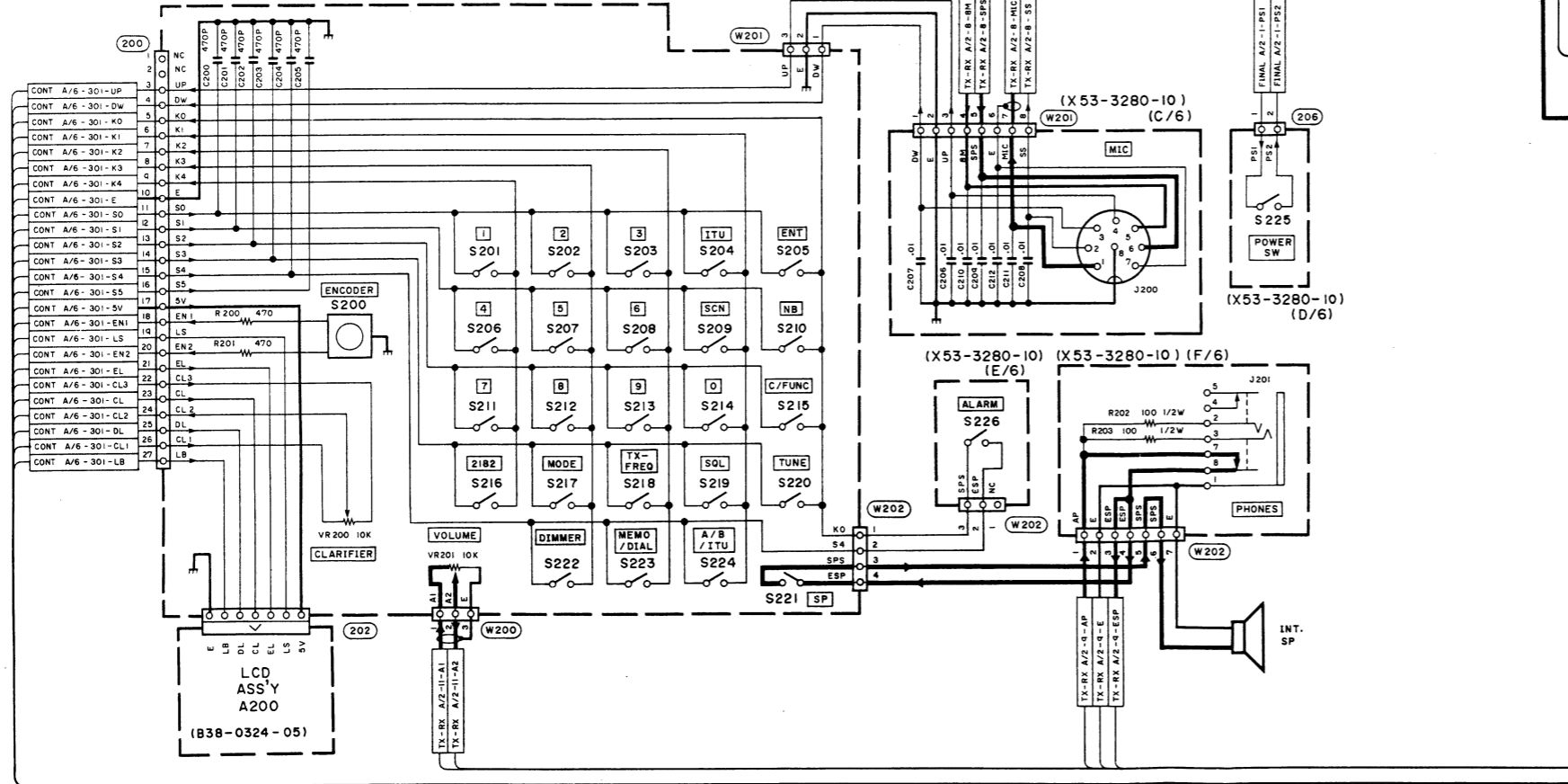

CONTROL UNIT (X53-3280-10)(A/6)

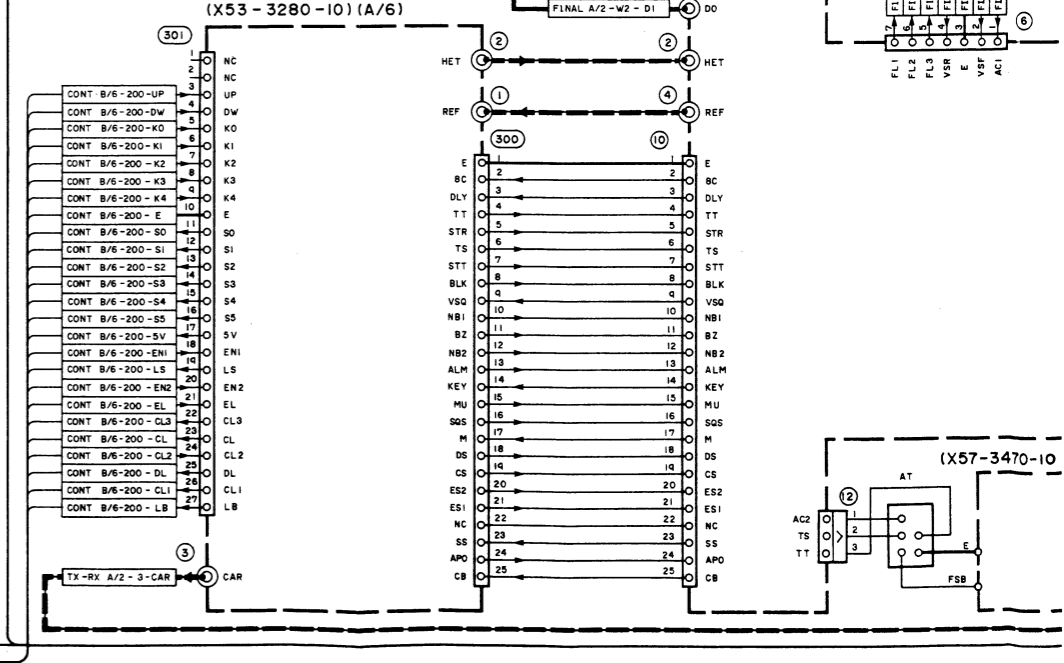

SCHEMATIC DIAGRAM TKM-707

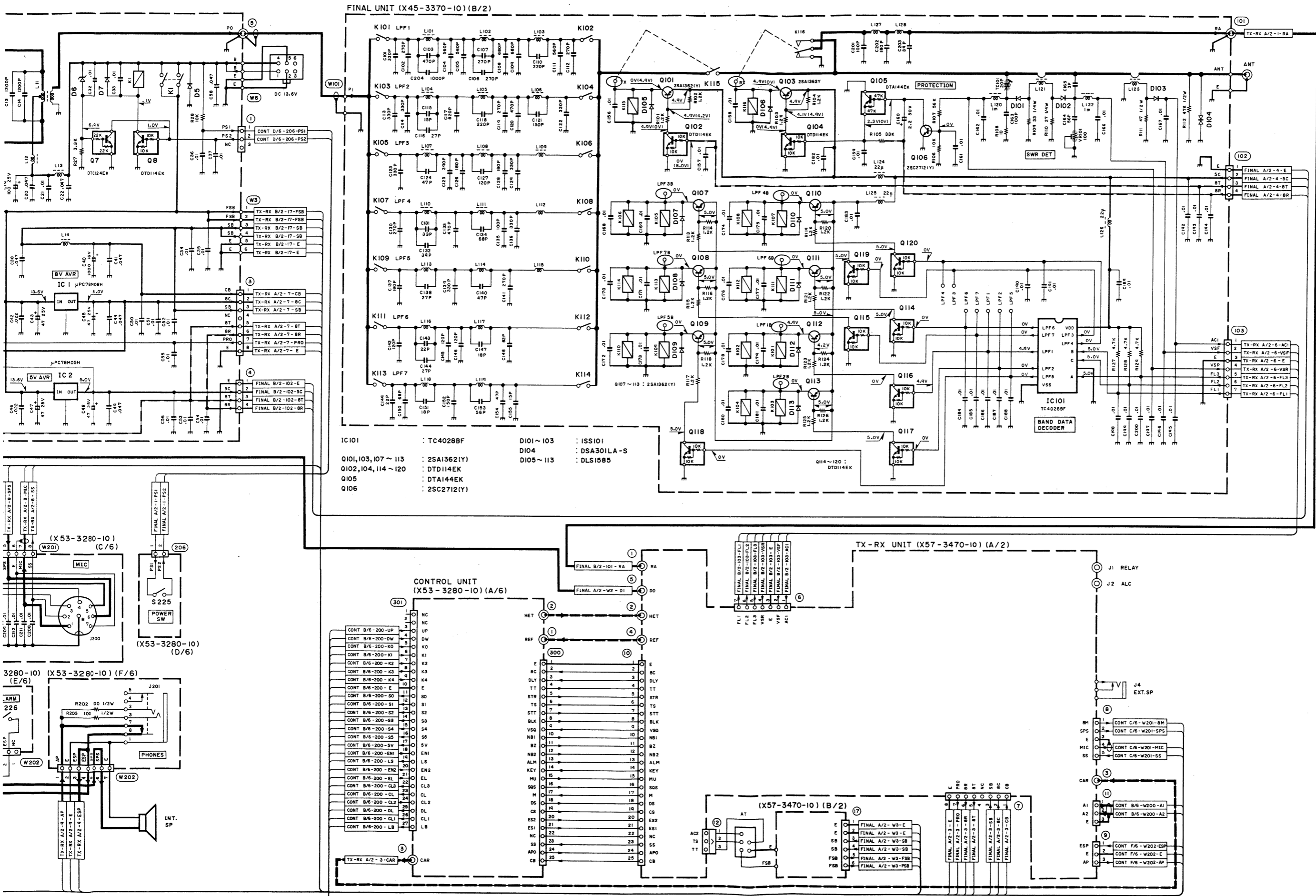

TKM-707

MAT-100 (AUTOMATIC ANTENNA TUNER)

Circuit Description

• Tuning

The MAT-100 is a high-frequency band automatic antenna tuner that can be remotely controlled. When tuning with a remote controller, the TS terminal of the control cable goes low and a tuning start signal is sent. When the MAT-100 detects that the TS terminal is low, the CPU is reset in order to start tuning. A tuning signal is sent from the remote controller to the sensor circuit of the MAT-100.

The sensor circuit detects the frequency count, forward voltage, reflected voltage, impedance, and phase voltage and sends the data to the CPU. The CPU then activates a tuning circuit relay to enter the tuning state. An LED indicator goes on to indicate the relay operation status. When tuning starts, the CPU memorizes the tuning state. When tuning with the same frequency, the current data is used and the tuning state is entered.

When tuning is completed, the TT terminal is set to high to send a termination signal. When the MAT-100 detects the termination signal, the STBY signal goes low to return the TS signal to high. The standby mode is then entered to stop the clock.

When DIP switch S4 of the LED unit (W02-0883-08) is set to MANUAL, tuning can be performed manually. The relay switch can be controlled with switches S1 through S3.

• Through mode

The MAT-100 can be set in the through mode in which an antenna and the remote controller are directly connected. In this case, the TT terminal of the remote controller goes low. The MAT-100 detects that the TT terminal is low. The CPU sets a relay through mode. When mode setting is completed, the CPU enters the standby mode.

• Tuning test

The MAT-100 has a TUNING START switch to test tuning or adjust an antenna. To test tuning, the MAT-100 must be connected to a remote controller with the POWER switch ON. When push-button switch S1 of the MAT-100 is pressed, tuning starts. Push-button switch S1 sets the TS terminal low and sends a tuning start command to the remote controller. When a tune signal is sent from the remote controller, the MAT-100 starts tuning. When tuning is performed normally, the test operation is completed.

Note : When tuning cannot be performed within 15 seconds, a tuning termination command is issued by the remote controller.

• Interface

Control signals are sent and received between the MAT-100 and remote controller using the TS and TT terminals. The TS and TT terminals are bi-directional signal lines.

1. Normal tuning

When the tuning state is set with a remote controller, the TS signal of the remote controller is set low (usually set to high). When the MAT-100 detects that the TS signal is low, the CPU clock is activated to reset the system. At this time, the CPU is activated to check the TS and TT signal status. The CPU sets the TT signal low and reports tuning start. When the TT signal goes low, the remote controller issues a tuning signal. When the MAT-100 completes tuning, the TT signal is returned to high to indicate completion. The tuning signal from the remote controller stops. The TS signal is set to high to complete the tuning. When the TS signal is set to high, the MAT-100 enters the standby mode and stops the clock operation.

2. Abnormal tuning

The remote controller counts for 15 seconds after the TS signal is set low and the TT signal is set to high. If the TT signal is not set low before the count is completed, the MAT-100 judges that tuning can not be performed normally. The remote controller then sets the TS signal to high and reports a tuning interruption. When the TS signal is set to high, the MAT-100's CPU returns the TT signal to high to stop tuning. The MAT-100 then enters the standby mode.

3. Through operation

When the TT signal from the remote controller is set low, a through operation is performed. The MAT-100 activates the CPU and sets the TS signal low. The remote controller then returns the TT signal to high. When tuning is completed, the MAT-100 returns the TS signal to high and sets the CPU in the standby mode to complete the through operation.

MAT-100 (AUTOMATIC ANTENNA TUNER)

For tuning

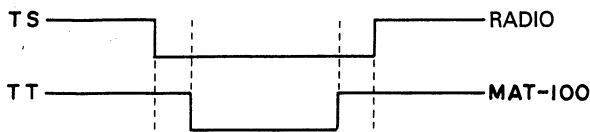

For abnormal tuning

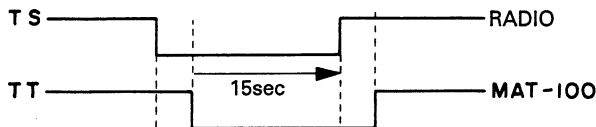

For through operation

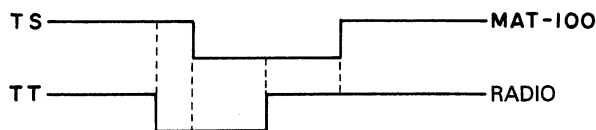

Fig. 1 Interface timing chart

• Manual Tuning

The MAT-100 can set the manual tuning. For manually tuning, change DIP switch S4 of the LED unit from AUTO to MANUAL. When DIP switch S4 is set to MANUAL, relays K1 and K2 are selected so that a sensor circuit is through-connected. LED indicator D48 goes on to indicate tuning completion.

When DIP switches S1 through S3 are selected, relays K1 and K2 are set on or off. The status of S1 through S3 is sent to IC10 through IC13 of the MAT-100 to drive the relays. Table 1 gives the relationships between the DIP switch settings and operation of the relays.

• Control cable terminals

+13.6 V MAT-100's +13.6 V DC

GND Ground

TS Bidirectional control terminal that controls tuning start and completion via a remote controller and reports through start and completion via the MAT-100.

TT Bidirectional control terminal that controls through start and completion via a remote controller and controls tuning start and completion via the MAT-100.

GND Ground

ANT.C Determines the antenna current via the MAT-100 and sends it to the remote controller.

• Tuning Circuit Selection

The tuning circuit is used as a PI matching circuit by connecting jumpers J5 and J6. When the tuning circuit is not matched using a PI match, remove the PI circuit and use an L-type matching circuit. The PI circuit is normally used.

DIP switch	RElay No.	DIP switch-on sequence operation
S1	1	K-3
	2	4
	3	5
	4	6
	5	7
	6	8
	7	9
	8	10
	9	11
	10	13
S2	1	14
	2	12
	3	15
	4	16
	5	17
	6	18
	7	19
	8	20
	9	21
	10	22
S3	1	23
	2	24

Table 1 DIP switch and relay number

TKM-707

MAT-100 (AUTOMATIC ANTENNA TUNER)

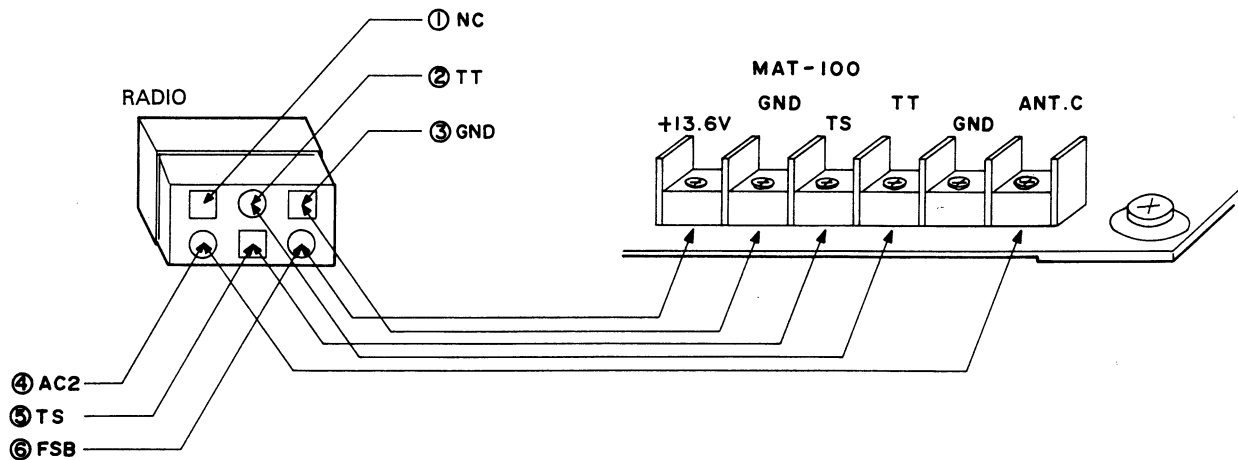

MAT-100

Pin name	Description
+13.6V	13.6VDC input
GND	Ground
TS	Control signal input/output
TT	Control signal input/output
GND	Ground
ANT. C	Antenna current output

TKM-707

Pin name	Description
NC	Unused
TT	Control signal input/output
GND	Ground
AC2	Antenna current
TS	Control signal input/output
FSB	Tuner power output

Fig. 2 Control cable connection

• Sensor block

An attenuator consisting of R1 through R7 is inserted into the sensor to stabilize impedance and reduce unwanted waves during tuning. High power signals are input from the remote controller to the J1 terminal and passed through this attenuator.

The high power signal is tapped off from the main signal and passed through R11 to the frequency read block.

The forward wave and reflected wave signals of the HF signal are detected by a coupler consisting of L12, L13, R9, and R10; converted into a control voltage using D1 and D2; then sent to the analog-to-digital converter.

The converted digital signal is used as an input signal for the input power check and reflection coefficient operation.

The forward and reflected waves are sent through buffers Q1 and Q2 to a DBM consisting of L16, L17, and D47 and sent to comparator IC15 (1/2) as impedance signal IZI. Impedance signal IZI is compared with a 50-ohm impedance.

Voltage and current signals are sent to a DBM consisting of L14, L15, and D46; compared with each other, then extracted as a phase signal.

Input power level range : 8~15 W

1. Overpower

When power exceeding approximately 20 W is detected during the power check, a 100 ms counter is set. When a tuning start (TS) is canceled after 100 ms or within 100 ms, the through mode is entered.

- 1 : Power check
- 2 : TS check
- 3 : Returned to 1 if within 100 ms

* If the power is proper in step 1, stop the above operation and proceed to the next operation.

MAT-100 (AUTOMATIC ANTENNA TUNER)

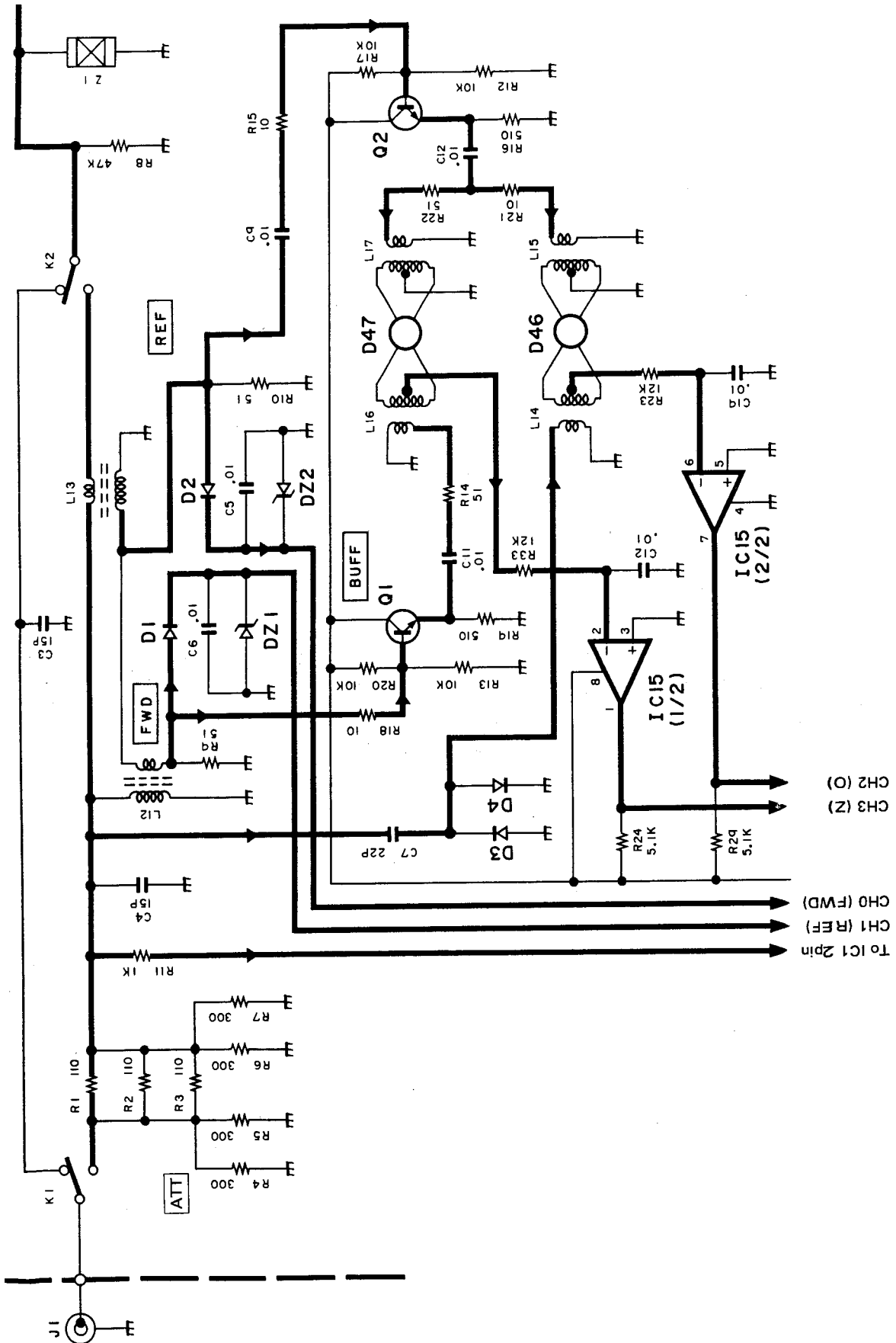

Fig. 3 Sensor circuit (Forward and reflected waves)

TKM-707

MAT-100 (AUTOMATIC ANTENNA TUNER)

• Frequency read block

The HF signal obtained by the sensor circuit is passed through a limiter consisting of C18, C21, D6, and D7, then sent to frequency divider IC1 (1/16) (μ PB553AC). The output level of IC1 is ECL level, so it is converted to TTL level by buffer amplifier Q9, then fed to counter IC2.

The CPU controls the counter at the timing shown in the Figure 4. The counter is cleared with a reset signal, a pulse of this duration is counted with a gate signal, and the count value is latched with a load signal. Meanwhile, data is sent from terminals 1 through 4. For terminals 10^0 , 10^1 , 10^2 , and 10^3 , a digit signal to indicate the data digit is output in an internal free-running period of approximately 700 Hz. IC3 is used to

control the bus line output. When an OE terminal is high, data is output to the bus line.

The above operation is performed only once during tuning start.

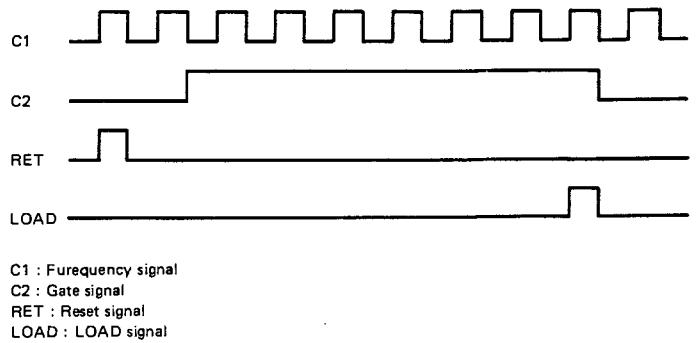

Fig. 4 Counter control timing chart

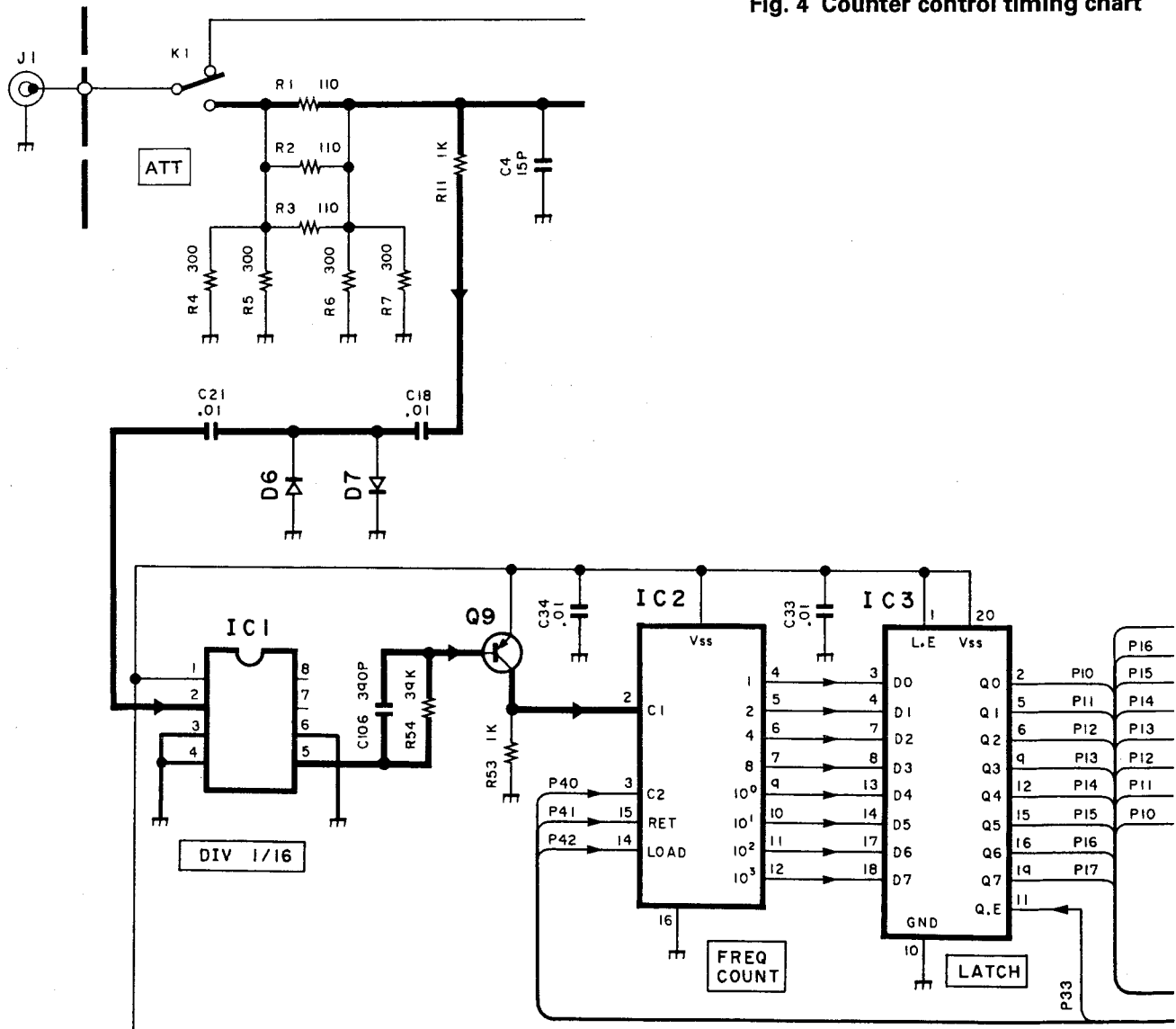

Fig. 5 Frequency read block

MAT-100 (AUTOMATIC ANTENNA TUNER)

• A/D converter

The forward wave, reflected wave, phase, and impedance $|Z|$ voltages obtained by the sensor circuit are

input to IC4. The CPU converts the signal voltage to an 8-bit digital signal and loads it, as required.

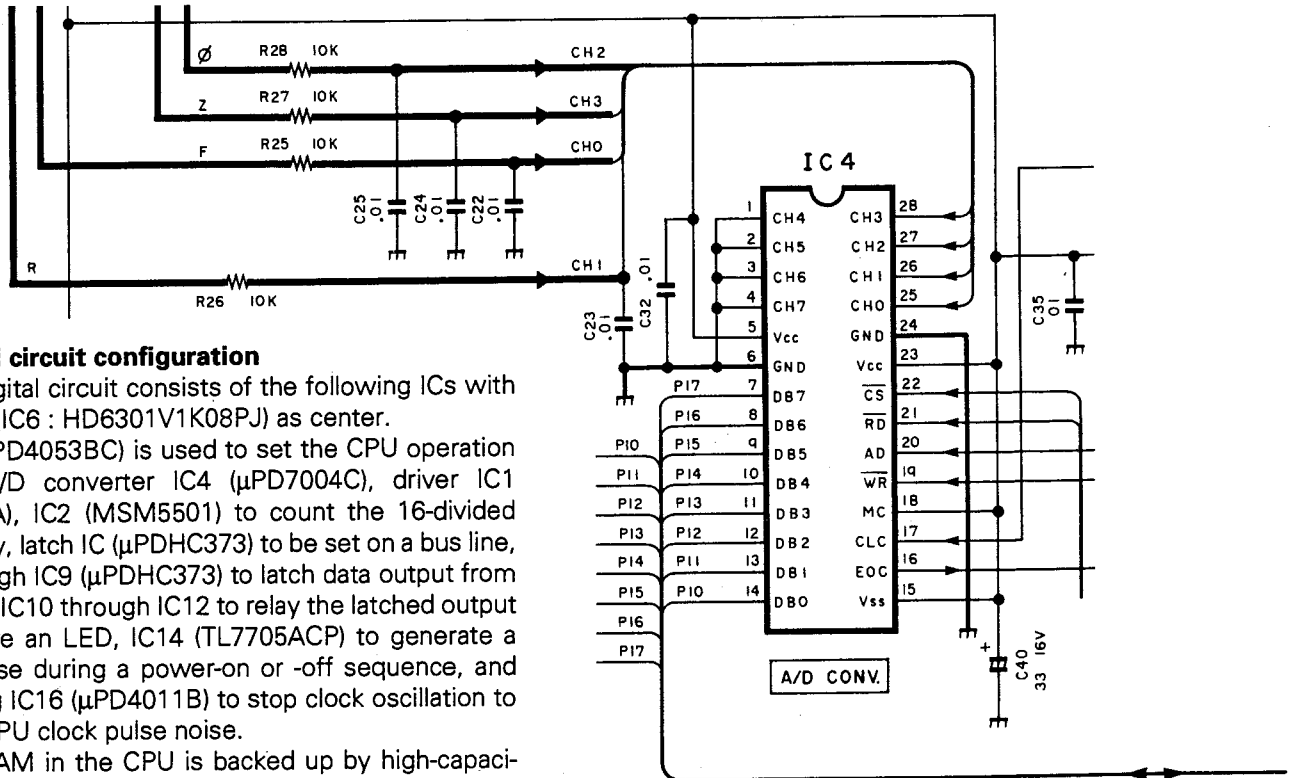

Fig. 6 A/D converter circuit

• Digital circuit configuration

The digital circuit consists of the following ICs with the CPU (IC6 : HD6301V1K08PJ) as center.

IC5 (μ PD4053BC) is used to set the CPU operation mode, A/D converter IC4 (μ PD7004C), driver IC1 (μ PB553A), IC2 (MSM5501) to count the 16-divided frequency, latch IC (μ PDHC373) to be set on a bus line, IC7 through IC9 (μ PDHC373) to latch data output from the CPU, IC10 through IC12 to relay the latched output or to drive an LED, IC14 (TL7705ACP) to generate a reset pulse during a power-on or -off sequence, and switching IC16 (μ PD4011B) to stop clock oscillation to reduce CPU clock pulse noise.

The RAM in the CPU is backed up by high-capacitance capacitor C39 (0.22 F) to retain the memory data items.

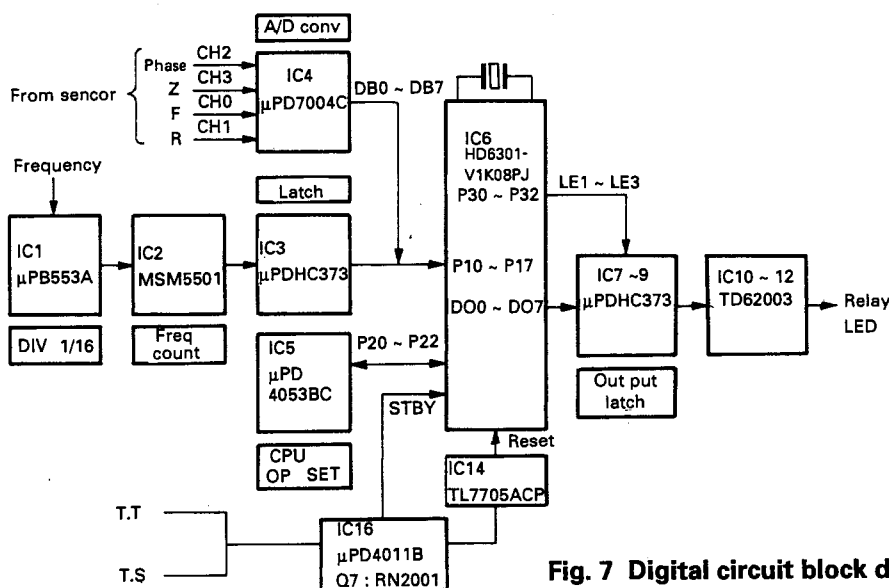

Fig. 7 Digital circuit block diagram

• Output block

Data processed by the CPU is output in 8-bit units, added to a latch pulse sequentially from IC7, then sent to IC9. A relay or LED is then driven by drivers IC10 through IC13.

When output enable circuits IC7 through IC9 are controlled, the relay circuit is manually activated and surge current is reduced during the power-on sequence.

TKM-707

MAT-100 (AUTOMATIC ANTENNA TUNER)

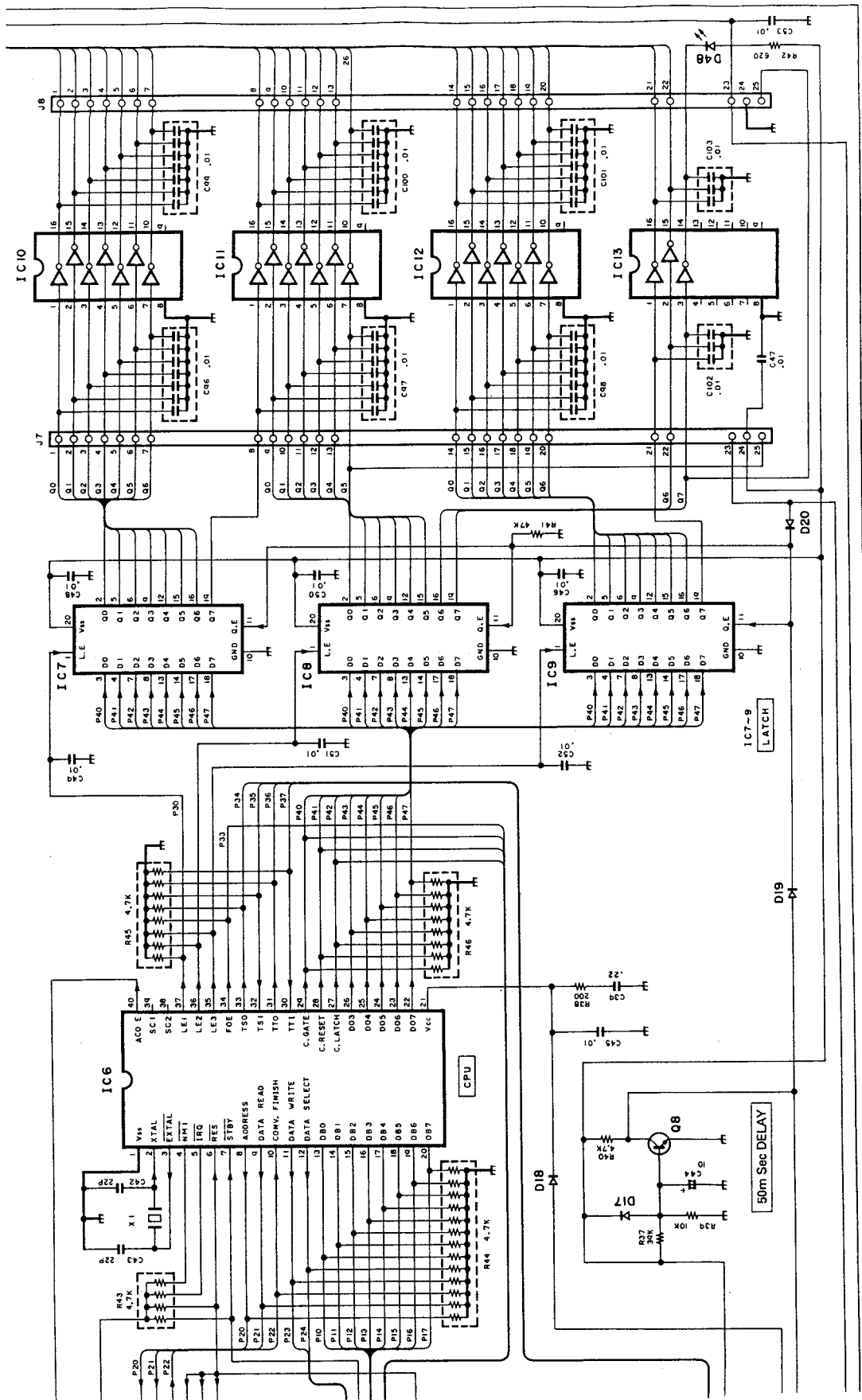

Fig. 8 Output block

MAT-100 (AUTOMATIC ANTENNA TUNER)

• Mode setting block

To set the CPU, terminals P20 through P22 of IC6 must be set high when activating the CPU. P20 through P22 control A/D converter IC4. Therefore, a signal is selected using IC5.

A reset signal is output from pin 5 of IC14 during mode selection. When the reset signal output is added to the A, B, and C terminals of IC5, terminals X0, Y0, and Z0 are selected. The terminal level is output to terminals X, Y, and Z and added to the P20, P21, and P22 terminals of IC6.

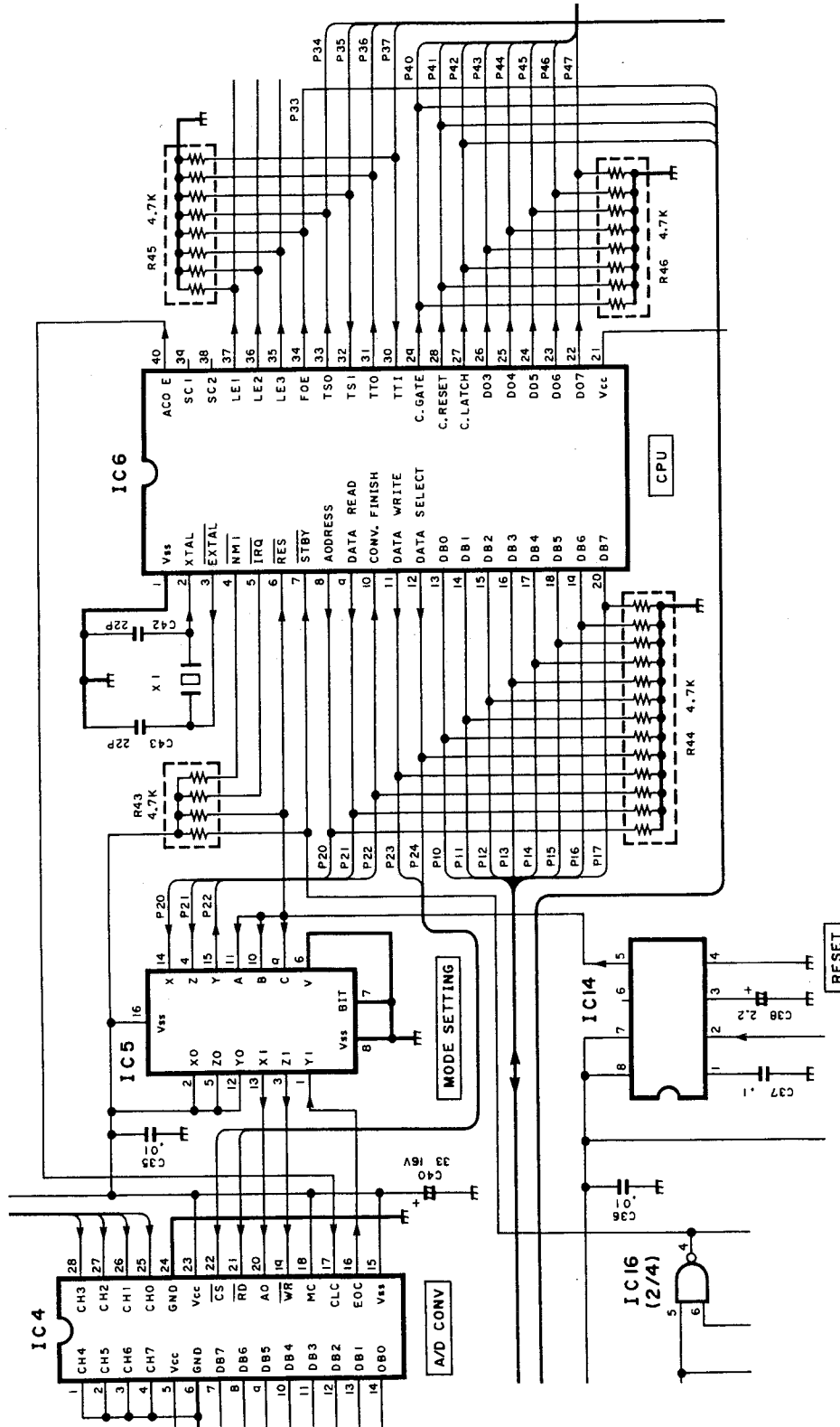

Fig. 9 Mode setting block

TKM-707

MAT-100 (AUTOMATIC ANTENNA TUNER)

• CPU standby operation and interface

The STBY signal is low and the CPU stops the clock oscillation, then enters the standby mode. When a TS or TT signal is set low in the standby mode, the TS signal sets the STBY signal high using Q4, IC16 (3/4), and IC16 (2/4). The TT signal sets the STBY signal high using Q6, IC16 (1/4), and IC16 (2/4).

The MAT-100 then exits the standby mode. When the STBY signal is set high, it is delayed by the time constant of R55 and C29, and pin 2 of IC14 is set high. When this terminal is set high, a reset signal (low) of the duration determined by C38 is output from pin 5.

When the reset signal is set high, the CPU starts operation. IC4 checks the P35 and P37 outputs, that is, the Q4 and Q6 outputs and judges whether the

drive signal is a TS or TT signal. A tuning or through operation is then performed.

When S4 is set to MANUAL, the STBY signal remains low by ORing diodes D13, D16, and R50. At this time, the CPU cannot be activated. A high signal is added to the base of Q8 via D12 during a power-on sequence, but it is delayed by the time constant determined by R37 and C44. This delay enables the STBY signal to be set high via D15 (D15, D9, and R35 are diode-ORed) using IC16 (3/4) and IC16 (2/4). This is done to initialize the CPU.

When the TS and TT signals are set high, the STBY signal is set low using Q4, Q6, IC16 (3/4), IC16 (1/4), and IC16 (2/4). The CPU thus enters the standby mode.

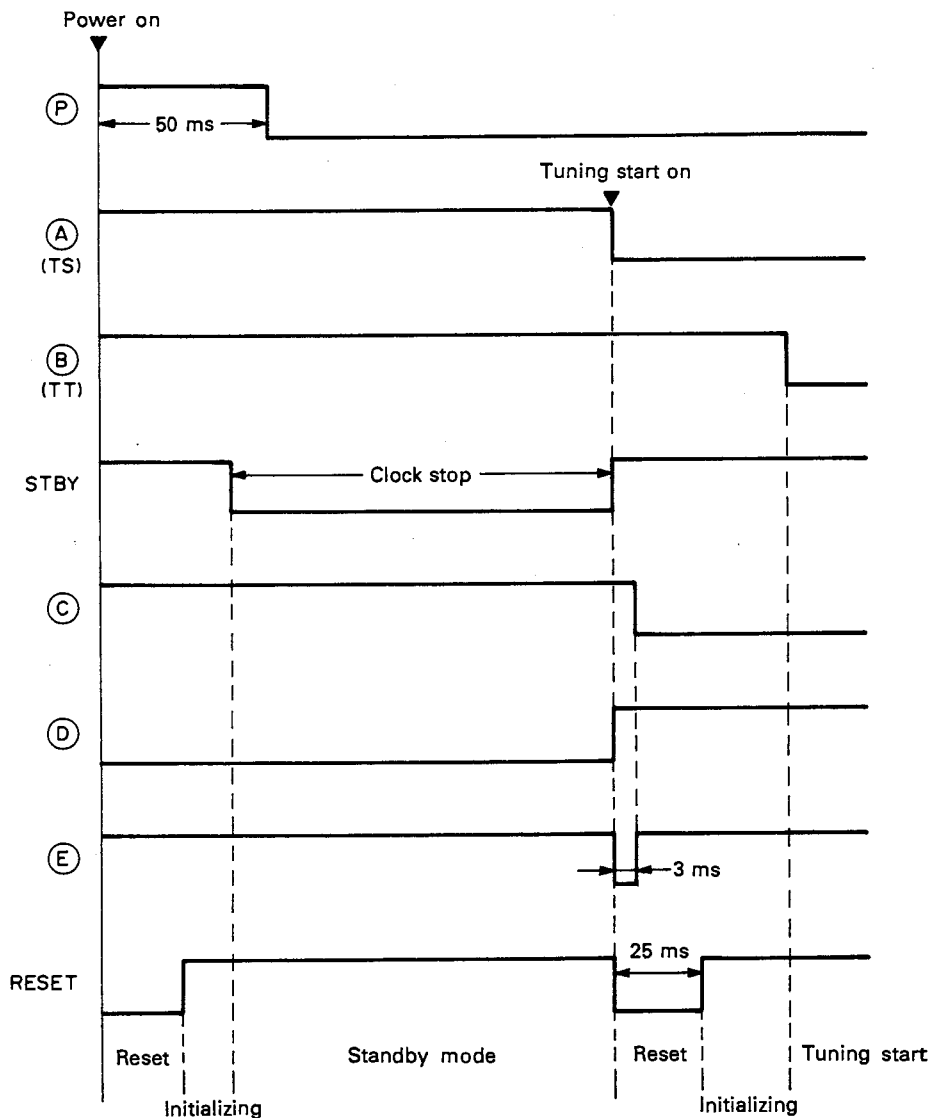

Fig. 10 Tuning start

MAT-100 (AUTOMATIC ANTENNA TUNER)

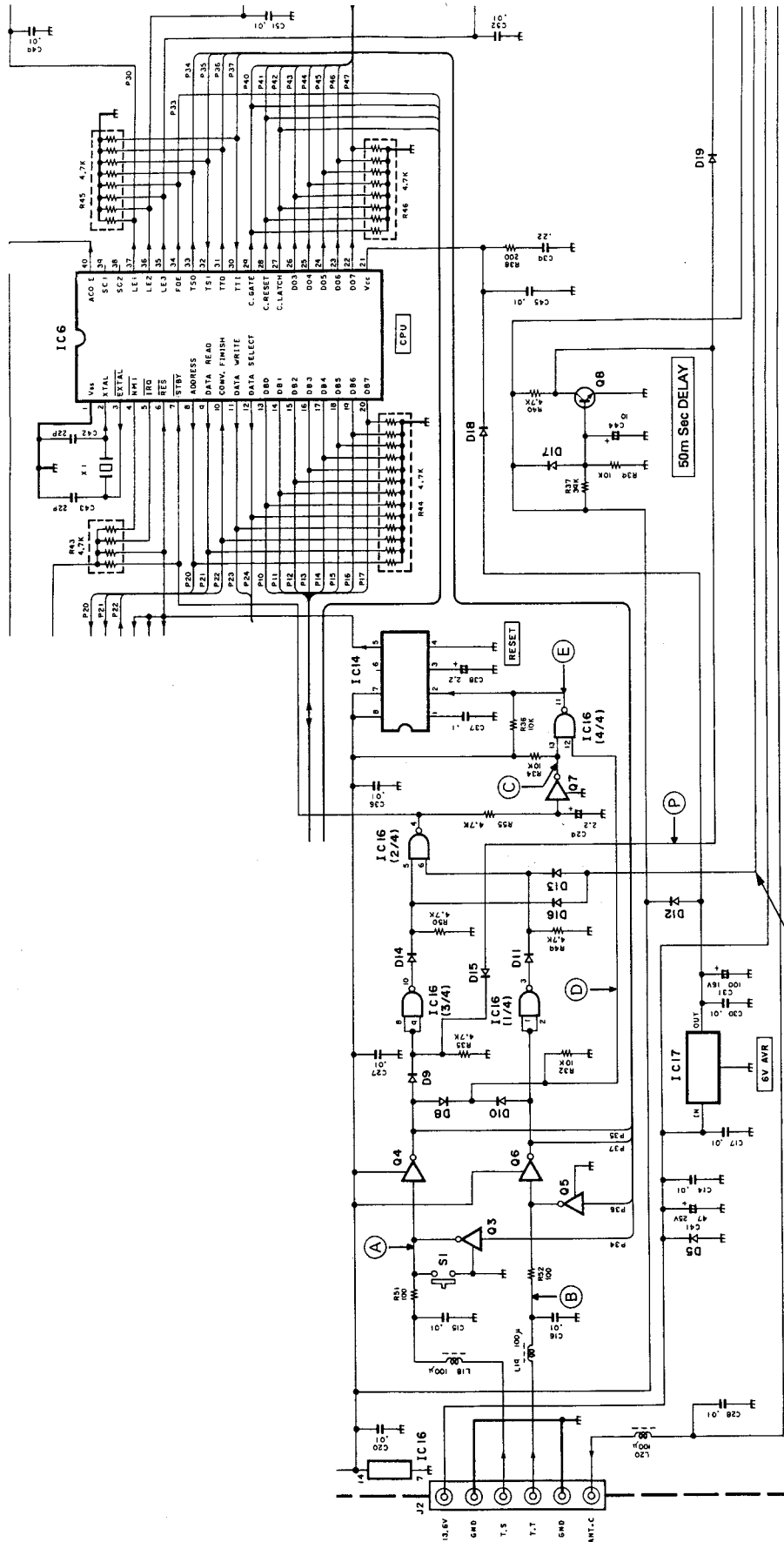

Fig. 11 Interface rest block

Auto : "L"
Manual : "H"

TKM-707

MAT-100 (AUTOMATIC ANTENNA TUNER)

- **LED unit**

This circuit consists of LED indicators D1 through D22, AUTO/MANUAL selector switch S4, and switches S1 through S3 to operate an LC tuning circuit relay during manual operation. LED indicators D1 through D22 go on when the corresponding LC tuning circuit relay is set on. The LED unit is also connected to J7 and J8 on the main unit's board via sockets J1 and J2.

AUTO or MANUAL is selected with switch S4. In the auto mode, ground (GND) is connected to pin 23 of J1 (output enable terminal of IC7, IC8, and IC9 on the main unit's board). In the manual mode, 5.3 V is connected to pin 23 of J1 as in auto mode.

In the manual mode, a voltage is applied to pins 1 through 22 of J1 (S1 through S3 are set to OFF). When switches S1 through S3 are set to ON, the voltage goes low. As a result, IC10 through IC13 on the main unit's board and the LC tuning circuit relay are activated.

1. Manual mode operation

When S1 through S3 set to OFF, the relay is set on and the corresponding LED indicator goes on.

When S1 through S3 are set to ON, the relay is set off and the corresponding LED indicator goes off.

2. Auto mode operation

The relay is set on and the corresponding LED indicator goes on irrespective of the setting of switches S1 through S3.

MAT-100 (AUTOMATIC ANTENNA TUNER)

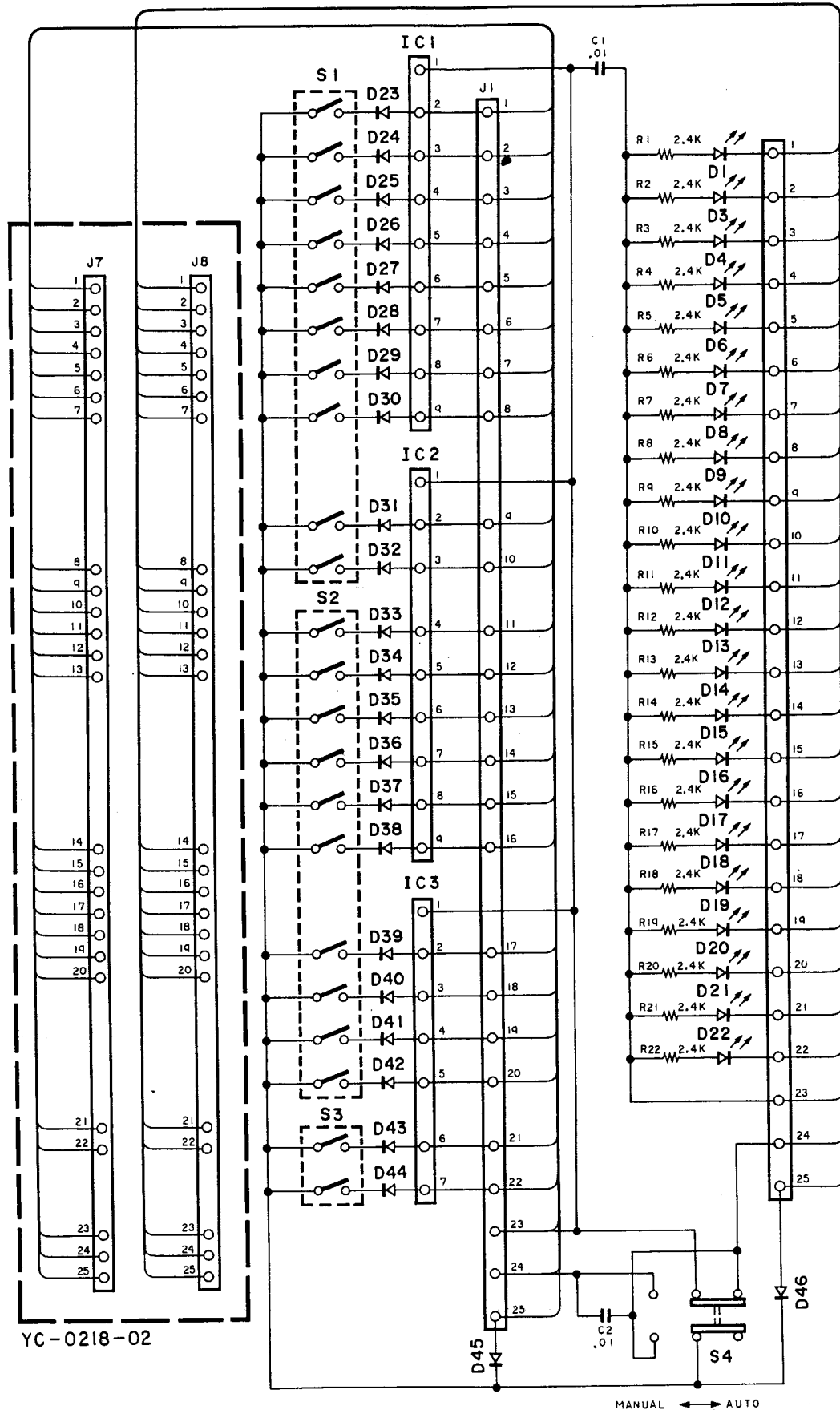

Fig. 12 LED unit

TKM-707

MAT-100 (AUTOMATIC ANTENNA TUNER)

• LC tuning circuit

This circuit is used for antenna tuning. It consists of coils L1 through L11 to enable a false and linear change, capacitors C76 through C92, and relays K3 through

K24 to set capacitors on or off. Capacitors can be set to IN (TX) or OUT (ANT) by relays K12 and K15. These relays are driven by a signal from the CPU.

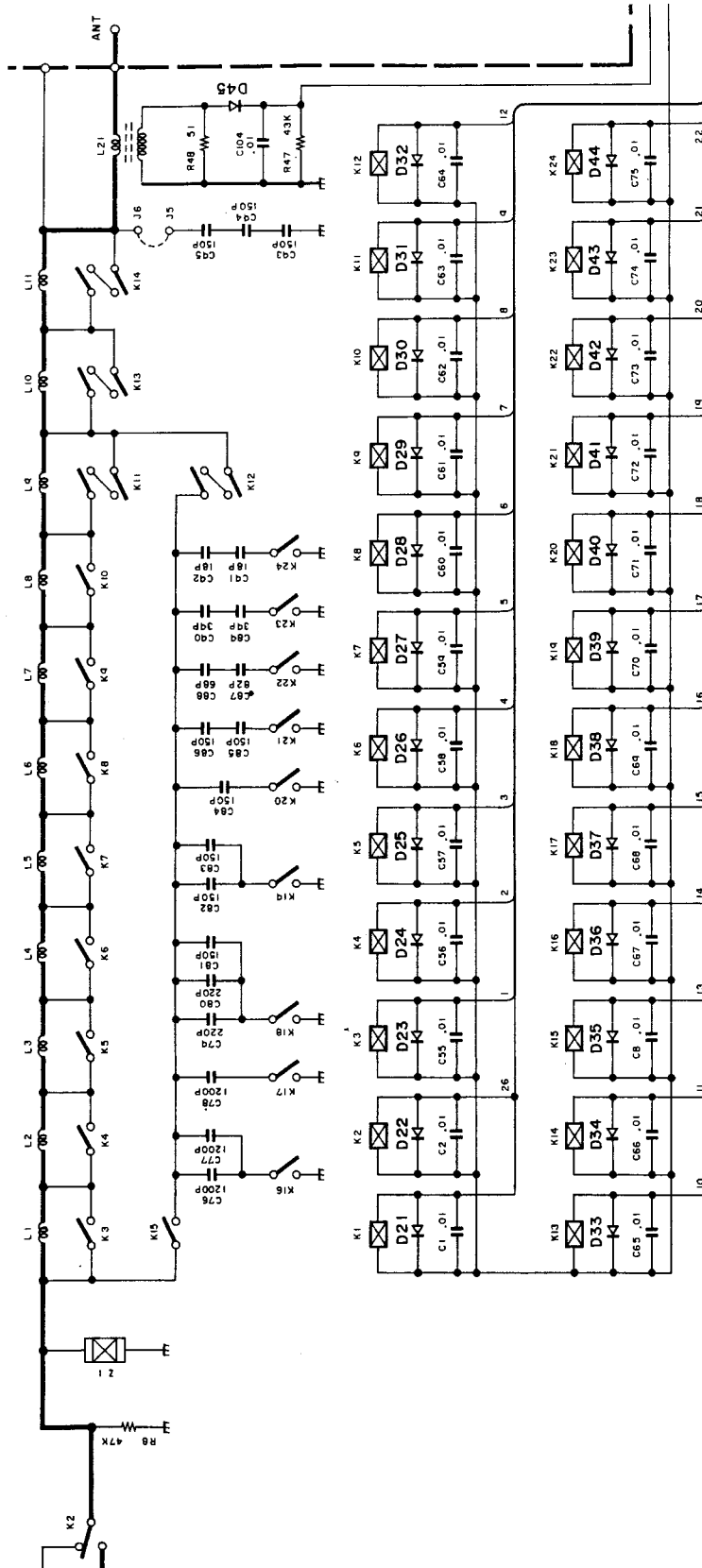

Fig. 13 LC tuning circuit

MAT-100 (AUTOMATIC ANTENNA TUNER)







	Port name	Pin No.	Name	Function	I/O	Remarks
Control signal	Vss	1	Vss	Ground terminal	-	
	XTAL	2	XTAL	Crystal connection terminal	I	
	XTAL	3	XTAL	Crystal connection terminal	O	
	NMI	4	-		-	
	IRQ	5	-		-	
	RES	6	RES	CPU reset terminal	I	
	STBY	7	STBY	CPU clock stop terminal	I	"L" : Stop
2 ports	P20	8	AO	A/D control address signal	O	
	P21	9	WR	A/D data read signal	O	
	P22	10	EOC	A/D conversion end signal	I	"L" : Conversion end
	P23	11	RD	A/D data write signal	O	
	P24	12	CS	A/D chip select signal	O	"L" : Select
1 ports	P10	13	DB0	A/D conversion, counter data bus	I/O	
	P11	14	DB1	A/D conversion, counter data bus	I/O	
	P12	15	DB2	A/D conversion, counter data bus	I/O	
	P13	16	DB3	A/D conversion, counter data bus	I/O	
	P14	17	DB4	A/D conversion, counter data bus	I/O	
	P15	18	DB5	A/D conversion, counter data bus	I/O	
	P16	19	DB6	A/D conversion, counter data bus	I/O	
	P17	20	DB7	A/D conversion, counter data bus	I/O	
4 ports	Vcc	21	Vcc	Power terminal	-	
	P47	22	DO7	Relay output signal	O	
	P46	23	DO6	Relay output signal	O	
	P45	24	DO5	Relay output signal	O	
	P44	25	DO4	Relay output signal	O	
	P43	26	DO3	Relay output signal	O	
	P42	27	DO2/L	Relay output signal / counter latch signal	O	
	P41	28	DO1/R	Relay output signal / counter reset signal	O	
	P40	29	DO0/G	Relay output signal / counter gate signal	O	
3 ports	P37	30	TTI	Through mode drive input	I	"H" : Drive
	P36	31	TTO	Through mode response output	O	"H" : Response
	P35	32	TSI	Tune mode drive input	I	"H" : Drive
	P34	33	TSO	Tune mode response output	O	"H" : Response
	P33	34	FOE	Frequency read circuit's separated signal	O	"H" : Separation
	P32	35	LE3	Output latch pulse 3	O	
	P31	36	LE2	Output latch pulse 2	O	
	P30	37	LE1	Output latch pulse 1	O	
	SC2	38	-		-	
	SC1	39	-		-	
	E	40	ACO	A/D clock output terminal	O	1/4 of clock

Table 2 CPU : HD6301V1K08PJ (IC6) terminal function

TKM-707

MAT-100 (AUTOMATIC ANTENNA TUNER)

Block Diagram

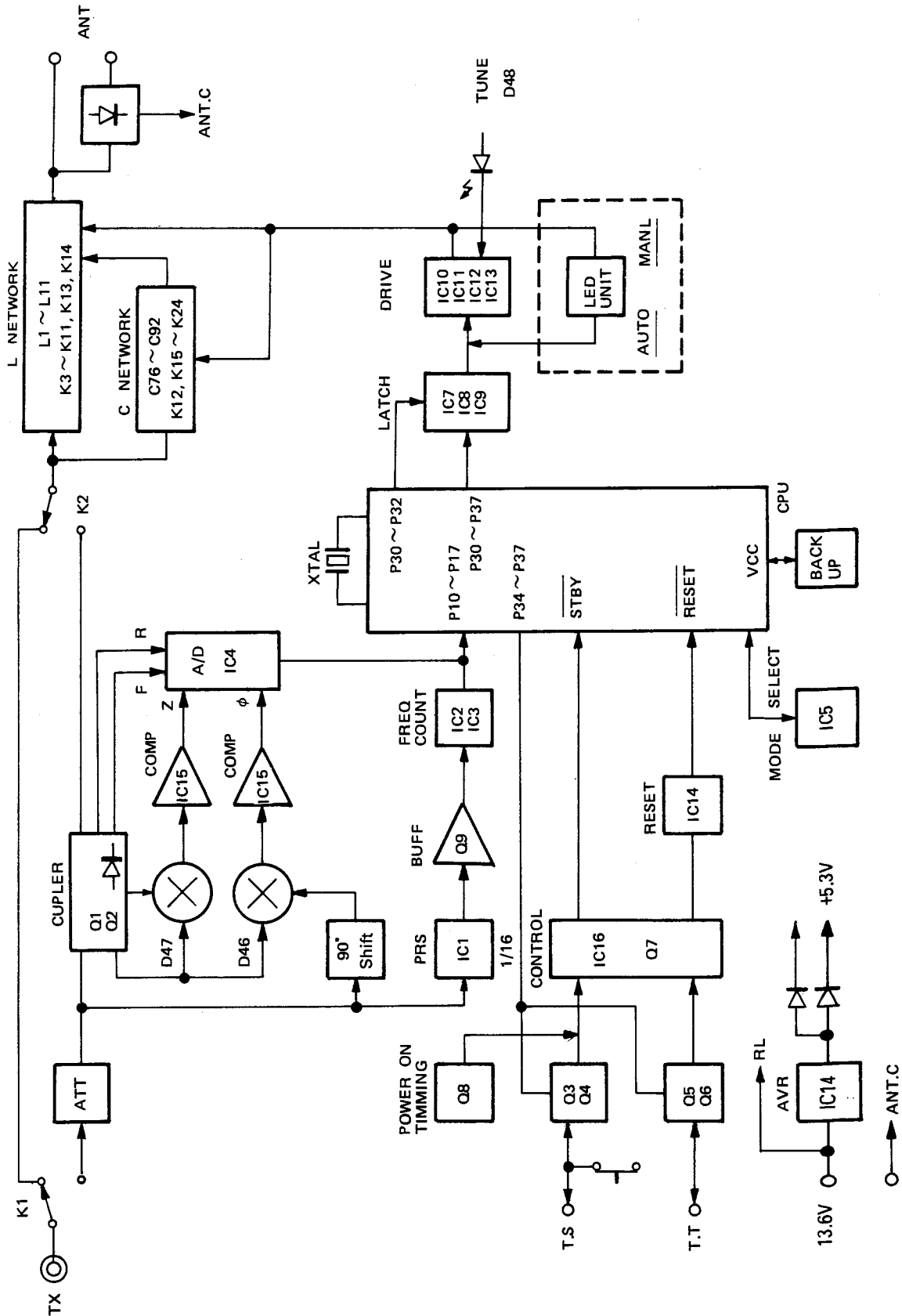

MAT-100 (AUTOMATIC ANTENNA TUNER)

Description of Components

ANT MODULE UNIT (W02-0883-08)

Component	Use/Function	Operation/Condition/Compatibility
IC1	1/16 Divider	
IC2	1/16 Divider counter	BCD code.
IC3	Latch	High impedance level without frequency read.
IC4	A/D converter	CH0 FWD voltage. CH1 REF voltage. CH2 phase voltage. CH3 Impedance voltage.
IC5	CPU mode setting	CPU P20, 21, 22=High.
IC6	CPU	Single chip mode operation.
IC7~9	Output latch	Auto mode O, E=Low. Manual mode O, E=High.
IC10~13	Output driver	
IC14	Reset making	25ms.
IC15	Comparator	Phase is "+"=High, "-"=Low. IZ is 50Ω>High, 50Ω<Low
IC16	Switching	STBY, RESET TRIG occur.
IC17	AVR	6V 1A.
Q1, 2	Buffer	Q1 : REF wave, Q2 : FWD wave.
Q3, 5	Switching	Q3 : "H" level when through mode response. Q5 : "H" level when tune mode.
Q4, 6	Switching	Q4 : Turn to LOW when tune mode. Q6 : Turn to LOW when through mode.
Q7	Switching	RESET TRIG occur.
Q8	Switching	"H" 50m sec when power switch is turned ON.
Q9	Buffer	ELC level → TTL level.

LED UNIT (W02-0884-08)

Component	Use/Function	Operation/Condition/Compatibility
IC1~3	Voltage supply	Network between diode resistor.

TKM-707

MAT-100 (AUTOMATIC ANTENNA TUNER)

× New Parts

Parts without Parts No. are not supplied.

Les articles non mentionnes dans le Parts No. ne sont pas fournis.

Teile ohne Parts No. werden nicht geliefert.

Parts List

Ref. No. 参照番号	Address 位置	New Parts 新	Parts No. 部品番号	Description 部品名 / 規格	Desti- nation 仕 向	Re- marks 備考
MAT-100						
1	1A	*	A01-2001-08	CABINET(TOP)		
2	3B	*	A01-2002-08	CABINET(BOTTOM)		
		*	B40-7645-08	MODEL NAME PLATE		
		*	B41-0671-08	LABEL(CAUTION)		
		*	B42-3397-08	LABEL(KENWOOD)		
		*	B42-3398-08	LABEL(MAT-100)		
		*	B46-0420-00	WARRANTY CARD	K	
		*	B50-8357-08	INSTRUCTION MANUAL		
C1 ,2		*	CK45B1H103K	CERAMIC 0.010UF	K	
C3 ,4		*	CM93CC2H150J	MICA C 15PF	J	
C5 ,6		*	CK45B1H103K	CERAMIC 0.010UF	K	
C7		*	CC45SL2H220J	CERAMIC 22PF	J	
C8 -25		*	CK45B1H103K	CERAMIC 0.010UF	K	
C27 ,28		*	CK45B1H103K	CERAMIC 0.010UF	K	
C29		*	CS15E1C2R2M	TANTALUM 2.2UF	16WV	
C30		*	CK45B1H103K	CERAMIC 0.010UF	K	
C31		*	CE04EW1C101M	ELECTRO 100UF	16WV	
C32 -37		*	CK45B1H103K	CERAMIC 0.010UF	K	
C38		*	CS15E1C2R2M	TANTALUM 2.2UF	16WV	
C39		*	C90-2127-08	ELECTRO 0.22UF		
C40		*	CE04EW1C330M	ELECTRO 33UF	16WV	
C41		*	CE04EW1E470M	ELECTRO 47UF	25WV	
C42 ,43		*	CC45SL2H220J	CERAMIC 22PF	J	
C44		*	CS15E1A100M	TANTALUM 10UF	10WV	
C45 -53		*	CK45B1H103K	CERAMIC 0.010UF	K	
C55 -75		*	CK45B1H103K	CERAMIC 0.010UF	K	
C76 -78		*	CM93D2H122J	MICA 1200PF	J	
C79 ,80		*	C91-1112-08	MICA 220PF	J	
C81 -86		*	C91-1111-08	MICA 150PF	J	
C87		*	C91-1110-08	MICA 82PF	J	
C88		*	C91-1109-08	MICA 68PF	J	
C89 ,90		*	C91-1108-08	MICA 39PF	J	
C91 -92		*	C91-1107-08	MICA 18PF	J	
C93 -95		*	C91-1111-08	MICA 150PF	J	
C96 -101		*	R90-0715-08	CAP.BLOCK 0.01 X7		
C102,103		*	R90-0716-08	CAP.BLOCK 0.01 X3		
C104		*	CK45B1H103K	CERAMIC 0.010UF	K	
C106		*	CK45B2H391K	CERAMIC 390PF	K	
		*	E09-0672-08	6P CONNECTOR(ACSY)		
		*	E23-0644-08	TERMINAL		
		*	E23-0645-08	TERMINAL		
		*	E23-0646-08	PIN CONNECTOR(ACSY)		
10	2A,3B	*	E23-0647-08	HOLD LUG		
		*	E23-0652-08	TERMINAL		
		*	E31-6143-08	WIRE(RF-IF)		
		*	E31-6144-08	WIRE(ANT)		
		*	E31-6145-08	WIRE(GND)		
J1	1A	*	E04-0167-05	ANT. RECEPTACLE		
J2		*	E22-0671-08	TERMINAL		
J5 ,6		*	E23-0648-05	TERMINAL		
		*	E31-6142-08	CABLE ASSY(J5-J6)		
J7 ,8		*	E40-5379-05	PIN HEADER		

E: Scandinavia & Europe K: USA P: Canada W: Europe

U: PX(Far East, Hawaii) T: England M: Other Areas

UE: AAFES(Europe) X: Australia

△ indicates safety critical components.

MAT-100 (AUTOMATIC ANTENNA TUNER)

× New Parts

Parts without Parts No. are not supplied.

Les articles non mentionnés dans le Parts No. ne sont pas fournis.

Teile ohne Parts No. werden nicht geliefert.

Ref. No. 参照番号	Address 位置	New Parts 新	Parts No. 部品番号	Description 部品名 / 規格	Desti- nation 仕 向	Re- marks 備考
15	3B	*	E31-6150-08	CABLE ASSY(J9-J10)		
		*	F09-0427-08	INSULATING COVER(ACSY)		
		*	F10-1432-08	ATT SHIELD CASE		
		*	F10-1433-08	CPU SHIELD CASE		
		*	F10-1434-08	CPU SHIELD PLATE		
		*	F10-1435-08	LATCH SHIELD PLATE		
		*	F10-1436-08	SHIELD CASE(BOTTOM)		
		*	F10-1437-08	SHIELD PLATE		
		*	F29-0441-08	STAYER TIGHT BUSHING		
		*	F29-0442-08	SLEEVE		
16	2B	*	G13-0958-08	CUSHION		
17	3B	*	G53-0588-08	PACKING		
18	2A, 3B	*	G53-0589-08	PACKING		
		*	G53-0590-08	PACKING		
		*	G53-0592-08	RUBBER SLEEVE		
		*	H01-9650-08	ITEM CARTON		
		*	H25-0029-04	PROTECTION BAG(ACSY)		
		*	H25-0103-04	PROTECTION BAG(ACSY)		
		*	H25-0106-04	PROTECTION BAG(INSTRUCTION M.)		
		*	H25-0736-08	PROTECTION BAG(RADIO)		
20	1A	*	J21-4300-08	MOUNTING BRACKET(ACSY)		
21	3A, 3B	*	J21-4301-08	CONNECTOR MOUNT HARDWARE		
23	1A, 2B	*	J21-4302-08	MOUNTING HARDWARE		
		*	J42-0469-08	CABLE CONNECTOR		
L1		*	L34-1293-08	COIL		
L2		*	L34-1294-08	COIL		
L3		*	L34-1295-08	COIL		
L4		*	L34-1296-08	COIL		
L5		*	L34-1297-08	COIL		
L6		*	L34-1298-08	COIL		
L7		*	L34-1299-08	COIL		
L8		*	L34-1300-08	COIL		
L9		*	L34-1301-08	COIL		
L10		*	L34-1302-08	COIL		
L11		*	L34-1303-08	COIL		
L12 ,13		*	L39-0486-08	DETECTION COIL		
L14 -17		*	L39-0488-08	DETECTION COIL		
L18 -20		*	L33-0736-08	FERRI INDUCTOR		
L21		*	L39-0487-08	DETECTION COIL		
X1		*	L77-1428-08	XTAL RESONATOR 4.0MHZ		
A B C	3B 2B 2A, 3B	*	N09-2095-08	U. BOLT(ACSY)		
		*	N09-2096-08	HEX. BOLT(ACSY)		
		*	N09-2097-08	HEX. BOLT(ANT)		
		*	N09-2099-08	HEX. BOLT (M5X25)GND TERMINAL		
		*	N09-2100-08	SCREW(M5X10)MOUNTING HARD WARE		
D E	2A, 3B 1A, 1B	*	N09-2101-08	SELF TAPPING SCREW		
		*	N09-2102-08	MACHINE SCREW(M4X16) COVER		
26	2A, 3B	*	N10-2030-41	NUT(M3) AVR IC		
		*	N14-0546-08	NUT		
		*	N14-0547-08	WING NUT		
27	3A, 3B	*	N14-0548-08	NUT(M4) COVER		
29	2A, 3B	*	N15-1030-41	FLAT WASHER		
		*	N15-1050-60	FLAT WASHER		

E: Scandinavia & Europe K: USA P: Canada W: Europe

U: PX(Far East, Hawaii) T: England M: Other Areas

UE: AAFES(Europe) X: Australia

△ indicates safety critical components.

TKM-707

MAT-100 (AUTOMATIC ANTENNA TUNER)

× New Parts

Parts without Parts No. are not supplied.

Les articles non mentionnés dans le Parts No. ne sont pas fournis.

Teile ohne Parts No. werden nicht geliefert.

Ref. No. 参照番号	Address 位置	New Parts 新	Parts No. 部品番号	Description 部品名 / 規格	Desti- nation 仕向	Re- marks 備考
31	2A, 3B	*	N16-0030-41	SPRING WASHER		
			N16-0050-60	SPRING WASHER		
			N30-2606-46	BINDING SCREW(M2.6X6)		
F	1A, 2A		N30-3006-46	BINDING SCREW(M3X6) AVR IC		
G	2A, 2B		N87-3008-46	SELF TAPPING SCREW(3X8)PC B.		
		*	N99-0344-08	SCREW SET		
R1 -3		*	RS14GB3D111J	FL-PROOF RS 110 J 2W		
R4		*	RS14GB3D301J	FL-PROOF RS 300 J 2W		
R7		*	RS14GB3D301J	FL-PROOF RS 300 J 2W		
R8			RD14BB2E473J	RD 47K J 1/4W		
R9 ,10			RD14BB2E510J	RD 51 J 1/4W		
R11			RD14BB2E102J	RD 1.0K J 1/4W		
R12 ,13			RD14CB2E103J	RD 10K J 1/4W		
R14		*	RD14CB2E510J	RD 51 J 1/4W		
R15			RD14CB2E100J	RD 10 J 1/4W		
R16		*	RD14CB2E511J	RD 510 J 1/4W		
R17			RD14CB2E103J	RD 10K J 1/4W		
R18			RD14CB2E100J	RD 10 J 1/4W		
R19		*	RD14CB2E511J	RD 510 J 1/4W		
R20			RD14CB2E103J	RD 10K J 1/4W		
R21			RD14CB2E100J	RD 10 J 1/4W		
R22		*	RD14CB2E510J	RD 51 J 1/4W		
R23			RD14CB2E123J	RD 12K J 1/4W		
R24			RD14CB2E512J	RD 5.1K J 1/4W		
R25 -28			RD14CB2E103J	RD 10K J 1/4W		
R29			RD14CB2E512J	RD 5.1K J 1/4W		
R32			RD14CB2E103J	RD 10K J 1/4W		
R33			RD14CB2E123J	RD 12K J 1/4W		
R34			RD14CB2E103J	RD 10K J 1/4W		
R35			RD14CB2E473J	RD 47K J 1/4W		
R36			RD14CB2E103J	RD 10K J 1/4W		
R37			RD14CB2E393J	RD 39K J 1/4W		
R38			RD14BB2E201J	RD 200 J 1/4W		
R39			RD14CB2E103J	RD 10K J 1/4W		
R40			RD14BB2E472J	RD 4.7K J 1/4W		
R41			RD14BB2E473J	RD 47K J 1/4W		
R41			RD14BB2E473J	RD 47K J 1/4W		
R42			RD14CB2E621J	RD 620 J 1/4W		
R43			R90-0286-05	MULTI-COMP 4.7KX4		
R44			R90-0452-05	MULTI-COMP 4.7KX12 J 1/4W		
R45 ,46			R90-0455-05	MULTI-COMP 4.7KX8 J 1/4W		
R47			RD14CB2E433J	RD 43K J 1/4W		
R48		*	RS14GB3D510J	FL-PROOF RS 51 J 2W		
R49 ,50			RD14CB2E472J	RD 4.7K J 1/4W		
R51 ,52			RD14CB2E101J	RD 100 J 1/4W		
R53			RD14CB2E102J	RD 1.0K J 1/4W		
R54			RD14CB2E393J	RD 39K J 1/4W		
R55			RD14CB2E472J	RD 4.7K J 1/4W		
K1 ,2		*	S51-1446-08	RELAY		
K3 -10		*	S51-1445-08	RELAY		
K11 -14		*	S51-2424-08	RELAY		
K15 -24		*	S51-1445-08	RELAY		
S1		*	S50-1426-08	SWITCH		

E: Scandinavia & Europe K: USA P: Canada W: Europe

U: PX(Far East, Hawaii) T: England M: Other Areas

UE: AAFES(Europe) X: Australia

⚠ indicates safety critical components.

MAT-100 (AUTOMATIC ANTENNA TUNER)

× New Parts

Parts without Parts No. are not supplied.

Les articles non mentionnés dans le Parts No. ne sont pas fournis.

Teile ohne Parts No. werden nicht geliefert.

Ref. No. 参照番号	Address 位置	New Parts 新	Parts No. 部品番号	Description 部品名 / 規格	Desti- nation 仕 向	Re- marks 備考
D1 ,2		*	2-1K261(イ)	DIODE		
D3 ,4			1S1588	DIODE		
D5			U05B	DIODE		
D6 -11			1S1588	DIODE		
DZ1		*	05AZ3X	ZENER DIODE		
D12			10D1	DIODE		
D13 -20			1S1588	DIODE		
D21 -44			10D1	DIODE		
DZ2		*	05AZ3X	ZENER DIODE		
D45		*	2-1K261(イ)	DIODE		
D46 ,47			ND487C2-3R	DIODE(DBM)		
D48			B30-0880-05	LED		
IC1			UPB553AC	IC		
IC2		*	MSM5501	IC		
IC3		*	UPD74HC373C	IC		
IC4		*	UPD7004C	IC		
IC5			TC4053BP	IC		
IC5			UPD4053BC	IC		
IC6		*	HD6301V1K08PJ	IC		
IC7 -9		*	UPD74HC373C	IC		
IC10 -13		*	T062003P	IC		
IC14		*	TL7705ACP	IC		
IC15		*	LM2903P	IC		
IC15			NJM2903D	IC		
IC16			TC4011BP	IC		
IC16			UPD4011BC	IC		
IC17		*	TA78006AP	IC		
Q1 ,2			2SC2408	TRANSISTOR		
Q3			DTC143ES	TRANSISTOR		
Q3		*	RN1001	TRANSISTOR		
Q4			DTA143ES	TRANSISTOR		
Q4		*	RN2001	TRANSISTOR		
Q5			DTC143ES	TRANSISTOR		
Q5		*	RN1001	TRANSISTOR		
Q6			DTA143ES	TRANSISTOR		
Q6		*	RN2001	TRANSISTOR		
Q7			DTC143ES	TRANSISTOR		
Q7		*	RN1001	TRANSISTOR		
Q8		*	2SC945A	TRANSISTOR		
Q9		*	2SA733A(P)	TRANSISTOR		
Z1		*	DSA-301LA	SURGE ABSORBOR		
35	2A	*	W02-0883-08	ANT MODULE UNIT		
36	1B	*	W02-0884-08	LED UNIT		
LED UNIT (W02-0884-08)						
C1 ,2			CK45B1H103K	CERAMIC 0.010UF K		
J1 ,2		*	E40-5380-05	SOCKET		
R1 -22			RD14CB2E242J	RD 2.4K J 1/4W		
S1 ,2		*	S59-0442-08	DIP SWICH		
S3		*	S59-0443-08	DIP SWICH		
S4		*	S31-0407-08	SWITCH		

E: Scandinavia & Europe K: USA P: Canada W: Europe

U: PX(Far East, Hawaii) T: England M: Other Areas

UE: AAFES(Europe) X: Australia

⚠ indicates safety critical components.

TKM-707

MAT-100 (AUTOMATIC ANTENNA TUNER)

× New Parts

Parts without Parts No. are not supplied.

Les articles non mentionnés dans le Parts No. ne sont pas fournis.

Telle ohne Parts No. werden nicht geliefert.

Ref. No. 参照番号	Address 位置	New Parts 新	Parts No. 部品番号	Description 部品名 / 規格	Desti- nation 仕 向	Re- marks 備考
D1 -22			B30 - 0880 - 05	LED		
D23 -46			1S1588	DIODE		
IC1 , IC2		*	DRL8-472	DIODE ARRAY		
IC3		*	DRL6-472	DIODE ARRAY		

E: Scandinavia & Europe K: USA P: Canada W: Europe

U: PX(Far East, Hawaii) T: England M: Other Areas

UE: AAFES(Europe) X: Australia

 indicates safety critical components.

MAT-100 (AUTOMATIC ANTENNA TUNER)

Exploded View

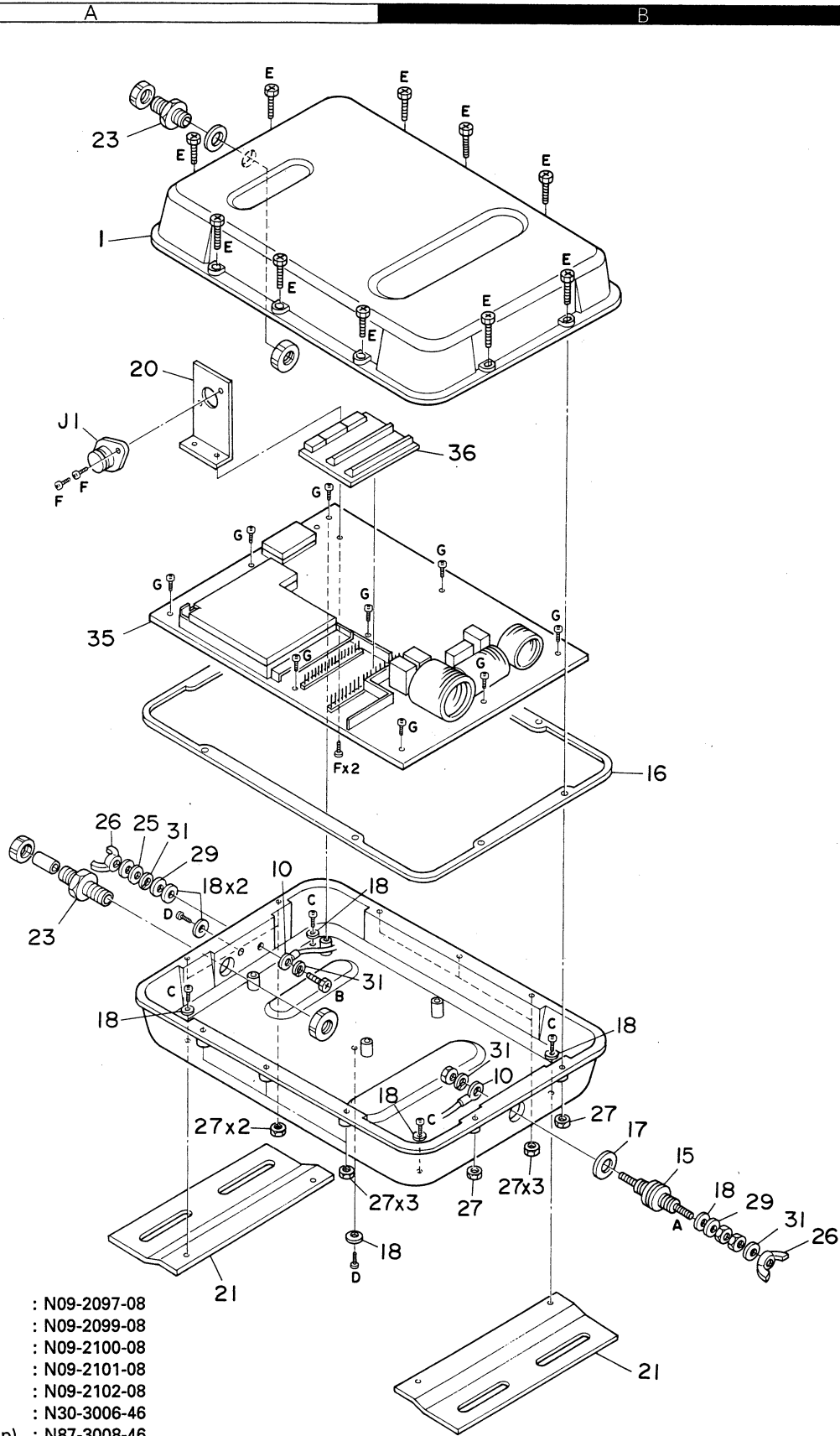

- | | | |
|---|-----------------|---------------|
| A | M5 x 65 | : N09-2097-08 |
| B | M5 x 25 | : N09-2099-08 |
| C | M5 x 10 | : N09-2100-08 |
| D | M5 x 8 | : N09-2101-08 |
| E | M4 x 16 | : N09-2102-08 |
| F | M3 x 6 | : N30-3006-46 |
| G | M3 x 8 (Br-Tap) | : N87-3008-46 |

MAT-100 (AUTOMATIC ANTENNA TUNER) TKM-707

PC Board View

LED UNIT (W02-0844-08) Component side view

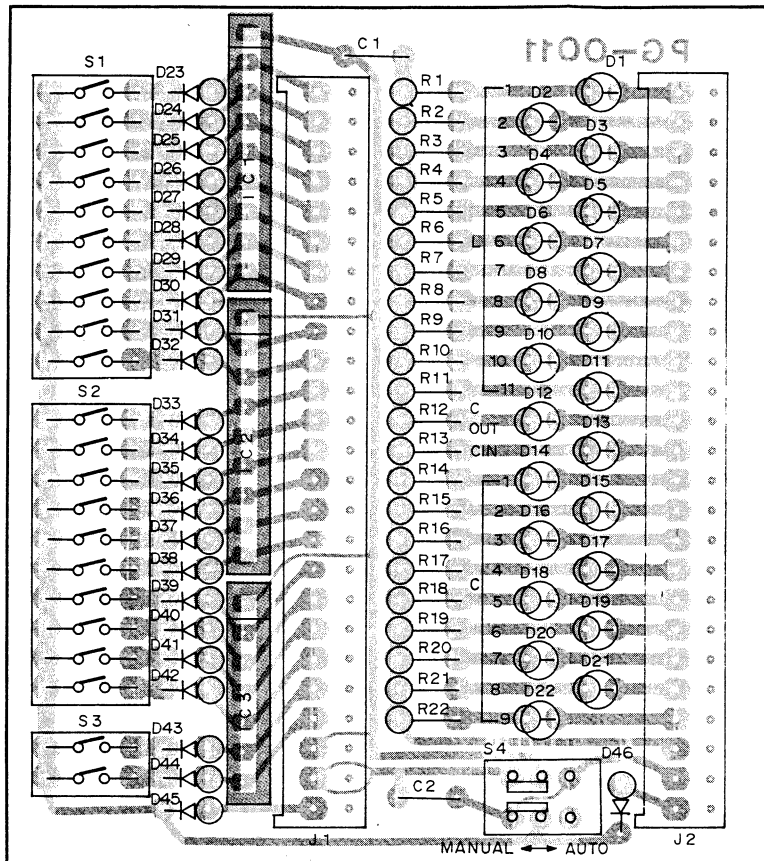

IC1, 2 : DRL8-472 IC3 : DRL6-472
 D1 - 22 : B30-0880-05 D23 - 46 : 1S1588

DTA143ES
 DTC143ES
 RN1001
 RN2001

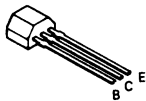

2SA733A
 2SC945A

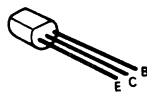

2SC2408

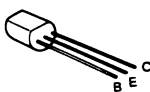

TA78006AP

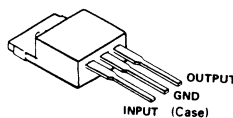

μPB553AC

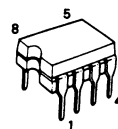

TC4011BP
 μPD4011BC

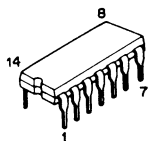

TC4053BP
 μPD4053BC

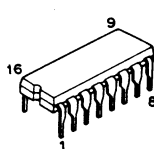

MSM5501

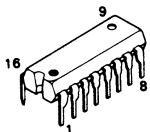

TD62003P

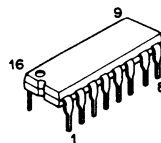

LM2903P
 NJM2903D
 TL7705ACP

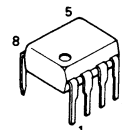

μPD7004C

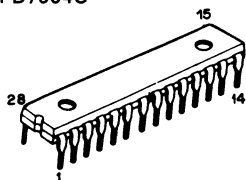

HD6301V1K08PJ

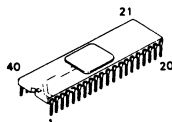

μPD74HC373C

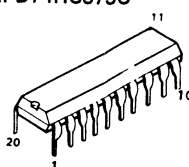

TKM-707 MAT-100 (AUTOMATIC ANTENNA TUNER)

ANT MODULE UNIT (W02-0883-08) Component side view

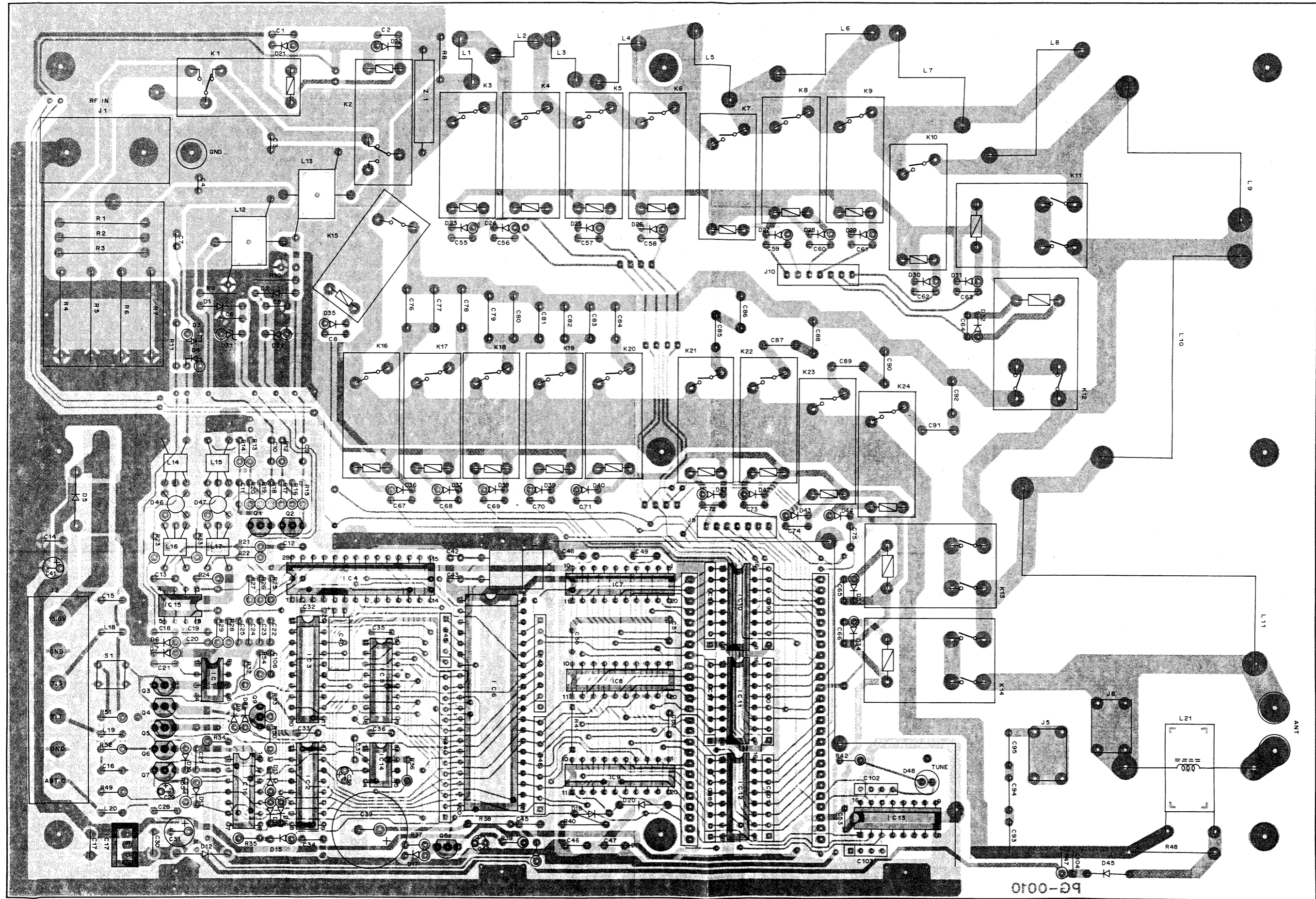

Schematic Diagram

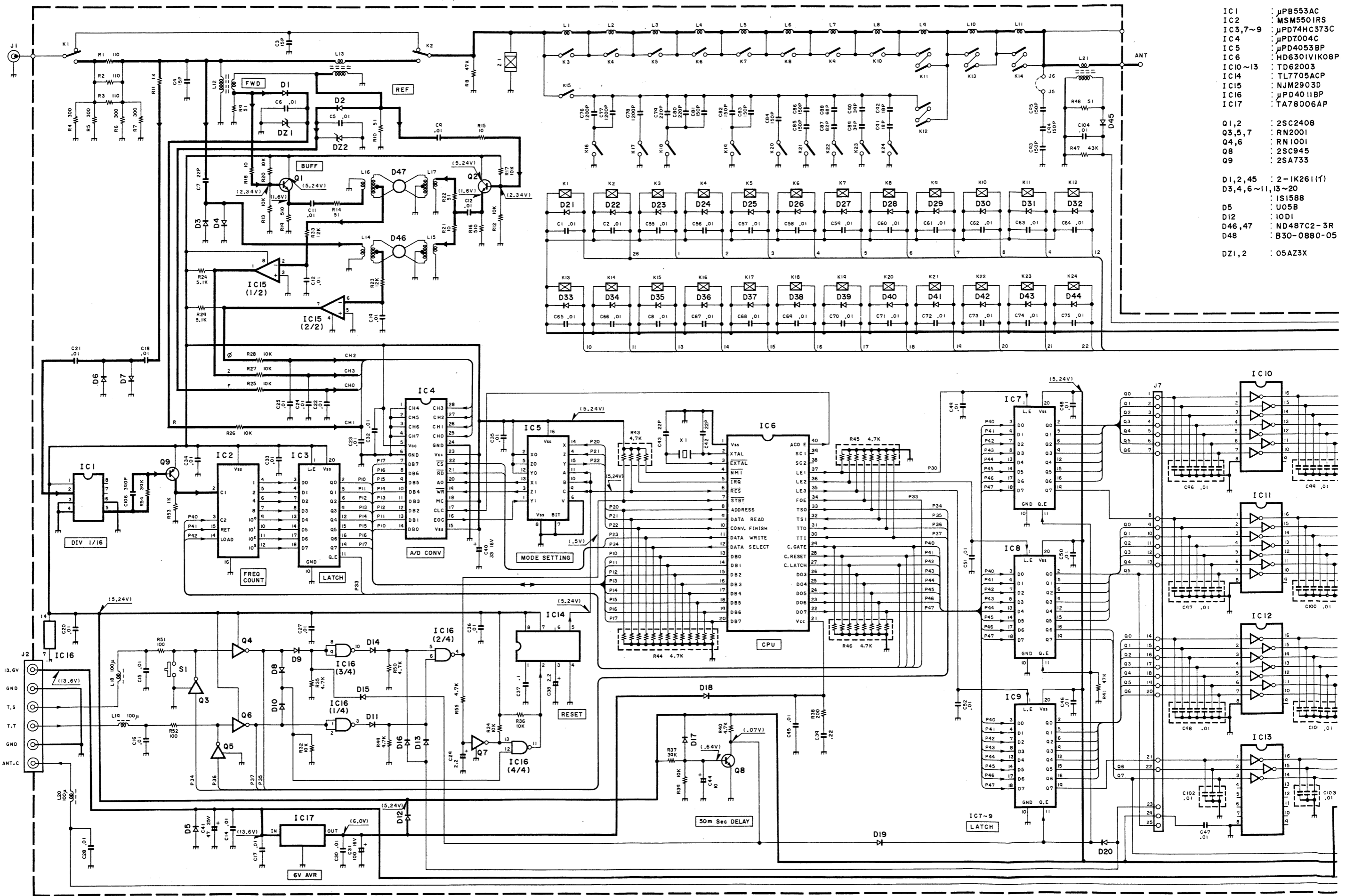

- | | |
|-----------------|----------------|
| IC1 | : µPB553AC |
| IC2 | : MSM5501RS |
| IC3,7~9 | : µPD74HC373C |
| IC4 | : µPD7004C |
| IC5 | : µPD4053BP |
| IC6 | : HD6301VIK08P |
| IC10~13 | : T62003 |
| IC14 | : TL7705ACP |
| IC15 | : NJM2903D |
| IC16 | : µPD4011BP |
| IC17 | : TA78006AP |
| Q1,2 | : 2SC2408 |
| Q3,5,7 | : RN2001 |
| Q4,6 | : RN1001 |
| Q8 | : 2SC945 |
| Q9 | : 2SA733 |
| D1,2,45 | : 2-1K261(1) |
| D3,4,6~11,13~20 | : 1S1588 |
| D5 | : U05B |
| D12 | : IOD1 |
| D46,47 | : ND487C2-3R |
| D48 | : B30-0880-05 |
| DZ1,2 | : 05A73X |

MAT-100 (AUTOMATIC ANTENNA TUNER) TKM-707

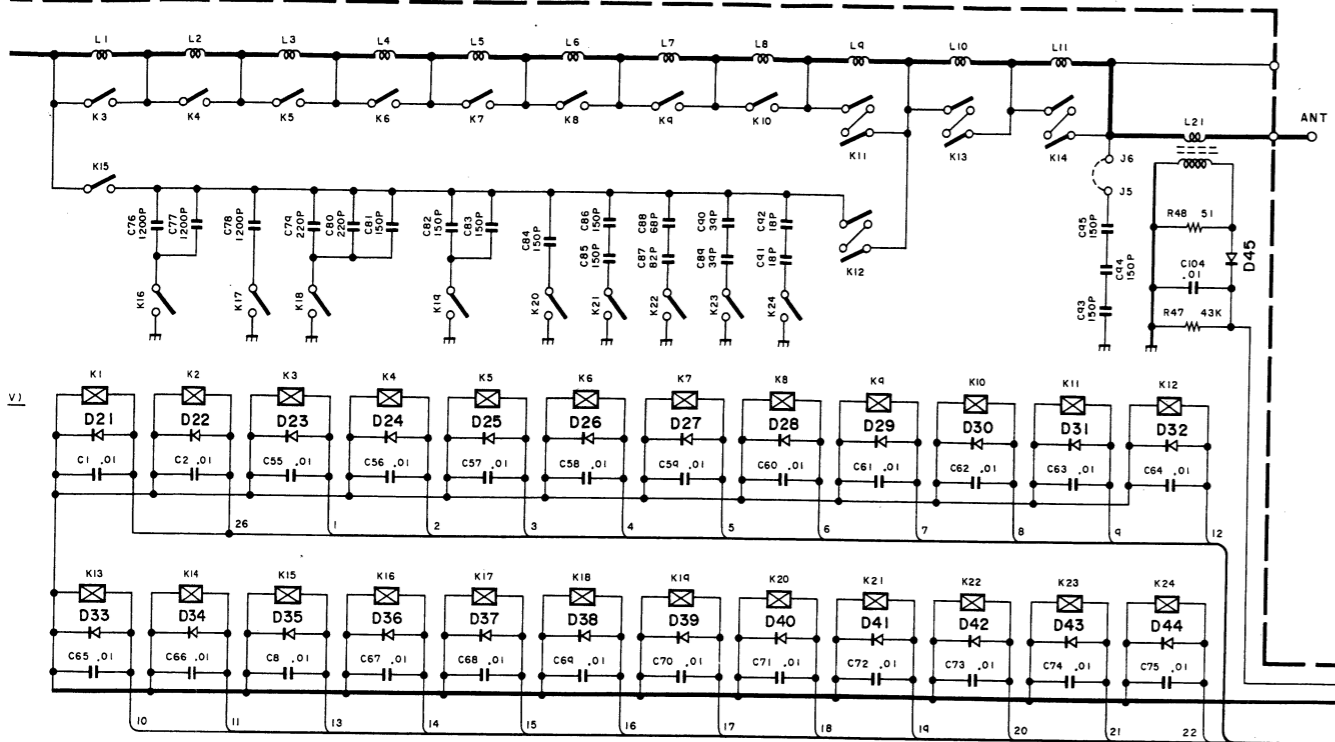

- IC 1 : JPB553AC
- IC 2 : MSM5501RS
- IC 3,7~9 : JPD74HC373C
- IC 4 : JPD7004C
- IC 5 : JPD4053BP
- IC 6 : HD6301VIK08PJ
- IC 10~13 : TD62003
- IC 14 : TL7705ACP
- IC 15 : NJM2903D
- IC 16 : JPD4011BP
- IC 17 : TA78006AP
- Q1,2 : 2SC2408
- Q3,5,7 : RN2001
- Q4,6 : RN1001
- Q8 : 2SC945
- Q9 : 2SA733
- D1,2,45 : 2-1K261(1)
- D3,4,6~11,13~20 : IS1588
- D5 : U05B
- D12 : IOD1
- D46,47 : ND487C2-3R
- D48 : B30-0880-05
- DZ1,2 : 05A23X

- IC1,2 : DRL8-472
- IC3 : DRL6-472
- D1~22 : B30-0880-05
- D23~46 : IS1588
- S1,2 : KSD-10
- S3 : KSD-02
- S4 : SSSS222A

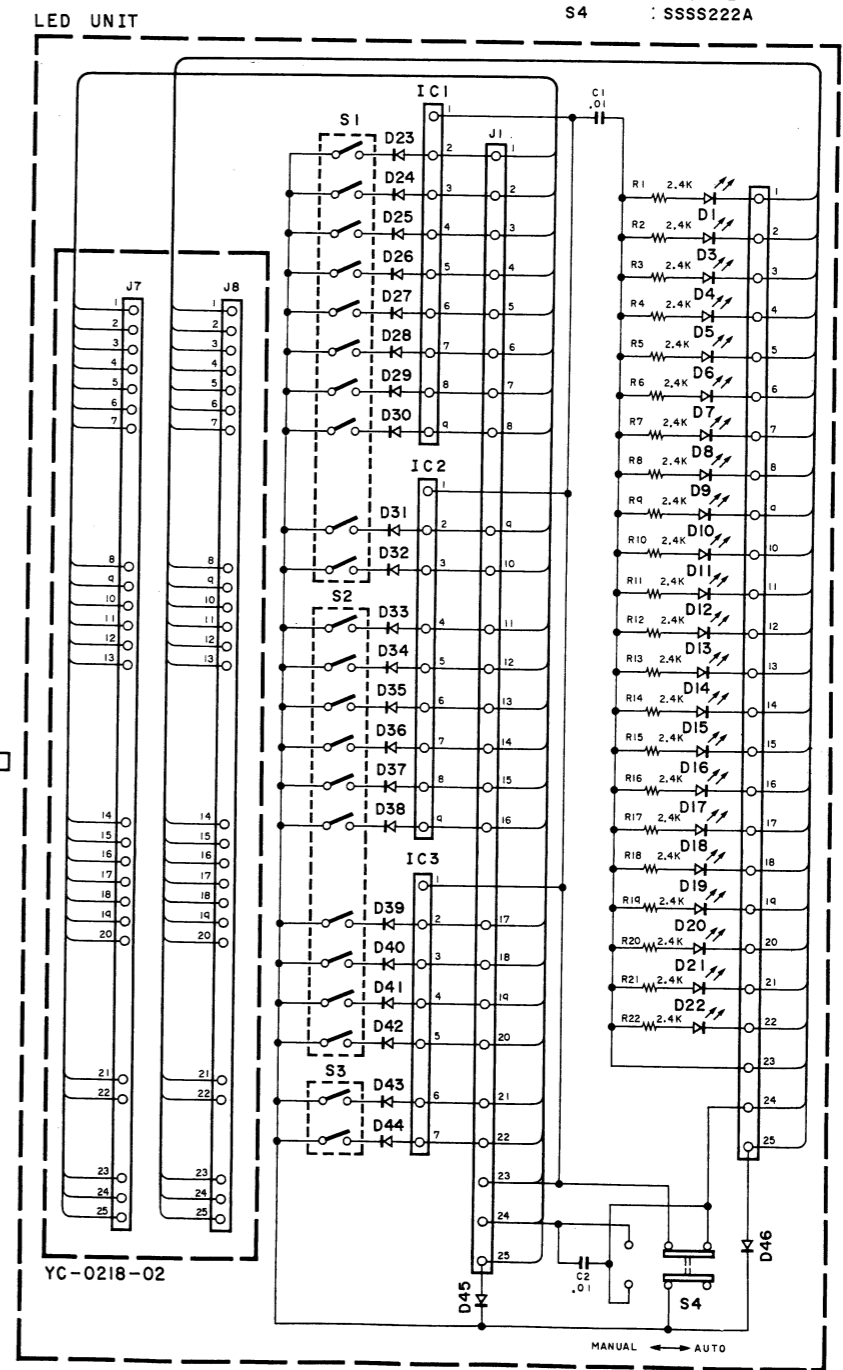
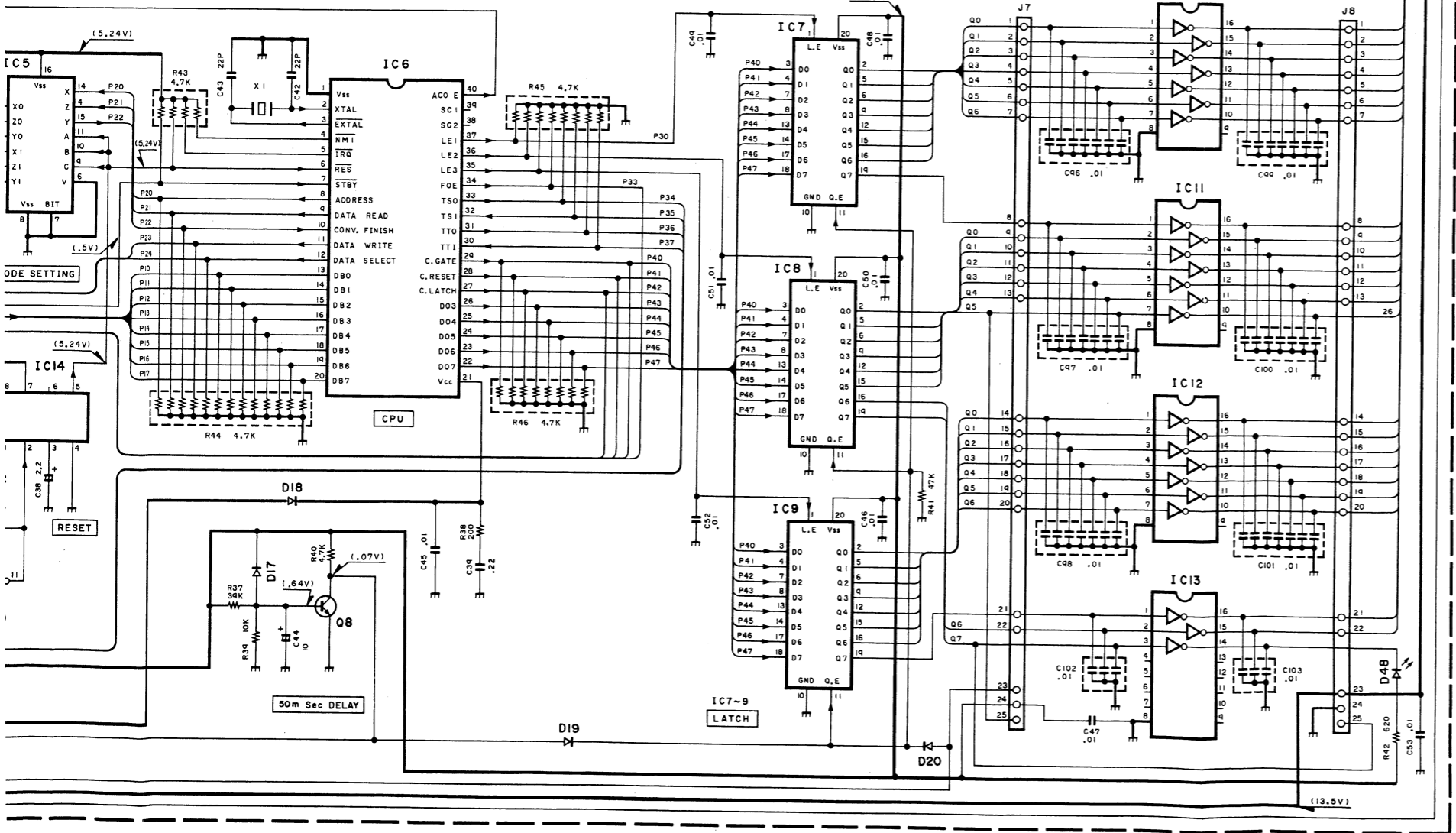

TKM-707

MAT-100 (AUTOMATIC ANTENNA TUNER)

Installation Instructions

• Antenna

The type of antenna that is used will greatly affect the performance of the equipment. The antenna should be erected as high as possible.

Keep the antenna as far from any object which may affect it's performance, such as metallic masts or other guy wires, as possible.

Insulator should be able to withstand leakage even when wet.

The base of the antenna is **HIGH VOLTAGE**.

It should be connected to the lead-in insulator.

Do not touch the base of the antenna.

Certain lengths of antenna element are difficult for the system to tune.

Element length to be avoided

$$= 300/\text{operating frequency (MHz)} \times 1/2 \times \text{integer}$$

• Ground

The MAT-100 must be connected to a good electrical ground. Without a good ground an SSB radio-telephone cannot work satisfactorily. It is of the utmost importance to ground the antenna coupler unit.

If boat provides a good ground, use less than 2 m of heavy gauge wire to connect. To extend the length use a copper strap.

When good ground is not provided use a copper strap to run from the outside of the boat to the ground terminal of the antenna coupler.

SHIP STATION

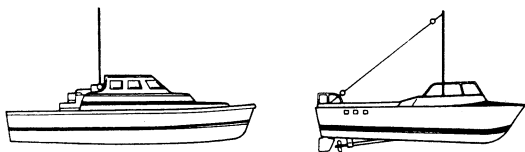

FIXED STATION

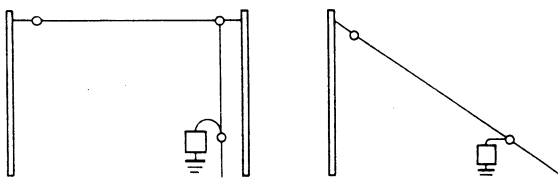

VEHICLES

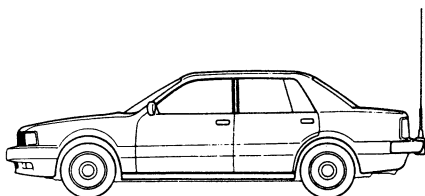

SHIPS WITH A NON-CONDUCTING STRUCTURE

A

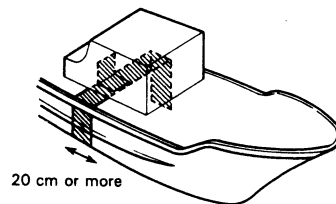

B

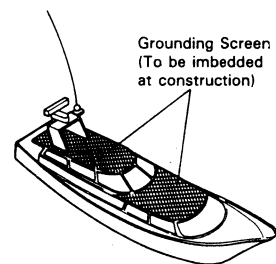

C

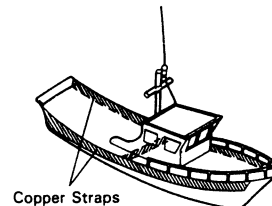

D

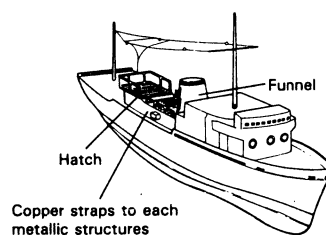

MAT-100 (AUTOMATIC ANTENNA TUNER)

• Antenna coupler

INSTALLATION

The MAT-100 is protected by weather proof construction which permits the flexibility of interior or exterior instruction.

Before installation note the following precaution.

1. Good ground connection
2. Avoid water spray
3. The base of the antenna is HIGH VOLTAGE.
4. Use caution when tightening the wing nut on the GND and antenna terminal. Over tightening may cause twisting of the terminals inside the coupler.

3. Installation by Hex Head Screws

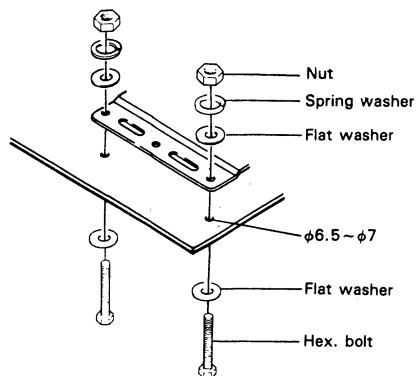

Two drain holes are provided.

If the coupler is installed horizontally remove screw A, and if installed vertically remove screw B.

Three kinds of installation are available for any type of ship.

1. Installation by U-clamp

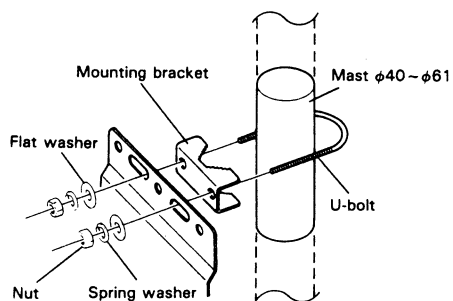

2. Installation by Self tapping Screws

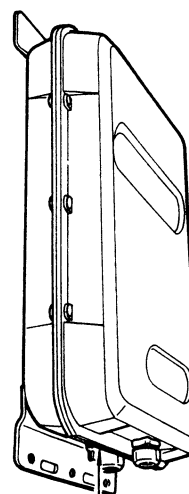
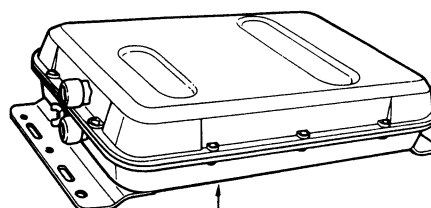
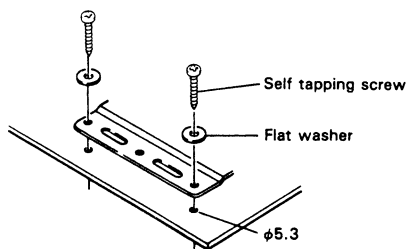

TKM-707

MAT-100 (AUTOMATIC ANTENNA TUNER)

• Connection

WIRE FOR ANTENNA

The insulator must be relieved from mechanical stress by using a short flexible wire between the insulator and a support.

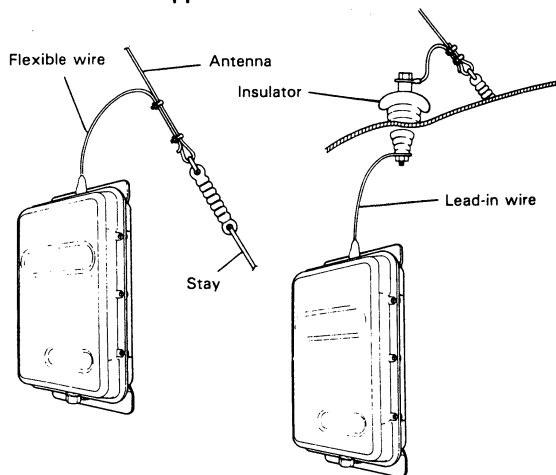

Lead-in insulator, such as GTO15 (15kV resisting presser) should be able to withstand high voltage.

CONTROL CABLES

The MAT-100 requires a control cable consisting of between 4-5 wires of at least AWG24 gauge. The cable must be shielded.

1. Connect the 6-pin plug to rear of the radiotelephone.

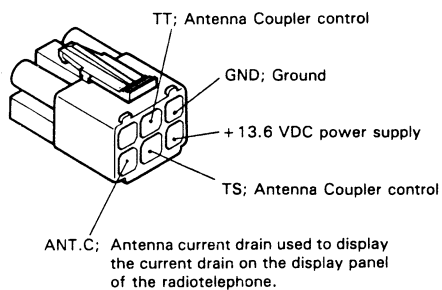

A 5 wire control cable is needed if you want to connect the ANT.C pin. Please refer to the MAT-100 Service Manual for further information on this function.

2. Strip the other side of the cable as shown below.

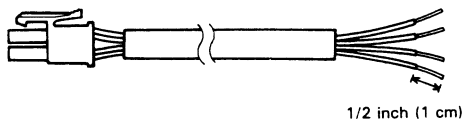

3. Connect the wires .

Be sure none of the wires are shorting against the others.

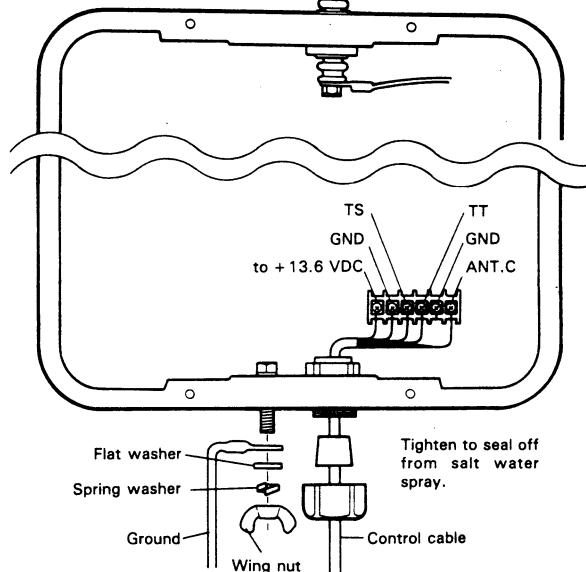
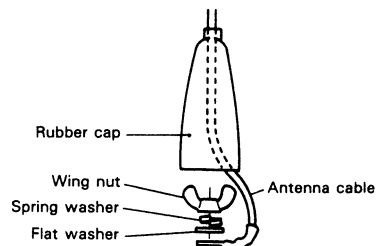
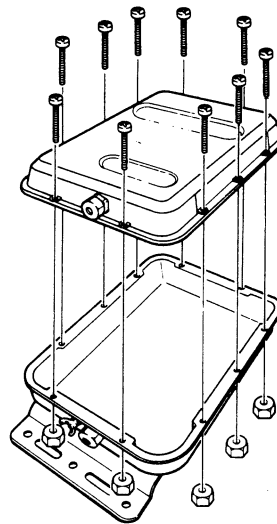

MAT-100 (AUTOMATIC ANTENNA TUNER)

4. Connect thru case of the Antenna coupler to Antenna connector of the radiotelephone with coaxial cable.

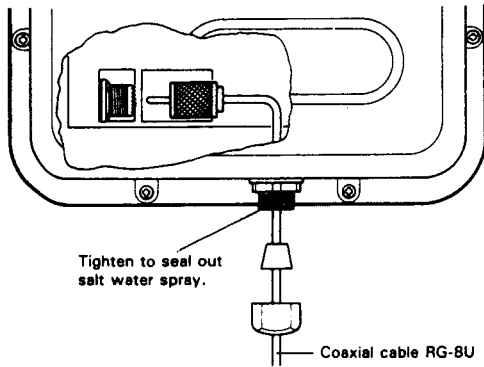

TYPICAL INSTALLATION

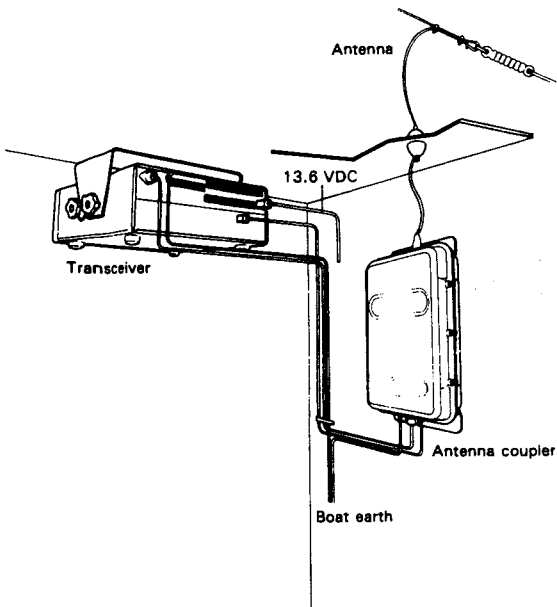

TKM-707

MAT-100 (AUTOMATIC ANTENNA TUNER)

Manual Tuning

If the control circuit in the MAT-100 does not function properly, should an emergency arise, you can still transmit on 2182 kHz ;The MARINE MOBILE EMERGENCY CHANNEL by switching the coupler to MANUAL OPERATION.

1. Turn the radiotelephone power switch off.
2. Remove the top cover of the antenna coupler.
3. Confirm S4 is in AUTO position.
4. Turn the radiotelephone power switch on.
Press the 2182 key and then the TUNE key.
5. After completing the tuning, D48 LED indicator of the antenna coupler will light.
6. Record the status of D1to D22 LED indicators on or off.
7. Set the S4 slide switch to MANUAL position.
8. Set the S1 to S3 dip switch as the same position as step 6.
9. Change the S4 switch back forth between AUTO and MANUAL position to confirm no change in the D1to D22 LED indicators.
10. Set S4 to be AUTO position.
11. Attach the top cover of the antenna coupler.

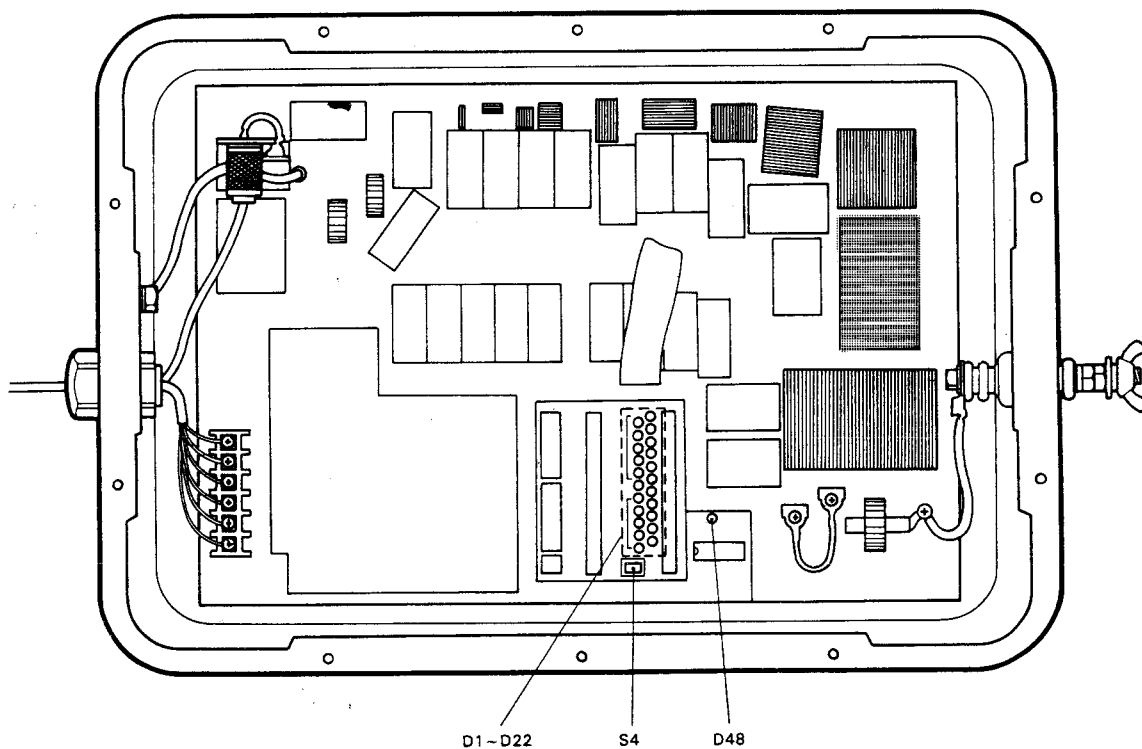

MAT-100 (AUTOMATIC ANTENNA TUNER)**Specifications**

Frequency range	1.6 MHz to 30.0 MHz
Power Capability	150W PEP 100W continuous
Input Impedance	50 Ω
VSWR	less than 2.0
Tuning Power	10 W
Antenna Required	7 to 23 m(23 to 75 feet); 2 to 30 MHz 2.7m(9 feet)whip; 3.5 to 30 MHz
Tune-up Time	Within 2 to 15 sec (Within 0.5 sec on pre-tuned frequencies)
Power Supply requirement	13.6 VDC \pm 15% Negative Ground max2 A (supplied from radiotelephone)
Operating temperature	-30 $^{\circ}$C to +60 $^{\circ}$C (-4 $^{\circ}$F to +140 $^{\circ}$F)
Dimensions	W258 \times H425 \times D90 [mm]
Weight	3.0kg
Case Construction	Weather Proof
Control Cable	5 cables (Not supplied)

TKM-707

SPECIFICATIONS

Receiver Frequency range	500 kHz to 30.0 MHz
Transmitter Frequency range	2.0 to 2.9999 MHz 4.0 to 4.9999 MHz 6.0 to 6.9999 MHz 8.0 to 8.9999 MHz 12.0 to 12.9999 MHz 16.0 to 16.9999 MHz 22.0 to 22.9999 MHz
Mode	J3E,H3E
Antenna impedance	50 Ohms
Operating temperature	-30 °C to +60 °C (-4 °F to +140 °F)
Power requirement	13.6 VDC \pm 15%
Grounding	Negative
Current drain	RX max. less than 2 A TX max. less than 30 A
Frequency stability	\pm 20Hz(After 10 minutes warm up)
Dimensions	W270×H96×D270
Weight	5.1kg
Output power	HI ;150 W PEP MEDIUM ;50 W PEP LOW ;25 W PEP

Spurious radiation	less than 65 dB
Microphone impedance	600 Ω
Circuitry	Double conversion superheterodyne
Intermediate frequency	1st; 71.295 MHz 2nd; 10.695 MHz
Sensitivity (12 dB SINAD)	500kHz~1.999MHz J3E;less than 1.0 μ V H3E;less than 5.6 μ V 2MHz~29.999MHz J3E;less than 0.5 μ V H3E;less than 2.8 μ V
Selectivity	-6dB J3E;more than 2.35kHz H3E;more than 6kHz -60dB J3E;less than 4.6kHz H3E;less than 20kHz
Spurious response	better than 70 dB
Output (10 % distortion)	more than 4 W
External speaker impedance	4 Ω

KENWOOD CORPORATION

Shionogi Shibuya Building, 17-5, 2-chome Shibuya, Shibuya-ku, Tokyo 150, Japan

KENWOOD U.S.A. CORPORATION

COMMUNICATIONS & TEST EQUIPMENT GROUP

P.O. BOX 22745, 2201 East Dominguez St., Long Beach, CA 90801-5745, U.S.A.

KENWOOD ELECTRONICS DEUTSCHLAND GMBH

Rembrücker Str. 15, 6056 Heusenstamm, West Germany

TRIO-KENWOOD U.K. LIMITED

KENWOOD House, Dwight Road, Watford, Herts., WD1 8EB, United Kingdom

KENWOOD ELECTRONICS BENELUX N.V.

Mechelsesteenweg 418 B-1930 Zaventem, Belgium

TRIO-KENWOOD FRANCE S.A.

13, Boulevard Ney, 75018 Paris, France

KENWOOD LINEAR S.P.A.

20125, Milano-via Arbe, 50, Italy

KENWOOD ELECTRONICS AUSTRALIA PTY. LTD.

(INCORPORATED IN N.S.W.)

4E, Woodcock Place, Lane Cove, N.S.W. 2066, Australia

KENWOOD & LEE ELECTRONICS, LTD.

Wang Kee Building, 5th Floor, 34-37, Connaught Road, Central, Hong Kong

KENWOOD ELECTRONICS CANADA INC.

P.O. BOX 1075, 959 Gana Court, Mississauga, Ontario, Canada L4T 4C2