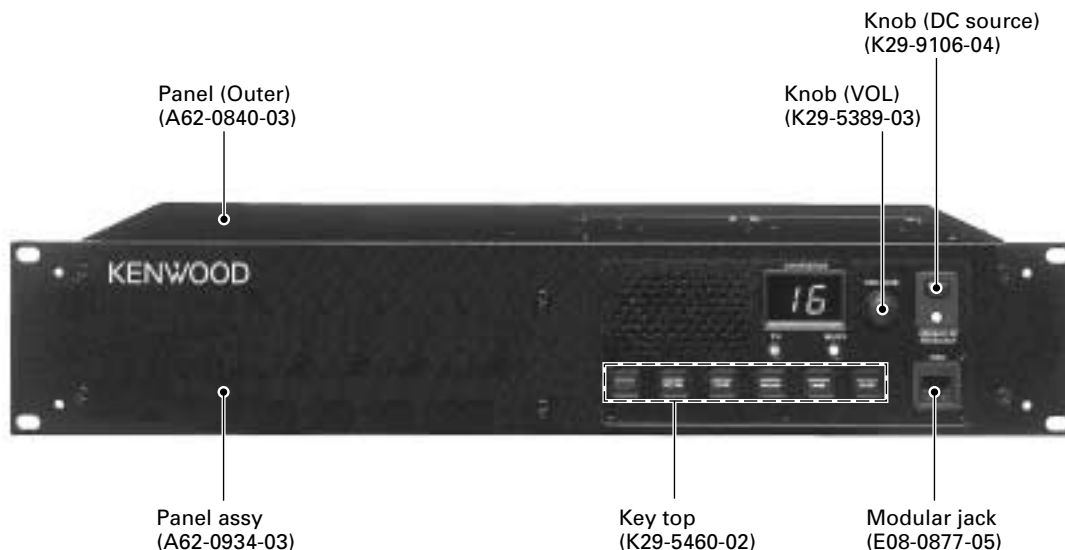


TKR-750

SERVICE MANUAL / 维修手册

KENWOOD

© 2001-2 在日本印刷
B51-8567-00 (N) 611

CONTENTS

GENERAL	2	WIRING	73
SYSTEM SET-UP	3	TERMINAL FUNCTION	75
OPERATING FEATURES	3	PC BOARD VIEWS	
REALIGNMENT	19	RX PLL/VCO (X58-4780-10)	83
INSTALLATION	22	TX PLL/VCO (X58-4790-10)	84
MODIFICATION	25	DISPLAY UNIT (X54-3330-20)	85
DISASSEMBLY FOR REPAIR	28	FINAL UNIT (X45-3620-XX)	89
CIRCUIT DESCRIPTION	29	TX-RX UNIT (X57-6260-XX) (A/2)	95
SEMICONDUCTOR DATA	39	TX-RX UNIT (X57-6260-XX) (B/2)	101
DESCRIPTION OF COMPONENTS	44	SCHEMATIC DIAGRAM	107
PARTS LIST	47	BLOCK DIAGRAM	119
EXPLODED VIEW	57	KES-4 (EXTERNAL SPEAKER)	122
PACKING	59	SPECIFICATIONS	BACK COVER
ADJUSTMENT	60		

概 述	2	总布线图	73
系统体系	3	端子功能	75
操作特性	4	PC板视图	
模式组合	19	RX PLL/VCO(X58-4780-10)	83
安 装	22	TX PLL/VCO(X58-4790-10)	84
改 装	25	DISPLAY UNIT(X54-3330-20)	85
为维修的拆卸	28	FINAL UNIT(X45-3620-XX)	89
电路说明	29	TX-RX UNIT(X57-6260-XX)(A/2)	95
半导体数据	39	TX-RX UNIT(X57-6260-XX)(B/2)	101
元件说明	44	原 理 图	107
零 件 表	47	方 块 图	119
部件分解图	57	KES-4(外部扬声器)	122
包 装	59	规 格	123
调 整	61		

INTRODUCTION

SCOPE OF THIS MANUAL

This manual is intended for use by experienced technicians familiar with similar types of commercial grade communications equipment. It contains all required service information for the equipment and is current as of the publication date. Changes which may occur after publication are covered by either Service Bulletins or Manual Revisions. These are issued as required.

ORDERING REPLACEMENT PARTS

When ordering replacement parts or equipment information, the full part identification number should be included. This applies to all parts : components, kits, or chassis. If the part number is not known, include the chassis or kit number of which it is a part, and a sufficient description of the required component for proper identification.

PERSONNEL SAFETY

The following precautions are recommended for personnel safety :

- DO NOT transmit until all RF connectors are verified secure and any open connectors are properly terminated.
- SHUT OFF and DO NOT operate this equipment near electrical blasting caps or in an explosive atmosphere.
- This equipment should be serviced by a qualified technician only.

SERVICE

This radio is designed for easy servicing. Refer to the schematic diagrams, printed circuit board views, and alignment procedures contained in this manual.

引言

本手册的范围

本手册是提供给熟悉通信专业并且具有维修经验的技术人员使用的。它包括了维修该设备所需要的全部资料和 现行出版日期。在出版后如果发生变动, 则根据需要使用《维修通报》或《手册修订本》进行补充。

替换零件的订购

当订购替换零件或设备资料时, 应注意完整的零件识别号码。所有的零件均有识别号码: 元件、组件或机壳。如果不知道零件的号码, 为了正确地识别, 必须注明此元件所属的机壳或组件的号码, 并对元件进行充分的说明。

个人安全

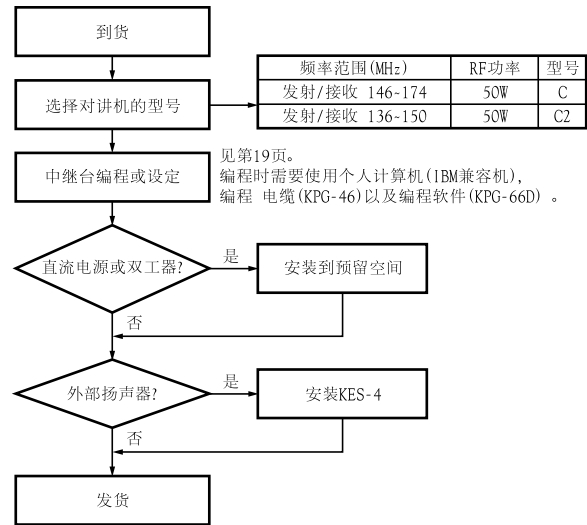
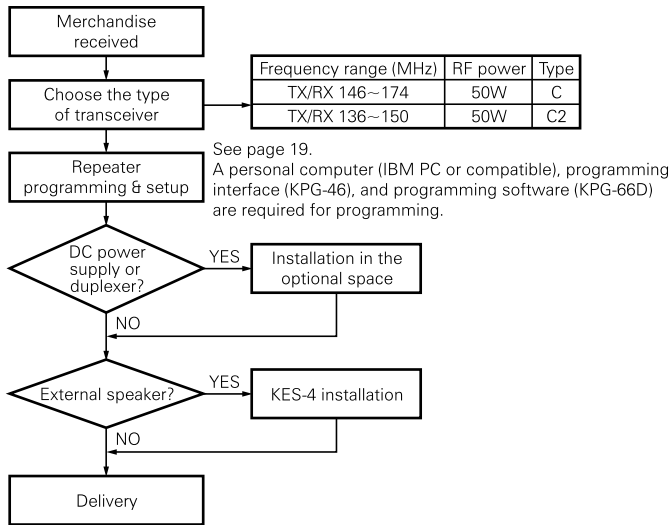
为了个人的安全, 请注意下列事项:

- 在没有认真核实所有射频插头之前或有任何一个脱开的插头没有连接到相应端口上的情况下均不要发射。
- 在电爆管附近或在易燃性气体环境中, 必须关闭电源, 不要操作本设备。
- 本设备只应该由有资格的技术人员进行维修。

维修服务

为了便于维修本设备, 建立了完整的维修服务体系, 提供了包括原理图、印刷电路板图和调整步骤在内的资料供参考。

SYSTEM SET-UP / 系统体系 / OPERATING FEATURES / 操作特性

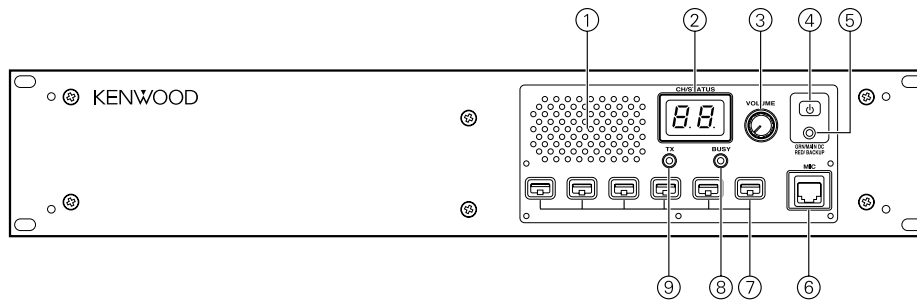


1. Controls and Functions

1-1. Front Panel

1. 控制和功能

1-1. 前面板



- ① **Speaker**
- ② **CH/STATUS Display**
Two, 7-segment digits display the channel number or status.
- ③ **VOLUME control**
Rotate to adjust the volume.
- ④ **DC source switch**
- ⑤ **DC source indicator**
Lights green when DC source is applied from the DC 13.6V jack. Lights red when DC source is applied from the BACK UP battery terminal.
- ⑥ **MIC jack**
Connect a microphone to this 8-pin modular jack.
- ⑦ **Programmable Function keys**
Press these keys to activate their programmable functions.

PF1 key (left side)	Default : None (No function)
PF2 key	Default : Repeat disable/enable
PF3 key	Default : TX disable/enable
PF4 key	Default : Take over
PF5 key	Default : Monitor on/off
PF6 key (right side)	Default : Channel up

- ⑧ **BUSY indicator**
Lights green while a signal is being received.
- ⑨ **TX indicator**
Lights red while transmitting.

- ① **扬声器**
- ② **CH/STATUS (信道/状态) 显示**
以2位7段数字显示信道号码或状态。
- ③ **VOLUME (音量) 控制**
顺时针旋转, 直到发出“咔哒”声响, 即解除音量的消音, 并可旋转调整音量。逆时针旋转到底可消音音量。
- ④ **电源开关**
- ⑤ **电源指示灯**
当电源从 DC13.6V 插座供电时, 点亮绿色; 当电源从 BACK UP (后备) 电池端子供电时, 点亮红色。
- ⑥ **MIC插座**
将麦克风连接至本8脚模件插座。
- ⑦ **可编程功能键**
按下这些键, 可开启它们的可编程功能。

PF1键(左侧)	出厂设定: 无(无功能)
PF2键	出厂设定: 中继关闭/开后
PF3键	出厂设定: 发射开后/关闭
PF4键	出厂设定: 接管
PF5键	出厂设定: 监听有效/无效
PF6键(右侧)	出厂设定: 信道上升

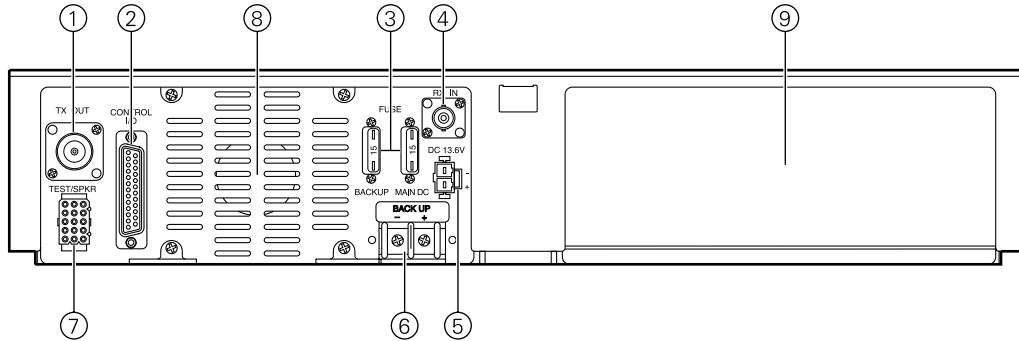
- ⑧ **BUSY (占用) 指示灯**
当正在接收信号时, 点亮绿色。
- ⑨ **TX指示灯**
当发射时点亮红色。

TKR-750

OPERATING FEATURES / 操作特性

1-2. Rear Panel

1-2. 后面板



① TX OUT jack

Connect a TX antenna or a duplexer to this receptacle.

② CONTROL I/O jack

Connect an external programming device or repeater controller to this DB-25 interface.

③ FUSE

Insert 15A blade fuses into these fuse holders.

④ RX IN jack

Connect a RX antenna or a duplexer to this BNC receptacle.

⑤ DC 13.6V jack

Connect a 13.6 V DC power supply to this jack.

⑥ BACKUP battery terminal

⑦ TEST/SPKR jack

Test input/output jack. Connect an external speaker to this jack.

⑧ Cooling fan

⑨ Optional space

For external DC power supply, or duplexer, etc.

① TX OUT插座

将TX天线或者双工器连接至本 BNC 插座。

② CONTROL I/O(控制输入/输出) 插座

将外部编程装置或者中继器控制器连接至本DB-25接口。

③ 保险丝

向这些保险丝座插入15A刀片型保险丝。

④ RX IN插座

将RX天线或者双工器连接至本BNC插座。

⑤ DC 13.6V插座

将13.6V DC电源连接至本插座。

⑥ BACKUP(后备) 电池端子

⑦ TEST/SPKR(测试/扬声器) 插口

测试输入/输出插口。将外部扬声器连接至本插口。

⑧ 冷却风扇

⑨ 可选固定支架

在可选固定支架上可固定放置DC电源和双工器等。

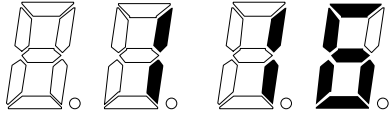
OPERATING FEATURES / 操作特性

2. Two 7-segment LED Displays

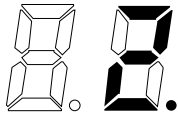
- Channel display (1~16) : While operating normally in user mode.

2. 双7段LED显示器

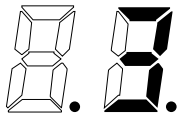
- 信道显示(1~16) : 以用户模式为主运行时。



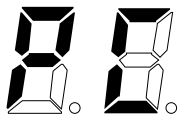
- When the displayed channel is contained in scan sequence, the right side decimal point is displayed.
- 显示的信道包含在扫描顺序中时, 显示右侧的小数点。



- When the displayed channel is the priority channel, the left side decimal point is displayed.
- 显示的信道为优先信道时, 显示左侧的小数点。



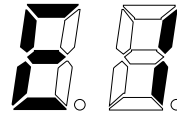
- "PC" is displayed while in PC mode.
- 在PC模式下时显示 "PC"。



- "PG" is displayed while in firmware programming mode.
2 decimal points displayed = 115,200bps
1 decimal point displayed = 57,600bps
No decimal = 38,400bps
- 在固件编程模式下时显示 "PG"。
显示2个小数点=115,200bps
显示1个小数点=57,600bps
无小数点=38,400bps



- "E1" is displayed when FPU data is not written.
- FPU数据没有写入时显示 "E1"。



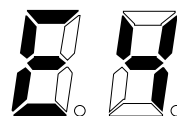
- "E2" is displayed when the channel data is not written.
- 信道数据没有写入时显示 "E2"。



- "E3" is displayed when PLL is unlocked.
Receiver PLL unlocked = flashing BUSY LED.
Transmitter PLL unlocked = flashing TX LED.
- PLL失锁时显示 "E3"。
接收机PLL失锁=BUSY(占用)LED闪烁。
发射机PLL失锁=TX(发射)LED闪烁。



- "E4" is displayed when PTT is attempted on a channel number that has no frequency data programmed.
- 试图在未编程频率数据的信道号码按下PTT时显示 "E4"。



- "SC" is displayed while in scan mode.
- 在扫描模式下显示 "SC"。



OPERATING FEATURES

3. Programmable Functions

TKR-750 contains many Programmable Functions tabled below.

Programmable Function	Description
AUX Out 1~5 Off	AUX Out 1 to 5 ports become deactivated, respectively.
AUX I/O 1~6 Off	AUX I/O 1 to 6 ports become deactivated, respectively.
AUX Out 1~5 On	AUX Out 1 to 5 ports become activated, respectively.
AUX I/O 1~6 On	AUX I/O 1 to 6 ports become activated, respectively.
AUX Out 1~5 On/Off	AUX Out 1 to 5 ports are toggled between its active and inactive states, respectively.
AUX I/O 1~6 On/Off	AUX I/O 1 to 6 ports are toggled between its active and inactive states, respectively.
Channel 1~16	Directly select Channel 1 to 16, respectively.
Channel Down	The channel decrements by one.
Channel Up	The channel increments by one.
CW ID On	The CW ID is transmitted.
CW Message 1~8 On	The CW Message 1 to 8 is transmitted, respectively.
Display Off	All panel LEDs are turned off except the Power LED.
Display On	All panel LEDs become active as normal status indicators on the repeater.
Display On/Off	All panel LEDs, with the exception of the Power LED, are toggled between off and their normal status on the repeater.
Hold Time Enable	The Parameter of Repeat Hold Time is enabled.
Hold Time Disable	The Parameter of Repeat Hold Time is disabled.
Hold Time Disable/Enable	The Parameter of Repeat Hold Time is toggled between disabled and enabled.
Local Tx Disable	The local mic's PTT is disabled.
Local Tx Enable	The local mic's PTT is enabled.
Local Tx Disable/Enable	The local mic's PTT is toggled between disabled and enabled.
Monitor Off	The QT/DQT decoder is disabled.
Monitor On	The QT/DQT decoder is enabled.
Monitor On/Off	The QT/DQT decoder is toggled between disabled and enabled.
Monitor Momentary	The QT/DQT decoder is momentarily disabled.
Multi Table Sub	Multi Table No. Select Signalling changes to the Multi Table Sub.
Multi Table Main	Multi Table No. Select Signalling changes to the Multi Table Main.
Multi Table Main/Sub	Multi Table No. Select Signalling changes between Multi Table Sub and Multi Table Main.
QT/DQT Dec Disable	Disables the QT/DQT decode operation.
QT/DQT Dec Enable	Enables the QT/DQT decode operation.
QT/DQT Dec Disable/Enable	Toggles between disabling and enabling the QT/DQT decode operation.
QT/DQT Enc Disable	Disables the QT/DQT encode operation.
QT/DQT Enc Enable	Enables the QT/DQT encode operation.
QT/DQT Enc Disable/Enable	Toggles between disabling and enabling the QT/DQT encode operation.
Repeat Disable	Disables repeater operation.
Repeat Enable	Enables repeater operation.
Repeat Disable/Enable	Toggles between disabling and enabling repeater operation.
Reset	Resets to default condition set up by FPU.
DC Power Save Off	Activates DC Power Save Mode Off.
DC Power Save On	Activates DC Power Save Mode On.
DC Power Save On/Off	Toggles between DC Power Save Mode On and Off.

操作特性

3. 可编程功能

TKR-750具备许多功能，如下表所示。

可 编 程 功 能	说 明
AUX输出1~5无效	AUX输出的1至5端口分别无效。
AUX输入/输出1~6无效	AUX输入/输出的1至6端口分别无效。
AUX输出1~5有效	AUX输出的1至5端口分别有效。
AUX输入/输出1~6有效	AUX输入/输出的1至6端口分别有效。
AUX输出1~5有效/无效	AUX输出的1至5端口分别在有效和无效状态之间切换。
AUX输入/输出1~6有效/无效	AUX输入/输出的1至6端口分别在有效和无效状态之间切换。
信道1~16	直接分别选择1至16信道。
信道下降	降低一个信道。
信道上升	升高一个信道。
CW ID有效	发射CW ID
CW信息1~8有效	分别发射CW信息1至8。
显示无效	除了电源LED以外，所有操作盘的LED熄灭。
显示有效	所有操作盘的LED有效为中继电器正常状态指示灯。
显示有效/无效	除了电源LED以外，所有操作盘的LED在无效和有效为中继电器正常状态之间切换。
保持时间开启	中继保持时间参数开启。
保持时间关闭	中继保持时间参数关闭。
保持时间关闭/开启	中继保持时间参数在关闭和开启之间切换。
本机Tx关闭	本机麦克风的PTT关闭。
本机Tx开启	本机麦克风的PTT开启。
本机Tx关闭/开启	本机麦克风的PTT在关闭和开启之间切换。
监听无效	QT/DQT解码器无效。
监听有效	QT/DQT解码器有效。
监听有效/无效	QT/DQT解码器在无效和有效之间切换。
瞬间监听	QT/DQT解码器瞬间无效。
多功能表(副)	多功能表No. 选择信令变成多功能表(副)
多功能表(主)	多功能表No. 选择信令变成多功能表(主)
多功能表(主)/(副)	多功能表No. 选择信令在多功能表(副)和多功能表(主)之间改变。
QT/DQT解码关闭	关闭QT/DQT解码运行。
QT/DQT解码开启	开启QT/DQT解码运行。
QT/DQT解码关闭/开启	在关闭和开启QT/DQT解码运行之间切换。
QT/DQT编码关闭	关闭QT/DQT编码运行。
QT/DQT编码开启	开启QT/DQT编码运行。
QT/DQT编码关闭/开启	在关闭和开启QT/DQT编码运行之间切换。
中继关闭	关闭中继运行。
中继开启	开启中继运行。
中继关闭/开启	在关闭和开启中继运行之间切换。
复位	将FPU复位到出厂设定条件。
DC电源节电关闭	关闭DC电源节电模式。
DC电源节电开启	开启DC电源节电模式。
DC电源节电开启/关闭	在开启和关闭DC节电模式之间切换。

OPERATING FEATURES

Programmable Function	Description
Scan Off	Inhibits scanning.
Scan On	Starts scanning.
Scan On/Off	Scanning is toggled between being enabled or inhibited.
Scrambler Off	Disables an installed optional voice scrambler board.
Scrambler On	Enables an installed optional voice scrambler board.
Scrambler On/Off	Toggles between enabling and disabling an installed optional voice scrambler board.
Squelch Off	The Squelch unmutes.
Squelch On	The Squelch mutes.
Squelch On/Off	The receiver's squelch toggles between muted and unmuted.
Squelch Momentary	The Squelch momentarily unmutes.
Take Over On/Off	Toggles between disabling and enabling remote wireline control.
Test Tone Off	The Test Tone is inhibited.
Test Tone On	The Test Tone is enabled.
Test Tone On/Off	Toggles between enabling and inhibiting the Test Tone.
TOT Disable	The Time Out Timer is disabled.
TOT Enable	The Time Out Timer is enabled.
TOT Disable/Enable	The Time Out Timer is toggled between disabled and enabled.
TX Disable	The transmitter is inhibited.
TX Enable	The transmitter is enabled (normal).
TX Disable/Enable	Toggles between transmitter inhibited and transmitter enabled (normal).

The following Programmable Functions are output functions used to tell the condition of the TKR-750 to an external device. The output functions can be assigned to only AUX Outputs as follows.

Programmable Function	Description
COR (Carrier Operate Relay)	This function becomes valid if an RF carrier is present.
TOR (Tone Operate Relay)	This function becomes valid if an RF carrier and the specified QT/DQT are present.
RX Unlock	This alarm function becomes valid if the RX PLL circuitry becomes unlocked.
TX Unlock	This alarm function becomes valid if the TX PLL circuitry become unlocked.
Power Supply Lower Limit	This alarm function becomes valid if the DC power supply voltage becomes less than the preset point. The preset point is selected in the range of 10.6V to 13.6V.
TXS (TX Sense)	This function becomes valid when the transmitter is keyed.
Selectable	AUX Outputs which are set up as Selectable appear in the available Function List for the AUX Input Functions and Key Assignment. This allows AUX Inputs and PF Keys to be used to control AUX Outputs.
RX Signal Detect	This function becomes valid if the RX signal level becomes less than the preset point. The preset point is selected in the range of -120dBm to -95dBm.
RF Power Down Detect	This alarm function becomes valid if the RF Power becomes less than about 10W.
Fan Status	This alarm function becomes valid when the Fan is turned on, either by sensing a high temperature condition or by its operating mode being set to Continuous.

操作特性

可 编 程 功 能	说 明
扫描关闭	禁止扫描。
扫描开启	开始扫描。
扫描开启/关闭	在开启和关闭扫描之间切换。
扰频器关闭	禁止安装的任选声音扰频器板运行。
扰频器开启	开启安装的任选声音扰频器板运行。
扰频器开启/关闭	在开启和禁止安装的任选声音扰频器板运行之间切换。
静噪关闭	静噪不静音。
静噪开启	静噪静音。
静噪开启/关闭	接收机的静噪在静音和不静音之间切换。
瞬时静噪	静噪瞬时不静音。
接管开启/关闭	在关闭和开启有线远程控制之间切换。
试验音频关闭	关闭试验音频。
试验音频开启	开启试验音频。
试验音频开启/关闭	在开启和关闭试验音频之间切换。
TOT关闭	关闭超时定时器。
TOT开启	开启超时定时器。
TOT开启/关闭	在开启和关闭超时定时器之间切换。
TX关闭	禁止发射。
TX开启	允许发射(通常)。
TX开启/关闭	在禁止发射和允许发射(通常)之间切换。

下列可编程功能是由于表示TKR-750条件而向外部装置的输出功能。

仅可以向AUX输出输出的功能如下所示。

可 编 程 功 能	说 明
COR(载波运行中继)	如果存在射频载波, 本功能有效。
TOR(音频运行中继)	如果存在射频载波和规定的QT/DQT, 本功能有效。
RX失锁	如果RX PLL电路系统失锁, 本报警功能有效。
TX失锁	如果TX PLL电路系统失锁, 本报警功能有效。
电源电压下限	如果DC电源供电电压低于预设值, 本报警功能有效。预设值可以在10.6V至13.6V的范围选择。
TXS(TX检测)	键控发射机时, 本功能有效。
可选	对于AUX输入功能和键分配, 作为在可用功能清单出现的可选AUX输出。 本功能可使AUX输入和PF键用于控制AUX输出。
RX信号检测	如果RX信号电平低于预设值, 本功能有效。预设值可以在-120dBm至-95dBm的范围选择。
RF功率降低检测	如果射频功率低于大约10W时, 本报警功能有效。
风扇状态	因检测到高温条件、或者因设定为“连续”运行模式使得风扇接通时, 本报警功能有效。

OPERATING FEATURES

4. Trigger Assignment

The Programmable Functions described above can be assigned to PF keys, AUX input, Save on/off, Start up, and Power supply according to following table.

In the last column of the table, when the Programmable Functions is assigned to any PF keys, it expresses that the LED in the PF key turns on either conditions. "Yes" expresses that the trigger is available the Programmable Function. "No" expresses that the trigger is not available the Programmable Function.

Function	Trigger	PF keys	AUX input	Save on/off	Start up	Power supply	Condition of LED in the PF key on
AUX Out 1~5 (I/O 1~6) Off		No	Yes	Yes	Yes	Yes	–
AUX Out 1~5 (I/O 1~6) On		No	Yes	Yes	Yes	Yes	–
AUX Out 1~5 (I/O 1~6) On/Off		Yes	Yes	No	No	No	Turns on in ON status.
Channel 1~16, Up/Down		Yes	Yes	Yes	Yes	Yes	Do not turn on.
CW ID On		Yes	Yes	Yes	Yes	Yes	Turns on while transmitting.
CW Message 1~8 On		Yes	Yes	Yes	Yes	Yes	Turns on while transmitting.
Display Off		No	Yes	Yes	Yes	Yes	–
Display On		No	Yes	Yes	Yes	Yes	–
Display On/Off		Yes	Yes	No	No	No	Turns on in ON status.
Hold Time Enable		No	Yes	Yes	Yes	Yes	–
Hold Time Disable		No	Yes	Yes	Yes	Yes	–
Hold Time Disable/Enable		Yes	Yes	No	No	No	Turns on in Disable status.
Local Tx Disable		No	Yes	Yes	Yes	Yes	–
Local Tx Enable		No	Yes	Yes	Yes	Yes	–
Local Tx Disable/Enable		Yes	Yes	No	No	No	Turns on in Disable status.
Monitor Off		No	Yes	Yes	Yes	Yes	–
Monitor On		No	Yes	Yes	Yes	Yes	–
Monitor On/Off		Yes	Yes	No	No	No	Turns on in ON status.
Monitor Momentary		Yes	No	No	No	No	Turns on in ON status.
Multi Table Sub		No	Yes	Yes	Yes	Yes	–
Multi Table Main		No	Yes	Yes	Yes	Yes	–
Multi Table Main/Sub		Yes	Yes	No	No	No	Turns on in Sub status.
QT/DQT Dec Disable		No	Yes	Yes	Yes	Yes	–
QT/DQT Dec Enable		No	Yes	Yes	Yes	Yes	–
QT/DQT Dec Disable/Enable		Yes	Yes	No	No	No	Turns on in Disable status.
QT/DQT Enc Disable		No	Yes	Yes	Yes	Yes	–
QT/DQT Enc Enable		No	Yes	Yes	Yes	Yes	–
QT/DQT Enc Disable/Enable		Yes	Yes	No	No	No	Turns on in Disable status.
Repeat Disable		No	Yes	Yes	Yes	Yes	–
Repeat Enable		No	Yes	Yes	Yes	Yes	–
Repeat Disable/Enable		Yes	Yes	No	No	No	Turns on in Disable status.
Reset		Yes	Yes	No	No	No	Do not turn on.
DC Power Save Off		No	Yes	No	Yes	Yes	–
DC Power Save On		No	Yes	No	Yes	Yes	–
DC Power Save On/Off		Yes	Yes	No	No	No	Do not turn on.
Scan Off		No	Yes	Yes	Yes	Yes	–

操作特性

4. 触发分配

上述说明的可编程功能可根据下表向PF键、AUX输入、节电接通/切断、启动以及电源供电分配。

在下表的最后一栏中，当可编程功能分配到任何PF键时，代表在两者之中之一的条件下PF键的LED点亮。“是”代表允许该可编程功能，“非”代表不允许该可编程功能。

功 能 \ 触 发	PF键	AUX输入	节 电 有效/无效	启 动	电源供电	PF键的LED点亮条件
AUX输出1~5(输入/输出1~6)无效	非	是	是	是	是	—
AUX输出1~5(输入/输出1~6)有效	非	是	是	是	是	—
AUX输出1~5(输入/输出1~6)有效/无效	是	是	非	非	非	在接通状态下点亮。
信道1~16. 上/下	是	是	是	是	是	不点亮。
CW ID 有效	是	是	是	是	是	发射时点亮。
CW信息1~8有效	是	是	是	是	是	发射时点亮。
显示无效	非	是	是	是	是	—
显示有效	非	是	是	是	是	—
显示有效/无效	是	是	非	非	非	在有效状态下点亮。
保持时间开启	非	是	是	是	是	—
保持时间关闭	非	是	是	是	是	—
保持时间关闭/开启	是	是	非	非	非	在关闭状态下点亮。
本机Tx关闭	非	是	是	是	是	—
本机Tx开启	非	是	是	是	是	—
本机Tx关闭/开启	是	是	非	非	非	在关闭状态下点亮。
监听无效	非	是	是	是	是	—
监听有效	非	是	是	是	是	—
监听有效/无效	是	是	非	非	非	在有效状态下点亮。
瞬间监听	是	非	非	非	非	在有效状态下点亮。
多功能表(副)	非	是	是	是	是	—
多功能表(主)	非	是	是	是	是	—
多功能表(主)/(副)	是	是	非	非	非	在(副)状态下点亮。
QT/DQT解码关闭	非	是	是	是	是	—
QT/DQT解码开启	非	是	是	是	是	—
QT/DQT解码关闭/开启	是	是	非	非	非	在关闭状态下点亮。
QT/DQT编码关闭	非	是	是	是	是	—
QT/DQT编码开启	非	是	是	是	是	—
QT/DQT编码关闭/开	是	是	非	非	非	在关闭状态下点亮。
中继关闭	非	是	是	是	是	—
中继开启	非	是	是	是	是	—
中继关闭/开启	是	是	非	非	非	在关闭状态下点亮。
复位	是	是	非	非	非	不点亮。
DC电源节电关闭	非	是	非	是	是	—
DC电源节电开启	非	是	非	是	是	—
DC电源节电开启/关闭	是	是	非	非	非	不点亮。
扫描无效	非	是	是	是	是	—

OPERATING FEATURES

Function \ Trigger	PF keys	AUX input	Save on/off	Start up	Power supply	Condition of LED in the PF key on
Scan On	No	Yes	Yes	Yes	Yes	–
Scan On/Off	Yes	Yes	No	No	No	Turns on in ON status.
Scrambler Off	No	Yes	Yes	Yes	Yes	–
Scrambler On	No	Yes	Yes	Yes	Yes	–
Scrambler On/Off	Yes	Yes	No	No	No	Turns on in ON status.
Squelch Off	No	Yes	Yes	Yes	Yes	–
Squelch On	No	Yes	Yes	Yes	Yes	–
Squelch On/Off	Yes	Yes	No	No	No	Turns on in OFF status.
Squelch Momentary	Yes	No	No	No	No	Turns on in OFF status.
Take Over On/Off	Yes	No	No	No	No	Turns on in ON status.
Test Tone Off	No	Yes	Yes	Yes	Yes	–
Test Tone On	No	Yes	Yes	Yes	Yes	–
Test Tone On/Off	Yes	Yes	No	No	No	Turns on in ON status.
TOT Disable	No	Yes	Yes	Yes	Yes	–
TOT Enable	No	Yes	Yes	Yes	Yes	–
TOT Disable/Enable	Yes	Yes	No	No	No	Turns on in Disable status.
TX Disable	No	Yes	Yes	Yes	Yes	–
TX Enable	No	Yes	Yes	Yes	Yes	–
TX Disable/Enable	Yes	Yes	No	No	No	Turns on in Disable status.
None	Yes	Yes	Yes	Yes	Yes	Do not turn on.

5. Simplex/Duplex Operation

The Simplex/Duplex function is used to specify whether the channel is used as simplex (receiver muted during transmit) or duplex (receiver unmuted during transmit). If the channel has same TX/RX frequency, it can operate only in Simplex mode.

6. Repeater/Base Station Operation

The Repeat function is used to specify whether the channel is used as a repeater or as a base station. A repeater simultaneously and automatically re-transmits its received audio, a duplex base station has independent simultaneous transmit and receive paths, a simplex base station are mutually exclusive transmit and receive paths.

7. Signalling Feature

7-1. Multiple QT/DQT

The TKR-750 can function as a multiple-QT/DQT decode/encode unit for operation as a community repeater or multiple-QT/DQT base station. Two Multi Tables, called Main and Sub, can be created, each consisting of 16 decode/encode combinations.

The Multi Table function enables the TKR-750 to decode any one of the 16 QT/DQTs pre-programmed into the Multi Table. When receiving a signal (repeater operation), the repeater uses the QT/DQT encode which corresponds to the decoded QT/DQT as set in the Multi Table. In the Multi Table, signalling pair of "No.1" (first column) is defined as "Primary". A receiving signalling (if it is contained within No.1 to No.16) is defined "Current".

From No.2 to No.16, signalling pairs that can be changed between "Main Table" and "Sub Table" using AUX I/O Ports 1-4 are assigned as "Multi Table Select" and the Multi Table Main, the Multi Table Sub or the Multi Table Main/Sub function is executed. When AUX I/O Ports 1~4 are set for "Multi Table Select", these are 4 bit Binary Coded Decimal (BCD) inputs. AUX I/O 1 is a least significant bit (LSB), and "1101" input (LSB on the right side) signifies the Table No.2 and "1100" input signifies the Table No.3.

7-2. Encode Tone in Multiple

When Local Microphone PTT or External PTT is active while the repeater is in use or the duplex-base station is receiving, the encode signalling is determined according to Encode Tone in Multiple function. The simplex-base station always transmits the "Primary" encode QT/DQT.

操作特性

功 能	触 发	PF键	AUX输入	节 电 有效/无效	启 动	电源供电	PF键的LED点亮条件
扫描有效		非	是	是	是	是	—
扫描有效/无效		是	是	非	非	非	在有效状态下点亮。
扰频器无效		非	是	是	是	是	—
扰频器有效		非	是	是	是	是	—
扰频器有效/无效		是	是	非	非	非	在有效状态下点亮。
静噪无效		非	是	是	是	是	—
静噪有效		非	是	是	是	是	—
静噪有效/无效		是	是	非	非	非	在无效状态下点亮。
瞬间静噪		是	非	非	非	非	在无效状态下点亮。
转发有效/无效		是	非	非	非	非	在有效状态下点亮。
试验音频关闭		非	是	是	是	是	—
试验音频有效		非	是	是	是	是	—
试验音频有效/无效		是	是	非	非	非	在有效状态下点亮。
TOT关闭		非	是	是	是	是	—
TOT开启		非	是	是	是	是	—
TOT关闭/开启		是	是	非	非	非	在关闭状态下点亮。
TX关闭		非	是	是	是	是	—
TX开启		非	是	是	是	是	—
TX关闭/开启		是	是	非	非	非	在关闭状态下点亮。
无		是	是	是	是	是	不点亮。

5. 单工/双工运行

单工/双工功能用于确定信道是用于单工(发射时接收机静音)还是用于双工(发射时接收机不静音)运行。具有相同TX/RX频率的信道只能进行单工模式运行。

6. 中继器/基地台运行

中继功能用于确定是使用信道作为中继器还是作为基地台。中继器可同时、自动转发接收的音频信号。双工基地台具备独立的同时发射和接收路径，而单工基地台为互斥性发射和接收路径。

7. 信令功能

7-1. 多QT/DQT

TKR-750具备多QT/DQT解码/编码单元功能，可作为公用中继器或多QT/DQT基地台运行。可以建立两个分别有16个编码/解码组合的多功能表，称为主表和副表。

多功能表可使TKR-750对向多功能表预编程的16个QT/DQT的其中之一进行解码。接收信号时(中继器运行方式)，中继器使用对应设定在多功能表的解码QT/DQT的QT/DQT编码。在多功能表中，信令对“No.1”(第一栏)定义为“基础”。接收信令(如果包含在No.1至No.16)定义为“当前”。

No.2至No.16信令对可以使用AUX I/O端口1~4在“主表”和“副表”之间更换，作为“多功能表选择”分配，并且执行多功能主表、多功能副表或多功能主表/副表功能。当AUX I/O端口1~4对于“多功能表选择”设定时，4比特二进制编码的十进制(BCD)信号输入AUX I/O。1是最低有效位(LSB)，“1101”输入(右侧的LSB)表示表No.2，“1101”输入表示表No.3。

7-2. 多功能中的编码音频

在中继器正在使用，或者双工基地台正在接收的情况下，本机麦克风PTT或外部PTT开启时，编码信令将按照多功能中的编码音频确定。单工基地台始终发射“基础”编码QT/DQT。

OPERATING FEATURES

Current : When any PTT as described above is active while the repeater is in use or the duplex-base station is receiving, the "paired" encode QT/DQT associated with receiving QT/DQT is transmitted. When any PTT is active while the repeater or the duplex-base station is in idle period, the "Primary" encode QT/DQT is transmitted.

Primary : When any PTT (provided that the Priority of any PTT is higher than the Priority of Repeat PTT) is active while the repeater is in use, the encode QT/DQT changes "paired" encode QT/DQT to "Primary" while continuing to transmit. When any PTT is active while the repeater is in idle period, the "Primary" encode QT/DQT is transmitted. In the base station, the "Primary" encode QT/DQT is always transmitted regardless of the receiver status.

7-3. QT Reverse Burst Time

During repeat with QT tones, the repeater re-transmits a phase-shifted burst of the QT tone ("reverse burst") when it detects the radio using the repeater has un-keyed and also sent a reverse QT burst (squelch-tail elimination). This mutes a receiving radio's speaker audio before its receiver circuit shuts off causing squelch tail noise in the speaker audio. The TKR-750 can select the time between 140 to 200 ms that the QT reverse burst is sent. Typically this time should not have to be adjusted from the default value. The transmission of the QT reverse burst can be also inhibited if the QT Reverse Burst function is set to "No".

7-4. DQT Turn Off Code Time

During repeat with DQT tones, the repeater re-transmits a specific turn-off code when it detects the radio using the repeater has un-keyed and also sent the turn-off code (squelch-tail elimination). This mutes a receiving radio's speaker audio before its receiver circuit shuts off causing squelch tail noise in the speaker audio.

The TKR-750 can select the time between 140 to 200ms that the DQT turn-off code is sent. Typically this time should not have to be adjusted from the default value.

7-5. Off Hook Decode

The TKR-750 is able to decode QT/DQT regardless whether the local microphone is in the on- or off-hook condition. When the Off Hook Decode function is enabled, the TKR-750 is capable of QT/DQT decode even though the microphone is in the off-hook condition (or a local microphone is not installed).

8. Scan Feature

8-1. Scan Operation

Providing that the TKR-750 contains two or more non-priority ADD channel or one or more non-priority ADD channel and Priority channel, it starts scanning once the Scan On function is executed and displays "SC" on the 7-seg LED. Scanning stops temporarily if any following conditions be come valid.

- 1) if a RF carrier and a valid QT/DQT is present. The receiving channel number is displayed and the received audio is heard from a speaker.
- 2) if a RF carrier is present, providing that the Monitor On function is executed.
- 3) if the Squelch Off function is executed. Scanning stops on the channel being scanned when Squelch Off is executed, the channel number is displayed and the received audio is heard from a speaker.
- 4) if a local microphone's hook is in off hook status, providing that the Off Hook Scan function is set to Disable. Scanning stops on the Revert channel, but the audio is not heard until a valid signal is received.

When the received call is ended, scanning automatically resumes after the period set in Dropout Delay Time function has expired. When the Scan Off function is executed, the TKR-750 inhibits scanning and displays the selected channel.

8-2. Scan Sequence

- 1) Normal Scan : When no Priority channel is set, scanning of ADD channels is done in ascending order.
- 2) Single Priority Scan : The Priority channel is set as either a fixed channel or a selected channel. When Priority channel is set, Priority channel and non Priority channel are scanned by turns. When scanning stops on the non Priority channel, calls from the Priority channel are still checked at set intervals while scanning is stopped. This operation is called Look Back and the interval period is selected by the Look Back Time function.

8-3. Revert Channel

The Revert channel is a channel that is used to transmit during scanning. The time from the end of transmission on Revert channel to the time scanning automatically resumes is set in Dwell Time function. The Revert channel types are Last Called, Last Used, Selected, Selected + TalkBack, Priority, and Priority + TalkBack.

- 1) Last Called : The TKR-750 reverts to the channel upon which a call was last received even if scanning has resumed (power on default = selected channel).
- 2) Last Used (with TalkBack) : The TKR-750 reverts to the channel that was last transmitted on (power on default = selected channel). However, if a call is received on a channel other than the last transmit channel and PTT is pressed before scanning resumes, the transceiver "talks back" on the current receive channel.
- 3) Selected : The transceiver reverts to the channel set by the function prior to scan initiation.
- 4) Selected+TalkBack : The TKR-750 reverts to the channel set by the Channel 'X' functions or Channel Select function prior to scan initiation. However, if a call is received on a channel other than the selected channel and PTT is pressed before scanning resumes, the transceiver "talks back" on the current receive channel.
- 5) Priority : The TKR-750 always reverts to the Priority channel.

操作特性

当前：在中继器正在使用、或者双工基地台正在接收的情况下，当上述的任何PTT开启时，使用接收的QT/DQT分配的“成对”编码QT/DQT被发射。在中继器或者双工基地台为空闲期间的情况下，当任何PTT开启时，“基础”编码QT/DQT被发射。

基础：在中继器正在使用的情况下，当任何PTT(任何PTT的优先高于中继PTT优先时除外)开启时，编码QT/DQT将“成对”编码QT/DQT改变成为“基础”而继续发射。在中继器为空闲期间的情况下，当任何PTT开启时，“基础”编码QT/DQT被发射。在基地台，“基础”编码QT/DQT始终被发射，而与接收机的状态无关。

7-3. QT反向字符组时间

在使用QT音频中继的情况下，当检测到使用中继器的电台具有非键控时，中继器重新发射相移QT音频的字符组(“反向字符组”)，并且也发送反向QT字符组(静音跟踪消除)。该功能在接收机电路切断之前，消音在扬声器音频中产生静音跟踪噪音的接收电台的扬声器音频。TKR-750可以在140至200ms的范围选择QT反向字符组的发送。在一般情况下，不应对该时间的出厂值进行调整。如果QT反向字符组功能设定为“No”，QT反向字符组的发射也可以被禁止。

7-4. DQT切断代码时间

在使用DQT音频中继的情况下，当检测到使用中继器的电台具有非键控时，中继器重新发射特定的切断代码，并且也发送切断代码(静音跟踪消除)。该功能在接收机电路切断之前，消音在扬声器音频中产生静音跟踪噪音的接收电台的扬声器音频。TKR-750可以在140至200ms的范围选择DQT切断代码的发送。在一般情况下，不应对该时间的出厂值进行调整。

7-5. 摘机解码

TKR-750可以解码QT/DQT，而与本机麦克风在钩或摘钩条件无关。摘机解码功能开启时，TKR-750能够进行QT/DQT解码，即使麦克风处于摘钩条件(或者未安装本机麦克风)。

8. 扫描功能

8-1. 扫描运行

除了TKR-750包含两个或更多的非优先ADD信道、或者一个或更多的非优先ADD信道和优先信道之外，只要执行开始扫描功能，本机即开始扫描，并且通过7段LED显示“SC”。如果下列任何条件有效，扫描将临时停止。

- 1) 如果存在射频载波和有效的QT/DQT。显示接收信道号码并且可以从扬声器听到接收的音频。
- 2) 如果存在射频载波，除非执行监听接通功能。
- 3) 如果执行静音切断功能，当执行静音切断时，扫描在被扫描的信道停止，显示信道号码，并且可以从扬声器听到接收的音频。
- 4) 如果本机麦克风的挂钩处于摘钩状态，除了摘钩扫描功能设定为禁止之外，扫描将在恢复信道停止，但无法听到音频，直到接收到有效的信号。

当接收的呼叫结束，在超过在退出延迟时间功能设定的时间后，扫描自动恢复。执行扫描停止功能时，TKR-750禁止扫描，并且显示选择的信道。

8-2. 扫描顺序

- 1) 通常扫描：未设定优先信道时，ADD信道扫描按照上行顺序进行。
- 2) 单优先扫描：优先信道或作为固定信道设定、或作为选择信道设定。当优先信道设定后，将交替扫描优先信道和非优先信道。当扫描在非优先信道停止时，在停止中仍旧以设定的间隔检查来自优先信道的呼叫。该运行称为回视，该间隔由回视时间功能选择。

8-3. 恢复信道

恢复信道是用于在扫描中发射的信道。从恢复信道的发射结束至扫描自动重新开始的时间由停延时间功能设定。恢复信道的形式为最后呼叫、最后使用信道、选择信道、选择信道+回讲、优先以及优先+回讲。

- 1) 最后呼叫：TKR-750恢复到最后接收的呼叫的信道，即使扫描重新开始(开机出厂设定=选择信道)。
- 2) 最后使用信道(带回讲)：TKR-750恢复到最后一次发射的信道(开机出厂设定=选择信道)。但是如果接收的信道不是最后一次发射的信道，并且在扫描重新开始之前按下了PTT，本机将在当前接收的信道“回讲”。
- 3) 选择信道：TKR-750恢复到在开始扫描之前的功能设定的信道。
- 4) 选择信道+回讲：TKR-750恢复到开始扫描之前由信道“X”功能或信道选择功能设定的频道。但是，如果接收呼叫的信道不是选择信道，并且在扫描重新开始之前按下了PTT，本机将在当前接收的信道“回讲”。
- 5) 优先：TKR-750始终恢复到优先信道。

OPERATING FEATURES

- 6) Priority+TalkBack : The TKR-750 always reverts to the Priority channel. However, if a call is received on a channel other than the Priority channel and PTT is pressed before scanning resumes, the transceiver “talks back” on the current receive channel.

9. CW ID and Message

The TKR-750 contains internal automatic station identifiers. The CW ID (Morse code) is set and transmitted on a per-channel basis. The CW ID is transmitted when the interval period is reached (TX Interval Time function), the channel is changed (CW ID on Channel Change function) or CW ID On function is executed. When CW ID is activated by any functions described above, it is actually sent after the total time of TX Delay Time (not applied to CW ID On function) and CW Modulation Delay Time has expired. TX Delay Time is a period from CW ID is activated to the transmitter is keyed.

CW Modulation Delay is a period from the transmitter is keyed to the CW ID tone is sent. The CW ID tone is routed to the Receive Audio (RA) port and a speaker if the Send CW ID to RA function is set to Yes. The TKR-750 contains 8 message banks for CW Message. CW Message 1 to 8 is transmitted on the current channel when the CW Message 1 to 8 On function is activated, respectively.

10. PTT Priority

A number of keying sources can be used to cause the TKR-750 to transmit.

The transmit audio path is switched according to their keying sources and when PTTs is simultaneously activated, the transmit audio path related to the PTT with higher priority is given priority. These are Local Microphone PTT, External PTT, and Repeat PTT.

11. Time Out Timer

The Time Out Timer function determines the period of time users can continuously transmit. When the selected period expires, the transmission is inhibited.

12. Repeat Hold Time

The Repeat Hold Time (hang timer) function is used to prevent the repeater from being repeatedly keyed and unkeyed in response to short message traffic. When a mobile transceiver unkeys, the repeater’s Hold Timer allows the repeater to continue transmitting for a brief period while waiting for a responding end user. If no valid QT/DQT is detected within the Hold Timer period, the transmitter is allowed to unkey. This function determines the period of time that the transmitter is allowed to remain keyed after the loss of a valid QT/DQT received signal.

13. Take Over

The Take Over function is used to disable the external wireline control of the repeater. When Take over function is enabled, the external AUX inputs and Outputs, transmit audio inputs and receive audio outputs, External PTT and External Monitor lines are disabled. All AUX Input functions assigned to any AUX Input stay in their current state. However External PTT and External Monitor switch to the “Off” state.

14. Test Tone

The Test Tone is a single-frequency audio sine wave and is turned On and Off by toggling Test Tone On/Off functions. The transmitter can be modulated without a local microphone by using the test tone. When Test Tone On function is executed and any PTT is activated, the TKR-750 transmits the test tone with mic mute and also routes the test tone to RA port.

15. RF Power

The TKR-750 is able to switch transmission output on a per-channel basis. When the TX High Power function is enabled, the transmission output is set to high power.

16. Fan Action

The TKR-750 has a cooling fan. The Fan Action function determines whether the fan is continuously operated or operates in response to high temperatures only.

17. AUX Input and Output

There are 6 programmable AUX I/O Ports 1~6 (pins 20~25) and 3 programmable AUX Input Ports 1~3 (pins 4~6) on the rear 25 pin D-Sub connector (CONTROL I/O) and 5 programmable AUX Output Ports 1~5 (pins 10, 11, 13~15) on the rear 15 pin TEST/SPKR connector.

The 6 programmable AUX I/O pins are primarily intended for remote control interfaces. Each AUX I/O Port can be set for AUX Input, AUX Output, remote Channel Select or Multi Table Select types. The AUX Input Port can be set execute a single input function or a set of up to three functions when the port is activated. If the port type for an AUX I/O Ports 1~6 is set for “AUX Input”, it will also appear AUX Input window for function programming. The input logic is fixed as active Low.

The AUX Output Port can be set execute a single output function. If the port type for an AUX I/O Ports 1~6 is set for “AUX Output”, it will also appear AUX Output window for function programming. The output logic of AUX Output can be set as either active High or active Low by the Logic Type function. Active High outputs a High (5V) when the programmed condition becomes valid, active Low outputs a Low (0V) when the condition becomes valid.

操作特性

- 6) 优先+回讲：TKR-750始终恢复到优先信道。但是如果接收呼叫的信道不是优先信道，并且在扫描重新开始之前按下了PTT，本机将在当前接收的信道“回讲”。

9. CW ID和信息

TKR-750具备内部自动电台识别。CW ID(莫尔斯码)按照每个信道设定和发射。当到达间隔时间(TX间隔时间功能)、或信道变更(CW ID接通信道变更功能)、或者执行CW ID接通功能时，发射CW ID。CW ID由上述的任何功能开启时，在TX延迟时间(不适用于CW ID接通功能)以及CW调制延迟时间的总时间超过之后实际发送。TX延迟时间为从CW ID开启至按下发射机键的时间间隔。

CW调制延迟是从按下发射机键至CW ID音频发送的时间。如果发送CW ID至RA功能设定为开启，CW ID音频将传递至接收音频(RA)端口和扬声器。TKR-750包含8个信息库可用于CW信息。信息1至8接通功能开启时，CW信息1至8分别在当前信道发射。

10. PTT优先

一些键控源可以用于TKR-750的发射。发射音频途径按照键控源切换。当PTT同时开启时，与较高优先PTT有关的发射音频途径获得优先。这些是本机麦克风PTT、外部麦克风PTT和中继PTT。

11. 超时定时器

超时定时器功能决定用户可以连续发射的时间。超过了选择的时间后，发射将被禁止。

12. 中继保留时间

中继保留时间(挂机定时器)功能用于防止中继器响应短信息通信量造成的反复键控和解除键控。当车载对讲机解除键控时，中继器的保留定时器允许中继器继续发射一段时间等待用户的响应。如果在保留定时器定时时间内没有检测到有效的QT/DQT，本机允许解除键控。本功能决定本机允许在丧失了有效的QT/DQT接收信号后的保留键控时间。

13. 接管

接管功能用于禁止中继器的外部有线控制。开启接管功能后，外部AUX输入和输出、发射音频输入和接收音频输出、外部PTT以及外部监听线被禁止。向任何AUX输入分配的所有AUX输入将保留在各自的当前状态。但是，外部PTT和外部监听开关切换为“切断”状态。

14. 试验音频

试验音频是单音频正弦波，由切换试验音频接通/切断功能控制接通和切断。本机使用试验音频可以无须本机麦克风进行调制。执行试验音频接通功能，并且开启PTT时，TKR-750在麦克风消音状态下发射试验音频，并传送到RA端口。

15. 射频功率

TKR-750可以按照每一信道切换发射输出。TX高功率功能开启时，发射输出设定为高功率。

16. 风扇运行

TKR-750具备冷却风扇。风扇运行功能决定风扇或是连续运行、或是仅对应高温运行。

17. AUX输入和输出

本机在背后的25插脚D-sub连接器上(CONTROL I/O)具备6个可编程AUX输入/输出端口1~6(插脚20~25)和3个可编程AUX输入端口1~3(插脚4~6)，在背后的15插脚TEST/SPKR连接器上具备5个可编程AUX输出端口1~5(插脚10、11、13~15)。

6个可编程AUX输入/输出插脚主要用于遥控接口。各AUX输入/输出端口可以设定为AUX输入、AUX输出、遥控信道选择或多功能表选择形式。端口开启时，AUX输入端口可以设定执行单输入功能或者设定最多达3项功能。如果将AUX输入/输出端口1~6的端口形式设定为“AUX输入”，它将出现在AUX输入窗口用于功能编程。输入逻辑被固定为开启低状态。AUX输出端口可设定执行单输出功能。

如果将AUX输入/输出端口1~6的形式设定为“AUX输出”，它也将出现在AUX输出窗口用于编程。输出逻辑可以由逻辑形式功能设定为或是开启高状态或是开启低状态。编程的条件有效时，开启高状态输出高电位(5V)；编程的条件有效时，开启低状态输出低电位(0V)。

18. Channel Select

AUX I/O Ports 1~4 (1 or all 4) can each be set for "Channel Select" providing up to 16 channel selection capability. These are 1 to 4 bit Binary Coded Decimal (BCD) inputs. AUX I/O 1 is a least significant bit (LSB). When all of AUX I/O Ports 1~4 set to Channel Select, "1110" input (LSB on the right side) signifies the Channel 1 and "1101" input signifies the Channel 2. When the Channel Select function is set to any AUX I/O ports, the Channel "X" function (Channel Up, Channel Down, Channel 1, etc.) can not be set to the AUX Input ports, but can be set to the PF Keys. Normally the channel control is controlled by the Channel Select function. If the Take Over function is executed, the channel control is disabled to be controlled by the Channel Select and enabled to be controlled by the PF Keys.

19. DC Power Save

The TKR-750 has the DC Power Save feature. The DC Power Save Mode is activated when the DC Power Save On function is executed. When the DC Power Save Mode is activated, all panel LEDs except the Power LED are turned off, and the audio amplifier and the DSP becomes inactive. When the Display On function is executed while the repeater is in the DC Power Save Mode, all panel LEDs become active as normal status indicators on the repeater, and the audio amplifier and the DSP becomes active. However, when the Save Delay Timer A period expires, all panel LEDs except the Power LED are turned off and the audio amplifier becomes inactive again, and when the Save Delay Timer B period expires, the DSP becomes inactive. When the DC Power Save Mode is turned on or off, up to 3 functions pre-programmed into the Save On function or Save Off function are executed in sequence.

20. Power Supply

The TKR-750 is able to use two Power sources that are called Main and Backup. When the Power source changes from Main to Backup or from Backup to Main, up to 3 functions pre-programmed into the Backup Power function or the Main Power function are executed in sequence.

21. Start Up

When the TKR-750 is first turned on or is reset, up to 3 functions pre-programmed into the Start Up function are executed in sequence.

22. Optional Board

An optional scrambler board can be installed in the TKR-750. Scrambler codes between 1 and 16 are available per channel. If the scrambler board is not to be used (although it is installed), set the parameter to "Off". When any Scrambler code is set up and the Scrambler On function is executed, the scrambler board is activated.

18. 信道选择

AUX输入/输出端口1~4(1或所有4)可以各设定为“信道选择”，提供最多达16个信道选择能力。它们是1至4位二进制十进制(BCD)输入。AUX输入/输出1是最低有效位(LSB)。所有AUX输入/输出端口1~4设定为信道选择时，“1110”输入(右侧LSB)表示信道1，“1101”输入表示信道2。信道选择功能设定至任何AUX I/O端口时，信道“X”功能(信道上升、信道下降、信道1等)无法设定为AUX输出端口，但可以设定为PF键。通常信道控制由信道选择功能控制。如果执行接管功能，信道控制禁止由信道选择控制，并且允许由PF键控制。

19. DC电源节电

TKR-750具备DC电源节电功能。执行DC电源节电接通功能时，DC电源节电模式开启。DC电源节电模式开启时，除了电源LED以外，所有操作盘的LED均被切断，音频放大器和DSP关闭。当中继器在DC电源节电模式下执行显示接通功能时，所有操作盘的LED作为正常状态中继器的指示灯开启，同时音频放大器和DSP开启。但是，当节电延迟定时器超过A时间后，除了电源LED以外，所有操作盘的LED均再次被切断，音频放大器再次关闭；当节电延迟定时器超过B时间后，DSP关闭。DC电源节电模式接通或切断时，可以对最多达3个预编程的功能依次执行进入节电开启功能或节电关闭功能。

20. 电源供电

TKR-750可使用两个电源，分别称为主电源和后备电源。当电源从主电源切换到后备电源，或者从后备切换到主电源时，可以对最多达3个预编程的功能依次执行进入后备电源功能或进入主电源功能。

21. 启动

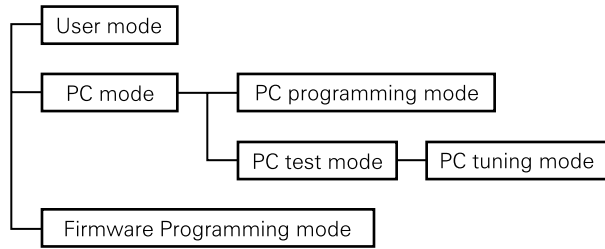
TKR-750首次开机或者复位时，可以对最多达3个预编程的功能依次执行进入启动功能。

22. 可选板

可选扰频器板可安装到TKR-750中。1至16的扰频器代码可用于每个信道。如果不使用扰频器板(虽然已经安装)，应将参数设定为“关闭”。设定任何扰频器代码并且执行扰频器接通功能时，扰频器板开启。

REALIGNMENT / 模式组合

1. Modes



Mode	Function
User mode	Use this mode for normal operation.
PC mode	Use this mode to make various settings by means of the FPU through the RS-232C port.
PC programming mode	Use to read and write frequency data and other features to and from the repeater.
PC test mode	Use to check the repeater using the PC. This feature is included in the FPU.
Firmware programming mode	Use when changing the firmware program of the flash memory.

2. How to Enter Each Mode

Mode	Operation
User mode	Power on.
PC mode	Received commands from PC.
Firmware Programming mode	[PF1] key + Power on (one second).

3. PC Mode

3-1. Preface

The TKR-750 repeater is programmed by using a personal computer, programming interface and KPG-66D software.

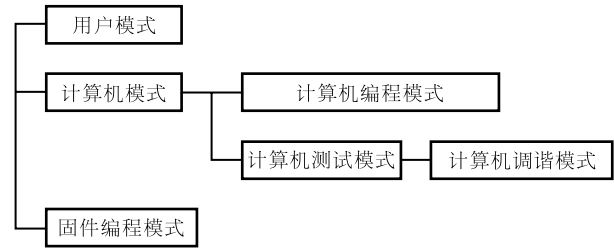
3-2. Connection Procedure

1. Connect the TKR-750 to the personal computer with the interface cable.
2. When power is applied, the user mode is entered immediately. When the PC sends a command, the repeater enters the PC mode and displays "PC" on the 7-segment LED. When data is being transmitted to the PC from the repeater, the TX LED flashes. The BUSY LED flashes when data from the PC is being received by the repeater.

Note :

- The data stored in the personal computer must match the model type, when it is written into the flash memory.
- Change the TKR-750 to PC mode, then attach the interface cable.

1. 模式



模式	功能
用户模式	一般使用。
计算机模式	使用外部写频器(计算机)通过RS-232C接口对通信机进行各种设定的模式。
计算机编程模式	用于阅读和写入频率数据以及其他功能。
计算机测试模式	用于使用计算机检测。此特性包括在FPU内。
固件编程模式	当改变FlashRom中操作主程序时使用。

2. 如何进入每一种模式

模式	操作
用户模式	接通电源
计算机模式	从计算机接收指令
固件编程模式	[PF1] + 接通电源(1秒钟)

3. 计算机模式

3-1. 前言

TKR-750车台使用计算机、编程电缆(KPG-46)和编程软件(KPG-66D)进行编程。

3-2. 连接步骤

1. 使用编程电缆将TKR-750与计算机连接。
2. 接通电源时立即进入用户模式。当计算机发出一个指令时，中继台进入计算机模式，并且在7段LED显示器上显示“PC”。当从中继器向计算机传送数据时，TX LED指示灯闪烁。当中继台接收来自计算机的数据时，BUSY LED指示灯闪烁。

注释：

- 储存在计算机内的数据必须与写入到EEPROM的格式相匹配。
- 将TKR-750改变为计算机编程模式，然后连接编程电缆。

REALIGNMENT / 模式组合

3-3. KPG-46 Description (PC Programming Interface Cable : Option)

The KPG-46 is required to interface the TKR-750 to the computer. It has a circuit in its D-sub connector (25-pin) case that converts the RS-232C logic level to the TTL level.

The KPG-46 connects the microphone connector of the TKR-750 to the computer's RS-232C serial port.

3-4. Programming Software Description

The KPG-66D programming disk is supplied in 3-1/2" disk format. The software on the disk allows a user to program TKR-750 repeater via the programming interface cable (KPG-46).

3-5. Programming With IBM PC

Data can be programmed into the flash memory in RS-232C format via the microphone connector.

3-3. KPG-46说明(计算机编程电缆：可选项)

KPG-46用于将TKR-750与计算机连接。在其D型副插座(25芯)中有一个电平转换电路。此电路可以把RS-232C逻辑电平转换为TTL电平。

KPG-46将TKR-750的话筒插座与计算机的RS-232C串行口连接。

3-4. 编程软件说明

KPG-66D编程软盘是一张3-1/2"软盘。软盘内的软件允许用户经由编程电缆(KPG-46)对TKR-750进行编程设定。

3-5. 使用IBM计算机编程

RS-232C格式的数据经由话筒插座输入到通信机的Flash Rom中。

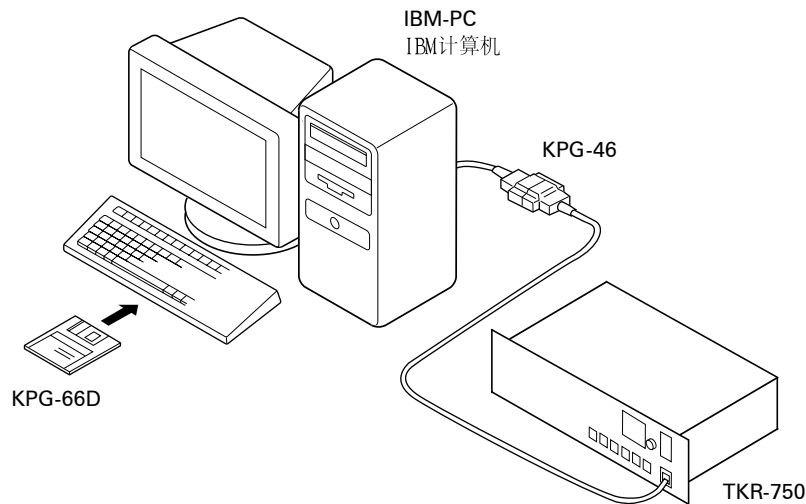


Fig. 1 / 图 1

4. Firmware Programming Mode

4-1. Preface

The TKR-750 uses flash memory to allow it to be easily upgraded when new features are released in the future.

4-2. Connection Procedure

Connect the TKR-750 to the personal computer (IBM PC or compatible) with the interface cable (KPG-46). (Connection is the same as in the PC mode.)

Notes :

You can only program firmware from the 8-pin microphone connector on the front panel. Using the 25-pin logic interface on the rear panel will not work.

4. 固件编程模式

4-1. 前言

Flash Rom被安装在TKR-750上。当将来出现新功能时,允许TKR-750升级。

4-2. 连接步骤

使用编程电缆(KPG-46)将TKR-750与计算机(IBM计算机或兼容机)连接。(与计算机编程模式中的连接方法一样。)

注释：

只能通过前面板上的8芯话筒插座进行编程。无法使用后侧面板上的25芯逻辑接口。

REALIGNMENT / 模式组合

4-3. Programming

1. Start up the programming software (Fpro. exe).
2. Set the communications speed (normally, 115200 bps) and communications port in the configuration item.
3. Set the firmware to be updated by file name item.
4. Turn the TKR-750 power on with the [PF1] key held down. Hold the key down for one second until the 7-segment display changes to "P.G.". When "P.G." appears, release your finger from the key.
5. Check the connection between the TKR-750 and the personal computer, and make sure that the TKR-750 is in the program mode.
6. Press write button in the window. A window opens on the display to indicate progress of writing.
7. If writing ends successfully, the TX LED on the TKR-750 lights.
8. If you want to continue programming other TKR-750s, repeat steps 3 to 6.

Notes :

This mode cannot entered if the firmware program mode is set to disable in the programming software (KPG-66D).

4-4. Function

If you press the [PF1] key (front panel), both decimal point on the 7-segment display will disappear. The writing speed is 38400 bps (low-speed mode). If you press the [PF1] key again, the right hand decimal points will light. The writing speed is 57600 bps (middle-speed mode).

Note :

Normally, write in the high-speed mode (115200 bps).

4-3. 编程

1. 启动编程软件 (FPRO. exe)。
2. 在设置项目中设定通信速率 (通常为 115200bps) 和通信端口。
3. 在文件名项中选定新固件。
4. 在按住 [PF1] 键的同时接通 TKR-750 的电源。按住该键 1 秒钟直到 7 段显示器的显示成为 "P.G."。当 "P.G." 出现时, 松开按键。
5. 检查 TKR-750 与计算机之间的连接, 并且确认 TKR-750 处于编程模式。
6. 按下窗口中的写入按钮, 显示器上开启一个窗口并提示写入步骤。
7. 当成功写入数据后, TKR-750 上的 TX LED 指示灯点亮。
8. 如果希望继续编程设制其他 TKR-750, 重复步骤 3 到 6。

注释 :

如果在编程软件 (KPG-66D) 中固件编程模式设定为禁用, 则不能进入此模式。

6-4. 功能

如果按下 [PF1] 键 (前面板), 7 段显示器上的两个小数点消失, 写入速率为 38400bps (低速模式)。如果再按下 [PF1] 键, 右侧小数点点亮, 写入速率为 57600bps (中速模式)。

注释 :

通常情况下在高速率模式中写入数据 (115200bps)。

1. External Power Supply Connection (Rear Connectors) : See Page 4

This unit has two external power supply connectors : Main DC and Backup.

If an external DC power supply is connected to the main DC connector and a backup battery is connected to the Backup connector at the same time, the DC power supply switches to the battery automatically if power failure occurs. Therefore, the operation of the repeater can be continued.

If the battery is used, but both the battery and power supply need not be connected (if an external switch is used or if only a solar battery is used), connect it to the Backup connector, not the Main DC connector. Current consumption can be reduced by approx. 120mA because the relay is not used.

If it is installed when the temperature at the repeater site is below freezing, check whether the switch (relay) works properly after installation.

2. Voice Scrambler

It operates only during base operation. The voice is not scrambled when it is repeated.

2-1. Modification

- 1) Remove R742 and R653 on the TX-RX unit (B/2) : control section.

2-2. Connection

- 1) The functions of pins of CN601 on the TX-RX unit (B/2) : control section are shown in the figure.
- 2) Join the CN601 connector to the voice scrambler board via the E37-0808-05 connector cable.

When the operation is checked in PC test mode after the modification, and the maximum deviation is adjusted, the voice from the local microphone is not modulated. In this case, remove the CN601 12-pin (PTO) cable and connect it to the land of the display unit (X54-333) from the voice scrambler. The voice from the local microphone can be modulated in PC test mode.

1. 外部电源的连接(背面端子)

本机具有主DC和后备两个外部电源连接端子。

主DC端子连接外部DC电源，后备端子连接后备电池，两部分同时连接。万一发生停电时，DC电源将自动切换到电池电源，因此可以继续进行中继运行。

但是当即使在使用电池的情况下也没有必要进行两部分同时连接时(如果已经在外部具备切换装置，或者仅使用太阳能电池运行时等)，请将电源连接到后备端子，而不要连接到主DC端子，这样可以在运行中节省大约120mA的驱动继电器消费电流。

当中继器设置现场为零度以下环境时，完成设置后，应首先确认上述的切换(继电器的动作)是否正常工作，然后开始使用。

2. 声音扰频器

仅在基本运行时动作。作为中继器使用时，对中继的声音不施加扰频。

2-1. 修改

- 1) 取消TX-RX单元B/2(控制部分)的R742和R653。

2-2. 连接

- 1) TX-RX单元B/2(控制部分)上的CN601管脚的功能如图所示。
- 2) 使用E37-0808-05连接电缆将CN601连接器与声音扰频器板连接。

完成上述修改后，在PC试验模式下进行动作检查时，对于最大偏差调整，本机麦克风的声调制将无法进行。这时，应拆除CN601 12管脚(PTO)的电缆，从声音扰频器连接至显示单元(X54-333)的纹间。

这样，在PC试验模式下也可以对来自本机麦克风的声进行调制。

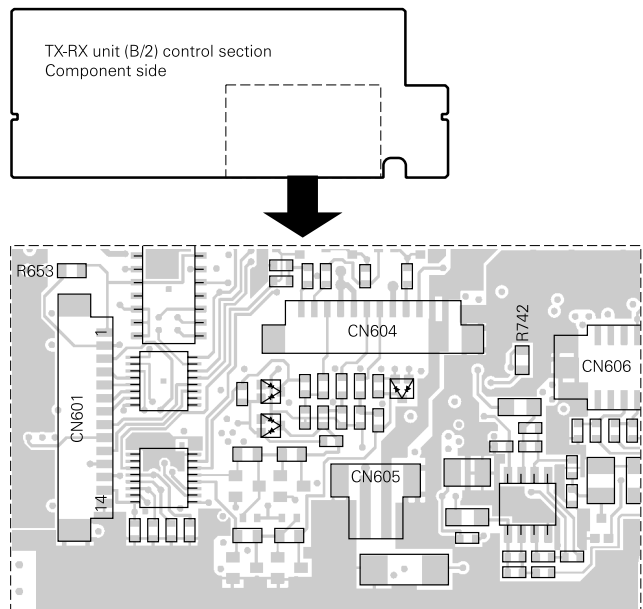


Fig. 1 / 图 1

INSTALLATION / 安装

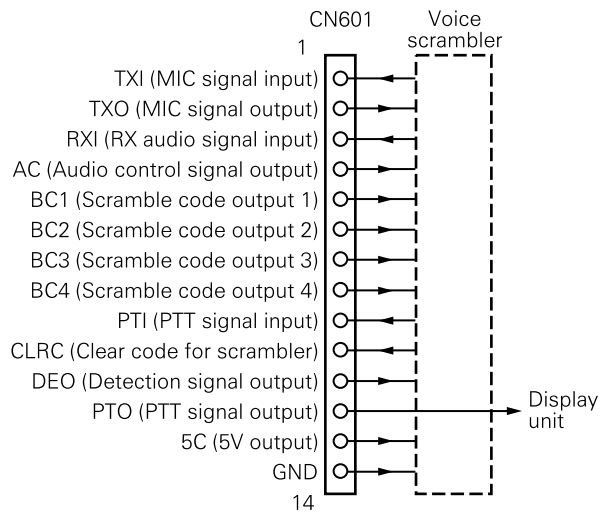


Fig. 2

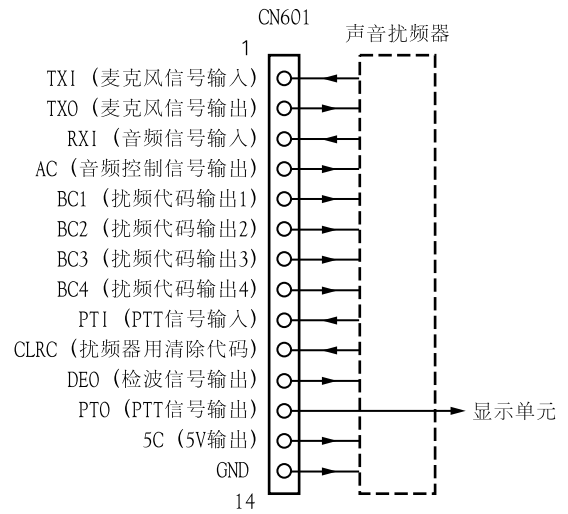


图 2

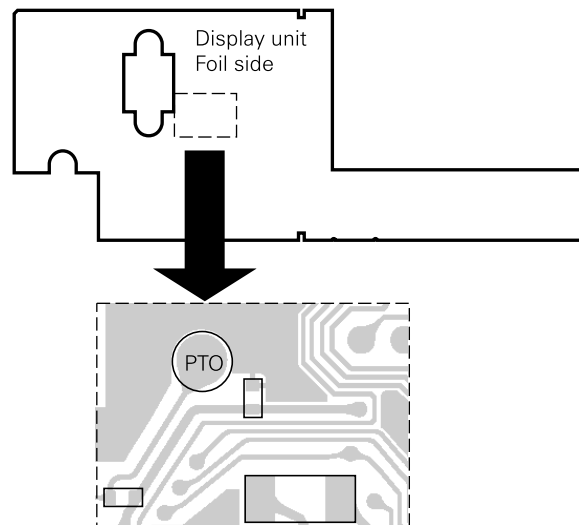


Fig. 3 / 图 3

3. External Speaker (KES-4)

The TKR-750 has a internal built-in speaker (5W/8Ω), and the external speaker output from the TEST/SPKR connector (15-pin) on the rear of the radio is 4W/4Ω. Use external speaker KES-4.

3-1. Connection for the KES-4 With the TKR-750

■ When taking the AF output from the TEST/SPKR connector (15-pin) on the rear of the radio

The following tools are required for changing the connector.

3. 外部扬声器(KES-4)

TKR-750设有内置扬声器(5W/8Ω)和从本机后侧的TEST/SPKR连接器(15插脚)输出的外部扬声器(4W/4Ω)。请使用KES-4作为外部扬声器。

3-1. KES-4与TKR-750的连接

■ 从本机后侧的TEST/SPKR连接器(15插脚)进行音频输出
更换连接器时, 需要使用以下工具。

● Extracting tool

The following extracting tool is recommended :
Molex Inc. Order No. : 11-03-0002

1. Remove the connector with jumper from the external speaker connector on the rear panel of the radio. (Fig. 4-1)
Note : Save the jumper, which is required when the radio is used without the external speaker.
2. Remove the terminals with the jumper from the connector housing holes number 9 and 12 using the extracting tool.

Removing the jumper lead (Fig. 4-2)

- 1) Insert the extracting tool (11-03-0002) into the connector while pushing the jumper lead in the direction of (a).
- 2) Push the extracting tool into collapse the barbs of the crimp terminal.
- 3) Pull out the lead while continuing to push the extracting tool in the direction (b).
3. Reinsert the terminal with the black and white stripe lead into hole number 12, and the terminal with the black lead into hole number 6. (Fig. 4-3)
4. Attach the connector to the external speaker connector on the radio.

Note :

Relationship between TEST/SPKR connector (15-pin) connection and speaker output.

When pins 9 and 12 are shorted : Built-in internal speaker is used.

When pins 9 and 12 are open and output is from pins 6 and 12 : KES-4 is used.

● 拆卸工具

建议使用以下拆卸工具:

Molex Inc. 订货编号:11-03-0002

1. 从本机后侧面板的外部扬声器连接器上拆下连接器和跳接器(图4-1)。
注: 请保存好跳接器以备本机不连接外部扬声器时使用。
2. 使用拆卸工具从连接器外壳的9号和12号孔中拆下端子。
拆下跳接器导线(图4-2)。
 - 1) 向(a)方向推跳接器导线, 将拆卸工具(11-03-0002)插入连接器。
 - 2) 将拆卸工具压入解除压接端子的倒钩。
 - 3) 在继续向(b)方向推拆卸工具的同时拉出导线。
3. 将黑白条纹的导线重新插入端子的12号孔, 将黑色导线重新插入6号孔。(图4-3)。
4. 将连接器与本机的外部扬声器插座连接。

注:

TEST/SPKR连接器(15插脚)的连接与扬声器输出的关系
插脚9与12短路时, 使用内置扬声器。

插脚9与12开路, 并且从插脚6和12输出时: 使用KES-4。

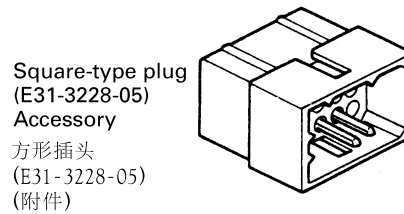


Fig. 4-1 / 图 4-1

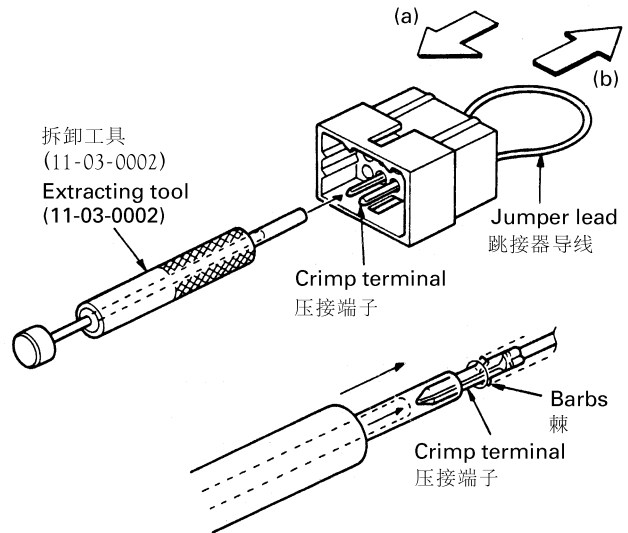


Fig. 4-2 / 图 4-2

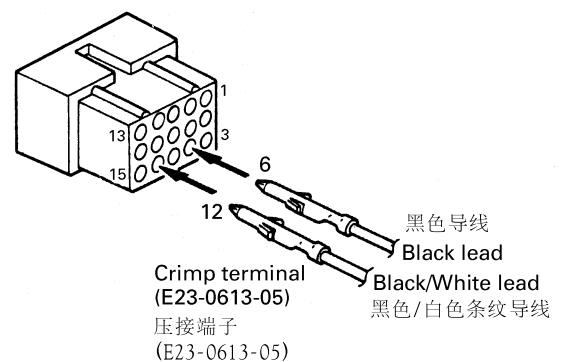


Fig. 4-3 / 图 4-3

MODIFICATION / 改装

1. Modification for Sinking the Collector Current Up

Auxiliary output 1 and 2 can each be modified to sink up to 600mA of the collector current. The following modification should be installed when Auxiliary output 1 or 2 is used to control external equipment.

1. Remove D625, R755, and R769 for Auxiliary output 1 (D624, R756, and R770 for Auxiliary output 2) on the component side of the control section for TX-RX unit PCB.
2. Install \$Q608, \$Q612, and \$R761 for Auxiliary output 1 (\$Q607, \$Q611, and \$R759 for Auxiliary output 2) on the component side of the control section for TX-RX unit PCB.
\$Q607, \$Q608, \$Q611, \$Q612 : DTD114EKA
\$R759, \$R761 : 3.9k Ω (RK73GB1J392J) chip resistor.
3. Change R801 for Auxiliary output 1 (R797 for Auxiliary output 2) from 1k Ω (RK73GB1J102J) to 0 Ω (R92-1252-05).

By making this modification, Auxiliary output 1 and 2 can now sink up to 600mA each.

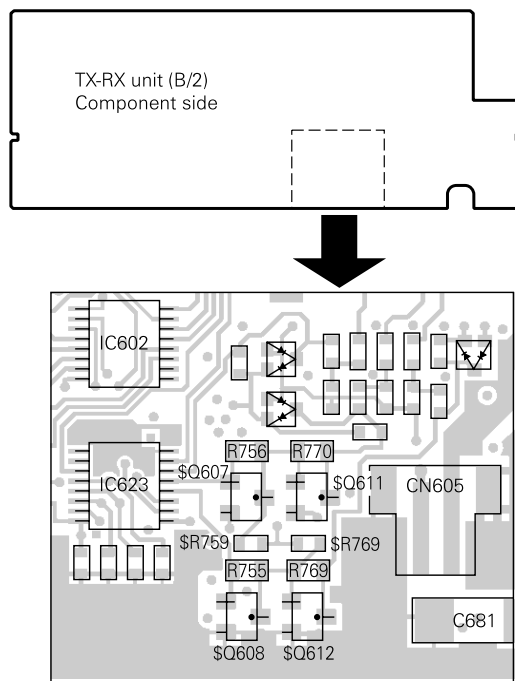


Fig. 1 / 图 1

1. 吸收集电极电流的改装

可以分别对辅助输出1和2进行改装，吸收600mA集电极电流。当辅助输出1和2用于控制外部设备时，需要进行下列改装。

1. 取下位于TX-RX单元PCB控制部分的器件侧的辅助输出1（对于辅助输出2为D624、R756和R770）的D625、R755和R769。
2. 安装位于TX-RX单元PCB控制部分的器件侧的辅助输出1（对于辅助输出2为\$Q607、\$Q611和\$R759）的\$Q608、\$Q612和\$R761。
\$Q607、\$Q608、\$Q611、\$Q612：DTD114EKA
\$R759、\$R761：3.9k Ω (RK73GB1J392J) 贴片形电阻器
3. 将辅助输出1（对于辅助输出2为R797）的R801从1k Ω (RK73GB1J102J) 换成0 Ω (R92-1252-05)。

通过上述改装，辅助输出1和2可以分别吸收600mA。

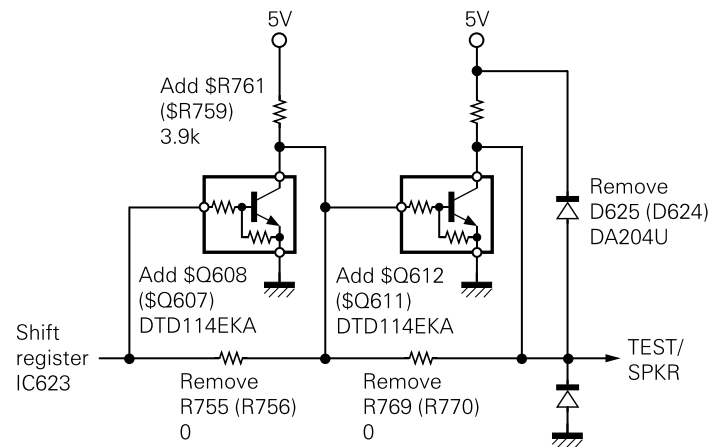


Fig. 2 / 图 2

2. DC Source Switch

To prevent the power supply from turning off due to misoperation of the DC source switch on the front panel or accidents (tampering) after installation, the main unit can be kept on regardless of the on/off of the DC source switch on the front panel.

Short the PSW land near K1 relay by soldering.

2. DC电源开关

本机设置后，为了防止对前面板的DC电源发生错误操作、以及意外(乱动)等产生本机电源切断等问题，可以事先使得本机的电源始终接通，而与前面板的DC电源开关的ON/OFF位置无关。

将在继电器侧面的PSW的纹间使用锡焊短路。

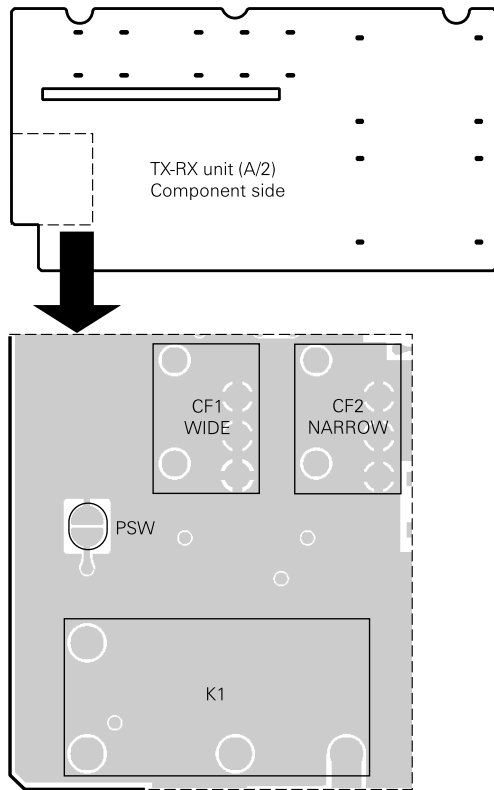


Fig. 3 / 图 3

3. Trickle Charge for Backup Battery

If the external DC power supply is connected to the Main DC connector and a backup battery (12V rechargeable type) is connected to the Backup connector at the same time, the battery can be trickle-charged from the external DC power supply with a maximum current of 0.5A.

Short the CHARGE land near R61.

Notes :

1. Make this modification after removing the DC power supply and battery for safety.
2. When the DC power supply is connected after the modification, DC voltage is output to the Backup connector. Be careful during setup.
3. When the backup battery is used for a long time, remove the battery from the repeater and recharge it because the trickle charge is not sufficient for recharging a completely discharged battery.

3. 后备电池的涓流充电

主DC端子连接外部DC电源、并且后备端子连接后备电池(12V充电电池)时，可以从外部DC电源对电池进行最大为0.5A的涓流充电。

将在R61侧面的充电纹间使用锡焊短路。

注意：

1. 为了确保安全，应先拆下DC电源和电池，然后进行改装。
2. 完成本改装后，连接DC电源时DC电压将向后备端子输出，因此请在设定时注意。
3. 使用后备电池进行长期间运行之后，应务必将电池从中继电器上取出，对电池进行单独充电。因为涓流充电无法对完全放电的电池进行充分的充电。

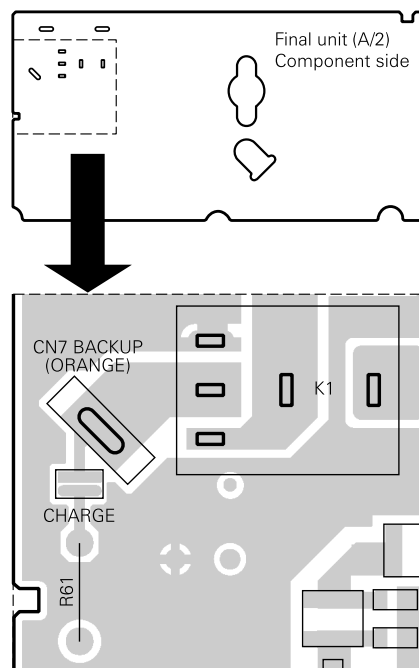


Fig. 4 / 图 4

MODIFICATION / 改装

Accessory Cabinet

You can install optional accessories, such as a DC power supply or duplexers in the accessory cabinet.

1. Place the optional accessory in the cabinet as shown below.
2. If necessary, attach cushions (G13-1801-04 and/or G13-1802-04) to the top plate (J21-8402-04) in order to adjust the space between the cabinet and the top plate. Then, insert the 3 tabs of the plate into the slots in the side of the cabinet. High, middle, or low positions are available. To affix the plate, insert and tighten 2 screws on the other side of the plate.

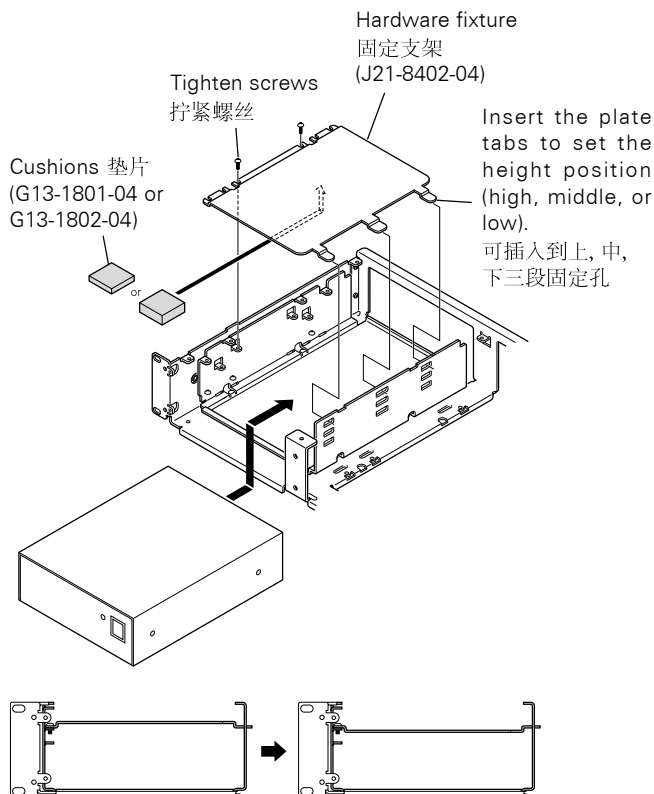
You can also flip the top plate upside-down to adjust a height of the cabinet space.

可选固定支架的使用方法

在可选固定支架上可固定放置DC电源和双工器等。

1. 在可选固定支架上放置DC电源、双工器等。
2. 根据需要在固定支架上粘接垫片，利用上、中、下分布的固定插孔调整，然后用附属螺丝固定。

固定支架可反转使高度改变



The top plate can be inverted to adjust the height of the cabinet space.

固定支架可反转使高度改变

Key Cover

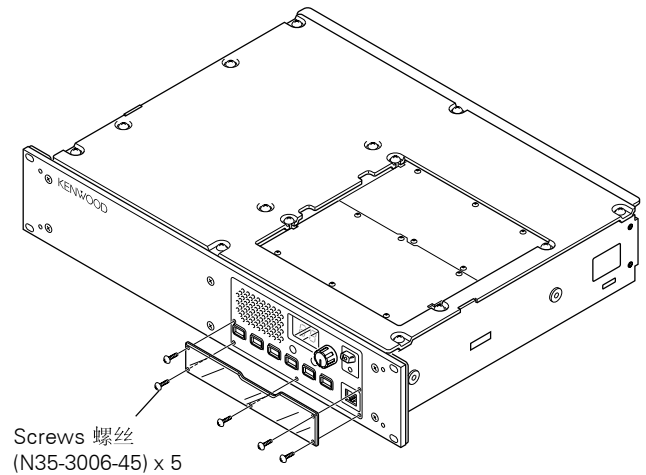
To avoid accidentally pressing the keys, you can install the key cover.

1. Install and fix the key protector using the 5 supplied screws (N35-3006-46).

前面板盖

中继台设置完后，为防止他人无意中按功能键，建议安装前面板盖。

1. 使用附属螺丝5个，按照图示安装前面板盖。



Desktop Repeater

When you use the repeater on the desktop, attach the 4 spacers to the base of the repeater as shown in figure. With these spacers attached, the front panel will not touch the desk surface.

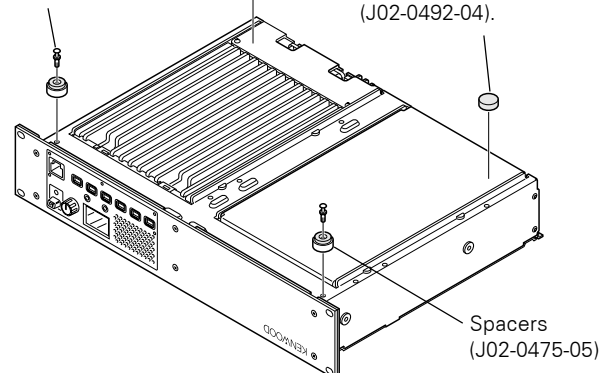
在桌上使用的场合

在桌上使用时，按照图所示安装支脚，然后放置于桌上。

Pegs

Firmly press these pegs (J59-0302-05) through the spacers to affix them to the repeater.

Peel off the backing paper to attach these spacers (J02-0492-04).



TKR-750

MODIFICATION / 改装 / DISASSEMBLY FOR REPAIR / 为维修的拆卸

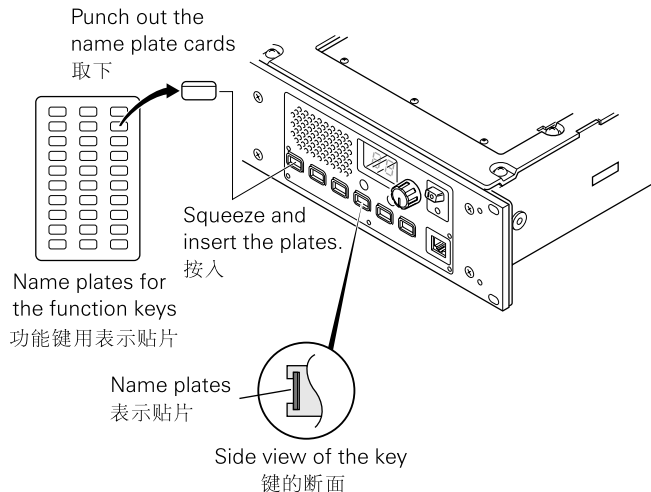
Installing Name Plates

Punch out the name plate card. Then insert the plates onto the relative function keys.

You can reconfigure the name plates at any time.

功能键功能表示贴片的使用方法

把想使用的贴片取下，按入按键的嵌沟内。
根据设定的按键自由使用。



How to Remove the Panel Assy (ABS)

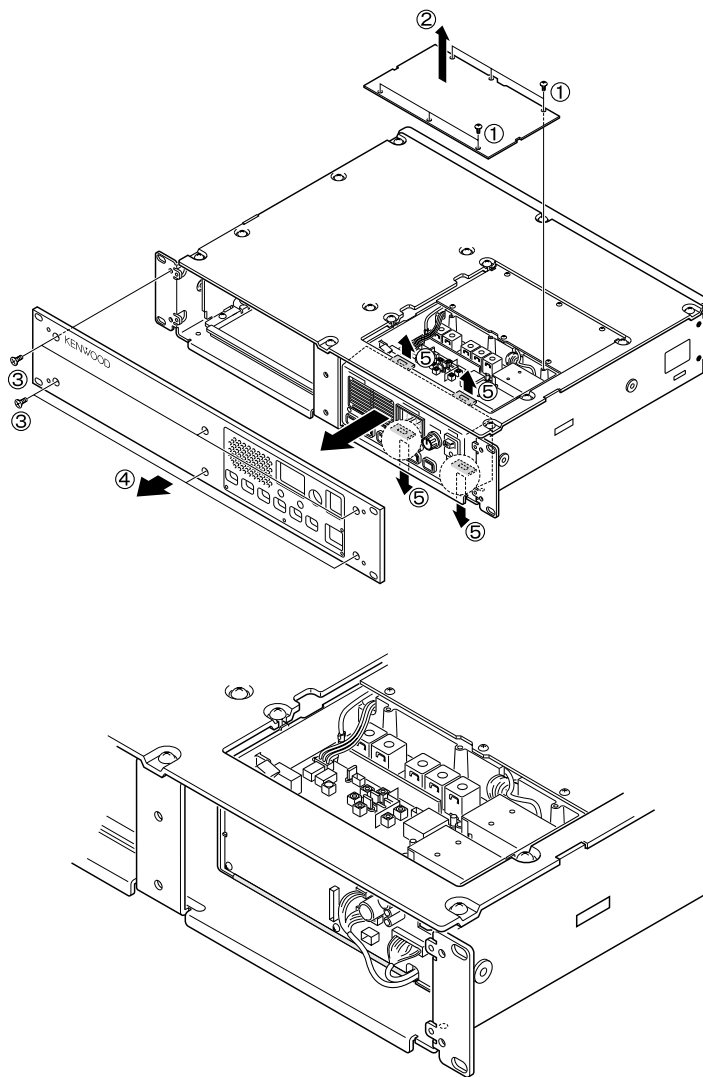
Note : You can remove the panel assembly (ABS) without removing the top panel (A62-0840-03).

1. To remove panel (TX-RX, ②), loose 6 screws (①).
2. To remove panel assembly (Front, ④), loose 6 screws (③).
3. The panel assembly (ABS) is security fastened by 4 tabs (⑤) on top and bottom. You can remove the panel assembly by pulling to front while you are pulling up the tabs.

怎样拆卸前面板 (ABS)

注意：你可以拆下前面板 (ABS) 使之离开控制面板 (A62-0840-03)。

1. 拆除外壳 (TX-RX, ②)，卸下6个螺丝 (①)。
2. 拆卸前面板 (前面板, ④)，卸下6个螺丝 (③)。
3. 在前面板的上部和下部的有4个锁扣 (⑤)，可以在拆卸推进或拉出时锁定。



CIRCUIT DESCRIPTION / 电路说明

1. Outline

The TKR-750 is a VHF/FM repeater designed to operate in the frequency range of 136 to 174MHz.

The unit consists of receiver, transmitter, phase-locked loop (PLL) frequency synthesizer, and control circuits.

2. Receiver Circuit

The receiver is double conversion super-heterodyne, designed to operate in the frequency range of 146MHz to 174MHz (C) or 136MHz to 150MHz (C2).

The receiver circuit located in TX-RX unit (X57 A/2) consists of the following : 2-1 front-end circuit, 2-2 first mixer, 2-3 IF amplifier circuit, 2-4 audio amplifier circuit, and 2-5 squelch circuit.

2-1. Front-end Circuit

The front-end circuit consists of BPF L2/L3, RF amplifier Q1, and BPF L5/L6/L7. The helical BPF covers frequency ranges 146 to 174MHz (C) and 136 to 150MHz (C2), with a passband of 3.0MHz.

The BPF L5/L6/L7 attenuates the unwanted signals, and sends only the necessary signal to the first mixer DBM A1.

1. 概要

TKR-750是VHF/FM中继台，在136至174MHz的频率范围内工作。

该单元由接收机，发射机，锁相环(PLL)频率合成器和控制电路构成。

2. 接收机电路

本接收部分为二次变频超外差式接收机，在146MHz至174MHz(C)、或136MHz至150MHz(C2)的频率范围内工作。接收机的电路设在TX-RX单元(X57-626 A/2)中，由以下部分构成：2-1 前置电路，2-2 第一混频器，2-3 中频放大电路，2-4 音频放大电路以及2-5 静音电路。

2-1. 前置电路

前置电路由BPF L2/L3、RF放大器Q1和BPF L5/L6/L7构成。螺旋BPF的覆盖频率范围为146MHz至174MHz(C)、以及136MHz至150MHz(C2)和3.0MHz。

BPF L5/L6/L7可衰减不需要的信号，并且仅向第一混频器DBM A1送出需要的信号。

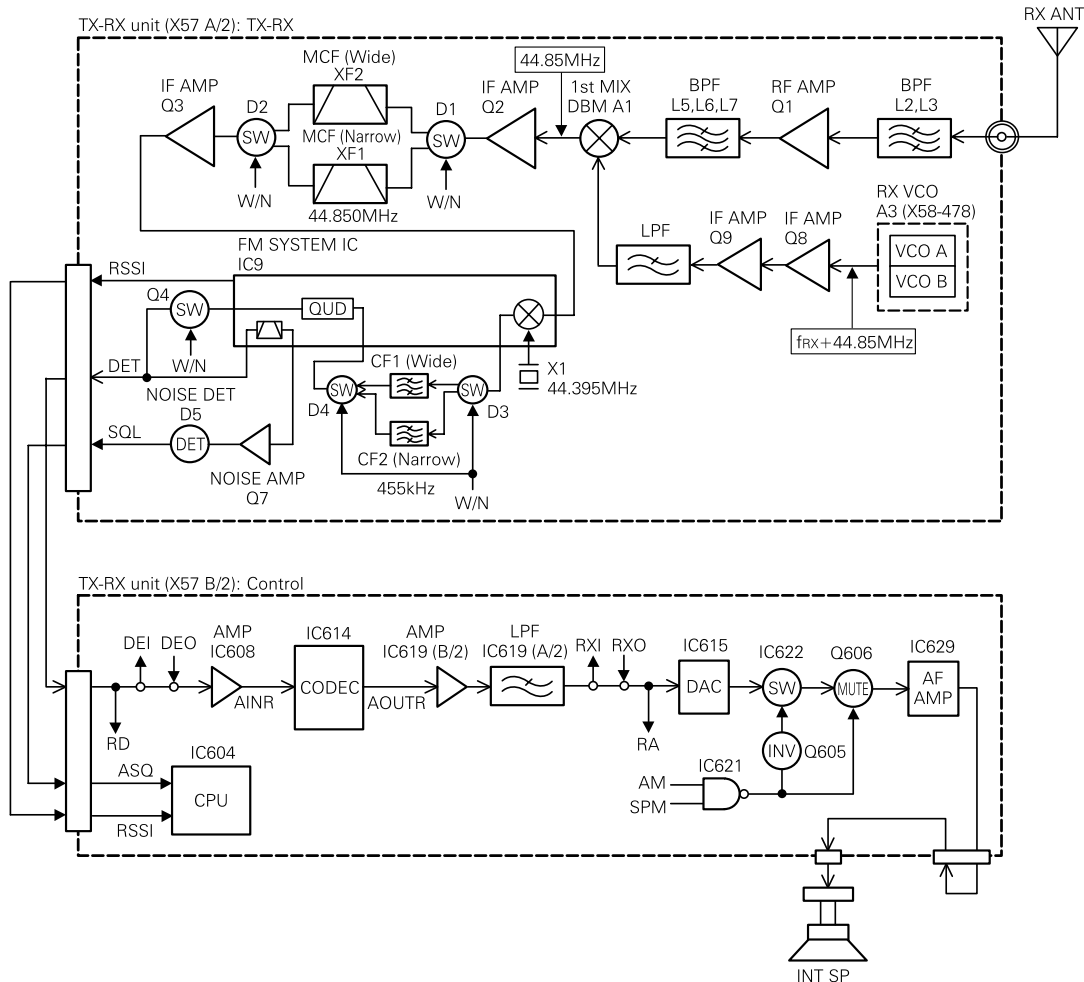


Fig. 1 Receiver circuit / 图1 接收机电路

2-2. First Mixer

The signal from the BPF is heterodyned with the first local oscillator signal from the PLL frequency synthesizer circuit at the first mixer DBM (A1) to become a 44.85MHz first intermediate frequency (IF) signal. The first IF signal is fed through two monolithic crystal filters (XF2; Wide, XF1; Narrow) to further remove spurious signals.

2-3. IF Amplifier

The first IF signal is amplified by Q2 and Q3, and then enters IC9 (FM system IC). The signal is heterodyned again with a second local oscillator signal (44.395MHz) with in IC9 to become a 455kHz second IF signal. The second IF signal is fed through a 455kHz ceramic filter, CF1 (Wide), CF2 (Narrow) to further eliminate unwanted signal, and the quadrature detection circuit FM-detects the signal to produce a base-band signal and output it from pin 11.

2-4. Audio Amplifier

The audio amplifier circuit is located in control section of TX-RX unit (X57-626 B/2). The recovered audio signal obtained from IC9 is amplified by IC608, input to the AINR terminal of CODEC IC (IC614), and audio processed by DSP (IC618).

The processed audio signal from AOUTR terminal of IC614 is amplified by IC619 (B/2) to a sufficient level, anti-aliasing filtered by IC619 (A/2). The audio signal goes to an electronic volume (IC615) V3/V4, to the input of multiplexer IC (IC622), and is amplified to drive a loudspeaker by an audio power amplifier (IC629). The 4W audio output can be provided to external 4 ohms speaker through the 15-pin test connector "SPO, SPG" on the rear panel.

2-5. Squelch Circuit

The output signal from IC9 enters FM IC again, then passed through a band-pass filter.

The noise component output from IC9 is amplified by Q7 and rectified by D5 to produce a DC Voltage corresponding to the noise level. The DC voltage is sent to the analog port of the CPU (IC604).

IC9 outputs a DC voltage (RSSI) corresponding to the input of the IF amplifier.

3. Transmitter Circuit

The transmitter circuit consists of the following circuits : 3-1 microphone circuit, 3-2 modulation level adjustment circuit, 3-3 driver and final power amplifier circuit, and 3-4 automatic power control circuit.

3-1. Microphone Circuit

The signal from the microphone is passed through AGC circuit located in display unit (X54-333), so that it does not saturate. This circuit consists of IC501, D501, D502, Q501, and Q502. The AGC is operated by controlling the + and - side levels of amplitude using the current obtained by positive and negative detection of the amplified audio signal. The audio signal goes to control section of TX-RX unit (X57-626 B/2) from display unit (X54-333).

2-2. 第一混频器

来自BPF的信号在第一混频器DBM(A1)与来自PLL频率合成电路的第一本振信号进行外差混频,生成44.85MHz的第一中频(中频)信号。第一中频信号通过两个单晶体滤波器(XF2:宽, XF1:窄),进一步滤除干扰信号。

2-3. 中频放大器

第一中频信号由Q2和Q3放大,然后进入IC9(FM系统IC)。信号再次与第二本机振荡器信号(44.395MHz)在IC9中进行外差混频,生成455kHz的第二中频信号。第二中频信号通过455kHz陶瓷滤波器(CF1:宽, CF2:窄),进一步滤除干扰信号,并且由正交检波电路进行FM信号检波,产生基带信号,最后从第11管脚输出。

2-4. 音频放大器

音频放大器电路设置在TX-RX单元(X57-626 B/2)的控制部分。来自IC9的接收音频信号经过IC608放大,然后输入到CODEC IC(IC614)的AINR端子,由DSP(IC618)处理音频信号。来自IC614的AOUTR端子的处理后的音频信号由IC619(B/2)放大至足够的电平,由IC619(A/2)进行抗混叠滤波。音频信号送入电子电位器(IC615)V3/V4,至多路转接器IC(IC622),并且经过音频功率放大器(IC629)放大驱动扬声器。4W的音频信号经过位于后面板上的15管脚试验连接器"SPO、SPG"向4欧姆的外接扬声器输出。

2-5. 静噪电路

来自IC9的输出信号再次进入FM IC,然后通过带通滤波器。

从IC9输出的噪音成分经过Q7放大,并且经过D5校正,形成对应噪音电平的直流电压。该直流电压被送到CPU(IC604)的模拟端口。

对应中频放大器的输入,IC9输出直流电压(RSSI)。

3. 发射电路

发射电路由下列电路构成:3-1 麦克风电路,3-2 调制电平调整电路,3-3 驱动器和末级功放电路以及3-4 自动功率控制电路。

3-1. 麦克风电路

来自麦克风的信号通过设置在DISPLAY单元(X54-333)中的AGC电路,因此不会发生饱和。该电路由IC501, D501, D502, Q501和Q502构成。使用对放大的音频信号的正、负检波获得的电流,控制振幅的正侧和一侧电平实现AGC的功能。音频信号从DISPLAY单元(X54-333)进入TX-RX单元(X57-626 B/2)的控制部分。

CIRCUIT DESCRIPTION / 电路说明

The transmit audio signal goes to the input of the multiplexer IC (IC605) for microphone muting. The audio signal is amplified by IC610, input to the AINL terminal of CODEC IC (IC614), and audio processed by DSP (IC618). The processed audio signal from the AOUTL terminal of IC614 is amplified by IC616 (B/2) to a sufficient level, anti-aliasing filtered by IC616 (A/2), and amplified by the summing amplifier IC611 (A/2).

发射音频信号进入多路转接器IC(IC605)用于麦克风静音。音频信号被IC610放大,输入CODEC IC(IC614)的AINL端子,音频信号由DSP(IC618)处理。来自IC614的AOUTL端子的处理后的音频信号被IC616(B/2)放大至足够的电平,由IC616(A/2)进行抗混叠滤波,然后由加法放大器IC611(A/2)放大。

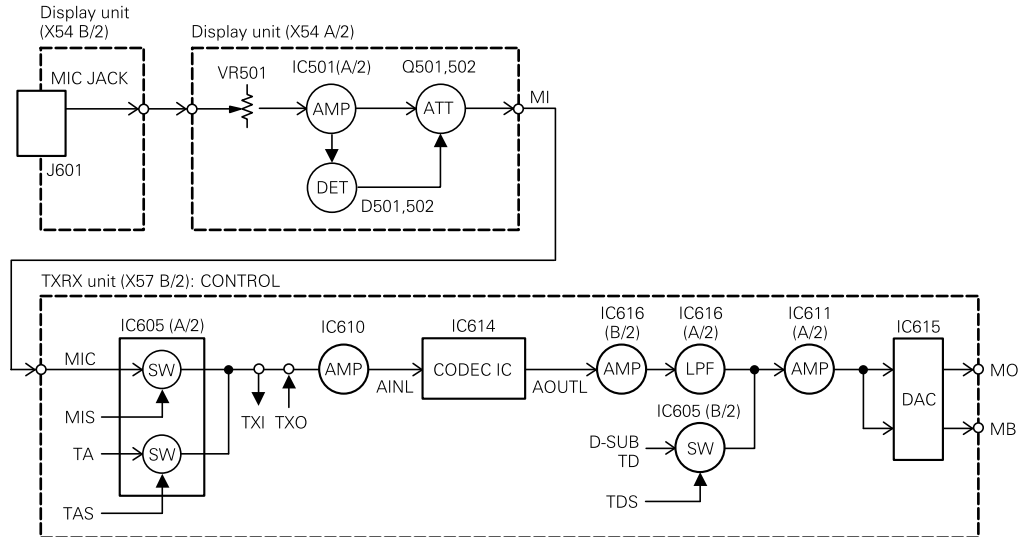


Fig. 2 Microphone circuit / 图2 麦克风电路

3-2. Modulation Level Adjustment Circuit

The output of the summing amplifier IC611 (A/2) is passed to an electronic volume (IC615) for maximum deviation adjustment before being applied to a varactor diode in the voltage controlled oscillator (VCO) A2 located in TX-RX unit (X57-626 A/2).

3-2. 调制电平调节电路

加法放大器IC611(A/2)的输出送入电位器(IC615),以便在送入设置在TX-RX单元(X57-626 A/2)的压控振荡器(VCO)A2的变容二极管之前,获得最大的偏差调节。

3-3. Driver and Final Power Amplifier Circuit

The transmit signal is generated by the TX VCO (A2), amplified by Q11, and sent to final unit (X45-362). This amplified signal is amplified by Q2, Q3, and Q4, and is passed to the FINAL stage. The RF power amplifier consists of MOS FET.

3-3. 驱动器和末级功率放大器电路

TX VCO(A2)产生发射信号,经过Q11放大后,送入末级单元(X45-362)。该放大信号由Q2、Q3和Q4放大,并且送入FINAL(末级)部分。RF功率放大器由MOS FET构成。

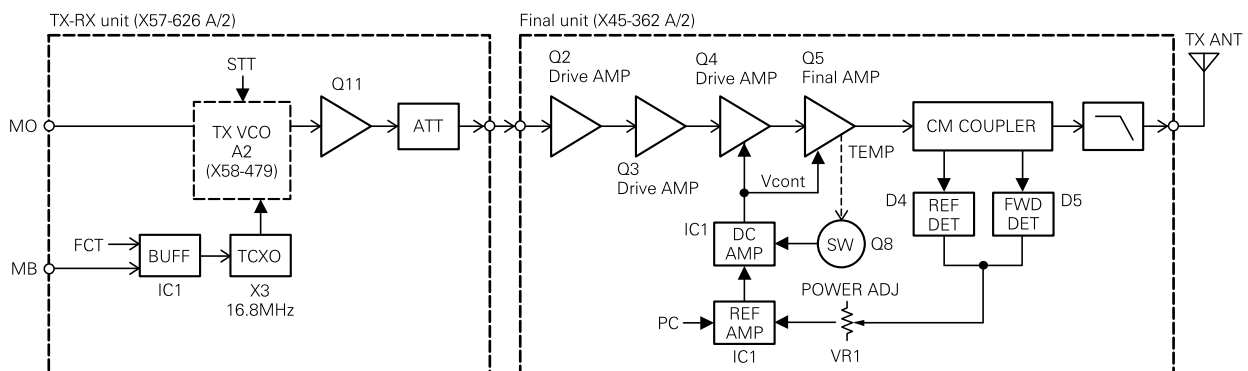


Fig. 3 Drive and final power amplifier circuit / 图3 驱动器和末级功率放大器电路

3-4. Automatic Power Control, Circuit and Transmitter

The automatic power control (APC) circuit stabilizes the transmitter output power at a pre-determined level, and consists of forward/reflected power detector circuits, and switching transistor Q8. The forward/reflected power detector circuit detects forward RF power and reflected RF power to DC voltage, and consists of a CM coupling type detection circuit formed by a strip line, RF detector D4/D5, and DC amplifier IC1 (A/2).

The voltage comparator (IC1 B/2) compares the above detected voltage with a reference voltage, set using the microprocessor and IC6 located in the TX-RX unit. An APC voltage proportional to the difference between the sensed voltage and the reference voltage appears at the output of IC1. This output voltage controls the gate voltage for the drive amplifier Q4 and final amplifier Q5, which keeps the transmitter output power constant.

3-5. Fan Action Control Circuit

If fan action is set to "Temperature", the cooling fan is turned ON or OFF according to temperature.

If the ambient temperature of the final unit exceeds approx. 40°C, the output from pin 6 of the temperature detection IC2 changes from L to H. This signal is sent to the CPU (IC604) by Q602 in the TX-RX unit B/2 (control section), and the output from pin 13 (FAS) of IC7 in the TX-RX unit A/2 controlled by the CPU goes H.

This signal turns Q9 in the final unit ON to run the cooling fan. It has a hysteresis of approx. 5°C by IC2. If fan action is set to "Continuous", the fan operates continuously, but Q9 stays ON.

3-4. 自动功率控制电路和发射机

自动功率控制(APC)电路可以将发射输出功率稳定在预定的电平。该电路由发射/反射功率检波器电路和开关晶体管Q8构成。发射/反射功率检波器对发射的RF功率和反射的RF功率进行检波形成直流电压。该检波器由CM耦合型检波电路构成,包括带状线、RF检波器D4/D5和直流放大器IC1(A/2)。

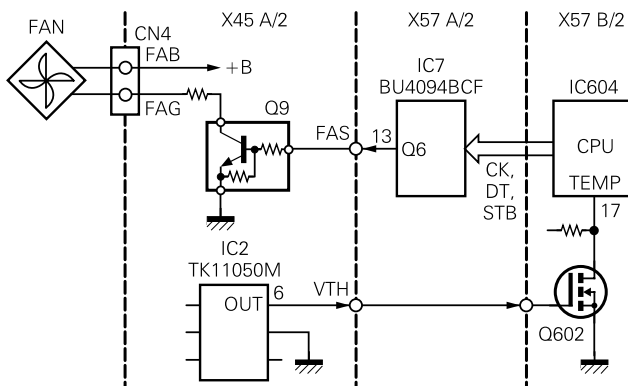
电压比较器(IC1 B/2)将上述检波电压与参考电压进行比较,使用设置在TX/RX单元中的微处理器和IC6进行设定。与检波电压和参考电压成正比的APC电压从IC1输出。该输出电压控制驱动放大器Q4和末级放大器Q5的栅电压,保持发射功率的稳定。

3-5. 风扇动作控制电路

将风扇动作设定为“温度”时,冷却风扇将根据温度接通/切断运行。

末级单元的周围温度达到40°C以上时,温度检测IC2的第6管脚输出由低→高变化。该信号通过TX-RX单元B/2(控制部分)内的Q602向IC604 CPU输入后,通过CPU控制的TX-RX单元A/2内的IC7第18管脚(FAS)的输出成为高状态。

该信号使得末级单元内的Q9接通,冷却风扇运行。另外,IC2具有大约5°C的滞后特性。将风扇动作设定为连续时,风扇“连续”动作,这时Q9始终接通。



[Fan operation/风扇动作]

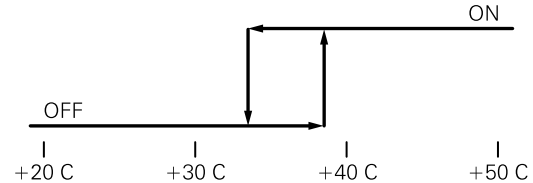


Fig. 4 Fan action control circuit / 图4 风扇动作控制电路

CIRCUIT DESCRIPTION / 电路说明

4. PLL Frequency Synthesizer

The PLL frequency synthesizer circuit consists of the following circuits : 4-1 receiver PLL circuit, 4-2 transmitter PLL circuit, and 4-3 unlocked detector circuit.

4-1. Receiver PLL

The receiver PLL circuit is located in VCO unit A3 (X58-478) on TX-RX unit (X57-626 A/2), and consists of VCXO X2, VCO's (Q350 and Q351), a single-chip PLL IC IC300, buffer amplifier Q355, and high-frequency amplifier Q302.

The VCXO generates 16.8MHz. The frequency stability is within $\pm 2.0\text{ppm}$ (Temperature range of -30 to $+60^\circ\text{C}$). The frequency tuning of the VCXO is done to apply a voltage to pin 1 of the VCXO. The output of the VCXO is applied to pin 8 of the PLL IC through the pin 7 of the VCO.

The first local oscillator is an upper heterodyne local oscillator, and the VCO oscillator frequency is 180.850 to 218.850MHz. Two VCOs cover the two bands : Q350 covers the lower band and Q351 VCO covers the upper band.

The oscillator frequency is controlled by applying the VCO control voltage, obtained from the phase comparator to the varactor diodes.

4. PLL频率合成器

PLL频率合成器电路由以下电路构成：4-1 接收机PLL电路，4-2 发射机PLL电路和4-3 失锁检波器电路。

4-1. 接收机PLL

接收机PLL电路设置在TX-TR单元(X57-626A/2)的VCO单元A3(X58-478)内，由VCXO X2、VCO's(Q350和Q351)、单片PLL IC IC300、缓冲放大器Q355以及高频放大器Q302构成。

VCXO产生16.8MHz频率。该频率的稳定性在 $\pm 2.0\text{ppm}$ 范围(温度范围： -30 至 $+60^\circ\text{C}$)。VCXO的频率调谐由向VCXO的管脚1施加的电压控制。VCXO的输出经过VCO的管脚7送至PLL IC的管脚8。

第一本振是上部外差本机振荡器，VCO振荡器频率为180.850至218.850MHz。两个VCO覆盖了两个波段：Q350覆盖下波段，Q351覆盖上波段。

振荡器的频率由向VCO提供的控制电压控制，该控制电压从相位比较器获得，送至变容二极管。

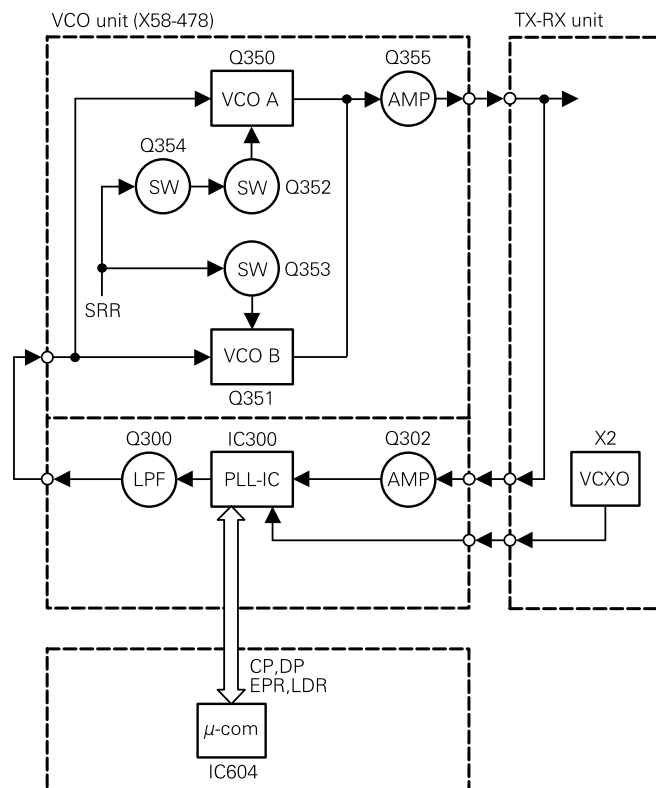


Fig. 5 Receiver PLL / 图5 接收机PLL

CIRCUIT DESCRIPTION / 电路说明

4-2. Transmitter PLL

The transmitter PLL circuit is located in VCO unit A2 (X58-479) on TX-RX unit (X57-626 A/2), and consists of VCXO X3, VCO's (Q350 and Q351), a single-chip PLL IC IC300, buffer amplifier Q355, and high-frequency amplifier Q302.

The VCXO generates 16.8MHz. The frequency stability is within $\pm 2.0\text{ppm}$ (Temperature range of -30 to $+60^\circ\text{C}$). The frequency tuning and modulation of the VCXO are done to apply a voltage to pin 1 of the VCXO. The output of the VCXO is applied to pin 8 of the PLL IC through the pin 15 of the VCO.

The VCO oscillator frequency is 136.00 to 174.00MHz. Two VCOs cover the two bands : Q350 covers the lower band and Q351 VCO covers the upper band.

The oscillator frequency is controlled by applying the VCO control voltage, obtained from the phase comparator to the varactor diodes.

4-3. Unlock Detector Circuit

If a pulse signal appears at the LD pin of IC300, an unlock condition occurs, causing the voltage applied to the pin of the microprocessor to go low. The names of this pin are LDT for TX PLL and LDR for RX PLL. When the microprocessor detects this condition, the transmitter is disabled.

4-2. 发射机PLL

发射机PLL电路设置在TX-TR单元(X57-626A/2)的VCO单元A2(X58-479)内,由VCXO X3、各VCO(Q350和Q351)、单片PLL IC IC300、缓冲放大器Q355以及高频放大器Q302构成。

VCXO产生16.8MHz频率。该频率的稳定性在 $\pm 2.0\text{ppm}$ 范围(温度范围: -30 至 $+60^\circ\text{C}$)。VCXO的频率调谐和调制由向VCXO的管脚1提供的电压控制。VCXO的输出经过VCO的管脚15送至PLL IC的管脚8。

VCO振荡器频率为136.00至174.00MHz。两个VCO覆盖了两个波段:Q350覆盖下波段, Q351 VCO覆盖上波段。

振荡器的频率由向VCO提供的控制电压控制,该控制电压从相位比较器获得,送至变容二极管。

4-3. 失锁检波器电路

如果IC300的LD管脚出现脉冲信号,则发生失锁条件,使得施加在微处理器管脚的电压变成低状态。该管脚的名称对于TX PLL为LDT,对于RX PLL为LDR。当微处理器检测到该条件时,发射机为无法工作状态。

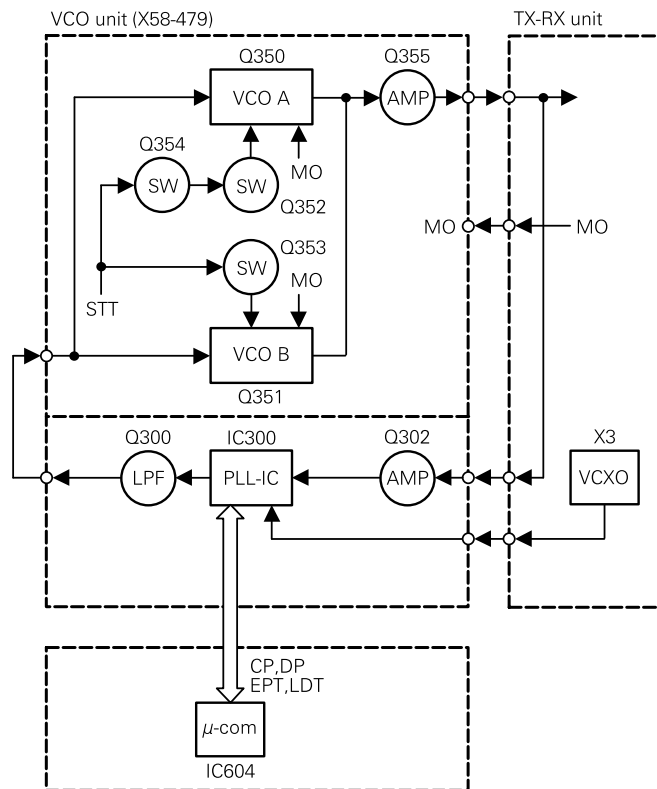


Fig. 6 Receiver PLL / 图6 发射机PLL

CIRCUIT DESCRIPTION / 电路说明

5. Control Circuit

The control circuit mainly located in the control section of TX-RX unit (X57-626 B/2) consists of the following : 5-1 CPU, 5-2 memory circuit, 5-3 CPU clock shift, 5-4 shift register circuit, 5-5 display circuit, 5-6 DSP circuit, 5-7 base-band circuit, 5-8 RS-232C circuit, and 5-9 power supply circuit.

5-1. CPU

The CPU (IC604) is a 16bit single-chip microcomputer containing a 32k ROM and 3k RAM. This CPU controls the flash ROM, the DSP, the receiver circuit, the transmitter circuit, the control circuit, and the display circuit and transfers data to or from an external device.

5-2. Memory Circuit

IC609 has a flash ROM with a capacity of 2M bits that contains the control program for the CPU, the signal processing program for DSP and data such as channels and operating features.

This program can be easily written from an external device. Data such as the operating status are programmed into the EEPROM (IC600).

5-3. CPU Clock Shift

There are the 14.754MHz clock for the CPU (IC604) and the 16.515MHz clock for the DSP (IC618) at the control section of TX-RX unit (X57-626). When these clocks are multiplexed with the reception frequency, they become an internal beat signal. To prevent this, by tuning Q600 and Q604 on the clock frequency is shifted. (Shift on/off can be set through programming.)

5. 控制电路

控制电路主要设置在TX-RX单元(X57-626B/2)的控制部分。由以下部分构成：5-1 CPU、5-2 存储器电路、5-3 CPU 时钟移位、5-4 移位寄存器电路、5-5 显示电路、5-6 DSP 电路、5-7 基带电路、5-8 RS-232C电路和5-9 电源供电电路。

5-1. CPU

CPU (IC604) 是16位单片微计算机，包括32k ROM和3k RAM。本CPU控制FLASHROM、DSP、接收机电路、发射机电路、控制电路以及显示电路和向外部单元传送或者从外部单元接收数据。

5-2. 存储器电路

IC609具备容量达2MB的FLASHROM，包括CPU的控制程序、DSP的信号处理程序和诸如频道和操作特性的数据。

该程序可以从外部装置方便地写入。诸如操作状态等数据编程在EEPROM (IC600)中。

5-3. CPU时钟移位

在TX-RX单元(X57-626)的控制部分，有用于CPU (IC604)的14.754MHz时钟和用于DSP (IC618)的16.515MHz时钟。这些时钟与接收的频率多路传输时，将成为内部节拍信号。为了防止出现这种现象，接通Q600和Q604，使得时钟频率移位。（移位的接通/切断可以通过编程设定）

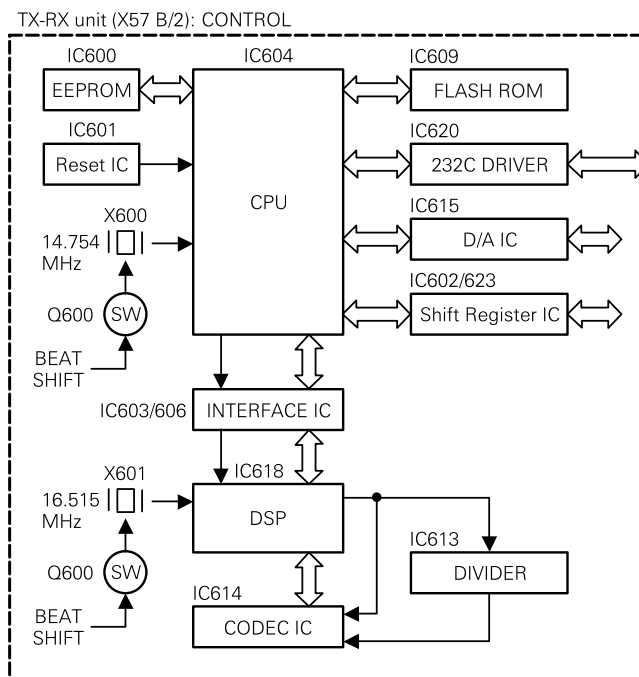


Fig. 7 Control circuit / 图7 控制电路

CIRCUIT DESCRIPTION / 电路说明

5-4. Shift Register Circuit

Serial data is sent to the shift register (IC502 to IC505 located in display unit, IC602, IC623, IC7 located in TX-RX unit) from the CPU (IC604) to control various functions in the unit.

5-5. Display Circuit

The display circuit (X54-333) contains two 7-segment LEDs D506, D507 (orange : see the operation manual for details of display), D503 (red : transmission), D504 (green : busy), two-color LED D505 (red : backup, green : main DC), LEDs in switches S501 to S506, IC502, IC503, IC504, and IC505 to display this model channels and states.

IC502 to IC505 are shift registers which convert serial data from the CPU to parallel data and light LEDs.

Q507, Q510, and Q511 are switching transistors which control two-color LED D505.

IC506, and IC507 are three-pin power supply ICs which produce power used for the display circuit.

5-4. 移位寄存器电路

串行数据从CPU (IC604) 送至本移位寄存器 (设置在显示单元的IC502至IC505和设置在TX-RX单元的IC602、IC603), 控制单元的各种功能。

5-5. 显示电路

显示电路 (X54-333) 包含两个7段LED D506、D507 (橙黄色 : 有关显示的详细内容, 请参照操作手册)、D503 (红色 : 发射)、D504 (绿色 : 占用)、双色LED D505 (红色 : 后备, 绿色 : 主DC) 和在开关S501至S506、IC502、IC503、IC504和IC505, 显示本机的信道和状态。

IC502至IC505为移位寄存器, 将串行数据从CPU转换成为并行数据, 并且点亮各LED。

Q507、Q510和Q511是开关晶体管, 控制双色LED D505。

IC506和IC507, 这是3管脚供电IC, 提供用于显示电路的电源。

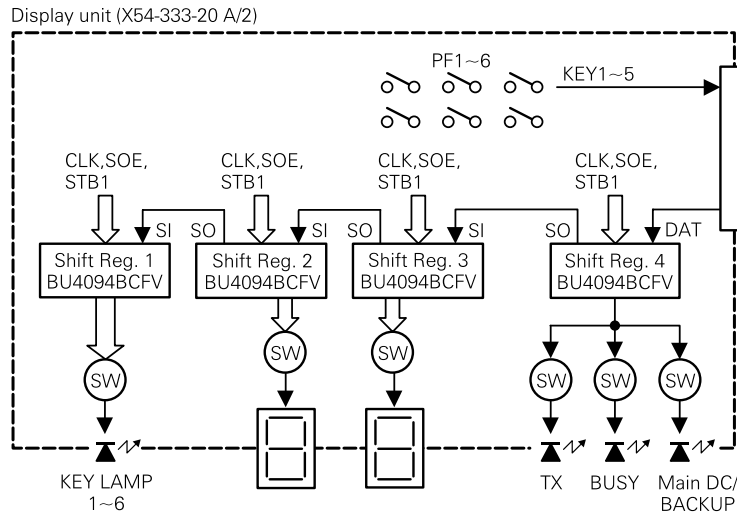


Fig. 8 Display circuit / 图8 显示电路

5-6. DSP

The DSP circuit filters transmit/receive audio signal and encode/decodes signaling (QT, DQT). This circuit consists of IC618, IC612, IC613, IC614, IC603, IC606, IC608, IC610, IC616, and IC619.

The receive signal DET is converted from analog to digital by IC614 with a sampling frequency of 16.128kHz. The digitized audio signal is sent to DSP IC618 to process the signaling signal and audio signal. The processed digital audio signal is fed to CODEC IC614, converted from digital to analog, and the analog signal is output from pin 16 (AOUTR). Then, the audio signal is amplified by IC619 (B/2), passes through the IC619 (A/2) low-pass filter, and goes to an electronic volume IC615.

5-6. DSP电路

DSP电路对发射/接收的音频信号进行滤波, 并且编码/解码信令 (QT、DQT)。本电路由IC618、IC612、IC613、IC614、IC603、IC606、IC608、IC610、IC616和IC619构成。

接收信号DET以16.128kHz的取样频率通过IC614进行模数转换。数码化了的音频信号送至DSP IC618, 对信令信号和音频信号进行处理。处理后的数码信号送至CODEC IC614进行数模转换, 然后模拟信号从管脚16 (AOUTR) 输出。音频信号由IC619 (B/2) 放大, 通过IC619 (A/2) 低通滤波器, 送至电子电位器IC615。

CIRCUIT DESCRIPTION / 电路说明

The transmit audio signal coming from IC605 is amplified by IC610, fed to pin 3 (AINL) of CODEC IC614, and converted from analog to digital at a sampling frequency of 16.128kHz. The digitized transmit audio signal is AGC-processed, pre-emphasized and filtered at 300Hz to 3kHz by DSP IC618, and the resulting signal is fed back to CODEC IC614, and converted from digital to analog, and the analog signal is output from pin 15 (AOUTL). The transmit signal from AOUTL is amplified by IC616 (B/2), passes through the IC616 (A/2) low-pass filter, and goes to the IC611 (A/2) summing amplifier.

IC613 is a counter IC and the clock required for the CODEC and DSP is generated by dividing the 16.515MHz clock signal produced by DSP IC618.

IC603 and IC606 are interface IC between the CPU operated at 5.0V and the DSP operated at 3.3V.

5-7. Base-Band Circuit

The base-band circuit switches between the modulation signal to the transmitter circuit, and remote audio and adjusts their levels. This circuit consists of IC605, IC607, IC611, IC615, and IC617.

Modulation inputs include local microphone input, low-speed data (LSD), high-speed data (HSD), external audio input (TA), and external data input (TD), and demodulation outputs include receive audio output (RA), and receive data output (RD).

The multiplexer (IC605) changes signals, the electronic volume (IC615) adjusts the level, and the operational amplifier (IC607, IC611, IC617) amplifiers and sums signals.

5-8. RS-232C Circuit

The RS-232C circuit connects the RS-232C serial port of a personal computer directly to this model to perform FPU operation. The FPU operation can also be performed by connecting a programming cable (KPG-46) to the local microphone on the front panel. But, if the D-sub connector on the rear panel is used, the programming cable is not required. The 232C driver IC (IC620) changes the TTL-232C level. The firmware can only be rewritten with the local microphone on the front panel.

5-9. Power Supply Circuit

The power supply circuit generates power to operate the CPU, DSP, flash ROM, bi-directional buffer, and base-band circuit. This circuit consists of IC624, IC625, IC626, IC627, IC628, and IC630.

来自IC605的发射音频信号由IC610放大，送至CODEC IC614的管脚3(AINL)，以16.128kHz的取样频率进行模数转换。数码化了的发射音频信号由DSP IC618在300Hz至3kHz进行AGC处理、预加重处理和滤波处理，将获得的信号反馈至CODEC IC614，从数码方式转换为模拟方式，然后模拟信号从管脚15(AOUTL)输出。来自AOUTL的发射信号由IC616(B/2)放大，通过IC616(A/2)低通滤波器，然后送至IC611(A/2)加法放大器。

IC613是计数IC，CODEC和DSP需要的时钟通过对DSP IC618产生的16.515MHz时钟信号进行分频获得。

IC603和IC606是以5.0V运行的CPU和以3.3V运行的DSP之间的接口IC。

5-7. 基带电路

基带电路在调制信号至发射机电路和遥控音频之间切换，并且调节其电平。该电路由IC605、IC607、IC611、IC615和IC617构成。

调制输入包括本机麦克风输入、低速数据(LSD)、高速数据(HSD)、外部音频输入(TA)以及外部数据输入(TD)，调制输出包括接收音频输出(RA)以及接收数据输出(RD)。

多路转接器(IC605)改变信号，电子电位器(IC615)调节电平，运算放大器(IC607、IC611、IC617)放大和总计信号。

5-8. RS-232C电路

RS-232C电路将个人电脑的RS-232C串行端口直接与本机连接，完成FPU运行。FPU运行还可以通过向前面板的本机麦克风连接编程电缆(KPG-46)完成。但是如果使用后面板上的D-sub连接器，则不需要本编程电缆。232C驱动器IC(IC620)调整TTL-232C电平。该固件仅可以使用前面板的本机麦克风重写。

5-9. 电源供电电路

电源供电电路提供CPU、DSP、FLASHROM、双向缓冲器和基带电路的运行电源。该电路由IC624、IC625、IC626、IC627、IC628和IC630构成。

6. DC Power Supply Circuit

6-1. DC Source Switching Relay Circuit

- The final unit contains a relay (K1) for switching between the Main DC and Backup Battery.
If an external power source is connected to the Main DC terminal, the Backup terminal is isolated by the relay. If the Main DC turns OFF due to power failure, it is switched to the Backup terminal by the relay.
The CPU monitors which is used, Main DC or Backup Battery.
- Trickle charge circuit
If both Main DC and Backup Battery are connected, trickle charging of 0.5A max. can be performed from the Main DC power supply to the Battery.
(The default is OFF. See the Modification section for information on the modification method.)
The battery is charged from the Main DC with D8, D9 and R61. If it exceeds 0.5A, the charging circuit is turned OFF by D9.

6-2. SB Switching Relay Circuit

- SB (Switched +B) is supplied through the relay (K1) in the TX-RX unit A/2.
When S507 (DC source switch) in the display unit is turned ON, the relay (K1) is turned ON to output SB.
- If +B exceeds 18V, the relay is forcibly turned OFF by D12 and Q25 to interrupt the power and protect the main unit.

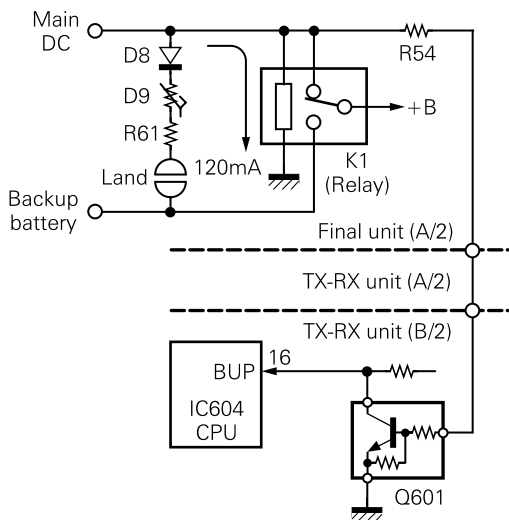


Fig. 9 DC source switching relay circuit
图9 DC电源切换中继电路

6. DC电源供电电路

6-1. DC电源切换中继电路

- 末级单元设有实现主DC与后备电池切换的继电器(K1)。外部电源与主DC端子连接时，继电器切断后备电池端子侧。当发生停电等主DC切断时，继电器切换到后备电池端子侧。
另外，CPU监视使用主DC或者后备电池。
- 涓流充电电路
主DC和后备电池同时连接时，可以从主DC电源向电池进行最大为0.5A的涓流充电。
(初始值为切断。有关变更方法请参照修改部分)
从主DC经过D8、D9、R61向电池充电。电流超过0.5A时，D9切断充电电路。

6-2. SB切换中继电路

- SB(切换的+B)由TX-RX单元A/2的继电器K1提供。接通显示单元的S507(DC电源开关)后，继电器K1接通SB输出。
- +B超过18V时，由D12、Q25强制关闭继电器，切断电源保护本机。

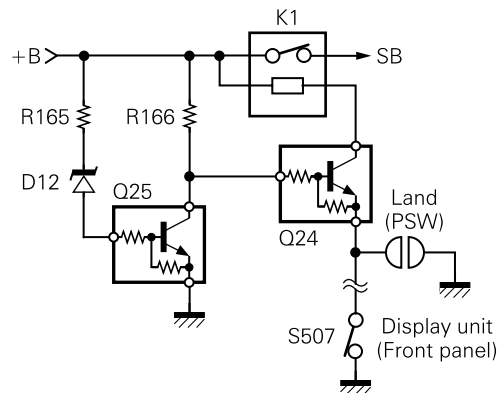


Fig. 10 SB switching relay circuit
图10 SB切换中继电路

SEMICONDUCTOR DATA / 半导体数据

Main CPU : 30622M4-113GP (TX-RX unit IC604) Main CPU : 30622M4-113GP (TX-RX单元IC604)

■ Pin Function

Pin No.	Name	I/O	Function
1~5	IO5~IO1	I/O	Aux I/O No.5~No.1 (Acc D-sub 25 pin)
6	BYTE	-	5V
7	CNV _{ss}	-	GND
8	ENT	O	TX PLL IC enable
9	ENR	O	RX PLL IC enable
10	Reset	I	Microcomputer reset input
11	Xout	-	14.7456MHz
12	V _{ss}	-	GND
13	Xin	-	14.7456MHz
14	V _{cc}	-	5V
15	NMI	-	Not used
16	BUP	I	Backup battery detect H : Backup, L : Main
17	TEMP	I	Temperature detect for fan action H : Temp high, L : Temp low
18	EPTT	I	Acc PTT (Acc D-sub 25 pin) H : Off, L : On
19	CLK	O	Common clock
20	DAT	O	Common data
21	SFT	O	Beat shift H : On, L : Off
22	LD1	O	Control D/A converter LD
23	STB3	O	Control shift register STB
24	LD2	O	TX/RX D/A converter LD
25	STB4	O	TX/RX shift register STB
26	RS	O	DSP reset H : Off, L : On
27	SC	O	Squelch control (Acc D-sub 25 pin) H : Inactive, L : Active
28	PTT	I	Mic PTT H : Off, L : On
29	TXD1	O	Mic TXD
30	RXD1	I	Mic HOOK/RXD
31	SCLK	O	EEPROM clock
32	SDAT	I/O	EEPROM data
33	TXD0	O	Acc TXD (Acc D-sub 25 pin)
34	RXD0	I	Acc RXD (Acc D-sub 25 pin)
35	CP	O	PLL IC clock
36	DP	O	PLL IC data
37	RDY	I	CPU ready input
38	ALE	-	Not used
39	HOLD	-	Not used

■ 端子功能

插脚号码	名称	输入/输出	功能
1~5	IO5~IO1	输入/输出	AUX输入/输出No.5~No.1 (Acc D-sub 25插脚)
6	BYTE	-	5V
7	CNV _{ss}	-	接地
8	ENT	输出	TX PLL集成电路开启
9	ENR	输出	RX PLL集成电路开启
10	Reset	输入	微机复位输入
11	Xout	-	14.7456MHz
12	V _{ss}	-	接地
13	Xin	-	14.7456MHz
14	V _{cc}	-	5V
15	NMI	-	不使用
16	BUP	输入	后备电池检测 H : 后备电源, L : 主电源
17	TEMP	输入	风扇运行温度检测 H : 高温, L : 低温
18	EPTT	输入	Acc PTT (Acc D-sub 25插脚) H : 切断, L : 接通
19	CLK	输出	公共时钟
20	DAT	输出	公共数据
21	SFT	输出	节拍位移 H : 开启, L : 关闭
22	LD1	输出	控制数/模变换器LD
23	STB3	输出	控制移位寄存器STB
24	LD2	输出	TX-RX数/模变换器LD
25	STB4	输出	TX-RX移位寄存器STB
26	RS	输出	DSP复位 H : 关闭, L : 开启
27	SC	输出	静噪控制 (Acc D-sub 25插脚) H : 无效, L : 有效
28	PTT	输入	麦克风PTT H : 关闭, L : 开启
29	TXD1	输出	麦克风TXD
30	RXD1	输入	麦克风HOOK/RXD
31	SCLK	输出	EEPROM时钟
32	SDAT	输入/输出	EEPROM数据
33	TXD0	输出	Acc TXD (Acc D-sub 25插脚)
34	RXD0	输入	Acc RXD (Acc D-sub 25插脚)
35	CP	输出	PLL集成电路时钟
36	DP	输出	PLL集成电路数据
37	RDY	输入	CPU就绪输入
38	ALE	-	不使用
39	HOLD	-	不使用

SEMICONDUCTOR DATA / 半导体数据

Pin No.	Name	I/O	Function
40	HLDA	-	Not used
41	BCLK	O	Not used
42	RD	O	Flash ROM WR/DSP HDS1
43	BHE	-	Not used
44	WR	O	Flash ROM WR/DSP HDS2
45	STB2	O	Control shift register STB
46	INTx	O	DSP interrupt H : Off, L : On
47	HCS	O	DSP HCS
48	CS0	O	Flash ROM CS
49	A19	O	Not used
50~59	A18~A9	O	Flash ROM address bus
60	Vcc	-	5V
61	A8	O	Flash ROM address bus
62	Vss	-	GND
63~70	A7~A0	O	Flash ROM address bus
71	EMON	I	Acc monitor (Acc D-sub 25 pin) H : Off, L : On
72	LDR	I	RX VCO lock detect H : Lock, L : Unlock
73	LDT	I	TX VCO lock detect H : Lock, L : Unlock
74,75	KEY5,KEY4	O	Key matrix output
76~78	KEY3~KEY1	I	Key matrix input
79~86	D7~D0	I/O	Flash ROM data bus
87	FWD	I	RF power down level input
88	RSSI	I	RSSI level input
89	ASQ	I	Squelch level input
90	VLI	I	Volume level input
91	BATT	I	Power supply voltage level input
92	A11	I	Aux input No.1 (Acc D-sub 25 pin)
93	A12	I	Aux input No.2 (Acc D-sub 25 pin)
94	AVss	-	GND
95	A13	I	Aux input No.3 (Acc D-sub 25 pin)
96	Vref	-	5V
97	AVcc	-	5V
98	STB1	O	Display shift register STB
99	SOE	O	Shift register common OE
100	IO6	I/O	Aux I/O No.6 (Acc D-sub 25 pin)

插脚号码	名称	输入/输出	功能
40	HLDA	-	不使用
41	BCLK	输出	不使用
42	RD	输出	FLASHROM WR/DSP HDS1
43	BHE	-	不使用
44	WR	输出	FLASHROM WR/DSP HDS2
45	STB2	输出	控制移位寄存器STB
46	INTx	输出	DSP中断 H : 关闭, L : 开后
47	HCS	输出	DSP HCS
48	CS0	输出	FLASHROM CS
49	A19	输出	不使用
50~59	A18~A9	输出	FLASHROM地址总线
60	Vcc	-	5V
61	A8	输出	FLASHROM地址总线
62	Vss	-	接地
63~70	A7~A0	输出	FLASHROM地址总线
71	EMON	输入	Acc监听器 (Acc D-sub 25插脚) H : 切断, L : 接通
72	LDR	输入	RX VCO锁定检测 H : 锁定
73	LDT	输入	TX VCO锁定检测 H : 锁定
74, 75	KEY5, KEY4	输出	键矩阵输出
76~78	KEY3~KEY1	输入	键矩阵输入
79~86	D7~D0	输入/输出	FLASHROM数据总线
87	FWD	输入	射频功率衰减电平输入
88	RSSI	输入	RSSI电平输入
89	ASQ	输入	静噪电平输入
90	VLI	输入	音量电平输入
91	BATT	输入	电源供电电平输入
92	A11	输入	AUX输入No.1 (Acc D-sub 25插脚)
93	A12	输入	AUX输入No.2 (Acc D-sub 25插脚)
94	Avss	-	接地
95	A13	输入	AUX输入No.3 (Acc D-sub 25插脚)
96	Vref	-	5V
97	AVcc	-	5V
98	STB1	输出	显示移位寄存器STB
99	SOE	输出	移位寄存器共用OE
100	IO6	输入/输出	AUX输入/输出No.6 (Acc D-sub 25插脚)

SEMICONDUCTOR DATA / 半导体数据

DSP : 320VC5402PGE (TX-RX unit IC618) DSP : 320VC5402PG(TX-RX单元IC618)

■ Pin Function

Pin No.	Name	I/O	Function
1,2	NC1,NC2	-	Not used (No connection)
3	Vss	-	GND
4	DVDD	-	VDD for I/O pins (+3.3V)
5	A0	O	Not used (No connection)
6	HD0	I/O	HPI data bus
7~11	A1~A5	O	Not used (No connection)
12	NC3	-	Not used (No connection)
13	HAS	I	HPI address strobe (Pull up)
14	Vss	-	GND
15	NC4	-	Not used (No connection)
16	CVDD	-	VDD for core CPU (+1.8V)
17	HCS	I	HPI chip select
18	HR/W	I	HPI read/write
19	READY	I	Data ready (Pull up)
20	PS	O	Not used (No connection)
21	DS	O	Not used (No connection)
22	IS	O	Not used (No connection)
23	R/W	O	Not used (No connection)
24	MSTRB	O	Not used (No connection)
25	IOSTRB	O	Not used (No connection)
26	MSC	O	Not used (No connection)
27	XF	O	CODEC control H : Power down, L : Active
28	HOLDA	-	Not used (No connection)
29	IAQ	-	Not used (No connection)
30	HOLD	I	Hold (Pull up)
31	BIO	I	Serial data synchronize input
32	MP/MC	I	Not used (Pull down)
33	DVDD	-	VDD for I/O pins (+3.3V)
34	Vss	-	GND
35~38	NC5~NC8	-	Not used (No connection)
39	HCNTL0	I	HPI control 0
40	Vss	-	GND
41	BCLKR0	I	Receive clock input (SCLK : 516.09375kHz)
42	BCLKR1	-	Not used (No connection)
43	BFSR0	I	Frame sync. for receiver input (LRCK : 16.128kHz)

■端子功能

插脚号码	名称	输入/输出	功能
1, 2	NC1, NC2	-	不使用(无连接)
3	Vss	-	接地
4	DVDD	-	输入/输出插脚的VDD(+3.3V)
5	A0	输出	不使用(无连接)
6	HD0	输入/输出	HPI数据总线
7~11	A1~A5	输出	不使用(无连接)
12	NC3	-	不使用(无连接)
13	HAS	输入	HPI地址选通(推上)
14	Vss	-	接地
15	NC4	-	不使用(无连接)
16	CVDD	-	主CPU的VDD(+1.8V)
17	HCS	输入	HPI选片
18	HR/W	输入	HPI读/写
19	READY	输入	数据就绪(推上)
20	PS	输出	不使用(无连接)
21	DS	输出	不使用(无连接)
22	IS	输出	不使用(无连接)
23	R/W	输出	不使用(无连接)
24	MSTRB	输出	不使用(无连接)
25	IOSTRB	输出	不使用(无连接)
26	MSC	输出	不使用(无连接)
27	XF	输出	CODEC控制 H : 功率下降, L : 有效
28	HOLDA	-	不使用(无连接)
29	IAQ	-	不使用(无连接)
30	HOLD	输入	保留(推上)
31	BIO	输入	串行数据同步输入
32	MP/MC	输入	不使用(下拉)
33	DVDD	-	输入/输出插脚的VDD(+3.3V)
34	Vss	-	接地
35~38	NC5~NC8	-	不使用(无连接)
39	HCNTL0	输入	HPI控制0
40	Vss	-	接地
41	BCLKR0	输入	接收时钟输入 (SCLK : 516.09375kHz)
42	BCLKR1	-	不使用(无连接)
43	BFSR0	输入	接收机输入的帧同步 (LRCK : 16.128kHz)

TKR-750

Pin No.	Name	I/O	Function
44	BFSR1	I	Frame sync. for receiver input (LRCK : 16.128kHz)
45	BDR0	I	Serial data receive input
46	HCNTL1	I	HPI control 1
47	BDR1	-	Not used (No connection)
48	BCLKX0	I	Transmit clock input (SCLK : 516.09375kHz)
49	BCLKX1	O	Master clock output (MCLK : 4.12875MHz)
50	Vss	-	GND
51	HINT/TOUT1	O	Boot mode select (Pull up)
52	CVDD	-	VDD for core CPU (+1.8V)
53	BFSX0	I	Frame sync. for transmitter input (LRCK : 16.128kHz)
54	BFSX1	I	Frame sync. for transmitter input (LRCK : 16.128kHz)
55	HRDY	-	Not used (No connection)
56	DVDD	-	VDD for I/O pins (+3.3V)
57	Vss	-	GND
58	HD1	I/O	HPI data bus
59	BDX0	O	Serial data transmit output
60	BDX1	-	Not used (No connection)
61	IACK	-	Not used (No connection)
62	HBIL	I	Byte identification (HPI)
63	NMI	I	Not used (Pull up)
64	INT0	I	Command interrupt from host CPU
65	INT1	I	Not used (Pull up)
66	INT2	I	Boot mode select (Pull up)
67	INT3	I	Not used (Pull up)
68	CVDD	-	VDD for core CPU (+1.8V)
69	HD2	I/O	HPI data bus
70	Vss	-	GND
71~74	NC9~NC12	-	Not used (No connection)
75	DVDD	-	VDD for I/O pins (+3.3V)
76	Vss	-	GND
77	CLKMD1	I	Clock mode select (Pull down)
78	CLKMD2	I	Clock mode select (Pull up)
79	CLKMD3	I	Clock mode select (Pull down)
80	NC13	-	Not used (No connection)
81	HD3	I/O	HPI data bus

插脚号码	名称	输入/输出	功能
44	BFSR1	输入	接收机输入的帧同步 (LRCK : 16.128kHz)
45	BDR0	输入	串行数据接收输入
46	HCNTL1	输入	HPI控制1
47	BDR1	-	不使用(无连接)
48	BCLKX0	输入	发射时钟输入 (SCLK : 516.09375kHz)
49	BCLKX1	输出	主时钟输入 (MCLK : 4.12875MHz)
50	Vss	-	接地
51	HINT/TOUT1		引导模式选择(推上)
52	CVDD	-	主CPU的VDD(+1.8V)
53	BFSX0	输入	发射机输入的帧同步 (LRCK : 16.128kHz)
54	BFSX1	输入	发射机输入的帧同步 (LRCK : 16.128kHz)
55	HRDY	-	不使用(无连接)
56	DVDD	-	输入/输出插脚的VDD(+3.3V)
57	Vss	-	接地
58	HD1	输入/输出	HPI数据总线
59	BDX0	输出	串行数据发射输出
60	BDX1	-	不使用(无连接)
61	IACK	-	不使用(无连接)
62	HBIL	输入	字节识别(HPI)
63	NMI	输入	不使用(推上)
64	INT0	输入	来自主CPU的指令中断
65	INT1	输入	不使用(推上)
66	INT2	输入	引导模式选择(推上)
67	INT3	输入	不使用(推上)
68	CVDD	-	主CPU的VDD(+1.8V)
69	HD2	输入/输出	HPI数据总线
70	Vss	-	接地
71~74	NC9~NC12	-	不使用(无连接)
75	DVDD	-	输入/输出插脚的VDD(+3.3V)
76	Vss	-	接地
77	CLKMD1	输入	时钟模式选择(拉下)
78	CLKMD2	输入	时钟模式选择(推上)
79	CLKMD3	输入	时钟模式选择(拉下)
80	NC13	-	不使用(无连接)
81	HD3	输入/输出	HPI数据总线

SEMICONDUCTOR DATA / 半导体数据

Pin No.	Name	I/O	Function	插脚号码	名称	输入/输出	功能
82	TOUT0	-	Not used (No connection)	82	TOUT0	-	不使用(无连接)
83	EMU0	I/O	Emulator 0 (to JTAG connector)	83	EMU0	输入/输出	仿真器0(至JTAG连接器)
84	EMU1/OFF	I/O	Emulator 1 (to JTAG connector)	84	EMU1/OFF	输入/输出	仿真器1(至JTAG连接器)
85	TDO	O	Test data output (to JTAG connector)	85	TDO	输出	试验数据输出(至JTAG连接器)
86	TDI	I	Test data input (to JTAG connector)	86	TDI	输入	试验数据输入(至JTAG连接器)
87	TRST	I	Test reset (to JTAG connector)	87	TRST	输入	试验复位(至JTAG连接器)
88	TCK	I	Test clock (to JTAG connector)	88	TCK	输入	试验时钟(至JTAG连接器)
89	TMS	I	Test mode select (to JTAG connector)	89	TMS	输入	试验模式选择(至JTAG连接器)
90	NC14	-	Not used (No connection)	90	NC14	-	不使用(无连接)
91	CVDD	-	VDD for core CPU (+1.8V)	91	CVDD	-	主CPU的VDD(+1.8V)
92	HPIENA	I	Not used (Pull up)	92	HPIENA	输入	不使用(推上)
93	Vss	-	GND	93	V _{ss}	-	接地
94	CLKOUT	O	Not used (No connection)	94	CLKOUT	输出	不使用(无连接)
95	HD4	I/O	HPI data bus	95	HD4	输入/输出	HPI数据总线
96	X1	-	16.515MHz (System clock)	96	X1	-	16.515MHz(系统时钟)
97	X2/CLKIN	-	16.515MHz (System clock)	97	X2/CLKIN	-	16.515MHz(系统时钟)
98	RS	I	DSP reset input	98	RS	输入	DSP预设输入
99~104	D0~D5	-	Not used (No connection)	99~104	D0~D5	-	不使用(无连接)
105	A6	O	Not used (No connection)	105	A6	输出	不使用(无连接)
106	Vss	-	GND	106	V _{ss}	-	接地
107~109	A7~A9	O	Not used (No connection)	107~109	A7~A9	输出	不使用(无连接)
110	NC15	-	Not used (No connection)	110	NC15	-	不使用(无连接)
111	Vss	-	GND	111	V _{ss}	-	接地
112	DVDD	-	VDD for I/O pins (+3.3V)	112	DVDD	-	输入/输出插脚的VDD(+3.3V)
113~119	D6~D12	-	Not used (No connection)	113~119	D6~D12	-	不使用(无连接)
120	HD5	I/O	HPI data bus	120	HD5	输入/输出	HPI数据总线
121~123	D13~D15	-	Not used (No connection)	121~123	D13~D15	-	不使用(无连接)
124	HD6	I/O	HPI data bus	124	HD6	输入/输出	HPI数据总线
125	CVDD	-	VDD for core CPU (+1.8V)	125	CVDD	-	主CPU的VDD(+1.8V)
126	NC16	-	Not used (No connection)	126	NC16	-	不使用(无连接)
127	HDS1	I	HPI data strobe 1 (Pull up)	127	HDS1	输入	HPI数据选通1(推上)
128	Vss	-	GND	128	V _{ss}	-	接地
129	HDS2	I	HPI data strobe 2 (Pull down)	129	HDS2	输入	HPI数据选通2(拉下)
130	DVDD	-	VDD for I/O pins (+3.3V)	130	DVDD	-	输入/输出插脚的VDD(+3.3V)
131~134	A10~A13	O	Not used (No connection)	131~134	A10~A13	输出	不使用(无连接)
135	HD7	I/O	HPI data bus	135	HD7	输入/输出	HPI数据总线
136~141	A14~A19	O	Not used (No connection)	136~141	A14~A19	输出	不使用(无连接)
142	CVDD	-	VDD for core CPU (+1.8V)	142	CVDD	-	主CPU的VDD(+1.8V)
143,144	NC17,NC18	-	Not used (No connection)	143,144	CN17, CN18	-	不使用(无连接)

DESCRIPTION OF COMPONENTS / 元件说明

Final Unit (X45-3620-XX)

Ref No.	Part name	Description
IC1	IC	DC amplifier
IC2	IC	Thermostat
IC3	IC	Voltage regulator
Q2,3	Transistor	RF amplifier
Q4	FET	TX drive amplifier
Q5	FET	Final amplifier
Q7	FET	RF switch
Q8,9	Transistor	DC switch
D1	Diode	Thermal sensor
D2	Zener diode	Voltage reference
D3	Diode	Surge absorption
D4,5	Diode	RF detector
D6	Diode	Surge absorption
D7	Zener diode	Surge protector
D8	Diode	Reverse current protection
D9	Varistor	Current protector
D51,52	Diode	Reverse connection protection

末级单元 (X45-3620-XX)

参考号码	部件名称	说明
IC1	集成电路	DC放大器
IC2	集成电路	自动调温器
IC3	集成电路	稳压器
Q2, 3	晶体管	射频放大器
Q4	场效应晶体管	TX驱动放大器
Q5	场效应晶体管	末级放大器
Q7	场效应晶体管	射频开关
Q8, 9	晶体管	DC开关
D1	二极管	热传感器
D2	稳压二极管	参考电压
D3	二极管	浪涌吸收
D4, 5	二极管	射频检波器
D6	二极管	浪涌吸收
D7	稳压二极管	过压保护
D8	二极管	反向电流保护
D9	变阻器	电流保护器
D51, 52	二极管	反向连接保护

Display Unit (X54-3330-20)

Ref No.	Part name	Description
IC501	MOS IC	MIC amplifier
IC502~505	MOS IC	Shift registers
IC506,507	MOS IC	Voltage regulator
Q501,502	Transistor	Level controller
Q504	FET	DC switch
Q506	Transistor	DC switch
Q507	FET	DC switch
Q508	Transistor	DC switch
Q510,511	Transistor	DC switch
Q512~514	FET	DC switch
Q516~519	FET	DC switch
Q521~525	FET	DC switch
D501,502	Diode	AF detector
D503~505	LED	LED
D506,507	LED	7 segment
D508~514	Diode	Surge absorption
D601,602	Diode	Surge absorption
D603	Varistor	Current protector

显示单元 (X54-3330-20)

参考号码	部件名称	说明
IC501	MOS集成电路	麦克风放大器
IC502~505	MOS集成电路	移位寄存器
IC506, 507	MOS集成电路	稳压器
Q501, 502	晶体管	电平控制器
Q504	场效应晶体管	DC开关
Q506	晶体管	DC开关
Q507	场效应晶体管	DC开关
Q508	晶体管	DC开关
Q510, 511	晶体管	DC开关
Q512~514	场效应晶体管	DC开关
Q516~519	场效应晶体管	DC开关
Q521~525	场效应晶体管	DC开关
D501, 502	二极管	音频保护器
D503~505	LED	LED
D506, 507	LED	7段
D508~514	二极管	浪涌吸收
D601, 602	二极管	浪涌吸收
D603	变阻器	电流保护器

DESCRIPTION OF COMPONENTS / 元件说明

TX-RX Unit (X57-6260-XX)

Ref No.	Part name	Description
IC1,2	IC	Buffer amplifier
IC3~5	IC	Voltage regulator
IC6	IC	D/A converter
IC7	IC	Shift register
IC9	IC	FM IF system
IC10,11	IC	Voltage regulator
IC600	IC	EEPROM
IC601	IC	Voltage detector
IC602	IC	Shift register
IC603	IC	Bus transceiver
IC604	MPU	CPU
IC605	IC	Multiplexer
IC606	IC	Bus transceiver
IC607,608	IC	AF amplifier
IC609	IC	Flash ROM
IC610,611	IC	AF amplifier
IC612	IC	Inverter
IC613	IC	Counter
IC614	IC	CODEC
IC615	IC	D/A converter
IC616,617	IC	AF amplifier
IC618	MPU	DSP
IC619	IC	AF amplifier
IC620	IC	RS-232C transceiver
IC621	IC	NAND gate
IC622	IC	Multiplexer
IC623	IC	Shift register
IC624~628	IC	Voltage regulator
IC629	IC	Audio amplifier
IC630	IC	Voltage regulator
Q1~3	Transistor	RF amplifier
Q4	Transistor	Wide/Narrow switch
Q5,6	Transistor	DC switch
Q7	Transistor	Noise amplifier
Q8,9	Transistor	RF amplifier
Q10	Transistor	Current control
Q11	Transistor	RF amplifier
Q12~15	Transistor	Ripple filter
Q16~19	Transistor	DC switch
Q20	Transistor	Inverter
Q23~25	Transistor	DC switch

TX-RX单元(X57-6260-XX)

参考号码	部件名称	说明
IC1, 2	集成电路	缓冲放大器
IC3~5	集成电路	稳压器
IC6	集成电路	数/模变换器
IC7	集成电路	移位寄存器
IC9	集成电路	FM中频系统
IC10, 11	集成电路	稳压器
IC600	集成电路	EEPROM
IC601	集成电路	电压检测
IC602	集成电路	移位寄存器
IC603	集成电路	总线收发器
IC604	MPU	CPU
IC605	集成电路	多路转接器
IC606	集成电路	总线收发器
IC607, 608	集成电路	音频放大器
IC609	集成电路	FLASHROM
IC610, 611	集成电路	音频放大器
IC612	集成电路	逆变器
IC613	集成电路	计数器
IC614	集成电路	编码译码器
IC615	集成电路	数/模变换器
IC616, 617	集成电路	音频放大器
IC618	MPU	DSP
IC619	集成电路	音频放大器
IC620	集成电路	RS-232C收发器
IC621	集成电路	NAND门
IC622	集成电路	多路转接器
IC623	集成电路	移位寄存器
IC624~628	集成电路	稳压器
IC629	集成电路	音频放大器
IC630	集成电路	稳压器
Q1~3	晶体管	射频放大器
Q4	晶体管	宽/窄开关
Q5, 6	晶体管	DC开关
Q7	晶体管	噪音放大器
Q8, 9	晶体管	射频放大器
Q10	晶体管	电流控制
Q11	晶体管	射频放大器
Q12~15	晶体管	纹波滤波器
Q16~19	晶体管	DC开关
Q20	晶体管	逆变器
Q23~25	晶体管	DC开关

DESCRIPTION OF COMPONENTS / 元件说明

Ref No.	Part name	Description
Q600	FET	DC switch
Q601	Transistor	DC switch
Q602	FET	DC switch
Q603	Transistor	Inverter
Q604	FET	DC switch
Q605	Transistor	Inverter
Q606	Transistor	AF mute switch
Q609	Transistor	DC switch
Q610	FET	DC switch
Q611	Transistor	DC switch
D1~4	Diode	Wide/Narrow switch
D5	Diode	Noise detection
D7	Diode	DC switch
D8	Diode	TX switch
D11	Zener diode	Surge protector
D12	Zener diode	Voltage reference
D600	Diode	Surge protector
D601	Diode	Voltage reduction
D606~625	Diode	Surge protector
D626	Varistor	Current protector
D627,628	Diode	Reverse current protector
D629	Diode	Surge protector

参考号码	部件名称	说明
Q600	场效应晶体管	DC开关
Q601	晶体管	DC开关
Q602	场效应晶体管	DC开关
Q603	晶体管	逆变器
Q604	场效应晶体管	DC开关
Q605	晶体管	逆变器
Q606	晶体管	音频消音开关
Q609	晶体管	DC开关
Q610	场效应晶体管	DC开关
Q611	晶体管	DC开关
D1~4	二极管	宽/窄开关
D5	二极管	噪音检测
D7	二极管	DC开关
D8	二极管	TX开关
D11	稳压二极管	过压保护
D12	稳压二极管	参考电压
D600	二极管	过压保护
D601	二极管	电压衰减
D606~625	二极管	过压保护
D626	变阻器	电流保护器
D627, 628	二极管	反向电流保护器
D629	二极管	过压保护

RX PLL/VCO Unit (X58-4780-10)

Ref No.	Part name	Description
IC300	IC	PLL
Q300~302	Transistor	Buffer amplifier
Q350,351	FET	VCO OSC
Q352~354	Transistor	DC switch
Q355	Transistor	Buffer amplifier
D350~353	Varicap	Frequency control

RX PLL/VCO单元(X58-4780-10)

参考号码	部件名称	说明
IC300	集成电路	PLL
Q300~302	晶体管	缓冲放大器
Q350, 351	场效应晶体管	VCO振荡器
Q352~354	晶体管	DC开关
Q355	晶体管	缓冲放大器
D350~353	VARICAP	频率控制

TX PLL/VCO Unit (X58-4790-10)

Ref No.	Part name	Description
IC300	IC	PLL
Q300,301	Transistor	Active filter
Q302	Transistor	Buffer amplifier
Q350,351	FET	VCO OSC
Q352~354	Transistor	DC switch
Q355	Transistor	Buffer amplifier
D350~353	Varicap	Frequency control
D354,355	Varicap	Modulation

TX PLL/VCO单元(X58-4790-10)

参考号码	部件名称	说明
IC300	集成电路	PLL
Q300, 301	晶体管	活性滤波器
Q302	晶体管	缓冲放大器
Q350, 351	场效应晶体管	VCO振荡器
Q352~354	晶体管	DC开关
Q355	晶体管	缓冲放大器
D350~353	VARICAP	频率控制
D354, 355	VARICAP	调制

PARTS LIST / 零件表

* New Parts. Δ indicates safety critical components.

Parts without **Parts No.** are not supplied.

Les articles non mentionnés dans le **Parts No.** ne sont pas fournis.

Teile ohne **Parts No.** werden nicht geliefert.

L : Scandinavia

Y : PX (Far East, Hawaii)

Y : AAFES (Europe)

K : USA

T : England

X : Australia

P : Canada

E : Europe

M : Other Areas

TKR-750

FINAL UNIT (X45-3620-XX)

Ref. No.	Address	New parts	Parts No.	Description	Destination	Ref. No.	Address	New parts	Parts No.	Description	Destination
TKR-750						FINAL UNIT (X45-3620-XX) -10 : C -11 : C2					
1	2B	*	A10-4037-01	CHASSIS ADC12		57	3F	*	H52-1621-02	ITEM CARTON CASE	
2	1B	*	A62-0836-04	PANEL TX-RX		59	1E		J02-0475-05	FOOT ACC	
3	1B	*	A62-0837-04	PANEL FINAL		60	1E	*	J02-0492-04	FOOT ACC	
4	1D	*	A62-0840-03	PANEL OUTER		61	1F	*	J21-8402-04	HARDWARE FIXTURE (ACC)	
5	3A	*	A62-0933-13	PANEL ASSY ABS		62	1E	*	J59-0302-05	GROMMET ACC	
6	3C	*	A62-0934-03	PANEL ASSY		64	1E		K01-0418-05	HANDLE ACC	
8	1F	*	B10-2635-04	FRONT GLASS F-KEY		65	3A		K29-5389-03	KNOB (VOL)	
-		*	B10-2636-04	FRONT GLASS PC SHEET		66	3A	*	K29-5460-02	KEY TOP	
10	1F	*	B11-1259-04	FILTER F-KEY		67	3A	*	K29-9106-04	KNOB (DC SOURCE)	
11	1F	*	B62-1458-10	INSTRUCTION MANUAL		A	2C		N09-2292-05	HEXAGON HEAD SCREW	
12	2C,3D	*	B72-1933-14	MODEL NAME PLATE	C	B	2C		N15-1030-46	FLAT WASHER	
12	2C,3D	*	B72-1934-14	MODEL NAME PLATE	C2	C	1C,2C		N30-2606-46	PAN HEAD MACHINE SCREW	
14	2C	*	E30-3414-05	DC CORD		D	2A,1E		N30-4006-46	PAN HEAD MACHINE SCREW	
15	1C	*	E30-3418-05	ANTENNA CABLE (BNC)		E	2B,2C		N30-4014-46	PAN HEAD MACHINE SCREW	
16	2C	*	E30-3419-05	ANTENNA CABLE (N)		F	1C	*	N30-4020-45	PAN HEAD MACHINE SCREW	
17	1E	*	E30-3427-15	DC CORD ACC		G	2C		N32-3006-46	FLAT HEAD MACHINE SCREW	
18	1E	*	E31-3228-05	LEAD WIRE WITH CONNECTOR (15P)		H	3B		N32-4008-45	FLAT HEAD MACHINE SCREW	
-		*	E37-0808-05	LEAD WIRE WITH CONNECTOR (14P)		J	1B		N33-3006-45	OVAL HEAD MACHINE SCREW	
20	1B	*	E37-0902-05	LEAD WIRE WITH TERMINAL (DC+)		K	1E	*	N35-3006-45	BINDING HEAD MACHINE SCREW	
21	1B	*	E37-0903-05	LEAD WIRE WITH TERMINAL (DC-)		L	2C		N35-3014-46	BINDING HEAD MACHINE SCREW	
22	2C	*	E37-0904-05	LEAD WIRE WITH CONNECTOR (D-SUB)		M	1C		N35-4006-45	BINDING HEAD MACHINE SCREW	
23	3B	*	E37-0905-05	LEAD WIRE WITH CONNECTOR (SP)		N	1B,3B	*	N67-3008-46	PAN HEAD SEMS SCREW W	
24	3A	*	E37-0906-05	LEAD WIRE WITH CONNECTOR (CONT-DISP)		O	1C,2C		N87-2606-46	BRAZIER HEAD TAPTITE SCREW	
25	3A	*	E37-0908-05	LEAD WIRE WITH CONNECTOR (11P)		P	3A	*	N87-3005-45	BRAZIER HEAD TAPTITE SCREW	
26	1B	*	E37-0909-05	LEAD WIRE WITH CONNECTOR (8P)		Q	2A,2B		N87-3006-46	BRAZIER HEAD TAPTITE SCREW	
27	1B	*	E37-0911-05	LEAD WIRE WITH CONNECTOR (3P)		69	3A		T07-0247-05	SPEAKER	
28	1B	*	E37-0912-05	LEAD WIRE WITH MINIPIN PLUG		FINAL UNIT (X45-3620-XX) -10 : C -11 : C2					
29	2C	*	E37-0913-05	LEAD WIRE WITH CONNECTOR (15P)		C1,2			CK73GB1H102K	CHIP C 1000PF	K
30	1B	*	E37-0934-05	LEAD WIRE WITH TERMINAL (ORANGE)		C3			C90-2146-05	ELECTRO 100UF	25WV
-		*	E37-0964-05	LEAD WIRE WITH TERMINAL (BLACK)		C7			CK73GB1H102K	CHIP C 1000PF	K
-		*	E37-0965-05	LEAD WIRE WITH TERMINAL (RED)		C9,10			CK73GB1H102K	CHIP C 1000PF	K
33	2B	*	E37-0967-05	FLAT CABLE (36P)		C11			CC73GCH1H470J	CHIP C 47PF	J
34	2C	*	E70-0402-05	TERMINAL BOARD		C11			CC73GCH1H680J	CHIP C 68PF	J
36	1C,1E	*	F05-1537-05	FUSE (BLADE) (15A/32V)		C12			CK73GB1H102K	CHIP C 1000PF	K
37	2C	*	F09-0445-05	CAP (D-SUB)		C13			CK73FB1E104K	CHIP C 0.10UF	K
38	1C	*	F09-0471-05	FANMOTOR		C14,15			CK73GB1H102K	CHIP C 1000PF	K
-		*	F10-2374-04	SHIELDING PLATE (TX-RX)		C16			CK73FB1H102K	CHIP C 1000PF	K
-		*	F10-2379-04	SHIELDING CASE (TX-RX COM)		C17			CC73GCH1H330J	CHIP C 33PF	J
-		*	F10-2409-04	SHIELDING CASE (TX-RX FOIL)		C19			C93-0601-05	CHIP C 680PF	K
42	1C	*	F20-3322-04	INSULATING SHEET		C21			C93-0565-05	CHIP C 27PF	J
44	1B	*	G02-0576-14	FLAT SPRING		C21			C93-0566-05	CHIP C 33PF	J
46	3B	*	G02-0885-13	EARTH SPRING		C22			C93-0570-05	CHIP C 68PF	J
47	2B,3B	*	G10-1263-04	FIBROUS SHEET (CHASSIS)		C27			CK73FB1H102K	CHIP C 1000PF	K
48	3C,2D	*	G10-1264-04	FIBROUS SHEET (PANEL)		C28			CK73GB1H102K	CHIP C 1000PF	K
49	1F	*	G13-1801-04	CUSHION (ACC)		C29			C93-0603-05	CHIP C 1000PF	K
50	1F	*	G13-1802-04	CUSHION (ACC)		C30,31			C93-0600-05	CHIP C 560PF	K
53	1E	*	H25-0029-04	PROTECTION BAG (60/110/0.07)		C32			C93-0603-05	CHIP C 1000PF	K
54	1F	*	H25-0747-04	PROTECTION BAG (250X350)		C33			CK73FB1C105K	CHIP C 1.0UF	K
55	1E	*	H25-0762-04	PROTECTION BAG (120X300)		C35			CK73GB1H102K	CHIP C 1000PF	K
56	1F	*	H25-2328-04	PROTECTION BAG (80/250/0.07)		C37			CK73FB1E474K	CHIP C 0.47UF	K
-		*	H25-2334-04	PROTECTION BAG		C39			CK73GB1H102K	CHIP C 1000PF	K

PARTS LIST / 零件表

FINAL UNIT (X45-3620-XX)

Ref. No.	Address	New parts	Parts No.	Description	Destination	Ref. No.	Address	New parts	Parts No.	Description	Destination
C42			CK73FB1H103K	CHIP C 0.010UF K		L8			L34-4517-05	AIR-CORE COIL	
C43,44			CK73GB1H102K	CHIP C 1000PF K		L9-11			L34-4520-05	AIR-CORE COIL	
C46			C93-0603-05	CHIP C 1000PF K		L12			L34-4523-05	AIR-CORE COIL	
C47			CM73F2H121J	CHIP C 120PF J	C	L13			L40-3375-34	SMALL FIXED INDUCTOR (33NH)	
C48,49			C93-0563-05	CHIP C 18PF J	C	L15			L40-4785-34	SMALL FIXED INDUCTOR (470NH)	C
C50,51			C93-0565-05	CHIP C 27PF J	C2	L15			L40-8285-34	SMALL FIXED INDUCTOR (820NH)	C2
C54			C93-0601-05	CHIP C 680PF K		L16,17			L40-8275-92	SMALL FIXED INDUCTOR (82NH)	C
C55			CK73GB1H103K	CHIP C 0.010UF K		R1			RK73FB2A100J	CHIP R 10 J 1/10W	
C57			C90-2143-05	ELECTRO 47UF 25WV		R6			RK73GB1J220J	CHIP R 22 J 1/16W	
C59,60			CK73GB1H102K	CHIP C 1000PF K		R7			RK73GB1J472J	CHIP R 4.7K J 1/16W	
C62			CK73FB1H102K	CHIP C 1000PF K		R8			RK73FB2A100J	CHIP R 10 J 1/10W	
C64			CK73GB1H102K	CHIP C 1000PF K		R9			RK73FB2A470J	CHIP R 47 J 1/10W	
C68			CK73GB1H102K	CHIP C 1000PF K		R10			RK73FB2A101J	CHIP R 100 J 1/10W	
C69			C93-0564-05	CHIP C 22PF J		R11			RK73GB1J472J	CHIP R 4.7K J 1/16W	
C71,72			C93-0564-05	CHIP C 22PF J	C	R13			RK73GB1J471J	CHIP R 470 J 1/16W	
C71,72			C93-0565-05	CHIP C 27PF J	C2	R15			R92-1217-05	CHIP R 0 OHM	
C74			C93-0567-05	CHIP C 39PF J		R17			RK73FB2A183J	CHIP R 18K J 1/10W	
C77			C93-0565-05	CHIP C 27PF J		R18			RK73EB2B180J	CHIP R 18 J 1/8W	C2
C80-87			CK73GB1H102K	CHIP C 1000PF K		R18			RK73EB2B330J	CHIP R 33 J 1/8W	C
C90			CK73GB1H102K	CHIP C 1000PF K		R19			RK73FB2A473J	CHIP R 47K J 1/10W	
C91			C92-0777-05	ELECTROLYTIC CAP		R20,21			R92-1252-05	CHIP R 0 OHM	
C92			C93-0601-05	CHIP C 680PF K		R22			R92-1215-05	CHIP R 470 J 1/2W	
C94			CC73GCH1H100D	CHIP C 10PF D		R23			RK73FB2A473J	CHIP R 47K J 1/10W	
C96			CC73FCH1H270J	CHIP C 27PF J		R24			RK73FB2A563J	CHIP R 56K J 1/10W	
C97			CC73FCH1H040C	CHIP C 4.0PF C		R25			RK73GB1J473J	CHIP R 47K J 1/16W	
C98			CK73GB1H102K	CHIP C 1000PF K		R26			RK73GB1J101J	CHIP R 100 J 1/16W	
C99			C90-2143-05	ELECTRO 47UF 25WV		R27			RK73GB1J471J	CHIP R 470 J 1/16W	
C106-109			CK73GB1H102K	CHIP C 1000PF K		R28			RK73GB1J105J	CHIP R 1.0M J 1/16W	
C110			C92-0628-05	CHIP-TAN 10UF 10WV		R29			RK73GB1J471J	CHIP R 470 J 1/16W	
C112			CM73F2H181J	CHIP C 180PF J	C	R30			RK73GB1J222J	CHIP R 2.2K J 1/16W	
C112			CM73F2H271J	CHIP C 270PF J	C2	R31			RK73GB1J471J	CHIP R 470 J 1/16W	
C113			CM73F2H121J	CHIP C 120PF J	C2	R32			RK73GB1J104J	CHIP R 100K J 1/16W	
C116			CM73F2H181J	CHIP C 180PF J	C	R34,35			RK73GB1J393J	CHIP R 39K J 1/16W	
C116			CM73F2H241J	CHIP C 240PF J	C2	R36			R92-1252-05	CHIP R 0 OHM	
C118			CK73FB1E474K	CHIP C 0.47UF K		R37			R92-0670-05	CHIP R 0 OHM	
C136,137			CK73GB1H102K	CHIP C 1000PF K		R38			RK73GB1J103J	CHIP R 10K J 1/16W	
C138			CM73F2H181J	CHIP C 180PF J	C	R40			RK73FB2A101J	CHIP R 100 J 1/10W	C2
C138			CM73F2H221J	CHIP C 220PF J	C2	R40			RK73FB2A121J	CHIP R 120 J 1/10W	C
C139			CM73F2H181J	CHIP C 180PF J	C	R41			R92-1252-05	CHIP R 0 OHM	
C139			CM73F2H241J	CHIP C 240PF J	C2	R43			RK73FB2A101J	CHIP R 100 J 1/10W	
C140			CC73FCH1H100D	CHIP C 10PF D		R45			RK73GB1J102J	CHIP R 1.0K J 1/16W	
C141			C93-0601-05	CHIP C 680PF K		R48			RK73GB1J471J	CHIP R 470 J 1/16W	
C142			CC73FCH1H020C	CHIP C 2.0PF C	C2	R49			R92-1217-05	CHIP R 0 OHM	
C151,152			CM73F2H390J	CHIP C 39PF J	C	R50			RK73EB2B222J	CHIP R 2.2K J 1/8W	
C151,152			CM73F2H680J	CHIP C 68PF J	C2	R52,53			RK73GB1J102J	CHIP R 1.0K J 1/16W	
CN1,2			E04-0154-05	PIN SOCKET		R55			RK73GB1J102J	CHIP R 1.0K J 1/16W	
CN3			E40-5632-05	PIN ASSY		R56			R92-1317-05	CHIP R 18 J 1W	
CN4			E40-3246-05	PIN ASSY		R57			RK73GB1J224J	CHIP R 220K J 1/16W	
CN5			E40-5703-05	PIN ASSY		R58			RK73GB1J104J	CHIP R 100K J 1/16W	
CN6-8			E23-0462-05	TERMINAL		R59			RK73GB1J393J	CHIP R 39K J 1/16W	
F1			F53-0217-05	FUSE		R60			RK73GB1J154J	CHIP R 150K J 1/16W	
CN51,52			J13-0071-05	FUSE HOLDER		R61		*	R92-2687-05	RESISTOR	
L2			L40-4775-34	SMALL FIXED INDUCTOR (47NH)		R62,63			R92-0670-05	CHIP R 0 OHM	
L3			L40-6875-34	SMALL FIXED INDUCTOR (68NH)		R64			RK73GB1J5R6J	CHIP R 5.6 J 1/16W	C2
L4			L34-4519-05	AIR-CORE COIL		R65,66			RK73GB1J821J	CHIP R 820 J 1/16W	C2
L5			L34-4518-05	AIR-CORE COIL		R68			RK73EB2B331J	CHIP R 330 J 1/8W	
L6			L34-4519-05	AIR-CORE COIL		VR1			R12-6427-05	TRIMMING POT. (47K)	
L7			L34-4523-05	AIR-CORE COIL		K1		*	S76-0426-05	RELAY	

PARTS LIST / 零件表

FINAL UNIT (X45-3620-XX)
 DISPLAY UNIT (X54-3330-20)
 TX-RX UNIT (X57-6260-XX)

Ref. No.	Address	New parts	Parts No.	Description	Desti-nation	Ref. No.	Address	New parts	Parts No.	Description	Desti-nation
D1			1SS226	DIODE		R511,512			RK73GB1J103J	CHIP R 10K J 1/16W	
D2			02DZ5.1(Y)	ZENER DIODE		R513			RK73GB1J104J	CHIP R 100K J 1/16W	
D3			1SS355	DIODE		R514			RK73GB1J154J	CHIP R 150K J 1/16W	
D4,5			HSM88AS	DIODE		R516			R92-2565-05	RESISTOR	
D6			1SS355	DIODE		R517			R92-2023-05	CHIP R 820 J 1/2W	
D7			ZSA5A27	ZENER DIODE		R519			R92-2565-05	RESISTOR	
D8			RB051L-40	DIODE		R520-526			R92-2023-05	CHIP R 820 J 1/2W	
D9			MINISMDC050-02	VARISTOR		R529-540			RK73GB1J102J	CHIP R 1.0K J 1/16W	
D51,52			DSA3A1	DIODE		R541-544			RK73GB1J103J	CHIP R 10K J 1/16W	
IC1		*	TA75W01FU	MOS IC		R601			RK73GB1J681J	CHIP R 680 J 1/16W	
IC2		*	TK11050M	ANALOG IC		R604,605			RK73GB1J102J	CHIP R 1.0K J 1/16W	
IC3			NJM78L05UA	BI-POLAR IC		R606			RK73GB1J473J	CHIP R 47K J 1/16W	
Q2			2SC3356(R24)	TRANSISTOR		VR501			R32-0643-05	SEMI FIXED VARIABLE RESISTOR	
Q3			2SC3357	TRANSISTOR		VR601			R31-0630-05	VARIABLE RESISTOR	
Q4			2SK3075	FET		S501-506			S70-0410-15	TACT SWITCH	
Q5		*	3SK3478-22	FET		S507			S68-0410-05	PUSH SWITCH	
Q7			2SK1824	FET		D501,502			HSM88AS	DIODE	
Q8			2SC4116(Y)	TRANSISTOR		D506,507		*	LA-501DD	LED	
Q9			DTD123EK	DIGITAL TRANSISTOR		D508-514			DA204U	DIODE	
DISPLAY UNIT (X54-3330-20)						D601,602			DA204U	DIODE	
D503-505			B30-2151-05	LED (RED/GRN)		D603		*	MINISM0020	VARISTOR	
C501			C92-0628-05	CHIP-TAN 10UF 10WV		IC501			NJM4558E	MOS IC	
C502,503			C92-0501-05	CHIP-TAN 1.5UF 10WV		IC502-505			BU4094BCFV	MOS IC	
C504,505			CK73GB1C104K	CHIP C 0.10UF K		IC506,507			TA78L05F	MOS IC	
C506			CC73GCH1H470J	CHIP C 47PF J		Q501			2SC4116(Y)	TRANSISTOR	
C507,508			CK73GB1C104K	CHIP C 0.10UF K		Q502			2SA1586(Y,GR)	TRANSISTOR	
C509			CK73GB1H103K	CHIP C 0.010UF K		Q504			UPA672T	FET	
C510			C92-0628-05	CHIP-TAN 10UF 10WV		Q506			DTA114EUA	DIGITAL TRANSISTOR	
C511,512			CK73GB1E103K	CHIP C 0.010UF K		Q507			UPA672T	FET	
C513-518			CC73GCH1H101J	CHIP C 100PF J		Q508			DTA114EUA	DIGITAL TRANSISTOR	
C519,520			CK73GB1E103K	CHIP C 0.010UF K		Q510,511			DTA114EUA	DIGITAL TRANSISTOR	
C521			C92-0628-05	CHIP-TAN 10UF 10WV		Q512-514			UPA672T	FET	
C522			CK73GB1C104K	CHIP C 0.10UF K		Q516-519			UPA672T	FET	
C523		*	CK73FB1E334K	CHIP C 0.33UF K		Q521-524			UPA672T	FET	
C524			C92-0628-05	CHIP-TAN 10UF 10WV		Q525			2SK1824	FET	
C525			CK73GB1C104K	CHIP C 0.10UF K		TX-RX UNIT (X57-6260-XX) -10 : C -11 : C2					
C526		*	CK73FB1E334K	CHIP C 0.33UF K		C1			CC73GCH1H060D	CHIP C 6.0PF D	
C601			CC73GCH1H101J	CHIP C 100PF J		C2			CC73GCH1H390J	CHIP C 39PF J	
C602			CK73GB1H102K	CHIP C 1000PF K		C3			CC73GCH1H020C	CHIP C 2.0PF C	
C603			CC73GCH1H101J	CHIP C 100PF J		C4			CC73GCH1H0R5C	CHIP C 0.5PF C	
C606			CC73GCH1H101J	CHIP C 100PF J		C5			CC73GCH1H060D	CHIP C 6.0PF D	C
C607			CK73GB1C104K	CHIP C 0.10UF K		C5			CC73GCH1H080D	CHIP C 8.0PF D	C2
CN501		*	E40-6140-05	PIN ASSY		C6			CC73GCH1H390J	CHIP C 39PF J	
CN502		*	E40-6102-05	PIN ASSY		C7			CK73GB1H103K	CHIP C 0.010UF K	
CN601		*	E40-6141-05	PIN ASSY		C8,9			CK73GB1H102K	CHIP C 1000PF K	
J601			E08-0877-05	MODULAR JACK		C10			CC73GCH1H101J	CHIP C 100PF J	
-			J31-0543-05	COLLAR (LH-5-1.5)		C11			CC73GCH1H060D	CHIP C 6.0PF D	C
CP501-504			RK75GB1J471J	CHIP-COM 470 J 1/16W		C11			CC73GCH1H080D	CHIP C 8.0PF D	C2
R502,503			R92-1252-05	CHIP R 0 OHM		C12			CC73GCH1H390J	CHIP C 39PF J	
R505			RK73GB1J683J	CHIP R 68K J 1/16W		C13			CC73GCH1H020C	CHIP C 2.0PF C	
R506			RK73GB1J103J	CHIP R 10K J 1/16W		C14			CC73GCH1H0R5C	CHIP C 0.5PF C	
R507			RK73GB1J682J	CHIP R 6.8K J 1/16W		C15			CC73GCH1H050C	CHIP C 5.0PF C	
R508			RK73GB1J102J	CHIP R 1.0K J 1/16W		C16			CC73GCH1H020C	CHIP C 2.0PF C	
R509			RK73GB1J103J	CHIP R 10K J 1/16W		C17			CC73GCH1H010C	CHIP C 1.0PF C	
R510			RK73GB1J224J	CHIP R 220K J 1/16W		C18			CC73GCH1H060D	CHIP C 6.0PF D	C
						C18			CC73GCH1H090D	CHIP C 9.0PF D	C2

PARTS LIST / 零件表

TX-RX UNIT (X57-6260-XX)

Ref. No.	Address	New parts	Parts No.	Description	Destination	Ref. No.	Address	New parts	Parts No.	Description	Destination
C19			CC73GCH1H180J	CHIP C 18PF J	C	C109			CC73GCH1H270J	CHIP C 27PF J	
C19			CC73GCH1H220J	CHIP C 22PF J	C2	C110			CC73GCH1H030C	CHIP C 3.0PF C	
C20			CC73GCH1H101J	CHIP C 100PF J		C111			CC73GCH1H270J	CHIP C 27PF J	
C22			CC73GCH1H100D	CHIP C 10PF D		C113			CC73GCH1H150J	CHIP C 15PF J	
C23			CC73GCH1H180J	CHIP C 18PF J		C120,121			CK73GB1H102K	CHIP C 1000PF K	
C24			C92-0519-05	CHIP-TAN 1.0UF 25WV		C122,123			CK73GB1H103K	CHIP C 0.010UF K	
C25			C92-0628-05	CHIP-TAN 10UF 10WV		C124,125			C92-1341-05	ELECTRO 100UF 16WV	
C30			CC73GCH1H680J	CHIP C 68PF J		C126,127			C92-0633-05	CHIP-TAN 22UF 10WV	
C31			CC73GCH1H331J	CHIP C 330PF J		C128,129			CK73GB1H103K	CHIP C 0.010UF K	
C32			CK73GB1H103K	CHIP C 0.010UF K		C130-133			CK73GB1H102K	CHIP C 1000PF K	
C33			CC73GCH1H330J	CHIP C 33PF J		C134,135			CK73GB1H103K	CHIP C 0.010UF K	
C34			CK73GB1H103K	CHIP C 0.010UF K		C136-139			C90-4016-05	ELECTROLYTIC CAP	
C36			CK73GB1H102K	CHIP C 1000PF K		C140,141			CK73GB1H103K	CHIP C 0.010UF K	
C37			CK73GB1H103K	CHIP C 0.010UF K		C142-144			CK73GB1H102K	CHIP C 1000PF K	
C38,39			CC73GCH1H680J	CHIP C 68PF J		C145			C92-0606-05	CHIP-TAN 4.7UF 10WV	
C40,41			CK73GB1H103K	CHIP C 0.010UF K		C146			CK73GB1H102K	CHIP C 1000PF K	
C42,43			CC73GCH1H030C	CHIP C 3.0PF C		C147			C92-0633-05	CHIP-TAN 22UF 10WV	
C44,45			CC73GCH1H040C	CHIP C 4.0PF C		C148			CK73GB1H102K	CHIP C 1000PF K	
C46,47			CC73GCH1H030C	CHIP C 3.0PF C		C149			CK73GB1H103K	CHIP C 0.010UF K	
C48			CK73GB1H103K	CHIP C 0.010UF K		C150			C92-0633-05	CHIP-TAN 22UF 10WV	
C49,50			CC73GCH1H680J	CHIP C 68PF J		C151			C92-0008-05	CHIP-TAN 3.3UF 16WV	
C51			CK73GB1H103K	CHIP C 0.010UF K		C152			CK73GB1H103K	CHIP C 0.010UF K	
C52			CK73GB1H103J	CHIP C 0.010UF J		C153			CK73GB1H102K	CHIP C 1000PF K	
C53			CK73GB1H102K	CHIP C 1000PF K		C154			C92-0560-05	CHIP-TAN 10UF 6.3WV	
C54			CK73GB1H103J	CHIP C 0.010UF J		C155			CK73GB1H103K	CHIP C 0.010UF K	
C55,56			CK73GB1H103K	CHIP C 0.010UF K		C156			CK73GB1H102K	CHIP C 1000PF K	
C57			CK73GB1H103J	CHIP C 0.010UF J		C157			CK73GB1H103K	CHIP C 0.010UF K	
C58			CC73GCH1H180J	CHIP C 18PF J		C158			C92-0008-05	CHIP-TAN 3.3UF 16WV	
C59			CC73GCH1H150J	CHIP C 15PF J		C159,160			CK73GB1H102K	CHIP C 1000PF K	
C60			CK73GB1H103J	CHIP C 0.010UF J		C161-163			CK73GB1H103K	CHIP C 0.010UF K	
C61			CC73GCH1H080D	CHIP C 8.0PF D		C164			CC73GCH1H471J	CHIP C 470PF J	
C62,63			CK73GB1H103K	CHIP C 0.010UF K		C166,167			CK73GB1H102K	CHIP C 1000PF K	
C64			CK73GB1C104K	CHIP C 0.10UF K		C171,172			CK73GB1H102K	CHIP C 1000PF K	
C65			C92-0628-05	CHIP-TAN 10UF 10WV		C173			CK73GB1H103K	CHIP C 0.010UF K	
C66,67			CC73GCH1H221J	CHIP C 220PF J		C174			C92-0008-05	CHIP-TAN 3.3UF 16WV	
C68-70			CK73GB1C104K	CHIP C 0.10UF K		C175			CK73GB1H102K	CHIP C 1000PF K	
C71			CK73GB1H103K	CHIP C 0.010UF K		C176			CK73GB1H103K	CHIP C 0.010UF K	
C72			C92-0628-05	CHIP-TAN 10UF 10WV		C177			CK73GB1H102K	CHIP C 1000PF K	
C73,74			CK73GB1H102K	CHIP C 1000PF K		C178			C92-0606-05	CHIP-TAN 4.7UF 10WV	
C75			CK73GB1C223K	CHIP C 0.022UF K		C179			CK73GB1H103K	CHIP C 0.010UF K	
C76			C92-0628-05	CHIP-TAN 10UF 10WV		C184,185			CK73GB1H102K	CHIP C 1000PF K	
C77			CK73GB1H102K	CHIP C 1000PF K		C189,190			CK73GB1H102K	CHIP C 1000PF K	
C78			CK73GB1C223K	CHIP C 0.022UF K		C191-195			CK73GB1H103K	CHIP C 0.010UF K	
C79			CK73FB1C334K	CHIP C 0.33UF K		C196			CK73GB1H472K	CHIP C 4700PF K	
C80,81			C92-0628-05	CHIP-TAN 10UF 10WV		C197			CK73FB1H333K	CHIP C 0.033UF K	
C82-84			CK73GB1H103K	CHIP C 0.010UF K		C198			CK73GB1C104K	CHIP C 0.10UF K	
C85			C92-0628-05	CHIP-TAN 10UF 10WV		C199			CK73GB1H103K	CHIP C 0.010UF K	
C86			CK73GB1H102K	CHIP C 1000PF K		C204-208			CC73GCH1H101J	CHIP C 100PF J	
C87			C92-0628-05	CHIP-TAN 10UF 10WV		C209-211			CK73GB1H103K	CHIP C 0.010UF K	
C88			CK73GB1H102K	CHIP C 1000PF K		C212-214			CC73GCH1H050C	CHIP C 5.0PF C	C
C89,90			CK73GB1H103J	CHIP C 0.010UF J		C212,213			CC73GCH1H060D	CHIP C 6.0PF D	C2
C91			CC73GCH1H100D	CHIP C 10PF D		C214			CC73GCH1H050C	CHIP C 5.0PF C	C2
C92,93			CK73GB1H102K	CHIP C 1000PF K		C600			CK73GB1C104K	CHIP C 0.10UF K	
C95			CC73GCH1H150J	CHIP C 15PF J		C602			CK73GB1C104K	CHIP C 0.10UF K	
C96-99			CK73GB1H102K	CHIP C 1000PF K		C605			CK73GB1C104K	CHIP C 0.10UF K	
C100			CC73GCH1H270J	CHIP C 27PF J		C613,614			CK73GB1E103K	CHIP C 0.010UF K	
C102-105			CC73GCH1H100D	CHIP C 10PF D		C616			CK73GB1E103K	CHIP C 0.010UF K	
C106			CK73GB1H102K	CHIP C 1000PF K		C623			CK73GB1C104K	CHIP C 0.10UF K	
C107			CC73GCH1H150J	CHIP C 15PF J		C629			CC73GCH1H101J	CHIP C 100PF J	
C108			CC73GCH1H030C	CHIP C 3.0PF C		C634,635			CC73GCH1H220J	CHIP C 22PF J	

PARTS LIST / 零件表

TX-RX UNIT (X57-6260-XX)

Ref. No.	Address	New parts	Parts No.	Description	Destination	Ref. No.	Address	New parts	Parts No.	Description	Destination
C638			CK73GB1C104K	CHIP C 0.10UF K		C752			CK73GB1H471K	CHIP C 470PF K	
C639			CK73GB1E103K	CHIP C 0.010UF K		C753,754			C92-0628-05	CHIP-TAN 10UF 10WV	
C640			C92-0628-05	CHIP-TAN 10UF 10WV		C755			CK73GB1H471K	CHIP C 470PF K	
C641			CK73GB1C104K	CHIP C 0.10UF K		C756,757			C92-0628-05	CHIP-TAN 10UF 10WV	
C642			CK73GB1E103K	CHIP C 0.010UF K		C758			CK73FB1C105K	CHIP C 1.0UF K	
C643			C92-0628-05	CHIP-TAN 10UF 10WV		C759			CK73GB1H471K	CHIP C 470PF K	
C644			CK73GB1E103K	CHIP C 0.010UF K		C760			CK73GB1H102K	CHIP C 1000PF K	
C645,646			C92-0628-05	CHIP-TAN 10UF 10WV		C761			CK73GB1C104K	CHIP C 0.10UF K	
C647			CC73GCH1H101J	CHIP C 100PF J		C762,763			CK73GB1H102K	CHIP C 1000PF K	
C648			CK73GB1E103K	CHIP C 0.010UF K		C764,765			CK73GB1E103K	CHIP C 0.010UF K	
C649			CC73GCH1H330J	CHIP C 33PF J		C766-768			CC73GCH1H101J	CHIP C 100PF J	
C652			CC73GCH1H101J	CHIP C 100PF J		C769-771			C92-0560-05	CHIP-TAN 10UF 6.3WV	
C657			CK73GB1E103K	CHIP C 0.010UF K		C772			C92-0633-05	CHIP-TAN 22UF 10WV	
C662			C92-0628-05	CHIP-TAN 10UF 10WV		C773			C92-0514-05	CHIP-TAN 2.2UF 10WV	
C663			C92-0519-05	CHIP-TAN 1.0UF 25WV		C774			CK73FB1C105K	CHIP C 1.0UF K	
C670			C92-0003-05	CHIP-TAN 0.47UF 25WV		C775-779			C92-0519-05	CHIP-TAN 1.0UF 25WV	
C679,680			C92-0628-05	CHIP-TAN 10UF 10WV		C780-782			CK73FB1C105K	CHIP C 1.0UF K	
C681			C92-0546-05	CHIP-TAN 68UF 6.3WV		C783			CK73GB1H471K	CHIP C 470PF K	
C684			CC73GCH1H101J	CHIP C 100PF J		C784			CK73FB1C105K	CHIP C 1.0UF K	
C685			CK73GB1E103K	CHIP C 0.010UF K		C785,786			CK73GB1C104K	CHIP C 0.10UF K	
C690			CC73GCH1H101J	CHIP C 100PF J		C787			CK73FB1C105K	CHIP C 1.0UF K	
C691,692			CK73GB1E103K	CHIP C 0.010UF K		C788			CC73GCH1H101J	CHIP C 100PF J	
C693,694			C92-0628-05	CHIP-TAN 10UF 10WV		C789			CE04EW1E331M	ELECTRO 330UF 25WV	
C695,696			CK73GB1H471K	CHIP C 470PF K		C790			CC73GCH1H101J	CHIP C 100PF J	
C697-702			C92-0628-05	CHIP-TAN 10UF 10WV		C791			CK73GB1H471K	CHIP C 470PF K	
C703,704			CK73GB1C104K	CHIP C 0.10UF K		C792-794			CK73GB1H102K	CHIP C 1000PF K	
C705			CK73GB1E103K	CHIP C 0.010UF K		C795			CC73GCH1H101J	CHIP C 100PF J	
C706			C92-0628-05	CHIP-TAN 10UF 10WV		C796,797			CK73GB1H102K	CHIP C 1000PF K	
C707-709			CK73GB1E103K	CHIP C 0.010UF K		C798			CE04EW1E470M	ELECTRO 47UF 25WV	
C710			C92-0628-05	CHIP-TAN 10UF 10WV		C799			CK73GB1H102K	CHIP C 1000PF K	
C711			CK73GB1H471K	CHIP C 470PF K		C800			CE04EW1E470M	ELECTRO 47UF 25WV	
C712			CK73GB1E103K	CHIP C 0.010UF K		C801			C92-0560-05	CHIP-TAN 10UF 6.3WV	
C713,714			C92-0628-05	CHIP-TAN 10UF 10WV		C802-805			CK73GB1H102K	CHIP C 1000PF K	
C715			CK73GB1E103K	CHIP C 0.010UF K		C806			CE04EW1E470M	ELECTRO 47UF 25WV	
C716,717			CK73GB1H471K	CHIP C 470PF K		C807-810			CK73GB1H102K	CHIP C 1000PF K	
C718,719			CK73GB1E103K	CHIP C 0.010UF K		C811			CE04EW1E470M	ELECTRO 47UF 25WV	
C720-722			C92-0628-05	CHIP-TAN 10UF 10WV		C812,813			CK73GB1H102K	CHIP C 1000PF K	
C723			CK73FB1C105K	CHIP C 1.0UF K		C814			C92-0777-05	ELECTROLYTIC CAP	
C724			CK73GB1H182K	CHIP C 1800PF K		C815			CK73FB1E104K	CHIP C 0.10UF K	
C725			CC73GCH1H470J	CHIP C 47PF J		C816			CK73GB1H102K	CHIP C 1000PF K	
C726			CC73GCH1H181J	CHIP C 180PF J		C817			CE04EW1E470M	ELECTRO 47UF 25WV	
C727,728			CK73GB1E103K	CHIP C 0.010UF K		C818-820			CK73GB1H102K	CHIP C 1000PF K	
C729			C92-0628-05	CHIP-TAN 10UF 10WV		C821,822			CC73GCH1H101J	CHIP C 100PF J	
C730,731			CK73GB1E103K	CHIP C 0.010UF K		C823			C92-0619-05	CHIP-TAN 47UF 4WV	
C732			CK73GB1H471K	CHIP C 470PF K		C824			CK73GB1H472K	CHIP C 4700PF K	
C733			C92-0628-05	CHIP-TAN 10UF 10WV		C825			CK73GB1C104K	CHIP C 0.10UF K	
C734			CC73GCH1H270J	CHIP C 27PF J		C826			C92-0560-05	CHIP-TAN 10UF 6.3WV	
C735			CC73GCH1H150J	CHIP C 15PF J		C827			C92-0633-05	CHIP-TAN 22UF 10WV	
C736			CK73GB1H182K	CHIP C 1800PF K		C828			C92-0514-05	CHIP-TAN 2.2UF 10WV	
C737			CC73GCH1H270J	CHIP C 27PF J		CN1			E04-0154-05	PIN SOCKET	
C738			CK73GB1E103K	CHIP C 0.010UF K		CN2			E40-5538-05	PIN ASSY	
C739			CC73GCH1H181J	CHIP C 180PF J		CN3			E04-0154-05	PIN SOCKET	
C740			CC73GCH1H101J	CHIP C 100PF J		CN4			E40-5538-05	PIN ASSY	
C741			CK73GB1E103K	CHIP C 0.010UF K		CN14			E40-6009-05	FLAT CABLE CONNECTOR	
C742			CK73GB1H471K	CHIP C 470PF K		CN15			E40-5703-05	PIN ASSY	
C743			CK73GB1E103K	CHIP C 0.010UF K		CN16			E40-5632-05	PIN ASSY	
C744-746			C92-0628-05	CHIP-TAN 10UF 10WV		CN18,19			E04-0154-05	PIN SOCKET	
C747,748			CK73GB1E103K	CHIP C 0.010UF K		CN600		*	E40-6102-05	PIN ASSY	
C749			CK73GB1H471K	CHIP C 470PF K		CN601			E40-5701-05	PIN ASSY	
C750,751			CK73GB1E103K	CHIP C 0.010UF K							

PARTS LIST / 零件表

TX-RX UNIT (X57-6260-XX)

Ref. No.	Address	New parts	Parts No.	Description	Destination	Ref. No.	Address	New parts	Parts No.	Description	Destination
CN602			E40-6009-05	FLAT CABLE CONNECTOR		R5			RK73GB1J680J	CHIP R 68 J 1/16W	
CN603			E40-5887-05	PIN ASSY		R6			RK73GB1J102J	CHIP R 1.0K J 1/16W	
CN604			E40-5702-05	PIN ASSY		R7			RK73GB1J103J	CHIP R 10K J 1/16W	
CN605			E40-5704-05	PIN ASSY		R8			RK73GB1J333J	CHIP R 33K J 1/16W	
CN606			E40-5960-05	PIN ASSY		R9			RK73GB1J101J	CHIP R 100 J 1/16W	
A4-8			F11-0844-05	SHIELDING CASE		R10			RK73GB1J473J	CHIP R 47K J 1/16W	
F1			F53-0217-05	FUSE		R11			RK73GB1J223J	CHIP R 22K J 1/16W	
CF1			L72-0366-05	CERAMIC FILTER		R13			RK73GB1J470J	CHIP R 47 J 1/16W	
CF2			L72-0376-05	CERAMIC FILTER		R14,15			RK73GB1J271J	CHIP R 270 J 1/16W	
L1			L34-4616-05	AIR-CORE COIL		R16			RK73GB1J180J	CHIP R 18 J 1/16W	
L2,3		*	L34-4666-05	COIL		R17			R92-0670-05	CHIP R 0 OHM	
L4			L40-1295-34	SMALL FIXED INDUCTOR (1.2UH)		R18			RK73GB1J474J	CHIP R 470K J 1/16W	
L5-7		*	L34-4666-05	COIL		R19			RK73GB1J224J	CHIP R 220K J 1/16W	
L8			L40-2275-34	SMALL FIXED INDUCTOR (22NH)		R20			RK73GB1J824J	CHIP R 820K J 1/16W	
L9			L40-5675-34	SMALL FIXED INDUCTOR (56NH)		R21			RK73GB1J684J	CHIP R 680K J 1/16W	
L10			L40-1581-37	SMALL FIXED INDUCTOR (0.150UH)		R22			RK73GB1J471J	CHIP R 470 J 1/16W	
L11			L40-1885-34	SMALL FIXED INDUCTOR (180NH)		R30			RK73GB1J821J	CHIP R 820 J 1/16W	
L12			L40-3381-37	SMALL FIXED INDUCTOR (0.330UH)		R31			RK73GB1J5R6J	CHIP R 5.6 J 1/16W	
L13			L40-1005-34	SMALL FIXED INDUCTOR (10UH)		R32			RK73GB1J821J	CHIP R 820 J 1/16W	
L14			L34-4527-05	COIL		R33			RK73GB1J470J	CHIP R 47 J 1/16W	
L15			L34-4526-05	COIL		R34			RK73GB1J102J	CHIP R 1.0K J 1/16W	
L16			L34-4527-05	COIL		R35			RK73GB1J182J	CHIP R 1.8K J 1/16W	
L17,18			L34-4526-05	COIL		R36			RK73GB1J102J	CHIP R 1.0K J 1/16W	
L19			L34-4527-05	COIL		R37			RK73GB1J682J	CHIP R 6.8K J 1/16W	
L20			L40-1095-34	SMALL FIXED INDUCTOR (1UH)		R38			R92-1252-05	CHIP R 0 OHM	
L21			L40-1005-34	SMALL FIXED INDUCTOR (10UH)		R39			RK73GB1J560J	CHIP R 56 J 1/16W	
L22			L40-8271-34	SMALL FIXED INDUCTOR (82NH)		R40			RK73GB1J270J	CHIP R 27 J 1/16W	
L23			L40-1095-34	SMALL FIXED INDUCTOR (1UH)		R41			RK73GB1J222J	CHIP R 2.2K J 1/16W	
L24			L34-4530-05	COIL		R42-45			RK73GB1J223J	CHIP R 22K J 1/16W	
L25			L40-5675-34	SMALL FIXED INDUCTOR (56NH)		R46			RK73GB1J222J	CHIP R 2.2K J 1/16W	
L26			L40-4775-34	SMALL FIXED INDUCTOR (47NH)		R47			RK73GB1J153J	CHIP R 15K J 1/16W	
L27,28			L40-1005-34	SMALL FIXED INDUCTOR (10UH)		R48			RK73GB1J473J	CHIP R 47K J 1/16W	
L29-31			L40-3375-34	SMALL FIXED INDUCTOR (33NH)		R49			RK73GB1J221J	CHIP R 220 J 1/16W	
L32			L40-1085-45	SMALL FIXED INDUCTOR (0.10UH)		R50			RK73GB1J153J	CHIP R 15K J 1/16W	
L33			L40-1005-34	SMALL FIXED INDUCTOR (10UH)		R51			R92-1252-05	CHIP R 0 OHM	
L34-38			L92-0140-05	FERRITE CHIP		R52			RK73GB1J223J	CHIP R 22K J 1/16W	
L39			L92-0158-05	FERRITE CHIP		R53			RK73GB1J682J	CHIP R 6.8K J 1/16W	
L40			L92-0140-05	FERRITE CHIP		R54			RK73GB1J102J	CHIP R 1.0K J 1/16W	
L41			L40-1085-92	SMALL FIXED INDUCTOR (100NH)		R55			RK73GB1J223J	CHIP R 22K J 1/16W	
L600-613			L92-0140-05	FERRITE CHIP		R56			RK73GB1J682J	CHIP R 6.8K J 1/16W	
X1			L77-1762-05	CRYSTAL RESONATOR (44.395MHZ)		R57			RK73GB1J182J	CHIP R 1.8K J 1/16W	
X2,3		*	L77-1848-05	VCXO (16.8MHZ)		R58			RK73GB1J153J	CHIP R 15K J 1/16W	
X600			L78-0431-05	RESONATOR (14.7456M)		R59			RK73GB1J223J	CHIP R 22K J 1/16W	
X601			L77-1799-05	CRYSTAL RESONATOR (16.515MHZ)		R60			RK73GB1J103J	CHIP R 10K J 1/16W	
XF1			L71-0513-05	MCF (44.85MHZ NARR)		R61			RK73GB1J274J	CHIP R 270K J 1/16W	
XF2			L71-0512-05	MCF (44.85MHZ WIDE)		R62			RK73GB1J222J	CHIP R 2.2K J 1/16W	
CP600,601			R90-0725-05	MULTI-COMP 1K X2		R63			RK73GB1J183J	CHIP R 18K J 1/16W	
CP602			R90-0724-05	MULTI-COMP 1K X4		R64			RK73GB1J220J	CHIP R 22 J 1/16W	
CP603			R90-1019-05	MULTI-COMP 100 X2		R65			RK73GB1J472J	CHIP R 4.7K J 1/16W	
CP604,605			R90-0725-05	MULTI-COMP 1K X2		R66			RK73GB1J334J	CHIP R 330K J 1/16W	
CP606			R90-0719-05	MULTI-COMP 4.7K X2		R67			RK73GB1J102J	CHIP R 1.0K J 1/16W	
CP607,608			R90-0725-05	MULTI-COMP 1K X2		R68			RK73GB1J332J	CHIP R 3.3K J 1/16W	
CP609			R90-1019-05	MULTI-COMP 100 X2		R69			RK73GB1J392J	CHIP R 3.9K J 1/16W	
CP610,611			R90-0750-05	MULTIPLE RESISTOR		R71			RK73GB1J104J	CHIP R 100K J 1/16W	
CP612-614			R90-0725-05	MULTI-COMP 1K X2		R72			RK73GB1J393J	CHIP R 39K J 1/16W	
CP615-619			R90-0750-05	MULTIPLE RESISTOR		R73			RK73GB1J474J	CHIP R 470K J 1/16W	
R1			RK73GB1J272J	CHIP R 2.7K J 1/16W		R74,75			RK73GB1J220J	CHIP R 22 J 1/16W	
R3			RK73GB1J681J	CHIP R 680 J 1/16W		R76			RK73GB1J104J	CHIP R 100K J 1/16W	
R4			RK73GB1J100J	CHIP R 10 J 1/16W		R77,78			RK73GB1J473J	CHIP R 47K J 1/16W	
						R79			RK73GB1J104J	CHIP R 100K J 1/16W	

PARTS LIST / 零件表

TX-RX UNIT (X57-6260-XX)

Ref. No.	Address	New parts	Parts No.	Description	Destination	Ref. No.	Address	New parts	Parts No.	Description	Destination
R82			RK73GB1J474J	CHIP R 470K J 1/16W		R637			R92-1252-05	CHIP R 0 OHM	
R83			R92-1252-05	CHIP R 0 OHM		R638			RK73GB1J102J	CHIP R 1.0K J 1/16W	
R87,88			RK73GB1J102J	CHIP R 1.0K J 1/16W		R639			R92-1252-05	CHIP R 0 OHM	
R90			R92-1252-05	CHIP R 0 OHM		R640			RK73GB1J102J	CHIP R 1.0K J 1/16W	
R91			RK73GB1J472J	CHIP R 4.7K J 1/16W		R641			R92-1252-05	CHIP R 0 OHM	
R92			RK73GB1J182J	CHIP R 1.8K J 1/16W		R642			RK73GB1J102J	CHIP R 1.0K J 1/16W	
R93			RK73GB1J101J	CHIP R 100 J 1/16W		R643			RK73GB1J473J	CHIP R 47K J 1/16W	
R94			RK73GB1J470J	CHIP R 47 J 1/16W		R644			RK73GB1J102J	CHIP R 1.0K J 1/16W	
R95			RK73GB1J472J	CHIP R 4.7K J 1/16W		R645,646			RK73GB1J473J	CHIP R 47K J 1/16W	
R96			RK73GB1J182J	CHIP R 1.8K J 1/16W		R647-652			RK73GB1J102J	CHIP R 1.0K J 1/16W	
R97			RK73GB1J472J	CHIP R 4.7K J 1/16W		R653,654			R92-0670-05	CHIP R 0 OHM	
R98			RK73GB1J182J	CHIP R 1.8K J 1/16W		R655			RK73GB1J473J	CHIP R 47K J 1/16W	
R99			RK73GB1J101J	CHIP R 100 J 1/16W		R656			RK73GB1J102J	CHIP R 1.0K J 1/16W	
R100			RK73GB1J220J	CHIP R 22 J 1/16W		R657-661			RK73GB1J473J	CHIP R 47K J 1/16W	
R104			R92-0670-05	CHIP R 0 OHM		R662			RK73GB1J102J	CHIP R 1.0K J 1/16W	
R106			R92-1252-05	CHIP R 0 OHM		R663-667			RK73GB1J473J	CHIP R 47K J 1/16W	
R109			RK73GB1J101J	CHIP R 100 J 1/16W		R668			RK73GB1J183J	CHIP R 18K J 1/16W	
R110			RK73GB1J821J	CHIP R 820 J 1/16W		R669-671			RK73GB1J223J	CHIP R 22K J 1/16W	
R111			RK73GB1J586J	CHIP R 5.6 J 1/16W		R672-674			RK73GB1J104J	CHIP R 100K J 1/16W	
R112			RK73GB1J821J	CHIP R 820 J 1/16W		R675			RK73GB1J333J	CHIP R 33K J 1/16W	
R120,121			RK73GB1J152J	CHIP R 1.5K J 1/16W		R676			RK73GB1J823J	CHIP R 82K J 1/16W	
R122,123			RK73GB1J100J	CHIP R 10 J 1/16W		R678			RK73GB1J104J	CHIP R 100K J 1/16W	
R124,125			RK73GB1J152J	CHIP R 1.5K J 1/16W		R679,680			RK73GB1J223J	CHIP R 22K J 1/16W	
R126,127			RK73GB1J100J	CHIP R 10 J 1/16W		R681			RK73GB1J183J	CHIP R 18K J 1/16W	
R128			RK73GB1J472J	CHIP R 4.7K J 1/16W		R682			RK73GB1J153J	CHIP R 15K J 1/16W	
R129,130			RK73GB1J473J	CHIP R 47K J 1/16W		R683			RK73GB1J124J	CHIP R 120K J 1/16W	
R133			RK73GB1J103J	CHIP R 10K J 1/16W		R684			RK73GB1J473J	CHIP R 47K J 1/16W	
R137,138			RK73GB1J102J	CHIP R 1.0K J 1/16W		R685,686			RK73GB1J104J	CHIP R 100K J 1/16W	
R139-142			R92-1252-05	CHIP R 0 OHM		R687			RK73GB1J223J	CHIP R 22K J 1/16W	
R143			RK73GB1J102J	CHIP R 1.0K J 1/16W		R688-690			RK73GB1J473J	CHIP R 47K J 1/16W	
R144			RK73GB1J223J	CHIP R 22K J 1/16W		R691-693			R92-1252-05	CHIP R 0 OHM	
R148			RK73GB1J223J	CHIP R 22K J 1/16W		R694,695			RK73GB1J101J	CHIP R 100 J 1/16W	
R150			RK73GB1J180J	CHIP R 18 J 1/16W		R696			RK73GB1J103J	CHIP R 10K J 1/16W	
R151-158			RK73GB1J102J	CHIP R 1.0K J 1/16W		R697			RK73GB1J101J	CHIP R 100 J 1/16W	
R159			RK73GB1J221J	CHIP R 220 J 1/16W		R698			RK73GB1J103J	CHIP R 10K J 1/16W	
R160			RK73GB1J271J	CHIP R 270 J 1/16W		R699			R92-1252-05	CHIP R 0 OHM	
R161,162			RK73GB1J471J	CHIP R 470 J 1/16W		R700			RK73GB1J101J	CHIP R 100 J 1/16W	
R163,164			RK73GB1J271J	CHIP R 270 J 1/16W		R701			R92-1252-05	CHIP R 0 OHM	
R165			RK73GB1J471J	CHIP R 470 J 1/16W		R702			RK73GB1J473J	CHIP R 47K J 1/16W	
R166			RK73GB1J223J	CHIP R 22K J 1/16W		R703			R92-1252-05	CHIP R 0 OHM	
R600			RK73GB1J473J	CHIP R 47K J 1/16W		R704-706			RK73GB1J473J	CHIP R 47K J 1/16W	
R601			R92-0670-05	CHIP R 0 OHM		R707-709			RK73GB1J223J	CHIP R 22K J 1/16W	
R602			RK73GB1J472J	CHIP R 4.7K J 1/16W		R710			RK73GB1J473J	CHIP R 47K J 1/16W	
R603			RK73GB1J102J	CHIP R 1.0K J 1/16W		R712			RK73GB1J473J	CHIP R 47K J 1/16W	
R604			RK73GB1J333J	CHIP R 33K J 1/16W		R713			RK73GB1J273J	CHIP R 27K J 1/16W	
R605			RK73GB1J104J	CHIP R 100K J 1/16W		R714			RK73GB1J223J	CHIP R 22K J 1/16W	
R606			RK73GB1J473J	CHIP R 47K J 1/16W		R715			RK73GB1J103J	CHIP R 10K J 1/16W	
R607-613			R92-1252-05	CHIP R 0 OHM		R717,718			RK73GB1J473J	CHIP R 47K J 1/16W	
R614			RK73GB1J473J	CHIP R 47K J 1/16W		R719			RK73GB1J104J	CHIP R 100K J 1/16W	
R615			R92-1252-05	CHIP R 0 OHM		R720			RK73GB1J473J	CHIP R 47K J 1/16W	
R616			RK73GB1J473J	CHIP R 47K J 1/16W		R721			RK73GB1J223J	CHIP R 22K J 1/16W	
R618			R92-1252-05	CHIP R 0 OHM		R722			RK73GB1J334J	CHIP R 330K J 1/16W	
R619			RK73GB1J473J	CHIP R 47K J 1/16W		R723,724			R92-1252-05	CHIP R 0 OHM	
R620-622			RK73GB1J102J	CHIP R 1.0K J 1/16W		R726			RK73GB1J473J	CHIP R 47K J 1/16W	
R623,624			R92-1252-05	CHIP R 0 OHM		R727			R92-1252-05	CHIP R 0 OHM	
R625-628			RK73GB1J102J	CHIP R 1.0K J 1/16W		R728,729			RK73GB1J223J	CHIP R 22K J 1/16W	
R629			R92-1252-05	CHIP R 0 OHM		R730			RK73GB1J101J	CHIP R 100 J 1/16W	
R630,631			RK73GB1J473J	CHIP R 47K J 1/16W		R731			RK73GB1J472J	CHIP R 4.7K J 1/16W	
R633,634			RK73GB1J473J	CHIP R 47K J 1/16W		R732			RK73GB1J473J	CHIP R 47K J 1/16W	
R635,636			RK73GB1J102J	CHIP R 1.0K J 1/16W		R733			R92-1252-05	CHIP R 0 OHM	

PARTS LIST / 零件表

TX-RX UNIT (X57-6260-XX)

Ref. No.	Address	New parts	Parts No.	Description	Destination	Ref. No.	Address	New parts	Parts No.	Description	Destination
R734			RK73GB1J473J	CHIP R 47K J 1/16W		R807			RK73GB1J473J	CHIP R 47K J 1/16W	
R735			RK73GB1J333J	CHIP R 33K J 1/16W		R808			RK73GB1J102J	CHIP R 1.0K J 1/16W	
R736,737			RK73GB1J473J	CHIP R 47K J 1/16W		R809			RK73GB1J473J	CHIP R 47K J 1/16W	
R738			RK73GB1J274J	CHIP R 270K J 1/16W		R810			RK73GB1J102J	CHIP R 1.0K J 1/16W	
R739			RK73GB1J103J	CHIP R 10K J 1/16W		R811			RK73GB1J473J	CHIP R 47K J 1/16W	
R740			RK73GB1J104J	CHIP R 100K J 1/16W		R812			RK73GB1J223J	CHIP R 22K J 1/16W	
R741			RK73GB1J154J	CHIP R 150K J 1/16W		R813,814			RK73GB1J473J	CHIP R 47K J 1/16W	
R742			R92-0670-05	CHIP R 0 OHM		R815			RK73GB1J104J	CHIP R 100K J 1/16W	
R743			RK73GB1J473J	CHIP R 47K J 1/16W		K1			S76-0401-05	RELAY	
R744			RK73GB1J393J	CHIP R 39K J 1/16W		D1-4			DAN235K	DIODE	
R745			RK73GB1J473J	CHIP R 47K J 1/16W		D5			MA742	DIODE	
R747			RK73GB1J103J	CHIP R 10K J 1/16W		D7			1SS355	DIODE	
R749-752			R92-1252-05	CHIP R 0 OHM		D8			DAN235K	DIODE	
R753,754			RK73GB1J473J	CHIP R 47K J 1/16W		D11			02DZ5.1(Y)	ZENER DIODE	
R755,756			R92-0670-05	CHIP R 0 OHM		D12			02DZ18(X,Y)	ZENER DIODE	
R758			RK73GB1J103J	CHIP R 10K J 1/16W		D600			DA204U	DIODE	
R760			RK73GB1J122J	CHIP R 1.2K J 1/16W		D601			MA2S111	DIODE	
R762			RK73GB1J472J	CHIP R 4.7K J 1/16W		D606-625			DA204U	DIODE	
R763			RK73GB1J103J	CHIP R 10K J 1/16W		D626			MINISMDE190	VARISTOR	
R764,765			RK73GB1J102J	CHIP R 1.0K J 1/16W		D627,628			1SS355	DIODE	
R766			RK73GB1J122J	CHIP R 1.2K J 1/16W		D629			DA204U	DIODE	
R767			RK73GB1J473J	CHIP R 47K J 1/16W		IC1			NJM2904E	MOS IC	
R768			RK73GB1J122J	CHIP R 1.2K J 1/16W		IC2			NJM4558E	MOS IC	
R769,770			R92-0670-05	CHIP R 0 OHM		IC3			NJM78L05UA	BI-POLAR IC	
R771			RK73GB1J122J	CHIP R 1.2K J 1/16W		IC4		*	NJM7808FA	BI-POLAR IC	
R772			RK73GB1J473J	CHIP R 47K J 1/16W		IC5			AN8009M	MOS IC	
R773			RK73GB1J102J	CHIP R 1.0K J 1/16W		IC6			M62354GP	MOS IC	
R774			RK73GB1J105J	CHIP R 1.0M J 1/16W		IC7			BU4094BCF	MOS IC	
R775			RK73GB1J473J	CHIP R 47K J 1/16W		IC9		*	TK14489V	BI-POLAR IC	
R776			RK73GB1J102J	CHIP R 1.0K J 1/16W		IC10			TA7808F	ANALOG IC	
R777			RK73GB1J473J	CHIP R 47K J 1/16W		IC11			NJM78L05UA	BI-POLAR IC	
R778			RK73GB1J102J	CHIP R 1.0K J 1/16W		IC600			AT2408N10SI2.5	ROM IC	
R779			RK73GB1J473J	CHIP R 47K J 1/16W		IC601			RH5VL42C	MOS IC	
R780			RK73GB1J102J	CHIP R 1.0K J 1/16W		IC602			BU4094BCFV	MOS IC	
R781			RK73GB1J471J	CHIP R 470 J 1/16W		IC603			TC74LVX4245FS	MOS IC	
R782			RK73GB1J473J	CHIP R 47K J 1/16W		IC604		*	30622M4-113GP	MPU	
R783			RK73GB1J102J	CHIP R 1.0K J 1/16W		IC605			BU4053BCF	MOS IC	
R784			RK73GB1J473J	CHIP R 47K J 1/16W		IC606			TC74LVX4245FS	MOS IC	
R785			RK73GB1J102J	CHIP R 1.0K J 1/16W		IC607			NJM4558E	MOS IC	
R786			RK73GB1J473J	CHIP R 47K J 1/16W		IC608			TA75S01F	MOS IC	
R787			RK73GB1J102J	CHIP R 1.0K J 1/16W		IC609			AT29C020-90TI	ROM IC	
R788			RK73GB1J473J	CHIP R 47K J 1/16W		IC610			TA75S01F	MOS IC	
R789			RK73GB1J102J	CHIP R 1.0K J 1/16W		IC611			NJM4558E	MOS IC	
R790			RK73GB1J473J	CHIP R 47K J 1/16W		IC612			TC7S04FU	MOS IC	
R791			RK73GB1J102J	CHIP R 1.0K J 1/16W		IC613			TC74VHC4040FT	MOS IC	
R792			RK73GB1J473J	CHIP R 47K J 1/16W		IC614			AK4550VT	MOS IC	
R793			RK73GB1J102J	CHIP R 1.0K J 1/16W		IC615			M62364FP	MOS IC	
R794			RK73GB1J473J	CHIP R 47K J 1/16W		IC616,617			NJM4558E	MOS IC	
R795			RK73GB1J102J	CHIP R 1.0K J 1/16W		IC618			320VC5402PGE	MPU	
R796			RK73GB1J473J	CHIP R 47K J 1/16W		IC619			TC75W51FU	MOS IC	
R797			RK73GB1J102J	CHIP R 1.0K J 1/16W		IC620		*	ADM202EARN	MOS IC	
R798			RK73GB1J473J	CHIP R 47K J 1/16W		IC621			TC7S00FU	MOS IC	
R799			RK73GB1J102J	CHIP R 1.0K J 1/16W		IC622			TC7S66FU	MOS IC	
R800			RK73GB1J473J	CHIP R 47K J 1/16W		IC623			BU4094BCFV	MOS IC	
R801			RK73GB1J102J	CHIP R 1.0K J 1/16W		IC624			XC62FP1802P	MOS IC	
R802			RK73FB2A2R2J	CHIP R 2.2 J 1/10W		IC625,626			XC62FP3302P	MOS IC	
R803			RK73GB1J473J	CHIP R 47K J 1/16W		IC627,628			TA78L05F	MOS IC	
R804			RK73GB1J102J	CHIP R 1.0K J 1/16W		IC629			LA4422	BI-POLAR IC	
R805			RK73GB1J473J	CHIP R 47K J 1/16W		IC630			TA78L05F	MOS IC	
R806			RK73GB1J102J	CHIP R 1.0K J 1/16W							

PARTS LIST / 零件表

TX-RX UNIT (X57-6260-XX)
RX PLL/VCO (X58-4780-10)

Ref. No.	Address	New parts	Parts No.	Description	Desti-nation	Ref. No.	Address	New parts	Parts No.	Description	Desti-nation
Q1,2			2SC3357	TRANSISTOR		C359			CC73GCH1H080B	CHIP C 8.0PF B	
Q3			2SC3356(R24)	TRANSISTOR		C360,361			CK73FB1C474K	CHIP C 0.47UF K	
Q4			DTC144EUA	DIGITAL TRANSISTOR		C362,363			CC73GCH1H470J	CHIP C 47PF J	
Q5			DTA144EUA	DIGITAL TRANSISTOR		C364,365			CK73GB1H102K	CHIP C 1000PF K	
Q6			DTC144EUA	DIGITAL TRANSISTOR		C366			CC73GCH1H180G	CHIP C 18PF G	
Q7			2SC4617(S)	TRANSISTOR		C367			CC73GCH1H150G	CHIP C 15PF G	
Q8			2SC3120	TRANSISTOR		C368			CC73GCH1H180G	CHIP C 18PF G	
Q9			2SC3357	TRANSISTOR		C369			CC73GCH1H150G	CHIP C 15PF G	
Q10			2SA1586(Y,GR)	TRANSISTOR		C370			CC73GCH1H180G	CHIP C 18PF G	
Q11			2SC3120	TRANSISTOR		C371			CC73GCH1H150G	CHIP C 15PF G	
Q12-15			2SC4116(GR)	TRANSISTOR		C372,373			CK73GB1H102K	CHIP C 1000PF K	
Q16			2SB1132(Q,R)	TRANSISTOR		C374,375			CC73GCH1H010B	CHIP C 1.0PF B	
Q17			DTC114EUA	DIGITAL TRANSISTOR		C376-378			CK73GB1H102K	CHIP C 1000PF K	
Q18			2SB1386(R)	TRANSISTOR		C379			CC73GCH1H100C	CHIP C 10PF C	
Q19,20			DTC114EUA	DIGITAL TRANSISTOR		C383			CK73GB1H102K	CHIP C 1000PF K	
Q23			DTC114EUA	DIGITAL TRANSISTOR		TC350,351	*		C05-0396-05	CERAMIC TRIMMER CAP (8P)	
Q24			DTD114EK	DIGITAL TRANSISTOR		CN300			E40-5699-05	PIN ASSY	
Q25			DTC114EUA	DIGITAL TRANSISTOR		CN350			E40-5755-05	PIN ASSY	
Q600			2SK1824	FET		CN351	*		E40-6098-05	PIN ASSY	
Q601			DTC114EUA	DIGITAL TRANSISTOR		-	*		F10-2377-04	SHIELDING CASE	
Q602			2SK1824	FET		L300			L92-0148-05	FERRITE CHIP	
Q603			DTC114EUA	DIGITAL TRANSISTOR		L301,302			L40-3975-34	SMALL FIXED INDUCTOR (39NH)	
Q604			2SK1824	FET		L303			L40-1085-34	SMALL FIXED INDUCTOR (100NH)	
Q605			DTC114EUA	DIGITAL TRANSISTOR		L350-355			L33-1268-15	SMALL FIXED INDUCTOR	
Q606			DTC363EK	DIGITAL TRANSISTOR		L356,357			L34-4612-05	AIR-CORE COIL	
Q609			DTC114EUA	DIGITAL TRANSISTOR		L358-361			L33-1268-15	SMALL FIXED INDUCTOR	
Q610			2SJ506(S)	FET		L362			L40-8271-34	SMALL FIXED INDUCTOR (82NH)	
Q611			DTC114EUA	DIGITAL TRANSISTOR		R300			RK73GB1J100J	CHIP R 10 J 1/16W	
TH1			157-503-53006	THERMISTOR		R301-304			RK73GB1J101J	CHIP R 100 J 1/16W	
A1			W02-1939-05	DBM		R305			R92-1252-05	CHIP R 0 OHM	
RX PLL/VCO (X58-4780-10)						R306			RK73GB1J220J	CHIP R 22 J 1/16W	
C304,305			CK73GB1H102K	CHIP C 1000PF K		R308			RK73GB1J560J	CHIP R 56 J 1/16W	
C306			CK73GB1H103K	CHIP C 0.010UF K		R309			RK73GB1J221J	CHIP R 220 J 1/16W	
C307			CK73GB1H102K	CHIP C 1000PF K		R310			RK73GB1J682J	CHIP R 6.8K J 1/16W	
C308-310			CK73FB1E104K	CHIP C 0.10UF K		R311			RK73GB1J223J	CHIP R 22K J 1/16W	
C311			C92-0001-05	CHIP C 0.1UF 35WV		R312			RK73GB1J221J	CHIP R 220 J 1/16W	
C312			CC73GCH1H150J	CHIP C 15PF J		R313			RK73GB1J222J	CHIP R 2.2K J 1/16W	
C313			CC73GCH1H030C	CHIP C 3.0PF C		R314			RK73GB1J474J	CHIP R 470K J 1/16W	
C314			CC73GCH1H270J	CHIP C 27PF J		R315			RK73GB1J331J	CHIP R 330 J 1/16W	
C315			CK73FB1H473K	CHIP C 0.047UF K		R316			RK73FB2A152J	CHIP R 1.5K J 1/10W	
C316			CC73GCH1H030C	CHIP C 3.0PF C		R317,318			R92-1252-05	CHIP R 0 OHM	
C317			CC73GCH1H150J	CHIP C 15PF J		R319			RK73GB1J330J	CHIP R 33 J 1/16W	
C318			C92-0514-05	CHIP-TAN 2.2UF 10WV		R320			RK73GB1J102J	CHIP R 1.0K J 1/16W	
C319			CK73GB1H102K	CHIP C 1000PF K		R321			RK73GB1J223J	CHIP R 22K J 1/16W	
C320			C92-0514-05	CHIP-TAN 2.2UF 10WV		R322			RK73GB1J103J	CHIP R 10K J 1/16W	
C321			CC73GCH1H470J	CHIP C 47PF J		R350-353			R92-1252-05	CHIP R 0 OHM	
C322			CK73GB1H102K	CHIP C 1000PF K		R354,355			RK73GB1J330J	CHIP R 33 J 1/16W	
C323			CK73FB1E224K	CHIP C 0.22UF K		R356,357			RK73GB1J271J	CHIP R 270 J 1/16W	
C324			C92-0003-05	CHIP-TAN 0.47UF 25WV		R358,359			RK73GB1J470J	CHIP R 47 J 1/16W	
C325			CC73GCH1H050C	CHIP C 5.0PF C		R360-363			RK73GB1J472J	CHIP R 4.7K J 1/16W	
C327			C92-0514-05	CHIP-TAN 2.2UF 10WV		R364			RK73GB1J103J	CHIP R 10K J 1/16W	
C354			CK73GB1H102K	CHIP C 1000PF K		R365			RK73GB1J473J	CHIP R 47K J 1/16W	
C355			CC73GCH1H390J	CHIP C 39PF J		R366			RK73GB1J103J	CHIP R 10K J 1/16W	
C356			CC73GCH1H330J	CHIP C 33PF J		R367			RK73GB1J221J	CHIP R 220 J 1/16W	
C357			CK73GB1H102K	CHIP C 1000PF K		R368			RK73GB1J330J	CHIP R 33 J 1/16W	
C358			CC73GCH1H040B	CHIP C 4.0PF B		D350-353			1SV282	VARIABLE CAPACITANCE DIODE	
						IC300			SA7025DK	MOS IC	

PARTS LIST / 零件表

RX PLL/VCO (X58-4780-10)

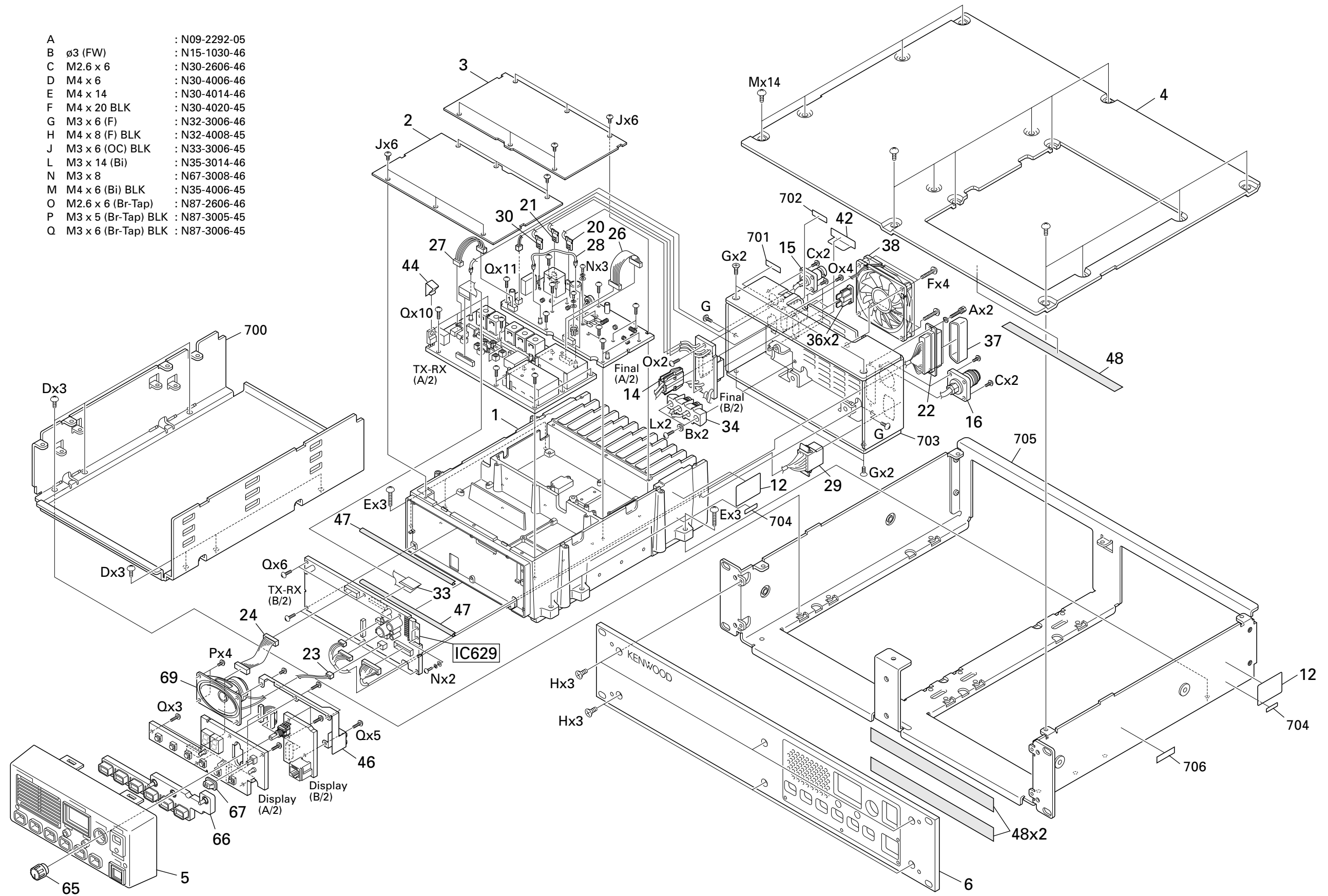
TX PLL/VCO (X58-4790-10)

Ref. No.	Address	New parts	Parts No.	Description	Destination
Q300,301			2SC4116(GR)	TRANSISTOR	
Q302			2SC4215(Y)	TRANSISTOR	
Q350,351			2SK508NV(K52)	FET	
Q352,353			2SC4116(Y)	TRANSISTOR	
Q354			DTC114EUA	DIGITAL TRANSISTOR	
Q355			2SC4215(Y)	TRANSISTOR	
TX PLL/VCO (X58-4790-10)					
C304,305			CK73GB1H102K	CHIP C 1000PF K	
C306			CK73GB1H103K	CHIP C 0.010UF K	
C307			CK73GB1H102K	CHIP C 1000PF K	
C308-310			CK73FB1E104K	CHIP C 0.10UF K	
C311			C92-0001-05	CHIP C 0.1UF 35WV	
C312			CC73GCH1H220J	CHIP C 22PF J	
C313			CC73GCH1H040C	CHIP C 4.0PF C	
C314			CC73GCH1H390J	CHIP C 39PF J	
C315			CK73FB1H473K	CHIP C 0.047UF K	
C316			CC73GCH1H040C	CHIP C 4.0PF C	
C317			CC73GCH1H220J	CHIP C 22PF J	
C318			C92-0514-05	CHIP-TAN 2.2UF 10WV	
C319			CK73GB1H102K	CHIP C 1000PF K	
C320			C92-0514-05	CHIP-TAN 2.2UF 10WV	
C321			CC73GCH1H470J	CHIP C 47PF J	
C322			CK73GB1H102K	CHIP C 1000PF K	
C323			CK73FB1E224K	CHIP C 0.22UF K	
C324			C92-0003-05	CHIP-TAN 0.47UF 25WV	
C325			CC73GCH1H050C	CHIP C 5.0PF C	
C354			CK73GB1H102K	CHIP C 1000PF K	
C355			CC73GCH1H180G	CHIP C 18PF G	
C356			CC73GCH1H270G	CHIP C 27PF G	
C357			CK73GB1H102K	CHIP C 1000PF K	
C360,361			CK73FB1C474K	CHIP C 0.47UF K	
C362			CC73GCH1H220G	CHIP C 22PF G	
C363			CC73GCH1H180G	CHIP C 18PF G	
C364,365			CK73GB1H102K	CHIP C 1000PF K	
C366			CC73GCH1H270G	CHIP C 27PF G	
C367			CC73GCH1H180G	CHIP C 18PF G	
C368			CC73GCH1H150G	CHIP C 15PF G	
C369			CC73GCH1H090B	CHIP C 9.0PF B	
C370			CC73GCH1H150G	CHIP C 15PF G	
C371			CC73GCH1H090B	CHIP C 9.0PF B	
C372,373			CK73GB1H102K	CHIP C 1000PF K	
C374,375			CC73GCH1H010B	CHIP C 1.0PF B	
C376-378			CK73GB1H102K	CHIP C 1000PF K	
C379			CC73GCH1H100C	CHIP C 10PF C	
C380,381			CC73GCH1HR75B	CHIP C 0.75PF B	
C382,383			CK73GB1H102K	CHIP C 1000PF K	
TC350,351		*	C05-0396-05	CERAMIC TRIMMER CAP (8P)	
CN300			E40-5699-05	PIN ASSY	
CN350			E40-5755-05	PIN ASSY	
CN351		*	E40-6098-05	PIN ASSY	
-		*	F10-2377-04	SHIELDING CASE	
L300			L92-0148-05	FERRITE CHIP	
L301,302			L40-3975-34	SMALL FIXED INDUCTOR (39NH)	
L303			L40-1085-34	SMALL FIXED INDUCTOR (100NH)	
L350-355			L33-1268-15	SMALL FIXED INDUCTOR	
L356,357		*	L34-4612-05	AIR-CORE COIL	
L360,361			L33-1268-15	SMALL FIXED INDUCTOR	
L362			L40-8271-34	SMALL FIXED INDUCTOR (82NH)	
R300			RK73GB1J100J	CHIP R 10 J 1/16W	
R301-304			RK73GB1J101J	CHIP R 100 J 1/16W	
R305			R92-1252-05	CHIP R 0 OHM	
R306			RK73GB1J220J	CHIP R 22 J 1/16W	
R308			RK73GB1J560J	CHIP R 56 J 1/16W	
R309			RK73GB1J221J	CHIP R 220 J 1/16W	
R310			RK73GB1J682J	CHIP R 6.8K J 1/16W	
R311			RK73GB1J223J	CHIP R 22K J 1/16W	
R312			RK73GB1J221J	CHIP R 220 J 1/16W	
R313			RK73GB1J222J	CHIP R 2.2K J 1/16W	
R314			RK73GB1J474J	CHIP R 470K J 1/16W	
R315			RK73GB1J331J	CHIP R 330 J 1/16W	
R316			RK73FB2A152J	CHIP R 1.5K J 1/10W	
R317,318			R92-1252-05	CHIP R 0 OHM	
R319			RK73GB1J330J	CHIP R 33 J 1/16W	
R320			RK73GB1J102J	CHIP R 1.0K J 1/16W	
R321			RK73GB1J223J	CHIP R 22K J 1/16W	
R322			RK73GB1J103J	CHIP R 10K J 1/16W	
R350-353			R92-1252-05	CHIP R 0 OHM	
R354,355			RK73GB1J330J	CHIP R 33 J 1/16W	
R356,357			RK73GB1J471J	CHIP R 470 J 1/16W	
R358,359			RK73GB1J470J	CHIP R 47 J 1/16W	
R360-363			RK73GB1J472J	CHIP R 4.7K J 1/16W	
R364			RK73GB1J103J	CHIP R 10K J 1/16W	
R365			RK73GB1J473J	CHIP R 47K J 1/16W	
R366			RK73GB1J103J	CHIP R 10K J 1/16W	
R367			RK73GB1J221J	CHIP R 220 J 1/16W	
R368			RK73GB1J330J	CHIP R 33 J 1/16W	
R370,371			RK73GB1J103J	CHIP R 10K J 1/16W	
R372			RK73GB1J223J	CHIP R 22K J 1/16W	
R373			RK73GB1J104J	CHIP R 100K J 1/16W	
R374			RK73GB1J223J	CHIP R 22K J 1/16W	
R375			RK73GB1J104J	CHIP R 100K J 1/16W	
D350-353			1SV282	VARIABLE CAPACITANCE DIODE	
D354,355			1SV214	VARIABLE CAPACITANCE DIODE	
IC300			SA7025DK	MOS IC	
Q300,301			2SC4116(GR)	TRANSISTOR	
Q302			2SC4215(Y)	TRANSISTOR	
Q350,351			2SK508NV(K52)	FET	
Q352,353			2SC4116(Y)	TRANSISTOR	
Q354			DTC114EUA	DIGITAL TRANSISTOR	
Q355			2SC4215(Y)	TRANSISTOR	

TKR-750 TKR-750

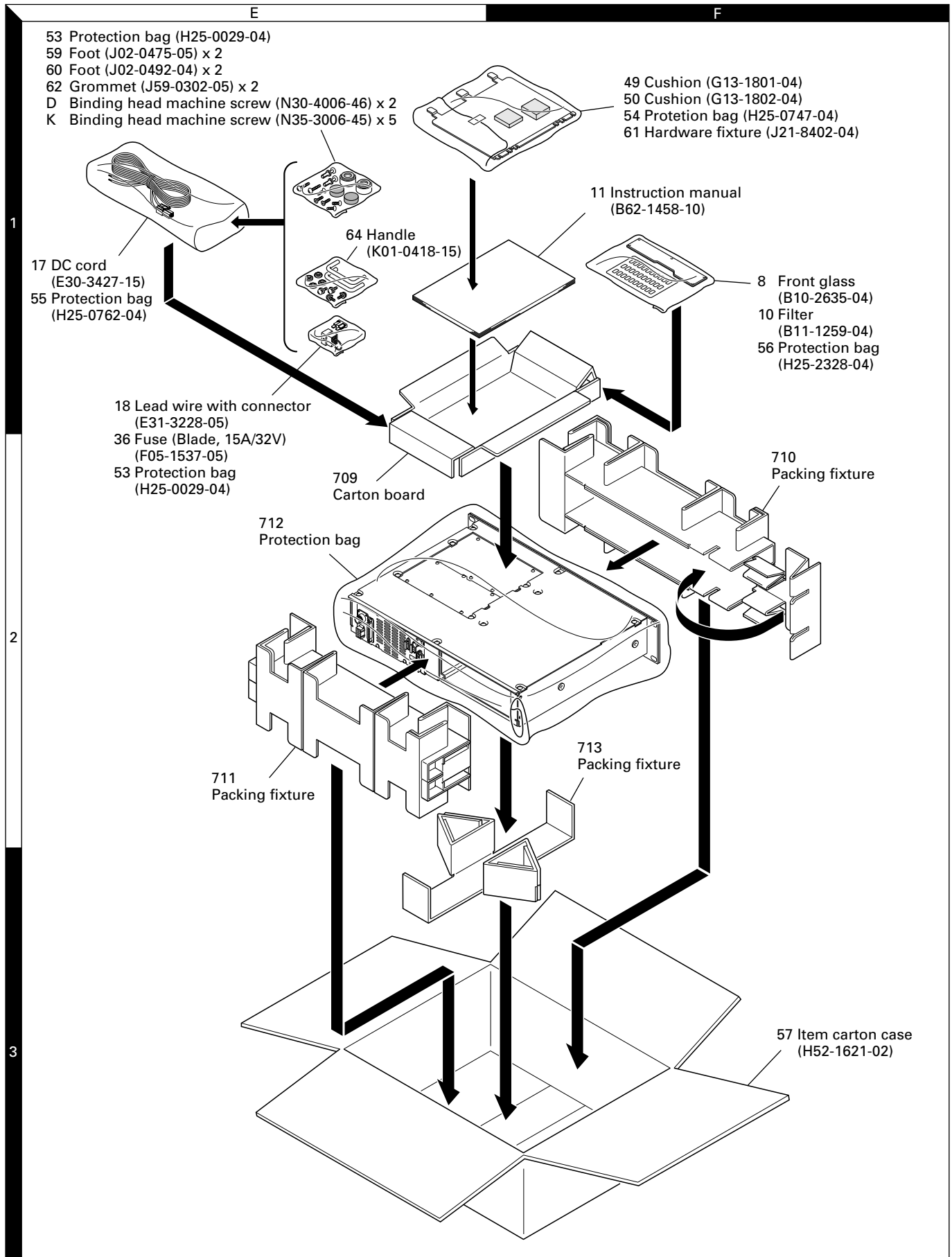
EXPLODED VIEW / 部件分解图

- | | | |
|---|---------------------|---------------|
| A | : | N09-2292-05 |
| B | ∅3 (FW) | : N15-1030-46 |
| C | M2.6 x 6 | : N30-2606-46 |
| D | M4 x 6 | : N30-4006-46 |
| E | M4 x 14 | : N30-4014-46 |
| F | M4 x 20 BLK | : N30-4020-45 |
| G | M3 x 6 (F) | : N32-3006-46 |
| H | M4 x 8 (F) BLK | : N32-4008-45 |
| J | M3 x 6 (OC) BLK | : N33-3006-45 |
| L | M3 x 14 (Bi) | : N35-3014-46 |
| N | M3 x 8 | : N67-3008-46 |
| M | M4 x 6 (Bi) BLK | : N35-4006-45 |
| O | M2.6 x 6 (Br-Tap) | : N87-2606-46 |
| P | M3 x 5 (Br-Tap) BLK | : N87-3005-45 |
| Q | M3 x 6 (Br-Tap) BLK | : N87-3006-45 |



Parts with the exploded numbers larger than 700 are not supplied.

PACKING / 包装



Parts with the exploded numbers larger than 700 are not supplied.

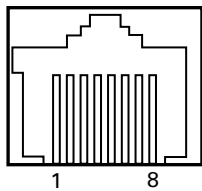
ADJUSTMENT

Test Equipment Required for Alignment

Test Equipment	Major Specifications	
1. Standard Signal Generator (SSG)	Frequency Range Modulation Output	136 to 174MHz Frequency modulation and external modulation 0.1μV to greater than 1mV
2. Power Meter	Input Impedance Operation Frequency Measurement Capability	50Ω 136 to 174MHz or more Vicinity of 50W
3. Deviation Meter	Frequency Range	136 to 174MHz
4. Digital Volt Meter (DVM)	Measuring Range Accuracy	1 to 20V DC High input impedance for minimum circuit loading
5. Oscilloscope		DC through 30MHz
6. High Sensitivity Frequency Counter	Frequency Range Frequency Stability	10Hz to 600MHz 0.2ppm or less
7. Ammeter		13A or more
8. AF Volt Meter (AF VTVM)	Frequency Range Voltage Range	50Hz to 10kHz 3mV to 3V
9. Audio Generator (AG)	Frequency Range Output	50Hz to 5kHz 0 to 1V
10. Distortion Meter	Capability Input Level	3% or less at 1kHz 50mV to 10Vrms
11. Voltmeter	Measuring Range Input Impedance	10 to 1.5V DC or less 50kΩ/V or greater
12. 4Ω Dummy Load		Approx. 4Ω, 5W

The following parts are required for adjustment

- Test cable for local microphone



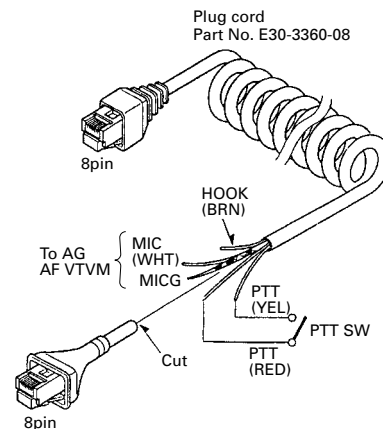
- 1 : NC
- 2 : +B
- 3 : GND
- 4 : PTT/TXD1 (PC serial data from radio)
- 5 : MIC GND
- 6 : MIC
- 7 : HOOK/RXD1 (PC serial data to radio)
- 8 : NC

MIC connector (Front panel view)

Test Channel (Default)

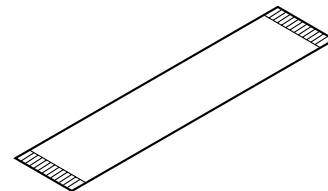
No.	C		C2	
	RX	TX	RX	TX
1	146.10	146.00	136.10	136.00
2	160.10	160.00	143.10	143.00
3	173.90	174.00	149.90	150.00
4	150.10	150.00	146.10	146.00
5	155.10	155.00	155.90	156.00
6	165.10	165.00	140.10	140.00
7	170.10	170.00	148.10	148.00
8	158.50	161.50	147.50	149.00
9	161.50	158.50	149.00	147.50
10	136.10	136.00	151.10	151.95
11	151.90	151.95	152.10	152.00
12	152.10	152.00	173.90	174.00

- The following test cables are recommended.



Test cable for microphone input

To connect the TX-RX unit A/2 (CN14) to the TX-RX unit B/2 (CN602) while in servicing, you can use the 36-pin flat cable, E37-0979-05, which is available from the KENWOOD parts center.



Flat cable (36-pin) about 256mm

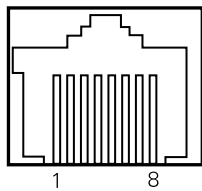
调 整

所需的用于调整的测试设备

测试设备	主要特性	
1. 标准信号发生器 (SSG)	频率范围 调制 输出	440到512MHz 调频和外部调制 0.1 μ V到大于1mV
2. 功率计	输入阻抗 工作频率 测量范围	50 Ω 440到512MHz或更高 50W左右
3. 频偏仪	频率范围	440到512MHz
4. 数字电压表 (DVM)	测量范围 输入阻抗	直流1V到20V 最小电路负载时为高输入阻抗
5. 示波器		直流到30MHz
6. 高灵敏度频率计数器	频率范围 频率稳定性	10Hz到600MHz 0.2ppm或更低
7. 电流表		13A或更高
8. 音频电压表 (AF VTVM)	频率范围 电压范围	50Hz到10kHz 3mV到3V
9. 音频发生器 (AG)	频率范围 输出	50Hz到5kHz或更高 0到1V
10. 失真测试仪	测量能力 输入电平	在1kHz时3%或更低 50mV到10Vrms
11. 电压表	测量范围 输入阻抗	直流10V到1.5V或更低 50k Ω /V或更高
12. 4 Ω 假负载		大约4 Ω , 5W

在调整时需要下列部件

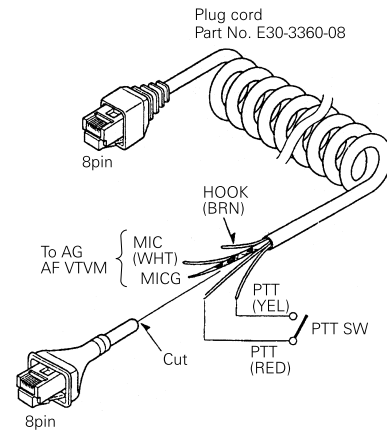
- 用于本机麦克风的调试电缆



- 1: NC
- 2: +B
- 3: GND
- 4: PTT/TXD1 (PC serial data from radio)
- 5: MIC GND
- 6: MIC
- 7: HOOK/RXD1 (PC serial data to radio)
- 8: NC

麦克风连接器 (前面板视图)

- 建议使用下列调试电缆

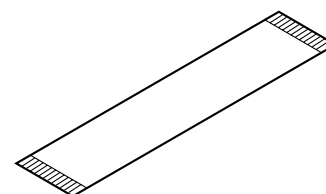


用于麦克风输入的测试电缆

试验信道 (出厂设定)

号码	C	
	接收频率	发射频率
1	450.10	450.00
2	465.10	465.00
3	479.90	480.00
4	455.10	455.00
5	460.10	460.00
6	470.10	470.00
7	475.10	475.00
8	462.60	462.50
9	467.60	467.50
10	440.10	440.00
11	459.90	460.00

- 控制部分与TX-RX部分连接用电缆 (E37-0979-05) 长度256mm



扁平电缆 (36芯)

ADJUSTMENT

Item	Condition	Measurement			Adjustment			Specifications/Remarks
		Test-equipment	Unit	Terminal	Unit	Parts	Method	
1. Setting & Firmware writing	1) Connect the unit to a suitable DC power supply. 2) Turn the DC source switch on after connecting a PC and FPU cable to the radio. 3) Write the firmware to radio. After the end of firmware writing.						→ "P.G." appears on LED display → Red (TX) LED lights up	
2. Write test frequency	1) Connect the unit to a suitable DC power supply. 2) Turn the DC source switch on after connecting a PC and FPU cable to the radio. 3) Write the test frequency to the radio. 4) End of test frequency writing.						→ "E1" appears on LED display → Green (BUSY) LED lights up	
3. Setting	1) Connect the unit to a suitable DC power supply. 2) Turn the power switch on after connecting a PC and FPU cable to the radio. 3) Start up the program for the adjustment.							
4. RX PLL lock voltage	1) RX VCO A high CH : 11 C CH : 10 C2	DVM	TX-RX (A/2)	RX-CV	RX VCO (A3)	TC350	1.50V	±0.1V
	2) RX VCO A low CH : 10 C CH : 1 C2						Check	8V or less
	3) RX VCO B high CH : 3 C CH : 12 C2				RX VCO (A3)	TC351	1.50V	±0.1V
	4) RX VCO B low CH : 12 C CH : 11 C2						Check	8V or less
5. TX PLL lock voltage	1) TX VCO A high CH : 11 C CH : 10 C2			TX-CV	TX VCO (A2)	TC350	1.50V	±0.1V
	2) TX VCO A low CH : 10 C CH : 1 C2						Check	8V or less
	3) TX VCO B high CH : 3 C CH : 12 C2				TX VCO (A2)	TC351	1.50V	±0.1V
	4) TX VCO B low CH : 12 C CH : 11 C2						Check	8V or less
6. RX frequency	1) Connect the frequency counter to CN3, then measure the frequency CH : 2	f. counter		CN3			PC adj. Test CH+44.85MHz	50Hz or less
Note : RX frequency means the local frequency of the RX VCO. So its frequency is wanted frequency plus the IF frequency.								
7. RX frequency (tune)	1) High CH (Automatically)	f. counter	TX-RX (A/2)	CN3			PC adj. 218.8475MHz	50Hz or less
	2) Low CH (Automatically)						PC adj. 180.8525MHz	
8. Setting	1) Remove 8 pin cable and the coaxial cable from CN16, and CN19 on TX-RX side.							
9. TX frequency	1) Connect the frequency counter to CN19, then measure the frequency CH : 2	f. counter	TX-RX (A/2)	CN19			PC adj.	50Hz or less

调 整

项 目	条 件	测 量			调 整			规 格 / 备 注
		测试设备	单元	端子	单元	部件	方 法	
1. 设定和 固件写入	1) 将单元与对应的DC电源连接。 2) 将电脑和FPU电缆与电台连接后接通电源开关。 3) 将固件写入电台。完成固件写入后。							→LED显示屏出现“P.G.”。 →红色(TX)LED点亮。
2. 写入试验和 出厂频率	1) 将单元与对应的DC电源连接。 2) 将电脑和FPU电缆与电台连接后接通电源开关。 3) 将试验和出厂频率写入电台。 4) 固件写入结束。							→LED显示屏出现“E1”。 →绿色(BUSY)LED点亮。
3. 设定	1) 将单元与对应的DC电源连接。 2) 将电脑和FPU电缆与电台连接后接通电源开关。 3) 启动调整程序。							
4. RX PLL锁定 电压调整	1) RX VCO A高 CH : 11	DVM	TX-RX (A/2)	RX-CV	RX VCO (A3)	TC350	1.50V	±0.1V
	2) RX VCO A低 CH : 10						检查	8V或更低
	3) RX VCO B高 CH : 3				RX VCO (A3)	TC351	1.50V	±0.1V
	4) RX VCO B低 CH : 5						检查	8V或更低
5. TX PLL锁定 电压调整	1) TX VCO 高 CH : 3			TX-CV	TX VCO (A2)	TC350	1.50V	±0.1V
	2) TX VCO 低 CH : 1						检查	8V或更低
6. RX频率调整	1) 将频率计与CN3连接, 然后测定频率。 CH : 2	频率计		CN3			PC调整 试验CH-44.85MHz	50Hz或更低
注意：频率表示RX VCO的本机频率。因此该频率为所需频率—中频频率。								
7. 设定	1) 从: TX-RX侧的CN16和CN19取下8插脚电缆和同轴电缆。							
8. TX频率调整	1) 将频率计与CN19连接, 然后测量频率。 CH : 2	频率计	TX-RX (A/2)	CN19			PC调整	50Hz或更低
9. 设定	1) 向: TX-RX侧的CN16和CN19插入8插脚电缆和同轴电缆。							
10. 最大功率 限制	1) 在TX天线测试射频功率。 高CH	功率计	后侧	TX天线	Final	VR1	将射频功率调整到 43W	±1W
11. TX射频 高功率调整	1) 在TX天线测试射频功率。 低CH 2) 中央CH 3) 高CH						PC调整 40W(出厂功率)	±1W

ADJUSTMENT

Item	Condition	Measurement			Adjustment			Specifications/Remarks	
		Test-equipment	Unit	Terminal	Unit	Parts	Method		
10. TX frequency (tune)	1) High CH (Automatically)	f. counter	TX-RX (A/2)	CN19			PC adj. 173.9975MHz	50Hz or less	
	2) Low CH (Automatically)						PC adj. 136.0025MHz		
11. Setting	1) Insert 8 pin cable and the coaxial cable to CN16, and CN19 on TX-RX side.								
12. Maximum power limiting	1) Measure the RF power at TX ANT. High CH	Power meter	Rear	TX ANT	Final	VR1	Adjust the RF power to 53W.	±1W	
13. TX RF high power	1) Measure the RF power at TX ANT. Low CH 2) Center CH 3) High CH						PC adj. 50W (Shipping power)	±1W	
14. TX RF low power	1) Measure the power level at TX ANT. Low CH 2) Center CH 3) High CH						PC adj. 25W (Shipping power)	±1W	
15. BPF	1) Connect the TG to RX ANT, then connect CN1 to the spectrum analyzer input. Spectrum analyzer setting Span : 50MHz Scale : 10dB to 5dB div Tracking generator setting Output : -30dBm	Tracking generator Spectrum analyzer	Rear TX-RX (A/2)	RX ANT CN1	TX-RX (A/2)	L2 L3 L5 L6 L7	Center the frequency you are using, then adjust it to look like the wave Fig. 1. (Page 72)		
16. MCF (Wide)	1) Connect the TG to CN2, then connect CN4 to the spectrum analyzer input. CH : 2 (Wide) Spectrum analyzer setting Span : 50kHz to 25kHz Scale : 10dB to 2dB div Center freq' : 44.850MHz Tracking generator setting Output : -30dBm			CN2 CN4			L14 L17 L18	Adjust it to look like the wave Fig. 2. (Page 72)	
(Narrow)	2) CH : 2 (Narrow)						L15 L16 L19	Adjust it to look like the wave Fig. 3. (Page 72)	
17. Discriminator	1) Connect the SSG to RX ANT. CH : 2 (Wide) SSG output : -53dBm/501μV SSG MOD : 1kHz SSG DEV : 3kHz AF : 2V/4Ω	SSG AF VM Distortion meter	Rear	RX ANT TEST/SPKR jack SPO (pin 12)		L24	Adjust the distortion to minimum.		
18. Threshold squelch (Wide)	1) Connect SSG to RX ANT. CH : 2 (Wide) SSG output : 3dB below to 12dB SINAD level SSG MOD : 1kHz SSG DEV : 3kHz AF : 2V/4Ω	SSG Audio analyzer VTVM Oscilloscope	Rear	RX ANT			PC adj. Adjust to point of opening squelch		
	2) SSG : OFF						Check	Squelch must be closed.	

调 整

项 目	条 件	测 量			调 整			规 格 / 备 注
		测试设备	单元	端子	单元	部件	方 法	
12. TX射频 低功率调整	1) 在TX天线测试射频功率。 低CH 2) 中央CH 3) 高CH	功率计	后侧	TX天线			PC调整 25W(出厂功率)	±1W
13. BPF调整	1) 将TG与RX天线连接, 然后将CN1与频谱分析仪的输入连接。 频谱分析仪 量程: 50MHz 刻度: 10dB至5dB 跟踪发生器 输出: -30dBm	频谱分析仪 跟踪发生器	后侧 TX-RX (A/2)	RX天线 CN1	TX-RX (A/2)	L2 L4 L5	将使用的频率置于中央, 然后将波形调整成为图1的形状。(请参照第72页)	
14. MCF调整 (宽)	1) 将TG与CN2连接, 然后将CN4与频谱分析仪的输入连接。 CH: 2(宽) 频谱分析仪 量程: 50kHz至25kHz 刻度: 10dB至2dB 中央频率: 44.850MHz 跟踪发生器 输出: -30dBm			CN2 CN4		L14 L17 L18	将波形调整成为图2的形状。(请参照第72页)	
(窄)	2) CH: 2(窄)					L15 L16 L19	将波形调整成为图3的形状。(请参照第72页)	
15. 判别器调整	1) 将SSG与RX天线连接。 CH: 2(宽) SSG输出: -53dBm/501 μV SSG MOD: 1kHz SSG DEV: 3kHz AF: 2V/4欧姆	SSG AF VM 失真计	后侧	RX天线 试验/ 扬声器 SPO端子 (插脚12)		L24	将失真调整成为最小。	
16. 静噪阈值 调整 (宽)	1) 将SSG与RX天线连接。 CH: 2(宽) SSG输出: 3dB以下至12dB SINAD电平 SSG MOD: 1kHz SSG DEV: 3kHz AF: 2V/4欧姆	SSG 音频分析仪 VTVM 示波器	后侧	RX天线 试验/ 扬声器 SPO端子 (插脚12)			PC调整 调整至开启静噪点	
	2) SSG: 切断						检查	静噪必须关闭
(窄)	1) CH: 2(窄) SSG输出: 3dB以下至12dB SINAD电平 SSG MOD: 1kHz SSG DEV: 1.5kHz AF: 2V/4欧姆						PC调整 调整至开启静噪点	
	2) SSG: 切断						检查	静噪必须关闭

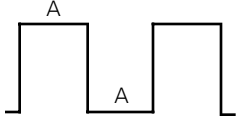
ADJUSTMENT

Item	Condition	Measurement			Adjustment			Specifications/Remarks
		Test-equipment	Unit	Terminal	Unit	Parts	Method	
(Narrow)	3) CH : 2 (Narrow) SSG output : 3dB below to 12dB SINAD level SSG MOD : 1kHz SSG DEV : 1.5kHz AF : 2V/4Ω	SSG Audio analyzer VTVM Oscilloscope	Rear	RX ANT			PC adj. Adjust to point of opening squelch	
	TEST/SPKR jack SPO (pin 12)							
	4) SSG : OFF						Check	Squelch must be closed.
19. Tight squelch (Wide)	1) Connect SSG to RX ANT. CH : 2 (Wide) SSG output : 7dB over to 12dB SINAD level SSG MOD : 1kHz SSG DEV : 3kHz AF : 2V/4Ω						PC adj. Adjust to point of opening squelch	
(Narrow)	2) CH : 2 (Narrow) SSG output : 7dB over to 12dB SINAD level SSG MOD : 1kHz SSG DEV : 1.5kHz AF : 2V/4Ω						PC adj. Adjust to point of opening squelch	
20. RD out level (Wide)	1) Connect SSG to RX ANT. CH : 2 (Wide) SSG output : -53dBm/501μV SSG MOD : 1kHz SSG DEV : 3kHz	SSG DVM	Rear	RX ANT CONTROL I/O jack RD (pin 10) 4.7kΩ load			PC adj. 80mV	±5mV
(Narrow)	2) CH : 2 (Narrow) SSG output : -53dBm/501μV SSG MOD : 1kHz SSG DEV : 1.5kHz							
21. RA out level (Wide)	1) Connect SSG to RX ANT. CH : 2 (Wide) SSG output : -53dBm/501μV SSG MOD : 1kHz SSG DEV : 3kHz	SSG DVM	Rear	RX ANT CONTROL I/O jack RA (pin 11) 4.7kΩ load			PC adj. 400mV	±20mV
(Narrow)	2) CH : 2 (Narrow) SSG output : -53dBm/501μV SSG MOD : 1kHz SSG DEV : 1.5kHz							
22. Maximum deviation (Wide)	1) Connect AG to the MIC terminal. A-low CH (TX VCO A low) A-center CH (VCO A center) A-high CH (TX VCO A high) B-low CH (TX VCO B low) B-center CH (VCO B center) B-high CH (TX VCO B high) Deviation meter filter HPF : OFF LPF : 15kHz De-emphasis : OFF AG : 1kHz/50mV (Terminal load) Transmission	MOD ANA or Deviation meter Oscilloscope AG AF VTVM	Rear Front	TX OUT MIC			PC adj. 4.1kHz	±0.1kHz

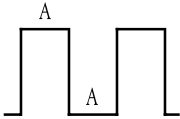
调 整

项 目	条 件	测 量			调 整			规 格 / 备 注
		测试设备	单元	端子	单元	部件	方 法	
17. 静音精确调整 (宽)	1) 将SSG与RX天线连接。 CH: 2(宽) SSG输出: 7dB以上至12dB SINAD电平 SSG MOD: 1kHz SSG DEV: 3kHz AF: 2V/4欧姆	SSG 音频分析仪 VTVM 示波器	后侧	RX天线 试验/ 扬声器 SPO端子 (插脚12)			PC调整 调整至开启静音点	
(窄)	1) CH: 2(窄) SSG输出: 7dB以下至12dB SINAD电平 SSG MOD: 1kHz SSG DEV: 1.5kHz AF: 2V/4欧姆						PC调整 调整至开启静音点	
18. RD输出电平调整 (宽)	1) 将SSG与RX天线连接。 CH: 2(宽) SSG输出: -53dBm/501 μV SSG MOD: 1kHz SSG DEV: 3kHz	SSG DVM	后侧	RX天线 控制输入 /输出 RD端子 (插脚10) 4.7kΩ 负载			PC调整 80mV	±5mV
(窄)	2) CH: 2(窄) SSG输出: -53dBm/501 μV SSG MOD: 1kHz SSG DEV: 1.5kHz							
19. RA输出电平调整 (宽)	1) 将SSG与RX天线连接。 CH: 2(宽) SSG输出: -53dBm/501 μV SSG MOD: 1kHz SSG DEV: 3kHz	SSG DVM	后侧	RX天线 控制输入 /输出 RA端子 (插脚11) 4.7kΩ 负载			PC调整 400mV	±20mV
(窄)	2) CH: 2(窄) SSG输出: -53dBm/501 μV SSG MOD: 1kHz SSG DEV: 1.5kHz							
20. 最大偏差调整 (宽)	1) 将AG连接麦克风端子。 低CH(TX VCO 低) 中央CH(VCO 中央) 高CH(TX VCO 高) 偏差计滤波器 HPF: 关闭 LPF: 15kHz 去加重: 关闭 AG: 1kHz/50mV(终端负载) 发射	MOD ANA 或偏差仪 示波器 AG AF VTVM	后侧 面板	TX OUT MIC			PC调整 4.1kHz	±0.1kHz
(窄)	1) 低CH(TX VCO 低) 中央CH(VCO 中央) 高CH(TX VCO 高) 发射						PC调整 2.05kHz	±0.1kHz

ADJUSTMENT

Item	Condition	Measurement			Adjustment			Specifications/Remarks
		Test-equipment	Unit	Terminal	Unit	Parts	Method	
(Narrow)	2) A-low CH (TX VCO A low) A-center CH (VCO A center) A-high CH (TX VCO A high) B-low CH (TX VCO B low) B-center CH (VCO B center) B-high CH (TX VCO B high) Transmission	MOD ANA or Deviation meter Oscilloscope AG AF VTVM	Rear Front	TX OUT MIC			PC adj. 2.05kHz	±0.1kHz
23. DQT balance (Wide)	1) Low CH (VCO-A center) High CH (VCO-B center) Deviation meter filter HPF : OFF LPF : 3kHz De-emphasis : OFF Transmission	MOD ANA or Deviation meter Oscilloscope	Rear	TX OUT			PC adj. Make the de-modulated waves into square waves.	Oscilloscope DC range flat "A" part 
(Narrow)	2) Low CH (VCO-A center) High CH (VCO-B center) Transmission							
24. QT deviation (Wide)	1) VCO-A CH (TX VCO A center) VCO-B CH (TX VCO B center) Deviation meter filter HPF : OFF LPF : 3kHz De-emphasis : OFF Detector : p-p/2 Transmission	MOD ANA or Deviation meter Oscilloscope	Rear	TX ANT			PC adj. 0.75kHz	±0.05kHz
(Narrow)	2) VCO-A CH (TX VCO A center) VCO-B CH (TX VCO B center) Transmission						PC adj. 0.35kHz	±0.05kHz
25. DQT deviation (Wide)	1) VCO-A CH (TX VCO A center) VCO-B CH (TX VCO B center) Deviation meter filter HPF : OFF LPF : 3kHz De-emphasis : OFF Detector : Peak hold Transmission						PC adj. 0.75kHz	±0.05kHz
(Narrow)	2) VCO-A CH (TX VCO A center) VCO-B CH (TX VCO B center) Transmission						PC adj. 0.35kHz	±0.05kHz
26. CW ID deviation (Wide)	1) VCO-A CH (TX VCO A center) VCO-B CH (TX VCO B center) Deviation meter filter HPF : OFF LPF : 15kHz De-emphasis : OFF Transmission						PC adj. 2kHz	±0.1kHz
(Narrow)	2) VCO-A CH (TX VCO A center) VCO-B CH (TX VCO B center) Transmission						PC adj. 1kHz	±0.05kHz

调 整

项 目	条 件	测 量			调 整			规 格 / 备 注
		测试设备	单元	端子	单元	部件	方 法	
21. DQT平衡 调整 (宽)	1) CH : 2 偏差仪滤波器 HPF : 关闭 LPF : 3kHz 去加重 : 关闭 发射	MOD ANA 或偏差仪 示波器	后侧	TX OUT			PC调整 使得解调波形为 方波	示波器DC范围 平坦的“A”部分。 
(窄)	2) CH : 2 发射							
22. QT偏差 调整(宽)	1) CH : 2 偏差仪滤波器 HPF : 关闭 LPF : 3kHz 去加重 : 关闭 检波器 : p-p/2 发射	MOD ANA 或偏差仪 示波器	后侧	TX天线			PC调整 0.75kHz	±0.05kHz
(窄)	2) CH : 2 发射						PC调整 0.35kHz	±0.05kHz
23. DQT偏差 调整(宽)	1) CH : 2 偏差仪滤波器 HPF : 关闭 LPF : 3kHz 去加重 : 关闭 检波器 : 峰值保持 发射						PC调整 0.75kHz	±0.05kHz
(窄)	2) CH : 2 发射						PC调整 0.35kHz	±0.05kHz
24. CW ID偏差 调整 (宽)	1) CH : 2 偏差仪滤波器 HPF : 关闭 LPF : 15kHz 去加重 : 关闭 发射						PC调整 2kHz	±0.1kHz
(窄)	2) CH : 2 发射						PC调整 1kHz	±0.05kHz
25. 试验音频 偏差调整 (宽)	1) CH : 2 偏差仪滤波器 HPF : 关闭 LPF : 15kHz 去加重 : 关闭 发射						PC调整 3kHz	±0.1kHz
(窄)	2) CH : 2 发射						PC调整 1.5kHz	±0.05kHz

ADJUSTMENT

Item	Condition	Measurement			Adjustment			Specifications/Remarks
		Test-equipment	Unit	Terminal	Unit	Parts	Method	
27. Test tone deviation (Wide)	1) VCO-A CH (TX VCO A center) VCO-B CH (TX VCO B center) Deviation meter filter HPF : OFF LPF : 15kHz De-emphasis : OFF Transmission	MOD ANA or Deviation meter Oscilloscope	Rear	TX ANT			PC adj. 3kHz	±0.1kHz
	(Narrow)	2) VCO-A CH (TX VCO A center) VCO-B CH (TX VCO B center) Transmission					PC adj. 1.5kHz	±0.05kHz
28. TA (TX audio input) deviation (Wide)	1) Insert AG output into the control I/O TA terminal (pin 9). VCO-A CH (TX VCO A center) VCO-B CH (TX VCO B center) Deviation meter filter HPF : OFF LPF : 15kHz De-emphasis : OFF AG freq' : 1kHz (Sine wave) AG level : 280mV Transmission	MOD ANA or Deviation meter Oscilloscope AG AF VTVM	Rear	TX ANT CONTROL I/O jack TA (pin 9)			PC adj. 3.0kHz	±0.1kHz
	(Narrow)	2) VCO-A CH (TX VCO A center) VCO-B CH (TX VCO B center) Transmission					PC adj. 1.5kHz	±0.05kHz
29. TD deviation (Wide)	1) Insert AG output into the control I/O TD terminal (pin 8). VCO-A CH (TX VCO A center) VCO-B CH (TX VCO B center) Deviation meter filter HPF : OFF LPF : 3kHz De-emphasis : OFF AG freq' : 100Hz (Sine wave) AG level : 0.5Vp-p (177mVrms) Transmission	MOD ANA or Deviation meter Oscilloscope AG AF VTVM	Rear	TX ANT CONTROL I/O jack TD (pin 8)			PC adj. 0.75kHz	±0.1kHz
	(Narrow)	2) VCO-A CH (TX VCO A center) VCO-B CH (TX VCO B center) Transmission					PC adj. 0.35kHz	±0.05kHz
30. Repeat gain level (Wide)	1) VCO-A CH (TX VCO A center) VCO-B CH (TX VCO B center) SSG output : -53dBm SSG MOD : 1kHz SSG DEV : 1kHz Deviation meter filter HPF : OFF LPF : 15kHz De-emphasis : OFF Transmission	SSG MOD ANA or Deviation meter Oscilloscope	Rear	RX ANT TX ANT			PC adj. 1kHz	±0.1kHz
	(Narrow)	1) VCO-A CH (TX VCO A center) VCO-B CH (TX VCO B center) Transmission						

调 整

项 目	条 件	测 量			调 整			规 格 / 备 注
		测试设备	单元	端子	单元	部件	方 法	
27. 试验音频 偏差调整 (宽)	1) VCO-A CH(TX VCO-A中央) VCO-B CH(TX VCO-B中央) 偏差仪滤波器 HPF: 关闭 LPF: 15kHz 去加重: 关闭 发射	MOD ANA 或偏差仪 示波器	后侧	TX天线			PC调整 3kHz	±0.1kHz
	(窄)							
28. TA(TX音频 输入)偏差 调整 (宽)	1) 将AG输出插入控制输入/输出TA端子(插脚9) VCO-A CH(TX VCO-A中央) VCO-B CH(TX VCO-B中央) 偏差仪滤波器 HPF: 关闭 LPF: 15kHz 去加重: 关闭 AG频率: 1kHz(正弦波) AG电平: 280mV 发射	MOD ANA 或偏差仪 示波器 AG AF VTVM	后侧	TX天线 控制输入 /输出 TA端子 (插脚9)			PC调整 3.0kHz	±0.1kHz
	(窄)							
29. TD偏差 调整 (宽)	1) 将AG输出插入控制输入/输出TD端子(插脚8) VCO-A CH(TX VCO-A中央) VCO-B CH(TX VCO-B中央) 偏差仪滤波器 HPF: 关闭 LPF: 3kHz 去加重: 关闭 AG频率: 100Hz(正弦波) AG电平: 0.5Vp-p(177mVrms) 发射	MOD ANA 或偏差仪 示波器 AG AF VTVM	后侧	TX天线 控制输入 /输出 TD端子 (插脚8)			PC调整 0.75kHz	±0.1kHz
	(窄)							
30. 中继增益 电平调整 (宽)	1) VCO-A CH(TX VCO-A中央) VCO-B CH(TX VCO-B中央) SSG输出: -53dBm SSG MOD: 1kHz SSG DEV: 1kHz 偏差仪滤波器 HPF: 关闭 LPF: 15kHz 去加重: 关闭 发射	SSG MOD ANA 或偏差仪 示波器	后侧	RX天线 TX天线			PC调整 1kHz	±0.1kHz
	(窄)			2) VCO-A CH(TX VCO-A中央) VCO-B CH(TX VCO-B中央) 发射				

ADJUSTMENT / 调整

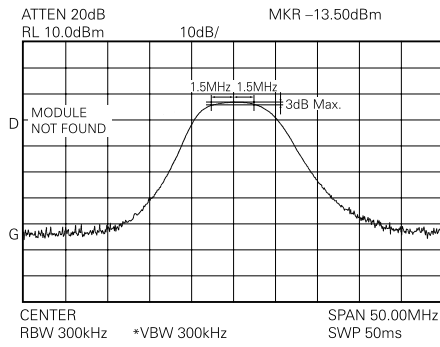


Fig. 1 / 图1

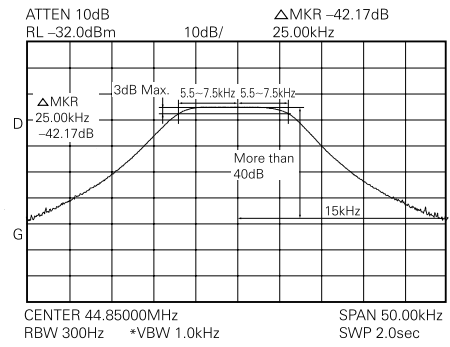


Fig. 2 / 图2

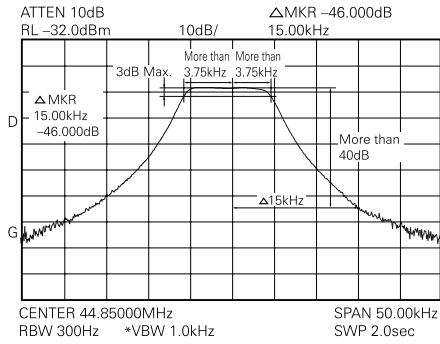
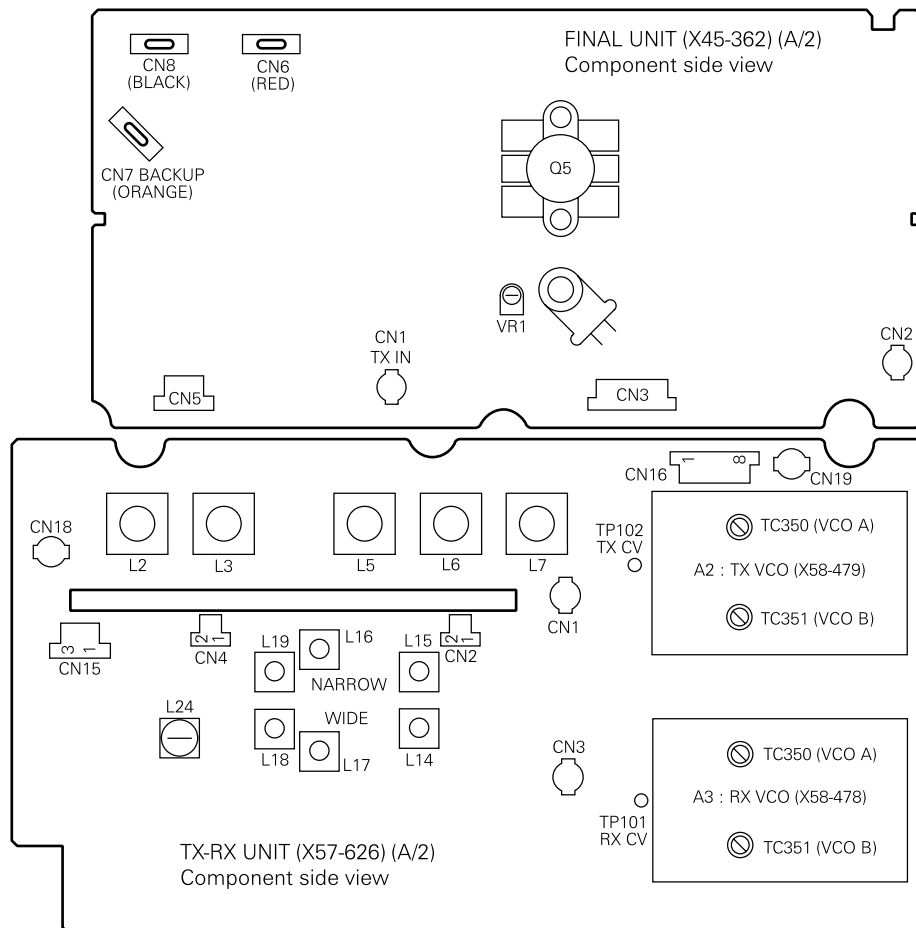


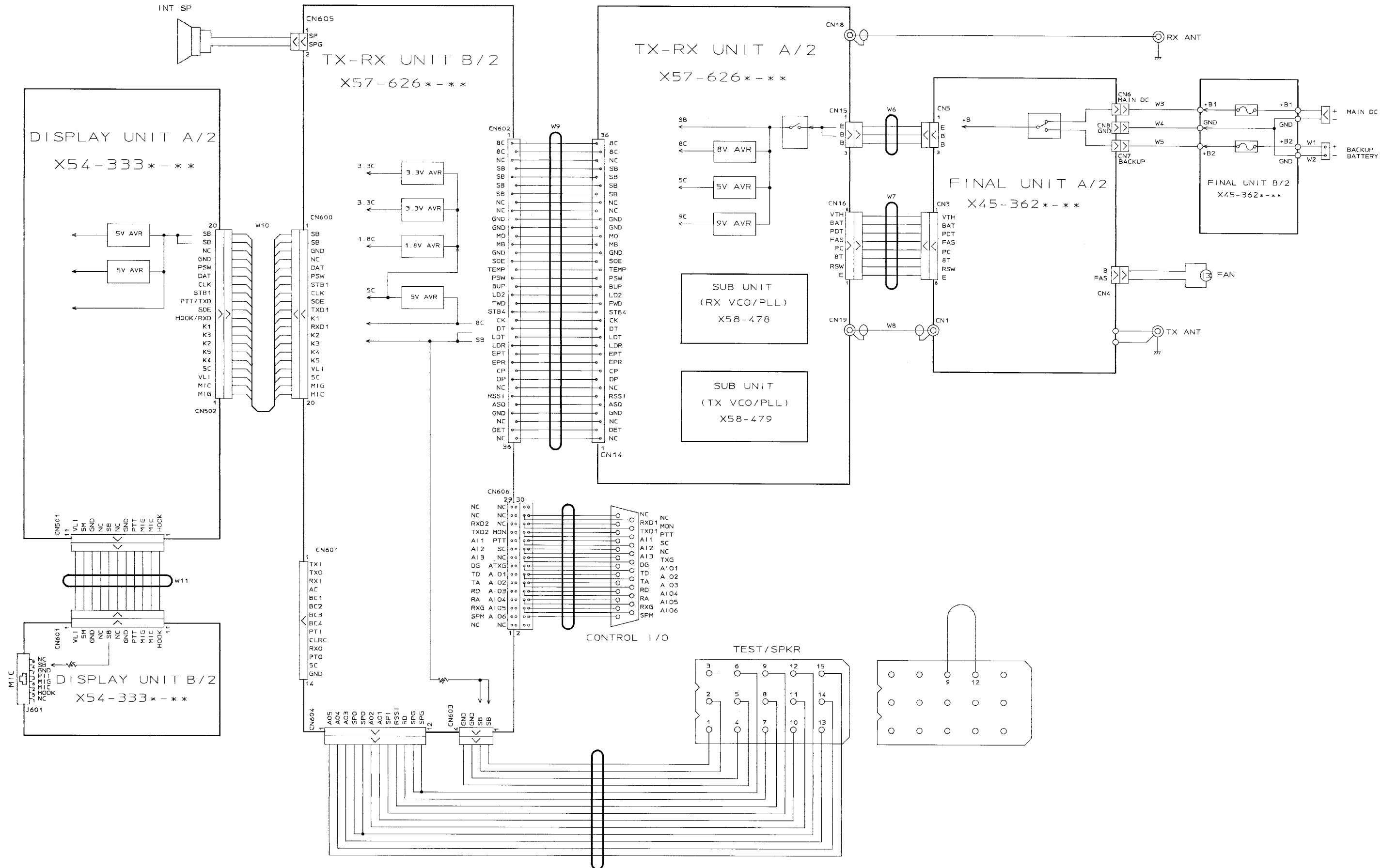
Fig. 3 / 图3

Adjustment Point / 调整点



TKR-750 TKR-750

WIRING / 总布线图



TERMINAL FUNCTION / 端子功能

Final Unit (X45-3620-XX)

Connector No.	Terminal No.	Terminal Name	I/O	Terminal function
CN1		DRV	I	TX driver input signal (Coaxial)
CN2		-	-	Reserved
To X57 (A/2) TX-RX unit	1	VTH	O	High temperature detector signal output
	2	BAT	O	Main DC/BACKUP status output
	3	PDT	O	RF power down signal output
	4	FAS	I	Fan control signal input
	5	PC	I	TX power control signal input
	6	8T	I	8V input during transmission
	7	RSW	-	Reserved
	8	E	-	Ground
CN4		B	O	Power supply output for cooling fan
		FAG	O	Fan ground
CN5	1	E	-	Ground
	2	+B	O	Power supply output
	3	+B	O	Power supply output
CN6	1	Main DC	I	Power supply input (from Main DC terminal)
CN7	1	BACKUP	I	Power supply input (from BACKUP terminal)
CN8	1	GND	-	Ground

未级单元(X45-3620-XX)

连接器号码	端子号码	端子名称	输入/输出	端子功能
CN1		DRV	输入	TX驱动器输入信号(同轴)
CN2		-	-	保留
CN3 至X57 (A/2) TX-RX 单元	1	VTH	输出	高温检测器信号输出
	2	BAT	输出	主DC/后备电源状态输出
	3	PDT	输出	射频功率下降信号输出
	4	FAS	输入	风扇控制信号输入
	5	PC	输入	TX功率控制信号输入
	6	8T	输入	发射时的8V输入
	7	RSW	-	保留
	8	E	-	接地
CN4		B	输出	冷却风扇的电源供电输出
		FAG	输出	风扇接地
CN5	1	E	-	接地
	2	+B	输出	电源供电输出
	3	+B	输出	电源供电输出
CN6	1	Main DC	输入	电源供电输入(来自主DC端子)
CN7	1	BACKUP	输入	电源供电输入(来自后备DC端子)
CN8	1	GND	-	接地

Display Unit (X54-3330-20) (A/2)

Connector No.	Terminal No.	Terminal Name	I/O	Terminal function
CN501 To X54 (B/2) display unit	1	HOOK	I	Hook detection input/RXD input
	2	MIC	I	MIC signal input
	3	MIG	-	MIC ground
	4	PTT	I/O	PTT input/TXD output
	5	GND	-	Ground
	6	NC	-	No connection
	7	SB	O	Power supply output after power switch
	8	NC	-	No connection
	9	GND	-	Ground
	10	5M	O	Common 5V output
	11	VLI	I	Volume control input for AF signal
CN502 To X57 (B/2) TX-RX unit control section	1	MIG	-	MIC ground
	2	MIC	O	MIC signal output
	3	VLI	O	Volume control output for AF signal
	4	5C	I	Common 5V input
	5	K4	I	KEY input 4
	6	K5	I	KEY input 5
	7	K2	O	KEY output 2
	8	K3	O	KEY output 3
	9	K1	O	KEY output 1
	10	HOOK/RXD	O	Hook detection output/RXD output
	11	SOE	I	Output enable for shift register
	12	PTT/TXD	I/O	PTT output/TXD input

显示单元(X54-3330-20) (A/2)

连接器号码	端子号码	端子名称	输入/输出	端子功能
CN501 至X54 (B/2) 显示 单元	1	HOOK	输入	挂钩检测输入/RXD输入
	2	MIC	输入	麦克风信号输入
	3	MIG	-	麦克风接地
	4	PTT	输入/输出	PTT输入/TXD输出
	5	GND	-	接地
	6	NC	-	无连接
	7	SB	输出	电源开关之后的电源供电输出
	8	NC	-	无连接
	9	GND	-	接地
	10	5M	输出	公共5V输出
	11	VLI	输入	音频信号音量控制输入
CN502 至X57 (B/2) TX-RX 单元 控制 部分	1	MIG	-	麦克风接地
	2	MIC	输出	麦克风信号输出
	3	VLI	输出	音频信号音量控制输出
	4	5C	输入	公共5V输入
	5	K4	输入	键输入4
	6	K5	输入	键输入5
	7	K2	输出	键输出2
	8	K3	输出	键输出3
	9	K1	输出	键输出1
	10	HOOK/RXD	输出	挂钩检测输出/RXD输出
	11	SOE	输入	对于移位寄存器开启输出
	12	PTT/TXD	输入/输出	PTT输出/TXD输入

TERMINAL FUNCTION / 端子功能

Connector No.	Terminal No.	Terminal Name	I/O	Terminal function
	13	STB1	I	Strobe data for shift register
	14	CLK	I	Clock data input
	15	DAT	I	Serial data input
	16	PSW	O	Power switch output
	17	GND	-	Ground
	18	NC	-	No connection
	19	SB	I	Power supply input after power switch
	20	SB	I	Power supply input after power switch

连接器号码	端子号码	端子名称	输入/输出	端子功能
	13	STB1	输入	对于移位寄存器的选通数据
	14	CLK	输入	时钟数据输入
	15	DAT	输入	串行数据输入
	16	PSW	输出	电源开关输出
	17	GND	-	接地
	18	NC	-	无连接
	19	SB	输入	电源开关之后的电源供电输入
	20	SB	输入	电源开关之后的电源供电输入

Display Unit (X54-3330-20) (B/2)

Connector No.	Terminal No.	Terminal Name	I/O	Terminal function
CN601 To X54 (A/2) display unit	1	VLI	O	Volume control output for AF signal
	2	5M	I	Common 5V input
	3	GND	-	Ground
	4	NC	-	No connection
	5	SB	I	Power supply input after power switch
	6	NC	-	No connection
	7	GND	-	Ground
	8	PTT	I/O	PTT output/TXD input
	9	MIG	-	MIC ground
	10	MIC	O	MIC signal output
	11	HOOK	O	Hook detection output/RXD output
J601 (Mic jack)	1	NC	-	No connection
	2	SB	O	Power supply output after power switch
	3	E	-	Ground
	4	PTT/TXD	I/O	PTT input/TXD output
	5	ME	-	MIC ground
	6	MIC	I	MIC signal input
	7	HOOK/RXD	I	Hook detection input/RXD input
	8	NC	-	No connection

显示单元(X45-3330-20) (B/2)

连接器号码	端子号码	端子名称	输入/输出	端子功能
CN601 至X54 (A/2) 显示 单元	1	VLI	输出	音频信号的音量控制输出
	2	5M	输入	公共5V输入
	3	GND	-	接地
	4	NC	-	无连接
	5	SB	输入	电源开关之后的电源供电输入
	6	NC	-	无连接
	7	GND	-	接地
	8	PTT	输入/输出	PTT输出/TXD输入
	9	MIG	-	麦克风接地
	10	MIC	输出	麦克风信号输出
	11	HOOK	输出	挂钩检测输出/RXD输出
J601 (麦克风 插孔)	1	NC	-	无连接
	2	SB	输出	电源开关之后的电源供电输出
	3	E	-	接地
	4	PTT/TXD	输入/输出	PTT输入/TXD输出
	5	ME	-	麦克风接地
	6	MIC	输入	麦克风信号输入
	7	HOOK/RXD	输入	挂钩检测输入/RXD输入
	8	NC	-	无连接

TX-RX Unit (X57-6260-XX) (A/2) : TX-RX Section

Connector No.	Terminal No.	Terminal Name	I/O	Terminal function
CN1	-	-	O	Use for RX helical BPF tuning (Coaxial)
CN2	-	-	I	Use for RX MCF tuning
CN3	-	-	O	Use for RX frequency adjustment (Coaxial)
CN4	-	-	O	Use for RX MCF tuning
CN14 To X57 (B/2) control section of TX-RX unit	1	NC	-	No connection
	2	DET	O	Detection signal output
	3	NC	-	No connection
	4	GND	-	Ground
	5	ASQ	O	Squelch signal output
	6	RSSI	O	RSSI signal output
	7	NC	-	No connection
	8	DP	I	Data input for PLL
	9	CP	I	Clock input for PLL

TX-RX单元(X57-6260-XX) (A/2) : TX-RX部分

连接器号码	端子号码	端子名称	输入/输出	端子功能
CN1	-	-	输出	用于RX螺旋BPF调谐(同轴)
CN2	-	-	输入	用于RX MCF调谐
CN3	-	-	输出	用于RX频率调整(同轴)
CN4	-	-	输出	用于RX MCF调谐
CN14 至X57 (B/2) TX-RX 单元 控制 部分	1	NC	-	无连接
	2	DET	输出	信号输出检测
	3	NC	-	无连接
	4	GND	-	接地
	5	ASQ	输出	静噪信号输出
	6	RSSI	输出	RSSI信号输出
	7	NC	-	无连接
	8	DP	输入	PLL的数据输入
	9	CP	输入	PLL的时钟输入

TERMINAL FUNCTION / 端子功能

Connector No.	Terminal No.	Terminal Name	I/O	Terminal function	连接器号码	端子号码	端子名称	输入/输出	端子功能		
	10	EPR	I	Enable input for RX PLL		10	EPR	输入	RX PLL的输入开启		
	11	EPT	I	Enable input for TX PLL		11	EPT	输入	TX PLL的输入开启		
	12	LDR	O	Lock detector for RX PLL		12	LDR	输出	RX PLL的锁定检测器		
	13	LDT	O	Lock detector for TX PLL		13	LDT	输出	TX PLL的锁定检测器		
	14	DT	I	Data input		14	DT	输入	数据输入		
	15	CK	I	Clock input		15	CK	输入	时钟输入		
	16	STB4	I	Strobe input for shift register		16	STB4	输入	移位检测器的选通输入		
	17	FWD	O	RF power down signal output		17	FWD	输出	射频功率下降信号输出		
	18	LD2	I	Latch data input for DA converter		18	LD2	输入	数/模变换器的锁存数据输入		
	19	BUP	O	Backup signal output		19	BUP	输出	后备信号输出		
	20	PSW	I	Power switch input		20	PSW	输入	电源开关输入		
	21	TEMP	O	High temperature detector signal output		21	TEMP	输出	高温检测器信号输出		
	22	SOE	I	Output enable for shift register		22	SOE	输入	移位寄存器的输出开启		
	23	GND	-	Ground		23	GND	-	接地		
	24	MB	I	Modulation signal input for VCXO		24	MB	输入	VCXO的调制信号输入		
	25	MO	I	Modulation signal input for VCO		25	MO	输入	VCO的调制信号输入		
	26	GND	-	Ground		26	GND	-	接地		
	27	GND	-	Ground		27	GND	-	接地		
	28	NC	-	No connection		28	NC	-	无连接		
	29	NC	-	No connection		29	NC	-	无连接		
	30	SB	O	Power supply output after power switch		30	SB	输出	电源开关之后的电源供电输出		
	31	SB	O	Power supply output after power switch		31	SB	输出	电源开关之后的电源供电输出		
	32	SB	O	Power supply output after power switch		32	SB	输出	电源开关之后的电源供电输出		
	33	SB	O	Power supply output after power switch		33	SB	输出	电源开关之后的电源供电输出		
	34	NC	-	No connection		34	NC	-	无连接		
	35	8C	O	Common 8V output		35	8C	输出	公共8V输出		
	36	8C	O	Common 8V output		36	8C	输出	公共8V输出		
	CN15	1	E	-		Earth	CN15	1	E	-	接地
		2	B	I		Power supply input		2	B	输入	电源供电输入
		3	B	I		Power supply input		3	B	输入	电源供电输入
	CN16 To X45 final unit	1	E	-		Earth	CN16 至X45 末级 单元	1	E	-	接地
		2	RSW	-		Reserved		2	RSW	-	保留
		3	8T	O		8V output during transmission		3	8T	输出	发射时的8V输出
		4	PC	O		TX power control signal output		4	PC	输出	TX电源控制信号输出
		5	FAS	O		Fan control signal output		5	FAS	输出	风扇控制信号输出
		6	PDT	I		RF power down signal input		6	PDT	输入	射频功率下降信号输入
7		BAT	I	Main DC/BACKUP status input	7	BAT		输入	主DC/后备DC状态输入		
8		VTH	I	High temperature detector signal input	8	VTH		输入	高温检测器信号输入		
CN18	1	RX IN	I	Receive signal input (Coaxial)	CN18	1	RX IN	输入	接收信号输入(同轴)		
CN19	1	DO	O	Transmission signal output (Coaxial)	CN19	1	DO	输出	发射信号输出(同轴)		

TERMINAL FUNCTION / 端子功能

TX-RX Unit (X57-6260-XX) (B/2) : Control Section

TX-RX单元(X57-6260-XX)(B/2) : 控制部分

Connector No.	Terminal No.	Terminal Name	I/O	Terminal function
CN600 To X54 (B/2) display unit	1	SB	O	Power supply output after power switch
	2	SB	O	Power supply output after power switch
	3	GND	-	Ground
	4	NC	-	No Connection
	5	DAT	O	Serial data output
	6	PSW	I	Power switch input
	7	STB1	O	Strobe data for shift register
	8	CLK	O	Clock data output
	9	SOE	O	Output enable for shift register
	10	TXD1	I/O	PTT input/TXD output
	11	K1	I	KEY input 1
	12	RXD1	I	Hook detection input/RXD input
	13	K2	I	KEY input 2
	14	K3	I	KEY input 3
	15	K4	O	KEY output 4
	16	K5	O	KEY output 5
	17	VLI	I	Volume control input for AF signal.
	18	5C	O	Common 5V output
	19	MIG	-	Mic ground
	20	MIC	I	MIC signal input
CN601 To optional board	1	TXI	I	MIC signal input
	2	TXO	O	MIC signal output
	3	RXI	I	RX audio signal input
	4	AC	O	Audio control signal output
	5	BC1	O	Scramble code output.
	6	BC2	O	Scramble code output.
	7	BC3	O	Scramble code output.
	8	BC4	O	Scramble code output.
	9	PTI	I	PTT signal input
	10	CLRC	O	Clear code for scramble
	11	RXO	O	RX audio signal output
	12	PTO	O	PTT signal output
	13	5C	O	Common 5V output
	14	GND	-	Ground
CN602 To X57 (A/2) TX-RX unit	1	8C	I	Common 8V input
	2	8C	I	Common 8V input
	3	NC	-	No connection
	4	SB	I	Power supply input after power switch
	5	SB	I	Power supply input after power switch
	6	SB	I	Power supply input after power switch
	7	SB	I	Power supply input after power switch
	8	NC	-	No connection
	9	NC	-	No connection
	10	GND	-	Ground
	11	GND	-	Ground
	12	MO	O	Modulation signal output for VCO
	13	MB	O	Modulation signal output for VCXO

连接器 号码	端子 号码	端子 名称	输入/输出	端子功能
CN600 至X54 (B/2) 显示 单元	1	SB	输出	电源开关之后的电源供电输出
	2	SB	输出	电源开关之后的电源供电输出
	3	GND	-	接地
	4	NC	-	无连接
	5	DAT	输出	串行数据输出
	6	PSW	输入	电源开关输入
	7	STB1	输出	移位寄存器的选通数据
	8	CLK	输出	时钟数据输出
	9	SOE	输出	移位寄存器的输出开启
	10	TXD1	输入/输出	PTT输入/TXD输出
	11	K1	输入	键输入1
	12	RXD1	输入	挂钩检测输入/RXD输入
	13	K2	输入	键输入2
	14	K3	输入	键输入3
	15	K4	输出	键输出4
	16	K5	输出	键输出5
	17	VL1	输入	射频信号的音量控制输入
	18	5C	输出	公共5V输出
	19	MIG	-	麦克风接地
	20	MIC	输入	麦克风信号输入
CN601 至可 选板	1	TXI	输入	麦克风信号输入
	2	TXO	输出	麦克风信号输出
	3	RXI	输入	RX音频信号输入
	4	AC	输出	音频控制信号输出
	5	BC1	输出	扰频代码输出.
	6	BC2	输出	扰频代码输出
	7	BC3	输出	扰频代码输出
	8	BC4	输出	扰频代码输出
	9	PTI	输入	PTT信号输入
	10	CLRC	输出	扰频的清除代码
	11	RXO	输出	RX音频信号输出
	12	PTO	输出	PTT信号输出
	13	5C	输出	公共5V输出
	14	GND	-	接地
CN602 至X57 (A/2) TX-RX 单元	1	8C	输入	公共8V输入
	2	8C	输入	公共8V输入
	3	NC	-	无连接
	4	SB	输入	电源开关之后的电源供电输入
	5	SB	输入	电源开关之后的电源供电输入
	6	SB	输入	电源开关之后的电源供电输入
	7	SB	输入	电源开关之后的电源供电输入
	8	NC	-	无连接
	9	NC	-	无连接
	10	GND	-	接地
	11	GND	-	接地
	12	MO	输出	VCO的调制信号输出
	13	MB	输出	VCXO的调制信号输出

TERMINAL FUNCTION / 端子功能

Connector No.	Terminal No.	Terminal Name	I/O	Terminal function	连接器号码	端子号码	端子名称	输入/输出	端子功能
	14	GND	-	Ground		14	GND	-	接地
	15	SOE	O	Output enable for shift register		15	SOE	输出	移位寄存器的输出开启
	16	TEMP	I	High temperature detector signal input		16	TEMP	输入	高温检测器信号输入
	17	PSW	O	Power switch output		17	PSW	输出	电源开关输出
	18	BUP	I	Backup signal input		18	BUP	输入	后备信号输入
	19	LD2	O	Latch data output for DA converter		19	LD2	输出	数/模变换器的锁存数据输出
	20	FWD	I	RF power down signal input		20	FWD	输入	射频功率下降信号输入
	21	STB4	O	Strobe output for shift register		21	STB4	输出	移位寄存器的选通输出
	22	CK	O	Clock output		22	CK	输出	时钟输出
	23	DT	O	Data output		23	DT	输出	数据输出
	24	LDT	I	Lock detector for TX PLL		24	LDT	输入	TX PLL的锁定检测器
	25	LDR	I	Lock detector for RX PLL		25	LDR	输入	RX PLL的锁定检测器
	26	EPT	O	Enable output for TX PLL		26	EPT	输出	TX PLL的输出开启
	27	EPR	O	Enable output for RX PLL		27	EPR	输出	RX PLL的输出开启
	28	CP	O	Clock output for PLL		28	CP	输出	PLL的时钟输出
	29	DP	O	Data output for PLL		29	DP	输出	PLL的数据输出
	30	NC	-	No connection		30	NC	-	无连接
	31	RSSI	I	RSSI signal input		31	RSSI	输入	RSSI信号输入
	32	ASQ	I	Squelch signal input		32	ASQ	输入	静噪信号输入
	33	GND	-	Ground		33	GND	-	接地
	34	NC	-	No connection		34	NC	-	无连接
	35	DET	I	Detection signal input		35	DET	输入	检测信号输入
	36	NC	-	No connection		36	NC	-	无连接
CN603 To ACC 15 pin connector	1	SB	O	Power supply output after power switch	CN603 至ACC 15插脚 连接器	1	SB	输出	电源开关之后的电源供电输出
	2	SB	O	Power supply output after power switch		2	SB	输出	电源开关之后的电源供电输出
	3	GND	-	Ground		3	GND	-	接地
	4	GND	-	Ground		4	GND	-	接地
CN604 To ACC 15 pin connector	1	AO5	O	Auxiliary output 5 (FPU selectable)	CN604 至ACC 15插脚 连接器	1	A05	输出	辅助输出5 (FPU可选)
	2	AO4	O	Auxiliary output 4 (FPU selectable)		2	A04	输出	辅助输出4 (FPU可选)
	3	AO3	O	Auxiliary output 3 (FPU selectable)		3	A03	输出	辅助输出3 (FPU可选)
	4	SPO	O	External speaker output		4	SPO	输出	外部扬声器输出
	5	SPO	O	External speaker output		5	SPO	输出	外部扬声器输出
	6	AO2	O	Auxiliary output 2 (FPU selectable)		6	A02	输出	辅助输出2 (FPU可选)
	7	AO1	O	Auxiliary output 1 (FPU selectable)		7	A01	输出	辅助输出1 (FPU可选)
	8	SPI	I	Internal speaker input		8	SP1	输入	内部扬声器输入
	9	RSSI	O	RSSI signal output		9	RSSI	输出	RSSI信号输出
	10	RD	O	RX data output		10	RD	输出	RX数据输出
	11	SPG	-	External speaker ground		11	SPG	-	外部扬声器接地
	12	SPG	-	External speaker ground		12	SPG	-	外部扬声器接地
CN605	1	SP	O	Internal speaker AF output	CN605	1	SP	输出	内部扬声器音频输出
	2	SPG	-	Internal speaker ground		2	SPG	-	内部扬声器接地
CN606 To ACC 25 pin D-sub connector	1	NC	-	No connection	CN606 至ACC 25插脚 D-sub 连接器	1	NC	-	无连接
	2	NC	-	No connection		2	NC	-	无连接
	3	SPM	I	Speaker mute signal input		3	SPM	输入	扬声器静音信号输入
	4	IO6	I/O	Programable I/O 6		4	IO6	输入/输出	可编程输入/输出6
	5	RXG	-	RX signal ground		5	RXG	-	RX信号接地
	6	IO5	I/O	Programable I/O 5		6	IO5	输入/输出	可编程输入/输出5
	7	RA	O	RX audio output (voice)		7	RA	输出	RX音频输出 (声音)
	8	IO4	I/O	Programable I/O 4		8	IO4	输入/输出	可编程输入/输出4

TERMINAL FUNCTION / 端子功能

Connector No.	Terminal No.	Terminal Name	I/O	Terminal function
	9	RD	O	RX data output (voice & data)
	10	IO3	I/O	Programable I/O 3
	11	TA	I	TX audio input (voice)
	12	IO2	I/O	Programable I/O 2
	13	TD	I	TX data input (data or signaling)
	14	IO1	I/O	Programable I/O 1
	15	DG	-	Control line ground
	16	TXG	-	TX signal ground
	17	AI3	I	Auxiliary input 3 (FPU selectable)
	18	NC	-	No connection
	19	AI2	I	Auxiliary input 2 (FPU selectable)
	20	SC	O	Squelch control output
	21	AI1	I	Auxiliary input 1 (FPU selectable)
	22	EPTT	I	External press-to-talk switch input
	23	TXD2	O	RS-232C output signal (for FPU)
	24	EMON	I	External monitor switch input
	25	RXD2	I	RS-232C input signal (for FPU)
	26	NC	-	No connection
	27	NC	-	No connection
	28	NC	-	No connection
	29	NC	-	No connection
	30	NC	-	No connection

连接器号码	端子号码	端子名称	输入/输出	端子功能
	9	RD	输出	RX数据输出(声音和数据)
	10	IO3	输入/输出	可编程输入/输出3
	11	TA	输入	TX音频输入(声音)
	12	IO2	输入/输出	可编程输入/输出2
	13	TD	输入	TX数据输入(数据或信令)
	14	IO1	输入/输出	可编程输入/输出1
	15	DG	-	控制线接地
	16	TXG	-	TX信号接地
	17	AI3	输入	辅助输入3(FPU可选)
	18	NC	-	无连接
	19	AI2	输入	辅助输入2(FPU可选)
	20	SC	输出	静噪控制输出
	21	AI1	输入	辅助输入1(FPU可选)
	22	EPTT	输入	外部PTT开关输入
	23	TXD2	输出	RS-232C输出信号(用于FPU)
	24	EMON	输入	外部监听开关输入
	25	RXD2	输入	RS-232C输入信号(用于FPU)
	26	NC	-	无连接
	27	NC	-	无连接
	28	NC	-	无连接
	29	NC	-	无连接
	30	NC	-	无连接

VCO (RX) Unit (X58-4780-10)

Connector No.	Terminal No.	Terminal Name	I/O	Terminal function
CN300	1	FIN	I	Prescaler RF signal input
	2	5C	I	Common 5V input
	3	LDR	O	Lock detector for RX PLL
	4	EPR	I	Enable input for RX PLL
	5	DP	I	Data input for PLL
	6	CP	I	Clock input for PLL
	7	REF	I	Reference frequency signal input
CN350	1	GND	-	Ground
	2	SRR	I	Switching signal input for RX VCO
	3	8CL	I	8V input through the ripple filter
	4	CV	I	RX PLL lock voltage
	5	9CL	I	9V input through the ripple filter
	6	NC	-	No connection
CN351	1	VO	O	RX VCO output
	2	GND	-	Ground

VCO(RX)单元(X58-4780-10)

连接器号码	端子号码	端子名称	输入/输出	端子功能
CN300	1	FIN	输入	预定标器射频信号输入
	2	5C	输入	公共5V输入
	3	LDR	输出	RX PLL的锁定检测器
	4	EPR	输入	RX PLL的输入开启
	5	DP	输入	PLL的数据输入
	6	CP	输入	PLL的时钟输入
	7	REF	输入	参照频率信号输入
CN350	1	GND	-	接地
	2	SRR	输入	RX VCO的切换信号输入
	3	8CL	输入	通过纹波滤波器的8V输入
	4	CV	输入	RX PLL锁定电压
	5	9CL	输入	通过纹波滤波器的9V输入
	6	NC	-	无连接
CN351	1	VO	输出	RX VCO输出
	2	GND	-	接地

VCO (TX) Unit (X58-4790-10)

Connector No.	Terminal No.	Terminal Name	I/O	Terminal function
CN300	1	FIN	I	Prescaler RF signal input
	2	5C	I	Common 5V input
	3	LDT	O	Lock detector for TX PLL
	4	EPT	I	Enable input for TX PLL
	5	DP	I	Data input for PLL

VCO(TX)单元(X58-4790-10)

连接器号码	端子号码	端子名称	输入/输出	端子功能
CN300	1	FIN	输入	预定标器射频信号输入
	2	5C	输入	公共5V输入
	3	LDT	输出	TX PLL的锁定检测器
	4	EPT	输入	TX PLL的输入开启
	5	DP	输入	PLL的数据输入

TERMINAL FUNCTION / 端子功能

Connector No.	Terminal No.	Terminal Name	I/O	Terminal function
	6	CP	I	Clock input for PLL
	7	REF	I	Reference frequency signal input
CN350	1	GND	-	Ground
	2	STT	I	Switching signal input for TX VCO
	3	8CL	I	8V input through the ripple filter
	4	CV	I	RX PLL lock voltage
	5	9CL	I	9V input through the ripple filter
	6	MO	I	Modulation signal input
CN351	1	VO	O	TX VCO output
	2	GND	-	Ground

连接器号码	端子号码	端子名称	输入/输出	端子功能
	6	CP	输入	PLL的时钟输入
	7	REF	输入	参照频率信号输入
CN350	1	GND	-	接地
	2	STT	输入	TX VCO的切换信号输入
	3	8CL	输入	通过纹波滤波器的8V输入
	4	CV	输入	RX PLL锁定电压
	5	9CL	输入	通过纹波滤波器的9V输入
	6	MO	输入	调制信号输入
CN351	1	VO	输出	TX VCO输出
	2	GND	-	接地

ACC 25 pin D-sub Connector

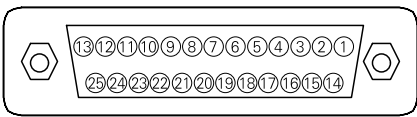
Connector No.	Terminal No.	Terminal Name	I/O	Terminal function
	1	NC	-	No connection
	2	RXD2	I	Serial data to radio
	3	TXD2	O	Serial data from radio
	4	AI1	I	Programmable function input 1
	5	AI2	I	Programmable function input 2
	6	AI3	I	Programmable function input 3
	7	DG	-	Control line ground
	8	TD	I	TX data input (data or signalling) Input impedance: 600Ω Coupling: AC coupling Deviation: 0.75kHz (wide)/ 0.35kHz (Narrow) (100Hz 0.5Vp-p input)
	9	TA	I	TX audio input (voice) Input impedance: 600Ω Coupling: AC coupling Deviation: 60% deviation (1kHz 280mVrms ±25mV input)
	10	RD	O	RX data output (voice & data) Output impedance: 1kΩ or less Coupling: AC coupling Frequency response: ±2.5dB at 10~3000Hz Output level: 70~90mVrms (standard modulation)
	11	RA	O	RX audio output (voice) Output impedance: 1kΩ or less Coupling: AC coupling Output level: 360~440mVrms (standard modulation)
	12	RXG	-	RX signal ground (for RA, RD ground only)
	13	SPM	I	Speaker mute signal input "L": Mute on
	14	NC	-	No connection

ACC25插脚D-sub连接器

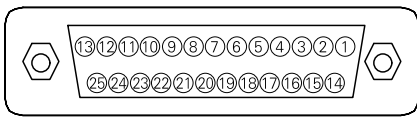
连接器号码	端子号码	端子名称	输入/输出	端子功能
	1	NC	-	无连接
	2	RXD2	输入	至电台的串行数据
	3	TXD2	输出	来自电台的串行数据
	4	AI1	输入	可编程功能输入1
	5	AI2	输入	可编程功能输入2
	6	AI3	输入	可编程功能输入3
	7	DG	-	控制线接地
	8	TD	输入	TX数据输入(数据或信令) 输入阻抗: 600欧姆 耦合: AC耦合 偏差: 0.75kHz(宽)/ 0.35kHz(窄) (100Hz 0.5Vp-p输入)
	9	TA	输入	TX音频输入(声音) 输入阻抗: 600欧姆 耦合: AC耦合 偏差: 60%偏差 (1kHz 280mVrms ±25mV输入)
	10	RD	输出	RX数据输出(声音和数据) 输出阻抗: 1k欧姆或以下 耦合: AC耦合 频率响应: 在10~3000Hz范 围, ±2.5dB 输出电平: 70~90mVrms (标准调制)
	11	RA	输出	RX音频输出(声音) 输出阻抗: 1k欧姆或以下 耦合: AC耦合 输出电平: 360~440mVrms (标准调制)
	12	RXG	-	RX信号接地(仅对于RA、RD接地)
	13	SPM	输入	扬声器静音信号输入 "L": 静音接通
	14	NC	-	无连接

TERMINAL FUNCTION / 端子功能

Connector No.	Terminal No.	Terminal Name	I/O	Terminal function
	15	EMON	I	External monitor switch input “L”: Monitor on, “H”: Monitor off
	16	EPTT	I	External press-to-talk switch input “L”: PTT on, “H”: PTT off
	17	SC	O	Squelch control output “L”: Busy, “H”: Not busy
	18	NC	-	No connection
	19	TXG	-	TX signal ground (for TA,TD ground only)
	20	AIO1	I/O	Programmable function input/output 1
	21	AIO2	I/O	Programmable function input/output 2
	22	AIO3	I/O	Programmable function input/output 3
	23	AIO4	I/O	Programmable function input/output 4
	24	AIO5	I/O	Programmable function input/output 5
	25	AIO6	I/O	Programmable function input/output 6

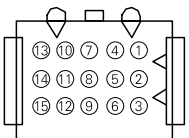


连接器号码	端子号码	端子名称	输入/输出	端子功能
	15	EMON	输入	外部监听开关输入 “L”: 监听接通, “H”: 监听切断
	16	EPTT	输入	外部PTT开关输入 “L”: PTT接通, “H”: PTT切断
	17	SC	输出	静噪控制输出 “L”: 占用, “H”: 非占用
	18	NC	-	无连接
	19	TXG	-	TX信号接地(仅对于TA、TD)
	20	AIO1	输入/输出	可编程功能输入/输出1
	21	AIO2	输入/输出	可编程功能输入/输出2
	22	AIO3	输入/输出	可编程功能输入/输出3
	23	AIO4	输入/输出	可编程功能输入/输出4
	24	AIO5	输入/输出	可编程功能输入/输出5
	25	AIO6	输入/输出	可编程功能输入/输出6



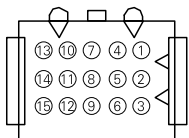
ACC 15 pin Connector

Connector No.	Terminal No.	Terminal Name	I/O	Terminal function
	1	SB	O	Power supply output after power switch; 1A maximum
	2	SB	O	Power supply output after power switch; 1A maximum
	3	NC	-	No connection
	4	GND	-	Ground
	5	GND	-	Ground
	6	SPG	-	Speaker ground
	7	RD	O	RX data output
	8	RSSI	O	RSSI output
	9	SPI	I	Internal speaker input
	10	AO1	O	Auxiliary output 1
	11	AO2	O	Auxiliary output 2
	12	SPO	O	External speaker output
	13	AO3	O	Auxiliary output 3
	14	AO4	O	Auxiliary output 4
	15	AO5	O	Auxiliary output 5



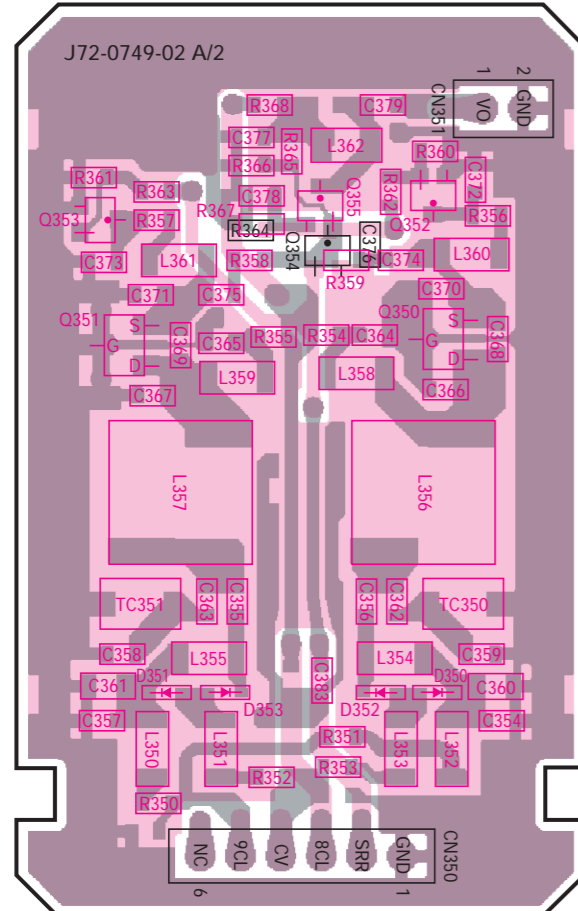
ACC 15插脚连接器

连接器号码	端子号码	端子名称	输入/输出	端子功能
	1	SB	输出	电源开关之后的电源供电输出, 最大1A
	2	SB	输出	电源开关之后的电源供电输出, 最大1A
	3	NC	-	无连接
	4	GND	-	接地
	5	GND	-	接地
	6	SPG	-	扬声器接地
	7	RD	输出	RX数据输出
	8	RSSI	输出	RSSI输出
	9	SPI	输入	内部扬声器输入
	10	AO1	输出	辅助输出1
	11	AO2	输出	辅助输出2
	12	SPO	输出	外部扬声器输出
	13	AO3	输出	辅助输出3
	14	AO4	输出	辅助输出4
	15	AO5	输出	辅助输出5

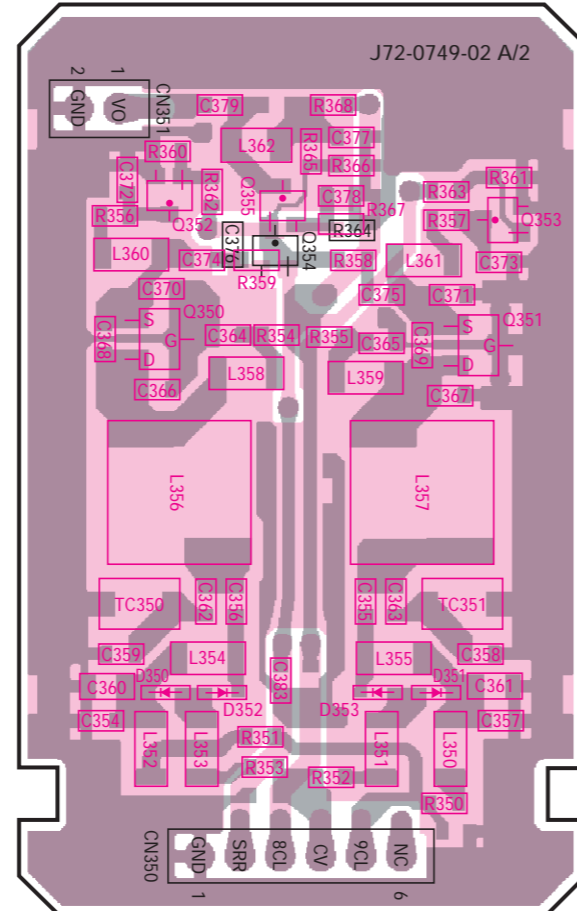


PC BOARD VIEWS / PC板视图 TKR-750

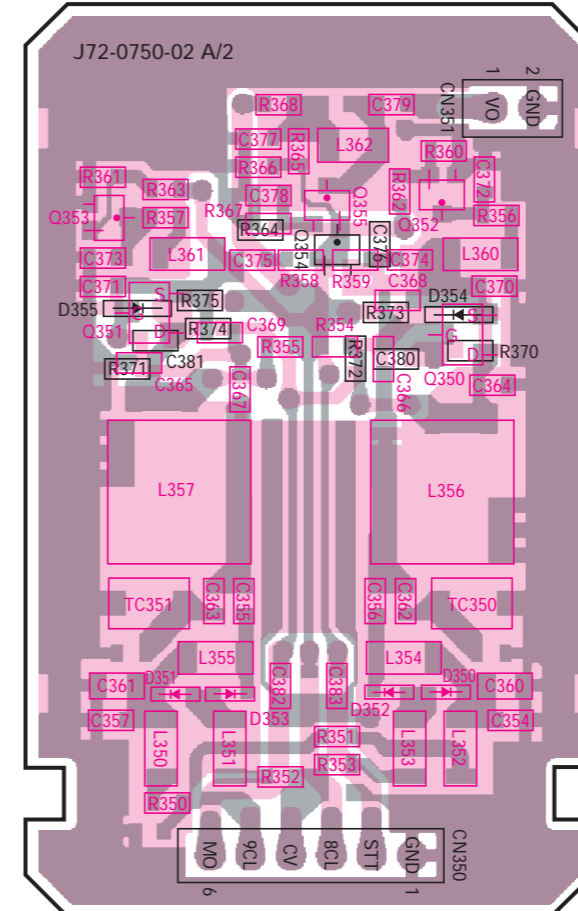
RX PLL/VCO (X58-4780-10)
Component side view



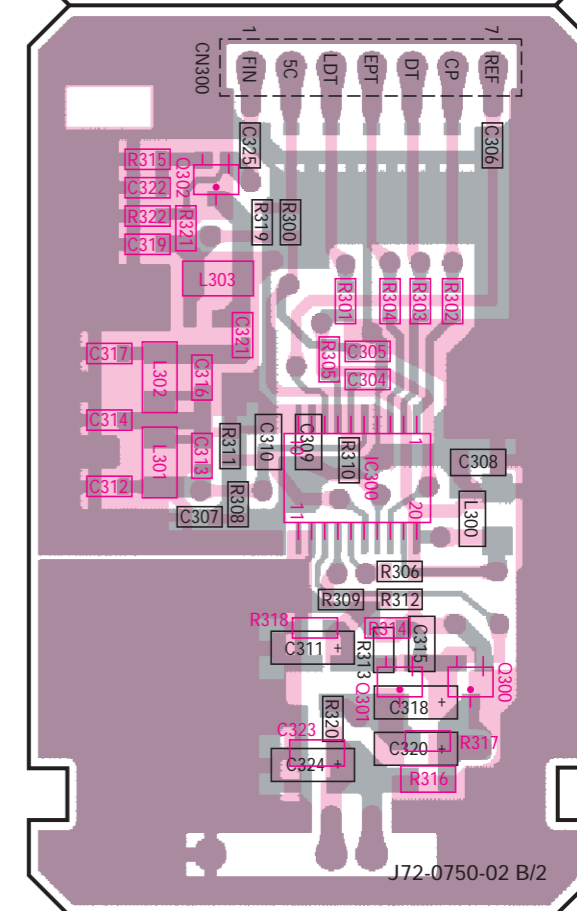
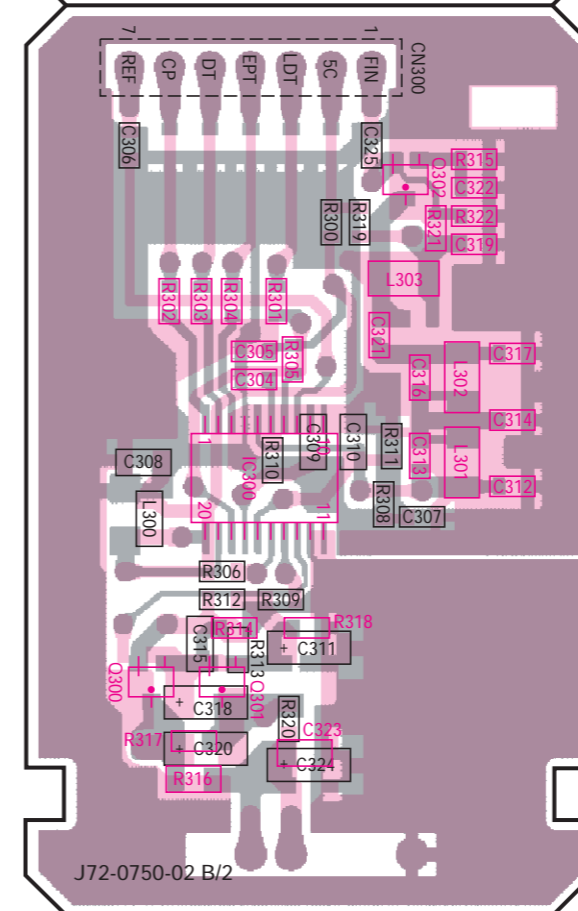
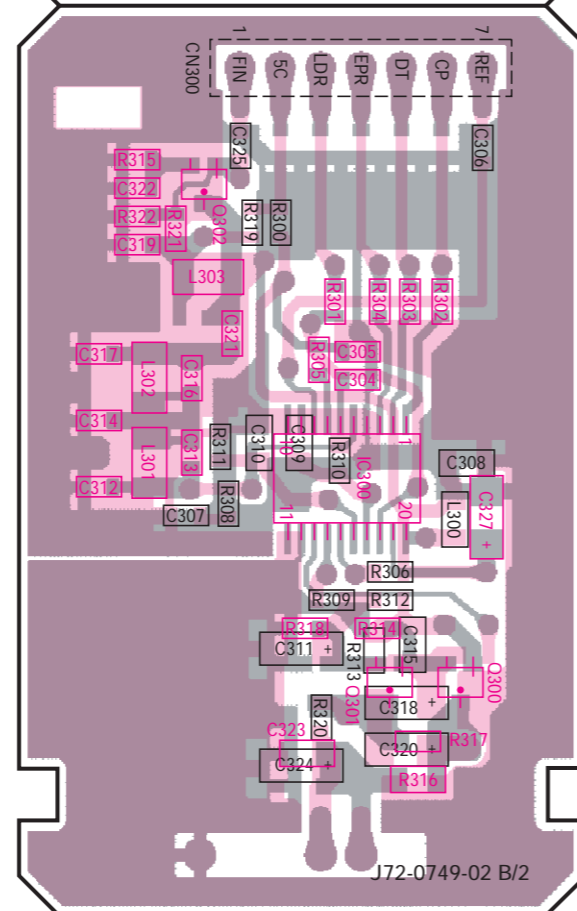
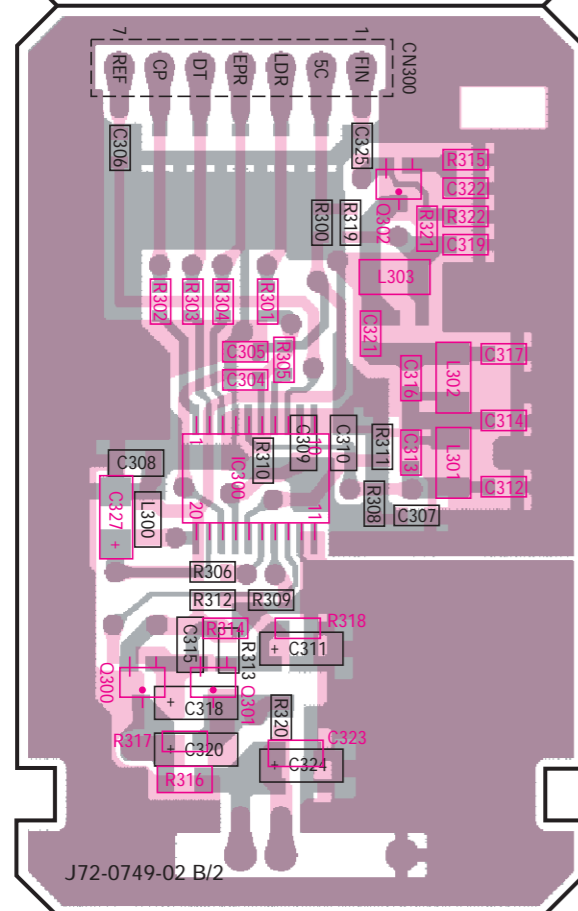
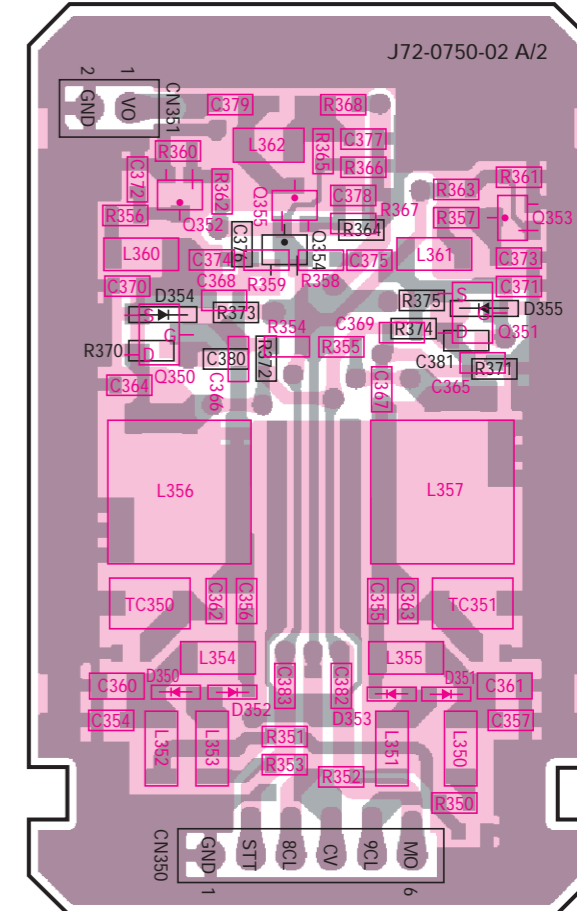
RX PLL/VCO (X58-4780-10)
Foil side view



TX PLL/VCO (X58-4790-10)
Component side view



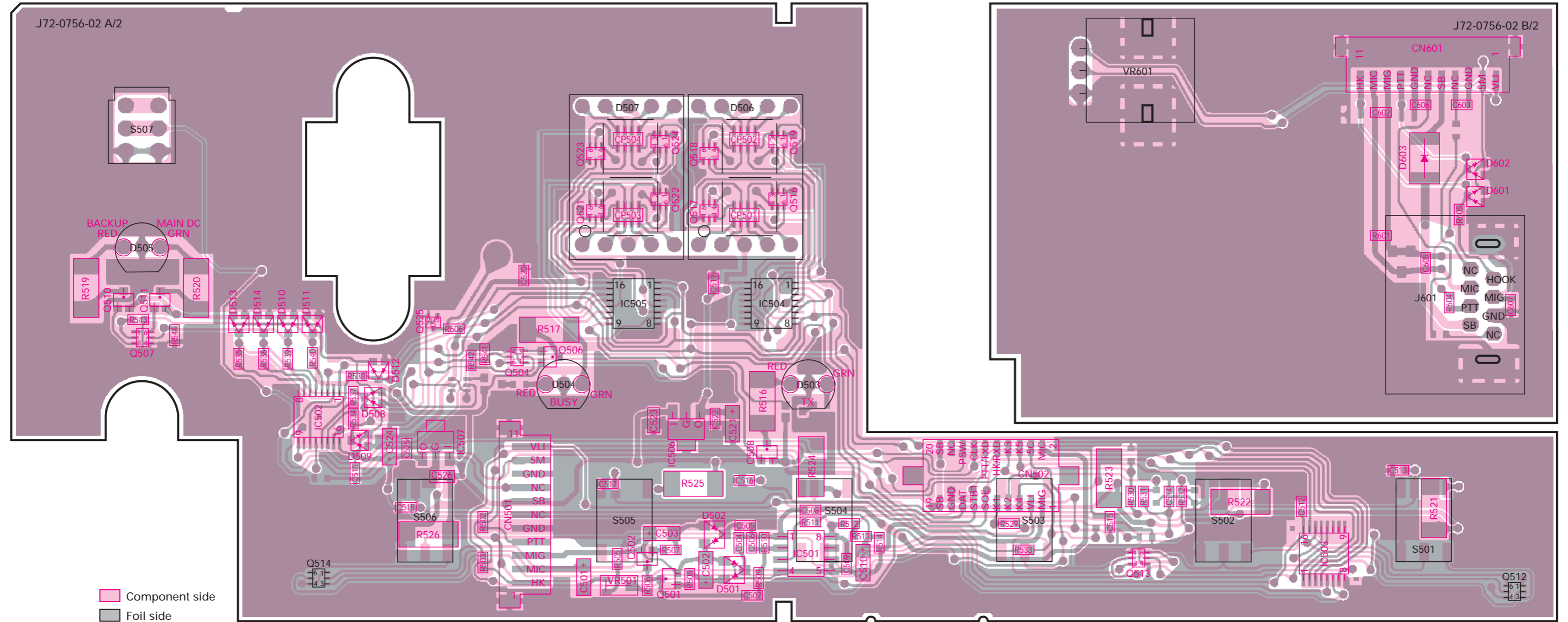
TX PLL/VCO (X58-4790-10)
Foil side view



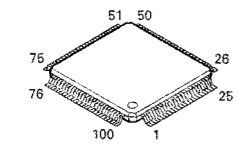
Component side Foil side

Component side Foil side

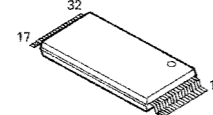
DISPLAY UNIT (X54-3330-20) Foil side view



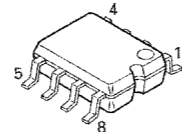
30622M4-113GP



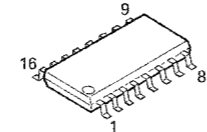
AT29C020-90TI



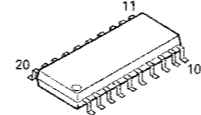
AT2408N10SI2.5



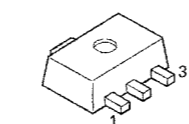
BU4053BCF



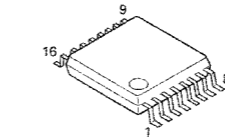
SA7025DK



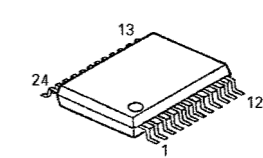
NJM78L05UA
RH5VL42C



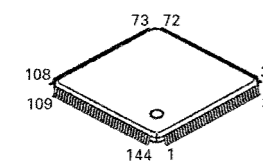
AK4550VT
BU4094BCFV
M62354GP
TC74VHC4040FT



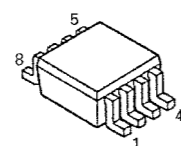
M62364FP
TC74LVX4245FS



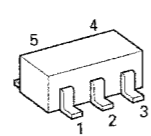
320VC5402PGE



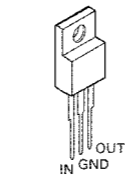
TA75W01FU
TC75W51FU



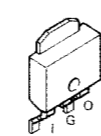
TA75S01F



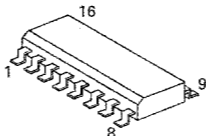
NJM7808FA



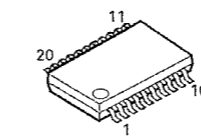
TA7808F



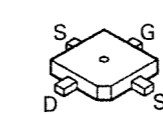
ADM202EARN



TK14489V

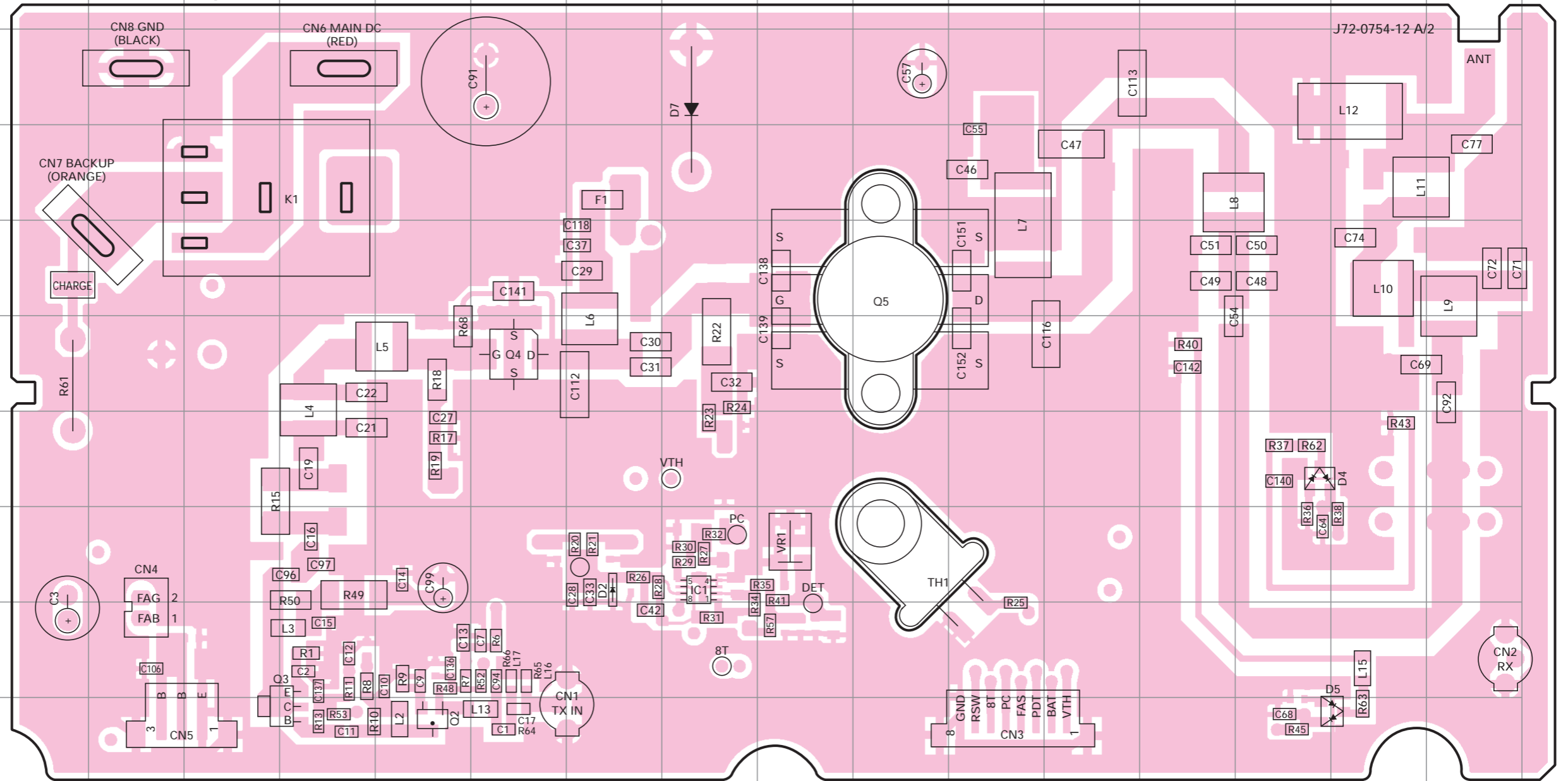


2SK3075

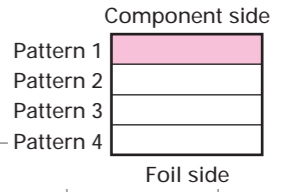


TKR-750 PC BOARD VIEWS / PC板视图

FINAL UNIT (X45-3620-XX) -10 : C -11 : C2 Component side view

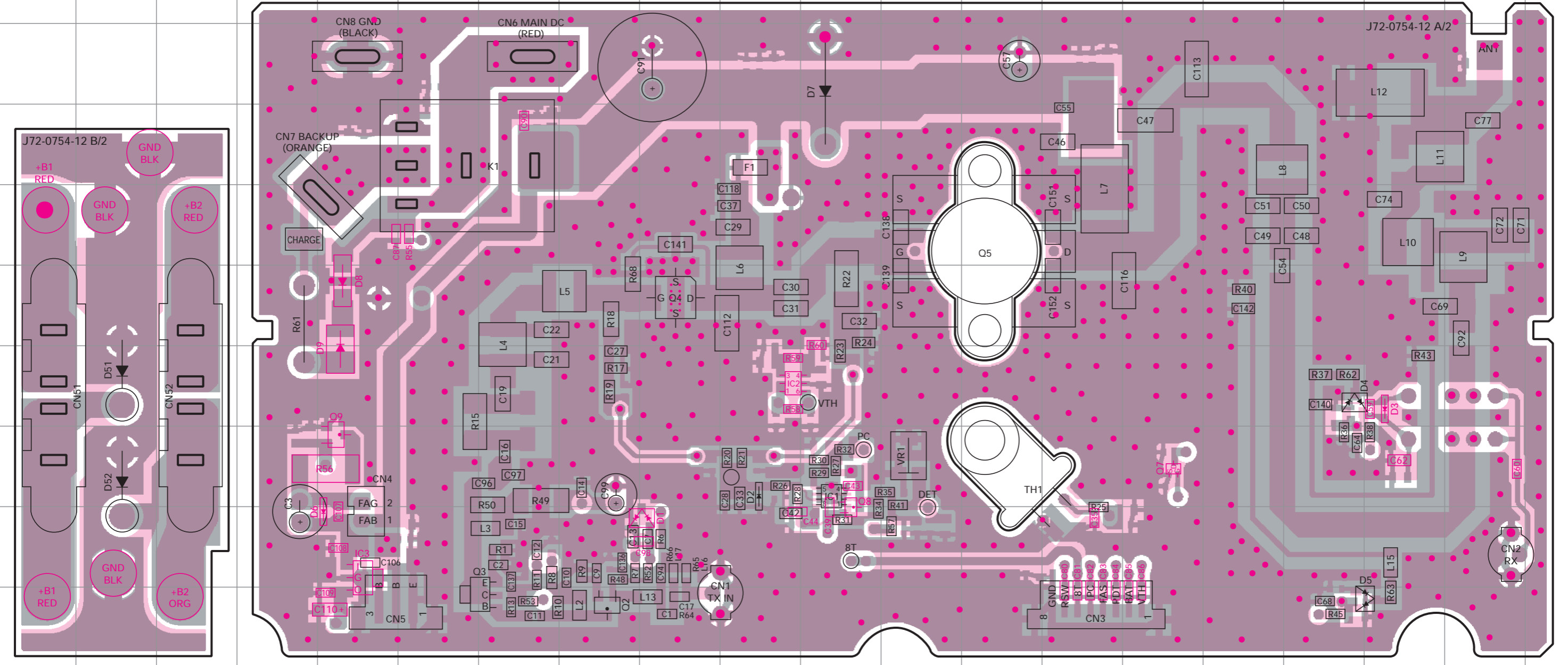


Ref No.	Address	Ref No.	Address	Ref No.	Address
IC1	8K	Q5	5M	D7	3K
Q2	10H	D2	8J	D51	7B
Q3	10G	D4	7Q	D52	8B
Q4	6I	D5	10R		

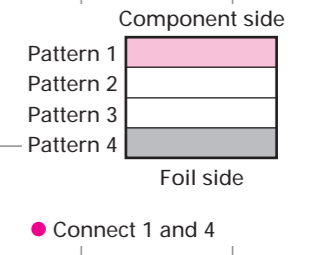


TKR-750 PC BOARD VIEWS / PC板视图

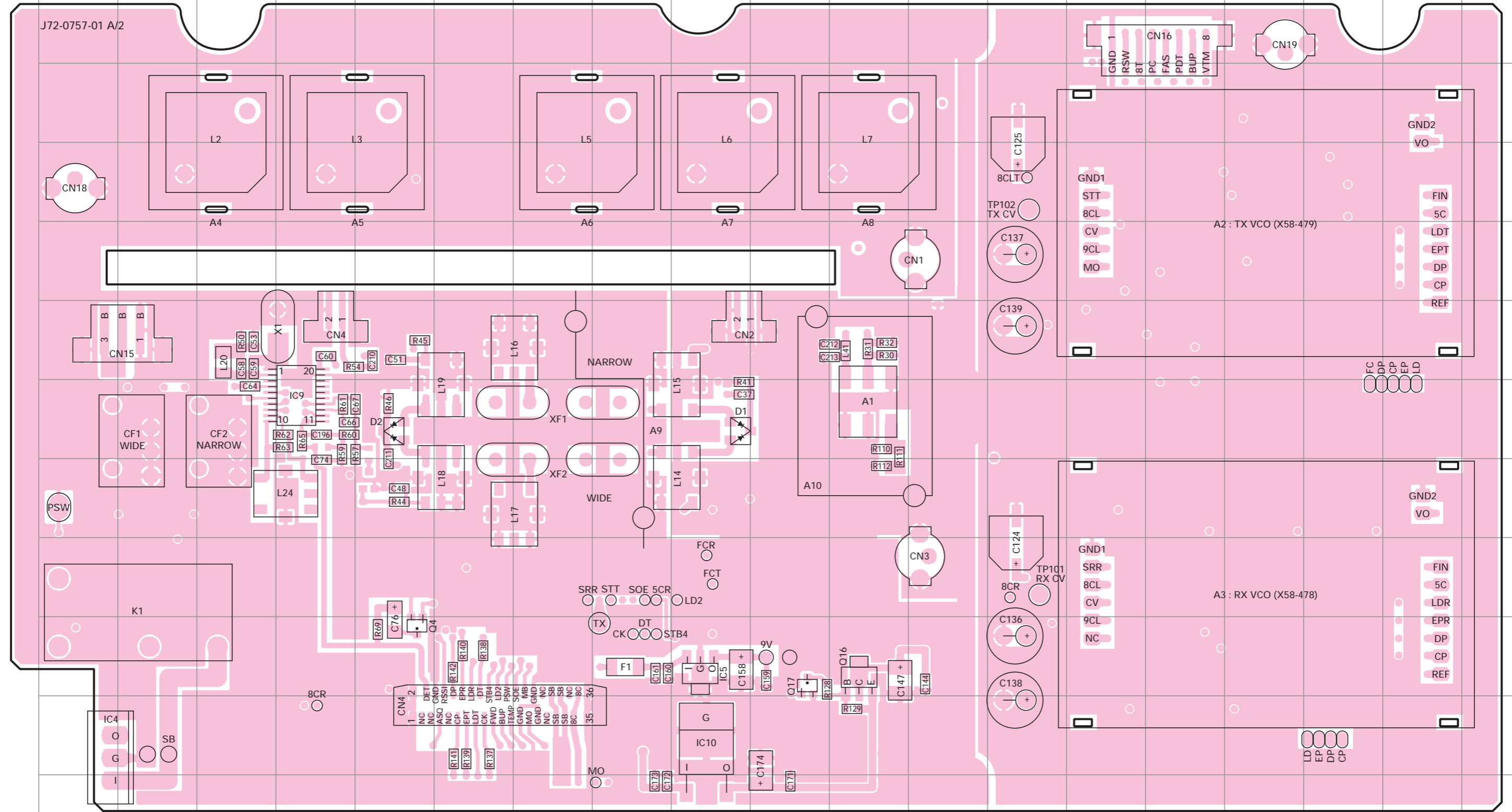
FINAL UNIT (X45-3620-XX) -10 : C -11 : C2 Component side view + Foil side



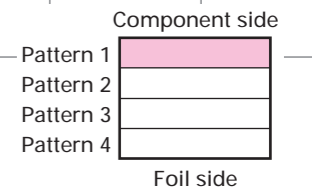
Ref No.	Address	Ref No.	Address	Ref No.	Address
IC1	8K	Q7	8O	D5	10R
IC2	7J	Q8	8K	D6	9E
IC3	9E	Q9	8E	D7	3K
Q2	10H	D1	9I	D8	6E
Q3	10G	D2	8J	D9	7E
Q4	6I	D3	7R	D51	7B
Q5	5M	D4	7Q	D52	8B



TX-RX UNIT (X57-6260-XX) (A/2) -10 : C -11 : C2 Component side view

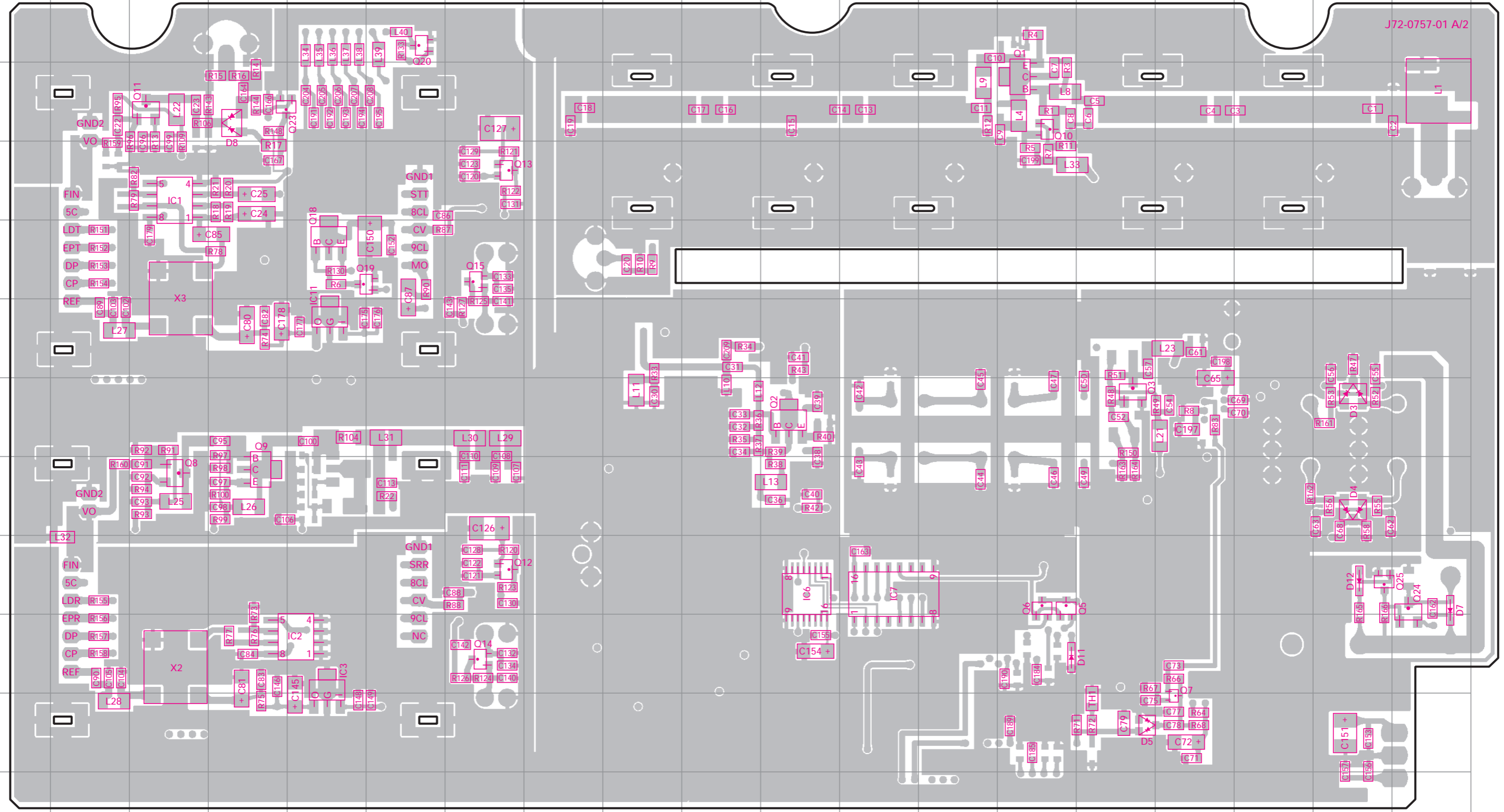


Ref No.	Address	Ref No.	Address	Ref No.	Address
IC4	11A	IC10	11I	Q17	10J
IC5	10I	Q4	10E	D1	7I
IC9	7D	Q16	10K	D2	7E



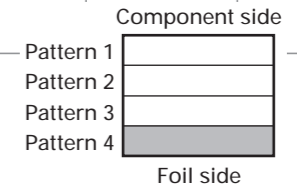
TKR-750 PC BOARD VIEW / PC板视图

TX-RX UNIT (X57-6260-XX) (A/2) -10 : C -11 : C2 Foil side view



J72-0757-01 A/2

Ref No.	Address	Ref No.	Address	Ref No.	Address	Ref No.	Address	Ref No.	Address	Ref No.	Address	Ref No.	Address
IC1	4C	IC11	6E	Q6	9N	Q11	3C	Q18	5E	Q25	9R	D8	3D
IC2	10E	Q1	3N	Q7	11P	Q12	3G	Q19	5F	D3	7R	D11	10N
IC3	10E	Q2	7K	Q8	8C	Q13	4G	Q20	2F	D4	8R	D12	9R
IC6	9K	Q3	7O	Q9	8D	Q14	10G	Q23	3D	D5	11O		
IC7	9L	Q5	9N	Q10	3N	Q15	5G	Q24	9S	D7	9S		

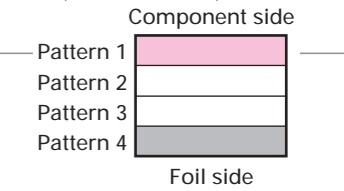


PC BOARD VIEW / PC板视图 TKR-750

TX-RX UNIT (X57-6260-XX) (A/2) -10 : C -11 : C2 Component side view + Foil side

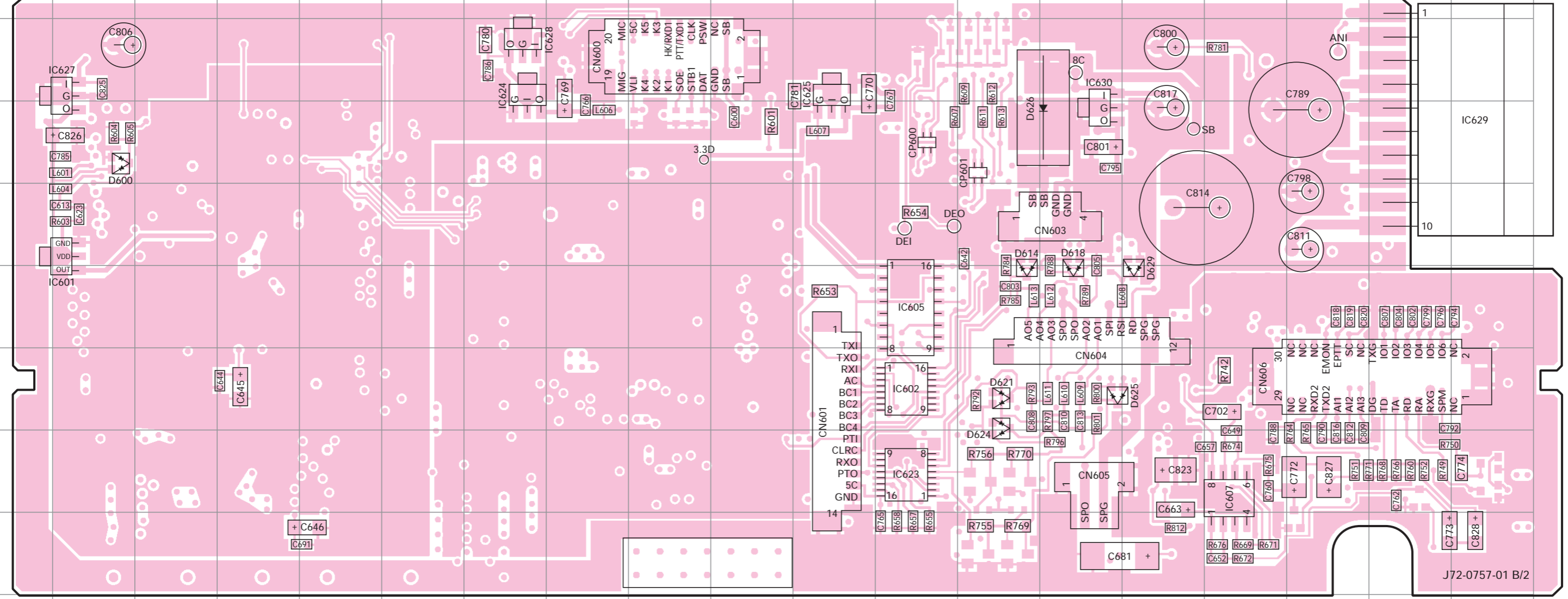


Ref No.	Address	Ref No.	Address	Ref No.	Address	Ref No.	Address	Ref No.	Address	Ref No.	Address	Ref No.	Address
IC1	4Q	IC7	9H	Q3	7E	Q9	8P	Q15	5M	Q23	3P	D4	8B
IC2	10Q	IC9	7D	Q4	10E	Q10	3F	Q16	10K	Q24	9A	D5	11E
IC3	10Q	IC10	11I	Q5	9F	Q11	3Q	Q17	10J	Q25	9B	D7	9A
IC4	11A	IC11	6O	Q6	9F	Q12	9M	Q18	5O	D1	7I	D8	3P
IC5	10I	Q1	3F	Q7	11D	Q13	4M	Q19	5N	D2	7E	D11	10F
IC6	9I	Q2	7I	Q8	8Q	Q14	10M	Q20	2N	D3	7B	D12	9B

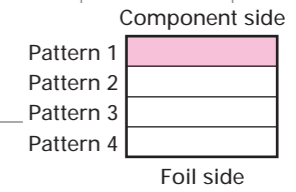


TKR-750 PC BOARD VIEW / PC板视图

TX-RX UNIT (X57-6260-XX) (B/2) -10 : C -11 : C2 Component side view

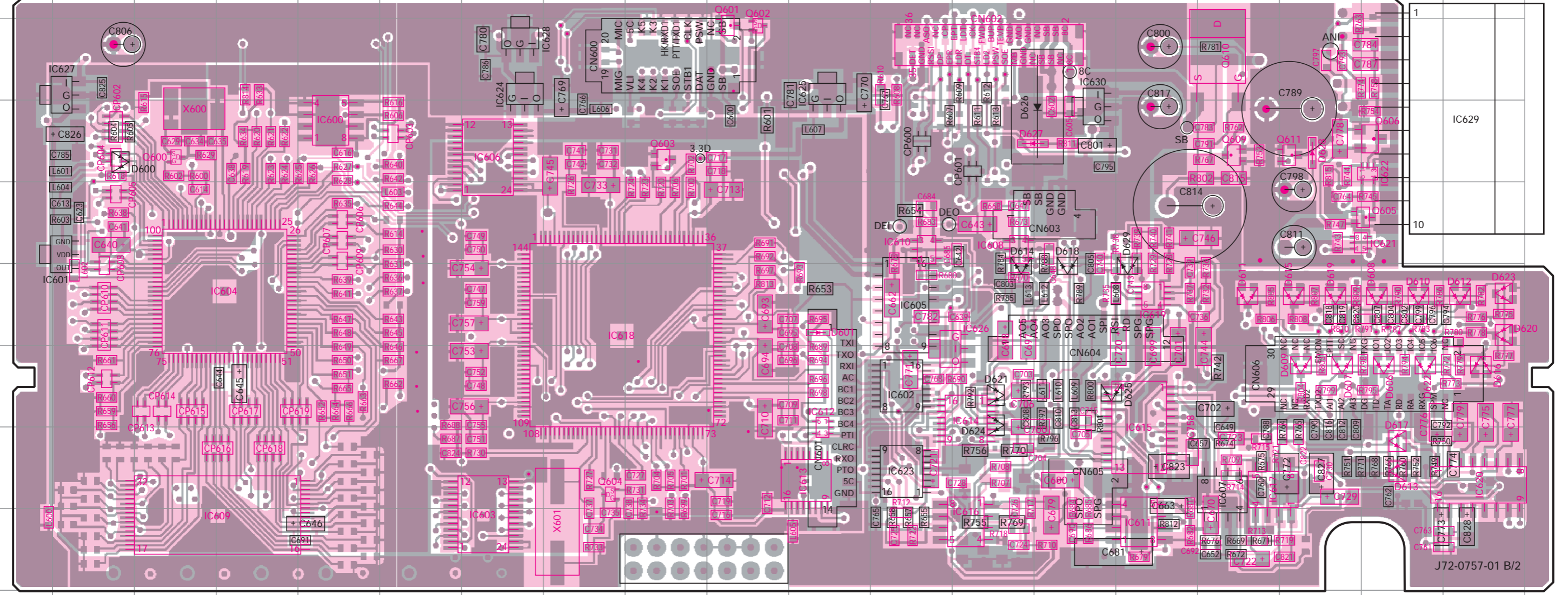


Ref No.	Address	Ref No.	Address	Ref No.	Address	Ref No.	Address
IC601	5B	IC624	3G	IC630	4N	D624	7M
IC602	7L	IC625	3K	D600	4B	D625	7N
IC605	6L	IC627	3B	D614	6M	D626	4N
IC607	8P	IC628	3G	D618	6N	D629	6O
IC623	8L	IC629	4S	D621	7M		



TKR-750 PC BOARD VIEW / PC板视图

TX-RX UNIT (X57-6260-XX) (B/2) -10 : C -11 : C2 Component side view + Foil side



Ref No.	Address	Ref No.	Address	Ref No.	Address	Ref No.	Address	Ref No.	Address	Ref No.	Address	Ref No.	Address	Ref No.	Address	Ref No.	Address
IC600	4E	IC607	8P	IC614	7M	IC621	5R	IC628	3G	Q604	8H	D601	6K	D612	6S	D619	6Q
IC601	5B	IC608	5M	IC615	7O	IC622	4R	IC629	4S	Q605	5R	D606	7R	D613	8R	D620	6S
IC602	7L	IC609	9D	IC616	9M	IC623	8L	IC630	4N	Q606	4R	D607	7Q	D614	6M	D621	7M
IC603	9G	IC610	5L	IC617	8P	IC624	3G	Q609	4P	D608	6R	D608	6R	D615	6Q	D622	7R
IC604	6D	IC611	9O	IC618	6H	IC625	3K	Q610	3P	D609	7Q	D609	7Q	D616	7S	D623	6S
IC605	6L	IC612	7K	IC619	6O	IC626	6M	Q611	4Q	D610	6R	D610	6R	D617	8R	D624	7M
IC606	4G	IC613	8K	IC620	8S	IC627	3B	Q603	4I	D600	4B	D611	6P	D618	6N	D625	7N

Component side

Pattern 1

Pattern 2

Pattern 3

Pattern 4

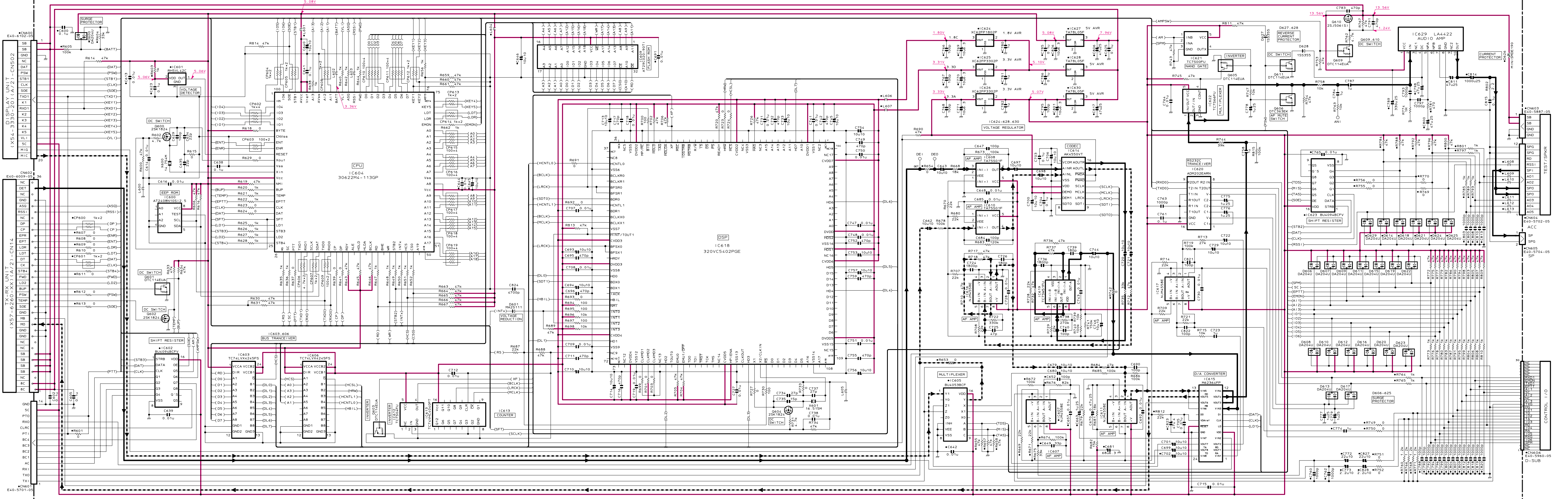
Foil side

● Connect 1 and 4

TKR-750 CIRCUIT DIAGRAM / 原理图

TX-RX UNIT: CONTROL SECTION (X57-6260-XX) (B/2)

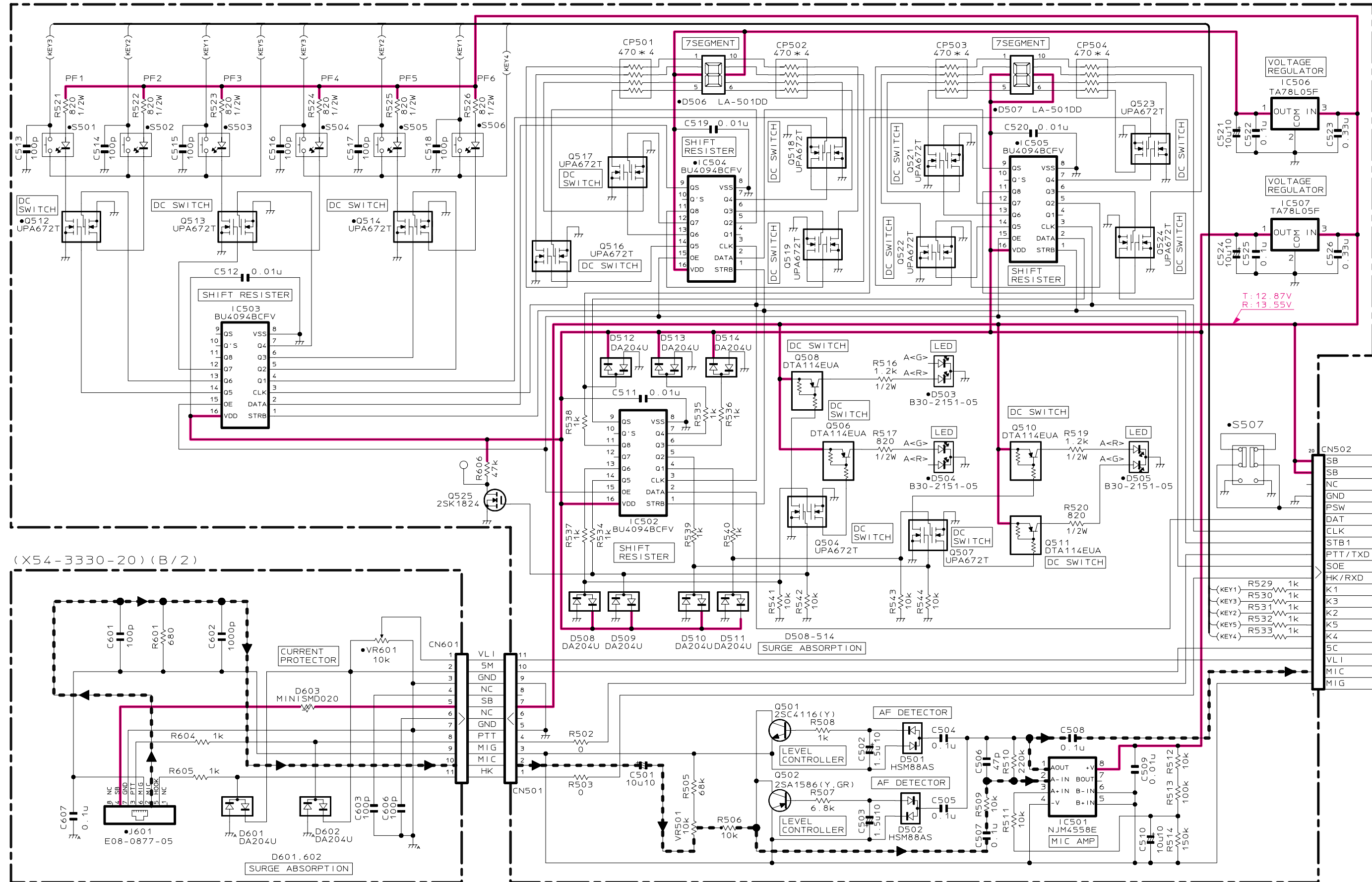
Note: Components marked with a dot (·) are parts of pattern 1.



D600, 606-625, 629	DA204U	D600, 602, 604	·2SK1824	IC600	·AT2408N10S12.5	IC604	·30622M4-113GP	IC609	·AT29C020-90T1	IC615	·M62364FP	IC620	·ADM202EARN	IC625, 626	·XC62FP3302P
D601	·MA2511	D601, 603, 605, 609, 611	·DT114EU4	IC601	·RH5VL42C	IC605	·BU40938CF	IC610	·TC7504FU	IC616	·320VC5402PGE	IC621	·TC7504FU	IC627, 628, 630	·TA78L05F
D626	·MINI SURGE 190	D606	·DT1363EK	IC602, 623	IC607, 611, 616, 617	IC608	·BU4094BCF	IC611	·TC7564F	IC619	·TC7564F	IC622	·TC7564F		
D627, 628	·15S355	D610	·25J506(1S)	IC603, 606	·TC74LVX4245P5	IC608, 610	·TA75001F	IC614	·AK4550VT	IC619	·TC7564F	IC624	·XC62FP1802P		

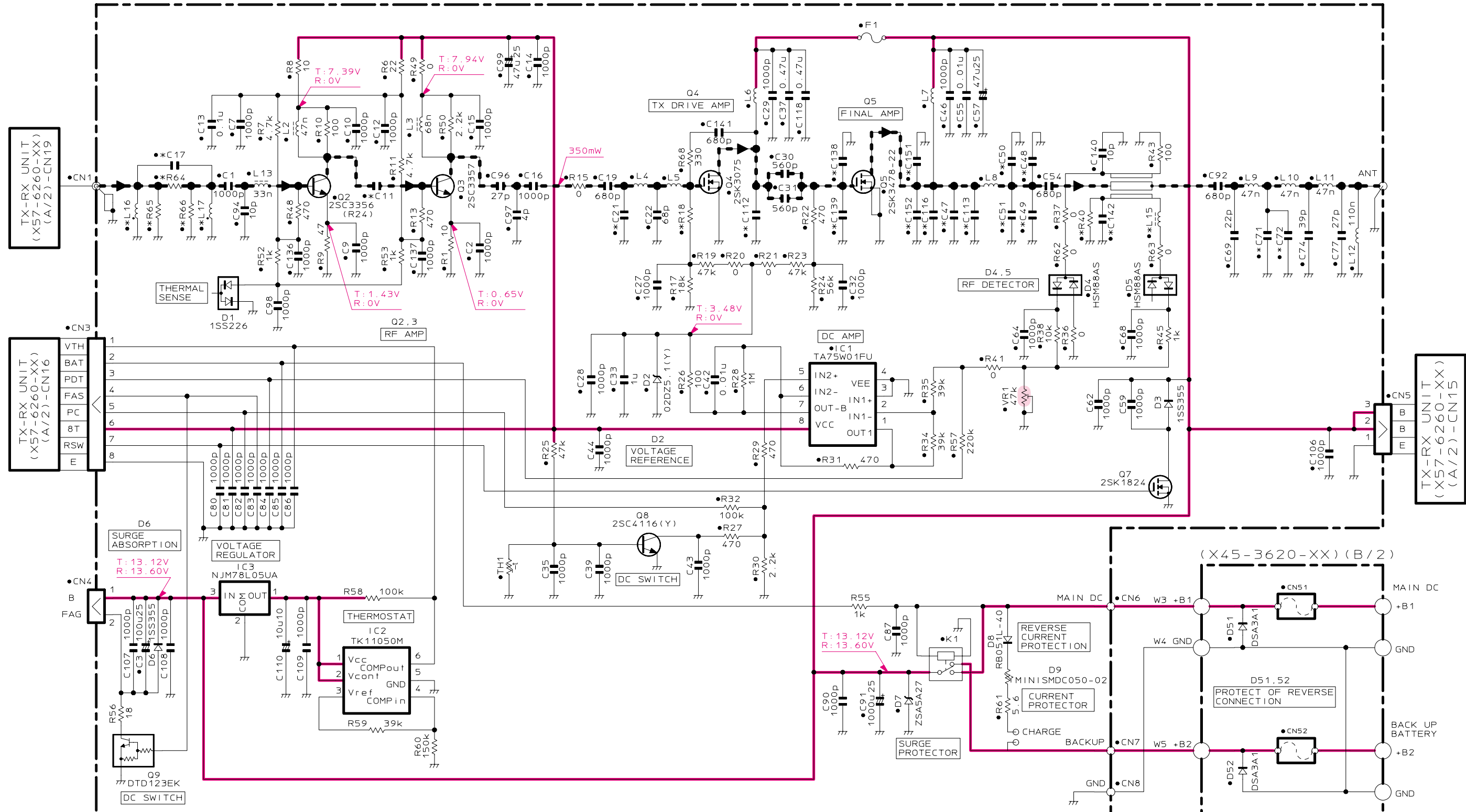
Note : Components marked with a dot (·) are parts of pattern 1.

DISPLAY UNIT
(X54-3330-20) (A/2)



- | | | | | |
|-------------------|------------------------|----------------------------|----------------------|------------------------|
| D601.602 : DA204U | D501.502 : HSM88AS | O501 : 2SC4116(Y) | O506.508 : DTA114EUA | IC501 : NJM4558E |
| D603 : MINISMD020 | D503-505 : B30-2151-05 | O502 : 2SA1586(Y,GR) | 510.511 : UPA672T | IC502-505 : BU4094BCFV |
| | D506.507 : LA-501DD | O504.507.512-514 : UPA672T | O525 : 2SK1824 | IC506.507 : TA78L05F |
| | D508-614 : DA204U | O516-519.521-524 : UPA672T | | |

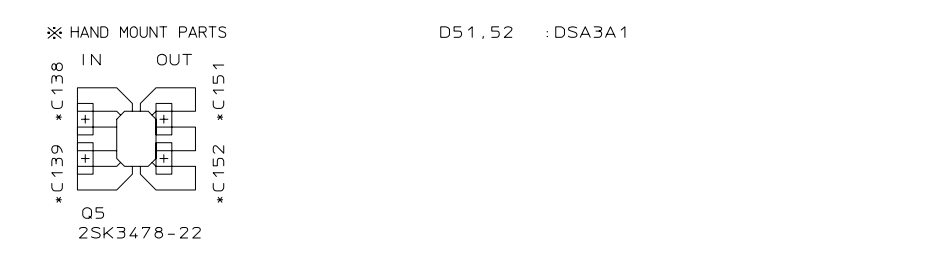
FINAL UNIT
(X45-3620-XX) (A/2)



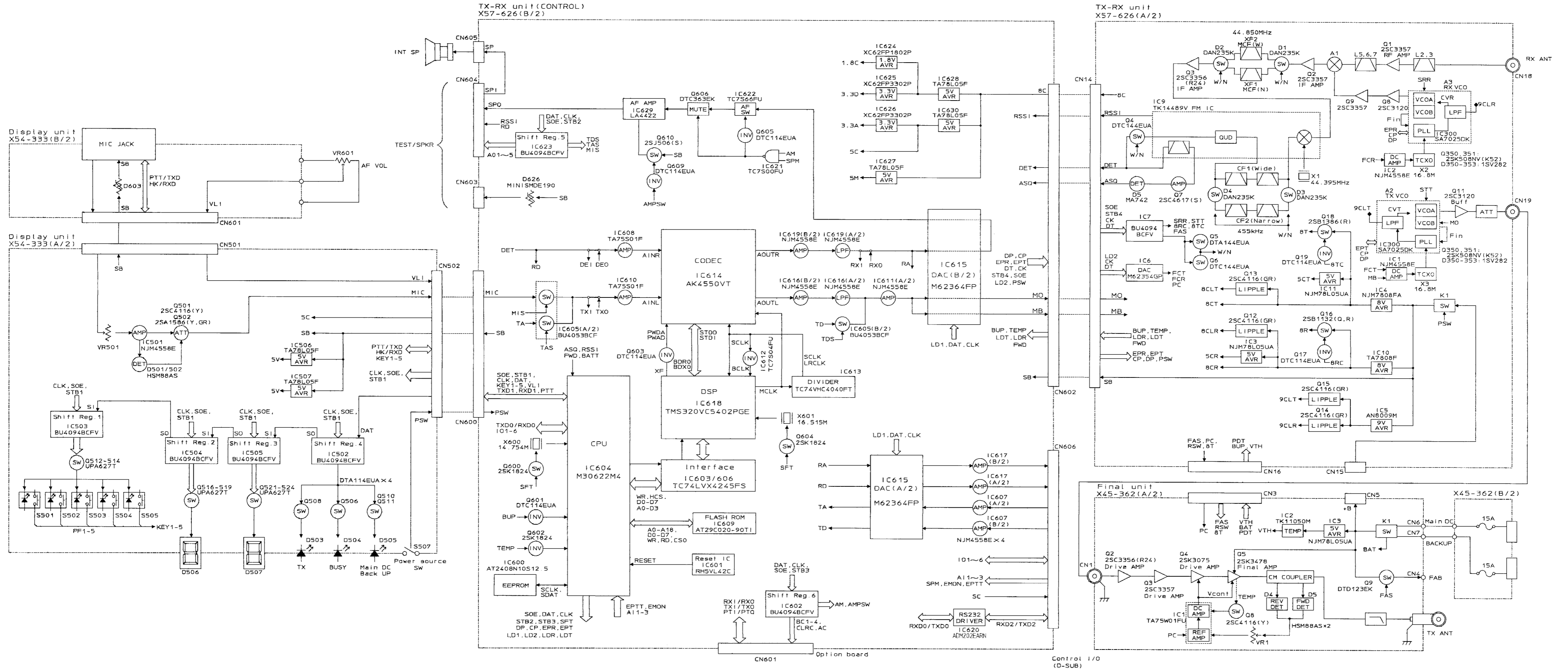
X45-3620-XX		C11	C17	C21	C47	C48	C49	C50	C51	C71	C72	C112	C113	C116	C138	C139	C142	C151	C152	L15	L16	L17	L18	R40	R64	R65	R66	
-10	C	47p	33p	33p	120p	18p	18p	NO	NO	22p	22p	180p	NO	180p	180p	180p	NO	39p	39p	470n	82n	82n	33	120	NO	NO	NO	
-11	C	2	68p	NO	27p	NO	NO	NO	27p	27p	27p	27p	27p	27p	240p	220p	240p	2p	68p	68p	820n	NO	NO	18	100	5.6	820	820

- | | | | | |
|-----------------|--------------------|--------------------|-----------------|------------------|
| D1 : 1SS226 | D7 : ZSA5A27 | O2 : 2SC3356 (R24) | O7 : 2SK1824 | IC1 : TA75W01FU |
| D2 : 02D25.1(Y) | O3 : RB051L-40 | O3 : 2SC3357 | O8 : 2SC4116(Y) | IC2 : TK11050M |
| D3.6 : 1SS355 | D9 : MINISMD050-02 | O4 : 2SK3075 | O9 : DTD123EK | IC3 : NJM78L05UA |
| D4.5 : HSM88AS | | O5 : 2SK3478-22 | | |

CIRCUIT DIAGRAM/原理图 TKR-750



BLOCK DIAGRAM / 方块图



TKR-750

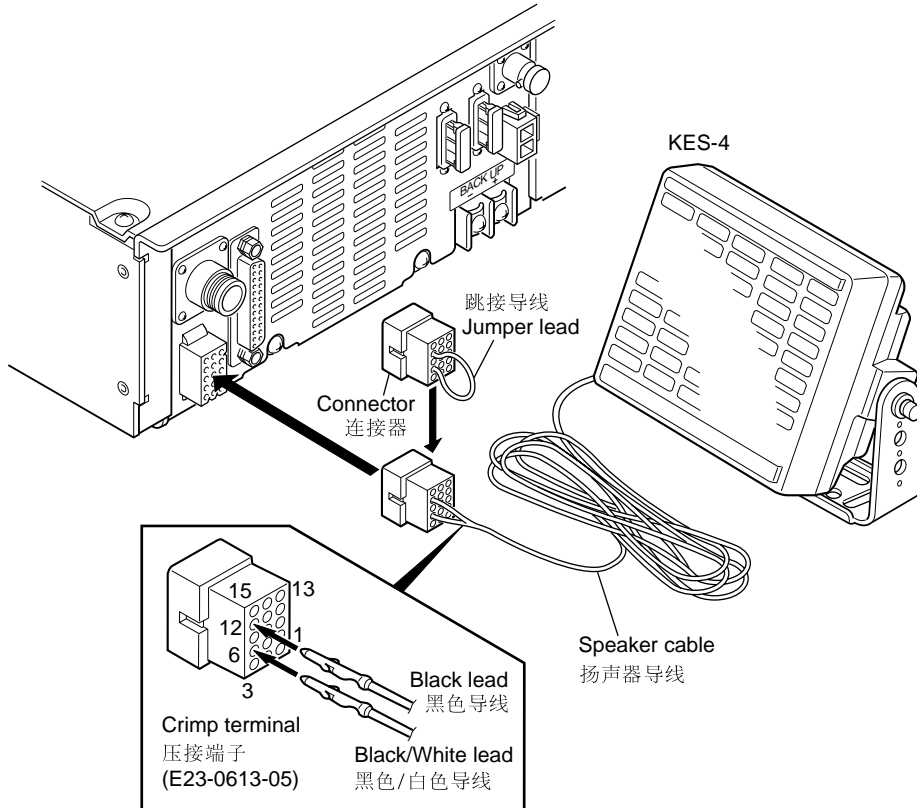
KES-4 (EXTERNAL SPEAKER / 外部扬声器)

When Using an External Speaker

1. Make sure the unit's power is tuned off.
2. When using the external speaker, remove the jumper lead from the connector, and attach the speaker cable.
3. When not using the external speaker, replace the jumper lead and insert the connector into the speaker jack (pin9 and 12).

使用外部扬声器时

1. 确认本机的电源已切断。
2. 使用外部扬声器时，从连接器上拆除跳接导线，连接扬声器导线。
3. 不使用外部扬声器时，恢复跳接导线，并且将连接器插入扬声器插座。（插脚9和12）



Specifications

Speaker size	120mm
Maximum input power	20W
Impedance	4Ω
Frequency response	100 to 5000Hz
Dimensions (W x H x D)	127 x 127 x 65 mm
projection not included	5 x 5 x 2-9/16 inch
Weight	780g / 1.72 lbs

规格

扬声器尺寸.....	120mm
最大输入功率.....	20W
阻抗.....	4Ω
频率响应.....	100到5000Hz
尺寸（宽×高×深）.....	127×127×65mm
不包括突出部分.....	5"×5"×2-9/16"
量重.....	780g (1.72磅)

规 格

概 述

频率范围	C: 146~174MHz	C2: 136~150MHz
信道数量	16个信道	
信道间距	宽: 25kHz 窄: 12.5kHz (锁相环电路步进频率5kHz/6.25kHz)	
工作电压	13.6V DC±15%	
电流消耗		
备用时	0.8A	
备用时/省电	0.3A(操作模式 DC-IN: 备用, FAN: 温度, 省电: 打开, 显示: 关闭)	
接收时	1.2A	
发射时/接收时	低于13A	
工作循环		
接收时	100%	
发射时	100%(100%在25W)	
频率稳定性	低于±0.0002% -30°C到+60°C	
天线阻抗	50Ω	
工作温度范围	-30°C到+60°C	
尺 寸	483宽×88高×340长 毫米	
重 量	9.7kg	

接收部(以每TIA/EIA-603进行测量)

灵 敏 度

12dB SIBAD	0.35 μV	
20dB Quieting	0.45 μV	
选 择 性	宽: 85dB(±25kHz)	窄: 77dB(±12.5kHz)
互 调	宽: 80dB(±25/50kHz)	窄: 75dB(±12.5/25kHz)
信号对剩余输出功率比	宽: 50dB	窄: 45dB
假信号响应	90dB	
音频功率输出(外部扬声器)	4Ω时4W, 失真低于5%	
音频失真(外部扬声器)	在1000Hz时低于2.5%	
信道频率扩展	3MHz	

发射部(以每TIA/EIA-603进行测量)

射频功率输出	50W	
调 制	宽: 16K0F3E	窄: 8K50F3E
寄生谐波	80dB	
频率调整噪音	宽: 50dB	窄: 45dB
音频失真	在1000Hz时低于3%	
麦克风阻抗	600Ω	
信道频率扩展	C: 28MHz	C2: 14MHz

SPECIFICATIONS

GENERAL

Frequency Range	C : 146 to 174MHz	C2 : 136 to 150MHz
Number of Channels	16 channel	
Channel Spacing	Wide : 25kHz	Narrow : 12.5kHz (PLL channel stepping 5kHz/6.25kHz)
Operating Voltage	13.6V DC±15%	
Current Drain		
Standby	0.8A	
Standby w/power save	0.3A (Operating mode DC-IN : Backup, FAN : Temp, SAVE : ON, DISP : OFF)	
Receive	1.2A	
Transmit/Receive	Less than 13A	
Duty Cycle	Receive : 100%	Transmit : 100% (100% @25W)
Frequency Stability	Less than ±0.0002% -30°C to +60°C	
Antenna Impedance	50Ω	
Operating Temperature Range.....	-30°C to +60°C	
Dimensions	483 W x 88 H x 340 D mm	
Weight	9.7kg	

RECEIVER (Measured by TIA/EIA-603)

Sensitivity		
12dB SINAD	0.35μV	
20dB Quieting	0.45μV	
Selectivity	Wide : 85dB (±25kHz)	Narrow : 77dB (12.5kHz)
Intermodulation	Wide : 80dB (±25kHz/±50kHz)	Narrow : 75dB (±12.5kHz/±25kHz)
Hum and Noise	Wide : 50dB	Narrow : 45dB
Spurious & Image Rejection.....	90dB	
Audio Output (Ext. Speaker).....	4W at 4Ω less than 5% distortion	
Audio Distortion (Ext. Speaker)	Less than 2.5% at 1000Hz	
Band Spread	3MHz	

TRANSMITTER (Measured by TIA/EIA-603)

RF Power Output	50W adjustable to 25W (100% duty @25W)	
Type of Emission	Wide : 16K0F3E	Narrow : 8K50F3E
Spurious Response	80dB	
FM Hum and Noise	Wide : 50dB	Narrow : 45dB
Audio Distortion	Less than 3% at 1000Hz	
Microphone Impedance	600Ω	
Band Spread	C : 28MHz	C2 : 14MHz

KENWOOD CORPORATION

14-6, Dogenzaka 1-chome, Shibuya-ku, Tokyo 150-8501, Japan

KENWOOD SERVICE CORPORATION

P.O. BOX 22745, 2201 East Dominguez Street, Long Beach, CA 90801-5745, U.S.A.

KENWOOD ELECTRONICS CANADA INC.

6070 Kestrel Road, Mississauga, Ontario, Canada L5T 1S8

KENWOOD ELECTRONICS DEUTSCHLAND GMBH

Rembrücker Str. 15, 63150 Heusenstamm, Germany

KENWOOD ELECTRONICS BELGIUM N.V.

Mechelsesteenweg 418 B-1930 Zaventem, Belgium

KENWOOD ELECTRONICS FRANCE S.A.

13, Boulevard Ney, 75018 Paris, France

KENWOOD ELECTRONICS U.K. LIMITED

KENWOOD House, Dwight Road, Watford, Herts., WD1 8EB United Kingdom

KENWOOD ELECTRONICS EUROPE B.V.

Amsterdamseweg 37, 1422 AC Uithoorn, The Netherlands

KENWOOD ELECTRONICS ITALIA S.p.A.

Via G. Sirtori, 7/9 20129 Milano, Italy

KENWOOD IBERICA S.A.

Bolivia, 239-08020 Barcelona, Spain

KENWOOD ELECTRONICS AUSTRALIA PTY. LTD.

(A.C.N. 001 499 074)

16 Giffnock Avenue, Centrecourt Estate, North Ryde, N.S.W. 2113 Australia

KENWOOD ELECTRONICS (HONG KONG) LTD.

Unit 3712-3724, Level 37, Tower one Metroplaza, 223 Hing Fong Road, Kwai Fong, N.T., Hong Kong

KENWOOD ELECTRONICS TECHNOLOGIES(S) PTE LTD.

Sales Marketing Division

1 Ang Mo Kio Street 63, Singapore 569110